

AD-A134 445

SIGNAL ENCODING AND TELEMETRY SYSTEMS FOR SPACE
VEHICLES(U) NORTHEASTERN UNIV BOSTON MASS ELECTRONICS
RESEARCH LAB J S ROCHEFORT ET AL. 01 MAY 83

1/2

UNCLASSIFIED

AFGL-TR-83-0135 F19828-80-C-0050

F/G 17/2

NL

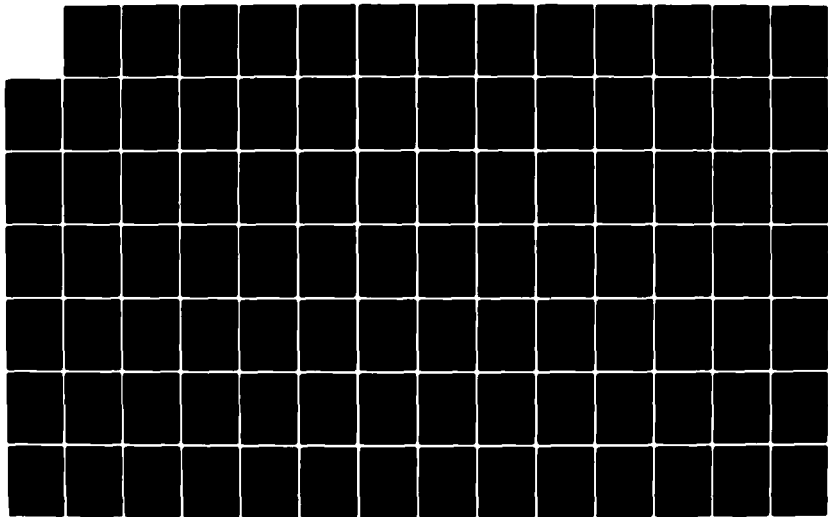

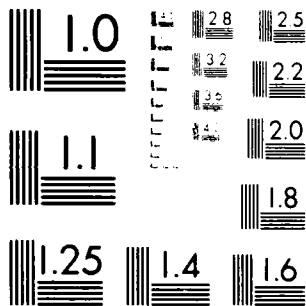

MICROCOPY RESOLUTION TEST CHART
NATIONAL BUREAU OF STANDARDS-1963-A

(12)

AFGL-TR-83-0135

SIGNAL ENCODING AND TELEMETRY SYSTEMS
FOR SPACE VEHICLES

J. Spencer Rochefort
Lawrence J. O'Connor
Norman C. Poirier
Thomas P. Wheeler

NORTHEASTERN UNIVERSITY
360 Huntington Avenue
Boston, Massachusetts 02115

FINAL REPORT

4 December 1979 through 3 December 1982

1 May 1983

Approved for public release: distribution unlimited.

Prepared for

AIR FORCE GEOPHYSICS LABORATORY
AIR FORCE SYSTEMS COMMAND
UNITED STATES AIR FORCE
HANSCOM AFB, MASSACHUSETTS 01731

[Handwritten signature]
A

AD. A134445

DTIC FILE COPY

83 11 04 00 9

This report has been reviewed by the ESD Public Affairs Office (PA) and is releasable to the National Technical Information Service (NTIS).

This technical report has been reviewed and is approved for publication

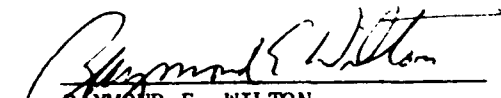
RAYMOND E. WILTON
Contract Manager

EDWARD F. MCKENNA
Branch Chief

FOR THE COMMANDER

C. NEALON STARK
Division Director

Qualified requestors may obtain additional copies from the Defense Technical Information Center. All others should apply to the National Technical Information Service.

If your address has changed, or if you wish to be removed from the mailing list, or if the addressee is no longer employed by your organization, please notify AFGL/DAA, Hanscom AFB, MA 01731. This will assist us in maintaining a current mailing list.

Do not return copies of this report unless contractual obligations or notices on a specific document require that it be returned.

Unclassified

MIL-STD-847A
31 January 1973

SECURITY CLASSIFICATION OF THIS PAGE (When Data Entered)

REPORT DOCUMENTATION PAGE		READ INSTRUCTIONS BEFORE COMPLETING FORM
1. REPORT NUMBER AFGL-TR-83-0135	2. GOVT ACCESSION NO. 48 3734 948	3. RECIPIENT'S CATALOG NUMBER
4. TITLE (and Subtitle) SIGNAL ENCODING AND TELEMETRY SYSTEMS FOR SPACE VEHICLES		5. TYPE OF REPORT & PERIOD COVERED Scientific - Final 4 Dec. 79 - 3 Dec. 82
		6. PERFORMING ORG. REPORT NUMBER
7. AUTHOR(s) J. Spencer Rochefort Norman C. Poirier Lawrence J. O'Connor Thomas P. Wheeler		8. CONTRACT OR GRANT NUMBER(s) F19628-80-C-0050
9. PERFORMING ORGANIZATION NAME AND ADDRESS Northeastern University Electronics Research Laboratory Boston, MA 02115		10. PROGRAM ELEMENT, PROJECT, TASK AREA & WORK UNIT NUMBERS 62101F 765904AS
11. CONTROLLING OFFICE NAME AND ADDRESS Air Force Geophysics Laboratory Hanscom AFB, MA 01731 Monitor/ Raymond E. Wilton/LCR		12. REPORT DATE May 1, 1983
		13. NUMBER OF PAGES 102
14. MONITORING AGENCY NAME & ADDRESS (if different from Controlling Office)		15. SECURITY CLASS (of this report) Unclassified
		15a. DECLASSIFICATION DOWNGRADING SCHEDULE
16. DISTRIBUTION STATEMENT (of this Report) Approved for public release; distribution unlimited.		
17. DISTRIBUTION STATEMENT (of the abstract entered in Block 20, if different from Report)		
18. SUPPLEMENTARY NOTES		
19. KEY WORDS (Continue on reverse side if necessary and identify by block number) Pulse Code Modulation Decoder Rockets ✓ Encoder Television Balloons Microprocessor Satellites		
20. ABSTRACT (Continue on reverse side if necessary and identify by block number) This report summarizes the main work carried out under this contract (December 4, 1979 through December 3, 1982). Contract effort can be grouped under research and development of airborne instrumentation systems, study and analysis programs, rocket and balloon field programs, and evaluation testing of telemetry components. Instrumentation systems developed have included		

DD FORM 1473 1 JAN 73 EDITION OF 1 NOV 65 IS OBSOLETE

Unclassified

SECURITY CLASSIFICATION OF THIS PAGE (When Data Entered)

MIL-STD-847A
31 January 1973

Unclassified

SECURITY CLASSIFICATION OF THIS PAGE (When Data Entered)

a programmable PCM encoder, a programmable data selector, slow scan television, preflight calibrator and a recovery beacon system. Studies have been conducted on uses of the TDRSS system and analysis has been made of the signal-to-noise ratio of the Aeronomy type sphere telemetry system. Rocket field programs have been involved with Field Widened Interferometer, Aeronomy, Energy Campaign, Tracer, Solar Proton Events, Auroral-E, Brazilian Ionospheric Modifications Experiment and Sensor Ejection Systems while Balloon field programs have been in support of an Extreme Ultra Violet Experiment. New testing procedures involving vacuum testing, RF power measurements and temperature monitoring is mentioned along with reference to the number of components tested.

X

✓



A-1

Unclassified

SECURITY CLASSIFICATION OF THIS PAGE (When Data Entered)

TABLE OF CONTENTS

	Page
TITLE PAGE	i
TABLE OF CONTENTS	iii
CHAPTER I. RESEARCH AND DEVELOPMENT PROGRAMS	1
A. Programmable PCM Encoder	1
1. The Encoder	1
a. Overview	1
b. Data Input Circuitry	5
c. Parity Generating Circuits	7
d. Bit Rate Frequency Synthesis	7
e. Output Code Generation and Selection	10
f. Premodulation Filter and Output Driver	12
g. Timing Circuits.	14
2. Program Development	18
a. The 8748/8749 Programmer	18
b. The VAX Assembler.	24
c. The Program.	24
3. Rocket Applications	30
a. BIME Program	30
b. SES Program.	30
B. Data Selector.	31
1. Data Selector	31
2. Data Selector External Characteristics.	32
3. Data Selector Operation	33
4. Field Application	36

	Page
C. Slow Scan Television	36
1. Slow Scan Converter	38
2. Camera Selection.	39
3. Video Pre-emphasis Filter	41
D. Preflight Calibrator	41
1. Receiver Section.	48
2. Control Section	49
E. Recovery Beacon.	51
CHAPTER II. STUDY AND ANALYSIS PROGRAMS.	54
A. NASA Tracking and Data Relay Satellite System.	54
B. The Aeronomy Sphere Study.	58
1. Preflight Analysis.	58
a. Bandwidth Measurements	59
b. Link CNR Calculations.	59
2. Postflight Analysis	60
a. Airborne Antenna	61
b. Receiving Stations	61
c. Records of AGC Reception at NASA Station	62
d. Records of AGC Reception at OSU Station.	63
3. Conclusions and Recommendations	63
C. A Master-Slave Transmission System Study	64
CHAPTER III. AIRBORNE INSTRUMENTATION.	68
A. Flight Systems	68
1. Extreme Ultra Violet Experiment (EUV)	68
2. Field Widened Interferometer.	69
3. Aeronomy.	70

	Page
4. Energy Campaign	71
5. Tracer.	72
6. Solar Proton Event.	72
7. Auroral-E Program	74
8. Brazil Ionospheric Modification Experiment.	75
9. Sensor Ejection Systems	82
B. Field Support.	84
CHAPTER IV. TESTING PROGRAMS	87
A. New Testing Procedures	87
1. Vacuum Tests.	87
2. RF Power Measurements	88
3. Temperature Monitor System.	90
B. Components Tested.	91
BIBLIOGRAPHY.	92
PERSONNEL	93
RELATED CONTRACTS AND PUBLICATIONS.	94

CHAPTER I
RESEARCH AND DEVELOPMENT PROGRAMS

A. Programmable PCM Encoder

1. The Encoder

a. Overview. PCM encoders, in general, have many operating parameters which must be specified to meet the requirements of a particular application. These include number and types of inputs, sampling rate of each input, accuracy of encoding, parity requirements, type of output code, type of synchronization codes, bit rates, and output filter requirements. Often the requirement of a particular application will change as the mission becomes better defined. This results in a decision to either specify a new encoder or relax the requirements to allow the existing encoder to be used.

During the first quarter of this contract a study was initiated to lead to the development of an encoder which would incorporate a single microprocessor chip and be software controlled. It was felt that with such an encoder it would merely be necessary to write the necessary program for storage in an EPROM in order to adapt to the changing requirements of an individual program. Furthermore, as new missions with changed requirements arose, the same basic encoder could be used and redesign with modified hard-wired logic would not be needed.

The resulting encoder can accept a number of analog and digital signals and multiplex them into a serial digital data stream for subsequent transmission. It is totally controlled by an on board single component 8-bit microcomputer. By programming the memory (an

EPROM contained within the microcomputer), all the operating parameters can be set to meet a specific application. This program memory is large enough to contain several completely different formats which could, if so desired, be changed by activating a single bit interrupt line. This feature would allow format changes in flight. This programming feature also allows complete changes in format at any point in a program by simply inserting a new preprogrammed microcomputer into the encoder or reprogramming the existing one. A block diagram of the entire system is shown in Figure 1-1 and a complete schematic drawing is available.*¹

The following is a tabulation of the various parameters available to the user:

ANALOG INPUTS - Up to 158 analog inputs can be serviced with full scale input levels from 80 mV to 10 volts. Each channel can have different full scale levels and the channels can be selected in any order. The analog channel frequency response is limited only by the rate at which a particular channel is sampled. For differential input capability, up to 8 different ground or signal returns may be selected.

DIGITAL INPUTS - Up to 64 direct digital entry channels are available. Each channel may contain up to 12 bits per word. All digital channels are connected to a single 12 bit bus and the user must present his data through a tristate gate which is accessed by the encoder. The encoder will accept signals which are compatible with low power schottky TTL.

*Numbered superscripts refer to the Bibliography.

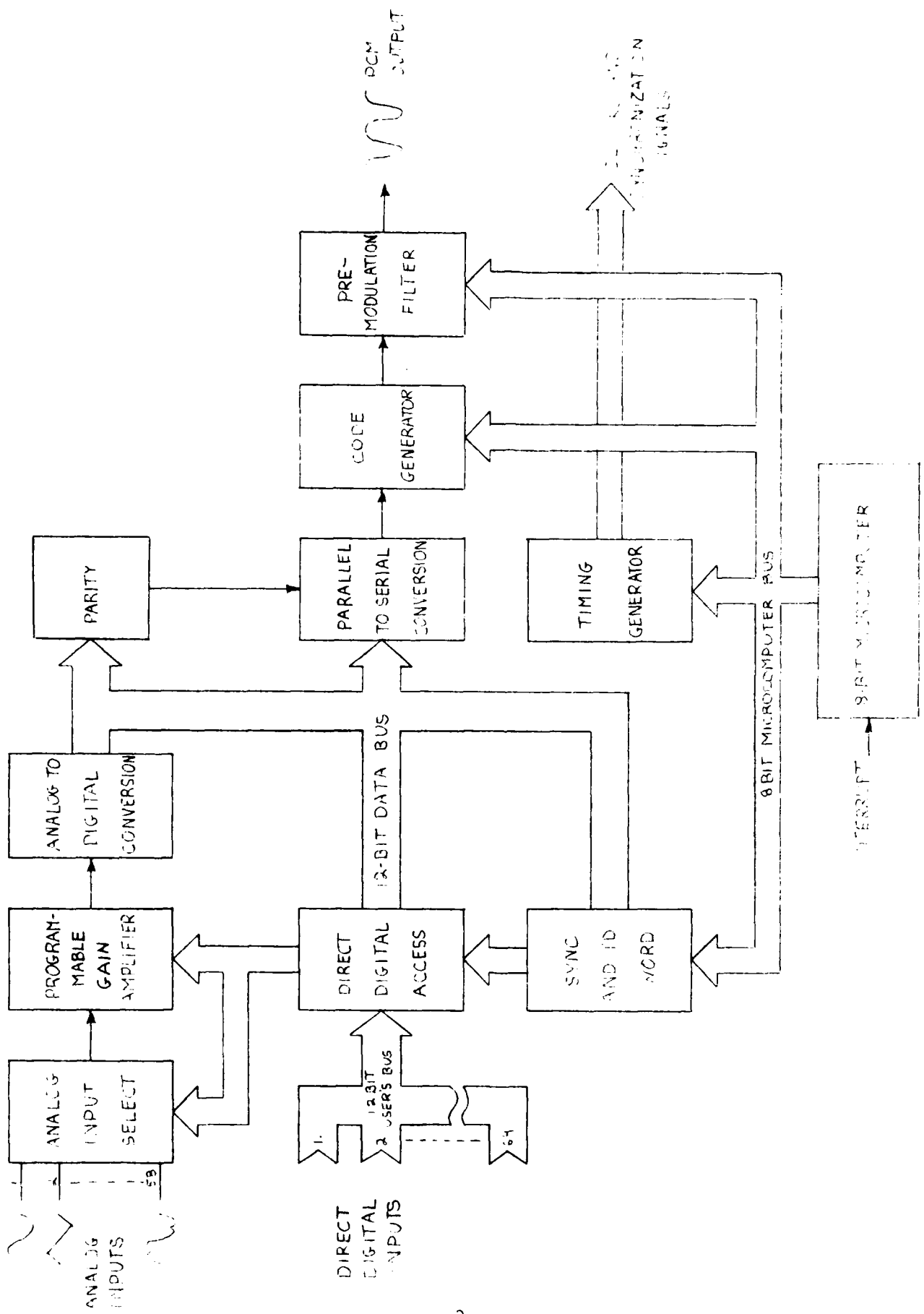

Figure 1-1. System Block Diagram.

WORD LENGTH AND PARITY - Word length from 8 to 12 bits plus a parity bit can be accommodated. Parity can be even or odd and is located in the MSB position if used.

BIT RATE - The bit rate can be programmed from 2 bits/sec. to 700 k bits/sec. All bit rates are digitally synthesized from a single crystal controlled oscillator.

OUTPUT CODE - The following codes are available. NRZ-L, NRZ-M, NRZ-S, Bi0-L, Bi0-M, Bi0-S, DM-M and DM-S.

PREMODULATION FILTER - The output filter is a 6 pole (36 dB/octave rolloff) linear phase low pass active filter with a 3 dB cutoff range of 640 Hz to 700 kHz.

OUTPUT SIGNALS - Besides the PCM output, two output synchronization clocks are available. They are a PCM bit rate and word rate clocks. Also outputted are the signals to synchronize the entry of the direct digital entry signals. Address lines are also outputted and could be decoded for synchronization purposes (major frame sync., minor frame sync.).

FRAME FORMATS - Any channel may be supercommutated and any channel may be subcommutated. The maximum number of minor frames to major frames is 256. The subframes synchronization may be accomplished by either ID mode, pattern mode or complimentary frame sync. mode. Maximum word rate is 61.1 kilowords per second.

PHYSICAL - ELECTRICAL - Power required for the encoder is approximately +15 V at 96 mA, -15 V at 96 mA, and +5 V at 750 mA. The physical dimensions are 8.5 x 5.75 x 3 inches or 21.59 x 14.61 x 7.62 cm and weighs 3.25 lbs. or 1.48 kg. Flight models flown in Brazil on the BIME program and those built for the SES program had different aspect ratios, but approximately the same volume.

b. Data Input Circuitry. Figure 1-2 is a block diagram of the data input circuits. Both analog and digital data sources may be accessed by the encoder and may be acquired in any sequence because they are under control of the program stored within the microcomputer.

Analog signals pass through a bank of analog multiplexers, which are protected to withstand input voltages exceeding the supply voltages by 10 volts and can withstand brief input transient spikes of several hundred volts. After selection, the desired signal goes to a programmable gain differential amplifier (PGDA) and is amplified such that the net result is a full scale voltage of 10 volts. The range of full scale input voltages is from 80 millivolts to 10 volts. The voltage range from each source can be different since the gain of the PGDA is under program control. The differential feature of the PGDA allow selection of the appropriate signal return such that ground loops and ground induced noise can be minimized.

All analog signals pass through a sample and hold circuit, and then are encoded to 12 bits. The actual number of bits transmitted is under software control and is determined during the initialization routine. After encoding, the data (now in digital form) is placed on to a data bus from which it will be converted to a serial pulse train at the proper time and bit rate.

The direct digital input signals are organized such that each user inputs his signals on a common 12 bit digital input bus through a tristate gate. These gates are under control of the PCM encoder microcomputer. Gating control signals are available to the user such that data will be ready for access at the proper time. The direct digital bus passes through a buffer before it enters the data bus for serial conversion.

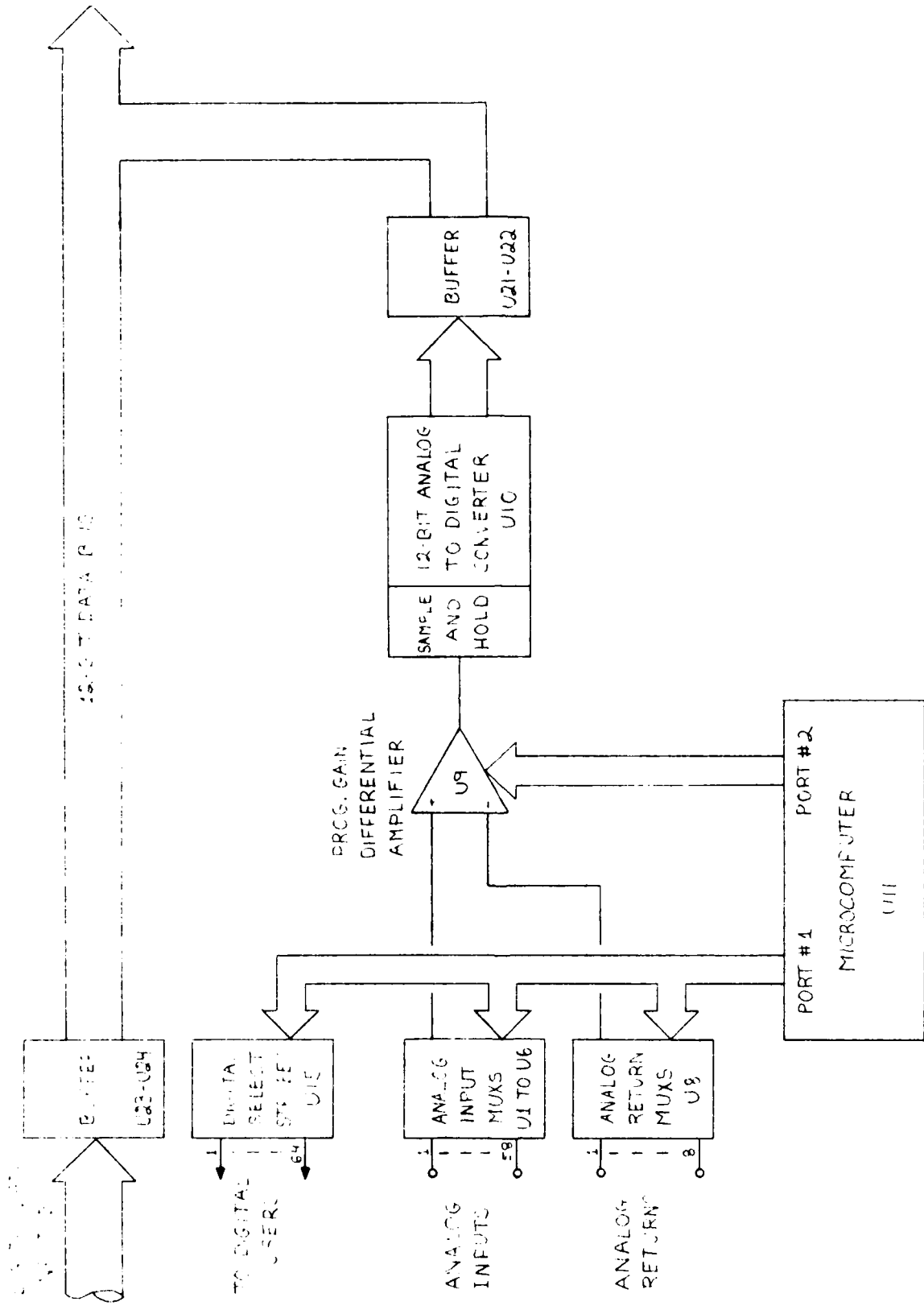

Figure 1-2. Data Input Circuitry.

c. Parity Generating Circuit. Figure 1-3 is a functional diagram of the parity generating circuit. This circuit generates an odd or even parity bit. The most significant 7 data bits from the data bus are applied to parity generator U25 directly. The least significant 5 data bits are applied to the 5 AND gates. These AND gates allow the masking of the data if the data length is less than 12 bits. The ODD/EVEN control adds an additional 1 or 0 to parity generator U26 to change the parity from odd to even. The parity bit is sent to the parallel to serial conversion circuit where, if selected, it is added to the serial data stream in the most significant bit position. The masking bits, odd/even control bit and parity select bit are controlled by the code latched into port 7 during the initialization routine.

d. Bit Rate Frequency Synthesis. A block diagram of the basic phase-locked-loop bit rate generator is shown in Figure 1-4. The elements of the system are a phase comparator, loop filter, a voltage controlled oscillator, and three 16-bit divide-by-N binary counters. The division ratio of each counter is set during the initialization routine. The voltage controlled oscillator, or VCO, is an oscillator whose frequency is proportional to an externally applied voltage. [When the loop is locked, the VCO frequency is exactly equal to the output of counter 0, which is derived from the T0 output of the microcomputer times the division factor of counter 1 which is driven by the VCO.] The phase detector produces a dc or low-frequency signal proportional to the phase difference between the outputs of counter 0 and counter 1. This phase sensitive signal is passed through the

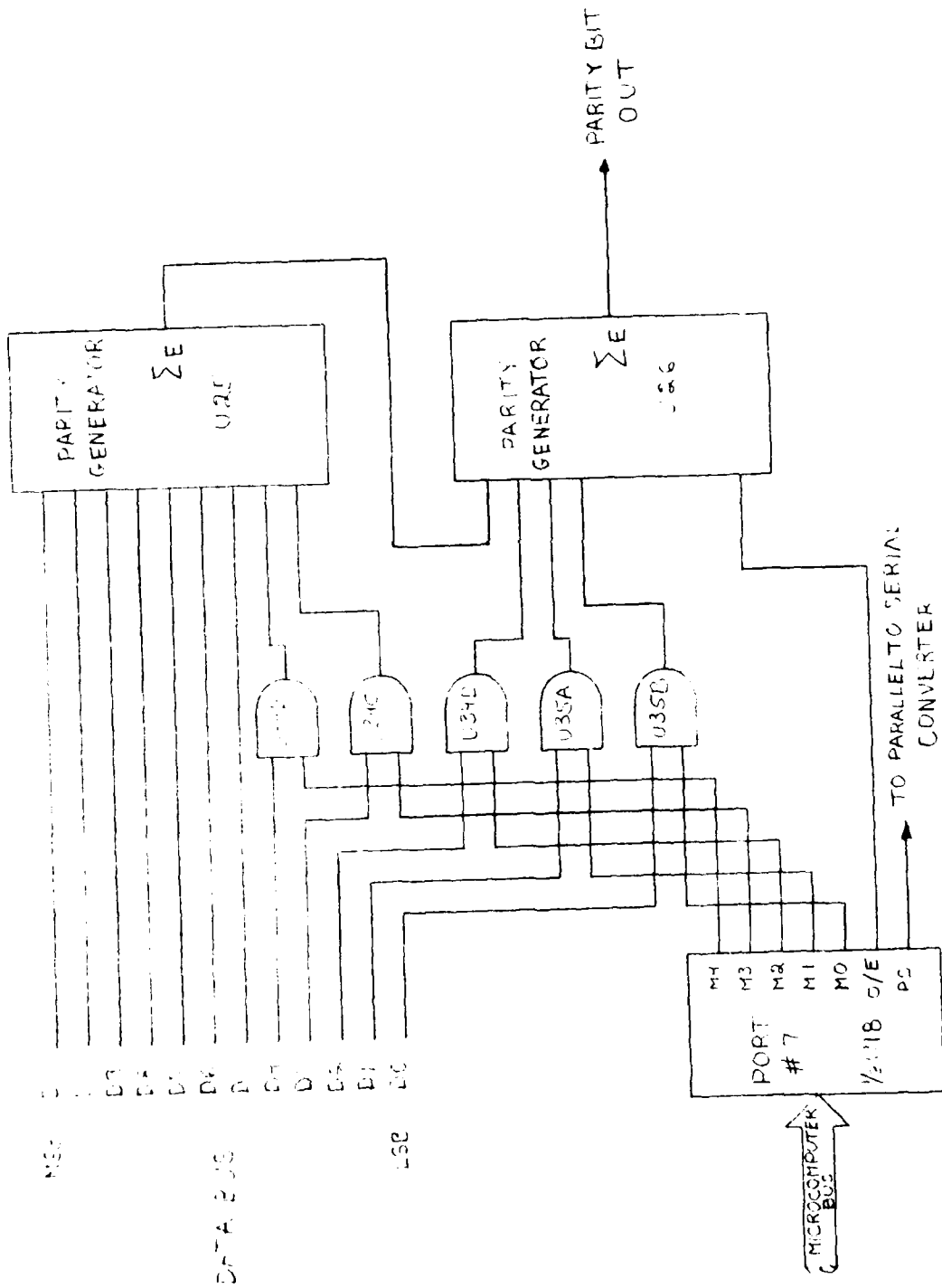

Figure 1-3. Parity Generating Circuit.

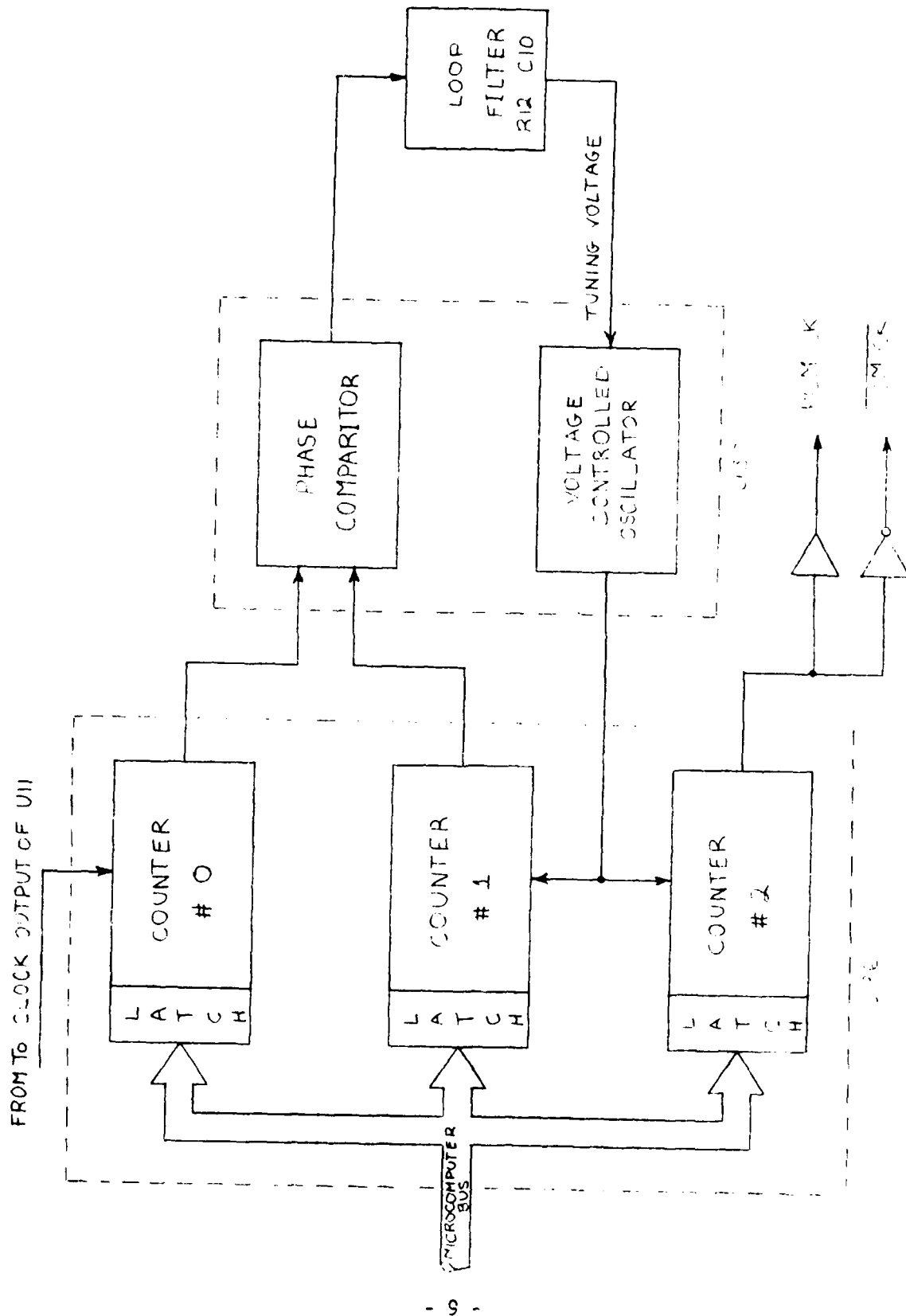

Figure 1-4. Bit Rate Frequency Synthesis.

loop filter and is applied to the control input of the VCO. The output of the VCO also drives the input to counter 2. The output of counter 2 is then buffered and inverted to become the bit rate clocks, PCM CK and $\overline{\text{PCM CK}}$. The frequency generated by this process has the same long term stability as the microcomputer clock crystal.

The bit rate can be calculated from the counter division factors and the T0 clock as shown below:

$$f_{\text{PCM}} = f_{\text{T0}} \times \frac{1}{N_0} \times N_1 \times \frac{1}{N_2}$$

$$= \frac{f_{\text{T0}} N_1}{N_0 N_2}$$

[When the loop is locked the VCO frequency is exactly equal to N_1 times the output of counter 0, thus both inputs to the phase comparator are equal in frequency.] where

f_{PCM} = Resultant bit rate

f_{T0} = Microcomputer clock frequency (3.667 MHz)

N_0 = Division rate of counter 0

N_1 = Division rate of counter 1

N_2 = Division rate of counter 2 (Counter 2 must be an even number for a symmetric output).

Including the constraints of other circuits in the encoder, bit rates from 2 Hz to 700 kHz are possible, with a maximum frequency error of 0.015%.

e. Output Code Generation and Selection. Figure 1-5 is excerpted from the master drawing. It includes the logic circuits which produce all the standard IRIG PCM codes (U42 through U49).

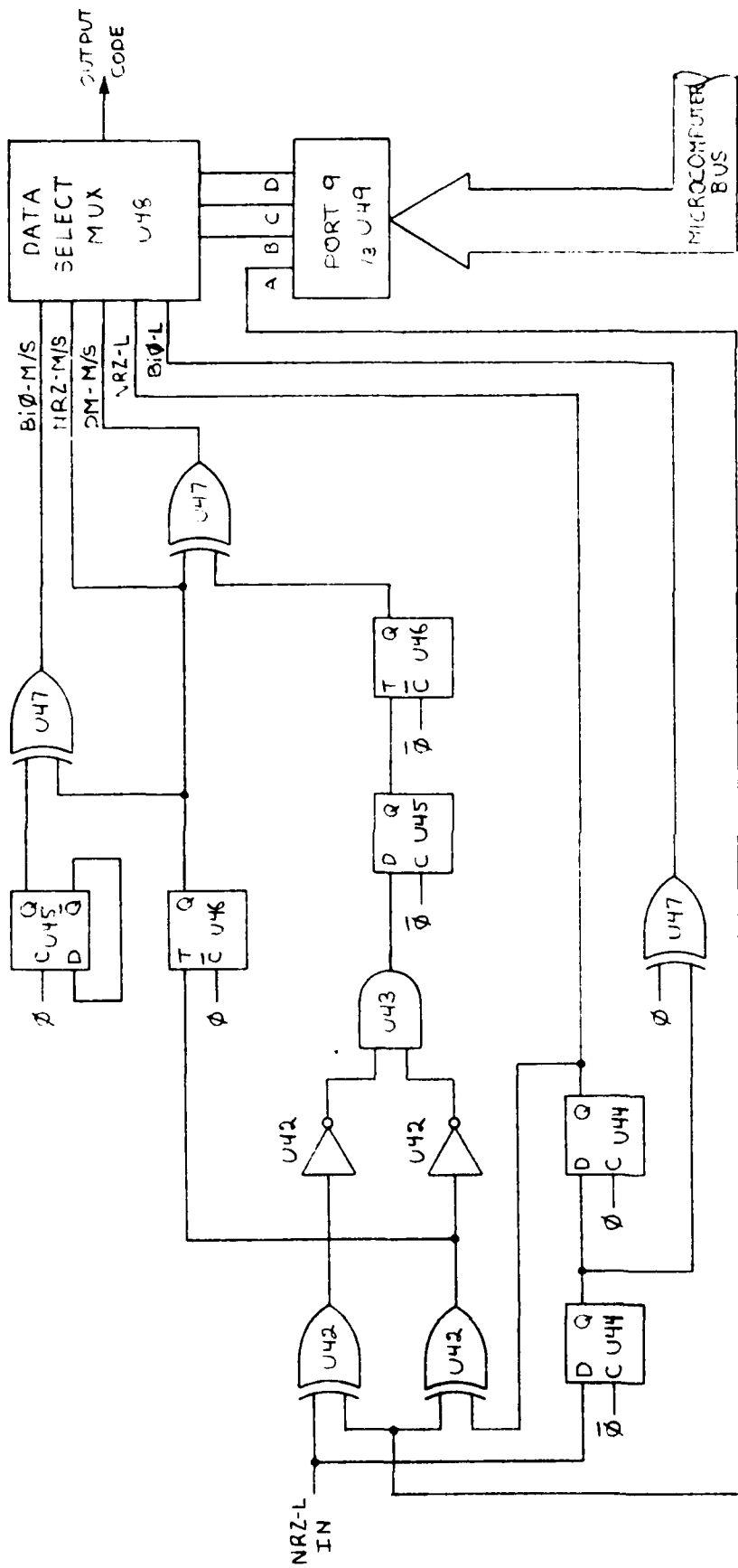

A	B	C	D	OUTPUT CODE
X	0	0	0	NRZ-L
0	0	0	1	NRZ-M
1	0	0	1	NRZ-S
X	0	1	0	Biφ-L
0	0	1	1	Biφ-M
1	0	1	1	Biφ-S
0	1	0	0	DM-M
1	1	0	0	DM-S

Figure 1-5. Output Code Generation and Selection.

All basic codes are continuously generated from the NRZ-I input and the PCM clocks (\emptyset and \emptyset). The specific code to be outputted is selected by a digital data selector, U48, which is controlled by the code latched into Port 9 (U49) during the initialization routine. The selected code is then routed to a six pole active filter. The codes produced and the binary code for selection is presented in the block inset of this figure.

f. Premodulation Filter and Output Drives. The premodulation filter, shown in abbreviated block form in Figure 1-6 is a 6-pole linear-phase low-pass active filter. The cutoff range can be varied from 640 Hz to 700 KHz. Selection of cutoff frequency is accomplished by selecting appropriate resistors and capacitors with digitally controlled analog gates. This active filter was designed using the unity gain Sallen-Key approach.

Each of the three filter sections provides a pair of complex poles which when properly positioned yield the desired linear-phase response. Programming of the cutoff frequency is accomplished during the initialization routine with the digital result being latched into port 10, a programmable peripheral interface (U49). This 6 bit digital word drives analog gates in the R and C block of the diagram. Preceding the filter is a unity gain buffer, U50 which provides isolation and DC offset adjustment. This offset adjustment is necessary because the transmitters are DC coupled and a DC component in the wave train would offset the center frequency of the radiated signal, possibly out of range of the crystal controlled receivers.

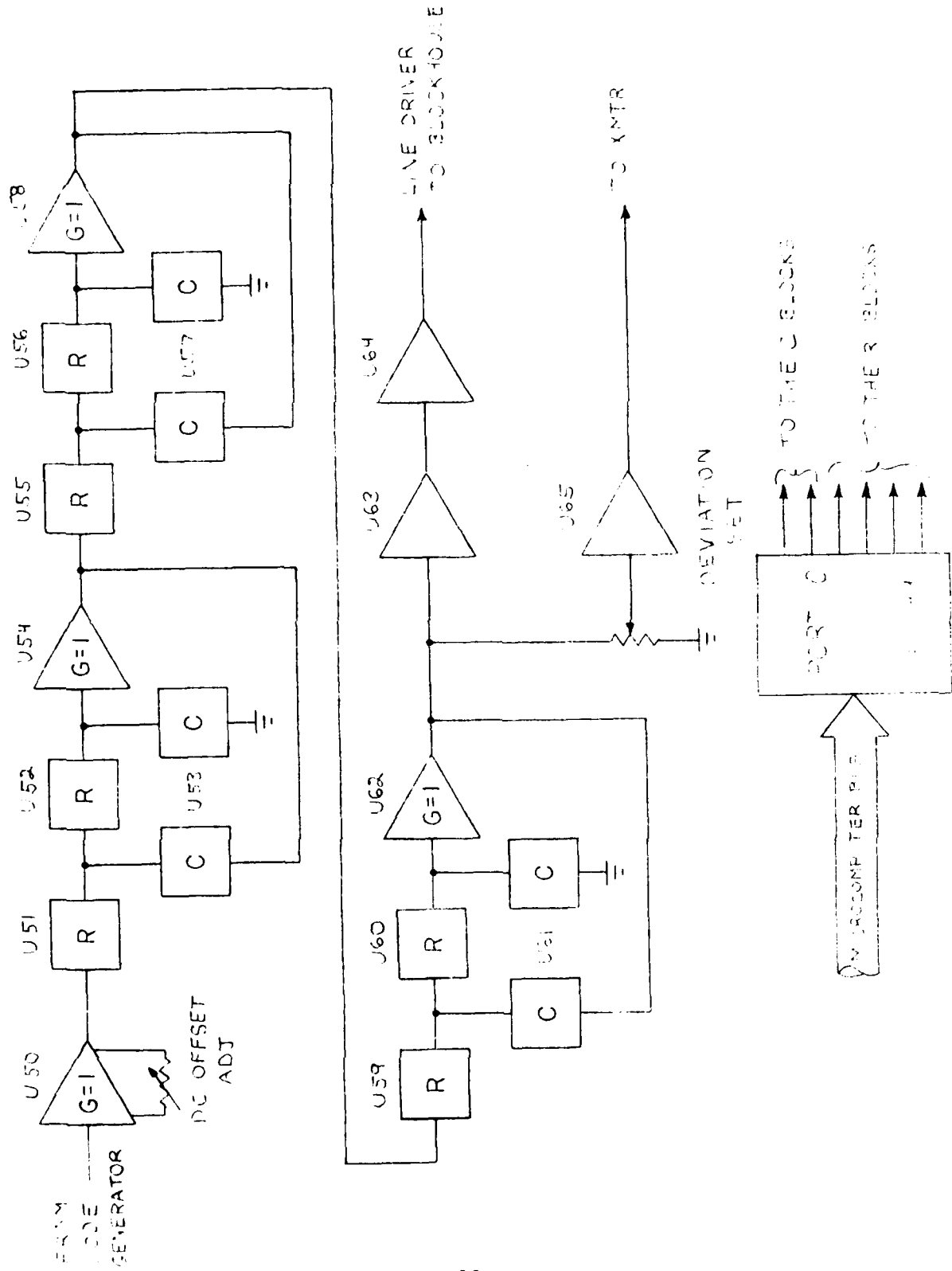

Figure 1-6. Prerodulation Filter and Output Drives.

Following the active filter are two drive circuits. The first is the transmitter modulation driver. Its main function is to provide variable gain for setting of the transmitter deviation. This is accomplished by driving a potentiometer followed by a unity gain amplifier, U65.

The second drive circuit is a video line driver consisting of U63 and U64, which drives a 50 ohm coaxial cable from the vehicle to the blockhouse. This allows full PCM monitoring without requiring that the RF system be activated. This feature is important in areas where RF radiation clearance is limited to short periods of time due to other programs in progress on the same range.

g. Timing Circuits. The timing circuits shown in block diagram form in Figure 1-7 provide all essential timing functions required for proper encoder operation. A timing diagram displaying these timing functions is shown in Figure 1-8 and an explanation of their operation is given below.

During the initialization routine the number of bits per word is outputted to PORT 8 which is on U49, a programmable peripheral interface. This binary number is applied to the data inputs on U39 a synchronous binary down counter. When this counter reaches its terminal count its output \overline{RCO} goes low for one bit period. This brings S/L low on the parallel to serial converter which permits the data on the data bus to be parallel loaded on the next leading edge of the PCM CK. \overline{RCO} is also applied to a D type flip-flop U40B where it is delayed by one-half bit period and inverted. The \overline{Q} output of this flip-flop designated T1 in Figure 1-7 accomplishes the following task on its lead edge: (1) it clocks out the next data bus control

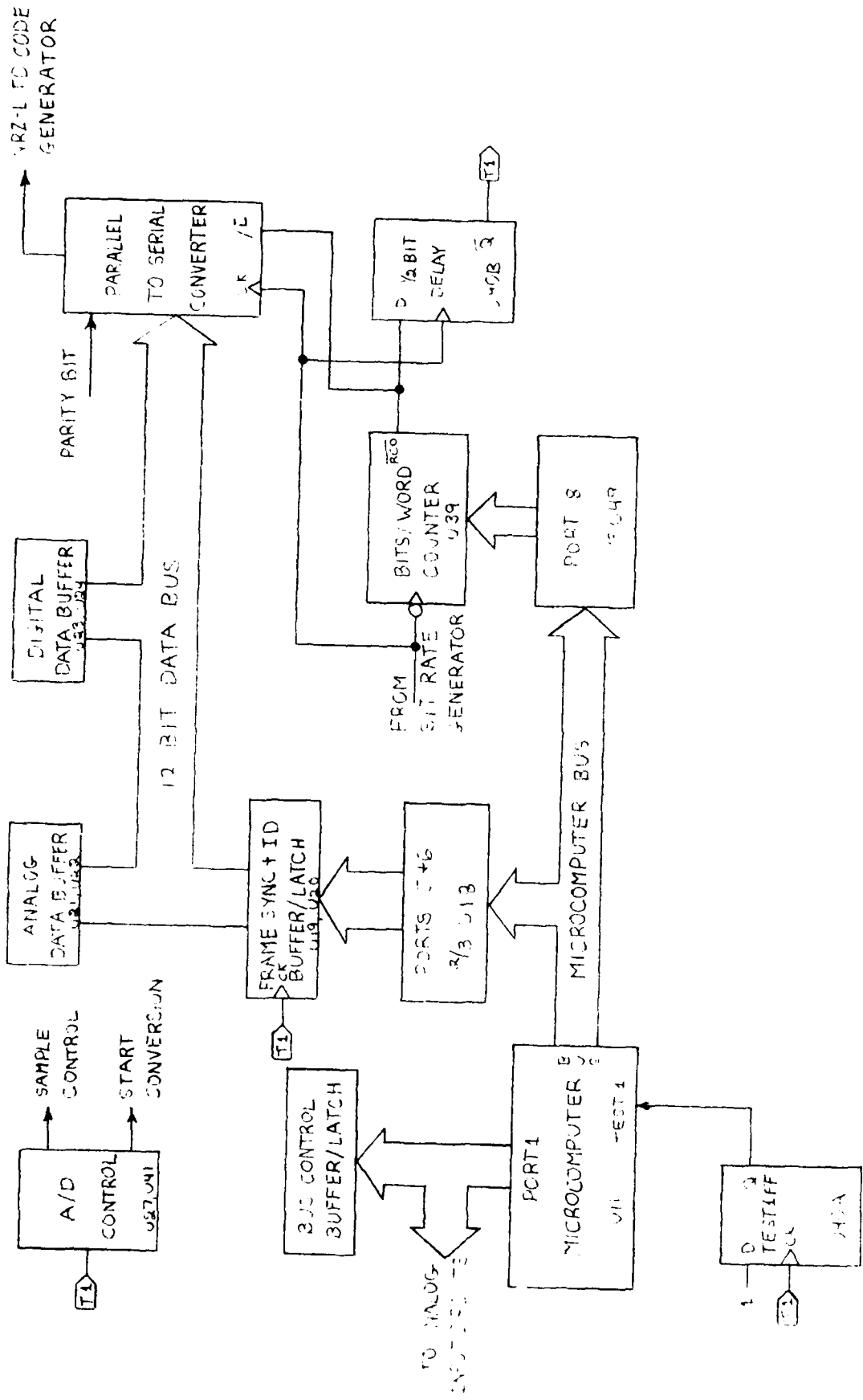

Figure 1-7. Timing Circuit Block Diagram

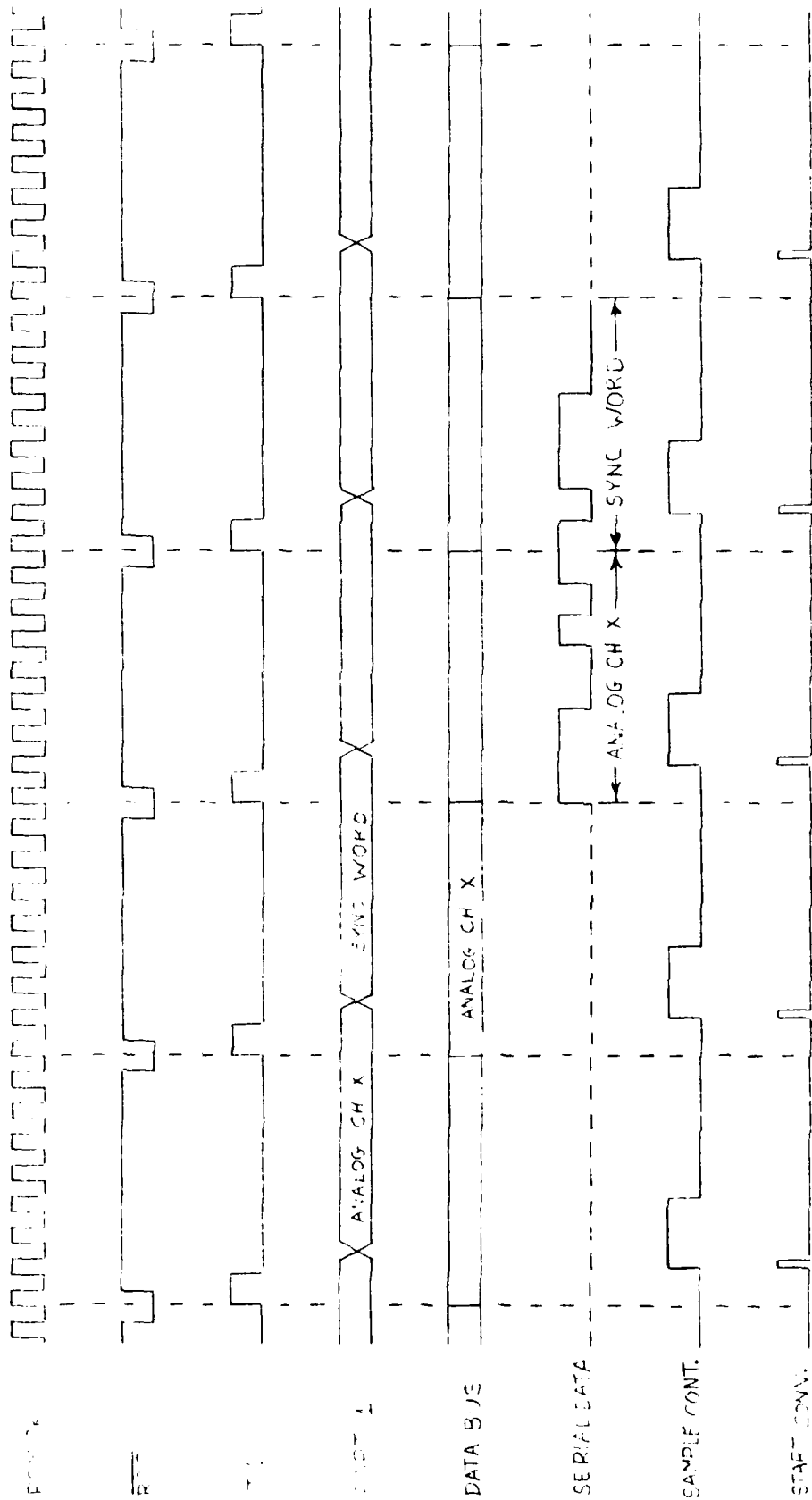

Figure 1-8. Timing Diagram.

word which determines whether an analog, digital, or sync word is placed on the bus, (2) it starts a 5 microsecond delay in the A/D control, (3) and it sets the TEST 1 flip-flop which causes a program branch within the microcomputer. After the 5 microseconds has elapsed the sample control goes high which places the sample and hold circuit into the hold mode as indicated in Figure 1-8. One microsecond later the start conversion pulse goes low initiating an analog to digital conversion with a conversion time of 8 microseconds.

As an illustration a typical analog channel X is followed from an analog signal input to a serial digital signal out. As mentioned earlier the leading edge of T1 sets the TEST 1 flip-flop which causes a program branch within the microcomputer. The analog channel X selection code and bus control word will appear at PORT 1 of the microcomputer within 6.0 to 9.82 microseconds. The selection code is applied to the data input circuits where analog channel X and its return are selected and allowed to settle. The bus control word is applied to the bus control buffer/latch until it is clocked out by the next T1 pulse. At this time the bus control word is decoded and enables the analog data buffer placing the outputs of the A/D converter onto the data bus. The same T1 pulse also starts a 5 microsecond delay in the A/D control circuit. This delay allows the maximum settling time in the analog circuits before going into the hold mode. One microsecond later the analog to digital conversion starts and is complete in 8 microseconds. The valid parallel data signal is placed onto the data bus through the already enabled analog data buffers. The next parallel load signal loads the data into the parallel to

serial converter. Now the data is clocked out one bit at a time in NRZ-L format to the code generator.

As a second illustration, the outputting of a SYNC or ID word will be examined. Again the sequence begins with the setting of the TEST 1 flip-flop. A program branch is initiated within the micro-computer and as before a bus control word appears at PORT 1. Also a SYNC or ID word is outputted to PORT 5 and PORT 6. The bus control word is applied to the bus control buffer/latch and the SYNC or ID word is applied to the frame sync and ID buffer/latch. At the next T1 pulse the bus control word is clocked out and decoded which enables the sync and ID buffer/latch placing this data on the data bus. The next parallel load signal loads the data into the parallel to serial converter where it is now clocked out in serial form.

2. Program Development

a. The 8748/8749 EPROM Programmer. During the development of the programmable PCM encoder, it became necessary to either buy or build an 8748/8749 programmer. The latter was chosen because of the availability of a Cramerkit microcomputer which met the requirements for memory, number of parallel input/output ports, and the ease of program development. The programming module that was constructed provides the necessary pulse shaping circuits while the microcomputer provides the control signals and data to be programmed. A schematic of the programming module is shown in Figure 1-9. The following is a list of functions and a description of circuit operation for the programming module.

XTAL 1 and XTAL 2 - These two pins on the programmer socket connect

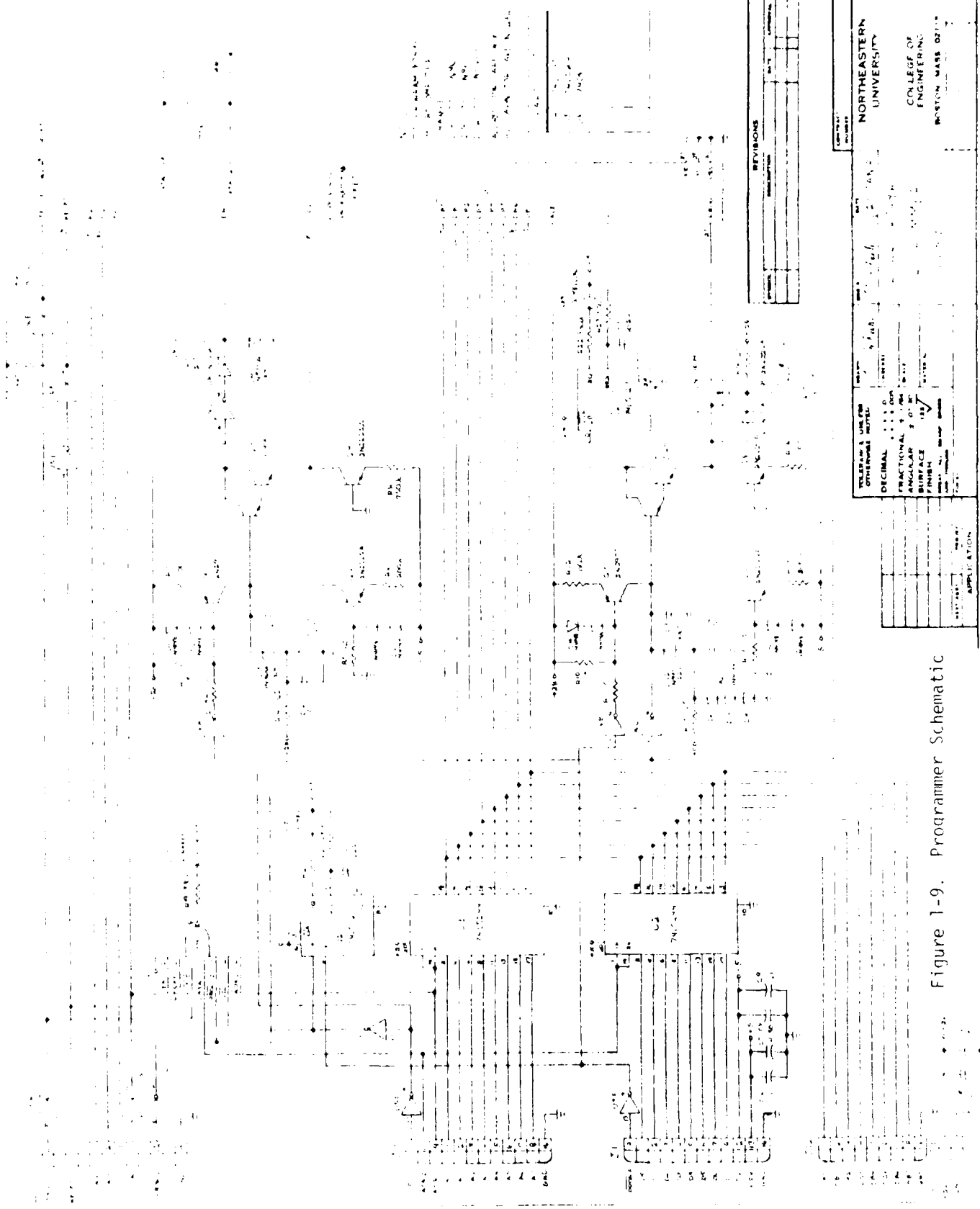

Figure 1-9. Programmer Schematic

to a 3 Mhz crystal and two capacitors C12 and C13 to provide the necessary feedback and phase shift to the 8748/8749 during programming.

RESET - This is used during initialization and address latching. The RESET command enters the programming module on J10 pin 11 and passes through two inverting buffers U5B and U6F. U6F is an open collector device with its output tied to +5V through pull-up resistor R24. A low on the RESET command sets the RESET pin on the programming socket equal to 0.15V and a high command sets the pin to 5.0V. These two values are within programming specifications.

TEST 0 - This function is used for the selection of the program or verify mode. The TEST 0 command enters the module on J10 pin 10 and passes through two inverting buffers U5A and U6E with the latter being an open collector device with its output tied to +5V through pull-up resistor R25. A low on the TEST 0 command set the TEST 0 pin on the programming socket equal to 0.15V, the programming mode, and a high sets the pin equal to 5.0V, the verify mode.

EA - This is used to activate the program/verify modes. The EA command enters the programming module on J10 pin 9 and passes through two inverting buffers U5C and U6D. Again the second is an open collector device with its output connected to the anode of zener diode D8. U6D, D8, D9 and R9 form a bilevel voltage source. When the EA command is low, the current from the +28V supply flows through R9, D8 and U6D to produce 4.85V at the EA pin of the programming socket. When the EA command is high, current flows through R9 and D9 only because the output of U6D is in a high impedance state. This produces 24.0V at the EA pin.

BUS - This is composed of DB0 through DB7 and allows addresses and data to the 8748/8749 during the program mode and allows data to be outputted during the verify mode. The lower 8 address bits A0 through A7 enter the module at J9 and are applied to the bus via the octal tristate buffer U1 when the \overline{ADR} control (J9 pin 10) is low. The data D0-D7 (J11) is applied to the bus through U2 an octal tristate buffer when $\overline{DATA\ \bar{Z}}$ (J9 pin 10) is low. The data output from the 8748/8749 during the verify mode goes directly to the Cramerkit at J12 pins 1-8.

P20-1 - These are the highest two (three for 8749) addresses bit A8 and A9 (A10 for 8749) and are used in both the program and verify modes. A8 and A9 (A10 for 8749) enter the module at J10 pins 1 and 2 (3 for 8749) and are applied directly to the programming socket.

VDD - This is the programming power supply voltage. The rise and fall time must be greater than 0.5 microseconds and less than 2.0 microseconds. This is accomplished with two current sources, one of which can be turned on and off, an integrating capacitor, a voltage limiter and an output buffer as shown in the simplified diagram Figure 1-10a. When the command \overline{VDD} is high (J9 pin 11) $VDD = 0$ and no current flows into node 1 from current source A. Current source B sinks 3 ma which is supplied by the forward bias zener D3. This produces a voltage at node 1 of 6.2V. When \overline{VDD} is low, $VDD = 1$ and 6 ma flow into node 1 from source A. Current source B sinks 3 ma and the excess 3 ma flows into capacitor C1 which produces a voltage ramp. When the voltage at the node reaches 26.8V D3 begins operating in the zener mode and sinks the excess current. Now returning \overline{VDD} back to 0 creates a 3 ma deficit at the node which is supplied by C1 producing a negative voltage ramp until D3 becomes forward

biased again. The output buffer provides current gain, input/output isolation and a 1.2V negative shift. This means the voltage at the VDD pin of the programming socket will range from 5.0V to 25.6V.

PROG - This provides the programming pulse necessary to write data into the 8748/8749 EPROM. The circuit operation Figure 1-10b, is similar to the VDD circuit, but with the following three differences: (1) the command pin $\overline{\text{PROG P}}$ is on J11 pin 9. (2) the voltage at the node ranges from 1.2V to 23.8V which means the voltage at the PROG would range from 0.0V to 22.6V, (3) the output buffer is followed by an electronic switch which is controlled by PROG Z (J10 pin 12) and allows the PROG pin on the programming socket to float. In² brief, the program/verify sequence is:

1. $V_{DD} = 5V$, clock applied or internal oscillator operating, $\overline{\text{RESET}} = 0V$, TEST 0 = 5V, EA = 5V, BUS and PROG floating.
2. Insert 8748 in programming socket.
3. TEST 0 = 0V (select program mode).
4. EA = 23V (activate program mode).
5. Address applied to BUS and P20-1.
6. $\overline{\text{RESET}} = 5V$ (latch address).
7. Data applied to BUS.
8. $V_{DD} = 25V$ (programming power).
9. PROG-0V followed by one 50 ms pulse to 23V.
10. $V_{DD} = 5V$.
11. TEST 0 = 5V (verify mode).
12. Read and verify data on BUS.
13. TEST 0 = 0V.

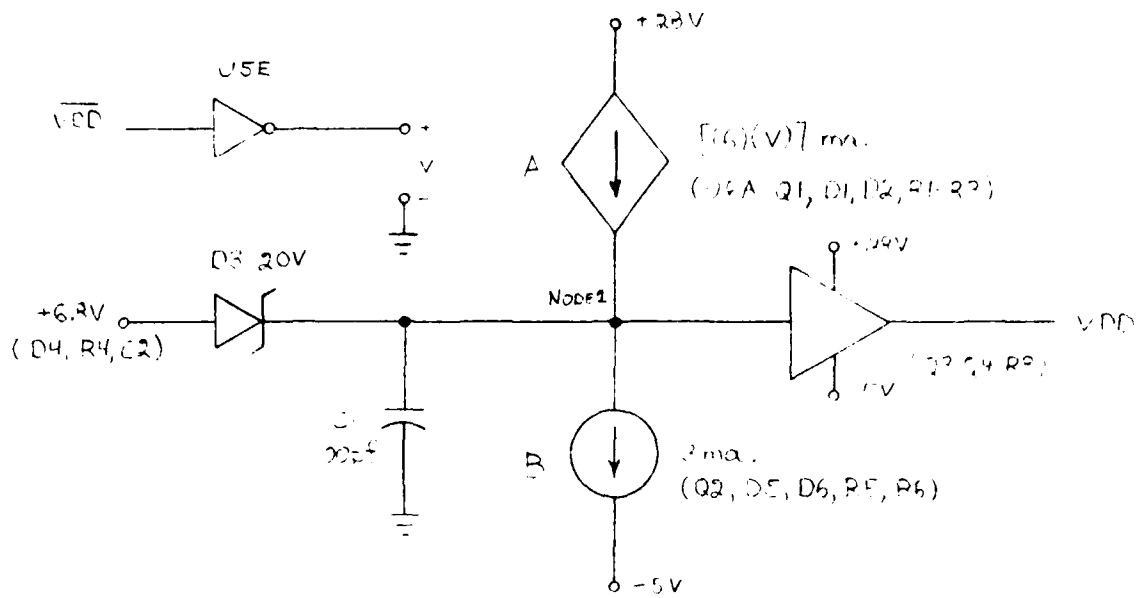

Figure 1-10a. Simplified V_{DD} Generator.

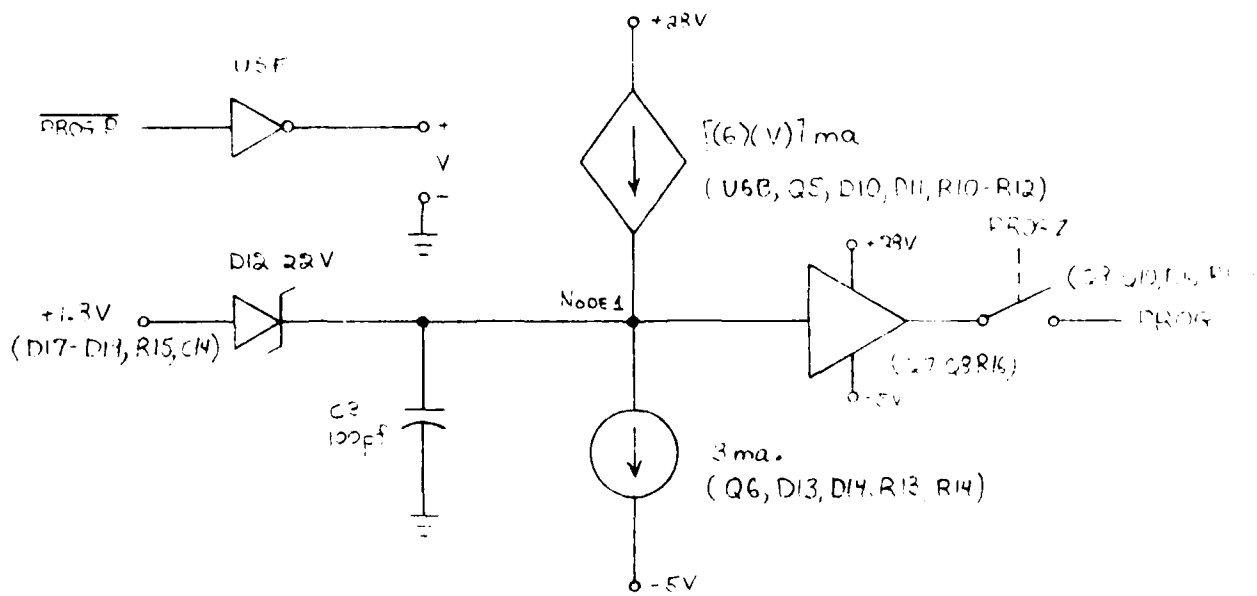

Figure 1-10b. Simplified PROG Generator.

14. RESET = 0V and repeat from step 5.

15. Programmer should be at conditions of step 1 when 8748 is removed from socket.

b. The VAX Assembler. An assembly program utilizing Northeastern University's VAX 11/780 Operating System was developed to reduce the manual programming required in connection with the 8748 microcomputer. The use of the VAX System, with its extensive conditional macroassembler and its assembler, enables the resulting 8748 assembler to employ linking, extensive macroprocessing and debugging. Furthermore, detailed knowledge of the VAX system is not required on the part of the user since Digital Command Language, DCL, is employed.

The user need merely

1. Create a file on the VAX system which uses Intel MCS-48 mnemonics.
2. Use the DCL commands to request assembly of the file for the 8748. The resulting output file repeats each original instruction and then proceeds to give the needed address location and instruction, both in hexadecimal code.
3. Write the resulting file into the 8748/8749 EPROM programmer.
4. Use the programmer to insert the program instructions into the appropriate memory location of the 8748 EPROM.

The design of the assembler was as a senior project by James R. Manley, Jr. and subsequently issued as Scientific Report No. 1 under this contract.³

c. The Program. The program consists of two different sections: first, an initialization routine where all the operating

parameters are set, and second, an operating routine where the PCM matrix is executed.

Figure 1-11 is a listing of a typical initialization routine in which the bit rate (lines 106-127), parity (lines 132-133), pre-modulation filter cutoff frequency (lines 138-139), output code (lines 141-142), word length (lines 144-145), analog gain (lines 146-147), and the sync word (lines 149-150) are set.

Figure 1-12 is an excerpt from the operating routine. Lines 167 through 170 in Figure 1-12a are required to output a single analog channel. The first instruction line number 167 is a conditional branch instruction which tests the status of the TEST 1 input of the microcomputer. This input is connected to the Q output of the TEST 1 flip-flop. When the flip-flop is reset, $Q = 0$, the instruction branches to itself forming a loop. When the TEST 1 flip-flop is set, $Q = 1$, the program control passes to the next instruction.

The next instruction line 168 moves into the accumulator of the microcomputer the selection code and bus control word for an analog channel. The next instruction moves the selection code and bus control word out to PORT 1. The last instruction line 170 resets the TEST 1 flip-flop preparing it for the next word.

Figure 1-12b lines 352 to 357 is a listing of the instruction required to output a SYNC word. Line 352 is the conditional branch instruction. Line 353 loads the accumulator with the bus control word to PORT 1. Line 355 move the SYNC word from register 2 to the addmulator and in line 356 outputs the accumulator to PORT 6. Line 357 resets the TEST 1 flip-flop.

<u>MACHINE CODE</u>	<u>ADDRESS</u>	<u>LINE NUMBER</u>	<u>MNEMONIC</u>	<u>COMMENT</u>
15	0000	102	DIS I	;DISABLE INTERRUPTS
	0001	103	ENTO CLK	;ENABLE CLOCK ON TO
75	0002	104	SEL MBO	
E5	0003	105	SEL RBO	
C5	0004	106	MOV RO,C36	;SET THE BIT RATE TO 20.480KHz
B8	0005			
0B	0006	107	MOV A,MC0	
23	0007			
36	0008	108	MOVX @RO,A	
90	0009	109	MOV A,MC1	
23	000A			
76	000B	110	MOVX @RO,A	
90	000C	111	MOV A,MC2	
23	000D			
B6	000E	112	MOVX @RO,A	
90	000F	113	DEC RO	;SET COUNTER 2
C8	0010	114	MOV A,LSB2	
23	0011			
30	0012	115	MOVX @RO,A	
90	0013	116	MOV A,MSB2	
23	0014			
00	0015	117	MOVX @RO,A	
90	0016	118	DEC RO	;SET COUNTER 1
C8	0017	119	MOV A,LSB1	
23	0018			
D7	0019	120	MOVX @RO,A	
90	001A	121	MOV A,MSB1	
23	001B			
03	001C	122	MOVX @RO,A	
90	001C			

Figure 1-11. Initialization Routine

<u>MACHINE CODE</u>	<u>ADDRESS</u>	<u>LINE NUMBER</u>	<u>MNEMONIC</u>	<u>COMMENT</u>
	001D	123	DEC R0	;SET COUNTER 0
C8	001D			
	001E	124	MOV A,LSB0	
23	001E			
D0	001F			
	0020	125	MOVX @R0,A	
90	0020			
	0021	126	MOV A,MSB0	
23	0021			
07	0022			
	0023	127	MOVX @R0,A	
90	0023			
	0024	128	MOV R0,C18	;SET ALL PORTS ON U18 TO OUTPUT
B8	0024			
03	0025			
	0026	129	MOV A,CW	
23	0026			
80	0027			
	0028	130	MOVX @R0,A	
90	0028			
	0029	131	DEC R0	;PORT 7
C8	0029			
	002A	132	MOV A,NP	;SET PARITY
23				
00	002B			
	002C	133	MOVX @R0,A	
90	002C			
	002D	134	MOV R0,C49	;SET ALL PORTS ON U49 TO OUTPUT
B8	002D			
07	002E			
	002F	135	MOV A,CW	
23	002F			
80	0030			
	0031	136	MOVX @R0,A	
90	0031			
	0032	137	DEC R0	;PORT 10
C8	0032			
	0033	138	MOV A,FC	;SET FILTER fc
23	0033			
12	0034			
	0035	139	MOVX @R0,A	
90	0035			
	0036	140	DEC R0	;PORT 9
C8	0036			
	0037	141	MOV A,OC	;SET OUTPUT CODE
23	0037			
09	0038			
	0039	142	MOVX @R0,A	
90	0039			
	003A	143	DEC R0	;PORT 8

Figure 1-11 (continued) Initialization Routine

<u>MACHINE CODE</u>	<u>ADDRESS</u>	<u>LINE NUMBER</u>	<u>MNEMONIC</u>	<u>COMMENT</u>
C8	003A			
	003B	144	MOV	A,WL ;SET WORD LENGTH
23	003B			
07	003C			
	003D	145	MOVX	@R0,A
90	003D			
	003E	146	MOV	A,PGA ;SET THE ANALOG GAIN
23	003E			
10	003F			
	0040	147	OUTL	P2,A ;PORT 2
3A	0040			
	0041	148	MOV	R0,P6 ;SET POINTER FOR SYNC PORTS
88	0041			
01	0042			
	0043	149	MOV	R2,SW1 ;SYNC WORD
8A	0043			
EB	0044			
	0045	150	MOV	R3,SW2
8B	0045			
90	0046			

Figure 1-11 (continued) Initialization Routine

<u>MACHINE CODE</u>	<u>ADDRESS</u>	<u>LINE NUMBER</u>	<u>MNEMONIC</u>	<u>COMMENT</u>
	005D	167 L2:	JNT1	L2 ;E2
46	005D			
5D'	005E			
	005F	168	MOV	A,E2
23	005F			
31	0060			
	0061	169	OUTL	P1,A
39	0061			
	0062	170	MOVD	P4,A
3C	0062			
	0063	171 L3:	JNT1	L3 ;E3
46	0063			
63'	0064			
	0065	172	MOV	A,E3
23	0065			
32	0066			
	0067	173	OUTL	P1,A
39	0067			
	0068	174	MOVD	P4,A

Figure 1-12a. Analog Channel Selection Routine

<u>MACHINE CODE</u>	<u>ADDRESS</u>	<u>LINE NUMBER</u>	<u>MNEMONIC</u>	<u>COMMENT</u>
	0158	352 L39:	JNT1	L39 ;SYNC WORD
46	0158			
58'	0159			
	015A	353	MOV	A,FS
23	015A			
D0	015B			
	015C	354	OUTL	P1,A
39	015C			
	015D	355	MOV	A,R2
FA	015D			
	015E	356	MOVX	@R0,A
90	015E			
	015F	357	MOVD	P4,A
3C	015F			
	0160	358 L40:	JNT1	L40
46	0160			
60'	0161			
	0162	359	MOV	A,R3
FB	0162			
	0163	360	MOVX	@R0,A

Figure 1-12b. Sync Word Selection Routine

3. Rocket Applications. The programmable encoders of the type described in the previous sections have been supplied for use in two of the rocket programs.

a. BIME Program. This program was the first application in which this design encoder was flown on two Brazilian Sonda III rockets. These encoders were programmed for the following operating parameters:

Code: Biphase L

Bit Rate: 2.21×10^5 bits/sec.

Frame Sync Pattern: 3 C D 40_{HEX}

Resolution: 9 bits/word

Subframe Sync Method: ID word and complimentary frame sync.

Number of Analog Channels: 24

Sampling Rate: 4096 samples/sec. max.

64 samples/sec. min.

The programmable feature of this encoder proved a valuable asset on its first flight. Upon arriving at Natal, Brazil for the BIME program, it was found that the Brazilian rocket support group needed three (3) additional data support channels. A new program was written to modify the PCM format to accommodate the extra channels, and the onboard microcomputer was reprogrammed with the new software changes.

b. SES Program. This program was the next application. This payload used a single Astrobee F vehicle to be launched from WSMR in early 1983. At the end of this contract, the payload was being prepared for system integration and environmental testing. The parameters for this encoder are as follows:

Code: NR1-S

Bit Rate: 20.48 K bits/sec.

Frame Sync Pattern: E R 90₄EX

Resolution: 8 bits/word

Subframe Sync Method: ID word and complimentary frame sync.

Number of Analog Channels: 71

Sampling Rate: 64 samples/sec. max.

16 samples/sec. min.

The encoders operated properly on both flights.

B. Data Selector

To provide full telemetry support for the BIME program, a full PCM data handling system was required for system integration, environmental testing, in field pre-launch testing including horizontal and vertical tests, as well as in flight monitoring. This system must include a receiver, bit synchronizer, frame and word synchronizer, a data selector with at least 16 channel capacity and strip chart recorders for presenting the data to the scientists. At the beginning of this program Northeastern had access to all the above equipment with the exception of the data selector. The design of a general purpose data selector to meet the BIME program requirements as well as future programs was started during this contract.

1. Data Selector Specifications. After an investigation of the particular requirements of the BIME program and those in past and upcoming programs, a list of desirable data selector characteristics was compiled.

The data selector was designed to meet the objectives of this list as tabulated below:

- a) Up to 32 output analog channels.
- b) Up to 12 bit input resolution on each channel.
- c) Adjustable 2 pole low pass filter on each analog channel.
- d) Super and subcommutated data handling capability.
- e) A special capability to process non-symmetrically sampled channels. (The ability to randomly access any combination of words from the data matrix to produce super commutated channels of unusual formats. This feature is not available in commercial data selectors which require symmetrical sampling.)
- f) Single channel selection and display on front panel (both analog and digital) for quick look and diagnostic applications.
- g) Operation at bit rates in excess of 1.0 M bits/sec.
- h) Output analog signals levels of 0.0 to +10 volts with inverting capability.
- i) Digital key board entry for all formatting with interactive display panel for prompting and verification.
- j) Self calibration of output analog channels at 0%, 50% and 100% points for ease of strip chart recorder adjustments.
- k) Non volatile storage of data display formats (via EEPROMS) such that power failures and daily power downs would not necessitate reprogramming.

2. Data Selector External Characteristics. The data selector is completely enclosed in an aluminum housing measuring 19" W x 7" H x 19" D, and weighs approximately 30 pounds. Power consumption is approximately 2 amperes at 110 V.A.C. The front panel controls/readout include the following:

- a) Lighted power on/off switch.
- b) 24 Key digital entry keypad.
- c) 8 character LED alphanumeric display.
- d) Meter and connector for analog channel.
- e) Two digit display for selected analog channel.
- f) 16 lamps for binary display.
- g) Lamp test switch for binary display.
- h) Indicator lamps (search, check and lock) for performance verification of major and minor frame detectors in word synchronizer.

The rear panel has a fuse holder, power connector, 32 isolated analog output connectors, a system 90° clock input connector, and two multipin connectors from the frame and word synchronizer.

3. Data Selector Operation. The data selector has two basic modes of operation: the program mode and the operate mode. Both of these modes, which will be briefly described below, and the alphanumeric display and keypad are controlled by a microprocessor. A block diagram is presented in Figure 1-13 and Figure 1-14.

In the program mode information pertaining to each analog output channel i.e. word numbers and frame numbers, is entered into the microprocessor's RAM via the keypad and prompting display. Upon completion of information entry, the PROGRAM key is depressed which initiates the EEPROM programming routine. In this routine each channel's information is scanned and a 32 bit mask for each word and each frame is generated. The frame and word masks are then programmed into their respective EEPROMS one byte at a time until all masks are completed.

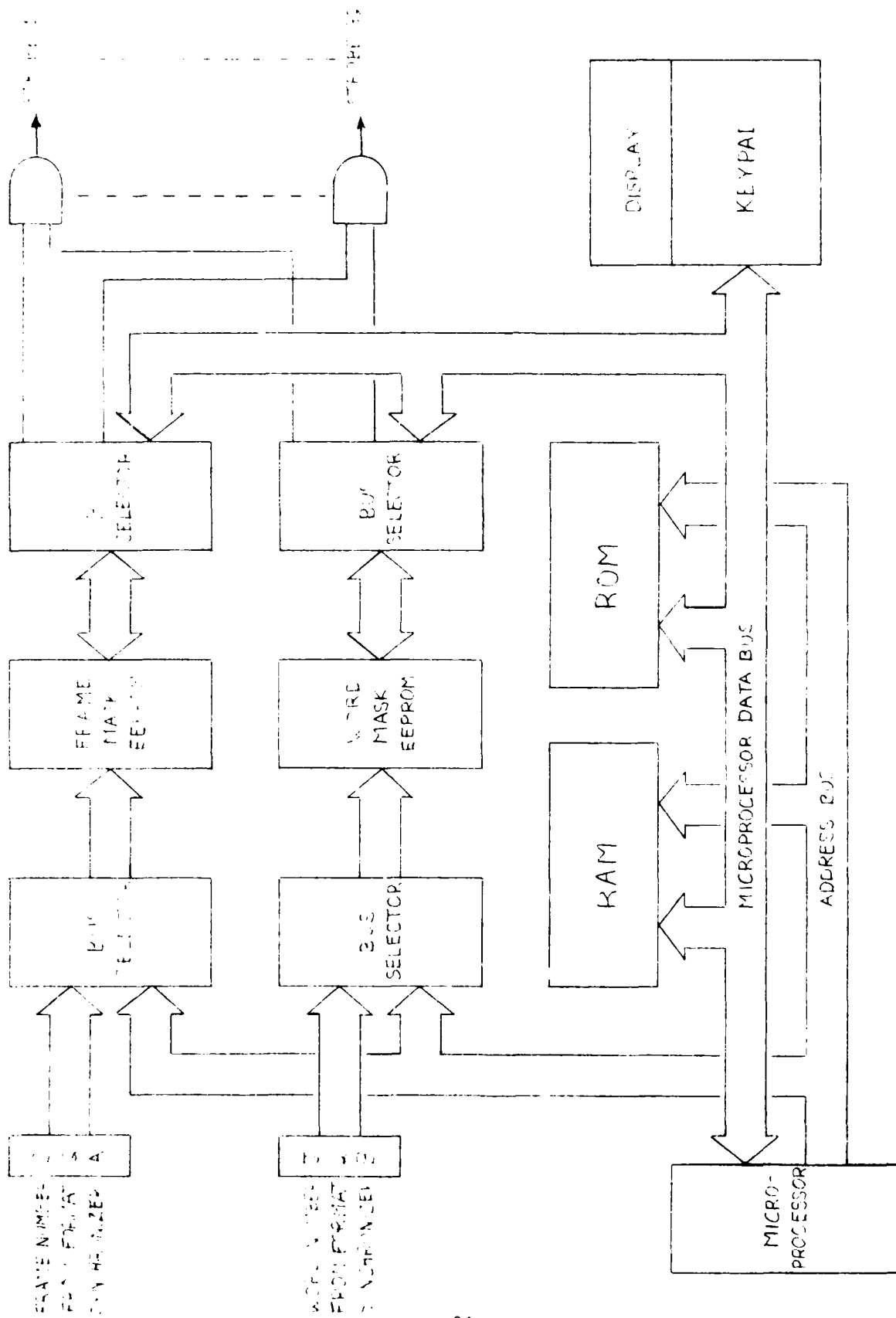

Figure 1-13. Programmable Strobe Generator and Format Storage.

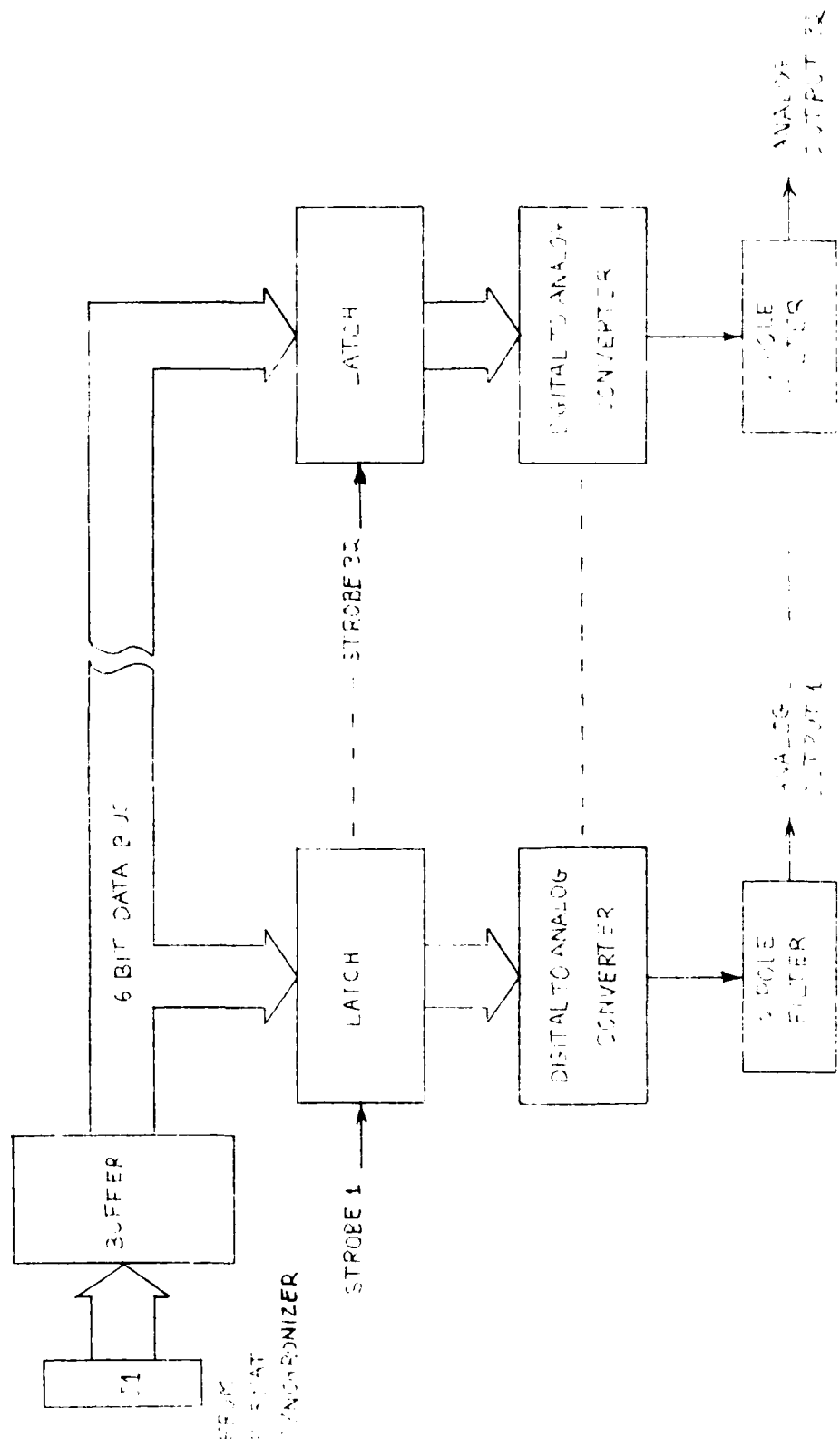

Figure 1-14. Digital to Analog Output Channels.

In the operate mode these EEPROMS are operated as logic arrays. The frame numbers and word numbers from the format synchronizer are applied to the address lines of the EEPROMS. The outputs of the EEPROMS form the frame mask and word mask. The frame mask and word mask are compared and when a comparison results, a strobe is generated to the desired output circuit. Each output circuit when strobed, converts the data on the data bus from the format synchronizer into an analog signal. This signal passes through a variable two pole linear phase filter before being outputted.

4. Field Application. At the time of the BIME field trip, the data selector had been completed to meet all the objective tabulated with the exception of the number of analog channel outputs, of which only 16 had been completed. These channels are built on printed circuits, two to a card. As the mother board is completely wired, the analog channel cards need only be plugged in when they are completed to give the selector its full 32 channel capacity.

The data selector was successfully utilized in all phases of the BIME program as well as integration and environmental testing of the SES payload. It is anticipated that this unit will also be used for ground support of the SES payload at WSMR in early 1983.

C. Slow Scan Television

On 4 January 1982, a meeting was held at AFGL to investigate methods of transmitting television signals from the HPTEM vehicle to ground. The previous system employed on the TEM II vehicle, used a television signal produced from a COHU 4510-103 camera. This signal had a standard RS-170 NTSC format with 30 frames per second

and a 2:1 interlace. This signal, after passing through a pre-emphasis filter, directly modulates a 10 watt FM video transmitter. Details of this system can be found in a scientific report of the previous contract.⁴ This system produced high quality pictures for slant ranges of up to 250 statute miles. Because of the extended range of the HPTEM vehicle, which could be as far as 1000 statute miles, the transmission link would have to be modified to compensate for the four fold increase in range.

The first possibility was to use the same system and increase the output power of the transmitter. This was deemed impractical because a fourfold increase in range necessitates a sixteen fold increase in power to maintain the same signal to noise ratio, thus the radiated power would have to increase from 10 watts to 160 watts. Even if such a transmitter were available, the volume and weight of the required batteries and the problem of the removal of the heat generated would make this approach impractical.

A more practical solution was to maintain the same signal-to-noise ratio by reducing the transmitted bandwidth by a factor of 16 or more. A proposed scheme to accomplish this was to reduce the frame scan rate of the camera by a factor of 10 and also to reduce the bandwidth of the resulting video signal by a factor of two. This would result in the video signal going from 30 frames per second to 3 frames per second and a reduction in bandwidth from 4 MHz to 200 KHz.

In accomplishing the above scheme, several problems are encountered. First is that at the reduced frame rate, the video monitor to display the picture would have to be greatly modified such

that it would also scan at the new slow rate and if a very disturbing flicker in the picture were to be avoided, a new phosphor for the cathode ray tube would have to be used. This high persistence phosphor would reduce the flicker, but would tend to blur any motion in the picture. The second problem is that the camera would have to be greatly modified to properly scan at this lower rate. The third problem is that the camera sensor would produce higher "dark currents" when used in a slow scan mode. The dark current, which is a term which applies to the signals produced by the sensor with no light reaching it, is a function of temperature and exposure time. At a one-tenth scan rate, the exposure time and thus the dark current would be ten times greater.

1. Slow Scan Converter. The solution to the first problem was to use a device called a slow scan converter (SSC). This device converts the slow scan video signal to a standard RS 170 format which can then drive a standard video monitor without any flicker problem. The SSC accomplishes this conversion by storing a complete frame of video information in digital memory, then while loading the second frame into an identical memory, the first frame is outputted repeatedly to the monitor at a rate of 30 frames per second until the second frame has been completely stored in the second memory. At this point the process is reversed. The second stored frame is read from the second memory at the high rate while the third frame is loaded into the first memory. This process results in each frame of video information being viewed 10 times on the monitor. A custom made SSC was built for Northeastern University by Colmek Systems Engineering.

When the SSC was received there was no slow scan camera to test the unit. A simulated test was made by recording normal video signals on magnetic tape, then replaying the tape at one tenth the record speed. This effectively produced a slow scan signal which when applied to the slow scan converter, produced flicker free signals on a standard monitor. This test was used to insure the operation of the SSC.

2. Camera Selection. It was felt that the second and third problems identified earlier (scan rate and dark current) could be solved by going to a solid state sensor which is digitally scanned by row/column counters rather than magnetic deflection coils. The clocking rate of the counters determines the scan rate, and in certain solid state cameras the entire video signal including synchronization and equalization pulses is totally determined by a master clock. A search of manufacturers found two cameras which, supposedly, could be slowed down by a factor of 10. These were made by Fairchild and NEC. NEC said they would provide a camera modified to meet this specification, or provide information to make this modification. Their price was economical and so the order was placed. After long delays from the stated delivery schedule, a camera was supplied to Northeastern University. The camera was received unmodified and came without any information or schematics. Attempts to modify the camera were fruitless. The camera would operate to .8 its normal scan rate but it then stopped altogether when further reduction was attempted. The camera was returned to the manufacturer and the order was canceled.

In June of 1982 a Fairchild model CCD 2000 was received for evaluation. This camera has provisions for external clocking and upon being tested showed it could be slowed to the one tenth scan rate, but the dark current levels were then approaching saturation of the video signal. This camera would have to be cooled to present an acceptable picture. At this time it was noted that Fairchild Camera was preparing to release a new improved camera (Model 3000) and it was supposed to have lower dark current level than its predecessor.

While waiting for an evaluation sample of the new camera, an investigation of a Peltier Effect solid state cooling unit was made as a fall back effort in the event the new camera was unsatisfactory. It was found that the device investigated could reduce the camera sensor temperature by 40⁰C if properly installed. Care, however, would have to be taken to prevent condensation on the lens if this cooling system were to be used.

In October of 1982 an evaluation sample of a Fairchild Model CCD 3000 camera was received. To reduce the scan rate, the crystal oscillator was disconnected and an external oscillator was connected in its place. The frequency was reduced by a factor of 10 to 1.432 MHz. The following results were noted:

- (1) The dark current levels of the sensor were not appreciably increased.
- (2) Using the SSC, good quality pictures were produced on a standard monitor.
- (3) Power requirement to operate the camera were 5 volts at 700 mA. + 15 volts at 300 mA., and -15 volts at 100 mA.

(4) The camera sensor/lens mount unit can be remotely operated from the camera body/electronics package if required.

(5) The camera body is suitable for aerospace applications with only small "ruggedizing" modifications to the printed circuit board.

It is anticipated that this model camera will be purchased with new contract funds in December of 1982.

3. Video Pre-emphasis Filter. The video pre-emphasis filter is shown in Figure 1-15. It is used to taper the FM deviation of the transmitter in such a way as to emphasize the frequencies above 4 KHz and to cut off frequencies above 200 KHz. A complimentary filter on the video output of the receiver would deemphasize the frequency response in such a way to make the overall response flat in the pass band. This response is shown in Figure 1-16.

D. Preflight Calibrator

Previously designed preflight calibrators have had undesirable limitations. These shortcomings include a limited number of calibration points (usually 0.0V, 2.5V and 5.0V), and the inability to maintain a given calibration for an indefinite period of time.

A new calibrator was designed to overcome these deficiencies and add several other features at the same time. This calibrator is capable of producing an 11 point staircase, going from 0 volts to 5 volts in 0.5V increments and be able to stop at 0.0, 2.5 and 5.0 volts indefinitely. The calibrator can also produce a linear triangular sweep going from 0.0 to 5.0 volt. All functions are under control of the operator in the blockhouse including the staircase stepping rate. The triangular sweep offers the ability to check

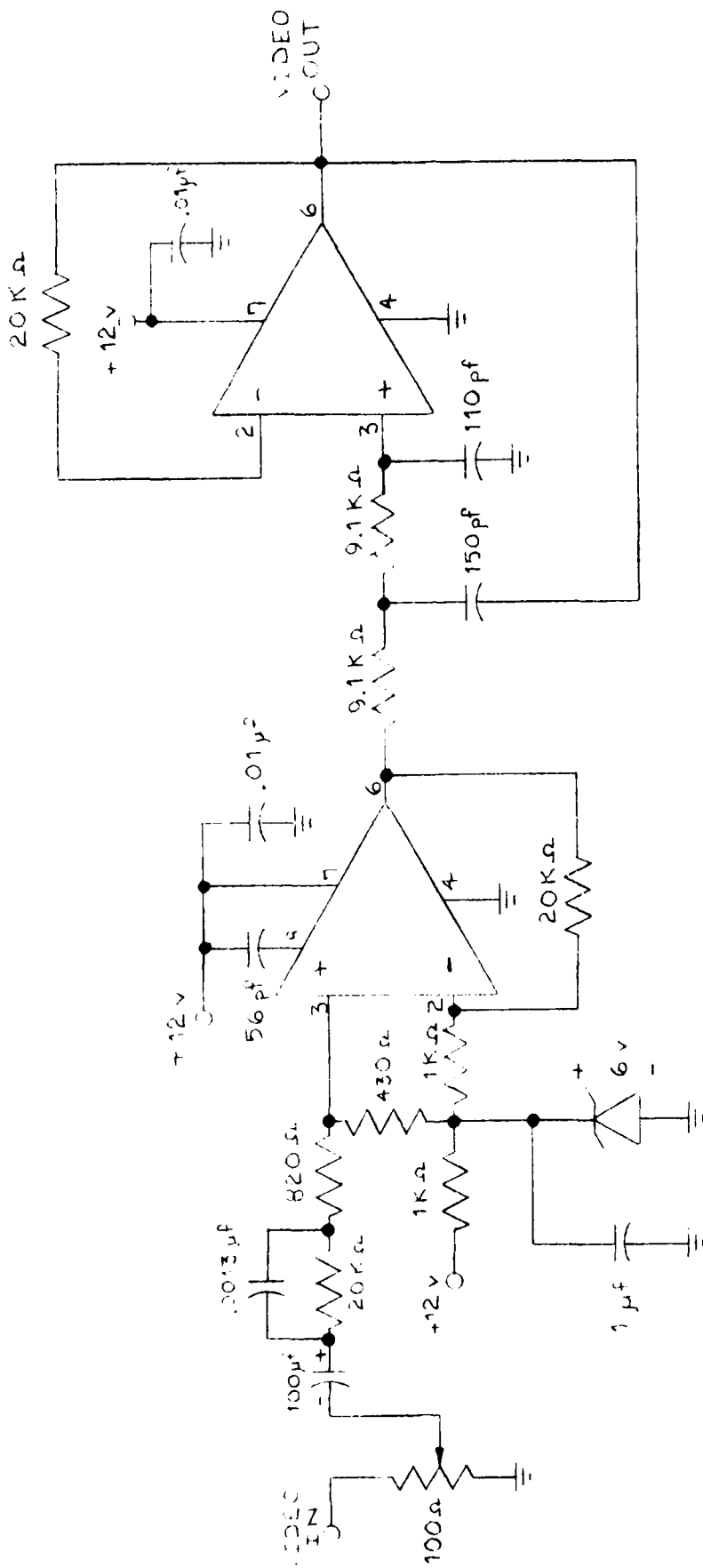

CA314C

2A2065

Figure 1-15. Video Pre-emphasis Filter.

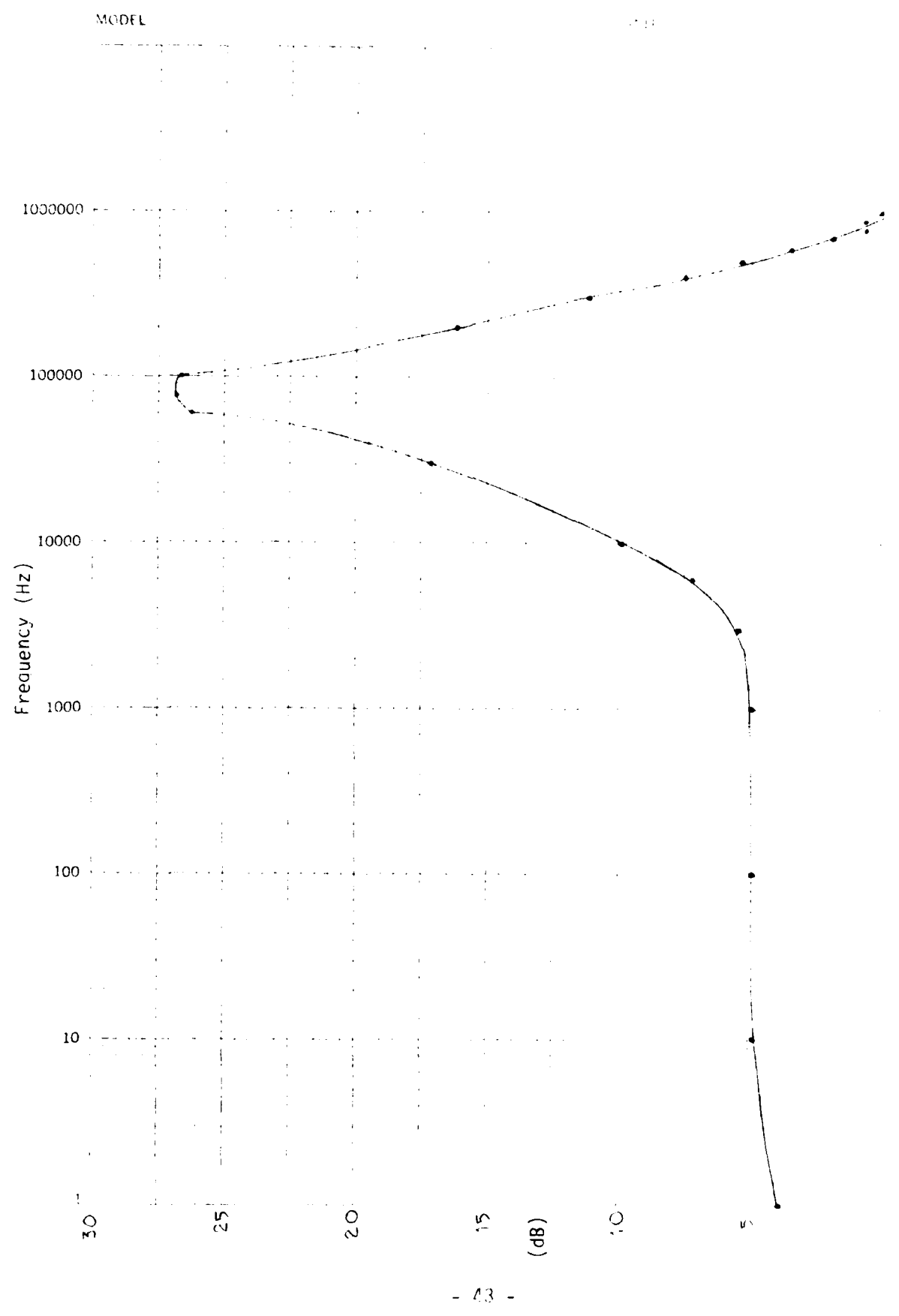

Figure 1-16. Response of TV Camera Pre-emphasis Filter.

the entire data acquisition system including subcarrier oscillators, discriminators and recorders for any non linear behavior over their entire operating range.

Due to the ever increasing scarcity of umbilical lines available to the blockhouse, the calibrator was designed to perform all its functions over a single umbilical line. As in previous designs, power for the calibrator comes directly from the blockhouse and thus prevents the possibility of flight in a calibrate condition. This is because the multipole relay which selects data or calibration functions is in a data acquisition state when unpowered.

The preflight calibrator system consists of two sections, the control section in the blockhouse and the receiver section in the vehicle. The control section has two functions. It must provide 24 Vdc to energize the 24 pole relay which selects data or calibration signals to be inputted to the subcarrier oscillators. The control section must also provide a series of pulses to select which of the calibration function is to be performed. Figure 1-17 is a block diagram of the entire system operation.

When the function selector switch, S1 is switched from off to any of the 5 calibration positions, a 24 Vdc signal is applied to the output line of the control section. This signal activates the data/calibration relay and the regulators in the receiver. These regulators power the logic circuits which are then ready to receive and decode the control pulses which determine which calibration function has been selected. The schematic diagrams for both the receiver and control sections are detailed in Figures 1-18 and 1-19 respectively.

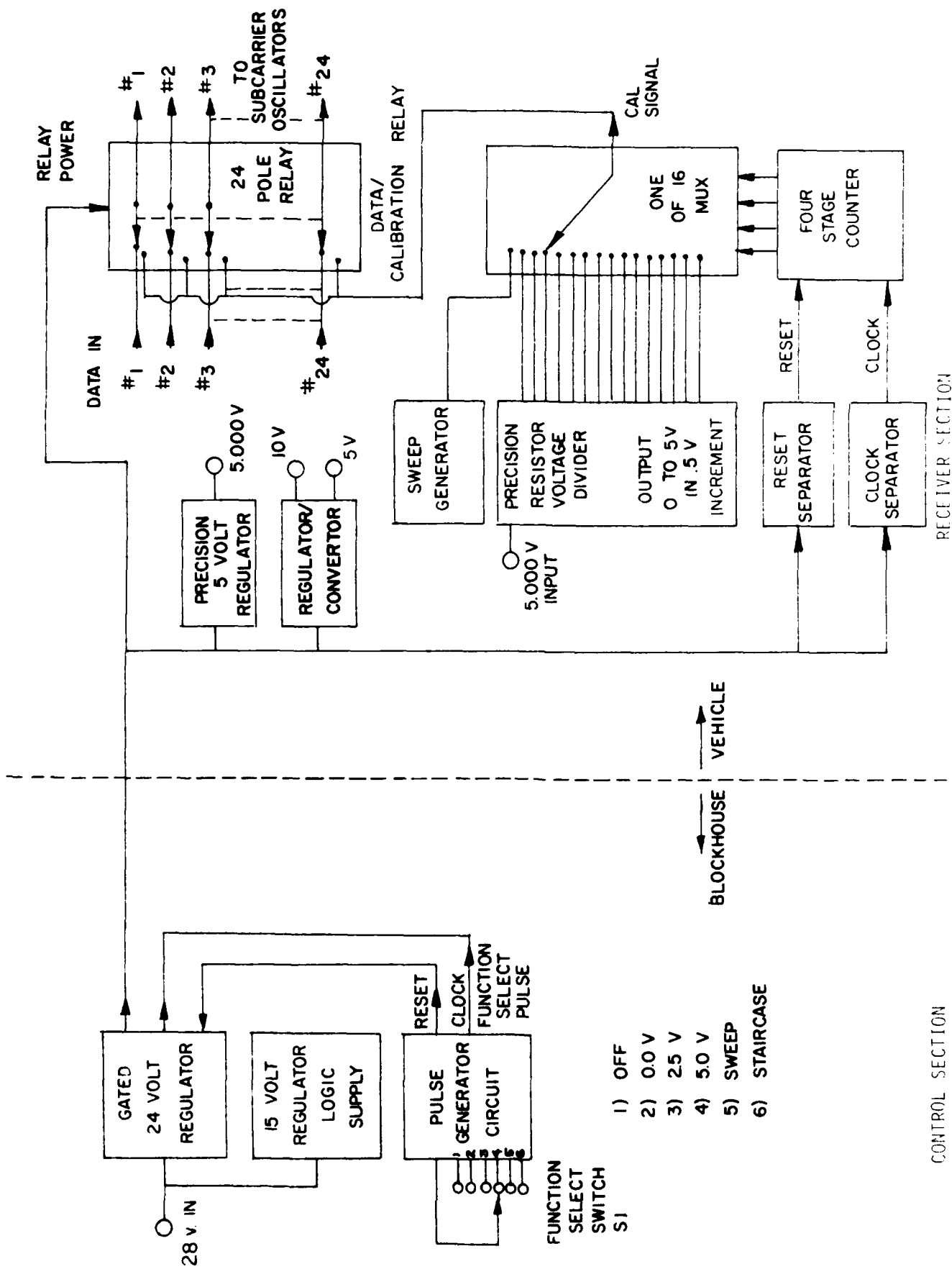

Figure 1-17. Block Diagram of Preflight Calibrator.

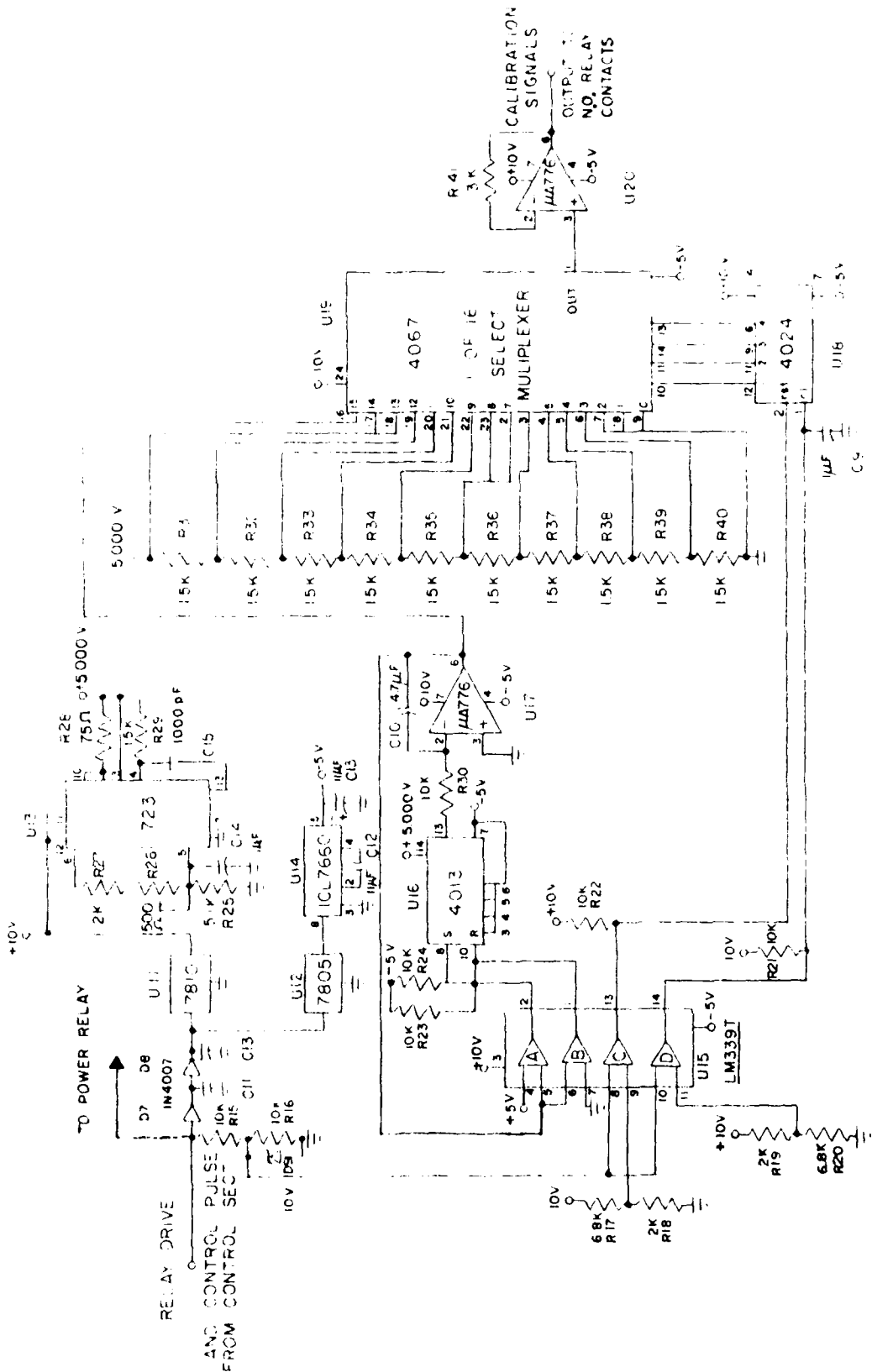

Figure 1-18. Receiver Section of Preflight Calibrator.

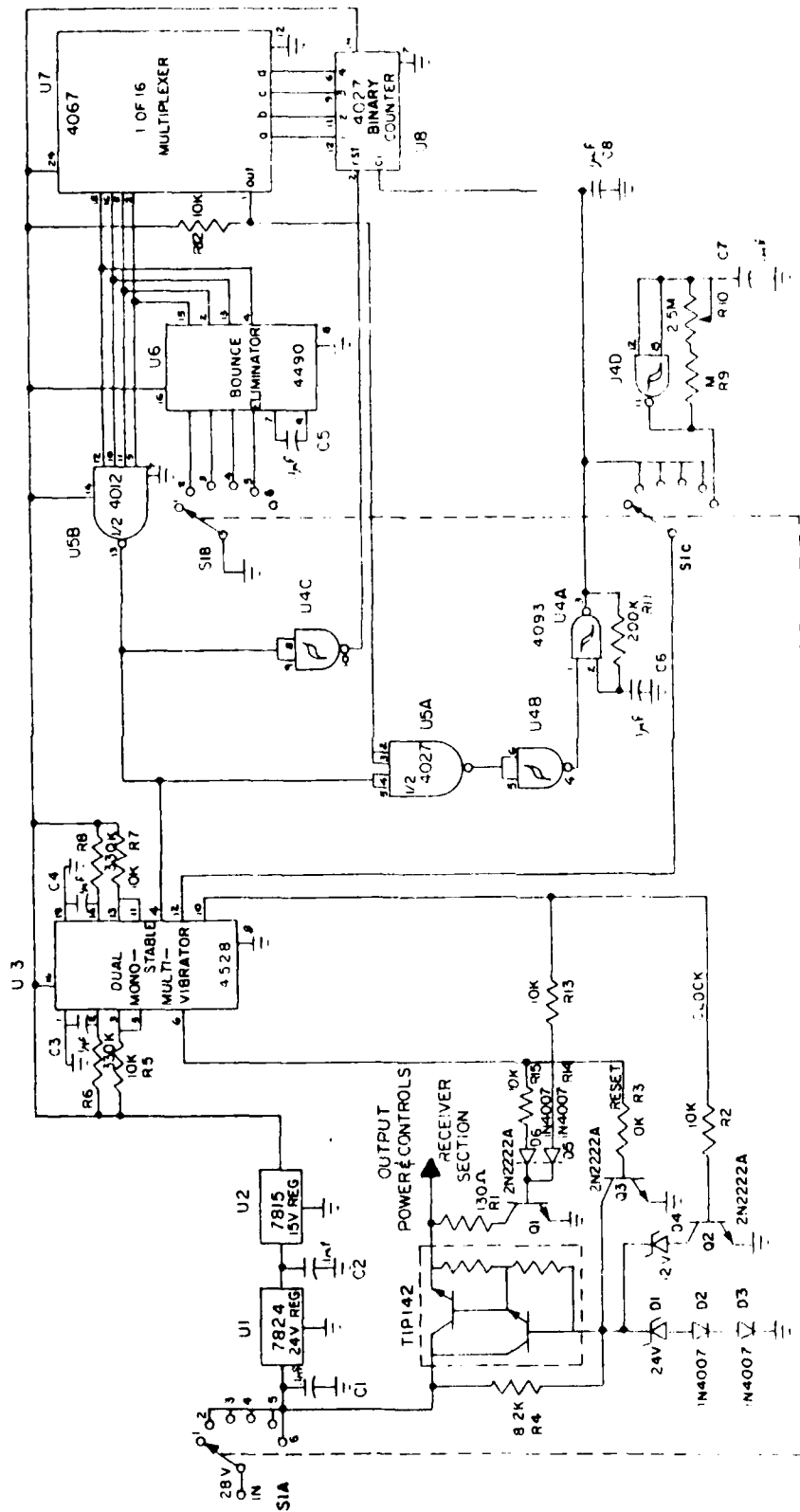

Figure 1-19. Control Section of Preflight Calibrator.

1. Receiver Section. Two different control pulses are required. The first is a reset pulse, which clears counter U18 in the receiver to zero. Next a series of clock pulses step the counter to a specific count. This count is decoded in U19, a 1 of 16 select multiplexer. The multiplexer selects the desired input which, through unity gain buffer U20, drives the inputs to the subcarrier oscillators. The reset and clock pulses are detected by comparitors U15C and U15D. The reset and clock pulses appear on the input to the receiver as negative going pulses. The reset pulse goes from 24V to zero and the clock pulses drop from 24 volts down to 12 volts. These pulses are 10 milliseconds in duration. The relay and regulators in the receiver are not effected by these pulses because of the decoupling circuit consisting of C11, C13, D7 and D8.

In the receiver section a precision voltage regulator, U13, produces 5.000 volts. This voltage drives a precision resistor divider (consisting of resistors R31 through R40) to produce voltages of 0 to 5V in 0.5 volt increments. There is also a DC/DC converter producing the -5V supply. This converter consists of U12, U14, C12 and C13. The free running sweep oscillator consists of U15A, U15B, U16 and U17. U17 is an integrator driven from flip flop U16 which produces either +5V or -5V output. The state of U16 is determined by comparitors U15A and U15B which set or reset the flip flop depending on the output of the integrator. U15A detects the output at 5 volts and U15B detects it at zero volts. The output thus changes linearly from 0 to 5V and back. The period of oscillation is approximately 0.1 seconds.

2. Control Section. The control section consists of a gated 24 volt regulator (TIP142 plus associated circuitry), a logic voltage supply consisting of regulators U1 and U2, and the control logic consisting of U3, U4, U5, U6, U7, U8 and associated resistors, capacitors, diodes and transistors.

The gated 24 volt regulator is a Darlington pair of transistors connected as an emitter follower. The base voltage can be switched from 24 volts to 12 volts or zero volts by transistor Q_2 and Q_3 respectively. Whenever Q_2 or Q_3 are gated on, Q_1 is also gated on to apply a 130 Ω load to the regulator which speeds up the response of the regulator output. U3, a dual one shot multivibrator, produces the ten millisecond pulses from the clock and reset logic to drive the regulator.

The reset pulse is generated at the output of U5B whenever switch S1 is changed. The B section of S1 places a ground on the input of the multiplexer U7 and nand gate U5B through contact bounce eliminator U6. This ground immediately changes the output of U5B generating a reset pulse, and also enables free running oscillator U4A through U5A and inverter U4B. This oscillator is the source of the clock pulses which drive the regulator and increment the binary counter U8. The oscillator will continue to operate until the counter advances to the desired count and through the U7 multiplexer, passes the grounded input state to the input of U5A which disables the oscillator. Figure 1-20 is a timing diagram of the reset, clock, regulator and calibrator outputs. When the staircase mode is selected, free running oscillator U4D is selected for the

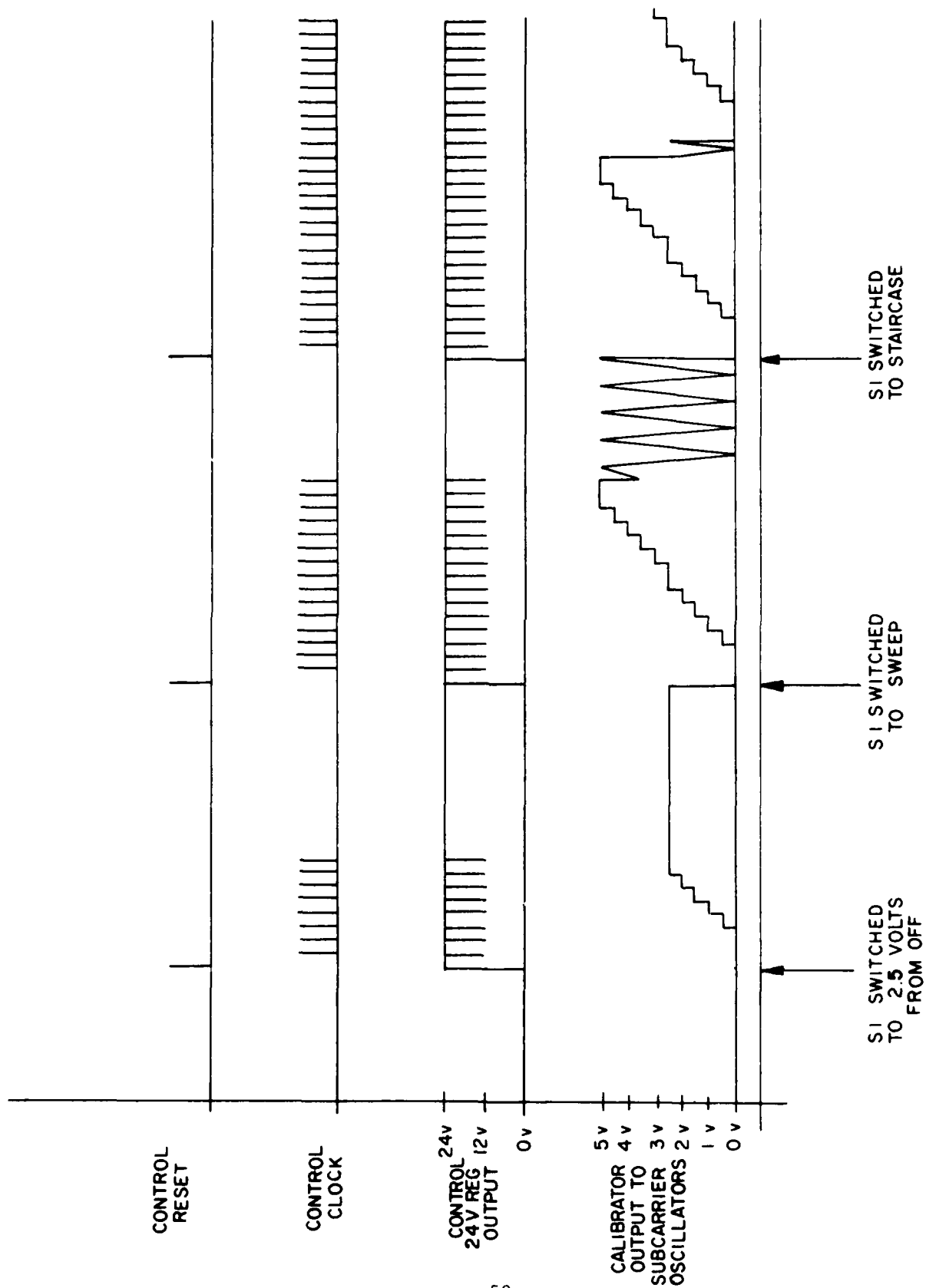

Figure 1-20. Timing Diagram of Preflight Calibrator.

clock pulses and will produce a continuous staircase. The rate of the staircase is operator controlled by potentiometer R10.

This calibrator was successfully launched on vehicle A13.277 of the Tracer Program.

E. Recovery Beacon

The SPE Payload section required a recovery beacon to assist in finding the payload in the Alaskan wilderness. The beacon would have to operate at temperatures as low as -60°C and operate continuously for 100 hours. The beacon used was a Conic CTB 200-0.5H which operates at a frequency of 242 MHz at a power output of 0.5 watts, and is powered by nine 3 volt lithium cells (Model 660-2S-NPT). The use of lithium cells was based on their high energy density and their ability to operate at low temperatures. To conserve battery power, the beacon was switched on and off at a one second rate with a 25% duty cycle. The beacon was self AM tone modulated to assist in operation of a radio direction finder.

The beacon is turned on in flight by an on board timer command on the down leg of the flight after the data gathering segment of the flight is over. This is done to preclude the possibility of interference with experiments which had been noticed on earlier flights. For testing purposes, the beacon can be turned on and off by control box command.

To assist in testing and recovery, a high gain Yagi-Uda antenna was designed. This antenna used a gamma match to provide proper interfacing of the single ended coaxial cable drive to the balanced

radiating element. The antenna was designed to be easily assembled and dismantled for field shipment. The antenna could be changed from vertical to horizontal polarization by the mounting fixture and the gain was approximately 12 dB (isotropic). Figure 1-21 is a schematic diagram of the beacon, battery, and control circuit.

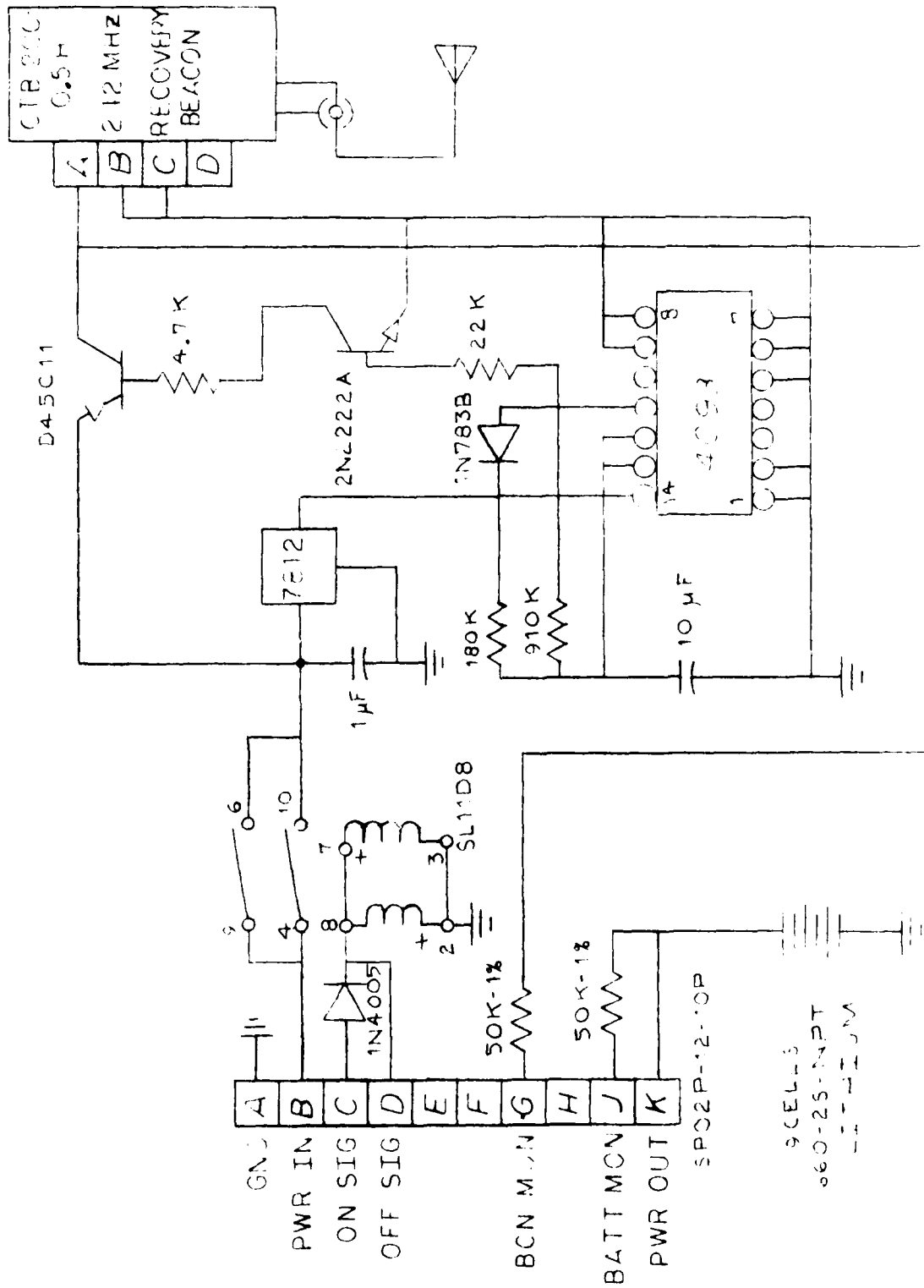

Figure 1-21. Recovery Beacon Control Circuitry.

CHAPTER II
STUDY AND ANALYSIS PROGRAMS

A. NASA Tracking and Data Relay Satellite System

A brief survey was made of the NASA Tracking and Data Relay Satellite System (TDRSS) in order to determine if it would be useful for future AFGL programs. TDRSS is being developed for use over the next decade to fulfill NASA's (and some of DOD's) tracking and data acquisition requirements for low-earth orbiting vehicles, including the Space Shuttle. Satellite-to-satellite communications and balloon-to-ground data relay can also be provided.

It does not appear that TDRSS is intended or ideally suited for use as a real-time data relay or command link for the short duration flights usually associated with AFGL sounding rockets. If an extremely high mission priority could be assigned to certain of these vehicles, then it would probably be possible to adapt TDRSS for mission coverage. It appears that a more feasible use would be to use TDRSS to relay recorded data from remote launch sites if other means of data relay (i.e. commercial telecommunications channels) were not suitable. If TDRSS were used to relay field data immediately after a launch then flight data would be available to scientists at AFGL far earlier than is currently the case. Quick look decisions could be made by senior people, immediate data reduction could be undertaken for selected material, and the experimental parameters could be modified for subsequent launches during the remainder of the field trip.

When completed,⁵ TDRSS will consist of 4 satellites in geosynchronous orbit plus a White Sands Ground Terminal (WSGT). All four satellites will be identical and will operate in a shared service (SS) mode. Two will be completely devoted to TDRSS, one will function as an Advanced Westar (AW) commercial communication satellite and the fourth will serve as a spare and can be shared by TDRSS and AW.

It is anticipated that the first Tracking and Data Relay Satellite (TDRS) will be placed in orbit by the sixth Space Shuttle flight (STS-6) during February 1983, the second TDRS by STS-7 several months later and a third will probably be inserted in orbit by STS-8 at some time in the future. The completed system is expected to handle NASA's needs for the next decade and eliminate the need for a worldwide network of land and shipborne earth stations. The two TDRSS dedicated satellites will be at 41°W and 171°W longitude, the AW satellite somewhere between 70°W and 99°W longitude, and the spare satellite is tentatively planned for a longitude of about 79°W . Their synchronous orbits will place them in an extension of the earth's equatorial plane (0° latitude) and at an altitude of approximately 22,300 miles.

The location of the satellites is such that earth's shadow and antenna beamwidths prevent world-wide coverage. The shadow effect causes a zone of exclusion (ZOE) which is centered about 74°E longitude and extends up to an altitude of 1200km. TDRS antenna beam angles constrain the maximum altitude at which coverage can be maintained at the various frequencies employed (approximately 2000km for S-band multiple access users and 9700km for S-band and K-band single access users).

All ground-to-air commands will travel over a "forward link" originating at WSGT, going over K-band to a specific TDRS and then over S or K-band to the user spacecraft (low-orbiting satellite, space shuttle, etc.). Ranging information, housekeeping telemetry and data for relay will travel over the "return link" by S or K-band to the TDRS and then over a K-band link to WSGT. The TDRSS will provide three categories of service for the user: forward and return link communications, tracking services, and simulation/verification services.

Two types of communications will be provided for users: single access (SA) and multiple access (MA). Between a TDRS and a user SA will use either S-band (SSA) or K-band (KSA), whereas MA will be confined to S-band. Under the SSA mode each satellite will have 2 forward links each capable of a 300 KBS rate and 2 return links which can each carry a 6MBS rate. Under the KSA mode each TDRS will have two 25MBS forward links and two 300MBS return links. MA service will consist of one 10KBS forward link and twenty 50KBS return links.

Each TDRS will also be equipped with 10 one-way doppler measurements, 1 MA and 1 SA two-way range and doppler measurements. When two TDRS are on station the capability of the TDRSS will roughly be double that of one satellite.

The Network Control Center (NCC) at Goddard Space Flight Center (GSFC) will provide operations control of the NASA use of TDRSS. The authorized user will carry on two-way communication with its spacecraft from its control center via the NASA Communication Network (NACOM), NCC, the NASA Ground Terminal (NGT) at White Sands, the WSGT, and TDRS.

Transmission over the radio links between the user spacecraft and TDRS will employ a non-return-to-zero-level (NRZ) format using pseudo random (PN) codes. Nomographs⁶ are provided to users to determine the G/T needed for reception and the EIRP needed for transmission for a bit error rate (BER) of 10^{-5} .

Current sounding rockets employed by AFGL use antennas with a power gain of about one, transmitted power of up to 10 watts and airborne command receivers with an equivalent temperature of about 200°K . These numbers result in a G/T of -23.0dB and an EIRP of 10.0dB. A minimum BER of 10^{-5} will result in each link under the MA mode if bit rates are limited to a maximum which is slightly above 1kB/S. Under the SSA mode the bit rates should not exceed about 13kBS for the same BER. These bit rates are far below those employed in current rockets (225kB/S for BIME) and consequently a real-time relay of flight data using TDRSS would require extremely directional flight antennas with all the related problems of size and pointing accuracy.

The study process and related thought associated with this brief survey have resulted in the following:

1. TDRSS is not intended to supply data relay for short duration sounding rocket flights.
2. If certain sounding rockets have a high priority associated with their mission then AFGL should explore with NASA the use of TDRSS in the SA or MA modes for data relay.
3. If TDRSS were used to support AFGL sounding rocket programs then high-gain pointing antennas with appropriate unfolding mechanisms would probably have to be developed (probably mechanisms similar to

those currently employed to open the skin, uncover instruments, and extend booms would have to be provided).

4. A more suitable use of TDRSS would appear to be in the area of post-flight data relay from a range ground station since a high-gain fixed-pointing antenna could communicate with the TDRS user over SSA, KSA or MA. Data received at the WSGT (earth station at White Sands) could then be relayed to AFGL over the NASCOM net.

5. The use of commercial telecommunication networks for data relay from ranges should be explored as an alternative to the use of TDRSS.

B. The Aeronomy Sphere Study

1. Preflight Analysis. During the first quarter of 1981 the technical monitor requested Northeastern to make a pre-flight analysis of the telemetry link carried on board the sphere in the Auroral-E rocket A10.903. The telemetry system had already been developed by Oklahoma State University, OSU, and launch was scheduled from PFRR, Alaska, in March 1981. Signal drop-outs had been encountered in telemetry reception from similar sphere experiments launched elsewhere and an additional review was requested.

The on board telemetry system consisted of three subcarrier oscillators, a two watt S-band transmitter at 2269.5 MHz and a modified strip line antenna which encircled the sphere. This antenna was modified so that it could receive a 550 MHz ranging signal as well as transmit the S-band signal. The data consisted of a Z-axis accelerometer which drove a channel 16 subcarrier oscillator, the instrument PCM which drove a channel H subcarrier oscillator at a 20 kB rate and the received

ranging signal which drove a channel 18 subcarrier oscillator. The FM transmitter was to have a peak deviation of about 340 kHz resulting from deviations of 215 kHz, 85 kHz and 40 kHz produced respectively by the band H, 18 and 16 subcarrier oscillators. It was planned to use 750 kHz bandwidth i-f amplifiers in all receivers supporting this (Link 2) telemetry link. Baseband filters of 24000, 4950 and 2100 Hz respectively had been planned for channels H, 18 and 16.

a. Bandwidth Measurements. Given the complexity of an analysis of a PCM/FM/FM system of this type, an experimental evaluation was undertaken with a mock-up system. It was found that a 750 kHz receiver bandwidth appeared adequate to pass about 98% of the transmitted spectrum. The next wider bandwidth, 1.0 MHz, would have downgraded the CNR at the discriminator input by 1.25 dB and did not appear warranted.

b. Link CNR Calculations. After discussions with OSU engineers the following parameters were assumed for the air-ground link between the sphere and the OSU ground station:

Transmitter Power:	2.0 watts
Airborne Antenna Gain:	-2 to -14.0 dBi
Ground Antenna Gain:	28.6 dBi
Polarization Loss:	3.0 dB
RF Frequency:	2269.5 MHz
Gain of Pre-amplifier:	26.0 dB
Noise Figure of Pre-amp.:	3.0 dB
Loss of Cable following	
Pre-amplifier:	8.0 dB
Bandwidth of IF Amplifier:	750.0 kHz
Equivalent Sky and Atmospheric	
Temperature:	20.0 ⁰ K

The anticipated slant range was expected to be between 160 to 200 km. A minimum carrier-to-noise, CNR, calculation was made using a 200 km range, -14.0 dBi airborne antenna gain and the other parameters tabulated above. The resulting CNR was 13.9 dB. Since the tuned discriminators of most receivers have a threshold of about 12 dB it appeared that adequate CNR would result at the input to the discriminator under most conditions. It was recognized, however, that antenna nulls causing losses exceeded the assumed -14 dBi by a few dB could cause problems under adverse conditions.

At the time of this analysis little information was available relative to the range support receiving systems, but they were reported to have better performance capability than the OSU portable station. It was accordingly assumed that the OSU CNR's were a worst-case calculation.

2. Postflight Analysis. On March 6, 1981, the falling sphere experiment was launched on a Paiute-Tomahawk vehicle out of Poker Flat Research Range, Alaska. The sphere reached an altitude of 186 Km and had a flight time of 8.5 minutes. The signals received from the sphere had severe dropouts. In general the OSU portable ground station at the blockhouse recorded better signals than the more sophisticated NASA/WALLOPS receiving facility at its hilltop site. The signals received at either site were in-the-noise or near noise level during portions flight when the range was less than the 200 km used in calculations of CNR. As a result of this performance an attempt to make a brief, post-flight study was undertaken. To this extent the characteristics of the airborne antenna, the ground receiving station and the AGC records of the flight were investigated.

a. Airborne Antenna. The antenna used was a model 55.511 circular stripline antenna designed and manufactured by Physical Sciences Laboratory (PSL) of New Mexico State University. For orientation purposes, the antenna can be considered as mounted on an equatorial surface encircling the sphere with the Z axis of the sphere being equivalent to the North Pole. It is primarily linearly polarized in a direction aligned with this Z axis.

The minimum radiated powers of -20 dBi occurred at the poles (Z axis) while the maximums of +4 dBi were located about 20 degrees from the poles. The gain in the equatorial plane was approximately -4 dBi with a variation of ± 2 dB. The average antenna gain was approximately -4 dBi.

Since both the OSU and NASA receiving stations used circularly polarized antennas, a 3 dB loss would be expected due to the polarization mismatch between transmit and receive antennas.

b. Receiving Stations. The NASA/WALLOPS receiving station located at the hilltop site employed two antennas, each receiving left and right hand circular polarized signals. Each had a gain of 32 dBi. Preamplifiers with gains of 26 dB and noise figures of 3.5 dB were used. Each antenna system output drove 4 receivers. Automatic diversity reception mode selected the receivers with the strongest signals to drive the automatic tracking system. During the flight, the trackers operated independently.

When the link assumptions of part 1.c are changed to reflect a pre-amplifier noise figure of 3.5 dB, receiving antenna gain of 32 dBi and the antenna gain values obtained from PSL, the following i-f amplifier outputs are calculated:

CNR = 10.5 dB when $G_t = -20$ dBi, and

CNR = 26.5 dB when $G_t = -4$ dBi.

If an additional 3 dB of loss is attributed to non-optimum operation of receivers and other unspecified causes, then values of CNR = 7.5 dB and 23.5 dB respectively result.

Except when the Z axis and its nulls are facing the receiving antenna, the average CNR should have been well above the discriminator threshold (assumed to be about 12 dB) and clean signals should have been received throughout the flight. Assuming a random positioning of the sphere drop-outs should have occurred a very small percent of the time.

c. Records of AGC Reception at NASA Station. Study of the AGC record and the received data led to the following observations:

(1) The right hand circular polarization antenna outputs yielded the strongest signals.

(2) Signals from both antennas were strong at lift off to approximately $T + 40$ seconds, at which time the signals went into noise. When the protective shield was removed and the sphere was released, strong signals were again received. The AGC at this time varied periodically, probably at the spin rate of the sphere. The left hand circular polarization signal varied with a peak-to-peak change of 40 dB with the low end of the signal in the noise. The right hand circular polarization out varied at the same rate but had only a 20 dB peak-to-peak change. The valleys dipped to just above noise threshold.

(3) Dropouts in data occurred about 10% of the time from the time the protective shield was removed up until about $T + 3.5$ minutes.

(4) At about T + 4.5 minutes the signal went into noise about 95% of the time with occasional clean data when one of the receivers came out of the noise.

(5) The dropouts were not simultaneous with both antennas. When one tracker had good signal, the other was sometimes totally in the noise and vice versa.

(6) The signals were not recovered on the down leg of the flight.

d. Records of AGC Reception at OSU Station. For comparison, the same records of the Oklahoma State University (OSU) Minitracker Station located in the blockhouse, were similarly analyzed. The following observations were made:

(1) The OSU tracker had good signals at liftoff and the signal gradually went into the noise until sphere release.

(2) For the first 3 minutes after sphere release, the signals were in the noise 25% of the time at which time it deteriorated to approximately 75%.

(3) At approximately T + 4.75 minutes the signal improved to 98% good signal with 2% noise. This good signal continued to Loss of Signal (LOS).

(4) The gain of the minitracker antenna was 28 dB, 4 dB less than the NASA trackers and yet a better performance was realized.

3. Conclusions and Recommendations. It is extremely difficult to explain the difference between the projected operation and the actual flight reception. Many unknowns are involved including vehicle attitude relative to each ground station throughout the flight, the actual flight antenna as opposed to the statically measured pattern, the actual ground station parameters as opposed to the tabulated values, and the actual pointing accuracy

of the station antennas in the autotrack mode. This being the case the most practical recommendations for the future involve improving the CNR.

It appears that a practical approach to signal-to-noise ratio improvement lies in transmitting the same information within a smaller bandwidth. At present the wide band (approximately 750 kHz) needed is primarily determined by PCM modulation of subcarrier H. Two systems have currently been proposed and are presented in Figure 2-1.

The first (System A) would use a NRZ coded PCM system for the experiment data and the Z axis accelerometer, and a channel 18 subcarrier oscillator for the ranging data. These two signals could be linearly added since their spectrums do not overlap and this summation would modulate the F.M. transmitter. Since the highest frequency involved would be the upper band edge of the channel 18 subcarrier oscillator, the I.F. bandwidth of the receiver could be reduced to 300 KHz or less with a S/N_{IF} improvement greater than 4 dB.

The second system proposed (System B) would utilize an encoder system suggested by OSU which would utilize one bit in each word of a PCM bit stream to transmit the ranging data. With such a system the overall IF bandwidth requirement would be reduced to 100 KHz or less, yielding a S/N_{IF} improvement of almost 9 dB.

C. A Master-Slave Data Transmission System Study

A Master of Science thesis was undertaken by James R. Manley⁶ in order to consider the possible use of a master-slave data transmission system. It was envisioned that a "Master" unit built about an Intel 3035 microcomputer would be located in the ground control unit and

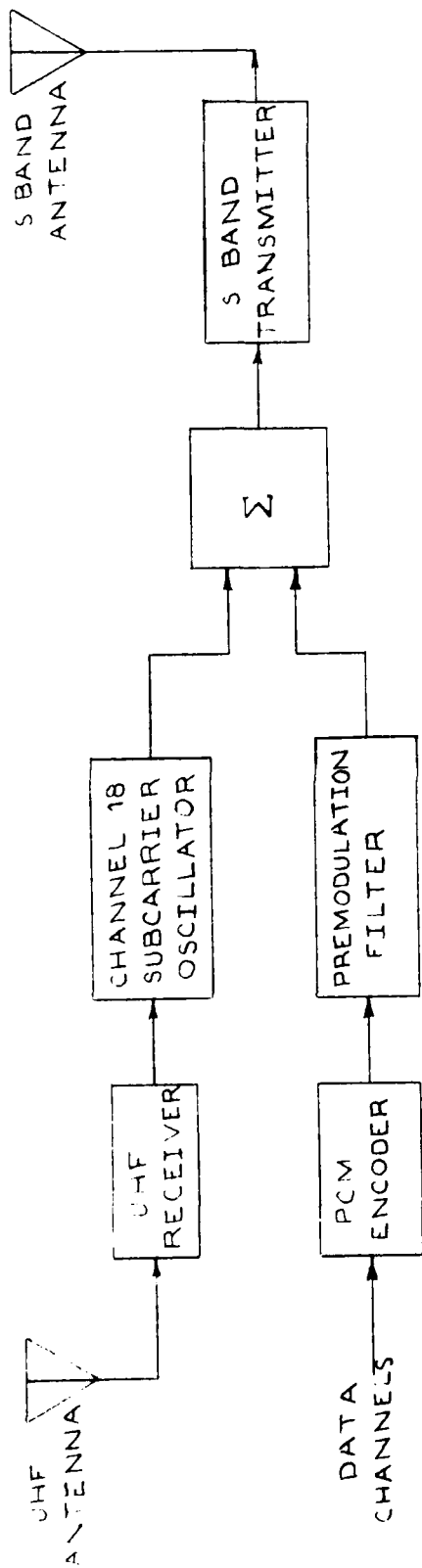

SYSTEM A

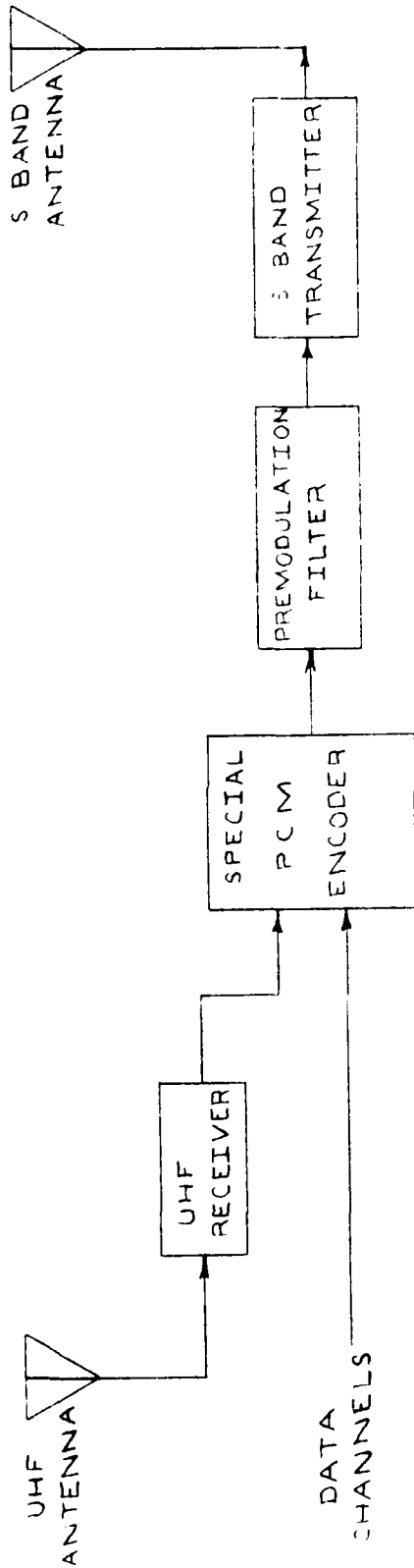

SYSTEM B

Figure 2-1. Recommended Systems for Reduction in Required Sphere Bandwidth.

another 3035 would be used as the "Slave" aboard a rocket or balloon located at its launch pad. Digitization of the various control and monitor signals now carried over the multi-conductor umbilical cables used with large vehicle systems would be unnecessary. Two-way serial digital data could be transmitted between the two units over a single umbilical link. After launch the on-board microcomputer could imitate all timing signals of the type now generated by various solid state timers. Software programs could be used in place of hard-wired logic and great flexibility would result from the use of microprocessors.

An overview approach is taken in the thesis and flow charts are presented so that they can be used as a guide by programmers considering specific applications. The technique used employs an interrupt structure. The main program runs continuously and subprograms are called for under interrupt requests. These subprograms are intended to synchronize real-time clocks in both locations, initiate the transmission of commands and data, etc.

A basic transmission unit consisting of 11 bits is proposed. This sequence consists of a start pulse, 8 signal bits, a parity bit and a stop bit. This 11-bit unit can be used for three different purposes: synchronization, data/instruction, or check sum. Various sequences of these units (5 combinations or types in all) are suggested for such purposes as

Type 1. Format of system input data at one unit for transmission to the system output of the other unit.

Type 2. Transmission of inquiries and instructions.

Type 3. Format of transmission received by a unit which is to be sent to its data outputs.

Type 4. Acknowledgement by receiver of Type 2 transmission.

Type 5. Termination of further transmission upon error detection until resynchronization is accomplished.

The slave station collects and digitizes monitor information for relay to the master station, initiates relay closures for various purposes and can rely upon its own clock for timing under certain circumstances (external control problems, after lift-off, etc.).

The master station would include a keyboard for the single-stroke input of commands and data, and a display comprised of one 8-place alphanumeric display of time and two 4-place hexadecimal displays. Master and slave time, monitor outputs and messages used for various command codes would be presented.

Thirteen different data commands together with formats are proposed.

CHAPTER III
AIRBORNE INSTRUMENTATION

A. Flight Systems

During the period of this contract Northeastern University has continued to provide engineering support for flight systems in the areas of telemetry systems, radar and tracking systems, recovery acquisition aids, attitude determining devices, including gyroscope platforms, and ground based receiving and recording checkout stations for the individual rocket and balloon payloads. This support has resulted in eight rocket launches and two balloon launches. Six other payloads systems were not launched due to improper scientific conditions. The details of this field support is covered in Section 3 of this chapter.

The specifications of certain subsystems and the resulting designs of circuit developments described in Chapter I of this report were usually a direct result of requirements set forth in these rocket or balloon systems.

The following sections describe the flight systems completed during this contract.

1. Extreme Ultra Violet Experiment (EUV). In the final report of Contract F19628-76-C-0111,⁷ the telemetry system configuration and an inflight UHF command system used by the balloon branch at Holloman AFB, New Mexico are described in detail. In anticipation of the sixth flight of this experiment all flight components including transmitters, receivers, subcarrier oscillators, commutators, cables and monitors

were recertified for flight. New hermetically sealed Lithium flight batteries were prepared and installed. The flight was successfully launched on 27 April 1980 and data was recorded for the ten hour flight period. The recovered payload was then refurbished in preparation for the seventh flight of the EUV experiment.

New antennas were constructed and tuned to replace those destroyed during recovery of the last flight. In addition, a circular polarized turnstile type antenna was prepared to provide good signal strength when the balloon is directly overhead (quarter wave stub antennas have a deep null at this point). A ground command was used to control a coaxial switch to select the desired antenna.

The balloon was launched successfully on 22 April 1981. The flight met all scientific objectives with all airborne and ground support systems operating properly. The payload was recovered in excellent condition and is currently awaiting subsequent launches on the follow on contract, F19628-83-C-0037.

2. Field Widened Interferometer. The FWIF program continued after two launches in the previous contract. Payload A30.072 was prepared for two field trips which were accomplished at the Poker Flat Research Range, Alaska during April/May 1980 and January/February 1981. No launches occurred during either of these trips due to improper scientific conditions. The vehicle was redesignated A30.175 and was returned to PFRR in September 1981. The payload was successfully launched and recovered on 7 November 1981 during the second launch window of this field trip.

Northeastern University was responsible for a dual link telemetry system at 2251.5MHz and 2279.5MHz multicoupled onto a stripline antenna.

The system was similar to that previously launched at PFRR and consisted of a PCM/FM link of an NRZ-L signal at 420Kbps. Link 2 was a PAM/FM/FM system consisting of seventeen subcarrier oscillators. Northeastern also had the responsibility for pre-launch and launch operation of an S-band radar transponder, an FM receiver at 430MHz for the Tradat ranging system and a recovery location beacon at 242MHz.

Plans are currently being implemented to continue into the next phase of the DNA-FWIF Program by the scheduling of the baffled instrument for flight at PFRR during March 1983 in a follow-on contract.

The baffled FWIF, A30.276 will be supplemented by two additional experiments, the Energy Quadrant Photometer (EQL) and an Atomic Oxygen Detector. All other systems are similar to that of previous FWIF flights with the exception of two basic changes in the telemetry system. The PCM/FM link at 2251.5MHz will now be modulated by a Bi ϕ -L signal at 420 Kbps and due to the two additional experiments there are nineteen subcarrier oscillators modulating the PAM/FM/FM link which is transmitting at 2279.5MHz.

3. Aeronomy. The Aeronomy payload, A11.074 was developed to be launched in conjunction with the FWIF payload, A30.072. The telemetry section is a refurbishment of the recovered Auroral Dynamics payload described in the final report of Contract F19628-76-C-0111.

The telemetry system consists of a single link FM/FM at 2259.5MHz modulated by seventeen subcarrier oscillators in support of a number of experiments. The experiments consisted of a Nitric Oxide Detector, an Atomic Oxygen Detector, two Plasma Frequency Probes, two Electro-Static Analyzers, a Solar Aspect Sensor, a DC Probe, two Photometers, a Magnetometer and a Midas Gyro Platform.

Vehicle tracking was accomplished by the use of a tone ranging system on an FM receiver at 430MHz and an S-band radar transponder. The front end of the rocket housed a "falling sphere" experiment with a PCM/FM/FM telemeter system at 2269.5MHz serviced and operated by Oklahoma State University. Chapter II of this report describes pre-flight analysis of this system.

This payload arrived at PFRR in April 1980 with the FWIF payload and was canceled during May 1980 due to lack of proper scientific conditions.

4. Energy Campaign. A combined program involving the United States, Great Britain, Sweden, Norway and Germany had been defined and designated as the Energy Campaign. This program consisted of the launching of some forty scientific research rocket and balloon payloads from the ranges located in Andoya, Norway and Kiruna, Sweden. The experiment supplied by the United States was an infrared detection measuring instrument consisting of a Circular Variable Filter and flown on a Taurus Orion sounding rocket designated A13.073.

The telemetry system consisted of a single link FM/FM system at 2279.5MHz and was modulated by seventeen subcarrier oscillators. The experiments consisted of the Circular Variable Filter, an Atomic Oxygen Detector, an Electron Deposition Scintillator, two Photometers, a DC Probe, a Magnetometer and an Analog Gyro Platform.

Vehicle tracking was accomplished by the use of an FM Receiver at 430MHz using the OSU Tradat ranging system and an S-band radar transponder.

The field party arrived at Andoya, Norway in October 1980 and launch was successfully accomplished on 16 November 1980.

5. Tracer. The Tracer payload, A13.277, was designed to examine and characterize emissions at specific wavelengths and measure critical neutral atmospheric parameters simultaneously. The telemetry consists of a single link FM/FM system at 2279.5MHz modulated by seventeen sub-carrier oscillators. The experiments consist of a Tri-channel Radiometer, an Atomic Oxygen Detector, a Nitric Oxide Detector, a Solar Aspect Sensor, three Photometers (Nitric Oxide, Ozone and 5577⁰A), a DC Probe, a Magnetometer and a Midas Gyro Platform.

Tracking was accomplished by installing a C-band radar transponder in the telemetry section. This payload was very similar to the Aeronomy payload described in section 3 of this chapter and also has a 10-inch diameter "Falling Sphere" experiment with telemetry being handled by personnel from Oklahoma State University. The transmission frequency for the sphere is at 2251.5MHz.

The payload was successfully launched from Wallops Flight Center, Virginia on 29 June 1982. All telemetry and tracking systems performed well without any problems. The Tri-channel radiometer instrument did not release its cover and its adjacent photometers saturated. All other experiments performed as expected.

6. Solar Proton Event Program. The SPE Program, using Piate Tomahawk launch vehicles, consists of Mass Spectrometer and Gerdien Condenser experiments for the purpose of measuring protons ejected from the sun after solar flare activity. The payloads are identical and consist of two FM/FM telemetry links at 2251.5MHz and 2279.5MHz. Each link has twelve and eleven subcarrier oscillators respectively. Vehicle tracking is accomplished by the use of an S-band radar transponder and a Tradat ranging system at a receiver frequency of 5' .1z.

Each payload has a recovery system with recovery beacons operating at 242MHz. When an event occurs two payloads will be launched, the first at night followed by the second during daylight of the next day.

Payloads, A10.901-1,2, were prepared at PFRR during August 1980 for an expected solar proton event. On 13 October 1980 the field party was alerted and arrived at PFRR. Payload A10.901-1, was launched on 22 October 1980 as a back ground measurement due to the lack of proper solar activity. This launch was successful and subsequently recovered.

Payloads, A10.901-2,3, were integrated, tested and shipped to PFRR during August 1981 in anticipation of any solar proton activity. The field crew was alerted and returned to PFRR on 13 October 1981. The activity diminished and again as in 1980 one vehicle A10.901-2, was launched to record any background activity. This launch and recovery was successful with all systems performing as expected. Payload A10.901-3 was stored at PFRR for future programs and recovered payload A10.901-2 was returned to Northeastern for refurbishment.

Payload A10.901-4 was shipped to PFRR during March 1982. The field crew arrived and prepared both A10.901-3 and A10.901-4 for possible SPE launches. Due to a lack of proper solar activity the payloads were stored at PFRR and the field crew returned to Northeastern during April 1982.

Again in September 1982 the field party arrived at PFRR and prepared the payloads for launch. And again due to lack of solar activity the launch was canceled and the field crew and payloads were returned to Northeastern University during October 1982. Any future activity

with this program will be handled during follow-on contract F19628-83-C-0037.

7. Auroral-E Program. This program consisted of four payloads successfully launched on 6 March 1981 at PFRR to test new theoretical models developed for obtaining ionospheric electron density profiles by observing auroral optical emissions during a diffuse aurora.

This contract was responsible for providing telemetry for payload A13.020, which contained three experiments. The first is a paired-pulsed-plasma probe (P^4) experiment produced by the Naval Research Laboratory in Washington, D.C. The second is an Electron Deposition Scintillator produced by Utah State University and the third is a Mass Spectrometer produced by AFGL and Northeastern University.

The P^4 experiment along with two magnetometer signals was encoded into a PCM format containing 10 bits per word (including parity) and transmitted at a 250Kbps rate. The PCM train has a 20 bit frame synchronization word. The encoder was developed and used CMOS type digital integrated circuits to reduce power requirements. This development lead to the Research and Development of the programmable encoder described in Chapter II of this report. This data was transmitted on a single PCM/FM link at 2251.5MHz.

A second link with FM/FM modulation at 2279.5MHz consisted of sixteen subcarrier oscillators in support of a Mass Spectrometer, Electron Deposition Scintillator and an analog gyro.

Vehicle tracking was accomplished by the use of the Tradat ranging system at an airborne receiver frequency of 547MHz and an S-band radar transponder.

8. Brazil Ionospheric Modification Experiment. This program, BIME, was designed to make measurements in the F-layer of the ionosphere by means of rocket, aircraft and ground based instruments. The launch of the program was in two separate sets of experiments to be conducted. Each experiment consisted of a first rocket which effectively released 56 kilograms of water vapor explosively and produced a "hole" or electron depletion layer in the F layer. A second rocket, instrumented with mass spectrometers and probes, was launched at a time and elevation angle which caused its payload to intercept the depleted region and make the desired measurements. The first experiment took place at sunset, the second in the early morning hours. The water releasing vehicles will be Nike/Black Brant rockets and will be instrumented by Oklahoma State University (OSU).

The depletion sensing vehicles will be Sonda III rockets and will be instrumented by Northeastern University. The experiments consist of a Mass Spectrometer and a pulsed-plasma probe (P^3). Monitoring was provided for housekeeping and engineering functions such as accelerometers, magnetometers, timers and batteries. Vehicle tracking was accomplished by use of the Tradat ranging system at a receiver frequency of 430MHz and a C-band radar transponder.

Due to the desired range being in excess of 500 kilometers, special effort was made to minimize size and weight. A single RF link was desirable since this would reduce not only the need of extra components such as a switching relay, diplexer and transmitter, but also the battery power required to service the link.

The scientific requirements of the instruments require that the analog data be encoded to 9 bit digital words at a minimum rate of

2048 samples per second for the P³ experiment and 1024 samples per second for the mass spectrometer.

Range and equipment considerations indicated that to insure a sufficient received carrier-to-noise ratio under worse case conditions, an 8 watt transmitter would be required with a maximum radiated bandwidth of 500 kHz. Table 3-1 lists the assumptions and results. The receiving antenna gain of 26dB is for the portable dish used by OSU. It is expected that the antenna located at the range at Natal will be available and it, having a much higher gain of 43dB, would insure very good signal strength at all times.

ASSUMPTIONS:

Freq.	2.25 x 10 ⁹ Hz
Xmtr. Ant. Gain	-8 dBI
Rec. Ant. Gain	+26 dBI
Noise Figure	2.5 dB
Preamp. Gain	400
Polarization Loss	3 dB
Safety Factor	3 dB
Xmtr. Power	3, 5 or 8 W

RESULTS

Xmtr. Power	CNR at IF
3 watts	9.7 dB
5	12.0
8	14.0

Sonda III Range Calculations

TABLE 3-1.

At the request of OSU range equations were solved to find the carrier-to-noise ratio that would be experienced on the TRADAT ranging link. (This is an up link and the rocket antenna looks at a warm earth as opposed to the usual background sky which is seen by a ground station receiving a down link transmission.) The following assumptions were made:

T_{earth}	300 ⁰ k
IF BW	550 kHz
Range	600 Km
Freq.	550 MHz
Xmtr. Ant. Gain	10 dBI
Rec. Ant. Gain	-10 dBI
Rec. NF	6 dB
T_{sky}	10 ⁰ k
Cable Loss	10 dB
IFBW	500 kHz
Range	550 Km

These assumed values would result in an airborne carrier-to-noise ratio of 8.2dB. (If a preamplifier with a 20dB gain and a 3.2dB NF were to be inserted after the antenna the CNR would increase to 10.9dB.) This level appeared inadequate and so two suggestions were made to improve reception.

The first suggestion was to modify the receiving antennas on the vehicles which had a deep null in the direction of the ground based

transmitter. By addition of two more stubs and properly phasing the signals from them, the antenna gain can be increased to greater than 0 dB in the aft looking direction, an improvement from the -10dB of the normally used antenna. The second suggestion was to reduce the IF bandwidth of the ranging receivers from 560kHz to 150kHz. This alone would result in an improvement of 5.7dB. New receivers were ordered with the reduced bandwidth and previously purchased units were returned to the manufacturer for modification. These two modifications resulted in a total improvement of greater than 15dB.

The PCM encoding system, a direct result of the development of the programmable encoder described in Chapter I, used a clock rate of 221.184 kilobits and a maximum sampling rate of 4096 bits per second for the twenty-one channels required. The PCM system used in the BIME Program is shown in Figure 3-1a. This system is in a bi-phase format and is added to the Tradat ranging PCM output directly. This system takes advantage of the fact that the spectrum of a bi-phase PCM signal has very little energy at low frequencies (a factor of 20 below its clock rate) and thus would not interfere with the 3.9kHz PCM of the ranging system. The IF bandwidth of this system is approximately 450kHz and also within the 500kHz bandwidth of the receiver. This system also allows a higher sampling rate of the NRL experiment.

A second system using a clock rate of 147.456 kilobits and a maximum sampling rate of 2048 bits per second is shown in Figure 3-1b. The output of the PCM would be in an NRZ-S format and directly modulate the transmitter. In this system the signal from the ranging receiver which is a 3.9 kilobit bi-phase PCM signal, modulates an

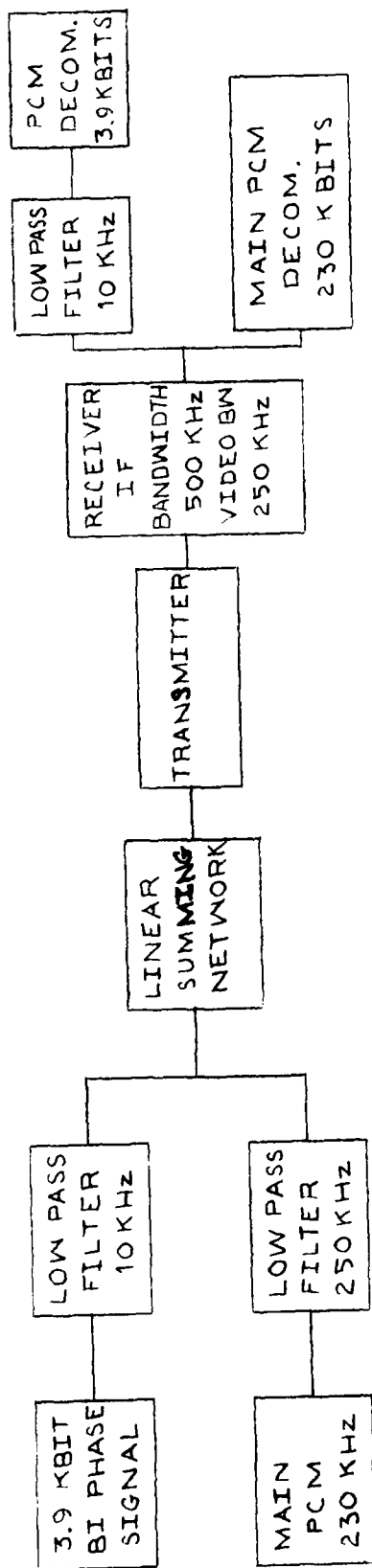

Figure 3-1a. BIME PCM System.

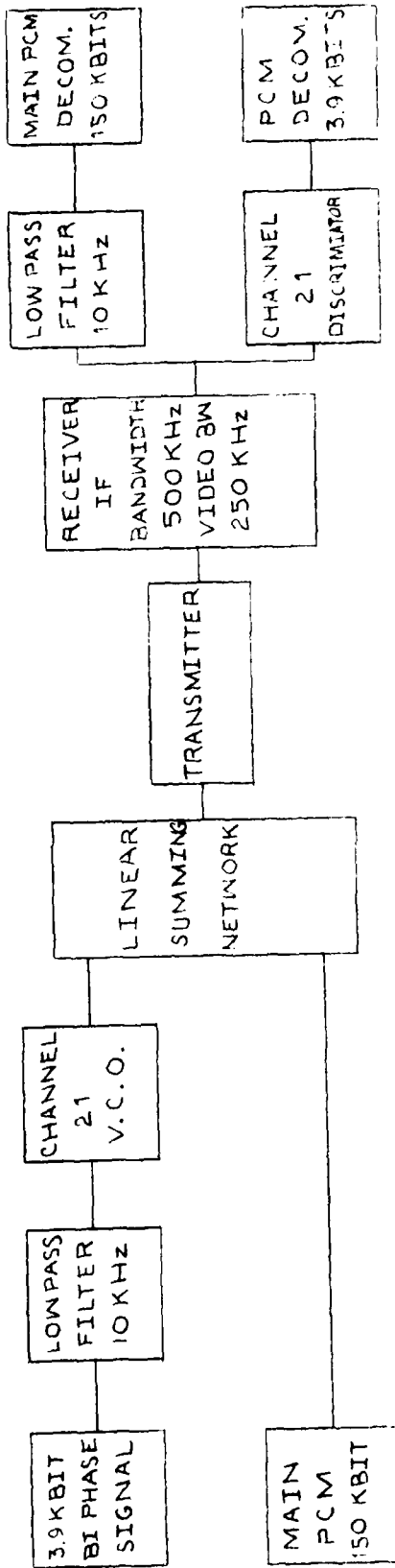
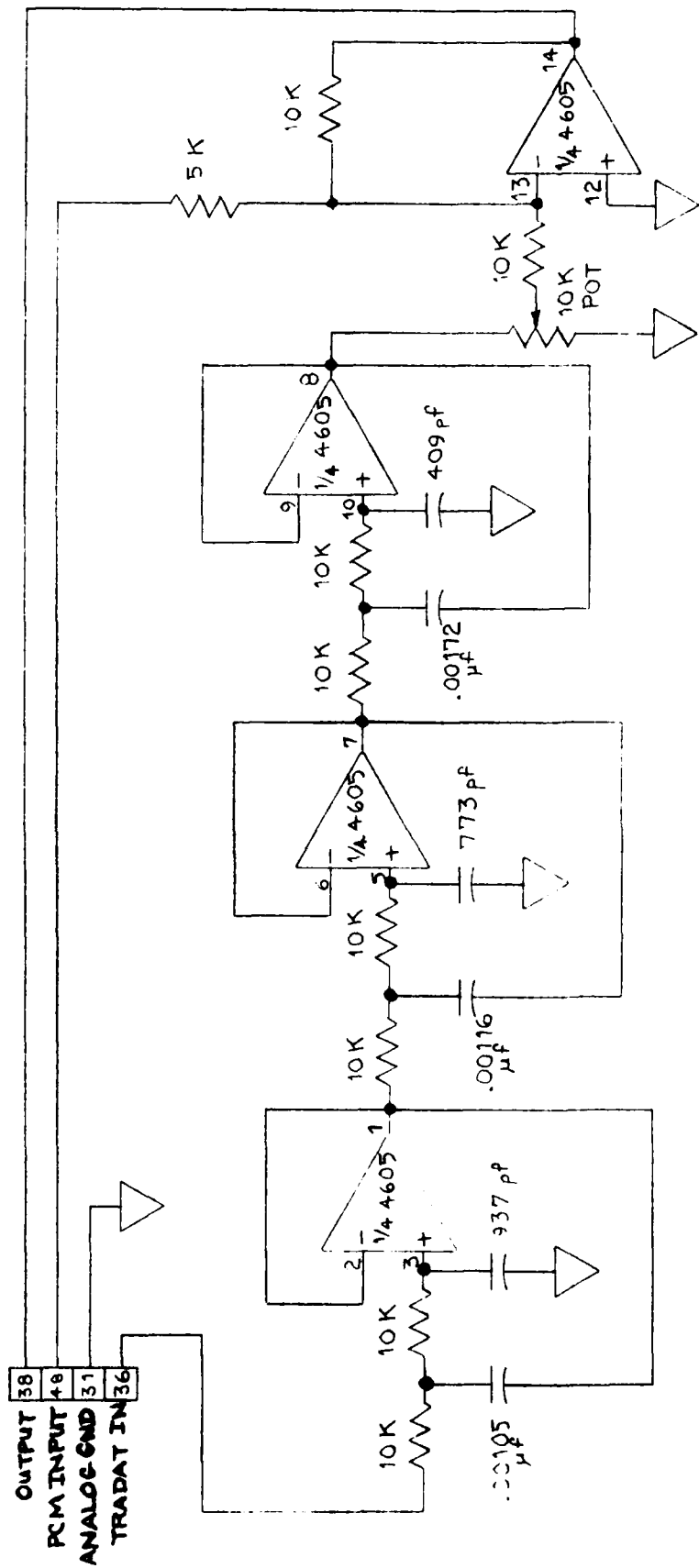

Figure 3-1b. Alternate BIME PCM System Investigated.

IRIG channel 21 subcarrier oscillator. The output of this subcarrier oscillator is linearly summed with the instrument PCM signal to modulate the transmitter. Because the instrument PCM signal is filtered at 100kHz (6 pole linear phase) and the output of the subcarrier varies between 152kHz to 177kHz. The signal will not interfere and can be separated at the ground station. By using narrow band FM deviation levels, the IF bandwidth of this system will be about 360kHz, well within the 500kHz IF bandwidth of the receiver. Both systems were tested in the laboratory under various conditions of signal-to-noise ratio and various filter cutoff points, and operated properly with no noticeable dropouts detected in the PCM output until the receiver signal-to-noise ratio was reduced to approximately 14dB. Since both formats occupy approximately the same IF bandwidth, the system using the higher bit rate in the main PCM encoder was selected. This selection allowed sampling the NRL experiment at twice the rate of the other proposed system without compromising the mass spectrometer experiment.

In order to mix the two PCM signals together without any harmonic intermodulation, premodulation filters had to be incorporated. The linear phase, 6 pole filter with a cutoff at 10kHz used in conjunction with the OSU Tradat ranging output is shown in Figure 3-2.

The Sonda III rockets, designated A20.123-1,2, were integrated and environmentally tested during May 1982. The field party arrived at Natal, Brazil on 17 August 1982. The field services were completed with two successful sets of launches accomplished on 8 September 1982 and 13 September 1982.



NOTES:

- ALL 10K RESISTORS ARE IN 16 PIN DIP (MIP (R)).
- ALL CAPS WITH 10K TRIMPOT AND 5K RESISTOR ARE MOUNTED ON ONE 24 PIN DIP CARRIER (F).

Figure 3-2. Premodulation Filter for OSU TRADAT Ranging output.

9. Sensor Ejection Systems. An experiment flown from the White Sands Missile Range, New Mexico in February 1983. The objective of the program is to demonstrate the feasibility of ejecting multiple sensors at altitudes greater than 100NM and obtaining the scientific data via the payload telemetry. The payload was launched via an Astrobee F, A31.200, on 22 February 1983. Two PCM/FM links at 2251.5MHz and 2279.5MHz were used for data transmission. The main PCM link (2251.5MHz) supported the main experiment data at a 1.0Mbps rate in an NRZ-S format. The encoder was built by the experimenter, Applied Physics Laboratory of John Hopkins University, Maryland. Northeastern University had the responsibility for the driver and receiver, for bringing the signal to the telemetry system, for providing the premodulation filter, and for providing a means to offset and level shift the signal to properly modulate the transmitter.

The second link was primarily for housekeeping data. It serviced the main experiment, the attitude control system and such level monitors associated with the support instrumentation as temperature, pressure, magnetic field, and battery voltage. Responsibility for this link was entirely with Northeastern including the PCM encoder and premodulation filter. Northeastern was also responsible for providing a hardline system to allow both PCM links to be monitored directly from vehicle to blockhouse.

The coaxial lines from the Aerobee 350 tower to the blockhouse were tested with a simulated 1 M Bit/sec. PCM pulse train and it was found that there were 9 operational 50 Ω cables (RG-9) capable of operating at this rate in a round trip test. This is twice the distance that would be required for operations. A line driver was designed and

tested that would meet these field requirements.

The encoder designed is an adaptation of the programmable encoder described in Chapter I and operates at a 20.48Kbps rate. The main experiment provided 23 analog signals and 4 digital signals. The ACS system requires 7 analog channels and the NU housekeeping requires 35 analog channels. Four spare channels are available for future revisions. Vehicle tracking was provided through the use of a C-band radar transponder.

Applied Physics Laboratory expressed concern that the experiment may be adversely affected by the RF fields present around the outside of the vehicle. A simple mathematical model yielded a first approximation to the field produced by the C-band transmitters. At a distance of 10cm from the S-band antenna, the field strength would be 17 MW/CM^2 and 10cm from the C-band antenna the field strength would be 0.8 MW/CM^2 . This approximation assumes uniform radiation from the antenna. It was suggested to AFGL that a field strength measurement system be obtained to verify the actual field strength. An equipment search found that Narda Microwave Corporation produced a radiation monitor (Model 8603) which could measure field strength in a frequency range of 10MHz to 26GHz with a dynamic range of 0.1 to 100 MW/CM^2 . Actual measurements of the system will be made during integration testing of the vehicle at AFGL in January 1983.

Integration of the payload and field services were provided under Contract F19628-83-C-0037 which is the follow-on contract between AFGL and Northeastern University.

B. Field Support

This section contains a tabulation of those instances in which field programs required Northeastern University personnel to provide professional and technician level support at field locations. In most instances the travel indicated was to launch ranges to install and operate airborne equipment or provide ground support. In some instances travel was involved with facility evaluation, conferences, or meetings. In any event whenever overnight travel was undertaken the trip was classified as field support and is consequently listed.

<u>Purpose or Launch Date</u>	<u>Location</u>	<u>Vehicle Type & Designation</u>	<u>Trip Duration</u>	<u>Staff</u>
Integration Checkout	Utah State Univ. Logan, Utah	Field Widened Interferometer A30.072	7 April 80 to 12 April 80	Marks
27 April 80	Holloman AFB, New Mexico	EUV Balloon	15 April 80 to 29 April 80	Poirier
No Launch	Poker Flat Research Range Alaska	Field Widened Interferometer A30.072 and Aeronomy A11.074	24 April 80 to 17 May 80	Marks O'Connor
No Launch	Poker Flat Research Range, Alaska	Solar Proton Event (A10.901-1,2)	4 Aug. 80 to 13 Aug. 80	Poirier Wheeler
Conference	San Diego, California	International Telemetry Conference	13 Oct. 80 to 16 Oct. 80	Rocheffort Poirier
22 Oct. 80	Poker Flat Research Range, Alaska	Solar Proton Event (A10.901-1)	14 Oct. 80 to 26 Oct. 80	Wheeler
16 Nov. 80	Andoya Research Range, Norway	Energy Campaign Circular Variable Filter (A13.073)	20 Oct. 80 to 21 Nov. 80	Marks

<u>Purpose or Launch Date</u>	<u>Location</u>	<u>Vehicle Type & Designation</u>	<u>Trip Duration</u>	<u>Staff</u>
5 Feb. 81	Poker Flat Research Range,	Field Widened Interferometer (A30.072)	12 Jan. 81 to 7 Feb. 81	Marks O'Connor
6 March 81	Poker Flat Research Range, Alaska	Auroral E Program (A13.020)	12 Feb. 81 to 9 March 81	Wheeler
22 April 81	Holloman AFB, New Mexico	Balloon (Hall)	14 April 81 to 24 April 81	Poirier
RCC/TG Conference	Picitinny Arsenal - Ledgewood, N.J.	66th. Meeting of Range Commanders Council IRIG Group	20 July 81 to 23 July 81	Rocheftort
No Launch	Poker Flat Research Range, Alaska	Solar Proton Event (A10.901-2,3)	5 Aug. 81 to 19 Aug. 81	Wheeler
No Launch	Poker Flat Research Range, Alaska	Field Widened Interferometer (A30.175)	10 Sept. 81 to 12 Oct. 81 10 Sept. 81 to 26 Sept. 81	Marks O'Connor
26 Oct. 81	Poker Flat Research Range, Alaska	Solar Proton Event (A10.901-2)	13 Oct. 81 to 28 Oct. 81	Wheeler
7 Nov. 81	Poker Flat Research Range, Alaska	Field Widened Interferometer (A30.175)	20 Oct. 81 to 8 Nov. 81	Marks
No Launch	Poker Flat Research Range, Alaska	Solar Proton Event (10.901-3,4)	18 March 82 to 6 April 82	Poirier
29 June 82	Wallops Flight Center, Virginia	Tracer (A13.277)	17 June 82 to 30 June 82	Marks
RCC/TG Conference	Seattle, Wash.	68th. Meeting of Range Commanders Council. IRIG Group	2 Aug. 82 to 5 Aug. 82	Rocheftort

<u>Purpose or Launch Date</u>	<u>Location</u>	<u>Vehicle Type & Designation</u>	<u>Trip Duration</u>	<u>Staff</u>
8 Sept. 82 (A20.123-1)	Natal Research Range, Brazil	BIME Program (A20.123-1,2)	17 Aug. 82 to 18 Sept. 82	Poirier Wheeler
13 Sept. 82 (A20.123-2)				
No Launch	Poker Flat Research Range, Alaska	Solar Proton Event (A10.901-3,4)	4 Oct. 82 to 31 Oct. 82	Marks

CHAPTER IV
TESTING PROGRAMS

A. New Testing Procedures

Evaluation studies and environmental tests of certain airborne telemetry system components have been carried out under this contract. This program was started under a previous contract, AF19(605)-3506 in April 1958, continued under later contracts, AF19(628)-2433, AF19(628)-5410, F19628-68-C-0197, F19628-71-C-0030, F19628-73-C-0148 and F19628-76-C-0111 and has been quite productive. In order to arrive at a comparative evaluation of commercial equipment, all major manufacturers were invited to submit certain categories of system components on consignment. The electrical and environment characteristics were then measured and evaluated, and the results classified as proprietary information and made available to AFGL and the individual manufacturers concerned.

This chapter refers to the fact that in recent years no new manufacturers have supplied components for testing on a consignment basis. As a result the test procedures have been modified to adhere to the requirements set forth in the Background Measurement and Multispectral Measurement Programs. New and upgraded procedures have been incorporated in the testing program and are described in the following sections of this chapter.

1. Vacuum Tests. This test is performed on all components susceptible to corona and arc-over when operated in partial atmospheric pressures. The procedure consists of monitoring input current, output

power and frequency of FM transmitters for a thrity (30) minute period when the unit is placed in a vacuum chamber at an altitude equivalent to 120K feet.

2. RF Power Measurements. The system developed meets the following specifications:

- a. Measure RF power levels from 100mw to 25w
- b. Has an operational frequency range from 2 to 4GHz
- c. Accuracy of +2% tracable to NBS
- d. Has 50 ohms impedance at all ports

The block diagram for this system is shown in Figure 4-1. The components have the following specifications:

a. Directional Coupler

Maximum Power - 500w
Attenuation - 30dB
Directivity - 27dB
Frequency Range - 2 to 4GHz

b. Precision Attenuator

Maximum Power - 25w
Attenuation - 20dB
Frequency Range - 0 to 4GHz

c. RF Sensor Head-Power Meter

Power Range - 100 μ W to 3W
Frequency Range - 100kHz to 4.2GHz

d. Variable Attenuator

Maximum Power - 1W
Attenuation - 0 to 20db
Frequency Range - 0 to 4GHz

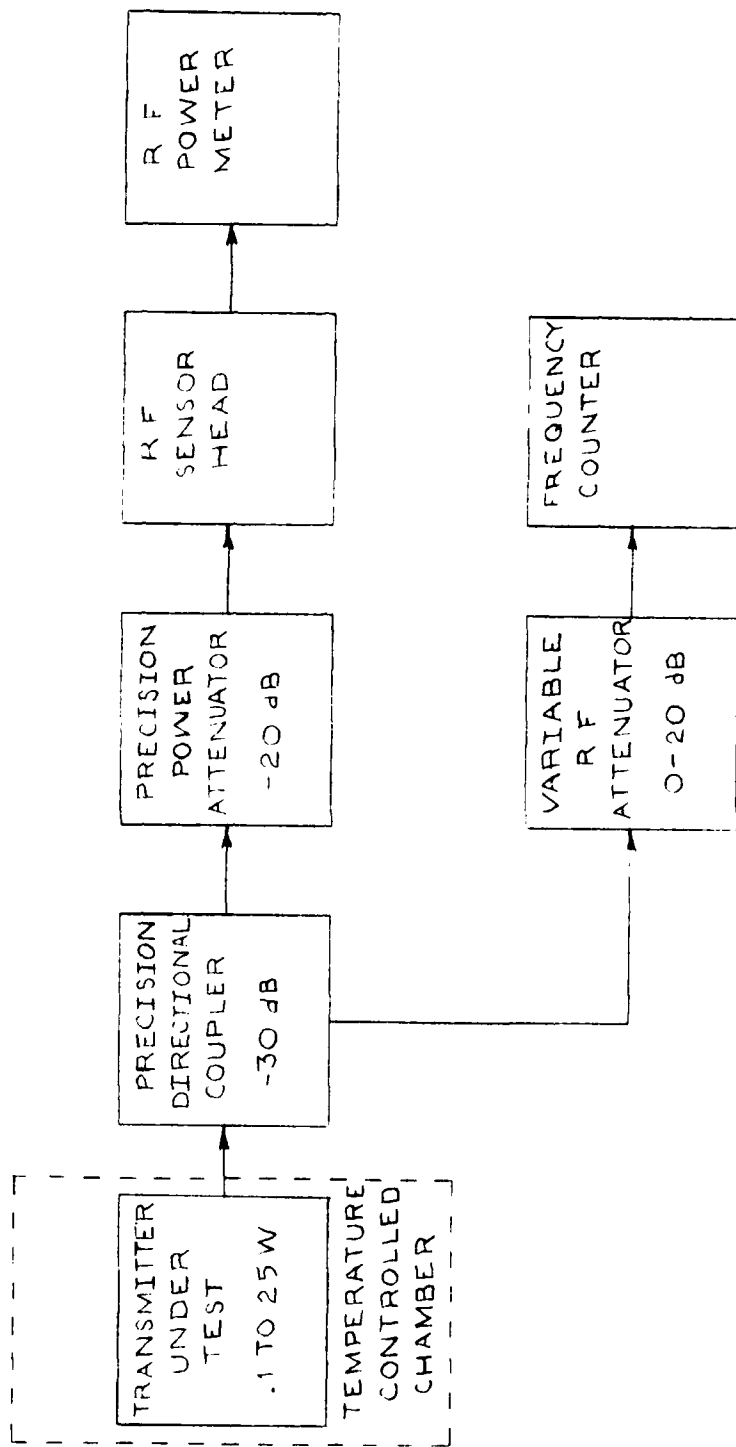

Figure 4-1. RF Power Measurement System.

AD-A134 445

SIGNAL ENCODING AND TELEMETRY SYSTEMS FOR SPACE
VEHICLES(U) NORTHEASTERN UNIV BOSTON MASS ELECTRONICS
RESEARCH LAB J S ROCHEFORT ET AL. 01 MAY 83

2/2

UNCLASSIFIED

AFGL-TR-83-0135 F19628-80-C-0050

F/G 17/2

NL



END
DATE
FILMED
11 83
DTIC

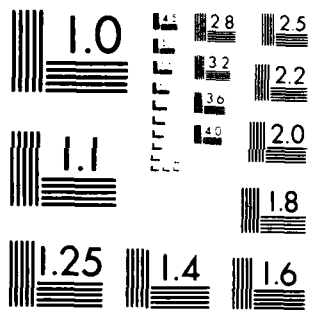

MICROCOPY RESOLUTION TEST CHART
NATIONAL BUREAU OF STANDARDS-1963-A

The temperature controlled chamber and frequency counter are the same as used in previous measurements. This new system is totally dedicated to these measurements and is sent out for calibration with cables and connectors to allow for all insertion losses to be calibrated out of measurements. With the exception of the directional coupler, the system has a frequency measurement range of 100kHz to 4GHz and this limitation could be overcome simply by the insertion of a coupler designed for a desired frequency.

3. Temperature Monitor System. A new temperature monitoring system was designed to replace existing monitors in the environmental test chamber. This was deemed necessary due to the large number of higher power transmitters which are received for testing. These transmitters have outputs in excess of 10 watts and have critical temperature limitations which are specified at their mounting base plates. If proper precautions are not taken, the transmitters can overheat and destroy themselves due to self heating. The previous system had heat sensors mounted on the heat sink to which the transmitter was mounted, but not in precise contact with the mounting plate. This allowed a steady state thermal gradient as well as a thermal time constant to occur between the base plate and the sensor.

The new system has a sensor mounted in a larger heat sink and located directly under, and in thermal contact with, the transmitter. A second sensor is mounted in the air to monitor chamber air temperature.

The temperature of either the air or base plate is read out on a digital meter, in Fahrenheit or Celsius, within a range of -55°C to $+150^{\circ}\text{C}$ and is accurate at $\pm 1^{\circ}\text{C}$ or ± 1 digit.

A safety shut-down feature was incorporated in the system to prevent accidental overheating which can occur due to self heating, loss of chamber coolant, or failure of the chamber temperature regulator. Overheating can quickly destroy a \$10,000 device in less than one minute. To prevent this occurrence, the binary coded decimal outputs of the read-out meter are compared, through logic gates, with the setting of a three digit thumbwheel switch. If the temperature exceeds the switch setting, the power to the device under test is disconnected and an over temperature lamp is lit. This power off state is latched and power on must be manually reset to resume operation.

B. Components Tested

In support of all the AFGL rocket and balloon programs, airborne components were tested using the previously described procedures as a quality control system prior to flight. All data is supplied to AFGL and placed on file at Northeastern. The following is a tabulation of all components tested during the period of this contract:

Voltage Controlled Oscillators	- 624
UHF Transmitters	- 166
UHF FM Receivers	- 27
Commutators	- 2

During this test phase procedures were continued to send certain test equipments out to Calibration and Standards Laboratories for calibration and certification which is traceable to the National Bureau of Standards. The details described in "Research and Development Equipment Information Report"⁸ have been adhered to and calibration of these specific equipments has been repeated every six months.

BIBLIOGRAPHY

1. PPCM-424-1 Programmable PCM Encoder Schematic, Northeastern University, College of Engineering, No. EE5102.
2. Intel Corporation, MCS-48 Family of Single Chip Microcomputers Users Manual, September 1980, pp 6-24.
3. James R. Manley, Jr., J. Spencer Rochefort and Thomas P. Wheeler, "A VAX Assembler for the Intel 8748 Microcomputer", Scientific Report No. 1, Contract F19628-80-C-0050, October 14, 1982, AFGL-TR-82-0306, ADA123378.
4. Willard F. Thorn, "FM Transmission of Television From Rockets and Balloons", Scientific Report No. 3, Contract F19628-76-C-0111, July 11, 1979, AFGL-TR-79-0160, ADA075489.
5. TDRSS Program Division, "TDRSS Data Book", Code: TX NASA, August 1982.
6. James R. Manley, Jr., "A Master-Slave Data Transmission System for Sounding Rockets and Balloons", Master of Science Thesis, Northeastern University, Contracts F19628-80-C-0050 and F19628-81-C-0029, June 1, 1982.
7. J. Spencer Rochefort, Lawrence J. O'Connor and Norman C. Poirier, "Communications and Instrumentation Systems for Space Vehicles", Final Report, Contract F19628-76-C-0111, January 1, 1980, AFGL-TR-80-0189, ADA087944.
8. J. Spencer Rochefort, "Research and Development Equipment Information Report", Contract F19628-76-C-0111, May 11, 1976.

PERSONNEL

A list of the engineers, technicians and student assistants who contributed to the work reported is given below:

J. Spencer Rochefort, Professor of Electrical Engineering,
Principal Investigator.

Lawrence J. O'Connor, Senior Research Associate, Engineer.

Norman C. Poirier, Research Associate, Engineer.

Thomas P. Wheeler, Research Assistant, Engineer.

Richard H. Marks, Technician, Electrical Engineering.

John E. Shields, Technician, Electrical Engineering.

James R. Manley, Jr., Graduate Assistant

Stephen Filippone, Project Assistant

James Mettie, Project Assistant

John O'Neill, Project Assistant

Richard Ricardi, Project Assistant

John Samalis, Project Assistant

James Thurber, Project Assistant

Joseph Vacchione, Project Assistant

Daniel Weinberg, Project Assistant

RELATED CONTRACTS AND PUBLICATIONS

AF19(604)-3506	1 April 1958 through 30 June 1963
AF19(628)-2433	1 April 1963 through 30 September 1966
AF19(628)-5140	1 April 1965 through 30 September 1968
AF19628-68-C-0197	1 April 1968 through 30 September 1971
AF19628-71-C-0030	1 April 1971 through 31 March 1974
AF19628-73-C-0148	9 January 1973 through 30 April 1976
AF19628-76-C-0111	12 January 1976 through 30 November 1979
AF19628-80-C-0050	4 December 1979 through 3 December 1982
AF19628-83-C-0037	4 December 1982 through present

Norman C. Poirier, Jack Griffin, Willard F. Thorn and R. Michael Fike, "Telemetry and Control Systems for the Balloon Attitude Mosaics Measurement Program" presented at the 1980 International Telemetry Conference, San Diego, California on October 14, 1980.

James R. Manley, Jr., "A Master-Slave Data Transmission System for Sounding Rockets and Balloons", A Masters of Science Thesis in Electrical Engineering at Northeastern University, Contracts F19628-80-C-0050 and F19628-81-C-0029, June 1982.

James R. Manley, Jr., J. Spencer Rochefort and Thomas P. Wheeler, "A VAX Assembler for the Intel 8748 Microcomputer", Scientific Report No. 1, Contract No. F19628-80-C-0050, October 14, 1982, Report AFGL-TR-82-0306, ADA123378.