

AD-A134 352

ELECTRON SPECTROSCOPY STUDY OF SiC(U) PITTSBURGH UNIV
PA SURFACE SCIENCE CENTER F 80250 ET AL. SEP 83

1/1

UNCLASSIFIED

F/G 7/4

NL



END

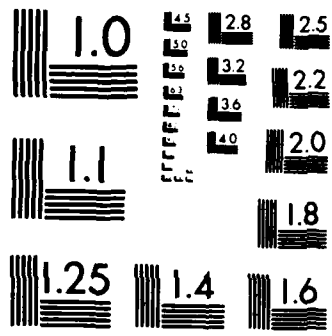

MICROCOPY RESOLUTION TEST CHART
NATIONAL BUREAU OF STANDARDS-1963 A

A134352

| REPORT DOCUMENTATION PAGE | | READ INSTRUCTIONS BEFORE COMPLETING FORM |
|--|----------------------------------|--|
| 1. REPORT NUMBER 2 | 2. GOVT ACCESSION NO. A134352 | 3. RECIPIENT'S CATALOG NUMBER |
| 4. TITLE (and Subtitle) Electron Spectroscopy Study of SiC | | 5. TYPE OF REPORT & PERIOD COVERED |
| | | 6. PERFORMING ORG. REPORT NUMBER |
| 7. AUTHOR(s) Ferenc Bozso, Lucia Muehlhoff, Michael Trenary, W. J. Choyke, and J. T. Yates, Jr. | | 8. CONTRACT OR GRANT NUMBER(s) NR 629-803 |
| 9. PERFORMING ORGANIZATION NAME AND ADDRESS Surface Science Center Department of Chemistry University of Pittsburgh | | 10. PROGRAM ELEMENT, PROJECT, TASK AREA & WORK UNIT NUMBERS |
| 11. CONTROLLING OFFICE NAME AND ADDRESS University of Pittsburgh Pittsburgh, PA 15260 | | 12. REPORT DATE September 1983 |
| | | 13. NUMBER OF PAGES 17 |
| 14. MONITORING AGENCY NAME & ADDRESS (if different from Controlling Office) | | 15. SECURITY CLASS. (of this report) |
| | | 15a. DECLASSIFICATION/DOWNGRADING SCHEDULE |
| 16. DISTRIBUTION STATEMENT (of this Report) <div style="border: 1px solid black; padding: 5px; width: fit-content; margin: 10px auto;"> This document has been approved for public release and sale; its distribution is unlimited. </div> | | |
| 17. DISTRIBUTION STATEMENT (of the abstract entered in Block 20, if different from Report) | | |
| 18. SUPPLEMENTARY NOTES Submitted Journal of Vacuum Science and Technology | | |
| 19. KEY WORDS (Continue on reverse side if necessary and identify by block number) Silicon Carbide Surface X-ray photoemission spectroscopy Plasmon losses | | |
| 20. ABSTRACT (Continue on reverse side if necessary and identify by block number) A silicon carbide single crystal has been studied using X-ray photoelectron spectroscopy and X-ray and electron excited Auger spectroscopy. A procedure for producing an atomically clean SiC crystal surface has been perfected. The SiC exhibits prominent bulk plasmon loss features associated with Si and C photoelectrons. This loss, at 22.5 eV, agrees well with optical data establishing the bulk plasmon energy. | | |

DTIC FILE COPY

NOV 3 1983
A

ELECTRON SPECTROSCOPY STUDY OF Si†

Ferenc Bozso^a, Lucia Muehlhoff^b, Michael Trenary^a,
W. J. Choyke^{*b,c}, and John T. Yates, Jr.^a

Surface Science Center
University of Pittsburgh
Pittsburgh, Pennsylvania 15260

- a. Department of Chemistry
- b. Department of Physics
- c. Westinghouse R and D Center, Pittsburgh, PA.

† Partially supported under ONR Grant NR 629-803.



A-1

ELECTRON SPECTROSCOPY STUDY OF SiC[†]

Ferenc Bozso^a, Lucia Muehlhoff^b, Michael Trenary^a, W. J. Choyke^{*b,c},
and John T. Yates, Jr.^a

Surface Science Center
University of Pittsburgh
Pittsburgh, Pennsylvania 15260

A silicon carbide single crystal has been studied using X-ray photoelectron spectroscopy and X-ray and electron excited Auger spectroscopy. A procedure for producing an atomically clean SiC crystal surface has been perfected. The SiC exhibits prominent bulk plasmon loss features associated with Si and C photoelectrons. This loss, at 22.5 eV, agrees well with optical data establishing the bulk plasmon energy.

- a. Department of Chemistry
- b. Department of Physics
- c. Westinghouse R & D Center, Pittsburgh, PA.

[†] Partially supported under ONR Grant NR 629-803.

I. Introduction

The remarkable properties of SiC as a hard, chemically and thermally stable material have been known for about a century. Large quantities of the material are produced for abrasives, reducing agents and heating elements. In recent years it has been used as a structural material in gas-cooled nuclear reactors, liners for bearings, armour plate on tanks and protective helmets. Use as part of the first-wall of a fusion reactor is being seriously considered. It has also been found useful as a neutron flux monitor in fission reactor environments. SiC optical elements show great promise for general experimentation with synchrotron radiation. Finally SiC is unequalled as a semiconductor for many electronic applications above 300°C and in harsh environments. This last application is receiving new world-wide attention due to recent advances in CVD growth of SiC.

Despite the fact that good SiC crystal surfaces have been available for years the surface characterization of this important material has not received adequate attention. Only a handful of papers can be found in the literature where modern surface diagnostic techniques have been reported.[1] In this communication we briefly describe experimental details of an apparatus dedicated to the surface study and synthesis of SiC under ultra-high vacuum conditions. Some preliminary results obtained with this apparatus are also reported.

II. Experimental

A. Vacuum System and SiC Crystal Mounting Procedure.

The experimental system was designed for preparation and characterization of SiC films grown on Si single crystal substrates. The apparatus consists of an analytical part (a Leybold-Heraeus custom designed UHV chamber) and of a preparative part.

The analytical part is equipped with a Leybold-Heraeus EA-10 hemispherical electron energy analyser, an X-ray source with an Al and Mg twin anode, an electron gun for AES, a UTI-100 quadrupole mass spectrometer and an LH IQP 10/63 broad profile discharge type sputter ion source.

The UHV chamber is isolated by a Torrvac SVB-5 all metal gate valve from the preparative chamber. The preparation chamber itself contains a 4" diameter bellows 15 inches long, which supports a rotatable sample manipulator. This preparation chamber is equipped with numerous ports for separate evacuation, gas inlet, electrical feedthroughs, pressure gauges, etc. A variable temperature sample holder (Fig. 1) is mounted on the end of the rotatable shaft of the translator. The sample holder consists of a central copper block (coolable by L-N₂), electrically isolated by sapphire disks from thinner copper blocks at both sides. The outer copper blocks hold 1.5 mm diameter W rods to which are welded a pair of 0.375 mm diameter Ta heating wires. The Ta heating wires are spotwelded to the back side of a small W disk. The SiC single crystal sample is attached to the W disk by a high temperature cement (Ultratem 516, a product of Aremco),

sandwiching a chromel-alumel thermocouple between them. As the high temperature cement in its original form is insulating, an adequate amount of graphite was mixed with the cement to ensure sufficient electrical conductivity to prevent sample charging effects during XPS and Auger measurements. We have found that minimal outgassing occurs from this cement up to 1400K. Liquid nitrogen cooling is supplied to the central copper block of the sample holder by flexible spiral stainless steel capillary. This cooling facility combined with resistive heating of the sample makes operation possible between 85K and 1400K. Control measurements indicated that above about 1000K the temperature indicated by the thermocouple between the W disk and the SiC crystal can be approximately 100K higher than the temperature of the SiC surface.

B. SiC Sample Characteristics.

The D138 SiC crystals used in these experiments were grown by a sublimation technique[2] at the Westinghouse Research Laboratories. Crystals were doped with nitrogen to about 1×10^{19} N/cm³ making them n-type. At this doping level the SiC polytype can be determined by its characteristic color. Crystals selected were of the 6H polytype. These hexagonal platelets had large well developed faces perpendicular to the crystal \hat{c} axis $\langle 0001 \rangle$. In this work the silicon face of SiC(0001) was investigated. Prior to insertion into the apparatus, the SiC crystals were treated in concentrated aqueous HF solution, then rinsed in distilled H₂O, and then further cleaned in electronic grade acetone and propyl alcohol and wiped dry.

III. Results and Discussion

A. Preparation of Atomically Clean SiC Surfaces.

In Figure 2, Mg K α ($h\nu = 1253.6$ eV) and Al K α ($h\nu = 1486.6$ eV) X-ray photoelectron spectra are shown for peak identification purposes of a SiC surface before thorough cleaning. The peaks aligned on the binding energy scale are the F(1s), O(1s), C(1s), Si(2s) and Si(2p) photoemission peaks, while the shifted ones (with the same electron kinetic energy) are the Si(LMM), C(KLL) and F(KLL) Auger peaks respectively as assigned on the spectra (AES).

The XPS spectra generally indicated that the contaminant elements on the SiC surfaces were fluorine, oxygen and probably Carbon. Although not indicated by XPS, surface hydrogen is probably also present. The broad feature around 700 eV is neither an XPS or an AES peak, but an anomalous analyser transmission characteristic. This is very probably a result of misalignment in the electron optics.

In order to work out a simple standard procedure to prepare atomically clean SiC surfaces, the crystal was subjected to high temperature annealing and to argon ion sputtering combined with annealing.

XPS spectra of the SiC after a sequence of annealing and sputtering with 500 eV Ar $^+$ ions at normal incidence are shown in Figure 3. These and all the following spectra were taken with Al K α radiation. Curve a in Fig. 3 is a spectrum of a heavily contaminated SiC surface, after insertion into the vacuum apparatus and ~ 72 hours bakeout of the vacuum system at 160 $^{\circ}$ C. After

five minutes heating at 800°C a considerable fraction of the oxygen and the total amount of fluorine disappeared from the surface (curve b).

Following 40 minutes of Ar⁺ sputtering at room temperature (500 eV, normal incidence) a further decrease in XPS intensity of oxygen, but an increase in fluorine and argon (at ~ 1240 eV electron kinetic energy) was discernible (curve c). After a further 90 minutes of sputtering (under similar conditions) the oxygen signal further decreased to the noise level, but the fluorine and the argon peaks remained at a constant, fairly high level. Mass spectrometric studies of the residual gas in the vacuum system indicate that F(^m/e = 19) and HF(^m/e = 20) are major mass spectrometric features, suggesting that HF(g) is a major residual gas component. A remarkable feature was that neither the F nor the Ar XPS peaks decreased even after a prolonged annealing at ~ 800°C. This observation indicated that the 500 eV ion energy used during the normal angle of incidence sputtering was sufficient to implant F⁺ and Ar⁺ ions deep enough in the SiC surface layer, so that the implanted F and Ar could not be removed by thermal activation of the rigid SiC lattice during annealing at ~ 800°C.

To overcome the problem of impurity and Ar implantation, we have used an alternative SiC cleaning procedure in which the sputtering was carried out at grazing incidence. The estimated angle between the Ar⁺ beam and the surface was ~ 7°. The effect of such low angle sputtering and subsequent annealing is shown in Figure 4. After 30 minutes grazing angle sputtering the XPS

spectrum still showed a considerable O, F and Ar contamination in the surface layer (curve a). However heating the crystal to 1000°C for 2 minutes removed all the O and F from the surface, but the argon peak remained unchanged. This result indicated that the O and F implanted during the low angle sputtering was restricted to a shallow sub-surface layer. The thermal activation of the lattice motions at 1000°C was sufficient to ensure the diffusion of the implanted atoms from that relatively thin layer to the surface for thermal desorption. The argon peak which remained was obviously the result of deeper implantation in our previous normal incidence sputterings. The XPS peak of the implanted argon was expected to decrease upon prolonged low angle sputtering, as more and more Ar-containing layers were stripped off the surface. The decrease of the Ar peak was indeed observed after a further 30 minutes of sputtering (curve c). Another 30 minutes of sputtering and annealing to 1000°C resulted in the complete disappearance of the argon peak (curve d), and produced a clean SiC surface as judged by XPS and AES measurements.

It can be concluded from the comparison of the XPS spectra of SiC surfaces after normal incidence and grazing incidence 500 eV argon ion sputtering, that at normal incidence the sputtering results mainly in ion implantation instead of surface cleaning. The low angle sputtering however followed by the heating of the crystal is a simple, fast and easy way to prepare an atomically clean SiC surface.

Preferential sputtering of Si or C was not observed in comparing Si(2s)/C(1s) or Si(2p)/C(1s) intensity ratios following

annealing of the sputtered surface at 1000°C for 360s. The ratios remain constant to within the experimental error (2%).

The carbon and silicon Auger spectra for the clean SiC surface are presented in Figure 5. These data will be useful as reference spectra in future studies of SiC film growth.

B. Plasmon Loss Feature in the XPS Spectrum of the SiC.

In all the SiC XPS spectra there were well developed peaks 23 eV below the C(1s), Si(2s) and Si(2p) photoemission peaks. These features are indicated by arrows in Fig. 2. These features could not be assigned to any atomic level or Auger transition in the SiC. Higher resolution spectra with the main C(1s), Si(2s), Si(2p) XPS emission features aligned and showing the lower kinetic energy loss peaks are shown in Fig. 6.

By aligning the C(1s), Si(2s) and Si(2p) peaks, it is apparent that the unidentified smaller peaks exhibit the same 23 eV loss, each associated with photoelectrons at different kinetic energies. The equal losses observed for the three photoemission features indicate a phenomenon originating from the same energy loss mechanism (a bulk plasmon excitation).

The bulk plasmon excitation by X-ray photoelectrons is well known, theoretically discussed [3,5], and experimentally observed [4,5,6,7] in the loss structure of photoelectrons.

The bulk plasmon energy of the SiC, calculated [8] and optically determined [9,10], was found to be 22.2 eV - 22.9 eV, essentially identical to the 23 eV loss measured in this work. To further support the bulk plasmon excitation origin for the

observed peaks, we looked for multiple plasmon loss feature in the XPS spectrum of the SiC. In Figure 7, the Si(2s) peak is shown accompanied by two loss peaks at 23 eV and 46 eV lower energies, corresponding to one and two plasmon losses respectively.

It should be mentioned here, that by exposing the SiC to a monoenergetic electron beam of 500 - 2000 eV, as many as 4 well-resolved plasmon losses could be detected. These multiple plasmon loss features yielded a more accurate (22.5 eV) for the plasmon energy of the SiC, in excellent agreement with the previous work cited above.

IV. Summary

The following results have been obtained in this exploratory study of SiC.

1. An ultrahigh vacuum cleaning procedure has been devised for SiC.
2. X-ray photoelectron spectra and Auger spectra of a clean SiC crystal surface have been obtained.
3. Direct evidence for the presence of a bulk plasmon feature at 22.5 eV has been obtained. The characteristic plasmon feature will be useful in future studies of SiC film growth by CVD and other methods.
4. A successful SiC crystal mounting procedure has been devised.

V. Acknowledgments

We would like to thank the Office of Naval Research for support of this work.

REFERENCES

- [1]. For a recent study, see K. Miyoshi and D. H. Buckley, Appl. of Surface Sci., 10, 357 (1982).
- [2]. D. R. Hamilton, J. Electrochemical Soc. 105, 735 (1958).
- [3]. J. W. Gadzuk, J. Electron Spectr. Relat. Phen. 11, 355 (1977).
- [4]. W. J. Pardee, G. D. Mahan, D. E. Eastman and R. A. Pollak, Phys. Rev. B 11, 3615 (1975).
- [5]. A. M. Bradshaw and Wyrobisch, J. Electron Spectr. Relat. Phen. 7, 45 (1975).
- [6]. J. C. Fuggle, L. M. Watson, D. J. Fabian and S. Affrossman, J. Phys. F: Metal Phys. 5, 375 (1975).
- [7]. S. A. Flodstrom, R. Z. Bachrach, R. S. Bauer, J. C. McMenamin and S.B.M. Hagstrom, J. Vac. Sci. Technol. 14, 303 (1977).
- [8]. B. Bartning: Optics Comm. 4, 78 (1971).
- [9]. V. Rehn, J. L. Stanford, V. O. Jones and W. J. Choyke, Physics of Semiconductors, Proceedings of the 13th International Conference Rome, 1976. p.985.
- [10]. J. Cazaux: Comp. Rend (Paris) B270, 700 (1970).

FIGURE CAPTIONS

Figure 1. Schematic Diagram of SiC Crystal Mounting Assembly.

The temperature of the SiC may be adjusted from 85K to 1400K.

Figure 2. XPS Spectrum of SiC Using Two X-Ray Energies.

The crystal has not been thoroughly cleaned at this point.

Figure 3. Impurity Implantation During Normal Incidence Ar Sputtering of SiC.

Figure 4. Surface Cleaning During Low Angle Ar Sputtering of SiC.

Figure 5. Auger Spectra of SiC Using Electron Excitation.

Figure 6. Bulk Plasmon Loss Feature From Different Core Level Excitations in SiC. (Analyzer constant pass energy (20 eV) mode).

Figure 7. Multiple Plasmon Loss Features - SiC. (Analyzer constant resolution mode).

SCHEMATIC DIAGRAM OF CRYSTAL MOUNTING

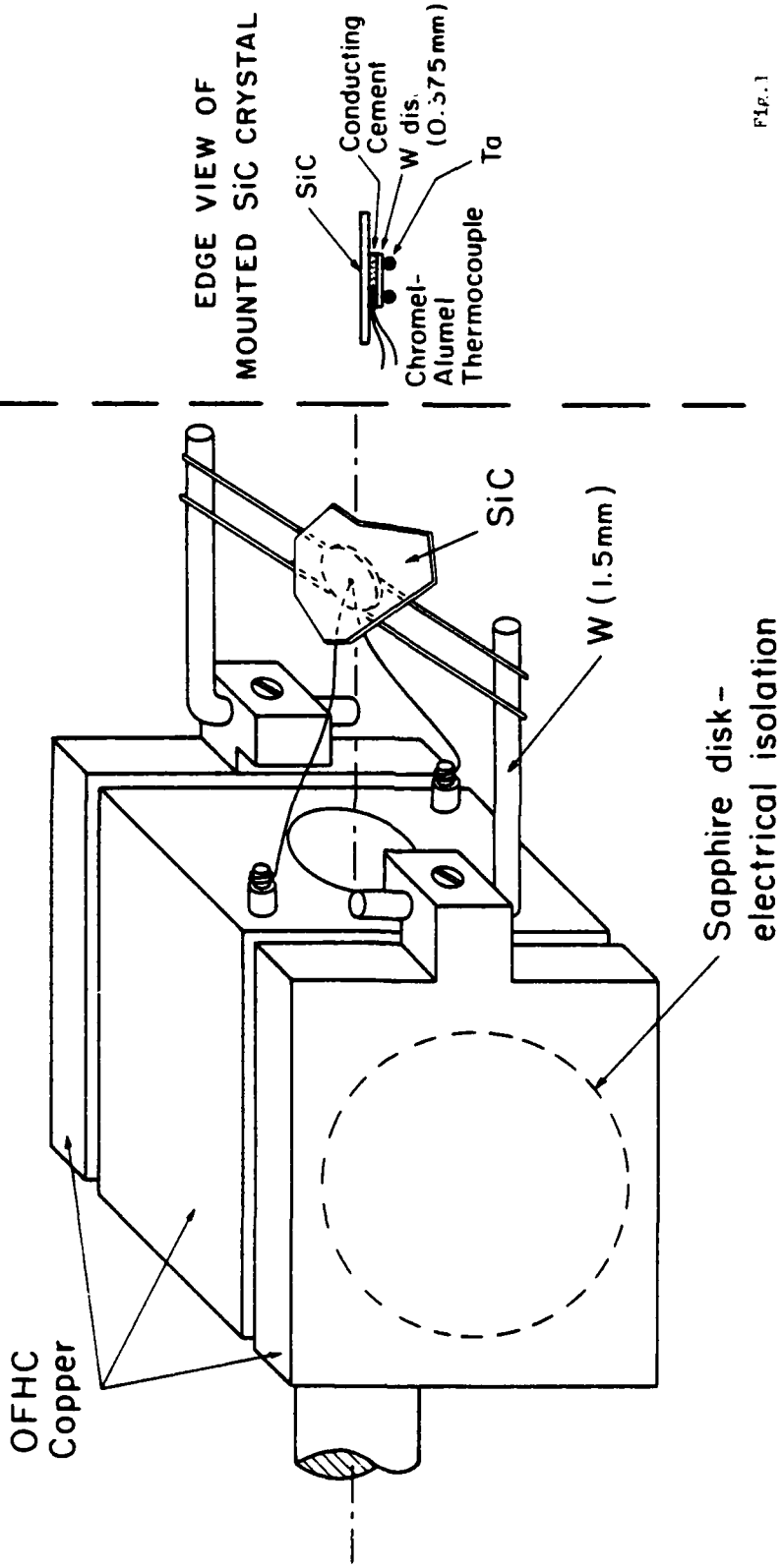

Fig. 1

XPS SPECTRUM OF SiC USING TWO X-RAY ENERGIES

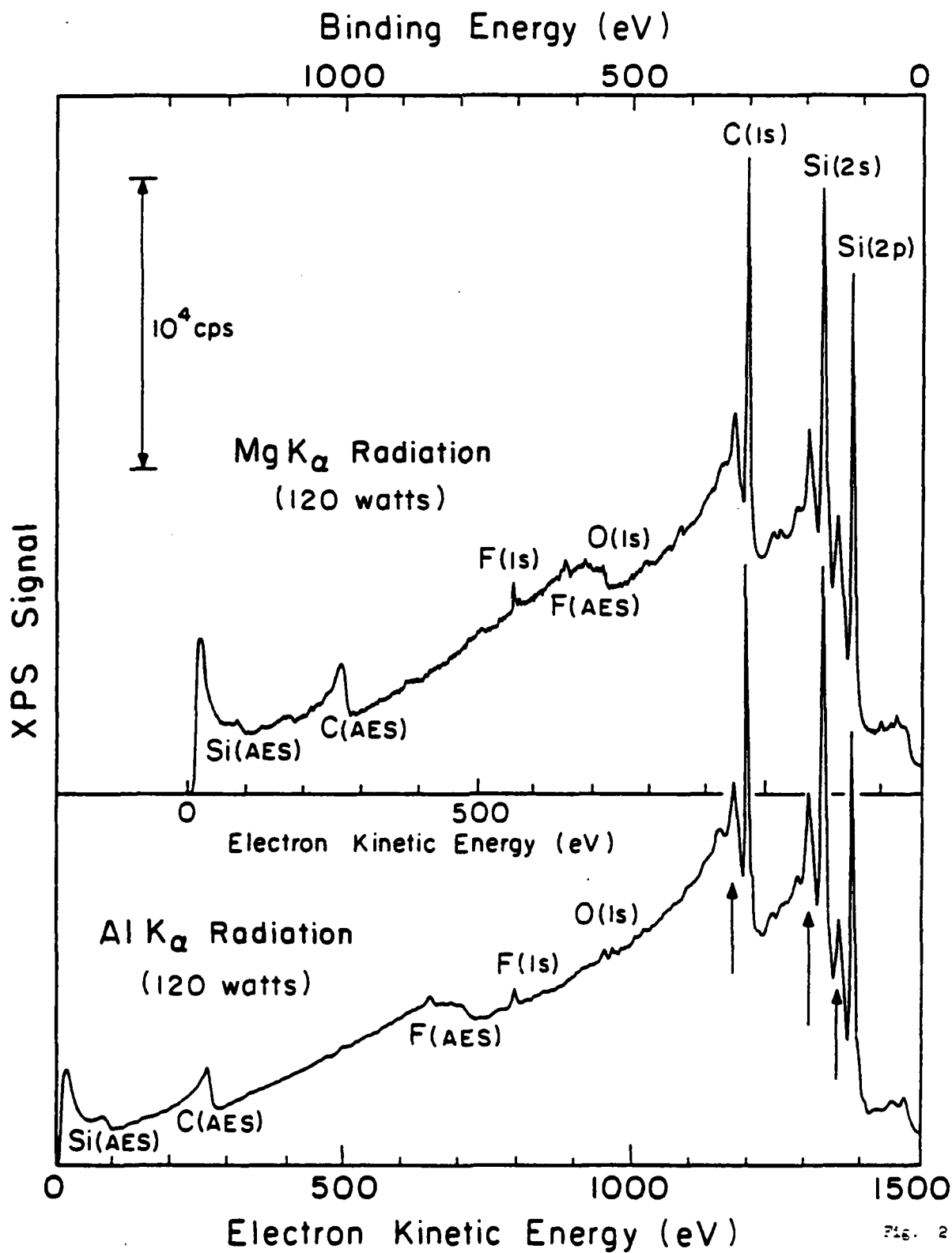

Fig. 2

IMPURITY IMPLANTATION DURING
NORMAL INCIDENCE SPUTTERING - SiC

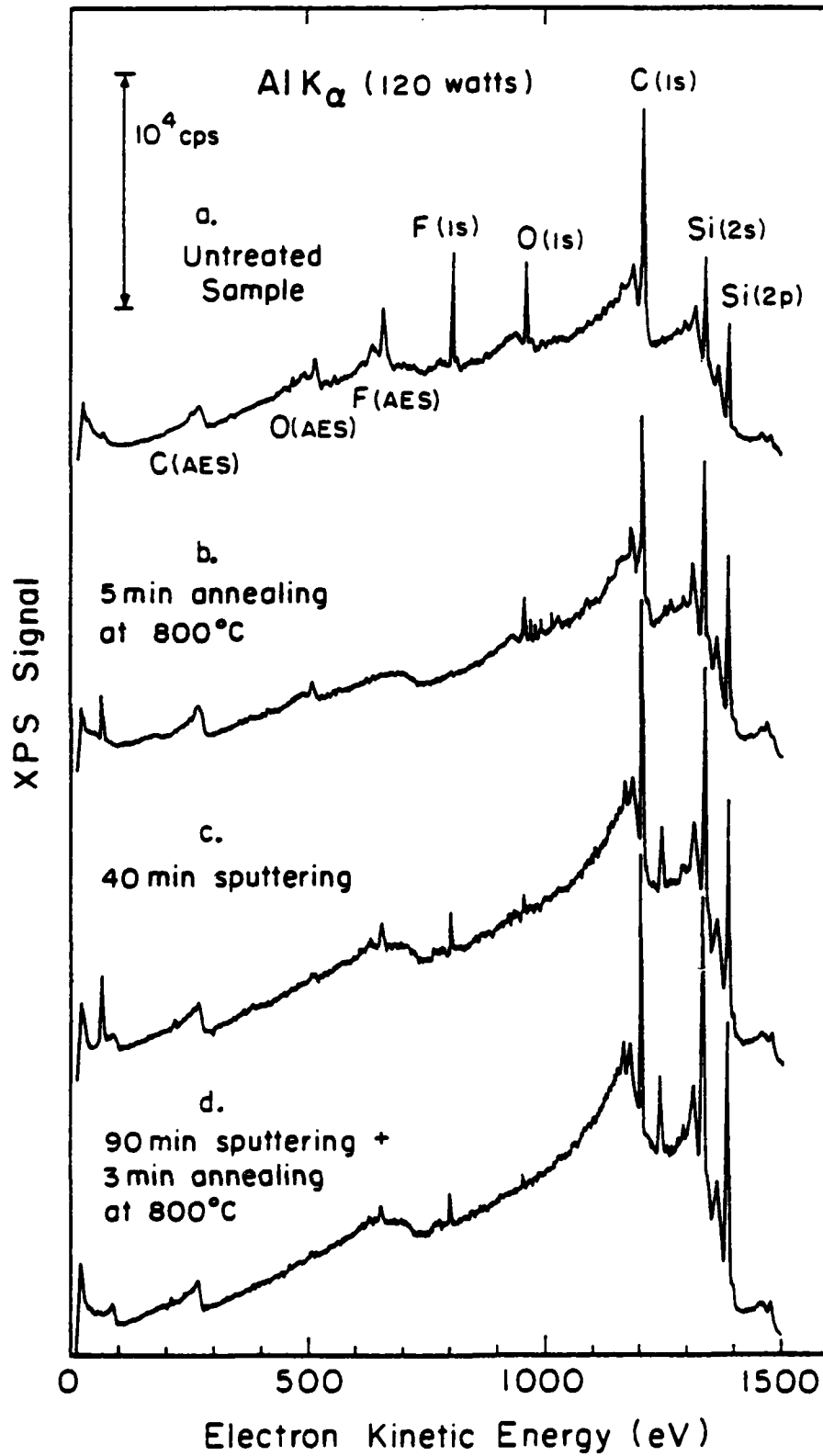

Fig. 3

SURFACE CLEANING DURING
LOW ANGLE SPUTTERING - SiC

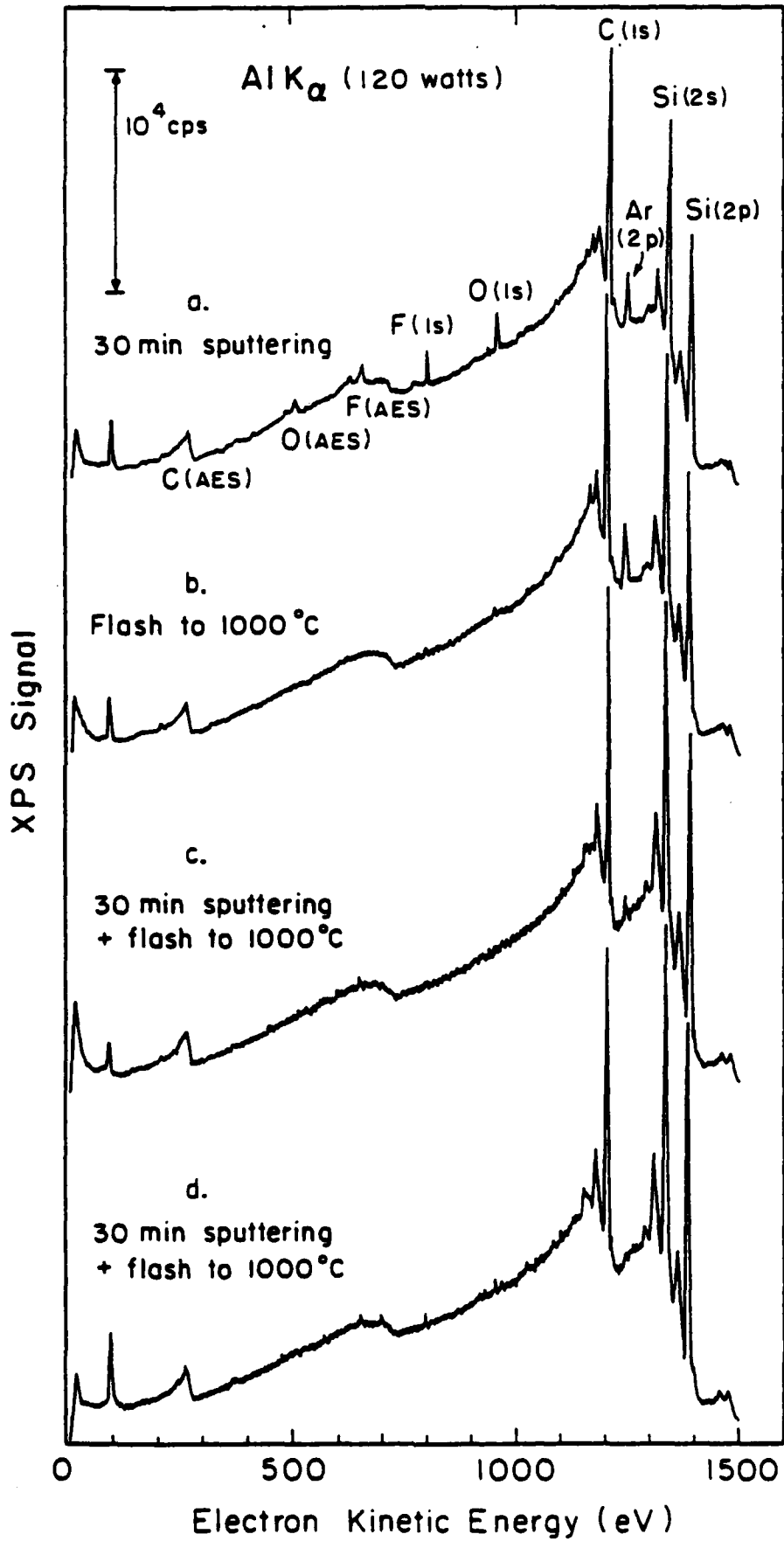

Fig. 4

SiC AUGER SPECTRA

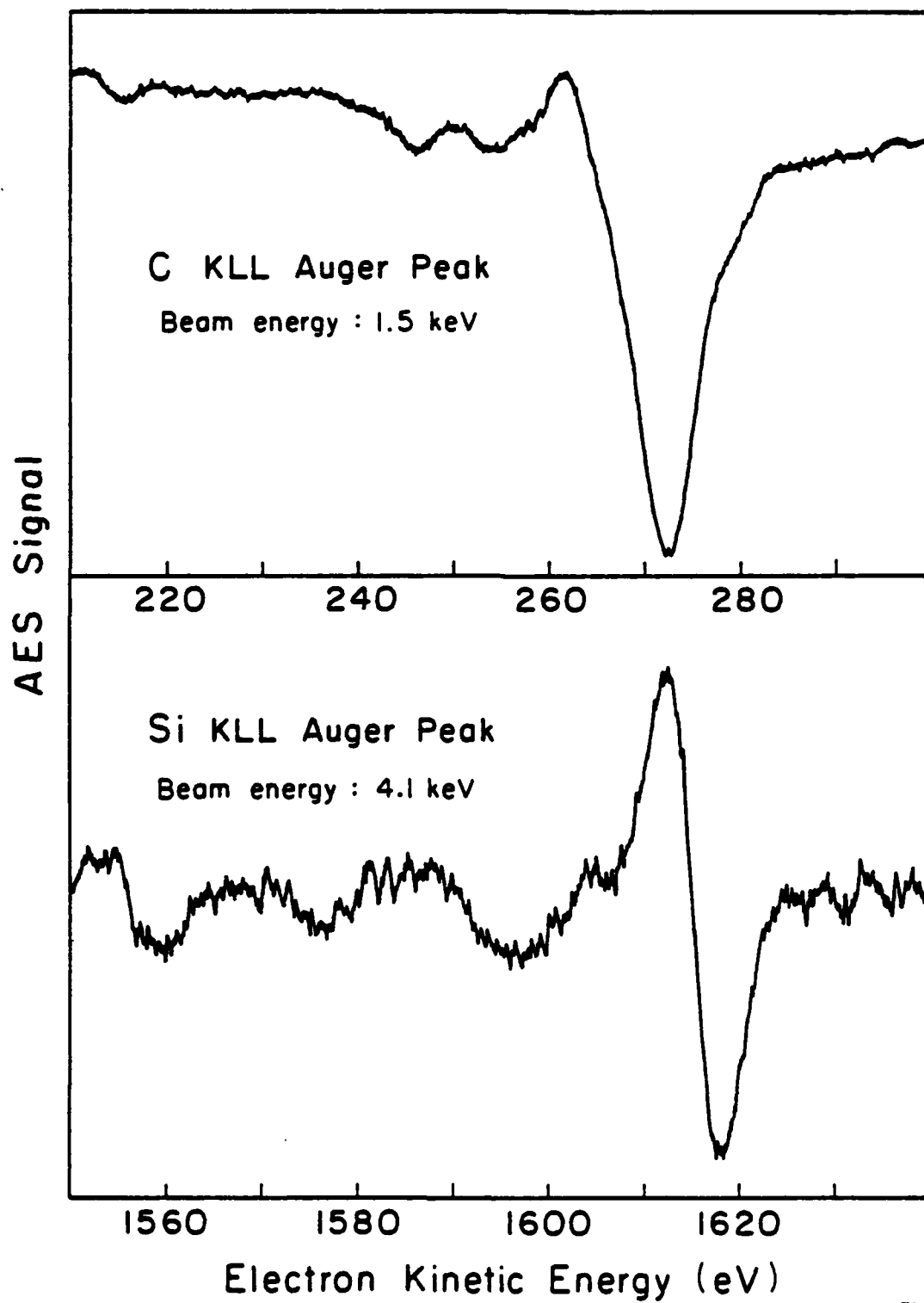

Fig. 5

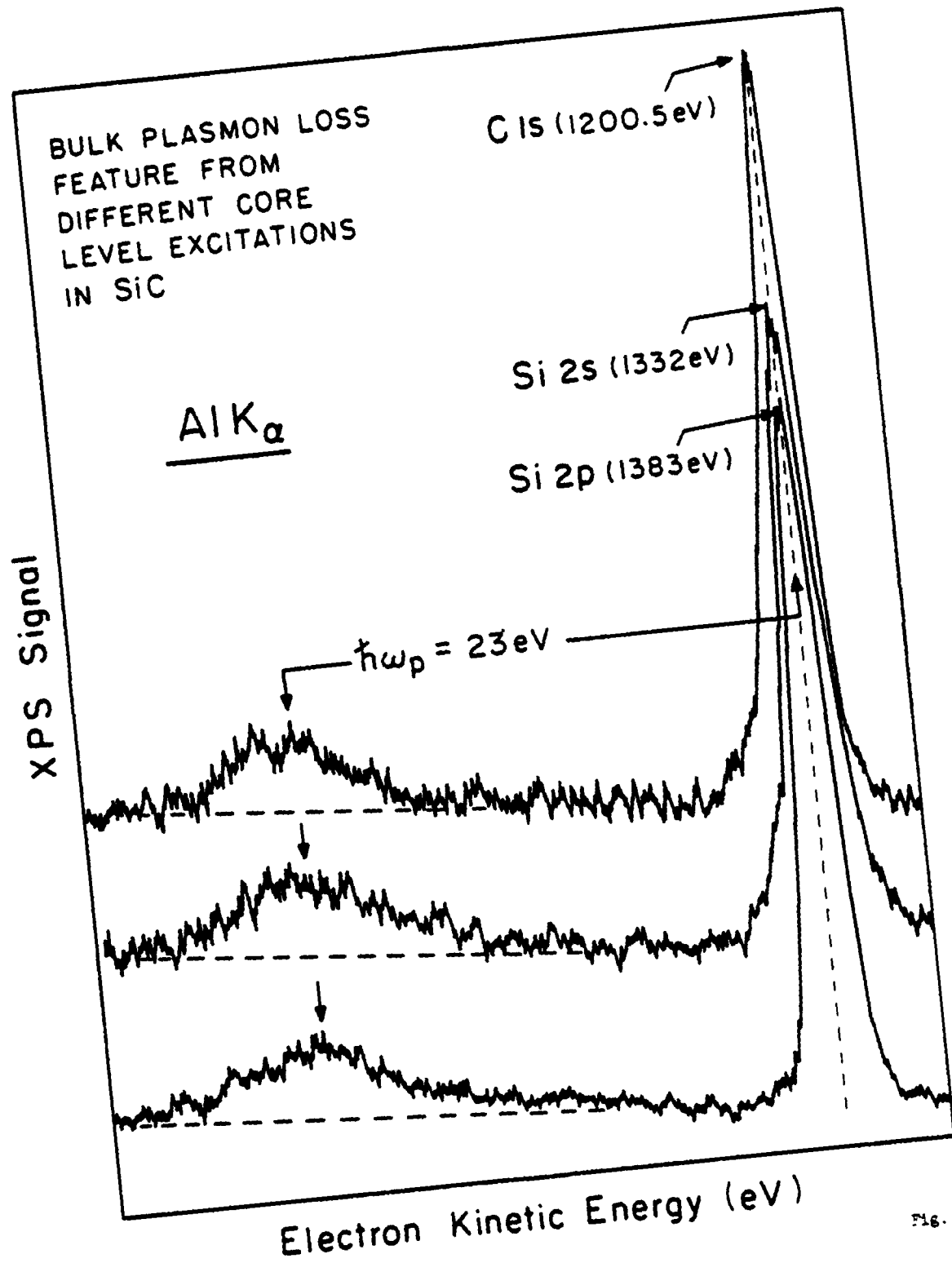
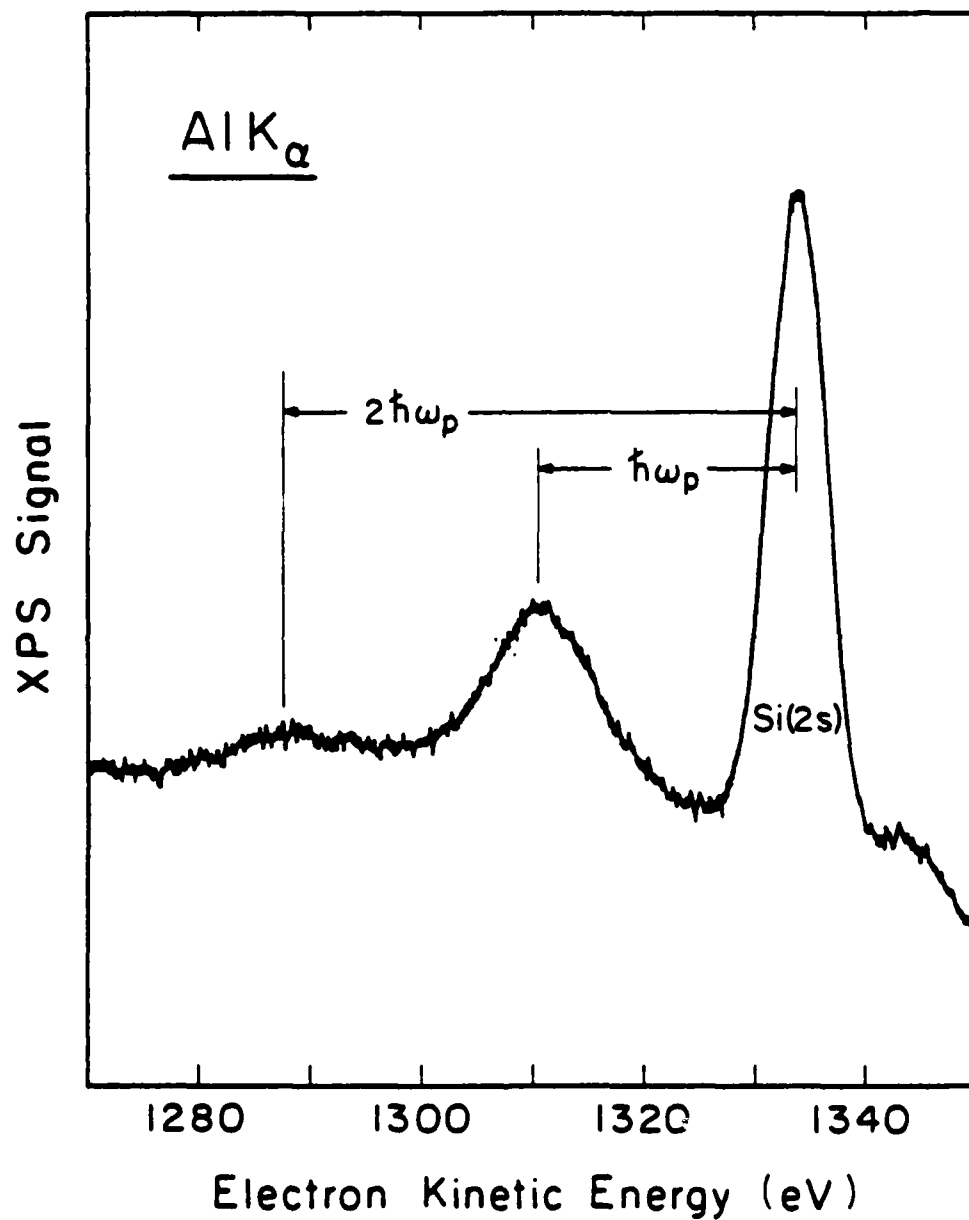
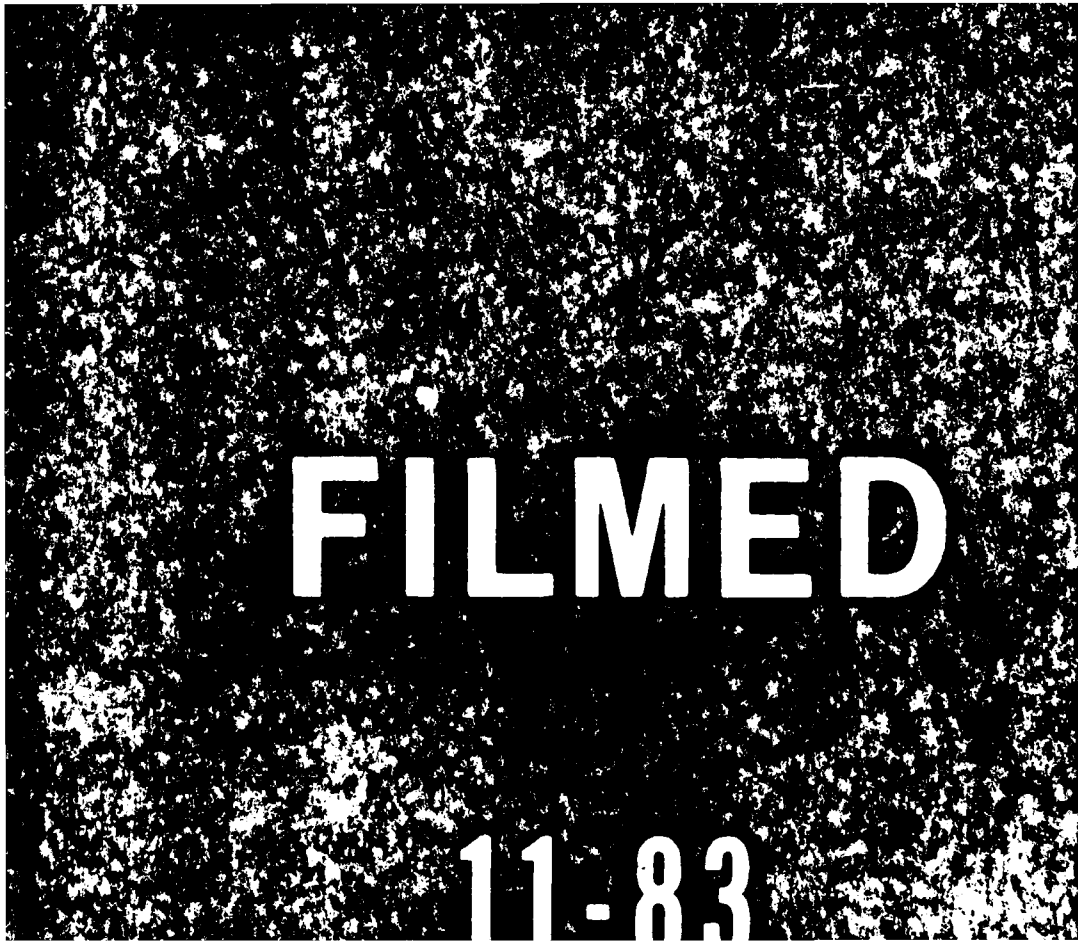

Fig. 6

MULTIPLE PLASMON LOSS - SiC





FILMED

11-83