

AD-A134 237

GRIPPERS FOR AN UNMANNED FORGING CELL(U)
CARNEGIE-MELLON UNIV PITTSBURGH PA ROBOTICS INST
M R CUTKOSKY ET AL. APR 83 CMU-RI-TR-83-3

1/1

UNCLASSIFIED

F/G 6/4

NL

a

END

2 FILMED

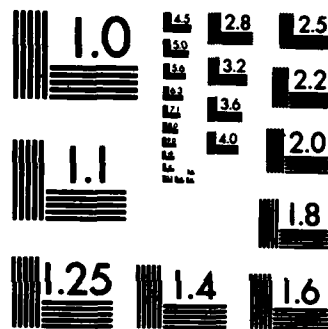

MICROCOPY RESOLUTION TEST CHART
NATIONAL BUREAU OF STANDARDS-15 3-A

AD-A134237

12

Carnegie-Mellon University

GRIPPERS FOR AN UNMANNED FORGING CELL

Mark R. Cutkosky and Eiki Kurokawa

The Robotics Institute
Carnegie-Mellon University
Pittsburgh, Pennsylvania 15213

NOV 1 1983

A

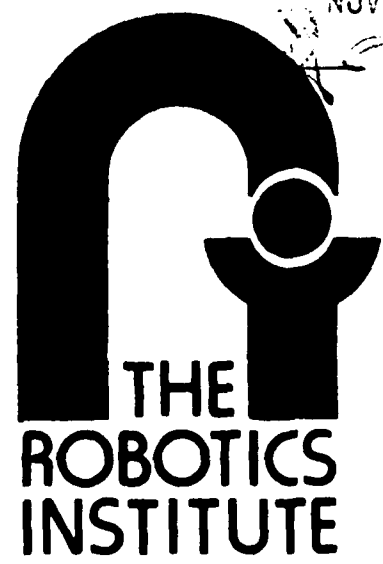

DMC

CMU-RI-TR-83-3

Approved
for release by NSA on 05-08-2014 pursuant to E.O. 13526

88

REPORT DOCUMENTATION PAGE		READ INSTRUCTIONS BEFORE COMPLETING FORM
1. REPORT NUMBER CMU-RI-TR-83-3	2. GOVT ACCESSION NO. A134237	3. RECIPIENT'S CATALOG NUMBER
4. TITLE (and Subtitle) GRIPPERS FOR AN UNMANNED FORGING CELL		5. TYPE OF REPORT & PERIOD COVERED Interim
7. AUTHOR(s)		6. PERFORMING ORG. REPORT NUMBER
9. PERFORMING ORGANIZATION NAME AND ADDRESS Carnegie-Mellon University The Robotics Institute Pittsburgh, PA. 15213		8. CONTRACT OR GRANT NUMBER(s)
11. CONTROLLING OFFICE NAME AND ADDRESS Office of Naval Research Arlington, VA 22217		10. PROGRAM ELEMENT, PROJECT, TASK AREA & WORK UNIT NUMBERS
12. REPORT DATE April 1983		13. NUMBER OF PAGES 18
14. MONITORING AGENCY NAME & ADDRESS (if different from Controlling Office)		15. SECURITY CLASS. (of this report) UNCLASSIFIED
		15a. DECLASSIFICATION/DOWNGRADING SCHEDULE
16. DISTRIBUTION STATEMENT (of this Report)		
<div style="border: 1px solid black; padding: 5px; display: inline-block;"> This document has been approved for public release and sale; its distribution is unlimited. </div>		
17. DISTRIBUTION STATEMENT (of the abstract entered in Block 20, if different from Report)		
Approved for public release; distribution unlimited		
18. SUPPLEMENTARY NOTES		
19. KEY WORDS (Continue on reverse side if necessary and identify by block number)		
20. ABSTRACT (Continue on reverse side if necessary and identify by block number)		

List of Figures

Figure 1: Arrangement of the automated forging cell	3
Figure 2: High temperature gripper - assembly	6
Figure 3: High temperature gripper - sections	7
Figure 4: Gripper for irregular shapes - plan view	12
Figure 5: Gripper for irregular shapes - profile view	13

1 Introduction

In the spring of 1981 the designs for two grippers were begun as part of a joint project between the Westinghouse Turbine Components Plant in Winston-Salem, NC, and the Robotics Institute at Carnegie-Mellon University. The project was to develop an automated cell for forging turbine blade preforms. The cell included two large industrial robots manufactured by Prab Conveyors Inc., each to be equipped with a gripper developed at CMU. Figure 1 shows a plan view of the cell, including the twin robots. (More detailed descriptions of the cell can be found in [1], [2], [3])

In Figure 1, The "A" robot is shown transferring parts between a vision-based station for incoming parts, a rotary hearth furnace, and the "A" chuck of an open die forging or swaging machine. The incoming parts are stainless steel or titanium billets. They are heated in the rotary hearth furnace to approximately 2000 deg F before they are forged. The gripper that the "A" robot uses is quite long (49 inches) so that the arm of the robot never extends inside the furnace.

Once a billet has been placed in the "A" chuck of the forging machine, the chuck starts to travel from left to right and the forging hammers deform the billet into a long, irregular, twisted shape. The preform is transferred from the "A" chuck to the "B" chuck during the forging process. When the preform is complete the "B" robot removes it from the forging machine and presents it to a cropper/stamper that marks the preform and to a vision-based gaging station for inspection. The gripper for the "B" robot faces less severe temperatures than the gripper for the "A" robot, although the forgings may still be as hot as 1000 deg F. The B gripper must also be able to accurately grasp a much wider variety of shapes than the A gripper encounters.

2 High Temperature Gripper

The most important function that the A gripper performs is the loading and unloading of billets from the large rotary hearth furnace shown in Fig. 1. Each time the gripper enters the furnace to load and/or remove a billet it is exposed for about 20 seconds to an enormous blast of radiant and convective heat at over 2000 deg F. When the cell is running at speed this exposure is repeated roughly once every two minutes. To withstand this sort of abuse, all moving parts of the gripper are shielded from direct radiant heat, and protected with a cooled enclosure.

The precision and dexterity requirements for the A gripper are not severe. Basically, it has to be able to pick cylindrical billets from a pallet, load them into ceramic vee blocks inside the furnace and load them into the four-jaw chuck of the forging machine. Because the Prab robots are difficult to program, it was decided to design the gripper so that one robot program could be used for several different billet diameters. Thus, the gripper fingers are designed to scoop up small billets and to center them. The only serious mechanical complication to the gripper design is the need for the gripper to rotate 90 deg about a vertical axis. The billets are arranged in a radial pattern in the rotary hearth furnace. They must be rotated 90 deg to be inserted into

the jaws of the "A" chuck of the forging machine. Since the Prab robot has only three axes the gripper must provide this extra motion. The gripper fingers are therefore mounted to a "wrist" that can bend 90 degrees to one side.

The final design is shown in figures 2 and 3. As the figures show, the fingers of the gripper extend down from a cylindrical drum which is mounted at the end of a long box beam. The drum is pivoted and can rotate 90 deg to the left when required. The actuators for the closing the fingers and for rotating the drum are located at the base of the box beam where they are least affected by heat from the furnace. The actuators are all small-bore hydraulic cylinders which tap pressure from the 1500 psi hydraulic system of the robot. Only one of the fingers (the one toward the box beam) is actually driven by the cylinders. The other finger is essentially stationary, although it can rock slightly to conform to the surface of the billets that the robot picks up. The moving finger is driven by stainless steel cables. As Fig. 2 shows, all pivot points and linkages are enclosed either by the box beam or the drum.

The individual elements of the high temperature gripper are now described in more detail:

the fingers

Among the most carefully designed parts of the prototype gripper were the fingers. A study of the forces required to hold a billet revealed that, with respect to any given plane, four point contact was inherently superior to three point contact for resisting moments (due to inertial torques or contact forces) imposed on long billets. This is an important consideration because the maximum width of the fingers is limited by the spacing between the vee block tiles in the furnace. The vee block spacing is four inches, and if we allow $\pm .375$ inches for combined robot and furnace inaccuracy then the maximum width for the fingers is about 3.25 inches. To ensure four point contact in any plane, the stationary finger can rock slightly to conform to the surfaces of billets that are not perfectly smooth and cylindrical. (see Fig. 3 "Fixed Arm")

As mentioned above, the fingers are designed so that they will scoop up small billets and center them in the vee formed by the stationary finger. This eliminates the need for slightly changing the robot program each time a new billet diameter is used. Whether a gripper succeeds in scooping up billets depends on the gripper geometry and the coefficient of friction. The coefficient of friction becomes much higher at very high temperatures and therefore a gripper that has no trouble scooping billets at room temperature may find that the billets get stuck at elevated temperatures.

Both the movable finger and the stationary finger are designed as Inconel weldments. Many materials were evaluated for the fingers (see Appendix). Inconel 600 was finally selected because it had the best combination of weldability, strength and corrosion resistance at high temperatures, fracture toughness, and availability in appropriate quantities. Other, stronger, materials could have been used for the fingers but they would have required casting the fingers instead of welding them. This would be a good solution if several grippers were being produced and not a single prototype. There was some concern that the weldments would distort when they were first exposed to their working temperature. To avoid this the weldments were made considerably oversized. They were heated to 1600 deg F for 12 hours and allowed to air-cool. They were then machined to final size. The fingers have not shown any tendency to warp during use, and no weld cracking has been observed.

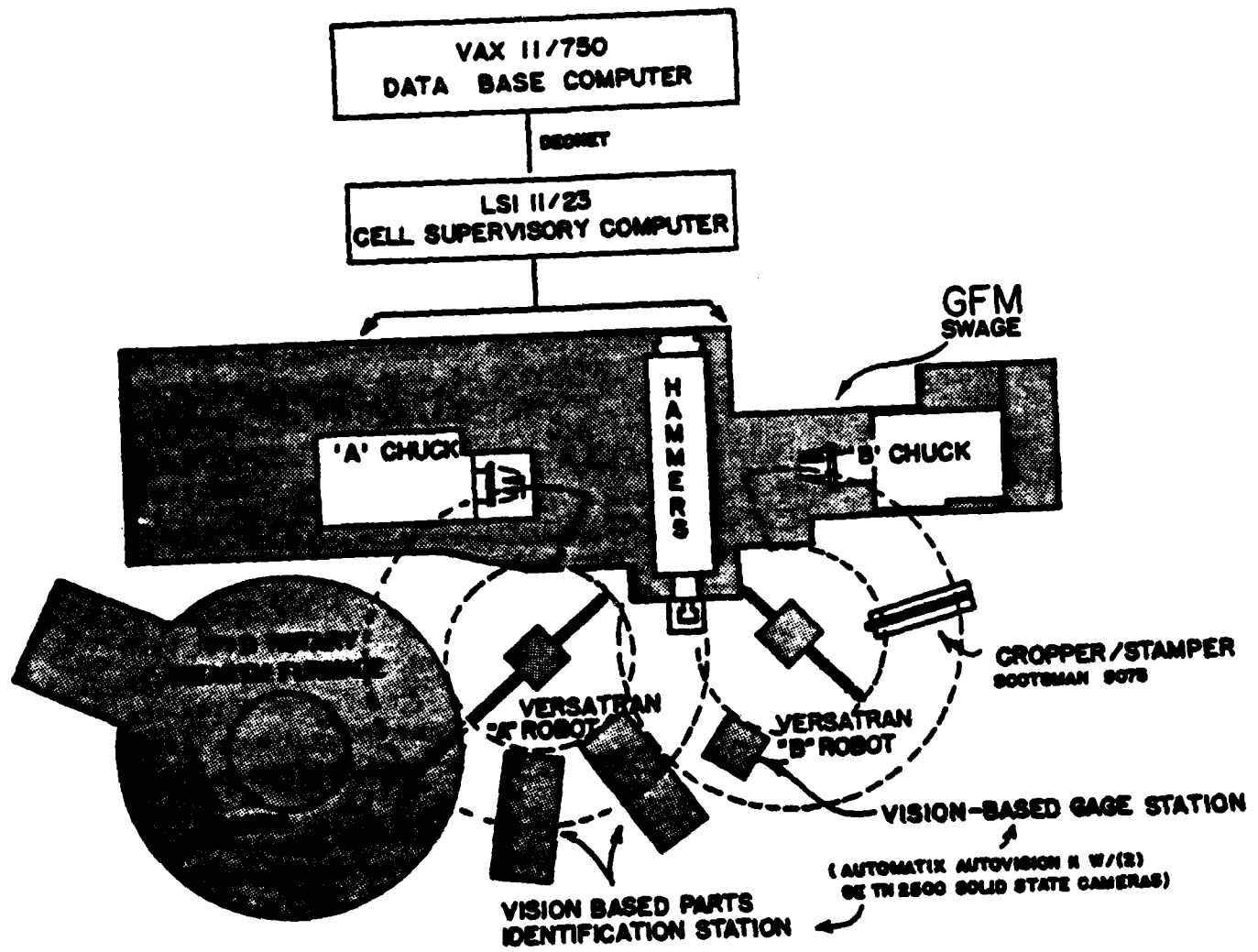

Figure 1: Arrangement of open-die forging cell.

The final constraint on the fingers, and the drum assembly that they protrude from, is that the furnace door is only 14.88 inches high (Fig. 2 "*View Looking Out Furnace Door*"). This leaves little room for maneuvering when the gripper is carrying an eight inch diameter billet.

the box beam

The main section of the gripper consists of a rectangular box beam. The beam serves as a structural member and as a protective enclosure for the hydraulic actuators and linkages. The gripper is fairly long (about 49 inches) to keep the robot arm out of the furnace. This extra length significantly increases the bending moment imposed on the robot and reduces its effective payload. For this reason it is important to keep the long beam as light as possible. The walls of beam are only .125 inches thick which makes it quite light. The beam is reinforced with lacing, primarily to prevent it from distorting due to temperature fluctuations but also to avoid the possibility of buckling failure. The material selected for the box beam is Incoloy 800 which is cheaper than Inconel 600, slightly easier to weld and slightly stronger at temperatures below 1500 deg F. (see Appendix) Since the beam does not get as hot as the fingers do Incoloy 800 makes a more practical choice.

Cooling panels are mechanically fastened to the inside walls of the box beam. Mechanical fastening permits differential thermal expansion and contraction between the panels and the beam. Each cooling panel consists of stainless steel tubes spot welded to a stainless steel sheet.

the cables

The problem that the stainless steel cables solve is: How do we get the motion produced by the cylinders to move the fingers *independently* of how the fingers are rotated? We need a linkage that can transmit motion to the fingers without being affected by the rotation of the drum. There are two basic ways to do this: The linkage movement can either take place as a vector, v , of linear motion parallel to the axis of rotation or as a vector, ω , of angular motion about the axis of rotation. A cam or a linkage that pulls or pushes along the axis of rotation of the drum is a mechanical realization of the former principle. Bevel gears, or cables that wrap about a pulley are examples of the latter. The high temperatures encountered by this gripper rule out many possibilities. Lubrication failure often occurs at high temperatures and there was concern that gears, cams, and linkages would be subject to galling or accelerated wear. A second problem is that the drum, the shafts, the fingers and any linkage parts will all be expanding, contracting, and distorting slightly as the temperature inside the drum fluctuates over several hundred degrees. This means that any mechanism that requiring close tolerances is unacceptable.

In the end, it appeared that stainless steel cables wrapping around a pulley were the simplest and most reliable solution. The cables do not require any lubrication and the cable-pulley system is insensitive to misalignment caused by slight distortions of the drum or the fingers due to heat. The selected cables are a 316 stainless steel alloy which has better high temperature properties than the more common 304 alloy. The cables stretch slightly, especially if they get hot, but the hydraulic actuators have some extra travel to allow for this.

Since a cable wrapped around a drum can only pull and not push, it is necessary to use a second cable to open the movable finger. This cable does not need to be as strong as the cable that closes the finger (Fig 3).

bearings

Bushings are used for all bearings because they are simple, tolerant of overloading and suited to low-speed intermittent motion. The bearing clearances are generous to allow for thermal expansion and contraction of parts. Because of the danger of lubrication failure it is important for the bushings and shafts to be made of dissimilar materials so that they will not bind or seize. Ceramics, graphite materials and tungsten carbide were investigated for bushing materials. Tungsten carbide was the toughest of the available materials. At temperatures above 1500 deg F tungsten carbide has some tendency to oxidize but the temperatures of the protected pivot points should never get as high as 1500 F.¹ An additional advantage to using tungsten carbide is that carbide drill jig bushings are stocked in a wide variety of sizes.

sensors

The most important sensors in the high temperature gripper are a pair of thermocouples to monitor internal temperatures. One thermocouple monitors the temperature near the fingers and the other records the temperature near the base of the arm where the hydraulic actuators are located.

The other sensors mounted on the gripper are a pair of strain gages. These are used to detect the "bump" that occurs when a billet held by the gripper makes contact with the jaws of the "A" chuck on the forging machine.

hydraulic system

There are three hydraulic cylinders located inside the box beam. Two are used to pull the cables that open and close the movable finger and the third is used to rotate the drum with a lever-crank mechanism. The cylinder that closes the gripper operates at a moderate pressure (about 900 psi) while the cylinder that opens the finger operates at a very low pressure (about 60 psi). The cylinder that rotates the drum requires a high pressure to rotate it to the left (against the pull of the cables for the fingers) and a low pressure to straighten it out again. The valve system to drive these cylinders, at their various pressures, is a bit complex and too bulky to fit inside the box beam. Instead, all the valves are mounted at the opposite end of the robot arm and tubes are run down the center of the robot arm to deliver hydraulic fluid to the gripper. By mounting the valves and their hydraulic manifold at the rear end of the arm we keep them as far away as possible from the radiant heat of the furnace. Since the valves are heavy they also help to counterbalance the robot arm against the weight of the gripper at the opposite end. The gripper is connected to the hydraulic lines using quick-disconnect fittings and teflon hoses with a stainless steel braid. The cooling water lines are connected in the same way.

2.0.1 Results and Discussion

The prototype high temperature gripper was first tested in July 1982. The gripper has since been used for a large number of tests, loading and unloading billets from the rotary hearth furnace. The results from these tests, as well as some observations made during fabrication and maintenance of the gripper, are discussed below.

¹They would be glowing brightly if they did!

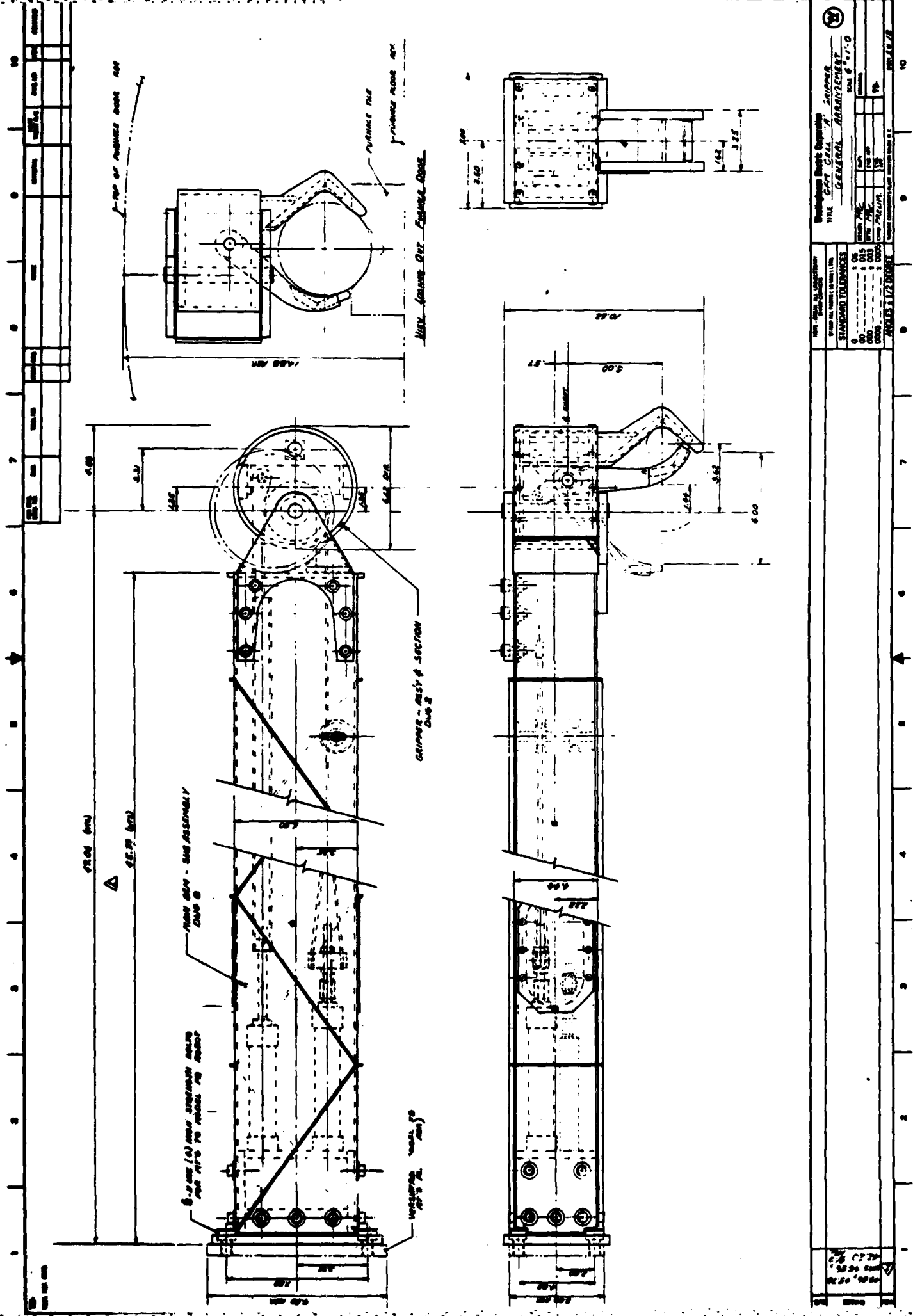

Figure 2: High temperature gripper - assembly

PART NAME: HIGH TEMPERATURE GRIPPER DRAWING NUMBER: 100-100-100-100 DATE: 10/10/10		DRAWN BY: [Name] CHECKED BY: [Name]	
STANDARD TOLERANCES:			
FRAMES	0.005	0.005	0.005
HOLES	0.005	0.005	0.005
OTHER	0.005	0.005	0.005
APPROVED BY: [Signature]			

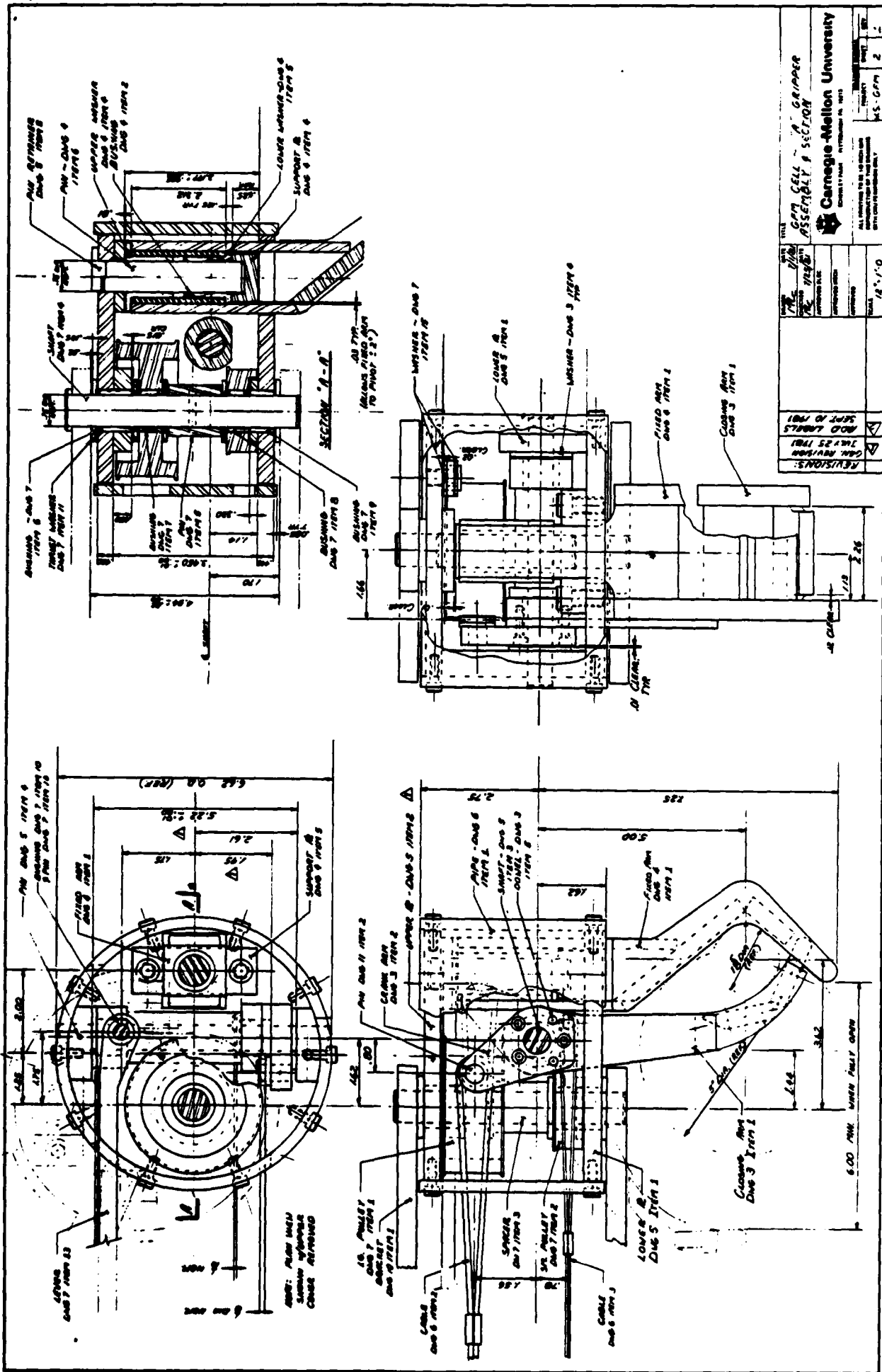

Figure 3: High temperature gripper - sections

structural integrity

The materials chosen for the high temperature gripper have performed beyond our expectations. There is no sign of welds cracking, no significant warping or distortion, and no appreciable corrosion or scaling of exterior surfaces. One of the fingers of the robot was bent slightly when the robot crashed into the furnace during a controller malfunction. It has since been straightened without damage to the welds. The internal parts and the tungsten carbide bushings have also performed well.

cooling

The ability of the gripper cooling panels to cool the walls of the box beam is not adequate to keep the hydraulic cylinders below their maximum permissible temperature during extended service. The two principal reasons are:

- The heat transfer area between the sheet and the tubes is not as high as it ideally should be.
- The pressure of the cooling water used at the Westinghouse Turbine Components plant is low and the flow rate through the stainless steel tubes is lower than it should be.

These problems could be rectified by using tubes of a larger diameter and brazing them to the stainless steel sheets. A much better solution, if fabrication facilities permitted it, would be to create a sandwich of two corrugated stainless steel sheets welded together. Water would flow between the corrugated sheets. Some commercially available cooling jackets use a similar construction (with dimpled sheets) and we might be able to modify them for our purposes. Four sandwiched panels would be fastened together to form a rectangular beam, serving both structural and cooling functions. The sandwich-beam assembly would be lighter and better cooled than the present construction.

maintenance

The box beam, while light and rigid, restricts access to the hydraulic cylinders and the cables. The only access to the interior of the box beam is through two oval ports. This is adequate for adjusting the cable take-ups but it is difficult to replace cables, check for hydraulic or water leaks, inspect the strain gages and so on. Adding more oval ports would help, but it would still be difficult to see inside the box beam. The gripper is designed so that the box beam can be removed while keeping the hydraulic cylinders attached to the robot arm. This is probably unnecessary. A better solution would be to have a U shaped beam with a removable top panel. All hardware should be mounted to the inside of the U so that the gripper can be cycled with the top removed for inspection. It will take some careful design to ensure that the U shaped beam with a mechanically fastened top panel is just as rigid as a welded rectangular box section.

sensors

The thermocouples have worked well. They have been very useful in indicating temperature fluctuations within the gripper.

The strain gages have also functioned as expected. Unfortunately, even though the gages are mounted at the base of the gripper where the bending moments are highest they are not able to detect loads of less than about 80lb. This basically confirms that the box beam is quite rigid.

cables

The cables are holding up about as well as expected. The small cable used to open the gripper should be replaced with a larger one, not because it is too weak to open the gripper but because it can be snapped if the gripper jams or malfunctions (due to an incorrect hydraulic pressure setting for example). This is primarily a nuisance while the gripper is being set up and "debugged". It has been important to keep the cables completely shielded from direct exposure to the radiant heat of the furnace. This requires a flap or a shield to cover the gap between the drum assembly and the box beam when the gripper is bent to the left (see Fig 2).

drum rotation

A modification that should be made to the lever-crank mechanism that rotates the drum at the end of the gripper is to substitute self-aligning bearings for the present sleeve bearings.² The long rod that actuates the crank tends to bind if the mechanism is not carefully adjusted.

hydraulic system

The hydraulic system required a great deal of tinkering before it performed adequately. Back-pressure in the system still occasionally causes problems. A simpler solution using a spring to open the gripper would be much easier to adjust and is worth looking at although we should bear in mind that springs lose their stiffness above a certain temperature. The hydraulic components have endured pretty well with the exception of one four-way solenoid valve that failed early in testing.

In general, the prototype high temperature gripper has done what we asked of it. It has withstood the heat of the furnace, it is able to grip billets securely and it can rotate to left when required. Its design represents a number of compromises including weight limitations, the inability of the Prab robots to control a sophisticated end effector, difficulties in obtaining exotic materials on short notice, and the limited manufacturing facilities available on campus. A number of modifications are suggested above for a production version of the gripper. Most of these are geared toward making the gripper easier to maintain and less fussy about accurate adjustment.

²It may, however, be difficult to find them in stainless steel.

3 Gripper for Irregular Shapes

The actions required of the B gripper are: To remove forged turbine blade preforms from the "B" chuck of the forging machine, to present them to a cropping and stamping machine which clips off the ends of the forgings, to present them to a vision based gaging system for inspection, and to place the preforms onto a conveyor or into bins which leave the forging cell.

Some of the criteria governing the design of the B gripper are listed below:

- While a turbine blade preform is clamped by the "B" chuck of the forging machine its orientation is known to a high accuracy. The shape and orientation of the part have been *defined* during the forging process and the forging machine has never let go of the preform. On the other hand, the position of the large industrial robot is only moderately well known because the robot is not particularly accurate. Reestablishing alignment is always a difficult process when complex shapes are involved. For this reason, it is often pointed out that a successful automated manufacturing process will try to preserve the orientation of parts as they travel from one process to another. Bearing the above considerations in mind, the B gripper was designed to automatically adapt itself to the orientation of the part in the "B" chuck of the forging machine. This principle is in contrast to many grippers that are designed to center or align the parts they pick up. Centering grippers are useful when the accuracy of the robot is *better* than the initial positional accuracy of the part.
- The linkage that allows the B gripper to adapt itself to the existing orientation of the preforms also allows it to grasp a wide variety of irregular, twisted shapes. This flexibility eliminates the need for an expensive inventory of grippers or gripper-adaptors each suited to a narrow range of preform styles. The expected batch sizes are small (under 100 parts) which means that a robot using a variety of different grippers would spend a significant amount of time changing between them.
- The preforms are still fairly hot (up to 1000 deg F) as they leave the "B" chuck of the forging machine. The fingers of the B gripper are made from Incoloy 800 and are equipped with insulated finger tips to avoid excessive wear or corrosion.
- The B gripper is mounted to a rotary unit at the end of the of the robot arm. The rotary unit effectively gives the second Prab robot four axes instead of three. The rotary unit also limits the permissible weight of the B gripper, especially since the B gripper has to be nearly as long as the A gripper so that it can reach into the forging machine.

The design which meets the above requirements is novel, and a patent has been applied for. The B gripper is shown in figures 4 and 5. The linkage represents an extension of the principles used in an earlier gripper for a robot in the authors' robotic machining cell at CMU. The earlier gripper has also been disclosed in a Westinghouse Invention Disclosure No. *PQC 81-003C*.

The individual elements of the B gripper are now described in more detail:

the linkage

The B gripper has four fingers. The two upper fingers are connected to a linkage with ball-joint pivots that is similar to the linkage developed for a gripper used in the authors' machining cell. The ball-joint linkage allows the upper fingers to settle independently against the twisted and uneven shapes of the preforms. The

two lower fingers move in unison, but they are hinged so that all four fingers can rotate approximately ± 10 deg about a common axis even while the gripper is holding a part. The upper and lower fingers are driven by a single hydraulic cylinder which is located near the base of the gripper to protect it from heat radiated by the forgings. As the cylinder rod retracts, the fingers settle, one by one, against the preform. The cylinder rod continues to travel until all fingers are pressing firmly against the part and any play in the linkage has been taken up.

Once the hydraulic cylinder has stopped traveling it becomes necessary eliminate the extra degree of freedom provided by the hinged lower fingers. Otherwise the part could shift with respect to the robot even though the fingers all continued to press tightly against the part. The extra degree of freedom is eliminated using a standard industrial disc brake that locks up part of the linkage. When the disc brake locks the linkage the gripper/part assembly becomes completely rigid and the original orientation of the part is preserved.

the disc brake

The disc brake is placed in a mounting bracket at the base of the gripper where it is protected from the heat of the preforms. It clamps a thin disc of carbon steel which is connected by two long rods to the lower fingers at the front of the gripper. (see Fig 5)

fingers and shafts

The most highly stressed parts of the gripper are the fingers and the shafts that move them. In addition, these parts are exposed to the radiant heat from the preforms. To withstand the heat of the preforms without undue wear or corrosion the fingers are made from Incoloy 800 (see Appendix). They have been given insulated finger tips to reduce the amount of heat conducted from the preform. The finger shafts are made from 316 Stainless Steel and are protected with thin sleeves of stainless steel tubing.

the box beam

The main section of the B gripper consists of a rectangular structural tube, 4 x 6 inches in cross section and 0.18 inches thick. Access holes are provided for adjusting the take-up nuts on the cylinder rod.

the hydraulic system

The hydraulic system is simpler than the one used in the high temperature gripper. The single hydraulic cylinder requires two lines and a standard four-way solenoid valve. The disc brake acts in the same way as a single-port spring-return cylinder. As with the high temperature gripper, the valves are mounted on the back end of the robot arm where they are farthest from radiant heat, and where they help to counterbalance the robot arm against the weight of the gripper.

3.0.1 Results and Discussion

The B gripper has been in use since July 1982. It has suffered virtually no problems in operation although at one point the jam nuts on the cylinder adjusting rod came loose and had to be re-torqued. The B gripper is ready to serve as a piece of production equipment. A few recommendations that we would make for a second flexible gripper, if one is built, are:

Key to Drawing:

- 1. upper finger (articulated)
- 2. lower finger
- 3. frame
- 4. fixed shaft
- 5. floating shaft
- 6. floating shaft
- 7. shaft with ball joints
- 8. link
- 9. structural tube
- 10. linkage for disc brake
- 11. cylinder
- 12. adjustment
- 13. cylinder pivot
- 14. disc brake

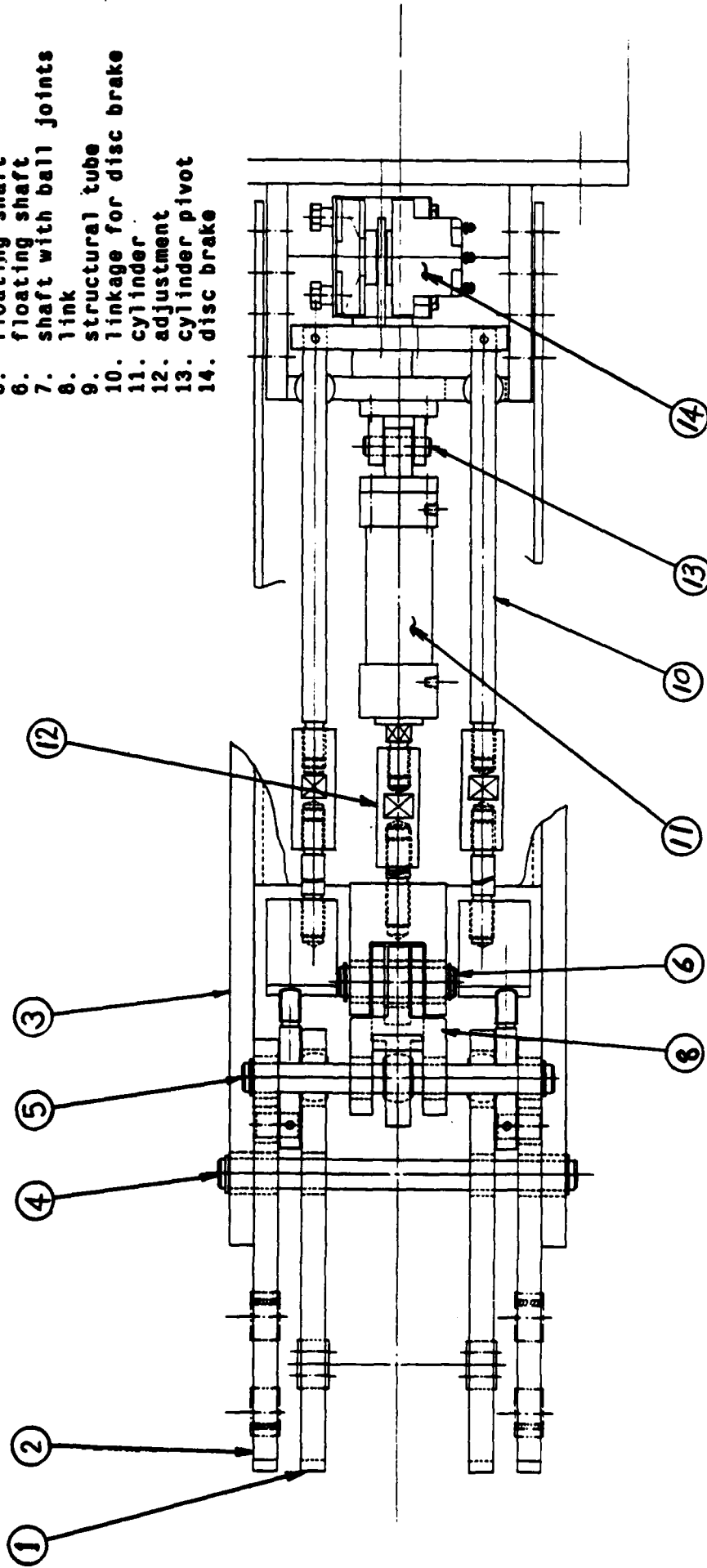

WORK ORDER NO. 100-1000 DRAWING NO. 100-1000-100 STANDARD TOLERANCES FINISH QUANTITY DATE APPROVED BY: M. DEWEESE		Manufacturing Service Corporation THE GEM FABRIK & SUPPLY ANY DRAINAGE, Pa. U.S.A. INC. 1921 1/1 100-1000-100 100-1000-100	
---	--	--	--

Figure 4: Gripper for irregular shapes - plan view

Key to Drawing:

1. upper finger (articulated)
2. lower finger
3. frame
4. fixed shaft
5. floating shaft
6. floating shaft
7. shaft with ball joints
8. link
9. structural tube
10. linkage for disc brake
11. cylinder
12. adjustment
13. cylinder pivot
14. disc brake

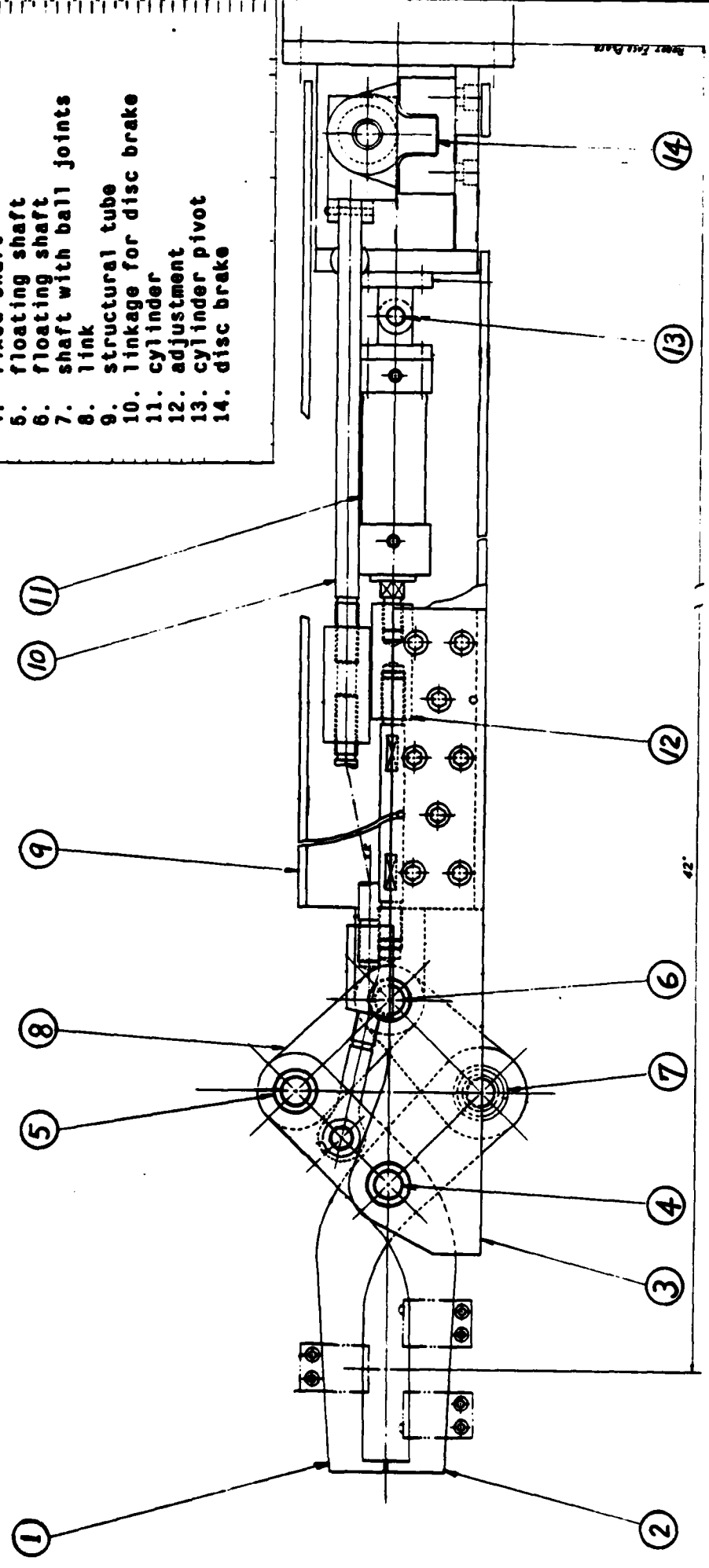

THE OFFICE OF THE ASSISTANT SECRETARY OF THE ARMY WASHINGTON, D. C. 20315		Developmental Graphic Corporation THE A. E. M. PROJECT, B. GARLAND ANN ARBOR, MICHIGAN DATE: 1/15/52	
STANDARD TOLERANCES FRACTIONS: ± 0.015 DECIMALS: ± 0.003 ANGLES: ± 0.0005	DRAWING NO. 100-466-100-1007 SHEET NO. 7 OF 8	PROJECT NO. 100-466-100-1007 SHEET NO. 7 OF 8	DATE: 1/15/52

Figure 5: Gripper for irregular shapes - profile view

- Modify the finger tips, or see if it is possible to remove them altogether. Look at the possibility of giving the contact surfaces of the fingers a slightly curved profile to increase the contact area between them and the preforms.
- A hydraulic cylinder with a longer stroke would allow the gripper linkage to be designed for more mechanical leverage and would allow more leeway in adjusting the connecting rod between the cylinder and the finger linkage.
- Examine some other ways of locking up the linkage after the fingers are pressing against the part. The present system has a little bit of "slop" in it. It may be possible to connect a brake more directly to the fingers by mounting it nearer the front of the gripper.
- The B gripper has many fewer parts to service than the high temperature gripper. Nonetheless, it may be worthwhile to design the rectangular box beam of the B gripper with a full-length removable top panel for convenient inspection of the hydraulic cylinder etc.

4 Acknowledgements

The authors thank Prof. Paul Wright for his support and encouragement during the design, construction and testing of the grippers. Mr. Jerry Colyer of Westinghouse provided many comments and suggestions during the design of the grippers and supervised the on-site testing at the Turbine Components Plant in Winston Salem. We thank Mr. Robert Milligan for useful discussions on choosing a design for the B gripper and finally, we owe a great deal to Messrs. Daniel McKeel and James Dillinger who provided invaluable advice and showed infinite resourcefulness in constructing our grippers with the available campus machining equipment.

I. Appendix

I.1 Notes on Materials Selection:

- References:
- "Handbook of Stainless Steels", Peckner and Bernstein.
 - "Welding Handbook, Vol. 4", American Society of Welding, 1966.
 - "Standard Handbook for Mechanical Engineers, 7th Ed.", Baumeister and Marks, 1967.
 - "Inconel alloy 600", Huntington Alloys, copyright 1962.
 - "Fabrication", Huntington Alloys, copyright 1970.

Available Materials:

- Monel 400, K500, K501 -- Corrosion resistant, very weldable, but less strong than stainless steel. Not suitable for highest temperatures. The K500, K501 alloys are precipitation hardened and stronger than 400. Monel is usually selected where extreme corrosion resistance, and not temperature resistance, is needed.
- Inconel 600, 601 -- Highest temperature resistance without scale, flaking, or corrosion. Good weldability (*see welding notes below*). The coefficient of thermal expansion is low, about the same as stainless steels. Inconel 601 is slightly stronger than 600, but has very slightly less corrosion resistance. Yield strength:
 - 71 ksi. at 1200 deg F
 - 32 ksi at 1500 deg F
 - 15 ksi at 1800 deg F
 - 8.8 ksi at 2000 deg F

(these figures do not account for long term creep at sustained high temperatures)
- Inconel X -- A "superalloy" stronger than Inconel 600 but harder to machine, much harder to weld, and less available in large pieces. Good oxidation resistance to at least 2000 deg F Yield strength:
 - 79 ksi at 1200 deg F
 - 50 ksi at 1500 deg F
- Inconel 700 series -- Hardened alloys, like Inconel X. Stronger than Inconel 600 series, especially at temperatures up to 1500 deg F, but hard to weld.
- Hanes Superalloys (eg. Stellite)-- Very strong, like Inconel X, brittle at room temperature.

- Molybdenum -- Excellent high temperature characteristics, but unfortunately Molybdenum forms a volatile oxide at temperatures above 1500 deg F and starts to disappear. Very ductile and strong. Melts at 4700 deg F Very low coefficient of thermal expansion: .003 inch/inch per thousand deg F
- Yield Strength:
 - 80 ksi below 2000 deg F
- Incoloy 800 -- A bit stronger than Inconel to about 1500 deg F, but should not be allowed to get hotter than 1800 deg F Contains more iron than Inconel and is cheaper and easier to weld.
- 300 series Stainless -- These are suitable for temperatures to about 1200 deg F The most common alloy, 304, is less suitable than 316, or 310 since it forms carbides at elevated temperatures and is more prone to deterioration. Typical yield strengths: (the higher figures are for 310 SS)
 - 35-40 ksi at room temp.
 - 20-26 ksi at 500 deg F

A good indication of safe stresses for stainless steel is found in the pressure vessel code for high temperature vessels. Maximum design stress: 13-17 ksi for 316 and 310 resp. at 500 deg F

- 400 series Stainless -- These are stronger than the 300 series till about 1000 deg F, above which there is not much difference.
- Tungsten Carbide -- for bushings. Rupture strength is 160 to 240 ksi. at room temp, 100 ksi at 1800 deg F There may be some oxidation if held at temperatures over 1200 deg F The coefficient of thermal expansion is about half that of most steels.

Welding Notes:

All of the more weldable metals above (Inconel 600, 601, 300 series SS, Incoloy, Monel 400) are easily welded using a gas tungsten arc. In general, the welds are stronger than the parent metal for these non-hardened alloys. The precipitation hardened alloys (Monel K500, Inconel X, etc.) are harder to weld.

With Inconel it is best to use full penetration joints with wide openings, especially if the weldment will later be subject to thermal cycling. Avoid fillet welds. Inconel weldments should be stress relieved in a furnace at a temperature above 1500 deg F to reduce later distortion. Welds on precipitation hardened alloys run the risk of strain-age cracking, (which basically means these alloys should only be used for things that don't need welding, like shafts and pins)

Other notes:

- Most of the socket head bolts on the present hot gripper are 18-8 stainless steel, and they seem to be holding up well enough. Inconel fasteners are available, but hard to find in stock.
- There is a problem with fasteners working loose due to thermal cycling. They should be wired or keyed (with Inconel wire)

- High temperature creep is not a big problem since the gripper does not stay at very high temperatures for long periods of time.
- Tungsten carbide was selected for bearings for a couple of reasons. It is important to have dissimilar materials for the shaft and the bearing at high temperatures to prevent galling in the event of lubrication failure. Ceramic bushings were considered, but they are generally more brittle and less readily available than tungsten carbide bushings. Antifriction (ball and roller) bearings were avoided because of the problems involving excessive preload at high temperatures and the possibility of lubrication failure. Ball bearings are also less suited to resisting very high static, or nearly static, loads than sleeve bearings.
- It was felt during the initial design of the prototype that wear at high temperatures would be a problem. The implications of this decision were to exclude many designs involving cams, levers, gears, and so on. The present design has a minimum of sliding contacts. The only places wear moving surfaces rub is in the bearings, which are tungsten carbide.

Some Suppliers:

- Inconel 600, 601, Incoloy 800, Stainless Steel and SS Fasteners: Williams and Company. Inconel is available in sizes up to:
 - .25 x 3 x 3
angles
 - .375 x 4
flats
 - .625 x 2
flats
 - 2" thk.
plate
 - 6.0 dia.
Schedule 40 pipe

Thinnest available sheet: .05" Inconel 601 and Incoloy 800 are available in most of the same sizes.

- 316 Stainless wire rope: Carolina Steel and Wire Corp.
- High temperature stainless and Stellite cable assemblies: Teleflex Inc.

References

1. P.K. Wright, D.A. Bourne, J.P. Colyer, G.C. Schatz and J.A.E. Isasi, "A Flexible Manufacturing Cell for Swaging," *The 14th CIRP Seminar on Flexible Manufacturing Systems*, Trondheim, Norway, June 1982.
2. P.K. Wright *et al.*, "A Flexible Manufacturing Cell for Swaging," *(ASME) Mechanical Engineering*, Vol. 104, No. 10, October 1982, pp. 76-83.
3. D. A. Bourne and P. S. Fussell, " Designing Programming Languages for Manufacturing Cells," Tech. report, The Robotics Institute, Carnegie-Mellon University, April 1982.

END

FILMED

11-83

DTIC