

AD-A134 049

DEVELOPMENT OF A COMPUTER CONTROLLED TRACE METAL
PRECONCENTRATOR 1 SYSTEM. (U) RHODE ISLAND UNIV
KINGSTON GRADUATE SCHOOL OF OCEANOGRAPHY
C C LEE ET AL. AUG 83 TR-83-2

1/1

UNCLASSIFIED

F/G 9/2

NL

END

FORMED
BY
DATE

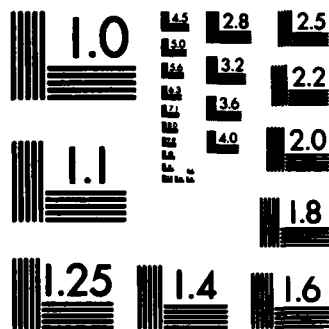

MICROCOPY RESOLUTION TEST CHART
NATIONAL BUREAU OF STANDARDS-1963-A

AD-A134049

12

DEVELOPMENT OF A COMPUTER CONTROLLED TRACE METAL PRECONCENTRATOR:

I. SYSTEM DESCRIPTION AND DESIGN

AUGUST 1983

C.C. Lee

Richard W. Zuenlke

Dana R. Kester

Graduate School of Oceanography

University of Rhode Island

Kingston, RI 02882

NO0014-81-C-0062

Technical Report 83-2

August 1983

DTIC
ELECTE
OCT 26 1983
S D
B

DISTRIBUTION STATEMENT A

Approved for public release;
Distribution Unlimited

83 10 19 002

DTIC FILE COPY

DEVELOPMENT OF A COMPUTER CONTROLLED TRACE METAL PRECONCENTRATOR:

I. SYSTEM DESCRIPTION AND DESIGN

AUGUST 1983

C.C. Lee

Richard W. Zuehlke

Dana R. Kester

Graduate School of Oceanography

University of Rhode Island

Kingston, RI 02882

Technical Report 83-2

August 1983

I. INTRODUCTION

→ This report describes the design principles, detailed circuit diagram, and software for a multiple sample automated preconcentrator (MSAP). The MSAP is designed to accept up to 12 samples of seawater. It can be expanded to a 24-sample system without major modification of the circuit design. The overall system includes sample bottles containing approximately 250 ml of seawater that flows through a chromatographic cartridge which extracts dissolved transition and heavy metals. The metals that are loaded on the cartridge are eluted with about 7 ml of a 2 N HCl-0.1 N HNO₃ mixture. The acid medium with the metals is injected into a graphite furnace for analysis. Nearly all components of the flow system are constructed of Teflon to avoid contamination. Provisions are made to wash the extraction cartridge at appropriate times and to precondition it between samples. Fluid flow through the system is controlled by nitrogen gas pressure at 5-15 psi using a series of two-way and three-way solenoid valves that are controlled by a CBM 4016 microcomputer.

The system will be described in terms of a typical operation cycle. The system consists of 12 sample modules, three types of cartridge elution media, and the nitrogen pressure system. ← Figure 1 illustrates the configuration with three of the twelve sample modules. Table 1 provides a list of all solenoid control valves in the system, indicating the type of valve, a descriptive name, and its function. The status of valves in module #1 will be used as an example in the following steps.

A. Seawater Loading: The seawater from each bottle is forced through a filter, then through a cartridge by energizing the solenoid valve VLO to pass a pressurized nitrogen gas (normally between 5 to 15 psi). In



✓

PER CALL JC

Codes
 /or

Dist	Special
A	

Table 1. Names, types and functions of valves.

Valve	Type ^a	Function	Name
VL0	2	Supply N ₂ pressure to entire system	Master N ₂
VL1	2	Off-on control of Milli-Q wash eluent	Milli-Q
VL2	2	Off-on control of Buffer wash eluent	Buffer
VL4	3	Fill Acid Measuring Reservoir (AMR) or deliver acid in AMR to cartridge	AMR
VL5	3	Select ventilation for AMR filling or N ₂ for acid elution	AMR N ₂
VL6	3	Select AMR for acid elution or acid bottle for acid wash	Acid E/W
VL7	3	Apply N ₂ pressure to sample manifold	Sample N ₂
VL8	3	Direct effluent to either waste or collection for module #1	Effluent 1
VL9	3	Direct effluent to either waste or collection for module #2	Effluent 2
VL10	3	Direct effluent to either waste or collection for module #3	Effluent 3
VL11	3	Direct effluent to either waste or collection for module #4	Effluent 4
VL12	3	Direct effluent to either waste or collection for module #5	Effluent 5
VL13	3	Direct effluent to either waste or collection for module #6	Effluent 6
VL14	3	Direct effluent to either waste or collection for module #7	Effluent 7
VL15	3	Direct effluent to either waste or collection for module #8	Effluent 8
VL16	3	Direct effluent to either waste or collection for module #9	Effluent 9
VL17	3	Direct effluent to either waste or collection for module #10	Effluent 10
VL18	3	Direct effluent to either waste or collection for module #11	Effluent 11
VL19	3	Direct effluent to either waste or collection for module #12	Effluent 12
VL20	3	Select Milli-Q, buffer, or acid as eluent for module #1	Eluent 1
VL21	3	Select Milli-Q, buffer, or acid as eluent for module #2	Eluent 2
VL22	3	Select Milli-Q, buffer, or acid as eluent for module #3	Eluent 3
VL23	3	Select Milli-Q, buffer, or acid as eluent for module #4	Eluent 4
VL24	3	Select Milli-Q, buffer, or acid as eluent for module #5	Eluent 5

^aTwo-way valve (2) or three-way valve (3) or two-way valve with fast wash out (2FW)

Table 1. continued.

Valve	Type	Function	Name
VL25	3	Select Milli-Q, buffer, or acid as eluent for module #6	Eluent 6
VL26	3	Select Milli-Q, buffer, or acid as eluent for module #7	Eluent 7
VL27	3	Select Milli-Q, buffer, or acid as eluent for module #8	Eluent 8
VL28	3	Select Milli-Q, buffer, or acid as eluent for module #9	Eluent 9
VL29	3	Select Milli-Q, buffer, or acid as eluent for module #10	Eluent 10
VL30	3	Select Milli-Q, buffer, or acid as eluent for module #11	Eluent 11
VL31	3	Select Milli-Q, buffer, or acid as eluent for module #12	Eluent 12
VL32	2FW	Select either sample or eluent as cartridge influent for module #1	Influent 1
VL33	2FW	Select either sample of eluent as cartridge influent for module #2	Influent 2
VL34	2FW	Select either sample of eluent as cartridge influent for module #3	Influent 3
VL35	2FW	Select either sample of eluent as cartridge influent for module #4	Influent 4
VL36	2FW	Select either sample of eluent as cartridge influent for module #5	Influent 5
VL37	2FW	Select either sample of eluent as cartridge influent for module #6	Influent 6
VL38	2FW	Select either sample of eluent as cartridge influent for module #7	Influent 7
VL39	2FW	Select either sample of eluent as cartridge influent for module #8	Influent 8
VL40	2FW	Select either sample of eluent as cartridge influent for module #9	Influent 9
VL41	2FW	Select either sample of eluent as cartridge influent for module #10	Influent 10
VL42	2FW	Select either sample of eluent as cartridge influent for module #11	Influent 11
VL43	2FW	Select either sample of eluent as cartridge influent for module #12	Influent 12
VL44	2	Off-on control of waste for module #1-#6	Waste 1-6
VL45	2	Off-on control of waste for module #7-#12	Waste 7-12

module #1 VL32 is set to connect the filter and the cartridge. VL8 is directed to waste. The corresponding valves of the other sample modules are in a similar configuration.

The cartridge contains 8-hydroxyquinoline that is chemically bonded to silica gel. The chemically bonded 8-hydroxyquinoline forms complexes with trace metals and retains them in the cartridge. The 12 sample bottles are arranged in two rows of six. One filter, one cartridge and three valves (e.g., valves VL8, 20 and 32 for sample 1) form the basic module for each sample. Six of these modules are arranged in a row. The waste water coming out of a row are combined and connected to a two-way valve (Figure 2, one of the VL44 and VL45). All of the waste water is combined into one stream. Nitrogen gas is forced into the waste stream. If the seawater loading is finished, the tubing downstream of the nitrogen inlet will be empty. Otherwise, small segments of seawater will keep flowing out of the tubing. An optical sensor is mounted on the tubing to detect seawater. After the seawater stops coming out for a period of time (ca. 30 sec.), the loading process is finished and the control goes to the next step.

Before the seawater loading begins, there may be some air trapped in the tubing between filter and sample bottle. The air may slow down or completely stop the seawater loading. This situation is avoided by filling each sampling tube with Milli-Q (MQ) water (open VL7 to ventilation; open VL1; close VL8 and VL44; connect VL20 to the filter via VL32; select Milli-Q with VL20).

B. MQ Wash: After the seawater is loaded, the cartridges are washed with MQ-water to remove salts by turning on the valve VL1, connecting VL20 to the cartridge via VL32 and selecting MQ with VL20.

C. Acid Elution: A fixed amount of acid is passed through each selected cartridge to elute trace metals from the cartridge. The elution is performed sequentially to process all selected cartridges. Each of the valves (VL8-VL19) has been turned to the collect position just before the acid elution for the selected cartridge begins. The fixed volume of acid is obtained by filling an acid measuring reservoir (Figure 3) (VL4 energized and VL5 de-energized).

The acid sensor is an optical sensor which is used to make sure that the reservoir is filled. A short time delay (ca. 0.5 sec) between the beginning of the filling and the activation of the sensor will avoid possible erratic signals produced by the acid residue in the tubing on which the sensor is mounted. After the reservoir is filled, VL5 is energized and VL4 is de-energized to force acid out of the reservoir with nitrogen pressure. Each of the valves (VL20-VL47) is turned to a proper position for the acid elution of a specific cartridge (e.g., for the acid elution of Cartridge 1, VL20 and VL32 are energized and others are de-energized).

D. Acid-Wash: Trace metal residues on the cartridges are washed with acid. This is performed by turning on the valve VL6 (Figure 3) for a fixed period of time (VL20 and 32 are energized).

E. MQ-Wash: The cartridges are then washed with MQ-water.

F. Buffer/MQ Wash: The cartridges are washed with NaHCO_3 or MQ to be ready for the next set of seawater samples by turning on the valve VL1 or VL2, respectively (VL20 is de-energized and VL32 is energized).

II. CIRCUIT DESIGN

The MSAP is to be controlled by a Commodore Business Machines (CBM) 16K or 32K microcomputer through its IEEE-488 interface. The controlling program is written in BASIC. The MSAP should be able to be controlled by other computers with an appropriate interface. Slight modifications to the program may be necessary.

The IEEE-488 primary address is assigned to be 6. It can be changed by changing the address selection jumpers on the MSAP interface board. To control the valves using the CBM computer, first open a logical file with a primary address and a secondary address. For example, the statement `OPEN 1,6,0` specifies that logical file 1 is to be opened, the device 6 is to be addressed, and a secondary address (SCG 00) will be issued. The statement `PRINT#1,CHR$(255)` sends a data 255 to the secondary address 0 of device 6. To read status information from the MSAP, one can use the `GET#` statement.

A. Control of the IEEE-488 Bus: Chapters 3, 4, and 5 of the book PET and the IEEE 488 Bus (GPIB) provide information on hardware, sample bus transactions, and timing sequences. As shown in Table 5-3 of the reference book (page 84), when the statements `OPEN 5,5,2` and `PRINT#5,"TEST"`, the computer lowers the Attention Line (ATN), places a byte 25_{16} (for primary address 5) on the data bus and lowers the data valid line (DAV) momentarily, then places a byte 62_{16} (for secondary address 02) and lowers the DAV line.

It is the responsibility of each of the devices connected to the general purpose interface bus (GPIB) to decode this address information to see if it is selected. If the device is selected, it should be ready to accept the information sent out by the computer. Each data byte sent to a

secondary address of the MSAP is stored in a D-type flip-flop chip (74LS374). There are maximum of 15 secondary addresses corresponding to 120 data ports or solenoid valves (15 x 8 bits each). At the present time, 45 valves are required to control a 12 sample system. The design can be extended to a 24 sample system without major modification of the circuit design.

Figure 4 shows the interface circuit diagram for the control and data signals. If the computer is powered up, the interface clear signal (IFC) goes low for a moment. This results in a momentarily low signal on CLRSYS which is used to bring all valves to their initial deenergized states. A power up clear for the MSAP controller is also implemented by using an RC circuit (R1,C1) to generate an initially low signal on the CLRSYS line. An override switch SW1 can also be used to generate a low signal on CLRSYS. The interface circuit of the MSAP controller responds very quickly (all information can be accepted within 400 ns after the falling edge of the DAV signal). Therefore, the MSAP controller can tell the computer that it is ready for data at any time. This is achieved by sending the Not Ready For Data (NRFD) signal to the computer using the DAV signal; in other words, when the computer raises its DAV signal to a high level to prepare sending the following byte, the MSAP controller sends a high NRFD signal to tell the computer that it is ready to accept another byte. The Not Data ACcepted (NDAC) signal sent from the MSAP controller is the inverted DAV signal. As soon as the computer lowers its DAV signal (to tell all devices that the data are valid), the MSAP controller sends a high level signal on NDAC line to tell the computer that the data is accepted.

Let's suppose that the statements "OPEN 1,6,0" and "PRINT#1,CHRS(255)" are to be executed: Two bytes, 26₁₆ (primary address) and 60₁₆

(secondary address), will be placed on the GPIB before the data (255) is sent. In order to distinguish which byte is being sent, a shift register (74LS95, DP) is used (Figure 5). This is done by loading the shift register with data 1110₂ when the ATN line goes low. Q_d-Q_a becomes 1110₂. The shift register is clocked by the DAV₁(data valid, input) signal. For example, right after the primary address is placed on the GPIB, the DAV line goes low to tell all devices that the data signals are correct. The DAV₁ (similar to DAV) signal clocks the shift register so that the outputs Q_d-Q_a = 1101₂. A low on the output Q_b is used to identify the primary address being sent when the DAV signal is low. When the computer sends the secondary address, the DAV₁ signal clocks the shift register again and the output of the shift register becomes 1011₂. A low on the output Q_c is used to signify that a secondary address is being sent when the DAV is low. The output Q_d is to identify the first data byte of the PRINT statement.

The primary address data is compared with 26₁₆. If they are the same, the data input of 74LS74, EP is high. This high input is then clocked and stored in the chip and the inverting Q output (the listening device select LDS) signal becomes low. The D-type flip-flop 74LS273, BP can store the secondary address information. The least significant three bits of the secondary address is decoded with a chip 74LS138, CR (a 3 to 8 line decoder) to generate 8 listening secondary device select (LSDS). One and only one of the eight outputs of 74LS138 can be low. When the computer sends the first data byte of the PRINT statement, the data are stored in the corresponding 74LS374 chip (Figure 6) depending on which output of the decoder chip is true (which secondary address has been selected). Each clock input signal to the chips 74LS374 is gated with the LDS signal so

that only when the computer writes information to the MSAP will one of the 74LS374 chips be clocked.

At the end of the PRINT statement, the computer lowers the ATN line and sends a universal unlisten (ULN) signal ($3F_{16}$) to the data bus of GPIB (page 84 of the reference book), the LDS signal (Figure 5) becomes high (listening device is not selected) because the data $3F_{16}$ are not equal to the data 26_{16} which is the primary address byte for the MSAP.

When a "CLOSE" statement is executed, the computer lowers the ATN line and sends 26_{16} as the primary address and $E0_{16}$ (when using OPEN 1,6,0 statement) as the secondary address (page 70 of the reference book). The 26_{16} data bring the LDS signal low. The higher 4 bits of the secondary address data byte (in this case, it is E_{16}) are compared with E_{16} . If they match, an active CLEAR signal is generated to bring the LDS signal high, and this prevents writing of data to the 74LS374 chips.

To read data from the MSAP, first open a logical file with a secondary address (e.g., OPEN 1,6,0), and then use the GET# statement to read data.

Table 5-11 of the reference book (page 120) shows the bus transaction for the GET# statement. When the computer sends the data 46_{16} on the GPIB bus as the primary address, the data input of the chip 74LS74 (Figure 7) becomes high and the Q output (Talking Device Select TDS) becomes low. The secondary address information 60_{16} is stored in the D flip-flop chip 74LS273,GT. The 74LS138,ET chip is used to select the proper output of the talking secondary device select(TSDS).

After this point, it is the responsibility of the talking device to control the data bus. The MSAP places the data on the bus after the ATN line goes high (Figure 8). The MSAP also raises the DAV line until a high level signal of the NRFD is detected (until the computer says ready to

receive data). When the computer tells the MSAP that the data are accepted (NDAC signal goes high), the MSAP raises the DAV line and releases the control on the data and control bus to other devices (e.g., the computer).

The optical sensors (Figures 2, 3 and 9) detect seawater or acid in the Teflon tubing. If liquid is in the tubing at the position of sensor, the voltage level is above 3.4 V; otherwise, it is below 0.6 V. The informations provided by the sensors can be read by the computer using the GET# statement. These informations can be used to control the operation of the MSAP. For example, during the seawater loading process the computer can read the status of the seawater sensor and can go into the next step as soon as the seawater loading step is finished.

Figure 9 shows the circuit for driving a solenoid valve manufactured by General Valve Corp. These valves have a rating of 12 V and 0.21 A and they require a minimum of 3 V to hold. A resistor and a capacitor is added to the circuit to provide enough power to initially energize a solenoid valve and to cut down the power for long period of operation (current is cut down to about 0.08 A). A 7407 driver gate can handle 0.04 A. Although it is not a good practice to tie three drivers together, it is more economical to use the 7407 than most transistors which can do the job, and the 7407 driver provides better noise rejection than most transistors. The circuit has been tested for more than one million operations (On-Off) without any failure (a resistor consuming the same current was used instead of a solenoid valve for the testing). Detailed descriptions of the physical locations of the chips and the signals on connectors can be found in Appendices A and B.

III. SOFTWARE DESIGN

A program "MSAP;8/83" has been written to control the MSAP. After execution of the program, all valves are restored to their initial states (all valves should be in their de-energized initial states when powered up). The operator can select 4 modes of operation:

- a. To process sample.
- b. To fill the tubing between the filter and the sample bottle with MQ water.
- c. To manually control valves with keyboard.
- d. To de-energize all valves.

When the first mode is selected, the operator can enter the timing parameters for each step from a disk file or manually. A set of default values are provided when the parameters will be entered manually. The operator can then change any parameters and/or save the parameters to a disk file. A few questions will be asked to remind the operator for preparing the preconcentration. The operator can choose any combination of the 12 channels to process samples. The program will output the status of processing to the screen and warn the operator when a few unexpected things happened (such as not finished seawater loading or nitric acid filling after a certain amount of time).

The subroutine addresses, the assignment of the order of valves in an array and the program listing can be found in Appendices C, D and E.

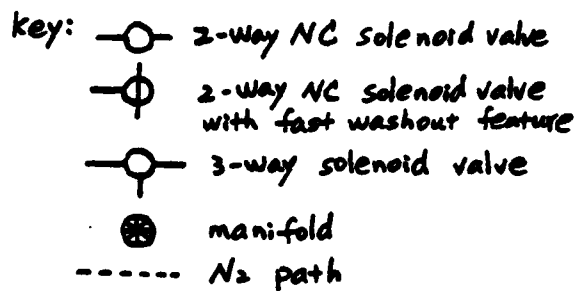
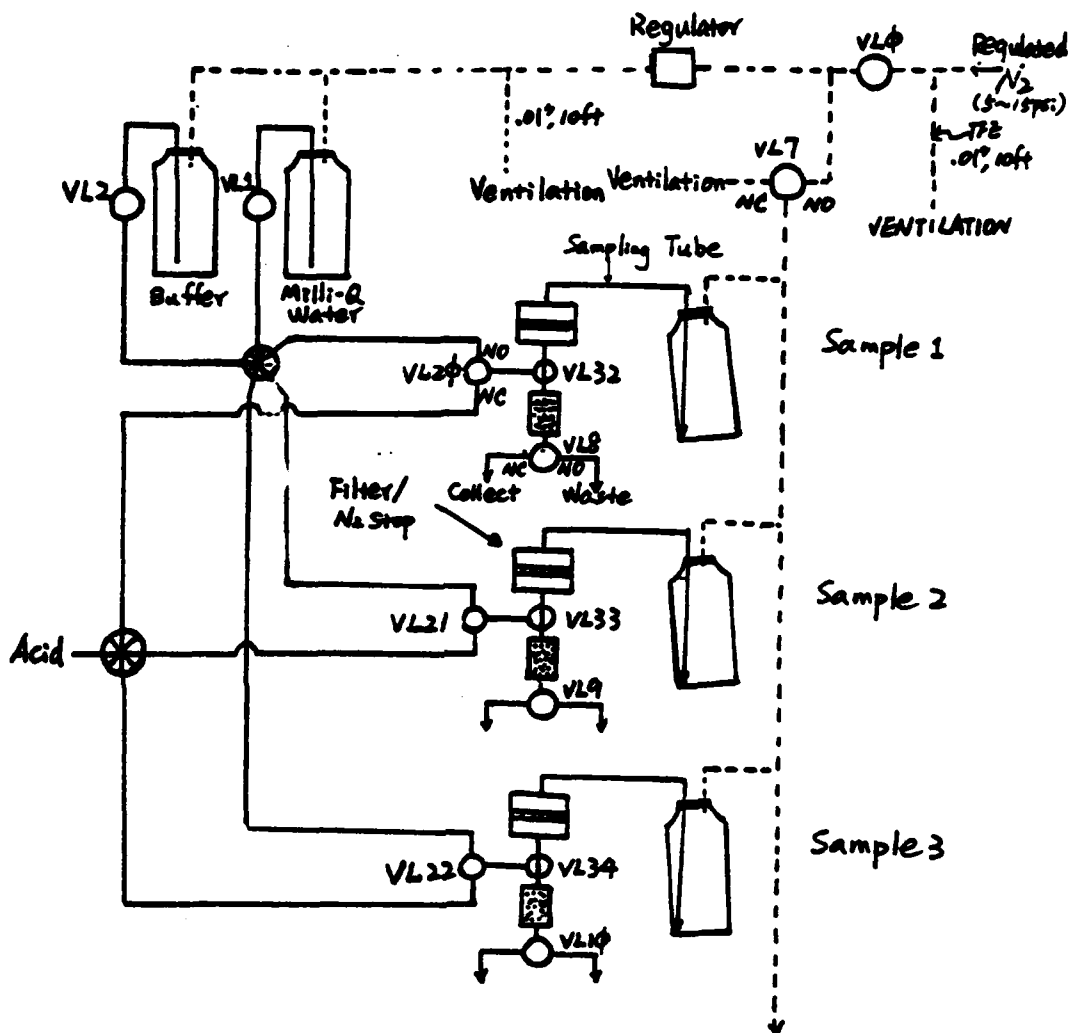

Figure 1. Flow diagram of the MSAP

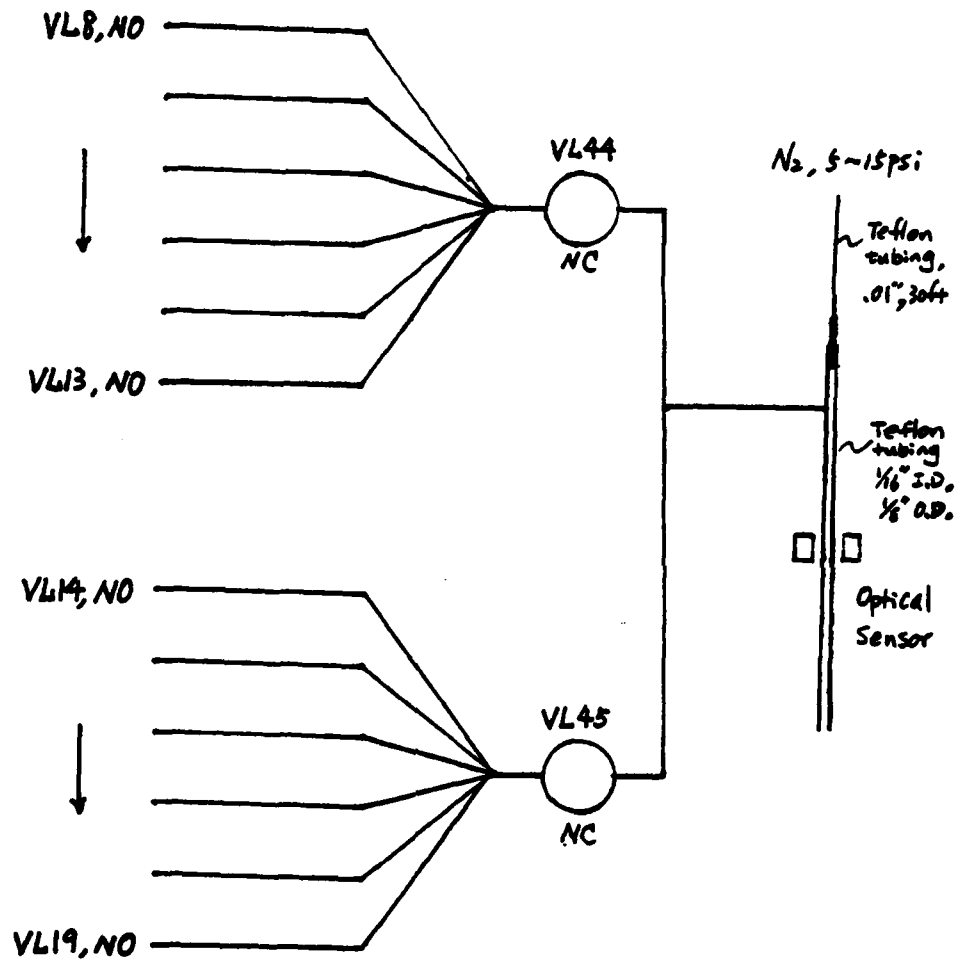

Figure 2. Waste stream and the seawater sensor.

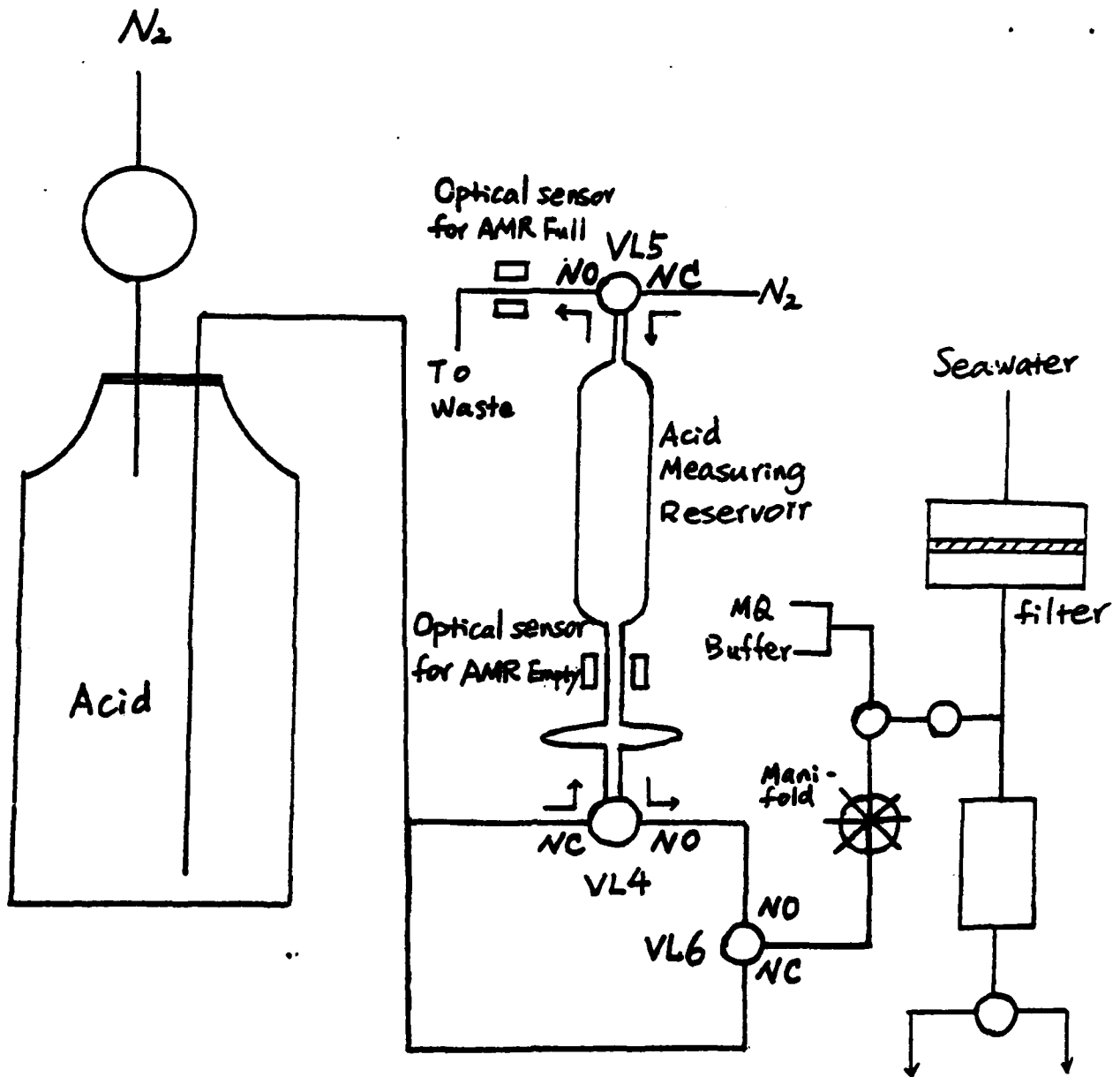

Figure 3. Acid Measuring System.

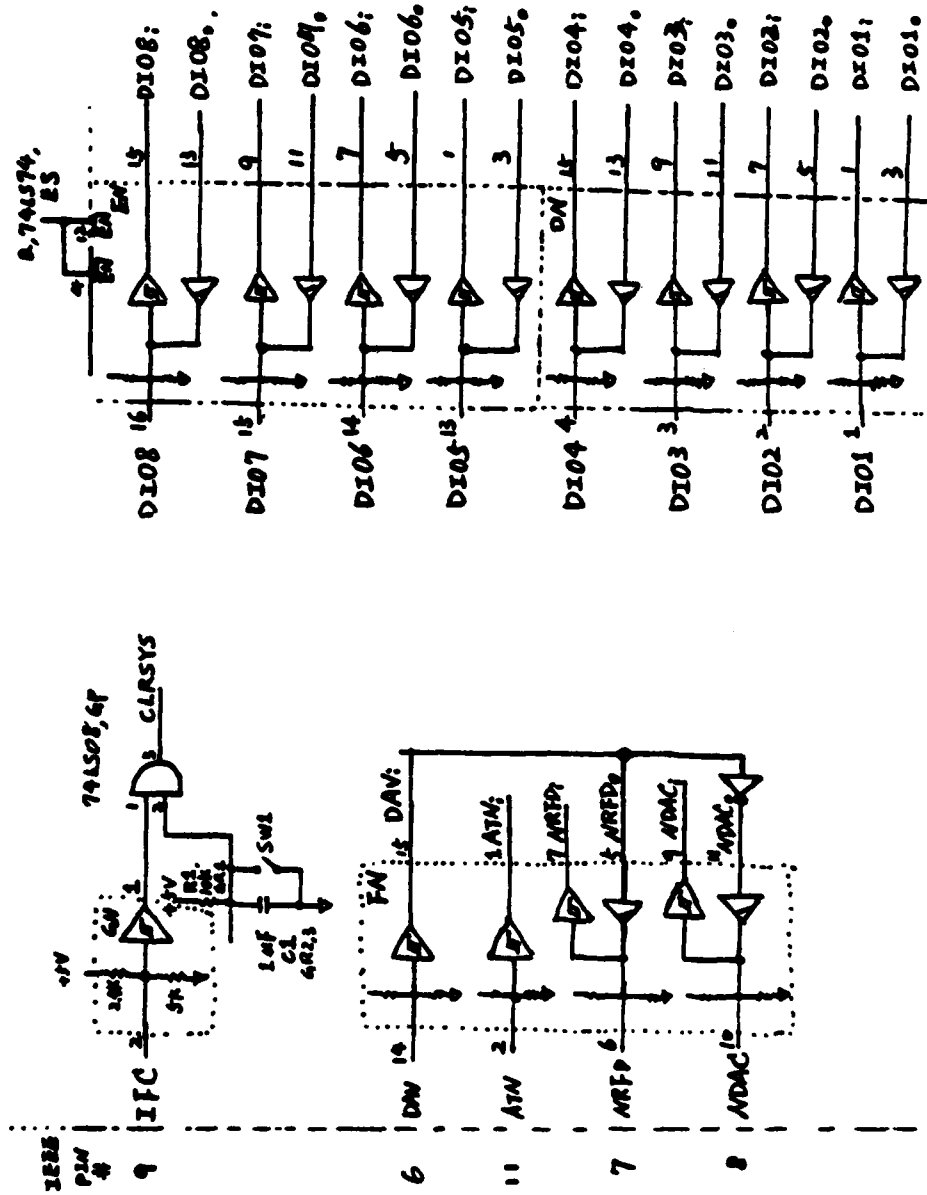

Figure 4. Interface circuits of the control and data signals.

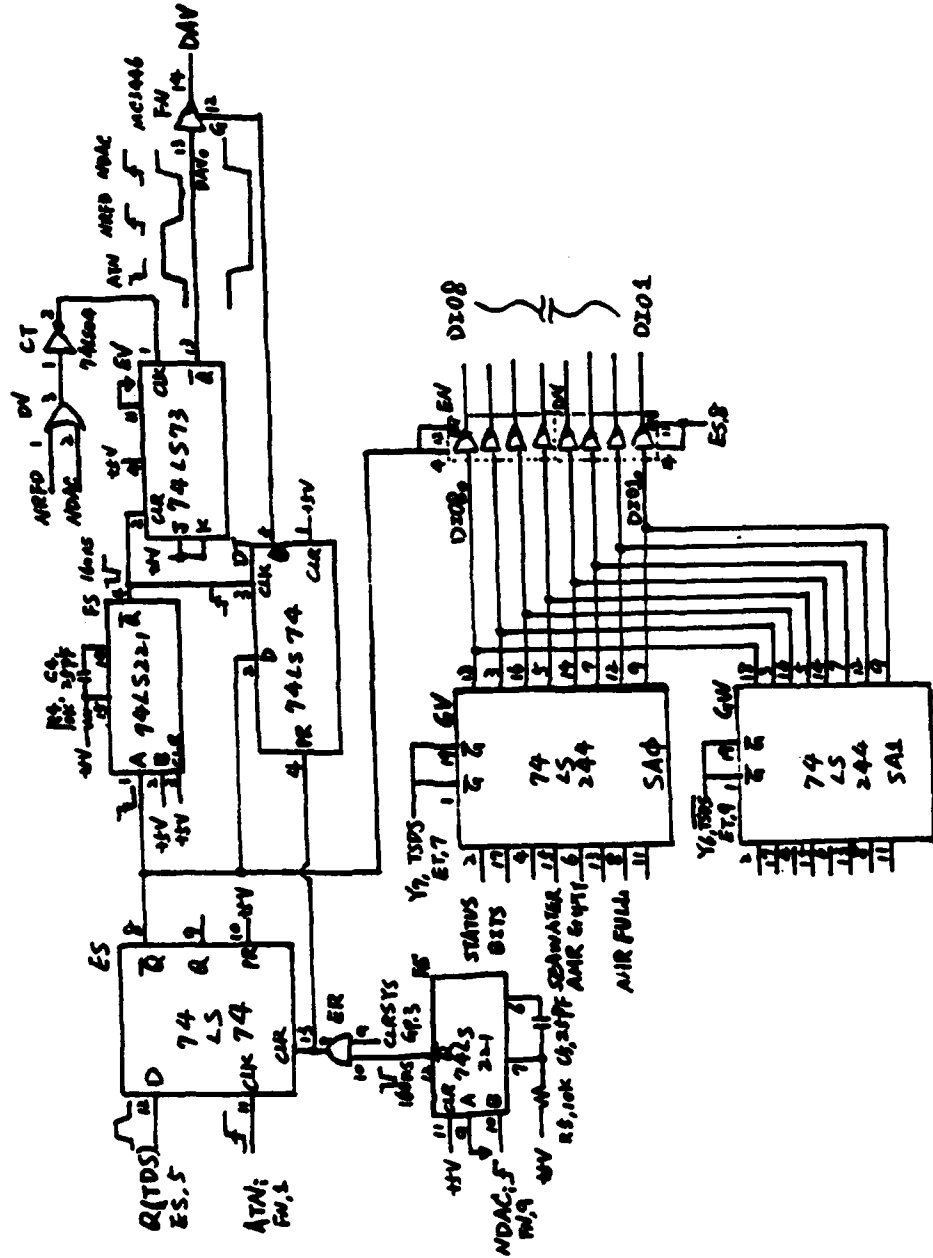
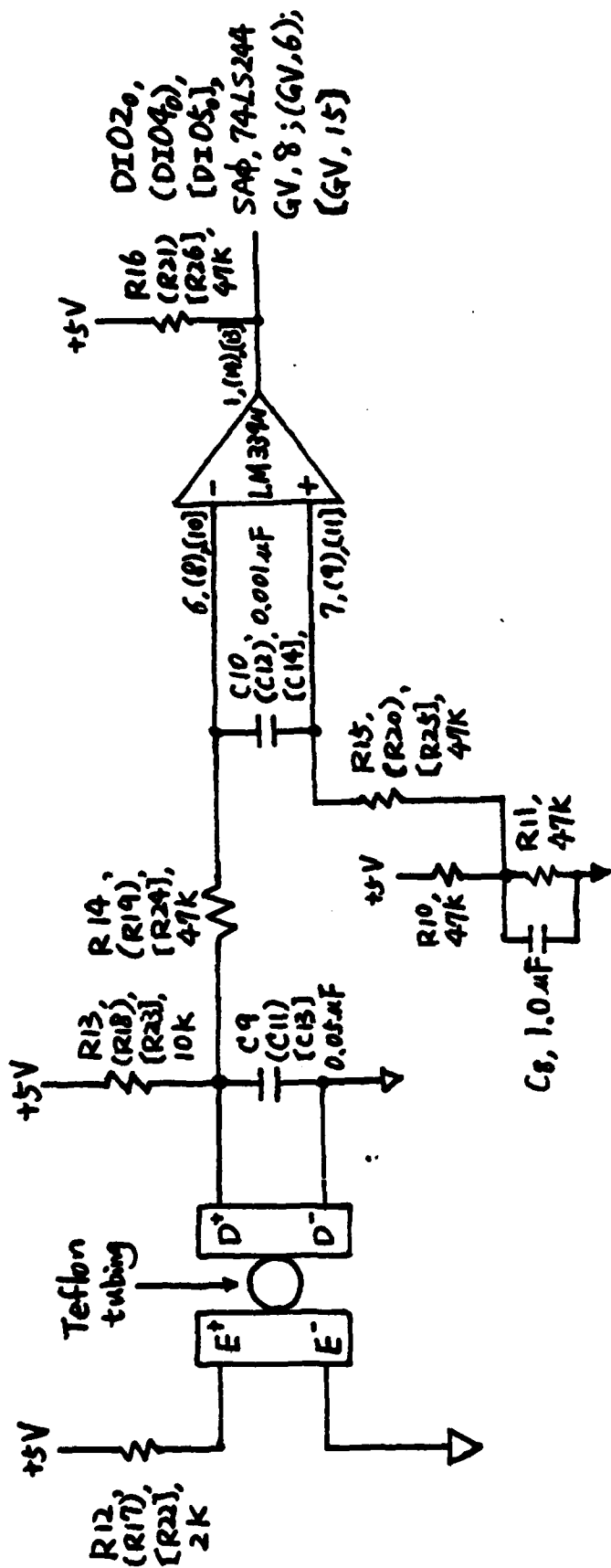

Figure 8. Interface logic for the status information.



DIO20,
(DIO40),
[DIO50],
SAφ, 74LS244
GV, 8; (GV, 6);
(GV, 15)

no parenthesis : components for AMR Full sensor
() : components for AMR Empty sensor
([] : components for seawater sensor

Figure 9. Circuits for sensors.

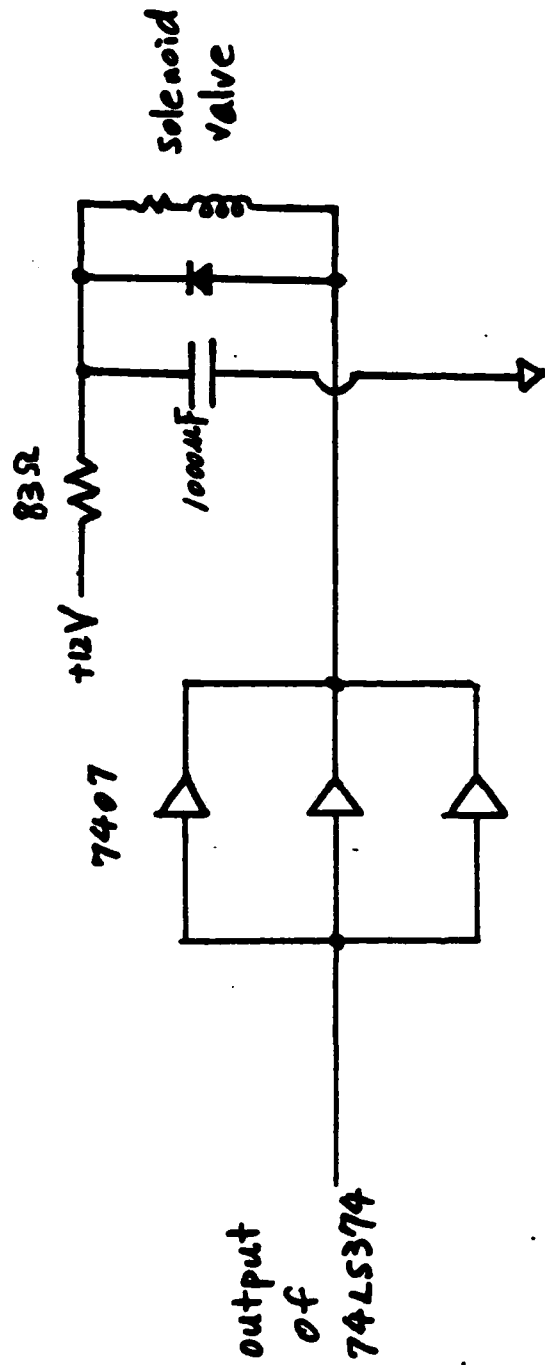

Figure 10. Circuit for driving a solenoid valve

APPENDIX B
PIN ASSIGNMENT OF CONNECTORS

CONNECTOR #1 (TO COMPUTER)		CONNECTOR #2 (TO VALVES AND SENSORS)		CONNECTOR #3 (TO VALVES AND SENSORS)	
PIN	FUNCTION	PIN	FUNCTION	PIN	FUNCTION
1	DI01	1,2	VL0	1,2	VL24
2	DI02	3,4	VL1	3,4	VL25
3	DI03	5,6	VL2	5,6	VL26
4	DI04	7,8	AMR EMPTY E ⁺ , E ⁻	7,8	VL27
5	NOT USED	9,10	VL4	9,10	VL28
6	DAV	11,12	VL5	11,12	VL29
7	NRFD	13,14	VL6	13,14	VL30
8	NDAC	15,16	VL7	15,16	VL31
9	IFC	18,19	VL8	18,19	VL32
10	NOT USED	20,21	VL9	20,21	VL33
11	ATN	22,23	VL10	22,23	VL34
12	NOT USED	24,25	VL11	24,25	VL35
13	DI05	26,27	VL12	26,27	VL36
14	DI06	28,29	VL13	28,29	VL37
15	DI07	30,31	VL14	30,31	VL38
16	DI08	32,33	VL15	32,33	VL39
17	NOT USED	34,35	VL16	34,35	VL40
18	GND	36,37	VL17	36,37	VL41
19	GND	38,39	VL18	38,39	VL42
20	GND	40,41	VL19	40,41	VL43
21	GND	42,43	VL20	42,43	VL44
22	GND	44,45	VL21	44,45	VL45
23	GND	46,47	VL22	46,47	AMR FULL E ⁺ , E ⁻
24	GND	48,49	VL23	48,49	AMR FULL D ⁺ , D ⁻
		17,50	AMR EMPTY D ⁺ , D ⁻	17,50	NOT USED

CONNECTOR #4
(TO SEAWATER SENSOR)

PIN	FUNCTION
1,2	SEAWATER SENSOR E ⁺ , E ⁻
3,4	SEAWATER SENSOR D ⁺ , D ⁻

APPENDIX C

DESCRIPTION OF MSAP SOFTWARE PARAMETERS

TO CONTROL MSAP, FIRST SPECIFY THE CONTENT OF CO(I) AND SPECIFY THE SECONDARY ADDRESS (E.G. SA=0) THEN GOSUB 15000

1:ENERGIZE A VALVE; 0:DEENERGIZE A VALVE
ALL TWO WAY VALVES ARE NORMALLY CLOSED. VALVE TYPE 2FW SPECIFIES A TWO WAY VALVE WITH FAST WASHOUT FEATURE.

WR	VALVE TYPE	ARRAY	PURPOSE	
SA=0	2	CO(0)	NITROGEN GAS	
	2	CO(1)	MQ	
	2	CO(2)	BUFFER	
	X	CO(3)	CLEAR SEAWATER SENSOR	
	3	CO(4)	0:RESERVOIR TO CARTRIDGE 1:ACID BOTTLE TO RESERVOIR	
	3	CO(5)	0:RESERVOIR TO NITROGEN 1:RESERVOIR TO WASTE	
	3	CO(6)	0:MANIFOLD TO ACID MEASURING RESERVOIR 1:MANIFOLD TO ACID BOTTLE	
	3	CO(7)	0:SAMPLE BOTTLE TO VENTILATION 1:SEAWATER TO NITROGEN	
WR	VALVE TYPE	CARTRIDGE #	ARRAY	PURPOSE
SA=1	3	1	CO(8)	0: TO WASTE; 1: TO COLLECT
	3	2	CO(9)	SAME
	3	3	CO(10)	SAME
	3	4	CO(11)	SAME
	3	5	CO(12)	SAME
	3	6	CO(13)	SAME
	3	7	CO(14)	SAME
	3	8	CO(15)	SAME
SA=2	3	9	CO(16)	SAME
	3	10	CO(17)	SAME
	3	11	CO(18)	SAME
	3	12	CO(19)	SAME
	3	1	CO(20)	0:CARTRIDGE TO MQ/BUFFER 1:CARTRIDGE TO ACID
	3	2	CO(21)	SAME
	3	3	CO(22)	SAME
	3	4	CO(23)	SAME
SA=3	3	5	CO(24)	SAME
	3	6	CO(25)	SAME
	3	7	CO(26)	SAME
	3	8	CO(27)	SAME
	3	9	CO(28)	SAME
	3	10	CO(29)	SAME
	3	11	CO(30)	SAME
	3	12	CO(31)	SAME

WR	VALVE TYPE	CARTRIDGE #	ARRAY	PURPOSE
SA=4	2FW	1	CO(32)	0:SEAWATER TO CARTRIDGE 1:ACID/MQ/BUFFER TO CARTRIDGE OR MQ TO SAMPLING TUBE
	2FW	2	CO(33)	SAME
	2FW	3	CO(34)	SAME
	2FW	4	CO(35)	SAME
	2FW	5	CO(36)	SAME
	2FW	6	CO(37)	SAME
	2FW	7	CO(38)	SAME
	2FW	8	CO(39)	SAME
SA=5	2FW	9	CO(40)	SAME
	2FW	10	CO(41)	SAME
	2FW	11	CO(42)	SAME
	2FW	12	CO(43)	SAME
	2		CO(44)	WASTE FOR SAMPLE # 1-6
	2		CO(45)	WASTE FOR SAMPLE # 7-12
			CO(46)	NOT USED
			CO(47)	NOT USED

TOTAL # OF VALVES OF 3-WAY: 28, OF 2-WAY: 17

RD	BIT	INFORMATION
SA=0	0	CONDUCTIVITY SENSOR; 0:HAD BEING CONDUCTING
	1	AMR FULL; 0:ACID IN THE TUBING
	2	CONDUCTIVITY SENSOR; 0:CONDUCTING
	3	AMR EMPTY; 0:ACID IN THE TUBING
	4	SEAWATER SENSOR; 0:SEAWATER IN THE TUBING
	5	NOT USED
	6	NOT USED
	7	NOT USED

APPENDIX D

SUBROUTINE ADDRESS	PURPOSE
2000	SEAWATER LOADING
3000	MQ WASH
4000	ACID ELUTION
5000	ACID WASH
6000	MQ WASH BEFORE BUFFER
7000	BUFFER OR MQ WASH
9000	INPUT SAMPLE #
10000	ENTER PARAMETERS MANUALLY
11000	INPUT PARAMETERS FROM DISK
12000	DEFINITIONS OF STRINGS AND VARIABLES
13000	SAVE PARAMETERS TO DISK
14000	LOAD PARAMETERS FROM DISK
15000	WRITE CONTROL SIGNALS TO TMPC
16000	DEENERGIZE ALL VALVES AND RESET TIMER
17000	PRINT TIME LEFT
17500	CLEAR PREVIOUS TIMING PRINTING
18000	READING STATUS BYTE
18500	CONVERTS STATUS BYTE TO INDIVIDUAL BITS
19000	CONTROL INDIVIDUAL VALVE WITH KEYBOARD
21000	FILL FILTER AND TUBING TO SAMPLE BOTTLE WITH MQ

STRING OR VARIABLE NAME	SUBJECT
DIM SM(12)	SAMPLE #
TT	TOTAL TIME
TL	TIME LEFT
S1	NUMBER OF SAMPLE USED

STRING	CONTENTS	VARIABLE FOR THE TIMING
A1\$(1)	LOADING	A1(1)
A1\$(2)	MQ WASH	A1(2)
A1\$(3)	ACID ELUTION	A1(3)
A1\$(4)	ACID WASH	A1(4)
A1\$(5)	MQ WASH BEFORE BUFFER	A1(5)
A1\$(6)	BUFFER WASH	A1(6)

APPENDIX E

```

10 PRINT "J"
20 PRINT "MSAP; 1/1/83"
25 PRINT "REV 6/30/83, 8/5/83"
30 PRINT "THIS PROGRAM CONTROLS THE TRACE"
40 PRINT "METAL PRECONCENTRATOR,"
50 PRINT "OUTPUTS THE STATUS OF PROCESS"
60 PRINT "TO SCREEN."
70 GOSUB 12000:REM STRING, PARAMETER DEF
80 GOSUB 16000:REM DEENERGIZE VALVES AND RESET TIMER
81 PRINT "":PRINT "1. PROCESS SAMPLES"
82 PRINT "2. FILL FILTER AND TUBING TO SAMPLE":PRINT "
83 PRINT "3. CONTROL INDIVIDUAL VALVE WITH KEYBOARD?"
84 PRINT "4. DEENERGIZE ALL VALVES"
85 INPUT I
86 ON I GOTO 90,21000,19000,80
87 GOTO 81
88 GOSUB 16000:GOTO 81
90 PRINT "":PRINT "ENTER TIMING PARAMETERS MANUALLY?"
100 INPUT A$
110 IF LEFT$(A$,1)="N" GOTO 140
120 GOSUB 10000
130 GOTO 150
140 GOSUB 11000:REM PARM FROM DISK
150 FOR I=1 TO 5:SM(I)=1:NEXT I
160 PRINT " ":PRINT "SAMPLES ON POSITION?"
170 INPUT A$
180 IF LEFT$(A$,1)<>"N" GOTO 200
190 GOTO 160
200 PRINT " ":PRINT "MQ,BUFFER,ACID FILLED?"
210 INPUT A$
220 IF LEFT$(A$,1)<>"N" GOTO 240
230 GOTO 200
240 PRINT " ":PRINT "NITROGEN ON AND BELOW 20 PSI?"
250 INPUT A$
260 IF LEFT$(A$,1)="Y" GOTO 280
270 GOTO 240
280 PRINT " ":PRINT "ALL SAMPLE POSITIONS USED?"
290 INPUT A$
300 IF LEFT$(A$,1)<>"Y" GOTO 340
310 FOR I=1 TO 12:SM(I)=1:NEXT I
320 S1=12
330 GOTO 360
340 PRINT " ":PRINT "PLEASE ANSWER Y/N"
350 GOSUB 9000
360 PRINT " ":PRINT "READY TO START?"
370 INPUT A$
380 IF LEFT$(A$,1)<>"Y" GOTO 360
390 FOR I=1 TO 6:B1(I)=A1(I):NEXT
400 B1(3)=S1#A1(3)
410 TI$="000000":REM INIT TIMER
420 TT=A1(1)+A1(2)+S1#A1(3)+A1(4)+A1(5)+A1(6):REM TOTAL TIME REQUIRED
430 TL=TT:REM TIME LEFT
440 PRINT "J"
450 PRINT " ":PRINTTAB(27);A2$(4):PRINT " "
460 FOR I=1 TO 7

```

BOTTLE WITH MQ WATER"

```

470 PRINTA$(I):PRINT " ":NEXT I
480 GOSUB 2000:REM LOADING
490 GOSUB 3000:REM MQ WASH
500 GOSUB 4000:REM ACID ELUTION
510 GOSUB 5000:REM ACID WASH
520 GOSUB 6000:REM MQ BEFORE BUFFER
530 GOSUB 7000:REM BUFFER OR MQ WASH
540 PRINT " ":PRINT"ALL DONE
541 FOR I=1 TO 5:PRINT".T";CHR$(7);CHR$(15):FOR N=1 TO 100:NEXT N:NEXT I
550 GOSUB 16000:REM REENERGIZE VALVES AND RESET TIMER
560 PRINT " ":PRINT"NEXT BATCH?"
570 INPUT A$
580 IF LEFT$(A$,1)="Y" GOTO 600
590 END
600 PRINT " ":PRINTTAB(24);"MINUTES"
601 FOR I=1 TO 6:PRINTA$(I);TAB(24);SPC(2);A1(I):NEXT I
602 PRINT " ":PRINTA2$(A2);SPC(1);A2$(3)
605 PRINT " ":PRINT"NEW PARAMETERS?"
610 INPUT A$
620 IF LEFT$(A$,1)="Y" GOTO 80
630 GOSUB 16000:REM DEENERGIZE VALVES AND RESET TIMER
640 GOTO 160
2000 REM *****
2010 REM LOADING
2020 T1=TI
2030 C0(0)=1:FOR I=1 TO 47:C0(I)=0:NEXT I
2035 C0(44)=1:C0(45)=1
2040 GOSUB 15500
2050 PRINT".TT"
2060 J=1:GOSUB 17000
2070 IF T3<0 GOTO 2230
2080 C=0
2090 D=0
2100 SA=0:GOSUB 18000
2110 IF D1(2)=0 GOTO 2060:REM WATER BETWEEN SENSOR
2120 C=C+1
2130 D=D+1
2140 IF D<10 GOTO 2100
2150 IF C>60 GOTO 2190
2160 J=1:GOSUB 17000
2170 IF T3<0 GOTO 2230
2180 GOTO 2090
2190 PRINT".M"
2200 GOSUB 17190
2210 PRINT".TTT"
2220 GOTO 2330
2230 PRINTCHR$(7);"LOADING TIME RUN OUT; TYPE QCE TO CONTINUE";CHR$(15);".TTT"
2250 C=0
2260 SA=0:GOSUB 18000
2270 IF D1(2)=0 THEN C=0
2280 GET A$
2290 IF A$="C" GOTO 2320
2300 C=C+1
2310 IF C<60 GOTO 2260
2320 PRINTCHR$(15);".M";".TTT"
2330 J=1:TL=TL-B1(J)
2340 RETURN
3000 REM *****
3010 REM MQ WASH
3030 C0(0)=1:C0(1)=1:FOR I=2 TO 31:C0(I)=0:NEXT I

```



```

3835 FOR I=32 TO 47:C0(I)=1:NEXT I
3836 C0(44)=1:C0(45)=1
3840 GOSUB 15500
3845 T1=TI
3850 PRINT"7"
3860 J=2:GOSUB 17000
3870 IF T3>0 GOTO 3860
3871 C0(0)=1:FOR I=1 TO 47:C0(I)=0:NEXT I
3872 GOSUB 15500
3880 TL=TL-B1(J)
3890 RETURN
4000 REM *****
4010 REM ACID ELUTION
4020 C0(0)=1:FOR I=1 TO 47:C0(I)=0:NEXT I
4025 C0(44)=1:C0(45)=1
4030 PRINT"7"
4040 GOSUB 15500
4050 PRINT"7"
4060 FOR I5=1 TO 12
4070 IF S1(I5)=0 GOTO 4350
4080 C0(4)=1:C0(5)=1
4090 SA=0:GOSUB 15000:REM FILL UP ACID MENSURING RESERVOIR
4100 T1=TI
4105 J=3:GOSUB 17000:M=0:GOSUB 4500
4110 T2=TI
4120 IF T2-T1<60 GOTO 4110
4130 T2=TI
4140 IF T2-T1>A1(3)*3600 GOTO 4330
4145 IF T2-T1>1800 GOTO 4330
4150 SA=0:GOSUB 18000
4160 IF D1(1)=0 GOTO 4190
4170 J=3:GOSUB 17000
4175 M=0:GOSUB 4500
4180 GOTO 4130
4190 C0(4)=0:SA=0:GOSUB 15000:REM RESERVOIR TO CARTRIDGE
4210 C0(I5+7)=1:C0(I5+19)=1:C0(I5+31)=1:C0(5)=0:GOSUB 15500
4220 REM CARTRIDGE TO COLLECT, TO ACID, NITROGEN TO RESERVOIR
4230 T5=TI:REM STARTING TIMING ELUTION
4240 J=3:GOSUB 17000
4245 M=0:GOSUB 4500
4250 S=0:GOSUB 18000
4255 IF D1(3)=1 GOTO 4260:REM AMR EMPTY
4256 GOTO 4240
4260 TE=TI
4265 T2=TI:IF (T2-TE)/(TE-T5)>=0.1 GOTO 4280
4270 GOTO 4265
4280 C0(I5+7)=0:C0(I5+19)=0:C0(I5+31)=0
4290 FOR SA=1 TO 5:GOSUB 15000:NEXT SA:REM CARTRIDGE TO WASTE, TO MQ/BUFFER
4300 TL=TL-A1(3):B1(3)=B1(3)-A1(3)
4310 NEXT I5
4320 GOTO 4355
4330 PRINT"ACID FILLING PROBLEM ON #";I5;CHR$(15);"7"
4335 FOR I1=1 TO 10:PRINTCHR$(7);"7";CHR$(15)
4340 FOR I2=1 TO 50:NEXT I2:NEXT I1
4345 TL=TL-A1(3):B1(3)=B1(3)-A1(3)
4347 C0(4)=0:C0(5)=0:SA=0:GOSUB 15000
4350 NEXT I5
4355 M=1:GOSUB 4500
4357 C0(0)=1:FOR I=1 TO 47:C0(I)=0:NEXT I:GOSUB 15500
4360 RETURN

```

```

4500 J=3:J1=7-J
4510 FOR I=1 TO J1:PRINT"TTT":NEXT I
4515 IF M=1 GOTO 4525
4520 PRINT"J";"XXXXXXXXXXXXXXXXXXXXX";I5;CHR$(15)
4521 GOTO 4530
4525 PRINT"J";"XXXXXXXXXXXXXXXXXXXXX";"                ";CHR$(15)
4530 FOR I=1 TO J1:PRINT"M":NEXT I
4540 RETURN
5000 REM *****
5010 REM ACID WASH
5020 C0(0)=1:FOR I=1 TO 7:C0(I)=0:NEXT I:C0(6)=1
5030 FOR I=8 TO 19:C0(I)=0:NEXT I
5040 FOR I=20 TO 47:C0(I)=1:NEXT I
5045 C0(44)=1:C0(45)=1
5050 GOSUB 15500
5070 T1=TI
5080 PRINT"J"
5090 J=4:GOSUB 17000
5100 IF T3>0 GOTO 5090
5110 C0(6)=0:FOR I=20 TO 47:C0(I)=0:NEXT I
5120 FOR SA=0 TO 5:GOSUB 15000:NEXT SA
5130 TL=TL-B1(J)
5140 RETURN
6000 REM *****
6010 REM MQ BEFORE (BUFFER/MQ)
6020 C0(0)=1:C0(1)=1:FOR I=2 TO 7:C0(I)=0:NEXT I
6025 FOR I=8 TO 31:C0(I)=0:NEXT I:FOR I=32 TO 47:C0(I)=1:NEXT I
6026 C0(44)=1:C0(45)=1
6030 GOSUB 15500
6040 T1=TI
6050 PRINT"J"
6060 J=5:GOSUB 17000
6070 IF T3>0 GOTO 6060
6080 C0(0)=1:FOR I=1 TO 47:C0(I)=0:NEXT I:GOSUB 15500
6090 TL=TL-B1(J)
6100 RETURN
7000 REM *****
7010 REM BUFFER OR MQ
7020 C0(0)=1
7030 IF A2=1 GOTO 7060
7040 C0(1)=1:C0(2)=0:REM MQ WASH
7050 GOTO 7070
7060 C0(1)=0:C0(2)=1:REM BUFFER WASH
7070 FOR I=4 TO 31:C0(I)=0:NEXT I
7075 FOR I=32 TO 47:C0(I)=1:NEXT I
7076 C0(44)=1:C0(45)=1
7080 GOSUB 15500
7085 T1=TI
7090 J=6:GOSUB 17000
7100 IF T3>0 GOTO 7090
7110 C0(1)=0:C0(2)=0:FOR I=32 TO 47:C0(I)=0:NEXT I
7120 GOSUB 15500
7130 TL=TL-B1(J)
7135 GOSUB 17250
7140 RETURN
9000 REM *****
9010 REM INPUT SAMPLE #
9020 S1=0:FOR I=1 TO 12
9030 PRINT"SAMPLE #";I
9040 INPUT A#

```

```

9050 IF LEFT$(A$,1)="Y" GOTO 9100
9060 SM(I)=0
9070 GOTO 9200
9100 SM(I)=1:S1=S1+1
9200 NEXT I
9210 FOR I=1 TO 12
9220 A$=" ":IF SM(I)=1 THEN A$="*"
9230 PRINT"SAMPLE #";I;TAB(12);A$:NEXT I
9240 PRINT"YES OR NO"
9250 INPUT A$
9260 IF LEFT$(A$,1)="Y" THEN RETURN
9270 GOTO 9020
10000 REM #####
10010 REM INPUT PARAMETERS MANUALLY
10020 A1(1)=25:A1(2)=2:A1(3)=2
10030 A1(4)=2:A1(5)=1:A1(6)=2
10040 A2=1
10050 PRINT " ":PRINT"DEFAULT VALUE FOR";TAB(24);"MINUTES"
10055 GOSUB 10060
10060 GOTO 10110
10060 FOR I=1 TO 6
10070 PRINTA1$(I);TAB(24);SPC(2);A1(I):NEXT I
10080 PRINT " ":PRINTA2$(A2);SPC(1);A2$(3)
10090 PRINT " ":PRINT"YES OR NO?"
10100 INPUT A$
10105 RETURN
10110 IF LEFT$(A$,1)="N" THEN GOTO 10160
10120 PRINT " ":PRINT"SAVE PARAMETERS TO A DISK?"
10130 INPUT A$
10140 IF LEFT$(A$,1)="Y" THEN GOSUB 13000
10150 RETURN
10160 FOR I=1 TO 6
10170 PRINTA1$(I);SPC(1);A1$(10):INPUT A:A1(I)=A
10180 NEXT
10190 PRINT"1:BUFFER WASH 2:MQ WASH"
10200 INPUT A2
10205 IF A2=1 GOTO 10210:IF A2=2 GOTO 10210
10206 GOTO 10190
10210 GOTO 10050
11000 REM #####
11010 REM LOADING PARAMETERS FROM DISK
11015 GOSUB 11020
11016 GOTO 11070
11020 PRINT"FILE NAME:"
11030 INPUT A$
11040 PRINT"DRIVE #:"
11050 INPUT E$
11060 DI$=D$+E$
11065 RETURN
11070 OPEN 1,8,8,DI$+" "+A$+",SEQ,READ"
11080 FOR I=1 TO 6:INPUT#1,A1(I):NEXT I
11085 INPUT#1,A2:DCLOSE#1
11090 PRINT " ":PRINTTAB(24);"MINUTES"
11100 GOSUB 10060:REM PRINT PARAMETERS, GET YES OR NO
11110 IF LEFT$(A$,1)="Y" THEN RETURN
11120 GOTO 11020
12000 REM #####
12010 REM DEFINITIONS
12020 A1$(1)="LOADING"
12030 A1$(2)="MQ WASH"

```

```

12040 A1$(3)="ACID ELUTION"
12050 A1$(4)="ACID WASH"
12060 A1$(5)="MQ WASH BEFORE BUFFER/MQ"
12065 A1$(7)="TOTAL TIME LEFT : "
12070 A1$(6)="BUFFER/MQ WASH"
12080 A1$(10)="TIME (MINUTES)"
12090 A2$(1)="BUFFER WASH"
12100 A2$(2)="MQ WASH"
12110 A2$(3)="FOR NEXT RUN"
12115 A2$(4)="TIME LEFT"
12120 SN=12
12130 DIM SM(12)
12135 DIM C0(48)
12136 C1(0)=.5
12137 FOR I=1 TO 8:C1(I)=C1(I-1)*2:NEXT I
12138 FOR I=1 TO 8:NEXT
12140 RETURN
13000 GOSUB 11020:REM INPUT DRIVE# AND FILE NAME
13010 OPEN 1,8,8,DI$+"": "+A$+",SEQ,WRITE"
13020 FOR I=1 TO 6:PRINT#1,A1(I):NEXT I
13030 PRINT#1,A2
13040 DCLOSE#1
13050 RETURN
15000 REM *****
15010 REM WRITE CONTROL SIGNALS TO TIPC
15020 C=SA#8
15030 D=0:E=1
15040 FOR I=C TO C+7:D=C0(I)*C1(E)+D:E=E+1:NEXT I
15050 OPEN 6,6,SA
15060 PRINT#6,CHR$(D)
15070 CLOSE 6
15080 RETURN
15500 FOR SA=1 TO 5:GOSUB 15000:NEXT SA
15510 SA=0:GOSUB 15000
15520 RETURN
16000 REM *****
16001 PRINT " ":PRINT"DEENERGIZE VALVES"
16010 FOR I=0 TO 47:C0(I)=0:NEXT I:REM DEENERGIZE VALVES
16015 TI$="000000"
16020 GOSUB 15500
16030 RETURN
17000 REM *****
17010 REM PRINT LEFT TIME
17020 T2=TI
17030 T=T2-T1
17040 T3=B1(J)*60*60-T
17050 S=INT(T/60)
17060 M=S/60:M1=TL-M:M2=INT(M1):S1=INT(C0*(M1-M2)+.4)
17070 S3=INT(T3/60):S3=S3+1:M3=INT(S3/60):S4=INT(S3-60*M3)
17080 REM PRINT"S";S;"M";M;"M1";M1:PRINT"M2";M2;"S1";S1
17090 IF T3<=0 GOTO 17190
17100 PRINT".T";"XXXXXXXXXXXXXXXXXXXXXXXXXXXX";" ";CHR$(15)
17110 PRINT".T";"XXXXXXXXXXXXXXXXXXXXXXXXXXXX";M2;" ";S1;CHR$(15)
17120 J1=7-J
17130 FOR I=1 TO J1:PRINT".TT":NEXT I
17140 PRINT".T"
17150 GOSUB 17250
17160 PRINT".T";"XXXXXXXXXXXXXXXXXXXXXXXXXXXX";M3;" ";S4;CHR$(15)
17170 FOR I=1 TO J1:PRINT".X":NEXT I
17180 RETURN

```

```

17190 GOSUB 17250
17200 J1=7-J:FOR I=1 TO J1:PRINT".TTT":NEXT I
17210 PRINT".T"
17220 GOSUB 17250
17230 FOR I=1 TO J1:PRINT".W":NEXT I
17240 RETURN
17250 PRINT".T";"#####";"                ";CHR$(15)
17260 RETURN
18000 REM #####
18010 REM READING STATUS
18020 OPEN 6,6,SA
18030 GET#6,A$
18035 CLOSE 6
18040 IF A$<CHR$(0) GOTO 18070
18050 A=ASC(A$)
18060 GOTO 18080
18070 A=0
18080 GOSUB 18500
18090 RETURN
18500 REM #####
18510 REM CONVERTS A NUMBER TO INDIVIDUAL BITS
18511 C1(0)=.5
18512 FOR I=1 TO 8:C1(I)=C1(I-1)*2:NEXT I
18520 FOR I=0 TO 7
18530 J=7-I:I1=J+1
18540 D1(J)=INT(A/C1(I1))
18550 A=A-D1(J)*C1(I1)
18560 NEXT I
18570 RETURN
19000 PRINT".CONTROL INDIVIDUAL VALVE BY KEYBOARD":PRINT""
19010 PRINT".ENTER VALVE STATUS FROM DISK?"
19020 INPUT A$
19030 IF A$="Y" GOTO 19500
19040 FOR I=0 TO 47:C0(I)=0:NEXT I
19050 GOSUB 19051:GOTO 19070
19051 GOSUB 19300
19055 PRINT""
19060 PRINT".ENTER VALVE # OR TYPE ## TO EXECUTE, ## TO SAVE.";
19061 PRINT".## TO CONTINUE CHANGING, ## TO STOP"
19062 PRINT".## TO LOAD, ## TO EXIT"
19063 RETURN
19070 INPUT A$
19075 PRINT"":PRINT".T"
19080 IF A$="E" GOTO 19200
19081 IF A$="S" GOTO 19600
19082 IF A$="X" GOTO 81
19083 IF A$="L" GOTO 19500
19084 IF A$="C" GOTO 19700
19089 IF A$="0" GOTO 19095
19090 A=VAL(A$)
19091 IF A=0 GOTO 19126
19092 GOTO 19100
19095 A=0:GOTO 19110
19100 IF A<0 OR A>47 GOTO 19126
19110 IF C0(A)=0 GOTO 19125
19120 C0(A)=0:B=0:GOTO 19126
19125 C0(A)=1:B=1
19126 PRINT".TTTTTTTTTTTT"
19130 GOTO 19050
19200 GOSUB 15300:PRINT".T":GOTO 19070

```

```

19300 PRINT"":PRINT"0:OFF 1:ON"
19310 PRINT " "
19320 PRINT" 0- 7 " ;:FOR I=0 TO 7:PRINTC0(I);:NEXT I:PRINT""
19330 PRINT" 8-15 " ;:FOR I=8 TO 15:PRINTC0(I);:NEXT I:PRINT""
19340 PRINT"16-23 " ;:FOR I=16 TO 23:PRINTC0(I);:NEXT I:PRINT""
19350 PRINT"24-31 " ;:FOR I=24 TO 31:PRINTC0(I);:NEXT I:PRINT""
19360 PRINT"32-39 " ;:FOR I=32 TO 39:PRINTC0(I);:NEXT I:PRINT""
19370 PRINT"40-47 " ;:FOR I=40 TO 47:PRINTC0(I);:NEXT I:PRINT""
19380 RETURN
19500 GOSUB 11020
19510 OPEN 1,8,8,DI$+"":+"A$+",SEQ,READ"
19520 FOR I=0 TO 47:INPUT#1,C0(I):NEXT I
19530 CLOSE 1
19531 PRINT"XXXXXXXX":GOTO 19050
19600 GOSUB 11020:REM INPUT DRIVE# AND FILE NAME
19610 OPEN 1,8,8,DI$+"":+"A$+",SEQ,WRITE"
19620 FOR I=0 TO 47:PRINT#1,C0(I):NEXT I
19630 CLOSE 1
19640 GOTO 19531
19700 PRINT" .T)"
19705 GET A$:IF A$="Q" GOTO 19800
19730 A=A+1:IF A>=48 GOTO 19800
19740 C0(A)=B:PRINTA
19750 PRINT".TTTTTTTTTTTTTTTT":GOSUB 19051:GOTO 19705
19800 PRINT" ISEETTTTTTTTTTTTTTTT":GOTO 19050
21000 PRINT"CFILL FILTER AND TUBING TO SAMPLE BOTTLE WITH MQ WATER"
21010 GOSUB 16000:REM DEENERGIZE VALVES AND RESET TIMER
21020 GOSUB 15500
21030 PRINT"":PRINT"INPUT TIME DELAY (SEC) FOR FILLING UP"
21040 INPUT A
21045 C0(7)=1:FOR I=32 TO 43:C0(I)=1:NEXT I
21046 GOSUB 15500
21050 T=TI
21060 GET A$
21070 IF A$="X" GOTO 21500
21080 IF TI>T+60*A GOTO 21500
21090 GOTO 21060
21500 GOTO 80

```

Unclassified

SECURITY CLASSIFICATION OF THIS PAGE (When Data Entered)

REPORT DOCUMENTATION PAGE		READ INSTRUCTIONS BEFORE COMPLETING FORM
1. REPORT NUMBER	2. GOVT ACCESSION NO.	3. RECIPIENT'S CATALOG NUMBER
4. TITLE (and Subtitle) DEVELOPMENT OF A COMPUTER CONTROLLED TRACE METAL PRECONCENTRATOR: I. SYSTEM DESCRIPTION AND DESIGN, AUGUST 1983		5. TYPE OF REPORT & PERIOD COVERED Technical Report
		6. PERFORMING ORG. REPORT NUMBER
7. AUTHOR(s) C.C. Lee, Richard W. Zuehlke and Dana R. Kester		8. CONTRACT OR GRANT NUMBER(s) N00014-81-C-0062
9. PERFORMING ORGANIZATION NAME AND ADDRESS Graduate School of Oceanography University of Rhode Island Kingston, RI 02881		10. PROGRAM ELEMENT, PROJECT, TASK AREA & WORK UNIT NUMBERS
11. CONTROLLING OFFICE NAME AND ADDRESS Office of Naval Research 800 North Quincy Street Arlington, VA 22217		12. REPORT DATE October 1983 AUGUST
		13. NUMBER OF PAGES 34
14. MONITORING AGENCY NAME & ADDRESS (if different from Controlling Office)		15. SECURITY CLASS. (of this report) Unclassified
		15a. DECLASSIFICATION/DOWNGRADING SCHEDULE
16. DISTRIBUTION STATEMENT (of this Report) Approved for public release; distribution unlimited		
17. DISTRIBUTION STATEMENT (of the abstract entered in Block 20, if different from Report)		
18. SUPPLEMENTARY NOTES		
19. KEY WORDS (Continue on reverse side if necessary and identify by block number) Computer control Preconcentrator IEEE-488 interface 8-hydroxyquinoline Trace metal Seawater		
20. ABSTRACT (Continue on reverse side if necessary and identify by block number) The first part of this report describes the hardware and software design of a multiple sample automatic preconcentrator (MSAP). The MSAP is primarily designed to preconcentrate trace metals in seawater. Chromatographic cartridges using chemically bonded 8-hydroxyquinoline on silica gel are employed to extract dissolved transition and heavy metals. Fluid flow through the system is controlled by nitrogen gas pressure at 5-15 psi using a series of two-way and three-way solenoid valves that are controlled by a CBM 4016 microcomputer through its IEEE-488 interface bus.		

DD FORM 1473

JAN 73

EDITION OF 1 NOV 65 IS OBSOLETE
S/N 0102-014-6601

Unclassified

SECURITY CLASSIFICATION OF THIS PAGE (When Data Entered)

MANDATORY DISTRIBUTION LIST

FOR UNCLASSIFIED TECHNICAL REPORTS, REPRINTS, & FINAL REPORTS
PUBLISHED BY OCEANOGRAPHIC CONTRACTORS
OF THE OCEAN SCIENCE AND TECHNOLOGY DIVISION
OF THE OFFICE OF NAVAL RESEARCH
(REVISED NOV 1978)

1 Deputy Under Secretary of Defense
(Research and Advanced Technology)
Military Assistant for Environmental Science
Room 3D129
Washington, DC 20301

Office of Naval Research
800 North Quincy Street
Arlington, VA 22217

3 ATTN: Code 483
1 ATTN: Code 460
2 ATTN: 102B

Commanding Officer
Naval Research Laboratory
Washington, DC 20375
6 ATTN: Library, Code 2627

12 Defense Documentation Center
Cameron Station
Alexandria, VA 22314
ATTN: DCA

Commander
Naval Oceanographic Office
NSTL Station
Bay St. Louis, MS 39522

1 ATTN: Code 8100
1 ATTN: Code 6000
1 ATTN: Code 3300

1 NODC/NOAA
Code D781
Wisconsin Avenue, N.W.
Washington, DC 20235

END

FILMED

11-83

DTIC