

AD-A133 688

CARBON DIOXIDE SENSOR TECHNOLOGY(U) BATTELLE COOUMBUS  
LABS OH A A BOIARSKI ET AL. APR 83 NCSC-CR-102-83  
N61331-82-C-0024

1/1

UNCLASSIFIED

F/G 6/11

NL

NCSC

END

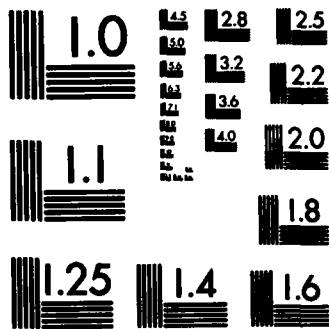

MICROCOPY RESOLUTION TEST CHART  
NATIONAL BUREAU OF STANDARDS-1963-A

AD F200 074

5

# NCSC

AD-A133688  
NCSC CR 102-83

Contractor Report 102-83

NCSC CR 102-83

## CARBON DIOXIDE SENSOR TECHNOLOGY

A.A. BOIARSKI, P.P. BALOG,  
R.H. BARNES, H.J. BYKER,  
G.B. GAINES, P.S. RIEGEL

DTIC  
ELECTE  
SEP 7 1983  
S D

BATTELLE COLUMBUS LABS.  
Approved for public release; distribution unlimited

DTIC FILE COPY



APRIL 1983

NAVAL COASTAL SYSTEMS CENTER  
PANAMA CITY, FLORIDA 32407



NAVAL COASTAL SYSTEMS CENTER, PANAMA CITY, FL 32407

AN ACTIVITY OF THE NAVAL MATERIAL COMMAND



**CAPT RAYMOND D. BENNETT, USN**  
Commanding Officer

**GUY C. DILWORTH**  
Technical Director

### ADMINISTRATIVE INFORMATION

This report was produced under Contract N61331-82-C-0024 as a portion of the effort on Project S0394-SL, Program Element 63702N, and Task 23924 sponsored by NAVSEA 05R4.

Released by  
J. W. Grimes, Jr., Head  
Diving, Salvage and Ship Husbandry  
Branch

Under authority of  
W. T. Odum, Head  
Diving and Coastal Systems  
Division

UNCLASSIFIED

SECURITY CLASSIFICATION OF THIS PAGE (When Data Entered)

REPORT DOCUMENTATION PAGE		READ INSTRUCTIONS BEFORE COMPLETING FORM
1. REPORT NUMBER NCSC CR 102-83	2. GOVT ACCESSION NO. ADA133 688	3. RECIPIENT'S CATALOG NUMBER
4. TITLE (and Subtitle) Carbon Dioxide Sensor Technology		5. TYPE OF REPORT & PERIOD COVERED Final
		6. PERFORMING ORG. REPORT NUMBER
7. AUTHOR(s) A. A. Boiarski, P. P. Balog, R. H. Barnes, H. J. Byker, G. B. Gaines, P. S. Riegel		8. CONTRACT OR GRANT NUMBER(s) N61331-82-C-0024
9. PERFORMING ORGANIZATION NAME AND ADDRESS Battelle Columbus Labs. 505 King Ave. Columbus, OH 43201		10. PROGRAM ELEMENT, PROJECT, TASK AREA & WORK UNIT NUMBERS PE63702N, Project S0394-SL, Task 23924
11. CONTROLLING OFFICE NAME AND ADDRESS Naval Coastal Systems Center Panama City, FL 32407		12. REPORT DATE April 1983
		13. NUMBER OF PAGES 82
14. MONITORING AGENCY NAME & ADDRESS (if different from Controlling Office)		15. SECURITY CLASS. (of this report)  UNCLASSIFIED
		15a. DECLASSIFICATION/DOWNGRADING SCHEDULE N/A
16. DISTRIBUTION STATEMENT (of this Report)  Approved for public release; distribution unlimited		
17. DISTRIBUTION STATEMENT (of the abstract entered in Block 20, if different from Report)		
18. SUPPLEMENTARY NOTES		
19. KEY WORDS (Continue on reverse side if necessary and identify by block number)  Sensor Carbon Dioxide Underwater Breathing Apparatus Swimmer Diver		
20. ABSTRACT (Continue on reverse side if necessary and identify by block number)  The current state of the art of carbon dioxide sensing technology was examined in this task. It was found that no current system can meet the desired requirements. However, several approaches were identified which show promise. The overall summary of approach used to identify the promising sensor concepts is provided in this section along with the basic conclusions that were reached regarding available sensor techniques. Overall recommendations are also summarized below to provide NCSC guidance regarding their consideration of future efforts.		

DD FORM 1473  
1 JAN 73

EDITION OF 1 NOV 68 IS OBSOLETE

S/N 0102-LF-014-6601

SECURITY CLASSIFICATION OF THIS PAGE (When Data Entered)

TABLE OF CONTENTS

	<u>Page</u>
INTRODUCTION . . . . .	1
SUMMARY. . . . .	2
Overall Approach. . . . .	2
Conclusions . . . . .	3
Recommendations . . . . .	5
TECHNICAL DISCUSSION . . . . .	7
Sensor Characteristics. . . . .	7
Concept Identification. . . . .	10
Literature, Patents, Manufacturers . . . . .	10
Literature Search . . . . .	10
Patents . . . . .	12
Manufacturers and R&D Groups. . . . .	12
Initial Screening . . . . .	13
Analysis of Selected Concepts . . . . .	16
Electrochemical CO <sub>2</sub> Detectors. . . . .	17
pH Type of Detector . . . . .	19
Electrodialysis Detector. . . . .	20
Reduced CO <sub>2</sub> Detector. . . . .	22
Nonaqueous Amperometric Detector. . . . .	22
Conductivity Detector . . . . .	24
High Temperature Electrolyte Detector . . . . .	24
Conclusions and Recommendations (Electrochemical) . . . . .	25

Accession For	
NTIS GRA&I	<input checked="" type="checkbox"/>
DTIC TAB	<input type="checkbox"/>
Unannounced	<input type="checkbox"/>
Justification	
By _____	
Distribution/	
Availability Codes	
Dist	Avail and/or Special
A	



PREVIOUS PAGE IS BLANK

TABLE OF CONTENTS

(Continued)

	<u>Page</u>
Infrared Absorption. . . . .	28
Operating Principles. . . . .	28
Commercially Available Devices. . . . .	34
Recommended Design. . . . .	36
Conclusions and Recommendations (IR Absorption) . . . .	38
Gas Sensors Based on Interaction of Gas with Solid Surface .	40
Prototype Configurations and Operating. . . . .	42
Principles of Surface Gas Sensors	
The Figaro Type. . . . .	42
The FET Type . . . . .	45
Conclusions and Recommendations (Solid State) . . . . .	49
Coated Piezoelectric Crystals. . . . .	50
Previous Efforts. . . . .	50
Estimated Sensor Characteristics. . . . .	52
Conclusions and Recommendations (Piezoelectric) . . . .	61
Surface Acoustic Wave (SAW) Devices. . . . .	62
Previous Efforts. . . . .	63
Estimated Operating Characteristics . . . . .	65
Conclusions and Recommendations (SAW) . . . . .	68
Calorimetric Technique . . . . .	68
Estimated Sensor Characteristics. . . . .	69
Conclusions and Recommendations (Calorimetric). . . . .	70

## TABLE OF CONTENTS

(Continued)

	<u>Page</u>
Miscellaneous Methods. . . . .	72
Chemical Change . . . . .	72
Conclusions and Recommendations (Chemical Change). . . . .	73
Complex Impedance Effects . . . . .	73
Conclusions and Recommendations (Complex Impedance) . . . . .	74
REFERENCES . . . . .	75

## LIST OF TABLES

Table 1. Desired Sensor Properties. . . . .	8
Table 2A. Candidate Sensor Techniques. . . . .	14
Selected for Further Analysis	
Table 2B. Candidate Sensor Techniques. . . . .	15
Eliminated in Initial Screening	
Table 3. Estimated Characteristics of . . . . .	26
Electrochemical CO <sub>2</sub> Detectors	
Table 4. Commercial Sources of Infrared CO <sub>2</sub> Sensors . . . . .	35
Table 5. Summary of Potential Capabilities of IR Sensor . . . . .	39
for Monitoring CO <sub>2</sub> in Diver's Breathing Air	
Table 6. Parameter Estimates for Figaro- and FET Sensors. . . . .	46
with Respect to the Detection of Carbon Dioxide	
Table 7. Piezoelectric Crystal Coatings and Performance Data. . . . .	53-55
Table 8. Summary of Piezoelectric Properties not. . . . .	60
Listed in Table 7.	
Table 9. SAW Characteristics. . . . .	67
Table 10. Summary of Properties for Calorimetric. . . . .	71
Sensor System	



TABLE OF CONTENTS

(Continued)

	<u>LIST OF FIGURES</u>	<u>Page</u>
Figure 1.	Schematic Diagram for Several Types of Electrochemical Detectors of CO <sub>2</sub> in Gases . . . . .	18
Figure 2.	Schematic Diagram of CO <sub>2</sub> Detector Using Electrodialysis . . . . .	21
Figure 3.	Schematic Diagram of Current Measuring Detector of CO <sub>2</sub> and O <sub>2</sub> . . . . .	23
Figure 4.	Infrared Absorption Spectra for Gaseous Carbon Dioxide and Water Vapor . . . . .	29
Figure 5.	Schematic Design for Portable Hyperbaric Infrared CO <sub>2</sub> Sensor . . . . .	37
Figure 6.	Structural Specifications of Figaro Device. . . . .	44
Figure 7.	Schematic of FET-Type Sensor (taken from U.S. Patent 3,999,122) . . . . .	48
Figure 8.	Enlarged View of an Individual Quartz Resonator . . . . .	51
Figure 9.	Glass Gas-Tight Piezoelectric Crystal, Side View. . . . .	57
Figure 10.	Typical Piezoelectric Crystal Holder. . . . .	58
Figure 11.	Details of a Typical Detector Cell Design . . . . .	59
Figure 12.	Coated Surface Acoustic Wave (SAW) Device . . . . .	64

## INTRODUCTION

Carbon Dioxide Sensor Technology, a report prepared by Battelle Memorial Institute and sponsored by the Naval Coastal Systems Center (NCSC), examines the concepts available to measure the amount of carbon dioxide ( $\text{CO}_2$ ) in an underwater breathing apparatus (UBA).

The Navy pioneered mixed-gas diving in the 1920's with the introduction of the helium-oxygen helmet, followed by the development of the closed-circuit oxygen rebreather, several semiclosed-circuit devices, and oxygen-controlled closed circuit rigs. In the rebreathing apparatus, consumed oxygen must be made up in the breathing gas and  $\text{CO}_2$  must be removed (i.e. scrubbed out). Control of oxygen level is monitored by small sensors which are available in several UBA systems. Confidence has been established due to their reliable record of operation.

$\text{CO}_2$ , a colorless, odorless, incombustible gas, formed during respiration, is safe to breathe at levels below 1 mm-Hg. However no equipment exists which the diver may use that indicates when the scrubber is inoperative and  $\text{CO}_2$  levels become dangerous. Instead, the scrubber is tested and statistical methods are used to estimate the length of time it may be expected to function properly. Although generally accurate, injuries and deaths occur, which may be prevented by the use of a sensor which accurately gauges the level of  $\text{CO}_2$ .

There are devices to measure the concentration of  $\text{CO}_2$  in a gas stream. However, the available units are too large to be used by the diver, are designed for use at atmospheric pressure, or are too fragile for deep sea use. Changing temperature, pressure, diver orientation, moisture, diluent gases and other practical realities of diving complicate the measurement and must be considered in the overall sensor system strategy.

The present study addresses the state of current sensor technology applicable to  $\text{CO}_2$  monitoring in a diver's breathing gas. A summary of Battelle's approach with overall conclusions and recommendations is first presented. Detailed discussions of candidate sensor concepts is then given to support the overall conclusions and recommendations.

## SUMMARY

The current state of the art of carbon dioxide sensing technology was examined in this task. It was found that no current system can meet the desired requirements. However, several approaches were identified which show promise. The overall summary of approach used to identify the promising sensor concepts is provided in this section along with the basic conclusions that were reached regarding available sensor techniques. Overall recommendations are also summarized below to provide NCSC guidance regarding their consideration of future efforts.

### OVERALL APPROACH

In the present study a team approach was used to survey existing and emerging technologies to identify sensor concepts for monitoring CO<sub>2</sub> in a diver's breathing gas. This team consisted of researchers knowledgeable in overall measurement technology and also particularly well versed in a specific class of sensors applicable to the CO<sub>2</sub> measurement area. Desired sensor characteristics were reviewed and various sources of information examined by team members. These sources include report and journal literature, patents, manufacturers' data, and recorded personal contacts with researchers from various organizations. Following an initial screening, selected concepts were examined in greater detail to determine how each candidate sensor concept ranked relative to the desired sensor characteristics. This process identified any shortcomings that existed in the various technologies and what might be done to overcome these shortcomings. Following the detailed analysis and evaluation, conclusions and recommendations were derived for each candidate concept.

Individual team member results were then collated and general discussions by all researchers involved resulted in a summary of the conclusions and recommendations which are provided in the following text.

### CONCLUSIONS

Based on a review of the current state-of-the-art in CO<sub>2</sub> sensors, it was found that no off-the-shelf sensor systems currently exist for monitoring CO<sub>2</sub> content of a diver's breathing gas. In fact, for all concepts reviewed in this study, further testing, engineering, or basic component development were required.

Another important conclusion is that current work abroad may eventually provide a suitable sensor system at no additional development costs to the U.S. Navy. It was found that Heriot-Watt University's Institute of Offshore Engineering in Edinburgh, Scotland is developing an infrared device for hyperbaric environments. A diving-bell version of their device is in the final marketing development stage at the present time and will be available for evaluation in the near future. Based upon Heriot-Watt's plans, it appears likely that they will proceed to further miniaturize this latter device for eventual use in UBA back pack applications.

A final conclusion, which resulted from this technology review effort, is that several other sensor concepts exist which could be further developed via U.S. Navy funding. This additional development effort would likely provide the U.S. Navy with the required CO<sub>2</sub> diving gas monitor prior to and independent of the Heriot-Watt effort. It was found that these promising sensor technologies could be grouped into the general categories of primary and backup techniques.

The primary technology identified during the present study is an electrochemical technique (i.e. nonaqueous amperometric method) which determines both CO<sub>2</sub> and O<sub>2</sub> simultaneously using a current measuring approach. CO<sub>2</sub> is consumed in the process so response time problems associated with previous electrochemical devices are absent in this new sensor technique. Engineering design must be undertaken to obtain minor improvements to the technique sensitivity, and to ruggedize the sensor for hyperbaric conditions. Proof-testing must also be undertaken for conditions of interest.

Several back-up technologies were also identified during the course of this technology review effort. These concepts are all theoretically sound and it was difficult to determine absolutely, at this time, which order of preference should be attached to these back-up sensor concepts. However, the authors have attempted to perform this ranking using the best current knowledge. The concluding ranking is listed as follows:

- (1) Electrochemical technique based on electro-dialysis principle
- (2) Calorimetric method
- (3) Electrochemical technique based on conductivity principle
- (4) Piezoelectric microbalance
- (5) Surface Acoustic Wave (SAW) device

The first three back-up technologies require some engineering and proof-testing but no basic research is required. However, for the latter two devices, a special coating must also be developed which is both sensitive and selective to CO<sub>2</sub>.

### RECOMMENDATIONS

Based on the above conclusions, the following recommendations are made to NCSC regarding the area of carbon dioxide sensor technology.

Since no sensor system for monitoring CO<sub>2</sub> content of a diver's breathing air is available at this time, an overall recommendation is that further action be taken by the Navy to fulfill this important sensor requirement. In some cases this action can be indirect (i.e. maintaining cognizance of work performed by others). However, in other cases the action must be direct funding of further development efforts.

The Navy should definitely stay abreast of the CO<sub>2</sub> sensor development efforts at Heriot-Watt University. NCSC should consider the purchase of a diving-bell version of their instrument for evaluation in hyperbaric environments of interest to the U.S. Navy. The results of this evaluation should be provided to Heriot-Watt for their consideration and use in any modification efforts. If Heriot-Watt is successful in developing a diving back pack version of this instrument and their tests are positive, the Navy should then evaluate this latter device as a possible sensor system that would meet the present NCSC criteria for CO<sub>2</sub> monitoring of a diver's breathing gas.

It is further recommended that the U.S. Navy fund one or more efforts to develop a CO<sub>2</sub> diver's gas monitor that operates on a different principle than the Heriot-Watt device. As a primary device, the Navy should proceed to develop an electrochemical sensor concept based upon the nonaqueous amperometric principle mentioned above and discussed in greater detail in the body of this report. If desired, there are several back-up technologies that could also be pursued in parallel with the primary concept, or following an evaluation of the primary development efforts. The authors would recommend the following efforts be undertaken by the U.S. Navy, in order of priority, as back-up strategies to the successful and timely development of a suitable CO<sub>2</sub> sensor:

- (1) Feasibility study to identify which one of the following three concepts would be most likely to succeed in providing a back-up sensor (i.e. Electrolysis/electrochemical, Calorimetric, Conductivity/electrochemical).
- (2) Feasibility study to test several likely CO<sub>2</sub> sensitive/selective coatings that would be applicable to Piezoelectric microbalance and SAW sensor technology.

## TECHNICAL DISCUSSION

Technical efforts in this CO<sub>2</sub> sensor review program were focused on three major areas:

- (1) Formulation of desired sensor characteristics
- (2) Sensor concept identification
- (3) Analysis of selected concepts.

These efforts are discussed in detail below and serve to substantiate statements made in the previous summary of conclusions, and recommendation sections.

### SENSOR CHARACTERISTICS

The desired characteristics of a CO<sub>2</sub> sensor for hyperbaric applications are, in general, set by the severe environment in which a diver must operate. However, other factors must also be considered. A list of these desired characteristics which were used in the present sensor evaluation study is given in Table 1.

Based upon the physiological effects experienced by humans exposed to CO<sub>2</sub>, the partial pressure measurement range was set at 0.4 - 4 mm Hg. This range could perhaps be narrowed somewhat since 4 mm Hg (.005 ATA) represents the upper bound, and the 0.4 mm Hg figure is somewhat arbitrary.

The accuracy requirements were somewhat arbitrarily selected at  $\pm 0.1$  mm Hg, which is a good goal for laboratory simulations, but this accuracy may not be reached in practical diving situations. To obtain these desired accuracies is, however, a worthwhile goal and techniques that are sensitive to small changes in CO<sub>2</sub> content at low overall CO<sub>2</sub> levels must be considered to be more advantageous.



TABLE 1. DESIRED SENSOR PROPERTIES

- 
- A. CO<sub>2</sub> measurement range: 0.4 mm - 4 mm Hg partial pressure (0.05 - 0.5% @ 1 atm.) Serious physiological problems occur near 20 mm Hg pressure (i.e. 3% @ 1 atm.)
  - B. Accuracy:  $\pm$  0.1 mm Hg (2.5% @ 4 mm Hg).
  - C. Specificity: Output not significantly affected by H<sub>2</sub>O vapor, O<sub>2</sub>, N<sub>2</sub>, or He.
  - D. Response time: 63% of final output in 10 - 30 seconds.
  - E. Operating temperature range: -2 to 35° C.
  - F. Operating pressure range: 1 - 20 atm.
  - G. Humidity effects: 0 to 100% relative humidity.
  - H. Compression/decompression effects: pressure changes of 3 atm/minute. (i.e. minimal dissolved gas problems)
  - I. Sensor system weight/volume: 1 Kg/1200 cm<sup>3</sup>.
  - J. Power requirements: <5 watts (battery life  $\approx$  1 month).
  - K. Calibration requirements: minimal.
  - L. EMI generated: minimal.
  - M. Sensor life: 500 diving hrs minimal (indefinite shelf life).
  - N. Reliability: high.
  - O. Risk associated with development: moderate.
  - P. Cost of development: reasonable (approximately 2-3 man years).
  - Q. Production unit cost: < \$10,000 desirable (100-1000 units).
-

The diving environment dictates that CO<sub>2</sub> must be sensed in the presence of other gases. Therefore, the technique must be as insensitive as possible to variations in the diving gas mixture. This means that sensor output should be specific to CO<sub>2</sub> molecules only in order to maintain good overall measurement accuracy. For diving environments this restriction implies that sensor output must change minimally following changes in the partial pressure of water vapor, oxygen, nitrogen, or helium. Furthermore, the sensor operating principle must not depend upon any specific mixture ratio of these gases since the divers breathing-gas mixture content will change according to a variety of diving scenarios.

The desired sensor response time given in Table 1 is somewhat arbitrary and 10 - 30 seconds was chosen as a good compromise between a number of factors including longer times needed to obtain good accuracy, balanced by the need to provide adequate warning time for the diver to take corrective action.

There are a number of environmental constraints which also must be considered in the process of sensor selection. The sensor must maintain the desired characteristics mentioned above while the diving system operates over a range of temperatures from -2 to 35° C, a range of pressure (i.e. depths) from 1 to 20 atmospheres, and a range of relative humidities from 0 to 100%. Water droplets can also be present in the vicinity of the sensor to complicate matters even further.

The sensor system must further be capable of accommodating increases and decreases of pressure during changes in the divers working depth. A limit of 3 atmospheres change per minute was selected as a goal. Problems arising from trapped gas within sensor components (i.e. "sensor bends") caused by these depth changes must be accounted for in any sensor selection procedure.

There are also some obvious limits given in Table 1 for sensor system weight and volume to provide a practical device for use on an operational rebreathing apparatus. Other practical, user-oriented, requirements such as low power drain limits (i.e. less than 5 watts), minimum recalibration, minimal EMI interference generation, long useful sensor life (i.e. at least 500 diving hours), and indefinite sensor shelf life are important.

Further, a sensor system that seeks to protect a diver from CO<sub>2</sub> scrubber failure should obviously be highly reliable.

Since no off-the-shelf sensor system is available (i.e. one must be developed), some economic factors must be considered. The risk of obtaining the desired sensor following the development period should be moderate. And, the cost associated with this development should be within a reasonable limit of approximately 2 - 3 man years of effort. The final production unit should also cost less than \$10,000 for an estimated 100 - 1000 total units produced.

### CONCEPT IDENTIFICATION

A number of Battelle researchers were contacted to identify various technologies that would be applicable to CO<sub>2</sub> measurements in a hyperbaric application. From this group, a team was selected that had broad general knowledge of gas composition measurement methods. Each team member also specialized in a particular sensor discipline (i.e. electrochemical, optical, etc.). This team approach was applied throughout the technology assessment effort to help identify the latest CO<sub>2</sub> sensor technology and improvements to existing technology. Specific methodology used to identify candidate concepts is given in the following text.

#### Literature, Patents, Manufacturers, R&D Groups

Various sources outside Battelle were identified, and information was gathered from these sources for further evaluation.

#### Literature Search

Several computer data bases were examined by NCSC and Battelle to identify literature on new and existing CO<sub>2</sub> measurement techniques. Of course, the art to any successful computer literature search is the proper choice of key descriptive words for the computer to use in this automated process.

NCSC searched the following data bases:

- MELINE (1972 - 82)
- COMPENDEX (1976 - 82)
- BIOSIS (1975 - 82)

using various combinations of the following descriptors:

- Carbon dioxide
- Detection
- Detector
- Sensor
- Sensing
- Measurement
- Measuring.

The number of abstracts examined as a result of this particular search was 659. The results were not very fruitful in that the measurements themselves were stressed in this literature base rather than the sensing devices. Also, the techniques identified tended to be standard analytical instrumentation rather than new measurement methodology. Battelle searched the following data bases:

- NTIS (1977 - 83)
- SCI.ABS. (1977 - 83)
- ENG. INDEX (1977 - 83)
- MECH. ENG. (1973 - 82)

using combinations of the following key descriptive words:

- Carbon dioxide
- Instrument
- Device
- Meter
- Equipment
- Measurement
- Measuring
- Detection
- Detecting
- Monitor
- Detector
- Sensor.

This latter search produced 304 abstracts which were also examined. Results from this literature were more encouraging and applicable literature (papers, reports, etc.) were ordered. The information contained in this literature was evaluated as part of this overall sensor technology assessment effort.

### Patents

NCSC performed a patent search to identify CO<sub>2</sub> sensors applicable to diving systems. Fifty-nine patents dated from 1960 were identified that were applicable to CO<sub>2</sub> sensing or involved related technology. The following subclassifications were searched:

23/232/R, 232C, 232E  
73/19, 23, 23.1, 24-27, 29; 861.04  
128/204.22, 205.28, 719  
250/281  
324/71SN, 464-470  
338/34  
240/632, 633, 634  
422/50, 83-93, 98  
435/807.

Very few sensors were found which were specifically directed to underwater or high pressure applications. Battelle staff examined each patent for specific technology applicable to this program.

### Manufacturers and R&D Groups

Previously known sources of information regarding CO<sub>2</sub> sensing in a hyperbaric environment were obtained from NCSC at the beginning of this study. These sources were investigated as well as other sources known to Battelle. In addition, a form letter of inquiry was sent to all manufacturers of CO<sub>2</sub> measurement devices who are listed in the Thomas Register. This latter inquiry produced responses from 25 firms, of whom 15 manufactured an actual product

that might be of potential use. This commercially available hardware falls into six main categories:

- Mass spectroscopy
- Chromatography
- Infrared (IR) absorption
- Chemical sensing (sample tubes/Orsat)
- Electrochemical cells (pH sensors)
- Thermal conductivity devices.

As would be expected, none of the commercial instrumentation was directly applicable to the diving environment. Specific commercial devices are discussed in this report.

Several research organizations were also<sup>o</sup> contacted to ascertain recent and/or unpublished efforts in the CO<sub>2</sub> sensing area. Comments provided by these organizations were considered in the final evaluation.

#### INITIAL SCREENING

Based upon the above concept identification, an alphabetical list of possible techniques for CO<sub>2</sub> measurement in a hyperbaric environment was compiled (i.e. see Table 2A). Also included in this table is a brief description of the operating principle of each sensor method. For completion, Table 2B includes a list of various measurement techniques that were eliminated from further consideration. A brief explanation is also provided as to why these methods were considered unusable for the present diving sensor application. This initial screening was based upon a comparison of what is currently known about a given sensor technology relative to the desirable sensor characteristics listed in Table 1. A more detailed discussion of the selected methods given in Table 2A is included in the following text.

TABLE 2A. CANDIDATE SENSOR TECHNIQUES  
SELECTED FOR FURTHER ANALYSIS

Technique	Operating Principle
Calorimetric	Measure of heat which is generated when CO <sub>2</sub> reacts with a metallic Hydroxide
Chemical Change	CO <sub>2</sub> reacted to produce another gas- which is more readily detected with current technology.
Complex Impedance	Change in complex impedance of sintered metal coated with material that interacts with CO <sub>2</sub>
Electrochemical (various types)	Electrochemical detection of CO <sub>2</sub> dissolved in solution
Infrared (IR) Absorption	Absorption of infrared light by CO <sub>2</sub> molecules
Piezoelectric	Mass change (i.e. frequency difference) measured when coated transducer adsorbs CO <sub>2</sub>
Solid State	Change in resistivity of a semiconducting film
Surface Acoustic Wave (SAW)	Variation in speed of an acoustic wave traveling in a thin film on the surface of a piezoelectric crystal

TABLE 2B. CANDIDATE SENSOR TECHNIQUES  
ELIMINATED IN INITIAL SCREENING

Technique	Operating Principle	Reason for Elimination
Acoustic Resonance	Phase change, frequency, attenuation of sound in a resonance cavity	Not specific to CO <sub>2</sub> (binary gas only)
Alpha Particle Absorption	Attenuation of alpha particle beam by gas molecules	Not specific to CO <sub>2</sub>
Chromatography	Microsized version of standard analytical method	Batch sampling implies long response time
Electron Capture	Attenuation of gases by electrons from a Beta emitter	Highly pressure and temperature sensitive
Gamma Ray Attenuation	Absorption of $\gamma$ rays by gases	Not specific to CO <sub>2</sub>
Mass Spectroscopy	Separation of gas by mass using a magnetic field	Can't presently meet weight, size and power requirements
Orsat Analysis	Color change in tubes due to chemical change involving CO <sub>2</sub>	Batch sampling implies long response time
Pressure difference	Pressure difference produced by variable diffusion through selective membrane	Not specific to CO <sub>2</sub> (binary gas only)
Thermal Conductivity	Change in thermal conductivity of gas	Not specific to CO <sub>2</sub> and interference from helium
Transcutaneous analysis of arterial PCO <sub>2</sub>	Electrical conductivity of skin is measured using platinum surface contact electrode	Inadequate response time



ANALYSIS OF SELECTED CONCEPTS

In this section, promising concepts identified in the screening procedure above (i.e. see Table 2A) are discussed in greater detail. Each concept is described briefly to provide background information and operating principles. Commercially available sensors are identified, as well as, prototype devices resulting from previous and current R&D efforts. A discussion is also included relative to the operating characteristics of each sensor concept as compared to the desired characteristics identified for ideal hyperbaric application. Where these characteristics were not known specifically, an attempt was made to estimate sensor system characteristics. Finally, conclusions and recommendations are given for each sensor technique.

## Electrochemical CO<sub>2</sub> Detectors

A number of electrochemical devices may be useful for detecting CO<sub>2</sub> under hyperbaric conditions. A schematic diagram is shown in Figure 1 which will help illustrate some general characteristics representative of a number of detectors. Typically a liquid phase is separated from a gas phase containing CO<sub>2</sub> by a semipermeable membrane. The membrane allows CO<sub>2</sub> to pass while inhibiting the escape of the liquid phase. The principal variation in this type of CO<sub>2</sub> detector is the method that is used to detect the dissolved CO<sub>2</sub> or its dissolution products.

In all cases the response at the detector should be a function of the amount of dissolved CO<sub>2</sub> which in turn should be a function of the partial pressure of CO<sub>2</sub> in the gas phase. However, an important distinction between detectors is whether or not they deplete the liquid phase of the CO<sub>2</sub> as it is detected. If the detector does not consume or remove CO<sub>2</sub>, the device may have a relatively poor response time at room temperature. This is especially true for cases where CO<sub>2</sub> partial pressure decreases. This long response time is due to the slow rate at which CO<sub>2</sub> dissolved in the liquid phase establishes equilibrium with the gas phase. Carbonated beverages take advantage of this behavior and often are observed to contain large amounts of dissolved CO<sub>2</sub> even after relatively long exposure to air containing little CO<sub>2</sub>.

On the other hand, if the detector does consume or remove CO<sub>2</sub>, the electrode would be similar to the Clark electrode that is used for oxygen detection in "rebreathing" systems. In this case the response at the detector is a function of the rate of diffusion of CO<sub>2</sub> to the detector and that rate is a function of the partial pressure of CO<sub>2</sub> in the gas phase. If the CO<sub>2</sub> is removed from the liquid phase, this type of detector can respond rapidly to decreases of CO<sub>2</sub> in the gas phase since the decrease immediately affects the rate of CO<sub>2</sub> diffusion to the detector.

In general, electrochemical CO<sub>2</sub> detectors are compact, low cost, require low power and show minimal interference from other gases. However the electrochemical detectors, in their present state of construction and testing, show relatively low accuracy for measurement of partial pressures of CO<sub>2</sub> in the range of 0.0 to 1.0 mm of Hg. All six of the different types

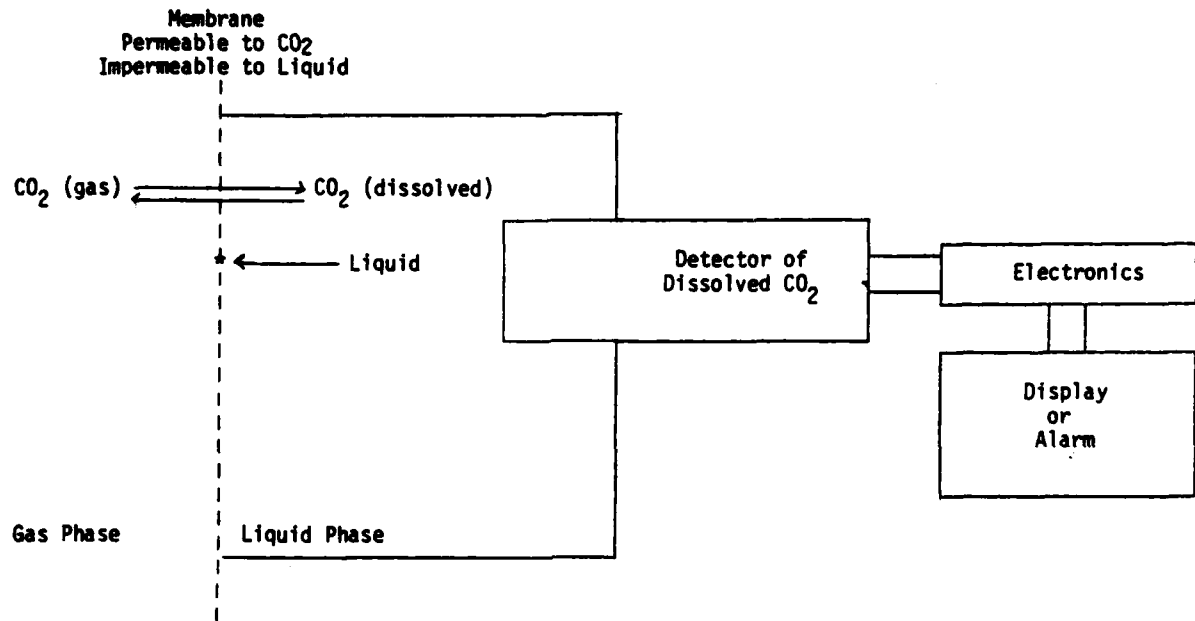
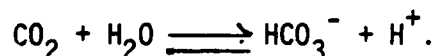

FIGURE 1. SCHEMATIC DIAGRAM FOR SEVERAL TYPES OF ELECTROCHEMICAL DETECTORS OF CO<sub>2</sub> IN GASES

of electrochemical CO<sub>2</sub> detectors described and evaluated in the following paragraphs, conceivably could, with varying difficulty, be made sensitive to low CO<sub>2</sub> pressures. However, only the detector using a conductivity measurement is potentially free from other problems and has an operating principle conducive to accurate measurements of low CO<sub>2</sub> pressures.

#### pH Type of Detector

The most common type of electrochemical device for measuring carbon dioxide is called a Severinghaus electrode.<sup>1</sup> A number of variations of this electrode are available commercially but generally they are used for measuring CO<sub>2</sub> dissolved in liquids. The electrode fits the scheme shown in Figure 1 with the detector being a conventional, pH measuring, glass electrode and the liquid phase being an aqueous solution. The CO<sub>2</sub> diffusing through the membrane effects the hydrogen ion concentration or pH in the liquid phase by the reaction:



The CO<sub>2</sub> is not consumed in this detector and the high impedance of the glass electrode requires electronics which might be susceptible to interference from electronic noise.

The reportedly successful use of a miniature Severinghaus electrode for detecting CO<sub>2</sub> gas for hyperbaric applications was described as early as 1968<sup>2</sup>. The detector appeared to operate well under widely varying helium pressures but the response time may have been rather long, on the order of an hour to reach equilibrium. Also the lowest CO<sub>2</sub> partial pressure measured was greater than 1.0 mm Hg. At a slightly elevated temperature, 44° C, a Severinghaus electrode for measuring CO<sub>2</sub> in gas was shown to have a response time of 4 to .6 minutes<sup>3</sup>, but this would require a heating element and careful temperature control which may be undesirable features for the present application.

### Electrodialysis Detector

In a report to the Office of Naval Research<sup>4</sup>, Chang and Chang describe the development of a CO<sub>2</sub> detector with the general configuration shown in Figure 1. However, the CO<sub>2</sub> detecting portion of the device involves a second membrane which is selectively permeable to anions and separates the aqueous liquid phase into two compartments. The two compartment arrangement is illustrated in Figure 2. Two electrodes, one in each compartment of the aqueous phase, are used to electro-dialyze the solution to remove the H<sup>+</sup>, HCO<sub>3</sub><sup>-</sup> and CO<sub>3</sub><sup>=</sup> ions formed by water and the CO<sub>2</sub> diffusing through the CO<sub>2</sub> permeable membrane. By applying a voltage between the two electrodes so that the negative electrode is in the compartment into which CO<sub>2</sub> from the gas phase is diffusing, the hydrogen ions are removed in a reduction reaction. The HCO<sub>3</sub><sup>-</sup> or CO<sub>3</sub><sup>=</sup> ions migrate through the anion selective membrane to the positive electrode. Thus the CO<sub>2</sub> is removed as it diffuses into the detector and at a constant applied voltage the current in the cell is proportional to the partial pressure of CO<sub>2</sub> in the gas phase.

Tests have shown this detector to have a linear response for partial pressures of CO<sub>2</sub> from 0 to 300 torr. The detector exhibited good stability over a period of 9 days and good response times of 5-10 seconds. Based on the sound operating principal and encouraging results of this detector, it is judged to be very promising for the present application if its sensitivity to low CO<sub>2</sub> pressures could be increased. This might be done by using a membrane which is more permeable to CO<sub>2</sub>, thus increasing the rate of CO<sub>2</sub> diffusion into the detector and increasing the current observed.

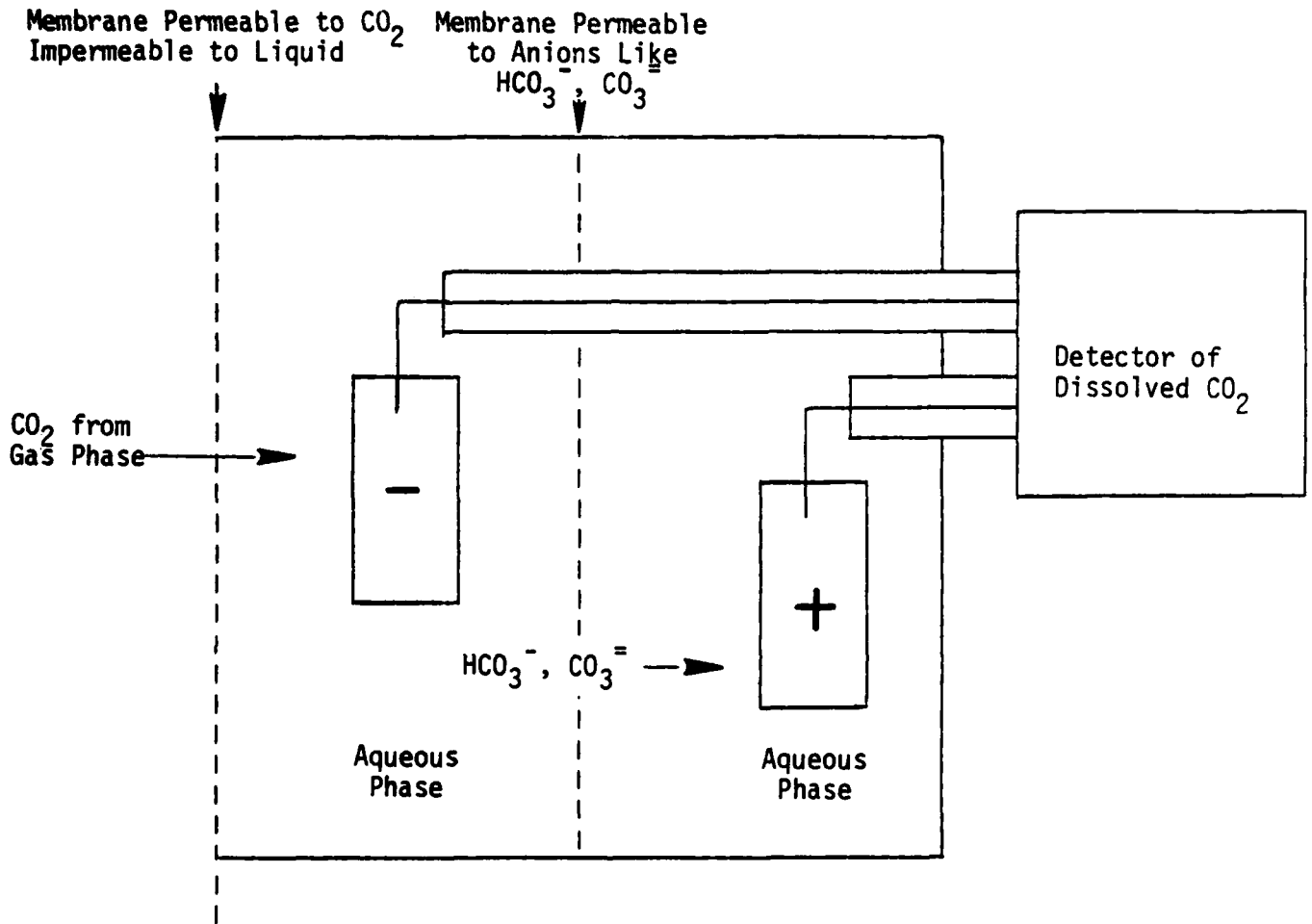

FIGURE 2. SCHEMATIC DIAGRAM OF  $\text{CO}_2$  DETECTOR  
USING ELECTRODIALYSIS

### Reduced CO<sub>2</sub> Detector

Wong and Giner<sup>5</sup> have reported to the Office of Naval Research on development of an electrochemical device for detecting CO<sub>2</sub>. Their device has the general configuration shown in Figure 1. The CO<sub>2</sub> detecting mechanism involves the formation of a chemisorbed "Reduced CO<sub>2</sub>" species on a noble metal electrode when the electrode is held for a period of time at a potential negative of a counter electrode. The amount of CO<sub>2</sub> in the aqueous liquid phase is determined by measuring the charge required to remove the "Reduced CO<sub>2</sub>" species when that electrode is made positive. However, since the dissolved CO<sub>2</sub> is regenerated on the positive pulse the detector does not consume or remove CO<sub>2</sub> and it was found that the response was non-linear with respect to partial pressure of CO<sub>2</sub> in the gas phase. The device does have the advantage of being able to concurrently determine O<sub>2</sub>.

### Nonaqueous Amperometric Detector

A recent report of an electrode system for determining both CO<sub>2</sub> and O<sub>2</sub> by amperometric or current measuring techniques has been given<sup>6</sup>. The device consists of an oxygen measuring Clark electrode and a CO<sub>2</sub> reducing system. The device has the general configuration shown in Figure 3. In the Clark electrode, oxygen diffusing through the membrane is electrochemically reduced to water thus giving a current proportional to the oxygen content of the gas phase. In the present device a second gas permeable membrane separates a compartment containing the non-aqueous solvent dimethylsulfoxide, (DMSO), from the aqueous solution compartment. In DMSO carbon dioxide can be irreversibly reduced electrochemically to non-interfering products.

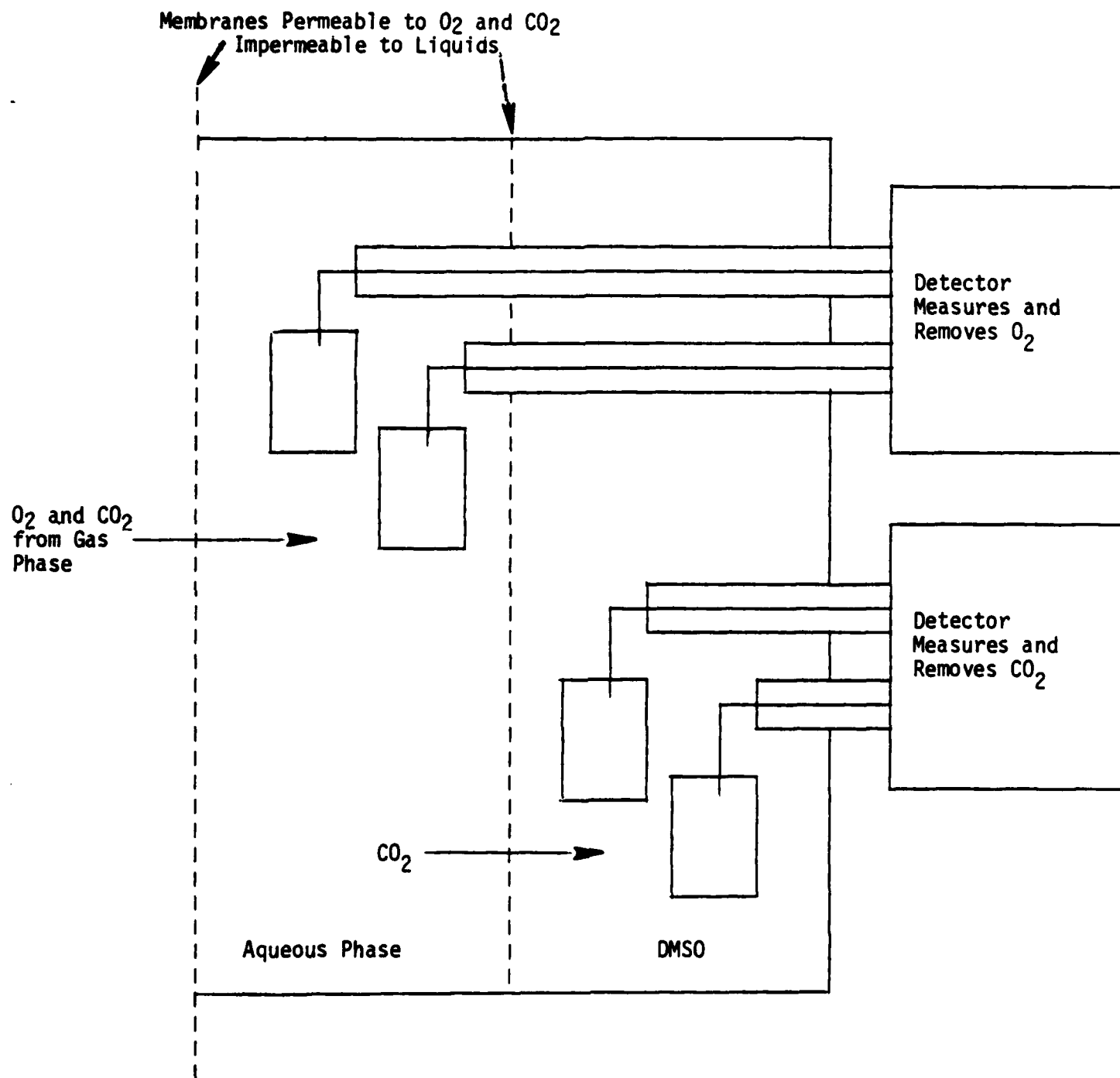

FIGURE 3. SCHEMATIC DIAGRAM OF CURRENT MEASURING  
DETECTOR OF  $CO_2$  AND  $O_2$



Thus  $O_2$  and  $CO_2$  diffuse through the permeable membrane exposed to the gas phase and only the  $O_2$  is electrochemically reduced and depleted in the aqueous compartment. The  $CO_2$  which is inactive in the aqueous media can diffuse through the second gas permeable membrane and the current due to its reduction in the DMSO solution is proportional to the partial pressure of  $CO_2$  in the gas phase. Overall, the linear response and fast response time make this device appear quite promising, however accurate measurement of  $CO_2$  at pressures below 1.0 mm of Hg has not been demonstrated.

### Conductivity Detector

A patent by J.A. Bushman<sup>7</sup> describes a novel device for measuring  $CO_2$  concentration in gas. Again, the device has the general configuration given in Figure 1 and operates on the principle of measuring conductivity of an aqueous liquid phase due to the presence of  $H^+$ ,  $HCO_3^-$  and  $CO_3^{=}$  ions, which are formed from  $H_2O$  and  $CO_2$ . However, in order to make the conductivity dependent on the rate of diffusion of  $CO_2$  through the gas permeable membrane the  $HCO_3^-$  and  $CO_3^{=}$  are continuously removed from solution by anion exchange resin which replaces these ions with  $OH^-$  ions. The  $OH^-$  and  $H^+$  ions reform  $H_2O$  and the conductivity of the solutions becomes a steady state function of the rate of  $CO_2$  diffusion rather than a function of the equilibrium concentration of  $CO_2$ . Although, no data is given in the patent this device conceivably could have fast response time and good stability. In addition the alternating current measurement of conductivity gives a high ratio of signal to noise and probably can be used to detect low levels of  $CO_2$  in the gas phase.

### High Temperature Electrolyte Detector

The patent by Chamberland and Gauthier<sup>8</sup> and the proposal to the Naval Coastal System Center<sup>9</sup> describe a high temperature, solid electrolyte device for the measurement of the  $CO_2$  content of gases. The principle involved

in determining the  $\text{CO}_2$  partial pressure is the measurement of the voltage or potential that is developed across a solid electrolyte, like a fused alkali metal carbonate, when one side is exposed to a known  $\text{CO}_2$  gas pressure and the other side is exposed to an unknown  $\text{CO}_2$  partial pressure. The voltage output can be a well behaved, accurate, fast responding measure of  $\text{CO}_2$  content of a gas. However, the major drawbacks for the present application are the need to maintain the detector at around  $500^\circ\text{C}$  with careful maintenance of constant temperature and the effect that moisture could have on the longevity of the heated metal carbonate solid electrolyte cell. The possible corrosion around and deterioration of the metal carbonate in a humid  $500^\circ\text{C}$  environment are major considerations which are not addressed in the proposed program of Feeney and Winnick<sup>9</sup>.

The preceding list of electrochemical methods of detecting  $\text{CO}_2$  is not intended to be exhaustive. A number of other electrochemical methods are possible, for example ion selective electrodes that respond directly to  $\text{HCO}_3^-$  or  $\text{CO}_3^{=}$  ions<sup>10</sup> or measurement of the electrical conductivity of a moist ion exchange resin as a function of the  $\text{CO}_2$  concentration in the gas flowing past it<sup>11</sup>. However, the methods described in detail above are judged to include the better electrochemical methods available for measuring  $\text{CO}_2$  for the "rebreathing" application considered here. An attempt to quantify some of the characteristics of the electrochemical devices described is given in Table 3.

### Conclusions and Recommendations (Electrochemical)

Of the electrochemical  $\text{CO}_2$  detectors, the only type that is in common use, the pH type, has too slow a response time. Due to the way it is commonly fabricated, this type of electrode also does not have the sensitivity to measure the low  $\text{CO}_2$  pressures required. While the electrodialysis and non-aqueous amperometric detectors have fast response times, their sensitivities also are inadequate as they are now constructed. These sensitivities are limited by the rate of  $\text{CO}_2$  diffusing into the detector and in principle both of these detectors could be made more sensitive by using membranes more permeable to  $\text{CO}_2$ , using larger membrane areas, or by using electronics capable



of measuring lower currents. The conductivity detector operates on a principle which is inherently more sensitive to lower level response, but to date, no specific information is available on this device. The non-linear response and poor sensitivity of the "reduced CO<sub>2</sub>" detector make this device a less likely choice for measuring gas phase CO<sub>2</sub>. Questions regarding stability of the high temperature electrolyte detector in humid environments is of prime concern with this later device. Therefore, no electrochemical device, as presently configured, has been shown to meet all the specified sensor requirements.

In order to develop an electrochemical detector meeting the requirements specified it is recommended that:

- An attempt be made to engineer the Electrolysis and Amperometric detectors for greater sensitivity.
- Operating characteristics and stage of development of conductivity detector be determined
- High temperature stability of the solid electrolyte detector in a humid environment be ascertained.

Further effort based on one or more of these recommendations could provide the desired sensor for hyperbaric applications.

### Infrared Absorption

A number of infrared devices that measure the CO<sub>2</sub> content in gases are commercially available. Devices of this type can be rugged and compact, and should be readily adaptable for monitoring CO<sub>2</sub> partial pressure in breathing air used for undersea diving systems. Described below are details on the general operating principles of the infrared devices, information on devices that are commercially available, and recommendations for a design approach for a continuous infrared sensor to meet the Navy's requirements. Most currently available commercial infrared monitors will require at least some modification to account for the range of total gas pressures that extend up to 20 atmospheres.

#### Operating Principles

Most infrared devices for measuring CO<sub>2</sub> are based on the  $\nu_3$  absorption band centered around 4.3  $\mu\text{m}$ . Infrared absorption spectra for gaseous CO<sub>2</sub> and water vapor are shown in Figure 4. As seen in this figure, water exhibits strong absorptions in many regions of the infrared, but does not interfere significantly with the CO<sub>2</sub> absorption near 4.3  $\mu\text{m}$ . The other major species in divers rebreathing air, nitrogen, oxygen and helium, do not absorb infrared radiation.

The relationship between infrared absorption and the concentration or partial pressure of the absorbing species can be represented by Beer's law.

$$p = \frac{1}{k(\tilde{\nu})L} \ln \left( \frac{I_0(\tilde{\nu})}{I(\tilde{\nu})} \right) \quad (2)$$

where

- p = partial pressure of absorber, mmHg  
 L = absorption pathlength, cm

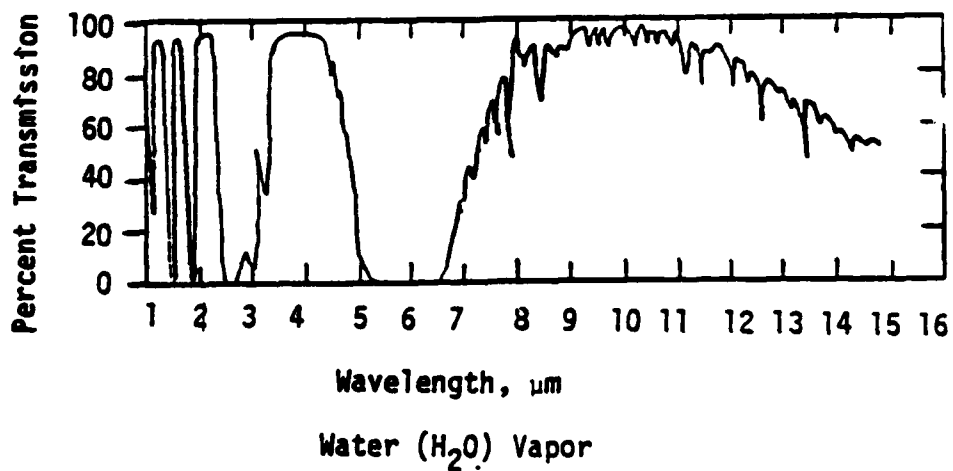
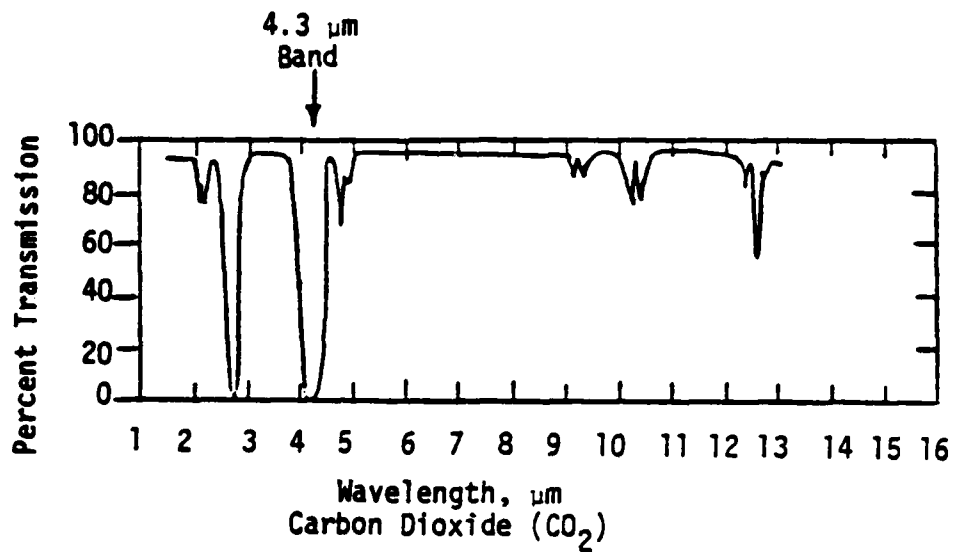

FIGURE 4. INFRARED ABSORPTION SPECTRA FOR GASEOUS CARBON DIOXIDE AND WATER VAPOR.

- $k(\tilde{\nu})$  = absorption coefficient at frequency  $\tilde{\nu}$ ,  $\frac{1}{\text{cm} \cdot \text{mmHg}}$   
 $I_0(\tilde{\nu})$  = intensity of radiation at frequency  $\tilde{\nu}$  with no absorber (Reference intensity)  
 $I(\tilde{\nu})$  = intensity of radiation at frequency  $\tilde{\nu}$  with absorber present.

The frequency is expressed in wavenumbers with units of  $\text{cm}^{-1}$ . The relationship between wavelength in  $\mu\text{m}$  and frequency in wavenumbers ( $\text{cm}^{-1}$ ) is

$$\lambda (\mu\text{m}) = \frac{10,000}{\tilde{\nu}(\text{cm}^{-1})} \quad (3)$$

The concentration can be related to partial pressure by

$$c = \frac{p}{RT} \quad (4)$$

where

- $c$  = concentration of absorber,  $\text{g-mole}/\text{cm}^3$   
 $R$  = gas constant,  $62,360 \frac{\text{cm}^3 \cdot \text{mmHg}}{\text{g-mole} \cdot ^\circ\text{K}}$   
 $T$  = absolute temperature,  $^\circ\text{K}$ .

Conceptually, an infrared absorption measurement for  $\text{CO}_2$  involves passing infrared radiation from a hot-filament source through a known pathlength of gas, then detecting the intensities of the transmitted radiation at either a specific wavelength or over a wavelength range in the  $\tilde{\nu}_3$  band with and without  $\text{CO}_2$  present. The ratio of the measured intensities without and with  $\text{CO}_2$  absorption is used as  $I_0/I$  in equation (2) to give the concentration of partial pressure of  $\text{CO}_2$ . The intensity without  $\text{CO}_2$ , or reference intensity  $I_0$ , can be determined either by a dual-beam approach or by using a wavelength different than the absorption wavelength where no absorption occurs. As can be seen in Figure 4, a good choice for the reference wavelength is in the region near  $3.9 \mu\text{m}$  where no absorption from either  $\text{CO}_2$  or  $\text{H}_2\text{O}$  vapor is observed. The dual-beam approach generally involves splitting the radiation from the infrared source into two beams. One beam is passed through the gas

containing  $\text{CO}_2$  while the other beam travels an equivalent optical path, however, with no  $\text{CO}_2$  present. Use of a reference signal is important because it compensates for the normal variations in the output of the infrared source, electronics, power sources, and detectors.

Generally, infrared absorption by  $\text{CO}_2$  in gas mixtures is a function not only of the  $\text{CO}_2$  partial pressure but of the total gas pressure. This is an important factor in hyperbaric diving applications where total pressures range up to 20 atmospheres. Near atmospheric pressure,  $\text{CO}_2$  absorption can be expressed by the relationship developed by Howard, Burch, and Williams<sup>(12)</sup>

$$\int_{\tilde{\nu}_1}^{\tilde{\nu}_2} \alpha(\tilde{\nu}) d\tilde{\nu} = 27.5 + 34 \log_{10} W + 31.5 \log_{10} (P+p). \quad (5)$$

In the above integral  $\alpha(\tilde{\nu})$  is the fractional absorption defined as a function of frequency in wavenumbers ( $\text{cm}^{-1}$ ) with the limits  $\tilde{\nu}_1$  and  $\tilde{\nu}_2$  ranging over the total  $\text{CO}_2$   $\nu_3$  band from 2200 to 2400  $\text{cm}^{-1}$ .  $P$  is the total pressure and  $p$  the partial pressure of  $\text{CO}_2$ , both expressed in mmHg.  $W$  is  $pL$ , the partial pressure of  $\text{CO}_2$  in atmospheres times the absorption pathlength in cm. The integral which has units of  $\text{cm}^{-1}$  can also be expressed as

$$\begin{aligned} \int_{\tilde{\nu}_1}^{\tilde{\nu}_2} \alpha(\tilde{\nu}) d\tilde{\nu} &= \bar{\alpha} (\tilde{\nu}_2 - \tilde{\nu}_1) = \int_{\tilde{\nu}_1}^{\tilde{\nu}_2} \left(1 - \frac{I(\tilde{\nu})}{I_0(\tilde{\nu})}\right) d\tilde{\nu} = \int_{\tilde{\nu}_1}^{\tilde{\nu}_2} \left(1 - e^{-pk(\tilde{\nu})L}\right) d\tilde{\nu} \\ &= (1 - e^{-p\bar{k}L}) (\tilde{\nu}_2 - \tilde{\nu}_1) \end{aligned} \quad (6)$$

or

$$\bar{\alpha} = 1 - \frac{I}{I_0} = 1 - e^{-p\bar{k}L} \quad (7)$$

The bars over the variables denote values averaged over the spectral range  $\tilde{\nu}_1$  to  $\tilde{\nu}_2$ .



A second relationship reported by Edwards<sup>(13)</sup> covers total pressures up to 70 atmospheres at about room temperature (294°K):

$$\int_{\nu_1}^{\nu_2} \alpha(\tilde{\nu}) d\tilde{\nu} = 75 w \frac{0.11}{P} \frac{0.08}{E} \quad (8)$$

where

$$w = x \frac{MPL_m}{RT}, \text{ g/m}^2$$

$$P_E = P (1 + x + 0.5 x^2 P), \text{ atm}$$

$$P = \text{total pressure, atm}$$

$$x = \text{mole fraction}$$

$$R = 8.206 \times 10^{-5} \frac{\text{m}^3 \cdot \text{atm}}{\text{g-mole} \cdot ^\circ\text{K}}$$

$$M = \text{molecular weight of CO}_2, \\ 44 \text{ g/g-mole.}$$

$$L_m = \text{absorption pathlength, m}$$

The pressure broadening of the rotational structure of the infrared vibration bands is mainly responsible for the sensitivity of the absorption to total pressure. To accurately account for this in a hyperbaric CO<sub>2</sub> sensing device for diving applications, it will be necessary to establish reliable absorption relationships for the appropriate gas mixtures within applicable total pressure and temperature ranges.

The presently available relationships for CO<sub>2</sub> absorption as a function of pressure can be employed to estimate some of the physical requirements of a conceptual instrument. To approximate the absorption pathlength required for the device of interest here, the average absorption coefficient,  $\bar{k}$ , for a temperature of 294°K (21°C), a partial pressure of CO<sub>2</sub> of 0.4 mmHg, and a total pressure of 10 atmospheres can be calculated to be about  $3.4 \times 10^{-4} \text{ (mmHg)}^{-1} \text{ cm}^{-1}$ . Detection sensitivity for an optical absorption measurement can be determined by differentiating the intensity  $I$  in the Beer's law relation

$$\frac{I}{I_0} = e^{-p\bar{k}L} \quad (9)$$

with respect to pressure ( $p$ ) to give

$$\frac{1}{I_0} \frac{dI}{dp} = -\bar{k}L e^{-p\bar{k}L} = -\bar{k}L \frac{I}{I_0} \quad (10)$$

or

$$\frac{1}{I} \frac{dI}{dp} = -\bar{k}L. \quad (11)$$

Assuming that at the desired lower detection limit of 0.4 mmHg CO<sub>2</sub> a practical achievable absorption level is 1% with a detection sensitivity of 0.1 mmHg corresponding to a change in absorption of 0.2%, the required path length can be estimated from the above expression as

$$L = - \frac{1}{\bar{k}I} \frac{dI}{dp} = \frac{1}{3.4 \times 10^{-4} \cdot 0.99} \frac{0.002}{0.1} \quad (12)$$

$$= 59.4 \text{ cm.}$$

This pathlength of about 60 cm can be achieved in a compact volume using state-of-the-art optical multipass techniques. At the upper detection limit of 4 mmHg CO<sub>2</sub>, the total absorption would be about 8%. The absorption data used for this estimate may overestimate the optical path requirements. The actual pathlength should be based on experimental absorption measurements covering the concentration and pressure ranges of interest.

To perform an absorption measurement for  $\text{CO}_2$  it will be necessary to spectrally isolate either all or a portion of the  $\text{CO}_2$   $\nu_3$  band. In the laboratory this is commonly achieved through the use of dispersive elements such as diffraction gratings or prisms, or interferometers. For field devices, however, it has been found to be more practical to use non-dispersive methods based on narrow-band interference filters or correlation filtering through a fixed sample of the absorber being measured. For the present application, the interference-filter approach is probably easier to use to cover the required temperature (-2 to + 35°C) and pressure (0 to 20 atm) ranges. To handle pressure and temperature variation, temperature and pressure signals can be fed to a small micro-processor along with optical absorption and reference signals, and the  $\text{CO}_2$  partial pressure calculated and formatted to provide the desired output. This type of instrument can be rugged, compact, reliable, and provide rapid response. Further details for a preliminary design of this type of device are described following the next section. Comparison of this approach with others being considered as part of this study, and the selection of a specific approach to meet the Navy's requirements for a  $\text{CO}_2$  sensor for diver's breathing air are discussed in the summary and recommendations section of this report.

#### Commercially Available Devices

Commercially available infrared devices are listed in Table 4. Only the Heriot-Watt and Anarad devices are designed specifically for hyperbaric diving applications, however, in principle, all the devices are adaptable to high-pressure use provided pressure broadening effects are compensated. In general, these devices are capable of covering the detection range of 0.4 to 4mmHg for  $\text{CO}_2$  with adequate sensitivity and response time, and can be compact, rugged, and operated with modest amounts of electrical power.

An infrared device for measuring  $\text{CO}_2$  in breathing air also has been reported in a U. S. Patent<sup>(14)</sup>, and work on the development of special infrared diodes for the detection of  $\text{CO}_2$  has been funded by the Gas Research Institute<sup>(15)</sup>.

TABLE 4. COMMERCIAL SOURCES OF INFRARED CO<sub>2</sub> SENSORS

Source	CO <sub>2</sub> Measurement Range	CO <sub>2</sub> Sensitivity	Pressure Range	Response Time	Power Consumption	Operating Principle	Intended Application
Institute of Offshore Engineering* Heriot-Watt University Research Park Riccarton Edinburgh EH 14 4AS Scotland Telephone: 031-449 5111	0-10% (ATA)	0.1% (ATA)	0-33 atm	1 sec	Sensor: 100mA at 15Vdc Signal processing: 450mA at 5Vdc Fan: 5 watts	Filters with single detector and source with microprocessor	Divers breathing air monitor
Hewlett Packard 1501 Page Mill Road Palo Alto, CA 94304 Telephone: (213) 877-1282	0-150 mmHG	±4.5 mmHG	~1 atm	<30 sec	5 watts	Filters with microprocessor	Respiration and cutaneous monitor
Beckman Instruments, Inc. P.O. Box C-19600 Irvine, CA 92713 Telephone: (714) 833-0751	0-700 ppm	--	~1 atm	--	--	Filter system	Process monitoring
Gould Inc.* 40 Gould Center Rolling Meadows, IL 60008 Telephone: (312) 640-4400	--	--	--	--	--	Filter with variable absorption path	--
Andros 2332 Fourth Street Berkeley, CA 94710 Telephone: (415) 849-1377	0-80 mmHG	--	~1 atm	<10 sec	24 Vac	Filters in rotating wheel	Automotive emissions analyzer and medical gas analysis
Sensors, Incorporated 6812 S. State Saline, MI 48176 Telephone: (313) 429-2100	0-2000 ppm	--	~1 atm	--	100 watts	Filter with dual beam and chopper	Automotive emissions and medical gas analyzer
Anarad, Incorporated P.O. Box 3160 Santa Barbara, CA 93105 Telephone: (805) 963-6583	0-76 mmHG	0.1 mmHG	--	5 sec to 90%	2.5 watts	Filters with rotating wheel	Monitor for hyperbaric diving application
Liston Edwards Incorporated 3975 Birch Street Newport Beach, CA 92660 Telephone:	0-10%	--	--	0.3 sec	--	Filter system	--
The Bendix Corporation P.O. Drawer 831 Lewisburg, WV 24901 Telephone: (304) 647-4358	0-30% 0-500 ppm	--	150 psi max.	8 sec to 90%	--	Filter system	Process monitoring

\*Instruments under development.

Typical size of an instrument is in the range of 12"x10"x36". The device being contemplated by Heriot-Watt will be about a third this size.

### Recommended Design

A possible design for a hyperbaric CO<sub>2</sub> sensor is presented in Figure 5. The design is based on a dual-beam approach using a modulated infrared source to eliminate moving parts. The infrared beam from the source passes through a multipass optical absorption cell through which breathing gas containing CO<sub>2</sub> is passed. The optical path in the cell is selected to give the required sensitivity over the CO<sub>2</sub> partial-pressure range of interest. After exiting the multipass cell the optical beam is split into two components, each of which pass through narrow-band interference filters and are focused onto small detectors. One beam is filtered to pass radiation in the 4.3 μm region to measure CO<sub>2</sub> absorption, while the other beam passes through a 3.9 μm bandpass filter where no gas absorption occurs serving as a reference channel. The signals from the detectors are fed along with temperature and pressure signals to a microprocessor. Using look-up tables in the microprocessor memory the above signals are used to calculate the CO<sub>2</sub> content of the gas, and format the output signal for alarm or control purposes. The system power supply can operate on either self-contained rechargeable batteries or from an external source. Filter bandpass characteristics are to be selected to give maximum sensitivity. Data for the look-up tables would be determined experimentally for the absorption pathlength and filters used in the instrument. All components required to manufacture the devices described here are commercially available from several different suppliers.

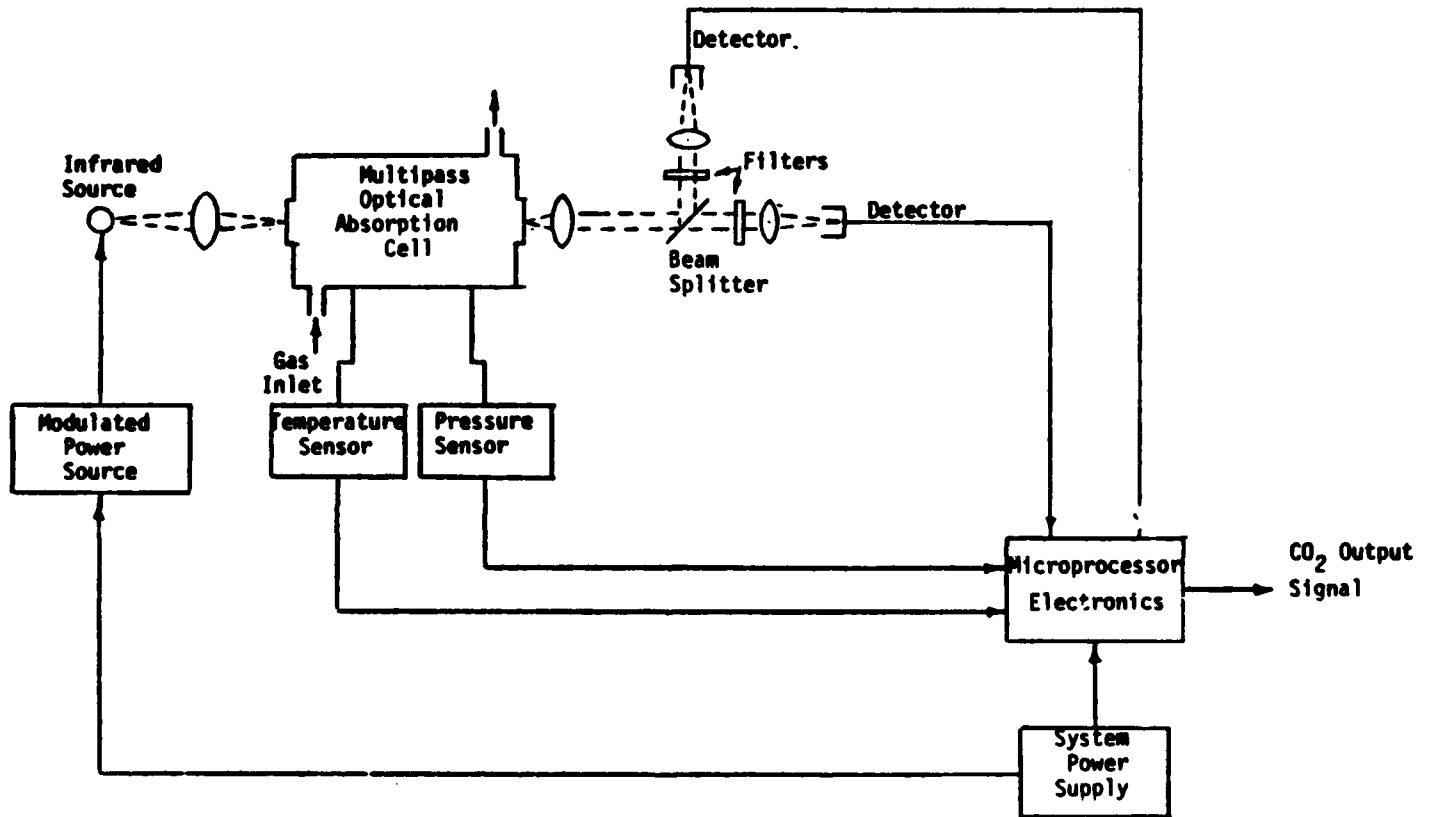

FIGURE 5. SCHEMATIC DESIGN FOR PORTABLE HYPERBARIC INFRARED CO<sub>2</sub> SENSOR

In principle, some commercially available sensors could be modified for this application. However, the commercial devices are generally not rugged and compact enough and would require sufficient modification that it would be more advisable to use an instrument designed and optimized specifically for diving applications. Use of currently available optical detectors and integrated circuitry will provide the ruggedness and compactness required for a practical package. Estimated cost for the development and testing of a prototype IR CO<sub>2</sub> sensor would be about \$150,000.

Anticipated performance capabilities for an IR sensor for CO<sub>2</sub> in divers breathing air are summarized in Table 5.

#### Conclusions and Recommendations (IR Absorption)

The IR absorption technique is a standard method of CO<sub>2</sub> analysis and the basic principle of this technology meets most of the desired sensor system requirements. It would seem logical that a hyperbaric CO<sub>2</sub> system could be engineered for diving applications especially since a commercial device (i.e. Anarad Corporation) has been used for undersea habitat and submarine environments.

To date, however, no device is commercially available for UBA application for a variety of reasons including:

- Absolute pressure and gas mixture effects on the pressure broadening phenomena which greatly affects technique accuracy and highly complicates calibration procedures
- Misalignment problems associated with pressure effects
- Contamination of the infrared source due to helium leaks
- Inadequate temperature control of the IR detector

Notwithstanding these difficulties, Heriot-Watt University in Scotland indicates that they are in the process of developing an IR CO<sub>2</sub> sensor for monitoring a diver's breathing air. It is recommended that the U.S. Navy keep abreast of developments at Heriot-Watt and consider obtaining a prototype or early commercial version of this sensor system for evaluation purposes if and when it becomes available.

TABLE 5. SUMMARY OF POTENTIAL CAPABILITIES OF IR  
SENSOR FOR MONITORING CO<sub>2</sub> IN DIVER'S  
BREATHING AIR

- 
- Range of CO<sub>2</sub> Measurement: 0.1 - 10% @ 1 atm
  - Sensitivity:  $\pm 0.1\%$  @ 1 atm
  - Specificity: No interference from normal atmospheric  
and breath species
  - Response Time: <0.5 sec.
  - Operating Temperature Range: -10 to 120 °F
  - Operating Pressure: 1-10 atm
  - Humidity Effects: None
  - Compression/Decompression Effects: None provided optical  
alignment is rigid
  
  - Size: Sensor - 2"x2"x5"  
Control - 4"x5"x5"
  - Weight: <2 lbs
  - Power Requirements: Battery or generator
  - Calibration: CO<sub>2</sub> cell or optical filter
  - EMI Generated: None
  - Sensor Life: >3 years
  - Reliability: High
  - Risk of Development: Low
  - Cost of Development: Approx. \$150,000
  - Unit Production Cost: \$<10,000.
-



Gas Sensors Based on Interaction of Gas  
with Solid Surface

When a gaseous molecular species with low kinetic energy impinges on a solid surface, it can be reflected, be physically adsorbed, or be chemically adsorbed. Depending upon the temperature of the surface, the adsorbed species can either remain on the surface or can be expelled from the surface. Generally, there exists an equilibrium concentration of adsorbed species at a given temperature. The concentration versus temperature often follows the well-known "S" curve for concentrations for which the surface coverage is in the range  $1 > \theta > 0$ .  $\theta$  is the fraction of possible surface sites filled. A  $\theta$  of 1 would indicate that all sites are filled; that is, the solid surface would have on it a layer one molecule thick. For  $\theta$ 's greater than 1, the adsorption energy changes, often drastically and often in the direction of decreasing energy. The fact that energy is exchanged upon adsorption can and has been used as a basis for gas sensors<sup>(16-21)</sup>.

To make any sensible evaluation of possible sensors based on gaseous adsorption and desorption, one needs to look further. In a rather simplistic sense, molecular species can be put into two general categories: those that are adsorbed with a small binding energy (physical adsorption) and those that are bound with a substantially larger binding energy (chemical adsorption). Which type of adsorption occurs depends also on the solid surface (material and structure). In physical adsorption, the binding energy derives from a surface polarization; in chemical adsorption, electron exchange can occur with a resulting binding energy of the order

of an electron volt. The two general types of existing surface sensors (mentioned subsequently) can be differentiated on the basis of the type of adsorption which occurs on a specific solid surface.

Adsorption type and three of the most important sensor characteristics--specificity, sensitivity, and response time--are highly interrelated. First and foremost, it must be understood that whether a specific molecular species will adsorb on a surface depends upon what species is already there and in what quantity. If an oxygen molecule (generally chemically adsorbed) approaches a surface site with a helium molecule (generally physically adsorbed) already there, the oxygen molecule will displace the helium molecule in time--not instantaneously. Thus, inherently, there is a delayed response. The time to reach an equilibrium condition can take from seconds to hours, depending upon the molecules involved, the nature of the surface, and, of course, the surface temperature. From the point of view of sensor development, it is fortunate that the adsorption isotherms for some species are decidedly different from others, making it possible to obtain a certain specificity by choosing an appropriate surface temperature. Differentiating between two species that are both chemically adsorbed is more difficult. Obviously, acceptable specificity is more easily obtained when the number of different species in the gas being sensed is small.

Another related characteristic is the detectable range of concentration achievable. The largest sensitivity is obtained when  $\theta < 1$ . Upon continued adsorption,  $\theta$ , for most species, can become greater than

one and the sensitivity decreases, as mentioned previously. Thus, there is a saturation effect for all species. Again the temperature is generally chosen for  $0 < \theta < 1$ , but it often is not possible to set the surface temperature to cover the same concentration range for more than one species at a time.

#### Prototype Configurations and Operating Principles of Surface Gas Sensors

As mentioned previously, there are two basic types of gas sensors, based on surface interactions. One is manifested in a commercial device, the so-called Figaro (or Taguchi) sensor. The other is a field-effect-transistor (FET) device, the commercial availability of which is unknown to the authors. Each is discussed in turn.

The Figaro Type. The Figaro type is based primarily on measuring the change in resistance of a thin semiconducting film upon impingement by molecular species. Although both n- and p- type semiconductors can be employed, the Figaro device uses n-type tin oxide. Operation is based primarily on chemical adsorption.

When an acceptor molecule such as  $O_2$  reaches the surface, an electron from the n-type semiconductor is drawn to the  $O_2$  molecule and is affixed to it. Such an action reduces the number of electrons available for conduction and the resistance increases. When a donor molecule strikes the surface, an electron is given up to the solid, and the resistance decreases. The semiconductor device is usually thin so

that the change in the number of electrons is a detectable fraction of the total. Clearly, if both donor and acceptor gaseous species are present, the result is, in part, a compensated conductivity. If more than one donor types are present, the final result is a summation of two or more responses.

The structure of the Figaro device is shown schematically in Figure 6, which is a reproduction of a figure taken from Figaro literature: "Gas-Electric Transducer", Figaro Engineering Inc., Osaka, Japan. The sensor itself is labeled "sensor" in the figure. It is not a planar thin film, the simplest configuration, but rather a three-dimensional body which can be made inexpensively. However, the same rule mentioned previously must apply: the number of electrons either given up to the sensor film or tied up by the adsorbing species must be a detectable fraction of the total number involved in the conduction process. The device is equipped with heaters so as to "purge" the surface prior to a measurement or to control the equilibrium adsorption for a given gaseous concentration.

Most of the data given by the manufacturer relate to the gaseous concentration of combustible gaseous--such as hydrogen, carbon monoxide, methane, etc.--and the device resistance. Thus, the sensitivity to carbon dioxide can only be estimated. However, some help in this estimation might be obtained from the device's response to oxygen. By rough curve fitting of the manufacturer's data for oxygen, the resistance of the device as a function of oxygen pressure can be represented by

$$R = 0.46 p^{0.59} \quad , \quad (13)$$

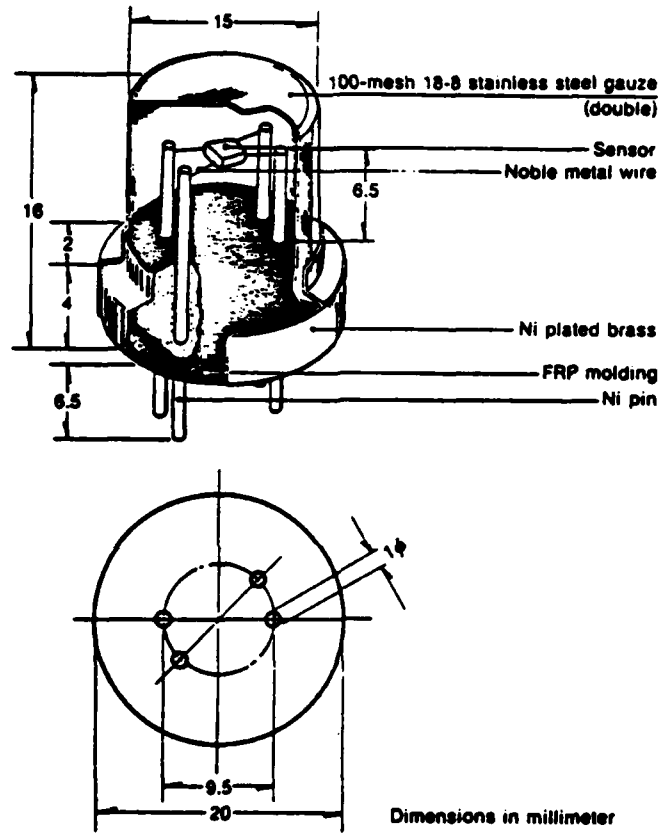

FIGURE 6. STRUCTURAL SPECIFICATIONS OF FIGARO DEVICE

where R is in kilo-ohms and p is the oxygen pressure in torr. Although it is not clear from the data, the total pressure was presumed to be 1 atmosphere and the "fill" gas was to be presumed to be nitrogen. The oxygen pressure ranged from  $10^{-2}$  to  $10^2$  torr. Whether the above equation fits data outside this range is unknown. One form of the device sensitivity can be obtained through the expression

$$\frac{1}{R} \frac{dR}{dp} = 0.59/p \quad . \quad (14)$$

In this form the sensitivity decreases with increasing oxygen pressure.

The sensitivity to carbon dioxide is likely to be equal to or less than the corresponding value for oxygen. However, the sign of the resistance change is expected to be the same as that for oxygen. (Resistance changes in the reverse direction occur for hydrogen, carbon monoxide, methane, etc.) Therefore, the sensitivity for carbon dioxide would depend heavily on the concentration of oxygen present. Some other aspects of the device parameters are summarized in Table 6.

The FET Type. The field-effect transistor (FET) has been considered as a sensor for fluids (gases and liquids). See U. S. Patent 3,999,122 (1976). In its simplest form, the FET consists of a thin-film semiconductor of one conductivity type (p or n). Affixed to either end of film are materials of the opposite conductivity type. A potential difference is applied between the end materials. At one end, electrons (or holes) are injected; at the other end, electrons (or holes) are collected (source, drain). Current is controlled by a third electrode (gate) electrically isolated from the thin-film conductor, usually by an oxide film. A potential applied to the gate "pinches off" the current through

TABLE 6. PARAMETER ESTIMATES FOR FIGARO- AND FET-TYPE SENSORS WITH RESPECT TO THE DETECTION OF CARBON DIOXIDE  
(Based on Attainable Values with Development, not on Present Devices)

Parameter	Desired Values	Figaro-Type Device	FET-Type Device
CO <sub>2</sub> measurement range	0.4-4 torr partial pressure (500-5000 ppm @ 1 atmos.)	0.01 to 100 torr if only two species present	0.01 to 100 torr if only two species present
Accuracy	±0.1 torr (2.5% @ 4 torr)	Meets accuracy requirement at low concentrations; less accurate at high concentration	Meets accuracy requirements at low concentrations; less accurate at high concentrations. With appropriate molecular filter, accuracy adequate over total range above
Specificity	Output not significantly affected by H <sub>2</sub> O, O <sub>2</sub> , N <sub>2</sub> of He	To be sufficiently specific, H <sub>2</sub> O, O <sub>2</sub> would have to be held constant	Promises sufficient specificity with appropriate polymer layer and molecular filter
Response time	63% of final output in 10 sec	Adequate response if surface "purged" with heat prior to measurement	Adequate response time
Operating temperature range	-2 to 35 C	Desired conditions could be met with built-in heaters	Desired conditions could be met with built-in heaters
Operation pressure range	1-20 atmos.	Further development of sensor structure required to meet high-pressure requirement	Variable pressure range would cause serious problems with molecular filter
Humidity effects	0-100% R.H.	See comments under <u>specificity</u> variable H <sub>2</sub> O would require surface purging	Unknown: depends on having molecular filter insensitive to H <sub>2</sub> O
Compression/decompression effects	Pressure changes of 3 atmos/min	Unknown; depends on development of adequate structure	Unknown; depends on development of adequate structure
Sensor size/weight/volume	Softball	Can better requirements	Can better requirements
Power requirements	< 5 watts (battery life ~ 1 mo.)	Can meet requirements	Can meet requirements
Calibration requirements	Minimal	Considerable first-time calibration required, especially for large total pressure range	Considerable first-time calibration required, especially for large total pressure range
EMI generated	Minimal	Very small	Very small
Sensor life	500 hrs minimal	No expected problems	No expected problems
Reliability	High	Repeatability among devices a possible problem	Repeatability among devices a possible problem
Risk associated with development	Moderate	Moderate to high	Moderate to high
Cost of development	Reasonable	Reasonable	Reasonable to high; appropriate filter the largest question
Production Unit Cost	< \$10,000	\$50	\$150

semiconductor to an extent which depends on the gate applied potential. When acting as a sensor, the gate potential is controlled by the degree of adsorption on the gate electrode.

As mentioned previously, gases can be adsorbed on a solid surface either physically or chemically, or both. The type depends on the temperature, as noted, and on the nature of the solid. Although the type is not identified in the referenced patent, it is likely that the FET sensor employs primarily physical adsorption. To force this type, a polymer film is placed over the thin-film semiconductor. The surface interaction is such that an equilibrium surface concentration of  $\theta < 1$  can occur at a lower temperature than for the Figaro sensor.

Still, the FET device is subject to interactions among several adsorbing gaseous species, if present. That is, the sensitivity to a particular molecular species depends upon how many species are present and the order (in time) of the surface exposure. As before, it takes time for one species to displace another. To help get around this problem, the referenced patent anticipates the use of a molecular filter which is placed between the atmosphere being sensed and the polymer film over the semiconducting element. This is shown as Item 41 in Figure 7, which is a reproduction of a diagram in the referenced patent. Just how effective this molecular filter can be for carbon dioxide is unknown. The patent does not specify which filter is appropriate for which molecular species. Inquiries to persons thought to be working in the area have revealed no further information. Furthermore, a commercial source of FET sensors for carbon dioxide has not been identified, although, as noted, some work in the area has occurred.



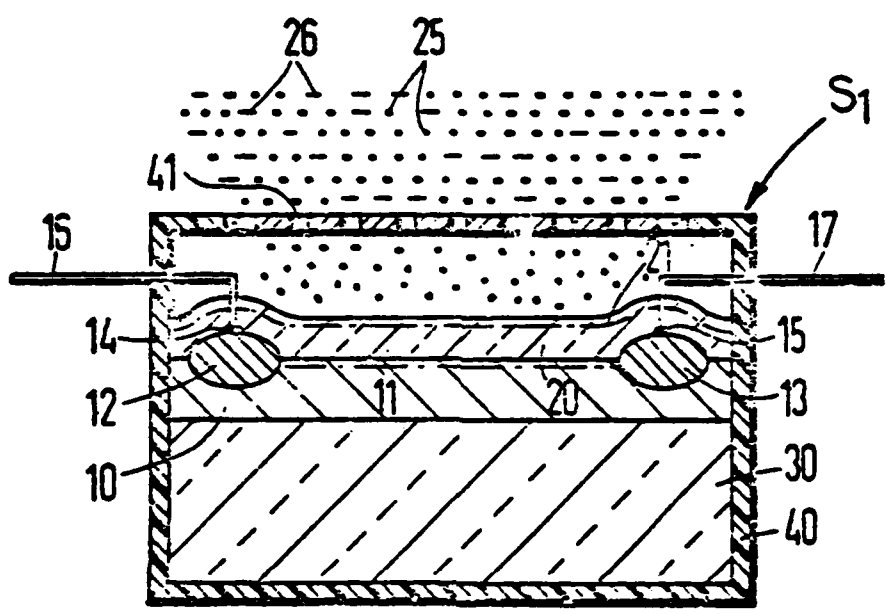

FIGURE 7. SCHEMATIC OF FET-TYPE SENSOR (taken from U. S. PATENT 3,999,122)

Many parameters are important to sensors other than sensitivity and specificity. In Table 6 certain parameters are listed for the FET devices, along with what is understood to be the desired parameters. It is to be emphasized that some of the values given in Table 6 are only estimates because present experience allows only estimates.

### Conclusions and Recommendations (Solid State)

Interactions between gaseous carbon dioxide and selected surfaces can form a basis for sensors. To date, there are at least two forms of such sensors: the Figaro and the FET types, the former involving primarily chemisorption, the latter physical absorption. In general, each promises adequate sensitivity under some sets of conditions. The chief advantages of such a sensor are compactness of size, low power utilization, and low cost. At this stage of development, however, there is a serious question of specificity to  $\text{CO}_2$ , especially in the Figaro device. In principle, the FET device could give sufficient specificity, but only with additional development. Particular attention would have to be given to the optimum selections of the polymer coating over the semiconductor film and the molecular filter for carbon dioxide. For either device, the smaller the number of different species present, the better will be the specificity and sensitivity.

At this time there are some European research efforts<sup>(21)</sup> directed at finding a suitable coating and molecular filter for an FET  $\text{CO}_2$  sensing application. It is therefore recommended that the U.S. Navy stay apprised of these efforts and respond accordingly.

### Coated Piezoelectric Crystals

Vibrating piezoelectric crystals can be utilized as carbon dioxide (CO<sub>2</sub>) sensors if a coating which is sensitive to CO<sub>2</sub> is applied to the surface of these crystals. The vibrating frequency is a function of the crystal material (e.g. quartz), the active area of the crystal, and the crystal's mass. (See Figure 8). If a coating is applied to the crystal, the overall mass is increased, which in turn reduces the resonant frequency. If this coating selectively and specifically interacts with CO<sub>2</sub> so that the overall mass of the crystal is again increased, then another decrease in oscillation frequency will be observed. The coating/CO<sub>2</sub> interaction would be reversible so that changes in frequency as a function of CO<sub>2</sub> concentration could be measured and monitored in real-time. (22-42)

This interaction involves the deposition of a small quantity of adsorbed species onto the surface of the oscillating piezoelectric crystal. The surface deposition, which occurs through adsorption or chemical reaction, results in a frequency change which (for an AT-cut quartz crystal) is given by the following equation

$$\Delta F = -2.3 \times 10^6 F^2 (\Delta m/A) , \quad (15)$$

where F is the base vibration frequency of the crystal,  $\Delta m$  is the mass of adsorbed material, and A is the active surface area of the crystal. With Equation (15), one may predict a detection response of 400 Hz/ $\mu$ g for a 9-MHz crystal, which should result in sensitivity approaching parts per billion concentrations of material such as CO<sub>2</sub>.

#### Previous Efforts

The U.S. Air Force has initiated a developmental program directed toward the application of a piezoelectric quartz crystal microbalance for use as an aircraft cockpit monitor, facility integrity monitor, or personal exposure monitor to detect hazardous levels of organophosphorous chemical warfare (CW) agents. The requirements for such a detector include accurate, rapid, and reliable performance with low power and space requirements and the ability to withstand many potential battlefield interferences, while

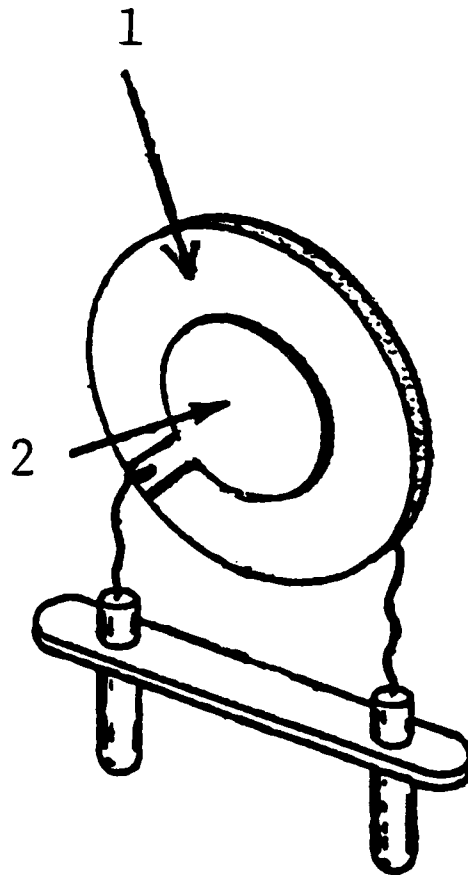

FIGURE 8. ENLARGED VIEW OF AN INDIVIDUAL QUARTZ RESONATOR: 1. QUARTZ 2. GOLD ELECTRODE COATED WITH MATERIAL SENSITIVE TO GASEOUS CONSTITUENT OF INTEREST (REF. 39)

remaining highly sensitive to trace levels of CW agents. Battelle's Columbus Laboratories recently completed an evaluation of Air Force-Supplied crystals against CW agents.

In recent years, the development and application of piezoelectric quartz microbalance crystals as environmental detectors and monitors has resulted in several devices capable of detecting trace levels of a variety of airborne materials, including hydrogen chloride, hydrogen sulfide, ammonia, mercury, pesticides, and other organophosphorous compounds and explosives.

Although coated crystals have been used to detect environmental pollutants, such as mercury, extensive work with such detectors has shown that enhanced sensitivity and selectivity may be achieved by appropriately coating the crystal with an adsorbent specific for the compounds of interest. Table 7 is an abbreviated compilation of coating types and their corresponding compound of interest. Sensitivity ranges, response and recovery times when available, and the effects of interferents have also been included. Coatings specific to CO<sub>2</sub> have not yet been developed. However, polyamines or porphyrin compounds are likely coating candidates for this sensor application.

#### Estimated Sensor Characteristics

The sensitivity of a coated piezoelectric sensor would depend on the coating type, thickness, binder, pigmentation, etc. Theoretically a coated piezoelectric can detect as little as  $10^{-12}$ g (for a 9 MHz resonant frequency). The sensitivity parameters could be adjusted to obtain the desired range of 500-5000 ppm. The accuracy should be excellent since a detector Battelle recently evaluated can distinguish a change of 1 Hz while oscillating at 9 MHz which means the error in detection is on the order of  $\pm 3$  nanograms.

The operating temperature range depends upon the choice of piezoelectric material substrate. Quartz, for example, is essentially unaffected by temperature variations (i.e.  $\pm 50^\circ$  C from ambient).

It is not known if a coated piezoelectric sensor will perform adequately at high pressures (20 atm) or for rapid changes in pressure (3 atm/min). Bulk acoustic waves are produced through the application of an AC electrical signal, and conversely, a stress X applied to a piezoelectric

TABLE 7. PIEZOELECTRIC CRYSTAL COATINGS AND PERFORMANCE DATA

Chemical Species of Interest	Coatings Used for Detection or Remarks	Sensitivity Range	Response Time	Recovery Time	Interferences
[22] SO <sub>2</sub>	Carbonax 20M	1-100 ppm	5 s	1 m	Species Concentration Relative Response SO <sub>2</sub> 30 ppm 46 H <sub>2</sub> O vapor Saturated 2 2 3 6 2 4 2 Air 992 992 992 992 992 992 992 CO CO <sub>2</sub> NO NO <sub>2</sub> H <sub>2</sub> O NH <sub>3</sub>
[23] SO <sub>2</sub>	Styrene-dimethylaminepropylmaleimide 1:1 copolymer	5-200 ppm			Species Interference? NO <sub>2</sub> Yes H <sub>2</sub> O Vapor Yes Air No O <sub>2</sub> No CO No CO <sub>2</sub> No
[24] SO <sub>2</sub>	1) P-Toluidine 2) Amine 220 3) Triethanolamine 4) Quadrol 5) Armeen 25	Too volatile Rapid saturation 10 ppb-30 ppm 10 ppb-30 ppm Rapid saturation	Few s	5 m	Species CO 10000 CO <sub>2</sub> 10000 NH <sub>3</sub> 10000 NO 1000 NO <sub>2</sub> 1000 O <sub>2</sub> None Dry Air None ppm
[25] SO <sub>2</sub>	Triethanolamine NO <sub>2</sub> causes irreversible change	25-761 ppm 1 m (761 ppm)	9 m (25 ppm) 1 m (761 ppm)	12 m	Species Concentration (ppm) AF/ppm NO 480 NO <sub>2</sub> 520 CO <sub>2</sub> Pure 20000 O <sub>2</sub> .07 H <sub>2</sub> O .84 H <sub>2</sub> O vapor 13.7
[26] SO <sub>2</sub>	Quadrol	Semi-permeable membranes used to eliminate H <sub>2</sub> O response which reduced SO <sub>2</sub> response by a factor of 4	10-700 ppm		Species H <sub>2</sub> S H <sub>2</sub> O vapor
[27] SO <sub>2</sub>	1) Triethanolamine (TEA) 2) Ethylenedinitrilotetraethanol (EDT) 3) "Thesol" (an alkanamine)	25-100 ppm 25-100 ppm Unstable			Species Concentration (ppm) Response (Hz/ppm) CO 1000 O <sub>2</sub> Pure NO 500 NO <sub>2</sub> 75 SO <sub>2</sub> 7 30
[28] NO <sub>2</sub>	1) Ucon 75-B-90,000 2) Ucon-LB-300X	Obtained from reacting ethylene oxide, propylene oxide and ethylene glycol	1 ppb-50 ppm 1 ppb-50 ppm		Species NO SO <sub>2</sub> H <sub>2</sub> S Acetone Methanol Chloroform Benzene 1) 1000 5000 10000 2000 1000 500 600 2) 1000 10000 20000 2000 1000 600 600
[29] HCl	1) Triphenylamine (TPA) 2) Trimethylamine-hydrochloride (TMA·HCl)	Hydrophilic and irreversible change with NH <sub>3</sub> at 1000 ppm	1 ppb-100 ppm 1 ppb-100 ppm	Few s 30 s	Species(1000 ppm) ΔF(Hz) 1) 82 2) 40 H <sub>2</sub> S 18 SO <sub>2</sub> 25 CO 24 NO <sub>2</sub> 36 NH <sub>3</sub> 27 CO <sub>2</sub> 30 TMA 41 -537 26 134

TABLE 7. (Continued)

Chemical Species of Interest	Coatings Used for Detection	Disadvantage(s) or Remarks	Sensitivity Range	Response Time	Recovery Time	Interferences
NH <sub>3</sub>	1) Extract of Capsicum Annum (chili pods) + AgNO <sub>3</sub>	Affected by humidity	.001-10 ppm	15 m		Chloro-10 form NH <sub>3</sub> 100 CO <sup>+</sup> NH <sub>3</sub> 300 MDZ <sup>+</sup> NH <sub>3</sub> 100 MDZ <sup>+</sup> NH <sub>3</sub> 100
	2) Ascorbic acid + AgNO <sub>3</sub>	Affected by humidity				-- -- 320 310 -10
NH <sub>3</sub>	1) L-glutamic acid-HCl (C <sub>6</sub> H <sub>11</sub> NO <sub>3</sub> ·HCl)	Hydrophilic	1 ppb-10000 ppb	< 1 m	5 m	H <sub>2</sub> S CO <sub>2</sub> Dry Air TMA
	2) Pyridoxime-HCl (C <sub>6</sub> H <sub>11</sub> NO <sub>3</sub> ·HCl)	Hydrophilic	.01 ppb-1 ppm (to ppt)	< 30 s	4 m	1) SO <sub>2</sub> NO <sub>2</sub> HCl SO <sub>2</sub> H <sub>2</sub> S CO <sub>2</sub> 1000 1000 1000 1000 2) NH <sub>3</sub> CO Gas Hexane Hexane 740 0 25 20 55 59 36 Conc.(ppm) 1.0 1000 100 100 100 1000 1000 ΔF(Hz) 1190 33 30 43 38 25 40
Aromatic Hydro-carbons	Mujol with trans-IrCl(O)(PPh <sub>3</sub> ) <sub>2</sub>	stylenes, benzaldehyde, 1,3,5-trimethylbenzene, anisole, n-butyl benzene, hexane, heptane, octane, cyclohexane, etc.	30-240 ppm	Species SO <sub>2</sub> 2000 Conc.(ppm) 2000	H <sub>2</sub> S NH <sub>3</sub> CO NO <sub>2</sub> None 100 100,000 100,000 100,000	Methane Propane Gas Hexane 100 100,000 100,000 600 Cyclo-hexane 600 Methyl-cyclo-hexane 240 p-Cymene 400 n-Hexyl-benzene 240
Hydro-carbons	Carbowax 400	Species of interest Minimum Detectable Quantity	n-Heptane .7 μg n-Octane .4 μg n-Nonane .04 μg n-Decane .02 μg n-Undecane .02 μg n-Dodecane .02 μg	Ethyl Hexanoate .2 μg Ethyl Hexanoate .2 μg Ethyl Hexanoate .2 μg Ethyl Hexanoate .2 μg Ethyl Hexanoate .2 μg Ethyl Hexanoate .2 μg	Ethyl Hexanoate .2 μg Ethyl Hexanoate .2 μg Ethyl Hexanoate .2 μg Ethyl Hexanoate .2 μg Ethyl Hexanoate .2 μg Ethyl Hexanoate .2 μg	Ethyl Hexanoate .2 μg Ethyl Hexanoate .2 μg Ethyl Hexanoate .2 μg Ethyl Hexanoate .2 μg Ethyl Hexanoate .2 μg Ethyl Hexanoate .2 μg
DIMP	1) Mercury(II) Bromide	10-500 microns of pressure	Air O <sub>2</sub> H <sub>2</sub> O Vapor	25 25 25	DIMP	
	2) Mercury(II) Chloride		Concentration(mm pressure)	20 20 100	0.7 400	
	3) Mercury(II) Iodide		1) ΔF(Hz)			

TABLE 7. (Continued)

Chemical Species of Interest	Coating Used for Detection	Disadvantage(s) or Remarks	Sensitivity Range	Response Time	Recovery Time	Interferences
<b>[35]</b> Organophosphorus Compounds	1) Fe(DIMP) <sub>2</sub> Cl <sub>3</sub> 2) Cu(DIMP) <sub>2</sub> Cl <sub>2</sub> 3) Ni(DIMP) <sub>2</sub> Cl <sub>2</sub> 4) Co(DIMP) <sub>2</sub> Cl <sub>2</sub> 5) FeCl <sub>3</sub> -Paraoxon	Most sensitive Not reversible	100-400 ppm 100-400 ppm 100-400 ppm 0-60 ppm	5) ΔF for 100 ppb 15 m	Species ΔF for 100 ppb	Drv Air 0 Lab Air 1 Air 3 CO <sub>2</sub> 2 H <sub>2</sub> O 0 SO <sub>2</sub> 8 PARAOXON 44
<b>[36]</b> Organophosphorus Compounds (Pesticides)	1) 2-Pyridylaldehyde methiodide (2-PAM) 2) Na-IBA 3) CO-IBA 4) CO-IBA-Paraoxon Note: IBA-Isonitrobenzoylaceton	Volatile Longer lifetime than Co-IBA	0-25 ppm 0-25 ppb for DIMP 0-100 ppb for DIMP	Response Time	Recovery Time	Species Conc. (ppm) Response (Hz) CO <sub>2</sub> 1000 7 NH <sub>3</sub> 20 20 Lindane 100 20 Hepta-chlor dans 0 Chloro-chlor saturat. 2 175 26 1000 10
<b>[37]</b> Organophosphorus Compounds	1) L-histidine hydrochloride 2) DL-histidine hydrochloride 3) Succinylcholine chloride 4) Succinylcholine iodide 5) 2-PAD 6) 3-PAD 7) 3-PAD+Triton X-100+NaOH		DIMP (15 ppm) 30 Malathion (1 ppm) 1414 Parathion (1.5 ppm) 126	Response Time	Recovery Time	Species Conc. (ppm) Response (Hz) ΔF (Hz) 126 23 23 474 76 76 519 44 44 490 -- -- 64 24 24
<b>[38]</b> Mononitrotoluenes (MNT) i.e., Explosives	Carbowax 1000		Species Conc. (ppm) ΔF (Hz) SO <sub>2</sub> 1000 6 H <sub>2</sub> S 100 7 NH <sub>3</sub> 1000 15 CO 100 4	Response Time 20 s Recovery Time 150 s		Benzene 10 Toluene 5 Chloroform 11 Ethyl Alcohol 25 100 18 100 9 100 71
						Species Conc. (ppm) ΔF (Hz) Ethyl alcohol 1000 10 Benzene 1000 5 Toluene 1000 20 Acetone 1000 11 Chloroform 1000 10 1000 50 500 21 200 9
						Conc. (ppm) ΔF (Hz) Gambit 20 0 Chantilly 25 8 Eau de Toilette 21 6



crystal will change the electric polarization. In schematic one-dimensional notation, the piezoelectric equations are:

$$P = Zd + Ex; e = Zs + Ed , \quad (16)$$

where P is the polarization, Z the stress, d the piezoelectric strain constant, E the electric field,  $\chi$  the dielectric susceptibility, e the elastic strain, and s the elastic compliance constant.

The size of the sensor can be somewhat realized from Figures 9, 10, and 11. In addition to the crystal and its holder, an amplifier, frequency counter, and power supply would be needed. It is highly probable that the system could be miniaturized to the size of a pocket calculator, especially if power is supplied by batteries.

The power requirements for two crystals, (one being an uncoated reference), amplifiers, mixers, and displays would be less than 100 mW. The crystals by themselves require only a few milliwatts. If a CMOS microcomputer is used to collect data, then 140-180 mW would be required. Little or no EMI would be generated since the conversion of electrical and mechanical energy is very efficient. Currently these devices are calibrated with a high frequency (>9 Mhz) oscilloscope to determine the resonant frequency after a CO<sub>2</sub>-sensitive coating is applied, and the maximum variation from this resonant frequency which would still permit the device to function. The device is then adjusted to vibrate at a frequency as high as possible above the resonant frequency but within the allowable range so that when the device is allowed to interact with CO<sub>2</sub>, the decrease in vibration frequency does not force the crystal to operate outside (i.e. below) the allowable range.

Coatings would be the primary factor in sensor operational life. Presently, provided the coatings are not degraded by interferences, sensors have an operational life of about one month (720 total hours).

These systems are highly reliable, and would involve a relatively moderate risk associated with development. The principal effort required to develop this device is in the selection and preservation of a coating. One year or less is estimated for the development of a CO<sub>2</sub> prototype and final production unit cost would, in all likelihood, be less than \$100. A summary of the above discussion is given in Table 8.

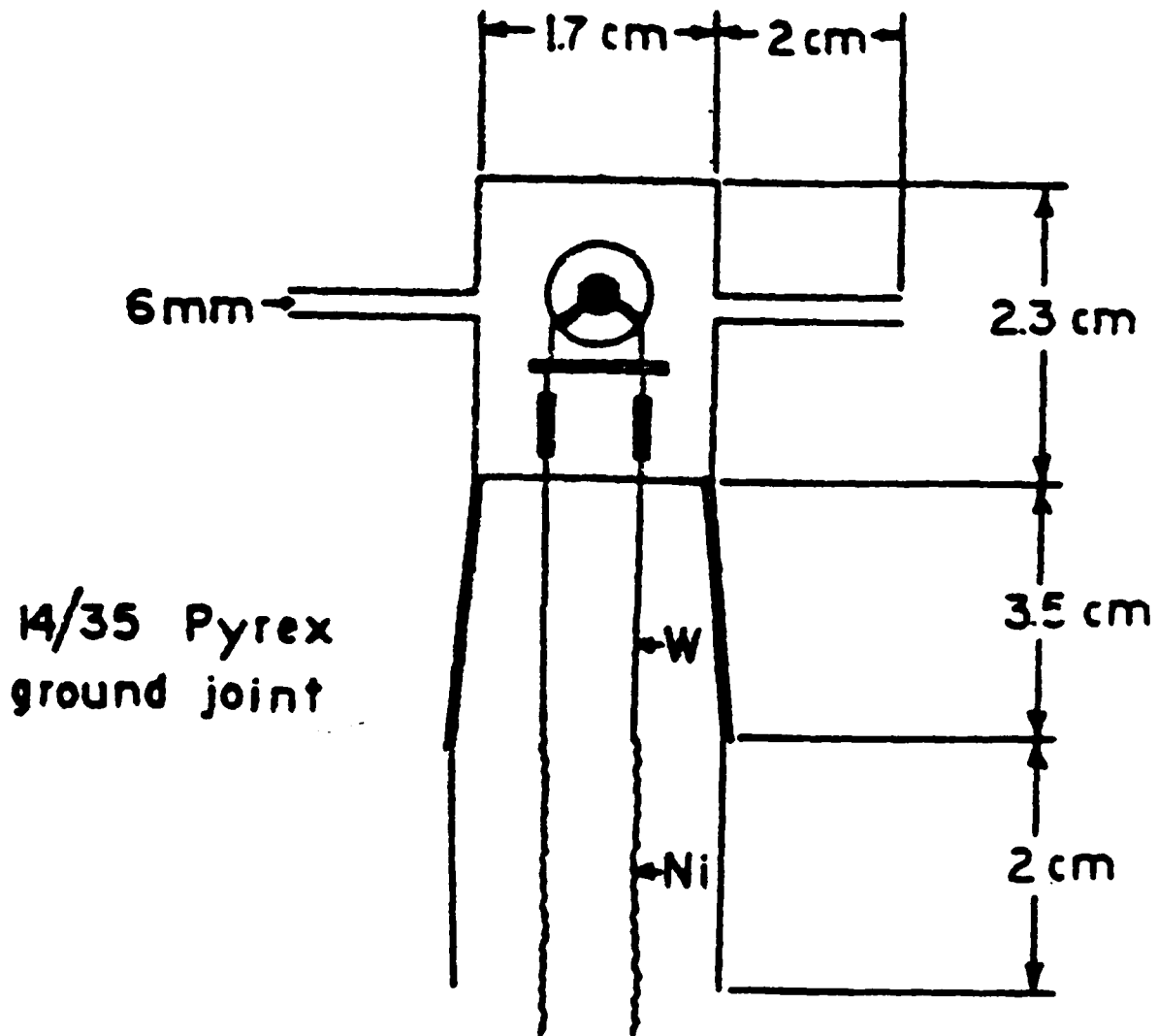

FIGURE 9. GLASS GAS-TIGHT PIEZOELECTRIC CRYSTAL CELL, SIDE VIEW (REF. 40)

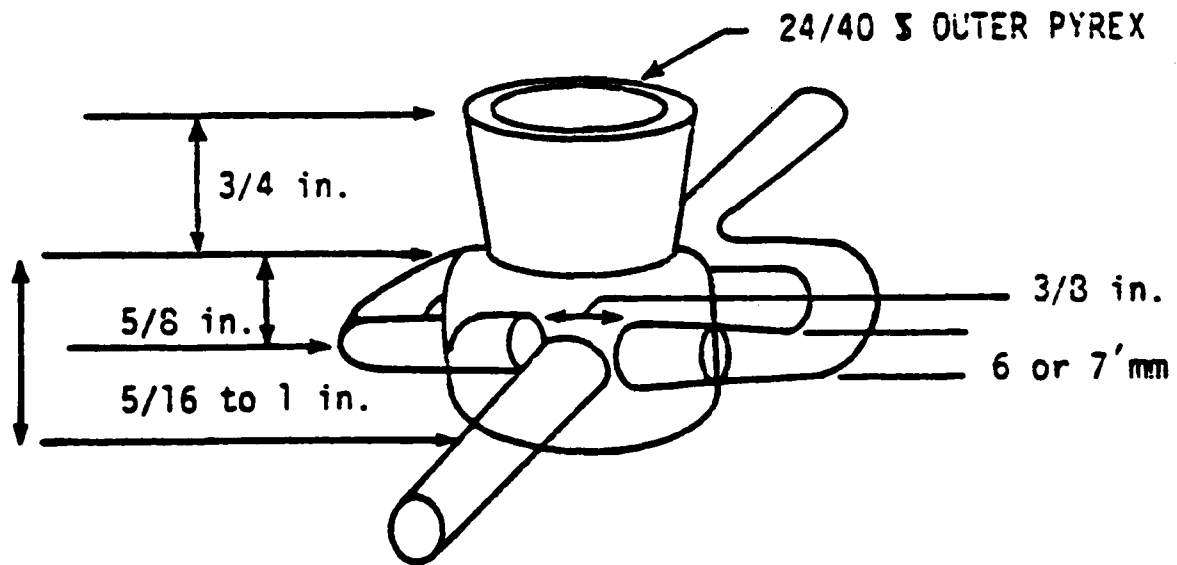

FIGURE 10. TYPICAL PIEZOELECTRIC CRYSTAL HOLDER (REF 41)

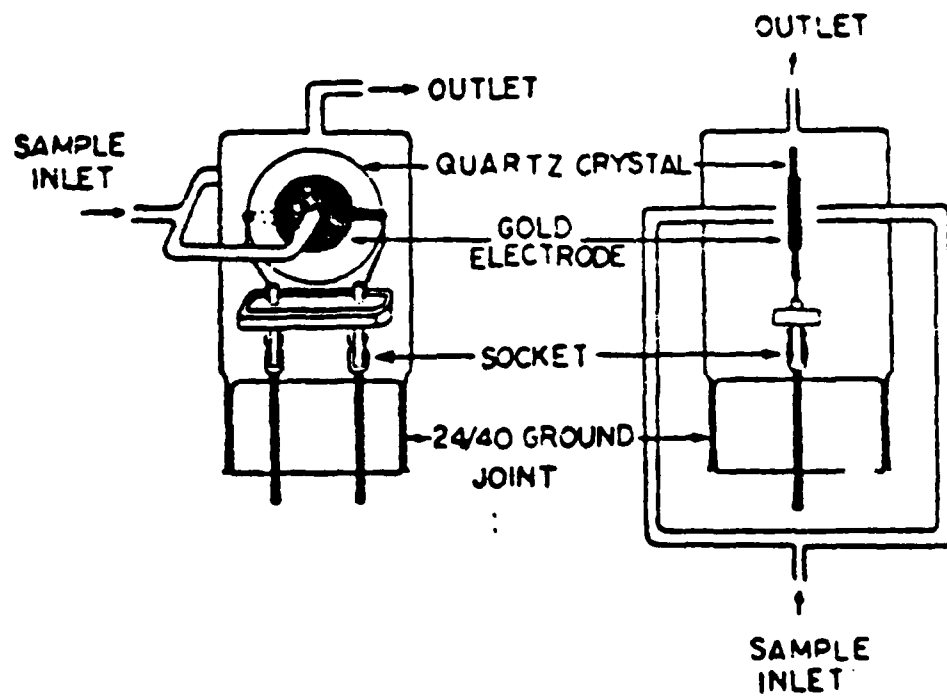

FIGURE 11. DETAILS OF A TYPICAL DETECTOR CELL DESIGN (REF. 42)

TABLE 8. SUMMARY OF PIEZOELECTRIC PROPERTIES  
NOT LISTED IN TABLE 7

Sensitivity	Adjustable (also see Table 7)
Accuracy	3 nanograms (@ 9 MHz)
Specificity and Humidity	Can be controlled or compensated (also see Table 7)
Response time	~5 s
Operating temp. range	Ambient $\pm$ 50° C
Operating pressure range and pressure changes	Unknown
Sensor size/wt/volume	Entire system the size of a pocket calculator
Power requirements	< 100 mW (<150 mW if microcomputer is used)
Calibration requirements	One time factory calibration
EMI generated	None
Sensor operational life	1 month (720 hours)
Reliability	High
Development risk	Moderate
Development cost	1-2 man-years
Production unit cost	<\$100

### Conclusions and Recommendations (Piezoelectric)

The piezoelectric microbalance technique could possibly be used to provide a sensor for application to hyperbaric environments. The chief advantages of this sensor concept are the compactness of size, minimal power requirements, and low cost. However, a key step in development of this sensor concept is the identification and testing of an as yet unknown coating material that would be both sensitive and selective to  $\text{CO}_2$ . Although coatings have been discovered for various other gases, no guarantee can be made that one will be satisfactory for  $\text{CO}_2$  detection. Furthermore, coating susceptibility to aging, as well as, temperature and pressure effects would have to be evaluated.

To our knowledge, no work is being done on coating development applicable to a  $\text{CO}_2$  sensitive piezoelectric microbalance. It is therefore recommended that the Navy consider funding a modest program to develop such a  $\text{CO}_2$  sensitive coating. Several candidate classes of coating materials have already been identified including polyamines and porphyrins. Quartz piezoelectric crystals are commercially available as well as the associated oscillator circuits, power supplies, and frequency counters. For this reason, piezoelectric microbalances would provide a rapid means by which experimental  $\text{CO}_2$ -sensitive coatings could be evaluated. The piezoelectric microbalance would also serve as an excellent breadboard device for testing of the coatings and the crystal in a simulated diving environment.

### Surface Acoustic Wave (SAW) Devices

A Surface Acoustic Wave (SAW) is created on the surface of a piezoelectric material, such as lithium niobate or quartz, by applying an alternating potential difference to a set of interdigital metal electrodes (transducers) that are physically attached to the surface of the solid. The metal electrodes are typically made of aluminum at a thickness between 500 Å and 5000 Å, and are oriented horizontally in the surface plane of the solid. (43, 44)

The periodic electrical signal applied to the input transducer creates a periodic mechanical deformation on the surface of the crystal. The center frequency of the transducer is determined by the electrode spacing and the acoustic velocity. When the spacing between the electrodes corresponds to the acoustic wavelength, constructive interference between the sets of electrodes occurs and an acoustic wave is generated. The center, or synchronous, frequency,  $f_0$ , of the SAW transducer is given by the equation:

$$f_0 = \frac{v}{d}, \quad (17)$$

where  $v$  is the acoustic velocity and  $d$  is the spatial period of the transducer.

Once the SAW is generated, it propagates away from the interdigital transducer in both directions perpendicular to the electrodes. When the SAW arrives at the output transducer, the inverse piezoelectric effect generates an electrical signal on the metal electrodes.

The velocity of the acoustic wave on the surface is typically 3500 meters per second (lithium niobate) which is about five orders of magnitude less than the velocity of light, and therefore relatively large delays can be achieved with a small path length. More than 95 percent of the SAW energy is confined to within one acoustic wavelength of the surface, so the propagation is essentially lossless.

The acoustic velocity can be altered by a number of techniques including changing the characteristics of the crystal, coupling into another material with a different velocity, or applying a coating to the surface of the crystal and forcing the SAW to travel through the coating. If a coating were made sensitive to carbon dioxide and the characteristics

changed as a function of the concentration of carbon dioxide, a device that monitors the velocity of the acoustic wave could be used to detect and monitor the concentration of carbon dioxide.

Such a device could be a coated delay line oscillator, shown in Figure 12. The basic SAW delay line oscillator recirculates the acoustic wave by electrically feeding back the signal of one transducer to the other. The circuit would have resonant frequencies whenever the phase shift around the loop is an integer multiple of  $2\pi$ . That is, the circuit oscillates when it satisfies the condition:

$$\frac{\omega L}{v} + \phi_E = 2n\pi, \quad (18)$$

where  $\omega$  is angular frequency,  $L$  is the length of the delay line,  $v$  is the acoustic velocity,  $\phi_E$  is the electrical phase shift associated with the amplifier and matching networks, and  $n$  is an integer. From this it can be seen that the oscillator will oscillate at multiple frequencies,

$$f = \frac{v}{2\pi L} (2n\pi - \phi_E). \quad (19)$$

To obtain single frequency operation, the SAW transducer must be designed to limit the loop gain to less than unity for all but the desired oscillation frequency.

### Previous Efforts

Battelle has for the past two years been engaged in internal R&D on SAW devices and their signal processing capabilities.

A general patent on coated SAW devices was granted on January 26, 1982 to Henry Wohltjen, currently of the Naval Research Laboratory. He is presently conducting research on the physics of interaction of the coating with atmospheric constituents of interest. Similar work has been reported in the literature (IEEE Vol. EDL-3, No. 6, June, 1982, p. 145) on an ZnO-on-Si SAW oscillator coated with polyvinylchloride to detect acetone vapor.



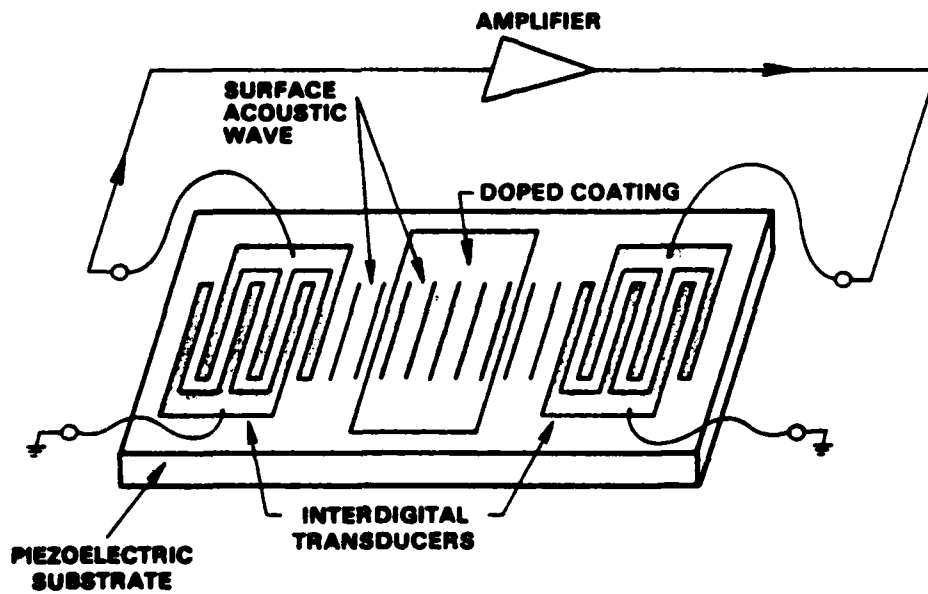

FIGURE 12. COATED SURFACE ACOUSTIC WAVE (SAW) DEVICE

### Estimated Operating Characteristics

Operating characteristics depend on the piezoelectric substrate material, SAW electronic configuration and the coating type, thickness, binders, pigmentation, and crosslink density. These parameters can be adjusted so that the range of detectable  $P_{CO_2}$  is 500-5000 ppm at 1 atm. A typical SAW oscillator might have a fundamental frequency of 400 MHz, a long term stability of better than 3 ppm/year and a short term (less than 10 s) stability of  $10^{-9}$ . The coating then would determine the overall accuracy, but for thin coatings, the accuracy will approach that of the bare SAW oscillator.

In general both the SAW oscillator and the coating will be affected by  $H_2O$  vapor. Provided the activity of the coating is not significantly impaired in the presence of  $H_2O$  vapor, the signal due to  $H_2O$  can be somewhat compensated by using two SAW devices in an interferometric mode. The SAW oscillator should not be affected by  $O_2$ ,  $N_2$ , or He, but the same is not necessarily true for the coating. The design of the coating, however, would be such that it interacts only with the atmospheric constituent of interest, (e.g.,  $CO_2$ ). In this case, response time is, in general, instantaneous.

The center frequency and delay of a SAW device are temperature dependent. There are several materials available for use as surface wave substrates and the choice of material depends on the required temperature characteristic, bandwidth, and insertion loss. Typical oscillators vary less than 80 ppm over a range of  $t_0^* \pm 50^\circ C$ . Delay lines vary less than 80 ppm over the same range if the bandwidth is less than 5%. If the delay line bandwidth is greater than 5%, then the device would vary about 94 ppm/ $^\circ C$ .

The piezoelectric and inverse piezoelectric effect, utilized in the SAW device, produce or is initiated by pressure variations, respectively. Ambient pressure changes of 3 atm/minute or an overall range of 1 to 20 atm may prevent the SAW device from operating altogether, or it may be possible to compensate for these pressure levels.

A SAW oscillator module (including maintaining amplifier) is less than 20mm x 20mm x 10mm. The size of a SAW delay line depends on the desired delay. A 1 $\mu s$  delay requires a substrate length of  $\approx 3$ mm. These estimates do not include the size of the battery pack.

\* Note that  $t_0$  = ambient temperature

In the case of radar with SAW pulse compression, a typical SAW unit for synchronous encoding, two similar SAW compression channels, along with hybrid circuits for digital control of the I.F. unit timing and the necessary gain elements can be enclosed in a volume of  $100 \times 100 \times 25\text{mm}^3$ , have a mass of 700 grams and consume about 10 watts of power. The SAW specifications for a  $\text{CO}_2$  detector will undoubtedly be different, requiring at most two SAW units instead of three and having different and possibly less power consumptive requirements on bandwidths, insertion losses, and delays.

As far as calibration requirements, and if a SAW interferometer is used, the only adjustment needed would be setting the display equal to zero, much like using a voltmeter or ohmmeter.

Ninety-five percent of the energy in the surface acoustic wave is contained within one wavelength of the surface, i.e., the propagation is essentially lossless. In addition, the transfer of electrical to mechanical energy in producing the SAW is very efficient so that little or no EMI is generated.

Aging rates for a base SAW oscillator or delay line are at ut 1-2 ppm/year and so are insignificant. The coating, on the other hand, is often volatile, or gradually diminished in sensitivity in the presence of interfering gaseous constituents. An operational life of 500 hours might be accomplished by the choice of coating binder, or the use of thin plastic perforated layers applied over the coating to increase specificity and reduce the rate of degradation due to interferants. Coatings last approximately one month from our experience which is greater than 500 hours.

The reliability of a coated SAW device should be high and the risk associated with development is probably moderate. A key element in this development process is the identification and testing of a coating sensitive and selective to  $\text{CO}_2$ . Provided such a coating or combination of coatings, can be formulated, a prototype device could be developed in two years or less (2 man-years effort). Finally, production unit cost could be as low as \$100 each. Table 9 contains a summary of the above discussion.

TABLE 9. SAW CHARACTERISTICS

CO <sub>2</sub> measurement range	Adjustable
Accuracy	Determined by coating (3 ppm/year for SAW)
Specificity and Humidity	Can be controlled or compensated
Response time	1-100 $\mu$ s
Operating temperature range	Ambient $\pm$ 50° C
Oper. press. range and press. changes	Unknown
Size/wt/vol	Overall (excl. power pack) 100 x 100 x 25mm, 700g
Power requirements	< 10 W
Calibration requirements	None
EMI generated	None
Sensor life	1 month (720 hrs)
Reliability	High
Devel. risk	Moderate
Cost of development	2-3 man-years
Production unit cost	< \$100

### Conclusions and Recommendations (SAW)

Sensors employing the surface acoustic wave (SAW) principle could possibly be used to measure CO<sub>2</sub> in a hyperbaric environment. Many of the comments made above regarding application of the piezoelectric microbalance principle also apply to SAW devices especially regarding the need to develop a special CO<sub>2</sub> sensitive/selective coating. In fact, the piezoelectric apparatus would serve as an excellent "proof of principle" device in screening coating materials that would also be applicable to SAW devices. However, SAW devices would display a significantly greater sensitivity, so a marginal performing coating on a piezoelectric microbalance should, in all likelihood, perform well on a SAW device.

### Calorimetric Technique

This sensor concept is based upon the fact that a fixed amount of heat is released for each mole of CO<sub>2</sub> that is passed over a granular bed of metallic hydroxide. (45, 46) CO<sub>2</sub> is also consumed in the reaction so the sensor would have a theoretically adequate response time. For example, nearly 2 joules (i.e. 0.5 calories) are released per milligram of CO<sub>2</sub> reacted with lithium hydroxide according to the reaction:

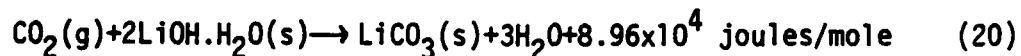

The above reaction is comparable to the process which occurs in the actual CO<sub>2</sub> scrubber worn by divers. A sensor based on this CO<sub>2</sub> scrubbing reaction might, therefore, be called a "diagnostic scrubber". To use the heat release (i.e. calorimetric) principle as a CO<sub>2</sub> sensor, either the amount of heat released is measured directly using a differential thermopile (i.e. calorimeter) or the temperature rise of the gas passing through the sensor is monitored using thermocouples or thermistors. The amount of heat released or temperature rise being directly proportional to the moles of CO<sub>2</sub> passing through the sensor per unit time period. For a fixed volume flow rate of gas through the sensor, the heat release or temperature rise would thereby be proportional to the volume (i.e. mole) fraction of CO<sub>2</sub>.

in the gas mixture under test. The calorimetric type, rather than temperature rise version of this heat release principle, seems most attractive at this time and it will be discussed below.

One gram of LiOH will absorb 0.7 grams of CO<sub>2</sub> and release 2 kilojoules of heat. The density of CO<sub>2</sub> for diving applications is approximately 0.01 grams/liter of test gas (i.e. 4 mm-Hg partial pressure) for both shallow and deep diving conditions. If a 1 ml/minute sample was extracted from the diver's breathing line, passed through the "diagnostic scrubber", and returned to the line, then  $1.67 \times 10^{-9}$  gr/sec of CO<sub>2</sub> would be consumed, which would generate 0.33 milliwatts of heat. At this sampling rate  $2.4 \times 10^{-7}$  gr/sec of LiOH would be used up. Therefore, a sensor containing 1 gram of LiOH would last  $4.2 \times 10^6$  sec or 1200 diving hours.

Lower levels (i.e. densities) of CO<sub>2</sub>,  $\rho_{CO_2}$  would result in less heat, Q, being generated as well as longer sensor life and vice versa according to the equation

$$Q = 2 \rho_{CO_2} \dot{V} \text{ [watts]} \quad (21)$$

where,

$$\rho_{CO_2} - \text{CO}_2 \text{ density in gm/cm}^3$$

$$\dot{V} - \text{sampling rate in cm}^3/\text{sec}$$

From equation (21) it can be noted that the heat released, which is measured with a small differential thermopile (i.e. calorimeter), is directly proportional to CO<sub>2</sub> density, provided a constant sampling rate is maintained.

#### Estimated Sensor Characteristics

No commercially available sensor employing this principle is known to exist. However, this device could be readily constructed. A calorimeter for detecting 1 microwatt of heat release was assembled by Vurek<sup>(46)</sup>. With this caloric sensitivity, sensor accuracy should be excellent. The sensor is specific to CO<sub>2</sub> via the reaction in Equation (20). Interference from other gases results only from variable gas mixtures since maintaining constant flow rates could be mixture dependent. Reference (46) quotes a 10% - 90% rise/fall time of 100 seconds using a rather long (i.e. 25 cm) sampling line. Operating pressure changes would not be a problem except

as gas mixture variations and total pressure changes affect the constancy of sampling rate. Temperature changes are important in that the reaction in Equation (20) is somewhat temperature dependent. The differential calorimeter should be well insulated to assure that temperature effects are minimal. Humidity and compression/decompression effects should be minimal and the sensor system weight and volume requirements should be easily attained. The sensor itself is passive, but the calorimeter requires readout electronics and a sampling system is needed which may use some power. However, overall power of 5 watts from batteries should be adequate. Calibration requirements should be minimal and EMI interference also minimal. The reliability of this device should be high, risk associated with development moderate (i.e. development costs less than 2-3 man years). Production unit costs should not exceed \$1000. These sensor properties are summarized in Table 10.

#### Conclusions and Recommendations (Calorimetric)

It appears that the basic principle behind the calorimetric sensing technique is sound. The fact that there is no commercial instrumentation using this technology is not surprising since sensor life is limited due to LiOH consumption. A key factor in the success of this method for hyperbaric applications is the adequate performance of the calorimeter sampling system which must maintain a constant sampling rate over a range of pressure, temperature and gas mixture. All the heat must be extracted from the sample for all conditions. Therefore, the device must be designed for the worst case. The greatest advantages of this sensor concept are its simplicity, excellent sensitivity and selectivity to CO<sub>2</sub>.

It is therefore recommended that a calorimetric device be considered as a candidate for the desired CO<sub>2</sub> sensor for hyperbaric application. The next step in the development process would be to engineer a device that would be applicable to the expected diving environment. Tests should then be performed in simulated UBA scenarios to demonstrate the applicability of this sensor concept.

TABLE 10. SUMMARY OF PROPERTIES FOR  
CALORIMETRIC SENSOR SYSTEM

Measurement range	0.04 - 10 mm-Hg
Sensitivity	.004 mm-Hg attainable
Accuracy	OK
Specificity	OK
Response time	<100 sec
Operating temperature range	OK
Pressure range	OK
Humidity	OK
Compression	OK
Size	<1000 cm <sup>3</sup>
Power	OK
Calibration	OK
EMI	OK
Life	10,000 diving hours @ 0.4 mm-Hg for 1 gram change
Reliability	Good
Development risk	Modest
Development cost	<2 man-years effort
Production cost	<\$1000



### Miscellaneous Methods

The operating principles of several concepts appear sound but also resemble, in some respects, the technology discussed above. For this reason they are classified as miscellaneous methods. The methods identified as miscellaneous include:

- Chemical change
- Complex impedance

These concepts are also less defined and are not likely to be a serious candidate for the desired CO<sub>2</sub> sensor even if more definition was provided. However, for completeness they are grouped in this section and discussed below.

#### Chemical Change

A measurement technique based upon chemically reacting CO<sub>2</sub> to produce another gas which can be detected using available methods can also form the bases for a sensor. Due to the small amount of CO<sub>2</sub> present, it would be advantageous if the gas produced in this reaction were not one of the gases normally present in diving environments (i.e. O<sub>2</sub>, He, N<sub>2</sub>) Of course, the gas produced should also not be hazardous to the diver's health.

One known art<sup>(47)</sup> for developing such a sensor involves reacting CO<sub>2</sub> with a solid hydroxide to consume the CO<sub>2</sub> and produce water vapor as in Equation (20) above. This concept is, therefore, another form of "diagnostic scrubber" except water vapor production rather than heat release is used. The amount of water vapor (i.e. mm-Hg) produced is directly proportional to the partial pressure of CO<sub>2</sub> present in the test gas stream. Since the water vapor is naturally present in a UBA system, the test gas must first be dried to remove any input vapor which would be confused with that produced via Equation (20). A desiccant such as calcium chloride or anhydrous calcium sulfate can be used to perform this drying function. Further, the sensor must be heated to assure that the water vapor does not

condense prior to its measurement at the exit of the diagnostic scrubber. A suitable Hygrometer (i.e. water vapor sensor) to measure the low water vapor content (i.e.  $H_2O$  from .4 - 4 mm Hg) must be used and temperature must be held constant during these humidity measurements to insure accurate results.

No commercially available instrument using this sensor concept is known to exist. However, a device could be assembled based upon the art described in Reference 47. The most difficult problems would be attaining complete drying of the input gas to the sensor, and obtaining a water vapor detector that could provide accurate measurements at low water vapor levels. Thunder Scientific (Albuquerque, N.M.) claims that their water vapor sensor could operate at 1-20 atm and -10 to 60° C to provide a measurement of vapor at 4 mm-Hg with an accuracy of 2%. However, this remains to be demonstrated in actual tests at hyperbaric conditions.

Conclusions and Recommendations (Chemical Change). Although the basic idea is sound, no suitable chemical reaction has been identified that would provide the desired sensor characteristics. Therefore, this sensor concept is less desirable than the calorimetric "diagnostic scrubber" techniques. The main reasons for this lower rating are difficulties in obtaining complete drying of the sensor input gas, and measurement of the low concentration of water vapor produced in the chemical reaction. For these reasons the chemical change sensor concept is not recommended for continued development at this time.

#### Complex Impedance Effects

This sensor concept is similar to the solid state sensor technique discussed above in that an unknown coating must be found whose electrical properties are affected by  $CO_2$  adsorbed on the sensor surface. In this particular case, a sintered metal is coated with the desired material. The coating is thin such that good porosity is still maintained. By using this type of material, a large surface area can be realized. It has been

postulated that a measurement of the complex impedance of this porous material could be used as a CO<sub>2</sub> sensor. Thunder Scientific (Albuquerque, N.M.) has produced a water vapor sensor based upon this concept. However, in discussions with representatives of this company, they admit that no coating has been discovered to date that provides satisfactory results for CO<sub>2</sub> monitoring.

Conclusions and Recommendations (Complex Impedance). There is no fundamental reason why the complex impedance sensor could not ultimately be applicable to CO<sub>2</sub> sensing for hyperbaric environments. If a suitable CO<sub>2</sub> sensitive/selective coating can be found, it is likely that a device can be engineered for UBA conditions. This confidence is based on the fact that the water vapor sensor, which uses the principle, has been successfully operated in environments similar to the hyperbaric case. As stated above in the discussion on solid state sensors, there is ongoing work in Europe by Plihal et al<sup>(21)</sup> directed toward the development of a coating for FET sensors. This work may also be applicable for providing the coating required for the complex impedance sensor concept. Therefore, the authors recommend that the U.S. Navy stay cognizant of this work since it also applies to this particular sensor technology area.

## REFERENCES

- (1) Severinghaus, J.W. and Bradley, A.F., *J. Appl. Physiol.*, 13, 515 (1958).
- (2) Greene, M.W., "Oxygen and Carbon Dioxide Partial Pressure Sensors for Hyperbaric Applications", *Mar. Sci. Instrum.*, 4, 116, (1968).
- (3) Eberhard, P. and Schäfer, R., "A Sensor for Non Invasive Monitoring of Carbon Dioxide", *J. Clin. Engin.*, 6, 35 (1981).
- (4) "Development of a Helium/Carbon Dioxide/Hydrogen Sensor System for Scuba", by Industrial and Biomedical Sensors Corp. for Office of Naval Research, Arlington, VA, Contract No. N00014-92-C-0134, August (1982).
- (5) "A New Carbon Dioxide Sensing Method Suitable for Use in Microelectrode Sensors" by Giner Inc. for Office of Naval Research, Arlington, VA, Contract No. N00014-82-C-0285, August (1982).
- (6) Albery, W.J. and Barron, P., "A Membrane Electrode for the Determination of CO<sub>2</sub> and O<sub>2</sub>", *J. Electroanal. Chem.*, 138, 79 (1982).
- (7) Bushman, J.A., "Gas Detecting and Measuring Apparatus," U.S. Patent No. 4,326,200, April 20, 1982, Assigned to Neotronic Ltd., Bishops Stratford, England.
- (8) Chamberland, A.M. and Gauthier, M., "Solid State Sensor for Anhydrides", Canadian Patent No. 1,040,264, October 10, 1978, granted to Hydro-Quebec, Canada.
- (9) "Feasibility of a Solid-State CO<sub>2</sub> Partial Pressure Monitor", proposal to Naval Coastal Systems Center by Georgia Institute of Technology, April, 1982.
- (10) See for example, Fogg, A.G., Pathan, S. and Burns, D.T., *Analytica Chim. Acta.*, 73, 220 (1974) or Herman, H.B. and Rechnitz, G.A., *Science*, 184, 1074 (1974).
- (11) McRae, W.A., McGriff, S.G. and Leitz, F.B., "Electrochemical Sensor Device", U.S. Patent No. 3,558,279, January 26, 1981, assigned to Ionics, Inc., Watertown, Mass.
- (12) J.N. Howard, D.L. Burch, and D. Williams, *J. Opt. Soc. Am.* 46, 186, 237, 334 (1956).
- (13) D.K. Edwards, *J. Opt. Soc. Am.* 50, 617 (1960).
- (14) U.S. Patent 4,011,859, "Method for Continuously Measuring the CO<sub>2</sub> Content in Breathing Gases", Inventor: Horst Frankenberger, Assignee: Drägerwerk Aktiengesellschaft, Germany (March 15, 1977).

REFERENCES  
(Continued)

- (15) H.J. Gerritsen, E.E. Crisman, and J.T. Daly, "Development of Solid State Infrared Emitters for Gas Detection Applications", GRI Contract Number: 5080-363-0310, Gas Research Institute, Chicago, Illinois, (May, 1981).
- (16) "The Electronic Theory of Catalysis on Semiconductors" by F. F. Vol'kenshtein, Pergamon Press, The Macmillan Company, New York (1963).
- (17) "The History of Chemically Sensitive Semiconductor Devices" by P. Bergveld and N. F. DeRooij, Sensors and Actuators, 1 (1981) 5-15.
- (18) "Field Effect Transistors to Detect Chemical Warfare Agents in Aircraft" by J. Janata, R. J. Huber, R. Cohen, E. S. Kolesar, Jr., USAF School of Aerospace Medicine, SAM-TR-80-25, August, 1980.
- (19) "A Surface Chemical View of Gas Detection" by J. R. Stetter, J. of Colloid and Interface Science, Vol. 65, No. 3, July, 1978, pp 432-443.
- (20) N. Taguchi, U.S. Patent 3,631,436 (1970).
- (21) Plihal, Manfred, et al., "Gas-Sensitive Semiconductor Field-Effect Sensors", Report No. BMFT-FB-T, 80-091 (1982).
- (22) A. Lopez-Roman and G.G. Guilbault, Use of piezoelectric crystals as sensitive and specific detectors for SO<sub>2</sub>, Anal. Lett., 5 (1972) 225-235.
- (23) M.W. Frechette and J.L. Fasching, Simple piezoelectric probe for detection and measurement of SO<sub>2</sub>, Environ. Sci. Technol., 7 (1973) 1135-1137.
- (24) K.H. Karmarkar and G.G. Guilbault, A new design and coatings for piezoelectric crystals in measurement of trace amounts of sulfur dioxide Anal. Chim. Acta, 71 (1974) 419-424.
- (25) J.L. Cheney and J.G. Homolya, A systematic approach for the evaluation of triethanolamine as a possible sulfur dioxide sorption detector coating, Anal. Lett., 8 (1975) 175-193.
- (26) K.H. Karmarkar, L.M. Webber and G.G. Guilbault, Measurement of sulfur dioxide in automobile exhausts and industrial stack gases with a coated piezoelectric crystal detector, Anal. Chem. Acta, 81 (1976) 265-271.

REFERENCES  
(Continued)

- (27) J. Cheney, T. Norwood and J. Homolya, The detection of sulfur dioxide utilizing a piezoelectric crystal coated with ethylenedinitrilotetraethanol, *Anal. Lett.*, 9 (1976) 361-377.
- (28) K.H. Karmarkar and G.G. Guilbault, The Detection of ammonia and nitrogen dioxide at the parts per billion level with coated piezoelectric crystal detectors, *Anal. Chim. Acta*, 75 (1975) 111-117.
- (29) J. Hlavay and G.G. Guilbault, Detection of hydrogen chloride gas in ambient air with a coated piezoelectric quartz crystal, *Anal. Chem.*, 50 (1978) 965-967.
- (30) L.M. Webber and G.G. Guilbault, Coated piezoelectric crystal detector for selective detection of ammonia in the atmosphere, *Anal. Chem.*, 48 (1976) 2244-2247.
- (31) J. Hlavay and G.G. Guilbault, Detection of ammonia in ambient air with coated piezoelectric crystal detector, *Anal. Chem.*, 50 (1978) 1044-1046.
- (32) K.H. Karmarkar and G.G. Guilbault, Detection and measurement of aromatic hydrocarbons in the air by a coated piezoelectric crystal detector, *Environ. Lett.*, 10 (1975) 237-245.
- (33) F.W. Karasek and J.M. Tiernay, Analytical performance of the piezoelectric crystal detector, *J. Chromatogr.*, 89 (1974) 31-38.
- (34) G.G. Guilbault, The use of mercury (II) bromide as coating in a piezoelectric crystal detector, *Anal. Chim. Acta*, 39 (1967) 260-264.
- (35) E.P. Scheide and G.G. Guilbault, Piezoelectric detectors for organophosphorous compounds and pesticides, *Anal. Chim.*, 44 (1972) 1764-1768.
- (36) W.M. Shackelford and G.G. Guilbault, A piezoelectric detector for organophosphorous pesticides in the air. *Anal. Chim. Acta*. 73 (1974) 383-389.
- (37) G.G. Guilbault and Y. Tomita, A coated piezoelectric crystal to detect organophosphorous compounds and pesticides, *Sensors and Actuators*, 2 (1981/82) 43-57.
- (38) Y. Tomita, M.H. Ho and G.G. Guilbault, Detection of explosives with a coated piezoelectric quartz crystal, *Anal. Chem.*, 51 (1979) 1475-1478.
- (39) King, William, H., Jr., "Using Quartz Crystals as Sorption Detectors... Part 2", *Research/Development*, Vol. 20, pp 28-34 (May, 1969).

REFERENCES  
(Continued)

- (40) Lopez-Roman, A., and Guilbault, George G., "Use of Piezoelectric Crystals as Sensitive and Specific Detectors for SO<sub>2</sub>", Analytical Letters, No. 5, Vol 4, pp 225-235 (1972).
- (41) Stanford, Thomas B., McGinniss, Vincent D., Balog, Paul P., Walters, Bobby L., and Haloostock, Frank T., "Evaluation of Selected Piezoelectric Crystals as Chemical Warfare Agent Detectors", Contract No. DAAH01-81-C-A277, Report SAM 4 (September 30, 1982).
- (42) Ho, Mat H., Guilbault, George C., and Scheide, Eugene P., "Detection of Carbon Monoxide in Ambient Air with a Piezoelectric Crystal", (to be published Anal. Chem. 1983).
- (43) Butler, M.B.N., "Surface Acoustic Wave Devices", Electronic Engineering, June, 1980, July, 1980, and February, 1981.
- (44) Murray, R.J. and White, P., "Surface Acoustic Wave Devices", Wireless World, March, 1981 and April, 1981.
- (45) Jones, W.J., "Gas Monitoring Apparatus", U.S. Patent No. 3,710,337, February 13, 1973, assigned to Westinghouse Electric Co.
- (46) Vurek, G.G., "Measurement of Carbon Dioxide", U.S. Patent No. 3,867,097, February 18, 1975, assigned to U.S. Government.
- (47) Jones, W.J., "Carbon Dioxide Monitor", U.S. Patent No. 3,567,387, January 9, 1969, assigned to Westinghouse Electric Co.

