

MICROCOPY RESOLUTION TEST CHART
NATIONAL BUREAU OF STANDARDS-1963-A

12

AD A133 557

AFGL-TR-83-0133

DEVELOPMENT OF THEORETICAL MODELS
AND ANALYSES OF THE MICRO-PHYSICS
OF CLOUD AND PRECIPITATION SYSTEMS

AD-A133 557

LAWRENCE E. BELSKY
FREDRICK B. KAPLAN
JAMES P. LALLY
D. KEITH ROBERTS
PETER MILLER
JOHN FOLEY
TERENCE O'TOOLE

DIGITAL PROGRAMMING SERVICES, INC.
60 HICKORY DRIVE
WALTHAM, MASSACHUSETTS 02154

31 MAY 83

FINAL REPORT FOR PERIOD 1 AUGUST 1981 to 31 MAY 1983

APPROVED FOR PUBLIC RELEASE; DISTRIBUTION UNLIMITED.

DTIC
OCT 14 1983
E

DTIC FILE COPY

AIR FORCE GEOPHYSICS LABORATORY
AIR FORCE SYSTEMS COMMAND
UNITED STATES AIR FORCE
HANSCOM AFB, MASSACHUSETTS 01731

83 10 12 257

This report has been reviewed by the ESD Public Affairs Office (PA) and is releasable to the National Technical Information Service (NTIS).

This technical report has been reviewed and is approved for publication

BARBARA MAIN
Contract Manager

ARNOLD A. BARNES, JR.
Chief, Cloud Physics Branch

FOR THE COMMANDER

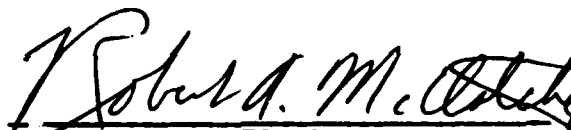
ROBERT A. McCLATCHEY
Director, Meteorology Division

Qualified requestors may obtain additional copies from the Defense Technical Information Center. All others should apply to the National Technical Information Service.

If your address has changed, or if you wish to be removed from the mailing list, or if the addressee is no longer employed by your organization, please notify AFGL/DAA/LYC Hanscom AFB, MA 01731. This will assist us in maintaining a current mailing list.

Do not return copies of this report unless contractual obligations or notices on a specific document requires that it be returned.

Unclassified

SECURITY CLASSIFICATION OF THIS PAGE (When Data Entered)

REPORT DOCUMENTATION PAGE		READ INSTRUCTIONS BEFORE COMPLETING FORM
1. REPORT NUMBER AFGL-TR-83-0133	2. GOVT ACCESSION NO. AD-A133 557	3. RECIPIENT'S CATALOG NUMBER
4. TITLE (and Subtitle) DEVELOPMENT OF THEORETICAL MODELS AND ANALYSES OF THE MICRO-PHYSICS OF CLOUD AND PRECIPITATION SYSTEMS		5. TYPE OF REPORT & PERIOD COVERED Final Report 1 Aug 81 - 31 May 83
		6. PERFORMING ORG. REPORT NUMBER
7. AUTHOR(s) Lawrence E. Belsky D. Keith Roberts Fredrick B. Kaplan Peter Miller James P. Lally John Foley Terence O'Toole		8. CONTRACT OR GRANT NUMBER(s) F19628-81-C-0141
9. PERFORMING ORGANIZATION NAME AND ADDRESS Digital Programming Services, Inc. 60 Hickory Drive Waltham, Massachusetts 02154		10. PROGRAM ELEMENT, PROJECT, TASK AREA & WORK UNIT NUMBERS 62101F 2310G5BC
11. CONTROLLING OFFICE NAME AND ADDRESS Air Force Geophysics Laboratory Hanscom AFB, MA 01731 Monitor/Barbara Main/LYC		12. REPORT DATE 31 May 1983
		13. NUMBER OF PAGES 227
14. MONITORING AGENCY NAME & ADDRESS (if different from Controlling Office)		15. SECURITY CLASS. (of this report) Unclassified
		15a. DECLASSIFICATION/DOWNGRADING SCHEDULE
16. DISTRIBUTION STATEMENT (of this Report) Approved for public release; distribution unlimited		
17. DISTRIBUTION STATEMENT (of the abstract entered in Block 20, if different from Report)		
18. SUPPLEMENTARY NOTES		
19. KEY WORDS (Continue on reverse side if necessary and identify by block number) Airborne data collection, closed physics, data processing, mathematical modeling, real time operating system		
20. ABSTRACT (Continue on reverse side if necessary and identify by block number) This report summarizes the mathematical procedures used on a variety of standard and non-standard cloud physics data. It includes the complete descriptions and operating instructions for all programs developed under this contract.		

TABLE OF CONTENTS

1.	INTRODUCTION	11
2.	AFGL CYBER 74 COMPUTER SYSTEM	12
	2.1 LYC CYBER 74 PROGRAMMING	16
3.	AIRBORNE DATA COLLECTION SYSTEMS DESCRIPTION	19
	3.1 PMS-1D SIZING SYSTEM	22
	3.2 PMS-2D SIZING SYSTEM	24
	3.3 LIQUID WATER CONTENT MEASURING SYSTEMS.	26
	3.4 METEOROLOGICAL PARAMETERS - VCO DATA	29
4.	METEOROLOGICAL & CLOUD PHYSICS DATA	30
	4.1 PRODUCTION JOB STREAM OVERVIEW	30
	4.2 PMS-1D DATA PROCESSING	36
	4.2.1 PROGRAM EXHAUST	37
	4.2.1.1 PROGRAM EXHAUST OPERATING INSTRUCTIONS AND SAMPLE OUTPUT	38
	4.2.2 PROGRAM SOUND	44
	4.2.2.1 PROGRAM SOUND OPERATING INSTRUCTIONS AND SAMPLE OUTPUT	46
	4.2.3 PROGRAM FILTER	49
	4.2.3.1 FILTER OPERATING INSTRUCTIONS	50
	4.2.3.2 SAMPLE OUTPUT	51
	4.2.4 JW-LWC CORRECTIONS	54
	4.2.5 DERIVATION AND IMPLEMENTATION OF EX-POTENTIAL FUNCTIONS	55
	4.2.5.1 WBLGMA OPERATING INSTRUCTIONS AND SAMPLE OUTPUT	58

PREVIOUS PAGE IS BLANK

4.3	ICE DETECTOR ANALYSIS	60
4.3.1	PROGRAM ICEEX	62
4.3.1.1	PROGRAM ICEEX OPERATING INSTRUC- TIONS & SAMPLE OUTPUT	65
4.3.2	PROGRAM ICEDMP	69
4.3.2.1	ICEDMP OPERATING INSTRUCTIONS AND SAMPLE OUTPUT	70
4.3.3	PROGRAM ICEDERIV	82
4.3.3.1	PROGRAM ICEDERIV OPERATING INSTRUC- TIONS & SAMPLE OUTPUT	86
4.3.4	PROGRAMS PLTEXTRACT & PLTEXTRACT2	94
4.3.4.1	PLTEXTRACT OPERATING INSTRUCTIONS.	95
4.3.4.2	PLTEXTRACT2 OPERATING INSTRUC- TIONS & SAMPLE OUTPUT	98
4.4	PMS-2D DATA PROCESSING	101
4.4.1	PROGRAM PMS-2D	103
4.5	SPECIAL ANALYSIS AND PROCESSING TECHNIQUES	108
4.5.1	PROGRAM CNVRT	108
4.5.1.1	OPERATING INSTRUCTIONS & SAMPLE OUTPUT FOR PROGRAM CNVRT	109
4.5.2	PROGRAM STEVERD	114
4.5.2.1	PROGRAM STEVERD OPERATING INSTRUC- TIONS & SAMPLE OUTPUT	115
4.5.3	PROGRAM ATTCHFLES	117
4.5.3.1	ATTCHFLES OPERATING INSTRUCTIONS.	118
4.5.4	PROGRAM KNOLL1D AND HDATSTAT	120
4.5.4.1	PROGRAM KNOLL1D OPERATING INSTRUC- TIONS	121
4.5.4.2	PROGRAM HDATSTAT OPERATING INSTRUC- TIONS AND SAMPLE OUTPUT	125
4.6	SNOW DATA PROCESSING - CDC 6600	130
4.6.1	PROGRAM CNVRTASCII TO CDC	130

4.6.2	PROGRAM MAKECRRELTAPE	132
4.6.2.1	PROGRAM MAKECRRELTAPE OPERATING INSTRUCTIONS	133
4.6.3	PROGRAM MAKELMINSNORATE	134
4.6.3.1	PROGRAM MAKELMINSNORATE OPERATING INSTRUCTIONS	135
4.6.4	PROGRAM COPYASCME	138
4.6.4.1	PROGRAM COPYASCME OPERATING INSTRU- CTIONS	139
4.6.5	PROGRAMS CORRSNOWRATEDATA/CORRSNOLOGSCALE. .	140
4.6.5.1	PROGRAMS CORRSNOWRATEDATA/CORRSNO- LOGSCALE OPERATING INSTRUCTIONS & SAMPLE OUTPUT	142
4.6.6	PROGRAM PLOTASCME	144
4.6.6.1	PROGRAM PLOTASCME OPERATING INSTRU- CTIONS AND SAMPLE OUTPUT	145
4.6.7	PROGRAMS SMOOTHAFGL/SMOOTHCRREL	147
4.6.7.1	PROGRAMS SMMOTHAFGL/SMOOTHCRREL OPERATING INSTRUCTIONS	148
4.6.8	PROGRAM FALLVEL	149
4.6.8.1	PROGRAM FALLVEL OPERATING INSTRU- CTIONS AND SAMPLE OUTPUT	150
5.	THEORETICAL CLOUD PHYSICS MODELING	152
5.1	PROGRAM CUMOD X2946: ONE DIMENSIONAL, MATHEMATICAL/ PHYSICAL MODEL	152
5.1.1	CURRENT STATUS OF PROGRAM CUMOD X2946	153
5.1.2	CUMOD X2946 JOB CARDS, INPUT DATA, AND SAMPLE OUTPUT	154
5.2	PROGRAM CUSLIDE	166
5.2.1	PROGRAM CUSLIDE COMMAND DECK, INPUT DATA	167
5.2.2	LIST OUTPUT	168

5.3	CRAY-1 AND CDC INTERFACE PROCEDURES AND DOCUMENTATION	169
6.	LYC POST PROCESSING: PDP-8/E COMPUTER	171
6.1	OS/8 OPERATING SYSTEM	172
6.2	FORTRAN IV	174
6.2.1	FORTRAN SYSTEM COMPONENTS	175
6.2.2	TECO-TEXT EDITOR	181
6.2.3	F4 FORTRAN IV COMPILER	183
6.2.4	RALF-RECOLATABLE ASSEMBLER	185
6.2.5	LOAD-RECOLATABLE LOADER	187
6.2.6	FRTS-FORTAN RUN-TIME SYSTEM	189
6.3	DATA PROCESSING PROGRAMS	192
6.3.1	PROGRAM PLOT.PA	192
6.3.2	PROGRAM KNOLID.FT	198
6.3.3	PROGRAM KNIUTL.FT	203
6.3.4	PROGRAM JWPLOT.FT	205
6.3.4.1	SUBROUTINE CONTIM.FT	210
6.3.4.2	SUBROUTINE INPUT.FT	210
6.3.4.3	SUBROUTINE DISPL.FT	211
6.3.4.4	FUNCTION JWCORR.FT	211
6.3.4.5	SUBROUTINE SCALE.FT	211
6.3.4.6	SUBROUTINE READ.FT	211
6.3.4.7	SUBROUTINE LINEAX.FT	212
6.3.5	PROGRAM SNOPLT.FT	213
6.3.6	FORTRAN SUBROUTINE	218
6.3.6.1	SUBROUTINE RMTA0.RA	219
6.3.6.2	SUBROUTINE CORE.RA	222
6.3.6.3	SUBROUTINE SCANT.RA	224

TABLE OF FIGURES

3.1 C130E DATA FLOW BLOCK DIAGRAM 20

3.2 LEAR DATA FLOW BLOCK DIAGRAM 21

3.3 PARTICLE TRACE THROUGH PMS-1D SYSTEM 23

4.1 PMS-1D PROCESSING PROGRAM FLOW 31

4.2 RADAR ANALYSIS AND CORRELATION PROGRAM FLOW 32

4.3 PMS-2D PROCESSING PROGRAM FLOW 33

4.4 EWER ANALYSIS PROGRAM FLOW. 34

4.5 ICE DETECTOR ANALYSIS PROGRAM FLOW 35

6.1 PREPARING A FORTRAN IV SOURCE FILE 176

6.2 COMPILING A SOURCE FILE 179

6.3 ASSEMBLING, LOADING AND EXECUTING A RALF FILE 180

6.4A KNOL1D.FT SAMPLE OUTPUT SECTION DEFINITIONS 201

6.4B KNOL1D.FT SAMPLE OUTPUT 202

6.5 JWPL0T.FT DIALOGUE 207

6.6A JWPL0T.SAMPLE OUTPUT - UNCORRECTED 208

6.6B JWPL0T.FT SAMPLE OUTPUT - CORRECTED 209

6.7 SNOPLT DIALOGUE 216

6.8 SNOPLT SAMPLE PLOT 217

Accession For	
NTIS GRA&I	<input checked="" type="checkbox"/>
DTIC TAB	<input type="checkbox"/>
Unannounced	<input type="checkbox"/>
Justification	
By _____	
Distribution / _____	
Availability Codes	
Dist	Special
A	

DTIC
COPY
INSPECTED
2

LIST OF TABLES

6.1	LAB DECTAPE LISTING	173
6.2	OS/8 FORTRAN IV SYSTEM	175
6.3	TECO COMMAND SUMMARY	182
6.4	F4 COMPILER OPTIONS	183
6.5	RALF OPTIONS.	185
6.6	LOAD OPTIONS	188
6.7	RUN-TIME SYSTEM OPTIONS	190
6.8	FORTRAN I/O UNIT ASSIGNMENT	190

LIST OF DEFINITIONS

The following abbreviations are used throughout this report.

AFGL	Air Force Geophysics Laboratory
ASCME	Airborne Snowmass Concentration Measurements
CRREL	Cold Region Research Laboratory
DPSI	Digital Programming Services, Inc.
LY	Meteorology Division - AFGL
LYC	Cloud Physics Branch - LY - AFGL

1. Introduction

During the period of August 1981 to May 1982 DPSI was under contract (F19628-81-C-0141) to the Cloud Physics Branch (LYC), Meteorology Division of the Air Force Geophysics Laboratory (AFGL). LYC is the Air Force office abbreviation for Cloud Physics Branch and will be used interchangeably throughout this report. The purpose of the contract was to develop and apply mathematical procedures to a variety of standard and non-standard cloud physics research data.

Work, under this latest contract, was performed on two distinct computer systems. The AFGL inhouse Cyber 74 Computer Systems (Control Data Corp.) and the DEC (Digital Equipment Corp.) PDP-8/E. This report is prepared with this distinction in mind. Chapter 2 describes CDC Cyber 74 programming while chapters 3 and 4 detail real-time programming for the PDP-8/E installed on an AFGL operated MC-130E instrumented aircraft; and inhouse LYC PDP-8/E for testing of flight programming and post flight analysis.

The work performed under this contract has been submitted, in detail, in a set of 22 monthly reports. This document will summarize changes to existing programs; in addition, new programs and procedures will be fully described in this document. A complete set of updated documentation and operating instructions for each program is included.



2. AFGL CYBER 74 Computer System

The AFGL computation center consists of two Control Data Corporation 6600 computers. The two machines are referred to as system I and system II. Each computer is composed of central memory, a high speed central processor, 14 peripheral processors, and a display console. Up to 15 user jobs in each system can be in central memory simultaneously, sharing the central processor at scheduled intervals. Each job in central memory gains access to the central processor sequentially until execution is complete. Each computer is under complete control of the NOS/BE operating system.

Both systems share a non-volatile disk package for permanent file storage. A permanent file is a mass storage file cataloged by either system, so that its location and identification are known to each system always. Frequently used programs, subroutines and data bases are immediately available to jobs requesting them without operator intervention. Permanent files cannot be destroyed accidentally during normal system operation, including normal dead start, because they are protected by the system from unauthorized access according to the privacy controls specified when they are created.

The plotting facilities, also available to both systems, consist of a single off-line mode of operation. This mode produces plots on one of two media; paper or film. A more detailed description of these facilities appear in later paragraphs of this document. Batch processing is, of course, supported by both systems. This allows the user access to

2. AFGL CYBER 72 Computer System (cont'd)

any peripheral device (tape drives, disks, plotters, etc.) that may be necessary for program execution.

System I, the more heavily used machine, supports the time sharing system, "INTERCOM", as well. Time sharing terminals are available to LYC using Bell system terminals via dedicated telephone lines to the 6600 at 300 baud rate. In addition, there are dial-up lines available for use with portable terminals. Dial-up terminals must be connected through an acoustic coupler over standard, voice-grade telephone lines.

INTERCOM allows the user to create, modify, or execute a program in real time. In addition it allows for data base modification such as permanent file creation or deletion.

There are two modes of operation using INTERCOM: COMMAND mode and EDIT mode. The EDIT mode is more often used, since the COMMAND mode is restrictive and anything performed in the COMMAND mode can be done in EDIT mode. For a complete list of INTERCOM commands with their description, the reader is referred to the CDC publication "6000 Series INTERCOM v5 Reference Manual".

As with all programming systems, INTERCOM will require a great deal of experience in order to gain expertise. There are many "shortcuts" that may be employed, and a rather long list of extended capabilities.

2. AFGL CYBER 74 Computer System (cont'd)

The plotting facilities available at the Computation Center are capable of producing either paper or film plots. These facilities offer a wide choice for data display. The pen and ink plotters will produce plots of large dimensions, excellent line definition and multiple colors. The film plotters offer high speed plots, large amount of shading and line flexibility.

The off-line hardware consists of a Calcomp 780 Magnetic Tape Unit with both a Drum-Type Digital Incremental Zip Mode 30 Inch Dual Step Size Plotter and a CRT plotter. Standard paper is available in either 12 or 30 inches. Ballpoint colors are black, red or blue, in addition to red liquid ink for photo reproduction.

There are two film systems available; 35mm microfilm and 105mm microfiche. We have found the microfiche system to be most beneficial. Programs like RAPP produce a multitude of plots which can easily be plotted on only a few sheet or film. This is very convenient for the LYC scientists. They can study the plots at a viewer and make hard copies of just the ones they find most useful. This eliminates the need to go through roll after roll of pen plots produced by the Calcomp plotters.

There is an interactive graphics system at AFGL. Located in the systems area are two Tektronix 4014 graphics terminals. The Tektronix terminals are available for fast plotting of small (less than 65K words) programs. The software in these

2. AFGL CYBER 74 Computer System (cont'd)

programs is similar to that used above except with the added ability for the user to interact with his program. For example, if a scientist sits at the terminal and produces a plot; he can replot the data "blowing up" a section that he find most interesting. Hard copies are produced by the pressing of a button.

The primary language used on the 6600 is Fortran extended. It is by far more efficient than the conventional Fortran IV. Numerous non-ANSI (American National Standards Institute) extensions have been introduced, including: implied typing, multiple system texts, and various masking and shifting functions. For a complete list of Fortran extended capabilities the reader is referred to the "6600 Series Fortran Extended v5 Reference Manual".

The assembler language used with the 6600 is COMPASS v4.0. In some instances where bit manipulation is heavily used, or when the timing of an inner loop is of paramount importance, COMPASS is more desirable to use than Fortran.

DPSI has used all the programming capabilities offered by the CDC system. The user of our programs will find FORTRAN, INTERCOM, COMPASS, and OFF-LINE PLOTS, etc. utilized throughout the program library and thus modification of these programs require all personnel to be well-versed in all the CDC systems.

2.1 LYC CYBER 74 Programming

LYC provides research and advanced development to the USAF in the area of cloud physics. Practical applications, rather than pure research are emphasized as the mission of the branch. At present these practical applications are in the following areas:

- aircraft icing rates
- melting layer research
- radar correlation
- Passarelli spiral
- Mathematical-Physical cloud modeling
- snow rate study

The following chapters describe the contributions that DPSI has made in the above areas during the length of this contract.

Specific programs are listed under each general application. For every program the inherent mathematical modeling will be fully described or referenced. In addition a sample output description will be included.

Full operating instructions are presented for each program. The user of this information should be familiar with the contents of the "AFGL USER'S GUIDE". That document describes most of the conventions that must be compiled with in order to run jobs on AFGL CYBER systems. Although the user's guide is a much simplified version of the set of CDC cyber manuals it gives enough information for the running of simple

2.1 LYC CYBER 74 Programming (cont'd)

jobs. This knowledge plus the detailed operating instructions presented in this document are quite sufficient for the proper running of the programs.

DPSI maintains all CYBER programming on a disk pack (LYCP0F) owned by the computer center (SOD). In the succeeding documentation DPSI uses the convention of attaching, in the instructions, the word BIN to the program "ATTACH" to make the compiled program local to a user job.

ex. ATTACH,LGO,PLTEXTTRACTBIN,ID-KAPLANF,MR=1.
LGO.

The binary of program PLTEXTTRACT is made local to the job as a file LGO. Repetition of the name tells the system to load it and begin execution. DPSI maintains several binaries on the shared system (ID=MILLERP,ROBERTSK,KAPLANF) using this convention. However not all programs are so saved. The computer center does not allow files to be stored on the shared disk system without their continued usage. For this reason DPSI maintains only the most frequently used binaries on the disk. If the user wants a program not currently on the shared system (determined by use of the "audit" command) there are two options. INTERCOM can be used to attach the program. This will compile and save the binary on the shared system as above. Or, the control deck can be altered by placing a "PK" parameter on the first card and replacing the original attach with the following cards:

ex. PAUSE. PLS MOUNT DISK LYCP07.
MOUNT,VSN=LYCP07,SN=LYCP07.
ATTACH,P,PLTEXTTRACT,ID=LALLY,SN=LYCP07.
FTN,I=P,PL=999999.
LGO.

2.1 LYC CYBER 74 Programming (cont'd)

In this example the compilation is actually done during the job. In the succeeding documentation the single attach convention will always be used. It is left to the user to determine if the particular program is or is not currently on the shared system.

3. Airborne Data Collection Systems Description

During the last data collection period, ending in 1981, two aircraft were used to perform the atmospheric sampling necessary for the desired analysis of the independent research projects. A USAF owned and operated MC-130E was used for data sampling to approximately 30,000 feet. High altitude observations to 45,000 were achieved with a USAF leased Lear jet model 36C.

Each aircraft had on-board equipment with the capability to derive a liquid water content (LWC) value, as well as other meteorological parameters, in real time. This was accomplished by utilizing the respective on-board computing facilities of each aircraft in conjunction with the data obtained from the PMS-1D systems. In addition each aircraft has three independent means of measuring and recording LWC.

The following sections of this chapter delineate a description of the equipment used and their functions. See figures 3.1 and 3.2 for a data flow diagram of the on-board systems.

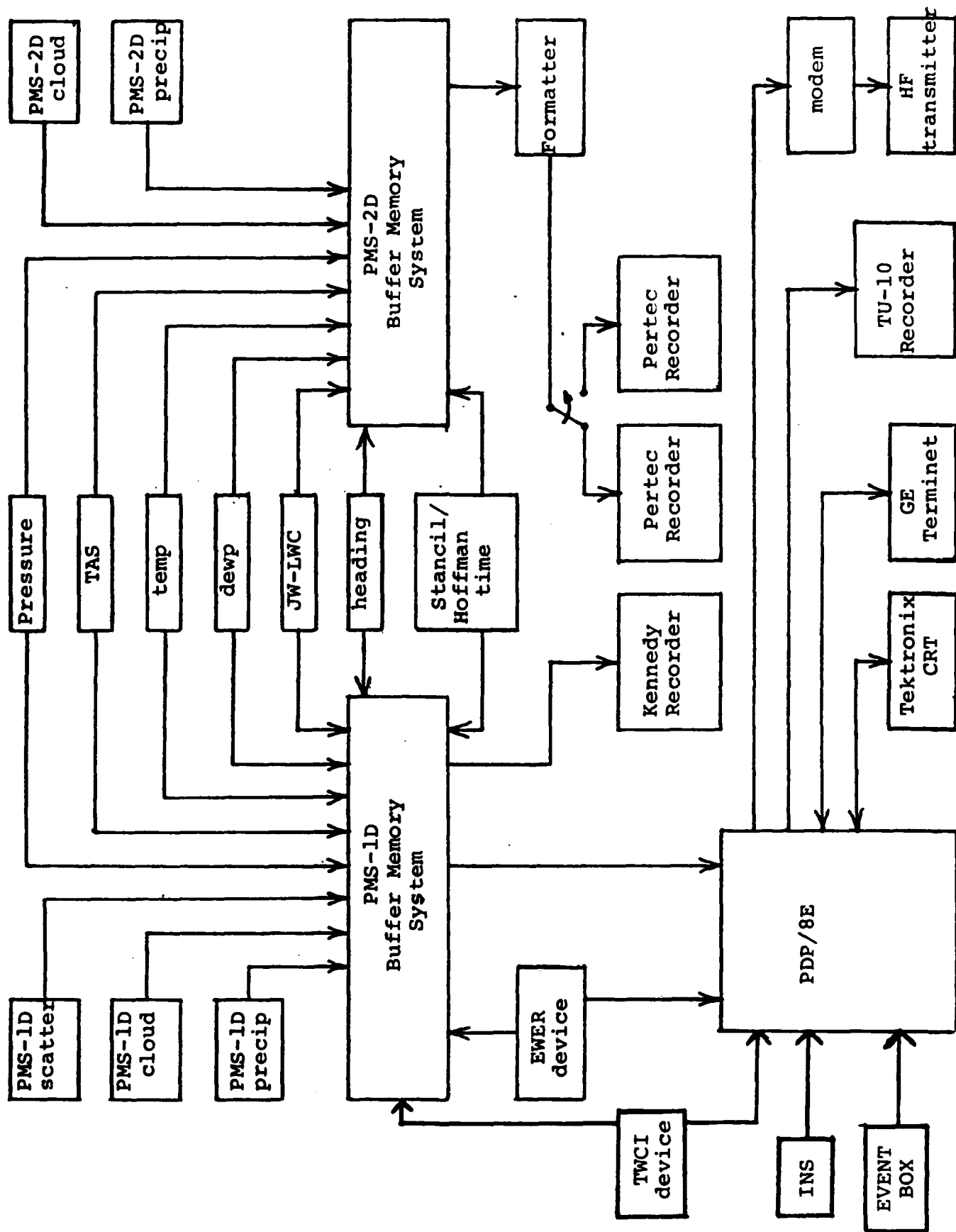

Figure 3.1: Cl30E Data Flow Block Diagram

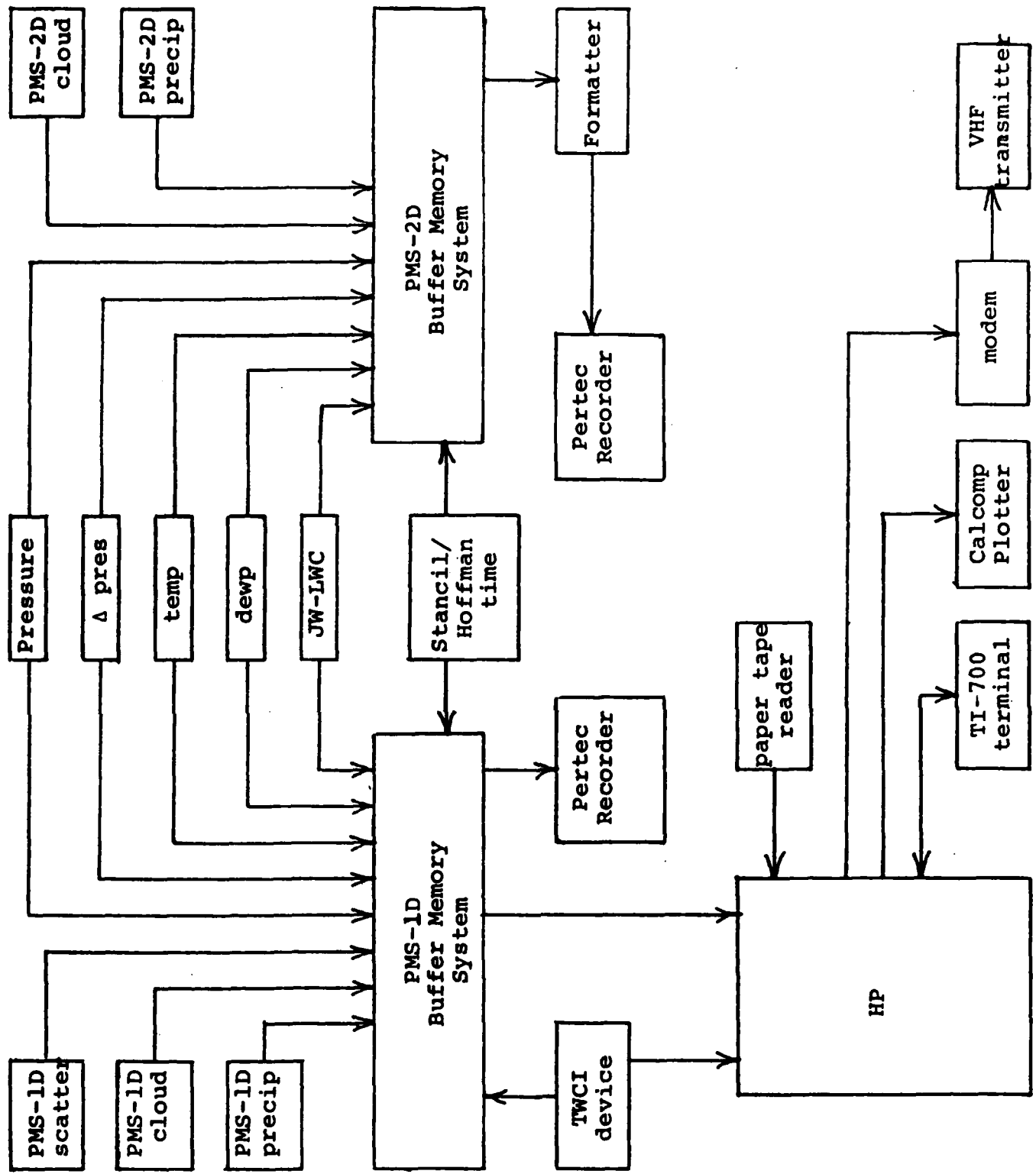

Figure 3.2: LEAR Data Flow Block Diagram

3.1 PMS-1D sizing system

The PMS-1D particle sizing system consists of three different probes that record particle counts in overlapping size ranges. The Axial Scattering Probe detects particles in the 2-30 μ range. The 20-300 μ particles are measured with the cloud probe. The Precip (or Precipitation) Probe is used for particles in the 200-4500 μ range. Actual size ranges for the probes in each aircraft are shown in the following chart.

	<u>C130</u>	<u>LEAR</u>
Axial Scatter	2-30 μ	2-30 μ
Cloud	20-300 μ	20-300 μ
Precipitation	300-4500 μ	200-3000 μ

The axial scattering probe is considerably different than the other two. It measures optical forward scattering from small particles in a constant size sampling volume. Dual photodiode detectors are used to verify that the particles are within the sampling volume. There is pulse height detection circuitry to classify the particles into fifteen size categories. The size classes are then read out by the data acquisition system at one second intervals.

This probe is specifically designed for water particles only. Since the scattering function of ice crystals is poorly understood, the probe is used only to indicate relative numbers but is not normally relied upon for determining mass of ice crystals.

The cloud and precip probes utilize a laser beam condensed and mirrored to a zoom lens which distributes light to a row

3.1 PMS-1D Sizing System (cont'd)

of diode sensors; the cloud probe has 22 sensors and the precip 24. As the aircraft flies, particles appear between the zoom lens and the sensors, interrupting the light. A shadow is cast, shutting off some of the diode sensors. The device is read when a diode is turned off, and the sampling is continued as any diode state changes until all diodes are back on. At the conclusion, then, a particle of known diode length has been counted; the output consists of the count of particles seen for lengths of one to fifteen diodes for each second. As an example, if a particle traces the following states in the diodes (0 = diode on; X = diode off)

```
00000000000000000000000000000000
0000000XX000000000000000000000000
000000XX0000000000000000000000000
0000XXX00000000000000000000000000
000000000000000000000000000000000
```

Figure 3.3: Particle trace through PMS-1D system

the result would be 1 particle of diode length 5. The "5" results from the maximum different number of diodes turned off from start to finish of the sampling (all within a fraction of a second). The reader should note that this 1D PMS device will suffer errors when two particles are seen at the same time, for then the maximum lengths will be added together. Of course the probability of the occurrence is low.

3.2 PMS-2D Sizing System

The PMS-2D hardware configuration is described below.

Cl30

Two PMS-2D particle display systems with two size ranges (25-800 μ and 200-6400 μ) tied to dual Pertec (model F5640-9) digital recorders. The recent PMS-2D data collection system aboard a Corvair 990 consisted of 60-1920 μ and 240-F680 μ particle size ranges.

LEAR

Two PMS-2D particle display systems with two size ranges (40-1280 μ and 160-512 μ) tied to a Pertec (model T7640-9) digital recorders.

The 2D Knolienberg has some important advantages over the earlier 1D model. Firstly, there are 32 sensors each exactly 25 μ in diameter. The second dimension is achieved by taking readings over time so that a two dimensional picture of the shadow is made. The sampling rate is adjusted to the speed of the aircraft so that a reading would be taken every 25 μ of length. That is, if the aircraft flies at 100 meters/sec, the sampling rate would have to be 4 megahertz. This exact ratio cannot be maintained perfectly, so the results are modified slightly in the computer according to the true airspeed of the aircraft. Like the 1D device, the output is turned on when a sensor is shut off, and continues until all sensors are back on, but this device will output the status of each of the 32 sensors every four-millionth of a second until all the sensors are back on. Thus the 2D device gives a picture of the particle(s) as subsequent readouts are placed together, and will not give incorrect results when two

3.2 PMS-2D sizing system (cont'd)

particles are seen simultaneously.

An additional advantage of the 2D system is the end rejection feature. If a particle occludes either ending diode, it is still recorded on magnetic tape. On the 1D system these particles are not counted and the data is lost.

The reason for this rejection is the philosophy of the 1D system; if the ending diode is occluded, there is no way to estimate the true particle length and it was felt, at the engineering design level, that it would be better to eliminate the particle rather than counting it as one with a lesser diameter. With that in mind, the end diode rejection feature was incorporated into the 1D system. An area of concern, however, is the number of particles being rejected; with the present 1D system there is no way to determine this. It may be of considerable consequence because the larger particles have the greatest probability of being rejected, and it is precisely these particles which will contribute heavily to the liquid water content and radar reflectivity.

3.3 Liquid Water Content Measuring Systems

Each aircraft had the capability to derive a calculated liquid water content value, (as well as numerous other meteorological parameters) LWC, in real time. This was accomplished by utilizing the respective on-board computing facilities of each aircraft in conjunction with the data obtained from the PMS-1D systems. In addition each aircraft had two independent means of measuring and recording the LWC.

On each aircraft there was a Johnson-Williams (model LWH) liquid water content meter that measured the concentration of water in cloud sized droplets. The device used calibrated resistance wires, both normal and parallel to the airflow, to measure the amount of cooling due to the evaporation of the impinging water droplets. It had a specified range of 0-6 g/m³, however, it was considered accurate only for particles in the 10-50 μ class.

On the C130 there was an additional device to measure LWC known by the acronym EWER (Evaporate the Water that aggravates Erosion on Rentry). This device took two samples of the free-stream airflow simultaneously. One sample was passed through a high-powered heater to melt and evaporate all the condensed water. In the other sample the condensate was mechanically separated from the air by a centrifuging action just inside the air inlet. A small portion of the evaporated sample, and all of the separated sample, were passed through small heaters to adjust the final temperature before entering the detector chamber.

3.3 Liquid Water Content Measuring Systems (cont'd)

The samples were passed between the source and receiver of a Lyman-Alpha humidimeter. The ultraviolet energy emitted by the source, was attenuated by the water vapor in the path between the source and receiver. The relative attenuation of the UV was a direct measure of the water vapor content in g/m^3 . The water vapor in the evaporated sample, and also the background water vapor, was optically sampled. A provision was also made for varying the gap between the source and receiver so that the best sensitivity in various ranges of LWC can be adjusted in flight.

The EWER system was under the complete control of a ROLM (model 1601) computer*. In addition to performing all the sequencing operations, the computer also performed the real time calculations of liquid water content. The shortcoming of this system was the method of data recording.

The EWER LWC analog output was directly tied to one of the digital VCO channels on the PMS-1D system. From there it was recorded on both the PMS-1D and TU-10 flight tapes. By applying the correct calibration equation to this data, LWC values were processed as a function of time in both a real time or post processing mode. This data was either presented in tabular or graphical form.

There was an additional device to measure LWC, known by

*DPSI recognizes this machine as a ruggedized version of the Data General NOVA computer. The remainder of this text refers to it as such.

3.3 Liquid Water Content Measuring Systems (cont'd)

the acronym TWCI (Total Water Content Indicator). The device was designed to measure total water content in both liquid and solid cloud particles.

A chamber was exposed to the air-flow where water and ice crystals are collected. Then butyl carbitol was introduced to the chamber. The sensor used a capacitor in a tuned circuit with the fluid as the dielectric. Water in the fluid changed the capacitance and the output frequency of the tuned circuit. Electronic circuits detected the shift by comparing it with an identical cell utilizing pure butyl carbitol as the dielectric. The output of this system was calibrated in terms of water content.

3.4 Meteorological Parameters - VCO Data

In addition to the computers, their peripherals, particle information systems, and various liquid water content devices, there were a number of other data sensors on-board each aircraft. These devices were fed directly to voltage controlled oscillators (VCO's) and were hard wired into the output stream by analog to digital converters. These sensors contained environmental information of pressure, temperature, and dewpoint, and also aircraft information of heading and airspeed. The data were multiplexed into both the PMS-1D and PMS-2D buffer memory systems and recorded redundantly on their respective digital tapes.

The placement of the output VCO data which were combined with the PMS data varies from aircraft to aircraft and from time to time. The numbers themselves were limited to four decimal digits each, giving a range of 0 to 9999. These VCO's were counts and had to be converted to proportionate values.

4. Meteorological & Cloud Physics Data

4.1 Production Job Stream Overview

This section graphically illustrates the interrelationship of existing programs in the product job stream. Figures 4.1 through 4.5 depict the logical processing flow within the general headings presented. Cross purpose use of programs for different headings is quite often done. Programs are listed, however, under the system that most often use them.

Figure 4.1 PMS-ID Processing Program Flow

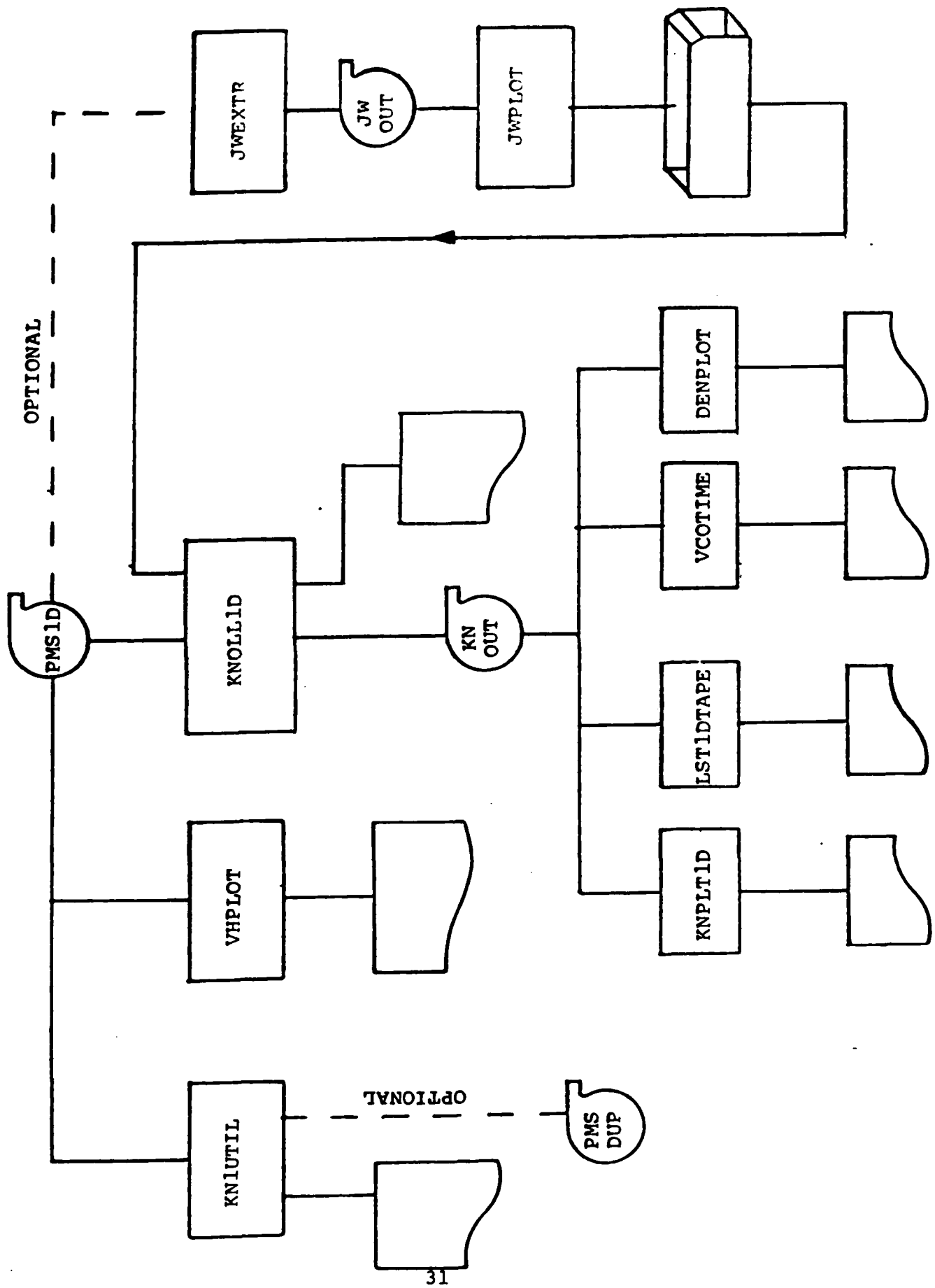

Figure 4.2 Radar Analysis and Correlation Program Flow

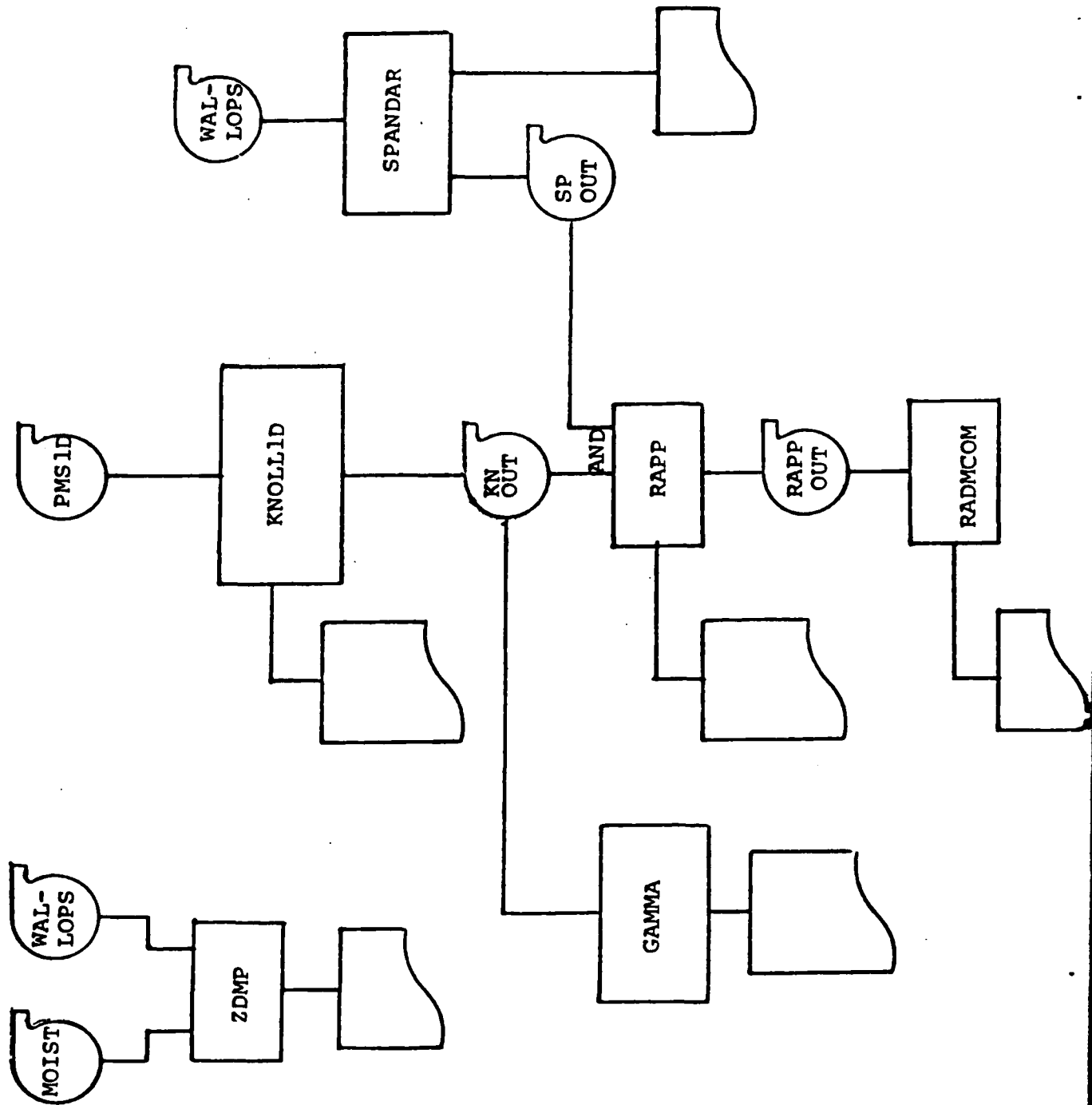

Figure 4.3 PMS-2D Processing Program Flow

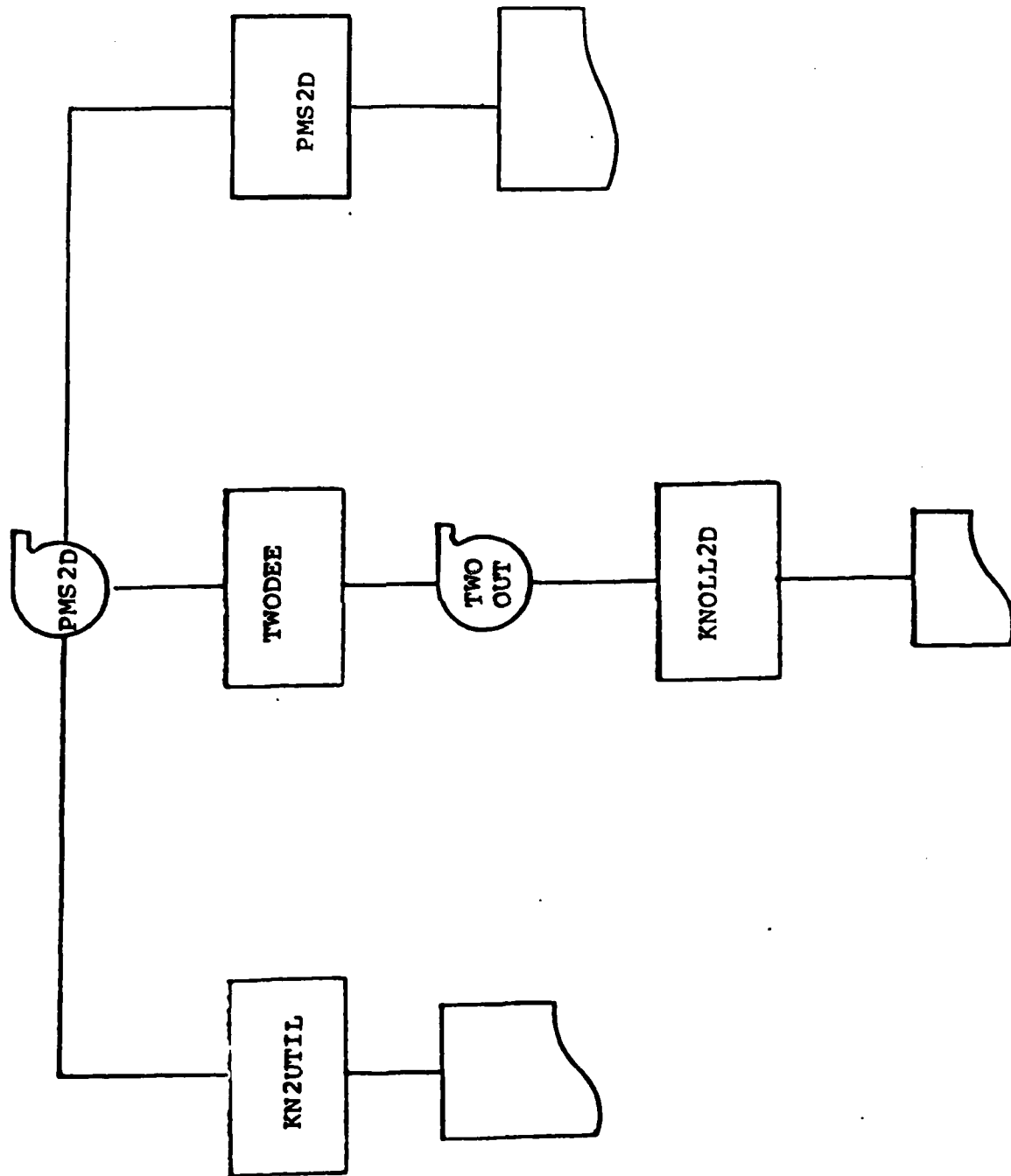

Figure 4.4 EWER Analysis Program Flow

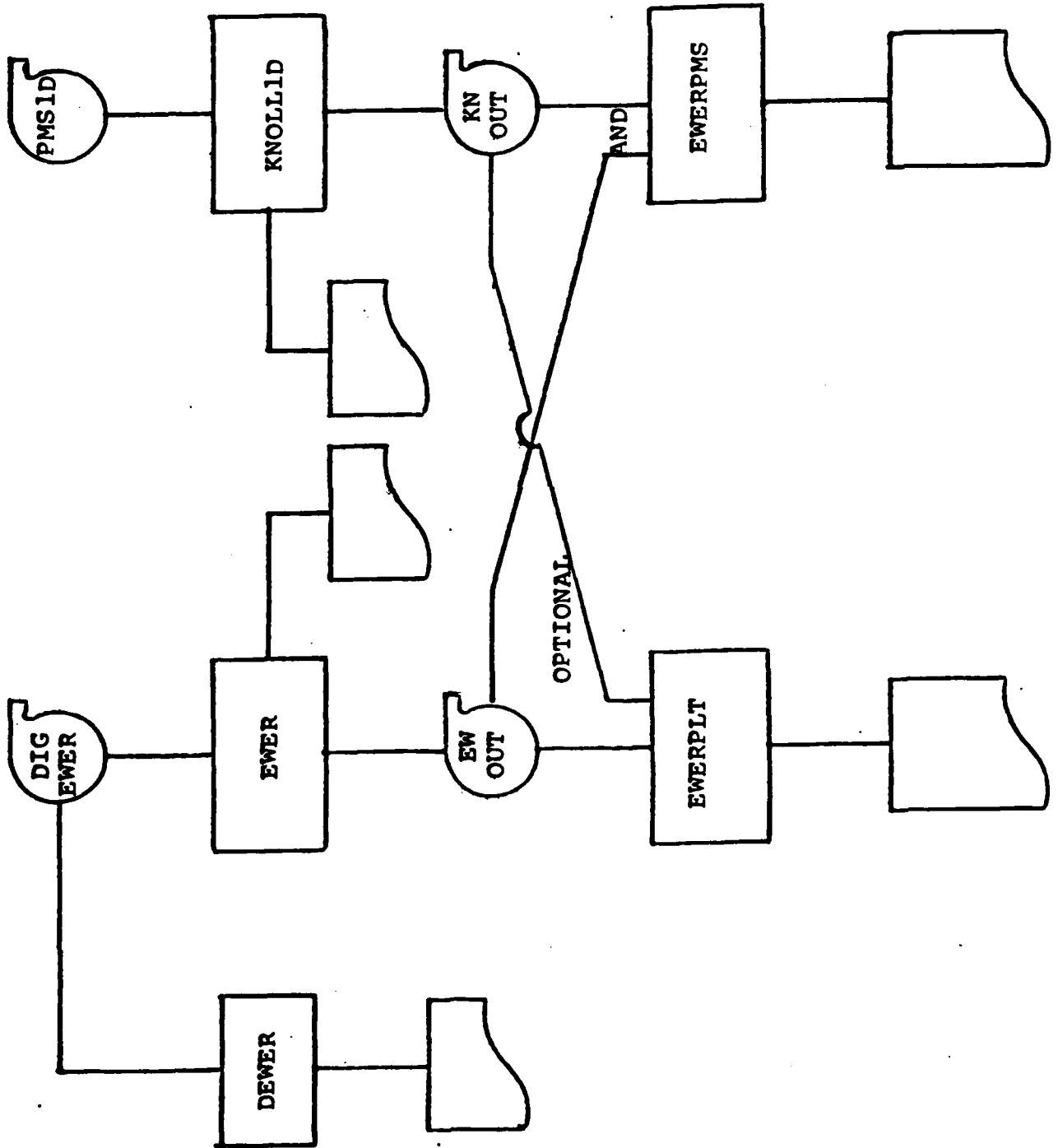
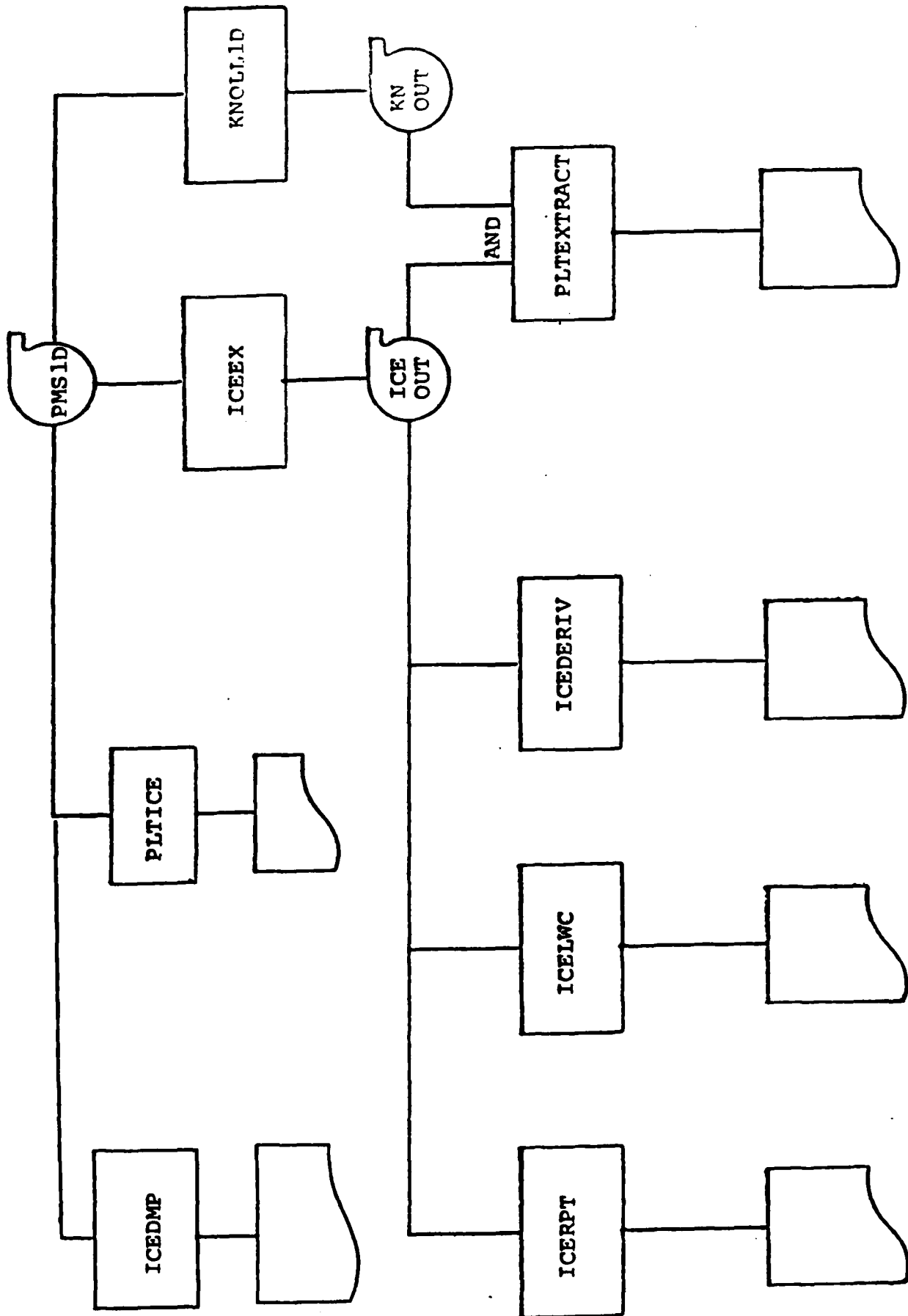

Figure 4.5 Ice Detector Analysis Program Flow



4.2 PMS-1D Data Processing

For the most part, the programs concerned with the processing of LYC's one-dimensional data have not been changed during the period of this contract and hence will not be reported on herein. Descriptions, operating instructions, and sample output for the programs may be found in the Final Report for Contract F19628-78-C-0131.

The following sections describe those programs, dealing with the one-dimensional data, which have been revised during the contract period (August 1981-May 1983).

4.2.1 Program EXAUST

At the request of AFSC/SD (Air Force Systems Command/Space Division), the cloud physics branch of AFGL used its PMS-1D probes to make measurements of particle distributions for the recent space shuttle launch.

During the March 22, 1982 launch of NASA's Space Shuttle the LYC scatter, cloud and precipitation probes were strategically placed 100 meters from the base of the launch pad atop a 12 foot pole. When the solid rocket boosters ignited and the rocket lifted off, LYC probes were directly in the path of its plume. Raw data collected by the probes is written to a PMS-1D data tape. This data tape will be returned to AFGL/LYC for post processing by the AFGL CDC CYBER Computer.

A new program, program EXAUST, has been written to process this data. Using the PMS-1D tape as input EXAUST reads in the raw channel counts from each probe. The following information is derived from each probe; channel number densities ($N/CM^{*3-\mu M}$), channel normalized number densities (N/M^{*3-MM}) and their totals are calculated and printed as output. No channel number adjustments or melting equations are used so the diameters are a straight forward calculation (center diameter = channel # * Diode Size).

An optional output tape has been included to provide processed data to NASA for use in their modeling studies. Complete operating instructions, output tape format, and sample output follow.

4.2.1.1 Program EXAUST Operating Instructions and Sample Output

COMMAND DECK

DPSI,T300,TP1,MT1. 2616 ID
ATTACH,LGD,EXAUSTBIN,ID= KAPLANF
MAP,OFF.
VSN,TAPE1=PMSXXX.
REQUEST,TAPE1,S,MT,MT,NORING.
VSN,TAPE2=LYCXXX/MT. (OPTIONAL OUTPUT TAPE)
REQUEST,TAPE2,N,RING,MT. (OPTIONAL OUTPUT TAPE)
FILE(TAPE1,RT=U,BT=K,MRL=1024,MBL=1024,RB=1,BFS=105)
LDSET,PRESET=ZERO.
LGD.
EXIT(U)

7/8/9

DATA CARDS

ID CARD

1-10 FLT ID IN FORM CXX-XX
11-20 FLT DATE IN FORM DD MON YR
21-26 PMS TAPE NUMBER IN FORM PMSXXX

OPTION CARD

5 ICLK - 0 USE A/C CLOCK (USED TO TEST)
1 USE PMS CLOCK
10 IAVE - AVERING INTERVAL IN 15 FORMAT
11-18 PMS ON TIME IN FORM HH MM SS
21 LYC - 0 NO OUTPUT TAPE
1 CREATE OUTPUT TAPE

PASS CARDS - AS MANY AS DESIRED IN INCREASING ORDER

1-6 PASS START TIME IN FORM HH MM SS
8-13 PASS STOP TIME IN FORM HH MM SS

6/7/6/9

OUTPUT TAPE FORMAT

WORDS	CONTENT
-----	-----
1	START TIME
2	STOP TIME
3	WIND SPEED
4-18	RAW COUNTS SCATTER
19-33	RAW COUNTS CLOUD
34-48	RAW COUNTS PRECIP.
49-63	NUMBER DENSITIES SCAT
64-78	NUMBER DENSITIES CLOUD
79-93	NUMBER DENSITIES PRECIP
94-108	NORMALIZED ND SCAT
109-123	NORMALIZED ND CLOUD
124-138	NORMALIZED ND PRECIP

FORMAT TYPES

A10	START, STOP TIMES
E10.5	WIND SPEED
I10	RAW CHANNEL COUNTS
E10.5	NORMALIZED AND UNNORMALIZED ND

ONE RECORD = 138 WORDS = 1380 CHARACTERS

SHUTTLE EXHAUST DISTRIBUTIONS

STS-3 ON 22 MAR 82

11 00 04 TO 11 00 08

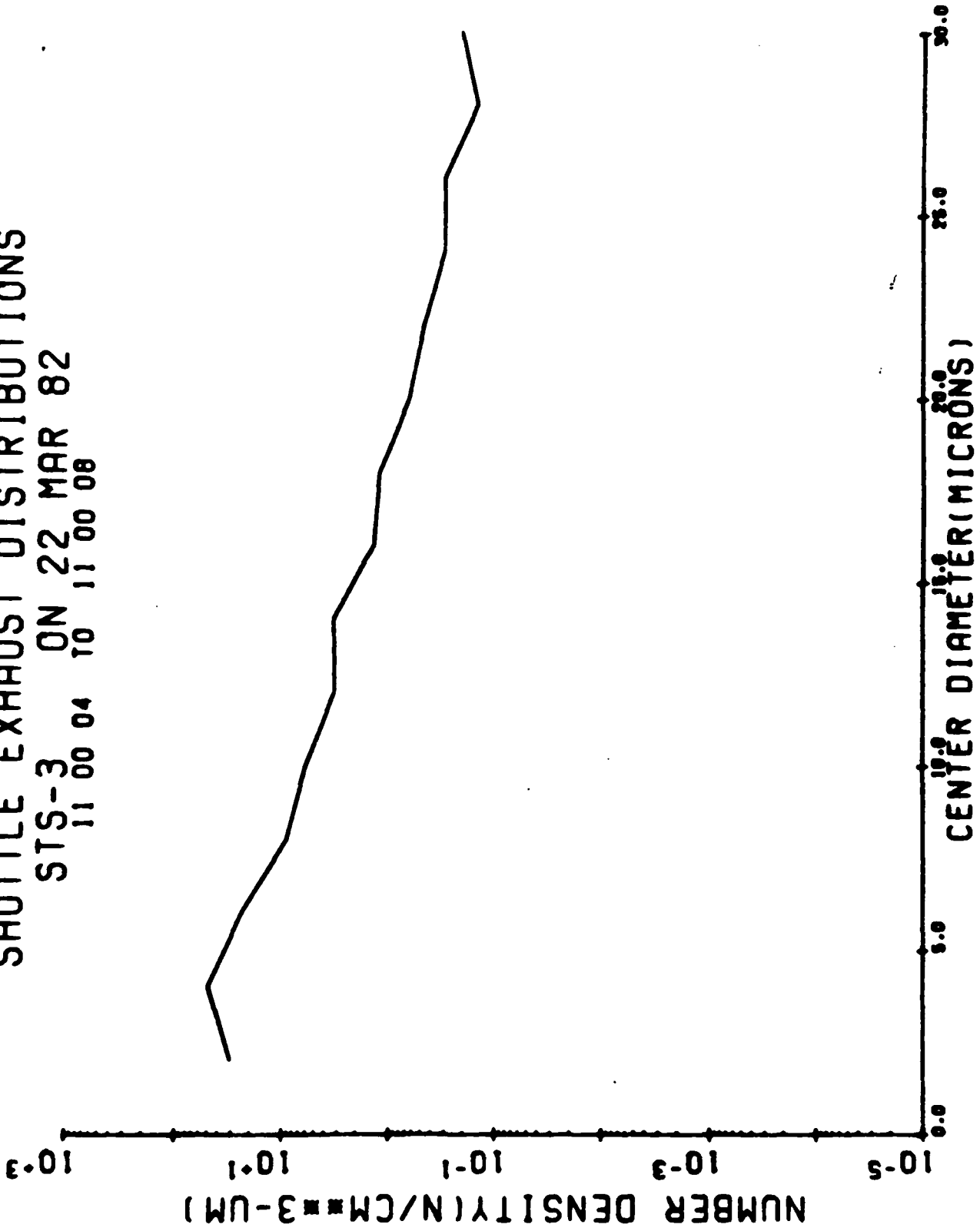

SHUTTLE EXHAUST DISTRIBUTIONS
STS-3 ON 22 MAR 82
11 00 05 TO 11 00 05

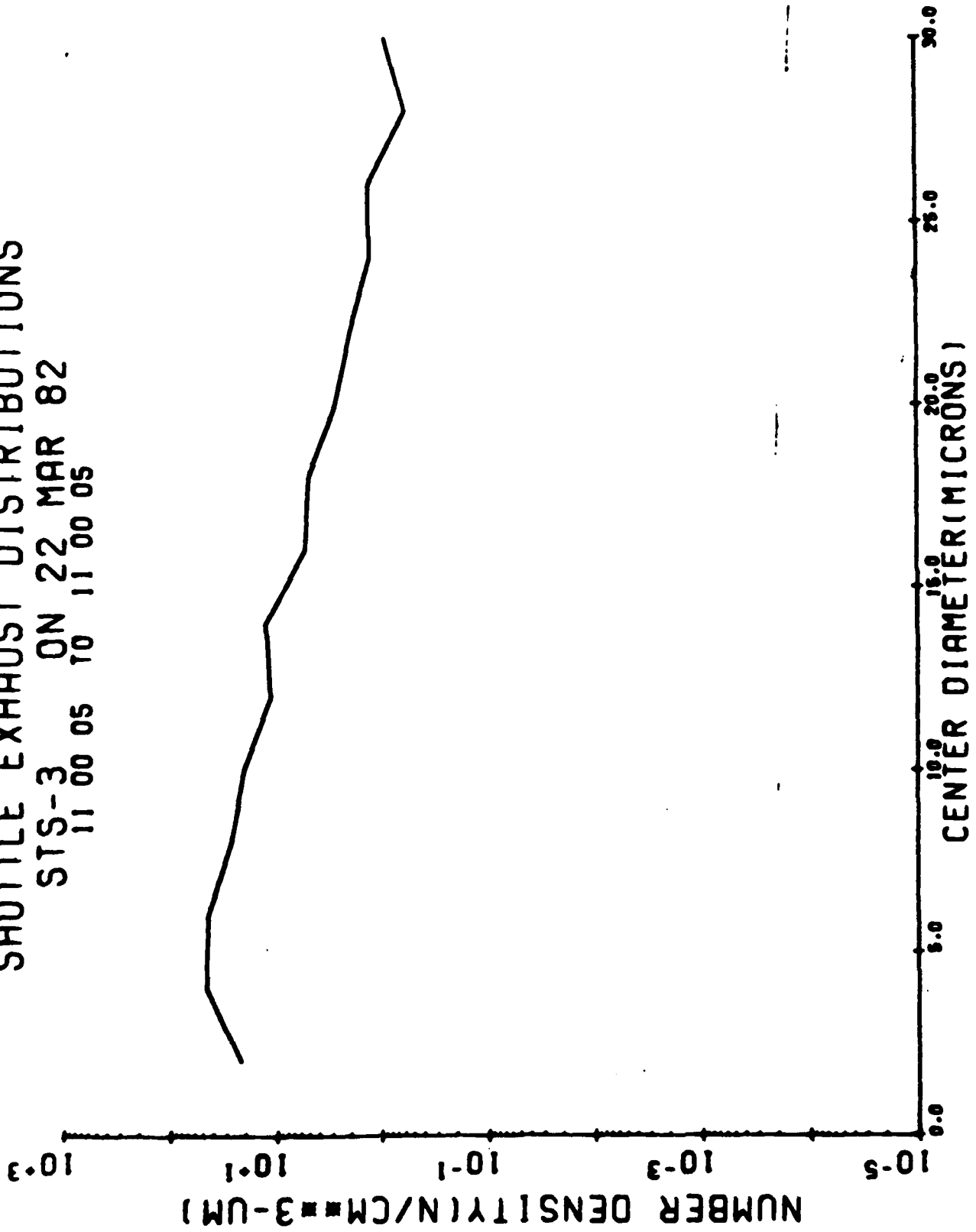

22 MAR 82

SHUTTLE EXHAUST DISTRIBUTIONS

AFGL

11:00:04 TO 11:00:04

WIND (M/SEC) = 24.9

CH #	CD (UM)	SCATTER PROBE		CH #	CD (UM)	RAW COUNTS	CLOUD PROBE		CH #	CD (UM)	RAW COUNTS	ND N/CM**3-UM	PRECIP PROBE		CH #	CD (UM)	RAW COUNTS	ND N/CM**3-UM	
		RAW COUNTS	ND N/CM**3				RAW COUNTS	ND N/CM**3					RAW COUNTS	ND N/CM**3					
1	2	0	0	1	20	103	1.0R86E+01	5.4428E-01	1	300	12	2.7659E-04	9.2196E-07						
2	4	1	8.1627E-02	2	40	72	2.0025E+00	1.0012E-01	2	600	10	2.4147E-04	8.0489E-07						
3	6	1	8.1627E-02	3	60	93	1.2134E+00	6.0672E-02	3	900	6	1.5212E-04	5.0708E-07						
4	8	0	0	4	80	60	4.6626E-01	2.3313E-02	4	1200	3	8.0065E-05	2.6688E-07						
5	10	0	0	5	100	76	4.0161E-01	2.0080E-02	5	1500	2	5.6342E-05	1.8781E-07						
6	12	0	0	6	120	38	1.4091E-01	7.0457E-03	6	1800	1	2.9828E-05	9.9427E-08						
7	14	0	0	7	140	68	2.0952E-01	1.0476E-02	7	2100	1	3.1692E-05	1.0564E-07						
8	16	0	0	8	160	27	6.8594E-02	3.4297E-03	8	2400	2	6.7611E-05	2.2537E-07						
9	18	0	0	9	180	27	7.4067E-02	3.7033E-03	9	2700	0	0	0						
10	20	0	0	10	200	16	4.7882E-02	2.3941E-03	10	3000	0	0	0						
11	22	0	0	11	220	28	9.2172E-02	4.6086E-03	11	3300	0	0	0						
12	24	0	0	12	240	12	4.3891E-02	2.1946E-03	12	3600	0	0	0						
13	26	0	0	13	260	13	5.3493E-02	2.6746E-03	13	3900	0	0	0						
14	28	0	0	14	280	7	3.2919E-02	1.6459E-03	14	4200	0	0	0						
15	30	0	0	15	300	24	1.3167E-01	6.5837E-03	15	4500	0	0	0						
.5		1.6325E-01 8.1627E-02				1.5865E+01 7.9323E-01				9.3572E-04 3.1191E-08									

11:00:05 TO 11:00:05

WIND (M/SEC) = 30.8

CH #	CD (UM)	SCATTER PROBE		CH #	CD (UM)	RAW COUNTS	CLOUD PROBE		CH #	CD (UM)	RAW COUNTS	ND N/CM**3-UM	PRECIP PROBE		CH #	CD (UM)	RAW COUNTS	ND N/CM**3-UM	
		RAW COUNTS	ND N/CM**3				RAW COUNTS	ND N/CM**3					RAW COUNTS	ND N/CM**3					
1	2	668	4.4082E+01	1	20	0	0	0	1	300	0	0	0						
2	4	1423	9.3905E+01	2	40	0	0	0	2	600	0	0	0						
3	6	1378	9.0935E+01	3	60	0	0	0	3	900	0	0	0						
4	8	854	5.6356E+01	4	80	0	0	0	4	1200	0	0	0						
5	10	656	4.3290E+01	5	100	0	0	0	5	1500	0	0	0						
6	12	364	2.4021E+01	6	120	0	0	0	6	1800	0	0	0						
7	14	406	2.6792E+01	7	140	0	0	0	7	2100	0	0	0						
8	16	171	1.1284E+01	8	160	0	0	0	8	2400	0	0	0						
9	18	160	1.0559E+01	9	180	0	0	0	9	2700	0	0	0						
10	20	89	5.8732E+00	10	200	0	0	0	10	3000	0	0	0						
11	22	65	4.2894E+00	11	220	0	0	0	11	3300	0	0	0						
12	24	42	2.7716E+00	12	240	0	0	0	12	3600	0	0	0						
13	26	43	2.8376E+00	13	260	0	0	0	13	3900	0	0	0						
14	28	19	1.2538E+00	14	280	0	0	0	14	4200	0	0	0						
15	30	30	1.9797E+00	15	300	0	0	0	15	4500	0	0	0						
TOTALS		4.2023E+02 2.1012E+02				0				0						0			

4.2.2 Program SOUND

Program SOUND is designed to provide graphical and numerical comparisons of aircraft vs Radiosonde temperature data.

When comparing aircraft temperature values with Radiosonde data it is necessary to reduce the array of aircraft data to discrete values for any given pressure level. Thus after the temperature data is read from the input tape it is internally sorted by pressure. Median values can then be obtained for every 10MB pressure band. It is these median values which are used for comparison and analysis. Median values, as opposed to a mean, were used because they are less affected by extraneous data points.

The first plot produced by program SOUND, is the raw data plot. The points will always be plotted in ascending order, visual inspection can verify the sorting procedure. After this (or any plot) a hard copy can be obtained by hitting the 'copy' button on the tektronix terminal. The next plot will not be displayed until a space followed by a carriage return is typed on the keyboard. This allows time to produce the hard copy between plots. If the user enters the letter "S" in place of a space the program will jump to the 'STOP(Y/N)' prompt. A 'Y' will stop the job and return to intercom. An 'N' will return the user to the beginning of SOUND. In a full sequence for any given data set, four plots and one page of output are produced. In order; the four plots consist of (1) raw data, (2) raw data with a median value line overlaid, (3) raw data with median and Radiosonde data overlaid (Radiosonde data distinguishable as a dashed line), and (4) a plot

4.2.2 Program SOUND (cont'd)

of median values and Radiosonde data without raw values. In addition, dry adiabatic lines are superimposed over the plot to aid in the analysis of the change in temperature of an air parcel due only to the change in pressure. Operating instructions and sample output follow.

4.2.2.1 Program SOUND Operating Instructions and Sample Output

turn on computer and hard copy unit
follow 'LOGIN' procedure

USER INPUT

ATTACH,LGO,SOUNDBIN,ID=OTOOLE,MR=1.
ATTACH,TAPE1,TEMPCKDATA,1D=OTOOLE,MR=1
ATTACH,TEK,TEKSIM
LIBRARY,TEK
REQUEST,TAPE6,*Q
ETL,500
LGO

refer to user dialogue on next page for examples
of prompts and replys.

DISPOSE,TAPE6,PR,IAC
LOGOUT

ENTER IN FLT IDELT E79-51
 ENTER IN FLT DATE 16 DEC 79
 CHOOSE TEMP TYPE
 1 . . TRUE TEMP
 2 . . CALC TEMP
 3 . . DEN POINT
 ENTER 01

DEFAULT LIMITS FOR TRUE TEMP
 ARE -20. TO 30.
 DO YOU WISH TO ALTER THE LIMITS YES
 ENTER NEW LIMITS (MIN,MAX) -10.0
 DEFAULT LIMITS FOR PRESSURE
 ARE 1050.0 TO 400.0
 DO YOU WISH TO ALTER THE LIMITS YES
 ENTER NEW LIMITS (MIN,MAX) 900,600
 SHOULD INPUT FILE BE REWOUND (Y,N)? ...Y

DO YOU WISH TO INPUT RAOB DATA (Y,N) ...Y
 ENTER IN # OF LEVELS ...13
 AFTER EACH LEVEL # ENTER PRESS,TEMP,DENPOINT.

1? --> 894,-2.3,-2.3
 2? --> 877,-1.3,-1.3
 3? --> 869,-1.5,-1.5
 4? --> 850,-2.3,-2.3
 5? --> 805,-4.3,-4.3
 6? --> 790,-5.1,-5.1
 7? --> 774,-5.3,-5.3
 8? --> 754,-5.7,-5.7
 9? --> 744,-3.7,-3.7
 10? --> 719,-6.1,-6.1
 11? --> 700,-7.1,-25.1
 12? --> 637,-11.1,-26.7
 13? --> 601,-13.7,-27.7

LEVEL #	1	894.00 (MB)	-2.30 (C)	-2.30 (C)
LEVEL #	2	877.00 (MB)	-1.30 (C)	-1.30 (C)
LEVEL #	3	869.00 (MB)	-1.50 (C)	-1.50 (C)
LEVEL #	4	850.00 (MB)	-2.30 (C)	-2.30 (C)
LEVEL #	5	805.00 (MB)	-4.30 (C)	-4.30 (C)
LEVEL #	6	790.00 (MB)	-5.10 (C)	-5.10 (C)
LEVEL #	7	774.00 (MB)	-5.30 (C)	-5.30 (C)
LEVEL #	8	754.00 (MB)	-5.70 (C)	-5.70 (C)
LEVEL #	9	744.00 (MB)	-3.70 (C)	-3.70 (C)
LEVEL #	10	719.00 (MB)	-6.10 (C)	-6.10 (C)
LEVEL #	11	700.00 (MB)	-7.10 (C)	-25.10 (C)
LEVEL #	12	637.00 (MB)	-11.10 (C)	-26.70 (C)
LEVEL #	13	601.00 (MB)	-13.70 (C)	-27.70 (C)

DO YOU WISH TO ALTER ANY VALUES (Y,N) ...N

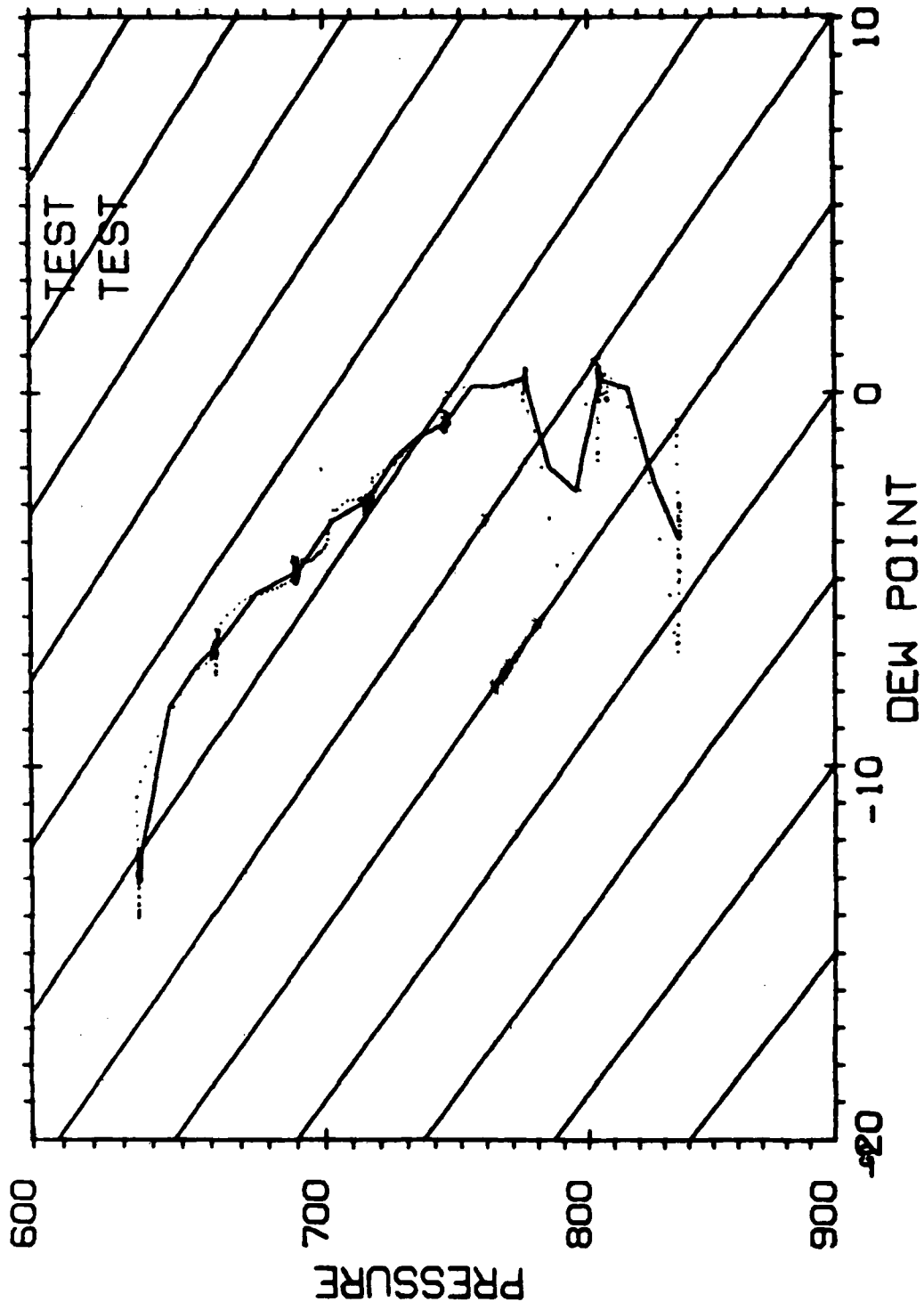

Program SOUND sample plot

4.2.3 Program FILTER

Several changes have been made to program FILTER. Originally this program was written to filter out persistence (non independence) of LWC icing data.

The program was modified to include the option of plotting either LWC or true temperature vs. distance (km) and time (sec). This modification also involved changing the plot axis and output to be labeled with appropriate captions.

The program was modified to calculate and print out a smoothed filtered power along side the filtered power. Each value is printed in tabular form with a one to one correspondence. The equation for calculating smoothed filtered power was provided by the scientist and is as follows:

$$\text{DATA}(I-1)*.23+ \text{DATA}(I)*.54 + \text{DATA}(I+1)*.23$$

For the sake of consistency, the scientist also requested that the plots of the output be put on a static scale which eliminates the need to calculate appropriate scales each time. Consult the sample plots to examine the limits used.

Operating instructions and a list of sample output follow.

4.2.3.1 FILTER Operating Instructions

COMMAND CARDS

DPSI,CM65000,T500,NT1. ACCT # NAME
ATTACH,LGO,FILTERBIN,ID=MILLERP, MR=1
VSN,TAPE1=LYCXXX/NT. (KNOLLID OUTPUT TAPE)
REQUEST,TAPE1,E,NORING,NT.
ATTACH,CRT,CRTPLOTS.
LIBRARY,CRT.
REQUEST,TAPE39,*Q.
LDSET,PRESET=ZERO.
LGO.
EXIT(U)
DISPOSE,TAPE39,FM.
7/8/9

DATA CARDS

CARD #1 (REQUIRED)

I PLOT,ZMIN,ZMAX (FREE FORMAT)

I PLOT - IF 1 TRUE TEMP, 0 IF LWC

ZMIN - MINIMUM PLOT LIMIT FOR CENTERED VALUES

ZMAX - MAXIMUM PLOT LIMIT FOR CENTERED VALUES

CARD 2-(N+1) (N PASSES IN ASCENDING TIME ORDER)

HH:MM:SS COL 1-8 PASS START TIME

HH:MM:SS COL 10-17 PASS STOP TIME

6/7/8/9

4.2.3.2 List of FILTER Sample Output Plots

1. Centered LWC Values vs Distance (KM) and Time (Sec)
2. Autocorrelation COEFS vs Distance (KM) and Time LAG
3. Unfiltered Power Density vs Frequency (cycles/KM)
4. Filtered Power Density vs Frequency (cycles/KM)
5. Centered Temp Values vs Distance (KM) and Time (Sec)

Each plot frame also includes as a heading

1. start time
2. stop time
3. averaging interval
4. number of data points
5. LWC mean
6. average altitude
7. average true air speed

Sample charts follow.

FLT E78-10

23 MAR 78

START 23 43 03

STOP 24 04 55

5 SEC INTERVAL

438 DATA POINTS

LMC MEAN

.22

AVE ALT(KH)

3.0588

AVE TAS(M/SEC)

85.5738

AUTOCORRELATION COEFS

1	.93357
2	.87494
3	.83549
4	.79245
5	.75513
6	.73093
7	.71938
8	.70705
9	.68298
10	.66211
11	.64895
12	.63297
13	.61901
14	.60496
15	.59655
16	.57277
17	.54356
18	.52240
19	.51532
20	.49376
21	.48797
22	.47282
23	.45776
24	.44345
25	.42986
26	.41939
27	.39235
28	.35928
29	.33525
30	.32692
31	.31387
32	.31199
33	.31735
34	.32281
35	.31023
36	.30554
37	.30528
38	.30907
39	.31931

FILTERED POWER

1	.80332
2	.46316
3	.26966
4	.96561
5	.55273
6	.86041
7	1.45223
8	.96203
9	.51447
10	1.66936
11	1.27524
12	1.09051
13	1.93949
14	.83216
15	.46534
16	.85847
17	1.34367
18	.84933
19	.52916
20	1.32508
21	1.17719
22	1.87272
23	2.78553
24	.48167
25	.68732
26	1.30855
27	.70725
28	1.26559
29	1.33785
30	.32719
31	1.23622
32	.91678
33	1.68696
34	.31697
35	1.16970
36	.66879
37	1.23351
38	.30365
39	.62331
40	1.56677
41	1.60993
42	.43649
43	1.29022

SMOOTHED FILTERED POWER

1	.80332
2	.49689
3	.47423
4	.71058
5	.71846
6	.92576
7	1.20337
8	.97184
9	.98303
10	1.31399
11	1.39270
12	1.27966
13	1.27004
14	.54035
15	.45214
16	.88425
17	1.11631
18	.88453
19	.78379
20	1.10801
21	1.37118
22	1.92271
23	2.84572
24	1.55887
25	.78290
26	1.02737
27	.92797
28	1.84579
29	1.24278
30	.76872
31	.95367
32	1.16737
33	1.19467
34	.82817
35	.85859
36	.91443
37	.88999
38	.59184
39	.76678
40	1.35970
41	1.33011
42	.90274
43	1.29022

4.2.4 JW-LWC Corrections

During this contract period the algorithm for making JW-LWC corrections has been modified so that specific corrections can be made over a specific time interval. Prior to this only one set of corrections was allowed throughout a run. Now more accurate corrections may be made by breaking them up into time segments.

The programs in the production job stream that use JW-LWC corrections are; KNOLL1D, ICEDMP, and ICEEX.

The new format of the JWADJ namelist are provided below:

```
NAMelist JWADJ
CONTAINS HEIGHT PROFILES FOR A JW-LWC ADJUSTMENT.
ELEMENTS ARE:
  L  NUMBER OF LEVELS (DEFAULT 0- NO CORRECTION) (MAXIMUM 10)
  HT HEIGHT OF LEVEL IN KM'S (HT(1)GT HT(2)GT...GT HT(L))
  XA ORIGIN OF LEVEL (ONE PER LEVEL)
  SLA SLOPE FROM LEVEL (I) TO LEVEL (I+1) (L-1 SLOPES REQUIRED)
  LTIM NUMBER OF TIME CORRECTION INTERVALS (DEFAULT 0-
      NO CORRECTIONS) (MAXIMUM 10)
  JWTIM INTEGER ARRAY (2.10) CONTAINING START AND STOP TIMES
      IN SECONDS
  SLATIM SLOPE OF TIME CHANGE
  XATIM INTERCEP OF TIME CHANGE
```

4.2.5 Derivation and Implementation of Exponential Functions

As part of the requirements under this contract, DPSI prepared an Interim Scientific Report (ISR) for submittal to the contract manager, AFGL/LYC. This report was a comprehensive discussion of the derivation and implementation of the Weibull and Gamma distribution functions to model axial scattering spectrometer data distributions.

These data were obtained from 26 discrete flight passes made by the Air Force Geophysics Laboratory's instrumental C130-E aircraft during the 1979-1980 winter. The data were collected in supercooled clouds associated with aircraft icing. The instrument probe was designed to collect water particle data in the 2-30 micron range at 2 micron intervals. The resultant 15 data values (channels) for each flight pass comprised the raw data sets. However, due to the excessively noisy data signal present in channel 1, these data were eliminated from the analysis. Thus data channels 2-15 were used as input to the Weibull and Gamma functions.

It was noted that the distribution of the data's number density spectra seemed to be describable by either the Weibull function or the Khrghian-Magin form of the Gamma distribution.

The main body of the ISR is concerned with the derivation of these two distribution functions. First, the Weibull, defined as:

4.2.5 Derivation and Implementation of Exponential Function (cont'd)

$$f(x) = N a x^{b-1} e^{-ax}$$

is derived by solving for 'a' and 'b' via the maximum likelihood method and the Newton-Raphson method, respectively. Similarly, the Gamma function, defined as:

$$f(x) = N \frac{a^3}{2} x^2 e^{-ax}$$

is derived by using the maximum likelihood method to solve for 'a'.

As part of the derivation for both the Weibull and Gamma functions, the independent factor N was introduced to enable 'a' and 'b' to be independent of the magnitude of the distribution's range, and dependent only on the nature of the respective function. However, solving for N by the way of the maximum likelihood method would result in the undefined expression

$$\frac{1}{N} \sum Y_i = 0$$

and thus another method had to be employed. Therefore, utilizing the method of least square analysis and partial derivatives, the value of N was determined.

The analysis section of the ISR identifies, with the aid of four figures, the shortcomings of the Weibull and the overall superiority of the Gamma function to model cloud droplet spectra data distributions.

4.2.5 Derivation and Implementation of Exponential Function (cont'd)

Program WBLGMA utilizes these functions, as derived, to model and analyze the raw channel counts (usually 2-15) collected by the axial probe. Section 4.2.5.1 contains sample output from the program for one time pass. The first line of output simply re-states flight and probe data for that pass, as well as which data channels are being used as input.

The main body of the output in the following table is the channel by channel comparison of the two modeled data distributions (G & W) to the raw data. The overall performance of each distribution function is provided by the LOG RMS value of each.

See scientific report no. 1 (AFGL-TR-82-0309), published 30 September 1982, for the complete discussion detailing the derivations and analysis techniques.

4.2.5.1 WBLGMA Operating Instructions & Sample Output

ATTACH,W,WBLGA

ATTACH,W,WBLGMA,ID=MILLERP
CONNECT,INPUT
CONNECT,OUTPUT
SCREEN 132
LGO

89.98 2.4 .004 2 15

TAS= 89.98 BIN=2.4 SAREA= .004 J= 2 K=15

RAW COUNTS	RAW ND	G COUNTS	G ND	U COUNTS	U ND
.22910E+04	.26522E+04	.25758E+04	.29820E+04	.19745E+04	.22858E+04
.32230E+04	.37312E+04	.26488E+04	.30665E+04	.25446E+04	.29458E+04
.22130E+04	.25619E+04	.21522E+04	.24915E+04	.24581E+04	.28457E+04
.13200E+04	.15281E+04	.15369E+04	.17792E+04	.18829E+04	.21798E+04
.65400E+03	.75711E+03	.10115E+04	.11710E+04	.11677E+04	.13518E+04
.48100E+03	.55684E+03	.62924E+03	.72844E+03	.59097E+03	.68414E+03
.14600E+03	.16902E+03	.37562E+03	.43484E+03	.24468E+03	.28326E+03
.83000E+02	.96086E+02	.21777E+03	.25153E+03	.82857E+02	.95921E+02
.36000E+02	.41676E+02	.12259E+03	.14192E+03	.22912E+02	.26524E+02
.24000E+02	.27784E+02	.67777E+02	.78486E+02	.51612E+01	.59750E+01
.17000E+02	.19680E+02	.36876E+02	.42690E+02	.94448E+00	.10934E+01
.17000E+02	.19680E+02	.19779E+02	.22898E+02	.13999E+00	.16206E+00
.10000E+02	.11577E+02	.10484E+02	.12137E+02	.16752E-01	.19394E-01
.17000E+02	.19680E+02	.55006E+01	.63679E+01	.16136E-02	.18681E-02

TOTND

.12193E+05 .13209E+05 .12706E+05

LOG RHS

Q=.61961E+03 N=.35687E+05 A=.32625E+00 N=.33231E+05 A=.49168E-02 B=.22697E+01
 .11187E+01 .55185E+01

4.3 Ice Detector Analysis

Data collection by ice detector can be characterized by three distinct modes of operation.

- 1) sensing mode
- 2) detecting mode, and
- 3) standby mode.

These modes occur in the sequence listed. The standby mode however, can be triggered manually at any time.

- A. In the sensing mode the probe is signaling that the ice is accumulating on it. The counts will range in the mode from 6250 to 9818. (The latter value being equal to 4.8 volts at which point the accumulation of ice triggers the detecting mode). If icing rates are very low it is possible that the probe will remain in the sensing mode, i.e., never accumulating enough ice to go into the detecting mode or the ice will evaporate and counts will decrease in value to approximately 6250.

In the detecting mode, an ice signal is generated and heating cycle is initiated. During this period random counts are generated. Typically values under 5000 are generated (see C) for a number of seconds. All these data (i.e., exceeding 9818 and less than 5000 counts) are to be disregarded as data, but to be used as the indicator of a change from the detecting to standby mode.

The standby mode follows the detecting mode and has a range of counts from 5350 to 5150. The most frequently observed values is 5250 counts. In this mode all ice

has been removed from the detector, and the DC current to the probe has been cutoff. Typically this mode lasts under 2 seconds.

The time needed for the ice detector to return from standby mode to the sensing mode depends on icing conditions, ambient temperature and airspeed. With moderate icing 7-10 seconds are typical. The return to the sensing mode occurs when counts equal 6250.

- B. It is possible while in the sensing mode for apparently random counts to be generated; that is, 9818 counts has not been reached nor exceeded and apparently random signals, (similar to those occurring when the instrument is in the detecting mode) are observed. Following the occurrence of these random counts, the counts recorded return to values indicating the unit is still in the sensing mode.

- C. Random counts are sudden large excursion in magnitude. Since these occur primarily in connection with the change from sensing to detecting mode and frequently occur with voltages exceeding 5V, causing a rollover in counts, (i.e., numbers > 9999 begin at 0001) it is useful to add 10000 counts to all values < 5000.

4.3.1 Program ICEEX

A flight was made on 06 DEC 79 in order to collect data using the Ice Detector device. As a "quick look" method to examine the data, a plotting program PLTICE was written (see section on PLTICE). This plot coupled with KN1UTIL's VCO listing for this flight enabled certain empirical relationships between the recorded data and the behavior of the Ice Detector device to be derived.

Mr. Morton Glass formulated these relationships on 19 DEC 79 and an updated version of his memo is given on the following pages. Program ICEEX incorporates these concepts and, as can be seen in figure 4.6, is at the heart of the icing data processing and analysis stream.

Data from the Ice Detector is given in VCO position ten of the PMS1D Kennedy tape. Program ICEEX reads this tape, identifies the modes, eliminates erroneous/redundant points, and produces an edited output tape.

ICEEX inputs a flight identification, a namelist card to change the default VCO calibrations, and a set of start stop time ranges.

For each start and stop time range the first standby mode is found by performing a three point running mean until this average is within 200 counts of 5250. The midpoint of this mean is then put onto the output tape with a code word

4.3.1 Program ICEEX (cont'd)

equal to one. The next step is to find the "trigger value". This value is the first count whose value exceeds 6000, thus marking the transition from standby to sensing mode (by ignoring the detecting mode completely). When this time is found (no averaging is used - only the raw count) the data record is sent with a code word equal to two. Now the ice detector is considered to be at the start of the sensing mode. Until the counts go below the "trigger value", exceed the maximum 9818 counts, or degrade into four consecutive "bad points", every data point is written to the output tape with a code word equal to three.

The cycle of finding the standby mode, trigger value, and then all sensing values is repeated until a time value exceeds the input stop time.

This inputting of start and stop times is terminated by the end of input cards or an end of file on the PMS1D tape.

Every point in the sensing mode is verified by extrapolating from the previously read two points. If the input value differs by more than 400 counts from the extrapolated value, the extrapolated value is used. The extrapolating method is designed to compromise between changing direction and having the data rise rapidly. The extrapolated point $C(i)$ is given by

$$C(\text{suggested}) = ((C(i-2) + C(i-1)) / 2 + 2 * C(i-1) - C(i-2)) / 2$$

4.3.1 Program ICEEX (cont'd)

Since ICEEX lists, on the printer, each value as it is being written to tape, an asterisk is printed to denote the fact that it is a "calculated" and not a "true" value. Every second of extracted data as well as PMS1D raw counts are written in groups of 59 words to the output tape. Operating instructions, a description of the output tape, and sample output follow.

4.3.1.1 Program ICEEX Operating Instructions and Sample Output

CONTROL CARDS

JOBID.T1000.TP1.NT1.	JOB #	PASSWORD
ATTACH.LG0.ICEEXBIN.ID=MILLERP,MR=1.		(KENNEDY TAPE - PMS ID TAPE)
VSN.TAPE1=PMSTAPENUMBER.		
REQUEST.TAPE1.S.HI.MT.		(PROCESSED DATA TAPE - OUTPUT)
VSN.TAPE2=OUTPUTTAPENUMBER/NT.		
REQUEST.TAPE2.PE.N.RING.MT.		
FILE(TAPE1,RT=J,RT=K,MRL=1120,MBL=1120,RB=1,BFS=115)		
LDSET.PRESET=ZERO.		
LG0.		

7/9/9

DATA CARDS

CARD 1

COL 1-10	FLIGHT ID
11-20	FLIGHT DATE
25	CLOCK (1=A/C,2=PMS)
30	PUT A 1 IN THIS COLUMN TO INDICATE USE OF KENNEDY TAPE
75-90	EXTRAPOLATION BOUND (15 FORMAT - DEFAULT 400)

CARD 2

VCOCHAN NAMELIST - VCO CALIBRATIONS
(SEE VCOEF IN KNOLLID)

CARD 3

JWADJ NAMELIST - JW-LWC ADJUSTMENT PROFILES
(SEE JWADJ IN KNOLLID)

CARD 4 - (4+N-1)

N PASS CARDS IN FORM(STARTING IN COLUMN 1) HH-MM-SS-HH-MM-SS
START STOP TIMES

5/7/3/9

WORD	CONTENTS
1	TIME OF RECORD (IN SECONDS)
2	FLIGHT IDENTIFICATION
3	FLIGHT DATE
4	LATITUDE (NOT USED)
5	LONGITUDE (NOT USED)
6	TEMPERATURE (TRUE IN DEGREES CENTIGRADE)
7	TEMPERATURE (TOTAL IN DEGREES CENTIGRADE)
8	DEWPOINT (IN DEGREES CENTIGRADE)
9	JW-LWC (UNADJUSTED GM/M**3)
10	PRESSURE (MILLIBARS)
11	TRUE AIRSPEED (M/SEC)
12	ICING COUNT
13	CODE 1=STANDBY RECORD, 2=TRIGGER RECORD, 3=SENSING RECORD
14	ALTITUDE (METERS)
15-29	CHANNEL COUNTS FOR CHANNELS 1-15 OF THE SCATTER PROBE
30-44	CHANNEL COUNTS FOR CHANNELS 1-15 FOR THE CLOUD PROBE
45-59	CHANNEL COUNTS FOR CHANNELS 1-15 OF THE PRECIP PROBE

ALL VALUES ARE IN FLOATING POINT FORMAT. REDCORD IS 59 WORDS
LONG WRITTEN BY A FORTRAN BINARY WRITE STATEMENT (WRITE(UNIT)LIST)

FLT E80 CODE	J 17 DEC 80 TIME	ICE D	JW	TIME FROM 00 00 00 TO 99 99 99 TOT T TRUE T	PMS ST DEMP	00 00 00 PRESS	ALT	TAS
TRIG	25 02 31	6043	.29	-1.80	-11.65	-14.01	593.9	140.8
SENSE	25 02 32	6109	.20	-1.82	-11.59	-13.92	594.5	140.3
SENSE	25 02 33	6166	.17	-1.81	-11.52	-13.83	595.1	139.9
SENSE	25 02 34	6294	.16	-1.80	-11.48	-13.69	595.8	139.6
SENSE	25 02 35	6360	.16	-1.75	-11.46	-13.54	596.5	139.9
SENSE	25 02 36	6373	.15	-1.69	-11.37	-13.37	597.2	139.7
SENSE	25 02 37	6370	.15	-1.63	-11.24	-13.18	597.9	139.1
SENSE	25 02 38	6368	.15	-1.58	-11.14	-12.96	598.4	138.8
SENSE	25 02 39	6352	.15	-1.57	-11.10	-12.72	599.0	138.6
SENSE	25 02 40	6353	.15	-1.57	-11.06	-12.48	599.6	138.2
SENSE	25 02 41	6359	.15	-1.51	-11.01	-12.21	600.1	138.3
SENSE	25 02 42	6355	.15	-1.48	-10.91	-11.94	600.6	137.8
SENSE	25 02 43	6352	.15	-1.47	-10.85	-11.65	601.3	137.4
SENSE	25 02 44	6335	.16	-1.48	-10.84	-11.36	601.7	137.3
SENSE	25 02 45	6350	.18	-1.51	-10.84	-11.07	602.3	137.1
SENSE	25 02 46	6392	.20	-1.49	-10.80	-10.76	602.8	137.0
SENSE	25 02 47	6417	.18	-1.46	-10.69	-10.47	603.4	136.4
SENSE	25 02 48	6465	.20	-1.42	-10.67	-10.15	604.0	136.5
SENSE	25 02 49	6547	.23	-1.35	-10.58	-9.88	604.5	136.4
SENSE	25 02 50	6596	.22	-1.36	-10.52	-9.58	605.1	135.8
SENSE	25 02 51	6650	.20	-1.35	-10.49	-9.31	605.6	135.7
SENSE	25 02 52	6663	.17	-1.33	-10.42	-9.04	606.4	135.3
SENSE	25 02 53	6656	.15	-1.32	-10.39	-8.79	607.0	135.2
SENSE	25 02 54	6643	.14	-1.27	-10.35	-8.55	607.5	135.2
SENSE	25 02 55	6632	.14	-1.22	-10.25	-8.32	608.2	134.9
SENSE	25 02 56	6625	.15	-1.19	-10.20	-8.12	608.8	134.7
SENSE	25 02 57	6611	.15	-1.12	-10.09	-7.94	609.4	134.5
SENSE	25 02 58	6601	.15	-1.05	-10.06	-7.77	610.1	134.7
SENSE	25 02 59	6595	.15	-1.00	-9.97	-7.64	610.7	134.4
SENSE	25 03 00	6587	.15	-.93	-9.91	-7.51	611.3	134.5
SENSE	25 03 01	6576	.14	-.85	-9.84	-7.42	612.0	134.6
SENSE	25 03 02	6567	.14	-.78	-9.76	-7.35	612.6	134.5
SENSE	25 03 03	6556	.14	-.79	-9.70	-7.29	613.2	134.0
SENSE	25 03 04	6542	.15	-.74	-9.63	-7.25	613.9	133.8
SENSE	25 03 05	6535	.15	-.71	-9.52	-7.24	614.5	133.3
SENSE	25 03 06	6523	.15	-.69	-9.51	-7.24	615.1	133.3
SENSE	25 03 07	6519	.14	-.63	-9.42	-7.25	615.8	133.1
SENSE	25 03 08	6505	.15	-.56	-9.36	-7.29	616.5	133.2
SENSE	25 03 09	6494	.15	-.53	-9.33	-7.34	617.2	133.2
SENSE	25 03 10	6485	.15	-.53	-9.30	-7.39	617.9	133.0
SENSE	25 03 11	6559	.15	-.46	-9.20	-7.46	618.5	132.7
SENSE	25 03 12	6470	.15	-.52	-9.26	-7.54	618.3	132.7
SENSE	25 03 13	6463	.15	-.48	-9.22	-7.63	619.8	132.7
SENSE	25 03 14	6453	.14	-.44	-9.17	-7.71	620.4	132.6
SENSE	25 03 15	6439	.15	-.36	-9.09	-7.81	621.0	132.6
SENSE	25 03 16	6436	.15	-.26	-9.02	-7.91	621.7	132.8
SENSE	25 03 17	6425	.14	-.15	-8.93	-8.01	622.3	132.9
SENSE	25 03 18	6419	.14	-.08	-8.85	-8.11	622.9	132.9
SENSE	25 03 19	6347	.15	-.03	-8.79	-8.21	623.6	132.8
SENSE	25 03 20	6331	.15	.02	-8.73	-8.31	624.2	132.7
SENSE	25 03 21	6322	.14	.10	-8.65	-8.41	624.9	132.7
SENSE	25 03 22	6316	.14	.10	-8.65	-8.50	625.4	132.7
SENSE	25 03 23	6310	.14	.11	-8.59	-8.59	626.1	132.3
SENSE	25 03 24	6300	.14	.11	-8.58	-8.69	626.7	132.3
SENSE	25 03 25	6294	.14	.15	-8.57	-8.76	627.3	132.5

FLT E80	TIME	ICE D	TIME FROM 00 00 00 TO 99 99 99	PMS ST,	00 00 00	ALT	TAS
CODE	T I M E		TOT T	TRUE T	DEWP	PRESS	
SENSE	25 03 26	6289	.15	-8.48	-8.83	628.0	3654
SENSE	25 03 27	6281	.15	-8.41	-8.89	628.8	3846
SENSE	25 03 28	6281	.17	-8.36	-8.96	629.4	3838
SENSE	25 03 29	6276	.16	-8.27	-9.01	630.1	3629
SENSE	25 03 30	6272	.16	-8.22	-9.07	630.9	3820
SENSE	25 03 31	6267	.16	-8.16	-9.04	631.2	3816
SENSE	25 03 32	6265	.16	-8.09	-9.11	631.3	3902
SENSE	25 03 33	6255	.16	-7.99	-9.12	633.0	3794
SENSE	25 03 34	6255	.16	-7.95	-9.13	633.8	3784
SENSE	25 03 35	6253	.16	-7.89	-9.12	634.5	3775
SENSE	25 03 36	6248	.16	-7.81	-9.11	635.3	3766
SENSE	25 03 37	6243	.16	-7.73	-9.04	636.2	3755
SENSE	25 03 38	6236	.17	-7.66	-9.06	637.1	3744
SENSE	25 03 39	6233	.17	-7.58	-9.01	638.0	3733
SENSE	25 03 40	6224	.17	-7.48	-8.96	638.8	3723
SENSE	25 03 41	6214	.17	-7.39	-8.91	639.7	3712
SENSE	25 03 42	6214	.16	-7.31	-8.83	640.9	3698
SENSE	25 03 43	6213	.16	-7.24	-8.77	641.8	3688
SENSE	25 03 44	6207	.16	-7.19	-8.70	642.7	3677
SENSE	25 03 45	6202	.17	-7.12	-8.62	643.8	3663
SENSE	25 03 46	6190	.17	-7.00	-8.53	644.8	3651
SENSE	25 03 47	6176	.17	-6.92	-8.43	645.7	3640
SENSE	25 03 48	6172	.17	-6.82	-8.35	646.8	3627
SENSE	25 03 49	6168	.17	-6.72	-8.24	647.8	3615
SENSE	25 03 50	6166	.17	-6.65	-8.14	648.7	3604
SENSE	25 03 51	6159	.17	-6.56	-8.04	649.8	3591
SENSE	25 03 52	6158	.17	-6.49	-7.94	650.8	3579
SENSE	25 03 53	6155	.17	-6.40	-7.82	651.8	3567
SENSE	25 03 54	6146	.17	-6.30	-7.72	652.8	3555
SENSE	25 03 55	6136	.18	-6.22	-7.62	653.8	3544
SENSE	25 03 56	6133	.18	-6.12	-7.50	654.8	3532
SENSE	25 03 57	6126	.18	-6.04	-7.39	655.8	3520
SENSE	25 03 58	6118	.18	-5.94	-7.28	656.7	3510
SENSE	25 03 59	6114	.18	-5.87	-7.17	657.7	3498
SENSE	25 04 00	6112	.18	-5.77	-7.07	658.6	3487
SENSE	25 04 01	6103	.18	-5.66	-6.96	659.6	3475
SENSE	25 04 02	6093	.18	-5.52	-6.85	660.4	3466
SENSE	25 04 03	6084	.17	-5.43	-6.75	661.2	3456
SENSE	25 04 04	6077	.17	-5.34	-6.65	661.7	3450
SENSE	25 04 05	6078	.17	-5.27	-6.57	661.9	3448
SENSE	25 04 06	6071	.17	-5.22	-6.48	662.2	3444
SENSE	25 04 07	6063	.17	-5.19	-6.40	662.1	3445
SENSE	25 04 08	6063	.18	-5.22	-6.33	661.7	3450
SENSE	25 04 09	6063	.17	-5.22	-6.25	661.7	3450
SENSE	25 04 10	6056	.17	-5.18	-6.18	661.5	3453
SENSE	25 04 11	6050	.17	-5.18	-6.13	661.6	3451
SENSE	25 04 12	6044	.17	-5.19	-6.08	661.5	3453
SENSE	25 04 13	6043	.18	-5.24	-6.04	661.6	3451

EOF ON CARD INPUT - OR INPUT TAPE

4.3.2 Program ICEDMP

The purpose of this program is to generate icing data output for inclusion within technical reports. ICEDMP produces output efficiently and quickly. It is highly modular in nature which allows changes to be made quickly with a minimum of additional programming. In addition, ICEDMP utilized the XEROX hard copy device at the AFGL Computer Center in order to facilitate the inclusion of quality, reduced size (8½ x 11) copy within technical reports.

ICEDMP uses the raw PMS-1D data tape for input and produces three distinct output files; one contains axial probe data; the second contains processed data. Additionally, the standard output file lists information singular to the particular flight being processed.

The following pages provide operating instructions and sample output.

4.3.2.1 ICEDMP Operating Instructions and Sample Output

COMMAND DECK

```
DPSI,T300,TP1,CM50000. ID # ID NAME
ATTACH,L60,ICEDMPBIN,ID= KAPLANF,MR=1.
ATTACH,TAPE8,VCOALS,ID= KAPLANF,MR=1.
VSN,TAPE1=PMSXXX.
REQUEST,TAPE1,S,HI,MT,NORING.
FILE(TAPE1,RT=U,BT=K,MRL=1024,MBL=1024,RB=1,BFS=105)
LDSET,PRESET=ZERO.
EXIT(U)
REWIND TAPE4,TAPE5,TAPE6,TAPE7.
COPY,TAPE4.
COPY,TAPE5.
COPY,TAPE6.
COPY,TAPE7.
```

7/8/9

DATA CARDS

ID CARD

```
CC 1-10 FLT ID IN FORM FLT EXX-XX
    11-20 FLT DATE IN FORM DD MON YR
    21-26 PMS TAPE NUMBER IN FORM PMSXXX
    52-59 PMS ON TIME IN FORM HH MM SS
```

NAMelist VCOEF - USING ARRAY C(3,13)

USED TO OVERRIDE VCO CALIBRATION FILE - SEE KNOLLID

NAMelist JUADJ - USING L AND ARRAYS HT(10), XA(10) AND SLA(10)

USED TO MAKE JU-LUC CORRECTIONS - SEE KNOLLID

OPTION CARD

```
CC 5 ICLK - 0 USE A/C CLOCK
    1 USE PMS CLOCK
    10 IVEL - 0 USE TRUE AIRSPEED
    1 USE CALCULATED AIRSPEED
    11-15 IAVE - AVERAGING INTERVAL IN 15 FORMAT
    20 PASSAVE - IF SET TO 1 IGNORE IAVE AND GIVE
    PASS AVERAGES
    25 ITMP 0 USE VCO TEMPERATURE CALIBRATION
    1 USE VCO TEMPERATURE CALIBRATION AND
    TRUE AIRSPEED
    26-30 NRTS - NUMBER OF RECORDS TO SKIP
    0 - SKIP NO RECORDS (DEFAULT)
    N - SKIP N RECORDS BEFORE PROCESSING ANY DATA
    79-80 CLOUD PARTICLE TYPE (DEFAULT = RAIN)
```

PASS CARDS - AS MANY AS DESIRED IN TIME INCREASING ORDER

```
CC 1-6 PASS START TIME IN FORM HHHMSS
    8-13 PASS STOP TIME IN FORM HHHMSS
    20 WHEN SET TO 1 USE THE JU-LUC FOR ICE THICKNESS
    CALCULATION(DEFAULT AXIAL FOR EACH PASS)
```

6/7/8/9

4.3.2.1 Program ICEDMP (cont'd)

AXIAL PROBE OUTPUT (TAPE 5) - See Appendix 23B

FLIGHT ID

FLIGHT DATE

TOP OF EACH PAGE

AVERAGING INTERVAL

Z TIME - START TIME OF AVERAGING INTERVAL

CHANNEL COUNTS - RAW AVERAGED AXIAL PROBE COUNTS

CONC - AXIAL PROBE NUMBER DENSITY IN CUBIC CENTIMETERS

$$\text{CONC} = \frac{15}{\sum_{i=1} \text{SCATVOL}_i} \left[\frac{\text{COUNTS}_i}{\text{CM}^{**3}} \right]$$

COUNTS_i = NUMBER OF PARTICLES FOR CHANNEL i

SCATVOL = [AXIAL CROSS SECTIONAL AREA (M**2) x AIRSPEED (M/SEC)] * 1.E-6

DBAR - MEAN DIAMETER OF AXIAL PARTICLES

$$\text{DBAR} = \frac{\sum_{i=1}^{15} (\text{COUNTS}_i) (\text{DIAM}_i)}{\sum_{i=1}^{15} \text{COUNTS}_i} \quad (\text{TOTAL COUNTS})$$

DIAM_i = CHANNEL ADJUSTED CENTER DIAMETER

DBARV - AXIAL PROBE VOLUME AVERAGED PARTICLE DIAMETER

$$\text{DBARV} = ((\text{ALWC} * \text{SCATVOL}) / (0.523598\text{E}-3 * \text{TOTCTS}))^{1/3} * 1.\text{E}3$$

4.3.2.1 Program ICEDMP (cont'd)

ALWC - AXIAL LWC (G/M**c)

SCATVOL - AXIAL VOLUME (M**3)

TOTCTS - TOTAL COUNTS

0.5235988 = $\pi/6 \times \rho$ (WATER DENSITY 1.E-3 G/MM**3)

DMAZ & D0 - 95% AND 50% AXIAL MEDIAN VOLUME DIAMETER

The diameter at which 95% (50% of the water is contained in channels less than this size; 5% (50%) of the water is contained in channels greater than this size. Consult KNOLL1D documentation.

ALWC - AXIAL LIQUID WATER CONTENT (G/M**3)

$$ALWC = \frac{\pi}{6} \rho \sum_{i=1}^{15} CONC_i DIAM_i^3$$

S-VOL - AXIAL SAMPLING VOLUME (CM**3)

S-VOL = CROSS SECTIONAL AREA (M**2) x AIRSPEED (M/SEC) x 1.E6

4.3.2.1 Program ICEDMP (cont'd)

CLOUD PROBE OUTPUT (TAPE7) - See appendix 23C

FLIGHT ID

FLIGHT DATE

TOP OF EACH PAGE

AVERAGING INTERVAL

Z TIME - START TIME OF AVERAGE INTERVAL

CHANNEL COUNTS - RAW AVERAGED CLOUD PROBE COUNTS

1D-C - CLOUD PROBE NUMBER DENSITY IN LITERS

$$1D-C = \sum_{i=15}^{15} \frac{COUNTS_i}{VOL_i} \times 1.E-3$$

$COUNTS_i$ = CLOUD CHANNEL COUNTS

VOL_i = CLOUD CHANNEL VOLUME (M**3)

= CHANNEL
CROSS SECTIONAL AREA (M**2) x AIRSPEED (M/SEC)

DBAR

DMAX

D0

SEE ABOVE (USE CLOUD INFORMATION)

CLWC - CLOUD LIQUID WATER CONTENT (g/M**3) (SEE ABOVE)

TLWC - TOTAL LIQUID WATER CONTENT (g/M**3)

TLWC = ALWC + CLWC - (LWC CONTRIBUTION OF ANY OVERLAPPING CLOUD CHANNELS)

PCT CLD - PERCENT CONTRIBUTION OF THE CLOUD LWC TO THE TOTAL LWC

$$PCT CLD = \frac{CLOUD CONTRIBUTION}{AXIAL \& CLOUD CONTRIBUTION} \times 100$$

4.3.2.1 Program ICEDMP (cont'd)

DEWP - DEWPOINT (C)
 IF FROST \geq 0 THEN DEWP = FROST
 ELSE
 DEWP = $9.84E-4 * FROST^2 + 1.1305 * FROST - 0.012$

EPT - EQUIVALENT POTENTIAL TEMPERATURE (KELVIN)
 EPT = $PT [LW_S / C_P T_C]$

WHERE T = TEMP °C
 TK = TEMP °K
 D = DEWP °C
 DK = DEWP °K
 P = PRESS (Mb)

PT = $TK (1000/P)^{.2857}$ POTENTIAL TEMPERATURE (K)
 L = $4.187(734. - .5|TK)$ LATENT HEAT OF VAPORIZATION (JOULES)
 W_S = $.622(e/P - e)$ SATURATED MIXING RATIO
 e = VAPOR PRESSURE (Mb) AT TK
 R_V = $.461$ (JOULES/°K MOLE) (SPECIFIC GAS CONSTANT FOR WATER VAPOR)
 C_P = 1.005 (JOULES/g °K) SPECIFIC HEAT OF DRY AIR AT CONSTANT PRESSURE
 T_C = $DK + (D^2(T-D)/(D^2-1543.307T))$
 ISENTROPIC CONDENSATION TEMPERATURE (°K)

CONC - AXIAL NUMBER DENSITY - (SEE ABOVE)
 ALWC - AXIAL LWC (SEE ABOVE)
 JW-LWC - JOHNSON-WILLIAMS LWC (g/M**3)

JW-LWC = $\frac{(CALIBRATED\ VALUE)\ 200}{TAS\ OR\ CAS}$

When desired JW-LWC may be adjusted based on an ALTITUDE profile - consult KNOLL1D documentation for more information.

4.3.2.1 Program ICEDMP (cont'd)

ID-C - CLOUD NUMBER DENSITY (SEE ABOVE)
*ICE-TK - ICE THICKNESS DERIVED FROM THE AXIAL LWC PER NAUTICAL MILE (USES THE DENSITY OF WATER)
ICETK = ALWC*.185325

* AN ALGORITHM HAS BEEN DEVELOPED TO DETERMINE WHEN WE ARE NOT IN AN ICING STATE. WHEN THIS OCCURS THE WORDS "NO ICE" REPLACE THIS CALCULATED VALUE.

TO BE IN AN ICING STATE ALL OF THE FOLLOWING MUST BE TRUE:

- 1) TRT < -0.5°C
- 2) JW-LWC > .01 g/m**3)
- 3) NOT PASS AVERAGING ONLY
 - A) IF ANY OF THE FIVE SECONDS AFTER INITIALLY REACHING 6000 COUNTS (FOR EACH CYCLE) ARE CONTAINED IN THE AVERAGING INTERVAL
 - OR
 - B) ANY VALUES WERE BELOW 6000 OR GREATER THAN 9818 (IN HEATING CYCLE)
 - OR
 - C) $6000 \leq \text{ALL COUNTS DURING AVERAGE} \leq 9818$ TEST AVERAGE SLOPE DURING PERIOD. IF 2 POINT AVERAGE OR LESS IGNORE THIS TEST, ELSE BREAK INTO 5 POINT MULTIPLES (4 OR 3 SECOND SEGMENT IF NECESSARY) AND USE A DERIVATIVE ROUTINE. IF THE AVERAGE DERIVATIVE ≥ 25 THEN ICEING.
- 4) PASS AVERAGING ONLY - THERE MUST BE AT LEAST ONE ICING CYCLE

ICING RATE METER - PASS AVERAGING ONLY

CYS/NT = NUMBER OF ICING CYCLES PER NAUTICAL MILE

$$= \frac{\text{CYCLE COUNT} * 1853.25}{(\# \text{ OF SECONDS OF PASS}) * (\text{AIRSPEED})}$$

CM/NT = CYS/NT*.05 = THICKNESS OF ICE BUILDUP PER NAUTICAL MILE

4.3.2.1 Program ICEDMP (cont'd)

PROCESSED OUTPUT (TAPE 6) - See appendix 23D

FLIGHT ID

FLIGHT DATE

TOP OF EACH PAGE

AVERAGING INTERVAL

Z TIME - START TIME OF AVERAGING INTERVAL

ALT - STANDARD PRESSURE ALTITUDE (METERS)

ALT - 44307.69 - 11872(P)^{0.190284}

P = PRESSURE (Mb)

STRAIGHT CALIBRATED VCO

TAS or CAS - TRUE AIRSPEED OR CALCULATED AIRSPEED (KNOTS)

TAS - STRAIGHT CALIBRATED VCO

CAS = $\sqrt{1516.4(\text{TRT}+273.16)\text{MCHSQ} + 3\sqrt{(\text{TRT}+273.16)}/\text{P}}$

P = PRESSURE (Mb)

TRT = TRUE TEMPERATURE (C)

MCHSQ = MACH SQUARED NUMBER

= $5 \left(1 + \frac{\text{DEL P}}{\text{P}}\right)^{0.2857143} - 1$

DEL P = DELTA PRESSURE (Mb)

= $((0.001865\text{IAS}) - 0.060149) * \text{IAS} + 3.96965$

IAS = INDICATED AIRSPEED (CALIBRATED VCO IN KNOTS)

TOT T - TOTAL TEMPERATURE (C)

STRAIGHT CALIBRATED VCO

TRT - TRUE TEMPERATURE (C)

TRT = $(\text{TOT T} + 273.16) / (1 + 0.1992 * \text{MCHSQ}) - 273.16$

FROST - FROST POINT/DEW POINT (C)

STRAIGHT CALIBRATED VCO

AFGL FLT E81-11 ON 29 APR 81 PMS371

VCD CALIBRATIONS (A,B,C)
-6.95670E+02 2.07000E-01 -1.15160E-05
-4.90500E+01 9.50007E-03 3.21616E-08
0. 1.00000E+00 0.
0. 1.00000E+00 0.
-5.00200E+01 1.04000E-02 -4.39530E-08
-3.30000E+00 6.37000E-04 0.
1.80000E+02 -3.60000E-02 0.
1.13576E+03 -1.00500E-01 5.00140E-08
-5.00000E+01 5.00000E-02 0.
0. 1.00000E+00 0.
0. 1.00000E+00 0.
0. 1.00000E+00 0.
0. 1.00000E+00 0.

OPTIONS IAVE= 6 IVEL= 0 ICLK= 1 ITMP= 1 PASSAVE= T PMS TIME= 15 13 39

SCATTER PROBE CALIBRATIONS
DIODE WIDTH(MU)= 2.0 CROSS SECTIONAL AREA(CM**2)= 4.5900E-03

CLOUD PROBE CALIBRATIONS - CLOUD DATA MANUALLY TYPED AS RAIN
DIODE WIDTH(MU)= 20.0 CROSS SECTIONAL AREA(M**2)= (DEPTH OF FIELD) X (EFFECTIVE APERTURE WIDTH)
DOF(M)= AMIN1(6.1,(0.095*(CHANNEL #)**2))+1.E-2 EAW(M)= (21 - CHANNEL #)*(DIODE WIDTH(MM))*1.E-3

PASSES
152610
153700 153100
154900 154400
160230 155600
161130 160830
162300 161630
163600 162300
164300 164300

PASS AVERAGING

AFGL FLT E81-11 ON 29 APR 81

Z TIME	AXIAL CHANNEL COUNTS (2-30 UM)											CONC DBAR		DBARV DMAX		DO		ALWC		S-VOL					
	1	2	3	4	5	6	7	8	9	10	11	12	13	14	15	NCM-3	UM	UM	UMI	UM	UM	GM-3	GM-3	CM-3	CM-3
152610	326	266	151	72	38	22	16	7	3	0	0	0	0	0	0	19.5	5.0	6.8	16.7	11.0	0.00	0.00	46.30	46.30	
153700	0	0	0	0	0	0	0	0	0	0	0	0	0	0	0	0.0	0.0	0.0	0.0	0.0	0.00	0.00	59.68	59.68	
154900	1	0	0	0	0	0	0	0	0	0	0	0	0	0	0	.0	2.3	2.3	2.3	2.3	2.3	0.00	0.00	50.78	50.78
160230	0	0	0	0	0	0	0	0	0	0	0	0	0	0	0	0.0	0.0	0.0	0.0	0.0	0.00	0.00	62.43	62.43	
161130	306	116	8	0	0	0	0	0	0	0	0	0	0	0	0	6.5	2.9	3.3	5.6	4.1	0.00	0.00	65.69	65.69	
162300	1921	1193	1291	783	331	110	94	11	3	1	0	0	0	0	0	116.3	5.3	6.8	14.2	9.3	0.02	0.02	49.32	49.32	
163600	22	11	6	4	4	1	1	0	0	0	0	0	0	0	0	1.1	4.8	6.6	13.8	10.2	0.00	0.00	45.24	45.24	

AFGL FLT E81-11 ON 29 APR 81 PASS AVERAGING

Z TIME	1	2	3	4	5	6	7	8	9	10	11	12	13	14	15	1D-C NL-1	DBAR UM	DMAX UM	DO UM	CLWC GM-3	TLWC PCT GM-3 CLD	
152610	0	0	0	0	0	0	1	0	0	0	0	0	0	0	0	.8	142.2	142.2	142.2	.00	.00	26
153700	0	0	0	0	0	0	0	0	0	0	0	0	0	0	0	0.0	0.0	0.0	0.0	0.00	0.00	0
154900	0	0	0	0	0	0	0	0	0	0	0	0	0	0	0	0.0	0.0	0.0	0.0	0.00	0.00	0
160230	0	0	0	0	0	0	0	0	0	0	0	0	0	0	0	0.0	0.0	0.0	0.0	0.00	0.00	0
161130	0	0	0	0	0	0	0	0	0	0	0	0	0	0	0	0.0	0.0	0.0	0.0	0.00	0.00	0
162300	0	0	0	0	0	0	0	0	0	0	0	0	0	0	0	0.0	0.0	0.0	0.0	0.00	0.00	0
163600	0	0	0	0	0	0	0	0	0	0	0	0	0	0	0	0.0	0.0	0.0	0.0	0.00	0.00	0

AFGL FLT E81-11 ON 29 APR 81 PASS AVERAGING

Z TIME	ALT	M	P	TAS	TOT T	TR T	T	FROST	DEWP	EPT	CONC	ALWC	JLWC	10-C	ICE-TK	ICING	RATE	METER	
			MB	KT	C	C	C	C	C	K	NCM-3	GM-3	GM-3	NL-1	CM/NT	CYS/NT	CM/NT	PCT	SENSE
152610	1266		869	196	18.1	13.0	11.4	11.4	324.0	19.46	.00	-.19	.8	NO ICE	.06313	.00627	1.4		
153700	3163		696	252	8.5	.1	NA	320.4	0.00	0.00	0.00	-.12	0.0	NO ICE	0.00000	0.00000	0.0		
154900	4592		570	215	-1.4	-7.4	NA	323.6	.02	.00	-.14	0.0	0.0	NO ICE	0.00000	0.00000	0.0		
160230	4678		563	264	.3	-8.9	NA	321.8	0.00	0.00	-.10	0.0	0.0	NO ICE	0.00000	0.00000	0.0		
161130	4689		562	278	.4	-9.7	NA	320.3	6.55	.00	-.09	0.0	0.0	NO ICE	.04302	.00402	13.3		
162300	4684		563	208	-3.1	-8.9	NA	321.9	116.33	.02	-.12	0.0	0.0	NO ICE	.16386	.01164	58.0		
163600	4601		569	191	-3.5	-8.3	NA	321.9	1.08	.00	-.17	0.0	0.0	NO ICE	0.00000	0.00000	100.0		

4.3.3 Program ICEDERIV

One facet of ice detector analysis is a study of how the ice detector VCO values vary with the amount of water observed by the JW-LWC and the PMS1D AXIAL devices.

At first, the analysis concerns itself with the rate at which the VCO readings vary; in other words the derivative of the ice detector VCO values. The first problem with numerically calculating a derivative is in choosing the neighborhood over which it is to be computed. The second problem is that a derivative calculation is extremely sensitive to minor fluctuations in the neighborhood in which it is computed.

The solution to the first problem is to calculate the derivatives over various intervals and deduce the best one to use. The second problem requires a smoothing function to be applied to the data and then utilize a derivative method to realize the rates of change.

In APPLIED ANALYSIS, by C. Lanczos (Prentice Hall 1961) a method to smooth the data and to compute the derivatives is given on pages 321-324.

The method calculates a smoothed polynomial of degree $2K$ (where K is the number of points on each side of the point at which the derivative is to be computed) and then develops its derivative. The general formula for the derivative of f at x with K neighbors on each side for equally spaced one

4.3.3 Program ICEDERIV (cont'd)

second data is then

$$f^1(x) = \frac{\sum_{\alpha=-K}^{+K} \alpha f(x+\alpha)}{\sum_{\alpha=1}^K \alpha^2} / s$$

The above formula works for $K \geq 2$.

This method requires the point which the derivative is to be computed to be in a neighborhood of K points. Thus for the first two and last two points the general formula fails.

The way to derive these values is to compute a least square second degree fit and use its normal equations:

$$f^1(1) = (-21f(1)+13f(2)+17f(3)-9f(4))/20$$

$$f^1(2) = (-11f(1)+3f(2)+7f(3)+f(4))/20$$

The last two points (x_{max} , $x_{max}-1$) are comparably calculated

$$f^1(x_{max}) = (21f(x_{max})-13f(x_{max}-1)-17f(x_{max}-2)+9f(x_{max}-3))/20$$

$$f^1(x_{max}-1) = (11f(x_{max})-3f(x_{max}-1)-7f(x_{max}-2)-f(x_{max}-3))/20$$

ICEDERIV was originally written to accept an ICEEX output tape, and for each data point calculate the derivative, using 2, 3, 4, 5, 6, and 7 neighboring points. The table printed by ICEDERIV is broken at every new icing cycle and contains the ICE count, time and derivatives.

4.3.3 Program ICEDERIV (cont'd)

Since a comparison is to be made with JW-LWC or PMS 1D AXIAL these other two parameters were added to the table. These data sources are also subject to one second "noise" and were smoothed. A five point smoothing formula is given in APPLIED ANALYSIS pages 316-320. The reasoning used for five points and not a higher number is that these LWC devices give "INSTANT" readings and as such they do give verifying answers from second to second. A longer smoothing interval would hide the data behavior while a short period would not sufficiently smooth the sample "noise".

For any given point x_i the smoothing formula is:

$$f_{\text{smooth}}(x_i) = [-3f(x_{i-2}) + 12f(x_{i-1}) + 17f(x_i) + 12f(x_{i+1}) - 3f(x_{i+2})] / 35$$

for the first two points $f(x_1)$, $f(x_2)$:

$$f_{\text{smooth}}(x_1) = f(x_1) + \Delta^3 f(x_1) / 5 + \Delta^4 f(x_1) / 35$$

$$f_{\text{smooth}}(x_2) = f(x_2) - \Delta^3 f(x_1) / 5 - \Delta^4 f(x_1) / 7$$

where:

$$\Delta^3 f(x_1) = f(x_4) - 3f(x_3) + 3f(x_2) - f(x_1)$$

$$\Delta^4 f(x_1) = f(x_5) - 4f(x_4) + 6f(x_3) - 4f(x_2) + f(x_1)$$

4.3.3 Program ICEDERIV (cont'd)

for the last two points $f(x_{\text{max}})$, $f(x_{\text{max}-1})$:

$$f_{\text{smooth}}(x_{\text{xmax}}) = f(x_{\text{xmax}}) - \Delta^3 f(x_{\text{xmax}}) 1/5 + \Delta^4 f(x_{\text{xmax}}) 3/35$$

$$f_{\text{smooth}}(x_{\text{xmax}-1}) = f(x_{\text{xmax}-1}) + \Delta^3 f(x_{\text{xmax}}) 2/5 - \Delta^4 f(x_{\text{xmax}}) 1/7$$

where:

$$f(x_{\text{xmax}}) = f(x_{\text{xmax}}) - 3f(x_{\text{xmax}-1}) + 3f(x_{\text{xmax}-2}) - f(x_{\text{xmax}-3})$$

$$f(x_{\text{xmax}}) = f(x_{\text{xmax}}) - 4f(x_{\text{xmax}-1}) + 6f(x_{\text{xmax}-2}) - 4f(x_{\text{xmax}-3}) + f(x_{\text{xmax}-4})$$

All the above equations in addition to the liquid water calculating module (for the JW-LWC and AXIAL probe devices) from KNOLL1D were encoded into ICEDERIV.

An additional feature of the program is the calculation of total pass LWC. Subroutine SIMPSON calculates the total water content measured during every icing cycle. SIMPSON uses two separate methods. SIMPSON's and the trapezoidal rules of numerical integration are used (see: "Introduction to Numerical Analysis," by F. B. Hildebrand, pages 91-95). Totals by both methods are calculated for the following: JW-LWC, JW-LWC smoothed data, PMS1D LWC, and PMS1D LWC smoothed data. Answers are presented at the end of the output for each cycle. Operating instructions and sample output follow.

4.3.3.1 Program ICEDERIV operating instructions & Sample Output

CONTROL CARDS

DPSI, CM100000, T400, NT1. ID# ID NAME

ATTACH, CRT, CRTPLOTS, MR=1, SN=SHARED.

LIBRARY, CRT.

REQUEST, TAPE39, *Q.

* VSN, TAPE1=LYCXXX/NT.

REQUEST, TAPE1, NT, E, NORING.

LGO, PL=99999999.

EXIT (U)

DISPOSE, TAPE39, FM.

REWIND, TAPE2, TAPE3, TAPE4.

COPY, TAPE2

COPY, TAPE4

COPY, TAPE3

7/8/9

6/7/8/9

* OUTPUT FILE FROM PROGRAM ICEEX

DATA CARDS (AS MANY AS NEEDED IN TIME ORDER)

CC

DESCRIPTION

1-2 MIN-PMS PROBE MINIMUM CHANNEL # TO USE
(I2 FORMAT - DEFAULT ZERO)

3-4 MAX-PMS PROBE MAXIMUM CHANNEL # TO USE
(I2 FORMAT - DEFAULT 15)

* 11-16 START - PASS START TIME IN FORM HHMMSS

* 18-23 STOP - PASS STOP TIME IN FORM HHMMSS

* 31-35 FCYC - FIRST PASS CYCLE (I5 FORMAT)

* 36-40 LCYC - LAST PASS CYCLE (I5 FORMAT)

46-50 PLIT - PASS IDENTIFIER (A5 FORMAT)

* either or both pass times and cycle numbers may be used.

4.3.3.1 Program ICEDERIV Sample Outputs (cont'd)

- A. Standard Output File for every cycle
1. second by second listing of the following parameters
ICE COUNT
2 PT RATE
* JW-LWC
* JW-LWC (SMOOTH)
* PMS1D-LWC
* PMS1D-LWC (SMOOTH)
PMS MVD
DEWPOINT DEPRESSION (TRUE TEMP - DEWP)
PRESSURE
ALTITUDE
TRUE TEMPERATURE
TOTAL TEMP
 2. Simpson's and trapezoidal rule calculation for each of the four LWC's above (*)
 3. mean values of DEWPOINT DEPRESSION through TOTAL TEMP in the list above. Also the DEWPOINT DEPRESSION and TRUE TEMP standard deviations.

4.3.3.1 Program ICEDERIV sample outputs (cont'd)

4. Calculated least square fit lines and correlations of the following pairs:

JW-LWC	-	PMS-LWC
RATE	-	JW-LWC
RATE	-	JW-LWC (SMOOTH)
RATE	-	PMS1D-LWC
RATE	-	PMS1D-LWC (SMOOTH)

B. TAPE2 Output File

Cycle summary data file containing one line of data for each cycle above.

C. TAPE3 Output File

Pass summary data file containing averages for every cycle within a pass.

D. TAPE4 Output File

Contains a one line summary of least square fit line coefficients for every cycle

NOTE: B and C above contain most of the parameters found in A-1

Additionally ICEDERIV produces graphic output on 105mm microfiche. The following plots are produced.

A. FOR EVERY CYCLE OF A PASS

1. Log normalized number density vs channel size
2. Scatter plot of PMS 1D-LWC (SMOOTH) vs channel size
3. Scatter plot of JW-LWC (SMOOTH) vs channel size

4.3.3.1 Program ICEDERIV sample outputs (cont'd)

4. time plot containing: rate, PMS 1D-LWC (SMOOTH), and JW-LWC (SMOOTH)
5. rate vs PMS1D-LWC (SMOOTH) scatter plot
6. rate vs JW-LWC (SMOOTH) scatter plot

B. FOR EVERY PASS

1. scatter plot of JW-LWC vs PMS1D-LWC
2. Log normalized number density vs channel size

THIS CYCLE BEGINS AT 25-01-59 FLT E80-38 17 DEC 80 CHANNELS 31-45 TYPE 01 RAIN CYCLE # 68

SECONDS	ICE COUNT	2 POINT RATE	JW LWC	JW SMOOTH	PMS-1D LWC	PMS-1D SMOOTH	MVD (MU)	DEWP DEPRE	PRESS (MB)	HEIGHT (METERS)	TRUE TEMP	TOTAL TEMP
0	6680	0.0000	.4334	.4334	3.6215	3.6215	2428	-3.3371	576.06	4514.23	-13.32	-1.96
1	6790	0.0000	.4009	.4009	4.0740	4.0740	2082	-3.0727	576.56	4507.59	-13.26	-1.95
2	6817	0.0000	.2846	.2846	5.5189	5.5189	2074	-2.8207	577.07	4500.96	-13.22	-1.99

SIMPSON'S RULE .77 .77 8.479 8.479
 TRAPEZOIDAL RULE .76 .76 8.644 8.644
 MEAN -13.27
 S.DEV. .04

THIS CYCLE BEGINS AT 25-01-59 FLT E80-38 17 DEC 80 CHANNELS 31-45 TYPE 01 RAIN CYCLE # 68

.....
 CORRELATION COEFFICIENTS

- .9998	JW-LWC	VS	PMS-LWC	.7205
- .9998	JW-LWC	VS	PMS-SMOOTH	
- .9998	JW-SMOOTH	VS	PMS-LWC	
- .9998	JW-SMOOTH	VS	PMS-SMOOTH	
JW-LWC	=	- .0789	X (PMS-LWC)	+
CORRELATION		-1.000		
REG. RMS		.0014		
INV. RMS		.0172		
RATE	=	0.0000	X (JW-LWC)	+
CORRELATION		0.0000		
REG. RMS		0.0000		
INV. RMS		0.0000		
RATE	=	0.0000	X (JW-SMOOTH)	+
CORRELATION		0.0000		
REG. RMS		0.0000		
INV. RMS		0.0000		
RATE	=	0.0000	X (PMS-LWC)	+
CORRELATION		0.0000		
REG. RMS		0.0000		
INV. RMS		0.0000		
RATE	=	0.0000	X (PMS-SMOOTH)	+
CORRELATION		0.0000		
REG. RMS		0.0000		
INV. RMS		0.0000		

CYCLE SUMMARY DATA

CYCLE NO.	REFERENCE TIME	START TIME	STOP TIME	T	1/T	*JW/T	*PMS/T	ALT (M)	PRESS (MB)	TOTAL TEMP	TRUE TEMP	TRUE S.DEV.	T DEWP DEPRE	D DEP S.DEV.	MWD	CHANNEL MIN MAX
1	22:32:49	22:32:31	22:33:08	37	.0270	.21115	6.81707	5881.8	479.4	-16.0	-22.4	.331	-1.1	.131	2742	31 45
2	22:36:47	22:33:28	22:40:07	399	.0025	.11268	.01648	6235.7	456.6	-14.3	-23.6	.437	.9	.883	4410	31 45
3	23:12:04	23:11:53	23:12:15	22	.0455	.448628	1.3358	2165.9	731.3	1.3	-3.3	.371	3.3	.065	1616	31 45
4	23:13:22	23:12:30	23:14:14	104	.0096	.58883	9.89031	2265.5	769.0	2.6	-1.4	.278	2.7	.676	1325	31 45
5	23:37:35	23:37:22	23:37:48	25	.0400	.44975	2558.4	741.3	1.6	-2.5	.045	-8	.247	2341	31 45
6	23:38:23	23:38:08	23:39:39	31	.0323	.43139	2945.9	742.4	1.6	-2.2	.050	-5	.107	2475	31 45
7	23:39:24	23:39:01	23:39:47	46	.0217	.3114367	.08457	2535.8	743.4	1.9	-1.7	.085	.0	.162	2437	31 45
8	23:40:46	23:40:08	23:41:24	76	.0132	.2926651	.14269	2556.0	741.5	1.8	-2.3	.228	-4	.189	2376	31 45
9	23:42:05	23:41:43	23:42:27	44	.0227	.2663042	.69148	2551.7	741.9	1.6	-2.2	.047	-3	.094	2550	31 45
10	23:42:54	23:42:46	23:43:03	17	.0588	.39038	2549.2	742.1	1.4	-2.3	.025	-5	.061	2458	31 45
11	23:43:39	23:43:23	23:43:55	32	.0313	.3040765	.58130	2546.5	742.4	1.6	-2.1	.150	-3	.224	2734	31 45
12	23:44:38	23:44:27	23:44:49	22	.0455	.3306187	.83123	2704.9	727.7	.9	-3.0	.260	-4	.123	2158	31 45
13	23:45:31	23:45:06	23:45:57	51	.0196	.2400727	.40745	2839.7	715.4	-1.1	-4.2	.147	-6	.394	2732	31 45
14	23:46:26	23:46:18	23:46:34	16	.0625	.3403091	.13287	2842.5	715.1	-2.2	-4.1	.087	-3	.117	2957	31 45
15	23:47:22	23:47:19	23:47:26	7	.1429	.44956	2886.5	711.2	-6	-4.6	.067	-8	.067	2904	31 45
16	23:47:54	23:47:46	23:48:02	16	.0625	.39958	2871.6	712.5	-4	-4.5	.055	-6	.054	2824	31 45
17	23:48:56	23:48:51	23:49:01	10	.1000	.44365	2874.6	712.2	-5	-4.5	.045	-6	.046	2465	31 45
18	23:49:28	23:49:21	23:49:35	14	.0714	.3285063	.65511	2872.4	712.4	-6	-4.5	.092	-5	.106	2762	31 45
19	23:50:24	23:49:57	23:50:51	54	.0185	.2570138	.33301	2866.5	713.0	-5	-4.3	.072	-2	.130	2923	31 45
20	23:51:27	23:51:12	23:51:43	31	.0323	.2295061	.95104	2914.6	708.6	-7	-4.4	.189	-5	.149	2763	31 45
21	23:52:28	23:52:11	23:52:45	34	.0294	.2229537	.74346	3052.1	696.3	-1.4	-5.7	.132	-4	.056	2835	31 45
22	23:53:10	23:53:04	23:53:17	13	.0769	.3566392	.75330	3157.3	687.1	-2.1	-6.4	.049	-9	.053	2910	31 45
23	23:53:38	23:53:34	23:53:43	9	.1111	.3367279	.51666	3147.5	687.9	-1.9	-6.1	.279	-5	.292	3004	31 45
24	23:54:36	23:54:01	23:55:11	70	.0143	.2242321	.87596	3148.4	687.8	-1.9	-6.0	.077	-1	.173	2863	31 45
25	23:56:40	23:56:23	23:56:57	34	.0294	.2705342	.20756	3157.3	687.1	-1.9	-6.0	.064	-2	.157	2422	31 45
26	23:57:36	23:57:30	23:57:43	13	.0769	.47519	3148.9	687.8	-2.0	-6.1	.037	-2	.034	3094	31 45
27	23:58:08	23:58:02	23:58:14	12	.0833	.40790	3145.5	688.1	-2.2	-6.1	.082	-4	.155	2995	31 45
28	23:59:05	23:58:53	23:59:18	25	.0400	.2975959	.38781	3157.1	687.1	-2.0	-6.4	.062	-6	.197	2950	31 45
29	23:59:49	23:59:36	24:00:02	26	.0385	.3160266	.18974	3155.1	687.3	-2.1	-6.4	.228	-5	.186	2968	31 45
30	24:00:39	24:00:37	24:00:41	4	.2500	.45232	3158.3	687.0	-2.2	-6.5	.055	-8	.053	2933	31 45
31	24:01:13	24:01:02	24:01:24	22	.0455	.3107966	.48252	3152.8	687.5	-2.0	-6.0	.146	-0	.113	2956	31 45
33	24:02:44	24:02:38	24:02:50	12	.0833	.3756785	.02829	3491.5	658.2	-4.3	-8.5	.147	-7	.091	3060	31 45
40	24:06:17	24:06:09	24:06:25	16	.0625	.34789	.07479	3478.9	659.3	-4.2	-8.5	.083	-6	.088	1076	31 45
41	24:07:31	24:07:24	24:07:38	14	.0714	.27773	.03921	3476.6	659.5	-4.0	-8.2	.027	-3	.030	1423	31 45
42	24:09:25	24:07:59	24:10:53	174	.0057	.19303	.00050	3734.6	637.9	-4.2	-8.7	.250	3.4	2.300	821	31 45
43	24:26:07	24:26:07	24:26:08	1	1.0000	.71969	3170.7	685.9	-2.1	-6.0	.096	.6	.091	3027	31 45
44	24:26:36	24:26:31	24:26:41	10	1.0000	.1784542	.09270	3156.2	687.2	-1.8	-6.0	.074	.2	.072	2460	31 45
45	24:27:04	24:27:04	24:27:05	1	1.0000	.70950	3155.8	687.2	-2.1	-6.2	.032	.2	.032	3044	31 45
46	24:27:27	24:27:26	24:27:28	2	5.000	.58635	3153.5	687.4	-1.8	-6.1	.133	.2	.123	3032	31 45
47	24:27:44	24:27:44	24:27:45	1	1.0000	.53012	3154.6	687.3	-2.0	-6.2	.067	-1	.072	2979	31 45
48	24:28:23	24:28:23	24:28:24	1	1.0000	.65628	3151.2	687.6	-1.8	-6.0	.027	.1	.021	3054	31 45
49	24:28:41	24:28:41	24:28:42	1	1.0000	.90678	3151.2	687.6	-1.6	-5.8	.016	.1	.016	3034	31 45
51	24:29:35	24:29:35	24:29:36	1	1.0000	.89855	3148.3	687.8	-1.6	-5.7	.005	.2	.001	2935	31 45
52	24:29:52	24:29:52	24:29:53	1	1.0000	.59630	3143.7	688.3	-2.1	-6.0	.013	.2	.007	2945	31 45
53	24:30:13	24:30:13	24:30:14	1	1.0000	.90560	3146.0	688.0	-1.6	-5.5	.035	.3	.035	2960	31 45
55	24:30:55	24:30:52	24:30:59	7	.1429	.56956	3148.0	687.9	-1.7	-5.8	.151	-7	.492	2779	31 45
56	24:31:28	24:31:20	24:31:37	17	.0588	.72005	3158.6	686.9	-1.8	-6.2	.177	-4	.171	2752	31 45
57	24:32:01	24:31:57	24:32:06	9	1.1111	.69250	3155.5	687.2	-1.4	-5.5	.048	.2	.054	2837	31 45
58	24:32:28	24:32:28	24:32:29	1	1.0000	.56987	3155.8	687.2	-2.1	-6.2	.002	-6	.007	2961	31 45
59	24:32:46	24:32:45	24:32:48	3	.3333	.71437	3154.1	687.3	-1.6	-5.7	.021	.2	.021	2811	31 45

PASS SUMMARY DATA

PASS NO.	START TIME	STOP TIME	TOTAL CYCLES	AVE \dot{T}	AVE \dot{T} S.DEV.	AVE 1/ \dot{T}	AVE JW S.DEV.	AVE PMS	PMS S.DEV.	PRESS (MB)	PRESS S.DEV.	ALT (M)	TOTAL TEMP	TRUE TEMP	TRUL S.DEV.	T DEMP	D DEP S.DEV.	
4	23:37:23	23:43:55	7	39	17.870	.0314	.330	.1023672	.01348	82292	742.1	.738	2549.4	1.7	-2.2	.262	-.4	.281
5	23:45:06	23:51:43	8	25	17.266	.0637	.292	.1206460	.50659	11849	712.9	2.628	2867.3	-.4	-4.3	.178	-.4	.303
6	23:53:04	24:01:24	10	23	17.949	.0766	.301	.1213360	.77257	69858	687.5	.587	3152.4	-2.0	-6.1	.218	-.3	.311
7	24:02:38	24:07:38	3	14	1.633	.0724	.339	.1087624	.14549	83880	659.1	.561	3481.7	-4.2	-8.4	.151	-.5	.202
9	24:26:07	24:36:42	23	4	3.939	.6031	.609	.23771	*****62.48406	687.4	.515	3153.8	-1.7	-5.9	.257	-.2	.369	

4.3.4 Programs PLTEXTTRACT & PLTEXTTRACT2

Program PLTEXTTRACT produces pen plots which contain icing data on the top half of the paper and two lines of VCO plots on the bottom half. The VCO data is triggered by icing cycles. VCO buffers are filled only when in an icing cycle. The buffers are then plotted and flushed when one-half hours' worth of data has been stored.

PLTEXTTRACT was written as a means of verifying the extraction program (see ICEEX). PLTEXTTRACT plots the extracted data on the same scale as PLTICE. This enables the PLTEXTTRACT to be overlaid on the PLTICE graph and visually check the extraction process. Processing was performed on the E79-49 06 DEC 79 flight (the benchmark data base) with no difference.

The usefulness of the PLTEXTTRACT plot is more than simply data verification. VCO information or various LWC parameters can be plotted at the bottom and LYC scientists can use this information to help them derive empirical relationships.

In addition, PLTEXTTRACT2 was written to disregard the presence or absence of icing cycles and only plot two VCO parameters. This is an important tool which allows the JW device adjustments, made by LYC scientists to be checked. PLTEXTTRACT2 uses the same KNOLL1D output tape as input as PLTEXTTRACT.

Operating instructions and sample output are provided on the following pages.

4.3.4.1 PLTEXTRACT Operating Instructions

CONTROL CARDS

* DPSI,CM130000,T500,NT2. ID# ID NAME
ATTACH,LGO,PLEXTRACTBIN,ID=KAPLANF,MR=1.
ATTACH,PEN,NEWOFFPEN.
LIBRARY,PEN.
REQUEST,TAPE39,*Q.
VSN,TAPE1=TAPE NO/NT. (ICEEX PRODUCED OUTPUT TAPE)
REQUEST,TAPE1,NT,NORING,E.
* VSN,TAPE2=TAPE NO/NT. (KNOLLID PRODUCED OUTPUT TAPE)
* REQUEST,TAPE2,NT,NORING,E.
LGO.
7/8/9

DATA CARDS

CARD 1

COL 1-10 FLIGHT ID (FLT EXX-XX)
 11-20 FLIGHT DATA (XX_XXX_XX)
* 80 set to 1 when tape2 available

CARD 2

COL 1-12 PLOT #1 LITERAL

CARD 3

COL 1-12 PLOT #2 LITERAL

CARD 4 (FREE FORMAT IN FOLLOWING ORDER)

PLOT #1 ID NUMBER
PLOT #2 ID NUMBER
PLOT #1 MINIMUM VALUE

Plot #1 MAXIMUM VALUE
Plot #2 MINIMUM VALUE
Plot #2 MAXIMUM VALUE

6/7/8/9

- * When tape 2 (KNOLL1D data) is not available change NT2 to NT1 on the job card.
Remove the tape request cards for tape 2 and set COL 80 to zero of data card 1.

AD-A133 557

DEVELOPMENT OF THEORETICAL MODELS AND ANALYSES OF THE
MICRO-PHYSICS OF CL. (U) DIGITAL PROGRAMMING SERVICES
INC WALTHAM MA L E BELSKY ET AL. 31 MAY 83
AFGL-TR-83-0133 F19628-81-C-0141

2/3

UNCLASSIFIED

F/G 4/2

NL

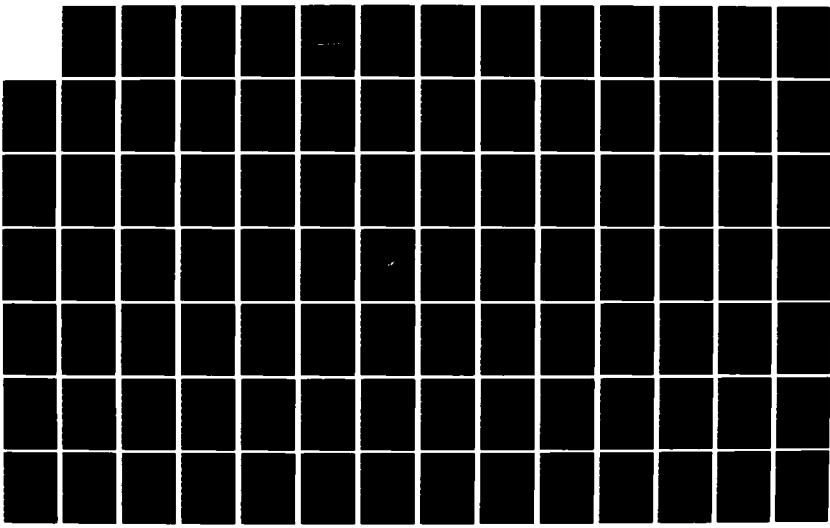

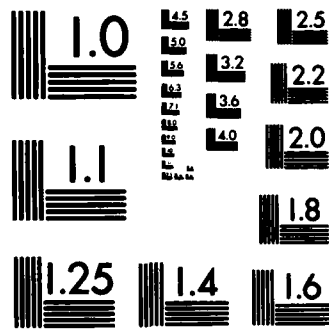

MICROCOPY RESOLUTION TEST CHART
NATIONAL BUREAU OF STANDARDS-1963-A

PLOT NUMBER	ID CODES DESCRIPTION	AVAILABILITY*	
		TAPE 1	TAPE 2
1	TRUE TEMPERATURE	YES	YES
2	TOTAL TEMPERATURE	YES	NO
3	DEWPOINT/FROSTPOINT	YES	YES
4	JW-LWC	YES	YES
5	PRESSURE	YES	YES
6	TRUE AIRSPEED	YES	YES
7	HEIGHT	YES	YES
8	ASSP PROBE LWC	NO	YES
9	CLOUD PROBE LWC	NO	YES
10	PRECIPITATION PROBE LWC	NO	YES
11	TOTAL PROBE LWC	NO	YES
12	LOG ASSP PROBE NT	NO	YES
13	LOG CLOUD PROBE NT	NO	YES
14	LOG PRECIPITATION PROBE NT	NO	YES
15	LOG TOTAL PROBE NT	NO	YES
16	ASSP PROBE D0	NO	YES
17	CLOUD PROBE D0	NO	YES
18	PRECIP PROBE D0	NO	YES
19	TOTAL PROBE D0	NO	YES
20	ASSP PROBE D0 TIMES LWC	NO	YES
21	CLOUD PROBE D0 TIMES LWC	NO	YES
22	PRECIP PROBE D0 TIMES LWC	NO	YES
23	TOTAL PROBE D0 TIMES LWC	NO	YES

TAPE2 (KNOLLID OUTPUT TAPE) IS USED IF COL 80 OF ID CARD IS SET - ELSE DEFAULT IS TAPE1 (ICEEX OUTPUT TAPE) WHICH LIMITS AVAILABILITY TO FIRST SEVEN OPTIONS.

4.3.4.2 PLTEXTTRACT2 Operating Instructions And Output

CONTROL CARDS

```
CLASS,CM130000,T200,NT1. ID # ID NAME
ATTACH,LGO,PLTEXTTRACT2BIN, ID=KAPLANF,MR=1.
ATTACH,PEN,OFFLINEPEN,SN=SHARED.
LIBRARY,PEN.
REQUEST,TAPE39,*Q.
*VSN,TAPE2=TAPENO/NT (KNOLLID PRODUCED OUTPUT TAPE)
*REQUEST,TAPE2,NT,NORING,E.
LGO.
7/8/9
```

DATA CARDS

CARD 1

```
COL 1-10 FLIGHT ID (FLT EXX-XX)
      11-20 FLIGHT DATE (XX-XXX-XX)
```

CARD 2

```
COL 1-12 PLOT #1 LITERAL
```

CARD 3

```
COL 1-12 PLOT #2 LITERAL
```

CARD 4

```
COL (FREE FORMAT)
```

```
PLOT #1 ID NUMBER
```

```
PLOT #2 ID NUMBER
```

```
PLOT #1 MINIMUM VALUE
```

```
PLOT #1 MAXIMUM VALUE
```

```
PLOT #2 MINIMUM VALUE
```

```
PLOT #2 MAXIMUM VALUE
```

```
6/7/8/9
```

4.3.4.2 PLTEXTRACT2 Operating Instructions And Output (cont'd)

PLOT ID CODES

<u>NUMBER</u>	<u>DESCRIPTION</u>
1	TRUE TEMPERATURE
2	NOT USED
3	DEWPOINT/FROSTPOINT
4	JW-LWC
5	PRESSURE
6	TRUE AIRSPEED
7	HEIGHT
8	ASSP PROBE LWC
9	CLOUD PROBE LWC
10	PRECIPITATION PROBE LWC
11	TOTAL PROBE LWC
12	LOG ASSP PROBE NT
13	LOG CLOUD PROBE NT
14	LOG PRECIPITATION PROBE NT
15	LOG TOTAL PROBE NT
16	ASSP PROBE D0
17	CLOUD PROBE D0
18	PRECIP PROBE D0
19	TOTAL PROBE D0
20	ASSP PROBE D0 TIMES LWC
21	CLOUD PROBE D0 TIMES LWC
22	PRECIP PROBE D0 TIMES LWC
23	TOTAL PROBE D0 TIMES LWC

NOTE: TAPE2 (KNOLLID Output Tape) is used. Column 80 of ID card must be set.

FLT E80-1810 MAR 80

0 SCAT LWC 10 22-10-00, START OF THIS HOUR

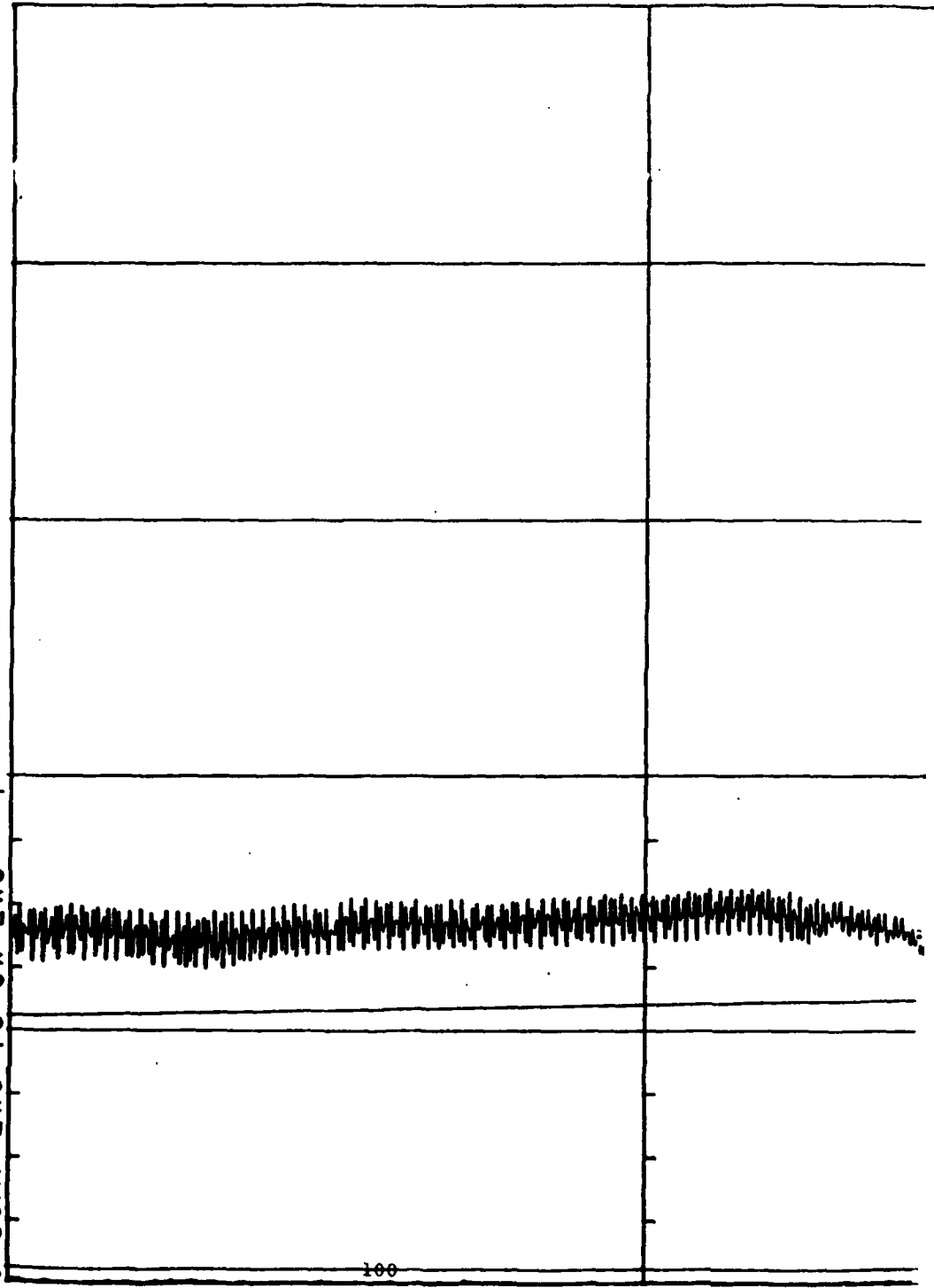

001

4.4 PMS-2D Data Processing

DPSI designed and developed a set of programs to analyze the data obtained from the PMS-2D Knollenberg devices. The details of this design were described in reports from previous contracts. A new program for automatic particle typing developed during this contract is described in the next section.

The 2D particle display system is a valuable source of data to LYC. Data was collected from two independent systems (one each on the C130E and Learjet) and recorded on magnetic tape using a nine-track Pertec recorder. Only the C130 tapes are processed on the AFGL CDC 6600 computer. PMS-2D data were collected aboard a Convair NASA 990 aircraft and those data were processed via the 2D programs described below.

These data tapes contain two types of records, composed of "fast" (long) and "slow" data. The fast data records contain the 2D particle image slices. One dimension, the columns, is represented by the 32 diode array. The other dimension, the rows, is achieved by taking readings over time so that a two dimensional picture of the shadow is obtained. The speed of the aircraft is, theoretically, kept at a predetermined constant speed based on the resolution (diameter) of the 2D probes and the frequency of the clock polling the sensors. That is, the C130 aircraft flew at approximately 200 knots in order for the 25 μ diameter diode sensor to produce a square image of each particle at the given sampling rate of 4 MHz. Likewise, the 2D system installed aboard the NASA Convair 990 was operated at true airspeeds of

4.4 PMS-2D Data Processing (cont'd)

of approximately 466 knots in order for the 60 μ diode sensor to obtain a square image at the same 4 MHz sampling rate. However, because true air speed of the aircraft cannot be kept constant, the data are modified slightly by the 2D data processing programs to maintain the square image representation of the particles. Thus the 2D device gives a picture of the particle(s) as subsequent readings are placed together.

The slow data records are written to tape once every ten seconds. These records contain VCO and analog information. In addition, selected 1D data is multiplexed in the 2D buffer and also recorded in the slow data records. The exact information contained in these records is different for each aircraft.

4.4.1 Program PMS2D

Program PMS2D takes the 2D automatic typing algorithm developed by Dr. Hunter of ADAPT, Inc. and packages them in a manner which allows maximum use and ease of operation by LYC personnel.

These routines take the 2D scans and converts them to normalized integer values called "hols". Other routines interpret these hols by converting them to "ANT" vectors for use by eigenvector analysis. The routines are copyrighted by Dr. Hunter and will not be described here. Essentially what DPSI has done is to write driver routines to process 2D data tapes. As originally delivered by Dr. Hunter the routines could only process at most 300 particles per computer run. The new program has been written to allow processing of 300 particles per data record. Experience has shown that there are only approximately a dozen acceptable particles per data record hence no particles should be lost during the processing of a run. Operating instructions and sample output are provided on the following pages.

4.4.1 PROGRAM PMS2D Operating Instructions & Sample Output

COMMAND DECK

COMMAND DECK

MILLR,CH115000,NT1,T500. 1416 MILLERP
USN,TAPE1=KNE370/NT.
REQUEST,TAPE1,PE,L,NR,NT.
ATTACH,P,PMS2D,ID=MILLERP,MR=1.
FTNS,I=P,B=LGO,L=0,PL=999999.
EILE(TAPE1,RT=U,BT=K,MRL=5576,MRL=5576,RB=1,BFS=560)
LDSET,FILES=TAPE1,PRESET=ZERO.
LGO.
EXIT(U)
7/8/9

INPUT DATA

NAMelist/IOPTS/
NAMelist/TYPDAT/
ID CARD

1-10 FLT ID (FLT E80-16)
11-20 FLT DATE(DDMMYYR)
21-30 KNE TAPE NO.(KNE370)
PASS TIMES(MAXIMUM 20)

1-6 START(HHMMSS)
7-10 STOP(HHMMSS)

7/8/9

TIME	TAS(KTS)	PRES(MB)	HED(DEG)	JW(G/M**3)	FROST(C)	TRUE(C)	IAS(KTS)	CAS(KTS)	ALT(M)	CLK PCT
242925	181.20	628.36	3.67	-12	-7.51	-9.57	146.42	178.92	3850.74	90.12
242926	181.65	628.46	1.22	-12	-7.52	-9.61	146.89	179.46	3849.50	
242927	182.25	628.66	-1.40	-12	-7.53	-9.60	147.30	179.92	3847.00	90.37
242928	182.55	628.76	-4.14	-12	-7.53	-9.57	147.42	180.06	3845.76	
242929	182.85	628.97	-6.98	-11	-7.54	-9.58	147.77	180.44	3843.27	90.75
242930	183.05	628.97	-9.72	-10	-7.56	-9.66	148.52	181.32	3843.27	
242931	183.70	629.17	-12.46	-11	-7.56	-9.66	148.23	180.95	3840.78	91.10
242932	183.05	629.27	-15.05	-11	-7.58	-9.67	148.58	181.35	3839.53	
242933	184.15	629.37	-17.60	-10	-7.59	-9.61	148.70	181.49	3838.29	91.21
242934	184.50	629.48	-20.12	-11	-7.61	-9.60	149.33	182.25	3837.04	

242934

RECORD 2314 ON FILE 1 PRECIP

FIRST CALL OF 01JUL82 CLDA41- 12
 THIS SUBROUTINE APPLIES THE 5 CLOUD PARTICLE ALGORITHMS IN Y SPACE.
 THIS IS *** VERSION 12*** WHICH WHICH INCORPORATES THE FINAL UNROTATED ALGORITHMS IN ONE STEP
 BUT SELECTS UNCLASSIFIED BASED ON LR'S > THRESHOLD PRESET TO ONE(1) OR VERSION 10, BUT CHANGEABLE TO RATIO LR1 TO LR2 INPUT
 S PROBT(1) .GT. 0.1 IN LISTIN
 THE USER MAY ADJUST THE THRESHOLD VALUES BY INPUTING TCON AS THE PROBT VECTOR IN LISTIN
 PRINT OUTPUT SET BY LR1= 1=> SUMMARY ON LY
 2=> SUMMARY AND TABLE OF LIKELIHOOD RATIOS
 3=>SUMMARY AND TABLES OF LIKLIHOOD RATIOS AND DETECTION STATISTICS

DENDRITES 4 NEEDLES 9 COLUMNS 6 PLATES 8 STREAKERS 0 MISC. 0

DENDR T :	4	NEEDLES	9	COLUMNS	6	PLATES	8	STREAKERS	0	MISC.	0
PASS TOTALS			9	6	6	8	0	0	0	0	

17 DATA HISTORIES WERE REJECTED BECAUSE THEY TOUCHED THE SIDE
 DATA HISTORIES WERE REJECTED BECAUSE THEY WERE INCOMPLETE
 DATA HISTORIES WERE REJECTED BECAUSE THEY WERE LONGER THAN 160 DIODES
 0 DATA RECORDS WERE REJECTED BECAUSE THE TEMPERATURE WAS GREATER THAN 30.0 DEGREES
 143 DATA HISTORIES WERE REJECTED BECAUSE THE PARTICLE WAS LESS THAN 3 DIODES
 10 DATA HISTORIES WERE REJECTED BECAUSE THEY ENTERED BROADSIDE
 7 DATA HISTORIES WERE REJECTED BECAUSE MORE THAN ONE PARTICLE WAS IN FIELD AT THE SAME TIME
 0 DATA RECORDS WERE REJECTED BECAUSE THEY WERE OBTAINED WITH THE PROBE

\$DPTS

OPROT = T,

OPCLD = T,

OPPRE = Y,

OPPRT = F,

STIME = -.1E+01,

NEOF = 4,

LMAX = 160,

DEBUG = F,

NGAP = 1,

LMIN = 3,

REJH = T,

NVREJ = 1,

TMAX = .3E+02,

SEND

\$TYPDAT

PROB1 = 0.0, 0.0, 0.0, 0.0, 0.0, 0.0,

VERA41 = 12,

LP1 = 3,

SEND

FLT E80-16 08MAR80 KNE370
242928 242934

4.5 Special Analysis and Processing Techniques

4.5.1 PROGRAM CNVRT

Program CNVRT is a data processing program written to aid LYC scientists in the analysis of data from NCAR CLOUD DATA TAPES. These tapes are recorded with 524 60-bit words per record. Each word contains 3 20-bit integers. These parameters are converted according to a given table and displayed in a format suitable to LYC scientists.

Operating instructions and sample output are provided on the following pages.

4.5.1.1 Operating Instructions for Program CNVRT

MILLER, T100, NT2. 1416 MILLERP
ATTACH, I, CNVRT, ID=KAPLANF.
ATTACH, TAPE5, IS=KAPLANF.
VSN, TAPE3=LYCBOB/NT.
REQUEST, TAPE3, NT, NORING, L, PE.
FTN, I=I, PL=99999.
REWIND, TAPE3.
LGO.
EXIT(U)
DISPOSE, OUTPUT, PR, *C.
EOR

4.5.1.1 PROGRAM CNVRT Sample Output

NCAR ELECTRA STRATEX-1, 17JUN75 FIRST TIME ON THIS FILE 11 15 55 THIS FILE 1
 S ALL OR PART OF TIME PERIOD 11 15 55 TO 16 39 40 DESCRIPTION OF RECORD -- 115 PARAMETERS WERE SAVED
 D AT THEIR RESPECTIVE RATES. THIS REPRESENTS 786 SAMPLES/PROGRAM CYCLE WHERE A CYCLE IS 1.000 SEC
 THE 2 CYCLES OF 786 SAMP/CYC = 1572 WERE THEN SCALED INTO 20 BIT INTEGERS AND PACKED 3 SAMPLES/MOR
 D INTO 524 60 BIT PACKED WORDS --METHOD OF SCALING-- A BIAS AD(1) WAS ADDED TO EACH SAMPLE
 OF EACH PARAMETER TO ELIMINATE ANY NEGATIVE VALUES. THE BIASED SAMPLE WAS THEN MULTIPLIED BY P(1)
 T INSURE THE PROPER NUMBER OF DECIMAL PLACES WERE SAVED. THE PACKED RECORD MAY BE UNPACKED BY RIGH
 T JUSTIFYING 20 BITS AT A TIME AND REVERSING THE ABOVE SCALING PROCESS. AS EXAMPLE, S(1)N/P(1)-AD(1
), WHERE N IS THE 20 BIT SCALED INTEGER, S(1) THE DESIRED UNSCALED PARAMETER, AD(1),P(1) THE CORRESP
 ONDING SCALE FACTORS. THE ORDER, RATE, PLOT TITLE, PRINT LAB. UNITS, AD AND P SCALE FACTORS OF EACH
 PARAMETER FOLLOW

1)	1	PROCESSOR TIME (SECONDS)	TIME	SECONDS	(N/	1)	0.0
2)	1	UNALTERED TAPE TIME (SECONDS)	TPTIME	SECONDS	(N/	1)	0.0
3)	1	CORRECTED STATIC PRESSURE (MB)	PSWC	(MB)	(N/	500)	0.0
4)	1	AIRBENT TEMPERATURE (ROSENOUNT) (C)	ATF	(C)	(N/	1000)	100.0
5)	1	UNUSED	UNUSED		(N/	1)	0.0
6)	1	DEWPOINT TEMPERATURE (THERMOELEC) (C)	DPAC	DEG C	(N/	1000)	100.0
7)	1	DEWPOINT TEMPERATURE (LYMN-ALPHA) (C)	DPLAC	(C)	(N/	1000)	100.0
8)	1	ABSOLUTE HUMIDITY (THERMOELEC) (GM/M3)	RHOD	(GM/M3)	(N/	1000)	100.0
9)	1	ABSOLUTE HUMIDITY (LYMN-ALPHA) (GM/M3)	RHOLY	(GM/M3)	(N/	1000)	100.0
10)	1	HORIZONTAL WIND DIRECTION (DEG)	WDRCTN	(DEG)	(N/	1000)	0.0
11)	1	HORIZONTAL WIND SPEED (M/S)	WSPD	(M/S)	(N/	1000)	0.0
12)	1	WIND VECTOR EAST COMPONENT (M/S)	U11	(M/S)	(N/	1000)	200.0
13)	1	WIND VECTOR NORTH COMPONENT (M/S)	V11	(M/S)	(N/	1000)	200.0
14)	1	WIND VECTOR VERT GUST COMPONENT (M/S)	W11	(M/S)	(N/	1000)	100.0
15)	1	WIND VECTOR LAGTGNL COMPONENT (M/S)	UX1	(M/S)	(N/	1000)	200.0
16)	1	WIND VECTOR LATERAL COMPONENT (M/S)	UY1	(M/S)	(N/	1000)	200.0
17)	1	UNUSED	UNUSED		(N/	1)	0.0
18)	1	UNUSED	UNUSED		(N/	1)	0.0
19)	1	NACA PRESSURE ALTITUDE (M)	HP	(M)	(N/	100)	100.0
20)	1	PRESSURE DAMPED INERTIAL ALTITUDE (M)	HP1	(M)	(N/	100)	100.0
21)	1	GEOMETRIC (PADIO) ALTITUDE (M)	HGM	(M)	(N/	1000)	100.0
22)	1	AIRCRAFT GROUND SPEED (M/S)	GS	(M/S)	(N/	1000)	0.0
23)	1	AIRCRAFT GROUND SPD EAS COMP (M/S)	VEM	(M/S)	(N/	1000)	500.0
24)	1	AIRCRAFT GROUND SPD NORTH COMP (M/S)	VNS	(M/S)	(N/	1000)	500.0
25)	1	DAMPED AIRCRAFT VERT VELOCITY (M/S)	WP31	(M/S)	(N/	1000)	100.0
26)	1	AIRCRAFT C.G. VERT ACCELERATION (M/S2)	CGAC1	(M/S2)	(N/	1000)	100.0
27)	1	AIRCRAFT TRUE HEADING (YAW) (DEG)	THF1	(DEG)	(N/	1000)	0.0
28)	1	AIRCRAFT ROLL ATTITUDE ANGLE (DEG)	ROLL1	(DEG)	(N/	1000)	100.0
29)	1	AIRCRAFT PITCH ATTITUDE ANGLE (DEG)	PITCH1	(DEG)	(N/	1000)	100.0
30)	1	AIRCRAFT TRUE AIRSPEED (M/S)	TASW	(M/S)	(N/	1000)	100.0
31)	1	CORCTD IR SURFACE TEMP (PRT-5) (C)	PRT5C	(C)	(N/	1000)	100.0
32)	1	DOWNWARD SW/MG-7 IRRADIANCE (WATTS/M2)	UPYR1	WATTS/M2	(N/	500)	100.0
33)	1	DOWNWARD SW/MG-1 IRRADIANCE (WATTS/M2)	UPYR2	WATTS/M2	(N/	500)	100.0
34)	1	DOWNWARD SW/RG-B IRRADIANCE (WATTS/M2)	UPYR3	WATTS/M2	(N/	500)	100.0
35)	1	UPWARD SW/MG-7 IRRADIANCE (WATTS/M2)	LPYR1	WATTS/M2	(N/	500)	100.0
36)	1	UPWARD SW/MG-1 IRRADIANCE (WATTS/M2)	LPYR2	WATTS/M2	(N/	500)	100.0
37)	1	UPWARD SW/RG-B IRRADIANCE (WATTS/M2)	LPYR3	WATTS/M2	(N/	500)	100.0
38)	1	UPPER PYRGEOMETER (U4) CORRECTED	UPYRGC	WATTS/M2	(N/	1000)	100.0
39)	1	LOWER PYRGEOMETER (D4) CORRECTED	LPYRGC	WATTS/M2	(N/	1000)	100.0
40)	1	UNUSED	UNUSED		(N/	1)	0.0
41)	1	UNUSED	UNUSED		(N/	1)	0.0
42)	1	UNUSED	UNUSED		(N/	1)	0.0
43)	1	CORCTD J-W LIQUID WATER CONTENT (GM/M3)	LMCC	(GM/M3)	(N/	1000)	100.0
44)	1	ROSENOUNT TOTAL TEMP (ROSENOUNT) (C)	TTBS	DEG C	(N/	1000)	100.0
45)	1	FUSELAGE TOTAL TEMP (ROSENOUNT) (C)	TTF	(C)	(N/	1000)	100.0
46)	1	UNUSED	UNUSED		(N/	1)	0.0
47)	1	LHS DEW/FROSTPOINT TEMP (C)	COLH	(C)	(N/	1000)	100.0
48)	1	RHS DEW/FROSTPOINT TEMP (C)	DPRH	(C)	(N/	1000)	100.0
49)	1	UNUSED	UNUSED		(N/	1)	0.0
50)	1	RAW WINGTIP STATIC PRESSURE (MB)	PS.1	(MB)	(N/	500)	0.0

51	RAW WING TIP DYNAMIC PRESSURE (MB)	(N/)	100.0	OCM
52	RAW NOSEBOOM STATIC PRESSURE (MB)	(N/)	0.0	PSB
53	RAW NOSEBOOM DYNAMIC PRESSURE (MB)	(N/)	100.0	OCB
54	RAW INS LATITUDE (DEG)	(N/)	200.0	ALAT
55	RAW INS LONGITUDE (DEG)	(N/)	200.0	ALON
56	RAW VLF LATITUDE (DEG)	(N/)	200.0	VLAT
57	RAW VLF LONGITUDE (DEG)	(N/)	200.0	VLONG
58	UNUSED	(N/)	0.0	UNUSE
59	INS WANDER ANGLE (DEG)	(N/)	100.0	ALPHA
60	AIRCRAFT TRUE HEADING (ARINC) (DEG)	(N/)	100.0	THI
61	RAW DNWARD IR IRRADIANCE (WATTS/M2)	(N/)	100.0	UPYRG
62	UPPER PYRGECOMETER SINK TEMP (C)	(N/)	100.0	UPYRST
63	LOWER PYRGECOMETER SINK TEMP (C)	(N/)	100.0	LPYRST
64	LOWER PYRGECOMETER SINK TEMP (C)	(N/)	100.0	LPYRST
65	LOWER PYRGECOMETER SINK TEMP (C)	(N/)	100.0	LPYRST
66	LOWER PYRGECOMETER SINK TEMP (C)	(N/)	100.0	LPYRST
67	PRT-5 IRYAN WINDOW TEMP (C)	(N/)	100.0	PR5MT
68	RAW IR SURFACE TEMP (PRT-5) (C)	(N/)	100.0	PR5TS
69	UNUSED	(N/)	0.0	UNUSE
70	UNUSED	(N/)	0.0	UNUSE
71	UNUSED	(N/)	0.0	UNUSE
72	UNUSED	(N/)	0.0	UNUSE
73	UNUSED	(N/)	0.0	UNUSE
74	UNUSED	(N/)	0.0	UNUSE
75	RAW J-W LIQUID WATER CONTENT (GM/M3)	(N/)	100.0	LWC
76	16MM CAMERA FRAME COUNT	(N/)	0.0	CAMFC
77	EVENT MARKERS	(N/)	0.0	EVMKS
78	INS/KNLBRG UPDATE FLAGS	(N/)	0.0	UNUSE
79	AMBIENT TEMPERATURE (FAST RESPONSE) (C)	(N/)	0.0	UNUSE
80	*** UNUSED ***	(N/)	0.0	UNUSE
81	*** UNUSED ***	(N/)	0.0	UNUSE
82	*** UNUSED ***	(N/)	0.0	UNUSE
83	WIND VECTOR EAST GUST COMPONENT (M/S)	(N/)	200.0	UI
84	WIND VECTOR NORTH GUST COMPONENT (M/S)	(N/)	200.0	VI
85	WIND VECTOR VERT GUST COMPONENT (M/S)	(N/)	200.0	WI
86	WIND VECTOR LNGTHNL GUST COMPONENT (M/S)	(N/)	200.0	WY
87	WIND VECTOR LATERAL GUST COMPONENT (M/S)	(N/)	200.0	UX
88	WIND VECTOR LONGITUD GUST COMPONENT (M/S)	(N/)	200.0	UY
89	ABSOLUTE HUMIDITY (REFRACT) (GM/M3)	(N/)	100.0	RHORL
90	ABSOLUTE HUMIDITY (LYMN-ALPHA) (GM/M3)	(N/)	100.0	RHOLA
91	REFRACTIVE INDEX (N UNITS)	(N/)	0.0	RFI
92	LYMAN-ALPHA HYGROMETER OUTPUT (VDC)	(N/)	100.0	LAV
93	FAST RESPONSE TOTAL TEMP (C)	(N/)	100.0	TTNP
94	NOSE ROSEMOUNT TOTAL TEMP (C)	(N/)	100.0	TTB
95	RAW GUST PROBE DYNAMIC PRESSURE (MB)	(N/)	100.0	OCG
96	ATTACK ANGLE - ROTATING VANE (DEG)	(N/)	100.0	ATKR
97	SIDESLIP ANGLE - ROTATING VANE (DEG)	(N/)	100.0	AFIX
98	SIDESLIP ANGLE - FIXED VANE (DEG)	(N/)	100.0	BTAR
99	GUST PROBE TIP VERT ACCEL (M/S2)	(N/)	100.0	BPIX
100	GUST PROBE TIP LATERAL ACCEL (M/S2)	(N/)	100.0	VAC
101	AIRCRAFT C.G. VERT ACCELERATION (M/S2)	(N/)	100.0	LAC
102	RAW INS VERTICAL VELOCITY (M/S)	(N/)	500.0	CGAC
103	AIRCRAFT ROLL ATTITUDE ANGLE (DEG)	(N/)	100.0	VZI
104	AIRCRAFT PITCH ATTITUDE ANGLE (DEG)	(N/)	100.0	ROLL
105	AIRCRAFT TRUE HEADING (YAH) (DEG)	(N/)	100.0	PITCH
106	RAW INS GROUND SPD X COMPONENT (M/S)	(N/)	500.0	THF
107	RAW INS GROUND SPD Y COMPONENT (M/S)	(N/)	500.0	XVI
108	LEFT WING STRAIN (MICRO-IN/IN)	(N/)	1000.0	YVI
109	RIGHT WING STRAIN (MICRO-IN/IN)	(N/)	1000.0	STRLW
110	KNOLLENBERG 64 WORDS	(N/)	1000.0	STRRM
111	FIXED ANGLE NEPHELOMETER (VDC) (NCAR)	(N/)	0.0	KNLBRG
112	CCN OUTPUT CHANNEL 55 (VDC) (DR1)	(N/)	100.0	FIXNEP
113	CCN OUTPUT CHANNEL 56 (VDC) (DR1)	(N/)	100.0	CCN55
114	RAW WET BULB TEMP (C) (NCAR)	(N/)	100.0	CCNS6
115	RAW PRT-6 TEMP (C) (CSU)	(N/)	100.0	PRT6

TIME(SEC)	PRES(MB)	DP. TEMP(C)	ABS HMD(CM/M3)	ALTITUDE(M)	INS. LAT(DEG)INS. LOMS(DEG)	TRUE HEADING(DEG)
11.15.55.	483.15	9.50	8.93	48.49	0.0	25.99
11.15.56.	483.15	9.52	8.94	48.49	-81.37	7.27
11.15.57.	483.15	9.52	8.94	48.50	-122.05	7.02
11.15.58.	483.15	9.52	8.93	48.49	-122.05	7.02
11.15.59.	483.15	9.47	8.92	48.50	-122.05	7.02
11.16.0.	483.24	9.44	8.90	47.72	-122.05	7.02
11.16.1.	483.15	9.41	8.88	48.49	-122.05	7.01
11.16.2.	483.15	9.39	8.85	48.49	-122.05	7.01
11.16.3.	483.15	9.36	8.84	48.50	-122.05	7.01
11.16.4.	483.15	9.36	8.83	48.49	-122.05	7.01
11.16.5.	483.15	9.35	8.83	48.49	-122.05	7.01
11.16.6.	483.15	9.35	8.83	48.49	-122.05	7.02
11.16.7.	483.15	9.35	8.83	48.48	-122.05	7.02
11.16.8.	483.15	9.34	8.82	48.49	-122.05	7.02
11.16.9.	483.15	9.33	8.82	48.49	-122.05	7.01
11.16.10.	483.15	9.33	8.82	48.50	-122.05	7.01
11.16.11.	483.33	9.37	8.84	48.49	-122.05	7.02
11.16.12.	483.15	9.37	8.85	46.99	-122.05	7.02
11.16.13.	483.24	9.39	8.86	48.50	-122.05	7.02
11.16.14.	483.15	9.37	8.86	47.72	-122.05	7.02
11.16.15.	483.16	9.37	8.85	48.50	-122.05	7.02
11.16.16.	483.15	9.35	8.84	48.42	-122.05	7.02
11.16.17.	483.15	9.33	8.82	48.45	-122.05	7.02
11.16.18.	483.15	9.28	8.79	48.50	-122.05	7.01
11.16.19.	483.15	9.26	8.78	48.49	-122.05	7.02
11.16.20.	483.15	9.25	8.78	48.48	-122.05	7.01
11.16.21.	483.15	9.24	8.78	48.49	-122.05	7.02
11.16.22.	483.15	9.29	8.80	48.49	-122.05	7.02
11.16.23.	483.15	9.35	8.83	48.50	-122.05	7.02
11.16.24.	483.06	9.42	8.87	49.23	-122.05	7.02
11.16.25.	483.06	9.47	8.90	49.26	-122.05	7.02
11.16.26.	483.15	9.47	8.91	48.50	-122.05	7.02
11.16.27.	483.15	9.45	8.90	48.49	-122.05	7.01
11.16.28.	483.15	9.42	8.88	48.50	-122.05	7.02
11.16.29.	483.15	9.39	8.86	48.50	-122.05	7.02
11.16.30.	483.15	9.36	8.84	48.49	-122.05	7.02
11.16.31.	483.15	9.33	8.83	48.49	-122.05	7.02
11.16.32.	483.16	9.31	8.81	48.43	-122.05	7.02
11.16.33.	483.15	9.29	8.79	48.50	-122.05	7.02
11.16.34.	483.15	9.25	8.78	48.49	-122.05	7.02
11.16.35.	483.15	9.23	8.76	48.49	-122.05	7.02
11.16.36.	483.06	9.20	8.75	49.26	-122.05	7.02
11.16.37.	483.15	9.20	8.75	48.50	-122.05	7.02
11.16.38.	483.15	9.24	8.76	48.50	-122.05	7.01
11.16.39.	483.15	9.30	8.80	48.49	-122.05	7.02
11.16.40.	483.15	9.37	8.84	48.50	-122.05	7.02
11.16.41.	483.15	9.42	8.88	48.50	-122.05	7.02
11.16.42.	483.33	9.45	8.89	46.99	-122.05	7.01
11.16.43.	483.15	9.47	8.90	48.50	-122.05	7.02
11.16.44.	483.15	9.46	8.90	48.49	-122.05	7.02
11.16.45.	483.15	9.46	8.88	48.49	-122.05	7.01
11.16.46.	483.14	9.42	8.88	48.50	-122.05	7.02
11.16.47.	483.15	9.37	8.85	48.52	-122.05	7.02
11.16.48.	483.15	9.34	8.83	48.50	-122.05	7.02
11.16.49.	483.06	9.33	8.82	48.50	-122.05	7.02
11.16.50.	483.15	9.34	8.82	49.23	-122.05	7.01
11.16.51.	483.15	9.35	8.83	48.49	-122.05	7.02
11.16.52.	483.15	9.35	8.84	48.50	-122.05	7.02

TIME(SEC)	PRES(MB)	DP. TEMP(C)	ABS HRD(CM/M3)	ALTITUDE(M)	INS. LAT(DEG)INS. LON:(DEG)	TRUE HEADING(DEG)
11-16-53.	483.15	9.35	8.84	48.50	-122.05	7.02
11-16-54.	483.24	9.34	8.83	47.72	-122.05	7.02
11-16-55.	483.15	9.29	8.82	48.48	-122.05	7.02
11-16-56.	483.15	9.30	8.80	48.50	-122.05	7.01
11-16-57.	483.15	9.26	8.79	48.49	-122.05	7.02
11-16-58.	483.15	9.25	8.78	48.50	-122.05	7.01
11-16-59.	483.06	9.24	8.77	49.25	-122.05	7.01
11-17.0.	483.15	9.25	8.78	48.50	-122.05	7.02
11-17.1.	483.15	9.20	8.78	48.50	-122.05	7.01
11-17.2.	483.14	9.37	8.85	48.52	-122.05	7.01
11-17.3.	483.15	9.46	8.88	48.50	-122.05	7.01
11-17.4.	483.06	9.47	8.91	49.21	-122.05	7.01
11-17.5.	483.15	9.53	8.93	48.50	-122.05	7.02
11-17.6.	483.15	9.56	8.96	48.50	-122.05	7.02
11-17.7.	483.06	9.56	8.97	49.24	-122.05	7.01
11-17.8.	483.06	9.58	8.97	49.23	-122.05	7.02
11-17.9.	482.98	9.54	8.95	48.93	-122.05	7.02
11-17.10.	483.15	9.51	8.92	48.50	-122.05	7.02
11-17.11.	483.15	9.42	8.88	48.49	-122.05	7.01
11-17.12.	483.15	9.36	8.85	48.50	-122.05	7.02
11-17.13.	483.06	9.34	8.83	49.25	-122.05	7.01
11-17.14.	483.15	9.34	8.82	48.50	-122.05	7.02
11-17.15.	483.14	9.35	8.83	48.52	-122.05	7.02
11-17.16.	483.33	9.35	8.83	48.98	-122.05	7.02
11-17.17.	483.07	9.36	8.84	49.16	-122.05	7.01
11-17.18.	483.15	9.37	8.84	48.50	-122.05	7.02
11-17.19.	483.24	9.37	8.85	47.73	-122.05	7.02
11-17.20.	483.15	9.41	8.87	48.50	-122.05	7.01
11-17.21.	483.15	9.47	8.90	48.50	-122.05	7.01
11-17.22.	483.15	9.56	8.95	48.50	-122.05	7.02
11-17.23.	483.14	9.63	9.00	48.52	-122.05	7.02
11-17.24.	483.24	9.67	9.03	47.73	-122.05	7.01
11-17.25.	483.24	9.70	9.05	47.72	-122.05	7.02
11-17.26.	483.14	9.72	9.06	48.52	-122.05	7.02
11-17.27.	483.24	9.70	9.05	47.73	-122.05	7.02
11-17.28.	483.15	9.67	9.03	48.50	-122.05	7.01
11-17.29.	483.15	9.61	8.99	48.50	-122.05	7.02
11-17.30.	483.15	9.52	8.95	48.50	-122.05	7.02
11-17.31.	483.15	9.50	8.92	48.50	-122.05	7.01
11-17.32.	483.15	9.47	8.91	48.50	-122.05	7.01
11-17.33.	483.24	9.47	8.90	47.73	-122.05	7.02
11-17.34.	483.15	9.50	8.92	48.50	-122.05	7.02
11-17.35.	483.15	9.53	8.93	48.50	-122.05	7.01
11-17.36.	483.33	9.53	8.95	46.99	-122.05	7.02
11-17.37.	482.97	9.57	8.97	50.01	-122.05	7.01
11-17.38.	483.15	9.61	8.98	48.49	-122.05	7.01
11-17.39.	483.15	9.64	8.98	48.50	-122.05	7.01
11-17.40.	483.24	9.65	8.92	47.72	-122.05	7.01
11-17.41.	483.24	9.65	8.92	47.72	-122.05	7.02
11-17.42.	483.15	9.67	8.92	48.49	-122.05	7.01
11-17.43.	483.24	9.65	8.91	47.72	-122.05	7.02
11-17.44.	483.24	9.63	8.90	47.72	-122.05	7.01
11-17.45.	483.15	9.59	8.98	48.50	-122.05	7.01
11-17.46.	483.14	9.56	8.95	48.52	-122.05	7.02
11-17.47.	483.24	9.51	8.92	47.73	-122.05	7.01
11-17.48.	483.14	9.44	8.89	48.52	-122.05	7.01
11-17.49.	483.15	9.41	8.85	48.50	-122.05	7.02
11-17.50.	483.24	9.40	8.85	47.73	-122.05	7.02

4.5.2 PROGRAM STEVERD

LYC scientists are continually searching for new sources of cloud physics or icing data. In early 1983 LYC began receiving icing data from West German scientists. This data is formatted so that the first two records contain flight information such as date, time, total records and comments. During each flight eleven parameters were collected and written to the tape (records 3-13,14-24...). Each record contains 600 words and pertains to one parameter. Each word in the record represents data collected over a one second interval.

This program reads and formats these data for LYC scientists.

The order of these parameters on the tape is: time, altitude, air speed, static temperature, dewpoint, difference, humidity potential, LWC, backscattering coefficient, degree of icing, icing rate, and ice warning signal.

The German data tapes are processed via the CDC job shown below:

```
DATA TAPE --> SYSTEM UTILITY COPYCF --> OUTPUT DATA FILE -->  
PROGRAM BUFFTNS --> OUTPUT DATA FILE --> PROGRAM STEVERD -->  
FORMATTED LISTING
```

NOTE: Program COPYCF is batched via a card deck
Program BUFFTNS and STEVERD are run interactively

Operating instructions and sample output for these programs follow.

4.5.2.1 PROGRAM STEVERD OPERATING INSTRUCTIONS

COPYCF UTILITY JOB
MILLR,NT1. 1416 MILLERP
REQUEST,GDATA16,*PF.
VSN,TAPE1=LYCGRM/NT.
REQUEST,TAPE1,PE,NT,EB,NORING,L.
FILE(TAPE1,RT=U,BT=K,MRL=10000,MBL=10000,RB=1,BFS=1005)
COPYCF(TAPE1,GDATA16)
CATALOG,GDATA16,,ID=KAPLANF.
7/8/9
6/7/8/9

PROGRAM BUFFTNS

ATTACH,B,BUFFTN5,ID=KAPLANF
ATTACH,TAPE3,GDATA16,ID=KAPLANF
FTN,I=B,PL=999999
LGO

PROGRAM STEVERD

ATTACH,S,STEVERD,ID=KAPLANF
FTN5,I=S,PL=999999
LGO
DISPOSE,OUTPUT,PR,I91

P50

TIME (SEC)	ALT (KM)	AIR SPEED KM/HR	STATIC TEMP (C)	DEWP DIFF (C)	HMDTY POT (V)	LWC (G/H**3)	RCK COEFF	DGR ICG	ICG RTE	ICE US
00.00.00	.2312	113.3	-2.453	1.090	3.991	.8165E-01	-1.301	.1726	-.2237	-.8083E-01
00.00.01	.2312	113.3	-2.453	1.123	3.981	.8165E-01	-1.301	.1828	-.2237	-.3587E-01
00.00.02	.2312	113.3	-2.453	1.140	3.976	.8165E-01	-1.301	.1726	-.2058	.1808E-01
00.00.03	.2312	113.3	-2.453	1.123	3.981	.8165E-01	-1.301	.1828	-.2237	-.6284E-01
00.00.04	.2312	113.3	-2.453	1.129	3.976	.8092E-01	-1.301	.1726	-.2147	.7203E-01
00.00.05	.2351	113.3	-2.454	1.120	3.986	.8072E-01	-1.301	.1726	-.2147	.2707E-01
00.00.06	.2351	113.3	-2.454	1.112	3.986	.8072E-01	-1.301	.1828	-.2237	.7203E-01
00.00.07	.2351	113.3	-2.454	1.100	3.986	.8092E-01	-1.301	.1726	-.1879	-.4486E-01
00.00.08	.2312	113.3	-2.453	1.083	3.991	.8132E-01	-1.301	.1828	-.2416	-.1789E-01
00.00.09	.2312	113.3	-2.453	1.071	3.996	.8126E-01	-1.301	.1726	-.2237	.7203E-01
00.00.10	.2312	113.3	-2.453	1.056	4.006	.8151E-01	-1.301	.1828	-.2147	-.1789E-01
00.00.11	.2312	113.3	-2.453	1.045	4.006	.8186E-01	-1.301	.1828	-.1879	-.4486E-01
00.00.12	.2312	113.3	-2.453	1.040	4.006	.8165E-01	-1.301	.1726	-.2147	.9823E-04
00.00.13	.2312	113.3	-2.453	1.041	4.006	.8186E-01	-1.301	.1726	-.2326	-.8083E-01
00.00.14	.2312	113.3	-2.453	1.043	4.006	.8151E-01	-1.301	.1726	-.2237	.8102E-01
00.00.15	.2312	113.3	-2.453	1.037	4.006	.8126E-01	-1.301	.1726	-.2237	.9089E-02
00.00.16	.2312	113.3	-2.453	.9846	4.006	.8111E-01	-1.301	.1828	-.2147	-.3587E-01
00.00.17	.2312	113.3	-2.453	1.069	4.011	.8106E-01	-1.301	.1828	-.2237	-.5385E-01
00.00.18	.2312	113.3	-2.453	1.140	4.011	.8111E-01	-1.301	.1726	-.2147	.9823E-04
00.00.19	.2312	113.3	-2.452	1.184	4.001	.8126E-01	-1.301	.1828	-.1968	-.1789E-01

4.5.3 Program ATTCHFLES

A procedure was written that eliminates the need to individually attach files every two weeks so that they will not expire. Every time a new program is written or an old program becomes obsolete it can be added or deleted by using this procedure. In addition, this procedure can be easily modified so that it will also catalog all files to the disk.

Operating instructions and a listing of the program may be found in the next section.

4.5.3.1 ATTCHFLES Operating Instructions

COMMAND-ATTACH,A,ATTCHFLES,ID=KAPLANF

AT CY= 001 SN=SHARED

COMMAND-BATCH,A,INPUT

4.5.3.1 PROGRAM ATTCHFLES (cont'd)

TOP OF FILE

MILLR,T100.
REQUEST,A,*PF.
ATTACH,B,BATCHPLT,ID=KAPLANF.
REWIND,A,B.
COPY,A,B.
UNLOAD,A,B.
REQUEST,A,*PF.
ATTACH,B,BUFFTN5,ID=KAPLANF.
REWIND,A,B.
COPY,A,B.
UNLOAD,A,B.
REQUEST,A,*PF.
ATTACH,B,CNVRT,ID=KAPLANF.
REWIND,A,B.
COPY,B,A.
UNLOAD,A,B.
REQUEST,A,*PF.
ATTACH,B,COPYLYCBOB,ID=KAPLANF.
REWIND,A,B.
COPY,B,A.
UNLOAD,A,B.
REQUEST,A,*PF.
ATTACH,B,ICEDERIVBIN,ID=KAPLANF.
REWIND,A,B.
COPY,B,A.
UNLOAD,A,B.
REQUEST,A,*PF.
ATTACH,B,ICEDMPBIN,ID=KAPLANF.
REWIND,A,B.
COPY,B,A.
UNLOAD,A,B.

1416 MILLERP

4.5.4 PROGRAM KNOLL1D AND HDATSTAT

In order to assist in the analysis of icing data collected during the flight of 11 DEC 79 (E79-50), DPSI has prepared a modified version (cycle 18) of KNOLL1D to produce an output file (tape 11) for additional processing. This file contains scatter probe counts for channels 1-15 (one channel per record), with VCO data (temp, dewpoint, and relative humidity) contained in the 16th record. This sequence is repeated for each second of the pass.

Subsequently, program HDATSTAT was written to process these scatter probe and VCO data. The program produces two types of output: first, the total count for channels 1-15 are provided for each second of the pass; and then the average value for each channel is completed for the pass (standard deviation and variance are also completed for each channel). In addition, the average values for temperature, dewpoint, and relative humidity for the pass are calculated after the channel 1 summary is printed. Since these VCO values occur only once per second, repetition of these averaged values after each subsequent channel summary would be meaningless.

Operating instructions for KNOLL1D (cycle 18) and operating instructions and sample output for HDATSTAT are provided in the next section.

4.5.4.1 PROGRAM KNOLL1D Operating Instructions

COMMAND DECK

MILLR,CM65000,TP1,T100. 1416 MILLERP
ATTACH,LGO,KNOLL1DBIN,ID=KAPLAN,MR=1,CY=18.
ATTACH,TAPE8,VCOALS,ID=KAPLANF,MR=1.
REQUEST,TAPE11,*PF.
VSN,TAPE1=PMS317.
REQUEST,TAPE1,S,HI,MT.
FILE(TAPE1,RT=U,BT=K,MRL=1024,RB=1,BFS=105)
LDSET,PRESET=ZERO,FILES=TAPE1.
LGO.
EXIT(U)
REWIND,TAPE3.
REWIND,TAPE11.
COPY,TAPE3.
CATALOG,TAPE11,HDATA43TD,ID=MILLERP.
7/8/9

4.5.4.1 KNOLL1D operating instructions (cont'd)

DATA CARDS

CARD 1 - ID CARD

COL 1-10 FLT XYR-NN
COL 12-20 DD MON YR
COL 21-30 INPUT TAPE NUMBER
COL 31-40 PLOT TAPE NUMBER
COL 52-59 PMS ZERO SECONDS - HH:MM:SS
COL 70 IOSKP(0=STANDARD OUTPUT;1=CREATE TAPE 11 DATA FILE)

CARD 2 - NAMELIST SCOE

ARRAY S(5) OF SOUNDING COEFFICIENTS (DEFAULTED INTERNALLY).

CARD 3 - NAMELIST VCOEF - USED TO OVERRIDE VCO CALIBRATIONS

ARRAY C(3,13) CONTAINING THE VCO CALIBRATION COEFFICIENTS IN THE FOLLOWING ORDER: INTERCEPT, FIRST DEGREE AND SECOND DEGREE COEFFICIENTS.
VCO'S ARE IN THE FOLLOWING ORDER:

- 1 INDICATED AIRSPEED
- 2 TEMPERATURE
- 3 EWER
- 4 TWCI-4
- 5 DEWPOINT/FROSTPOINT
- 6 LWC-JW
- 7 MAGNETIC HEADING
- 8 PRESSURE KISTLER
- 9 TRUE AIRSPEED
- 10 ICEING RATE
- 11 TWCI-1
- 12 TWCI-2
- 13 TWCI-3

CARD 4 - NAMELIST JWADJ

CONTAINS HEIGHT PROFILES FOR A JW-LWC ADJUSTMENT.
ELEMENTS ARE:

L NUMER OF LEVELS (DEFAULT 0-NO CORRECTION) (MAX 10)
HT HEIGHT OF LEVELS IN KM'S (HT(1) GT HT(2) GT...GT HT(L))
XA ORIGIN OF LEVEL (ONE PER LEVEL)
SLA SLOPE FROM LEVEL (I) TO LEVEL (I+1) (L-1 SLOPES REQUIRED)

4.5.4.1 KNOLLd operating instructions (cont'd)

CARD 5 - OPTION CARD (ALL I5 FORMAT)

COL	1-5	NFHDR	- SET TO 1 WHEN CONDENSED FORMAT HEADER CARD DESIRED
	6-10	ICLK	1 = USE A/C CLOCK 2 = USE PMS CLOCK
	11-15	IDAT	1 = USE FINALIZED DATA LITERAL 0 = USE PRELIMINARY LITERAL
	16-20	IPLT	1 = PLOT TAPE PRODUCED 0 = NO PLOT TAPE
	21-25	N2PROBE	2 = TWO CLOUD PROBES 3 = TWO PRECIP PROBES
	26-30	ITMP	0 = TEMPERATURE DETERMINATION BY VCO PROFILE 1 = TEMPERATURE DETERMINATION BY STANDARD ATMOSPHERE 2 = TEMPERATURE DETERMINATION BY RADIOSONDE PROFILE
	31-35	JVCO	- NUMBER OF VCOFIX CARDS DESIRED (0-10)
	36-40	NSKP	>0 IS THE NUMBER OF END-OF-FILES TO SKIP BEFORE PROCESSING THE DATA <0 IS THE NUMBER OF RECORDS TO SKIP BEFORE PROCESSING THE DATA
	41-45	IDEK	1 = PRODUCE A PUNCHED DECK CONTAINING THE TIME, HEIGHT, LWC AND D0 VALUES, 0 = NO DECK
	46-50	MXLINES	- NUMBER OF PASS LITERALS DESIRED FOR THE CONDENSED OUTPUT FORMAT (0-15)
	51-55	INTRP	1 = USE INTERPOLATION 0 = NO INTERPOLATION
	56-60	IDMZ	1 = SUMMARY FILE OF D0,LWC AND Z VALUES PRODUCED 0 = NO SUMMARY FILE PRODUCED
	61-65	IVEL	1 = USE TRUE AIRSPEED 0 = USE CALCULATED AIRSPEED
	66-70	IFORM	1 = CONDENSED OUTPUT FORMAT PRINTED AND THE PLOT TAPE USES UNMELTED BARWIDTH'S 0 = NORMAL OUTPUT AND NORMAL PLOT TAPE
	71-75	IOUT	1 = NO STANDARD OUTPUT 0 = STANDARD OUTPUT PRODUCES
	76-80	ISCAT	1 = USE .9 FACTOR IS SCATTER CALCULATIONS 0 = .9 FACTOR NOT USED

4.5.4.1 KNOLLd operating instructions (cont'd)

CARD 6 NEW FORMAT HEADER CARD (IF NFHEADR .EQ. 1)
CENTERED LINE (A80) TO BE PRINTED AT THE TOP OF EACH
NEW FORMAT OUTPUT.

CARD 7 TYPE LITERAL LINE
IF MXLINES > 0 MXLINES CARDS ARE REQUIRED HERE IN
CENTERED A80 FORMAT. THESE LINES ARE PRINTED ON
NEW FORMAT OUTPUT; BENEATH THE INTERVAL PARTICLE
TYPE.

CARD 8 ONWARDS

- A) ANY DATA CARDS REQUIRED BY SWITCHED SET ON OPTION
CARD JVCO 0 IMPLIES VCO PROFILES IN HERE
ITEMP=2 IMPLIED RADIOSONDE PROFILES HERE
- B) TYPE, EDIT, HTOX, XTOD CARDS INTERSPERED IN HERE

TYPE (15 MAXIMUM)

COL 1-4 TYPE
COL 6-13 HH:MM:SS (START TIME)
COL 16-23 HH:MM:SS (STOP TIME)
COL 25-26 CLOUD TYPE
COL 27-28 PRECIP TYPE
COL 31-35 AVERAGING INTERVAL (15)
COL 45-64 LEFT JUSTIFIED PASS LITERAL FOR HEADER OF NEW
FORMAT (A20)

EDIT (5 MAXIMUM)

COL 1-4 EDIT
COL 6-13 HH:MM:SS (START TIME)
COL 16-23 HH:MM:SS (STOP TIME)
COL 26,28,30 PROBES TO BE EDITED (1,2,3)
COL 31-54 CHANNELS TO BE EDITED (I3 FORMAT, 8 MAXIMUM)

HTOX (NO MAXIMUM)

COL 1-4 HTOX
COL 6-7 TYPE CODE (ODD NUMBER)
COL 9-10 EQUATION NUMBER
COL 12-13 ARGUMENT TO BE CHANGED (1=M, 2=B, 3=BREAKPT)
COL 15-30 NEW VALUE (F15.0)

XTOD (NO MAXIMUM) SAME AS HTOX

COL 12-13 ARGUMENT TO BE CHANGED (1=CO, 2=EX, 3=BREAKPT)

4.5.4.2 PROGRAM HDATSTAT Operating Instructions and Sample Output

ATTACH FILES

CONNECT, INPUT
 COMMAND- CONNECT, OUTPUT
 COMMAND- ATTACH, S, HDATSTAT, ID=MILLERP
 AT CY= 014 SM=SHARED
 COMMAND- ATTACH, TAPE1, HDATA3TD, ID=MILLERP
 AT CY= 001 SM=SHARED
 COMMAND- FTN, I=S
 .416 CP SECONDS COMPILATION TIME
 COMMAND- LG0
 E79-50 233208 233250
 688

TOT CNT PER SEC =	10338	FOR SECOND	1
TOT CNT PER SEC =	17915	FOR SECOND	2
TOT CNT PER SEC =	16080	FOR SECOND	3
TOT CNT PER SEC =	7349	FOR SECOND	4
TOT CNT PER SEC =	17426	FOR SECOND	5
TOT CNT PER SEC =	18769	FOR SECOND	6
TOT CNT PER SEC =	18277	FOR SECOND	7
TOT CNT PER SEC =	16984	FOR SECOND	8
TOT CNT PER SEC =	18530	FOR SECOND	9
TOT CNT PER SEC =	20031	FOR SECOND	10
TOT CNT PER SEC =	20374	FOR SECOND	11
TOT CNT PER SEC =	20008	FOR SECOND	12
TOT CNT PER SEC =	20105	FOR SECOND	13
TOT CNT PER SEC =	20132	FOR SECOND	14
TOT CNT PER SEC =	20205	FOR SECOND	15
TOT CNT PER SEC =	20431	FOR SECOND	16
TOT CNT PER SEC =	20208	FOR SECOND	17
TOT CNT PER SEC =	20045	FOR SECOND	18
TOT CNT PER SEC =	19543	FOR SECOND	19
TOT CNT PER SEC =	19114	FOR SECOND	20
TOT CNT PER SEC =	18498	FOR SECOND	21
TOT CNT PER SEC =	19133	FOR SECOND	22
TOT CNT PER SEC =	20303	FOR SECOND	23
TOT CNT PER SEC =	19120	FOR SECOND	24
TOT CNT PER SEC =	18296	FOR SECOND	25
TOT CNT PER SEC =	14413	FOR SECOND	26
TOT CNT PER SEC =	17501	FOR SECOND	27
TOT CNT PER SEC =	14317	FOR SECOND	28
TOT CNT PER SEC =	17198	FOR SECOND	29
TOT CNT PER SEC =	11013	FOR SECOND	30
TOT CNT PER SEC =	12464	FOR SECOND	31
TOT CNT PER SEC =	16624	FOR SECOND	32
TOT CNT PER SEC =	18429	FOR SECOND	33
TOT CNT PER SEC =	19317	FOR SECOND	34
TOT CNT PER SEC =	21359	FOR SECOND	35

TOT CNT PER SEC = 18547 FOR SECOND 37
TOT CNT PER SEC = 18643 FOR SECOND 38
TOT CNT PER SEC = 18530 FOR SECOND 39
TOT CNT PER SEC = 17984 FOR SECOND 40
TOT CNT PER SEC = 17935 FOR SECOND 41
TOT CNT PER SEC = 18028 FOR SECOND 42
TOT CNT PER SEC = 7384 FOR SECOND 43

FUNCTION = E79-50 233208 233250
CH. NO. = 1
TOT NO. OF CHCNTS = 688 43
IDENOM =
MEAN = 1542
STD. DEV. = 1443.76
VARIANCE = 2084432.53

*****AVG. TEMP = 1.56
*****AVG. DP = 2.74
*****AVG. RH = 0.00

FUNCTION = E79-50 233208 233250
CH. NO. = 2
TOT NO. OF CHCNTS = 688 43
IDENOM =
MEAN = 2656
STD. DEV. = 1589.43
VARIANCE = 2526273.74

FUNCTION = E79-50 233208 233250
CH. NO. = 3
TOT NO. OF CHCNTS = 688 43
IDENOM =
MEAN = 4161
STD. DEV. = 1674.51
VARIANCE = 2803977.14

FUNCTION = E79-50 233208 233250
CH. NO. = 4
TOT NO. OF CHCNTS = 688 43
IDENOM =
MEAN = 3500

VARIANCE = 2000444.28

FUNCTION = E79-50 233208 233250
CH. NO. = 5
TOT NO. OF CHCMTS = 688
IDENOM = 2533
MEAN = 1490.52
STD. DEV. = 2221644.12
VARIANCE =

43

FUNCTION = E79-50 233208 233250
CH. NO. = 6
TOT NO. OF CHCMTS = 688
IDENOM = 1353
MEAN = 1055.71
STD. DEV. = 1114518.44
VARIANCE =

43

FUNCTION = E79-50 233208 233250
CH. NO. = 7
TOT NO. OF CHCMTS = 688
IDENOM = 1101
MEAN = 824.52
STD. DEV. = 679836.98
VARIANCE =

43

FUNCTION = E79-50 233208 233250
CH. NO. = 8
TOT NO. OF CHCMTS = 688
IDENOM = 375
MEAN = 362.65
STD. DEV. = 131516.13
VARIANCE =

43

FUNCTION = E79-50 233208 233250
CH. NO. = 9
TOT NO. OF CHCMTS = 688
IDENOM = 182
MEAN = 190.71
STD. DEV. =

43

FUNCTION = E79-50 233208 233250
CH. NO. = 10
TOT NO. OF CHCNTS = 688
IDENOM = 43
MEAN = 60
STD. DEV. = 57.84
VARIANCE = 3346.01

FUNCTION = E79-50 233208 233250
CH. NO. = 11
TOT NO. OF CHCNTS = 688
IDENOM = 43
MEAN = 34
STD. DEV. = 34.75
VARIANCE = 1207.49

FUNCTION = E79-50 233208 233250
CH. NO. = 12
TOT NO. OF CHCNTS = 688
IDENOM = 43
MEAN = 28
STD. DEV. = 28.08
VARIANCE = 788.55

FUNCTION = E79-50 233208 233250
CH. NO. = 13
TOT NO. OF CHCNTS = 688
IDENOM = 43
MEAN = 33
STD. DEV. = 32.63
VARIANCE = 1064.98

FUNCTION = E79-50 233208 233250
CH. NO. = 14
TOT NO. OF CHCNTS = 688
IDENOM = 43
MEAN = 16
STD. DEV. = 16.30
VARIANCE = 245.63

FUNCTION = E79-50 233208 233250
CH. NO. = 15
TOT NO. OF CHCNTS = 688
IDENOM = 43
MEAN = 35
STD. DEV. = 35.17
VARIANCE = 1236.65

STOP
035700 MAXIMUM EXECUTION FL.
6.095 CP SECONDS EXECUTION TIME.
COMMAND-

4.6 Snow Data Processing - CDC 6600

4.6.1 Program CNVRTASCII to CDC

There have been problems using the CDC built-in data (ASCII) conversion software. DPSI has developed a program which will read an ASCII file and perform a table look up in order to convert the data the CDC display code.

Program CNVRTASCII to CDC incorporates the binary buffer-in I/O technique preventing the CDC operating system from assisting in the conversion. Three types of output are provided; formatted display code, octal bytes, and record by record output of the display file.

4.6.1 Program CNVRTASCII to CDC (cont'd)

```
JOB NAME,NT1*,T100.                aaaa ppppppp
ATTACH,I,CNVRTASCIITOCDC,ID=ROBERTSK.
FTN,I=I,SL,R=3.
(A) { VSN,TAPE1=_____INT*.
      REQUEST,TAPE1,HD*,S,VS,NT*,NORING.
      LGO.
      EXIT(u)
(B) { CATALOG,TAPE2,_____,ID=_____.
      CATALOG,TAPE3,_____,ID=_____.
      CATALOG,TAPE4,_____,ID=_____.
      6/7/8/9
```

* 7 or 9 track, and bit density may change for each specific job.

(A) If the source ASCII data is on disk, replace with:
ATTACH,TAPE1,_____,ID_____.

(B) Rearrange as required, for just a printout, replacement:
REWIND, TAPE_x.
COPY, TAPE_x, OUTPUT.

4.6.2 Program MAKECRRELTAPE

Program MAKECRRELTAPE is a data conversion program which will convert a snow weight, 7track, OS/8 tape generated by the PDP-8 to a 9track,ASCII format supplied to CRREL. Since this program uses tapes, it executes under batch. Excluding the media change, the apparent difference between the input and output of the program can be seen in section 4.6.3.1.

The input data tape containing 384 characters per record is converted to the standard 9track format with each record containing three, 60 bit words.

4.6.2.1 Program MAKECRRELTAPE Operating Instructions

```
JOB NAME, TP1, NT1, T100.          aaaa ppppppp
ATTACH, I, MAKECRRELTAPE, ID=ROBERTSK.
FTN, I=I, SL, R=3.
VSN, TAPE1= _____.
REQUEST, TAPE1, S, MT, NORING.
FILE(TAPE1, RT=u, BT=K, MRL=10000, MBL=10000, RB=1, BFS=1005)
VSN, TAPE2= _____/NT.
REQUEST, TAPE2, NT, VS, RING.
LGO.
7/8/9
6/7/8/9
```

```
TAPE1=INPUT=PDP-8 OS/8 7TRACK TAPE
TAPE2=OUTPUT=CRREL9TRACK ASCII TAPE
```

4.6.3 Program MAKELMINSNORATE

The techniques employed for snow fall analysis requires compatible data sets with respect to time. The CRREL ASCME data is recorded as a one minute average. Therefore to present an accurate representation of fall velocity, it becomes necessary to calculate AFGL snow rates as one minute averages.

Program MAKELMINSNORATE has been designed to provide one minute averaged snow rates and an instantaneous value (snow rate as taken from the nearest whole minute). This program operates under INTERCOM and accepts as input an AFGL format #2 snow weight data file (see section 4.6.3.1) Output consists of three data files; averaged snow tape, instantaneous snow rate, and snow rates for each 2.809 second period.

4.6.3.1 Program MAKELMINSNORATE Operating Instructions

ATTACH, I, MAKELMINSNORATE, ID=ROBERTSK.

FTN, I=I, SL, R=3.

ETL, 100.

ATTACH, TAPE1, _____ *, ID= _____ .

LGO

TAPE1=INPUT=AFGL SNOW WEIGHT DATA*

TAPE2=OUTPUT=AVERAGED 1 MINUTE SNOW RATE **

TAPE3=OUTPUT=INSTANTANEOUS 1 MINUTE SNOW RATE **

TAPE4=OUTPUT=SNOW RATE FOR EACH 2.809 SECONDS

* AFGL DATA IN FORMAT #2

** AFGL DATA IN FORMAT #3

AFGL FORMAT #1

COL	COL
1	8
↓	↓
+ XXX.XX	
+ XXX.XX	

DATA A RECORDED BY THE TEKTRONIX 4023 TAPE RECORDER, F8.2

AFGL FORMAT #2

COL	COL
1	30
↓	↓
HH MM SS DATE	
+ XXX.XX + XXX.XX	
+ XXX.XX + XXX.XX + XXX.XX	

DATA SUPPLIED TO CRREL ON A 9 TRACK ASCII TAPE, RECORD LENGTH,
3-60 BIT WORDS

AFGL FORMAT #3

COL	COL
1	20
↓	↓
HH MM SS + XXX.XX	
HH MM SS + XXX.XX	

DATA FORMAT USED IN CDC PROCESSING PROGRAMS

AFGL SNOW RATE FORMAT

1	17	28	39	50	57
↓	↓	↓	↓	↓	↓
MM/YY HH;MM;SS	.XXXXXXXX	.XXXXXXXX	.XXXXXXXX	.XXXXXXXX	
	X	X	X	X	

An X in the decimal point columns indicates that the ASCME device was imperative; or out for maintenance. When CRREL tapes are processed initially, the X's are replaced with '-1.000000'. This will simplify the post processing stream programs.

CRREL DATA FORMAT

4.6.4 Program COPYASCME

At times CRREL (Cold Regions Research Laboratory) supplies LYC with data tapes containing field observation values from their ASCME (Airborne Snow Mass Concentration Measurements) device. The ASCME data is used at LYC for comparison with LYC snow rates and for fall velocity analysis.

In order to process these data tapes, they must be read and converted to CDC display code. Program COPYASCME is a quick and simple program which will read each file (usually there is more than one file) from a CRREL tape and allow them to be catalogued.

The CRREL data tapes have been formatted on a 9 track magnetic tape written in ASCII at 800 BPI (Bits Per Inch). This format could change, but only the "REQUEST" job card would then require modification.

Presently, COPYASCME will extract five files from the CRREL tape, if more files are required, change the "PROGRAM" statement within the COPYASCME program. Only one data card is necessary when operating this program; it defines the number of files to transfer.

4.6.4.1 Program COPYASCME Operating Instructions

```
JOB NAME,NT1*,T100.                aaaa ppppppp
ATTACH,I,COPYASCME,ID=ROBERTSK.
FTN,I=I,SL,R=3.
VSN,TAPE1=_____/NT.
REQUEST,TAPE1,HD*,S,VS*,NT*,NORING.
LGO.
EXIT(u)
CATALOG,TAPE2,_____,ID=_____.
CATALOG,TAPE3,_____,ID=_____.
CATALOG,TAPE4,_____,ID=_____.
CATALOG,TAPE5,_____,ID=_____.
CATALOG,TAPE6,_____,ID=_____.
7/8/9
xxx    ←  number of files to copy,column 1-3
6/7/8/9
```

- * 7 or 9 track, bit density, and recording format could be changed at any time.

TAPE1=INPUT=CRREL DATA TAPE (see Appendix 2)

TAPE2
⋮
⋮
TAPE6 } =OUTPUT=CDC FORMATTED FILES

4.6.5 Programs CORRSNOWRATEDATA/CORRSNOLOGSCALE

In order to complete analysis of the snow data collected by both LYC and CRREL, DPSI has developed two data correlation programs; CORRSNOWRATEDATA and CORRSNOLOGSCALE. Both programs operate in an identical fashion, however, the former generates a linear interpretation of the data, whereas the latter is a logarithmically based comparison.

Both programs have been designed to generate Tektronix CRT plots in an interactive environment (INTERCOM). However, with a few modifications, output can easily be sent to any of the plotting devices available.

The ASCME tapes contain data for three devices, and thus three plots are created. At the conclusion of each plot "FRAME" is called allowing the operator time to produce a hardcopy of the plotted image.

It is suggested that the 19 inch Tektronix be used for final copies as the resolution is preferable to the twelve inch CRT's.

All output generated by both correlation programs is displayed on the plot and includes such parameters as:

- standard deviation of x and y
- correlation and convenience
- the first degree best fit equations

4.6.5 Programs CORRSNOWRATEDATA/CORRSNOLOGSCALE (cont'd)

The correlation is produced on a point by point comparison of the two data sets, and therefore identical times must be present. If a time discrepancy is found, "INCONSISTENT CLOCK TIMES" is printed. The data files could be edited using "NETED" as required.

4.6.5.1 Programs CORRSNOWRATEDATA/CORRSNOLOGSCALE Operating Instructions and Sample Output

```
ATTACH,I, _____ *,ID=ROBERTSK.  
FTN,I=I.  
ATTACH,TAPE1,afgldata,ID=_____.  
ATTACH,TAPE2,crreldata,ID=_____.  
ATTACH,TEK,TEXSIM,CY=2**.  
ATTACH,LIB,LIBNEWX5951,ID=WARD,MR=1.  
LIBRARY,TEK,LIB.  
LGO
```

* EITHER CORRSNOWRATEDATA OR CORRSNNOLOGSCALE

** CY=Z FOR ALL TEKTRONIX EXCEPT SYNCHRONOUS TERMINAL DOWNSTAIRS
AT THE CDC CENTER, USE CY=1.

```
TAPE1=INPUT=AFGL DATA, FORMAT#3 (see Appendix #1)  
TAPE2=INPUT=CRRL DATA (see Appendix #2)
```

SE
E
TION

CORRELATION OF ASCE # 1

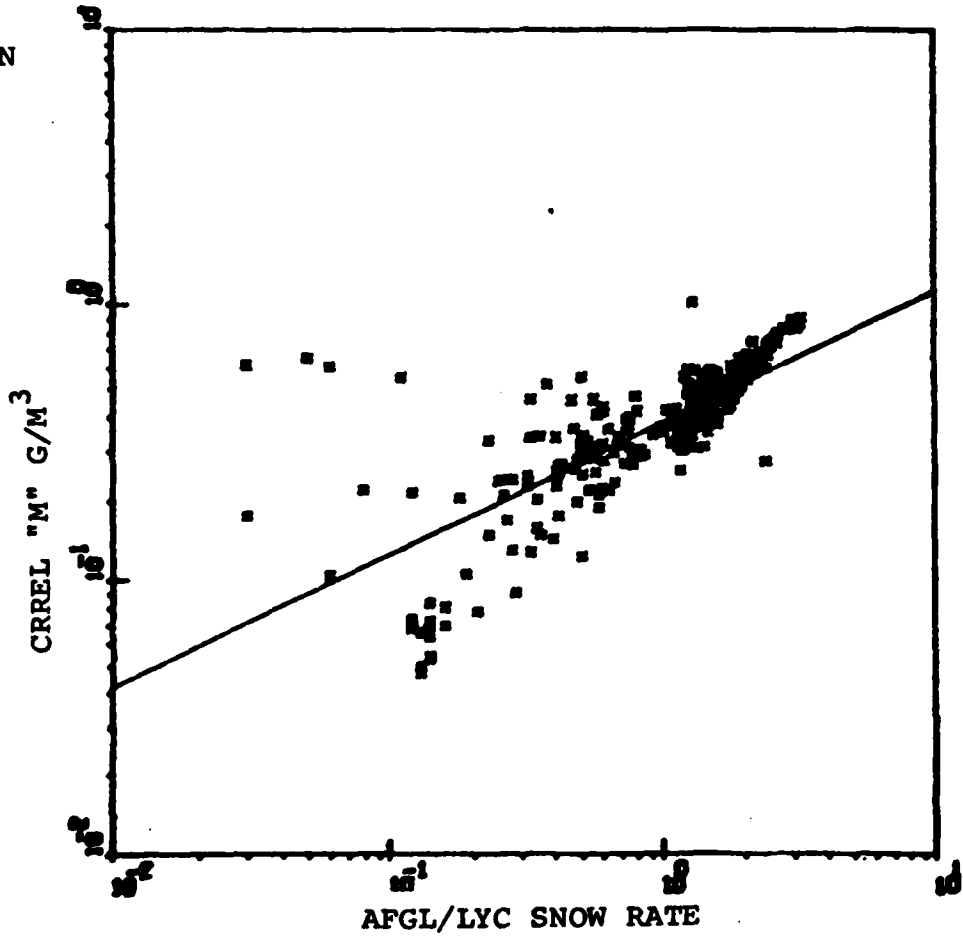

Y = .4815 X + .2482
289 POINTS PLOTTED
COR = .7288-01
COV = .7889
SD(X) = .2881
SD(Y) = .2482

4.6.6 Program PLOTASCME

During the initial processing of the CRREL ASCME data, LYC scientists require time VS ASCME plots. Therefore an INTERCOM interactive plotting program, PLOTASCME, was written to produce three ASCME plots on the Tektronix CRT terminal.

4.6.6.1 Program PLOTASCME Operating Instructions and Sample Output

```
ATTACH, I, PLOTASCME, ID=ROBERTSK.  
FTN, I=I.  
ATTACH, TAPE1, _____, ID=_____.  
ATTACH, TEK, TEKSIM, CY=2.  
LIBRARY, TEK.  
LGO
```

TAPE1=INPUT=CRREL DATA (see section 4.6.3.1)

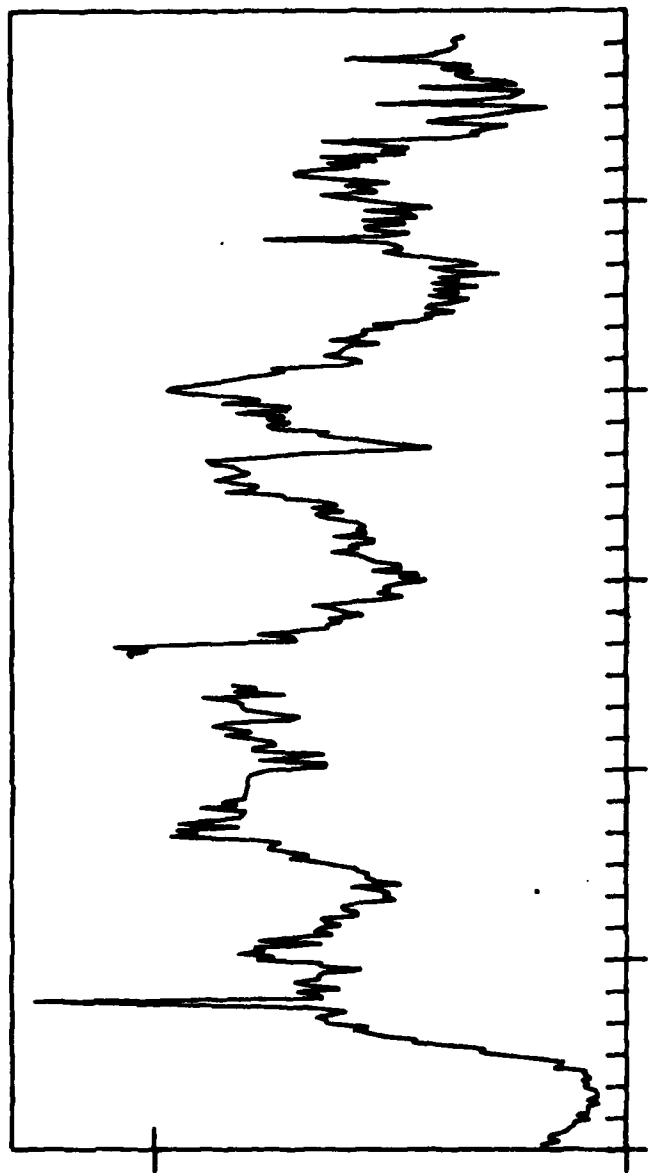

16.0017.0018.0019.0020.0021.00

ASCME 31 - JAN - 82 " 2

||

4.6.7 Programs SMOOTHAFGL/SMOOTHCRREL

During snow post processing development it became necessary to smooth the AFGL snow rates and CRREL ASCME data as a technique to remove inherent noise. To expedite such activities, DPSI has written two programs, both of which run interactively, SMOOTHAFGL and SMOOTHCRREL.

Both programs operate identically. The former requires the input file (TAPE1) to be in AFGL format #3 and the latter requires a CRREL data file (see section 4.6.3.1)

Provisions have been made to readily alter the smoothing neighborhood. In both programs, variable "SMOOTH" will define the number of points taken for each averaging pass. NOTE- this number must be odd for the program to function properly.

4.6.7.1 Programs SMOOTHAFGL/SMOOTHCRREL Operating Instructions

```
ATTACH, I, _____ *, ID=ROBERTSK.  
FTN, I=I.  
ATTACH, TAPE1, _____, ID=_____.  
LGO
```

```
TAPE1=INPUT=AFGL OR CRREL DATA FILE  
TAPE2=OUTPUT=SMOOTHED DATA OUTPUT
```

```
*  
EITHER  
    SMOOTHAFGL  
    OR  
    SMOOTHCRREL
```

4.6.8 Program FALLVEL

The end product of the LYC snow analysis is the generation of a snow fall velocity plot. This plot is calculated by comparing the ratio of AFGL snow rates to that of the CRREL ASCME data ($\frac{\text{AFGL}}{\text{CRREL}}$). The plot is then presented on a time axis.

FALLVEL runs interactively under INTERCOM and generates three frames, one for each ASCME device. Output is presented on the Tektronix graphics terminal.

4.6.8.1 Program FALLVEL Operating Instructions & Sample Output

```
ATTACH, I, FALLVEL, ID=ROBERTSK.  
FTN, I=I.  
ATTACH, TAPE1, _____*, ID= _____.  
ATTACH, TAPE2, _____, ID= _____.  
ATTACH, TEK, TEKSIM, CY=Z.  
ATTACH, LIB, LIBNEWX5551, ID=WARD, MR=1.  
LIBRARY, TEK, LIB.  
LGO
```

```
TAPE1=INPUT=AFGL DATA*  
TAPE2=INPUT=CRREL DATA
```

* AFGL FORMAT #3 (see section 4.6.3.1)

ASCHE PROBE # 1

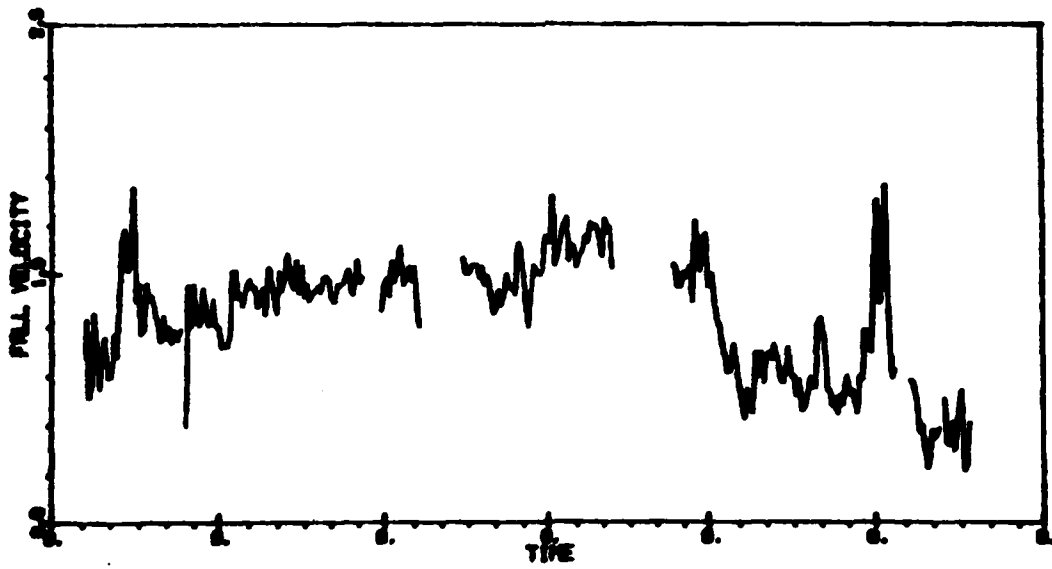

5. Theoretical Cloud Physics Modeling

5.1 Program CUMOD X2946: One-Dimensional, Mathematical/Physical Model

As part of past research efforts, LYC scientists developed a mathematical-physical model of the life cycle and precipitation process of an isolated warm cumulus cloud (Silverman & Glass 1973). The model integrates the vertical equation of motion and mass continuity, first law of thermodynamics, and the equations of continuity of water vapor and liquid hydrometeors. All equations are formulated in one-dimensional space.

The dynamic interaction between the cloud and the environment is modelled by two entrainment terms: turbulent entrainment representing horizontal mixing at the sides of the cloud; and dynamic entrainment representing the systematic inflow or outflow of air required to satisfy mass continuity. However, the unique feature of this model is the handling of the microphysical processes. Starting with a cloud condensation nucleus spectrum, the formation/growth of cloud droplets and raindrops are modeled in detail for 67 logarithmically spaced size classes that include a range of particle radii from 2 to 4040 μ .

In addition, LYC scientists investigated the feasibility of reducing the amount of computer memory and processing time required to perform these detailed microphysical and dynamic calculations by devising a numerical method of simulating the microphysical process by a set of parameterized expressions.

5.1.1 Current Status of Program CUMOD X2946

A rigorous microphysical model such as CUMOD X2946 could be applied not only to the analysis of the life cycle of a warm cumulus cloud, but also to the detailed study of the formation, growth, and evaporation process of the cloud droplet spectra and their role in the precipitation process.

The original version of CUMOD X2946 (cycle 22) has been modified to produce cycle 25. As part of the modeling experimentation during late 1982, this latest version of the model was re-created in a non-update form (CUMOD, cycle 15) in preparation for execution on the CRAY-1 at the Air Force Weapons Laboratory, Albuquerque, NM. This CRAY compatible version of CUMOD is called WARMCU, cycle 14.

The command deck for a production run of CUMOD X2946 (cycle 25), along with input data and sample output are provided in the following pages.

5.1.2 CUMOD X2946 Job Cards, Input Data, and Sample Output

COMMAND DECK

```
MILLR,CM150000,T500.                1416 MILLERP  
RFL,150000.  
ATTACH,OLDPL,CUMODX2946,ID=ROBERTSK,MR=1.  
UPDATE(F).  
FTN,I=COMPILE,PL=999999,PD=6,OPT.  
LDSET(PRESET=ZERO)  
LGO(,,,OUTPUT)  
EXIT(U).  
REWIND,TAPE8.  
COPY(TAPE8OUTPUT)  
DISPOSE,OUTPUT,*PR,C.  
7/8/9
```

```
UPDATE CARDS AS NECESSARY  
7/8/9
```

\$RUN
SEGNU = 0.
NT = 1.
RUNT = 0.0,
SMA = .1+100.
TEND = .45E+04,
NTMAX = 720,
NP = 1.
HIVAL = .1+101,
TIMLIM = .6E+04,
NDMP = 10.
IPRT11 = F.
PRINC = .6E+02,
STEP2 = .25E+02,
TMSZ = .15E+02,
DTMAX = .15E+02,
KMAX = 52,
MAXBF = 72,
NLOCS = 7488,
\$END

FLORIDA OCEAN 408 NUCLEI

FMIN= 1.0E-03

FMO= 8.7842000640E-17

FKO= 2.6423483210E+00

MDO= 1 2 3 4 5 6 7 8 9 10 11 12 13 14 15 16 17 5 0 0 0

MAXM=17

MAXFCL=17

FIN(2, 1,1)= 7.500E+07

FIN(2, 2,1)= 5.500E+07

FIN(2, 3,1)= 3.000E+07

FIN(2, 4,1)= 1.350E+07

FIN(2, 5,1)= 6.200E+06

FIN(2, 6,1)= 2.500E+06

FIN(2, 7,1)= 1.200E+06

FIN(2, 8,1)= 5.800E+05

FIN(2, 9,1)= 3.100E+05

FIN(2,10,1)= 1.500E+05

FIN(2,11,1)= 8.000E+04

FIN(2,12,1)= 4.000E+04

FIN(2,13,1)= 2.000E+04

FIN(2,14,1)= 1.000E+04

FIN(2,15,1)= 4.600E+03

FIN(2,16,1)= 2.700E+03

FIN(2,17,1)= 1.300E+03

FIN(2,18,1)= 0.

FIN(2,19,1)= 0.

FIN(2,20,1)= 0.

\$ADAT
DELL = .1E+01.
FU0 = .865617024533E+01,
X0 = .321817109E-10,
MAXX = 69,
MNTH = .5845E+02,
PNU = .2E+01,
RHOSH = .12023E+01,
RHOH = .2165E+01,
SMAXH = .36E+00,
DELZ3 = .1E+03,
CH1 = .998252E+00,
CH2 = -.3713E-01,
CH3 = .2642E-02,
CH4 = -.71E-04,
CH5 = .92E-02,
DCOT = .125E+03,
DCOW = .125E+03,
DCOV = .125E+03,
DCOF3 = .125E+03,
DCENT = .125E+03,
MU = 0.0,
BASE = .1E+04,
\$END

SPROFI

NCARD = 16,

STPR = 0.0,

P = .1015E+04, .1E+04, .95E+03, .935E+03, .9E+03, .85E+03, .8E+03,
.6E+03, .55E+03, .5E+03, .45E+03, .4E+03, -.999E+02, -.999E+02,
0.0, 0.0, 0.0, 0.0, 0.0, 0.0, 0.0, 0.0, 0.0, 0.0, 0.0, 0.0, 0.0, 0.0,
.75E+03, .709E+03, .7E+03, .662E+03,
-.999E+02, -.999E+02, 0.0, 0.0, 0.0, 0.0,

T = .271E+02, .26E+02, .22E+02, .21E+02, .184E+02, .152E+02, .126E+02,
.3E+00, -.31E+01, -.75E+01, -.128E+02, -.188E+02, -.999E+02,
0.0, 0.0, 0.0, 0.0, 0.0, 0.0, 0.0, 0.0, 0.0, 0.0, 0.0, 0.0, 0.0, 0.0,
.1E+02, .79E+01, .75E+01, .69E+01,
-.999E+02, -.999E+02, -.999E+02, -.999E+02, 0.0,

RH = .737E+00, .749E+00, .89E+00, .889E+00, .91E+00, .896E+00, .864E+00,
.14E+00, .94E-01, .191E+00, .9E-01, .223E+00, -.999E+02, -.999E+02,
0.0, 0.0, 0.0, 0.0, 0.0, 0.0, 0.0, 0.0, 0.0, 0.0, 0.0, 0.0, 0.0, 0.0,
.868E+00, .872E+00, .801E+00, .408E+00,
-.999E+02, -.999E+02, 0.0, 0.0, 0.0, 0.0,

SEND

29 SEP 71 SOUNDING FLA STD MOD BY A/C

K	VDA	TKA	W3A	TEA	PVEA	PRES
1	6.749E-04	2.715E+02	0.	2.715E+02	6.749E-04	5.704E+02
2	6.749E-04	2.715E+02	0.	2.715E+02	6.749E-04	5.704E+02
3	6.749E-04	2.715E+02	0.	2.715E+02	6.749E-04	5.704E+02
4	7.318E-04	2.720E+02	0.	2.725E+02	7.318E-04	5.776E+02
5	7.909E-04	2.725E+02	0.	2.730E+02	7.909E-04	5.849E+02
6	8.523E-04	2.730E+02	0.	2.734E+02	8.523E-04	5.923E+02
7	9.162E-04	2.734E+02	0.	2.743E+02	9.162E-04	5.998E+02
8	1.186E-03	2.743E+02	0.	2.751E+02	1.186E-03	6.072E+02
9	1.486E-03	2.751E+02	0.	2.759E+02	1.486E-03	6.148E+02
10	1.812E-03	2.759E+02	0.	2.767E+02	1.812E-03	6.225E+02
11	2.166E-03	2.767E+02	0.	2.776E+02	2.166E-03	6.303E+02
12	2.548E-03	2.776E+02	0.	2.784E+02	2.548E-03	6.381E+02
13	2.961E-03	2.784E+02	0.	2.792E+02	2.961E-03	6.460E+02
14	3.406E-03	2.792E+02	0.	2.801E+02	3.406E-03	6.540E+02
15	3.886E-03	2.801E+02	0.	2.809E+02	3.886E-03	6.620E+02
16	4.688E-03	2.802E+02	0.	2.803E+02	4.688E-03	6.701E+02
17	5.484E-03	2.803E+02	0.	2.805E+02	5.484E-03	6.784E+02
18	6.276E-03	2.805E+02	0.	2.806E+02	6.276E-03	6.867E+02
19	7.062E-03	2.806E+02	0.	2.808E+02	7.062E-03	6.951E+02
20	7.828E-03	2.808E+02	0.	2.812E+02	7.828E-03	7.036E+02
21	8.359E-03	2.812E+02	0.	2.817E+02	8.359E-03	7.122E+02
22	8.510E-03	2.817E+02	0.	2.821E+02	8.510E-03	7.209E+02
23	8.663E-03	2.821E+02	0.	2.826E+02	8.663E-03	7.297E+02
24	8.818E-03	2.826E+02	0.	2.830E+02	8.818E-03	7.386E+02
25	8.975E-03	2.830E+02	0.	2.835E+02	8.975E-03	7.476E+02
26	9.150E-03	2.835E+02	0.	2.840E+02	9.150E-03	7.566E+02
27	9.333E-03	2.840E+02	0.	2.845E+02	9.333E-03	7.658E+02
28	9.518E-03	2.845E+02	0.	2.850E+02	9.518E-03	7.750E+02
29	9.706E-03	2.850E+02	0.	2.854E+02	9.706E-03	7.844E+02
30	9.896E-03	2.854E+02	0.	2.859E+02	9.896E-03	7.939E+02
31	1.013E-02	2.859E+02	0.	2.865E+02	1.013E-02	8.034E+02
32	1.042E-02	2.865E+02	0.	2.870E+02	1.042E-02	8.130E+02
33	1.073E-02	2.870E+02	0.	2.875E+02	1.073E-02	8.228E+02
34	1.104E-02	2.875E+02	0.	2.880E+02	1.104E-02	8.326E+02
35	1.137E-02	2.880E+02	0.	2.885E+02	1.137E-02	8.426E+02
36	1.171E-02	2.885E+02	0.	2.892E+02	1.171E-02	8.526E+02
37	1.212E-02	2.892E+02	0.	2.899E+02	1.212E-02	8.627E+02
38	1.254E-02	2.899E+02	0.	2.905E+02	1.254E-02	8.730E+02
39	1.297E-02	2.905E+02	0.	2.912E+02	1.297E-02	8.833E+02
40	1.342E-02	2.912E+02	0.	2.919E+02	1.342E-02	8.938E+02
41	1.387E-02	2.919E+02	0.	2.927E+02	1.387E-02	9.043E+02
42	1.432E-02	2.927E+02	0.	2.935E+02	1.432E-02	9.149E+02
43	1.477E-02	2.935E+02	0.	2.943E+02	1.477E-02	9.257E+02
44	1.525E-02	2.943E+02	0.	2.950E+02	1.525E-02	9.365E+02
45	1.579E-02	2.950E+02	0.	2.958E+02	1.579E-02	9.474E+02
46	1.626E-02	2.958E+02	0.	2.967E+02	1.626E-02	9.584E+02
47	1.613E-02	2.967E+02	0.	2.976E+02	1.613E-02	9.695E+02
48	1.621E-02	2.976E+02	0.	2.985E+02	1.621E-02	9.808E+02
49	1.626E-02	2.985E+02	0.	2.994E+02	1.626E-02	9.921E+02
50	1.642E-02	2.994E+02	0.	3.003E+02	1.642E-02	1.003E+03
51	1.687E-02	3.003E+02	0.	3.003E+02	1.687E-02	1.015E+03
52	1.687E-02	3.003E+02	0.	3.003E+02	1.687E-02	1.015E+03

\$PULSE
KPUL = 50,
THPUL = 0.0, .122E+00, .206E+00, .289E+00, .373E+00, .473E+00, .1453E+01, 0.0, 0.0, 0.0, 0.0, 0.0,
KTOP = 46,
PULSTP = .6E+03,
RHSW = 0,
RHPUL = 0.0, 0.0, 0.0, 0.0, 0.0, 0.0, 0.0, 0.0, 0.0, 0.0, 0.0, 0.0, 0.0, 0.0, 0.0,
\$END

TEMPERATURE PULSE TITLE CARD

K	TKA	VDA
1	2.715E+02	6.749E-04
2	2.715E+02	6.749E-04
3	2.715E+02	6.749E-04
4	2.720E+02	7.318E-04
5	2.730E+02	7.909E-04
6	2.730E+02	8.523E-04
7	2.734E+02	9.162E-04
8	2.743E+02	1.186E-03
9	2.751E+02	1.486E-03
10	2.759E+02	1.812E-03
11	2.767E+02	2.166E-03
12	2.776E+02	2.548E-03
13	2.784E+02	2.961E-03
14	2.792E+02	3.406E-03
15	2.801E+02	3.886E-03
16	2.802E+02	4.688E-03
17	2.803E+02	5.484E-03
18	2.805E+02	6.276E-03
19	2.806E+02	7.062E-03
20	2.808E+02	7.828E-03
21	2.812E+02	8.359E-03
22	2.817E+02	8.510E-03
23	2.821E+02	8.663E-03
24	2.826E+02	8.818E-03
25	2.830E+02	8.975E-03
26	2.835E+02	9.150E-03
27	2.840E+02	9.333E-03
28	2.845E+02	9.518E-03
29	2.850E+02	9.706E-03
30	2.854E+02	9.896E-03
31	2.859E+02	1.013E-02
32	2.865E+02	1.042E-02
33	2.870E+02	1.073E-02
34	2.875E+02	1.104E-02
35	2.880E+02	1.137E-02
36	2.885E+02	1.171E-02
37	2.892E+02	1.212E-02
38	2.899E+02	1.254E-02
39	2.905E+02	1.297E-02
40	2.912E+02	1.342E-02
41	2.919E+02	1.387E-02
42	2.927E+02	1.432E-02
43	2.935E+02	1.477E-02
44	2.943E+02	1.525E-02
45	2.950E+02	1.579E-02
46	2.960E+02	1.614E-02
47	2.970E+02	1.634E-02
48	2.979E+02	1.650E-02
49	2.989E+02	1.664E-02
50	2.999E+02	1.690E-02
51	3.017E+02	1.842E-02
52	3.003E+02	1.687E-02

KD	VD	TEMP	WIND	BUOYANCY	RH
1	6.749053E-04	2.714791E+02	0.	0.	1.131991E-01
2	6.749053E-04	2.714791E+02	0.	0.	1.131991E-01
3	6.749053E-04	2.714791E+02	0.	0.	1.131991E-01
4	7.317758E-04	2.719703E+02	0.	0.	1.198453E-01
5	7.909011E-04	2.724615E+02	0.	0.	1.264915E-01
6	8.523395E-04	2.729528E+02	0.	0.	1.331377E-01
7	9.161505E-04	2.734440E+02	0.	0.	1.397839E-01
8	1.185707E-03	2.742616E+02	0.	0.	1.725494E-01
9	1.486001E-03	2.750901E+02	0.	0.	2.061926E-01
10	1.812130E-03	2.759186E+02	0.	0.	2.398359E-01
11	2.165598E-03	2.767472E+02	0.	0.	2.734791E-01
12	2.547973E-03	2.775757E+02	0.	0.	3.071223E-01
13	2.960914E-03	2.784042E+02	0.	0.	3.407655E-01
14	3.406169E-03	2.792328E+02	0.	0.	3.744088E-01
15	3.885990E-03	2.800602E+02	0.	0.	4.081326E-01
16	4.687841E-03	2.801912E+02	0.	0.	4.939362E-01
17	5.484478E-03	2.803222E+02	0.	0.	5.797398E-01
18	6.275917E-03	2.804532E+02	0.	0.	6.655434E-01
19	7.062175E-03	2.805842E+02	0.	0.	7.513470E-01
20	7.828448E-03	2.808205E+02	0.	0.	8.294833E-01
21	8.358817E-03	2.812279E+02	0.	0.	8.716802E-01
22	8.510007E-03	2.816803E+02	0.	0.	8.708185E-01
23	8.663152E-03	2.821326E+02	0.	0.	8.699569E-01
24	8.818265E-03	2.825850E+02	0.	0.	8.690952E-01
25	8.973575E-03	2.830374E+02	0.	0.	8.682335E-01
26	9.150107E-03	2.835127E+02	0.	0.	8.674573E-01
27	9.332656E-03	2.839966E+02	0.	0.	8.667129E-01
28	9.517708E-03	2.844804E+02	0.	0.	8.659686E-01
29	9.705560E-03	2.849643E+02	0.	0.	8.652242E-01
30	9.896143E-03	2.854481E+02	0.	0.	8.644798E-01
31	1.012560E-02	2.859414E+02	0.	0.	8.662330E-01
32	1.042464E-02	2.864519E+02	0.	0.	8.725152E-01
33	1.073080E-02	2.869623E+02	0.	0.	8.787973E-01
34	1.104222E-02	2.874727E+02	0.	0.	8.850794E-01
35	1.136502E-02	2.879831E+02	0.	0.	8.913615E-01
36	1.171245E-02	2.885326E+02	0.	0.	8.967551E-01
37	1.212114E-02	2.891922E+02	0.	0.	8.996410E-01
38	1.254176E-02	2.898122E+02	0.	0.	9.048549E-01
39	1.305375E-02	2.904914E+02	3.841860E-02	-3.551682E-04	9.121249E-01
40	1.363980E-02	2.911533E+02	3.309905E-01	7.463651E-04	9.242445E-01
41	1.443826E-02	2.918032E+02	6.727702E-01	7.180867E-04	9.495975E-01
42	1.543364E-02	2.924716E+02	1.479527E+00	-2.475960E-04	9.842807E-01
43	1.627260E-02	2.932315E+02	2.355471E+00	8.057707E-04	1.000654E+00
44	1.669583E-02	2.941078E+02	2.814081E+00	3.494368E-03	9.828789E-01
45	1.685110E-02	2.95018E+02	2.882070E+00	8.353946E-03	9.459741E-01
46	1.692210E-02	2.960176E+02	2.720054E+00	1.095097E-02	9.048688E-01
47	1.701261E-02	2.970081E+02	2.563879E+00	1.395004E-02	8.655641E-01
48	1.711508E-02	2.980138E+02	2.304800E+00	1.764885E-02	8.280426E-01
49	1.727042E-02	2.990540E+02	1.931407E+00	2.292776E-02	7.931617E-01
50	1.756484E-02	3.001787E+02	1.323036E+00	3.172480E-02	7.620876E-01
51	1.842255E-02	3.017130E+02	0.	0.	7.370000E-01
52	1.687076E-02	3.002600E+02	0.	0.	7.370000E-01

GENERATING LEVEL = 43 AT TIME = 3.97311E+02 DELTA T = 9.29011E+00
 RHOAIR = 1.086575E+03 TEMP = 2.932315E+02 VD = 1.627260E-02 WMAX = 2.882070E+00

	1	2	3	4	5	6	7	8	9	10
0	0.	8.9605E+04	5.0712E+04	1.6173E+04	2.4802E+03	4.0655E+02	1.6697E+02	9.5014E+01	7.1145E+01	4.5319E+0
10	3.8075E+01	2.4233E+01	1.9488E+01	1.3405E+01	9.0860E+00	8.3822E+00	4.2303E+00	4.6871E+00	3.2280E+00	1.7309E+0
20	2.2828E+00	8.8203E-01	1.3643E+00	1.0300E+00	3.2357E-01	8.3582E-01	2.2114E-01	1.5444E-02	3.7377E-04	3.5238E-0
30	1.3864E-08	2.3673E-11	1.8042E-14	6.2676E-18	1.0092E-21	7.6368E-26	2.7448E-30	4.7124E-35	3.8474E-40	1.4546E-4
40	2.3516E-51	1.2642E-57	0.	0.	0.	0.	0.	0.	0.	0.
50	0.	0.	0.	0.	0.	0.	0.	0.	0.	0.
60	0.	0.	0.	0.	0.	0.	0.	0.	0.	0.
70	2.9978E+02	2.3625E+00								1.6271E-0

SEED TITLE CARD

NCP=0
PTM= 0.0
KS= 0
MAXS= 0
SMASS= .1295E-06
ENWTS= 60.056
PNUS=1.00
RHOS=1.1300
RHOS=1.3350
SMAXS= .85
SNUC= .1092E-07 .4474E-07 .1295E-06 .2502E-06 .5623E-06 0. 0. 0. 0.

FIN(2, 1,1)= 0.
FIN(2, 2,1)= 0.
FIN(2, 3,1)= 0.
FIN(2, 4,1)= 0.
FIN(2, 5,1)= 0.
FIN(2, 6,1)= 0.
FIN(2, 7,1)= 0.
FIN(2, 8,1)= 0.
FIN(2, 9,1)= 0.
FIN(2,10,1)= 0.

AFTER STEP 1 AT TIME 9.29 SECONDS .2 MINUTES

KD	WATER G/M**3	CLOUD #/M**3	SEEDING #/M**3	RADAR REFL MM**6/M**3	RH FRACTION	TEMP DEG C	WIND M/SEC	BUOY	TEMP EXCESS	DENSITY KG/M3
2	0.000 + 0.000	0.	0.	0.	.1132	-1.681	0.0000	0.	0.000	.730153
3	0.000 + 0.000	0.	0.	0.	.1132	-1.681	0.0000	0.	0.000	.730153
4	0.000 + 0.000	0.	0.	0.	.1198	-1.190	0.0000	0.	0.000	.738036
5	0.000 + 0.000	0.	0.	0.	.1265	-.698	0.0000	0.	0.000	.745988
6	0.000 + 0.000	0.	0.	0.	.1331	-.207	0.0000	0.	0.000	.754011
7	0.000 + 0.000	0.	0.	0.	.1398	.284	0.0000	0.	0.000	.762104
8	0.000 + 0.000	0.	0.	0.	.1725	1.102	0.0000	0.	0.000	.769139
9	0.000 + 0.000	0.	0.	0.	.2062	1.930	0.0000	0.	0.000	.776290
10	0.000 + 0.000	0.	0.	0.	.2398	2.759	0.0000	0.	0.000	.783472
11	0.000 + 0.000	0.	0.	0.	.2735	3.587	0.0000	0.	0.000	.790686
12	0.000 + 0.000	0.	0.	0.	.3071	4.416	0.0000	0.	0.000	.797930
13	0.000 + 0.000	0.	0.	0.	.3408	5.244	0.0000	0.	0.000	.805202
14	0.000 + 0.000	0.	0.	0.	.3744	6.073	0.0000	0.	0.000	.812502
15	0.000 + 0.000	0.	0.	0.	.4081	6.900	0.0000	0.	0.000	.819822
16	0.000 + 0.000	0.	0.	0.	.4939	7.031	0.0000	0.	0.000	.829089
17	0.000 + 0.000	0.	0.	0.	.5797	7.162	0.0000	0.	0.000	.838458
18	0.000 + 0.000	0.	0.	0.	.6655	7.293	0.0000	0.	0.000	.847932
19	0.000 + 0.000	0.	0.	0.	.7513	7.424	0.0000	0.	0.000	.857512
20	0.000 + 0.000	0.	0.	0.	.8295	7.560	0.0000	0.	0.000	.866875
21	0.000 + 0.000	0.	0.	0.	.8717	8.068	0.0000	0.	0.000	.875890
22	0.000 + 0.000	0.	0.	0.	.8708	8.520	0.0000	0.	0.000	.885087
23	0.000 + 0.000	0.	0.	0.	.8700	8.973	0.0000	0.	0.000	.894365
24	0.000 + 0.000	0.	0.	0.	.8691	9.425	0.0000	0.	0.000	.903724
25	0.000 + 0.000	0.	0.	0.	.8682	9.877	0.0000	0.	0.000	.913164
26	0.000 + 0.000	0.	0.	0.	.8675	10.353	0.0000	0.	0.000	.922552
27	0.000 + 0.000	0.	0.	0.	.8667	10.837	0.0000	0.	0.000	.932040
28	0.000 + 0.000	0.	0.	0.	.8660	11.320	0.0000	0.	0.000	.941606
29	0.000 + 0.000	0.	0.	0.	.8652	11.804	0.0000	0.	0.000	.951253
30	0.000 + 0.000	0.	0.	0.	.8645	12.288	0.0000	0.	0.000	.960980
31	0.000 + 0.000	0.	0.	0.	.8625	12.781	0.0000	0.	0.000	.970682
32	0.000 + 0.000	0.	0.	0.	.8725	13.292	0.0000	0.	0.000	.980418
33	0.000 + 0.000	0.	0.	0.	.8788	13.802	0.0000	0.	0.000	.990229
34	0.000 + 0.000	0.	0.	0.	.8851	14.313	0.0000	0.	0.000	1.000116
35	0.000 + 0.000	0.	0.	0.	.8914	14.823	0.0000	0.	0.000	1.010080
36	0.000 + 0.000	0.	0.	0.	.8968	15.373	0.0000	0.	0.000	1.019904
37	0.000 + 0.000	0.	0.	0.	.8996	16.032	0.0000	0.	0.000	1.029440
38	0.000 + 0.000	0.	0.	0.	.9092	16.652	.0045	0.	-.029	1.039139
39	0.000 + 0.000	0.	0.	0.	.9129	17.332	.0552	-2.10E-04	-.004	1.048702
40	0.000 + 0.000	0.	0.	0.	.9278	17.984	.2745	7.03E-04	.019	1.058333
41	0.000 + 0.000	0.	0.	0.	.9567	18.622	.7674	5.77E-04	.012	1.067876
42	.001 + .000	3.2655E+07	0.	2.52E-05	.9924	19.289	1.5998	-4.26E-04	-.017	1.077325
43	.008 + .000	1.8460E+08	0.	1.50E-04	.9952	20.060	2.4295	7.47E-04	.020	1.086581
44	0.000 + 0.000	0.	0.	0.	.9844	20.942	2.8278	3.42E-03	.102	1.095728
45	0.000 + 0.000	0.	0.	0.	.9463	21.890	2.8797	8.32E-03	.252	1.104866
46	0.000 + 0.000	0.	0.	0.	.9051	22.857	2.7233	1.10E-02	.334	1.113949
47	0.000 + 0.000	0.	0.	0.	.8656	23.848	2.5628	1.39E-02	.426	1.123067
48	0.000 + 0.000	0.	0.	0.	.8281	24.854	2.3037	1.76E-02	.540	1.132163
49	0.000 + 0.000	0.	0.	0.	.7932	25.894	1.9315	2.29E-02	.705	1.141139
50	0.000 + 0.000	0.	0.	0.	.7621	27.019	1.3231	3.17E-02	.978	1.149712
51	0.000 + 0.000	0.	0.	0.	.7370	28.553	0.0000	0.	1.754	1.156389

VAPOR(G/G) 3.8513E-03
 RAIN(G/G) 8.7188E-31
 CLOUD(G/G) 9.1511E-06
 DCWAT(G/G) 0.
 DGMAT(G/G) 0.
 TOTCN(G/G) 9.1511E-06
 WLTDE(G/G) 0.
 DCVAP(G/G) 7.5536E-03
 BRKNO (GM-1) = 850. METERS
 CLOUD TOP =

5.2 PROGRAM CUSLIDE

This program utilizes the output tape from CUMOD X2946 to produce CRT plots on microfiche. The resultant plots are divided into two categories: Key meteorological parameters involved in cloud development and cloud droplet spectra analysis. The former group consists of summaries of precipitation, LWC (cloud, precipitation and total), velocity, relative humidity, buoyancy, and radar reflectivity; while the latter provides a three-dimensional display of the droplet spectra within the cloud at user specified heights and intervals (IPROG=1).

As an alternative, a modified output file (IPROG=2) exists which contains contour plots without symbols for the cloud development parameters; altitude axes in kilometers instead of meters; plot titles with larger characters, and deletes the printing of the flight identification data on the plots. This format was chosen for usage in reports and slide or overhead presentations.

Appropriate command deck card input data and a list of plots produced follow.

5.2.1 PROGRAM CUSLIDE Command Deck and Input Data

COMMAND DECK

```
MILLR,CM120000,T200,PK.                1416 MILLERP
PAUSE PLEASE MOUNT DISK LYCP07
MOUNT,VSN=LYCP07,SN=LYCP07.
ATTACH,TAPE8,DATA,ID=MILLERP,MR=1,SN=LYCP07.
ATTACH,S,CUSLIDE,ID=MILLERP,MR=1.
FTN,I=S,R=3,SL,PL=999999,OPT.
REQUEST,TAPE39,*Q.
ATTACH,CRT,CRTPLOTS.
LIBRARY,PRESET=ZERO.
LGO.
EXIT(U).
7/8/9
```

INPUT DECK

```
CARD 1
      PLTARR(1) USER SPECIFIED ID(A10)
      PLTARR(2) PROB. NO. & ID
CARD 2
      IDENT FLIGHT ID,DATE,SELECTED INPUT VARIABLES(8A10)
CARD 3
      IPROG,OPTS,NCYCLE,DELZ,TZERO,RIMAX,RCMAX(15,10I1,
      15,3F10.0,2F5.2)
CARD 4
      LEVTOP,LEVBOT(215)
```

5.2.2 List of Plots Produced by Program CUSLIDE

- 1) RAIN INTENSITY (MM/HR) VS TIME (Minutes)
- 2) CUMULATIVE RAINOUT (MM) VS TIME (Minutes)
- 3) ALTITUDE (METERS) VS TOTAL LWC (GM/M3) VS TIME (Minutes)
- 4) ALTITUDE (METERS) VS CLOUD LWC (GM/M3) VS TIME (Minutes)
- 5) ALTITUDE (METERS) VS PRECIPITATION LWC (GM/M3) VS TIME (Minutes)
- 6) ALTITUDE (METERS) VS VELOCITY (M/SEC) VS TIME (Minutes)
- 7) ALTITUDE (METERS) VS RELATIVE HUMIDITY (%) VS TIME (Minutes)
- 8) ALTITUDE (METERS) VS BUOYANCY (M/SEC²) VS TIME (Minutes)
- 9) ALTITUDE (METERS) VS LOG10 (RADAR REFLECTIVITY) VS TIME (Minutes)
- 10) DROPLET SPECTRA
HEIGHT (METERS M.S.I.) VS RADIUS (MICRONS) VS TIME (Minutes)

5.3 CRAY-1 and CDC Interface Procedures and Documentation

LYC increased its cloud modeling research effort by developing and applying time-dependent, numerical models which integrate the numerous and complicated microphysical and dynamic characteristics of the atmosphere. Such computer programs require extensive amounts of both CPU memory and execution time in order to model these processes. Unfortunately, the two CDC 6600 computers available at AFGL do not adequately meet these needs in a cost effective manner. In order to meet the new computer needs of LYC, use of the CRAY-1 facilities at Kirtland AFB (AFWL), Albuquerque, NM was initiated. To utilize the computer systems at AFWL from AFGL, DPSI became familiar with the three distinct communication options available.

- Direct link to CRAY
- IBM to CRAY
- SAMMET (military CDC communication network)

Direct link to CRAY-1 or linking with IBM are the simplest procedures. They require a terminal, modem, long distance telephone line and knowledge of CRAY-1 and IBM procedures. Each of these communication procedures only allows for the execution/editing of programs and viewing (via CRT terminal) of output, and neither provides for the transferral of programs or data files between the two sites. Another drawback of these options is the fact that only one user may access the CRAY-1 or IBM computer at a given time.

5.3 CRAY-1 and CDC Interface Procedures and Documentation (cont'd)

A second alternative, SAMNET, will allow multiple users access to the AFWL CDC 6600 computer. In order to use SAMNET, a variety of commands and procedure must first be understood. DPSI has been extensively involved in their identification and implementation for the LYC applications.

DPSI helped AFGL test and evaluate a variety of procedures for interfacing with the CRAY-1. These are to be published as an AFGL technical memorandum.

An interesting approach to job execution at AFWL (via SAMNET) allows users to batch jobs into the AFGL 6600. The CDC, in turn, activates SAMNET and transmits the job control cards to the AFWL 6600, from which control can be forwarded to the CRAY. When the job terminates on the destination host, it follows the flow path back to AFGL and output is printed on the terminal (Central, AC, AB) specified by the job cards.

6. LYC Post Processing: PDP-8/E Computer

The PDP-8/E computer at LYC consists of the following equipment

- 1) 32K (MOS memory and CPU)
- 2) Twin Dectapes (non-interruptable)
- 3) Tektronix I/O Screen/Keyboard
- 4) Input or output $\frac{1}{2}$ " magnetic tape
- 5) Dec-writer
- 6) Bootstrap loader in read-only memory (ROM)
- 7) Centronics printer
- 8) High speed paper tape reader
- 9) Calcomp Plotter

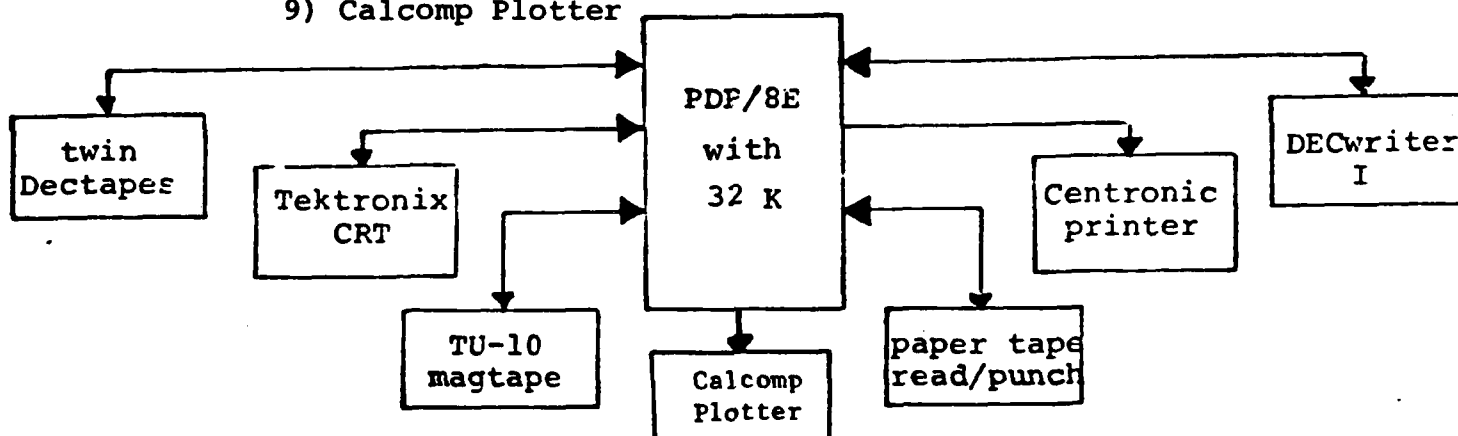

The TU-10 magtape drive is primarily used as an output device and for creating backups (Program FUTIL) of Dectapes. Using a 7 track magnetic tape it is also possible to transfer data to the CDC 6600 computer. For example, once PDP-8 snow scale data has been cataloged on the 6600 (transferred via tape) it can then be sent to one of the LYC Tektronix 4052 computers via a telephone modem.

6.1 OS/8 operating system

OS/8 is a sophisticated operating system designed for the PDP-8/E. Besides the monitor facilities, OS/8 includes a library of powerful system programs which allow the user to develop programs using Fortran IV and assembly language.

To bring up OS/8, the PDP8/E must be bootstrapped:

Turn the power key to the "on" position. A DECTAPE with the OS/8 operating system (see below) must be mounted on DEC tape drive unit 0, write lock, REMOTE. The switch register must then be set to 7470₈. Lower then raise the "HALT/SINGLE STEP" keys. Press "LOAD ADDR", "EXT LOAD ADDR", "CLEAR" and "CONT". The DECTAPE will spin and the terminal will respond by typing a monitor dot "."; OS/8 is running the keyboard monitor.

Any system or user program can be run from this point. At any time if a program "bombs", OS/8 can instantly be restarted by this boot procedure. Detailed instructions on the OS/8 operating system may be found in the "OS/8 Handbook".

A list of the DECTAPES and their titles that are used on the Cloud Physics PDP8/E is given in table 6.1. The contents of each tape are included in a file on the DECTAPE and can be accessed by typing:

```
.DIR +
```

6.1 OS/8 operating system (cont'd)

<u>TAPE NO</u>	<u>TITLE</u>
1	* SYSTEM WORK TAPE
2	* OS/8 BACK UP
3	* QWIK4 AND PLOT
4	* MAINDECS DIAGNOSTICS
5	* MORT'S TAPE
6	* BACK UP
7	* A/C BACK UP
8	RTX/8 DEVELOPMENT
9	* FORTRAN IV SYSTEM
10	* BASIC
11	* FLAP TAPE
12	RTX/8 TAPE
13	LWC TAPE
14	FORTTRAN PROGRAMS
15	TKPLOT
16	WORKING STORAGE 1
17	WORKING STORAGE 2
18	WORKING STORAGE 3
19	WORKING STORAGE 4
20	* BACK UP

* indicates the tape contains the OS/8 operating system and can be bootstrapped

Table 6.1: Lab DECTape Listing

6.2 FORTRAN IV

This chapter will describe the FORTRAN IV system available on the LYC PDP-8/E computer. The steps necessary to create and run a FORTRAN program are described in the next few sections, however it is assumed the reader has prior knowledge of FORTRAN programming.

OS/8 FORTRAN IV provides full standard ANSI FORTRAN IV under the OS/8 operating system. The FORTRAN IV package requires a hardware environment consisting of a PDP-8/E with 32k of memory, a console terminal and a mass storage device. The system is designed to employ a KE8-E Extended Arithmetic Element, FPP-8/E Floating Point Processor, and any bulk storage or peripheral I/O device.

The FORTRAN system is highly optimized with respect to memory requirements, and an overlay feature is included that can permit programs requiring up to 300k of virtual storage. The library functions permit the user to access a number a laboratory peripherals, to evaluate a complete set of transcendental functions, to manipulate alphanumeric strings, and to output to the Tektronix graphics terminal or the calcomp incremental plotter.

6.2.1 FORTRAN system components

OS/8 FORTRAN IV is a system of five programs. (table 6.2)
Each program is a necessary part of the system and must be run in proper sequential order.

- A. TECO - text editor
- B. F4 - FORTRAN IV compiler
 - 1. PASS1
 - 2. PASS2
 - 3. PASS20
 - 4. PASS3
- C. RALF - Relocatable Assembler
- D. LOAD - Relocatable binary loader
- E. FRTS - FORTRAN Run-time system

Table 6.2: OS/8 FORTRAN IV system

A FORTRAN IV program written by the user is called a source program, to distinguish it from the various object programs generated by the OS/8 FORTRAN IV system. (see figure 6.1). Source programs are prepared on-line by means of the system editor, TECO.

6.2.1 FORTRAN system components (cont'd)

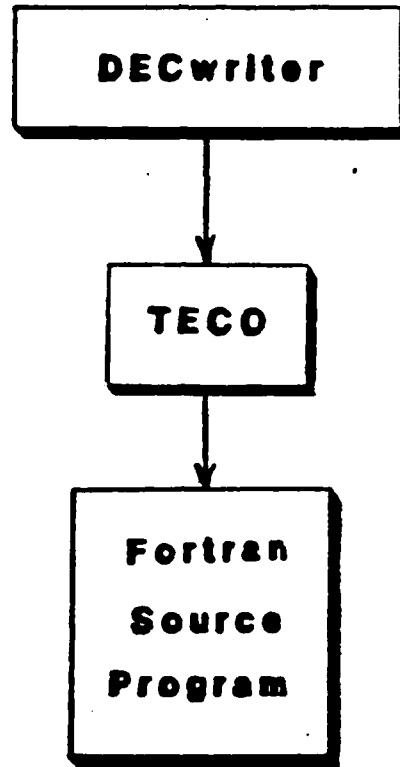

Figure 6.1: Preparing a FORTRAN IV Source File

6.2.1 FORTRAN system components (cont'd)

Once a source program has been prepared, it is supplied as input to the FORTRAN IV compiler, F4, which translates each FORTRAN statement into one or more RALF (Relocatable Assembly Language, Floating Point) statements and produces an output file containing an assembly language version of the source program.

Compilation errors are printed on the DECwriter in two letter codes. (see "OS/8 Handbook, pages 8-14 for F4 error messages). If a source listing has been requested, the errors are printed, after the line in error in plain English.

The RALF assembly language output produced by the compiler must be assembled by the RALF assembler. During assembly each RALF Assembly Language Statement is translated into one or more instruction for either the PDP-8/E computer or the Floating Point Processor and an output file is created containing a relocatable binary version of the assembly language input. (See figure 6.2)

The relocatable binary file produced by the RALF assembler is a machine language version of a single program or subroutine. This file, called a RALF module, must be linked with its main program (if it is a subroutine) and with any other subroutines or functions, including subroutines from the system library, that it requires in order to execute. The OS/8 FORTRAN IV loader, LOAD, accepts a list of RALF module specifications from the DECwriter and builds a loader image file containing a relocated main program linked to relocated versions of all subroutines and library components that the mainline requires to execute. (see figure 6.3)

6.2.1 FORTRAN system components (cont'd)

The loader image file is an executable core load, complete except for run-time I/O specifications. It may be saved on the DECTapes and run at any time. The loader also provides for an optional core load map that indicates memory allocation of the individual routines loaded. The overlay feature of the loader permits certain user defined modules of a program to be stored in the loader image file during execution and read into memory only as needed, which effectively provides a ten-fold increase in maximum program size. (See figure 6.3)

The loader image file is read and executed by FRTS, the FORTRAN RUN-TIME SYSTEM. FRTS configures an I/O supervisor to handle any FORTRAN input or output request. The run-time system assigns I/O device handlers to the I/O unit numbers referenced by the FORTRAN program, allocates I/O buffer space, and also diagnoses certain types of run-time errors; Such as, I/O errors, numeric underflow/overflow, hardware malfunctions, etc. Run-time errors are indicated at the DECwriter; fatal errors cause the program to abort, however.

The system provides complete error traceback to identify the full sequence of FORTRAN statements that terminated in the error condition.

The compiler, assembler, loader and run-time system each accept standard OS/8 command decoder option specifications.

"OUTPUT1,OUTPUT2,OUTPUT3 < INPUT1,...,INPUT9/OPTION"

Options are alphanumeric characters preceded by a slash. They can be anywhere in the command line, but usually placed on the right.

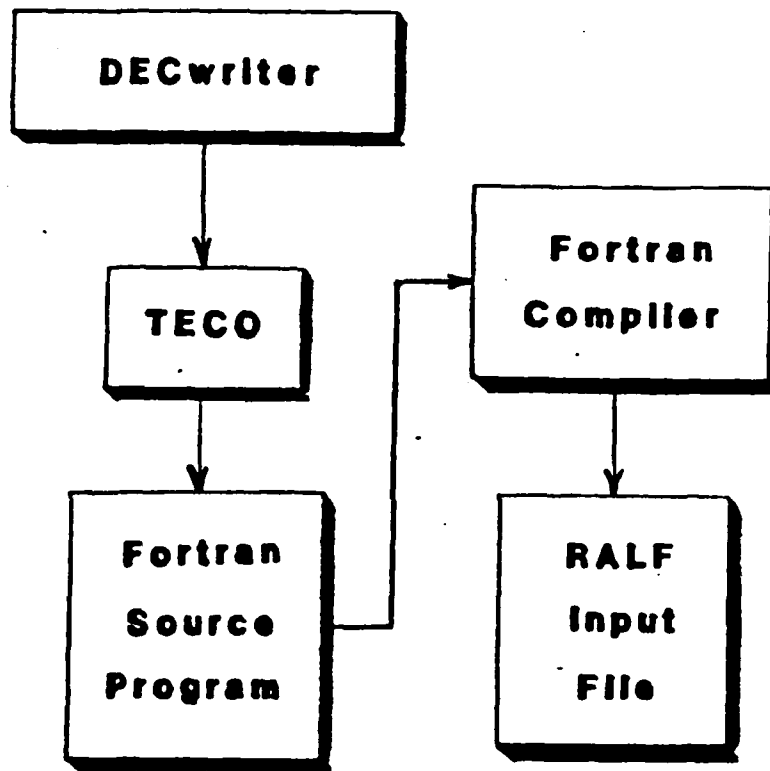

Figure 6.2: Compiling a Source File

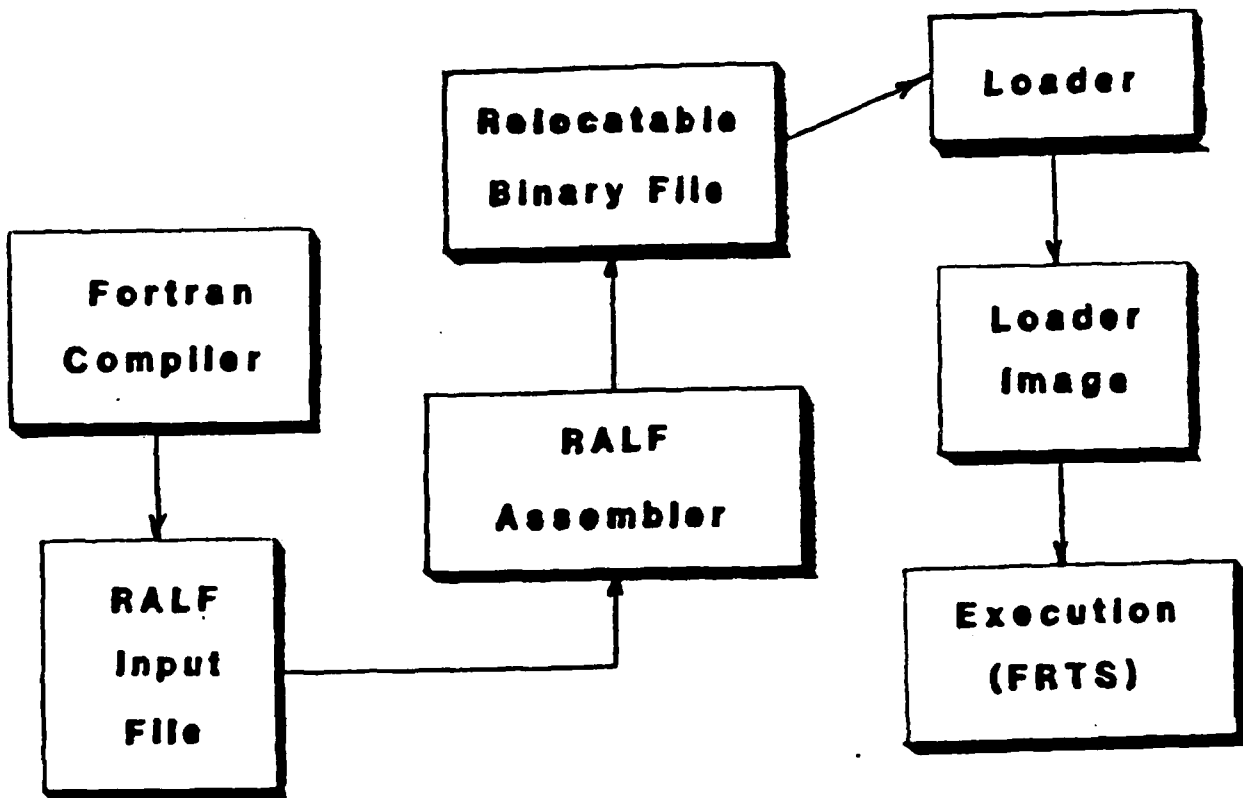

Figure 6.3: Assembling, loading and executing a RALF file

6.2.2 TECO-Text Editor

OS/8 TECO is a powerful text editing and correcting program that runs under the OS/8 operating system. TECO may be used to edit any form of ASCII text such as program listings, manuscripts, correspondence and the like. Since TECO is a character-oriented editor rather than a line editor, text edited with TECO does not have line numbers associated with it, nor is it necessary to replace an entire line of text in order to change one character.

Writing a FORTRAN program begins with the text editor. TECO is called by typing:

```
.R TECO ↓
```

and responds with an asterik "*", the OS/8 prompt. Editing with TECO is actually very simple. All commands are one or two letters with or without arguments. The following table briefly illustrates some commonly used TECO commands.

ERdev:filnam.ex	Open for <u>READ</u> (input) 'filnam.ex' on device 'dev'
EWdev:filnam.ex	Open for <u>WRITE</u> (output) 'filnam.ex' on device 'dev'
Y	Clear the text buffer, then read the next page from input
P	Write the text buffer to output Read the next page from input
L	Move the character pointer (cp) to the beginning of the next line
T	Type the content of the text buffer from the cp to the beginning of the next line.
Itext	Insert mode. All subsequent characters are placed before the cp

6.2.2 TECO-text editor (cont'd)

S	text	Search for string 'text', cp positioned after search string
J		move the cp to the beginning of the text buffer
F	text1\$text2	search for sting 'text1' and replace with 'text2'
EX		write text buffer to output. copy remaining input to output, close Input/Output. exit to OS/8 monitor.

Table 6.3: TECO Command Summary

note: all commands are separated by one 'ALT MODE' key (which echos as a dollar sign) and a command string is terminated by two consecutive altmodes.

For more information regarding TECO, see the "OS/8 Handbook" pages 2-132.

6.2.3 F4 FORTRAN IV compiler

The FORTRAN IV compiler accepts one FORTRAN source language program or subroutine as input, examines each FORTRAN statement for validity, and produces a list of errors plus a RALF assembly language version of the source program, along with an optional source listing. A job which requires more than one module (i.e. subroutine) must have each program compiled separately, then combined using the loader. F4 terminates by chaining to the RALF assembler automatically unless it was requested to exit to the monitor after compilation. The compiler is called by typing:

```
.R F4↓
```

F4 responds with the Command Decoder prompt, the asterik "*". The file/option specification line is entered as:

```
dev:RALF.RL,dev:LIST.LS<dev:FTCODE.FT/(options)
```

terminated with a carriage return. The compiler accepts four options. Any run-time options recognized by RALF,LOAD or FRTS may be specified to the compiler.

OPTION	OPERATION
A	return to keyboard monitor after compilation. RALF is not called
F	produce a RALF listing on 'dev:LIST.LS'
N	do not include error traceback facilities (decreases memory requirements)
Q	optimize cross-statement subscripting during compilation.

Table 6.4: F4 Compiler Options

6.2.3 F4 FORTRAN IV compiler (cont'd)

Any errors detected by the compiler are reported on the DECwriter in short form (see "OS/8 Handbook", pages 8-14). If a listing is requested, the errors are printed in English.

6.2.4 RALF - relocatable assembler

The RALF assembler accepts one RALF assembly language program or subroutine as input and produces a relocatable binary file, called a RALF module, as output. An optional listing of the assembled input file is also available. RALF terminates an assembly by exiting to the keyboard monitor unless it was requested to chain to the loader.

RALF honors three options:

OPTION	OPERATION
G	After assembly, chain to the loader, then to the Run-Time system
L	After assembly, chain to the loader, but not the Run-time system
T	If a listing file has been specified in the command line, surpress the listing and produce only the symbol table

Table 6.5: RALF Options

RALF is called by typing:

```
.R RALF+
```

and responds with an asterik. The command line appears as:

```
dev:RALF.RL,dev:LIST.LS<dev:RALF1.RA,...,dev:RALF9.RA/(options)
```

6.2.4 RALF - relocatable assembler (cont'd)

If more than one Input is specified, they are combined into one module and assembled as if it were one file.

When an error is detected, the error code (see "OS/8 Handbook" pages 5-38 for RALF error codes) and the line in error are printed on the DECwriter. If a listing was requested, the error code appears before the line in error.

For more details on the RALF assembler and how to code Floating Point programs, see the "OS/8 Handbook", chapter 5 and pages 8-15 to 8-20.

6.2.5 LOAD - relocatable loader

The OS/8 FORTRAN IV loader accepts up to 128 RALF modules along with any necessary library components, to form a loader image file that may be loaded and executed by the run-time system. This is accomplished by replacing the relative starting location of each section (module) with an absolute core address. Absolute addresses are also assigned to all entry points defined in the input modules. Once all RALF modules and library components have been assigned to some portion of memory and linked, absolute addresses are assigned to the relocatable binary text and to the externals.

The overlay feature of the loader facilitates running programs which are too large to fit into memory, allowing programs which require 300K of memory to run in less than 32K actual core memory.

An overlay is a set of subroutines stored on a bulk storage device. When any subroutine in an overlay is called by the mainline or other subroutine, the entire overlay is read into memory, where it generally replaces another overlay of equivalent size.

Overlays are variable-size portions of memory reserved for specific sets of overlays. FORTRAN IV permits eight levels, 0-7. Level 0 is always present in memory, and contains the mainline, common blocks, PDP8 mode code, and library components.

Levels 1 thru 7 each may contain up to 16 overlays, one of which is core resident at any given time during execution.

6.2.5 LOAD - relocatable loader (cont'd)

As execution begins, overlay MAIN is loaded into level 0 and started. Other overlays are read into memory when one of their constituent subroutines is called. No two overlays from any given level are ever co-resident

To call the loader, type:

```
.R LOAD †
```

Load will respond with an asterik. The command string appears as:

```
dev:IMAGE.LD,dev:MAP.LS<dev:PROG9.RL,...,dev:PRO9.RL/(options)
```

IMAGE.LD is the loader image output file. MAP.LS is the loader symbol map output file. Possible run-time options are:

OPTION	OPERATION
C	Continue the current line of input on the next line. The command decoder only permits nine input files per line. This option circumvents this.
G	Treat the current line of input as the last and chain to the run-time system.
L	Accept the single input file on this line as an alternate library, used in place of the system library.
O	Close the current level, and open the next sequential level for input.
S	If a symbol map has been requested, include system symbols.
U	Ignore the rules governing subroutine calls between overlays

TABLE 6.6: LOAD OPTIONS

6.2.6 FRTS - FORTRAN run-time system

The OS/8 FORTRAN IV run-time system reads, loads, and executes a loader image file produced by the loader. It also configures a software I/O interface between the FORTRAN IV program and the OS/8 operating system, then monitors program execution to direct I/O processes and identifies certain types of run time errors. The run-time system is called automatically to load and execute the loader image file produced by the loader whenever the "G" option is specified to the loader.

The run-time system is able to accept file I/O specifications. This allows the user to write a source program which refers to an I/O device as an integer constant or variables. This program may be compiled, assembled and loaded into an image file. This image file may be run any number of times, each time specifying different physical I/O devices. Thus logical unit #8 may refer to the DECwriter in one run, and the line printer in another run.

To call the run-time system, type:

```
.R FRTS+
```

FRTS calls the command decoder and responds with an asterisk. The run-time system accepts two classes of input. (1) the load module to be executed. (2) Run-time file assignments. To define the image file, type:

```
*dev:IMAGE.LD/(options)
```

6.2.6 FRTS - FORTRAN run-time system (cont'd)

Possible options to FRTS are:

OPTION	OPERATION
H	Halt after loading, but before executing the program. Pressing 'cont' switch starts the program.
E	Ignore the following run-time errors a. Illegal subroutine call b. Reference an external in an overlay other than in the form 'JSR EXTERN' c. Reference to an undefined symbol

TABLE 6.7: Run-Time System Options

Once the image file has been defined, FRTS returns with another asterisk to accept I/O specifications. Four out of nine possible I/O unit numbers are initially assigned by FRTS.

I/O UNIT	INTERNAL HANDLER
1	paper tape reader
2	paper tape punch
3	line printer
4	DECwriter
5	
6	
7	user defined
8	
9	

TABLE 6.8: FORTRAN I/O Unit Assignment

To associate a device with a unit number type:

dev:/n

where "n" is the unit number, and "dev:" is any name of a non-directory device (LPT:,MTA0:)

6.2.6 FRTS - FORTRAN run-time system (cont'd)

To define a file structured data file type:

```
dev:file.ex/n  for previously created files  
dev:file.ex</n for non-existent files.
```

In any case, only one file or device specification is permitted on each line, and no more than six directory devices files may be created by the Fortran program. A specification terminated with an ALTMODE starts the Fortran program.

6.3 Data Processing Programs

6.3.1 Program PLOT.PA

Program PLOT was written to aid LYC scientists in the calibration procedure of aircraft VCO data and for general data plotting where best fit (1st and 2nd degree) equations can be calculated. Input is accepted through the DEC-Writer terminal, output is displayed on the Tektronix CRT.

Program PLOT will

- (a) plot an x-y table on the Tektronix plotter; the table is input at the Decwriter. If desired, the x and/or y values can be modified by logging them in order to produce a linear-linear, a linear-log, a log-linear or a log-log plot.
- (b) generate the x values automatically after a specification of the first x and x-step is given
- (c) allow the user to select the low and high values of x and y to be used on the plot
- (d) plot each point with a '+'; the user can choose whether or not to connect the plotted points with a line
- (e) label the plot with an alphabetic description
- (f) plot a least square best fit curve to the data (first or second degree), and print out the fitting function
- (g) generate a table of deviations of the least square fit to the original data, and calculate the RMS error.
- (h) allow the user to modify the data, limits and descriptions and replot, with a new least square fit, without having to retype the entire x-y table.

AD-A133 557

DEVELOPMENT OF THEORETICAL MODELS AND ANALYSES OF THE
MICRO-PHYSICS OF CL. (U) DIGITAL PROGRAMMING SERVICES
INC WALTHAM MA L E BELSKY ET AL. 31 MAY 83

3/3

UNCLASSIFIED

AFGL-TR-83-0133 F19628-81-C-0141

F/G 4/2

NL

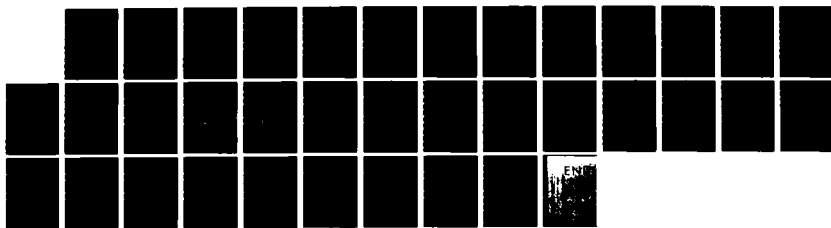

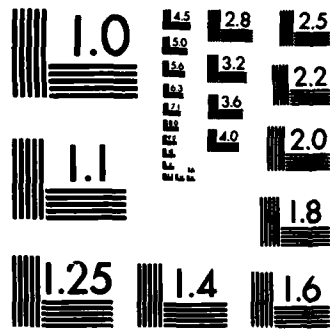

MICROCOPY RESOLUTION TEST CHART
NATIONAL BUREAU OF STANDARDS-1963-A

6.3.1 Program PLOT.PA (cont'd)

In order to execute program PLOT, and perform the many optional capabilities, the following step-by-step procedure should be executed:

1. Mount Dectape 5 on unit 0, write enabled and remote
2. Switches set to 7470
3. Press ADDR-load, EXT.-addr-load, Clear, Cont
4. Computer responds with a dot
5. Type R PLOT
6. Within 22 seconds the computer responds with
PLOTTING PROGRAM
7. IS X ON LOG SCALE?
If the x-data is to be logged base 10, answer Y otherwise N
8. IS Y ON LOG SCALE?
If the y-data is to be logged base 10, answer Y otherwise N
9. IS DELTA X CONSTANT?
If the x-data (before taking logs) is equally spaced,
answer Y, otherwise N
10. If delta x is constant, the computer will request X-START
and DELTA-X, as X-START?
Type the starting value and return,
DELTA X?
Type the difference between successive x-values and return
11. The computer responds with
ENTER X,Y TABLE
or ENTER Y TABLE (for constant delta-x)
12. For each value input the computer will first print the
index number (1,2,3,...,etc) When only y-values are being
input, the user will type the y-value followed by a

6.3.1 Program PLOT.PA (cont'd)

return; if both x and y values are being input, the user will type the x-value, followed by a comma, followed by the y-value and a return.

13. When all values have been inputted, type

1E35 return

14. The computer will respond with

LIMITS OF X ARE xxxxx, xxxxx

which indicate the low and high values of the x-table.

Then it prints

TYPE LIMITS TO USE

The computer expects two numbers, separated by a comma, the first number is the value of x at the left end of the plot; the second is the value of x at the right end of the plot. There will automatically be 10 divisions in this range. If the first limit typed is unacceptable (larger than the limit found) or if the second limit typed (smaller than the limit found) is unacceptable, step 14 is repeated.

15. Step 14 is done for Y

16. The computer will print

CONNECTING LINE?

If a line is desired between points in the order they were typed in, answer Y. An answer of N will eliminate the connecting line.

17. The computer will respond

TURN ON PLOTTER, TYPE DESCRIPTION

Type a description to be printed on the bottom of the plot. This description is limited to 67 characters. A rubout will respond with a carriage return, and the user

6.3.1 Program PLOT.PA (cont'd)

should type the entire description over again. Make sure plotter is on, and "on-line" before pressing return.

18. The plot will be made. At its conclusion, the computer will ask

LEAST SQUARE FIT?

If a curve fitting the data is desired answer Y; otherwise answer N and proceed to step 22.

19. The computer responds

DEGREE (1 OR 2)?

Degree 1 is a straight line fit; degree 2 is a quadratic fit. Respond either 1 or 2. Any other response will force step 19 again.

20. The fitting curve will be plotted. The least square polynomial will be printed

- (a) at the top of the plot, and
- (b) on the Decwriter

21. The computer then asks

DEVIATIONS?

If the table of x, y, calculated-y, deviation-y and RMS is desired, answer Y; otherwise answer N

22. The computer will ask

REPLOT?

If the data is to be modified, eliminated, or extended, or if another plot is to be made changing either x or y limits, or the description, or the fitting function, respond with Y; otherwise respond N and proceed at step 6

23. The computer will ask

NUMBER?

If there are no changes go to step 23(c).

6.3.1 Program PLOT.PA (cont'd)

(a) The computer expects the index number of the data point being changed. It will accept an index number one greater than the length of the table (omit the number corresponding to 1E35) with the assumption that the table is being extended. The table may be extended repeatedly by entering an index number equal to one more than the previous maximum number. If the number typed is invalid, step 23 is repeated. After the number is accepted, the computer will type X,Y=

Respond with the value of x, a comma, the value of y and return. Step 23 will be repeated. The data being typed will be logged according to responses made in steps 7,8

CAUTION: DO NOT ENTER 1E35 FOR THE LAST NUMBER.

The program knows how many points there are in the table.

(b) If a value of x,y is to be eliminated, after its index number has been accepted, and X,Y = has printed, type

1E35,1E35 return

(c) When all changes have been made, answer NUMBER? with 0 return

The procedure restarts at step 14

ERRORS

1. Alphabetic errors: If an error is discovered before return is pressed, and the information was alphabetic, as in steps 7,8,9,16,17,18,19,21,22, type the rubout key; the computer will respond with a carriage return; retype the entire response, beginning with the first character.

6.3.1 Program PLOT.PA (cont'd)

2. Numeric errors: If an error is discovered before a comma or return is pressed, and the information was a number, as in steps 10,12,14 and 23, type the rubout key; the computer will not respond (automatic feature of the 27 bit floating point package); then type the entire number over again, beginning with the first character. CAUTION: If two numbers were being inputted, separated by a comma, the rubout will erase the CURRENT NUMBER ONLY.

3. Incorrect responses to Y or N: The computer will specifically look for the Y. Any character other than Y will be treated as N except a carriage return, which should be used only after a character has been typed.

RESTART ADDRESS: 0200

6.3.2 Program KNOL1D.FT

Introduction

KNOL1D is a PDP-8/E Fortran IV program which has been developed for the Cloud Physics Branch to obtain quick and informative printer display of aircraft data from the lab PDP-8/E computer.

KNOL1D will accept input from either the PMS1D Kennedy recorder or the PDP-8/E TU-10 flight tape. The output device is the line printer and an example may be found in figure 6.3 Note however, the example contains one 'block' of data, whereas, KNOL1D prints two per page.

Operation

The KNOL1D program is currently stored on the "Fortran System" DECTape (#9), the source code is on tape 14, "Fortran programs". To run KNOL1D, tape #9 must be mounted on unit 0 and the operating system booted up. The TU-10 or Kennedy tape should be mounted on the magtape drive, set to unit 0, write protect, and on-line. In response to the OS/8 monitor dot on the DECwriter, type 'EXECUTE KNOL1D.LD.' FRTS will load and start running KNOL1D.

KNOL1D begins by asking a battery of questions:

"PDP-8/E KNOL1D VX.YY"

1 "FLIGHT NUMBER?"

THE FLIGHT NUMBER IS ENTERED IN THE FORM "EYY-NN"

6.3.2 KNOLLD.FT (cont'd)

2 "TAPE FORMAT?"

- 0 - PMS
- 1 - TU-10 (RAWINS)
- 2 - TU-10 (FPPINS)
- 3 - TU-10 (SEMI-INS)"

THE TAPE FORMAT MAY BE PMS OR TU-10 (SELF EXPLANATORY), RAWINS IS FOR TAPES WITH INS FORMATTED LAT/LON. FPPINS IS DATA CONVERTED TO FORTRAN FLOATING-POINT, SEMI-INS IS THE CURRENT FORMAT AND CONTAINS LAT/LON IN BINARY FORMAT-ADJUST FORM.

3 "A-D BUFFER?"

- 0 = NEW (> APRIL 80)
- 1 = OLD (< APRIL 80)"

IN APRIL 1980 THE A-D BUFFER FORMAT WAS CHANGED. FLIGHTS BEFORE APRIL 1980 ARE #0, OTHERWISE #1.

4 "FLIGHT DATE?"

THE FLIGHT DATE IS ENTERED IN THE FORM "DD-MMM-YY"

5 "MAG HEADING DEVIATION = 0.0, CHANGE?"

THE MAGNETIC DEVIATION IS PRESET TO ZERO AND MAY BE MANUALLY CHANGED TO ACCOMODATE FLIGHTS IN AN INFINITE RANGE OF LATITUDES AND LONGITUDES. AN ANSWER OF "Y" RESPONDS WITH:

6 "CHANGE TO?"

THE USER NOW ENTERS THE NEW MAGNETIC DEVIATION IN DEGREES.

6.3.2 KNOL1D.FT (cont'd)

- 7 "AVERAGING INTERVAL IN SECONDS?"
THE NUMBER OF SECONDS TO AVERAGE PER BLOCK OF DATA
(i.e. 60 SECOND AVERAGE).
- 8 "START,STOP TIMES (AS 'HH MM SS HH MM SS')?"
ENTER START AND STOP TIMES AS INDICATED. TO PROCESS AN
ENTIRE TAPE, TYPE: "00 00 00 99 99 99"
- 9 "PARTICLE TYPE: HARDWARE INPUT OK?"
IF HARDWARE INPUT OF PARTICLE TYPE (ONLY TU-10 FLIGHT
TAPES) FROM THE C130 EVENT SWITCHES IS DESIRED, TYPE
"Y", OTHERWISE MANUAL RESPONSE IS NECESSARY, AND ...
- 10 "PARTICIPATE TYPE (1,2,3,4,5)?"
ENTER THE NUMBER 1-5 CORRESPONDING THE APPROPRIATE
WEATHER CONDITIONS.
1 = RAIN (DEFAULT FOR PMS TAPES)
2 = WET SNOW
3 = SMALL SNOW
4 = LARGE SNOW
5 = BULLET-ROSETTES
- 11 "COMMENTS?"
TWENTY-FOUR CHARACTERS ARE RESERVED FOR ADDITIONAL
USER COMMENTS

TAPE errors are reported on the DECwriter terminal,
and could be: parity errors, incorrect record length and
end of tape/file. When KNOL1D has reached the stop time,
it will return to question 8.

6.3.2 KNOL1D.FT (cont'd)

- (A)** FLIGHT ID
FLIGHT DATE
INITIAL AIRCRAFT AND ELAPSED SECONDS
DATA AVERAGING CYCLE
COMMENTS
- (B)** INITIAL LATITUDE AND LONGITUDE
- (C)** PARTICLE TYPE; HARDWARE OR USER INPUT
- (D)** AVERAGED VCO'S; RAW AND CALIBRATED
- (E)** SUMMED SCATTER, CLOUD AND PRECIP PROBE COUNTS
- (F)** PROBE CHANNEL SIZES
NUMBER/METERS**3 - MM BANDWIDTH
- (G)** SCATTER, CLOUD AND PRECIP PROBE HOUSEKEEPING STATUS WORDS
- (H)** VARIOUS SELECTED PARAMETERS

Figure 6.4A: KNOL1D.FT sample output section definitions

FLIGHT E79-78 DATE 28-MAY-79		A 2:59:58 ESEC 0		PARTICLE TYPE: RAIN C	
*** FINAL ***		60 SECOND INTERVAL		LAT B 42 13.05 NORTH	
				LONG 71 54.33 EAST	
CHN	VCO LABEL	RAIN	CALIBRATED	NUMBER - DEN S I L Y	(N/VOL/UM)
1	T A S	5148	34.8 INOTS	SIZE SCATTER	SIZE SIZE
2	TOTAL TEMP	5963	8.8 DEG C	24	0.0E-01
3	EMFR	64	64.0 COUNTS	44	0.0E-01
4	TW1 (TMP2)	0	0.0 COUNTS	63	0.0E-01
5	DEW POINT	4315	-6.0 DEG C	83	0.0E-01
6	J/M LW	4974	-0.1 G/M ³	103	0.0E-01
7	HWS HEADING	2836	77.9 DEG	123	0.0E-01
8	PRESSURE	1403	994.8 MB	143	0.0E-01
9	T A S	3665	133.2 INOTS	162	0.0E-01
10	ICE DETECTOR	0	0.0 COUNTS	182	0.0E-01
11	TW1 (CTR1)	0	0.0 COUNTS	202	0.0E-01
12	TW1 (TMP1)	0	0.0 DEG C	222	0.0E-01
13	TW1 (CTR2)	0	0.0 COUNTS	242	0.0E-01
14	DELTA P	5148	7.9 MB	261	0.0E-01
15				281	0.0E-01
16				301	0.0E-01
(N/VOL) 1.1E+04					
LRC 0.0E-01 67M ³					
Z 0.0E-01 N/A H					
T WCI 0.00 N/A					
WIND 0.00 DEG					
COURSE 0.0 DEG					
GNDSPD 0.0 KNOTS					
T A S 69.43 KNOTS					
HEIGHT 506.25 FEET					
T A S T. A. S 35.71 M/S					
TRUE T 8.12 DEU C					
PRECIP 0					
SCATTER 21					
CLOUD 0					
PRECIP 0					
FROBE COUNTS					
SCATTER 4					
CLOUD 0					
PRECIP 0					
+15S PTMP -15S ETMP +5VS 5TMP +15S PTMP					
SCA	471	223	2024	6698	523 2072 4027 15 470 223
+15S MTMP EL01 EL24 -15S 5TMP +5VS ELRT +15S MTMP					
CLD	1491	2465	780	881	1519 2804 4886 3699 1489 2468
PRE	1490	277	1952	1249	1520 2636 4992 2661 1498 278
FROBE HOUSEKEEPING					

Figure 6.4B: KNOLLID.FT sample output

6.3.3 Program KN1UTL.FT

Introduction

DPSI has developed a PDP-8/E quick look dump of PMS1D or TU-10 flight tapes. Program KN1UTL will read either tapes and produce a raw VCO dump of user selected areas contained in the Knollenberg buffer.

KN1UTL accepts user input from the DECwriter terminal as to which type of tape to process and what area of the tape to list. Currently, KN1UTL will process either a PMS1D tape or a TU-10 flight tape (in any of three formats: RAWINS, FPPINS, SEMINS), and dump VCO, scatter probe, cloud probe or precip probe data.

Operation

The source of KN1UTL is stored on DECTape 14; the image file is on tape 9. To run KN1UTL mount tape 9 on unit 0, write enable, boot-up the OS/8 monitor and type 'EXECUTE KN1UTL.LD'. FRTS will load and start running KN1UTL.

The following list represents operator dialogue with KN1UTL. Note: under score indicates user response.

- (1) KN1UTL V 2.20
ENTER FLIGHT ID/DATE? E80-38 ON 17-DEC-80
- (2) TAPE FORMAT?
0=PMS 1=TU-10(RAWINS) 2=TU-10(FPPINS) 3=TU-10(SEMINS)
0

6.3.3 Program KN1UTL.FT (cont'd)

- (3) A TO D BUFFER (not asked if PMS tape)
0=OLD 1=NEW
- (4) OPTIONS ENTER 'T' OR 'F'
DUMP VCO DATA? T
DUMP SCA DATA? F
DUMP CLD DATA? T
DUMP PRE DATA? F
- (5) TAPE STARTS AT XX:XX:XX
ENTER START AND STOP TIMES (HH MM SS HH MM SS)
XX XX XX XX XX XX

NOTE: If a start time of "00 00 00" is entered, the first time on the tape is substituted. If "-1" is entered KN1UTL will restart itself (used if a new tape is to be dumped, with out reloading KN1UTL, and return to question #1.

6.3.4 Program JWPLOT.FT

One of the liquid water content measurement systems used by Cloud Physics on board the MC130E aircraft was known as the "JW" (Johnson and Williams). While the device was a good means of measuring LWC, it has problems. As aircraft pitch changed during climbs and descents, it produced values below zero. DPSI has developed a program (JWPLOT), run on the PDP-8/E computer, which will correct JW data in real-time on the Tektronix CRT. Running JWPLOT is a little different than other PDP-8 Fortran programs because it requires a DECTape data file used as a temporary scratch space. The DECTape must initially be zeroed. This can be accomplished via the PIP program (Peripheral Interchange Program). With tape #9 on unit 0, and the data tape on unit 1, write enabled, type:

```
.R PIP↓  
* A:</Z$ (ALTMODE PRODUCES DOLLAR SIGN)
```

The tape on unit 1 is now zeroed. Type

```
.R FRTS↓  
*JWPLOT↓  
*A:JWPLOT.DF</8$ (ALTMODE)
```

This generates a data file on unit 1 called JWPLOT.DF.

6.3.4 Program JWPLLOT.FT (cont'd)

The PDP-8/E JWPLLOT program is constructed from eleven programs.

JWPLLOT	main code
CORE	memory device buffer
RMTA0	PMS tape processor
TEKLIB	Tektronix library
CONTIM	seconds to H:M:S subroutine
INPUT	accepts start/stop times flight ID/date
DISPL	displays plot area
JWCORR	JW correction subroutine
SCALE	scales x,y coordinates to plot area
READT	returns one second of JW/ALT data per call
LINEAX	draws x or y line axis

JWPLLOT, CONTIM, INPUT, DISPL, JWCORR, SCALE and READT are taken directly from the CDC code. RMTA0, CORE and TEKLIB are commonly used PDP-8/E library routines. LINEAX is a newer version of the line axis routine previously used on the PDP-8/E.

Figure 6.4 contains terminal dialogue between the operator and JEWPLOT. Figures 6.5A and 6.5B are sample plot output of uncorrected and corrected data, respectively.

CALIBRATION DATE IS 26-SEP-80. CHANGE VALUES? (Y/N)

Y

ENTER THE JW-LWC CALIBRATION (A, B, C)

-3.68, 4.7, 4E-4, 0.0

3.68000E+00 7.40000E-04 0.00000E-01

ENTER THE PRESSURE CALIBRATION (A, B, C)

1132.0, -.0992, -.1649E-6

1.13200E+03 -9.92000E-02 -1.64900E-07

ENTER THE TAS CALIBRATION (A, B, C)

-50.0, .05, 0.0

5.00000E+01 5.00000E-02 0.00000E-01

ENTER THE IAS CALIBRATION (A, B, C)

-637.94, .1866, -.9991E-5

6.37940E+02 1.86600E-01 -9.99100E-06

ENTER THE TEMP CALIBRATION (A, B, C)

-50.74, .0098, .2525E-7

5.07400E+01 9.80000E-03 2.52500E-08

RAW DATA OUTPUT? (T/F)

F

USE CALCULATED TAS (T/F)

F

INPUT THE START AND STOP TIMES (HH MM SS HH MM SS)

00 00 00 99 99 99

DEFAULT VALUES FOR HT(KM) ARE 0.0, 10.0

DO YOU WISH TO CHANGE THE LIMITS? (Y/N)

Y

ENTER THE NEW LIMITS (MIN, MAX)

0.0, 5.0

DEFAULT LIMITS FOR JW-LWC ARE -0.3, 1.5

DO YOU WISH TO CHANGE THE LIMITS? (Y/N)

N

ENTER FLT ID (EXX-XX)

E80-04

ENTER FLT DATE (DD-MMM-YY)

?8-JAN-80

Figure 6.5: JWPL0T.FT Dialogue

6.3.4 Program JWPLLOT.FT (cont'd)

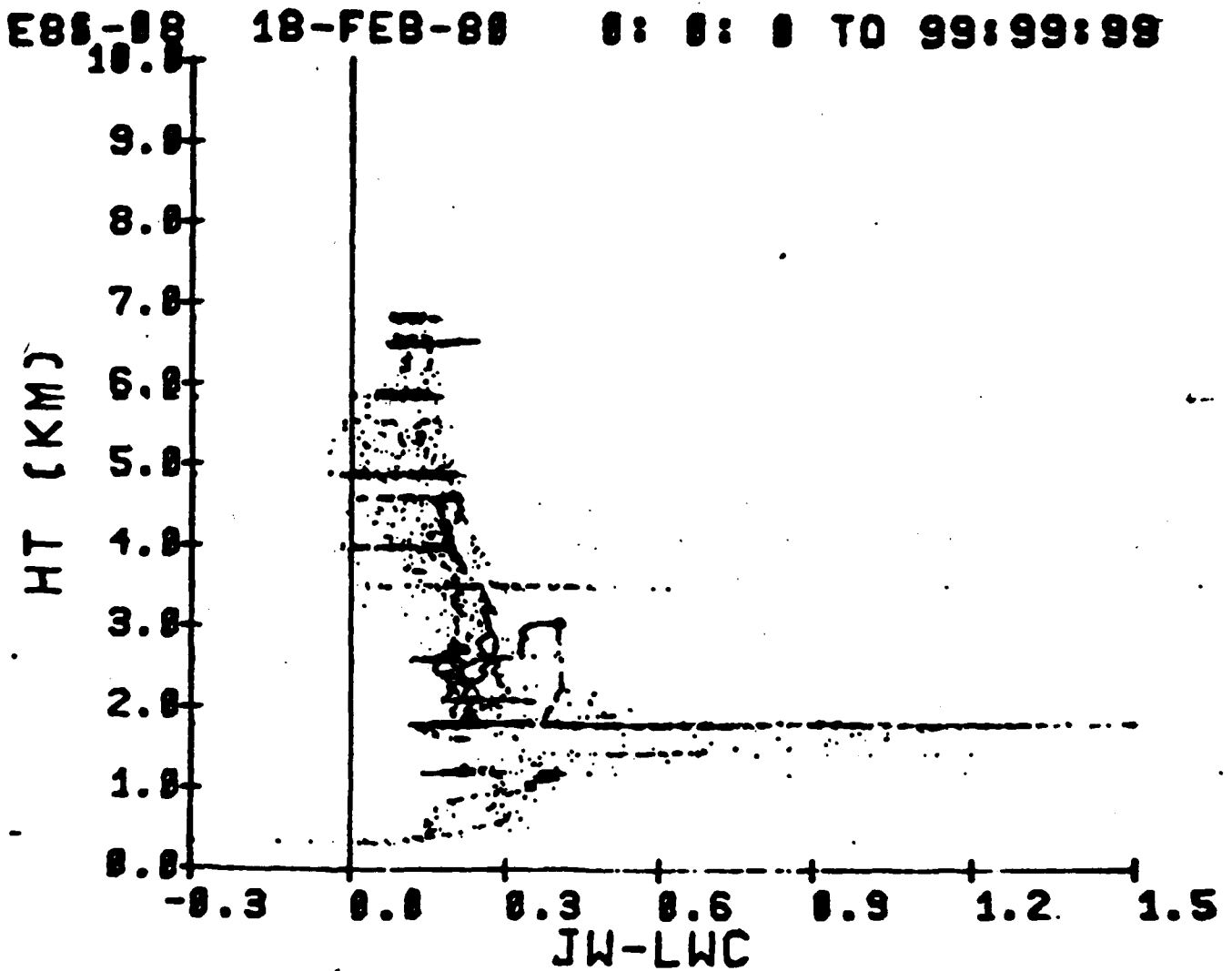

Figure 6.6A: JWPLLOT sample output - uncorrected

6.3.4 Program JWPLLOT.FT (cont'd)

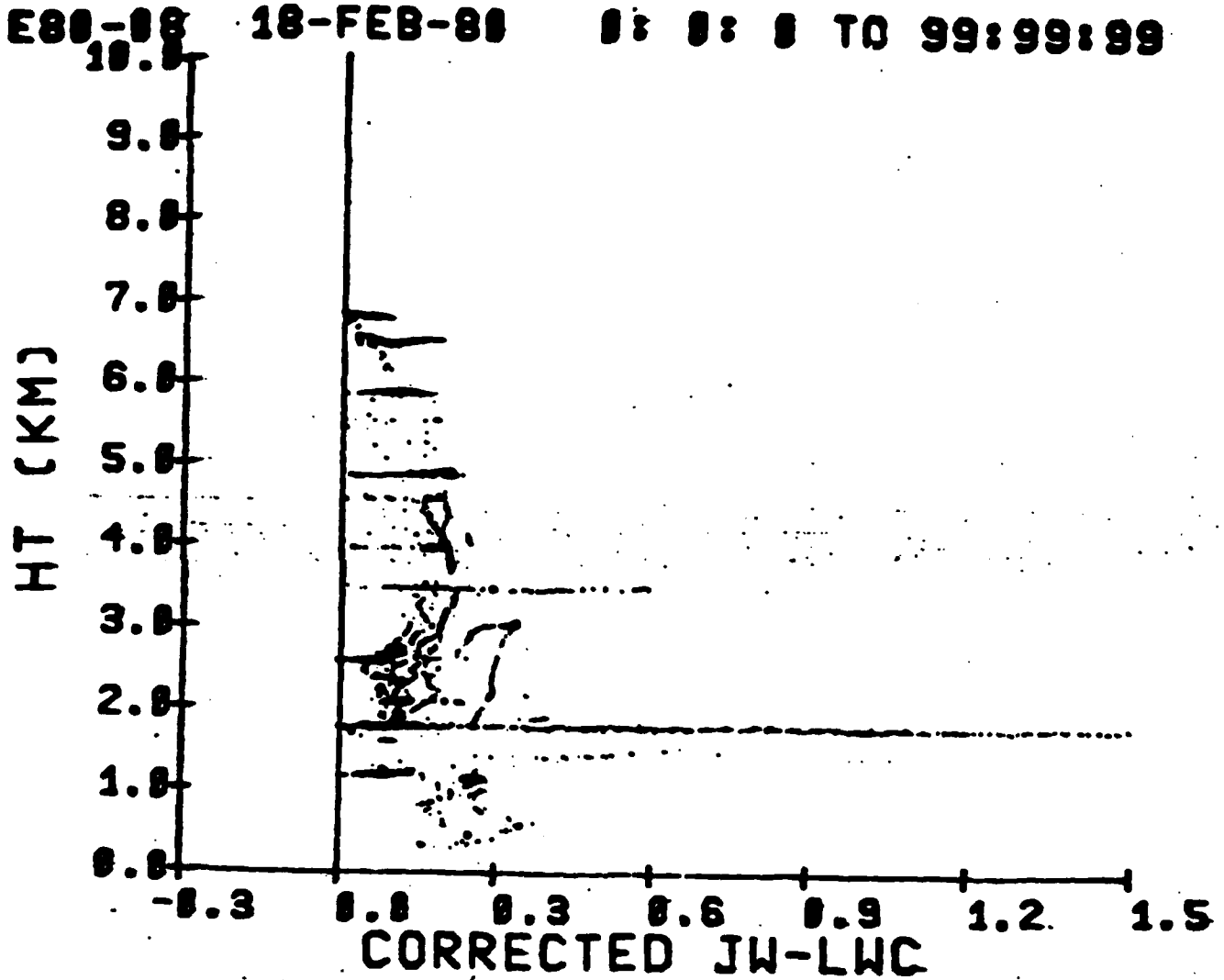

Figure 6.6B: JWPLLOT.FT sample output - corrected

6.3.4.1 Subroutine CONTIM.FT

CONTIM is used by JWPLLOT and will convert total seconds to "HH:MM:SS".

```
CALL CONTIM (SECS,TIME)
```

where:

SECS are total seconds

TIME is a two element array which will contain "HH:MM:SS"

NOTE: CONTIM will insert leading zeros for time parameters less than ten. i.e. 12:03:00

↑ ↑

6.3.4.2 Subroutine INPUT.FT

INPUT is another JWPLLOT subroutine which will accept from the user:

- (1) start and stop times (HH MM SS HH MM SS)
- (2) new height (km) limits
- (3) new JW-LWC limits
- (4) flight ID
- (5) flight date

This information is returned to JWPLLOT through common memory.

6.3.4.3 Subroutine DISPL.FT

DISPL is used in JWPLLOT to draw the plotting area of the JW graph. Flight ID, flight data, start and stop times are drawn at the top; x and y axis are drawn and labelled. Whether the plot is corrected or uncorrected data is indicated at the bottom.

6.3.4.4 Function JWCORR.FT

JWCORR is used in JWPLLOT to perform the JW=LWC correction. By building a table of intercept points using the Tektronix cross-hairs (identifying true zero values), JWCORR can subtract or add the proper offset to align the JW-LWC data point to zero.

6.3.4.5 Subroutine SCALE.FT

SCALE is used to program JWPLLOT to scale JW/HT data points to the plotting area and to ensure that no points fall beyond x and y limits. If so, the points are set to extreme x and y values and plotting occurs on the graph boundaries.

6.3.4.6 Subroutine READT.FT

READT was developed from JWPLLOT to return one second data from a PMS1D flight tape. READT uses the RMTA0 subroutine which processes four second tape data; however for every call to READT, a pointer (KNBASE) to the current second's data is incremented to the next second. After four calls (four seconds of data), READT reads another tape record and resets

6.3.4.6 Subroutine READT.FT (cont'd)

KNBASE to second #1. Errors are directed by READT and generate an error message on the DECwriter terminal:

"TAPE ERROR X"

Where X is the error (1-7)

Error codes are then returned to JWPLLOT for further processing. (i.e. END OF TAPE CONDITION).

6.3.4.7 Subroutine LINEAX.FT

LINEAX is a Fortran subroutine which will draw and label an X or Y axis on the Tektronix CRT. It replaces an older version also called LINEAX. The major differences being: (1) numbers plotted on the y axis are at 0° angles as is the x axis, and (2) axis max and min limits are scaled down automatically by LINEAX to ensure a maximum field width of 4 characters for each tic mark numeric-label.

6.3.5 Program SNOPLT.FT

SNOPLT has been developed by DPSI for analysis of snow data collected during LYC's SNOWIA project (1981). SNOPLT contains many options for manipulating the data via a smoothing technique, zeroing negative weights or rates, enlarging and reducing plot sizes, and specifying the smoothing neighborhood for the 'DERIV' function.

SNOPLT requires as input a data file processed by the OS/8 operating system (either DECTape or magtape). Snow data contained on this tape will be buffered into a 2400 element array (=1:52:21 hours). Data is then processed in one hour increments (weight and rate plots as defined by user input options) and then shifted left through the array leaving 300 original data points. The remaining space in the array (2100 points) is filled with the tape data and the next hour processed.

This method of shifting the data left through the array is known as "the mobile page" and simulates virtual memory. This was necessary in order to properly implement the "Deriv" function; whereas data from the previous hour is required in the N-point neighborhood smoothing.

Figure 6.6 contains the dialogue for operating SNOPLT and figure 6.7 is a sample plot. A brief description of each question (from figure 6.6 follows:

- 1) The frequency of each snow weight (Delta 'T') has been timed at 2.809 seconds. This is a default, but can be changed. Note: <N> indicates that pressing carriage return is the same as typing 'N' (NO).

6.3.5 Program SNOPLT.FT (cont'd)

- 2) If question one was yes, accept a new delta 'T'.
- 3) Not a question; prints date/ID of collection mission.
- 4) Allows output selection of printer, plotter or both.
- 5) Page width is default to 11 inches - allows redefining this to any size.
- 6) Defines how many hours of data to plot on each page.
- 7) Fixed hour size determined by questions five & six. This will adjust the frame size to center the number of hours within a page. Adjustable for plotting overlays of other department's snow data.
- 8) Should a snow rate plot be produced, enter T(true) or F(false).
- 9) Minimum and maximum scale of snow weight plot.
- 10) If snow rate plot selected (question eight); minimum and maximum scale of snow rate plot; and smoothing neighborhood 'N' for derivative function.
- 11) Should the snow weight be smoothed prior to plotting; T(true) or F(false)

6.3.5 Program SNOPLT.FT (cont'd)

- 12) If question eleven is true; should the snow weight be generated from snow rate data (True) or by smooth function (False).

- 13) Should negative weights and negative rates be set to zero (True or False).

6.3.5 Program SNOPLT.FT (cont'd)

NOTE: User responses are identified by underscores

- 1) SNO PLOT -- SNOW RATE PLOTTING PROGRAM
SNOW WEIGHT DELTA 'T' = 2.809
CHANGE DELTA 'T' (Y/N) <N>?
- 2) Y1 ENTER NEW DELTA 'T' (XX.XXX):
- 3) SNOW MISSION ID: S82-04 31-JAN-82
- 4) PLOTTER OUTPUT (T/F):
PRINTER OUTPUT (T/F):
- 5) PAGE WIDTH = 11.0, CHANGE TO (CR=SKIP):
- 6) HOW MANY HOURS OF DATA PER PAGE (XX)?
- 7) ENTER FIXED HOUR FRAME SIZE (CR=x.y)?
- 8) YOU WANT TO INCLUDE A SNOW RATE PLOT (T/F)?
- 9) SNOW WEIGHT PLOTS
ENTER MIN,MAS:
- 10) Y8 SNOW RATE PLOTS
ENTER MIN,MAX:
ENTER NEIGHBORHOOD FOR DERIVATIVE FUNCTION:
- 11) SMOOTH WEIGHT DATA (T/F):
- 12) Y11 SMOOTH WEIGHT FROM RATE DATA (T/F):
- 13) ZERO NEGATIVE WEIGHTS (T/F):
ZERO NEGATIVE RATES (T/F):

Figure 6.7: SNOPLT dialogue

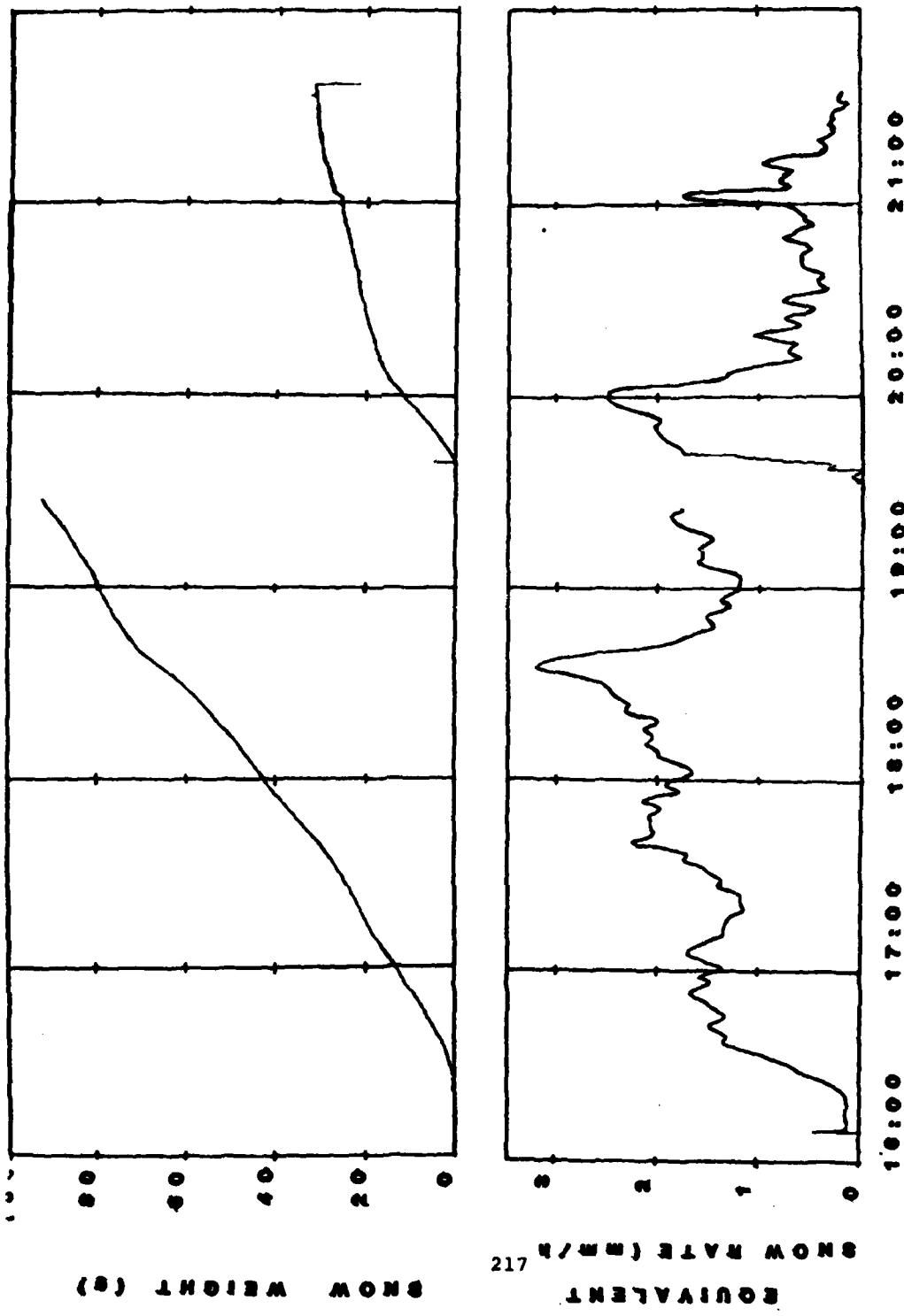

Figure 6.8: SNOPLT sample plot

6.3.6 Fortran subroutines

There is a set of Fortran (also written in RALF assembler) subroutines used on the PDP8/E for processing aircraft data.

- (1) **RMTA0:** was written in RALF assembler to convert PMS 1D or TU-10 flight tapes to Fortran format
- (2) **CORE:** was received through the "PDP-8 Software News" Fall 1980 magazine. CORE enables Fortran IV to execute the ENCODE and DECODE functions not possible before in PDP8/E Fortran IV
- (3) **SCANT:** was developed to eliminate the drudgery of processing tape errors when using RMTA0. SCANT also implements the binary search method, and thus, very quickly searches tapes for start times.

6.3.6.1 Subroutine RMTA0.RA

RMTA0 is a RALF coded subroutine used by Fortran programs to read PMS 1D and TU-10 flight tapes. Since its inception, many revisions have been developed to make RMTA0 an extremely versatile addition to the PDP8 Fortran library. RMTA0 features include:

- 1) processes PMS or flight tapes
- 2) seven diagnostic error codes
- 3) five tape functions (expandable to eight)
- 4) TU-10 tapes include LAT/LON and event word data
- 5) economical memory resources

RMTA0 requires six arguments per call:

```
CALL RMTA0 (A1,A2,A3,A4,A5,A6)
```

where:

A1 = 276 element array tape buffer

1-64	Second 1	
65-128	Second 2	Knollenberg buffer see Appendix 1
129-192	Second 3	
193-256	Second 4	
257-258	Second 1	
259-260	Second 2	Latitude/Longitude (in radians)
261-262	Second 3	
263-264	Second 4	
265	Second 1	
266	Second 2	Event word data (1 through 5)*
267	Second 3	
268	Second 4	

6.3.6.1 Subroutine RMTA0.RA (cont'd)

269-270 Second 1
271-272 Second 2 SIGN & ID data word for LAT/LON
273-274 Second 3
275-276 Second 4

* event word codes

1 = RAIN
2 = WET SNOW
3 = SMALL SNOW
4 = LARGE SNOW
5 = BULLET ROSETTES

A2 = tape format

0 = Kennedy tape
1 = TU-10 tape
INS data in RAW format
2 = TU-10 tape
INS in FPP format
3 = TU-10 tape
INS in semi-FPP format

A3 = A-D buffer tape

0 = OLD (BEFORE APRIL 1980)
1 = NEW (AFTER APRIL 1980)

A4 = tape error code

<u>CODE</u>	<u>MEANING</u>
0	NO ERROR
1	PARITY
2	END OF FILE
3	INCORRECT RECORD LENGTH
4	BEGINNING OF TAPE
5	DRIVE OFF LINE
6	END OF TAPE (AT EOT, RMTA0 AUTOMATICALLY REWINDS)
7	BLANK TAPE READ

6.3.6.1 Subroutine RMTA0.RA (cont'd)

A5 = - number of second to process for READ (FUNCTION 0)
OR + number of records to space forward or backward
(FUNCTIONS 3 and 4)

A6 = tape drive function

<u>CODE</u>	<u>MEANING</u>
0	READ A RECORD & CONVERT TO FPP FORMAT
1	REWIND DRIVE, TURN OFF LINE
2	REWIND DRIVE
3	FORWARD SPACE
4	BACKSPACE
5 } 6 } 7 }	UNUSED

The source file of RMTA0 is on tape number 14 and
is called RMTA0.RA.

6.3.6.2 Subroutine CORE.RA

The CORE subroutine, received from "PDP-8 Software News" Fall 1980 magazine, is a RALF assembler coded program which will create a memory I/O buffer accessible via Fortran READ/ WRITE commands. CORE requires only one call to define the I/O unit number. More than one call will produce unpredictable results. Calling format is:

```
CALL CORE (u)
```

Where: u is the I/O unit to assign the memory buffer not previously used in system configuration (the LYC PDP8/E system uses unit 5)

A write to the memory device is like printing on the terminal. A read will transfer the buffer to the Fortran program as though the characters were typed on the keyboard.

ENCODE - Simulated feature

A number can be written to the memory device using a numeric format (I,F,D) then read back using alphanumeric format (A).

```
example:      CALL CORE(5)
              NUMBER=12.3
              WRITE (5,10) NUMBER
10           FORMAT (F6.2)
              READ (5,20) ALPHA
20           FORMAT (A6)
```

At this point, Alpha = "12.3"

5.3.6.2 Subroutine CORE.RA (cont'd)

The ENCODE feature is a particularly useful tool in formatting for plotter output.

DECODE - Simulated feature

Virtually identical to ENCODE, DECODE will convert an alphanumeric string to numeric format.

```
CALL CORE(5)
ALPHA=6H 14.67
WRITE (5,10) ALPHA
10  FORMAT (A6)
   READ (5,20) NUMBER
20  FORMAT (F6.2)
```

NUMBER is now set to 14.67

6.3.6.3 Subroutine SCANT.RA

Every job run on the PDP8/E computer which processes aircraft data tapes requires TU-10 drive control. Every job must also process tape error messages, should an error occur during execution. Most jobs handle data in a time frame; that is, within a start and stop time. For these reasons DPSI has developed a RALF assembler routine (SCANT) to handle magtape overhead control.

Subroutine SCANT interfaces the user Fortran IV program with the RMTA0 (read magtape 0) subroutine. SCANT features include:

- 1) reset, read and scan functions
- 2) common memory communication block
- 3) stop time detection and start time not located
- 4) full tape error diagnostics in simple English
- 5) aircraft clock rollover algorithm

All communication variables and parameters are passed through common 'A'. This common block contains the following:

KNBUF	Knollenberg tape buffer
KNBASE	PTR to current second in KNBUF
FORMAT	tape format (PMS/TU-10)
ATOD	A to D buffer type
ERROR	RMTA0 error code
SECCNT	number of second to process per record (1,2,3,4)
CURSEC	current second
RECORD	current tape record
STARTT	search start time

6.3.6.3 Subroutine SCANT.RA (cont'd)

STOPT	search stop time
FIRSTT	first time on tape
FUNCT	SCANT function
TERROR	SCANT error code

Internal time is always maintained in a total seconds format ($H*3600 + M*60 + S$) as in variables CURSEC, STARTT, STOPT, and FIRSTT. Whenever time is printed, as in an error message, it is converted back to a normal format (HH:MM:SS). When a rollover condition occurs, 24 hours (86400 seconds) is added to CURSEC, therefore if a start time greater than 23:59:59 is specified, it too should include a 24 hour rollover, i.e. 25:05:00.

The three functions RESET, READ and SCAN of subroutine SCANT are selected through an arithmetic variable, FUNCT:

FUNCT.LT.0	<u>RESET</u> rewind the tape drive and read record one. FIRSTT is set to the first time on the tape.
FUNCT.EQ.0	<u>READ</u> One second of tape data is read.*
FUNCT.GT.0	<u>SCAN</u> The time in STARTT is searched for in whatever direction necessary (forward or backward).

* One tape record contains four seconds of data. When a record is physically read, KNBASE is set to second 1, (=0); when a READ is processed, KNBASE is incremented to second 2 (=64), second 3 (=128), second 4 (=192), second 5; next record is read, and KNBASE is reset to zero.

6.3.6.3 Subroutine SCANT.RA (cont'd)

If SCANT detects a search error, it reports it through another arithmetic variable, TERROR.

TERROR.LT.0 the stop time (in STOPT) has been exceeded by
 the last read. *

TERROR.EQ.0 no error

TERROR.GT.0 the start time (in STARTT) has not been located.
 It could be either before FIRSTT or after the
 EOF, EOT or BTR (blank tape read).

* A stop time will result if a) the stop time has been passed,
b) or if an EOF, EOT or BTR has been detected. ERROR will
contain the actual situation. See section 4.5.5.1 for RMTA0
error codes.

After each call to subroutine RMTA0, SCANT interrogates
the tape error word, a non-zero value calls the error message
processor. There are seven possible errors:

1) PARITY

displays error message

"HH:MM:SS PARITY ERROR ON RECORD: XXXX"

the next record is read

2) END OF FILE (EOF)

displays error message

"HH:MM:SS END OF FILE AT RECORD: XXXX"

if SCANT was currently searching for a start time, TERROR=+1

if the EOF occurred during a read, TERROR=-1

6.3.6.3 Subroutine SCANT.RA (cont'd)

3) INCORRECT RECORD LENGTH (IRC)

displays error message

"HH:MM:SS INCORRECT RECORD LENGTH ON RECORD: XXXX"

the next record is read

4) BEGINNING OF TAPE (BOT)

no error message, used for search function. If BOT is hit twice in a row during a search, TERROR=+1

5) OFF LINE

"*** TU-10 OFF-LINE... FIX AND PRESS RETURN!"

Correct the tape drive problem and press the keyboard return key.

6) END OF TAPE (EOT)

displays error message

"physical end of tape"

the end of tape marker has been sensed. If SCANT was currently searching, TERROR=+1. If the EOT occurred during a read, TERROR=-1.

7) BLANK TAPE READ (BTR)

displays error message

"BLANK TAPE READ (HH:MM:SS)"

The last read took too long, and therefore no data is on the tape. If SCANT was currently searching for a start time, TERROR=+1. If the BTR occurred during a read, TERROR=-1.

