

(12)

SSI 8143-14

September 1983

A/B 358

DEVELOPMENT OF DAMAGE AND CASUALTY FUNCTIONS FOR BASEMENT SHELTERS PHASE II

FINAL REPORT

20030108203

DTIC FILE COPY

for
FEDERAL EMERGENCY MANAGEMENT AGENCY
WASHINGTON, D.C. 20472

DTIC
ELECTE
OCT 11 1983
A

Approved for public release;
distribution unlimited

Contract No. EMW-C-0678
Work Unit 1622D

SCIENTIFIC SERVICE, INC.

83 10 06 012

SSI
8143-14

REPRODUCTION QUALITY NOTICE

This document is the best quality available. The copy furnished to DTIC contained pages that may have the following quality problems:

- Pages smaller or larger than normal.
- Pages with background color or light colored printing.
- Pages with small type or poor printing; and or
- Pages with continuous tone material or color photographs.

Due to various output media available these conditions may or may not cause poor legibility in the microfiche or hardcopy output you receive.

If this block is checked, the copy furnished to DTIC contained pages with color printing, that when reproduced in Black and White, may change detail of the original copy.

(This document contains
blank pages that were
not filmed)

UNCLASSIFIED

SECURITY CLASSIFICATION OF THIS PAGE (When Data Entered)

REPORT DOCUMENTATION PAGE		READ INSTRUCTIONS BEFORE COMPLETING FORM
1. REPORT NUMBER SSI 8143-14	2. GOVT ACCESSION NO. A133 358	3. RECIPIENT'S CATALOG NUMBER
4. TITLE (and Subtitle) DEVELOPMENT OF DAMAGE AND CASUALTY FUNCTIONS FOR BASEMENT SHELTERS PHASE II		5. TYPE OF REPORT & PERIOD COVERED Final Report
7. AUTHOR(s) C. Wilton, T.C. Zsutty, and A.B. Willoughby		6. PERFORMING ORG. REPORT NUMBER
9. PERFORMING ORGANIZATION NAME AND ADDRESS Scientific Service, Inc. 517 East Bayshore Redwood City, CA 94063		8. CONTRACT OR GRANT NUMBER(s) EMW-C-0678
11. CONTROLLING OFFICE NAME AND ADDRESS Federal Emergency Management Agency Washington, D.C. 20472		10. PROGRAM ELEMENT, PROJECT, TASK AREA & WORK UNIT NUMBERS Work Unit 1622D
14. MONITORING AGENCY NAME & ADDRESS (if different from Controlling Office)		12. REPORT DATE September 1983
		13. NUMBER OF PAGES 157 pages
		15. SECURITY CLASS. (of this report) Unclassified
		15a. DECLASSIFICATION/DOWNGRADING SCHEDULE
16. DISTRIBUTION STATEMENT (of this Report) Approved for Public Release; Distribution Unlimited		
17. DISTRIBUTION STATEMENT (of the abstract entered in Block 20, if different from Report)		
18. SUPPLEMENTARY NOTES		
19. KEY WORDS (Continue on reverse side if necessary and identify by block number) Civil Defense; casualty functions; damage functions nuclear weapons effects; shelters; survivability		
20. ABSTRACT (Continue on reverse side if necessary and identify by block number) > This report describes progress during the second year's work on a Civil Defense program to provide FEMA with a range of damage functions and casualty functions to determine the survivability of people in various basement shelters. The characteristics of flat plate and two-way slab systems and the effects of code specified design procedures, engineering practice, and construction procedures were discussed. Non-upgraded two-way slabs are approximately twice as strong as the flat plate slabs. For upgraded (shored) systems, however, specific building characteristics are not important. → all		

DD FORM 1 JAN 73 1473 EDITION OF 1 NOV 65 IS OBSOLETE

UNCLASSIFIED

SECURITY CLASSIFICATION OF THIS PAGE (When Data Entered)

UNCLASSIFIED

SECURITY CLASSIFICATION OF THIS PAGE(When Data Entered)

4
factors: any shored slab, with standard reinforcing and dimensions, has about the same capacity as any other slab.

A mathematical model for the fragility curve of slab systems was developed. Fatality curves have been developed for ceiling collapse and a variety of other casualty mechanisms (nuclear weapons effects) with emphasis to date on non-upgraded shelters areas. This review of casualty producing mechanisms is continuing and all casualty curves should be considered as provisional.

UNCLASSIFIED

SECURITY CLASSIFICATION OF THIS PAGE(When Data Entered)

(DETACHABLE SUMMARY)

SSI 8143-14 Final Report
September 1983

Approved for public release,
Distribution unlimited

DEVELOPMENT OF DAMAGE AND CASUALTY FUNCTIONS
FOR BASEMENT SHELTERS
PHASE II

by
C. Wilton, T.C. Zsutty, and A.B. Willoughby

for
Federal Emergency Management Agency
Washington, D.C. 20472

Contract No. EMW-C-0678, Work Unit 1622D

FEMA REVIEW NOTICE:

This report has been reviewed in the Federal Emergency Management Agency and approved for publication. Approval does not signify that the contents necessarily reflect the views and policies of the Federal Emergency Management Agency.

Scientific Services, Inc.
517 East Bayshore, Redwood City, CA 94063



Accession For	
GRA&I	<input checked="" type="checkbox"/>
TAB	<input type="checkbox"/>
Unbound	<input type="checkbox"/>
Microfilm	<input type="checkbox"/>
Distribution/	
Availability Codes	
Special and/or	
Special	

A

(DETACHABLE SUMMARY)

DEVELOPMENT OF DAMAGE AND CASUALTY
FUNCTIONS FOR BASEMENT SHELTERS
PHASE II

This report describes the progress during the second year of a projected five-year program to provide FEMA with a range of damage and casualty functions to determine the survivability of people in various basement shelters.

Developments this year can be divided into three groups.

- (1) Characteristics of flat plate and two-way slab systems
- (2) Formulation of a mathematical model and associated damage effects curves
- (3) Description of casualties/fatalities for given damage effects in non-upgraded slab shelters

(1) **Characteristics of slabs** - The effects of code specified design procedures, engineering practice, and construction procedures were discussed along with the particular architectural aspects of flat plates and two-way slabs. It was seen that these general design and functional characteristics can result in important differences in the non-upgraded strength of slab systems: where two-way slabs are approximately twice as strong as the flat plate slabs.

A most important conclusion, however, was reached for upgraded (shored) systems. Here, where only flexure between shore supports can lead to failure, there is essentially no difference in failure capacities for any slab system (flat plate, two-way, or flat slab), given the same thickness and shore span. Specific building

characteristics are not important factors: any shored slab, with standard reinforcing and dimensions, has about the same capacity as any other slab.

(2) **Formulation of a Mathematical Model** - The log-normal probability model proved to be both realistic and tractable for the fragility curve of slab systems. The model has the advantages of incorporating any new strength data (concerning median value and coefficient of variation) and it can be incorporated into future complex models involving products of factors (since $\ln(AB) = \ln A + \ln B$, a sum of normal random variables). The concept of a damage effects curve with important differences in behavior depending on the general blast load range (high, medium, or low) was developed.

(3) **Casualty/Fatality Evaluation** - Fatality curves have been developed for ceiling slab collapse and a variety of other casualty mechanisms with emphasis to date on non-upgraded shelter areas. It appears at present that, for as-built shelters, ceiling collapse is by far the most serious of all the casualty producing mechanisms. Several others, such as impact by fragments from heavy frangible exterior or interior walls, also can contribute significantly to the casualty curves depending on the specific shelter conditions. Jet flow damage mechanisms cannot be ignored, particularly for large shelters where it is estimated that up to 20% to 30% casualties could occur for the strongest of the two-way slabs. This review of casualty producing mechanisms is continuing and all casualty curves should be considered as provisional. Several areas have not been completed, even in a preliminary way. These include, for example, dust and debris, which are briefly discussed in the appendices.

SSI 8143-14 Final Report
September 1983

Approved for public release,
Distribution unlimited

**DEVELOPMENT OF DAMAGE AND CASUALTY FUNCTIONS
FOR BASEMENT SHELTERS
PHASE II**

by

C. Wilton, T.C. Zsuttly, and A.B. Willoughby

for

Federal Emergency Management Agency
Washington, D.C. 20472

Contract No. EMW-C-0678, Work Unit 1622D

FEMA REVIEW NOTICE:

This report has been reviewed in the Federal Emergency Management Agency and approved for publication. Approval does not signify that the contents necessarily reflect the views and policies of the Federal Emergency Management Agency.

Scientific Service, Inc.
517 East Bayshore, Redwood City, CA 94063

ACKNOWLEDGEMENTS

This report describes the progress during the second year of a projected five-year program to provide FEMA with a range of damage and casualty functions to determine the survivability of people in various types of basement shelters. The authors wish to take this opportunity to thank all those who contributed to previous research in the area and to those who assisted and supported the current program. We particularly wish to thank Donald Bettge of the Federal Emergency Management Agency for his overall project direction; R. Peterson who guided the program through its first year; Dr. A. Longinow and his colleagues at the IIT Research Institute for their pioneering efforts in the study of people survivability in civil defense shelters; Dr. D.R. Richmond of the Lovelace Research Institute for his invaluable assistance in the area of blast biology; and the staff of Controlled Demolition, Inc., for allowing us access to demolition sites and for allowing us the use of data and photographs.

The assistance provided by members of the SSI professional staff including Dr. B.L. Gabrielsen, R.S. Tansley, and G.J. Cuzner is also appreciated. Special thanks go to Elisabeth Moss for her work on dust. The excellent work by members of the SSI staff, Larue Wilton, Evelyn Kaplan, Maureen Ineich, and Michele Boyes, in the preparation and reproduction of the report is also gratefully acknowledged.

TABLE OF CONTENTS

	Page
Acknowledgements	iii
List of Figures	vii
List of Tables	xi
Section	
1. Introduction	1
2. Two-Way and Flat Plate Reinforced Concrete Construction	5
3. Damage Function Rating Procedure Development	29
4. Casualty Mechanisms	47
5. Summary and Plans for Future Work	65
References	71
Appendix	
A. Analysis of Representative Buildings	A-1
B. Blast Attenuation in As-Built Shelters	B-1
C. Jet Flow Phenomena	C-1
D. Calculation of Velocity of Missiles from Blast Loading of Exterior Frangible Wall Panels	D-1
E. Consideration of Impact with Non-Rigid Surfaces	E-1
F. Debris	F-1
G. Preliminary Investigation of the Dust Problem	G-1

LIST OF FIGURES

Number		Page
1.	Damage Function/Casualty Function Relationships	4
2.	Typical Examples of Slab Structures	6
3.	Sequence of Behavior Under Increasing Levels of Vertical Load	8
4.	Failure Modes - Flat Slab System	9
5.	Failure Modes for the Two-Way Slab System	11
6.	Failure Modes for Flat Plate Structures	12
7.	Weakness of a Two-Way Slab System	15
8.	Slab Steel Cut vs Bent Bars	16
9.	Yield Line Patterns for Slab Systems	13
10.	Moment-Torsion Failure of Interior Slab-Column Connection	20
11.	Damage Effects Curves	21
12.	Punching Shear Shoring Conditions	23
13.	Flat Plate Shoring Scheme	25
14.	Two-Way Slab Shoring Schemes	27
15.	Log-Normal Model for W	33
16.	Fragility Curve Plot on Log-Normal Probability Paper	34
17a.	Fragility Curves for Non-Upgraded Flat Plate Slabs	37
17b.	Fragility Curves for Non-Upgraded Two-Way Slabs	38
18a.	Fragility Curves for Upgraded Slabs (L/4 Shoring)	39
18b.	Fragility Curves for Upgraded Slabs (L/3 Shoring)	40
19.	"Overload Effects" and Debris Impact Area Curves	42
20.	Fragility Curve for Example Calculation	45

Number	Page
21. Direct Blast Fatality/Survival Curves	50
22. Indirect Blast - Translation Impact Fatality/Survival Curves	51
23. Impact by Exterior Frangible Walls	53
24. Impact by Interior Frangible Walls, 8-Inch Concrete Block and 6-Inch Clay Tile	54
25. Predicted Failure Value for Various Values of W_c	56
26. Indirect Blast - Structural Collapse of Roof Slab	57
27. Combined Ceiling Collapse Curves	59
28. Casualty Curves for Initial Nuclear Radiation	60
29. Heavy Interior Wall Missile Curve and Ceiling Collapse Curves	61
30. Exterior Wall Missile Curve and Ceiling Collapse Curves	63
A-1. Building 1, Single Story Parking Structure	A-5
A-2. Building 1, Single Story Parking Structure	A-6
A-3. Building 2, Multi-Story Parking Garage	A-6
A-4. Building 2, Basement Parking Garage	A-7
A-5. Building 3, Basement Parking Garage	A-8
A-6. Building 4, Basement Parking Garage	A-9
A-7. Building 4, Basement Parking Garage	A-10
A-8. Building 5, Entrance to Hotel Parking Garage	A-10
A-9. Building 5, Hotel Basement Parking Garage	A-11
A-10. Building 6, Single Story Parking Structure	A-12
A-11. Building 6, Single Story Parking Structure	A-13
A-12. Fragility Curves for Representative Buildings: Non-Upgraded Slabs	A-16
A-13. Fragility Curves for Representative Buildings: Upgraded Slabs	A-17

Number		Page
B-1.	Prediction Curve for Axial Shock Front Pressure	B-3
C-1.	Jet Translation Impact Fatalities - On Axis	C-7
C-2.	Jet Translation/Impact of People	C-8
E-1.	Impact by Interior Frangible Walls of 4-Inch Timber Stud/Sheetrock	E-3
F-1.	Phases of Structural Failure, Continental Life Building, Atlanta, Georgia	F-4
F-2.	Damage to Veterans Administration Hospital in San Fernando Earthquake, February 1971	F-5
F-3.	Henry Grady Hotel Demolition	F-6
F-4.	Debris From Demolition of Henry Grady Hotel	F-6
F-5.	The Newhouse Hotel in Salt Lake City, Utah Before Demolition	F-8
F-6.	Demolition of the Newhouse Hotel in Salt Lake City, Utah	F-9
F-7.	Debris Pile From the Newhouse Hotel in Salt Lake City, Utah	F-10
F-8.	Arched Hollow Clay Tile Basement Ceiling With Plaster Cover	F-11
F-9.	Collapse of the Basement in the Newhouse Hotel	F-12
F-10.	Outside Column in the Basement of the Newhouse Hotel	F-13
G-1.	Dust Generated by Collapse of Cuyahoga-Williamson Buildings, Cleveland, Ohio	G-2
G-2.	Demolition of American Industrial Building, Hartford, CT	G-2
G-3.	Dust Generated From the Biltmore Hotel, Oklahoma City, OK	G-3
G-4.	Dust Generated From Abe Lincoln Hotel, Springfield, IL	G-3

LIST OF TABLES

Number		Page
1.	Symbols and Definitions	30
2.	Non-Upgraded Slabs	35
3.	Upgraded Slabs	36
4.	Casualty Producing Mechanisms of a Nuclear Explosion	48
5.	Summary of Fatality Estimates for As-Built Shelters Having Flat Plates and Flat Slabs as Ceilings	67
A-1.	Representative Building Structures	A-4
A-2.	Structural Properties	A-14
A-3.	Slab Capacity Evaluation	A-15
B-1.	Estimated Shock Wave Attenuation in Shelters	B-4
B-2.	Approximate Loading Durations as a Function of Location	B-7
C-1.	Overpressures for Equal Dynamic Pressure	C-1
C-2.	Typical Jet Formation Times and Chamber Fill Times	C-3
C-3.	Maximum Fatalities From Jet Translation/Impact in Shelters as a Function of Shelter Size and Opening Area	C-9

Section 1
INTRODUCTION

BACKGROUND

Population protection from nuclear disaster, or most other disasters, can be achieved by two means: removing the population at risk from the area of the disaster or providing adequate shelter in the area of the disaster. Current civil defense planning is based on these two postures and is called Crisis Relocation Planning. Under this concept, the majority of the population, located in the likely targeted areas, would be evacuated to rural host areas. In these host areas, which are expected to be exposed to two psi or less, the evacuated population can be protected by minimal blast and fallout protection.

In spite of this evacuation program, it will be necessary for several million essential workers to remain behind in the risk areas to maintain vital services such as furnishing support to the evacuated population and maintaining production of necessary military equipment and supplies. These persons will require higher levels of protection in adequate shelters. Current planning is to provide risk area personnel shelters capable of surviving peak overpressures of 40 to 50 psi and corresponding levels of other effects.

Shelter will, of course, be required for all of the population in the risk areas and for most of the population in the host areas. Although a program was recently enacted to build prototype key worker shelters, it is not anticipated that funding will be available in the near future to supply shelters for all key workers. Thus, current plans are to utilize available existing structures for shelters, with upgrading to be accomplished during a crisis period to allow these structures to survive the anticipated nuclear environment.

In order for a program to shelter both the risk area and host area populations to be effective, a major prior planning effort by Federal, State, and local civil defense agencies will be required. Included in this effort is the location of suitable existing buildings with basement areas that can be upgraded. Some, of course, are

more suitable for upgrading than others; in the crisis period, with severe limits on the available time, manpower, equipment, and materials, it is necessary for the success of the effort to know the effects level to which structures will survive in their as-built condition, as well as which structures have the best potential for upgrading.

A national shelter survey program has been in existence since 1962. Some 300,000 structures have been identified as potential shelters. Existing techniques for the selection of potential shelter structures, while they give some assurance that a structure will furnish a level of fallout protection, do not, for the most part, differentiate between structures as to the degree of blast or other nuclear effects protection they would provide under as-built or upgraded conditions.

PROGRAM OBJECTIVES

The general objective of this program is to provide practical techniques to facilitate the comparative evaluation of basements being considered for use as either risk area or host area shelters. The project was originally envisioned as primarily structurally oriented, and the work plan specified that so many of each type of floor (or basement ceiling) system would be evaluated each year. Under last year's program, Ref. 1, flat slab systems were investigated. During this current year flat plate and two-way slab on concrete beam systems were investigated. The objective of analyzing each of these systems was to develop damage functions, which are primarily a means of relating structural damage to an overpressure. These would then be used to develop casualty functions, which are a means of relating people casualties to overpressure.

Based on previous research, for example Refs. 2 through 19, it was anticipated that structural response and collapse would be the primary casualty mechanism. With few exceptions, however, these research programs considered in detail only the air blast portion of the nuclear effects and also were concerned only with the basement ceiling and not the effects of the possible collapse of the structure above it. The results of the first and second years of this program have indicated that a valid program on casualty function development should consider more than the structural collapse aspects, i.e., damage functions, and should consider some of the other weapons effects that affect survivability in a shelter either in an as-built or in an upgraded structure. This full range of weapons effects is illustrated in the flow

chart in Figure 1. In this figure it will be noted that a nuclear detonation results in a range of effects: air blast, ground shock, thermal, initial nuclear radiation, and in the long term, fallout. The air blast and ground shock, if of sufficient magnitude, can result in what is termed a damage function, with primary effects of structural collapse, debris and dust, and possible secondary effects of fire spread and secondary fires.

The primary objective of the program is to look at the damage function/casualty function relationships with emphasis on structural damage. In the course of the study it has been determined that some of the other weapons effects and resulting damage mechanisms may be equally as important in the prediction of casualties. This has led to a slightly different approach than was originally envisioned, in that the casualty functions that are being developed are more complicated and in many cases are guided by damage mechanisms other than structural collapse.

It should be noted that the level of effort available in the program has not permitted us to include all of the damage mechanisms. Effort to date has been concentrated on the structural damage related mechanisms (ceiling collapse, missile generation, debris, and dust), the air blast damage mechanisms (direct blast, translation/impact, jet phenomena), and initial nuclear radiation. It is not anticipated that there will be sufficient effort to include fallout or the thermal radiation and fire effects to any significant extent.

It should also be noted that this report presents the results of the second year of what is projected to be a five-year program, and only partial results are available in many of the casualty prediction areas. This report is organized as follows: Section 2 discusses two-way and flat plate reinforced concrete construction. Sections 3 and 4 present the progress to date on the damage function and casualty function rating procedures, and Section 5 presents a summary and the plans for future work on the program. There are seven Appendices: A - Analysis of Representative Buildings, B - Blast Attenuation in As-Built Shelters, C - Jet Flow Phenomena, D - Calculation of Velocity of Missiles From Blast Loading of Exterior Frangible Wall Panels, E - Consideration of Impact With Non-Rigid Surfaces, F - Debris, and G - Preliminary Investigation of the Dust Problem.

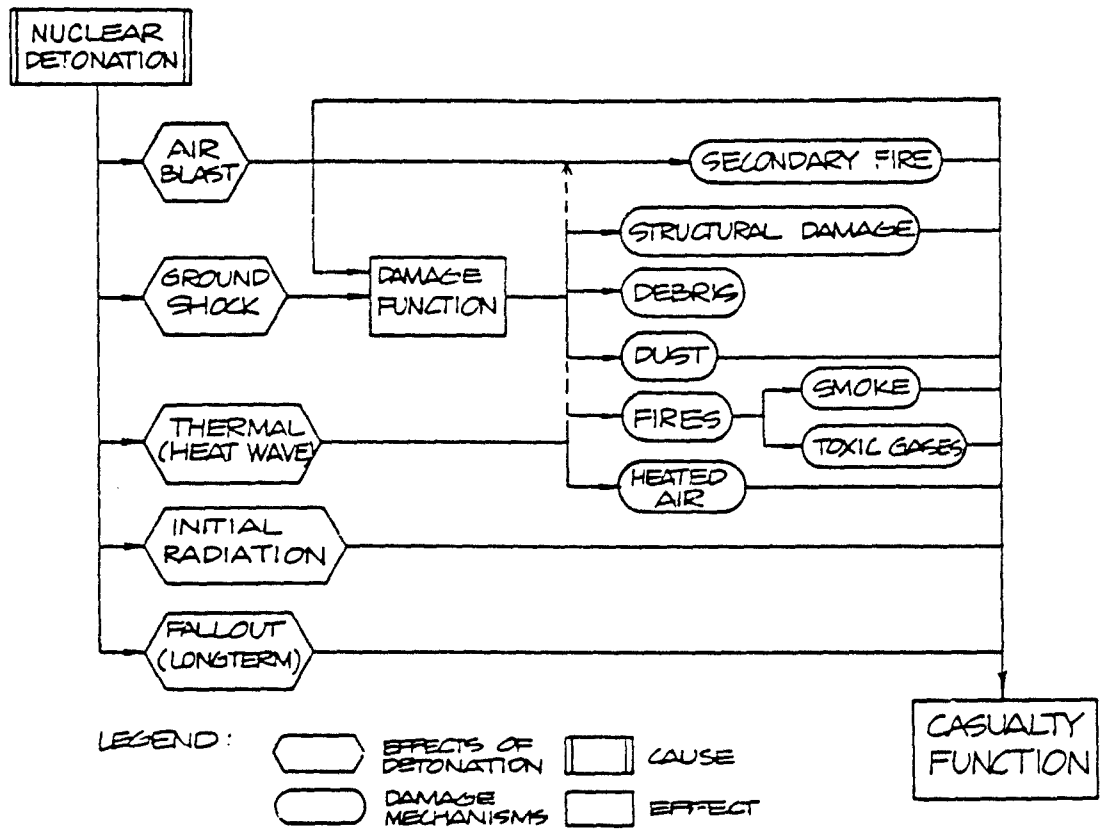

Fig. 1. Damage Function/Casualty Function Relationships.

Section 2
TWO-WAY AND FLAT PLATE REINFORCED CONCRETE CONSTRUCTION

INTRODUCTION

The purpose of this section is to describe and discuss the blast resistant strength properties of reinforced concrete flat plate and two-way slab systems. The objective is to develop damage functions for basement shelters having these types of construction. Both as-built and upgraded (shored) conditions will be treated.

In References 1, 20, 21, and 22 the general definitions, strength characteristics, methods of design, and shoring strength characteristics were given for flat slabs, flat plates and two-way slabs. Portions of the material from these reports will be abstracted in this section so as to provide a reasonably complete basis for the development of upgrading procedures, damage functions and casualty functions for flat plates and two-way slabs. The flat slab system was treated in the first year's report on this program (Ref. 1); however, this section will present improvements on the probabilistic model for the damage function for all slab systems. The casualty functions for flat slabs, as given in Ref. 1, have been revised according to this new model.

Apart from the common one-way slab system, which is designed as a series of adjacent one-foot wide beams, there are three distinct slab systems that employ the two-dimensional strength aspects of plate action.* The three plate action slab systems that exist in reinforced concrete structures are: the flat slab, the flat plate, and the two-way slab. These are shown in Figure 2. In the non-upgraded state, each system has its own unique strength and failure characteristics, both for vertical floor loading and for lateral loading of the complete building structure. These differences in performance characteristics are due not only to the type of slab configuration, but also to the specified design procedures for each type as given in

* Beam action carries load on a one-directional beam span, whereas a simple model of plate action is a load carried by two perpendicular beams, in contact and crossing at their midspan.

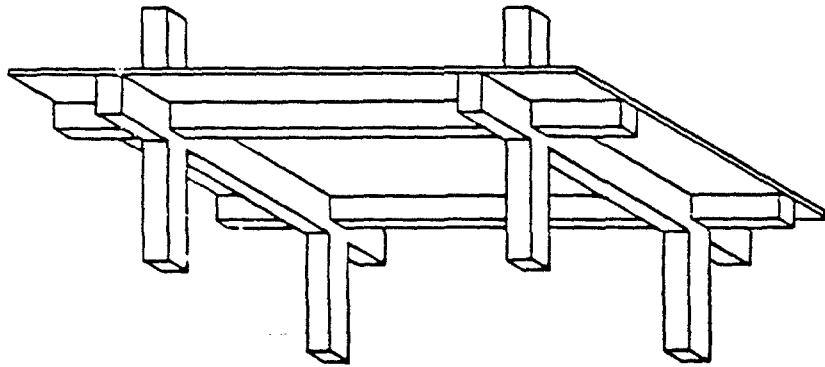
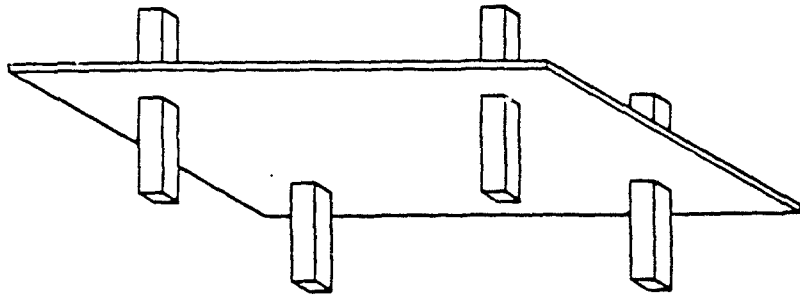
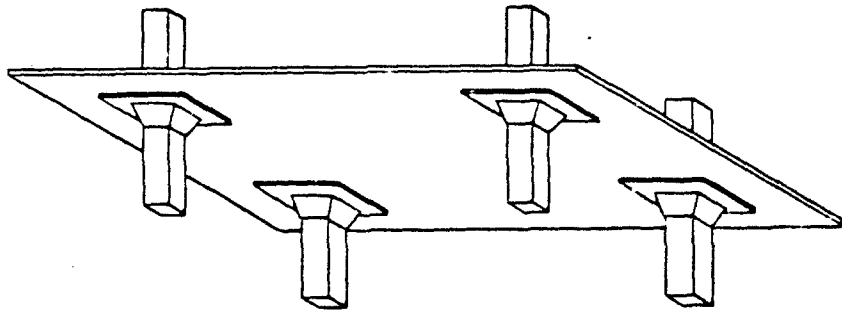

Fig. 2. Typical Examples of Slab Structures.

reinforced concrete building codes. This will be discussed in detail after the following section on resistance mechanisms and failure modes. However, it is important to state here that the differences in non-upgraded performance do not carry over to the upgraded state; all slab systems have nearly identical capacities when properly shored.

RESISTANCE AND FAILURE CHARACTERISTICS

This section will treat slab structure characteristics according to first, slab behavior, given that the supporting elements and slab boundary at these supports do not fail and second, support element and slab boundary behavior.

Slab Behavior Under Conditions of Adequate Boundary Support

Figure 3 shows a typical slab element that may be applicable either to a flat plate system where the element is bordered by the column lines, or to a two-way slab system where this slab element is bordered by the beam lines. The sequence of behavior under increasing levels of vertical load is given in Figure 3:

- a) A definite arch action of the uncracked slab against its support elements;
- b) Development of enough flexural bending and twisting to a state of plate bending action;
- c) Cracking and yielding at maximum moment regions to form a yield line mechanism;
- d) Further yielding and deformation such that the reinforcement develops a tensile membrane or net.

It has been reported in tests and in actual building demolition work that the slab itself can take almost any load, and that failure occurs when the slab tears away from the supports, or the supports fail. Thus, except for the difficulties in repair of highly "dished" slabs, the main avenues of failure are concerned with the slab support boundaries (in shear) and the support elements themselves.

Support Elements and Slab Boundaries

Figure 4 shows the failure modes for the flat plate system. Assuming that flexural yield line behavior is included in the slab element failure modes, then the critical failure mode is either a symmetrical punching shear around the column

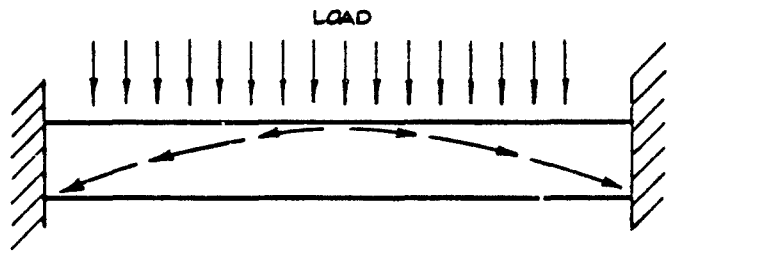

A. ARCH ACTION

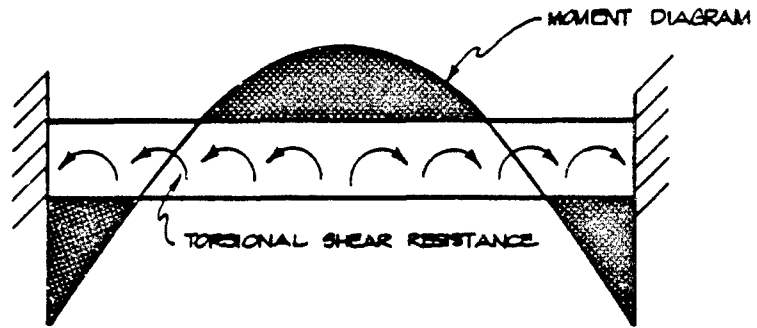

B. ELASTIC PLATE BEHAVIOR

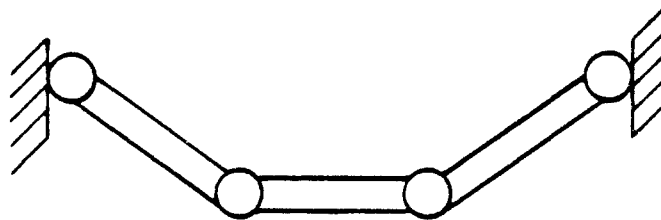

C. INELASTIC PLATE BEHAVIOR OR YIELD LINE MECHANISM

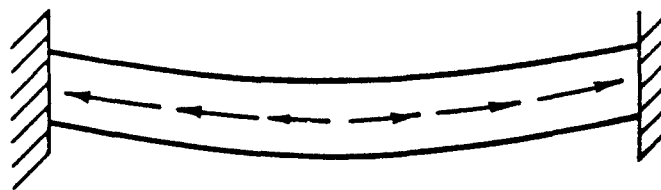

D. MEMBRANE ACTION IN REINFORCING STEEL

Fig. 3. Sequence of Behavior Under Increasing Levels of Vertical Load.

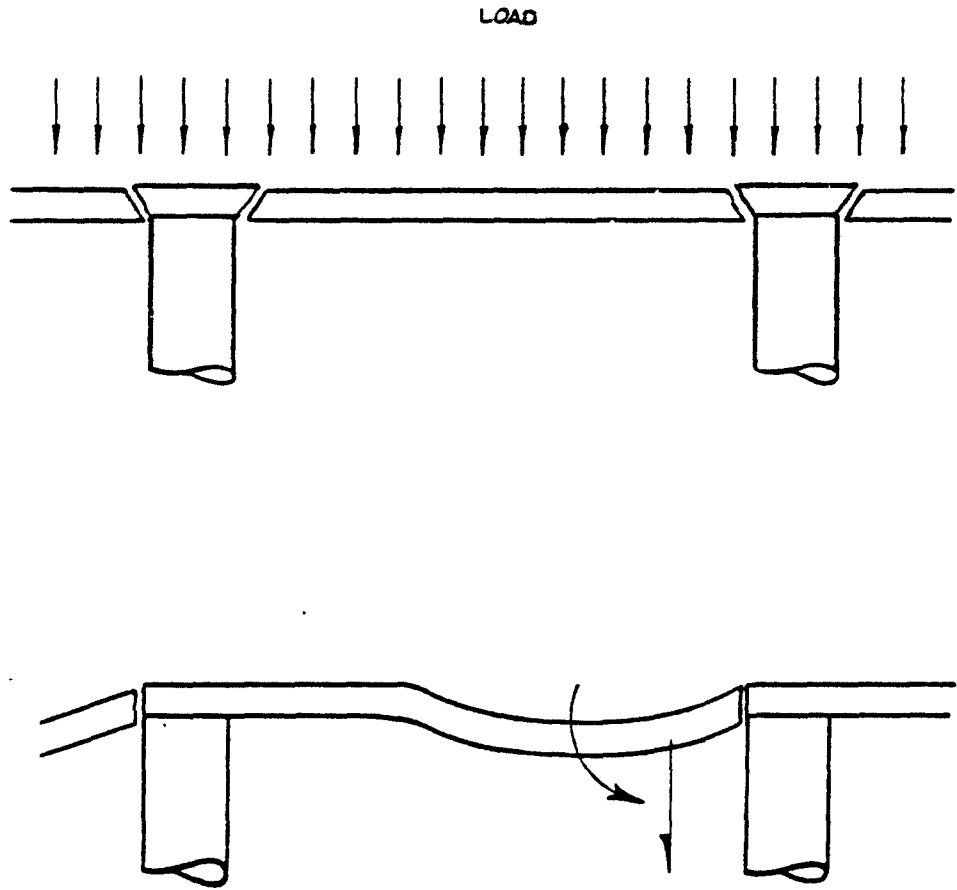

Fig. 4. Failure Modes - Flat Slab System.

support boundary as shown in Figure 4a; or an eccentric or flexural punching shear due to non-uniform loading or non-symmetrical support conditions. This eccentric mode may occur at an exterior span location or as a result of support failure or punching failure at an adjacent span or because of lateral loading of the entire frame. The flexural punching shear failure is shown in Figure 4b. This failure mode may occur whenever there is a moment transfer requirement at the column, and it therefore represents the primary weakness of the flat plate system.

Figure 5 shows the failure modes for the two-way slab support system. Basically these are identical to the modes for an ordinary reinforced concrete frame: Figure 5a is flexure, 5b is shear, 5c is bond development failure and shear, and 5d is column failure. These all may be due to excess vertical load or to combinations of vertical and lateral loads on the entire frame structure.

GENERAL SUMMARY

This summary is given to provide the reader with an overall understanding of the capabilities and weaknesses of slab systems. The detailed discussion and justifications for conclusions have been taken from the stated references.

Flat Plates

Existing flat plate structures as designed by stated code procedures (up to 1971 ACI Building Code, Ref. 23) have a safety factor of about 1.7 to 2 against failure (primarily punching shear around support column) for symmetrical and uniform (all panels loaded) vertical loads, see Figure 6a and Refs. 24 through 28. These structures, however, may have a much lower margin of safety if moment transfer is required at a column joint. Flexural punching shear can occur, because of this moment transfer condition, at vertical load values significantly smaller than the failure loads with symmetrical conditions (Ref. 29), see sketch below.

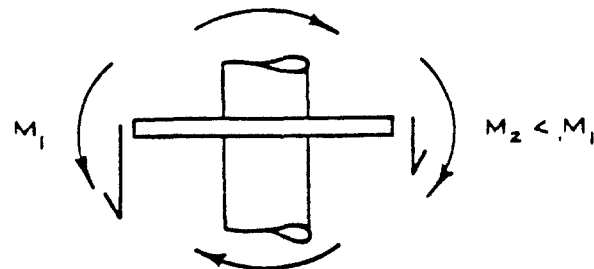

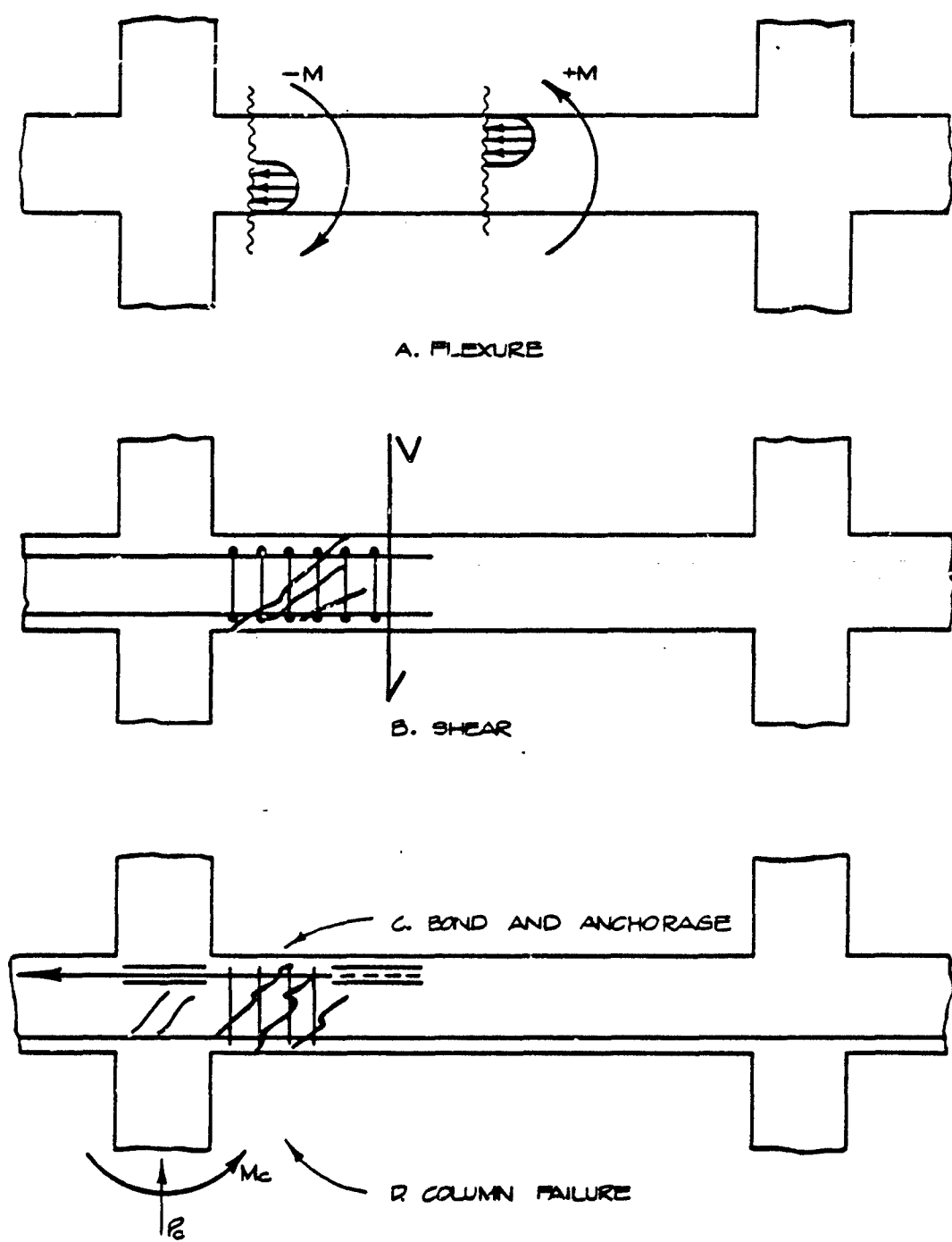
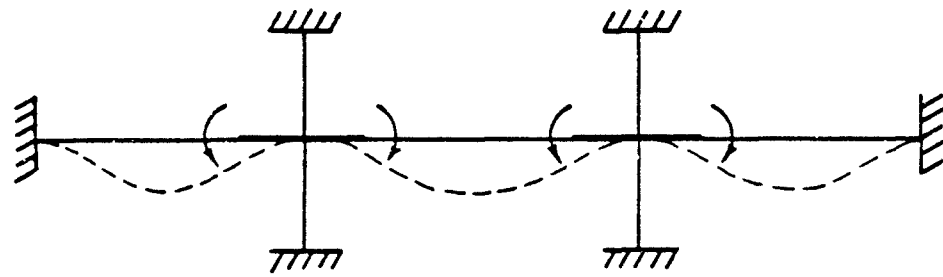
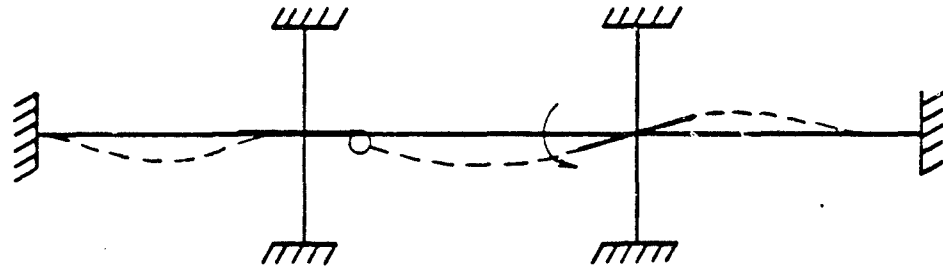
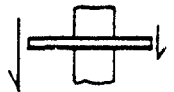

Fig. 5. Failure Modes for the Two-Way Slab System.



A. SYMMETRICAL PUNCHING SHEAR FAILURE



B. NON-SYMMETRICAL FLEXURAL-SHEAR FAILURE DUE TO EITHER NON-SYMMETRICAL LOAD PATTERN OR TO FAILURE OF AN ADJACENT JOINT

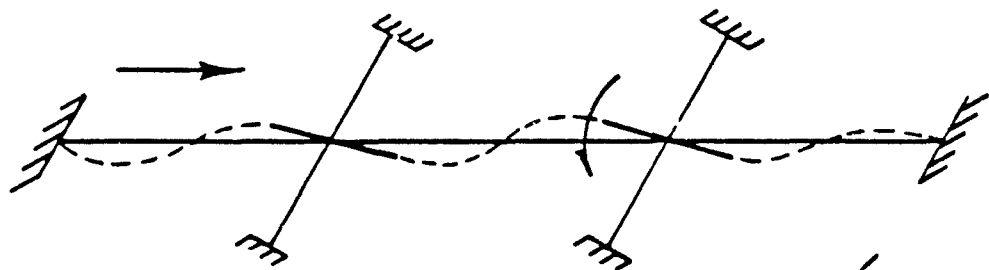
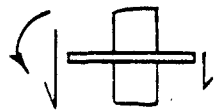

C. NON-SYMMETRICAL FLEXURAL-SHEAR FAILURE DUE TO LATERAL LOADING.

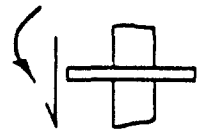

Fig. 6. Failure Modes for Flat Plate Structures.

This flexural shear weakness affects the stability of the entire structure since the moment transfer condition can occur because of the following events:

See Figure 6b, non-symmetrical vertical load pattern, or loss of flexural capacity at one local column joint. In these cases the redistributed moments create the moment of transfer requirements at adjacent column joints and a progressive collapse condition throughout the entire structural frame.

See Figure 6c, lateral loads or deformations create moment transfer requirements at all joints, and progressive collapse can occur if one or more joints fail.

Therefore, the primary function of a strengthening scheme for flat plate systems is support at the slab/support column boundaries where potential flexural shear can occur. The scheme must also provide lateral support so as to protect the basic equivalent frame from moment transfer due to lateral deformation. As a first step, it will be assumed that the structure (i.e., the basement) is braced by walls against lateral deformation.

Two-Way Slabs

Two-way slab structures have been shown, both by tests and by comparison of design procedures (with those for flat plates), to have nearly twice the safety factor of flat plates (e.g., $2(1.7 \text{ to } 2.0) = 3.4 \text{ to } 4.0$) under symmetrical vertical loading (Refs. 25 through 29). Moreover, the design procedure in the ACI code dictates that alternate or non-symmetrical vertical load patterns be considered in the evaluation of design stresses; it is significant to recall that this pattern load condition is not required for flat plate design. The main strength advantage, however, is that the two-way system is free from the flexural-shear problem of flat plates. The beam-column support system resists any imposed moment transfer conditions. Failure mechanisms are flexural-shear failure of the support beams, or torsional shear failure of exterior spandrel support beams, or perhaps column failure due to combined axial load, shear, and flexure. Therefore, a primary function of a strengthening scheme for two-way slabs is to provide support at beam sections subject to shear failure and lateral bracing for control of lateral load deformation on the frame.

The principal weakness of the beam-column support frame is caused by the

"economical" code provisions for reinforcing steel. These provisions -- such as the allowed cut-off of all negative moment steel at the 1/4 span length, or the "non-requirement" of stirrups when calculated shear stress is below a given limit -- are justified by the moment and shear diagrams for the design vertical load conditions on the all-elastic structure. No safety margin is available if these load diagrams change significantly owing to redistribution caused by inelastic behavior or failure at one or more locations; and certainly no provision is made (except in seismic zones) for lateral load effects. These conditions (not included in the standard design) may cause radical changes in shear and moment requirements. Thus, in the classical, very common economically designed, two-way system there are potential weaknesses due to lack of some continuous negative steel and stirrups at possible failure sections such as section A-A in Figure 7. It is important to recognize that economics or the understandable quest for minimum cost and maximum profit can generate two sources of weakness in the slab capacity of existing structures. First, engineering design office economics dictate that standard (or empirical coefficient) design for vertical loads be used whenever possible. Therefore, there will be very few cases where any extra analysis (and reinforcement) will be added beyond "code" requirements. This means that resistance to non-calculated lateral loads or moment redistribution will not be present. Second, the economics of construction related to reinforcing steel fabrication (cutting and bending) dictates that the use of bent or truss bars be avoided whenever possible. These bent bars are both hard to fabricate and difficult to place in comparison with multiple straight bars. Therefore, the lines of continuous reinforcement as furnished by the bent truss bars will become more rare as time goes on (and costs go up). This will significantly affect the final development of slab membrane action (which is so well evident in slab blast tests in Refs. 30 and 31), see Figure 8.

The literature concerning slab and related reinforced concrete behavior is listed in the reference section. In addition to those papers already quoted with respect to slab performance, the following categories are given:

Punching shear prediction: Refs. 32, 33, 34, 35, 36 and 37
Slab analysis by beam and frame analogy: Refs. 34 and 38
Dynamic blast tests: Refs. 30, 31 and 34
Slab analysis with elastic supports (basis for elastic strut action): Refs. 39 and 40

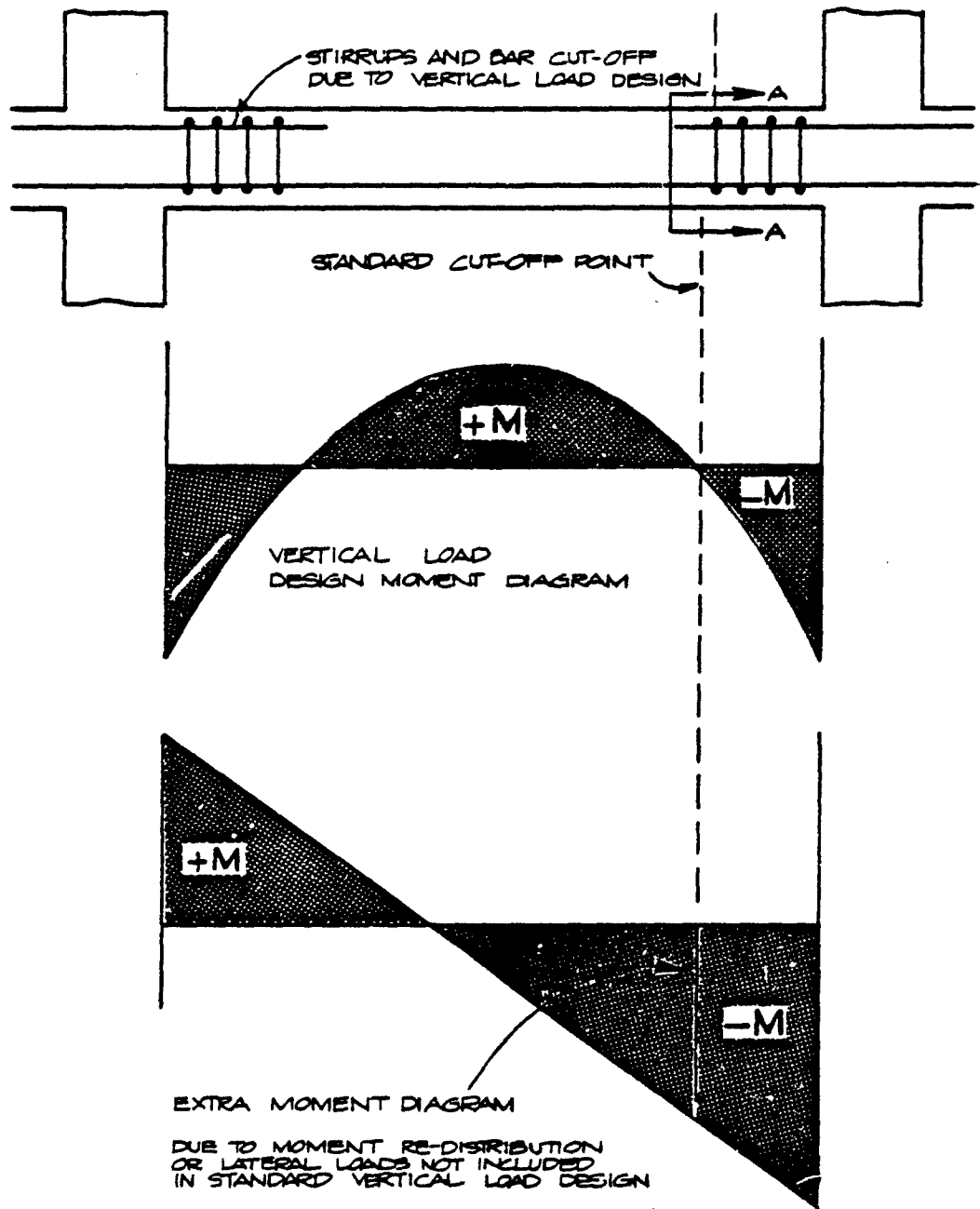

Fig. 7. Weakness of a Two-Way Slab System.

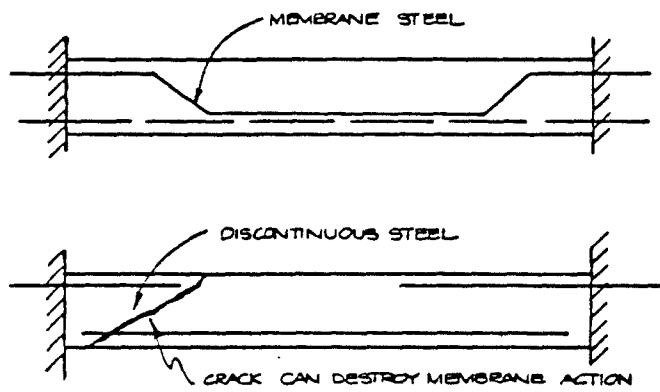

Fig. 8. Slab Steel Cut vs Bent Bars.

UPGRADING CHARACTERISTICS OF FLAT PLATES

These plate systems have several properties and characteristics that can strongly influence their strength and feasibility for upgrading. Those that are disadvantages are:

- o A lower design safety factor with respect to two-way slab design capacity
- o A weak limit-state yield line pattern
- o Punching shear weakness at column supports
- o Weak lateral stability

Those that are advantages are:

- o A uniformly thick and strongly reinforced slab surface
- o Simplicity of shoring layouts for upgrading

These topics will be discussed in detail in the following paragraphs.

A Lower Safety Factor

Both flat slabs and flat plates are governed by the same empirical design procedure, which evolved during the commercial development of flat slab buildings in the early part of this century. This empirical method used an 8/10 reduction of calculated statical moments due to uniform distributed dead and live loads, with no alternating live load patterns. On the other hand, two-way slab systems, since they are logically modeled as classical rigid frames, are designed for both the statical moments and for increased negative and positive moments due to live load patterns. Further, the beams of the two-way slab provide complete edge supports for the slab panels, and the punching shear condition of flat plates is not present because of the beam-column support configuration. While recent building codes (such as ACI 318-71, Ref. 23) have increased flat slab and flat plate design requirements to make them compatible with two-way slab design, the major portion of existing flat plate structures (built from 1950's to middle 1970's) would have the "weaker" design properties.

A Weak Yield Line Pattern

In Figure 9, the yield line patterns are shown for both the flat plate and the two-way slab. For a typical multiple bay floor plan, and for equal slab thickness the limit load capacity of the two-way slab yield line pattern is 1.5 to 2 times stronger than the flat plate pattern. Therefore, considering both the design safety factor

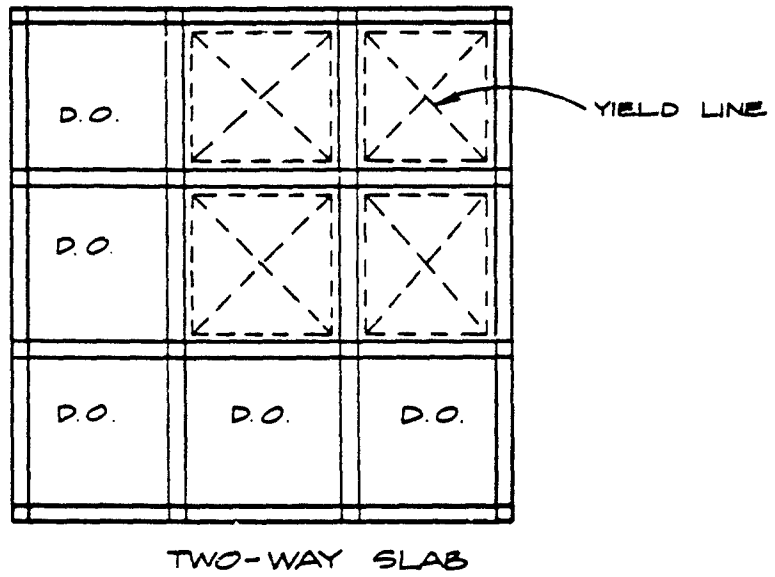
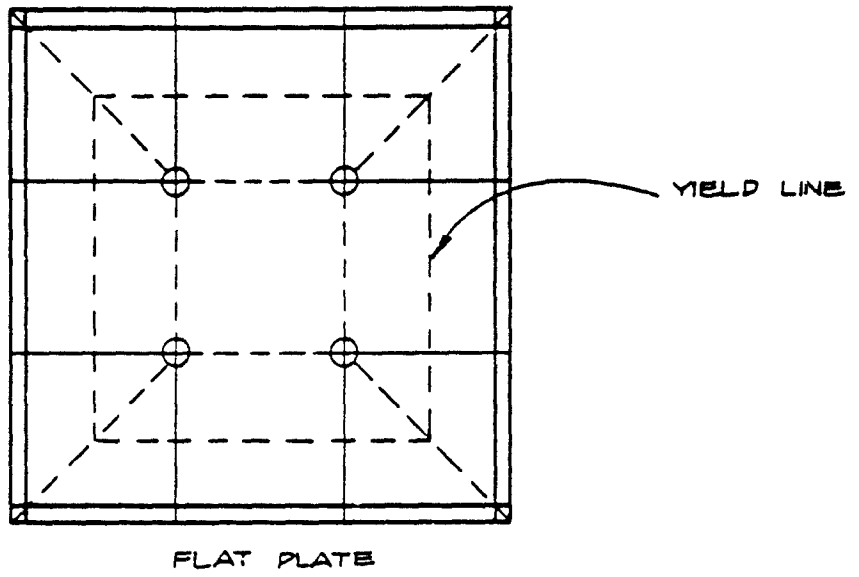

Fig. 9. Yield Line Patterns for Slab Systems.

difference and this yield line effect, a two-way slab system is easily twice as strong as an equivalent span flat plate system in the non-upgraded state. However, it will be shown that with an effective upgraded shore configuration, the flat plate has slab strength properties that can overcome this initial strength difference. The primary weak point of column punching shear in flat plates usually requires an overall extra slab thickness, which can provide for a very strong upgraded shored system.

Punching Shear

Clearly, the weak point of a flat plate system is the low punching shear capacity at the column support points. While special reinforcing or steel shear head details can improve the punching capacity, these are expensive and not particularly effective in reducing slab thickness requirements. Therefore, where ordinary two-way slabs can have a 4 to 6 in. thickness, the flat plate requires 6, 8, and even 10 in. thicknesses to satisfy punching shear requirements. The flexural strength requirements are nearly equal for both two-way and plate systems; however, it is important to note that the first step in the design of a flat plate is to choose a thickness that will satisfy punching shear requirements.

Weak Lateral Stability

From the preceding discussion concerning flat plate behavior, it was shown that the column-to-slab interface snaps off like a cap on a beer bottle when there is either side loading or an imbalance of vertical loading on adjacent slab spans (see Figure 10). This unbalanced shear weakness of the column support makes the non-shored slab system exceedingly fragile and prone to total collapse; where any local panel failure would propagate unbalanced moments, shears, and side loads to the remaining spans. The qualitative result, in terms of the damage effects curve (see Section 3), is a steep rate toward total failure. This is shown with comparison to a non-upgraded two-way slab system in Figure 11. Of course, when the flat plate is shored, then the column is shielded from the destructive unbalanced shear and the behavior is much the same as for the upgraded two-way slab system. In fact, the shored flat plate may have better strength performance because of its greater thickness and extra density of reinforcing steel in the slab panel areas. Therefore, properly shored flat plates, having proper shore grouping for column protection, are viable shelter systems from a strength standpoint. It is most important that the shoring be braced laterally (either by friction wedge action, bracing or kick plates) so that it will not be displaced by debris or blast jet action. There is perhaps one item of concern -- can stable blast and debris resistant shoring be installed without

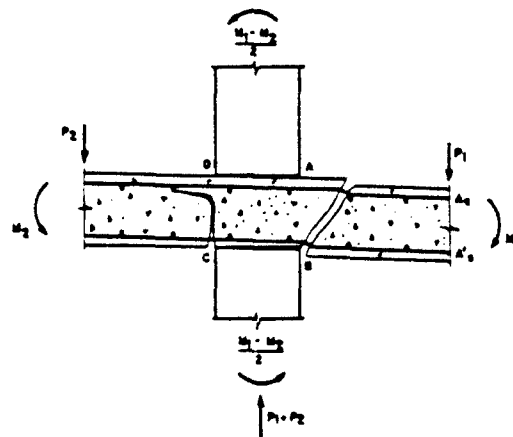
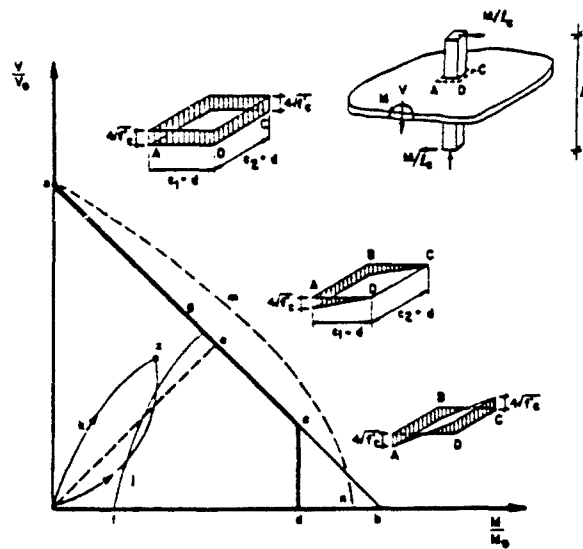
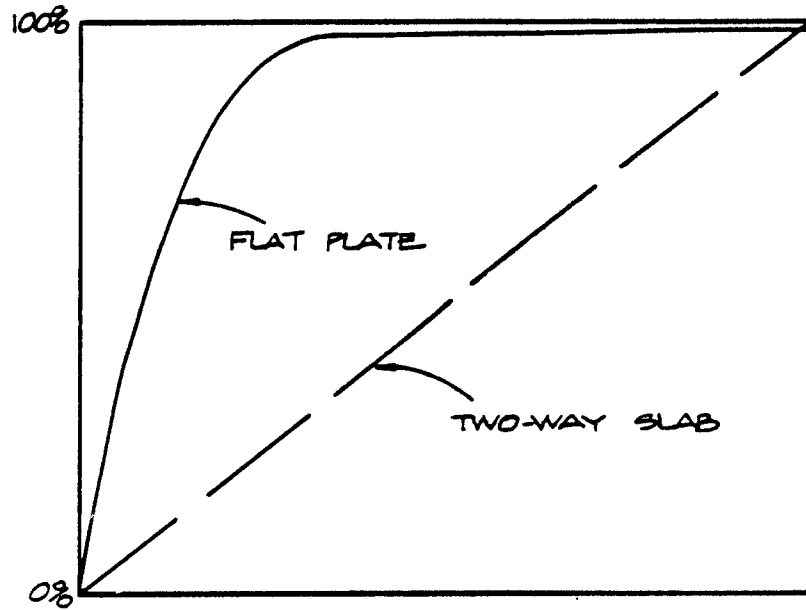
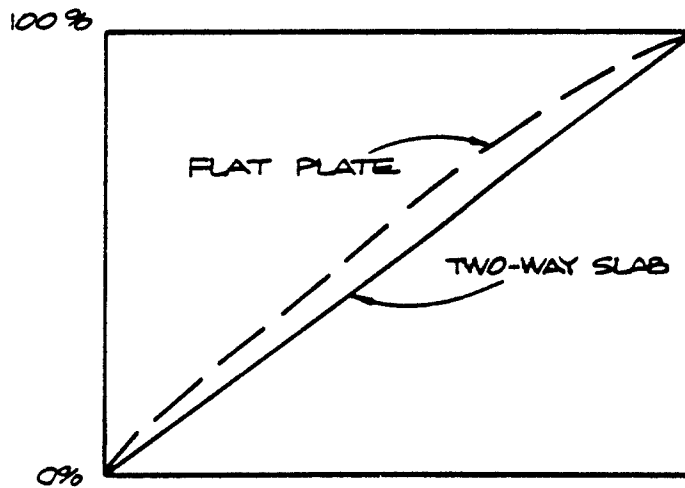

Fig. 10. Moment-Torsion Failure of Interior Slab-Column Connection.



NON-UPGRADED DAMAGE EFFECTS CURVE



UPGRADED DAMAGE EFFECTS CURVE

Fig. 11. Damage Effects Curves.

excess installation labor and materials and skill, and without excess obstruction of shelter space?

The Advantages of the Uniform Thickness of Flat Plate

The principal advantage of a flat plate system is its clear unobstructed ceiling surface; without drop panels or column capitals. This offers a maximum number of stories for a given structure height, along with the clean line quality of architectural expression. Therefore, the extra concrete volume material cost, can in many cases, be offset by simplicity in construction formwork and by the mobility and repetitive use of this formwork.

From the standpoint of shelter upgrading by a selected shoring scheme, the uniform plate thickness also provides the very important advantage of using equal shore lengths, where these do not have to be cut to fit the drop panel areas or the beam soffits of flat slabs and two-way slabs. Given the uniform floor to ceiling height, the shores can be quickly placed without the sorting and stockpiling efforts necessary in the variable height slab systems.

Shoring Scheme for Flat Plates

In order to prevent column punching failure, it is necessary to provide additional shoring around the column, as shown in Figure 12. The objective is to create a type of equivalent "drop panel" support for the column. The extent of this column shoring should be a distance B_u ; such that when punching shear capacity is evaluated on the perimeter $4B_u$, then this capacity should equal or exceed the modes of shoring failure in the inner supported area of the slab. Slab overpressure resistance will then be equal to the shoring capacity of the interior panel area. The shoring width B_u will be conservative and will provide punching strength in excess of interior panel shore capacity if arch action is neglected. B_u can be evaluated by:

Column Load = Punching Capacity

$$V_c = w_B t^2 = 4 \sqrt{f'_c} (B_u t)$$

Example evaluation of B_u :

$$w_B = 40 \text{ psi}$$

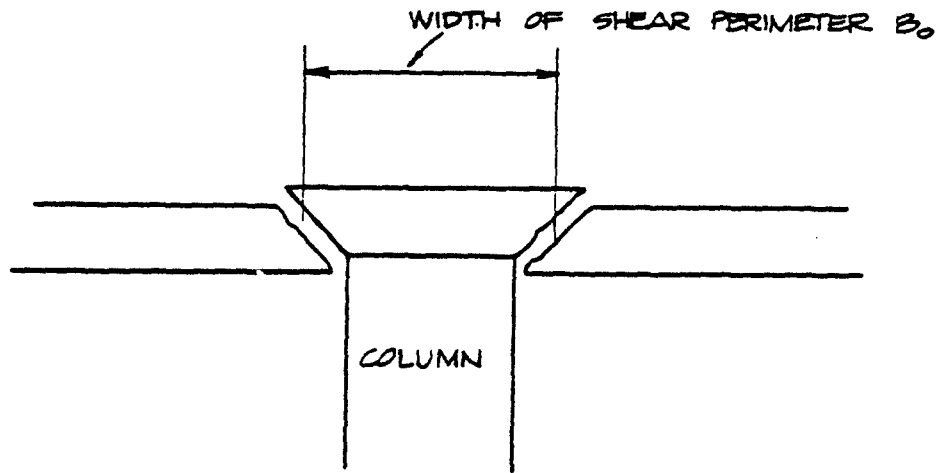

PUNCHING FAILURE MODE FOR NON-UPGRADED FLAT PLATE

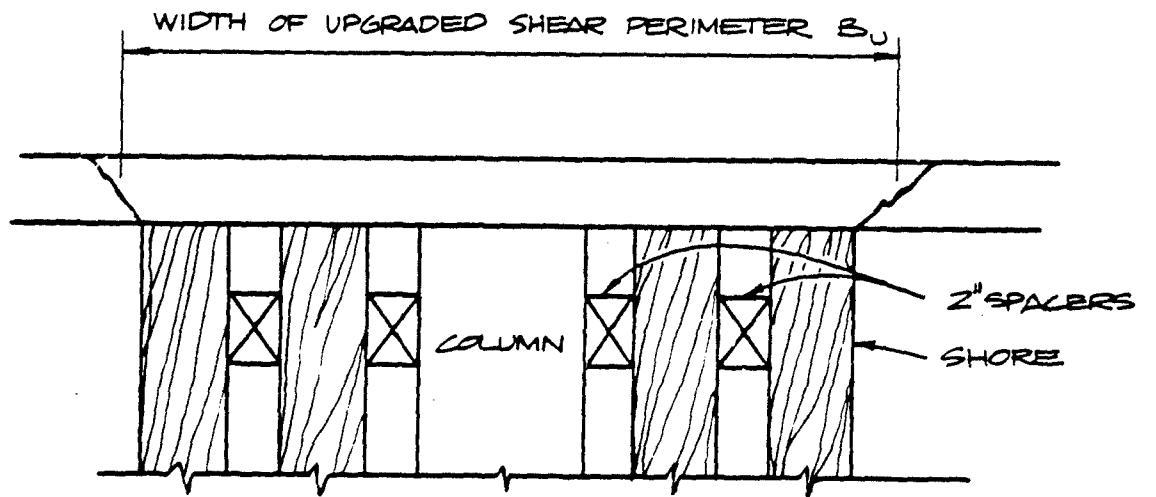

PUNCHING FAILURE MODE FOR UPGRADED FLAT PLATE

Fig. 12. Punching Shear Shoring Conditions.

Shore Space $\ell = 5$ ft

Slab $t = 6$ in.

$$f'_c = 3600 \text{ psi}, 4 \sqrt{f'_c} = 240 \text{ psi}$$

$$V_c = (40 \text{ psi})(144)(5^2) = (240 \text{ psi})(B_u)(6)$$

giving $B_u = 25$ inches, for a column $D = 12$ in. x 12 in., 6 in. x 6 in. shoring, 2 in. spacer. A typical column shoring scheme is shown below.

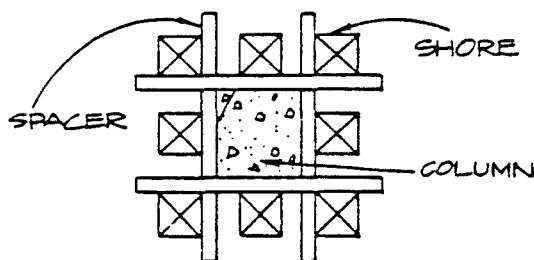

The remainder of the shoring scheme involves support of the interior panel and column strips. With the absence of any type of beam support it is necessary to provide this support by means of shoring along the column lines; then, the interior of the panel area is provided with a square pattern of shores, see Figure 13. The decision concerning shore spacing, ℓ , such as at third points, $L/3$ or quarter points $L/4$ should be based on the punching shear capabilities of the slab.

UPGRADING CHARACTERISTICS OF TWO-WAY SLABS

For the purpose of upgrading, the two-way slab system with its framing beams is nearly ideal. The beams can be shored to prevent beam shear or flexure. These same shores take out vertical load and thereby serve to protect against column buckling. The beams provide a continuous perimeter support for the slab such that full membrane action could develop in the event of slab shore failure. Finally, when the slab panel is supported by interior patterns of shores with the minimum spacing required to prevent punching failure, then a very stable and strong system is produced.

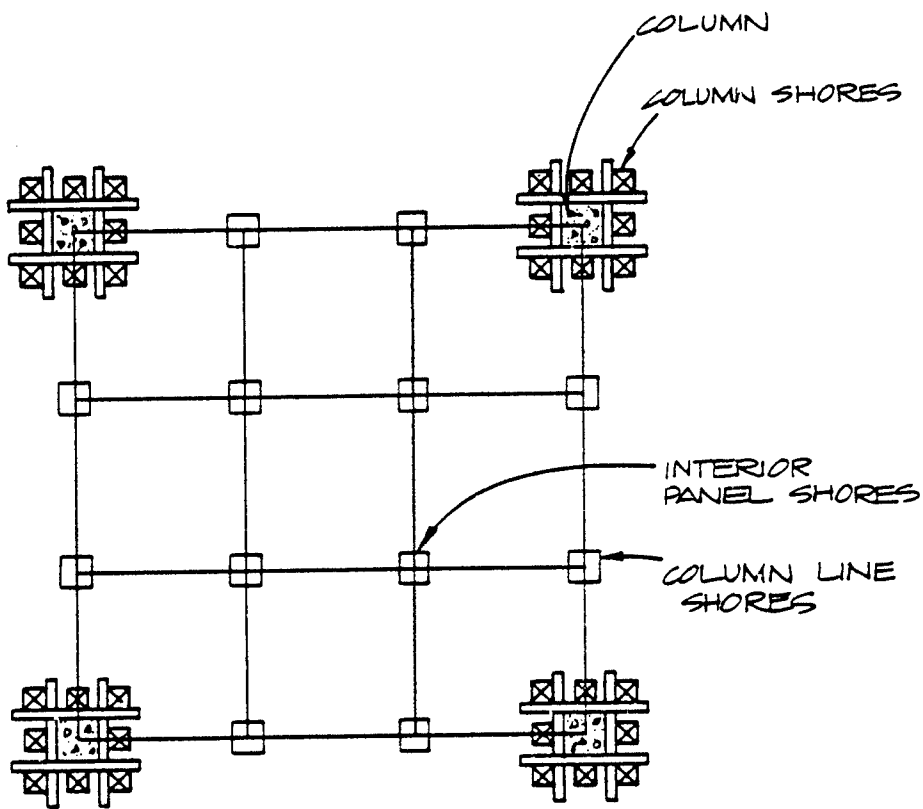

Fig. 13. Flat Plate Shoring Scheme.

The two-way slab, because of its backup beam framing, does not have the fragility and associated disadvantages of the flat plate. The beams provide an ideal support for the interior slab panel.

Shoring Scheme for Two-Way Slabs

Ordinarily, unless the imposed blast load w_B is exceptionally large, it is not necessary to provide shoring under the beams of the two-way system. Shores need only be placed in the interior panel area such as shown in Figure 14a. The spacing is chosen according to the punching capacity of the slab (see Table A-1 of Ref. 22).

For heavy w_B loading, the beam support shoring of Figure 14b may be necessary to prevent either slab shear failure at the beam edge, or beam failure. Double-sided beam shoring (as shown) can be used, or single shores can be placed under the beam soffit; these, however, would require a shortening of the standard shore length, and rather than cutting to length, it may be easier to put in the pairs of shores at the sides of the beam.

THE GENERAL CHARACTER OF SHORED SLAB SYSTEMS

Unshored Case with Normal Loads

The three types of plate action slab systems, flat slab, flat plate, and two-way slab, each have particular types of advantages for normal (not shelter) use. Flat slabs have maximum story clearance along with the drop panel (and column capital) protection against column shear; flat plates have the clear unobstructed surface for ease of formwork; and two-way slabs have both maximum strength and minimum materials requirements. The choice of which slab system to use is usually dictated by either or both of the particular advantages of architectural form or construction. For the usual span lengths, any one of the slab systems can be designed to satisfy load criteria. Structural strength requirements can easily be satisfied by relatively small changes in thickness and amounts of longitudinal reinforcing. For example, if panel span is 20 feet, a 7-inch slab will do for any system with the only difference being the rebar spacing of 6 to 12 inches for flat plate to two-way systems. Similarly if span is 30 feet, then a 10-inch slab could do for all systems.

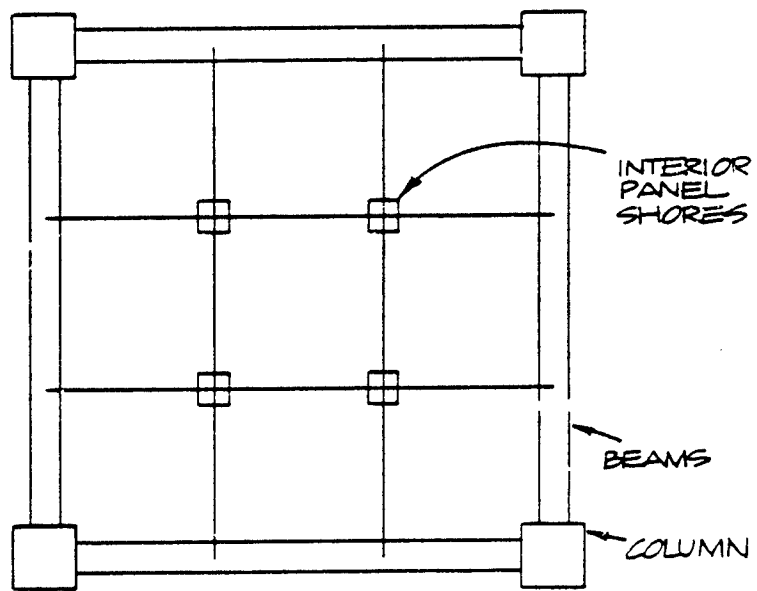

a. Moderate w_B (low and medium load range)

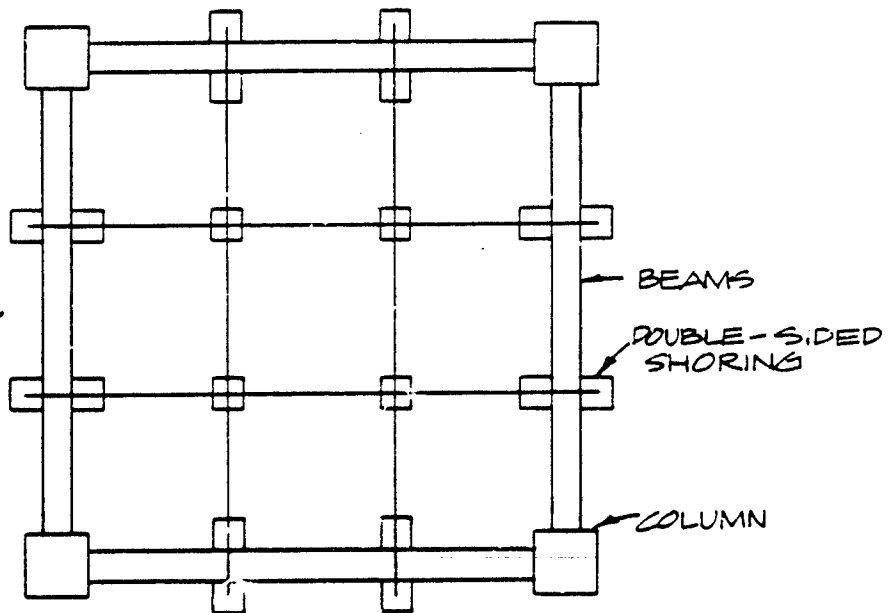

b. Heavy w_B (high load range)

Fig. 14. Two-Way Slab Shoring Schemes.

Shored Slabs Under Blast Loading

Now, what is most important to recognize, is that when any slab system is properly shored, where columns are supported for punching shear and where shore spacing provides adequate arch action for slab punching shear, any slab system of given thickness and span can be made to match the shored capacity of any other slab system. There will be minor variations in shore groupings around columns and in shore spacing, but these are relatively insignificant in any upgrading program. Therefore, it is concluded here that only the panel span and slab thickness are of real concern in establishing any level of upgraded shored overpressure capacity, and that the type of slab system is really not an important factor in either the cost or practicality of a shoring program for given overpressure load levels.

Section 3

DAMAGE FUNCTION RATING PROCEDURE DEVELOPMENT

In the first year's report (Ref. 1) simple damage and casualty functions were proposed, using the assumption that casualty rate was equal to the probability that the slab structure capacity, W , would be less than the imposed blast loading, w_B . This simple model therefore implied that a 100% casualty rate would occur if the slab structure failed, as indicated by the event of capacity, W , less than load, w_B . For the purpose of evaluating the probability of the event ($W \leq w_B$), this model assumed that the slab capacity, W , was a normally distributed (Gaussian or bell-shaped) random variable, with a mean value of w_c or w'_c equal to the predicted or calculated capacity, and with a standard deviation of $\sigma = 0.10 w_c$ or $\sigma' = 0.15 w'_c$ (where w_c and σ are for the non-upgraded case, and w'_c and σ' are for the upgraded case).

In this present report, a damage ratio model is given in which a more realistic variable casualty rate occurs when the slab fails ($W \leq w_B$), and a more realistic log-normal probability distribution function is employed for the slab fragility curve.

DEVELOPMENT OF THE SLAB FRAGILITY CURVE

The symbols used in this section are defined in Table 1. All loads and capacities are in pounds per square foot (psf) unless otherwise noted. The following values and relations are based upon those developed in Ref. 1:

$$w_{DL} = 10 \sqrt{w_{LL}} \quad (\text{an approximate empirical rule})$$

$$w_{LL} = 40, 75, 100, 150, 250 \text{ psf will be considered.}$$

$$w_{DL} = 63, 87, 100, 122, 158 \text{ psf, corresponding to the five } w_{LL} \text{ values}$$

$$w_{SL} = 200 \text{ psf}$$

Table 1
SYMBOLS AND DEFINITIONS

w_{DL} = Dead Load
 w_{LL} = Live Load
 w_P = Flexural Failure Load
 w_{SL} = Radiation Soil Cover Load
 w_c = Computed Blast Load Resistance
 W = Actual Random Resistance
 \bar{w} = Median Value of W
 V_W = Coefficient of Variation of W
 w_B = Specified Blast Loading
 v_c = Column Punching Shear Stress (ksi)
 A_V = Punching Shear Perimeter Area (in.²)
 $P_V = v_c A_V$ = Column Punching Shear (kips)
 f_c = Column Buckling Stress (ksi)
 P_c = Column Buckling Load (kips)
 $\Delta w = w_B - w_c$

Note: Primes such as w' indicate upgraded slab conditions.

Upgraded Slab

Given the shoring span fraction L/f , where $f = 2, 3, 4, 5$ ($f = 3$ and 4 used in this report),

$$w'_F = f^2 w_F$$

$$w_F = 2 (w_{DL} + w_{LL})$$

for both the flat plate and the two-way slab.

$$w'_c = w'_F - w_{DL} - w_{SL}$$

Non-Upgraded Slab

$$w_F = 2(w_{DL} + w_{LL}) \text{ for flat plate}$$

$$w_F = 4(w_{DL} + w_{LL}) \text{ for two-way slab}$$

Note that the doubling of w_F for the two-way slab does not apply to the upgraded slab, since both flat plate and two-way slabs have nearly equal flexural behavior within the shored spans. The double load factor is to allow for extra design strength and stronger yield hinge pattern in the unshored two-way slab.

$$w_c = w_F - w_{DL} \text{ for both slab systems}$$

Probabilistic Model for W

The actual slab capacity W (or W') is assumed to be a log-normal random variable, such that the natural logarithm ($\ln W$) is a normal random variable (gaussian probability function) with mean value

$$\overline{\ln W} = \ln \bar{w}, \text{ (the logarithm of the median } \bar{w}\text{),}$$

and standard deviation

$$\sigma_{\ln W} = V_W \text{ (valid for coefficient of variation } V_W \leq 0.2)$$

It is further assumed that the calculated capacity w_c (or w'_c) is a 95 percent lower bound on W such that

$$P(W > w_c) = P(\ln W > \ln w_c) = 95\%$$

This 95 percent bound allows the relation

$$\ln \bar{w} = \ln w_c + 1.64 V_W$$

where 1.64 is the standardized normal distribution value for a one-sided 5 percent tail, see Figure 15. This relation allows the construction of what may be termed a fragility curve on log-normal graph paper.

Fragility Curve for Slab Failure

Figure 16 shows a straight line plot on log-normal probability paper. This plot provides the "fragility" or probability of failure of a given slab system due to any specified blast load w_B . The line is determined by two points:

- (1) w_c at the 5 percent abscissa value, corresponding to $P(W \leq w_c) = 5\%$ and
- (2) \bar{w} at the 50 percent value, corresponding to $P(W \leq \bar{w}) = 50\%$ (the statistical definition of a median value).

Note that these points are plotted at their arithmetic psf values. The vertical log-scale converts these to the log values. Also the log (Base 10) scale of the paper does not affect the natural ln relation because $\log w = 0.4343 \ln w$, a linear scale relation.

These fragility curves have been developed for the five w_{LL} values for non-upgraded and upgraded slab systems: calculated values are given in Tables 2 and 3 and the curves in Figures 17a, 17b, 18a, and 18b. The upgraded fragility curves are applicable to both flat plate and two-way slabs and may also be used for flat slab systems.

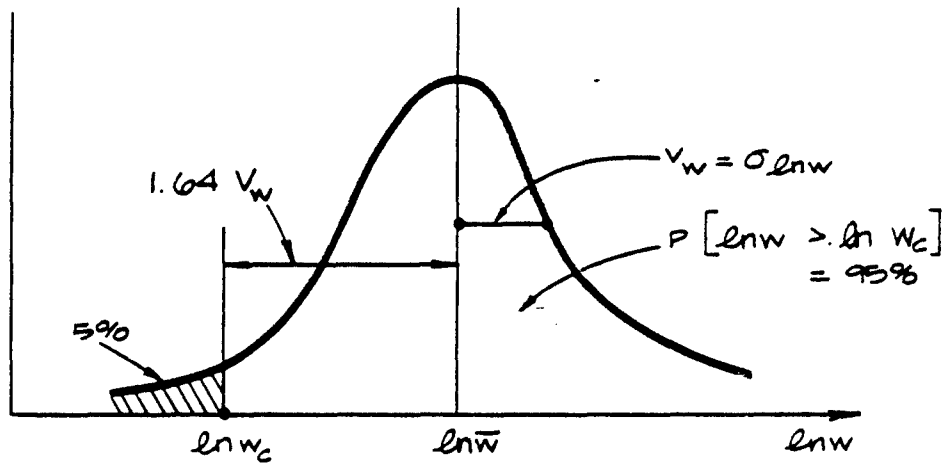

Fig. 15. Log-Normal Model for W.

LOG W SCALE

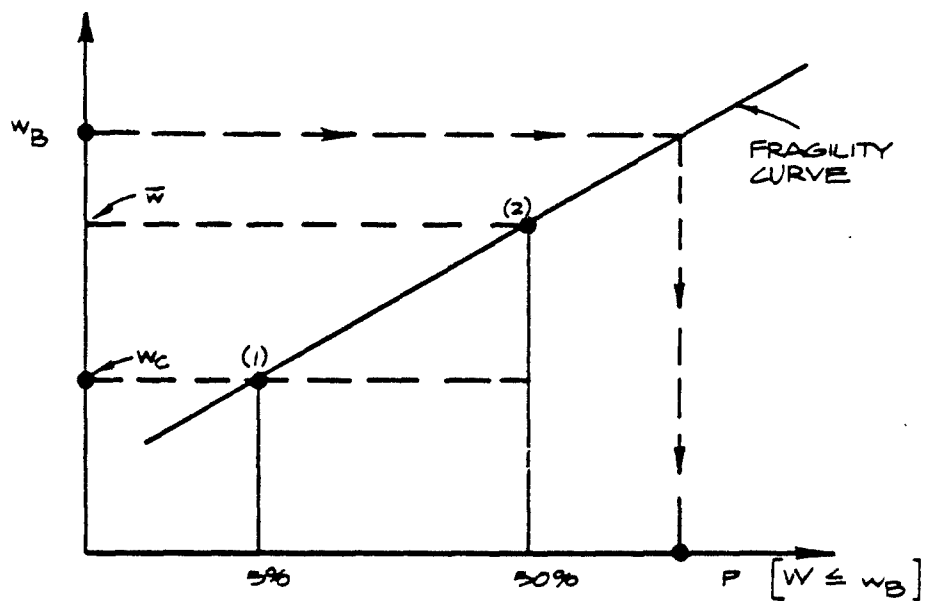

Fig. 16. Fragility Curve Plot on Log-Normal Probability Paper.

Table 2
NON-UPGRADED SLABS

Flat Plate

w_{LL}	w_{DL}	w_F^*	w_c	\bar{w}
10	63	206	143	168
75	87	324	237	279
100	100	400	300	353
150	122	544	422	497
250	158	816	658	775

*To be used in calculation of w'_c for two-way slab

Two-Way

w_{LL}	w_{DL}	w_F	w_c	\bar{w}
40	63	412	349	411
75	87	648	561	661
100	100	800	700	825
150	122	1,088	966	1,138
250	158	1,632	1,474	1,737

Table 3
UPGRADED SLABS

Flat Slabs and Two-Way Slabs (L/4 Shoring)

w_{LL}	w_{DL}	$16w_P$	w_c'	\bar{w}' psf	\bar{w}' psi
40	63	3,926	3,663	4,685	33
75	87	5,184	4,897	6,263	43
100	100	6,400	6,100	7,801	54
150	122	8,704	8,832	10,720	74
250	158	13,040	12,682	16,219	113

Upgraded Slabs (L/3 Shoring)

w_{LL}	w_{DL}	$9w_P$	w_c'	\bar{w}' psf	\bar{w}' psi
40	63	1,854	1,591	2,035	14
75	87	2,916	2,629	3,362	23
100	100	3,600	3,300	4,220	29
150	122	4,986	4,664	5,965	41
250	158	7,344	6,986	8,934	62

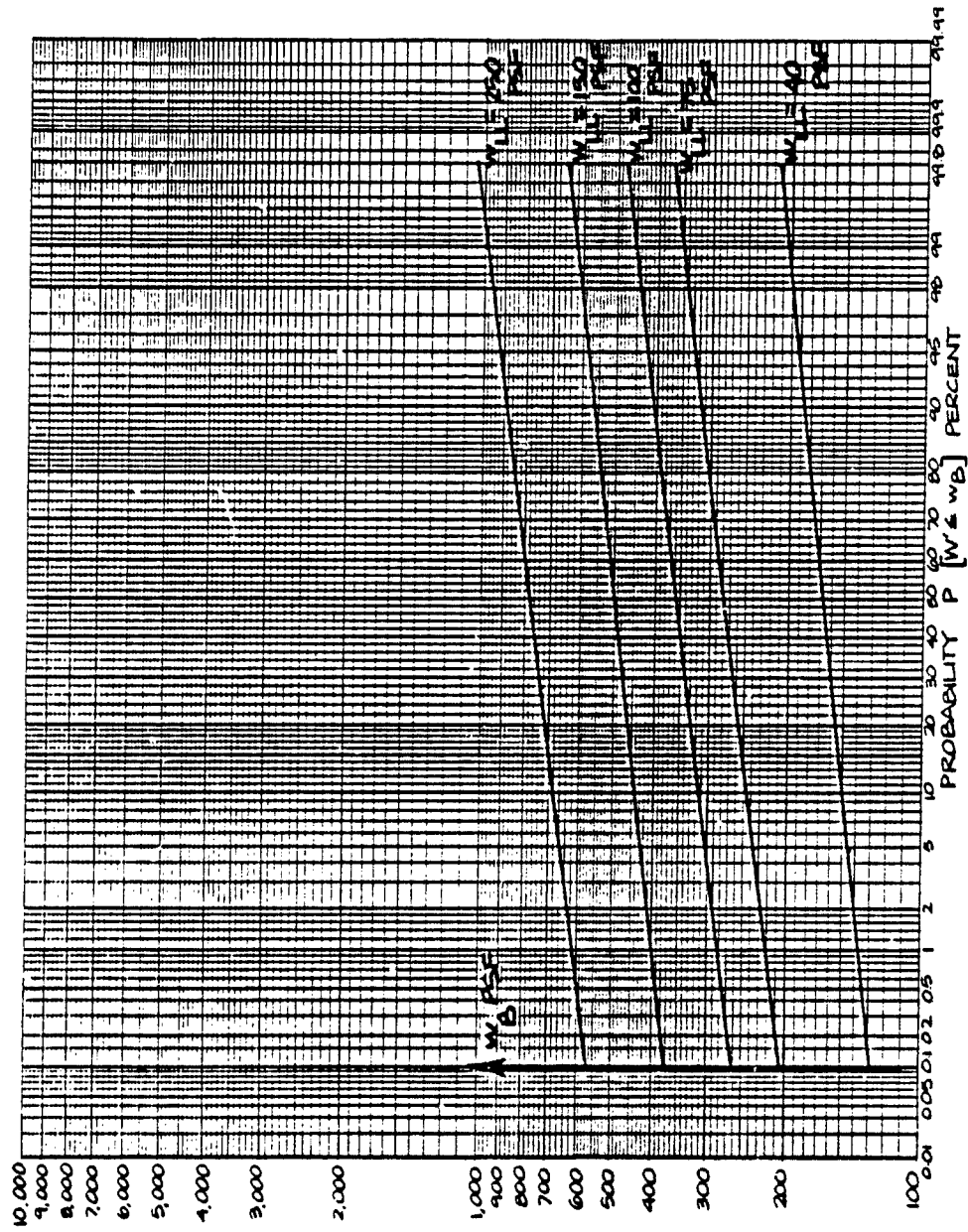

Fig. 17a. Fragility Curves for Non-Upgraded Flat Plate Slabs.

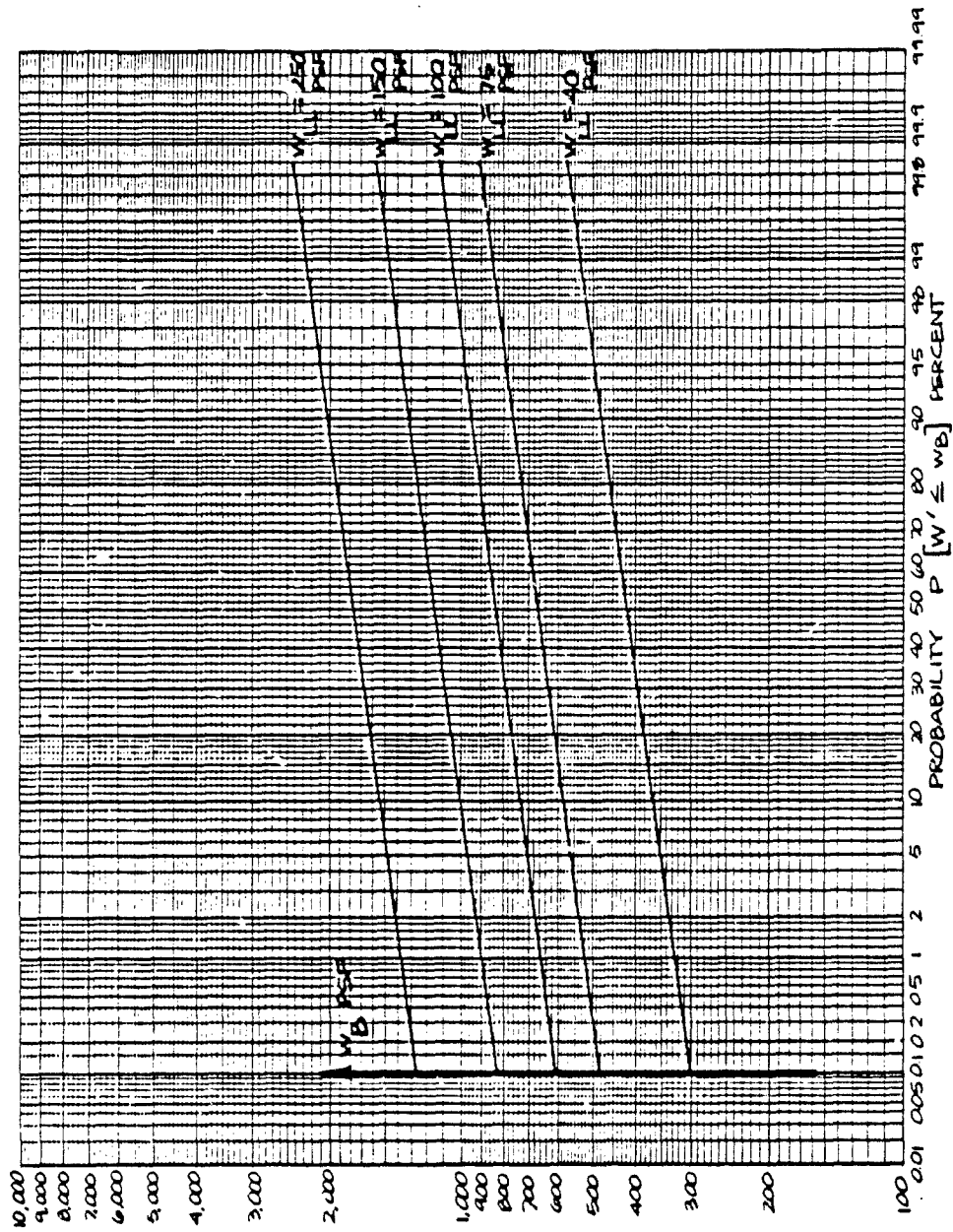

Fig. 17b. Fragility Curves for Non-Upgraded Two-Way Slabs.

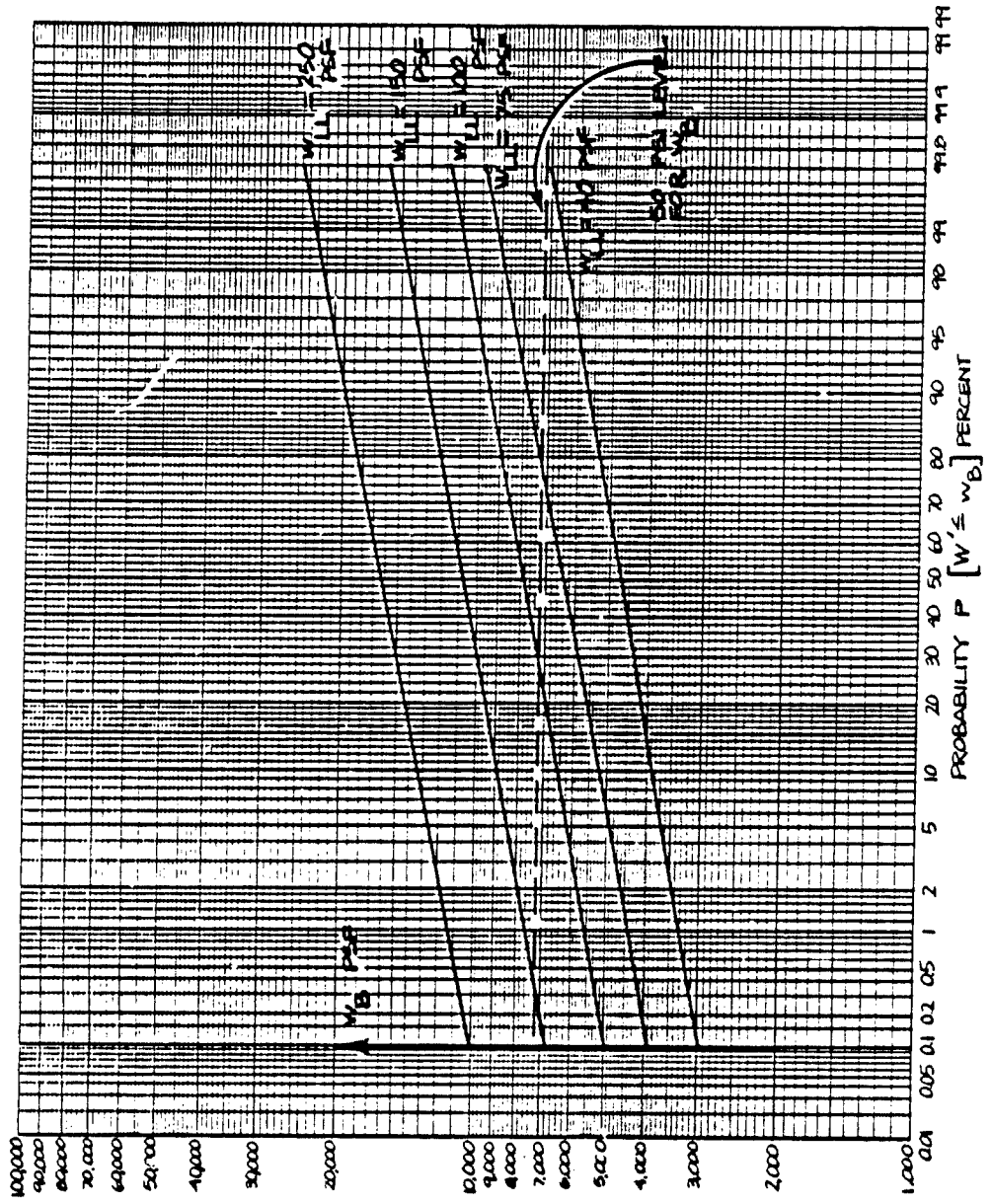

Fig. 18a. Fragility Curves for Upgraded Slabs (L/4 Shoring).

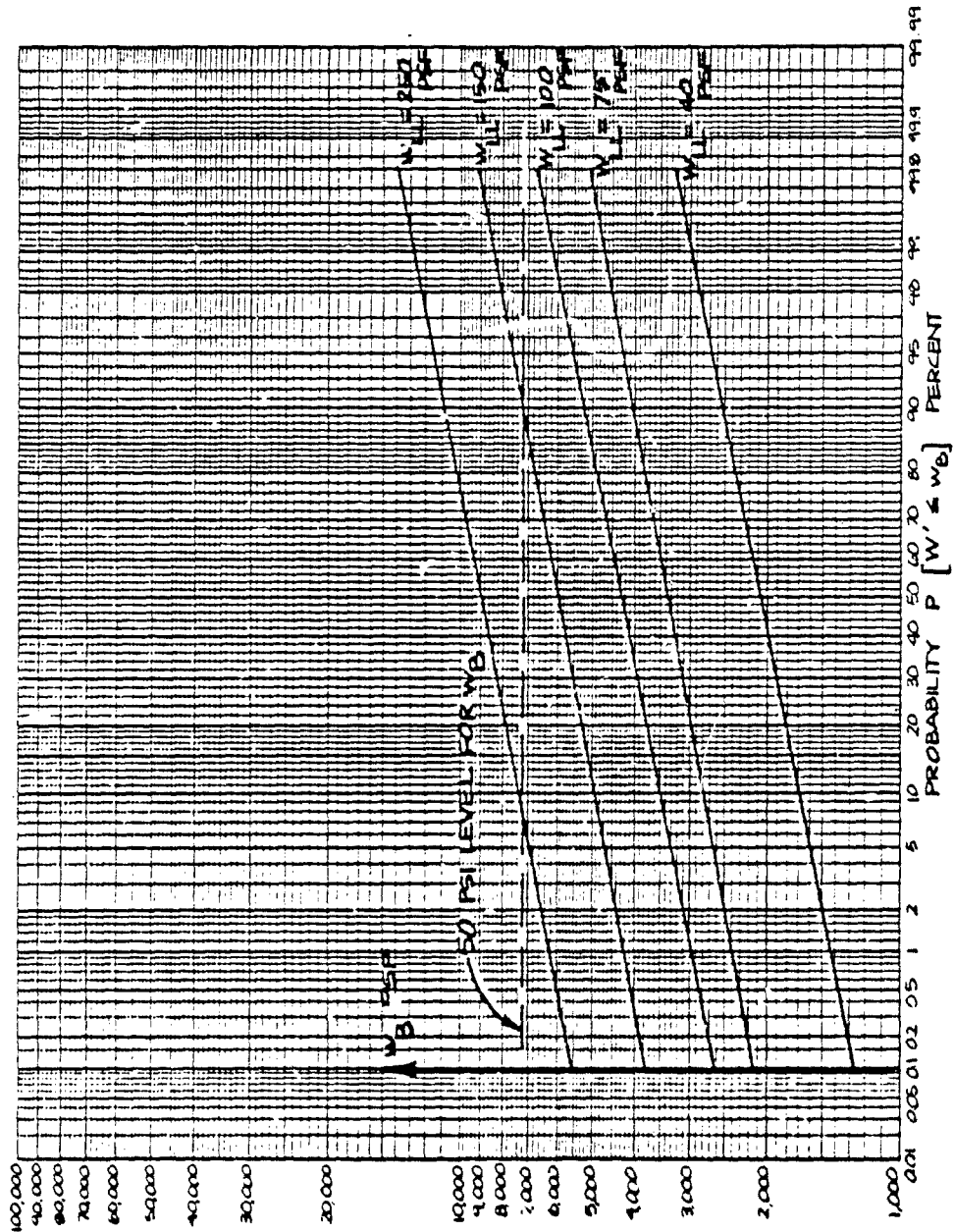

Fig. 18b. Fragility Curves for Upgraded Slabs (L/3 Shoring).

DEVELOPMENT OF THE OVERLOAD OR DAMAGE EFFECTS CURVE

Depending on range of specified loading w_B :

Low = 2 - 10 psi

Medium = 10 - 40 psi

High = 40 - 80 psi

and given the event that the slab has been breached ($w \leq w_B$), the intensity of the effects of this failure increases with the amount of overload as measured by the overload ratio

$$\Delta w/w_c = (w_B - w_c)/w_c$$

This growth of intensity is expressed by an effects curve as described by the general form

$$C = 100 (\Delta w/w_c)^b, 0 \leq w/w_c \leq 1$$

where $b = 1, 1/2, 1/5$ for the respective low, medium, high range of prescribed blast loads, w_B . Note that these exponents provide a representation of the behavior that effects increase rapidly as the load range increases. This curve is based upon the assumption that no damaging effects occur at $w_B = w_c$, and full collapse occurs at $w_B = 2w_c$ or when $\Delta w = w_c$.

For upgraded slab systems this curve, shown in Figure 19, is practically independent of the type of slab or the shoring system, and is strongly a function of the overload ratio, $\Delta w/w_c$. It may be argued that different types of non-upgraded slabs may have different effects in the low load range: for example, a two-way slab curve may be convex (\cup) because of its backup beam support, and a flat plate curve may be concave (\cap) because of column punching fragility. These differences, however, are relatively slight, and they are not present in the upgraded or shored systems. In a properly shored slab, where columns are protected from punching shear, and where beams are supported against diagonal shear failure, then the

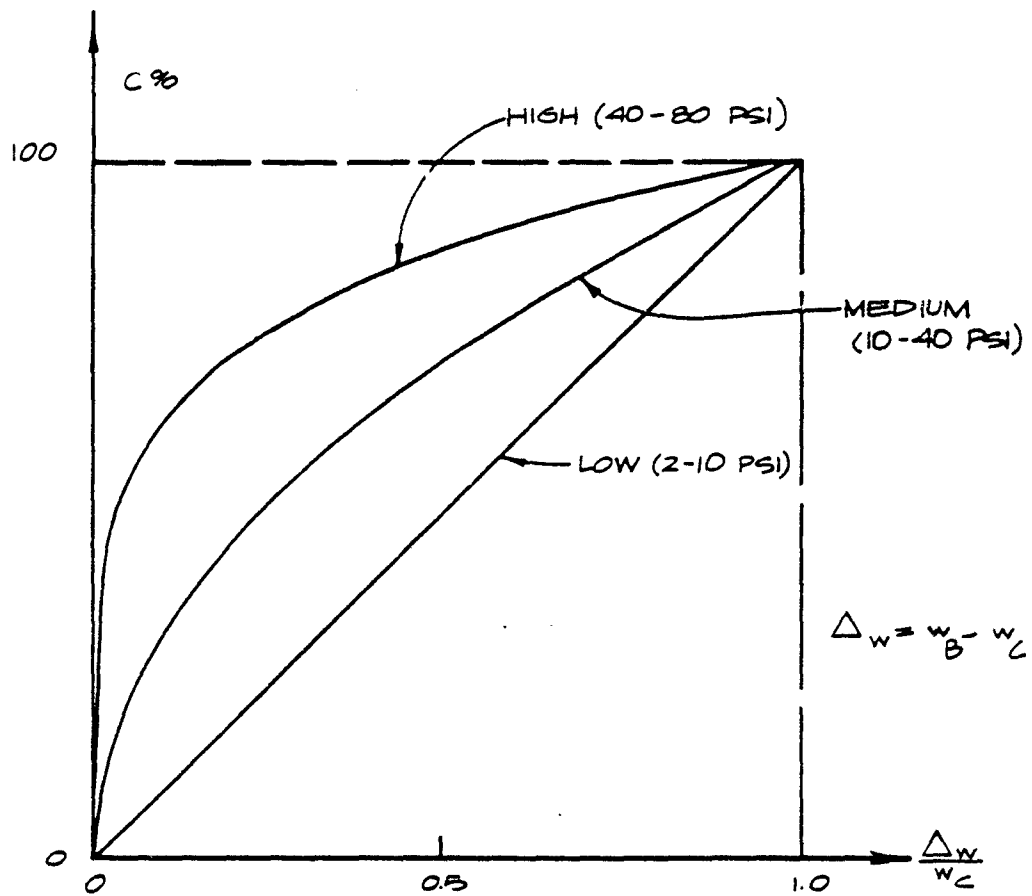

$$C = 100 \left[\frac{\Delta w}{w_c} \right]^b \quad b = 1, 1/2, 1/5 \text{ FOR LOW, MEDIUM, HIGH}$$

Fig. 19. "Overload Effects" and Debris Impact Area Curves.

capacity, w_c , and failure behavior or effects curve, C, are nearly the same for either flat slabs, two-way slabs, or flat plates having equal thickness.

The availability of the overload effects curve, C, allows the evaluation of the extent of damage as a percent of total collapse (100%) and gives a direct estimate of casualty rates given that the slab fails. This assumes that casualties are due primarily to debris impact and are therefore proportional to the percent of floor area covered by debris.

EXAMPLE CALCULATION FOR EXPECTED CASUALTY RATE

Given: Load $w_B = 60 \text{ psi} = 8640 \text{ psf}$
High load range, H

Slab Resistance Properties:

upgraded $w'_c = 40 \text{ psi} = 5760 \text{ psf}$
coefficient of variation, $V'_W = 0.15$

Probability of Failure

$$P(W' \leq w_B) = P(\ln W' \leq \ln w_B)$$

$$\begin{aligned} \ln \bar{w}' &= \ln w'_c + 1.64 V'_W \\ &= 3.69 + 0.25 = 3.94 \text{ (giving } \bar{w}' = 7366 \text{ psf)} \end{aligned}$$

$\ln W'$ has a normal distribution with mean value $\ln \bar{w}'$ and standard deviation $\sigma'_{\ln w} = V'_W$. The normal probability table value is,

$$(\ln w_B - \ln \bar{w}') / V'_W = (4.09 - 3.94) / 0.15 = 1.00, \text{ which gives}$$

$$P(\ln W' \leq \ln w_B) = 84\%$$

and therefore, $P(W' \leq w_B) = 84\%$

This can also be found from a fragility curve such as Figure 20 (plotted for the data of this example).

Damage State for High Load Range

$$\Delta w' = w_B - w'_c = 60 - 40 = 20 \text{ psi}$$

$$C = 100(\Delta w'/w'_c)^{1/5} = 100 (0.5)^{1/5} = 87\%$$

Expected casualty rate

$$\begin{aligned} E[C] &= [C] \cdot [P(W' \leq w_B)] \\ &= (87\%)(0.84) = 73\% \end{aligned}$$

FAILURE LIMITATIONS

The fragility curves have been constructed on the basis of flexural failure of the slab. At high blast load levels ($w_B > 40$ psi), however, other elements could reach failure. These would include strut punching shear and shore buckling.

For an example:

Let $L/4 = 5$ ft

Slab $t = 10$ in.

Shore size = 8 in. x 8 in.

(1) Punching

$$v_c = 6 \sqrt{f'_c} = 360 \text{ psi}$$

$$A_v = 4(8 + 10)(10) = 720 \text{ in.}^2$$

$$P_v = 0.360 \text{ ksi} \times 720 = 260 \text{ kips}$$

(2) Buckling

$$f_c = 4,000 \text{ psi at buckling failure of the shore.}$$

$$P_c = 4 \text{ ksi} (8 \text{ in.} \times 8 \text{ in.}) = 260 \text{ kips}$$

$$w_B = 260,000 / 5 \text{ ft} \times 5 \text{ ft} = 10,400 \text{ psf or } 70 \text{ psi}$$

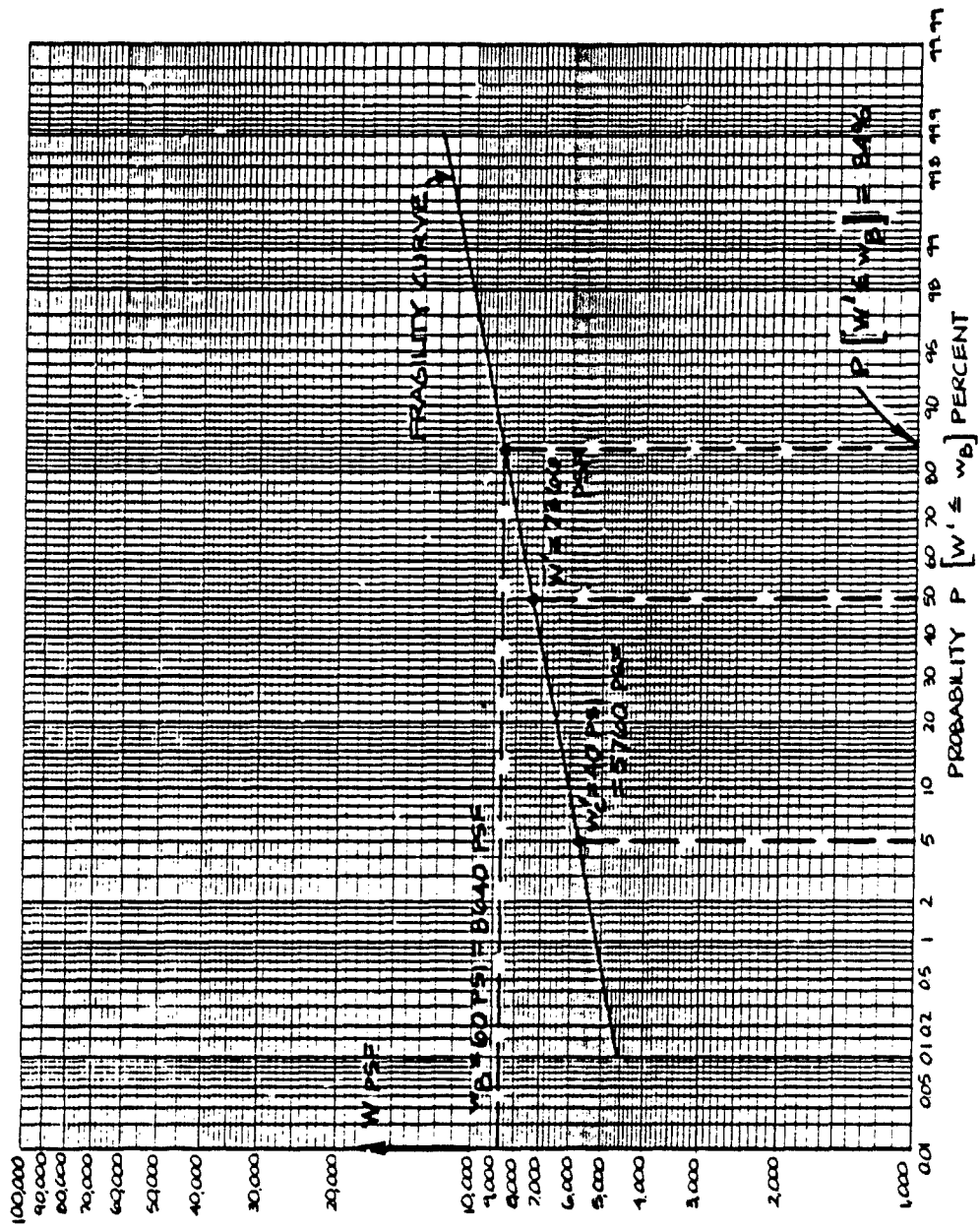

Fig. 20. Fragility Curve for Example Calculation.

These rough numbers are applicable for 5 ft spans, 10 in. slabs, and 8 in. x 8 in. shores, yet they are reasonably typical (maximum condition) sizes, and similar upgraded shelter load resistances should be available using 1/4-point shoring with other slab systems. Actual use, however, should be limited to 50 psi, at most, until the problems of ground shock and other casualty functions are better understood.

Section 4 CASUALTY MECHANISMS

INTRODUCTION

The casualty producing mechanisms of a nuclear explosion that have been reviewed to date are given in Table 4. As noted earlier, there is insufficient effort to include the remaining damage mechanisms of fallout and thermal radiation and fire. Before these casualty mechanisms are considered it is appropriate to discuss to some extent the range of conditions of primary interest for this study. First, we are concerned with basement shelters, both as-built and upgraded to pressure levels as high as 50 psi, in which the basement ceiling is a reinforced concrete plate or slab. Further, we are concerned primarily with reasonably large sized basements, both because of their sheltering capacity and their (relatively) greater ease of upgrading. Specifically for these initial considerations, the shelter sizes were assumed to be from 50 ft x 50 ft x 10 ft (high) to 200 ft x 200 ft x 10 ft (high).

It was also assumed that as-built basement shelters have openings that will permit the blast wave to enter. These openings may be there normally, as in the case of entranceways for vehicles and people, or they may be created by the blast wave blowing out doors or sections of above-grade walls. The opening sizes have been assumed to be rectangular, having the full height of the basement (10 ft), and having a total width varying from 0.1 to 0.3 of the width of the shelter.*

The range of weapon yields of interest has been taken as 0.2 to 1.0 Mt; however, to date, calculations have only been made for 1 Mt.

Because of its importance as a base case and because all weapons effects need to be considered, the initial effort has been concentrated on the as-built basement

* For the 50 ft x 50 ft shelter, the 0.1 opening width is 5 ft, which could correspond to two small doorways or one large one; the 0.3 opening is 15 ft and could include a 10-ft driveway as well as the above. For the 200 ft x 200 ft shelter, the 0.1 opening is 20 ft, equivalent to a large driveway or a small driveway and several doorways. The 0.3 opening is 60 ft and is equivalent to several large driveways and doorways.

Table 4
CASUALTY PRODUCING MECHANISMS OF A NUCLEAR EXPLOSION

Direct Blast	Exposure to fast rising, long duration pressure pulses
Indirect Blast	
Translation/impact	Translation of the body by dynamic pressure of the blast wave or jet flow and exposure to impact on the ground or other surface
Missiles	Exposure to impact of missiles and other objects such as portions of frangible walls accelerated by the blast wave or jet flow
Structural collapse	Exposure to collapse of the shelter ceiling or other structural elements
Initial Nuclear Radiation	Early time (less than 1 min.) exposure to gamma and neutron radiation

shelter, which is the most difficult part of the development of casualty functions. The majority of the existing information on casualty producing mechanisms is for free field exposure to the weapons effect; e.g., blast wave, initial nuclear dose, fallout dose. Thus, in the following discussion of casualty producing mechanisms the free field case is generally considered first, followed by the modifications induced by the shelter conditions. The general blast modifications in as-built shelters are discussed in Appendix B and the jet flow phenomenon in Appendix C.

It is recognized that there is interest both in injuries and in fatalities; however, for this initial review fatality prediction has been emphasized.

DIRECT BLAST

The casualty curve for people exposed to direct blast in the free field is given in Figure 21 as curve A. The estimated uncertainty is also shown. This curve was derived from Table 12.38 of Ref. 41 with the assumption that the lethality threshold means 2% fatalities and that the 100% fatality level can be approximated by 98% (the log probability paper used does not permit 0% or 100%).

In Appendix B it is shown that the peak shock wave pressures in the shelters of concern are estimated to range from about 20% to 50% of the free field value and curves based on these reductions are also shown in Figure 21 as curves B and C.

It is evident that very large pressures are required to cause any significant fatalities for the shelter case, pressures that are much greater than for the other casualty mechanisms as will be seen later.

INDIRECT BLAST - TRANSLATION/IMPACT

Translation of people by the blast wave and impact against rigid surfaces is one of the more hazardous free field casualty mechanisms. This can be seen from the casualty curves in Figure 22, which indicate that, except for the prone parallel position, 50% fatalities are expected for overpressure levels as low as 4 to 6 psi. These curves are based on the fatality criteria given in Table 12.49 of Ref. 41 and the velocities received under blast loading given in Ref. 42. Again, the threshold

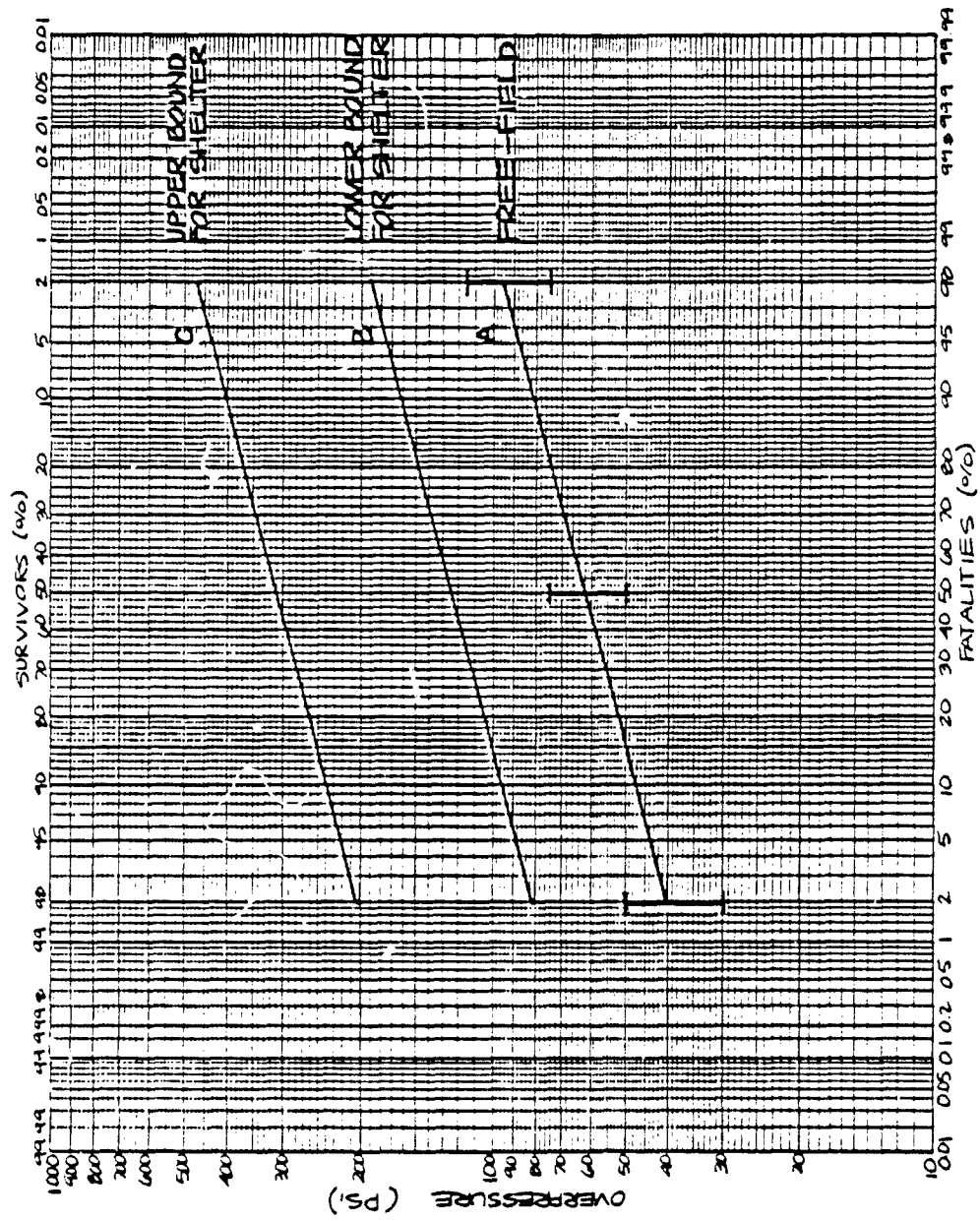

Fig. 21. Direct Blast Fatality/Survival Curves.

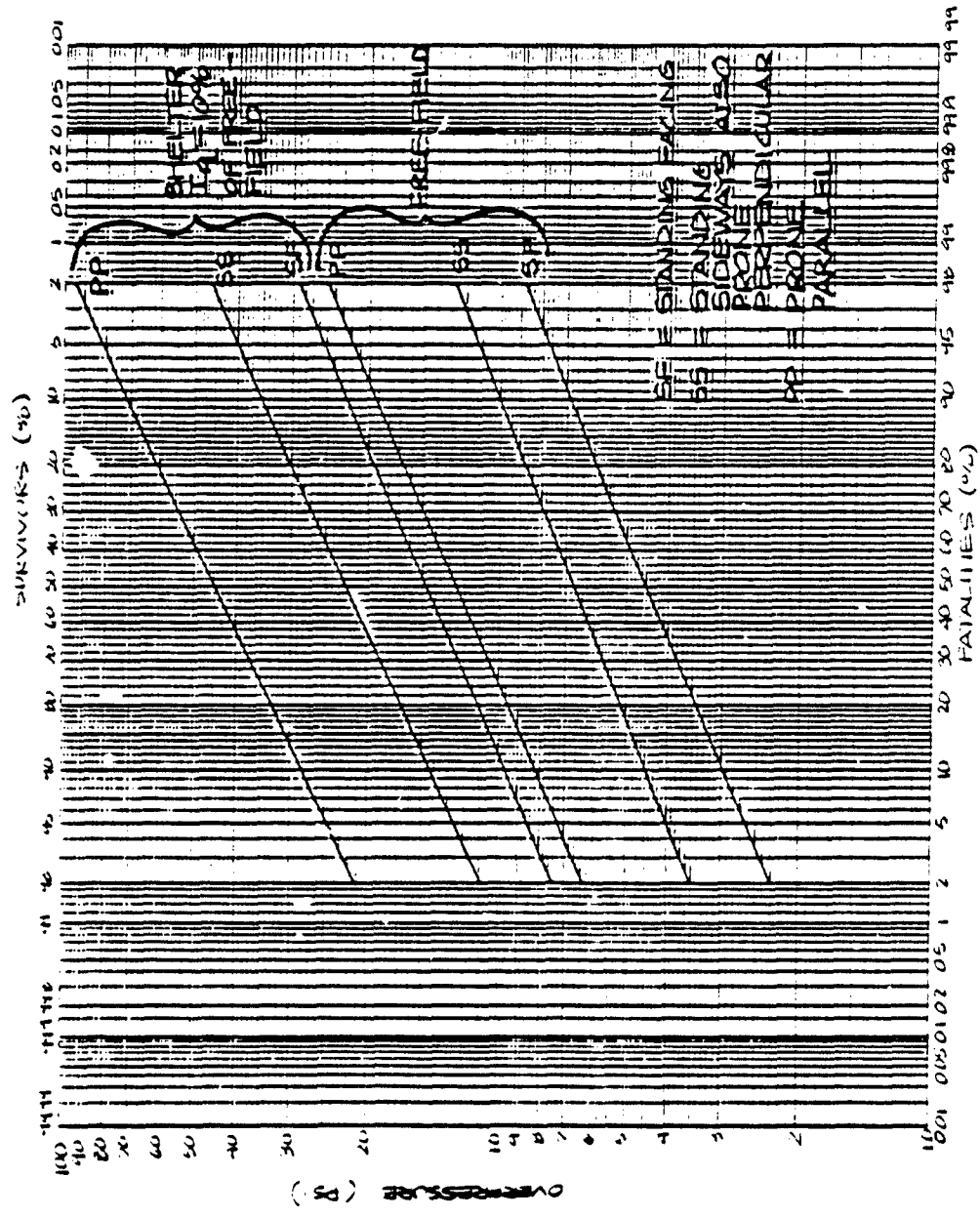

Fig. 22. Indirect Blast - Translation Impact Fatality/Survival Curves.

for fatalities was taken as 2% fatalities, and approaching 100% fatalities was taken as 98% fatalities.

These free field curves need considerable modification to make them applicable to the shelter conditions of interest. This is because the translation of a person by a blast wave is dependent primarily on the dynamic pressure impulse (I_q) of the blast wave. In Appendix B it is shown that the I_q would be reduced to a maximum of 15% of the free field value and more likely to 5% to 10%*. Taking 10% as an average gives the three curves marked "shelter" in Figure 22. Note that the region within one to two opening diameters of the opening is excluded from these curves. For this zone, the casualty curves would lie about in the middle between the free field and shelter values.

INDIRECT BLAST - MISSILES - IMPACT BY FRANGIBLE WALLS

If an exterior wall of an as-built basement shelter is above or partially above grade and is constructed of frangible material such as brick or concrete block, there is the possibility of people in the shelter being struck by these walls or their fragments after they have been accelerated to high velocities. Figure 23 shows estimates of the fatalities that might occur in this manner for several wall types and two loading conditions: head-on and side-on blast. These curves were derived using the same impact velocity/fatality criteria as for the impact of people on rigid walls (Table 12.49 of Ref. 41). Note that the curves as shown do not include any significant effects of rigid arching or in-plane loading. The method used for calculating the velocity of the walls under blast loading is given in Appendix D.

Interior walls of a shelter also need to be considered, with the main difference being that the shock wave is attenuated before hitting the wall. Estimates of the fatality curves for several interior wall types are shown in Figure 24. The walls were assumed to be primarily peak pressure sensitive (see Appendix D) so that blast attenuation factors ranging from 2 to 5 were used in accordance with Appendix B.

* When an object's velocity reaches some significant portion of the shock wave particle velocity, some reduction in loading occurs, and the velocities computed using pure impulse loading will be on the high side. However, for the purpose of adjusting the curves for the shock attenuation in the shelter it is a reasonable approximation.

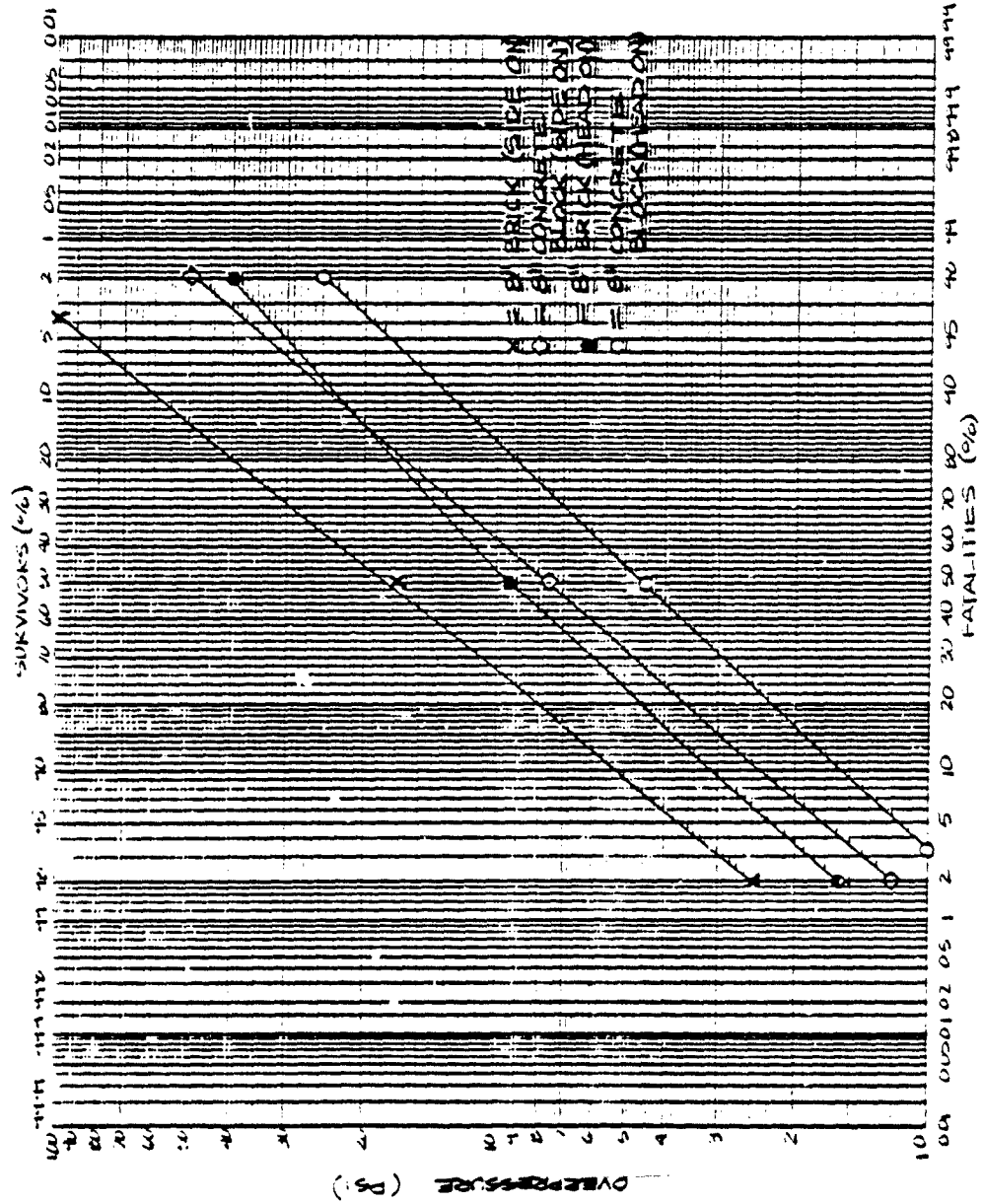

Fig. 23. Impact by Exterior Frangible Walls.

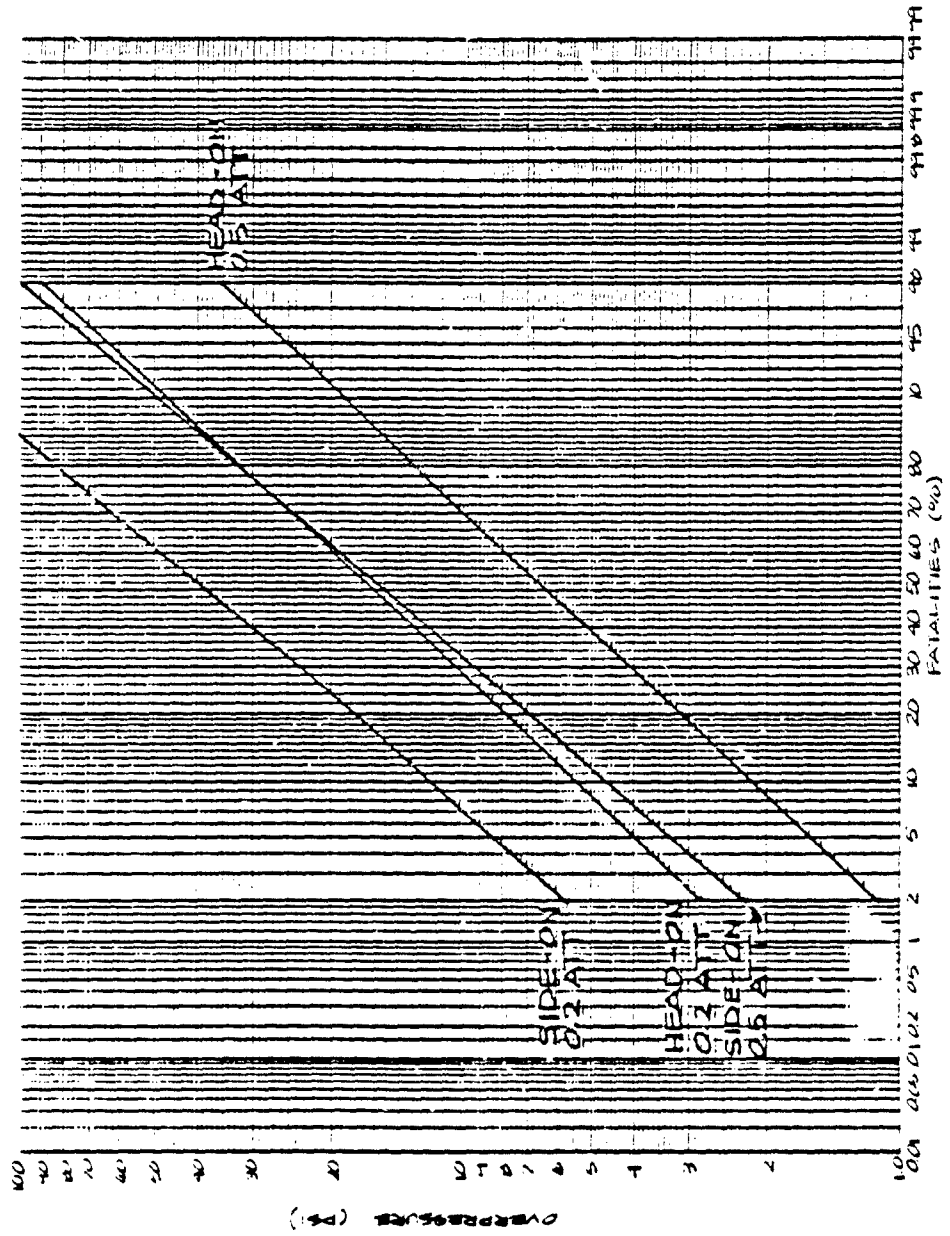

Fig. 24. Impact by Interior Frangible Walls, 8-Inch Concrete Block and 6-Inch Clay Tile.

In an interim report, some preliminary curves were given for a 4-in. sheetrock interior wall. These curves were quite uncertain because it was doubtful that the walls were sufficiently rigid for the rigid surface impact velocity/fatality criteria to hold. However, for lack of any other criteria at that time they were used. This problem has been studied further since then, and the results indicate considerable justification for not using the rigid surface impact criteria, but instead one based on an effective impact velocity derived from the conservation of momentum. This approach greatly reduces the seriousness of this casualty mechanism for lightweight interior partitions. See Appendix E for a discussion of this problem.

INDIRECT BLAST - STRUCTURAL COLLAPSE OF THE CEILING SLAB

The structural collapse theory given elsewhere in this report leads to the ceiling collapse curves given in Figure 25. These curves give the percent of the shelter ceiling collapsed onto the shelter floor. To a first approximation they can also be used as fatality curves by assuming that any person under the collapsed ceiling is a fatality.

From even a brief examination of these curves it can be seen that high fatality percentages can be obtained at quite low overpressure levels and that, as will become evident later, this is the most serious of the casualty producing mechanisms for the as-built shelter case.

Because of the high fatality percentages for such low overpressures it seems worth considering further the assumption that all the people who are impacted by a portion of the collapsing ceiling are fatalities.

The only available fatality information that bears on this problem is the impact of people on rigid surfaces given in Table 12.49 of Ref. 41. Using these criteria and the impact velocity of the roof slab on the floor under the combination of gravity and pressure loading gives the curves labeled impact fatalities on Figure 26. Now, it is obvious that a person on the floor impacted by the collapsing slab at a given velocity, v , is more likely to be a fatality than if he is simply thrown against a rigid surface at the same velocity, v , because he can suffer a double impact as well as be squeezed between the two surfaces. Furthermore, he is likely to be trapped under the slab. For these reasons it would seem that a velocity that would lead to 25% to

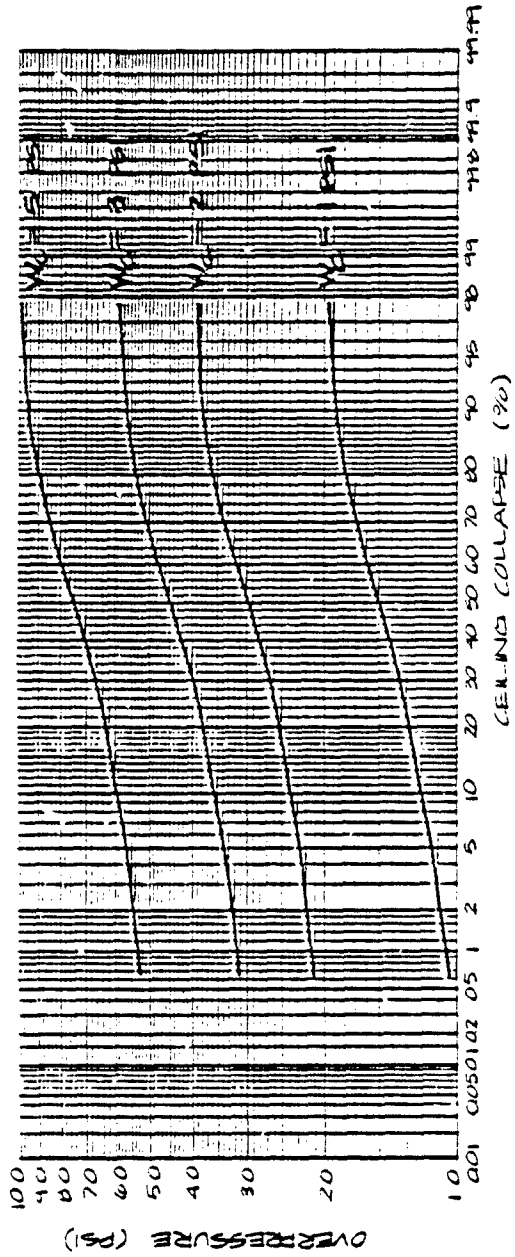

Fig. 25. Predicted Failure Value for Various Values of w_c .

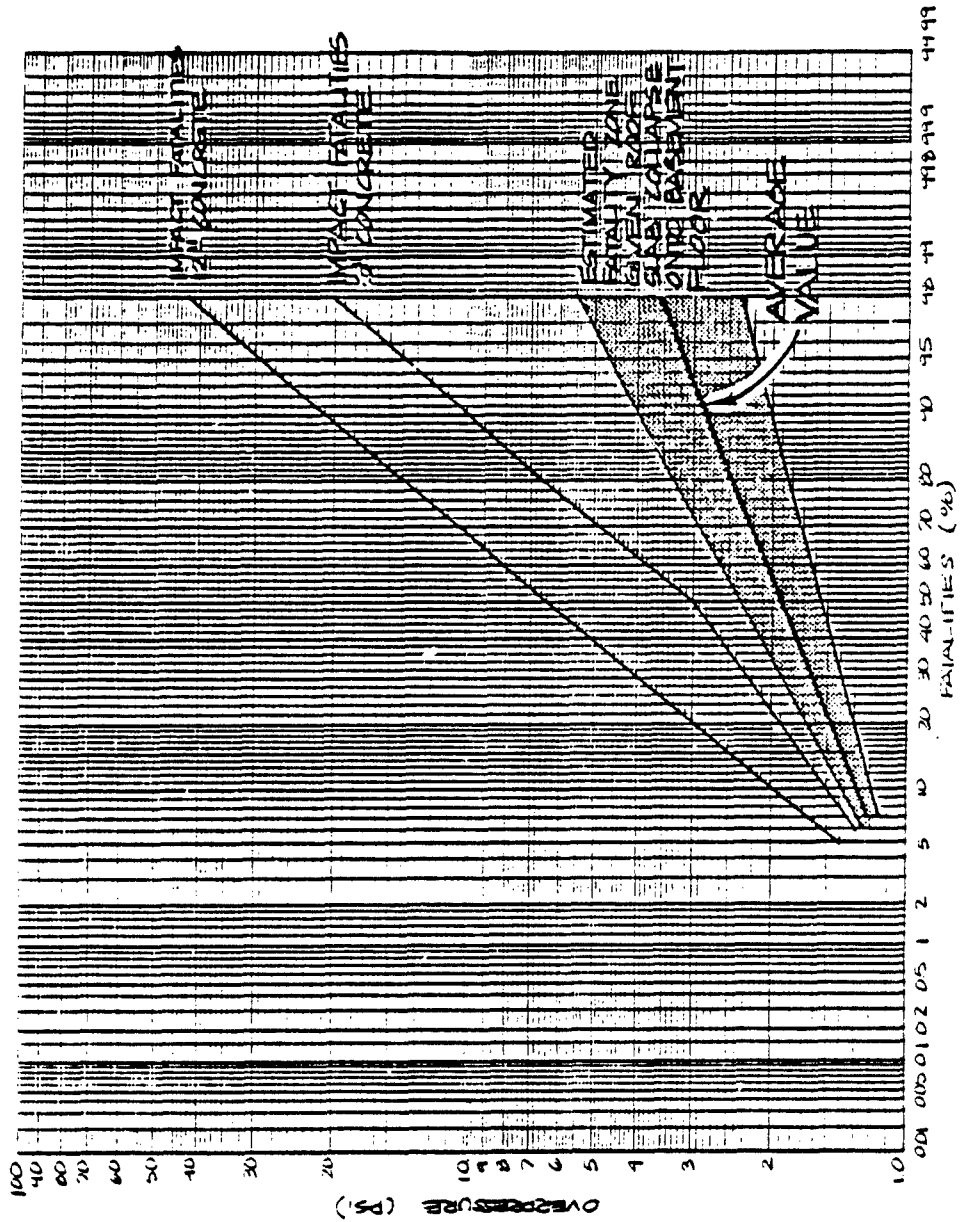

Fig. 26. Indirect Blast - Structural Collapse of Roof Slab.

50% fatalities for a simple impact would more likely yield close to 100% fatalities for the falling slab case. This line of reasoning gives the shadowed zone shown in Figure 26. The average value of the shadowed zone is plotted in the upper part of Figure 27 and combined with the ceiling collapse curves in the lower part of the figure. It can be seen that this curve has a negligible effect for $w_c = 2$ psi, but a large effect for $w_c = 1$ psi.

INITIAL NUCLEAR RADIATION

The casualty curves for initial nuclear radiation are given in Figure 28. The dose-fatality criteria were taken from Table 12.108 of Ref. 41, the dose vs distance from the procedures described on pages 378 through 380 of Ref. 41, and the overpressure vs distance from Figures 373b and 373c of Ref. 41.

Curves are shown both for the free field condition, $PF = 1$, and for a typical as-built shelter, shielding equivalent to 11 in. of concrete, or a $PF = 10$ (Table 8.72 of Ref. 41). Also shown are the differences between a contact surface burst and a low air burst.

From an examination of Figure 28 it can be seen that at a given overpressure the fatalities from a surface burst are much higher than those from the low air burst. Note that for the as-built shelter use of the $PF = 10$ curve is quite uncertain because, as discussed earlier, the basement roof slab may well be completely collapsed at these pressure levels.

CASUALTY CURVE COMBINATIONS

Interior Walls

Figure 29 shows the effect of combining a typical heavy interior wall missile curve with the various ceiling collapse curves. The missile curve is for an 8 in. concrete block or 6 in. clay tile wall side-on to the blast with a 50% attenuation (see Figure 24).

The effect of the missile curve for a W_c of 3 psi is small and negligible below that. At 5 psi the effect is larger particularly for probabilities below 20%. It will

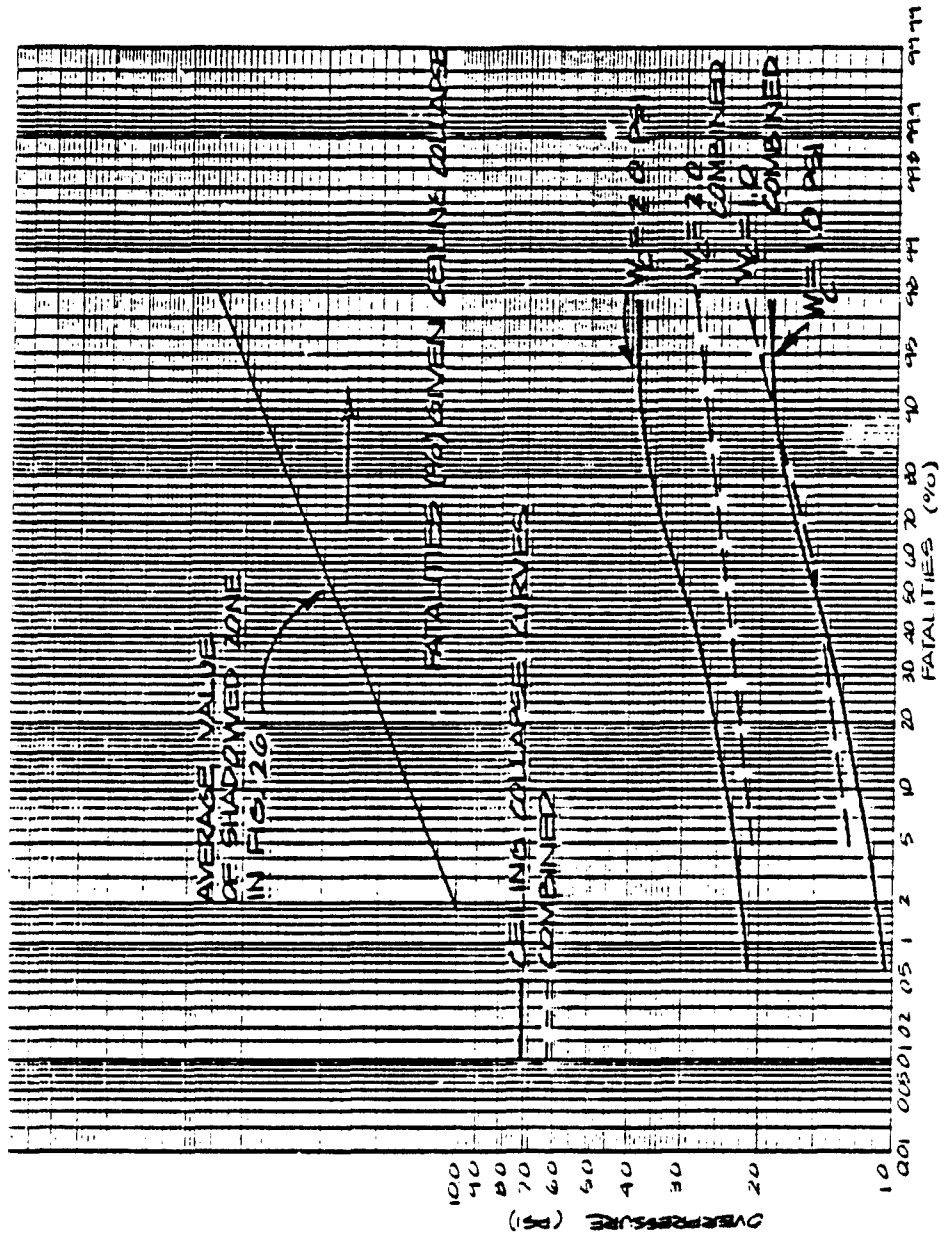

Fig. 27. Combined Ceiling Collapse Curves.

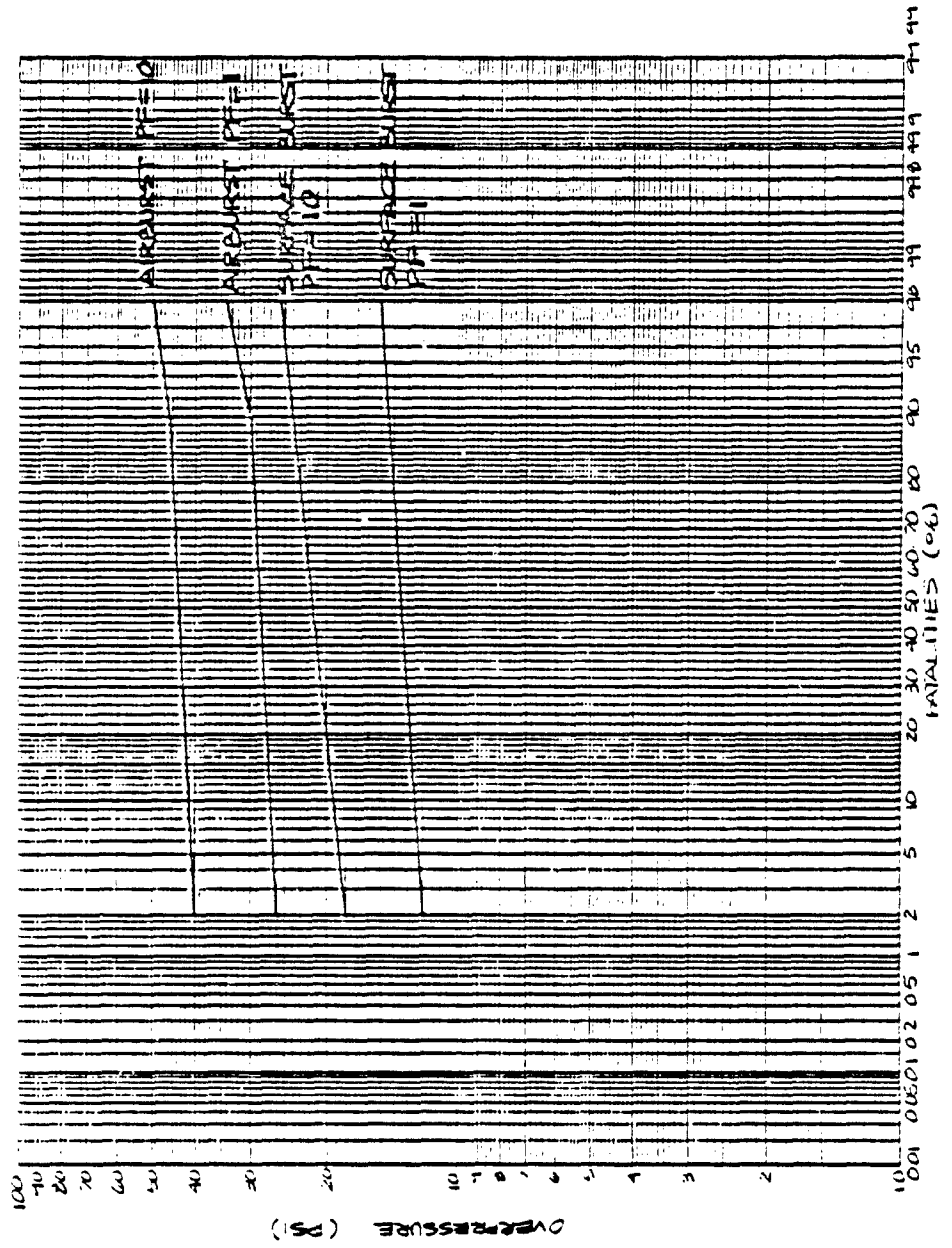

Fig. 28. Casualty Curves for Initial Nuclear Radiation.

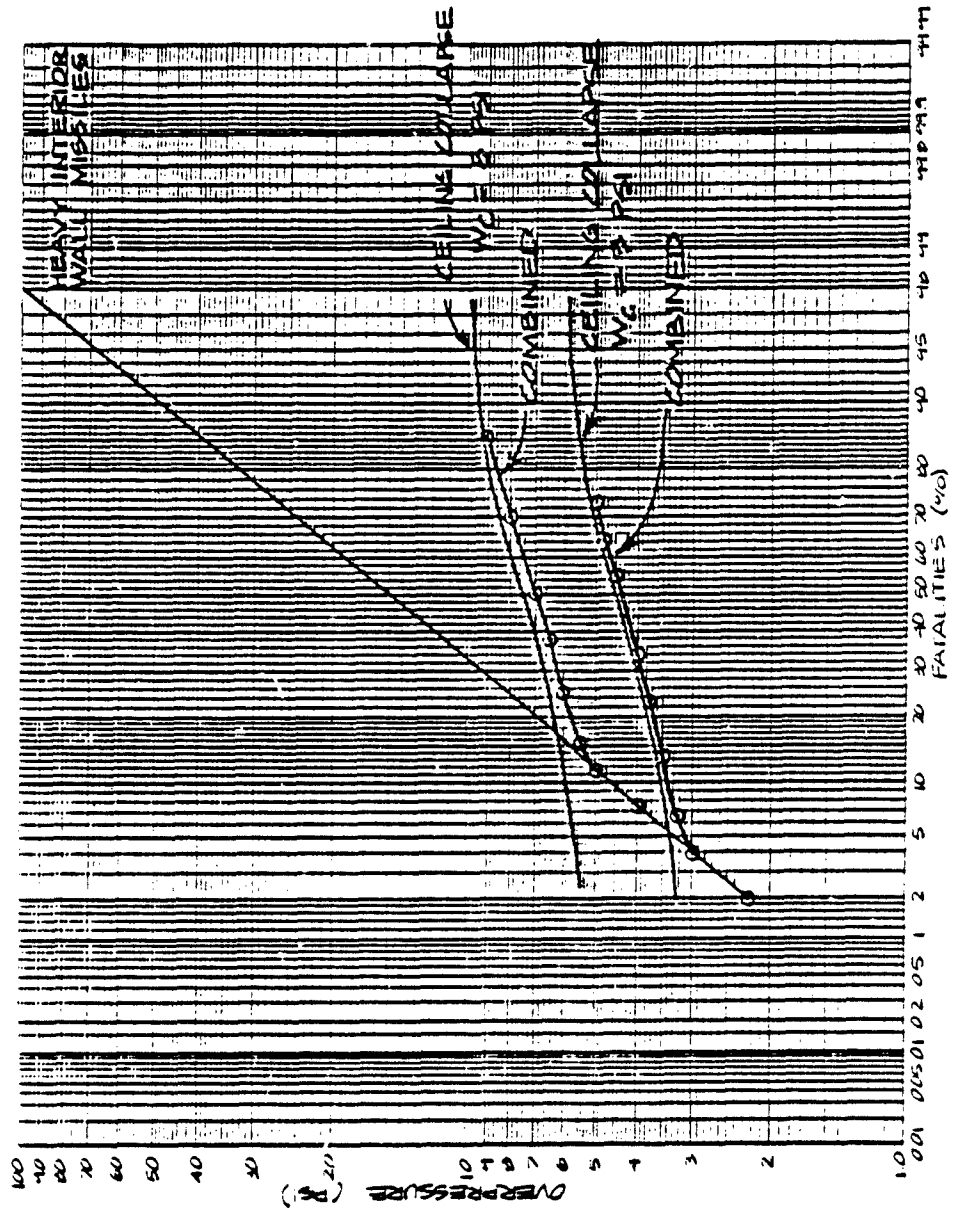

Fig. 29. Heavy Interior Wall Missile Curve and Ceiling Collapse Curves.

be noted that the effects of an effective impact velocity have not been included in these curves yet.

Exterior Walls

Figure 30 shows the effect of combining a typical exterior wall missile curve with the various ceiling collapse curves. The exterior wall missile curve is for an 8-in. brick wall (or approximately a 16-in. concrete block wall) face-on to the blast (see Appendix C). The combined curve is only valid for those portions of the shelter behind such an exterior wall.

It can be seen that the effects of the exterior wall missiles are negligible for a W_c of 1 psi and quite small for a W_c of 2 psi. At 3 psi the effects are moderate, and at 5 psi they are large.

SUMMARY

This review of casualty producing mechanisms is continuing, and all casualty curves should be considered as provisional. Several areas have not been completed, even in a preliminary way. These include, for example, dust and debris, which are briefly discussed in the appendices. Even in the areas that have been included here, a number of expansions are desirable, such as: non-symmetrical shelter geometries, consideration of other weapon yields, casualty curves for injuries in addition to those for fatalities, and consideration by blast biologists of the effective impact velocity concept (impact on non-rigid surfaces). Finally and most important is the extension of the work to upgraded shelters.

It appears at present that for as-built shelters, ceiling collapse is the most serious of all the casualty producing mechanisms. Several others, such as impact by fragments from heavy frangible exterior or interior walls also can contribute significantly to the casualty curves, depending on the specific shelter conditions. Jet flow damage mechanisms cannot be ignored, particularly for the larger shelters where it is estimated that up to 20% to 30% casualties could occur for the strongest two-way slabs. It should be noted that these numbers were derived on the assumption that people are uniformly distributed in the shelter; if an alternate assumption is made — that people try to stay out of the jet area — this would considerably reduce the number of casualties.

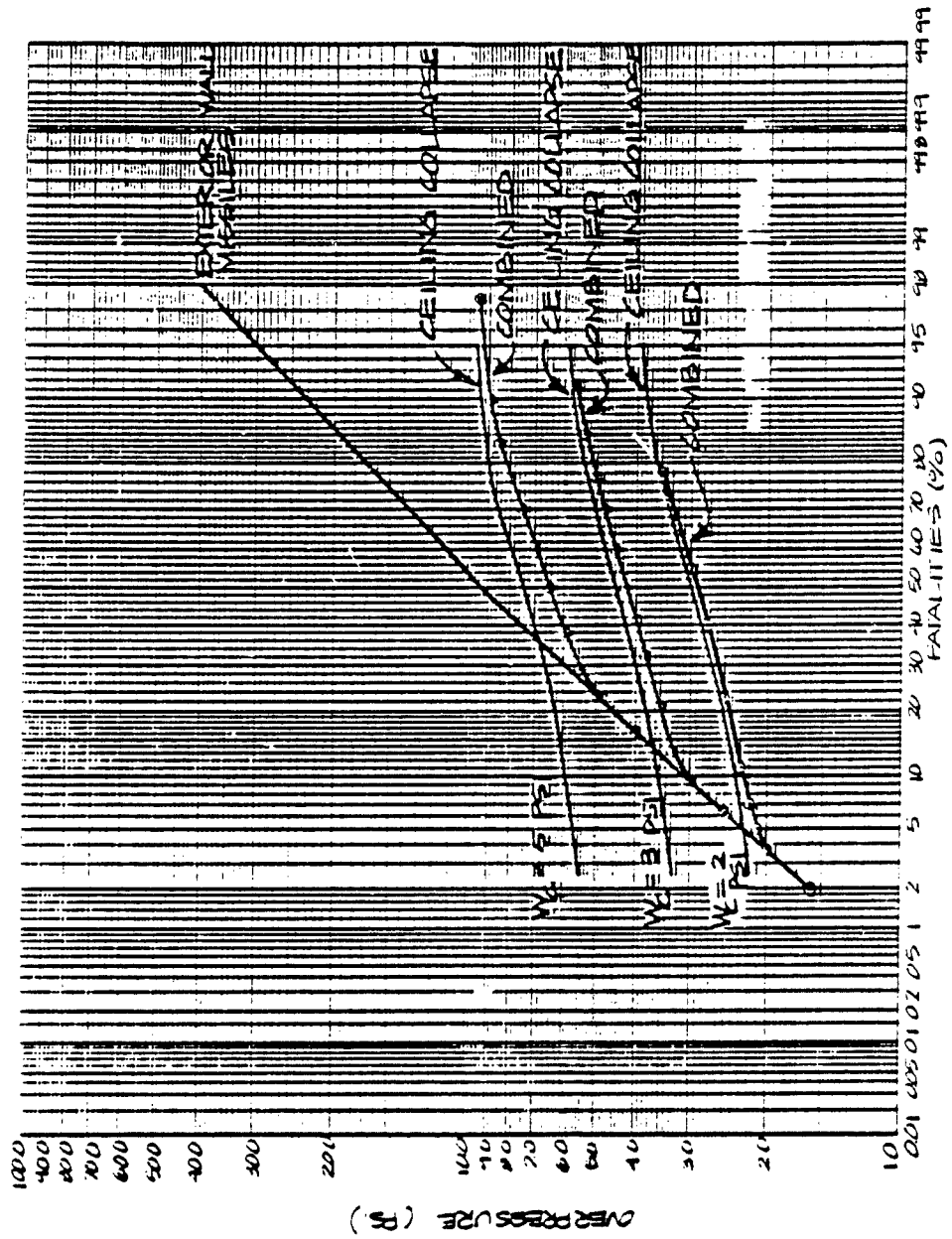

Fig. 30. Exterior Wall Missile Curve and Ceiling Collapse Curves.

Section 5
SUMMARY AND PLANS FOR FUTURE WORK

SUMMARY OF THIS YEAR'S WORK

Developments this year can be divided into three groups:

- (1) Characteristics of flat plate and two-way slab systems
- (2) Formulation of a mathematical model and associated damage effects curves
- (3) Description of casualties/fatalities for given damage effects in non-upgraded slab shelters

Characteristics of Slabs

The effects of code specified design procedures, engineering practice, and construction procedures were discussed along with the particular architectural aspects of flat plates and two-way slabs. It was seen that these general design and functional characteristics can have important differences in the non-upgraded strength of slab systems: where two-way slabs are approximately twice as strong as the flat plate slabs.

A most important conclusion, however, was reached for upgraded (shored) systems. Here, where only flexure between shore supports can lead to failure, there is essentially no difference in failure capacities for any slab system (flat plate, two-way or flat slab), given the same thickness and shore span. Specific building characteristics are not important factors: any shored slab, with standard reinforcing, and dimensions has about the same capacity as any other slab.

Formulation of a Mathematical Model

The log-normal probability model proved to be both realistic and tractable for the fragility curve of slab systems. The model has the advantage of incorporating any new strength data (concerning median value and coefficient of variation), and it

can be incorporated into future complex models involving products of factors (since $\ln(AB) = \ln A + \ln B$, a sum of normal random variables). The concept of a damage effects curve was developed with important differences in behavior depending on the general blast load range (high, medium, or low).

Casualty/Fatality Evaluation

Fatality estimates have been developed for ceiling slab collapse and a variety of other casualty mechanisms with emphasis to date on non-upgraded shelter areas. It appears at present that, for as-built shelters, ceiling collapse is by far the most serious of all the casualty producing mechanisms. Several others, such as impact by fragments from heavy frangible exterior or interior walls also can contribute significantly to the casualty estimates depending on the specific shelter conditions. Jet flow damage mechanisms cannot be ignored, particularly for large shelters where it is estimated that up to 20% to 30% casualties could occur for the strongest of the two-way slabs. A summary of fatality estimates for as-built for as-built shelters with flat plate and flat slab ceilings is present in Table 5. The following commentary applies to that table.

Internal Walls - Internal walls are either 8-inch concrete block or 6-inch clay tile. They both have approximately the same A/M value. Timber stud/sheetrock walls were ruled out on the basis of the effective impact velocity concept (see Appendix E). The effective impact velocity concept may also apply to the concrete block and clay tile walls although it is less certain, since the weight per unit area of a person and the walls are roughly equal, rather than being almost 10 to 1 as in the case of the sheetrock wall. It is interesting to note, however, that if this concept is applied the loading pressure would be about quadrupled, and this case would be negligible compared to the ceiling collapse case.

External Walls - The calculations show that the concrete block wall is more hazardous than the brick wall. This, of course, results from the higher velocity obtained by the concrete block because of its lower weight per unit area. It is interesting to note that if the effective impact velocity concept is applied, the fatality curves for the two walls are almost identical and both would be negligible compared to the ceiling collapse case.

Table 5
**SUMMARY OF FATALITY ESTIMATES FOR AS-BUILT SHELTERS
 HAVING FLAT SLABS AND FLAT SLABS AS CEILING.**
 (not applicable to two-way slabs)

Weapon Effect	Casualty Mechanism	Primary Variables	WLL	Overpressure (psi) for Fatalities		
				of 2%	50%	98%
Blast	Ceiling Slab Collapse	Slab Design Live Load - WLL	40	1.1	1.5	2.0
			75	1.8	2.5	3.3
			100	2.3	3.1	4.2
			150	3.2	4.4	5.9
			250	5.0	6.8	9.1
Blast	Impact by External Wall Fragments	Wall Material Shock Orientation (1)	Condition			
			CB - HO	0.9	4.4	25
			CB - SO	1.2	7.7	50
			BR - HO	1.6	9.5	40
			BR - SO	2.5	17	100
Blast	Impact by Internal	Shock Attenuation Shock Orientation (2)	0.5 - HO	1.1	6.7	36
			0.5 - SO	2.2	15	100
			0.2 - HO	2.8	17	89
			0.2 - SO	5.6	39	100

(1) CB is 6-inch concrete block; BR is 8-inch brick; HO is head-on to blast; SO is side-on to blast.
 (2) 0.5 and 0.2 mean shock front is reduced to 0.5 and 0.2 of the free field value.

Table 5 (cont'd)

Weapon Effect	Casualty Mechanism	Primary Variables	W.L.L.	P (psi)	Max. Fatalities (%)
Blast	Translation/Impact by Jet Flow	W.L.L. and Shelter Size and Opening Area (3)	40 75 100 150 250	1.0 1.7 2.1 3.0 4.8	0 to 3 0 to 4 0 to 5 0 to 7 0 to 15
Blast	Translation/Impact by Blast Flow	Orientation of People (4)	Orientation	Overpressure (psi) for Fatalities of	
			SF SF PP	2% 50% 98%	7.4 15 29 23 46 45 94
Blast	Direct Blast	Shock Attenuation	Attenuation		
			0.5 0.2	80 200	125 360 190 460
Initial Nuclear	Radiation	Protection Factor (PF)	PF		
			1 10	12 18	15 26

(3) Range in fatalities is due to range in size and opening area (see Table C-3 in Appendix C). The overpressure given is for the maximum fatality level.

(4) SF means standing facing the blast; SS means standing sideways to the blast; and PP means prone parallel to the blast. Assumes the dynamic pressure impulse in the shelter is 10% of the free field value.

Translation/Impact by Jet Flow - Note that the loading from jet flow drops very rapidly as portions of the ceiling start to collapse so that the maximum jet effect for a given strength ceiling slab will occur at or slightly above a pressure equal to the calculated w_c .

Translation/Impact by Blast Flow - Actually the fatalities are dependent also on the attenuation of the dynamic pressure impulse in the shelter and the location of the people in the shelter. However, relative to the other casualty mechanisms, this one is not too important and conditions were selected to generally maximize its effects. Typical peak pressure reductions were shown in the text to be from 0.5 to 0.2, while typical impulse reduction due to duration shortening ranged from 0.02 to 0.3. Combining these gives a minimum reduction to 0.15 of the free field value of dynamic pressure impulse. For the curves given, a more realistic upper limit of 0.10 was used.

This review of casualty producing mechanisms is continuing and all casualty curves should be considered as provisional. Several areas have not been completed, even in a preliminary way. These include, for example, dust and debris, which are briefly discussed in the appendices.

RECOMMENDATIONS FOR FUTURE WORK

As noted in the introduction, this report presents the results of the second year of what is projected to be a five-year program. Some of the work that will be emphasized during the upcoming year is as follows:

(1) Refinement of the strength prediction method for each slab system and configuration, both as-built and upgraded: improvements on the assigned median values w , and variations V_w .

(2) Extension of the probabilistic model to incorporate both the probabilistic damage state matrix, and the probabilistic description or hazard area of the various levels of blast loading. This would allow calculation of expected state of damage (with corresponding casualty value) as a matrix multiplication scheme.

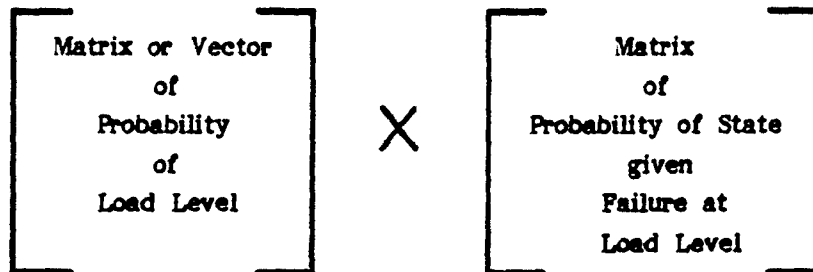

The model also should be extended to include numbers of shelters and occupants within designated hazard areas of given load levels. Expected numbers of casualties, rather than rates, could then be computed. Further refinement of probabilistic models may utilize:

Poisson Model - Representing rates of occurrences within given areas of blast load exposure, and giving probabilities of given numbers of failures.

Markov Model - Representing the state matrix of damage at different steps or increases in the overload ($w_b - w_c$); giving numbers of damage transition steps to a given total damage state. This model could also incorporate the various causes of casualties: debris, jet flow, radiation, etc., in the description of states in the Markov state matrix.

(3) Extension of casualty estimates to non-symmetrical shelter geometries, consideration of other weapon yields, casualty curves for injuries in addition to those for fatalities, and consideration by blast biologists of the effective impact velocity concept (impact on non-rigid surfaces). Finally, and most important, is the extension of the work to upgraded shelters.

REFERENCES

1. Peterson, R.E., R.D. Bernard, R.S. Tansley, A.B. Willoughby, C. Wilton, and T. Zsutty, **Damage Function Rating Procedure for Flat Slab Basement Shelters**, 8143-9, Scientific Service, Inc., Redwood City, CA, December 1982.
2. Longinow, A., **Civil Defense Shelter Options for Fallout and Blast Protection (Dual-Purpose)**, IIT Research Institute, Chicago, IL, May 1967.
3. Longinow, A., and O.J. Stepanek, **Civil Defense Shelter Options for Fallout and Blast Protection (Single Purpose)**, IIT Research Institute, Chicago, IL, June 1968.
4. Longinow, A., J. Kalinowski, C.A. Kot, and F. Salzberg, **Civil Defense Shelter Options: Deliberate Shelters**, IIT Research Institute, Chicago, IL, December 1971.
5. Longinow, A., and G. Ojdrovich, **Survivability in a Direct Effects Environment (Analysis of 25 NFSS Buildings)**, IIT Research Institute, Chicago, IL, January 1973.
6. Longinow, A., G. Ojdrovich, L. Bertram, and A. Wiedermann, **People Survivability in a Direct Effects Environment and Related Topics**, IIT Research Institute, Chicago, IL, May 1973.
7. Longinow, A., and L.A. Bertram, "Casualty Mechanisms Associated With Building Failures," **Conference, Designing to Survive Disaster**, IIT Research Institute, Chicago, IL, November 1973.
8. Longinow, A., **Survivability in a Direct Effects Environment (Analysis of 50 NFSS Buildings)**, IIT Research Institute, Chicago, IL, July 1974.
9. Longinow, A., E. Hahn, A. Wiedermann, and S. Citko, **Casualties Produced by Impact and Related Topics of People Survivability in a Direct Effects Environment**, IIT Research Institute, Chicago, IL, August 1974.
10. Longinow, A., A. Wiedermann, S. Citko, and N. Iwankiw, **Debris Motion and Injury Relationships in All Hazard Environments**, IIT Research Institute, Chicago, IL, July 1976.
11. Longinow, Anatole, Edward E. Hahn, and Lee A. Bertram, "Personnel Survivability in Blast Wind Environment," **Journal of the Engineering Mechanics Division**, ASCE, EM2, 12853, April 1977.
12. Longinow, A., and A. Wiedermann, **Relative Structural Considerations for Protection From Injury and Fatality at Various Overpressures**, IIT Research Institute, Chicago, IL, June 1977.

13. Longinow, A., **Survivability in Crisis Upgraded Shelters**, IIT Research Institute, Chicago, IL, February 1978.
14. Longinow, A., **Survivability on the Fringe of High Risk Areas**, IIT Research Institute, Chicago, IL, October 1978.
15. Longinow, A., **Survivability in a Nuclear Weapon Environment**, IIT Research Institute, Chicago, IL, May 1979.
16. Longinow, A., **Probability of People Survival in a Nuclear Weapon Blast Environment**, IIT Research Institute, Chicago, IL, May 1980.
17. Longinow, A., and R.P. Joyce, **Load Tests of a Wood Floor Over a Basement**, IIT Research Institute, Chicago, IL, June 1980 (draft).
18. Longinow, A., M-Y. Wu, and J. Mohammadi, **Damage Functions for Upgraded Shelters**, IIT Research Institute, Chicago, IL, January 1982 (draft).
19. Longinow, A., T.E. Waterman, and A.N. Takata, **Assessment of Combined Effects of Blast and Fire on Personnel Survivability**, IIT Research Institute, Chicago, IL, June 1982.
20. Gabrielsen, B.L., R.S. Tansley, and G. Cuzner, **Upgrading of Existing Structures: Phase II**, SSI 7910-5, Scientific Service, Inc., Redwood City, CA, June 1980.
21. Tansley, R.S., G.J. Cuzner, and C. Wilton, **Research on Upgrading Structures for Host and Risk Area Shelters**, SSI 8144-7, Scientific Service, Inc., Redwood City, CA, September 1982.
22. Tansley, R.S., R.D. Bernard, G.J. Cuzner, and C. Wilton, **Research on Upgrading Structures for Host and Risk Area Shelters, Phase II**, 8144-12, Scientific Service, Inc., Redwood City, CA, May 1983.
23. **Building Code Requirements for Reinforced Concrete (ACI 318-71)**, American Concrete Institute, Detroit, MI, 1971.
24. Sozen, M.A., and C.P. Seiss, "Investigation of Multiple-Panel Reinforced Concrete Floor Slabs, Design Methods - Their Evolution and Comparison," **Journal of the ACI**, Vol. 60, No. 8, August 1963.
25. Hatcher, D.S., M.A. Sosen, and C.P. Seiss, "Test of a Reinforced Concrete Flat Slab," **Journal of the Structural Division, Proc. of ASCE**, Vol. 95, No. ST6, June 1969.
26. Gamble, W.L., M.A. Sosen, and C.P. Seiss, "Tests of a Two-Way Reinforced Concrete Floor Slab," **Journal of the Structural Division, Proc. of ASCE**, Vol. 95, No. ST6, June 1969.

27. Vanderbilt, M.D., M.A. Sosen, and C.P. Seiss, "Tests of a Modified Two-Way Slab," *Journal of the Structural Division, Proc. of ASCE*, Vol. 95, No. ST6, June 1969.
28. Jirsa, J.O., M.A. Sosen, and C.P. Seiss, "Pattern Loadings on Reinforced Concrete Floor Slabs," *Journal of the Structural Division, Proc. of ASCE*, Vol. 95, No. ST6, June 1969.
29. Hawkins, N.M., and D. Mitchell, "Progressive Collapse of Flat Plate Structures," *Journal of the ACI*, Vol. 76, No. 7, July 1979.
30. Criswell, M.E., *Design and Testing of a Blast-Resistant Reinforced Concrete Slab System*, Technical Report N-72-10, U.S. Army Engineer Waterways Experiment Station, Weapons Effects Laboratory, Vicksburg, MS.
31. Criswell, M.E., *Strength and Behavior of Reinforced Concrete Slab-Column Connections Subjected to Static and Dynamic Loadings*, Technical Report N-70-1, U.S. Army Engineer Waterways Experiment Station, Vicksburg, MS, December 1970.
32. Joint ASCE-ACI Task Committee 426, "The Shear Strength of Reinforced Concrete Members - Slabs," *Journal of the Structural Division*, Vol. 100, No. ST8, August 1974.
33. Joint ASCE-ACI Task Committee 426, "The Shear Strength of Reinforced Concrete Members," *Journal of the Structural Division*, Vol. 99, No. ST6, June 1973.
34. Publication SP 42, *Shear in Reinforced Concrete, Vol. 2, Part 4, Shear in Slabs*, American Concrete Institute, Detroit, 1974.
35. Long, A.E., "A Two-Phase Approach to the Prediction of Punching Strength of Slabs," *Journal of the ACI*, Vol. 72, No. 2, February 1975.
36. Ghali, A., M.Z. Elmasri, and W. Dilger, "Punching of Flat Plates Under Static and Dynamic Horizontal Forces," *Journal of the ACI*, Vol. 73, No. 10, October 1976.
37. Hewitt, B.E., and V.B. de Barrington, "Punching Shear Strength of Restrained Slabs," *Journal of the Structural Division, Proceedings of ASCE*, Vol. 101, No. ST9, September 1975.
38. Corley, W.G., and J.O. Jirsa, "Equivalent Frame Analysis for Slab Design," *Journal of the ACI*, Vol. 67, No. 11, November 1970.
39. Gozetas, G., and T.P. Tassios, "Elastic-Plastic Slabs on Elastic Foundation," *Journal of the Structural Division, Proceedings of ASCE*, Vol. 104, No. ST4, April 1978.

40. Meyerhoff, G.G., "Load Carrying Capacity of Concrete Pavements," *Journal of the Soil Mechanics and Foundations Division, ASCE*, Vol. 88, No. SM3, Proc. Paper 3174, June 1962.
41. Glasstone, S., and P. Dolan (eds.), *The Effects of Nuclear Weapons* (Third Edition), U.S. Department of Defense, Washington, D.C., 1977.
42. Bowen, I.G., et al., *A Model Designed to Predict the Motion of Objects Translated by Classical Blast Waves*, CEX 58.9, Lovelace Foundation for Medical Education and Research, Albuquerque, NM, June 1961.

APPENDIX A
ANALYSIS OF REPRESENTATIVE BUILDINGS

Appendix A
ANALYSIS OF REPRESENTATIVE BUILDINGS

In this appendix, a selected number of actual buildings are presented and analyzed for their shelter resistance qualities. An extensive walk-through survey of possible building and parking structure shelter areas was conducted in the cities of San Jose, San Francisco, and Berkeley, California. While, as will be explained later, it was difficult to find a viable closed basement area having either an ordinary reinforced concrete flat plate or two-way slab system, the walk-through survey provided useful information as to the predominant types of shelter area slab systems that exist in the San Francisco Bay Area, and most probably in any major California community. This existing building system information is as follows:

- o Older, pre-1960 structures have: one-way slabs on girder-beam frames; one-way slab joist systems on girder-beam frames; or flat slabs with drop panels and column capitals.

- o Newer, post-1960 structures have: one-way slabs on beam-girder frames and usually post-tensioned; one-way slabs with pan joists on beam-girder frames; flat slabs, usually with waffle slab panels; and post-tensioned flat plates.

- o Ordinary concrete flat plates are virtually non-existent.

Therefore, it was necessary to select structural slab types and basement areas that most closely, but actually not exactly, represented flat slab and two-way slab basement shelter spaces. The selected buildings and their descriptions are as listed in Table A-1, and their photographs are shown in Figures A-1 through A-11. The representative slab types and assigned design load levels for each building are given in Table A-2, and the slab capacity calculations for non-upgraded, third-point and quarter-point shoring are summarized in Table A-3. The corresponding fragility

curves for the non-upgraded and upgraded slabs in each building are given in Figures A-12 and A-13.

COMMENTARY

The fragility curves for the upgraded representative shelter areas indicate the feasibility of obtaining reliable high blast pressure resistance. For quarter-point (L/4) shoring these resistance values can, in most cases, achieve the recommended limit value of 50 psi (7,200 psf). However, from a structural engineering standpoint, it is most essential to recognize that these upgraded capacity values are conditioned upon the idealized case of a purely uniform a vertical blast pressure loading; and where the slab structure is rigidly constrained against lateral deformation effects.

In the walk-through survey of actual buildings and their shelter areas, it was most apparent that the attainment of these idealized load and constraint conditions can be either difficult or nearly impossible to achieve because of the following factors:

- o Shelter areas are rarely fully enclosed or constrained by a complete perimeter wall system. Sides adjacent to streets may have large openings or even framing, while the sides next to neighboring buildings usually have rigid closed wall systems. Full constraint against lateral or torsional distortion would require extensive structural bracing, which is not provided by the conventional shoring. Also the shelter closure problem can be quite formidable.

- o Most viable basement shelter areas are basement parking garages under large multi-story buildings. The main columns of these structures extend through the shelter slab and are also the support columns for the slab. Under the indicated high blast pressures (10 to 50 psi), it is most probable that the multi-story superstructure will be either severely deformed or destroyed. The result will be a prying and breaking action at the slab-column support perimeter, which can seriously reduce the capacity of the slab - since the ordinary shoring could not prevent this strong column movement. Coupled with this structural interaction damage of the

slab-column support, the slab can be heavily impacted by the failing portions of the multi-story superstructure. This impact loading can be highly non-uniform and also can have concentrated punching loads from the ends of fractured elements.

Therefore, while shoring can provide a very high, reliable vertical load blast pressure resistance, it will be necessary to consider the factors of lateral constraint, closure, and superstructure distortion and impact, in addition to environmental and human factors, in order to determine if shelter systems are viable for high blast loads.

Table A-1
REPRESENTATIVE BUILDING STRUCTURES

	Location	Size	Description
Building 1	Single story parking structure San Francisco	100' x 120'	Post-tensioned flat plate single story structure small drop panels at circular column supports
Building 2	Multi-story parking garage basement San Francisco	240' x 320'	Actually a flat slab with tapered drop panels, but representative of a flat plate, and a good base- ment shelter area
Building 3	Multi-story hotel parking basement San Francisco	100' x 120'	Actually a one-way slab on beams and girders, but representative of a two- way slab, and a good basement shelter area. Many ceiling utility lines
Building 4	Multi-story admin- istrative building parking basement San Francisco	200' x 240'	Actually a flat waffle slab but with a wide beam sys- tem representative of a two-way slab, and a good basement shelter
Building 5	Multi-story hotel parking basement San Francisco	100' x 120'	Actually a one-way slab on beams and girders, but representative of a two- way slab, and a good basement shelter area
Building 6	Single story parking structure Berkeley	240' x 240'	A true two-way slab, but a non-viable shelter because of open sides with no exterior walls

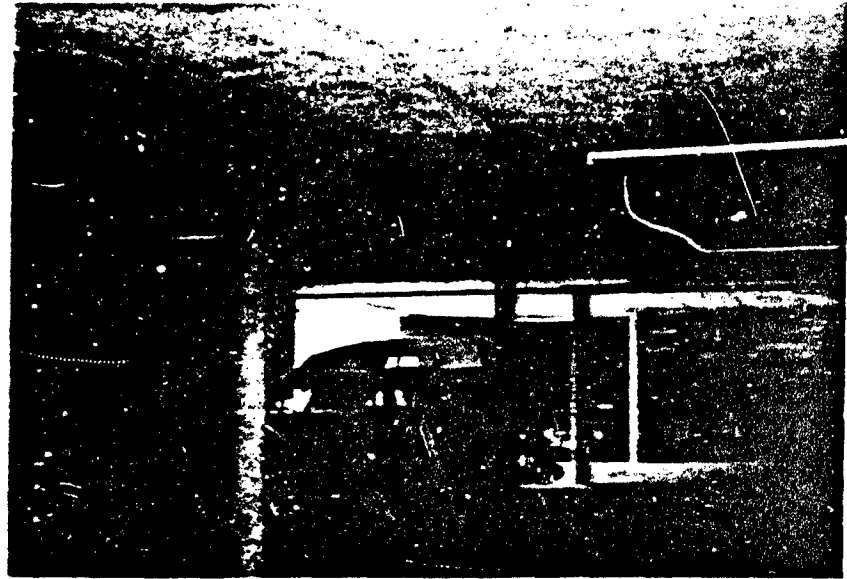

Fig. A-1. Building 1, Single Story Parking Structure.

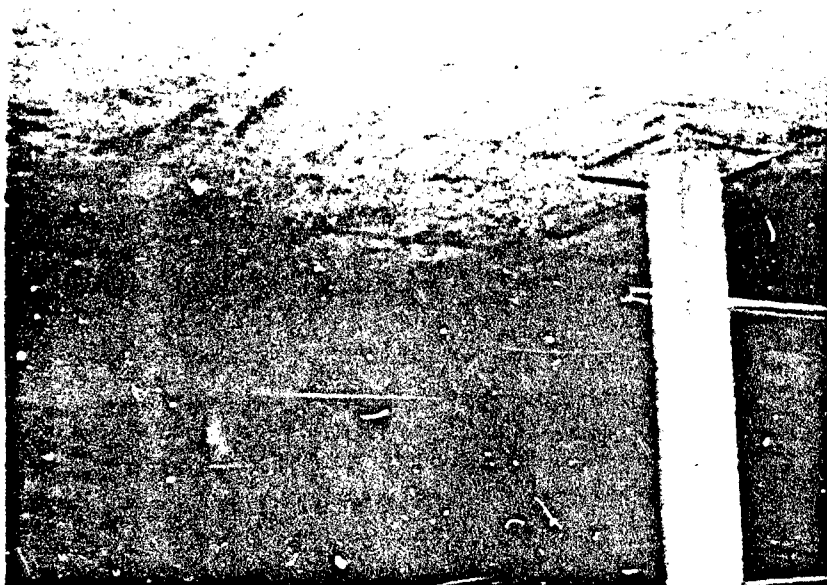

Fig. A-2. Building 1, Single Story Parking Structure.

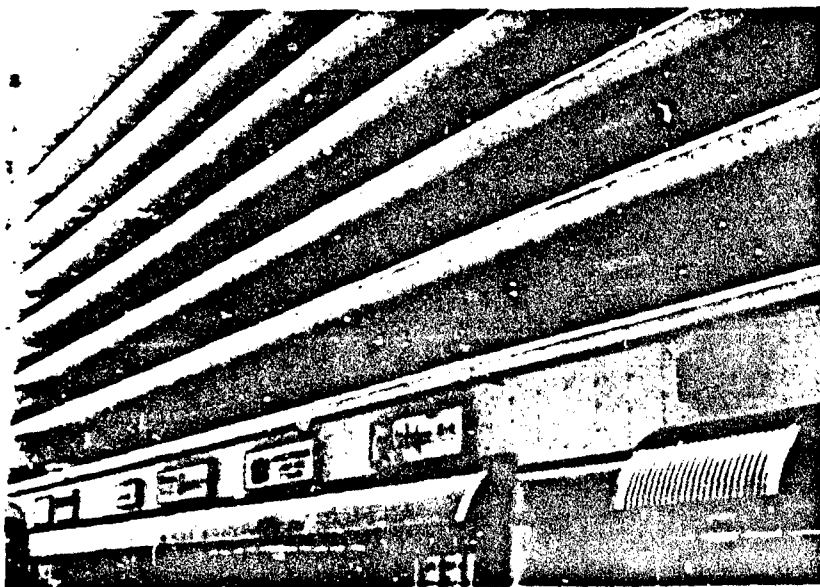

Fig. A-3. Building 2, Multi-Story Parking Garage.

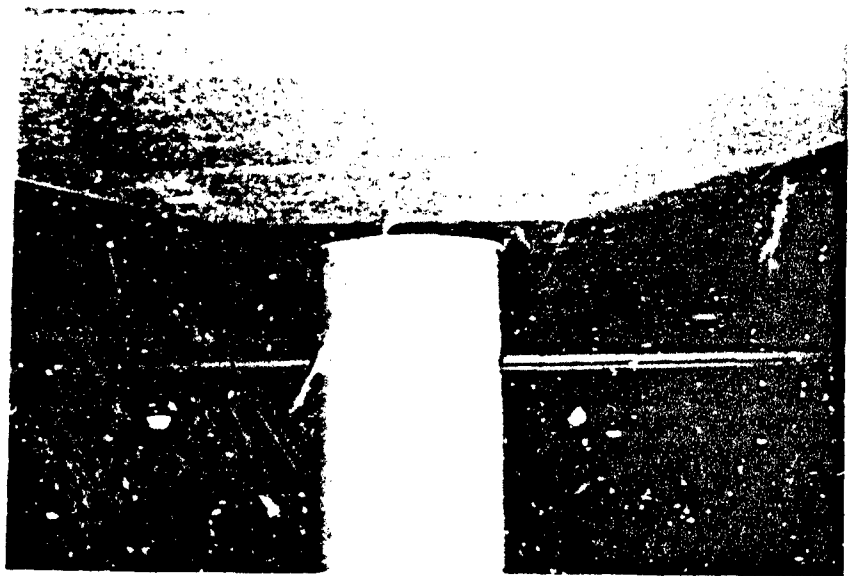

Fig. A-4. Building 2, Basement Parking Garage.

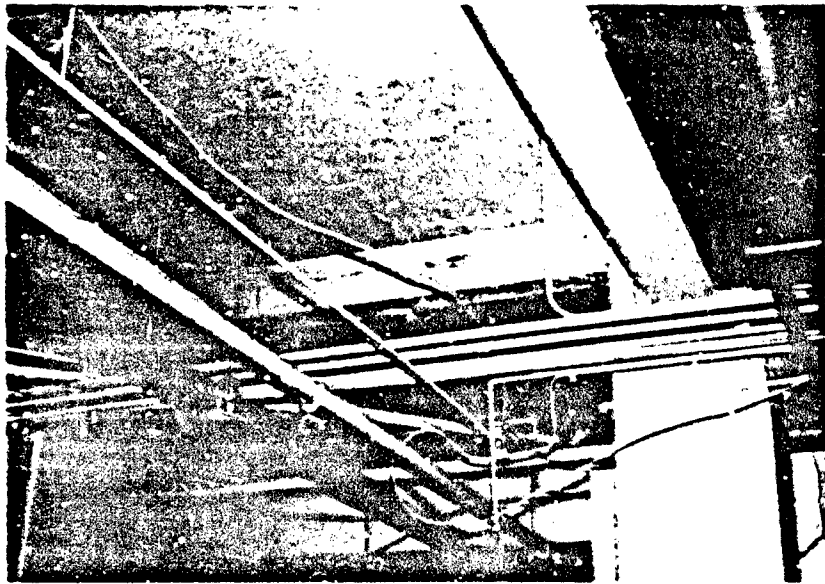
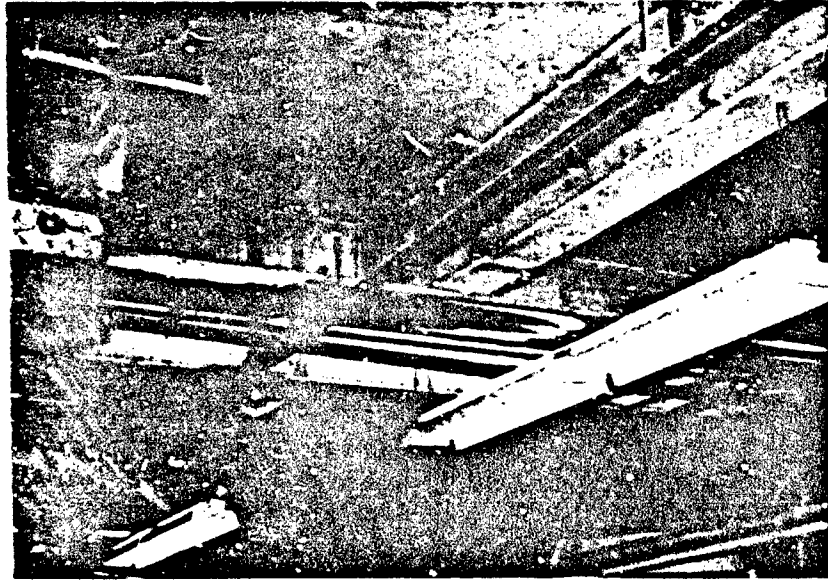

Fig. A-5. Building 3, Basement Parking Garage.



Fig. A-6. Building 4, Basement Parking Garage.

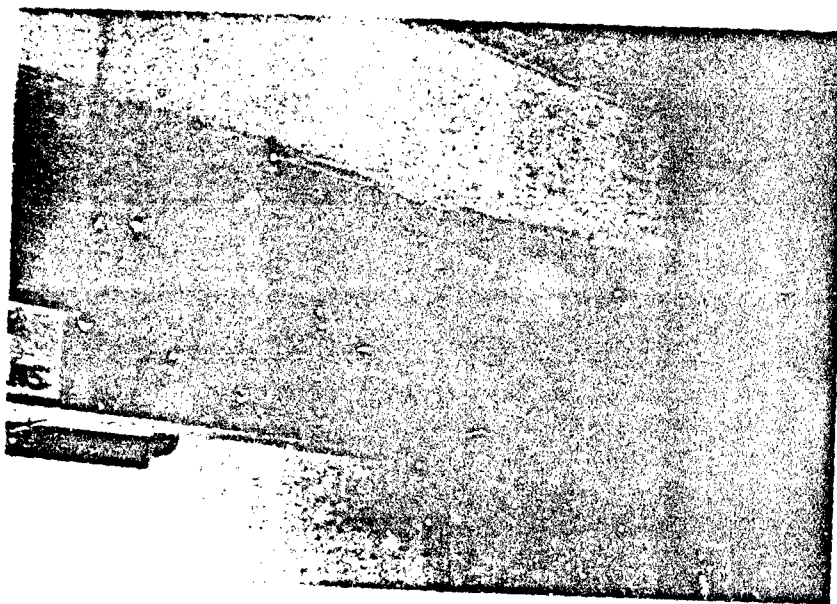

Fig. A-7. Building 4, Basement Parking Garage.

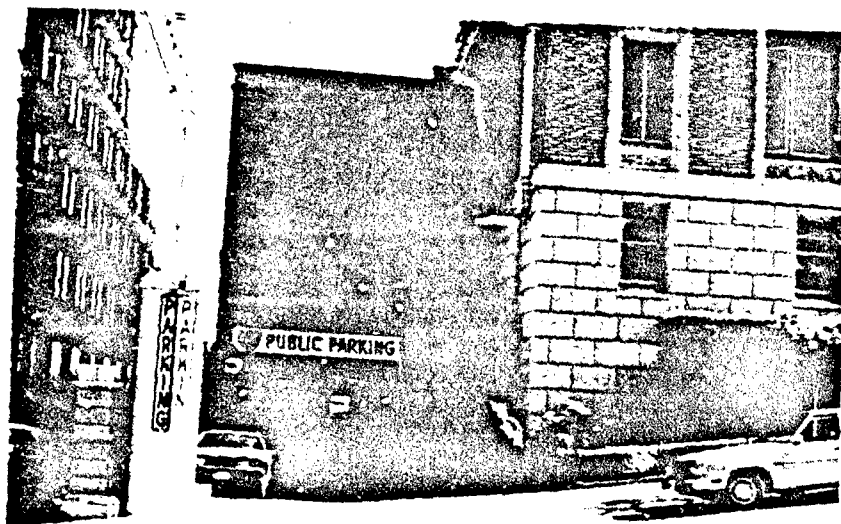

Fig. A-8. Building 5, Entrance to Hotel Parking Garage.

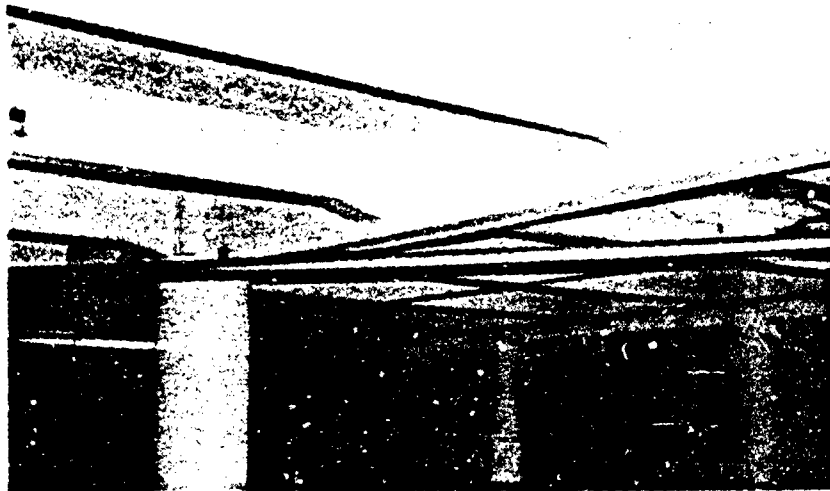

Fig. A-9. Building 5, Hotel Basement Parking Garage.

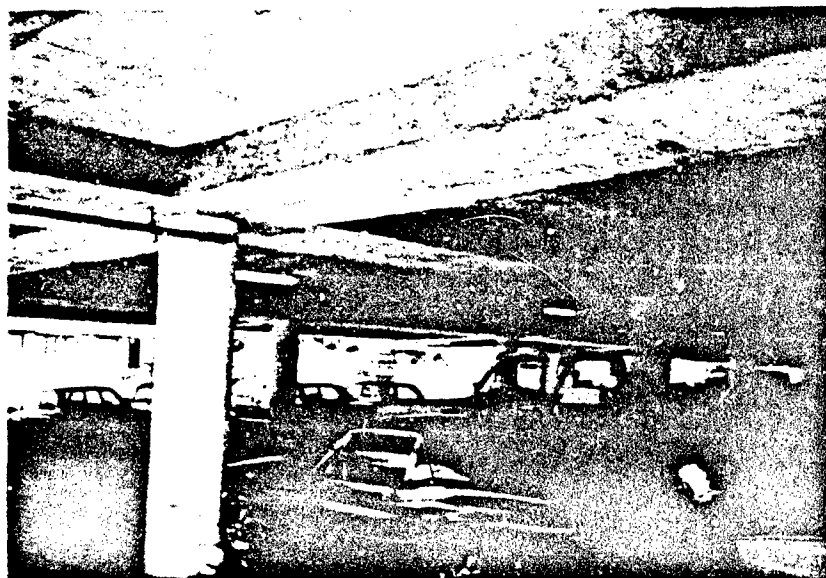
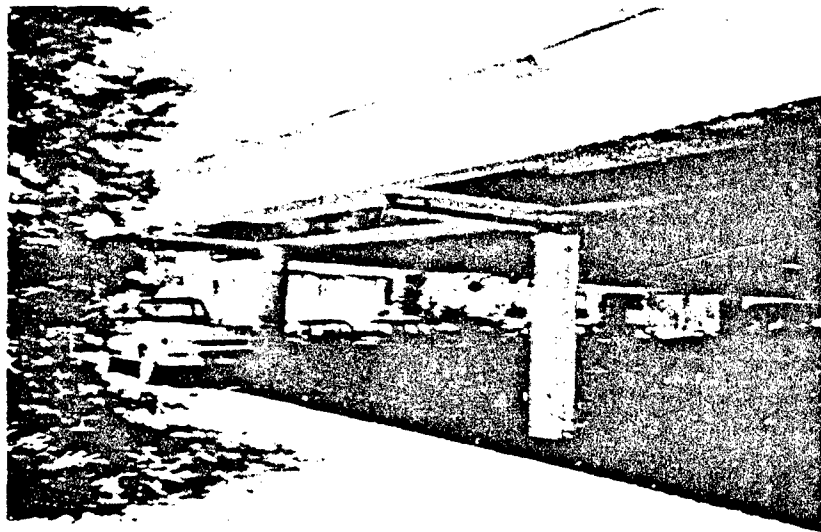

Fig. A-10. Building 6, Single Story Parking Structure.



Fig. A-11. Building 6, Single Story Parking Structure.

Table A-2
STRUCTURAL PROPERTIES

Building	Type Represented	Estimated w_D (psf)	Estimated w_L (psf)	Shelter Area
1	flat plate	110	100	100' x 120'
2	flat plate	110	50	240' x 320'
3	two-way	90	70	100' x 120'
4	two-way	100	70	200' x 240'
5	two-way	90	70	100' x 120'
6	two-way	100	100	240' x 240'

Table A-3
SLAB CAPACITY EVALUATION
 (all capacities are in psf)

Building	Non-Upgraded			Third-Point Shoring, L/3			Quarter-Point Shoring L/4		
	w _P	w _C	w	9w _F	w' _C	w'	16w _P	w' _C	w
1	420	110	130	3780	3470	4438	6720	6410	8198
2	320	10	12	2880	2570	3287	5120	4810	6152
3	640	350	412	2880	2590	3312	5120	4830	6177
4	680	380	448	3060	2760	3530	5440	5140	6574
5	640	350	412	2880	2590	3312	5120	4830	6177
6	800	500	589	3600	3300	4220	6400	6100	7801

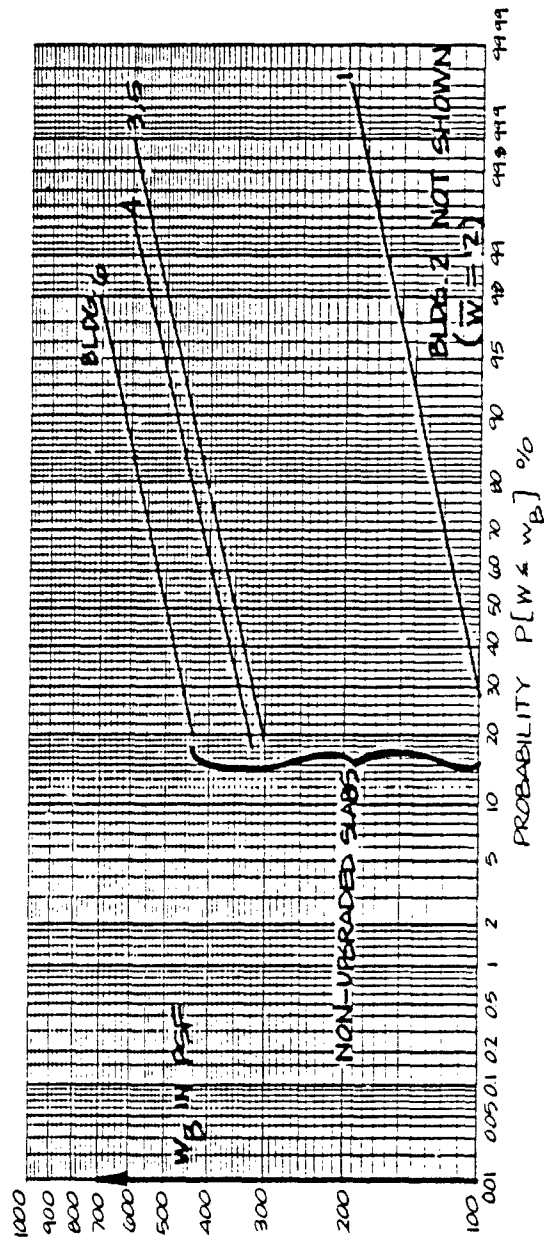

Fig. A-12. Fragility Curves for Representative Buildings: Non-Upgraded Slabs.

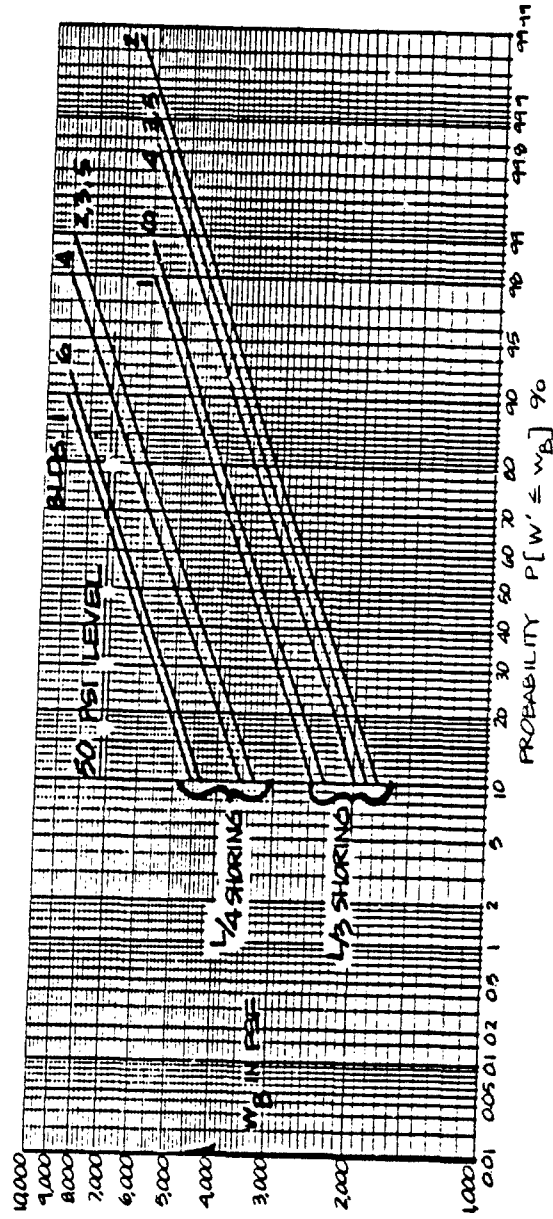

Fig. A-13. Fragility Curves for Representative Buildings: Upgraded Slabs.

APPENDIX B
BLAST ATTENUATION IN AS-BUILT SHELTERS

Appendix B
BLAST ATTENUATION IN AS-BUILT SHELTERS

As noted earlier, it seems reasonable to assume that as-built basement shelters of the type of interest in this study have openings that will permit the blast wave to enter. Since these openings generally will not be the full width (or height) of the shelter wall, there usually will be a substantial modification (and attenuation) of the blast wave as it proceeds into the shelter area. Thus, in order to use the basic blast casualty curves, which are based on free field blast levels, it is necessary to determine the nature and magnitude of these blast modifications.

According to Ref. B-1, the behavior of a shock wave after passing through an opening can be divided into three phases:

1. An initial plane wave phase, which lasts from the time the blast wave enters the opening to the time it has progressed into the interior a distance of between one and two opening widths. During this phase the portion of the shock wave that passed through the center of the opening proceeds as if there were no opening at all, since the diffracted portion of the wave front has not had sufficient time to send back rarefaction waves to reduce its pressure. The pressure at the front of the diffracted wave along the wall near the opening is essentially zero.
2. An intermediate, curved wave, phase during which the shock wave front is decreasing in strength because of the diffraction effects and is curved along its entire front.
3. The third phase occurs only if the back wall is sufficiently distant from the opening, and reflections from the side walls (and roof or floor) have occurred. In these cases the shock wave again becomes essentially plane and proceeds down the axis of the shelter.

The shock front pressures during the first two phases are continually changing, not only in the direction of wave propagation, but along the shock front itself, while in the third phase they become uniform again.

It should also be noted that, if the duration of the incident shock is long enough and if the ratio of the volume of the interior relative to the opening area (V/A ratio) is great enough, the pressure difference between the exterior of a structure and its interior will result in the formation of a jet of air through the opening. This jet, which is potentially very hazardous, was discussed to some extent in the first yearly report (Ref. B-2) and is considered further here in Appendix C.

Ref. B-1 gives methods for estimating the magnitude of the shock front during each of the phases; for phases 1 and 2 these results are given in Figure B-1. It must be kept in mind that this curve is for pressures along the axis of propagation and that the various reflecting surfaces are assumed to be far enough away to not significantly influence the shock front pressures. The only effects are those due to the opening. The distance to which phase 2 extends is given in Table B-1 and depends on the ratio of the opening area to the area of the wall of the shelter (A_p).

Data are given for a range of A_p values from 0.1 to 0.3, which is considered the range of interest for the shelters of concern.* Table B-1 also compares the axial pressures given at the limit of phase 2 with those for phase 3. It can be seen that in phase 3 the pressures are higher than those on the centerline for phase 2. This is because in phase 3 the reflections from the side walls (and/or roof and ceiling) have strengthened the shock front. From an examination of the information given in Figure B-1 and Table B-1 it appears that, except in the vicinity of the opening (within 1 to 2 opening diameters) the blast attenuation ranges from about a factor of 2 to 5 with the majority of the conditions in the neighborhood of 3 to 4.

* This is based on shelter sizes ranging from about 50 to 200 ft on a side, a height of 10 ft, and openings in the range of 100 to 400 sq ft.

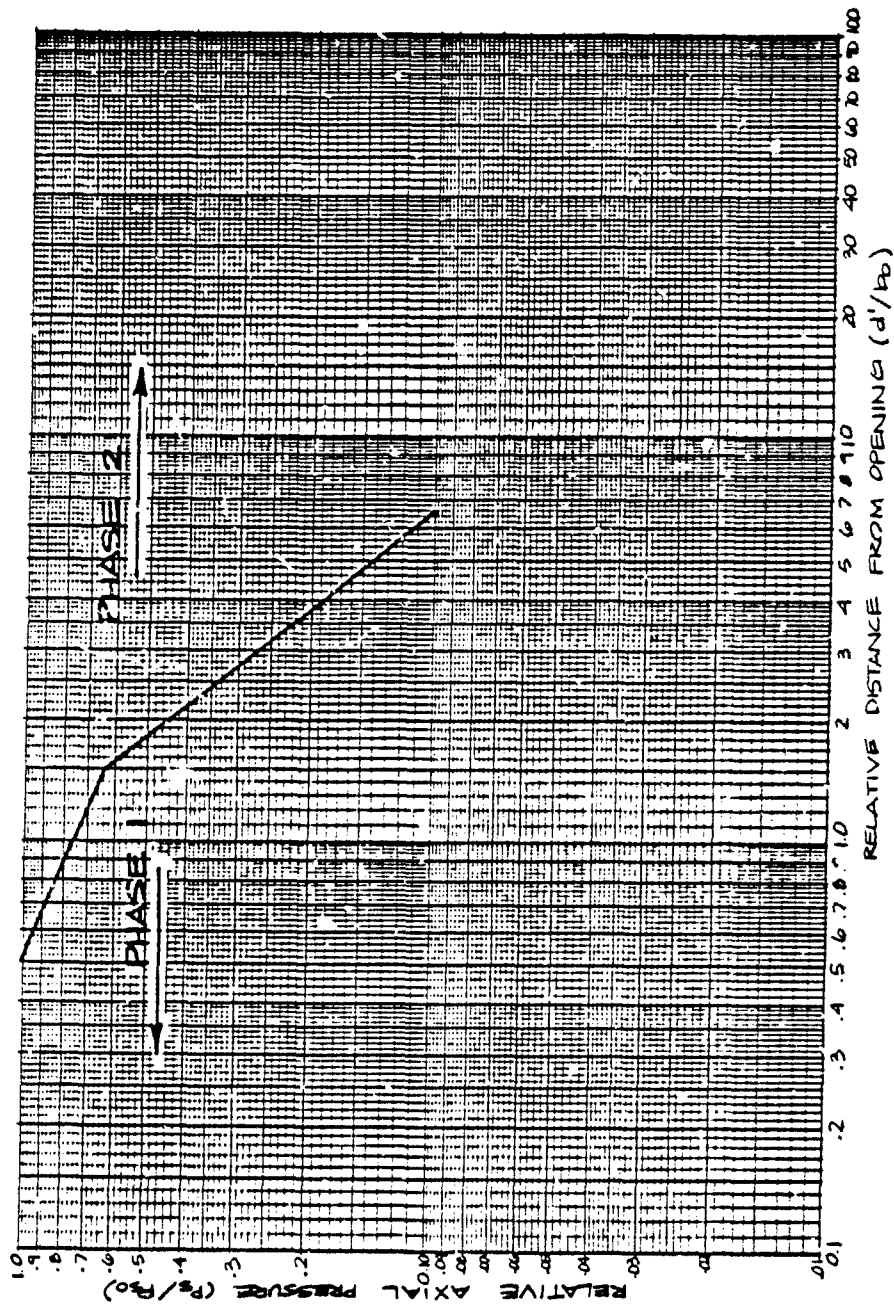

Fig. B-1. Prediction Curve for Axial Shock Front Pressure.

Table B-1
ESTIMATED SHOCK WAVE ATTENUATION IN SHELTERS
 (for normally incident shock waves)

A_r	Limit of Phase 2 (d'/b_o)	P_s/P_{so}	
		Phase 2	Phase 3
0.3	2.6	0.32	0.55
0.2	3.1	0.27	0.45
0.1	4.1	0.19	0.32

P_s = shock front overpressure in shelter

P_{so} = free field shock front overpressure

d' = distance from opening along axis

b_o = width of opening

Phase 2 pressures are at given d'/b_o value.

In the first yearly report, Ref. B-2, consideration was given to the relation between peak pressure reduction and the volume-to-area ratio (V/A) of the shelter based on field test data, primarily from the Nevada Proving Grounds. It was noted that for medium V/A ratios (say, on the order of 50) the pressures in the shelters would be from about 1/2 to 3/4 of the free field values and that for large V/A ratios (greater than several hundred) the maximum pressures are as low as 1/4 to 1/10.

It may be noted that even though the V/A ratios of the shelters covered by Table B-1 are all greater than 170 and thus generally fit the large V/A category, the peak reductions in Table B-1 are lower than those given by the field test data. There are believed to be two primary reasons for this. First, the numbers in Table B-1 were derived assuming that the shock wave impinges normally on the opening while in the field tests the entrance was typically side-on. Second, plane wave considerations were used for the present calculations, while the field test data were based on kt range weapons tests. Since the side-on loading is likely to be even more important than the head-on loading, it will be included in the continuing work on this task.

Up to the time that the reflection arrives from the back wall of the shelter the major changes in the shock wave have been in a reduction in its overpressure. However, once the reflected wave arrives, traveling back towards the opening, the flow behind the initial wave will be largely stopped and can even be reversed depending on conditions.* This means that the dynamic pressure loading on people and objects will be essentially terminated at this time. Thus, the casualty mechanisms that depend on dynamic pressure impulse will be reduced in two ways: first, because the peak dynamic pressure, which depends on the peak overpressure, will be reduced; and second, because the loading duration will be limited essentially to the time it takes the shock front to travel to the back of the shelter and return, instead of the full positive phase duration of dynamic pressure.

* The peak overpressures behind the reflected waves will be higher than those in the incident waves; however, this is only of concern for direct blast casualties and, as will be noted later, the V/A ratios in the shelters of concern are such as to make even these reflected pressures well below free field values.

For the typical structures assumed earlier (50 ft to 200 ft on a side), the approximate durations of loading for objects at various fractions of the structure depth are given in Table B-2. The number in parentheses after each item is the loading duration expressed as a percent of the total positive phase duration of dynamic pressure for a 1 Mt weapon in the 5 to 30 psi region — taken as 3.7 s.* The fraction of the total impulse delivered in various percentages of the total pulse duration are given below:**

Loading Duration as a Percent of Total Duration	Percent of Total Impulse Delivered
0.5	2
1	5
2	9
5	22
10	40

From this it can be seen that, for the range of conditions assumed, the percent of the free field dynamic pressure impulse delivered (based on duration changes alone and not including the previously discussed pressure reductions) will be from about 2% to 30%. Combining this with the previously discussed pressure reductions of a factor of 2 to 5 indicates that at the very least the dynamic pressure impulses will be reduced to a maximum of 15% of their free field values and for the majority of the locations the impulse would be less than 5% to 10% of the free field value. This again excepts the area within one or two opening diameters of the opening for which the overall reduction is only a factor of 2 to 3.

Note that the above, again, applies to openings head-on to the blast wave.

* Ref. B-3, Fig. 3.76 gives a range from 3.4 to 4.0 using optimum HOB.

** Based on the following equation from Ref. B-1: +

$$q(t) = q(0) (1 - t/t^+) e^{-2t/t^+}$$
 for $q(0) \leq 10$ psi

Table B-2
APPROXIMATE LOADING DURATIONS AS A FUNCTION OF LOCATION

Location d'/D	Approximate Loading Duration (ms)*		
	D = 50 ft	D = 100 ft	D = 200 ft
0.25	70(2)	140(4)	270(7)
0.50	40(1)	90(2)	180(5)
0.75	20($\frac{1}{2}$)	50(1)	90(2)

d' = distance from opening along axis

D = distance from opening of back wall along axis

* Assumes average velocity of incident and reflected waves is 1100 ft/s.

REFERENCES

- B-1 Kaplan, K., and P.D. Price, **Accidental Explosions and Effects of Blast Leakage into Structures**, ARLCD-CR-79009, U.S. Army Armament Research and Development Command, Dover, NJ, June 1979.
- B-2 Peterson, R.E., et al., **Damage Function Rating Procedure for Flat Slab Basement Shelters**, SSI 8143-9, Scientific Service, Inc., Redwood City, CA, December 1982.
- B-3 Glasstone, S., and P. Dolan (ed.), **The Effects of Nuclear Weapons** (Third Edition), U.S. Department of Defense, Washington, D.C., 1977.

APPENDIX C
JET FLOW PHENOMENA

Appendix C
JET FLOW PHENOMENA

When the pressure on the exterior of an opening remains larger than that on the interior for a sufficient length of time, a jet will be formed, which starts at the opening and proceeds into the interior of the chamber. The effects of the jet were discussed to some extent in the first yearly report and will be considered further here.

The reason the jet is of such concern is that its dynamic pressures can be very much higher than in normal shock flow. For example, a 5 psi overpressure loading on the wall of a building will produce a dynamic overpressure in the jet flow equal to that produced by a 14 psi overpressure shock wave in the free field. Note also that the 5 psi loading can be produced by as little as a 2.2 psi overpressure shock wave incident normally on the wall. The relationships for other overpressures are given in Table C-1.(Table 2-7 from Ref. C-1).

Table C-1
Overpressures for Equal Dynamic Pressure

<u>Free Field Shock Flow</u> (psi)	<u>Jet Flow From Side-on Shock</u> (psi)	<u>Jet Flow From Normal Incidence Shock</u> (psi)
10	2.5	1.2
14	5	2.2
19	10	4.3
26	15	6.1

Besides the high dynamic pressures, the other main characteristics of the jet are:

1. It does not form instantaneously;
2. Filling of the chamber by the air flow in the jet reduces its magnitude and eventually terminates it;
3. The lateral extent of the jet is limited primarily to a cross-sectional area of the same order of magnitude as the jet.

JET TIME CONSIDERATIONS

According to Ref. C-2, the jet formation time is given by:

$$t_s = 4B_o/C_o$$

where t_s is the jet formation time
 B_o is the effective circular opening diameter*
 C_o is the speed of sound in the opening (≈ 1130 ft/s)

and the chamber filling time as:

$$t_f = V/2A$$

where V is the chamber volume (ft^3)
 A is the opening area (ft^2)

In order to determine how these times actually limit the jet flow, it is necessary to be somewhat specific about the ranges of shelter sizes and opening sizes. For the following considerations the ranges of sizes selected earlier will be used. These are:

Shelter size - from 50 ft x 50 ft x 10 ft (high)
to 200 ft x 200 ft x 10 ft (high)

* For noncircular opening $B_o = (4A/\pi)^{1/2}$ where A is the area of the opening.

Opening size - rectangular opening 10 ft high with a width varying from 0.1 to 0.3 of the width of the shelter.

Applying the foregoing equations with the above dimensions gives the results shown in Table C-2.

Table C-2
Typical Jet Formation Times and Chamber Fill Times

Shelter Size	Opening Ratio	V/A (ft)	t_s (ms)	t_f (ms)
50' x 50' x 10'	0.1	500	28	250
	0.2	250	40	125
	0.3	170	52	83
100' x 100' x 10'	0.1	1000	40	500
	0.2	500	57	250
	0.3	330	69	170
200' x 200' x 10'	0.1	2000	57	1000
	0.2	1000	80	500
	0.3	670	98	330

First it should be noted that all of the times given in Table C-2 are significantly less than the typical shock wave durations from a 1 Mt weapon. For example, in the range from 5 to 20 psi the positive phase duration of the shock wave is about 2.6 ± 0.5 seconds (optimum HOB). This is more than 5 times greater than all of the chamber filling times, except for the 200 ft x 200 ft shelter with the smallest opening area (0.1), where it is some $2\frac{1}{2}$ times greater. Thus, it can be concluded that the duration of the jet flow is controlled almost entirely by the filling time.

From an examination of Table C-2 it can also be seen that the jet formation times are in general less than about one-third of the filling times, and assuming that filling of the shelter occurs more rapidly after the jet has formed than before, good arguments can be made to ignore the formation time; that is what has been done in the following material. For those few cases where the formation time is considerably larger, e.g., the 50 ft x 50 ft shelter with the 0.3 opening, it is possible this approach overestimates the loading.

CONSIDERATION OF THE EXTENT OF JET FLOW

Along the axis of the flow the maximum dynamic pressures persist for a considerable distance. According to Ref. C-2, there is no significant attenuation out to about a distance of 12 R, where R is the opening radius, and even at 16 R the particle velocity is still about 80% of maximum. Considering the range of shelter conditions specified earlier, the 12 R distance is greater than the shelter depth for all conditions except the opening ratio of 0.1 where it is 60% of the shelter depth. The data given in Ref. C-3 are somewhat similar, although they show that attenuation starts a little earlier, at about 8 to 10 R. Ref. C-3 also shows that off-axis stagnation pressures do not decrease significantly out to a distance of 0.5 R. Even at a distance of 0.8 R the stagnation pressures tend to be 60% to 70% of the maximum values.

It should be noted that both of the above sources considered a jet expanding in three dimensions while the case of concern here is two-dimensional, so it is reasonable to expect somewhat less attenuation than that given above with both axial and off-axial distances. As a first approximation, it will be assumed that a reasonable upper limit to the floor area of the shelter covered by the jet is a rectangular area 12 R long (or the shelter length in the direction of the jet, whichever is smaller) by R wide. With these assumptions the fraction of the shelter floor area covered by the jet as a function of A_p is given below:

Fraction of Shelter
Wall Open - A_p

Fraction of Floor Area
Covered by Jet

0.1

0.06

0.2

0.2

0.3

0.3

This assumes a single jet - if there are several the fraction of floor area covered is the same or less. It also assumes a square shelter; for rectangular shelters with the opening on the narrow side, the fraction covered will be the same or less; with the opening on the long side, the fraction covered could be up to 0.1 for an A_p of 0.1 and the same for the other A_p values.

TRANSLATION OF PEOPLE BY JET FLOW

Because of the short duration of the jet, it is appropriate to assume a purely impulsive form of loading such as used in Ref. C-2:

$$v = C_A I_q$$

where C_A = acceleration coefficient - $C_D A/M$

I_q = dynamic pressure impulse of jet - $0.5q_o t_f$

C_D = drag coefficient of object

A = cross-sectional area of object

M = mass of object

q_o = peak dynamic pressure in jet

t_f = filling time

v = velocity achieved by an object on the axis of the jet

for C_A in $\text{ft}^3/\text{lb-s}^2$, I_q in psi-s , and v in ft/s

$$v = 72 C_A q_o t_f$$

Using the above equation, a $C_A = 0.7$, and the fatality impact criteria in Ref. C-4 gives the fatality curves in Figure C-1. A $C_A = 0.7$ is applicable to a man standing sidewise to the wind, crouching facing the wind, and prone perpendicular to the wind (Ref. C-5). It should be emphasized that these curves only apply to people in the zone of the jet; to estimate the overall effects in the shelter it is necessary to assume a distribution of people in the shelter and combine this with the previously discussed extent of jet flow. If it is assumed, for example, that the people in a shelter are uniformly distributed, then only 6% of them are exposed to the jet effect for an A_p of 0.1, 20% for an A_p of 0.2, and 30% for an A_p of 0.3. Applying these factors to the curves of Figure C-1 gives the curves in Figure C-2.

There is one other important factor that influences the magnitude of the jet fatality curves: the fraction of the ceiling that collapses. Consider, for example, the large shelter case with an A_p of 0.1. If only 0.5% of the ceiling collapses, the resultant collapsed area is equal to the opening area for this A_p value. The total collapsed area will likely be scattered out in a number of small openings and as such will likely not constitute a jet problem itself, but it certainly will contribute to reducing the filling time and shortening the loading duration of the basic jet. Assume, for example, that for the large shelter case 2% of the ceiling area collapses. This means the total filling area is 5 times greater than the basic opening area so that the filling time is reduced to 1/5, which in turn reduces the total loading to about 1/5 of its original value. Because of this very large effect of only a small percentage ceiling collapse the maximum jet effect will occur at or only slightly above the calculated ceiling slab strength, w_c . Table C-3 shows the above effects.

TRANSLATION OF FRAGMENTS OF HEAVY INTERIOR WALLS BY JET FLOW

Calculation of the velocities of the wall fragments is essentially the same as for a man although the very early time loading can amount to $2q(t)$ rather than $q(t)$. As soon as the wall shatters, however, the loading should drop to $q(t)$ and it is expected that this will happen early enough in the loading process so this additional loading is not significant. The C_A values of both an 8-in. concrete block wall and a 6-in. clay tile wall are about 20% higher than for a man (side-on), which leads to

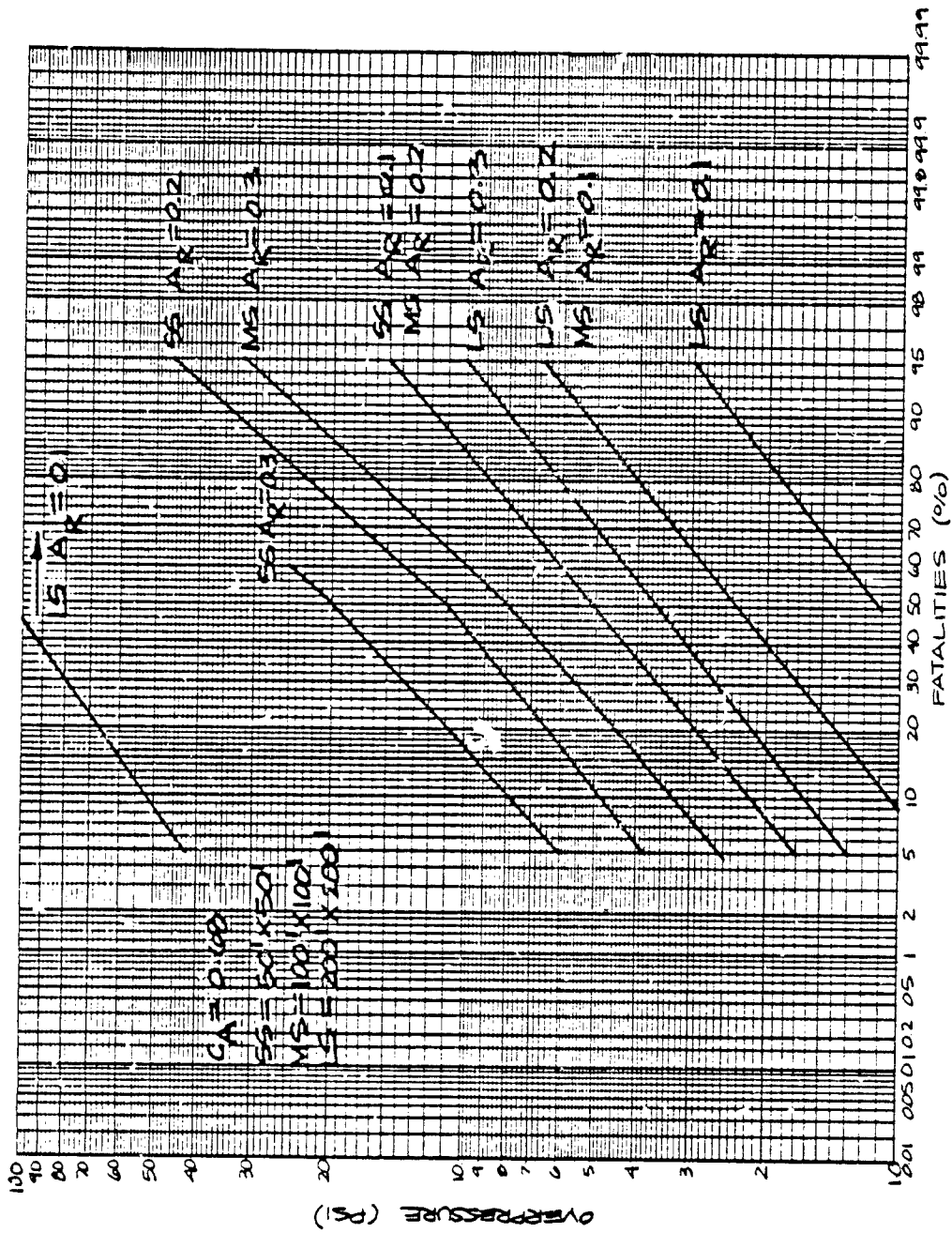

Fig. C-1. Jet Translation Impact Fatalities - On Axis.

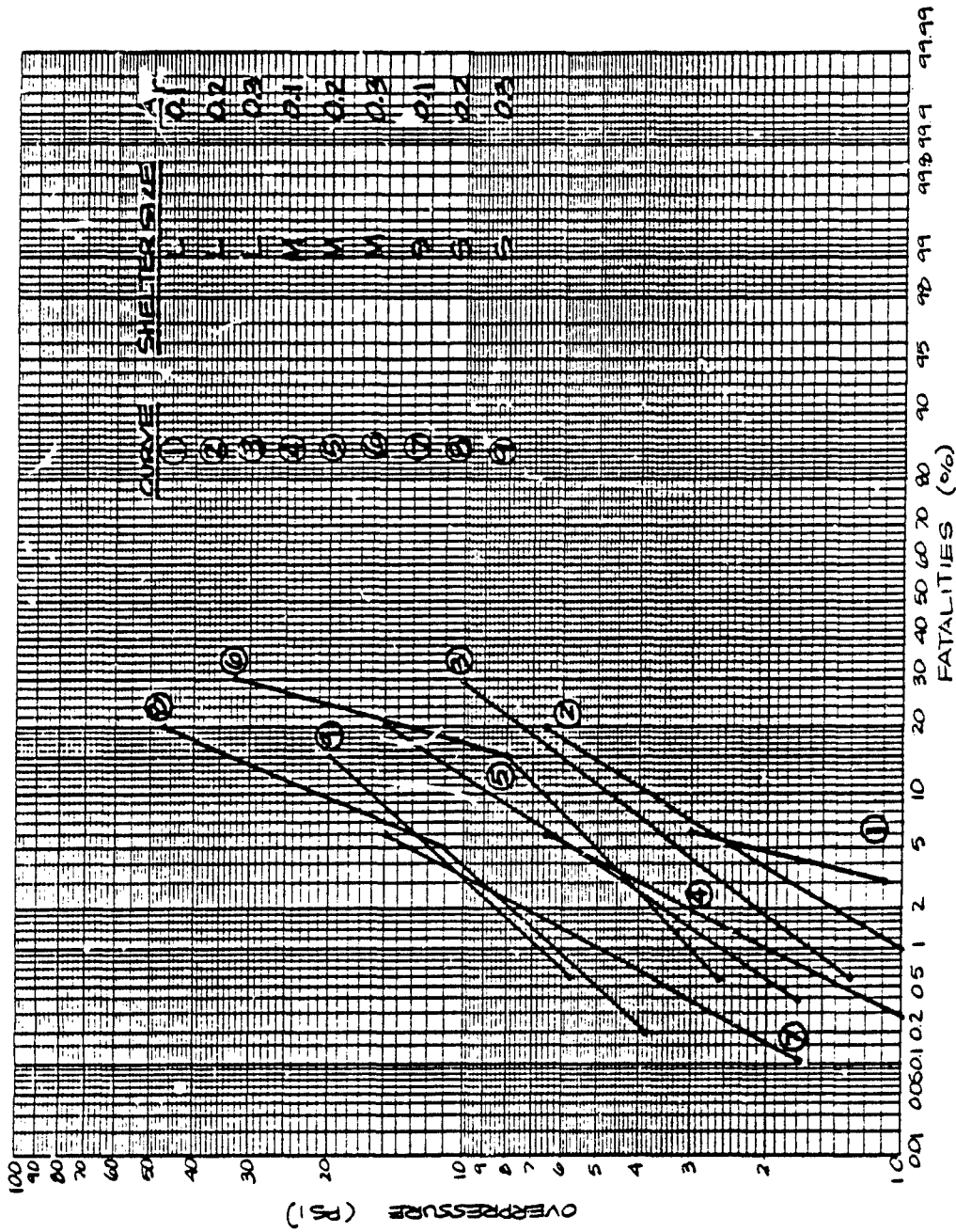

Fig. C-2. Jet Translation/Impact of People.

Table C-3
Maximum Fatalities From Jet Translation/Impact in Shelters
as a Function of Shelter Size and Opening Area

Shelter Size	A_r	Maximum Fatalities %		
		$W_c = 5 \text{ psi}$	$W_c = 3 \text{ psi}$	$W_c = 1 \text{ psi}$
Large*	0.1	6	6	3
	0.2	15	7	1
	0.3	11	3	< 0.5
Medium*	0.1	4	2	0.5
	0.2	4	1	0.5
	0.3	5	1	< 0.5
Small*	0.1	1	< 0.5	0.5
	0.2	0.5	< 0.5	0.5
	0.3	< 0.5	< 0.5	< 0.5

* Large = 200 ft x 200 ft
Medium = 100 ft x 100 ft
Small = 50 ft x 50 ft

pressure values roughly 20% lower to achieve the same velocity. This, however, does not necessarily mean that this case is worse than impact of a man on a rigid surface, since the walls are not rigid surfaces. In the section on impact against non-rigid surfaces it is shown that when punching occurs (which is the case here, since the wall will be in fragments when it impacts the man) an effective impact velocity can be derived from the conservation of momentum. Following this approach the effective impact velocity would be slightly less than 50% of the actual velocity. Overall this case seems less hazardous than for direct acceleration and impact of a man, which has been shown to not be too important for most shelter conditions (maximum of 15% to 30% fatalities). Further, this case will always occur in conjunction with the direct acceleration and impact of a man, which is likely to further significantly reduce the relative impact velocities. For these reasons this case will not be considered further at this time.

REFERENCES

- C-1 Peterson, R.E., et al., **Damage Function Rating Procedure for Flat Slab Basement Shelters**, SSI 8143-9, Scientific Service, Inc., Redwood City, CA, December 1982.
- C-2 Kaplan, Kenneth, and Paul D. Price, **Accidental Explosions and Effects of Blast Leakage into Structures**, ARLCD-CR-79009, U.S. Army Armament Research and Development Command, Dover, NJ, June 1979.
- C-3 **Injuries Produced by the Propagation of Airblast Waves Through Orifices**, DNA 5618 T, Lovelace Foundation, Albuquerque, NM, December 1980.
- C-4 Glasstone, S., and P. Dolan (ed.), **The Effects of Nuclear Weapons** (Third Edition), U.S. Department of Defense, Washington, D.C., 1977.
- C-5 Bowen, I.G., et al., **A Model Designed to Predict the Motion of Objects Translated by Classical Blast Waves**, CEX 58.9, Lovelace Foundation for Medical Education and Research, Albuquerque, NM, June 1961.

APPENDIX D

**CALCULATION OF VELOCITY OF MISSILES FROM BLAST
LOADING OF EXTERIOR FRANGIBLE WALL PANELS**

Appendix D

CALCULATION OF VELOCITY OF MISSILES FROM BLAST LOADING OF EXTERIOR FRANGIBLE WALL PANELS

CONSIDERATION OF BUILDING LOADING

It is generally assumed that the average front face loading on a building is as shown below:

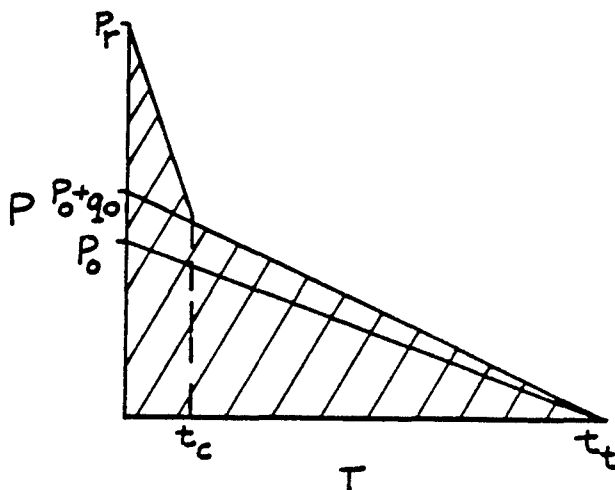

where P_r = peak reflected pressure
 P_o = peak incident pressure
 q_o = peak dynamic pressure
 t_t = effective triangular pulse duration
 t_c = clearing time for the front face

at $t = 0$ loading is P_r
 $t = t_c$ loading is the sum of $p + q$
 $t = t_t$ loading is 0

CONSIDERATION OF WALL PANEL LOADING

The actual loading on an individual frangible wall panel on the front face of a building can initially be approximated by that described above for the building, but as the wall panel starts to break up, the loading will be reduced until it reaches pure drag phase loading, i.e., q . For the range of pressures of interest the drag loading is so much smaller than the diffraction phase loading that it can generally be ignored.

The manner in which the loading changes is very complicated: it depends on a number of factors including the manner in which the panel breaks up, which in turn depends on the type of panel and its mounting; it depends on the location of the panel in the face of the building and on what types of wall panels surround it; and it depends on the panel and building sizes.

To get some reasonable estimate of the criteria to use for establishing the end of the diffraction phase loading on the wall panel, it is helpful to consider several limiting cases.

First, we will consider the case of a simple beam mounted wall with supports top and bottom. From Ref. D-1* it is shown that such a wall panel cracks along the horizontal center line with each piece initially tending to rotate about its support and opening up a horizontal gap in the center of the panel. This is perfectly analogous to the opening space of a double doorway, as both doors are pushed outward. As shown in Calculation D-1 for such a geometry, when the middle of the panel has moved a distance of 25% of the wall height, the open area (doorway opening) in the gap is some 13% of the total panel (plus open) area; and when it has moved a distance of 37.5% of the wall height, the open area is some 34% of the total area.

Now in order to evaluate the load on the "swung-open" wall panel at the instant when the opening is equal to a given percent of the panel area, it is assumed

* Wilton, C., K. Kaplan, and B.L. Gabrielsen, **The Shock Tunnel: History and Results**, SSI 7618-1, Scientific Service, Inc., Redwood City, CA, December 1982.

that this load is equal to the load felt by an undamaged wall panel having a door or window opening equal to the cracked opening percentage. The loading study data given in the same reference show that the net loading on a wall with an opening of 15% of the wall area is from 60% to 75% of that for a solid wall depending on whether the opening is in the shape of a window in the middle of the wall or a door at the edge of the wall. Further, they show that, when the opening is 34% of the total area, the loading has reduced to about 30% for the case of the window geometry.

Since there is still a significant loading for the 25% wall height travel distance (roughly $2/3$) and relatively little for the 37.5% distance (roughly $1/3$), it seems reasonable to approximate the actual loading by a steady state loading equal to the initial value up to about a 30% wall height travel distance and then to assume the loading drops to zero.

Another limiting case of concern is where essentially the entire panel punches out and moves more or less as one piece even though fragmented. This could occur, for example, with a fixed beam mounting where the maximum stress occurs initially near the edges of the panel rather than in the middle as for the simple beam. For this geometry several subcases are of interest. First, consider the situation where there are floors above and below the panel so the pressure relief can only come from the sides as indicated in sketch A, a plan view of the wall. As shown in Calculation D-2 for this geometry, when the wall has moved a distance of 25% of its height the open area is 18% of the total and for a distance of 37.5% the open area is 28%. These values do not differ greatly from those for the previous case so that again it seems reasonable to select a 30% wall height travel distance as the termination of the loading.

If there were no floors, the travel distance should be somewhat less because there is pressure relief top and bottom as well as on the side. However, if there are other similar wall panels surrounding the panel of

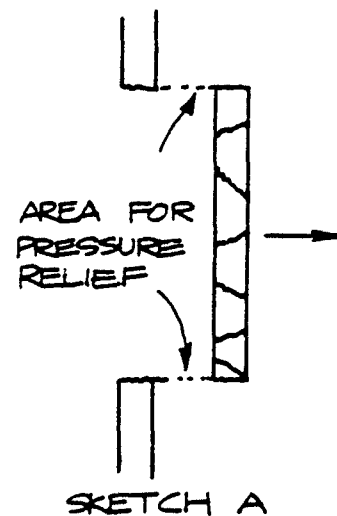

concern, then the travel distance would likely be greater because these other panels would reduce the pressure relief.

One other method of pressure relief is by fragmenting of the walls combined with a range in velocities of fragments, which is only reasonable to expect. Consider, for example, a wall of thickness x , which travels, on the average, a distance of $4x$ in a time t . If some fragments are traveling 25% faster than the average and some 25% slower, then there will be a space of one wall thickness between the trailing edge of the faster fragment and the leading edge of the slower fragment, giving significant potential for blast leakage. To compare these results with those above, assume a typical wall thickness and height, say 8 in. and 8 ft respectively. This gives 2.4 ft from the 30% wall height travel distance and 2.6 ft from the 4 wall thickness distance. The value of 2.4 ft was used for comparison against a scale model test of 9 in. brick walls. These results, which are discussed in more detail later, show that in all cases the calculated velocities were higher than the measured ones. For the shock tunnel tests the experimental values were from about 70% to 75% of the calculated ones, while in the scale model brick wall tests the measured values ranged from about 80% to 90%. For this reason it seems desirable to empirically adjust the 2.4 ft value enough to reduce the velocity values by 20%. This results in a value of 1.5 ft, which will be used in future calculations.

As will become evident later in the discussion, the times for the wall panels to travel this distance are very short compared to the pulse durations, so that both p and q can be considered to remain constant during this time. Thus, the loading pulse of concern is shown in sketch B.

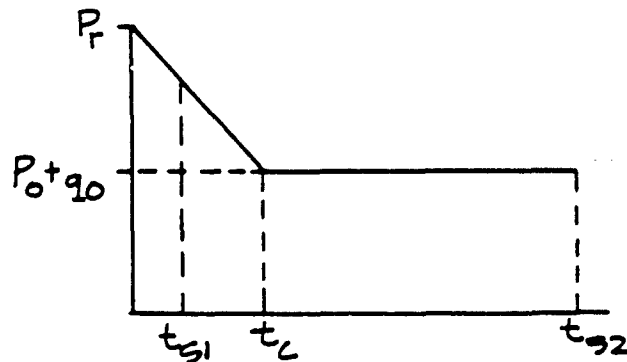

SKETCH B

For this type of pulse, a convenient lower limit to the loading can be obtained by ignoring the reflected pressure spike and using a flat-topped loading of $p = p_o + q_o$. Similarly, a convenient upper limit can be established by using a flat-topped loading of $p = p_r$. The first case corresponds most closely to that for a very small building where the time available for the missiles to accelerate, t_{s2} , is much larger than t_o ; while the second corresponds to a very large building where t_{s1} is significantly less than t_o . All actual buildings will fall between these two limits. As will be shown later velocities computed for these two limits do not differ greatly, and an average value can be used with an uncertainty of $\pm 20\%$, which covers both limits. Thus, at the present time, it does not seem warranted to include the complexities of building size in the evaluational procedure.

CALCULATION OF MISSILE VELOCITIES

$$F = PA = M(dv/dt)$$

for P constant

$$v = (A/M)Pt$$

and

$$x = (A/M)(Pt^2/2)$$

or

$$t = (2Mx/AP)^{\frac{1}{2}}$$

and

$$v = (2APx/M)^{\frac{1}{2}}$$

Now for

v in ft/s

P in lb/in.²

A/M in ft³/lb-s²

x in ft

$$v = 12(2APx/M)^{\frac{1}{2}}$$

and for

x = 2.4 ft - the assumed travel distance

$$v = 26.3(AP/M)^{\frac{1}{2}}$$

$$t = 0.182(M/AP)^{\frac{1}{2}}$$

CALCULATION D-1

x = horizontal travel distance

4 ft = wall 1/2 height

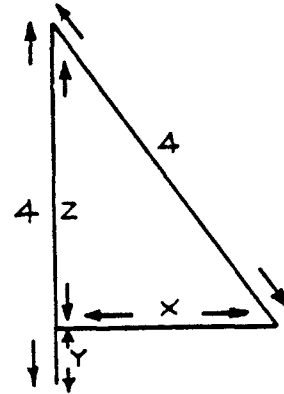

$$f = \text{fraction open area} = y/4 = 4-z/4$$

$$\text{and } z = (4^2 - x^2)^{\frac{1}{2}}$$

$$\text{so } f = 1 - (1-x^2/4^2)^{\frac{1}{2}}$$

x (ft)	f (%)
1	0.03
2	0.13
2.5	0.22
3	0.34

CALCULATION D-2

horizontal travel distance = x

wall thickness = $2/3$ ft

wall height = H = 8 ft

wall length = L = 12 ft

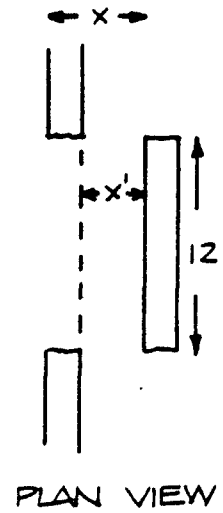

$$\text{fraction open area} = f = \frac{2x'}{12 + 2x'}$$

$$\text{and } x' = x - 0.67$$

$$\text{so } f = \frac{2(x - 0.67)}{12 + 2(x - 0.67)}$$

x (ft)	f (%)
1	0.05
2	0.18
2.5	0.23
3	0.28

APPENDIX E
CONSIDERATION OF IMPACT WITH NON-RIGID SURFACES

Appendix E
CONSIDERATION OF IMPACT WITH NON-RIGID SURFACES

In previous work it was noted that lightweight internal partitions achieved very high velocities for very low loading pressures and thus might represent a considerable hazard. Further consideration of this problem suggests that a man impacted by such a wall will likely punch through it and that the effective impact velocity may be far less than the actual wall velocity. The best evidence for the punching effect is a test carried out in the shock tunnel* in which a sheet rock/timber stud wall was accelerated to a velocity of some 140 ft/s and then allowed to impact an anthropomorphic dummy seated behind a desk (the dummy was designed to simulate the weight distribution of a 168 lb man). It was observed that the dummy punched through the wall leaving a hole not much larger than the size of the dummy. The wall and desk continued on to smash against the far wall while the dummy still seated in the chair only moved some 35 ft. Others arguments supporting this punching theory are the low shear strength of such walls and the much greater weight per unit area of a body to that of the wall - approximately 46 lbs/ft² compared to 5.6 lb/ft² (46 lb/ft² is for a man standing sideways - C_A of 0.7 ft³/lb-s²).

It is proposed here that the effective impact velocity can be taken as the velocity of the body after being impacted by the wall. Assuming an inelastic collision this can be calculated on the basis of conservation of momentum, i.e.,

$$V_e/V_w = W_w/W_e$$

where V_e is the velocity of the body after impact by the wall
 V_w is the initial wall velocity
 W_w is the weight of the portion of the wall that punches out
and goes with the body
 W_e is the weight of the body plus W_w

* Gabrielsen, B., C. Wilton, and K. Kaplan, *Response of Arching Walls and Debris From Interior Walls Caused by Blast Loading*, URS 7030-23, URS Research Company, San Mateo, CA, February 1975.

If a perfect punch is obtained, i.e., the same cross-sectional area of the wall is punched out as the body then

$$V_e/V_w = 5.6/(46 + 5.6) = 0.11$$

Assuming that a 25% larger hole is punched out leads to a velocity ratio of 0.13 a value that will be used in the subsequent calculations.

The method used for calculating the velocity of internal walls by normal blast loading results in the velocity being dependent on the square root of the pressure. Thus, if the velocity needs to be increased by a factor of $1/0.13 = 7.7$ then the pressure needs to be increased by a factor of about 60. Applying this factor to what could be considered the worst practical case in Figure E-1, side-on loading and 0.5 attenuation give 2% fatalities for 13.2 psi and 5% for 19.2 psi. The percent fatalities for these same two overpressures for ceiling collapse for even a w_c as large as 10 psi (corresponds to a $W_{LL} = 250$ psf for a two-way slab) are 28% and 93% respectively — very much greater values. Thus, providing that the concept of effective velocity is at least approximately correct, this damage mechanism, impact by lightweight interior partitions accelerated by the blast wave directly, can be ignored for un-upgraded shelters.

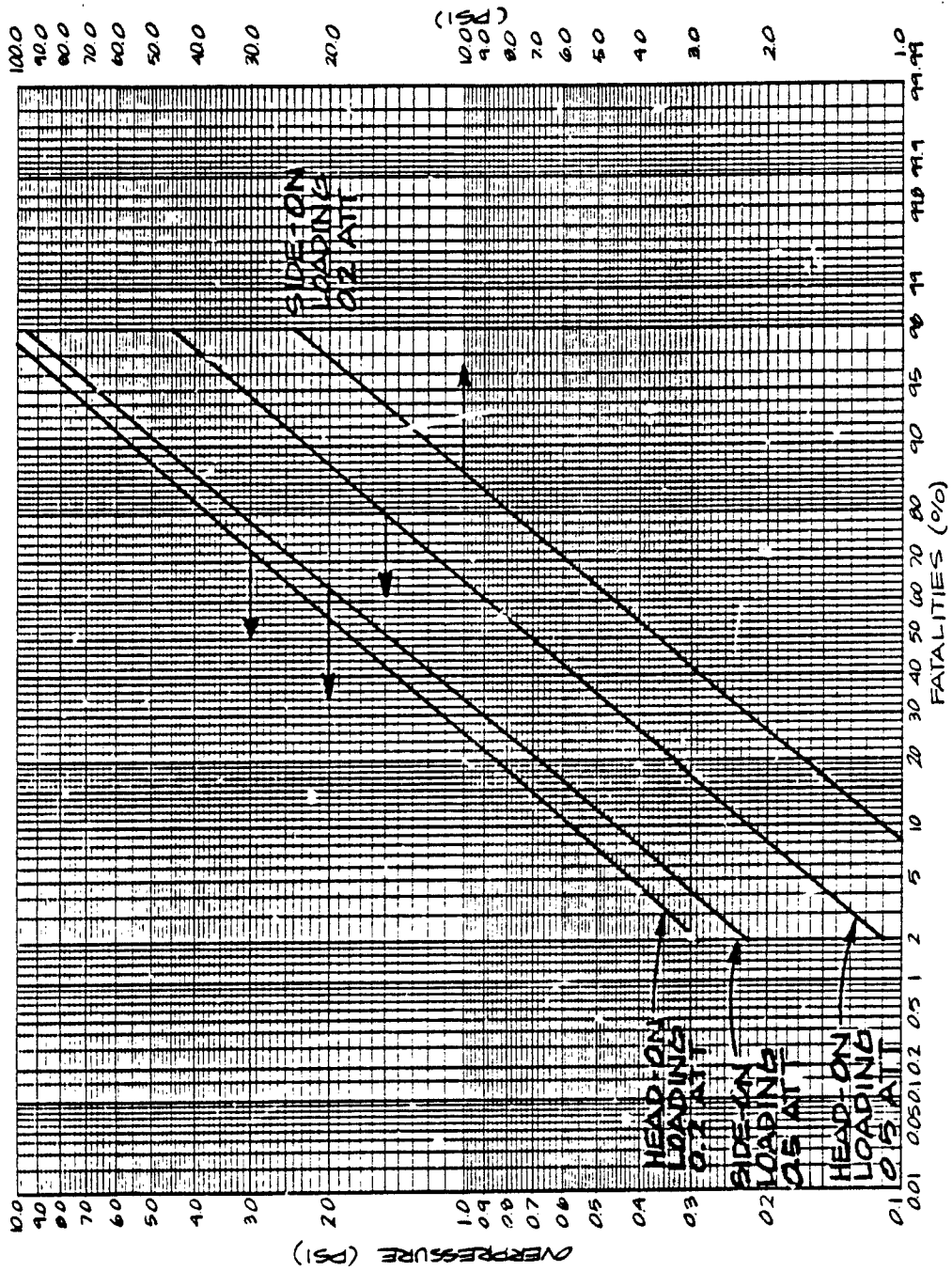

Fig. E-1. Impact by Interior Frangible Walls of 4-Inch Timber Stud/Sheetrock.

APPENDIX F

DEBRIS

Appendix F
DEBRIS

INTRODUCTION

The past survey procedures, using fallout shelter criteria, identified the basements of high-rise buildings in urban areas as suitable shelter areas. A number of these structures were reevaluated and considered as upgradable structures in recent surveys. SSI and a number of other investigators have questioned this extension of fallout survey criteria into the blast resistance and other nuclear effects areas. For example, the SSI Key Worker Shelter Manual, Ref. F-1, noted that, based on then current data (1979), the basements of high-rise buildings in urban areas should not be considered as shelters; only the basements of specific low rise buildings (less than two stories) should be considered and then only if they were at least a building height away from any high-rise building. Admittedly, this may have been a bit premature. Subsequent research, however, has indicated that this criterion is basically correct.

Debris can be a problem in numerous ways. The debris from a collapsing building can cause partial or total collapse of the shelter ceiling. The debris landing on or near a shelter can trap the inhabitants and hinder rescue efforts. Fires burning in debris piles tend to smolder and last for long periods of time, possibly posing a hazard to the shelterees either from heat or from toxic gas production.

Previous work in the debris area has been intermittent with considerable work being done during the second world war and in the late 1960's. The early work was primarily concerned with crater debris prediction, debris trajectories, debris distribution from planned and accidental explosions, and the prediction of injuries from debris fragments. Typical references from this era are Refs. F-2 and F-3.

During the late 1960's much of the research was devoted to postattack recovery. Estimates were made of the type and depth of debris, debris translation

and distribution, and the time and type of equipment necessary to clear paths through the debris field. Typical references are Refs. F-4 through F-10.

BUILDING COLLAPSE DEBRIS

The most recent work in the debris area is a building collapse program conducted by SSI, Ref. F-11. The basic objective of this program was to determine if the results from explosively demolished buildings could be used to improve the current and future guidance for the development of key worker shelters in urban areas. The program involved participation in the explosive demolition of five high-rise buildings and a review of the files of the demolition contractor, Controlled Demolition, Inc. of Phoenix, MD.

The results of this program were very enlightening and are very useful to the damage function/casualty function program reported here. For example, the results indicated that the current survey procedures were, in most cases, totally inadequate to determine the upgradability of structures. In numerous cases it was noted that, where architectural features obscured structural features, it was impossible to determine the condition of the structure and in most cases to determine enough of the structural characteristics to ascertain if the structure could be upgraded to the 40 to 50 psi levels required. Exceptions to this were where the structural characteristics were not obscured or where accurate as-built plans were available.

Debris studies, the subject of this section, conducted during the program raised serious questions about the use of basements of high-rise structures as shelters because of possible entrapment of the shelterees by the location, quantity, and type of debris from the structure or surrounding structures and because of the impact load of the debris and its effect on the integrity of the basement ceiling.

With regard to the location, quantity, and type of debris, it might be expected that, when a high-rise building is destroyed by a high overpressure (40 to 50 psi) blast wave, the contents and structural debris would be swept off site, and very little would land on the basement ceiling. This is possibly true with regard to some of the

contents and lightweight interior partitions, but as predicted in Figure F-1 (from Ref. F-12), and as noted in the building collapse program, much of the structural debris will land onsite. In the case of load bearing buildings, it is predicted that the structure will pancake, with the floor slabs being displaced by approximately one story height or less. An excellent example of this type of failure is the earthquake damaged San Fernando Veteran's Hospital shown in Figure F-2. In the case of steel or concrete framed structures, the debris from a single building would probably look like Figures F-3 and F-4, which show the demolition of the Henry Grady Hotel, Atlanta, Georgia, which was purposely "laid down" by Controlled Demolition, Inc. As will be noted in Figure F-4, a significant portion of the debris remains on the foundation site. It should also be noted that these examples show single buildings only. In a highly urbanized area, debris from adjacent structures would also impact on the shelter site.

The building collapse program gave the first full scale data on what the debris field might look like from a blast wave-demolished structure. For example, the structural material in the Cornhusker Hotel, a typical 10-story reinforced concrete building, was estimated at 120 lb per square foot of floor space, and this mass represents about 0.8 cubic feet of concrete per square foot of floor space per story prior to demolition. The building dimensions, approximately 120 ft by 158 ft, result in 152,000 cubic feet of solid material in the 10-story structure. The volume of debris after demolition, based on field observations, was approximately 320,000 cubic yards, indicating that the pile contained roughly 59% voids. This translates to approximately 20 inches of debris per one story height. Similar comparisons were made for two other buildings demolished during the program, the Olympic National Life Building and the Cuyahoga-Williamson Buildings. The debris depths were approximately 19 inches and 16 inches per story, respectively. Previous studies of debris (see, for example, Refs. F-9 and F-10) used either estimates obtained by computing the quantity of materials and contents in a building, or truck load estimates from conventionally demolished buildings. The results of this program suggest that such techniques tend to underestimate the depth of debris by almost 30%.

It should also be noted that the debris estimates made from the data obtained during the building collapse program do not take into account building contents, since

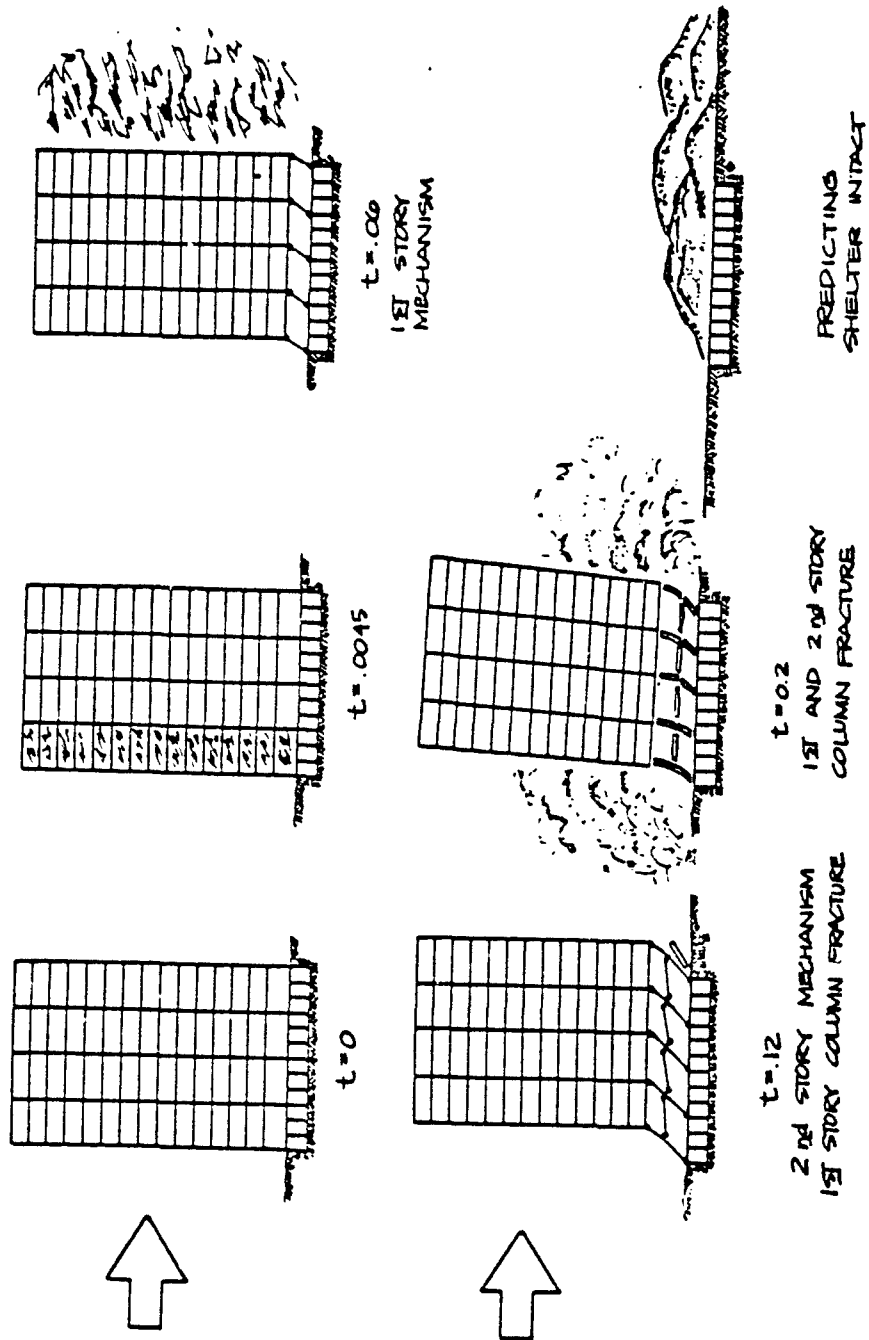

Fig. P-1. Phases of Structural Failure, Continental Life Building, Atlanta, Georgia.



Fig. F-2. Damage to Veterans Administration Hospital in San Fernando Earthquake, February 1971.



Fig. F-3. Henry Grady Hotel Demolition.



Fig. F-4. Debris From Demolition of Henry Grady Hotel.

Photos courtesy of
Controlled Demolition, Inc.

the buildings studied under this program were empty. Estimates from Ref. F-9 indicate that the contents would increase the quantity of debris from 24% to 62% depending on the use classification of the building. It should be noted that these estimates are probably low since they were calculated values and did not take into account possible voids.

With regard to the problem of impact of debris on the shelter ceiling two sources of information are available, the frame response program noted earlier (Ref. F-12) and a recent full scale building demolition. In the frame response program it was estimated that a typical 12-story building would result in a total debris weight equivalent to 120 psf for the structural materials in each floor and 12 psf for the contents:

$$132 \text{ psf} \times 12 \text{ stories} = 1,584 \text{ psf, or } 11 \text{ psi}$$

Impact of the falling debris is estimated at two times the static weight of debris, or 22 psi. Since typical basement ceilings, using a hotel as an example, are designed for loadings of 100 psf (0.69 psi), an as-built ceiling, i.e., without upgrading, would fail under the debris load.

In June of 1983 SSI personnel participated in the demolition of the 12 story Newhouse Hotel in Salt Lake City, Utah. This structure was on the NSS survey and still contained some civil defense supplies. Photographs of this steel framed, masonry walled building before and during its demise are shown in Figures F-5 through F-7. The demolition of this building was unique in that all charges were placed on the first floor and above. None was placed in the basement, enabling us to document what was done to an as-built, i.e., not upgraded, basement when the rest of the structure collapsed. The ceiling of the basement was arched, hollow clay tile similar to that shown in Figure F-8.

As expected, the basement under the collapsed portion of the building was totally collapsed as shown in Figure F-9. Figure 10 shows one interesting item: one of the outside columns of the 12-story portion that was driven several feet down through the basement floor. To put this in the proper perspective, it is estimated

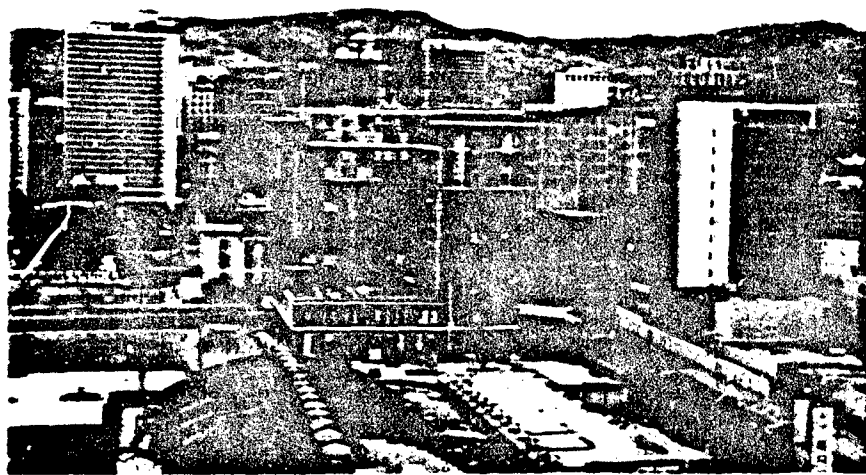
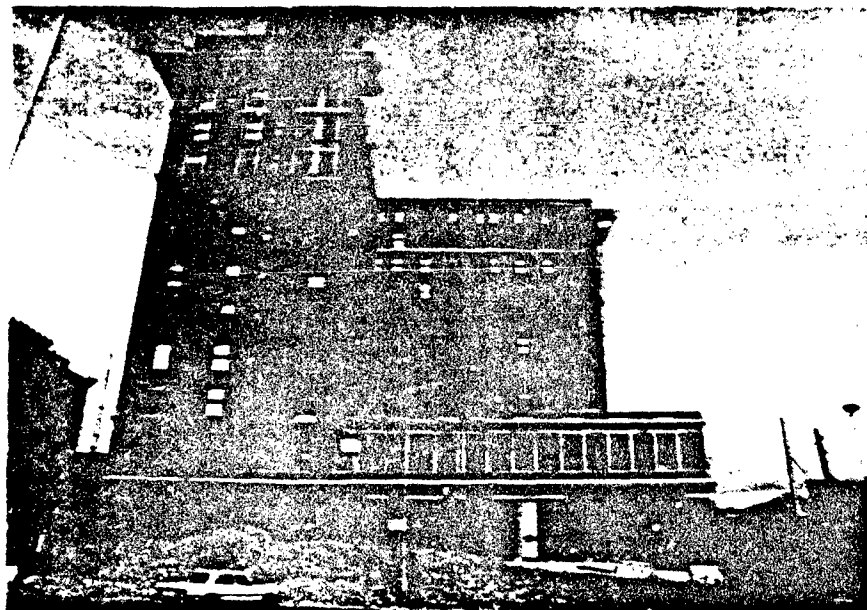

Fig. F-5. The Newhouse Hotel in Salt Lake City, Utah Before Demolition.

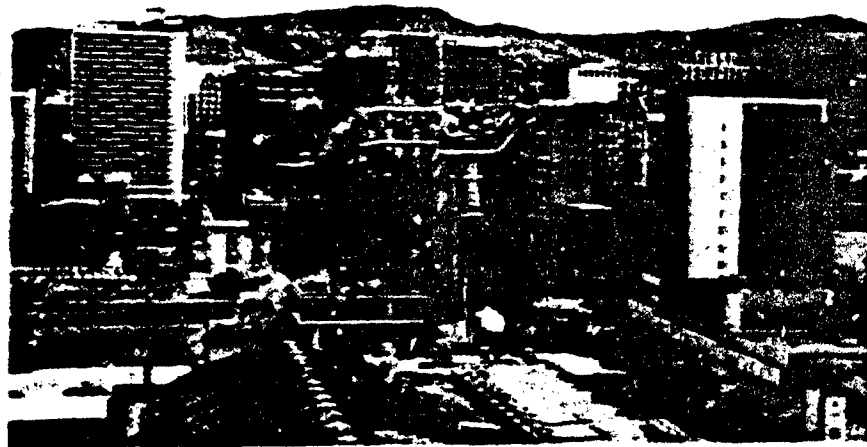
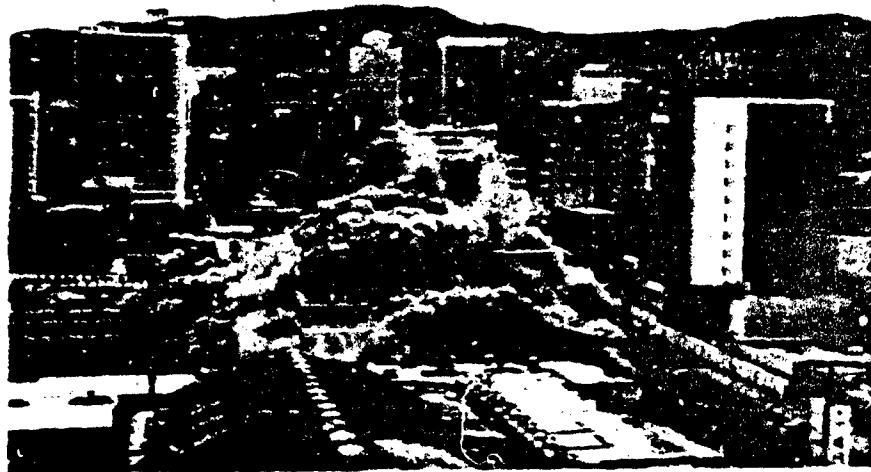

Fig. F-6. Demolition of the Newhouse Hotel in Salt Lake City, Utah.



Fig. F-7. Debris Pile From the Newhouse Hotel in Salt Lake City, Utah.

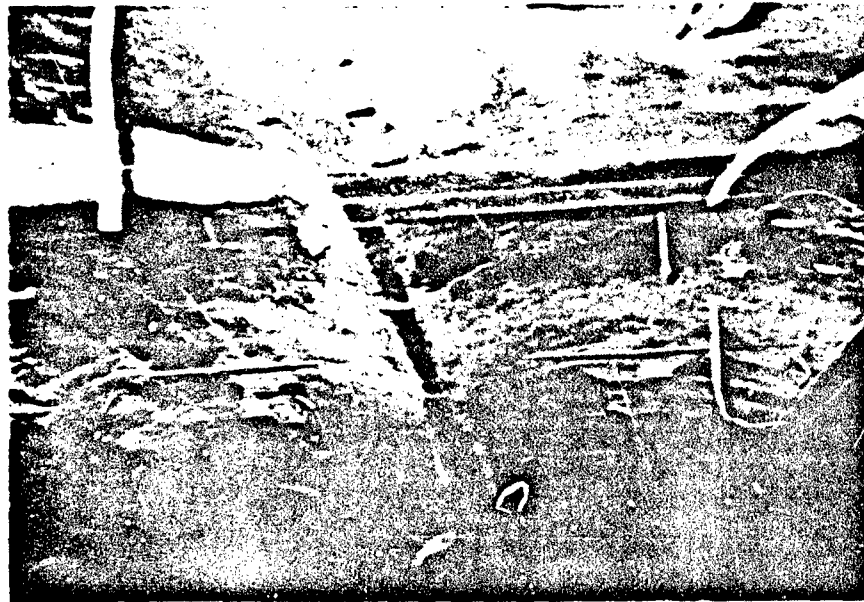

Fig. F-8. Arched Hollow Clay Tile Basement Ceiling With Plaster Cover.

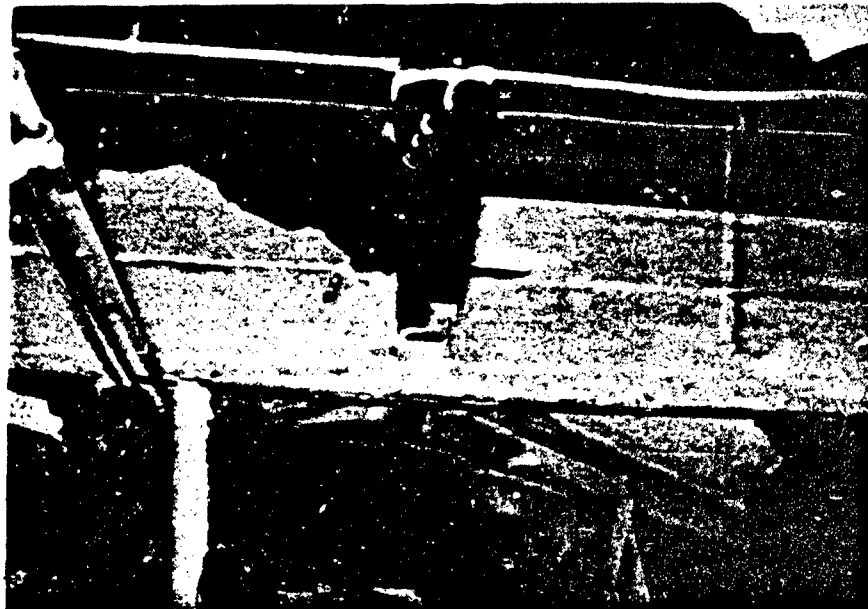

Fig. F-9. Collapse of the Basement in the Newhouse Hotel.

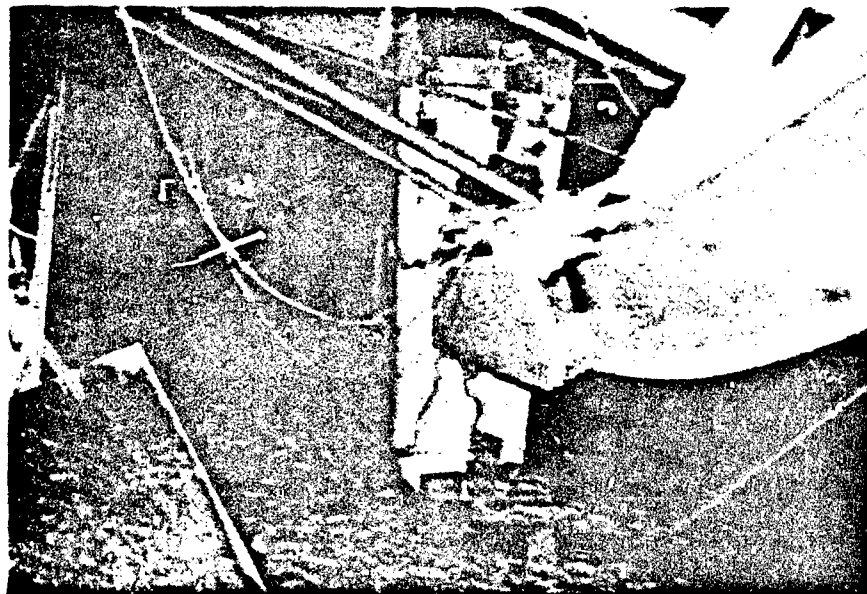

Fig. F-10. Outside Column in the Basement of the Newhouse Hotel.

that a blast overpressure of 4 to 5 psi would have collapsed this building causing similar damage to the basement and most likely 100% casualties.

CONCLUSIONS

The debris problem will require further investigation throughout the program and in other programs in the future. The primary concerns with regard to the damage function/casualty function aspects of this program are: the additional damage caused by impact of debris on the shelter, possible trapping of the shelterees by debris creating additional casualties and, although beyond the scope of this program, the effect debris will have on the intensity and spread of fires. Future plans during the remainder of the program are to continue to participate in building demolitions as funds become available and to incorporate any new research in the debris area into the damage and casualty predictions.

REFERENCES

- F-1. Tansley, R.S., and R.D. Bernard, **Shelter Upgrading Manual: Key Worker Shelters**, SSI 8012-7, Scientific Service, Inc., Redwood City, CA, May 1981.
- F-2. Ahlers, E.B., **Debris Hazards, A Fundamental Study**, DASA-1362, IIT Research Institute, Chicago, IL.
- F-3. **Effects of Impact and Explosion**, Summary Technical Report of Division 2, National Defense Research Committee, Washington, DC, 1946.
- F-4. Feinstein, D.I., **Debris Distribution**, IIT Research Institute, Chicago, IL, March 1966.
- F-5. Wickham, G.E., **Debris Removal, Civil Defense Operations**, Jacobs Associates, San Francisco, CA, March 1969.
- F-6. Barnett, R.L., J.F. Costello, and D.I. Feinstein, **Accumulation and Removal of Blast-Initiated Debris**, IIT Research Institute, Chicago, IL, November 1965.
- F-7. Barnett, R.L., J.F. Costello, and D.I. Feinstein, **Debris Formation and Translation**, IIT Research Institute, Chicago, IL, November 1966.
- F-8. Ahlers, E.B., **Trajectory Analysis for Structural Fragments**, IIT Research Institute, Chicago, IL, August 1965.
- F-9. Rotz, J., J. Edmonds, and K. Kaplan, **Formation of Debris from Buildings and Their Contents by Blast and Fire Effects of Nuclear Weapons**, URS 651-4, URS Corporation, Burlingame, CA, 1966.
- F-10. Edmonds, J.E., C.K. Wiehle, and K. Kaplan, **Structural Debris Caused by Nuclear Blast**, URS 639-4, URS Corporation, Burlingame, CA, October 1964.
- F-11. Bernard, R.D., and C. Wilton, **The Effects of Building Collapse on Basement Shelters in Tall Buildings**, 8130-8, Scientific Service, Inc., Redwood City, CA, January 1983.
- F-12. Gabrielsen, B.L., et al., **The Analysis of the Effects of Frame Response on Basement Shelters in Tall Buildings**, 8142-6, Scientific Service, Inc., Redwood City, CA, October 1982.

APPENDIX G
PRELIMINARY INVESTIGATION OF THE DUST PROBLEM

Appendix G

PRELIMINARY INVESTIGATION OF THE DUST PROBLEM

INTRODUCTION

In January 1983 SSI published a report of an investigation done on explosively demolished buildings (Ref. G-1).^{*} The objective of this program was to evaluate the effect of building collapse on basement shelters of tall buildings. One of the biggest surprises noted during the study, however, was the large quantities of dust created during the collapse process. As each building was destroyed, a huge cloud of dust was created which engulfed the building and the surrounding area for several minutes. Typical examples are contained in the photographs in Figures G-1 through G-4. They include the Cuyahoga-Williamson Building in Cleveland, Ohio, the American Industrial Building in Hartford, Connecticut, the Biltmore Hotel in Oklahoma City, Oklahoma, and the Abe Lincoln Hotel, Springfield, Illinois.

As the dust problem could seriously affect the survivability of shelterees in open shelters, particularly when one considers that each of the examples shown was for a single event, while in a nuclear blast environment the whole neighborhood would be collapsing and generating dust at the same time, it was decided to take some samples of the dust during two of the demolitions and to perform a literature search to determine how dangerous this dust might be to shelterees.

PAST RESEARCH

Most experimental biological studies on dust have been concerned with prolonged inhalation diseases and very little has been done on the subject of sudden dust asphyxia. The most informative source found, after a lengthy literary search,

^{*}Ref. G-1: Bernard, R.D., and C. Wilton, *The Effects of Building Collapse on Basement Shelters in Tall Buildings*, SSI 8130-8, Scientific Service, Inc., Redwood City, CA, January 1983.



Fig. G-1. Dust Generated by Collapse of Cuyahoga-Williamson Buildings, Cleveland, Ohio.



Fig. G-2. Demolition of American Industrial Building, Hartford, CT.
Photo courtesy of Controlled Demolition, Inc.



Fig. G-3. Dust Generated From the Biltmore Hotel, Oklahoma City, OK.

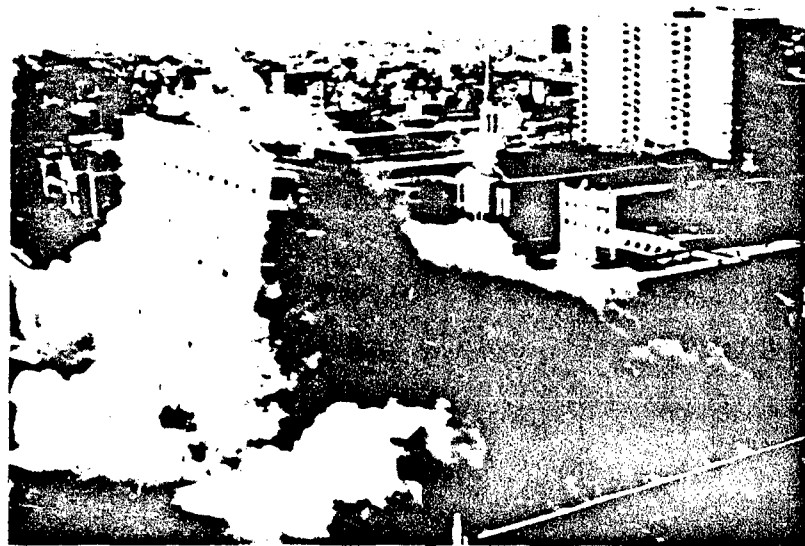

Fig. G-4. Dust Generated From Abe Lincoln Hotel, Springfield, IL.

Photos courtesy of Controlled Demolition, Inc.

was a report prepared by the Surgeon General, U.S. Air Force, Ref. G-2.* Most of the observations were done by German professionals either during or following World War II. The examples given in the report of the autopsies done on the air raid victims showed that asphyxiation can be caused by dust created from the collapse of buildings following an explosion.

Suffocation

There are three principal ways of suffocating in dust. The first two are proven and the last one is theoretical.

- 1) The amounts of dust inhaled are so massive and the particles so coarse that the upper respiratory tracts, especially the larynx, are very rapidly blocked. This represents a purely mechanical, acute asphyxia.
- 2) The amounts of dust inhaled are very large, but the particles are comparatively fine. There is no direct mechanical occlusion. The dust penetrates to the lower respiratory tracts, the bronchi and the bronchioles. Together with the mucus, the dust forms a viscid substance and foam, which gradually occlude the bronchioles, causing slow suffocation.
- 3) The gas exchange is impeded by dust deposits in the alveoli, the ridge just above and behind the upper front teeth.

Numerous experiences were quoted in Ref. G-2 indicating that dust could be a severe problem. Some examples are as follows:

"A case of dust asphyxia involved 29 school children that had taken refuge in the school hallway during an air-raid. The house next door was destroyed by a bomb and the approaches to the hallway were sealed off. Thirty minutes later when the hallway was opened up, there was no debris on the floor, no cracks in the ceilings or walls but twenty-five of the children were dead, the remaining four died soon thereafter.

* Ref. G-2: Desaga, Hans, "Experimental Investigations of the Action of Dust," *German Aviation Medicine, World War II, Volume II*, U.S. Government Printing Office, Washington D.C., 1950, Chapter XIII-B, pp. 1188-1203.

None of the children had external injuries; however, there was marked cyanosis of the skin. The autopsies showed that the upper respiratory passages were completely occluded by fine dust. All the children showed signs of asphyxiation (eyes rolled, tongue between teeth). Further observations made in the cellar of the same house showed a nun that had three children under her gown. The nun died from dust suffocation, but the children remained unharmed."

In another war-time experience (1942), "thick dust deposits were found extending from the nasopharyngeal passages down to the bronchi in 15 victims killed in an undestroyed cellar. The bodies were quite unharmed externally and completely covered with dust. Since no other cause of death could be found, asphyxia following the inspiration of large amounts of dust was assumed. A large bomb had exploded directly beside the cellar without caving in the wall."

Very little has been reported with regard to peacetime fatal inhalation of dusts. A case of acute asphyxia by flour dust was reported in Ref. G-2. A sack of Thomas meal burst, and the dust struck the man who was carrying it in the face. He inhaled the powder and was asphyxiated at once. A similar case was reported by Breitenecker of Vienna. A laborer examined the lower part of a vertical coal dust conveyor to see whether additional coal was being loaded. A heavy cloud of dust struck his face the moment he inhaled and he suffocated at once. At the autopsy, large carbon sediments were found in the finest bronchial ramifications.

Ref. G-2 also reported on some experiments conducted in the laboratory and in the field. The laboratory experiments used dogs, and it was found that a concentration of 80 gm/m^3 was sufficient to threaten the life of a dog. To put this number in perspective, the most dense road dust has from 0.1 to 0.3 gm/m^3 ; the most dense industry dust (badly ventilated cement works) has from 0.5 to 1 gm/m^3 . The highest concentration in the open, other than the building collapse data discussed below, that we have been able to document so far was recorded during armored combat in Africa and the Southeast, during World War II where up to 4 gm/m^3 was measured by the motor transport training school, Vienna (Ref. G-2).

One of the problems noted in the discussion of the above experiments was the difficulty of obtaining large concentrations of dust in the laboratory. This prompted a series of experiments using explosives to determine the concentrations of dust generated by spalling from concrete surfaces. The results of these experiments indicated that it was possible to obtain close to lethal quantities in concrete bunkers from spalling if the explosive was quite close to the bunker wall.

Additional World War II data tend to indicate that lethal quantities are not created by mere collapse of a structure but require a close hit by a fairly large explosive device. Relating that to the nuclear experience will probably be difficult.

BUILDING COLLAPSE DATA

To attempt to gain some preliminary data on the quantity, particle size, and settle time of dust from explosively demolished buildings, SSI in the study noted above participated in the demolition of five buildings. Photographs were obtained from all five and dust samples were obtained from two: the Olympic National Life Building in Seattle, Washington, and most recently, in June 1983, a 12-story structure in Salt Lake City, Utah. Photographs of this latter demolition were presented in Appendix F, Figures F-6, F-7, F-9, and F-10. The quantity of dust generated in both demolitions was impressive — as high as $1,300 \text{ gm/m}^2$ in some locations and averaging over 400 gm/m^2 in all locations within 100 ft of the building. This density, combined with the settle time and particle size, suggests that lethal quantities were present in many areas close to the building.

CONCLUSIONS

The results, while very sparse and preliminary, indicate that, indeed, there could be a problem with dust in open shelters; dust could also have a serious effect on the ventilation and filter systems of closed shelters. It is suggested that further research be performed in this area including some tests in and around explosively demolished buildings.

DISTRIBUTION LIST

(One copy unless otherwise specified)

Federal Emergency Management Agency
Attn: Assistant Associate Director
for Research
National Preparedness Programs
Directorate
Washington, D.C. 20472 (60)

Mr. Donald A. Bettge
Office of Civil Preparedness
National Preparedness Programs
Federal Emergency Management Agency
Washington, D.C. 20472

Mr. Phillip M. Smith
Associate Director
Natural Resources & Commercial
Services
Office of Science and Technology Policy
Executive Office Building
Washington, D.C. 20500

Defense Technical Information Center
Cameron Station
Alexandria, VA 22314 (12)

Mr. Carl Wiehle
Defense Intelligence Agency
Attn: CKW DB-4C2
Washington, D.C. 20301

Director, Defense Nuclear Agency
Attn: Technical Library
Washington, D.C. 20305

Assistant Secretary of the Army (R&D)
Attn: Assistant for Research
Washington, D.C. 20306

Director, Army Materials and Mechanics
Research Center
Attn: Technical Library
Watertown, MA 02172

Chief of Engineers
Department of the Army
Attn: ENGEME-RD
Washington, D.C. 20314

Director, U.S. Army Ballistic Research
Laboratory
Attn: Document Library
Aberdeen Proving Ground, MD 21005

Mr. William Taylor
Ballistic Research Laboratory
Aberdeen Proving Ground, MD 21005 (2)

Director, U.S. Army Engineer
Waterways Experiment Station
Attn: Document Library
P.O. Box 611
Vicksburg, MS 39180

Mr. W.L. Huff
USAE Waterways Experiment Station
P.O. Box 631
Vicksburg, MS 39180

Chief of Naval Research
Washington, D.C. 20306

Commanding Officer
U.S. Naval Civil Engineering Laboratory
Attn: Document Library
Port Hueneme, CA 93041

Civil Engineering Center AF/PRECET
Attn: Technical Library
Wright-Patterson Air Force Base
Dayton, OH 45433

Air Force Weapons Laboratory
Attn: SUL Technical Library
Kirtland Air Force Base
Albuquerque, NM 87117

Air Force Weapons Laboratory
Civil Engineering Division
Kirtland Air Force Base
Albuquerque, NM 87117

Mr. Lewis V. Spencer
National Bureau of Standards
Room C313 - Building 245
Washington, D.C. 20234

Mr. Samuel Kramer, Chief
Office of Federal Building Technology
Center for Building Technology
National Bureau of Standards
Washington, D.C. 20234

R.G. Hickman
Lawrence Livermore National Laboratory
University of California
Box 808,
Livermore, CA 94550

Oak Ridge National Laboratory
Attn: Librarian
P.O. Box X
Oak Ridge, TN 37830

Emergency Technology Division
Oak Ridge National Laboratory
Attn: Librarian
Oak Ridge, TN 37830

Los Alamos Scientific Laboratory
Attn: Document Library
Los Alamos, NM 87544

Dr. Clarence R. Mehl
Division 1112
Sandia National Laboratories
Box 5800
Albuquerque, NM 87185

GARD, Inc.
7449 N. Natchez Ave.
Niles, IL 60648

Mr. C. Wilton
Scientific Service, Inc.
517 East Bayshore
Redwood City, CA 94063 (2)

Mr. Raymond Alger
SRI International
333 Ravenswood
Menlo Park, CA 94025

Mr. Fred Sauer
Physics International Company
2700 Merced Street
San Leandro, CA 94577

The Dikewood Corporation
1613 University Blvd, N.E.
Albuquerque, NM 87102

Mr. Thomas E. Watermann
IITRI
10 West 35th Street
Chicago, IL 60616 (2)

Mr. Leo A. Schmidt
Institute for Defense Analyses
Program Analysis Division
1801 N. Beauregard Street
Alexandria, VA 22311

The RAND Corporation
Attn: Document Library
1700 Main Street
Santa Monica, CA 90401

Director,
Lovelace Foundation
5200 Gibson Blvd, S.E.
Albuquerque, NM 87108

Dr. William Chenault
Human Sciences Research, Inc.
Westgate Industrial Park
7710 Old Springhouse Road
McLean, VA 22102

Mr. John Rempel
Center for Planning and Research
2483 E. Bayshore
Palo Alto, CA 94303

Mr. Jud Leech
BDM Corporation
1801 Randolph Road, S.E.
Albuquerque, NM 87106

Applied Research Associates, Inc.
Attn: Cornelius J. Higgins
2102 San Pedro Blvd, N.E., Suite A
Albuquerque, NM 87110

Research Triangle Institute
Attn: Mr. Ed. L. Hill
P.O. Box 12194
Research Triangle Park,
North Carolina 22709

Dr. John Cockayne
Senior Scientist
Science Applications, Inc.
1710 Goodridge Drive
P.O. Box 1303
McLean, VA 22101

Mr. Kenneth Kaplan,
30 White Plains Court
San Mateo, CA 94402

H.L. Murphy Associates
Box 1727
San Mateo, CA 94401

Mr. James Beck Associates
4216 Los Palos Avenue
Palo Alto, CA 94306

Dr. Ben Sussholz
R1/2094
TRW
One Space Park
Redondo Beach, CA 90278

Dr. Joseph E. Minor, Director
Institute for Disaster Research
Department of Civil Engineering
Box 4089
Lubbock, TX 79409

Professor R.K. Pefley
University of Santa Clara
Santa Clara, CA 95053

Dr. Michael A. Pachuta
4563 Braeburn Drive
Fairfax, VA 22032

**DEVELOPMENT OF DAMAGE AND CASUALTY
FUNCTIONS FOR BASEMENT SHELTERS PHASE II**

Scientific Service, Inc., Redwood City, CA
Contract EMW-C-0678, Work Unit 1622D

Unclassified

September 1983

157 pages

This report describes progress during the second year's work on a Civil Defense program to provide FEMA with a range of damage functions and casualty functions to determine the survivability of people in various basement shelters. The characteristics of flat plate and two-way slab systems and the effects of code specified design procedures, engineering practice, and construction procedures were discussed. Non-upgraded two-way slabs are approximately twice as strong as the flat plate slabs. For upgraded (shored) systems, however, specific building characteristics are not important factors: any shored slab, with standard reinforcing and dimensions, has about the same capacity as any other slab.

A mathematical model for the fragility curve of slab systems was developed. Fatality curves have been developed for ceiling collapse and a variety of other casualty mechanisms (nuclear weapons effects) with emphasis to date on non-upgraded shelters areas. This review of casualty producing mechanisms is continuing and all casualty curves should be considered as provisional.

**DEVELOPMENT OF DAMAGE AND CASUALTY
FUNCTIONS FOR BASEMENT SHELTERS PHASE II**

Scientific Service, Inc., Redwood City, CA
Contract EMW-C-0678, Work Unit 1622D

Unclassified

September 1983

157 pages

This report describes progress during the second year's work on a Civil Defense program to provide FEMA with a range of damage functions and casualty functions to determine the survivability of people in various basement shelters. The characteristics of flat plate and two-way slab systems and the effects of code specified design procedures, engineering practice, and construction procedures were discussed. Non-upgraded two-way slabs are approximately twice as strong as the flat plate slabs. For upgraded (shored) systems, however, specific building characteristics are not important factors: any shored slab, with standard reinforcing and dimensions, has about the same capacity as any other slab.

A mathematical model for the fragility curve of slab systems was developed. Fatality curves have been developed for ceiling collapse and a variety of other casualty mechanisms (nuclear weapons effects) with emphasis to date on non-upgraded shelters areas. This review of casualty producing mechanisms is continuing and all casualty curves should be considered as provisional.

**DEVELOPMENT OF DAMAGE AND CASUALTY
FUNCTIONS FOR BASEMENT SHELTERS PHASE II**

Scientific Service, Inc., Redwood City, CA
Contract EMW-C-0678, Work Unit 1622D

Unclassified

September 1983

157 pages

This report describes progress during the second year's work on a Civil Defense program to provide FEMA with a range of damage functions and casualty functions to determine the survivability of people in various basement shelters. The characteristics of flat plate and two-way slab systems and the effects of code specified design procedures, engineering practice, and construction procedures were discussed. Non-upgraded two-way slabs are approximately twice as strong as the flat plate slabs. For upgraded (shored) systems, however, specific building characteristics are not important factors: any shored slab, with standard reinforcing and dimensions, has about the same capacity as any other slab.

A mathematical model for the fragility curve of slab systems was developed. Fatality curves have been developed for ceiling collapse and a variety of other casualty mechanisms (nuclear weapons effects) with emphasis to date on non-upgraded shelters areas. This review of casualty producing mechanisms is continuing and all casualty curves should be considered as provisional.

**DEVELOPMENT OF DAMAGE AND CASUALTY
FUNCTIONS FOR BASEMENT SHELTERS PHASE II**

Scientific Service, Inc., Redwood City, CA
Contract EMW-C-0678, Work Unit 1622D

Unclassified

September 1983

157 pages

This report describes progress during the second year's work on a Civil Defense program to provide FEMA with a range of damage functions and casualty functions to determine the survivability of people in various basement shelters. The characteristics of flat plate and two-way slab systems and the effects of code specified design procedures, engineering practice, and construction procedures were discussed. Non-upgraded two-way slabs are approximately twice as strong as the flat plate slabs. For upgraded (shored) systems, however, specific building characteristics are not important factors: any shored slab, with standard reinforcing and dimensions, has about the same capacity as any other slab.

A mathematical model for the fragility curve of slab systems was developed. Fatality curves have been developed for ceiling collapse and a variety of other casualty mechanisms (nuclear weapons effects) with emphasis to date on non-upgraded shelters areas. This review of casualty producing mechanisms is continuing and all casualty curves should be considered as provisional.