

AD-A133 224

DISPOSAL OF CHEMICAL AGENT IDENTIFICATION SETS AT ROCKY MOUNTAIN ARSENAL. (U) ARMY TOXIC AND HAZARDOUS MATERIALS AGENCY ABERDEEN PROVING GR.

1/2

UNCLASSIFIED

W R BRANKOWITZ ET AL. MAR 83

F/G 15/2

NL

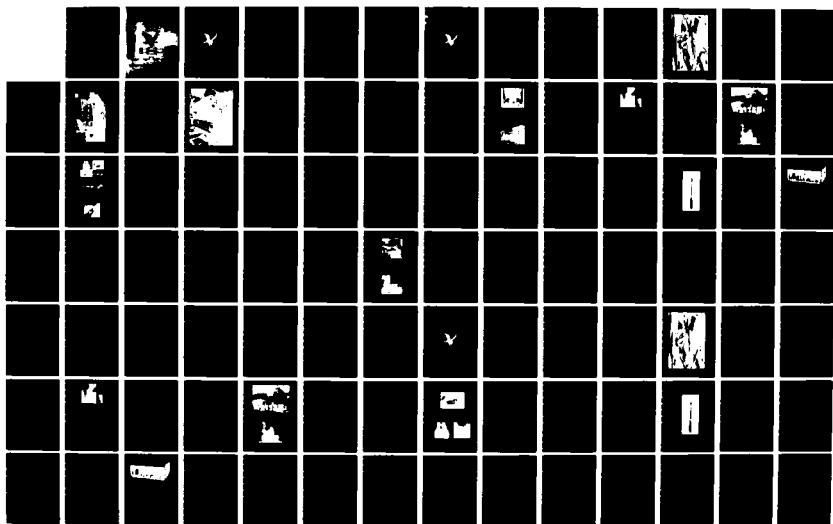

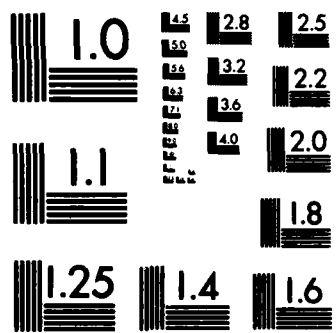

MICROCOPY RESOLUTION TEST CHART
NATIONAL BUREAU OF STANDARDS-1963-A

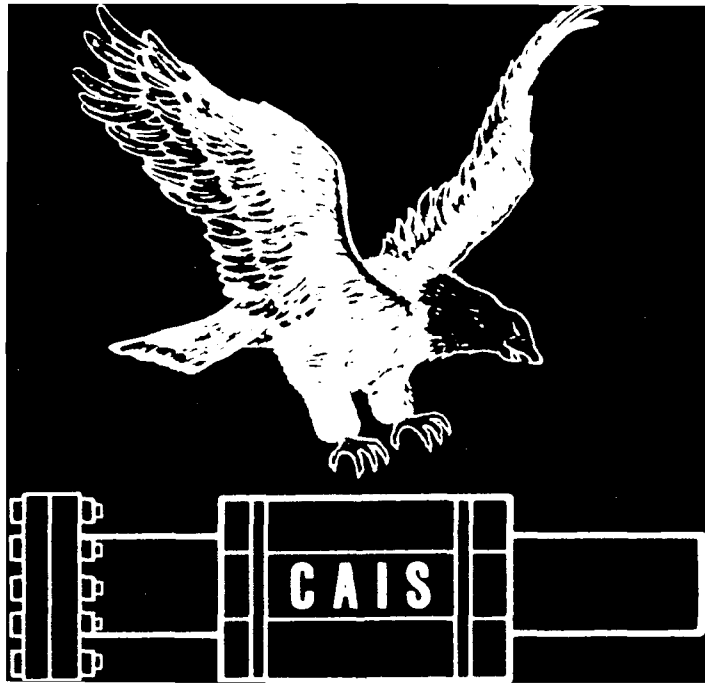

6

DISPOSAL OF CHEMICAL AGENT IDENTIFICATION SETS AT ROCKY MOUNTAIN ARSENAL, COLORADO

FINAL REPORT VOLUME I

AUGUST 1983

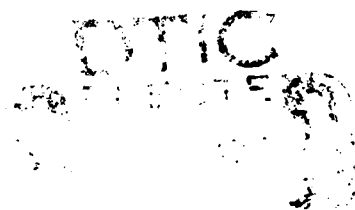

Prepared By

William R. Brankowitz
USATHAMA

Dr. Michael E. Witt
RMA

John A. Ursillo
RMA

Dr. Jack C. Pantleo
Data Processing Associates

DISTRIBUTION UNLIMITED. CLEARED FOR PUBLIC RELEASE

**DEPARTMENT OF THE ARMY
US ARMY TOXIC AND HAZARDOUS MATERIALS AGENCY
ABERDEEN PROVING GROUND, MARYLAND 21010**

REPORT DOCUMENTATION PAGE		READ INSTRUCTIONS BEFORE COMPLETING FORM
1. REPORT NUMBER DRXTH-IS-FR-83203	2. GOVT ACCESSION NO. A133 224	3. RECIPIENT'S CATALOG NUMBER
4. TITLE (and Subtitle) Disposal of Chemical Agent Identification Sets At Rocky Mountain Arsenal, Colorado Final Report	5. TYPE OF REPORT & PERIOD COVERED Final Operations Report 8 May 1981 - 22 December 1982	
	6. PERFORMING ORG. REPORT NUMBER	
7. AUTHOR(s) Mr. William R. Brankowitz, Dr. Jack C. Pantleo, Mr. John A. Ursillo and Dr. Michael E. Witt	8. CONTRACT OR GRANT NUMBER(s)	
9. PERFORMING ORGANIZATION NAME AND ADDRESS Rocky Mountain Arsenal, Commerce City, Colorado and US Army Toxic & Hazardous Materials Agency, Aberdeen Proving Ground, MD	10. PROGRAM ELEMENT, PROJECT, TASK AREA & WORK UNIT NUMBERS	
11. CONTROLLING OFFICE NAME AND ADDRESS US Army Toxic and Hazardous Materials Agency Aberdeen Proving Ground, MD	12. REPORT DATE March 1983	
	13. NUMBER OF PAGES 740	
14. MONITORING AGENCY NAME & ADDRESS (if different from Controlling Office) NA	15. SECURITY CLASS. (of this report) Unclassified	
	15a. DECLASSIFICATION/DOWNGRADING SCHEDULE	
16. DISTRIBUTION STATEMENT (of this Report) APPROVED FOR PUBLIC RELEASE Distribution Unlimited		
17. DISTRIBUTION STATEMENT (of the abstract entered in Block 20, if different from Report)		
18. SUPPLEMENTARY NOTES		
19. KEY WORDS (Continue on reverse side if necessary and identify by block number)		
Chemical Agent Identification Set (CAIS)	Incineration	Lewisite (L)
Rocky Mountain Arsenal (RMA)	Waste Disposal	Triphosgene (T)
Demilitarization	Mustard	Chloroacetophenone (CN)
X-Type Set	GB	SF ₆ Tracer Gas
Data Analysis	Downtime	Air Monitoring
20. ABSTRACT (Continue on reverse side if necessary and identify by block number)		
<p>This report covers all demilitarization and disposal activities carried on in the Chemical Agent Identification Sets Disposal Plant from 8 May 1981 to 22 December 1982. Chemical Agents demilitarized included mustard, GB and Lewisite. Agents were destroyed in three phases. Phase 1 (8 May 1981 - 28 January 1982) included only the sets containing mustard. Phase 2 (2 February 1982 - 19 April 1982) disposed of most of the CAIS Sets packaged in wooden boxes. Phase 3 (22 April 1982 - 22 December 1982) destroyed all remaining sets. The report summarizes operations, air monitoring, laboratory efforts, data collection and data analysis methods. Also given is a concise history of air monitoring, downtime and number of sets destroyed.</p>		

Acknowledgements

A special acknowledgement is made to Mr. Jim White and Ms. Kit Mead of Stearns-Roger Inc. for their significant contributions to this report.

The assistance of the following in providing review and input to the report is also acknowledged:

Mr. Jim Clark	DP Associates
Mr. Dan Wilcox	DP Associates
Mr. Greg Mohrman	RMA
Mr. Elijah Jones	RMA
Mr. Larry Dale	RMA
Mr. Jim Mullins	RMA
Mr. Gene Crabtree	RMA
Mr. Jeff Kline	USATHAMA
MAJ Gerald Moss	USATHAMA
Mr. Jan Kolakowski	USATHAMA
Mr. George Norris	USATHAMA
Mr. Robert Magardo	CSL
Mr. Paul Wagner	CSL

Accession No.	
No. of Pages	11
Date Acquired	7/1/68
Source of Acquisition	
Classification	
Administrative Notes	
Remarks	
DTIC COPY IMPROVED	

PHASE 1

**DISPOSAL OF CHEMICAL AGENT
IDENTIFICATION SETS
AT ROCKY MOUNTAIN ARSENAL, COLORADO
MUSTARD OPERATIONS: PHASE 1
FINAL REPORT
JULY 1982**



Prepared By

William R. Brankowitz
USATHAMA

Dr. Michael E. Witt
RMA

John A. Ursillo
RMA

Dr. Jack C. Pantleo
Data Processing Associates

DISTRIBUTION UNLIMITED. CLEARED FOR PUBLIC RELEASE

**DEPARTMENT OF THE ARMY
US ARMY TOXIC AND HAZARDOUS MATERIALS AGENCY
ABERDEEN PROVING GROUND, MARYLAND 21010**

CONTENTS

CHAPTER 1 PROCESS DESCRIPTION

- 1.1 Purpose
- 1.2 Disposal Procedures
 - 1.2.1 Transportation from Interim Storage
 - 1.2.2 Pig Sets
 - 1.2.3 Box Sets
- 1.3 Waste Disposal

CHAPTER 2 PRODUCTION SUMMARY

- 2.1 Set Descriptions
- 2.2 Numerical Summary of Sets Destroyed - By Day
- 2.3 Numerical Summary of Waste Generated
- 2.4 Downtime Synopsis By Day and By Subsystem

CHAPTER 3 AIR MONITORING SUMMARY

- 3.1 Description of Sampling Technique
- 3.2 Description of Analysis Technique
- 3.3 Summary of Standards to Be Maintained
- 3.4 Summary of Air Monitoring Readings by Day

CHAPTER 4 DATA COLLECTION AND QUALITY CONTROL

- 4.1 Method of Data Collection
- 4.2 Description of Air Monitoring Data Analysis
- 4.3 Description of Inventory Data Collection
- 4.4 Description of Downtime Data Collection

CHAPTER 5 CONCLUSIONS

- 5.1 Introduction
- 5.2 Plant Operations
 - 5.2.1 General
 - 5.2.2 Air Monitoring Results
 - 5.2.3 Disassembly Room Operations and Set Characteristics
 - 5.2.4 Downtime Analysis

LIST OF FIGURES

1	ID Sets Demilitarization Program, Building 1611
2	CAIS Facility Site Layout
3	Chemical Agent Identification Sets, Demilitarization Facility
4	Disassembly/Storage Glovebox
5	Screw Conveyor and Feed Chute Locations
6	Disassembly Glovebox and Decontamination Module
7	ID Sets Process Flow Diagram - K941/K942
8	Pigs Being Deposited in Decontamination Furnace
9	Pigs After Decontamination
10	ID Sets Process Flow Diagram - X Sets
11	Box Feed Chute
12	Residue Handling Equipment
13	Electrostatic Precipitator
14	Spray Dryer
15	Identification and Training Sets
16	Toxic Gas Set K941
17	Gas Set Identification, Instructional, X-Sets
18	Typical Mustard Bubbler
19	Sampling Station Locations, Bldg 1611
20	SF ₆ Detector/Analyzer
21	SF ₆ Flow Diagram
22	Dynascience Monitor, Bldg 1611 Stack
23	Data Collection Flow Chart
24	Laboratory Equipment
25	Data Processing Equipment
26	Calibration Instrument Response
27	Actual Data for H Report
28	Accuracy Control Chart for H
29	Precision Control Chart for H

LIST OF TABLES

1	Numerical Summary of Sets Destroyed by Day
2	Numerical Summary of Waste Generated
3	Downtime Synopsis By Day and By Subsystem
4	Work Area Readings
5	Stack Readings
6	Downtime Analysis By Sets Destroyed

CHAPTER 1 PROCESS DESCRIPTION

1.1 PURPOSE

The purpose of the Mustard Phase (Phase 1) of the Chemical Agent Identification Sets (CAIS) Demilitarization Program was to completely dispose of all CAIS containing only mustard agent. The types of sets to be destroyed were: pig sets K941 and K942, and box sets X302, X547, X550, and X551. The reader is referred to Chapter 2 for a detailed description of the contents of these sets. Disposal of Phase 1 sets was performed in Building 1611 at Rocky Mountain Arsenal (RMA), Denver, Colorado (see Figure 1), commencing 8 May 1981 and concluding 28 January 1982.

1.2 DISPOSAL PROCEDURES

1.2.1 TRANSPORTATION FROM INTERIM STORAGE

The Chemical Agent Identification Sets for Phase 1 were shipped to RMA as part of SETCON II. The sets were then stored in sheds at the toxic storage yard. They were stored on pallets (16 to 25 pigs or 40 boxes) and lethal X sets were stored in CNU-80 shipping containers (20 in each). Containers were arranged in order of planned disposal.

The sets were loaded on trucks and transported approximately two miles by convoy on paved roads, during daylight hours, from the toxic storage yard to Bldg. 1611. The demilitarization site layout is shown on Figure 2. A maximum of four containers were loaded by forklift onto a stake body truck and blocked and braced into place. The truck bed was equipped with two roller conveyors, length-wise, so the pallets could be loaded from the rear. Convoy speed was held at 10 mph or less during transportation.

Sets arrived at the covered unloading dock, located on the east end of Bldg. 1611. The sets were unloaded and held in the supply conveyor room until they were ready for processing. No sets were held in the building overnight. In the disassembly room, the shipping containers or pallets were moved to the box feed chute or to the disassembly module for processing.

1.2.2 DISASSEMBLY AND DISPOSAL OF PIG SETS

1.2.2.1 Equipment Description

The Chemical Agent Identification Set operation was designed and constructed to reduce personnel contact with chemical agents by reducing the disassembly of sets to a minimum. The K941 and K942 sets were packaged and transported in steel shipping containers referred to as "pigs." These pigs were opened in a glovebox, and the six cans inside were removed. Then the ends of the six cans, each containing four bottles of mustard were opened, the material overpacked, and the overpack was inserted into the deactivation furnace. Figure 3 illustrates the system used for the processing of K941 and K942 sets.

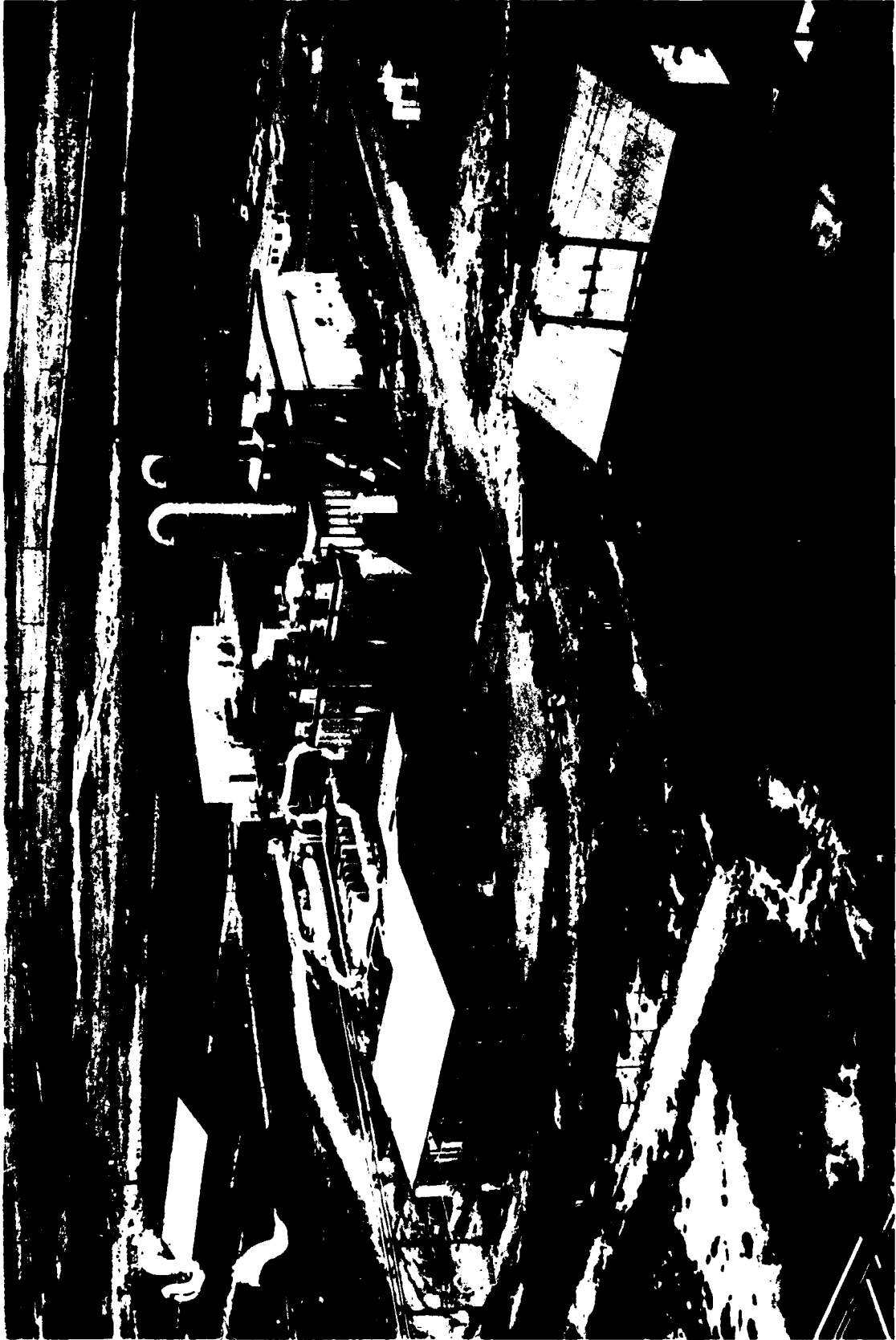

Figure 1 ID SETS DEMILITARIZATION PROGRAM, BUILDING 1611

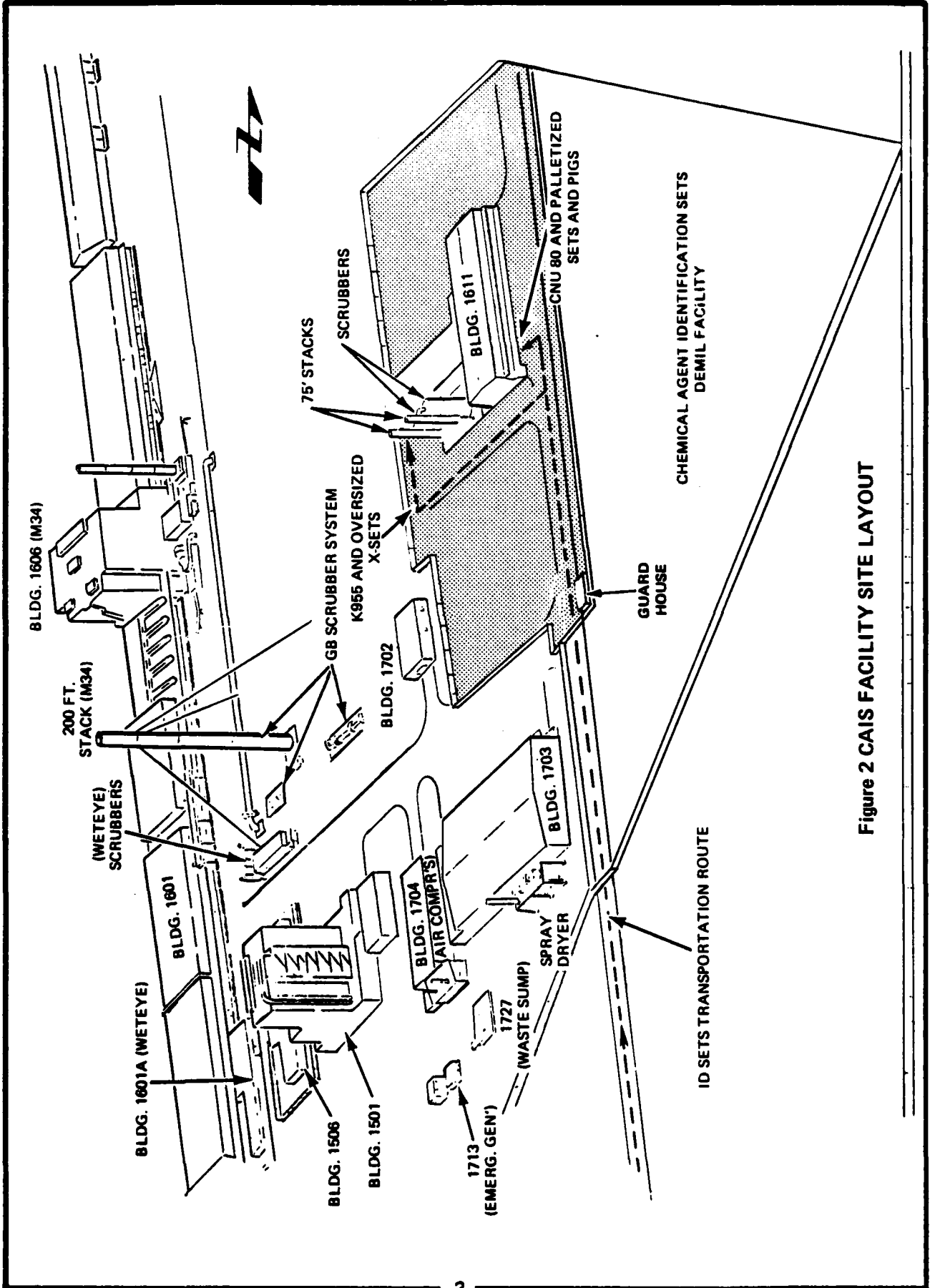

Figure 2 CAIS FACILITY SITE LAYOUT

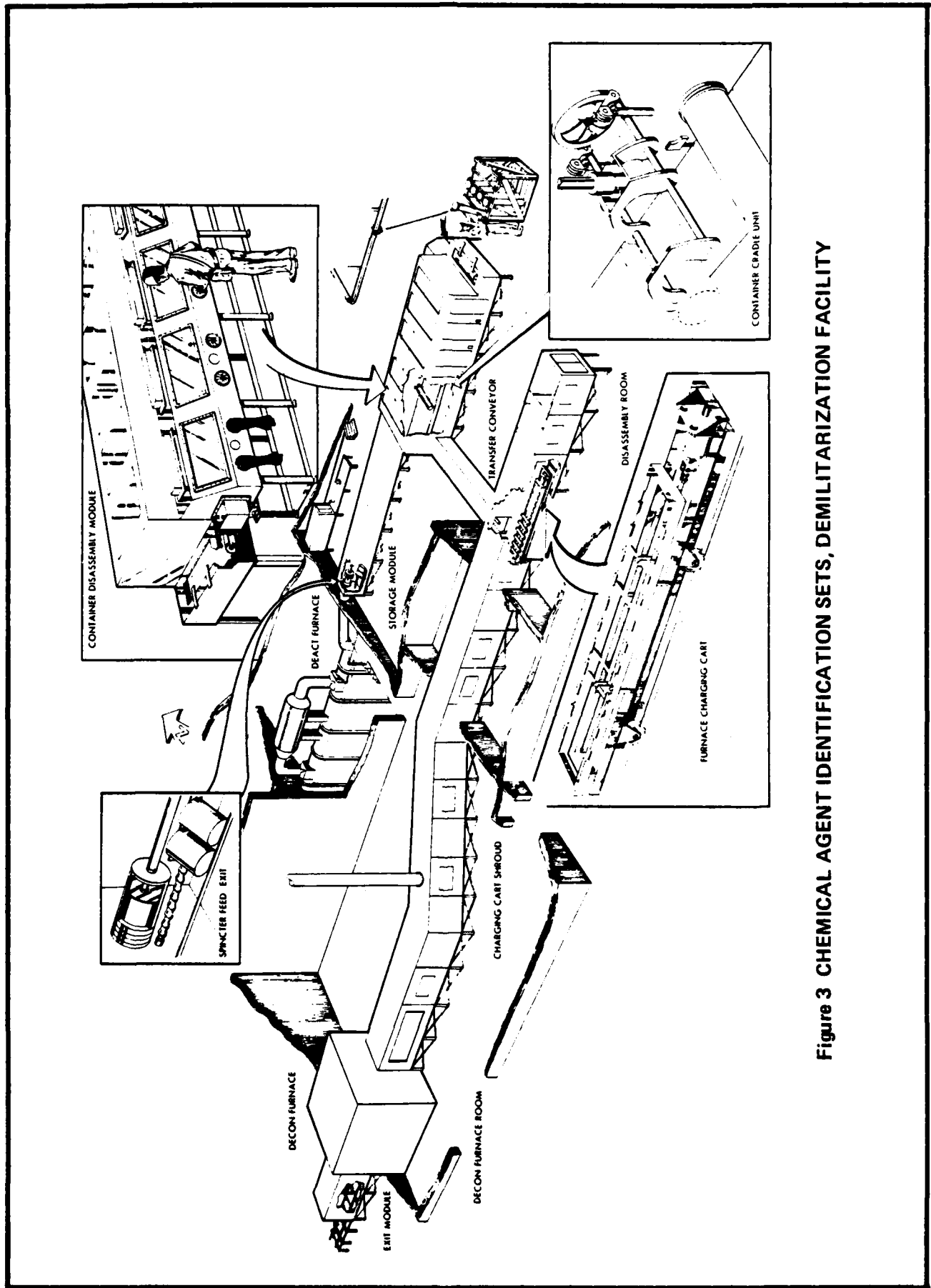

Figure 3 CHEMICAL AGENT IDENTIFICATION SETS, DEMILITARIZATION FACILITY

The glovebox used for disassembly and feeding of Chemical Agent Identification Set hazardous materials consisted of two modules sealed to form a single integral unit (see Figure 4). These are referred to herein as the disassembly module and the storage/feed module.

The disassembly module consisted of five work stations for the disassembly of the steel cylinders and the removal of set material. This section was approximately 20 feet in length. Two glove ports were provided at each work station to provide access within the glovebox. An opening at the back of each station was controlled by an iris valve and permitted entry and exit of the steel cylinder. Electrical interlocks were provided so that only one cylinder at a time was allowed to enter or discharge from the glovebox. A screw type conveyor, as shown in Figure 5, was provided for the transport of material to the storage/feed module portion of the glovebox. This glovebox had a maximum disassembly rate of 20 sets per hour.

The storage/feed module, approximately 24 feet in length, consisted of one operational station at the end of the storage area for inserting materials through a feed device directly into the deactivation furnace. Two gloveports were used in the feeding of set materials. In addition to these gloveports, eight sets of gloveports were provided evenly spaced along the length of the glovebox on one side, for access throughout the box, if required. Under normal operating conditions, these gloveports were sealed. Temporary storage of set cans was provided throughout the length of the glovebox as items were conveyed on the screw type conveyor from the disassembly section. The screw type conveyor had a storage capacity of at least 40 cans. Storage for additional cans was readily available by removing the cans from the conveyor and placing them on the floor of the storage/feed module.

The glovebox was maintained at a negative pressure of approximately 0.8" H₂O with respect to the disassembly room, and had sufficient air flow to provide a minimum of 25 air changes per hour and surface interface velocity of 150 fpm. Potentially contaminated air was swept through the glovebox and exhausted as part of the air supplied to the afterburner. Fail-safe indicating lamps, and emergency conveyor stops were provided to assure safe operations.

For transporting the ID set shipping containers to and from the disassembly module, a shroud, referred to herein as the decontamination module shroud (Figure 6), paralleled the disassembly room, to and through air lock #3, and then was sealed to the entrance door of the decontamination furnace. Within the shroud was a belt drive to transport pigs from the pallet to each disassembly station in the disassembly glovebox.

After disassembly, the containers were transported within the shroud to a decontamination furnace charging cart. The chain-driven charging cart, with a carrying capacity of 12 empty containers, ran on a track within the shroud from the disassembly room to the decontamination furnace. There it unloaded the containers onto a pedestal within the decontamination furnace. Another charging cart on the opposite end of the furnace was used to remove the containers after they have been thermally decontaminated. All operations in the shroud were done remotely using push-button electric/pneumatic actuated devices. This shroud also had the capacity to store up to 36 containers.

A-3.82.128

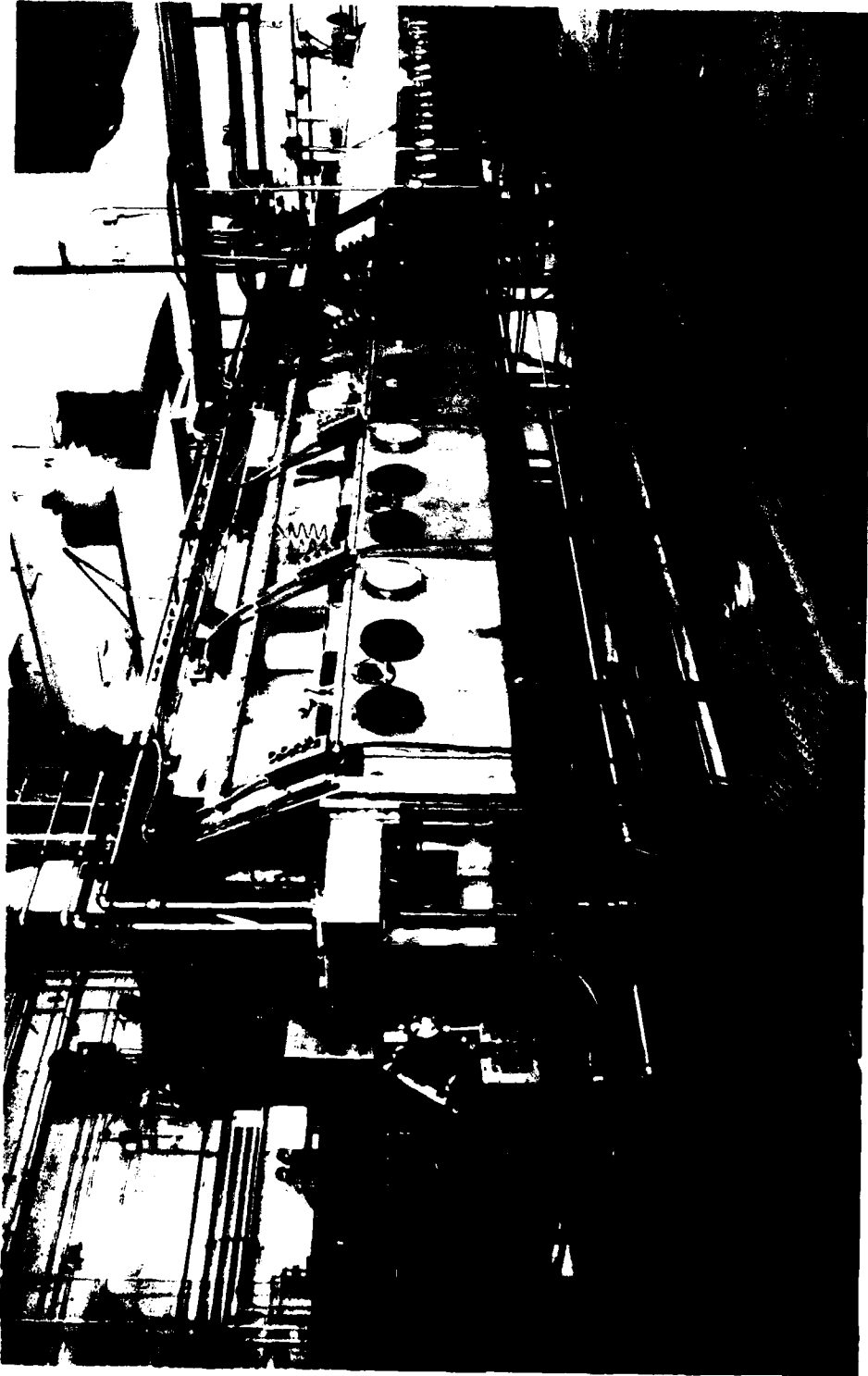

Figure 4 DISASSEMBLY/STORAGE GLOVEBOX

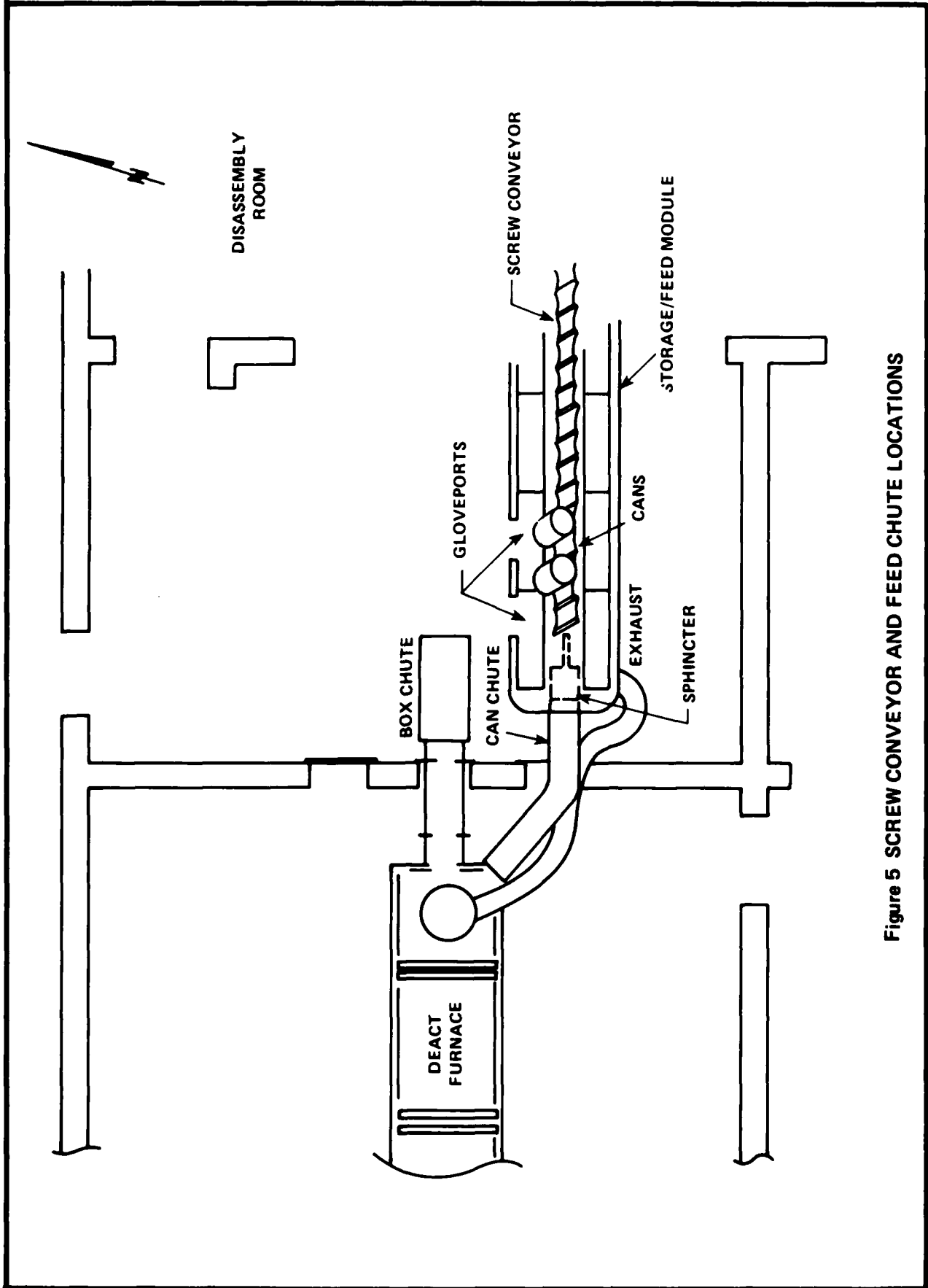

Figure 5 SCREW CONVEYOR AND FEED CHUTE LOCATIONS



Figure 6 DISASSEMBLY GLOVEBOX AND DECONTAMINATION MODULE

The decontamination module was kept under a negative pressure (approximately 0.1" H₂O) and sufficient air flow to provide a minimum of 25 air changes per hour with an air flow face velocity at all openings of 150 fpm minimum. The decontamination module shroud was connected to the building exhaust air system with room air being drawn through the pig load station (air flow within the shroud in the direction of the decontamination furnace). An air lock, approximately the length of the charging cart, was used on both sides of the decontamination furnace to prevent furnace flameouts when the furnace door was opened.

Handling of the shipping containers (pigs) within the shroud was accomplished by means of a cradle mechanism to lift the pig from the shroud transport conveyor into place in the disassembly module. Remote pushbutton controls were installed at each work station to assist operators in working pneumatic hardware. The operations featured logic sequencing as well as overload stops to assure safe operations while working in and around the equipment.

A process flow diagram for disassembly and feeding of K941 and K942 sets in metal shipping containers is shown in Figure 7.

1.2.2.2 Process Description

To start operations, steel cylinder pigs were removed from their pallet using an overhead crane. The pigs were then placed on a load tray adjacent to the air inlet to the decontamination module shroud. The operator then pressed a button marked LOAD and several sequenced functions took place. They were as follows:

- a. When a container (pig) was required at a disassembly station, stops located at the appropriate disassembly station were raised slightly above the surface of the belt.
- b. A pig was lowered into the decontamination module onto a continuously moving conveyor. When the pig reached the stops at the disassembly station, its forward motion ceased.
- c. The stops raised the pig into the jaws of the cradle clamp.
- d. The jaws closed and firmly gripped the pig.
- e. The stops returned below the top surface of the belt; concurrently, the iris was opened.
- f. The cradle was pushed toward the disassembly glovebox until the head of the pig was approximately six inches inside the glovebox.
- g. The iris valve closed.
- h. The disassembly operations began.

The disassembly operator, working through gloveports, removed the cans from the pig and resealed the pig with a rubber gasket. The eight bolts, lid and lead gasket were removed and set aside. The cylinder was remotely tipped 35 degrees, to facilitate removal of the cans from the cylinder. The cans were removed one at a time and placed on a screw-type conveyor which transported them through the disassembly module to the storage/feed module. Cans which were ruptured or rusty, or loose ampules/trash, were packed into a fiberboard overpack prior to being placed on the conveyor. The steel cylinder was then inspected to assure all agent containers (cans) were removed. Cans stuck in the the shipping container were removed using a special rotary motion tool that reached up into the shipping container and

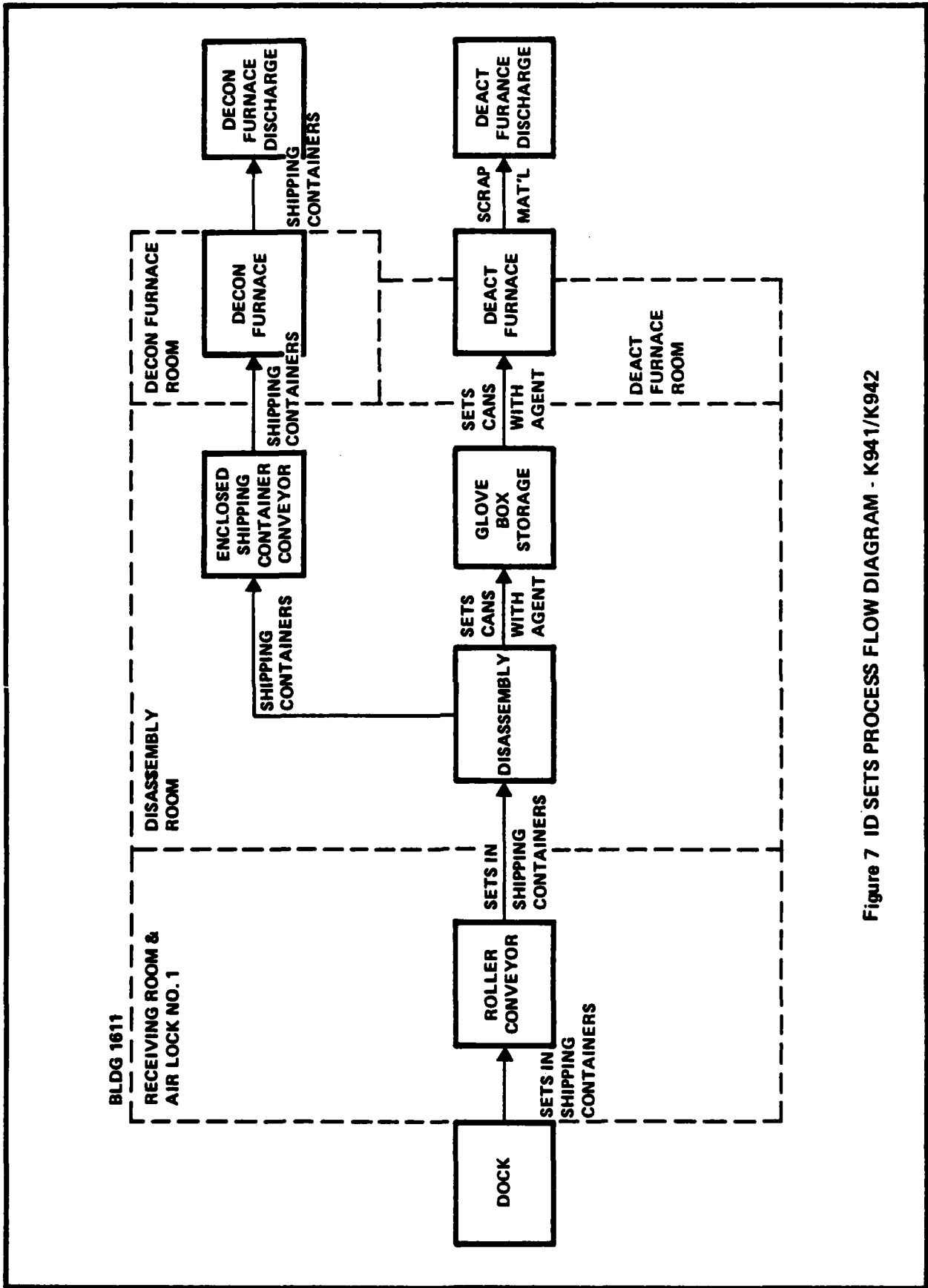

Figure 7 ID SETS PROCESS FLOW DIAGRAM - K941/K942

removed or scraped the can free. After it had been certified that all cans had been removed from the shipping container, the lead gaskets from two containers, or 12 bolts were inserted into the container. The lid of the container was reassembled using a consumable rubber gasket in place of the lead gasket and the two remaining bolts. Excess bolts and lead gaskets were not disposed of in the same container.

The operator inspected for any contamination, and if required, brushed that portion of the pig with methylcellosolve/caustic for decontamination. The work area was also decontaminated if required. The trash generated during decontamination was placed in an overpack and then inserted into the deactivation furnace. The QA inspector then used a key release to allow the decontamination module operator to remove this empty container and to supply a fresh one.

Concurrent with disassembly operations, cans were inserted into the deactivation furnace at the rate of one per minute. They were inserted from the west end of the storage/feed module into the deactivation furnace through a sphincter feed system as previously shown in Figure 5. This system used a can held by two rubber sleeves to seal the feed chute. As a can was pushed into the sphincter, it replaced the previous can, thus retaining the integrity of the seal. The cans were pushed through the sphincter and into the feed tube using a pneumatic ram controlled by a preset timer.

An operator, working through gloveports, removed a can from the conveyor and placed it on the sphincter loading tray. After 60 seconds had elapsed from the feeding of the previous can, the station became operational and the next can could be fed. The last can to be fed was an empty can which was used to push out the previous agent filled can and seal the feed tube until the next operational period.

Prior to removal of an emptied pig from the disassembly module, the decontamination module operator received a green light signal from the QA inspector's key control on the disassembly glovebox. He then pressed the unload button at that station and the following sequence took place:

- a. The iris opened.
- b. The pig was pulled out of the glovebox.
- c. The iris closed and simultaneously stops raised up and rested against the pig.
- d. The jaws of the clamp opened releasing the pig.
- e. The stops descended leaving the pig unobstructed on the moving conveyor belt.

This conveyor transported the pig to a transfer conveyor which moved it onto an intermediate holding table. The holding table has a capacity to hold 24 empty pigs. The intermediate table was manually indexed to provide room for the pigs as they came off the conveyor and also for positioning pigs onto the decontamination furnace charging cart. The transfer conveyor, the intermediate table, and path to the decontamination furnace are enclosed in a shroud which was purged by air coming from the end of the decontamination module and the load station.

When there were 12 pigs on the table, the charging cart operator, located in the disassembly room, positioned the motorized charging cart under the 12 containers. He then raised the cart up and lifted the 12 containers off the intermediate table. He then started a load sequence which automatically conveyed the pigs through the

furnace room to the decontamination furnace door, where the cart stopped. A door closed behind the cart isolating the cart from the shroud thus forming an air lock. At this point, controls were operated to open the furnace door and start the final portion of the load sequence into the furnace. When the cart reached the opposite end, the cart stopped and lowered leaving the pigs to rest on firebrick pedestals (Figure 8). The cart then retracted, the furnace door closed, the air lock opened, and the cart returned to the intermediate table area.

The removal of pigs was accomplished from the discharge end of the furnace. The operator worked an exit cart (same configuration as the unit in the decontamination shroud) using pushbutton controls. The operator started an automatic removal sequence that opened the furnace door and drove the cart into the furnace in the down position. Once in the furnace, the cart was raised lifting the decontaminated pigs off of the firebricks. The cart then left the furnace and stopped in an air lock outside the furnace until the furnace door closed. The door to the air lock was then opened and cart and pigs were brought to the outside (Figure 9). The cart was unloaded using a forklift and was returned to the air lock in a down position. After removal from the furnace, the pigs were marked as decontaminated to a "5X" condition. They were then transported to the salvage yard for reissue in accordance with existing procedures.

1.2.3 DISPOSAL OF BOXED SETS

1.2.3.1 General

Boxed sets (X302, X547, X550 and X551) were transported by truck to Bldg. 1611 in CNU-80 containers. See Figure 10 for a flow diagram of boxed set operations. The CNU-80's were moved from the trucks into the receiving room of Bldg. 1611 and placed on a supply conveyor. The supply conveyor extended through an airlock into the disassembly room. The containers were moved from the supply conveyor, by an electric/manual forklift, to the box feed chute area. The CNU-80 lid was removed once the container was in the disassembly room. These boxed sets required no disassembly. They were manually inserted into the deactivation furnace through the box feed chute assembly (See Figure 11).

1.2.3.2 Equipment Description

The Box Feed Chute assembly was a small airlock that isolated the deactivation furnace from the disassembly room. The chute was inclined at an angle of 51 degrees above horizontal. The upper (outer) door was manually opened and closed with a pneumatically operated cylinder providing a lock when the assembly was sequenced. The flapper (lower) door was operated by a pneumatic cylinder to rotate upward 90 degrees, thereby allowing the ID Set box, within the airlock, to slide down into the deactivation furnace.

As soon as the box cleared the flapper door, the cylinder closed the door and a two-minute purge began. Purging air was induced into the airlock chamber at 5.0 PSIG and 690 SCFH. This provided the capability of 20 air charges during the two-minute purge cycle.

The controls were time-sequenced, so that a box set could be inserted into the deactivation furnace every five minutes.



Figure 8 PIGS BEING DEPOSITED IN DECONTAMINATION FURNACE

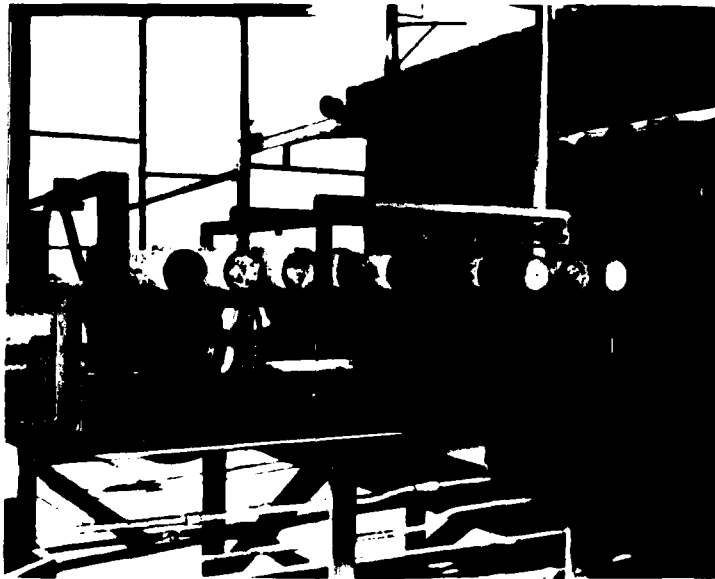

Figure 9 PIGS AFTER DECONTAMINATION

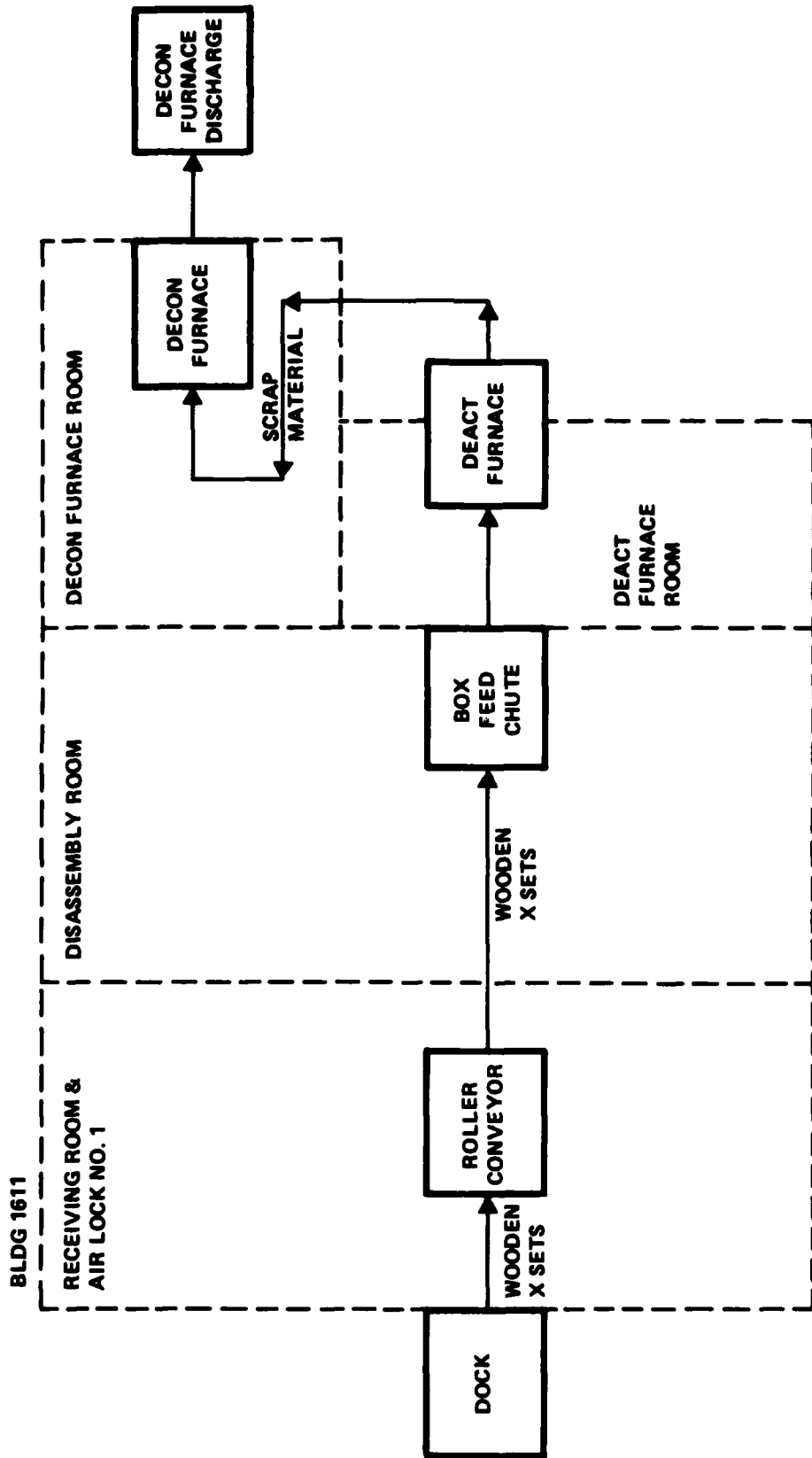

Figure 10 ID SETS PROCESS FLOW DIAGRAM - X SETS

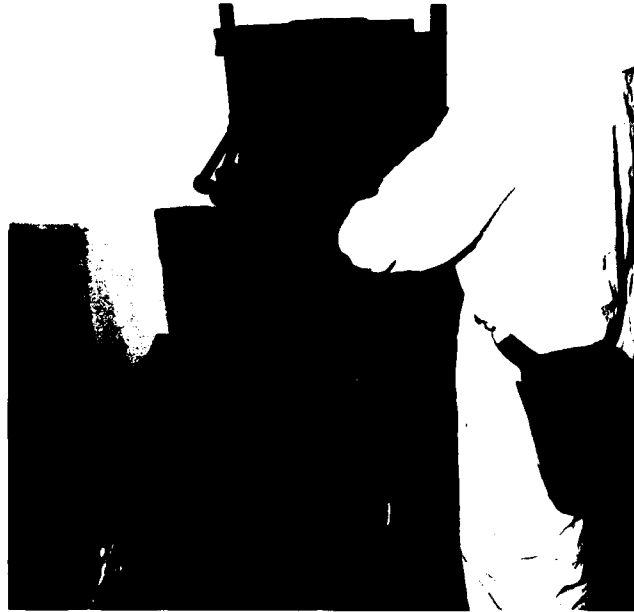

Figure 11 BOX FEED CHUTE

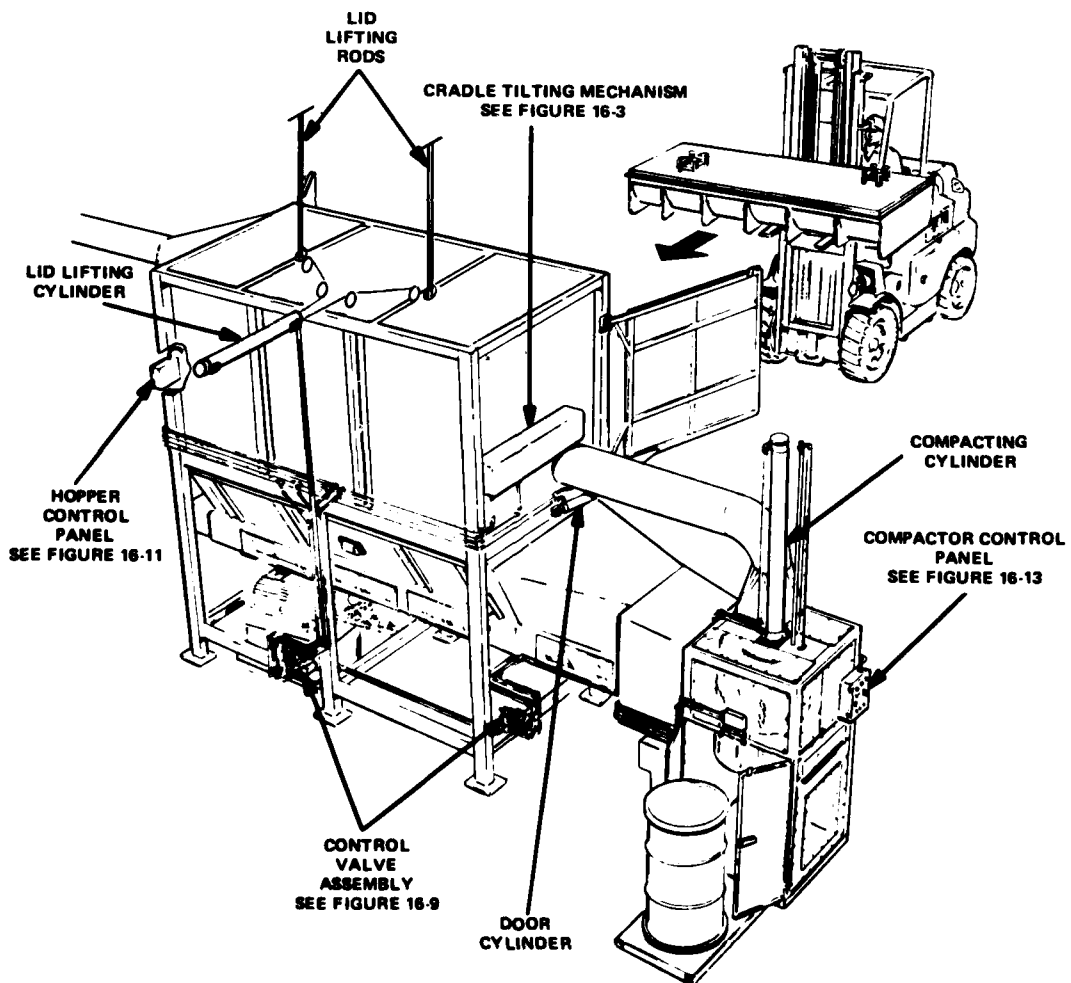

Figure 12 RESIDUE HANDLING EQUIPMENT

1.2.3.3 Process Description

The box feed chute operator opened the upper door and inserted a box set. The door was closed and the PUSH TO CYCLE pushbutton was pressed. The flapper door opened and the boxed set slid into the deactivation furnace. The two-minute purge immediately started upon closing of the flapper door. A delay-loading timer also started and prevented cycling a set to the furnace for five minutes. At the end of five minutes, the BOX FEED CHUTE READY lamp lit and a new feed sequence could commence.

The residue from the deactivation furnace was conveyed to the decontamination furnace for further thermal treatment. A residue tray was inserted into the decontamination furnace to catch this residue and continue treatment. Periodically the tray was raked (from the rear of the furnace) to prevent residue buildup and spilling onto the floor of the decontamination furnace. When operations were completed, the tray was removed and the residue was packaged in 55 gallon drums.

1.3 WASTE DISPOSAL

The waste residue from the CAIS disposal included the furnace trash, electrostatic precipitator (ESP) residue, and the dried salts from spray drying the brines and other liquid industrial wastes (see Figures 12, 13 and 14). The furnace trash, both deactivation and decontamination furnaces, was processed through the residue compactor and placed in 55 gallon drums. The ESP residue was placed in 55 gallon drums directly from the bins at the bottom of the ESP cells. The waste liquid was pumped to the spray dryer holding tanks in Bldg. 1703, dried to salts, and then placed in 55 gallon drums. All drums have been stored in warehouses awaiting determination of final disposition. Refer to Section 2, Paragraph 2.3, for a summary of the wastes generated during mustard operations.



Figure 13 ELECTROSTATIC PRECIPITATOR



Figure 14 SPRAY DRYER

CHAPTER 2. PRODUCTION SUMMARY

2.1. SETS DESCRIPTION

There were a total of seven types of Chemical Agent Identification Sets scheduled for disposal under this program. Mustard Operations, Phase I of the program, disposed completely of two of the seven types (K941 and K942, Toxic Gas Sets), and the sets containing mustard agent from a third type (X302, X547, X550, and X551, Gas Set Identification, Instruction (Navy)). See Figure 15.

2.1.1 K941, TOXIC GAS SET

These sets were contained in a steel cylinder (pig) 6 $\frac{5}{8}$ inches (168.3mm) in diameter, approximately 38 inches (956.2mm) long, and a 0.145 inch (3.7mm) thick wall (see Figure 16). The open end was closed by a flanged end cover which was secured by eight bolts and sealed with a lead gasket between the body of the pig and the flange cover. There were six sealed metal containers (cans) packed in each cylinder. Each can contained four, 4 oz. bottles, and each bottle was placed in a layer of sawdust to preclude breakage. Each bottle contained 3 $\frac{1}{2}$ oz. - 4 oz. (0.103 - 0.188 liter) of mustard agent (H) or distilled mustard (HD) for a total of 84 oz. - 96 oz. (2.433 - 2.839 liters) per cylinder.

2.1.2. K942, TOXIC GAS SET

These sets were originally packaged in steel drums (3.15 liters per drum) and were repacked in pigs prior to transportation. Two ampules, each 1 $\frac{1}{8}$ inches (31.8 mm) in diameter and approximately 4 $\frac{5}{8}$ inches (117.48 mm) long, containing 0.1125 liter of distilled mustard (HD, neat) agent, were packed in vermiculite or sawdust in a K951 type press-fit can. There were two ampules in each can and four cans in each cylinder for a total agent per cylinder of 0.9 liter. Total cylinder weight was 110 lbs.

2.1.3 X SETS, GAS SET IDENTIFICATION, INSTRUCTIONAL (NAVY)

These sets were packed in wooden boxes with hinged covers (see Figure 17). The boxes measured 7 $\frac{1}{2}$ inches (191 mm) wide by 16 inches (406 mm) long by 11 $\frac{3}{4}$ inches (298 mm) high, and were divided into two compartments. Each compartment held a can 4 $\frac{1}{4}$ inches (110 mm) in diameter and 6 $\frac{3}{4}$ inches (175 mm) high, surrounded by packing material. Inside each can was a bottle with a ground glass top. Contents of the bottles for the mustard operations were as follows:

X302 - One bottle with 1.7 fl. oz. (0.025 liter) nitrogen mustard (HN-1) and one bottle with 1.7 fl. oz. (0.025 liter) nitrogen mustard (HM-3). Both agents were absorbed on 3 fl. oz. (90 cc) of activated charcoal.

X547 - Same as X302, except agent was mustard gas (H or HD) in both bottles.

X550 - Same as X302, except agent was nitrogen mustard (HN-1) in both bottles.

X551 - Same as X302, except agent was nitrogen mustard (HN-3) in both bottles.

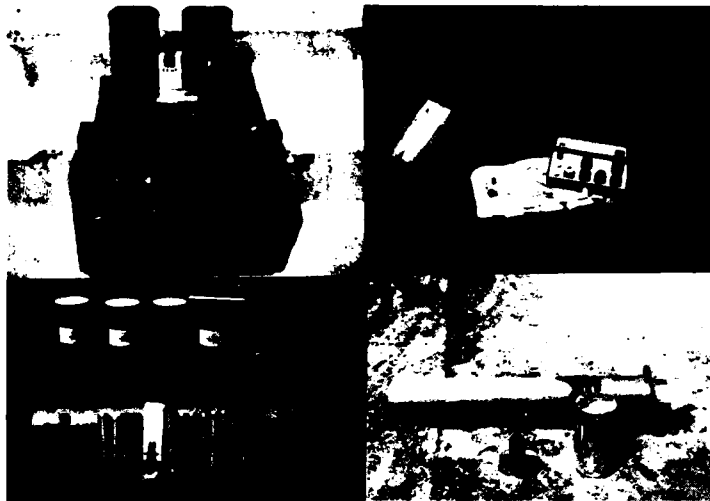

Figure 15 IDENTIFICATION AND TRAINING SETS



TOXIC GAS SET, NO. K941: NO, 2.5-LITERS, 24 BOTTLES

Figure 16 TOXIC GAS SET K941

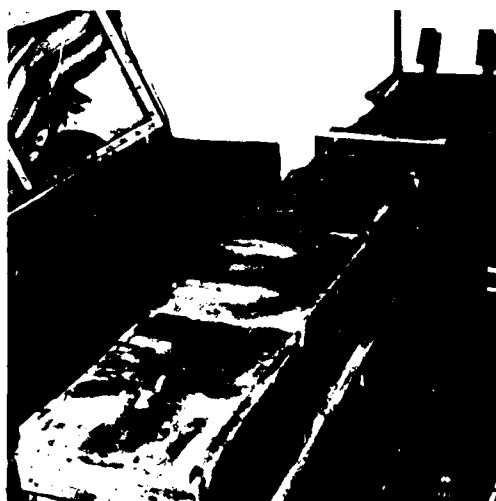

Figure 17 GAS SET IDENTIFICATION,
INSTRUCTIONAL, X-SETS

2.2 NUMERICAL SUMMARY OF SETS DESTROYED

DATE	TYPE OF SET		X547	X550	X551
	K941/K942	X302			
5/8/81		17			
5/11/81		28			
5/12/81		34			
5/13/81		2	45		
5/14/81			45		
5/19/81			20		
5/20/81			45		
5/21/81			40		
5/22/81			45		
5/26/81	10				
5/27/81	14				
5/28/81			15		
5/29/81			60		
6/1/81			19		
6/4/81			12		
6/5/81			50		
6/8/81	7				
6/9/81	17				
6/11/81	16				
6/12/81			24		
6/17/81	20				
6/18/81			64		
6/19/81			71		
6/22/81	22				
6/23/81	22				
6/24/81	24				
6/25/81			53		
6/26/81			79		
6/29/81	22				
6/30/81	26				
7/1/81	19				
7/2/81			60		
7/6/81	18				
7/7/81	24				
7/8/81	18				
7/9/81			75		
7/10/81			60		
7/13/81			15		
7/14/81			75		
7/15/81			60		
7/16/81			60		
9/24/81			15		
9/25/81			60		
9/28/81			30	30	
9/29/81				60	
9/30/81				75	
10/1/81				75	

DATE	TYPE OF SET		X547	X550	X551
	K941/K942	X302			
10/2/81				60	
10/5/81				45	
10/6/81				60	
10/7/81	11				
10/8/81	17		5		
10/9/81				60	
10/13/81	10				
10/14/81				60	
10/15/81				45	
10/19/81				45	
10/20/81				60	
10/21/81				21	
10/22/81				54	
10/23/81				60	
10/26/81				45	
10/27/81				52	
10/28/81				68	
10/29/81				75	
11/2/81	14				
11/3/81	19				
11/4/81	22				
11/5/81	7				
11/6/81				75	
11/9/81	17				
11/10/81	21				
11/12/81	20				
11/13/81				75	
11/16/81	11				
11/17/81	24				
11/18/81	25				
11/19/81	25				
11/20/81				72	
11/23/81	20				
12/7/81	19				
12/9/81	24				
12/10/81	26				
12/11/81	27				
12/14/81	24				
12/15/81	26				
12/16/81	28				
12/17/81	28				
12/18/81	14				
12/22/81					45
12/28/81					60
12/29/81					30
12/30/81					90
1/4/82					75
1/5/82	22				

DATE	TYPE OF SET				
	K941/K942	X302	X547	X550	X551
1/6/82	22				
1/8/82					75
1/11/82					30
1/12/82					45
1/13/82					90
1/14/82					75
1/15/82					90
1/18/82					70
1/19/82					84
1/20/82					75
1/21/82					90
1/22/82					75
1/25/82					60
1/26/82		1		8	59
1/27/82				22	3
1/28/82					25
<hr/> TOTAL	<hr/> 802	<hr/> 82	<hr/> 1202	<hr/> 1302	<hr/> 1246

PHASE I TOTAL 4634 SETS

2.3 NUMERICAL SUMMARY OF WASTE GENERATED

DATES	FURNACE RESIDUE DRUMS	SPRAY DRYER SALTS DRUMS	ESP RESIDUE DRUMS
5/11/81		3	
5/12/81	1	7	
5/14/81	1		
5/19/81	1	16	
5/20/81		1	
5/21/81	1	1	
5/22/81	1		
5/26/81	1		5
5/28/81		15	
5/29/81		5	
6/1/81	2		
6/8/81	4		
6/11/81	1	14	
6/12/81		11	
6/15/81	1	1	
6/16/81		14	
6/18/81	1		
6/19/81	1		
6/22/81	2		
6/23/81	2		
6/25/81	4		
6/26/81	1		
6/29/81			13
7/1/81	3	34	
7/6/81	4		
7/7/81	4		
7/8/81	2		
7/9/81	2		
7/10/81	2		
7/13/81	4	31	
7/14/81		15	
7/15/81	2		
7/16/81	1		
7/21/81			4
8/3/81		28	
8/5/81		20	
8/6/81		32	
8/7/81		32	
8/10/81		32	
8/11/81		8	
9/1/81	1		
9/3/81		6	
9/8/81		7	
9/25/81	2		
9/28/81	2		3
9/29/81	2		
9/30/81	2		
10/1/81	2		
10/2/81	2		

DATE	FURNACE RESIDUE DRUMS	SPRAY DRYER SALTS DRUMS	ESP RESIDUE DRUMS
10/5/81	3		
10/6/81	2	30	
10/7/81	3		
10/8/81	2		
10/9/81	2		
10/13/81	3		
10/14/81	1		
10/15/81	2		
10/16/81	2		
10/20/81	2		
10/22/81	2	45	
10/23/81	2		
10/26/81	2		
10/27/81		46	
10/28/81	3		
10/29/81	2	19	
10/30/81		27	
11/2/81	1		6
11/3/81	1		
11/4/81	1		
11/5/81	2		
11/6/81	1		
11/9/81	4		
11/10/81	2		
11/12/81	2		
11/13/81	2	14	
11/16/81	3	7	
11/17/81	2		
11/18/81	3		
11/19/81	2		
11/20/81	2		
11/23/81	2		
12/7/81	2		
12/9/81	2		
12/11/81	4		
12/14/81	2		
12/15/81	2		
12/16/81	2		
12/22/81	2		
12/23/81			4
1/5/82	7		
1/11/82	7		
1/14/81	5		
1/19/82	4		
1/25/82	6		
1/26/82	4	1	
1/27/82		1	
TOTAL	<u>174</u>	<u>523</u>	<u>35</u>

2.4 SYNOPSIS OF MAJOR DOWNTIME

2.4.1 GENERAL

In the interpretation of downtime data, three methods are widely used. These are the "frequency of occurrence," "subsystem downtime," and "process downtime" methods. Each method has inherent advantages and disadvantages.

The most familiar, and most widely used by management, is the "process downtime" method which measures the overall time the plant is not processing. This method fails to identify problems specifically enough for engineering purposes.

Another method, used by maintenance at RMA, is the "frequency of occurrence" method, which is a good "rule-of-thumb" for how a given subsystem is performing. For historical purposes, however, it fails to indicate the extent of an event.

In this report the "subsystem downtime" method is used. This method is very specific and historically accurate. Its main disadvantage is that of being open to misinterpretation in that the breakdown of a certain subsystem does not necessarily mean the overall process is down. One can *not* total hours and arrive at the hours the process was down by this method.

2.4.2 SUBSYSTEM DOWNTIME

DATE	SUB-SYSTEM	PRIMARY COMPONENT	DOWN TIME HRS	COMMENTS
5/12/81	Enviro. Monitor	Alarm	1.5	
5/13/81	Decon. Furnace	Burner	2.0	
5/14/81	Decon. Furnace	Burner	8.0	
5/15/81	Decon. Furnace	Burner	8.0	
5/18/81	Decon. Module	Battery	8.0	Battery charger failed
5/19/81	Decon. Module	Ski	2.83	Battery charger failed
5/20/81	Decon. Furnace	Burner	6.05	Replaced burner
5/26/81	Decon. Furnace	Burner	8.0	Flow control valve failed
5/28/81	Set movement	Box set	5.0	Delay due to CAIC exercise
6/2/81	Deact Furnace	Conveyor	8.0	
6/3/81	Deact Furnace	Conveyor	8.0	
6/4/81	Set movement	Box set	3.0	
	Enviro Monitor	Other	2.0	No lab coverage
6/8/81	Set movement	Pig Set	3.5	
6/9/81	Decon Furnace	Burner	1.93	Burner #3 defective
	Glovebox	Pig set	6.5	Bolts from 7 pigs could not be removed; 1 K941 pig contained K 951 cans; manual can opener slow.
6/10/81	Administration	Other	8.0	CAIS exercise
6/12/81	Scrubbers	Fan	8.0	Scrubber fan repair
6/15/81	Scrubbers	Fan	8.0	Scrubber fan repair
6/16/81	Scrubbers	Fan	8.0	Scrubber fan repair
6/22/81	Decon furnace	Conveyor	1.95	Replaced limit switch
6/23/81	Decon furnace	Inside cart	3.97	

6/24/81	Decon furnace	Inside cart	5.98	
6/29/81	Decon furnace	Pilot	8.0	
6/30/81	Electro. Precip.	Other	1.75	Burned out cell resistor
7/1/81	Decon Module	Bridge	8.0	Cart emergency caused bridge track jam
7/8/81	Administrative	Other	1.75	Lab not in control
7/13/81	Deact furnace	Solenoid valve	5.67	
7/16/81	HVAC	AHU-2	8.0	
9/24/81	Box feed chute	Actuator feeler	1.0	Flapper repaired in-place
10/13/81	Decon furnace	Pilot	3.25	Fuel-air mixture adjustment
	Residue handling	Conveyor	4.73	Failures due to switch adjustment
10/15/81	Afterburner	Burner	7.02	Oil-air regulator malfunction
10/16/81	Residue handling	Conveyor	8.0	Repaired conveyor head shaft
10/19/81	Decon furnace	Conveyor	2.0	Final adjustment
10/20/81	Enviro Monitor	Bubbler filter	2.62	SF ₆ recirculating from stack
10/21/81	Decon module	Switch	2.05	Damper adjustment
10/22/81	Administrative	Other	2.00	Dead battery in ambulance
10/26/81	Glovebox	Door	1.32	Glovebox door unlatched
10/27/81	Set movement	Other	2.5	Convoy arrived late
10/30/81	Scubbers	Other	7.0	Acid washing
11/4/81	Glovebox	Pigset	1.0	Set misidentified
11/5/81	Glovebox	Pigset	4.8	Jackscrew malfunction
11/9/81	Decon furnace	Fireye	1.35	Dirty lens
11/12/81	Enviro Monitor	Bubbler-filter	1.22	Bubbler tests not completed
11/16/81	Administrative	Other	2.25	Admin. delay
11/23/81	Deact furnace	Conveyor	8.0	Discharge conveyor jammed
12/8/81	Quench	Spraytree	8.0	Water leak into decon furnace room
12/11/81	Decon furnace	Burner	3.0	Flame detector failure
12/21/81	Administrative	Other	1.5	Admin. procedures
	Control room	Fuse	4.8	Loose fuse in processor
12/22/81	Decon furnace	Controller	2.5	UV scanner malfunction
12/23/81	Decon furnace	Controller	8.0	UV scanner ground fault
12/24/81	Decon furnace	Controller	4.0	Fireye system malfunction
	Administrative	Other	4.0	Admin procedures
12/29/81	Residue handling	Tray	2.0	Forklift malfunction
	Control room	Controller	3.5	Processor malfunction
12/31/81	Decon furnace	Burner	8.0	Boxset cans blocked burner port
1/4/82	Enviro Monitor	Bubbler-Filter	1.58	Late bubbler test delayed start
1/6/82	Decon furnace	Burner	1.8	Burner dirty
	Decon furnace	Switch	4.9	Cart limit switch failure
1/7/82	Decon furnace	Burner	3.5	Controller malfunction
1/11/82	Scrubbers	Controller	2.42	Press. & flow gages reset
	Quench	Tank	3.0	Ice in tank
	Scrubbers	Fan	3.0	Ice in damper control

DATE	SUB-SYSTEM	PRIMARY COMPONENT	DOWN TIME HRS	COMMENTS
1/12/82	Scrubbers	Stack	5.83	West scrubber iced up
	Decon furnace	Fireye	1.33	Decon fireye cable shorted
1/14/82	Decon Module	Outside cart	1.75	Cart manually removed from furnace
1/20/82	Box feed chute	Hopper	1.08	Jammed
1/25/82	Afterburner	Fireye	2.33	Dirty lens
	Decon furnace	Controller	3.28	
1/26/82	Decon furnace	Switch	2.57	Draft damper malfunction
1/27/82	Decon furnace	Inside cart	8.0	Cart rails replaced
1/28/82	Residue handling	Hopper	8.0	Hopper conveyor failure

2.4.3 PROCESS DOWNTIME

A process downtime of 34.9% was calculated which, allowing for startup problems, was not unexpected. Major failures in terms of process downtime were caused by the microprocessor and the deactivation furnace conveyor. These two items accounted for 10.1% of the downtime experienced. A more detailed process downtime analysis is provided in Paragraph 5.2.4 of the Conclusion Section.

CHAPTER 3 AIR MONITORING SUMMARY

3.1 DESCRIPTION OF SAMPLING TECHNIQUES

3.1.1 MUSTARD AGENT SAMPLING

Sampling for mustard was accomplished by drawing air from the areas to be sampled through a container filled with a liquid. The liquid of choice, diethylphthalate, had a particular affinity for mustard and collected it with essentially 100% efficiency. The air passed through the solution in the container obviously bubbled, lending the name to this sampling apparatus - the bubbler (see Figure 18).

The bubbler tubes used for mustard were made of glass and were filled with glass beads to maintain high collection efficiency. Air samples were drawn through these bubblers at a rate of 6 liters per minute. The flow was maintained by the use of in-line critical orifices. The standard fill for a mustard bubbler was 10 ml. of diethylphthalate. The bubblers were marked with a ring of brown tape to color-code identify them as mustard bubblers. In addition, at each sampling location was a constant temperature bath in which the bubblers were immersed. The temperature was set at 2 to 8° C and monitored during the two hour sampling period.

Each day, the bubblers were inspected, cleaned, and filled at the laboratory (Bldg. 313) and then transported to the CAIS disposal plant (Bldg. 1611). Monitoring station personnel obtained the bubblers from the plant chemist's office and installed them at four locations: the disassembly room (DR), control room (CR), residue area (RA), and the stack (ST) (see Figure 19).

Bubblers were replaced sequentially after a two-hour sampling period at all locations. In addition, a staggered shift of two hour bubblers was started every hour in the disassembly room. Bubblers in the disassembly room therefore typically ran 0800-1000, 0900-1100, 1000-1200, etc. Upon completion of a sampling term, each bubbler was retrieved, returned to the plant chemist's office, and packed for transportation to the laboratory. They were then taken to the laboratory for analysis. All bubblers, when in transit were packed in ice.

3.1.2 SF₆ TRACER GAS SAMPLING

Sulfur hexafluoride (SF₆) gas was metered into the disassembly glovebox and box feed chute at a pressure of 35 psi to act as a tracer gas. SF₆ is non-toxic, chemically inert, odorless, tasteless, and can be detected at very low concentrations (10⁻¹² parts of SF₆ per part of air). Samples of disassembly room and control room air were drawn, automatically by the detector (see Figures 20 & 21), every five minutes. The detector was set to sense buildups of SF₆ outside of the glovebox or box feed chute of 10 parts per trillion to indicate potential leakage.

3.1.3 NO_x AND SO₂ SAMPLING

The Dynascience monitor sampled Bldg. 1611 exhaust stack gas on a continuous basis (see Figure 22). The stack gas was drawn through a 100 micron Cuno stainless steel filter by a sampler pump. The gas was cooled by a water bath, analyzed, and then returned to the stack. Calibration was maintained by periodically sampling known concentrations of NO_x and SO₂.

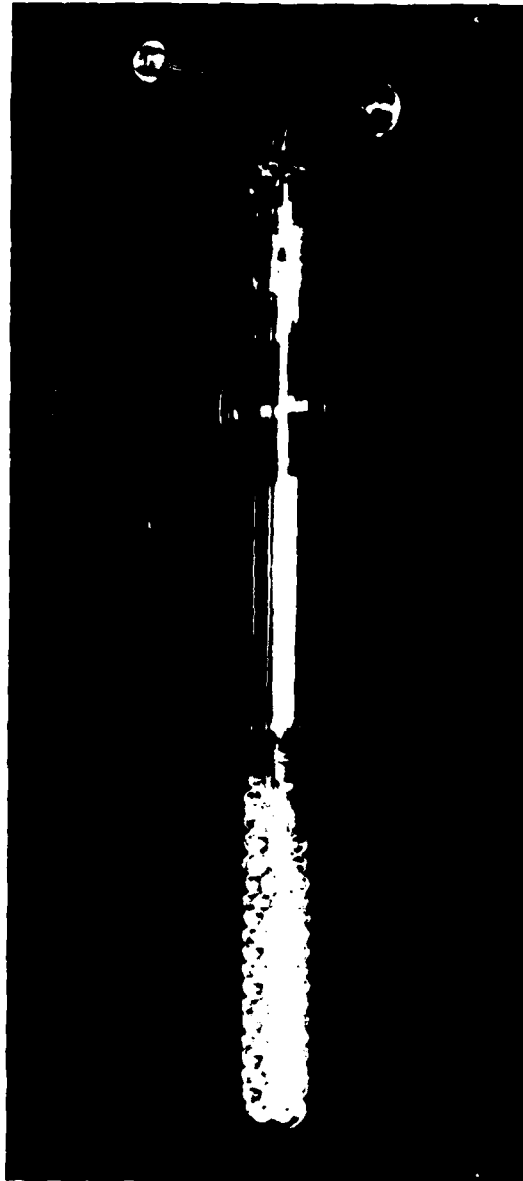

A382137

Figure 18
TYPICAL MUSTARD BUBBLER

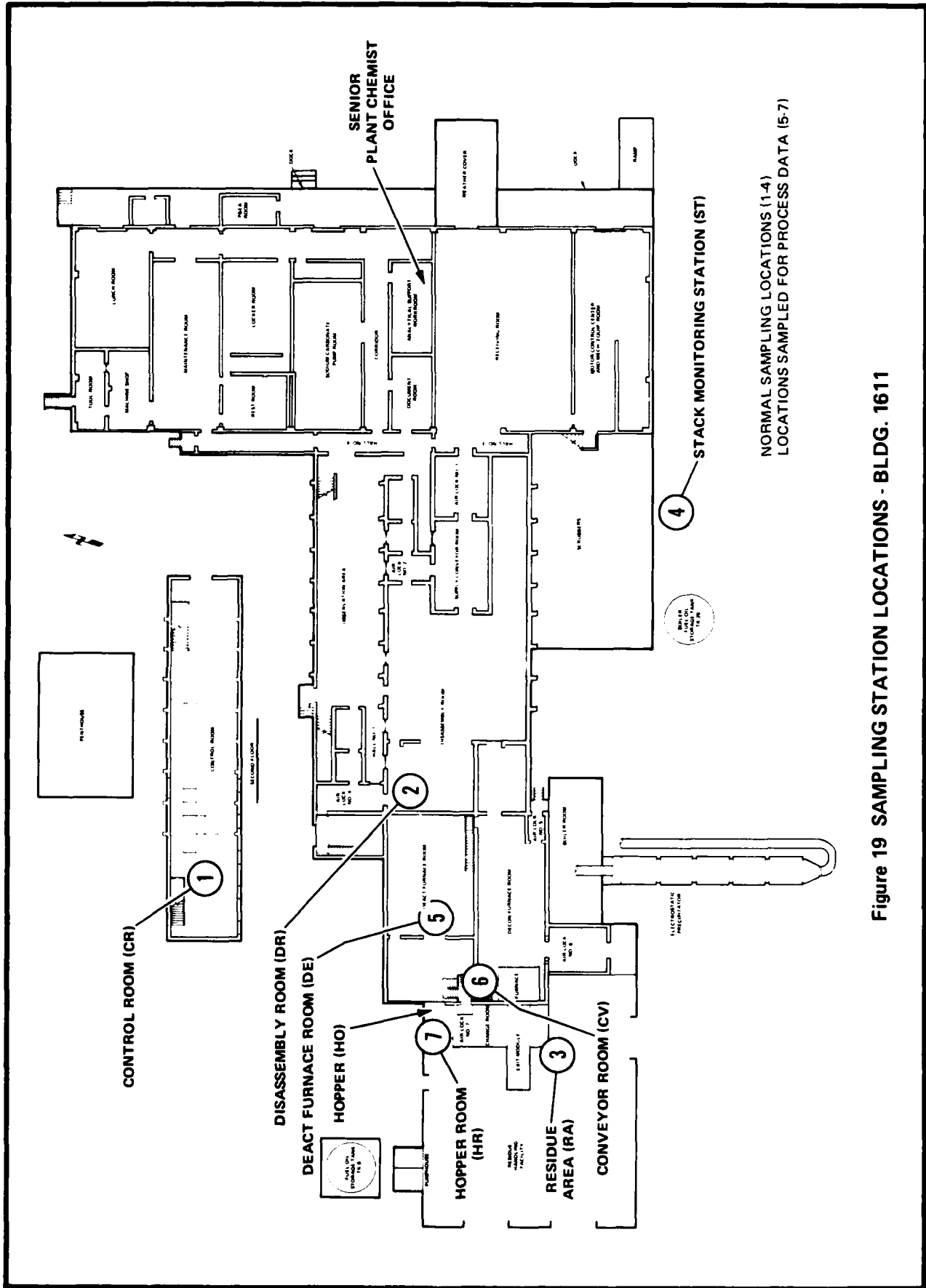

NORMAL SAMPLING LOCATIONS (1-4)
LOCATIONS SAMPLED FOR PROCESS DATA (5-7)

Figure 19 SAMPLING STATION LOCATIONS - BLDG. 1611

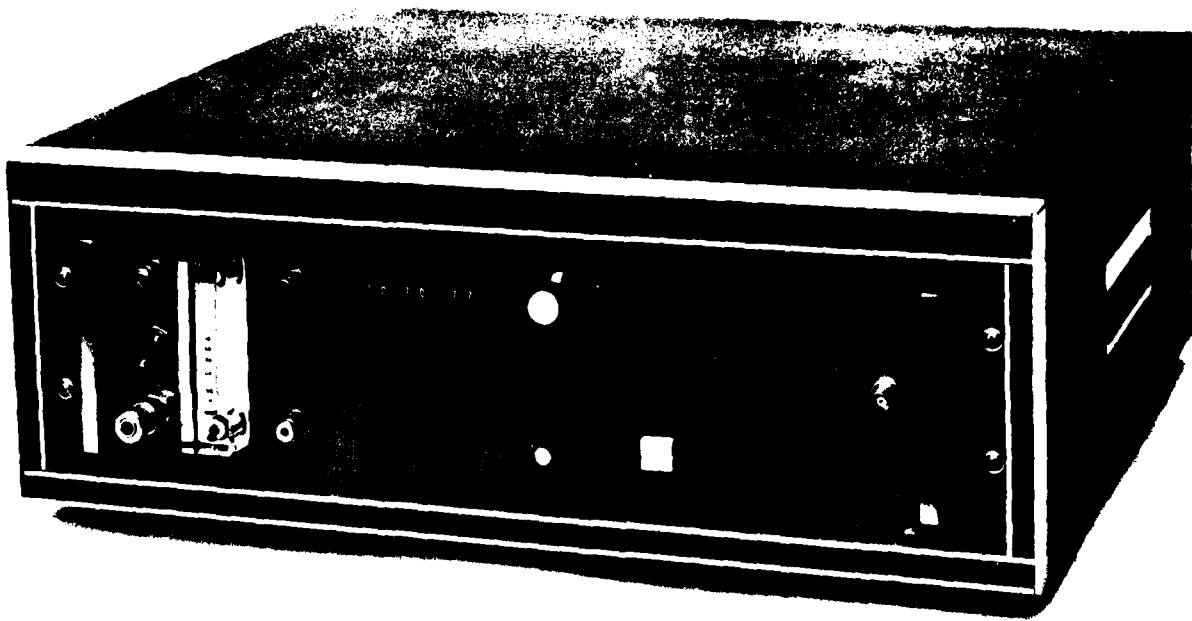

Figure 20 SF₆ DETECTOR/ANALYZER

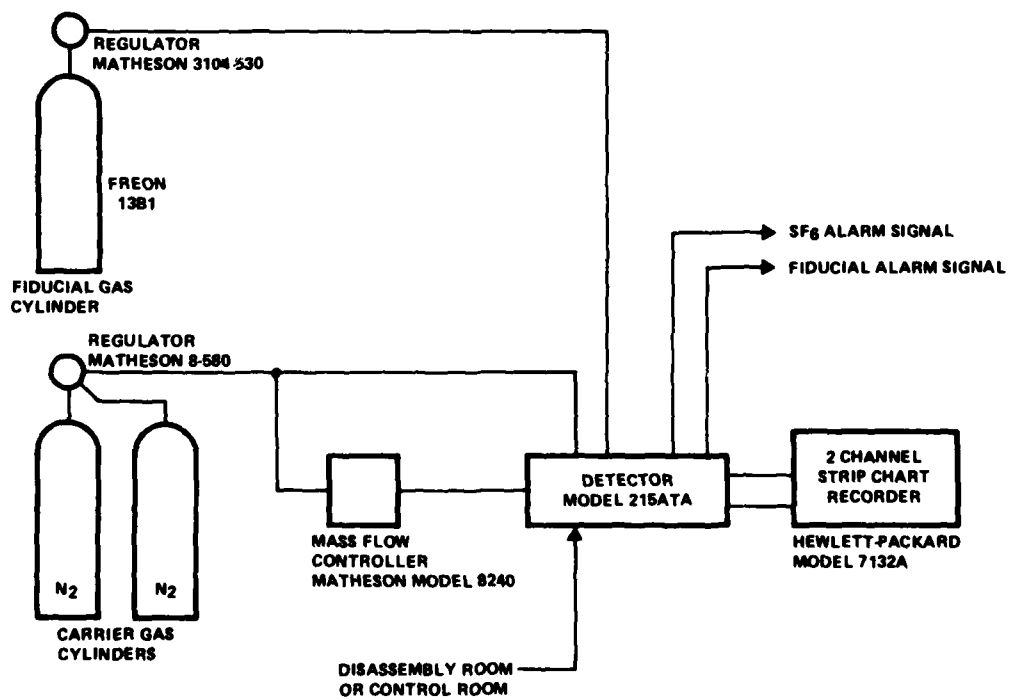

Figure 21 SF₆ FLOW DIAGRAM

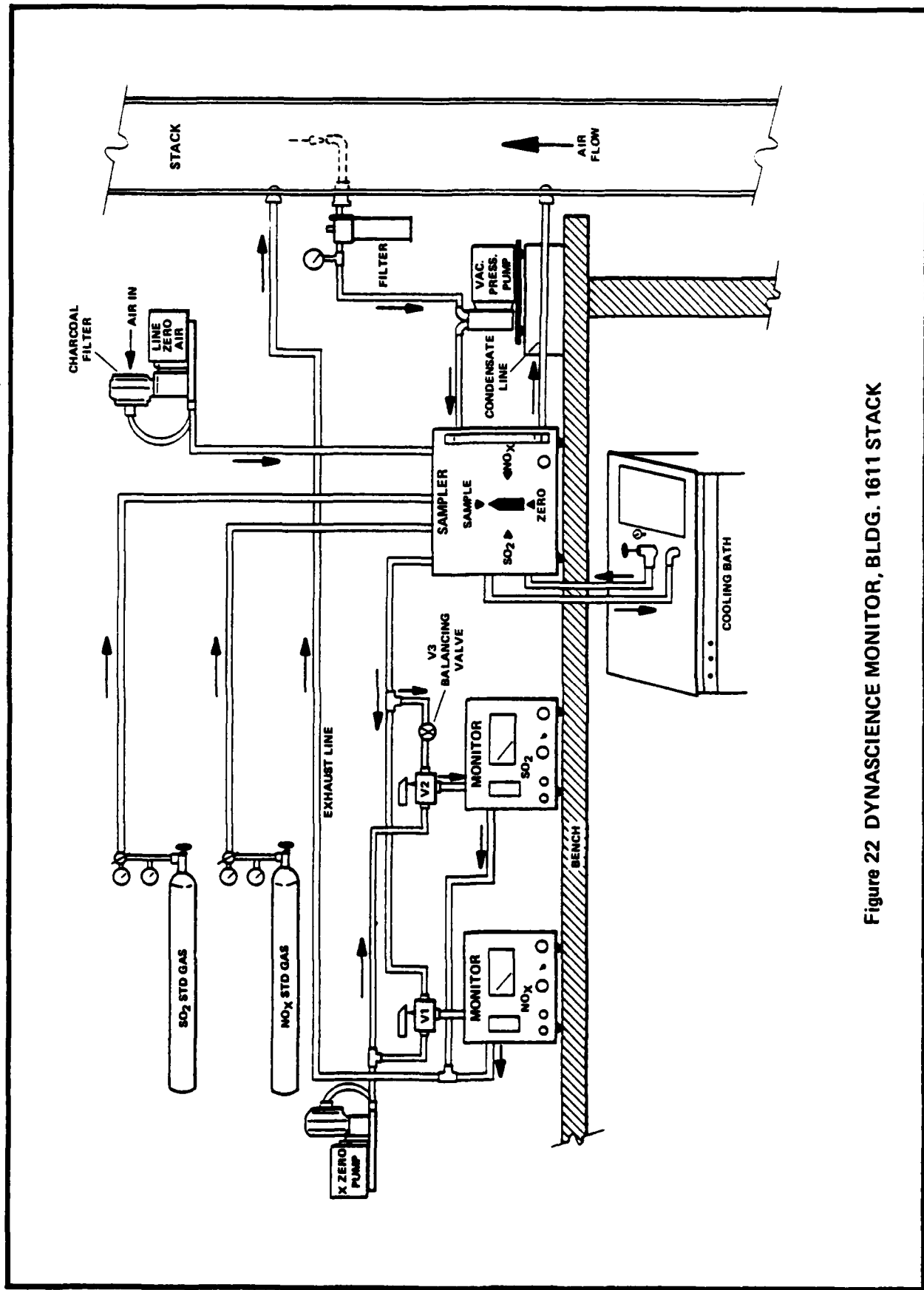

Figure 22 DYNASCIENCE MONITOR, BLDG. 1611 STACK

3.2 DESCRIPTION OF ANALYSIS TECHNIQUES

3.2.1 MUSTARD AGENT ANALYSIS

3.2.1.1 Analysis of Calibration Standards

The analysis for mustard was colorimetric. The instrument used was a Technicon Autoanalyzer. To initiate the analysis of standards, a 1.21 $\mu\text{g}/\text{ml}$ standard solution was prepared. One aliquot of this solution was placed into the auto-analyzer. The STANDARD CAL control was used to adjust the recorder to a peak height of 80 chart units. This first standard was checked after a 30-minute warm-up period.

Following this initial procedure, duplicate aliquots of three calibration standards (0.0, 0.24, and 1.21 $\mu\text{g}/\text{ml}$) were placed on the auto-sampler tray followed by a single aliquot of each of the blank standards. Approximately 30 minutes after each standard was sampled, the peak appeared on the recorder. The peaks were spaced six minutes apart resulting in a sample analysis once every six minutes. The analyst recorded these results on an Analyst Work Sheet designated for calibration.

A standards curve (see Figure 26) was prepared by linear least squares regression of peak height vs. concentration. The acceptable limits for slope were 66 ± 5 units/ $\mu\text{g}/\text{ml}$ and the coefficient of variance (determination of R-squared) could not be below 0.995.

The analyst was required to compare his results at the three standards to the following criteria:

Concentration	Max Peak Height	Min Peak Height
0.00 $\mu\text{g}/\text{ml}$ (2 ea)	0.5 chart units	-1.25 chart units
0.24 $\mu\text{g}/\text{ml}$ (2 ea)	17.25 chart units	13.25 chart units
1.21 $\mu\text{g}/\text{ml}$ (2 ea)	83.00 chart units	77.25 chart units

If the analytical results did not meet all of the above criteria, the operator was required to recalibrate his instrument. If the results were satisfactory the operator was allowed to begin the analysis of actual plant samples.

3.2.1.2 Analysis of Actual Plant Samples and Quality Control Samples

The liquid level in each glass bubbler was checked and changes recorded. If the level was low, the bubbler was brought to the mark by adding DEP. The solution was transferred to test tubes and any water present was removed.

Aliquots were taken from each test tube and transferred to sample cups, which were then placed on the auto-sampler tray. Known Standards were placed as "markers" before and after the unknowns, and periodically among the unknown samples as quality control samples. As with standards analysis, approximately 30 minutes were initially required before results appeared on the recorder. Results were attained every six minutes following the initial reading.

3.2.1.3 Final Analysis of Calibration Standards

At the completion of analysis of actual plant samples, the analyst was required to again run the three calibration standards (0.00, 0.24, 1.21 $\mu\text{g}/\text{ml}$) and assure that they met the criteria stated in Paragraph 3.2.1.1. In addition, these results were also

analyzed by computer as described in Paragraph 4.1.1. If the analyst's results did not meet the standardized criteria, he was required to recalibrate his instrument and reanalyze the actual plant samples.

3.2.2 SF₆ TRACER GAS ANALYSIS

SF₆ tracer gas analysis was accomplished at ambient temperature, using an electron-capture detector in series with a gas chromatograph column, a sampling valve, and an N₂ carrier gas (see Figure 21). Two detectors were used: one each for the control room and the disassembly room. Sampling was done by drawing air from these rooms into the sampling valve by means of an internal pump. A fixed internal sample volume determined the quantity of the sampled air to be analyzed.

An electron-capture gas chromatograph used the high electron affinity of gases with halogen group elements to provide a measurable signal. A sample was separated into component gases by means of a gas chromatographic column. In the case of SF₆ detection, this column was made of finely ground molecular sieve.

In the detector module, a tritium foil source, provided a stream of beta particles which ionized the dry nitrogen carrier gas and developed a secondary electron flow, termed the standing current. An electronegative gas captured electrons from this ionized gas stream in proportion to the concentration of the gas present in the sample. The detector collected these electrons, and an electrometer measured the current. The presence of an electronegative gas flowing through the detector decreased the standing current (by absorbing electrons) in proportion to the concentration of the electronegative gas. The electrometer operational-amplifier detected the change in current, and provided an output voltage proportional to the concentration of the gas. Through the use of a reference calibration chart, the read-out was directly readable as parts per trillion of SF₆.

3.2.3 NO_x and SO₂ ANALYSIS

The Dynascience monitor used a unique electro-chemical transducer. The transducer was a sealed electrolytic device, in which the direct electro-oxidation of absorbed gas molecules at a sensing electrode resulted in a current directly proportional to the partial pressure of the pollutant gas. In operation, the gas diffused through the membrane and the thin film electrolyte layer, where it was directly proportional to the concentration of the gas being monitored.

3.3 SUMMARY OF REGULATORY STANDARDS MAINTAINED

Work Area Mustard Standard

.003 mg/m³ [.216 μg/ml] (Action level .0025 mg/m³ [.18 μg/ml])

Stack Mustard Standard

.03 mg/m³ (Action level .015 mg/m³)

SF₆ Alarm Level

12 ppt

3.4 SUMMARY OF AIR MONITORING READINGS BY DAY

The following two tables are a summary of monitor readings from 8 May 1981 through 26 January 1982 for the various work areas (Table 4) and for the plant exhaust stack (Table 5). Both tables indicate only a single incident where the readings exceeded the established standards. As discussed in Chapter 5, diesel fuel oil adversely affects the ability of the monitors to differentiate it from mustard agent. When there were no malfunctions in the fuel oil delivery system there were no monitor readings that exceeded the standards.

Three ID Set facility improvements were undertaken to correct these misreadings. They consist of:

1. Installation of a small blower in the fuel oil pump house to dissipate the fumes, from the pumping operation, to the field north of Bldg. 1611.
2. Sealing any small leaks in the fuel oil delivery system.
3. Replacement of a defective burner assembly on the decontamination furnace.

TABLE 4

8 MAY 81 - 28 JAN 82
28 READINGS/1985 SAMPLES

DATE	LOCATION	TIME	READING mg/m ³	RANGE mg/m ³	SET
29 DEC 81	RA	1400-1600	.005	.004 - .005	X-551

CAUSE: GC CONFIRMATION OF .005 READINGS SHOWS IT WAS *NOT* MUSTARD. FORKLIFTS WERE PULLED INTO AREA OUT OF SNOW STORM, DRY GAS PUT IN TANKS AND ENGINES RUN — AREA "FILLED WITH SMOKE."

TABLE 5

STACK READINGS
8 MAY 81 - 28 JAN 82
50 READINGS/500 SAMPLES

DATE	LOCATION	TIME	READING mg/m ³	SET
26 MAY 81	ST	1515-1715	.042	K941

CAUSE: PROCESSED K941 SETS IMPROPERLY IN DEACTIVATION FURNACE

CHAPTER 4 DATA COLLECTION AND QUALITY CONTROL

4.1 METHOD OF DATA COLLECTION

For the Mustard Operations (Phase 1) of the CAIS disposal program, there were four generic categories for which data was collected, processed, and stored. These categories were: calibration, air monitoring, inventory control, and plant downtime. See Figure 23 for an illustrated diagram of data collection.

4.1.1 CALIBRATION

To establish daily calibration curves, known agent concentrations of 0.00, 0.24, and 1.21 $\mu\text{g}/\text{ml}$ were measured by each man/instrument combination each day (see Figure 24). For each man/instrument combination, one calibration run (0.00, 0.24, 1.21 $\mu\text{g}/\text{ml}$) was done before actual sample analysis to establish control, and a second was done at the completion of the actual data analysis, to demonstrate continued control. The data from all calibration runs was pooled and the multiple measurements of each concentration were used to establish confidence intervals around the complete regression line. The results of these measurements were taken to the data processing group each evening. The data was visually scanned for obvious errors and then entered onto magnetic cassette tape. The Tektronix min-computer (see Figure 25) then produced the daily calibration reports.

4.1.2 AIR MONITORING

For Phase I operations, air monitoring data was taken from the Analyst and Lab Data Coordinator Worksheets for mustard agent. Collected data was processed through the use of two Tektronix programs: Data Entry and Data Print. The purpose of the data entry program was to place the information, from the handwritten data sheets, onto magnetic cassette tape. The data print program was used to "echo" the input data for checking and verification that the data was entered correctly.

After entering any corrections, the air monitoring statistical program was run. This statistical program used data previously recorded on tape as input, and generated the reports required by CAIS management to verify reliability of laboratory analysis.

4.1.3 INVENTORY CONTROL

Inventory data was collected, processed, and stored for the following six items:

- a. Receipt Inspection of CAIS at Bldg. 1611.
- b. Process Data on Furnace Residue (Pigs).
- c. Process Data on Furnace Residue (Drums).
- d. Process Data on Spray Dryer (Drums).
- e. Process Data on Electrostatic Precipitator (Drums).
- f. Process Data on Disassembly Room (Exception Report).

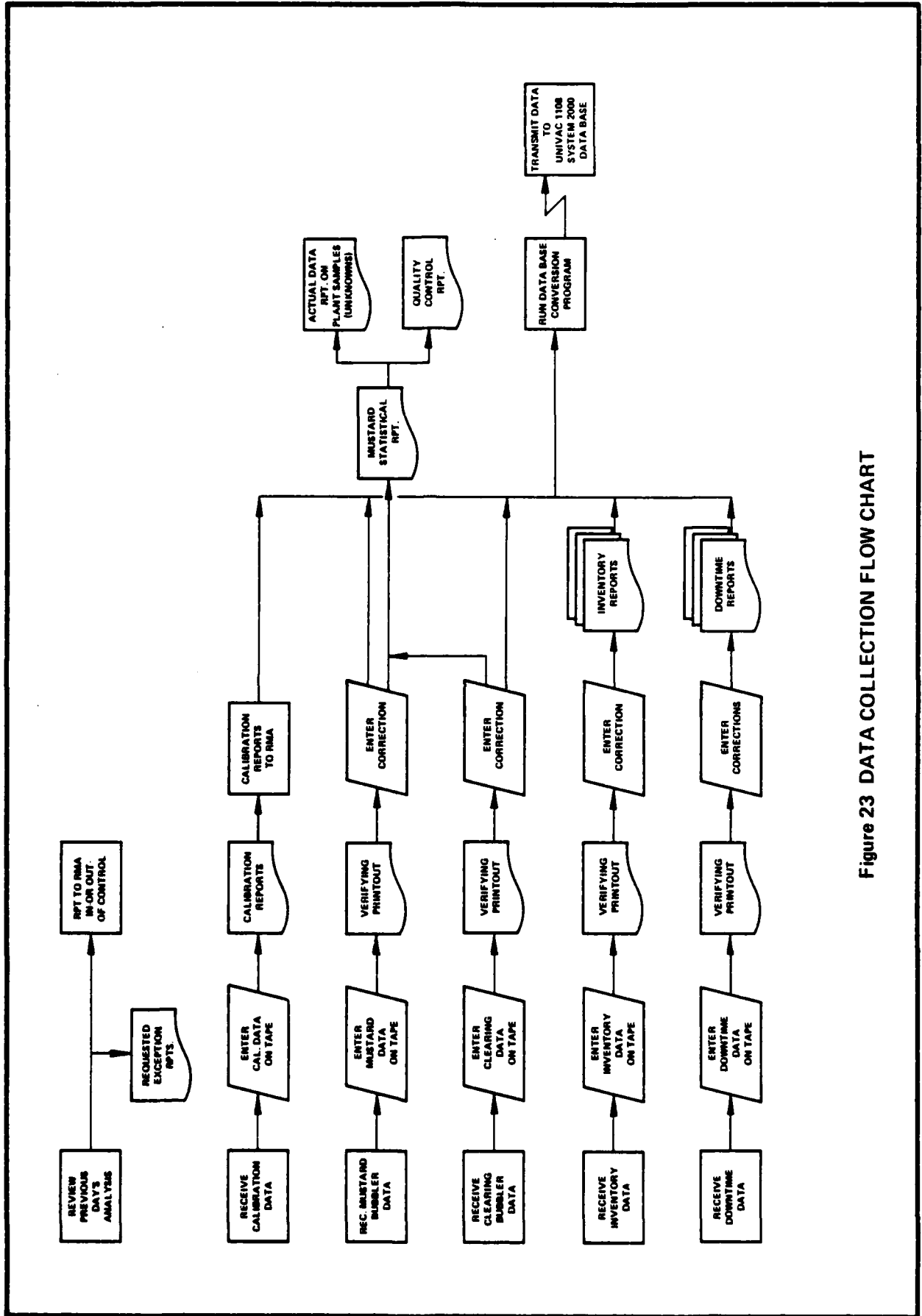

Figure 23 DATA COLLECTION FLOW CHART



Figure 24 LABORATORY EQUIPMENT

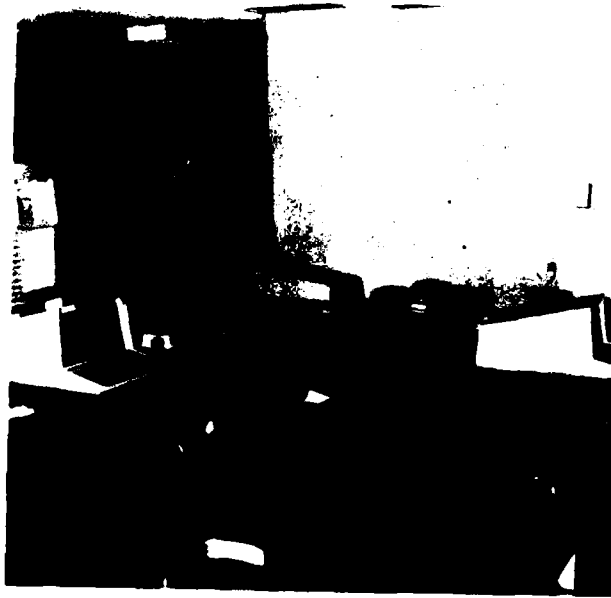

Figure 25 DATA PROCESSING EQUIPMENT

The data entry and data print programs were used in the same manner as for air monitoring (refer to Paragraphs 4.1.1). The data stored on the tape was manipulated by a program to produce desired inventory summary reports of various formats.

4.1.4 DOWNTIME

Building 1611 downtime was recorded on a data sheet and then entered, verified, and reported in the same manner as other data entry-data print programs. A daily report was required, even if it only stated "NO DOWNTIME." Various summary reports (normally monthly) were produced.

4.1.5 DATA CONVERSION AND PERMANENT STORAGE

At the end of each operating day, data was placed on a condensed or "merged" tape which was then sent to USATHAMA on a weekly basis. Inventory data was condensed from multiple files into a single file in this operation. At USATHAMA the processed data for each day was converted to a format that was acceptable to the Univac 1108 System 2000 data base.

To create a merged data tape, the computer operator inserted the program tape, the current day's data entry tape, and a blank tape in the Tektronix. The program tape obtained data from the data entry tape, converted it to Univac 1108 format, and entered the newly formatted data on the blank "merged" tape. The new "merged" tape was then sent to USATHAMA and used there to transmit the "merged" data to the Univac 1108 System 2000 Data Base. The Univac 1108 automatically scanned the data to assure that the format was acceptable.

At the conclusion of the transmission, the operator required the Univac 1108 to "playback" the transmitted data in order to confirm that the original transmission was correct and accurate.

4.2 DESCRIPTION OF AIR MONITORING DATA ANALYSIS

4.2.1 GENERAL

The purpose of the air monitoring statistical program was to determine the relationship between a known concentration of mustard agent and an instrument/man response (measurement). The three main components of this program are: calibration, wherein each man/machine combination relationship established a daily curve; actual data analysis, wherein the accuracy and confidence limits of measurements taken in the CAIS disposal plant were established; and quality control charting, which determined accuracy and the precision of lab measurements. The statistical program drew its source data from the air monitoring data tape for the day under consideration.

4.2.2 PROGRAM OPERATION

In the early production runs, calibration curves for mustard were established at concentrations of 0.04, 0.24, 0.61, 0.97 and 1.21 $\mu\text{g}/\text{ml}$ for each man/instrument combination each day. In later operations, this was reduced to known concentrations

of 0.00, 0.24 and 1.21 $\mu\text{g}/\text{ml}$ were measured by each man/instrument combination each day. Two measurements of each concentration were used to establish confidence intervals around the complete regression line.

The statistical program drew upon the mustard air monitoring data tape, extracting the calibration data for the day. Using the peak heights obtained for each known concentration, the computer constructed a plot of known concentrations (X-axis) vs. peak height/instrument response (y-axis). The computer provided this plot (see Figure 26) as a report, along with the following information:

- a. Standard Army agent code for mustard.
- b. Date.
- c. Bartlett's - a probability for the Bartlett's test, indicating the tendency of the variance of this small data set to be either homogeneous (a probability greater than 0.05) or non-homogeneous (a probability less than 0.05).
- d. R-squared - a statistical evaluation of how well the computer-selected equation fits the data. An R-squared value of 0.995 or greater was acceptable.
- e. MSE - mean square error - a statistical evaluation of the "distance" that the points fell from the selected regression line. No set criteria was used.
- f. (a) - the intercept of the regression line with the Y-axis.
- g. (b) - the slope of the selected regression line.
- h. (f), (g) and (h) - correction factors for data that might fit non-linear or special cases.

Using information from the calibration curve, the peak height readings from the actual data sheets were factored to establish a "true" value with corresponding upper and lower limits of accuracy. The actual measurements were revised to take into account the measurement errors determined by the calibration report. The upper and lower limits of accuracy were determined by the computer, which used a previously entered data base. The data base was kept in the statistical program. A report was then produced (see Figure 27) which displayed the following information:

- a. Actual data for Mustard agent (in mg/m^3).
- b. Date.
- c. Sample - control number corresponding to the data entry print routines.
- d. Location - location of the ID Sets where the sample was collected.
- e. True - the value calculated by the computer, based on the previously constructed calibration curve (in mg/m^3).
- f. Lower 95% - the value calculated by the computer, based on the IDS/HISTORY data base for the lower confidence value (in mg/m^3). Values were printed only for work area samples.
- g. Upper 95% - the value calculated by the computer, based on the IDS/HISTORY data base for the upper confidence value (in mg/m^3). Values were printed only for work area samples.
- h. Time - sampling interval.

The IDS/HISTORY tape contained statistical limits, established by USATHAMA and the Department of Health and Human Sciences (DHHS), used for accuracy and precision charts. These charts provided the upper and lower bounds for accuracy of measurements (mean value) and the precision (standard deviation) or variance of mean readings.

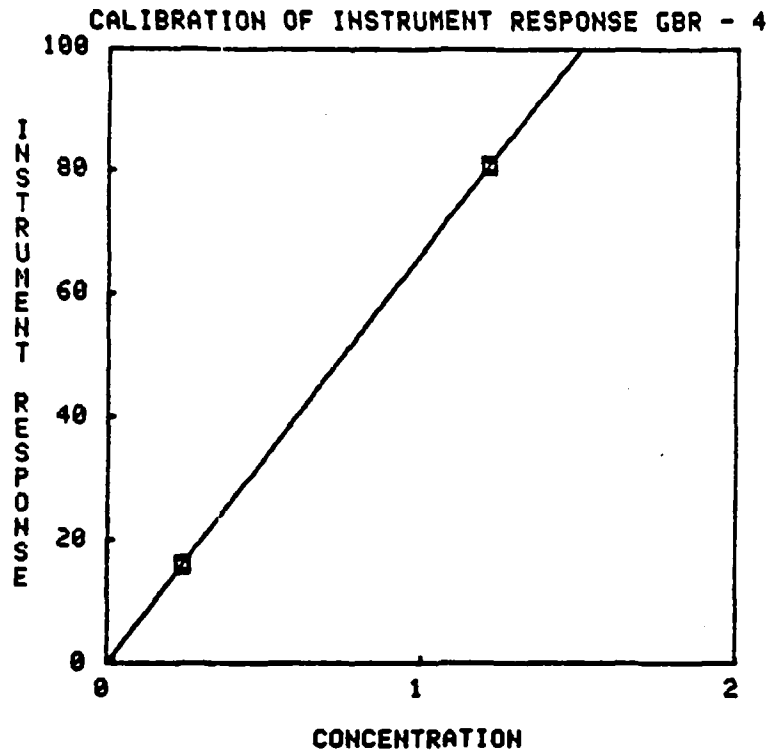

AGENT: H
DATE: 11/17/81

STATISTICS

BARTLETTS:
0.752
R-SQUARED:
1.000
MSE:
3.943E-002

PARAMETERS

$Y' = a + bX'$
a = -2.850E-002
b = 6.686E+001
 $Y' = (Y + f) + g$
 $X' = X + h$
f = 0.000E+000
g = 1.000E+000
h = 0.000E+000

Figure 26

ACTUAL DATA FOR H

DATE: 07/14/81

SAMPLE	LOCATION	AGENT CONCENTRATION		
		TRUE	LOWER 95%	UPPER 95%
AYEH04	DR	0.000*		
AYFH02	ST	0.000*		
AYFH03	CR	0.000*		
AYFH05	RA	0.000*		
AYFH06	DR	0.000*		
AYGH07	DR	0.000*		
AYHH01	DR	0.000*		
AYHH03	RA	0.000*		
AYHH04	CR	0.000*		
AYHH06	ST	0.001		
AYIH01	DR	0.000*		
AYIH04	CR	0.000*		
AYIH05	RA	0.000*		
AYIH06	DR	0.000*		
AYIH07	ST	0.000*		

Figure 27

Accuracy and precision charts (see Figures 28 through 29) were produced as quality control with respect to the laboratory and the calibration chart for each day. The measurements of each of four bubblers, spiked with known concentrations of 0.04 and 0.216 $\mu\text{g}/\text{ml}$, were averaged to determine the accuracy. USATHAMA and DHHS had established upper and lower limits for accuracy measurements for mustard agent as follows:

MEAN CONCENTRATION	LIMITS	
	LOWER	UPPER
0.04 $\mu\text{g}/\text{ml}$	0.023 $\mu\text{g}/\text{ml}$	0.057 $\mu\text{g}/\text{ml}$
0.216 $\mu\text{g}/\text{ml}$	0.191 $\mu\text{g}/\text{ml}$	0.241 $\mu\text{g}/\text{ml}$

Daily points should scatter about the mean. Points above the upper line or below the lower line constituted the measuring process as being "out-of-control" statistically. Seven continuous runs above or below the mean line also constituted the measuring process as being "out-of-control" statistically.

Precision charts indicated the standard deviation of the mean accuracy readings. Average deviations, using past data as a base, had been established of 0.04 and 0.216 concentrations, as follows:

CONCENTRATION	AVG. DEVIATION	UPPER LIMIT
0.04 $\mu\text{g}/\text{ml}$	0.009	0.029
0.216 $\mu\text{g}/\text{ml}$	0.013	0.042

It was expected that precision calculations would scatter above and below the average deviation. The desirable situation was for all calculations to fall between 0 and the upper limit. If a point fell above the upper limit, the measuring process was considered to be "out-of-control" statistically. After an initial period of operations, control charting and quality control at the 0.04 $\mu\text{g}/\text{ml}$ level was discontinued. Quality control at 0.216 $\mu\text{g}/\text{ml}$ continued throughout all operations.

4.3 DESCRIPTION OF INVENTORY DATA COLLECTION

For the CAIS disposal program, inventory control can be divided into two basic categories: incoming or receipt inspection; and outgoing or process recording. Receipt inspection for Phase I consisted of recording the serial numbers of incoming ID Sets (pigs and boxes) and noting that they were either destroyed or returned to the toxic storage yard. Process inspections were conducted to record any unusual observations in the disassembly room (leakers, rusted cans, etc.) and the final disposition of the pigs, furnace residue, and the salts from the spray dryer and the electrostatic precipitator.

4.3.1 RECEIPT INSPECTION

Each day the Bldg. 1611 Receipt Inspection form was delivered to the computer group for processing. The data entry and data print programs were used to insert and verify the entry of the data. After corrections (if any) were made, the day's report was run. The report showed the date, serial number of received ID Sets, whether they were destroyed or returned to the toxic storage yard, and pertinent comments.

ACCURACY CONTROL CHART FOR H QL.216
 HQH QL.216

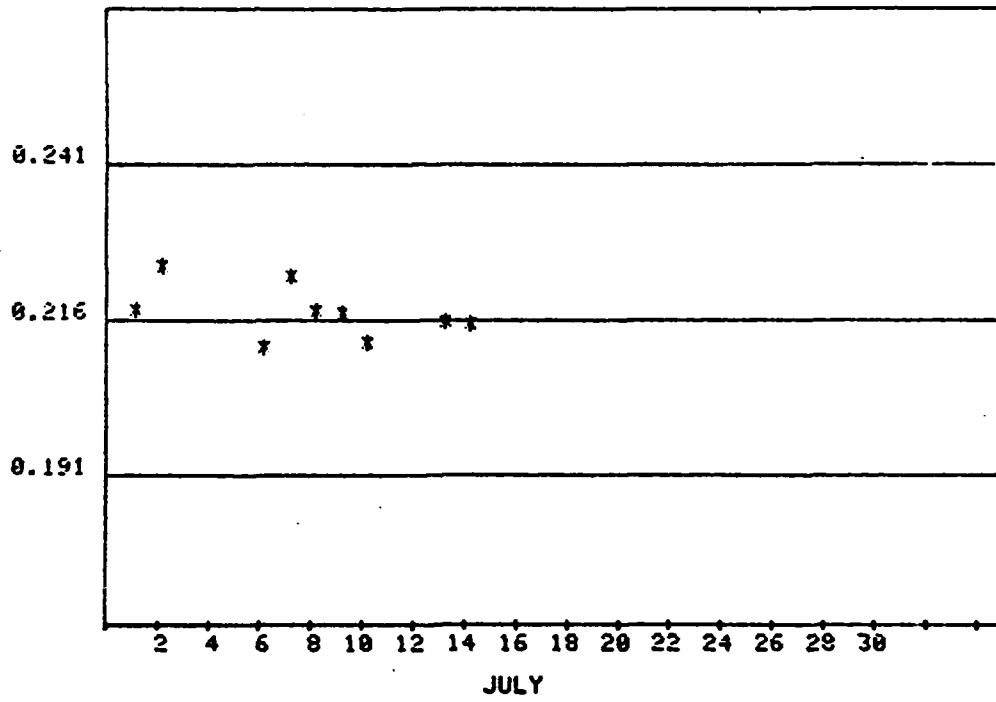

Figure 28

PRECISION CONTROL CHART FOR H QL.216
 HQH QL.216

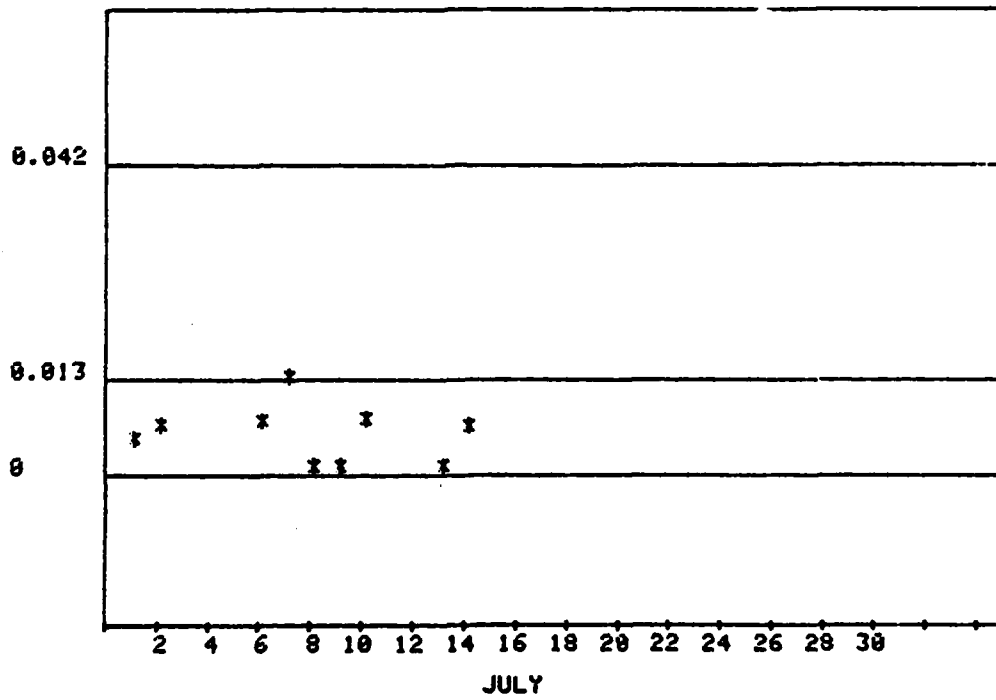

Figure 29

4.3.2 PROCESS INSPECTION

The process data sheet for the disassembly room for the current day was delivered to the computer group. The data sheet contained notes on any unusual occurrences or observations for the day's operation. If there were none noted for the day, the data sheet was not taken to the computer group. The data was processed in the same manner as other data entry/print programs and produced a report showing the ID Sets type, serial number, any unusual occurrence or observation, and action taken.

4.3.3 FINAL DISPOSITION

Data sheets from the residue area (daily), and spray dryer and electrostatic precipitator (as required) were processed by the computer group. Processing procedures were the same as for other data sheets. Reports were produced as follows:

- a. Decontaminated (Deconned) pigs
- b. Furnace residue (drums)
- c. Spray dryer residue (drums)
- d. Electrostatic precipitator residue (drums)

4.3.4 DATA CONVERSION

All inventory data for the day was converted to Univac 1108 format and sent to USATHAMA, in accordance with the details of Paragraph 4.1.5.

4.4 DESCRIPTION OF DOWNTIME DATA COLLECTION

A coded downtime data sheet was provided each day, even for those days when there was no downtime. Data was processed in the same manner as other program inputs: ie: entered, verified, corrected as required, and reports generated. The reports were printed with definitions rather than the numerical-code data entries. These reports provide the following information:

- a. Date.
- b. Start and Stop times of the downtime.
- c. Whether or not this was a simultaneous experience with other malfunctions.
- d. Subsystem affected.
- e. Primary components affected.
- f. Secondary components affected.
- g. Description action.
- h. Failure modes.
- i. Corrective action taken.
- j. Effect on operation.
- k. Operator comments.

If there was no downtime experienced during the day, the report so stated. Thus, there was a downtime report each day.

The downtime report data was converted to Univac 1108 format and sent to USATHAMA, in accordance with the procedures outlined in Paragraph 4.1.5.

CHAPTER 5 CONCLUSIONS AND RECOMMENDATIONS

5.1 INTRODUCTION

The purpose of this section is to provide a summary of lessons learned which can be applied to future phases of the ID Sets operation as well as other demilitarization programs. The conclusions are collected into the three functional areas of demilitarization operations, which are: plant operations, laboratory operations, and data center operations. It must be emphasized that the overall demilitarization operation was found to operate as a "tripod"; that is that all three functional areas had to be simultaneously operational. No two of the functional areas could be allowed to continue operation if the remaining area was experiencing problems which kept it from functioning properly. This is the first time that a demilitarization program has been run such that the data center operations and laboratory operations were considered a prerequisite for daily plant operations. It is also the first time that daily quality control acceptance criteria were used as a prerequisite for daily plant operations.

5.2 PLANT OPERATIONS

5.2.1 GENERAL

In looking at how the plant operated during the period of 8 May 1981 to 28 January 1982 there are three areas which were evaluated. These are as follows:

1. Air Monitoring results
2. Disassembly room operations and set characteristics
3. Downtime analysis

5.2.2 AIR MONITORING RESULTS

The air monitoring results in specific terms are addressed in Chapter 4. In general terms, and in the form of conclusions, a number of findings were made as follows:

- 5.2.2.1 The concepts of removing the worker from the ID Sets to a maximum extent and minimizing set disassembly were major factors in the almost total lack of disassembly room readings. The one operation which occurred outside of the glovebox—bolt replacement—was responsible for two of the five minimal readings recorded. It is noteworthy that this occurred during a violation of Standing Operating Procedures. The conclusion is that it is better to build safety into the materials handling equipment than it is to try to write it into the procedures.
- 5.2.2.2 Forklift exhaust and/or dry gas additive cause a positive indication in the DB3 colorimetric analysis for mustard. This was eliminated, however, by the use of a gas chromatographic verification.
- 5.2.2.3 It was concluded from the overall plant air monitoring results over the period of 21 December 1981 - 26 January 1982 that unburned fuel oil vapor in an incineration system could cause low level positive indications for mustard in the DB3 colorimetric

analysis technique. This was particularly aggravated in work areas by cold, still conditions. It was also seen where the workers close doors to keep out the chill winds and, in so doing, allowed fuel oil vapor to build up. It should be noted that the gas chromatographic verification did not work in distinguishing this type of reading due to a peak with similar retention time in the fuel oil spectrum. The following are recommendations to mitigate this condition:

- a. In future demilitarization incinerator designs, further attention should be paid to ventilating non-toxic work areas to prevent a build up of fuel oil vapor, particularly in residue disposal areas.
- b. Future designs of demilitarization systems should attempt to minimize fuel oil leakage around furnaces, afterburners, and in work areas to allow for more accurate air monitoring data.
- c. The separation of the fuel oil pump transfer station from plant facilities is advisable due to fuel oil vapor build up which is unavoidable at this point. This has a definite negative effect on cold weather bubbler results for mustard.
- d. Over an operational period of seven months, only one reading was recorded (26 May 81, .042 $\mu\text{g}/\text{m}^3$, stack) which exceeded either work area or stack standards agreed to by the Department of the Army, the Department of Health and Human Services, and the State of Colorado. This reading was the result of a transitory upset which was quickly corrected and represented by itself no threat to the work force or the environment. It is again noteworthy that this was the result of running the deactivation furnace in an improper mode in violation of Standing Operating Procedures. This was unintentional and due to operator error. The RMA response to this event was the installation of a "K941/K942 mode" switch on the deactivation furnace panel which automatically performed the function properly. Again, the design of the control equipment to handle the function was proved to be more effective than attempting to handle the problem procedurally.

5.2.3 DISASSEMBLY ROOM OPERATIONS AND SET CHARACTERISTICS

5.2.3.1 Box Sets

The X-Sets packaged into wooden boxes were generally in good condition. They did not appear fundamentally different than those which were destroyed in the 1979 Pilot Test. These sets were generally handled without incident, although a number became jammed in the chute or resulted in breaking the pins upon which the "flapper" — a counting mechanism installed in the feed chute — was hung. All of these were cleared to the furnace without incident.

5.2.3.2 Pig Sets

- a. K941/K942. The K941/K942 pig sets encountered during the 1981-1982 production run were significantly more deteriorated than those encountered in 1979 during the Pilot Test. This is to some extent due to the prolonged storage of about 800 of the total 847 of these items on Johnston Atoll. This was

particularly true for the eight bolts around the flanged end of the pig. The salt air had rusted these to such an extent that even the impact wrenches used in the glovebox could not easily free the bolts. A manual one-for-one replacement operation using special tools was performed at the loading station to alleviate this problem. It is suggested that items stored on Johnston Atoll in overpacks be physically inspected prior to designing materials handling or unpack equipment such that problems caused by the highly corrosive environment will be anticipated.

The interior of the K941/K942 sets were also significantly worse than expected. The incidence of leaking sets was, for all intents and purposes, 100%. Many cans were significantly deteriorated and mustard leakage within the glovebox was common. Although an unusually high amount of cardboard overpacks were used during this period, no other problems were caused by this condition. There is no question that the glovebox operation was essential in preventing mustard exposure of the workers.

- b. X-Sets. A certain group of X-sets, specifically those packaged at Aberdeen Proving Ground, were placed into pigs prior to shipment. These items were handled in the same mode as K941/K942 sets and were handled without incident.

5.2.3.3 Engineering Drawings

During the development of the equipment to process both pigs and boxes, U.S. Army drawings of the ID Sets were used to prepare process equipment. It cannot be emphasized enough that these drawings were frequently in error or incomplete. The item, be it a box or a pig, was rarely delivered as shown or described on the engineering drawings. It is imperative in designing equipment for future demilitarization that the actual items to be destroyed should be physically surveyed for key design parameters or mistakes made in this regard on the ID Sets program will be repeated.

5.2.4 DOWNTIME ANALYSIS

5.2.4.1 General

There are a number of methods as to how downtime can be calculated (refer to Paragraph 2.4.1). As this was essentially a production oriented operation, the management yardstick chosen was the number of sets "produced" — therefore destroyed — on any given day versus the number of those type of sets which should have been destroyed on a normal full production day. This was the calculation made to produce "process downtime." By month, this "process downtime" is shown as follows:

Table 6
Downtime Analysis By Sets Destroyed

Month	Days Of Scheduled Opns	Sets Destroyed	Sets Scheduled	Percent Downtime
May 81	15	420	984	57.3%
Jun 81	22	548	912	39.9%
Jul 81	11	484	600	19.3%
Sep 81	10	270	576	53.1%
Oct 81	21	928	1368	32.2%
Nov 81	19	447	600	25.5%
Dec 81	22	441	864	49.0%
Jan 82	19	1096	1176	6.8%

Using the results of Table 6 and calculating downtime by an average weighted by days results in the following calculation:

$$1. \frac{(57.3)(15)+(39.9)(22)+(19.3)(11)+(53.1)(10)+(32.2)(21)+(25.5)(19)+(49.0)(22)+6.8(19)}{(15)+(22)+(11)+(10)+(21)+(19)+(22)+(19)}$$

$$2. \frac{859.5+877.8+212.3+531+676.2+484.5+1078.0+129.2}{139}$$

$$3. \frac{4848.5}{139} = 34.9\% \text{ or } 49 \text{ lost days out of } 139 \text{ potential operating days.}$$

This total represents, at least initially, a higher figure than the 30% predicted in the Pilot Test report. Two major contributing factors to this 34.9% figure were a lightning strike which destroyed the plant microprocessor (3.6% or 5 days) and the failure of the deactivation furnace conveyor (6.5% or 9 days). These two items alone account for 10.1% of the available processing time of 139 days. Downtime excepting these two major failures then drops to 24.8%.

Another contributing factor was startup which saw an unusually high downtime figure of 57.3% for the month of May. Generally speaking, downtime improved considerably as the operation progressed. This is somewhat mitigated by the December 1981 figure, but that month is traditionally one when higher downtime is experienced due to the holidays and cold weather problems. The month of January 1982 was unusually trouble-free, but the weather was also unusually mild for the later part of the month.

5.2.4.2 Specific Action

Excepting the two major failures of the microprocessor and the deactivation furnace conveyor, downtime occurred primarily in the decontamination furnace subsystem and in a number of cold weather related areas. Other causes were essentially random among the various process modules. Given this situation the following actions were taken:

- a. All exposed water/fuel lines were extensively heat traced. Old heat tracing is being replaced, as a good deal of this has been found to be defective.
- b. The preventive maintenance program was revitalized by the use of extensive contractor assistance. This was in response to limiting the various random failures experienced.

5.2.4.3 Conclusions

Some conclusions and recommendations in observing the downtime encountered on the ID Set Program and attempting to extrapolate the experience to other future work is as follows:

a. Preventive Maintenance

The initial attempt to staff this work with the three full time maintenance people currently available was a failure. This was due to a constant demand for these people to handle unscheduled maintenance. It was obvious that this area had been undermanned and future demilitarization projects should look toward adequately manloading it with personnel separate from the unscheduled maintenance personnel.

b. Furnace Operation

As an overall comment, the constant shutting down and firing up of furnaces every weekend at RMA definitely took a toll on the equipment. While this was unavoidable at RMA with the existing manpower constraints, it should be studiously avoided in planning for operations of other facilities. Other lessons learned included the following:

- (1) Include on the control panel the ability to monitor the status of fuel oil storage.
- (2) Include flow meters on all fuels lines to indicate oil usage. This would undoubtedly provide clues or early warning for burner malfunctions.
- (3) For cold weather facilities (all CONUS) provide testing of all plant heat tracing every fall, particularly for fuel lines. If possible, design these lines such that they are inside, not outside, the facility or run underground.
- (4) Use of the Kaiser product "Helskote" has greatly relieved slagging at the afterburner throats and has enabled these to be cleaned rapidly. Maintenance to clean the burner throats was scheduled once a week, on the weekend.

c. Microprocessor Operation

This unit, while essential to various plant operations, was not as trouble-free as was first expected. When using a microprocessor to control plant functions, two important "back-up" strategies should be maintained:

- (1) A spare unit should be kept plugged in and pre-programmed to reduce switch-over time if the primary unit fails.
- (2) Back-up magnetic tapes of the microprocessor programs should be strictly maintained and kept up to date. Also a log of all program changes should be maintained.

PHASE 2

**DISPOSAL OF CHEMICAL AGENT
IDENTIFICATION SETS
AT ROCKY MOUNTAIN ARSENAL, COLORADO
BOX SET OPERATIONS: PHASE 2
FINAL REPORT
NOVEMBER 1982**



Prepared By

William R. Brankowitz
USATHAMA

Dr. Michael E. Witt
RMA

John A. Ursillo
RMA

Dr. Jack C. Pantleo
Data Processing Associates

DISTRIBUTION UNLIMITED. CLEARED FOR PUBLIC RELEASE

**DEPARTMENT OF THE ARMY
US ARMY TOXIC AND HAZARDOUS MATERIALS AGENCY
ABERDEEN PROVING GROUND, MARYLAND 21010**

CONTENTS

CHAPTER 1	PROCESS DESCRIPTION
1.1	Purpose
1.2	Disposal Procedures
1.3	Waste Disposal
CHAPTER 2	PRODUCTION SUMMARY
2.1	Sets Description
2.2	Numerical Summary of Sets Destroyed
2.3	Downtime Analysis
CHAPTER 3	AIR MONITORING SUMMARY
3.1	Description of Sampling Techniques
3.2	Description of Analysis Techniques
3.3	Summary of Regulatory Standards Maintained
3.4	Summary of Air Monitoring Readings
CHAPTER 4	DATA COLLECTION AND QUALITY CONTROL
4.1	Method of Data Collection
4.2	Description of Air Monitoring Data Analysis
4.3	Description of Inventory Data Collection
4.4	Description of Downtime Data Collection

LIST OF FIGURES

1	ID Sets Demilitarization Program, Building 1611
2	CAIS Facility Site Layout
3	X-TYPE and K945 Box Sets Process Flow Diagram
4	Box Feed Chute
5	Residue Handling Equipment
6	Electrostatic Precipitator
7	Spray Dryer
8	K945 Box Set
9	X-TYPE Box Set
10	Typical Bubbler
11	Sampling Station Locations, Building 1611
12	SF ₆ Detector/Analyzer
13	SF ₆ Flow Diagram
14	Dynascience Monitor, Building 1611 Stack
15	Calibration Curve and Actual Data Analysis - GB
16	Calibration Curve and Actual Data Analysis - Lewisite
17	Calibration Curve and Actual Data Analysis - Mustard
18	Data Collection Flow Chart
19	Laboratory Equipment
20	Data Processing Equipment
21	Accuracy Control Chart for Mustard
22	Precision Control Chart for Mustard
23	Accuracy Control Chart for Lewisite
24	Precision Control Chart for Lewisite
25	Accuracy Control Chart for GB
26	Precision Control Chart for GB

LIST OF TABLES

1	Numerical Summary of Sets Destroyed
2	Downtime Analysis by Sets Destroyed
3	Work Area Monitor Readings

CHAPTER 1 PROCESS DESCRIPTION

1.1 PURPOSE

The purpose of the Box Disposal Phase (Phase 2) of the Chemical Agent Identification Sets (CAIS) Demilitarization Program was to dispose of a significant portion of the remaining CAIS sets packaged in wooden boxes. The only box sets retained for Phase 3 were those which could be easily burned as production fill-in during times when pig processing equipment was down - K955 and X552 (PS - nonlethal) sets. The types of sets destroyed during Phase 2 included the following:

X548 sets (Lethal)	L
K945 sets (Lethal)	L, GB, H, CG sim (triphosgene)
X549 sets (Nonlethal)	DM
X545 sets (Nonlethal)	CG sim (triphosgene)
X546 sets (Nonlethal)	CN

The reader is referred to Chapter 2 for a detailed description of the contents of these sets. Disposal of Phase 2 sets was performed in Building 1611 at Rocky Mountain Arsenal (RMA), Denver, Colorado (see Figure 1) commencing 2 February 1982 and concluding 19 April 1982.

1.2 DISPOSAL PROCEDURES

1.2.1 TRANSPORTATION FROM INTERIM STORAGE

The lethal Chemical Agent Identification Sets for Phase 2 were shipped to RMA as part of SETCON II. These sets were then stored in sheds at the toxic storage yard. They were stored in CNU-80 shipping containers, approximately 20 per container.

The nonlethal Chemical Agent Identification Sets for Phase 2 were shipped to RMA during SETCON I and in succeeding moves including SETCON II. They were stored in a locked igloo in the North Plants Area of RMA. They were stored on wooden pallets, generally 72 or less per pallet.

The sets were loaded on trucks and transported by convoy on paved roads, during daylight hours, from the toxic storage yard or the North Plant igloo to Bldg. 1611. The demilitarization site layout is shown on Figure 2. A maximum of four containers were loaded by forklift onto a stake body truck and blocked and braced into place. The truck bed was equipped with two roller conveyors, length-wise, so the pallets could be loaded from the rear. Convoy speed was held at 10 mph or less during transportation.

Sets arrived at the covered unloading dock, located on the east end of Bldg. 1611. The sets were unloaded and held in the supply conveyor room until they were ready for processing. No lethal sets were held in the building overnight. In the disassembly room, the shipping containers or pallets were moved to the box feed chute for processing.

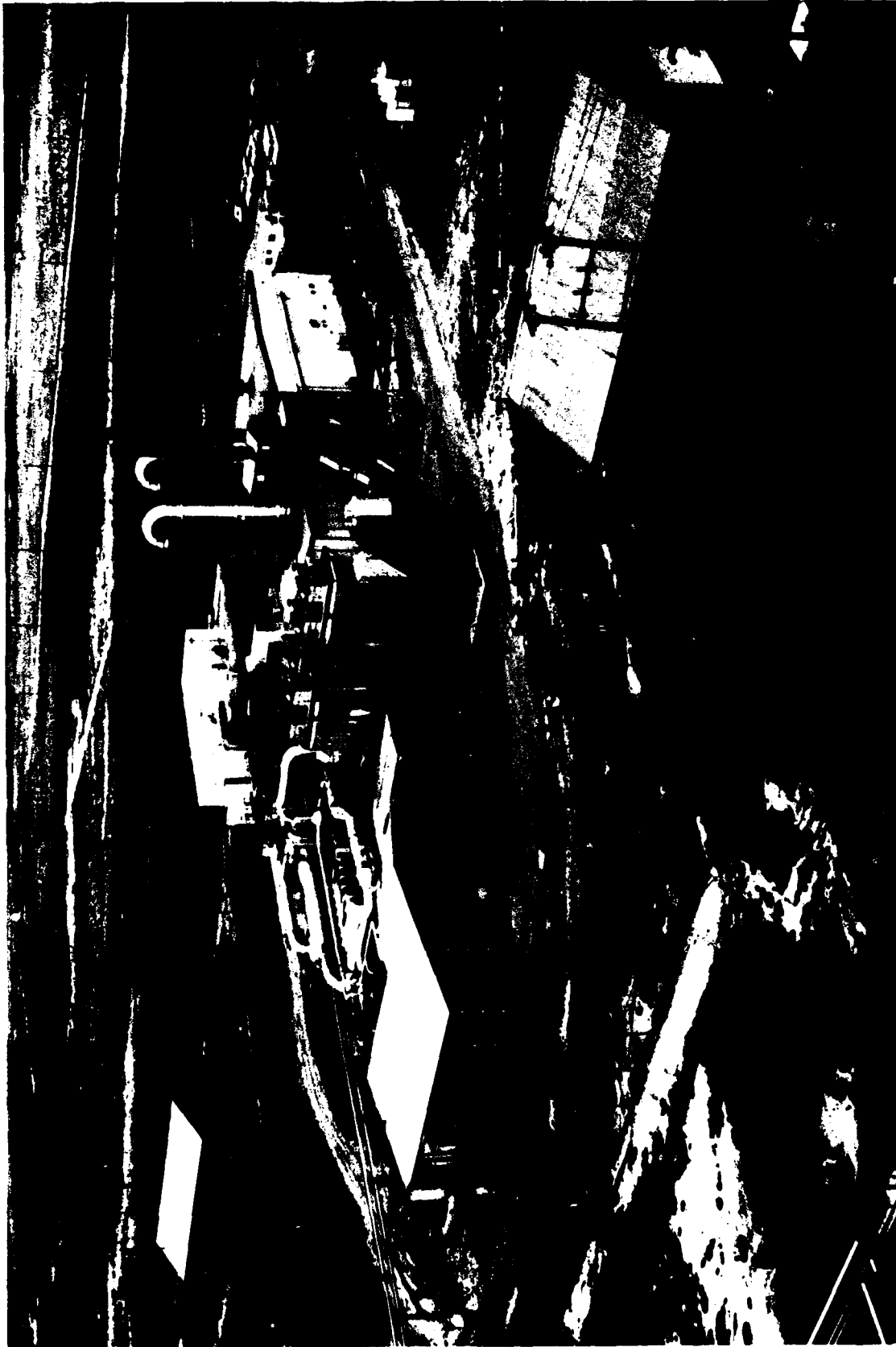

Figure 1 ID SETS DEMILITARIZATION PROGRAM, BUILDING 1611

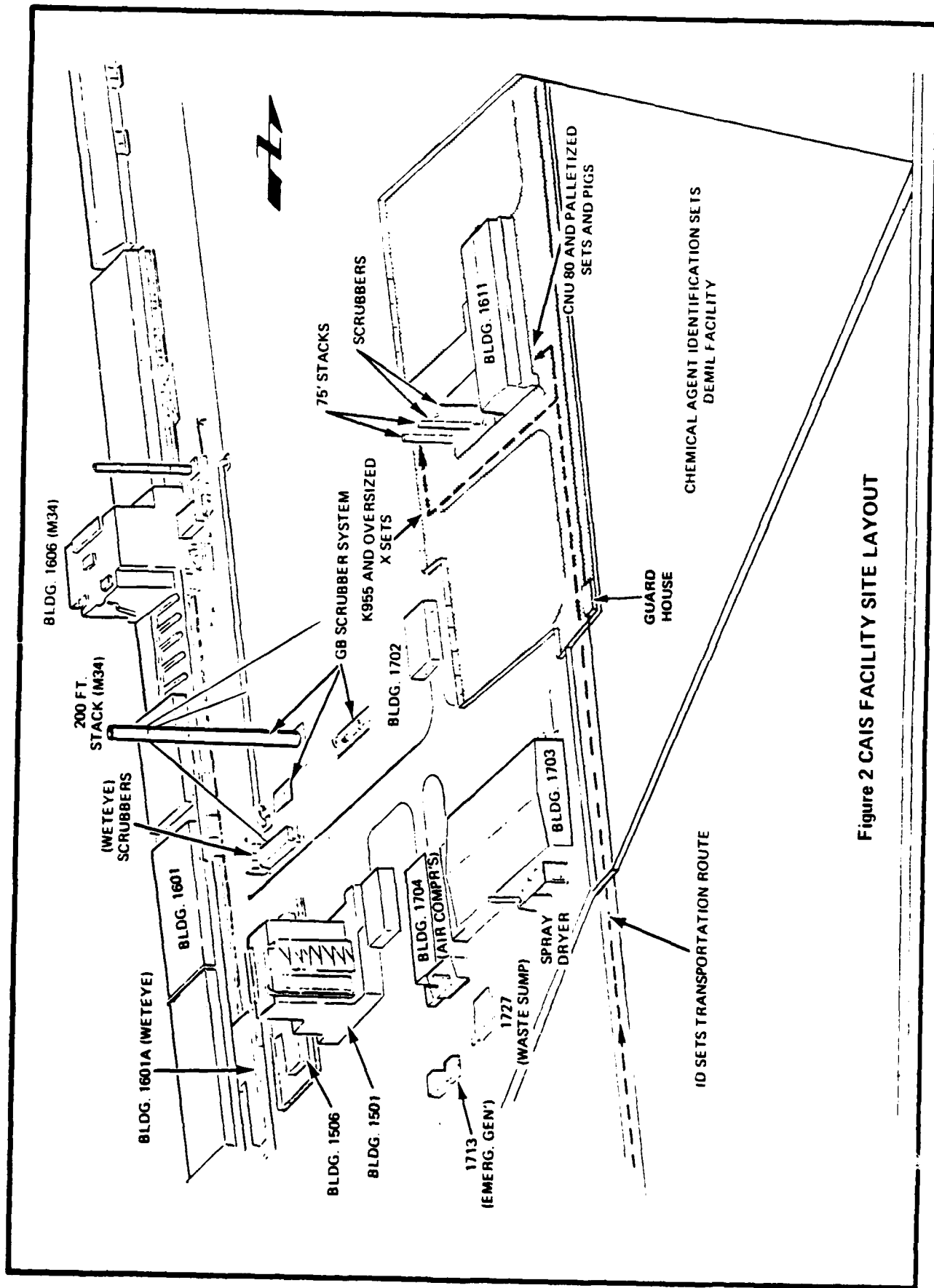

Figure 2 CAIS FACILITY SITE LAYOUT

1.2.2 DISPOSAL OF X-TYPE BOX SETS

1.2.2.1 General

X-type box sets were transported to Building 1611 in CNU-80 containers (X548) or on wooden pallets (X545, X546, and X549). The sets were stored approximately 20 in each CNU-80 and approximately 72 on each wooden pallet. Only the lethal X548 sets were containerized.

Upon arrival at the loading dock of Building 1611, the X-type sets were moved into the receiving room by forklift or overhead monorail crane. Here they were inventoried, inspected, and placed on a roller conveyor referred to as the supply conveyor. The supply conveyor extended through an airlock into the disassembly room. The sets were manually pushed along the conveyor, through the airlock, and into the disassembly room.

The disassembly room was the location where the sets were processed to the incinerator. Each pallet or CNU-80 was removed from the supply conveyor by a manual/electric forklift and taken to the box feed chute area. Prior to arriving at the box feed chute, the lid of the CNU-80 was removed using the overhead crane in the room. The X-type sets required no disassembly. Upon reaching the box feed chute area, boxes were inserted into the chute airlock and fed to the deactivation furnace at five minute intervals.

Figure 3 provides a summary flow diagram of how X-type boxes were processed.

1.2.2.2 Equipment Description

The Box Feed Chute assembly (see Figure 4) was a small airlock that isolated the deactivation furnace from the disassembly room. The chute was inclined at an angle of 51 degrees above horizontal. The upper (outer) door was manually opened and closed with a pneumatically operated cylinder providing a lock when the assembly was sequenced. The flapper (lower) door was operated by a pneumatic cylinder to rotate upward 90 degrees, thereby allowing the ID Set box, within the airlock, to slide down into the deactivation furnace.

As soon as the box cleared the flapper door, the cylinder closed the door and a two-minute purge began. Purging air was induced into the airlock chamber at 5.0 psig and 690 scfh. This provided the capability of 20 air changes during the two-minute purge cycle.

The controls were time-sequenced, so that a box set could be inserted into the deactivation furnace every five minutes.

1.2.2.3 Process Description

The box feed chute operator opened the upper door and inserted a box set. The door was closed and the PUSH TO CYCLE pushbutton was pressed. The flapper door opened and the boxed set slid into the deactivation furnace. The two-minute purge immediately started upon closing of the flapper door. A delay-loading timer also started and prevented cycling a set to the furnace for five minutes. At the end of five minutes, the BOX FEED CHUTE READY lamp lit and a new feed sequence could commence.

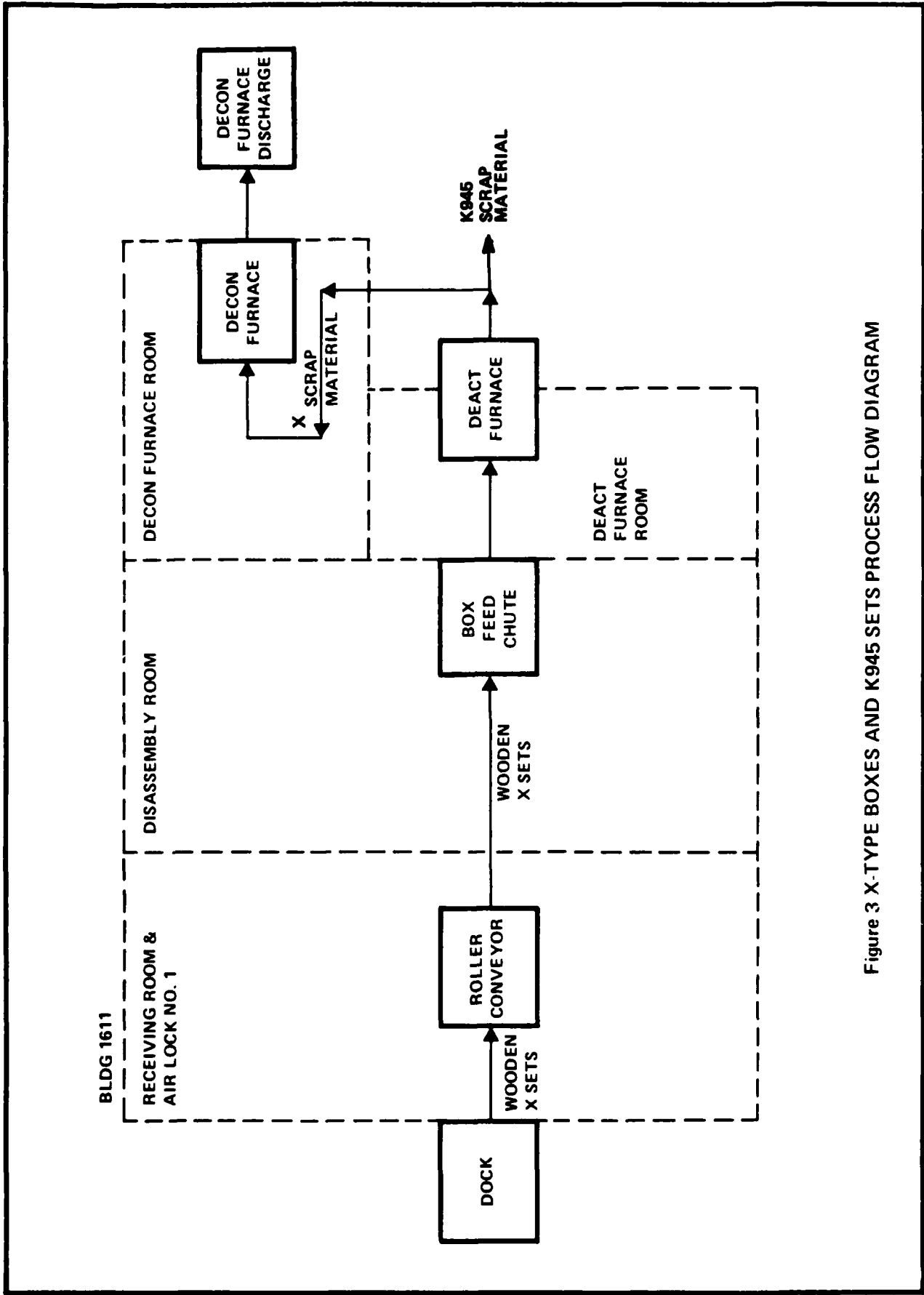

Figure 3 X-TYPE BOXES AND K945 SETS PROCESS FLOW DIAGRAM



Figure 4 BOX FEED CHUTE

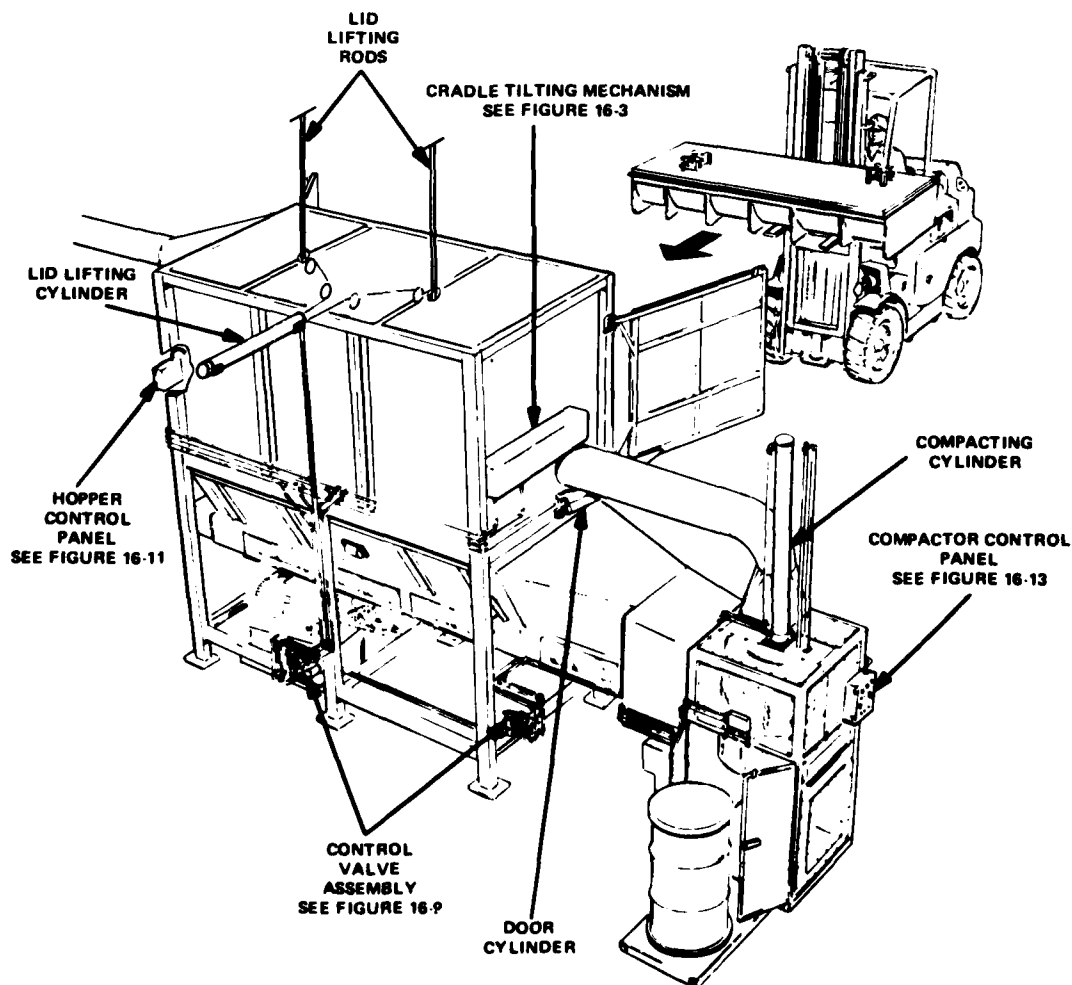

Figure 5 RESIDUE HANDLING EQUIPMENT

The residue from the deactivation furnace was conveyed to the decontamination furnace for further thermal treatment. A residue tray was inserted into the decontamination furnace to catch this residue and continue treatment. Periodically the tray was raked (from the rear of the furnace) to prevent residue buildup and spilling onto the floor of the decontamination furnace. When operations were completed, the tray was removed and the residue was packaged in 55 gallon drums.

1.2.3 DISPOSAL OF K945 SETS

1.2.3.1 General

K945 box sets were transported to Building 1611 on their wooden storage pallets. No containerization in CNU-80 overpacks was necessary, as each K945 had its own vapor-proof barrier bag packaged around the set materials inside each wooden box. There were usually 72 sets on each wooden pallet, although quantities varied.

Upon arrival at the loading dock of Building 1611, the K945 sets were moved into the receiving room by forklift. Here they were inventoried, inspected and then placed on the supply conveyor. The sets were manually pushed along the supply conveyor, through the airlock, and into the disassembly room.

The disassembly room was the location where these sets were processed to the incinerator. Each pallet was removed from the supply conveyor by a manual/electric forklift and taken to the box feed chute area. The K945 boxes required no disassembly. Upon reaching the box feed chute area, boxes were inserted into the chute airlock and fed to the deactivation furnace at five minute intervals.

Figure 3 provides a summary flow diagram of how K945 sets were processed.

1.2.3.2 Equipment Description

The Box Feed Chute assembly was a small airlock that isolated the deactivation furnace from the disassembly room. The chute was inclined at an angle of 51 degrees above horizontal. The upper (outer) door was manually opened and closed with a pneumatically operated cylinder providing a lock when the assembly was sequenced. The flapper (lower) door was operated by a pneumatic cylinder to rotate upward 90 degrees, thereby allowing the ID Set box, within the airlock, to slide down into the deactivation furnace.

As soon as the box cleared the flapper door, the cylinder closed the door and a two-minute purge began. Purging air was induced into the airlock chamber at 5.0 psig and 690 scfh. This provided the capability of 20 air changes during the two-minute purge cycle.

The controls were time-sequenced, so that a box set could be inserted into the deactivation furnace every five minutes.

1.2.3.3 Process Description

The box feed chute operator opened the upper door and inserted a box set. The door was closed and the PUSH TO CYCLE pushbutton was pressed. The flapper door opened and the boxed set slid into the deactivation furnace. The two-minute purge

immediately started upon closing of the flapper door. A delay-loading timer also started and prevented cycling a set to the furnace for five minutes. At the end of five minutes, the BOX FEED CHUTE READY lamp lit and a new feed sequence could commence.

The residue exiting the deactivation furnace was conveyed directly to a residue hopper in a ventilated room. When operations were completed, the hopper was removed and the residue was packaged into 55 gallon drums.

1.3 WASTE DISPOSAL

The waste residue from the CAIS disposal included the furnace trash, electrostatic precipitator (ESP) residue, and the dried salts from spray drying the brines and other liquid industrial wastes (see Figures 5, 6 and 7). The furnace trash, both deactivation and decontamination furnaces, was processed through the residue compactor and placed in 55 gallon drums. The ESP residue was placed in 55 gallon drums directly from the bins at the bottom of the ESP cells. The waste liquid was pumped to the spray dryer holding tanks in Bldg. 1703, dried to salts, and then placed in 55 gallon drums. All drums have been stored in warehouses awaiting determination of final disposition.

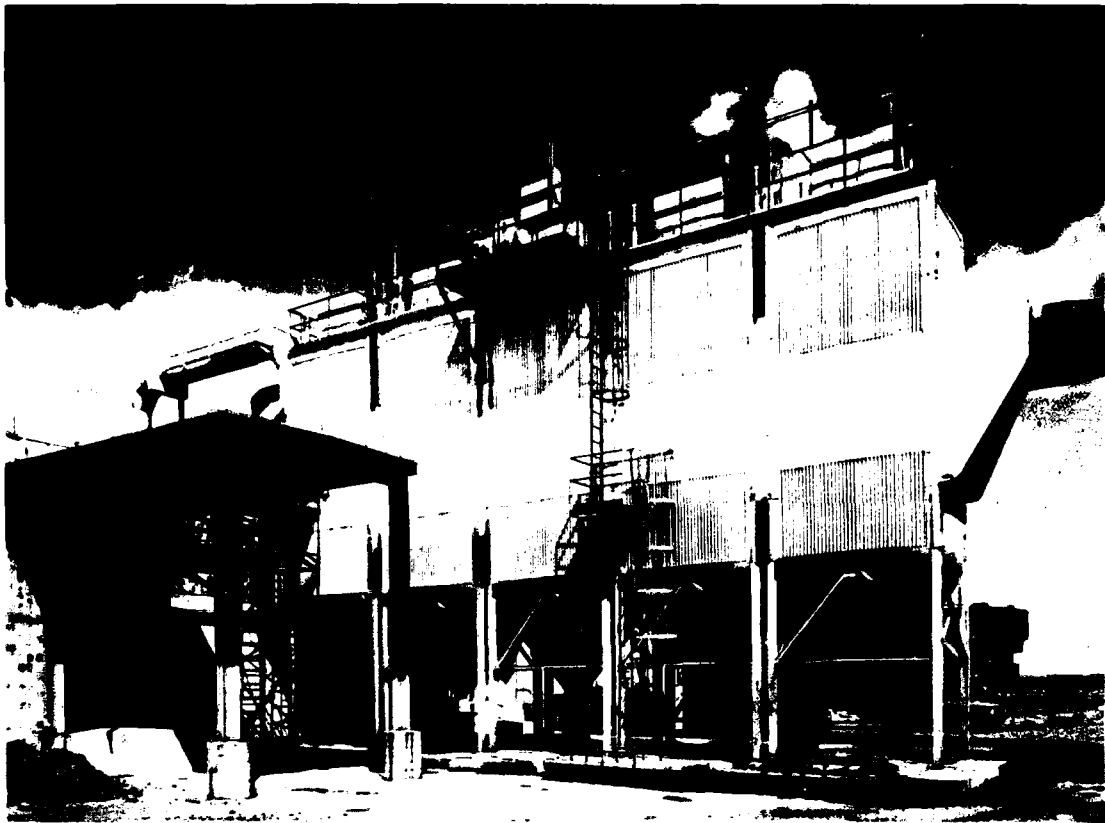

Figure 6 ELECTROSTATIC PRECIPITATOR



Figure 7 SPRAY DRYER

CHAPTER 2 PRODUCTION SUMMARY

2.1 SETS DESCRIPTION

There were a total of seven types of Chemical Agent Identification Sets scheduled for disposal under this program. Phase 1 destroyed two types (K941 and K942) as well as those X-type sets containing mustard. Phase 2 destroyed a third type of set (K945) and the majority of the remaining X-type sets. The remaining sets were disposed of as part of Phase 3.

2.1.1 K945 CHEMICAL AGENT IDENTIFICATION TRAINING SET (CAITS) M72

These sets measured approximately 12 x 5.5 x 4 inches (305 x 140 x 102 mm), weighed about three pounds (1.4 kg), and consisted of eight bottles of agent and three of simulant. The bottles were packaged in a gray plastic carrying case. The plastic case was enclosed in a vapor barrier bag packed in a fiberboard box which was in turn packed into a wooden box secured by metal straps (see Figure 8). The bottles in the set were plastic coated and contained agent dissolved into plastic pellets enclosed in a two-layer laminated plastic bag. The bottles contained nerve agent (GB, 4 bottles), lewisite (L, 1 bottle), mustard (H, 1 bottle), phosgene simulant (triphosgene, 1 bottle) and potassium cyanide simulant (1 bottle). Each set contained about 0.7 fluid ounces (21 ml) of agent.

2.1.2 X SETS, GAS SET IDENTIFICATION, INSTRUCTIONAL (NAVY)

These sets were packed in wooden boxes with hinged covers (see Figure 9). The boxes measured 7½ x 16 x 11¾ inches (191 x 406 x 298 mm) and were divided into two compartments. Each compartment held a can 4¼ inches (110 mm) in diameter and 6¾ inches (175 mm) high, surrounded by packing material. Inside each can was a bottle with a ground glass top. Contents of the bottles varied by type of set as follows:

X548 - Two bottles each containing approximately 1.7 fluid ounces (0.025 liters) lewisite. Agent absorbed on 3 fluid ounces (90 cc) activated charcoal.

X549 - Two bottles each containing about 2.5 grams of adamsite (DM) as a solid.

X545 - Two bottles each containing about 3 grams of triphosgene (CG-simulant) as a solid.

X546 - Two bottles each containing about 2.5 grams of chloroacetophenone (CN) as a solid.

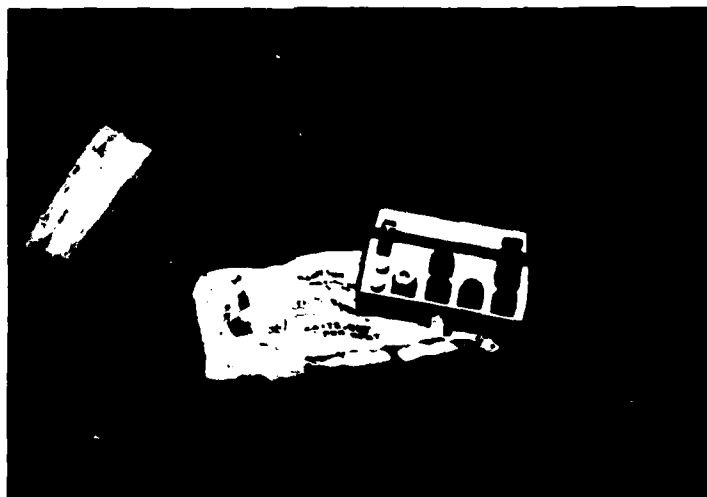

Figure 8 K945 BOX SET



Figure 9 GAS SET IDENTIFICATION,
INSTRUCTION, X-SETS

2.2 NUMERICAL SUMMARY OF SETS DESTROYED

TABLE 1

Date	X548	X549	X545	X546	K945
2/2/82	60				
2/4/82	75				
2/9/82				8	
2/10/82	60			17	
2/11/82	75				
2/12/82	75				
2/17/82	60				
2/18/82	75				
2/19/82	75				
2/22/82	60				
2/23/82	74				
2/24/82	34	39			
2/25/82	1	11			
2/26/82				80	
3/1/82				70	
3/2/81				50	
3/3/82				80	
3/4/82		1	19	27	
3/5/81			75	1	
3/8/82			80		
3/9/82			85		
3/10/82			55		
3/11/82			75		
3/12/82			75		
3/15/82			61		
3/17/82					42
3/18/82					72
3/19/82					72
3/22/82					72
3/23/82					72
3/24/82					72
3/25/82					38
3/26/82					72
3/29/82					65
3/30/82					72
3/31/82					79
4/1/82					72
4/2/81					72
4/5/82					58
4/6/82					72
4/8/81					84
4/9/82					60
4/12/82					70
4/13/82					62
4/14/82					13
4/15/82					14
4/19/82					30
TOTAL	724	51	525	333	1335

PHASE II TOTAL 2968 SETS

2.3 DOWNTIME ANALYSIS

General

In the interpretation of downtime data, three methods are widely used. These are the "frequency of occurrence," "subsystem downtime," and "process downtime." As this is essentially a production oriented operation, the management yardstick chosen was the number of sets "produced" - therefore destroyed - on any given day versus the number of those type of sets which should have been destroyed on a normal full production day. This is the calculation made to produce "process downtime." By month, this "process downtime" is shown as follows:

TABLE 2
Downtime Analysis By Sets Destroyed

Month	Days of Scheduled Opns	Sets Destroyed	Sets Scheduled	Percent Downtime
Feb 82	19	879	1368	35.75%
Mar 82	23	1482	1656	10.51%
Apr 82	13*	607	792	23.36%

* Includes 3 days of set material in pigs at 24/day

Using the results of Table 2 and calculating downtime by an average weighted by days results in the following calculation:

$$1. \frac{(35.75)(19) + (10.51)(23) + (23.36)(13)}{(19) + (23) + (13)}$$

$$2. \frac{1224.66}{55} = 22.27\% \text{ or } 12 \text{ lost days out of } 55 \text{ potential operating days.}$$

CHAPTER 3 AIR MONITORING SUMMARY

3.1 DESCRIPTION OF SAMPLING TECHNIQUES

3.1.1 GB AGENT SAMPLING

Sampling for GB was accomplished by drawing air from the areas to be sampled through a container filled with liquid. The liquid of choice, pH 4.5 sulfuric acid solution, has a particular affinity to GB and demonstrated a collection efficiency of 100% in laboratory conditions and 90% in plant conditions. The air passed through the solution in the container bubbled, lending the name to this sampling apparatus -the bubbler (see Figure 10).

The bubbler tubes used for GB were made of glass and were filled with glass beads to maintain high collection efficiency. Air samples were drawn through these bubblers at a rate of 2.0 liters per minute. The flow was maintained by the use of in-line critical orifices. The standard fill for the GB bubbler was 15 ml. of pH 4.5 sulfuric acid solution. The bubblers were marked with a ring of green tape to color-code identify them as GB bubblers. In addition, at each sampling location was a constant temperature bath in which the bubblers were immersed. The temperature was set at 2 to 8°C and monitored during the two hour sampling period.

Each day, fresh GB bubblers were prepared at the laboratory (Bldg. 313) and transported to the CAIS disposal plant. Bubblers were transported in crushed ice to guarantee that quality control samples would not be affected.

Monitoring personnel at building 1611 obtained the bubblers from the plant chemist's office. They were then installed at four locations: the disassembly room (DR), control room (CR), residue area (RA) and the stack (ST) (see Figure 11). Bubblers were replaced sequentially after a two-hour sampling period at all locations.

Upon completion of a sampling period, each bubbler was retrieved, returned to the plant chemist's office and iced for transportation to the laboratory. They were then taken to the laboratory for analysis. It was particularly important to insure icing the GB bubblers. Failure to do so could result in differences of up to 15% in actual concentrations observed based on quality control standards.

3.1.2 LEWISITE (L) AGENT SAMPLING

Bubbler collection was used for lewisite sampling. The liquid of choice, a 2% solution of sodium hydroxide, reacted with lewisite to form arsenic oxide. Lewisite was trapped in this fashion with a 94.5% efficiency in the laboratory and 93% efficiency in the plant environment.

The bubbler tubes used for lewisite were made of plastic and were disposable. They were used only one time. Air samples were drawn through these bubblers at a rate of 2.0 liters per minute. The flow was maintained by the use of in-line critical orifices. The standard fill for the lewisite bubbler was 10 ml of 2% sodium hydroxide solution. The bubblers were marked with a ring of yellow tape to color-code identify

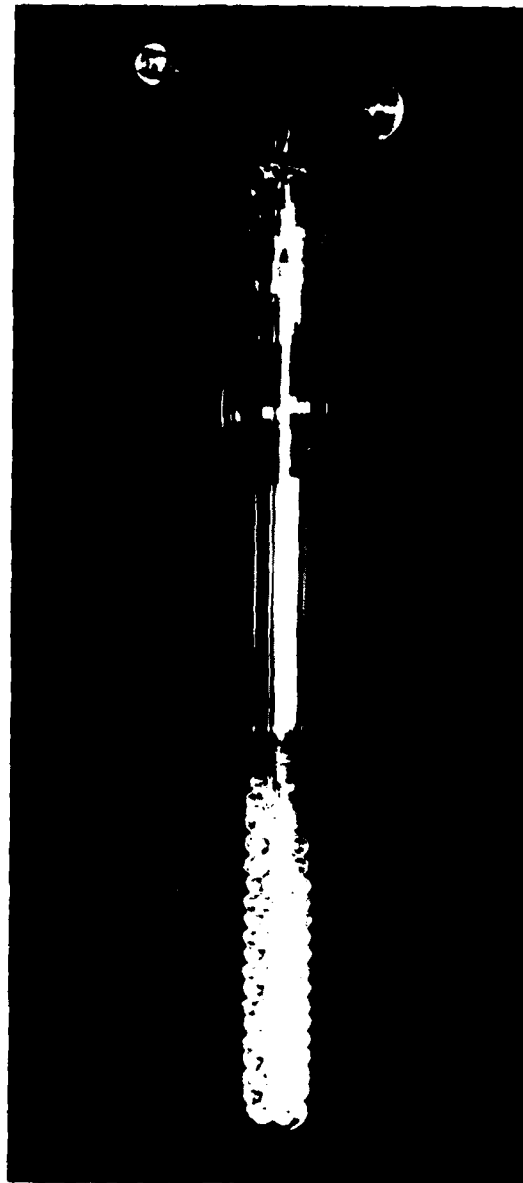
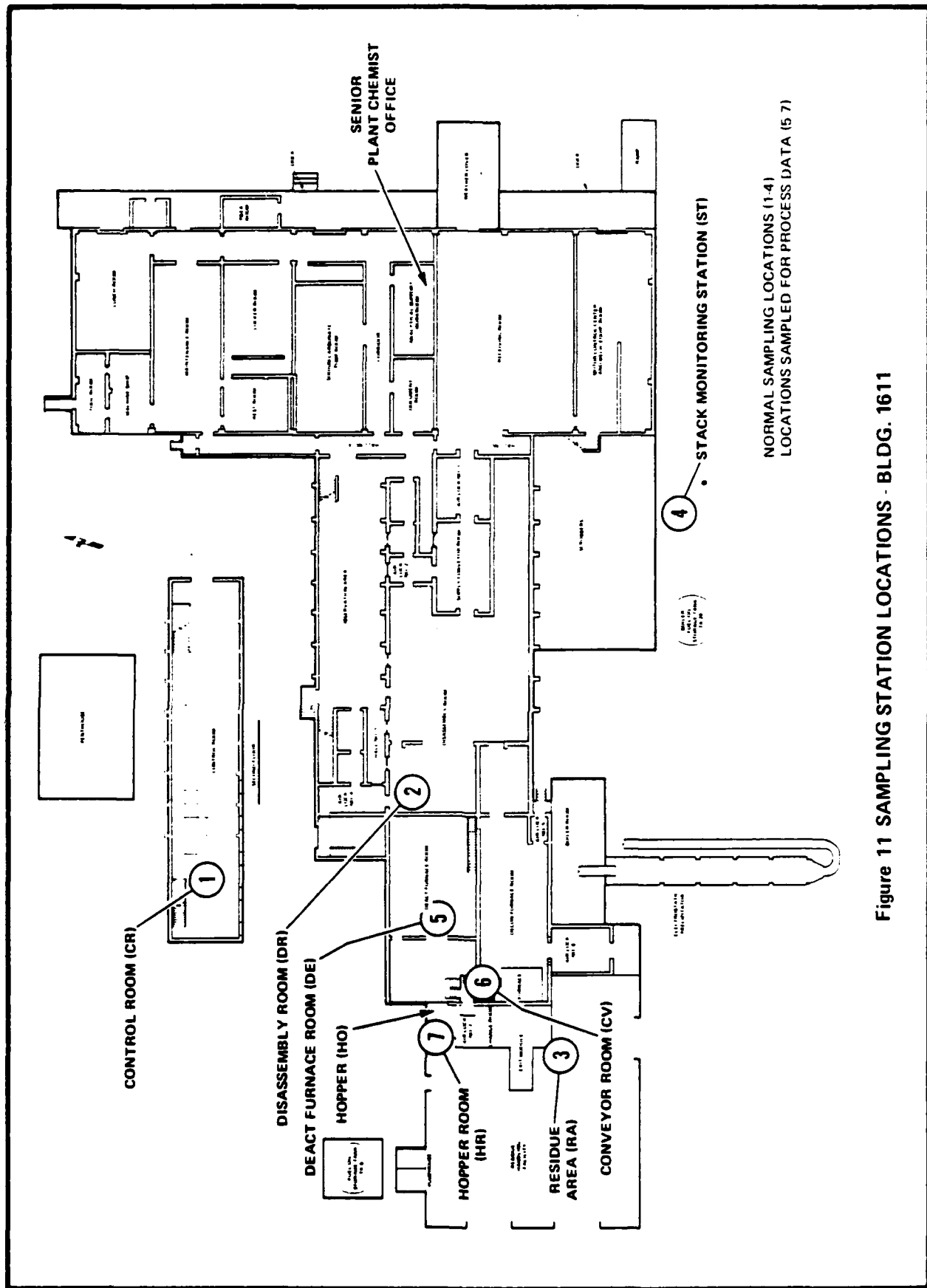

Figure 10 TYPICAL BUBBLER



NORMAL SAMPLING LOCATIONS (1-4)
 LOCATIONS SAMPLED FOR PROCESS DATA (5-7)

Figure 11 SAMPLING STATION LOCATIONS - BLDG. 1611

them as lewisite bubblers. In addition, at each sampling location was a constant temperature bath in which the bubblers were immersed. The temperature was set at 2 to 8°C and monitored during the eight hour sampling period.

Each day fresh lewisite bubblers were prepared at the laboratory (Bldg 313) and transported to the CAIS disposal plant. Bubblers were transported in crushed ice to insure that quality control samples would not be affected.

Monitoring personnel at Building 1611 obtained the bubblers from the plant chemist's office. They were then installed in the disassembly room, control room, residue area, and the stack.

Bubblers were collected after an eight hour sampling period at all locations.

Upon completion of a sampling period, each bubbler was retrieved, returned to the plant chemist's office and iced for transportation to the laboratory. They were then taken to the laboratory for analysis.

3.1.3 MUSTARD AGENT SAMPLING

Sampling for mustard was achieved by drawing air from the areas to be sampled through a bubbler. The liquid of choice, diethylphthalate, had a particular affinity for mustard and collected it with essentially 100% efficiency.

The bubbler tubes used for mustard were made of glass and were filled with glass beads to maintain high collection efficiency. Air samples were drawn through these bubblers at a rate of 6 liters per minute. The flow was maintained by the use of in-line critical orifices. The standard fill for a mustard bubbler was 10 ml of diethylphthalate. The bubblers were marked with a ring of brown tape to color-code identify them as mustard bubblers. In addition, at each sampling location was a constant temperature bath in which the bubblers were immersed. The temperature was set at 2 to 8°C and monitored during the two hour sampling period.

Each day, the bubblers were inspected, cleaned, and filled at the laboratory (Bldg. 313) and then transported to the CAIS disposal plant (Bldg. 1611). Monitoring station personnel obtained the bubblers from the plant chemist's office and installed them in the disassembly room, control room, residue area, and the stack.

Bubblers were replaced sequentially after a two-hour sampling period at all locations. In addition, a staggered shift of two hour bubblers was started every hour in the disassembly room. Bubblers in the disassembly room therefore typically ran 0800-1000, 0900-1100, 1000-1200, etc. Upon completion of a sampling term, each bubbler was retrieved, returned to the plant chemist's office, and packed for transportation to the laboratory. They were then taken to the laboratory for analysis. All bubblers, when in transit were packed in ice.

3.1.4 TRIPHOSGENE (T) AGENT SAMPLING

Sampling for triphosgene was accomplished by bubbler collection. The liquid of choice for collecting triphosgene was diethylphthalate with proportions of 4 p-nitrobenzylpyridine and N-benzylamine. This solution had an affinity for trapping triphosgene. Since triphosgene was classed as a nonlethal chemical, the laboratory

work on collection efficiency was not as well documented as for lethal agents. Nevertheless the collection efficiency was estimated as over 90%.

The bubbler tubes used for triphosgene were made of plastic and were disposable. They were used only one time. Air samples were drawn through these bubblers at a rate of 2.0 liters per minute. The flow was maintained by the use of in-line critical orifices. The standard fill in the triphosgene bubbler was 10 ml of solution. The solution for triphosgene bubblers was made by adding 5 grams of 4 p-nitrobenzylpyridine and 10 grams of N-benzylamine to 2 liters of diethylphthalate. The bubblers were marked with a ring of blue tape to color-code identify them as triphosgene or "T" bubblers. In addition, at each sampling location was a constant temperature bath in which the bubblers were immersed. The temperature was set at 2 to 8°C and monitored during the two hour sampling period.

Each day fresh triphosgene bubblers were prepared at the laboratory (Bldg. 313) and transported to the CAIS disposal plant. Bubblers were transported in crushed ice to insure that quality control samples would not be affected.

Monitoring personnel at Building 1611 obtained the bubblers from the plant chemist's office. They were then installed in the disassembly room, control room, residue area and the stack. Bubblers were sequentially replaced at all locations after a two hour sampling period.

Upon completion of a sampling period, each bubbler was retrieved, returned to the plant chemist's office and iced for transportation to the laboratory. They were then taken to the laboratory for analysis.

3.1.5 CHLOROACETOPHENONE (CN) AGENT SAMPLING

Sampling for chloroacetophenone (CN) was accomplished by drawing air from the areas to be sampled through a bubbler. The liquid of choice for collecting CN was propylene glycol which has an affinity for trapping CN. Since CN was classed as nonlethal chemical, the laboratory work in collection efficiency was not as well documented as for lethal agents. Nevertheless the collection efficiency was estimated as over 90%.

The bubbler tubes used for CN were made of plastic and were disposable. They were used only one time. Air samples were drawn through these bubblers at a rate of 2.0 liters per minute. The flow was maintained by the use of in-line critical orifices. The standard fill in the CN bubbler was 10 ml of propylene glycol.

The bubblers were marked with a ring of red tape to color-code identify them as CN bubblers. In addition, at each sampling location was a constant temperature bath in which the bubblers were immersed. The temperature was set at 2° to 8°C and monitored during the two hour sampling period.

Each day fresh CN bubblers were prepared at the laboratory (Bldg. 313) and transported to the CAIS disposal plant. Bubblers were transported in crushed ice to insure that quality control samples would not be affected.

Monitoring personnel at Building 1611 obtained the bubblers from the plant chemist's office. They were then installed at four locations: the disassembly room, control room, residue area and the stack. Bubblers were replaced sequentially after a two hour sampling period at all locations.

Upon completion of a sampling period, each bubbler was retrieved, returned to the plant chemist's office and iced for transportation to the laboratory. They were then taken to the laboratory for analysis.

3.1.6 SF₆ TRACER GAS SAMPLING

Sulfur hexafluoride (SF₆) gas was metered into the disassembly glovebox and box feed chute at a pressure of 35 psi to act as a tracer gas. SF₆ is non-toxic, chemically inert, odorless, tasteless, and can be detected at very low concentrations (10⁻¹² parts of SF₆ per part of air). Samples of disassembly room and control room air were drawn automatically by the detector (see Figures 12 and 13) every five minutes. The detector was set to sense buildups of SF₆ outside of the glovebox or box feed chute of 10 parts per trillion to indicate potential leakage.

3.1.7 NO_x AND SO₂ SAMPLING

The Dynascience monitor sampled Bldg. 1611 exhaust stack gas on a continuous basis (see Figure 14). The stack gas was drawn through a 100 micron Cuno stainless steel filter by a sampler pump. The gas was cooled by a water bath, analyzed, and then returned to the stack. Calibration was maintained by periodically sampling known concentrations of NO_x and SO₂.

3.2 DESCRIPTION OF ANALYSIS TECHNIQUES

3.2.1 GB AGENT ANALYSIS

3.2.1.1 Analysis of Calibration Standards

The analysis for GB was colorimetric. The analysis was conducted using a Technicon Auto-Analyzer. To initiate the analysis of GB standards, the Technicon was first flushed by pumping with deionized water for a minimum of 30 minutes. All reagents were then fed to their proper lines and circulated until a stable baseline was achieved. The baseline normally stabilized in about 25 minutes. The reagent used was bovine enzyme.

The primary standard used to set the Technicon initially was a 5 ng/ml standard of GB. One aliquot of this solution was placed into the Technicon. The STANDARD CAL control was then used to adjust the recorder to a peak height of 80 chart units. The first standard was then checked with a second 5 ng/ml sample.

Following this initial procedure, duplicate aliquots of 8 calibration standards (0.0, 0.1, 0.25, 0.5, 1.0, 1.6, 2.5 and 5.0 ng/ml) were placed on the autosampler tray. Each was followed by a single aliquot of the blank standards to wash the instrumentation and return it to proper background between samples. Approximately 25 minutes after each standard was sampled, the peak appeared on the recorder. The peaks were spaced three minutes apart resulting in a sample analysis once every three minutes. The analyst recorded these results on an Analyst Work Sheet designated for calibration.

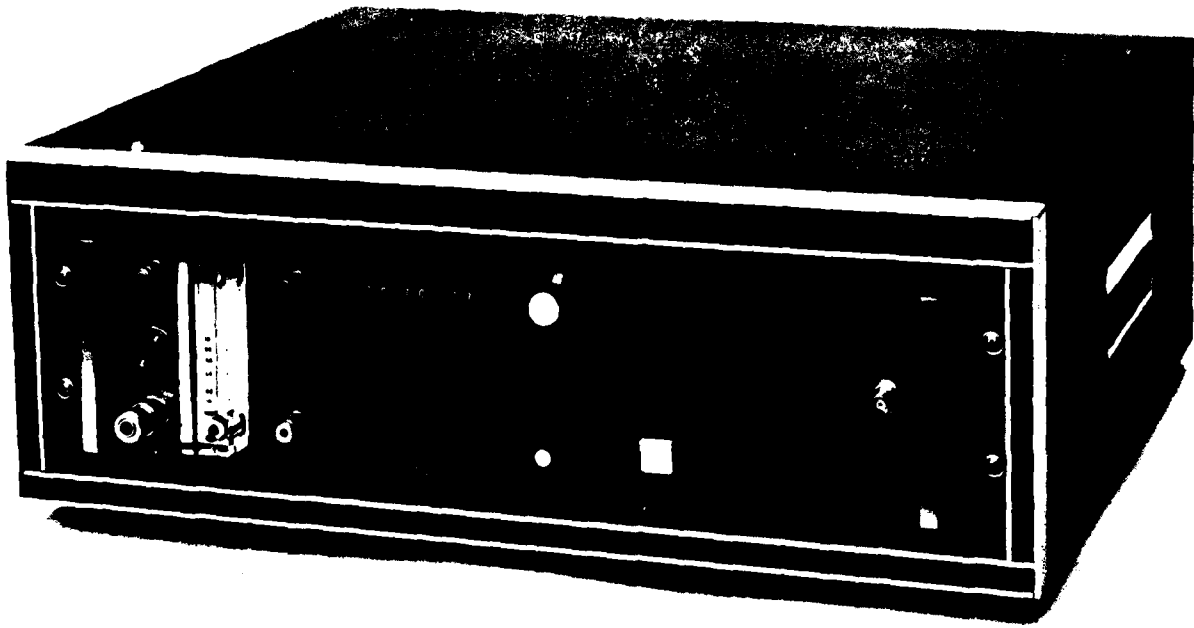

Figure 12 SF₆ DETECTOR/ANALYZER

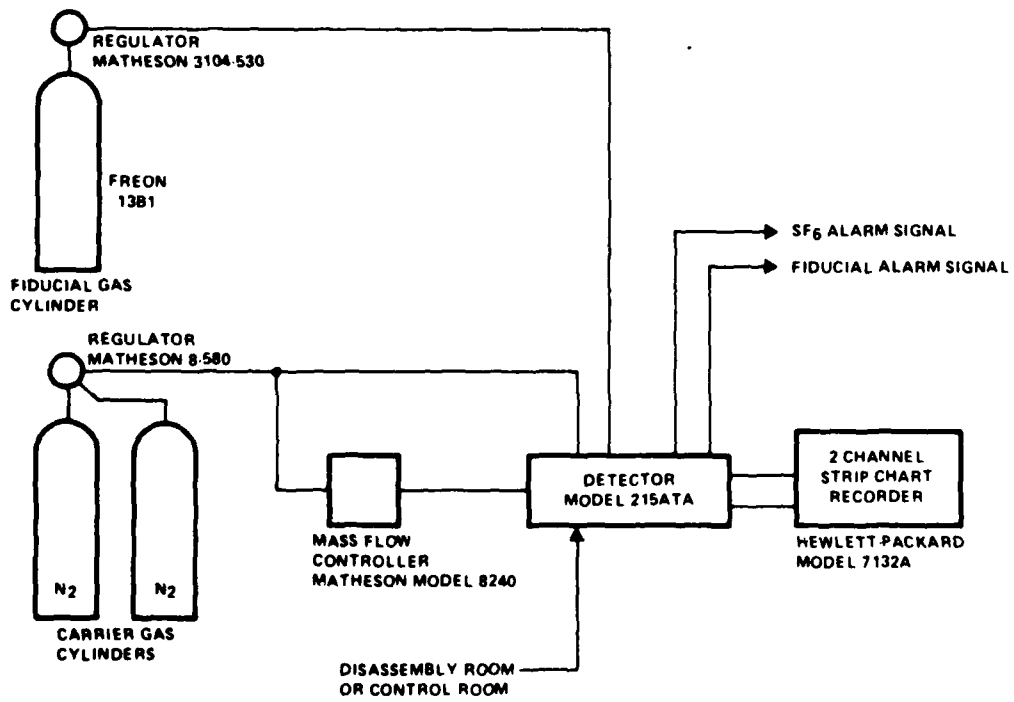

Figure 13 SF₆ FLOW DIAGRAM

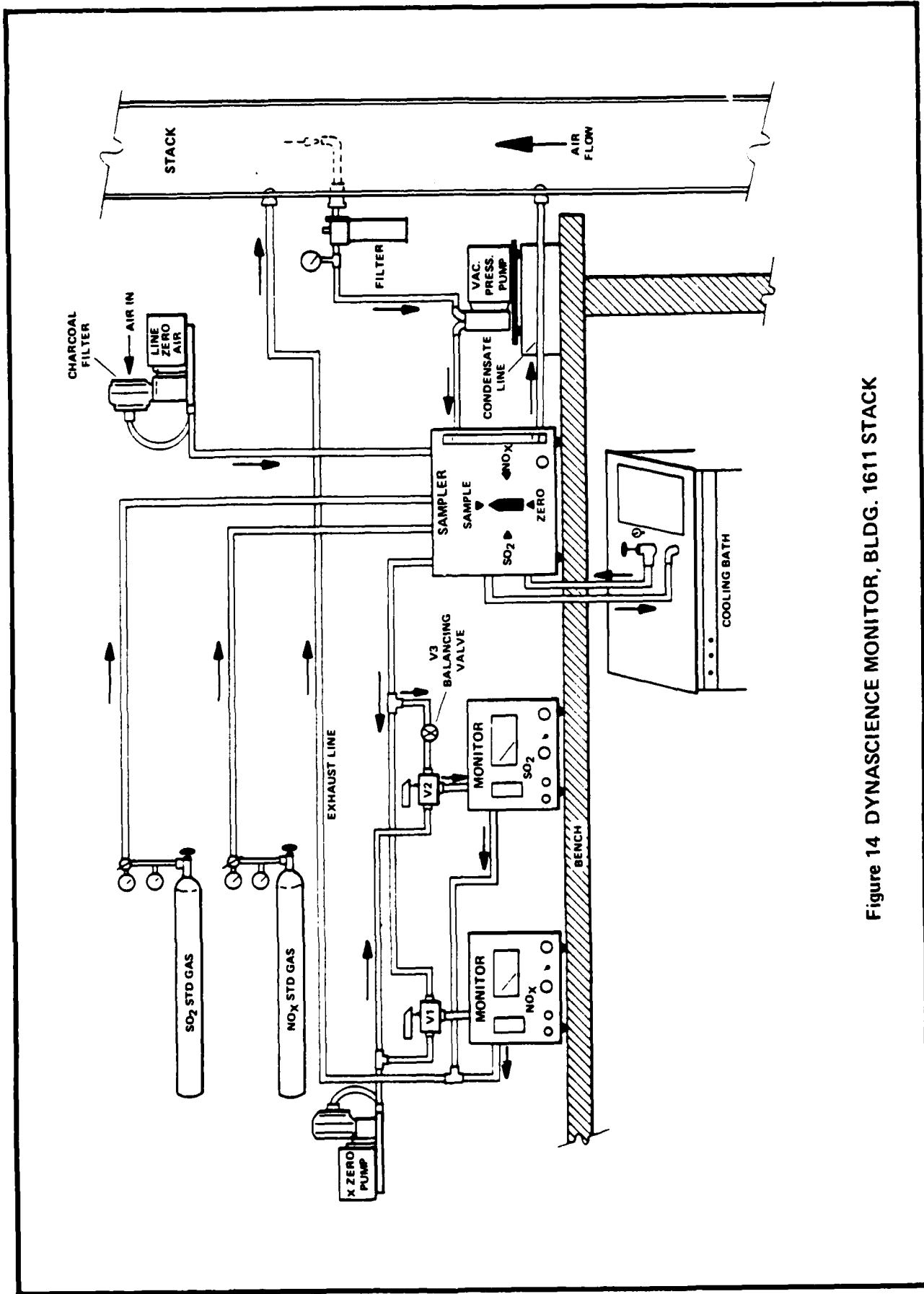

Figure 14 DYNASCIENCE MONITOR, BLDG. 1611 STACK

A calibration curve (see Figure 15) was prepared by a logarithmic fit of the peak height versus concentration. The analyst was required to compare three of the eight standards to the following criteria:

Concentration	Max Peak Height	Min Peak Height
0.10 ng/ml	2.0 chart units	4.0 chart units
1.60 ng/ml	35.8 chart units	43.4 chart units
5.00 ng/ml	77.4 chart units	83.6 chart units

If the analytical results did not meet all of the above criteria, the operator was required to recalibrate his instrument. In addition, secondary criteria were proposed by the Department of Health and Human Services (DHHS) to further insure the fit of the curve. The additional criteria are:

Concentration	Max Peak Height	Min Peak Height
0.0 ng/ml	-.25 chart units	+.25 chart units
0.25 ng/ml	6.0 chart units	9.0 chart units
0.50 ng/ml	13.0 chart units	16.0 chart units
1.0 ng/ml	24.75 chart units	28.75 chart units
2.5 ng/ml	53.75 chart units	57.75 chart units

If the analytical results did not meet this criteria at any given point, the point was repeated. Then the analyst was allowed to proceed to actual plant samples.

3.2.1.2 Analysis of Actual Plant Samples and Quality Control Samples

The liquid level in each plastic bubbler was checked and changes recorded. If the level was low, the bubbler was brought back to volume by addition of pH 4.5 sulfuric acid.

Aliquots were taken from each bubbler and transferred to sample cups which were then placed on the auto-sampler tray. Known standards were placed as markers before and after the unknowns, and periodically among the unknown samples as quality control samples. In addition, at the mid-point in each analyst's shift, he was required to run a .25 ng/ml and 1.6 ng/ml sample and compare them to the calibration criteria. Although no resetting of the machine was done, if the criteria were not met the standards were repeated for documentation. After obtaining the initial GB reading, results were obtained approximately every 3 minutes.

3.2.1.3 Final Analysis of Calibration Standards

At the completion of analysis of actual plant samples, the analyst was required again to run the 8 calibration standards (0.0, 0.1, 0.25, 0.5, 1.0, 1.6, 2.5 and 5.0 ng/ml) and assure that they met the criteria established in paragraph 3.2.1.1. In addition these results were analyzed by computer as described in Chapter 4. If the analyst's results did not meet the three primary criteria, he was required to recalibrate his instrument and reanalyze the plant samples.

Calibration of Instrument Response GBR - 2

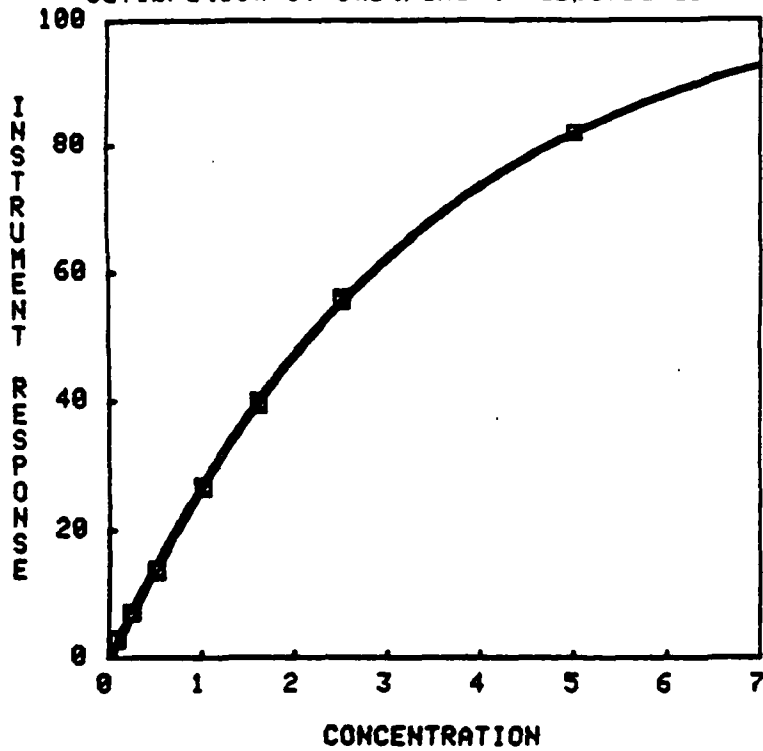

AGENT: GB
DATE: 04/12/82

STATISTICS

BARTLETTS:
0.855
R-SQUARED:
1.000
MSE:
2.323E-005

PARAMETERS

$\ln(Y) = a + bX$
a = 4.667E+000
b = -2.987E-001
 $Y' = (-Y + f) \uparrow g$
 $X' = X + h$
f = 1.059E+002
g = 1.000E+000
h = 0.000E+000

SCALE FACTORS:

X axis: 10†0
Y axis: 10†0

Actual Data for GB

Date: 04/12/82

Sample	Location	Agent Concentration			TIME	
		True	Lower 95%	Upper 95%		
CTNG02	RA	0.0000*			0800	1000
CTNG03	ST	0.0000*			0800	1000
CTNG05	CR	0.0000*			0800	1000
CTNG06	DR	0.0000*			0800	1000
CTPG02	RA	0.0000*			1000	1200
CTPG03	ST	0.0000*			1000	1200
CTPG05	DR	0.0000*			1000	1200
CTPG06	CR	0.0000*			1000	1200

Figure 15a CALIBRATION CURVE AND ACTUAL DATA ANALYSIS - GB

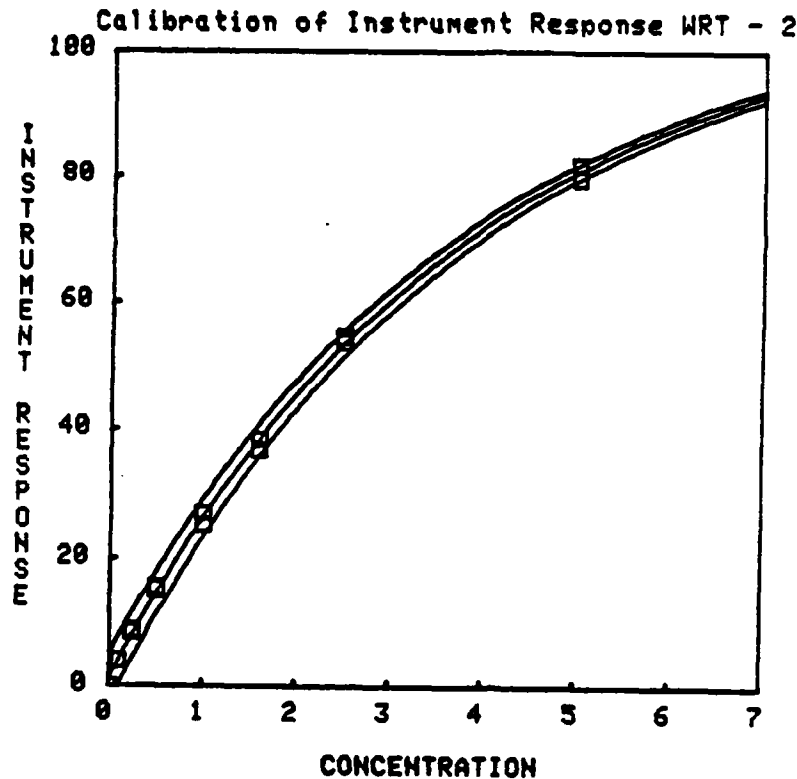

AGENT: GB
DATE: 04/12/82

STATISTICS

BARTLETTS:
0.033
R-SQUARED:
0.999
MSE:
2.536E-004

PARAMETERS

$\ln(Y) = a + bX$
a = 4.699E+000
b = -2.591E-001
 $Y' = (-Y + f) \uparrow g$
 $X' = X + h$
f = 1.111E+002
g = 1.000E+000
h = 0.000E+000

SCALE FACTORS:

X axis: 10[†]0
Y axis: 10[†]0

Actual Data for GB

Date: 04/12/82

Sample	Location	Agent Concentration			TIME	
		True	Lower 95%	Upper 95%		
CTRG02	ST	0.0000*			1200	1400
CTRG03	DR	0.0000*			1200	1400
CTRG05	CR	0.0000*			1200	1400
CTRG08	RA	0.0000*			1200	1400
CTTG01	RA	0.0000*			1400	1600
CTTG02	ST	0.0000*			1400	1600
CTTG03	CR	0.0000*			1400	1600
CTTG08	DR	0.0000*			1400	1600

Figure 15b CALIBRATION CURVE AND ACTUAL DATA ANALYSIS - GB

3.2.2 LEWISITE (L) AGENT ANALYSIS

3.2.2.1 Analysis of Calibration Samples

The analysis for lewisite was actually an analysis for arsenic. All arsenic found was factored by the relative molecular weights of the two components (lewisite: arsenic) and computed as an equivalent amount of lewisite. The analysis was performed using a Perkin-Elmer Atomic Adsorption Spectrophotometer, referred to as an "AA."

The sequence of analysis for all samples (calibration, plant and quality control) followed the sequence described here:

- 1) Reconstitution of the sample to 10 ml.
- 2) Acidification of a 5 ml portion of the sample by addition of 3 ml of 12N sulfuric acid.
- 3) Reduction of the sample by addition of 2 ml of 10% potassium iodide (KI) which reduced any As^{+5} in solution to As^{+3} . Samples must be analyzed at least 60 minutes but not more than 4 hours after reduction.
- 4) Preparation for analysis by removing 1 ml of solution to a Perkin-Elmer reaction flask and adding 10 ml of 3.2% HCl. The reaction flask was then placed in the Mercury Hydride System (MHS-20) portion of the AA.
- 5) Addition of sodium borohydride (approximately 6 ml) by a pre-programmed sequence in the MHS-20.
- 6) Reaction of the sodium borohydride with the solution in the reaction flask to form arsine (AsH_3) which is vented into the quartz furnace.
- 7) Breakdown of the AsH_3 at 1000°C in the quartz furnace to elemental arsenic which is measured spectrophotometrically.

To initiate the analysis of standards, a .576 $\mu g/ml$ standard solution was prepared. One aliquot was analyzed on the AA and a nominal response of approximately .9 for the Model 503 AA or 1.0 for the Model 603 was obtained. This first standard was checked only after the AA was allowed a two hour warm-up period.

Following the initial procedure, duplicate aliquots of three calibration standards (0.000, 0.288 and 0.576 $\mu g/ml$) were analyzed. Each was interspaced with blank samples.

The time between samples involved about 3-4 minutes, not including the sample preparation time referenced above. The analyst recorded these results on an Analyst Work Sheet designated for calibration.

A calibration curve (see Figure 16) was prepared according to a natural logarithmic function determined during laboratory testing. In addition, the analyst was required to compare his results against criteria determined during the prior laboratory testing. Since two distinct models of Perkin-Elmer AA's were used at RMA, a separate criteria was developed for each spectrophotometer as follows:

Concentration	Model 503		Model 603	
	Minimum Reading	Maximum Reading	Minimum Reading	Maximum Reading
0.00 $\mu g/ml$	0.0	0.05	0.0	0.04
0.288 $\mu g/ml$	0.47	0.58	0.53	0.67
0.576 $\mu g/ml$	0.80	1.00	0.86	1.12

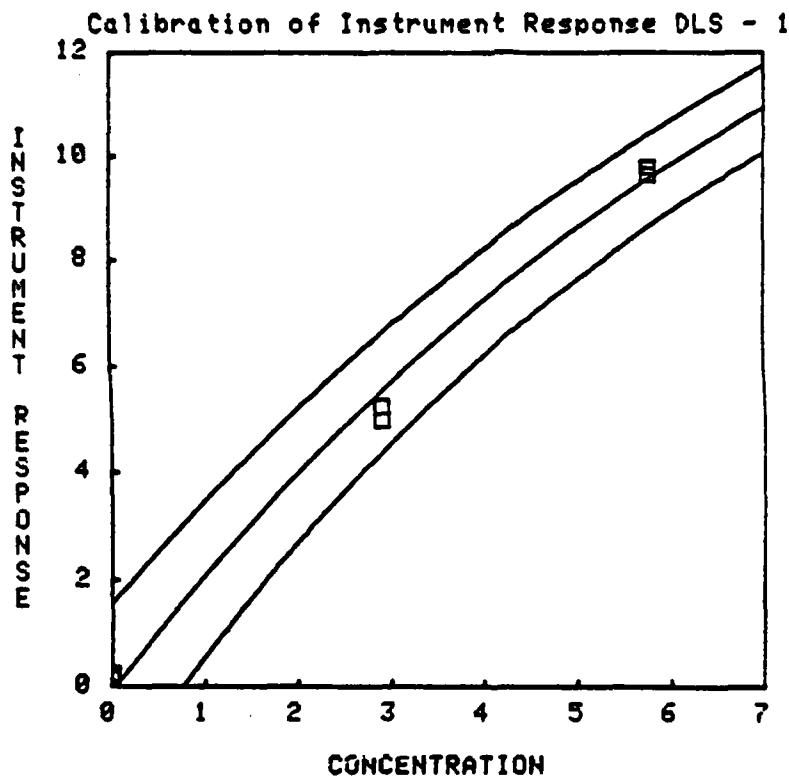

AGENT: L
DATE: 05/05/82

STATISTICS

BARTLETTS:
0.657
R-SQUARED:
0.994
MSE:
6.678E-004

PARAMETERS

$\ln(Y) = a + bX$
a = 6.973E-001
b = -1.140E+000
 $Y' = f - Y$
 $X' = X + h$
f = 2.000E+000
h = 0.000E+000

SCALE FACTORS:

X axis: $10^{\uparrow-1}$
Y axis: $10^{\uparrow-1}$

Actual Data for L

Date: 05/05/82

Sample	Location	Agent Concentration			TIME	
		True	Lower 95%	Upper 95%		
CZPL01	ST	0.000*			0800	1600
CZPL04	CR	0.000*			0800	1600
CZPL07	RA	0.000*			0800	1600
CZPL10	DR	0.000*			0800	1600

Figure 16 CALIBRATION CURVE AND ACTUAL DATA ANALYSIS - LEWISITE

If the analytical results did not meet all of the above criteria, the operator was required to recalibrate his instrument. If the results were satisfactory the operator was allowed to begin the analysis of actual plant samples.

3.2.2.2 Analysis of Actual Plant Samples and Quality Control Samples

The liquid level in each plastic bubbler was checked and changes were recorded. If the level was low, the bubbler was returned to 10 ml volume by the addition of 2% caustic. The solution was transferred then to test tubes and treated according to the preparation steps outlined in section 3.2.2.1.

After the samples had been prepared for analysis each was individually analyzed on the AA. As with standard analysis, results were obtained about 3-4 minutes apart. Known standards were placed among the unknowns as quality control standards. They were analyzed in an identical fashion.

3.2.2.3 Final Analysis of Calibration Standards

At the completion of analysis of actual plant samples, the analyst was required to again run the three calibration standards (0.000, 0.288, 0.576 $\mu\text{g}/\text{ml}$) and assure that they met the criteria stated in paragraph 3.2.2.1. In addition these results were analyzed by computer as described in Chapter 4. If the analyst's results did not meet the standardized criteria, he was required to recalibrate his instrument and reanalyze the actual plant samples.

3.2.3 MUSTARD AGENT ANALYSIS

3.2.3.1 Analysis of Calibration Standards

The analysis for mustard was colorimetric. The analysis was conducted using a Technicon Autoanalyzer. To initiate the analysis of standards, a 1.21 $\mu\text{g}/\text{ml}$ standard solution was prepared. One aliquot of this solution was placed into the auto-analyzer. The STANDARD CAL control was used to adjust the recorder to a peak height of 80 chart units. This first calibration standard was checked after a 30-minute warm-up period.

Following this initial procedure, duplicate aliquots of three calibration standards (0.0, 0.24, and 1.21 $\mu\text{g}/\text{ml}$) were placed on the auto-sampler tray followed by a single aliquot of each of the blank standards. Approximately 30 minutes after each standard was sampled, the peak appeared on the recorder. The peaks were spaced six minutes apart resulting in a sample analysis once every six minutes. The analyst recorded these results on an Analyst Work Sheet.

A calibration curve (see Figure 17) was prepared by linear least squares regression of peak height vs. concentration. The acceptable limits for slope were 66 ± 5 units/ $\mu\text{g}/\text{ml}$ and the coefficient of variance (determination of R-squared) could not be below 0.995.

The analyst was required to compare his results at the three standards to the following criteria:

Concentration	Max Peak Height	Min Peak Height
0.00 $\mu\text{g}/\text{ml}$ (2 ea)	0.5 chart units	-1.25 chart units
0.24 $\mu\text{g}/\text{ml}$ (2 ea)	17.25 chart units	13.25 chart units
1.21 $\mu\text{g}/\text{ml}$ (2 ea)	83.00 chart units	77.25 chart units

CALIBRATION OF INSTRUMENT RESPONSE

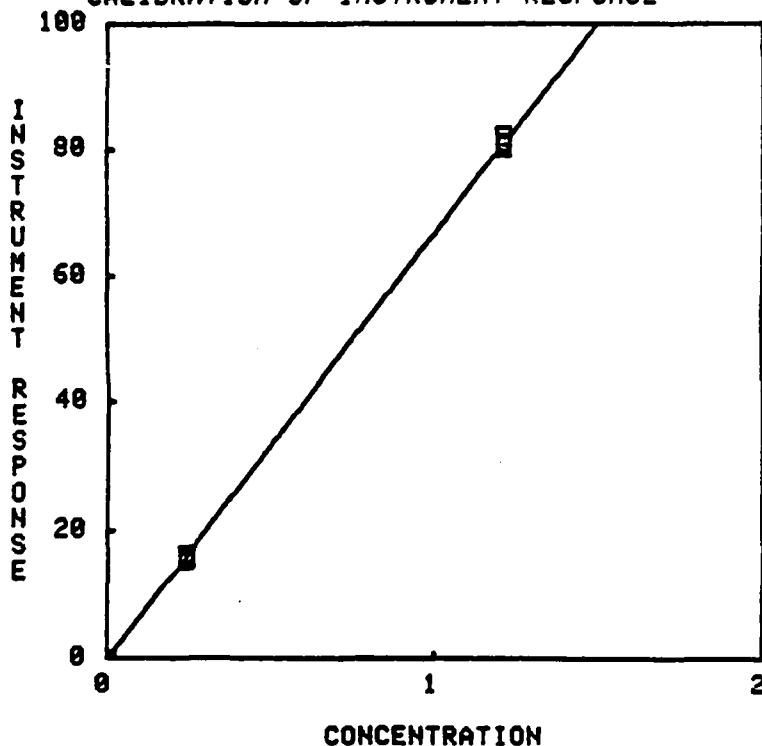

AGENT: H
DATE: 03/29/82

STATISTICS

BARTLETTS:
0.086
R-SQUARED:
1.000
MSE:
3.283E-001

PARAMETERS

$Y' = a + bX'$
a = -1.903E-001
b = 6.708E+001
 $Y' = (Y + f) \uparrow g$
 $X' = X + h$
f = 0.000E+000
g = 1.000E+000
h = 0.000E+000

ACTUAL DATA FOR H

DATE: 03/29/82

AGENT CONCENTRATION

SAMPLE	LOCATION	AGENT CONCENTRATION			TIME	
		TRUE	LOWER 95%	UPPER 95%		
CRBH01	DR	0.000*			0400	0600
CRCH01	DR	0.000*			0800	1000
CRCH02	CR	0.000*			0800	1000
CRCH04	ST	0.000*			0800	1000
CRCH05	RA	0.000*			0800	1000
CRDH03	DR	0.000*			0900	1100
CREH01	DR	0.000*			1000	1200
CREH02	CR	0.000*			1000	1200
CREH03	ST	0.000*			1000	1200
CREH05	RA	0.000*			1000	1200
CRHH01	DR	0.000*			1300	1500
CRFH02	DR	0.000*			1100	1300
CRGH01	ST	0.000*			1200	1400
CRGH03	RA	0.000*			1200	1400
CRGH04	CR	0.000*			1200	1400
CRGH05	DR	0.000*			1200	1400
CRIH01	ST	0.000*			1400	1600
CRIH03	RA	0.000*			1400	1600
CRIH04	CR	0.000*			1400	1600
CRIH05	DR	0.000*			1400	1600

Figure 17 CALIBRATION CURVE AND ACTUAL DATA ANALYSIS - MUSTARD

If the analytical results did not meet all of the above criteria, the operator was required to recalibrate his instrument. If the results were satisfactory the operator was allowed to begin the analysis of actual plant samples.

3.2.3.2 Analysis of Actual Plant Samples and Quality Control Samples

The liquid level in each glass bubbler was checked and changes recorded. If the level was low, the bubbler was brought to the mark by adding DEP. The solution was transferred to test tubes and any water present was removed.

Aliquots were taken from each test tube and transferred to sample cups, which were then placed on the auto-sampler tray. Known standards were placed as markers before and after the unknowns, and periodically among the unknown samples as quality control samples. As with calibration standards analysis, approximately 30 minutes were required before results appeared on the recorder. Results were attained every six minutes following the initial reading.

3.2.3.3 Final Analysis of Calibration Standards

At the completion of analysis of actual plant samples, the analyst was required to again run the three calibration standards (0.00, 0.24, 1.21 $\mu\text{g}/\text{ml}$) and assure that they met the criteria stated in Paragraph 3.2.3.1. In addition, these results were also analyzed by computer as described in Chapter 4. If the analyst's results did not meet the standardized criteria, he was required to recalibrate his instrument and reanalyze the actual plant samples.

3.2.4 TRIPHOSGENE (T) ANALYSIS

The analysis for triphosgene was spectrophotometric. The analysis was conducted using a Turner or Spectronix 20 model direct reading spectrophotometer. To initiate the analysis for triphosgene, 9 ml of the bubbler solution (a blank) was mixed with 1 ml of isopropyl alcohol and placed on the spectrophotometer. The absorbance reading of the spectrophotometer was then adjusted to 0.0 at 475 nm.

Next a series of 5 calibration standards were prepared by mixing 9 ml of bubbler solution with 1 ml of a standard amount of triphosgene dissolved in isopropyl alcohol.

Following the initial procedures, single aliquots of the 5 calibration standards (0.2, 0.5, 1.0, 1.5 and 2.5 $\mu\text{g}/\text{ml}$) were analyzed on the spectrophotometer and the appropriate absorbances recorded. Blank samples were run between each standard to assure a return to baseline conditions. Results were produced approximately every minute. The analyst recorded the results on an Analyst Work Sheet.

A standard calibration curve was manually prepared by the analyst. This curve was linear. A typical calibration run produced the following results:

Concentration	Absorbance at 475 nm
0.2 $\mu\text{g}/\text{ml}$.02 absorbance units
0.5 $\mu\text{g}/\text{ml}$.05 absorbance units
1.0 $\mu\text{g}/\text{ml}$.10 absorbance units
1.5 $\mu\text{g}/\text{ml}$.16 absorbance units
2.5 $\mu\text{g}/\text{ml}$.28 absorbance units

Following calibration of the instrument, actual plant bubbler and quality control samples were read. These were analyzed by directly pouring them into sampling cups and processing them through the spectrophotometer.

At the end of the analysis for actual plant and quality control samples, a final calibration was done to verify that the spectrophotometer had not markedly changed in character during the course of the analysis. This calibration was accomplished by analyzing one aliquot of each of the 5 calibration standards (0.2, 0.5, 1.0, 1.5 and 2.5 $\mu\text{g}/\text{ml}$).

3.2.5 CN ANALYSIS

The analysis used for chloroacetophenone (CN) was spectrophotometric. The analysis was done using a Turner or Spectronix 20 model direct reading spectrophotometer. To initiate the analysis for CN, a baseline was established on the spectrophotometer. This was done by mixing 3 ml of blank (0.0 $\mu\text{g}/\text{ml}$ CN) propylene glycol solution with 1 ml of dinitrobenzene (DNB). Then 1 ml of NaOH was added and exactly 2 minutes timed. At this point the standard was analyzed on the 540 nm band and the instrument was adjusted to read 0.00 absorbance units.

Next a series of 6 calibration standards were prepared in propylene glycol. As in preparing the baseline sample, 3 ml of standard solution was mixed with 1 ml of dinitrobenzene. Then 1 ml of NaOH was added and exactly 2 minutes timed from the NaOH addition. At this point each standard was read. Single aliquots of each of the six calibration standards (0.0, 0.5, 1.0, 3.0, 6.0 and 10.0 $\mu\text{g}/\text{ml}$) were analyzed in this fashion and the appropriate absorbances recorded. Blank samples were run between each standard to assure a return to baseline conditions. Results were produced approximately every two minutes. The analyst recorded the results on an Analyst Work Sheet.

A standard calibration curve was manually prepared by the analyst. This curve was approximately, although not strictly, linear. A typical calibration produced the following results:

Concentrations	Absorbance at 540 nm
0.0 $\mu\text{g}/\text{ml}$	0.00 absorbance units
0.5 $\mu\text{g}/\text{ml}$	0.01 absorbance units
1.0 $\mu\text{g}/\text{ml}$	0.03 absorbance units
3.0 $\mu\text{g}/\text{ml}$	0.14 absorbance units
6.0 $\mu\text{g}/\text{ml}$	0.31 absorbance units
10.0 $\mu\text{g}/\text{ml}$	0.58 absorbance units

Following the calibration of the instrument, actual plant bubbler and quality control samples were read. These were analyzed by directly pouring them into sampling cups and adding 1 ml of DNB, 1 ml of NaOH, waiting exactly 2 minutes, then performing the analysis on the spectrophotometer.

At the end of the analysis for actual plant and quality control samples, a final calibration was done to verify that the spectrophotometer had not markedly changed in character during the course of the analysis. This calibration was accomplished by analyzing one aliquot of each of the six calibration standards (0.0, 0.5, 1.0, 3.0, 6.0 and 10.0 $\mu\text{g}/\text{ml}$).

3.2.6 SF₆ TRACER GAS ANALYSIS

SF₆ tracer gas analysis was accomplished at ambient temperature, using an electron-capture detector in series with a gas chromatograph column, a sampling valve, and an N₂ carrier gas (see Figure 13). Two detectors were used: one each for the control room and the disassembly room. Sampling was done by drawing air from these rooms into the sampling valve by means of an internal pump. A fixed internal sample volume determined the quantity of the sampled air to be analyzed.

An electron-capture gas chromatograph used the high electron affinity of gases with halogen group elements to provide a measurable signal. A sample was separated into component gases by means of a gas chromatographic column. In the case of SF₆ detection, this column was made of finely ground molecular sieve.

In the detector module, a tritium foil source provided a stream of beta particles which ionized the dry nitrogen carrier gas and developed a secondary electron flow, termed the standing current. An electronegative gas captured electrons from this ionized gas stream in proportion to the concentration of the gas present in the sample. The detector collected these electrons, and an electrometer measured the current. The presence of an electronegative gas flowing through the detector decreased the standing current (by absorbing electrons) in proportion to the concentration of the electronegative gas. The electrometer operational-amplifier detected the change in current, and provided an output voltage proportional to the concentration of the gas. Through the use of a reference calibration chart, the units displayed were directly readable as parts per trillion of SF₆.

3.2.7 NO_x AND SO₂ ANALYSIS

The Dynascience monitor used a unique electro-chemical transducer. The transducer was a sealed electrolytic device, in which the direct electro-oxidation of absorbed gas molecules at a sensing electrode, resulted in a current directly proportional to the partial pressure of the pollutant gas. In operation, the gas diffused through the membrane and the thin film electrolyte layer, where it was directly proportional to the concentration of the gas being monitored.

3.3 SUMMARY OF REGULATORY STANDARDS MAINTAINED

3.3.1 GB

Work Area	Action Level	.00008 mg/m ³ (1.34 ng/ml)
	Standard	.00010 mg/m ³ (1.6 ng/ml)
Stack	Action Level	.00015 mg/m ³
	Standard	.00030 mg/m ³

3.3.2 LEWISITE

Work Area	Action Level	.0022 mg/m ³ (.210 µg/ml)
	Standard	.003 mg/m ³ (.288 µg/ml)
Stack	Action Level	.015 mg/m ³
	Standard	.03 mg/m ³

AD-A133 224

DISPOSAL OF CHEMICAL AGENT IDENTIFICATION SETS AT ROCKY MOUNTAIN ARSENAL. (U) ARMY TOXIC AND HAZARDOUS MATERIALS AGENCY ABERDEEN PROVING GR.

2/2

UNCLASSIFIED

W R BRANKOWITZ ET AL. MAR 83

F/G 15/2

NL

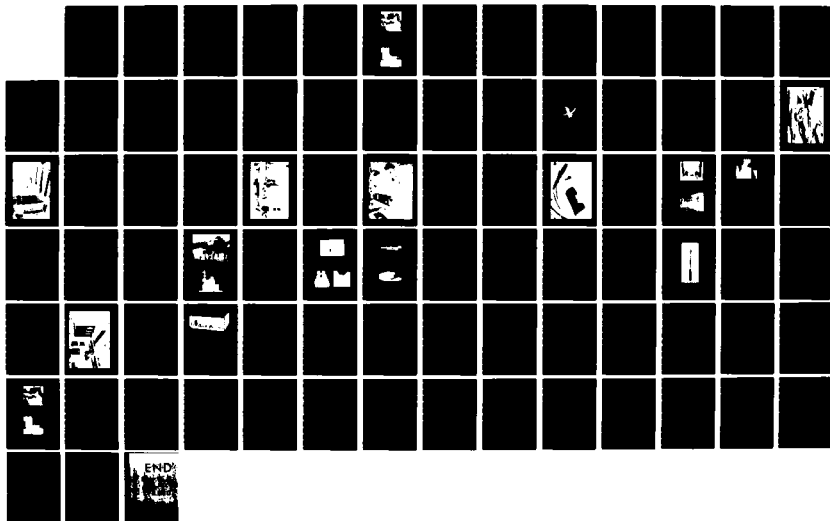

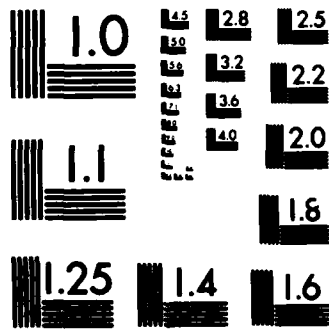

MICROCOPY RESOLUTION TEST CHART
NATIONAL BUREAU OF STANDARDS-1963-A

3.3.3 MUSTARD

Work Area	Action Level	.0025 mg/m ³ (.18 µg/ml)
	Standard	.003 mg/m ³ (.216 µg/ml)
Stack	Action Level	.015 mg/m ³
	Standard	.03 mg/m ³

3.3.4 TRIPHOSGENE (AS PHOSGENE)

Work Area	Action Level	.16 mg/m ³ (3.8 µg/ml)
	Standard	.2 mg/m ³ (4.8 µg/ml)
Stack	Action Level	5 mg/m ³
	Standard	10 mg/m ³

3.3.5 CHLOROACETOPHENONE (CN)

Work Area	Action Level	.24 mg/m ³ (5.8 µg/ml)
	Standard	.3 mg/m ³ (7.2 µg/ml)
Stack	Action Level	1.3 mg/m ³
	Standard	2.5 mg/m ³

3.3.6 SF₆ TRACER GAS

Alarm Level	12 ppt
-------------	--------

3.4 SUMMARY OF AIR MONITORING READINGS BY DAY

The accompanying table is a summary of monitor readings from 2 February 1982 to 19 April 1982 for the various work areas (Table 3). There were no stack readings above established standards for Phase 2.

**TABLE 3
WORK AREA
2 February 1982 - 19 April 1982
1 Reading/1199 Samples**

Date	Location	Time	Agent	Reading	Set
26 MAR 82	RA	1400-1600	H	.007 mg/m ³	K945

CAUSE: GC CONFIRMED NOT MUSTARD - FORKLIFT EXHAUST

CHAPTER 4 DATA COLLECTION AND QUALITY CONTROL

4.1 METHOD OF DATA COLLECTION

For the Box Set Operations (Phase 2) of the CAIS disposal program, there were four generic categories for which data was collected, processed, and stored. These categories were calibration, air monitoring, inventory control, and plant downtime. See Figure 18 for an illustrated diagram of data collection and Figure 19 for laboratory equipment used.

4.1.1 CALIBRATION

4.1.1.1 Mustard Calibration

To establish daily calibration curves, known agent concentrations of 0.00, 0.24, and 1.21 $\mu\text{g}/\text{ml}$ were measured by each analyst/instrument combination each day. For each analyst/instrument combination, one calibration run (0.00, 0.24, 1.21 $\mu\text{g}/\text{ml}$) was done before actual sample analysis to establish control, and a second was done at the completion of the actual analysis to demonstrate continued control. The data for all calibration runs was pooled and multiple measurements of each concentration were used to establish confidence intervals around the complete regression line. The results of these measurements were taken to the data processing group each evening. The data was visually scanned for obvious errors and then entered onto magnetic cassette tape. The Tektronix minicomputer (see Figure 20) then produced the daily calibration reports.

4.1.1.2 Lewisite Calibration

To establish daily calibration curves, known agent concentrations of 0.000, 0.288 and 0.576 $\mu\text{g}/\text{ml}$ were measured on the Perkin Elmer Atomic Adsorption Spectrophotometer (AA) by each analyst each day. For each analyst, one calibration run (0.000, 0.288, 0.576 $\mu\text{g}/\text{ml}$) was done before actual sample analysis to establish control and a second was done at the completion of the actual sample analysis, to demonstrate continued control. The data from all calibration runs was pooled and the multiple measurements of each concentration were used to establish confidence intervals around the complete regression line. The results of these measurements were taken to the data processing group each evening. The data was visually scanned for obvious errors and then entered onto magnetic cassette tape. The Tektronix minicomputer then produced the daily calibration reports.

4.1.1.3 GB Calibration

To establish daily calibration curves, known agent concentrations of 0.0, 0.1, 0.25, 0.5, 1.0, 1.6, 2.5 and 5.0 ng/ml were measured by each analyst/instrument combination each day. For each analyst/instrument combination, one calibration run (0.0, 0.1, 0.25, 0.5, 1.0, 1.6, 2.5 and 5.0 ng/ml) was done before actual sample analysis to establish control and a second was done at the completion of actual sample analysis to demonstrate continued control. The data from all calibration runs was pooled and the multiple measurements of each concentration were used to establish confidence intervals around the complete regression line. The results of

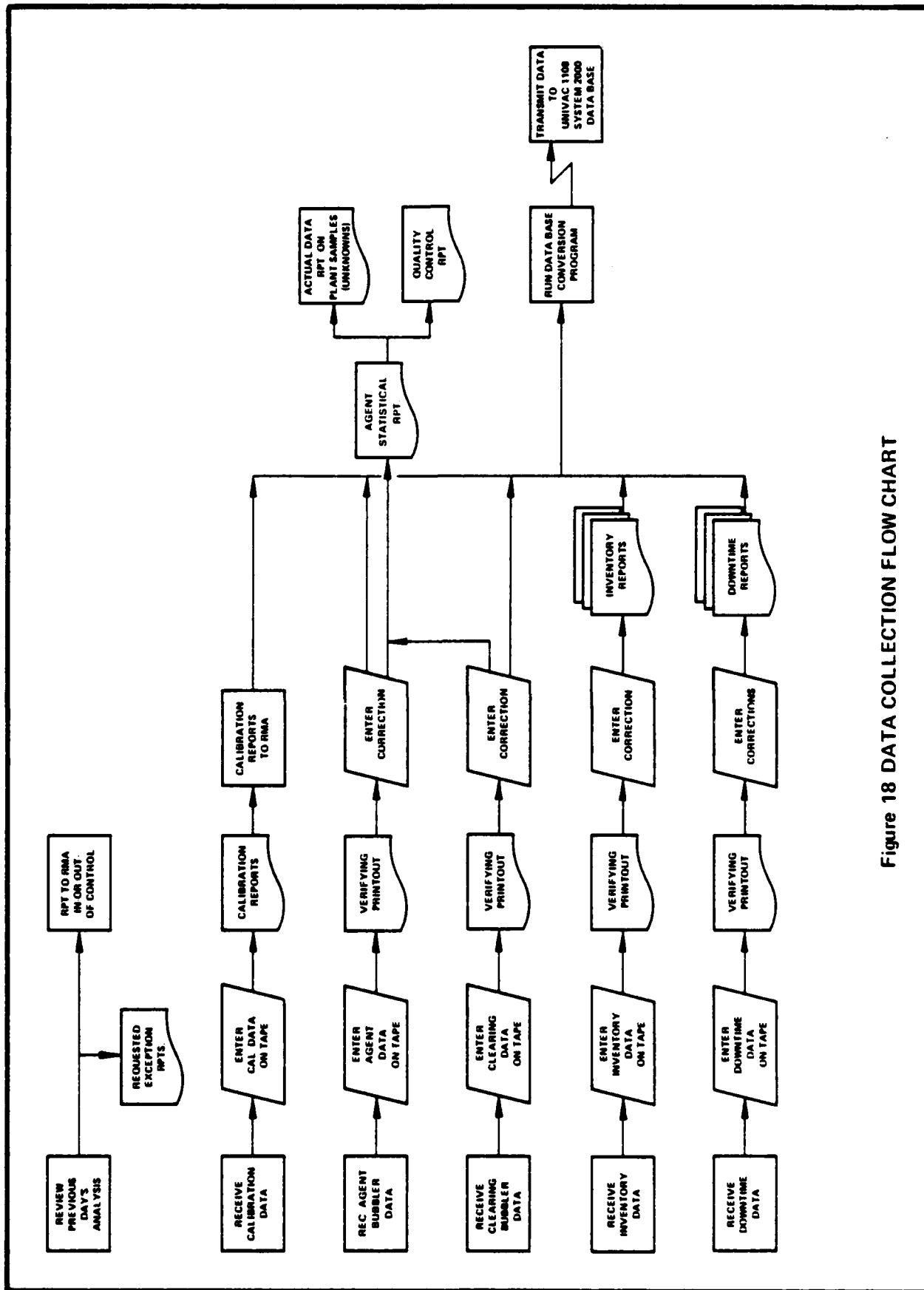

Figure 18 DATA COLLECTION FLOW CHART

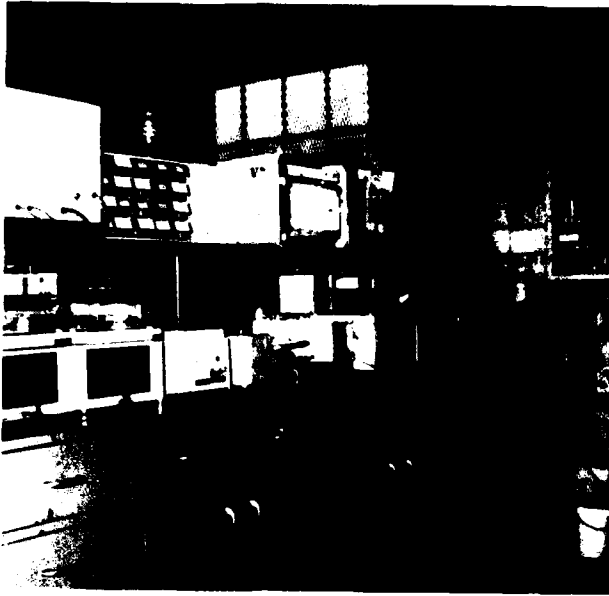

Figure 19 LABORATORY EQUIPMENT



Figure 20 DATA PROCESSING EQUIPMENT

these measurements were taken to the data processing group each evening. The data was visually scanned for obvious errors, entered onto magnetic cassette tape, and a daily calibration report produced.

4.1.1.4 Triphosgene Calibration

To establish daily calibration curves, known agent concentrations of 0.2, 0.5, 1.0, 1.5 and 2.5 $\mu\text{g}/\text{ml}$ were measured on a spectrophotometer by each analyst/instrument combination each day. For each analyst/instrument combination, one calibration run (0.2, 0.5, 1.0, 1.5 and 2.5 $\mu\text{g}/\text{ml}$) was done before actual sample analysis to establish a baseline for analysis. A second calibration was done at the completion of the actual sample analysis to verify that the spectrophotometer had not markedly changed in character during the course of the analysis. The results of these measurements were taken to the data processing group each evening. The data was visually scanned for obvious errors and then entered onto magnetic cassette tape.

4.1.1.5 Chloroacetophenone (CN)

To establish daily calibration curves, known agent concentrations of 0.0, 0.5, 1.0, 3.0, 6.0 and 10.0 $\mu\text{g}/\text{ml}$ were measured on a spectrophotometer by each analyst/instrument combination each day. For each analyst/instrument combination, one calibration run (0.0, 0.5, 1.0, 3.0, 6.0 and 10.0 $\mu\text{g}/\text{ml}$) was done before actual sample analysis to establish a baseline for analysis. A second calibration was done at the completion of the actual sample analysis to verify that the spectrophotometer had not markedly changed in character during the course of the analysis. The results of these measurements were taken to the data processing group each evening. The data was visually scanned for obvious errors and then entered onto magnetic cassette tape.

4.1.2 AIR MONITORING

For Phase II operations, air monitoring data was taken from the Analyst and Lab Data Coordinator Worksheets for mustard, lewisite, GB, triphosgene and chloroacetophenone (CN). Collected data was processed through the use of two Tektronix programs: Data Entry and Data Print. The purpose of the data entry program was to place the information, from the handwritten data sheets, onto magnetic cassette tape. The data print program was used to "echo" the input data for checking and verification that the data was entered correctly.

After entering any corrections, the data for the lethal agents (mustard, lewisite and GB) was further analyzed by use of air monitoring statistical programs developed for each of these agents. These statistical programs used the data previously recorded on tape as input and generated reports required by CAIS management to verify reliability of laboratory analysis. They are described in further detail in section 4.2.

4.1.3 INVENTORY CONTROL

Inventory data was collected, processed, and stored for the following items:

- a. Receipt Inspection of CAIS at Bldg. 1611.
- b. Process Data on Furnace Residue (Pigs).
- c. Process Data on Furnace Residue (Drums).
- d. Process Data on Spray Dryer (Drums).
- e. Process Data on Electrostatic Precipitator (Drums).
- f. Process Data on Disassembly Room (Exception Report).

The data entry and data print programs were used in the same manner as for air monitoring (refer to Paragraph 4.1.2). The data stored on the tape was manipulated by a program to produce desired inventory summary reports of various formats.

4.1.4 DOWNTIME

Building 1611 downtime was recorded on a data sheet and then entered, verified and reported in the same manner as other data entry-data print programs. A daily report was required, even if it only stated "No Downtime." Various summary reports (normally monthly) were produced.

4.1.5 DATA CONVERSION AND PERMANENT STORAGE

At the end of each operating day, data was placed on a condensed or "merged" tape which was then sent to USATHAMA on a weekly basis. Inventory data was condensed from multiple files into a single file in this operation. At USATHAMA the processed data for each day was converted to a format that was acceptable to the Univac 1108 System 2000 data base.

To create a merged data tape, the computer operator inserted the program tape, the current day's data entry tape, and a blank tape in the Tektronix. The program tape obtained data from the data entry tape, converted it to Univac 1108 format, and entered the newly formatted data on the blank "merged" tape. The new "merged" tape was then sent to USATHAMA and used there to transmit the "merged" data to the Univac 1108 System 2000 data base. The Univac 1108 automatically scanned the data to assure that the format was acceptable.

At the conclusion of the transmission, the operator required the Univac 1108 to playback the transmitted data in order to confirm that the original transmission was correct and accurate.

4.2 DESCRIPTION OF AIR MONITORING DATA ANALYSIS

4.2.1 GENERAL

The purpose of the air monitoring statistical program was to determine the relationship between a known concentration of mustard, lewisite, or GB agent and an instrument/analyst response (measurement). The three main components of these programs are: calibration, wherein each analyst/machine combination relationship established a daily curve; actual data analysis, wherein the accuracy and confidence limits of measurements taken in the CAIS disposal plant were established; and quality control charting, which determined accuracy and the precision of lab and plant measurements. The statistical program drew its source data from the air monitoring data tape for the day under consideration.

4.2.2 MUSTARD PROGRAM OPERATION

Calibration curves for mustard were established at known concentrations of 0.00, 0.24 and 1.21 $\mu\text{g}/\text{ml}$ which were measured by each analyst/instrument combination each day. Two measurements of each concentration were used to establish confidence intervals around the complete regression line.

The statistical program drew upon the mustard air monitoring data tape, extracting the calibration data for the day. Using the peak heights obtained for each known concentration, the computer constructed a plot of known concentrations (X-axis) vs. peak height/instrument response (Y-axis). The computer provided this plot (see Figure 17) as a report, along with the following information:

- a. Standard Army agent code for mustard.
- b. Date.
- c. Bartlett's - a probability for the Bartlett's test, indicating the tendency of the variance of this small data set to be either homogeneous (a probability greater than 0.05) or non-homogeneous (a probability less than 0.05).
- d. R-squared - a statistical evaluation of how well the computer-selected equation fits the data. An R-squared value of 0.995 or greater was acceptable.
- e. MSE - mean square error - a statistical evaluation of the distance that the points fell from the selected regression line. No set criteria was used.
- f. (a) - the intercept of the regression line with the Y-axis.
- g. (b) - the slope of the selected regression line.
- h. (f), (g) and (h) - correction factors for data that might fit non-linear or special cases.

Using information from the calibration curve, the peak height readings from the actual data sheets were factored to establish a "true" value with corresponding upper and lower limits of accuracy. The actual measurements were revised to take into account the measurement errors determined by the calibration report. The upper and lower limits of accuracy were determined by the computer, which used a previously entered data base. The data base was kept in the statistical program. A report was then produced (see Figure 17) which displayed the following information:

- a. Actual data for mustard agent (in mg/m³).
- b. Date.
- c. Sample - control number corresponding to the data entry print routines.
- d. Location - location in the plant where the sample was collected.
- e. True - the value calculated by the computer, based on the previously constructed calibration curve (in mg/m³).
- f. Lower 95% - the value calculated by the computer, based on the IDS/HISTORY data base for the lower confidence value (in mg/m³). Values were printed only for work area samples.
- g. Upper 95% - the value calculated by the computer, based on the IDS/HISTORY data base for the upper confidence value (in mg/m³). Values were printed only for work area samples.
- h. Time - sampling interval.

The IDS/HISTORY tape contained statistical limits, established by USATHAMA and the Department of Health and Human Services, used for accuracy and precision charts. These charts provided the upper and lower bounds for accuracy of measurements (mean value) and the precision (standard deviation) or variance of mean readings.

Accuracy and precision charts (see Figures 21 and 22) were produced as quality control with respect to the laboratory. The measurements of each of four bubblers, spiked with known concentrations of 0.216 µg/ml, were averaged to determine the accuracy. USATHAMA and DHHS had established upper and lower limits for accuracy measurements for mustard agent as follows:

ACCURACY CONTROL CHART FOR H QL.216
HGH QL.216

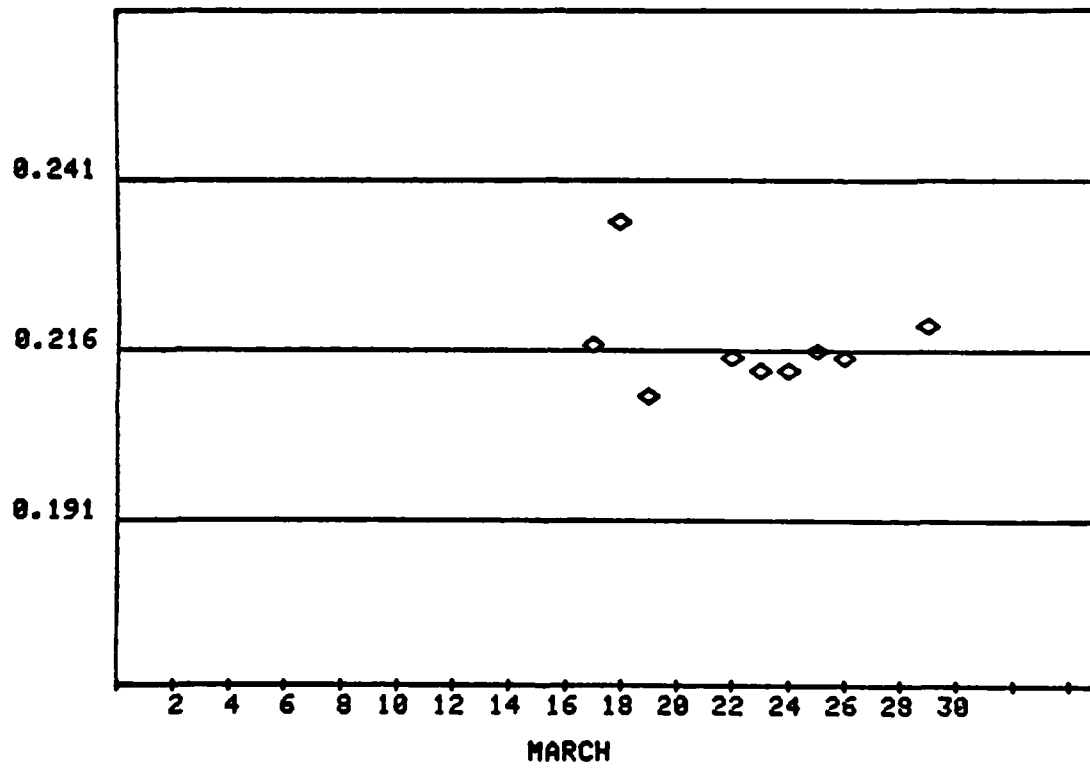

Figure 21 ACCURACY CONTROL CHART FOR MUSTARD

PRECISION CONTROL CHART FOR H QL.216
HQH QL.216

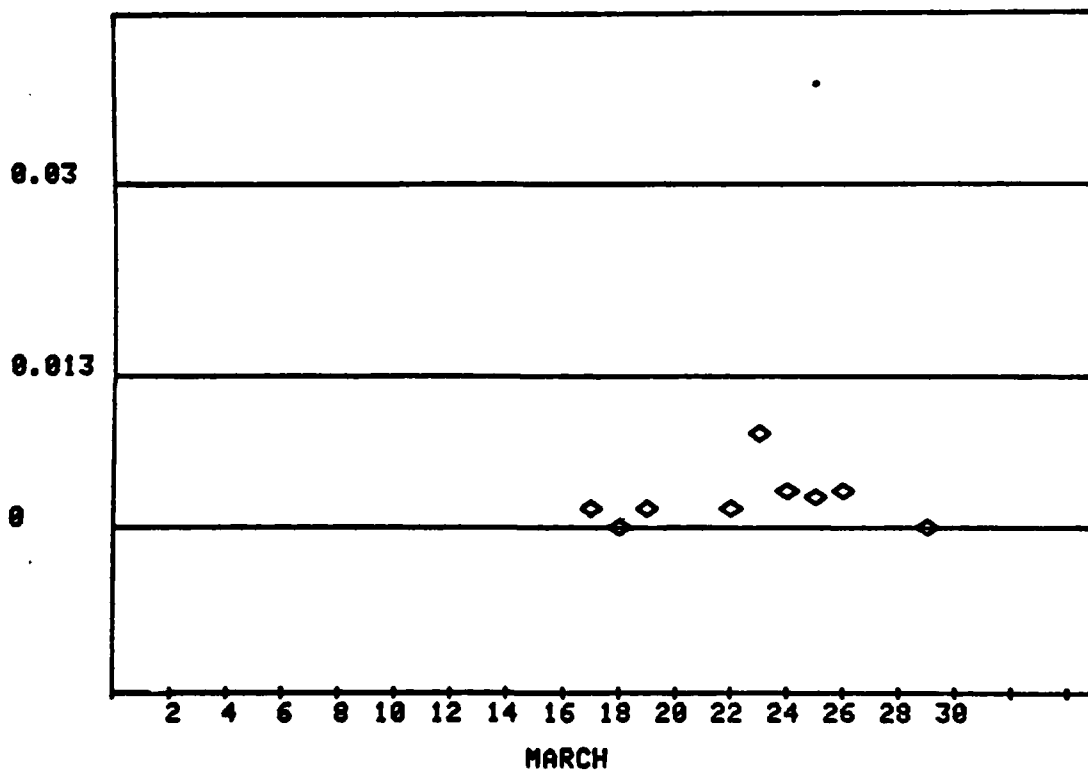

Figure 22 PRECISION CONTROL CHART FOR MUSTARD

Mean Concentration	Lower	Limits Upper
0.216 $\mu\text{g/ml}$	0.191 $\mu\text{g/ml}$	0.241 $\mu\text{g/ml}$

Daily points should scatter about the mean. Points above the upper line or below the lower line constituted the measuring process as being "out-of-control" statistically. Seven continuous runs above or below the mean line also constituted the measuring process as being "out-of-control" statistically.

Precision charts indicated the standard deviation of the mean accuracy readings. Average deviations and limits, using past data as a base, had been established as follows:

Concentration	Avg. Deviation	Upper Limit
0.216 $\mu\text{g/ml}$	0.013	0.042

It was expected that precision calculations would scatter above and below the average deviation. The desirable situation was for all calculations to fall between 0 and the upper limit. If a point fell above the upper limit, the measuring process was considered to be "out-of-control" statistically.

4.2.3 LEWISITE PROGRAM OPERATION

Calibration curves for lewisite were established at known concentrations of 0.000, 0.288 and 0.576 $\mu\text{g/ml}$ which were measured by each analyst/instrument combination each day. Two measurements of each concentration were used to establish confidence intervals around the complete regression line.

The statistical program drew upon the lewisite air monitoring data tape, extracting the calibration data for the day. Using the absorbances obtained for each known concentration, the computer constructed a plot of known concentrations (X-axis) vs. absorbance/instrument response (Y-axis). The computer provided this plot (see Figure 16) as a report, along with the following information:

- a. Standard Army agent code for lewisite.
- b. Date.
- c. Bartlett's - a probability for the Bartlett's test, indicating the tendency of the variance of this small data set to be either homogeneous (a probability greater than 0.05) or non-homogeneous (a probability less than 0.05).
- d. R-squared - a statistical evaluation of how well the computer-selected equation fits the data.
- e. MSE - mean square error - a statistical evaluation of the distance that the points fell from the selected regression line.
- f. (a) - the intercept of the regression line with the Y-axis.
- g. (b) - the slope of the selected regression line.
- h. (f), (g) and (h) - correction factors for data that might fit non-linear or special cases. Lewisite was a special case fitting the general equation $\ln(2-y) = a + bx$.

Using information from the calibration curve, the absorbance readings from the actual data sheets were factored to establish a "true" value with corresponding upper and lower limits of accuracy. The actual measurements were revised to take

ACCURACY CONTROL CHART FOR L QL.288
HQL QL.288

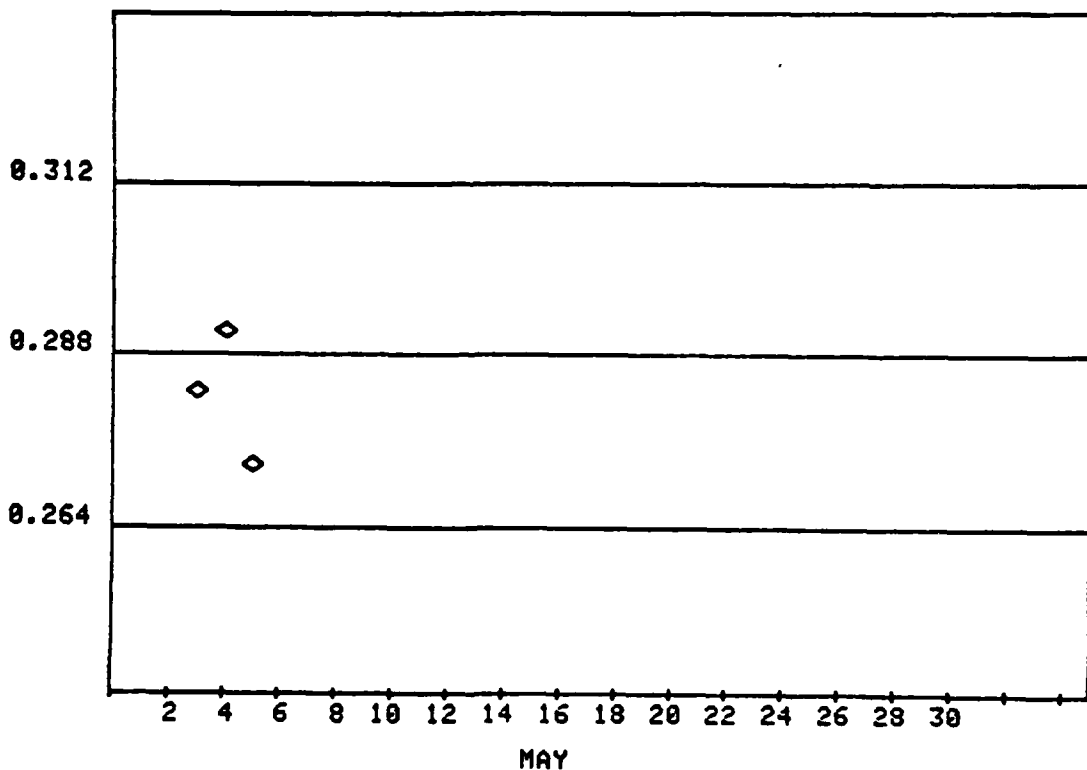

ACCURACY CONTROL CHART FOR L QP.288
HQL QP.288

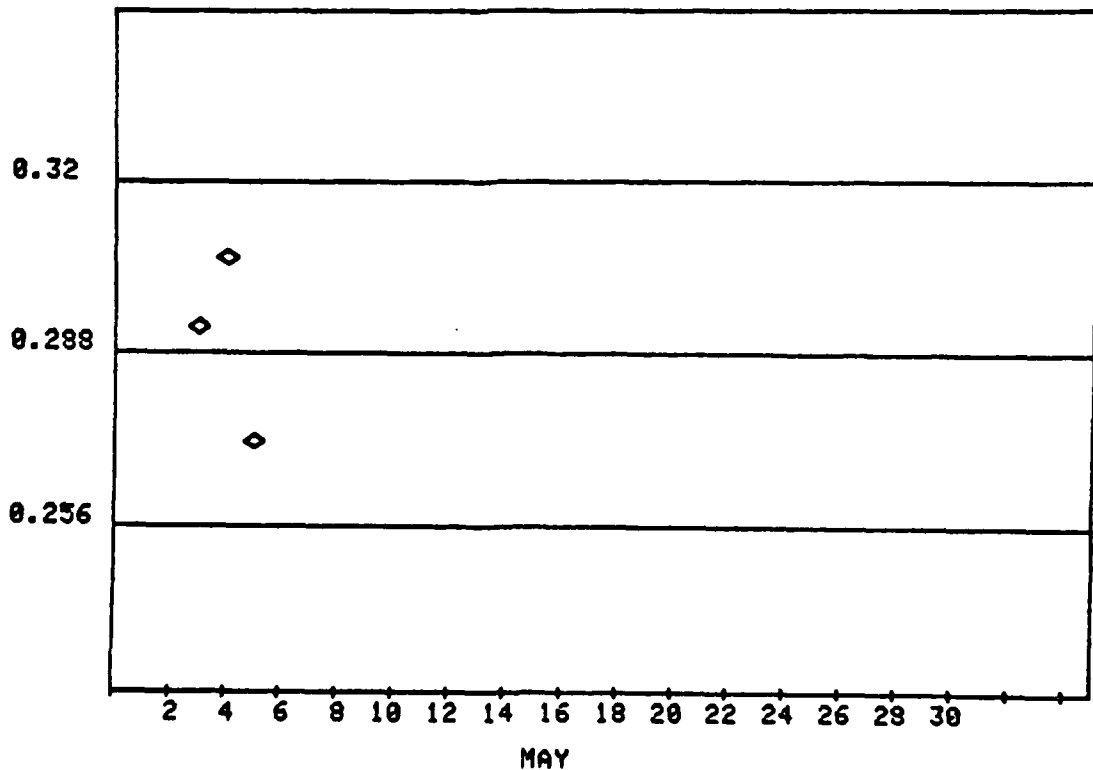

Figure 23 ACCURACY CONTROL CHART FOR LEWISITE

into account the measurement errors determined by the calibration report. The upper and lower limits of accuracy were determined by the computer, which used the confidence bounds calculated around each individual day's calibration curve to yield these ranges. A report was then produced (see Figure 16) which displayed the following information:

- a. Actual data for lewisite agent (in mg/m³).
- b. Date.
- c. Sample - control number corresponding to the data entry print routines.
- d. Location - location in the plant where the sample was collected.
- e. True - the value calculated by the computer, based on the previously constructed calibration curve (in mg/m³).
- f. Lower 95% - the value calculated by the computer, based in the confidence bounds around the calibration curve for the lower confidence value (in mg/m³). Values were printed only for work area samples.
- g. Upper 95% - the value calculated by the computer, based on the confidence bounds around the calibration curve for the upper confidence value (in mg/m³). Values were printed only for work area samples.
- h. Time - sampling interval.

The IDS/HISTORY tape contained statistical limits, established by USATHAMA and the Department of Health and Human Services, used for accuracy and precision charts. These charts provided the upper and lower bounds for accuracy of measurements (mean value) and the precision (standard deviation) or variance of mean readings.

Accuracy and precision charts (see Figures 23 and 24) were produced as quality control with respect to the laboratory (QL) and the plant (QP). The measurements of each of four bubblers, spiked with known concentrations of 0.288 µg/ml, were averaged to determine the accuracy. USATHAMA and DHHS had established upper and lower limits for accuracy measurements for lewisite agent as follows:

Location	Mean Concentration	Limits	
		Lower	Upper
Laboratory (QL)	0.288 µg/ml	0.264 µg/ml	0.312 µg/ml
Plant (QP)	0.288 µg/ml	0.256 µg/ml	0.320 µg/ml

Daily points should scatter about the mean. Points above the upper line or below the lower line constituted the measuring process as being "out-of-control" statistically. Seven continuous runs above or below the mean line in the laboratory (QL) also constituted the measuring process as being "out-of-control" statistically.

Precision charts indicated the standard deviation of the mean accuracy readings. Average deviations, using past data as a base, had been established as follows:

Location	Concentration	Avg. Deviation	Upper Limit
Laboratory (QL)	0.288 µg/ml	0.013	0.029
Plant (QP)	0.288 µg/ml	0.017	0.039

PRECISION CONTROL CHART FOR L QL.288
HQL QL.288

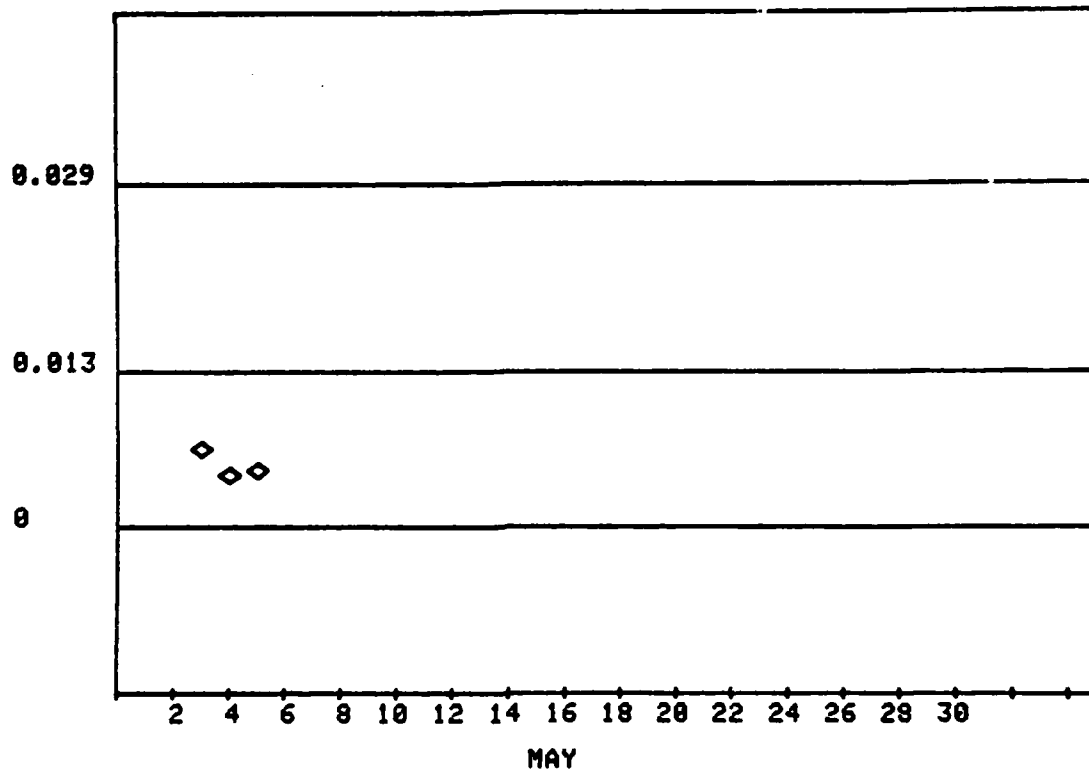

PRECISION CONTROL CHART FOR L QP.288
HQL QP.288

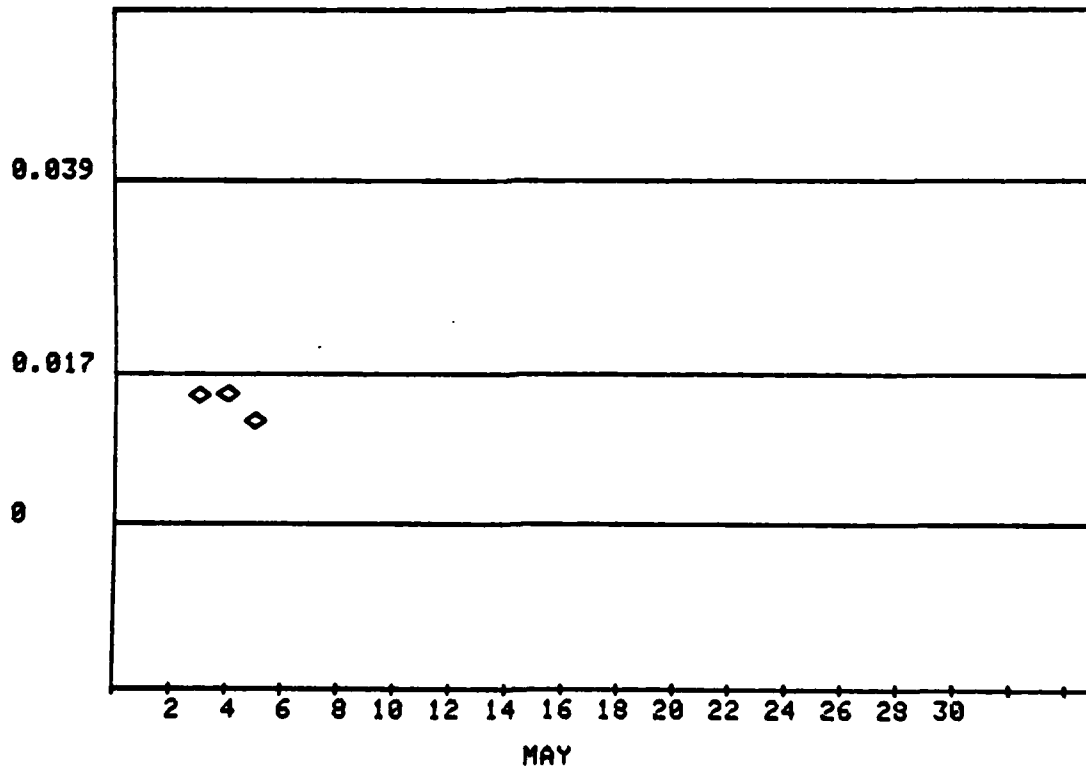

Figure 24 PRECISION CONTROL CHART FOR LEWISITE

It was expected that calculations would scatter above and below the average deviation. The desirable situation was for all calculations to fall between 0 and the upper limit. If a point fell above the upper limit, the measuring process was considered to be "out-of-control" statistically.

4.2.4 GB PROGRAM OPERATION

Calibration curves for GB were established at known concentrations of 0.0, 0.1, 0.25, 0.5, 1.0, 1.6, 2.5 and 5.0 ng/ml which were measured by each analyst/instrument combination each day. Two or more measurements of each concentration were used to establish confidence intervals around the complete regression line.

The statistical program drew upon the GB air monitoring data tape, extracting the calibration data for the day. Using the peak heights obtained for each known concentration, the computer constructed a plot of known concentrations (X-axis) vs. peak height/instrument response (Y-axis). The computer provided this plot (see Figure 15) as a report, along with the following information:

- a. Standard Army agent code for GB.
- b. Date.
- c. Bartlett's - a probability for the Bartlett's test, indicating the tendency of the variance of this small data set to be either homogeneous (a probability greater than 0.05) or non-homogeneous (a probability less than 0.05).
- d. R-squared - a statistical evaluation of how well the computer-selected equation fits the data.
- e. MSE - mean square error - a statistical evaluation of the distance that the points fell from the selected regression line.
- f. (a) - the intercept of the regression line with the Y-axis.
- g. (b) - the slope of the selected regression line.
- h. (f), (g) and (h) - correction factors for data that might fit non-linear or special cases. GB is a non-linear case and conforms (with bovine enzyme) to the general equation $\ln(f-y) = a + bx$. The factor f is an important part of the equation in the case of GB; its function being to maximize the fit of the logarithmic curve. This fit has a significant effect on the accuracy of the results and, therefore, quality control.

Using information from the calibration curve, the peak height readings from the actual data sheets were factored to establish a "true" value with corresponding upper and lower limits of accuracy. The actual measurements were revised to take into account the measurement errors determined by the calibration report. The upper and lower limits of accuracy were determined by the computer, which used the confidence bounds calculated around each instrument/analyst combination for each day's calibration curve to yield these ranges. A report was then produced (see Figure 15) which displayed the following information:

- a. Actual data for GB agent (in mg/m³).
- b. Date.
- c. Sample - control number corresponding to the data entry print routines.
- d. Location - location in the plant where the sample was collected.
- e. True - the value calculated by the computer, based on the previously constructed calibration curve (in mg/m³).

ACCURACY CONTROL CHART FOR GBQL1.60
HQGBQL1.60

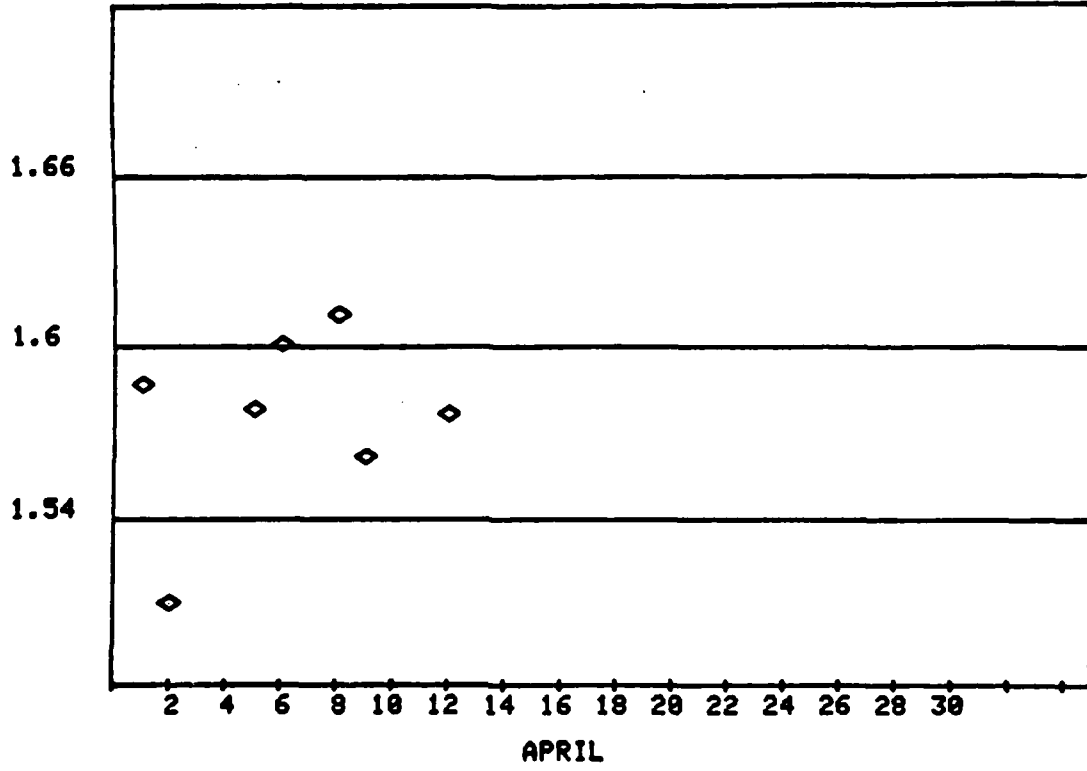

ACCURACY CONTROL CHART FOR GBQP1.60
HQGBQP1.60

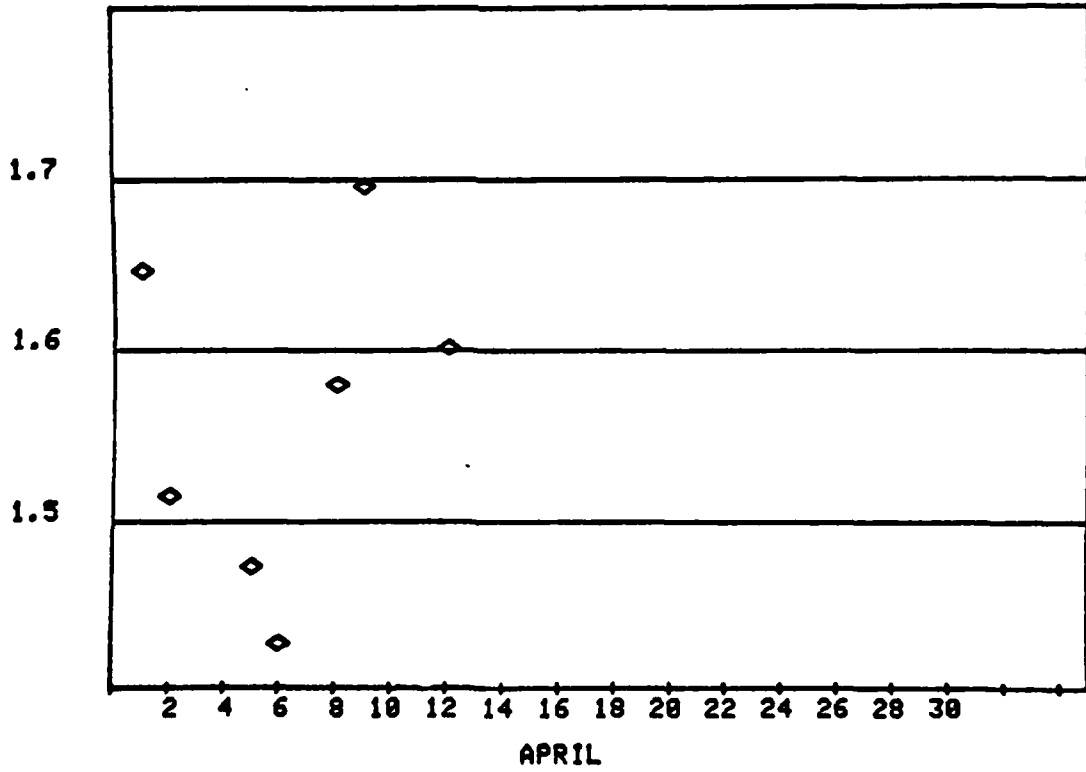
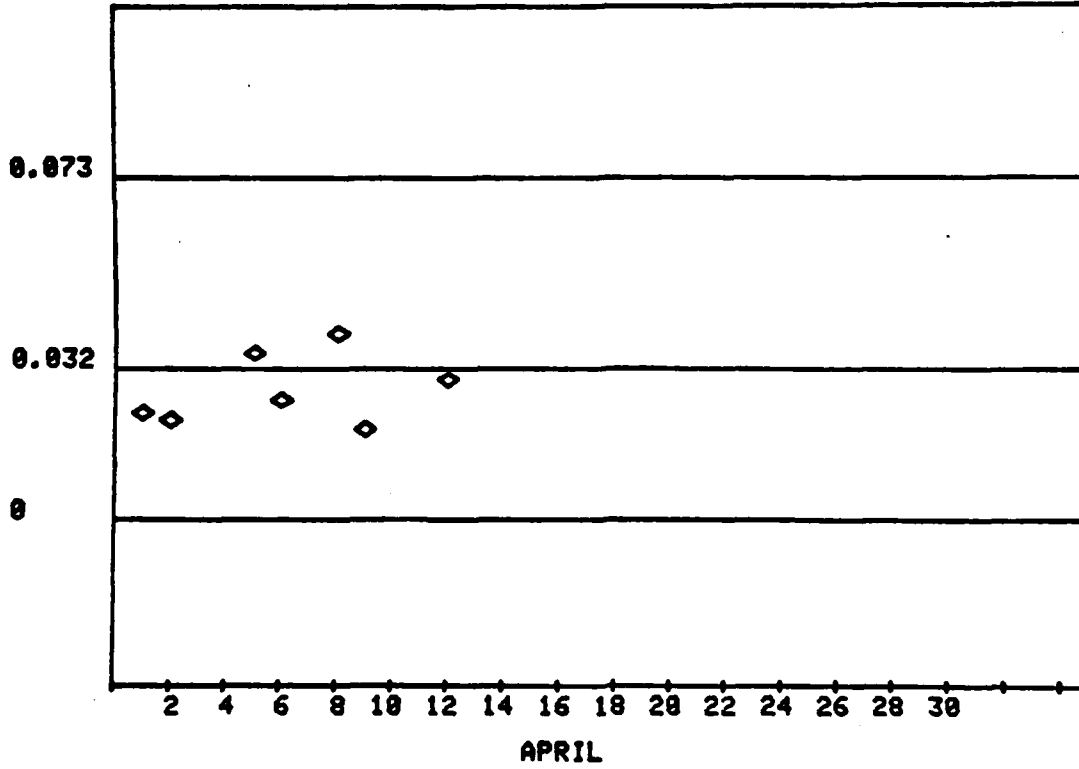

Figure 25 ACCURACY CONTROL CHART FOR GB

PRECISION CONTROL CHART FOR GBQL1.60
 HQGBQL1.60



PRECISION CONTROL CHART FOR GBQP1.60
 HQGBQP1.60

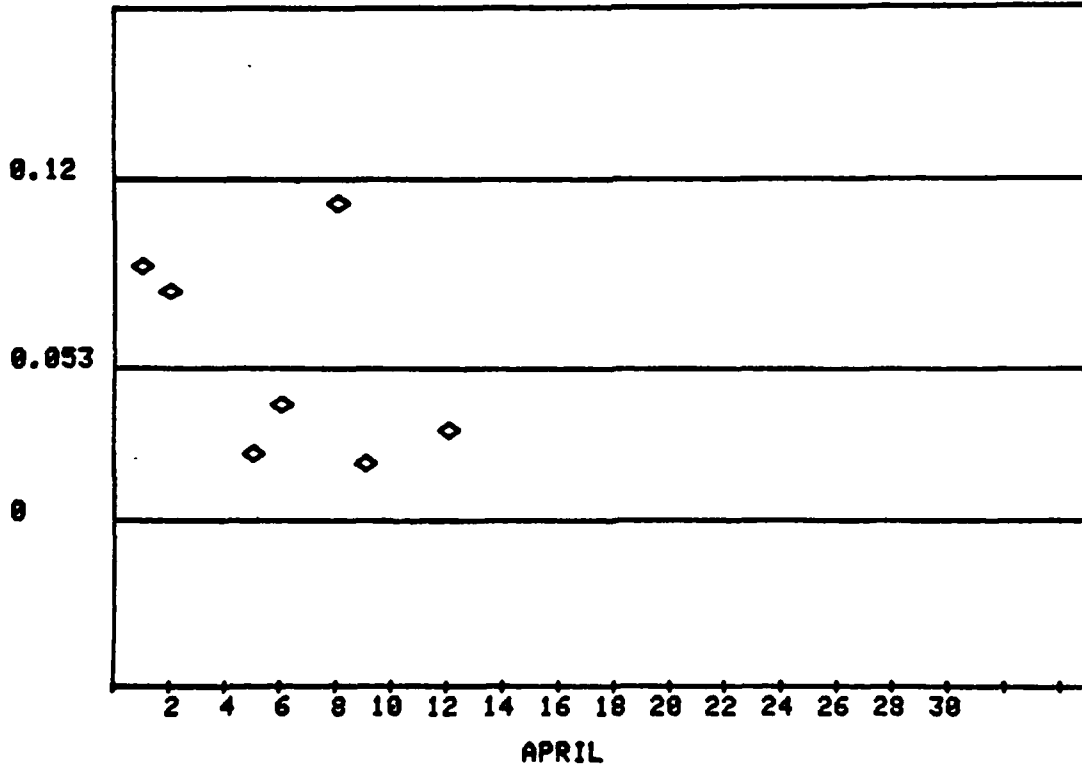

Figure 26 PRECISION CONTROL CHART FOR GB

- f. Lower 95% - the value calculated by the computer, based on the confidence bounds around the calibration curve for the lower confidence value (in mg/m³). Values were printed only for work area samples.
- g. Upper 95% - the value calculated by the computer, based on the confidence bounds around the calibration curve for the upper confidence value (in mg/m³). Values were printed only for work area samples.
- h. Time - sampling interval.

The IDS/HISTORY tape contained statistical limits, established by USATHAMA and the Department of Health and Human Services, used for accuracy and precision charts. These charts provided the upper and lower bounds for accuracy of measurements (mean value) and the precision (standard deviation) or variance of mean readings.

Accuracy and precision charts (see Figures 25 and 26) were produced as quality control with respect to the laboratory (QL) and the plant (QP). The measurements of each of four bubblers, spiked with known concentrations of 1.6 ng/ml, were averaged to determine the accuracy. Upper and lower limits for accuracy measurements were determined by USATHAMA and DHHS for GB agent as follows:

Location	Mean Concentration	Limits	
		Lower	Upper
Laboratory (QL)	1.6 ng/ml	1.54 ng/ml	1.66 ng/ml
Plant (QP)	1.6 ng/ml	1.50 ng/ml	1.70 ng/ml

Daily points should scatter about the mean. Points above the upper line or below the lower line constituted the measuring process as being "out-of-control" statistically. Seven continuous runs above or below the mean line also constituted the measuring process as being "out-of-control" statistically.

Precision charts indicated the standard deviation of the mean accuracy readings. Average deviations, using past data as a base, had been established as follows:

Location	Concentration	Avg. Deviation	Upper Limit
Laboratory (QL)	1.6 ng/ml	0.032	0.073
Plant (QP)	1.6 ng/ml	0.053	0.120

It was expected that precision calculations would scatter above and below the average deviation. The desirable situation was for all calculations to fall between 0 and the upper limit. If a point fell above the upper limit, the measuring process was considered to be "out-of-control" statistically.

4.3 DESCRIPTION OF INVENTORY DATA COLLECTION

For the CAIS disposal program, inventory control can be divided into two basic categories: incoming or receipt inspection; and outgoing or process recording. Receipt inspection for Phase II consisted of recording the serial numbers of incoming ID Sets (pigs or boxes) and noting that they were either destroyed or returned to the toxic storage yard. Process inspections were conducted to record any unusual observations in the disassembly room (leakers, rusted cans, etc.) and the final disposition of the pigs, furnace residue, and the salts from the spray dryer and the electrostatic precipitator.

4.3.1 RECEIPT INSPECTION

Each day the Bldg. 1611 Receipt Inspection form was delivered to the computer group for processing. The data entry and data print programs were used to insert and verify the entry of the data. After corrections (if any) were made, the day's report was run. The report showed date, serial number of received ID Sets, whether they were destroyed or returned to the toxic storage yard, and pertinent comments.

4.3.2 PROCESS INSPECTION

The process data sheet for the disassembly room for the current day was delivered to the computer group. The data sheet contained notes on any unusual occurrences or observations for the day's operation. If there were none noted for the day, the data sheet was not taken to the computer group. The data was processed in the same manner as other data entry/print programs and produced a report showing the ID Sets type, serial number, any unusual occurrence or observation, and action taken.

4.3.3 FINAL DISPOSITION

Data sheets from the residue area (daily), and spray dryer and electrostatic precipitator (as required) were processed by the computer group. Processing procedures were the same as for other data sheets. Reports were produced as follows:

- a. Decontaminated (Deconned) pigs.
- b. Furnace residue (drums).
- c. Spray dryer residue (drums).
- d. Electrostatic precipitator residue (drums).

4.3.4 DATA CONVERSION

All inventory data for the day was converted to Univac 1108 format and sent to USATHAMA, in accordance with the details of Paragraph 4.1.5.

4.4 DESCRIPTION OF DOWNTIME DATA COLLECTION

A coded downtime data sheet was provided each day, even for those days when there was no downtime. Data was processed in the same manner as other program inputs, i.e., entered, verified, corrected as required, and reports generated. The reports were printed with definitions rather than the numerical-code data entries. These reports provided the following information:

- a. Date.
- b. Start and stop times of the downtime.
- c. Whether or not this was a simultaneous experience with other malfunctions.
- d. Subsystem affected.
- e. Primary components affected.
- f. Secondary components affected.
- g. Description of the failure.
- h. Failure modes (further specifying the nature of the failure).

- i. Corrective action taken.
- j. Effect on operation.
- k. Operator comments.

If there was no downtime experienced during the day, the report so stated. Thus, there was a downtime report each day.

The downtime report data was converted to Univac 1108 format and sent to USATHAMA, in accordance with the procedures outlined in Paragraph 4.1.5.

PHASE 3

**DISPOSAL OF CHEMICAL AGENT
IDENTIFICATION SETS
AT ROCKY MOUNTAIN ARSENAL, COLORADO
CAIS OPERATIONS: PHASE 3
FINAL REPORT
MARCH 1983**



Prepared By

William R. Brankowitz
USATHAMA

Dr. Michael E. Witt
RMA

John A. Ursillo
RMA

Dr. Jack C. Pantleo
Data Processing Associates

DISTRIBUTION UNLIMITED. CLEARED FOR PUBLIC RELEASE

**DEPARTMENT OF THE ARMY
US ARMY TOXIC AND HAZARDOUS MATERIALS AGENCY
ABERDEEN PROVING GROUND, MARYLAND 21010**

CONTENTS

CHAPTER 1	PROCESS DESCRIPTION
1.1	Purpose
1.2	Disposal Procedures
1.3	Waste Disposal
CHAPTER 2	PRODUCTION SUMMARY
2.1	Sets Description
2.2	Numerical Summary of Sets Destroyed
2.3	Downtime Analysis
2.4	Subsystem Downtime
CHAPTER 3	AIR MONITORING SUMMARY
3.1	Description of Sampling Techniques
3.2	Description of Analysis Techniques
3.3	Summary of Air Monitoring Readings
CHAPTER 4	DATA COLLECTION AND QUALITY CONTROL
4.1	Method of Data Collection
4.2	Description of Air Monitoring Data Analysis
4.3	Description of Inventory Data Collection
4.4	Description of Downtime Data Collection

LIST OF FIGURES

1. ID Sets Demilitarization Program, Building 1611
2. ID Sets in Storage
3. CAIS Facility Site Layout
4. ID Set Process Flow Diagram
5. Disassembly/Storage Glovebox
6. Screw Conveyor and Feed Chute Locations
7. Disassembly Glovebox and Decontamination Module
8. Can Feed System
9. Pigs Being Deposited in Decontamination Furnace
10. Pigs After Decontamination
11. Box Feed Chute
12. Residue Handling Equipment
13. X-Set Process Flow Diagram
14. K955 Process Flow Diagram
15. Electrostatic Precipitator
16. Spray Dryer
17. Identification and Training Sets
18. Gas Set Identification, Instructional, K955 and X-Sets
19. Toxic Gas Set
20. Gas Set Identification, Instructional K955 and X-Sets
21. Typical Bubbler
22. Sampling Station Locations, Bldg 1611
23. MIRAN 80 with Three-Compound Quality Control Permeation Generator
24. SF⁶ Detector/Analyzer
25. SF⁶ Flow Diagram
26. Dynascience Monitor, Bldg 1611 Stack

27. Calibration Curve - Lewisite
28. Calibration Curve - Mustard
29. Data Collection Flow Chart
30. Laboratory Equipment
31. Data Processing Equipment
32. Typical Label for Laboratory Samples
33. Analyst Work Sheet
34. Lab Data Coordinator Work Sheet
35. Accuracy and Precision Chart - Lewisite
36. Accuracy and Precision Chart - Mustard

LIST OF TABLES

1. Downtime Analysis By Sets Destroyed

CHAPTER 1 PROCESS DESCRIPTION

1.1 PURPOSE

The purpose of Phase 3 of the Chemical Agent Identification Sets Disposal Program was to completely destroy all remaining CAIS. The types of sets destroyed in Phase 3 were: the pig sets K951/952 and K953/954; the large box set K955; and the small box set X552. For a detailed description of the contents of these sets refer to Chapter 2. Disposal of Phase 3 sets was performed in Building 1611 at Rocky Mountain Arsenal (RMA), Denver, Colorado (see Figure 1), commencing 22 April 1982 and concluding 22 December 1982. Cleanup operations ran from 23 December 1982 through 25 January 1983.

1.2 DISPOSAL PROCEDURES

1.2.1 TRANSPORTATION FROM INTERIM STORAGE

The Chemical Agent Identification Sets (CAIS) for Phase 3 were shipped to RMA during movement operations SETCON I and SETCON II. Figure 2 shows various types of ID Sets in storage prior to being moved to RMA. After movement to RMA, they were stored in sheds at the toxic storage yard on pallets of 16 to 25 pigs or 40 boxes. Lethal X sets were stored in CNU-80 shipping containers of 20 each. Containers were arranged in order of planned disposal. On 5 November 1982, the sets remaining in the toxic storage yard were moved to Building 1607. They were then transported from that location to the disposal plant.

The sets were loaded on trucks and transported by convoy on paved roads, during daylight hours, from the toxic storage yard to Bldg. 1611, a distance of 2.5 miles. Convoy speed was held at 10 mph or less during transportation. A maximum of four containers were loaded by forklift onto a stake body truck and blocked and braced into place. The truck bed was equipped with two roller conveyors, length-wise, so the pallets could be loaded from the rear.

The demilitarization site layout is shown on Figure 3. Sets arrived at the covered unloading dock, located on the east end of Bldg. 1611. The sets were unloaded and held in the receiving room until they were ready for processing. No lethal sets were held in the building overnight. Any remaining at the completion of operations were returned to the toxic storage area. In the disassembly room, the shipping containers or pallets were moved to the box feed chute or to the disassembly module for processing.

1.2.2 DISASSEMBLY AND DISPOSAL OF K951, K952, K953, K954 SETS

1.2.2.1 Equipment Description

The CAIS operation facility was designed and constructed to reduce personnel contact with chemical agents by minimizing the disassembly of sets. The K951/952, K953/954 sets were packaged and transported in steel shipping containers referred

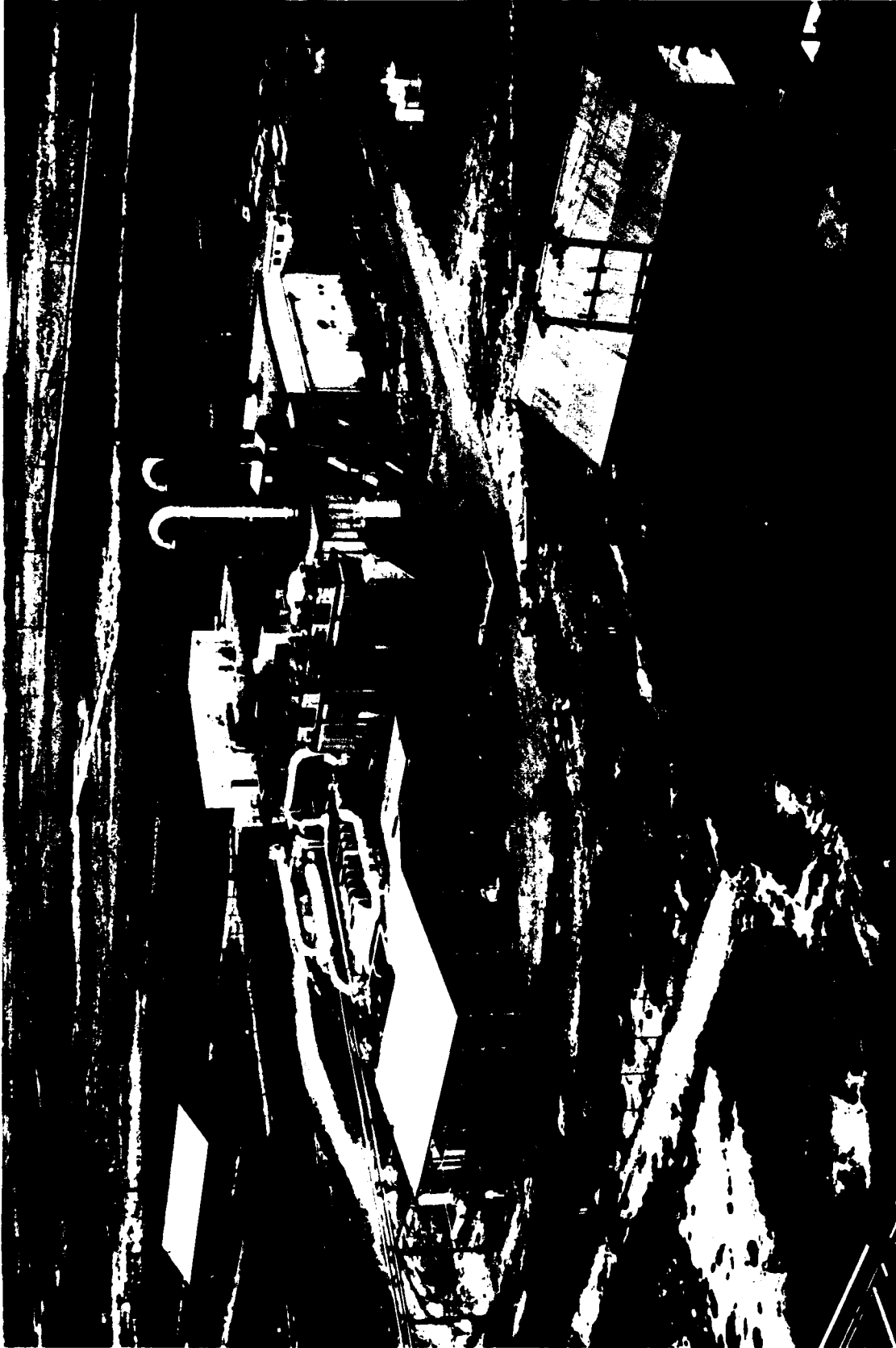

Figure 1 ID SETS DEMILITARIZATION PROGRAM, BUILDING 1611



Figure 2 (U) SETS IN STORAGE

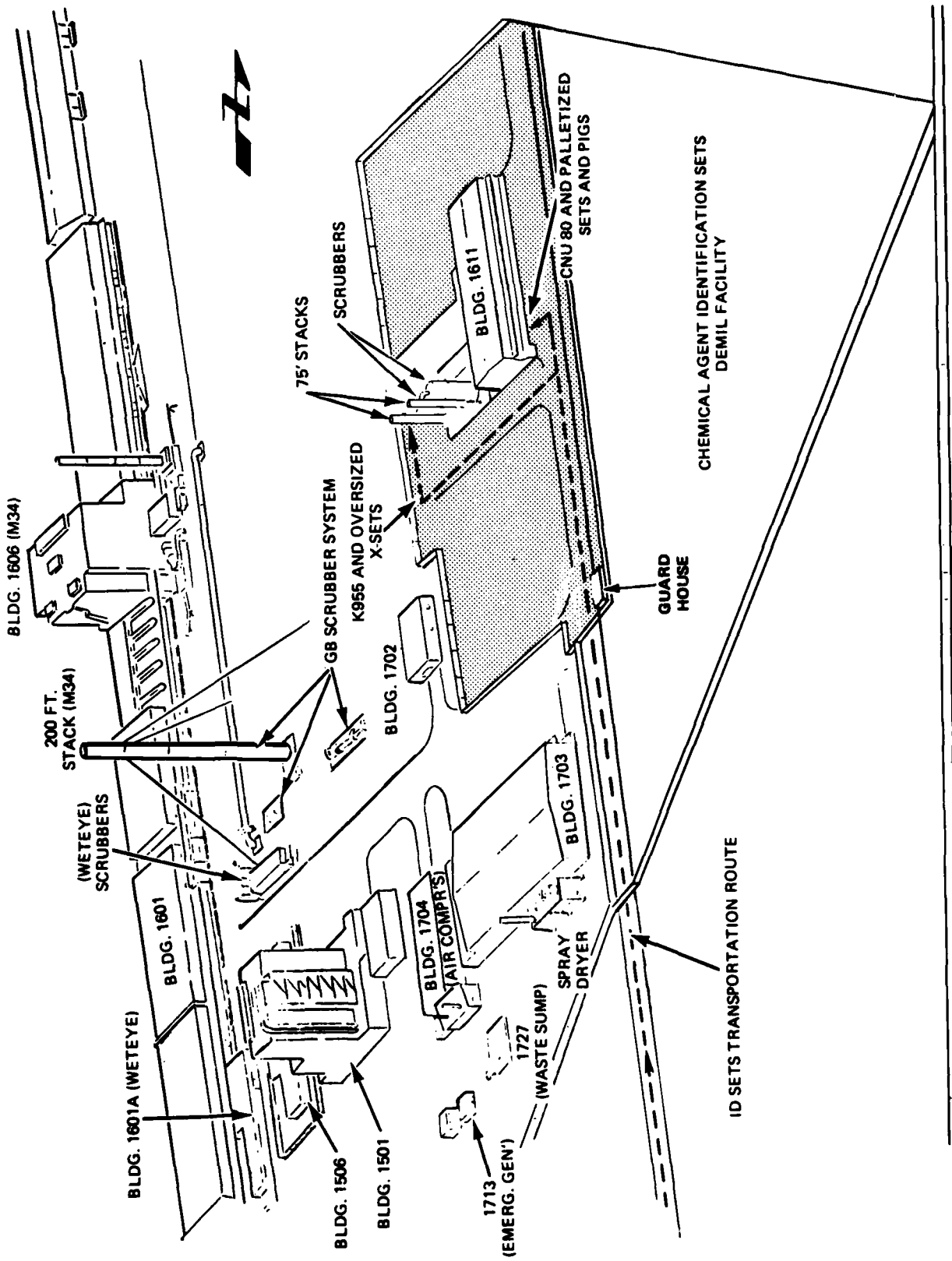

Figure 3 CAIS FACILITY SITE LAYOUT

to as "pigs." These pigs were opened in a negative pressure glovebox, and the four cans inside were removed. The cans were placed on a screw conveyor for transport to the can feed station. At the can feed station the cans were processed to the deactivation furnace. Figure 4 illustrates the process flow diagram for pigs.

The glovebox used for disassembly and feeding of CAIS hazardous materials consisted of two modules sealed to form a single integral unit (see Figure 5). These are referred to herein as the disassembly module and the storage/feed module.

The disassembly module was approximately 20 feet in length and consisted of five work stations for the disassembly of the pigs and the removal of set material. Two glove ports were provided at each work station to provide access within the glovebox. An opening at the back of each station was controlled by an iris valve to permit entry and exit of the pig. Electrical interlocks were provided so that only one pig at a time was allowed to enter or discharge from the glovebox. A screw type conveyor, as shown in Figure 6, provided transport of material to the storage/feed module portion of the glovebox. This glovebox had a maximum disassembly rate of 20 sets per hour.

The storage/feed module, approximately 24 feet in length, consisted of one operational station at the end of the storage area for inserting materials through a feed device directly into the deactivation furnace. The deactivation furnace was operated at 1100°F. Two gloveports were used to feed the set materials. In addition to these gloveports, eight sets of gloveports were provided evenly spaced along the length of the glovebox on one side, for access throughout the box, if required. Under normal operating conditions, these gloveports were sealed. Temporary storage of set cans was provided throughout the length of the glovebox as items were conveyed on the screw type conveyor from the disassembly section. The screw type conveyor had a storage capacity of at least 40 cans. Storage for additional cans was readily available by removing the cans from the conveyor and placing them on the floor of the storage/feed module.

The glovebox was maintained at a negative pressure of approximately 0.8" H₂O with respect to the disassembly room, and had sufficient air flow to provide a minimum of 25 air changes per hour and surface interface velocity of 150 fpm. Airflows were checked periodically by a contractor to assure compliance. Negative pressure was maintained by direct reading manahelic gauges on the glovebox. Potentially contaminated air was swept through the glovebox and exhausted to the afterburner. The afterburner was operated at 1650°F. Fail-safe indicator lamps and emergency conveyor stops were provided to assure safe operations.

For transporting the CAIS pigs to and from the disassembly module, a shroud, referred to herein as the decontamination module shroud (Figure 7), paralleled the disassembly room, to and through air lock #3, and then was sealed to the entrance door of the decontamination furnace. Within the shroud was a belt drive to transport pigs from a loading station to each disassembly station in the disassembly glovebox.

After disassembly, the pigs were transported within the shroud to a decontamination furnace charging cart. The chain-driven charging cart, with a carrying capacity of 12 empty pigs, ran on a track within the shroud from the disassembly room to the decontamination furnace. For pigs, the decontamination furnace was operated at

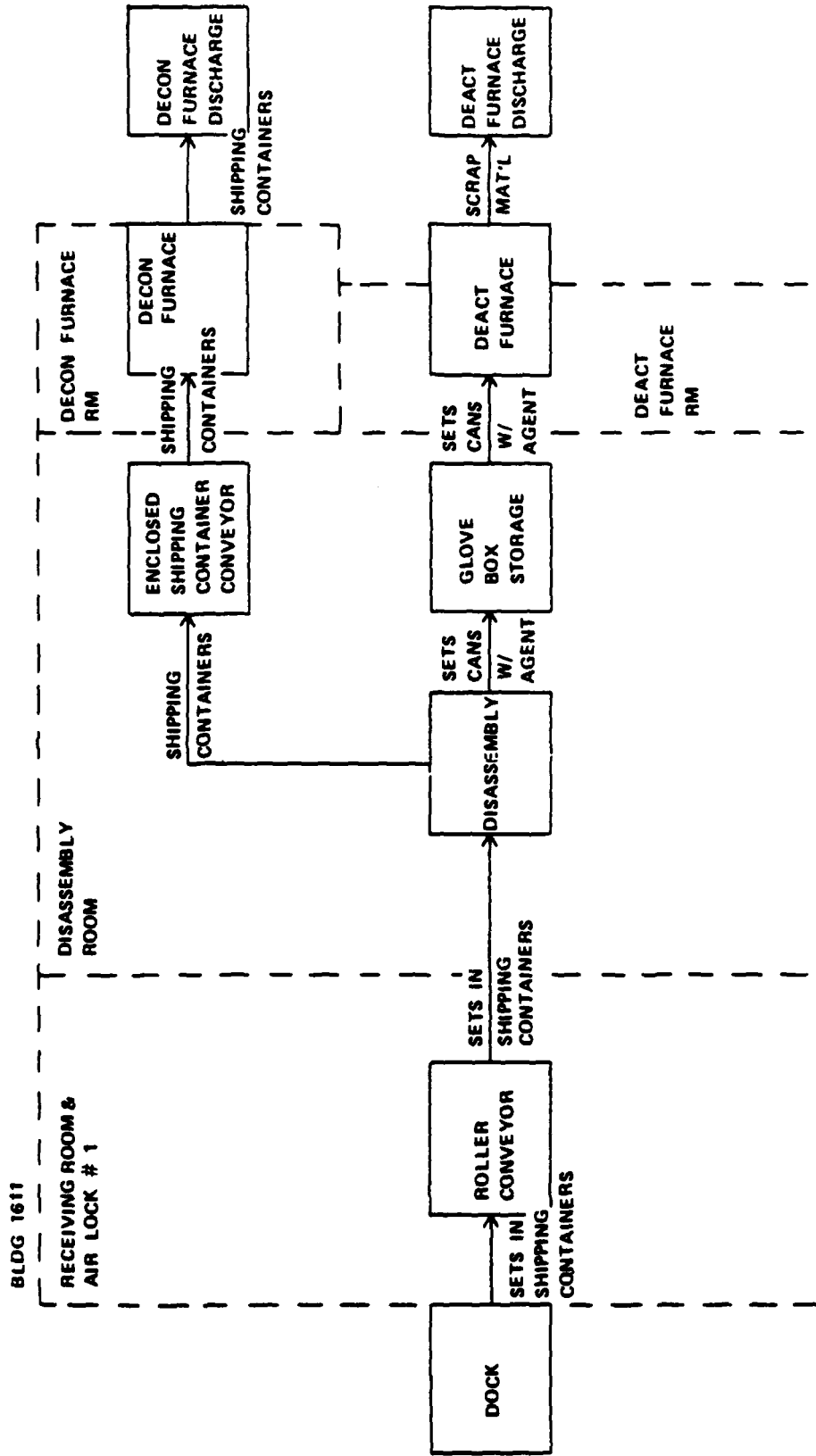

Figure 4 ID SET PROCESS FLOW DIAGRAM
(K941/K942, K951/K952, K953/K954)

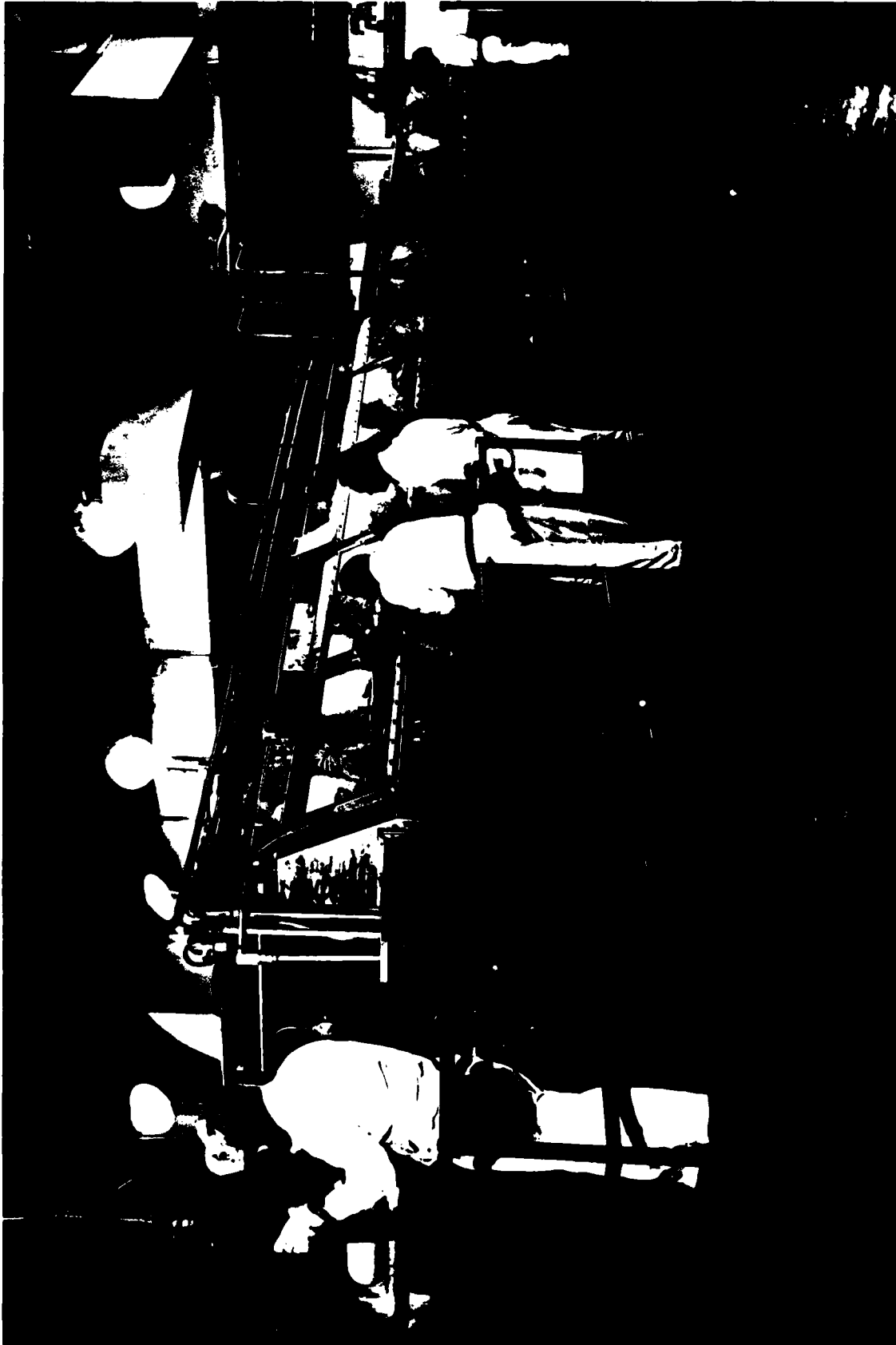

Figure 5 DISASSEMBLY/STORAGE GLOVEBOX

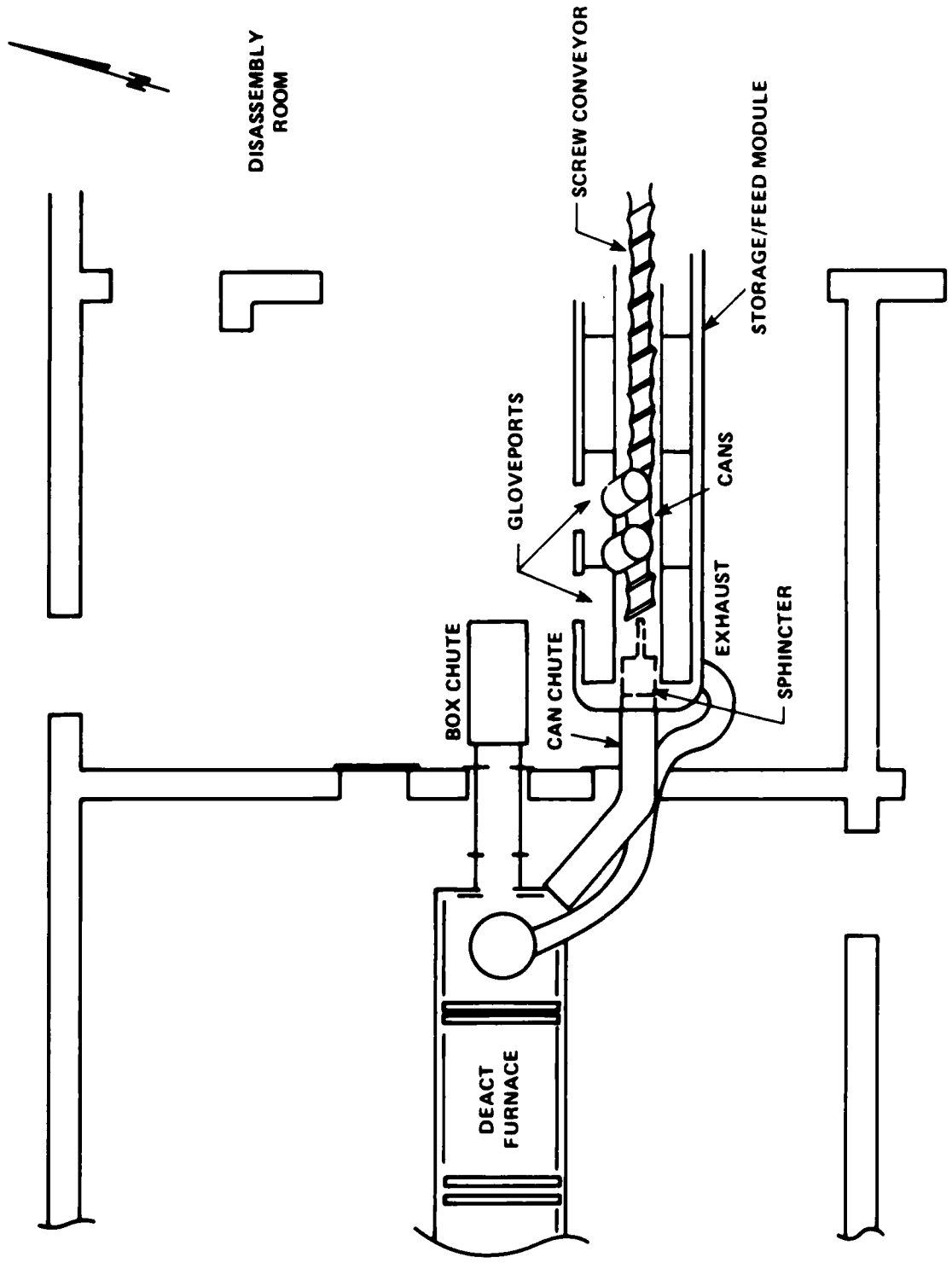

Figure 6 SCREW CONVEYOR AND FEED CHUTE LOCATIONS



Figure 7 DISASSEMBLY GLOVEBOX AND DECONTAMINATION MODULE

1100°F. There it unloaded the pigs onto two pedestals within the furnace. Pigs were retained in the furnace for 30 minutes at temperature. Another charging cart on the opposite end of the furnace was used to remove the pigs after they had been thermally decontaminated. All operations in the shroud were done remotely using push-button electric/pneumatic actuated devices. This shroud also had the capacity to store up to 36 containers.

The decontamination module shroud was kept under a negative pressure (approximately 0.1" H₂O) and provided sufficient air flow for a minimum of 25 air changes per hour with an air flow face velocity at all openings of 150 fpm minimum. The decontamination module shroud was connected to the building exhaust air system with room air being drawn through the pig loading station (air flow within the shroud was in the direction of the decontamination furnace). An air lock, approximately the length of the charging cart, was used on both sides of the decontamination furnace to prevent furnace flameouts when the furnace door was opened. Without the airlock, ventilation air in the decontamination module would have blown out the furnace burners (flameouts).

Handling of the pigs within the shroud was accomplished by means of a cradle mechanism to lift the pig from the shroud transport conveyor into place in the disassembly module. Remote pushbutton controls were installed at each work station to assist operators in working pneumatic hardware. The operations featured logic sequencing as well as overload stops to assure safe operations while working in and around the equipment.

1.2.2.2 Process Description

To start operations, steel cylinder pigs were removed from their pallet using an overhead crane. The pigs were then placed on a load tray adjacent to the air inlet to the decontamination module shroud. The operator then pressed a button marked LOAD and the following sequenced functions took place:

- a. When a pig was required at a disassembly station, stops located at the appropriate disassembly station were raised slightly above the surface of the belt.
- b. A pig was lowered into the decontamination module onto a continuously moving conveyor. When the pig reached the stops at the disassembly station, the forward motion ceased.
- c. The stops raised the pig into the jaws of the cradle clamp.
- d. The jaws closed and firmly gripped the pig.
- e. The stops returned below the top surface of the belt. Then the iris opened.
- f. The cradle was pushed toward the disassembly glovebox until the head of the pig was approximately six inches inside the glovebox.
- g. The iris closed.
- h. The disassembly operations began.

The disassembly operator, working through gloveports, removed the cans from the pig and resealed the pig with a rubber gasket. The eight bolts, lid and lead gasket were removed and set aside. The cylinder was remotely tipped 35 degrees, to facilitate removal of the cans from the cylinder. The cans were removed one at a time and placed on a screw-type conveyor which transported them through the disassembly module to the storage/feed module. Cans were processed to the furnace

from the storage/feed module. Cans which were ruptured or rusty, or contained loose ampules and trash, were packed into a fiberboard overpack prior to being placed on the conveyor. The steel cylinder was then inspected to assure all agent containers (cans) were removed. Cans stuck in the the shipping container were removed using a special rotary motion tool that reached up into the shipping container and removed or scraped the can free. After a Quality Assurance (QA) inspector certified that all cans had been removed from the shipping container, the lead gaskets from two containers, or 12 bolts were inserted into the container in alternating sequence. The lid of the container was reassembled using a consumable rubber gasket in place of the lead gasket and the two remaining bolts. Excess bolts and lead gaskets were not disposed of in the same container.

The operator visually inspected for any contamination and, if required, brushed that portion of the pig with methylcellosolve/caustic for decontamination. The work area was also decontaminated, if required. The trash generated during decontamination was placed in an overpack and inserted into the deactivation furnace. The QA inspector then used a key release to allow the decontamination module operator to remove this empty container and to supply a fresh one.

Concurrent with disassembly operations, cans were inserted into the deactivation furnace at the rate of one per minute. Insertion was made from the west end of the storage/feed module through a can feed system as shown in Figure 8. This system used a pneumatic switch, activated by the operator, to open a sliding door. A pneumatic ram then pushed the can down the feed chute. This can feed mechanism provided a positive seal: the sliding door covered the opening to the furnace when the chute was not in use. Thus, there was no possibility of smoke or heat coming from the furnace into the glovebox. (This system replaced an earlier one which provided a seal with a series of rubber glands, referred to as a sphincter.)

An operator, working through gloveports, removed a can from the conveyor and placed it on the can feed loading tray. After approximately 50 - 60 seconds had elapsed from the feeding of the previous can, the station became operational and the next can could be fed.

Prior to removal of an emptied pig from the disassembly module, the decontamination module operator received a green light signal from the QA inspector's key control on the disassembly glovebox. He then pressed the unload button at that station and the following sequence took place:

- a. The iris opened.
- b. The pig was pulled out of the glovebox.
- c. The iris closed and simultaneously stops raised up and rested against the pig.
- d. The jaws of the clamp opened releasing the pig.
- e. The stops descended leaving the pig unobstructed on the moving conveyor belt.

This conveyor transported the pig to a transfer conveyor which moved it onto an intermediate holding table. The holding table had a capacity to hold 24 empty pigs. The intermediate table was manually indexed to provide room for the pigs as they came off the conveyor and also for positioning pigs onto the decontamination furnace charging cart. The transfer conveyor, the intermediate table, and path to the decontamination furnace were enclosed in a shroud which was purged by air



Figure 8 CAN FEED SYSTEM

coming from the end of the decontamination module and the load station.

When 12 pigs were on the table, the charging cart operator, located in the disassembly room, positioned the motorized charging cart under the 12 containers. The cart was then raised to lift the 12 containers off the intermediate table. A load sequence was then started to automatically convey the pigs through the furnace room to the decontamination furnace door, where the cart stopped. A door closed behind the cart isolating the cart from the shroud, thus forming an air lock. At this point, controls were operated to open the furnace door and start the final portion of the load sequence into the furnace. When the cart reached the opposite end, the cart stopped and lowered leaving the pigs on firebrick pedestals (Figure 9). The cart then retracted, the furnace door closed, the air lock opened, and the cart returned to the intermediate table area.

The removal of pigs was accomplished from the discharge end of the furnace. The operator worked an exit cart (same configuration as the unit in the decontamination shroud), using pushbutton controls. The operator started an automatic removal sequence that opened the furnace door and drove the cart into the furnace in the down position. Once in the furnace the cart was raised, lifting the decontaminated pigs off the firebricks. The cart then left the furnace and stopped in an air lock outside the furnace until the furnace door closed. The door to the air lock was then opened and cart and pigs were brought to the outside (Figure 10). The cart was unloaded using a forklift and was returned to the air lock in a down position. After removal from the furnace, the pigs were marked as decontaminated to a "5X" condition. They were then transported to a holding area for reissue in accordance with existing procedures.

1.2.3 DISPOSAL OF BOXED SETS

1.2.3.1 General

X552 boxed sets were transported by truck to Bldg. 1611 in CNU-80 containers. The CNU-80's were moved from the trucks into the receiving room of Bldg. 1611 and placed on a supply conveyor which extended through an airlock into the disassembly room. The containers were moved from the supply conveyor, by an electric/manual forklift, to the box feed chute area. The CNU-80 lid was removed once the container was in the disassembly room. These boxed sets required no disassembly. They were manually inserted into the deactivation furnace through the box feed chute assembly (See Figure 11).

1.2.3.2 Equipment Description

The box feed chute assembly was a small airlock that isolated the deactivation furnace from the disassembly room. The chute was inclined at an angle of 51 degrees above horizontal. The upper (outer) door was manually opened and closed with a pneumatically operated cylinder providing a lock when the assembly was sequenced. The lower (flapper) door was operated by a pneumatic cylinder to rotate upward 90 degrees, thereby allowing the CAIS box, within the airlock, to slide down into the deactivation furnace. The deactivation furnace was operated at 1100°F. The afterburner treating gases from the deactivation furnace was operated at 1650°F.



Figure 9 PIGS BEING DEPOSITED IN DECONTAMINATION FURNACE

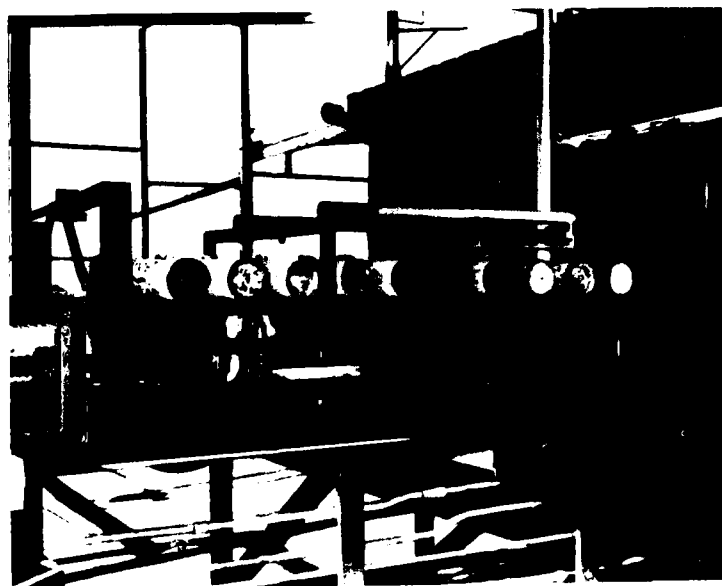

Figure 10 PIGS AFTER DECONTAMINATION

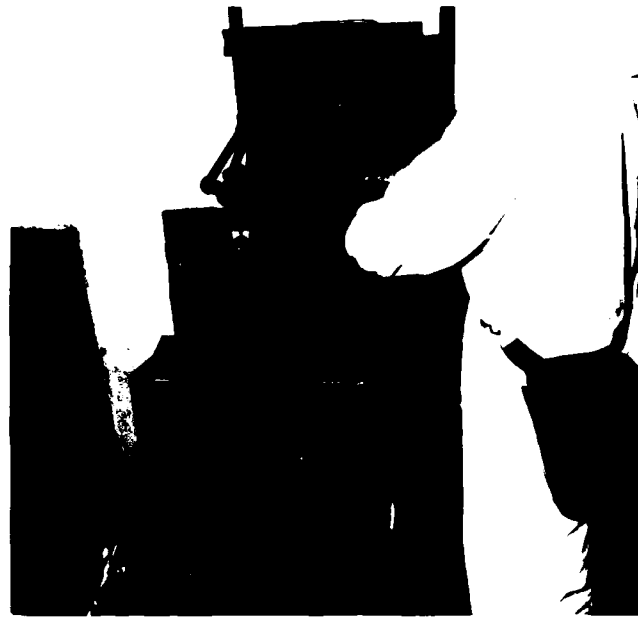

Figure 11 BOX FEED CHUTE

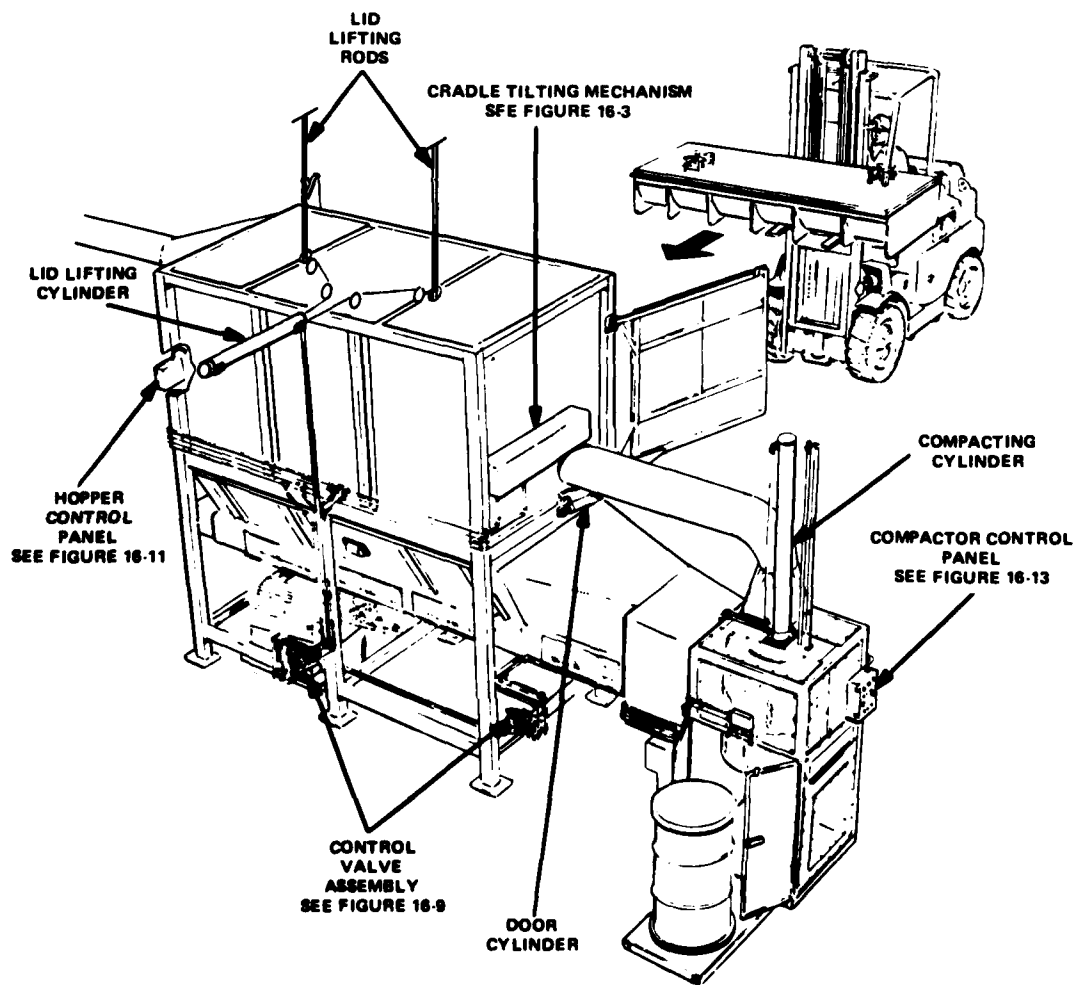

Figure 12 RESIDUE HANDLING EQUIPMENT

As soon as the box cleared the flapper door, the cylinder closed the door and a two-minute purge began. Purging air was induced into the airlock chamber at 5.0 PSIG and 690 SCFH. This provided the capability of 20 air changes during the two-minute purge cycle. The purge cycle was increased to a 4 minute purge near the end of Phase 3.

The controls were time-sequenced, so that a box set could be inserted into the deactivation furnace every five minutes.

1.2.3.3 Process Description

The box feed chute operator opened the upper door and inserted a box set. The door was closed and the PUSH TO CYCLE pushbutton was pressed. The flapper door opened and the boxed set slid into the deactivation furnace. The two-minute purge immediately started upon closing of the flapper door. A delay-loading timer also started and prevented cycling a set to the furnace for five minutes. At the end of five minutes, the BOX FEED CHUTE READY lamp lit and a new feed sequence could commence.

The residue from the deactivation furnace was conveyed to the decontamination furnace for further thermal treatment. A residue tray was inserted into the decontamination furnace to catch this residue and continue treatment. Periodically the trash was raked from the rear of the furnace to prevent residue buildup from spilling onto the floor of the decontamination furnace. After 96 minutes had elapsed since feeding the last box, the tray was removed and the residue was cooled and packaged in 55-gallon drums. (Refer to Figure 12). A flow chart of the overall process is shown in Figure 13.

1.2.4 DISASSEMBLY AND DISPOSAL OF K955 SETS

1.2.4.1 General

K955 Box sets were disposed of somewhat differently than the other types of CAIS due to their physical size. Since only a small quantity of these sets existed, large production rates were not attempted.

K955 Box sets were placed in a furnace tray, three to a tray, in the toxic storage yard. The furnace tray was then moved to the Residue Area of Building 1611. The tray was unloaded by forklift and taken directly from the truck to the charging cart located in the Residue Area.

1.2.4.2 Process Description

K955 sets were destroyed by direct feeding to the decontamination furnace. The nominal operating temperature of the decontamination furnace was 1400°F for K955 box sets insertion. This was governed from the Control Room. The Control Room, upon noting that proper conditions had been achieved, notified the Residue Area that a charge of the furnace was ready and then enabled a local control switch allowing the Residue Area workers to feed the furnace tray to the decontamination furnace.

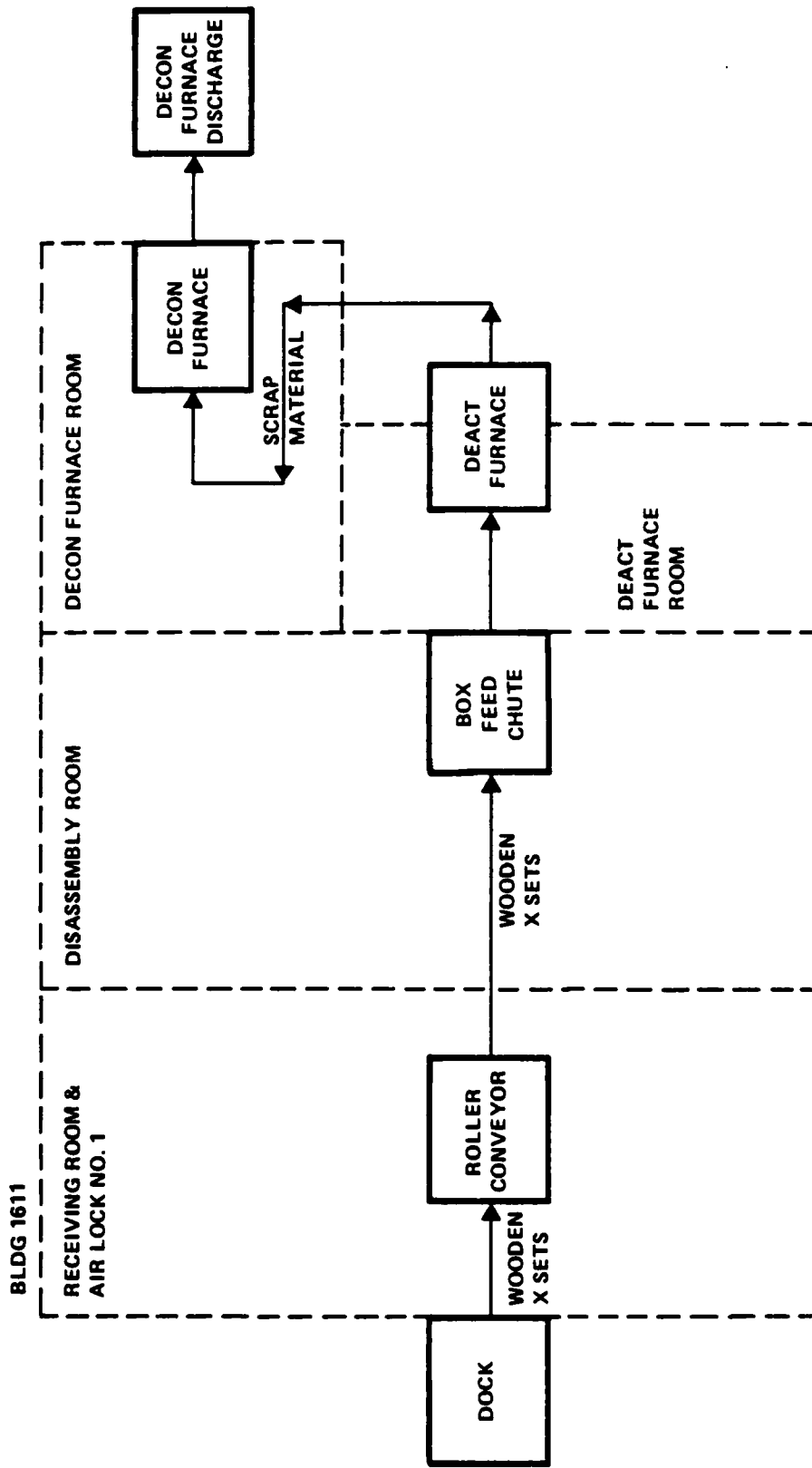

Figure 13 ID SETS PROCESS FLOW DIAGRAM (X-SET)

The K955 Box sets were kept in the decontamination furnace for a period of 2 hours at 1400°F to 1650°F. This was regulated in the Control Room. Upon verifying that these conditions had been met, the personnel in the Control Room again contacted the Residue Area Operators and enabled the local control switch that allowed the Residue Area workers to remove the furnace tray.

The furnace tray was then removed from the charging cart and placed in a corner of the residue area for cooling. After cooling, the remaining trash was processed through a compacter into 55 gallon drums. A flow chart of the overall process is shown in Figure 14.

1.2.5 ADDITIONAL ITEMS DESTROYED

On 20 December 1982, at the request of the U.S. Army Armament Materiel Readiness Command, two miscellaneous items were destroyed as part of the CAIS program. These were as follows:

1. Two glass vials, one containing mustard and one containing chloropicrin (PS), which had been collected as souvenirs by a World War I soldier and which were brought to Rocky Mountain Arsenal after his death.
2. A ten-gallon pail filled with glass vials, thought to contain mustard, which were recovered from Basin A at RMA.

These items were destroyed as part of the CAIS program because of their structural similarity to the sets and because they contained agents identical to those being handled in the CAIS program.

In addition, during cleanup operations in January 1983, an unbroken vial (K951) containing 6 ml of mustard dissolved in chloroform was found under the east end of the deactivation furnace. This vial was temporarily moved to storage. The vial was subsequently moved to the laboratory, in light of the small quantity of agent involved, and was destroyed under existing laboratory procedures on 9 February 1983. Chemical neutralization in caustic was used. Following certification that the remaining liquid was agent free, the lab waste was incinerated.

1.3 WASTE DISPOSAL

There were three types of waste generated during the CAIS disposal: furnace waste, spray dried salts and electrostatic precipitator (ESP) residue (see Figures 12, 15 and 16).

The furnace waste drums contained trash from both the deactivation and decontamination furnaces. The furnace wastes consisted primarily of burned cans, crushed glass and ash.

The spray dried salts were the result of spray drying the scrubber and quench liquids referred to as brines. These salts were largely sodium carbonate (Na_2CO_3) and sodium chloride (NaCl). Waste liquid was pumped to the spray dryer holding tanks in Bldg. 1703, dried to salts and then placed in 55 gallon drums.

The ESP residue was fly ash, salts and heavy metals and was placed in 55 gallon drums directly from the bins at the bottom of the ESP cells. All drums, labelled to indicate contents, were placed in warehouses awaiting final disposition.

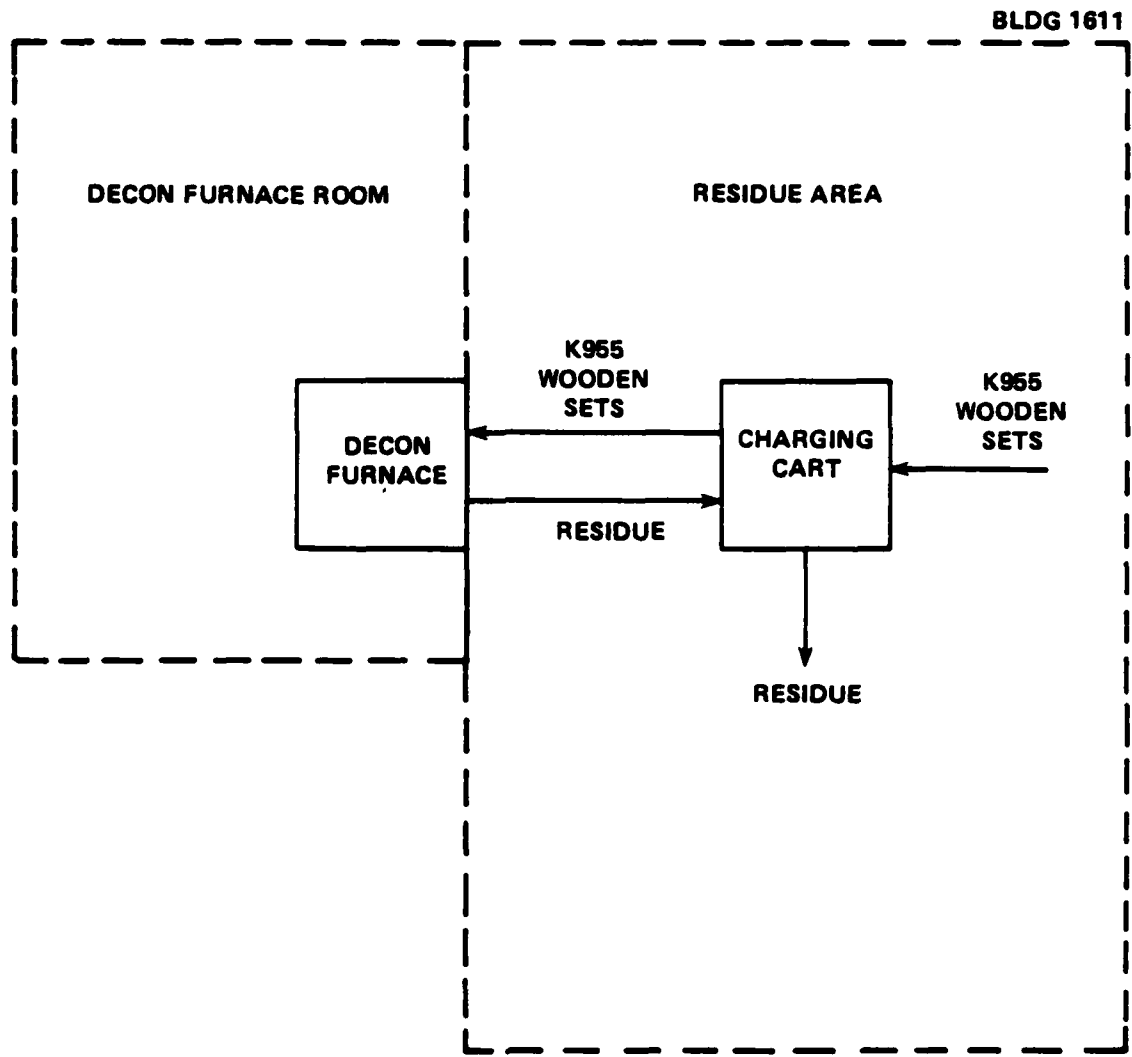

Figure 14 ID SET PROCESS FLOW DIAGRAM (K955)

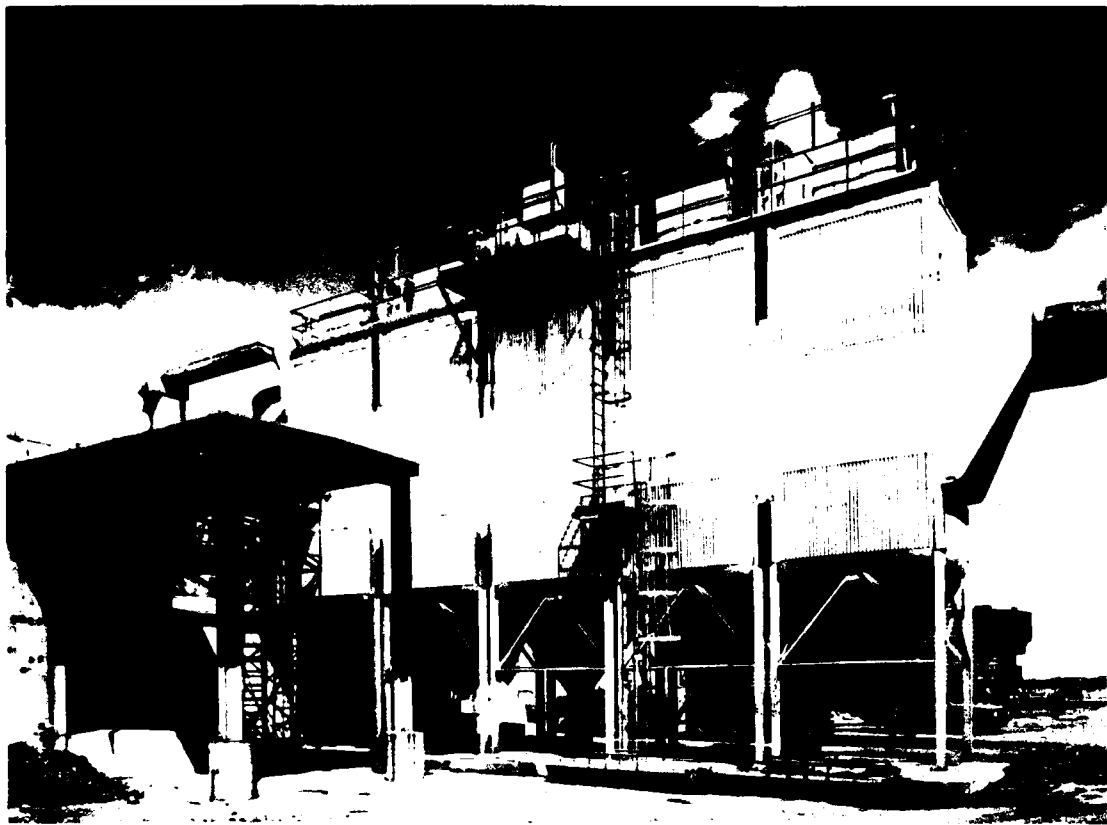

Figure 15 ELECTROSTATIC PRECIPITATOR



Figure 16 SPRAY DRYER

CHAPTER 2 PRODUCTION SUMMARY

2.1 SETS DESCRIPTION

There were a total of seven types of Chemical Agent Identification Sets scheduled for disposal under this program. Phase 1 destroyed two types (K941 and K942) as well as those X-type sets containing mustard. Phase 2 destroyed a third type of set (K945) and the majority of the remaining X-type sets. The remaining sets were disposed of as part of Phase 3 (see Figures 17, 18, 19 and 20). A full description of sets destroyed in all three phases is given in Appendix F.

2.1.1 K951 and K952, WAR GAS IDENTIFICATION SET, INSTRUCTIONAL

The sets were contained in a steel cylinder 6-5/8 inches (168.3 mm) in diameter, approximately 38 inches (965.2 mm) long and 0.145 inches (3.7 mm) thick wall. The open end was closed by a flanged end cover which was secured by eight bolts. There were four press-fit metal containers packed into the steel container. Inside of each press-fit container were 12 cardboard screw cap containers, each containing a hermetically sealed glass tube 1 inch (25.4 mm) in diameter and 7-1/2 inches (190.5 mm) long. Of the 12 tubes, three tubes contained a 1.4 fl oz (40 cc) solution of Mustard (H, 5 percent in chloroform), three tubes contained Lewisite (L, 5 percent in Chloroform), three tubes contained Chloropicrin (PS, 50 percent in Chloroform) and three tubes contained Phosgene (CG, neat). There was a total of 26 fl oz (0.768 liters) of agent or 0.528 liters of lethal agent per steel cylinder. The only difference between the K951 and K952 sets is that blasting caps were issued with the K951, but these caps were packed and shipped in a separate container. The blasting caps were not part of this disposal operation.

2.1.2 K953 AND K954, WAR GAS IDENTIFICATION SET, INSTRUCTIONAL

The sets were contained in a steel cylinder 6-5/8 inches (168.3 mm) in diameter, approximately 38 inches (956.2 mm) long with a 0.145 inch (3.7 mm) thick wall. The one open end was closed by a flanged end cover which was secured by eight bolts. There were four press-fit metal containers packed into the steel container. Inside of each press-fit metal container were 12 cardboard screw cap containers, each containing a hermetically sealed glass tube 1 inch (25.4 mm) in diameter and 7-1/2 inches (190.5 mm) long. Of the twelve tubes, two tubes each contained 1.4 fl oz (40 cc) of the following: Mustard, Lewisite, Phosgene, Cyanogen Chloride (CK), Nitrogen Mustard (HN-1) and GA-simulant. The Mustard and Lewisite were in 5 percent chloroform solutions, Cyanogen Chloride and Phosgene were neat agent and Nitrogen Mustard was in a 10 percent chloroform solution. There was a total of 23.8 fl oz (.704 liters) of agent per steel cylinder. The only difference between the K953 and K954 sets is that blasting caps were issued with the K953, but these caps were packed and shipped in a separate container. These blasting caps were not part of this disposal operation.

2.1.3 K955 SETS, GAS IDENTIFICATION, INSTRUCTION (NAVY)

Each set was contained in a wooden box with a hinged cover. The box measures 11-3/4 inches by 15-1/2 inches by 30-3/8 inches (298.5 x 393.7 x 771.5 mm). The wooden box was divided into eight sections. Seven of the sections contained cans



Figure 17 K951/K952/K953/K954 WAR GAS IDENTIFICATION SET, INSTRUCTIONAL



Figure 18 GAS SET IDENTIFICATION, INSTRUCTION X-SETS



Figure 19 TOXIC GAS SET K941



Figure 20 K955 SET, GAS IDENTIFICATION INSTRUCTIONAL

approximately 4-1/4 inches (110 mm) in diameter x 6-3/4 inches (175 mm) high, painted olive drab. Each can contained a ground-glass stoppered bottle. Four of the bottles contained 3 fl oz (90 cc) of activated charcoal on which an agent was adsorbed. One bottle contained Lewisite (L), one Chloropicrin (PS), and two contained Mustard (H). A fifth bottle contained solid Triphosgene (CG simulant). The remaining two bottles contained 15 grams each of solid Chloroacetophenone (CN) and Adamsite (DM). There is a total of 3.5 fl oz (0.103 liters) of agent or 0.075 liters of lethal agent. CN, PS, CG-Simulant and DM are not classified as lethal chemical agents.

2.1.4 X552 SETS, GAS IDENTIFICATION, INSTRUCTIONAL (NAVY)

These sets were contained in a wooden box with a hinged cover. The box measured 7-1/2 inches wide x 16 inches long x 11-3/4 high (191 mm x 406 mm x 298 mm) and was divided into two compartments. In each compartment was a can 4-1/4 inches (110 mm) in diameter and 6-3/4 inches (175 mm) high, surrounded by packing material. Inside each can was a bottle with ground glass top. The X552 set contained 1.7 fl oz (0.050 liters) agent, chloropicrin (PS).

2.2 NUMERICAL SUMMARY OF SETS DESTROYED

During Phase I, from 5 May 1981 to 28 January 1982, 802 K941/K942 sets were destroyed, 82 X302 sets, 1202 X547 sets, 1302 X550 sets and 1246 X551 sets were destroyed, for a total of 4634 sets destroyed. During Phase II, from 2 February 1982 to 19 April 1982, 724 X548 sets, 51 X549 sets, 525 X545 sets, 333 X546 sets and 1335 K945 sets were destroyed, for a total of 2968 sets destroyed. During Phase III, 6995 K951, 3804 K952, 243 K953, 254 K954, 94 K955, 4 K941 and 701 X552 sets were destroyed, for a total of 12,095 sets destroyed. This results in a total of 19,697 sets destroyed during operations. During the 1979 Pilot Test, 1761 sets were destroyed. The program, therefore, destroyed a total of 21,458 sets. For further analysis on sets destroyed by day, refer to Appendix L.

2.3 DOWNTIME ANALYSIS

2.3.1 GENERAL

In the interpretation of downtime data, three methods are widely used. These are the "frequency of occurrence," "subsystem downtime," and "process downtime" methods. Each method has inherent advantages and disadvantages.

2.3.2 FREQUENCY OF OCCURRENCE

The method used by maintenance at RMA is the "frequency of occurrence" method, which is a good rule-of-thumb for how a given subsystem is performing. For historical purposes, however, it fails to indicate the extent of an event.

2.3.3 PROCESS DOWNTIME

The most familiar method, and the one most widely used by management, is the "process downtime" method which measures the overall time the plant is not processing. This method fails to identify problems in enough detail for engineering purposes; however, it provides an excellent yardstick with which to measure overall plant performance. It is also best used for scheduling purposes. Table 1 shows an analysis by month of process downtime.

TABLE 1
Downtime Analysis By Sets Destroyed

Month	Days of Scheduled Opns	Sets Destroyed	Sets Scheduled	Percent Downtime
May 81	15	420	984	57.3%
Jun 81	22	548	912	39.9%
Jul 81	11	484	600	19.3%
Sep 81	10	270	576	53.1%
Oct 81	21	928	1368	32.2%
Nov 81	19	447	600	25.5%
Dec 81	22	441	864	49.0%
Jan 82	19	1096	1176	6.8%
Feb 82	19	879	1368	35.8%
Mar 82	23	1482	1656	10.5%
Apr 82	22*	968	1584	38.9%
May 82	20	970	1800	46.1%
Jun 82	22	887	1350	34.3%
Jul 82	21	1008	1890	46.7%
Aug 82	22	1319	1980	33.4%
Sep 82	21	1732	1890	8.4%
Oct 82	20	2606	1800	0.0%**
Nov 82	20	1667	1800	7.4%
Dec 82	16	1545	1296	0.0%**

* included 3 days set material in pigs at 24/day

** use of overtime to extend operations

It should be noted that the "sets scheduled" column denotes a theoretical number of sets which could have been processed in the given number of operating days had no downtime occurred.

Using the results of Table 1 and weighting each month by the number of operating days which it contained, an overall downtime of 28.3% was calculated. By the use of extensive overtime during the months of October and December 1982, this was effectively reduced to 23.2%. It should be noted that the original project planning used a downtime factor of 30%, which proved to be a good estimate of the anticipated overall downtime.

There are two observations which can readily be made by studying Table 1. The first is that each time the operation was shut down, such as for the Weteye move in July 1981, the restarting of the facility resulted in initial high downtime which gradually decreased. The second observation is that each time a major set type was changed, a similar phenomenon was seen. Set types were changed in February 1982, April 1982, June 1982 and July 1982.

It should also be observed that one particular piece of equipment contributed significantly to the downtime of the system during late 1981 and again from April to June 1982. This was the deactivation furnace conveyor. Repeated rebuilds of this

unit failed to correct the problem. The unit was finally replaced in June 1982. The new conveyor, which was of considerably simpler design, succeeded in eliminating this major bottleneck in the system. Following an initial break-in period, it ran successfully with a minimum of trouble through the end of the program.

2.3.4 SUBSYSTEM DOWNTIME

The last method used in reporting downtime is the "subsystem downtime" method. This was used operationally by the engineering staff on the CAIS program. This method is very specific and historically accurate. Its main disadvantage is that of being open to misinterpretation in that a breakdown of a certain subsystem does not necessarily mean that the overall process is down. One cannot total hours and arrive at the hours the process was down by this method.

A complete listing of "subsystem downtime" is provided in Appendix P. This list gives the following information:

- 1) Date.
- 2) Subsystem which failed.
- 3) Primary component of that system which caused the failure.
- 4) Downtime *for that subsystem* (not the process) in hours.
- 5) Comments made by the plant engineer or foreman.

CHAPTER 3 AIR MONITORING SUMMARY

3.1 DESCRIPTION OF SAMPLING TECHNIQUES

3.1.1 LEWISITE (L) AGENT SAMPLING

Bubbler collection was used for lewisite sampling. The liquid of choice, a 2% solution of sodium hydroxide, reacted with lewisite to form arsenic oxide. Lewisite was trapped in this fashion with a 94.5% efficiency in the laboratory and 93% efficiency in the plant environment.

The bubbler tubes used for lewisite (see Figure 21) were made of plastic and were disposable. They were used only one time. Air samples were drawn through these bubblers at a rate of 2.0 liters per minute. The flow was maintained by the use of in-line critical orifices. The standard fill for the lewisite bubbler was 10 ml of 2% sodium hydroxide solution. The lewisite bubblers were marked with a ring of yellow tape to color-code identify them. In addition, at each sampling location was a constant temperature bath in which the bubblers were immersed. The temperature was set at 2° to 8°C and monitored during the eight-hour sampling period.

Each week, fresh lewisite bubblers were prepared at the laboratory (Bldg. 313) and transported to the CAIS disposal plant. Monitoring personnel at Building 1611 obtained the bubblers from the plant chemist's office. They were then installed in the disassembly room (DR), control room (CR), residue area (RA), and the stack (ST) (see Figure 22).

Bubblers were collected after an eight hour sampling period at all locations.

Upon completion of a sampling period, each bubbler was retrieved and returned to the plant chemist's office for transportation to the laboratory for analysis.

The Standing Operating Procedure for the analytical method for L is given in Appendix J.

3.1.2 MUSTARD AGENT SAMPLING

Sampling for mustard was achieved by drawing air from the areas to be sampled through a bubbler. The liquid of choice, diethylphthalate, had a particular affinity for mustard and collected it with essentially 100% efficiency.

The bubbler tubes used for mustard were made of glass and were filled with glass beads to maintain high collection efficiency. Air samples were drawn through these bubblers at a rate of 6 liters per minute. The flow was maintained by the use of in-line critical orifices. The standard fill for a mustard bubbler was 10 ml of diethylphthalate. The mustard bubblers were marked with a ring of brown tape to color-code identify them. In addition, at each sampling location was a constant temperature bath in which the bubblers were immersed. The temperature was maintained between 2° and 8°C and monitored during the two hour sampling period.

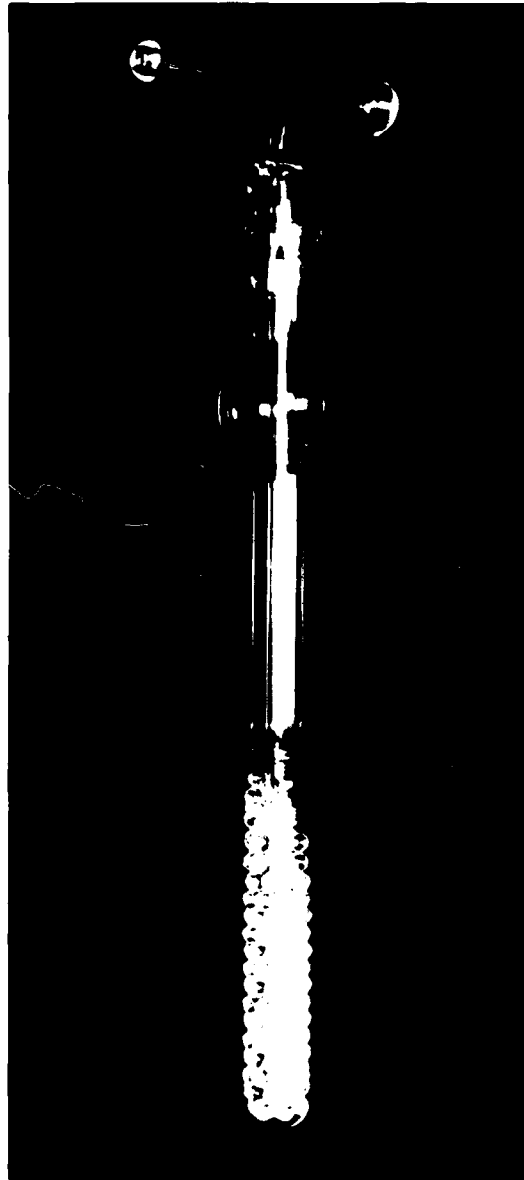
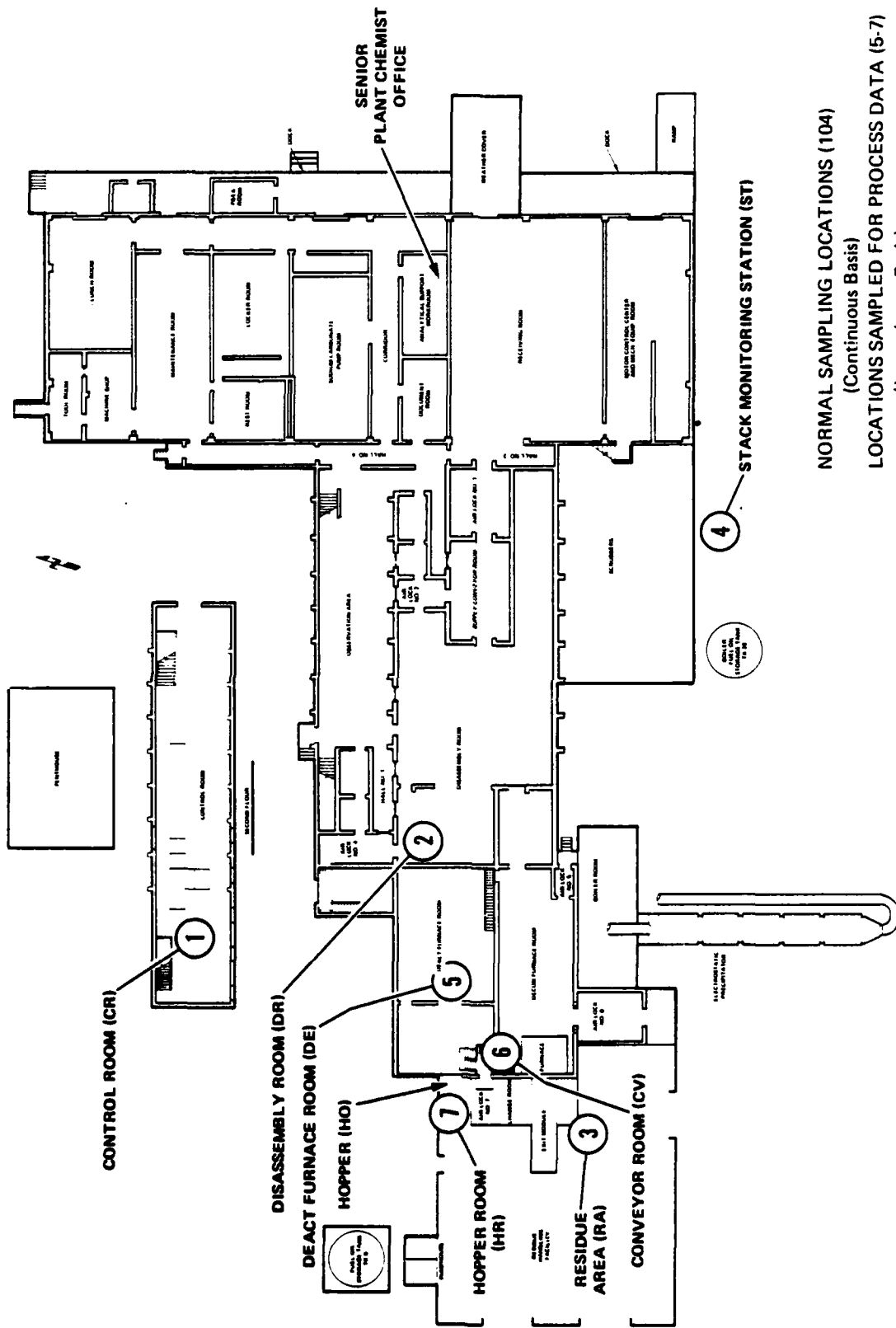

Figure 21 TYPICAL BUBBLER



NORMAL SAMPLING LOCATIONS (104)
 (Continuous Basis)
 LOCATIONS SAMPLED FOR PROCESS DATA (5-7)
 (Intermittent Basis)

Figure 22 SAMPLING STATION LOCATIONS - BLDG. 1611

Each day, the bubblers were inspected, cleaned, and filled at the laboratory (Bldg. 313) and then transported to the CAIS disposal plant (Bldg. 1611). Monitoring station personnel obtained the bubblers from the plant chemist's office and installed them in the disassembly room, control room, residue area, and the stack.

Bubblers were replaced sequentially after a two-hour sampling period at all locations. In addition, a staggered shift of two hour bubblers was started every hour in the disassembly room. Bubblers in the disassembly room therefore typically ran 0800-1000, 0900-1100, 1000-1200, etc. Upon completion of a sampling period, each bubbler was retrieved, returned to the plant chemist's office, and packed for transportation to the laboratory for analysis.

A copy of the Standing Operating Procedure for the analytical method for H is presented in Appendix K.

3.1.3 TRIPHOSGENE (T) AGENT SAMPLING

Sampling for triphosgene was accomplished by bubbler collection. The liquid of choice for collecting triphosgene was diethylphthalate with proportions of 4 p-nitrobenzylpyridine and N-benzylamine. Since triphosgene was classed as a non-lethal chemical, the laboratory work on collection efficiency was not as well documented as for lethal agents. Nevertheless, the collection efficiency was estimated as over 90%.

The plastic tubes used for triphosgene were disposable bubblers used only one time. Air samples were drawn through these bubblers at a rate of 2.0 liters per minute. The flow was maintained by the use of in-line critical orifices. The standard fill in the triphosgene bubbler was 10 ml of solution. The solution for triphosgene bubblers was made by adding 5 grams of 4 p-nitrobenzylpyridine and 10 grams of N-benzylamine to 2 liters of diethylphthalate. The bubblers were marked with a ring of blue tape to color-code identify them as triphosgene or "T" bubblers. At each sampling location was a constant temperature bath in which the bubblers were immersed. The temperature was maintained between 2° and 8°C for the two hour sampling period.

Each day fresh triphosgene bubblers were prepared at the laboratory (Bldg. 313) and transported to the CAIS disposal plant. Monitoring personnel at Building 1611 obtained the bubblers from the plant chemist's office. They were then installed in the disassembly room, control room, residue area and the stack. Bubblers were sequentially replaced at all locations after a two hour sampling period.

Upon completion of a sampling period, each bubbler was retrieved and returned to the plant chemist's office for transportation to the laboratory for analysis.

3.1.4 CHLOROACETOPHENONE (CN) AGENT SAMPLING

Sampling for chloroacetophenone (CN) was accomplished by drawing air from the areas to be sampled through a bubbler. The liquid of choice for collecting CN was propylene glycol. Since CN was classed as a nonlethal chemical, the laboratory work in collection efficiency was not as well documented as for lethal agents. Nevertheless the collection efficiency was estimated as over 90%.

The bubbler tubes used for CN were made of plastic and were disposable. They were used only one time. Air samples were drawn through these bubblers at a rate of 2.0 liters per minute. The flow was maintained by the use of in-line critical orifices. The standard fill in the CN bubbler was 10 ml of propylene glycol.

The bubblers were marked with a ring of red tape to color-code identify them. In addition, at each sampling location was a constant temperature bath in which the bubblers were immersed. The temperature was maintained between 2° and 8°C and monitored during the two hour sampling period.

Each day fresh CN bubblers were prepared at the laboratory and transported to the CAIS disposal plant. Monitoring personnel at Building 1611 obtained the bubblers from the plant chemist's office. They were then installed at four locations: the disassembly room, control room, residue area and the stack. Bubblers were replaced sequentially after a two hour sampling period at all locations.

Upon completion of a sampling period, each bubbler was retrieved and returned to the plant chemist's office for transportation to the laboratory for analysis.

3.1.5 CYANOGEN CHLORIDE (CK) AGENT SAMPLING

Sampling for CK was accomplished by the use of industrial air monitoring sample tubes. These tubes were manufactured by the Draeger Company and were direct reading in parts per million. Calibration of these tubes was accomplished in preliminary laboratory testing at Rocky Mountain Arsenal, which indicated the industrial calibration as marked on the tubes was sufficient.

3.1.6 MIRAN SAMPLING

A programmable miniature infrared analyzer, the MIRAN 80 was used to monitor for three toxic or harmful compounds: chloroform, chloropicrin, and phosgene. The concentration ranges that were monitored were at or below the Time Weighted Average (TWA) levels, which are concentrations a worker may be exposed to during a normal forty hour work week without suffering any adverse effects. For example, the TWA for phosgene is 0.06 ppm (parts per million). Monitors for each individual compound were used in all areas where personnel were allowed to work unmasked.

The MIRAN 80 (see Figure 23) utilizes a gas cell through which the air to be analyzed is drawn. A beam of infrared light is passed through the sample over a 20 meter path length achieved by a mirror system. It then exits the cell where it strikes a detector which measures light absorption at wavelengths related to the molecular structure. A specific wavelength of the infrared spectrum is chosen which identifies each compound by vibrational energy absorption. As the light passes through the cell containing the particular contaminant, the molecules of that compound absorb a portion of the light energy proportional to the concentration present. The result is a net loss of energy reaching the detector. The energy difference between a clean zero gas and the contaminated sample gas can be used to quantify the amount of contaminant present.

The monitoring system consisted of four primary instruments with two back-up instruments which could be brought on line quickly in the event of primary instrument malfunction. The areas monitored by this system were the control room,

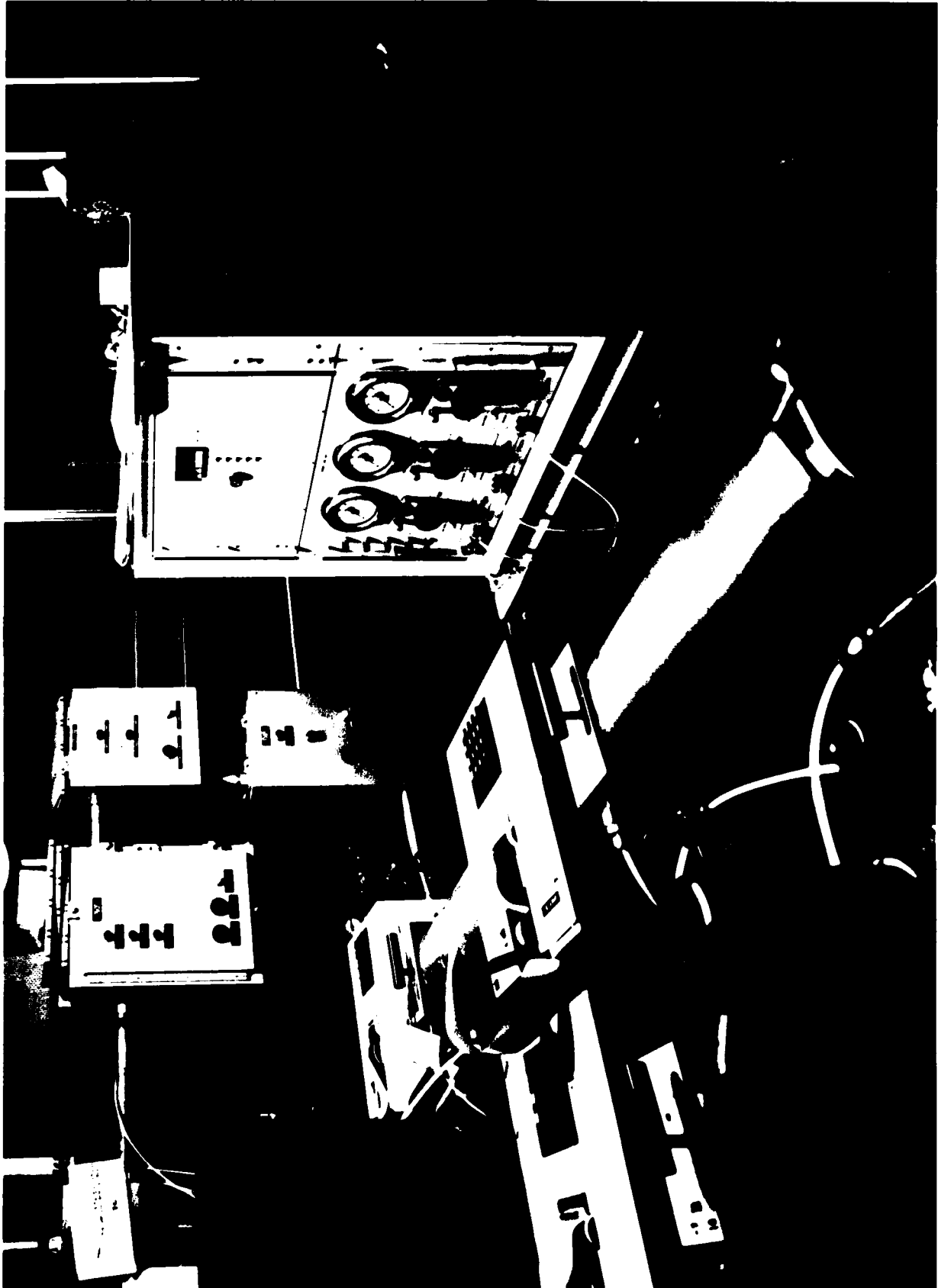

Figure 23 MIRAN 80 WITH THREE-COMPOUND QUALITY CONTROL
PERMEATION GENERATOR

disassembly room, residue handling area, and the stack. Each of these areas was monitored twice per hour during normal conditions, with each sample requiring approximately twenty minutes for complete analysis. In the event of upset conditions, samples were run continuously until the area again proved to be clear.

The MIRAN system was used to provide a two stage alarm for the areas monitored. The first alarm was the "Notification Level" which was set below the TWA concentration for the work areas and below the standard maintained at the stack. This alarm was used to signal a possible low level leak and required personnel in the area to mask. The second stage alarm was the "Shutdown Level" concentration, which required all operations to cease, with all personnel masking and taking appropriate safety actions. Due to the fact that analysis turn-around time was short, the MIRAN system provided a near real-time monitor for worker safety.

3.1.7 SF₆ TRACER GAS SAMPLING

Sulfur hexafluoride (SF₆) gas was metered into the disassembly glovebox and box feed chute at 10 cubic centimeters per minute and a pressure of 35 psi to act as a tracer gas. SF₆ is non-toxic, chemically inert, odorless, tasteless, and can be detected at very low concentrations (10⁻¹²) parts of SF₆ per part of air. Samples of disassembly room and control room air were drawn automatically by the detector (see Figures 24 and 25) every five minutes. The detector was set to sense buildups of SF₆ outside of the glovebox or box feed chute of 10 parts per trillion to indicate potential leakage.

For a complete and detailed coverage of SF₆ analysis, refer to Appendix E.

3.1.8 NO_x AND SO₂ SAMPLING

A Dynascience monitor sampled Bldg. 1611 exhaust stack gas on a continuous basis (see Figure 26). The stack gas was drawn through a 100 micron Cuno stainless steel filter by a sampler pump. The gas was cooled by a water bath, analyzed for NO_x and SO₂ and then returned to the stack. Calibration was maintained by periodically sampling known concentrations of NO_x and SO₂.

3.2 DESCRIPTION OF ANALYSIS TECHNIQUES

3.2.1 LEWISITE (L) AGENT ANALYSIS

3.2.1.1 Analysis of Calibration Samples

The analysis for lewisite was actually an analysis for arsenic. All arsenic found was factored by the relative molecular weights of the two components (lewisite: arsenic) and computed as an equivalent amount of lewisite. The analysis was performed using a Perkin-Elmer Atomic Adsorption Spectrophotometer, referred to as an "AA."

The sequence of analysis for all samples (calibration, plant and quality control) followed the sequence described here:

- 1) Reconstitution of the sample to 10 ml.
- 2) Acidification of a 5 ml. portion of the sample by addition of 3 ml of 12N sulfuric acid.

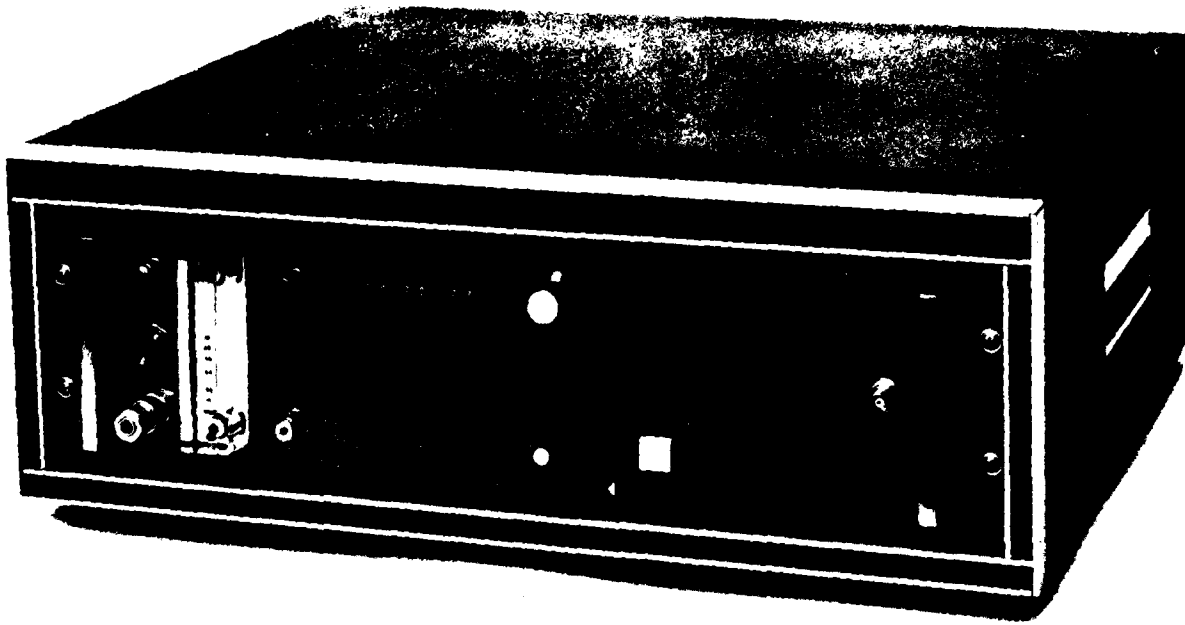

Figure 24 SF₆ DETECTOR/ANALYZER

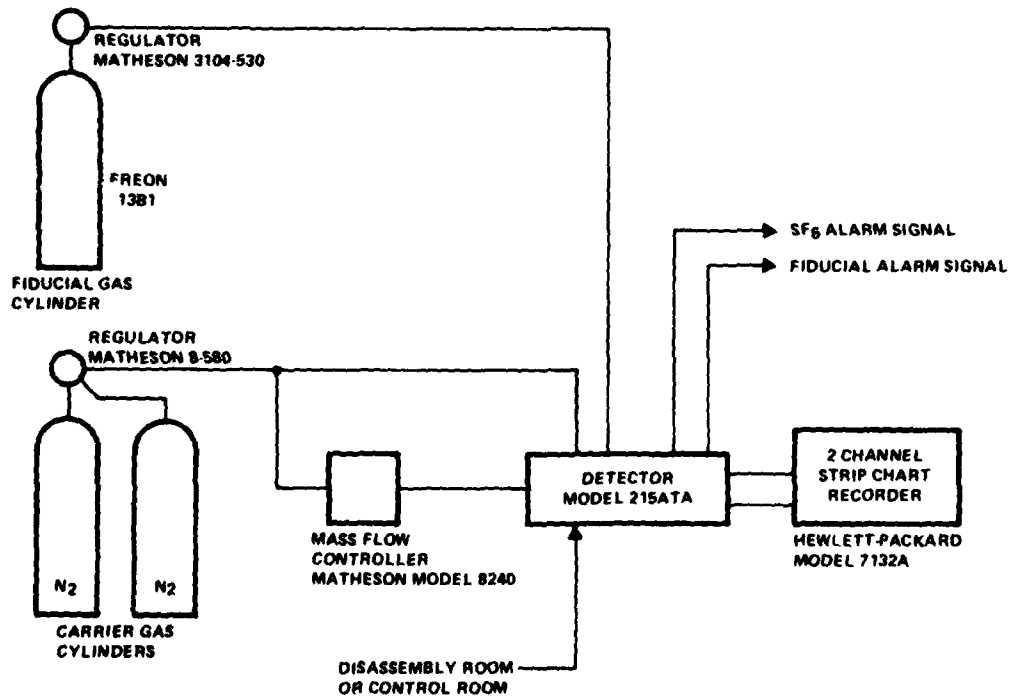

Figure 25 SF₆ FLOW DIAGRAM

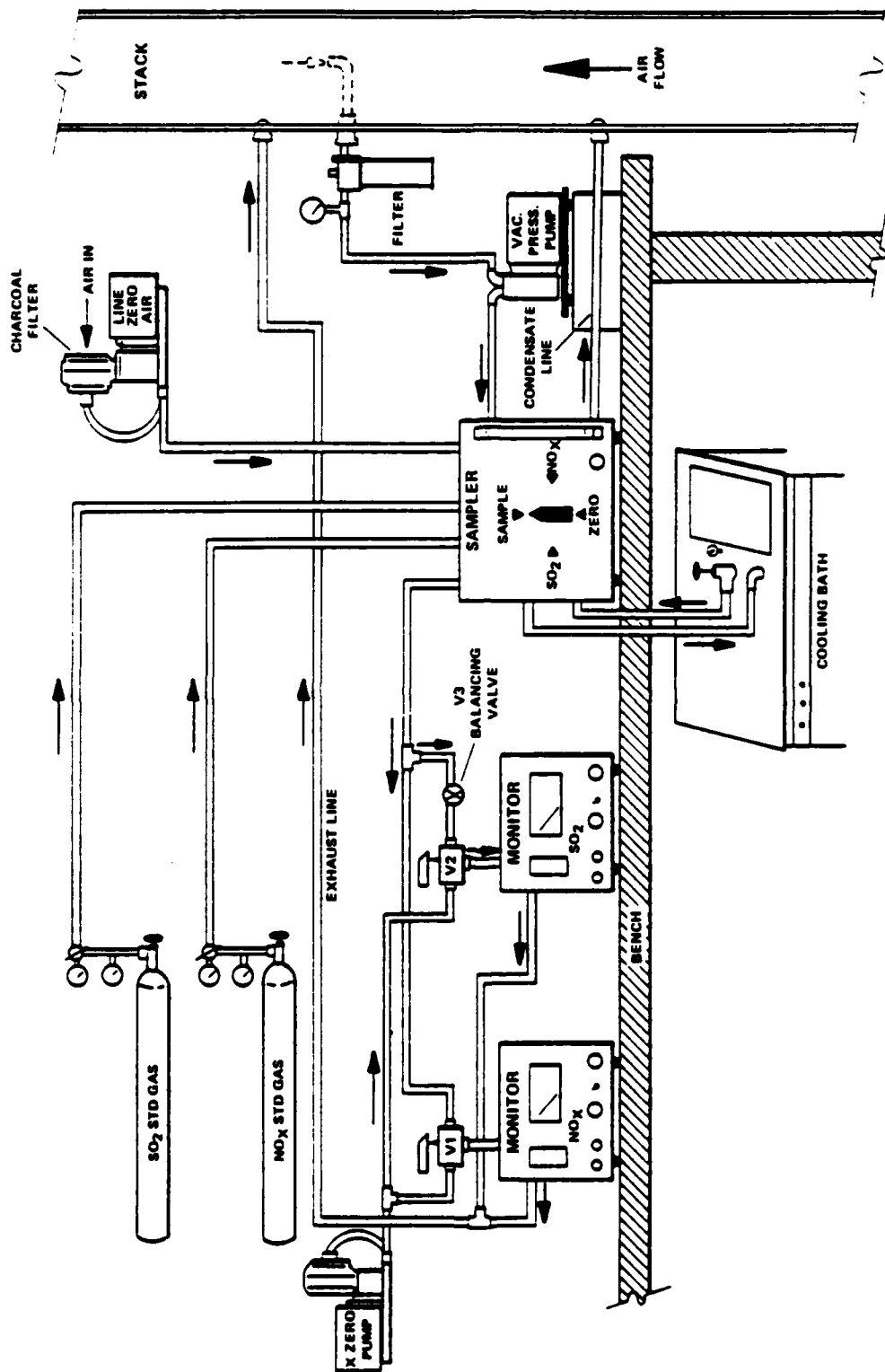

Figure 26 DYNASCIENCE MONITOR, BLDG. 1611 STACK

- 3) Reduction of the sample by addition of 2 ml. of 10% potassium iodide (KI) which reduced any As^{+5} in solution to As^{+3} . Samples must be analyzed at least 60 minutes but not more than 4 hours after reduction.
- 4) Preparation for analysis by removing 1 ml. of solution to a Perkin-Elmer reaction flask and adding 10 ml. of 3.2% HCl. The reaction flask was then placed in the Mercury Hydride System (MHS-20) portion of the AA.
- 5) Addition of sodium borohydride (approximately 6 ml.) by a pre-programmed sequence in the MHS-20.
- 6) Reaction of the sodium borohydride with the solution in the reaction flask to form arsine (AsH_3) which is vented into the quartz furnace.
- 7) Breakdown of the AsH_3 at $1000^{\circ}C$ in the quartz furnace to elemental arsenic which is measured spectrophotometrically.

To initiate the analysis of standards, a $.576 \mu g/ml$ standard solution was prepared. One aliquot was analyzed on the AA and a nominal response of approximately .9 for the Model 503 AA or 1.0 for the Model 603 was obtained. This first standard was checked only after the AA was allowed a two hour warm-up period.

Following the initial procedure, duplicate aliquots of three calibration standards (0.000, 0.288 and $0.576 \mu g/ml$) were analyzed. Each was interspaced with blank samples.

The time between samples involved about 3-4 minutes not including the sample preparation time referenced above. The analyst recorded these results on an Analyst Work Sheet designated for calibration.

A calibration curve (see Figure 27) was prepared according to a natural logarithmic function determined during laboratory testing. In addition, the analyst was required to compare his results against criteria determined during the prior laboratory testing. Since two distinct models of Perkin-Elmer AA's were used at RMA, a separate criteria was developed for each spectrophotometer as follows:

Concentration	Model 503		Model 603	
	Minimum Reading	Maximum Reading	Minimum Reading	Maximum Reading
0.00 $\mu g/ml$	0.0	0.05	0.0	0.04
0.288 $\mu g/ml$	0.47	0.58	0.53	0.67
0.576 $\mu g/ml$	0.80	1.00	0.86	1.12

If the analytical results did not meet all of the above criteria, the operator was required to recalibrate his instrument. If the results were satisfactory the operator was allowed to begin the analysis of actual plant samples.

3.2.1.2 Analysis of Actual Plant Samples and Quality Control Samples

The liquid level in each plastic bubbler was checked and changes were recorded. If the level was low, the bubbler was returned to 10 ml volume by the addition of 2% caustic. The solution was then transferred to test tubes and treated according to the preparation steps outlined in section 3.2.1.1.

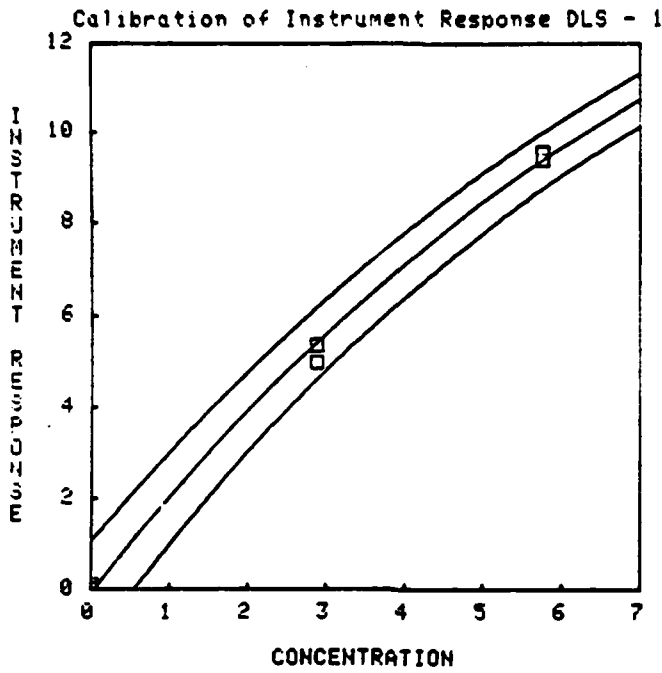

AGENT: L
 DATE: 06/24/82

STATISTICS

BARTLETTS:
 0.489
 R-SQUARED:
 0.997
 MSE:
 3.207E-004

PARAMETERS

$\ln(Y) = a + bX$
 $a = 6.975E-001$
 $b = -1.110E+000$
 $Y' = f - Y$
 $X' = X + h$
 $f = 2.000E+000$
 $h = 0.000E+000$

SCALE FACTORS:
 X axis: 10^{+1}
 Y axis: 10^{+1}

Calibration Curve # 2

Figure 27 CALIBRATION CURVE LEWISITE

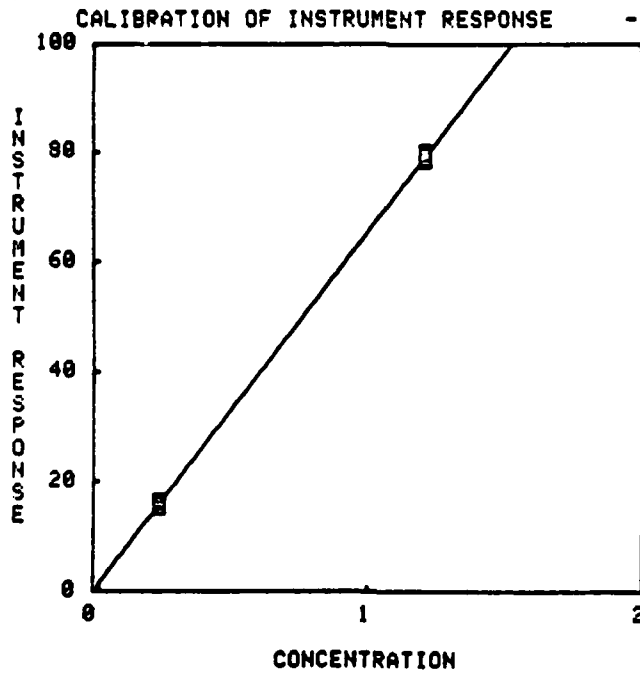

AGENT: H
 DATE: 06/24/82

STATISTICS

BARTLETTS:
 0.468
 R-SQUARED:
 1.000
 MSE:
 2.945E-001

PARAMETERS

$Y' = a + bX'$
 $a = 9.823E-002$
 $b = 6.549E+001$
 $Y' = (Y + f) \uparrow g$
 $X' = X + h$
 $f = 0.000E+000$
 $g = 1.000E+000$
 $h = 0.000E+000$

Figure 28 CALIBRATION CURVE MUSTARD

After the samples had been prepared for analysis, each was individually analyzed on the AA. As with standard analysis, results were obtained about 3-4 minutes apart. Known standards were placed among the unknowns as quality control standards. They were analyzed in an identical fashion.

3.2.1.3 Final Analysis of Calibration Standards

At the completion of analysis of actual plant samples, the analyst was required to again run the three calibration standards (0.000, 0.288, 0.576 $\mu\text{g}/\text{ml}$) and assure that they met the criteria stated in paragraph 3.2.1.1. In addition, these results were analyzed by computer as described in Chapter 4. If the analyst's results did not meet the standardized criteria, he was required to recalibrate his instrument and reanalyze the actual plant samples.

3.2.2 MUSTARD AGENT ANALYSIS

3.2.2.1 Analysis of Calibration Standards

The analysis for mustard was colorimetric. The analysis was conducted using a Technicon Autoanalyzer. To initiate the analysis of standards, a 1.21 $\mu\text{g}/\text{ml}$ standard solution was prepared. One aliquot of this solution was placed into the autoanalyzer. The STANDARD CAL control was used to adjust the recorder to a peak height of 80 chart units. This first calibration standard was checked after a 30-minute warm-up period.

Following this initial procedure, duplicate aliquots of three calibration standards (0.0, 0.24, and 1.21 $\mu\text{g}/\text{ml}$) were placed on the auto-sampler tray followed by a single aliquot of each of the blank standards. Approximately thirty minutes after each standard was sampled, the peak appeared on the recorder. The peaks were spaced six minutes apart resulting in a sample analysis once every six minutes. The analyst recorded these results on an Analyst Work Sheet.

A calibration curve (refer to Figure 28) was prepared by linear least squares regression of peak height vs. concentration. To assure the curve was acceptable at the operator level, the analyst was required to compare his results at the three standards to the following criteria:

Concentration	Max Peak Height	Min Peak Height
0.00 $\mu\text{g}/\text{ml}$ (2 ea)	0.5 chart units	-1.25 chart units
0.24 $\mu\text{g}/\text{ml}$ (2 ea)	17.25 chart units	13.25 chart units
1.21 $\mu\text{g}/\text{ml}$ (2 ea)	83.00 chart units	77.25 chart units

If the analytical results did not meet all of the above criteria, the operator was required to recalibrate his instrument. If the results were satisfactory the operator was allowed to begin the analysis of actual plant samples.

3.2.2.2 Analysis of Actual Plant Samples and Quality Control Samples

The liquid level in each glass bubbler was checked and changes recorded. If the level was low, the bubbler was brought to the mark by adding DEP. The solution was transferred to test tubes and any water present was removed.

Aliquots were taken from each test tube and transferred to sample cups, which were then placed on the auto-sampler tray. Known standards were placed as markers before and after the unknowns, and periodically among the unknown samples as quality control samples. As with calibration standards analysis, approximately 30 minutes were required before results appeared on the recorder. Results were attained every six minutes following the initial reading.

3.2.2.3 Final Analysis of Calibration Standards

At the completion of analysis of actual plant samples, the analyst was required to again run the three calibration standards (0.00, 0.24, 1.21 $\mu\text{g}/\text{ml}$) and assure that they met the criteria stated in Paragraph 3.2.2.1. In addition, these results were also analyzed by computer as described in Chapter 4. If the analyst's results did not meet the standardized criteria, he was required to recalibrate his instrument and reanalyze the actual plant samples.

3.2.3 TRIPHOSGENE (T) ANALYSIS

The analysis for triphosgene was spectrophotometric. The analysis was conducted using a Turner or Spectronix 20 model direct reading spectrophotometer. To initiate the analysis for triphosgene, 9 ml of the bubbler solution (a blank) was mixed with 1 ml of isopropyl alcohol and placed on the spectrophotometer. The absorbance reading of the spectrophotometer was then adjusted to 0.0 at 475 nm.

Next a series of 5 calibration standards were prepared by mixing 9 ml of bubbler solution with 1 ml of a standard amount of triphosgene dissolved in isopropyl alcohol.

Following the initial procedures, single aliquots of the 5 calibration standards (0.2, 0.5, 1.0, 1.5 and 2.5 $\mu\text{g}/\text{ml}$) were analyzed on the spectrophotometer and the appropriate absorbances recorded. Blank samples were run between each standard to assure a return to baseline conditions. Results were produced approximately every minute. The analyst recorded the results on an Analyst Work Sheet.

A standard calibration curve was manually prepared by the analyst. This curve was linear. A typical calibration run produced the following results:

Concentration	Absorbance at 475 nm
0.2 $\mu\text{g}/\text{ml}$.02 absorbance units
0.5 $\mu\text{g}/\text{ml}$.05 absorbance units
1.0 $\mu\text{g}/\text{ml}$.10 absorbance units
1.5 $\mu\text{g}/\text{ml}$.16 absorbance units
2.5 $\mu\text{g}/\text{ml}$.28 absorbance units

Following calibration of the instrument, actual plant bubbler and quality control samples were read. These were analyzed by directly pouring them into sampling cups and processing them through the spectrophotometer.

At the end of the analysis for actual plant and quality control samples, a final calibration was done to verify that the spectrophotometer had not markedly changed

in character during the course of the analysis. This calibration was accomplished by analyzing one aliquot of each of the 5 calibration standards (0.2, 0.5, 1.0, 1.5 and 2.5 $\mu\text{g}/\text{ml}$).

3.2.4 CHLOROACETOPHENONE (CN) AGENT ANALYSIS

The analysis used for chloroacetophenone (CN) was spectrophotometric. The analysis was done using a Turner or Spectronix 20 model direct reading spectrophotometer. To initiate the analysis for CN, a baseline was established on the spectrophotometer. This was done by mixing 3 ml of blank (0.0 $\mu\text{g}/\text{ml}$ CN) propylene glycol solution with 1 ml of dinitrobenzene (DNB). Then 1 ml of NaOH was added and exactly 2 minutes timed. At this point the standard was analyzed on the 540 nm band and the instrument was adjusted to read 0.00 absorbance units.

Next a series of 6 calibration standards were prepared in propylene glycol. As in preparing the baseline sample, 3 ml of standard solution was mixed with 1 ml of dinitrobenzene. Then 1 ml of NaOH was added and exactly 2 minutes timed from the NaOH addition. At this point each standard was read. Single aliquots of each of the six calibration standards (0.0, 0.5, 1.0, 3.0, 6.0 and 10.0 $\mu\text{g}/\text{ml}$) were analyzed in this fashion and the appropriate absorbances recorded. Blank samples were run between each standard to assure a return to baseline conditions. Results were produced approximately every two minutes. The analyst recorded the results on an Analyst Work Sheet.

A standard calibration curve was manually prepared by the analyst. This curve was approximately, although not strictly, linear. A typical calibration produced the following results:

Concentrations	Absorbance at 540 nm
0.0 $\mu\text{g}/\text{ml}$	0.00 absorbance units
0.5 $\mu\text{g}/\text{ml}$	0.01 absorbance units
1.0 $\mu\text{g}/\text{ml}$	0.03 absorbance units
3.0 $\mu\text{g}/\text{ml}$	0.14 absorbance units
6.0 $\mu\text{g}/\text{ml}$	0.31 absorbance units
10.0 $\mu\text{g}/\text{ml}$	0.58 absorbance units

Following the calibration of the instrument, actual plant bubbler and quality control samples were read. These were analyzed by directly pouring them into sampling cups and adding 1 ml of DNB, 1 ml of NaOH, waiting exactly 2 minutes, then performing the analysis on the spectrophotometer.

At the end of the analysis for actual plant and quality control samples, a final calibration was done to verify that the spectrophotometer had not markedly changed in character during the course of the analysis. This calibration was accomplished by analyzing one aliquot of each of the six calibration standards (0.0, 0.5, 1.0, 3.0, 6.0 and 10.0 $\mu\text{g}/\text{ml}$).

3.2.5 CYANOGEN CHLORIDE (CK) AGENT ANALYSIS

Cyanogen chloride (CK) agent analysis is a direct reading technique. For a more detailed discussion, see Section 3.1.5, CK Agent Sampling Technique.

3.2.6 MIRAN ANALYSIS

The MIRAN is also a direct reading method. Section 3.1.6, gives a detailed description of MIRAN Sampling Technique.

3.2.7 SF₆ TRACER GAS ANALYSIS

SF₆ tracer gas analysis was accomplished at ambient temperature, using an electron-capture detector in series with a gas chromatograph column, a sampling valve, and an N₂ carrier gas (refer to Figures 24 and 25). Two detectors were used: one each for the control room and the disassembly room. Sampling was done by drawing air from these rooms into the sampling valve by means of an internal pump. A fixed internal sample volume determined the quantity of the sampled air to be analyzed. An electron-capture gas chromatograph used the high electron affinity of gases with halogen group elements to provide a measurable signal. A sample was separated into component gases by means of a gas chromatographic column. In the case of SF₆ detection, this column was made of finely ground molecular sieve.

In the detector module, a tritium foil source provided a stream of beta particles which ionized the dry nitrogen carrier gas and developed a secondary electron flow, termed the standing current. An electronegative gas captured electrons from this ionized gas stream in proportion to the concentration of the gas present in the sample. The detector collected these electrons and an electrometer measured the current. The presence of an electronegative gas flowing through the detector decreased the standing current (by absorbing electrons) in proportion to the concentration of the electronegative gas. The electrometer operational-amplifier detected the change in current and provided an output voltage proportional to the concentration of the gas. Through the use of a reference calibration chart, the units displayed were directly readable as parts per trillion of SF₆.

3.2.8 NO_x AND SO₂ ANALYSIS

The Dynascience monitor used a unique electro-chemical transducer. The transducer was a sealed electrolytic device in which the direct electro-oxidation of absorbed gas molecules at a sensing electrode resulted in a current directly proportional to the partial pressure of the pollutant gas. In operation, the gas diffused through the membrane and the thin film electrolyte layer, where it was directly proportional to the concentration of the gas being monitored.

3.3 SUMMARY OF AIR MONITORING READINGS

During the CAIS Disposal operating period, a total of 51 readings in excess of the prescribed air monitoring standards were recorded out of a total of 20,315 air monitoring readings taken in the plant. Of these readings, 29 were in the work area and 22 were in the stack. These readings were generated almost exclusively as a result of extraneous interferences or identifiable plant upsets which were quickly corrected. None were grossly in excess of the standards maintained and none were of any great duration. A summary of Air Monitoring Standards is presented in Appendix G, and a summary of Air Monitoring Calibration Criteria and Recoveries is given in Appendix H. Daily Air Monitoring Results are provided in Appendix M.

CHAPTER 4 DATA COLLECTION AND QUALITY CONTROL

4.1 METHOD OF DATA COLLECTION

For the CAIS Operations (Phase 3) of the CAIS disposal program, there were four categories for which data was collected, processed, and stored. These categories were calibration, air monitoring, inventory control, and plant downtime. See Figure 29 for an illustrated diagram of data collection and Figure 30 for laboratory equipment used.

4.1.1 CALIBRATION

4.1.1.1 Mustard Calibration

To establish daily calibration curves, known agent concentrations of 0.00, 0.24, and 1.21 $\mu\text{g}/\text{ml}$ were measured by each analyst/instrument combination each day. For each analyst/instrument combination, one calibration run (0.00, 0.24, 1.21 $\mu\text{g}/\text{ml}$) was done before actual sample analysis to establish control, and a second was done at the completion of the actual analysis to demonstrate continued control. The data for all calibration runs was pooled and multiple measurements of each concentration were used to establish confidence intervals around the complete regression line. The results of these measurements were taken to the data processing group each evening. The data was visually scanned for obvious errors and then entered onto magnetic cassette tape. The Tektronix minicomputer (see Figure 31) then produced the daily calibration reports.

4.1.1.2 Lewisite Calibration

To establish daily calibration curves, known agent concentrations of 0.000, 0.288 and 0.576 $\mu\text{g}/\text{ml}$ were measured on the Perkin Elmer Atomic Adsorption Spectrophotometer (AA) by each analyst each day. For each analyst, one calibration run (0.000, 0.288, 0.576 $\mu\text{g}/\text{ml}$) was done before actual sample analysis to establish control and a second was done at the completion of the actual sample analysis, to demonstrate continued control. The data from all calibration runs was pooled and the multiple measurements of each concentration were used to establish confidence intervals around the complete regression line. The results of these measurements were taken to the data processing group each evening. The data was visually scanned for obvious errors and then entered onto magnetic cassette tape. The Tektronix minicomputer then produced the daily calibration reports.

4.1.1.3 Triphosgene Calibration

To establish daily calibration curves, known agent concentrations of 0.2, 0.5, 1.0, 1.5 and 2.5 $\mu\text{g}/\text{ml}$ were measured on a spectrophotometer by each analyst/instrument combination each day. For each analyst/instrument combination, one calibration run (0.2, 0.5, 1.0, 1.5 and 2.5 $\mu\text{g}/\text{ml}$) was done before actual sample analysis to establish a baseline for analysis. A second calibration was done at the completion of the actual sample analysis to verify that the spectrophotometer had not markedly

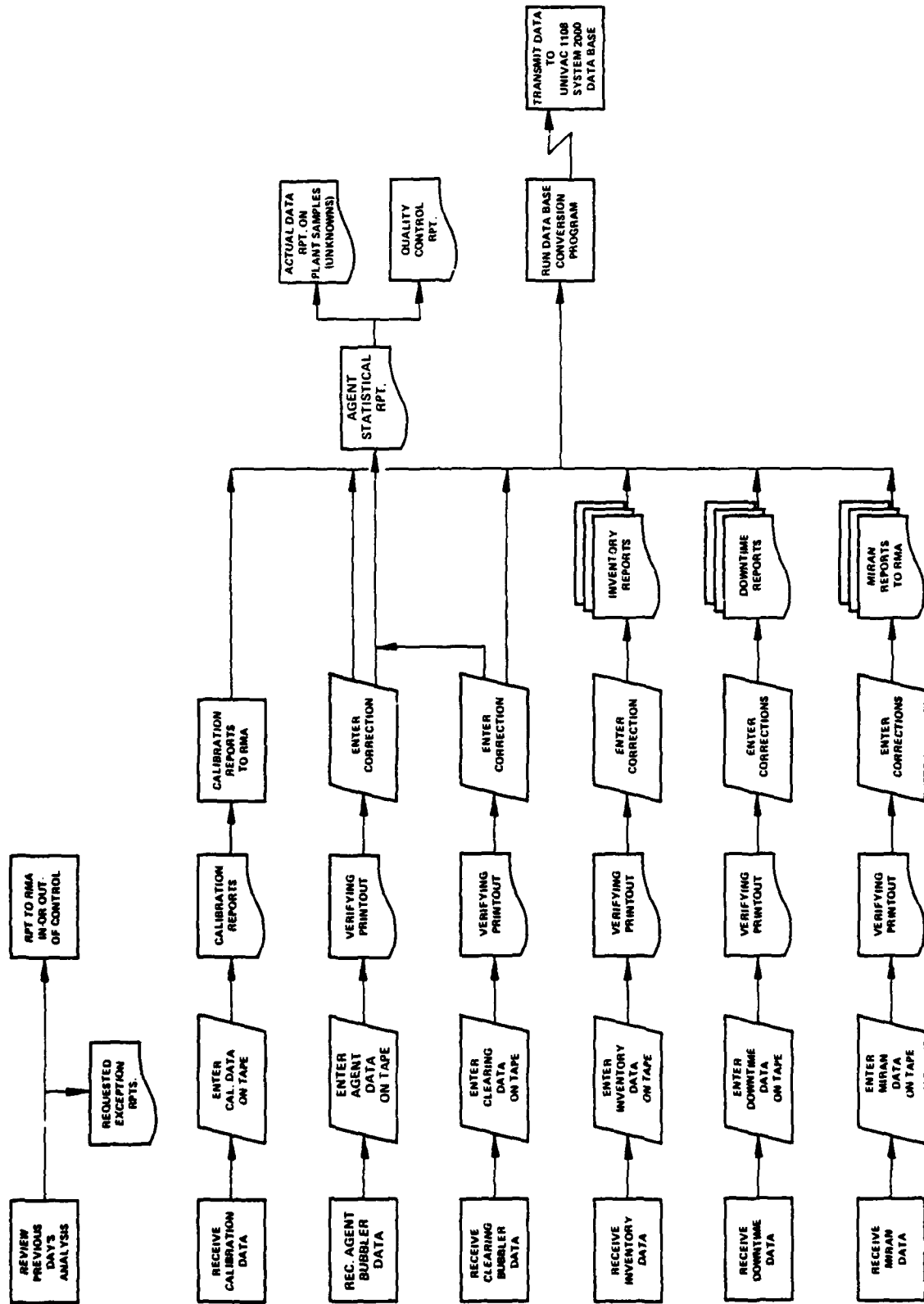

Figure 29 DATA COLLECTION FLOW CHART

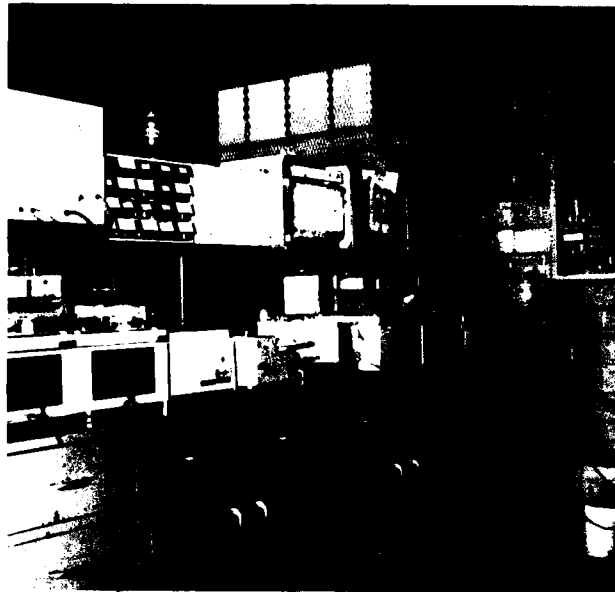

Figure 30 LABORATORY EQUIPMENT



Figure 31 DATA PROCESSING EQUIPMENT

changed in character during the course of the analysis. The results of these measurements were taken to the data processing group each evening. The data was visually scanned for obvious errors and then entered onto magnetic cassette tape.

4.1.1.4 Chloroacetophenone (CN)

To establish daily calibration curves, known agent concentrations of 0.0, 0.5, 1.0, 3.0, 6.0 and 10.0 $\mu\text{g}/\text{ml}$ were measured on a spectrophotometer by each analyst/instrument combination each day. For each analyst/instrument combination, one calibration run (0.0, 0.5, 1.0, 3.0, 6.0 and 10.0 $\mu\text{g}/\text{ml}$) was done before actual sample analysis to establish a baseline for analysis. A second calibration was done at the completion of the actual sample analysis to verify that the spectrophotometer had not markedly changed in character during the course of the analysis. The results of these measurements were taken to the data processing group each evening. The data was visually scanned for obvious errors and then entered onto magnetic cassette tape.

4.1.1.5 Cyanogen chloride (CK)

Industrial air monitoring sample tubes, manufactured by the Draeger Company, and direct reading in parts per million, were used for sampling cyanogen chloride. As this was a direct reading technique, no daily calibration was necessary after preliminary laboratory testing was accomplished at Rocky Mountain Arsenal.

4.1.1.6 MIRAN

The MIRAN 80 is stable and requires infrequent adjustment when maintained in an environment of relatively constant temperature ($\pm 5^\circ\text{F}$). In spite of this, each instrument was challenged with four quality control (QC) checks each day to verify instrument sensitivity to chloropicrin, chloroform, and phosgene. The QC tests were made at approximately the TWA for chloropicrin (.13 ppm) and phosgene (.06 ppm). A QC test for chloroform was done at 1.2 ppm, considerably lower than the established TWA of 10 ppm. These QC tests, or "challenges," checked the instrument's response to all three compounds simultaneously in a mixed sample (refer to Figure 23). The results of the challenges were required to fall within both accuracy and precision statistical control bounds established for all of the instruments collectively. If the challenge results did not meet the criteria, the instrument was re-challenged or replaced, whichever was appropriate. Challenge concentrations of chloroform, chloropicrin and phosgene were obtained from precalibrated stable permeation sources. Using this method, assurance was given of the instrument's ability to detect and quantify the contaminants.

4.1.2 AIR MONITORING

4.1.2.1 Receipt of Samples in Laboratory (Bldg. 313)

Samples from the CAIS plant monitoring for mustard, lewisite, GB, triphosgene and chloroacetophenone were received in the Bldg. 313 lab by Survey Evaluation Office (SEO) personnel. Each sample was assigned a laboratory identification number and logged into a permanent lab record book. The sample volumes were measured and recorded. Any sample which had lost volume during the sampling period was

brought back to the original 10 ml volume using the prescribed sample matrix (refer to Section 3.2). Samples were poured into disposable test tubes, labeled using part number 2 of the four part label (Figure 32) and placed in a rack for the analyst.

4.1.2.2 Quality Control (QC) Samples

All samples for the same agent, which were received in the lab at the same time, were considered a batch. A QC sample was included with each batch of plant samples and was logged in and labeled in the same way. Blind QC samples were included and placed randomly in the sample rack.

4.1.2.3 Analyst Work Sheet

All samples were listed on an Analyst Work Sheet (Figure 33) by placing part number 3 of the appropriate four part label on successive lines of the form. The Analyst Work Sheet(s) was given to the Analyst with the rack of samples for recording analytical results.

4.1.2.4 Lab Data Coordinator Work Sheet

All samples were listed on a Lab Data Coordinator Work Sheet (Figure 34) by placing part number 1 of the appropriate four part label on successive lines of the form. The Lab Data Coordinator calculated the concentration of agents in the air from the data on the Analyst Work Sheet and recorded the data on the Lab Data Coordinator Work Sheet. The data from these two forms were also used to plot precision and accuracy control charts (see Section 4.2.2 and Figure 35) as a daily quality control check.

For Phase 3 operations, air monitoring data was taken from the Analyst and Lab Data Coordinator Worksheets for mustard, lewisite, CK, triphosgene and chloroacetophenone (CN). Data for chloropicrin, phosgene and chloroform was also taken from a single MIRAN data sheet. Collected data was processed through the use of two Tektronix programs: Data Entry and Data Print. The purpose of the data entry program was to place the information, from the handwritten data sheets, onto magnetic cassette tape. The data print program was used to "echo" the input data for checking and verification that the data was entered correctly. For a discussion of the Data Entry and Data Print programs, see Appendices A and B.

After entering any corrections, the bubbler (wet chemistry) data for the lethal agents (mustard and lewisite) was further analyzed by use of air monitoring statistical programs developed for each of these agents. These statistical programs used the data previously recorded on tape as input and generated reports required by CAIS management to verify reliability of laboratory analysis. They are described in further detail in section 4.2. For a complete discussion of the statistical programs see Appendices C and D.

4.1.3 INVENTORY CONTROL

Inventory data was collected, processed, and stored for the following items:

- a. Receipt Inspection of CAIS at Bldg. 1611.
- b. Process Data on Furnace Residue (Pigs).
- c. Process Data on Furnace Residue (Drums).

Label Section for Lab Data
Coordinator Work Sheet
(Part 1)

CONTROL NUMBER DZDH01	AGENT H	LOCATION DRPL	TIME 0800-1000	AIRFLOW μ /M 2.0	CONTROL CONC
DATE 18-11-82	COMMENTS				

CONTROL NO. DZDH01	AGENT H	—/ML
COMMENTS		

CONTROL NO. DZDH01	AGENT H	—/ML
COMMENTS		

CONTROL NO. DZDH01	AGENT H	—/ML
COMMENTS		

SARRM LABEL 4 (3 Nov 80)

Label Section for
Analyst Work Sheet
(Part 2)

Label Section for
Sample
(Part 3)

Label Section for
Lab Notebook
(Part 4)

Figure 32 TYPICAL LABEL FOR LABORATORY SAMPLES

MOD 2 - FOR 1 MAY 81

ANALYST WORK SHEET H / CK / CN / PS

FOR USE BY DATA CLERK

COMPUTER PAGE _____

AGENT H

H 1.7 µg/SAMPLE
 CK 2.4 µg/SAMPLE
 CN 57.6 µg/SAMPLE
 PS 67.2 µg/SAMPLE

SERIAL NUMBER OF INSTRUMENT 4

DAY MONTH YEAR
24 09 82

PASTE CONTROL NUMBER HERE	CALIBRATION STD CONC µg/ml	PEAK HT OR ABSORBANCE UNIT	AGENT CONC µg/ml	DILUTION	BUBBLER VOLUME ml	CONC-µg/SAMPLE	ANALYSIS TIME AND INIT	COMMENTS
DSMH01	H	0.00	10.02	1.0	10.0	10.20	1156	GRM
DSMH02	L	"	"	"	"	"	1202	
DSMH03	L	3.25	0.05	"	"	0.50	1208	
DSMH04	L	0.00	10.0?	"	"	10.20	1214	
DSMH05	H	15.00	0.23	"	"	2.30	1220	
DSMH06	H	0.00	10.02	"	"	10.20	1226	

NOTIFY LAB DATA COORDINATOR IMMEDIATELY IF CONCENTRATION EXCEEDS NORMAL VALUES

Figure 33 ANALYST WORK SHEET

LAB DATA COORDINATOR WORKSHEET H / CK / CN / PS

FOR USE BY DATA CLERK

COMPUTER PAGE _____

AGENT H

DAY MONTH YEAR
24 09 82

COORDINATOR'S INITIALS
JWS

SET TYPE
K-951

NOTE: ANY READING ABOVE THE NOTIFICATION LEVEL MUST BE REPORTED IMMEDIATELY TO THE PLANT CHEMIST. THE NOTIFICATION LEVELS ARE SPECIFIED IN THE CONTINGENCY PROCEDURES FOR LABORATORY PERSONNEL WHICH ARE POSTED AT EACH STATION.

PASTE BUBBLER TAG HERE										REANALYSIS		
CONTROL NUMBER AAAAXX	AGENT AA	LOCATION AAAA	TIME XXXX.XXXX	AIRFLOW L/M XXXX X	CONTROL CONC X.XXX	MEASURED CONC µg/SAMPLE XXX XX	AIR SAMPLE CONC µg/m3 XXX.XXXX	COMMENTS 36 SPACES	DATE XXXXXX	MEASURED CONC µg/SAMPLE XXX.XX	AIR SAMPLE CONC µg/m3 XXX.XXXX	
DSMH01	H	LAQL	NA	NA	0.000							
DATE 24-09-82	COMMENTS											
DSMH02	H	DRPL	0800-1000	6.0		1.020	---					
DATE 24-09-82	COMMENTS											
DSMH03	H	STPL	0800-1000	6.0		1.020	0.28					
DATE 24-09-82	COMMENTS											
DSMH04	H	CRPL	0800-1000	6.0		0.50	0.69					
DATE 24-09-82	COMMENTS											
DSMH05	H	LAQL	NA	NA	0.216	1.020	1.020					
DATE 24-09-82	COMMENTS											
DSMH06	H	RAPL	0800-1000	6.0		2.30	---					
DATE 24-09-82	COMMENTS											
						1.020	1.028					

Figure 34 LAB DATA COORDINATOR WORK SHEET

- d. Process Data on Spray Dryer (Drums).
- e. Process Data on Electrostatic Precipitator (Drums).
- f. Process Data on Disassembly Room (Exception Report).

The data entry and data print programs were used in the same manner as for air monitoring (refer to Paragraph 4.1.2). The data stored on the tape was manipulated by a program to produce desired inventory summary reports of various formats.

4.1.4 DOWNTIME

Building 1611 downtime was recorded on a data sheet and then entered, verified and reported in the same manner as other data entry-data print programs. A daily report was required, even if it only stated "No Downtime." Various summary reports (normally monthly) were produced.

4.1.5 DATA CONVERSION AND PERMANENT STORAGE

At the end of each operating day, data was placed on a condensed or "merged" tape which was then sent to USATHAMA on a weekly basis. Inventory data was condensed from multiple files into a single file in this operation. At USATHAMA the processed data for each day was converted to a format that was acceptable to the Univac 1108 System 2000 data base.

To create a merged data tape, the computer operator inserted the program tape, the current day's data entry tape, and a blank tape in the Tektronix. The program tape obtained data from the data entry tape, converted it to Univac 1108 format, and entered the newly formatted data on the blank "merged" tape. The new "merged" tape was then sent to USATHAMA and used there to transmit the "merged" data to the Univac 1108 System 2000 Data Base. The Univac 1108 automatically scanned the data to assure that the format was acceptable.

At the conclusion of the transmission, the operator required the Univac 1108 to playback the transmitted data in order to confirm that the original transmission was correct and accurate.

4.2 DESCRIPTION OF AIR MONITORING DATA ANALYSIS

4.2.1 GENERAL

The purpose of the air monitoring statistical program was to determine the relationship between a known concentration of mustard or lewisite agent and an instrument/analyst response (measurement). The three main components of these programs are: calibration, wherein each analyst/machine combination relationship established a daily curve; actual data analysis, wherein the accuracy and confidence limits of measurements taken in the CAIS disposal plant were established; and quality control charting, which determined accuracy and the precision of lab and plant measurements. The statistical program drew its source data from the air monitoring data tape for the day under consideration. A complete discussion of the statistical program is given in Appendices C and D.

4.2.2 LEWISITE PROGRAM OPERATION

Calibration curves for lewisite were established at known concentrations of 0.000, 0.288 and 0.576 $\mu\text{g}/\text{ml}$ which were measured by each analyst/instrument combination each day. Two measurements of each concentration were used to establish confidence intervals around the complete regression line.

The statistical program drew upon the lewisite air monitoring data tape, extracting the calibration data for the day. Using the absorbances obtained for each known concentration, the computer constructed a plot of known concentrations (X-axis) vs. peak absorbance/instrument response (Y-axis). The computer provided this plot (refer to Figure 27) as a report, along with the following information:

- a. Standard Army agent code for lewisite.
- b. Date.
- c. Bartlett's - a probability for the Bartlett's test, indicating the tendency of the variance of this small data set to be either homogeneous (a probability greater than 0.05) or non-homogeneous (a probability less than 0.05).
- d. R-squared - a statistical evaluation of how well the computer-selected equation fits the data. An R-squared value of 0.995 or greater was acceptable.
- e. MSE - mean square error - a statistical evaluation of the distance that the points fell from the selected regression line. No set criteria was used.
- f. (a) - the intercept of the regression line with the Y-axis.
- g. (b) - the slope of the selected regression line.
- h. (f), (g) and (h) - correction factors for data that might fit non-linear or special cases. Lewisite was a special case fitting the general equation $\text{Ln}(2-y) = a + bx$.

Using information from the calibration curve, the absorbance readings from the actual data sheets were factored to establish a "true" value with corresponding upper and lower limits of accuracy. The actual measurements were revised to take into account the measurement errors determined by the calibration report. The upper and lower limits of accuracy were determined by the computer, which used the confidence bounds calculated around each individual day's calibration curve to yield these ranges. A report was then produced (refer to Figure 26) which displayed the following information:

- a. Actual data for lewisite agent (in mg/m^3).
- b. Date.
- c. Sample - control number corresponding to the data entry print routines.
- d. Location - location in the plant where the sample was collected.
- e. True - the value calculated by the computer, based on the previously constructed calibration curve (in mg/m^3).
- f. Lower 95% - the value calculated by the computer, based on the IDS/HISTORY data base for the lower confidence value (in mg/m^3). Values were printed only for work area samples.
- g. Upper 95% - the value calculated by the computer, based on the confidence bounds around the calibration curve for the upper confidence value (in mg/m^3). Values were printed only for work area samples.
- h. Time - sampling interval.

The IDS/HISTORY tape contained statistical limits, established by USATHAMA and the Department of Health and Human Services, used for accuracy and precision

charts. These charts provided the upper and lower bounds for accuracy of measurements (mean value) and the precision (standard deviation) or variance of mean readings.

Accuracy and precision charts (see Figure 35) were produced as quality control with respect to the laboratory (QL) and the plant (QP). The measurements of each of four bubblers, spiked with known concentrations of 0.288 $\mu\text{g}/\text{ml}$, were averaged to determine the accuracy. USATHAMA and DHHS had established upper and lower limits for accuracy measurements for lewistie agent as follows:

Location	Mean Concentration	Limits	
		Lower	Upper
Laboratory (QL)	0.288 $\mu\text{g}/\text{ml}$	0.264 $\mu\text{g}/\text{ml}$	0.312 $\mu\text{g}/\text{ml}$
Plant (QP)	0.288 $\mu\text{g}/\text{ml}$	0.256 $\mu\text{g}/\text{ml}$	0.320 $\mu\text{g}/\text{ml}$

Daily points should scatter about the mean. Points above the upper line or below the lower line constituted the measuring process as being "out-of-control" statistically. Seven continuous runs above or below the mean line in laboratory (QL) also constituted the measuring process as being statistically "out-of control."

Precision charts indicated the standard deviation of the mean accuracy readings. Average deviations, using past data as a base, had been established as follows:

Location	Concentration	Avg. Deviation	Upper Limit
Laboratory (QL)	0.288 $\mu\text{g}/\text{ml}$	0.013	0.029
Plant (QP)	0.288 $\mu\text{g}/\text{ml}$	0.017	0.039

It was expected that calculations would scatter above and below the average deviation. The desirable situation was for all calculations to fall between 0 and the upper limit. If a point fell above the upper limit, the measuring process was considered to be "out-of-control" statistically.

4.2.3 MUSTARD PROGRAM OPERATION

Calibration curves for mustard were established at known concentrations of 0.00, 0.24 and 1.21 $\mu\text{g}/\text{ml}$ which were measured by each analyst/instrument combination each day. Two measurements of each concentration were used to establish confidence intervals around the complete regression line.

The statistical program drew upon the mustard air monitoring data tape, extracting the calibration data for the day. Using the peak heights obtained for each known concentration, the computer constructed a plot of known concentrations (X-axis) vs. peak height/instrument response (Y-axis). The computer provided this plot (refer to Figure 28) as a report, along with the following information:

- a. Standard Army agent code for mustard.
- b. Date.
- c. Bartlett's - a probability for the Bartlett's test, indicating the tendency of the variance of this small data set to be either homogeneous (a probability greater than 0.05) or non-homogeneous (a probability less than 0.05).

ACCURACY CONTROL CHART FOR L QL.288
HQL QL.288

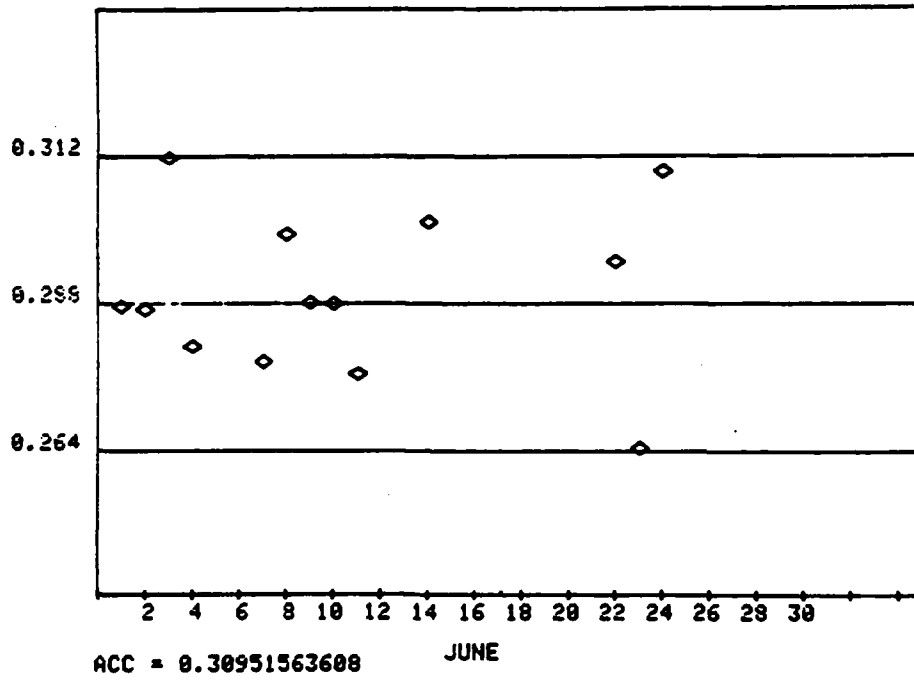

PRECISION CONTROL CHART FOR L QL.288
HQL QL.288

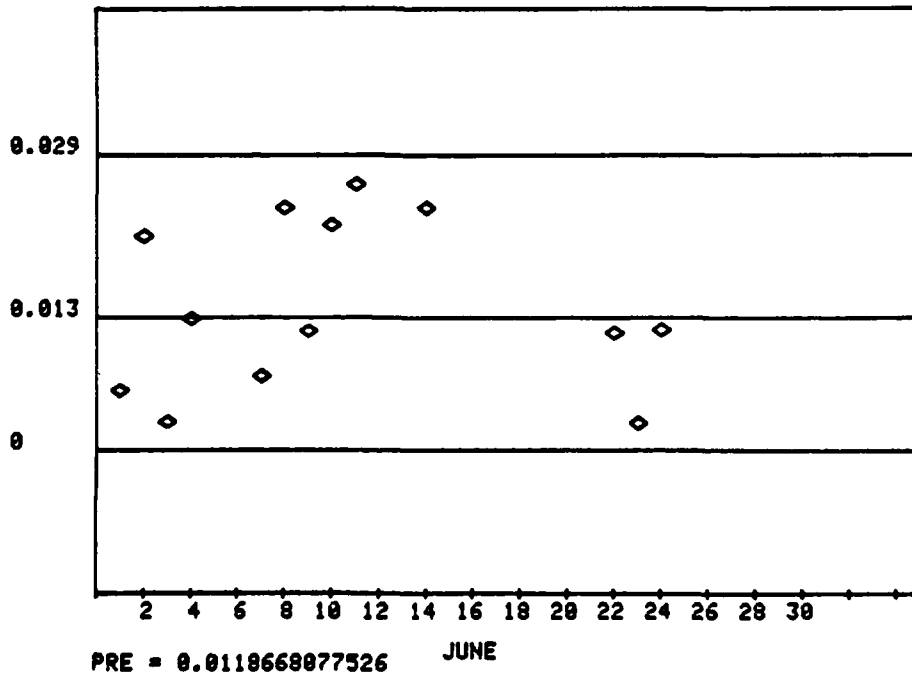
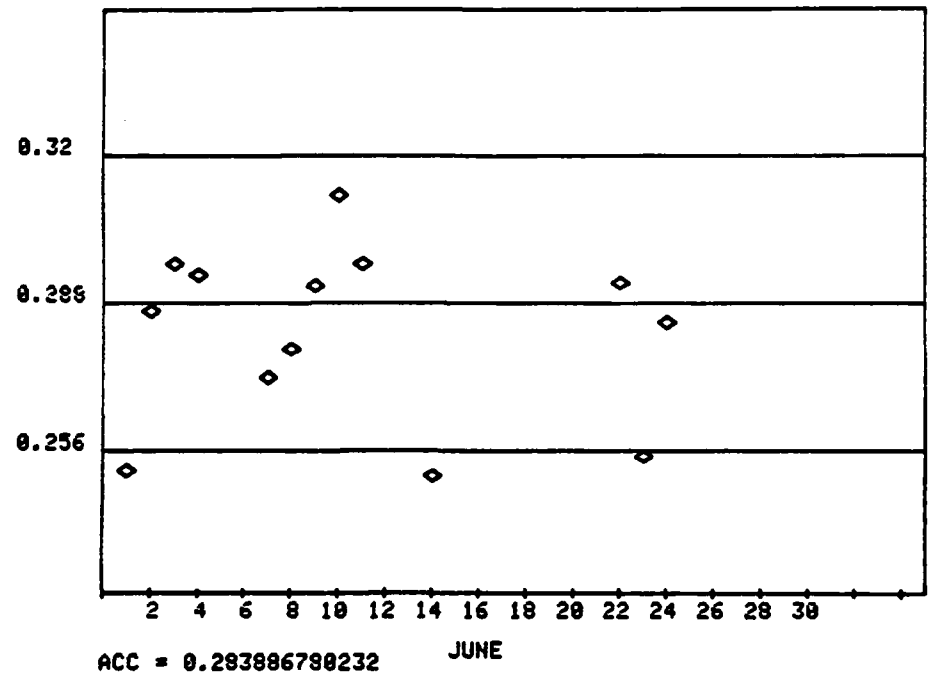

Figure 35A ACCURACY AND PRECISION CONTROL CHART - LEWISITE

ACCURACY CONTROL CHART FOR L QP.288
HQL QP.288



PRECISION CONTROL CHART FOR L QP.288
HQL QP.288

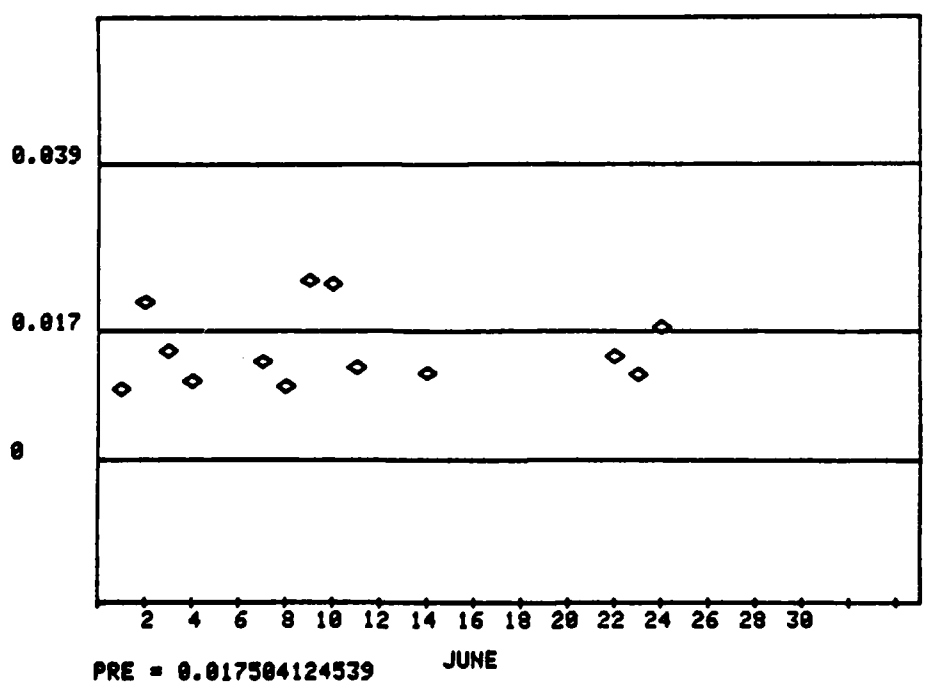

Figure 35B ACCURACY AND PRECISION CONTROL CHART - LEWISITE

- d. R-squared - a statistical evaluation of how well the computer-selected equation fits the data. An R-squared value of 0.995 or greater was acceptable.
- e. MSE - mean square error - a statistical evaluation of the distance that the points fell from the selected regression line. No set criteria was used.
- f. (a) - the intercept of the regression line with the Y-axis.
- g. (b) - the slope of the selected regression line.
- h. (f), (g) and (h) - correction factors for data that might fit non-linear or special cases.

Using information from the calibration curve, the peak height readings from the actual data sheets were factored to establish a "true" value with corresponding upper and lower limits of accuracy. The actual measurements were revised to take into account the measurement errors determined by the calibration report. The upper and lower limits of accuracy were determined by the computer, which used the confidence bound calculated around each individual day's calibration curve to yield these ranges. A report was then produced (refer to Figure 26) which displayed the following information:

- a. Actual data for mustard agent (in mg/m³).
- b. Date.
- c. Sample - control number corresponding to the data entry print routines.
- d. Location - location in the plant where the sample was collected.
- e. True - the value calculated by the computer, based on the previously constructed calibration curve (in mg/m³).
- f. Lower 95% - the value calculated by the computer, based on the IDS/HISTORY data base for the lower confidence value (in mg/m³). Values were printed only for work area samples.
- g. Upper 95% - the value calculated by the computer, based on the confidence bounds around the calibration curve for the upper confidence value (in mg/m³). Values were printed only for work area samples.
- h. Time - sampling interval.

The IDS/HISTORY tape contained statistical limits, established by USATHAMA and the Department of Health and Human Services, used for accuracy and precision charts. These charts provided the upper and lower bounds for accuracy of measurements (mean value) and the precision (standard deviation) or variance of mean readings.

Accuracy and precision charts (see Figure 36) were produced as quality control with respect to the laboratory. The measurements of each of four bubblers, spiked with known concentrations of 0.216 µg/ml, were averaged to determine the accuracy. USATHAMA and DHHS had established upper and lower limits for accuracy measurements for mustard agent as follows:

Mean Concentration	Limits	
	Lower	Upper
0.216 µg/ml	0.191 µg/ml	0.241 µg/ml

ACCURACY CONTROL CHART FOR H QL.216
HQH QL.216

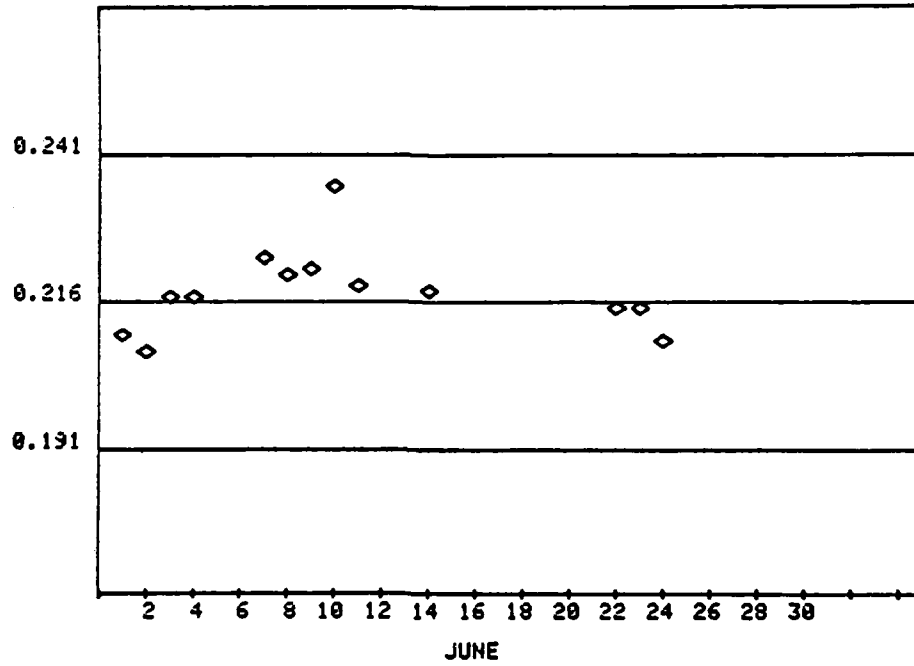

PRECISION CONTROL CHART FOR H QL.216
HQH QL.216

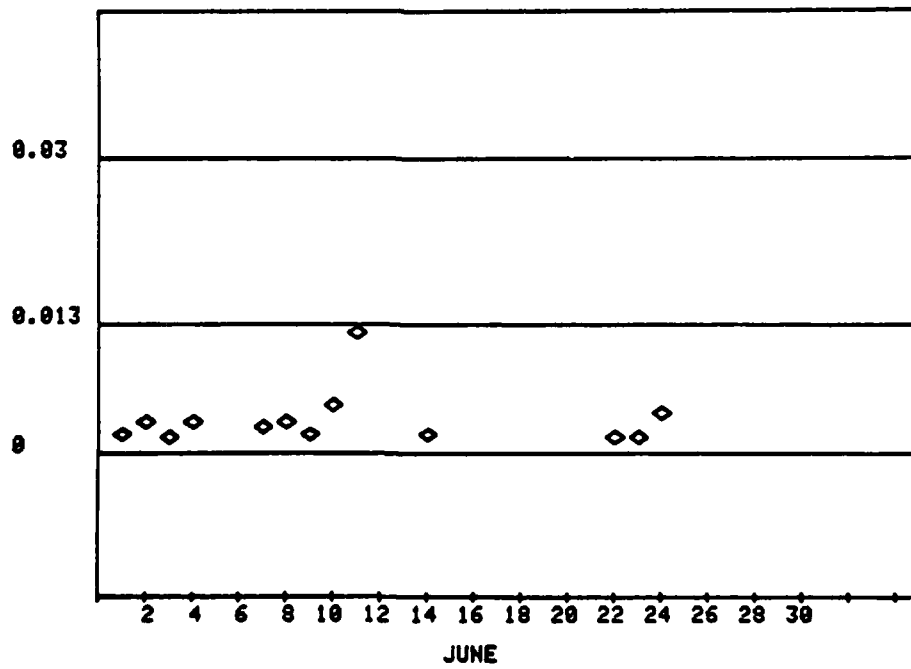

Figure 36 ACCURACY AND PRECISION CONTROL CHART - MUSTARD

Daily points should scatter about the mean. Points above the upper line or below the lower line constituted the measuring process as being "out-of-control" statistically. Seven continuous runs above or below the mean line in also constituted the measuring process as being statistically "out-of-control."

Precision charts indicated the standard deviation of the mean accuracy readings. Average deviations, using past data as a base, had been established as follows:

Concentration	Avg. Deviation	Upper Limit
0.216 $\mu\text{g/ml}$	0.013	0.042

It was expected that calculations would scatter above and below the average deviation. The desirable situation was for all calculations to fall between 0 and the upper limit. If a point fell above the upper limit, the measuring process was considered to be "out-of-control" statistically.

4.3 DESCRIPTION OF INVENTORY DATA COLLECTION

For the CAIS disposal program, inventory control can be divided into two basic categories: incoming or receipt inspection; and outgoing or process recording. Receipt inspection for Phase 3 consisted of recording the serial numbers of incoming ID Sets (pigs or boxes) and noting that they were either destroyed or returned to the toxic storage yard. Process inspections were conducted to record any unusual observations in the disassembly room (leakers, rusted cans, etc.) and the final disposition of the pigs, furnace residue, and the salts from the spray dryer and the electrostatic precipitator.

4.3.1 RECEIPT INSPECTION

Each day the Bldg. 1611 Receipt Inspection form was delivered to the computer group for processing. The data entry and data print programs were used to insert and verify the entry of the data. After corrections (if any) were made, the day's report was run. The report showed the date, serial number of received ID Sets, whether they were destroyed or returned to the toxic storage yard, and pertinent comments.

4.3.2 PROCESS INSPECTION

The process data sheet for the disassembly room for the current day was delivered to the computer group. The data sheet contained notes on any unusual occurrences or observations for the day's operation. If there were none noted for the day, the data sheet was not taken to the computer group. The data was processed in the same manner as other data entry/print programs and produced a report showing the ID Sets type, serial number, any unusual occurrence or observation, and action taken.

4.3.3 FINAL DISPOSITION

Data sheets from the residue area (daily), and spray dryer and electrostatic precipitator (as required) were processed by the computer group. Processing procedures were the same as for other data sheets. Reports were produced as follows:

- a. Furnace residue (drums)
- b. Spray dryer residue (drums)
- c. Electrostatic precipitator residue (drums)

4.3.4 DATA CONVERSION

All inventory data for the day was converted to Univac 1108 format and sent to USATHAMA, in accordance with the details of Paragraph 4.1.5.

4.4 DESCRIPTION OF DOWNTIME DATA COLLECTION

A coded downtime data sheet was provided each day, even for those days when there was no downtime. Data was processed in the same manner as other program inputs; ie., entered, verified, corrected as required, and reports generated. The reports were printed with definitions rather than the numerical-code data entries. These reports provide the following information:

- a. Date
- b. Start and stop times of the downtime.
- c. Whether or not this was a simultaneous experience with other malfunctions.
- d. Subsystem affected.
- e. Primary components affected.
- f. Secondary components affected.
- g. Description of the failure.
- h. Failure modes (further specifying the nature of the failure).

A detailed listing of these is provided in Appendix P.

DISTRIBUTION LIST

Names	Copies
Commander U.S. Army Toxic and Hazardous Materials Agency Aberdeen Proving Ground, MD 21010	
Attn: DRXTH-SE	20 Copies
Attn: DRXTH-ES	2 Copies
Commander Rocky Mountain Arsenal Commerce City, Colorado 80022	
Attn: SARRM-TO	5 Copies
DP Associates Field Office Rocky Mountain Arsenal Commerce City, Colorado 80022	
Attn: Dr. Jack Pantleo	2 Copies
Defence Technical Information Center Cameron Station Alexandria, VA 22314	
	6 Copies
Defense Logistics Studies Information Exchange U.S. Army Logistics Management Center Fort Lee, VA 23801	
	2 Copies
Commander U.S. Army Armament Command Rock Island, IL 61299	
Attn: DRSAR-DR (Mr. Lathrop)	1 Copy
Attn: DRSAR-ASN (Mr. Baker)	1 Copy
Attn: DRSAR-PEC (Mr. Cecil)	1 Copy
Commander U.S. Army Development and Readiness Command 5001 Eisenhower Avenue Alexandria, VA 22333	
Attn: DRCNC	1 Copy

