

AD-A133 027

A TORSION TESTING MACHINE FOR MEASUREMENT OF SHEAR  
STRENGTH OF FOAM(U) MATERIALS RESEARCH LABS ASCOT VALE  
(AUSTRALIA) W J BALDWIN DEC 82 MRL-TN-469

1/1

UNCLASSIFIED

F/G 7/4

NL

END  
DATE  
FILMED  
1983  
01-2

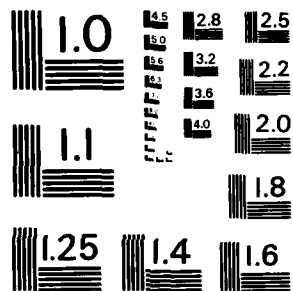

MICROCOPY RESOLUTION TEST CHART  
NATIONAL BUREAU OF STANDARDS - 1963 - A

AD - A133027

MRL-TN-469

12

AR-003-054



DEPARTMENT OF DEFENCE  
DEFENCE SCIENCE AND TECHNOLOGY ORGANISATION  
MATERIALS RESEARCH LABORATORIES  
MELBOURNE, VICTORIA

TECHNICAL NOTE

MRL-TN-469

A TORSION TESTING MACHINE FOR MEASUREMENT OF  
SHEAR STRENGTH OF FOAM

N.J. Baldwin

Approved for Public Release

DTIC  
ELECTE  
SEP 28 1983  
B

DTIC FILE COPY



C Commonwealth of Australia  
DECEMBER, 1982

83 09 25 006

**DEPARTMENT OF DEFENCE  
MATERIALS RESEARCH LABORATORIES**

**TECHNICAL NOTE**

**MRL-TN-469**

**A TORSION TESTING MACHINE FOR MEASUREMENT OF  
SHEAR STRENGTH OF FOAM**

**N.J. Baldwin**

**ABSTRACT**

A torsion machine has been developed to measure shear strength and shear modulus of foam. The machine is compact, portable, easy to use and is an essential link in quality assurance of foam core material for the Australian Minehunter Catamaran. ←

Approved for Public Release

---

**POSTAL ADDRESS: Director, Materials Research Laboratories  
P.O. Box 50, Ascot Vale, Victoria 3032, Australia**

---

SECURITY CLASSIFICATION OF THIS PAGE

UNCLASSIFIED

DOCUMENT CONTROL DATA SHEET

REPORT NO. MRL-TN-469	AR NO. AR-003-054	REPORT SECURITY CLASSIFICATION UNCLASSIFIED
--------------------------	----------------------	--

TITLE  
A TORSION TESTING MACHINE FOR MEASUREMENT OF  
SHEAR STRENGTH OF FOAM

AUTHOR(S) BALDWIN, N.J.	CORPORATE AUTHOR Materials Research Laboratories P.O. Box 50, Ascot Vale, Victoria 3032
----------------------------	--

REPORT DATE December, 1982	TASK NO. Nav 81/146	SPONSOR Navy Office
-------------------------------	------------------------	------------------------

CLASSIFICATION/LIMITATION REVIEW DATE	CLASSIFICATION/RELEASE AUTHORITY Superintendent, MRL Metallurgy Division
---------------------------------------	--

SECONDARY DISTRIBUTION

Approved for Public Release

ANNOUNCEMENT

Announcement of this report is unlimited

KEYWORDS

Torsion tests	Sandwich panels
Foam	Shear properties
	Minesweepers

COSATI GROUPS

1402 1104

ABSTRACT

A torsion machine has been developed to measure shear strength and shear modulus of foam. The machine is compact, portable, easy to use and is an essential link in quality assurance of foam core material for the Australian Minehunter Catamaran.

SECURITY CLASSIFICATION OF THIS PAGE

UNCLASSIFIED

C O N T E N T S

	<u>Page</u>
1. INTRODUCTION	1
2. TEST RELEVANCE	1
3. DESCRIPTION	1
3.1 Specimen	2
3.2 Grips	2
3.3 Torque Application	2
3.4 Torque Transducer	2
3.5 Angular Deflection Transducer	2
3.6 Base	2
3.7 Instrumentation	3
4. CALIBRATION	3
4.1 Torque	3
4.2 Angular Deflection	3
5. PSEUDO SPECIMEN	4
6. CALCULATIONS	4
6.1 Shear Strength	4
6.2 Shear Modulus	4
7. SPECIAL FEATURES	5
7.1 Ball Spline	5
7.2 Built In Calibration	5
7.3 Differential Angular Deflection	5
7.4 Synchronous Motor and Gearbox	5
7.5 Non Slip Grips	5
7.6 High Torsional Stiffness Base	5
7.7 Pseudo Specimen	5
7.8 Minimum Sample Preparation	6
8. DISCUSSION	6
9. CONCLUSION	7

FIGURE 1 Torsion testing machine

FIGURE 2 Foam and glass reinforced plastic sandwich specimen.

FIGURE 3 Pseudo Specimen.

FIGURE 4 Typical torque versus angular deflection curves.

For	
MI	<input checked="" type="checkbox"/>
ed	<input type="checkbox"/>
tion	<input type="checkbox"/>

Distribution/ Availability Codes	
Dist	Avail and/or Special
<b>A</b>	



A TORSION TESTING MACHINE FOR MEASUREMENT OF  
SHEAR STRENGTH OF FOAM

1. INTRODUCTION

A torsion testing machine has been designed and developed at the Materials Research Laboratories to test the shear properties of foam to be used in the construction of the Australian Minehunter Catamaran. The hulls and bulkheads of the minehunter are to be constructed from a foam and glass reinforced plastic sandwich composite. Although the torsion test was originally designed to assess the degradation of shear properties after underwater blast testing, it is now a specified proof test for the foam core.

2. TEST RELEVANCE

The foam, when subjected to blast loading, normally fails in a shear mode. Early tests have established a relationship between shear property degradation and the distance from the centre of blast during panel testing. Subsequent large scale tests have also indicated that shear properties are more critical than tensile and compressive properties. Therefore, minimum values of shear strength and shear modulus for minehunter foam have been specified. The test also incorporates proof stress of the bond between the foam and the glass reinforced plastic (GRP) since the torsional load is applied to the GRP and is transmitted by the bonds.

3. DESCRIPTION

A cylindrical sample of foam sandwich is subjected to torsional loading at a predetermined rate by the machine sketched in Fig. 1. A torque vs angular deflection curve is measured and analysed to determine values of shear strength and shear modulus.

### 3.1 Specimen

A commercial coring tool is used to cut a 45 mm diameter sample from the foam sandwich (Fig. 2). The sample is then lightly sanded to a final size to fit into the grips. (Fig. 1).

### 3.2 Grips

The specimen is held in the machine by one fixed and one axially free grip. Three specially profiled set screws on each grip are tightened radially onto the GRP to a predetermined torque\* which ensures non-slip grip without splitting the GRP.

### 3.3 Torque Application

A synchronous electric motor driving a reduction gearbox applies torque to the axially free grip via a ball spline at 1/25 RPM. The ball spline serves two purposes, firstly to provide axial freedom of the moving grip, thus eliminating tensile force components on the specimen; and secondly to permit insertion of the specimen in the machine. (Fig. 1).

### 3.4 Torque Transducer

The fixed grip is attached directly onto a torque transducer which gives an electrical output (mV) proportional to the applied torque.

### 3.5 Angular Deflection Transducer

A transducer, mounted directly on the fixed grip is rotated by a belt and pulley mounted on the moving grip, Fig. 1. The transducer gives an electrical output (V) proportional to the relative angular displacement of the moving grip to the fixed grip. The assembly is spring loaded to maintain tension in the belt, and to permit substantial axial movement of the moving grip during specimen insertion and removal.

### 3.6 Base

The base of the machine is constructed from two sections of rectangular hollow section steel tube. It is extremely stiff in torsion and locates the motor/gearbox unit relative to the torque transducer. Its outriggers have adjustable feet for accurate levelling of the machine.

---

\* as described in the Instruction Manual



### 3.7 Instrumentation

Instrumentation consists of two variable D.C. power supplies and one X-Y recorder with 50  $\mu\text{V}/\text{cm}$  sensitivity, which is usually available in a laboratory. The machine can therefore be supplied with or without instrumentation. During testing the outputs from the torque and angular deflection transducers are fed into an X-Y recorder, which continuously traces a torque versus angular deflection curve for the foam under test.

## 4. CALIBRATION

The machine has built-in calibration for torque and angular deflection.

### 4.1 Torque

A torque lever is permanently attached to the torque transducer. The transducer is electrically offset to eliminate the output due to this lever. Five 20 N weights are suspended incrementally from the V notch of the lever to exert a 50 Nm torque on the torque transducer. The lever is dog-legged to shift the plane of the torque to the centre of the transducer. The input voltage to the torque transducer (i.e. power supply 1)\* is adjusted until the X-Y recorder indicates 50 Nm full scale deflection. The weights are removed before specimens are inserted for testing.

### 4.2 Angular Deflection

A protractor mounted on the output shaft of the gearbox provides a reference for angular deflection. The X channel of the recorder is calibrated from 0 to 60° by adjusting power supply 2\* and selecting the appropriate voltage range on the X-Y recorder.

Once calibrated the machine requires only check calibrations and rare adjustments for power supply drifts, X-Y recorder paper shrinkage and possibly X-Y recorder span drifts.

---

\* Refer Instruction Manual

## 5. PSEUDO SPECIMEN

An additional calibration facility has been provided in the form of a pseudo specimen. This is a steel sample, shown in Fig. 3, designed to reproduce the minimum slope and torque ( $T_d$ ) at departure from linearity characteristics required by the foam specification. The length and diameter of the inner steel rod determines the initial slope of the torque versus angular deflection curve. The steel rod is protected from overload by mating tongues and grooves in the specimen jacket. The radial clearance between each tongue and groove has been adjusted so that it becomes zero at departure torque. This results in a change in gradient of the torque vs angular deflection curve. The intersection of these two gradients occurs at  $T_d$  shown in Fig. 4. It also provides a means of checking the operation and calibration of the machine and instrumentation. The pseudo specimen also provides ready comparison between machines should there be any need for crosschecking.

A typical torque versus angular displacement curve for this specimen is shown in Fig. 4. This curve can be used as a go - no go gauge.

## 6. CALCULATIONS

### 6.1 *Shear Strength*

The shear strength  $\tau$  in MPa is given by

$$\tau = \frac{T \times 2}{\pi r^3} \quad (1)$$

where  $T$  = Departure torque (Nm)  
i.e. first deviation from linearity  
 $\pi$  = 3.1416.  
 $r$  = foam radius (m).

### 6.2 *Shear Modulus*

The shear modulus  $G$  in MPa is given by

$$G = \frac{\tau l}{r \theta_d} \quad (2)$$

where  $\tau$  = shear strength (MPa)  
 $l$  = foam length (m)  
 $r$  = foam radius (m)  
 $\theta_d$  = angle of rotation (radian).

N.B. Both these formulae are used in the elastic region of the curve.

## 7. SPECIAL FEATURES

### 7.1 *Ball Spline*

This provides rapid specimen mounting and accommodates changes in the specimen length during the test, thereby eliminating tensile axial forces on the specimen.

### 7.2 *Built-in Calibration*

This consists of a lever and a set of weights for calibration of torque, and a protractor for calibration of angular deflection. This feature permits the user to adapt his own recording instruments to the machine, provides reproducibility of calibration between machines, and eliminates costly periodic calibration by outside sources.

### 7.3 *Differential Angular Deflection*

Measuring the angular deflection of one end of the specimen relative to the other avoids the necessity of measuring and subtracting the angular deflection due to distortion within the machine itself.

### 7.4 *Synchronous Motor and Gearbox*

This guarantees a constant test speed of 1/25 RPM unaffected by load or changes in settings when using 240 volt 50 Hz electricity supply.

### 7.5 *Non Slip Grips*

The use of these grips as described in 3.2 has virtually eliminated test invalidation due to slippage or failure of the GRP ends. In rare cases where slippage has occurred through under torquing the set screws, scour marks on the GRP provide visual evidence of an invalid test.

### 7.6 *High Torsional Stiffness Base*

Even though the differential deflection measuring system eliminates angular deflections of the base, a high torsional stiffness is still necessary to avoid misalignment of the grips.

### 7.7 *Pseudo Specimen*

This ready reference provides a simple calibration specimen and a direct means of comparison between machines.

### 7.8 Minimum Sample Preparation

The apparatus has the advantage of using a much smaller, more compact specimen than samples made to ASTM C 273, an in-plane shear test. The time to prepare specimens is also considerably reduced.

## 8. DISCUSSION

The torsion testing machine serves two purposes. The first is to ensure quality control of the manufactured foam. In this case, layers of glass reinforced plastic are built up on each side of the foam before the coring tool cuts out a sample. Alternatively, discs of other material (such as aluminium) could be adhered to the ends of a precored foam sample. The second purpose of the machine is to ensure quality control of the construction of the minehunter itself by removing core samples of the sandwich from selected areas of the vessel which were designed to be cut out during construction. In these tests the bonding of the GRP to the foam can also be proof tested.

The torsion machine is self contained, compact, portable and easy to use. The time per test is approximately ten minutes which includes insertion and removal of the specimen.

Shear strength ( $\tau$ ) is calculated by substituting the value of the departure torque ( $T_d$ ) in Fig. 4, and measured radius  $r$  in equation (1), 6.1.

Shear modulus is calculated by substituting the above calculated  $\tau$ , the measured length of foam ( $l$ ), foam radius ( $r$ ) and corresponding angle of rotation  $\theta_d$  (radians) in equation (2), 6.2.

These values of shear strength and shear modulus are based on testing to the elastic limit and are therefore reliable values. This contrasts with "modulus of rupture in torsion" which is a calculated shear strength based on the applied torque  $T$  at failure. The present values of shear strength and shear modulus assume an elastic stress gradient through the cross section of the sample and are theoretically exact. This contrasts with "modulus of rupture in torsion" which is a calculated shear strength based on the applied torque  $T$  at failure. At failure there is a non-uniform elasto-plastic distribution of shear stress through the foam section which renders this type of calculation only an approximation. Therefore the failure torque has been rejected in favour of the torque at the departure from linearly when calculating shear strength and shear modulus.

## 9. CONCLUSION

A torsion testing machine which was originally designed to assess blast damage in GRP/foam sandwich composites has now become incorporated in quality assurance for the Australian Minehunter Catamaran.

The machine is light, compact, easy to use and has built-in calibration for torque and angular deflection. Specimen preparation requires simple tooling and minimum time.

The specimen design and preparation gives the machine a dual role in performing shear tests on the raw foam and also in testing the finished sandwich material used in the minehunter construction.

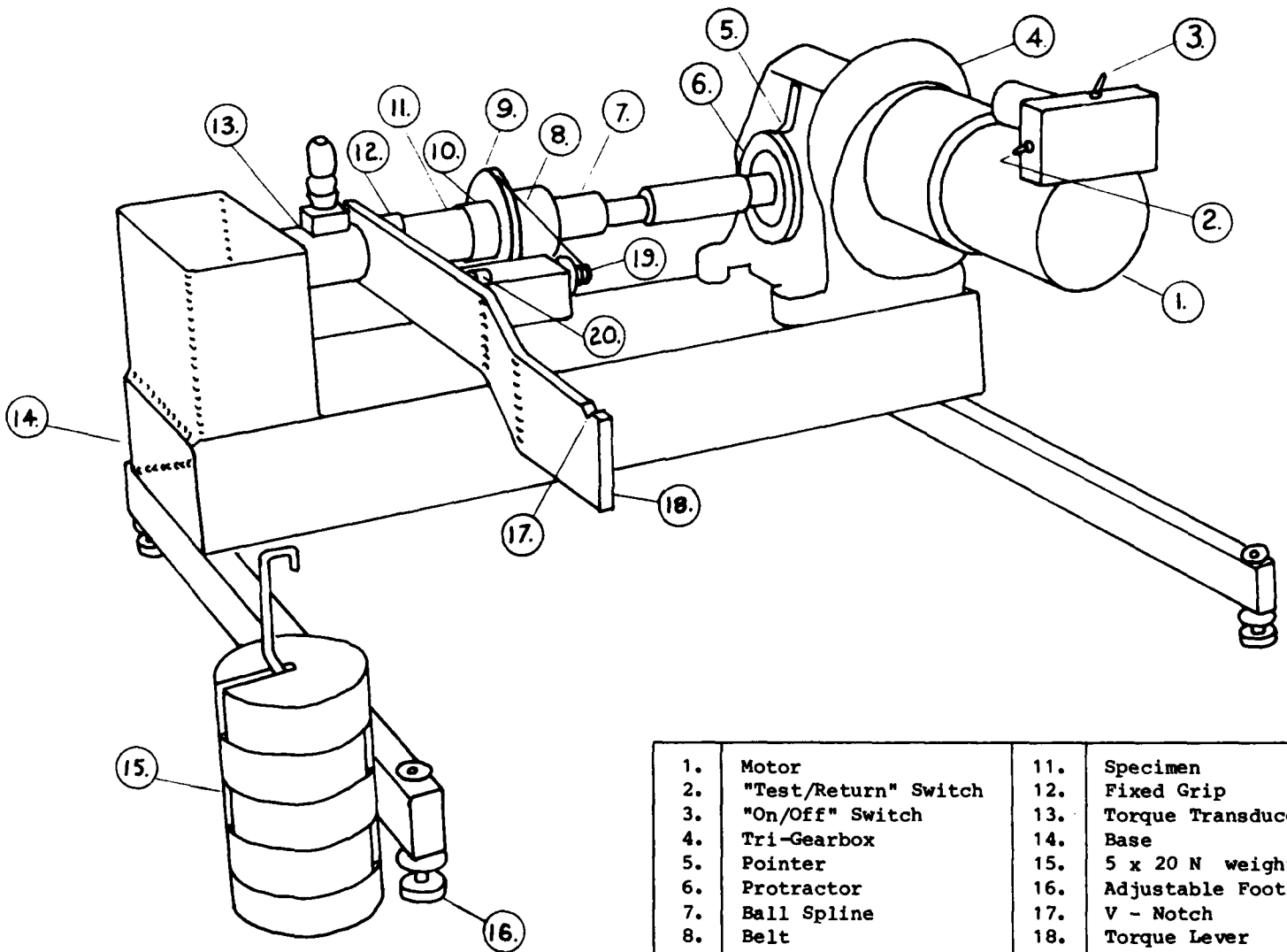

Fig. 1. Torsion testing machine

1.	Motor	11.	Specimen
2.	"Test/Return" Switch	12.	Fixed Grip
3.	"On/Off" Switch	13.	Torque Transducer
4.	Tri-Gearbox	14.	Base
5.	Pointer	15.	5 x 20 N weights
6.	Protractor	16.	Adjustable Foot
7.	Ball Spline	17.	V - Notch
8.	Belt	18.	Torque Lever
9.	Large Pulley	19.	Small Pulley
10.	Moving Grip	20.	Helipot

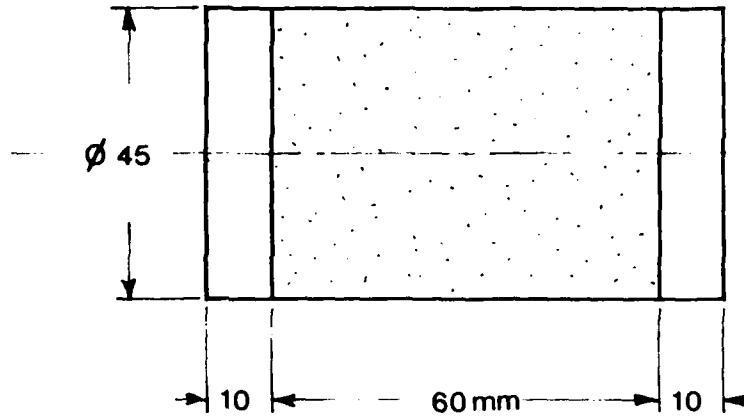

Fig. 2. Foam and glass reinforced plastic sandwich specimen

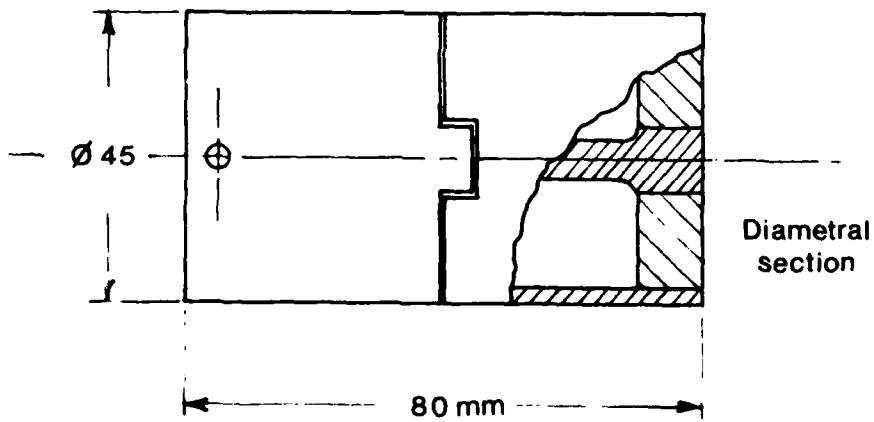

Fig. 3. Pseudo specimen.

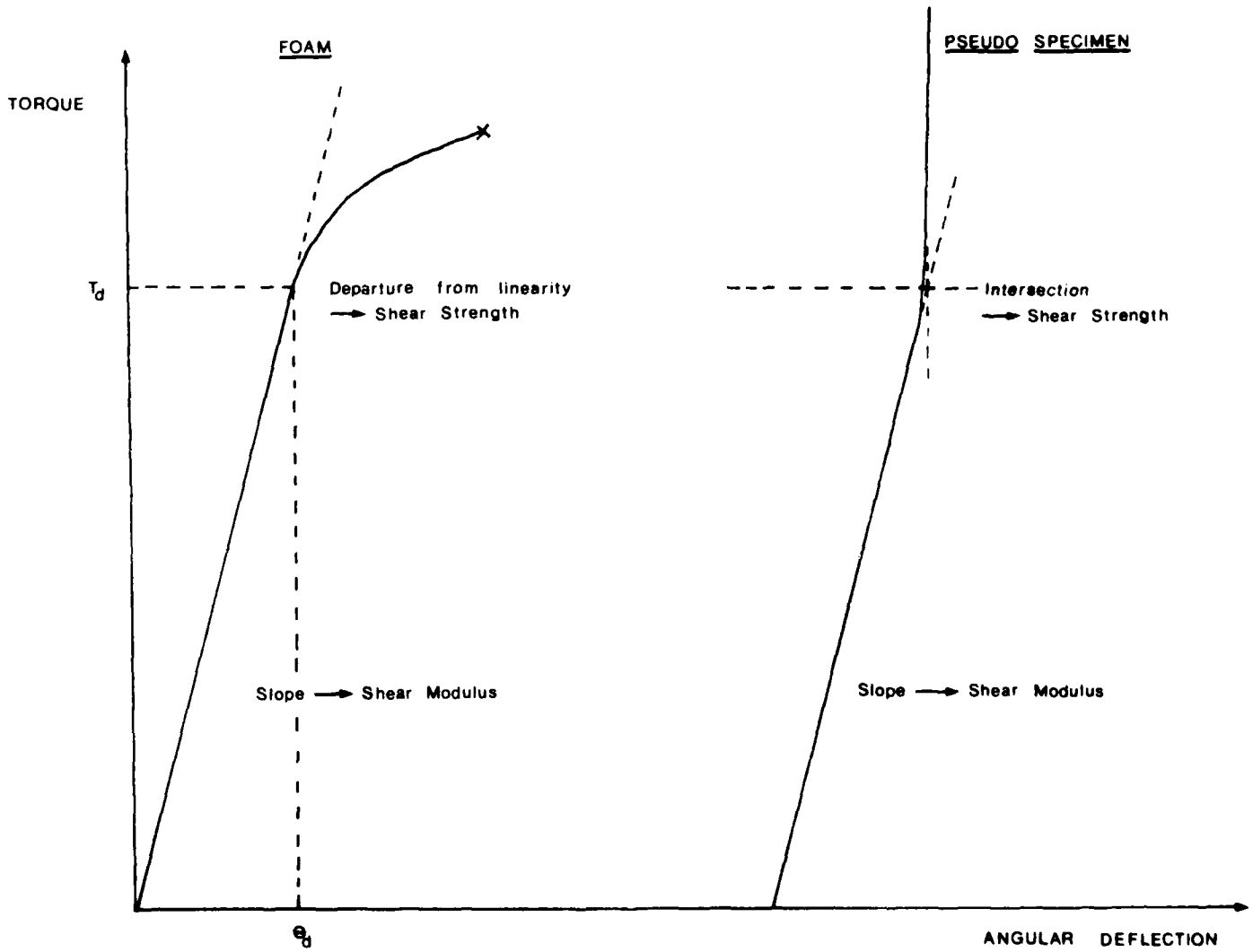

Fig. 4. Typical torque versus angular deflection curves on foam-GRP sandwich and pseudo-specimen.



MRL-TN-469

DISTRIBUTION LIST

MATERIALS RESEARCH LABORATORIES

Director, MRL  
Superintendent, Metallurgy Division  
Dr C.W. Weaver  
Library (2 copies)  
Mr N. Baldwin

DEPARTMENT OF DEFENCE

Chief Defence Scientist/Deputy Chief Defence Scientist/ (1 copy)  
Controller, Projects and Analytical Studies/  
Superintendent, Science and Technology Programme  
Army Scientific Adviser  
Air Force Scientific Adviser  
Navy Scientific Adviser  
Officer-in-Charge, Document Exchange Centre (17 copies)  
Technical Reports Centre, Defence Central Library  
Central Office, Directorate of Quality Assurance - Air Force  
Deputy Director Scientific and Technical Intelligence, Joint  
Intelligence Organisation.  
Librarian, Bridges Library  
Librarian, Engineering Development Establishment  
Librarian, (Through Officer-in-Charge), Materials Testing  
Laboratories, ALEXANDRIA, N.S.W.  
Senior Librarian, Aeronautical Research Laboratories  
Senior Librarian, Defence Research Centre Salisbury, S.A.  
Defence Science Representative, (Summary Sheets Only)  
Australia High Commission, London.  
Counsellor Defence Science, Washington, D.C. (Summary Sheets Only)

DEPARTMENT OF DEFENCE SUPPORT

Deputy Secretary, DDS  
Head of Staff, British Defence Research & Supply Staff (Aust.)

OTHER FEDERAL AND STATE DEPARTMENTS AND INSTRUMENTALITIES

NASA Canberra Office, Woden, A.C.T.  
The Chief Librarian, Central Library, C.S.I.R.O.  
Library, Australian Atomic Energy Commission Research Establishment

(MRL-TN-469)

DISTRIBUTION LIST

(Cont.)

MISCELLANEOUS - AUSTRALIA

Librarian, State Library of NSW, Sydney NSW  
University of Tasmania, Morris Miller Library, Hobart, Tas.

MISCELLANEOUS - OVERSEAS

Library - Exchange Desk, National Bureau of Standards, U.S.A.  
UK/USA/CAN/NZ ABCA Armies Standardisation Representative (4 copies)  
The Director, Defence Scientific Information & Documentation  
Centre, India  
Military, Naval and Air Adviser, High Commission of India,  
Canberra  
Director, Defence Research Centre, Kuala Lumpur, Malaysia  
Exchange Section, British Library, U.K.  
Periodicals Recording Section, Science Reference Library,  
British Library, U.K.  
Library, Chemical Abstracts Service  
INSPEC: Acquisition Section, Institute of Electrical  
Engineers, U.K.  
Engineering Societies Library, U.S.A.  
Aeromedical Library, Brooks Air Force Base, Texas, U.S.A.  
Ann Germany Documents Librarian, The Centre for Research Libraries,  
Chicago I11.  
Defence Attache, Australian Embassy, Bangkok, Thailand Att. D. Pender

END

DATE  
FILMED

10 83

DT