

AD-A130 443

CHRONOPSYCHOLOGICAL APPROACH FOR OPTIMIZING HUMAN
PERFORMANCE(U) NAVAL HEALTH RESEARCH CENTER SAN DIEGO
CA P NAITOH MAR 80 NAVHLTHRSCHC-80-9

1/2

UNCLASSIFIED

F/G 5/10

NL

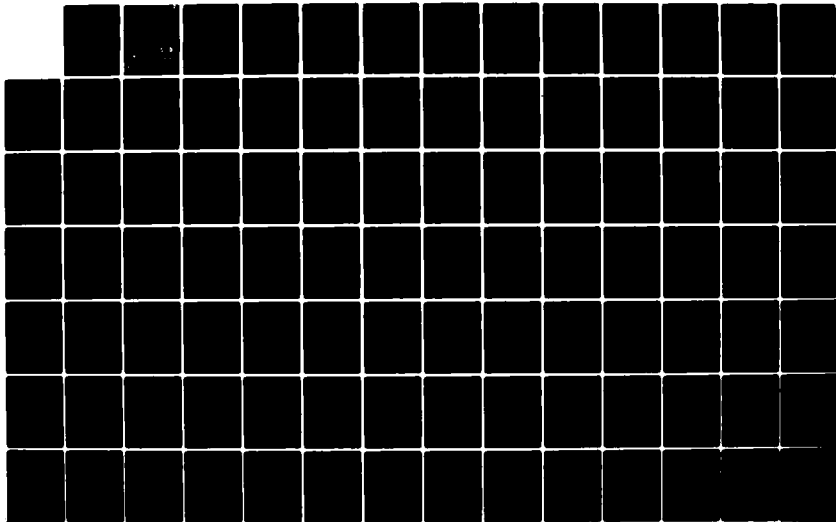

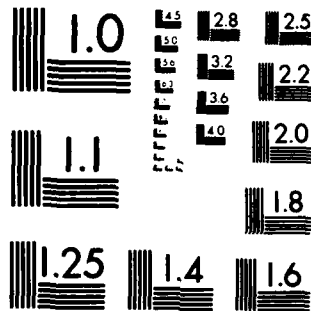

MICROCOPY RESOLUTION TEST CHART
NATIONAL BUREAU OF STANDARDS-1963-A

CHRONOPSYCHOLOGICAL APPROACH FOR OPTIMIZING HUMAN PERFORMANCE

P. NAITOH

REPORT NO. 80-9

AD A 130443

DTIC FILE COPY



DTIC
ELECTE
JUL 18 1983
S D
E

NAVAL HEALTH RESEARCH CENTER

P. O. BOX 65122
SAN DIEGO, CALIFORNIA 92138

NAVAL MEDICAL RESEARCH AND DEVELOPMENT COMMAND
BETHESDA, MARYLAND

This document has been approved
for public release and sale its
distribution is unlimited.

83 07 18 038

Chronopsychological Approach for Optimizing Human Performance

Paul Naitoh

Naval Health Research Center, San Diego, California, U.S.A.

DTIC COPY MARKED 2

Accession For	
NTIS GRA&I	<input checked="" type="checkbox"/>
DTIC TAB	<input type="checkbox"/>
Unannounced	<input type="checkbox"/>
Justification	
By _____	
Distribution/	
Availability Codes	
Dist	Avail and/or Special
A	

Published in: F. Brown & RC Graeber (eds), Rhythmic Aspects of Behavior.
Hillsdale, NJ: Erlbaum Associates, 1982. pp 41-103

Report No. 80-9, supported by the Naval Medical Research and Development Command, Department of the Navy, under Work Unit MF58.524.004-9026. The views presented in this work are those of the author. No endorsement by the Department of the Navy has been given or should be inferred.

The author would like to thank Dr. L. C. Johnson and Dr. Carl E. Englund for critical reading of the entire manuscript and for editorial suggestions.

This document has been approved
for public release and sale; its
distribution is unlimited.

INTRODUCTION

The purpose of this chapter is to introduce the concepts and methods of chronopsychology, and to discuss how the chronopsychological approach can be used to sustain human performance round-the-clock.

Before the invention in 1803 of coal gas illumination by William Murdock (1754-1839), which was used to light the interior of the Soho Steam Works of England, humans were not required to be on the job round-the-clock. Up to that time, there was little work during the dark period. Night was left to the priests in prayer vigils in temples, soldiers in all-night military encampments, sentinels on guard duty at city gates, and sailors on watch on ships. Now, great numbers of people are working during the dark period, rendering necessary social services and completing business transactions. These people are doctors, nurses, policemen, shiftworkers at all-night factories, computer operators, executives of the multi-national corporations, airline pilots, personnel at foreign embassies, newspaper printers, installers of plate glass, and suppliers of clean diapers and bed sheets. Melbin (1979) has commented on the significant increase in both continuous radio broadcasts and telecasts during the 1-7 AM period, as well as the increase in the number of 24-hr general stores. Thus, the city no longer becomes quiet at sundown. The dark period can be used, or even exploited, for products and extra services.

The exploitation of the dark period of day is as tangible as that of a new geographical territory for new goods and services. Society no longer sleeps. It has become "incessant," forcing humans to be on the job day and night. Society needs improved performance of humans working at night time. Such societal demands disregard the fact that humans are still a biologically "diurnal" species whose efficiency will necessarily be lowered during the night due to circadian variations. Humans are neither a nocturnal nor "incessant" species. They are

actively engaged in their jobs mainly during the "light" phase of the day, and they relax and sleep during the "dark" period of the day. Society does, however, demand human attention round-the-clock on three main justifications: (a) social: to provide 24-hr services of medical care, transportation facilities, security and others, (b) technological: to continue operations of steel production, oil refineries, and other similar industries, and (c) economic: for optimal use of invested capital by constant operation of costly machinery (Rutenfranz et al., 1977). The response to these demands has been the institution of shiftwork. Shiftwork has, according to Rutenfranz and his colleagues (1977), resulted in "an improvement in the quality of life of society as a whole," but it "disturbs the life of individual workers (and their families) who provide the services." Thus, a balance should be struck between the needs of society in general and those of shiftworkers in particular.

In another area, society's exploitation of time has led to the familiar problem of "jet lag." When individuals travel from one geographical area to another by rapidly crossing many time zones, their "day" would no longer be in synchrony with the day of the geographical location to which they have traveled. Jet lag is a psychophysiological disturbance which has resulted from requiring diurnal humans to work during their customary rest and sleep period.

The diurnal nature of humans can be clearly shown in the shiftwork schedule in a well-defined miniature society represented by naval ships at sea. Figure 1 shows the normal life style in the activity-sleep records of a group of 20 young

Figure 1 About Here , see pg 2a

sailors during shore duty. These men were strictly confined within a building, and lived under four experimental conditions of "Ping-B," 80 dB, 85 dB and 90 dB.

Figure 1. Sleep fraction, inter-sleep intervals and uninterrupted sleep durations of 20 young sailors in Project "ping". Sailors lived in an environment with simulated normal-acoustical features ('ping'-B(baseline)), then they lived in an acoustical environment with simulated air-borne sonar noises at 80 db Sp, 85 db Sp and 90 db Sp. These simulated air-borne sonar noises recurred regularly every 22 seconds round-the-clock for 30 days. Despite the drastic change in the acoustical environments, the sailors maintained a normal sleep-wakefulness pattern. The data were obtained with Sleep Logs.

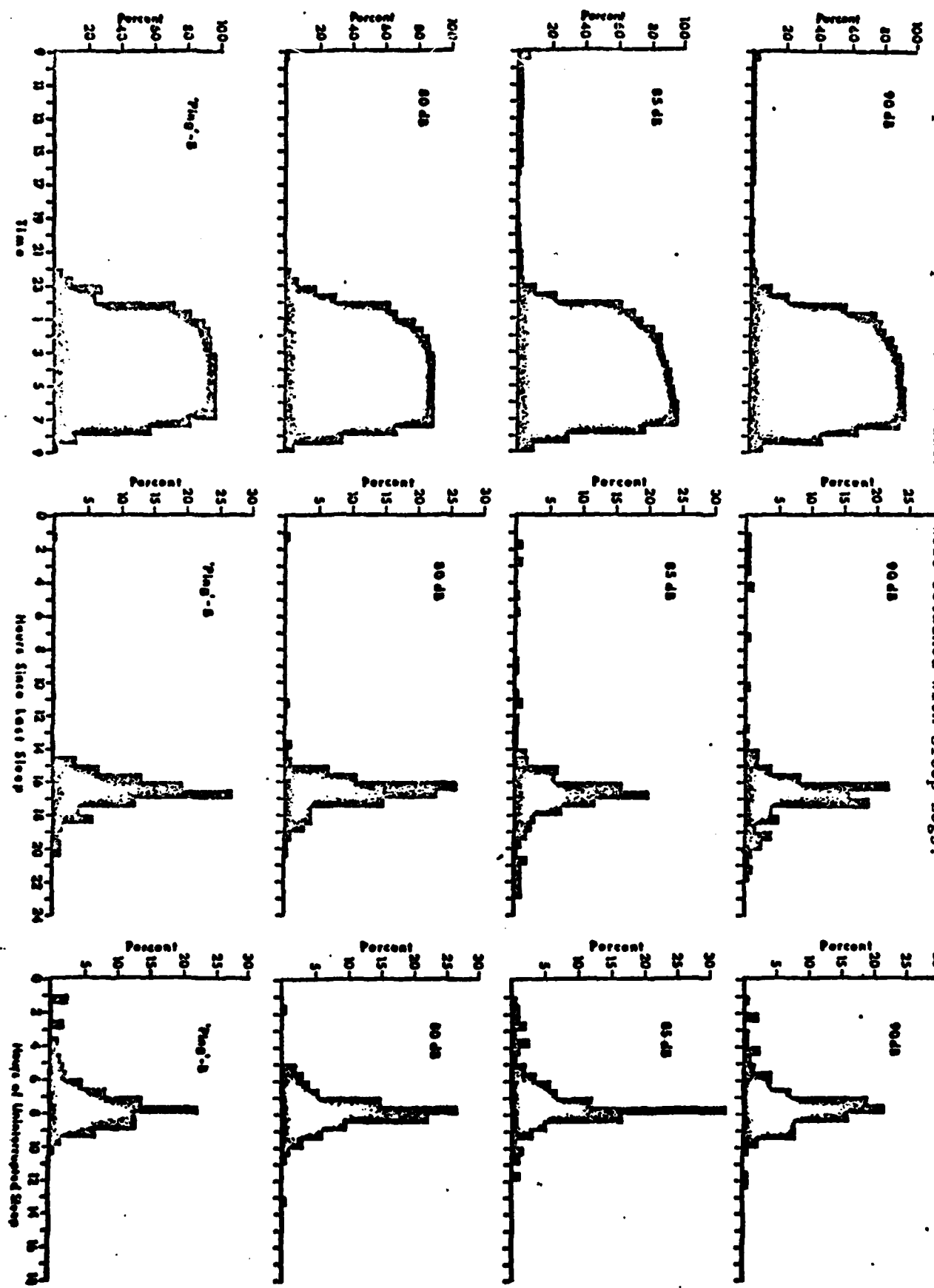

Figure 1

Sleep-wakefulness data from these sailors were obtained by asking them to complete Sleep Logs (Figure 2). The sailors performed a variety of tasks during the day.

 Figure 2 About Here, see pg 3a

From day 1 to day 15 of their stay in the building, they lived under a normal background noise of about 70 dB during the daytime, and about 50 dB at night in the berthing area. This period represented "Ping-B(aseline)" phase of the study. After the baseline phase, air-borne sonar noise, "ping," at the pre-set intensity was introduced to the living environment. This "pinging" noise which lasted .66 seconds, approximately 3.5 K Hz tone, was repeated every 22 seconds over many loud-speakers installed in the building around the clock for the remainder of the study, that is for 30 days. From day 16 to day 25, "ping" had 80 dB SP intensity. For the next ten days (from day 26 to 35), the "ping" intensity was raised to 85 dB SP, and during the last phase of this study (from day 36 to day 45), the "ping" noise was further raised to 90 dB SP.

Figure 1 shows three different sleep measures extracted from Sleep Logs. The leftmost column shows a sleep fraction which is the percentage of individuals in a group who are asleep during the clock time indicated along the X-axis. The black area of the graph shows sleep, while the white area shows wakefulness. In the middle column of Figure 1 is the histogram of distribution of inter-sleep intervals; i.e., the interval between the end of the sleep period and the start of the next sleep period. The graphs show the percentage of the inter-sleep intervals corresponding to the labels along the X-axis. Normally, the average of inter-sleep interval is 16 hrs, because the average sleep duration is about 8 hrs. The rightmost column is the distribution of uninterrupted sleep durations. Since human sleep usually consists of one nocturnal sleep of 8 hrs (monophasic) per

NAME _____	DATE _____	TIME _____	DUTY _____
------------	------------	------------	------------

1. On the chart below draw a horizontal line through the squares corresponding to the half hour periods during which you were asleep during the last 24 hours. Put an X in the square corresponding to any half hour period during which you recall waking up for 15 to 30 minutes.

DAYTIME

0900	1000	1100	1200	1300	1400	1500	1600	1700	1800	1900	2000	2100	2200	2300	2400	0100	0200	0300	0400	0500	0600	0700	0800

NIGHTTIME

2100	2200	2300	2400	0100	0200	0300	0400	0500	0600	0700	0800	0900	1000	1100	1200	1300	1400	1500	1600	1700	1800	1900	2000

2. How much trouble did you have going to sleep last night? <input type="checkbox"/> NONE <input type="checkbox"/> SLIGHT <input type="checkbox"/> MODERATE <input type="checkbox"/> CONSIDERABLE	Time to fall asleep _____ MINUTES	3. How many times do you recall waking up last night? _____
4. How rested do you feel? <input type="checkbox"/> WELL RESTED <input type="checkbox"/> MODERATELY RESTED <input type="checkbox"/> SLIGHTLY RESTED <input type="checkbox"/> NOT AT ALL	5. Do you feel that you could have used more sleep? <input type="checkbox"/> YES <input type="checkbox"/> NO	
6. Today's Mood <input type="checkbox"/> VERY POOR <input type="checkbox"/> POOR <input type="checkbox"/> AVERAGE <input type="checkbox"/> GOOD	Number of dreams recalled _____	7. Hours of work in last 24 hours? _____

REMARKS (Make especially reference for loss of sleep, such as duty, noise, cold, personnel, etc.)

Figure 2

SLEEP LOG 11ND-COM-6520-1 (REV. 8-72)

NAMPRI (11-73)

Figure 2: Sleep Logs. Sleep Logs can be administered to subjects in a form of either a card (as shown) or an optically scannable sheet. Sleep Log is to be completed upon awakening from the major sleep period. Sleep Log was originally designed by Bryce Hartman at School of Aerospace Medicine (SAM), Brooks Air Force Base, San Antonio, Texas. Sleep Log card has Stanford Sleepiness Scale printed on its reverse side.

24-hr day, the mode of the histogram is at about 8 hrs. The bottom row of Figure 1 describes the sleep-wakefulness data during the Ping-B condition, a highly regulated but normal life style. The effects of three experimentally sonified environments with 80 dB SP, 85 dB SP, or 90 dB SP ping noise are shown row-wise in Figure 1. Despite the recurring ping noise, 20 young sailors kept their diurnal habits rather well.

This diurnal pattern of sleep-wakefulness appeared to be retained even when the sailors were under a shiftwork or a "watch-standing" schedule. In other words, life on the naval ship retains diurnal characteristics. Figure 3 shows

 Figure 3 About Here, *see pg 4a*

the sleep fraction of men sampled from the crew on board three ships at sea. Sleep Logs were used to obtain the data. The names of the ships appear on the top left-hand corner: USS Tucker, USS Kitty Hawk, and USS Roark. The USS Tucker is a 3,500 ton (full load weight) destroyer with a crew of 270. The USS Kitty Hawk is a large modern carrier which weighs 80,000 tons (full load weight) with a complement of about 2,800 to man the ship and an air wing of 2,150, for a total of about 5,000 naval personnel. The USS Roark is a frigate weighing 4,000 tons (full load weight) with a crew of about 270. A typical naval watch-standing schedule for surface ships is shown in Table 1.

 Table 1 About Here, *see pg 4b*

The sleep fraction for the USS Tucker is based on 473 Sleep Log cards obtained from 107 naval personnel, some of whom recorded up to five consecutive nights. At least 30% of the sampled crew members are awake around the clock to meet

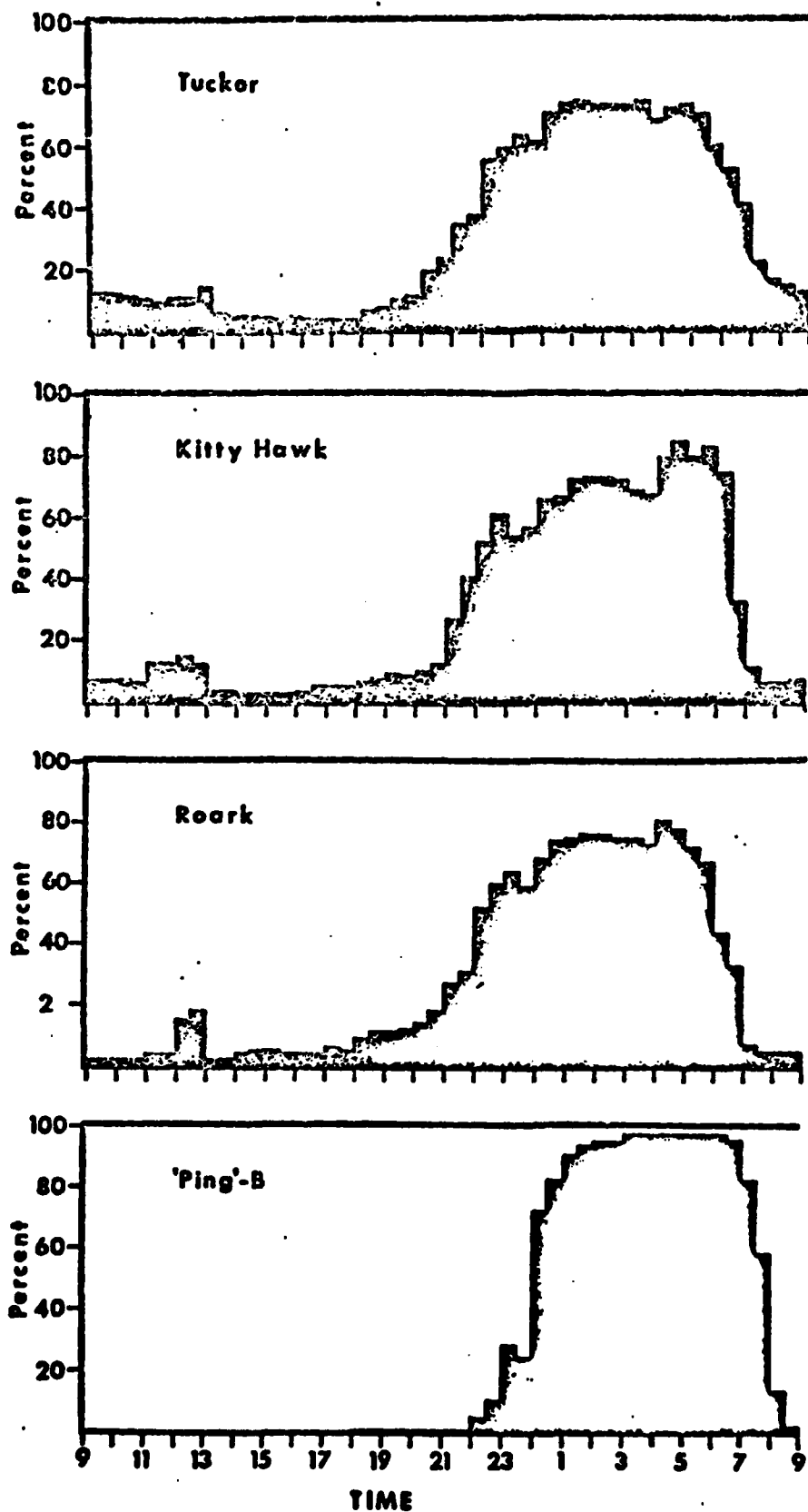

Fig. 3.

Sleep fractions of naval ratings sampled from three U.S. Navy ships. For comparison purposes, the sleep fraction of a group of 20 young sailors in Project "Ping" is also shown.

Figure 3

Table 1 Surface Ship Watch Standing Schedule of 4 Hours 3 Section Watch (US Navy)

Time	Name of Watch	Day 1	Day 2	Day 3
00 ⁰⁰ - 04 ⁰⁰	Mid Watch	A	B	C
04 ⁰⁰ - 08 ⁰⁰	Morning Watch	B	C	A
08 ⁰⁰ - 12 ⁰⁰	Forenoon Watch	C	A	B
12 ⁰⁰ - 16 ⁰⁰	Afternoon Watch	A	B	C
16 ⁰⁰ - 18 ⁰⁰	First Dog Watch	B	C	A
18 ⁰⁰ - 20 ⁰⁰	Second Dog Watch	C	A	B
20 ⁰⁰ - 24 ⁰⁰	First Watch	A	B	C

Three teams, A, B and C, take a turn to cover a 24-hr period per day. In submarine services, 6 hrs on/12 hrs off (18 hrs/day) schedule is often used.

An Example of "Navy Day" For Team A (Day 1 only)

Time	Types of Activities
00 ⁰⁰ - 04 ⁰⁰	Mid Watch
04 ⁰⁰ - 06 ⁰⁰	<i>Rest</i>
06 ⁰⁰ - 08 ⁰⁰	<i>Cleaning ship/ Breakfast</i>
08 ⁰⁰ - 11 ⁰⁰	<i>Ship's works</i>
11 ⁰⁰ - 12 ⁰⁰	<i>Lunch</i>
12 ⁰⁰ - 16 ⁰⁰	Afternoon Watch
16 ⁰⁰ - 18 ⁰⁰	<i>Rest</i>
18 ⁰⁰ - 20 ⁰⁰	<i>Dinner/ Rest</i>
20 ⁰⁰ - 24 ⁰⁰	First Watch

Standing watches are only a part of the sailors' job. See Stolgitis (1969).

the ship's demands at sea. As far as the watch-standing goes, one-third of the crew should be on watch at any one time during the 24-hr period. But the sleep fraction of the USS Tucker reveals that about 90%, or better than 90%, of the sampled crew members are awake and presumably at work for the light period of the day, 09⁰⁰-20⁰⁰ and 50% or more are asleep from 22⁰⁰-06⁰⁰; i.e., the sleep-wakefulness cycle has retained the diurnal characteristics shown by the Ping B subjects (see the lowermost sleep fraction of Figure 3, "Ping"-B, for comparison). The size of the naval ship appears not to change this fundamental diurnal sleep-wakefulness pattern. The sleep fraction for the USS Kitty Hawk is based on a return of 130 Sleep Log cards from a small sample of 39 men. The sleep fraction obtained from naval personnel from the USS Roark is based on 128 Sleep Log cards obtained from a sample of 42 men, some of whom recorded sleep-wakefulness data up to six consecutive nights. Three sleep fraction plots from three different naval ships clearly show that the diurnal nature of humans will persist in a miniature society. This rhythm of sleep-wakefulness in ships finds a counterpart in a similar rhythm of a city (Melbin, 1978a).

The sleep fraction plots reveal clearly that the watch schedule (shiftwork) is operating to meet the ship's demands for human attention round-the-clock. Shiftwork does not appear to have been particularly disturbing to the diurnal pattern of the crew, because they appear to maintain their shore-based diurnal pattern. The physiological cost of the ship's demands to maintain continual performance of the crew, or at least one-third of the crew, is hidden in the sleep fraction, but it is clearly revealed in analyses of the inter-sleep intervals and the uninterrupted sleep durations (Figures 4 and 5).

Figures 4 & 5 About Here , see pgs 5a-5b

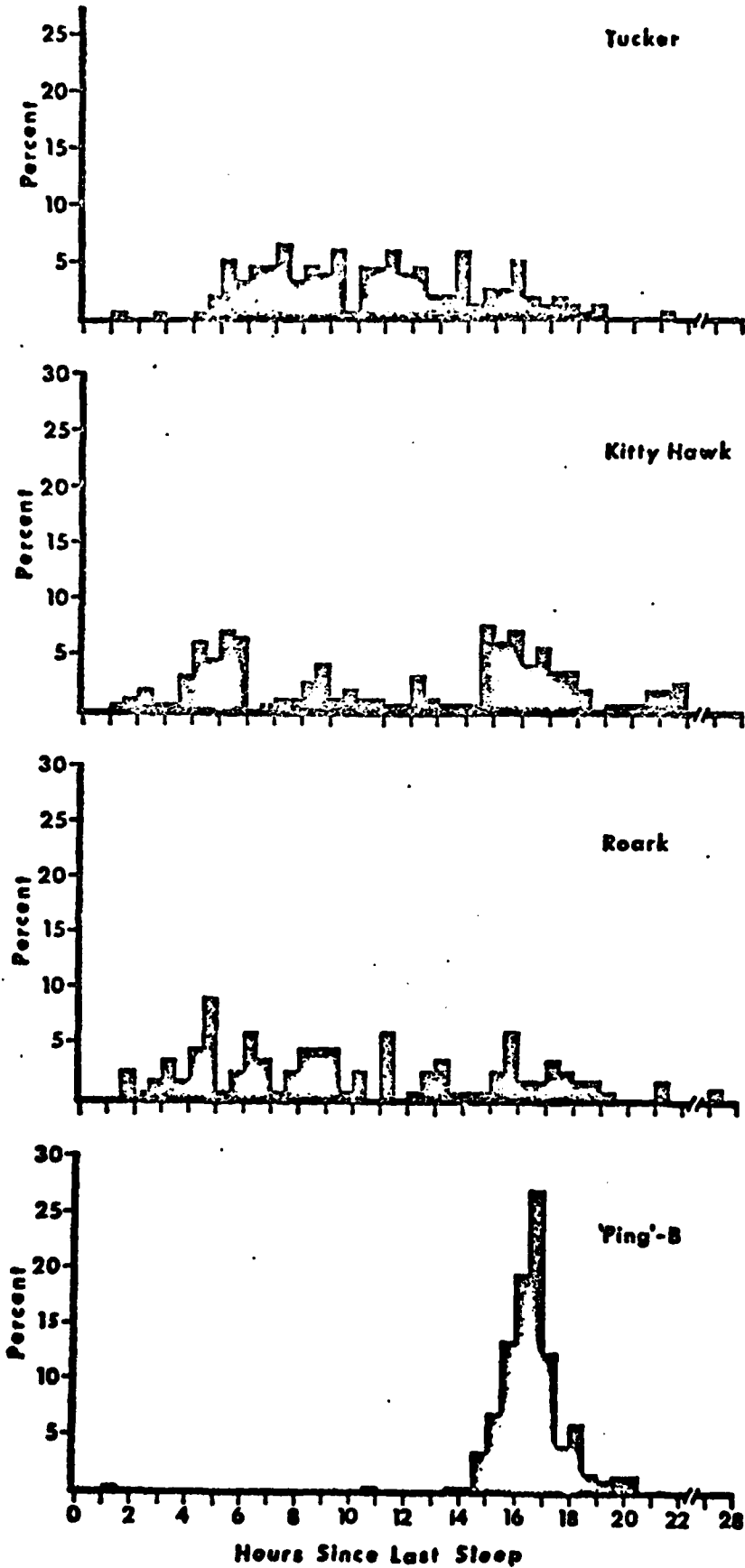

Fig. 4
Intersleep intervals of naval ratings sampled from three U.S. Navy ships.

Figure 4

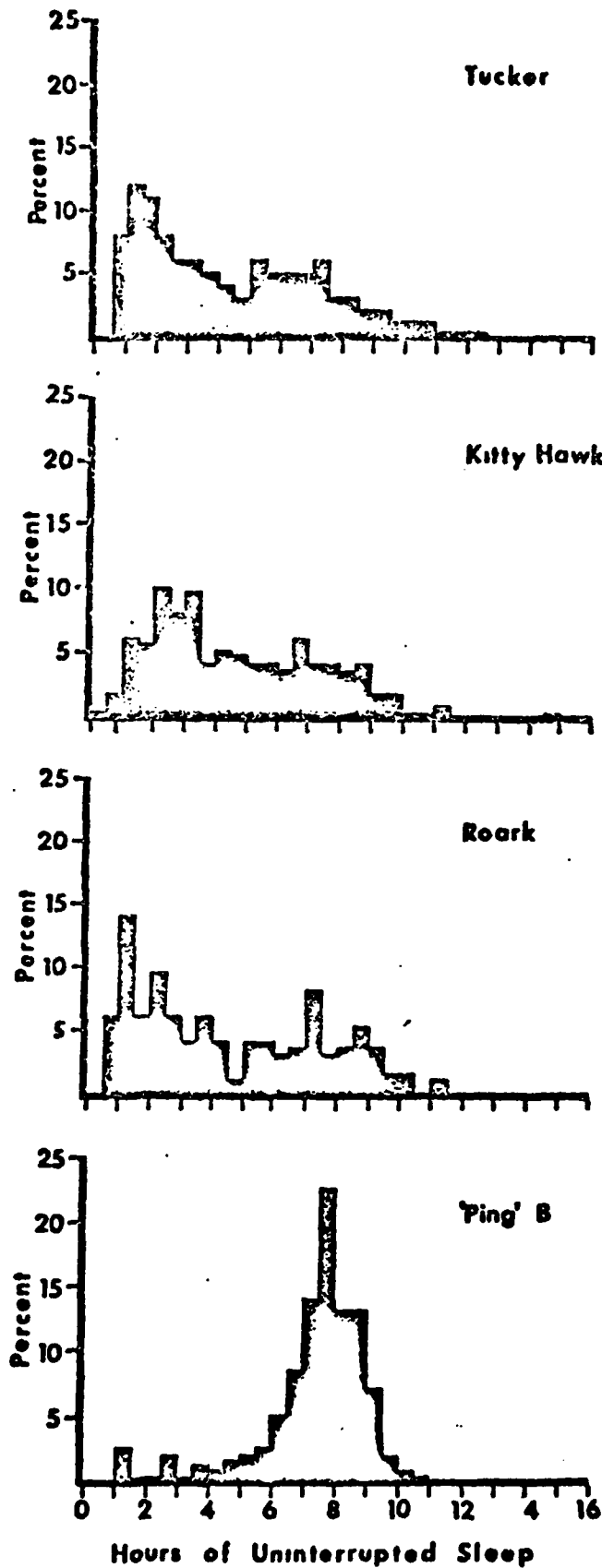

Fig. 5

Durations of un-interrupted sleep of naval ratings sampled from three U.S. Navy ships.

Figure 5

Figure 4 shows the inter-sleep intervals of the crew members on board the USS Tucker, USS Kitty Hawk, USS Roark, and of the men in the "Ping" study. The mode of the histogram of the inter-sleep intervals of the "Ping"-B group is located in the time period of 16.5 and 17 hrs, as expected of monophasic sleep. For crew members of the USS Tucker and USS Roark, the histograms are flat and a single peak cannot easily be found. Two peaks, one at 5.0-5.5 hrs and another at 14.5-15.0 hrs, are observed for the crew of the USS Kitty Hawk. Figure 4 suggests that there is considerable irregularity in the inter-sleep intervals, obviously one of the results of shiftwork. Figure 5 similarly reveals sleep fragmentation. The monophasic sleep pattern of one 8-hr sleep episode per 24-hr day is changed into multiphasic sleep of many shorter sleep episodes. In Figure 5, the crew of the USS Tucker most frequently reported a sleep period that lasted from 1.0-1.5 hrs. Those on board the USS Roark reported similar sleep episode durations to those for the crew on board the USS Tucker. For the USS Kitty Hawk crew, the modal sleep episode duration was one hour longer than the smaller ships, at 2.0 and 2.5 hrs. Thus, crew members paid a price for maintaining continual alertness by fragmentation of their sleep.

The basic problem, then, is to match the needs of the society (the naval ship in the above example) with the cost (fragmented sleep in the above example) that the individual must pay.

So far, the diurnal nature of humans has been discussed in terms of the sleep-wakefulness patterns when humans attempt to cope with varying work-sleep schedules. But, does human task performance show a similar diurnal variation? If so, how should diurnal individuals meet society's needs for high quality job performance round-the-clock? If humans are diurnal in task performance, or, more broadly speaking, if humans show circadian rhythm in task performance, they can be expected to be efficient at their jobs during the day time, but their

efficiency will inevitably deteriorate during the night time. As Wever (1970) points out, proposals to improve performance of an individual during the night time that disregard the diurnal nature of humans are not feasible, if the same individual is also expected to be efficient during the day time.

Circadian rhythms in task performance, as well as subjective ratings of mood, fatigue and willingness to work (motivation), have been well established. From their many studies, Reinberg and his colleagues (1974) have suggested that there is a "best time" to work, and a "best time" to sleep in any temporal environment. The research obligation of defining the extent of diurnal or circadian variations in performances has been shouldered by a new interdisciplinary group of psychologists who refer to themselves as chronopsychologists. The name, chronopsychology (derived from *χρονος*, meaning time, and psychology), was first introduced by Folkard (1977), but earlier Halberg (1973) proposed "educative chronobiology" to represent the young interdisciplinary science of chronopsychology. In his paper, Halberg stressed the importance of time-of-day in instructing students. Mainstream experimental psychologists tend to ignore the time-of-day effect.

An example of chronopsychological study is the report of Monk and Folkard (1978). They have shown that studying late at night, i.e. "burning the midnight oil," is much less efficient than studying at other times of the day. The materials learned late at night will be more easily forgotten than materials learned at other times of the day. Another example can be found in a study by Englund (1979) who reported that reading comprehension of historical texts (Miller's Reading Efficiency Test) was superior in the afternoon and early evening in comparison to mid-morning and late evening. Speed of reading these historical texts followed a different time course with a morning rise and an afternoon fall. Englund concluded that there appears to be a "best time" to

read the printed English texts for comprehension, and a "best time" for rapid reading. Posner (1975) has reported an increase from the morning to late evening in the ability to discriminate signals (d'). In these studies, the chronopsychological approach has been applied to humans, but it should not be confined within human psychology. Ghiselli and Patton (1976) studied one colony of rats which lived under the light phase from 06⁰⁰ to 18⁰⁰, and the dark phase from 18⁰⁰ to 06⁰⁰ the next morning. For another colony of rats, the light phase started from 18⁰⁰ and ended at 06⁰⁰ the next day. They have found that shock avoidance behavior in rats was best in the middle of the dark phase of the day, and worst during the latter part of the light phase. This difference was not due to an overall increase in general activity level of this nocturnal species, but was due to a true increase in the rats' ability to avoid shock due to circadian variation.

Chronopsychologists undertake to define circadian variations of a variety of psychological tasks as well as self-ratings of mood, fatigue and motivational state. In addition, chronopsychologists are interested in finding ways to achieve a balance between high quality job performance on a 24-hr day basis and the diurnal humans whose efficiency fluctuates between the day high to night low. Thus, a chronopsychologist might try to improve performance by shifting the time of peak performance of some individuals to a different time of day. If such shifting of time of peak performance is possible, there will always be some individuals who are at top efficiency at any given time of the day.

In this chapter, some basic principles and major concepts, as well as applications, of chronopsychology will be presented. Statistical analysis methods to express rhythms in task performance by mean value, amplitude and time-of-peak or acrophase angle will be discussed. A brief review of past studies will be made to evaluate currently available information about circadian rhythms in task performance. Then, the use of chronopsychological methods for optimizing human

performance by adjusting time-of-peak performance will be examined by considering many studies on shiftwork and jet lag.

BASIC MODEL OF CHRONOPSYCHOLOGY

Chronopsychology is based on the fundamental observation that human (or animal) task performance, fatigue, mood and motivation to work show a daily pattern of predictably increasing and decreasing efficiency, which recurs reliably over a long period of time. Efficiency of task performance has a period of approximately 24 hrs, circadian. Furthermore, chronopsychology assumes that time of maximal performance efficiency (time-of-peak, TOP, or acrophase angle) can be estimated from the data, and it can be shifted in time by changing time for sleep, meals, social activities and other factors. These are the "zeitgebers" first used by Aschoff (1954) or "synchronizers" of Halberg (1954).

The human circadian performance curve can be modeled by a cosinusoidal wave of amplitude (a difference between the maximal value and mean value) of 20 arbitrary units with the exact period of 24-hrs per cycle as shown in Figure 6

 Figure 6 About Here, see pg 9a

(the top graph). The maximal value of this cosinusoidal rhythm occurred -195 degrees away from midnight, or equivalently at 13⁰⁰, and its minimum at -15 degrees away from midnight, or at 01⁰⁰ of each day. Performance efficiency is shown along the Y-axis from the high of 30 to the low of -50. The X-axis shows time-of-day. If an efficiency value higher than 10 units is needed to assure an acceptable level of job performance, the hours of the acceptable level of efficiency are indicated on the top of the graph as the first horizontal bar. If the level of efficiency is lowered toward the mean efficiency, the hours of

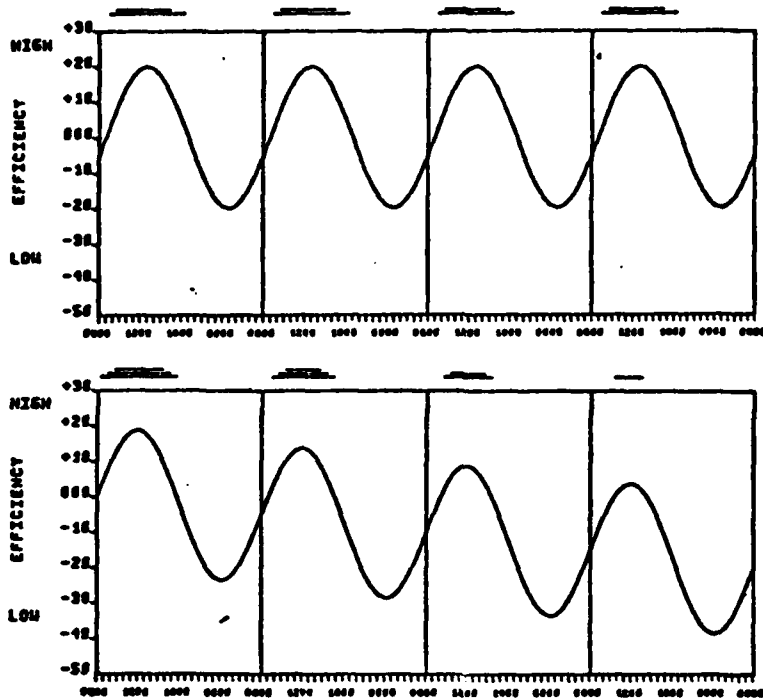

Figure 6. Circadian rhythm model of human performance efficiency. When a cosinusoidal rhythm in this model is replaced by actually observed rhythm in human task performance efficiency, the plot is called "chronogram". The chronogram is individual or averaged display of data along the X-axis representing time-of-day. The top plot shows a model with a steady level of task performance efficiency, while the lower plot demonstrates a model with a declining efficiency.

the acceptable level are much longer than the case of the first example, as shown by the second horizontal bar on the top of the graph. The model could represent the performance efficiency of an individual, or a group of individuals who happen to have the same circadian rhythm in task performance. From this model, it can be seen that human performance efficiency is predictable if this performance rhythm continues over days and an acceptable level of efficiency remains fixed for a job. This kind of plot, using real empirical data from an individual subject or a group of subjects, is called a "chronogram." By construction of a chronogram, the duration of high efficiency which is available daily for doing a "satisfactory job" can be estimated for an individual or a group of individuals. The lower graph of Figure 6 shows a model where performance efficiency has a slow overall decline over four days of "observation." The three horizontal bars on the top of this graph show the hours of the acceptable efficiency level and correspond to the acceptable lowest efficiency of 10, 5 and 0. The top "chronogram" of Figure 7 shows four individuals (or groups) whose curves for performance

 Figure 7 About Here, see pg 10a

efficiency are very close to each other. The horizontal bars on the top of this "chronogram" are prepared, as before, to show the hours of 10 or better efficiency index. Since these four curves are so close that all four individuals (or all four groups) are efficient and inefficient at the same time, a time period for each day is left when none of the four individuals (or groups) is efficient enough to respond to the job demands. This model represents the life style of most working people. The lower graph of Figure 7 shows, however, four individuals (or four groups) whose efficiency curves are sufficiently separated in time so that one individual (or group) is always at a high efficiency level at any one time of

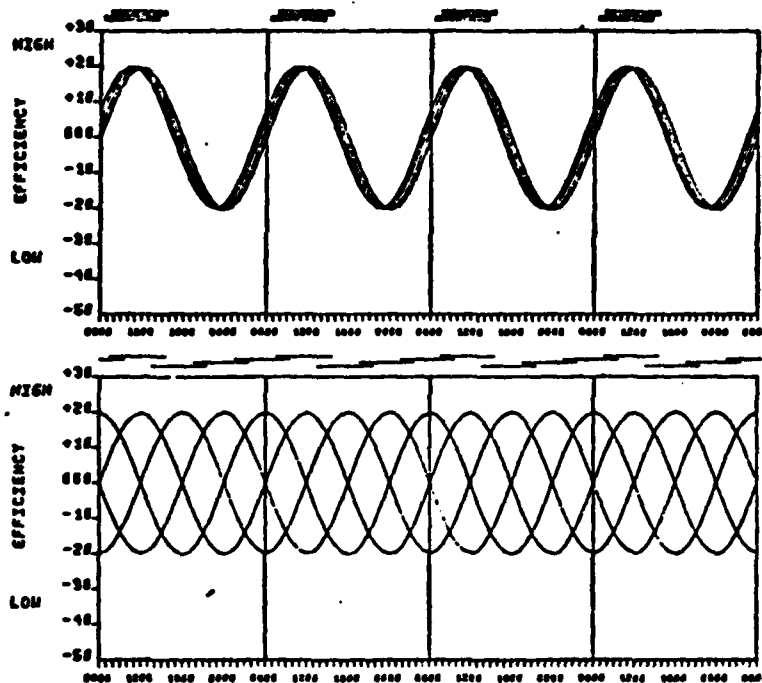

Figure 7. A model of circadian rhythm in human efficiency is shown for (a) four individuals or four groups of individuals possessing a similar Time-of-Peak efficiency (the top plot), and (b) four individuals or four groups of individuals having a widely different Time-of-Peak efficiency (the lower plot). The demand for round-the-clock human participation and attention can only be satisfied by having the individuals or groups whose Time-of-Peak performance differ widely, as shown in the lower plot.

the day. Chronobiologists strive to devise this ideal situation of a variety of shiftwork schedules.

The basic model of chronopsychology is not to create a group of men and women who would remain highly efficient round-the-clock over many days, but to accept and work with the diurnal nature of humans and their circadian rhythms in efficient task performance. Then, the chronopsychologists will attempt to match the hours of work demanded by society with the hours of peak performance of an individual worker (or group of workers). In other words, the chronopsychologists will attempt to change the life style of the workers so that they will be on the job at their "best time."

METHODOLOGICAL AND STATISTICAL ASPECTS OF CHRONOPSYCHOLOGY

The first major decision which must be made in chronopsychological research is whether it should be conducted in the laboratory or in the field. One advantage of the laboratory environment is that it provides the necessary degree of control over many factors which are known to influence circadian rhythms in task performance. These factors include variations in the level of ambient lighting and temperature, social interactions, meal times, and sleep-activity schedules. Another advantage of the laboratory study is that it can handle complex biochemical and physiological variables, since the required instrumentation for acquisition and analysis is available in a laboratory.

Although chronopsychological studies in the field can sample complex variables, such as the electroencephalogram (EEG), electrocardiogram (ECG) and electrooculogram (EOG), ordinarily they are based on the autorhythmometric (AR) approach proposed by Halberg (1972), Reinberg et al. (1975), Halberg et al. (1976) and by Englund (1979). In AR, an experimental subject repeatedly measures his own physiological and psychological variables, and records these as a function

of time. To facilitate these do-it-yourself measurements, each subject is provided with a kit containing the necessary tools sometimes accompanied by a flow-diagrammed instruction or comic-strip instruction prepared by Reinberg et al. (1975). Currently, a standard AR kit (see, for example, Levine and Halberg, 1972) permits each subject to measure systematically the following variables while he or she is on the job: (1) oral temperature, (2) self-ratings of mood and physical vigor each on a 7-point scale, (3) elapsed time estimation of one minute by counting 1 to 60 silently, (4) pulse rate, (5) blood pressure, (6) speed of finger-counting to 25, (7) speed of adding consecutive pairs of digits in single columns of 50 random numbers, (8) grip-strength of right and left hands, (9) peak expiratory flow, and (10) urinary variables (e.g., urine temperature). Since AR measurements are usually taken in the normal daily on-the-job environment, the subjects are encouraged to note the occurrences of special events previous to the AR measurements or urine collection. Special events are: smoking (coded as S), exercise (E), strenuous exercise (E'), consumption of alcohol (A1) and of coffee, tea or coke (C), anxiety (Ax), anger (Ag), any medication (the name of the drug should be listed), sleep and meal times, and extremes of weather conditions. Clearly, the exact choice of the variables which will be examined autorhythmometrically will depend on the research objectives and the feasibility of obtaining the measurements from individuals at work.

The second major decision for chronopsychological research will be to choose the number of experimental subjects. The observation of a single subject, however long he or she might have been observed, would not provide definitive evidence that a chronopsychological rhythm, detected in this subject, qualifies as a truly endogenous new rhythm. Such a rhythm could be a unique personal characteristic of this person. A rhythm must be observed

in a majority of experimental subjects before it can be called a genuine new rhythm. This criterion is the third one to be added to the usually offered two criteria which must be experimentally satisfied before any new rhythmic activities can qualify as the true chronopsychological rhythm (Halberg et al., 1971). The two usual criteria are: (1) the rhythm should gradually follow an abrupt shift of 90 degrees or more (i.e., 6 hrs or more) in the environment and eventually will be in synchronization with the shifted environment, and (2) the rhythm should persist as a statistically significant rhythm for two or more cycles even after the environmental time as well as social cues are removed. To meet the second criterion, the rhythm must clearly persist even when the subjects do not sleep for two or three days (that is, the removal of sleep-wakefulness alternations), and it must also persist when the subjects live in a completely dark or constantly illuminated underground chamber in the absence of time and social cues (see Wever, 1979). The third criterion assures that a chronopsychological rhythm newly detected is shared by a majority of human beings (Halberg et al., 1969), and is not a unique characteristic of a few individuals.

The third major decision for chronopsychological research is concerned with the repeated testing of the same individuals with a multiple test battery at each session. Two methodological decisions are required of experimenters. First, the experiment must be designed so that circadian changes in task performance can be as little contaminated by practice and cumulative fatigue as possible. Perhaps this methodological point can be best explained by an example. In an hypothetical study, an experimenter wishes to test all four subjects every six hours at 06⁰⁰, 12⁰⁰, 18⁰⁰ and at midnight. The experimental design calls for all subjects to start at 06⁰⁰ and to be tested in that order. A second possible experimental design, however, requires that each subject will

start the testing at a different time. Thus, one subject will start at 06⁰⁰, and continue to take the tests at 12⁰⁰, 18⁰⁰ and at midnight, but another subject may start at 12⁰⁰, and continue testing at 18⁰⁰, midnight and at 06⁰⁰ of the next day. If the experimenter uses the first experimental design, this experimenter cannot tell whether the changes in task performance are due to a circadian effect, an improvement as the result of practicing the task over four sessions, or cumulative fatigue, and even boredom, resulting from repeated testing with the same task battery. If, however, the experimenter has adopted the second design (a rolling Latin Square design; see Monk, in press, Fort and Mills, 1972), at least the effects of practice and fatigue are averaged out at each testing time and any systematic change in task performance would probably be due to circadian variation. This is because each testing time includes the subjects having a different number of prior test experiences.

A shortcoming of the first design mentioned above can be minimized if the subjects are thoroughly pre-trained with the tasks so that there will be little improvement with further practice. Then that experimental design is more attractive than the rolling Latin Square design because the experiment starts and ends at the same time for all subjects. The second experimental design is attractive in the sense that it does not require an extensive pre-training of the subjects. But an actual execution of this experimental design gets rather complex (see Bethea, 1975), and its success depends on the similarity of circadian curves among the subjects.

In addition to controlling practice and fatigue effects, another methodological decision involves the question of the sequence of tasks in the test battery. Should the sequence of tasks be constant throughout a study, or should it be randomized from one test session to another? Certain tasks may interact (that is, either interfere or facilitate) with another task which immediately

precedes or follows it. In many past studies, a sequence of tasks within a test battery has usually been fixed, mainly because of the ease of its administration.

The fourth major design decision for chronopsychological research will center on the many questions related to data sampling. For laboratory studies, data should be obtained regularly over the entire duration of the experiment, including the sleep period. This means that the experimental subjects must be awakened from sleep for testing. Previous studies by Aschoff et al. (1972, 1974) have shown that the waveform of the circadian rhythm is not affected by interruptions of sleep for testing purposes. Two aspects of sampling are important to simplify the statistical analysis. Sampling should be done at regular intervals (say every 4 hrs), and sampling should be done over the entire 24-hr period (if the sampling is to be done at midnight, 06⁰⁰, 12⁰⁰, and 18⁰⁰, it should not stop at any other time period than 18⁰⁰). With such careful sampling at regular intervals for the complete 24-hr periods, a standard periodic regression analysis of Bliss (1970) and of BMD 4R program (Dixon, 1974) can be used to find the rhythmicity in the data.

Regularly scheduled sampling is not always feasible in most field studies. Statistical analysis is available for irregularly sampled data (e.g., Halberg et al., 1972; Naitoh et al., in press), but the interpretation of the analysis of irregularly sampled data is more difficult and uncertain than that obtained from the regularly sampled data.

If statistical frequency analysis has been planned, two further aspects of the data collection procedure require careful consideration. They are: (1) sampling interval, and (2) total duration of experimental observation. The sampling interval should be as short as possible, especially when defining the TOP and TOT values in the raw data by inspection of the chronogram. The total duration of experimental observation (i.e., the total number of data points

multiplied by the sampling interval) plays a critical part in circadian analysis. A longer observation period will result in a more reliable construction of the Buys-Ballot table. A Buys-Ballot table is prepared by cutting a long string of data (time-series) into small segments. Each segment has a time span corresponding to the periodicity suspected to be present in the data string. These segments are then laid down row by row to make a table (Enright, 1965; Williams and Naylor, 1978; Orth et al., 1979; Monk, in press). If the time-series happens to have a rhythm at the period length corresponding to the time span which has been used to cut it, then the column-wise averages of this Buys-Ballot table will show that rhythm. A plot of these averages is called a "plexogram" (see Halberg et al., 1977), and it is helpful in seeing an emerging rhythm from the data string, as one segment after another is added to the already summed segments. It is similar to the manner in which an evoked brain potential emerges out of background EEG activity after repeated summation of the post-stimulation segments of the EEGs. As in frequency analysis, the duration of observation determines the frequency resolution and the slowest frequency that can be found from the data. For example, if the observation duration happens to be 48 hrs, then the slowest frequency that can be detected from the data is given by the reciprocal of the total duration of observation, i.e., $1/48 = 0.0208$ cycle per hour or 0.5 cycle per day (cpd). This means also that the activities within a range from 0.5 cpd to 1.5 cpd cannot be separated from 1 cpd because the frequency resolution is 0.5 cpd. If the research objective is to resolve 1.1 cpd from 1.0 cpd, the observation period must be 240 hrs or 10 days.

The total number of data points plays an additional important role in the statistical identification of rhythms in data. Before this can be adequately explained, it is necessary to understand the essentials of frequency

analysis of fitting a cosinusoidal wave to data. Frequency analysis (Bliss, 1970; Halberg et al., 1972; Rummel et al., 1974; Monk, in press) is an attempt to measure the similarity between the observed string of data points and a trigonometric function describing the frequency of interest. The similarity is expressed by the multiple correlation between the data points and a pair of predictors, sine and cosine waves with the same frequency. Frequency analysis can be understood as an effort to explain the variance in the data by means of combining sine and cosine waves of the same frequency. Both sine and cosine waves are needed to find the starting phase of the resulting cosinusoidal wave which best fits the data. The multiple correlation coefficient between the data and a cosinusoidal function is squared and multiplied by 100 to represent the percentage of the variance in the data which has been successfully accounted for by this cosinusoidal wave. This multiple correlation coefficient which is squared and multiplied by 100 is the "percent rhythm" (PR; see Halberg et al., 1977). If the cosinusoidal wave used for the frequency analysis has a rhythm of 24 hrs/cycle or 1 cpd, the PR is called a "circadian quotient" (CQ; see Halberg et al., 1977). All statistical warnings against careless interpretation of the multiple correlation apply to PR and CQ. The most important warning concerns the fact that PR and CQ will approach 100 as fewer and fewer data points are used for its computation, regardless of the true value of the multiple correlation existing between the data and cosinusoidal wave. Thus, even when the population PR or CQ is in fact zero, the expected value of a sample PR or CQ has non-zero value. It will have a value of $2/(N-1)$. It is positively biased. ("N" is the number of independent data points used in the computation and it must be equal to or greater than 3.) In other words, PR and CQ cannot be directly compared in terms of its size because

of this bias, unless they are based on the same number of data points.

Analysis of data starts once a sufficiently large number of data has been collected from many subjects over a reasonably long period of observation. Statistical analysis can be applied to data without frequency analysis. First, many plexograms can be prepared to choose the plexogram which has the largest rhythmic appearance (e.g., "average day" analysis of Orth et al., 1979). Then, univariate analysis of variance for the repeated measures (e.g., BMD P2V of Dixon, 1975) or multivariate profile analysis (e.g., Traquini et al., 1979) can be used to establish the presence of significant deviations, possibly of circadian origin, at certain time periods of the plexogram.

Most often, however, frequency analysis is applied to the data so that a large volume data set can be simply and objectively represented by a few basic "parameters" of the rhythm. They are (a) mesor, the value midway between the peak and trough of the fitted cosinusoidal wave, (b) amplitude, the difference between the peak and the mesor of the fitted cosinusoidal wave, (c) TOP or acrophase angle (in reference to midnight or midsleep), (d) period length, if many periods are tried out in the analysis, and (e) PR or CR. Sometimes, a few additional derived measures are used to express the magnitude of rhythmic oscillation: (a) range of change (ROD) is the difference between the peak and trough being expressed as a percentage increase over the lowest value (Kanabrocki et al., 1973), and (b) amplitude expressed as a percent of the mesor. Many methods are available for frequency analysis. Most common to these methods is the idea of representing the data by a single cosinusoidal waveform (Naitoh et al., in press). The details of frequency analysis are presented elsewhere in this volume.

After frequency analysis, each experimental subject is represented by

a matrix in which the rows correspond to the variables under study. Each row will contain all of the parameters of the rhythm for each variable. The group-mean cosine vector (cosinor) analysis of Halberg et al. (1972) uses only two parameters in this matrix, and does the bivariate analysis of amplitudes and TOPs of a group of subjects to determine if a statistically significant rhythm can be found in the group, and if so, to estimate ^{the} average TOP and average amplitude. In the group-mean cosinor, the 95% confidence interval (CI) for amplitude and for TOP can be calculated. The 95% CI defines an interval within which future sample values will be included 95% of ^{the} time. Figure 8 shows plexo-

 Figure 8 About Here, see pg 19a

grams and cosinor plots for oral temperature and systolic blood pressure.

If the cosinor analysis establishes that some variables under study have statistically significant circadian rhythms, the experimenter can go further in examining the data for possible interrelations among the circadian variables. Correlations can be calculated between the circadian variables, and cross-spectrum analysis (Orr and Naitoh, 1976) can be applied. A simple analysis of the interrelations among the circadian variables is to prepare an "acrophase map" (for example, Reinberg, 1979; Reinberg et al., 1975), or ^{the} "phase map" of Wever (Figure 3 of his 1979 book). The phase map of Wever consists of plotting average curves of variables in a single graph on the common X-axis showing time-of-day (over a 24-hr span). The acrophase map plots the acrophases (TOPs) and associated 95% CI's of many circadian variables in a single graph along the common X-axis showing time-of-day. These maps summarize ^{the} temporal pattern of the human organism.

Figure 8. Plexogram and cosinor plot for oral temperature (top row) and those for Systolic blood pressure (bottom row). The line identified by the squares shows the values observed during the baseline (b), and Xs during the vigil (V). A Cosinor plot shows the 95% confidence ellipse with 2 lines tangent to the ellipse. The ellipse with longer tangent lines cutting into a clock represents that for the Time-of-Peak values observed during the vigil, and that with shorter lines for the baseline. In the cosinor analysis, eleven data points were used. For the cosinor analysis of baseline data, data points from 08⁰⁰ to 04⁰⁰ were used (see the plexograms) which correspond to 1 to 21 hours of continuous wakefulness. Similarly for the cosinor analysis of the vigil, 11 data points from 08⁰⁰ to 04⁰⁰ of the next day, which corresponded to 25 to 45 hours of continuous wakefulness, were used. The same analysis procedures were used for Figures 9 through 12. The numerical summary of the cosinor analysis for Figures 8 through 12 can be found in Table 2 (pg 30a+). X-axis shows time-of-day. Y-axis for oral temperature is in °F, and that for systolic blood pressure is in mm Hg. Data for oral temperature were obtained from 23 sailors. Systolic blood pressure data were collected from 19 sailors.

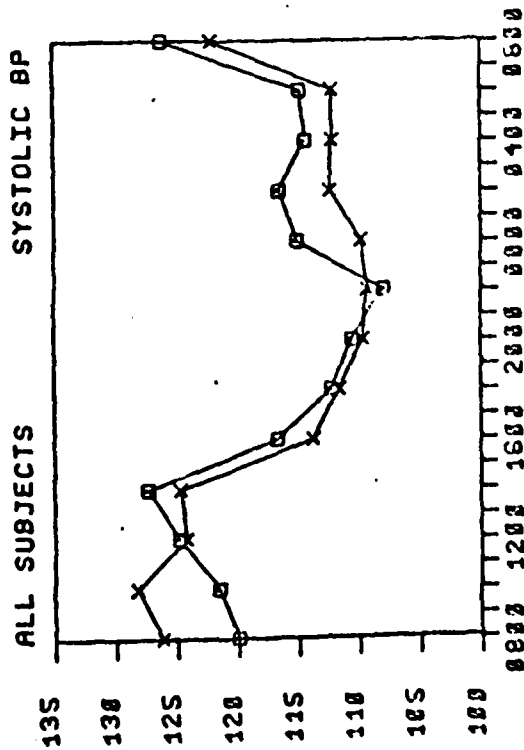
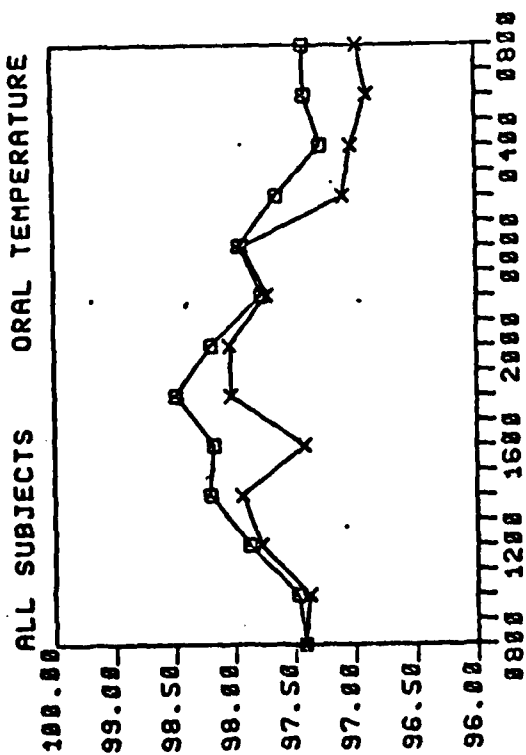
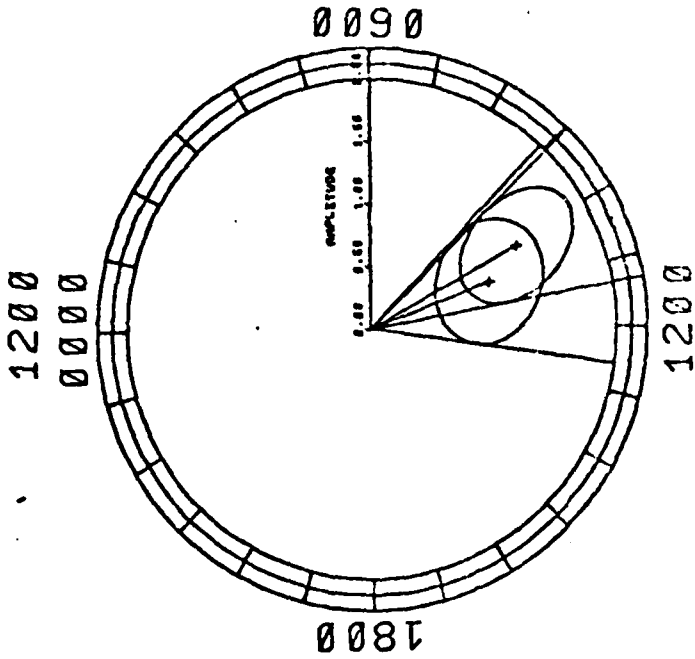
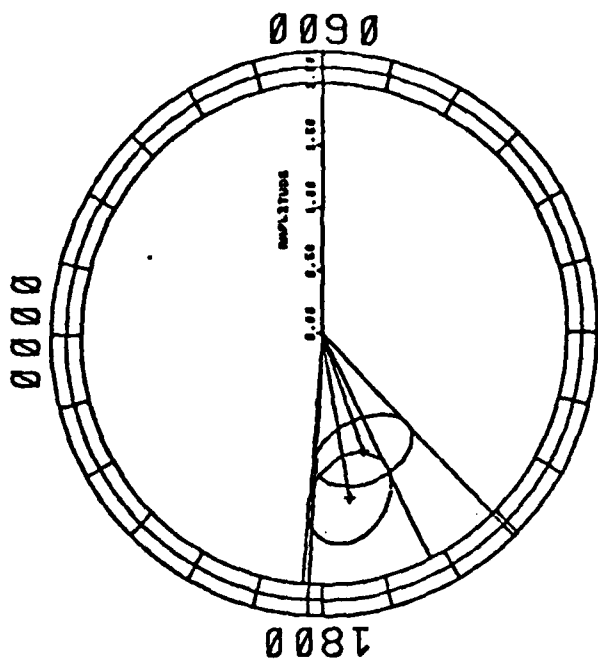

Figure 8

CIRCADIAN CYCLES IN HUMAN PERFORMANCE EFFECTIVENESS

An earlier review of rhythm in human performance efficiency has been published by Freeman and Hovland (1934). More recent reviews are: Kleitman (1939, 1963), Colquhoun (1971), Hockey and Colquhoun (1972), Froberg (1975), Conroy and Mills (1970), Klein and Wegmann (1979), Folkard (this volume) and Englund (1979).

After reviewing early studies which investigated performance during the normal "waking" day period, Freeman and Hovland (1934) came up with four types of curves in describing the diurnal variation in sensory, motor and mental performances. They concluded that "the balance of evidence apparently favors an afternoon superiority for sensory and motor performance, but there is little agreement as to the time when complicated mental work can be done most efficiently (P. 786)." Kleitman (1939, 1963) reiterated this view, suggesting that the peak of task performance is likely to be in the middle of the waking day.

Browne (1949) studied reaction time before switchboard operators answered calls in a day shift (08⁰⁰-16⁰⁰), an evening shift (16⁰⁰-23⁰⁰), and night shift (23⁰⁰-08⁰⁰). He found that the delay in answering the call became progressively shorter from 08⁰⁰ to 18⁰⁰, and progressively longer after 22⁰⁰. Speed was the slowest for the time period of 01⁰⁰-04⁰⁰. Bjerner et al. (1955) analyzed all logging errors in reading meters at Swedish Gas Works by shiftworkers over a period of 20 to 30 years in reference to time-of-day. They observed that a steady increase in the number of errors occurred during the night shift of 22⁰⁰-06⁰⁰, reaching its peak around 03⁰⁰, the same time period when Browne (1949) found the longest delay in answering the calls. The graph of number of errors revealed a very stable level during the day time, except for the increase around 15⁰⁰, most probably explained by the postprandial dip in performance efficiency.

Hildebrandt et al. (1974) studied 2,238 automatic brakings of trains,

which occurred because of the failure of locomotive drivers to respond to warning signals. When the drivers failed to respond to warning signals by operating an attention switch, a hooter was sounded for 30 seconds during which time they had to operate safety gear to avoid automatic brakings. The occasion of a hooter sounding indicated extremely drowsy or asleep drivers. They found that the peak of hooter sounding occurred about 03⁰⁰, and also around 15⁰⁰. Folkard et al. (1978) have demonstrated reduced safety in a large hospital during the night due to lowered human efficiency. They analyzed hospital forms, listing all accidents and unusual incidents over a five-year period and they found 1,576 reports involving patients with clear indications of time of accidents. The frequency of accidents was observed to decrease over the normal waking time, and to increase over the night. They pointed out, however, that it is unclear whether the increase in accidents was due to a circadian variation of the patients' vigilance or to that of the nurses. These studies have agreed that human efficiency in job performance is low during night shifts. They established that the minimal efficiency can be anticipated from 02⁰⁰-04⁰⁰.

Many laboratory studies have been conducted to show circadian rhythms in human efficiency in task performances. Froberg (1975) reviewed 15 studies involving circadian rhythms in a variety of tasks. The 15 studies were published in the 60's and early 70's, except one study done in 1938. They examined the efficiency in performing such tasks as reaction time, sorting, letter cancellation, mirror drawing, tracking, flying flight simulator, and adding. Froberg noted that performance efficiency for short and simple tasks was minimal in the early morning, and maximal in the afternoon. Tasks heavily loaded with memory, however, appeared to be better in the morning. Blake (1967) evaluated performance of eight tasks at 08⁰⁰, 10³⁰, 13⁰⁰, 15³⁰, and 21⁰⁰ in a group of naval ratings. The tasks were (a) five-choice serial reaction for 30 min.,

(b) auditory vigilance for 53 min., (c) sorting of 64-card pack for 12-15 min., (d) letter cancellation for 30 min., (e) time estimation for 5 min., (f) digit span memory for 5 min., (g) simple reaction time for 20 min., and (h) adding columns of five 2-digit numbers for 60 min. Tasks (a), (b), (c), (d) and (h) showed an improvement in at least one aspect of performance over the test period from 08⁰⁰ to 21⁰⁰. For example, auditory vigilance improved significantly over days in terms of percent correct detection. The highest score was obtained at the 21⁰⁰ session. The number of false reports, however, did not show such a diurnal improvement. For the five-choice serial reaction time task, the highest number of correct choices and the smallest number of "gaps" were observed at the 21⁰⁰ session. The 21⁰⁰ session was also the best time to do the letter cancellation and adding tasks. Blake was not able to identify visually a circadian rhythm for simple reaction time or for time estimation.

Some studies on circadian rhythms in performance have examined individuals who remained awake to avoid the "masking effects" (see Aschoff (1960) and Wever (1979) for the definition) of sleep on the expression of circadian rhythms. Aschoff et al. (1972) reported on the psychomotor performance of groups of individuals who remained awake one or two days in normal living quarters under constant light, i.e., LL. In one study, a group of 12 subjects was kept together for the duration of an experiment. For this group of individuals, reaction time and time estimation remained shorter throughout the 24-hr period during which they were awake. Only the number of taps showed a typical circadian minimum during the time period from midnight to 09⁰⁰. In the second experiment, 7 subjects were each kept in isolation in an underground chamber with an artificial light-dark period (LD) for one day, and then they remained awake under the LL condition for about 40 hrs. The effects of this living routine on task performance were quite different from those living as a group. Clear

circadian rhythm was observed in task performance. The task performance rhythm was generally similar on days with sleep (but sleep was interrupted three times for testing) and without sleep. During the vigil under LL, however, the nocturnal lengthening of time estimation was found to be smaller. The minimum for tapping occurred normally around 03⁰⁰-06⁰⁰, but the time of minimal value was delayed to 06⁰⁰-09⁰⁰ during the vigil. Similarly, the trough in grip strength rhythm was delayed from normal time span of 03⁰⁰-06⁰⁰ to 06⁰⁰-09⁰⁰. In the third experiment, two groups of three subjects each were kept in the underground chamber. For the first two days, they lived in a LD cycle, where the D cycle started from 23³⁰ and continued till 08⁰⁰. Sleep during this D period was interrupted three times for testing. Then they experienced two days of sleep deprivation under the LL condition. Finally, they went back to the LD cycle for two days. During the first recovery night, sleep was not interrupted for performance testing. During the vigil, the range of the circadian rhythm for tapping speed was reduced, mainly because of an elevation of night values, but the circadian rhythm remained discernible especially for the first vigil night. The postprandial dip for the tapping task appeared rather large during the second vigil day. Sleep loss effects were large for digit cancellation and "concentration" tasks, their values being extremely low during the second night of the vigil. The circadian rhythms in these tasks were too small to see, because of the fact that the circadian drop in task performance during the first night of the vigil was small, and there was no circadian daytime improvement in performance during the second day of the vigil.

Ringer (1972) studied four groups of three subjects each. Each group stayed in the underground chamber for eight consecutive days. For the first one-and-one-half days, the subjects received practice and orientation sessions to get accustomed to the living conditions. Then followed two days of controlled LD

cycles, where a light-dark schedule (LD: 15.5; 8.5 hrs) was used. The D phase started at 23³⁰ and ended at 08⁰⁰. Sleep during the D phase was interrupted twice for 30-min testing. So the maximal sleep that could be obtained during this D phase was 7.5 hrs. Following this D phase, lights were kept on for 63.5 hrs continuously, and the subjects remained awake. After the 63.5-hr vigil, three recovery days were provided. Sleep during the first recovery night was not interrupted for testing and the maximal sleep duration was 8.5 hrs. From the second recovery night on, sleep was interrupted as before. In order to avoid an end spurt in performance during the last day of the vigil and also during the last day of the experiment, the subjects were misinformed that they must stay awake for three nights (instead of two nights) and that the experiment would continue for nine days (instead of eight days). The tasks employed were (1) reaction time, (2) tapping at the fastest speed and at a normal speed, (3) digit cancellation, (4) complex computation, (5) simple addition, and (6) time estimation. In addition, the subjects rated their own well-being and collected urine. Rectal temperature was continuously monitored. One of the most important findings of this study was that, after two days of the vigil, the phases of all rhythms drifted as much as 2 to 4 hrs toward later times (see also, Aschoff et al., 1975; Aschoff, 1978). This strongly suggests that sleep may have phase controlling powers (i.e., advancing the acrophase) over some circadian rhythms. Sleep may be one of numerous zeitgebers. Ringer's detailed analysis showed that the TOP for reaction time, digit cancellation, simple addition, and complex computation was delayed by 4 hrs during the vigil. TOP for time estimation and for tapping speed did not change between the LD control and vigil days. Vigil also delayed the TOP for self-rating of well-being by 8 hrs. Rectal temperature was delayed, but by only 2 hrs during the vigil. Ringer noted that the vigil of one day reduced the circadian amplitude in tapping and time estimation

by subjects keeping a high performance efficiency even during ^{the} night period. There was no dramatic drop in performance efficiency in these tasks even during the second night of the vigil. This resulted in a very small circadian amplitude in the tapping task and an almost complete abolishment of circadian rhythm in time estimation after the two-night vigil.

Fort and Mills (1972) tested 13 subjects every two hours for 24 hrs. Their main research objective was to determine whether the deterioration of performance efficiency during the night was attributable to circadian rhythms, or direct effect of sleep (sleep inertia). No clear circadian rhythm for the cancellation task was found during the vigil. Performance on the syllogism test improved from a very poor performance observed at 04⁰⁰ to a peak efficiency around 13⁰⁰. An aiming task showed peak performance around 13⁰⁰, and was poor during the period from midnight to 06⁰⁰. Under continuous wakefulness, performance was still poor in the early morning hours. They observed, in another experiment involving the same subjects, that the decrement in performance was greater when the subjects were awakened from sleep for testing than when they stayed awake all night. They concluded that the nightly decrease in performance efficiency was due to both time-of-day (the circadian factor) and awakening from sleep (the sleep inertia factor).

Since 1972, Froberg et al. have reported on the results of a series of experiments involving sustained performance up to 75 hrs. In their studies, the first 3 hrs were a control period. The remaining 72 hrs were divided into 24 periods of 3 hrs each. Each 3-hr period consisted of two parts: 2 hrs 45 min of "firing" an electronic rifle at small moving targets containing photo-diodes, and 15 min to void urine, drink 300 ml of water, eat two sandwiches, and subjectively to rate fatigue and stress. The subjects did this shooting task as a group, and they were informed of the number of "shots fired" and hits after

each run. Subjects sat in chairs during the task, and were awakened immediately when they fell asleep. Illumination of the shooting range alternated from one session with hanging ceiling lights on, to the next session with weak floodlights only near the target area. In the latter sessions, tape-recorded battle-noise was played back to the subjects. Half the subjects began the sustained work at 08⁰⁰ and ^{the} other half at 11⁰⁰. The subjects did not see daylight and were deprived of their watches but knew that urine voiding occurred every 3 hrs. In the 1972 study, Froberg et al. reported on two experiments: experiment I studied 31 officers and corporals, ages 20-44 (mean of 29 years), and experiment II examined 32 senior officers, ages 49-64 (mean of 56). Frequency analysis was applied to ^{the} means of each variable and each 24-hr period (starting at 11⁰⁰ or 14⁰⁰). The shooting task failed to show a circadian rhythm. Both fatigue and distress ratings crested around 03⁰⁰-05⁰⁰, and had troughs around 14⁰⁰-17⁰⁰. Urinary adrenal excretion had a well-defined peak at 12⁰⁰-13⁰⁰ for both experimental groups during the first 24-hr period, and a well-defined trough at 23⁰⁰. Vigil delayed the TOP for urinary adrenaline excretion, and increased its amplitude. Circadian amplitude of fatigue rating decreased over three days of sleep loss in group I, but not in group II. TOP of fatigue was delayed about one hour in group I over three days of continuous wakefulness, but it came earlier by 1-1.5 hrs in group II. In 1975, Froberg et al. reanalyzed the data presented in their 1972 paper, but they used only ^{those} 29 subjects out of the group of 32 officers and corporals (group I) whose data were complete for further detailed statistical evaluation. First, they tested differences between 3-hr time blocks within each day by analysis of variance. Then, frequency analysis was applied to those variables which were found to differ significantly within days. As before, frequency analysis was applied to each variable and each 24-hr period. In this study, however, frequency analysis was applied to each subject,

not to the means of the variables as was done in 1972. Clear-cut circadian rhythms were found in the urinary adrenaline excretion, subjective ratings of fatigue, and the number of shots fired. The number of shots fired peaked around 15⁰⁰-19⁰⁰. The 24-hr cosinusoidal wave explained from 46% to 96% of the total variance of data. Circadian amplitude ranged from 130 to 404 shots/3 hrs, and the mesor from a high of 1,289 to a low of 644 shots/3 hrs. Sleep-loss effects were most obvious in the decline of the number of shots fired and a loss of circadian rhythms in some subjects during the third day of the vigil. No consistent delays or advances in the phase of circadian rhythms in the shooting performance were seen over the three days of the vigil. Self-ratings of fatigue peaked around 03⁰⁰-06⁰⁰ with the CQs accounting for 68% to 90% of the total variance of the data. Sleep loss increased the level of fatigue, but it did not affect other parameters of the circadian rhythm, except for decreased amplitude in some subjects.

Using a similar experimental design, Akerstedt, Froberg and others studied 15 female subjects, and reported the results in two separate papers. One paper emphasized "morning" and "evening" types in coping with 72 hrs of sleep deprivation (Froberg, 1977). The second paper focused on male and female differences in psychophysiological circadian rhythms during the 72-hr vigil (Akerstedt et al., 1977). Froberg selected 7 "morning" and 8 "evening" type females from a group of 47 females with a morningness-eveningness questionnaire. Four tasks were given to the subjects: (1) an auditory vigilance task where three successively presented odd digits in a sequence should be detected, (2) a complex letter cancellation which required applications of three different rules in cancelling letters, (3) a spiral maze which consisted of tracing a spiral printed on paper from its center outward to the opening without touching the walls or the obstacles (i.e., a test of hand-steadiness), and (4) syllogisms, each of which consisted of 2 premises and 4 alternative derivations, only one of which was

logically correct. Self-ratings of alertness-energy and tiredness were obtained, in addition to values of urinary adrenaline, urinary noradrenaline, pulse and oral temperature. As anticipated, TOP of oral temperature was earlier for the morning type than for the evening type over three days of sleep loss. During day 1 of the vigil, the morning type showed oral temperature peak at 16¹⁴ and the evening type had its peak value 15 min later at 16²⁹. During day 2, the morning type peaked at 16⁵⁵, and the evening type peaked 10 min. later at 17⁰⁵. During day 3, the morning type had its peak at 14¹⁴, while the evening type peaked about two hours later at 16¹⁷. Out of four tasks reported in this study, vigilance (in terms of errors of omission) and ^{the} complex cancelling task (in terms of the number of errors) showed clear circadian rhythms. The vigilance performance efficiency cre sted between 16⁴⁷ and 18⁴⁴ and the evening type subjects tended to peak at a later time of day in comparison with the morning type. ^{The} complex cancellation task showed a significant rhythm only during day 2 and day 3. It was most efficiently performed around 18⁰⁰-19⁰⁰, but CQs had a generally very low value of about 10%. The morning type showed very clear circadian rhythms in alertness-energy, peaking around 16⁰⁰-18⁰⁰ over ^a 3-day period of the vigil with ^a high CQ of 74-90%, whereas the evening type had a flatter and much less clear ^{er} circadian rhythm (and only for day 1). These differences between the morning and evening types were only suggestive and not reliable.

Correlational analyses have suggested that oral temperature and alertness-energy would be good predictors of performance rhythm, because they are in phase. For some of the subjects, performance measures, self-ratings and adrenaline excretion covaried.

Akerstedt and Froberg (1977) contrasted data obtained from the same group of 15 females to those from male subjects in previous studies. In this paper, they reported on self-ratings of distress and fatigue, and the shooting task.

Males and females showed almost identical circadian patterns in adrenaline excretion, oral temperature, the shooting task (in terms of the number of shots), and self-ratings. ^{The} only difference was that the males showed increasing trends in self-ratings of fatigue and distress, while these trends were not observed among females.

Again no consistent shifting of TOPs to later time due to sleep loss was observed in circadian variables in this study. There appear to be a discrepancy regarding the delays of TOPs of circadian rhythms due to sleep loss. Aschoff, Ringer and their group have seen that sleep loss delayed TOPs of circadian rhythms, whereas Akerstedt, Froberg and their associates have failed to see such delays in TOPs. In other words, these two groups have not agreed on the "power" of sleep to advance TOPs of the circadian rhythms. Perhaps this discrepancy might have resulted from large differences in the laboratory environments. Aschoff, Ringer and their group used an underground chamber which permitted rigorous controls of lighting regimen and complete isolation of the experimental subjects. Froberg, Akerstedt and their associates used an above-ground building with changing levels of illumination and less rigorous isolation of the subjects. The studies by Aschoff, Ringer, Akerstedt, Froberg and others suggest that the power of sleep as a zeitgeber is revealed during the vigil only when all of the social and temporal cues are completely removed and the lighting regimen is kept strictly constant. Perhaps such complete control of many zeitgebers would only be possible in an underground chamber. Further confirmation that sleep loss delays the phase of some circadian rhythms only when there are rigorous controls of temporal and social cues as well as the lighting regimen is provided by ^aU.S. Navy study. In this study, 23 sailors remained sleepless for two nights. Frequency analysis was done on each variable for both baseline and sleep loss phases. The baseline in this study represented

the time period from 08⁰⁰ to 04⁰⁰, corresponding to 1 to 25 hrs of continuous wakefulness. The sleep loss phase covered the time period of 08⁰⁰ to 04⁰⁰ of the next day, corresponding to 25 to 45 hrs of the vigil. Table 2 and Figures 8 through 12 show the results. The sailors were studied in a wooden barrack

 Table 2, see pg 30a
 Figures 9-12, see pgs 30b - 30e

with many large windows, located close to a street with considerable traffic. This barrack is located in a large closely built compound with many busily occupied barracks of the same architectural design. Thus, the sailors were under all of the zeitgebers Nature can offer. They were fully aware of the time, and they were fully exposed to social cues. This experimental environment was quite different from that of Aschoff, Ringer, and their groups. Under this experimental environment, sleep loss did not always cause the delays in TOPS of circadian rhythms. Subjective ratings of positive and negative feelings as measured by the NHRC Mood Scale (Moses et al., 1974) and subjective sleepiness as measured by the Stanford Sleepiness Scale (Hoddes et al., 1973) and the SAM subjective fatigue checklist (Pearson and Byars, 1956) showed significant delays of their TOPs with sleep loss, but oral temperature and systolic blood pressure showed small but significant TOP advances of 41 min and 31 min, respectively, with sleep loss. Performance measures did not show significant changes in TOPs.

Table 3 was compiled from 8 autorhythmometric studies to show that human performance efficiency has reliable circadian rhythms, and it should be examined

 Table 3 About Here, pgs 30f-30-i

together with the laboratory results listed in Table 2. In preparing Table 3, it is assumed that the data were reasonably represented by one cosinusoidal wave.

Table 2 - Cosinor Summary of Circadian Rhythm During Baseline (B) and Vigil (V) Periods

Variable	Epoch	N	PR	Mesor (SD)	Amplitude Mean (95% C.I.)	Acrophase (hrs min) Mean (95% C.I.)	% Amp/ Mesor	Rayleigh Z
Oral Temp (°F)	B	23	54.5%	97.8(0.3)	0.5(0.4 to 0.7)	1722(1614 to 1819)	0.6%	15.6***
	V	23	43.5%	97.5(0.5)	0.4(0.3 to 0.5)	1641(1504 to 1813)	0.4%	
Blood Press. Systolic (mmHg)	B	19	38.3%	120.3(7.5)	6.9(3.8 to 10.0)	1037(0856 to 1234)	5.8%	10.7***
	V	19	51.2%	120.4(6.4)	9.0(5.6 to 12.5)	1006(0902 to 1119)	7.5%	
Blood Press. Diastolic	B	19	27.7%	71.3(6.4)	2.7(1.0 to 4.6)	0420(0048 to 0605)	3.8%	1.4
	V	19	29.9%	70.2(6.2)	1.8	0550	----	
Pulse (beats/min)	B	19	31.5%	63.7(5.7)	2.8(0.7 to 5.2)	1503(1032 to 1736)	4.4%	2.8
	V	19	37.5%	65.0(5.4)	3.3(1.3 to 5.4)	1525(1306 to 1702)	5.1%	
NRC +	B	23	47.3%	31.9(7.4)	4.0(2.3 to 5.7)	1432(1231 to 1623)	12.6%	10.8***
	V	23	31.7%	27.5(8.9)	3.2(1.4 to 5.2)	1500(1328 to 1722)	11.7%	
NRC -	B	22	48.6%	3.5(2.8)	1.6(0.8 to 2.5)	0327(0206 to 0438)	45.7%	6.1**
	V	22	39.2%	6.8(4.0)	1.6(0.8 to 2.5)	0355(0154 to 0638)	23.6%	
SSS	B	22	55.7%	2.3(0.5)	0.7(0.5 to 1.0)	0236(0132 to 0321)	31.3%	8.8***
	V	22	35.7%	3.3(0.8)	0.5(0.3 to 0.8)	0339(0138 to 0538)	16.1%	
SAM Fatigue	B	23	56.1%	12.4(1.6)	2.1(1.3 to 3.0)	1407(1255 to 1504)	17.0%	5.6**
	V	23	35.3%	9.8(2.6)	1.6(1.0 to 2.7)	1511(1308 to 1728)	16.4%	
TRAP 1 (# Responses)	B	19	36.7%	1033.6(237.0)	43.8(24.3 to 66.0)	1946(1741 to 2234)	4.3%	2.5
	V	19	32.6%	1006.9(247.0)	45.7(4.35 to 88.2)	1707(1208 to 2120)	4.6%	
TRAP 2 (msec)	B	19	33.2%	503.9(151.9)	70.0(29.6 to 121.3)	0637(0410 to 1055)	13.9%	1.0
	V	19	24.2%	798.9(372.9)	68.7	0623	----	
2-WAST (# Lines)	B	19	25.5%	57.2(15.1)	4.3(1.3 to 7.3)	1516(1319 to 1741)	7.5%	2.0
	V	19	24.1%	53.1(15.0)	2.5(0.2 to 4.9)	2045(1931 to 0058)	4.8%	
4-Choice (# Responses)	B	8	36.8%	547.8(59.7)	19.1(4.8 to 42.2)	1837(1445 to 2353)	3.5%	1.1
	V	8	10.2%	489.5(85.5)	3.6	0701	----	

** 1% or better.
*** Better than 1%

Figure 9. Plexogram and cosinor plot for TRAP (Task of Response Alternation Performance) 1 measure (top row) and those for TRAP 2 (bottom row). TRAP consisted of tapping with an index finger two response keys alternately at subject's own pace, eyes closed. TRAP yielded two measures: Measure 1 - a total number of key presses in a 5-minute session, and Measure 2 - ten percentile of the slowest inter-response intervals. For TRAP 1 measure, y-axis is given in terms of the total number of key presses; for TRAP 2 measure, y-axis is in milliseconds.

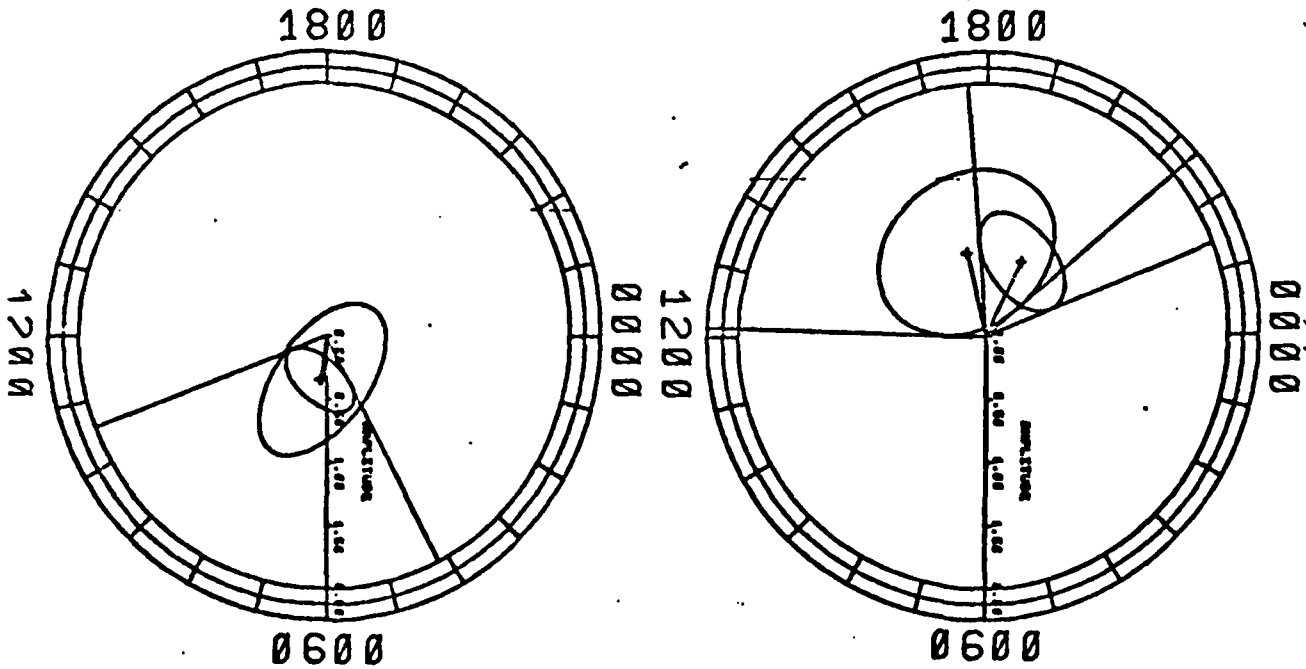
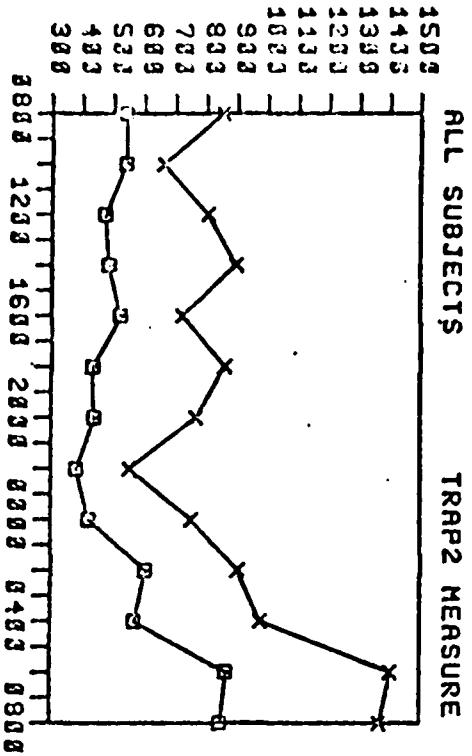
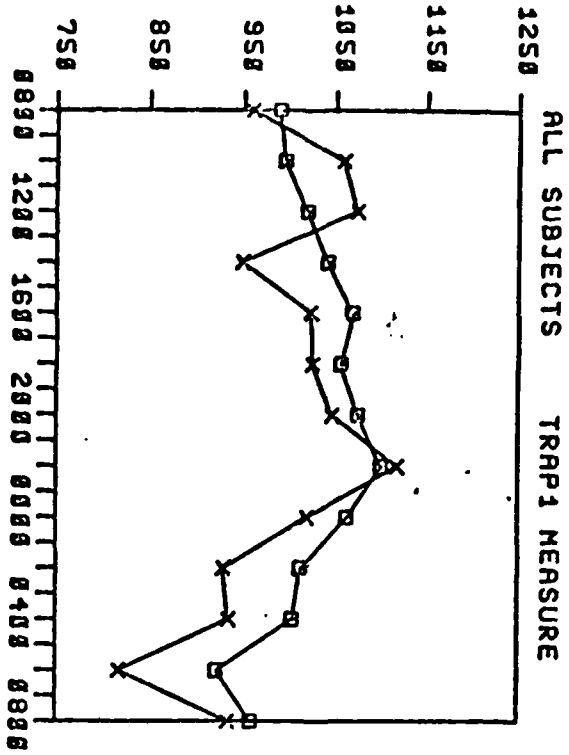

Figure 9

Figure 10. Plexogram and cosinor plot for MAST (Memory and Search Task) (2 letters) scores (top row) and those for four-choice serial reaction time task (bottom row). The MAST is a task to memorize the target letters (two letters in this study) and to search them in a printed line containing 20 letters. The score for MAST used here is a total number of lines scanned in two minutes. Data were obtained from 19 sailors. Four-choice serial reaction time task consists of pressing one of the four keys arranged to form a square. The key pressed should correspond geometrically to one illuminated LED light of four LED lights arranged to form a square. The total number of key presses (including both correct and incorrect responses) is used as a score for this task. Y-axis for MAST shows a total number of lines scanned in 2 minutes. Y-axis for four choice test shows a total number of key presses in 5-minute session. Data for MAST (2 letters) are based on 19 sailors. Only 8 sailors provided performance data for four choice reaction time task.

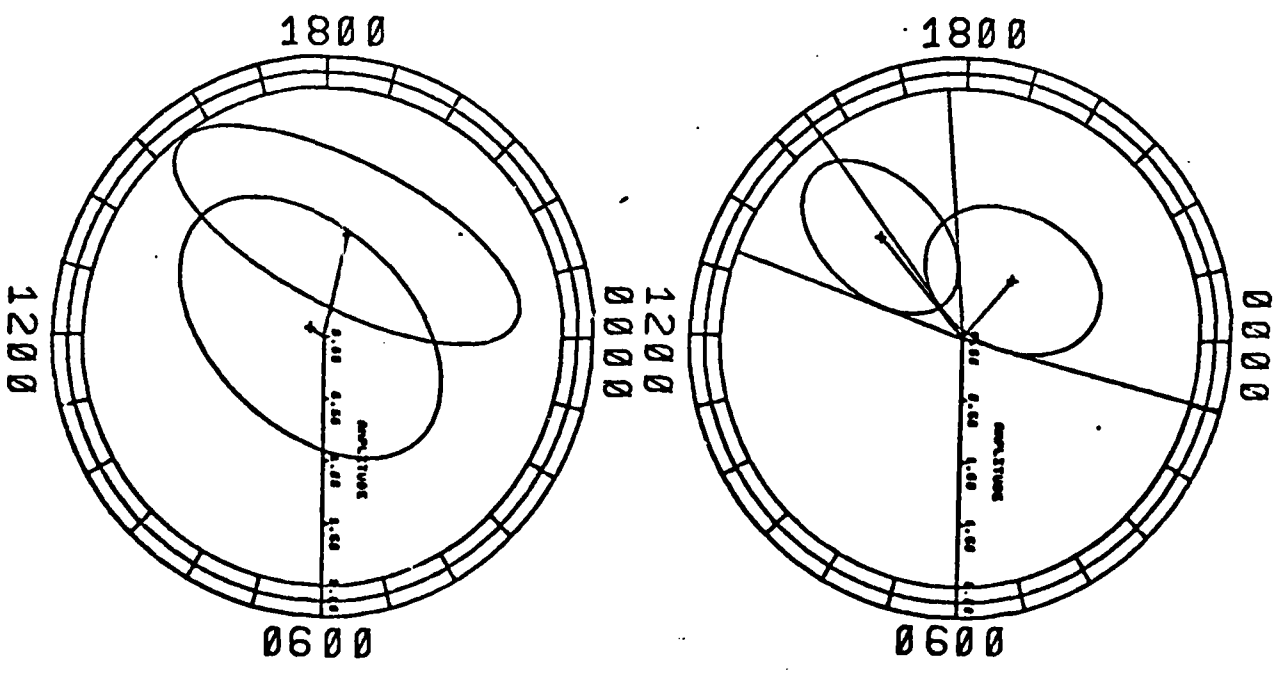
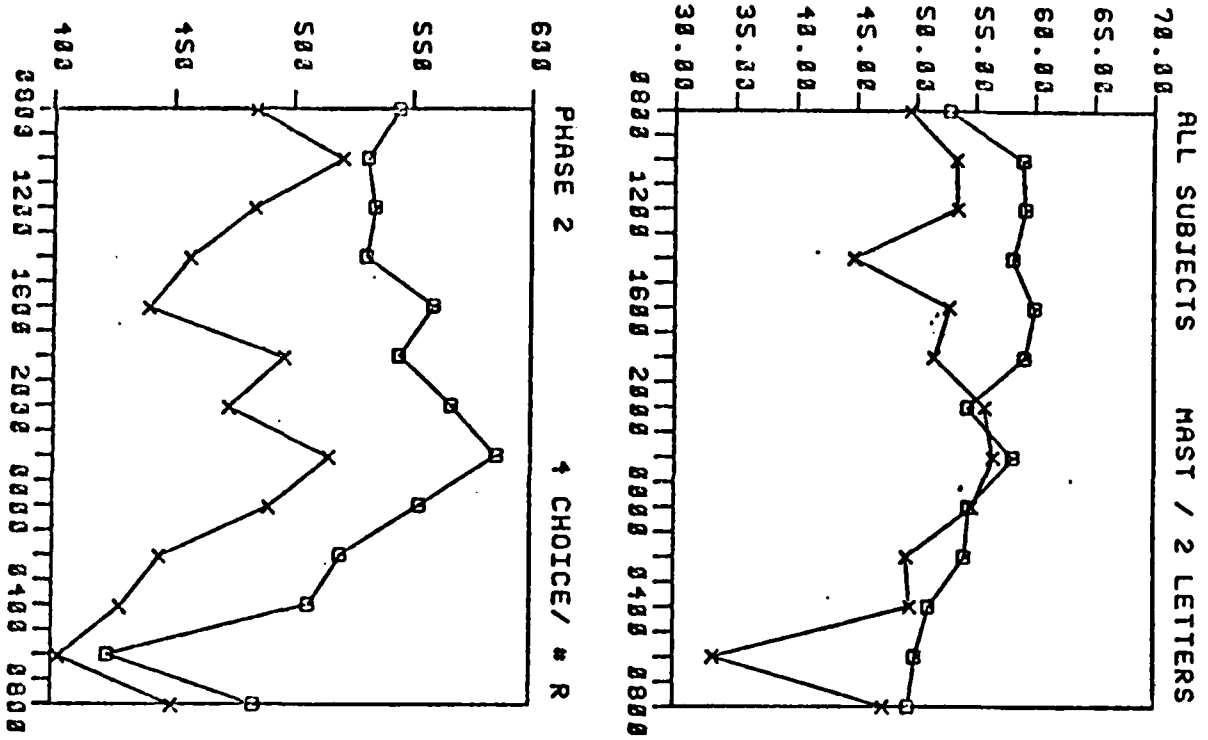

Figure 10

Figure 11. Plexogram and cosinor plot for NIHRC Mood Scale - Negative score, and those for NIHRC Mood Scale - Positive Score. The Mood Scale was completed by subjects' checking off the most descriptive adjectives of their negative or positive feeling tones. The negative scale ranges from zero to 40, and the larger score represents a more negative affect. The positive scale ranges from zero to 76, and the later score represents a more positive affect.

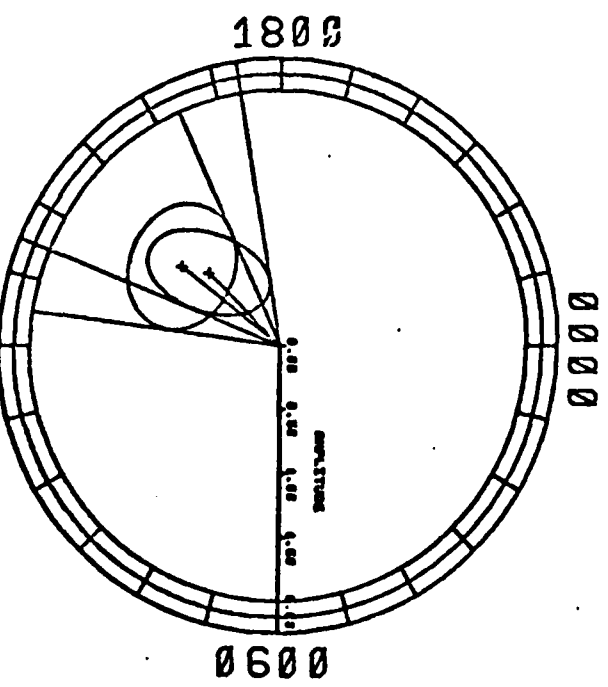
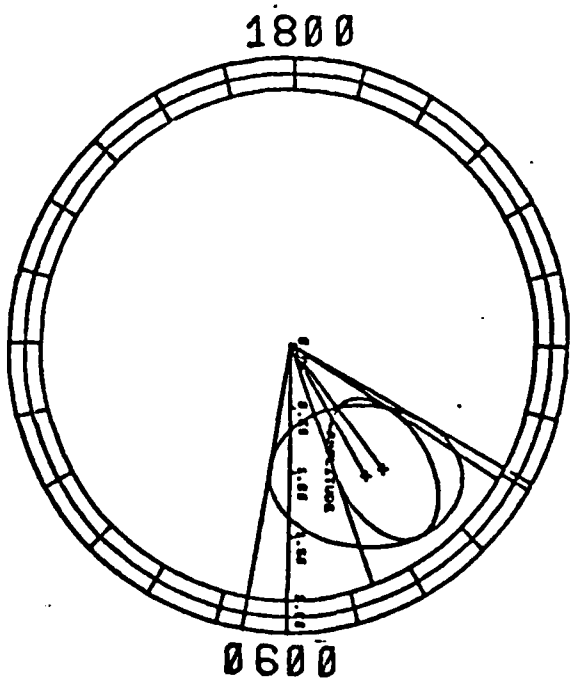
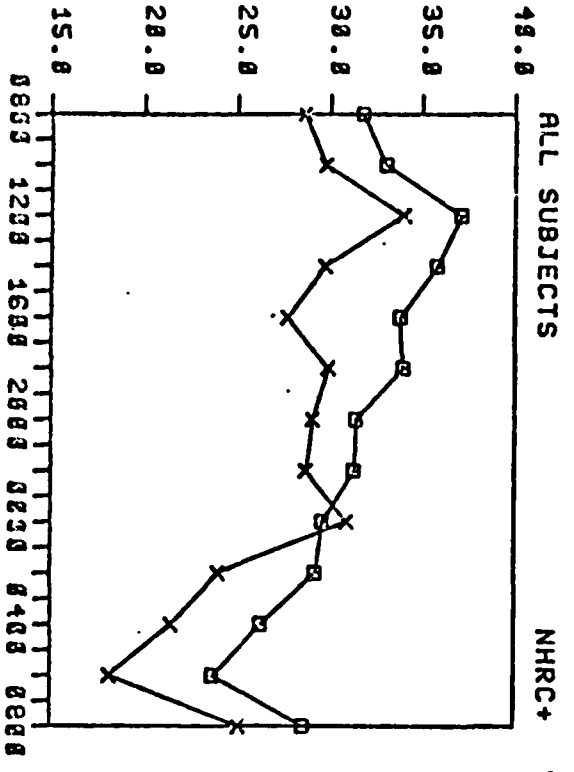
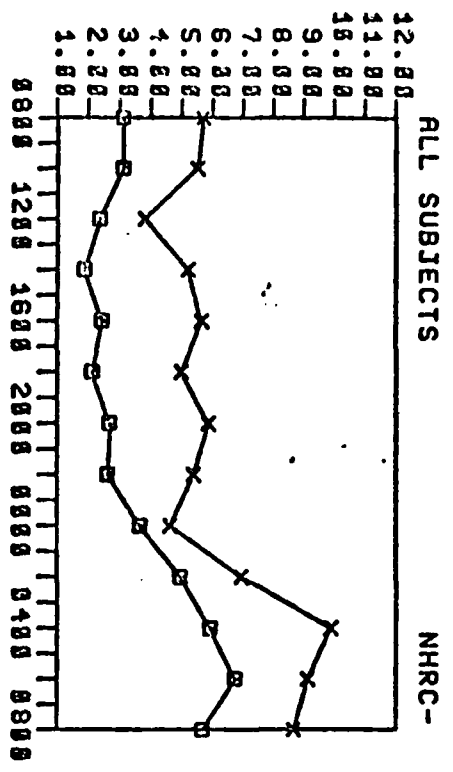

Figure 11

Figure 12. Plexogram and cosinor plot for SAM (School of Aerospace Medicine) fatigue scale (top row) and those for SSS (Stanford Sleepiness Scale, bottom row). SAM subjective fatigue checklist is a paper-and-pencil test to measure subjective fatigue. Its score ranges from zero to 20, and large score means greater subjective fatigue. SSS is a 7 point scale to measure subjective sleepiness, and a larger score means greater sleepiness.

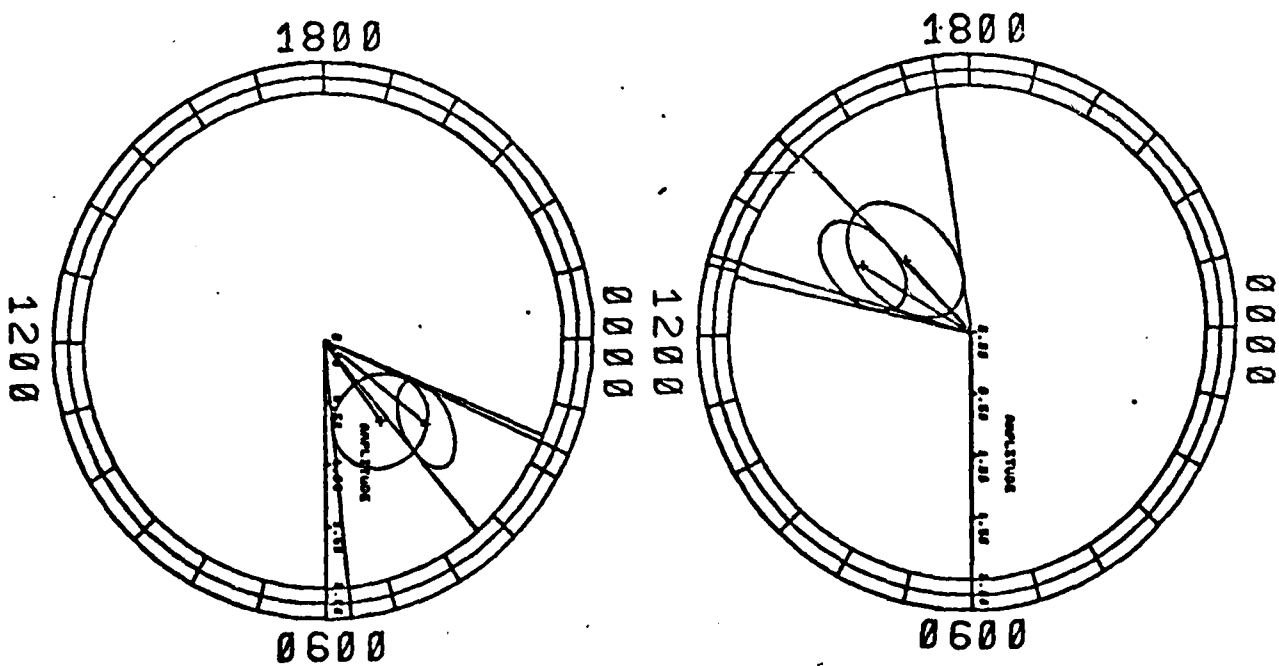
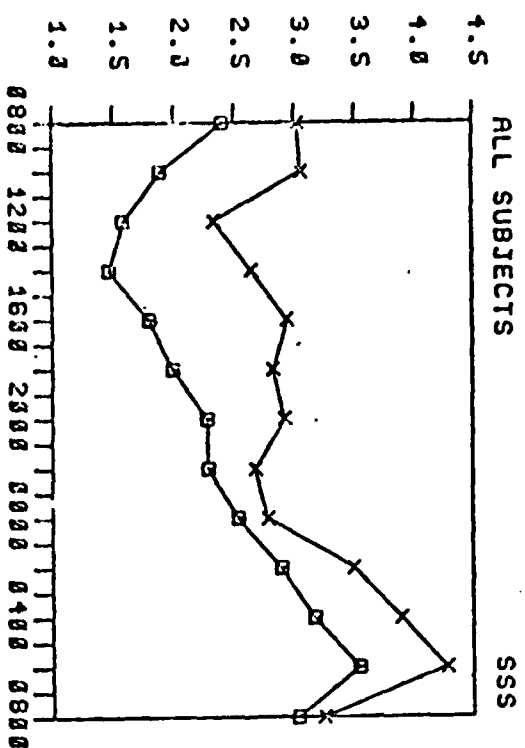
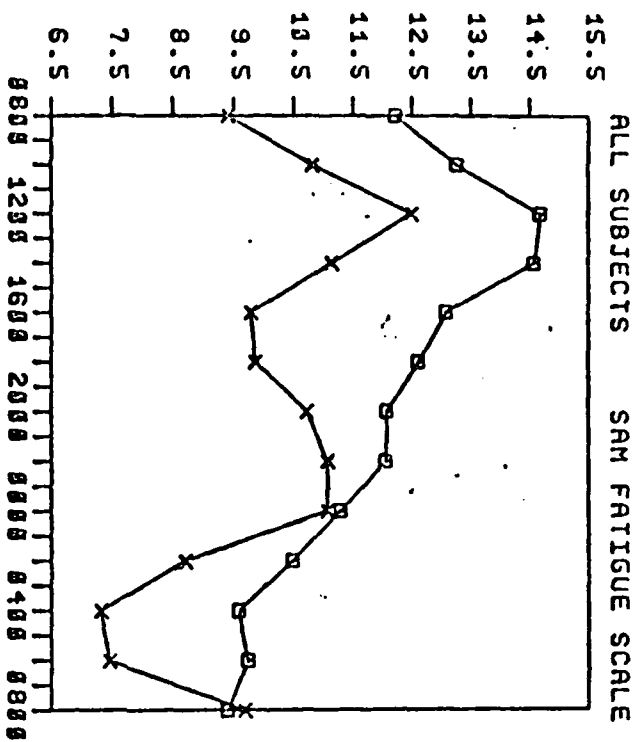

Figure 12

Table 3 Circadian Rhythms in Task Performances and Self-Ratings (Cosinor Analysis of AR Data)

Dependent Variable	Exp't'l Routine	Subj Nos (M/F)	Measurement Frequency	Percent Rhythm (CQ)	Time-Of-Peak Mean (95% CI) (hr: min)	Study
Eye-hand Coordination	Normal	12M	3 hourly	35.0	14 ²² (13 ²⁶ - 15 ³⁸)	Kanabrocki et al.(1973)
Eye-hand Coordination	Normal	26F	6 hourly	----	14 ⁵³ (12 ⁵⁵ - 16 ⁵¹)	Reinberg et al.(1973)
Eye-hand Coordination	Diet	26F	6 hourly	----	14 ⁴⁸ (13 ²⁸ - 16 ⁰⁷)	Reinberg et al.(1973)
Eye-hand Coordination	Diet	26F	6 hourly	----	13 ³⁵ (10 ³² - 16 ⁴³)	Reinberg et al.(1973)
Finger Counting	Normal	12M	3 hourly	26.8	14 ⁴² (11 ³⁰ - 17 ¹⁸)	Kanabrocki et al. (1973)
Finger Counting	Ad lib meals	17	2 to 3 hourly	19.5	16 ³⁶ (15 ²⁸ - 18 ⁰⁴)	Graeber et al.(1978)
Finger Counting	Breakfast only	18	2 to 3 hourly	14.3	15 ⁵⁶ (14 ⁵⁶ - 17 ⁰⁸)	Graeber et al.(1978)
Finger Counting	Dinner only	18	2 to 3 hourly	17.6	16 ²⁴ (14 ⁴⁰ - 18 ²⁴)	Graeber et al.(1978)
Finger Counting	Normal	17	2 to 3 hourly	26.8	15 ⁴⁸ (14 ⁴⁰ - 16 ³²)	Graeber et al.(1978)
Finger Counting	Normal	13M 11F	6 times daily	17.0	14 ²⁷ (12 ⁴⁰ - 15 ³⁶)	Englund(1979)
Time Estimation	Normal	12M	3 hourly	11.8	15 ⁵⁴ (13 ⁰⁸ - 21 ²²)	Kanabrocki et al.(1973)

Time Estimation	Normal	26F	6 hourly	----	13 ⁵⁶ (09 ²⁹ - 18 ²⁴)	Reinberg et al.(1973)
Time Estimation	Diet	26F	6 hourly	----	15 ²⁷ (12 ²⁷ - 18 ²⁷)	Reinberg et al.(1973)
Time Estimation	Diet	26F	6 hourly	----	17 ¹¹ (13 ⁴¹ - 20 ⁴²)	Reinberg et al.(1973)
Time Estimation	Normal	5	4 hourly	----	16 ⁰⁸ (14 ⁵⁶ - 22 ³²)	Halberg et al.(1969)
Time Estimation	Normal	10	1.5 hourly	----	16 ⁵⁷ (15 ²⁵ - 20 ⁰¹)	Gunther et al.(1968)
Time Estimation	Normal	10	1.5 hourly	----	18 ⁰¹ (17 ⁰¹ - 18 ³³)	Gunther et al.(1968)
Time Estimation	Normal	10	1.5 hourly	----	17 ⁰⁵ (16 ⁴¹ - 20 ³³)	Gunther et al.(1968)
Adding Speed	Normal	12M	3 hourly	29.9	14 ¹⁸ (13 ¹⁸ - 14 ⁵⁰)	Kanabrocki et al.(1973)
Adding Speed	Normal	4M 4F	5 to 9 times daily	----	14 ⁵² (12 ⁵⁶ - 17 ³²)	Halberg(1973)
Adding Speed	Ad lib meals	18	2 to 3 hourly	18.1	16 ²⁹ (14 ⁴⁵ - 18 ⁰⁹)	Graeber et al.(1978)
Adding Speed	Breakfast only	19	2 to 3 hourly	21.8	16 ²⁴ (13 ⁴⁸ - 18 ¹²)	Graeber et al.(1978)
Adding Speed	Dinner	19	2 to 3 hourly	14.5	17 ⁵² (16 ¹² - 19 ⁵⁶)	Graeber et al.(1978)
Adding Speed	Normal	17	2 to 3 hourly	27.4	15 ⁴⁴ (14 ³² - 16 ³⁶)	Graeber et al.(1978)

Adding Speed	Normal	13M	6 times daily	13.0	15 ²⁷ (13 ²⁰ - 17 ⁴⁵)	Englund(1979)
Short-term Memory	Normal	12M	3 hourly	27.6	13 ³⁴ (12 ⁴² - 14 ⁵⁰)	Kanabrocki et al.(1973)
Short-term Memory	Normal	12M	5 to 9 times daily	----	15 ²⁴ (14 ³⁶ - 16 ⁴⁸)	Halberg (1973)
Short-term Memory	Normal	15M	6 times daily	----	15 ⁴⁰ (12 ³² - 19 ⁰⁸)	Jovanovich et al.(1975)
Short-term Memory	Normal	13M	6 times daily	17.0	15 ²⁷ (13 ⁰⁷ - 17 ²³)	Englund(1979)
Fitts' Tapping	Ad lib meals	18	2 to 3 hourly	21.7	16 ⁰¹ (14 ¹³ - 17 ⁴¹)	Graeber et al.(1978)
Fitts' Tapping	Breakfast only	19	2 to 3 hourly	20.2	15 ⁵⁹ (14 ⁰³ - 17 ⁰⁷)	Graeber et al.(1978)
Fitts' Tapping	Dinner only	19	2 to 3 hourly	21.4	15 ¹⁶ (11 ⁵⁶ - 17 ²⁴)	Graeber et al.(1978)
Fitts' Tapping	Normal	17	2 to 3 hourly	25.3	15 ¹⁰ (14 ¹⁸ - 15 ⁵⁸)	Graeber et al.(1978)
Fitts' Tapping	Normal	13M 11F	6 times daily	19.0	14 ⁰⁹ (12 ²⁶ - 16 ²²)	Englund(1979)
Grip Strength	Normal	26F	6 hourly	----	14 ²⁹ (10 ³⁸ - 18 ¹⁰)	Reinberg et al.(1973)
Grip Strength	Diet	26F	6 hourly	----	15 ⁰⁰ (11 ⁴⁶ - 18 ¹⁴)	Reinberg et al.(1973)
Grip Strength	Diet	26F	6 hourly	----	15 ²² (13 ¹³ - 17 ³⁰)	Reinberg et al.(1973)

Grip Strength	Ad lib meals	18	2 to 3 hourly	24.9	16 ⁴¹ (15 ⁴⁵ - 18 ⁰¹)	Graeber et al.(1978)
Grip Strength	Breakfast only	19	2 to 3 hourly	28.3	17 ⁴⁸ (16 ⁴⁴ - 19 ⁰⁴)	Graeber et al.(1978)
Grip Strength	Dinner only	19	2 to 3 hourly	29.9	17 ²² (16 ¹⁰ - 19 ¹⁰)	Graeber et al.(1978)
Grip Strength	Normal	17	2 to 3 hourly	34.2	16 ⁵⁵ (16 ¹² - 17 ⁴⁸)	Graeber et al.(1978)
Mood Vigor	Normal	12M	3 hourly	37.1	14 ³⁵ (13 ⁴² - 15 ³⁸)	Kanabrocki et al.(1973)
Mood Vigor	Ad lib meals	18	2 to 3 hourly	38.6	14 ³⁶ (13 ⁰⁸ - 15 ⁴⁴)	Graeber et al.(1978)
Mood Vigor	Breakfast only	19	2 to 3 hourly	32.8	15 ²⁰ (14 ¹⁶ - 16 ²⁸)	Graeber et al.(1978)
Mood Vigor	Dinner only	19	2 to 3 hourly	34.6	15 ⁰⁰ (13 ²⁰ - 16 ¹⁶)	Graeber et al.(1978)
Mood Vigor	Normal	17	2 to 3 hourly	30.4	14 ⁵⁶ (13 ⁰⁸ - 15 ⁵²)	Graeber et al.(1978)
Mood Activity	Normal	15M	6 times daily	----	15 ²⁰ (14 ³⁶ - 15 ⁵⁶)	Jovanovich et al.(1973)
General Activation	Normal	13M	6 times daily	43.0	12 ⁵⁹ (12 ¹⁴ - 13 ⁴¹)	Englund (1979)

Key to abbreviations used: M = Male; F = Female; Nos = Numbers; CQ = Circadian Quotient; CI = Confidence Interval.

In reading Table 3, it should be remembered that many different versions of a task (e.g., time estimation) are called by one most commonly used name. The details of the actual tests and the instructions should be consulted in the original papers.

PHASE ADJUSTMENT IN SHIFTWORK AND TRANSMERIDIAN DYSCHRONISM

In a previous section of this chapter, human performance efficiency has been shown to have a significant circadian component. This observation reflects the fact that diurnal humans have a limited period of time of high performance efficiency every 24-hr period, and that this optimal time to work is reliably constant with reference to local time as long as workers live in a community with normal daily routines. Also, as noted earlier, there are increasing demands for work at odd times of day, and individuals are asked to travel across many time zones. Researchers on shiftwork study the many consequences of the mismatch for the best time to work (as determined by the circadian rhythms) with the working hours demanded of the humans by society. Transmeridian dyschronism (commonly known as "jet lag") is the term for the effects of travel across time zones.

Shiftwork and "jet lag" researchers seek methods to adjust the TOPs or phases of the circadian rhythms of shiftworkers and jet-travellers to the new working environment so that their best time to work (as determined by shifted circadian rhythms) is again matched with the time period during which the new work environment demands their services. The chronopsychological approach to shiftwork and transmeridian dyschronism is to attempt to understand and manipulate the many zeitgebers. More than 200 zeitgebers are known to exist. Each of them may entrain or change the phase of the circadian rhythms. For humans, several zeitgebers have been identified to play especially significant roles, singly or jointly. Previously, the role of sleep loss in controlling the TOP or phase of the circadian rhythm was discussed. Wever (1979) has evaluated the

relative strengths of many zeitgebers which control the phase of the circadian rhythm. His broad categories of zeitgebers include the Light-Dark (LD), social, and electrical fields. Past studies have indicated that social zeitgebers are most influential in controlling the phases of human circadian rhythms. One task of the chronopsychologists is to determine the direction and amount of phase change introduced in the rhythms in response to the presentation of a well-defined zeitgeber at all time points in the 24-hr day. This is a study of "phase-response-curve" with respect to a single zeitgeber. The phase-response-curve is usually defined by a single zeitgeber, as it is the way to define its potency in controlling the phase. Unfortunately, our knowledge about the effect of most zeitgebers on the phase-response-curve is very incomplete.

In this section, research concerned with shiftwork will be evaluated to see how shiftworkers can best adjust their phases of circadian performance rhythms. Then, some observations on transmeridian dyschronism will be discussed to show how the phase adjustments are completed. The difference between shiftwork and "jet lag" will be discussed with respect to the influence of jointly operating zeitgebers, and these differences are used to suggest some countermeasures to diminish the burdens imposed by shiftwork and transmeridian dyschronism.

Researchers on shiftwork have been concerned with the type of shift schedule which will bring the necessary adjustment of the phase most rapidly and accurately. Many shift systems have been examined in both laboratories and the field. Rutenfranz and Knauth (1976) have categorized shift systems: (1) systems without night work, (2) systems with night work, and (3) systems with night work and weekend work. Shiftwork can also be characterized by (a) rotating (non-permanent) system, (b) stabilized (permanent) system, and (c) a mixture of the rotating and stabilized system. An example of the latter

is a system of rapidly alternating morning and afternoon shifts combined with a permanent night shift, which is recommended by Wilkinson (1971). In the rotation system, the period of work changes systematically to cover the entire 24-hr period in a few days (see, for example, Table 1). Rutenfranz et al. (1977) have defined some key concepts of shiftwork. A shift is defined as a unit of work time usually of 8-hr duration. A normal day in shiftwork means morning and afternoon work with a lunch break of not more than 2 hrs. The rotation period is defined as the number of consecutive days on the same shift. A cycle is given as time elapsed between identical points in a sequence of rotating shifts. An example of the rapidly rotating regular 8-hr system is "continental rota" where four teams share the work. Under the continental rota, a team will work the morning shift (06⁰⁰-14⁰⁰) for two consecutive days, the afternoon shift (14⁰⁰-22⁰⁰) for the next two consecutive days, the night shift (22⁰⁰-06⁰⁰) for the next three consecutive nights, and day-off for two days. This system is usually identified as the 2-2-3 system.

Kleitman and Jackson (1950) studied shiftwork of 9 naval recruits to find a relation between oral temperature and task performance. Their study involved eight variations in living routines, and was conducted in a large, air-conditioned, well-insulated simulated ship. Performance tests were a simulated flight efficiency task using a Link trainer, choice reaction time, and color naming. They observed that the speed of naming 600 colors followed very closely the circadian rhythm of oral temperature, but the scores on the choice reaction time task and flight efficiency followed the oral temperature curve during the day only, not during the night. They found that the less deviation there was of shiftwork from the normal day routine, the better was the adjustment of oral temperature to the new shiftwork schedule. In a 1968 report, Chiles, Alluisi and Adams summarized their studies in a simulated aerospace

cabin, which was aimed at finding the practical limits of work-load and the work-rest ratio over prolonged periods. In their studies, the subjects worked under a stabilized shift for up to 30 days. This shiftwork consisted of either 4 hrs On/4 hrs Off, or 4 Hrs On/2 hrs Off. Under these shiftwork environments, body temperature retained its circadian rhythm over 30 days, but it did tend to become flatter, showing a reduced circadian amplitude near the end of the experiment. Several task performances were measured in these studies. A detection speed of probability monitoring task showed a visually obvious circadian rhythm, but it disappeared when the subjects were instructed to put forth extra effort whenever they sensed any drop in their "sharpness." A red warning light and arithmetic computation without code-lock task showed circadian rhythms. These circadian rhythms in task performances paralleled but lagged by from 2 to 4 hrs those of physiological variables, such as pulse, skin resistance, and body temperature. Despite multiple cycles of the work period, a polycyclic curve did not develop in the subjects. Chiles et al. noted that the circadian rhythm appeared very strongly when the subjects were under performance stress, such as sleep loss and an earlier phase of learning and practicing the tasks. The 4 hrs On/4 hrs Off or 4 hrs On/2 hrs Off schedules were no more detrimental to performance efficiency than a "control" group which worked under a schedule of 4 hrs On/4 hrs Off/4 Hrs On/12 hrs Off. Thus, humans are able to work 12 hrs per day on a 4 hrs On/4 hrs Off work-rest schedule for a period of at least 30 days; and, for a shorter period, they can work 16 hrs per day on a "4/2" schedule.

In an attempt to generate an optimal watch-keeping system for personnel engaged in maritime operations, Colquhoun et al. (1968a, 1968b, 1969) conducted a series of three studies on rotating and stabilized split systems. During routine maritime operations, naval personnel were divided into three teams or

"watches" and duty periods were rotated among these teams in such a manner that ensured fair allocation of unpopular work periods. The day was divided into six equal parts starting from midnight. This shift configuration, a 3-man 4-hr system, completes its cycle in 72 hrs. In the first paper, Colquhoun et al. (1968a) compared the rotating 4-hr system with a stabilized 4 hr On/8 hr Off system, using 28 young naval personnel. The subjects worked up to 23 shifts over a period of 12 consecutive days. The subjects in the rotating system were permitted to sleep during off-duty periods, but the sleep period was fixed for those subjects in the stabilized system to be from 04³⁰ to 11³⁰. Vigilance and calculation tasks were used to evaluate the impact of the shift system. The results indicate that the average total sleep time was the same for both shift groups. In the stabilized system, sleep was delayed by about 5 hrs from the normal day, because sleep followed the night portion (24⁰⁰-04⁰⁰) of the split work schedule. The phase shift of the body temperature rhythm, in response to the altered sleep-wakefulness schedule, started on the sixth day on the stabilized shift system, and was quickly completed by the eighth day. The low point for body temperature normally seen around 04⁰⁰ moved to 08⁰⁰, but its peak remained at the usual evening point. Generally, body temperature remained higher in the day shift than during the second split shift of 24⁰⁰ to 04⁰⁰ throughout the 12-day experiment. In the rotating system, the circadian cycle in body temperature persisted throughout the experiment. Performance scores were lowest at low temperature (02⁰⁰-08⁰⁰) and highest at high temperature (16⁰⁰-22⁰⁰). In the second experiment (1968b), Colquhoun et al. tried 8-hr stabilized shifts. Three 8-hr shifts were: night shift (22⁰⁰-06⁰⁰), morning shift (04⁰⁰-12⁰⁰), and day shift (08⁰⁰-16⁰⁰). Twenty-one sailors participated in this study, working over 12 consecutive days. Sleep time was fixed for these three shifts at 23⁰⁰-06³⁰ for the day shift, 08⁰⁰-15³⁰ for the night

shift, and 19³⁰-03⁰⁰ for the morning shift. Apparently the official sleep hours of 19³⁰-03⁰⁰ for the morning shift were rarely kept; subjects usually started their sleep after 22⁰⁰. The subjects in the night shift experienced 9 hrs of phase delay in sleep, and the adjustment to this shift in body temperature was by flattening of its profile and not by the anticipated inversion of the normal temperature curve. For the morning shift, the start of sleep hours was advanced by 3.5 hrs officially, but only by 1 hr when measured from the observed starting time of sleep. In the third study (1969), Colquhoun et al. examined a 12-hr stabilized system. The night shift was from 20⁰⁰ to 08⁰⁰, and the morning shift from 08⁰⁰ to 20⁰⁰. Twenty sailors were involved in this study over 12 consecutive days. Sleep time for the day shift was from 23⁰⁰-06³⁰, and that for the night shift was from 10³⁰-17³⁰, or 11³⁰-18³⁰. For both night and morning shifts under the 12-hr stabilized shift system, adaptation in the phase of body temperature was less marked than that observed for the 8-hr stabilized shift system, and it was characterized by a flattening for the night shift. The morning shift showed a pronounced postprandial dip, probably due to long working hours, and the average body temperature increased throughout the shift. Fatigue appeared not to influence task performance. One of the important observations in this 12-hr stabilized shift system was the absence of a comparable shift in body temperature coinciding with the inversion of the sleep-wakefulness habit during the night shift even after 12 consecutive nights. Thus, Colquhoun (1976) does not see any advantage in "permanent" night shiftwork over the rapidly rotating shift, because the night shiftworkers tend to revert back to normal day routines on their days off and their rhythms must start re-adapting all over again. In addition, even under a completely "permanent" schedule, human adaptation remains incomplete, at least over 12 days. He pointed

out that rapidly rotating shift systems are becoming increasingly popular and he expects the number of people on permanent shifts to decline in the future. Colquhoun found that one popular shift system was the "2-2-2-3" (two morning shifts, two afternoons, two nights, and three days off) because of its social acceptability. The general conclusions of the series of studies by Colquhoun et al. were: (1) a close relationship exists between performance efficiency and circadian body temperature change during the day or night, and with 4-, 8-, and 12-hr shifts, (2) both body temperature and performance rhythms adapt to shifts in less than a week, but "adaptation" of body temperature is of a flattening curve and not of an inversion, and (3) sleep loss and fatigue reduce the closeness of the relationship between body temperature and efficiency in task performance.

This lack of inversion of body temperature rhythm when the sleep-wakefulness cycle has been inverted is critical for understanding the difference between shiftworkers and jet travellers who stay at their destination for an extended period of time. Jet travellers will eventually show the "inversion" (see Aschoff et al., 1975), but shiftworkers usually do not. This fact was convincingly shown by Knauth and Rutenfranz (1976). They studied four subjects who worked on a night shift of 22⁰⁰-06⁰⁰ for three consecutive weeks. Rectal temperature of the subjects was continuously monitored with a resistance thermometer, and printed out every minute. Heart rate was also continuously monitored. Day shift sleep usually started from 22⁰⁰-23⁰⁰ and ended around 07⁰⁰-08⁰⁰. Night shift sleep started from 08⁰⁰ and ended around 14⁰⁰-18⁰⁰. Total sleep duration varied considerably. This change in sleep pattern meant that workers in the night shift experienced a delay of as much as 10 hrs at the start of the sleep phase. This shift of working time and sleep did not change the phase of body temperature whose maximal value was observed at around 20⁰⁰-23⁰⁰

even on the 21st night shift. Only the time of the minimal body temperature shifted from the normally anticipated 05⁰⁰ to 16⁰⁰. Thus, no complete inversion in the body temperature was observed even after 3 weeks on the night shift. However, re-entrainment to the normal day routine was partially regained by the second or third day. Knauth and Rutenfranz observed that the effect of sleep was to lower the body temperature so that the minimal value occurred during sleep. They re-plotted the temperature curve in reference to the middle of the sleep hours (the midsleep). The new plot of day-shift body temperature and of the 21st night of the night shift in one graph revealed that the minima of both shifts were very close to each other, indicating that perhaps sleep may control the phase of the minimum. The maximum body temperature of the day shift was quite different from that of the night shift. For the day shift, the maximum body temperature occurred 17 hrs after the midsleep, while that for the night shift occurred only 8 hrs after the midsleep. The findings of this study suggest that sleep is an incomplete zeitgeber in controlling the circadian phase of body temperature. Knauth and Rutenfranz concluded that slowly rotating shift systems are physiologically undesirable, and rapidly rotating shift systems are preferable to either slowly rotating or permanent shift systems.

In a more recent paper, Knauth et al. (1978) reported three experiments. Experiment I was on six subjects who worked on a permanent night shift for three weeks without a break for the weekends. Experiment II consisted of four subjects on the 1-1-1 shift system (one morning shift, one afternoon, one night and one day off). Experiment III was on two subjects on the 2-2-2 metropolitan rota (two morning shifts, two afternoon, two night, and two days off). These subjects did not have previous shiftwork experience. The cosinor analysis was applied to the rectal temperature data. Work hours for the day, morning,

afternoon, and night shifts were 09⁰⁰-17⁰⁰, 06⁰⁰-14⁰⁰, 14⁰⁰-22⁰⁰, and 22⁰⁰-06⁰⁰, respectively. The cosinor analysis revealed that the TOP of body temperature on the day shift was at 16³⁶, and that for the night shift was at 00³⁴. This time difference of just over 8 hrs was a significant phase shift, resulting from "permanent" night shift for three weeks without a weekend break. The amount of this phase shift differed from one subject to another, ranging from 7 hrs 19 min to 9 hrs. Frequency analysis suggested an overall change in the waveform of body temperature due to permanent night shift. Also, a larger circadian amplitude was related to slower adjustment of the phase of body temperature. Most interestingly, time of sleep was observed to influence the adjustment of the phase more than the change in the time of work.

In a two-part study, Folkard et al. (1978) studied nurses who worked on a night shift of 20⁴⁵-07⁴⁵, either on a full-time basis (4 nights on, then off 3 nights) or on a part-time basis (2 nights on, then off 3 nights). Folkard et al. wished to determine if a "long-term" adjustment to night shift had occurred in those who have had prolonged experience of night shift, and, if it did, how did this long-term adjustment take effect. In most studies previously discussed, the experimental subjects were inexperienced with shiftwork. In this study, the nurses had prolonged experience of working as either full-time or part-time night nurses. Long experience working the night shift should be sufficient to develop a long-term adjustment to night shifts. The data suggested that a long-term adjustment did occur among the nurses in the form of accelerating and enhancing the short-term adjustment. There was a reduction of drop in body temperature and self-ratings during the night shift. A long-term adjustment of body temperature to night shift did not, however, show the anticipated chronic and persistent flattening of the circadian rhythm during the non-working off-duty days. Further analysis revealed that a long experience with a particular shift

system was relatively unimportant in bringing out the long-term adjustment. What has contributed most to an establishment of the long-term adjustment was the nurses' "commitment" to night shift work. The part-time nurses were observed to schedule their lives to a predominantly day oriented activity pattern, while the full-time nurses were committed to a nocturnal way of life. Thus, an observed smaller drop in oral temperature and self-ratings during night shift among the full-time nurses reflected more of a "life style" than of physiological adaptation. No inversion of body temperature was observed among the experienced night nurses.

Akerstedt (1977) studied two groups of railroad workers who alternated from a three-week long day shift (07³⁰-16³⁰), to a three-week long night shift (23³⁰-07³⁰) which involved an inversion of ^{the} sleep-wakefulness pattern. Urinary adrenaline and noradrenaline excretion, oral temperature and self-rating of alertness were measured. During the day shift, urinary adrenaline excretion showed a strong circadian rhythm. Adrenaline circadian rhythms did not change immediately after switching from the day shift to ^{the} night shift. By the third week of the night shift, urinary adrenaline excretion was low, its circadian rhythm was replaced by a flat line, and it did not show the phase adjustment commensurate to the inversion of the sleep-wakefulness pattern. Similarly body temperature showed a strong circadian rhythm during the day shift, but it lost its circadian rhythm and became flat during the night shift. Urinary noradrenaline excretion also showed a strong circadian rhythm. This variable inverted its rhythm rapidly in response to the inversion of the sleep-wakefulness pattern. Self-rating of alertness had a clear circadian rhythm during the day shift. During the night shift, TOP of alertness remained approximately the same, but its amplitude was small and the average level was lower than that observed during the day shift. Thus, urinary noradrenaline excretion was the only variable which showed a complete adjustment (inversion) of the circadian rhythm after the switch

from day to night shift.

Akerstedt, ^{etal.} ~~Parkai~~ and ~~Dahtonen~~ (1977) studied 13 newspaper type-setters who worked seven consecutive nights from 22³⁰-05⁰⁰, and after one day off, worked two day shifts from 07³⁰-16³⁰. Urinary adrenaline excretion was found to be very low and showed almost no time-of-day effects. The slowness of urinary adrenaline excretion in adjusting to night shift suggested that its circadian characteristics were not easily influenced by the environment. Urinary nor-adrenaline showed no time-of-day effect, but there was a significant adjustment of increase of excretion between the beginning and end of the night shift. Body temperature showed a strong circadian rhythm and did not show a flattening effect. General activation self-rating showed a very clear pattern similar to that found for body temperature.

The lack of complete adjustment to the altered schedule of work-at-night and sleep-in-the-day^{time} in permanent night-shift workers is seen in many studies. This is one of the most reliable findings in shiftwork research. Complete adaptation to the new work environment can be defined as the case where only the phase of the circadian rhythm is displaced without any alterations in the mesor, amplitude or skewness (Akerstedt et al., 1977). Complete adaptation had not occurred so far among the shiftworkers. However, as Aschoff et al. (1975) have summarized, most biological and psychological activities would be entrained to the rhythm of the new community to which jet travellers have moved in about two weeks after the transmeridian flight, although the rate of re-entrainment would differ among rhythmic functions. Why does this crucial difference exist between shiftworkers and transmeridian travellers? Aschoff et al. (1975) have referenced a 1917 study by Lindhard who commented on failures of early attempts to reverse the rhythm, because "one cannot disconnect the individual from society; so long as the latter follows a fixed rotation, the single individual

will, consciously or unconsciously, tend towards the same mode of life." Recently, the Shift Work Committee of the Japan Association of Industrial Health (1979) referred to this contrast between shiftworkers and jet travellers, and submitted recommendations to make the best of the circumstances by improving working hours and work schedules for shiftworkers. The Committee suggested twelve specific measures to be taken to insure good health and safety. These recommendations were made to minimize the inherently "anti-physiological" effects of shiftwork. One of the most interesting recommendations made by this Committee was the use of a short sleeping period within the midnight shift. Taub (1979) reported that habitual napping of 1/2 to 2 hrs in non-sleep deprived subjects would improve task performance and mood.

Since a complete self-supporting community of people for night time work is not expected to evolve in the near future for the sole benefit of shiftworkers, three chronopsychological alternatives for optimizing human efficiency in shiftwork should be considered. First, as previously mentioned, some types of shiftwork were found easier to live with than others, such as a rapidly rotating system. Efforts should continue to find a better shiftwork schedule. Second, attempts should be made to see if some individuals can tolerate shiftwork better than others, and, if they are found, studies should be made to find the determinants of this tolerance. Third, studies should be made to identify the zeitgebers (such as sleep, meal times, social and local time cues) which can be used to shift the phase of the circadian rhythms.

Leaving the question of the best shiftwork schedule to practitioners of shiftwork design, two remaining chronopsychological alternatives should be carefully examined. There are several studies concerning shiftwork tolerant individuals. Reinberg et al. (1976) observed that some shiftworkers were able to rapidly adjust the timing of their physiological circadian rhythms to the

new work environment. They studied seven healthy adult male oil refinery operators. The autorhythmometric method was used to collect the data six times per day, at 01⁰⁰, 05⁰⁰, 09⁰⁰, 13⁰⁰, 17⁰⁰ and 21⁰⁰ for eight consecutive weeks. These subjects were experienced shiftworkers. Reinberg and his group found that biological and performance rhythms of this group adjusted very rapidly to a 6-hr shift of the work schedule. Their adjustment took place within one or two days. The adjustment for the phase advance or phase delay was equally rapid. They felt that the rapid adjustment derives from the individuals' genetic makeup. They noticed, however, that the TOPs of many variables clustered around the time of the midwork (that is, local time corresponding to the middle of working hours) in day and evening shifts, but this did not happen after the morning and night shifts. This lack of clustering of the TOPs around the midwork time was considered to have contributed to fatigue in the shiftworkers. They felt that the schedule of physical and mental work per se would be a poor zeitgeber, but the rest-activity rhythm would be a strong zeitgeber. Mills et al. (1978) suggested that the rapid complete entrainment observed by Reinberg and his group reflected the selection of the individuals whose endogenous rhythms were not prominent so that the shift of the exogenous influences was enough to alter the phase of the rhythms. Earlier, Reinberg et al. (1974) examined 30 healthy adults, including 20 shiftworkers and 10 control subjects. The shiftworkers were on a schedule of two day shifts, two night shifts, two days off, two evening shifts, one day off, two morning shifts, and four days off. Again, an autorhythmometric method was used to collect the data at 4-hr intervals for six weeks. The subjects were observed to adjust their circadian rhythms quickly to the change in the sleep-wakefulness pattern in reference to the midsleep. However, as noted previously, time of the midwork failed to coincide with the peaks of the variables studied, suggesting that the shiftworkers adjusted to the non-occupational, rather than

the occupational, environment. The timing of sleep in relation to shiftwork appeared to be the most critical factor for adjusting the phase of the circadian rhythm. Although the speed of the rhythm adjustment varied from variable to variable in any one subject, and from subject to subject in any one variable, the adjustment to the phase shift of the socio-ecological zeitgeber was quick. The phase adjustment was completed in 6 out of the 20 subjects on the first day of the shift, and 2/3 of the subjects by the seventh day. Recently, Reinberg and his group (1978 , 1979) clarified the relations between the circadian amplitude of body temperature and the speed of adjustment during shiftwork, and tolerance to shiftwork. From a study of 25 oil refinery operators, they found that the mean amplitude of circadian body temperature was negatively correlated (-0.63) to the speed of the acrophase shift measured during the first night shift. This negative correlation means that the circadian rhythm with a larger amplitude showed a smaller shift in its acrophase during the first night shift. From another study involving 23 steel workers and 25 chemical industry workers, Reinberg learned that the circadian amplitude of oral temperature was larger in those individuals who tolerated shiftwork than in those who were intolerant. Tolerance to shiftwork was measured by the number of digestive troubles, persistent fatigue, and altered pattern of sleep. From another study which involved 29 oil refinery workers, Reinberg found that a good tolerance to shiftwork appeared to be associated with a larger circadian amplitude and slow adjustment during the night shift. A negative correlation of -0.55 was observed again between the circadian amplitude of oral temperature and the acrophase shift. The best shiftwork schedule will be that which does not allow workers to adjust to a new work environment; that is, a rapidly rotating system where the shifts rotate every 2 to 4 days. The shiftwork tolerant individuals seemed , then, to be those who could hang on to the fixed rotation mode of society, in general, because they had a strong circadian

rhythm that had been resistant to the influences of the work environment.

Hildebrandt and Stratmann (1979) tested the hypothesis that the circadian phase position of individuals, that is "morning" versus "evening" chronotypes, could be related to the individual differences in tolerance to night work and to shift work in general. They selected six experienced night nurses. The Horn-Ostberg questionnaire (1977) was administered to the nurses to identify three morning and three evening types. Rectal temperature, heart rate, and subjective ratings of vigilance were obtained. After one night shift, they found that the morning-type nurses had poorer circadian rhythms in body temperature and heart rate than the evening-type nurses. The evening-type nurses reacted to the night shift by a flattening of the rhythm, while the morning-type nurses reacted to the night shift by increasing the circadian amplitude. Thus, a chronotype of morning and evening may have some value in predicting if an individual is more suitable for night or shiftwork, in general, than others.

Colquhoun (1979) was similarly interested in the relation between the individual phase and a speed of adjustment to a new socio-ecological work environment. He examined the data from a study of transmeridian flight, called "Exercise Medex." In this flight, 38 young, physically fit enlisted men were transported eastward through eight time zones from the U.K. to Malaysia. Oral temperature was recorded at 4-hr intervals for five days before the flight and for 12 days after it. Significant positive correlations, ranging from 0.27 to 0.70, were found between the time of preflight TOPs and the extent of phase shift post-flight. The "late peaking" or evening-type individuals in the pre-flight stage were observed to have a greater shifting of the phase of body temperature in the post-flight stage. Colquhoun could not confirm the association of the extent of the phase shifting post-flight to the circadian amplitude.

The extent of the phase shift post-flight was not correlated significantly with extraversion-introversion, or with neuroticism. In this study, the late peakers or the evening-type subjects shifted phases more than the early peakers or the morning-type subjects so that the pre-flight difference in the TOPs between these two chronotypes disappeared in the new time zone. An eastward flight means a shorter day, and the phase adjustment was accomplished most directly by a phase advance. Colquhoun noted, however, that one subject adapted his rhythm by phase delay rather than by phase advance.

Perhaps the most direct approach to study individual differences in adapting to night- and shiftwork was taken by Folkard et al. (1979). The purpose of their study was to develop a paper and pencil test which would identify the individuals whose circadian rhythms readily adjusted to shiftwork from those who did not. The paper and pencil test or questionnaire was based on an assumption that low amplitude and flexible rhythms would lead to a better adjustment to night and shiftwork. Twenty questions were asked and the results were factor-analyzed. The first factor was concerned with rigidity of sleeping habits. A high score on this factor meant an inability to sleep at unusual times and a preference for a regular sleeping schedule. The second factor was concerned with an ability to overcome drowsiness. A high score on this factor meant a relatively low level of drowsiness after reduced sleep and an ability to overcome drowsiness when necessary. The third factor was related to the chronotype of morningness. A high score on this factor meant that an individual felt lively and preferred working at normal times-of-day, and found it easy to get up early in the morning. These factors have been named by the two extremes associated with each factor: the first factor was named R/F, i.e., rigid sleep type versus flexible sleep type; the second factor as V/L, vigorous versus languid type; the third factor as M/E, morning versus evening types. These factors were later correlated with a variety of measures of shiftwork adjustment for their validation. The

measures of adjustment were oral temperature, subjective ratings of alertness and well-being, urinary volume, urinary excretions of potassium, sodium and chloride, and day sleep. The flexibility of individuals' sleeping habits (the factor R/F) and an ability to overcome drowsiness (the factor V/L) were found more important in determining the degree of adjustment than ^{the} more frequently examined factor of morningness and eveningness. The authors cautioned that the best prediction of adjustment will be a combination of these factors, including the personality factors.

Colquhoun and Folkard (1978) suggested that extraverts might be more rapid in the phase adjustment of the body temperature rhythm than introverts. They felt that the "neurotic extraverts" would show especially rapid phase adjustment.

From the above studies, some individuals seemed to tolerate work periods at odd times of the day better than others. Some "neurotic extraverts" with flexible sleep habits, a vigorous life style, and ultra-stable large amplitude circadian rhythms might be considered the best suited to night- and shift-work. To be successful in night- and shift-work means perhaps that the individuals have developed a commitment to be night- or shift-workers, as Folkard and his associates (1978) discovered in their study of night nurses. That is, an individual's psychological decision to accept a certain socio-ecological zeitgeber, and to reject other zeitgebers appears to be critical in achieving adaptation to night- or shift-work. A particular biological and personality structure of the individual might make such ^{an} adaptation easier. The primary factor, however, for successful adjustment to work at odd times of day remains the individuals' commitment to live and work in the world of night- and shift-work.

Before discussing ^{other} zeitgebers, however, one curious aspect of the flattened body temperature curve should be examined. Smith (1979) found that the flat

body temperature profile of night workers was probably a product of the normal circadian rhythm of body temperature which was masked by the new activity-sleep cycle. The fact that (a) the temperature curve was flattened immediately on the first night of the night shift, (b) the value of the maximal body temperature was not displaced in time, and (c) the temperature curve returned immediately to the day pattern on the first complete day-off have convinced Smith that the flattened night temperature curve was the result of an unaltered (un-shifted) circadian rhythm that was expressed through the altered sleep routines. Taking this further, Wever (1979) showed that a clear inversion of body temperature could be seen if we compensated for the masking effect of sleep on body temperature by raising all values taken during sleep by some arbitrary amount. Wever demonstrated the above by using van Loon's data (1968) on three naive subjects who worked on a night shift for 13 weeks by raising their temperature by 0.4°C during sleep time (see Figure III of Wever, 1979). Thus, the inversion of body temperature would have gone unnoticed during the night shift in many studies due to the masking (body temperature lowering) effect of sleep. The flattened appearance of the curve has been misunderstood as an effect of the night shift, or as a sign of "adaptation". Further research is needed to clarify the masking effect of sleep-activity on body temperature (see Akerstedt and Gillberg, in press).

Light-dark (LD) zeitgebers were shown to be most effective in controlling the phase of the circadian rhythm in most animals. But LD zeitgebers were too weak to synchronize humans (Wever, 1979). Aschoff et al. (1971) studied three groups of two subjects each, who lived in an underground chamber for eight days. For the first four days, lights were on from 07³⁰ to 23³⁰. Then, there were no lights at all for 96 hrs. Meal times, bedtime, urine collection times and times of psychomotor testing were rigorously fixed in time to

provide social cues. Circadian rhythms of urinary excretions of total catecholamines, 17-hydroxycorticosteroids, and sodium, as well as rectal temperature, did not change during the 96-hr continuous darkness (DD) period. The conclusions were that a LD cycle was not necessary to entrain human circadian rhythms at least for four days, and the human circadian rhythm could be entrained to 24 hrs by social cues from the environment. The results of a tapping task, hand grip strength and time estimation were reported by Aschoff (1972), Aschoff et al. (1972) and Aschoff (1978). A figure provided by Aschoff et al. (1972) on the tapping, time estimation, and grip strength tasks showed no apparent differences between the LD and DD environments.

Perhaps for humans, social zeitgebers are the most powerful in controlling the phases (TOPs and Time of Troughs) of circadian rhythms. Any environmental physical events or stimuli can exercise their influences as social zeitgebers, so long as these events and stimuli are given social meaning. An example is given by Wever (1979) who described an experiment where subjects lived under a 24-hr zeitgeber consisting only of a LD cycle. Another group of subjects lived under the same LD regimen, but they received a "gong" at 3-hr intervals "only to facilitate the analysis of the experiments." No one expected the "gong" to become a zeitgeber, until it failed one day to operate shortly after the beginning of an experiment. Then the body temperature rhythm started to free-run in spite of the LD cycle. This serendipitous finding disclosed that all subjects perceived the "gong" sound as a personal call of the experimenter; that is, a social contact. Perhaps the most convincing evidence that social zeitgebers are powerful can be found in studies summarized by Klein and Wegmann (1979). They reported on a group of travellers who were kept in the relative isolation of hotel rooms after a 6-hr transmeridian flight, and another group which was allowed to leave the hotel rooms to join in outdoor

social activities every second day. Time for 95% resynchronization of psychomotor performance rhythms was 50% longer for those who were confined in the hotel rooms than those who were permitted to participate in social activities. This provides clear evidence that social contacts constitute an effective zeitgeber for human circadian rhythms.

Mealtimes are important for controlling the circadian phase in rats and monkeys, but Minors and Waterhouse (1979) commented that regular mealtimes were not sufficient to maintain stable 24-hr rhythms in humans. With completely random sleep, stable 24-hr rhythms were not obtained even though the subjects ate meals regularly. Thus, mealtimes are not a strong zeitgeber in humans. However, Graeber et al. (1978) showed that the internal timing of rhythms in relation to one another can be changed by adjusting mealtimes. In this study, three groups of subjects ate either dinner only, breakfast only, or ad libitum meals for three consecutive weeks. These groups remained in the study for three additional weeks, but the dinner-only group was now assigned to eat breakfast only, and the previous breakfast-only group was reassigned to eat dinner only. The breakfast-only condition shifted the peak of oral temperature one hour earlier, and the dinner-only by about one hour later, in reference to the TOP of the ad lib meal group. Pulse rate also shifted significantly. The breakfast-only group shifted the TOP to be earlier (towards breakfast time) by about 4 hrs, and the dinner-only group delayed its TOP (moved it towards dinner time) by about 5 hrs. Diastolic blood pressure was affected only by the breakfast-only condition where the circadian TOP shifted away from the breakfast time in reference to TOP in the ad lib meal condition. For some subjects, cortisol, growth hormone, insulin and glucagon were measured to examine the relation of mealtimes to circadian rhythms of some hormones related to carbohydrate metabolism. The TOP of the secretion of insulin and glucagon differed,

depending on the mealtimes. The TOP of insulin shifted toward the times of the single daily meal. Since this rhythm peaked in the late afternoon under the normal meal timing of breakfast, lunch and dinner, there was less shift involved in switching to dinner-only than to breakfast-only. In general, the metabolic hormones peaked within one hour of each other for the breakfast-only condition, but the peaks of these hormones were about 5 hrs apart in the dinner-only condition. None of the performance tasks showed significant shifts in response to the single mealtime. Overall, the direct effect of the single mealtime appeared to be minimal for task performances.

As previously discussed, sleep can be regarded as a powerful zeitgeber. Mills et al. (1978) and Minors and Waterhouse (in press) observed that sleep from midnight to 04⁰⁰ was a sufficiently powerful zeitgeber in stabilizing circadian rhythms, even if the subjects obtained the remainder of their sleep at irregular hours. Colquhoun et al. (1978) observed that the temperature rhythm of a submarine patrol crew, who slept at as regular hours as the watch-standing would allow, was more stable. Minors and Waterhouse (in press) found that a sleep period from 04⁰⁰ to 08⁰⁰ also served to stabilize, or "anchor," the circadian rhythm (anchor sleep). They observed that the phase shifts in body temperature and urinary components were approximately equal to the hours by which the midsleep was shifted. The greater the difference was between usual bedtime and the start of the anchor sleep, the greater was the number of days needed for stabilization of the TOPs.

Mills et al. (1978) stated that sleep at any time of the day or night would lower body temperature. Akerstedt and Gillberg (in press) made an extensive study of the effects of unrestricted sleep on body temperature, hormones and subjective alertness. In this study, six subjects were given a chance to sleep at different times of day. The starting times of sleep were at

23⁰⁰, 03⁰⁰, 07⁰⁰ and so on in 4-hr intervals to cover a 24-hr period. Sleep duration was not restricted. They observed the interaction between sleep and circadian rhythms. Sleep affected some circadian rhythms, and, in turn, the circadian rhythm of body temperature affected the sleep pattern. Sleep was observed to lower body temperature at any time of day, but the extent of the temperature drop was dependent on the phase of circadian body temperature when sleep started. When the circadian body temperature was on an increase, the sleep-induced drop in body temperature was small (e.g., sleep starting at 07⁰⁰), while a sleep-induced drop in body temperature was very large when the circadian body temperature was dropping (e.g., 23⁰⁰). A circadian rhythm in urinary adrenaline excretion was clearly identified in the waking period. During sleep, it was almost completely shut off. Cortisol showed a circadian rhythm during waking and sleeping, but it was less so during sleep. Melatonin exhibited a strong circadian rhythm during waking and sleeping, and was completely unaffected by the sleep-wakefulness cycle. Self-ratings of alertness revealed a pronounced circadian rhythm during waking. The same alertness measure that was obtained upon awakening from sleep followed approximately the same pattern observed in subjects who remained awake, suggesting that an "arousal" system continued to run during sleep. They also observed that circadian rhythms of body temperature and others appeared to influence the pattern of sleep. Sleep duration was found to be short, when sleep was taken on the ascending portion of the circadian rhythm of body temperature, alertness and adrenaline, and the descending portion of the circadian melatonin rhythm. Akerstedt and Gillberg felt that this characteristic of sleep was a direct function of time-of-day or of an underlying "arousal" system. The short and disturbed sleep of shiftworkers was, therefore, not caused by the daytime sleep environment, but by the endogenous arousal rhythm which terminated sleep

earlier than usual. The infra-structure of sleep appears to be affected by circadian rhythms of body temperature. Wever (in press) reported that Rapid Eye Movement density decreased when body temperature was on the rise, and its density increased with decreasing body temperature. For more details of sleep and circadian rhythms, Zulley's thesis should be consulted.

In discussing the effects of sleep on circadian phase or the effects of circadian rhythms on sleep, careful consideration must be given to determine whether the observed effects are truly affecting the rhythm of an endogenous oscillator. Perhaps they reflect the expression of an endogenous rhythm without changing the basic characteristics of the oscillator. This is the question of endogenous versus exogenous rhythms discussed by Aschoff (1960) or of masking effects (Wever, 1979). Mills et al. (1978) cited an example of urinary potassium excretion which was low during the night even if the subjects remained awake, reflecting that it is an endogenous rhythm. But urinary potassium excretion can be reduced to a low level by sleeping during the daytime, because sleep is an exogenous influence on urinary potassium excretion (without changing the basic characteristics of endogenous rhythm). Similarly, urinary phosphate was high during the night, even when the subjects remained awake due to its endogenous rhythm, but sleep increased it at any time of day, masking its endogenous rhythm. Mills and his associates stressed an overall difficulty in changing the characteristics of an endogenous rhythm or "internal clock." They cautioned that the changes in the endogenous rhythms are most often only apparent and deceptive because these changes were due to changed expression of the endogenous rhythm by exogenous factors. Under a strictly controlled constant environment (Mills' test; see Minors and Waterhouse, in press), an 8-hr sudden phase advance would result in neither advance nor delay of the phase of urinary potassium excretion. But, under nyctohemeral conditions, all of the urinary constituents

advanced their phases in response to the phase advance in the socio-ecological environment. Obviously this synchronization was achieved by the exogenous influence of activity, sleep, meals and social cues over the internal clock(s). Thus, whether sleep does, in fact, change the phase of internal clock(s) controlling body temperature and other circadian rhythms could only be answered in future experiments meeting the Mills' test criteria.

Many zeitgebers have been discussed so far, but crucial knowledge about the impact of zeitgebers on the phases of the circadian rhythms along the time-of-day is not available. No definite information is available about the phase-response-curve for mealtimes, social contacts, sleep, and others. Akerstedt and Gillberg (in press) and Minors and Waterhouse (in press) have just embarked on evaluation of the phase-response-curve studies of sleep. Such studies would be very critical in understanding zeitgebers.

One way to study the influence of zeitgebers operating harmoniously to change the circadian phases is research on transmeridian dyschronism. Aschoff et al. (1975) and Klein and Wegmann (1979) have reviewed many studies on transmeridian dyschronism or "jet lag." After transmeridian travel in either an eastward or westward direction, all zeitgebers work together harmoniously to shift the phases of circadian rhythms of the travellers. Nevertheless, complete re-entrainment takes several days. One of the well-established observations is that phase adjustments take longer after an east-bound time-zone crossing than after west-bound travel. This "direction asymmetry" was assessed to be about 50% faster for the west-bound travel by Klein and Wegmann (1979). They have computed the rate of resynchronization to be 88 min/day and 56 min/day after west- or east-bound transportation, respectively. Aschoff (1978) gave an average shift rate to be 92 min/day and 57 min/day for west- and east-bound flights, respectively. Wever (1979) noted that this direction asymmetry was

independent of the temporal sequence of flights and of actual time-of-day of the flight. Wever (1979) interpreted this direction asymmetry to represent the fundamental temporal preference of humans. The free-running rhythm of human temperature is not 24 hrs, but closer to 25 hrs per cycle. Also, the range of entrainment (ROE) is known to be shorter than 27 hrs per cycle, but longer than 23 hrs per cycle (Wever, in press). If the period length of zeitgebers is out of this range, they could not control human rhythms. It should be noted that the middle of the human ROE is not 24 hrs per cycles, but 25 hrs per cycle.

Two aspects of findings in simulated east- or west-bound travel in an isolation chamber deserve closer examination (Wever, in press). Wever reported an experiment where a subject was first exposed to a simulated eastward flight across six time zones, and later to a "return trip" of simulated westward flight across six time zones. The subject reported not to have perceived consciously any changes of days in the chamber. The subject believed that he lived in "temporal agreement with his environment" during the experiment, with no experiences of subjective suffering of "jet lag." The subject's activity rhythm, however, did change with the 6-hr shift of time, and it became re-synchronized within two days, and body temperature more slowly. Wever also observed a clear decrement in task performance following the eastward simulated flight (phase advance), but no detectable changes following the westward simulated flight (phase delay). This study suggested clearly that the well-known subjective fatigue of time-zone crossings would be due to the conflict of external demands with the internal state of travellers. Another aspect was that the laboratory simulation produced the direction asymmetry which was opposite of the actual flight experiments (Aschoff et al., 1975; Wever, 1979). That is, a shift in the isolation chamber showed that the phase advance (i.e., eastward flight) had a rate of 70 min/day, but 54 min/day for the phase delay (i.e., westward flight).

Mills et al. (1978) maintained that re-entrainment was usually achieved by lengthening the cycle. They suggested that an abrupt shift in zeitgebers resulted in the free-running rhythm of lengthened period until the rhythm became in phase with zeitgebers again after going through one complete cycle. Thus, after a phase advance of zeitgebers by 8 hrs, the rhythms would have to move through 16 hrs of the delay before re-entrainment was completed. An observation made by Colquhoun from his 1979 study can be recalled to compare with the results by Mills et al. (1978). Human preference of the phase delay was inferred by Mills et al., when they experimented with a group of subjects who were exposed to an artificial time shift of 12 hrs, which eliminated directional difference of the phase advance or delay. A 12-hr shift meant that both the phase advance or phase delay had to proceed through 12 hrs to achieve resynchronization. Mills et al. found that 34 of the adjustments were done by a phase delay (lengthening the cycle), and only 4 by a phase advance (shortening the cycle).

Studies on shiftwork and transmeridian dyschronism suggest that the best way to achieve phase shift would be to use multiple zeitgebers at the same time but harmoniously, that is "orthochronal application of multiple zeitgebers" (Ehret, Personal communication). Ehret et al. (1978) were the first group of researchers who have addressed the question of the use of multi-zeitgebers in assisting transmeridian travellers. The first large-scale applications of the concept outlined by Ehret et al. were studies by Graeber and his group (1979; In press; this volume). Ehret and his associates show a plan for travellers from the United States (say, Chicago) to Paris, which results in a 6-hr phase advance under daylight saving time. Since this flight is eastward, the length of the day of departure becomes shorter by 6 hrs, and by 7 hrs under central standard time (CST). Thus, Ehret and his group have

wished to accelerate the process of advancing the phase of circadian rhythms by judicious manipulation of multiple zeitgebers. Figure 13 illustrates some of

 Figure 13 About Here, see pg 57a

the major manipulations suggested by Ehrét and his colleagues. As Figure 13 shows, a traveller takes off at 21³⁰ on Wednesday from the city in the CST zone to Paris. In this plan, three major groups of zeitgebers are mobilized to advance the phases of circadian rhythms: (1) chronobiotic actions of the methylated xanthines (such as caffeine in coffee and theophylline in tea), and orthochronal use of carbohydrate- and protein-rich meals, (2) light-dark cycle, and (3) social cues (e.g., social interactions with other passengers, and best attempt to sleep). The procedure starts four days ahead of the departure time. On Sunday, a traveller should eat well (feast), but on Monday the traveller should eat sparingly (fast). The traveller should feast again on Tuesday, and fast on Wednesday, the day of departure. The traveller is asked to fast, not because it is related to advancing or delaying the phases of circadian rhythms, but ^{because} it would make the traveller more sensitive to time-of-day information provided by the fresh presentation of food. A day of feast is provided so that the traveller would not be too weakened by the fast. The addition of an extra cycle of feast-fast appears to enhance the effectiveness of food as the cue of time-of-day during and after transmeridian flight. The traveller should remain fasting through "dinner" served on board a jet, and avoid snacks, cream, and sugar so that the very first meal would really have strong information about the phase of the day. Chronobiotic actions, that is actions of biochemical substances to change the phase of biological rhythms, of caffeine and theophylline can be used to advance or delay the phases of biological

MAY 1977 EASTBOUND TRANSATLANTIC - DEPARTURE TIME 2130

SUNDAY	MONDAY	TUESDAY	WEDNESDAY	THURSDAY	FRIDAY	SATURDAY
1	2	3	4	5	6	7
FEAST	FAST	FEAST	FAST	Break-the-fast with breakfast on Paris time + large lunch + large supper	Three full meals Paris time	ETC.

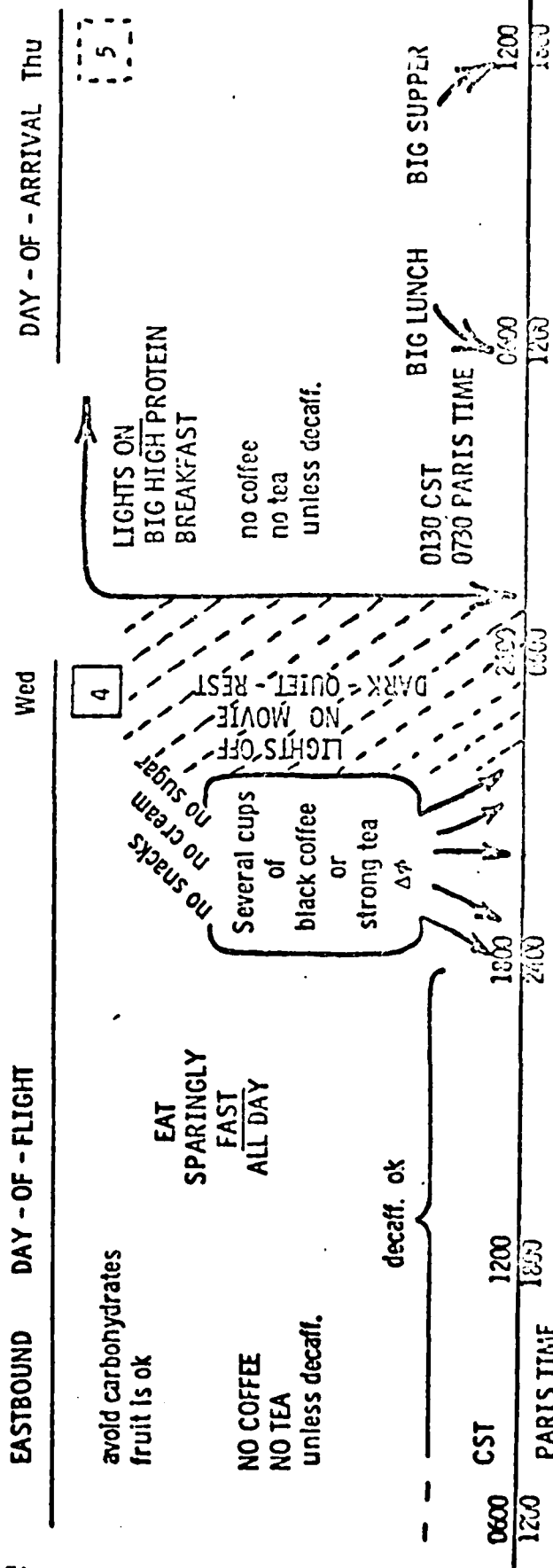

Figure 13

Figure 13. A "diet" plan for eastbound transmeridian travel by Ehret and his group (1978). For details, see text. Courtesies of the Authors and Planum press.

rhythms. The phase response curves of caffeine and theophylline show that they will delay the phases if they are ingested in the morning, but they will advance the phase if they are taken later in the day. So, several cups of black coffee or strong tea are recommended during the evening (in reference to the CST) on board the jet to advance the phases of circadian rhythms. This manipulation should be coupled with reductions of social interactions, of watching no movies, of turning lights off, and of attempting to sleep or at least to remain quiet. If the traveller is highly sensitive to methylated xanthines, eliminate the coffee and tea phase from the plan. Another element in this chronopsychological approach to transmeridian flights is the orthochronal concept applied to the chemical quality of the meals. A meal rich in carbohydrates usually signals a sleep period to come, as carbohydrates turn the indoleamine system on, while a meal rich in proteins biochemically signal the start of an active day, as proteins turn the catecholamine system on. Thus, in terms of the quality of the meals, a chronopsychologically correct way to start and end the day would be: high protein breakfast (catecholamines ON) -- get up and go -- high carbohydrate dinner (indoleamines ON) -- ready to sleep. Thus, the breakfast to be served a few hours prior to arrival at the destination should be a big, high protein meal. In a study by Graeber et al. (this volume), the jet travellers were served a high protein breakfast on board the jet at 04³⁰. The meal consisted of a 6 oz. filet steak, a 2-egg cheese omelet, a 4 oz. cut of orange juice, a cup of orange and grapefruit slices, a hard roll with 1 pat of butter, and 1/2 pint of milk. Those who requested more had a second serving. No coffee and tea should be taken with this breakfast, because they would delay the phase of the circadian rhythms. After arrival in Paris, the traveller should stick with Paris time, eating a big lunch and big supper at Paris time.

This "diet" plan of Ehret and his group for the transmeridian traveller

can be applied to shiftworkers. The field research by Graeber and his associates appear to show the procedure of Ehret and his group to be an effective countermeasure for transmeridian dyschronism.

CONCLUSIONS: POINTERS FOR THE FUTURE

As long as society remains unimodal in the face of continued colonization of the night, a conflict will remain between the individuals' well-being and the demands of society. If a 24-hr society emerges out of the single-mode society which now sleeps during the night, shiftworkers and night workers increasingly will be asked to work at unphysiological hours with lowered performance efficiency. With the energy crisis, however, the trend toward colonization of night could be significantly slowed down (Melbin, 1978). At one time, it appeared that "jet lag" problems could be resolved by intensive use of supersonic transports which could overtake the sun's movement across the sky. However, pollution and energy problems associated with the supersonic transport seem to have persuaded the airline industry to opt for jet travel of less than 600 miles per hour. Thus, for some time to come, shiftwork problems and transmeridian dyschronism will stay with us. Shiftworkers must continue to cope with, and chronopsychologists must continue to look for, ways to minimize the detrimental effects.

Chronopsychological approaches to optimize the performance of shiftworkers and jet travellers will be needed particularly for occupations which require human attention and participation around the clock. The recent development of the autorhythmometric approach in chronopsychology makes it possible for researchers to examine job performance in the field. The AR approach should continue to enjoy wide acceptance among the chronobiologists and psychologists. However, the standard AR kit covers a very limited range of human skills necessary

in performing daily jobs. Table 3 of this chapter shows this severe limitation vividly. Knowledge about the circadian rhythms in memory, attention, mood, psychomotor skills, visual and auditory acuities, and many other psychological functions remains either poorly measured or still in stages of being gathered from laboratory studies. A future task of chronopsychologists should be to collect data on the circadian rhythms in human basic skills as well as capabilities of acquiring these skills.

Once the circadian rhythms are established for each and every critical human skill and the capability to learn and acquire these skills, the critical task of the chronopsychologists will be to find zeitgebers which could control the phases of the circadian rhythms in psychological activities. The goal is to find a single zeitgeber or a group of multiple zeitgebers which could advance or delay the phases of the circadian rhythms in performance efficiency so that humans would always be working at their best times and resting when rest would be most beneficial. Research on zeitgebers will be difficult, because they require a highly controlled environment (Mill's test) to differentiate the masking effects from the true phase-controlling actions. Also, the phase response curve of a zeitgeber should be evaluated explicitly experimentally so that its phase-controlling power would be known at any time of a 24-hr period. Further, interactions between zeitgebers should be carefully defined because, in real life, a set of zeitgebers will be in action, and rarely will a single zeitgeber control the circadian rhythms. Knowledge of the phase response curves for each zeitgeber should lead to increased ability to optimize human performance under any socio-ecological environment.

Although this chapter was mainly concerned with shiftwork and "jet lag", chronopsychology should be incorporated eventually into the main stream of experimental psychology. The importance of "time of day" in psychological experi-

ments involving vigilance, learning and memory has been clearly seen in experimental studies of performance and mood. Because of this "time of day" effect, most psychologists now obtain their data at the same time of day. But many still fail to realize that the circadian rhythm of performance may be affected by the experimental treatment per se. The same time of day could represent a different phase of the rhythm. Without this knowledge, the experimenter might have been hit by an unwanted variance from an unexpected source. Also, unsuspecting experimenters might try to teach subjects, animal or human, at low points in their circadian efficiency, resulting in a puzzling discrepancy in learning ability from that reported by other experimenters who used, unknown to these experimenters, a different time of day to teach.

Perhaps the single most important future task of chronopsychologists will be to convince experimental, industrial, educational psychologists, and personnel staff of the merits of the chronopsychological approaches in their specialities so that they will begin to re-evaluate the old data and established "facts" from this new point of view.

- Alford, J., & Halberg, F. M. The circadian pattern of unrestricted sleep in relation to body temperature, hormones, and alertness. (Paper presented at ONR/NIOSH Symposium on Variations in Work-Sleep Schedules: Effects on Health and Performance, San Diego, Calif., Sept. 1979).
- Fellard, S. Shiftwork and performance. (ibid.)
- Craeber, EC; Gentry, F; Halberg, F & Levine, H. Human Eating Behavior: Preferences, Consumption Patterns, and Biorhythms. (Tech Report NATICK/TR-78/022), Natick, Mass.: U.S. Army Research & Development Command, June 1978.
- Humphries, J & Naitoh, P. A response alternation device for monitoring lapses in attention. (in preparation)
- Kanabrocki, EL; Scheving, LE; Halberg, F; Brewer, RL; & Bird, TJ. Circadian variation in presumably healthy young soldiers. (NTIS Document #PB 228427) 361st Medical Laboratory, USAR, 6230 North Kedzie Ave., Chicago, Ill.
- Klein, KE & Wegmann, HM. Circadian rhythms in air operations. (AGARD-LS-105), Advisory Group for Aerospace Research and Development Lecture Series on "Sleep, Wakefulness and Circadian Rhythm", Sept 1979.
- Levine, H & Halberg, F. Circadian rhythms of the circulatory system (SAM-TR-72-3). Brooks Air Force Base, Tex.: USAF School of Aerospace Medicine, Aerospace Medical Division (AFSC), April 1972.
- Minors, D & Waterhouse, JH. Anchor sleep as a synchronizer of rhythms on abnormal routines. (Paper presented at ONR/NIOSH Symposium on Variations in Work-Sleep Schedules: Effects on Health and Performance, San Diego, Calif., Sept 1979.)
- Moses, JM; Lubin, L; Naitoh, P & Johnson, LC. Subjective evaluation of the effects of sleep loss: The NPRU Mood Scale. (Tech Report No. 74-25). San Diego, CA: Navy Medical Neuropsychiatric Research Unit, 1974.
- Pearson, RG & Byars, GE. The development and validation of a check list for measuring subjective fatigue. (USAF Tech Report No. 56-115). Randolph Air Force Base, Texas, Dec. 1956.
- Reinberg, A. Tolerance to shift work: A chronobiological approach. Agard Lecture Series on "Sleep, Wakefulness and Circadian Rhythm", AGARD-LS-105, 1979.

and a Work Committee (Japan Association of Occupational Health).
Opinion on night work and shift work. Journal of Science of Labour, Part II of 2 Parts, 1979.

Stolgitis, WC. The effects of sleep loss on rotating work/rest cycles: An Analysis of the traditional system and a proposed alternative.

Weaver, Ra. On varying work-sleep schedules: A biological rhythm perspective. (Paper presented at 4th World Symposium on Variations in Work-Sleep Schedules: Effects on Health and Performance, San Diego, Calif., Sept 1979.)

* Pages for "Reference Notes" and "References" were retyped to reduce the number of pages for this large report.

REFERENCES

- Adam, J; T Brown, WP Colquhoun, P Hamilton, J Osborn, I Thomas, & P Worsley. Nychthemeral rhythms and air trooping: Some preliminary results from "Exercise Medex". In: WP Colquhoun (ed), Aspects of Human Efficiency: Diurnal Rhythm and Loss of Sleep. London: The English Universities Press, 1972.
- Akerstedt, T. Inversion of the sleep wakefulness pattern: Effects on circadian variations in psychophysiological activation. Ergonomics, 1977, 20, 459-474.
- Akerstedt, T & J Froberg. Shiftwork and health - interdisciplinary aspects. In: PG Rentos & RD Shepard (eds), Shiftwork and Health. Washington, DC: U.S. Dept of Health Publication No. (NIOSH) 76-203, 1975.
- Akerstedt, T & JE Froberg. Psychophysiological circadian rhythms in women during 72 h of sleep deprivation. Waking and Sleeping, 1977 1, 387-394.
- Akerstedt, T; P Patkai & K Dahlgren. Field studies of shiftwork: II. Temporal patterns in psychophysiological activation in workers alternating between night and day work. Ergonomics, 1977, 20, 621-631.
- Alluisi, EA. Influence of work-rest scheduling and sleep loss on sustained performance. In: WP Colquhoun (ed), Aspects of Human Efficiency: Diurnal Rhythm and Loss of Sleep. London: The English Universities Press, 1972.
- Aschoff, J. Zeitgeber der tierischen Tagesperiodik. Naturwissenschaften, 1954, 41, 49-56.
- Aschoff, J. Exogenous and endogenous components in circadian rhythms. Cold Spring Harbor Symposium on Quantitative Biology 1960, 14, 11-28.
- Aschoff, J. Eigenschaften der menschlichen Tagesperiodik. In: J. Rutenfranz (ed), Aktuelle Probleme der Arbeitsumwelt. Stuttgart: A. W. Gentner, 1971.
- Aschoff, J. Features of circadian rhythms relevant for the design of shift schedules. Ergonomics, 1978, 21, 739-754.
- Aschoff, J; M Patranska, U Gerecke & H Giedke. Twenty-four hour rhythms of rectal temperature in humans: Effects of Sleep Interruptions and test sessions. Pflügers Archiv. European Journal of Physiology (Berlin), 1977, 346, 215-222.

- Aschoff, J; M Patranska, H Giedke, P Doerr, D Stamm, & H Wisser. Human circadian rhythms in continuous darkness: Entrainment by social cues. Science, 1971, 171, 213-215.
- Aschoff, J; H Giedke, E Poppel & R Wever. The influence of sleep interruption and of sleep deprivation on circadian rhythms in human performance. In: WP Colquhoun (ed), Aspects of Human Efficiency: Diurnal Rhythm and Loss of Sleep. London: The English Universities Press, 1972.
- Aschoff, J; K Hoffman, H Pohl & R Wever. Re-entrainment of circadian rhythms after phase-shifts of the zeitgeber. Chronobiologia, 1975, 2, 23-78.
- Bethea, NJJ. Human Performance, Physiological Rhythms, and Circadian Time Relations (Doctoral dissertation, Texas Technical University, Lubbock, Texas, 1975). (University Micro - films No. 75-26, 834)
- Bjerner, B; A Holm & A Swensson. Diurnal variation in mental performance. British Journal of Industrial Medicine, 1955, 12, 103-110.
- Blake, MJF. Temperature and time of day. In: WP Colquhoun (ed) Biological Rhythms and Human Performance. New York: Academic Press, 1971.
- Blake, MJF. Time of day effects on performance in a range of tasks. Psychonomic Sciences, 1967, 9, 349-350.
- Bliss, CI. Statistics in Biology (Vol. 2). New York: McGraw-Hill, 1970.
- Breithaupt, H; G Hildebrandt, D Dohre, R Josch, U Sieber & M Werner. Tolerance to shift of sleep as related to the individual's circadian phase position. Ergonomics, 1978, 21, 767-774.
- Browne, RC. The day and night performance of teleprinter switchboard operators. Occupational Psychology, 1949, 23, 121-126.
- Bugge, JF; OP Opstad & PM Magnus. Changes in the circadian rhythm of performance and mood in healthy young men exposed to prolonged, heavy physical work, sleep deprivation, and caloric deficit. Aviation, Space, & Environmental Medicine, 1979, 50, 663-668.
- Chiles, WD; FA Allred & O Adams. Work schedules and performance during continuous work. Human Factors, 1968, 10, 143-196.

- Czeisler, CA. A Human Circadian Physiology: Internal Organization of Temperature, Sleep-Wake and Neuroendocrine Rhythms Monitored in an Environment Free of Time Cues (Doctoral dissertation, Stanford University, Calif. 1978) (University Microfilms No. 79-5, 838).
- Dixon, WJ (ed), BMD Biomedical Computer Programs. University of California, Berkeley, 1974.
- Dixon, WJ (ed), BMD Biomedical Computer Programs. University of California, Berkeley, 1975.
- Ehret, CF; KR Groh & JC Mmeinert. Circadian desynchronism and chronotypic ecophilia as factors in aging and longevity. In: HV Samis & S Capobianco (eds), Aging and Biological Rhythms. New York: Plenum, 1978.
- Englund, CE. Human Chronopsychology: An Autorhythmometric Study of Circadian Periodicity in Learning, Mood and Task Performance. Unpublished doctoral dissertation, U.S. International University, San Diego, Calif, 1979.
- Enright, JT. The research for rhythmicity in biological time-series. Journal of Theoretical Biology, 1965, 8, 426-468.
- Folkard, S. Chronopsychology, implication for education. Chronobiologia, 1977, 4, 111.
- Folkard, S. Circadian rhythms and human memory. This volume.
- Folkard, S; TH Monk & MC Lobban. Short and long-term adjustment of circadian rhythms in 'permanent' night nurses. Ergonomics 1978, 21, 785-799.
- Folkard, S; P Knauth, TH Monk, & J Rutenfranz. The effect of memory load on the circadian variation in performance efficiency under a rapidly rotating shift system. Ergonomics 1976, 4, 479-488.
- Folkard, S; TH Monk, R Bradbury & J Rosenthal. Time of day effects in school children's immediate and delayed recall of meaningful material. British Journal of Psychology, 1977, 68, 45-50.
- Folkard, S; TH Monk & MC Lobban. Towards a predictive test of adjustment to shift work. Ergonomics, 1979, 22, 79-91.
- Fort, A & JM Mills. Influence of sleep, lack of sleep, and circadian rhythm on short psychometric tests. In: WP Colquhoun (ed), Aspects of Human Efficiency: Diurnal Rhythm and Loss of Sleep. London: The English Universities Press, 1972.

- Colquhoun, WP. Circadian variations in mental efficiency. In: WP Colquhoun (ed), Biological Rhythms and Human Performance. New York: Academic Press, 1971.
- Colquhoun, WP. Accidents, injuries and shift work. In: PG Rentos & RD Shepard (eds), Shiftwork and Health. Washington, DC: U.S. Dept of Health Publication No. (NIOSH) 76-203, 1975.
- Colquhoun, WP. Phase shift in temperature rhythm after trans-meridian flight as related to pre-flight phase angle. International Archives of Occupational and Environmental Health, 1979, 423, 149-157.
- Colquhoun, WP & Edwards, RS. Circadian rhythms of body temperature in shiftworkers at a coalface. British Journal of Industrial Medicine, 1979, 27, 266-272.
- Colquhoun, WP; MFJ Blake & RS Edwards. Experimental studies of shift work I: A Comparison of 'rotating' and 'stabilized' 4-hour shift systems. Ergonomics, 1968a, 11, 437-453.
- Colquhoun, WP; MJF Blake & RS Edwards. Experimental Studies of shift work II: Stabilized 8-hour shift work. 1968b, 11, 527-546.
- Colquhoun, WP; MJF Blake, & RS Edwards. Experimental studies of shift work III: Stabilized 12-hour shift system. Ergonomics, 1969, 12, 856-882.
- Colquhoun, WP; P Hamilton & RS Edwards. Effects of circadian rhythm, sleep deprivation, and fatigue on watch keeping performance during night hours. In: P Colquhoun, S Folkard, P Knauth & J Rutenfranz (eds), Experimental Studies of Shiftwork. Opladen: Westdeutscher Verlag, 1975.
- Colquhoun, WP; MWP Paine & A Fort. Circadian rhythm of body temperature during prolonged undersea voyages. Aviation, Space and Environmental Medicine, 1978, 49, 671-678.
- Conroy, RTW & JN Mills. Human Circadian Rhythms. London: J & A Churchill, 1970.
- Cuthbert, BN; RC Graeber, HC Sing & RJ Schneider. Rapid trans-meridian deployment: II. Effects of age and countermeasures under field conditions. Proceedings of XIV International Conference of the International Society of Chronobiology. Hannover, FRG, 8-12 July 1979.

- Frøberg, JE. Circadian and ultradian rhythms in human performance. Acta Physiologica Scandinavica, 1975, 9, 6, pp 27.
- Frøberg, JE. Circadian and ultradian patterns in human performance, subjective and physiological variables and differences between morning and evening active subjects. Biological Psychology, 1977, 5, 119-134.
- Frøberg, JE. Psychobiological 24-Hour Patterns. Theory, Methods and Summary of Empirical Studies. Unpublished doctoral dissertation, University of Stockholm, 1979.
- Frøberg, J; C-G Karlsson, L Levi & Lidberg. Circadian variations in performance, psychological ratings, catecholamine excretion, and diuresis during prolonged sleep deprivation. International Journal of Psychobiology, 1972, 2, 23-36.
- Frøberg, JE; C-G Karlsson, L Levi & L Lidberg. Circadian rhythms of catecholamine excretion, shooting range performance and self-ratings of fatigue during sleep deprivation. Biological Psychology, 1975, 2, 175-188.
- Freeman, GL & CI Hovland. Diurnal variation in performance and related physiological processes. Psychological Bulletin, 1934, 31, 777-799.
- Ghiselli, WB & RA Patton. Diurnal variation in performance of free-operant avoidance behavior of rats. Psychological Reports, 1976, 38, 83-90.
- Graeber, RC; BN Cuthbert, HC Sing, RJ Schneider & GR Sessions. Rapid transmeridial deployment: I. Use of chronobiologic countermeasures to hasten time zone adjustment in soldiers. Proceedings, XIV International Conference of the International Society of Chronobiology, Hannover, FRG, 8-12 July '79
- Graeber, RC. Recent studies relative to the airlifting of military units across time zones. In: L Scheving & F Halberg (eds), Principles and Application of Chronobiology to Shifts in Schedules with Emphasis on Man. New York, Plenum (in press)
- Halberg, F. More on educative chronobiology, health and the computer. International Journal of Chronobiology, 1973, 2, 87-105.
- Halberg, F & MB Visscher. Some physiological effects of lighting.. In: Proceedings, First International Photobiological Congress. Amsterdam, 1954. pp 396-398
- Halberg, F; R Leuro, & F Carandente. Autorhythmoemetry. In: Ricerca in Clinica e in Laboratorio, 1976, 67, 207-250.

- Halberg, F; A Reinberg & A Reinberg. Chronobiologic serial sections gauge circadian rhythm adjustments following transmeridian flight and life in novel environment. Waking and sleeping, 1977, 1, 259-279.
- Halberg, F; F Carandente, G Cornelissen & G Katinas. Glossary of Chronobiology. Chronobiologia, 1977, 4, Supplement 1.
- Halberg, F; J Halberg, F Halberg & E Halberg. Reading, 'riting, 'rithmetic - and rhythms: A new 'relevant' "R" in the education process. Perspectives in Biology and Medicine, 1973, 17, 128-141.
- Halberg, F; EA Johnson, W Nelson, W Runge & A Sothern. Auto-rhythmometry-procedures for physiological self-measurements and their analysis. The Physiology Teacher, 1972, 1, 1-11.
- Halberg, F; W Nelson, WJ Runge, OH Schmitt, GC Pitts J Tremor & O Reynolds. Plans for orbital study of rat biorhythms: Results of interest beyond the biosatellite program. Space Life Sciences, 1971. 2, 437-471.
- Halberg, F; J Reinhardt, F Nartter, C Delea, R Gordon, S Wolff, A. Reinberg, et al.. Agreement in endpoints from circadian rhythmometry on healthy human beings living on different continents Experientia, 1969, 25, 107-112
- Hildebrandt, G & I Stratmann. Circadian system response to night work in relation to the individual circadian phase position. International Archives of Occupational and Environmental Health, 1979, 43, 73-83.
- Hildebrandt, GW; W Rohmert & J Rutenfranz. Twelve and Twenty-hour rhythms in error frequency of locomotive drivers and the influence of tiredness. International Journal of Chronobiology, 1974, 1, 197-210.
- Hoagland, H. The physiological control of judgments of duration: Evidence for a chemical clock. Journal of Genetical Psychology, 1933, 9, 267-287.
- Hockey, GRJ & WP Colquhoun. Diurnal variation in human performance: A review. In: WP Colquhoun (ed), Aspects of Human Efficiency: Diurnal Rhythm and Sleep Loss. London: The English Universities Press, 1972.
- Hoddes, E; V Zazzo, H Smythe, R Phillips & WE Dement. Quantification of sleepiness: A new approach. Psychophysiology, 1973 10, 411-430.

- Horn, JA & O Ostberg. Individual differences in circadian rhythms. Biological Psychology, 1977, 5, 179-190.
- Jovonovich, J; J Jovonovich, P Kaiser & L Luttmers. Circadian rhythmicity in presumably healthy seminarians. Chronobiologia, 1975, 1 (Supplement 1), 34.
- Klein, KE; HM Wegmann & H Bruner. Circadian rhythm in indices of human performance, physical fitness and stress resistance. Aerospace Medicine, 1968, 39, 512-513.
- Klein, KE; HM Wegmann, G Athanassenas, H Hohlweck, & P Kuklinski. Air operations and circadian performance rhythms. Aviation, Space and Environmental Medicine, 1976, 47, 221-230.
- Kleitman, N. Studies on the physiology of sleep. VIII. Diurnal variation in performance. American Journal of Physiology, 1933, 104, 449-456.
- Kleitman, N. Sleep and Wakefulness. Chicago: University of Chicago Press, 1939. 1963.
- Kleitman, N & DP Jackson. Body temperature and performance under different routines. American Journal of Applied Physiology, 1950, 3, 309-328.
- Kleitman, N; S Titelbaum & P Feiveson. The effect of body temperature on reaction time. American Journal of Physiology, 1938 3, 309-328.
- Kogi, K; M Takahashi & N Onishi. Experimental evaluation of frequent eight-hour versus less frequent longer night shifts. In: P Colquhoun, S Folkard, P Knauth & J Rutenfranz (eds), Experimental Studies of Shiftwork. Opladen: Westdeutscher Verlag, 1975.
- Kanabrocki, EL; LE Scheving, F Halberg, RL Brewer & TJ Bird. Circadian variations in presumably healthy man under conditions of peace-time Army Reserve Unit Training. Space and Life Sciences, 1973, 4, 258-270.
- Knauth, P & J Rutenfranz. Experimental shift studies of permanent night and rapidly rotating, shift systems. International Archives of Occupational and Environmental Health, 1976, 37, 125-137.
- Knauth, P; J Rutenfranz, G Herrmann & SJ Poeggel. Re-entrainment of body temperature in experimental shiftwork studies. Ergonomics, 1978, 21, 775-783.

- Melbin, M. Behavior rhythms in mental hospital. American Journal of Sociology, 1969, 74, 650-665.
- Melbin, M. City rhythm. In: JT Fraser, N Lawrence & D Park (eds), The Study of Time III. New York: Springer, 1978a.
- Melbin, M. Night as frontiers. American Sociological Review, 1978b, 43, 3-22.
- Melbin, M. The colonization of time.. In: T Carlstein, D Park & N Thrift (eds), Timing Space and Spacing Time II. Human Activity and Time Geography. London: Edward Arnold, 1978.
- Miller, LL. Miller Reading Efficiency Test. Developmental Reading Distributors, Sheridan, Laramie, Wyoming.
- Mills, JN; DS Minors & JM Waterhous. Exogenous and endogenous influences on rhythms after sudden time shift. Ergonomics, 1978, 21, 755-761.
- Mills, JN; DS Minors, JM Waterhous. Adaptation to abrupt time shifts of the oscillator(s) controlling human circadian rhythms. Journal of Physiology, 1978a, 285, 455-470.
- Monk, TH. Research method in chronobiology. In: WB Webb (ed), Sleep and Biorhythm. New York: Wiley (in press)
- Monk, Th & S Folkard. Concealed inefficiency of late-night study. Nature, 1978, 273, 296-297.
- Naitoh, P; A Lubin & WP Colquhoun. Comparisons of monosinusoidal with bisinusoidal (two-wave) analysis. Proceedings, XIV International Conference, International Society of Chronobiology. Il Ponte, Milan (in press)
- Orr, WC & P Naitoh. Coherence: An extension of correlation analysis with applications to chronobiology. International Journal of Chronobiology, 1976, 3, 171-192.
- Orth, DN; GM Besser, PH King & WE Nicholson. Free-running circadian plasma cortisol rhythm in a blind human subject. Clinical Endocrinology, 1979, 10, 603-617.
- Posner, MI. Psychobiology of attention. In: MS Gazzaniga & C Blakemore (eds), Handbook of Psychobiology. New York: Academic Press, 1975.
- Reinberg, A; M Agilónor & R Assan. Chronophysiologic effects of a restricted diet (220 cal/24 H as casein) in young healthy middle-aged women. International Journal of Chronobiology, 1978, 5, 391-404.

- Taub, JM. Effects of habitual variations in napping on psychomotor performance, memory and subjective states. International Journal of Neurosciences, 1979, 9, 97-112.
- van Loon, H. Diurnal body temperature curves in shift workers. Ergonomics, 1968, 6, 267-273.
- Wever, R. Circadian rhythms of some psychological functions under different conditions. In: AJ Benson (ed), Rest and Activity Cycles for the Maintenance of Efficiency of Personnel Concerned with Military Flight Operations. NATO/AGARD Conference Proceedings No. 74, 1970.
- Wever, R. Internal phase-angle differences in human circadian rhythms: Causes for changes and problem of determinations. International Journal of Chronobiology, 1973, 1, 371-390.
- Wever, R. The Circadian System of Man: Results of Experiments Under Temporal Isolation. New York: Springer, 1979.
- Wilkinson, RT. Hours of work and the twenty-four-hour cycle of rest and activity. In: PB Warr (ed), Psychology of Work. Baltimore, MD: Penguin Book, 1971.
- Williams, JA & E Naylor. A procedure for the assessment of significance of rhythmicity in time-series data. International Journal of Chronobiology, 1978, 5, 435-444.
- Zulley, J. Der Einfluss von Zeitgebern auf den Schlaf des Menschen. Frankfurt am Main: Rita Fischer Verlag, 1979.

AD-A130 443

CHRONOPSYCHOLOGICAL APPROACH FOR OPTIMIZING HUMAN
PERFORMANCE(U) NAVAL HEALTH RESEARCH CENTER SAN DIEGO
CA P NAITOH MAR 80 NAVHLTHRSCHC-80-9

2/2

UNCLASSIFIED

F/G 5/10

NL

			END
			DATE
			FILED
			8 83
			DTIC

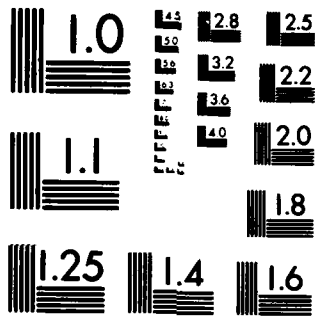

MICROCOPY RESOLUTION TEST CHART
NATIONAL BUREAU OF STANDARDS-1963-A

PAGE		NS FORM																
1. REPORT NUMBER SO-9	2. GOVT ACCESSION NO. ADA130443	3. REPORT CATALOG NUMBER																
4. TITLE (and Subtitle) (U) Chronopsychological Approach for Optimizing Human Performance	5. TYPE OF REPORT & PERIOD COVERED Interim																	
	6. PERFORMING ORG. REPORT NUMBER																	
7. AUTHOR(s) Paul NAITOH	8. CONTRACT OR GRANT NUMBER(s)																	
9. PERFORMING ORGANIZATION NAME AND ADDRESS Naval Health Research Center P.O. Box 85122 San Diego, CA 92138	10. PROGRAM ELEMENT, PROJECT, TASK AREA & WORK UNIT NUMBERS MF58.524.004-9026 6278																	
11. CONTROLLING OFFICE NAME AND ADDRESS Naval Medical Research and Development Command Bethesda, MD 20014	12. REPORT DATE March 1980																	
	13. NUMBER OF PAGES 93																	
14. MONITORING AGENCY NAME & ADDRESS (if different from Controlling Office) Bureau of Medicine and Surgery Department of the Navy Washington, DC 20372	15. SECURITY CLASS. (of this report) Unclassified																	
	15a. DECLASSIFICATION/DOWNGRADING SCHEDULE																	
16. DISTRIBUTION STATEMENT (of this Report) Approved for public release; distribution unlimited.																		
17. DISTRIBUTION STATEMENT (of the abstract entered in Block 20, if different from Report)																		
18. SUPPLEMENTARY NOTES																		
19. KEY WORDS (Continue on reverse side if necessary and identify by block number)																		
<table border="0"> <tr> <td>Adding</td> <td>Circadian Rhythm</td> <td>Memory</td> </tr> <tr> <td>Autorhythmometry</td> <td>Cosinor Analysis</td> <td>Optimization</td> </tr> <tr> <td>Chronobiology</td> <td>Frequency Analysis</td> <td>Performance</td> </tr> <tr> <td>Chronobiotics</td> <td>Hand-Eye Coordination</td> <td>Plexogram</td> </tr> <tr> <td>Chronogram</td> <td>Jet Lag</td> <td>Shiftwork</td> </tr> </table> <p style="text-align: right;">(continued)</p>				Adding	Circadian Rhythm	Memory	Autorhythmometry	Cosinor Analysis	Optimization	Chronobiology	Frequency Analysis	Performance	Chronobiotics	Hand-Eye Coordination	Plexogram	Chronogram	Jet Lag	Shiftwork
Adding	Circadian Rhythm	Memory																
Autorhythmometry	Cosinor Analysis	Optimization																
Chronobiology	Frequency Analysis	Performance																
Chronobiotics	Hand-Eye Coordination	Plexogram																
Chronogram	Jet Lag	Shiftwork																
20. ABSTRACT (Continue on reverse side if necessary and identify by block number)																		
<p>(U) A new interdisciplinary science of chronopsychology is discussed with respect to its methods, concepts, theories, and applications, especially to shiftwork and transmeridian dyschronism ("jet lag"). Chronopsychology is introduced to show the impact of circadian rhythmic components, as seen in shiftwork and transmeridian flight environments, on human performance efficiency, feeling-tones, fatigue, and sleepiness. The source materials on circadian components of human effectiveness in shiftwork and in a rapid deployment across many time</p> <p style="text-align: right;">(continued)</p>																		

UNCLASSIFIED

SECURITY CLASSIFICATION OF THIS PAGE (When Data Entered)

19. KEY WORDS (continued)

Sleep Loss
Transmeridian Dyschronism
Vigil
Vigilance

20. ABSTRACT (continued)

Studies suggest that the timing of the work period should be optimized on the basis of the fundamental circadian rhythms to assure the best time for work and rest. Differences between the adjustment of shiftworkers and jet travelers to new work environments are discussed, with suggestions on how to accelerate this process.