

AD-A129 596

RELIABILITY MAINTAINABILITY AND LIFE CYCLE COST EFFECTS
OF COMMERCIAL OFF..(U) ROCKWELL INTERNATIONAL CEDAR
RAPIDS 1A COLLINS GOVERNMENT AVI.. N E SCHMIDT ET AL.
FEB 83 RADC-TR-83-29-VOL-1 F30602-80-C-0306 F/G 15/5

1/3

UNCLASSIFIED

NL

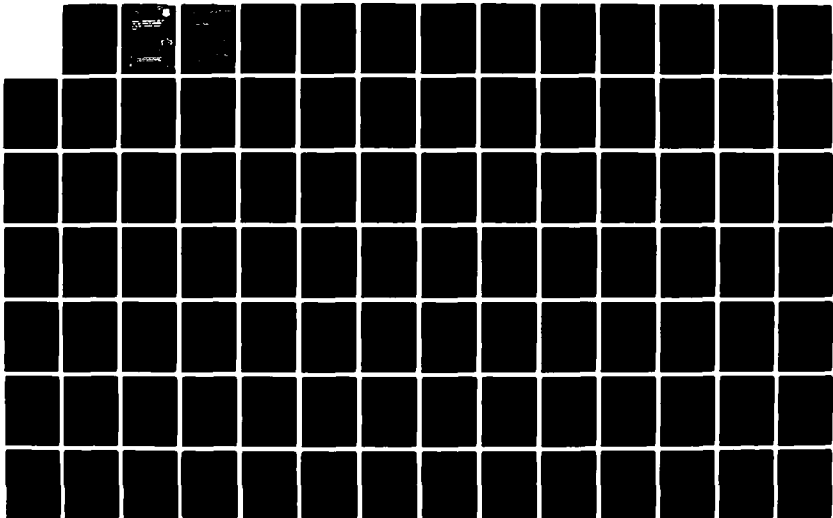

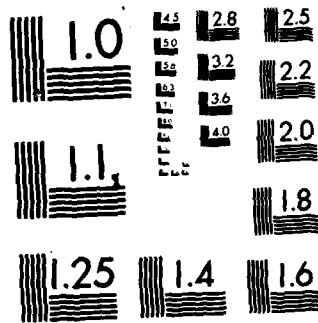

MICROCOPY RESOLUTION TEST CHART
NATIONAL BUREAU OF STANDARDS-1963-A

ADA I 29590

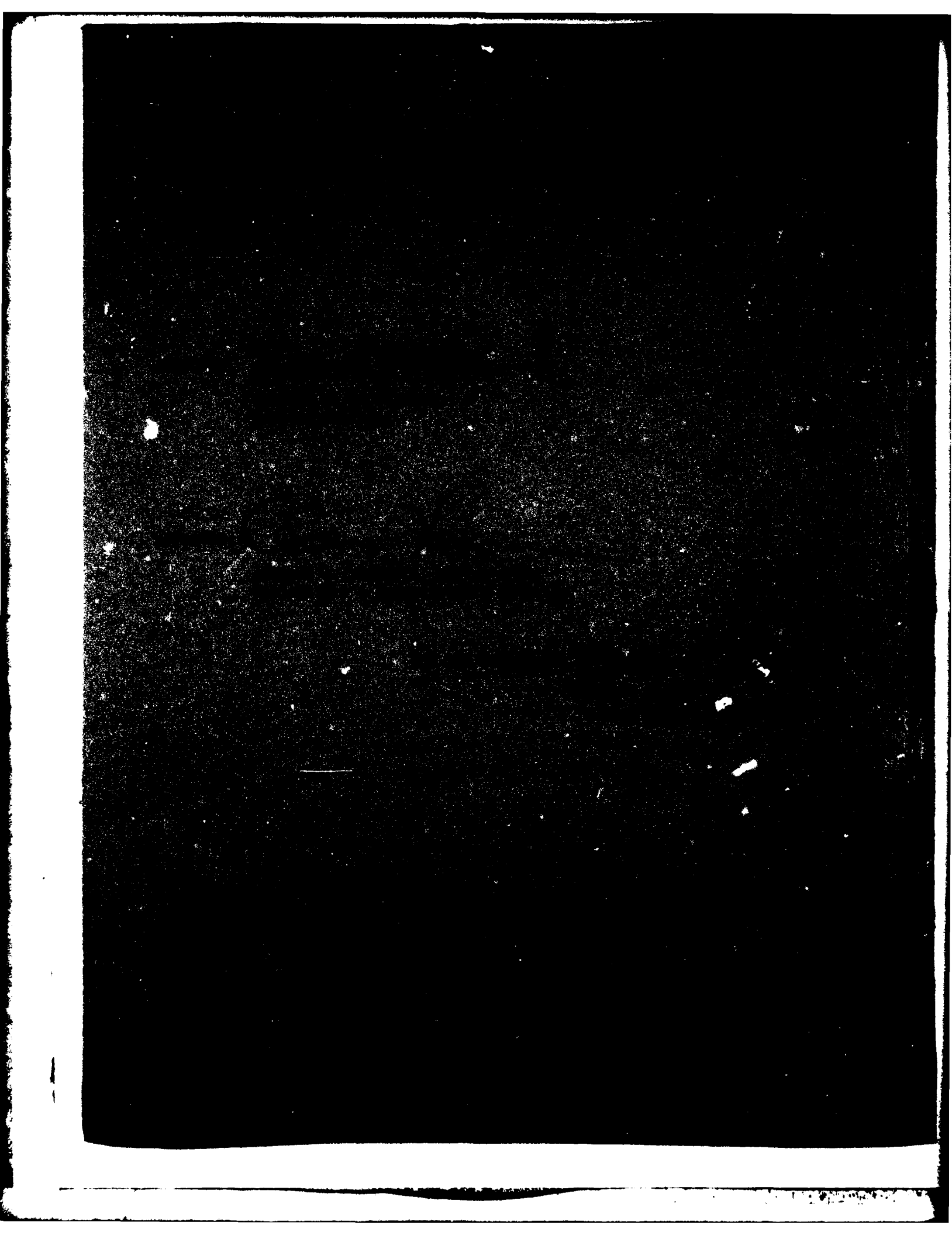

UNCLASSIFIED

SECURITY CLASSIFICATION OF THIS PAGE (When Data Entered)

REPORT DOCUMENTATION PAGE		READ INSTRUCTIONS BEFORE COMPLETING FORM
1. REPORT NUMBER	2. GOVT ACCESSION NO.	3. RECIPIENT'S CATALOG NUMBER
RADC-TR-83-29 Vol I (of two)	AD-A129 596	596
4. TITLE (and Subtitle)		5. TYPE OF REPORT & PERIOD COVERED
RELIABILITY, MAINTAINABILITY, AND LIFE CYCLE COST EFFECTS OF COMMERCIAL OFF-THE SHELF EQUIPMENT - Technical Results		Final Technical Report 15 Sep 80 - 15 Sep 81
		6. PERFORMING ORG. REPORT NUMBER
		N/A
7. AUTHOR(s)		8. CONTRACT OR GRANT NUMBER(s)
Norbert E. Schmidt J.G. Vecellio		F30602-80-C-0306
9. PERFORMING ORGANIZATION NAME AND ADDRESS		10. PROGRAM ELEMENT, PROJECT, TASK AREA & WORK UNIT NUMBERS
Rockwell International Corporation Collins Government Avionics Corporation Cedar Rapids, IA 52406		62702F 23380244
11. CONTROLLING OFFICE NAME AND ADDRESS		12. REPORT DATE
Rome Air Development Center (RBER) Griffiss AFB NY 13441		February 1983
		13. NUMBER OF PAGES
		212
14. MONITORING AGENCY NAME & ADDRESS (if different from Controlling Office)		15. SECURITY CLASS. (of this report)
Same		UNCLASSIFIED
		15a. DECLASSIFICATION/DOWNGRADING SCHEDULE
		N/A
16. DISTRIBUTION STATEMENT (of this Report)		
Approved for public release; distribution unlimited		
17. DISTRIBUTION STATEMENT (of the abstract entered in Block 20, if different from Report)		
Same		
18. SUPPLEMENTARY NOTES		
RADC Project Engineer: Preston R. MacDiarmid (RBER)		
19. KEY WORDS (Continue on reverse side if necessary and identify by block number)		
Electronic Equipment	Environmental Effects	
Life Cycle Cost		
Acquisition Strategy		
Program Management		
20. ABSTRACT (Continue on reverse side if necessary and identify by block number)		
→ The report documents the results of a study to determine the effects of using commercial off-the-shelf electronic equipment in a military environment. A key element of confusion in applying commercial technology is understanding what design criteria is a part of such terms as "best commercial practices," etc. The report clarifies how this term and other common ones relate to "militarized." The choice of a militarized vs. commercial approach must be done on a case-by-case basis. Therefore, (over) 806		

CMH

UNCLASSIFIED

SECURITY CLASSIFICATION OF THIS PAGE(When Data Entered)

rather than firm acquisition strategy being given for all cases, an analytical procedure is presented that may be applied for each unique acquisition situation. Key to making the best decision is the determination of the appropriate weighting for the operational factors necessary for program success as well as the relative weighting of cost and risk. The results indicate that there is merit in considering the use of "best commercial practices" in "ground fixed" and airborne inhabited transport environments, but it is unlikely that they can be applied successfully in "airborne inhabited fighter" applications. Regardless of the choice of acquisition strategy, use of the guideline technique formalizes management consideration of all factors contributing to the strategy decision and identifies areas of potential risk reduction.



UNCLASSIFIED

SECURITY CLASSIFICATION OF THIS PAGE(When Data Entered)

EVALUATION

1. The objective of this study was to develop guidelines indicating the most advantageous class of equipment, militarized or commercial off-the-shelf, for a given military environment. The guidelines were to define for a Program Manager the advantages/disadvantages of each class in terms of reliability, maintainability, cost, risk and other pertinent factors. Precautionary steps that a Program Manager should take to minimize the risks and disadvantages of each class of equipment were to be pointed out for each of the given environments.

2. The objectives have been achieved in a broad sense. Although clearcut decision guidelines could not be developed for all acquisition situations, a procedure tailorable for each unique acquisition situation was formulated. The procedure serves as a guideline in the decision process by forcing the Program Manager to address the risk of achieving success with respect to a variety of program variables. The procedure enables trading off risk against cost and identifies elements for further risk reduction. Terms such as "best commercial practices," "ruggedized" and "militarized" are clarified in terms of how they compare with respect to a series of design disciplines.

3. Use of the procedure introduced will provide a more rigorous process for acquisition decision making. Use of a team of experts in risk quantification is recommended. Clarification of commonly used design descriptions aids the Program Manager in further understanding the risks and payoffs of a particular acquisition decision.

PR MacDiarmid

PRESTON R. MACDIARMID
PROJECT ENGINEER



Accession For	
NTIS GRA&I	<input checked="" type="checkbox"/>
DTIC TAB	<input type="checkbox"/>
Unannounced	<input type="checkbox"/>
Justification	
By _____	
Distribution/	
Availability Codes	
Dist	Avail and/or Special
A	

VOLUME I
TABLE OF CONTENTS

<u>PARAGRAPH</u>	<u>SUBJECT</u>	<u>PAGE</u>
Section A	Acquisition Strategy Guidelines	
Section B	Study Results	
1.0	Objective	1-1
1.1	Scope	1-1
1.2	Background	1-1
2.0	Summary and Conclusions	2-1
3.0	Industrial Survey	3-1
4.0	Design Practice Definitions	4-1
4.1	Good Commercial Practices	4-1
4.2	Best Commercial Practices	4-1
4.3	Ruggedized	4-1
4.4	Militarized	4-2
5.0	<i>Development of Guidelines</i>	5-1
5.1	Initial Approach	5-2
5.2	Revised Approach	5-3
5.2.1	Operational Factor Assessment	5-8
5.3	Acquisition Strategy	5-13
5.4	Risk Assessment	5-13
6.0	Selection of Equipment	6-1
6.1	Equipment Descriptions	6-3
6.1.1	Ground Fixed Environment	6-3
6.1.1.1	Communication Types	6-3

VOLUME I

TABLE OF CONTENTS

<u>PARAGRAPH</u>	<u>SUBJECT</u>	<u>PAGE</u>
6.1.1.2	Data Processing Types	6-5
6.1.1.3	Data Processing Peripheral Types	6-7
6.1.2	Airborne Inhabited Transport/Fighter	6-7
6.1.2.1	Communication Types	6-7
6.1.2.2	Data Processor Types	6-9
6.1.2.3	Data Processor Peripheral Types	6-13
7.0	LCC Analysis	7-1
7.1	LCC Approach	7-1
7.2	LCC Results	7-1
7.3	LCC Analysis Input Data	7-21
7.3.1	Standard Logistics Parameter	7-32
7.3.2	Operational Parameters	7-40
8.0	Acquisition Strategy Comparison Example	8-1

VOLUME I

LIST OF FIGURES

<u>FIGURE</u>	<u>TITLE</u>	<u>PAGE</u>
2.1	Recommended Acquisition Strategy Matrix	2-2
2.2	Acquisition Strategy Analysis Flow	2-5
6.1	RT-980/GRC-171 Radio Receiver-Transmitter	6-4
6.2	618M-1C Radio Receiver-Transmitter	6-4
6.3	FPS-77V Radar Meteorological Set	6-6
6.4	FPS-103 Weather Tracking Radar System	6-6
6.5	GSH-34 Sound Data Recorder/Reproducer	6-8
6.6	VR-3700 Signal Data Recorder/REproducer	6-8
6.7	RT-967/ARC-109(V) Receiver-Transmitter	6-8
6.8	C-5A Autopilot Computers	6-10
6.9	F-15A/B Autopilot Computers	6-10
6.10	KC-135 Autopilot Computers	6-11
6.11	C-5A Flight Instruments	6-14
6.12	F15A/B Flight Instruments	6-15
6.13	KC-135 Flight Instruments	6-16
7.1	DO-56 6 Log Example	7-22
7.2	DO-56 14 Log Example	7-24
7.3	AF 66-1 Data - Aircraft Quantity	7-25
7.4	DO-56 Part I Example	7-26

VOLUME I

LIST OF FIGURES

<u>FIGURE</u>	<u>TITLE</u>	<u>PAGE</u>
7.5	DO-56 5 Log Part II	7-28
7.6	DO-56 5 Log Part III	7-30
7.7	KO-51 Example	7-33

VOLUME I
LIST OF TABLES

<u>TABLE</u>	<u>TITLE</u>	<u>PAGE</u>
1.1	Selected Equipment For Study	1-2
3.1	Summary of Industrial Survey Results	3-2
4.1	Good Commercial Practice	4-3
4.2	Best Commercial Practice	4-5
4.3	Ruggedized	4-9
4.4	Militarized	4-13
5.1	Operational Factors	5-1
5.2	LCC Data and Results	5-5
5.3	Ground Fixed Environment	5-9
5.4	Airborne Inhabited Transport Environment	5-10
5.5	Airborne Inhabited Fighter Environment	5-11
5.6	Recommended Acquisition Strategy Matrix	5-14
5.7	Risk Assessment Example	5-15
6.1	Selected Equipment For Study	6-2
7.1	Order of LCC Results	7-2
7.2	GR-171 Receiver-Transmitter	7-3
7.3	FPS-77V Weather Radar	7-4
7.4	GSH-34 Recorder/Reproducer	7-5
7.5	618M-1C Receiver-Transmitter	7-6
7.6	FPS-103 Radar System	7-7
7.7	VR-3700 Recorder/Reproducer	7-8
7.8	ARC-109 VHF R/T	7-9

VOLUME I

LIST OF TABLES

<u>TABLE</u>	<u>TITLE</u>	<u>PAGE</u>
7.9	ASW-28 Roll/Pitch Computer	7-10
7.10	C-5A Aircraft HSI/ADI	7-11
7.11	618M-1C Receiver-Transmitter	7-12
7.12	562R1E/P1E1 Roll/Pitch Computer	7-13
7.13	331A-6P/329B-8G HSI/ADI	7-14
7.14	ARC-109 RT-967 Transceiver	7-15
7.15	CP-1104/1105 Pitch/Roll Computer	7-16
7.16	ARV-39A/AJN-18 ADI/HSI	7-17
7.17	ARC-109 RT-967 Transceiver	7-18
7.18	CP-1104/1105 Pitch/Roll Computer	7.19
7.19	ARV-39/AJN-18 ADI/HSI	7.20
7.20	Equipment Manuals	7-35
7.21	Standard Cost Factors	7-37
7.22	Logistic Factors	7-38
7.23	Contractor Data	7-39
7.24	Hardware Definition Parameters	7-41
7.25	Support Equipment Parameters	7-42
8.1	Operating Factor Weighting	8-3
8.2	Operational Risk Assessment	8-4
8.3	LCC Comparison	8-4
8.4	Recommended Strategy Example	8-5

SECTION A
MILITARY VS COMMERCIAL OFF-THE-SHELF
ACQUISITION STRATEGY GUIDELINES

ACQUISITION STRATEGY GUIDELINES

TABLE OF CONTENTS

<u>SECTION</u>	<u>SUBJECT</u>	<u>PAGE</u>
1.	INTRODUCTION	1
1.A	OBJECTIVE	1
1.B	SUMMARY	1
2.	ACQUISITION STRATEGY	5
2.A	DECISION MILESTONES	5
2.B	DOCUMENTATION REQUIREMENTS	5
2.C	SYSTEM REQUIREMENTS	6
2.C.1	Military Design Candidate	6
2.C.2	Commercial Off-The-Shelf Candidate	7
3.	ANALYSES	8
3.A	SELECT OPERATIONAL FACTORS	8
3.B	MILITARY DESIGN CANDIDATE ANALYSES	8
3.B.1	Risk Assessment	8
3.B.1.a	Weighting Factor Assignment	10
3.B.1.b	Risk Factor Assignment	12
3.B.1.c	Risk Measure Determination	15
3.B.2	Life Cycle Cost (LCC) Analyses	16
3.B.2.a	Reliability and Maintainability Parameters	17
3.B.2.b	Operational & Maintenance (O&M) Costs	18
3.B.2.c	Acquisition Cost Impact	18
3.B.2.d	Development Cost Impact	19
3.B.3	Advantage Indicator Development	20
3.B.3.a	Normalization of LCC	20
3.B.3.b	Combine LCC Value and Risk Measure	20
3.C	COMMERCIAL OFF-THE-SHELF CANDIDATE ANALYSES	21
3.C.1	Risk Assessment	21
3.C.1.a	Weighting Factors Assignment	21
3.C.1.b	Risk Factor Assignment	21
3.C.1.c	Risk Measure Determination	23
3.C.2	Life Cycle Cost (LCC) Analyses	23
3.C.2.a	Reliability & Maintainability Considerations	24
3.C.2.b	Operational & Maintenance (O&M) Costs	24
3.C.2.c	Acquisition Cost Impact	25
3.C.2.d	Development Cost Impact	28
3.C.3	Advantage Indicator Development	28
3.C.3.a	Normalization of LCC	28
3.C.3.b	Advantage Indicator Comparison	28
4	CONCLUSION	29

ACQUISITION STRATEGY GUIDELINES

TABLE OF CONTENTS (Continued)

<u>TABLE</u>	<u>SUBJECT</u>	<u>PAGE</u>
3.1	Operational Factors	9
3.2	Relative Weighting Factors	11
3.3	Military Candidate Risk Factors	14
3.4	Commercial Candidate Risk Factors	22
3.5	Most Likely O & M Cost Factors Requiring Change	26
3.6	Most Likely Acquisition Cost Factors Requiring Change	27

FIGURES

<u>FIGURE</u>	<u>SUBJECT</u>	<u>PAGE</u>
1.1	Design Acquisition Strategy Analysis Flow	3

APPENDICES

APPENDIX A	Procurement Strategy Analysis Example	A1-1 - A1-11
APPENDIX B	LCC-2 Analysis Factors - Section 1 - O & M Cost LCC-2 Analysis Factors Standard Logistics Parameters Operational Parameters	B1-1 B1-2
	Section 2 - Acquisition Cost LCC-2 Analysis Factors Standard Logistics Parameters Operational Parameters	B2-1 B2-2

ACQUISITION STRATEGY GUIDELINES

APPENDICES (Continued)

APPENDIX C

Equipment Design Practice Definition
Summary

C1-1 - C1-8

1. INTRODUCTION

A. OBJECTIVE

The increasing cost of developing and producing systems for utilization by the Air Force has prompted the DOD to investigate alternate procurement policies to reduce these costs. An alternative policy highlighted in DOD directive 5000.37 encourages procurement of commercial-off-the-shelf systems that satisfy the users needs. However, in order to utilize this alternative policy, the program manager must have a technique to allow an intensive comparison to be made between the military design candidate and its commercial-off-the-shelf counterpart.

This technique was developed under contract F30602-80-C-0306 performed by Collins Air Transport Division of Rockwell International for the Rome Air Development Center and was documented as a final technical report.

The section that follows is intended to provide a guideline, based on the technical report detail, for comparison of a military design vs. a commercial off-the-shelf system procurement. The end result of utilizing the guidelines is a quantified pair of advantage indicators (AI's) that, when compared, indicate a preferred procurement strategy.

B. SUMMARY

The procurement strategy developed using the guideline is the result of systematically comparing the military design candidate with the proposed commercial-off-the-shelf candidate. The primary attributes

1. B. SUMMARY (Continued)

that must be compared to determine the strategy are: (1) compliance with the DOD acquisition directive 5000.1 documentation, (2) weighting factor selection for the 20 operational parameters, (3) risk assessment to quantify the risk elements, and (4) life-cycle cost (LCC) analyses to quantify the cost elements. If the commercial-off-the-shelf candidate cannot satisfy the intent of the major system acquisition documentation, it is not a viable alternative and the military design candidate must be the procurement strategy selected. However, if the acquisition decision documentation is satisfied, the analyses as described in items (2) thru (4) above should be completed for each candidate. Key elements of the risk assessment are: assigning weighting factors for the applicable operational parameters; assigning risk factors on a scale of 1 to 10 based on program requirements; and determining risk measures for the candidate systems. The LCC analysis must include operational maintenance (O/M), acquisition and development costs. Since reliability and maintainability are prime drivers of the O/M cost element, emphasis must be placed on determination of these parameters. The results of the risk assessment and the normalized LCC analyses are then combined to yield an advantage indicator (AI) for each of the candidate systems. These AI's are quantitative and are a single value result of each candidate system analysis. The AI's are then compared, with the lowest AI representing that candidate selected for the indicated procurement strategy.

Figure 1-1 represents the procurement strategy analysis flow described in the prior paragraphs. Each military vs. commercial

FIGURE 1.1 DESIGN ACQUISITION STRATEGY ANALYSIS FLOW

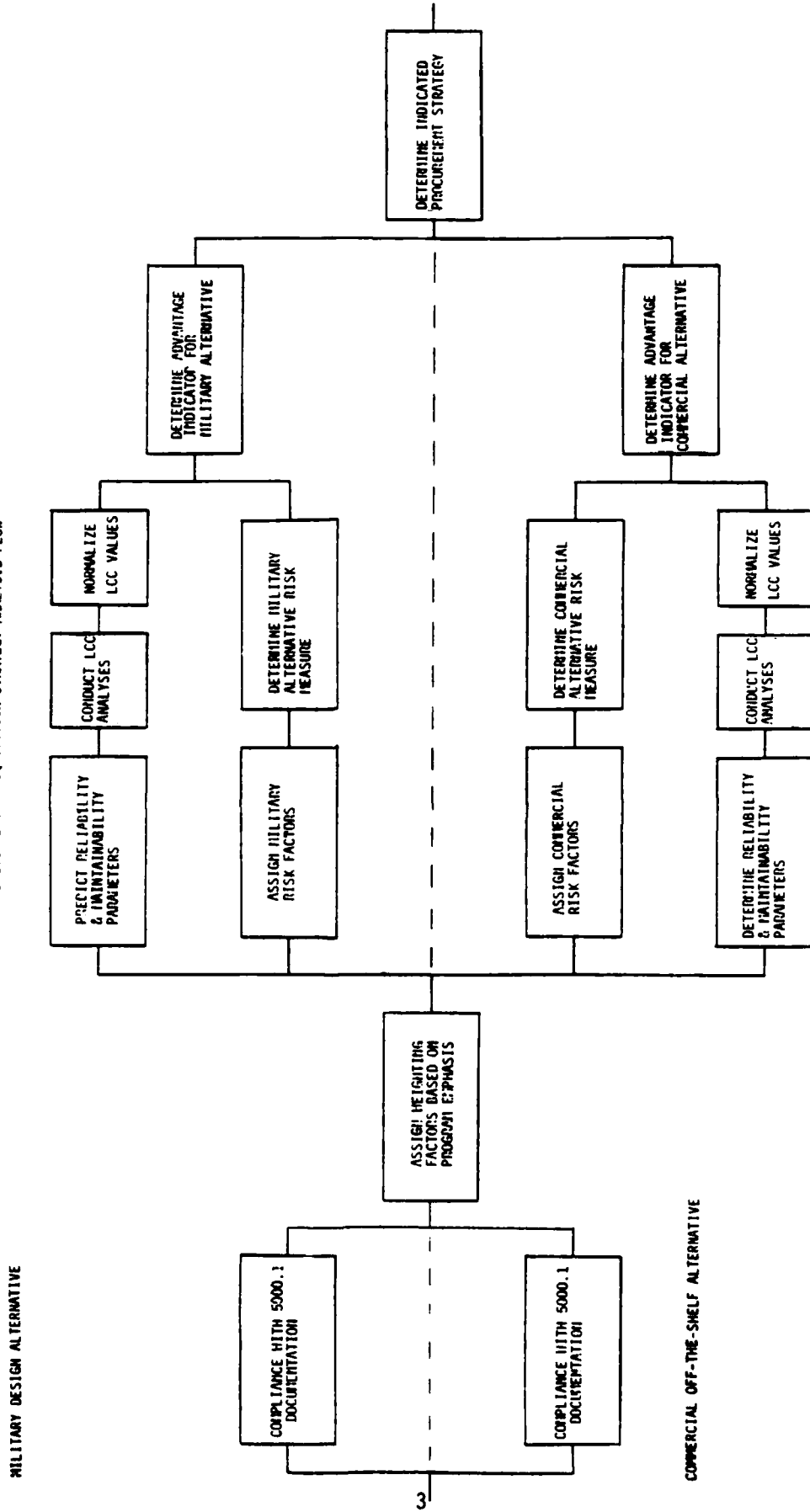

MILITARY DESIGN ALTERNATIVE

COMMERCIAL OFF-THE-SHELF ALTERNATIVE

1. B. SUMMARY (Continued)

system procurement is unique and as such this guideline should be consulted for each strategy determination. The remainder of the guideline will expand upon each step in the technique providing insight for the program manager in developing a military vs. commercial off-the-shelf procurement strategy. An example is included in Section A, Appendix A to foster better understanding and to provide additional insight into the procedure.

2. ACQUISITION STRATEGY

DOD directive 5000.1 defines the policies and procedures to be followed regarding major system acquisitions.

A. DECISION MILESTONES

Several key decision points defined in this policy are: (A) program initiation (Milestone 0); (B) demonstration and validation (Milestone I); (C) full-scale development (FSD) (Milestone II); and (D) production and deployment (Milestone III).

B. DOCUMENTATION REQUIREMENTS

Documentation must be provided by DOD personnel for DSARC (Defense Systems Acquisition Review Council) review in support of the decision process. Key documentation elements that must be prepared are: (1) the Mission Element Needs Statement (MENS); (2) the System Concept Paper (SCP), and (3) the Decision Coordinating Paper (DCP). The MENS, which is prepared for the Milestone 0 decision point, describes major system deficiencies in meeting mission requirements which a new system acquisition will correct. Dependent upon the nature of the threat as defined in the MENS, a commercial off-the-shelf system may be available to satisfy the intent of the MENS.

The SCP is prepared for the Milestone I decision point. Prime elements of the SCP are: (1) identification of program alternatives based on initial design concept analyses; and (2) alternative acquisition strategy determination. Viable commercial off-the-shelf candidates need to be identified at this point in the acquisition

2. B. DOCUMENTATION REQUIREMENTS (Continued)

decision process. This guideline should be utilized primarily to support the Milestone II (FSD approval) decision process. Preparation of the DCP, which is required for the Milestone III decision, can be accomplished more easily with the implementation of this guideline's systematic procedure. The Life Cycle Cost (LCC) analyses described in later sections of this guideline are necessary requirements of the formal DCP. Thus, a detailed LCC analysis must be conducted to indicate a preferred procurement strategy, which is consistent with formal DSARC documentation requirements. The risk assessment described in the guideline augments the DCP LCC analyses.

C. SYSTEM REQUIREMENTS

The system requirements evolve prior to the Milestone II decision. Broad system requirements such as system type, operational environment, and prospective host vehicles are defined in the MENS and the SCP. However, typically the hardware specification requirements are not defined until the beginning of the demonstration and validation phase. The initial step in the determination of the procurement strategy is to compare the features of the two procurement candidates with the system requirements.

1. Military Design Candidate

In the case of the military design candidates, the comparison should yield exact compliance since the system conceptual design would have been based on the MENS, SCP, and the preliminary hardware specification requirements.

2. C. 2. Commercial Off-The-Shelf Candidate

Since the commercial candidate is existing hardware, its comparison to system requirements may yield varied results. For example, comparison to the MENS and SCP may result in the realization that there is no applicable commercial off-the-shelf system available. This conclusion will result in the military design candidate being the indicated procurement strategy. On the other hand, even if the commercial candidate satisfies the intent of the MENS and SCP, a comparison with the detailed system specification still may prohibit the availability of any viable commercial candidate. For example, an anti-jamming requirement for a combat communication system very likely would eliminate the commercial off-the-shelf equipment. However, if a commercial off-the-shelf candidate is available, then alternate procurement strategies must be evaluated. This guideline provides the program manager with a technique to select the better procurement strategy.

3. ANALYSES

After the military design and commercial off-the-shelf candidates have been selected, the program manager is ready to conduct the required analyses to obtain an indicated procurement strategy. To summarize, these analyses consist of: (1) operational factor selection; (2) risk assessment for the two candidates; (3) life-cycle cost studies for the candidates; (4) advantage indicator (AI) development for the candidates; and (5) candidate advantage indicator comparison.

A. SELECT OPERATIONAL FACTORS

The operational factors define those mission and/or program variables that are important for the deficiency described in the MENS. The key operational factors considered in the Rockwell-Collins study are listed in Table 3.1. It is recommended that all 20 operational parameters listed in Table 3.1 be used by the program manager. The relative importance of these factors for the parameter operational mission scenario under consideration can be varied by adjusting the weighting factors discussed in the next paragraph. Additional operational factors deemed important by the program manager may be included in the analyses at this step.

B. MILITARY DESIGN CANDIDATE ANALYSES

1. Risk Assessment

At this point in the procurement strategy development, the program manager has a list of the key operational factors. These factors are program sensitive and will be applicable for the military design candidate and the commercial off-the-shelf candidate.

TABLE 3.1
OPERATIONAL FACTORS

Procurement Schedule	Configuration Management
Reliability	Guarantees and Warranties
Maintainability	Non-Standard Parts
Personnel Safety	Special Handling
Personnel Training	QA Test and Inspection
Technical Publications	Combat Readiness
Spares Provisioning	Input Power
Parts Quality	EMC
Part Availability	Data Rights
Interchangeability (i.e. LRU's, SRU's, piece parts)	Small Business

3. B. 1. Risk Assessment (Continued)

A risk assessment for the military design candidate must be conducted to quantify the operational factor risk contribution to the advantage indicator.

a. Weighting Factor Assignment

A relative weighting factor must be assigned by the program manager for each of the operational factors chosen. The selection of these weighting factors should be based on specific program emphasis. Each operational factor must be given a weighting factor relative to the others so that the sum is 100. The median value for the twenty weighting factors is 5; the maximum range is 0-100; and the expected range (dispersion) is 0-20. A weighting factor of 0 is equivalent to eliminating the operational factor from contribution to program risk. Recommended values of the relative weighting factors for the three operational environments are listed in Table 3.2. These recommended values were compiled based on the contractors analysis of the data utilized in the study. These values were generated based on the assumption that all three environments were being evaluated as part of the same mission definition. If the program manager feels that a particular operating factor should receive further emphasis for his program, then some of the other

TABLE 3.2
RELATIVE WEIGHING FACTORS

<u>OPERATIONAL FACTOR</u>	<u>OPERATIONAL ENVIRONMENT*</u>		
	<u>AIRBORNE FIGHTER</u>	<u>AIRBORNE TRANSPORT</u>	<u>GROUND FIXED</u>
Procurement Schedule	10	10	10
Reliability	10	10	10
Maintainability	10	10	10
Personnel Safety	7	7	7
Personnel Training	7	7	7
Technical Publications	8	8	8
Spares Provisioning	7	7	7
Parts Quality	5	5	5
Part Availability	2	2	2
Interchangeability	5	5	5
Configuration Management	7	7	7
Guarantees and Warranties	1	1	1
Non-Std. Parts	5	5	5
Special Handling	1	1	1
QA Test and Inspection	8	8	8
Combat Readiness	2	2	2
Input Power	1	1	1
EMC	2	2	2
Data Rights	1	1	1
Small Business	<u>1</u>	<u>1</u>	<u>1</u>
	$\Sigma = 100$	$\Sigma = 100$	$\Sigma = 100$

*No variation because they are program related rather than environment sensitive.

3. B. 1. a. Weighting Factor Assignment (Continued)

weighting factor values must be reduced to satisfy the constraint requiring a sum of 100. For example, if parts quality were to be emphasized to attain a higher degree of producibility because of less part variations, then increasing the relative weight from the recommended value of 5 to 8 would require a reduction of 3 points in the remaining 19 parameters.

b. Risk Factor Assignment

The next step in the analysis technique is establishing a risk factor for each of the operational factors that were selected for this procurement. Although it is the program manager's responsibility to determine these factors, assistance from several areas of expertise is recommended. The risk assessment described herein is based on the Delphi-technique and as such, the competence of the panel of experts will greatly influence the decision. The areas of expertise represented should be sufficient to cover those operational factors that were assigned high weighting factors.

The risk factor quantifies the probability of the candidate meeting the operational parameter requirements. A set of risk factors was defined as a result of the study conducted by Rockwell-Collins. These factors for the military design candidates are contained in Table

3. B. 1. b. Risk Factor Assignment (Continued)

3.3. The absolute range of these risk factors is 1-10. The value 1 represents the minimum risk whereas the value 10 represents the maximum risk. The table shows the expected range for the three operational environments and the recommended value shown in parentheses.

These values are based on analysis of data from the study contract. The recommended value occurred most frequently in the data; whereas, the expected range represents the end points of the data.

For the military candidate risk assessment, the recommended values should be used as a starting point for the risk factor determination. The range of expected values (i.e. 6-10 for Procurement Schedules) can be used by the program manager to conduct sensitivity analyses. The program manager can adjust these factors based on prior procurement program knowledge. For the military design candidate, the knowledge may be in the form of: (1) direct information from the prospective contractor for the system procurement under consideration; (2) past performance of the prospective contractor; or (3) internal DOD expertise.

In order to better understand the rationale for selecting risk factors within the range, consider the reliability operational parameter as an example. Even though the

TABLE 3.3
MILITARY CANDIDATE RISK FACTORS

<u>OPERATIONAL FACTOR</u>	<u>OPERATIONAL ENVIRONMENT</u>		
	<u>AIRBORNE FIGHTER</u>	<u>AIRBORNE TRANSPORT</u>	<u>GROUND FIXED</u>
Procurement Schedule	6-10 (10)	6-10 (10)	6-10 (10)
Reliability	3-9 (8)	2-8 (8)	1-4 (2)
Maintainability	3-6 (5)	3-6 (5)	1-4 (2)
Personnel Safety	2-6 (5)	2-6 (5)	1-3 (1)
Personnel Training	2-5 (3)	2-5 (3)	2-5 (3)
Technical Publications	2-4 (3)	2-4 (3)	2-5 (3)
Spares Provisioning	1-4 (4)	1-4 (4)	1-4 (4)
Parts Quality	1-4 (2)	1-4 (2)	1-4 (2)
Part Availability	2-5 (5)	2-5 (5)	2-5 (5)
Interchangeability	2-5 (2)	2-5 (2)	1-5 (2)
Configuration Management	1-5 (3)	1-3 (3)	1-3 (3)
Guarantees and Warranties	1-3 (1)	1-5 (1)	1-5 (1)
Non-Std. Parts	1-5 (1)	1-3 (1)	1-3 (1)
Special Handling	1-3 (1)	1-3 (1)	1-3 (1)
QA Test and Inspection	1-5 (3)	1-5 (3)	1-5 (3)
Combat Readiness	1-5 (1)	1-3 (1)	1-3 (2)
Input Power	1-3 (1)	1-3 (1)	1-3 (1)
EMC	1-3 (2)	1-3 (2)	1-3 (1)
Data Rights	1-3 (1)	1-3 (1)	1-3 (1)
Small Business	1-3 (1)	1-3 (1)	1-3 (1)

Note: Recommended Values in Parenthesis.

3. 8. 1. b. Risk Factor Assignment (Continued)

military candidate will be designed with the established reliability requirement in mind, there is a significant risk that the requirement will be met, depending upon the stringency of the operational environment requirement. For example, if the prospective contractor has historically demonstrated the capability of achieving required reliability performance, then the risk value should be adjusted toward the lower end of the range (3-5). Similarly, based on equipment type, processor systems have better demonstrated reliability than their corresponding peripherals. This situation would also warrant a reduction of the risk factor toward the lower end of the range. Conversely, if prospective contractor demonstrated reliability performance is unacceptable or the system requirement is unrealistic, then the risk factor should be set equal to 10.

c. Risk Measure Determination

The product of the risk factor and the weighting factor represent a quantified risk measure. A quantitative risk measure is calculated for each operational factor. The sum of these products represents the total risk measure.

After the risk measures have been determined for each operational factor, the program manager should note those with the highest risk measures. The risk measures for

3. B. 1. c. Risk Measure Determination (Continued)

these operational factors would be prime candidates for further sensitivity analyses. The total risk measure, which is the sum of the individual operational factor risk measures, represents the quantified risk that the military design candidate will comply with the operational parameter requirements in fulfilling the mission.

3. B. 2. Life Cycle Cost (LCC) Analyses

The risk assessment quantified the risk associated with the pertinent operational parameters for the military design candidate. The next step in the analysis process is to quantify the total or life cycle cost for the candidate. As stated in Section 2, LCC analyses are an integral part of the Decision Coordination Paper required for the Milestone II decision point or FSD approval. Thus, the data necessary for the LCC analyses used to develop the procurement strategy should be available to the program manager.

The life-cycle analysis (LCC) should include: (1) operational and maintenance (O & M) costs; (2) acquisition costs; and (3) development costs. The O & M costs include: maintenance costs for the system hardware and required support equipment; logistics costs for inventory management (i.e. data and hardware) and repair cycle transportation. The acquisition costs include: production hardware costs for system components, necessary support equipment, and required spares; system installation

3. B. 2. Life Cycle Cost (LCC) Analyses (Continued)

costs; initial training and data (i.e. acquisition and management) costs; and inventory item entry costs. Development costs are incurred prior to initial production of the system. These costs should be included in the LCC analysis, where applicable. The LCC candidate analysis should be conducted for the expected operational life, which is typically 10 years.

Although any LCC model may be used to conduct the analyses, it is recommended that the Air Force accepted LCC-2A model be used. LCC-2A is a life cycle cost analysis program developed to evaluate the combined costs of acquiring modern systems and supporting them over their operational life. Cost comparisons can be used in the selection of appropriate hardware alternatives as well as in the evaluation of various maintenance philosophies.

This model was chosen because of the Air Force familiarity and confidence in the model due to frequent use in source selection (ARC-186, Standard Navigator, etc.), flexibility in modeling various hardware configurations and support concepts, ease of use, and the output detail.

a. Reliability and Maintainability Parameters

Since the reliability and maintainability parameters are prime drivers in the determination of the O & M costs, the program manager must emphasize the necessity of

3. B. 2. a. Reliability and Maintainability Parameters (Continued)

obtaining high confidence level values. In the military design alternative, these parameters are requirements established in the System Concept Paper (SCP).

b. Operational & Maintenance (O & M) Costs

In general, the O & M costs account for the largest portion of the system total life cycle cost. Several logistics and operation factors must be acquired to utilize the LCC-2A model. A list of these factors is contained in Section 1 of Appendix B. This list is included to acquaint the program manager with the required analysis data. It is not the intent of this guideline to provide a treatise on LCC. These parameters, since they are required for DSARC LCC analyses, should be available to the program manager for the military design alternative. The program manager should rely on DOD LCC specialists to conduct or review the analysis.

c. Acquisition Cost Impact

The acquisition cost element is the next major cost segment of the system life cycle cost. This cost primarily consists of the prime and spare operational hardware and the support equipment. The elements required to conduct the LCC analysis of the acquisition cost are contained in Section 2 of Appendix B. For the military design alternative, estimates for these

3. B. 2. c. Acquisition Cost Impact (Continued)

parameters should be available to the program manager. The analyses should be conducted or reviewed by DOD LCC specialists.

d. Development Cost Impact

Development costs, although typically the smallest segment of the LCC, should be included in the analysis. For the military design candidate these costs should represent the expenses borne directly by the Government for the development of a specific product. Cost data for systems similar to the military candidate under consideration can be obtained by the program manager from Government records of either contracts awarded for development or proposals solicited for development. The program manager should consult the Directorate of Procurement to obtain these costs. If cost data is not available from these sources, then a nominal 15% of total LCC could be used for the development costs. The figure is based on DOD studies of electronic system acquisitions.¹

Total LCC is the sum of the O & M, acquisition, and development costs.

¹O'Donahue, Jr. R.F., Design to Cost presentation, American Institute of Industrial Engineers Symposium (February, 1977).

3. B. 3. Advantage Indicator Development

a. Normalization of LCC

Since the number of systems deployed will be identical for the candidates, normalization may not be required. Differences in complexity will be reflected in the reliability, maintainability, and LCC measures. The LCC should be represented on an operating or flight hour basis; thus, the unit of measure would be dollars per operating hour or dollars per flight hour. Operating hours should be used for ground-based systems and flight hours for airborne systems.

For the study contract, normalization was required because different communication, processor, and peripheral systems were analyzed for each operational environment. As a result, there were wide differences in complexity (part count) and operational hours (number of deployed systems) for each operational environment.

b. Combine LCC Value and Risk Measure

The next step in the analysis technique is to combine the LCC value and the risk measure. These measures are combined by calculating the product of the LCC value and the risk measure. This result is termed an "advantage indicator". Low advantage indicators represent the preferred candidate considering risk of attaining operational performance and LCC.

3. C. COMMERCIAL OFF-THE-SHELF CANDIDATE ANALYSES

The technique for the analyses of the commercial off-the-shelf candidate parallels that of the military design candidate. The differences lie in the sources of data required to conduct the analyses. The following paragraphs will describe the differences, where appropriate, for the various steps in the analysis technique.

1. Risk Assessment

a. Weighting Factors Assignment

The weighting factors for the operational parameters in the commercial candidate analysis are identical to those for the military candidate since they are based on the same operational scenario.

b. Risk Factor Assignment

The ranges and recommended risk factors for the commercial off-the-shelf candidates are contained in Table 3.4. These values are based on the contractors analysis of the data utilized in the study. The recommended values may be considered as default values and should be used as a starting point. Variations from the initial values must be based on the program manager's knowledge of the commercial system contractor's past system performance history, in general, and specifically, prior success with the candidate system.

TABLE 3.4
COMMERCIAL CANDIDATE RISK FACTORS

<u>OPERATIONAL FACTOR</u>	<u>OPERATIONAL ENVIRONMENT</u>		
	<u>AIRBORNE FIGHTER</u>	<u>AIRBORNE TRANSPORT</u>	<u>GROUND FIXED</u>
Procurement Schedule	1-4 (2)	1-4 (2)	1-4 (2)
Reliability	9-10 (10)	5-7 (5)	1-5 (2)
Maintainability	7-8 (8)	6-8 (8)	1-5 (2)
Personnel Safety	6-7 (7)	4-7 (7)	1-5 (1)
Personnel Training	6-7 (7)	4-6 (5)	4-8 (6)
Technical Publications	5-7 (6)	4-6 (6)	4-9 (5)
Spares Provisioning	5-6 (5)	5-6 (5)	5-8 (5)
Parts Quality	4-8 (4)	4-8 (4)	4-6 (4)
Part Availability	1-5 (1)	1-5 (1)	1-5 (1)
Interchangeability	3-8 (4)	3-8 (4)	3-8 (4)
Configuration Management	5-9 (5)	5-9 (5)	4-9 (5)
Guarantees and Warranties	1-6 (1)	1-6 (1)	1-5 (1)
Non-Std. Parts	3-8 (3)	3-8 (3)	3-7 (3)
Special Handling	1-6 (1)	1-6 (1)	1-4 (3)
QA Test and Inspection	7-8 (8)	6-8 (6)	4-7 (4)
Combat Readiness	1-8 (1)	1-7 (1)	2-5 (2)
Input Power	2-4 (2)	2-5 (2)	1-4 (1)
EMC	7-9 (7)	7-8 (7)	1-7 (1)
Data Rights	7-8 (8)	7-8 (8)	7-9 (8)
Small Business	5-8 (8)	5-8 (8)	3-8 (8)

Note: Recommended Values in Parenthesis.

3. C. 1. b. Risk Factor Assignment (Continued)

The rationale for risk factor variation for the commercial candidate is the same as that for the military design candidate. For example, variation of the factor for procurement schedule would be dependent upon the prospective commercial contractor inventory and production capacity. In general, since the systems are off-the-shelf, the risk of achieving schedule requirements is low (2). However, for those cases where inventory is low, then the program manager would use a value of 4 for the procurement analysis. For those situations where production capacity is marginal, then the upper end of the range (9) should be selected.

c. Risk Measure Determination

The risk measure is the product of the operational parameter weighting factor and the risk factor. The LCC analyses must now be conducted for the commercial candidate so that an advantage indicator, which is required for the indicated procurement strategy, can be determined.

3. C. 2. Life Cycle Cost (LCC) Analyses

In general, the parameters to be used for the commercial candidate LCC analyses will be identical to those utilized in the military candidate analyses; however, their values will be different. Where there is concern regarding the applicability of

3. C. 2. Life Cycle Cost (LCC) Analyses (Continued)

the available commercial data in the LCC analysis, the program manager must reflect his degree of concern via the risk assessment by assigning higher risk factor values for those operational factors.

a. Reliability & Maintainability Considerations

As stated before, since the reliability and maintainability parameters can have a significant impact on the O & M costs, care must be exercised by the program manager in selecting the appropriate values to be used in the LCC analyses. The determination of these values should be a joint effort between the prospective commercial contractor, the DOD reliability and maintainability specialists, and the program manager. Based on the results of this effort, the risk factors used during risk assessment, may require modification for some parameters. The results of the industrial survey indicate that the risk factors assigned for reliability and maintainability are influenced by the prospective usage environment. A higher risk factor applies to airborne-inhabited fighter usage, whereas, a lower risk factor applies to ground-fixed usage.

b. Operational & Maintenance Costs

The LCC analysis procedure for the O & M costs of the commercial off-the-shelf system is identical to the

3. C. 2. b. Operational & Maintenance Costs (Continued)

procedure used for the military candidate. However, different results are obtained because of the hardware factors involved. Referring to Appendix B, Section 1, the factors most likely requiring change are listed in Table 3.5. The prime source for the factors required for this analysis is the prospective commercial equipment contractor. These factors should be reviewed by DOD LCC specialists relying on knowledgeable areas of expertise within DOD as the analysis is conducted. The analyses should be conducted or reviewed by DOD LCC specialists.

c. Acquisition Cost Impact

The acquisition cost element for commercial off-the-shelf equipment will require values for the same set of parameters contained in Appendix B, Section 2. The acquisition cost for the commercial off-the-shelf equipment may be less than its military equipment counterpart because of the economics of scale associated with a commercial product. The larger quantities of total equipment built will generally result in lower material costs because of volume purchases and lower labor costs from accelerated learning curve factors. Acquisition cost factors (Reference Appendix B, Section 2) that may require modification for the commercial candidate analysis are listed in Table 3.6.

TABLE 3.5

MOST LIKELY O & M COST FACTORS REQUIRING CHANGE
(COMMERCIAL OFF-THE-SHELF CANDIDATE)

STANDARD LOGISTICS PARAMETERS

Contractor Data

Pages of Data - Base Level Manuals

Pages of Data - Depot Level Manuals

Pages of Data - Other

OPERATIONAL PARAMETERS

Hardware Definition Parameters

Cost/Spare Unit

Condemnation Probability

Mean Time Between Failure/
Maintenance (Hours)

Level of Failure
Verification

Unverified Failure Probability

Support Equipment
Required to Verify Failure

Weight (Pounds)

Usage Time for
Verification (Hours)

Failure Verification Standard (Hours)

Level of Repair

Repair Labor Standard (Hours)

Support Equipment
Required for Repair

Removal Labor Standard (Hours)

Usage Time for Repair
(Hours)

Not Base Repairable Probability

Number of New Inventory
Items

Support Equipment Parameters

Support Equipment Cost/Set

Support Equipment Operation Maintenance Cost Factor

TABLE 3.6
 MOST LIKELY ACQUISITION COST FACTORS REQUIRING CHANGE
 (COMMERCIAL OFF-THE-SHELF CANDIDATE)

STANDARD LOGISTICS PARAMETERS

Standard Cost Factors

Initial Data Management

Contractor Data

Acquisition Cost/System	Contractor Base Resupply Time - CONUS
Base Level Training Cost	Contractor Base Resupply Time - Overseas
Depot Level Training Cost	Contractor Repair Cycle Time
Data Acquisition Cost - Base Level Manuals	Pages of Data - Base Level Manuals
Data Acquisition Cost - Depot Level Manuals	Pages of Data - Depot Level Manuals
Data Acquisition Cost - Other	Pages of Data - Other
Number of New Inventory Items	

OPERATIONAL PARAMETERS

Hardware Definition Parameters

Cost/Spare Unit

Support Equipment Parameters

Support Equipment Cost/Set

3. C. 2. d. Development Cost Impact

Development costs are a necessary LCC segment of any prospective system being considered for acquisition. However, in the case of the commercial off-the-shelf candidate, commercial funding expended for development of these systems is not borne directly by the Government. As such, the line item for development costs in the commercial system LCC analyses should be zero dollars.

3. C. 3. Advantage Indicator Development

a. Normalization of LCC

Since a direct comparison is being made between the military and commercial candidates using identical operational scenarios, the LCC results for the commercial analysis requires the same normalization as applied to the military design candidate. The recommendation is to represent them on a per flight hour or per operating hour basis.

b. Advantage Indicator Comparison

The final step in the procurement strategy decision technique is comparing the resultant "advantage indicator" for the military design and the commercial off-the-shelf candidates. The candidate with the lowest advantage indicator becomes the indicated procurement strategy.

4. CONCLUSION

Indicated Procurement Strategy

The indicated procurement strategy is a direct result of the advantage indicator comparison. The candidate with the lowest advantage indicator is the system to be procured.

The choice of the most appropriate acquisition strategy must be done on a case-by-case basis. An analytical procedure has been presented that may be applied for each unique acquisition situation. Key to making the best decision is the determination of the appropriate weighting for the operational factors necessary for program success as well as the weighting of the relative importance of cost and risk. The results of the RADC sponsored Rockwell-Collins study indicated that there is merit in considering the use of best commercial practice designs in "ground fixed" and "airborne inhabited transport" environments, but it is unlikely that they can be applied successfully in "airborne inhabited fighter" applications. Regardless of the choice of acquisition strategy, use of the guideline technique formalizes management consideration of all factors contributing to the strategy decision.

SECTION A
ACQUISITION STRATEGY GUIDELINES

APPENDIX A
PROCUREMENT STRATEGY ANALYSIS EXAMPLE

Insight and guidance in the use of the acquisition strategy procedure can best be provided by means of an analysis example. Before the actual analysis can be conducted, a number of assumptions must be made regarding the mission scenario and the constraints on the system acquisition.

The mission scenario for the example acquisition is a deployed group of fighters to provide a strike force against an enemy base with support consisting of transport type aircraft for refueling and countermeasures and the necessary ground equipment required for maintenance.

The mission needs require a new communication subsystem for the fighter aircraft and a data processor for the transport aircraft. The transport will be used as an ECM-type aircraft. The schedule requires that the hardware for each system will be available in a 2 year time period.

The example described in the following paragraphs will be developed for both the airborne-fighter and the airborne-transport environments. Insight into selection of the parameters for the risk assessment will be the primary purpose for the example. The step-by-step procedure defined in the body of the guideline will be followed in the example development.

Before proceeding with the example, it is assumed that a viable commercial candidate exists for the systems. A viable candidate is one that meets the basic intent of the conceptual requirements i.e. size and weight, power output, probable R & M performance, etc.

Following the recommendation of the guideline, all 20 operational parameters will be used for the procurement strategy development. In general, the recommended values for the operational parameter weighting factors will be applied. However, because of the emphasis on the ECM mission for the transport aircraft, the recommended weighting factor value for the EMC parameter will be increased from 2 to 6. In order to satisfy the constraint that the sum of the weighting factors equals 100, other parameters must be reduced by 4.

In the example, spares provisioning and configuration management were reduced because the supply lines are short, providing ready access to parts inventory and the operational life of the system will be limited. The weighting factors for the two environments are shown in Table A-1 for the defined operational scenario.

The next step is to assign risk factors for the military candidate and the commercial candidate. The recommended values and expected range for risk factors based on the Rockwell-Collins study are repeated in the left hand columns of Tables A-2 and A-3. In general, the recommended values for the military candidate should remain the same; however, because of the less stringent reliability and maintainability requirements on the system, the military risks should be reduced to the lower end of the range for both environments.

TABLE A-1
OPERATIONAL PARAMETER WEIGHTING FACTORS

	OPERATIONAL ENVIRONMENT	
	COMMUNICATIONS <u>A/B FIGHTER</u>	DPS <u>A/B TRANSPORT</u>
Procurement Schedule	10	10
Reliability	10	10
Maintainability	10	10
Personnel Safety	7	7
Personnel Training	7	7
Technical Publications	8	8
Spares Provisioning	7	5
Parts Quality	5	5
Part Availability	2	2
Interchangeability	5	5
Configuration Management	7	5
Guarantees and Warranties	1	1
Non-Std. Parts	5	5
Special Handling	1	1
QA Test and Inspection	8	8
Combat Readiness	2	2
Input Power	1	1
EMC	2	6
Data Rights	1	1
Small Business	1	1
	$\Sigma = 100$	$\Sigma = 100$

TABLE A-2
RISK FACTORS (MILITARY CANDIDATES)

<u>OPERATIONAL FACTOR</u>	<u>RECOMMENDED VALUES</u>		<u>MODIFIED VALUES</u>	
	<u>OPERATIONAL ENVIRONMENT</u>		<u>OPERATIONAL ENVIRONMENT</u>	
	<u>A/B FIGHTER</u>	<u>A/B TRANSPORT</u>	<u>A/B FIGHTER</u>	<u>A/B TRANSPORT</u>
Procurement Schedule	10	10	10	10
Reliability	8	8	4	3
Maintainability	5	5	3	3
Personnel Safety	5	5	5	5
Personnel Training	3	3	3	3
Technical Publications	3	3	3	3
Spares Provisioning	4	4	4	4
Parts Quality	2	2	2	2
Part Availability	5	5	5	5
Interchangeability	2	2	2	2
Configuration Management	3	3	3	3
Guarantees and Warranties	1	1	1	1
Non-Std. Parts	1	1	1	1
Special Handling	1	1	1	1

TABLE A-2
 RISK FACTORS (MILITARY CANDIDATES) (CONTINUED)

<u>OPERATIONAL FACTOR</u>	<u>RECOMMENDED VALUES</u>		<u>MODIFIED VALUES</u>	
	<u>OPERATIONAL ENVIRONMENT</u>		<u>OPERATIONAL ENVIRONMENT</u>	
	<u>A/B FIGHTER</u>	<u>A/B TRANSPORT</u>	<u>A/B FIGHTER</u>	<u>A/B TRANSPORT</u>
QA Test and Inspection	3	3	3	3
Combat Readiness	1	1	1	1
Input Power	1	1	1	1
EMC	2	2	2	2
Data Rights	1	1	1	1
Small Business	1	1	1	1

TABLE A-3
RISK FACTORS (COMMERCIAL CANDIDATES)

<u>OPERATIONAL FACTOR</u>	<u>RECOMMENDED VALUES</u>		<u>MODIFIED VALUES</u>	
	<u>OPERATIONAL ENVIRONMENT</u>		<u>OPERATIONAL ENVIRONMENT</u>	
	<u>A/B FIGHTER</u>	<u>A/B TRANSPORT</u>	<u>A/B FIGHTER</u>	<u>A/B TRANSPORT</u>
Procurement Schedule	2	2	2	2
Reliability	10	5	8	4
Maintainability	8	8	6	6
Personnel Safety	7	7	7	7
Personnel Training	7	5	7	5
Technical Publications	6	6	6	6
Spares Provisioning	5	5	5	5
Parts Quality	4	4	4	4
Part Availability	1	1	1	1
Interchangeability	4	4	4	4
Configuration Management	5	5	5	5
Guarantees and Warranties	1	1	1	1
Non-Std. Parts	3	3	3	3

TABLE A-3
 RISK FACTORS (COMMERCIAL CANDIDATES) (CONTINUED)

<u>OPERATIONAL FACTOR</u>	<u>RECOMMENDED VALUES</u>		<u>MODIFIED VALUES</u>	
	<u>OPERATIONAL ENVIRONMENT</u>		<u>OPERATIONAL ENVIRONMENT</u>	
	<u>A/B FIGHTER</u>	<u>A/B TRANSPORT</u>	<u>A/B FIGHTER</u>	<u>A/B TRANSPORT</u>
Special Handling	1	1	1	1
QA Test and Inspection	8	6	8	6
Combat Readiness	1	1	1	1
Input Power	2	2	2	2
EMC	7	7	7	8
Data Rights	8	8	8	8
Small Business	8	8	8	8

The adjustment of the risk values for the commercial candidate must be based upon knowledge of the prospective commercial contractor performance. The contractor being considered uses best commercial practices in the manufacture of his equipment for the domestic airline market place. The recommended values were derived assuming this condition. If good commercial practices were to be used, then the program manager should increase the risk values toward the upper end of the range for parameters such as interchangeability, configuration management, part quality, QA test and inspection, etc.

Since the EMC requirements are more stringent for the data processor system, the commercial risk factor for EMC should be increased to the upper risk limit. The R & M risks should be reduced to reflect the less stringent requirement.

Based on the discussion in the previous paragraphs, the modified list of risk parameters are contained in the right hand columns of Tables A-2 and A-3. These are the risk factors that will be used for the remainder of the analysis.

The next step is to determine the risk measure for the military and commercial candidates for the A/B inhabited fighter environment and the A/B inhabited transport environment. This measure is a product of the weighting factor and risk factor. The individual operational parameter risk measures are then summed to get the total risk. The risk assessment matrix for the example is contained in Table A-4.

TABLE A-4
RISK MEASURE TABULATION

	<u>OPERATIONAL ENVIRONMENT</u>	
	<u>COMMUNICATIONS A/B FIGHTER</u>	<u>DPS A/B TRANSPORT</u>
Military Candidate	369	353
Commercial Candidate	533	477

Life cycle cost analyses for the two alternate candidates are required for the Milestone III (FSD approval) DSARC decision point. The analyses to determine this information are conducted by DOD LCC specialists with input from applicable sources. Only the pertinent LCC results for the alternative candidates are presented since these LCC techniques are well known within DOD and the body of the guideline contains more details, (Sections 3.B.2 and 3.C.2). Table A-5 lists these values by major category for the alternate candidates. These costs were derived from the results of the Rockwell-Collins study. The development costs for the military were assumed to be 15% of the total LCC as suggested in paragraph 3.B.2.d of the guideline. For the commercial off-the-shelf candidate, the development costs are zero because the equipment is currently in production. Note that the LCC costs were normalized on a flight hour basis to obtain an "advantage indicator" that can be easily compared.

With the risk assessment and LCC analyses completed, an "advantage indicator" (AI) must be determined to provide the indicated procurement strategy. With an equal weight assumption, the AI matrix for the operational environments being considered is shown in Table A-6.

TABLE A-5
LCC ELEMENTS

	A/B FIGHTER COMMUNICATIONS		A/B TRANSPORT DPS	
	<u>MILITARY</u>	<u>COMMERCIAL</u>	<u>MILITARY</u>	<u>COMMERCIAL</u>
Development Cost	\$ 1.6M	\$0.0M	\$26M	\$0.0M
Acquisition Cost	\$ 1.0M	\$0.9M	\$8M	\$1M
Operational & Maintenance Cost	<u>\$ 8.2M</u>	<u>\$8.4M</u>	<u>\$28M</u>	<u>\$14M</u>
Life Cycle Cost	\$10.8M	\$9.3M	\$62M	\$15M
Flight Hours	5,000,000	5,000,000	14,000,000	14,000,000
LCC Per Flt. Hr.	2.2	1.9	4.4	1.1

TABLE A-6
ADVANTAGE INDICATOR MATRIX

	<u>COMMUNICATIONS A/B FIGHTER</u>	<u>DPS A/B TRANSPORT</u>
Military Candidate	812	1553
Commercial Candidate	1013	524

Based on the AI matrix shown above, the indicated procurement strategy for the communication subsystem is the military design candidate; whereas, the commercial candidate is indicated as the procurement strategy for the data processor subsystem. Additional analysis could be conducted on the high risk measure parameters (i.e. reliability, maintainability, and procurement schedule) to test the sensitivity of the decision point.

SECTION A
ACQUISITION STRATEGY GUIDELINES

APPENDIX B
LCC-2 ANALYSIS FACTORS
SECTION 1 O & M FACTORS
SECTION 2 ACQUISITION FACTORS

SECTION 1
O & M COST LCC-2 ANALYSIS FACTORS

STANDARD LOGISTICS PARAMETERS

Standard Cost Factors

Item Mgmt. Cost/Item/Year	Depot Labor and Material Consumption Rate/Hour
Data Mgmt. Cost/Page/Year	Packaging and Shipping Cost/Pound - CONUS
Base Labor and Material Consumption Rate/Hour	Packaging and Shipping Cost/Pound - Overseas

Logistic Factors

Study Duration (Years)	Number of Bases - CONUS
Activation Schedule Array	Number of Bases - Overseas
System Operating Hours/Month	Number of Intermediate Sites - CONUS
Number of Depot Work Shifts	Number of Intermediate Sites - Overseas
Number of Intermediate Site Work Shifts	Number of Bases, Systems at Base

Contractor Data

Pages of Data - Base Level Manuals
Pages of Data - Depot Level Manuals
Pages of Data - Other

OPERATIONAL PARAMETERS

Hardware Definition Parameters

Identure	Removal Labor Standard (Hours)
Number of Replaceable Units	Not Base Repairable Probability
Quantity in System	Condemnation Probability
Cost/Spare Unit	Level of Failure Verification
Mean Time Between Failure/Maintenance (Hours)	Support Equipment Required to Verify Failure
Unverified Failure Probability	Usage Time for Verification (Hours)
Weight (Pounds)	Level of Repair
Failure Verification Standard (Hours)	Support Equipment Required for Repair
Repair Labor Standard (Hours)	Usage Time for Repair (Hours)

Support Equipment Parameters

Support Equipment Cost/Set
Support Equipment Operation and Maintenance Cost Factor

SECTION 2
ACQUISITION COST LCC-2 ANALYSIS FACTORS

STANDARD LOGISTICS PARAMETERS

Standard Cost Factors

Item Entry Cost/New Item	Cost/Copy/Page
Initial Data Management	

Logistic Factors

Base Resupply Time - CONUS (Hours)	Base Turnaround Time (Hours)
Base Resupply Time - Overseas (Hours)	Spares Objective - System
Depot Replacement Cycle Time (Hours)	Spares Objective - Shop
Depot Repair Cycle Time (Hours)	Depot Stock Safety Factor
Shipping Time to Depot - CONUS (Hours)	Activation Schedule Array
Shipping Time to Depot - Overseas (Hours)	

Contractor Data

Acquisition Cost/System	Pages of Data - Depot Level Manuals
Base Level Training Cost	Pages of Data - Other
Depot Level Training Cost	Number of New Inventory Items
Data Acquisition Cost - Base Level Manuals	Contractor Base Resupply Time - CONUS
Data Acquisition Cost - Depot Level Manuals	Contractor Base Resupply Time - Overseas
Data Acquisition Cost - Other	Contractor Repair Cycle Time
Pages of Data - Base Level Manuals	

OPERATIONAL PARAMETERS

Hardware Definition Parameters

Cost/Spare Unit

Support Equipment Parameters

Support Equipment Cost/Set

SECTION A
ACQUISITION STRATEGY GUIDELINES

APPENDIX C
EQUIPMENT DESIGN PRACTICE
DEFINITION SUMMARY

R, M & LCC EFFECTS OF USING COMMERCIAL EQUIPMENT DESIGN PRACTICE DEFINITION

GOOD COMMERCIAL PRACTICE	BEST COMMERCIAL PRACTICE
--------------------------	--------------------------

THERMAL DESIGN

TYPICALLY CONVECTION COOLED LIMITED THERMAL TESTING NO SPECIAL HEAT EXCHANGER CRITICAL PARTS NOT IDENTIFIED	TYPICALLY CONVECTION COOLED EXTENSIVE THERMAL TESTING IDENTIFICATION OF CRITICAL PARTS DESIGNED TO ACCEPT COOLING AIR
--	--

DERATING PRACTICES

APPLICATIONS WITHIN VENDORS MAXIMUM RATING NO DERATING POLICY	FORMAL COMPANY DERATING POLICY PRIMARILY ACTIVE DEVICES MINIMAL PASSIVE DEVICES
---	---

PART QUALITY

LIMITED VENDOR CONTROL VENDOR STANDARD PARTS NO CHANGE CONTROL AUTHORITY NO SPECIAL QUALITY RESTRICTIONS LIMITED RECEIVING INSPECTION MINIMAL SPECIFICATION DEFINITION	CHANGE CONTROL AUTHORITY SPECIFICATIONS DEFINED IN PURCHASING DOCUMENT VENDOR QUALIFICATION PROGRAM VENDOR QUALITY AUDITS RECEIVING INSPECTION SAMPLING PLANS ON ACTIVE DEVICES MULTIPLE SOURCES
---	---

PACKAGING CONCEPT

NOT COMPACT LIGHTWEIGHT CONSTRUCTION PLASTIC RATHER THAN METAL STRUCTURE	SOLID STRUCTURE STANDARD CONFIGURATION MEDIUM DENSITY ARINC DEFINED INTERFACE
--	--

R, M & LCC EFFECTS OF USING COMMERCIAL EQUIPMENT DESIGN PRACTICE DEFINITION

RUGGEDIZED	MILITARIZED
THERMAL DESIGN	
SAME AS BEST COMMERCIAL PRACTICE	FORMAL TESTING REQUIRED CRITICAL PARTS IDENTIFIED WITH ADEQUATE MARGINS PROVIDED MORE EMPHASIS BECAUSE OF GREATER THERMAL DENSITY IN HIGH-PERFORMANCE A/C
DERATING PRACTICES	
SAME AS BEST COMMERCIAL PRACTICE	CONTRACTUALLY REQUIRED TYPICALLY MORE STRINGENT REQUIRED FOR ALL PARTS
PART QUALITY	
TYPICALLY SAME AS BEST COMMERCIAL PRACTICE FREQUENTLY MILITARY QPL PARTS USED	QPL (QUALIFIED PRODUCT LIST) REQUIRED ER (ESTABLISHED RELIABILITY) PASSIVE PARTS SCREENED (TX, TXV) ACTIVE PARTS PROGRAM PARTS SELECTION LIST (PPSL) ESTABLISHED
PACKAGING CONCEPT	
<p><u>GROUND BASED</u></p> <ul style="list-style-type: none"> ● SAME AS BEST COMMERCIAL PRACTICE <p><u>AIRBORNE</u></p> <ul style="list-style-type: none"> ● TRANSPORT - SAME AS BEST COMMERCIAL PRACTICE <p>HIGH PERFORMANCE</p> <ul style="list-style-type: none"> ● MORE SHIELDING (EMI/RFI) ● STURDIER STRUCTURE 	<p><u>GROUND BASED</u></p> <ul style="list-style-type: none"> ● ENCLOSURES DEFINED ● COOLING METHODS STANDARDIZED <p><u>AIRBORNE</u></p> <ul style="list-style-type: none"> ● PACKAGING STANDARDS ● UNIQUE FOR HIGH PERFORMANCE A/C ● HIGH DENSITY <p>MORE SHIELDING (EMI/RFI)</p>

R, M & LCC EFFECTS OF USING COMMERCIAL EQUIPMENT DESIGN PRACTICE DEFINITION

GOOD COMMERCIAL PRACTICE	BEST COMMERCIAL PRACTICE
--------------------------	--------------------------

TEMPERATURE LIMITS

<p><u>GROUND BASED</u></p> <ul style="list-style-type: none"> ● OPERATING 0°C TO 30°C ● NON-OPERATING NO LIMIT <p><u>DO-138 AIRBORNE</u></p> <ul style="list-style-type: none"> ● OPERATING -15°C TO +71°C ● NON-OPERATING -54°C TO +85°C 	<p><u>GROUND BASED</u></p> <ul style="list-style-type: none"> ● OPERATING 0°C TO 55°C ● NON OPERATING -40°C TO +60°C <p><u>DO-160 AIRBORNE (TRANSPORT AIRCRAFT ONLY)</u></p> <ul style="list-style-type: none"> ● NOT COMBINED WITH ALTITUDE ● COCKPIT <ul style="list-style-type: none"> ● OPERATING -15°C TO +55°C (+71°C DASH) ● NON-OPERATING -55°C TO +85°C ● FUSELAGE <ul style="list-style-type: none"> ● OPERATING -55°C TO +71°C ● NON-OPERATING -55°C TO +85°C
---	---

HUMIDITY LIMITS

<p><u>GROUND BASED</u></p> <ul style="list-style-type: none"> ● 80 TO 90% AT 30°C (8 HRS.) <p><u>DO-138 AIRBORNE</u></p> <ul style="list-style-type: none"> ● 95 TO 100% AT 50°C (2 DAY) 	<p><u>GROUND BASED</u></p> <ul style="list-style-type: none"> ● 90 TO 95% AT 50°C (10 DAY) <p><u>AIRBORNE</u></p> <ul style="list-style-type: none"> ● 95 TO 100% AT 65°C (10 DAY)
--	--

QUALITY ASSURANCE PROVISIONS

<p><u>GROUND BASED AIRBORNE</u></p> <ul style="list-style-type: none"> ● FINAL TEST (ALL EQUIPMENT) ● LIMITED RUN-IN ● NO SAMPLING PLANS ● LOW QUALITY AUDIT LEVEL OF EFFORT ● NO FAILURE REPORTING TO CUSTOMER 	<p><u>GROUND BASED AIRBORNE</u></p> <ul style="list-style-type: none"> ● FINAL TEST (ALL EQUIPMENT) ● TEMPERATURE CYCLING W/VIBRATION BURN-IN ● RELIABILITY GROWTH TESTING ● RELIABILITY DEMONSTRATION TESTING ● QUALIFICATION TESTING ● PRODUCTION SAMPLING RELIABILITY TEST ● HIGH QUALITY AUDIT LEVEL OF EFFORT ● EXTENSIVE FAILURE REPORTING TO CUSTOMER
--	--

R, M & LCC EFFECTS OF USING COMMERCIAL EQUIPMENT DESIGN PRACTICE DEFINITION

RUGGEDIZED	MILITARIZED
TEMPERATURE LIMITS	
<p><u>GROUND BASED</u></p> <ul style="list-style-type: none"> ● SAME AS BEST COMMERCIAL PRACTICE <p><u>AIRBORNE</u></p> <ul style="list-style-type: none"> ● COMBINED TEMPERATURE ALT. TESTING REQUIRED (MILITARIZED LIMITS) ● TEMPERATURE EXTREMES - SAME AS BEST COMMERCIAL PRACTICE 	<p><u>GROUND BASED</u></p> <ul style="list-style-type: none"> ● OPERATING (0°C TO 52°C) ● NON-OPERATING (-62°C TO +71°C) <p><u>AIRBORNE (COMBINED WITH ALTITUDE)</u></p> <ul style="list-style-type: none"> ● COCKPIT (50,000 FT.) <ul style="list-style-type: none"> ● OPERATING (-54°C TO +55°C) (71°C DASH) ● NON-OPERATING (-57°C TO +85°C) ● FUSELAGE (70,000 FT.) <ul style="list-style-type: none"> ● OPERATING (-54°C TO +71°C) (95° DASH) ● NON-OPERATING (-57°C TO +95°C)
HUMIDITY LIMITS	
<p><u>GROUND BASED</u></p> <ul style="list-style-type: none"> ● SAME AS BEST COMMERCIAL PRACTICE <p><u>AIRBORNE</u></p> <ul style="list-style-type: none"> ● 95-100% AT 65°C (10 DAY) 	<p><u>GROUND BASED</u></p> <ul style="list-style-type: none"> ● 90 TO 95% AT +50°C (2 DAY) <p><u>DO-160 AIRBORNE (TRANSPORT AIRCRAFT ONLY)</u></p> <ul style="list-style-type: none"> ● 95 TO 100% AT +50°C (2 DAY)
QUALITY ASSURANCE PROVISIONS	
<p><u>SAME AS BEST COMMERCIAL PRACTICE EXCEPT:</u></p> <ul style="list-style-type: none"> ● PRODUCTION SAMPLING TESTS ● INCREASED LEVEL OF FAILURE REPORTING TO CUSTOMER ● HIGHER QUALITY AUDIT LEVEL OF EFFORT 	<p><u>GROUND BASED AIRBORNE</u></p> <ul style="list-style-type: none"> ● FINAL TEST (ALL EQUIPMENT) ● TEMPERATURE CYCLING BURN-IN ● DISCRETIONARY RELIABILITY/LONGEVITY TESTING ● PRODUCTION QUALIFICATION TESTING ● MEDIUM QUALITY AUDIT LEVEL OF EFFORT ● LIMITED FAILURE REPORTING TO CUSTOMER

R, M & LCC EFFECTS OF USING COMMERCIAL EQUIPMENT DESIGN PRACTICE DEFINITION

GOOD COMMERCIAL PRACTICE

BEST COMMERCIAL PRACTICE

SHOCK AND VIBRATION LIMITS

GROUND BASED

- NO SPECIFICATION

DO-138 AIRBORNE

- 6G OPERATIONAL SHOCK
- 15G CRASH SAFETY SHOCK
- 1.5G PK (5-55HZ)
- 0.25G PK (55-2000HZ)

GROUND BASED

- 15G OPERATIONAL SHOCK
- NO CRASH SAFETY LIMIT
- SINUSOIDAL VIBRATION
 - 1.5G PK (5-55HZ)
 - PRIMARILY EQUIPMENT TRANSPORT REQUIREMENT

DO-160 AIRBORNE (TRANSPORT AIRCRAFT ONLY)

- 6G OPERATIONAL SHOCK
- 15G CRASH SAFETY SHOCK
- NO RANDOM VIBRATION
- NO ENDURANCE LEVEL TESTING

R, M & LCC EFFECTS OF USING COMMERCIAL EQUIPMENT DESIGN PRACTICE DEFINITION

RUGGEDIZED	MILITARIZED
------------	-------------

SHOCK AND VIBRATION LIMITS

GROUND BASED

- SAME AS BEST COMMERCIAL PRACTICE

AIRBORNE

- SHOCK - SAME AS BEST COMMERCIAL PRACTICE
- TRANSPORT AIRCRAFT VIBRATION
 - DO-160 RANDOM VIBRATION (1 HR. PER AXIS)
 - COCKPIT (0.32G RMS/ 10-2000HZ)
 - FUSELAGE (0.76G RMS/ 10-2000HZ)
- ENDURANCE LEVEL (3 HRS. PER AXIS)
 - DO-160 ROBUSTNESS TEST*
 - COCKPIT (0.74G RMS/ 10-2000HZ)
 - FUSELAGE (8.65G RMS/ 10-2000HZ)
- HIGH PERFORMANCE AIRCRAFT VIBRATION
 - MILITARIZED LIMITS REQUIRED

GROUND BASED

- 30G PEAK OPERATIONAL SHOCK
- NO CRASH SAFETY LIMIT
- SINUSOIDAL VIBRATION
 - 2.5G PK (5-2000HZ)

AIRBORNE

- SHOCK - SAME AS BEST COMMERCIAL PRACTICE
- VIBRATION
 - RANDOM PER MIL-STD-810C
 - PERFORMANCE LEVELS (1 HR. PER AXIS)
 - TRANSPORT AIRCRAFT
 - COCKPIT (0.7G RMS/ 15-2000HZ) KC-135
 - FUSELAGE (8.0G RMS/ 15-2000HZ) TYPICAL
 - HIGH PERFORMANCE AIRCRAFT
 - COCKPIT (6.0G RMS/ 15-2000HZ) GPS
 - FUSELAGE (9.8G RMS/ 15-2000HZ) GPS
 - ENDURANCE LEVELS (3 HR. PER AXIS)
 - TRANSPORT AIRCRAFT
 - COCKPIT (2.0G RMS/ 15-2000HZ) KC-135
 - FUSELAGE (17.0G RMS/ 15-2000HZ) TYPICAL
 - HIGH PERFORMANCE AIRCRAFT
 - COCKPIT (10.5G RMS/ 15-2000HZ) GPS
 - FUSELAGE (19.9G RMS/ 15-2000HZ) GPS

R, M & LCC EFFECTS OF USING COMMERCIAL EQUIPMENT DESIGN PRACTICE DEFINITION

GOOD COMMERCIAL PRACTICE

BEST COMMERCIAL PRACTICE

SHOCK AND VIBRATION LIMITS

- SINUSOIDAL VIBRATION
 - COCKPIT
 - LESS THAN 3G PK (5-54HZ)
 - 0.25G PK (54-2000HZ)
 - FUSELAGE
 - LESS THAN 3G PK (5-54HZ)
 - 3.0G PK (54-2000HZ)

R, M & LCC EFFECTS OF USING COMMERCIAL EQUIPMENT DESIGN PRACTICE DEFINITION

RUGGEDIZED

MILITARIZED

SHOCK AND VIBRATION LIMITS (CONT.)

*MILITARIZED LIMITS REQUIRED

● SINUSOIDAL

● TRANSPORT AIRCRAFT

● COCKPIT/FUSELAGE

- LESS THAN 2G PK (5-14HZ)
- 2G PK (14-33HZ)
- LESS THAN 5G PK (33-52HZ)
- 5G PK (52-2000HZ)

● HIGH PERFORMANCE AIRCRAFT

● COCKPIT/FUSELAGE

- LESS THAN 2G PK (5-14HZ)
- 2G PK (14-33HZ)
- LESS THAN 5G PK (33-52HZ)
- 5G PK (52-2000HZ)

SECTION B
STUDY RESULTS

1.0 OBJECTIVE

The objective of this study effort has been to develop guidelines indicating the more advantageous class of equipment, military designed or commercial off-the-shelf, for three operating environments, airborne inhabited-transport (A_{IT}), airborne inhabited-fighter (A_{IF}) and ground-fixed (G_F) as defined in MIL-HDBK-217 for three types of equipments. These guidelines have been formulated to define for a Program Manager, the advantages and disadvantages of each class of equipment in terms of reliability, maintainability, cost, and risk. The guidelines include recommended steps for the Program Manager to consider to minimize risks and disadvantages of each class of equipment for a given environment.

1.1 Scope

This study was designed to develop Program Manager guidelines for the selection of commercial off-the-shelf equipments of three generic types of equipments used in three military environments. These guidelines were developed after the performance of detailed life cycle cost (LCC) studies involving current operational commercial off-the-shelf and military designed equipments of the three specified types. The equipments selected for study are shown in Table 1.1.

1.2 Background

The increasing cost of acquiring and maintaining equipment for use in Air Force systems has reduced the amount of equipment which can be procured within a fixed and/or constrained budget. Additionally, the lengthy acquisition times cause equipment to be outdated by the time they are received into the inventory. The Air Force is investigating alternatives in an attempt to optimize the amount of equipment which can be acquired for a given number of dollars. One alternative is to

TABLE 1.1
SELECTED EQUIPMENT FOR STUDY

ENVIRONMENT	CLASS	TYPES	DESIGNATION	NOMENCLATURE	PLATFORM	DESIGN YEAR
Ground	Military	Communications	RT-980/GRC-171	Receiver Transmitter	Ground	1974
		Data Processing	AN/FPS-77(V)	Radar Meteorological Set	Ground	1967
Fixed	Commercial	Data Peripheral	AN/ESH-34	Sound Recorder Reproducer	Ground	1970
		Communications	618M-1C	Radio Receiver-Transmitter	Ground	1966
		Data Processing	AN/FPS-103	Weather Tracking Radar System	Ground	1966
		Data Peripheral	VR-3700	Signal Data Recorder Reproducer	Ground	1968
Airborne Inhabited Transport	Military	Communications	RT-967/ARC-109(V)	Radio Receiver-Transmitter	C-5A	1966
		Data Processing	BG489C BG488C	AFCS Pitch/Pacs Computer AFCS Roll/Yaw/Pacs Computer	C-5A	1972
		Data Peripheral	AQU-4/A	Horizontal Situation Indicator Attitude Director Indicator	C-5A	1963/1971
Airborne Inhabited Fighter	Commercial	Communications	618M-1C	Radio Receiver-Transmitter	C-141A/B	1963
		Data Processing	562P-1E1 562R-1E	Pitch Computer Roll Computer	KC-135A	1967
		Data Peripheral	331A-8H 329B-86	Horizontal Situation Indicator Attitude Director Indicator	KC-135A	1967
		Communications	RT-967/ARC-109(V)	Radio Receiver-Transmitter	F-15A/B	1966
Airborne Inhabited Fighter	Military	Data Processing	CP-1104 CP-1105	Pitch Flight Control Computer Roll/Yaw Flight Control Computer	F-15A/B	1979
		Data Peripheral	ID-1805/AJN-18 ARU-39/A	Horizontal Situation Indicator Attitude Indicator	F-15A/B	1972
		Communications	*			
Airborne Inhabited Fighter	Commercial	Data Processing	*			
		Data Peripheral	*			

*No examples of commercial off-the-shelf equipments used in an airborne inhabited-fighter environment were identified.

(1.2 - Continued)

procure commercially available off-the-shelf nonmilitarized equipment. This approach has been used in the past as evidenced by the examples of commercial equipment currently operating in the airborne transport and ground environment. The following paragraphs contain brief summaries of other instances of the successful use of commercial off-the-shelf equipment in a military environment.

DATA FOR NATIONAL SECURITY INDUSTRIAL ASSOCIATION

1. **SUBJECT:** Commercial C³ Equipment/Systems Currently in Use.
2. **IDENTIFICATION:** AN/TSC-60V0 Communications Central.
3. **DESCRIPTION OF USE:** The TSC-60 series radio sets have been in use in combat communications organizations for some time and field experience has been generally satisfactory. The TSC-60s equipped with orthogonal antenna systems are used for short haul HF communications in the tactical range. With the log periodic antenna, long haul strategic or DCS-entry communication is possible. The TSC-60 is emerging as the standard tactical HF system in combat communications and Tactical Air Control System (TACS) use.
4. **PERFORMANCE:**
 - a. **Operational Suitability:** With a possible exception of the time needed to install the antenna system, the TSC-60 has been found suitable for most tactical HF radio roles. Most units have found it to have a high in-commission rate once the system is on the air and the equipment has stabilized. The built in test equipment is a particularly desirable feature as it speeds fault isolation. The unit has been used in a variety of roles, ranging from ground-to-air, ground-to-ground, and ship-to-shore, with a good measure of success in all roles.
 - b. **Logistics Supportability:** Supportable.
 - c. **Maintainability (MTTR, MTBF):** Two configurations have been considered. 24 months of data has been accumulated:

AN/TSC-60(V2)-5 each-MTTR-8.67 hr-MTBF 3689.2 hr
AN/TSC-60(V3)-3 each-MTTR-8.57 hr-MTBF-22436.47 hr
This is tactical use equipment and figures are misleading due to in Garrison (powered-down) times.
 - d. **Adequacy of Commercial Tech Data:** N/A (USAF Technical Orders).
5. **Logistics Support System:** Centrally Supported.
6. **Acquisition Method:**

Performance specification prepared by AFCC and TAC, using and operating commands. Acquisition agency was Sacramento Air Logistics Center using performance spec. Negotiated procurement from Rockwell International (Collins Communications Systems Division). The only reference to Mil Specs was in reference to Technical Manuals.

DATA FOR NATIONAL SECURITY INDUSTRIAL ASSOCIATION

1. Subject: Commercial C³ Equipment/Systems Currently in Use.
2. Identification: SCOPE CONTROL, G/A/G Aeronautical Station (Collins URG).
3. Description of Use: SCOPE CONTROL Equipment is used to control HF air-ground-air clear analog voice and secure/nonsecure radio teletype data for the entire Department of Defense (DOD) airborne fleet.
4. Performance:
 - a. Operational Suitability: Excellent.
 - b. Logistics Supportability: Supportable (support promised for 10 years as of 1978).
 - c. Maintainability (MTTR, MTBF): The following information is based on 24 months of maintenance data from 15 SCOPE Control stations: MTTR: 4.86 hours; MTBF: 2945.96 hours.
 - d. Adequacy of Commercial Tech Data: N/A (military technical orders).
5. Logistic Support System: Centrally Supported.
6. Acquisition Method:

SCOPE CONTROL is the code name of the world-wide Ground-Air-Ground High Frequency Radio Systems located at about 22 locations, 18 of which are overseas. The system was acquired through the Oklahoma City Air Logistics Center using performance specification prepared jointly by AFCC/MAC/SAC. The final specification identified commercial hardware by manufacturers type number. The system was acquired direct from the Collins Radio Company on a negotiated basis in the mid-1960's.

DATA FOR NATIONAL SECURITY INDUSTRIAL ASSOCIATION

1. Subject: Commercial C³ Equipment/Systems Currently in Use.
2. Identification: MW-518 DCS Standard Analog Microwave (AN/FRC-155 thru 160, 162, 165, and 169).
3. Description of Use: To provide highly reliable wideband communications over a digital microwave LOS link supporting the DCA throughout the world.
4. Performance:
 - a. Operational Suitability: The digital transmission systems operated by AFCC are operable and maintainable by military personnel, are working well, meet performance standards and provide communications satisfactory to all customers.
 - b. Logistics Supportability: Supportable.
 - c. Maintainability (MTTR, MTBF): MTTR: 0.23 hrs; MTBF: 3500 hrs.
 - d. Adequacy of Commercial Tech Data: N/A (military tech data).
5. Logistics Support System: Centrally Supported
6. Acquisition Method:

The DCA Standard Microwave Program was initiated in 1972. The program was initiated by the Defense Communications Agency to acquire a standard off-the-shelf microwave system that would be used throughout the Defense Communications System and would be used by all three military services.

A performance spec was provided to all companies that had existing hardware that would meet the specifications. As the central procurement agency for the program the Army Electronics Command at Ft. Monmouth procured three microwave sets from each of three companies. DCA and the services arranged to have the sets extensively tested by NBS, Boulder, Colo. After 4 months of rigorous testing, the radios produced by the Rockwell International (Collins Transmission Systems Division) were declared the winner of the technical competition and Ft. Monmouth was directed to negotiate a contract for the radio with options for three years.

The equipment was commercially developed and was adapted to meet the spectrum requirements of the military.

DATA FOR NATIONAL SECURITY INDUSTRIAL ASSOCIATION

1. Subject: Commercial C³ Equipment/Systems Currently In-Use.
2. Identification: KWM-2A (AN/FRC-93/153) HF transceiver.
3. Description of Use: Two descriptions are provided, describing different uses.
 - A. HF Point/Point. Primary equipment used in MARS facilities in support of base/MAJCOM contingency/emergency plans, and moral/welfare traffic for military and authorized government authorized civilians.
 - B. The FRC-153 HF terminal is used for both fixed and tactical HF communications in either the SSB voice or CW mode. Its applicability to combat communications missions is very much the same as its uses in the civilian world where it is used in amateur radio applications for both hobbies and disaster relief roles in a mobile or transportable configuration.
4. Performance:
 - a. Operational Suitability: The equipment has generally been considered to be dependable and easily maintained. However, due to the advanced age of most KWM-2A's in the inventory, the MTBF has understandably decreased.

When used as the FRC-153, packaged in fiberglass suitcases, it is a highly transportable package that can be carried to any location by virtually any mode of transportation. It can be set up in a very short period of time and is quite easy for a trained operator to keep on the air. The tube technology, the need for crystals because of the lack of frequency synthesis capability, and the frequency instability make it unsuitable for some roles, especially when used with a voice encryption device for secure voice transmissions.
 - b. Logistics Supportability: Very poor/unsupportable (majority are to be replaced under Project PACER BOUNCE).
 - c. Maintainability (MTTR, MTBF): MTTR: 8.06 hrs; MTBF: 2447.82 hrs.
 - d. Adequacy of commercial tech data: N/A (military tech data).
5. Logistics Support System. Centrally Supported.
6. Acquisition Method:

The KWM-2A was procured on an emergency basis by the U. S. Air Force to meet urgent tactical needs in 1960. There were no specifications prepared as the equipment had proven itself as a commercial amateur set and was used on a limited basis in the military MARS net. Several thousand sets were procured direct to Collins Radio over a 15 year period. Because of the reliability and extensive use of the set, it was assigned a military nomenclature and military tech data was acquired in the late 1960's.

DATA FOR NATIONAL SECURITY INDUSTRIAL ASSOCIATION

1. Subject: Commercial C³ Equipment/Systems Currently In Use.
2. Identification: AN/TRC-136 mobile HF system.
3. Description of use: The TRC-136 is used in tactical HF communications in areas where the size and portability of the unit can be used to best advantage. The van mounted whip antenna system, and the use of a one-ton four-wheel drive pickup to carry the facility makes it a highly mobile system for the tactical communication role.
4. Performance:
 - a. Operational Suitability: The TRC-136 provides local and long distance HF communications teletype, voice, or radio operation. The data systems can be secured using cryptographic equipment. When it is used for all these roles, the shelter becomes quite crowded as separate operators are needed for the radio equipment and the teletype and voice patching console. Other than the small shelter size, the TRC-136 is quite suitable for many tactical HF roles.
 - b. Logistics Supportability: Poor/marginal.
 - c. Maintainability: MTTR, MTBF: (24 month data; 4 each items), MTTR: 12.33 hrs, MTBF: 7361.45 hrs.
 - d. Adequacy of Commercial Tech Data: N/A (military tech data).
5. Logistics Support Systems: Centrally Supported.
6. Acquisition Method:

The AN/TRC 136 tactical HF set was procured based on a commercial performance specification to replace the obsolete AN/TSC-15 set. The TRC-136 used the 1 KW HF components that were used in SCOPE CONTROL and was a proven piece of commercial equipment. The Oklahoma City Air Logistics Center (now at Sacramento) was the procuring agency. This was a directed source negotiated procurement based on proven commercial equipment already in inventory and only one contractor could meet the time schedule for delivery.

2.0 SUMMARY AND CONCLUSIONS

The objectives of this study have been to provide definitions for four levels of common design practices and to provide guidelines for Air Force Program managers to determine whether to select commercial off-the-shelf equipment for a military environment.

Paragraph 4 contains an extensive definition of 1) good commercial practices, 2) best commercial practices, 3) ruggedized, and 4) militarized. These definitions contain differentiation in component screening, burn-in testing, component selection, thermal and vibration environments, etc. These definitions will enhance design practice communications among the technical electronic community.

The Program Manager guidelines for procurement of commercial off-the-shelf electronic equipment for a military environment are an analysis technique. The technique combines the development program risks across 20 operational factors and the equipment life cycle cost, consisting of the production (acquisition), support and maintenance cost elements, to obtain a single measurement for comparison of alternate procurement strategies. This technique is defined in Paragraph 5.

The results of this analysis technique on the 9 equipment comparisons in the study are shown in Figure 2.1. Development costs were not included in the application of the technique to the 9 equipment comparisons because

RECOMMENDED ACQUISITION STRATEGY MATRIX

FIGURE 2.1

ENVIRONMENT TYPE	COMMUNICATION	DATA PROCESSING	DATA PROCESSING PERIPHERALS	OPERATIONAL FACTORS REQUIRING EMPHASIS
GROUND, FIXED	MILITARY	COMMERCIAL	COMMERCIAL	<ul style="list-style-type: none"> • PERSONNEL TRAINING • TECHNICAL PUBS • SPARES PROVISIONING • CONFIGURATION MANAGEMENT
AIRBORNE, INHABITED TRANSPORT	COMMERCIAL	COMMERCIAL	COMMERCIAL	<ul style="list-style-type: none"> • MAINTAINABILITY • RELIABILITY • PERSONNEL TRAINING
AIRBORNE INHABITED FIGHTER	MILITARY	COMMERCIAL	MILITARY	<ul style="list-style-type: none"> • PROCUREMENT SCHEDULE • RELIABILITY • MAINTAINABILITY

(2.0 - Continued)

of the difficulty in obtaining cost data and because they were assumed to represent a relatively small part of the life cycle costs. The recommended more general situation of including the development costs is addressed in Section A "Acquisition Strategy Guidelines." Note that in these 9 comparisons, this analysis technique developed measures recommending commercial procurement for all three classes of equipment in the Airborne Inhabited Transport (A_{IT}) environment and for 2 of the 3 types of equipment in the Ground Fixed (G_F) environment.

Two of the nine comparisons provided mild surprises. We had expected a commercial procurement decision in the comparison analysis of communication equipment in a Ground Fixed environment. However, the data clearly indicates that the military procurement has a lower LCC/risk measurement. The other surprise was in the LCC/risk advantage of commercial procurement for data processing type equipment in an Airborne Inhabited Fighter (A_{IF}) environment. It had been a prior impression that military procurements would, predominately, show advantages in the Airborne Inhabited Fighter (A_{IF}) environment and that commercial procurements would show advantages in the Ground Fixed (G_F) environment.

The selection of these particular equipments, the segment of operational data and our assignment of relative weight and risk to the operational factors in a commercial off-the-shelf or military procurement does not result in LCC/risk measures that apply for all future procurements. Rather,

2.0 SUMMARY AND CONCLUSIONS (Continued)

the analytical techniques developed during this study and illustrated in this report (see Section A) should be used to compare commercial off-the-shelf procurements with alternate military procurements.

Unquestionable differences exist in how commercial and militarized equipments are designed, manufactured and supported. In some cases the risks associated with using a commercial design in a military environment are outweighed by the cost savings. The most appropriate acquisition strategy decision can be determined by an analytical procedure for each unique acquisition situation. The procedure consists of choosing a set of weighted operational factors that are necessary for program success and having a team of experts assess the risk associated with each. Combining these results gives a quantitative measure of the overall operational risk of that acquisition approach not succeeding in that particular application. The next step consists of determining what the life cycle cost impact is likely to be. One way is by analyzing field data on similar equipments of each acquisition approach under consideration; another is by predicting the LCC. The life cycle cost measures must be normalized to account for different complexities, quantities of equipment and usage. The third step consists of combining the risk and LCC measures in accordance with a pre-determined weighted formula (to account for their relative importance) to arrive at an overall "advantage indicator," with the lowest being the best choice of acquisition strategy. The last step is a review of the highest contributors toward the program risk so that extra effort can be placed on them to reduce their risks. This procedure is illustrated in the analysis flow chart shown in Figure 2.2.

CONCLUSIONS

The choice of the most appropriate acquisition strategy must be done on a case by case basis. An analytical procedure has been presented that may be applied for each unique acquisition situation. Key to making the best decision is the determination of the appropriate weighting for the operational factors necessary for program success as well as the weighting of the relative importance of cost and risk. The results of the RADC sponsored Rockwell-Collins study indicated that there is merit in considering the use of best commercial practice designs in "ground fixed" and "airborne inhabited transport" environments, but it is unlikely that they can be applied successfully in "airborne inhabited fighter" applications. Regardless of the choice of acquisition strategy, use of the analytical approach presented forces management to consider all factors affected by its strategy decision and points out areas where extra program emphasis should be applied to minimize risks.

FIGURE 2.2 DESIGN ACQUISITION STRATEGY

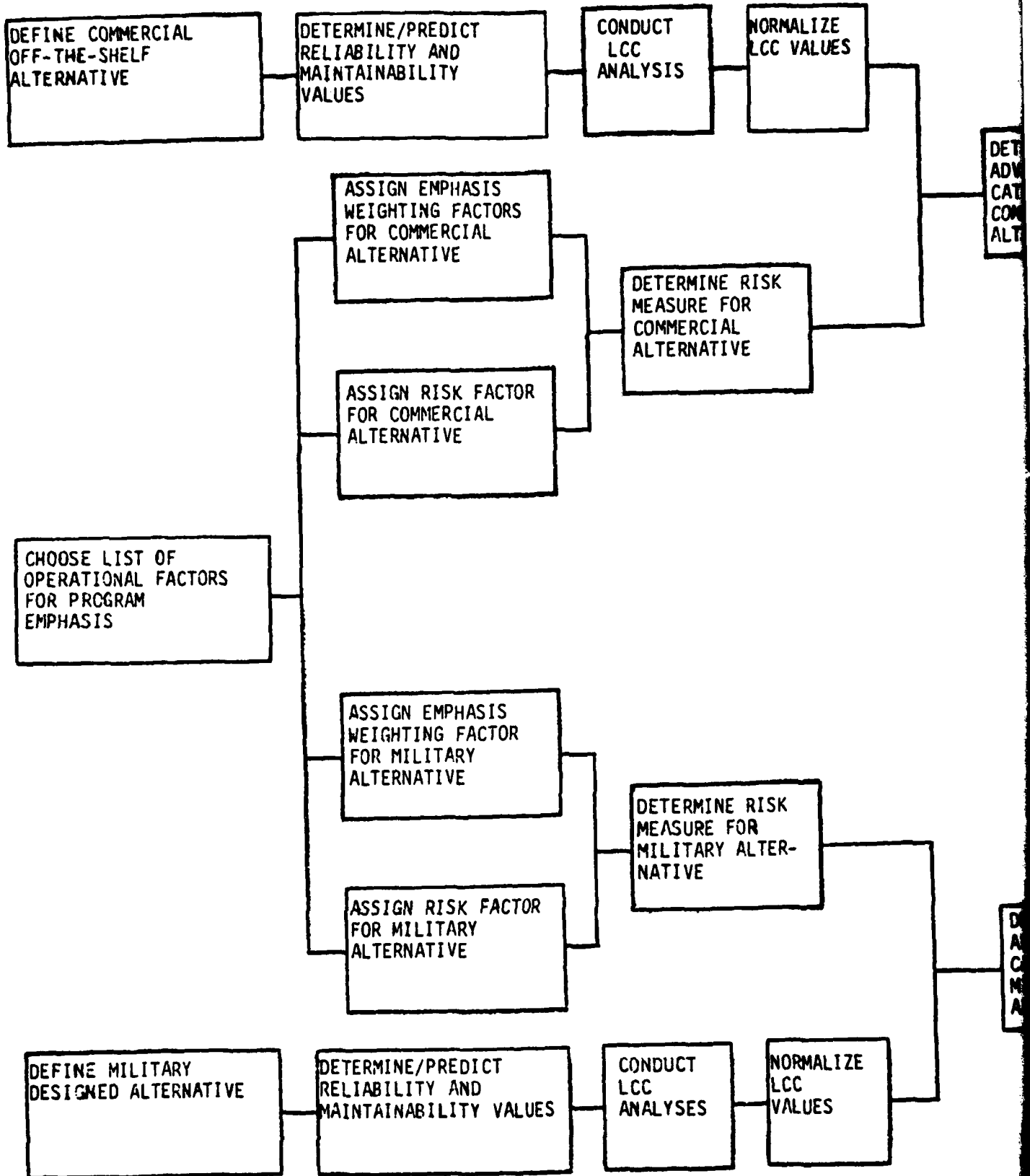

ACQUISITION STRATEGY ANALYSIS FLOW

RE
UES

DETERMINE
ADVANTAGE INDI-
CATOR FOR
COMMERCIAL
ALTERNATIVE

DETERMINE
ADVANTAGEOUS
ACQUISITION
ALTERNATIVE

DEFINE HIGH
CONTRIBUTORS TO
PROGRAM RISK

DEVELOP
ACQUISITION
PROGRAM TO
ATTENUATE RISK

DETERMINE
ADVANTAGE INDI-
CATOR FOR
MILITARY
ALTERNATIVE

E

1

2

3.0 INDUSTRIAL SURVEY

In order to assure that the results represented a range of manufacturer's practices, not just those of Rockwell-Collins, a survey was conducted of industrial firms having substantial background in both commercial and military electronics manufacturing. The responses to the following questions would aid in establishing guidelines for using commercial off-the-shelf equipment.

- a. Discuss the design difference in 1.) Good Commercial Practices, 2.) Best Commercial Practices, 3.) Ruggedized and, 4.) Militarized, all of which are commonly used equipment manufacturer's terms. The discussion may consider any of the following factors:
 1. Thermal design
 2. Derating practices
 3. Part qualities
 4. Packaging concepts
 5. Shock and vibration limits
 6. Temperature limits
 7. Humidity limits
 8. Quality assurance provisions
- b. Briefly discuss, if applicable, your experiences in adapting commercial off-the-shelf equipment to a military environment.
- c. Discuss benefits which you have or would expect to experience in using commercial off-the-shelf equipment in a military environment.
- d. Discuss drawbacks which you have or would expect to experience in using commercial off-the-shelf equipment in a military environment.

Survey kits were sent out to 17 firms. This action was followed up by phone calls to each of the addressees. Of these 17 firms, only 4 were willing to respond. Most of the remaining firms required funding to complete the survey. The four firms that responded are:

1. Bendix Avionics Division
2. Hughes Aircraft Company
3. Teledyne Microwave
4. Westinghouse Electric Corporation, AFSD

The results of these surveys for each category of aircraft are summarized in Table 3.1.

TABLE 3.1. SUMMARY OF INDUSTRIAL SURVEY RESULTS

MAJOR FACTORS	MILITARY AIRBORNE INHABITED FIGHTER			MILITARY AIRBORNE INHABITED TRANSPORT			MILITARY GROUND FIXED ENVIRONMENT		
	LOW RISK	MODERATE RISK	HIGH RISK	LOW RISK	MODERATE RISK	HIGH RISK	LOW RISK	MODERATE RISK	HIGH RISK
Reliability	2	8	22	4	27	2	15	15	0
Maintainability	12	6	14	15	10	8	18	10	2
Availability	16	13	4	17	14	2	17	12	0
Personnel, Safety, Training	16	8	8	19	8	6	24	2	4
Part Quality Level	2	18	10	5	27	2	7	24	0
Non-Standard Parts	11	10	8	21	8	4	20	3	6
Special Handling	12	10	8	12	19	2	21	9	0
Quality Assurance Provisions	2	19	8	1	31	0	11	19	2
Combat Readiness	4	10	15	4	26	3	13	17	0
Non-Standard Power Demands	23	4	2	23	8	2	27	3	0
Electromagnetic Compatibility	8	7	14	9	14	10	7	17	6
Small Business Opportunity	14	3	4	14	5	4	13	6	5
Spares Provisioning Availability	14	6	9	16	6	6	10	6	13
Guarantees & Warranties	12	4	10	14	10	6	14	10	4
Government Data Rights	9	7	10	10	8	12	7	7	14

3.0 INDUSTRIAL SURVEY (Continued)

Under each of the major headings in Table 3.1, are three columns titled low risk, medium risk and high risk. The numbers in each column indicate the number of responses under each risk level for each element covered in the survey beginning with the reliability element. Not all companies responded to all elements and several companies did not respond to all of the major categories. However, other companies distributed the questionnaire to several divisions and solicited responses from several interested, knowledgeable people in each division. Consequently, the number of responses exceed the number of responding companies.

Conclusions

Table 3.1 shows the number of individual respondents to the industry survey and their indication of risk for 15 major factors in 3 military environments. In general, the respondents (approximately 30) indicated that they see less risk in using commercial off-the-shelf electronics equipment in a military environment than had been expected. Even in the airborne inhabited-fighter environment, more respondents indicated "low risk" in 8 of the 15 "major factors" categories and only 1/3 of the respondents indicated "high risk." However, in the reliability factor, the majority of respondents indicated "high risk" in the airborne inhabited-fighter environment. In several other factors such as maintainability, combat readiness, electromagnetic compatibility and government data rights, about half of the respondents indicated "high risk."

As expected, the respondents indicated risk levels in descending order in the airborne inhabited-fighter, airborne inhabited transport and ground-fixed environments respectively.

4.0 DESIGN PRACTICE DEFINITIONS

The following paragraphs contain the four design practice definitions required in this study. The defined terms are (1) good commercial (design) practices, (2) best commercial (design) practices, (3) ruggedized (design) and (4) militarized (design). The definition details are shown in tables 4.1 through 4.4 respectively. The definitions are given in terms of differentiating within the following classifications:

- a. Thermal design.
- b. Derating practices.
- c. Parts quality.
- d. Packaging concepts.
- e. Shock and vibration limits
- f. Temperature limits.
- g. Humidity limits.
- h. Quality Assurance provisions.

These definitions were based primarily on in-house information. Several engineering and program managers within the Rockwell-Collins organization provided their definitions. In addition, the industry survey responses were reviewed to determine the viewpoints of other companies with respect to these design practice definitions. This information was composited into these definitions.

4.1 Good Commercial Practices

Good commercial practices apply to manufacturers that supply equipment to the "consumer" or private market place. For ground-based equipment, the "consumer" market could be CB radio users, high fidelity recording equipment, household computers, or household television receivers. For airborne equipment, the avionics supplied to the small privately owned

4.1 Good Commercial Practices (Continued)

general aviation market place would be in this category. Refer to Table 4.1.

4.2 Best Commercial Practices

Best commercial practices apply to manufacturers that supply equipment to the industrial market place. For ground-based equipment, this would apply to top of the line amateur radio equipment, broadcasting industry recording equipment, and production control minicomputers. For airborne equipment, the avionics supplied to the commercial airline industry would be in this category. Refer to Table 4.2.

Equipment contained in the good/best commercial practices category would be off-the-shelf equipment with no modification to permit usage in the military sector.

4.3 Ruggedized

Ruggedized equipment would be designed and built using best commercial practices with minor modification to the existing mature design to meet performance criteria under more severe environments that would be experienced in military usage (e.g., temperature or vibration limits). Refer to Table 4.3.

4.4 Militarized

Militarized equipment would be a commercially developed concept or philosophy that would be implemented in hardware which satisfied military requirements with regard to controlled material selection/change, controlled design disciplines, quality performance through first article testing, and quality concurrence through sample testing. Refer to Table 4.4.

TABLE 4.1 GOOD COMMERCIAL PRACTICE

CHARACTERISTIC

DESIGN PRACTICE

THERMAL DESIGN

- TYPICALLY CONVECTION COOLED
- LIMITED THERMAL TESTING
- NO SPECIAL HEAT EXCHANGER
- CRITICAL PARTS NOT IDENTIFIED

DERATING PRACTICES

- APPLICATIONS WITHIN VENDORS MAXIMUM RATING
- NO DERATING POLICY

PARTS QUALITY

- LIMITED VENDOR CONTROL
- VENDOR STANDARD PARTS
- NO CHANGE CONTROL AUTHORITY
- NO SPECIAL QUALITY RESTRICTIONS
- LIMITED RECEIVING INSPECTION
- MINIMAL SPECIFICATION DEFINITION

TABLE 4.1 GOOD COMMERCIAL PRACTICE (CONTINUED)

<u>CHARACTERISTIC</u>	<u>DESIGN PRACTICE</u>
PACKAGING CONCEPT	<ul style="list-style-type: none">• NOT COMPACT• LIGHTWEIGHT CONSTRUCTION• PLASTIC RATHER THAN METAL STRUCTURE
SHOCK & VIBRATION LIMITS	<ul style="list-style-type: none">• GROUND BASED<ul style="list-style-type: none">• NO SPECIFICATION• DO-138 AIRBORNE*<ul style="list-style-type: none">• 6G OPERATIONAL SHOCK• 15G CRASH SAFETY SHOCK• 1.5G PK (5-55HZ)• 0.25G PK (55-2000HZ)
TEMPERATURE LIMITS	<ul style="list-style-type: none">• GROUND BASED<ul style="list-style-type: none">• OPERATING 0°C TO 30°C• NON-OPERATING NO LIMIT• DO-138 AIRBORNE*<ul style="list-style-type: none">• OPERATING -15°C TO +71°C• NON-OPERATING -54°C TO +85°C

*DO-138: RADIO TECHNICAL COMMISSION FOR AERONAUTICS (RTCA) REPORT:
"ENVIRONMENTAL CONDITIONS AND TEST PROCEDURES FOR AIRBORNE ELECTRICAL/ELECTRONIC EQUIPMENT
AND INSTRUMENTS, JUNE 28, 1968.

TABLE 4.1 GOOD COMMERCIAL PRACTICE (CONTINUED)

<u>CHARACTERISTIC</u>	<u>DESIGN PRACTICE</u>
HUMIDITY LIMITS	<ul style="list-style-type: none">● GROUND BASED<ul style="list-style-type: none">● 80 TO 90% AT 30°C (8 HRS.)● DO-138 AIRBORNE*<ul style="list-style-type: none">● 95 TO 100% AT 50°C (2 DAY)
QUALITY ASSURANCE PROVISIONS	<ul style="list-style-type: none">● AIRBORNE/GROUND BASED<ul style="list-style-type: none">● FINAL TEST (ALL EQUIPMENT)● LIMITED RUN-IN● NO SAMPLING PLANS● LOW QUALITY AUDIT LEVEL OF EFFORT● NO FAILURE REPORTING TO CUSTOMER

*DO-138: RADIO TECHNICAL COMMISSION FOR AERONAUTICS (RTCA) REPORT:
"ENVIRONMENTAL CONDITIONS AND TEST PROCEDURES FOR AIRBORNE ELECTRICAL/ELECTRONIC
EQUIPMENTS AND INSTRUMENTS, JUNE 28, 1968.

AD-A129 596

RELIABILITY MAINTAINABILITY AND LIFE CYCLE COST EFFECTS
OF COMMERCIAL OFF... (U) ROCKWELL INTERNATIONAL CEDAR
RAPIDS IA COLLINS GOVERNMENT AVI... N E SCHMIDT ET AL.
FEB 83 RADC-TR-83-29-VOL-1 F30602-80-C-0306 F/G 15/5

2/3

UNCLASSIFIED

NL

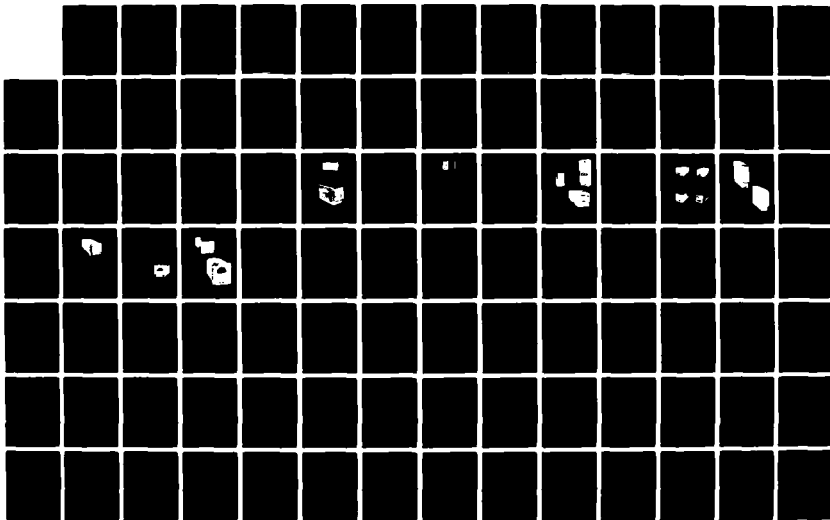

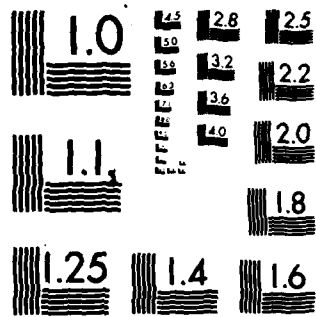

MICROCOPY RESOLUTION TEST CHART
NATIONAL BUREAU OF STANDARDS-1963-A

TABLE 4.2 BEST COMMERCIAL PRACTICE

<u>CHARACTERISTIC</u>	<u>DESIGN PRACTICE</u>
THERMAL DESIGN	<ul style="list-style-type: none">• TYPICALLY CONVECTION COOLED• EXTENSIVE THERMAL TESTING• IDENTIFICATION OF CRITICAL PARTS• DESIGNED TO ACCEPT COOLING AIR
DERATING PRACTICES	<ul style="list-style-type: none">• FORMAL COMPANY DERATING POLICY• PRIMARILY ACTIVE DEVICES• MINIMAL PASSIVE DEVICES
PARTS QUALITY	<ul style="list-style-type: none">• CHANGE CONTROL AUTHORITY• SPECIFICATIONS DEFINED IN PURCHASING DOCUMENT• VENDOR QUALIFICATION PROGRAM• VENDOR QUALITY AUDITS• RECEIVING INSPECTION SAMPLING PLANS ON ACTIVE DEVICES• MULTIPLE SOURCES

TABLE 4.2 BEST COMMERCIAL PRACTICE (CONTINUED)

<u>CHARACTERISTIC</u>	<u>DESIGN PRACTICE</u>
PACKAGING CONCEPT	<ul style="list-style-type: none">• SOLID STRUCTURE• STANDARD CONFIGURATION• MEDIUM DENSITY• ARINC DEFINED INTERFACE
SHOCK & VIBRATION LIMITS	<ul style="list-style-type: none">• GROUND BASED<ul style="list-style-type: none">• 15G OPERATIONAL SHOCK• NO CRASH SAFETY LIMIT• SINUSOIDAL VIBRATION<ul style="list-style-type: none">• 1.5G PK (5-55HZ)• PRIMARILY EQUIPMENT TRANSPORT REQUIREMENT• DO-160 AIRBORNE (TRANSPORT AIRCRAFT ONLY)*<ul style="list-style-type: none">• 6G OPERATIONAL SHOCK• 15G CRASH SAFETY SHOCK• NO RANDOM VIBRATION• NO ENDURANCE LEVEL TESTING

*DO-160: RADIO TECHNICAL COMMISSION FOR AERONAUTICS (RTCA) REPORT:
"ENVIRONMENTAL CONDITIONS AND TEST PROCEDURES FOR AIRBORNE ELECTRICAL/ELECTRONIC
EQUIPMENT AND INSTRUMENTS, FEBRUARY 28, 1975.

TABLE 4.2 BEST COMMERCIAL PRACTICE (CONTINUED)

<u>CHARACTERISTIC</u>	<u>DESIGN PRACTICE</u>
<u>SHOCK & VIBRATION LIMITS (CONTINUED)</u>	
	● SINUSOIDAL VIBRATION
	● COCKPIT
	● LESS THAN 3G PK (5-54HZ)
	● 0.25G PK (54-2000HZ)
	● FUSELAGE
	● LESS THAN 3G PK (5-54HZ)
	● 3.0G PK (54-2000HZ)
<u>TEMPERATURE LIMITS</u>	
	● GROUND BASED
	● OPERATING 0°C TO 55°C
	● NON-OPERATING -40°C TO +60°C
	● DO-160 AIRBORNE (TRANSPORT AIRCRAFT ONLY)*
	● NOT COMBINED WITH ALTITUDE
	● COCKPIT
	● OPERATING -15°C TO +55°C (+71°C DASH)
	● NON-OPERATING -55°C TO +85°C
	● FUSELAGE
	● OPERATING -55°C TO +71°C
	● NON-OPERATING -55°C TO +85°C

*DO-160: RADIO TECHNICAL COMMISSION FOR AERONAUTICS (RTCA) REPORT:
"ENVIRONMENTAL CONDITIONS AND TEST PROCEDURES FOR AIRBORNE ELECTRICAL/ELECTRONIC
EQUIPMENT AND INSTRUMENTS, FEBRUARY 28, 1975.

TABLE 4.2 BEST COMMERCIAL PRACTICE (CONTINUED)

<u>CHARACTERISTIC</u>	<u>DESIGN PRACTICE</u>
<u>HUMIDITY LIMITS</u>	<ul style="list-style-type: none">• GROUND BASED<ul style="list-style-type: none">• 90 TO 95% AT 50°C (10 DAY)• AIRBORNE<ul style="list-style-type: none">• 95 TO 100% AT 65°C (10 DAY)
<u>QUALITY ASSURANCE PROVISIONS</u>	<ul style="list-style-type: none">• AIRBORNE/GROUND BASED<ul style="list-style-type: none">• FINAL TEST (ALL EQUIPMENT)• TEMPERATURE CYCLING W/VIBRATION BURN-IN• RELIABILITY GROWTH TESTING• RELIABILITY DEMONSTRATION TESTING• QUALIFICATION TESTING• PRODUCTION SAMPLING RELIABILITY TEST• HIGH QUALITY AUDIT LEVEL OF EFFORT• EXTENSIVE FAILURE REPORTING TO CUSTOMER

TABLE 4.3 RUGGEDIZED

<u>CHARACTERISTIC</u>	<u>DESIGN PRACTICE</u>
THERMAL DESIGN	<ul style="list-style-type: none">• SAME AS BEST COMMERCIAL PRACTICE
DERATING PRACTICES	<ul style="list-style-type: none">• SAME AS BEST COMMERCIAL PRACTICE
PARTS QUALITY	<ul style="list-style-type: none">• TYPICALLY SAME AS BEST COMMERCIAL PRACTICE• FREQUENTLY MILITARY QPL PARTS USED
PACKAGING CONCEPT	<ul style="list-style-type: none">• GROUND BASED<ul style="list-style-type: none">• SAME AS BEST COMMERCIAL PRACTICE• AIRBORNE<ul style="list-style-type: none">• TRANSPORT - SAME AS BEST COMMERCIAL PRACTICE• HIGH PERFORMANCE<ul style="list-style-type: none">• MORE SHIELDING (EMI/RFI)• STURDIER STRUCTURE

TABLE 4.3 RUGGEDIZED (CONTINUED)

- SHOCK & VIBRATION
LIMITS
- GROUND BASED
 - SAME AS BEST COMMERCIAL PRACTICE
 - AIRBORNE
 - SHOCK - SAME AS BEST COMMERCIAL PRACTICE
 - TRANSPORT AIRCRAFT VIBRATION
 - DO-160 RANDOM VIBRATION (1 HR. PER AXIS)*
 - COCKPIT (0.32G RMS/10-2000HZ)
 - FUSELAGE (0.76G RMS/10-2000HZ)
 - ENDURANCE LEVEL (3 HRS. PER AXIS)
 - DO-160 ROBUSTNESS TEST*
 - COCKPIT (0.74G RMS/10-2000HZ)
 - FUSELAGE (8.65G RMS/10-2000HZ)
 - HIGH PERFORMANCE AIRCRAFT VIBRATION
 - MILITARIZED LIMITS REQUIRED

*DO-160: RADIO TECHNICAL COMMISSION FOR AERONAUTICS (RTCA) REPORT:
"ENVIRONMENTAL CONDITIONS AND TEST PROCEDURES FOR AIRBORNE ELECTRICAL/ELECTRONIC
EQUIPMENT AND INSTRUMENTS, FEBRUARY 28, 1975.

TABLE 4.3 RUGGEDIZED (CONTINUED)

<u>CHARACTERISTIC</u>	<u>DESIGN PRACTICE</u>
TEMPERATURE LIMITS	<ul style="list-style-type: none">● GROUND BASED - SAME AS BEST COMMERCIAL PRACTICE● AIRBORNE<ul style="list-style-type: none">● COMBINED TEMPERATURE ALTITUDE TESTING REQUIRED (MILITARIZED LIMITS)● TEMPERATURE EXTREMES - SAME AS BEST COMMERCIAL PRACTICE
HUMIDITY LIMITS	<ul style="list-style-type: none">● GROUND BASED - SAME AS BEST COMMERCIAL PRACTICE● AIRBORNE<ul style="list-style-type: none">● 95-100% AT 65°C (10 DAY)
QUALITY ASSURANCE PROVISIONS	<ul style="list-style-type: none">● SAME AS BEST COMMERCIAL PRACTICE EXCEPT:<ul style="list-style-type: none">● PRODUCTION SAMPLING TESTS● INCREASED LEVEL OF FAILURE REPORTING TO CUSTOMER● HIGHER QUALITY AUDIT LEVEL OF EFFORT

TABLE 4.4 MILITARIZED

<u>CHARACTERISTIC</u>	<u>DESIGN PRACTICE</u>
THERMAL DESIGN	<ul style="list-style-type: none">• FORMAL TESTING REQUIRED• CRITICAL PARTS IDENTIFIED WITH ADEQUATE MARGINS PROVIDED• MORE EMPHASIS BECAUSE OF GREATER THERMAL DENSITY IN HIGH-PERFORMANCE A/C
DERATING PRACTICES	<ul style="list-style-type: none">• CONTRACTUALLY REQUIRED• TYPICALLY MORE STRINGENT• REQUIRED FOR ALL PARTS
PARTS QUALITY	<ul style="list-style-type: none">• QPL (QUALIFIED PRODUCT LIST) REQUIRED• ER (ESTABLISHED RELIABILITY) PASSIVE PARTS• SCREENED (TX, TXV) ACTIVE PARTS• PROGRAM PARTS SELECTION LIST (PPSL) ESTABLISHED

TABLE 4.4 MILITARIZED (CONTINUED)

<u>CHARACTERISTIC</u>	<u>DESIGN PRACTICE</u>
<u>PACKAGING CONCEPT</u>	<ul style="list-style-type: none">• GROUND BASED• ENCLOSURES DEFINED• COOLING METHODS STANDARDIZED• AIRBORNE• PACKAGING STANDARDS• UNIQUE FOR HIGH PERFORMANCE A/C• HIGH DENSITY• MORE SHIELDING (EMI/RFI)
<u>SHOCK & VIBRATION LIMITS</u>	<ul style="list-style-type: none">• GROUND BASED• 30G PEAK OPERATIONAL SHOCK• NO CRASH SAFETY LIMIT• SINUSOIDAL VIBRATION<ul style="list-style-type: none">• 2.5G PK (5-200HZ)• AIRBORNE<ul style="list-style-type: none">• SHOCK - SAME AS BEST COMMERCIAL PRACTICE• VIBRATION<ul style="list-style-type: none">• RANDOM PER MIL-STD-810C• PERFORMANCE LEVELS (1 HR. PER AXIS)

TABLE 4.4 MILITARIZED (CONTINUED)

CHARACTERISTIC

SHOCK & VIBRATION
LIMITS

DESIGN PRACTICE

- TRANSPORT AIRCRAFT
 - COCKPIT (0.7G RMS/15-2000HZ)
 - FUSELAGE (8.0G RMS/15-2000HZ)
- HIGH PERFORMANCE AIRCRAFT
 - COCKPIT (6.0G RMS/15-2000HZ)
 - FUSELAGE (9.8G RMS/15-2000HZ)
- ENDURANCE LEVELS (3 HR. PER AXIS)
- TRANSPORT AIRCRAFT
 - COCKPIT (2.0G RMS/15-2000HZ)
 - FUSELAGE (17.0G RMS/15-2000HZ)
- HIGH PERFORMANCE AIRCRAFT
 - COCKPIT (10.5G RMS/15-2000HZ)
 - FUSELAGE (19.9G RMS/15-2000HZ)
- SINUSOIDAL
 - TRANSPORT AIRCRAFT
 - COCKPIT/FUSELAGE
 - LESS THAN 2G PK (5-14HZ)
 - 2G PK (14-33HZ)
 - LESS THAN 5G PK (33-52HZ)
 - 5G PK (52-2000HZ)

TABLE 4.4 MILITARIZED (CONTINUED)

<u>CHARACTERISTIC</u>	<u>DESIGN PRACTICE</u>
SHOCK & VIBRATION LIMITS (CONTINUED)	<ul style="list-style-type: none">• HIGH PERFORMANCE AIRCRAFT• COCKPIT/FUSELAGE<ul style="list-style-type: none">• LESS THAN 2G PK (5-14HZ)• 2G PK (14-33HZ)• LESS THAN 5G PK (33-52HZ) 5G PK (52-2000HZ)
TEMPERATURE LIMITS	<ul style="list-style-type: none">• GROUND BASED<ul style="list-style-type: none">• OPERATING (0°C TO 52°C)• NON-OPERATING (-62°C TO +71°C)• AIRBORNE (COMBINED WITH ALTITUDE)<ul style="list-style-type: none">• COCKPIT (50,000 FT)<ul style="list-style-type: none">• OPERATING (-54°C TO +55°C) (71°C DASH)• NON-OPERATING (-57°C TO +85°C)• FUSELAGE (70,000 FT)<ul style="list-style-type: none">• OPERATING (-54°C TO +71°C) (95°C DASH)• NON-OPERATING (-57°C TO +95°C)

TABLE 4.4 MILITARIZED (CONTINUED)

CHARACTERISTIC

DESIGN PRACTICE

HUMIDITY LIMITS

• GROUND BASED

- 90 TO 95% AT +50°C (2 DAY)
- DO-160 AIRBORNE (TRANSPORT AIRCRAFT ONLY)*
- 95 TO 100% AT +50°C (2 DAY)

QUALITY ASSURANCE
PROVISIONS

• AIRBORNE/GROUND BASED

- FINAL TEST (ALL EQUIPMENT)
- TEMPERATURE CYCLING BURN-IN
- DISCRETIONARY RELIABILITY/LONGEVITY TESTING
- PRODUCTION QUALIFICATION TESTING
- MEDIUM QUALITY AUDIT LEVEL OF EFFORT
- LIMITED FAILURE REPORTING TO CUSTOMER

*DO-160: ENVIRONMENTAL CONDITIONS AND TEST PROCEDURES FOR AIRBORNE ELECTRICAL/
ELECTRONIC EQUIPMENT AND INSTRUMENTS, FEBRUARY 28, 1975.

5.0 DEVELOPMENT OF GUIDELINES

The objective of this study was to develop guidelines for Air Force Program Managers through the analysis of the Reliability, Maintainability, and Life Cycle Cost impact of using commercial off-the-shelf equipment in a military environment. These guidelines consider the entire gamut of operational factors influencing the use of commercial off-the-shelf vs. military specification designed equipment in a military use environment. Twenty operational factors, shown in Table 5-1, have been incorporated into this study. This list of factors was developed from the list of major factors identified in paragraph 4.1.2.1.1 of the contract statement of work with 2 additions. The two factors, procurement schedule and technical publications, were added.

TABLE 5.1
OPERATIONAL FACTORS

Procurement Schedule	Configuration Management
Reliability	Guarantees and Warranties
Maintainability	Non-Std. Parts
Personnel Safety	Special Handling
Personnel Training	QA Test and Inspection
Technical Publications	Combat Readiness
Spares Provisioning	Input Power
Parts Quality	EMC
Part Availability	Data Rights
Interchangeability	Small Business

5.1 Initial Approach

Initially, our approach to this study was to assess the life cycle cost, consisting of the development and maintenance cost elements, of both commercially designed and military designed equipments in each class and environment. These analyses, under this assumption, would address each of the 20 operational factors in both the development and the operational phases of the equipment life. Some of these parameters such as reliability, maintainability, and spares provisioning were available from the operations and maintenance data provided by the Air Force; however, data on the reliability or maintainability effort expended during the development phase to achieve the operational reliability and maintainability levels was not as readily obtained.

This became a major problem to the approach of using only an LCC analysis result to provide guidelines. When this difficulty became apparent, we altered our approach. However, the data that had been collected on the development phase effort on these operational parameters has been provided in Appendix 5.

5.2 Revised Approach

When it became apparent to us that our original approach was not feasible, we revised our approach. An LCC analyses was conducted for each selected equipment with that analysis quantifying the production, support and maintenance cost elements. Development cost elements were not included.

Operational and maintenance data was obtained from the Air Force data center at Wright-Patterson Air Force Base for each equipment discussed in Section 6. Data was extracted from these reports and used as the reliability and maintainability parameters in the calculation of the support and maintenance cost elements. Other data sources and the resultant data are discussed in Section 7.

These analyses provided values for the logistics support cost (LSC) and life cycle cost (LCC) in which the LCC is defined as only production, support and maintenance costs. At this point, we still recognized several problems. They were:

1. When comparing two systems doing similar jobs, we found wide differences in the equipment weight and complexity especially as measured by electrical parts count.
2. Operational hours and number of systems in the field varied widely.
3. In order to properly assess program risk, consideration had to be given to the 20 identified operational factors during the development phase.

5.2 Revised Approach (Continued)

4. A lack of equipment and data for analysis of commercial off-the-shelf equipment in an Airborne Inhabited Fighter (A_{IF}) environment existed.

The first two of these problems were solved by normalizing the analysis results by flight hour and by part. The principal measures were as follows:

1. Reliability measure, "FR/Part ($\times 10^{-6}$)" or failures per million operating hours per part.
2. Maintainability measure, "MMH/FH/Part ($\times 10^{-6}$)" or maintenance manhours per million flight hours per part.
3. Support cost measure, "LSC/FH/Part ($\times 10^{-6}$)" or logistic support cost per million flight hours per part.
4. Life cycle cost measure, "LCC/FH/Part ($\times 10^{-6}$)" or life cycle cost per million flight hours per part.

The results of this normalization for the 18 LCC analyses are shown in Table 5.2.

The third problem, consideration of the operational factors during the development phase is discussed in paragraph 5.2.1.

The lack of operational data on commercial off-the-shelf equipment in Airborne Inhabited Fighter environment threatened to leave a large gap in our analyses. For the purposes of this report, we opted to develop data for this missing class of equipment from the commercial

LCC DATA & RESULTS
TABLE 5-2

FILE NAME	AT-PR-NIL	AT-PR-COM	AF-PR-NIL	AF-PR-COM	AT-RA-NIL	AT-RA-COM	AF-RA-NIL	AF-RA-COM	AT-PE-NIL	AT-PE-COM	AF-PE-NIL	AF-PE-COM
ENVIRONMENT	MILITARY TRANSPORT	MILITARY TRANSPORT	FIGHTER DATA	FIGHTER DATA	MILITARY TRANSPORT COMMUN- CATIONS	MILITARY TRANSPORT COMMUN- CATIONS	FIGHTER COMMUN- CATIONS	FIGHTER COMMUN- CATIONS	MILITARY TRANSPORT PERIPHERALS	MILITARY TRANSPORT PERIPHERALS	FIGHTER PERIPHERALS	FIGHTER PERIPHERALS
EQUIPMENT TYPE	DATA PROCESSING	DATA PROCESSING	PROCESSING	PROCESSING	COMMUN- CATIONS	COMMUN- CATIONS	COMMUN- CATIONS	COMMUN- CATIONS	PERIPHERALS	PERIPHERALS	PERIPHERALS	PERIPHERALS
EQUIPMENT CLASS	MILITARY	COMMERCIAL	MILITARY	COMMERCIAL	MILITARY	COMMERCIAL	MILITARY	COMMERCIAL	MILITARY	COMMERCIAL	MILITARY	COMMERCIAL
A/C	C-SA	KC-135	F-15	F-15	C-SA	C-141	F-15	F-15	C-SA	KC-135A	F-15A/B	F-15
FLEET SIZE	74	615	364	364	74	269	364	364	74	615	364	364
* MTR												
* MTRF												
FIU/VR/AC	697	345	229	229	697	533	229	229	697	345	229	229
UC	128,294	9,447	37,069	9,447	10,711	9,327	11,462	9,327	30,528	5,328	16,586	5,328
ACQUISITION COST	13,742,708	13,895,637	14,415,982	4,072,266	1,979,378	5,850,433	5,115,763	4,265,233	6,161,287	9,384,983	6,406,104	2,924,062
LSC	3,544,264	4,564,523	2,681,628	8,317,429	2,692,182	3,132,794	6,645,712	6,645,712	3,040,679	6,692,479	2,316,393	5,215,942
LCC	17,286,972	16,460,160	17,097,527	12,324,694	4,671,560	8,973,228	11,261,974	10,911,944	9,201,966	16,082,462	8,720,497	8,140,003
PARTS COUNT	8,250	3,800	3,300	3,800	810	190	810	790	497	490	454	490
* FR/PART (X 10 ⁻⁶)												
LSC/OP HR/PART (X 10 ⁻⁶)	555	189	650	1,750	2,150	922	6,562	6,722	3,954	2,147	4,077	8,514
LCC/SYSTEM	233,608	15,008	46,971	33,860	31,565	16,716	32,312	29,978	62,175	13,075	23,957	22,363
LCC/AIRCRAFT	233,608	30,017	46,971	33,860	63,129	33,432	32,312	29,978	124,351	26,150	23,957	22,363
LCC/OP HR/PART (X 10 ⁻⁶)	2,706	763	4,144	2,594	3,727	2,647	11,613	11,037	11,966	5,156	15,362	13,286
* MTR/TH												
* MTR/TH/PART (X 10 ⁻⁶)												

*values omitted to prevent misinterpretation.

TABLE 5.2 LCC DATA & RESULTS

ENVIRONMENT	GN-PR-MIL		GN-PR-COM		GN-RA-MIL		GN-RA-COM		GN-PE-MIL		GN-PE-COM	
	GROUND DATA PROCESSING	MILITARY	GROUND DATA PROCESSING	COMMERCIAL	GROUND COMMUNICATIONS	MILITARY	GROUND COMMUNICATIONS	COMMERCIAL	GROUND PERIPHERALS	MILITARY	GROUND PERIPHERALS	COMMERCIAL
INVENTORY SIZE	82		6		205		99		92		13	
* MTBR												
* MTBF												
OP HR/YR/SYSTEM	452		1,020		4,390		688		556		1,662	
UC	46,800		34,700		11,000		10,087		20,506		146,639	
ACQUISITION COST	7,170,500		360,600		8,919,110		1,490,689		8,603,611		873,200	
LSC	5,904,600		324,000		5,405,166		293,598		11,022,430		229,600	
LCC	13,075,000		684,600		14,324,276		1,784,286		19,626,040		1,102,800	
PARTS COUNT	2,350		1,875		1,900		790		1,168		5,270	
* FR/PART (X10 ⁻⁶)												
LSC/OP HR/PART (X10 ⁻⁶)	4,519		1,882		211		364		15,385		134,4	
LCC/SYSTEM	152,452		114,100		69,875		18,023		213,327		84,828	
LCC/OP HR/PART (X10 ⁻⁶)	10,008		3,977		558		2,213		27,394		646	
* MMH/FH												
* MMH/FH/PART (X10 ⁻⁶)												

*Values omitted to prevent misinterpretation.

5.2 Revised Approach (Continued)

off-the-shelf equipment data from the Airborne Inhabited Transport (A_{IT}) environment.

Our basic assumption was that all data from commercial off-the-shelf equipment in the Airborne Inhabited Transport environment except equipment failure rate would be used for the Airborne Inhabited Fighter environment analyses. The failure rate was adjusted to reflect the more strenuous environment. In the cases of the data processing and data processing peripherals equipment, the failure rate per part was doubled as shown in Table 5.2. This adjustment is approximately in accordance with the guidelines of MIL-HDBK-217C. In the case of communications equipment, doubling the Airborne Inhabited Transport commercial off-the-shelf equipment failure rate would leave it one fourth of the military designed equipment failure rate per part and, in our opinion, bias the analysis in favor of a commercial off-the-shelf decision. We compromised by giving the commercial off-the-shelf equipment a failure rate per part equal to the military designed equipment. Even at that, the analysis indicated a commercial off-the-shelf procurement decision for communications equipment as shown in Table 2.1.

5.2.1 Operational Factor Assessment

Any decision that is reached regarding the selection of commercial off-the-shelf or military (designed) equipment must consider the operational factors that may be affected. The impact of various operational factors will be different dependent upon the equipment environment (i.e., ground-fixed, airborne inhabited transport or airborne inhabited fighter).

To better represent the operational factor influences, a quantitative risk assessment matrix was developed for each of the operational environments for commercial and military equipment. Twenty operational factors were considered for this comparison. Initially, a relative weighting factor must be determined from the viewpoint of the procuring offices. The factors represent emphasis to be placed on the operational factors with the higher numbers representing increased emphasis. The sum of the relative weight should be 100.

A scale of 1 to 10 was then established as a means of quantifying risk for the various operational parameters. A one represents a very low risk whereas a 10 represents the highest risk. Based on the results of the industry survey and Rockwell-Collins expertise, a risk measure was determined for each of the operational factors for both commercial and military equipment. The product of the risk measure and the weighting factor represents a quantified risk measure. The sum of these products depicts the total risk measure for the commercial or military alternative.

Tables 5-3, 5-4, and 5-5 contain the individual operational parameter risk measures and the total risk measures for the two procurement alternatives and the three operational environments.

GROUND-FIXED ENVIRONMENT
TABLE 5-3

OPERATIONAL FACTOR	REL. WGT	COM. G _F	COM. RISK MEASURE	MIL. G _F	MIL. RISK MEASURE
Procurement Schedule	10	2	20	10	100
Reliability	10	2	20	2	20
Maintainability	10	2	20	2	20
Personnel Safety	7	1	7	1	7
Personnel Training	7	6	42	3	21
Technical Publications	8	5	40	3	24
Spares Provisioning	7	5	35	4	28
Parts Quality	5	4	20	2	10
Part Availability	2	1	2	5	10
Interchangeability	5	4	20	2	10
Configuration Management	7	5	35	3	21
Guarantees and Warranties	1	1	1	1	1
Non-Std. Parts	5	3	15	1	5
Special Handling	1	3	3	1	1
QA Test and Inspection	8	4	32	3	24
Combat Readiness	2	2	4	2	4
Input Power	1	1	1	1	1
EMC	2	1	2	1	2
Data Rights	1	8	8	1	1
Small Business	1	8	8	1	1
			336		311
			1.08		1.0

AIRBORNE INHABITED TRANSPORT ENVIRONMENT

TABLE 5-4

OPERATIONAL FACTOR	REL. WGT	COM. A _{IT}	COM. RISK MEASURE	MIL. A _{IT}	MIL. RISK MEASURE
Procurement Schedule	10	2	20	10	100
Reliability	10	5	50	8	80
Maintainability	10	8	80	5	50
Personnel Safety	7	5	35	5	35
Personnel Training	7	7	49	3	21
Technical Publications	8	6	48	3	24
Spares Provisioning	7	5	35	4	28
Parts Quality	5	4	20	2	10
Part Availability	2	1	2	5	10
Interchangeability	5	4	20	2	10
Configuration Management	7	5	35	3	21
Guarantees and Warranties	1	1	1	1	1
Non-Std. Parts	5	3	15	1	5
Special Handling	1	1	1	1	1
QA Test and Inspection	8	6	48	3	24
Combat Readiness	2	1	2	1	2
Input Power	1	2	2	1	1
EMC	2	7	14	2	4
Data Rights	1	8	8	1	1
Small Business	1	8	8	1	1
	100		493 1.15		429 1.0

OPERATIONAL FACTOR ASSESSMENT
 AIRBORNE INHABITED-FIGHTER ENVIRONMENT
 TABLE 5-5

OPERATIONAL FACTOR	REL. WGT	COM. A _{IF}	COM. RISK MEASURE	MIL. A _{IF}	MIL. RISK MEASURE
Procurement Schedule	10	2	20	10	100
Reliability	10	10	100	8	80
Maintainability	10	8	80	5	50
Personnel Safety	7	7	49	5	35
Personnel Training	7	7	49	3	21
Technical Publications	8	6	48	3	24
Spares Provisioning	7	5	35	4	28
Parts Quality	5	4	20	2	10
Part Availability	2	1	2	5	10
Interchangeability	5	4	20	2	10
Configuration Management	7	5	35	3	21
Guarantees and Warranties	1	1	1	1	1
Non-Std. Parts	5	3	15	1	5
Special Handling	1	1	1	1	1
QA Test and Inspection	8	8	64	3	24
Combat Readiness	2	1	2	1	2
Input Power	1	2	2	1	1
EMC	2	7	14	2	4
Data Rights	1	8	8	1	1
Small Business	1	8	8	1	1
			611		429
			1.42		1.0

5.2.1 Operational Factor Assessment (Continued)

Referring to Table 5-3 for the ground-fixed environment, the total risk measure for commercial procurement is 336 compared to 311 for military procurement. Thus, the operational factor risk for the commercial procurement is 8% more than for the military procurement. The incremental risks for airborne inhabited transport and airborne inhabited fighters are 15% and 42% respectively.

5.3 Acquisition Strategy

The rationale for determining the Recommended Acquisition Strategy Matrix, (Table 5-6), requires combining the results of the Life Cycle Cost Data/Results matrices, (Table 5-2), and the Operational Factor Assessment matrices, (Tables 5-3, 5-4 and 5-5).

Referring to Table 5-2, the Airborne Inhabited Transport LCC/OP HR/PART (10^{-6}) for the military data processing equipment is 2,708. The operational factor on Table 5-4 is 429 for the military equipment. Comparable results for the commercial equipment are 763 and 493 respectively. The product of these parameters is 1.6×10^6 for the military equipment and 0.4×10^6 for the commercial equipment. This results in the LCC advantages of the commercial acquisition far outweighing the operational risks. There is about a 3:1 advantage with the commercial acquisition; therefore, the recommended acquisition strategy is the commercial equipment procurement. This same logic can be followed to arrive at the recommended acquisition strategy for the other elements of the matrix.

The far right column of Table 5-4 indicates the areas where further risk reduction could be achieved by additional requirements imposed by the procuring activity. The operational factors listed represent those factors with the highest risk measure on the Operational Factor Assessment matrices, (Tables 5-3, 5-4 and 5-5).

5.4 Risk Assessment

The Risk Assessment example, (Table 5-7) was derived assuming that the recommended acquisition strategy was not followed. In this case, the operational factors that would suffer are listed in the far right column.

RECOMMENDED ACQUISITION STRATEGY MATRIX

TABLE 5-6

ENVIRONMENT TYPE	COMMUNICATION	DATA PROCESSING	DATA PROCESSING PERIPHERALS	OPERATIONAL FACTORS REQUIRING EMPHASIS
GROUND, FIXED	MILITARY	COMMERCIAL	COMMERCIAL	<ul style="list-style-type: none"> • PERSONNEL TRAINING • TECHNICAL PUBS • SPARES PROVISIONING • CONFIGURATION MANAGEMENT
AIRBORNE, INHABITED TRANSPORT	COMMERCIAL	COMMERCIAL	COMMERCIAL	<ul style="list-style-type: none"> • MAINTAINABILITY • RELIABILITY • PERSONNEL TRAINING
AIRBORNE INHABITED FIGHTER	MILITARY	COMMERCIAL	MILITARY	<ul style="list-style-type: none"> • PROCUREMENT SCHEDULE • RELIABILITY • MAINTAINABILITY

RISK ASSESSMENT EXAMPLE

TABLE 5-7

TYPE ENVIRONMENT	COMMUNICATION	DATA PROCESSING	DATA PROCESSING PERIPHERALS	OPERATIONAL FACTORS REQUIRING EMPHASIS
GROUND, FIXED	COMMERCIAL	MILITARY	MILITARY	<ul style="list-style-type: none"> • PROCUREMENT SCHEDULE • SPARES PROVISIONING • TECHNICAL PUBS • QA TEST AND INSPECTION
AIRBORNE, INHABITED TRANSPORT	MILITARY	MILITARY	MILITARY	<ul style="list-style-type: none"> • PROCUREMENT SCHEDULE • RELIABILITY • MAINTAINABILITY
AIRBORNE, INHABITED FIGHTER	COMMERCIAL	MILITARY	COMMERCIAL	<ul style="list-style-type: none"> • RELIABILITY • MAINTAINABILITY • QA TEST AND INSPECTION

5.4 Risk Assessment (Continued)

These factors should be emphasized by the Program Manager to reduce the additional risk incurred by not using the recommended acquisition strategy.

6.0 SELECTION OF EQUIPMENT

Table 6.1 contains a summary of equipment selected by Rockwell-Collins and approved by RADC to be used for the LCC study.

These equipments have been chosen to provide reliability, maintainability, and usage data for the development of guidelines indicating the most advantageous class of equipment, military or commercial off-the-shelf, for a given military environment. Equipments were selected based on the following criteria:

- (1) Their agreement with the type, class and environmental constraints.
- (2) Availability of significant maintenance data.
- (3) Functional similarity between types of equipment in the given environments.

Candidates for selection were compiled after a search was made of reference documents such as Collins Equipment Type Listing Manual, various Aircraft Maintenance Work Unit Code Manuals, Interval Data and The Maintenance Data Collection System (TO 00-20-2), where each candidate was required to fit the type, class and environmental constraints.

Final selection was then made in part by the significance of the maintenance data available. Equipments with higher populations and usage rates are preferred, to maintain a high confidence in

TABLE 6.1

SELECTED EQUIPMENT FOR STUDY

ENVIRONMENT	CLASS	TYPES	DESIGNATION	NOMENCLATURE	PLATFORM	DESIGN YEAR	
Ground Fixed	Military	Communications	RT-980/SRC-171	Receiver Transmitter	Ground	1974	
		Data Processing	AN/FPS-77(V)	Radar Meteorological Set	Ground	1967	
		Data Peripheral	AN/GSH-34	Sound Recorder Reproducer	Ground	1970	
	Commercial	Communications	618H-1C	Radio Receiver-Transmitter	Ground	1966	
		Data Processing	AN/FPS-103	Weather Tracking Radar System	Ground	1966	
		Data Peripheral	VR-3700	Signal Data Recorder Reproducer	Ground	1968	
Airborne Inhabited Transport	Military	Communications	RT-967/ARC-109(V)	Radio Receiver-Transmitter	C-5A	1966	
		Data Processing	BG489C BG488C	AFCS Pitch/Pacs Computer AFCS Roll/Yaw Pacs Computer	C-5A	1972	
		Data Peripheral	AQU-4/A	Horizontal Situation Indicator Attitude Director Indicator	C-5A	1963/1971	
	Commercial	Communications	618H-1C	Radio Receiver-Transmitter	C-141A/B	1963	
		Data Processing	562-1E1 562R-1E	Pitch Computer Roll Computer	KC-135A	1967	
		Data Peripheral	331A-8H 329B-8G	Horizontal Situation Indicator Attitude Director Indicator	KC-135A	1967	
Airborne Inhabited Fighter	Military	Communications	RT-967/ARC-109(V)	Radio Receiver-Transmitter	F-15A/B	1966	
		Data Processing	CP-1104 CP-1105	Pitch Flight Control Computer Roll/Yaw Flight Control Computer	F-15A/B	1979	
		Data Peripheral	ID-1805/AJW-18 ARU-39/A	Horizontal Situation Indicator Attitude Indicator	F-15A/B	1972	
	Commercial	Communications	*				
		Data Processing	*				
		Data Peripheral	*				

* No examples of commercial off-the-shelf equipments used in an airborne inhabited-fighter environment were identified.

6.0 SELECTION OF EQUIPMENT (CONTINUED)

the accuracy of the data to be analyzed. In addition, equipments which have reached maturity (also referred to as constant failure rate period or useful life period) are preferable to reduce the impact of incipient faults or defects that result in early failures.

In the three environments, functionally similar equipment types are desirable between the military and commercial classes. This functional similarity will reduce comparison variables, increasing the credibility of the resultant guidelines. In addition, the problem of the absence of commercial equipment in an airborne inhabited fighter environment can be resolved analytically without degradation of the study contract results. Since maintenance practices and personnel are common for commercial and military equipment installed in airborne inhabited transport environments, the derived relationship can be applied to military equipment in airborne inhabited fighter environments to provide results for the commercial equipment on fighters.

6.1 Equipment Descriptions

Additional information on the selected equipments (Refer to Table 6-1) are contained in the following paragraphs. Included are purpose of equipment, vendor, approximate design year and equipment illustration.

6.1.1 Ground Fixed Environment

6.1.1.1 Communications Types

The RT-980/GRC-171 (Refer to Figure 6-1) and 618M-1C (Refer to Figure 6-2) are receiver-transmitters designed by Rockwell-Collins in 1974 and 1966 respectively.



FIGURE 6-1
RT-980/GRC-171
RADIO RECEIVER-TRANSMITTER

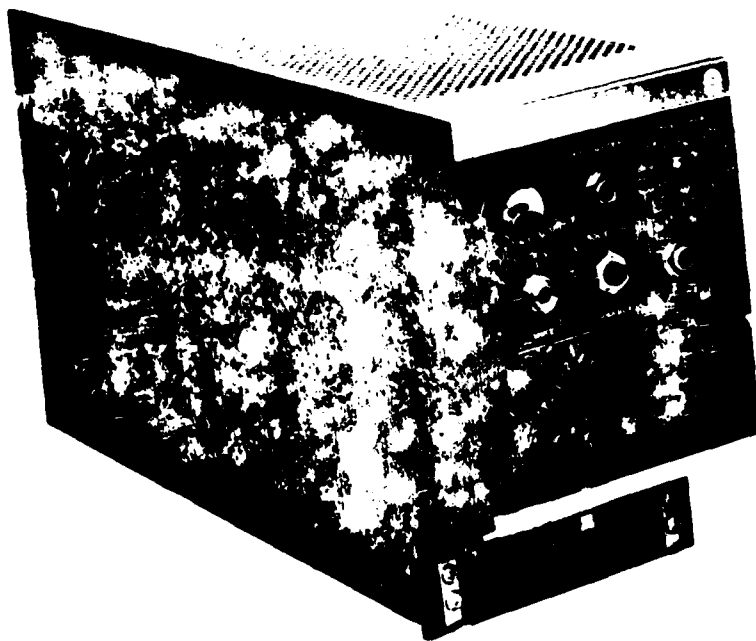

FIGURE 6-2
619M-16
RADIO RECEIVER-TRANSMITTER

The military designed RT-980/GRC-171 is a UHF R/T for air traffic control communications at collocated VHF/UHF receiver-transmitter sites. The equipment is solid state, consisting of a case, front panel and ten electrical subassemblies, with a total electrical parts count of approximately 1900 components.

The commercially designed 618M-1C issued for VHF communications between aircraft and fixed or mobile ground stations. The equipment is made up of a case, chassis assembly, front panel and nineteen electrical subassemblies with a total parts count of approximately 790 components.

6.1.1.2 Data Processing Types

The FPS-77V (Refer to Figure 6-3) and FPS-103 (Refer to Figure 6-4) are weather radar systems designed respectively, by Lear Siegler in 1967 and Bendix Avionics Division in 1966.

The military designed FPS-77V system is of search type, detecting, displaying and recording the true height, true range and azimuth bearing of atmospheric conditions such as storms, precipitation and other weather phenomena. The portion of the system studied consists of an electronic cabinet and console which contains twenty-two assemblies (four are mechanical), and twenty-nine electronic subassemblies with a total electronic parts count of 2350 components.

The FPS-103 is a commercially designed system which provides the observer/operator with a visual indication of weather conditions including contour presentation of storm activity within clouds. The portions of the system studied consist of the following six

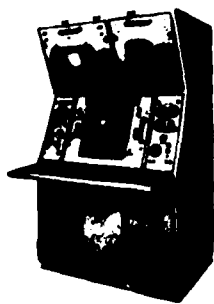

CONSOLE GROUP



CABINET GROUP

FPS-77V

RADAR METEOROLOGICAL SET

FIGURE 6-3

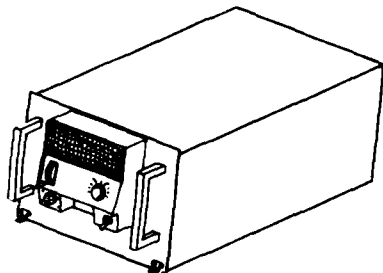

TRANSMITTER-RECEIVER

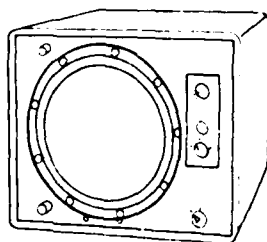

INDICATOR

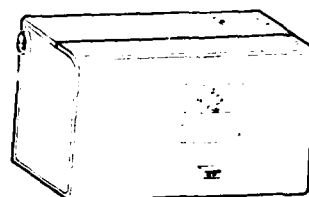

STARTER BOX

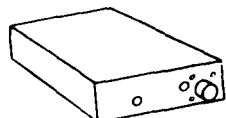

JUNCTION BOX

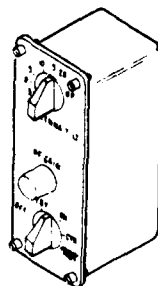

CONTROL PANEL

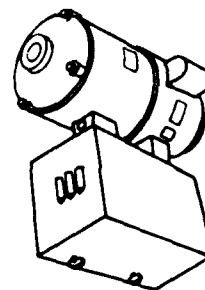

MOTOR/ALTERNATOR/
EXCITER-REGULATOR

FPS-103

WEATHER TRACKING RADAR SYSTEM

FIGURE 6-4

equipments: CNG-1B Control, WTR-1A Indicator, STG-1A Starter Box, ROR-1E Transmitter-Receiver, JBG-1E Junction Box and MGG-1A-1 Motor-Alternator/Exciter-Regulator.

6.1.1.3 Data Processing Peripheral Types

The AN/GSH-34 (Refer to Figure 6-5) and VR-3700 (Refer to Figure 6-6) are recorder reproducers designed respectively, by Stencil Corporation in 1970 and Bell & Howell in 1968.

The AN/GSH-34 is a military designed Voice Recorder Reproducer which handles multiple channels using one inch magnetic tape as its storage medium. Its principle usage is to record/reproduce conversations between aircraft and air traffic controllers.

The commercially designed VR-3700 Signal Recorder Reproducer provides multi-channel analog data recording/reproduction at various tape speeds onto fourteen track, one inch magnetic tape. Its single cabinet is made up of thirty-three assemblies (six of which are mechanical) within ten modules for a total electrical parts count of approximately 5270 components.

1.2 Airborne Inhabited Transport/Fighter

6.1.2.1 Communications Types

The RT-967/ARC-109(V) (Refer to Figure 6-7) and 618M-1C (Refer to Figure 6-2) are AM Transceivers designed by Rockwell-Collins in 1966 and 1963 respectively.

The military designed RT-967/ARC-109(V) is utilized in both a transport environment, aboard the C-5A aircraft, and a fighter environment aboard the F-15 A/B aircrafts. It operates on any of

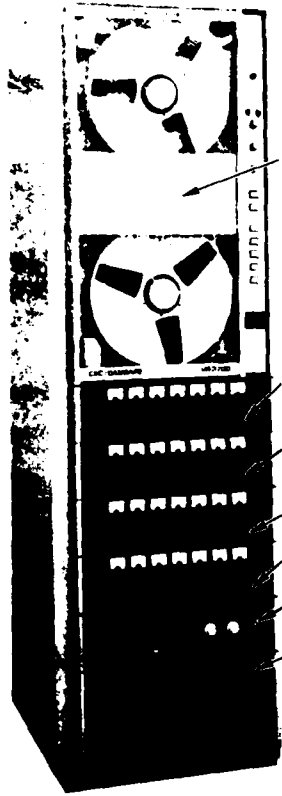

GSH-34
SOUND RECORDER REPRODUCER →
FIGURE 6-5

VR-3700
+ SIGNAL DATA RECORDER-
REPRODUCER
FIGURE 6-6

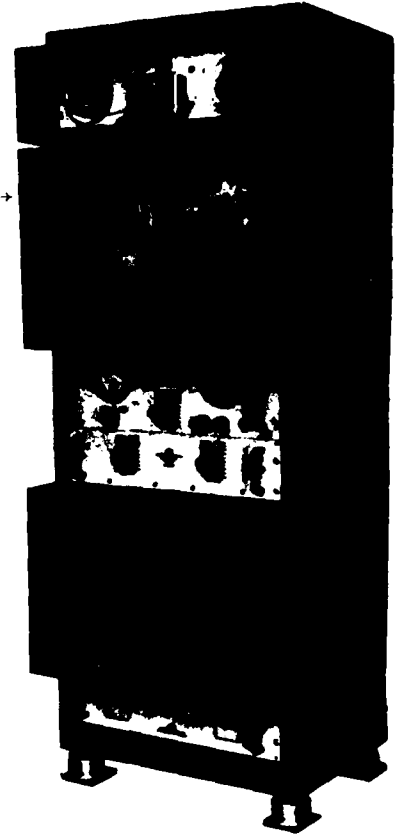

RT-967/ARC-109(V)
RECEIVER-TRANSMITTER
FIGURE 6-7



6.1.2.1 Communication Types (Continued)

3500 channels in the UHF band for radiotelephone communication between aircraft in flight, aircraft and ground, and aircraft and ship. The radio is made up of a case, chassis assembly, front panel and ten plug-in modules which have a total parts count of approximately 810 electronic components.

The commercially designed 618M-1C is utilized in a transport environment aboard C-141A's and C-141B's, for VHF communications between aircraft and fixed or mobile ground stations. The equipment is made up of a case, chassis assembly, front panel and nineteen electrical subassemblies for a total electrical parts count of approximately 790 components.

6.1.2.2 Data Processor Types

The BG489C(), BG488C() set (Refer to Figure 6-8), CP-1104, CP-1105 set (Refer to Figure 6-9) and 562P-1E1, 562R-1E set (Refer to Figure 6-10) are autopilot pitch and Roll/Yaw Computers.

The military designed BG498C() (AFCS Pitch/PACS Computer) and BF488C() (AFCS Roll/Yaw/PACS Computer) were built by Honeywell, Inc. in 1972 for usage aboard the C-5A transport aircraft. The pitch computer receives control signals from the aircraft attitude and heading reference subsystem, the central air data computer, navigation subsystems, and pilot controls, and furnishes output signals to control the aircraft pitch surface actuators. The Roll/Yaw Computer receives control signals from the horizontal situation indicator, inertial measurement unit as well as those

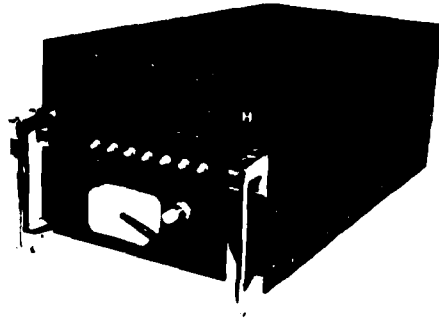

BG489C ()
AFCS PITCH/PACS COMPUTER

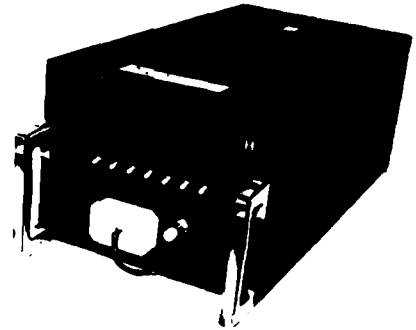

BG488C ()
RECEIVER-TRANSMITTER

C-5A AUTOPILOT COMPUTERS

FIGURE 6-8

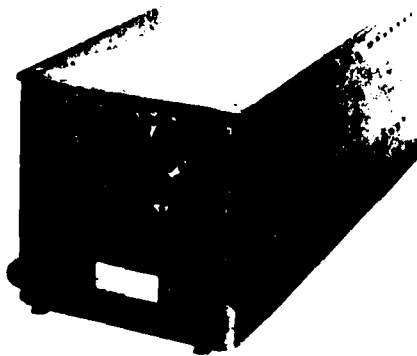

CP-1104
PITCH FLIGHT CONTROL COMPUTER

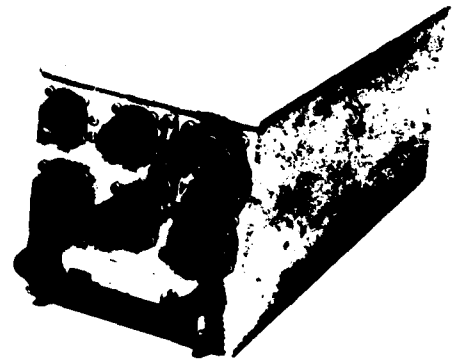

CP-1105
ROLL/YAW FLIGHT CONTROL COMPUTER

F-15A/B AUTOPILOT COMPUTERS

FIGURE 6-9

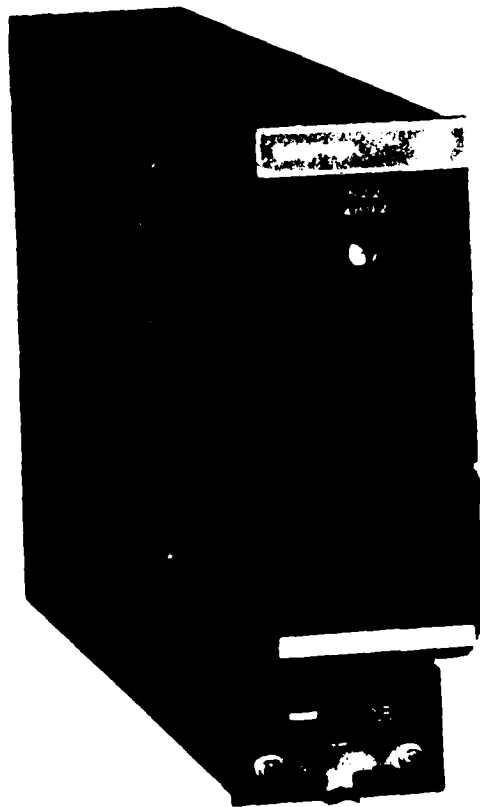

562P-1E1
PITCH COMPUTER

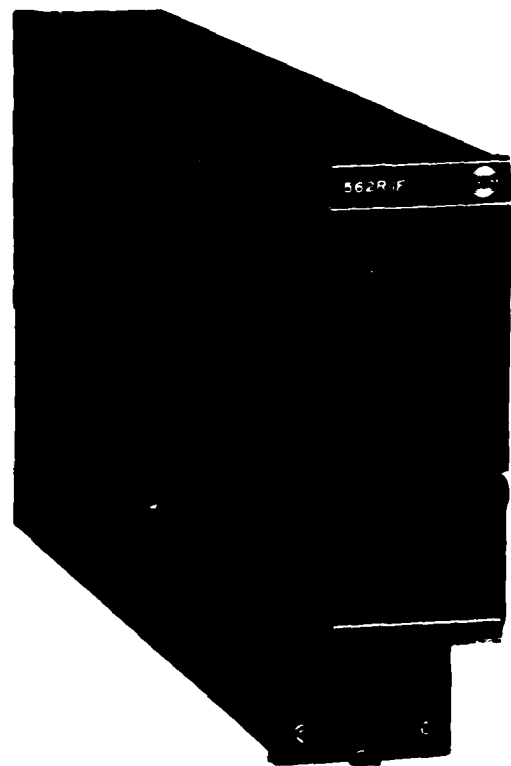

562R-1E
ROLL COMPUTER

FIGURE G-10
KC-135 AUTOPILOT COMPUTERS

6.1.2.2 Data Processor Types (Continued)

received by the pitch computer and furnishes output signals for controlling the aircraft roll autopilot and roll PACS servos.

Each computer consists of a chassis and multiple circuit boards (36 boards in pitch computer, 32 in roll computer) for a total parts count in the pitch and roll computer of 2640 and 1860 components respectively.

The military designed CP-1104 (Pitch Flight Control Computer) and CP-1105 (Roll/Yaw Flight Control Computer) are built by General Electric Company starting in 1979 for use on the F-15 A/B aircraft. Functionally they perform the same functions as the C-5A equipment in the preceding paragraph. The CP-1104 consists of a chassis and twelve interconnected circuit boards with a total parts count of approximately 1600 components. The CP-1105 consists of a chassis and fifteen interconnected circuit boards with approximately 1700 electrical components.

The commercially designed 562P-1E1 (Pitch Computer) and 562R-1E (Roll Computer) are built by Rockwell-Collins, designed in 1967 and are utilized in a dual configuration aboard the KC-135 transport aircraft. Their inputs and computational functions are similar to the preceding data processor equipments. Rather than the outputs being applied to surface actuators, the 562P-1E1 and 562R-1E outputs are displayed to the pilot and copilot using the HSI (Horizontal Situation Indicator) and ADI (Attitude Director Indicator). Each equipment consists of a case, rear assembly and five interconnected electronic assemblies with a total parts count of 730 components in the 562P-1E1 and 890 components in the 562R-1E.

6.1.2.3 Data Processor Peripheral Types

The AQU-4/A and associated ADI (Refer to Figure 6-11), ID-1805/AJN-18 and ARU-39/A (Refer to Figure 6-12) and 331A-8H, 329B-8G (Refer to Figure 6-13) are HSI (Horizontal Situation Indicator), ADI (Attitude Director Indicator) sets.

The military designed AQU-4/A (built by Astronautics Corporation of America) and associated ADI (built by Bendix Corporation) are utilized aboard the C-5A transport aircraft in a dual installation. The HSI, designed in 1963, is a hermetically sealed, panel mounted, aircraft navigation instrument consisting of a chassis, four mechanical assemblies and an electronic assembly for a total parts count of 70 electronic components. The ADI, designed in 1971 provides the pilot with primary aircraft attitude indication, presents a symbolic picture of aircraft pitch and bank attitude and provides command information for following a selected flight path. It is made up of a chassis, five mechanical subassemblies and three electronic assemblies for a total parts count of 270 electronic components.

The ID-1805/AJN-18 (HSI) and ARU-39/A (ADI) are military flight instruments designed in 1972 for use in the F-15 A/B aircraft. The ID-1805/AJN-18, designed by Rockwell-Collins, is the aircraft instrument portion of the AJN-18 indicator set which displays a pictorial plan view of aircraft course and heading. It displays selected heading/course, bearing, course deviation, range to destination, validity flags and a to-from indicator. The HSI consists of three mechanical subassemblies and three circuit boards containing approximately 300 electronic components, all enclosed in a hermetically sealed case. The ARU-39/A, designed

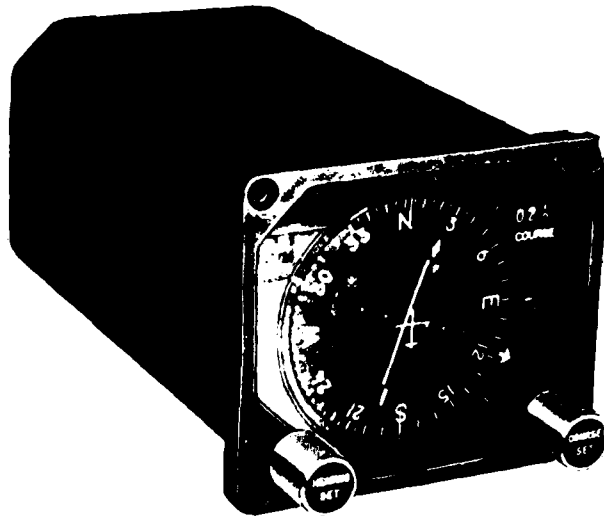

AQU-4/A

HORIZONTAL SITUATION INDICATOR

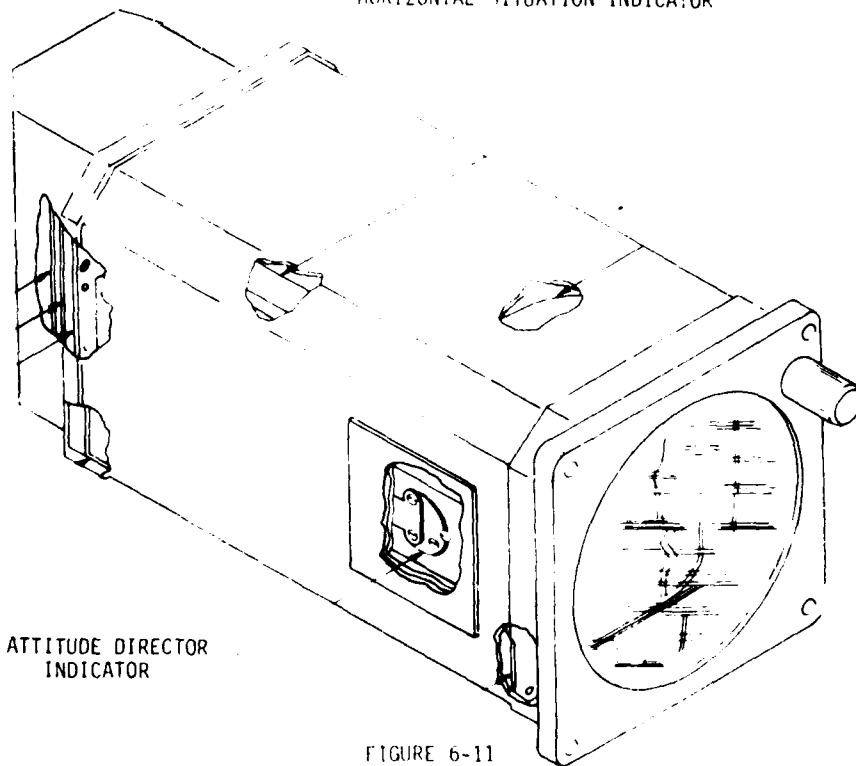

ATTITUDE DIRECTOR
INDICATOR

FIGURE 6-11
C-5A FLIGHT INSTRUMENTS

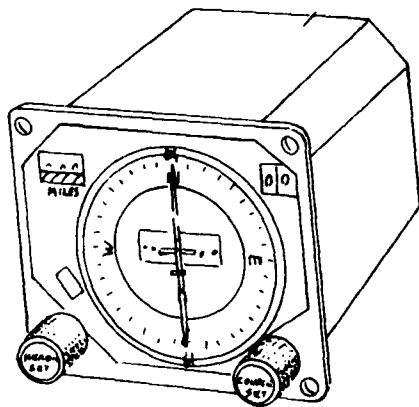

ID-1805/AJN-18
HORIZONTAL SITUATION INDICATOR

ARU-39/A
ATTITUDE DIRECTOR INDICATOR

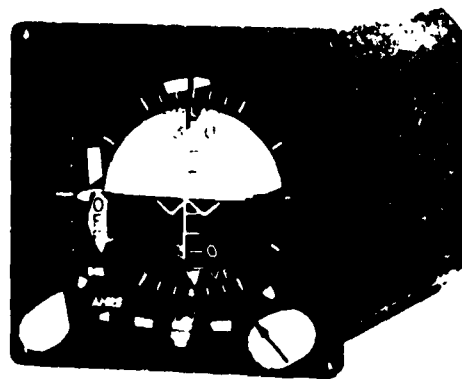

F-15A/B FLIGHT INSTRUMENTS

FIGURE 6-12

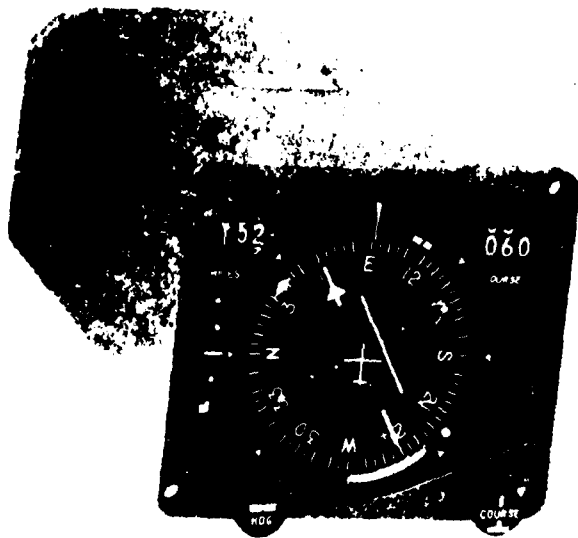

331A-8H
HORIZONTAL SITUATION INDICATOR

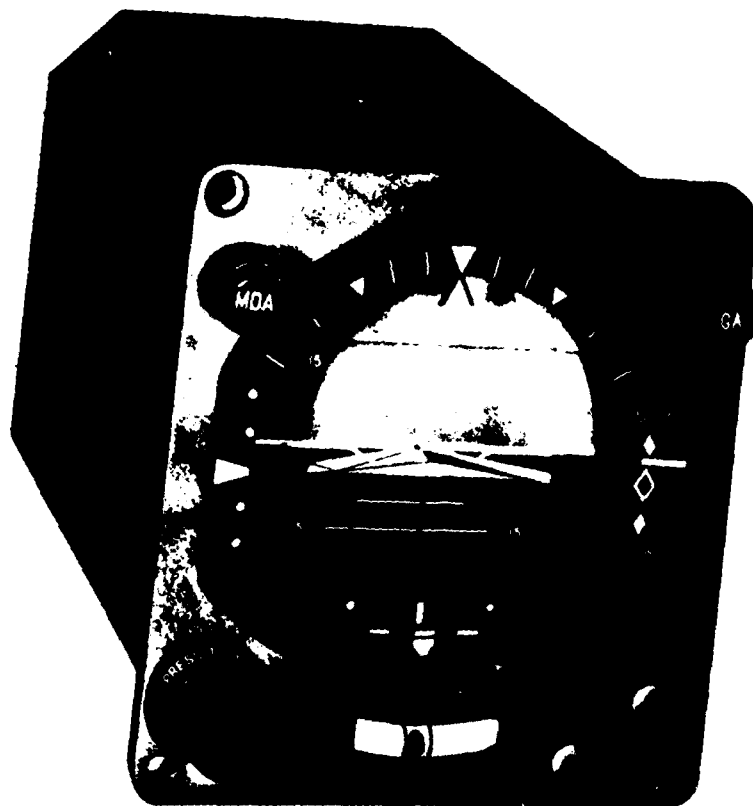

3298-8G
ATTITUDE DIRECTOR INDICATOR

FLIGHT INSTRUMENTS
TYPE 7-13

6.1.2.3 Data Processor Peripheral Types (CONTINUED)

by Astronautics Corporation of America, provides a pictorial display of aircraft roll and pitch attitude relative to the horizon, flight direction, rate of turn information, displacement data and bank data. It consists of a hermetically sealed case enclosing three mechanical assemblies and a total of 41 electronic components.

The 331A-8H (HSI) and 329B-8G (ADI) are commercially designed flight instruments built by Rockwell-Collins in 1967. The 331A-8H is an aircraft navigation instrument displaying a pictorial plan view of an aircraft with respect to magnetic north, selected heading and selected course. It is made up of a dust-sealed enclosure, four electromechanical assemblies and one electronic assembly with a total parts count of 110 electronic components. The 329B-8G provides the pilot with primary aircraft attitude indication, presents a symbolic picture of aircraft pitch and bank attitude and provides command information for following a selected flight path. It consists of five electromechanical assemblies and a total of 50 electronic components all enclosed in a dustproof enclosure.

7.0 LCC ANALYSES

7.1 LCC Approach

The LCC analyses were conducted for 10 years of operations and maintenance. Since each of the systems analyzed was already a deployed operational system, each analysis was conducted as if all operational systems were introduced in the first month.

Standard and logistics factors are discussed in Section 7.3 and are maintained in each LCC analysis. This was done in order to maintain consistency between competing analyses. In practice, one could use the LCC analysis technique to compare alternatives and use appropriate delivery schedules and logistics factors.

The Air Force accepted LCC-2A model was used for this study. This model was chosen because of the Air Force familiarity and confidence in the model due to its frequent use (ARC-186, Standard Navigation) in source selection, its flexibility in modeling various hardware configurations and support concepts, its ease of use, and the detail of its output.

LCC-2A is a life cycle cost analysis program developed to evaluate the combined costs of acquiring modern systems and supporting them over their operational life. Cost comparisons can be used in the selection of appropriate hardware alternatives as well as in the evaluation of various maintenance philosophies.

7.2 LCC Results

Fifteen LCC analyses were conducted in the course of this study. The results for the equipment identified in Table 6.1 are shown in the order given in Table 7.1. These results are shown in Tables 7.2 through 7.19.

TABLE 7.1 ORDER OF LCC RESULTS

<u>TABLE</u>	<u>ENVIRONMENT</u>	<u>EQUIPMENT TYPE</u>	<u>CLASS</u>
7.2	Ground-Fixed	Communications	Military
7.3	Ground-Fixed	Data Processing	Military
7.4	Ground-Fixed	Data Peripherals	Military
7.5	Ground-Fixed	Communications	Commercial
7.6	Ground-Fixed	Data Processing	Commercial
7.7	Ground-Fixed	Data Peripherals	Commercial
7.8	Airborne Inhabited - Transport	Communications	Military
7.9	Airborne Inhabited - Transport	Data Processing	Military
7.10	Airborne Inhabited - Transport	Data Peripherals	Military
7.11	Airborne Inhabited - Transport	Communications	Commercial
7.12	Airborne Inhabited - Transport	Data Processing	Commercial
7.13	Airborne Inhabited - Transport	Data Peripherals	Commercial
7.14	Airborne Inhabited - Fighter	Communications	Military
7.15	Airborne Inhabited - Fighter	Data Processing	Military
7.16	Airborne Inhabited - Fighter	Data Peripherals	Military
7.17	Airborne Inhabited - Fighter	Communications	Commercial
7.18	Airborne Inhabited - Fighter	Data Processing	Commercial
7.19	Airborne Inhabited - Fighter	Data Peripherals	Commercial

TABLE 7.2

GR-171 RECEIVER TRANSMITTER 180215 82 0711
 TOTAL COST SUMMARY (BY CATEGORY)

	UNDISCOUNTED COST	PRESENT VALUE COST
INITIAL TRAINING	15,990.	15,990.
DATA ACQUISITION	5,000.	5,000.
ITEM ENTRY	31,360.	31,360.
DATA MANAGEMENT	825.	825.
PRIME HARDWARE	2,255,000.	2,255,000.
SUPPORT EQUIPMENT	4,392,144.	4,392,144.
INITIAL SPARES	2,218,791.	2,218,791.
INSTALLATION	0.	0.
TOTAL ACQUISITION COST	8,919,110.	8,919,110.
FLIGHT LINE MAINT.	1,006,206.	1,006,206.
BASE LEVEL MAINT.	1,668,367.	1,668,367.
DEPOT LEVEL MAINT.	1,030,739.	1,030,739.
ITEM MANAGEMENT	64,800.	64,800.
DATA MANAGEMENT	61,478.	61,478.
PACKING & SHIPPING	255,933.	255,933.
S.E.MAINTENANCE	1,317,643.	1,317,643.
TOTAL O&M COST	5,405,166.	5,405,166.
TOTAL LIFE CYCLE COST	14,324,276.	14,324,276.

TABLE 7.3

FPS-77V WEATHER RADAR 180215 82 0711
 TOTAL COST SUMMARY (BY CATEGORY)

	UNDISCOUNTED COST -----	PRESENT VALUE COST -----
INITIAL TRAINING	15,990.	15,990.
DATA ACQUISITION	5,000.	5,000.
ITEM ENTRY	31,360.	31,360.
DATA MANAGEMENT	514.	514.
PRIME HARDWARE	3,558,800.	3,558,800.
SUPPORT EQUIPMENT	0.	0.
INITIAL SPARES	0.	0.
INSTALLATION	0.	0.
<hr/>		
TOTAL ACQUISITION COST	3,611,664.	3,611,664.
FLIGHT LINE MAINT.	5,395,158.	5,395,158.
BASE LEVEL MAINT.	0.	0.
DEPOT LEVEL MAINT.	0.	0.
ITEM MANAGEMENT	64,800.	64,800.
DATA MANAGEMENT	61,478.	61,478.
PACKING & SHIPPING	383,124.	383,124.
S.E.MAINTENANCE	0.	0.
<hr/>		
TOTAL O&M COST	5,904,559.	5,904,559.
TOTAL LIFE CYCLE COST	9,516,222.	9,516,222.
@XQT 021924*TASC.PROG3		
@ADD,P RADC*TASC.GN-RA-COM		

TABLE 7.4

GSH-34 RECORDER/REPRODUCER 190215 82 0710
 TOTAL COST SUMMARY (BY CATEGORY)

	UNDISCOUNTED COST	PRESENT VALUE COST
INITIAL TRAINING	15,990.	15,990.
DATA ACQUISITION	5,000.	5,000.
ITEM ENTRY	31,360.	31,360.
DATA MANAGEMENT	467.	467.
PRIME HARDWARE	1,886,552.	1,886,552.
SUPPORT EQUIPMENT	0.	0.
INITIAL SPARES	6,664,242.	6,664,242.
INSTALLATION	0.	0.
TOTAL ACQUISITION COST	8,603,611.	8,603,611.
FLIGHT LINE MAINT.	9,027,486.	9,027,486.
BASE LEVEL MAINT.	480,501.	480,501.
DEPOT LEVEL MAINT.	975,583.	975,583.
ITEM MANAGEMENT	64,800.	64,800.
DATA MANAGEMENT	61,478.	61,478.
PACKING & SHIPPING	412,583.	412,583.
S.E.MAINTENANCE	0.	0.
TOTAL O&M COST	11,022,430.	11,022,430.
TOTAL LIFE CYCLE COST	19,626,040.	19,626,040.

@XQT 021924*TASC.PROG3
 @ADD,P RADC*TASC.GN-PR-COM

TABLE 7.5

618M-1C RECEIVER TRANSMITTER 180215 82 0711
 TOTAL COST SUMMARY (BY CATEGORY)

	UNDISCOUNTED COST -----	PRESENT VALUE COST -----
INITIAL TRAINING	15,990.	15,990.
DATA ACQUISITION	5,000.	5,000.
ITEM ENTRY	31,360.	31,360.
DATA MANAGEMENT	305.	305.
PRIME HARDWARE	998,613.	998,613.
SUPPORT EQUIPMENT	7,000.	7,000.
INITIAL SPARES	432,421.	432,421.
INSTALLATION	0.	0.
	-----	-----
TOTAL ACQUISITION COST	1,490,689.	1,490,689.
FLIGHT LINE MAINT.	28,651.	28,651.
BASE LEVEL MAINT.	100,673.	100,673.
DEPOT LEVEL MAINT.	31,987.	31,987.
ITEM MANAGEMENT	64,800.	64,800.
DATA MANAGEMENT	61,478.	61,478.
PACKING & SHIPPING	3,909.	3,909.
S.E.MAINTENANCE	2,100.	2,100.
	-----	-----
TOTAL O&M COST	293,598.	293,598.
	-----	-----
TOTAL LIFE CYCLE COST	1,784,286.	1,784,286.
@XQT 021924*TASC.PROG3		
@ADD,P RADC*TASC.GN-RA-MIL		

TABLE 7.6

FPS-103 RADAR SYSTEM 180215 82 0710
 TOTAL COST SUMMARY (BY CATEGORY)

	UNDISCOUNTED COST	PRESENT VALUE COST
INITIAL TRAINING	15,990.	15,990.
DATA ACQUISITION	5,000.	5,000.
ITEM ENTRY	31,360.	31,360.
DATA MANAGEMENT	49.	49.
PRIME HARDWARE	208,200.	208,200.
SUPPORT EQUIPMENT	100,000.	100,000.
INITIAL SPARES	0.	0.
INSTALLATION	0.	0.
TOTAL ACQUISITION COST	360,599.	360,599.
FLIGHT LINE MAINT.	167,731.	167,731.
BASE LEVEL MAINT.	0.	0.
DEPOT LEVEL MAINT.	0.	0.
ITEM MANAGEMENT	64,800.	64,800.
DATA MANAGEMENT	61,478.	61,478.
PACKING & SHIPPING	0.	0.
S.E.MAINTENANCE	30,000.	30,000.
TOTAL O&M COST	324,008.	324,008.
TOTAL LIFE CYCLE COST	684,608.	684,608.

@XQT 021924*TASC.PROG3
 @ADD,P RADC*TASC.GN-PR-MIL

TABLE 7.7

VR-3700 RECORDER REPRODUCER 190215 82 0710
 TOTAL COST SUMMARY (BY CATEGORY)

	UNDISCOUNTED COST ----	PRESENT VALUE COST ----
INITIAL TRAINING	15,990.	15,990.
DATA ACQUISITION	5,000.	5,000.
ITEM ENTRY	31,360.	31,360.
DATA MANAGEMENT	52.	52.
PRIME HARDWARE	606,307.	606,307.
SUPPORT EQUIPMENT	1,500.	1,500.
INITIAL SPARES	212,974.	212,974.
INSTALLATION	0.	0.
TOTAL ACQUISITION COST	873,183.	873,183.
FLIGHT LINE MAINT.	55,216.	55,216.
BASE LEVEL MAINT.	8,349.	8,349.
DEPOT LEVEL MAINT.	26,524.	26,524.
ITEM MANAGEMENT	648.	648.
DATA MANAGEMENT	61,478.	61,478.
PACKING & SHIPPING	76,922.	76,922.
S.E.MAINTENANCE	450.	450.
TOTAL O&M COST	229,586.	229,586.
TOTAL LIFE CYCLE COST	1,102,769.	1,102,769.
@XQT 021924*TASC.PROG3		
@ADD,P RADC*TASC.GN-PE-MIL		

TABLE 7.8

ARC-109 VHF R/T 190215 82 0710
TOTAL COST SUMMARY (BY CATEGORY)

	UNDISCOUNTED COST -----	PRESENT VALUE COST -----
INITIAL TRAINING	15,990.	15,990.
DATA ACQUISITION	5,000.	5,000.
ITEM ENTRY	31,360.	31,360.
DATA MANAGEMENT	204.	204.
PRIME HARDWARE	1,585,228.	1,585,228.
SUPPORT EQUIPMENT	80,527.	80,527.
INITIAL SPARES	293,281.	293,281.
INSTALLATION	0.	0.
	-----	-----
TOTAL ACQUISITION COST	2,011,590.	2,011,590.
FLIGHT LINE MAINT.	592,120.	592,120.
BASE LEVEL MAINT.	889,682.	889,682.
DEPOT LEVEL MAINT.	1,053,068.	1,053,068.
ITEM MANAGEMENT	64,800.	64,800.
DATA MANAGEMENT	61,478.	61,478.
PACKING & SHIPPING	16,540.	16,540.
S.E.MAINTENANCE	24,158.	24,158.
	-----	-----
TOTAL O&M COST	2,701,846.	2,701,846.
TOTAL LIFE CYCLE COST	4,713,436.	4,713,436.
@XQT 021924*TASC.PROG3		
@ADD, P RADC*TASC.GN-PE-COM		

TABLE 7.9

ASW-28 ROLL/PITCH COMPUTER 1 4AUG0215 82 0709
 TOTAL COST SUMMARY (BY CATEGORY)

	UNDISCOUNTED COST	PRESENT VALUE COST
INITIAL TRAINING	15,990.	15,990.
DATA ACQUISITION	5,000.	5,000.
ITEM ENTRY	31,360.	31,360.
DATA MANAGEMENT	204.	204.
PRIME HARDWARE	9,493,756.	9,493,756.
SUPPORT EQUIPMENT	40,000.	40,000.
INITIAL SPARES	4,156,398.	4,156,398.
INSTALLATION	0.	0.
TOTAL ACQUISITION COST	13,742,708.	13,742,708.
FLIGHT LINE MAINT.	790,716.	790,716.
BASE LEVEL MAINT.	913,123.	913,123.
DEPOT LEVEL MAINT.	1,569,012.	1,569,012.
ITEM MANAGEMENT	64,800.	64,800.
DATA MANAGEMENT	61,478.	61,478.
PACKING & SHIPPING	133,136.	133,136.
S.E.MAINTENANCE	12,000.	12,000.
TOTAL O&M COST	3,544,264.	3,544,264.
TOTAL LIFE CYCLE COST	17,286,972.	17,286,972.
DATA IGNORED - IN CONTROL MODE		
@XQT 021924*TASC.PROG3		
@ADD,P RADC*TASC.AT-RA-COM		

TABLE 7.10

C-5A AIRCRAFT HSI AND ADI 10215 82 0706
TOTAL COST SUMMARY (BY CATEGORY)

	UNDISCOUNTED COST	PRESENT VALUE COST
	-----	-----
INITIAL TRAINING	15,990.	15,990.
DATA ACQUISITION	5,000.	5,000.
ITEM ENTRY	31,360.	31,360.
DATA MANAGEMENT	204.	204.
PRIME HARDWARE	4,518,144.	4,518,144.
SUPPORT EQUIPMENT	150,000.	150,000.
INITIAL SPARES	1,440,589.	1,440,589.
INSTALLATION	0.	0.
	-----	-----
TOTAL ACQUISITION COST	6,161,287.	6,161,287.
FLIGHT LINE MAINT.	643,004.	643,004.
BASE LEVEL MAINT.	365,202.	365,202.
DEPOT LEVEL MAINT.	1,816,162.	1,816,162.
ITEM MANAGEMENT	64,800.	64,800.
DATA MANAGEMENT	61,478.	61,478.
PACKING & SHIPPING	45,034.	45,034.
S.E.MAINTENANCE	45,000.	45,000.
	-----	-----
TOTAL O&M COST	3,040,679.	3,040,679.
TOTAL LIFE CYCLE COST	9,201,966.	9,201,966.
@XQT 021924*TASC.PROG3		
@ADD,P RADC*TASC.AT-PR-COM		

TABLE 7.11

618M-1C RECEIVER/TRANSMITTER 180215 82 0710
 TOTAL COST SUMMARY (BY CATEGORY)

	UNDISCOUNTED COST	PRESENT VALUE COST
	-----	-----
INITIAL TRAINING	15,990.	15,990.
DATA ACQUISITION	5,000.	5,000.
ITEM ENTRY	31,360.	31,360.
DATA MANAGEMENT	689.	689.
PRIME HARDWARE	5,017,926.	5,017,926.
SUPPORT EQUIPMENT	6,000.	6,000.
INITIAL SPARES	783,468.	783,468.
INSTALLATION	0.	0.
	-----	-----
TOTAL ACQUISITION COST	5,860,433.	5,860,433.
FLIGHT LINE MAINT.	657,808.	657,808.
BASE LEVEL MAINT.	580,683.	580,683.
DEPOT LEVEL MAINT.	1,667,548.	1,667,548.
ITEM MANAGEMENT	64,800.	64,800.
DATA MANAGEMENT	61,478.	61,478.
PACKING & SHIPPING	98,678.	98,678.
S.E.MAINTENANCE	1,800.	1,800.
	-----	-----
TOTAL O&M COST	3,132,794.	3,132,794.
TOTAL LIFE CYCLE COST	8,993,228.	8,993,228.
@XQT 021924*TASC.PROG3		
@ADD,P RADC*TASC.AT-RA-MIL		

TABLE 7.12

562R1E/P1E1 ROLL/PITCH COMPU TER 0215 82 0706
 TOTAL COST SUMMARY (BY CATEGORY)

	UNDISCOUNTED COST	PRESENT VALUE COST
	-----	-----
INITIAL TRAINING	15,990.	15,990.
DATA ACQUISITION	5,000.	5,000.
ITEM ENTRY	31,360.	31,360.
DATA MANAGEMENT	1,660.	1,660.
PRIME HARDWARE	11,619,810.	11,619,810.
SUPPORT EQUIPMENT	885,903.	885,903.
INITIAL SPARES	1,335,914.	1,335,914.
INSTALLATION	0.	0.
	-----	-----
TOTAL ACQUISITION COST	13,895,637.	13,895,637.
FLIGHT LINE MAINT.	801,464.	801,464.
BASE LEVEL MAINT.	514,803.	514,803.
DEPOT LEVEL MAINT.	2,731,289.	2,731,289.
ITEM MANAGEMENT	64,800.	64,800.
DATA MANAGEMENT	61,478.	61,478.
PACKING & SHIPPING	124,919.	124,919.
S.E.MAINTENANCE	265,771.	265,771.
	-----	-----
TOTAL O&M COST	4,564,523.	4,564,523.
TOTAL LIFE CYCLE COST	18,460,160.	18,460,160.

TABLE 7.13

331A-6P/329B-8G HSI/ADI 180215 82 0706
TOTAL COST SUMMARY (BY CATEGORY)

	<u>UNDISCOUNTED</u> <u>COST</u>	<u>PRESENT VALUE</u> <u>COST</u>
INITIAL TRAINING	15,990.	15,990.
DATA ACQUISITION	5,000.	5,000.
ITEM ENTRY	31,360.	31,360.
DATA MANAGEMENT	1,660.	1,660.
PRIME HARDWARE	6,553,440.	6,553,440.
SUPPORT EQUIPMENT	1,228,721.	1,228,721.
INITIAL SPARES	1,548,812.	1,548,812.
INSTALLATION	0.	0.
TOTAL ACQUISITION COST	9,384,983.	9,384,983.
FLIGHT LINE MAINT.	1,667,356.	1,667,356.
BASE LEVEL MAINT.	758,993.	758,993.
DEPOT LEVEL MAINT.	3,568,432.	3,568,432.
ITEM MANAGEMENT	64,800.	64,800.
DATA MANAGEMENT	61,478.	61,478.
PACKING & SHIPPING	207,805.	207,805.
S.E.MAINTENANCE	368,616.	368,616.
TOTAL O&M COST	6,697,479.	6,697,479.
TOTAL LIFE CYCLE COST	16,082,462.	16,082,462.
@XQT 021924*TASC.PROG3		
@ADD,P RADC*TASC.AT-PE-MIL		

TABLE 7.14

ARC-109 RT-967 TRANSCEIVER 120215 82 0706
 TOTAL COST SUMMARY (BY CATEGORY)

	UNDISCOUNTED COST	PRESENT VALUE COST
INITIAL TRAINING	15,990.	15,990.
DATA ACQUISITION	5,000.	5,000.
ITEM ENTRY	31,360.	31,360.
DATA MANAGEMENT	908.	908.
PRIME HARDWARE	4,172,168.	4,172,168.
SUPPORT EQUIPMENT	220,000.	220,000.
INITIAL SPARES	670,337.	670,337.
INSTALLATION	0.	0.
TOTAL ACQUISITION COST	5,115,763.	5,115,763.
FLIGHT LINE MAINT.	1,648,586.	1,648,586.
BASE LEVEL MAINT.	2,230,176.	2,230,176.
DEPOT LEVEL MAINT.	2,510,451.	2,510,451.
ITEM MANAGEMENT	64,800.	64,800.
DATA MANAGEMENT	61,478.	61,478.
PACKING & SHIPPING	64,221.	64,221.
S.E.MAINTENANCE	66,000.	66,000.
TOTAL O&M COST	6,645,712.	6,645,712.
TOTAL LIFE CYCLE COST	11,761,474.	11,761,474.

@XQT 021924*TASC.PROG3
 @ADD,P RADC*TASC.AT-PE-COM

TABLE 7.15

CP-1104/1105 PITCH/ROLL COMP 180215 82 0705
TOTAL COST SUMMARY (BY CATEGORY)

	UNDISCOUNTED COST -----	PRESENT VALUE COST -----
INITIAL TRAINING	15,990.	15,990.
DATA ACQUISITION	5,000.	5,000.
ITEM ENTRY	31,360.	31,360.
DATA MANAGEMENT	813.	813.
PRIME HARDWARE	13,489,476.	13,489,476.
SUPPORT EQUIPMENT	120,000.	120,000.
INITIAL SPARES	753,263.	753,263.
INSTALLATION	0.	0.
	-----	-----
TOTAL ACQUISITION COST	14,415,902.	14,415,902.
FLIGHT LINE MAINT.	648,959.	648,959.
BASE LEVEL MAINT.	993,487.	993,487.
DEPOT LEVEL MAINT.	894,910.	894,910.
ITEM MANAGEMENT	63,000.	63,000.
DATA MANAGEMENT	57,802.	57,802.
PACKING & SHIPPING	23,468.	23,468.
S.E.MAINTENANCE	0.	0.
	-----	-----
TOTAL O&M COST	2,681,626.	2,681,626.
TOTAL LIFE CYCLE COST	17,097,527.	17,097,527.
@XQT 021924*TASC.PROG3		
@ADD,P RADC*TASC.AF-RA-COM		

TABLE 7.16

ARV-39A/AJN-18 ADI/HSI 180215 82 0705
 TOTAL COST SUMMARY (BY CATEGORY)

	UNDISCOUNTED COST	PRESENT VALUE COST
INITIAL TRAINING	15,990.	15,990.
DATA ACQUISITION	5,000.	5,000.
ITEM ENTRY	31,360.	31,360.
DATA MANAGEMENT	908.	908.
PRIME HARDWARE	5,309,304.	5,309,304.
SUPPORT EQUIPMENT	358,000.	358,000.
INITIAL SPARES	685,542.	685,542.
INSTALLATION	0.	0.
TOTAL ACQUISITION COST	6,406,104.	6,406,104.
FLIGHT LINE MAINT.	980,225.	980,225.
BASE LEVEL MAINT.	376,296.	376,296.
DEPOT LEVEL MAINT.	690,612.	690,612.
ITEM MANAGEMENT	64,800.	64,800.
DATA MANAGEMENT	61,478.	61,478.
PACKING & SHIPPING	33,582.	33,582.
S.E.MAINTENANCE	107,400.	107,400.
TOTAL O&M COST	2,314,393.	2,314,393.
TOTAL LIFE CYCLE COST	8,720,497.	8,720,497.
@XQT 021924*TASC.PROG3		
@ADD,P RADC*TASC.AF-PR-COM		

TABLE 7.17

ARC-109 RT-967 TRANSCEIVER 120215 82 0706
TOTAL COST SUMMARY (BY CATEGORY)

	UNDISCOUNTED COST	PRESENT VALUE COST
	-----	-----
INITIAL TRAINING	15,990.	15,990.
DATA ACQUISITION	5,000.	5,000.
ITEM ENTRY	31,360.	31,360.
DATA MANAGEMENT	908.	908.
PRIME HARDWARE	3,395,028.	3,395,028.
SUPPORT EQUIPMENT	220,000.	220,000.
INITIAL SPARES	597,947.	597,947.
INSTALLATION	0.	0.
	-----	-----
TOTAL ACQUISITION COST	4,266,233.	4,266,233.
FLIGHT LINE MAINT.	1,648,586.	1,648,586.
BASE LEVEL MAINT.	2,230,176.	2,230,176.
DEPOT LEVEL MAINT.	2,510,451.	2,510,451.
ITEM MANAGEMENT	64,800.	64,800.
DATA MANAGEMENT	61,478.	61,478.
PACKING & SHIPPING	64,221.	64,221.
S.E.MAINTENANCE	66,000.	66,000.
	-----	-----
TOTAL O&M COST	6,645,712.	6,645,712.
TOTAL LIFE CYCLE COST	10,911,944.	10,911,944.
@XQT 021924*TASC.PROG3		
@ADD,P RADC*TASC.AF-RA-MIL		

TABLE 7.18

CP-1104/1105 PITCH/ROLL COMP 180215 82 0705
 TOTAL COST SUMMARY (BY CATEGORY)

	UNDISCOUNTED COST	PRESENT VALUE COST
	<hr/>	<hr/>
INITIAL TRAINING	15,990.	15,990.
DATA ACQUISITION	5,000.	5,000.
ITEM ENTRY	31,360.	31,360.
DATA MANAGEMENT	813.	813.
PRIME HARDWARE	3,438,708.	3,438,708.
SUPPORT EQUIPMENT	150,000.	150,000.
INITIAL SPARES	365,395.	365,395.
INSTALLATION	0.	0.
	<hr/>	<hr/>
TOTAL ACQUISITION COST	4,007,266.	4,007,266.
FLIGHT LINE MAINT.	2,075,562.	2,075,562.
BASE LEVEL MAINT.	3,180,496.	3,180,496.
DEPOT LEVEL MAINT.	2,865,443.	2,865,443.
ITEM MANAGEMENT	63,000.	63,000.
DATA MANAGEMENT	57,802.	57,802.
PACKING & SHIPPING	75,125.	75,125.
S.E.MAINTENANCE	0.	0.
	<hr/>	<hr/>
TOTAL O&M COST	8,317,428.	8,317,428.
TOTAL LIFE CYCLE COST	12,324,694.	12,324,694.
@XQT 021924*TASC.PROG3		
@ADD,P RADC*TASC.AF-PR-MIL		

TABLE 7.19

ARV-39A/AJN-18 ADI/HSI 180215 82 0705
 TOTAL COST SUMMARY (BY CATEGORY)

	UNDISCOUNTED COST	PRESENT VALUE COST
INITIAL TRAINING	15,990.	15,990.
DATA ACQUISITION	5,000.	5,000.
ITEM ENTRY	31,360.	31,360.
DATA MANAGEMENT	908.	908.
PRIME HARDWARE	1,939,392.	1,939,392.
SUPPORT EQUIPMENT	428,000.	428,000.
INITIAL SPARES	503,412.	503,412.
INSTALLATION	0.	0.
TOTAL ACQUISITION COST	2,924,062.	2,924,062.
FLIGHT LINE MAINT.	2,344,914.	2,344,914.
BASE LEVEL MAINT.	895,569.	895,569.
DEPOT LEVEL MAINT.	1,640,864.	1,640,864.
ITEM MANAGEMENT	64,800.	64,800.
DATA MANAGEMENT	61,478.	61,478.
PACKING & SHIPPING	79,918.	79,918.
S.E.MAINTENANCE	128,400.	128,400.
TOTAL O&M COST	5,215,942.	5,215,942.
TOTAL LIFE CYCLE COST	8,140,003.	8,140,003.
@XQT 021924*TASC.PROG3		
@ADD,P RADC*TASC.AF-PE-MIL		

7.3 LCC Analysis Input Data

To perform the life cycle cost portion of the study, Air Force operational and logistics data was collected and analyzed for all the systems. Descriptions of the various operational data sources are as follows:

1. D056B5006 (6-log) was acquired through HQAFLC (Refer to Figure 7.1). It provides on and off aircraft historical data on the maintenance actions, man-hours and aborts by work unit code (WUC). Primary use is for reliability/maintainability studies and to verify the effectiveness of modifications.
2. D056B5014 (14-log) was acquired through HQAFLC for ground based equipment only (Refer to Figure 7.2). Fourteen-log lists the serial number and location of an equipment or system.
3. AFM66-1 data has been distributed to Rockwell-Collins for several years. It is a compilation of raw AFTO maintenance reports as well as reference type listings which include a listing of aircraft quantities by command and location. The latter being the portion used for this study (Refer to Figure 7.3).
4. D056B5005 (5-log) was acquired through HQAFLC. This report provides detailed maintenance information presented in three parts for each WUC. Part I - On Equipment Actions (Refer to Figure 7.4); Part II - Shop Actions (Refer to Figure 7.5); Part III - Parts Replacement (Refer to Figure 7.6).

J 01
WRALC-ACF
FO15 52400

MAINTENANCE ACTIONS, MANHOURS, AND ABORTS BY WORK UNIT CODE
PERIOD ENDING 80 JUN 30
FORMERLY 6-LOG-K261

WUC	MOJIN	MONTH	INV	OP TIME	ABO	-----OCCURRENCES----			-----MANHOURS-----				SHOP REPR	ACTION CONDN	UNITS- MKTS		
						FAIL	OTH/ NAL	TOT	FAIL	MAINT	SCHED	UNSCH				SHOP	
52A00 AUTO FLT CT AMASW38 CAT QPA ACT LMT 8 1 896		JUN*	371	7156	3	6	1	97	742	80	8	951	4				
		MAY*	371	6362	2	13	1	90	631	75	7	1090					
		APR*	375	8002	1	10	2	83	767	78	29	881					
		MAR*	373	7102	1	11	1	112	670	85	51	854					
		FEB*	379	7145	1	8	1	89	781	94	47	1094					
		JAN*	381	7868	2	14	1	58	736	91	15	495					
TOT.			381	43635	9	62	6	529	704	82	5365	4					
52A00 COMP FLT CONT CAT QPA ACT LMT 8 1 NO LMT		JUN	371	7156	1	12	28	598	316	8	305	284				1	
		MAY	371	6362	2	16	24	650	370	19	297	570				2	
		APR	375	8002	1	8	16	795	405		179	311				1	
		MAR	373	7102	2	9	18	737	375		164	246				1	
		FEB	379	7145	1	11	21	781	347		191	240				1	
		JAN	381	7868	1	10	20	877	374		129	340				5	
TOT.			381	43635	7	66	1	661	344	27	2265	1991	50		2		
52AAA ORD PICH COMP AZ A4 CAT QPA ACT LMT 8 2 NO LMT		JUN	371	7156				43040	43040			2					
		MAY	371	6362			1	42932	42932								
		MAR	373	7102													
		FEB	379	7145													
		JAN	381	7868													
		TOT.			381	43635			1	87270	87270		2	2	2		2
52AAC CARD SPEED STABA3A5 CAT QPA ACT LMT 8 2 NO LMT		JUN	371	7156									8				
		MAY	371	6362									14			2	
		APR	375	8002									6			1	
		FEB	379	7145									18			2	
		JAN	381	7868									46			3	
		TOT.			381	43635							6	6	1		3
52AAF ORD PICH SYNC DR A6 CAT QPA ACT LMT 8 1 NO LMT		JUN	371	7156													
		APR	375	8002									6			1	
		MAR	373	7102									6			1	
		JAN	381	7868									6			1	
		TOT.			381	43635							6	6	1		3
		52AAG ORD PICH PLT REL A/ CAT QPA ACT LMT 8 1 NO LMT		JUN	371	7156											
MAY	371			6362													
MAR	373			7102													
FEB	379			7145													
TOT.					379	43635											
TOT.					379	43635											

FIGURE 7.1 00-56 6-LOG EXAMPLE

K 01
WRALC-ACE
F015 52A00

MAINTENANCE ACTIONS, MANHOURS, AND ABORTS BY WORK UNIT CODE
PERIOD ENDING 80 JUN 30 FORMERLY 6-LOG-K261

MHC	MOD	MONTH	LN	OP TIME	ABO	-----OCCURRENCES-----			TOT	-----MANHOURS-----				ACTION COMMON	UNITS- MRTS	
						FAIL	MAL	OTH		SCHED	UNSCH	SHOP	SHOP REPR			
52AAH CRD PITCH COMP FAIL CAT QPA ACT LMT B 2 NO LMT		JUN	371	7156											1	
		APR	375	8002												
		MAR	373	7102												
		JAN	381	7868												
TOT.				43635											1	
52AAJ CRD SERVO FAIL DETC CAT QPA ACT LMT B 1 NO LMT		JUN	371	7156												
		MAY	371	6362												
		APR	375	8002								2				
		MAR	373	7102												
FEB	379	7145								3					3	
JAN	381	7868														
TOT.				43635											5	
52AAM MOD PAR SUP PS1 CAT QPA ACT LMT B 1 NO LMT		JUN	371	7156												
		APR	375	8002												
		MAR	373	7102												
		FEB	379	7145												
JAN	381	7868														
TOT.				43635												
52AMR MODULE FILTER A1 CAT QPA ACT LMT B 1 NO LMT		JUN	371	7156												
		APR	375	8002												
		FEB	379	7145												
		TOT.				43635										
52ABO CPTR FLT CON CPI105 CAT QPA ACT LMT B 1 688		JUN	371	7156	1	9	1	15	897	538	2	175	260	5	2	
		MAY	371	6362	1	10		13	976	550	12	181	418	17	1	
		APR	375	8002		5	1	12	1171	543		136	360	5	1	
		MAR	373	7102		7		14	1229	614		117	196	4	3	
FEB	379	7145		7		15	912	521		78	137	3				
JAN*	381	7868		4		7	671	415		68	171	6				
TOT.				43635	4	42	76	1039	574	16	755	1542	40	10		
52ABA CRD ROLL COMPT A6A9 CAT QPA ACT LMT B 2 NO LMT		JUN	371	7156												
		APR	375	8002												
		FEB	379	7145												
		JAN	381	7868												
TOT.				43635												
52ABC CRD YAM CAS A5 A8 CAT QPA ACT LMT B 2 NO LMT		JUN	371	7156												
		MAY	371	6362												
		APR	375	8002		1		1	42932	42932		9	10	1	2	
		JAN	381	7868					44498	44498						
TOT.				43635				87270	87270					2		

FIGURE 7.1 DO-56 6-LOG EXAMPLE (CONTINUED)

<u>BASE</u>	<u>CMO</u>	<u>QTY.</u>	<u>SERIAL NO.</u>	<u>ACCUM TIME</u>
HAHN AB GERMY	CSV		00000116	
INCIRLIK AB	CSV		00000016	
KELLY AFB TEX	CSV		00000053	
KUNSAN AB KOREA	CSV		00000042	
LAKENHEATH UK	CSV		00000017	
LAKENHEATH UK	CSV		00000113	
LANGLEY AFB VA	CSV		00000093	
LAUGHLIN AB TEX	CSV		00000066	
LAUGHLIN AB TEX	CSV		00000071	
LAUGHLIN AB TEX	CSV		00000072	
LI ROCK 8AF ARK	CSV		00000074	
LUKE AFB ARIZ	CSV		00000107	
MACDILL AFB FLA	CSV		00000082	
MACDILL AFB FLA	CSV		00000092	
MARCH 15AF CALI	CSV		00000037	
MCGUIRE AFB NJ	CSV		00000139	
MCGUIRE AFB NJ	CSV		00000525	
MCGUIRE AFB NJ	CSV		00000532	
MILDENHALL UK	CSV		00000114	
MINOT 15AF ND	CSV		00000111	
MRTLE BCH AB SC	CSV		00000110	
MRTLE BCH AB SC	CSV		00000112	
MT HOM 15AF IDA	CSV		00000108	
NELLIS AFB NEV	CSV		00000518	
OFFUTT 15AF NEB	CSV		00000062	

FIGURE 7.2 DO-56 14-LOG EXAMPLE

EC135LSACCTGC	0004	000143	000059	00023	10/81	L
EC135NLOGWWYK	0000	000000	000000	00000	10/81	L
EC135NSYSZHTP	0005	000060	000141	00019	10/81	L
EC135PTACMUHJ	0002	000070	000022	00015	10/81	L
EC135AAFRCTGC	0003	000285	000197	00073	10/81	L
KC135AAFRPCZP	0004	000293	000233	00071	10/81	L
KC135AAFRPLXL	0007	000284	000174	00070	10/81	L
KC135AAFRQFQE	0004	000000	000000	00000	10/81	L
KC135AANGDPLH	0003	000320	000176	00087	10/81	L
KC135AANGFKNN	0007	000263	000164	00080	10/81	L
KC135AANGGKAY	0008	000336	000240	00090	10/81	L
KC135AANGGUQG	0008	000331	000238	00103	10/81	L
KC135AANGHTUV	0007	000297	000209	00094	10/81	L
KC135AANGJLSQ	0003	000293	000180	00091	10/81	L
EC135ASACFXBM	0004	000059	000023	00015	10/81	L
EC135ATACMUHJ	0001	000072	000090	00015	10/81	L
EC135BSYSZHTP	0002	000030	000039	00008	10/81	L
EW135CLOGWWYK	0001	000000	000000	00000	10/81	L
EC135CSAFXBM	0003	000113	000049	00020	10/81	L
EC135CSACSGBP	0009	000892	000255	00110	10/81	L
EC135GSACCTGC	0001	000046	000032	00010	10/81	L
EC135GSACFXBM	0003	000128	000083	00025	10/81	L
EC135HAFEQFQE	0003	000128	000120	00026	10/81	L
EC135HLOGWWYK	0001	000000	000000	00000	10/81	L
EC135JPAFKNMD	0003	000158	000077	00030	10/81	L
EC135KTACWWYK	0001	000074	000034	00012	10/81	L
EC135LLOGWWYK	0001	000000	000000	00000	10/81	L

FIGURE 7.3 A.F. 66-1 DATA - AIRCRAFT QUANTITY
BY BASE EXAMPLE

KC135AANGNKAT	0004	000263	000135	00060	10/81	L
KC135AANGNLZL	0007	000285	000163	00089	10/81	L
KC135AANGPSXE	0007	000236	000150	00079	10/81	L
KC135AANGPTFN	0008	000295	000214	00075	10/81	L
KC135AANGSZDW	0004	000288	000192	00081	10/81	L
KC135AANGUSEB	0007	000246	000182	00068	10/81	L
KC135AANGVTNB	0007	000247	000185	00074	10/81	L
KC135ALOGB XFN	1008	000009	000020	00006	10/81	L
KC135ALOGDESR	0000	000000	000000	00000	10/81	L
KC135ALOGF XBM	0001	000000	000000	00000	10/81	L
KC135ALOGGUQG	0001	000000	000000	00000	10/81	L
KC135ALOGJFSD	0001	000000	000000	00000	10/81	L
KC135ALOGKH YR	0020	000006	000006	00006	10/81	L
KC135ALOGW WYK	0005	000009	000010	00005	10/81	L
KC135ASACAGGN	0015	000426	000381	00086	10/81	L
KC135ASACAJJY	0007	000386	000101	00081	10/81	L
KC135ASACAWUB	0016	000426	000323	00100	10/81	L
KC135ASACB WKR	0013	000323	000203	00083	10/81	L
KC135ASACCTGC	0021	000724	000533	00158	10/81	L
KC135ASACDDPF	0015	000455	000362	00103	10/81	L
KC135ASACDESR	0034	001724	002140	00328	10/81	L
KC135ASACFNWZ	0013	000260	000232	00068	10/81	L
KC135ASACFTQW	0004	000308	000145	00061	10/81	L
KC135ASACF XBM	0010	000332	000204	00077	10/81	L

FIGURE 7.3 A.F. 66-1 DATA - AIRCRAFT QUANTITY
BY BASE EXAMPLE (CONTINUED)

DISTRIBUTION: AFLC/LDEP
SUMMARIZED MAINTENANCE ACTIONS FOR SELECTED WORK UNIT CODES

PERIOD ENDING 81 JUNE 30
MUC: 51AFA

ALC: SAALC RCN: MC1747 TYP EQP: ACF EAD: C005A

IND HORIZ SITUATION CAT IND B
PART I - ON EQUIPMENT ACTIONS

-NON MALFUNCTION- CODE	CURR MO UNIT COUNT FAIL	THWELVE MONTH UNIT COUNT FAIL	THWELVE MONTH UNIT COUNT BY ACTION TAKEN										THWELVE MONTH UNITS	THWELVE MONTH W/RS		
			F REPR	PR REN	6 ATCH	KL ADJ	Z CISM	M CLM	X TEST	S RMP	EHJ OTHER					
TYPE 1																
008 MOISY	1	1														1.0
037 FLUCTUATES	26	21			4											77.9
070 BROKEN	6	6			2											21.8
080 DEFECTIVE LAMP	4	2			1											14.5
127 ADJUST IMPROP	28	18			10											111.7
135 STUCK OR JAM	57	55			3											158.9
169 VOLTAGE INCDR	1	1			2											27.1
242 FAIL TO OPER	6	6			2											6.0
255 NO OUTPUT	1	1			1											3.0
374 INTERNAL FAIL	1	1			1											6.0
450 OPEN	8	8			1											15.5
622 WET/CONDENSATION	1	1														5.0
658 BERING DEST ERR	1	1														2.0
660 STRIPPED	1	1														3.0
718 IMP RE MEC IMPT	2	2														4.0
721 IMP RE ELE IMPT	3	3			1											9.0
730 LOOSE	3	3			2											14.0
901 INTERMITTENT	5	4			1											8.0
958 INCORRECT DISP	155	133			11											489.4
TOTAL																
TYPE 2																
105 BOLTS LOOSE	21	1			19											42.0
106 BOLTS MISSING	4	4			4											2.5
108 BRKN SAFETY WR	1	1														6.0
230 DIRTY	14	14								2						35.6
602 ASSOC EQ MAL	155	16			23					2						4.0
TOTAL																90.1

FIGURE 7.4 DO-56 PART I EXAMPLE

DISTRIBUTION: AFCLC/LOEP
SUMMARIZED MAINTENANCE ACTIONS FOR SELECTED WORK UNIT CODES

ALC: SAALC RCN: NC1747 TYP EQP: ACF EAD: COOSA WUC: 51AFA PERIOD ENDING 81 JUNE 30

IND HORIZ SITUATION CAT IND B
PART 1 - ON EQUIPMENT ACTIONS

-HOW MALFUNCTION- CODE	NOUN	CURR MO UNIT COUNT	TWELVE MONTH UNIT COUNT		F REPR	PR REM	G ATCH	KL ADJ	Z CRSH	TWELVE MONTH UNIT COUNT BY ACTION TAKEN				S REP	EHJ OTHER	TWELVE MONTH UNITS	TWELVE MONTH M/HR
			FAIL	OTHMAL						W CLM	X TEST	Y A/T UNITS	HOURS				
TYPE 6																	
799	NO DEFECT		155	51	3	155	34	22	2	83	2	83	1	55	355	997.5	
800	NO D FAC MAIN															.0	
812	NO D EQ MAL																
**TOTAL*																	
MUC TOTAL																	
12 MONTHS UNITS & MANHOURS FOR OTHER ACTIONS																	
COMMAND BASE																	
AFR	DOVER AFB DELA		12	6	1	11	5	1	2	7	2	7	1	6	26	128.7	
AFR	TRAVIS AFB CALF		15	6	1	16	5	1	1	7	1	7		6	21	56.9	
**TOTAL*																	
MAC	ALTUS AFB OKLA		11	1	10	2	14	2	2	2	2	2	1	2	17	49.2	
MAC	ANGSN AB BAF GU		4	1	5	2	1	1	1						1	1.0	
MAC	CLARK AB PHILI		62	13	2	58	5	14	2	67	2	67		45	193	519.8	
MAC	DOVER AFB DELA		2	2	2	2	2	2	2						2	4.0	
MAC	HICKAM AB HAWAI		2	2	2	2	2	2	2						2	8.0	
MAC	HILDENHALL UK		3	3	3	3	3	3	3						3	5.5	
MAC	RHEIN MAIN GER		36	29	42	42	23	2	7					2	76	176.1	
MAC	TRAVIS AFB CALF		8	1	6	6	1	2	2	76	2	76	1	49	9	27.0	
MAC	YOKOTA AB JAPAN		128	45	2	128	29	21	2						308	811.9	
**TOTAL*																	
MUC TOTAL																	
			155	51	3	155	34	22	2	83	2	83	1	55	355	997.5	

FIGURE 7.4 DD-56 PART 1 EXAMPLE (CONTINUED)

DISTRIBUTION: AFLC/LOEP

SUMMARIZED MAINTENANCE ACTIONS FOR SELECTED WORK UNIT CODES

ALC:SALLC RCN: MC1747 TYP EOP: ACF EAD: C005A WUC: 51AFA
 IND HORIZ SITUATION CAT IND B
 PART II - SHOP ACTIONS

PERIOD ENDING 81 JUNE 30
 FSC 6610 P/N 101000 - NITN/MHC 009923096

--HOW MALFUNCTION-- CODE	MOUNT	REPAIR AFG		ADJUST KL		CLM/TEST/CRSN VYZ		SRVCBLE 8J		---NRTS & CONDEMNED--- 1 2-6 7-8 9			TOTAL		DELAYED COMM		
		UNITS	HOURS	UNITS	HOURS	UNITS	HOURS	UNITS	HOURS	UNITS	HOURS	UNITS	HOURS	UNITS	HOURS	UNITS	HOURS
037	FLUCTUATES	3	9.9	.0	.0	.0	.0	.0	.0	9			12.0	12	21.9	1	2.7
070	BROKEN	2	6.6	.0	.0	.0	.0	.0	.0	1			1.0	3	7.6		.0
080	DEFECTIVE LAMP	2	36.5	.0	.0	.0	.0	.0	.0	2			.0	2	36.5		.0
127	ADJUST IMPROP		.0	.0	.0	.0	.0	.0	.0	2			1.3	2	1.3		.0
135	STUCK OR JAM	1	3.3	.0	.0	.0	.0	.0	.0	18			35.5	19	38.8	1	1.0
230	DIRTY		.0	.0	.0	.0	.0	.0	.0	2			3.0	2	3.0		.0
255	NO OUTPUT	1	3.0	.0	.0	.0	.0	.0	.0	1			2.0	1	2.0		.0
381	LEAKING		.0	.0	.0	.0	.0	.0	.0				.0		.0		.0
622	WET/CONDENSATN		.0	.0	.0	.0	.0	.0	.0				.0		.0		.0
721	IMP RE ELE INPT	10	710.4	.0	.0	.0	.0	.0	.0				710.4	10	710.4	1	.8
	TOTAL	19	769.7	.0	.0	.0	.0	.0	.0	33			54.8	52	824.5	3	4.5

BASE MOUNT		REPAIR AFG		ADJUST KL		CLM/TEST/CRSN VYZ		SRVCBLE 8J		---NRTS & CONDEMNED--- 1 2-6 7-8 9			TOTAL		DELAYED COMM		
CODE	MOUNT	UNITS	HOURS	UNITS	HOURS	UNITS	HOURS	UNITS	HOURS	UNITS	HOURS	UNITS	HOURS	UNITS	HOURS	UNITS	HOURS
DVLC	CLARK AB PHILLI	1	.0	.0	.0	.0	.0	.0	.0	2			.0	3	5.3	2	3.5
FJXT	DOVER AFB DELA	1	3.0	.0	.0	.0	.0	.0	.0				2.3	1	3.3		.0
MIST		17	763.4	.0	.0	.0	.0	.0	.0				.0	17	763.4		.0
UPMV	SMALC MRS		.0	.0	.0	.0	.0	.0	.0	31			52.5	31	52.5		.0
XDAT	TRAVIS AFB CALF		.0	.0	.0	.0	.0	.0	.0				.0		.0		.0
ZNRE	YOKOTA AB JAPAN	19	769.7	.0	.0	.0	.0	.0	.0	33			54.8	52	824.5	3	4.5
	TOTAL																

--HOW MALFUNCTION-- CODE	MOUNT	REPAIR AFG		ADJUST KL		CLM/TEST/CRSN VYZ		SRVCBLE 8J		---NRTS & CONDEMNED--- 1 2-6 7-8 9			TOTAL		DELAYED COMM		
		UNITS	HOURS	UNITS	HOURS	UNITS	HOURS	UNITS	HOURS	UNITS	HOURS	UNITS	HOURS	UNITS	HOURS	UNITS	HOURS
037	FLUCTUATES	1	3.5	.0	.0	.0	.0	.0	.0	1			3.0	2	6.5		.0
127	ADJUST IMPROP		.0	.0	.0	.0	.0	.0	.0	1			2.0	1	2.0		.0
135	STUCK OR JAM	1	13.3	.0	.0	.0	.0	.0	.0	6			11.0	7	24.3		.0
230	DIRTY		.0	.0	.0	.0	.0	.0	.0	1			2.0	1	2.0		.0
242	FAIL TO OPER		.0	.0	.0	.0	.0	.0	.0	2			.0	2	.0	1	1.0
622	WET/CONDENSATN		.0	.0	.0	.0	.0	.0	.0				.0		.0		.0
720	BRUSH FAILURE	1	3.3	.0	.0	.0	.0	.0	.0				.0	1	3.3		.0
721	IMP RE ELE INPT	27	537.5	.0	.0	.0	.0	.0	.0				.0	27	537.5		.0
799	NO DEFECT		.0	.0	.0	.0	.0	.0	.0	1			.0	1	6.0		.0
	TOTAL	30	557.6	.0	.0	.0	.0	.0	.0	11			27.0	42	590.6	1	1.0

FIGURE 7.5 DO-56 5-LOG PART II

DISTRIBUTION: AFLC/LOEP
SUMMARIZED MAINTENANCE ACTIONS FOR SELECTED WORK UNIT CODES

PERIOD ENDING 81 JUN 30
ALC:SALLC RCN: MC1747 TYP EOP: ACF EAD: C005A WUC: 5JAF6
IND HORIZ SITUATION CAT IND B
PART II - SHOP ACTIONS

--HOW MALFUNCTION-- BASE	NOUN	REPAIR AFG		ADJUST KL		CLM/TEST/CRSN VXZ		SRVCBLE BJ		--NRTS & CONDEMNED--			TOTAL		DELAYED COMM	
		UNITS	HOURS	UNITS	HOURS	UNITS	HOURS	UNITS	HOURS	UNITS	HOURS	UNITS	HOURS	UNITS	HOURS	UNITS
AGN	ALTS AFB OKL	.0	.0	.0	.0	.0	.0	.0	.0	1	2	1	2	4.0	.0	.0
FJXT	DOVER AFB DELA	.0	.0	.0	.0	.0	.0	.0	.0	1	2	1	2	14.0	.0	.0
UPWV	SMALC MRS	30	557.6	.0	.0	.0	.0	.0	.0	8	30	8	30	557.6	.0	.0
XDAT	TRAV AFB CALF	.0	.0	.0	.0	.0	.0	.0	.0	8	8	8	8	15.0	.0	.0
ZNRE	YOKOTA AB JAP	.0	.0	.0	.0	.0	.0	.0	.0	11	11	11	11	1.0	1	1.0
TOTAL		30	557.6	.0	.0	.0	.0	.0	.0	1	42	11	42	590.6	1	1.0
FSC 6610 P/N 1880843-2A - NIIN/MHC 000180683 LH																

--HOW MALFUNCTION-- CODE	NOUN	REPAIR AFG		ADJUST KL		CLM/TEST/CRSN VXZ		SRVCBLE BJ		--NRTS & CONDEMNED--			TOTAL		DELAYED COMM	
		UNITS	HOURS	UNITS	HOURS	UNITS	HOURS	UNITS	HOURS	UNITS	HOURS	UNITS	HOURS	UNITS	HOURS	UNITS
127	ADJUST IMPROP	2	18.0	.0	.0	.0	.0	.0	.0	1	2	1	2	18.0	.0	.0
TOTAL		2	18.0	.0	.0	.0	.0	.0	.0	1	2	1	2	18.0	.0	.0

BASE	NOUN	REPAIR AFG		ADJUST KL		CLM/TEST/CRSN VXZ		SRVCBLE BJ		--NRTS & CONDEMNED--			TOTAL		DELAYED COMM	
		UNITS	HOURS	UNITS	HOURS	UNITS	HOURS	UNITS	HOURS	UNITS	HOURS	UNITS	HOURS	UNITS	HOURS	UNITS
FJXT	DOVER AFB DELA	2	18.0	.0	.0	.0	.0	.0	.0	1	2	1	2	18.0	.0	.0
TOTAL		2	18.0	.0	.0	.0	.0	.0	.0	1	2	1	2	18.0	.0	.0
FSC 6610	P/N 1000104500															
FSC 6610	P/N 10450009217															

--HOW MALFUNCTION-- CODE	NOUN	REPAIR AFG		ADJUST KL		CLM/TEST/CRSN VXZ		SRVCBLE BJ		--NRTS & CONDEMNED--			TOTAL		DELAYED COMM	
		UNITS	HOURS	UNITS	HOURS	UNITS	HOURS	UNITS	HOURS	UNITS	HOURS	UNITS	HOURS	UNITS	HOURS	UNITS
037	FLUCTUATES	.0	.0	.0	.0	.0	.0	.0	.0	1	1	1	1	1.0	.0	.0
135	STUCK OR JAM	.0	.0	.0	.0	.0	.0	.0	.0	1	1	1	1	1.0	.0	.0
901	INTERMITTENT	.0	.0	.0	.0	.0	.0	.0	.0	1	1	1	1	1.0	.0	.0
988	VACUUM LOSS	.0	.0	.0	.0	.0	.0	.0	.0	1	1	1	1	6.0	1	.0
TOTAL		.0	.0	.0	.0	.0	.0	.0	.0	3	3	3	3	8.0	.0	.0

BASE	NOUN	REPAIR AFG		ADJUST KL		CLM/TEST/CRSN VXZ		SRVCBLE BJ		--NRTS & CONDEMNED--			TOTAL		DELAYED COMM	
		UNITS	HOURS	UNITS	HOURS	UNITS	HOURS	UNITS	HOURS	UNITS	HOURS	UNITS	HOURS	UNITS	HOURS	UNITS
FJXT	DOVER AFB DELA	.0	.0	.0	.0	.0	.0	.0	.0	1	1	1	1	6.0	.0	.0
XDAT	TRAV AFB CALF	.0	.0	.0	.0	.0	.0	.0	.0	2	2	2	2	2.0	.0	.0
ZNRE	YOKOTA AB JAP	.0	.0	.0	.0	.0	.0	.0	.0	3	3	3	3	8.0	.0	.0
TOTAL		.0	.0	.0	.0	.0	.0	.0	.0	3	3	3	3	8.0	.0	.0

--HOW MALFUNCTION-- **MUC TOTAL**	UNITS	HOURS	ADJUST KL		CLM/TEST/CRSN VXZ		SRVCBLE BJ		--NRTS & CONDEMNED--			TOTAL		DELAYED COMM	
			UNITS	HOURS	UNITS	HOURS	UNITS	HOURS	UNITS	HOURS	UNITS	HOURS	UNITS	HOURS	
	51	1345.3	.0	.0	.0	.0	.0	.0	1	1	6.0	47	89.8	99	1441.1

FIGURE 7.5 00-56 5-LOG PART II (CONTINUED)

DISTRIBUTION: AFLC/LOEF
 SUMMARIZED MAINTENANCE ACTIONS FOR SELECTED WORK UNIT CODES
 PERIOD ENDING 31 JUN 30
 ALC: SAALC RCN: MD1747 TYP EQP: ACF EAD: COOSA MUC: STAFA
 IND HORIZ SITUATION CAT IND 8
 PART III - PARTS REPLACED

FSC	PART NUMBER	---HOW MALFUNCTION--- CODE	NOUN	REF. SYM	BASE	---QUANTITY--- CURR	TWELVE	
5945	10136	037	FLUCTUATES	SOLENOID	SMALC MRS	1	1	
		070	BROKEN	SOLENOID	SMALC MRS	1	1	
		135	STUCK OR JAM	SLUTTHOGS	SMALC MRS	1	1	
		135	STUCK OR JAM	SOLENOID	SMALC MRS	2	2	
		553	NOT MEET SPEC	THOURSHUT	SMALC MRS	1	1	
		P/N TOTAL						
		2A1195						6
		SA1195						1
		SA1195						2
								1
5950 5990	10120-1	135	STUCK OR JAM	BRKSOL	SMALC MRS	1	1	
		135	STUCK OR JAM	SOLENOIDB	SMALC MRS	2	2	
		135	STUCK OR JAM	BRAKE	SMALC MRS	1	1	
		135	STUCK OR JAM	BRAKE	SMALC MRS	2	2	
		135	STUCK OR JAM	BRAKE	SMALC MRS	2	2	
		135	STUCK OR JAM	BRAKE	SMALC MRS	1	1	
		135	STUCK OR JAM	BRAKE	SMALC MRS	2	2	
		135	STUCK OR JAM	BRAKE	SMALC MRS	2	2	
		135	STUCK OR JAM	SOLENOIDB	SMALC MRS	1	1	
								9
6105	10126	135	STUCK OR JAM	TRANSFORM	SMALC MRS	1	1	
		037	FLUCTUATES	SYNCIRO	SMALC MRS	1	1	
		037	FLUCTUATES	RECEIVER	SMALC MRS	1	1	
		710	BEARING FAIL	RECEIVER	SMALC MRS	3	3	
		721	IMP RE ELE INPT	REC	SMALC MRS	2	2	
		P/N TOTAL						
		0X01002900						6
		10126						1
								1
								1
6610	100762	190	CRACKED	COURSESYN	SMALC MRS	1	1	
		750	MISSING	MOTOR	SMALC MRS	1	1	
		553	NOT MEET SPEC	MOTOREN	SMALC MRS	1	1	
		553	NOT MEET SPEC	PRISM	SMALC MRS	2	2	
		553	NOT MEET SPEC	STARGEAR	SMALC MRS	1	1	
		553	NOT MEET SPEC	AMPS	SMALC MRS	2	2	
		553	NOT MEET SPEC	AMP	SMALC MRS	1	1	
		P/N TOTAL						
		100888						2
		100986						1
		780	BENT	COURSECOU	SMALC MRS	1	1	
		070	BROKEN	LAMP	SMALC MRS	1	1	
		080	DEFECTIVE LAMP	LHLIGHT	SMALC MRS	1	1	
		080	DEFECTIVE LAMP	LAMP	SMALC MRS	1	1	
		080	DEFECTIVE LAMP	LIGHTASSY	SMALC MRS	1	1	
		080	DEFECTIVE LAMP	LAMP	SMALC MRS	1	1	
		080	DEFECTIVE LAMP	LH	SMALC MRS	1	1	
		080	DEFECTIVE LAMP	LAMP	SMALC MRS	1	1	
		080	DEFECTIVE LAMP	LAMP	SMALC MRS	1	1	
		080	DEFECTIVE LAMP	LIGHTASSY	SMALC MRS	1	1	
P/N TOTAL								
						10		

FIGURE 7.6 DD-56 5-LOG PART III

DISTRIBUTION: AFLC/LOEP
 SUMMARIZED MAINTENANCE ACTIONS FOR SELECTED WORK UNIT CODES
 PERIOD ENDING 31 JUN 68
 ALC: SAALC RCN: M01747 TYP EQP: ACF EAD: COOSA WUC: STAFA
 IND HORIZ SITUATION CAT IND B
 PART III - PARTS REPLACED

FSC	PART NUMBER	---HOW MALFUNCTION--- CODE	NOUN	REF. SYM NOUN	BASE	---QUANTITY--- CURR	TWELVE
	100987	070	BROKEN	LAMP	SMALC MRS	1	
		080	DEFECTIVE LAMP	LAMP	SMALC MRS	1	
		080	DEFECTIVE LAMP	LIGHTASSY	SMALC MRS	1	
		080	DEFECTIVE LAMP	LIGHTS	SMALC MRS	1	
		080	DEFECTIVE LAMP	LAMP	SMALC MRS	1	
		080	DEFECTIVE LAMP	LAMP	SMALC MRS	1	
		080	DEFECTIVE LAMP	LAMP	SMALC MRS	1	
		080	DEFECTIVE LAMP	LIGHTASSY	SMALC MRS	1	
		080	DEFECTIVE LAMP	RH	SMALC MRS	1	
		080	DEFECTIVE LAMP	RH	SMALC MRS	1	
		080	DEFECTIVE LAMP	RHLIGHT	SMALC MRS	1	
						11	
	P/N TOTAL						
	101505	080	DEFECTIVE LAMP	AMP	SMALC MRS	2	
	10221	080	DEFECTIVE LAMP	DEVALARM	SMALC MRS	1	
		080	DEFECTIVE LAMP	METER	SMALC MRS	1	
		080	DEFECTIVE LAMP	METER	SMALC MRS	1	
		080	DEFECTIVE LAMP	METER	SMALC MRS	1	
	P/N TOTAL					4	
	10223	080	DEFECTIVE LAMP	OFFLAG	SMALC MRS	1	
		080	DEFECTIVE LAMP	OFFLAG	SMALC MRS	1	
		080	DEFECTIVE LAMP	METER	SMALC MRS	1	
		080	DEFECTIVE LAMP	CAN	SMALC MRS	1	
		080	DEFECTIVE LAMP	LH	SMALC MRS	1	
		037	FLUCTUATES	COUNTER	SMALC MRS	1	
		070	BROKEN	COUNTER	SMALC MRS	1	
		070	BROKEN	COUNTER	SMALC MRS	1	
		070	BROKEN	COUNTER	SMALC MRS	1	
		135	STUCK OR JAM	COUNTER	SMALC MRS	1	
		135	STUCK OR JAM	COURSE	SMALC MRS	1	
		135	STUCK OR JAM	COURSE	SMALC MRS	1	
		135	STUCK OR JAM	CC	SMALC MRS	1	
		135	STUCK OR JAM	CC	SMALC MRS	1	
	P/N TOTAL					10	
	95C8A64	553	NOT MEET SPEC	ETI	SMALC MRS	1	
	0961-0627	080	DEFECTIVE LAMP	DEWMETER	SMALC MRS	1	
6695		080	DEFECTIVE LAMP	DEVIATIONM	SMALC MRS	1	
		080	DEFECTIVE LAMP	DEWMETER	SMALC MRS	1	
		080	DEFECTIVE LAMP	METER	SMALC MRS	1	
	P/N TOTAL					5	
09610627		080	DEFECTIVE LAMP	METER	SMALC MRS	1	
	WUC TOTAL					84	

7.3 LCC ANALYSIS INPUT DATA (Continued)

5. K051 is an Air Force airborne equipment data source titled, Logistic Support Cost Ranking, for which Rockwell-Collins is on distribution (Refer to Figure 7.7). Report Q-K051-PN8-LQ-MQZ (LSC File Maintenance Register) reflects all valid work unit codes, reported National Stock Numbers and applicable available management control data including unit price.
6. The various equipment manuals used for this study are listed in Table 7.17.

7.3.1 Standard Logistics Parameter

The standard factors represent values that are common to all data sets. The values are listed in Tables 7.18 through 7.20. These values were obtained as a result of our on-going experience with Global Positioning System (GPS) and Joint Tactical Information Distribution System (JTIDS) LCC programs and our recent experience with Air Force proposals such as the Combined Altitude Radar Altimeter (CARA) proposal (RFP F-09603-82-R-0003) and the Fuel Savings Advisory and Cockpit Avionics System (FSA/CAS). All values have been adjusted to reflect 1982 dollars.

Most of the standard cost factors shown in Table 7.18 were obtained from the CARA proposal. The average hourly labor rates are combined with the average hourly material consumption rates and adjusted to 1982 dollars. These values times the appropriate mean time to repair (MTTR) provide the cost per repair action.

To determine the quantity of systems in use and their distribution by CONUS and overseas bases (Refer to Table 7.19), three sources of

102 WEAPON SYSTEM CO05A SAALC LOGISTIC SUPPORT COST FILE MAINTENANCE REGISTER
 CHANGED DATA ELEMENTS ARE DENOTED BY C (COMPUTER) OR M (MANUAL)

LOG-LO(Q). 7953

WUC	CAT IND	ACC	MSN	PRIME ALC	NOUN	ERRC	UNIT PRICE	WEIGHT SPEC	OR INV	QPA	SRA OR USE FCTR	% DEP CMD	SPCL GFAE	CODES EXMPT	OLD WUC
51AC0	G	G	6610001691601LH	F	INDICATOR, ATTTT	T	\$24,894.00	C	23	2	C \$1178	00			
	B	A	6615001320287	-	*NEW ITEM	-	-----				---				
	B	A	999999999999999	-	IND ATTITUDE DIR	-	\$0.00			2	1.00				
51AC9	C	Y	999999999999999	-	MOC	-	\$0.00			99	1.00				
51ACA	G	C	6610001691601LH	-	INDICATOR, ATTTT	C T	C \$24,894.00	C	23	2	C \$1178	C 00			
	B	A	999999999999999	-	AMP ASSY	-	\$0.00			2	1.00				
51ACF	B	Y	999999999999999	-	MECHANISM SECT1	-	\$0.00			2	1.00				
51ACG	B C	Y	66100002601179LM	***	DELETED NO FIELD DATA HISTORY ***	-	\$0.00			1	1.00				
	B	A	999999999999999	-	MDL CRAB ANGLE	-	\$0.00			1	1.00				
51ACH	G	G	6610003501096LH	F	MORULE, GLIDESLO	T	\$952.00	C	2	1	C \$58	00			
	B	A	999999999999999	-	MDL GLIDESLOPE	-	\$0.00			1	1.00				
51AEO	G	G	6340010557374	F	COMPARATOR FLAG	L	\$ 3,900.00	C	9	2	\$319	00			
	G	G	6340010638382	***	DELETED NO FIELD DATA HISTORY ***	-									
	G	G	6605002353003LH	F	INDICATOR, SYMBO	T	\$ 2,985.00	C	6	2	C \$372	02			
	B	A	66100005061745LH	F	COMPUTER, FLIGHT	L	\$28,892.00	C	28	2	C \$1047	C 03			
51AE9	C	Y	999999999999999	-	IND PHERIL COMM	-	\$0.00			99	1.00				
	B	Y	999999999999999	-	MOC	-	\$0.00			2	1.00				
51AEA	B	Y	999999999999999	-	AMPLIFIER	-	\$0.00			2	1.00				
51AEB	B	Y	999999999999999	-	CIRCUIT CARD AM	-	\$0.00			2	1.00				
51AEC	B	Y	999999999999999	-	CTR CARD PHR SU	-	\$0.00			2	1.00				
51AED	B	Y	999999999999999	-	COMPONENT ASSY	-	\$0.00			2	1.00				
51AEE	B	Y	999999999999999	-	BLOCK ASSY	-	\$0.00			2	1.00				
51AFO	A	Y	999999999999999	-	MISC FLT DIR CO	-	\$0.00			1	1.00				
51AF9	C	G	6610001202047LH	CF	CIRCUIT CARD AS	T	\$ 1,015.00		1	99	C \$126	00			
	B	A	999999999999999	-	MOC	-	\$0.00			1	1.00				
51AFA	G	G	660500814146LH	F	PANEL NAVIGATIO	T	\$ 3,290.00	C	13	2	\$933	00			
	G	G	6610003715953LH	F	PANEL ASSEMBLY	T	\$ 2,101.00		3	2	C \$322	00			
	G	G	6610009923096	D	INDICATOR HORIZ	T	\$ 5,634.00		14	2	C \$530	00			
	B	A	999999999999999	-	IND HORIZ SITUA	-	\$0.00			2	1.00				

302 WEAPON SYSTEM C005A SAALC LOGISTIC SUPPORT COST FILE MAINTENANCE REGISTER
 CHANGED DATA ELEMENTS ARE DELETED BY C (COMPUTER) OR M (MANUAL)

LOG-LO(O) 7953

WUC	CAT IND	ACC	NSN	PRIME ALC	NOUN	ERRC	UNIT PRICE	WEIGHT SPEC	OR INV	OPA	SRA OR USE FCTR	% NEP COMD	SPCL GFAE	CODES EXMPT	OLD MUC
51AFB	B	G	6610001132245LH	F	PANEL, REMOTE CO	T	\$ 1,867.00	C	1		\$140	00			
		G	6610003715953LH	CF	PANEL, ASSEMBLY	T	\$ 2,101.00	C	3		C \$322	00			
		A	9999999999999999		SELECTOR REMOTE	-	\$0.00			2	1.00				
51AFC	B	G	6605008144146LH	F	PANEL NAVIGATIO	T	\$ 3,290.00	C	13		\$933	00			
		G	6605008144150LH	F	PANEL NAVIGATIO	T	\$ 3,084.00	C	13		C \$930	00			
		G	6605009432896	D	SELECTOR, NAVIG	T	\$ 598.00		9		C \$1184	00			
		G	6610003715953LH	F	PANEL ASSEMBLY	T	\$ 2,101.00		3		C \$322	00			
		A	9999999999999999		PNL SELECTOR PI	-	\$ 0.00			1	1.00				
51AFD	B	G	6605008144146LH	*** DELETED NO FIELD DATA HISTORY ***											
		A	6605008144150LH	F	PANEL, NAVIGATIO	T	\$ 3,084.00	C	13		C \$930	00			
		A	9999999999999999		PNL SELECTOR COP	-	\$ 0.00			1	1.00				
51AFE	B	G	5826001345980	J	SENSOR, RATE OF	T	\$ 1,591.00	C	10		C \$389	00			
		A	9999999999999999		SENSOR, RATE OF	-	\$ 0.00			2	1.00				
51AFF	B	Y	9999999999999999		CIRCUIT BREAKER	-	\$ 0.00			12	1.00				
51AFG	B	Y	9999999999999999		WIRING CONNECTO	-	\$ 0.00			99	1.00				
51AFH	B	G	6610001202044LH	F	CIRCUIT CARD AS	T	\$ 634.00		1		\$157	00			
		G	6610001202047LH	F	CIRCUIT CARD AS	T	\$ 1,015.00		1		C \$126	00			
		G	6610003715953LH	F	PANEL ASSEMBLY	T	\$ 2,101.00		3		C \$322	00			
		A	9999999999999999		AX NAV SEL PNL	-	\$ 0.00			2	1.00				
51AGD	B	G	6615000228315LH	F	COMPUTER, YAW	L	\$62,081.00		81		\$1053	00			
		G	6615004041990LH	F	GYROSCOPE, DISPL	T	\$15,656.00		46		\$766	--			
		G	6615004995940LH	F	GYROSCOPE, ASSY	T	\$20,085.00		46		C \$2970	50			
		G	6615004995941LH	F	COUPLER, ELECTR	L	\$16,995.00		39		C \$1573	C 52			
		A	9999999999999999		GYRO DISPLACEME	-	\$ 0.00			2	1.00				
51AG9	C	Y	9999999999999999		MDC	-	\$ 0.00			99	1.00				
51AGA	B	Y	9999999999999999		OUTR ROLL ASSY	-	\$ 0.00			2	1.00				
51AGB	B	G	6615004995940LH	F	GYROSCOPE ASSY	T	\$20,085.00		46		C \$2970	50			
		A	9999999999999999		OUTER PITCH AX	-	\$ 0.00			2	1.00				
51AGC	B	Y	9999999999999999		INNER ROLL AX A	-	\$ 0.00			2	1.00				
51AGD	B	Y	9999999999999999		INNER PITCH AX	-	\$ 0.00			2	1.00				
51AGE	B	Y	9999999999999999		PITCH AXIS DIR	-	\$ 0.00			2	1.00				

FIGURE 7.7 KO-51 EXAMPLE (CONTINUED)

EQUIPMENT MANUALSTABLE 7.20

<u>STUDY EQUIPMENT</u>	<u>MANUAL TITLE</u>	<u>PART NUMBER</u>
AN/GRC-171	Service and Circuit Diagrams	TO 31R2-2GRC171-2
AN/GRC-171	Illustrated Parts Breakdown	TO 31R2-2GRC171-4
618M-1C	Service and Circuit Diagrams	TO 12R2-4-62-2
618M-1C	Illustrated Parts Breakdown	CPN 523-0755817-601115
618M-1C	MRC-108() Service and Circuit Diagrams	TO 31R2-2MRC108-2/-2S-1
618M-1C	MRC-108() Illustrated Parts Breakdown	TO 31R2-2MRC108-4S-1
FPS-77V	Service	TO 31M6-2FPS77-2
FPS-77V	Illustrated Parts Breakdown	TO 31M6-2FPS77-4
FPS-103	WTR-IE Installation Operation	TO 31M6-2FPS103-21
GSH-34	Illustrated Parts Breakdown	TO 31S3-2GSH34-4
VR-3700	Operation, Maintenance, Instructions and Circuit Diagrams	TO 31S3-4-53-12
VR-3700	Illustrated Parts Breakdown	TO 31S3-4-53-14
ARC-109	Maintenance Instructions	CPN 523-0759235-002511
BG489C()	Overhaul Instructions	TO 5A7-3-25-13
BF488C()	Overhaul Instructions	TO 5A7-3-26-13
CP-1104/CP-1105	Illustrated Parts Breakdown	TO 5A1-2-43-4
562P-1E1	Field Maintenance and Overhaul	TO 12R5-4-82-22
562P-1E1	Illustrated Parts Breakdown	TO 12R5-4-82-24
562R-1E	Field Maintenance and Overhaul	TO 12R5-4-81-22
AQU-4A	Overhaul	TO 5F8-16-4-3
AQU-4A	Illustrated Parts Breakdown	TO 5F8-16-4-4
CIE No. MA0001A	Illustrated Parts Breakdown	TO 5N8-5-15-4
AJN-18	Illustrated Parts Breakdown	TO 5F8-16-7-4

EQUIPMENT MANUALS

TABLE 7.20 (CONTINUED)

<u>STUDY EQUIPMENT</u>	<u>MANUAL TITLE</u>	<u>PART NUMBER</u>
ARU-39	Overhaul with Illustrated Parts	TO 5F8-3-33-3
331A-8H	Field Maintenance with Overhaul	TO 12R5-4-93-12
329B-8G	Field Maintenance with Overhaul	TO 12R5-4-91-22

TABLE 7.21
STANDARD COST FACTORS

FACTOR	LCC SYMBOL	VALUE
Item Entry Cost/New Item Base Labor and Material	SIE	1,568
Consumption Rate/Hour Depot Labor and Material	SBR	26.63
Consumption Rate/Hour Packaging and Shipping	SDR	42.09
Cost/Pound - CONUS Packaging and Shipping	SPSC	.85
Cost/Pound - Overseas Initial Data Mgmt.	SPSO	1.22
Cost/Copy/Page	SID	.0067
Item Mgmt. Cost/Item/Year	SIM	216
Data Mgmt. Cost/Page/Year	SDM	11.71

NOTE: All costs are in dollars.

Table 7.22
LOGISTIC FACTORS

FACTOR	LCC SYMBOL	VALUE
Study Duration (Years)	NY	15
Number of Bases - CONUS	NBC	*
Number of Bases - Overseas	NBO	*
Number of Intermediate Sites - CONUS	NIC	*
Number of Intermediate Sites - Overseas	NIO	*
Number of Bases, Systems at Base	NBASE, N SYS.	*
System Operating Hours/Month	OH	*
Number of Depot Work Shifts	NOS	1
Number of Intermediate Site Work Shifts	NIS	1
Base Resupply Time - CONUS (Hours)	RSTC	240
Base Resupply Time - Overseas (Hours)	RSTO	360
Depot Replacement Cycle Time (Hours)	DMC	360
Depot Repair Cycle Time (Hours)	DRC	985
Shipping Time to Depot - CONUS (Hours)	BDSC	408
Shipping Time to Depot - Overseas (Hours)	BDSO	528
Base Turnaround Time (Hours)	TAT	146
Spares Objective - System	A01	.995
Spares Objective - Shop	A02	.999
Depot Stock Safety Factor	DSSF	1.65
Activation Schedule Array	K, M, NAC	*

*Values vary with individual equipment.

TABLE 7.23
CONTRACTOR DATA

FACTOR	LCC SYMBOL	VALUE
Base Level Training Cost	BTC	8,610
Depot Level Training Cost	DTC	7,380
Data Acquisition Cost - Base Level Manuals	DCB	1,000
Data Acquisition Cost - Depot Level Manuals	DCD	2,000
Data Acquisition Cost - Other	DCO	2,000
Pages of Data - Base Level Manuals	NPB	100
Pages of Data - Depot Level Manuals	NPD	200
Pages of Data - Other	NPO	50
Number of New Inventory Items	NI	500
Contractor Base Resupply Time - CONUS	CRSC	240
Contractor Base Resupply Time - Overseas	CRSO	360
Contractor Repair Cycle Time	CDMC	528
Acquisition Cost/System	ACS	*

NOTE: All costs are in dollars and all times are in hours.

*Values vary with individual equipment.

7.3.1 Standard Logistics Parameter (Continued)

data were utilized: D056B5006 (6-log), D056B5014 (14-log) and Air Force 66-1 tapes. The 6-log provided inventory size for both ground and airborne systems. The 14-log provided a straight forward listing of equipment location by serial number for ground equipment. The 66-1 tapes were used to identify the quantity of aircraft by base.

7.3.2 Operational Parameters

The operational parameters required for the LCC model are identified in Table 7.21 and Table 7.22.

The number of replaceable units (NRU) is a summation of data records which include the system and each replaceable unit (LRU and SRU). Nomenclatures for each record were obtained from Work Unit Code (WUC) Manuals or 5-log/6-log data and include the WUC for each record. The indenture (IN) indicates whether the data record pertains to a system (IN = 1), LRU (IN = 2) or SRU (IN = 3). The NQ entry is obtained directly from the 6-log data and indicates the quantity of a unit (LRU or SRU) which is required per system. Cost per spare unit (CRU) was obtained from the "Logistic Support Cost File Maintenance Register" section of the Air Force K051 data base, for airborne systems or directly from the system vendors for the ground systems. The following parameters were acquired from equipment maintenance manuals or illustrated parts books: weight (W), maintenance level performing fault verification (LV) and maintenance level performing repair (LR).

TABLE 7.24
HARDWARE DEFINITION PARAMETERS

FACTOR	LCC SYMBOL	VALUE
Number of Replaceable Units	NRU	*
Nomenclature	ANAME (I)	*
Line Item Number	LN (I) (I = 1 to NRU)	*
Indenture	IN (I)	*
Quantity in System	NQ (I)	*
Cost/Spare Unit (Dollars)	CRU (I)	*
Mean Time Between Failure/ Maintenance (Hours)	MTBF/MTBM (I)	*
Unverified Failure Probability	UFP (I)	*
Weight (Pounds)	W (I)	*
Failure Verification Standard (Hours)	FVS (I)	*
Repair Labor Standard (Hours)	RLS (I)	*
Removal Labor Standard (Hours)	RRS (I)	*
Not Base Repairable Probability	NRTS (I)	*
Condemnation Probability	COND (I)	*
Level of Failure Verification	LV (I)	*
Line Item of Support Equipment to Verify Failure	LSEV (I)	*
Usage Time for Verification (Hours)	USEV (I)	*
Level of Repair	LR (I)	*
Line Item of Support Equipment Required for Repair	LSEV (I)	*
Usage Time on Support Equipment for Repair (Hours)	USER (I)	*

*Values vary with individual equipment.

TABLE 7.25
SUPPORT EQUIPMENT PARAMETERS

FACTOR	LCC SYMBOL	VALUE
Number of Line Item of Support Equipment	NSE	*
Nomenclature	ANSE (J)	*
Line Number	LSE (J)	*
Cost/Set (Dollars)	CSE (J)	*
Operation and Maintenance Cost Factor	COM (J)	.02

*Values vary with individual equipment.

7.3.2 Operational Parameters (Continued)

The remaining parameters were computed from data contained in the 5-log and 6-log reports which covered a twelve month period of time. They will be explained as they apply to the three indenture levels, system, LRU and SRU. The codes referred to in the following equation are Action Taken Codes which are listed in Figure 7.8 as defined in USAF Work Unit Code Manuals.

System mean time between maintenance (MTBM) represents the frequency of maintenance actions (in place repairs or LRU removals) due to an apparent system failure and is computed using the following formula.

$$\text{System MTBM} = \frac{\text{Hours} \times \text{NQ}}{\text{Maintenance Actions}}$$

where: Hours are the total installation hours for 12 months from 6-log NQ is systems per installation from LCC inputs sheet.

Maintenance Actions =

$$6\text{-log LRU} + \text{SRU Total Occurrences} \left(1 - \frac{5\text{-Log Part I Total Actions for Codes G, S}}{5\text{-Log Part I Total Actions for All Codes}} \right)$$

The maintenance action formula reduces total occurrences by a factor representing occurrences of action taken codes G (repairs and/or replacement of minor parts, hardware and soft goods) and S (remove and reinstall).

System RLS is the average manhours of labor per in-place repair and is computed using the following formula using data from 5-log, Part I.

7.3.2

$$\text{System RLS} = \frac{(\text{Total Hrs.} - \text{Hrs. for Codes P, R, G, S})}{(\text{Total Actions} - \text{Actions for Both Codes P, R, G, S})} + \frac{(\text{Hours For Code Y})}{(\text{Total Actions} - \text{Actions for Codes G, S})}$$

System NRTS (Not Repairable This Station) is the expected fraction of system faults which are repaired by LRU removal and replacement and is computed using 5-log, Part I as follows:

$$\text{System NRTS} = \frac{(\text{Actions for Codes P, R})}{(\text{Total Actions} - \text{Actions for Codes G, S})}$$

LRU mean time between failure (MTBF) represents the frequency of failures excluding those which are repaired in-place, and is computed using the following formula:

$$\text{LRU MTBF} = \frac{\text{Hours} \times \text{NQ}}{\text{LRU Failures}}$$

where: Hours are the same as for System MTBF, NQ is now the quantity of this LRU per installation.

$$\text{LRU Failures} = (6\text{-log LRU} + \text{SRU Failures}) \times \frac{(5\text{-log Part II Total Actions for Codes AFG, KL, 1-8})}{(5\text{-log Part II Total Actions for All Codes})}$$

The LRU unverified failure probability (VFP) is the expected fraction of LRU removals that will be unverified failures and is computed from 5-log, Part II data as follows:

$$\text{LRU UFP} = \frac{\text{Actions for Codes BJ, VXZ}}{\text{Total Actions}}$$

LRU failure verification standard (FVS) is the average manhours of labor required for a bench check of the LRU. They are computed

7.3.2 Operational Parameters (Continued)

from 5-log, Part II data using the following formula:

$$\text{LRU FVS} = \frac{\text{Total Hours for Codes VXZ, BJ, 1-8}}{\text{Total Actions for Codes VXZ, BJ, 1-8}}$$

LRU repair labor standard (RLS) is the average manhours of labor required for NRTS repairs of the LRU and is computed using 5-log, Part II data as follows:

$$\text{LRU RLS} = \frac{\text{Total Hours for Codes AFG}}{\text{Total Actions for Codes AFG}}$$

LRU remove replace standard (RRS) is the average manhours of labor required at the flight line to isolate a system failure to the LRU, remove the LRU, replace it with a spare, and verify that the system is operational. RRS is computed using 5-log, Part I data as follows:

$$\text{LRU RRS} = \frac{(\text{Total Hours for Code PR, Q})}{(\text{Total Actions for Codes PR})} + \frac{(\text{Hours for Code Y})}{(\text{Total Actions for All Codes}) - (\text{Actions for Codes G-S})}$$

LRU NRTS is the fraction of LRU failures not repairable at base level. It is computed using 5-log, Part II as follows:

$$\text{LRU NRTS} = \frac{(\text{Total Actions for NRTS Codes 1-8})}{(\text{Total Actions for Codes 1-8, AFG, KL})}$$

LRU COND is the expected fraction of failures of the LRU resulting in condemnation. LRU COND is computed using 5-log, Part II data and the following formula:

7.3.2 Operational Parameters (Continued)

$$\text{LRU COND} = \frac{(\text{Total Actions for Code 9})}{(\text{Total Actions for Codes 9, AFG, KL})}$$

Usage time of the support equipment indicated by LSEV (Line Item of Support Equipment to Verify Failure) is entered as USEV and is equal to FVS (Failure Verification Labor Standard) which was previously computed. Similarly usage time of the support equipment indicated by LSER (Line Item of Support Equipment Required for Repair) is entered as USER and is equal to RLS (Repair Labor Standard) which was previously computed.

LSEV and LSER refer to Table 7.22, Support Equipment Parameters, which lists all non-standard support equipment required for the system.

SRU MTBF represents the frequency of SRU failures and is computed using the following formula:

$$\text{SRU MTBF} = \frac{\text{Hours} \times \text{NQ}}{\text{SRU Failures}}$$

where: Hours are the same as for System MTBM, NQ is the quantity of an SRU per installation.

$$\text{SRU Failures} = (\text{LRU Failures}) \times \frac{(6 - \log \text{SRU NRTS})}{(6 - \log \text{SRU NRTS}) + (6 - \log \text{LRU NRTS})}$$

If 5-log data was available on the SRU level the remaining SRU parameters (UFP, FVS, RLS, RRS, NRTS, COND, LSEV, USEV, LSER and USER) are computed in the same manner as for the LRU. If SRU 5-log were unavailable data was used which are based on the LRU/SRU relationships exhibited where full data was used.

8.0 ACQUISITION STRATEGY COMPARISON EXAMPLE

Any decision process regarding the choice of commercial off-the-shelf or military equipment must consider the operational factors that may be affected and it is clear that the impact on these factors will be different for different environments. The appropriate strategy for a particular acquisition situation becomes a case of determining whether the life cycle cost savings outweigh the risks.

A risk assessment approach whereby approximately twenty of the most important operational factors are weighted according to their importance to program success has been designed. Two examples are given in Table 8.1 indicating the most significant thirteen factors and their weighting for the possible situations of an airborne fighter radio receiver/transmitter and a ground fixed computer processor. Each of these weighted factors is then assigned a score for each acquisition class "military" and "commercial off-the-shelf" (mature best commercial practice design). The score represents a team of experts' quantitative evaluation of the risk of achieving success with respect to that operational factor. Continuing the above examples, the quantitative risk assessment results are indicated in Table 8.2. The conclusion to be drawn for the set of weighted factors used in this example is that the commercial approach represents a 23% greater risk for the ground application than the military design approach and it represents a 94% greater risk for the airborne fighter application. This difference in risk must be weighed against the potential for life cycle cost savings. For example, life cycle cost data can be determined for similar equipments of a military and commercial design in military operational use. This data should be normalized to account for

(8.0 - Continued)

different equipment complexities, quantities and usage. The resulting measure would be life cycle cost per operational hour per part. Sample LCC data are shown in Table 8.3.

The appropriate strategy to be used is determined by considering the two resultant analysis factors: (1) the operational risk assessment measure and (2) the life cycle cost measure. How these measures are combined depends again on their relative importance. If equally weighted, an "advantage indicator" for each acquisition strategy could be determined by simply multiplying the two factors together and choosing the lowest "advantage indicator" as the best strategy. For other situations, it might be more appropriate to weight one factor more heavily than the other to account for a particular program emphasis. Continuing the previous example using the life cycle cost data and a equal weight "advantage indicator" approach, the most appropriate acquisition strategies are indicated in Table 8.4.

Also indicated in Table 8.4 are the operational factors requiring extra program emphasis to reduce risk. They are the factors from the risk determination analysis having the greatest contribution to the overall operational risk.

TABLE 8.1
OPERATING FACTOR WEIGHTING

	<u>A</u>	<u>G</u>
Procurement Schedule	10	10
Reliability & Quality	10	8
Maintainability	7	6
Personnel Safety	10	8
Training/Publications	7	5
Spares Provisioning	6	5
Configuration Management	6	6
Non-Standard Parts	6	5
Special Handling	6	3
Input Power	6	3
EMC	8	5
Data Rights	3	3
Size & Weight	8	5

A = Airborne Fighter Radio Receiver/Transmitter
G = Ground Fixed Computer Processor

TABLE 8.2

Operational Risk Assessment

	<u>GROUND FIXED*</u>	<u>AIRBORNE INHABITED FIGHTER</u>
Military	298	361
Best Commercial Practices	366	699
*Environment defined by MIL-HDBK-217		

TABLE 8.3

LCC Comparison

LCC/Op Hour/Part ($\times 10^{-6}$)		
Ground Fixed Data Processing	Military	\$10008
	Commercial	\$ 3977
Airborne Inhabited Communications	Military	\$11613
	Commercial	\$11299

AD-A129 596

RELIABILITY MAINTAINABILITY AND LIFE CYCLE COST EFFECTS
OF COMMERCIAL OFF. (U) ROCKWELL INTERNATIONAL CEDAR
RAPIDS IA COLLINS GOVERNMENT AVI. N E SCHMIDT ET AL.
FEB 83 RADC-TR-83-29-VOL-1 F30602-80-C-0306 F/G 15/5

3/3

UNCLASSIFIED

NL



END
DATE
FILMED
DTIC

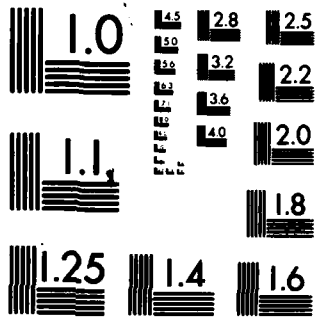

MICROCOPY RESOLUTION TEST CHART
NATIONAL BUREAU OF STANDARDS-1963-A

TABLE 8.4
Recommended Strategy Example

Environment	Type		Factors Requiring Emphasis
	Communications	Data Processing	
Ground Fixed		Commercial	Personnel Training Technical Publications Spares Provisioning Configuration Management
Airborne Inhabited Fighter	Militarized		Procurement Schedule Reliability Maintainability

