

AD-A128 699

DRAFT ENVIRONMENTAL IMPACT REPORT/ENVIRONMENTAL IMPACT
STATEMENT CULLINAN RANCH SPECIFIC PLAN APPENDICES(U)
TORREY AND TORREY INC SAN FRANCISCO CA MAY 83

1/6

UNCLASSIFIED

F/G 13/2

NL

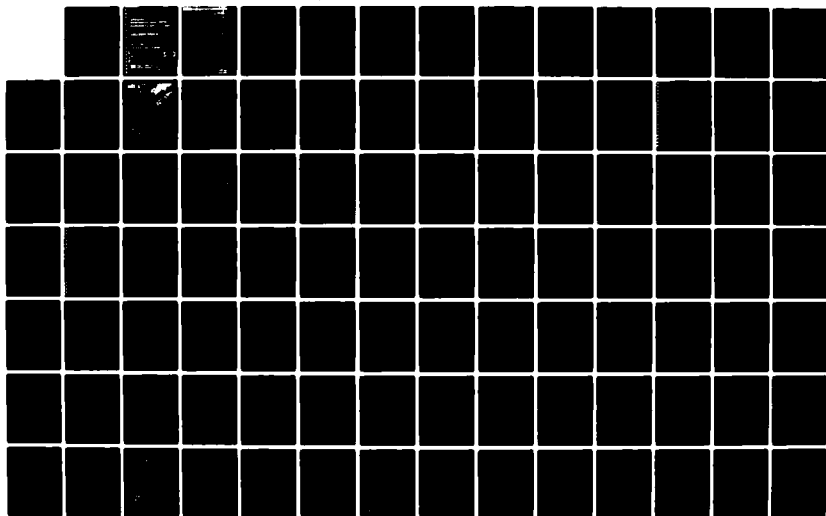

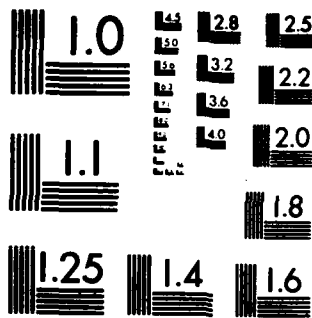

MICROCOPY RESOLUTION TEST CHART
NATIONAL BUREAU OF STANDARDS-1963-A

9

**APPENDICES
ENVIRONMENTAL IMPACT REPORT/
ENVIRONMENTAL IMPACT STATEMENT**

CULLINAN RANCH

**City of Vallejo
U.S. Army Corps of Engineers**

May 1983

**DTIC
ELECTE
MAY 24 1983
S A**

AD A 128699

FILE COPY

This document has been
for public use and is
available to all persons

REPORT DOCUMENTATION PAGE		READ INSTRUCTIONS BEFORE COMPLETING
1. REPORT NUMBER	2. GOVT ACCESSION NO. AD-A128 699	3. REPORT'S CATALOG NUMBER
4. TITLE (and Subtitle) Draft Environmental Impact Report/Environmental Impact Statement, Cullinan Ranch Specific Plan		5. TYPE OF REPORT & PERIOD COVERED
7. AUTHOR(s) Torrey & Torrey, Inc. San Francisco, CA		6. PERFORMING ORG. REPORT NUMBER
9. PERFORMING ORGANIZATION NAME AND ADDRESS U.S. Army Corps of Engineers, San Francisco Dist. 211 Main Street San Francisco, CA 94105		8. CONTRACT OR GRANT NUMBER(s)
11. CONTROLLING OFFICE NAME AND ADDRESS Office of the Chief of Engineers U.S. Department of the Army Washington, D.C. 20316		10. PROGRAM ELEMENT, PROJECT, TASK AREA & WORK UNIT NUMBERS
14. MONITORING AGENCY NAME & ADDRESS (if different from Controlling Office)		12. REPORT DATE May 1983
		13. NUMBER OF PAGES
		15. SECURITY CLASS. (of this report) Unclassified
		15a. DECLASSIFICATION/DOWNGRADING SCHEDULE
16. DISTRIBUTION STATEMENT (of this Report) Approved for public release; distribution unlimited		
17. DISTRIBUTION STATEMENT (of the abstract entered in Block 20, if different from Report)		
18. SUPPLEMENTARY NOTES - Prepared in cooperation with the City of Vallejo Planning Department Solano County, California - Appendices are bound in a separate volume		
19. KEY WORDS (Continue on reverse side if necessary and identify by block number) Environmental Impact Excavation/Fill Waterfront residential/commercial development Recreational Boating <i>This report is a</i>		
20. ABSTRACT (Continue on reverse side if necessary and identify by block number) Joint State/Federal environmental impact document concerning a regulatory permit application by Pan Pacific and Redwood Realty under Section 10 of the River and Harbor Act of 1899 and Section 404 of the Clean Water Act. The proposed project involves a water-oriented predominantly residential community with public and private marina facilities.		

83 05 23 025

APPENDICES
TABLE OF CONTENTS

- I. INITIAL STUDY FOR CULLINAN RANCH PREPARED BY THE CITY OF VALLEJO
 - A. DESCRIPTION OF THE PROJECT
 - B. ENVIRONMENTAL CHECKLIST FORM WITH ATTACHED EXPLANATIONS

- II. TECHNICAL REPORTS SUBMITTED BY TORREY & TORREY INC.
 - A. TRAFFIC
TJKM Associates. "Capacity Calculations for Cullinan Ranch Project." 1983.
 - B. NOISE
Charles Salter Associates. "Fundamental Concepts of Environmental Noise."
 - C. AIR QUALITY
Donald Ballanti. "Air Quality Assumptions and Methodology." 1983.

- III. TECHNICAL REPORTS SUBMITTED BY W. R. WILLIAMS & ASSOCIATES REPRESENTING PAN PACIFIC AND REDWOOD REALTY
 - A. SOILS, GEOLOGY, SEISMICITY AND EROSION
Harding Lawson Associates. "Preliminary (Phase I) Soil Investigation: Cullinan Ranch - Island No. 1; Vallejo, California." November 13, 1982.

Moffat & Nichol, Engineers. "Cullinan Ranch Shoreline Protection Study." January 1982.
 - B. HYDROLOGY, WATER QUALITY AND SEDIMENTATION
R. B. Krone & Associates/Resource Management Associates. "Water Circulation, Sedimentation and Algae Growth in the Cullinan Ranch Development Project." February 1982.
 - C. TRAFFIC AND CIRCULATION
Basmaciyani-Darnell, Inc. "Traffic Study for Cullinan Ranch and Guadalcanal Village." August 1982.

Moffat & Nichol, Engineers. "Cullinan Ranch Boat Traffic Study." December 1981.
 - D. VEGETATION AND WILDLIFE
Harvey & Stanley Associates, Inc. "Cullinan Ranch Wildlife Monitoring Program Interim Report." February 1983.

E. AGRICULTURE

Richard B. Bahme, AgriDevelopment Company. "Technical and Economic Evolution of the Cullinan Ranch Property for Agricultural Production." August 1982.

A. Doyle Reed, Agricultural Economist. "Economic Feasibility of the Cullinan Ranch for Agricultural Production." October 1982.

F. ECONOMIC/FISCAL

Alfred Gobar Associates, Inc. "Preliminary Fiscal Impact Evaluation - Cullinan Ranch Development; Vallejo, California." September 1982.

Alfred Gobar Associates, Inc. "Cullinan Ranch Fiscal Impact - Phased Development." December 1982.



DEPARTMENT OF THE ARMY
SAN FRANCISCO DISTRICT, CORPS OF ENGINEERS
211 MAIN STREET
SAN FRANCISCO, CALIFORNIA 94105

87 MAY 1983

Project Evaluation Section

SUBJECT: DRAFT ENVIRONMENTAL IMPACT REPORT/ENVIRONMENTAL IMPACT STATEMENT
CULLINAN RANCH SPECIFIC PLAN
CITY OF VALLEJO, SOLANO COUNTY, CALIFORNIA
REGULATORY PERMIT APPLICATION NO. 14775E57
MAY 1983

TO WHOM IT CONCERNS:

ERRATA SHEET

The subject environmental document, jointly prepared for the City of Vallejo Planning Department and the U.S. Army, Corps of Engineers, San Francisco District, was recently transmitted to your office along with a separate Appendices volume titled Cullinan Ranch Environmental Impact Report/Environmental Impact Statement Appendices, May 1983.

The enclosed analysis titled "Cullinan Ranch Fiscal Impact - Phased Development" by Alfred Gobar Associates, Inc. and dated December 13, 1982 was inadvertently omitted from the Appendices volume of the subject environmental document. Please insert this analysis as the last item in Chapter III.F. (reference: TABLE OF CONTENTS) of the Appendices volume.

Edward M. Lee, Jr.
Edward M. Lee, Jr.
Lieutenant Colonel, CE
District Engineer

Enclosure

ALFRED GOBAR ASSOCIATES, INC.

December 13, 1982

Mr. W. R. Williams
W. R. WILLIAMS & ASSOCIATES
P. O. Box 268
Huntington Beach, CA 92648

Subject: Cullinan Ranch Fiscal Impact - Phased Development

Dear Walden:

Enclosed is a summary of the analysis of the fiscal consequences to the affected agencies - the City, the County, and the Recreation District - of phased development of the Cullinan Ranch. In every case, the phasing does not imply any potential for the Cullinan Ranch's development to add more to public agency costs than it does to public agency revenues at any stage in the Ranch's development.

Even using high estimates of City costs, the project is fiscally beneficial to all of the agencies involved with the possible exception of the school district. Projections for the school district were not made for the reasons described in the brief covering description of the Exhibits.

If you have any questions concerning this, please feel free to call us.

Very truly yours,

ALFRED GOBAR ASSOCIATES, INC.

A. J. Gobar
President

AJG/jlb
Enclosure

RECEIVED DEC 17 1982

CULLINAN RANCH FISCAL IMPACT - PHASED DEVELOPMENT

The phasing plan for the Cullinan Ranch has been converted into estimates of the phasing of development of public facilities including streets, bicycle paths, schools, parks, etc. These phasing assumptions are summarized in Exhibit I.

The fiscal consequences of phased development for the City of Vallejo for each phase and for the cumulative impact are projected in Exhibit II, showing a benefit/cost ratio for the City of Vallejo in excess of one-to-one for all phases. Note that the benefit/cost ratio actually increases on a cumulative basis for phases A through E and decreases marginally (on a cumulative basis) for phases F and G.

Phases F and G have a lower incremental benefit-to-cost ratio than is typical of the previous phases, although the benefit/cost ratios of phases F and G are still attractive with regard to City revenues as compared with City costs.

Similar comparisons of the phased fiscal impact of the Cullinan Ranch's development, according to the patterns in Exhibit I, as they affect the greater Vallejo Recreation District are summarized in Exhibit III, showing a rising benefit/cost ratio for phases A and B, a slight decrease with the introduction of phase C, an increase with phase D, a decrease with phase E and subsequent increases as phases F and G are completed. These projections indicate that the cost of providing services to the Cullinan Ranch through the Greater Vallejo Recreation District will be more than recovered by the incremental revenue flows to the District implicit in the phasing assumptions used.

Similar comparisons of the fiscal impact on Solano County of the phased development shown in Exhibit IV indicate a high benefit-to-cost ratio for each phase and on a cumulative basis.

These projections are based on a more detailed fiscal impact study developed in September 1982 to evaluate the overall fiscal impact of the project on affected local agencies. A detailed review of Exhibits I, II, III, and IV with relationship to the revenue and cost assumptions requires reference to this report which projected public agency revenues and costs at the Cullinan Ranch's full development.

Note that in the cost projections for the City of Vallejo, a range of City costs was used to reflect some ambiguity in the assignment of City costs to the Cullinan Ranch project. Even with the use of high estimates of City costs, the project has a highly beneficial fiscal impact on the City as well as on the other agencies involved.

Projections of the fiscal impact on the school district were not included for reasons discussed in the more detailed report referred to above. The Cullinan Ranch's impact on school costs has not been fully defined. These costs do not become an issue until at least the third phase (phase C). The principal cost issue with regard to the impact of the project on schools deals with the capital costs of providing additional capacity if needed. The need for additional capacity, however, is difficult to define in light of declining enrollments in existing schools throughout many parts of California, suggesting that existing capacity may obviate the need for the construction of new schools as a direct result of the Cullinan Ranch's development and occupancy as planned.

EXHIBIT I

ASSUMPTIONS REGARDING PHASED DEVELOPMENT FOR ITEMS AFFECTING FISCAL IMPACT

CULLINAN RANCH DEVELOPMENT

Type of Development	Cumulative Development thru:					
	Phase A	Phase B	Phase C	Phase D	Phase E	Phase F
Single Family Units	305	770	1,380	1,590	1,905	2,345
Multi-Family Units	0	0	285	565	1,136	1,500
Neighborhood Center (Acres)	-	-	-	-	-	7.5
Specialty Center (Acres)	-	-	20	40	55	55
Hotel (Acres)	-	-	-	-	5	5
Public Marina (Slips)	100	200	350	500	500	500
Private Marina (Slips)	-	-	-	100	200	200
Total Boats in Development	200	455	805	1,125	1,330	1,480
Public Streets:* (Miles)	-	-	0.60	1.20	1.70	1.70
Major Collector Streets	0.84	1.26	1.68	2.10	2.62	3.15
Frontage Road	0-1.68	0-4.24	0-7.59	0-8.75	0-10.48	0-12.90
Local Streets	0.84-2.52	1.26-5.50	2.28-9.87	3.30-12.05	4.32-14.80	4.85-17.75
Total (Miles)	0-0.8	0-1.6	0-2.4	0-3.2	0-4.0	0-5.0
Bicycle Paths* (Miles)	-	-	1	1	1	2
Schools: Elementary	-	-	-	-	-	1
Junior High	-	-	-	-	-	1
Parks:* (Acres)	-	-	6.5	6.5	6.5	13
Neighborhood	-	-	-	-	20	20
Community	4	7	10	10	10	10
Marina Park	-	-	-	-	-	-
Population	854	2,156	4,434	5,582	7,606	9,566

*Only those that will involve public costs for maintenance and/or operation.

Source: Alfred Gobar Associates, Inc., Based on Phasing Projections Provided by M. R. Williams and Associates, Inc.

EXHIBIT II

CUMULATIVE FISCAL IMPACT ON THE CITY OF VALLEJO THROUGH EACH DEVELOPMENT PHASE CULLINAN RANCH PROJECT

	Cumulative Thru: Phase A	Phase B	Phase C	Phase D	Phase E	Phase F	Phase G
Revenues:							
Property Tax	\$ 247,015	\$ 609,155	\$ 1,264,325	\$ 1,660,228	\$ 2,242,490	\$ 2,733,822	\$ 3,210,624
Sales Tax*			304,920	609,840	914,760	1,029,105	1,067,220
Utility Users Tax	33,431	84,400	182,501	236,210	333,324	423,450	493,245
Business License Tax			18,968	37,936	56,904	64,017	66,388
Franchise Tax	4,175	10,541	22,794	29,502	41,531	52,638	61,605
Property Transfer Tax	14,314	36,138	78,435	101,802	139,264	173,142	204,468
Per Capita Revenues	9,052-18,523	22,854-46,764	47,000-96,172	59,159-121,074	80,624-164,974	101,400-207,487	120,840-247,266
Total Revenue	\$307,987-317,458	\$763,088-786,998	\$1,918,943-1,968,116	\$2,734,687-2,796,592	\$3,808,997-3,893,347	\$4,575,574-4,681,661	\$5,224,390-5,350-816
Costs:							
Police Protection**	\$22,474-82,640	\$ 56,737-158,143	\$116,684-325,234	\$146,895-409,440	\$200,158-557,900	\$251,737-701,666	\$300,000-836,190
Fire Protection**	11,719-45,160	29,586-114,009	60,847-234,470	76,600-295,176	104,315-402,205	131,272-505,850	156,439-602,851
Public Works	5,855-21,564	8,782-46,335	15,882-80,794	23,001-99,989	30,110-123,156	33,805-148,718	41,123-196,828
Library	4,748	11,987	24,653	31,036	42,289	53,187	63,384
Overhead Costs	11,450-34,279	27,373-84,469	55,740-170,013	70,937-213,590	96,344-287,691	120,132-360,248	143,378-434,789
Total Costs	\$56,246-168,391	\$134,665-414,943	\$273,816-835,164	\$348,469-1,049,231	\$473,276-1,413,241	\$590,133-1,769,669	\$704,324-2,135,842
Range of Net Revenues	\$139,596-261,212	\$348,145-652,533	\$1,083,779-1,694,300	\$1,685,456-2,448,123	\$2,395,756-3,420,071	\$2,805,905-4,091,528	\$3,088,548-4,646,492
Range of Benefit:Cost Ratios	1.82-5.64:1	1.84-5.85:1	2.29-7.19:1	2.61-8.03:1	2.70-8.22:1	2.59-7.93:1	2.45-7.60:1

*Does not allow for increased spending by residents in development off the property during early years of development.
 **Cost estimates made by agencies for total project (low estimates) were allocated by phase according to population growth. While these are only an approximation and costs will occur in step functions, the high estimates are also shown which are based on the current per capita costs.

Source: Alfred Gobar Associates, Inc.

EXHIBIT III
 CUMULATIVE FISCAL IMPACT* ON GREATER VALLEJO RECREATION
 DISTRICT THROUGH EACH DEVELOPMENT PHASE

CULLINAN RANCH PROJECT

Phase	Number of Developed Park Acres**	Property Tax Revenue***	Costs****	Net Revenue	Benefit: Cost Ratio
A	4.0	\$ 53,458	\$ 24,000	\$ 29,458	2.2:1
B	7.0	131,832	42,000	89,832	3.1:
C	16.5	273,622	99,000	174,622	2.8
D	16.5	359,303	99,000	260,303	3.6:
E	36.5	485,315	219,000	266,315	2.2.
F	43.0	591,647	258,000	333,647	2.3:1
G	43.0	694,836	258,000	436,836	2.7:1

* Operating revenues and costs only, as amount of and responsibility for capital costs not yet determined.

** Parks which are projected to be dedicated to the Park District only.

*** Excludes any possible revenue from fees which cannot be determined at this stage in planning.

**** High end estimate was used based on \$6,000 per acre for park maintenance. An alternative cost estimate based on current District costs of \$16.62 per capita produces a lower cost figure.

Source: Alfred Gobar Associates, Inc.

EXHIBIT IV
CUMULATIVE FISCAL IMPACT ON SOLANO COUNTY
THROUGH EACH DEVELOPMENT PHASE
CULLINAN RANCH PROJECT

Phase	Revenues	Costs	Net Revenue	Benefit: Cost Ratio
A	\$ 272,004	\$ 47,931	\$ 224,073	5.7:1
B	676,204	121,006	555,198	5.6:1
C	1,407,467	248,858	1,158,609	5.7:1
D	1,849,352	313,290	1,536,062	5.9:1
E	2,499,240	426,887	2,072,353	5.9:1
F	3,047,636	536,892	2,510,744	5.7:1
G	3,579,815	639,826	2,939,989	5.6:1

Source: Alfred Gobar Associates, Inc.

I. THE SITE

A. LOCATION

The site is located on State Highway 37 (i.e., Sears Point Road), west of the Napa River. The northerly and northeasterly boundary is formed by Dutchman's Slough, a navigable waterway. The southerly and southwesterly boundary is formed by the State Highway 37 right-of-way. The most southeasterly boundary abuts the site of the former Guadalcanal Village. The westernmost boundary is defined by a levee separating the property from a first stage salt evaporation pond (Leslie Salt). About 90% of the site is in Solano County, with the northwesternmost 10% in Napa County.

(U.S.G.S. quadrangle maps Cuttings Wharf and Mare Island)

B. PHYSICAL SITE CHARACTERISTICS

The 1493 acre site is more than 3 miles long and averages about a mile in width. It is currently used for dry land farming of oat and hay crops.

The agricultural fields average from 2 feet above to 3 feet below mean sea level. Drainage ditches are 4 to 6 feet below mean sea level.

Levees along Dutchman's Slough, some of which date back to 1902, range from 7 to 10 feet above mean sea level.

Highway 37 serves as the southwesterly levee, with elevations comparable to the Dutchman's Slough levee, to provide protection against Bay tides and storms.

There are inferred seismic faults parallel to and near the southwesterly and northeasterly property boundaries. An historically recorded epicenter of 6.0-6.9 (Richter) is located in the vicinity of Mare Island.

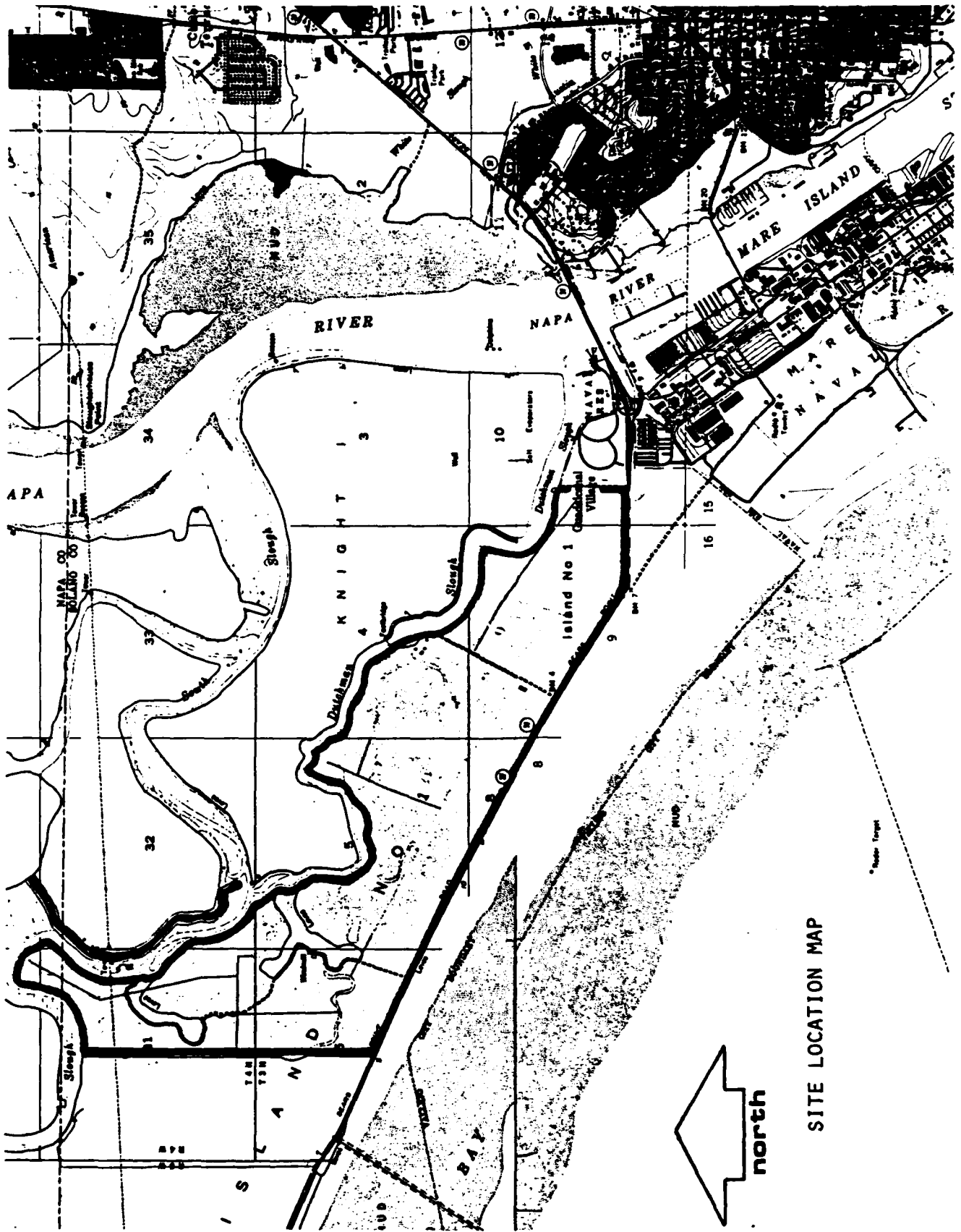

B. THE CONCEPT PLAN

1. Residential Uses and Related Private Boat Facilities

The plan proposes 1820 detached single family units. About 40% of these would have direct water exposure, with the remaining 60% on interior lots.

Lots with water exposure would be 90 x 50 feet, and interior lots would be 105 x 50 feet. The added depth of interior lots is to compensate for the lack of water exposure. The overall density of the detached units would be approximately 3.6 units per acre.

The plan also proposes 1805 townhouses or condominiums, at a density of approximately 10.0 units per acre. Some of these units -- those with peripheral locations -- would have water views. The 3 townhouse/condominium areas have been located nearer frontage road access, so that heavy traffic will not have to circulate through the entire development.

Private boat facilities would be developed along the periphery of each residential peninsula, with about two berths per house frontage. This would result in about 1500 berths, depending on design details.

Periodic public walkways between the detached single family houses with water exposure would provide access to waterways for occupants of houses on interior lots and also occupants of the townhouses or condominiums. Berth lease potentials, therefore, would be flexible -- they would be easily accessible to all occupants.

2. Commercial Facilities

There would be two commercial areas. The largest, about 60 acres, would be located at the southeasterly end of the site, near the main channel entrance and adjacent to the commercial marina. This large area could accommodate (a) a hotel/motel, (b) boat service facilities,

c) restaurants, d) retail shops, and e) offices. While these facilities would be available to residents, they would be intended to attract a wider range of clientele, including persons using the adjacent commercial boat berths.

This area would be developed according to an overall plan, so that there would be a continuity of pedestrian movement, view points and other features that would attract clients to the area. The location adjacent to the frontage road makes the site easily accessible.

A second, smaller commercial complex of 10 acres would be located in the western portion of the site, between two of the townhouse/condominium areas. This would be intended to serve the daily needs of residents and would accommodate a supermarket, cleaner/laundry, and similar convenience commercial facilities. It is also located adjacent to the frontage road.

3. Boat Berthing Facilities, Waterways and Land/Water Interfaces

There would be two kinds of berthing facilities: the approximately 1500 private berths located in the residential areas (see Residential Uses, above) and the 350-400 berths to be located in the commercial marina adjacent to the main commercial area. The total number of boats that could be accommodated would be 1850-1900.

A turning basin of some 40 acres would be located adjacent to the commercial marina, near the entrance of the main channel. The main channel would provide water access to the secondary channels serving the residential peninsulas and the private boat berths.

The typical secondary channel would be 300 feet wide. There would be a 120 foot wide deep water (8') lane in the center of each channel, with sloping banks approximately 90 feet wide on either side of the channel bottom. The banks would slope at a grade of 6:1 between the high and low water levels, and 4:1 between the low water level and the channel bottom (see following illustration).

The main channel would be of varying widths, with the detailed design depending on (a) marsh restoration plans and (b) slope requirements for the levee. The main channel widths, as shown on the accompanying concept plan, would vary between approximately 400 and 600 feet, with deep water lanes between 200 and 400 feet wide.

While land-water interfaces between the channels and marsh and detached single family homes areas would be stabilized by the slopes described above, additional measures may have to be taken along channel interfaces with condominium/townhouse areas and with some of the commercial areas, depending on building types and locations. Bulkheads, special foundation treatments, and/or other techniques may be employed in these areas.

4. Marsh Restoration and Other Open Spaces

A series of marsh islands will be restored along the northerly and northeasterly sides of the main channel. The openings between these islands, which would be spanned by pedestrian bridges, would permit a continuous flow of water between Dutchman's Slough and the main channel and secondary channels of the marina.

The marsh islands would be accessible by foot from a natural park located at the terminus of the frontage road in the northernmost part of the project site. This natural park and the access system through the marsh islands would be available for use by regional visitors, as well as by residents. Design details will depend on ecological requirements and the previous agreement with the State Lands Commission.

Smaller parks and/or recreational areas, specifically for the use of residents, would be located in detached single family and condo-

minium/townhouse areas. These could take various forms, including smaller green areas, walkways and viewpoints on the residential peninsulas, and active recreation areas.

5. Areas Abutting Guadalcanal Village and Mare Islands

The southeasterly portion of the site abuts the former Guadalcanal Village area. This area is now owned by the City of Vallejo.

The City's plans for the property have not yet been determined and include a number of possibilities. The specific planning for the major Cullinan Ranch commercial area, which would be located adjacent to Guadalcanal Village, can respond to the City's plans in a number of ways, including a physical integration of commercial uses on the two properties, integration and common use of waterfront parks and other public facilities, etc.

6. Circulation

An 80 foot frontage road would serve the residential, commercial, marina and public recreational areas. Access to this frontage road from Highway 37 would be taken at approximately 5 locations.

Some of these access points may require overhead highway crossings, if surface turning action is restricted. Other access points may be restricted to right turns.

The site plan has been designed to locate the most intense land uses (i.e., commercial and condominium/townhouse areas) adjacent to the frontage road. At its terminus the frontage road also serves the public access areas along the marsh islands.

ENVIRONMENTAL CHECKLIST FORM
(To be completed by Lead Agency)

I. BACKGROUND

1. Name of Proponent Pan Pacific & Redwood Realty
2. Date of Checklist Submitted 8/4/82
3. Name of Proposal Cullinan Ranch

II. ENVIRONMENTAL IMPACTS

(Explanations of all "yes" and "maybe" answers are required on attached sheets).

1. <u>Earth.</u> Will the proposal result in:	Yes	Maybe	No
a. Unstable earth conditions or in changes in geologic sub-structures?	—	X	—
b. Change in topography or of any unique geologic or physical features?	X	—	—
c. Any increase in wind or water erosion of soils, either on or off the site?	—	X	—
d. Changes in siltation, deposition or erosion which may modify the channel of a river or stream or the bed of any bay, inlet or lake?	X	—	—
e. Exposure of people or property to geologic hazards such as earthquakes, landslides, mudslides, ground failure, or similar hazards?	—	X	—
2. <u>Air.</u> Will the proposal result in:			
a. Substantial air emissions or deterioration of ambient air quality?	—	X	—
b. The creation of objectionable odors?	—	—	X
3. <u>Water.</u> Will the proposal result in:			
a. Changes in the course or direction of water movements?	X	—	—
b. Changes in drainage pattern or the rate and amount of surface water runoff?	X	—	—
c. Alterations to the course or flow of flood waters?	X	—	—
d. Discharge into surface waters, or in any alteration of surface water quality, including but not limited to temperature, dissolved oxygen or turbidity?	X	—	—
e. Exposure of people or property to water related hazards such as flooding or tidal waves?	—	X	—
4. <u>Plant Life.</u> Will the proposal result in:			
a. Change in diversity of species, or number of any species?	X	—	—
b. Reduction of the numbers of any unique rare or endangered species?	—	X	—
c. Introduction of new species into an area, or in a barrier to the normal replenishment of existing species?	X	—	—
5. <u>Animal Life.</u> Will the proposal result in:			
a. Change in the diversity of species, or numbers of any species?	X	—	—
b. Reduction of numbers of any unique, rare or endangered species?	—	X	—
c. Introduction of new species into an area, or result in a barrier to the migration or movement of animals?	X	—	—
d. Deterioration to existing fish or wildlife habitat?	—	X	—
6. <u>Noise.</u> Will the proposal result in:			
a. Increases in existing noise levels?	X	—	—
b. Exposure of people to severe noise levels?	—	X	—
7. <u>Light and Glare.</u> Will the proposal produce new light or glare?			
	X	—	—
8. <u>Land Use.</u> Will the proposal result in a substantial alteration of the present land use of an area?			
	X	—	—
9. <u>Risk of Upset.</u> Does the proposal involve a risk of an explosion or the release of hazardous substances (including, but not limited to, oil, water under pressure, pesticides, chemicals or radiation) in the event of an accident or upset conditions?			
	—	—	X

- | | Yes | Maybe | No |
|---|-------------------------------------|-------------------------------------|-------------------------------------|
| 10. <u>Transportation/Circulation.</u> Will the proposal result in: | | | |
| a. Generation of substantial additional vehicular movement? | <input checked="" type="checkbox"/> | <input type="checkbox"/> | <input type="checkbox"/> |
| b. Effects on existing parking facilities, or demand of new parking? | <input checked="" type="checkbox"/> | <input type="checkbox"/> | <input type="checkbox"/> |
| 11. <u>Public Services.</u> Will the proposal result in a need for new or altered governmental services in: | | | |
| a. Fire protection? | <input checked="" type="checkbox"/> | <input type="checkbox"/> | <input type="checkbox"/> |
| b. Police protection? | <input checked="" type="checkbox"/> | <input type="checkbox"/> | <input type="checkbox"/> |
| c. Schools? | <input checked="" type="checkbox"/> | <input type="checkbox"/> | <input type="checkbox"/> |
| d. Parks? | <input checked="" type="checkbox"/> | <input type="checkbox"/> | <input type="checkbox"/> |
| e. Other governmental services? | <input checked="" type="checkbox"/> | <input type="checkbox"/> | <input type="checkbox"/> |
| 12. <u>Energy.</u> Will the proposal result in? | | | |
| a. Use of substantial amounts of energy? | <input checked="" type="checkbox"/> | <input type="checkbox"/> | <input type="checkbox"/> |
| 13. <u>Aesthetics.</u> Will the proposal result in the obstruction of any scenic vista or view open to the public, or will the proposal result in the creation of an aesthetically offensive site open to public view? | <input type="checkbox"/> | <input type="checkbox"/> | <input checked="" type="checkbox"/> |
| 14. <u>Archeological/Historical.</u> Will the proposal result in an alteration of significant archeological or historical site, structure, object or building? | <input type="checkbox"/> | <input type="checkbox"/> | <input checked="" type="checkbox"/> |
| 15. <u>Mandatory Findings of Significance.</u> | | | |
| a. Does the project have the potential to degrade the quality of the environment, substantially reduce the habitat of a fish or wildlife species, cause a fish or wildlife population to drop below self sustaining levels, threaten to eliminate a plant or animal or eliminate important examples of the major periods of California history or prehistory? | <input type="checkbox"/> | <input checked="" type="checkbox"/> | <input type="checkbox"/> |
| b. Does the project have the potential to achieve short-term, to the disadvantage of long-term environmental goals? (A short-term impact on the environment is one which occurs in a relatively brief, definitive period of time while long-term impacts will endure well into the future). | <input checked="" type="checkbox"/> | <input type="checkbox"/> | <input type="checkbox"/> |
| c. Does the project have impacts which are individually limited, but cumulatively considerable? (A project may impact on two or more separate resources where the impact on each resource is relatively small, but where the effect of the total of those impacts on the environment is significant). | <input checked="" type="checkbox"/> | <input type="checkbox"/> | <input type="checkbox"/> |
| d. Does the project have environmental effects which will cause substantial adverse effects on human beings, either directly or indirectly? | <input type="checkbox"/> | <input checked="" type="checkbox"/> | <input type="checkbox"/> |

III. DISCUSSION ON ENVIRONMENTAL EVALUATION

IV. DETERMINATION

(To be completed by the Lead Agency)

On the basis of this initial evaluation:

I find the proposed project COULD NOT have a significant effect on the environment, and a NEGATIVE DECLARATION will be prepared.

I find that although the proposed project could have a significant effect on the environment, there will not be a significant effect in this case because the mitigation measures described on an attached sheet have been added to the project. A NEGATIVE DECLARATION WILL BE PREPARED.

I find the proposed project MAY have a significant effect on the environment, and an ENVIRONMENTAL IMPACT REPORT is required.

Date

8/16/82

Christy Huddle
(Signature)

For

Business Development Director

II. Explanations to "Environmental Impacts" section.

- 1.a. The addition of fill which is partially dredge spoils on top of bay mud may result in unstable earth conditions.
- 1.b. The site will be filled.
- 1.c. The introduction of channels for boating activities into the project may increase the incidence of soil erosion.
- 1.d. During construction, earth moving and dredging activities may increase the amount of downstream siltation.
- 1.e. A trace (uncertain) of the Franklin fault is projected along the west side of Mare Island, continuing along the San Pablo Bay frontage adjacent to this site. The Seismic Safety Element of the General Plan states on p. 25: "Except for the earthquake of 1898, the Franklin fault has been relatively inactive in historic time; it should be considered potentially active."
- 2.a. The proposal is for 4,500 housing units, two marinas, two elementary schools, one junior high school, and some commercial development. This will generate a significant amount of traffic and the concomitant air pollution.
- 3.a. The project includes the addition of several channels for access to the housing units on water. The Dutchman Slough channel will be dredged.
- 3.b. The drainage pattern will be changed as a result of filling the site. The addition of nonpermeable surfaces will increase the amount of runoff.
- 3.c. The project will open up an area to the river and bay, thereby increasing the holding capacity during times of heavy rains.
- 3.d. Drainage from the dredge spoils area will be into the channel.
- 3.e. The project will be designed to accommodate a 100-year flood.
- 4.a. & c. The project will introduce a great amount of ornamental and native vegetation.
- 5.a. & c. With the introduction of ornamental and native vegetation, additional wildlife can be expected.
- 5.d. During construction and dredging operations, some deterioration of fish habitat will probably occur.
- 6.a. The additional traffic will generate higher noise levels. Boating traffic, if not properly regulated, will also add to the noise environment.

- 6.b. Traffic from Sears Point Road creates a high noise band which will have an adverse impact on the uses of land closest to the roadway.
7. The urban development will introduce normal street lighting where none exists.
8. The land is currently being used to grow hay and oats. The proposed use will eliminate farming from the site.
- 10.a. The 4,500 housing units, marinas, and commercial areas will generate a significant amount of new traffic. There are currently no access points to Sears Point Road that could handle the proposed use.
- 10.b. The proposed uses will generate a need for parking.
11. The site is currently in the county unincorporated area. Before development, it will be annexed to the city of Vallejo. This will create a need for expanded police and fire protection, schools, parks, and general governmental services.
12. The buildings, street lighting and other utilities, and transportation methods will use significant amounts of energy.
- 15.a. See 5.d. above.
- 15.b. The project will irremediably remove land from the possibility of being restored to wetlands. It will be adding to the amount of water area of the Napa River.
- 15.c. Water runoff, air quality, noise levels, traffic, energy and public services will be cumulatively significant impacts.
- 15.d. See the above.

II. TECHNICAL REPORTS SUBMITTED BY TORREY & TORREY INC.

Fundamental Concepts of Environmental Noise

This section provides background information to aid in understanding the technical aspects of this report.

Three dimensions of environmental noise are important in determining subjective response. These are:

- a. the intensity or level of the sound;
- b. the frequency spectrum of the sound;
- c. the time-varying character of the sound.

Airborne sound is a rapid fluctuation of air pressure above and below atmospheric pressure. Sound levels are usually measured and expressed in decibels (dB), with 0 dB corresponding roughly to the threshold of hearing.

The "frequency" of a sound refers to the number of complete pressure fluctuations per second in the sound. The unit of measurement is the cycle per second (cps) or Hertz (Hz). Most of the sounds which we hear in the environment do not consist of a single frequency, but of a broad band of frequencies, differing in level. The quantitative expression of the frequency and level content of a sound is its sound spectrum. A sound spectrum for engineering purposes is typically described in terms of octave bands which separate the audible frequency range (for human beings, from about 20 to 20,000 Hz) into ten segments.

Many rating methods have been devised to permit comparisons of sounds having quite different spectra. Fortunately, the simplest method correlates with human response practically as well as the more complex methods. This method consists of evaluating all of the frequencies of a sound in accordance with a weighting that progressively and severely deemphasizes the importance of frequency components below 1000 Hz, with mild deemphasis above 5000 Hz. This type of frequency weighting reflects the fact that human hearing is less sensitive at low frequencies and extreme high frequencies than in the frequency midrange.

The weighting curve described above is called "A" weighting, and the level so measured is called the "A-weighted sound level", or simply "A-level".

The A-level in decibels is expressed "dBA"; the appended letter "A" is a reminder of the particular kind of weighting used for the measurement. In practice, the A-level of a sound source is conveniently measured using a sound level meter that includes an electrical filter corresponding to the A-weighting curve. All U.S. and international standard sound level meters include such a filter. Typical A-levels measured in the environment and in industry are shown in Figure A-1.

Although the A-level may adequately describe environmental noise at any instant in time, the fact is that the community noise level varies continuously. Most environmental noise includes a conglomeration of distant noise sources which creates a relatively steady background noise in which no particular source is identifiable. These distant sources may include traffic, wind in trees, industrial activities, etc. These noise sources are relatively constant from moment to moment, but vary slowly from hour to hour as natural forces change or as human activity follows

its daily cycle. Superimposed on this slowly varying background is a succession of identifiable noisy events of brief duration. These may include nearby activities or single vehicle passages, aircraft flyovers, etc., which cause the environmental noise level to vary from instant to instant.

To describe the time-varying character of environmental noise, the statistical noise descriptors L10, L50, and L90 are commonly used. The L10 is the A-weighted sound level equaled or exceeded during 10 percent of a stated time period. The L10 is considered a good measure of the "average peak" noise. The L50 is the A-weighted sound level that is equaled or exceeded 50 percent of a stated time period. The L50 represents the median sound level. The L90 is the A-weighted sound level equaled or exceeded during 90 percent of a stated time period. The L90 is used to describe the background noise.

As it is often cumbersome to describe the noise environment with these statistical descriptors, a single number descriptor called the Leq is also widely used. The Leq is defined as the equivalent steady-state sound level which in a stated period of time would contain the same acoustic energy as the time-varying sound level during the same time period. The Leq is particularly useful in describing the subjective change in an environment where the source of noise remains the same but there is change in the level of activity. Widening roads and/or increasing traffic are examples of this kind of situation.

In determining the daily measure of environmental noise, it is important to account for the difference in response of people to daytime and nighttime noises.

During the nighttime, exterior background noises are generally lower than the daytime levels. However most household noise also decreases at night and exterior noises become very noticeable. Further most people are sleeping at night and are very sensitive to noise intrusion.

To account for human sensitivity to nighttime noise levels a descriptor, Ldn, (day-night equivalent sound level) was developed. The Ldn divides the 24-hour day into the daytime of 7 am to 10 pm and the nighttime of 10 pm to 7 am. The nighttime noise level is weighted 10 dB higher than the daytime noise level. The Ldn, then, is the A-weighted average sound level in decibels during a 24-hour period with 10 dBA added to the hourly Leqs during the nighttime. For highway noise environments the Leq during the peak traffic hour is approximately equal to the Ldn.

The effects of noise on people can be listed in three general categories:

- 1) subjective effects of annoyance, nuisance, dissatisfaction;
- 2) interference with activities such as speech, sleep, learning;
- 3) physiological effects such as startle, hearing loss.

The sound levels associated with environmental noise, in almost every case, produce effects only in the first two categories. Unfortunately, there is as yet no completely satisfactory measure of the subjective effects of noise, or of the corresponding reactions of annoyance and dissatisfaction. This is primarily because of the wide variation in individual thresholds of annoyance, and habituation to noise over differing individual past experiences with noise.

Thus, an important parameter in determining a person's subjective reaction to a new noise is the existing noise environment to which one has adapted: the so-called "ambient" noise. "Ambient" is defined as "the all-encompassing noise associated with a given environment, being a composite of sounds from many sources, near and far". In general, the more a new noise exceeds the previously existing ambient, the less acceptable the new noise will be judged by the hearers.

With regard to increases in noise level, knowledge of the following relationships will be helpful in understanding the quantitative sections of this report:

- a) Except in carefully controlled laboratory experiments, a change of only 1 dBA cannot be perceived.
- b) Outside of the laboratory, a 3-dBA change is considered a just-noticeable difference.
- c) A change in level of at least 5 dBA is required before any noticeable change in community response would be expected.
- d) A 10-dBA change is subjectively heard as approximately a doubling in loudness, and would almost certainly cause an adverse change in community response.

**A-WEIGHTED SOUND
PRESSURE LEVEL,
IN DECIBELS**

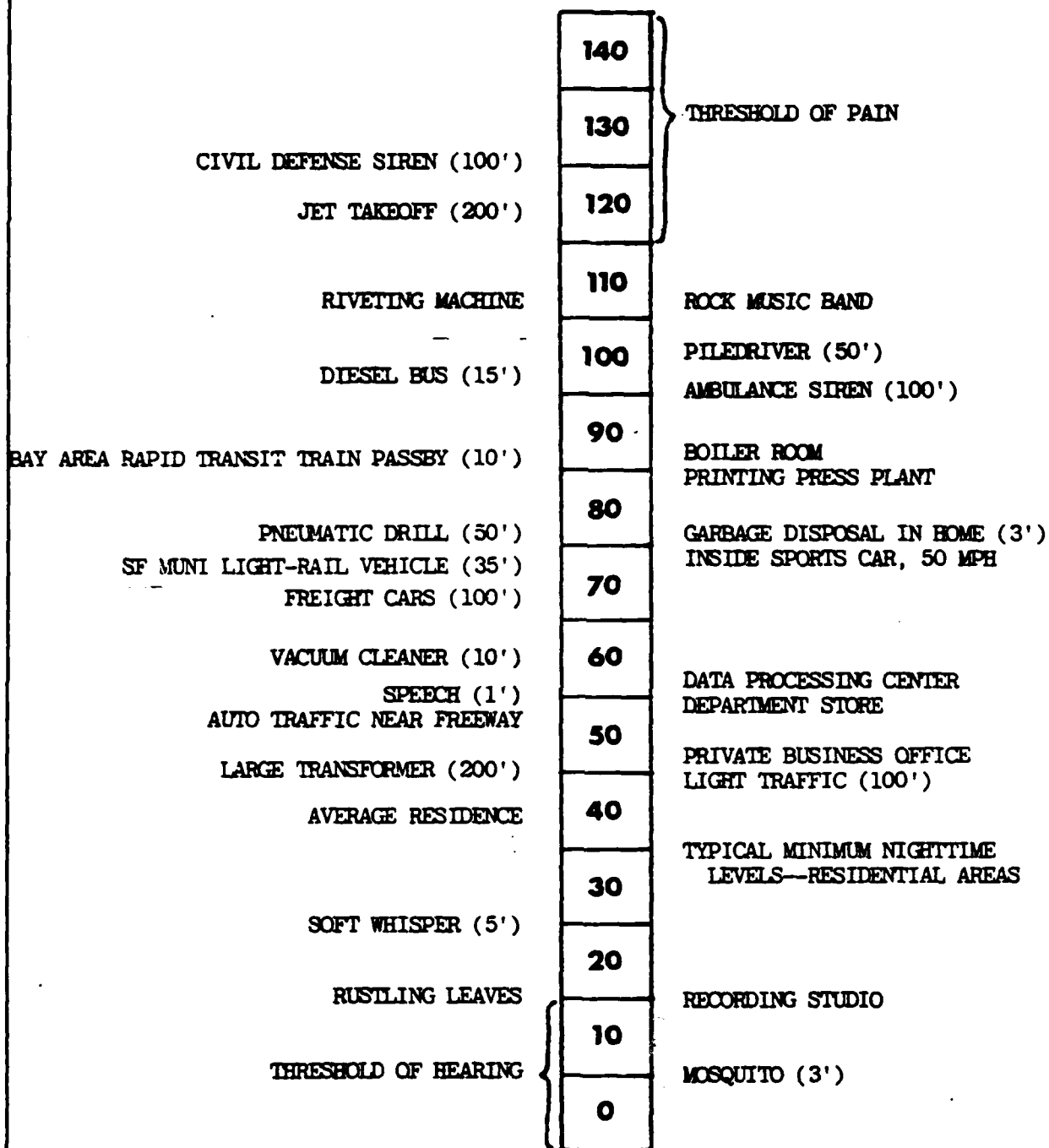

(100') = DISTANCE IN FEET
BETWEEN SOURCE
AND LISTENER

FIGURE A-1: TYPICAL SOUND LEVELS MEASURED IN THE ENVIRONMENT AND INDUSTRY

12/81

CAPACITY CALCULATIONS
for
CULLINAN RANCH PROJECT

Prepared By TJKM Associates

TABLE V INTERSECTION CAPACITY ANALYSIS

JKM

INTERSECTION A STREET AND B STREET P.M. PEAK HOUR

LANE PATTERN & TRAFFIC VOLUMES

SIGNAL PHASING

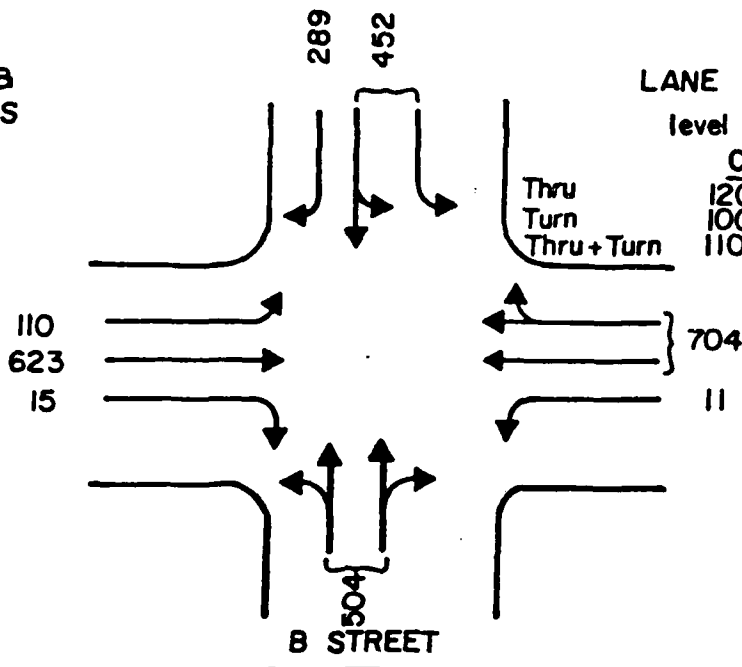
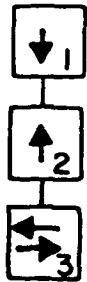

LANE CAPACITIES (vph)

level of service

	C	D	E
Thru	1200	1380	1500
Turn	1000	1150	1250
Thru+Turn	1100	1265	1375

A STREET



PHASE	CRITICAL MOVEMENT	CAPACITY OF * CRITICAL MOVEMENT	VOLUME	V/C
1		2100 (1000 + 1100)	452	0.215
2		2200 (1100 + 1100)	504	0.229
3		2300 (1200 + 1100)	704	0.306
	OPPOSING LEFT 	1000	110	0.110
YELLOW TIME / CYCLE LENGTH				0.10
V/C OF INTERSECTION				0.96
LEVEL SERVICE OF INTERSECTION				C

1/ CAPACITIES CALCULATED AT LEVEL OF SERVICE C

INTERSECTION CAPACITY ANALYSIS

JKM

INTERSECTION ROUTE 37 & WESTERLY ACCESS TO GULLINAW PARK
 CONDITION PM PEAK

LANE PATTERN &
TRAFFIC VOLUMES

SIGNAL PHASING

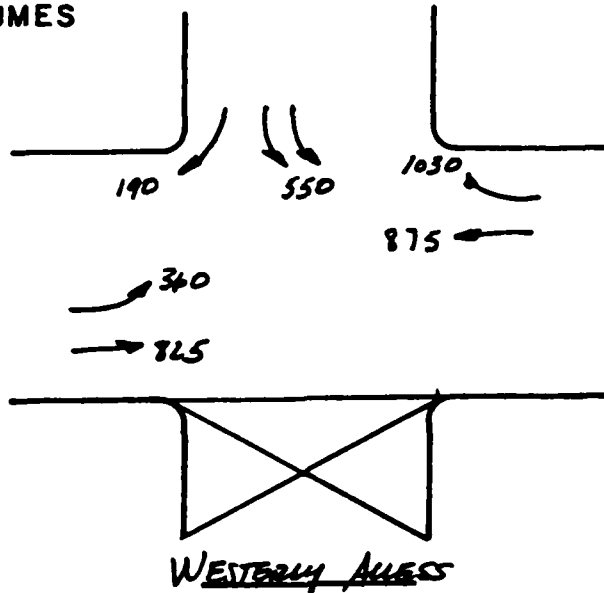

PRIORITY	CRITICAL MOVEMENT	* CAPACITY OF CRITICAL MOVEMENT	EXISTING + C & G		EXISTING + C & G MITIGATED		YEAR 2005 + C & G MITIGATED		PRIORITY	VC	
			VELOCITY	VC	VELOCITY	VC	VELOCITY	VC			
1	↗	1000	360	0.36	360	0.36	360	0.36			
2	↖ ↔	2300 3400	1905 - 306 = 1599	0.695	1905 - 306 = 1599	0.470	2140 - 306 = 1834	0.539			
3	↘	1800	550	0.306	550	0.306	550	0.306			
YELLOW TIME / CYCLE LENGTH				-		0.01		-			
V/C OF INTERSECTION				1.36		1.15		1.21			
LEVEL OF SERVICE OF INTERSECTION				F		D		E			

* CAPACITIES CALCULATED AT LEVEL OF SERVICE C

INTERSECTION CAPACITY ANALYSIS

JKM

INTERSECTION ROUTE 37 & WESTERLY AVE TO CULLINAN RANCH
 CONDITION A.M. PEAK

LANE PATTERN &
TRAFFIC VOLUMES

SIGNAL PHASING

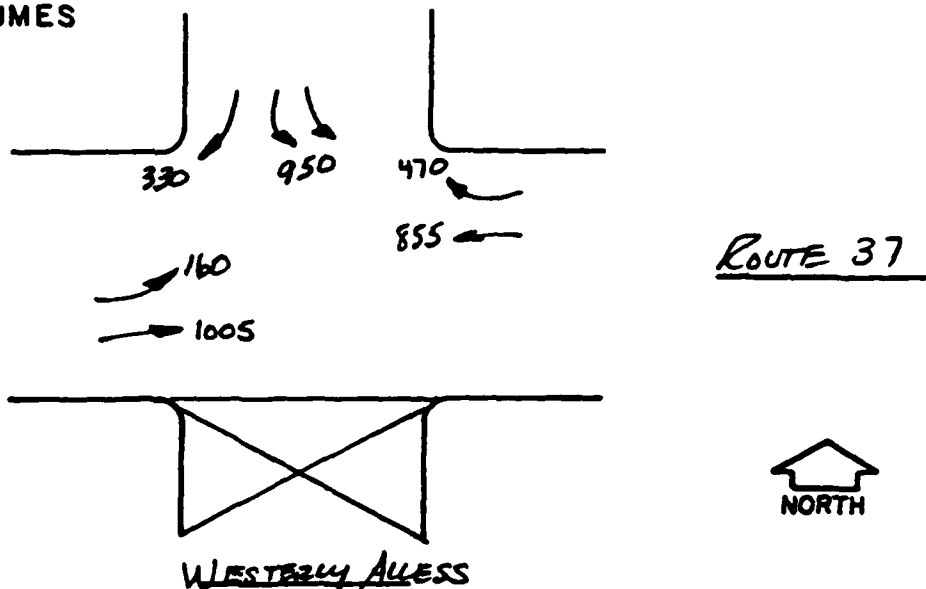

PHASE	CRITICAL MOVEMENT	* CAPACITY OF CRITICAL MOVEMENT	EXISTING + C & G		EXISTING + C & G MITIGATED		YEAR 2005 + C & G MITIGATED		VOLUME	VC	
			VOLUME	VC	VOLUME	VC	VOLUME	VC			
1	↘	1000	160	0.16	160	0.16	160	0.16			
2	↘ ↔	2300 2400	1325	0.576	955	0.356	1090	0.454			
3	↙	1800	950	0.528	950	0.528	950	0.528			
YELLOW TIME / CYCLE LENGTH				-		0.06		0.01			
V/C OF INTERSECTION				1.26		1.10		1.15			
LEVEL OF SERVICE OF INTERSECTION				F		D		D			

* CAPACITIES CALCULATED AT LEVEL OF SERVICE

INTERSECTION CAPACITY ANALYSIS

JKM

INTERSECTION ROUTE 37 & EASTERLY ACCESS TO CULLINAN PARK
 CONDITION A.M. PEAK

LANE PATTERN &
 TRAFFIC VOLUMES

SIGNAL PHASING

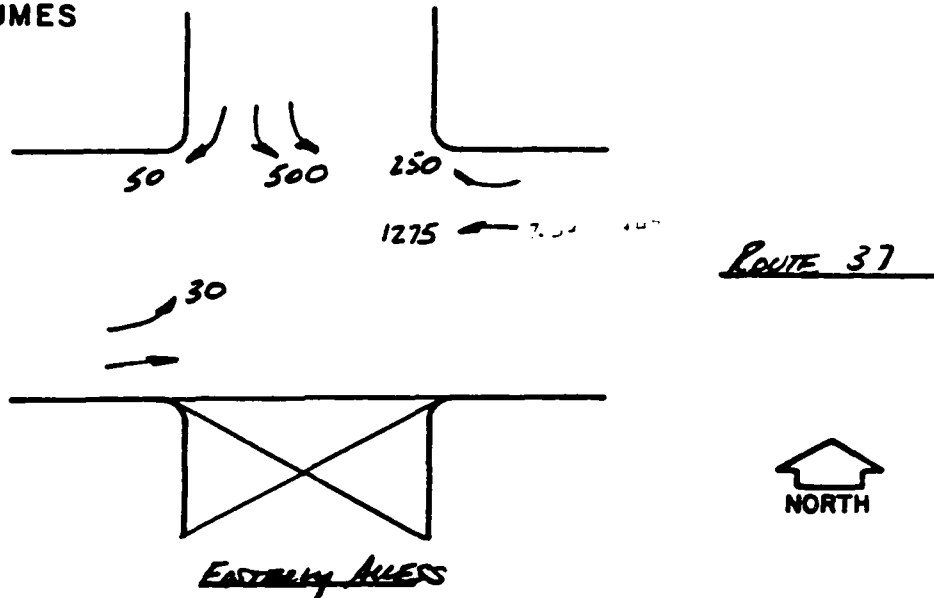

PHASE	CRITICAL MOVEMENT	* CAPACITY OF CRITICAL MOVEMENT	EXISTING + C & G		EXISTING + C & G MITIGATED		YEAR 2005 + C & G MITIGATED		PHASE	VC
			PHASE	VC	PHASE	VC	PHASE	VC		
1	↘	1000	30	0.03	30	0.03	30	0.03		
2	↔	2300 2400	1525	0.663	1275	0.531	1510	0.629		
3	↙	1800	500	0.278	500	0.278	500	0.278		
YELLOW TIME / CYCLE LENGTH				0.10		0.10		0.10		
VC OF INTERSECTION				1.07		0.94		1.04		
LEVEL OF SERVICE OF INTERSECTION				D		C		D		

* CAPACITIES CALCULATED AT LEVEL OF SERVICE C

INTERSECTION CAPACITY ANALYSIS

JKM

INTERSECTION ROUTE 37 & EASTERLY ACCESS TO CULLINAN RANCH
 CONDITION PM PEAK

LANE PATTERN &
TRAFFIC VOLUMES

SIGNAL PHASING

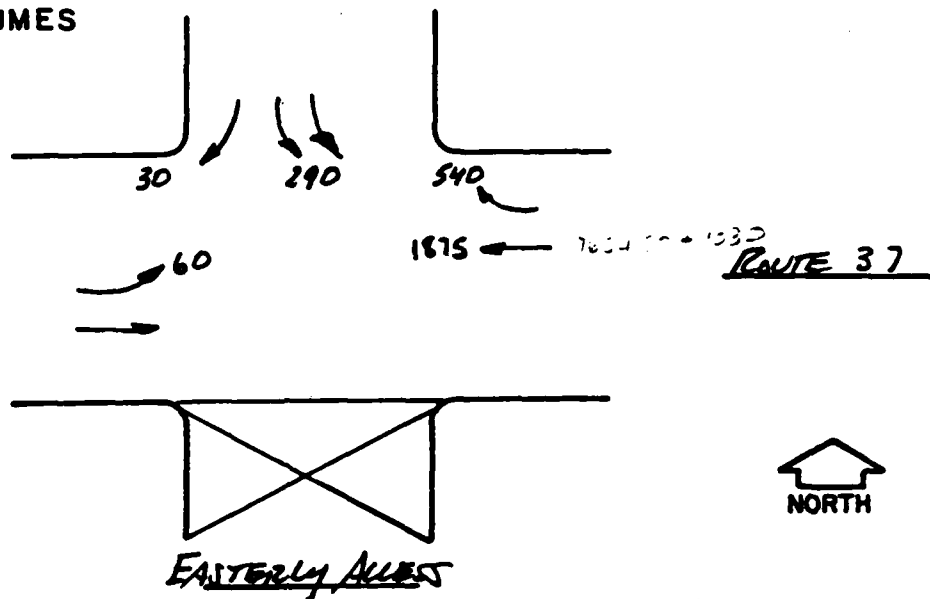

PHASE	CRITICAL MOVEMENT	* CAPACITY OF CRITICAL MOVEMENT	EXISTING C & G		EXISTING + C & G MITIGATED		YEAR 2005 + C & G MITIGATED		MEC/OV	VC	
			MEC/OV	VC	MEC/OV	VC	MEC/OV	VC			
1	↗	1000	60	0.06	60	0.06	60	0.06			
2	↖ ↔	2300 2400	2415	1.05	1875	0.78	2110	0.879			
3	↘ ↘	1500	290	0.161	290	0.161		0.161			
YELLOW TIME / CYCLE LENGTH				-		0.08		0.03			
WC OF INTERSECTION				1.27		1.08		1.13			
LEVEL OF SERVICE OF INTERSECTION				F		D		D			

* CAPACITIES CALCULATED AT LEVEL OF SERVICE C

Air Quality Assumptions and
Methodology
Prepared by Donald Ballanti

A. Caline-3 Model and Assumptions

Normalized concentrations generated by the Caline-3 model were adjusted for the appropriate emission factor (a function of average speed) and hourly traffic volume.¹ The Caline-3 model² is a third-generation line source air quality model that is based on the Gaussian diffusion equation and employs a mixing zone concept to characterize pollutant dispersion over the roadway. Given source strength, meteorology, site geometry and site characteristics, the model predicts pollutant concentrations for receptors located within 150 meters of the roadway.

The following variables were specified as worst-case conditions for the roadway segment analysis:

- windspeed: 1 mps for 1-hour, 2 mps for 8-hour
- wind direction: parallel to road
- atmospheric stability: Pasquill E
- mixing height: 100 meters
- receptor location: 25 feet from roadway
- traffic volumes: 1-hour volume of 10% of ADT
8-hour volume of 57% of ADT.
- traffic speed: as specified by transportation consultant.

¹Ranzieri, A. and E. J. Mulberg, Estimating Carbon Monoxide Concentrations for Hot Spots Analysis, CARE, May 1980.

²California Department of Transportation, CALINE-3: A Versatile Dispersion Model for Predicting Air Pollutant Levels near Highways and Arterial Streets. Report No. FHWA/CA/TL-79/23, November 1979.

The intersection modeling involved superimposing two infinite line sources at right angles. The following variables were specified as worst-case conditions:

- windspeed: 1 mps for 1-hour, 2 mps for 8-hour
- wind direction: 23° to the roadway with highest emission rate
- atmospheric stability: Pasquill E (worst case for an urban roadside)
- mixing height: 100 M
- receptor location: height of 5 feet, 25 feet from curb, equidistant from both roadways.
- traffic volumes: 1-hour volume of 10% of ADT,
8-hour volume of 57% of ADT
- traffic speed: 10 mph.

B. Background Carbon Monoxide Levels

The 1982 Bay Area Air Quality Plan estimates that background levels of carbon monoxide are 50% of measured levels. Traffic volumes are anticipated to increase by 1.5% per year. At the same time, emissions per vehicle would decrease each year as newer, cleaner cars replace older cars. The maximum 1- and 8-hour concentrations measured in Vallejo in 1981 were adjusted for future traffic increases and anticipated emission-rate reductions (assuming a 20 mph average speed). Table 1 below shows the resulting background concentrations.

Table 1
Estimated Background Concentrations, ppm

<u>Year</u>	<u>1-hour</u>	<u>8-hour</u>
1981	7.0	4.3
1983	6.2	3.8
1987	5.0	3.1
2000	4.2	2.6

C. Emission Factors for Vehicles

Emission factors for various vehicle speeds were provided by the California Air Resources Board using the EMFAC-6c computer model. For the local-scale carbon monoxide analysis the following assumptions were made:

Ambient temperature: 35° F.

Vehicle Mix: 73.8% light-duty auto
16.3% light-duty truck
1.7% medium-duty truck
3.5% heavy-duty gas truck
3.7% heavy-duty diesel truck
1.0% motorcycle

Operation: 21% cold start
27% hot start
52% stabilized.

The emission factor for road-dust was calculated by dividing the daily contribution of road dust in the 1987 Emissions Inventory by estimated VMT in the Bay Area in 1987.¹ The resulting emission factor was 0.005 pounds per VMT.

¹ Association of Bay Area Governments, 1982 Bay Area Air Quality Plan, December 1982.

Table 2
Emission Factors for Carbon Monoxide

<u>Average Speed (mph)</u>	<u>Emission Factor (grams/mile)</u>		
	<u>1983</u>	<u>1987</u>	<u>2000</u>
5	122.4	91.2	61.5
10	67.5	50.6	33.7
15	47.9	36.2	24.3
20	38.1	29.0	19.7
25	31.7	24.2	16.5
30	26.9	20.5	14.0
35	23.3	17.8	13.2
40	21.0	15.1	11.0
45	19.9	15.2	10.4
50	19.5	15.0	10.2
55	19.0	14.5	9.7

D. Emissions from Boats

Emissions from motorized vessels have been estimated using the general methodology used by the Bay Area Air Quality Management District in estimating region-wide boat emissions.¹ The following assumptions were made:

- 50% of the vessels berthed at the project would be powered by internal combustion engines
- of this 50%, 6.5% would be diesel-powered, 46.75% would have 2-stroke gasoline engines and 46.75% would have 4-stroke gasoline engines
- average monthly fuel use would be 12 gallons for diesel-powered boats, and 15 gallons for gas-powered boats.

Under the above assumptions daily average fuel consumption for Alternatives A and B would be:

- 22.1 gallons of diesel fuel
- 198 gallons of gasoline by both 4- and 2-stroke gasoline engines.

The above daily fuel use was combined with emission factors for pleasure craft shown below² to estimate boat related emissions.

¹ Bay Area Air Quality Management District, Base Year 1979 Emissions Inventory: Source Category Methodologies, August 26, 1981.

² U.S. Environmental Protection Agency, Compilation of Air Pollutant Emission Factors, 3rd edition, August 1977.

Table 3
Estimated Emissions From Boats

	<u>Emissions in pounds per 1000 gallons</u>			
	<u>Sulfur oxides</u>	<u>Carbon monoxide</u>	<u>Hydro- carbons</u>	<u>Nitrogen oxides</u>
Diesel	27	140	180	340
Gas 2-stroke	6.4	1240	86	131
Gas 4-stroke	6.4	3300	1100	6.6

Gasoline distribution would also generate hydrocarbons through escape of gas vapors and spillage. Average daily fuel use of 396 gallons would result in a hydrocarbon emission of an additional 3.8 lbs. per day based on emission factors for uncontrolled service station gasoline pumps.¹

¹ U.S. Environmental Protection Agency, Compilation of Air Pollutant Emission Factors, 3rd edition, August 1977.

E. VMT Estimation

VMT was calculated by using an estimation of trip distribution and trip length to generate an average trip length. The following trip destination and distance information was used to generate the average trip length of 14.7 miles.

<u>Destination</u>	<u>Percent of Trips</u>	<u>Distance</u>
Marin Co.	20%	20
Fairfield	10%	20
Benicia	15%	12
Napa	5%	12
Vallejo	25%	5
Other	25%	20

VMT is then calculated by multiplying total trips by average length, as shown below in Table 4 .

Table 4
VMT Calculation

<u>Alternative</u>	<u>Year</u>	<u>Trips</u>	<u>VMT</u>
A.	1987	4000	58,600
	2000	43500	637,300
B.	1987	3815	56,100
	2000	41500	609,900
C.	1987	6280	92,300
	2000	68240	1,003,100
D.	1987	0	0
	2000	0	0

**III. TECHNICAL REPORTS SUBMITTED BY W. R. WILLIAMS & ASSOCIATES
REPRESENTING PAN PACIFIC AND REDWOOD REALTY**

A Report Prepared for

W. R. Williams Associates, Inc.
2130 Main Street, Suite 230
Huntington Beach, California 92648

PRELIMINARY (PHASE 1) SOIL INVESTIGATION
CULLINAN RANCH - ISLAND NO. 1
VALLEJO, CALIFORNIA

HLA Job No. 11,539,002.02

by

Robert M. Smith,
Civil Engineer - 28634

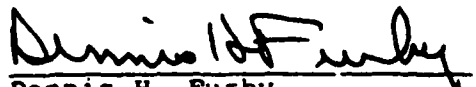
Dennis H. Furby,
Civil Engineer - 24480

Harding Lawson Associates
7655 Redwood Boulevard, P.O. Box 578
Novato, California 94948
415/892-0821

November 13, 1981

TABLE OF CONTENTS

INTRODUCTION1
Previous Investigations.2
Purpose and Scope of Investigation2
SUMMARY.3
FIELD EXPLORATION AND LABORATORY TESTING5
Field Exploration.5
Laboratory Testing7
SITE CONDITIONS.8
Surface Conditions8
Subsurface Conditions.9
GEOLOGY, SEISMICITY AND GEOLOGIC HAZARDS	11
Regional Geology	11
Fault Activity	12
Geologic Hazards	13
DISCUSSIONS AND CONCLUSIONS.	16
Excavation, Dredging and Filling	16
Settlement	19
Slopes	23
Bulkheads and Structurally Supported Slopes.	27
Building Support	28
RECOMMENDATIONS.	30
Site Grading	30
Structural Slope Support	32
Building Support	32
Additional Geotechnical Services	34

ILLUSTRATIONS. 36

APPENDIX 47

 Boring Logs and Results of Laboratory Testing.

REFERENCES 89

DISTRIBUTION 90

LIST OF ILLUSTRATIONS

Plate	1	Site Plan and Location Map.37
Plate	2	Boring Location Plan	38
Plate	3	Location and Thickness of Peat.39
Plate	4	Generalized Geologic Map San Francisco Bay Region.40
Plate	5	Regional Fault and Epicenter Map for Earthquakes 1900-197441
Plate	6	Expected 50-Year Settlement42
Plate	7	Expected Rate of Settlement43
Plate	8	Undrained Shear Strength.44
Plate	9	Typical Slope Cross-Section and Stability Analysis.45
Plate	10	Schematic - Sheetpile Bulkhead.46
Plates through	A-1 A-25	Logs of Rotary Borings 1-17	Appendix A
Plates through	A-26 A-31	Logs of 30-Inch-Diameter Bucket Auger Borings B1 - B11	Appendix A
Plate	A-32	Soil Classification System and Key to Test Data.	Appendix A
Plate	A-33	Plasticity Chart.	Appendix A
Plate through	A-34 A-40	Consolidation Test Reports.	Appendix A
Plate	A-41	Triaxial Compression Test Report.	Appendix A

INTRODUCTION

This report presents the results of our preliminary or Phase I soil investigation for the Cullinan Ranch development, Island No. 1, located northwest of Vallejo and Mare Island. The approximately 1500-acre site is bounded on the south by Highway 37 and on the north by Dutchman Slough and South Slough. The east and west boundaries are respectively Guadalcanal Village and a dike adjacent to a Leslie Salt Company evaporating pond. The Site Plan and Location Map are shown on Plate 1.

As stated in the Cullinan Ranch Preliminary Development Plan, prepared by Haworth and Anderson, dated July 22, 1981, the development will provide approximately 3700 residential units and two commercial centers. Approximately 40 percent of the 1900 planned single-family units would have direct water-front exposure. The combination of excavation and land fill is planned to construct waterways and raise the land surface above the City of Vallejo and/or Solano County flood control elevation requirements. Waterways will include a main channel along the north side of the property approximately 400 to 600 feet wide. Secondary channels approximately 300 feet wide will separate the residential areas and a turning basin of approximately 40 acres will be located adjacent to a commercial marina near the east edge of the property. Two commercial areas are planned: one located at the southeasterly end of the site

project. In accordance with our Service Agreement dated August 4, 1981, we performed field exploration, laboratory testing and engineering analyses to develop conclusions or recommendations on the following:

1. Variation in bay mud thickness across the site.
2. The range of 50-year settlements expected over the site and the rate at which settlements are expected to occur.
3. Stability of the channel slopes, recommended slope angles and alternative slope retaining structures.
4. Feasibility of crust management excavation methods and alternatives for channel excavation.
5. Geologic hazards evaluation.

We observed the surface conditions at the site on July 30, 1981, in the company of Mr. Walden Williams, the client, Mr. Ed Haworth, the project planner, and Mr. Jack Nichol of Moffatt & Nichol Engineers. Field exploration began on August 5, 1981, and was completed on August 19, 1981. Three meetings were held during the course of this investigation to discuss the findings with the design team.

SUMMARY

Based on the results of this investigation, we believe that construction of the proposed Cullinan Ranch project, Island No. 1 is geotechnically feasible. Most excavations can be performed

"in the dry" using crust management and localized dewatering techniques. Dredging and/or dragline excavation will be for required for the deep channel area adjacent to the north levee. With proper drying and compaction, the excavated mud can be re-used as fill. A pilot or test excavation and fill should be conducted early in the design phase to fully evaluate excavation methods, settlement and construction costs.

Settlement due to consolidation of soft "bay mud" beneath the weight of the fill is a major consideration at Island No. 1. The amount and rate of settlement expected are typical of other similar sites developed around San Francisco Bay. Differential settlements will result from the varying thicknesses of peat in the upper 15 feet of soft mud. However, a large portion of the settlement will occur during the first five years after construction, and we believe that surcharging (additional fill placed for a short time period) will be effective in reducing the differential settlements.

Lightly-loaded structures such as wood frame residential units may be supported on conventional spread footings bottomed in the fill; reinforced grade beams will add rigidity where needed to resist differential settlement. Alternatively, shallow drilled piers supported by skin friction in the compacted fill can be used for residences with wood floors supported above grade. Driven piles gaining support in firm soil beneath the bay mud will be required for heavy foundation

loads and for structures that cannot tolerate the anticipated settlements. We expect that piles used to support docks and piers can develop adequate support within the bay mud. Pile length will be governed primarily by lateral load and deflection.

Channel excavation and fill slopes should not be steeper than five horizontal to one vertical (5:1) above Mean Lower Low Water (MLLW) elevation and 4:1 below MLLW. Steeper slopes will increase the risk of localized failures during construction and during strong ground shaking. Alternative methods, such as sheet piles or steeper slopes with buttressing, can be used to provide more land area where flatter slopes are not desirable. Buildings should be set back from the edge of channel slopes to reduce the risk resulting from differential settlement or earthquake.

The details of our exploration program, the site conditions encountered and the various geotechnical factors and alternatives evaluated for project feasibility and master planning comprise the remainder of the report. Once a master plan is complete, a final soil investigation should be performed to provide specific design recommendations.

FIELD EXPLORATION AND LABORATORY TESTING

Field Exploration

During this investigation, we explored subsurface conditions

with 16 rotary wash borings and 11 bucket auger (30-inch-diameter) borings. Boring locations are shown on Plate 2. Rotary borings were drilled to depths ranging from 70 to 110 feet, and penetrated the total thickness of the soft younger bay mud. Selected borings were extended approximately 20 feet into the underlying stiff older bay mud and alluvial gravels. One additional six-inch-diameter auger boring (Boring 17) was drilled to a depth of 13 feet to observe the thickness of peat and depth of groundwater adjacent to the levee. To further define limits and the thickness of a sand layer encountered near the surface in Boring 2, four additional six-inch diameter auger probes were drilled to a depth of 13 feet. The probe locations and thicknesses of sand and peat encountered are listed below (no logs were prepared).

<u>Probe</u>	<u>Location (From Boring 2)</u>	<u>Thickness (feet)</u>	
		<u>Sand</u>	<u>Peat</u>
2a	5' South	1	4
2b	100' North	0	6.5
2c	100' East	0	7
2d	40' West	3	5.5

The large diameter bucket auger borings were drilled to depths of from 6 to 18 feet to observe the thickness and distribution of peat, and to evaluate the dewatering characteristics of the bay mud within the zone of planned excavation.

Our field geologist located and logged each boring and probe

and obtained undisturbed samples of the soils encountered for subsequent visual examination and laboratory testing. Logs of Borings 1 through 17 and bucket auger Borings B1 through B11 are presented in the Appendix on Plates A-1 through A-31. The soils encountered were classified in accordance with the Unified Soil Classification System described on Plate A-32, Soil Classification Chart and Key to Test Data.

The locations and ground surface elevations of the borings were established by pacing from existing landmarks and by interpolating between spot elevations shown on a topographic map dated June 10, 1970 prepared by Cartwright Aerial Surveys. The locations and ground surface elevations therefore should be considered accurate only to the limit implied by the methods used.

Laboratory Testing

We tested selected samples in the laboratory to determine their applicable engineering properties. Laboratory tests included natural dry density, water content, Atterberg Limits, shear strength (triaxial compression), and consolidation tests. The results of moisture content/dry density determinations and shear strength tests performed on undisturbed samples are shown on the boring logs in the manner explained on the Key to Test Data, Plate A-32. Atterberg Limits are presented on Plate A-33. Consolidation test results are presented on Plates A-34

though A-40, and the results of triaxial compression tests on remolded samples of the bay mud crust are shown on Plate A-41.

SITE CONDITIONS

Surface Conditions

Island No. 1 was originally marsh land that was reclaimed in the early 1900's by constructing perimeter dikes. Additional dikes constructed in the 1940's brought the site to its current configuration. The site has been farmed almost continuously since the early 1900's.

The site is relatively level with minor undulations between approximate Elevations -2 and +3 feet, Mean Sea Level Datum (MSL). A few swampy remnants of old sloughs exist that cannot be drained for farming, but they do not show response to tidal fluctuations.

The tops of the perimeter dikes are approximately +8 feet MSL and are slightly lower than Highway 37. The existing dike slopes average 4:1 to 5:1, but some of the exterior dike slopes have been eroded to almost 2:1. Several locations show evidence of slumping and erosion, and the present tenant farmer indicates that they need intermittent repair. Small amounts of seepage were observed along the north dike west of the existing farm buildings during the July 30, 1981 field observation.

Man-made interior drainage ditches collect surface water runoff and channel it to a pump station adjacent to Dutchman

Slough at the north end of the main access road. These drainage channels are pumped as required during the winter; during the summer they are almost dry. During our field exploration, the water surface in the deeper channels was 5 to 6 feet below the adjacent ground surface. Slopes in the drainage channels vary from 2:1 to as steep as 1:1, and show signs of erosion and slumping where not covered by vegetation.

Subsurface Conditions

Based on our observations and the subsurface exploration, it appears that Island No. 1 is blanketed with 3 to 5 feet of desiccated (dried) bay mud crust that is presently being farmed. A few isolated areas contain imported fill for roads. The crust is underlain by younger San Francisco bay mud which is in turn underlain by older bay mud and dense alluvial soils; these are described in more detail in the following paragraphs.

The younger bay mud deposits vary in thickness from approximately 50 feet below the existing surface in the southeastern corner of the site to over 90 feet in the western portion. Plate 2 shows the approximate contours of equal thickness of the younger bay mud across the site. Thicknesses are measured from the ground surface to the bottom of the bay mud.

The uppermost approximately 25 feet of the younger bay mud consists of soft, low density clayey silt that is highly

compressible and very weak. Beneath the 25-foot depth, the mud becomes increasingly stiff with higher densities and contains lenses of sandy silt. Based on laboratory consolidation tests, this stiffer mud appears to be an overconsolidated layer similar to that encountered at depth in other areas around San Francisco Bay. Overconsolidated materials have at some time in the past been compressed under pressures larger than existing and are therefore only moderately compressible under light loads.

The upper 15 feet of soft mud contains lenses of peat and highly peaty bay mud ranging in thickness from zero to 8 feet. Plate 3 shows approximate contours of equal thickness of material which contains at least 70 percent peat encountered in shallow borings reported by Gribaldo Jones in 1970 and in the borings drilled for this investigation. The peat appears to occur in intermittent layers of varying thickness and may not be continuous over large areas. Thick peat layers were encountered at or very near the existing surface in the vicinity of Borings 2, 7 and B1; however, the peat generally occurs in thin lenses or pockets in the crust.

A loose uniform, fine sand layer approximately 4 feet thick was encountered in the uppermost 10 feet in Boring 2. Subsequent auger probes indicated the sand was not continuous over a large area but, may follow a westerly trending old stream channel or slough.

The younger bay mud deposits are underlain by stiff to very stiff clays of the older bay mud and interbedded dense alluvial gravels and sands. Borings drilled for this investigation penetrated the underlying older bay mud and alluvial deposits approximately 20 feet. None of the borings encountered the underlying bedrock.

Measurements made in test borings drilled for this investigation show ground water to be approximately 5 feet below the surface. In one boring, however, near the Dutchman Slough levee, ground water rose rapidly to within 3-1/2 feet of the surface. The ground water encountered was brackish or saline.

GEOLOGY, SEISMICITY AND GEOLOGIC HAZARDS

Regional Geology

The site is within the northern Coast Ranges geomorphic province of California. The generalized geology of Island No. 1 and the surrounding region of the northern San Francisco Bay is shown on Plate 4.

No rock is exposed on the site, although it is present both to the east and west. Exposed at the surface one mile east are highly consolidated Cretaceous sedimentary rocks of the Great Valley Sequence. Their close proximity indicates that the rocks may also constitute the bedrock beneath the property. The depth to bedrock at the site is not known. From the borings, rock is more than 110 feet deep and may be several hundred feet

below the surface. Approximately five miles northwest of the site, Pliocene sedimentary and volcanic rocks are present, and four miles north, late Pliocene to Quaternary age alluvial deposits are exposed.

Fault Activity

Although no active faults have been mapped as passing through the property, several historically active faults are nearby that could cause strong ground motion at the site. Approximate locations of active faults in the San Francisco Bay Region are shown on Plate 5.

The active fault nearest this site is the Healdsburg-Rodgers Creek fault about four miles to the west. Other active faults in this region are the San Andreas fault, 25 miles to the southwest; the Hayward fault, 10 miles south; and the Green Valley fault, 10 miles east. The Franklin fault is shown on a 1963 geologic map compiled by the California Division of Mines & Geology (CDMG) extending northwest from Crockett across San Pablo Bay. Here the Franklin fault is inferred to split into two traces, extending both northeast and southwest of Island No. 1. However, no surface evidence for the Franklin fault in the site vicinity exists and subsequent mapping (Sims, et al, 1973) does not show the fault extending northwest beyond Crockett. From discussions with Mr. Earl Hart (CDMG), there is currently no evidence that the Franklin fault is active.

Two damaging earthquakes were generated on the Healdsburg-Rodgers Creek fault in the Santa Rosa area in 1969 with Richter magnitudes of 5.6 and 5.7. Movement on the San Andreas fault has caused several damaging earthquakes in historic time, the most notable of which occurred in 1905 and had an estimated Richter magnitude of 8.3. The Hayward fault experienced major earthquakes (estimated magnitude 6.6 to 7.0) in 1836, 1868, and 1911; and the Green Valley has had micro-earthquake activity. An earthquake reportedly centered near Mare Island, having a Modified Mercalli intensity of VII occurred in 1898. However, the earthquake was not recorded by instrumentation, and the causative fault is unknown.

Geologic Hazards

Potential hazards which have been considered during this investigation include: fault rupture, strong ground shaking, flooding, liquefaction and slope failure. These are discussed in the following sections.

Faulting

No active fault traces are known to cross the property therefore, we believe the potential for fault rupture is nil.

Ground Shaking

Strong ground shaking from an earthquake generated on the

Hayward, San Andreas, Green Valley or Rodgers Creek faults is probable during the average life of the planned structures (50 to 100 years) and represents a primary seismic related geologic hazard at the site. The bay mud modifies the bedrock motion occurring during earthquake damping out high frequency motion. The resulting long period (low frequency) ground motions are generally less damaging to short period structures such as light frame residential and one and two story commercial construction than to more flexible high rise structures. For planning purposes the Characteristic Site Period is estimated at more than 1-1/2 seconds. A detailed seismicity and ground response analysis is beyond the scope of this investigation.

Flooding

Flooding of the property by seismically-induced sea waves (tsunamis) is extremely unlikely. The potential runup from a once in a 100-year tsunami in this portion of San Pablo Bay has been estimated to be less than one foot (U.S. Geological Survey 1972). The Highway 37 road embankment would likely shield the property from such a tsunami wave. Flooding from storm runoff and high tide is not discussed herein since Vallejo and Solano County minimum grade elevations established for this property reflect the probability of flooding.

Liquefaction

Liquefaction can occur in loose cohesionless soils below the groundwater level in response to strong ground shaking.

Liquefaction is a condition in which a soil loses virtually all resistance to deformation and is due to the buildup of high pore water pressures during the application of shearing stresses.

Cohesionless soils (sands and silty sands) which tend to contract (densify) during shearing, present the highest potential for liquefaction. The loose fine sands encountered near the surface) in the vicinity of Boring No. 2 are judged likely to liquefy during a strong earthquake. This sand deposit and any similar deposits encountered during excavation will need to be removed during construction. Sand lenses which are not exposed in the excavation will be confined by the fill, reducing the risk of surface effect. Sandy soils encountered within the overconsolidated bay mud appear to be thin lenses and discontinuous zones and contain appreciable clayey fines which resist densification. Therefore, the potential for liquefaction of the deeper soils is judged to be low.

Slope Failure

A special consideration at this site and all bay margin sites is the absence of lateral support adjacent to the excavated channels or unfilled marsh. Tensile lurch cracks can

develop near the edge of fills in the event of an earthquake. The risk of structural damage induced by lurch cracking can be minimized by locating all buildings away from the fill edge. Cracking and the stability of slopes during earthquakes has been considered in our engineering analysis and is discussed in a subsequent section of this report.

DISCUSSION AND CONCLUSIONS

Excavation, Dredging and Filling

Based on the observations made during drilling of the 30-inch-diameter bucket auger borings, we believe that most of the excavation can be made "in the dry" using crust management techniques. With the exception of two of the borings, very little seepage was observed following drilling to depths up to 18 feet. In Borings B8 and B9, however, significant seepage was encountered immediately after drilling and both borings caved rapidly to approximately the bottom of the peat layer. In Boring B8, which is near the levee along Dutchman Slough, the inflow was measured at 10 gallons per minute and the water level rose to within 3-1/2 feet of the surface approximately 10 minutes after drilling. Areas near the existing perimeter dike may therefore require dredging or drag line excavation methods.

The crust management technique involves excavating a thin surface crust of dried mud using relatively light, self-loading scrapers and small track-mounted dozers. Then, after a period

of drying, the exposed soft mud would form a new crust capable of supporting the light excavation equipment and the crust removal process would be repeated. The time period during which crust management is normally feasible usually extends from mid-April to mid-October or until the start of the winter rains. Excavations to approximately -9 feet MSL have been completed using this method at a nearby site, and excavations to below -11 MSL are under construction near Novato.

While observations from the bucket auger borings appear to confirm the feasibility of crust management excavation techniques, a pilot excavation project conducted prior to construction would provide valuable information on full-scale operations. This would allow prospective grading contractors to evaluate methods of removing the crust and interbedded peats, ground water control, and placement and compaction of excavated soil. This would also presumably result in more accurate construction bids.

After removal of peat layers, the bay mud can be reused as fill. When it has dried sufficiently, the bay mud can be placed and compacted using conventional spreading and compacting equipment. If the organic material is uniformly distributed throughout the fill, material containing as much as 30 to 40 percent peat probably can be used. Where possible, the highly organic and pure peat layers should be removed and wasted or placed in areas where structures are not planned. Because of

the organic content of the upper 10 to 15 feet of mud, we expect shrinkage will be more than 50 percent (volume reduction between natural and compacted conditions).

If the excavations are performed by dredging or dragline methods, crust management procedures as described above can be used for drying the mud for reuse as fill. Alternatively, the bay mud excavated by dredging could be pumped to a diked pond area and used as uncompacted hydraulic fill. The soil particles in the dredge slurry would settle to the bottom and free water could be removed by decanting or pumping. This method of filling would result in less shrinkage between excavation and fill volumes because of the lower density of the dredged mud. There would however, be an increase in site settlement due to the consolidation within the uncompacted fill, and very flat fill slopes would be necessary because of the low strength of the hydraulic fill.

Typically, compacted bay mud fill is capped with a layer of select fill at least two feet thick to inhibit seasonal moisture changes in the moderately expansive bay mud and provide a more manageable and uniform surface for construction of buildings and roadways. Alternatively, the select fill cap could be eliminated within compacted dried mud areas provided spread footings are bottomed below the zone of seasonal moisture change, and structurally supported floors are used. Flexible asphalt pavement sections can be increased to offset the

decreased supporting capacity of the uncapped mud. In that instance a filter blanket or fabric (geotextiles) placed over the compacted bay mud subgrade would help prevent pumping of mud into the aggregate base. We estimate that five to seven inches of additional aggregate base would be needed if the select cap is eliminated. A further disadvantage of eliminating the select fill cap is that the compacted mud being silty, does not provide a good working surface for construction equipment, particularly during rainy weather; this can result in increased construction costs.

We anticipate that there will not be sufficient on-site material to achieve the required grades. Materials generated from dredging at Mare Island may be a possible source of import. This could be either the pumped dredge material or drier material excavated from the existing Mare Island ponds. We could assist in discussions with Mare Island Navy staff if this source of import fill is considered. Receiving and placing imported soil prior to actual construction would need to be carefully evaluated for adverse impacts on the development.

Settlement

Settlement will occur due to consolidation of the bay mud and peat under the weight of new fill. The amount and rate of settlement expected to occur across the site will be influenced by the thickness of the fill to be placed, the thickness and

distribution of peat layers, and the thickness and compressibility of the bay mud. From consolidation test data, the bay mud occurring below a depth of 25 to 30 feet is overconsolidated to approximately 3000 pounds per square foot. Since this is the approximate level of stress anticipated following placement of proposed new fill, the resultant settlement in this layer will be small. The majority of the expected 50-year settlement will therefore occur in the upper 25 to 30 feet of soft bay mud. Plate 6 presents the results of our settlement analysis based on consolidation test data developed during this investigation. From our analysis, the presence of a 6 foot thick layer of peat will increase 50-year settlement by about 30 percent.

The expected rate at which settlement will occur beneath 12 to 13 feet of fill is presented on Plate 7. The consolidation test data indicate that approximately 50 percent of the total 50-year settlement will occur in the first 4 to 5 years following placement of the fill. Since the peat zones are generally confined to the uppermost 10 to 15 feet, large settlement will be experienced during the early years.

We estimate differential settlement of about 6 to 12 inches will occur over a distance of about 200 feet or less because of the varying thickness of peat. Differential settlement occurring because of the varying thickness of the total bay mud section will be most pronounced after 10 years, and is estimated

to be approximately 4 to 6 inches.

Settlement analysis was based on compacted bay mud fill weighing 110 pounds per cubic foot, and placed in two-foot-thick increments during a one-year construction period. A further assumption for the analysis was that, during placement of the fill, the ground water level would rise until it reached Mean Sea Level. The incremental construction analysis was chosen to more realistically estimate the settlement during the early years. Secondary or long-term settlement of the peat is not included in the analysis, but we estimate that it would amount to an additional approximately two inches during the 50-year analysis period.

At the edges of fills, the pressure induced by the fill decreases more rapidly with depth. Typically, settlements beneath the outer 20 to 30 feet at the edge of a fill, with 4:1 and 5:1 slopes, will be from 85 to 90 percent of that occurring beneath the center of the filled area; at the toe of the fill slope, settlements are typically 25 to 30 percent of that occurring beneath the center. Lateral deformation of the excavated channel slopes, and heave of the channel bottom, will further affect settlement near the edge of the fill. We expect lateral deformation will be extremely variable depending on the thickness of peat encountered. We estimate heave of the channel bottom will be on the order of six inches due to stress relief during excavation to -10 MLLW.

Two methods of accelerating consolidation (and therefore settlement) of the uppermost 25 to 30 feet of bay mud have been considered: surcharging, and installation of vertical drains. We expect settlement would be 4 to 6 inches beneath surcharge fills of compacted bay mud approximately 4 feet high and left in place for six months to one year. Following the surcharge period, the surcharge fill can be removed and replaced as compacted fill in other areas.

Vertical drains are typically spaced 8 to 9 feet on centers and are expected to accelerate the consolidation such that 50-year settlements would occur in approximately 2 years. However, additional long-term settlements which would occur normally at periods longer than 50 years would be introduced through the use of vertical drains. Therefore, about 1 foot of additional fill would be needed to achieve the planned 50-year grades. Vertical drains have the added advantage of rapidly increasing the shear strength of compressible materials which would improve slope stability as will be discussed in the following section. Vertical drain systems presently in use, such as wick drains consisting of a fabric strip driven inside of a hollow mandrel, can be installed rapidly. The cost is typically on the order of \$50 per drain for the 30-foot depth anticipated for Island No. 1.

Slopes

The main consideration in determining excavation and fill slopes for the Island No. 1 site is the strength of the underlying peaty bay mud and its ability to support the overlying fill. Typically, slopes in bay mud above the Mean Lower Low Water (MLLW) are constructed in the range of 5:1 to 6:1. Below MLLW, the slopes may be made steeper to reflect the balancing effect of the water.

We performed stability analyses for a variety of slope angles for both static and earthquake conditions. The strength profile used for analysis is shown on Plate 8. We developed the profile using previously reported strength data, field torque tests and laboratory compression tests made during this investigation. We made static slope stability analyses for the following conditions with and without a tension crack extending through the fill parallel to the edge of the slope: 1) at the end of construction with dry excavation, 2) end of construction with the water surface at Mean Low Low Water. The purpose of considering a tension crack is to evaluate the reduced factor of safety that could result after the slope experiences some minor yielding during construction operations or strong groundshaking. Pseudostatic (earthquake) stability analyses were performed for condition (2) both with and without a tension crack, and also for estimated surface elevations and strength

characteristics corresponding to 5 years of consolidation.

In pseudostatic analysis earthquake forces are represented by a static force applied horizontally through the center of gravity of the sliding mass. Typically, this force ranges from .1 to .15 times the weight of the sliding mass (.1g and .15g respectively). The results of the stability analyses are summarized on Plate 9, along with a typical cross-section of the slope showing the subsurface profile used in the analysis.

Acceptable factors of safety for slope conditions in flooded channels at the end of construction are typically 1.5 or greater. Prior to filling of the channels, lower factors of safety on the order of 1.1 to 1.2 are normally acceptable. For earthquake loading with a pseudostatic force of .1g (10 percent gravity), a calculated factor of safety of 1.1 is normally required. The minimum factors of safety for earthquake conditions are normally applied assuming that a crack will develop through the fill parallel to the edge of the embankment. Cracks commonly develop parallel to the unsupported slope due to differential settlement, lateral deformation of the underlying soft bay mud following excavation, and lurching during earthquake loading.

Our analyses indicate adequate factors of safety for the static loading conditions. However, for the conditions of a crack through the embankment and a design pseudostatic earthquake force of .1g, calculated factors of safety were below

1:1 for the slope combinations steeper than 5:1 above MLLW and 4:1 below MLLW.

The sequence of embankment construction and channel slope excavation can influence the development of cracks parallel to the edge of the slope. Placement of fill prior to making any excavation promotes the development of cracks due to lateral deformation of the soft bay mud exposed in the excavation immediately beneath the embankment. Excavation of channels and placement of embankment using crust management techniques over a long period of time will reduce the potential for tension cracks.

The stability of the slopes, particularly in the cracked condition, are greatly influenced by small changes in strength in the upper layers of peaty mud. We expect, therefore, that the number of localized failures during construction would increase as slopes are steepened. Repair of local slope failures would involve excavation of the failed material and replacement with compacted fill.

Several alternatives have been considered for improving the stability of the slopes. These included a compacted fill keyway and buttress at the toe of the channel excavation slope, a slurry cutoff wall, and reducing the height of slope by lowering the fill elevation along the outer approximately 20 feet of the embankment.

Preliminary stability analyses indicated construction of a keyway and buttress beneath the excavated slope could result in

approximately a 10 percent increase in stability. To be effective, the keyway would need to extend approximately 20 to 25 feet horizontally beneath the excavated slope. This would require excavation and rebuilding of the entire slope below Mean Low Low Water which would be expensive and probably not feasible.

A slurry cutoff wall would need to be constructed about 25 feet back from the toe of the slope and would need to extend to a depth of at least 20 feet below dredge line. Although substantial increases in stability could be expected through the use of a cutoff wall, we believe that relatively thin, unreinforced walls would be subject to cracking from lateral deformation, reducing their effectiveness.

Since the keyway and cutoff methods are costly and of limited effectiveness; we suggest using them only where more space is critical. We estimate that a reduction in fill height of on the order of 3 feet in the outermost 20 feet of the embankment would result in an increase of approximately 10 percent in factor of safety and would reduce slightly the quantity of fill needed.

Structures located near the top edges of fills would be within the zone of potential tension crack formation. The risk of structural damage induced by lurch cracking during earthquake and differential settlement can be minimized by locating all buildings away from the fill edge. The most critical failure surface developed during the stability analysis intersect the

embankment surface approximately 20 to 30 feet back from the edge of the fill. Buildings set back at least 35 feet from the edge of the fill would, therefore, have a substantially lower risk.

Low walls on the order of two to three feet high constructed at the top of a fill slope would have a relatively small effect on the static factor of safety, and the location of the critical failure surface would remain nearly the same. The additional surface area created by the construction of a low wall would be only partially effective in increasing buildable areas, but could be used for yards and landscaping.

Bulkheads and Structurally Supported Slopes

To maximize the area available for development in the high density residential and commercial areas, structural support of the excavated channel slopes and embankment was considered. We analyzed the stability of a sheet pile bulkhead using the free earth support method; that is, we assumed the sheet piles to be bottomed in the mud and not fixed at the tip. Based on the strength profile developed during this investigation, a vertical face approximately 11 feet high above MLLW elevation could be supported with a tied back sheet pile bulkhead. To develop stability in the low strength soils at the dredge line, a 3:1 or flatter slope would be necessary from MLLW down to dredge line, and fill slopes behind the wall would need to be essentially

level or constructed on a very flat slope for a distance of about 20 feet behind the wall. The stability analysis of the soil-pile system indicated that sheet piles would need to be driven to a depth of at least 30 feet below the dredge line and the setback distance for structures increased to approximately 45 feet. Plate 10 shows a typical cross section of the sheet pile installation analyzed and includes the estimated lateral pressures.

Alternative structural support schemes such as closely spaced vertical and batter pile systems have been installed on similar sites in the Bay Area and may be feasible here. Pile spacings on the order of three feet are typical, but we anticipate bulkheads would probably be necessary between piles to restrain the bay mud fill. Again this method would be expensive, and should be considered only where space limitations are critical.

Building Support

A compacted bay mud fill is capable of supporting light to moderately loaded structures. Foundation dead load pressures on the order of 1000 to 1500 pounds per square foot are typically used on compacted bay mud. With the thickness of fill anticipated, we believe wall loads of about 4 kips per linear foot and column loads of 15 to 20 kips could be supported in the fill.

Differential settlements in the peat layers of about 2 to 6 inches could occur across individual buildings. Therefore, foundations would have to be designed to allow the structures to settle as a unit and to resist localized areas of nonuniform settlement. More heavily loaded structures or buildings that could not tolerate the anticipated settlements would require deep foundation support such as driven piles.

Although the overconsolidated bay mud could provide adequate support for lightly loaded piles, downdrag loads would result from settlement of the surrounding fill, this would require pile penetration of nearly 70 feet below existing ground surface to support net loads of 20 to 25 kips. Long term pile settlements would also occur in the overconsolidated bay mud. These long term settlements are estimated to be 4 to 8 inches. To develop net pile loads of 40 to 50 kips, piles would need to penetrate at least 25 feet beneath the bottom of the bay mud, resulting in pile lengths of 80 to 120 feet. Waterfront structures that can tolerate settlement, such as boat piers and docks extending out over the water could be supported on shorter piles that do not penetrate fully through the mud.

Surcharging as previously discussed could be an effective method of accelerating settlements in the upper few feet of the peaty mud. This would reduce the differential settlements in areas which will support structures.

RECOMMENDATIONS

Site Grading

Prior to adding new fill, the site should be cleared of vegetation. Excavation of the channel slopes and placement of adjacent fill should proceed simultaneously and the fill should be placed slowly and carefully adjacent to the edge of the slope to inhibit the formation of tension cracks. Fill should be left approximately 3 feet below final grade within the outer 20 feet along the edge of the slope. This will allow initial consolidation of the peat layers to occur during construction, thereby increasing the strength and stability prior to completing fill slopes. Average fill thicknesses required to develop the grading plan should be determined using Plates 6 and 7. Grades should be reviewed, and adjusted if necessary based on the results of settlement monitoring data developed both from the pilot excavation and fill program and during actual construction.

Based on the results of this investigation, we believe that excavation using crust management techniques will be feasible over most of the project. To more thoroughly evaluate specific construction techniques, the performance of excavated fill slopes, and settlement under new fill, we recommend a pilot or test excavation and fill. Instrumentation in the test section

should include settlement monuments, slope inclinometers and piezometers to assist in evaluating the excavation and fill slopes. This full scale test should be performed prior to or simultaneously with the planning, design and review process so that it would not delay the start of actual construction process. The pilot project should be located such that the completed excavation and fill can form a part of the actual development.

For the purposes of feasibility studies and master planning, slopes should be designed at 5:1 above MLLW and 4:1 below MLLW. Slopes as steep as 4:1 above MLLW or steeper may be constructed in isolated areas of the site where space is critical. However, this will result in increased risk of failures and should be further evaluated for specific cases during the final soil investigation. Once the specific plans are completed, slope designs should be evaluated for both static and dynamic conditions to estimate the deformation and stability during earthquake. The feasibility of lowering the fill elevation within the area approximately 20 feet wide adjacent to open channels should be considered to increase the developable land area.

When construction of the project begins, a system of settlement measuring points should be placed at the level of the existing ground surface to monitor the rate and amount of settlement occurring during construction. Periodic measurements

of these settlement monuments will permit a more accurate estimate of the future settlement, and allow appropriate adjustment of finished grades, if necessary. The exact layout and details of settlement monuments can be produced when a final grading plan is developed.

Structural Slope Support

If sheet pile walls are required, preliminary designs should be designed in accordance with the minimum and maximum dimensions, and the earth pressures shown on Plate 10. If they are then considered feasible, actual design should be based on specific soil data obtained during the final soil investigation.

Building Support

Relatively light wood-frame structures should be supported in the fill on shallow foundations heavily reinforced in a grid system to act as grade beams. For planning purposes foundation wall loads should not exceed approximately 4 kips per linear foot, and dead plus live load bearing pressures should be limited to 1500 pounds per square foot. For wind and earthquake loads, bearing pressures may be increased by 35 percent. Structure set back from the top edge of fill slopes adjacent to the channels should be as shown on Plates 9 and 10. For structures designed using the above pressures, additional settlement due to the foundation loads is estimated to be about

one inch. Differential settlements of approximately 4 to 6 inches may occur over a distance of about 100 feet due to consolidation of the peat under the weight of the fill. Therefore, construction of buildings and utilities should be delayed as long as possible after filling to allow initial consolidation of the peat to occur.

To reduce the potential for differential settlement under multi unit and commercial structures, the fill area should be surcharged. Surcharge fills should be at least 4 feet high and consist of compacted bay mud from excavation. Surcharge fills should be built with relatively flat slopes (on the order of 6:1) to minimize the "edge effect", and should be left in place for at least six months. Since surcharge fill will induce settlements outside the surcharge area, surcharge fills should extend, full height, at least 5 feet beyond the perimeter of the planned structure, and the toe of the fill should be located at least 10 feet from any unsurcharged structure.

Specific foundation recommendations and surcharge limits should be based on specific soil data obtained from the final soil investigation and from the results of monitoring the test excavation and fill.

For planning purposes, piles supporting waterfront structures such as boat piers and docks extending out over the water and outside the influence of the fill should be designed based on penetration of at least 30 feet below the dredge line.

Actual pile size and length will be primarily dependent on the magnitude and point of application of lateral loads and on the tolerable deflection. Piles supporting heavy loads or structures which cannot tolerate settlement should penetrate in the dense alluvial soils below the bay mud. Pile capacity and penetration should be evaluated during the final soil investigation once the development plan is completed.

If structures are planned with relatively large area loading (such as a water tank) may be supported on a compacted gravel pad at least three feet thick provided the area loading does not exceed approximately 1000 pounds per square foot. Settlements will be quite large but could be approximately predicted from Plate 6 using an equivalent weight of area fill. If area loadings will exceed 1000 pounds per square foot, the structures should be supported on piles. The combination of the weight of the fill and that of area loads greater than 1000 psf could exceed the bearing capacity of the bay mud resulting in large settlements and heaving of the adjacent fill.

Additional Geotechnical Engineering Services

This report is intended for use in completing cost and feasibility studies, master planning and for the Environmental Impact Report. Additional geotechnical services should be provided to develop detailed soil and geologic design recommendations once a specific plan has been developed.

Subsequent investigations should include additional field exploration of the uppermost 25-30 feet of mud, and laboratory testing to determine specific design parameters. We anticipate that the subsequent investigations could also include dynamic analysis to evaluate site response and ground shaking during future earthquakes. We expect that the final investigations would be performed in several stages over a long period of time to correspond to the sequence of site development. Once the project master plans are developed, we could develop specific scopes of services and fee estimates for subsequent investigations.

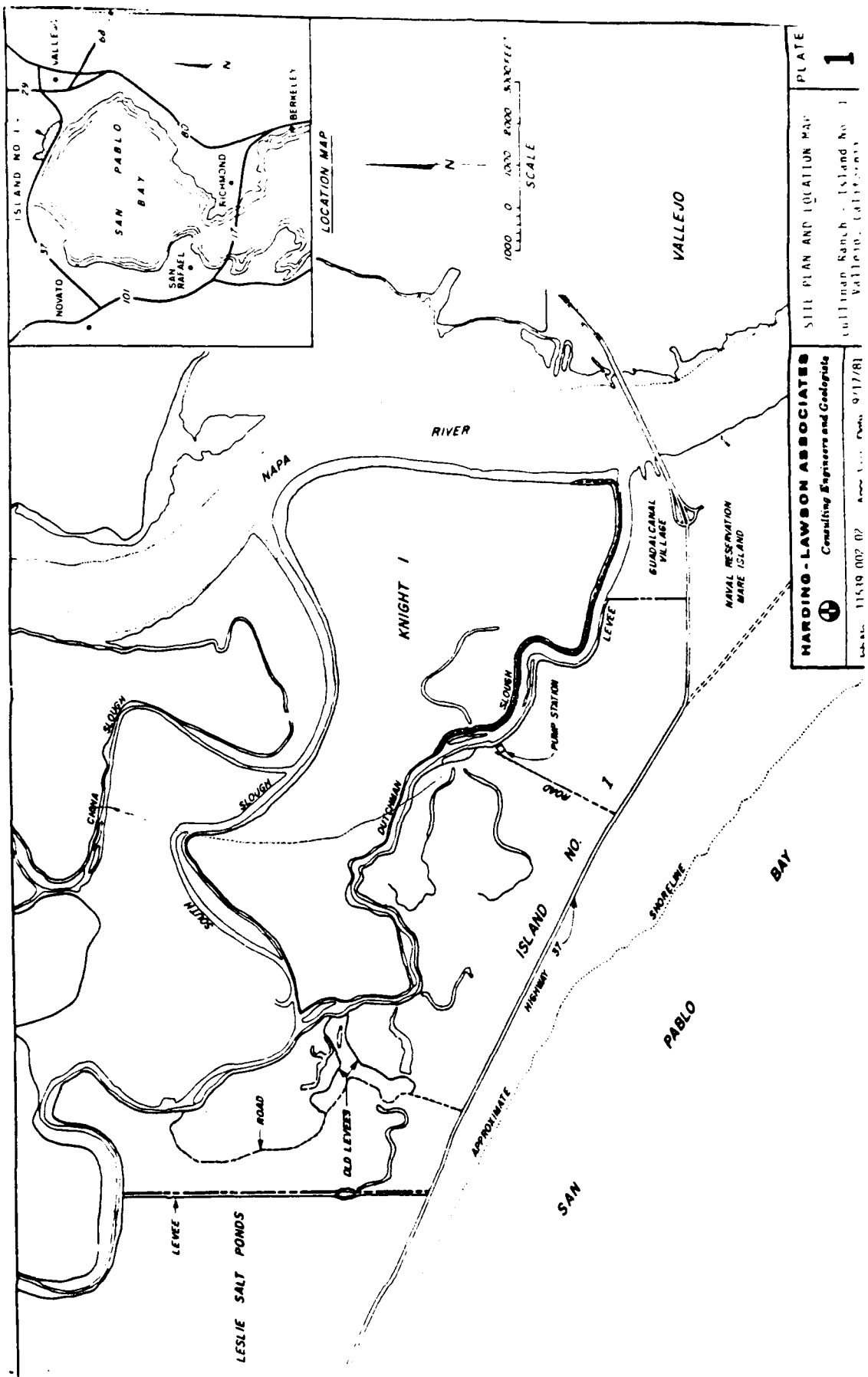

HARDING - LAWSON ASSOCIATES
 Consulting Engineers and Geologists
 11419 002 02
 9/17/81

SITE PLAN AND LOCATION MAP
 Fullman Ranch - Island No. 1
 Vallejo, California

PLATE
1

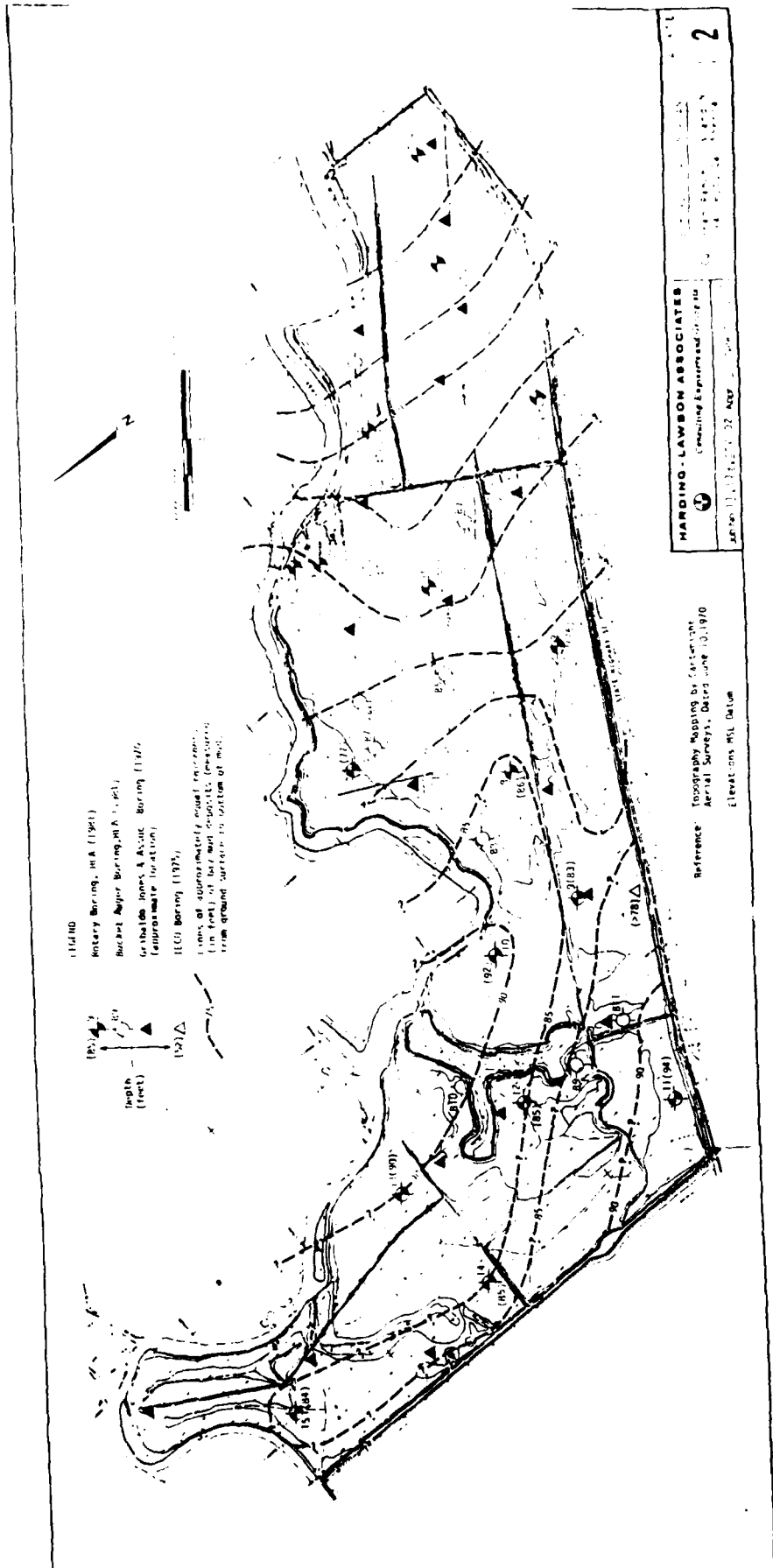

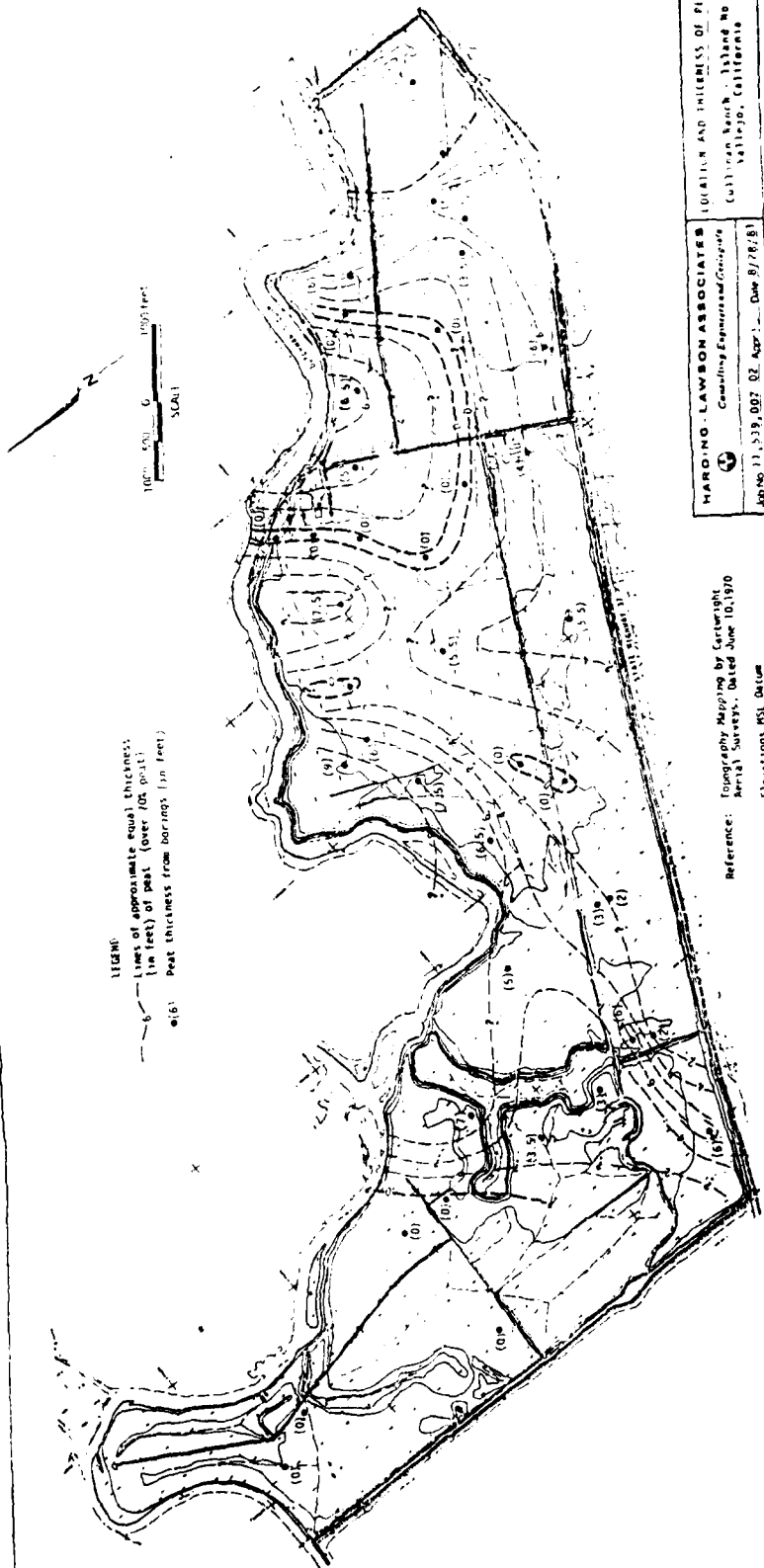

LEGEND:
 --- Limit of approximate sand thickness (in feet) of peat (over 100 post)
 o/6 Peat thickness from borings (in feet)

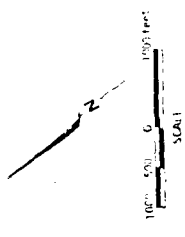

HARDING - LAWSON ASSOCIATES
 Consulting Engineers and Geographers
 Job No. 11,539, 007 Q.E. Appr. Date 2/78/8

Reference: Topography Mapping by Certificate Series Surveys, Dated June 10, 1970
 Elevations MSL Datum

LOCATION AND INTEREST OF PLAT
 Callahan Ranch, Island No 1
 Vallejo, California

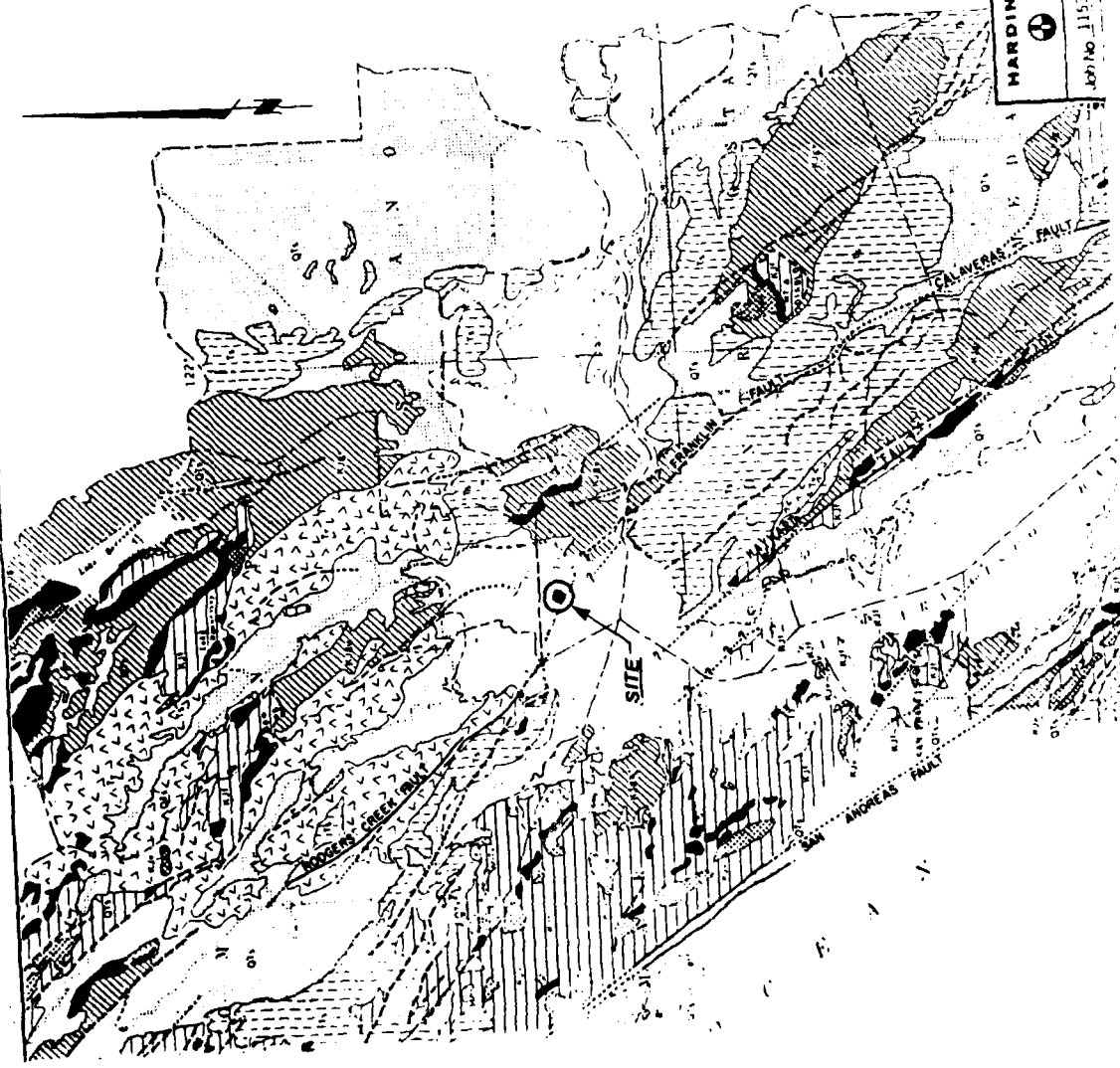

- EXPLANATION**
- 1 Mud
 - 2 O₁
 - 3 Unconsolidated sediments
 - 4 Moderately consolidated to well-consolidated sedimentary rocks
 - 5 Franciscan assemblage (KJ) - sandstone and shale, chert, metamorphic rocks, limestones, sheared rocks (melange)
 - 6 KJy - volcanic rocks
 - 7 Sandstone, shale, and conglomerate, locally in oldest part basaltic volcanic rock and chert
 - 8 Serpentine and peridotite
 - 9 Granitic rocks
 - 10 Volcanic rocks
- AGT** TERTIARY QUATERNARY
- 11 Fault known to be active
 - 12 Fault shown where concealed
 - 13 Fault not known to be active
 - 14 Dashed where concealed
 - 15 Faults shown Query indicates uncertainty as to existence of fault

CALIFORNIA
San Francisco Bay



REFERENCE: J. SCHLOCKER 1970, USGS OPEN FILE REPORT

HARDING-LAWSON ASSOCIATES
Consulting Engineers and Geologists

Job No. 11539,002,02 App. No. Date 9/17/81

PLATE
4

GENERALIZED GEOLOGIC MAP
SAN FRANCISCO BAY REGION
Cullinan Ranch - Island No. 1

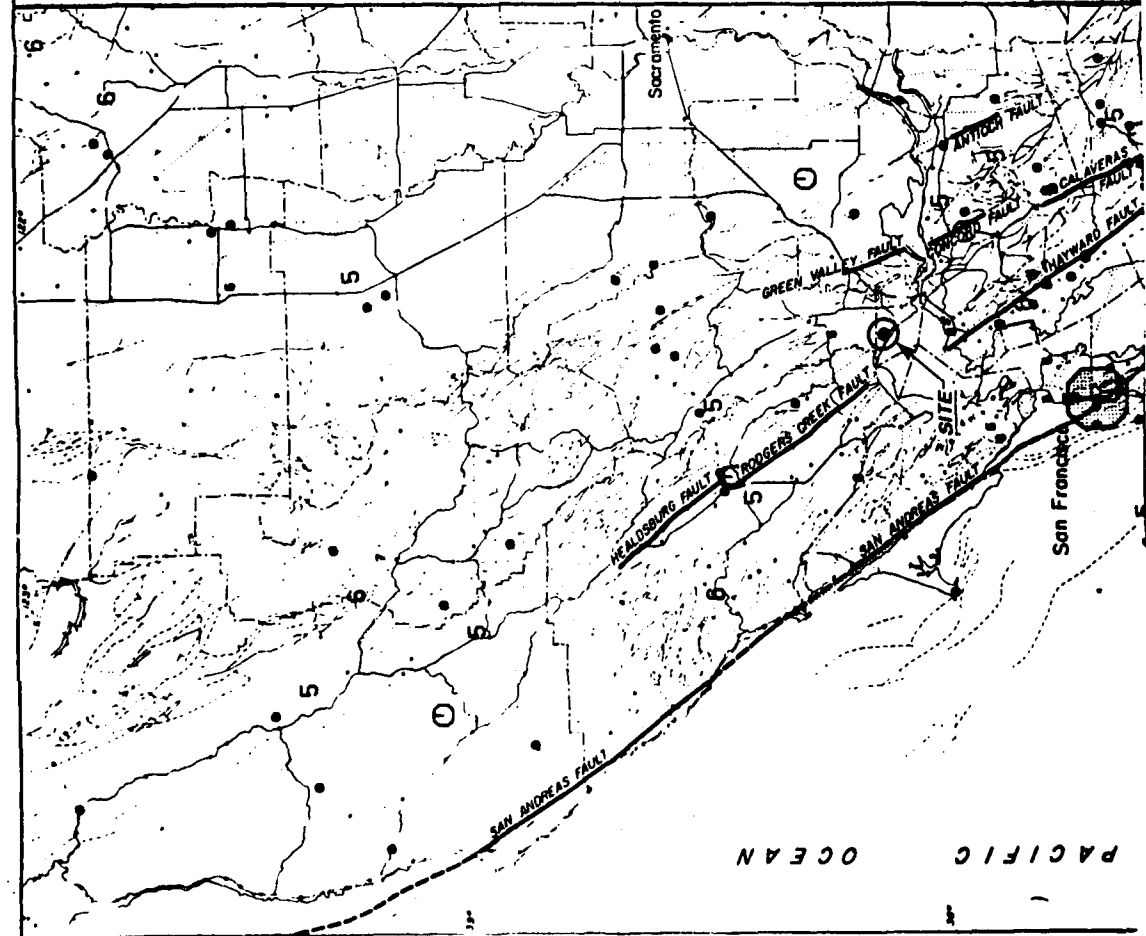

EARTHQUAKE MAGNITUDE

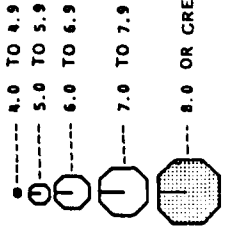

INTEGER - MAXIMUM REPORTED INTENSITY
(ONLY FOR EARTHQUAKES OF UNKNOWN MAGNITUDE)

FAULT SYMBOL

UNDIFFERENTIATED FAULT
(Dotted where concealed, dashed where inferred, solid where definitely located, barbs on the upper thrust block)

ACTIVE FAULT
(All dashed offshore faults are based on acoustic reflection profile records)

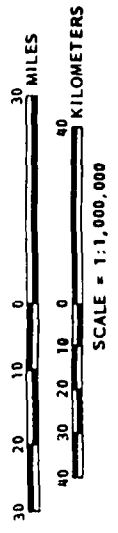

- REFERENCES:**
1. Earthquake Epicenter Map of California, 1978, Map Sheet 39, California Division of Mines and Geology
 2. Fault Map of California, 1975, Map No. 1, California Geologic Data Map Series, California Division of Mines and Geology

HARDING - LAWSON ASSOCIATES Consulting Engineers and Geologists Job No. J11539.002.02 Apr 85p Date 9/17/78	REGIONAL FAULT AND EPICENTER MAP FOR EARTHQUAKES 1900 TO 1974	PLATE 5
	Cullinan Ranch - Island No. 1	

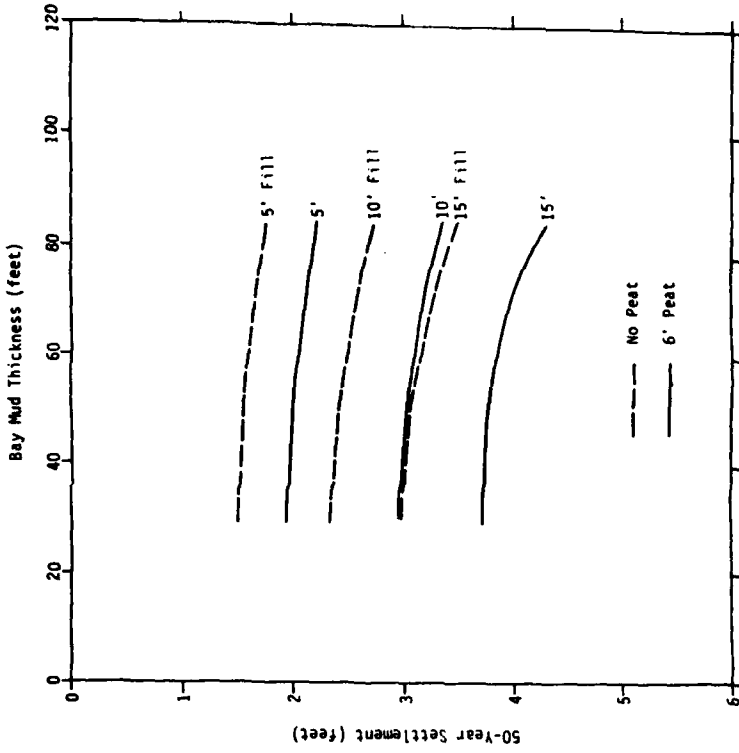
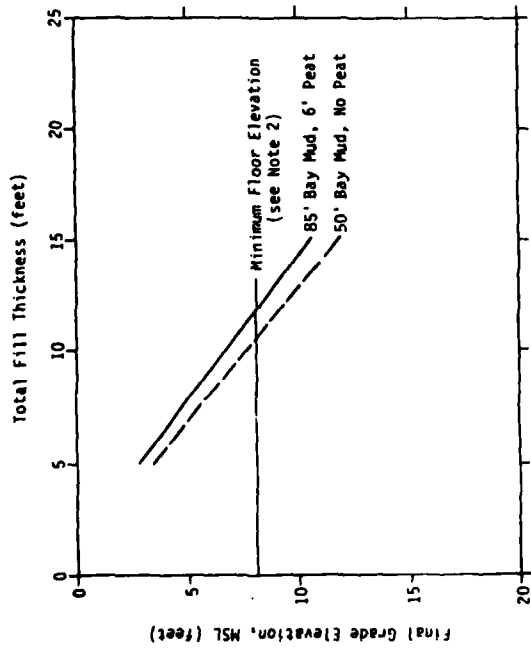

- NOTES:
1. Based on a pre-fill surface elevation of +0' MSL.
 2. Minimum floor elevation is +8 MSL (+1.5' City of Vallejo Datum) based on current City of Vallejo requirements.
 3. Includes effect of submergence; does not include rise in water level due to fill.
 4. Based on fill wet unit weight of 110 pcf.
 5. Thickness of bay mud measured from existing ground surface and includes crust.

HARDING - LAWSON ASSOCIATES Consulting Engineers and Geologists 	EXPECTED 50-YEAR SETTLEMENT	PLATE
	Cullinan Ranch - Island No. 1 Vallejo, California	6
Job No. 11539_002_02 Appr. Date 9/17/81		

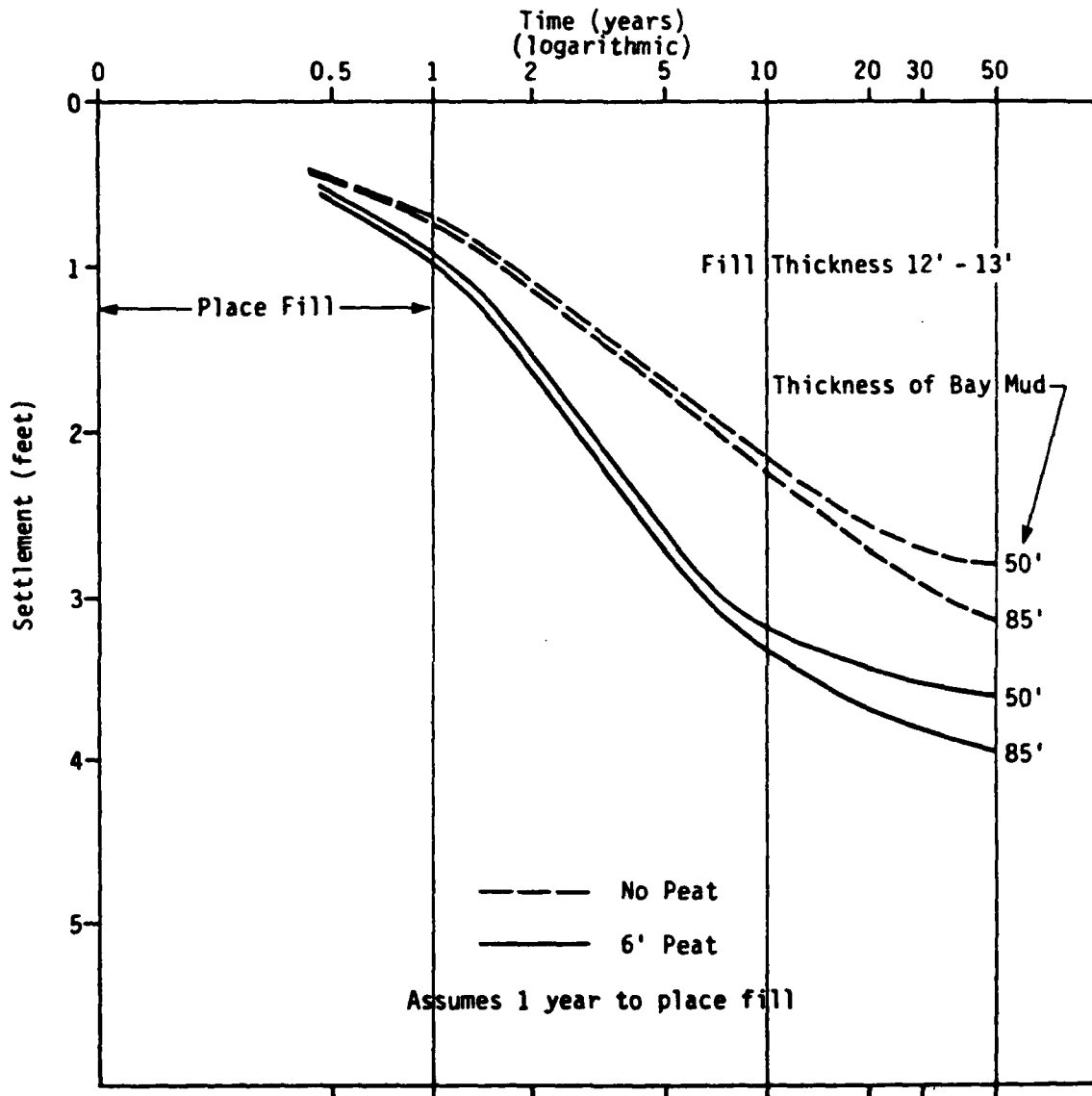

HARDING - LAWSON ASSOCIATES
Consulting Engineers and Geologists

Job No. 11539,002.02 Appr. By Date 9/17/81

EXPECTED RATE OF SETTLEMENT

Cullinan Ranch - Island No. 1
 Vallejo, California

PLATE
7

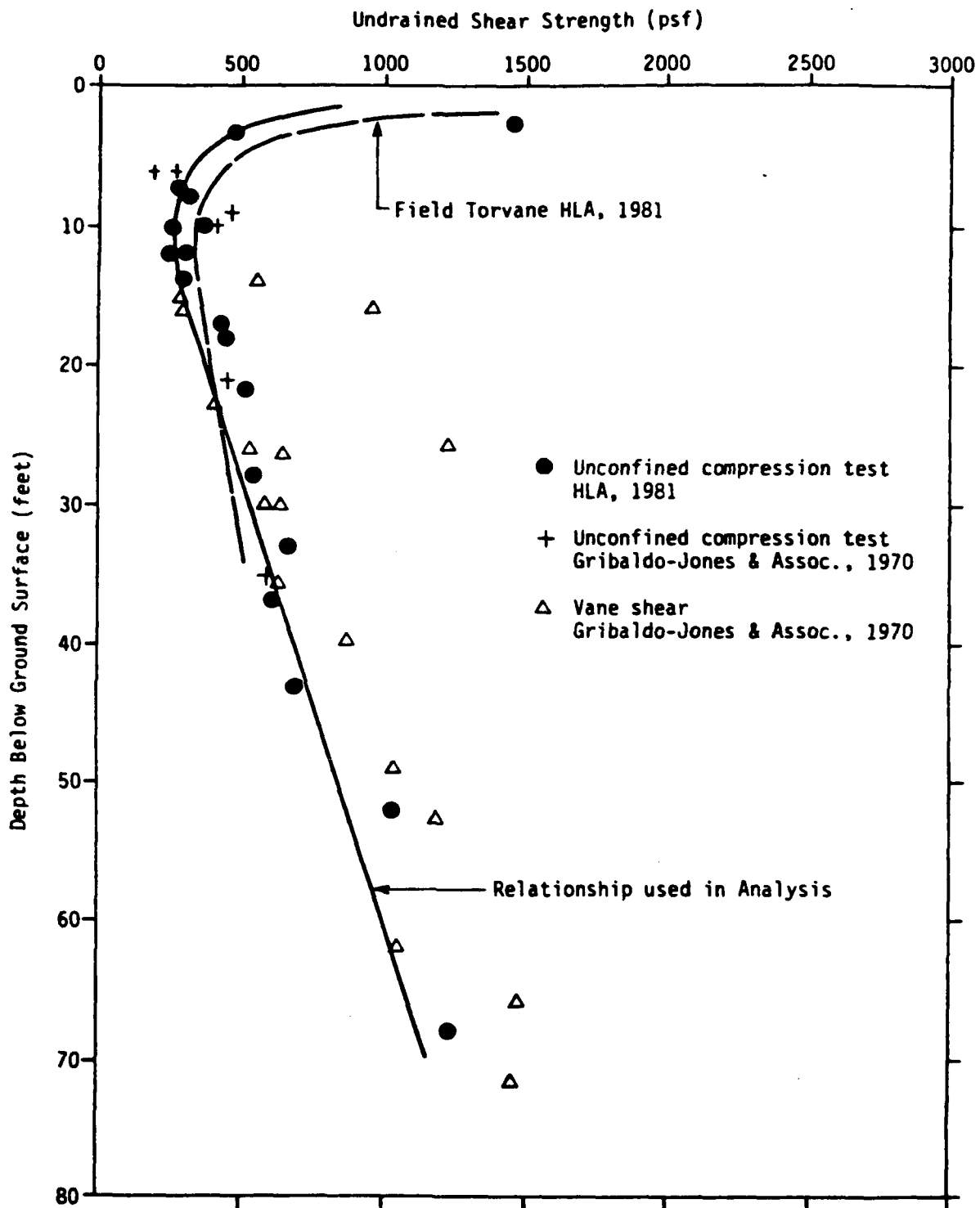

HARDING - LAWSON ASSOCIATES



Consulting Engineers and Geologists

Job No. 11539,002.02 Appr. RMS Date 9/17/81

UNDRAINED SHEAR STRENGTH

Cullinan Ranch - Island No. 1
Vallejo, California

PLATE

8

RESULTS OF STABILITY ANALYSIS

A	B	F	Factor of Safety Calculated	Minimum Recommended Factor of Safety	Notes
4.1	4.1	-	1.5	1.5	End of construction - U.S. 9'-0" M.L.L. - no crest
-	-	-	1.5	1.5	Slope - 12'-deep crest
0.10	0.10	1.2	1.2	1.0	Slope - no crest
0.10	0.10	1.0	1.0	1.0	Slope - 12'-deep crest
0.10	0.10	1.1	1.1	1.1	After 5 years - U.S. 9'-0" M.L.L. - 12'-deep crest
4.1	4.1	-	1.4	1.4	End of construction - U.S. 9'-0" M.L.L. - 12'-deep crest
-	-	-	0.9	0.9	Same
4.1	3.1	-	1.2	1.5	End of construction - U.S. 9'-0" M.L.L. - no crest
-	-	-	1.3	1.3	Slope - 12'-deep crest
-	-	-	1.3	1.3	End of construction - dry channel - no crest
-	-	-	1.1	1.1	Same - 12'-deep crest
0.10	0.10	1.3	1.3	1.3	End of construction - U.S. 9'-0" M.L.L. - no crest
0.10	0.6	1.0	1.0	1.0	Same - 12'-deep crest
0.10	1.0	1.1	1.1	1.1	Same - 12'-deep crest

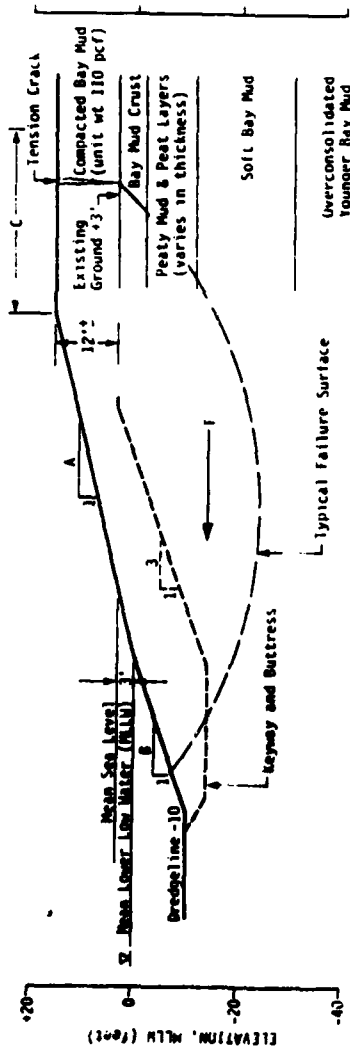

KEY

- A Slope ratio above MLL
- B Slope ratio below MLL
- C Set-back distance for structures, 35 ft. minimum
- F Earthquake (horizontal) force coefficient (0.10 = 10% gravity)

Notes and further information are on page 10 of this report.
Minimum recommended factors of safety for feasibility evaluation.

HARDING - LAWSON ASSOCIATES Consulting Engineers and Geologists	TYPICAL SLOPE CROSS-SECTION AND STABILITY ANALYSIS PLATE 9
Job No. 11539-002-02 Date: 9/30/71	Cullinan Ranch - Island No. 1 Vallejo, California

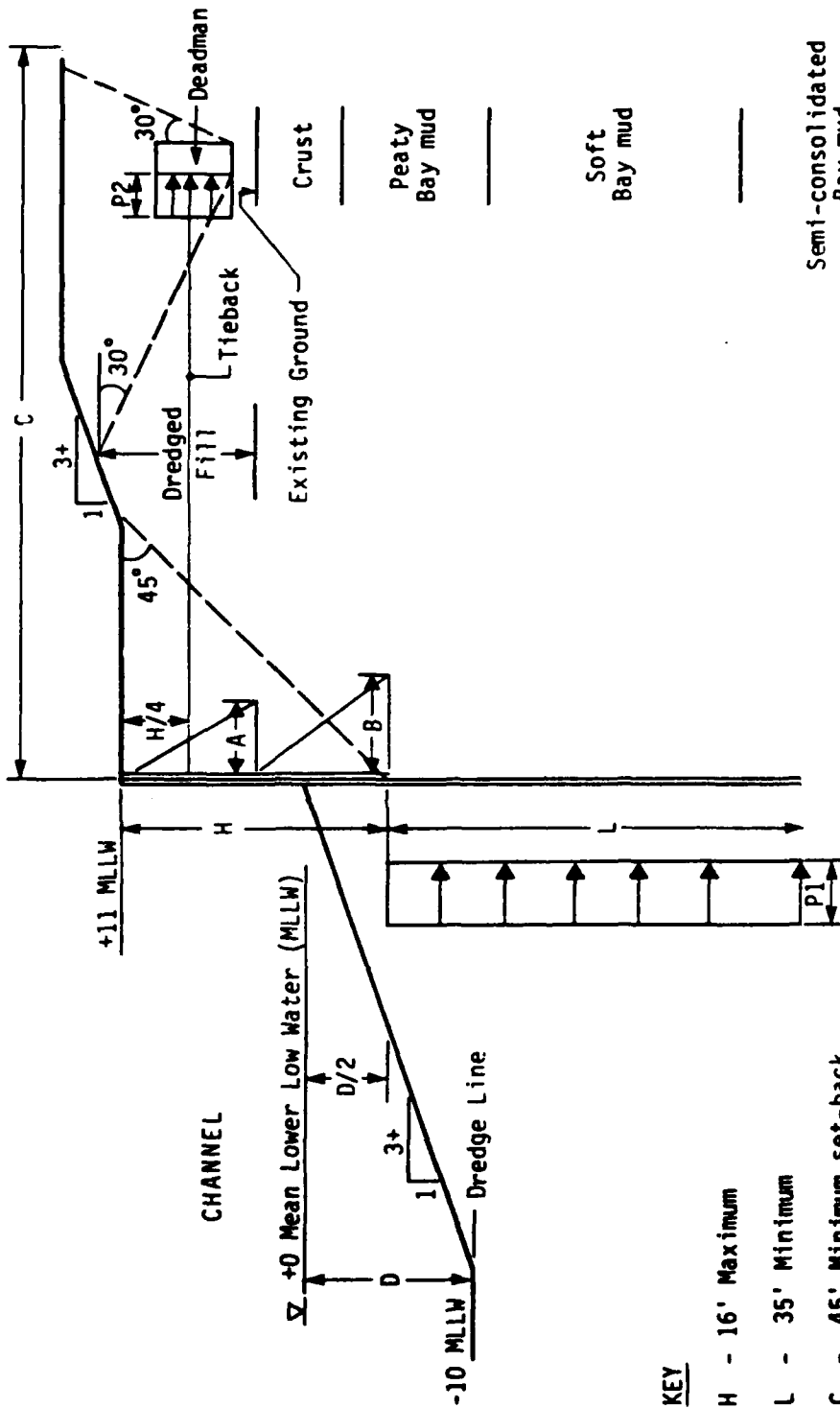

(not to scale)

KEY

H - 16' Maximum

L - 35' Minimum

C - 45' Minimum set-back

A 550 psf Estimated net active pressures

B 600 psf Estimated net active pressures

P1 160 psf Estimated net passive pressures

P2 1000 psf Estimated net passive pressures

NOTES:

Dimensions and pressures above are based on average soil properties developed during this investigation, and may vary depending on actual conditions. Minimum length, L, is dependent on slope stability analyses and may need to be increased, depending on local

HARDING-LAWSON ASSOCIATES



Consulting Engineers and Geologists

Job No. 11539,002.02 Appr. RLS Date 9/17/81

SCHEMATIC SHEETPILE BULKHEAD

Cullinan Ranch - Island No. 1
Vallejo, California

PLATE

10

APPENDIX

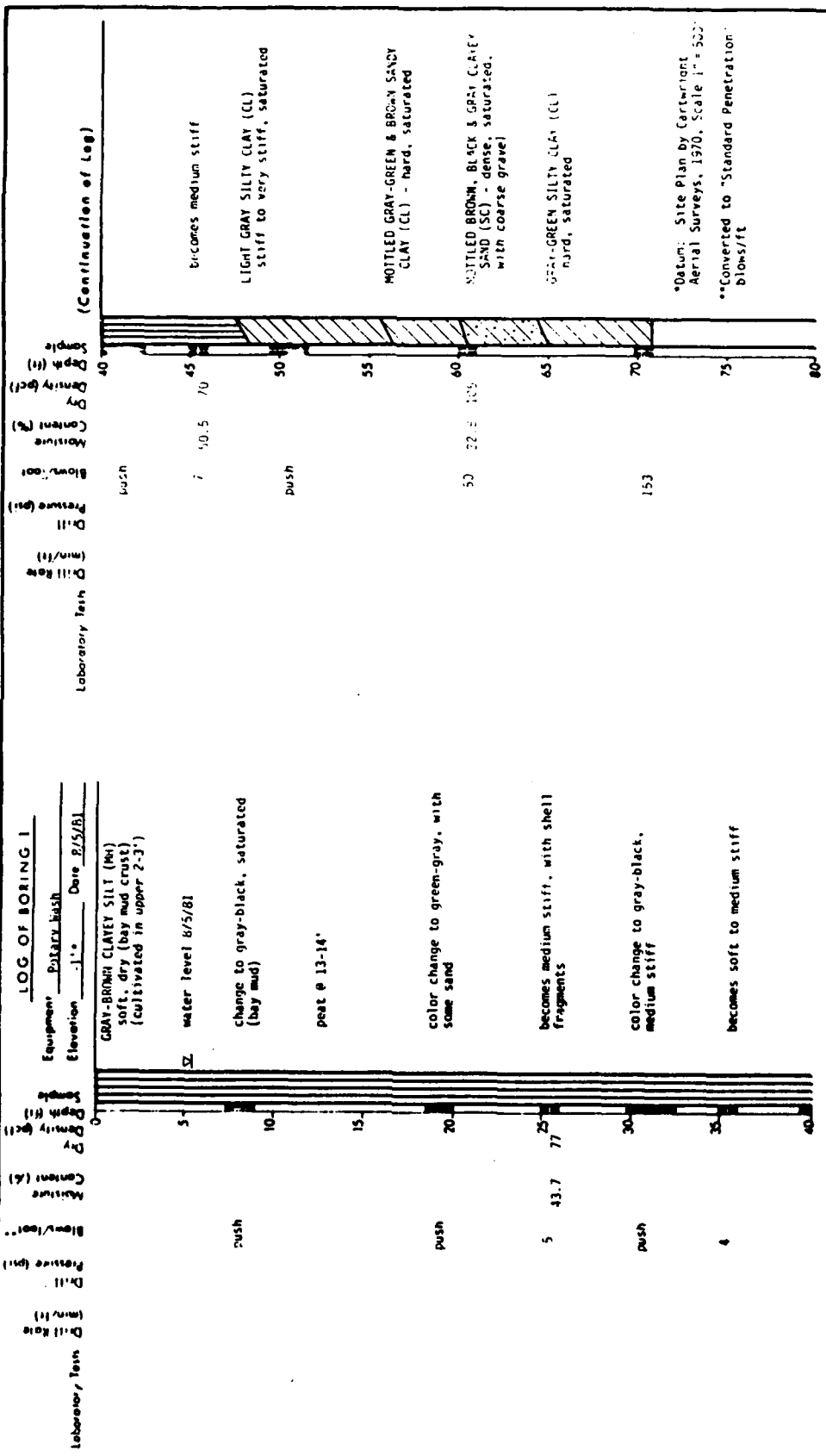

*Datum: Site Plan by Cartwright Aerial Surveys, 1970, Scale 1" = 500'

**Converted to "Standard Penetration" blows/ft

HARDING - LAWSON ASSOCIATES <small>Consulting Engineers and Geologists</small>  11539, 002 DC Ave. No. 101, 416/81	LOG OF BORING 1	PLATE
	Cullinan Ranch - Island No 1	A-1

LOG OF BORING 2

Equipment: Black Wash
 Elevation: _____ Date: 8/16/81

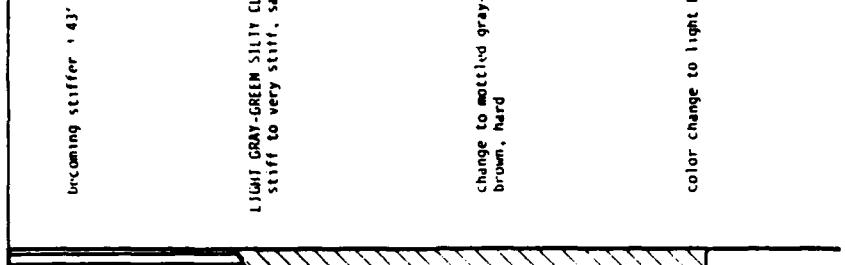
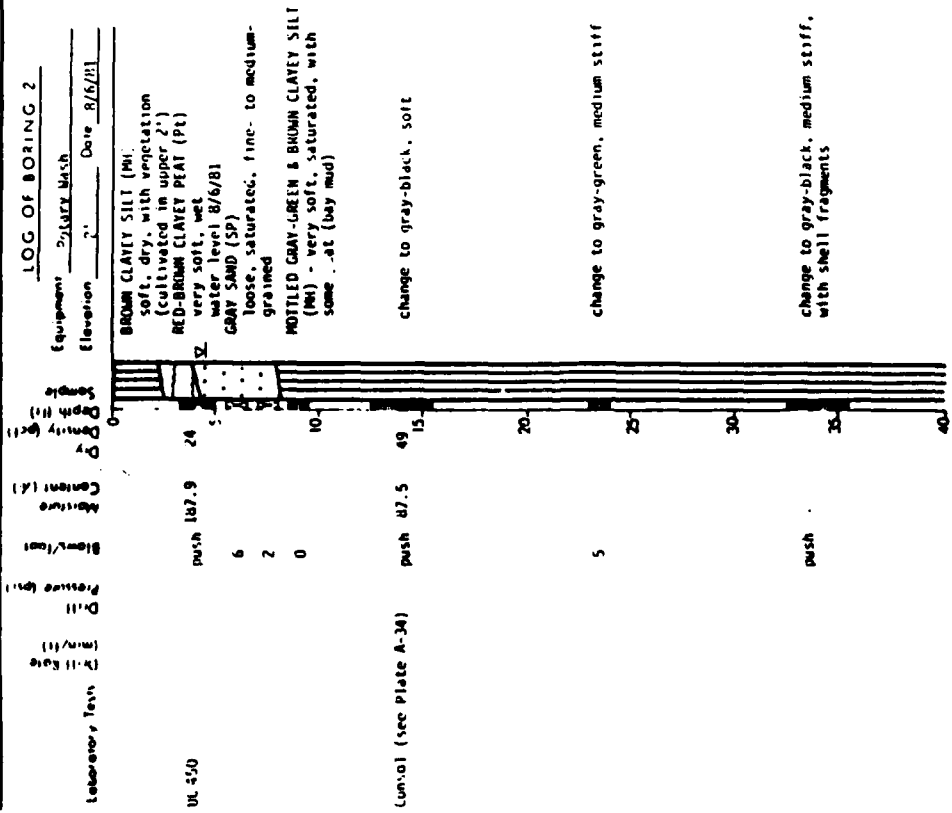

HARDING-LAWSON ASSOCIATES
 Consulting Engineers and Geologists
 11519, 002-02 Ave. Date: 9/16/81

LOG OF BORING 2
 Cullinan Ranch - Island No. 1
 Vallejo, California

PLATE
A2

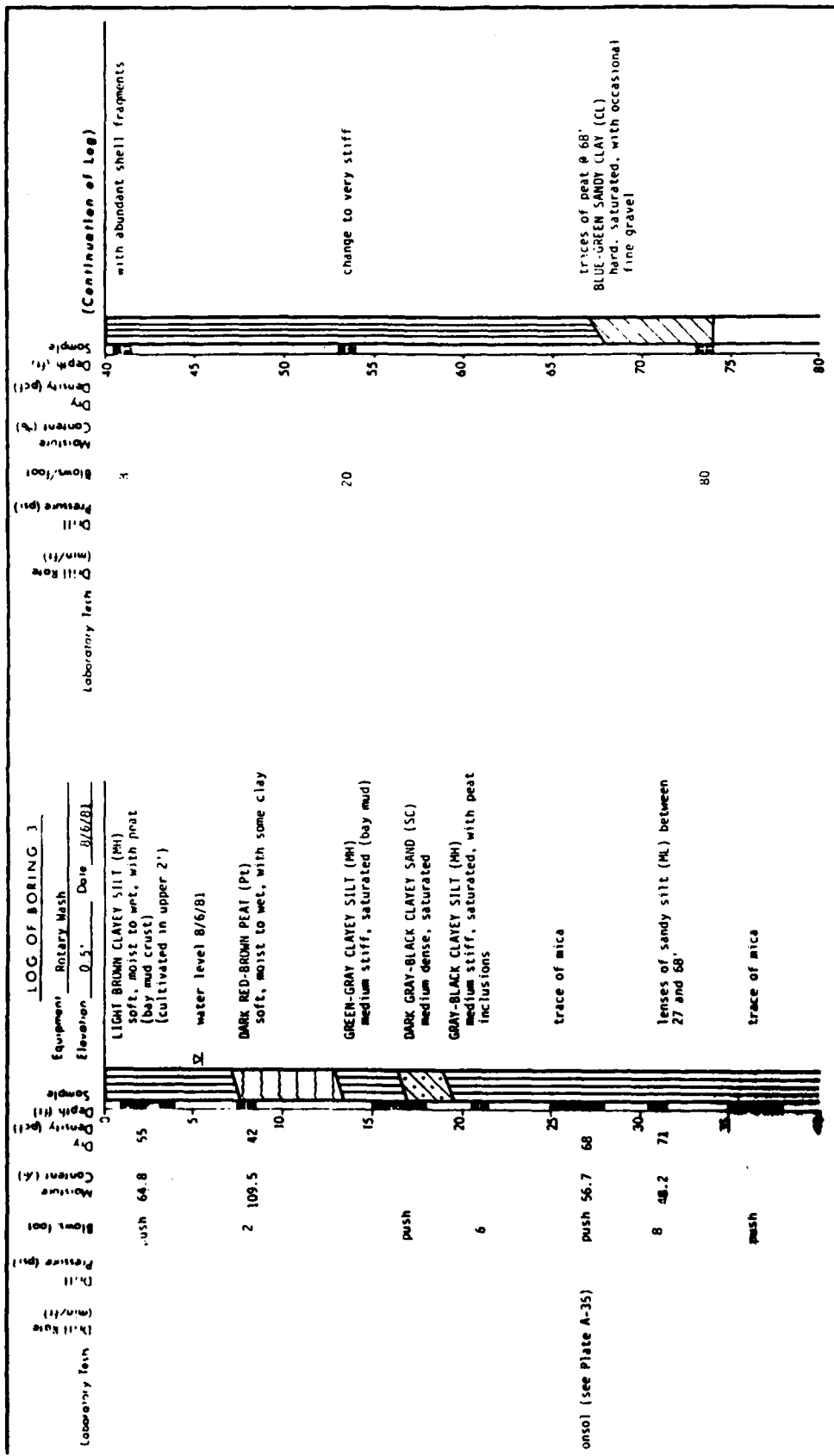

LOG OF BORING 3

PLATE A3

Cullinan Ranch - Island No. 1
Vallejo, California

HARDING - LAWSON ASSOCIATES
Consulting Engineers and Geologists

11539, 002.02 APP Date: 9/16/81

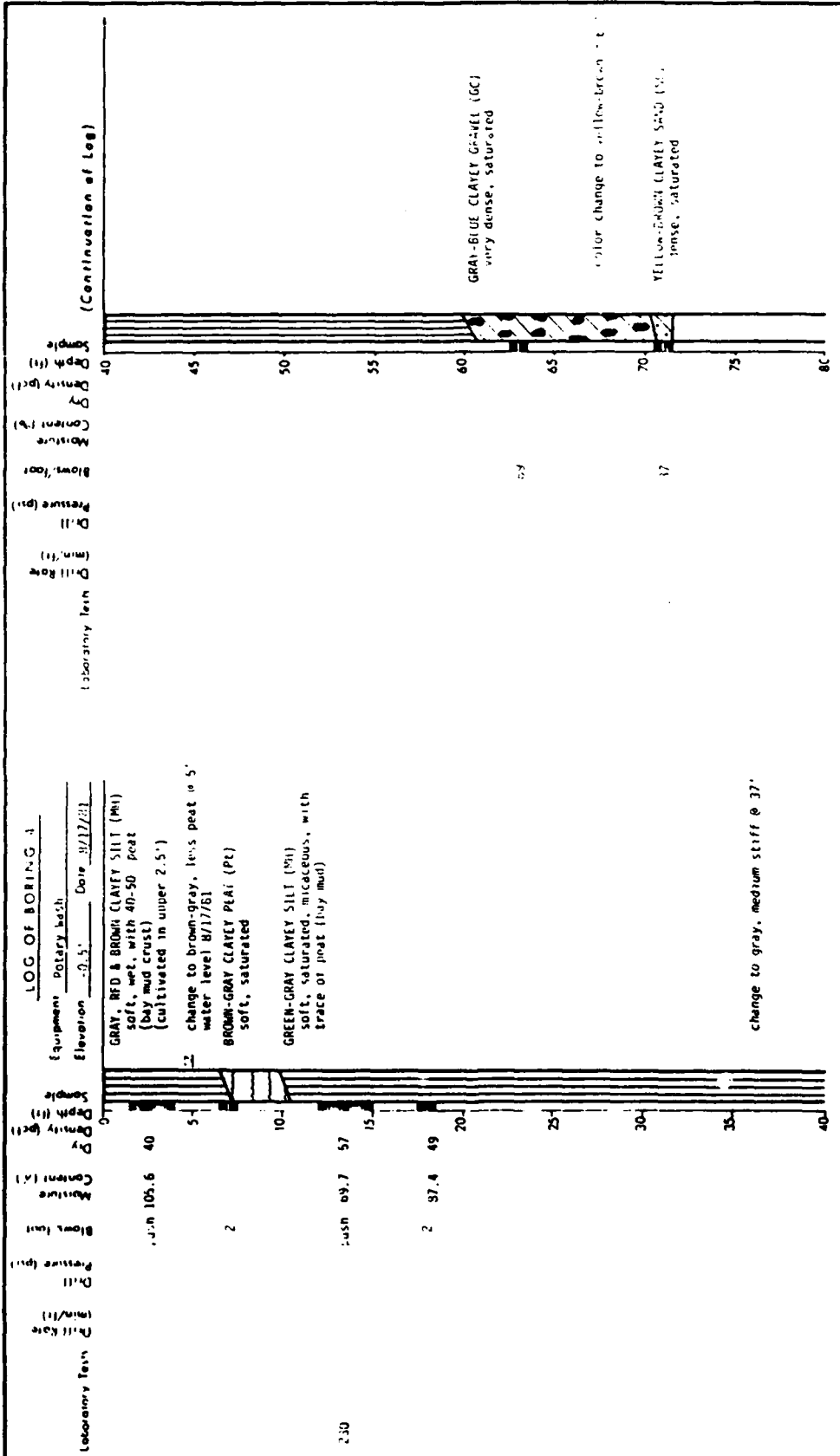

HARDING-LAWSON ASSOCIATES
 Consulting Engineers and Geologists
 11535 166th St. Alder, D.R. 57102

LOG OF BORING:
 William Ranch Island No. 1
 Vallejo, California

PLATE A4

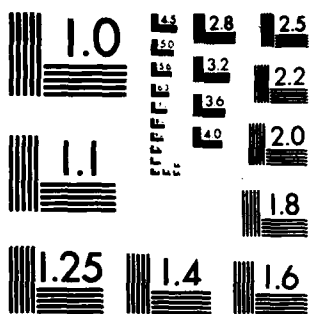

MICROCOPY RESOLUTION TEST CHART
NATIONAL BUREAU OF STANDARDS-1963-A

LOG OF BORING 5

Equipment: Rotary Wash
 Elevation: 0.5' Date: 8/17/81

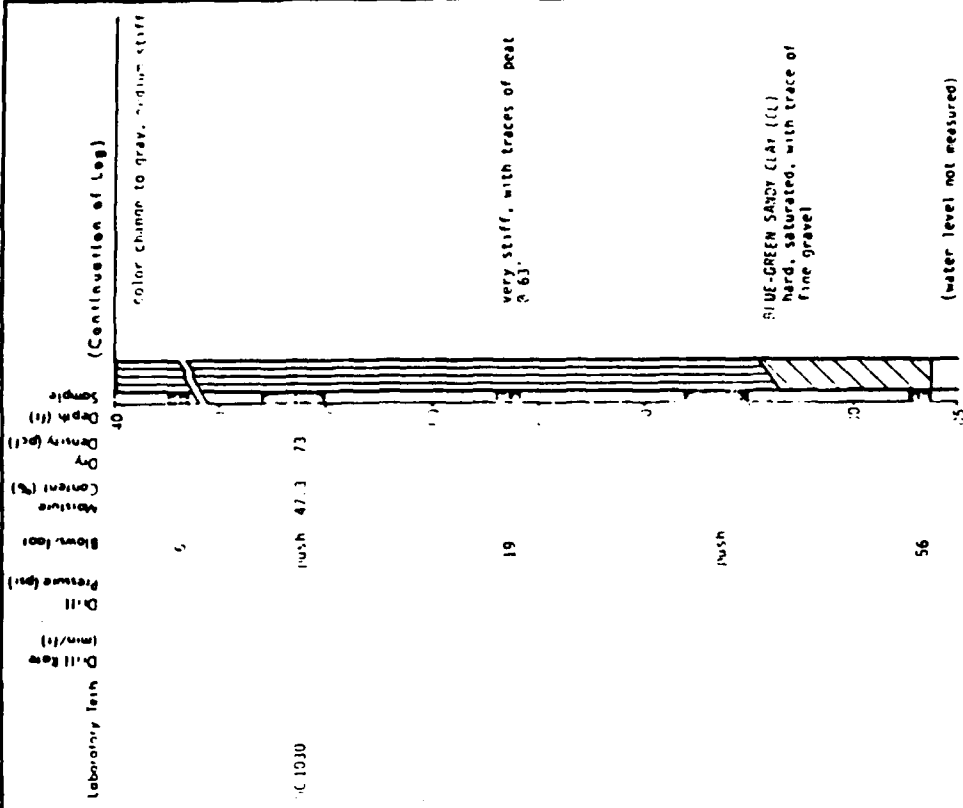
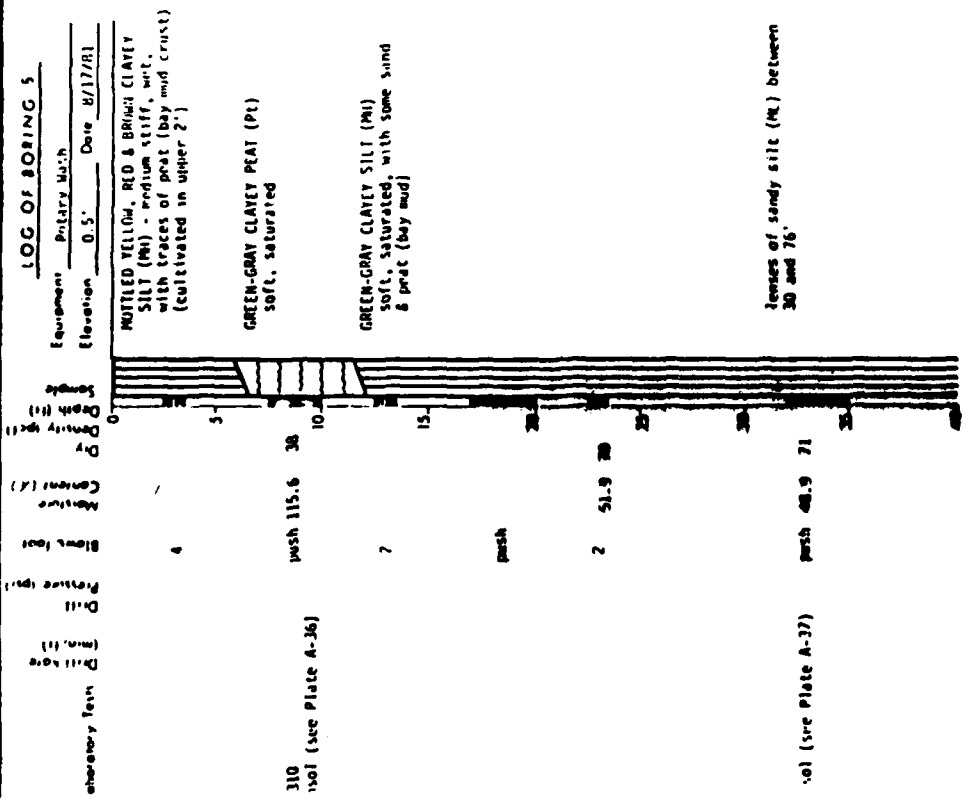

HARDING-LAWSON ASSOCIATES
 Consulting Engineers and Geologists
 11111
 Cullinan Ranch - Island No. 1
 Vallejo, California.

LOG OF BORING 5
PLATE
10.5

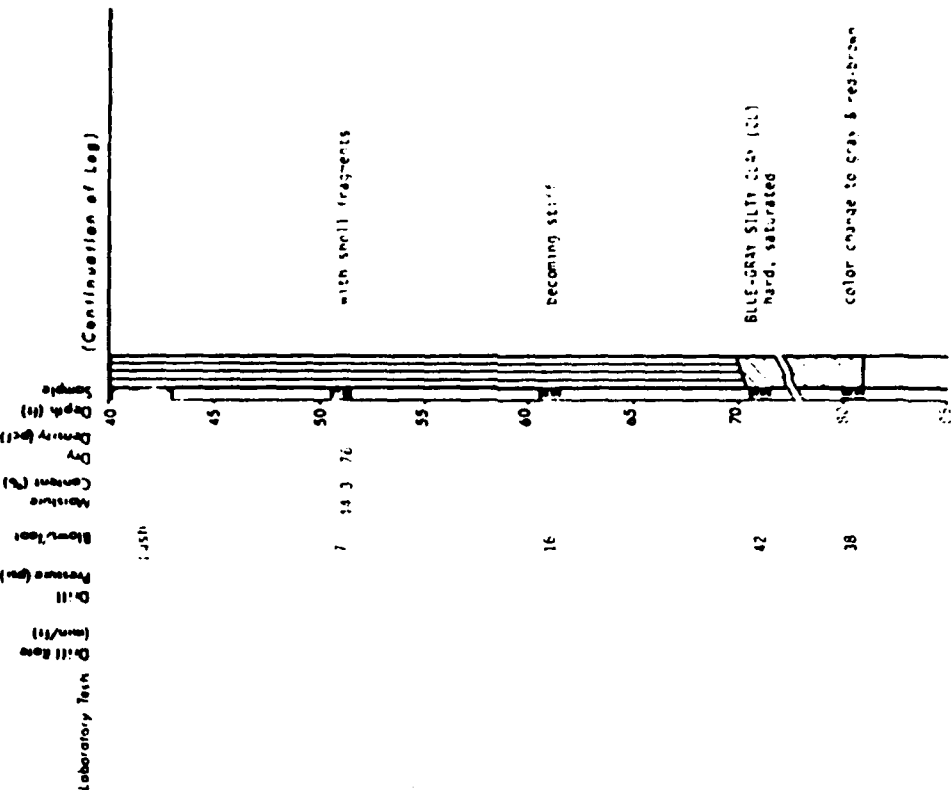
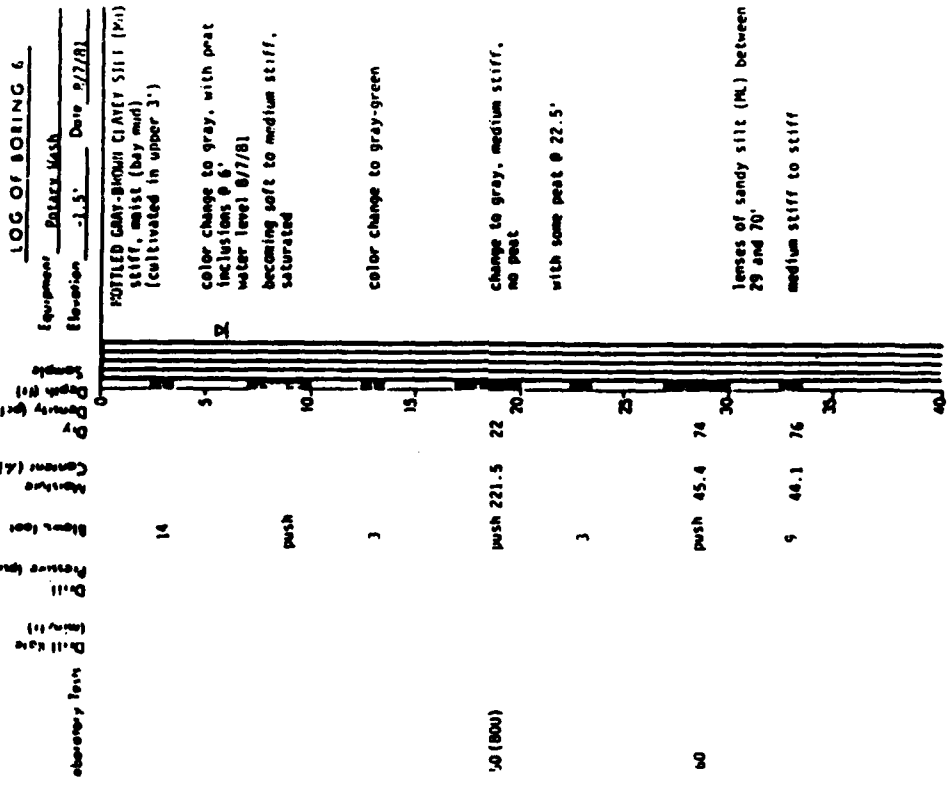

HARDING-LAWSON ASSOCIATES
 Consulting Engineers and Geologists

LOG OF BORING 6
 Collingwood Ranch - Station No. 1
 Colleton, California

PLATE
A-6

FORM 11418-002 07 Rev. 11-68

LOG OF BORING 7

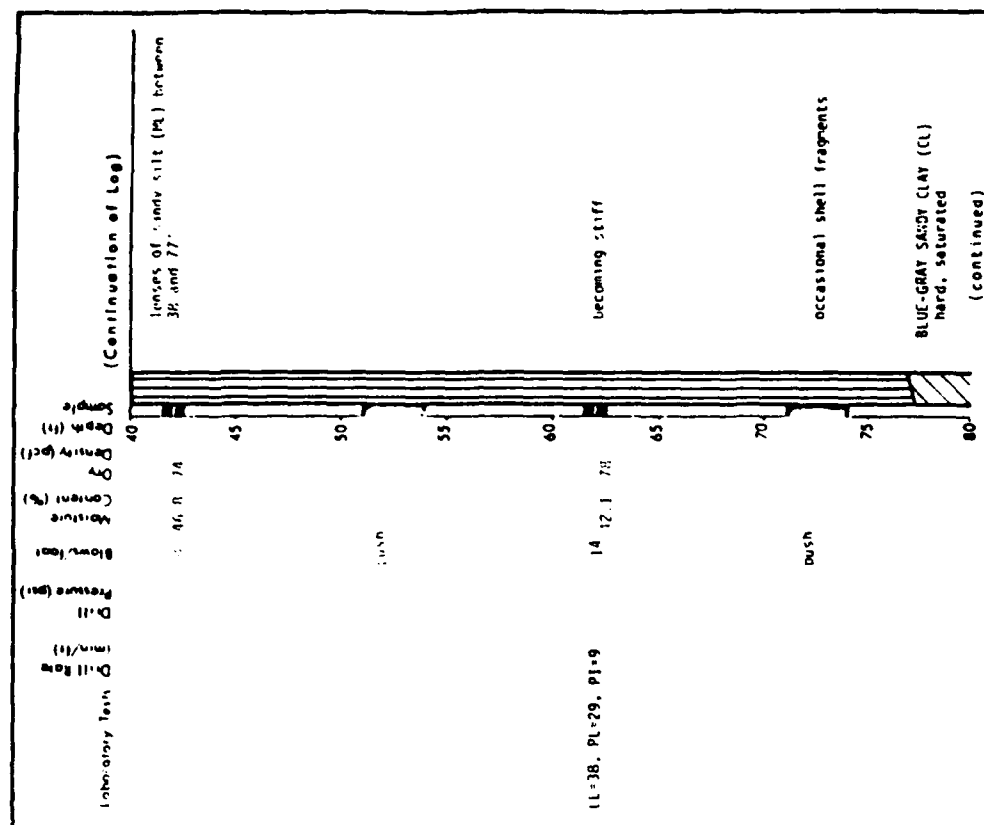
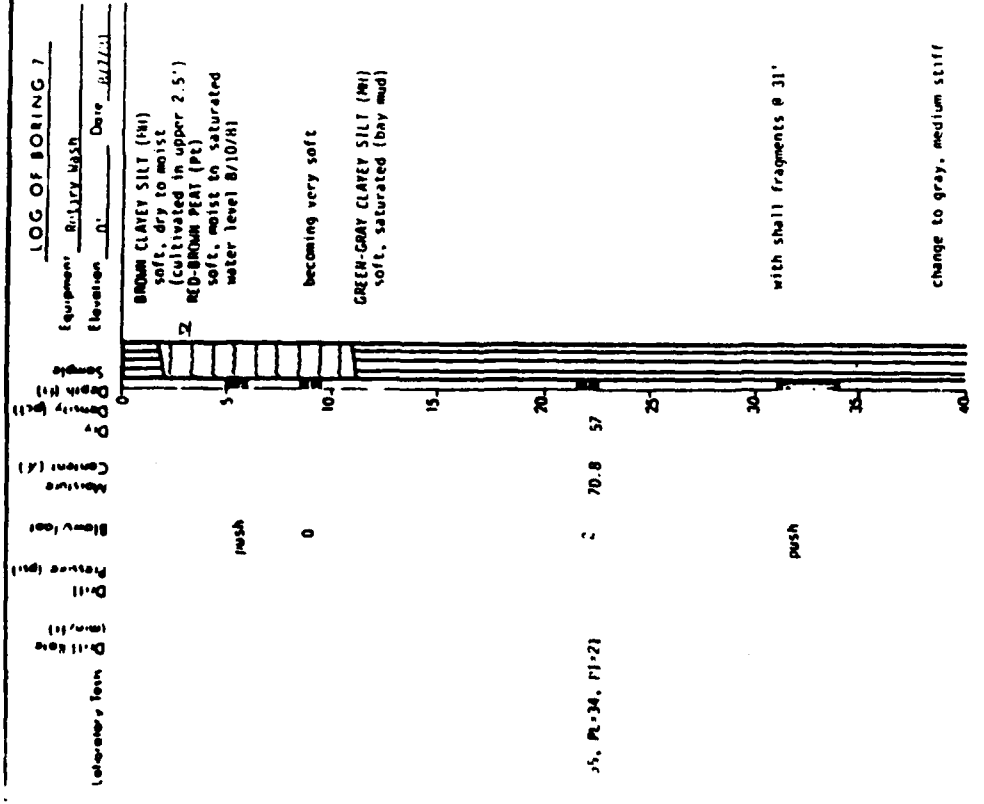

HARDING-LAWSON ASSOCIATES
Consulting Engineers and Geologists

Job No 11539.002.02 App to Date 9/16/81

LOG OF BORING 7

Cullinan Ranch - Island No. 1
 Vallejo, California

PLATE A-7

LOG OF BORING 7 (cont'd)

Laboratory Tests Drill Rate (min/ft) Drill Pressure (psi) Blows/foot Moisture Content (%) Dry Density (pcf) Depth (ft) Sample

Equipment _____
Elevation _____ Date _____

32 24.8 101

color change to green-brown @ 82'



94

95

HARDING - LAWSON ASSOCIATES



Consulting Engineers and Geologists

Job No. 11539.002.02 Appr. E.M.S. Date 9/16/81

LOG OF BORING 7

Cullinan Ranch - Island No. 1
Vallejo, California

PLATE

A-8

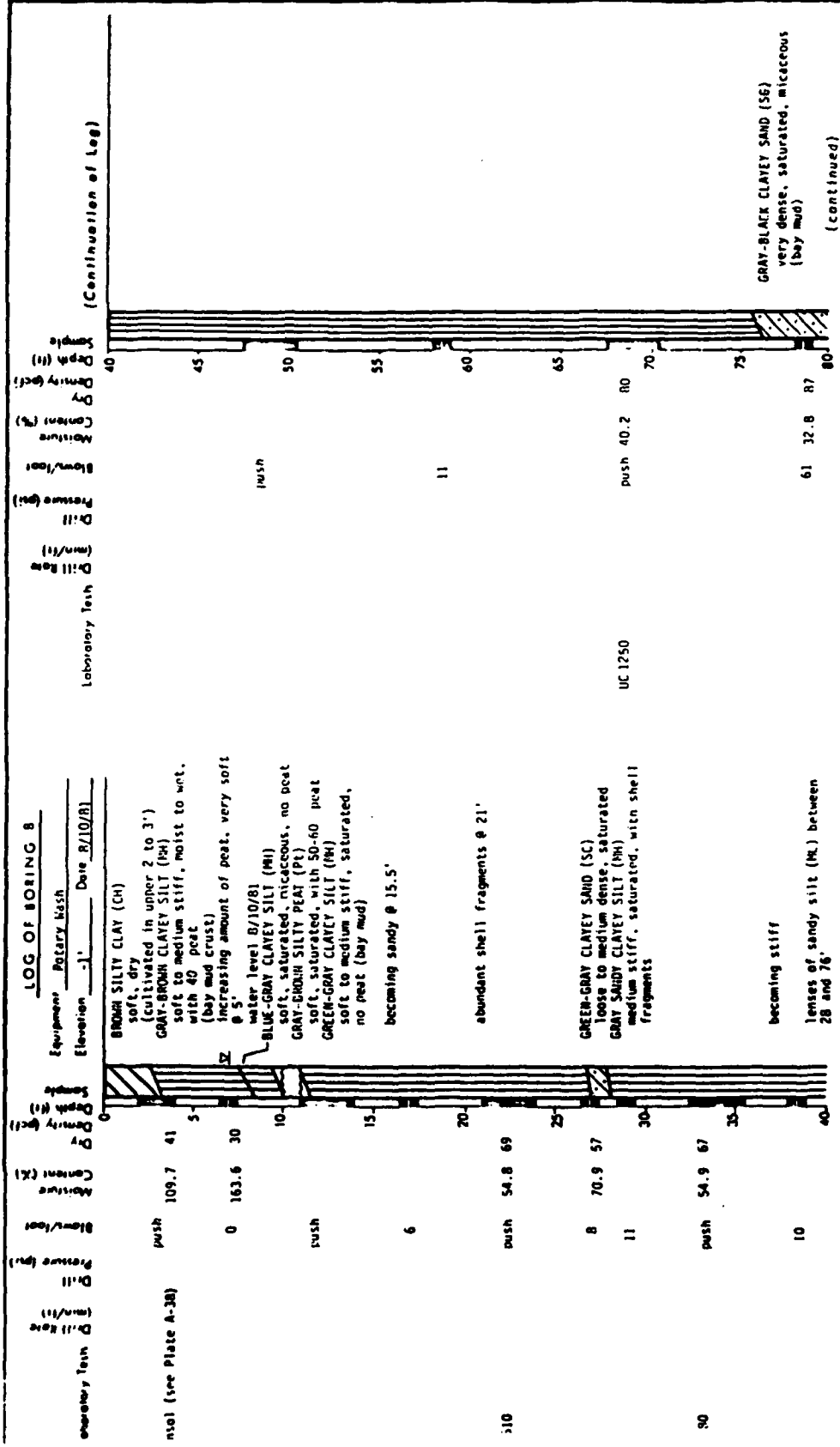

HARDING - LAWSON ASSOCIATES
 Consulting Engineers and Geologists
 11516 007 07

LOG OF BORING 8
 Cullinan Ranch - Island No. 1
 Vallejo, California

PLATE
A.9

(Continuation of Log)

GRAY-BROWN CLAYEY SILT (MH)
 soft to medium stiff, moist to wet, with 40 peat (bay mud crust) increasing amount of peat, very soft @ 5'

BLUE-GRAY CLAYEY SILT (MH)
 soft, saturated, micaceous, no peat

GRAY-BROWN SILTY PEAT (PT)
 soft, saturated, with 50-60 peat

GREEN-GRAY CLAYEY SILT (MH)
 soft to medium stiff, saturated, no peat (bay mud) becoming sandy @ 15.5'

abundant shell fragments @ 21'

GREEN-GRAY CLAYEY SAND (SC)
 loose to medium dense, saturated

GRAY SANDY CLAYEY SILT (MH)
 medium stiff, saturated, with shell fragments

becoming stiff

lenses of sandy silt (ML) between 28 and 76'

GRAY-BLACK CLAYEY SAND (SE)
 very dense, saturated, micaceous (bay mud)

(continued)

LOG OF BORING 8 (contd)

Laboratory Tests Drill Rate (min/ft) Drill Pressure (psi) Blows/foot Moisture Content (%) Dry Density (pcf) Depth (ft) Sample . Equipment _____
 Elevation _____ Date _____

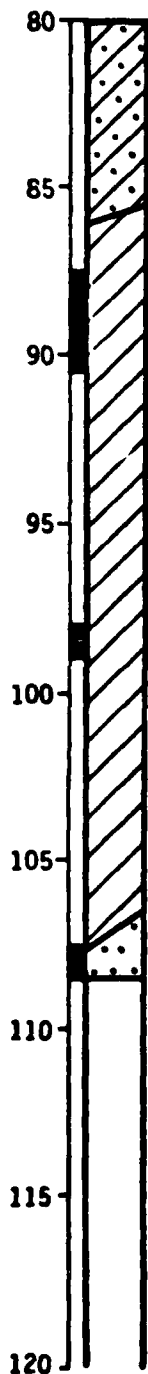

BLUE-GRAY SANDY CLAY (CL)
 very stiff, saturated

push

color change to mottled gray &
 red brown @ 97'

17

RED-BROWN CLAYEY GRAVELLY SAND (SP)
 very dense, saturated, gravel
 to 1/2"

69

HARDING - LAWSON ASSOCIATES
 Consulting Engineers and Geologists

LOG OF BORING 8
 Cullinan Rancy - Island No. 1
 Vallejo, California

PLATE
A-10

Job No. 11539.002.02 Appr. DLS Date 9/16/81

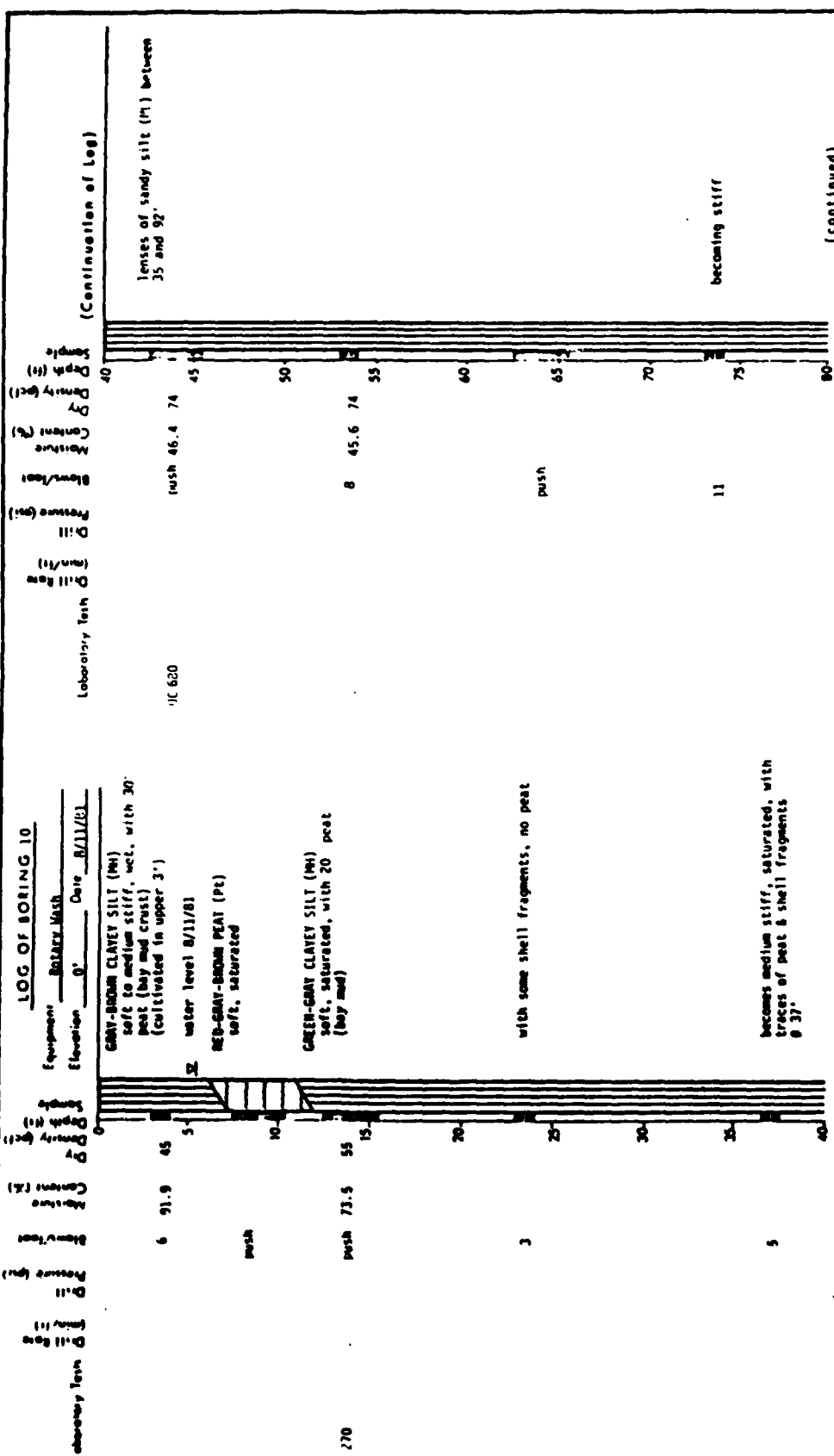

HARDING - LAWSON ASSOCIATES
 Consulting Engineers and Geologists
 1
 LOG OF BORING 10
 Cullinan Ranch - Island No. 1
 PLATE
 A-17

LOG OF BORING 10 (cont'd)

Laboratory Tests Drill Rate (min/ft) Drill Pressure (psi) Blows/foot Moisture Content (%) Dry Density (pcf) Depth (ft) Sample

Equipment _____
 Elevation _____ Date _____

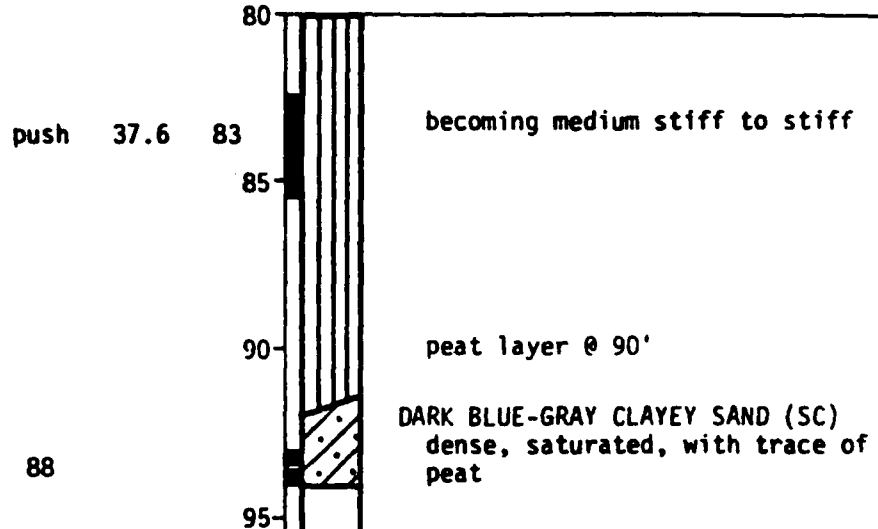

HARDING - LAWSON ASSOCIATES
 Consulting Engineers and Geologists

Job No. 11539_002_02 Appr. Eng. Date 9/17/81

LOG OF BORING 10
 Cullinan Ranch - Island No. 1
 Vallejo, California

PLATE
A-13

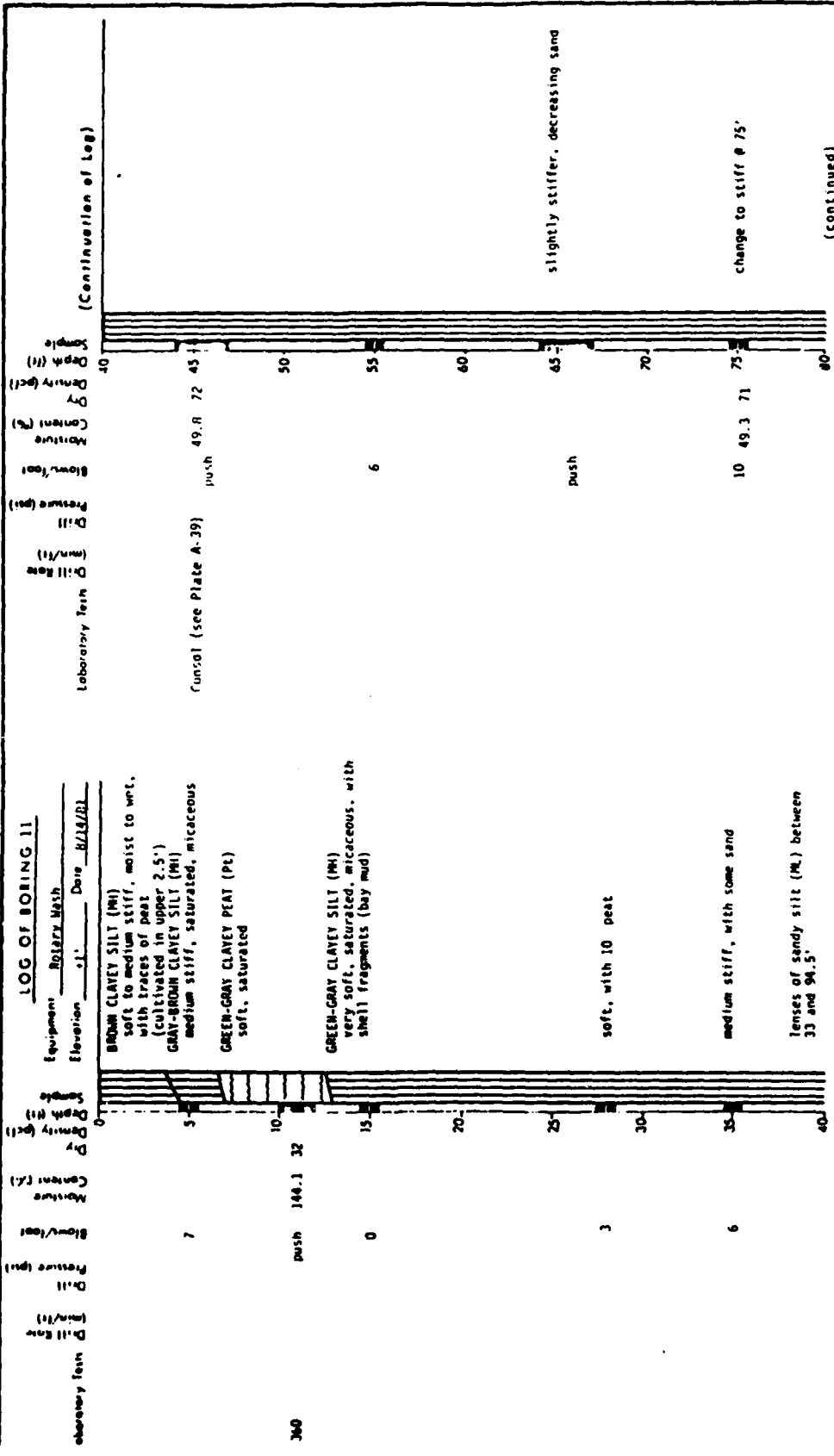

HARDING - LAWSON ASSOCIATES
 Consulting Engineers and Geologists
 Job No 11539,002.02 Accr y Date 9/17/61

LOG OF BORING II
 Cullinan Ranch - Island No. 1
 Vallejo, California

PLATE A-14

LOG OF BORING 11 (cont'd)

Laboratory Tests Drill Rate (min/ft) Drill Pressure (psi) Blows/foot Moisture Content (%) Dry Density (pcf) Depth (ft) Sample

Equipment _____
 Elevation _____ Date _____

11

85

decreasing sand

90

34

95

DARK BLUE-GRAY CLAYEY SAND (SC)
 dense, saturated, with trace of peat
 (water level not stabilized)

HARDING-LAWSON ASSOCIATES
 Consulting Engineers and Geologists



Job No. 11539.002.02 Appr. Eng. Date 9/17/81

LOG OF BORING 11
 Cullinan Ranch - Island No. 1
 Vallejo, California

PLATE
A-15

LOG OF BORING 12

Equipment: Pinsky Wash

Elevation: +0.5' Date: 9/13/81

Sample	Depth (ft)	Dry Density (pcf)	Moisture Content (%)	Blow Count	Pressure (psi)	Drill Rate (min/ft)	Laboratory Test	Remarks
	0							Equipment: Pinsky Wash
	0							Elevation: +0.5' Date: 9/13/81
	0							LIGHT BROWN SILTY CLAY (CH)
	0							soft, dry (cultivated in upper 2')
	0							GRAY-BROWN TO RED-BROWN CLAYEY SILT (ML) - stiff, moist, with peat (bay mud crust)
	0							GRAY-BROWN CLAYEY PEAT (Pt) water level 8/14/81
	0							very soft, saturated (50-90 peat)
	0							GRAY CLAYEY SILT (ML)
	0							soft, saturated, with 20 peat (bay mud)
	0							change to gray-green, very soft, with 10' peat
	0							soft, trace of peat
	0							medium stiff @ 29'
	0							change to gray, soft, with some sand
	0							lenses of sandy silt (ML) between 28 and 85
	0							500

Sample	Depth (ft)	Dry Density (pcf)	Moisture Content (%)	Blow Count	Pressure (psi)	Drill Rate (min/ft)	Laboratory Test	Remarks
	40							(Continuation of Log)
	45							
	50			5				medium stiff
	55							
	60			push				
	65							
	70			10				change to mottled yellow-gray, stiff @ 70.5'
	75							
	80			20				very stiff, decreasing sand content, soil
	85							
	90							

HAZARD ASSOCIATES
 339,002.02
 9/17/81
 LOG OF BORING 12
 Cullinan Ranch - Island No. 1
 Vallejo, California
 PLATE
A-16

LOG OF BORING 12(cont'd)

Laboratory Tests Drill Rate (min/ft) Drill Pressure (psi) Blows/foot Moisture Content (%) Dry Density (pcf) Depth (ft) Sample

Equipment _____
Elevation _____ Date _____

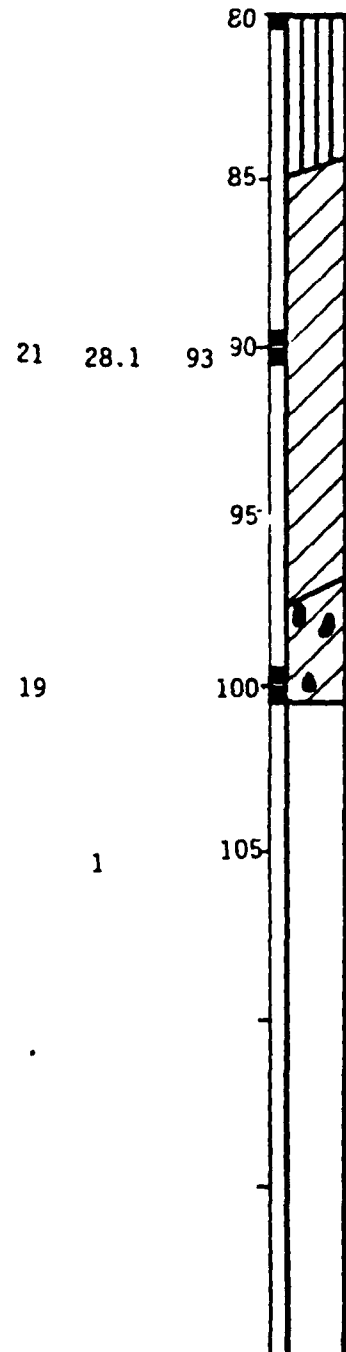

DARK BLUE-GRAY SANDY CLAY (CL)
very stiff, saturated, with some sand

DARK BLUE-GRAY CLAYEY GRAVEL (GC)
medium dense, saturated, gravel to 1.5" diameter

HARDING-LAWSON ASSOCIATES



Consulting Engineers and Geologists

Job No. 11539.002.02 Appr. E.L. Date 9/17/81

LOG OF BORING 12

Cullinan Ranch - Island No. 1
Vallejo, California

PLATE

A-17

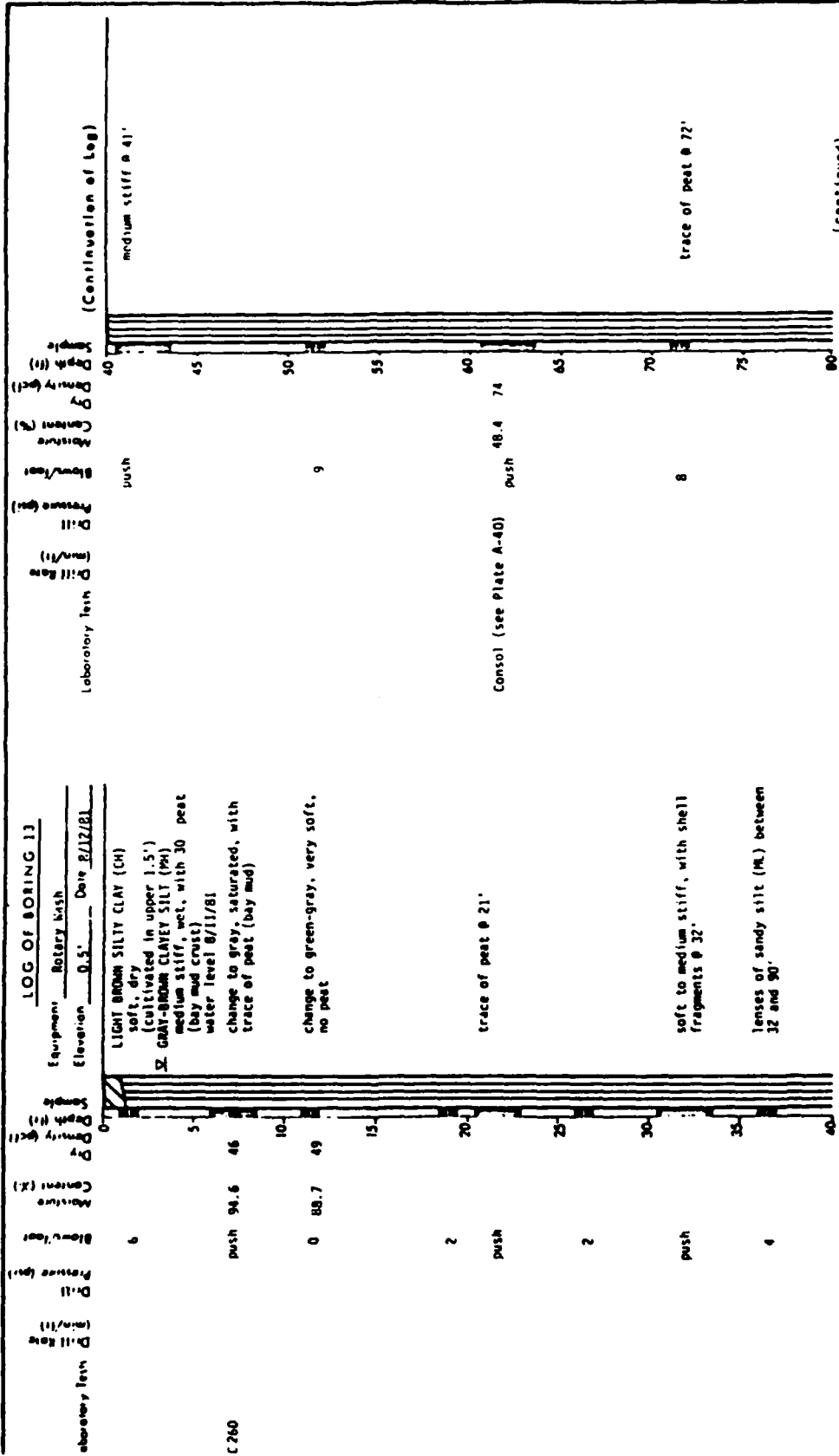

LOG OF BORING 13
 Equipment: Rotary Wash
 Elevation: 0.5' Date: 8/12/81

(Continuation of Log)

[continued]

LOG OF BORING 13
 Cullinan Ranch - Island No. 1
 Vallejo, California

PLATE A-18

HARDING - LAWSON ASSOCIATES
 Consulting Engineers and Geologists

Job No 11539.002.02 Date: 9/17/81

LOG OF BORING 13(cont'd)

Laboratory Tests	Drill Rate (min/ft)	Drill Pressure (psi)	Blows/foot	Moisture Content (%)	Dry Density (pcf)	Depth (ft)	Sample	Equipment	Elevation	Date
			push			80				
						85				
						90				
			26							
						95				

DARK BLUE-GRAY SANDY CLAY (CL)
very stiff, saturated

HARDING - LAWSON ASSOCIATES

 Consulting Engineers and Geologists
 Job No 11539.002.02 Appr. Rev. Date 9/17/81

LOG OF BORING 13
 Cullinan Ranch - Island No. 1
 Vallejo, California

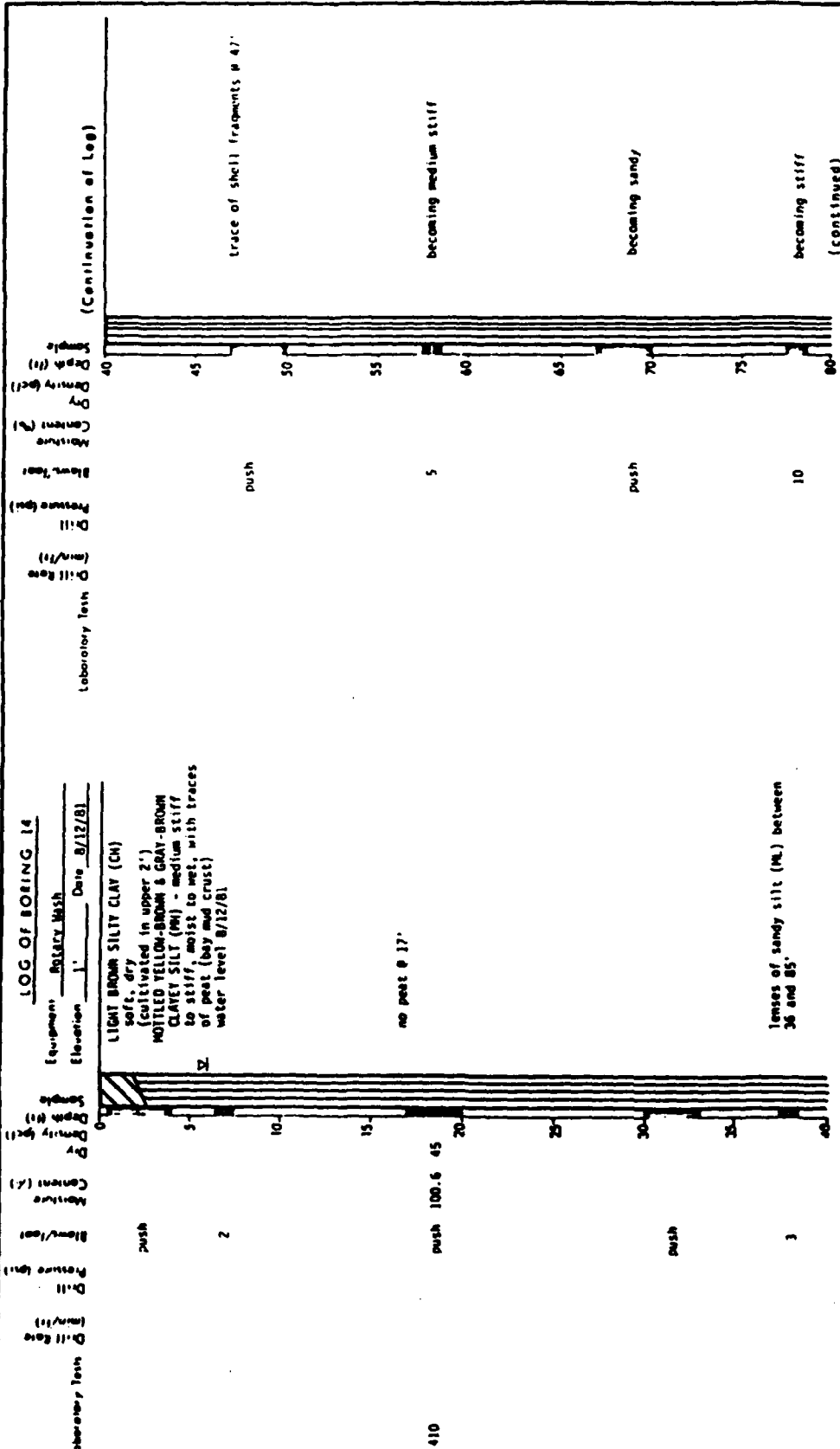
PLATE
A-19



LOG OF BORING 14
 Equipment: RELLEY Wash Date: 8/12/81
 Elevation: 1'
 Laboratory Tests: 410
 Description: LIGHT BROWN SILTY CLAY (CH)
soft, dry
(cultivated in upper 2')
MOTTLED YELLOW-BROWN & GRAY-BROWN
CLAYEY SILT (MH) - medium stiff
to stiff, moist to wet, with traces
of peat (bay mud crust)
water level 8/12/81

lenses of sandy silt (ML) between 35 and 85'

NY 19

LOG OF BORING 14(cont'd)

Laboratory Tests

Drill Rate (min/ft)

Drill Pressure (psi)

Blows/foot

Moisture Content (%)

Dry Density (pcf)

Depth (ft)

Sample

Equipment _____

Elevation _____

Date _____

80
85
90
95
100

15

18

GRAY-BLACK SANDY CLAY (CL)
stiff, saturated, micaceous

change to dark blue-gray, very stiff

HARDING-LAWSON ASSOCIATES



Consulting Engineers and Geologists

Job No. 11539.002.02 Appr. S.V. Date 9/17/81

LOG OF BORING 14

Cullinan Ranch - Island No. 1
Vallejo, California

PLATE

A-21

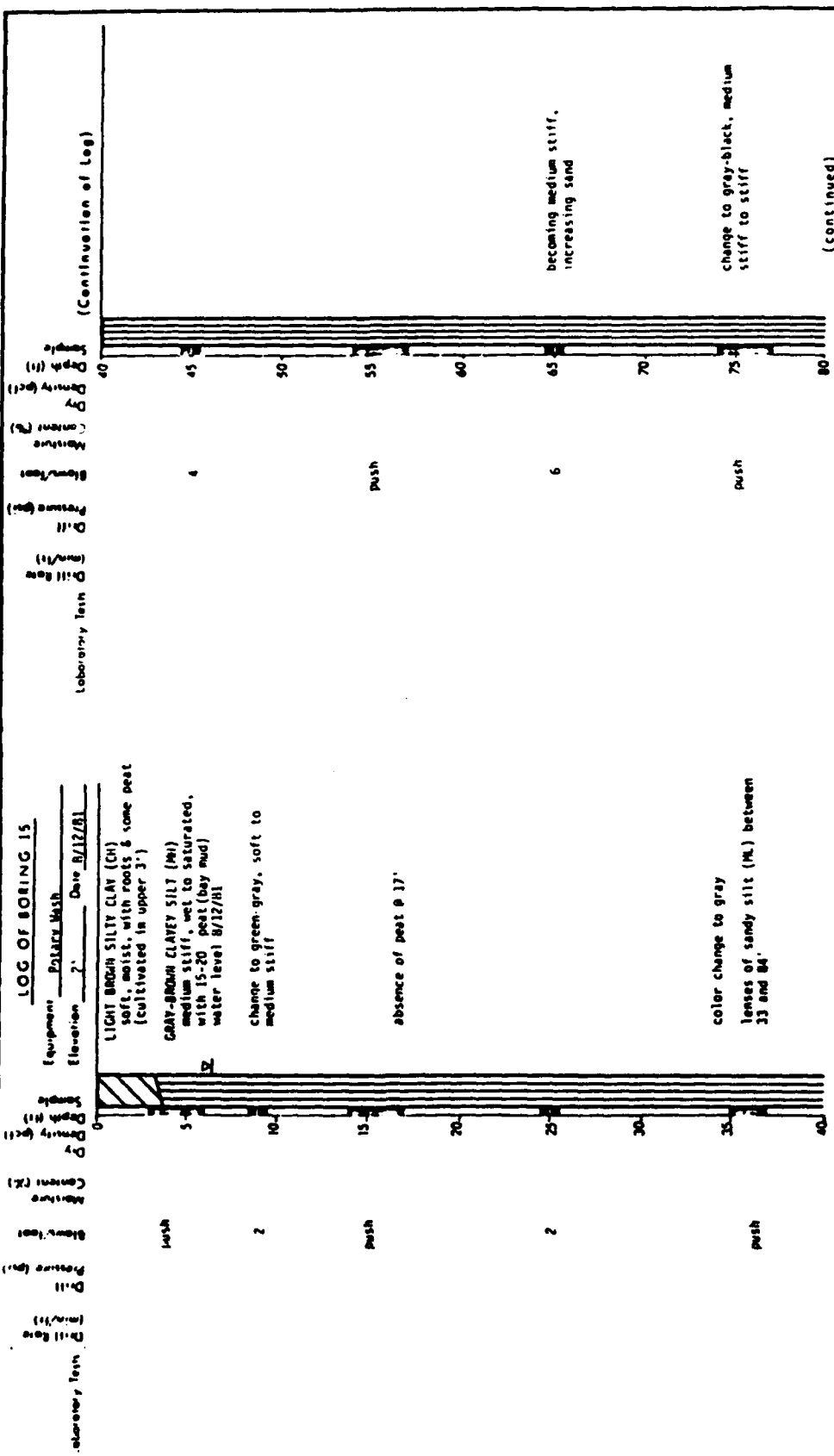

LOG OF BORING 15
 Equipment: Palacy Wash
 Elevation: 2' Date: 8/12/81
 Sample: 0
 Laboratory Test: Moisture Content (MC) 2
 Density (pcf): 10
 Depth (ft): 10
 Description: LIGHT BROWN SILTY CLAY (LH) soft, moist, with roots & some peat (cultivated in upper 3')
 Description: GRAY-BROWN CLAYEY SILT (MH) medium stiff, wet to saturated, with 15-20 peat (bay mud) water level 8/12/81
 Description: change to green-gray, soft to medium stiff
 Description: absence of peat @ 17'
 Description: color change to gray lenses of sandy silt (ML) between 33 and 84'
 Description: becoming medium stiff, increasing sand
 Description: change to gray-black, medium stiff to stiff
 (continued)

HARDING-LAWSON ASSOCIATES
 Consulting Engineers and Geologists
 11539.002.02
 Date: 9/17/81
LOG OF BORING 15
 Cullinan Ranch - Island No. 1
 Vallejo, California
PLATE A-22

LOG OF BORING 15(cont'd)

Laboratory Tests Drill Rate (min/ft) Drill Pressure (psi) Blows/foot Moisture Content (%) Dry Density (pcf) Depth (ft) Sample

Equipment _____
Elevation _____ Date _____

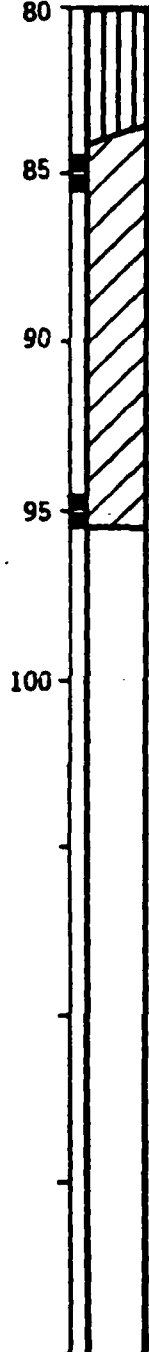

23

GRAY-BLACK SANDY CLAY (CL)
very stiff, saturated

14

change to dark blue-gray, stiff

HARDING - LAWSON ASSOCIATES



Consulting Engineers and Geologists

LOG OF BORING 15

Cullinan Ranch - Island No. 1
Vallejo, California

PLATE

A-23

Job No. 11539,002.02 Appr. By: _____ Date 9/17/81

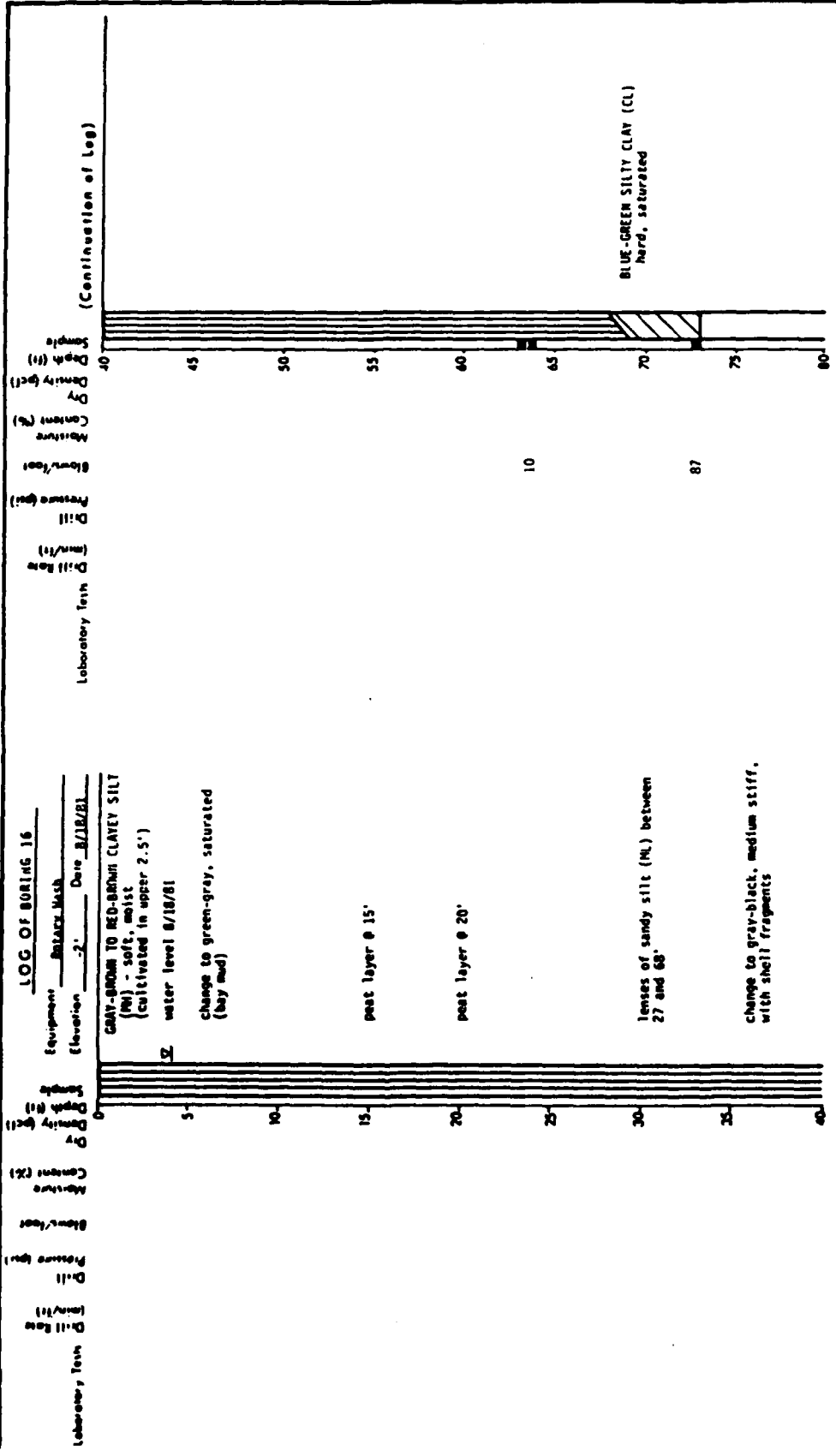

HARDING-LAWSON ASSOCIATES
 Consulting Engineers and Geologists
 11520 115th Ave. S.E.
 Bellevue, WA 98004

LOG OF BORING 16
 Cullinan Ranch - Island No. 1
 Vallejo, California

PLATE **A-74**

21 13

LOG OF BORING B1

Laboratory Tests Drill Rate (min/ft) Drill Pressure (psi) Blows/foot Moisture Content (%) Dry Density (pcf) Depth (ft) Sample

Equipment 30" Bucket Auger
 Elevation -2' Date 8/12/81

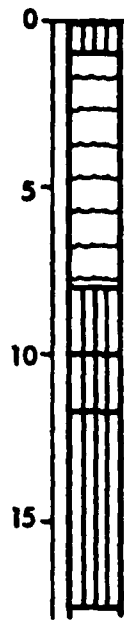

GRAY-BROWN CLAYEY SILT (MH)
 soft, dry, with 20-30% peat
 GRAY-BLACK CLAYEY PEAT (Pt)
 soft, wet

seepage @ 8'
 BLUE-GRAY CLAYEY SILT (MH)
 soft, saturated

BLUE-GRAY SANDY SILT (MH)
 soft, saturated, with shell
 fragments

BLUE-GRAY CLAYEY SILT (MH)
 soft, saturated, with 0-10% peat
 10-20% peat @ 14'

(water level not measured)

LOG OF BORING B2

Equipment 30" Bucket Auger
 Elevation 0' Date 8/12/81



GRAY-BROWN CLAYEY SILT (MH)
 soft to medium stiff, moist

change to blue-gray, soft, wet,
 with 10-20% peat @ 5.5'
 traces of peat @ 7', saturated
 10-20% peat @ 8'

becoming stiffer @ 11'

medium stiff @ 15'
 (water level not measured)

JARDING-LAWSON ASSOCIATES



Consulting Engineers and Geologists

LOG OF BORINGS B1 & B2

Cullinan Ranch - Island No. 1
 Vallejo, California

PLATE

A-26

Job No. 11539.002.02 Appr. BUS Date 9/16/81

RF 15

Laboratory Tests
 Drill Rate (min/ft)
 Drill Pressure (psi)
 Blows/foot
 Moisture Content (%)
 Dry Density (pcf)
 Depth (ft)
 Sample

LOG OF BORING B3

Equipment 30" Bucket Auger
 Elevation -0.5' Date 8/12/81



GRAY-BROWN CLAYEY SILT (MH)
 soft, dry, with 20-30% peat
 moist, with 10-20% peat @ 1.5'

change to gray-blue @ 5'

becoming saturated, with 20-30%
 peat @ 8.5'

20-30% peat @ 11'

BLUE-GRAY SANDY SILT (MH)
 medium stiff, saturated, with
 shell fragments
 (water level not measured)

LOG OF BORING B4

Equipment 30" Bucket Auger
 Elevation -2' Date 8/12/81



GRAY-BROWN CLAYEY SILT (MH)
 soft, dry to wet, with 20-40%
 peat
 stiffer @ 2.5'

soft, with 40-60% peat @ 4.5'
 change to blue-gray, with 30-40%
 peat, saturated @ 5.5'
 5-10% peat @ 6.5'
 30-40% peat @ 8'

10-20% peat @ 11.5'

0-10% peat @ 13.5'

(water level not measured)

JARDING-LAWSON ASSOCIATES
 Consulting Engineers and Geologists

LOG OF BORINGS B3 & B4
 Cullinan Ranch - Island No. 1
 Vallejo, California

PLATE
A-27

Job No. 11539.002.02 Appr. Eng. Date 9/16/81

18

LOG OF BORING B5

Laboratory Tests Drill Rate (min/ft) Drill Pressure (psi) Blows/foot Moisture Content (%) Dry Density (pcf) Depth (ft) Sample

Equipment 30" Bucket Auger
 Elevation -1' Date 8/12/81

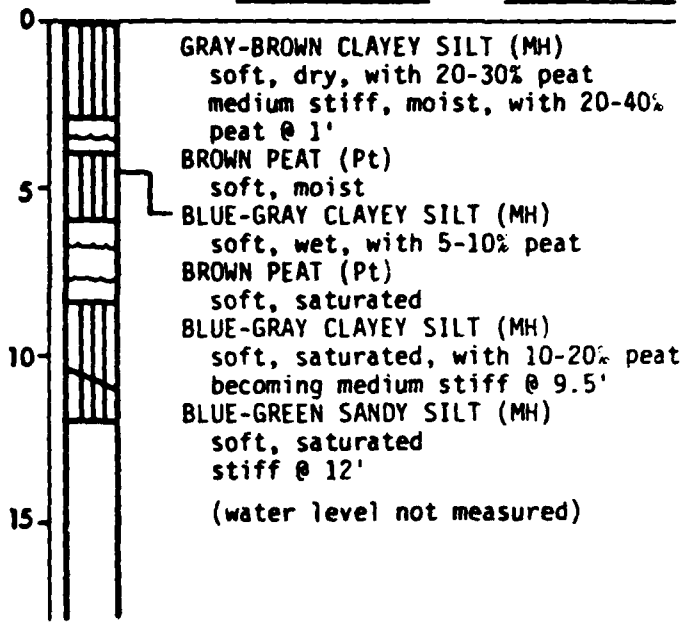

LOG OF BORING B6

Equipment 30" Bucket Auger
 Elevation -0.5' Date 8/13/81

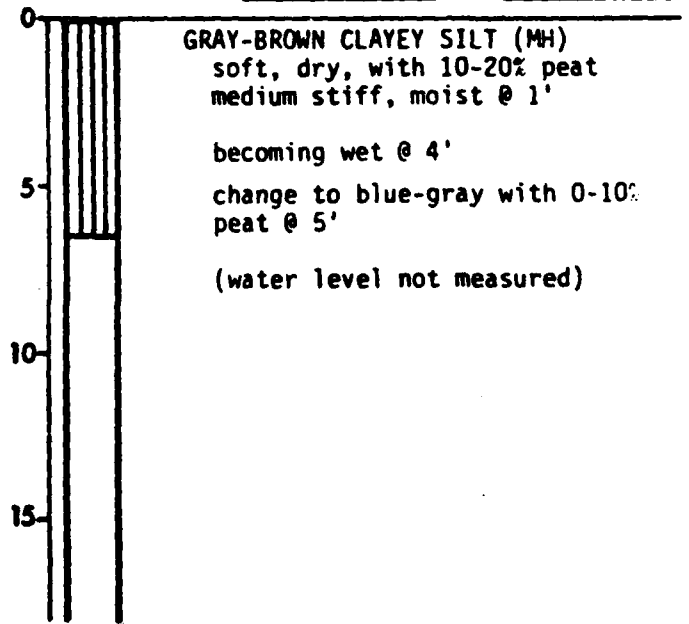

HARDING-LAWSON ASSOCIATES
 Consulting Engineers and Geologists

LOG OF BORINGS B5 & B6
 Cullinan Ranch - Island No. 1
 Vallejo, California

PLATE
A-28

Job No. 11539.002.02 Appr. S&S Date 9/16/81

15

LOG OF BORING B7

Laboratory Test Drill Rate (min/ft) Drill Pressure (psi) Blows/foot Moisture Content (%) Dry Density (pcf) Depth (ft) Sample

Equipment 30" Bucket Auger
 Elevation -0.5' Date 8/13/81

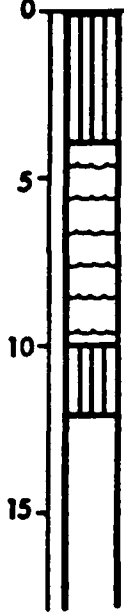

GRAY-BROWN CLAYEY SILT (MH)
 soft, dry
 10-20% peat @ 3'

BROWN PEAT (Pt)
 soft, wet to saturated,
 color change to green-blue,
 80-90% peat @ 6'

GRAY-GREEN CLAYEY SILT (MH)
 soft, saturated, with 40-60% peat
 0-10% peat @ 12'
 (water level not measured)

LOG OF BORING B8

Equipment 30" Bucket Auger
 Elevation -0.5' Date 8/13/81

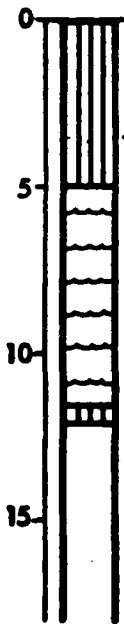

GRAY-BROWN CLAYEY SILT (MH)
 soft, dry
 change to dark brown, medium
 stiff, moist @ 1'
 water level 8/13/81
 saturated, with 30-40% peat @ 3.5'

GREEN-BROWN CLAYEY PEAT (Pt)
 soft, saturated
 80-90% peat @ 7.5'

60-80% peat @ 10'

BLUE-GRAY CLAYEY SILT (MH)
 very soft, saturated, with 0-5%
 peat

HARDING - LAWSON ASSOCIATES
 Consulting Engineers and Geologists

Job No. 11539,002.02 Appr. S.M.S. Date 9/16/81

LOG OF BORINGS B7 & B8
 Cullinan Ranch - Island No. 1
 Vallejo, California

PLATE
A-29

LOG OF BORING B9

Laboratory Tests

Drill Rate (min/ft)
 Drill Pressure (psi)
 Blows/foot
 Moisture Content (%)
 Dry Density (pcf)

Equipment 30" Bucket Auger
 Elevation -2' Date 8/13/81

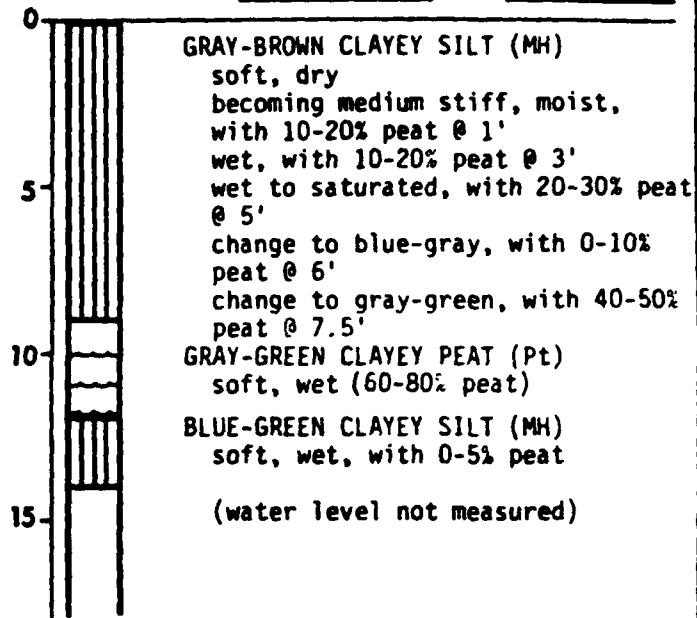

LOG OF BORING B10

Equipment 30" Bucket Auger
 Elevation 0' Date 8/13/81

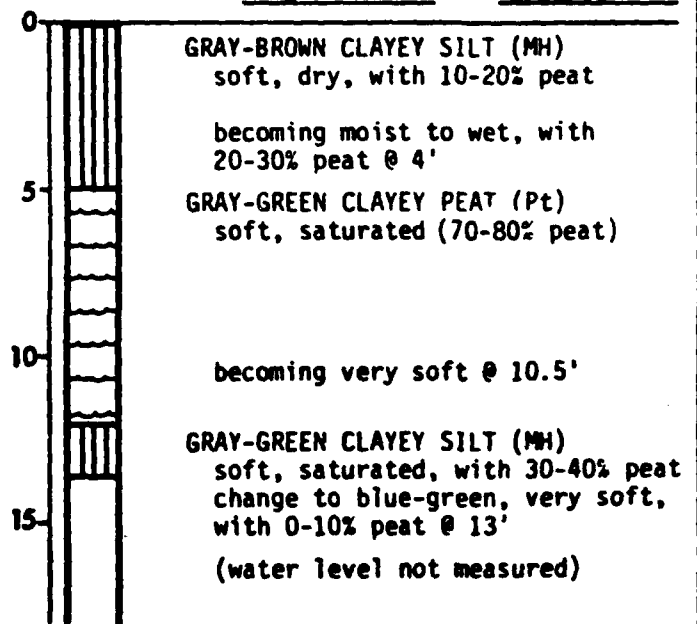

HARDING - LAWSON ASSOCIATES
 Consulting Engineers and Geologists

LOG OF BORINGS B9 & B10

Cullinan Ranch - Island No. 1
 Vallejo, California

PLATE
A-30

Job No. 11539.002.02 Appr. E.V.S. Date 9/16/81

RF 14

LOG OF BORING B11

Laboratory Tests
 Drill Rate (min/ft)
 Drill Pressure (psi)
 Blows/foot
 Moisture Content (%)
 Dry Density (pcf)
 Depth (ft)
 Sample

Equipment 30" Bucket Auger
 Elevation 0' Date 8/13/81

0
5
10
15
20
25
30
35
40



GRAY-BROWN CLAYEY SILT (MH)
 soft, dry
 10-20% peat @ 1'
 DARK BROWN-BLACK PEAT (Pt)
 soft, wet
 GRAY-GREEN CLAYEY SILT (MH)
 soft, saturated, with 10% peat
 20-30% peat @ 6.5'
 GRAY-GREEN CLAYEY PEAT (Pt)
 soft, saturated (60-80% peat)
 GRAY-GREEN CLAYEY SILT (MH)
 soft, saturated, with 40-50% peat
 0-10% peat @ 11.5'

 (water level not measured)

JARDING-LAWSON ASSOCIATES
 Consulting Engineers and Geologists
 Job No. 11539_002_02 Appr: RMS Date 9/16/81

LOG OF BORING B11
 Cullinan Ranch - Island No. 1
 Vallejo, California

PLATE
A-31

MAJOR DIVISIONS		TYPICAL NAMES			
COARSE GRAINED SOILS MORE THAN HALF IS LARGER THAN #200 SIEVE	GRAVELS MORE THAN HALF COARSE FRACTION IS LARGER THAN NO. 4 SIEVE SIZE	CLEAN GRAVELS WITH LITTLE OR NO FINES	GW GP	WELL GRADED GRAVELS, GRAVEL - SAND MIXTURES POORLY GRADED GRAVELS, GRAVEL - SAND MIXTURES	
		GRAVELS WITH OVER 12% FINES	GM GC	SILTY GRAVELS, POORLY GRADED GRAVEL - SAND - SILT MIXTURES CLAYEY GRAVELS, POORLY GRADED GRAVEL - SAND - CLAY MIXTURES	
			SANDS MORE THAN HALF COARSE FRACTION IS SMALLER THAN NO. 4 SIEVE SIZE	CLEAN SANDS WITH LITTLE OR NO FINES	SW SP
		SANDS WITH OVER 12% FINES		SM SC	SILTY SANDS, POORLY GRADED SAND - SILT MIXTURES CLAYEY SANDS, POORLY GRADED SAND - CLAY MIXTURES
	FINE GRAINED SOILS MORE THAN HALF IS SMALLER THAN #200 SIEVE			SILTS AND CLAYS LIQUID LIMIT LESS THAN 25	ML CL OL
		SILTS AND CLAYS LIQUID LIMIT GREATER THAN 25			MH CH OH
			HIGHLY ORGANIC SOILS		PT

UNIFIED SOIL CLASSIFICATION SYSTEM

<p>Compil — Consolidation</p> <p>LL — Liquid Limit (in %)</p> <p>PL — Plastic Limit (in %)</p> <p>G_s — Specific Gravity</p> <p>SA — Sieve Analysis</p> <p>■ *Undisturbed* Sample</p> <p>□ Bulk Sample</p> <p>Notes: (1) All strength tests on 2.8" or 3.6" diameter samples unless otherwise indicated.</p> <p>(2) * indicates 1.4" diameter sample.</p>	<p>Shear Strength, psf</p> <p>Confining Pressure, psf</p> <p>*T_c 320 (2400) Unconsolidated Undrained Triaxial</p> <p>T_cCU 320 (2400) Consolidated Undrained Triaxial</p> <p>DS 3750 (2800) Consolidated Drained Direct Shear</p> <p>FVS 470 Field Vane Shear</p> <p>*UC 2000 Unconfined Compression</p> <p>LVS 700 Laboratory Vane Shear</p>
---	--

KEY TO TEST DATA

<p>HARDING - LAWSON ASSOCIATES</p> <p>Consulting Engineers and Geologists</p>	<p>SOIL CLASSIFICATION CHART AND KEY TO TEST DATA</p>	<p>PLATE A-32</p>
	<p>Job No. 11539.002.02 Appr. P.M.S. Date 9/16/81</p>	

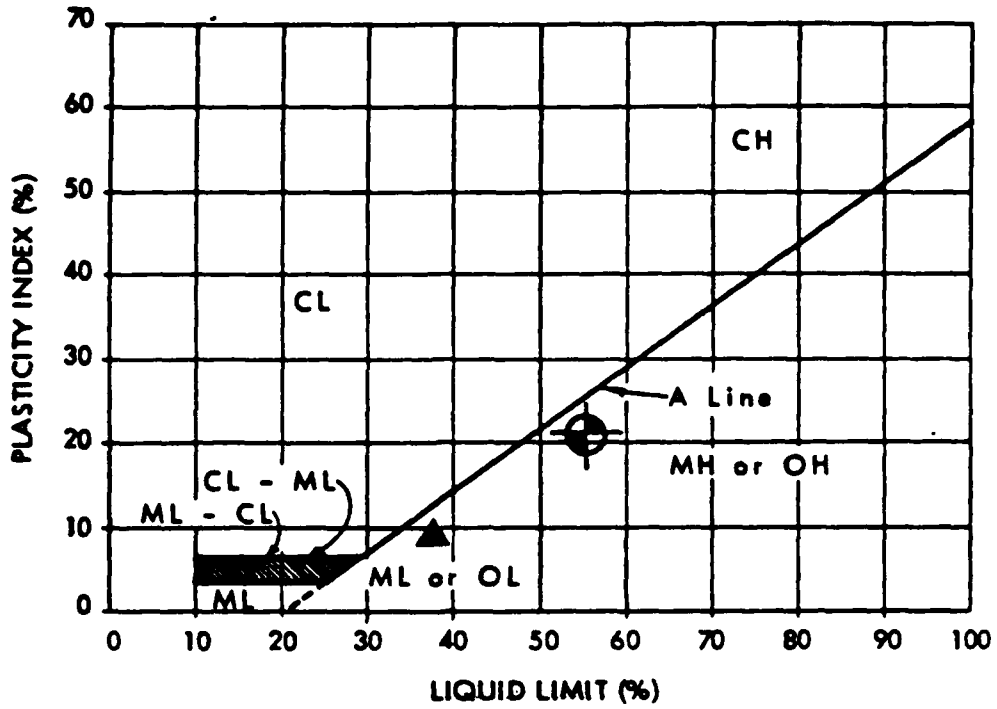

Symbol	Classification and Source	Liquid Limit (%)	Plastic Limit (%)	Plasticity Index (%)	% Passing #200 Sieve
⊕	GRAY CLAYEY SILT (MH) Boring 7 @ 22'	55	34	21	--
▲	GRAY SANDY CLAYEY SILT (ML) Boring 7 @ 62'	38	29	9	--

HARDING - LAWSON ASSOCIATES  <i>Consulting Engineers and Geologists</i>	PLASTICITY CHART Cullinan Ranch - Island No. 1 Vallejo, California	PLATE A-33
	Job No. <u>11539.002.02</u> Appr. <u>R.V.S.</u> Date <u>9/17/81</u>	

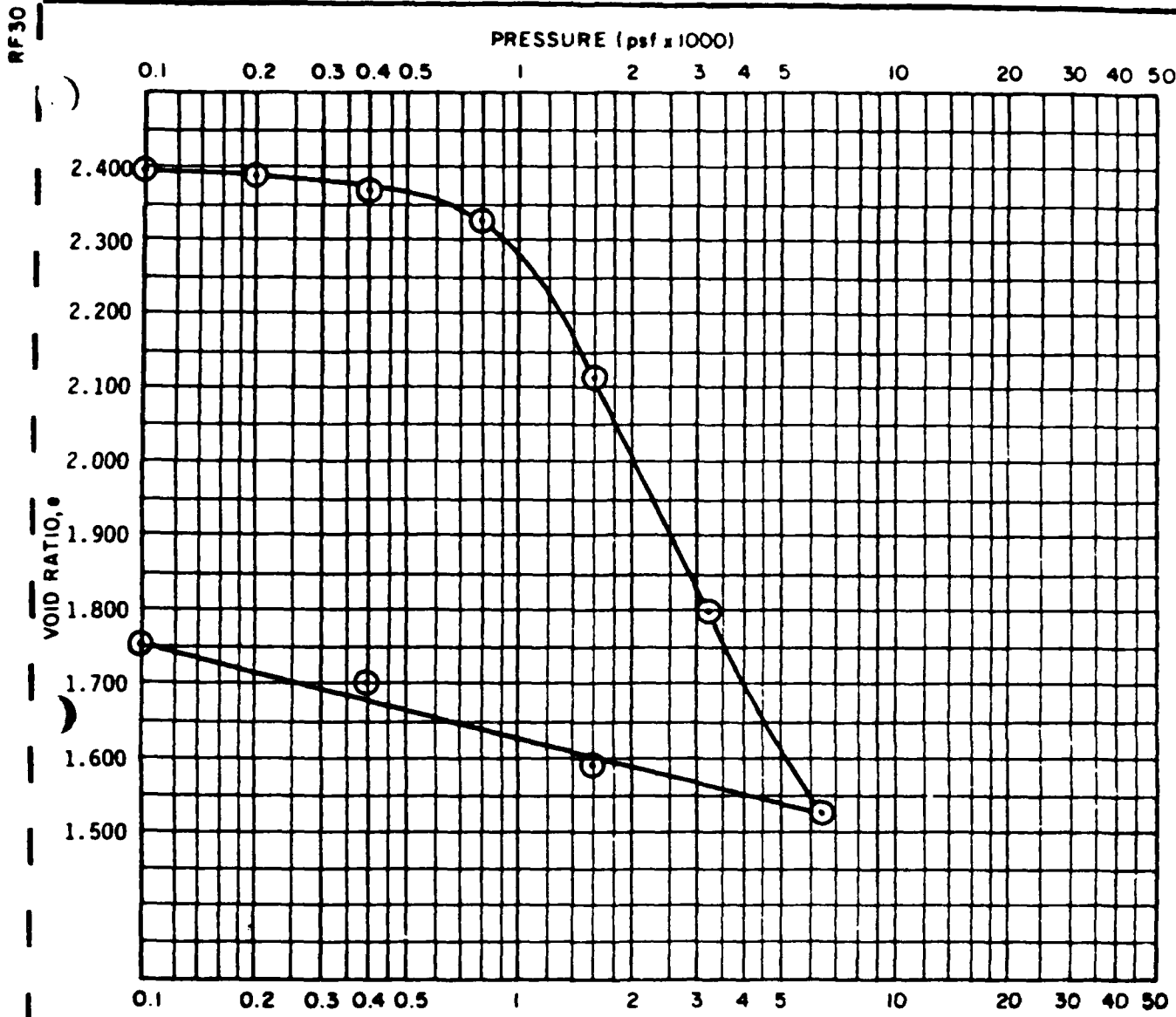

TYPE OF SPECIMEN		Undisturbed		BEFORE TEST				AFTER TEST		
DIAMETER (in.)	2.43	HEIGHT (in.)	0.80	MOISTURE CONTENT	w _o	87.5	%	w _f	65.0	%
OVERBURDEN PRESS., P _b	700	psf		VOID RATIO	e _o	2.420		e _f	1.755	
PRECONSOL. PRESS., P _c	1000	psf		SATURATION	S _o	98	%	S _f	100	%
COMPRESSION INDEX, C _c	1.040			DRY DENSITY	γ _d	49	pcf	γ _d	61	pcf
LL	--	PL	--	PI	--	G _s 2.70				

CLASSIFICATION GRAY-BLACK CLAYEY SILT (MH) SOURCE Boring 2 @ 14'

HARDING - LAWSON ASSOCIATES

 Consulting Engineers and Geologists

Job No. 11539.002.02 Appr. FWS Date 9/16/81

CONSOLIDATION TEST REPORT
 Cullinan Ranch - Island No. 1
 Vallejo, California

PLATE
A-34

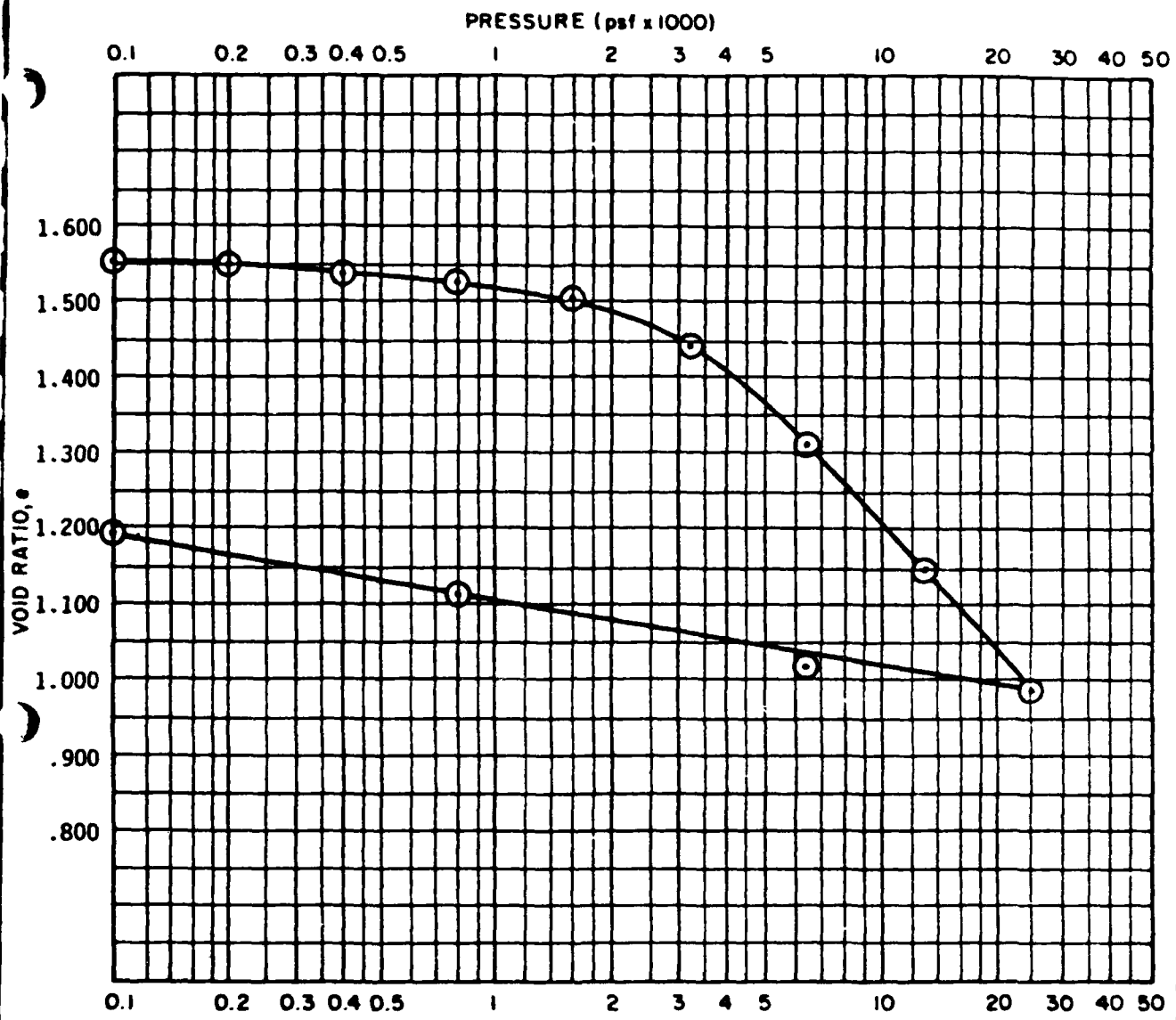
RF30



TYPE OF SPECIMEN		BEFORE TEST				AFTER TEST			
Undisturbed		MOISTURE CONTENT		%		%		%	
DIAMETER (in.)	2.43	HEIGHT (in.)	0.80	w ₀	56.7	w ₁	43.1	e ₀	1.194
OVERBURDEN PRESS., P ₀	1050	psf	VOID RATIO	e ₀	1.559	s ₀	100	s ₁	100
PRECONSOL. PRESS., P _c	3500	psf	SATURATION	S ₀	100	γ _d	68	γ _d	79
COMPRESSION INDEX, C _c	0.550	DRY DENSITY	γ _d	68	pcf	G _s	2.77		
LL	--	PL	--	PI	--				
CLASSIFICATION GRAY-BLACK CLAYEY SILT (ML)					SOURCE Boring 3 @ 27'				

HARDING - LAWSON ASSOCIATES

Consulting Engineers and Geologists

Job No. 11539.002.02 Appr. S.M.S. Date 9/16/81

CONSOLIDATION TEST REPORT
 Cullinan Ranch - Island No. 1
 Vallejo, California

PLATE
A-35

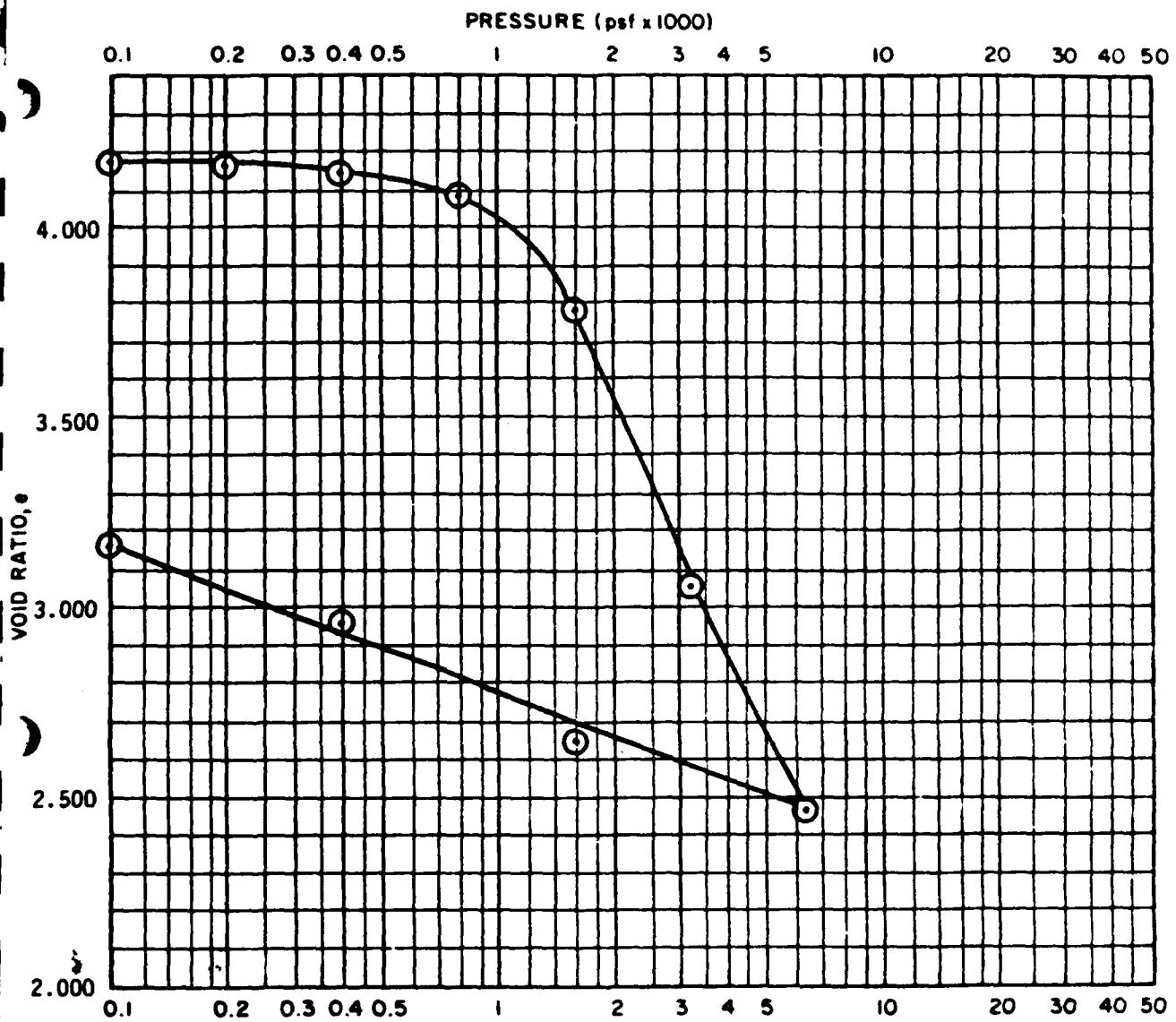
RF30



TYPE OF SPECIMEN		BEFORE TEST				AFTER TEST	
Undisturbed		DIAMETER (in.) 2.43		HEIGHT (in.) 0.80		MOISTURE CONTENT	
		OVERBURDEN PRESS., P_o 550 psf		VOID RATIO			
		PRECONSOL. PRESS., P_c 1200 psf		SATURATION			
		COMPRESSION INDEX, C_c 2.330		DRY DENSITY			
LL	--	PL	--	PI	--	G_s	2.39

CLASSIFICATION GREEN-GRAY CLAYEY PEAT (Pt)		SOURCE Boring 5 @ 8.5'	
HARDING - LAWSON ASSOCIATES  Consulting Engineers and Geologists		CONSOLIDATION TEST REPORT Cullinan Ranch - Island No. 1 Vallejo, California	
Job No. 11539.002.02 Appr: PMS Date 9/16/81		PLATE A-36	

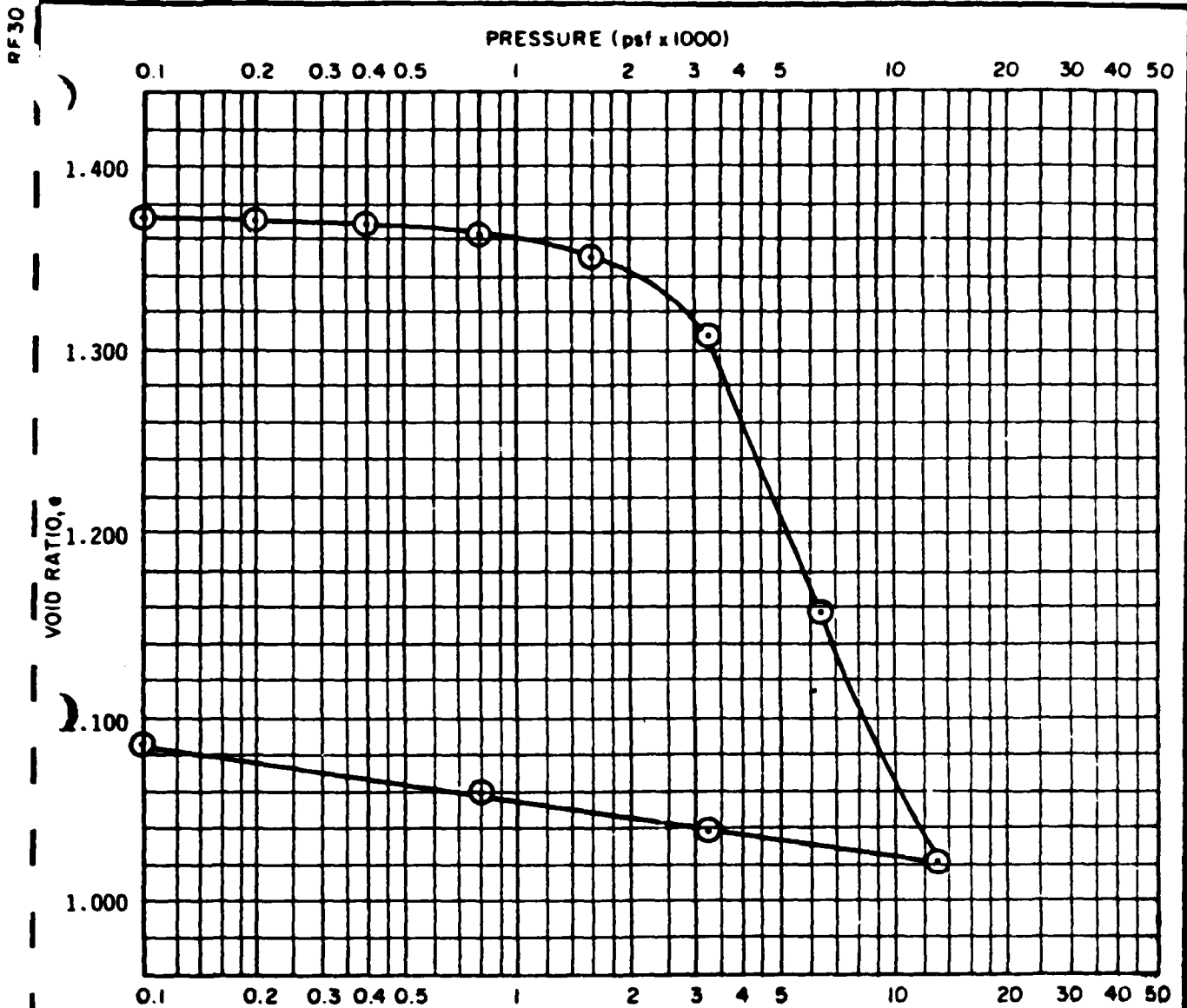

TYPE OF SPECIMEN		Undisturbed		BEFORE TEST				AFTER TEST		
DIAMETER (in.)	2.43	HEIGHT (in.)	0.80	MOISTURE CONTENT	w_g	48.9	%	w_f	40.0	%
OVERBURDEN PRESS. P_0	1250	psf		VOID RATIO	e_0	1.379		e_f	1.085	
PRECONSOL. PRESS. P_c	3000	psf		SATURATION	S_p	97	%	S_f	100	%
COMPRESSION INDEX, C_c	0.515			DRY DENSITY	γ_d	71	pcf	γ_{df}	82	pcf
LL	--	PL	--	PI	--			G_s	2.72	

CLASSIFICATION GREEN-GRAY SANDY SILT (ML) SOURCE Boring 5 @ 33'

HARDING - LAWSON ASSOCIATES
 Consulting Engineers and Geologists

CONSOLIDATION TEST REPORT
 Cullinan Ranch - Island No. 1
 Vallejo, California

PLATE
A37

Job No 11539.002.02 Appr RMS Date 9/16/81

RF 30

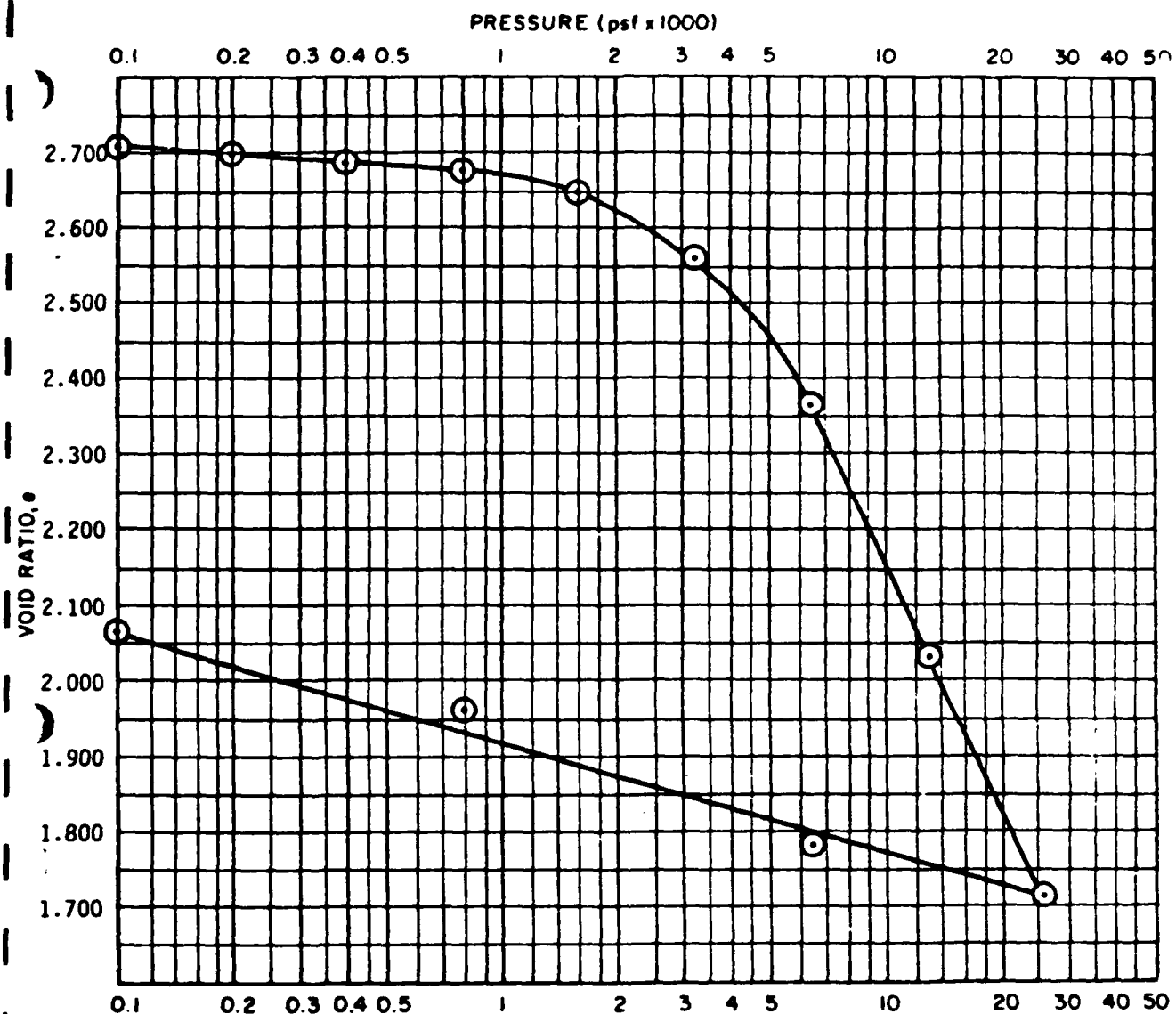

TYPE OF SPECIMEN		Undisturbed		BEFORE TEST				AFTER TEST	
DIAMETER (in.)	2.43	HEIGHT (in.)	0.80	MOISTURE CONTENT	w_0	109.7 %	w_f	84.0 %	
OVERBURDEN PRESS. P_0	300	psf		VOID RATIO	e_0	2.715	e_f	2.065	
PRECONSOL. PRESS. P_c	4500	psf		SATURATION	S_0	99 %	S_f	100 %	
COMPRESSION INDEX, C_c	1.110			DRY DENSITY	γ_d	41 pcf	γ_d	50 pcf	
LL	--	PL	--	PI	--	G_s 2.45			

CLASSIFICATION GRAY-BROWN CLAYEY SILT (MH)

SOURCE Boring 8 @ 3.5'

HARDING - LAWSON ASSOCIATES



Consulting Engineers and Geologists

CONSOLIDATION TEST REPORT

Cullinan Ranch - Island No. 1
Vallejo, California

PLATE

A-38

Job No. 11539.002.02 Appr. R.M.S. Date 9/16/81

RF 30

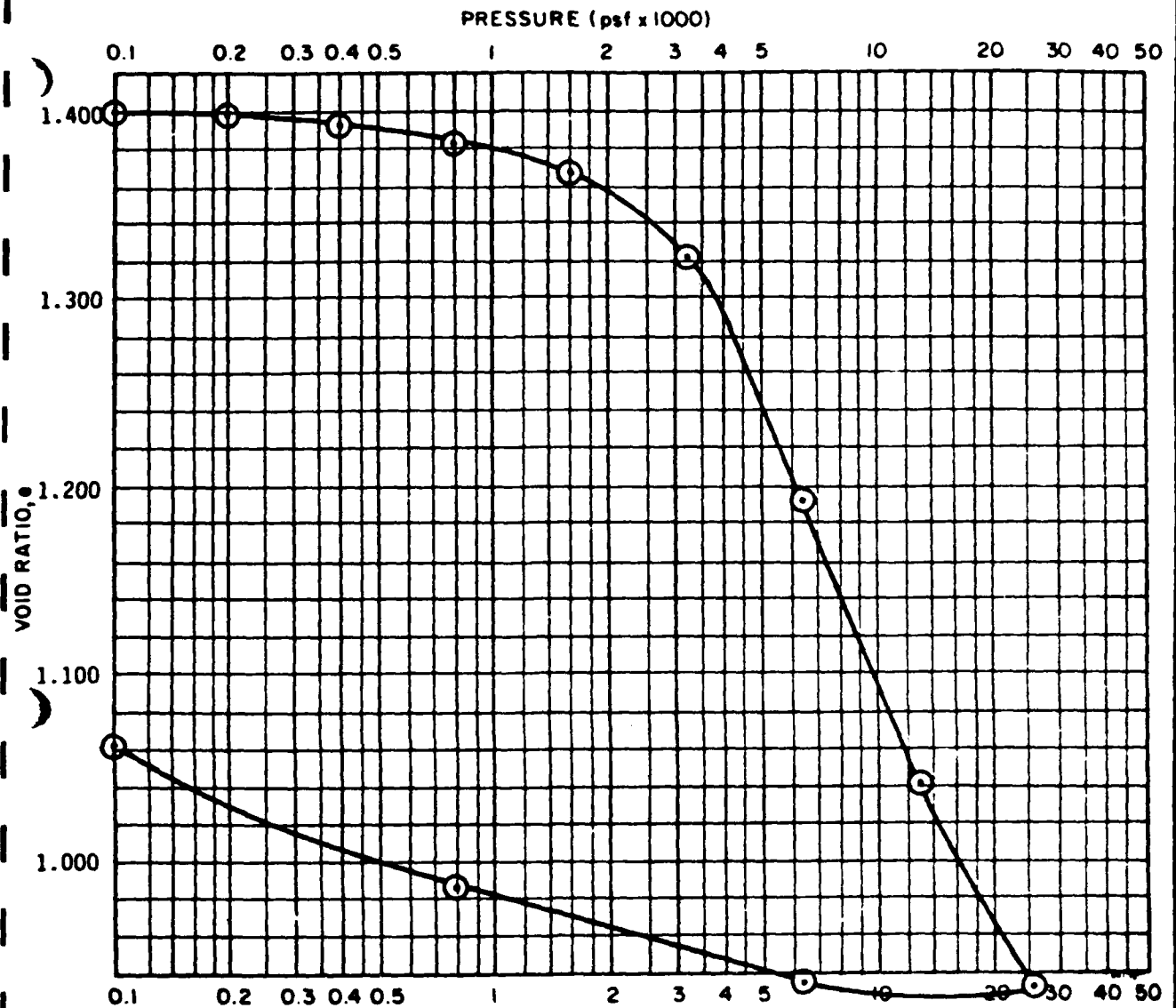

TYPE OF SPECIMEN	Undisturbed		BEFORE TEST				AFTER TEST	
	DIAMETER (in.)	2.43	HEIGHT (in.)	0.80	MOISTURE CONTENT	w_0	49.8 %	w_1
OVERBURDEN PRESS., P_b	1800	psf		VOID RATIO	e_0	1.407	e_1	1.062
PRECONSOL. PRESS., P_c	3000	psf		SATURATION	S_0	98 %	S_1	100 %
COMPRESSION INDEX, C_c	0.486			DRY DENSITY	γ_d	72 pcf	γ_d	84 pcf
LL	--	PL	--	PI	--	G_s 2.76		

CLASSIFICATION GREEN-GRAY SANDY SILT (MH)

SOURCE Boring 11 @ 45'

HARDING - LAWSON ASSOCIATES

Consulting Engineers and Geologists

CONSOLIDATION TEST REPORTCullinan Ranch - Island No. 1
Vallejo, California

PLATE

A-39

Job No 11539,002.02

Appr. E.M.S. Date 9/16/81

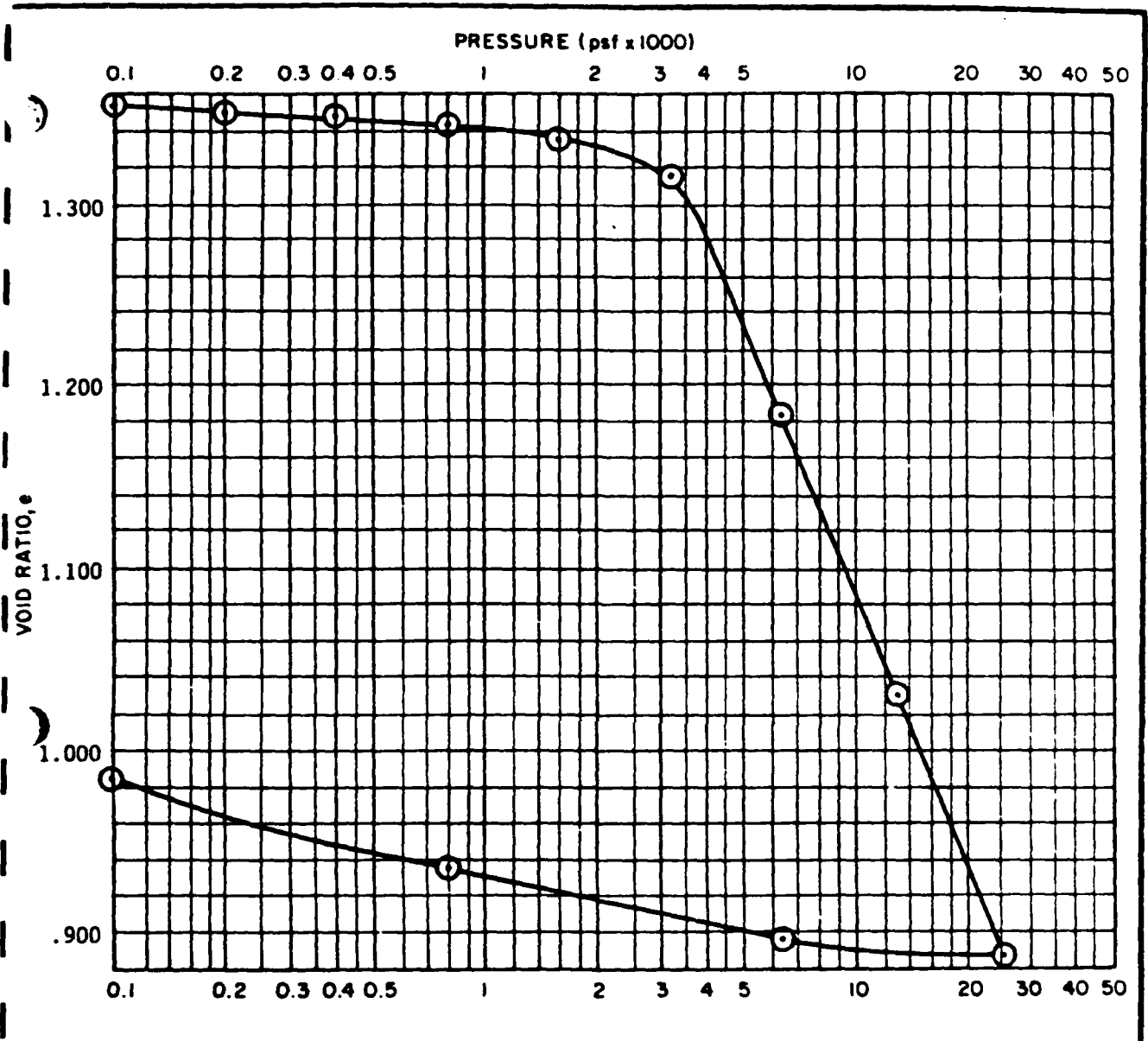

TYPE OF SPECIMEN		Undisturbed		BEFORE TEST				AFTER TEST	
DIAMETER (in.)	2.43	HEIGHT (in.)	0.80	MOISTURE CONTENT	w ₀	48.4 %	w ₁	35.4 %	
OVERBURDEN PRESS., P ₀	2500	psf		VOID RATIO	e ₀	1.359	e ₁	0.984	
PRECONSOL. PRESS., P _c	3500	psf		SATURATION	S ₀	99 %	S ₁	100 %	
COMPRESSION INDEX, C _c	0.500			DRY DENSITY	γ _d	74 pcf	γ _d	88 pcf	
LL	--	PL	--	PI	--	G _s	2.79		
CLASSIFICATION GRAY SANDY SILT (MH)				SOURCE Boring 13 @ 61'					

HARDING-LAWSON ASSOCIATES
 Consulting Engineers and Geologists

Job No. 11539.002.02 Appr. RALS Date 9/16/81

CONSOLIDATION TEST REPORT
 Cullinan Ranch - Isand No. 1
 Vallejo, California

PLATE
A-40

RF

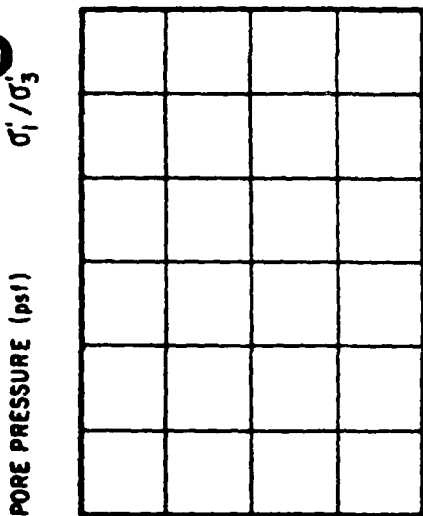
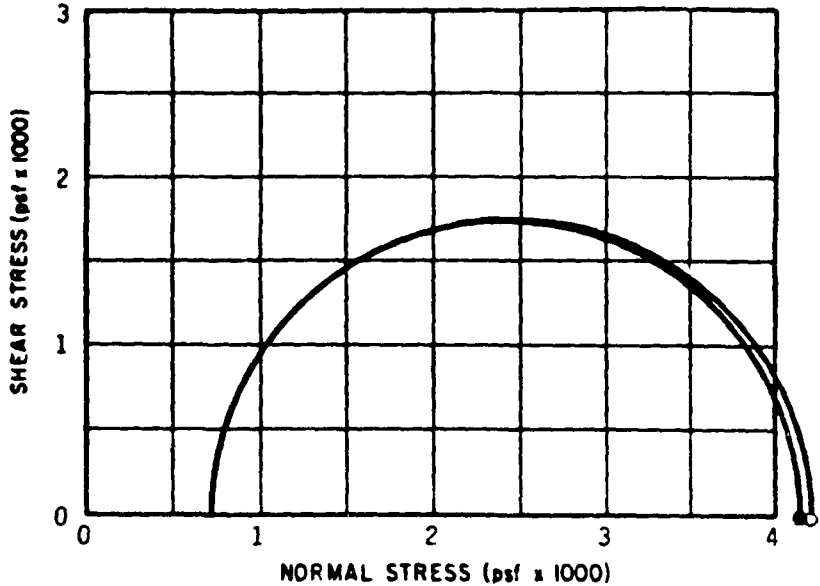
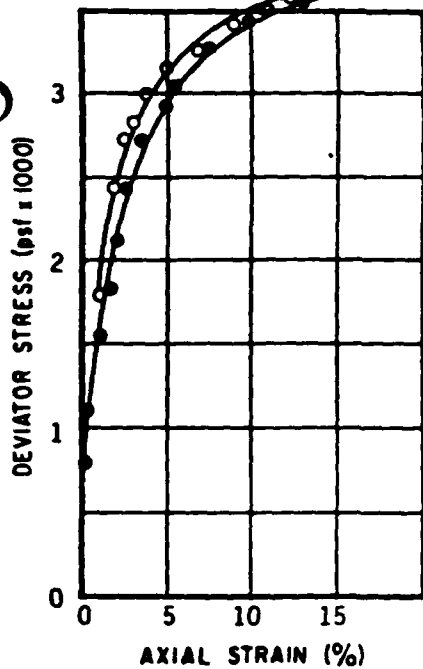

σ_1 / σ_3

PORE PRESSURE (psf)

AXIAL STRAIN (%)

$\phi =$
 $c =$

Test Type: Unconsolidated-Undrained Controlled Strain rate
Saturation Method: Back Pressure G_s 2.56

Test No	A	B	C
Initial Diameter (in.)	2.43	2.43	
Initial Height (in.)	6.00	6.00	
Initial Moisture Content	26.7 %	40.8 %	%
Initial Void Ratio	0.862	1.132	
Initial Saturation	82 %	87 %	%
Initial Dry Density (pcf)	88	87	
Before Test Moisture Content	40.8 %	47.9 %	%
Before Test Void Ratio	1.073	1.225	
Before Test Saturation	100 %	100 %	%
Before Test Pressure (psf)	720	720	
Final Moisture Content	40.8 %	47.9 %	%
Final Void Ratio	1.073	1.225	
σ_1 Major Prin. Stress (psf)	4130	4190	
σ_3 Minor Prin. Stress (psf)	720	720	
Time to Failure (min)	30	20	
Sample Source: Borings 1 @ 7.5, 6 @ 7.0 (remolded)			
Classification: A - GRAY CLAYEY SILT (MH)			
B - BROWN-GRAY CLAYEY SILT w/ Organics (MH)			

HARDING - LAWSON ASSOCIATES



Consulting Engineers and Geologists

TRIAXIAL COMPRESSION TEST REPORT

PLATE

Cullinan Ranch - Island No. 1
Vallejo, California

A-41

Job No. 11539-002-02 Appr. SWA Date 9/30/81

SELECTED REFERENCES

1. California Division of Mines and Geology, 1963, Santa Rosa Sheet: Geologic Map of California, Olaf Jenkins edition, 1:250,000 scale
2. Gribaldo Jones and Associates, 1970, Valnaples Soil Feasibility Study, Solano County, California
3. Gribaldo Jones and Associates; 1970, Valnaples, Levee Stability Study, Solano County, California. unpublished.
4. Harding Lawson Associates, 1981, Geotechnical Evaluation, Island No. 1 Project, Vallejo, California
5. Leighton and Associates, 1975, Seismic Safety Element for The City of Vallejo General Plan, Vallejo, California
6. Ritter, J. R. and Dupre, W. R., 1972, Maps showing areas of Potential Inundation by Tsunamis in the San Francisco Bay Region: U. S. Geological Survey Basic Data Contribution 52
7. Sims, J. D., Fox, K. F., Bartow, J. A. and Helley, E. J.. 1973, Preliminary geologic map of Solano County and parts of Napa, Contra Costa, Marin, and Yolo Counties, California: U.S. Geological Survey Map MF-484

DISTRIBUTION

2 copies: W. R. Williams and Associates, Inc.
2130 Main Street, Suite 230
Huntington Beach, California 92648

2 copies: Haworth and Anderson, Inc.
31882 Camino Capistrano, Suite 270
San Juan Capistrano, California 92675

Attention: Mr. Ed Haworth

1 copy: Moffatt & Nichol Engineers
250 West Wardlow Road
Long Beach, California 90807

Attention: Mr. Walter E. Hurtienne

RMS/DHF/bt

QUALITY CONTROL REVIEWER

Donald G. Edwards

CULLINAN RANCH
SHORE PROTECTION

Prepared for
W.R. Williams & Associates
P.O. Box 268
Huntington Beach, California 92648

by
Moffatt & Nichol, Engineers
250 West Wardlow Road
Long Beach, California 90807

January, 1982

Cullinan Ranch
Shore Protection

Introduction

The proposed channels will be subjected to currents and waves. The banks and slopes of the sides comprise a loose silty clay with lenses of peat. The currents are primarily tidal induced and secondarily wind generated. Waves are generated by winds and boat traffic. The banks of the channels should be stable to protect the development and prevent meanders. The north side is a dike separating the project from Dutchman's Slough. A main channel, 350'-400' wide will transport tidal flow primarily to the west. Several small, narrow bays will be created on the south side for the marina-oriented development. These channels will be subjected to lesser tidal currents and wave forces.

Currents

R.B. Krone & Associates has predicted that tidal currents in the proposed development will be a maximum of one foot per second for a 6.0 foot tide range. Allowing for a maximum design tide range 20% higher, the maximum mean channel velocity should be about 1.2 feet per second. Calculation of shear stresses indicates that they are on the order of 0.01 pounds per square foot. A bed shear of this magnitude is insufficient

to move a slightly compacted silty clay, but could move loose peaty material, however, the Harding Lawson soils report recommends removal of the peaty material as part of the site preparation. The bank slope should therefore be stable against current-induced erosion.

Bed shear can increase if shoaling reduces the flow area. Flow around bends also increases higher shear stresses on outer banks of a curved channel. These shears, however, are still below the threshold of movement. If shoaling does occur on the inner banks, increased outer bank shear may induce some localized erosion. This could be mitigated by rip rap, or by dredging the shoaled area. Dredging would most likely occur prior to this problem developing. Therefore, all reaches of the channel with depths 10 feet and greater should be stable, providing the peat lenses are removed.

Waves

Wind waves generated in the main channels are estimated to be less than 1.5 feet high with periods less than 2.3 seconds. These wave heights are calculated for a narrow fetch of less than 5,000 feet in the winding or meandering channel with a 20 foot depth. Boat waves can generate 1.5 foot waves if the boats travel at high speeds. Calculations indicate that boat waves should be minimal if the boats travel at less than 12.6 knots. Fireboats or tug boats can create waves of 3 feet if

they travel at speeds greater than 12 knots.

Design Criteria

The heavy boat traffic and wind waves will generate waves of sufficient force to erode the banks. Natural cord grass and pickleweed can grow in this region, however, its growth is limited to the intertidal zone above mean sea level. Below MSL, the wave action will continuously cut the bank. Therefore, some shore protection will be required. The shore protection must be stable in waves and currents and aesthetically pleasing. Furthermore, piles will be driven through the section and the shore protection should present minimum difficulty to the pile driving operation. The soils are soft bay mud and are susceptible to settlement. Therefore the structure should be light weight. The least costly and maintenance-free protection is desirable.

Vegetation

Cordgrass and pickleweed are natural saltmarsh plants that grow well in the bay area in the intertidal zone. The plants grow above MSL which is about +3 feet MLLW. They can withstand the mild wave climate that will exist in the development. Boat traffic should not have a significant adverse affect on the vegetation once it has taken root. The buildings on the development side will cast shadows and some of the banks may

not have as healthy a planting as others.

Rip Rap

Continuous boat waves and wind waves will undercut the vegetated slope below MSL. Rip rap may be required to prevent erosion below MSL. A section of 50 lb. graded rip rap would be stable in two foot waves over the 1:4 and 1:5 slopes. For preliminary planning a two foot thick section is proposed. This can be refined by making a specification compatible with a local quarry product. The rip rap should be placed over a filter cloth which is covered with 6 inches of gravel bedding. The rip rap should extend from MSL where the vegetation starts to one wave height below low water. Maximum low water is -2.5' MLLW and in the main channels the wave height is 1.5 feet. Therefore the rip rap should extend to -4 MLLW. A small, 3-foot berm should be provided at the toe to prevent the stones from rolling down the slope. The interior channels in the development bays are subject to less boat traffic and slower moving boats. This rip rap should extend to -3 feet MLLW.

Flows in the entrance and tide gate areas will be on the order of 2.5 feet per second. While this velocity should be ample to prevent shoaling, it should not induce erosion except perhaps in isolated locations. In the event erosion occurs, rip rap may be required in the channels near these structures.

Sections

Sloping Bank:

Three sections are proposed for different reaches. The bank on the slough side of the main channel is a dike. Because erosion rates are expected to be low and the risk of damage to structures is low, it may not be necessary to provide rip rap for this area. The following is therefore suggested. Provide vegetation above MSL. Place a 10-foot wide berm at MSL. This would be a sacrificial berm that can erode slowly. Some areas will be more susceptible to erosion than others and rip rap may eventually be required. This would defer capital costs which may not be required. However, plans should include an allowance for rip rapping the entire reach should erosion prove excessive. A typical section is shown in Figure 1.

The banks of the main channels on the development side face north. Building shadows and north-facing slopes should not support as healthy a vegetative cover as on the other side of the channel. Furthermore, the development requires a more permanent degree of protection. A cut bank at MSL which slowly erodes will not be aesthetically pleasing and will give residents cause for concern. Therefore the rip rap section in Figure 2 is proposed. Note, the rip rap extends up to 3.5 MLLW to provide added protection on the main channel to account for heavy boat traffic and reduced sunlight.

The bays have shorter fetches and lighter boat traffic. The section shown in Figure 3 applies to this area. The rip rap is placed between +3 and -3 MLLW.

Sloping Bank Alternatives:

In addition to the various systems described above, there are three alternative shore protection methods that may be considered.

The first system utilizes a manufactured armor mat which consists of concrete blocks glued on filter cloth. This type of protection is called Erco-mat (formerly known as Gobi-Block) and is shown in Figure 4.

The second alternative consists of a small wood retaining wall which has rip-rap placed on the exposed side to prevent scour of the slope toe. This type of section is shown in Figure 5.

The third alternative consists of a plastic mat to which filter cloth has been attached. This mat reinforces the channel slopes thus reducing erosion and provides a surface to which vegetation can attach. See Figure 6 for details.

Neither alternative one or two are recommended due to their questionable appearance. Alternative three is an acceptable

protection system for the interior channels.

Bulkhead:

The conceptual development plan for the Cullinan Ranch project indicates various areas where concrete bulkheads will be required in the medium density/commercial marina areas. The Harding Lawson soils report provided a preliminary design for this structure. The concrete bulkhead as designed by HLA has been reproduced for this report and is shown as Figure 7.

Cost Estimates

Preliminary cost estimates have been prepared for the various shore protection systems that could be used in the project. The results of these estimates have been summarized in Table 1. The costs indicated are for one linear foot of waterfront and are exclusive of any excavation and compaction costs that are associated with the preparation of the channels.

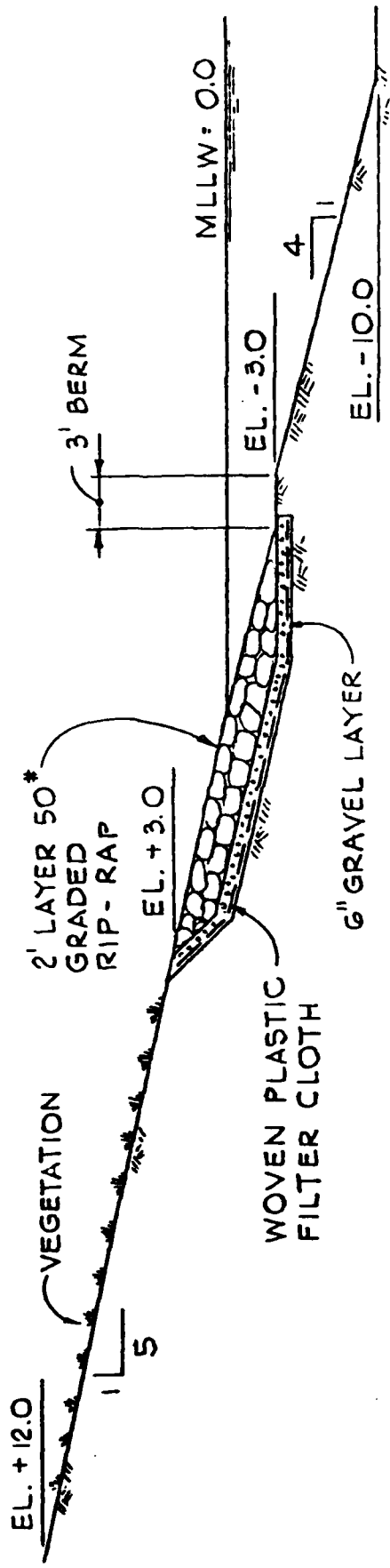

FIGURE 3. INTERIOR CHANNEL

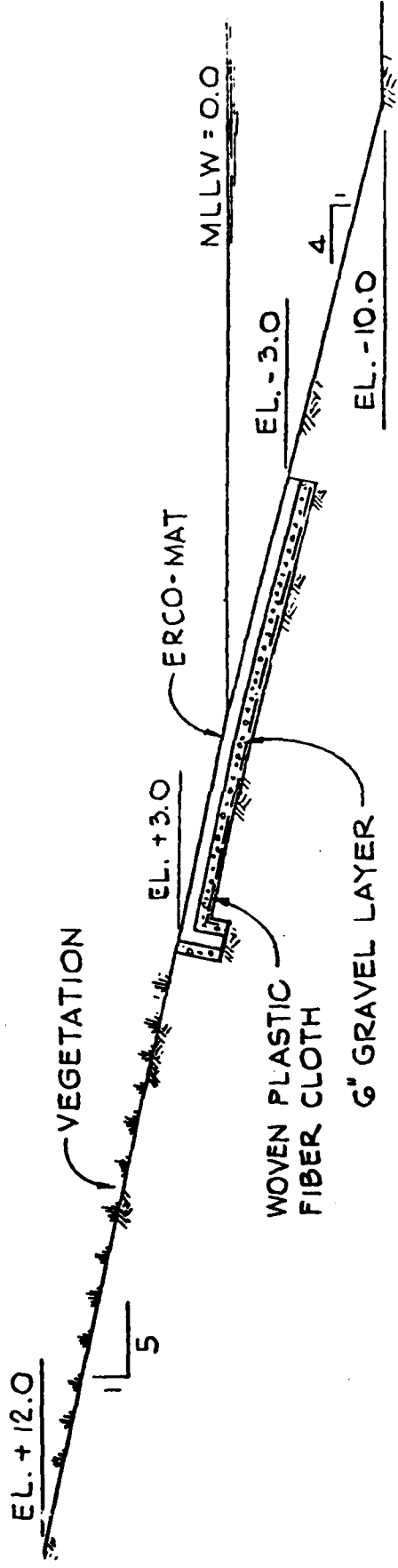

FIGURE 4. ERCO-MAT - INTERIOR CHANNEL.

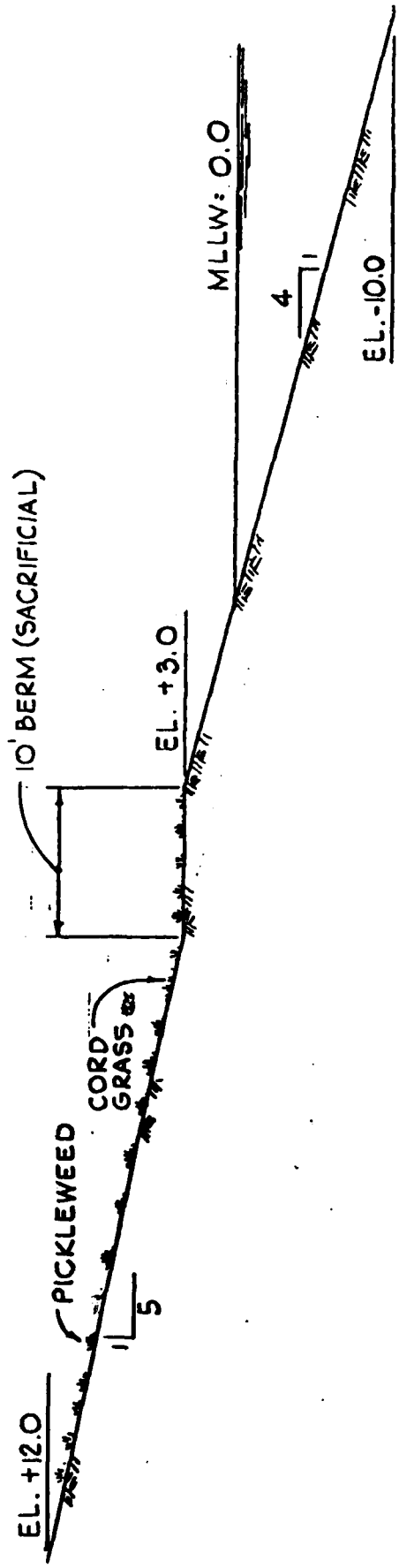

FIGURE 1. MAIN CHANNEL - SLOUGH SIDE

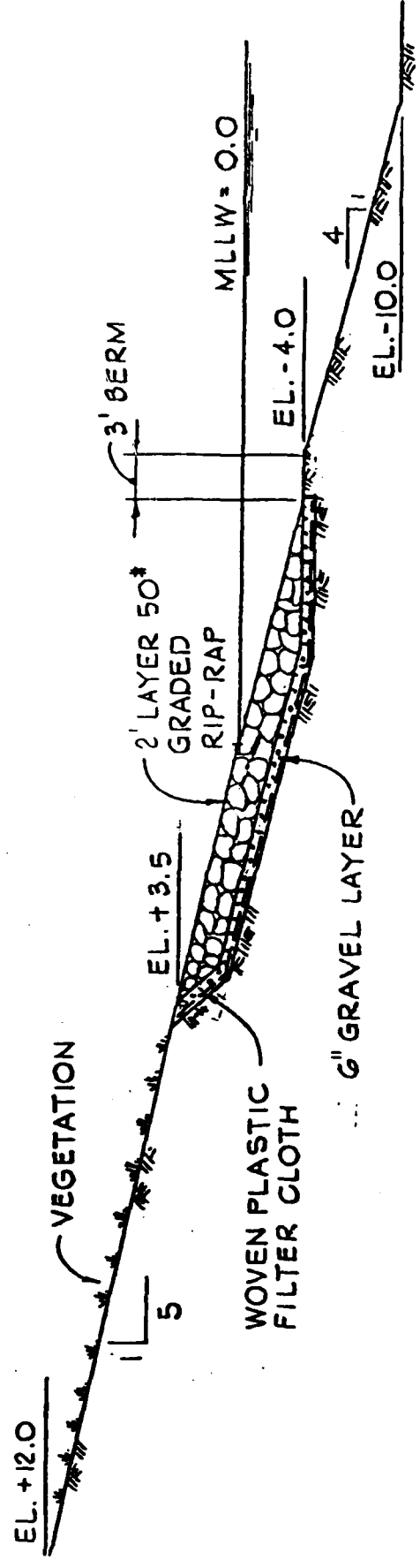

FIGURE 2. MAIN CHANNEL - DEVELOPMENT SIDE

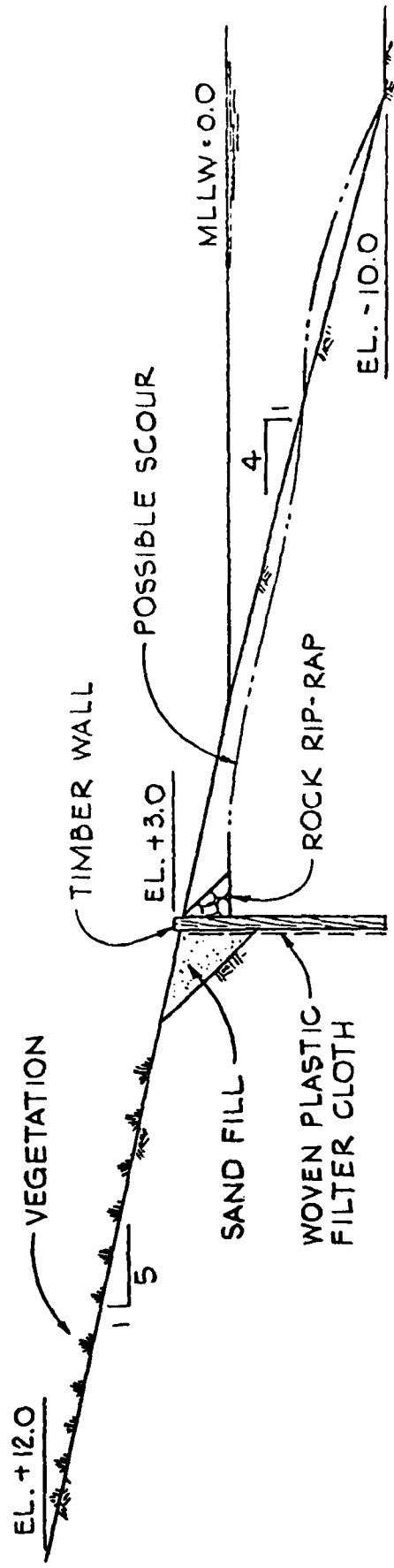

FIGURE 5. TIMBER WALL - INTERIOR CHANNELS

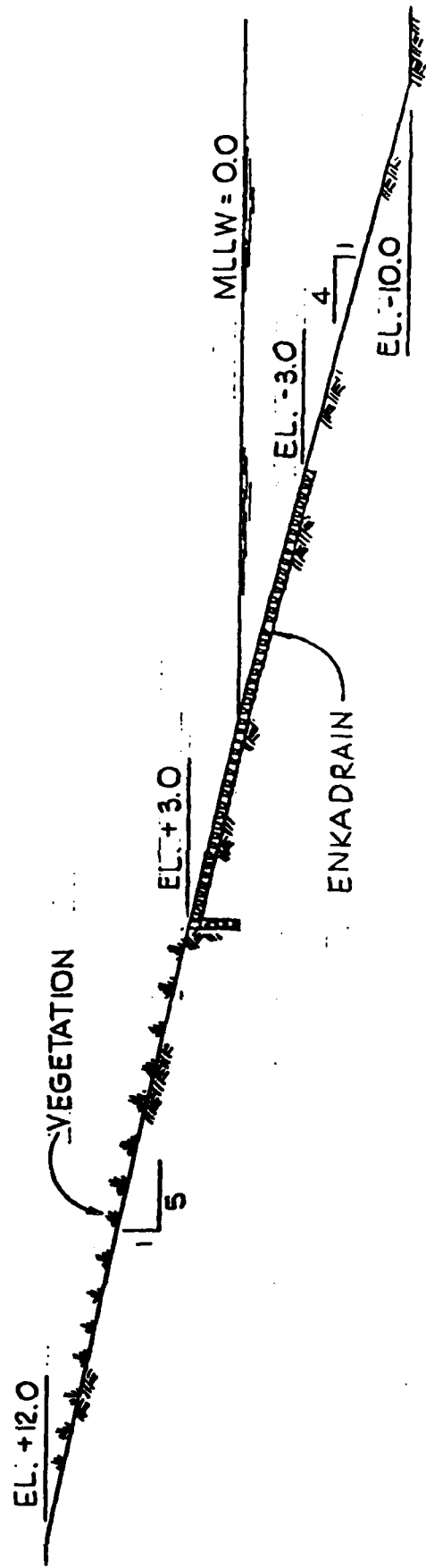

FIGURE 6. ENKADRAIN - INTERIOR CHANNEL

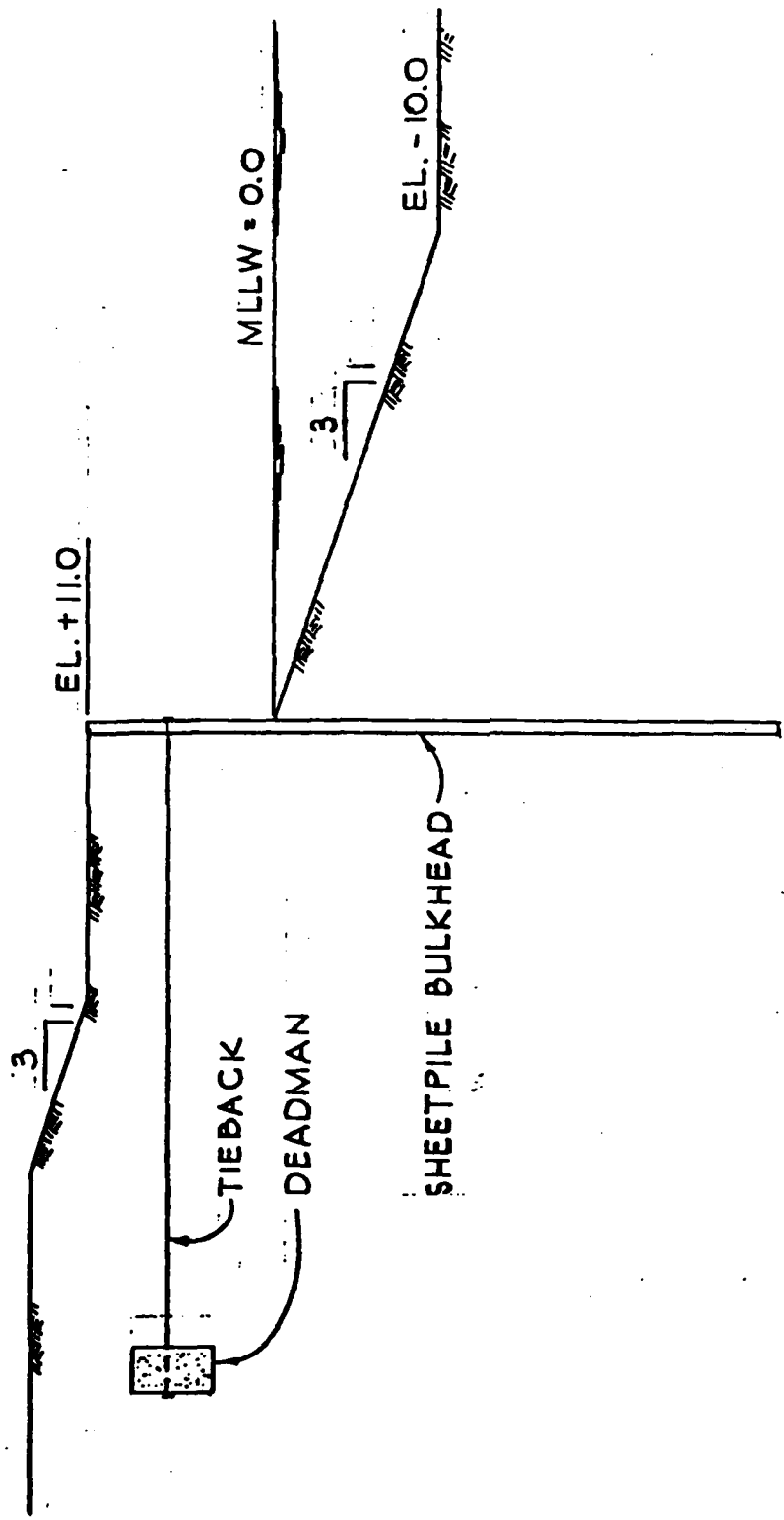

FIGURE 7. INTERIOR CHANNEL BULKHEAD

TABLE 1

<u>SECTION</u>	<u>COST</u> <u>(\$/LF)</u>
1. Main Channel- Slough Side Fig. 1	6.00
2. Main Channel- Dev. Side Fig. 2	198.00
3. Interim Channel Fig. 3	150.00
4. Erco-Mat-Interior Channel Fig. 4	202.00
5. Timber Wall-Interior Channel Fig. 5	150.00
6. Enkadrain-Interior Channel Fig. 6	101.00
7. Interior Channel Bulkhead Fig. 7	1200.00

**WATER CIRCULATION, SEDIMENTATION, AND ALGAE GROWTH
IN THE
CULLINAN RANCH DEVELOPMENT PROJECT**

by

**Resource Management Associates
3738 Mt. Diablo Blvd., Suite 200
Lafayette, CA 94549**

**R. B. Krone & Associates
P.O. Box 694
Davis, CA 95617**

February, 1982

TABLE OF CONTENTS

	<u>Page</u>
INTRODUCTION	1
TIDAL FLOWS	3
Effects Of The Tide Gates	7
Flows Within The Development	8
Flows In Adjacent Sloughs	8
TIDAL FLUSHING	17
Flushing For The Five Configurations	17
Algae Growth	23
SEDIMENTATION	27
Sediment Transport In The San Francisco Bay System	27
Sedimentation In The Cullinan Ranch Project	29
Sedimentation In The Project Channels	31
Sedimentation In Dutchman	32
: Sediment Disposal	32
OTHER MODIFICATIONS	39
CONCLUSIONS AND RECOMMENDATIONS	41

LIST OF FIGURES

<u>Figure</u>	<u>Page No.</u>
1. Link-Node Representation of the Sloughs and San Pablo Bay in the Vicinity of the Cullinan Ranch Development	4
2. Link-Node Representation of the Cullinan Ranch Development	5
3. Tides at Point Richmond and at the Entrance to the Cullinan Ranch Development	6
4a. Flows Between The Northwest End Of The Project and South Slough With An Open Channel and With Tide Gates	9
4b. Water Surface Elevations On Either Side Of The Levee With Tide Gates Installed	9
5. Typical Velocities Within The Channels Of The Northwestern Portion Of The Cullinan Ranch Development	10
6. Typical Velocities Within The Channels Of The Eastern Portion Of The Cullinan Ranch Development	11
7. Velocities Within The Channels Of The Cullinan Ranch Development For Case 4 and Case 5 Configurations	12
8. Velocities in South and Dutchman Sloughs Without The Development and For The Case 4 Configuration	13
9. Velocities in South Slough Without The Development and For The Case 4 Configuration	14
10. Velocities in Dutchman Slough Between The Development Entrance and Napa River for Cases 4 and 5	16
11. Residence Times for Case 1 Configuration	18
12. Residence Times for Case 2 Configuration	19

<u>Figure</u>	<u>Page No.</u>
13. Residence Times for Case 3 Configuration	20
14. Residence Times for Case 4 Configuration	21
15. Residence Times for Case 5 Configuration	22
16. Entrance for the Cullinan Ranch Marina	30
17. Dredged Entrance to Dutchman Slough for Partial Development	33
18. Sediment Disposal Pond Configuration	35
19. Schedule of Pond Operation	36

INTRODUCTION

The planned Cullinan Ranch residential and commercial development will be located on Island No. 1 northwest of Vallejo, California, between Dutchman Slough and State Highway 37. The present land area is 1498 acres and has an average elevation between 2 and 3 feet below mean sea level. The planned development will provide elevated land by excavating a marina and numerous channels throughout the area and using the excavated soil for fill. The channels will provide open spaces within the project and sites for private moorings. Dutchman Slough will provide access from project waters to the Napa River and thence to the waters of the entire San Francisco Bay-delta system.

The importance of maintaining the quality of the waters in the project for aesthetic enjoyment is evident. No waste discharges into the channels or basins in the project will be permitted. The waters will ebb and flow with the tides of the slough system to which they are connected. Impacts of the project on the quality of slough waters will be limited to those resulting from reduced mixing in the relatively quiet waters of the project, and possibly to nutrients supplied by runoff from the residential areas.

Reduced mixing in the project waters could allow time for the growth of algae. The concern for accumulation of algae is greatest for summertime conditions because lower summertime flows in the Napa River result in increased concentrations of nutrients from waste discharges. Longer days, warmer waters, and lowered suspended solids concentrations in Bay system waters that allow increased penetration of sunlight during summer combine with the increased availability of nutrients to make algae multiplication rates greatest then. The major differences between project waters and those of the adjacent sloughs will be increased residence times and greater water depths. If the residence times in the project are too long and the growth rates too high, algae could accumulate to nuisance levels.

Suspended solids carried into the project by tidal waters will tend to settle in the waterways because of the longer residence times there

compared to the sloughs. Rates of accumulation of sediment in the channels will determine the frequency of maintenance dredging and the need for sediment disposal. The primary means for minimizing sedimentation rates in an enclosed marina and waterway system is finding ways to minimize the amount of sediment-laden waters that enter or pass through parts of the system with the tides. Reduction of sedimentation by this method could result in longer residence times, clearer waters, and increased algae concentrations. This study is therefore concerned with the evaluation of project configurations for optimum hydraulic conditions that lead to minimum obtainable summertime algae growths and annual sedimentation rates.

The project will slightly enlarge the local tidal prism and can therefore alter the flows in adjacent sloughs. An additional objective of this study is the evaluation of the impact of the project on flows in adjacent sloughs.

TIDAL FLOWS

Evaluation of retention times in project waters and of the effects of the project on adjacent sloughs requires the computation of flows and tides throughout the region of concern. These computations were made using an existing well developed link-node mathematical model of the upper San Francisco Bay system by extending it up the Napa River and through neighboring sloughs. The configuration of the model is shown in Figure 1. Circled numbers in the grid shown in Figure 1 identify the nodes. The links between the nodes show the channels in which flows and tides were computed. Figure 1 shows that flows in surrounding channels that might be influenced by the project were included in the model, together with a sufficient portion of the Bay system to assure reliable fixed hydraulic boundary conditions.

The model was extended into the proposed Cullinan Ranch development as shown in Figure 2. This portion of the model includes 45 nodes and 53 interconnecting channels. Alternate configurations were evaluated by closing various channels.

A typical summertime average tide at Point Richmond was used for all of the computations. The tide at Point Richmond and the computed tide at the entrance to the project are shown in Figure 3. This tide has a diurnal range of 6.2 ft and a mean range of 4.7 ft. These ranges are slightly higher than those presented in the U.S. Department of Commerce Tide Tables for Mare Island Straight at Vallejo and are lower than those presented for the Napa River at Napa. The entrance of Dutchman Slough is between these points, indicating that the hydraulic computations are consistent with the observations made by the Department of Commerce.

Five different channel configurations within the development were simulated. These variations included:

- Case 1. The development as shown in Figure 2.
- Case 2. The development as shown in Figure 2 without the channel connecting the westernmost turning basin with South Slough (node 1 to node 48).

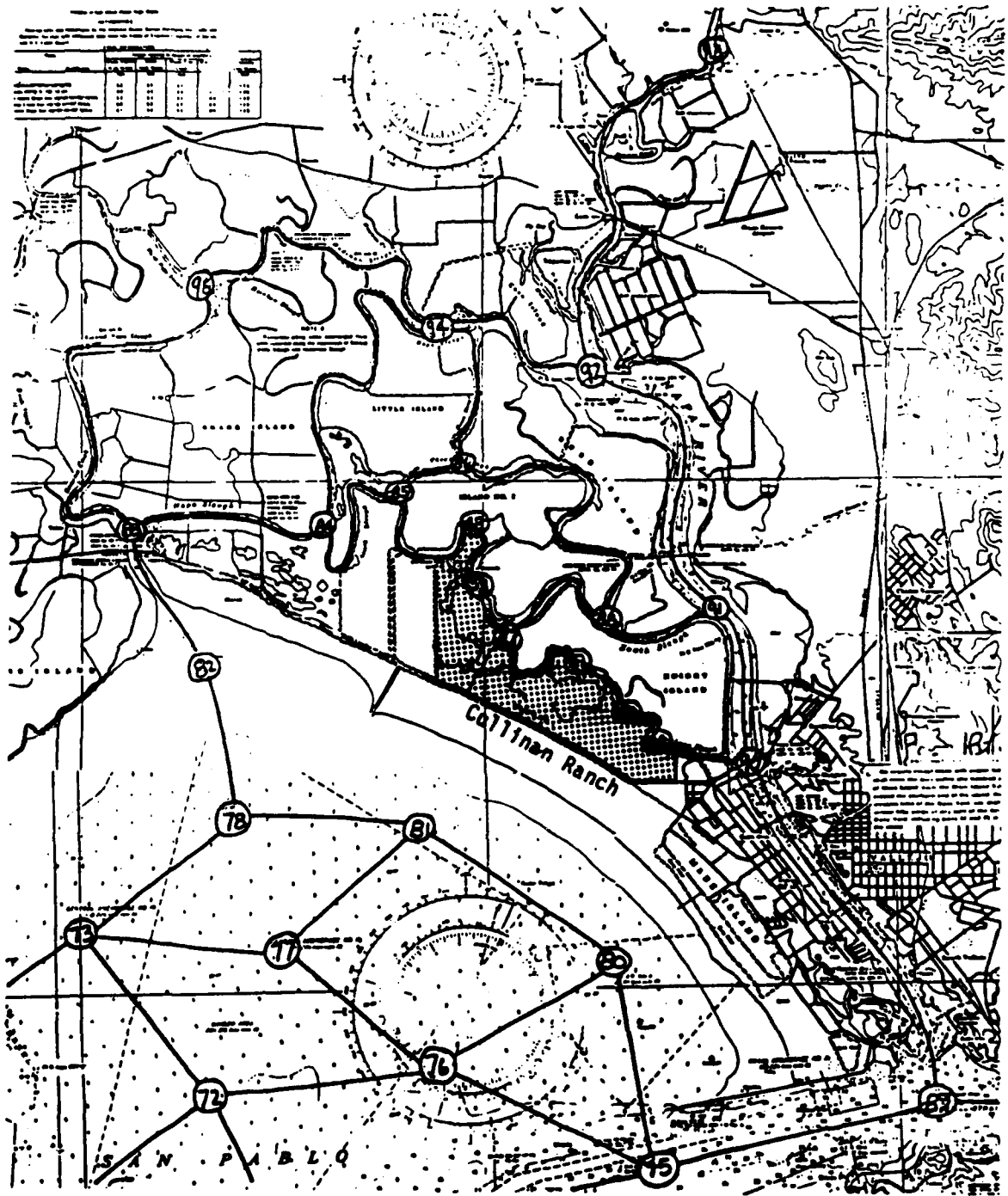

FIGURE 1

LINK NODE REPRESENTATION OF THE SLOUGHS AND
SAN PABLO BAY IN THE VICINITY OF
THE CULLINAN RANCH DEVELOPMENT

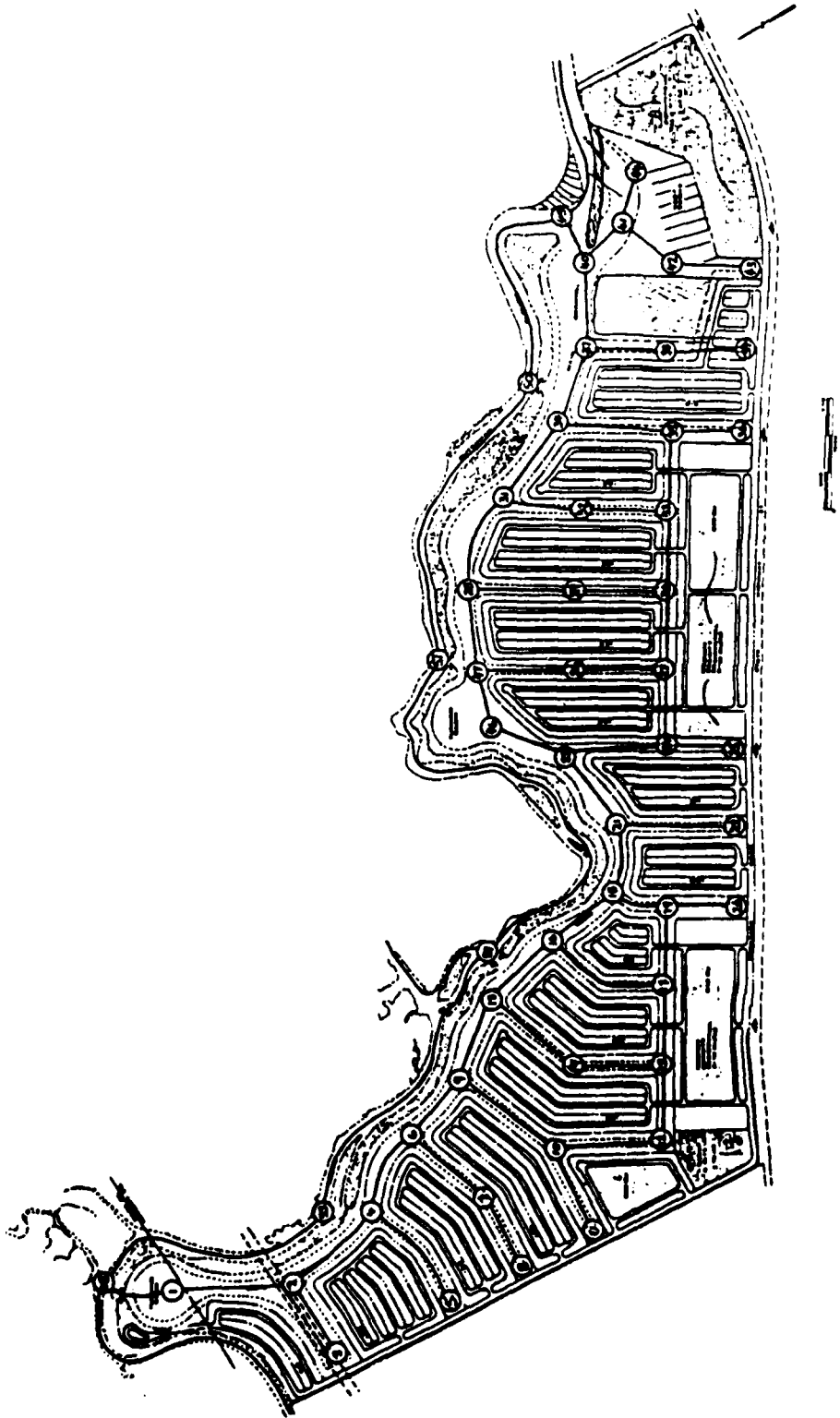

FIGURE 2
LINK NODE REPRESENTATION OF THE
CULLINAN RANCH DEVELOPMENT

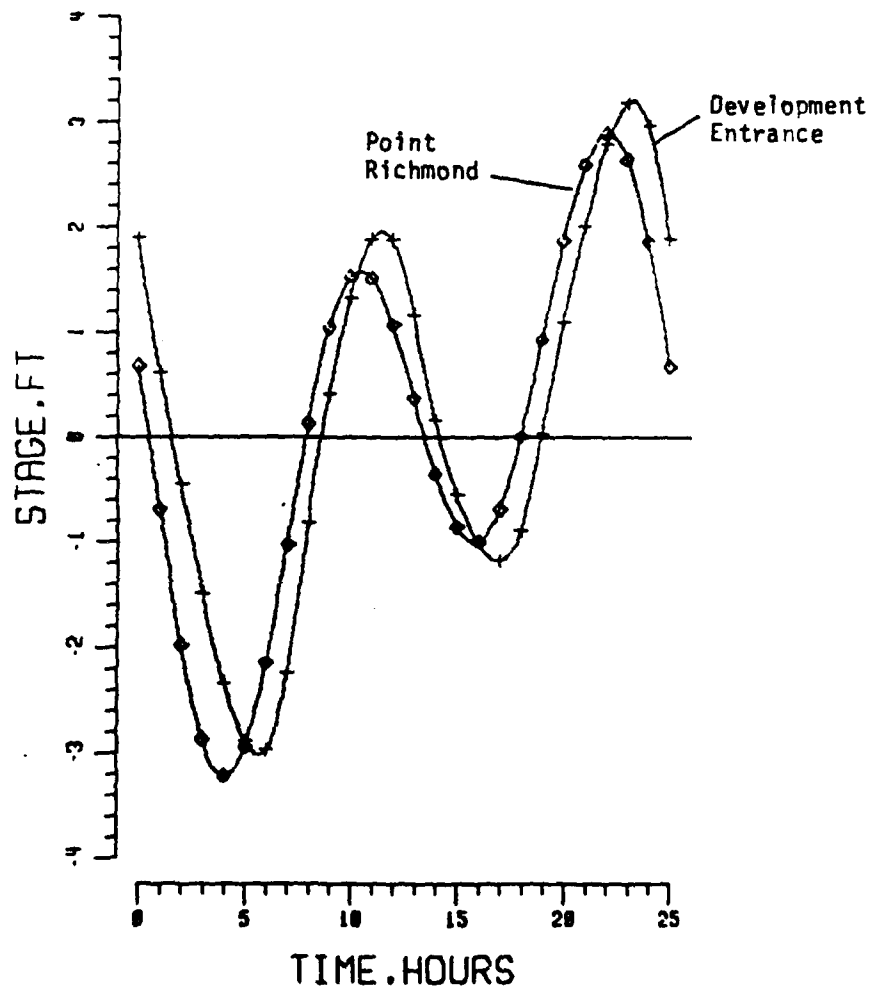

FIGURE 3
TIDES AT POINT RICHMOND AND AT
THE ENTRANCE TO THE CULLINAN RANCH DEVELOPMENT

- Case 3. The development as shown in Figure 2 with pipes and tide gates that would permit flow from South Slough into the westernmost turning basin only.
- Case 4. The development with all waterways northwest of the power line easement eliminated, the waterways connecting the distal ends of the lateral channels (channels connecting nodes 12, 15, 17, and 19 and nodes 24, 27, 30, 33, and 35) closed, and with pipes and tide gates connecting node 2 to South Slough installed.
- Case 5. An interim project configuration with all waterways northwest of nodes 28, 29, and 30 closed.

Cases 1, 2, and 3 were designed to evaluate alternate connections of the northwest end of the project to South Slough. Cases 4 and 5 were evaluations of the currently proposed project configuration that was established after consultation with the developer and the planners and engineers participating in the project.

Channel cross-sections were taken from the plot plan. The lateral channel cross-sections were trapezoidal with a 120 foot base at -10 ft MLLW, 4:1 slopes to 0 ft MLLW, and 5:1 slopes above 0 MLLW. The main channel varies in width as shown in Figure 2, but the same slopes were used. The connection to South Slough consisted of eight 72-inch corrugated metal pipes 100 ft long, equipped with tide gates at their southern end. Flow rates through the pipes were calculated using a Manning's "n" of .023 and minor losses totalling 1.5 times the velocity head.

Water depths and widths of the sloughs were taken from USC and GS navigation charts. The portion of Dutchman Slough between the entrance of the project and Napa River was set at -10 ft MLLW for navigation.

Effects of The Tide Gates

The use of tide gates to enhance flushing of the project waters was investigated when it became evident during computation for Case 2 that there would be a difference in water surface elevations between that in South Slough and that in the northwestern end of the project waters. The use of tide gates to cause flow only into the project enhances flushing of interior channels, as described later. The effect of the tide gates on flows into

the project, compared to flows with an open connection, is shown in Figure 4a. In this figure only, flood flow is downward, ebb is upward. This figure shows the very large flood flows through the project that would occur with an open connection because the project channel parallel to Dutch and South Sloughs is larger than the sloughs and has less resistance to flow. Such flow through the project would increase sedimentation rates and would not enhance flushing.

Figure 4b shows the tides at either end of the pipes when tide gates are installed. There is almost a two ft. difference in water surface elevation during flood flows.

Flows Within The Development

The maximum tidal velocities within the development for Cases 1 through 4 range from near zero at the distal ends of the lateral channels to nearly 2 ft/sec in the main channels near the entrance. Velocities computed for the Case 4 configuration at four locations within the project are shown in Figures 5 and 6. These plots show that the flows are moderate throughout the tidal cycle.

The partial project configuration, Case 5, has a very much reduced tidal prism. Velocities of tidal flows in interior channels for this configuration are plotted together with velocities for Case 4, the entire project, in Figure 7. These plots show that currents will be slow in the first stage project.

Flows In Adjacent Sloughs

The velocities of tidal flows in South and Dutchman Sloughs adjacent to the project for the full project, Case 4, and without the project are plotted in Figures 8 and 9. Flows in South Slough between its junction with Dutchman Slough and the tide gates (nodes 53 to 48), shown on the left plot of Figure 8, are affected during ebb because of flow to the tide gates. Flows during flood are nearly unaffected. Flows in Dutchman Slough between the project entrance and the junction with South Slough are only slightly altered by the full development, as shown in the right-hand plot of Figure 8.

Velocities in the reaches of South Slough that extend north and west of the project are plotted in Figure 9. Velocities between nodes 48 and

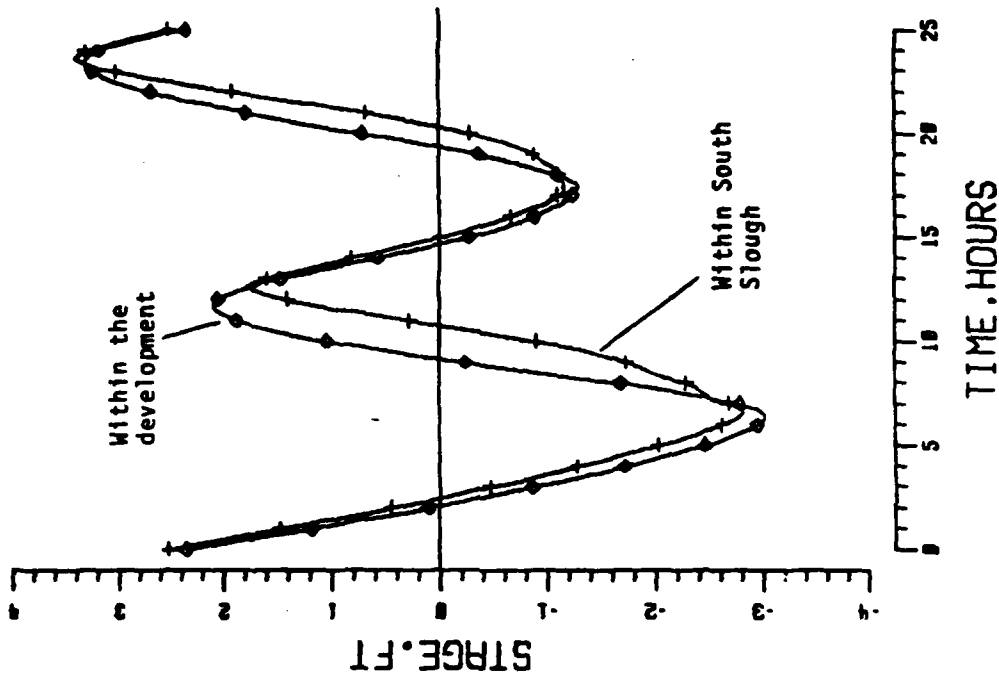

FIGURE 4b

WATER SURFACE ELEVATIONS ON EITHER SIDE OF THE LEVEE WITH TIDE GATES INSTALLED

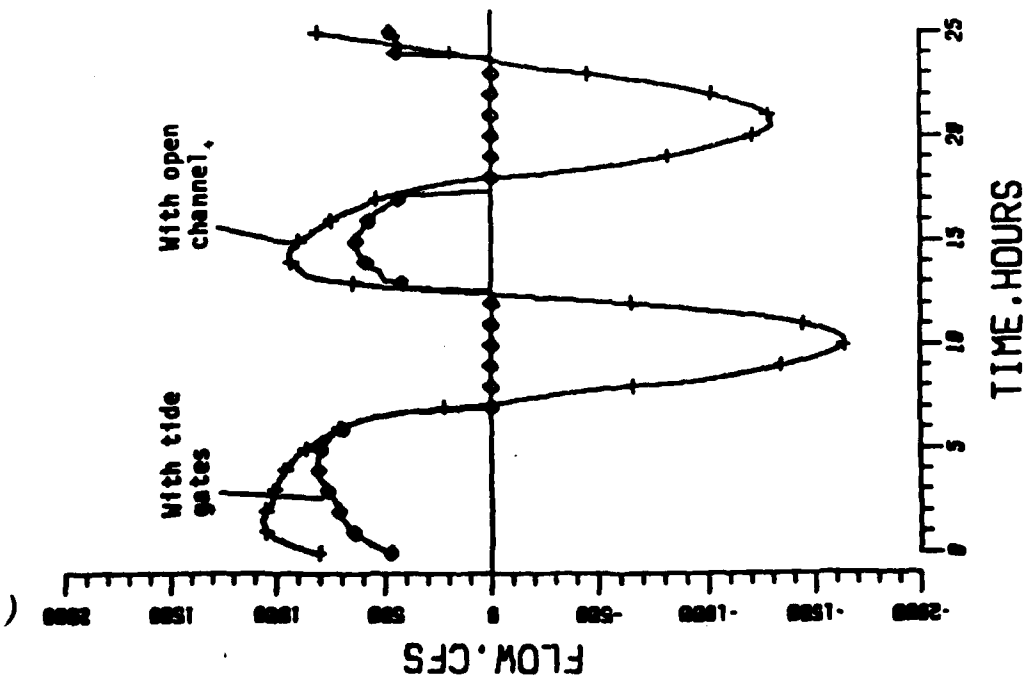

FIGURE 4a

FLOWS BETWEEN THE NORTHWEST END OF THE PROJECT AND SOUTH SLOUGH, WITH AN OPEN CHANNEL AND WITH TIDE GATES

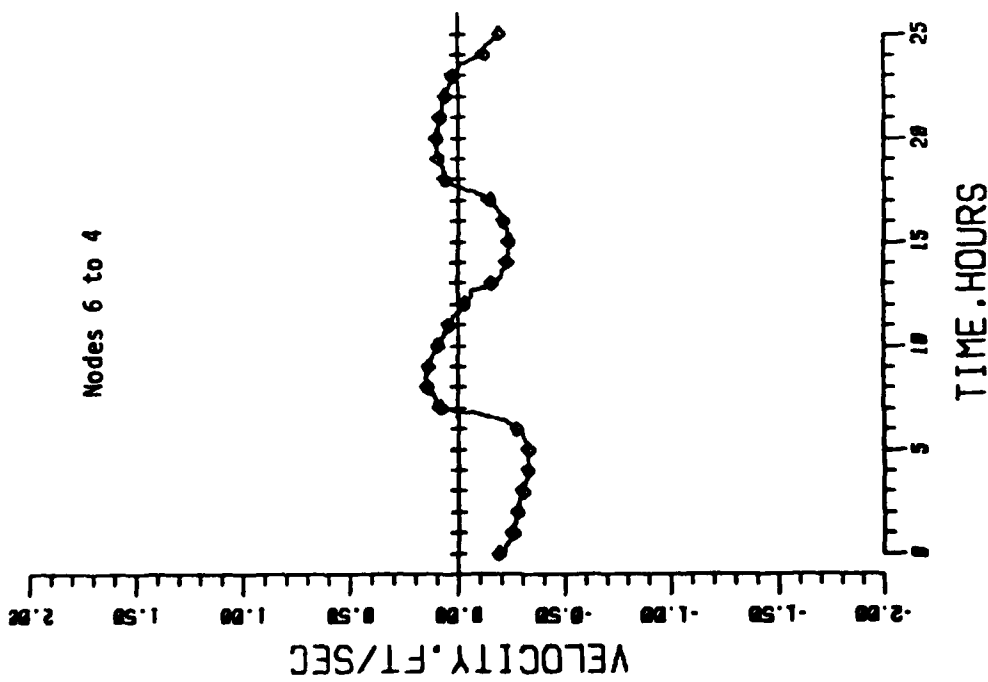
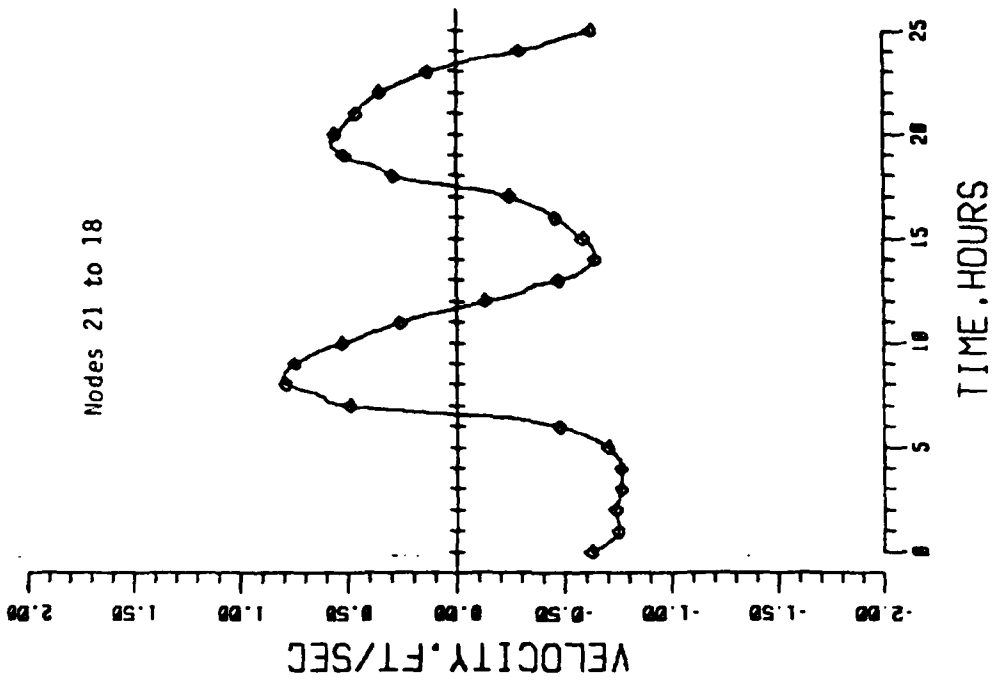

FIGURE 5
TYPICAL VELOCITIES WITHIN THE CHANNELS OF THE NORTHWESTERN
PORTION OF THE CULLINAN RANCH DEVELOPMENT

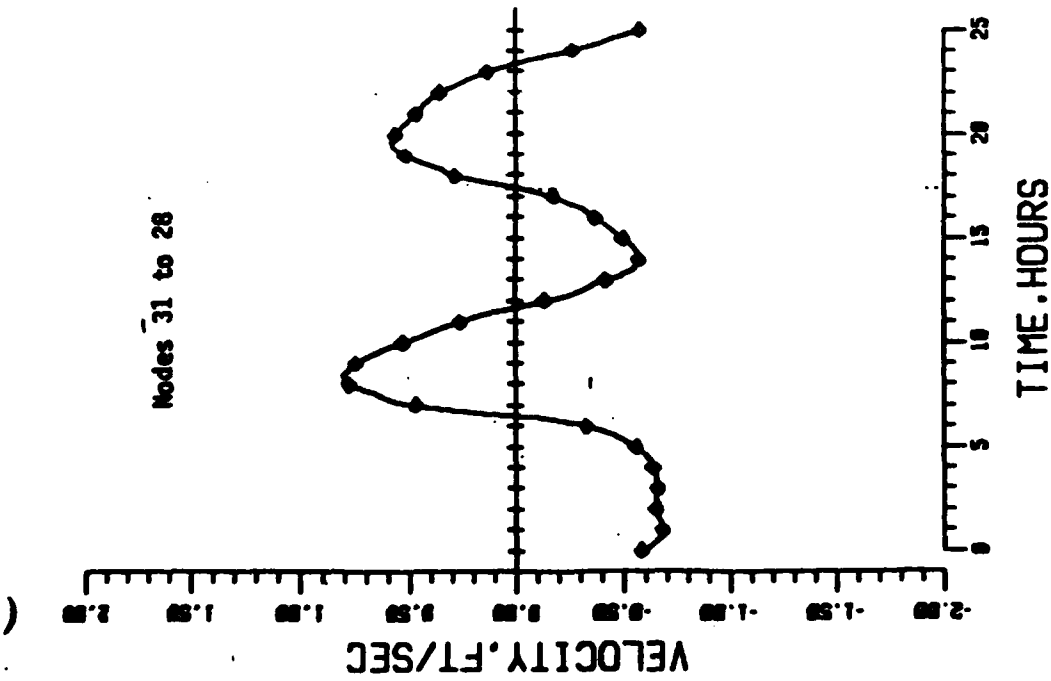
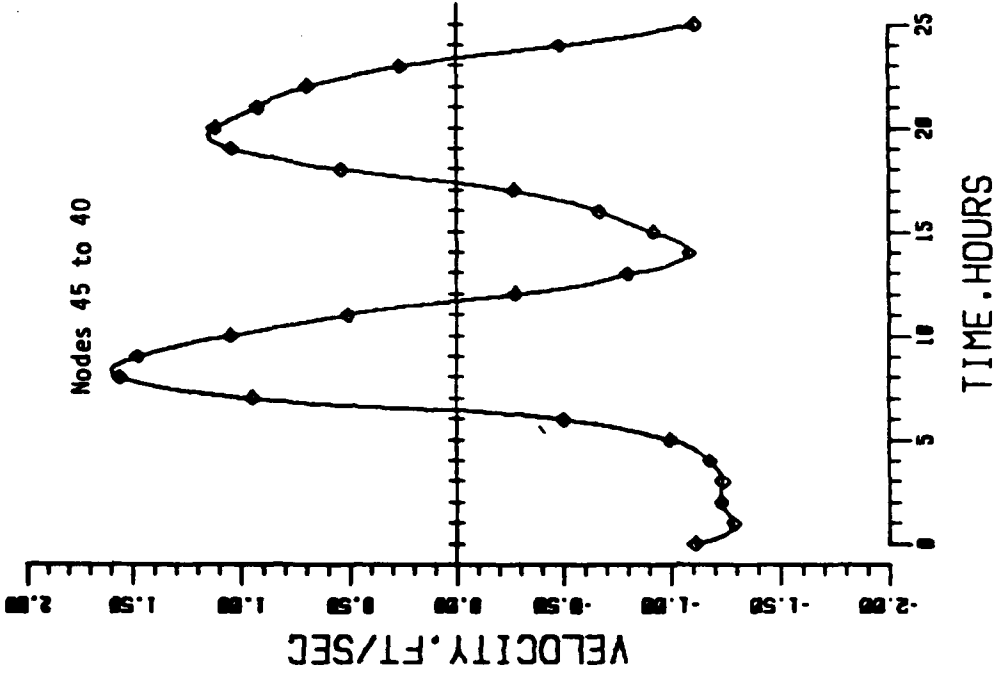

FIGURE 6
TYPICAL VELOCITIES WITHIN THE CHANNELS OF THE
EASTERN PORTION OF THE CULLINAN RANCH DEVELOPMENT

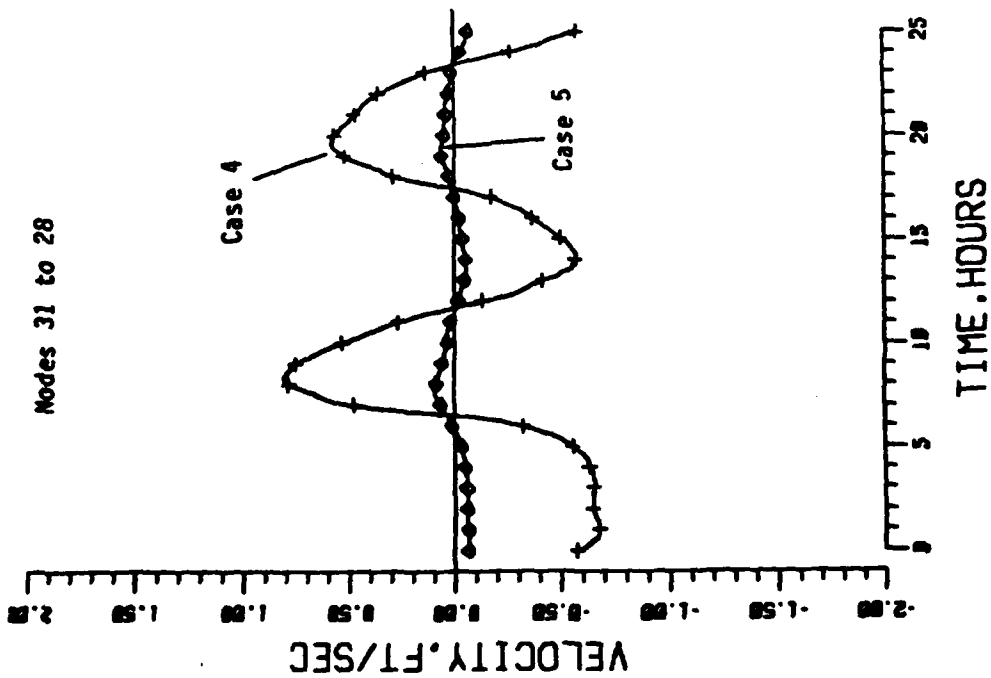
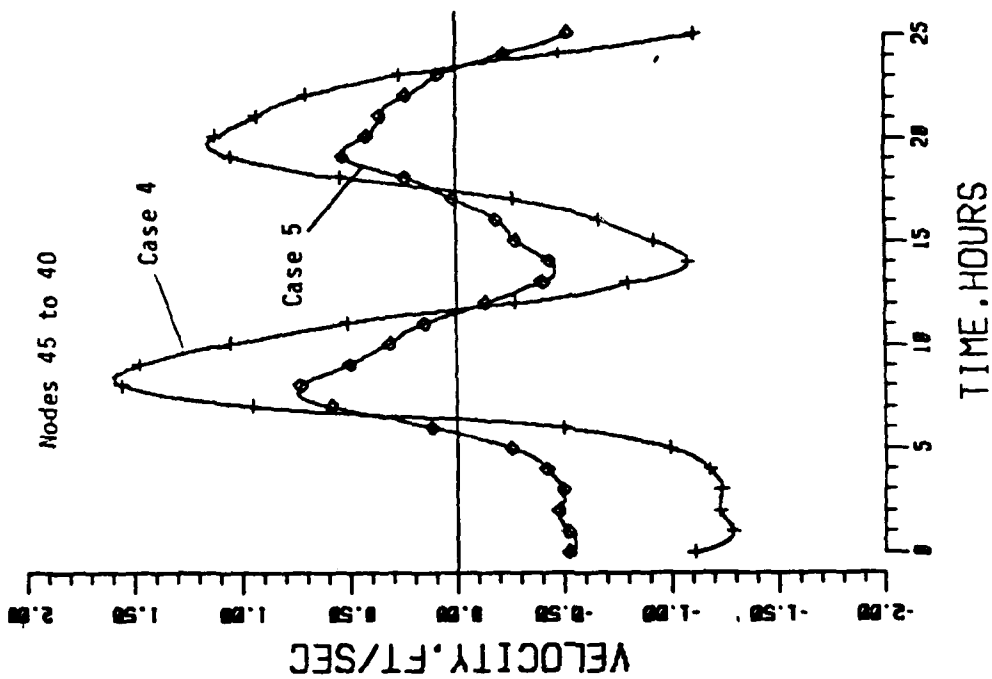

FIGURE 7
VELOCITIES WITHIN THE CULLINAN RANCH DEVELOPMENT
FOR CASE 4 AND CASE 5 CONFIGURATION

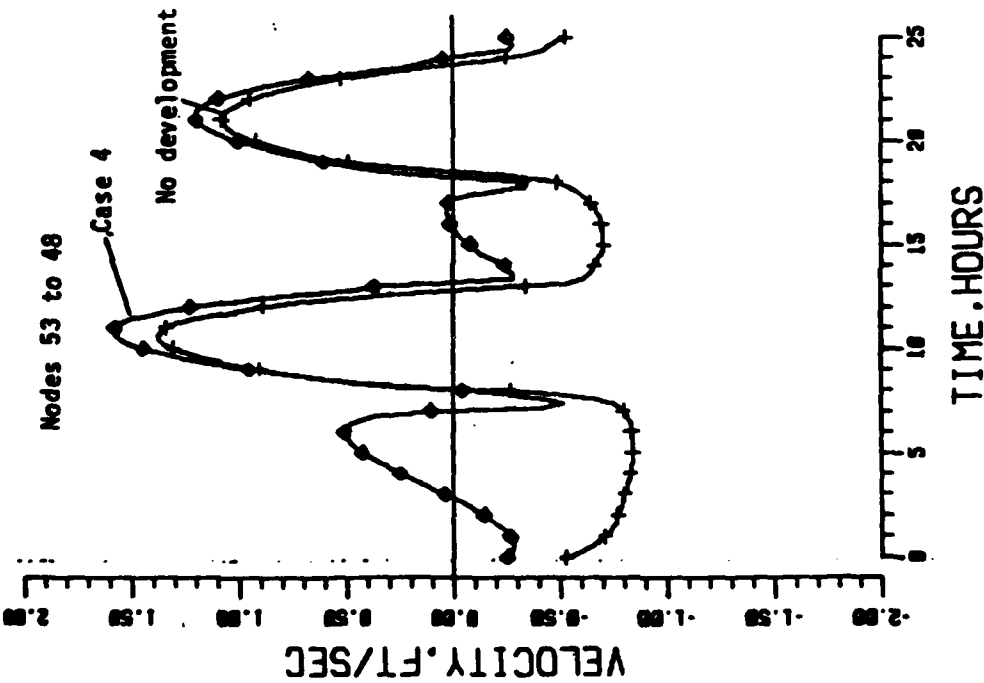
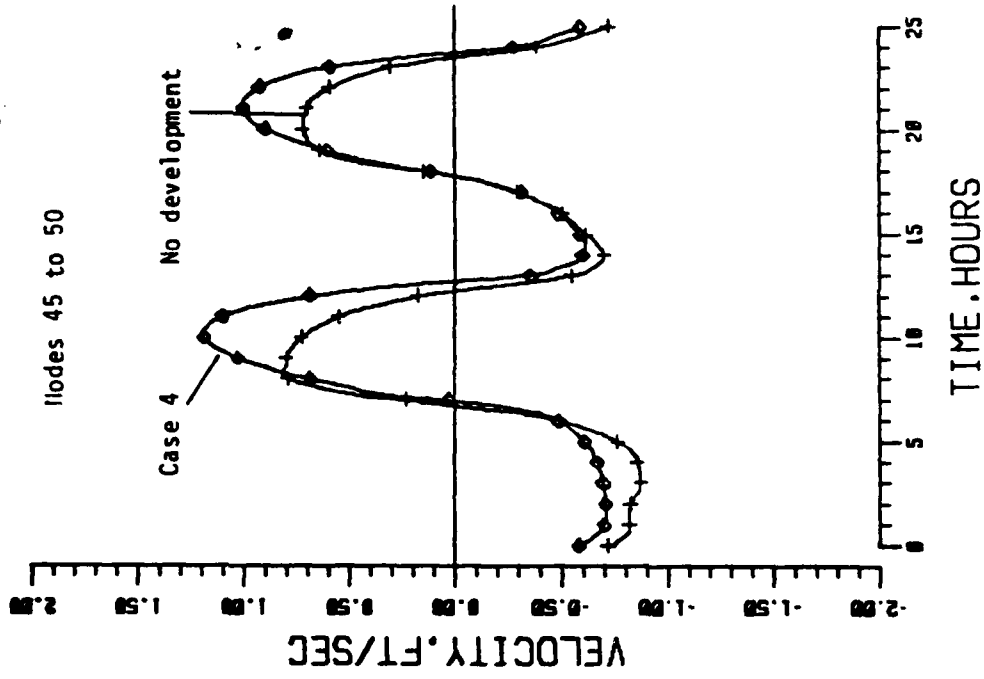

FIGURE 8
COMPUTED VELOCITIES IN SOUTH AND DUTCHMAN SLOUGHS
WITHOUT THE DEVELOPMENT AND FOR THE CASE 4 CONFIGURATION

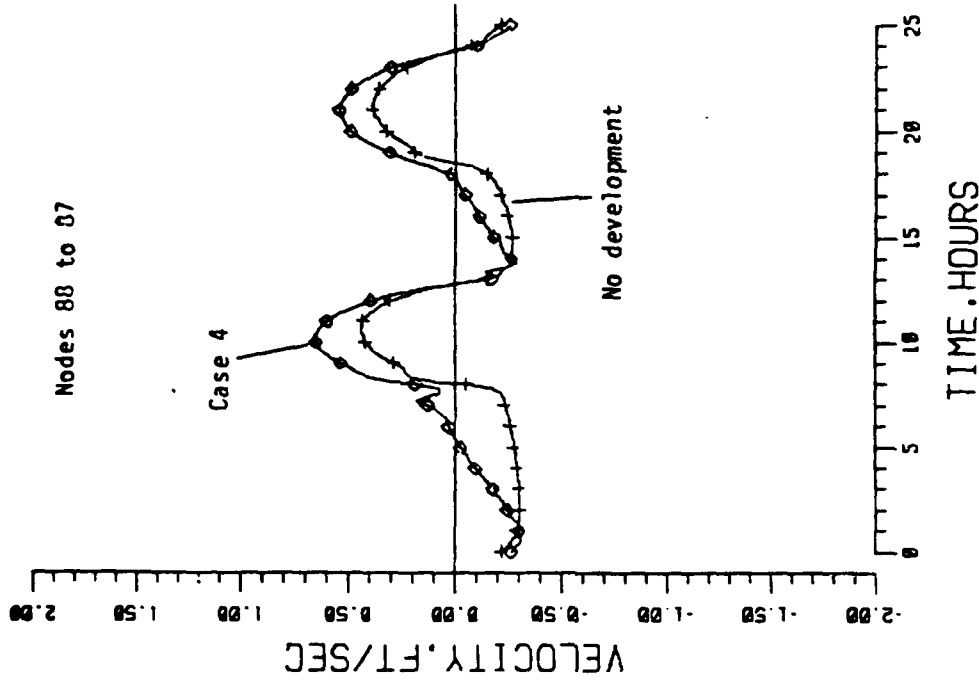
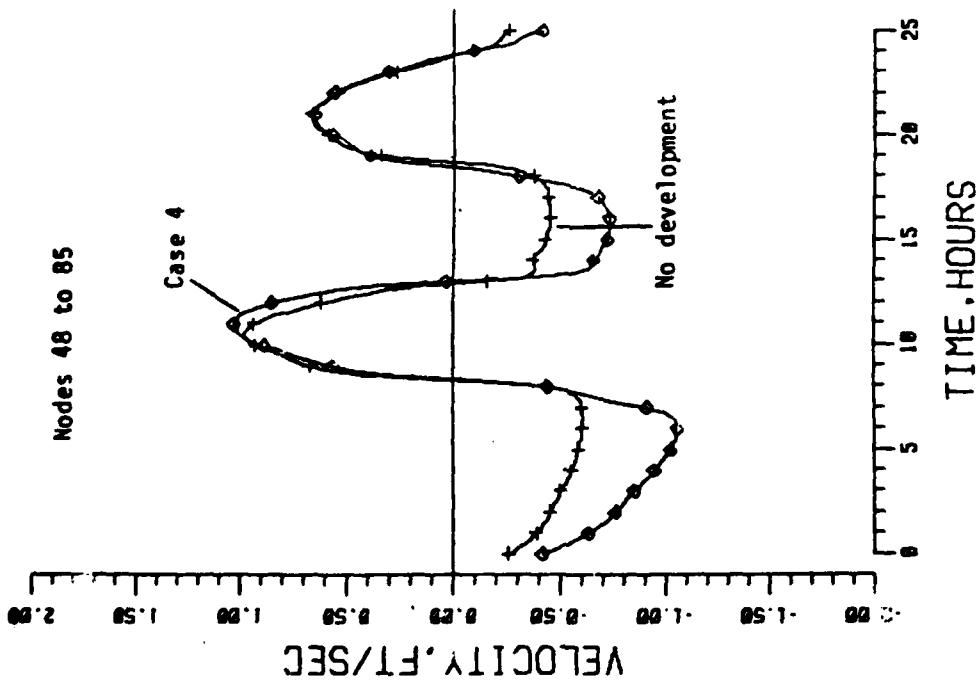

FIGURE 9
 VELOCITIES IN SOUTH SLOUGH WITHOUT THE DEVELOPMENT
 AND FOR THE CASE 4 CONFIGURATION

85, west of the project, are affected only during ebb. The peak ebb velocities are increased to about one foot per second. Velocities between nodes 88 and 87 are increased during flood, but would still be less than one foot per second.

Flows in the portion of Dutchman Slough between the project entrance and Napa River are plotted for both the full project, Case 4, and the partial project, Case 5, in Figure 10. Flows under existing conditions are also plotted in Figure 10 to show the effect of the increased tidal prism created by the project. Peak flows of two ft/sec or more would be desirable to prevent sediment accumulation in this channel. A smaller cross-section would be desirable during the first stages of the project in order to assure adequate velocities for channel maintenance.

Flows in the slough channels are now very much smaller than they were prior to diking the islands. At that time, the waters that flooded the islands during high tides flowed in and out through the sloughs. The channels were undoubtedly deeper then, and the flows varied over a wider range. The Cullinan Ranch project will provide a small amount of tidal prism and hydraulic conditions that will increase currents slightly toward the earlier condition. No undesirable impacts of the project on flows in adjacent sloughs are evident.

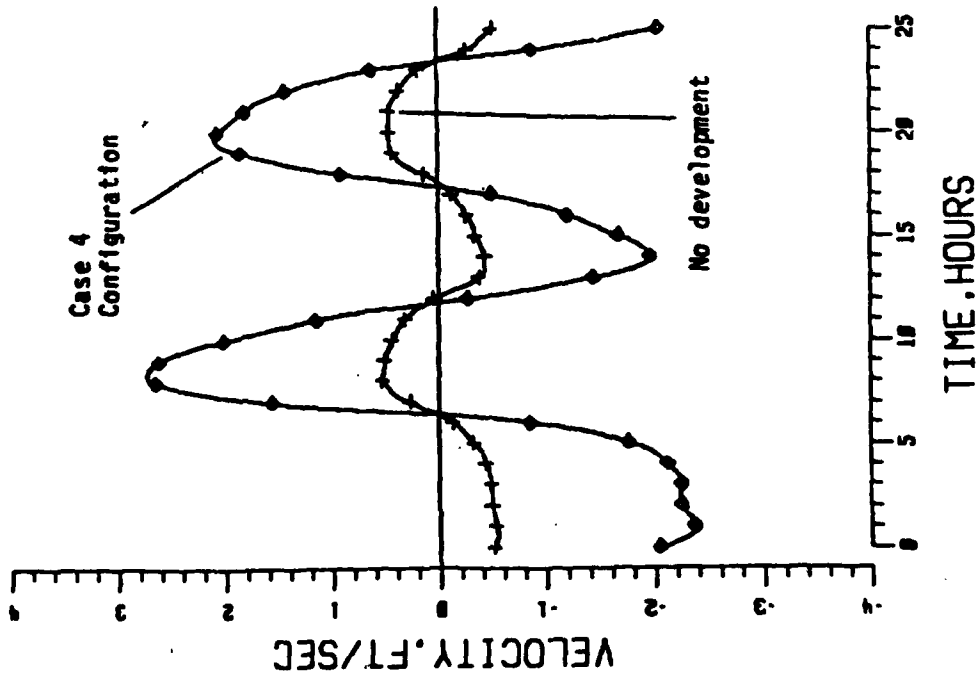
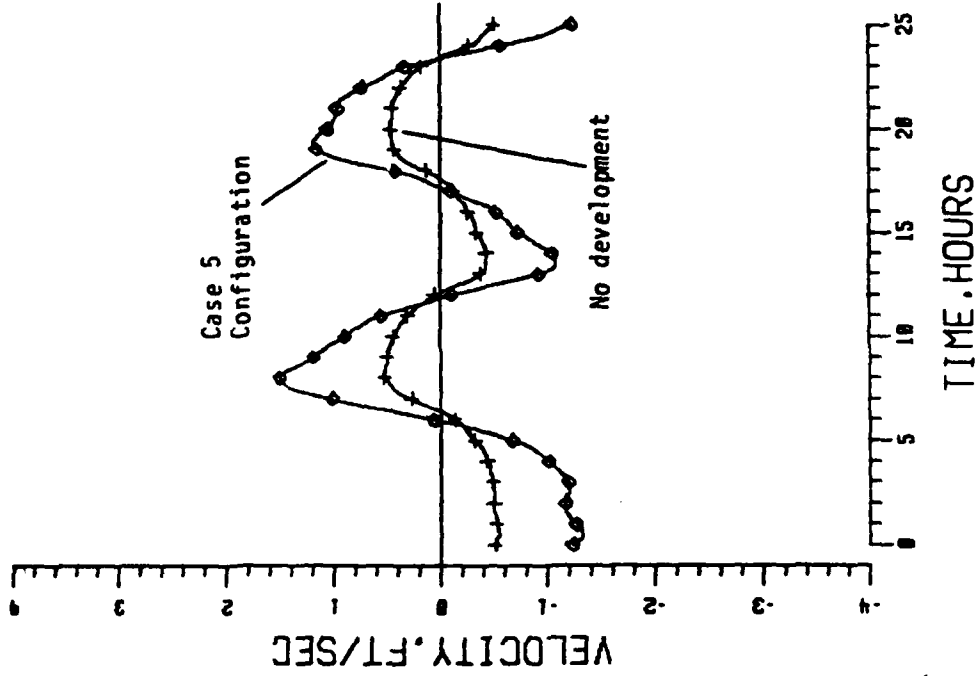

FIGURE 10
COMPUTED VELOCITY IN DUTCHMAN SLOUGH BETWEEN THE
DEVELOPMENT ENTRANCE AND NAPA RIVER WITHOUT THE
DEVELOPMENT AND WITH THE CASE 4 AND CASE 5 CONFIGURATION

TIDAL FLUSHING

A second mathematical model was used to calculate average residence times, in days, at the nodes of the grid used for the hydraulic computations. This model uses the discharges computed with the hydraulic model to calculate dilution and transport of water constituents. Residence times in the project were found by starting the computation with a tracer uniformly distributed throughout the project and none in the sloughs. The rate of decay of concentration in the project was then used to calculate average residence times. This method includes effects of waters that move out of the project during ebb and partially return during flood: the average residence time is the average time for waters in the project to be replaced by new water.

Flushing For The Five Configurations

Average residence times in the project waters for the full project with an open connection at the northwest end to South Slough, no connection, and with tide gates (Cases 1, 2, and 3) are plotted in Figures 11, 12 and 13. Figure 11 shows that average residence times ranging up to 14 days would occur in the western part of the project with the connection to South Slough. Figure 12 shows that very much longer average residence times would prevail without a connection to South Slough. Figure 13 shows that installation of tide gates will greatly reduce average residence times. The maximum residence time with tide gates installed would be 7 days. Clearly this alternative is advantageous.

Case 4, the presently planned configuration, will not have connecting channels between distal ends of the lateral channels, and the land area northwest of the power line easement will not have the channel system shown for Cases 1, 2, and 3. A plot showing the average residence times for this configuration is presented in Figure 14. Comparison of Figures 13 and 14 shows that closing the channels across the ends of the laterals affects residence times only slightly. This configuration provides short residence times throughout the full development.

Average residence times for a partial project without tide gates are plotted in Figure 15. Residence times are longest in the southwest corner

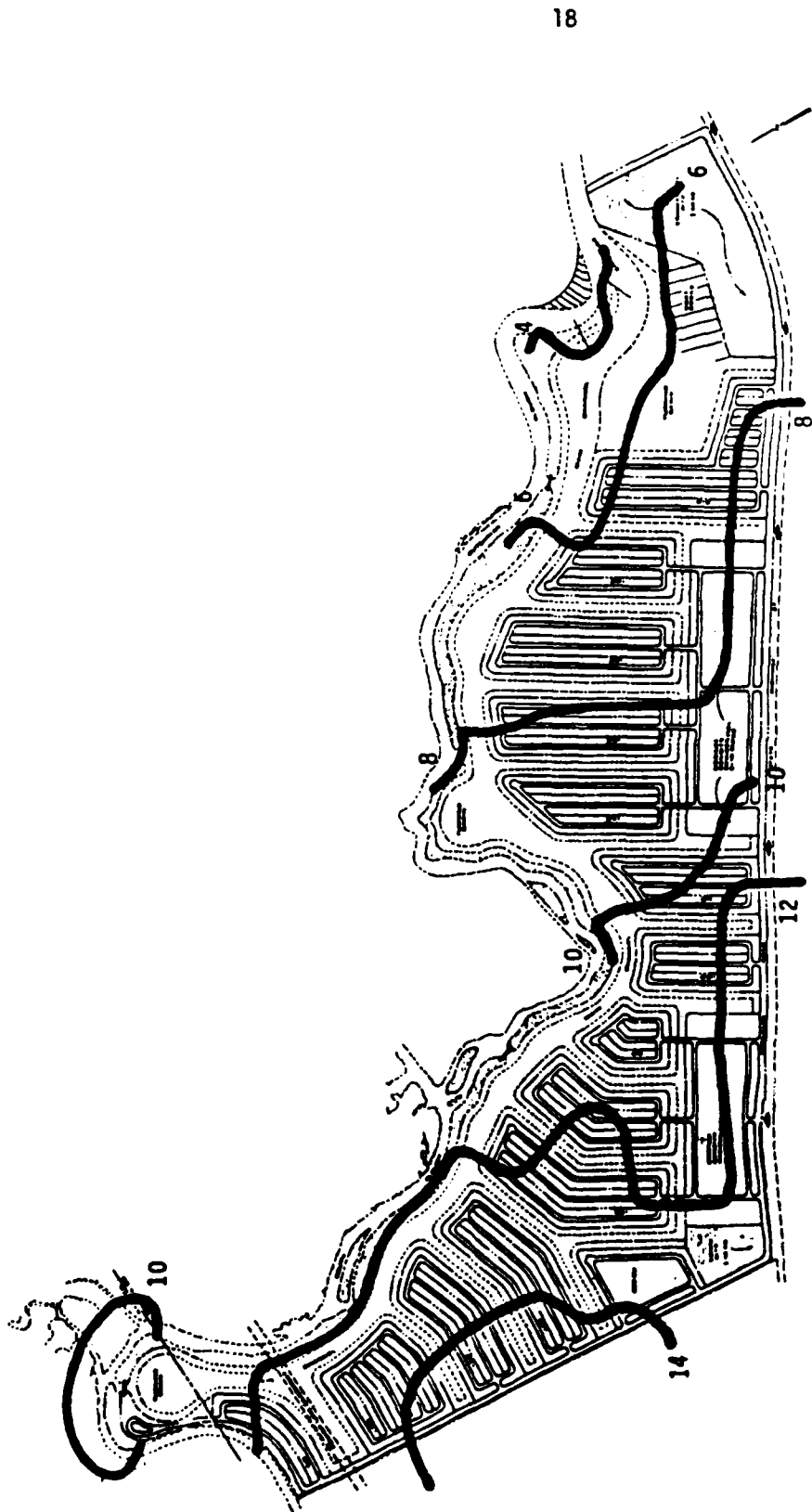

FIGURE 11
RESIDENCE TIMES FOR CASE 11 CONFIGURATION

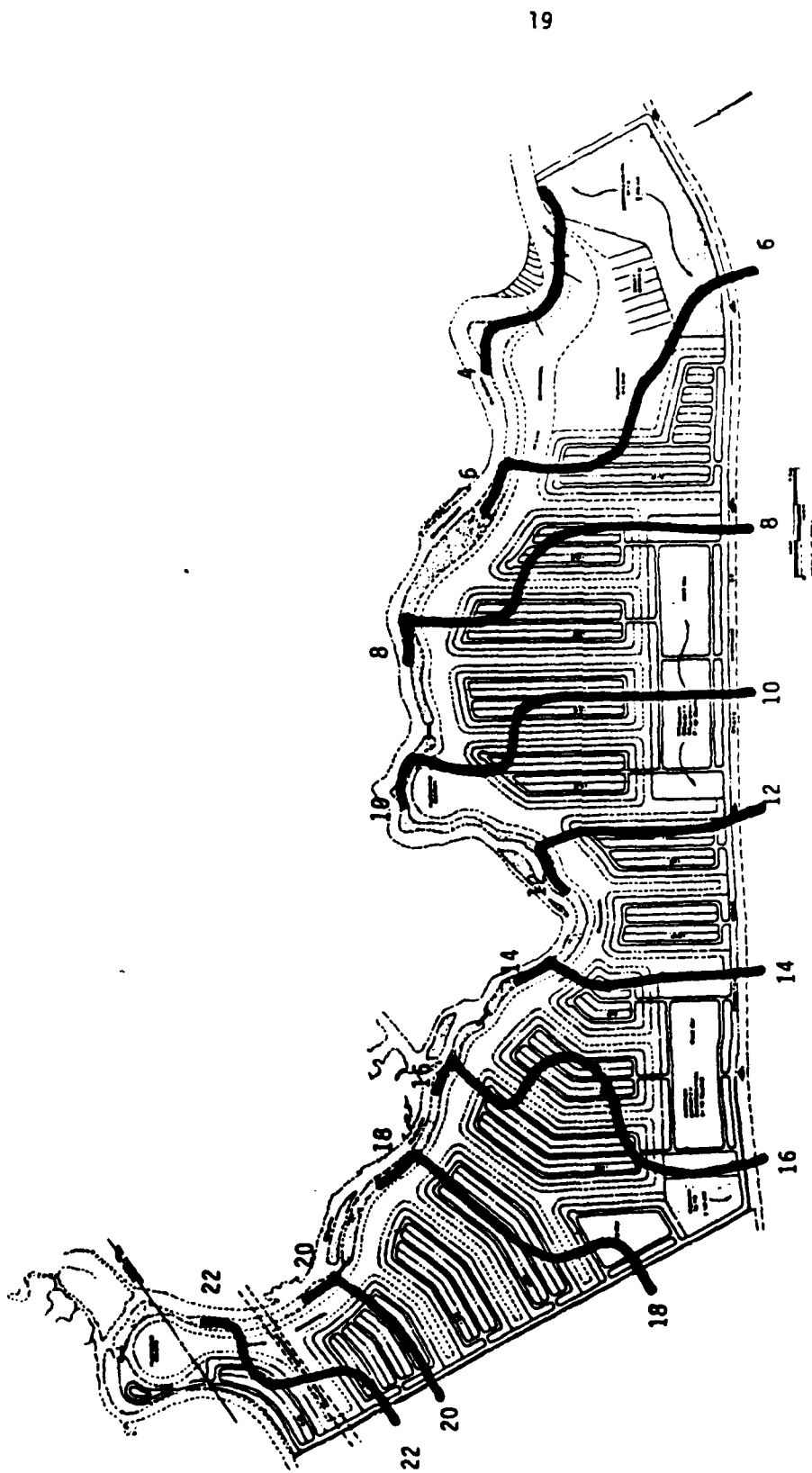

FIGURE 12
RESIDENCE TIMES FOR CASE 2 CONFIGURATION

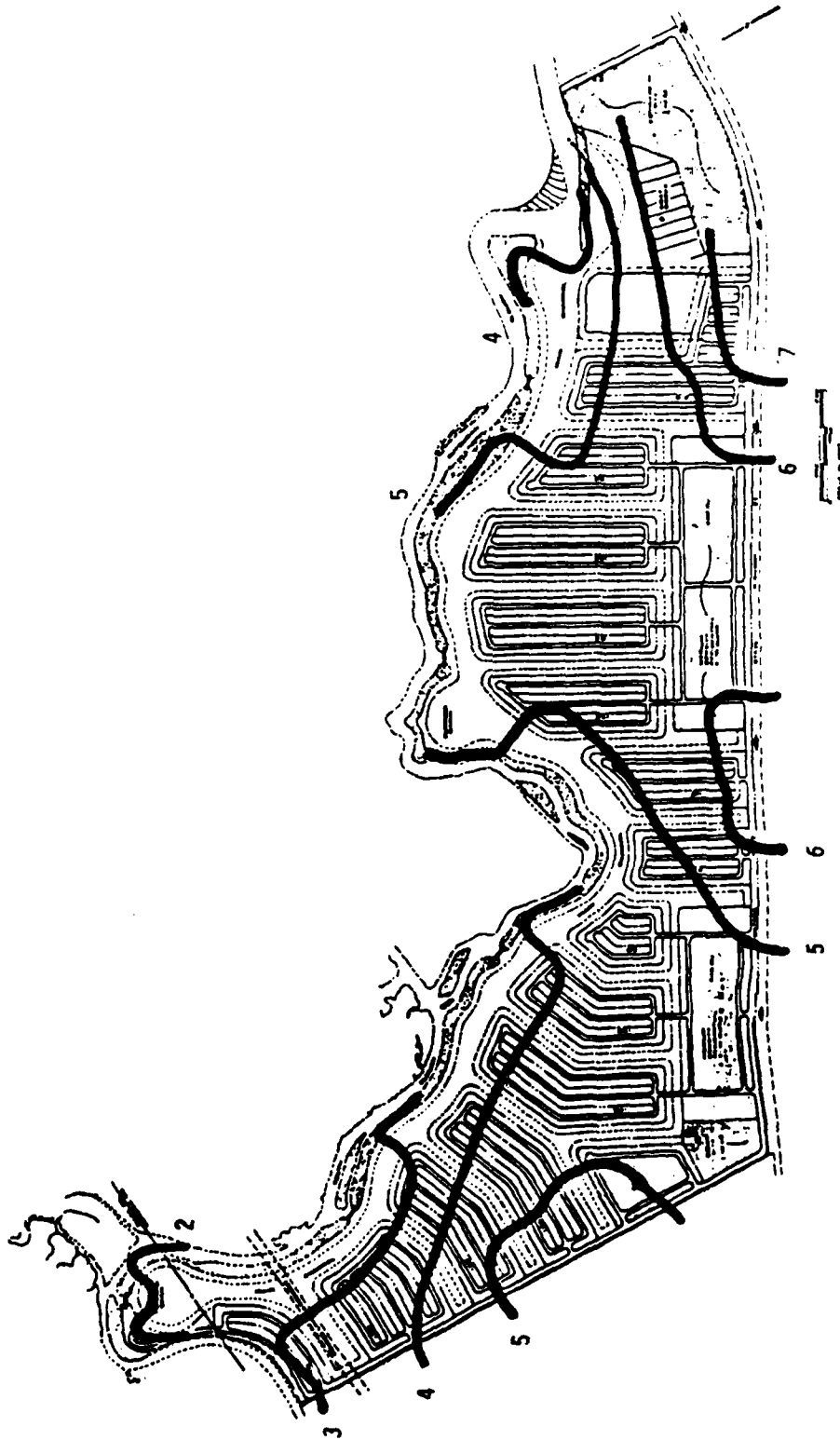

FIGURE 13

RESIDENCE TIMES FOR CASE 3 CONFIGURATION

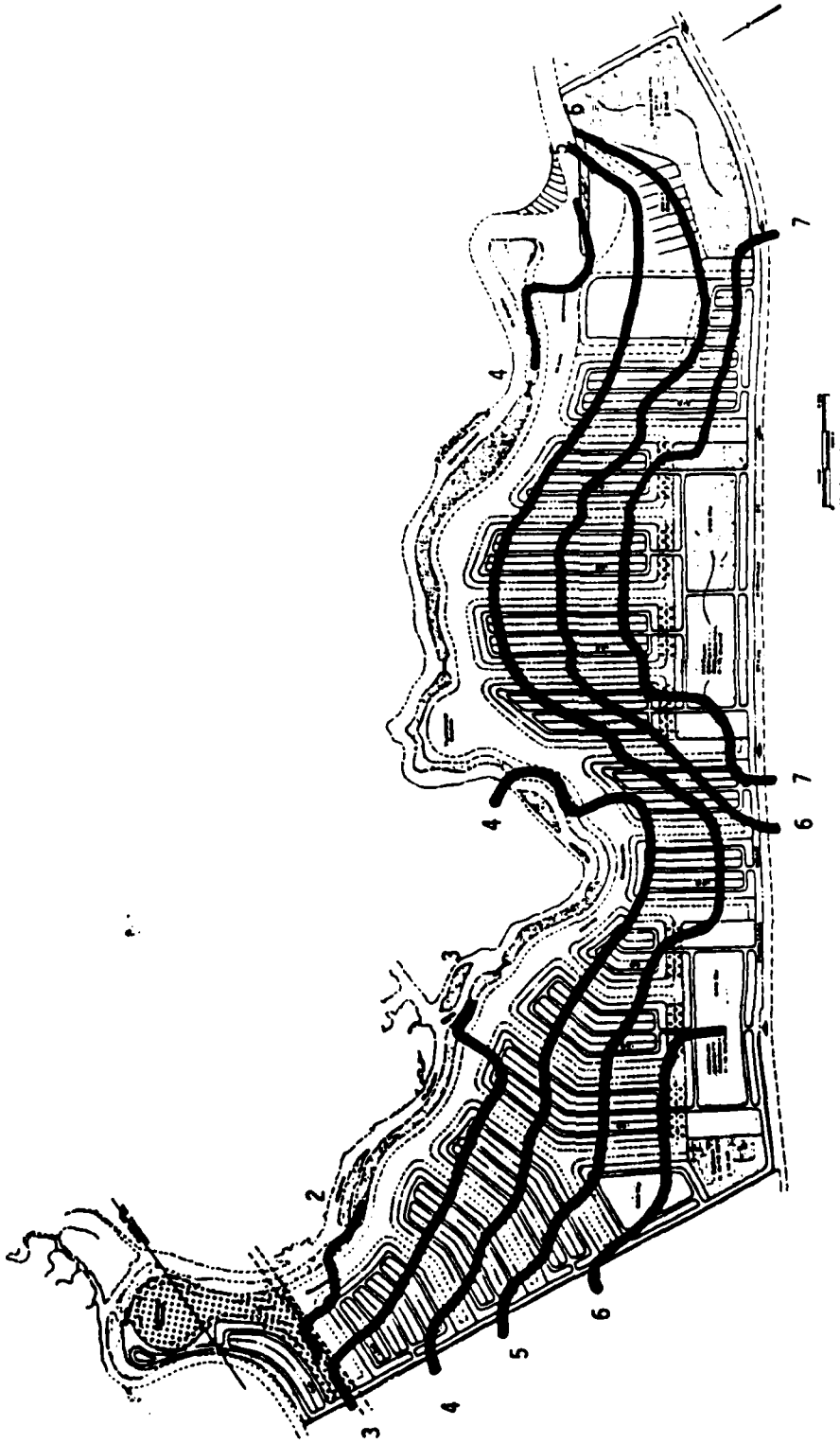

FIGURE 14
RESIDENCE TIMES FOR CASE 4 CONFIGURATION

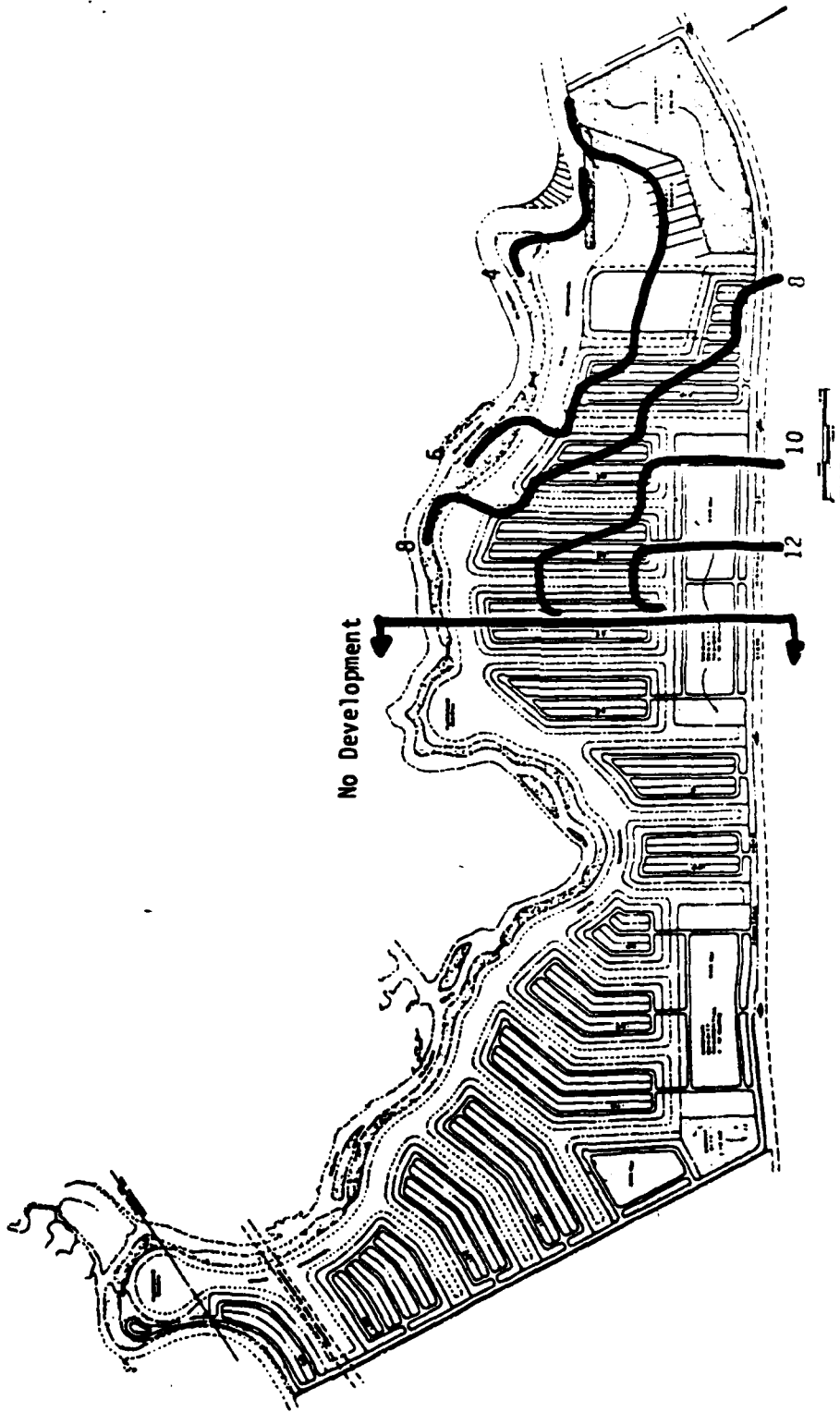

FIGURE 15
RESIDENCE TIMES FOR CASE 5 CONFIGURATION

of the project with this configuration. The 12 day maximum time at the end of the last lateral should be acceptable, however.

Algae Growth

As described in the introduction, a number of factors affect growth rates and accumulation of algae. Important aspects of the Cullinan Ranch project are the water depths, turbidities, and the average retention times. Other factors, such as nutrient supply, usually do not limit algae growth in summer.

The project will have average water depths of 13.2 ft (-10 ft MLLW and 3.2 ft to MTL).

Turbidities are not known for waters of the Napa River above the State Highway 37 bridge. The useful dimension is the extinction coefficient, which describes the fraction of light reduction for each successive foot. Arthur and Ball* report an average extinction coefficient for April through October, 1969-74, in Carquinez Strait at the entrance to Mare Island Strait of 0.77 per ft. Their report also shows chlorophyll concentrations in Carquinez Strait of 5 µg/l. DiToro** developed an expression for the extinction coefficient, k_e in fraction of light per meter:

$$k_e = .052 N + 0.174 D + .031 C, \quad (1)$$

where N is the non-volatile suspended solids concentration in mg/l, D is the suspended detritus concentration in mg/l, and C is the chlorophyll-a concentration of the algae in µg/l per liter. The extinction coefficient in units of ft^{-1} is $0.305 k_e$. Neglecting the detritus and taking $C = 5 \text{ µg/l}$ leads to $N = 46 \text{ mg/l}$. The median suspended solids concentrations shown

* Arthur, J. F., and Ball, M. D., The Significance of the Entrapment Zone Location to the Phytoplankton Standing Crop in the San Francisco Bay-Delta Estuary, U.S. Dept. Interior Water and Power Resource Service, 2800 Cottage Way, Sacramento, CA 95825.

** DiToro, D. M., "Optics of Turbid Estuarine Waters II. Application to San Francisco Bay Estuary," Environmental Engineering, Manhattan College, Bronx, NY, 1977.

for the same area* is reported as falling between 50 and 60 mg/l. Suspended material settles in Mare Island Strait, so that the summertime suspended solids concentration is probably slightly lower at the mouth of Dutchman Slough.

The rate of increase of algae in project waters can be estimated by the following relation** :

$$\frac{dP}{dt} = (G_p - D_p) P + \frac{1}{t_d} (P_0 - P) \quad (2)$$

where P is the concentration of phytoplankton, in the project, P_0 is the concentration of phytoplankton in entering waters, G_p is the growth rate, D_p the death rate, t is time in days, and t_d is the average retention time. In our calculation of maximum concentrations of algae, it is assumed that nutrients are plentiful, and that the algae concentrations are limited only by light penetration into the water, death due to endogeneous respiration, and flushing, as specified by equation 2.

G_p and D_p are given by the following relations:

$$G_p = k_1(1.066)^{(T - 20)} \left[\frac{ef}{k_e H} (e^{-\alpha_1} - e^{-\alpha_0}) \right] \quad (3)$$

where k_1 is the maximum multiplication rate, T is water temperature, f is fraction of a day that is light, and H is the water depth. α_1 and α_0 are

$$\alpha_1 = \frac{I_a}{I_s} e^{-k_e H}$$

$$\alpha_0 = \frac{I_a}{I_s}$$

*Storrs, P. N., Pearson, E. A., and Selleck, R. E., Final Report: "A Comprehensive Study of San Francisco Bay," V. 5, SERL and School of Public Health, U. CA, Berkeley. SERL Report 67-2, December, 1966.

**"Analysis of Phytoplankton Growth and Death Kinetics in the Central Delta," HydroQual, Inc., 1 Lethbridge Plaza, Mahwah, N. J. 07430.

where I_a is the incident light intensity and I_s is the light intensity for maximum growth rate

$$D_p = k_2 T + k_3 \quad (4)$$

where k_2 and k_3 are empirical constants.

The summertime suspended solids concentrations at the project are not known, except that they will probably be slightly lower than 50 mg/l. The chlorophyll-a concentration in Dutchman Slough can conservatively be taken to be 10 µg/l. Taking P to be proportional to C , we can combine equations 1 through 4 to obtain the maximum chlorophyll-a concentrations in the project for any non-volatile suspended solids concentration: that is the concentration at which self-shading plus absorption of light by solids combines with flushing and death to limit further growth.

The following conservative conditions were used in the calculations:

$$k_1 = 2.0 \text{ day}^{-1}$$

$$T = 20^\circ \text{ C}$$

$$k_3 = 0.5$$

$$L = 13.2 \text{ ft}$$

$$I_a = 600 \text{ langleys/day}$$

$$I_s = 300 \text{ langleys/day}$$

$$C_0 = 10 \text{ µg/l}$$

$$k_2 = .01/^\circ \text{C}$$

$$k_2 = 0$$

$$t_d = 7 \text{ days (Case 4), and 12 days (Case 5)}$$

These values were obtained from the references given except the value of C_0 , which allows for some growth in Napa River. The results of the calculations are:

Non-volatile S.S. mg/l	Chlorophyll-a μg/l	
	$t_d = 12$	$t_d = 7$
10	55	43
20	39	30
30	26	19
40	16	13
50	11	10

These figures show that for typical suspended solids concentrations near 50 mg/l, the algae concentrations in the remote parts of the project will be at most only slightly more than those in Dutchman Slough now. These results are especially encouraging when the additional limitations due to suspended detritus and removal by sedimentation are considered. Algae should not be a nuisance in the Cullinan Ranch project.

SEDIMENTATION

Tidal flows into the project will carry suspended solids. These solids, as demonstrated by sediment that accumulates in Mare Island Strait,* are composed of about 60 percent clay sized particles, and the remainder is silt. Such particles have settling velocities that are too slow to cause significant deposition rates unless they become aggregated. Cohesion of suspended particles results from the presence of sea salts in the tidal waters, and collisions of suspended material are facilitated by velocity gradients throughout the flow. Material suspended in waters of Dutchman Slough will be aggregated and will have settling velocities that can cause significant deposition rates.

The supply of suspended solids is variable throughout a year, and from year to year. A brief description of sediment transport in the San Francisco Bay-Delta system** will provide a basis for describing the supply to Dutchman Slough.

Sediment Transport in the San Francisco Bay System

Approximately 80 percent of the sediment entering the Bay system in tributary streams comes from erosion of the soils in the 59,000 square mile Central Valley drainage basin. The remainder enters with runoff from local tributaries. Most of the sediment arrives with the high winter and early spring high flows from rainfall and snowmelt. It first deposits in the upper bays. San Pablo Bay contains most of the new sediment, and new deposits up to two feet thick are observed there in early spring. This sediment consists of about 60 percent clay sized minerals, 30 percent silt sized mineral, and the remainder is fine sand.

* Krone, R. B., "Flume Studies of the Transport of Sediment in Estuarial Shoaling Processes," Sanitary Engrg. Res. Lab., U.C. Berkeley 1962.

** Krone, R. B., "Sedimentation in the San Francisco Bay System," in San Francisco Bay, the Urbanized Estuary, T. J. Conomos, Ed., AAAS Pacific Division, 1979.

During late spring and summer months, the air rises over the hot Central Valley, causing daily onshore breezes across the San Francisco Bay system. These breezes generate waves on the shallow bays. The waves suspend the deposited material and hold the material in suspension while tidal currents transport it back and forth. Each night, when the wind dies, material settles to the bed in shallow areas, then is resuspended the following day. The current patterns in the system cause circulation of the waters from the upper bays to Central and South San Francisco Bays and return, so that the supply of sediment from the Central Valley works its way through the system, and a portion is continually lost to the ocean.

Waves are more effective for suspending fine particles than coarser ones. Successive deposition and resuspension by waves results in transport of finer particles as the material works its way through the system.

The ability of waves of a given height and period to suspend sediment diminishes rapidly with water depth. At some depth a given wave will no longer erode bottom material. The upper bays, including most of San Pablo Bay, have filled to an elevation where the wave action during a year erodes nearly all of the annual supply of new sediment and facilitates its movement on through the system. Sea level is rising at about 0.6 ft per century. The elevations of the beds of the shallow upper bays follow this rise, so that a portion of the new material remains there, but most moves on. Half of the annual supply of sediment now remains in the system and the remainder is carried through the Golden Gate to the Pacific Ocean.

The water circulation in the estuary between the middle of San Pablo Bay and, say, Chipps Island has an impact on sedimentation in Mare Island Strait and the Napa River. This region is often described as the "mixing zone" because it is the portion of the system most affected by the mixing of fresh river waters and saline ocean waters. The ocean waters are more dense than are river waters and tend to intrude upstream along the bed under the seaward flowing fresher water. Tidal currents cause the waters to alternately flood and ebb in this region with an excursion of about 6 miles. The tidal flow, combined with roughnesses of the bed, causes vertical mixing of these waters and reduces the salinity differences between the water at the surface and near the bed to a few parts per

thousand. This difference is enough to maintain a net landward flow of more saline water near the bed. The near-bed water mixes upward over the length of the mixing zone and augments the seaward flow near the surface by as much as 10 times the freshwater inflow.

Sediment suspended by waves in San Pablo Bay is carried upstream by this near-bed flow in very large amounts during March through May or June. It mixes upward into the seaward flow and is carried back downstream to settle in San Pablo Bay. If the Bay is quiet, the material will remain until winds generate waves the next day, then re-enter this circulation. As described earlier, sediment is continually lost from San Pablo Bay to the lower bays, and by early summer the supply for the upstream circulation dwindles.

Mare Island Strait is a deepened and widened arm off of Carquinez Strait. Tidal flows into Mare Island Strait are out of phase with those in Carquinez Strait, but the denser sediment-laden waters near the bed flow up into the deepened portion of Mare Island Strait, which extends to the causeway. There is a net upstream flow near the bed and downstream flow near the surface in this region. A large fraction of the suspended sediment settles to the bed and the water, depleted of its load, rises as it is displaced by more dense sediment-laden water. An average of 2.2 million cubic yards settles in Mare Island Strait annually.

Tidal waters moving upstream from the causeway are waters that have had a large part of their load removed. No suspended solids data for waters in this region have been found.

Sedimentation in the Cullinan Ranch Project

The rate of sediment accumulation in the marina can be minimized by minimizing the amount of sediment-laden water that passes through the marina during a tidal cycle. The entrance to the marina should be not wider than 400 ft at the water surface and the marina enclosure should otherwise be water tight. The entrance should be oriented parallel to the flow into the remainder of the project so that there is little circulation induced within the marina during a rising tide.

An example of a suitable entrance configuration is shown in Figure 16. The entrance should not be located east of the location shown in

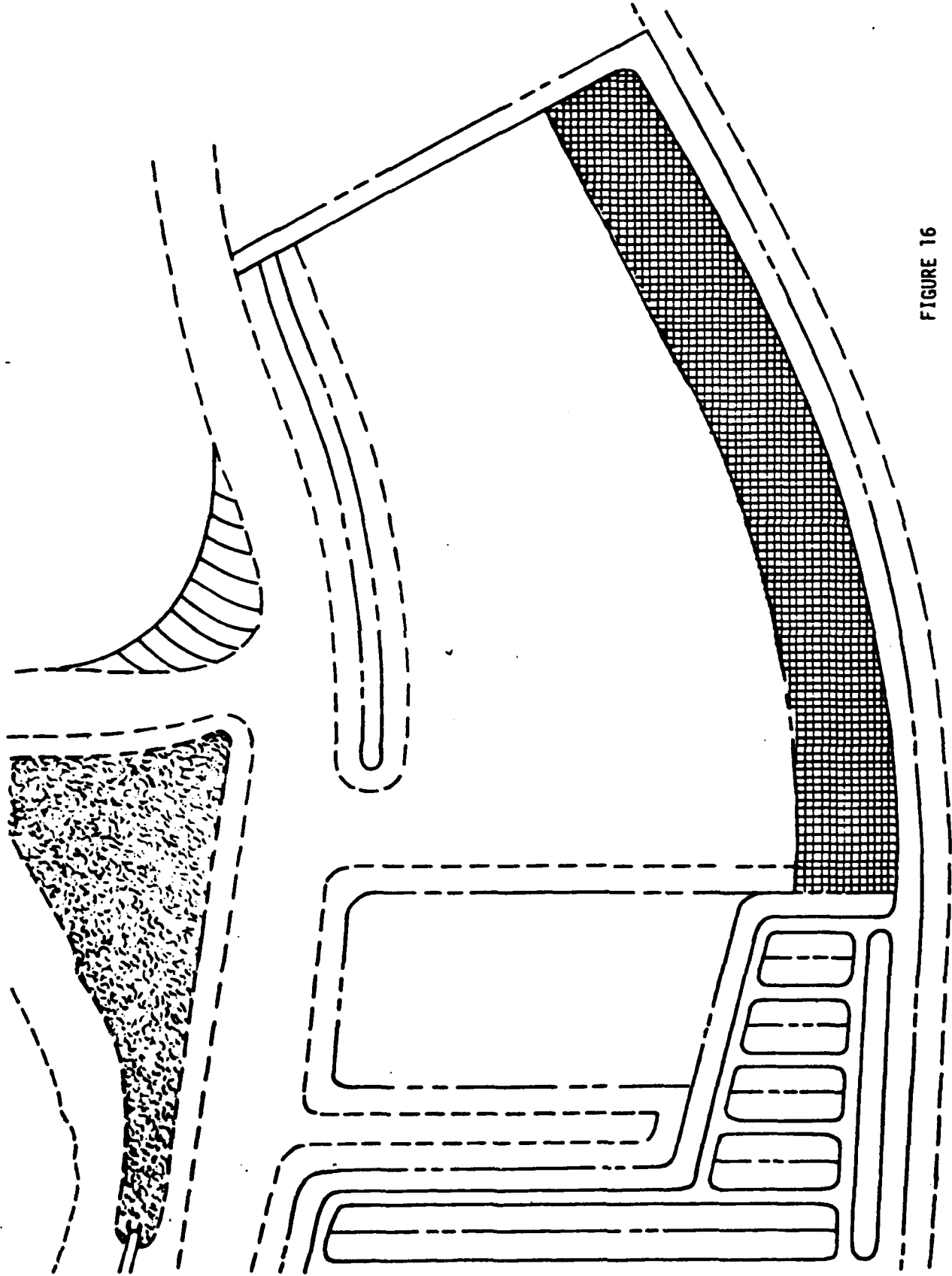

FIGURE 16
ENTRANCE FOR THE CULLINAN RANCH PROJECT

order to avoid undesirable currents from Dutchman's Slough.

A direct computation of sedimentation rates in the marina or in the remainder of the project is precluded by the absence of suspended solids data. An estimate can be made, however, by comparison with sedimentation rates at other harbors. From measured sedimentation rates, tide amplitudes, sediment density, laboratory test data, and harbor configuration an "effective" suspended solids concentration can be calculated. This concentration is one that would cause the observed rate of deposition if it prevailed all of the time. Such calculations for Palo Alto Yacht Harbor and Cove Apartments in San Rafael, which have entrances directly off of mud flat areas, yielded effective suspended solids concentrations of 250 mg/l. The sedimentation rate reported by the Harbormaster at Point San Pablo Marina led to an effective suspended solids concentration of 180 mg/l. This marina is connected to deep water by a short channel across a shallow region. In view of the removal of suspended sediment from waters flowing from San Pablo Bay in Mare Island Strait, a reasonable estimate of the effective suspended solids concentration in Dutchman's Slough would be 180 mg/l.

The mathematical model was used to calculate the deposition rate in the Cullinan Ranch marina. The sediment deposit density was taken to be 1.270-g/cu cm (as in Mare Island Strait), the side slopes 1:4, and the mean tide range was 4.6 ft. This computation yielded a sedimentation rate of 0.48 ft/year. In order to provide storage volume for the sediment that would last 20 years, the marina should be excavated to -20 ft MLLW or -22.6 ft NGVD. This depth would provide a 10 ft MLLW depth at the end of the 20 year period.

Sedimentation in the Project Channels

In order to minimize future dredging costs and the nuisance of dredging in the lateral channels, it would be desirable to localize deposition to a convenient location for future dredging. The main channel along the north edge of the project should be deepened to provide a sediment trap. Deepening to -23 ft NGVD should provide at least a 20 year storage volume.

Sedimentation in Dutchman Slough

The increased tidal prism provided by the project will cause increased flows in Dutchman Slough between the entrance and Napa River. This increased flow will maintain a larger cross-section than that of the natural slough. The prism provided by the full development, Case 4, plus flows in the remaining sloughs would maintain a channel with a 3000 sq ft cross-section below mean tide level: -12.6 ft NGVD by 188 ft across the bottom with 1 on 4 side slopes. For the partial development, Case 5, a cross-section of 1730 sq ft will maintain itself. For a 10 ft channel at mean lower low water, this cross section would be met by a trapezoidal channel -12.6 ft NGVD by 87 ft across the bottom with 1:4 side slopes.

If the Napa River entrance to Dutchman Slough is deepened across the shallow edge of Napa River, the deposition rate there will be appreciable. Flow across the cut will create hydraulic conditions in the cut that will promote very rapid accumulation of mud unless the cut has slopes of 1:10 or flatter. This slope can be achieved by dredging steps on either side with 2 ft risers and 20 ft treads. Deposition will fill the steps to form smooth slopes. A sketch showing such a dredged cut for the Case 5 channel is presented in Figure 17. Alternatively, parallel jetties to deep water can be constructed. If this option is selected, the design of the entrance should be made to produce scour across the entrance.

Sediment Disposal

An area of 90 acres, including perimeter dikes, is available at the northwest end of the project for use in disposing of dredged material. This area can either be filled by land disposal of sediment or used for settling and drying facilities that would prepare the sediment material for use as fill or for dike maintenance. A hydraulic dredge and a permanently installed pipeline to the disposal site would be the most economical and convenient facility for dredging and transporting sediment to the disposal facilities. Sediment disposal operations, using these facilities, are described in this section.

Maintenance dredging would begin when the marina and channels have filled to about -10 ft MLLW, approximately 20 years after construction of

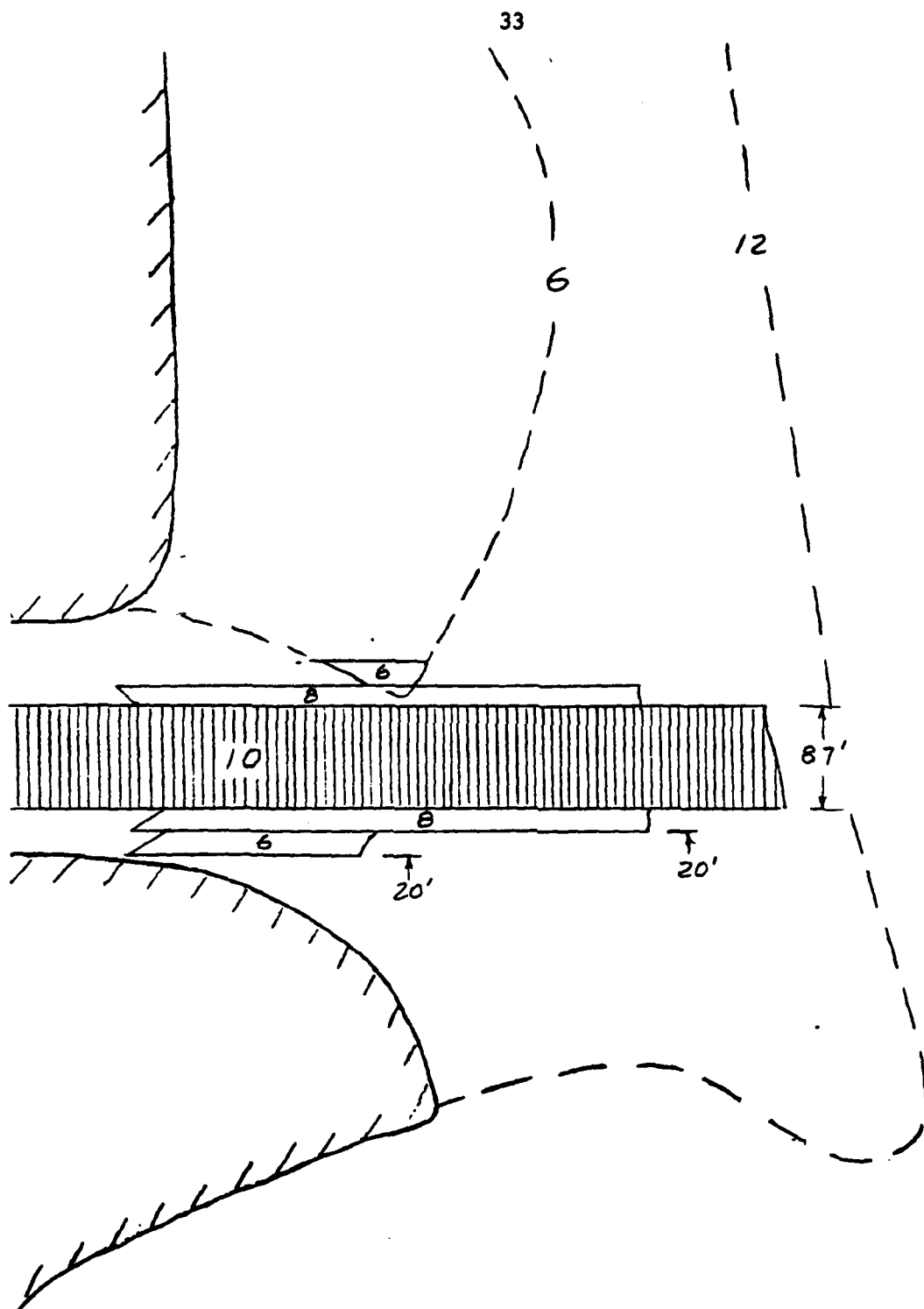

) FIG 17. DREDGED ENTRANCE TO DUTCHMAN SLOUGH FOR PARTIAL DEVELOPMENT

the marina. An estimate of sedimentation in the main channel plus that in the marina at that depth leads to an annual in-place sediment volume of 4.8 million cubic feet. A rotating annual maintenance operation is recommended, with a dredging cycle of five years. This mode of operation would remove a layer about 2.5 ft thick as dredging progressed through the waterways.

The disposal area should be divided into three ponds as shown in Figure 18. The ponds should be prepared with smooth beds sloping downward from the inlet ends at a slope of 1:1000. The enclosed dikes should have a top elevation seven feet above the shallow end. A manifold with two or more valved discharge ports at the shallow end of each pond should be installed to provide a reasonably uniform distribution across the width of the pond. Floating outlet weirs with crest lengths exceeding 10 ft should be located at the ends of the ponds. These weirs are required to decant the supernatant water after the mud has settled.

A small suction dredge capable of 75 cubic yards per hour (cy/hr) net production is envisaged. A MUDCAT dredge would be capable of such production. Twenty-four hour operation for five days of each week is planned, with the dredge quiet on week ends to avoid obstruction to weekend boaters and to simplify personnel scheduling. It is estimated that the dredge will be required to operate for 20 weeks each year. The dredge should be operated to produce a slurry not more than 5.0 times the volume of sediment removed.

The operation of the ponds includes filling, settling, decanting, and drying. The ponds should be filled to 5.6 ft average depth. At a dredging rate of 75 cy/h, and with a bulking factor of 5.0, the ponds 1, 2, and 3 would be filled in 5, 6, and 4.5 weeks, respectively. The ponds should be filled one at a time so that the processing is staggered.

Settling should continue five days after a pond has been filled to allow a high degree of clarification. The supernatant water should then be removed through the adjustable floating weirs, using caution to prevent disturbance of settled mud. The weirs should be lowered finally below the surface of the mud to facilitate continued drainage of the deposit. The supernatant water will be aerobic and should have very low suspended solids

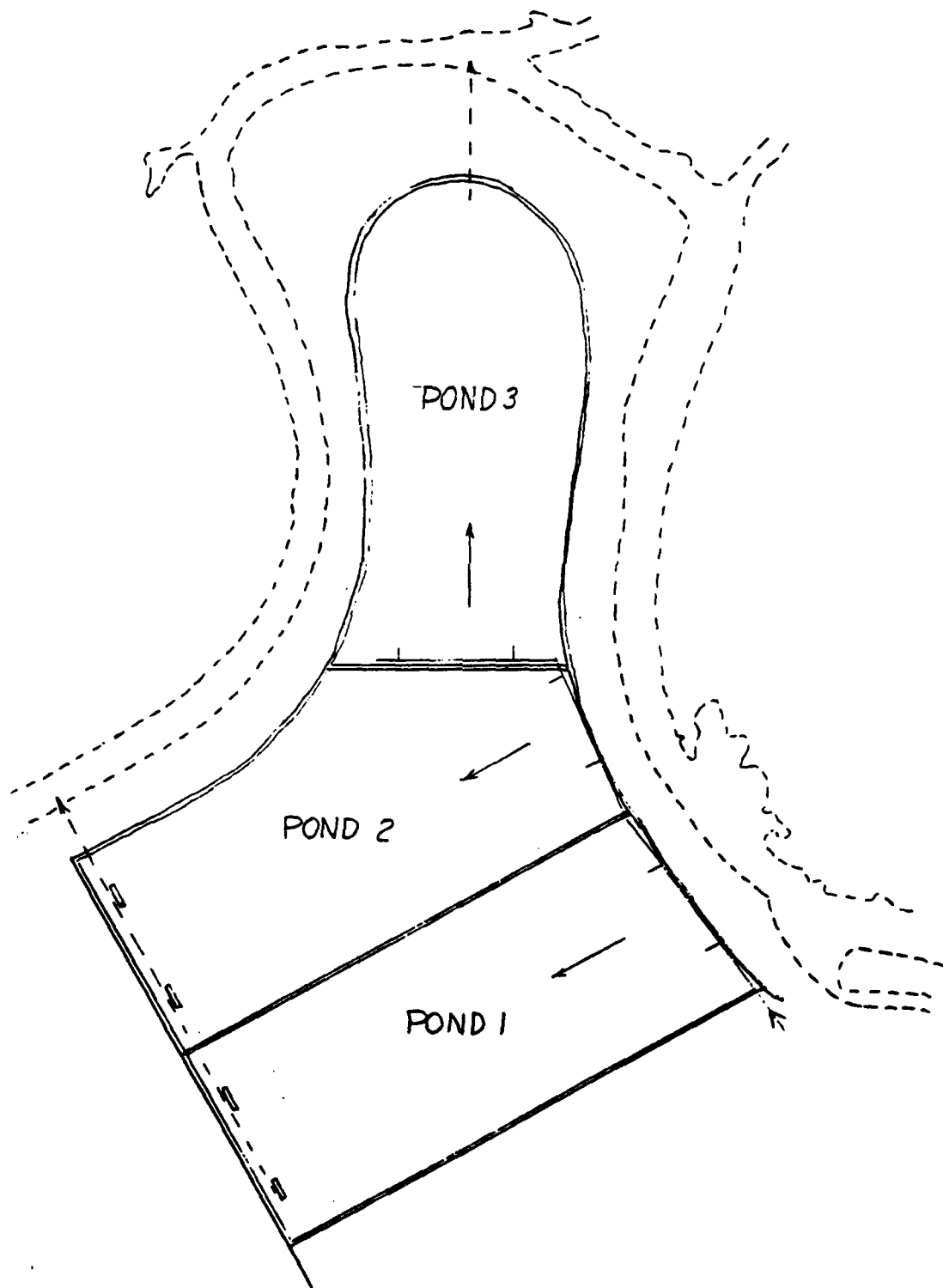

FIG 18 SEDIMENT DISPOSAL POND CONFIGURATION

POND

1		2		3	
FILL	DRAIN	FILL	DRAIN	FILL	DRAIN
DRY	DRY	DRY	DRY	DRY	DRY
FILL	FILL	FILL	FILL	FILL	FILL
DRAIN	DRAIN	DRAIN	DRAIN	DRAIN	DRAIN
DRY	DRY	DRY	DRY	DRY	DRY

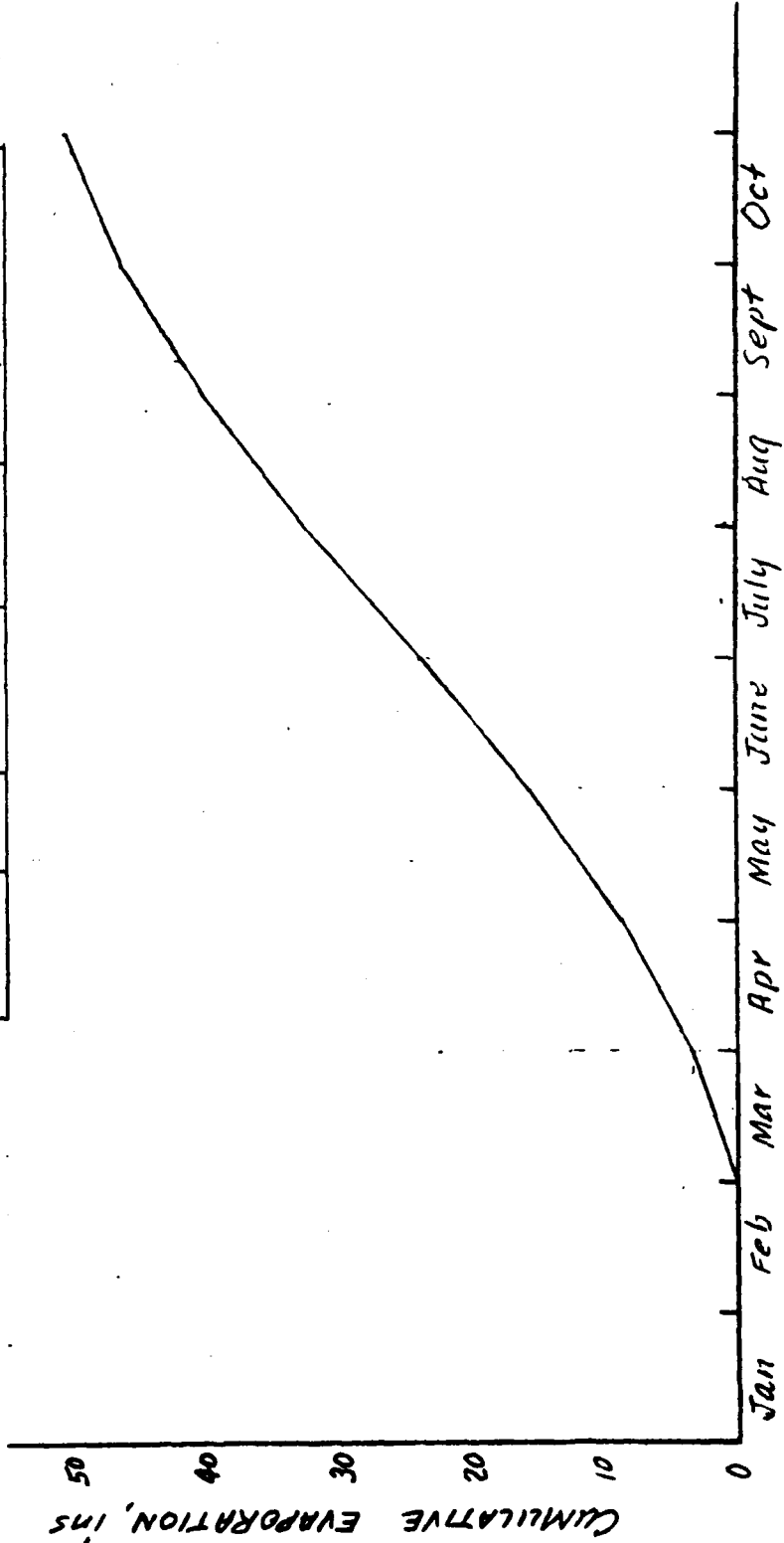

FIG 19 SCHEDULE OF POND OPERATION

contents so that discharge either within the project or into South Slough would not be objectionable.

The new mud deposit will average 12 inches in thickness. Drainage would be accelerated if grooves are cut toward the drain. The soil in the region is clayey, however, and it might not be feasible to operate even a tractor with a light tread load in the ponds. Decanting and draining should require about two weeks.

Drying to 30 percent (dry basis) moisture content will require evaporation of 8.5 inches of water. The mean monthly pan evaporation rates at Dutton's Landing^{*} are as follows:

Month	Evaporation, ins.
October	4.70
November	2.28
December	1.47
January	1.42
February	2.12
March	3.87
April	5.71
May	7.80
June	9.17
July	9.48
August	8.53
September	7.00

The evaporation rate from the mud surface is expected to be 0.9 times the pan evaporation rate. These data were used to construct the cumulative evaporation curve shown in Figure 19. The curve, together with the pond filling times and three weeks to decant and drain, led to the schedule of pond operation shown at the top of Figure 19. The schedule shows that the dredge could work from January 15 to August 15 and that all ponds could

^{*} California Department of Water Resources Bulletin No. 73-1, "Evaporation from Water Surfaces in California, May, 1974.

dry two fillings. The total in-place sediment volume accommodated by this operation annually would be 6.8 million cubic feet (253,000 cubic yards). This capacity is 1.4 times as much as needed for annual maintenance, and provides flexibility of operation. The dredge can operate 20 weeks every year within the fill times shown in Figure 19, or the dredge could operate throughout the period shown two years out of three.

A volume shrinkage on drying to 0.60 of the in-place volume is expected, based on laboratory tests. The pond operation outline above should yield an average 6.6-inch layer of dried mud having a moisture content of 30 percent (dry basis). The dried material can be harvested and used for project fill, used for dike maintenance in the region, or used for sanitary land fill cover, etc. It would not be suitable for agriculture or horticulture without further treatment. Harvesting and use would provide a disposal capacity that would last as long as a use for the dried mud can be found.

Alternatively, the mud can be left in the ponds and accumulated year after year. The pond dikes and inlet and outlet structures would have to be raised every year or so. Dried material from the ponds would be used to raise the dikes. As the elevation of the ponds rise, however, pumping costs increase, and at some level the "artificial mountain" would become aesthetically objectionable. A 30-year life would leave a mound 23 ft above the original bed.

OTHER MODIFICATIONS

During the remainder of the planning and design phases of the project it may be desirable to alter the present plans. This section of the report is included to facilitate such changes and to encourage changes that favorably affect algae growth and sedimentation rates.

The computations presented utilized the worst case situations that are likely to be encountered. For example, water depths for the algae growth rate calculations were taken to be 10 ft at MLLW. If the marina and main channel are made deeper, as recommended, the algae growth rate will be sharply reduced: algae concentrations can be lower than those in Dutchman Slough when the water is deeper. On the other hand, shallower depths will cause increased algae concentrations. Similarly, the flushing rates, algae computations, and impacts on flows in nearby sloughs were evaluated for the completed project. Partial project development will have generally lesser impact on the sloughs.

Case 5 was included to show about the largest partial project that should be developed without tide gates at its west end. Development beyond that point should include one set of tide gates, and the tide gates should be relocated to the westerly end of the project on the completion of each subsequent stage. If it is desired to locate the tide gates beyond the western limits of development, the channel along the north edge of the developed area to the tide gates will be needed. The tops of the conduits should be at elevation 0 ft MLLW or lower to assure full flow during most of the tidal cycle. 72-inch circular conduits would place the bottom below -6 ft MLLW. Pipe arches or box-section conduits would raise this elevation slightly. In any case, the bottom of the channel at the discharge should be about 2 ft lower than the bottom of the conduit to assure clearance for the tide gates. The channel from the tide gates to the main project waterway should have a cross-section of 320 sq ft below MLLW: for side slopes of 1:4, this cross-section would be provided by a V-shaped ditch with the bottom at -9 ft MLLW (-11.6 ft NGVD). This cross-section would provide velocities adequate to prevent deposition in the channel. An enlargement at the discharge end, if needed to accommodate multiple tide

gates, would have to be cleaned out regularly to prevent accumulation of sediment. Tide gates discharging directly into the large main waterway would be maintained by the regular maintenance operation.

Effects of other modifications are included in appropriate sections of this report.

CONCLUSIONS AND RECOMMENDATIONS

The study of tides, currents, flushing, and sedimentation in the waterways of the Cullinan Ranch development project led to the following conclusions and recommendations:

1. The increased tidal prism provided by the project will enhance flows in Dutchman Slough between the project entrance and Napa River. Adjusting the cross-section of this reach at each stage of the project to provide peak velocities of 2.5 ft/sec will keep the reach free of sedimentation. The channel entrance in Napa River will require flat side slopes to prevent sedimentation there.
2. The effects of the project on flows in the other nearby sloughs will be small.
3. The best flushing rates and least sedimentation rates will be obtained if tide gates are provided at the northwest end of the project. These tide gates will permit flow only into the project. No other connections between the project and the sloughs except the entrance should be made. Tide gates should be installed when the development stage is larger than half the completed project (Case 5).
4. Flushing rates, turbidity, and water depths combine to prevent nuisance growths of algae. Computation of chlorophyll-a concentrations in areas having longest retention times show that for typical suspended solids concentrations the algae concentrations should be at most only slightly higher than those in Dutchman slough now.
5. The marina should have one narrow entrance, and the enclosure should otherwise be water tight. The entrance configuration should minimize circulation inside of the marina.

AD-A128 699

DRAFT ENVIRONMENTAL IMPACT REPORT/ENVIRONMENTAL IMPACT
STATEMENT CULLINAN RANCH SPECIFIC PLAN APPENDICES(U)
TORREY AND TORREY INC SAN FRANCISCO CA MAY 83

3/6

UNCLASSIFIED

F/G 13/2

NL

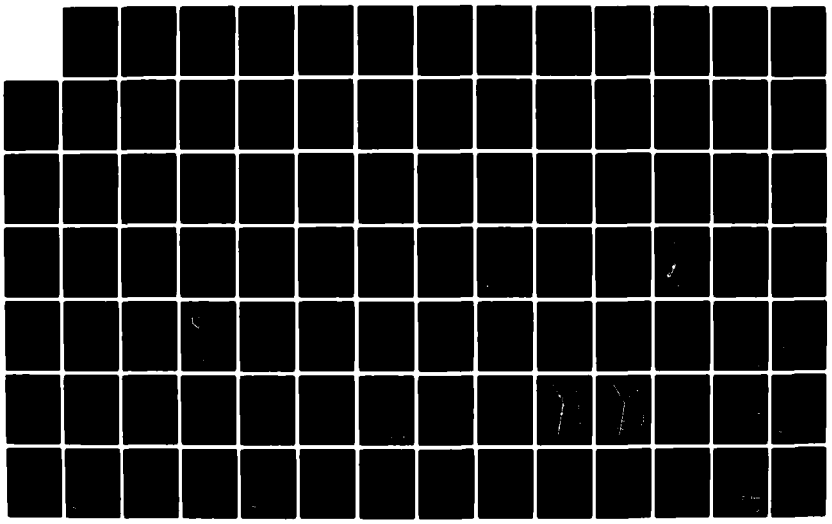

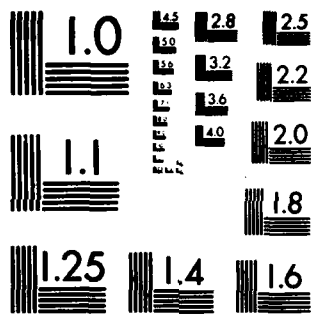

MICROCOPY RESOLUTION TEST CHART
NATIONAL BUREAU OF STANDARDS-1963-A

6. Based on limited information, the sedimentation rates were calculated to be 0.5 ft per year. At this rate, twenty years of storage can be provided by making the initial depth in the marina and in the main channel along the north edge of the project -20 ft MLLW.

7. A 90 acre site at the northwest end of the project site can be used to settle and dry sediment dredged for waterway maintenance. If the dried material is harvested for on-site or off-site uses, the capacity for sediment disposal is indefinite. Otherwise storage volume of this site is limited to 30 years after the start of maintenance dredging.

8. Maintenance dredging, after the 20 years' in-channel storage is filled, will require a pipeline to the sediment processing site and the use of a small dredge for twenty weeks or more during the period January through the middle of August.

9. Because of the importance of accurate information on sedimentation rates to future costs of the project, sounding surveys of the initial stage marina and channels should be made at intervals of two years or less. These survey data can then be used to calculate sedimentation rates in subsequent stages of development.

10. The dredging and disposal operations described require effective management if they are to be successful. Maintenance of equipment, scheduling, and monitoring the ponds are essential.

11. This report investigated impacts on neighboring sloughs, flushing rates, and algae growth for the completed project and for a mid stage of completion. Effects of other stages of development should be within those shown. Minor modifications of lateral channel bends or removing lateral channels would not increase residence times significantly.

**CULLINAN RANCH
BOAT TRAFFIC STUDY**

Prepared for

**W.R. Williams & Associates
P.O. Box 263
Huntington Beach, California 92648**

by

**Moffatt & Nichol, Engineers
250 West Wardlow Road
Long Beach, California 90807**

December, 1981

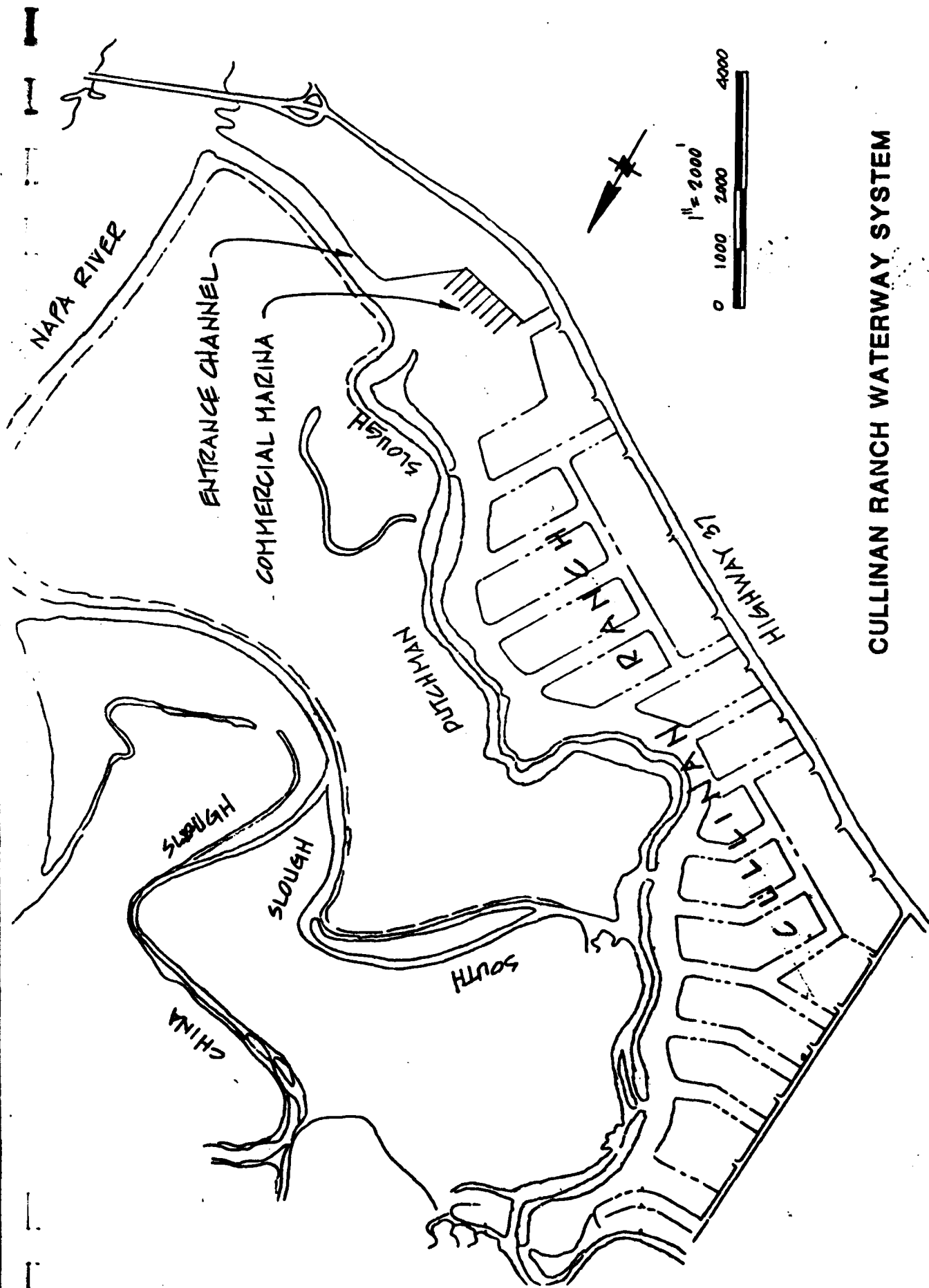

CULLINAN RANCH WATERWAY SYSTEM

FIGURE 1

1,450 additional boats.

Boat Characteristics

Assumed vessel and traffic characteristics are based on observations at Channel Islands Harbor, Oxnard, California.⁽¹⁾ Of primary interest is the use factor, or percentage of the boats which leave their slips on a given day. Other relevant data are size distribution, method of propulsion (sail or power), use pattern, and operating speed.

Channel Islands Harbor has a public marina area and also private docks associated with waterfront residential tracts. The breakdown of sail and power boats in the two areas is as follows:

	<u>Sail</u>	<u>Power</u>
Residential slips	38%	62%
Public slips	57%	43%

The anticipated split between sailboats and power boats at Cullinan Ranch, obtained from the above figures by assuming a 4:1 ratio between private and public slips, is 42% sail and 58% power.

The number of boats active at a particular time is strongly dependent on weather, and peak traffic naturally occurs on summer weekends. Counts made at Channel Islands on three summer Sundays in 1980 indicated that about 20% of the boats from the private area were active, while the public berth fleet had a peak daily use of around 25%. Public marinas appear to generate higher use rates than private slips. Both Alamitos Bay and Marina del Rey have peak daily use factors approaching 30%. In Anaheim-Sunset Bay the majority of slips belong to waterfront tracts similar to Cullinan Ranch, and there the peak summer use as measured in 1975 was 16%.⁽²⁾ In estimating the traffic at Cullinan Ranch the peak daily use was taken as 25%.

Daily use patterns for recreational boats have an approximately triangular shape, with traffic increasing steadily during the morning until some hour in the afternoon, and thereafter steadily decreasing. At the entrance to harbors and berthing areas, the peak for outbound traffic naturally precedes the inbound peak. Also, sailboat peaks occur later in the afternoon than power boat peaks. Figure 2 gives idealized hourly distributions which approximate the counts made at Channel Islands Harbor. The plots for combined traffic were constructed by adding sail and power together in proportions of 42% and 58%, respectively.

SAILBOATS

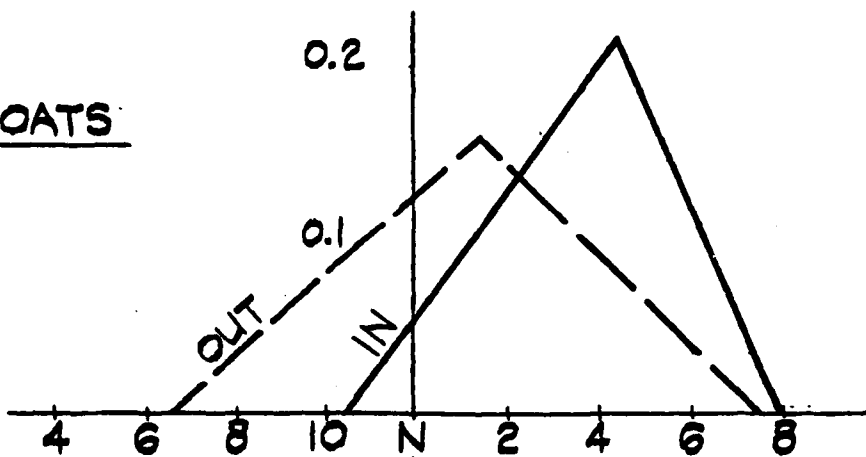

POWER BOATS

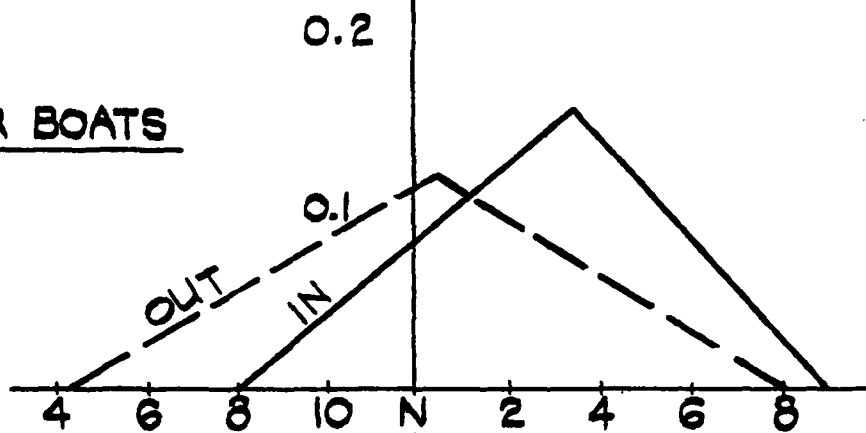

COMBINED

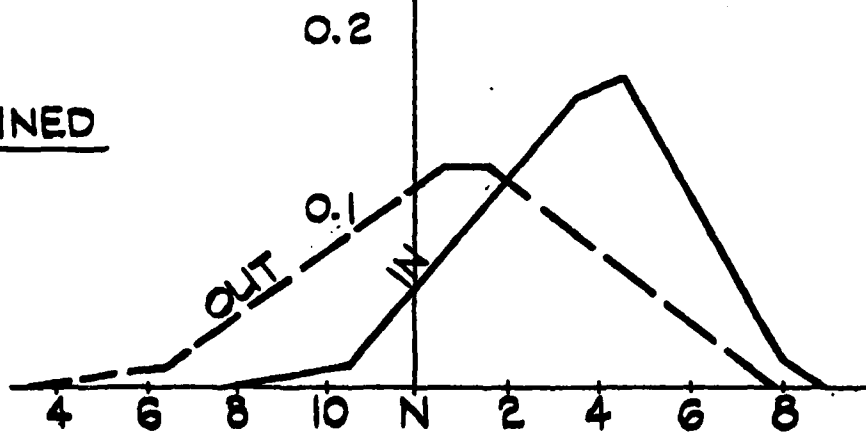

TIME OF DAY

FIGURE 2
HOURLY TRAFFIC DISTRIBUTIONS

The size distribution of the berthed boats can be estimated only generally. A length range of roughly 20 feet to 60 feet may be expected, with an average length of about 35 feet. The corresponding beam is about 10 feet.

Prevailing Winds

Winds at the project site are typified by data from San Pablo Station, shown in Figure 3 in the form of a wind rose. A strong sea breeze characterizes the Bay Area throughout spring and summer; west of Vallejo it blows from the southwest along the axis of the Napa Valley. Due east or west winds occur only 6% of the time. This means that boats under sail will normally be able to reach along the entrance channel without tacking.

Entrance Channel Traffic

Because of relatively long travel distances from the project waterways to open water in San Pablo Bay, there will be relatively few dry-stored sail boats using the entrance channel. Most of the traffic will be made up of boats berthed within the development that are making trips up the Napa River or into San Pablo Bay. Virtually all berthed sailboats will be equipped with auxiliary engines, and because of the long trip between the berthing areas and

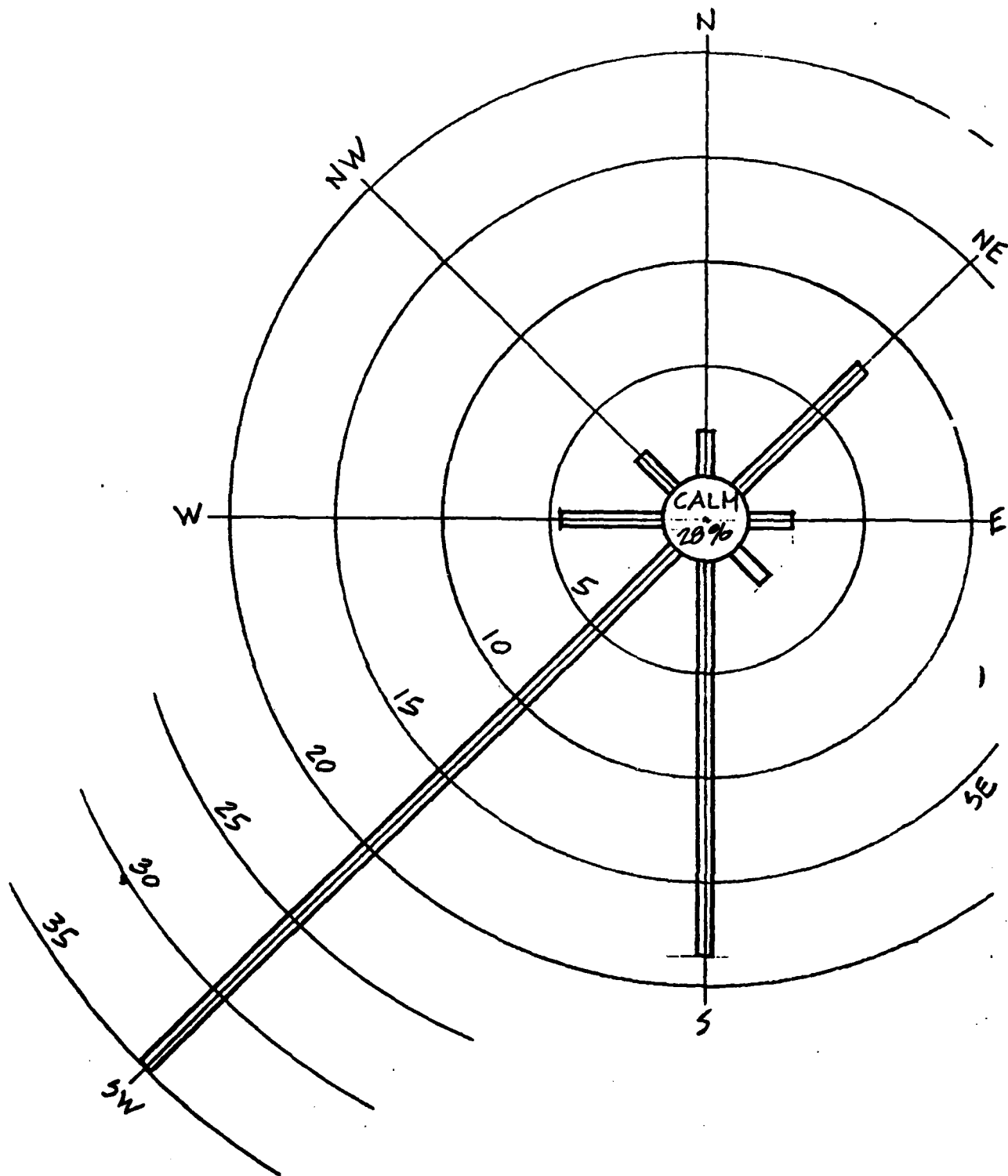

FIGURE 3

**ANNUAL WIND ROSE
SAN PABLO, CALIF.**

(37°59'N 122°09'W)

outside destinations, they will generally be under power through the entrance channel whenever the wind is from a direction which requires tacking. The entrance channel traffic figures developed herein are based on only the projected traffic due to slip-moored boats.

Several criteria are available to describe boat traffic congestion. The simplest is area density, expressed in number of boats per acre of waterway. In addition, it is possible to apply concepts of molecular collision theory to estimate the frequency with which boat operators must alter course to avoid contact with another boat.⁽³⁾ Each such maneuver is called an "interference" and a "congestion index" can be defined as the number of interferences per hour per acre of waterway. It is computed by assigning a blockading area to each boat and assuming random distribution of boat positions over the channel surface. An interference is said to have occurred when the blockading areas of two boats overlap. The frequency of such interferences may be calculated when the velocity distribution of the boats is given. Generally the blockading areas are taken to be rectangles having length and width somewhat greater than the actual length and beam of the boats, in order to provide for safe clearance.

Once the interference frequency has been determined for a given traffic situation, it is a simple matter to obtain

the average number of interferences that a boat will encounter during passage through the entrance channel. The "interferences per transit" value provides a basis for comparing different harbor entrances in terms of the amount of avoidance maneuvering required.

The Cullinan Ranch entrance channel is about 4,000 feet long and 240 feet wide. It is probable that the channel will be divided into inbound and outbound traffic lanes. This procedure generally minimizes interference frequencies. Allowing for 20 feet of clearance at the channel edge, the effective lane width would be 100 feet. With the traffic divided in this manner, the greatest congestion would occur in the inbound lane between 4 and 5 PM (See Figure 2). With a total boat population of 2,000, 25% use factor, and a peak hourly to daily traffic ratio of 0.175, the peak inbound traffic will be 87.5 boats per hour. Boat velocities will be limited by the speed limit, which is normally set at 5 knots in confined waterways. The estimated average speed is 4.5 knots and the standard deviation of boat speed is 1.0 knot; with parallel traffic, interferences occur only as a result of speed differences.

An expression for congestion index applicable to boats travelling along a channel in the same direction is

$$C = N^2 B S/\sqrt{\pi} \times F$$

Where C = Interferences/acre/hr

N = Number of boats per acre

B = Twice the average boat width plus an allowance for safe clearance

S = Standard deviation of speed (knots)

F = Conversion factor

The factor F converts units of acres and nautical miles into feet. It also contains a coefficient of 4/3 to allow for the fact that the distribution of traffic transversely across the channel is not uniform, but has a roughly triangular shape. Values used in applying the above formula to the Cullinan Ranch entrance channel are as follows:

Boat density, N: From traffic flow of 87.5 boats per hour, velocity 4.5 knots, and channel width 100 ft, N = 1.39 boats/acre

Interference width, B: Two times average beam of 10 feet plus clearance of 20 feet = 40 feet

Speed standard deviation, S: 1 knot

The conversion factor F has a numerical value of 0.186.

With these values the peak congestion index is 8.2 interferences per acre per hour. To obtain the average number of interferences per transit, the interference rate per boat is multiplied by the transit time:

$$\begin{aligned}\text{Rate per boat} &= 8.2/\text{Ac/hr} \times 2 \text{ boats/encounter} \div 1.39 \text{ boats/Ac} \\ &= 11.8/\text{hr}\end{aligned}$$

$$\begin{aligned}\text{Transit time} &= 4,000 \text{ ft channel} \div (4.5 \text{ kt} \times 6,080 \text{ ft/mile}) \\ &= 0.146 \text{ hr}\end{aligned}$$

$$\begin{aligned}\text{Interferences/transit} &= 11.8 \times 0.146 \\ &= 1.7\end{aligned}$$

For comparison, congestion indices have also been calculated assuming no division into traffic lanes and uniform distribution of both outbound and inbound boats across the entire channel width. In this case the congestion index becomes

$$C = N_1 N_2 B (V_1 + V_2)$$

Where N_1 and N_2 are the area densities of inbound and outbound boats; V_1 and V_2 are their speeds. Peak congestion now occurs at about 3 PM, when the traffic is 74 boats per hour inbound and 46 per hour outbound. Corresponding densities in the channel, which now has an effective width of 200 feet, are 0.59 and 0.37 boats per acre. The collision

index has three components, namely interferences between boats travelling in opposite directions plus interferences between two inbound boats and between two outbound boats. The numbers are

Opposite directions,	10.8
Inbound-inbound,	1.1
Outbound-outbound,	<u>0.4</u>
Collision index	12.3 interferences/ Ac/hr

Average interferences per transit are 3.8 inbound and 4.6 outbound.

The entrance channel is subject to tidal currents of up to 1.8 knots. An opposing tide tends to aggravate congestion by reducing the actual velocities of boats and thereby increasing their numerical density in the channel. However, there are some compensating effects. Engines can be turned up so that the absolute speed remains near the legal limit. If most of the incoming boats are returning from San Pablo Bay, an ebb tide may delay the arrival times of many boats and thereby reduce the peak traffic. In purposes of the present study it is assumed that a 1.5-knot ebb current will reduce the average absolute speed of incoming boats by 0.9 knots, to a value of 3.6 knots. The resulting boat density is 1.74 per acre (a 25% increase); the collision index

Table I
COMPUTED ENTRANCE CHANNEL CONGESTION

<u>Condition</u>	<u>Traffic Density (boats/acre)</u>	<u>Congestion Index interferences/acre/hr (boats/Ac-hr)</u>	<u>Interferences per Transit</u>
Cullinan, inbound lane, no tide	1.39	8.2	1.7
Cullinan, inbound lane, ebb tide	1.74	12.9	2.7
Cullinan, two-way traffic, slack tide	0.96	12.3	4.6
Marina del Rey (4) inbound lane	1.45	8.8	2.2
Alamitos Bay, (5) inbound lane	1.70	12.2	2.0

It may be seen that during slack tide the Cullinan Ranch congestion will be less severe than at the reference harbors, but will be worse during a strong ebb flow. Over all, the degree of congestion is generally in line with normal peak conditions that occur elsewhere. Figure 8 shows the dependence of congestion index on channel width for the lane traffic case and all conditions as previously assumed. The current Marina del Rey and Alamitos Bay congestion indices are shown for reference. Clearly any reduction in channel width would be inadvisable. Because of the many assumptions needed to estimate congestion, some safety factor is included in selecting a channel width. A satisfactory

congestion level would be somewhat less than that which prevails at Marina del Rey, or say 8 interferences per acre per hour. To limit congestion to this maximum for all but extreme ebb tides would require that the entrance channel be widened to about 270 feet.

Figures 4, 5, 6 and 7 show examples of entrance channel traffic at four levels of congestion. Figure 5 corresponds to peak hour inbound traffic for a total boat population of 2,000 as projected. Figures 4, 6, and 7 represent boat populations of 1,500, 2,500, and 3,000, respectively. In all cases, the total number of boats shown in the channel is the average number. Actually, the number present at any moment (during peak hours) fluctuates rather widely, and the presence of twice as many boats as shown will occur fairly often.

Recommendation

The analysis indicates that at full development, peak hour congestion in the entrance channel will be about the same as at popular recreational harbors elsewhere. Congestion will be tolerable if the surface width at low water remains about 240 feet. It is recommended, however, that the channel be widened to 270 feet in order to provide a safety factor against the unexpected presence of dry-stored

SIMULATED PEAK HOUR TRAFFIC

NAPA RIVER

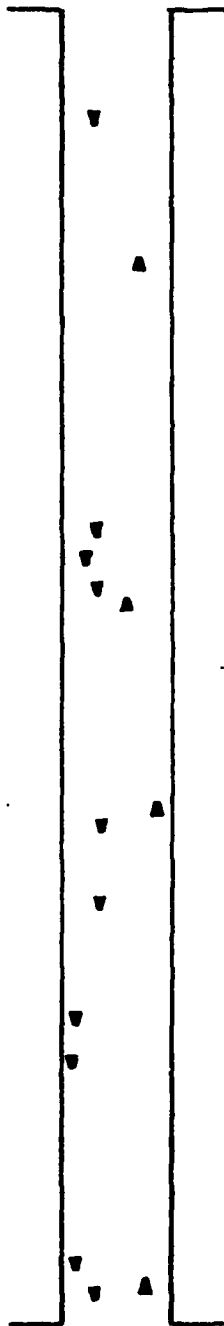

FIGURE 4. BOAT POPULATION = 1,500

NAPA RIVER

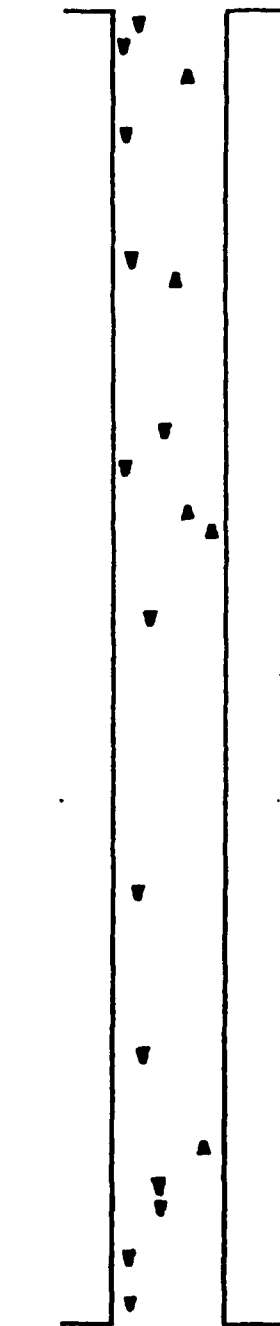

FIGURE 5. BOAT POPULATION = 2,000

SIMULATED PEAK HOUR TRAFFIC

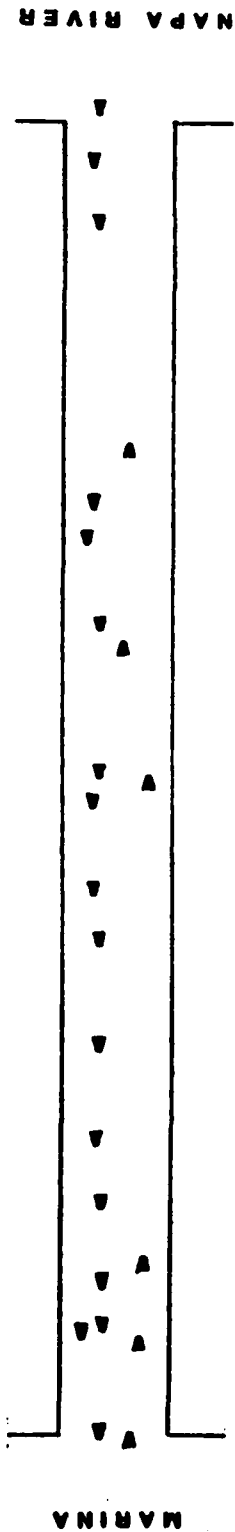

FIGURE 6. BOAT POPULATION = 2,500

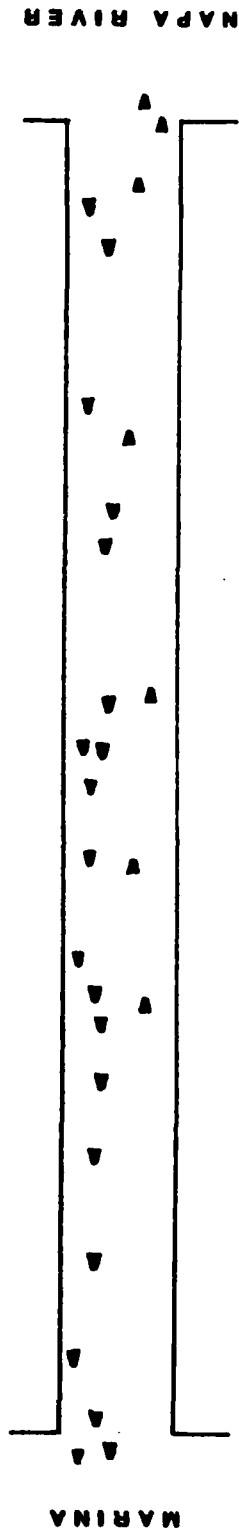

FIGURE 7. BOAT POPULATION = 3,000

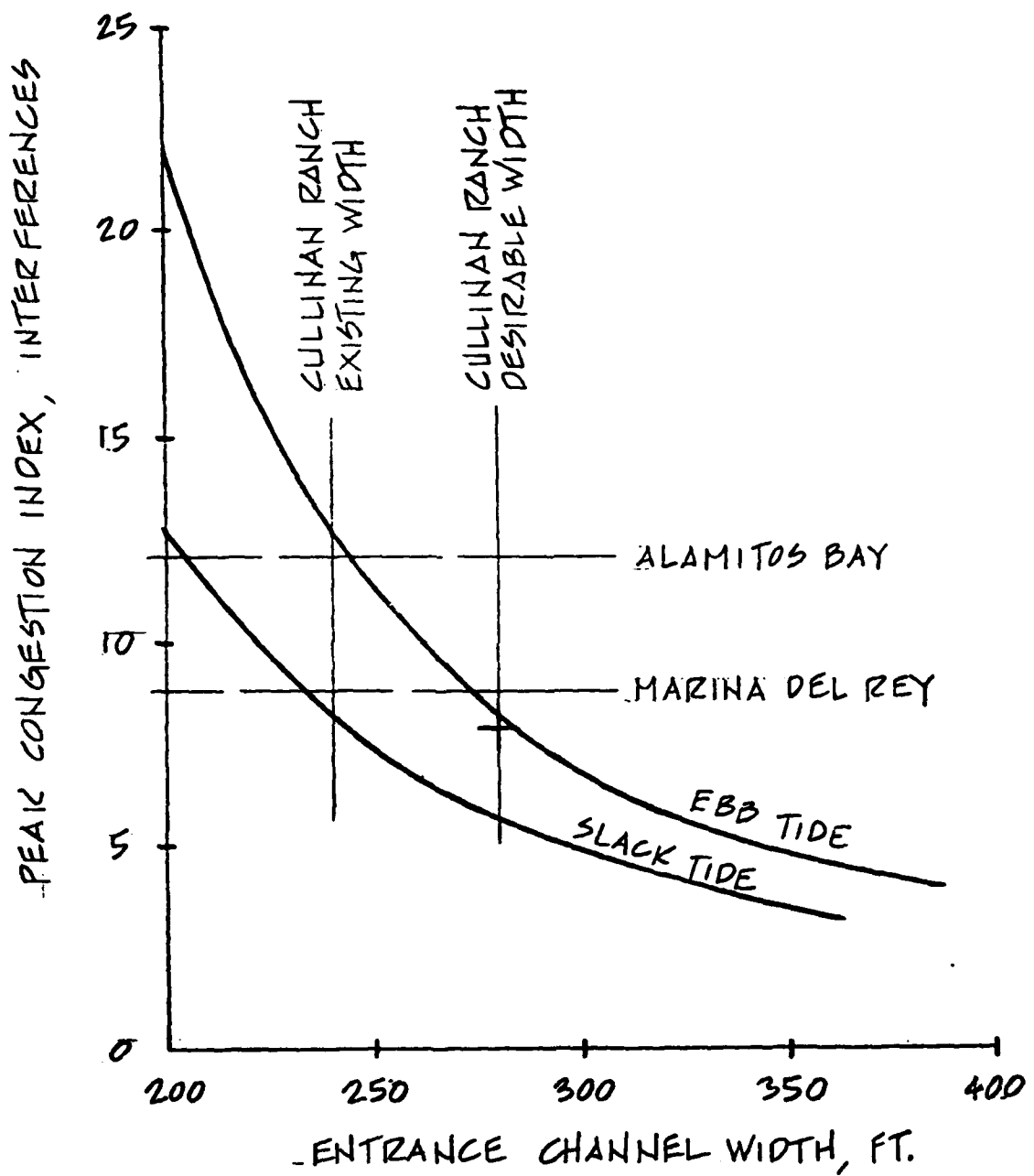

FIGURE 8
EFFECT OF CHANNEL WIDTH ON CONGESTION

sailboats. The channel should definitely be divided by marker buoys to form separate traffic lanes for travel in both directions.

References

1. Moffatt & Nichol, Engineers: "Channel Islands Harbor Entrance Congestion Study". November, 1980.
2. Environmental Impact Profiles: "Huntington Harbour Capacity Study". EIR 75-1, City of Huntington Beach, Calif. September, 1975.
3. Ely, A.L., and J.M. Nichol: "Congestion in Marina Entrance Channels Due to Sailboats", Tour Waterways, Harbors, & Coastal Engrg. Div., Am. Soc. Civil Engrs., November, 1973.
4. Williams-Kuebelbeck and Associates, Inc.: "Marina del Rey Boat Traffic Study". October, 1980.
5. Williams-Kuebelbeck and Associates, Inc.: "Alamitos Bay Boat Traffic Study". December, 1978.



HARVEY & STANLEY ASSOCIATES, INC.
Ecological Consultants

CULLINAN RANCH:
ECOLOGICAL ASPECTS

Prepared by

H. Thomas Harvey, Ph.D.
James M. Hale, B.A.
Robert L. Hassur, Ph.D.

of

HARVEY & STANLEY ASSOCIATES, INC.

Prepared for

Mr. Walden Williams

of

W. R. WILLIAMS & ASSOCIATES

June, 1982

PRESENT HABITAT CHARACTERISTICS

Seven habitat types were recognized in the study area. They are listed in the following table (Table 1) in order of their wildlife use. Wildlife use is based on variety and number of species and presence (observed or inferred) of unique forms.

Table 1. Habitat and Wildlife Use

Habitat Type	Wildlife Use
Tidal Marsh	Very high
Mud Flats	High
Open Water	High
Shrub/Levee	High
Ornamental Plantings	Moderate
Swales in Fields	Moderate
Grain Fields	Low

Tidal Marsh

The tidal marshes along Dutchman Slough and south of Highway 37 are rich both in plant species and wildlife use. The water in the marshes probably varies sufficiently to account for the increased diversity along Dutchman Slough. The marsh south of Highway 37 is dominated by pickleweed and cordgrass (Technical names in Appendix A). The Dutchman Slough marsh is a mosaic of alkali bulrush, pickleweed, cattails, cordgrass, yarrow, silverweed and tules. This diversity aided by the presence of alkali bulrush makes the marsh particularly high in wildlife use. Alkali bulrush is generally recognized as the major waterfowl food in central California. In Table 2 are listed the wildlife observed or suspected of using the marshes immediately adjacent to the proposed project.

Table 2. Marsh Wildlife

 Vertebrates Observed or Predicted to be Present on or Near
 the Cullinan Ranch Site

Key: O- Observed on Cullinan Ranch property.
 OA- Observed on property adjacent to Cullinan Ranch.
 P- Species predicted to be present on Cullinan Ranch
 property.
 *- Introduced (non-native) species.

Birds

OA Great blue heron	OA Virginia rail
OA Great egret	OA Sora
OA Snowy egret	OA Clapper rail
OA Black-crowned night heron	OA Black rail
O Marsh hawk	O American coot
O American kestrel	OA Common snipe
O Black phoebe	OA Long-billed marsh wren
OA Salt marsh yellowthroat	O Short-eared owl
O Red-winged blackbird	O Brewers blackbird
	OA Samuel's song sparrow

Mammals

OS *Norway rat	P Vagrant shrew
OS Raccoon	OA,P Salt marsh harvest mouse
OS *House mouse	P Long-tailed weasel
OS Calif. meadow mouse	

Reptiles

P Gopher snake

Rare or endangered species

Species	Status	
	Federal	State
P American peregrine falcon	listed	endangered
OA Calif. black rail	candidate	rare
OA Calif. clapper rail	listed	endangered
OA Calif. brown pelican	listed	endangered
O Samuel's song sparrow	candidate	
P Salt marsh harvest mouse	listed	endangerea

Species of special concern

- OA White pelican
 - O Marsh hawk
 - O Burrowing owl
 - O Short-eared owl
 - OA Salt marsh yellowthroat
-

From the above table it can be seen that not only is there a great diversity of wildlife, but eleven species are of special concern or are listed as rare or endangered. Only the pelicans and burrowing owls would probably use the marsh in a limited way. The other species are either residents of the marsh or in season dependent on these productive wetlands.

In addition to wildlife species that are endangered or rare there are four plant species of concern; two species were observed at the site and two species may be present. They are, respectively, soft bird's beak and delta tule pea, and, Mason's lilaeopsis and caper-fruited tropidocarpum. All four species are candidates for the Federal list, and the first of each pair is considered rare or endangered respectively.

Mud Flats

Mud flats are those areas of the slough banks which are exposed at low tide and extend from the water line at low tide up to the edge of vegetation.

When exposed at low tide the mud flats provide important food sources for wintering shorebirds. When covered, with water at high tide, the mud flats serve as a feeding ground for fish, diving birds (waterfowl) and water birds (herons). This habitat type is considered one of high wildlife use. In Table 3, wildlife observed or expected to be present are listed.

Table 3. Wildlife of the Mud Flats

Birds

OA Great blue heron	OA Shoveler
OA Great egret	OA Canvasback
OA Snowy egret	OA Lesser scaup
OA Black-crowned night heron	OA Common goldeneye
OA American bittern	P Bufflehead
O Mallard	OA Ruddy duck
OA Gadwall	CA Black-bellied plover
OA Pintail	OA Long-billed curlew
O Cinnamon teal	OA Willet
OA American wigeon	OA Greater yellowlegs
OA Dowitcher	OA Least sandpiper
OA Western sandpiper	OA Dunlin
OA Marbled godwit	O Herring gull
OA American avocet	O Calif. gull
OA Black-necked stilt	O Ring-billed gull

Mammals

OA Harbor seal
OS *Muskrat

It is to be realized that a variety of invertebrate inhabit the mud and serve as the food for many of the above species. Common forms observed or expected to be present included: amphipods, fresh-water clams, horse mussels and shore crabs. All of these forms serve as food for the vertebrates. They in turn have consumed the detritus from the marsh and the algae from the slough, thus linking the living components into a web of life.

Open Water

The open water habitat is also one of high wildlife use. It supports a dynamic rotating group of populations. The daily exchange of the tides and the seasonal migrations of animals contribute to the ever-changing attributes of this habitat. The medium of water changes both daily and seasonally. Salinity at Mare Island, for example, varied from a high of 27 ppt in autumn to a low of fresh water in winter (Fig. 2). The marsh plants and

Harvey & Stanley Associates

open water organisms are therefore exposed to essentially fresh to brackish water. For reference, marine (salt water) conditions are arbitrarily set at 30 ppt to 40 ppt of salinity.

The open water habitat supports species of fish, diving birds, and water birds. Table 3 lists the species of wildlife that were observed in this habitat or are expected to be there.

Table 4. Wildlife of Open Water

Birds

OA Horned grebe	OA Canvasback
OA Eared grebe	OA Lesser scaup
OA Western grebe	OA Common goldeneye
OA Pied-billed grebe	OA Ruddy duck
OA White pelican	P Red-breasted merganser
OA Double-crested cormorant	P Common gallinule
O Mallard	OA Herring gull
OA Gadwall	O California gull
OA Pintail	O Ring-billed gull
O Cinnamon teal	P Bonapartes gull
OA American wigeon	OA Forster's tern
OA Shoveler	OA Caspian tern

Mammals

OA Harbor seal
OS *Muskrat

Amphibians

P *Bullfrog

Fish

P Stag-horn sculpin	P Bat ray
P Starry flounder	P Leopard shark
P Striped bass	P Dog fish
P Shiner perch	P Salmon
P Top smelt	P Steelhead
P Oriental goby	P Sturgeon
P Long-jaw mudsucker	P English sole
	P Diamond turbot

Shrub/Levee

The shrub/levee habitat occurs primarily along the perimeter of the property, on either side of the service road.

The shrub/levee habitat is a high wildlife use area which compliments the adjacent marsh. It is in general a mix of native and exotic plants, but heavily used by native animals, especially birds. The shrubby characteristic of this habitat provides good cover for a variety of small birds and mammals, such as white-crowned sparrows, bushtit, goldfinches, and racoons, skunks and hares.

The vegetation of the levees is dominated by coyote brush. In addition there are considerable numbers of gumplant, sweet fennel, and mustard. Also present were bee plant, mugwort and Australian saltbush.

Table 5. Shrub/levee Wildlife

Birds

O	Great blue heron	O	Belted kingfisher
OA	American bittern	O	Plain titmouse
O	Turkey vulture	O	Long-billed marsh wren
O	White-tailed kite	O	Loggerhead shrike
O	American kestrel	O	Yellow-rumped warbler
P	California quail	O	Salt marsh yellowthroat
O	Ring-necked pheasant	O	Red-winged blackbird
O	American coot	O	Brewer's blackbird
O	Mourning dove	O	House finch
O	Burrowing owl	O	American goldfinch
O	Short-eared owl	O	Brown towhee
O	Anna's hummingbird	O	White-crowned sparrow
O	Black phoebe	O	Golden-crowned sparrow
		O	Samuel's song sparrow

Mammals

OS	Raccoon	O	Black-tailed hare
OS	Striped skunk	OS	*Feral dog
OS	*Opossum	OS	*Feral cat

Harvey & Stanley Associates

Reptiles

- O Western fence lizard
 - P Southern alligator lizard
 - P Gopher snake
 - P Garter snake
-

Ornamental Plantings

The wildlife uses of ornamental planting is probably moderate when compared with the high use of the above four habitats. Ornamental plants occur primarily around the farm buildings of the Cullinan Ranch and at Guadacanal Village. The vegetation was primarily trees and shrubs with such species as eucalyptus, acacia, and Monterey pine.

Table 6. Wildlife Use of Ornamental Plantings

Birds

- | | |
|----------------------|--------------------------|
| P Sharp-shinned hawk | O American robin |
| O Cooper's hawk | O Water pipit |
| O Red-tailed hawk | O Loggerhead shrike |
| O American kestrel | O Starling |
| O Mourning dove | O Yellow-rumped warbler |
| O Barn owl | O House sparrow |
| O Great horned owl | O Western meadowlark |
| O Anna's hummingbird | O Brewer's blackbird |
| O Common flicker | P Brown-headed cowbird |
| O Black phoebe | O House finch |
| O Barn swallow | O American goldfinch |
| O Cliff swallow | O Brown towhee |
| O Common bushtit | O White-crowned sparrow |
| O Mockingbird | O Golden-crowned sparrow |

Mammals

- | | |
|-------------------------|------------------------|
| OS *Common opossum | OS Calif. meadow mouse |
| O Pallid bat | OS *Norway rat |
| O Black-tailed hare | OS *House mouse |
| P Western harvest mouse | OS Raccoon |
| P Deer mouse | P Long-tailed weasel |
| | OS Striped skunk |

Harvey & Stanley Associates

Reptiles

P Gopher snake

Swales in Fields

Remanent sloughs behind the dikes have developed into vegetated swales. The common plants were brass buttons and sand spurry. Also present were pickleweed and salt grass. Although some wildlife use was observed, their relative ranking when compared to the above habitats is moderate. The wildlife use for the swales is listed in Table 7.

Table 7. Wildlife Use of Swales

Birds

O Savannah sparrow	O Rock dove
O House sparrow	O Mourning dove
O House finch	O Horned lark
	O Starling

Mammals

OS *Common opossum	OS *House mouse
P Western harvest mouse	OS *Feral dog
OS Calif. meadow mouse	OS *Feral cat
P Deer mouse	

Reptiles

P Gopher snake

Grain Fields

The major habitat interior of the levees is the cultivated grain fields. The most frequently planted species over most of the area is cultivated oats. Some weedy species of plants were also present, such as wild oats and brome grasses. Although certain native species of wildlife use this habitat they are low in diversity and do not include any rare or endangered species. Specifically the wildlife uses are listed in Table 8.

Table 8. Wildlife of the Grain Fields

Birds

O Turkey vulture	O Water pipit
O White-tailed kite	O Loggerhead shrike
O Red-tailed hawk	O Starling
O American kestrel	O House sparrow
O Ring-necked pheasant	O Western meadowlark
O Mourning dove	O Red-winged blackbird
O Barn owl	O Brewer's blackbird
O Great horned owl	P Brown-headed cowbird
	O House finch
	O American goldfinch
	O Savannah sparrow

Mammals

O Black-tailed hare
OS *Norway rat
OS *House mouse
P Western harvest mouse
OS California meadow mouse
OS Botta pocket gopher
O Beechey ground squirrel

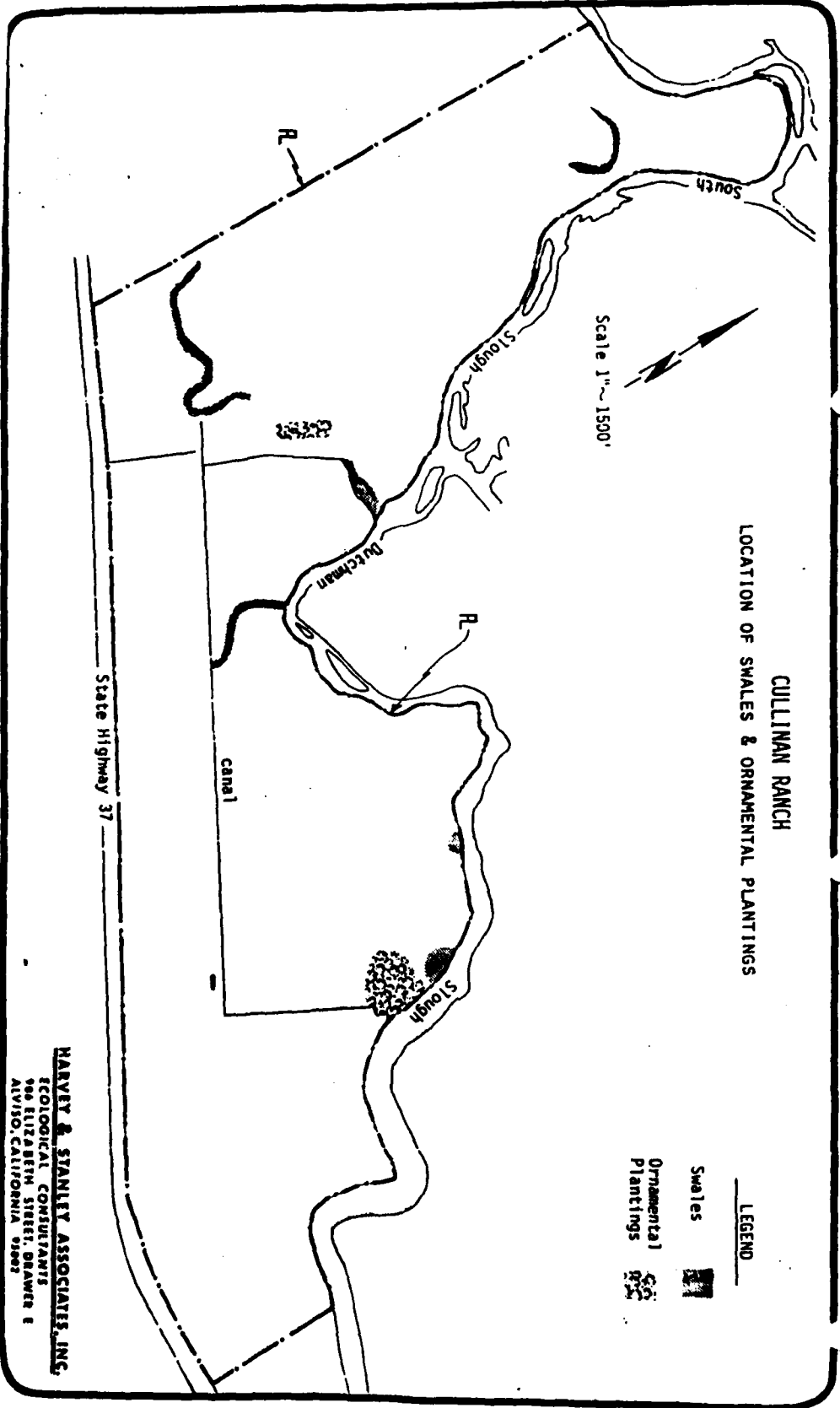

CULLINAN RANCH
LOCATION OF SWALES & ORNAMENTAL PLANTINGS

LEGEND
 Swales
 Ornamental Plantings

Scale 1" ~ 1500'

State Highway 37

HARVEY & STANLEY ASSOCIATES, INC.
 ECOLOGICAL CONSULTANTS
 900 ELIZABETH STREET, DRAWER 8
 AVISO, CALIFORNIA 94002

POTENTIAL WILDLIFE USE

The potential for improvement of habitat for wildlife is great. The proposed project would increase significantly the four high use habitats; namely, tidal marsh, mud flats, open water and shrub/levee. It would also increase ornamental plantings which we have evaluated at moderate use by wildlife. These increases in the above habitats would be at the expense of the low use habitats of grain fields and swales in fields.

Determinations of the land/tidal evaluations by leveling revealed a spectrum of plant species at the site. In Fig. 3, an idealized profile is shown of land and tidal elevations, and plants. From this it was possible to project that at least 35 acres and probably as much as 40 acres of tidal marsh could become established along the slopes of the channels and in the proposed project. Additionally, 80 acres of the area to be used for dredge disposal could be restored if it remains below 10' above MLLW and is open to tidal action. This habitat is of very high wildlife use and supports rare and endangered plants and animals of concern. The plants would easily tolerate the close proximity of human activity and so would most of the animal species. Specifically, the salt marsh harvest mouse, California black rail, California clapper rail and salt marsh yellow throat would readily establish in the newly created marsh.

The mud flat zone will also be increased and thus improve the wildlife use of the area. It would probably be on the order of 50 acres, even though some of it would possibly be covered with enkadrain.

The open water habitat will be increased on the order of 423 acres. As this, too, is a high wildlife use habitat, more individuals will be provided a resource base.

The shrub/levee habitat has the potential of being increased by about 30 acres. This was evaluated in the earlier section of present habitats, as being of high wildlife use, and therefore an increase in the habitat would be of benefit to the wildlife listed under the shrub/levee category.

Harvey & Stanley Associates

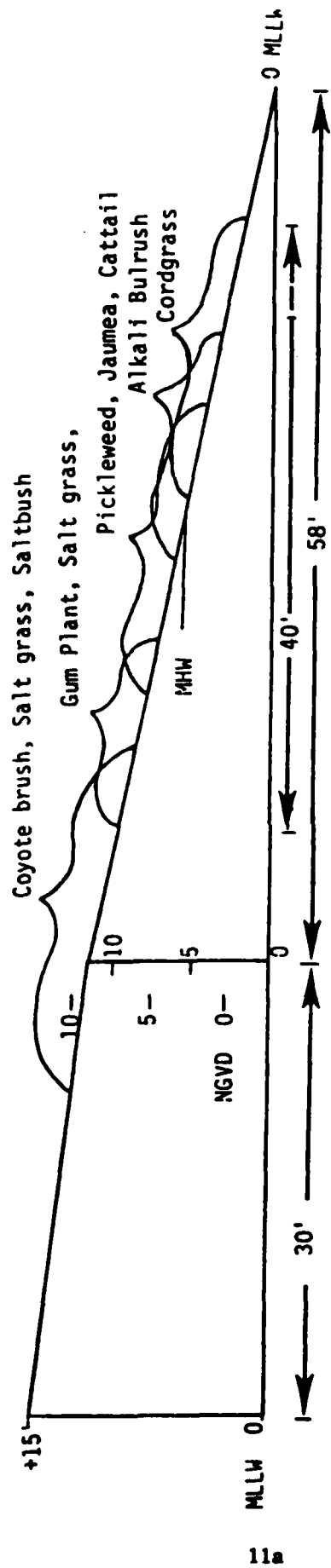

11a

Fig. 3. Vegetation and Elevations in Dutchman Slough.

Harvey & Stanley Associates

The ornamental plantings were ranked as moderate in their wildlife use. This habitat would also be increased on the site. The exact acreage is difficult to estimate, but would probably be on the order of 300 acres (one-third of the approximately 600 acres of residents and schools plus 2/3 of those areas planned for parks and other landscaped open space). This habitat could be further enhanced by planting species known to favor wildlife, e.g. pyracantha and cotoneaster.

In summary, about 60 acres of improved habitat would result from the proposed project. Specifically, low wildlife use habitats, i.e. grain fields and swales in fields, would be replaced with very high to moderate wildlife use habitats. The replacement habitats would be; tidal marsh, mud flat, open water, shrub/levee, and ornamental plantings.

ENHANCEMENT ALTERNATIVES

In the main, manipulation of the vegetation on the newly created surfaces will allow for enhancement alternatives. The various manipulations will in turn affect the number and kinds of wildlife. Many wildlife species are cover dependent and even if food is available they will not remain in the area. For example, the endangered salt marsh harvest mouse requires dense cover and a food source that can be the same species namely, common pickleweed. The pickleweed, however, must be dense and over a foot in height. A basic ecological principle seems applicable to this site. It is that high diversity is ecologically sound. To that end a mosaic of plantings of native plant species should be planned. The planning of the plantings needs to take into consideration the elevational distribution of plants as depicted in Fig. 3. Inasmuch as there are a variety of species at most elevations a mosaic of planting is possible as well as desirable.

The alternatives for shore protection as outlined by Moffatt & Nichol (1982) would provide diversity of habitat below the vegetated (marsh zone). The mud flat alternative would increase shorebird habitat.

MANAGEMENT RECOMMENDATIONS

Two basic approaches are recommended for management, namely, monitoring and planning. By monitoring is meant the periodic assessment of vegetation and wildlife use, linked to physical environmental factors. A monitoring program which assesses establishment and development of vegetation needs to be outlined. It should include descriptive narration on the vegetation plantings, quantitative statements of the success of vegetation in erosion control, and evaluation of natural revegetation and spread.

Wildlife use should be monitored on a regular basis. Transect lines with stations should be established throughout the site. Bimonthly observations on vertebrates and their signs, should be made and compared with similar adjacent natural habitats.

The planning process for long-range management will require evaluating the data from the monitoring program. The objectives would be to create habitat which duplicates primarily the present natural systems, e.g. marsh, mud flat and open water. The shrub/levee and ornamental plantings habitats should also be evaluated as they become established and developed. They too should then be modified or re-done so as to produce high to moderate wildlife use in light of the monitoring.

APPENDIX A

Plant Species

Common Name

Acacia
 Wild alfalfa
 Salt marsh baccharis
 Foxtail barley
 Meadow barley
 Mediterranean barley
 Wild barley
 Soft bird's beak
 California bee-plant
 Bentgrass
 Bindweed
 Himalaya blackberry
 Alkali bulrush
 California bulrush
 Brass buttons
 Coyote brush

Cattail
 Common cattail
 Narrow-leaf cattail
 Cheeseweed
 Soft chess
 Chickweed
 Bur clover
 Cordgrass
 Salt marsh dodder
 Dock
 Curly-leaved dock
 Sweet fennel
 Fescue
 Common fiddle-neck
 Filaree
 Farmer's foxtail
 Arrow grass
 Bermuda grass
 Blue grass
 Rabbitsfoot grass
 Ripgut grass

Technical Name

Acacia sp.
 Medicago sativa
 Baccharis douglasii
 Hordeum jubatum
 Hordeum californicum
 Hordeum hystrix
 Hordeum sp.
 Cordylanthus mollis ssp. mollis
 Scrophularia californica
 Agrostis sp.
 Convolvulus arvensis
 Rubus discolor
 Scirpus robustus
 Scirpus californicus
 Cotula coronopifolia
 Baccharis pilularis ssp.
 consanguinea
 Typha domingensis
 Typha latifolia
 Typha angustifolia
 Malva parviflora
 Bromus mollis
 Stellaria littoralis
 Medicago hispida
 Spartina foliosa
 Cuscuta salina
 Rumex occidentalis var. procensus
 Rumex crispus
 Foeniculum vulgare
 Festuca sp.
 Amsinckia intermedia
 Erodium botrys
 Hordeum leporinum
 Triglochin maritima
 Cynodon dactylon
 Poa sp.
 Polypogon monspeliensis
 Bromus rigidus

Harvey & Stanley Associates

Wire grass

Alkali heath
Poison hemlock
Hottentot-fig
Jaumea
Sea lavender
Miner's lettuce
Linanthus
Lupine
Red maids

Mugwort
Black mustard
Field mustard
Wild oats
Wild oats
Bristly ox-tongue
Delta tule pea
Peppergrass
Monterey pine
Gum plant
Plantain
Plantain
Common pickleweed
Lamb's quarters
Wild radish
Western ragweed
California rose
Baltic rush
Ryegrass
Ryegrass
Italian ryegrass
Wild ryegrass
Australian saltbush
Halberd-leaved saltbush
Saltgrass

Silverweed
Common sow-thistle
Saltmarsh sand spurry
Cultivated sweetpea
Bull thistle
Milk thistle

Polygonum aviculare var.
littorale

Frankenia grandifolia
Conium maculatum
Mesembryanthemum edule
Jaumea carnososa
Limonium californicum
Montia perfoliata
Linanthus grandiflorus
Lupinus sp.
Calandrinia ciliata var.
menziesii

Artemisia vulgare
Brassica nigra
Brassica campestris
Avena barbata
Avena patua
Picris echioides
Lathyrus jepsonii spp. jepsonii
Lepidium latifolium
Pinus radiata
Grindelia humilis
Plantago sp.
Plantago juncooides
Salicornia pacifica
Chenopodium album
Raphanus sativus
Ambrosia psilostachya
Rosa californica
Juncus balticus
Elymus mollis
Elymus vancouverensis
Lolium multiflorum
Lolium perenne
Atriplex semibaccata
Atriplex patula spp. hastata
Distichlis spicata var.
stolonifera
Potentilla eggedii var. grandis
Sonchus oleraceus
Spergularia marina
Lathyrus sp.
Cirsium vulgare
Silybum marianum

Harvey & Stanley Associates

Plant Species - cont.

Timothy
Common tule
Vetch
Willow
Yarrow

Phleum pratense
Scirpus acutus
Vicia spp.
Salix sp.
Achillea borealis

APPENDIX B

Vertebrates Observed or Predicted to be Present on or Near the Cullinan Ranch Site

- Key: O- Observed on Cullinan Ranch property. (91 species)
OA- Observed on property adjacent to Cullinan Ranch.
(10 species)
P- Species predicted to be present on Cullinan Ranch
property. (27 species)
*- Introduced (non-native) species.

Birds

- | | |
|-----------------------------|--------------------------|
| O Horned Grebe | OA Common Merganser |
| O Eared Grebe | P Red breasted Merganser |
| O Western Grebe | O Turkey Vulture |
| O Pied-billed Grebe | O White-tailed Kite |
| O White Pelican | P Sharp shinned Hawk |
| OA Brown Pelican | O Cooper's Hawk |
| O Double-crested Cormorant | O Red-tailed Hawk |
| O Great Blue Heron | P Bald Eagle |
| O Great Egret | O Marsh Hawk |
| O Snowy Egret | P Osprey |
| O Black-crowned Night Heron | P Peregrine Falcon |
| OA American Bittern | OA Merlin |
| O Mallard | O American Kestrel |
| OA Gadwall | P California Quail |
| O Pintail | O Ring-necked Pheasant |
| O Green-winged Teal | OA Clapper Rail |
| OA Blue-winged Teal | O Virginia Rail |
| O Cinnamon Teal | O Sora |
| O American Wigeon | OA Black Rail |
| O Northern Shoveler | P Common Gallinule |
| P Redhead | O American Coot |
| O Canvasback | P Semipalmated Plover |
| O Lesser Scaup | O Anna's Hummingbird |
| P Snowy Plover | O Belted Kingfisher |
| O Killdeer | O Common Flicker |
| OA American Golden Plover | O Black Phoebe |
| O Black-bellied Plover | O Say's Phoebe |
| O Common Snipe | O Horned Lark |

Harvey & Stanley Associates

Birds - cont.

- O Long-billed Curlew
- OA Whimbrel
- O Greater Yellowlegs
- O Willet
- O Least Sandpiper
- O Dunlin
- O Western Sandpiper
- P Short-billed Dowitcher
- O Long-billed Dowitcher
- O Marbled Godwit
- O American Avocet
- O Black-necked Stilt
- O Western Gull
- O Herring Gull
- O California Gull
- O Ring-billed Gull
- P Bonaparte's Gull
- O Forester's Tern
- O Caspian Tern
- O *Rock Dove
- O Mourning Dove
- O Barn Owl
- O Great Horned Owl
- O Burrowing Owl
- O Short-eared Owl
- O Common Goldeneye
- P Bufflehead
- O Ruddy Duck
- O Violet-green Swallow
- O Barn Swallow
- O Cliff Swallow
- O Scrub Jay
- P Common Crow
- O Plain Titmouse
- O Bushtit
- O Long-billed Marsh Wren
- O Mockingbird
- O American Robin
- O Water Pipit
- O Loggerhead Shrike
- O *Starling
- O Yellow-rumped Warbler
(Audubon's Warbler)
- O Salt marsh Yellowthroat
- C *House Sparrow
- O Western Meadowlark
- O Red-winged Blackbird
- O Brewer's Blackbird
- P Brown-headed Cowbird
- O House Finch
- O Lesser Goldfinch
- O Brown Towhee
- O Savannah Sparrow
- O Dark-eyed Junco
- O White-crowned Sparrow
- O Golden-crowned Sparrow
- O Samuel's Song Sparrow

Harvey & Stanley Associates

Mammals

Key: OS- Observed Sign (track, scat, etc.).
*- Introduced (non-native) species.

OS *Common opossum
P Vagrant shrew
P *Ornate shrew
P Suisun shrew
P Big brown bat
O Pallid bat
P Brazilian free-tailed bat
O Black-tailed hare
P Western harvest mouse
P Salt marsh harvest mouse
P Deer mouse
OS California meadow mouse
OS *Muskrat
OS *Norway rat
OS *House mouse
OS Raccoon
P Long-tailed weasel
P *Mink
OS Striped skunk
OS River otter
OS *Feral dog
OS *Feral cat
OS Harbor seal
OS Botta pocket gopher
O Beechy ground squirrel

Reptiles and Amphibians

Key: *- Introduced (non-native) species.

P *Bullfrog
O Western fence lizard
P Gopher snake
P Garter snake
P Southern Alligator Lizard

Harvey & Stanley Associates

LITERATURE CITED

Moffat & Nichol, Engrs. 1982. Cullinan Ranch: shore protection. 12 pp. Report for W.R. Williams & Associates.

Storr, Philip N., Robert E. Selleck and Erman A. Pearson. April 1963. Appendixes to a comprehensive study of San Francisco Bay Area; Suisun Bay-Lower San Joaquin River Area; San Pablo Bay Area. SERL, University of California Berkeley.

I
I
I

TRAFFIC STUDY
FOR
CULLINAN RANCH
AND
GUADALCANAL VILLAGE

Prepared for

W. R. Williams Co.
2130 Main Street
Huntington Beach, CA 92648

Prepared by:

Basmaciyani-Darnell, Inc.
4262 Campus Drive, Suite B-1
Newport Beach, California 92660

August 1982

CONTENTS

	<u>Page</u>
SECTION I. INTRODUCTION	
Proposed Development.	I-1
Study Objectives and Report Format.	I-1
Traffic Impact Analysis Area.	I-3
SECTION II. EXISTING ROADWAY AND TRAFFIC CONDITIONS	
Street and Highway System	II-1
Existing Traffic Volumes.	II-3
Problem Areas	II-3
Planned Roadway Improvements.	II-5
SECTION III. FUTURE TRAFFIC VOLUMES	
General	III-1
Future Traffic Without Cullinan Ranch	III-1
Traffic to/from Cullinan Ranch and Guadalcanal Village.	III-2
Traffic Impacts of Phase 1 Development.	III-13
SECTION IV. ACCESS AND INTERNAL CIRCULATION	
General	IV-1
Methodology	IV-1
Access to/from Route 37	IV-1
Sizing of Internal Streets.	IV-8
Traffic Controls on the Internal Street System.	IV-12
Bikeway/Pedestrian Facility Crossings	IV-12
APPENDIX A: DESCRIPTION OF CAPACITY AND TABLE OF CAPACITIES	
APPENDIX B: TRIP TABLE	
APPENDIX C: CRITICAL MOVEMENT ANALYSES	

TABLES

		<u>Page</u>
II-1	Existing Traffic Volume on State Routes.	II-4
III-1	Comparison of Estimated Potential Future Daily Traffic Volumes and Capacities (Year 2005) Without Cullinan Ranch or Guadalcanal Village	III-3
III-2	Cullinan Ranch/Guadalcanal Village Land Use Summary.	III-4
III-3	Cullinan Ranch/Guadalcanal Village Trip Generation Rates	III-5
III-4	Cullinan Ranch/Guadalcanal Village Anticipated Daily and Peak Hourly Trip Ends.	III-6
III-5	Internal/External Project Trip Distribution Assumptions.	III-7
III-6	Estimated Potential Future Daily Traffic Volumes (Year 2005) Including Ultimate Development of Cullinan Ranch and Guadalcanal Village.	III-11
III-7	Comparison of Estimated Potential Future Daily Traffic Volumes and Capacities (Year 2005) With Ultimate Development of Cullinan Ranch and Guadalcanal Village.	III-12
III-8	Comparison of Existing Traffic and Traffic to/from Phase 1 of Cullinan Ranch Development.	III-14
III-9	Phase 1 Traffic Impacts on Walnut Street Interchange	III-15
IV-1	Summary of Capacity Analysis	IV-7

FIGURES

	<u>Page</u>
I-1 Vicinity Map	I-2
II-1 Existing Street and Highway System	II-2
II-2 Planned Street and Highway Improvements.	II-8
III-1 Percentage Distribution of External Trips to/from Cullinan Ranch	III-9
III-2 Percentage Distribution of External Trips to/from Guadalcanal Village.	III-10
IV-1 Internal Street System and Traffic Analysis Zones.	IV-2
IV-2 Daily Traffic on Internal Streets (Full Development)	IV-3
IV-3 Morning Peak Hourly Traffic at Access Points - Year 2005 With Cullinan Ranch and Guadalcanal Village.	IV-5
IV-4 Afternoon Peak Hourly Traffic at Access Points - Year 2005 With Cullinan Ranch and Guadalcanal Village.	IV-6
IV-5 Intersection Configurations at Westerly Access Point	IV-
IV-6 Intersection Configurations at Easterly Access Point	IV-10
IV-7 Typical Intersection Configurations Along Frontage Road.	IV-11
IV-8 Recommended Traffic Signal Locations	IV-13
IV-9 Typical Intersection with Bikeway Crossing (At Entrance to Peninsula).	IV-14

SECTION I
INTRODUCTION

PROPOSED DEVELOPMENT

The proposed Cullinan Ranch development would be on a site in Solano County immediately west of the Napa River and the City of Vallejo and north of State Route 37. Figure I-1 is an illustration of the project location and the street system in the vicinity.

Ultimately, the development would consist of up to 4,500 dwelling units, a marina for the use of residents (this is subsequently referred to as a "secondary" marina as opposed to the "primary" marina for general use), a neighborhood commercial center, two elementary schools, a junior high school, and parks. An initial development phase consisting of 400 dwelling units, referred to as Phase 1 of Cullinan Ranch, is also analyzed for circulation and access needs.

Immediately to the east and part of the Cullinan Ranch development would be a primary marina with approximately 500 boat slips. Adjacent to the marina would be Guadalcanal Village, to consist of specialty/water-oriented commercial facilities. This study addresses the combined traffic expected to be generated by Cullinan Ranch and Guadalcanal Village because:

1. Cullinan Ranch and Guadalcanal Village are adjacent to one another
2. There will be tripmaking between the two developments
3. Traffic to/from both areas would take access off Route 37 in close proximity

Also taken into consideration is the potential development (light industry and warehousing) on the so-called "North Housing Area" or "South Parcel." This land is owned by the City of Vallejo and redevelopment proposals are being formulated.

STUDY OBJECTIVES AND REPORT FORMAT

The objectives of this traffic study are to:

1. Review and evaluate the access requirements for Cullinan Ranch at ultimate development -- in conjunction with development at Guadalcanal Village
2. Review and evaluate the access requirements for Cullinan Ranch in its initial phases of development
3. Review and evaluate the impacts of the traffic to/from Cullinan Ranch and Guadalcanal Village on selected streets and highways in the City of Vallejo
4. Evaluate the internal circulation system for Cullinan Ranch

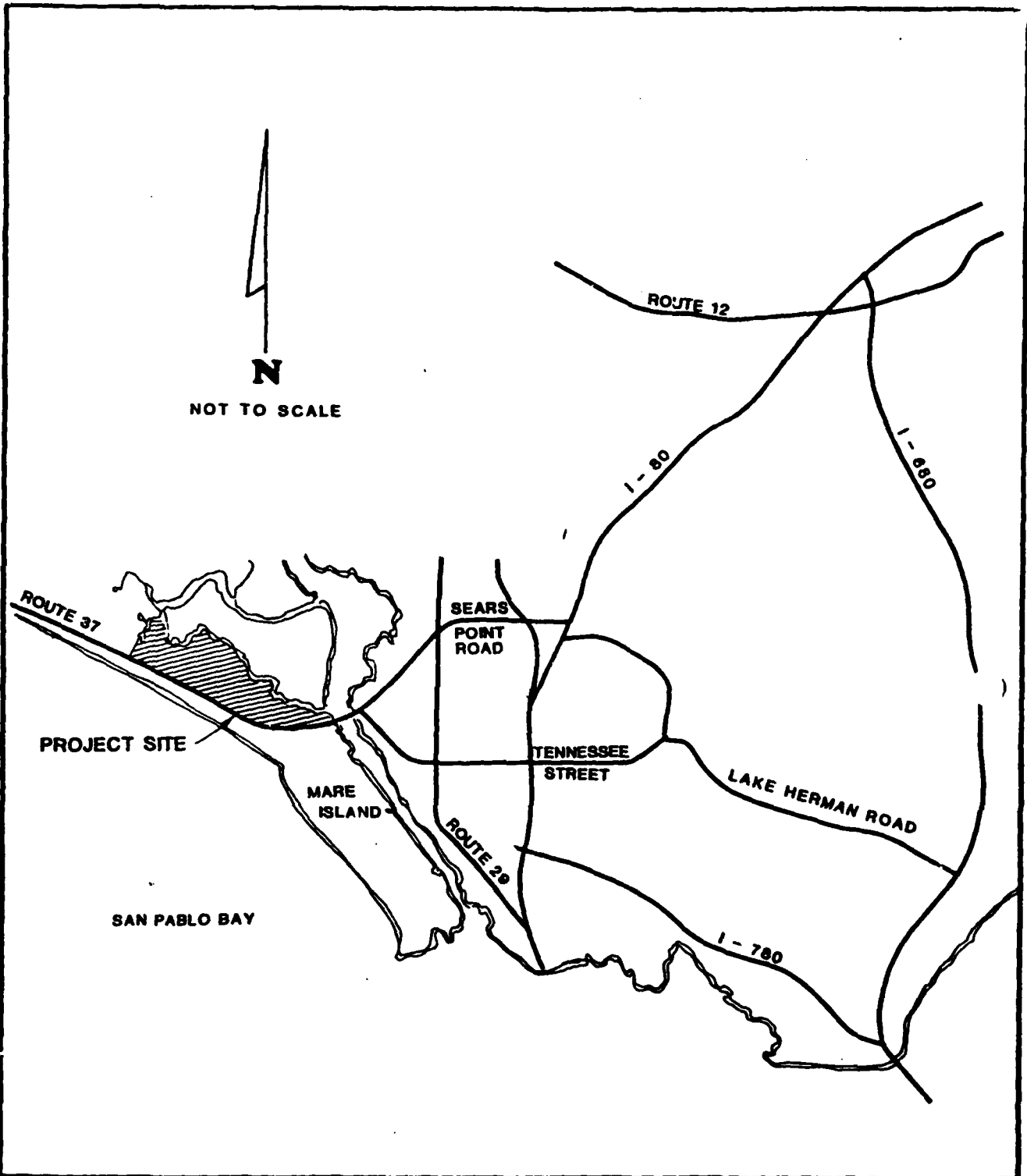

BASMACIYAN-DARNELL, INC.

4262 Campus Drive, Suite B-1
Newport Beach, California 92660
(714) 549-9940

FIGURE I - 1

VICINITY MAP

The report is structured to address each of the study objectives. Following this introductory Section I, the report format consists of:

- SECTION II: A discussion of existing roadway and traffic conditions/problems and roadway improvements planned by Caltrans and the City of Vallejo
- SECTION III: Estimates of future traffic volumes with and without the proposed development at Cullinan Ranch and Guadalcanal Village and a discussion of the traffic impacts of the proposed development on streets and highways in and near Vallejo.
- SECTION IV: A discussion of improvements necessary to accommodate future traffic volumes, including access provisions to/from Route 37 for Phase 1 and ultimate development.
- SECTION V: A discussion of the internal circulation system for Cullinan Ranch.

TRAFFIC IMPACT ANALYSIS AREA

In discussions with Caltrans and the City of Vallejo, there was general consensus that the traffic impacts of the proposed development on the following roadways should be analyzed:

- Route 37, between the proposed development area and Interstate 80
- Route 29, generally from the vicinity of Redwood Street to north of Route 37
- Sacramento Street, between Route 37 and Redwood Street
- Redwood Street, between Sacramento Street and Interstate 80
- Interstate 80, north of Route 37 and south of Route 29
- Wilson Way, between Route 37 and Tennessee Street

SECTION II

EXISTING ROADWAY AND TRAFFIC CONDITIONS

STREET AND HIGHWAY SYSTEM

The street and highway system in the impact analysis area is illustrated in Figure II-1. Following is a brief discussion of the characteristics of some of the key roadways.

Route 37, or Sears Point Road, constitutes a major travel route between Solano and Marin Counties. The proposed development would lie immediately north of Route 37, and Route 37 would be the only means of access to/from the proposed development.

West of the Napa River, along the Cullinan Ranch property and west of the property, Route 37 is a three-lane road. Two travel lanes are available in one direction and one in the other along alternating segments. Thus, traffic in either direction has an opportunity to pass at regular intervals. Along the Cullinan Ranch property frontage, there are two westbound and one eastbound travel lane on Route 37. There are no paved shoulders, and the unpaved areas adjacent to the travel lanes are very narrow.

From a point just west of the Walnut Street (Mare Island) Interchange, across the Napa River, and to a point just east of Sacramento Street, Route 37 has two travel lanes in each direction. In this segment, the road has a median divider except that on the bridge span the median consists of a modified concrete barrier (Type 50 A.Z.). On the bridge, a width of approximately 33' - 4" is available between the bridge railing and the base of the concrete divider in each direction. There are grade-separated interchanges at Walnut Street (Mare Island) and at Wilson Way.

From a point just east of Sacramento Street to a point near Enterprise Street, Route 37 has one travel lane in each direction; it has two lanes in each direction between that point and Route 29 (Sonoma Boulevard). Between Route 29 and Mini Drive there are two lanes in each direction on Route 37 plus a two-way left-turn lane. Between Mini Drive and Fairgrounds Drive, Route 37 has one travel lane in each direction. Between Fairgrounds Drive and Interstate 80, Route 37 is improved to expressway standards.

Route 29, or Sonoma Boulevard, has two through travel lanes, left turn pockets and a median divider along its entire section in the vicinity of Sacramento Street and Route 37.

Sacramento Street is a two-lane facility between Route 37 and Redwood Street and to the south.

Wilson Avenue between Route 37 and Tennessee Street is a two-lane facility with a large number of curves. The signalized intersection with Tennessee Street has six legs (Wilson Avenue, Mare Island Causeway, Mare Island Way, Butte Street, Tennessee Street, and Yolo Avenue). During peak travel periods, this intersection is severely congested.

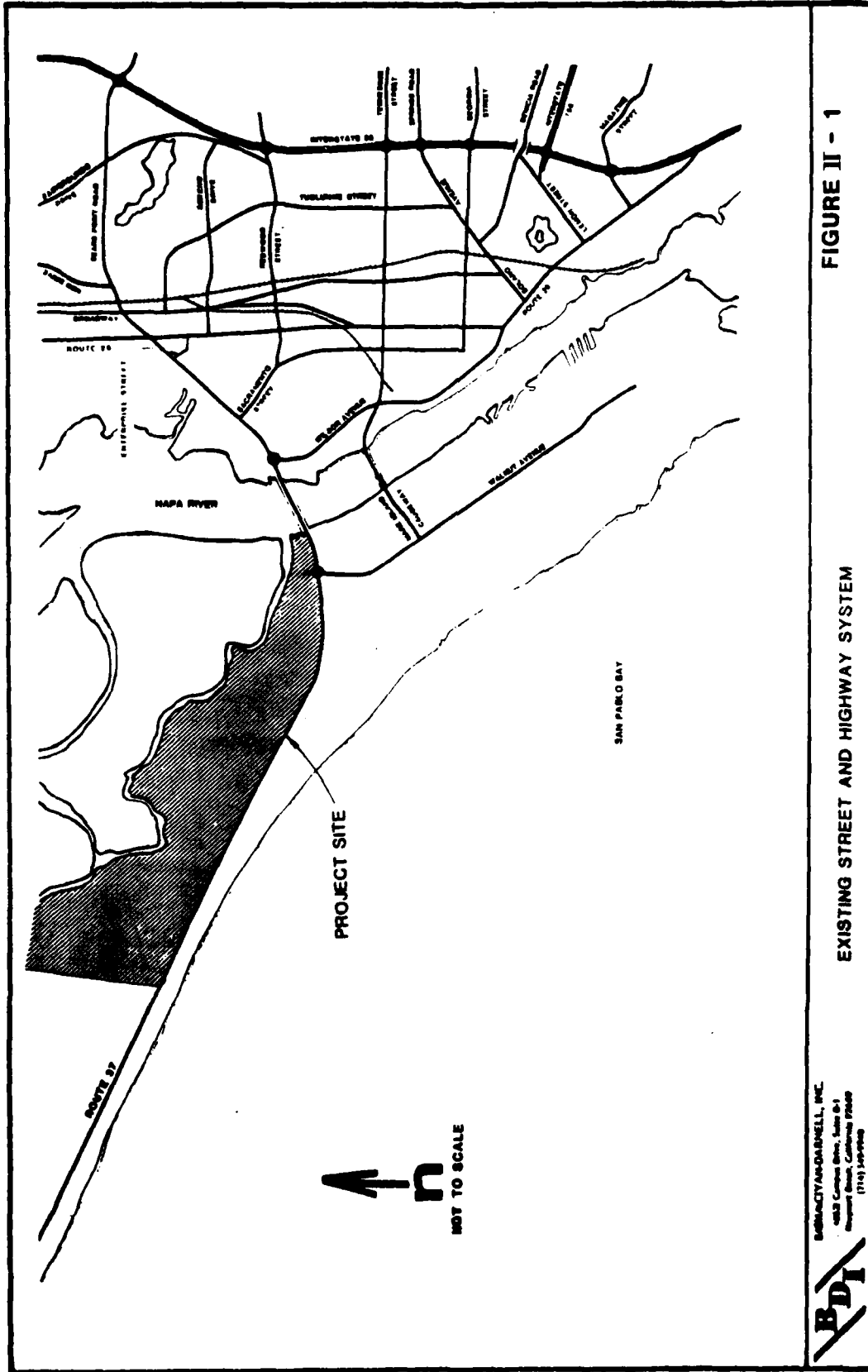

B/D
 BENTLEY & DUNN, INC.
 4435 Campus Drive, Suite 81
 Pleasanton, California 94569
 (925) 466-4400

EXISTING STREET AND HIGHWAY SYSTEM

FIGURE II - 1

Redwood Street has one travel lane in each direction in the area immediately east of Sacramento Street. Between Larwin Plaza area west of Route 39 (Sonoma Boulevard) and Tuolumne Street, Redwood Street has two lanes of traffic in each direction. Between Tuolumne Street and I-80, Redwood Street has one travel lane in each direction. Although the bridge (overpass) over I-80 is quite narrow, it is striped to accommodate two westbound lanes and one eastbound lane.

Mare Island Way between Tennessee Street and Florida Street has one travel lane in each direction. Between Florida Street and Maryland Street, Mare Island Way has two travel lanes in each direction with left-turn pockets and a landscaped median divider. Virtually complete access control exists on this stretch putting the facility in a four-lane expressway category.

EXISTING TRAFFIC VOLUMES

The traffic volumes on State routes in the analysis area are presented in Table II-1.

PROBLEM AREAS

In the impact analysis area the known or observed traffic problems are described in the following paragraphs. This is not meant to be a compilation of all traffic problems on State routes or City streets (a task clearly beyond the scope of this work) but merely an indication of the congestion problems along those routes likely to be used by traffic to/from Cullinan Ranch and Guadalcanal Village.

Route 37

During peak travel periods, severe congestion is observed along Route 37. The most critical problem is associated with the two-lane segment between Sacramento Street and Enterprise Street. During the afternoon peak period in the eastbound direction, between approximately 4:15 P.M. and 4:45 P.M., substantial delay is encountered by eastbound motorists at the traffic signal at the intersection of Route 37/Sacramento Street. A queue of vehicles starts forming on the eastbound approach to the intersection starting shortly after 4:00 P.M. on weekdays. At approximately 4:30 to 4:35 P.M., the queue reaches its maximum length and stretches as far west as the crest of the bridge on the Napa River-- a queue approximately three quarters of a mile long. While the queue forms west of Sacramento Street, the root cause is the two-lane segment east of Sacramento Street. During the morning peak period, westbound motorists encounter substantial congestion and delay on the two-lane segment east of Sacramento Street.

During peak travel periods, traffic moves very slowly along other segments of Route 37 east of the Napa River, especially on the two-lane segment between Mini Drive and Fairgrounds Drive. However, the level of congestion or delays to motorists are lesser than that experienced by eastbound motorists approaching Sacramento Street.

TABLE II-1
EXISTING TRAFFIC VOLUME
ON STATE ROUTES

<u>Facility/Location</u>	<u>Daily Traffic (a)</u>
Interstate 80:	
South of Sonoma Boulevard	63,000
Between Sonoma Boulevard and I-780	61,000
Between I-780 and Tennessee Street	71,000
Between Tennessee Street and Redwood Street	70,000
Between Redwood Street and Route 37	64,000
North of Route 37	55,000
Interstate 780:	
East of Interstate 80	23,000
Route 29:	
North of Interstate 80	9,000
Between Lemon Street and Maryland Street	15,000
Between Maryland Street and Route 37	20,000 (b)
Route 37:	
West of Walnut Street (Mare Island)	15,300
Napa River Bridge (between Walnut Street and Wilson Avenue)	20,500
Between Wilson Street and Sacramento Street	19,000
Between Sacramento Street and Route 29	18,500
Between Route 29 and Broadway	16,500
Between Broadway and Fairgrounds Drive	18,000
Between Fairgrounds Drive and Interstate 80	33,000

Source: Caltrans, 1980 Traffic Volumes

(a) This is annual average daily traffic or AADT; average daily traffic over a shorter period may differ from the annual average

(b) Traffic in this section varies depending on location; this is the highest reported by Caltrans in the entire section.

Tennessee Street/Mare Island Causeway

During peak periods of travel, congestion occurs near the guarded gate entrance to the Mare Island Causeway. The six-legged intersection configuration at Wilson Way/Mare Island Causeway/Mare Island Way/Butte Street/Tennessee Street, and Yolc Avenue is not very efficient and presents operational problems.

Lemon Street

The problem here is not one of congestion but rather the lack of a continuous and direct route between I-80/I-780 and Mare Island Way. The routing available now is circuituous. A motorist westbound on Interstate 780 destined to the Municipal Dock area has the following routing available: west to Lemon Street, southwest to Sonoma Boulevard, northwest to Maryland Street/Mare Island Way. This routing entails out of direction travel and loss of time. A motorist northbound on Interstate 80 has the option of using the routing just described or the Sonoma Boulevard exit off Interstate 80. While the latter routing eliminates out of direction travel, it does entail lengthy travel along an arterial in what is primarily an industrial area.

The lack of a direct connection diminishes the usefulness of Mare Island Way which does not appear to carry traffic volumes commensurate with its capacity.

Redwood Street

The two-lane section between Tuolumne Street and Interstate 80 and the narrow bridge over the freeway present operational problems. Congestion occurs during peak travel periods.

PLANNED ROADWAY IMPROVEMENTS

A number of roadway improvements by Caltrans and the City of Vallejo are in various stages of planning and implementation. These are discussed in the following paragraphs.

Route 37

Caltrans has plans for improving Route 37 between approximately Sacramento Street and Fairgrounds Drive to a four-lane "conventional highway," generally along the present alignment. While this improvement has been identified as a very high priority item, funding is not provided in the five year State Transportation Improvement Program (STIP). Without funding in the STIP, implementation cannot be initiated.

The planned improvements would raise the traffic carrying capacity of the facility, substantially. Caltrans estimates that the capacity of the two-lane portions of the route is approximately 20,000 vehicles per day (vpd). With high design standards, the capacity of the planned

four-lane facility would be approximately 50,000 vpd. The capacities quoted are "Maximum Capacity" figures from the Solano County Transportation Plan. "Maximum Capacity" means that if the travel demand on the facility were to reach this level, stop-and-go traffic for extended periods would be observed. A detailed description of capacity levels, extracted from the Solano County Transportation Plan, is presented in Appendix A to this report.

The portion of Route 37 east of the Napa River had been designated as a full freeway, to be developed on new right-of-way, generally parallel to and slightly north of the present route. Recently, this portion of Route 37 was dropped from "Freeway" status with the understanding that a four-lane "conventional" facility generally along the present alignment would be constructed expeditiously. To achieve early implementation, this item must be included in the STIP as soon as possible.

The portion of Route 37 west of the Napa River is still in "Freeway" status. Caltrans has not actively pursued the development of a freeway since early in the 1970's when environmental documentation was prepared. Because of substantial opposition expressed during that period, no further efforts were made to implement a freeway. Caltrans made some improvements, primarily consisting of striping the third lane to permit alternating passing opportunities for traffic in both directions. With the deletion of Route 37 from "Freeway" status east of the Napa River, it is highly unlikely that Caltrans will make any improvements west of the River in the foreseeable future.

Redwood Street

The City of Vallejo is considering the widening of Redwood Street between Tuolumne Street and Interstate 80 in conjunction with a project to widen the Redwood Street bridge over Interstate 80. No specific timetable is available for this improvement. The City's General Plan includes a future "Major Road" along Redwood Street east of Interstate 80, which would accentuate the need for such an improvement.

Route 141

Route 141 is the designation of a future four-lane expressway-type facility between the junction of Interstates 80/780 and Route 37. The route would start at the present ramp terminal area just east of Lemon Street and would lie generally parallel to and north of Carlson Street to approximately Beach Street, passing in between Lake Dalvigk and Wilson Park. North of Beach Street it would follow an alignment approximately midway between Scott and 6th Streets to Maryland Street/Solano Avenue. The route would lie along Maryland Street (improved) between Solano Avenue and Mare Island Way/Sonoma Boulevard. The presently fully improved Mare Island Way would constitute Route 141 between Sonoma Boulevard and Florida Street. North of Florida Street a new alignment would be developed to make a direct connection with Wilson Avenue. This alignment would cross Mare Island Causeway at a point west of the present six-legged intersection at Tennessee Street. Wilson Avenue would be realigned and/or improved to Route 37 and would

complete Route 141. The realignment of Mare Island Way to intersect Tennessee Street west of the present intersection will necessitate the relocation of the guard gate under the jurisdiction of the U.S. Navy. It is our understanding that discussions with the Navy have taken place to bring about the relocation of the gate.

Recognizing the value of and need for Route 141, the City of Vallejo has let a construction contract for the portion of the route between the ramp terminals and Solano Avenue. In addition, the City has an engineering contract for the design of the necessary improvements along Maryland Street. It appears that, aside from some preliminary work and discussions with the Navy, there is no substantive effort to improve the portion of Route 141 between Florida Street and Route 37. While Caltrans has indicated it will improve the portion between Florida Street and Tennessee Avenue, there appears to be no specific timetable.

The completion of Route 141 as a four-lane expressway-type facility will have substantial benefits for many motorists travelling to/from Mare Island, the downtown area of Vallejo, City Hall, and the waterfront facilities.

Sacramento Street

The City of Vallejo is planning to widen Sacramento Street between Route 37 and Redwood Street to four lanes. While no specific timetable is available, the City recognizes this as a high priority need.

Summary of Planned Improvements

Figure II-2 is a summary illustration of the improvements planned by the City of Vallejo and Caltrans, as discussed in the preceding paragraphs.

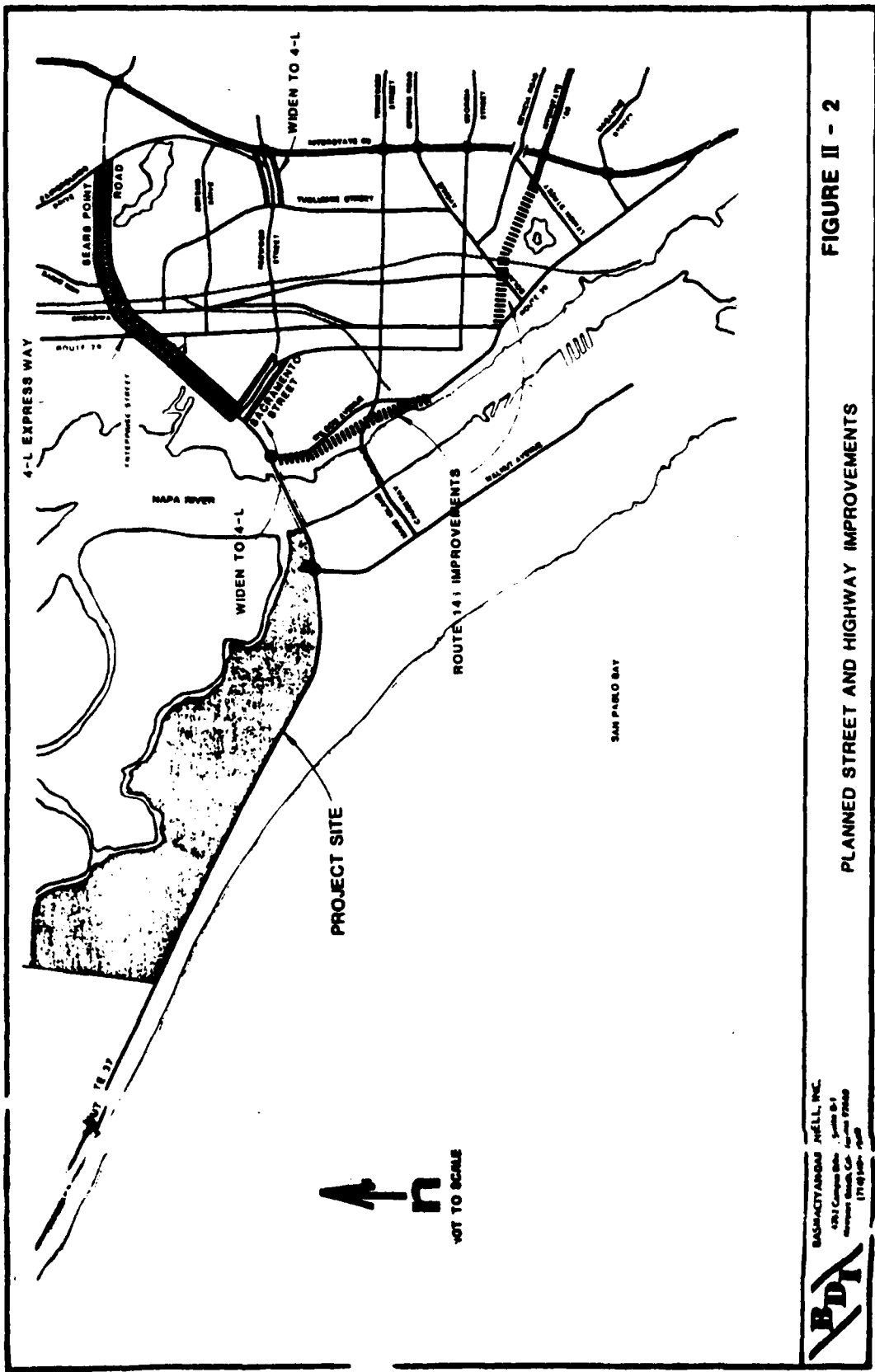

FIGURE II - 2

PLANNED STREET AND HIGHWAY IMPROVEMENTS

11-8

BPA
 BARNHARTMAN HELL, INC.
 1281 Campus Drive, Suite 81
 Menlo Park, CA 94025
 (415) 321-1000

FUTURE TRAFFIC VOLUMES

GENERAL

The procedure for estimating future traffic volume is the following:

- A. Estimate future traffic assuming that there would be no development at Cullinan Ranch or Guadalcanal Village. Traffic projections for this condition have been made by Caltrans for the Year 2005 using a county-wide traffic forecasting model. This planning horizon year used by Caltrans is approximately when ultimate development at Cullinan Ranch would be expected.
- B. Estimate the amount of traffic to/from Cullinan Ranch when the ultimate development level is achieved.
- C. Superimpose the traffic to/from Cullinan Ranch on the background traffic projections described in Step A.
- D. As a separate analysis, estimate traffic to/from Cullinan Ranch for the Phase 1 level of development to assess transportation system improvements required for that level of development.

FUTURE TRAFFIC WITHOUT CULLINAN RANCH

The countywide traffic projection model developed by Caltrans was used as the source for future traffic volumes without Cullinan Ranch or Guadalcanal Village. The following assumptions are inherent in the Caltrans estimates:

- A. A planning horizon year of 2005.
- B. Employment growth in Solano County will be such that commuting to jobs outside the County will be at a lower rate than if present trends were to continue. (Caltrans has also studied a "low" County employment scenario in which commuting to jobs outside the County would be at a high level. With this latter assumption, traffic volume projections on certain routes, including Route 37 would be higher.)
- C. The present level of activity at Mare Island would prevail in the Year 2005 (due to historically fluctuating levels of activity at installations such as Mare Island, no other reasonable assumption can be made).
- D. The North Housing Area would not be developed. This assumption was considered no longer valid, since the City is pursuing the development of the North Housing Area in light industrial/warehousing use. Accordingly, the likely level of traffic to/from the North Housing Area (or the "South Parcel," as it is called on occasion) was estimated and added to the Caltrans traffic projections.

E. No development at Cullinan Ranch or Guadalcanal Village. Traffic to/from these facilities is estimated separately. The impacts of this traffic constitute the major focus of this report.

Presented in Table III-1 are the estimated traffic volumes on selected roadways for the Year 2005, assuming that no development would take place at Cullinan Ranch or Guadalcanal Village. Also presented in Table III-1 are the estimated present capacity of the facility and the type of improvement required, if any, to accommodate the projected traffic volume. The necessary improvements are:

- Route 37: Widening and improving to four-lane expressway standard between Sacramento Street and Fairgrounds Drive. This will raise the maximum capacity to 50,000 vpd. Except for the segment between Mini Drive and Fairgrounds Drive, where the traffic projection is 52,000 vpd, the capacity of 50,000 vpd would be sufficient to accommodate the future traffic demand.
- Redwood Street: Widening of the two-lane segment west of Interstate 80 to a four-lane arterial along with the widening of the bridge across I-80.

These improvements are two of those described in Section II under "Planned Roadway Improvements." Two other planned improvements discussed in that Section are: Sacramento Street and Route 141. Based on the traffic volume projections yielded by the traffic model, no need for those improvements would be indicated. It is our opinion that the model projections for Sacramento Street and Wilson Avenue are low and that those improvements would be needed.

TRAFFIC TO/FROM CULLINAN RANCH AND GUADALCANAL VILLAGE

Proposed Land Use

The proposed land use for Cullinan Ranch and Guadalcanal Village is presented in Table III-2. While further refinements of the land use plan may alter the type or intensity of uses proposed, and specific acreage figures for individual uses may be revised, such changes are not expected to have a significant effect on traffic generation.

Potential Traffic Generation

The expected trip generation rates typical for the types of land uses at Cullinan Ranch and Guadalcanal Village are presented in Table III-3. The potential traffic to/from the ultimate level of development at Cullinan Ranch and Guadalcanal Village is presented in Table III-4.

Many of the tripmaking needs of the residents of Cullinan Ranch will be satisfied internally because the proposed development will contain schools, parks, and a neighborhood commercial center. In addition, Guadalcanal Village will contain some services to cater to Cullinan Ranch residents. The estimated internal and external portion of the tripmaking is presented in Table III-5. Overall, 36 percent of all Cullinan Ranch and Guadalcanal Village trips are expected to remain internal and will not contribute to traffic on Route 37. The remaining 64 percent of the traffic will use Route 37, which is the only access route to the proposed development.

COMPARISON OF ESTIMATED POTENTIAL FUTURE DAILY TRAFFIC VOLUMES AND CAPACITIES
(Year 2005)
WITHOUT CULLINAN RANCH OP GUADALCANAL VILLAGE

Facility/Location	Future Traffic (a)	Present Facility Type	Present Capacity (b)	Improvements Needed
Route 37				
Along Cullinan Ranch Frontage	20,000	2-L Rural	20,000	None
On Napa River Bridge	27,000	4-L Freeway	100,000 (f)	None
Between Wilson Avenue and Sacramento Street	29,000	4-L Expressway	50,000 (f)	None
Between Sacramento Street and Route 29	30,000	2-L Arterial	20,000	4-L Expressway
Between Route 29 and Broadway	45,000	4-L Arterial (64-ft.)	40,000	4-L Expressway
Between Broadway and Mini Drive	47,500	4-L Arterial (64-ft.)	40,000	4-L Expressway (f)
Between Mini Drive and Fairgrounds Drive	52,000	2-L Arterial	20,000	4-L Expressway
Between Fairgrounds Drive and I-80	58,000	4-L Freeway	100,000	None
Wilson Avenue				
South of Route 37	6,000 (c)	2-L Arterial	20,000	None (e)
Sacramento Street				
Between Route 37 and Redwood Street	6,000 (c)	2-L Arterial	20,000	None (e)
Route 29				
North of Route 37	37,000	4-L Divided Arterial	45,000	None
North of Redwood Street	16,000	4-L Divided Arterial	45,000	None
North of Tennessee Street	27,000	4-L Divided Arterial	45,000	None
Redwood Street				
East of Sacramento Street	6,000 (c)	2-L Arterial	20,000	None
West of Route 29	17,000	4-L Arterial (64-ft.)	40,000	None
East of Route 29	8,000	4-L Arterial (64-ft.)	40,000	None
West of I-80	25,000	2-L Arterial	20,000	4-L Arterial (64-ft.)
I-80				
North of Route 37	111,000	6-L Freeway	150,000	None
North of Redwood Street	82,000	6-L Freeway	150,000	None
North of Tennessee Street	118,000	6-L Freeway	150,000	None
South of Route 29	80,000	6-L Freeway	150,000	None
I-780				
East of I-80	58,000	4-L Freeway	100,000	None

(a) Per Caltrans projections using the scenario of "High" employment in Solano County. Estimated traffic to/from South Parcels (North Housing Area) has been added by BDI to the Caltrans projections.

(b) Capacity values are for "Maximum Capacity." If travel demand reaches the level of maximum capacity, stop-and-go traffic for extended periods would be observed.

(c) These estimates from the model appear to be low, but no better way of estimating is available at this time.

(d) Since the maximum capacity of a 4-L Expressway would be 50,000 vpd, a capacity deficiency would remain.

(e) Widening of these facilities is planned. (f) The capacity of this segment is controlled by the traffic signal at

Table III-2

CULLINAN RANCH/GUADALCANAL VILLAGE
LAND USE SUMMARY

<u>Land Use</u>	<u>Acreage</u>	<u>Dwelling Units</u>
<u>PHASE 1 OF CULLINAN RANCH</u>		
Low Density Residential (6.6 units/acre)	60.0	400
<u>PHASE 2 OF CULLINAN RANCH</u>		
Low Density Residential (6.6 units/acre)	397.5	2,600
Medium Density Residential (11.5 units/acre)	130.5	1,500
Neighborhood Commercial (a)	13.5	-
Secondary Marina	19.0	-
Community Parks	46.0	-
Public Schools	<u>23.0</u>	<u>-</u>
Phase 2 Developed Acreage/ Dwelling Units	629.5	4,100
Total Cullinan Ranch Developed Acreage/Dwelling Units	689.5	4,500
<u>GUADALCANAL VILLAGE AREA</u>		
Specialty/Water-Oriented Commercial (b)	56.5	-
Primary Marina (c)	<u>60.5</u>	<u>-</u>
Total Guadalcanal Village Developed Acreage	117.0	-
TOTAL	806.5	4,500

(a) Supermarket, convenience stores, etc.

(b) Hotel, restaurants, shops, offices, marine service and storage facilities

(c) The primary marina is part of the Cullinan Ranch Development, but is shown as part of the development in the Guadalcanal Village area because it has traffic characteristics similar to those of Guadalcanal Village.

Table III-3

**CULLINAN RANCH/GUADALCANAL VILLAGE
TRIP GENERATION RATES**

<u>Land Use</u>	<u>Daily Rates</u> (a)	<u>AM Peak Hour</u>		<u>PM Peak Hour</u>	
		<u>In</u>	<u>Out</u>	<u>In</u>	<u>Out</u>
Low Density Residential (6.6 du/acre)	10.0/du	0.3	0.6	0.7	0.4
Medium Density Residen- tial (11.5 du/acre)	8.0/du	0.2	0.5	0.5	0.2
Guadalcanal Village: Specialty/Water- Oriented Commercial (b)	258/ac	8.8	6.5	10.7	12.3
Neighborhood Commercial	650/ac	18.0	15.0	30.0	30.0
Marinas	20.9/ac	-	-	-	-
Community Parks	5/ac	.1	.1	.25	.25
Public Schools	30/ac	.5	.5	.5	1.0

(a) Based on trip generation rates presented in Institute of Transportation Engineers Information Report on Trip Generation

(b) Derived from a composite of trip generation rates based on assumed development within Guadalcanal Village

NOTE: "du" means dwelling units; "ac" means acres

Table III-4

CULLINAN RANCH/GUADALCANAL VILLAGE
 ANTICIPATED DAILY AND PEAK HOURLY
 TRIP ENDS

Land Use	Units	Daily	Trip Ends			
			AM Peak Hour In	AM Peak Hour Out	PM Peak Hour In	PM Peak Hour Out
PHASE 1 OF CULLINAN RANCH						
Low Density Residential (6.6 units/acre)	400 du	4,000	120	240	280	160
Total Phase 1 Trip Ends		4,000	120	240	280	160
PHASE 2 OF CULLINAN RANCH						
Low Density Residential (6.6 units/acre)	2,600 du	26,000	780	1,560	1,820	1,040
Medium Density Residential (11.5 units/acre)	1,500 du	12,000	300	750	750	300
Neighborhood Commercial	13.5 ac	8,775	243	203	405	405
Secondary Marina	19.0 ac	397	-	-	-	-
Community Parks	46.0 ac	230	5	5	12	12
Public Schools	23.0 ac	690	12	12	12	23
Total Phase 2 Trip Ends		48,092	1,340	2,540	2,999	1,780
Total Cullinan Ranch Trip Ends (Phases 1 and 2)		52,092	1,460	2,770	3,279	1,940
GUADALCANAL VILLAGE AREA						
Specialty/Water-Oriented Commercial	56.5 ac	14,577	497	367	605	694
Primary Marina (a)	60.5 ac	1,265	-	-	-	-
Total Guadalcanal Village Trip Ends		15,842	497	367	605	694
TOTAL		67,934	1,957	3,137	3,884	2,634

NOTE: "du" means dwelling units; "ac" means acres

(a) The primary marina is part of the Cullinan Ranch Development, but is shown as part of the development in the Guadalcanal Village area because it has traffic characteristics similar to those of Guadalcanal Village.

Table III-5
INTERNAL/EXTERNAL PROJECT TRIP DISTRIBUTION ASSUMPTIONS

Total Trip Ends	Cullinan Ranch				Guadalcanal Village Area			Total Trip Ends
	Residential	Neighborhood Commercial	Secondary Marina	Community Parks	Public Schools	Specialty/Water-Oriented Commercial	Primary Marina	
Daily	42,000	9,775	397	230	690	14,577	1,265	67,934
AM Peak In	1,200	243	-	5	12	497	-	1,957
AM Peak Out	2,550	203	-	5	12	367	-	3,137
PM Peak In	2,850	405	-	12	12	605	-	3,884
PM Peak Out	1,500	405	-	12	23	694	-	2,634
<u>Internal Trip Ends</u>								
Percent of Daily	30%	75%	100%	60%	82%	25%	33%	36%
Daily	12,600	6,581	397	138	566	3,790	417	24,489
AM Peak In	360	182	-	3	10	129	-	684
AM Peak Out	765	152	-	3	10	95	-	1,025
PM Peak In	855	304	-	7	10	157	-	1,033
PM Peak Out	450	304	-	7	19	180	-	960
<u>External Trip Ends</u>								
Percent of Daily	70%	25%	-	40%	18%	74%	67%	64%
Daily	29,400	2,194	-	92	124	1,787	848	43,445
AM Peak In	840	61	-	2	2	368	-	1,273
AM Peak Out	1,785	51	-	2	2	272	-	2,112
PM Peak In	1,995	101	-	5	2	448	-	2,551
PM Peak Out	1,050	101	-	5	4	514	-	1,674

(a) The primary marina is part of the Cullinan Ranch Development, but is shown as part of the development in the Guadalcanal Villages area because it has traffic characteristics similar to those of Guadalcanal Villages.

Of the total estimated daily trip ends of approximately 67,900, approximately 43,400 would be external. The remaining 24,500 would consist of tripmaking totally internal to Cullinan Ranch/Guadalupe Village.

Phase 1 tripmaking will be almost entirely external, since the development proposed in Phase 1 is residential only. Residents would need to travel outside the development for trip purposes such as shopping, schools, and all other services. When the 400-unit development is in place (the Phase 1 level), there will be approximately 4,000 daily external trips.

Trip Distribution

The spatial allocation, or distribution, of external trips to/from Cullinan Ranch and Guadalupe Village was estimated on the basis of the location of employment opportunities and shopping, recreational and other activity centers. It is expected that there would be some differences between the distribution pattern of trips to/from Cullinan Ranch and trips to/from Guadalupe Village. The estimated distribution is presented in Figures III-1 (Cullinan Ranch) and III-2 (Guadalupe Village). The distribution of Phase 1 trips to/from Cullinan Ranch is assumed to be the same as the distribution for ultimate development.

Traffic Loads

The load that traffic to/from Cullinan Ranch and Guadalupe Village would impose on streets and highways in the vicinity is presented in Table III-6 along with the background future traffic volumes as estimated by the countywide traffic projection model.

The traffic loads attributable to Cullinan Ranch and Guadalupe Village constitute a small percentage (less than 12) of the total traffic on I-80, I-780, Route 29, on the portion of Route 37 east of Route 29, and on Redwood Street near I-80. The significant traffic impacts, in terms of total daily traffic loads would be on Route 37 (between the Cullinan Ranch property and Route 29), on Wilson Avenue, on Sacramento Street, and on Redwood Street (on the portion between Sacramento Street and Route 29).

Comparison of Future Traffic and Capacity

Table III-7 presents a comparison of future traffic volume (assuming ultimate development at Cullinan Ranch and Guadalupe Village) and estimated capacity. For purposes of this comparison, future capacity is estimated on the assumption that the improvements described previously are in place. Briefly, these improvements consist of Route 37 as a four-lane expressway, widening of Sacramento Street, widening of Redwood Street near I-80, and Route 141.

After these improvements are made, remaining potential traffic problems would be confined to Route 37. Specifically, it would be necessary to widen Route 37 to four lanes along the Cullinan Ranch frontage as far west as the most westerly access point to/from the development.

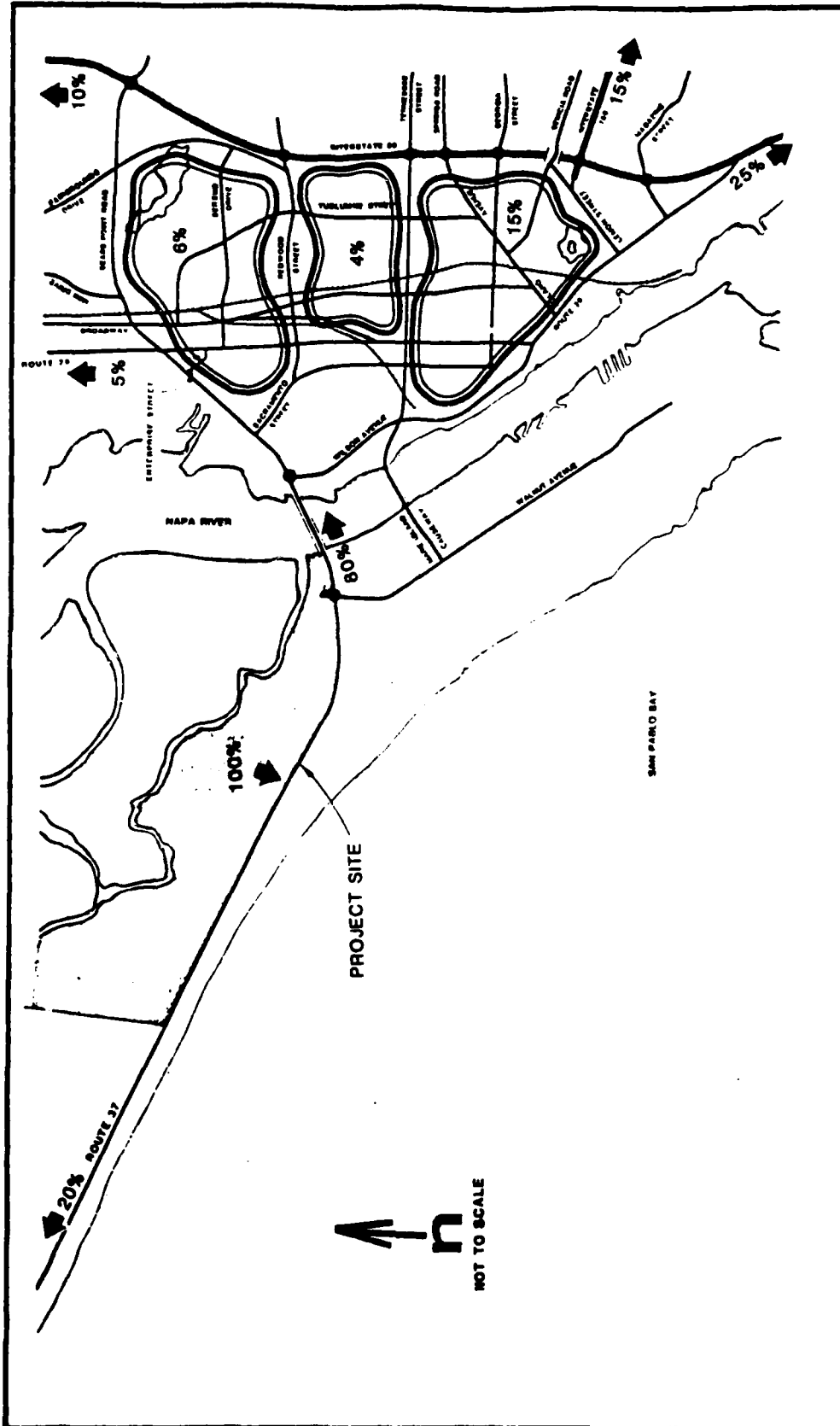



 NOT TO SCALE

 PDI
 BASINACLY MEMBERSHIP, L.L. INC.
 1701 Commercial Street, Suite 201
 Berkeley, CA 94704
 (925) 841-1000

FIGURE III - 1

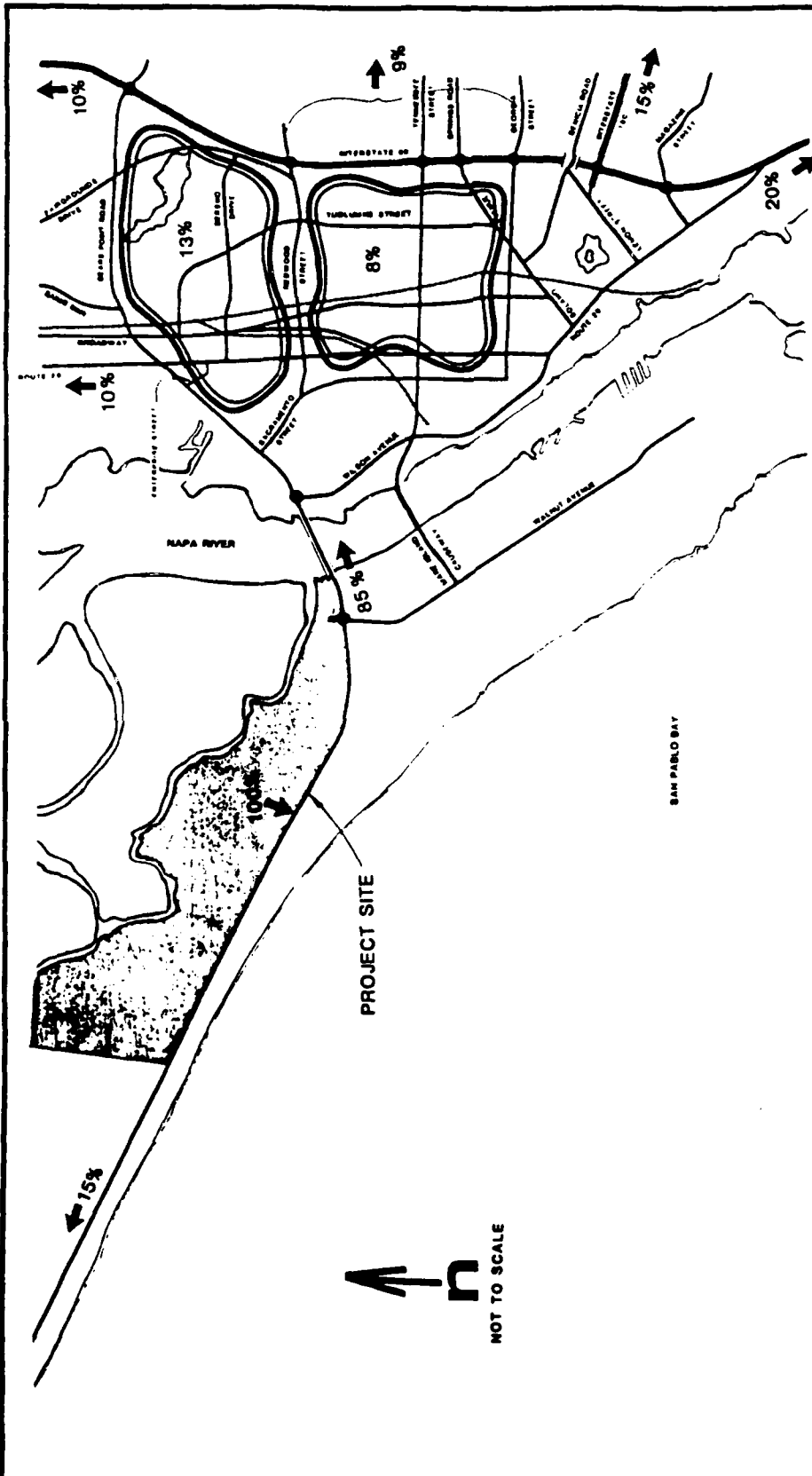
PERCENTAGE DISTRIBUTION OF EXTERNAL TRIPS TO/FROM CULLINAN RANCH



↑
 N
 NOT TO SCALE

BDI
 BASMAJIAN DARNELL, INC.
 4202 Canyon Blvd., Suite 811
 Mountain View, California 92040
 (714) 548-9948

PERCENTAGE DISTRIBUTION OF EXTERNAL TRIPS TO/FROM GUADALUPE VILLAGE **FIGURE III - 2**

Table 1-6

ESTIMATED POTENTIAL FUTURE DAILY TRAFFIC VOLUMES
(Year 2005)
INCLUDING ULTIMATE DEVELOPMENT OF CULLINAN RANCH AND GUADALCANAL VILLAGE

Facility/Location	Background Traffic (a)	Traffic to/from		Traffic to/from Guadalcanal Village (b)	Total Traffic		Percent Cullinan Ranch Traffic Is Of Total		Percent Guadalcanal Village Traffic Is of Total	
		Cullinan Ranch (b)	Guadalcanal Village (b)		Cullinan Ranch Traffic	Guadalcanal Village Traffic	Cullinan Ranch Traffic	Guadalcanal Village Traffic		
Route 37										
Along Cullinan Ranch Frontage	20,000	6,400	1,700	1,700	28,100	23%	6%			
On Napa River Bridge	27,000	25,400	9,900	9,900	62,300	41%	16%			
Between Wilson Avenue and Sacramento Street	29,000	14,300	6,200	6,200	49,500	29%	13%			
Between Sacramento Street and Route 29	30,000	5,400	2,900	2,900	38,300	14%	8%			
Between Route 29 and Broadway	45,000	3,800	1,700	1,700	50,500	8%	3%			
Between Broadway and Mini Drive	47,500	3,800	1,700	1,700	53,000	7%	3%			
Between Mini Drive and Fairgrounds Drive	52,000	3,200	1,200	1,200	56,400	6%	2%			
Between Fairgrounds Drive and I-80	58,000	3,200	1,200	1,200	62,400	5%	2%			
Wilson Avenue										
South of Route 37	6,000 (c)	11,100	3,700	3,700	20,800	53% (d)	18% (d)			
Sacramento Street										
Between Route 37 and Redwood Street	6,000 (c)	8,900	3,300	3,300	18,200	49% (d)	18% (d)			
Route 29										
North of Route 37	37,000	1,600	1,200	1,200	39,800	4%	3%			
North of Redwood Street	16,000	600	300	300	16,900	4%	2%			
North of Tennessee Street	27,000	2,500	300	300	29,800	8%	1%			
Redwood Street										
East of Sacramento Street	6,000 (c)	5,400	2,100	2,100	13,500	40% (d)	16% (d)			
West of Route 29	17,000	5,400	2,100	2,100	24,500	22%	9%			
East of Route 29	8,000	1,600	1,400	1,400	11,000	15%	13%			
West of I-80	25,000	1,600	800	800	27,400	6%	3%			
I-80										
North of Route 17	111,000	3,200	1,200	1,200	115,400	3%	1%			
North of Redwood Street	82,000	Nom	Nom	Nom	82,000	Nom	Nom			
North of Tennessee Street	138,000	1,600	600	600	120,200	1%	Nom			
South of Route 29	80,000	3,000	2,300	2,300	90,300	9%	3%			
I-780										
East of I-80	58,000	4,800	1,700	1,700	64,500	7%	3%			

(a) Base Caltrans projections using the scenario of "high" employment in Solano County. Estimated traffic to/from South Parkway North (using 2005) has been added by BDI to the Caltrans projections.

(b) Ultimate development level (c) These estimates from model appear to be low.

(d) These percentages are high because the estimates of background traffic are low.

COMPARISON OF ESTIMATED POTENTIAL FUTURE DAILY TRAFFIC VOLUMES AND CAPACITIES
(Year 2005)
WITH ULTIMATE DEVELOPMENT OF CULLINAN RANCH AND GUADALCANAL VILLAGE

Facility/Location	Future Traffic (a)	Future Facility Type (b)	Future Capacity (c)	Improvement Needed
Route 37				
Along Cullinan Ranch Frontage	28,100	2-L Rural	20,000	4-L Expressway
On Napa Pivoy Bridge	62,300	4-L Freeway	100,000	None
Between Wilson Avenue and Sacramento Street	49,500	4-L Expressway	50,000	None
Between Sacramento Street and Route 29	38,300	4-L Expressway	50,000	None
Between Route 29 and Broadway	50,500	4-L Expressway	50,000	(e)
Between Broadway and Mini Drive	53,000	4-L Expressway	50,000	(e)
Between Mini Drive and Fairgrounds Drive	56,400	2-L Expressway	50,000	(e)
Between Fairgrounds Drive and I-80	62,400	4-L Freeway	100,000	None
Wilson Avenue				
South of Route 37	20,800 (d)	4-L Arterial (56-ft.)	40,000	None
Sacramento Street				
Between Route 37 and Redwood Street	18,200 (d)	4-L Arterial (56-ft.)	40,000	None
Route 29				
North of Route 37	39,800	4-L Divided Arterial	45,000	None
North of Redwood Street	16,900	4-L Divided Arterial	45,000	None
North of Tennessee Street	29,800	4-L Divided Arterial	45,000	None
Redwood Street				
East of Sacramento Street	13,500 (d)	2-L Arterial	20,000	None
West of Route 29	24,500	4-L Arterial (64-ft.)	40,000	None
East of Route 29	11,000	4-L Arterial (64-ft.)	40,000	None
West of I-80	27,400	4-L Arterial	40,000	None
I-80				
North of Route 37	115,400	6-L Freeway	150,000	None
North of Redwood Street	82,000	6-L Freeway	150,000	None
North of Tennessee Street	120,200	6-L Freeway	150,000	None
South of Route 29	90,300	6-L Freeway	150,000	None
I-780				
East of I-80	64,500	4-L Freeway	100,000	None

(a) Base is Caltrans' projection using the scenario of "High" employment in Solano County. Estimated traffic to/from South Parcels (North Housing Area), to/from Cullinan Ranch, and to/from Guadalcanal Village has been added by HPI to the Caltrans' projections. See Table III-6 for details.

(b) Assuming that improvements identified in Table III-1 for the "Without Cullinan Ranch or Guadalcanal Village" condition have been made.

(c) Capacity values are for "Maximum Capacity." If travel demand reaches the level of maximum capacity, stop-and-go traffic for extended periods would be observed. Capacity is for "Future Facility Type."

(d) The estimates with the model as the base appear to be low, but no better way of estimating is available at this time.

(e) Since the maximum capacity of a 4-L Expressway would be 50,000 vph, there would be a capacity deficiency.

There would be some capacity deficiencies along Route 37 (improved to four-lane expressway) between Broadway and Fairgrounds Drive and possibly between Route 29 and Broadway, as well. Along this segment of Route 37, traffic to/from Cullinan Ranch and Guadalcanal Village would constitute a relatively small percentage of the total traffic. Thus, congestion would prevail along Route 37 whether or not the proposed development occurs. The superimposition of traffic to/from Cullinan Ranch and Guadalcanal Village will make a likely bad condition worse.

TRAFFIC IMPACTS OF PHASE 1 DEVELOPMENT

The 400 dwelling units anticipated for Phase 1 of the Cullinan Ranch development would generate approximately 4,000 daily vehicular trips. It is expected that the directional orientation of these trips would be the same as that for the ultimate development level. Thus, 80 percent of the traffic would be oriented to the east adding a daily traffic volume of approximately 3,200 vehicles on the Napa River bridge. To the east of the bridge, traffic would disperse to Wilson Avenue, Sacramento Street, Route 29, and Route 37. The additional traffic on any one of these facilities would be very small. Table III-8 is a comparison of existing traffic and traffic to/from Phase 1 of the Cullinan Ranch development. The impact of Phase 1 traffic would be five percent or less except on Route 37 on the Napa River bridge and as far east as Sacramento Street.

Peak Hour Traffic Impacts

Traffic on the Napa River Bridge is highly directional during peak traffic hours. In the afternoon, the heavy movement is eastbound whereas in the morning, heavy traffic is in the westbound direction. The peak hour orientation of tripmaking to/from Cullinan Ranch is opposite to this pattern. In the afternoon, the heavy traffic would be westbound into the development and in the morning, eastbound out of the development. Phase 1 of Cullinan Ranch would add approximately 130 vehicles eastbound and approximately 220 vehicles westbound. In the morning peak, approximately 100 vehicles would be added westbound and approximately 190 vehicles eastbound.

Impacts on Walnut Street Interchange

It is proposed that Phase 1 of the Cullinan Ranch development take access via the Walnut Street (Mare Island) Interchange, via a frontage road extending west from the interchange area into the development. While Phase 1 development would add substantial traffic in the interchange area (see Table III-9), the total volume on the ramps will not be very high. Because of the opposing directional orientation of Mare Island and Cullinan Ranch traffic, problems should not be very severe. During the morning peak hour, traffic approaching Mare Island from the east (westbound on Route 37) and Phase 1 traffic outbound from Cullinan Ranch destined eastbound on Route 37 must share the loop overpass over Route 37. This would represent the only instance where two heavy peak period traffic components would be additive. If the actual time of the peak flows were to coincide, potential operational problems may arise and some modification of traffic controls and channelization may be necessary.

Table III-8

COMPARISON OF EXISTING TRAFFIC AND TRAFFIC
TO/FROM PHASE 1 OF CULLINAN RANCH DEVELOPMENT

<u>Facility/Location</u>	<u>Existing Traffic</u>	<u>Traffic To/From Phase 1 Cullinan Ranch</u>	<u>Percent Added by Cullinan Ranch Traffic</u>
Route 37			
West of Project Site	15,300	800	5%
On Napa River Bridge	20,500	3,200	16%
Between Wilson Avenue and Sacramento Street	19,000	1,800	9%
Between Sacramento Street and Route 29	18,500	700	4%
Between Route 29 and Broadway	16,500	500	3%
Between Broadway and Mini-Drive	18,000	500	3%
Between Mini Drive and Fairgrounds Drive	18,000	300	2%
Between Fairgrounds Drive and I-80	33,000	200	1%
Wilson Avenue			
South of Route 37	N/A	1,400	N/A
Sacramento Street			
Between Route 37 and Redwood Street	N/A	1,100	N/A
Route 29			
North of Route 37	37,000	200	1%
North of Redwood Street	16,000	100	1%
North of Tennessee Street	27,000	300	1%
Redwood Street			
East of Sacramento Street	N/A	700	N/A
West of Route 29	N/A	700	N/A
East of Route 29	N/A	200	N/A
West of I-80	N/A	200	N/A
I-80			
North of Route 37	55,000	400	1%
North of Redwood Street	64,000	Nom	Nom
North of Tennessee Street	70,000	200	Nom
South of Route 29	63,000	1,000	2%
I-780			
East of I-80	23,000	600	3%

NOTE: Expectedly, traffic volume growth will occur between now and the time Phase 1 of Cullinan Ranch is in place, probably sooner than in three years. Thus, the percentage of traffic to be added by Phase 1 of Cullinan Ranch would be smaller than the numbers indicated.

The results of recent traffic counts by the City of Vallejo (on Wilson Avenue, Sacramento Street, and Redwood Street) are expected to be available soon.

Table III-9

PHASE 1 TRAFFIC IMPACTS ON
WALNUT STREET INTERCHANGE

<u>Ramp/Movement</u>	<u>Present Daily Traffic (a)</u>	<u>Daily Traffic To/From Phase 1 of Cullinar Ranch</u>	<u>Total Traffic</u>
Eastbound Off	530	400	930
Westbound Or.	620	400	1,020
Eastbound Or.	3,750	1,600	5,350
Westbound Off	3,770	1,600	5,370

(a) Caltrans counts in March 1981

SECTION IV

ACCESS AND INTERNAL CIRCULATION

GENERAL

The major issues associated with access and internal circulation are:

1. The number of access points to/from Route 37 and the type of access
2. The sizing of the internal streets
3. Traffic controls on the internal street system
4. Traffic control and safety at those locations where bicycle and pedestrian facilities cross streets

METHODOLOGY

To address the issues enumerated above, traffic generation was estimated by small analysis areas. For purposes of this analysis, the entire development was subdivided into 28 traffic analysis zones (TAZ's). The tripmaking between each pair of TAZ's was estimated, and the estimated traffic was allocated to the internal street system. Similarly, external traffic to/from each TAZ was estimated and allocated to the internal street system and the appropriate access point to/from Route 37.

Figure IV-1 is an illustration of the arrangement of land uses within the development, the internal street system, the TAZ's, assumed generalized access points from each TAZ to the internal street system, and the access points off Route 37. The matrix of tripmaking between each pair of TAZ's and between each TAZ and external areas is presented in Appendix B.

The estimated daily traffic loads on the internal street system and at the access points to/from Route 37 are presented in Figure IV-2. The ensuing paragraphs consist of a discussion of the five major issues listed at the outset of this Section, with frequent reference in the discussion to Figures IV-1 and IV-2. Unless otherwise specified, all discussion pertains to the ultimate level of development for Cullinan Ranch and Guadalcanal Village.

ACCESS TO/FROM ROUTE 37

It is proposed that access to/from Cullinan Ranch would be provided at two locations off Route 37 in addition to the Walnut Street Interchange. The Guadalcanal Village area would be served by the Walnut Street Interchange. A small number of the residential areas near Guadalcanal Village (those near the eastern end of the property) could also be served by the Walnut Street Interchange.

LEGEND

- 1 - Westerly Cullinan Ranch Access
- 2 - Easterly Cullinan Ranch Access
- 3 - Guadalupe Village Access and Minor Access to Cullinan Ranch
- xx - Traffic Analysis Zone Number and Access Connectors

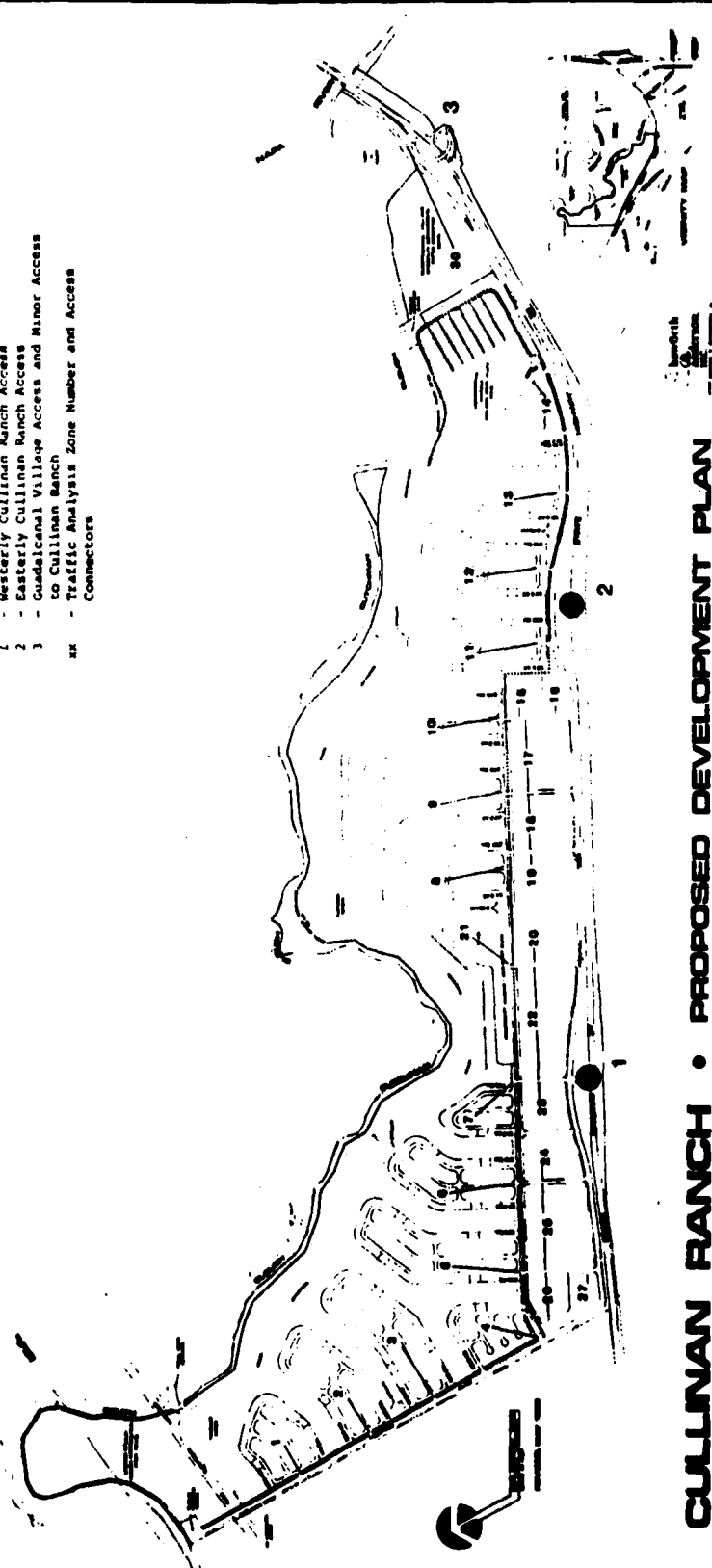

CULLINAN RANCH • PROPOSED DEVELOPMENT PLAN



FIGURE IV - 1

INTERNAL STREET SYSTEM AND TRAFFIC ANALYSIS ZONES

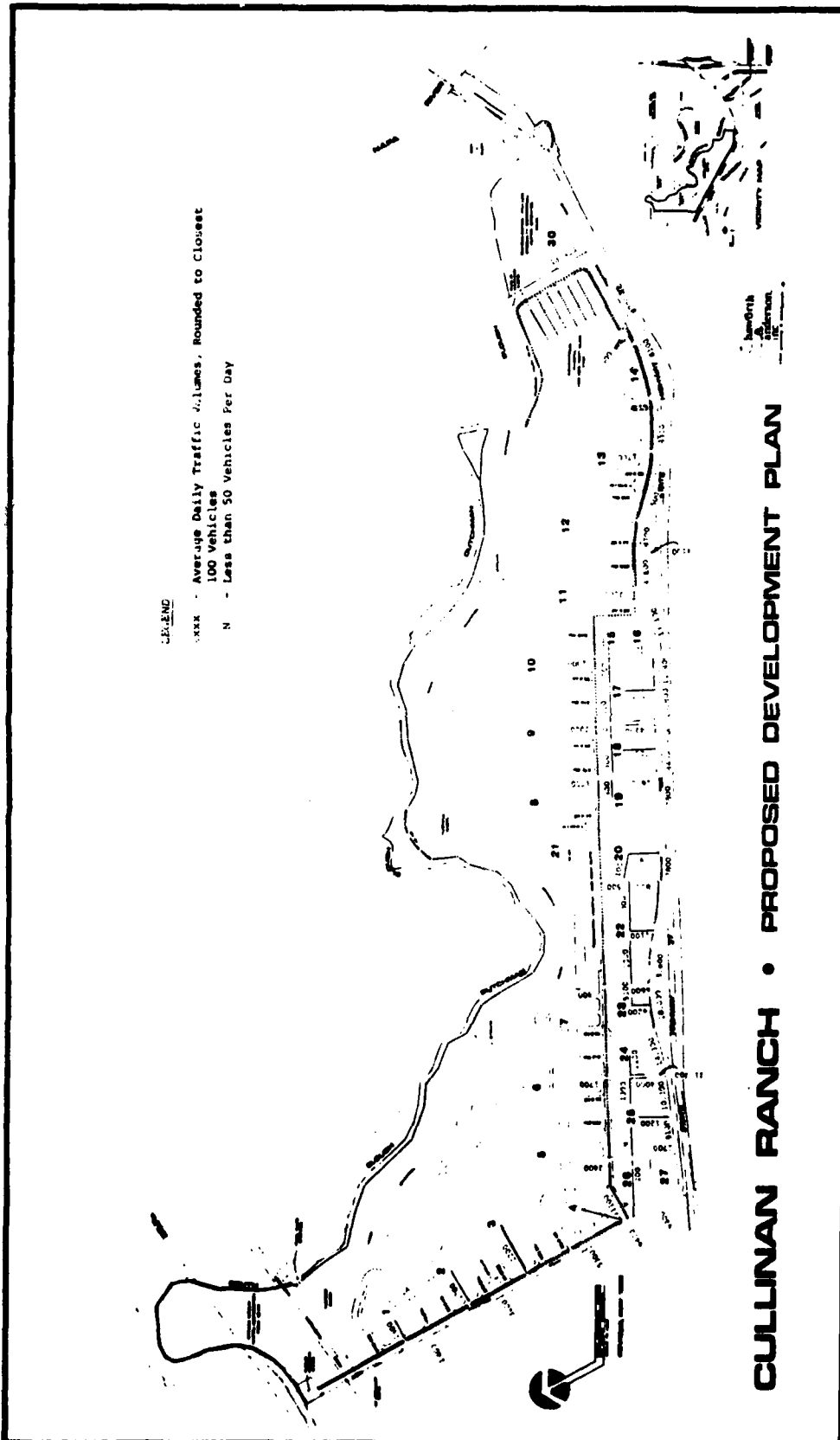

xxx - Average Daily Traffic Volumes, Rounded to Closest
 100 Vehicles
 N - Less than 50 Vehicles Per Day

CULLINAN RANCH • PROPOSED DEVELOPMENT PLAN

B/D
 BARNETT & DORRIS, INC.
 4333 Canyon Blvd., Suite 201
 Boulder, Colorado 80504
 (303) 440-7900

DAILY TRAFFIC ON INTERNAL STREETS
 (FULL DEVELOPMENT)

FIGURE IV - 2

It is estimated that the westerly Cullinan Ranch access point would serve approximately 21,300 vehicles per day (vpd) and the easterly Cullinan Ranch access point would serve approximately 9,100 vpd. At the Walnut Street Interchange approximately 13,000 vpd would be served, of which 11,600 vpd would be travelling to/from the Guadalcanal Village area, the remainder (1,400 vpd) to/from Cullinan Ranch.

Peak Hourly Analysis

Presented in Figures IV-3 and IV-4 are the morning and afternoon peak hourly traffic volumes on Route 37, including estimated turning movements at the two access locations serving Cullinan Ranch. Based on the estimated traffic volumes, the following conclusions are reached:

1. Two signalized at-grade intersections on Route 37 would be sufficient to accommodate traffic to/from Cullinan Ranch. The capacity computation forms for the two intersections for both morning and afternoon peak hours are presented in Appendix C. Capacity computations were performed in accordance with Transportation Research Circular Number 212, "Interim Materials on Highway Capacity." A summary of the results of the capacity analysis is presented in Table IV-1.
2. The configuration of the two Cullinan Ranch access road intersections on Route 37 would be identical. At each intersection, there would be two east-west through traffic lanes in each direction on Route 37; the north leg of each intersection would consist of three lanes southbound (one westbound right-turn lane outbound and two eastbound left-turn lanes outbound) and two northbound (inbound) lanes. At each intersection, there would be a left-turn lane in the eastbound direction on Route 37 to serve traffic inbound to Cullinan Ranch. At each intersection, there would be an exclusive right turn lane in the westbound direction on Route 37 to serve traffic inbound to Cullinan Ranch. The proposed lane configuration at the westerly and easterly access intersections is presented in sketches on the capacity computation forms in Appendix C.

Need For Grade Separation at Access Points

From a traffic capacity standpoint, two signalized at-grade intersections on Route 37 would be sufficient to serve traffic to/from Cullinan Ranch, assuming that there would be overall traffic growth commensurate with Caltrans projections and that Guadalcanal Village and the South Parcels (North Housing Area) would also be developed. Accordingly, grade separations with diamond interchanges at the access locations would not be required.

The portion of Route 37 west of the Napa River is in "Freeway" status although Caltrans has not actively pursued the implementation of a freeway-type facility since environmental documentation was prepared early in the 1970's. The roadway has been improved to provide alternating passing lanes on a basic three-lane section. Caltrans does not plan any further improvements. Since the portion of Route 37 east of the Napa River was dropped from freeway status, the likelihood that Caltrans would undertake any major upgrading of the portion west of the Napa River is small. The improvement of Route 37 through Vallejo has been a

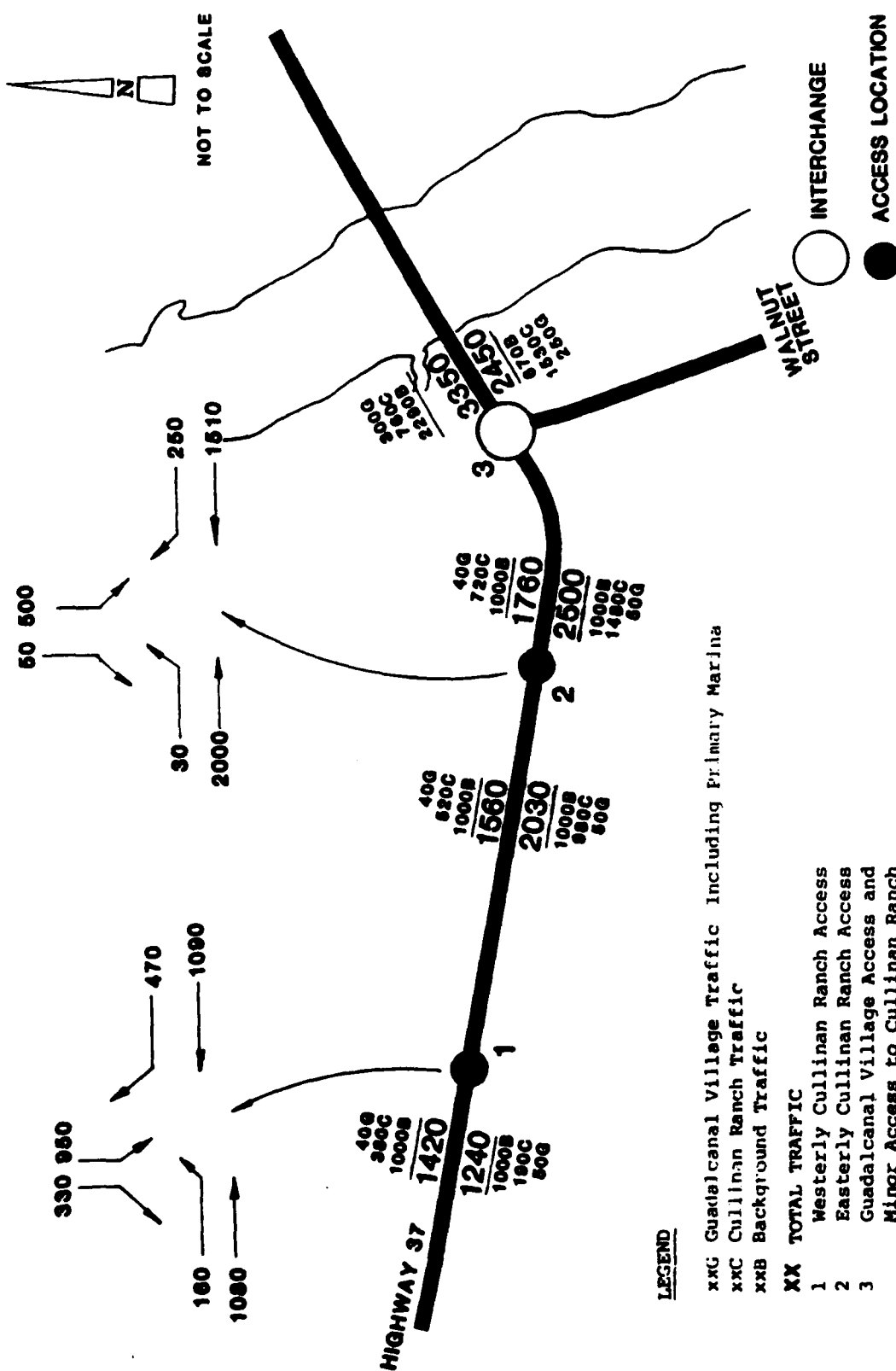

LEGEND

- xxG Guadalcanal Village Traffic Including Primary Marina
- xxC Cullinan Ranch Traffic
- xxB Background Traffic
- XX TOTAL TRAFFIC
- 1 Westerly Cullinan Ranch Access
- 2 Easterly Cullinan Ranch Access
- 3 Guadalcanal Village Access and Minor Access to Cullinan Ranch

FIGURE IV - 3

**MORNING PEAK HOURLY TRAFFIC AT ACCESS POINTS - YEAR 2005
WITH CULLINAN RANCH AND GUADALCANAL VILLAGE**

BDI
 BARNETT DARNELL, INC.
 12400 S. 10th St.
 Phoenix, AZ 85048
 (602) 998-1100

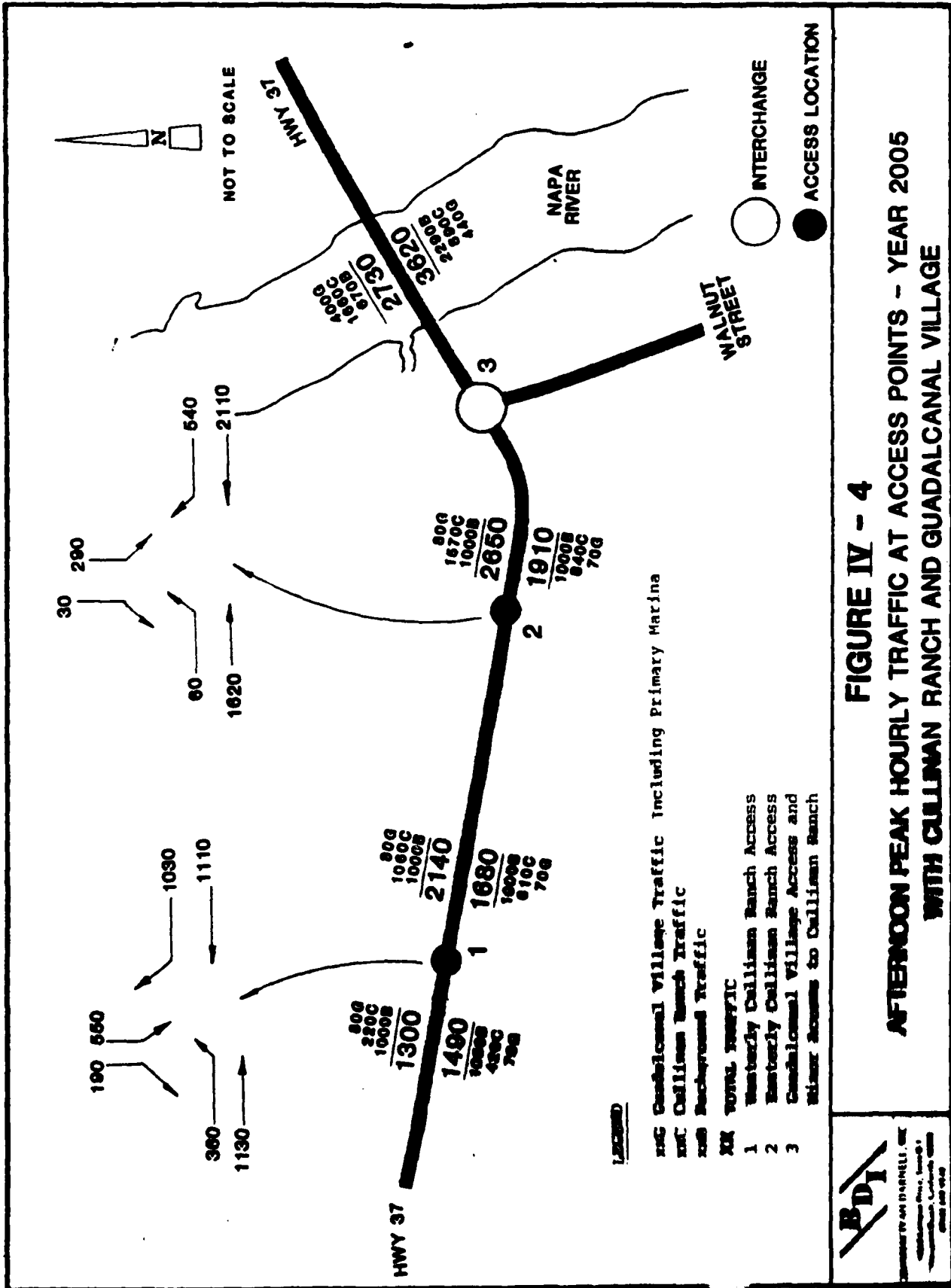

FIGURE IV - 4

AFTERNOON PEAK HOURLY TRAFFIC AT ACCESS POINTS - YEAR 2005

WITH CULLINAN RANCH AND GUADALCANAL VILLAGE

BDI

BRIDGE DESIGN INCORPORATED, INC.

10000 N. 10th Street, Suite 200

Phoenix, Arizona 85020

Phone: 602.998.8888

Fax: 602.998.8889

www.bdi-engineers.com

Table IV-1

SUMMARY OF CAPACITY ANALYSIS

	Level of Service	
	<u>Morning Peak Hour</u>	<u>Afternoon Peak Hour</u>
Route 37 and:		
Westerly Access to/from Cullinan Ranch	C	C
Easterly Access to/from Cullinan Ranch	D	D

- Note: 1) Level of Service (LOS) is a designation to describe the operation of an intersection. Five LOS designations, A through E, describe various degrees of freedom of movement or congestion. LOS "A" represents an entirely uncongested condition with no delays at the intersection except a routine stop at the signal. LOS "E" represents a capacity condition where a substantial portion of vehicles do not clear the intersection on one signal cycle and must wait through another cycle. LOS "B", "C", and "D" represent intermediate levels. In urban areas, LOS "D" is accepted design practice.
- 2) LOS is computed on the basis of Transportation Research Circular Number 212, "Interim Materials on Capacity." This procedure is consistent with Caltrans methodology.

high-priority item in the Regional Transportation Improvement Program (RTIP), but has not been included in the State TIP (STIP). Undoubtedly, any Caltrans funds for Route 37 would be allocated to the portion east of the Napa River to improve it to a conventional four-lane facility before any major expenditures (aside from those for spot improvements) on the west side are considered.

The installation of traffic signals at the two access intersections to Cullinan Ranch would result in the interruption of other traffic. Such interruption could be avoided by the construction of diamond interchanges. Considering that through traffic on Route 37 would have a green signal indication about 60 percent of the time during peak periods (and significantly more during non-peak periods) the total potential delay to traffic would tend to be small.

From a safety standpoint, in general, diamond interchanges would be expected to have a lower incidence of accidents than signalized intersections. The extent of the potential safety benefits attributable to a diamond interchange would depend on the specific type of design and the actual accident experience at the signalized intersections.

The frontage of Cullinan Ranch along Route 37 is sufficiently large to allow adequate spacing between the two access points, as well as between an easterly access point and the existing Walnut Street interchange area, to accommodate either signalized intersections or diamond interchanges. Thus, it would be possible to develop satisfactory designs for either type of access.

SIZING OF INTERNAL STREETS

With the exception of the frontage road and the streets connecting to the Route 37 access points, the internal streets are in the category of local or residential collector streets. They should be designed in accordance with the guidelines of the City of Vallejo for such streets,

The frontage road from the vicinity of TAZ 26 on the west to the Walnut Street Interchange on the east should be developed as a divided arterial with a minimum of two through travel lanes in each direction plus left-turn pockets at major cross streets. At selected locations, especially along the commercial center and near the easterly access point, it would be desirable to provide additional capacity. Exactly how additional capacity might be provided would be a function of the specific design of the sites. As examples of potential intersection configuration, Figures IV-5 and IV-6 are illustrations of the westerly and easterly access roads and the frontage road.

Typical intersection configurations elsewhere along the frontage road are illustrated in Figure IV-7.

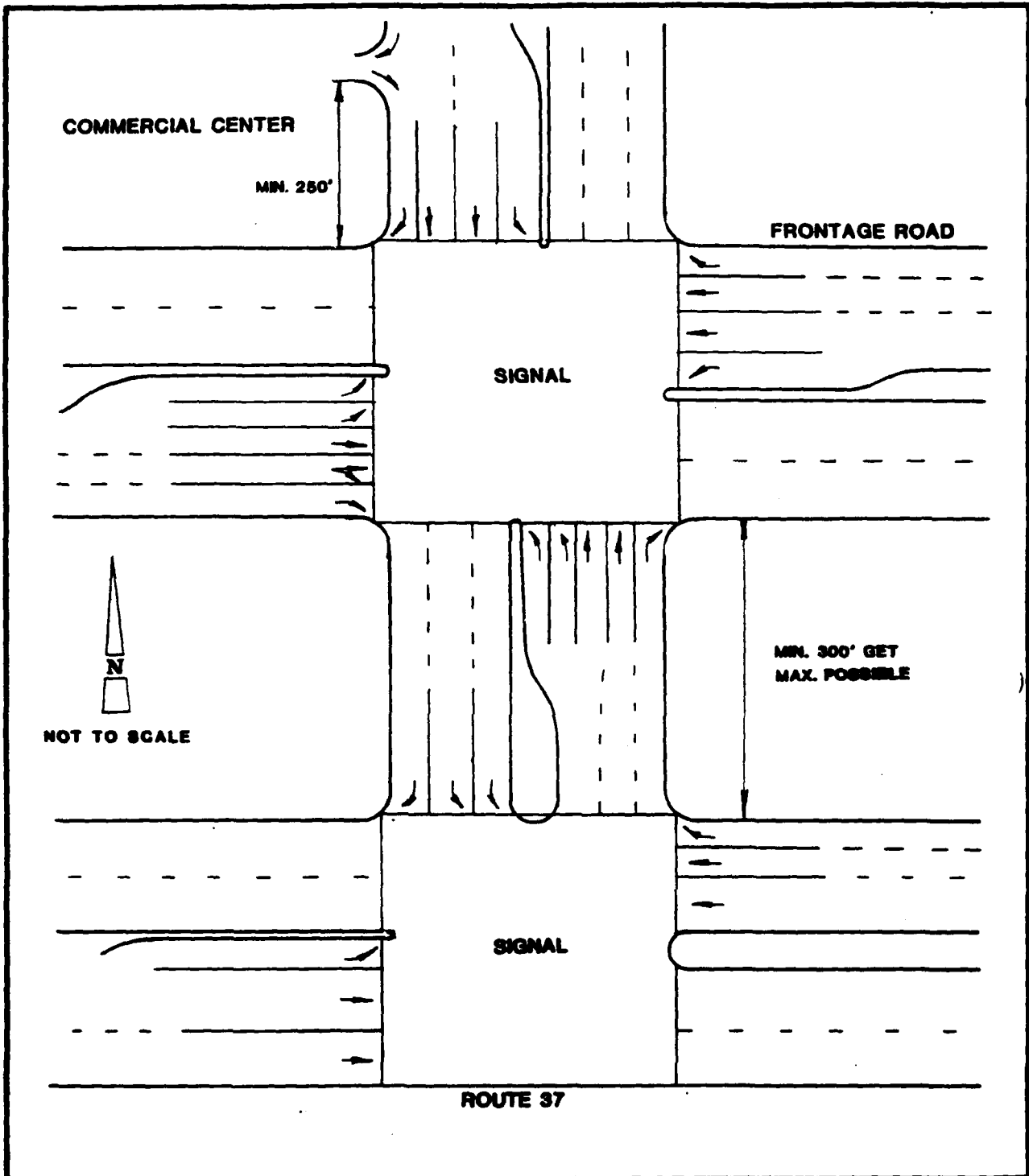

FIGURE IV - 5

**INTERSECTION CONFIGURATIONS
AT WESTERLY ACCESS POINT**



BASMACIYAN-DARNELL, INC.

4262 Campus Drive, Suite B-1
Newport Beach, California 92660
(714) 549-9940

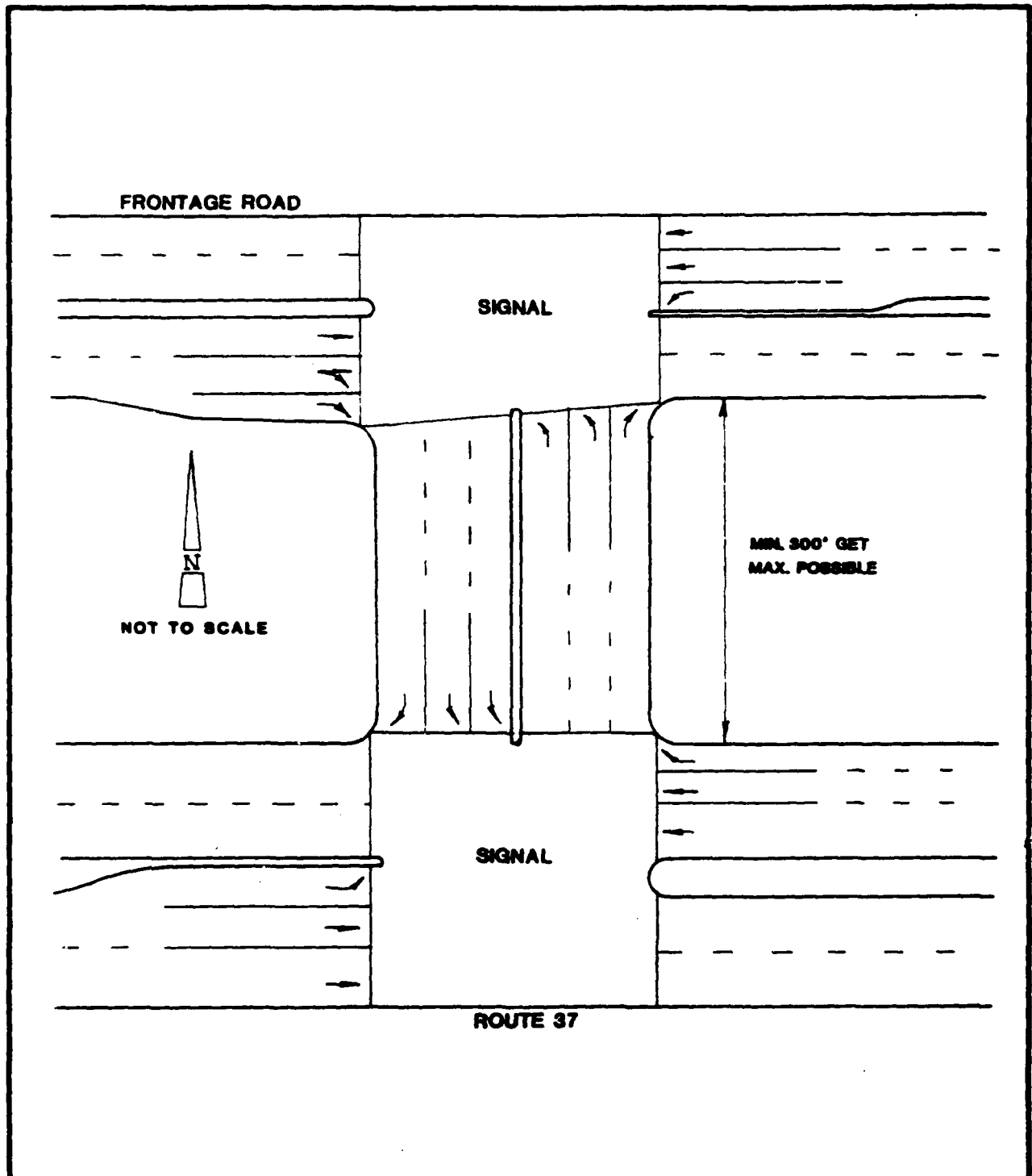

**B
D
I**

BASMACIYAN-DARNELL, INC.
 4262 Campus Drive, Suite B-1
 Newport Beach, California 92660
 (714) 549-9940

FIGURE IV - 6
INTERSECTION CONFIGURATIONS
AT EASTERLY ACCESS POINT

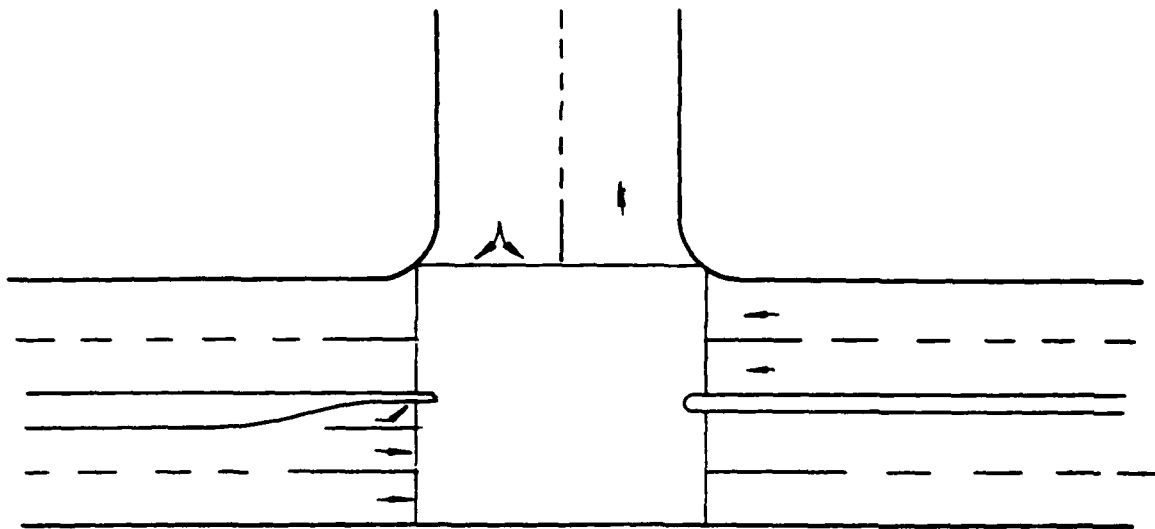

FRONTAGE ROAD

SIDE STREET TRAFFIC LESS THAN ABOUT 2,500 VPD

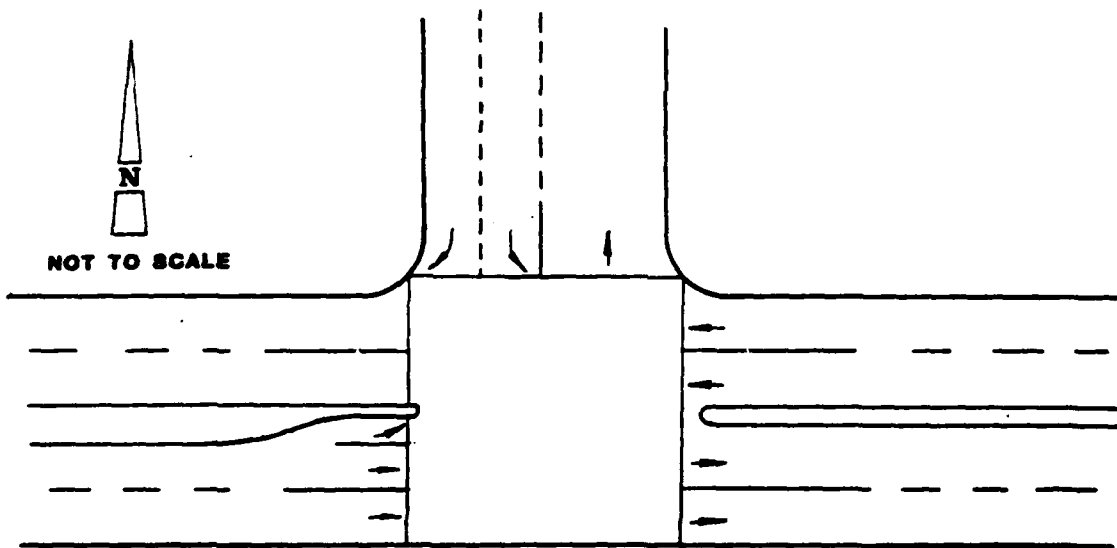

NOT TO SCALE

FRONTAGE ROAD

SIDE STREET TRAFFIC MORE THAN ABOUT 2,500 VPD

FIGURE IV-7

**TYPICAL INTERSECTION CONFIGURATIONS
ALONG FRONTAGE ROAD**



BASMACIYAN-DARNELL, INC.

4262 Campus Drive, Suite B-1
Newport Beach, California 92660
(714) 549-9940

TRAFFIC CONTROLS ON THE INTERNAL STREET SYSTEM

The locations where traffic signals are recommended are illustrated in Figure IV-8. Elsewhere, all side street approaches to the frontage road should be controlled by a stop sign. Again, depending upon the specific design, traffic controls at other locations may be necessary or desirable. The special case of bikeway/pedestrian facilities crossing streets is discussed in the following paragraph.

BIKEWAY/PEDESTRIAN FACILITY CROSSINGS

The crossings of the bikeway/pedestrian facility at the collector roads leading to the peninsulas should be designed carefully and with specific attention to safety. Since both bike and auto traffic volumes at these crossings may be high, especially near the school sites, this is an important consideration. Several alternatives were considered for traffic control at these crossings. Grade separating bike and auto traffic was also considered. After considerable deliberation, the typical configuration presented in Figure IV-9 was selected as most likely to be safe and cost effective.

The primary advantage of this configuration is that all traffic (auto, bike, and pedestrian) converges at a four-way stop. Motorists do not make a special stop for a bike/pedestrian facility but at what would be similar to a typical suburban four-way intersection. Thus, motorists are more likely to obey the stop sign than if they were asked to stop at what they would consider a "mere bikeway crossing." Also, because of the curved approach to the crossing, bicyclists would need to slow down and would become aware of the upcoming crossing.

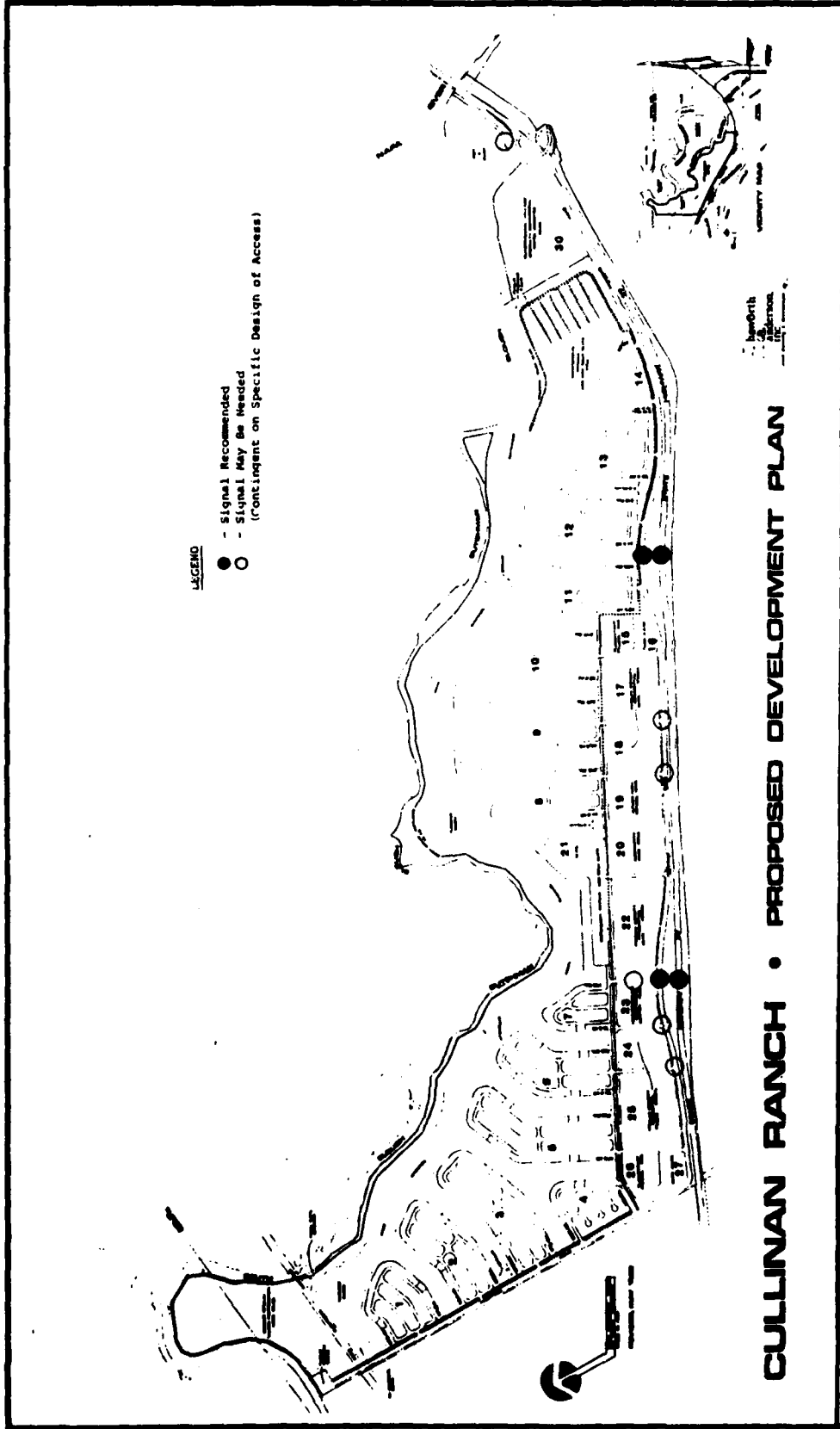

LEGEND

- - Signal Recommended
- - Signal May Be Needed
(contingent on Specific Design of Access)

CULLINAN RANCH • PROPOSED DEVELOPMENT PLAN



BARNHART DEVELOPMENT, INC.
 1787 Canyon Blvd., Suite 211
 Denver, Colorado 80202
 (303) 733-9900

RECOMMENDED TRAFFIC SIGNAL LOCATIONS

FIGURE IV - 8

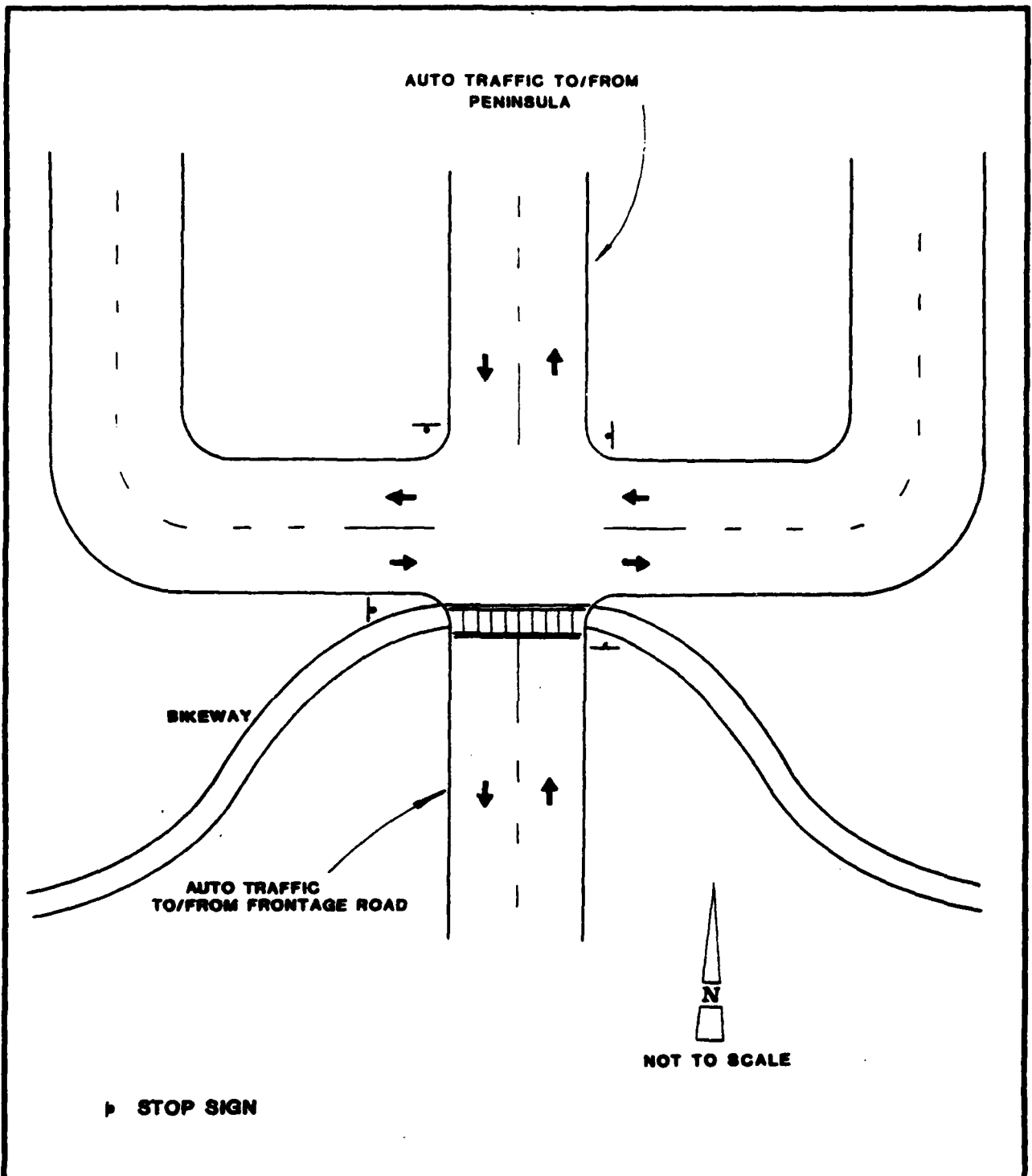

BDI
 BASMACIYAN-DARNELL, INC.
 4262 Campus Drive, Suite B-1
 Newport Beach, California 92660
 (714) 549-9940

FIGURE IV - 9
 TYPICAL INTERSECTION
 WITH BIKEWAY CROSSING
 (At Entrance to Peninsula)

APPENDIX A
DESCRIPTION OF CAPACITY
and
TABLE OF CAPACITIES

Source: Solano County Transportation Plan

APPENDIX A
DESCRIPTION OF CAPACITY
and
TABLE OF CAPACITIES

Source: Solano County Transportation Plan.

1. Design Capacity (various jurisdictions use different levels for design capacity). For uniformity, the design capacity referenced to here is 70% of the higher figure shown in the 24-hour ADT column, Table IV-3. The routes designated range in traffic volume from design capacity (C+) level of service to practical capacity (E level of service for a one-hour peak). Since this depicts average daily traffic, there will be occasional periods when the duration of heavy traffic will substantially exceed a one-hour peak, and stop-and-go driving conditions may occur (F level of service).
2. Practical Capacity (route has one-hour peak at levels accepted as maximum capacity for the particular facility type and area -- rural or urban, Table IV-3). The routes designated range in traffic volume from practical capacity (E level of service for one-hour peak) to maximum capacity (force flow, E to F level of service) for extended periods. Since this depicts average daily traffic, there will be frequent periods when the traffic demand exceeds the capacity of these routes, resulting in stop-and-go driving conditions and diversion of traffic to other routes.
3. Maximum Capacity: The routes designated will have extended periods of E and F level of service with traffic demands at or exceeding that listed for peak hour/lane (Table IV-3). Since this depicts average daily traffic, there will be frequent extended periods of stop-and-go driving and subsequent traffic diversion to any reasonable alternate route -- local or regional.

Source: Solano County Transportation Plan

TABLE IV-3
GUIDE TO ROADWAY CAPACITIES

ROADWAY TYPE	TOTAL VEHICLES IN BOTH DIRECTIONS		
	Maximum Pk Hr/Ln	Peak hour	24 Hours ***
8-Lane Freeway		8,000 - 12,000	80,000 - 120,000
6-Lane Freeway		6,000 - 9,000	60,000 - 90,000
4-Lane Freeway	2000	4,000 - 6,000	40,000 - 60,000
6-Lane Expressway	1500*	3,000 - 5,000	30,000 - 55,000
4-Lane Expressway		2,000 - 3,600	20,000 - 40,000
6-Lane Divided Arterial (72 ft. no parking)		3,200 - 4,500	32,000 - 50,000
4-Lane Divided Arterial (64 ft. incl. parking)	1500*	1,750 - 3,000	17,500 - 31,000
4-Lane Divided Arterial (48 ft. no parking)		2,000 - 3,000	20,000 - 31,000
6-Lane Arterial (88 ft. incl. parking)		2,200 - 4,000	25,000 - 45,000
4-Lane Arterial (64 ft. incl. parking)		1,500 - 2,700	17,000 - 30,000
4-Lane Arterial (56 ft. incl. parking)	1350*	1,250 - 2,000	14,000 - 22,500
2-Lane Arterial (40 ft. incl. parking)		800 - 1,100	9,000 - 15,000
4-Lane Major Business St. (64 ft. incl. parking)		1,200 - 2,400	13,000 - 27,000
4-Lane Major Business St. (56 ft. incl. parking)	1350*	900 - 1,900	10,000 - 21,000
2-Lane One-Way Arterial (44 ft. parking one side)	1500*	1,600 - 2,700	17,000 - 27,000
2-Lane One-Way Arterial (40 ft. parking)		1,100 - 1,800	12,000 - 18,000
4-Lane Rural Road		1,100 - 2,500	11,000 - 25,000
2-Lane Rural Road	1400**	450 - 1,400	5,000 - 14,000

FACILITY DESCRIPTION	Peak Hour/Lane DESIGN	Peak Hour/Lane DEMAND
FREEWAY	1800	2000
FREEWAY DIRECT CONNECTION	1500	1800
FREEWAY RAMP	1500	1600
FREEWAY RAMP LOOP	1000	1200
CITY STREET	800	1000

* Per hour of green time
 ** For one direction of flow
 *** The higher figures represent the upper limit of the practical capacities; the lower figures represent the minimum levels used for design capacities.
 † In the Bay Area, 2-way 2-lane volumes as high as 30,000+ have been recorded.

Source: Ken Berner, P.E., Caltrans District 4, and B. J. Biffel, P.E., Caltrans District 10.

APPENDIX B

TRIP TABLE

APPENDIX B
TRIP TABLE

CULLINAN RANCH TRIP TABLE

	Zj →	1	2	3	4	5	6	7	8	9	10	11	12	13	14	15	16	17	18	19	20	21	22
Pi	Zi/Ai	30	36	45	24	51	36	17	36	63	41	42	36	36	16	161	38	37	39	345	144	397	53
1,393	1			2						2		2				3	2		2	5	3	7	
1,711	2	2	2					2			2					3	2			7	4	8	2
2,109	3			2						2		2				3	2		2	9	5	11	2
1,114	4	2	2					2			2					2	2			4	3	5	
2,387	5			2						2		2				4	2			9	6	13	2
1,711	6	2	2							2						3	2			7	4	8	
796	7			2							2					2	2			3	2	4	
1,671	8	2	2					2			2					3	2			6	4	8	2
2,944	9			2						2		2				5	2		2	11	7	15	2
1,910	10	2	2					2			2					3	2			8	5	8	2
1,989	11	2	2							2		2				2	2		2	8	5	9	
1,711	12			2						2						4	2			6	4	8	2
1,671	13	2	2					2			2					3	2			7	4	8	
756	14			2						2		2				2	2			7	4	8	
23	15															2	2			3	2	4	
1,758	16															3	2			7	4	8	
1,838	17	2	2					2			2					3	2			8	4	9	2
60	18			2						2		2				3	2			2	4	9	
95	19															3	2			8	4	9	
2,481	20															2	2			2	2	3	
3,444	21	2	2					2			2					5	2			10	6	13	2
1,034	22			2						2		2				3	2			8	12	12	2
2,434	23									3						2	2			3	3	4	2
28	24	2	2									2				4	2			9	6	12	2
2,809	25			2				2			2					2	2			3	3	4	
11,236	26	3	3							7	4	4				19	3			4	13	40	5
4,932	27	12	14	18	10	21	14	7	14	26	16	17	14	14	6	76	13	15	15	154	50	158	21
	28	3	3	4	2	3	5	5	5	3	3	3	3	3	3	4	2	2	3	12	12	21	3
56,045	29	30	36	45	24	51	36	17	36	63	41	42	36	36	16	161	38	37	39	345	144	397	53

Note: Z1 means zone of origin or production
Zj means zone of destination or attraction
Pi means productions in each zone

CULLINAN RANCH TRIP TABLE

Pi	Zj/Aj	23	24	25	26	27	28	29	30	Σ Aj
1,393	1	126		2	3	48	197	786	253	1,393
1,711	2	152			4	2	243	976	298	1,711
2,109	3	187			4	2	299	1,202	367	2,109
1,114	4	99		2	4		158	635	196	1,114
2,387	5	211	2		3	3	340	1,362	414	2,387
1,711	6	153		2	3		243	976	298	1,711
796	7	70		2	2		114	453	140	796
1,671	8	149		2	3	2	237	953	292	1,671
2,944	9	262		2	6	2	422	1,678	512	2,944
1,910	10	170	2	2	3	2	272	1,090	329	1,910
1,989	11	177	2		4	2	286	1,132	342	1,989
1,711	12	152			3	2	243	976	299	1,711
1,671	13	148			3	2	237	953	292	1,671
756	14	66			2		108	432	137	756
23	15	8					1	3	11	23
	16									
1,758	17	155		2	5	2	252	1,003	303	1,758
1,838	18	159		2	4	2	263	1,057	311	1,838
60	19	19					3	8	28	60
	20									
95	21	37							53	95
2,481	22	219		2	4	2	355	1,415	428	2,481
3,444	23	453	2	2	4		456	1,828	649	3,444
1,034	24	92			3	2	149	590	180	1,034
2,434	25	215	2		7	2	347	1,389	420	2,434
28	26	9					1	4	13	28
	27									
2,809	28	928	2	5	21	4			1,254	2,809
1,236	29	3716	8	21	84	17			7,104	11,655
4,932	30	643	2	5	5		491	2,782	919	4,932
56,045		2775	22	51	184	48	5717	23,683	15,842	56,045

note: Zi means zone of origin or production
 Zj means zone of destination or attraction
 Pi means productions in each zone

APPENDIX C
CRITICAL MOVEMENT ANALYSES

APPENDIX C

Critical Movement Analysis: PLANNING Calculation Form 1

Intersection Route 37 and Westerly Access to Cullinan Ranch Design Hour Morning Peak

Problem Statement Assess Adequacy of Proposed Intersection Configuration

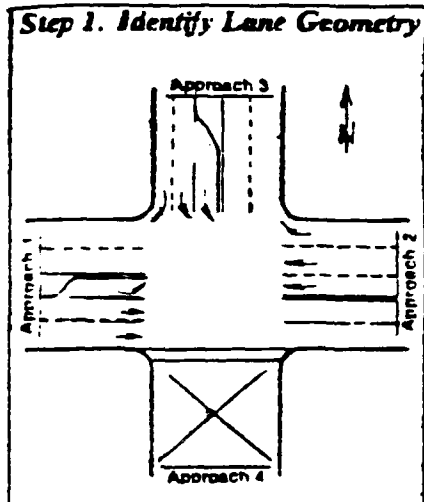

Step 4. Left Turn Check

	Approach			
	1	2	3	4
a. Number of change intervals per hour:				
b. Left turn capacity on change interval, in vph:				
c. G/C Ratio:				
d. Opposing volume in vph:				
e. Left turn capacity on green, in vph:				
f. Left turn capacity in vph (b - e):				
g. Left turn volume in vph:				
h. Is volume > capacity (g > f)?				

37

Step 6b. Volume Adjustment for Multiphase Signal Overlap

Probable Phase	Possible Critical Volume in vph	Volume Carryover to next phase	Adjusted Critical Volume in vph
A3B4	475	0	475
A1B2	160	0	160
A1A2	545	0	545

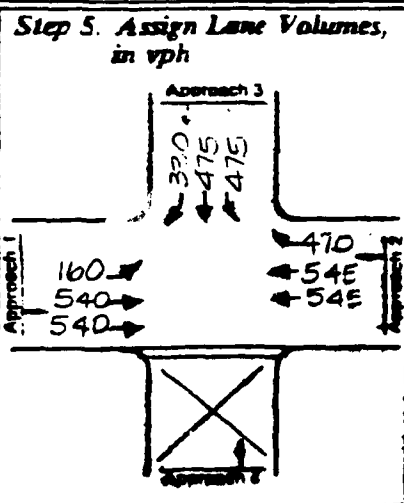
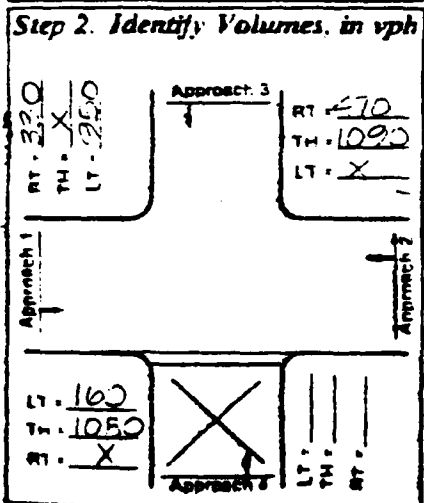

Step 7. Sum of Critical Volumes

475 + 160 + 545 = 1180 vph

Step 8. Intersection Level of Service
(Compare Step 7 with Table 6)

C

Step 9. Recalculate

Geometric Check: _____

Signal Check: _____

Volume Check: _____

Step 3. Identify Phasing

	A3B4
	A1B2
	A1A2

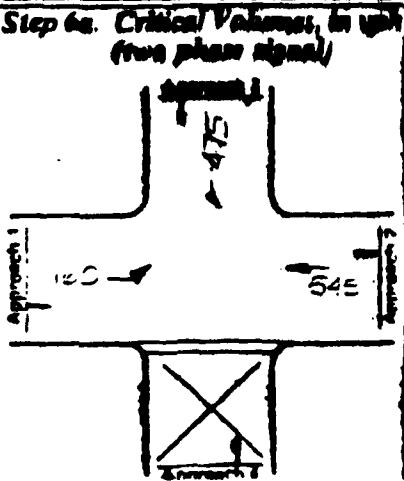

Comments

Intersection would function very satisfactorily

Critical Movement Analysis: PLANNING Calculation Form 1

Intersection Route 37 and Easterly Access to Cullinan Ranch **Design Hour** Morning Peak
Problem Statement Assess Adequacy of Proposed Intersection Configuration

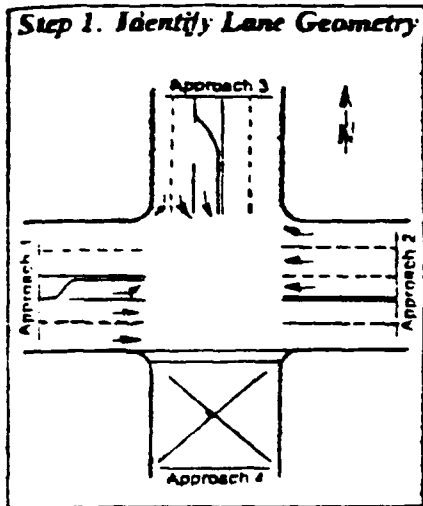

Step 4. Left Turn Check

Approach			
1	2	3	4
30			

a. Number of change intervals per hour:
 b. Left turn capacity on change interval, in vph:
 c. G/C Ratio:
 d. Opposing volume in vph:
 e. Left turn capacity on green, in vph:
 f. Left turn capacity in vph (b * e):
 g. Left turn volume in vph:
 h. Is volume > capacity (g > f)?

Step 6b. Volume Adjustment for Multiphase Signal Overlap

Phase	Possible Cross Volume in vph	Volume Carryover in next phase	Adjusted Cross Volume in vph
A3B4	250	0	250
A1B2	30 (B1)	970 (A1)	30
A1A2	970	0	970

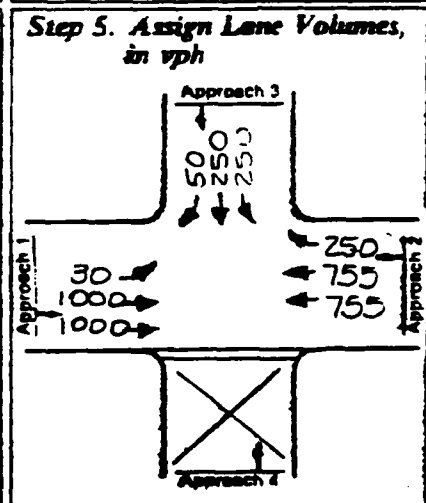
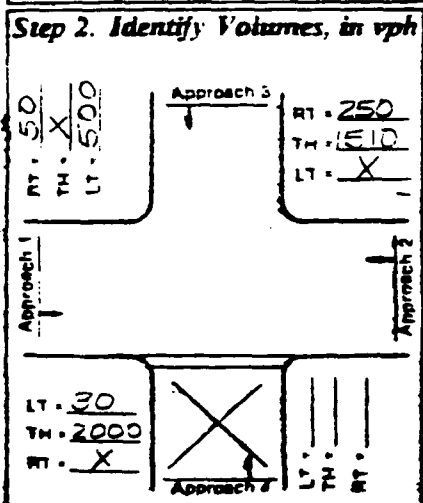

Step 7. Sum of Critical Volumes

250 + 30 + 970 = 1250 vph

Step 8. Intersection Level of Service
 (compare Step 7 with Table 6)

D

Step 9. Recalculate

Geometric Change: _____
 Signal Change: _____
 Volume Change: _____

Step 3. Identify Phasing

	A3B4
	A1B2
	A1A2

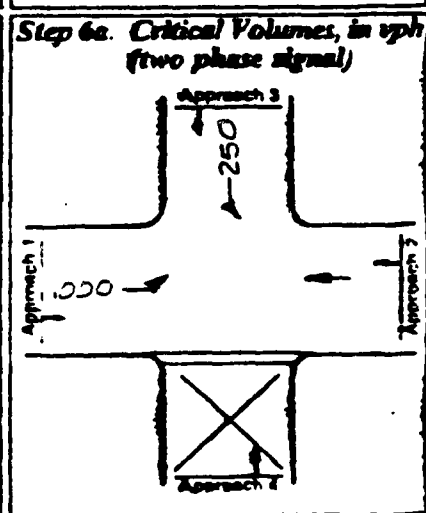

Comments
 Intersection would function adequately.

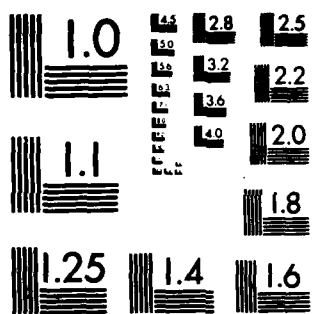

MICROCOPY RESOLUTION TEST CHART
NATIONAL BUREAU OF STANDARDS-1963-A

Critical Movement Analysis: PLANNING Calculation Form 1

Intersection Route 37 and Easterly Access to Cullinan Ranch **Design Hour** Afternoon F

Problem Statement Assess Adequacy of Proposed Intersection Configuration

Step 1. Identify Lane Geometry

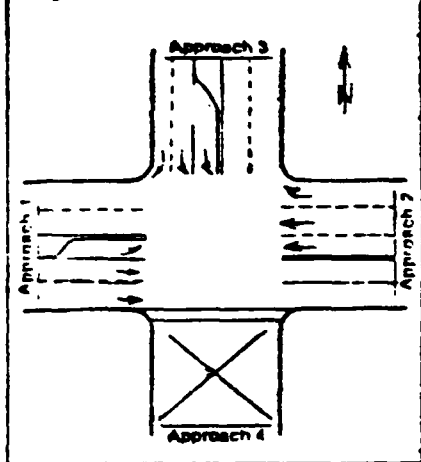

Step 4. Left Turn Check

a. Number of change intervals per hour: _____

b. Left turn capacity on change interval, in vph _____

c. G/C Ratio _____

d. Opposing volume in vph _____

e. Left turn capacity on green, in vph _____

f. Left turn capacity in vph (b * e) _____

g. Left turn volume in vph _____

h. Is volume > capacity? $145 > 110$?

Approach			
1	2	3	4
30			

Step 6b. Volume Adjustment for Multiphase Signal Overlay

Priority Phase	Priority Critical Volume in vph	Volume Carryover to next phase	Adjusted Critical Volume in vph
A3B4	145	0	145
A1B2	60	0	60
A1A2	1055	0	1055

Step 2. Identify Volumes, in vph

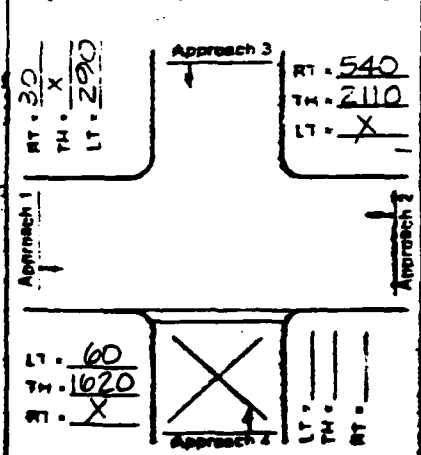

Step 5. Assign Lane Volumes, in vph

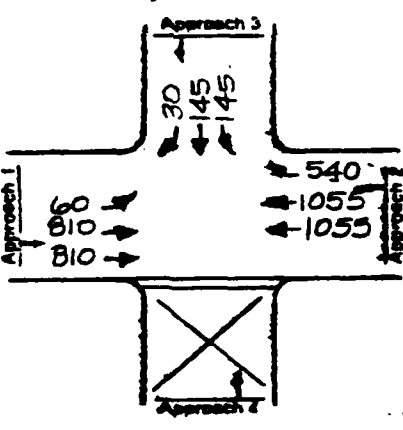

Step 7. Sum of Critical Volumes

$$145 + 60 + 1055 = 1260 \text{ vph}$$

Step 8. Intersection Level of Service

(compare Step 7 with Table 6)

D

Step 9. Recalculate

Geometric Change: _____

Signal Change: _____

Volume Change: _____

Step 3. Identify Phasing

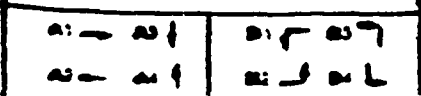
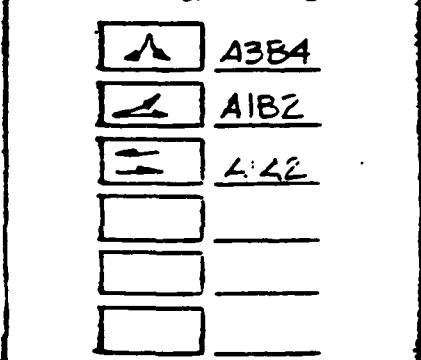

Step 6a. Critical Volumes, in vph (two phase signal)

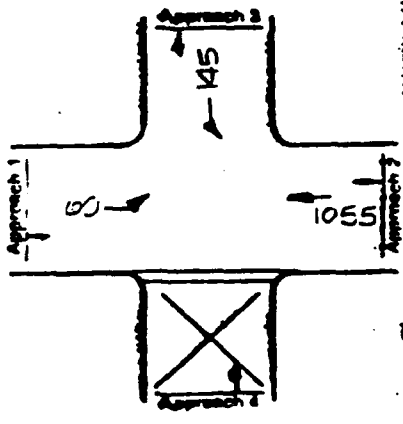

Comments
Intersection would function adequately.



BASMACIYAN-DARNELL, INC.

ENGINEERING AND PLANNING
Transportation, Traffic, Municipal, Transit

262 Campus Drive, Suite B-1

Newport Beach, California 92660

(714) 549-9940

August 16, 1982

Mr. Walden Williams
W. R. Williams Co.
2130 Main Street
Huntington Beach, CA 92648

Dear Mr. Williams:

Shortly after we completed our traffic study for Cullinan Ranch and Guadalcanal Village, we received the results of the traffic counts made by the City of Vallejo. A copy of the letter documenting the traffic counts is attached for your reference and information.

The place in the traffic study where the traffic counts would have appeared, had we had them in time, would have been Table III-8 on page III-14. Enclosed is a revised sheet which contains Table III-8 with the traffic counts inserted in the appropriate places. The impact of traffic to and from Phase I of Cullinan Ranch would be, as expected, relatively high on Wilson Avenue and Sacramento Street.

The traffic volume counts also support our statement in the traffic study report (Table III-6) that the Caltrans projections on Wilson Avenue, Sacramento Street and Redwood Street are low. The 1982 traffic counts are higher than or nearly as high as the Caltrans projections for the year 2005.

Please call me if I can answer any questions or provide any further details about this matter.

Sincerely,

BASMACIYAN-DARNELL, INC.

Herman Basmacıyan, P.E.

HB/llf

Enclosures



CITY OF VALLEJO

DEPARTMENT OF PUBLIC WORKS
ENGINEERING DIVISION

AUG 13 1982

11 August 1982

SUBJECT: Vehicle Volumes

Mr. Herman Basmacıyan, P.E.
Basmacıyan - Darnell, Inc.
4262 Campus Drive, Suite B-1
Newport Beach, CA 92660

Dear Mr. Basmacıyan:

This letter will confirm our telephone conversation of August 9 and 10, 1982, concerning subject. The following tabulations show 24 hour counts and peak hour counts, which were made by automatic counters:

Mare Island Way So. of Florida:	24 Hrs.	Peak	Time
Northbound - Wed. - 7/28/82	5,396	885	7-8 A.M.
Southbound - Thur. - 7/29/82	<u>5,306</u>	<u>913</u>	4-5 P.M.
	10,702	1,798	
 Wilson Ave. So. of SSR37:			
Both Directions - Fri. 7/30/82	5,062	799	4-5 P.M.
 Sacramento St. So. of Baldwin:			
Northbound - Wed. - 8/4/82	4,366	397*	5-6 P.M.
Southbound - Thur. - 8/5/82	<u>4,959</u>	<u>639</u>	4-5 P.M.
	9,325	1,036	
 *4-5 P.M. = 376			
 Redwood East of Sonoma Blvd.:			
Westbound - Fri. - 8/6/82	7,519	581	4-5 P.M.
 Redwood West of Sonoma Blvd.:			
Eastbound - Fri. - 8/6/82	<u>6,494</u>	<u>850</u>	4-5 P.M.
	14,013	1,431	

SUBJECT: Vehicle Volumes
Mr. Herman Basmaciyan, P.E.
Page 2.

11 August 1982

The difference between the southbound and northbound Sacramento Street peak hour volumes was checked by manual counts, and was found to be a true reflection of Mare Island traffic returning home after work. As I mentioned to you, my concern was based on the possibility of vandals tampering with the counters.

Should you have any questions, please contact me.

Very truly yours,

L. O. DONOVAN
Traffic Engineer

/jc

cc: Director of Public Works

Table III-B
(Revised 8/16/82)
COMPARISON OF EXISTING TRAFFIC AND TRAFFIC
TO/FROM PHASE 1 OF CULLINAN RANCH DEVELOPMENT

<u>Facility/Location</u>	<u>Existing Traffic</u>	<u>Traffic To/From Phase 1 Cullinan Ranch</u>	<u>Percent Added by Cullinan Ranch Traffic</u>
Route 37			
West of Project Site	15,300	800	5%
On Napa River Bridge	20,500	3,200	16%
Between Wilson Avenue and Sacramento Street	19,000	1,800	9%
Between Sacramento Street and Route 29	18,500	700	4%
Between Route 29 and Broadway	16,500	500	3%
Between Broadway and Mini-Drive	18,000	500	3%
Between Mini Drive and Fairgrounds Drive	18,000	300	2%
Between Fairgrounds Drive and I-80	33,000	200	1%
Wilson Avenue			
South of Route 37	5,100*	1,400	27%*
Sacramento Street			
Between Route 37 and Redwood Street	9,300*	1,100	12%*
Route 29			
North of Route 37	37,000	200	1%
North of Redwood Street	16,000	100	1%
North of Tennessee Street	27,000	300	1%
Redwood Street			
East of Sacramento Street	N/A	700	N/A
West of Route 29	13,000*	700	5%*
East of Route 29	15,000*	200	1%*
West of I-80	N/A	200	N/A
I-80			
North of Route 37	55,000	400	1%
North of Redwood Street	64,000	Nom	Nom
North of Tennessee Street	70,000	200	Nom
South of Route 29	63,000	1,000	2%
I-780			
East of I-80	23,000	600	3%

NOTE: Expectedly, traffic volume growth will occur between now and the time Phase 1 of Cullinan Ranch is in place, probably sooner than in three years. Thus, the percentage of traffic to be added by Phase 1 of Cullinan Ranch would be smaller than the numbers indicated.

The results of recent traffic counts by the City of Vallejo (on Wilson Avenue, Sacramento Street, and Redwood Street) are expected to be available soon.

*This is the new information.

**CULLINAN RANCH
WILDLIFE MONITORING PROGRAM**

Interim Report

February 1983

Prepared for

**Mr. Walden Williams
W. R. Williams Associates**

Prepared by

HARVEY & STANLEY ASSOCIATES

**Ronald Duke, M.A. - Wildlife Ecologist
James Hale, B.A. - Wildlife Biologist
Robert Hassur, Ph.D. - Fisheries Biologist
Donald Alley, M.A. - Fisheries Biologist
H. Thomas Harvey, Ph. D. ---Principal-in-Charge**

TABLE OF CONTENTS

	Page
I. Introduction	I-1
II. Outline of Concerns	II-1
III. Materials and Methods	III-1
A. Ground Avian Transects	III-1
B. Aerial Surveys	III-5
C. Marina Monitoring	III-8
D. Survey of Fishes of Dutchman's Slough	III-8
IV. Results and Discussions	IV-1
A. Ground Avian Transects	IV-1
1. Overflights at the Cullinan Ranch	IV-4
B. Aerial Survey of San Pablo Bay and the Napa Marshes	IV-8
C. Alternate Marina Sites	IV-13
D. Fish Sampling	IV-15
V. Summary	V-1
VI. Bibliography	VI-1

LIST OF TABLES

Table		Page
1	Flushing Distances at Alternate Marinas	IV-14
2	Dutchman Slough Physical Parameters	IV-16

LIST OF FIGURES

Figure		Page
1	Area Location Map	III-2
2	Location of Ground Avian Transects	III-3
3	Aerial Survey Route	III-7
4	Overflight Heights of Birds over Cullinan Ranch	IV-6
5	Compass Direction of Overflights	IV-7
6	Cullinan Ranch Aerial Survey Data	IV-9

TECHNICAL APPENDICES

Appendix

- A Preliminary Report

- B Ground Avian Transect Data
 - B-1 Species Observed in Dutchman Slough
 - B-2 Species Observed in the Fields of Cullinan Ranch
 - B-3 Overflight Heights
 - B-4 Overflight Data for Selected Species
 - ✓ B-5 Compass Direction of Overflight by Station

- C Aerial Survey Data
 - C-1 Data for Aerial Survey by Locations
 - C-2 Listing of Abbreviations for Aerial Survey Work

- D Alternate Marina Surveys
 - D-1 Utilization of Alternate Marinas
 - D-2 Flushing Distances at Alternate Marinas

- E Dutchman Slough Fish Sampling Data

- F Scientific and Common Names of Species Presented

INTRODUCTION

In March, April and May of 1982, Harvey and Stanley Associates conducted a preliminary ecological survey of the Cullinan Ranch and adjoining areas of Dutchman Slough. Twelve separate visits to the site were made during this period. Our June 1982 Report (Presented in Appendix A) identified seven major habitat types and categorized the usage by and relative importance of these habitats to wildlife and fish. A program for monitoring the wildlife and fish populations in and around the Cullinan Ranch was recommended to assist in planning and long term management. We then designed and implemented a monitoring program to give accurate year-round baseline information regarding fish and wildlife utilization of the area. The results of this will give a more complete picture of the wildlife uses of the site and surrounding area.

The end product of this year long monitoring program will be first, data regarding habitat utilization, population numbers, densities and seasonal trends for the various bird and fish species found at the Ranch and in the vicinity. Secondly, data are being collected concurrently regarding utilization of selected marinas in the San Francisco Bay Area by waterfowl and shorebirds, and interactions of these bird species with foot traffic, and boat traffic where feasible. Finally, detailed discussions of the potential impacts of the project on fish and wildlife populations will be presented, and project mitigation recommendations made.

This interim report represents the results of the monitoring program which was designed in July and implemented in early August of 1982. Results are presented for sampling through January of 1983, so in most cases six full months of data collection under the monitoring program are presented. The ecological survey for the preliminary report was conducted in March, April and May of 1982, lending additional observations and data from last spring. The ongoing monitoring is scheduled to carry through the end of July to complete the year-long program. Results to date are presented herein, with the understanding that seasonal changes in utilization are expected, as well as differences based on weather patterns within the next six months.

The final report for the project in August of 1983 will deal more completely with these aspects.

While considerable analysis of the data has been completed and some striking trends apparent, comprehensive statistical analysis has not been attempted at this stage, nor have density calculations been made from the transect data. The final report in August will include these analyses.

OUTLINE OF CONCERNS

The fish & wildlife monitoring program has been designed to provide information regarding a number of key issues surrounding the proposed marina and housing development at Cullinan Ranch. The issues addressed have been identified as being of potential concern variously by our researchers, personnel from the California Department of Fish and Game, U. S. Fish and Wildlife Service, Army Corps of Engineers, and other agency personnel and interested parties.

The Cullinan Ranch lies between two ecologically important areas, the San Francisco Bay (and the marshes and mud flats of the San Pablo Bay National Wildlife Refuge) to the south and the Napa Marshes and Leslie Salt Ponds to the north (and east). These areas support substantial populations of waterfowl and shorebirds, particularly during winter months.

The potential utilization of the ranch for resting, feeding or nesting by waterfowl and shorebirds is an important subject of the monitoring. Agricultural fields which are seasonally inundated with water can provide important habitats for these birds. Thus, the swale habitats and agricultural fields of the Cullinan Ranch could be of particular importance if seasonally inundated with water. Additionally agricultural fields in general are sometimes important as refuges during storm conditions, or for feeding by shorebirds during high tides. These concerns are generalizations based on knowledge of the habits of waterbirds through a variety of habitats and geographic regions. The significance of these concerns with respect to Cullinan Ranch is a major question for the monitoring program to resolve. Additionally, a variety of terrestrial birds utilize the property as is outlined in the preliminary report (Appendix A). The relative abundance of these birds and patterns of utilization are also questions to be addressed.

Another key question involves the potential importance of the Cullinan Ranch as a corridor for movement of waterfowl and shorebirds between the Napa marshes and the San Pablo Bay. These movements take two general forms, migratory flights and daily movements of seasonally resident birds. The crucial topics to be answered by the monitoring program then, are which species fly

over the ranch, in what numbers, at what heights at what frequencies and in which sections of the ranch.

Movement across the ranch is a function of a variety of factors. Season, state of the tide, time of the day and weather conditions all influence patterns of movement. Most importantly, the general patterns of utilization of the other sections of the Napa Marshes and San Pablo Bay will have important influences on the patterns of movement across the Cullinan Ranch. The mosaic of salt ponds to the north and west of the ranch, with differing and variable salinity and water levels will potentially have strong influences on patterns of movement through the area in general.

These key questions are designed to help assess the potential impacts of the proposed development at the Cullinan Ranch. It is crucial to the assessment to understand what the wildlife value of the new habitats will be. The open water habitats are particularly important, to waterfowl and to shorebirds as well. The key questions here revolve around the habitat value of the open water of a marina. There are no concrete answers in the literatures, and it is therefore important to collect concurrent data from present Bay Area Marinas in order to predict future use of open water habitats at Cullinan by waterfowl. Of particular importance are which species are found in similar marinas, how do they react to developed areas, human activity and boat traffic.

A final key question revolves around the fishes of Dutchmans Slough. Little is known about the fishes of the northern part of San Francisco Bay, especially in the shallow waters and sloughs. Results of previous sampling have been reported (Skinner 1962, California Dept. of Fish and Game 1977), but over the years human activity and introduction of exotic species have had unknown impacts. The monitoring program is designed to determine which species inhabit this part of the bay/delta system and to gather data on physical parameters which may affect the abundance and distribution of fishes. It should then be possible to determine the potential impacts of the proposed marina on the species found in Dutchmans Slough.

MATERIALS & METHODS

Ground Avian Transects

The primary emphasis of the wildlife monitoring program is on bird populations at the ranch itself. ^{on} In July 1, two mile-long variable-strip transects through the ranch were established using methods modified from Emlen (1971, 1977). The mile-long transects are broken into the tenth/mile sections represented and all species recorded while passing through the section at a fixed rate. Distance to each bird sited is recorded per standard technique for variable width transects. These transects (Transects 1 and 2) were positioned to encompass those areas identified as important, with particular attention to the swales, other agricultural areas and sections of Dutchman Slough bordering the property.

The transect locations are identified in Figure 2. They cover virtually all of the habitat types represented in the initial report. Transect #1 is along the top of the dike, encompasses shrub/levee and grain fields on one side, and tidal marsh, mudflats, open water and shrub levee on the other. Transect #2 begins at an existing brackish pool approximately 2.5 meters wide and 4 meters long, borders a remnant slough which is now cultivated, passes ornamental plantings (*Eucalyptus* sp.) and then turns along one of the drainage ditches (care of course must be taken not to duplicate species counted on such a turn in a transect). The other side of Transect #2 is entirely in the cultivated fields. These transects have been surveyed trimonthly beginning in August.

The original two transect locations were chosen because they incorporated areas which were representative of the ranch in general with respect to habitat types. Transect #1 also was positioned to incorporate areas of potential future marsh restoration, the confluence of Dutchman and South Slough, and to study potential effects on bird movement of the power lines which cross the property at station 5 of the transect. Transect #2 two was positioned to include areas where seasonal ponding might occur. Additionally, general observations of bird activity in



Figure 1. Location map of Cullinan Ranch, Napa County, California.

CULLINAN RANCH PROPERTY

Location of Ground Avian Transects and Fish Sampling Locations

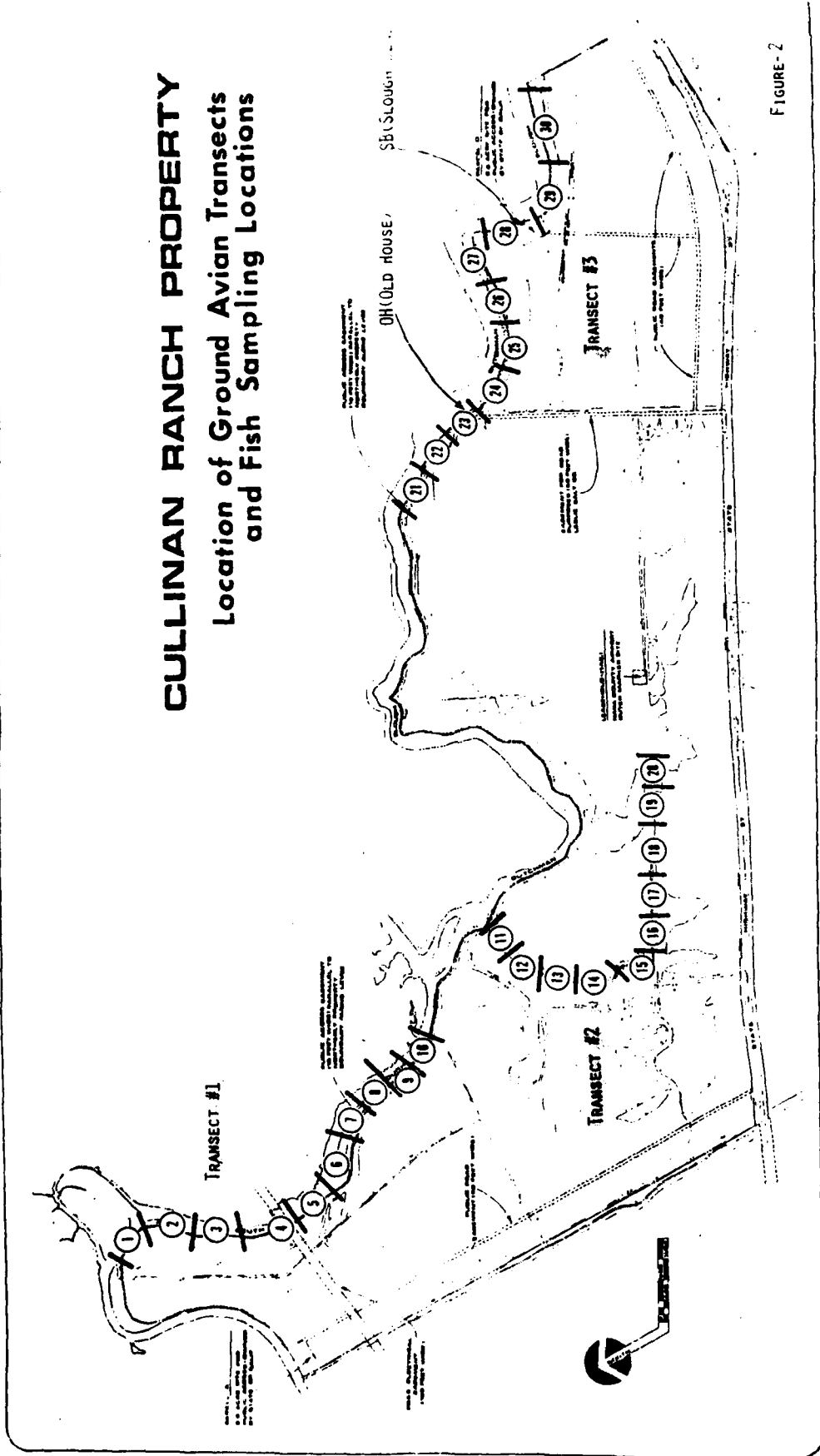

FIGURE-2

other regions of the ranch have been made during each of the transect dates, though not on a systematic basis.

In January a decision was made to add a third transect to the study. Two factors prompted the decision. The first was a concern about the wildlife utilization of those areas of the slough and levee which would eventually be breached to create the marina opening to the slough. While our field investigations to date had given no reason to expect differential utilization of slough, dike, or field between the eastern and western ends of the property, a third transect would quantify this interpretation. The second factor contributing to the decision revolved around the question of overflights. General field observations had indicated that the northwest corner of the property was experiencing a greater number of overflights than other sections of the ranch. Systematic data collection along the third transect will provide valuable additional information regarding the extent of any differential trends seen (additional discussion of these points will be presented later).

Along each transect, the following information is being recorded: station, side, species, distance to the birds, number seen, number called, number flushed and whether the birds are resting, flying locally, or overflying the property. Additionally, a record is made of the weather conditions, time of day, and state of tide -- factors which have significant impact on bird movement in the vicinity. For birds which pass overhead, moving from one side of the ranch to another, the height of the overflight is being recorded, as well as the compass direction. Overflights are periodically mapped for future reference. All distances are estimated visually, with the observers range estimates periodically checked with a range finder.

The transects established will yield information regarding the population densities and habitat utilization of bird species on the ranch proper and along the adjoining slough. They will also quantify the use of the property as a corridor for overflights, as each time the transect is run, those species crossing the property will be noted including height, numbers, time of day, and compass direction.

This transect method will provide the detailed information required to adequately assess the potential impacts of development. It will give estimates of species density, diversity,

relative abundance, distribution and habitat utilization which can then be taken into account in minimizing potential impacts through early planning.

Aerial Waterfowl and Shorebird Surveys

Our June 1982 report (Appendix A) preliminarily rated the wildlife value of sections of the property (fields, etc.) as low. The working hypothesis is that migrating waterfowl and shorebirds cue on the waterbodies -- salt ponds, sloughs, Napa River and San Pablo Bay and utilize these areas as migration corridors. Thus the ranch property would be less important in this regard, and the open water created by the project would have higher wildlife value than agricultural fields.

The general patterns of use and the patterns of movement between the Napa marshes/salt ponds and the San Francisco Bay and San Pablo marshes is then a key question. Patterns of occurrence of species in the surrounding habitats can be documented, and when combined with the information from transects run on the ranch, the overall patterns of movement through the area inferred. Additional data regarding the patterns of occurrence in the surrounding area can best be gathered through the use of aerial survey techniques, similar to those used by California Dept. Fish and Game in their annual waterfowl surveys.

Waterfowl censusing is traditionally accomplished by aerial survey techniques. Flying over the edges of the bay, the San Pablo Marshes and basically circling the property at elevations of ~500 feet will allow for mapping of species occurrence, species numbers and also give an indication of breeding locations of larger shorebirds and waterfowl. Precise identification of the smaller birds is of course difficult/impossible at that altitude and speed. FAA regulations require a minimum distance of 500 feet from structures, etc., without special variance. Surveys by the California Dept. Fish and Game or U.S. Fish and Wildlife Service are traditionally flown at elevations of approximately 200 feet, dropping at times to approximately 80 feet, and thus can identify the smaller species as well. At these lower elevations, most of the birds are flushed, allowing for more detailed counts as well. FAA regulations as well as the

protection of the San Pablo Bay National Wildlife refuge preclude our flying at those lower elevations, but we feel that the 500 foot level is adequate. ✓

This mapping will be very useful in determining the overall patterns of use in the area. In the south bay, significant changes in distribution of waterfowl have been documented based on changes in the salinity of the water in salt ponds, and associated changes in the flora and fauna of the ponds. Additionally, draining of the ponds as water is transferred to the next pond brings temporarily high concentrations of shorebirds, feeding on the mudflats created and in the shallow pools. Understanding the nature of these shifts in concentration will be highly valuable in determining importance of the ranch as a corridor of bird movement. The relative importance of the various habitat types can also be ascertained.

The additional information gathered regarding the distribution and utilization of surrounding habitats will lend great strength to the results of the ground monitoring on the ranch property. The overall patterns of species movement can be inferred, knowing the habits of the species involved. Aerial surveys allow for some quantification of flocks in flight, but most information gathered are of birds on the water or ground.

This survey work required a pilot, plane, two individuals counting the birds and an additional observer identifying locations and plotting distribution. In October 1982 a reconnaissance flight was made to determine the efficiency of the method, lay out the aerial survey route and acquaint observers with the species found in the ponds, marshes and San Pablo Bay. The survey route and numbering system set up for recording data are presented in Figure 3 (with overlay). Since that time flights have occurred at approximately ten day intervals, weather permitting. The work will continue through April, to insure coverage of the peak migratory and winter resident periods. The ten day intervals are designed to insure adequate coverage of migratory peaks.

When possible, ground work is used supplementally to the aerial monitoring. A check of species present and numbers is made shortly after a flyover. While there is obviously lag time, it is possible to obtain a fair degree of verification from the ground. The principal concern of the aerial surveys is to deter-

CULLINAN RANCH
WILDLIFE AND FISH MONITORING PROGRAM

LEGEND

- MF= MUD FLAT
- M = MARSH
- SP= SALT POND
- NR= NAPA RIVER
- GC= SUN CLUB
- ////// CULLINAN RANCH

Original base map from:
Defense Mapping Agency, 1978, 1:50,000

HARVEY & STANLEY ASSOCIATES, INC.
ECOLOGICAL CONSULTANTS
906 ELIZABETH STREET, DRAWER E
ALVISO, CALIFORNIA 95002

Aerial Waterbird Survey Map

Figure 3

Date: February 1983

File No. 147-02

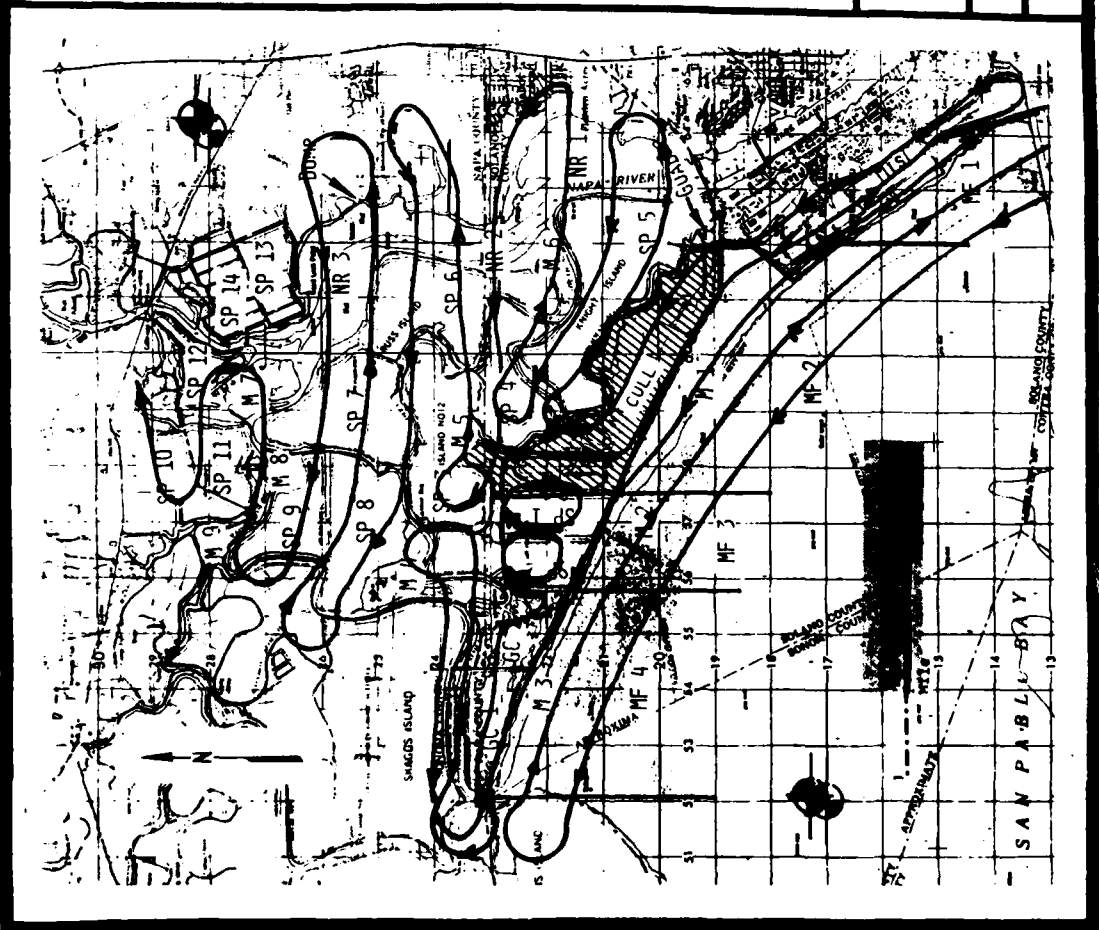

mine patterns of concentration and relative abundance. Aerial surveys as described do allow sufficient accuracy, for this purpose.

Marina Monitoring

The general utilization of marinas by waterbirds, and the potential impacts of the residences, foot traffic, levee access and boat traffic on these birds is another issue to be addressed. The transects and aerial monitoring will provide baseline data as described regarding species distribution and utilization of the ranch and surrounding areas. Observing and quantifying the interactions of particular species with the activities mentioned at established marina areas will assist in the assessment of potential impacts of development at the Cullinan Ranch. We have examined marinas around the bay and find that there simply is not a single marina which is similar enough to the proposed development to allow for concentration of effort. We have therefore spread our efforts to a variety of somewhat similar sites, with the understanding that the principal thrust of this portion of the research will be the flushing distances and other interactions. Some of the sites to date which have been sampled include Redwood Shores, Bell Marin Keys and the Palo Alto Yacht Harbor. Other expected sites are in San Rafael, Berkeley, and Foster City along the Napa River.

Each marina examined has been separated into sections, with each section monitored for a fixed length of time, with species occurrence, numbers, flushing distance and flushing agent recorded. Additionally, overflights of the area have been recorded, including height. An active effort has been made to flush those individuals near shore (to measure the effects of foot traffic), using techniques similar to those incorporated in our analysis of the impacts of a shoreline at the Emeryville Crescent (Harvey & Stanley Associates 1978).

The data is being collected year round, with primary emphasis on the winter months. Early samplings were made at Bell Marin keys, with later samplings concentrated at Redwood Shores.

Survey of Fishes of Dutchman Slough

This study will attempt to determine which species of fish inhabit this part of the bay/delta system. The study will also gather data on physical parameters that may affect the abundance and distribution of fishes. It will determine which fishes occur in the slough and their relative abundance and size class. It will additionally determine the presence of certain species relative to physical parameters including salinity, temperature, turbidity/transparency, dissolved oxygen, pH, and state of the tide.

After an initial review of available records of fish catches for the central, northern and delta regions of the bay system, a field sampling program was initiated. Emphasis has been placed on shoreline shallow water areas since little or no data are available from such habitats.

Two sampling locations were chosen and are indicated on Figure 3 as OH (Old House) and SB (Slough Bend). The slough bend site is directly at the opening to the proposed Marina. Collection began in October and will continue through the length of the study. Collections are being made on the flood tide or at high tide. Size of the seine is variously 100 or 200 feet long, 8 feet deep with a stretch mesh size of 3/4 inch. Physical parameters are being measured prior to seine collection and the state of wind and tide noted.

Seine samples are repeated in the same general area until no new species are collected. Two to three hauls have been necessary to date.

The data collected will allow for several forms of analysis. Included will be overall abundance, changes in abundance with time, size class of each species over time and correlation of physical parameters with abundance of each species. Additionally, species may be grouped by feeding strategy - filter feeder, cruising predator, foraging predator, lurking predator.

Analysis of these data will indicate how the fishes utilize Dutchman Slough and how any alterations to the Slough might affect them, i.e. impact of the proposed marina.

RESULTS AND DISCUSSIONS

Ground Avian Transects

A total of (14,917) birds, representing 43 species were observed in the grain fields and associated habitats during 17 running of the transects from August 17, 1982 through January 23, 1983. The results of these transects are presented in technical Appendix B-2 and represent those birds seen on the Cullinan Ranch Property, per se. Some species, mostly flocking birds, were found to have fairly high total numbers during this period. The introduced European starling with a total of (9,470) individuals was the most abundant. A total of (975) red-winged and brewer's blackbirds were observed. Native grassland or field-dwelling birds such as the savannah sparrow, western meadowlark, and horned lark totaled (674, (761), and (532) birds respectively. Wintering shorebirds included (223) black-bellied plovers, (217) long-billed curlew, (251) killdeers, and 250 gulls. Transect totals for the flocking birds observed in the field were 403 rock doves, 302 house finches, and 157 water pipits.

Two upland game birds were found to have low total numbers during the transect period. Only 1 ring-necked pheasant and 213 mourning doves were observed. Raptors seemed to be fairly common. Totals for the four observed species were 68 northern harriers, 47 red-tailed hawks, 48 American kestrels, and 26 white-tailed kites. 46 turkey vultures were counted during the 17 transect samplings.

A brackish pool within a swale, irrigation ditches, and a small grove of blue-gum eucalyptus trees in Transect #2 offered some habitat variation in the grain fields. Certain birds were found associated with these areas. In the swale, an individual black phoebe, common snipe, and greater yellowlegs were seen. Birds observed only in the eucalyptus grove during the transects included 36 yellow-rumped warblers, 1 ruby-crowned kinglet, 1 American robin, 3 barn owls, 2 great horned owls, 5 common flickers, 56 dark-eyed juncos, 1 scrub jay, and 1 mockingbird. An individual great blue heron, 13 great egrets, and one snowy egret were observed along irrigation ditches.

A total of 2256 birds from 35 different species were observed along Dutchman Slough during 17 samplings from August 17, 1982 through January 23, 1983. Results are presented in Appendix B-2 and represent those species observed on the slough side of Transect #1. These habitats adjoin the Cullinan Ranch but are not ranch property. Waterfowl were represented by a total of 9 American wigeon, 15 cinnamon teal, 132 American coots, 13 green-winged teal, 9 mallard, 8 unidentified ducks, and 11 pied-billed grebes. Shorebirds identified along the mud flats of Dutchman Slough included a total of 20 sandpipers, 23 snowy egrets, 17 willets, 7 black-bellied plover, 17 great egrets, 23 great blue herons, 72 gulls, 4 marbled godwits, and 10 ring-billed gulls.

Typical marsh birds found associated with the cattails, tules, and marsh vegetation included a total of 58 long-billed marsh wrens, 103 song sparrows, 4 soras, 2 Virginia rails, 3 American bitterns, and 3 common yellowthroats. Two belted kingfishers and 15 forster's terns were observed foraging for fish along the slough. Raptors were represented by 4 marsh hawks and 4 white-tailed kites. Total numbers for birds utilizing the levee bank vegetation for cover were 870 red-winged and brewer's blackbirds, and 638 white-crowned and golden-crowned sparrows.

The total number of birds observed in the grain field (14,917) is substantially greater than those observed along the slough (2,256). In the final report birds per unit area will be presented. This difference in numbers is attributed to the fact that approximately 75% of the transect area is in the grain fields while approximately 25% includes Dutchman Slough. Transect 1 has one side in the grain field and the other along Dutchman Slough. Transect 2 is entirely in the grain fields. Transect 3 which presently has been sampled only three times has one side each in the slough and field.

The importance of the grain fields to insects, crows and granivorous birds is shown by the relatively large numbers of flocking birds inhabiting the field. These birds include the starling, savannah sparrow, western meadowlark, blackbirds, house finch, horned lark, water pipit, and rock dove. One species, the european starling, represents 63% of the total birds counted in the grain field. Overwintering shorebirds such as the long-billed curlew, black-bellied plover, killdeer, and gulls, find

foraging habitat in the field as well. Ring-necked pheasants and mourning doves, both upland game species, have been seen in relatively low numbers in apparently suitable habitat. Raptors such as the red-tailed hawk, marsh hawk, white-tailed kite, and American kestrel, regularly occur in fair numbers in the field, suggesting that a substantial rodent and insect prey-base exists. Although a greater number of bird species were observed in the field (43 species) than in the slough (35 species), eight of the 43 species were observed in the isolated grove of blue-gum eucalyptus trees. These birds, including the yellow-rumped warbler, ruby-crowned kinglet, American robin, barn owl, great horned owl, common flicker, dark-eyed junco, scrub jay, and mockingbird found refuge or forage in these ornamental plantings. Another six of the species were associated with the irrigation ditches and swale. Great blue herons, great egrets, and snowy egrets were observed foraging in the irrigation ditches while a black phoebe, common snipe, and greater yellowlegs were associated with the swale. Killdeer were found throughout the field and on occasion were observed feeding at the edge of the swale.

Waterfowl observed along Dutchman Slough were typical species one might expect to find associated with brackish water marsh habitat. Dabbling ducks such as green-winged teal, cinnamon teal, mallard, and American wigeon sought protection and food near the aquatic and emergent vegetation at the edge of the slough. Diving ducks and waterfowl such as the ruddy duck, pied-billed grebe, western grebe, and coot pursue fish under water. The belted kingfishers and forster's terns observed along the slough forage overhead for fish near the water's surface. High tides during some of the transect sampling may account for the comparative paucity to date of shorebirds. As one might expect, few raptors were observed. The slough is marginal foraging habitat for most birds of prey. Large numbers of brewer's and red-winged blackbirds spend the night in the protective tules and cattails which will serve as nesting sites in the spring. By day, they forage in the fields. During the transect sampling a total of 870 blackbirds were observed along the slough. White-crowned sparrows and a few golden-crowned sparrows, both winter visitors, seek shelter amongst the coyote bush and other levee bank vegetation. A total of 63 white-crowned and golden-crowned sparrows were observed during the sampling periods. Marsh birds

such as the song sparrow, long-billed marsh wren, sora, and Virginia rail were observed in expected numbers along the slough. Somewhat unexpected were the 3 common yellowthroats and 3 American bitterns. These two species are relatively uncommon birds. A complete list of birds observed along the transects during the sampling period can be found in Appendix B-1 & B-2.

Wetlands on the ranch property consist of irrigation ditches and swales. They cover approximately no more than 2% of the entire ranch area. Field surveys of the wetlands including aerial flights and ground transects suggest they are not used extensively by wildlife. Great blue herons, great egrets, and snowy egrets are occasionally observed along the ditches. The swales occasionally attract killdeer, and other shorebirds. Their continued monitoring will yield more information as to the extent of their use by wildlife.

Seven habitat types were recognized during the preliminary field survey of Cullinan Ranch. They were listed in order of their wildlife use based on variety and number of species and presence (observed or inferred) of unique forms. Field surveys including avian ground transects have verified the initial listing. However, the grain fields which were considered low in wildlife use have been found to be used extensively by granivorous and seed-eating birds during the winter. The European starling and blackbirds which constituted the vast majority of sightings are not considered unique or particularly valuable species, the large numbers of birds recorded in the fields this winter indicates the need for a reevaluation of the classification of the wildlife value of the fields. The wildlife value of the grain fields in winter could now be considered moderate, but additional assessment should wait for the full year of data.

Overflights at the Cullinan Ranch

As each transect is run, birds flying over a transect section are recorded. Included in the recording are the height, numbers, and compass direction, as was described earlier. The data in analysis have yielded a number of interesting trends. First of all, a total of 2809 birds passing over in 299 separate flights were recorded for all samplings to date (6 months of

data). The most critical trends with respect to the property have been presented graphically in Figures 4 & 5. Figure 4 represents the height at which birds passed overhead. It presents the heights for all birds, as well as the five species most often recorded (excluding gulls). These data are also represented in technical Appendices B-3 & B-4.

The first striking detail is that only 7 birds (.3%) flew over the transects during sampling periods at heights less than 25 meters. 78 (2.8%) birds flew at heights between 25 and 50 meters. 448 (16%) from 50 to 75 meters, 1095 (39%) from 75 to 100 meters and 1172 (42%) above 100 meters.

While the presence of a ground observer may have affected the height data to some degree, general observations of overflights well away from the transect stations support the general distribution of flight heights from the transect data.

The other pattern which emerges is in the compass direction of the overflights by birds. The numbers of flights and numbers of birds crossing Transect 1 and Transect 2 by 45° sections are presented graphically in Figure 5. August transect data are not included in Figure 5 because no compass direction was recorded during August but are included in Technical Appendix B-5. There is a definite pattern of direction of the flights, with most of the birds moving to and from areas immediately NNE and SSW of the property in the areas in which the transects were run. North-north-east of the ranch in the areas the transects were run are Salt Ponds 3&4 (and areas beyond). South-South West of the transects are Salt Ponds 2, the San Pablo Bay and areas beyond. Thus, most of the movement across the west end of the Cullinan Ranch has occurred to date within a narrow range of direction, In Transect #1, there were also a large number of birds moving to the WSW (compass direction 90-135°) toward Salt Pond 4, 5 and areas beyond. However, of the 496 crossings at this angle, 376 were by White Pelicans (primarily in October).

This corresponds with a period when white pelicans were often seen resting on islands in Salt Pond 5, as well as in the northern sections of Salt Ponds 1 and 2. There is a similar, but much smaller effect in Transect #2 with white pelicans comprising 111 of the total 146 birds which crossed the ranch in this SSW direction (90-135°). Again, this movement occurred in October.

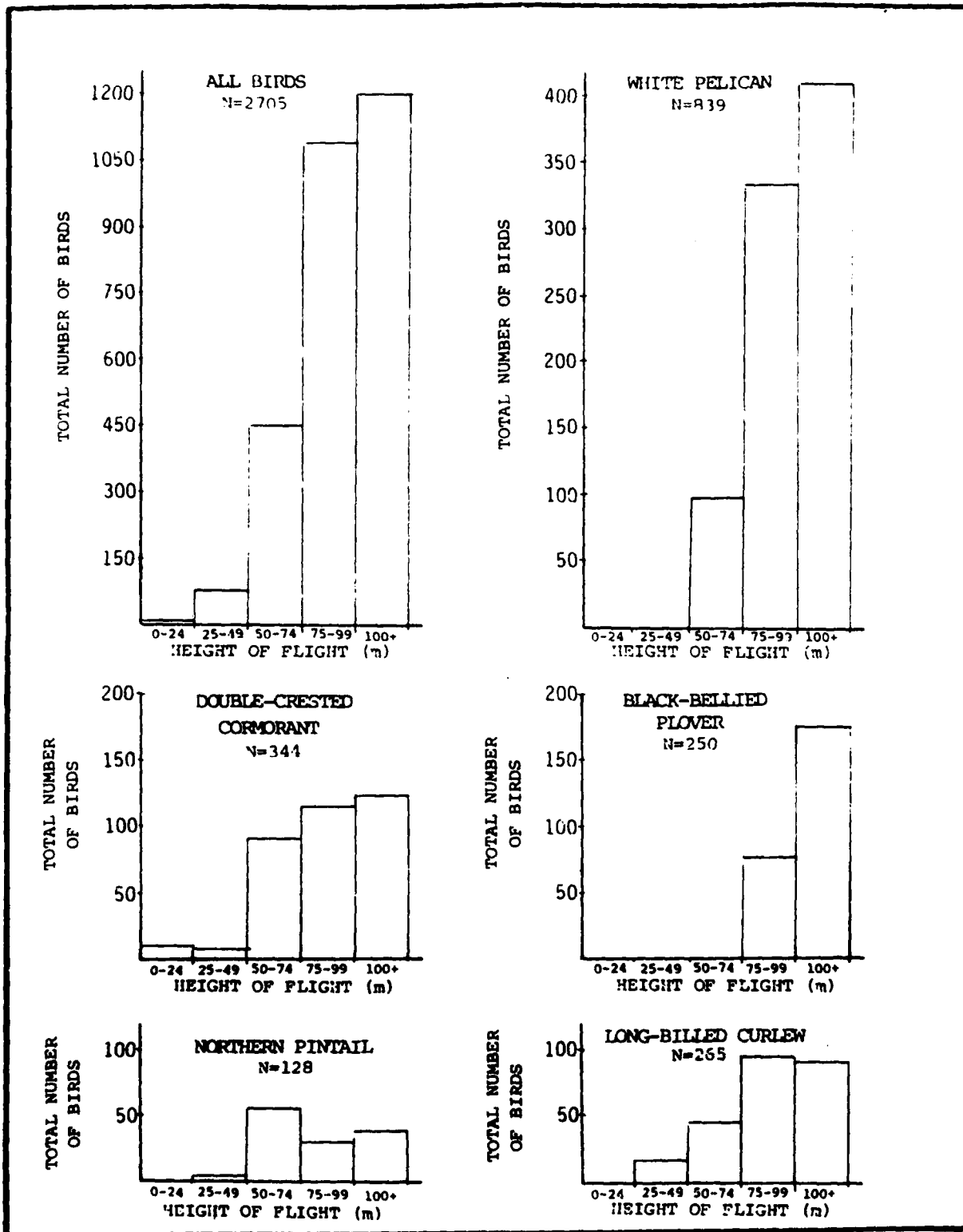

Figure 4. Overflight Heights of Birds at Cullinan Ranch.

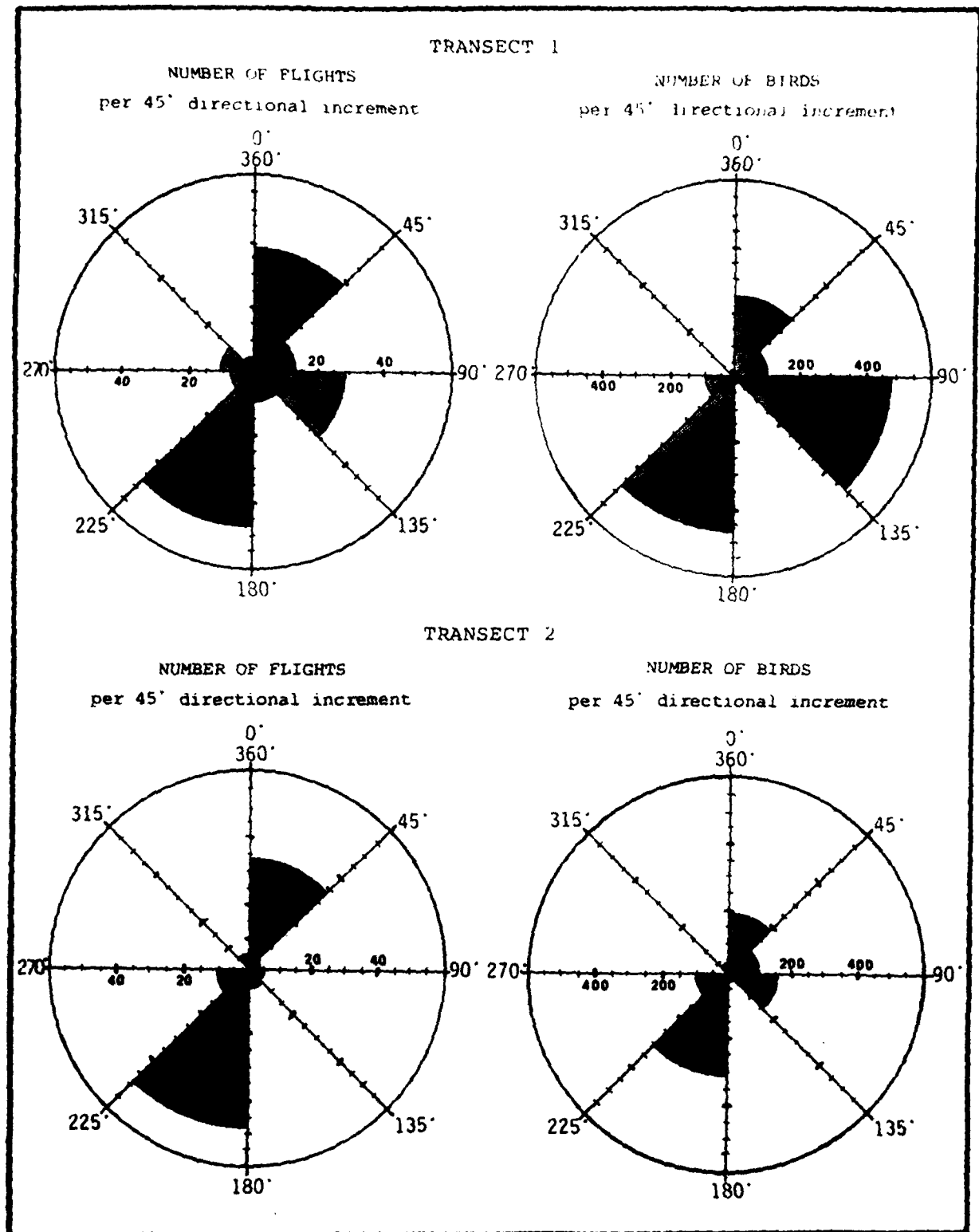

Figure 5. Compass Direction of Overflights.

If the movement by white pelicans in October in the WSW direction in October in the WSW direction were excluded from Figure 5, the balance of the movement is then overwhelmingly in the corridor of NNE and SSW. This is particularly interesting because of the powerlines which cross the ranch at approximately 80° through Transect 1. The birds to date have been moving in directions which would cross the lines (though origin and destination of the flights are unknown).

Double-crested cormorants are the second most common bird seen overflying the ranch. 344 double-crested cormorants have flown over in 84 separate flights. Less than 10% of these flights have been below 50 meters. Other species observed commonly include the black-bellied plover, northern pintail, and long-billed curlew. Heights and numbers of birds are seen in Figure 4 and Appendices B-3 and B-4.

There are several factors which are interesting in their absence. First of all, with the exception of pintails, there has been little movement by ducks at low elevations across the property. Dawn and dusk transects, a night transect, and additional night observations have not shown any additional movement by ducks.

During one aerial survey (December 15th) there was eastward movement of thousands of ducks in a variety of species across the entire San Pablo Bay and Napa marsh at elevations between 500 and 2000 feet. This movement also crossed the Cullinan Ranch, and was immediately prior to a major storm.

The other factors influencing movement patterns of birds revolve around differential utilization of the ponds surrounding the Ranch. These factors will be described in more detail in the aerial survey section which follows.

Aerial Survey of San Pablo Bay and the Napa Marshes

The distribution of shorebirds and waterfowl through the study area has verified, as expected, a highly variable situation. There are a myriad of interacting factors which determine distribution on any one day. First of course, are the habitat preferences and individual requirements of the species involved. Interacting factors include state of the tide, weather, currents

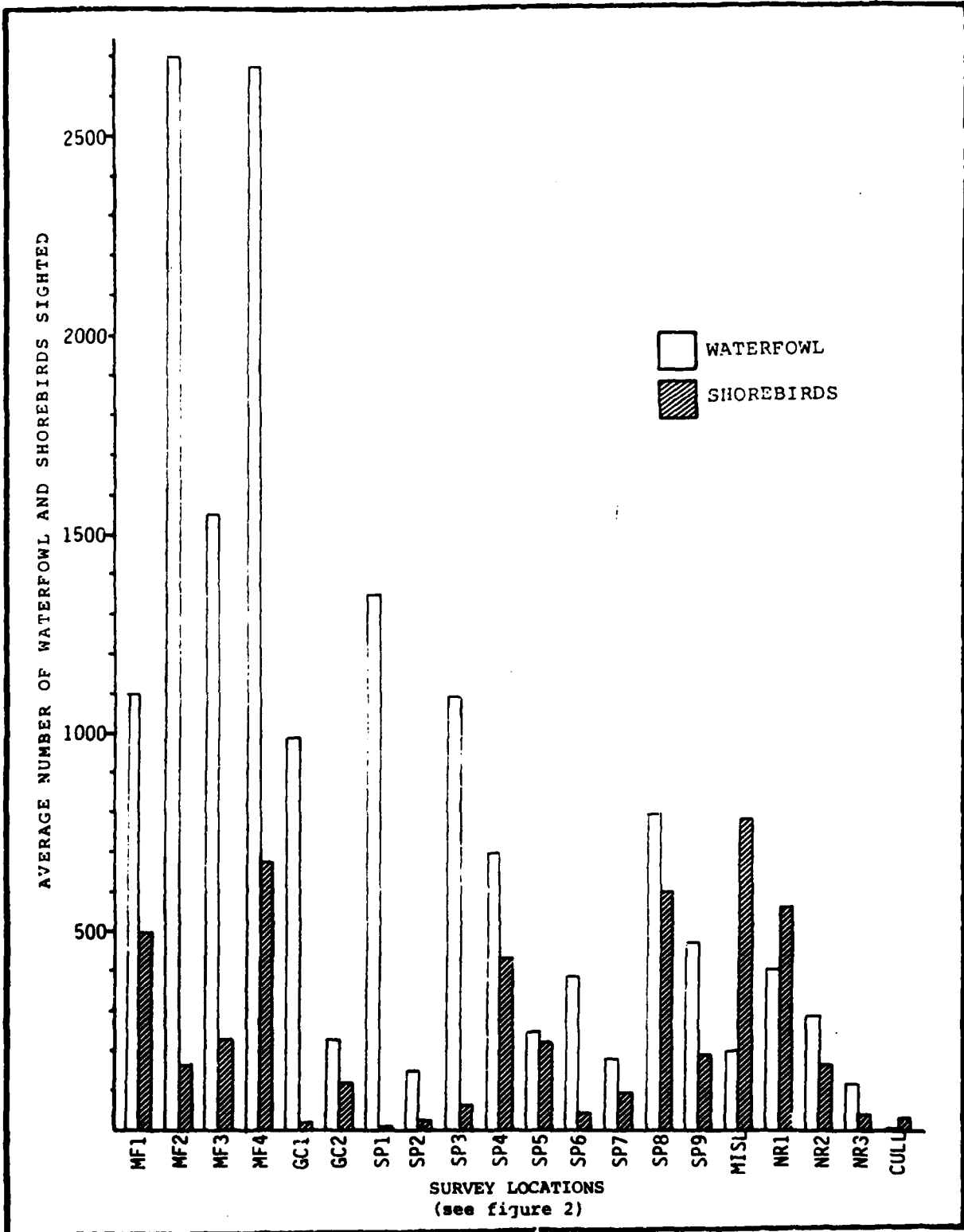

Figure 6. Cullinan Ranch Aerial Survey Data.

(open water), water depth, salinity, and food availability to mention a few.

The eight flights to date have primarily occurred at mid-morning hours on clear or high overcast days. Wind speeds have varied considerably, from calm to gusty, and a variety of conditions with respect to incoming fronts have been encountered. There have been times where three full weeks have passed between flights, primarily due to weather conditions. In spite of the variable environment, a number of trends and observations can be discussed at this time.

With respect to the total numbers of birds seen in various areas through the study area the average number of waterfowl seen each day in the study area is nearly 16,000 with an additional 5,000 shorebirds.

The highest numbers of waterfowl were found in San Pablo Bay. Our survey route covers from the vegetated edge of the marshes to approximately one mile out, and the average number of waterfowl are represented for MF1, 2, 3, and 4 in Figure 6 and in Appendix C-1. The average number of waterfowl for these four habitats combined over the 8 trips has been close to 7,000 birds. While Figure 6 indicates higher total numbers of birds for MF2 and MF4, these locations are not equal in size. In fact, the overall density of waterfowl is approximately equal for the four habitats (MF2 and MF4 are roughly 2 times the size of MF3 and 2.5 times that of MF1). There is apparently, a distribution pattern of species. Canvasback are generally rafted in large loose flocks in MF2 and MF3, while MF4 had more mixed flocks with scoters, scaup, coots, and fewer canvasback.

The unusual point in the data is represented by the December 15th flight discussed earlier. Flown several hours before an incoming storm, there were far more birds present at most survey locations, but especially in the open waters of San Pablo Bay. On that day, over 22,000 waterfowl were found in MF1, MF2, MF3, and MF4, mostly rafting to the west in MF4 (over 14,000 in this area alone).

With respect to the salt ponds and other areas surrounding Cullinan Ranch, a number of patterns appear to be emerging. First of all, Salt Ponds 1, 3, 4, and 8 have had comparatively higher utilization by waterfowl during the survey period than Salt Ponds 2, 5, 7, and 9. Salt Ponds 10, 11, 12, 13, and 14 are surveyed

sporadically because they lie within the approach pattern to the Napa Airport. In general, when surveyed, utilization has been low in these ponds as well.

This does not give a full picture, however, of the shifting patterns of utilization. Salt Pond 1, adjacent to the west end of Cullinan Ranch had very high utilization in late November and December by American coots. Prior to November, Salt Pond 1 was drained by Leslie Salt and for several weeks was a favorite location for thousands of shorebirds (this was before the aerial surveys began).

Salt Pond 3 and 4 experienced their had highest utilization by waterfowl in late December and January. In late November and early December, Salt Pond 4 had been drained and the influx of shorebirds is apparent in the aerial counts. The effects of this draining appeared also in the data for overflights of Cullinan Ranch by shorebirds moving to and from Salt Pond 4.

Salt Pond 5 has in general far less utilization to date by waterfowl than 1, 3, 4 and 8. There are islands, however, which in December were resting areas for avocets, other shorebirds and white pelicans. Most of the waterfowl seen in Salt Pond 5 have been rafted up along the eastern edge close to the Napa River.

Salt Pond 6 has also averaged lower utilization by waterfowl. However, Salt Pond 6 has a windrow of eucalyptus directly under the power lines which serve as roosting areas and have had active nests of double-crested cormorants in past years. The existence and location of these roosts is expected to influence overflight at Cullinan Ranch, but a clear pattern had not yet emerged.

Salt Pond 8 is a very active pond, both for waterfowl and shorebirds. An island runs east-west for several hundred yards in the west end of Salt Pond 8, and is used heavily by shorebirds, as is the dike between Pond 8 and 9.

Salt Pond 7, on the other hand, to date had very low utilization. During the course of the survey, the pond has remained dark-green in appearance from the air and has had low populations on virtually all of the surveys.

Other areas with occasionally large concentrations of birds are certain sections along the Napa River. NR1 and NR2 periodically have fair populations of canvasback and NR3 has large gull populations in the water adjacent to the dump.

Significance With Respect to Cullinan Ranch

The survey distribution of birds in the Salt Ponds and San Pablo Bay was designed to give insight with respect to movement over the ranch. The differential utilization of the ponds seen during the past 3 months has indeed added significant insight with respect to the ranch.

The northwestern tip of the ranch is bordered on three sides by ponds which have had high utilization during the past three months. The direction and numbers of overflights by birds of this tip of the ranch indicate that there has been considerable movement between the ponds and possibly San Pablo Bay, or beyond.

A full 25% of the overflights have been by white pelicans and double-crested cormorants. These overflights were concentrated for the white pelican in October and earlier. White pelicans are common in July-December on primary salt ponds about San Francisco Bay. Flocks "commuting" between feeding areas circle in rising thermals of air, then glide to the next thermal or flap on to a feeding or resting area (Cogswell 1977). Many of the overflights recorded for white pelicans were such flocks circling above thermals generated by the land mass of Cullinan Ranch. During this time the white pelicans were often seen in Salt Pond 1 and 2.

The comparatively low utilization of SP5 (and 6) by birds, in part, explains the lack of overflights on the east end of the ranch. Since Transect #3 was established, only 5 overflights have been recorded along it, by a total of 41 birds. Forty of these birds were gulls, possibly moving from the Napa Dump to the Dump at Mare Island. This compares with 20 flights by a total of 115 birds in Transect #1 and 18 flights by a total of 122 birds for Transect #2 for the same period.

The question remains regarding the changes in utilization of the ponds through the year. The progressive concentration of salt in the Leslie Salt harvesting process will mean that some of the ponds will remain of low habitat value throughout the year. The salt evaporation process in the San Francisco Bay area is a four or five year process, where water is transferred through a series of concentrating ponds. Within the ponds the distribution of wigeon grass, phytoplankton, copepods, fairy shrimp, brine shrimp and other invertebrates depends in large extent upon the

salinity of the ponds. Whether the utilization pattern seen to date remains the same for Salt Pond 5 through the year (and 2, 3, and 4 for that matter) remains to be seen.

Several other important factors bear discussion. First of all, through much of the aerial survey work, hunting season has meant that there have periodically been hunters in ponds in boats and in the duck blinds which dot the ponds. The flights have been scheduled for weekday mornings, so the effect of this hunting activity would probably be less than on weekends. Hunting season is now over, and there may be additional changes in utilization on that basis. Particularly, there seem to be a movement of canvasback to additional areas along the Napa River.

The other important point to note is the lack of activity by waterfowl and shorebirds at Cullinan Ranch. In nine flights (including the reconnaissance flights) there simply has been exceedingly low utilization. On an early flight one group of ruddy ducks was seen in the larger drainage ditch in the southwest section of the ranch. On another flight (January 20), hunters from the slough had apparently put large decoys in the fields along the slough, but no activity near them was noted either on a field excursion to the ranch January 19th or from the air on the 20th. The January 25th flight (as well as others) clarified part of the reason for this low utilization. After days of heavy rains, flying over the ranch revealed very little ponding, in comparison to other agricultural and grazing fields which surround the Napa marshes and Salt Ponds. Fields east of the Napa River were completely flooded as were large sections north of Salt Pond 10. These areas had concentrations of waterfowl, shorebirds and gulls, where they had not been seen before in such large numbers. Fields east of the Sears Point Road (State Route 37) and also south of Sonoma Creek in the vicinity of Tubbs Island also were largely under water (with less bird utilization however).

That flight in particular emphasizes the point that presently the Cullinan Ranch is one of the best drained properties in the area, and is under intensive agricultural management.

Alternate Marina Sites

Principal data collection to date has occurred at Bell Marin Keys and Redwood Shores. Additional observations have been made at the Alviso Marina, the Napa River, and other marinas around the Bay.

Bell Marin Keys is the largest marina housing development in the general vicinity of the Cullinan Ranch. It is inland from the bay, bordered by a slough on one section, with agricultural fields on all other sides.

Redwood Shores is situated within a much more active area with respect to shorebirds and waterfowl, and additionally is near a series of salt ponds similar to those near Cullinan Ranch. Neither Redwood Shores nor Bell Marin Keys are open to tidal action, however.

Sampling at Bell Marin Keys has shown to date lower utilization of the waterways of the marina than at Redwood Shores. Redwood Shores has consistently shown high utilization by a variety of species. Particularly high numbers of American coot and mallard are consistently seen. Ruddy ducks and common goldeneye have also been seen in abundance. Other species occurring on a regular basis are double-crested cormorant, pied-billed grebe, western grebe and snowy egrets. Total census of the ponds at Redwood Shores have shown up to 1042 (November count) waterbirds of various species. December and January counts have been between 700 and 1000 birds.

The censusing of Redwood Shores has been made at times when highest boating activity would be expected - Saturday or Sunday - late morning to early afternoon. The question of the impact of boating traffic on utilization of the marinas waterbirds was to be answered. During the censuses to date, only one boat was recorded in use, and one class of sail-surfers. This low utilization of the boating areas is somewhat unexpected for mid-winter months. It has been possible to record flushing distances for species by foot traffic, and the results are presented in Table 1.

TABLE 1
SUMMARY OF FLUSHING DISTANCES
OBSERVED AT ALTERNATE MARINA SITES

<u>Flushing Distance (meters)</u>	<u>American Coot</u>	<u>Mallard</u>	<u>Goldeneye</u>	<u>Ruddy Duck</u>	<u>Double-crested Cormorant</u>
0-10	3	42	2	0	0
11-20	261	20	7	33	9
21-30	45	16	25	27	5
31-40	9	6	20	0	2
41-50	69	0	15	0	3
51-60	0	0	0	0	0
61-70	0	0	0	3	0
71-80			7	30	3
81-90					
91-100	11	5	9	0	7

In general, double-crested cormorants on the water have been the first to flush from a water body with mixed flocks. Coots will maintain a minimum distance of approximately 10 meters, swimming slowly away if the approach is made slowly.

Mallards are more approachable, primarily because they often will come up along the shore or on boat docks at Redwood Shores. The grassy slopes leading to waterways at Redwood Shores are regularly covered with mallards. These birds will flush into the water only upon close approach.

The common goldeneye and ruddy ducks found at Redwood Shores are consistently in the centers of the waterbodies and maintain distances of more than 10 meters and often more than 20 meters. This behavior is to be expected of diving ducks, while dabblers like the mallard will often be closer to shore.

There have also been fair populations of pied-billed grebes at Redwood Shores and a few lesser scaup. No canvasback have been seen in the Redwood Shores ponds. However, a flock (52 birds) of canvasback were seen on a pond at Bell Marin Keys one

stormy day in December (December 12).

The spring should prove more productive with respect to the effect of boat traffic on waterfowl at marina/residential developments, if the weather clears before migration begins to the breeding grounds. In one instance at Redwood Shores, a fair population of waterfowl moved completely out of one pond when a group of surf-sailers began their lessons. The birds swam to other areas of the waterways, rather than taking flight or moving out of the development entirely.

Fish Population Monitoring

Data on physical factors for Dutchman Slough for October to January are given below.

TABLE 2

PHYSICAL FACTORS RELATED TO DUTCHMAN SLOUGH

	10/4/82	10/9	11/20	12/11	1/29
Time of Tide	1345	700	1418	918	1415
Height of tide (ft)	+5.2	+4	+4.3	+4.2	+5.5(9.5)*
Air temp °C	22	21	15	12	15
Water temp °C	18	18	12	10	11
Salinity (ppt)	11	11	9	8	<1
D.O. (ppm)	(16)	(16.5)	10.4	8.7	9.5
Transparency (%)	34	35	60	44	<1
pH	8	8	6.5	6.5	6.5

Water temperature and salinity decreased with the progress of a wet winter. The very low January salinity was certainly due to the heavy rain run off (high tide was estimated by a Vallejo radio station at + 9.5). The October dissolved oxygen (D.O.) readings were so high as to be suspect. A check of the instrument showed it to be in error and it was corrected for the November sample. In any event, the October D.O. was probably at or near saturation as it was for all the other months. The

amount of oxygen dissolved in the water is a factor of temperature, wind and current mixing and photosynthesis by phytoplankton and other aquatic plants. Comparing D.O. and water transparency for November and December, it can be seen that as the water cleared (less silt) photosynthesis increased raising the D.O. The high D.O. in January, with a transparency of less than 1%, was certainly due to water agitation by strong winds and current (over 3 ft/sec) rather than photosynthesis. Salinity decreased over the sample period which correlates with the rain fall runoff in the Napa River drainage.

The fishes collected to date in Dutchman's Slough at Cullinan Ranch are presented in Appendix E. They are those to be expected in an estuary in central California. Included are typical San Francisco Bay forms, anadromous and typically freshwater forms which have a wide salinity tolerance. The salinity measured at the sample station at high tide ranged from 11 to less than 1 ppt. The average salinity, excluding the very low salinity in January, was 9.8 ppt. The January sample was made during the flooding which followed a series of very heavy rain storms.

The San Francisco Bay forms include the starry flounder, staghorn sculpin, longfinned smelt, shiner surfperch, and yellow-fin goby. All of these species either spawn in brackish water or have juveniles that will enter fresh water. The longfinned smelt prefers water of 10 ppt salinity. Juveniles of all these species move to sluggish turbid sloughs to feed on the abundant plankton. Many of the specimens taken were juveniles or subadults. It is likely that all these species complete their life cycle either in the slough or in the near by waters of San Francisco Bay.

The freshwater forms include the native tule perch, sacramento splittail and the introduced threadfin shad and inland silversides. The tule perch, a member of the family of live bearing marine surfperches, is usually found in freshwater. It obviously can tolerate brackish water especially where food and cover are abundant. They require extensive rooted vegetation along the shoreline in which to feed and hide to escape the rigors of currents and large predators. It was once common in streams throughout the S. F. Bay area but is now confined to those areas which have not been altered by man or his introduced predatory game fishes.

The sacramento splittail is a native minnow which, at one

time, was found throughout the Sacramento/San Joaquin drainage. It is now confined to a population in the Delta and one in the Napa marsh. It prefers low salinity water (5 ppt) but can tolerate 12 ppt and higher. They are plankton feeders and require deadend sloughs for reproduction.

The threadfin shad and inland silversides have been planted in lakes throughout the state as a forage fish for sportfishes. It is common to find them down stream from lakes where they have been carried by overflows following heavy rains. The silversides can tolerate brackish water while the shad can tolerate seawater conditions. Both species, however, must reproduce in fresh or near fresh water. They are both plankton feeders and actually reach record sizes in food rich estuaries.

The american shad and striped bass are introduced sport fishes. They are anadromous species (move from the sea to freshwater to spawn) which commonly spawn in the Delta and attendant Sacramento/San Joaquin drainages. Most of the striped bass taken were juveniles. However, two larger specimens (36 and 38 cm) taken in October were large enough to be reproductives. It is not known whether striped bass use the Napa River for spawning. The juvenile fishes collected in Dutchman Slough could have hatched up river or could have come from the main population in the Sacramento/San Joaquin estuary. Young bass feed heavily on zooplankton and as they grow larger they feed on small fishes, both of which are abundant in sloughs.

The american shad captured in October and November were the appropriate size for down stream migrants. As with the striped bass, it is not known if these shad use the Napa River for spawning or if these came from the Sacramento/San Joaquin drainages. However, the plankton rich sloughs are important food resources for these filter feeding sport fishes.

SUMMARY

The monitoring program for the Cullinan Ranch has yielded considerable information regarding the wildlife utilization of the ranch and adjacent areas of the San Pablo Bay and Napa Marshes. Some preliminary trends have been noted in this interim report. Particularly, while the agricultural fields have experienced large numbers of flocking granivorous and insectivorous birds this winter, and expected numbers of shorebirds feeding upland, the utilization of the property to date waterfowl has been negligible. There are some early trends in the direction of birds flying over the property which seem to correspond with differential utilization of the adjoining salt ponds. Overflights additionally have been at relatively high altitudes.

There remain a number of tasks which have been relegated to the final report. First of all, complete year-round data for the samplings will then give a clearer picture of the trends mentioned above and potential changes in the trends. Density calculations for birds using the various habitats will illustrate additional trends not developed on an interim basis. The addition of a third ground transect will aid in the analyses of apparent trends.

Aerial surveys will continue through the peak of waterfowl migration periods and allow for more in-depth analyses correlation or distribution patterns with salinities or other environmental factors can then be made.

Fish sampling and surveys of alternate marinas will continue and intensify in the case of the latter as boat activity increases in the early spring.

Conclusions and planning recommendations have been reserved for the most part for our final report. At that time we will make specific recommendations regarding methods of minimizing potential impacts on the basis of the findings of the completed study.

Additional topics will be addressed this spring as well. These include a survey of Dutchman Slough for the presence of rare plants, with complete mapping. Of particular concern are potential populations of soft-birds beak (Cordylanthus mollis ssp. mollis).

A trapping program for the salt marsh harvest mouse will also be undertaken this spring. Although habitat is thought to be marginal, trapping will definitely answer questions regarding the potential presence of the species.

BIBLIOGRAPHY

- Aplin, J. A. 1967. Biological survey of San Francisco Bay 1963-66. MRO Reference No. 67-4. Calif. Dept. Fish and Game. 131 pp.
- California Department of Fish and Game. 1977. The natural resources of the Napa Marsh. Coastal Wetland Series No. 19. August, 1977.
- Chadwick, H. K. 1964. Annual abundance of young striped bass, Roccus saxatilis, in the Sacramento-San Joaquin Delta, California. Calif. Dept. Fish and Game 50(2):69-99.
- _____, D. E. Stevens, and L. W. Miller. 1977. Some factors regulating the striped bass population in the Sacramento-San Joaquin Estuary, California. In: Proc. of the Conference on assessing the effects of power-plant-induced morality on fish populations (W. Van Winkle, ed.). Pergamon Press. pp. 18-35.
- Cogswell, H. L. 1977. Water birds of California. University of California Press, Berkeley. 399 pp.
- Emlen, J. T. 1971. Population densities of birds derived from transect courts. Auk 88:323-342.
- _____. 1977. Estimating breeding season bird densities from transect counts. Auk 88:455-468.
- Franzreb, K. E. 1981. The determination of avian densities using the variable-strip and fixed width transect surveying methods. In: Estimating numbers of terrestrial birds. C. J. Ralph and J. M. Scott, Editors. Studies in avian biology No. 6. Cooper Ornith. Soc. pp. 139-145.
- Harvey & Stanley Associates. 1978. Biological impacts of a shoreline trail at the Emeryville Crescent. Report to the East Bay Regional Parks Dist. May 1978.

Harvey & Stanley Associates. 1982. Cullinan Ranch: ecological aspects. Report to W. R. Williams Associates. June 1982. 22 pp.

Ralph, J. C., and J. M. Scott. 1981. Estimating numbers of terrestrial birds. Studies in avian biology No. 6. Cooper Ornith. Soc. 630 pp.

Skinner, J. E. 1962. An historical review of the fish and wildlife resources of the San Francisco Bay Area. California Department of Fish and Game, Water Projects Branch Report. No. 1. 225 pp.

TECHNICAL APPENDICES

APPENDIX A. PRELIMINARY REPORT

CULLINAN RANCH:
ECOLOGICAL ASPECTS

Prepared by

H. Thomas Harvey, Ph.D.

James M. Hale, B.A.

Robert L. Hassur, Ph.D.

of

HARVEY & STANLEY ASSOCIATES, INC.

Prepared for

Mr. Walden Williams

of

W. R. WILLIAMS & ASSOCIATES

June, 1982

INTRODUCTION

The Cullinan Ranch study area consisted of the 1551 acres of the proposed project (Fig. 1), plus Guadacanal Village, Dutchman Slough and the marsh south of State Highway 37. This report will cover present habitat characteristics, potential improvement of habitat, enhancement alternatives and management recommendations.

Inasmuch as the water entering the proposed project waterways will be from Dutchman Slough, this study emphasized the characteristics of the Slough habitat. In addition to noting the prevalent vegetation and wildlife, rare and endangered species were also considered. From these approaches one can infer what the habitat enhancement potential or impact of the proposed project will be.

Ground surveys of the property were conducted in the months of March, April and May with twelve separate visits to the site. The perimeter of the property was surveyed, as well as transects through the ranch and surveys of surrounding lands, including the Guadacanal Village. Dusk and dawn surveys were included to complete the survey and give a thorough understanding of ecological processes in the area.

PRESENT HABITAT CHARACTERISTICS

Seven habitat types were recognized in the study area. They are listed in the following table (Table 1) in order of their wildlife use. Wildlife use is based on variety and number of species and presence (observed or inferred) of unique forms.

Table 1. Habitat and Wildlife Use

Habitat Type	Wildlife Use
Tidal Marsh	Very high
Mud Flats	High
Open Water	High
Shrub/Levee	High
Ornamental Plantings	Moderate
Swales in Fields	Moderate
Grain Fields	Low

Tidal Marsh

The tidal marshes along Dutchman Slough and south of Highway 37 are rich both in plant species and wildlife use. The water in the marshes probably varies sufficiently to account for the increased diversity along Dutchman Slough. The marsh south of Highway 37 is dominated by pickleweed and cordgrass (Technical names in Appendix A). The Dutchman Slough marsh is a mosaic of alkali bulrush, pickleweed, cattails, cordgrass, yarrow, silverweed and tules. This diversity aided by the presence of alkali bulrush makes the marsh particularly high in wildlife use. Alkali bulrush is generally recognized as the major waterfowl food in central California. In Table 2 are listed the wildlife observed or suspected of using the marshes immediately adjacent to the proposed project.

Table 2. Marsh Wildlife

Vertebrates Observed or Predicted to be Present on or Near
the Cullinan Ranch Site

- Key: O- Observed on Cullinan Ranch property.
 OA- Observed on property adjacent to Cullinan Ranch.
 P- Species predicted to be present on Cullinan Ranch
 property.
 *- Introduced (non-native) species.

Birds

- | | |
|------------------------------|---------------------------|
| OA Great blue heron | OA Virginia rail |
| OA Great egret | OA Sora |
| OA Snowy egret | OA Clapper rail |
| OA Black-crowned night heron | OA Black rail |
| O Marsh hawk | O American coot |
| O American kestrel | OA Common snipe |
| O Black phoebe | OA Long-billed marsh wren |
| OA Salt marsh yellowthroat | O Short-eared owl |
| O Red-winged blackbird | O Brewers blackbird |
| | OA Samuel's song sparrow |

Mammals

- | | |
|------------------------|-------------------------------|
| OS *Norway rat | P Vagrant shrew |
| OS Raccoon | OA,P Salt marsh harvest mouse |
| OS *House mouse | P Long-tailed weasel |
| OS Calif. meadow mouse | |

Reptiles

- P Gopher snake

Rare or endangered species

Species	Status	
	Federal	State
P American peregrine falcon	listed	endangered
OA Calif. black rail	candidate	rare
OA Calif. clapper rail	listed	endangered
OA Calif. brown pelican	listed	endangered
O Samuel's song sparrow	candidate	
P Salt marsh harvest mouse	listed	endangerea

Species of special concern

- OA White pelican
 - O Marsh hawk
 - O Burrowing owl
 - O Short-eared owl
 - OA Salt marsh yellowthroat
-

From the above table it can be seen that not only is there a great diversity of wildlife, but eleven species are of special concern or are listed as rare or endangered. Only the pelicans and burrowing owls would probably use the marsh in a limited way. The other species are either residents of the marsh or in season dependent on these productive wetlands.

In addition to wildlife species that are endangered or rare there are four plant species of concern; two species were observed at the site and two species may be present. They are, respectively, soft bird's beak and delta tule pea, and, Mason's lilaepsis and caper-fruited tropidocarpum. All four species are candidates for the Federal list, and the first of each pair is considered rare or endangered respectively.

Mud Flats

Mud flats are those areas of the slough banks which are exposed at low tide and extend from the water line at low tide up to the edge of vegetation.

When exposed at low tide the mud flats provide important food sources for wintering shorebirds. When covered, with water at high tide, the mud flats serve as a feeding ground for fish, diving birds (waterfowl) and water birds (herons). This habitat type is considered one of high wildlife use. In Table 3, wildlife observed or expected to be present are listed.

Table 3. Wildlife of the Mud Flats

Birds

OA Great blue heron	OA Shoveler
OA Great egret	OA Canvasback
OA Snowy egret	OA Lesser scaup
OA Black-crowned night heron	OA Common goldeneye
OA American bittern	P Bufflehead
O Mallard	OA Ruddy duck
OA Gadwall	OA Black-bellied plover
OA Pintail	OA Long-billed curlew
O Cinnamon teal	OA Willet
OA American wigeon	OA Greater yellowlegs
OA Dowitcher	OA Least sandpiper
OA Western sandpiper	OA Dunlin
OA Marbled godwit	O Herring gull
OA American avocet	O Calif. gull
OA Black-necked stilt	O Ring-billed gull

Mammals

OA Harbor seal
OS *Muskrat

It is to be realized that a variety of invertebrate inhabit the mud and serve as the food for many of the above species. Common forms observed or expected to be present included: amphipods, fresh-water clams, horse mussels and shore crabs. All of these forms serve as food for the vertebrates. They in turn have consumed the detritus from the marsh and the algae from the slough, thus linking the living components into a web of life.

Open Water

The open water habitat is also one of high wildlife use. It supports a dynamic rotating group of populations. The daily exchange of the tides and the seasonal migrations of animals contribute to the ever-changing attributes of this habitat. The medium of water changes both daily and seasonally. Salinity at Mare Island, for example, varied from a high of 27 ppt in autumn to a low of fresh water in winter (Fig. 2). The marsh plants and

open water organisms are therefore exposed to essentially fresh to brackish water. For reference, marine (salt water) conditions are arbitrarily set at 30 ppt to 40 ppt of salinity.

The open water habitat supports species of fish, diving birds, and water birds. Table 3 lists the species of wildlife that were observed in this habitat or are expected to be there.

Table 4. Wildlife of Open Water

Birds

OA Horned grebe	OA Canvasback
OA Eared grebe	OA Lesser scaup
OA Western grebe	OA Common goldeneye
OA Pied-billed grebe	OA Ruddy duck
OA White pelican	P Red-breasted merganser
OA Double-crested cormorant	P Common gallinule
O Mallard	OA Herring gull
OA Gadwall	O California gull
OA Pintail	O Ring-billed gull
O Cinnamon teal	P Bonapartes gull
OA American wigeon	OA Forster's tern
OA Shoveler	OA Caspian tern

Mammals

OA Harbor seal
OS *Muskrat

Amphibians

P *Bullfrog

Fish

P Stag-horn sculpin	P Bat ray
P Starry flounder	P Leopard shark
P Striped bass	P Dog fish
P Shiner perch	P Salmon
P Top smelt	P Steelhead
P Oriental goby	P Sturgeon
P Long-jaw mudsucker	P English sole
	P Diamond turbot

Shrub/Levee

The shrub/levee habitat occurs primarily along the perimeter of the property, on either side of the service road.

The shrub/levee habitat is a high wildlife use area which compliments the adjacent marsh. It is in general a mix of native and exotic plants, but heavily used by native animals, especially birds. The shrubby characteristic of this habitat provides good cover for a variety of small birds and mammals, such as white-crowned sparrows, dushtit, goldfinches, and racoons, skunks and hares.

The vegetation of the levees is dominated by coyote brush. In addition there are considerable numbers of gumplant, sweet fennel, and mustard. Also present were bee plant, mugwort and Australian saltbush.

Table 5. Shrub/levee Wildlife

Birds

O	Great blue heron	O	Belted kingfisher
OA	American bittern	O	Plain titmouse
O	Turkey vulture	O	Long-billed marsh wren
O	White-tailed kite	O	Loggerhead shrike
O	American kestrel	O	Yellow-rumped warbler
P	California quail	O	Salt marsh yellowthroat
O	Ring-necked pheasant	O	Red-winged blackbird
O	American coot	O	Brewer's blackbird
O	Mourning dove	O	House finch
O	Burrowing owl	O	American goldfinch
O	Short-eared owl	O	Brown towhee
O	Anna's hummingbird	O	White-crowned sparrow
O	Black phoebe	O	Golden-crowned sparrow
		O	Samuel's song sparrow

Mammals

OS	Raccoon	O	Black-tailed hare
OS	Striped skunk	OS	*Feral dog
OS	*Opossum	OS	*Feral cat

Reptiles

- O Western fence lizard
 - P Southern alligator lizard
 - P Gopher snake
 - P Garter snake
-

Ornamental Plantings

The wildlife uses of ornamental planting is probably moderate when compared with the high use of the above four habitats. Ornamental plants occur primarily around the farm buildings of the Cullinan Ranch and at Guadacanal Village. The vegetation was primarily trees and shrubs with such species as eucalyptus, acacia, and Monterey pine.

Table 6. Wildlife Use of Ornamental Plantings

Birds

- | | |
|----------------------|--------------------------|
| P Sharp-shinned hawk | O American robin |
| O Cooper's hawk | O Water pipit |
| O Red-tailed hawk | O Loggerhead shrike |
| O American kestrel | O Starling |
| O Mourning dove | O Yellow-rumped warbler |
| O Barn owl | O House sparrow |
| O Great horned owl | O Western meadowlark |
| O Anna's hummingbird | O Brewer's blackbird |
| O Common flicker | P Brown-headed cowbird |
| O Black phoebe | O House finch |
| O Barn swallow | O American goldfinch |
| O Cliff swallow | O Brown towhee |
| O Common bushtit | O White-crowned sparrow |
| O Mockingbird | O Golden-crowned sparrow |

Mammals

- | | |
|-------------------------|------------------------|
| OS *Common opossum | OS Calif. meadow mouse |
| O Pallid bat | OS *Norway rat |
| O Black-tailed hare | OS *House mouse |
| P Western harvest mouse | OS Raccoon |
| P Deer mouse | P Long-tailed weasel |
| | OS Striped skunk |

Reptiles

P Gopher snake

Swales in Fields

Remanent sloughs behind the dikes have developed into vegetated swales. The common plants were brass buttons and sand spurry. Also present were pickleweed and salt grass. Although some wildlife use was observed, their relative ranking when compared to the above habitats is moderate. The wildlife use for the swales is listed in Table 7.

Table 7. Wildlife Use of Swales

Birds

O Savannah sparrow	O Rock dove
O House sparrow	O Mourning dove
O House finch	O Horned lark
	O Starling

Mammals

OS *Common opossum	OS *House mouse
P Western harvest mouse	OS *Feral dog
OS Calif. meadow mouse	OS *Feral cat
P Deer mouse	

Reptiles

P Gopher snake

Grain Fields

The major habitat interior of the levees is the cultivated grain fields. The most frequently planted species over most of the area is cultivated oats. Some weedy species of plants were also present, such as wild oats and brome grasses. Although certain native species of wildlife use this habitat they are low in diversity and do not include any rare or endangered species. Specifically the wildlife uses are listed in Table 8.

Table 8. Wildlife of the Grain Fields

Birds

O Turkey vulture	O Water pipit
O White-tailed kite	O Loggerhead shrike
O Red-tailed hawk	O Starling
O American kestrel	O House sparrow
O Ring-necked pheasant	O Western meadowlark
O Mourning dove	O Red-winged blackbird
O Barn owl	O Brewer's blackbird
O Great horned owl	P Brown-headed cowbird
	O House finch
	O American goldfinch
	O Savannah sparrow

Mammals

O Black-tailed hare
OS *Norway rat
OS *House mouse
P Western harvest mouse
OS California meadow mouse
OS Botta pocket gopher
O Beechey ground squirrel

POTENTIAL WILDLIFE USE

The potential for improvement of habitat for wildlife is great. The proposed project would increase significantly the four high use habitats; namely, tidal marsh, mud flats, open water and shrub/levee. It would also increase ornamental plantings which we have evaluated at moderate use by wildlife. These increases in the above habitats would be at the expense of the low use habitats of grain fields and swales in fields.

Determinations of the land/tidal evaluations by leveling revealed a spectrum of plant species at the site. In Fig. 3, an idealized profile is shown of land and tidal elevations, and plants. From this it was possible to project that at least 35 acres and probably as much as 40 acres of tidal marsh could become established along the slopes of the channels and in the proposed project. Additionally, 80 acres of the area to be used for dredge disposal could be restored if it remains below 10' above MLLW and is open to tidal action. This habitat is of very high wildlife use and supports rare and endangered plants and animals of concern. The plants would easily tolerate the close proximity of human activity and so would most of the animal species. Specifically, the salt marsh harvest mouse, California black rail, California clapper rail and salt marsh yellow throat would readily establish in the newly created marsh.

The mud flat zone will also be increased and thus improve the wildlife use of the area. It would probably be on the order of 50 acres, even though some of it would possibly be covered with enkadrain.

The open water habitat will be increased on the order of 423 acres. As this, too, is a high wildlife use habitat, more individuals will be provided a resource base.

The shrub/levee habitat has the potential of being increased by about 30 acres. This was evaluated in the earlier section of present habitats, as being of high wildlife use, and therefore an increase in the habitat would be of benefit to the wildlife listed under the shrub/levee category.

The ornamental plantings were ranked as moderate in their wildlife use. This habitat would also be increased on the site. The exact acreage is difficult to estimate, but would probably be on the order of 300 acres (one-third of the approximately 600 acres of residents and schools plus 2/3 of those areas planned for parks and other landscaped open space). This habitat could be further enhanced by planting species known to favor wildlife, e.g. pyracantha and cotoneaster.

In summary, about 960 acres of improved habitat would result from the proposed project. Specifically, low wildlife use habitats, i.e. grain fields and swales in fields, would be replaced with very high to moderate wildlife use habitats. The replacement habitats would be; tidal marsh, mud flat, open water, shrub/levee, and ornamental plantings.

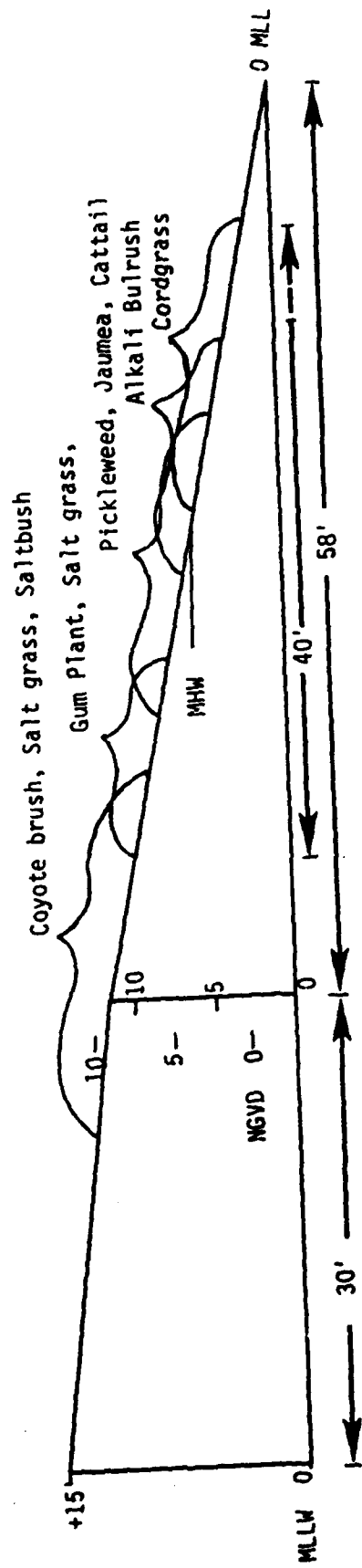

Fig. 3. Vegetation and Elevations in Dutchman Slough.

ENHANCEMENT ALTERNATIVES

In the main, manipulation of the vegetation on the newly created surfaces will allow for enhancement alternatives. The various manipulations will in turn affect the number and kinds of wildlife. Many wildlife species are cover dependent and even if food is available they will not remain in the area. For example, the endangered salt marsh harvest mouse requires dense cover and a food source that can be the same species namely, common pickleweed. The pickleweed, however, must be dense and over a foot in height. A basic ecological principle seems applicable to this site. It is that high diversity is ecologically sound. To that end a mosaic of plantings of native plant species should be planned. The planning of the plantings needs to take into consideration the elevational distribution of plants as depicted in Fig. 3. Inasmuch as there are a variety of species at most elevations a mosaic of planting is possible as well as desirable.

The alternatives for shore protection as outlined by Moffatt & Nichol (1982) would provide diversity of habitat below the vegetated (marsh zone). The mud flat alternative would increase shorebird habitat.

MANAGEMENT RECOMMENDATIONS

Two basic approaches are recommended for management, namely, monitoring and planning. By monitoring is meant the periodic assessment of vegetation and wildlife use, linked to physical environmental factors. A monitoring program which assesses establishment and development of vegetation needs to be outlined. It should include descriptive narration on the vegetation plantings, quantitative statements of the success of vegetation in erosion control, and evaluation of natural revegetation and spread.

Wildlife use should be monitored on a regular basis. Transect lines with stations should be established throughout the site. Bimonthly observations on vertebrates and their signs, should be made and compared with similar adjacent natural habitats.

The planning process for long-range management will require evaluating the data from the monitoring program. The objectives would be to create habitat which duplicates primarily the present natural systems, e.g. marsh, mud flat and open water. The shrub/levee and ornamental plantings habitats should also be evaluated as they become established and developed. They too should then be modified or re-done so as to produce high to moderate wildlife use in light of the monitoring.

APPENDIX A

Plant Species

<u>Common Name</u>	<u>Technical Name</u>
Acacia	Acacia sp.
Wild alfalfa	Medicago sativa
Salt marsh baccharis	Baccharis douglassii
Foxtail barley	Hordeum jubatum
Meadow barley	Hordeum californicum
Mediterranean barley	Hordeum hystris
Wild barley	Hordeum sp.
Soft bird's beak	Cordylanthus mollis ssp. mollis
California bee-plant	Scrophularia californica
Bentgrass	Agrostis sp.
Bindweed	Convolvulus arvensis
Himalaya blackberry	Rubus discolor
Alkali bulrush	Scirpus robustus
California bulrush	Scirpus californicus
Brass buttons	Cotula coronopifolia
Coyote brush	Baccharis pilularis ssp. consanguinea
Cattail	Typha domingensis
Common cattail	Typha latifolia
Narrow-leaf cattail	Typha angustifolia
Cheeseweed	Malva parviflora
Soft chess	Bromus mollis
Chickweed	Stellaria littoralis
Bur clover	Medicago hispida
Cordgrass	Spartina foliosa
Salt marsh dodder	Cuscuta salina
Dock	Rumex occidentalis var. procensus
Curly-leaved dock	Rumex crispus
Sweet fennel	Foeniculum vulgare
Fescue	Festuca sp.
Common fiddle-neck	Amsinckia intermedia
Filaree	Erodium botrys
Farmer's foxtail	Hordeum leporinum
Arrow grass	Triglochin maritima
Bermuda grass	Cynodon dactylon
Blue grass	Poa sp.
Rabbitsfoot grass	Polypogon monspeliensis
Ripgut grass	Bromus rigidus

Wire grass

Alkali heath
Poison hemlock
Hottentot-fig
Jaumea
Sea lavender
Miner's lettuce
Linanthus
Lupine
Red maids

Mugwort
Black mustard
Field mustard
Wild oats
Wild oats
Bristly ox-tongue
Delta tule pea
Peppergrass
Monterey pine
Gum plant
Plantain
Plantain
Common pickleweed
Lamb's quarters
Wild radish
Western ragweed
California rose
Baltic rush
Ryegrass
Ryegrass
Italian ryegrass
Wild ryegrass
Australian saltbush
Halberd-leaved saltbush
Saltgrass

Silverweed
Common sow-thistle
Saltmarsh sand spurry
Cultivated sweetpea
Bull thistle
Milk thistle

Polygonum aviculare var.
littorale

Frankenia grandifolia
Conium maculatum
Mesembryanthemum edule
Jaumea carnosae
Limonium californicum
Montia perfoliata
Linanthus grandiflorus
Lupinus sp.
Calandrinia ciliata var.
menziesii

Artemisia vulgare
Brassica nigra
Brassica campestris
Avena barbata
Avena patua
Picris echioides
Lathyrus jepsonii spp. jepsonii
Lepidium latifolium
Pinus radiata
Grindelia humilis
Plantago sp.
Plantago juncoidea
Salicornia pacifica
Chenopodium album
Raphanus sativus
Ambrosia psilostachya
Rosa californica
Juncus balticus
Elymus mollis
Elymus vancouverensis
Lolium multiflorum
Lolium perenne
Atriplex semibaccata
Atriplex patula spp. hastata
Distichlis spicata var.
stolonifera
Potentilla agadii var. grandis
Gnaphalium glaucum
Spergularia maxima
Lathyrus sp.
Cirsium vulgare
Silybum marianum

Plant Species - cont.

Timothy
Common tule
Vetch
Willow
Yarrow

Phleum pratense
Scirpus acutus
Vicia spp.
Salix sp.
Achillea borealis

APPENDIX B

Vertebrates Observed or Predicted to be Present on or Near the Cullinan Ranch Site

- Key: O- Observed on Cullinan Ranch property. (91 species)
OA- Observed on property adjacent to Cullinan Ranch.
(10 species)
P- Species predicted to be present on Cullinan Ranch
property. (27 species)
*- Introduced (non-native) species.

Birds

- | | |
|-----------------------------|--------------------------|
| O Horned Grebe | OA Common Merganser |
| O Eared Grebe | P Red breasted Merganser |
| O Western Grebe | O Turkey Vulture |
| O Pied-billed Grebe | O White-tailed Kite |
| O White Pelican | P Sharp shinned Hawk |
| OA Brown Pelican | O Cooper's Hawk |
| O Double-crested Cormorant | O Red-tailed Hawk |
| O Great Blue Heron | P Bald Eagle |
| O Great Egret | O Marsh Hawk |
| O Snowy Egret | P Osprey |
| O Black-crowned Night Heron | P Peregrine Falcon |
| OA American Bittern | OA Merlin |
| O Mallard | O American Kestrel |
| OA Gadwall | P California Quail |
| O Pintail | O Ring-necked Pheasant |
| O Green-winged Teal | OA Clapper Rail |
| OA Blue-winged Teal | O Virginia Rail |
| O Cinnamon Teal | O Sora |
| O American Wigeon | OA Black Rail |
| O Northern Shoveler | P Common Gallinule |
| P Redhead | O American Coot |
| O Canvasback | P Semipalmated Plover |
| O Lesser Scaup | O Anna's Hummingbird |
| P Snowy Plover | O Belted Kingfisher |
| O Killdeer | O Common Flicker |
| OA American Golden Plover | O Black Phoebe |
| O Black-bellied Plover | O Say's Phoebe |
| O Common Snipe | O Horned Lark |

Birds - cont.

- O Long-billed Curlew
- OA Whimbrel
- O Greater Yellowlegs
- O Willet
- O Least Sandpiper
- O Dunlin
- O Western Sandpiper
- P Short-billed Dowitcher
- O Long-billed Dowitcher
- O Marbled Godwit
- O American Avocet
- O Black-necked Stilt
- O Western Gull
- O Herring Gull
- O California Gull
- O Ring-billed Gull
- P Bonaparte's Gull
- O Forester's Tern
- O Caspian Tern
- O *Rock Dove
- O Mourning Dove
- O Barn Owl
- O Great Horned Owl
- O Burrowing Owl
- O Short-eared Owl
- O Common Goldeneye
- P Bufflehead
- O Ruddy Duck
- O Violet-green Swallow
- O Barn Swallow
- O Cliff Swallow
- O Scrub Jay
- P Common Crow
- O Plain Titmouse
- O Bushtit
- O Long-billed Marsh Wren
- O Mockingbird
- O American Robin
- O Water Pipit
- O Loggerhead Shrike
- O *Starling
- O Yellow-rumped Warbler
(Audubon's Warbler)
- O Salt marsh Yellowthroat
- O *House Sparrow
- O Western Meadowlark
- O Red-winged Blackbird
- O Brewer's Blackbird
- P Brown-headed Cowbird
- O House Finch
- O Lesser Goldfinch
- O Brown Towhee
- O Savannah Sparrow
- O Dark-eyed Junco
- O White-crowned Sparrow
- O Golden-crowned Sparrow
- O Samuel's Song Sparrow

Mammals

Key: OS- Observed Sign (track, scat, etc.).
*- Introduced (non-native) species.

OS *Common opossum
P Vagrant shrew
P *Ornate shrew
P Suisun shrew
P Big brown bat
O Pallid bat
P Brazilian free-tailed bat
O Black-tailed hare
P Western harvest mouse
P Salt marsh harvest mouse
P Deer mouse
OS California meadow mouse
OS *Muskrat
OS *Norway rat
OS *House mouse
OS Raccoon
P Long-tailed weasel
P *Mink
OS Striped skunk
OS River otter
OS *Feral dog
OS *Feral cat
OS Harbor seal
OS Botta pocket gopher
O Beechy ground squirrel

Reptiles and Amphibians

Key: *- Introduced (non-native) species.

P *Bullfrog
O Western fence lizard
P Gopher snake
P Garter snake
P Southern Alligator Lizard

LITERATURE CITED

Moffat & Nichol, Engrs. 1982. Cullinan Ranch: shore protection. 12 pp. Report for W.R. Williams & Associates.

Storrr, Philip N., Robert E. Selleck and Erman A. Pearson. April 1963. Appendixes to a comprehensive study of San Francisco Bay Area; Suisun Bay-Lower San Joaquin River Area; San Pablo Bay Area. SERL, University of California Berkeley.

SURVEY MAP

(EXISTING CONDITIONS)

LEGEND

HABITAT TYPE	WILDLIFE USE	APPROXIMATE ACREAGE
TOTAL HABITAT	VERY HIGH	0
WILD PLANTS	HIGH	0
OPEN WATER	HIGH	0
SHRUB/LEVEE	HIGH	0
ORIPALMANTAL PLANTINGS	MODERATE	0
GRAVELLY FIELDS	MODERATE	0
GRAVELLY FIELDS	LOW	0

NOTE: THESE HABITAT TYPES DO NOT
EXIST UNDER PRESENT MANAGEMENT SCHEMATIC

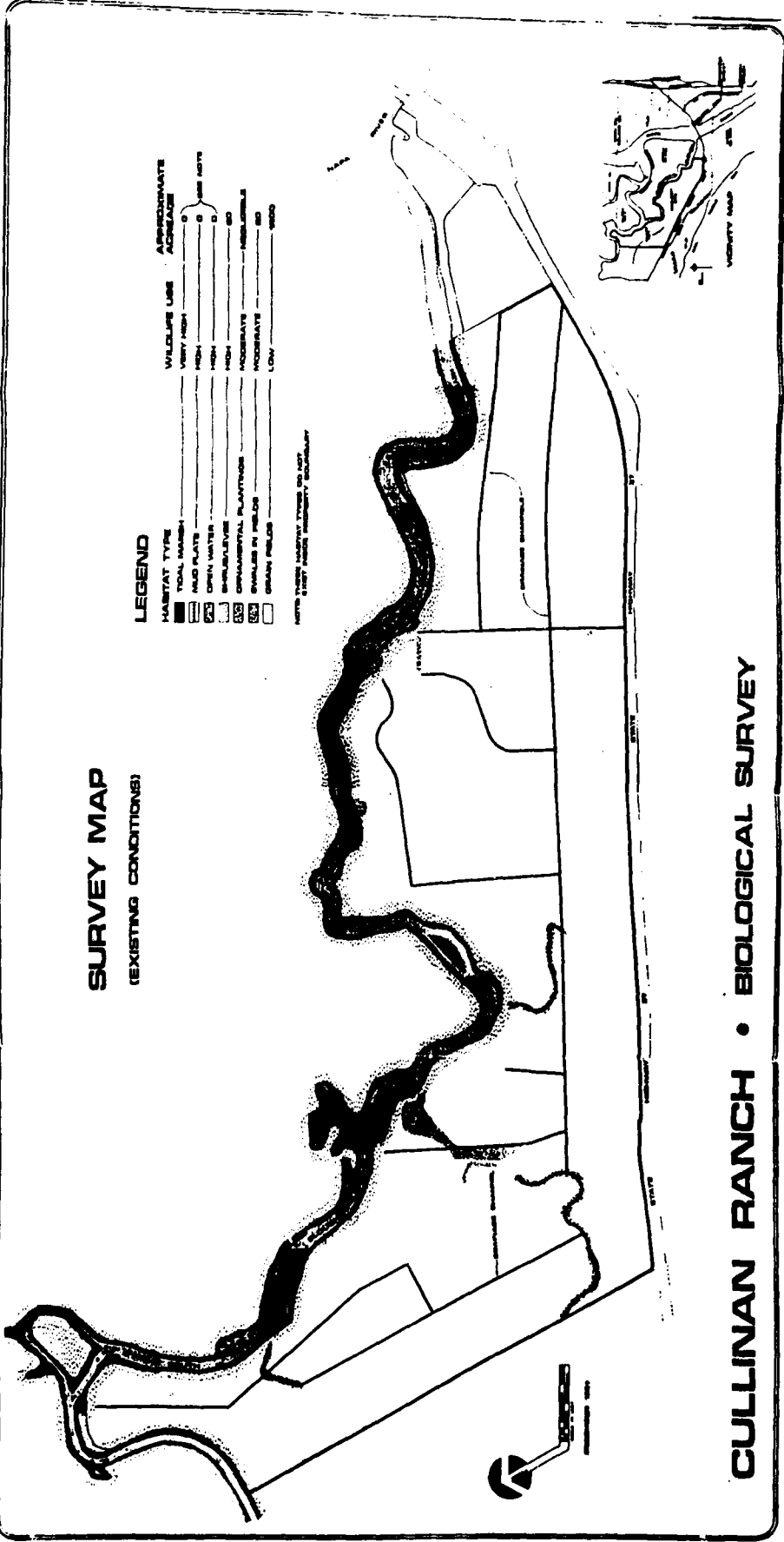

CULLINAN RANCH • BIOLOGICAL SURVEY

APPENDIX B. GROUND AVIAN TRANSECT DATA.

B-1. GROUND AVIAN TRANSECT DATA.
SPECIES OBSERVED IN
DUTCHMAN SLOUGH.

02/18/83

SLOUGH SIDE

DATE	SPECIES	RF/OF	# SEEN	# CALL	# FLUSH
* SPECIES: Red-winged/Brewer's Blackbird					
821228	Red-winged/Brewer's Blackbird	R	0	0	35
830104	Red-winged/Brewer's Blackbird	R	0	0	50
830104	Red-winged/Brewer's Blackbird	F	0	0	42
830113	Red-winged/Brewer's Blackbird	F	0	8	26
830123	Red-winged/Brewer's Blackbird	R	0	0	125
830123	Red-winged/Brewer's Blackbird	F	0	0	25
** SUBTOTAL **			344	8	368
* SPECIES: Ring-billed Gull					
821128	Ring-billed Gull	F	10	0	0
** SUBTOTAL **			10	0	0
* SPECIES: Ruddy Duck					
821228	Ruddy Duck	R	0	0	6
830113	Ruddy Duck	R	7	0	0
** SUBTOTAL **			7	0	6
* SPECIES: Sandpiper spp.					
820805	Sandpiper spp.	F	20	0	0
** SUBTOTAL **			20	0	0
* SPECIES: Savannah Sparrow					
820817	Savannah Sparrow	R	0	6	0
821128	Savannah Sparrow	R	0	0	3
** SUBTOTAL **			0	6	3
* SPECIES: Snowy Egret					
820817	Snowy Egret	R	3	0	0
820831	Snowy Egret	R	4	0	0
820909	Snowy Egret	R	6	0	0
821108	Snowy Egret	F	0	0	1
821117	Snowy Egret	R	1	0	0

02/18/83

SLOUGH SIDE

DATE	SPECIES	RF/OF	# SEEN	# CALL	# FLUSH
* SPECIES: Pied-billed Grebe					
821117	Pied-billed Grebe	R	1	0	0
821128	Pied-billed Grebe	R	1	0	0
821208	Pied-billed Grebe	R	1	0	0
821218	Pied-billed Grebe	R	1	0	0
830104	Pied-billed Grebe	R	1	0	0
830113	Pied-billed Grebe	R	1	0	0
830113	Pied-billed Grebe	R	1	0	0
830123	Pied-billed Grebe	R	0	2	0
** SUBTOTAL **			9	2	0
* SPECIES: Red-winged Blackbird					
820805	Red-winged Blackbird	R	6	0	0
820805	Red-winged Blackbird	R	3	0	0
820805	Red-winged Blackbird	R	5	0	0
820805	Red-winged Blackbird	F	0	0	5
820817	Red-winged Blackbird	R	5	0	0
820817	Red-winged Blackbird	R	2	0	0
820817	Red-winged Blackbird	F	3	0	0
820831	Red-winged Blackbird	F	8	0	0
820909	Red-winged Blackbird	R	16	0	0
821004	Red-winged Blackbird	F	23	0	0
821017	Red-winged Blackbird	F	3	0	0
** SUBTOTAL **			74	0	5
* SPECIES: Red-winged/Brewer's Blackbird					
820925	Red-winged/Brewer's Blackbird	F	50	0	0
821004	Red-winged/Brewer's Blackbird	R	55	0	0
821004	Red-winged/Brewer's Blackbird	F	26	0	0
821017	Red-winged/Brewer's Blackbird	F	56	0	0
821017	Red-winged/Brewer's Blackbird	F	53	0	0
821017	Red-winged/Brewer's Blackbird	F	43	0	0
821117	Red-winged/Brewer's Blackbird	F	0	0	26
821128	Red-winged/Brewer's Blackbird	R	28	0	0
821208	Red-winged/Brewer's Blackbird	R	0	0	10
821208	Red-winged/Brewer's Blackbird	F	33	0	0

02/18/83

SLOUGH SIDE

DATE	SPECIES	RF/OF	# SEEN	# CALL	# FLUSH
* SPECIES: Long-billed Marsh Wren					
830104	Long-billed Marsh Wren	R	0	1	0
830104	Long-billed Marsh Wren	R	0	0	1
830104	Long-billed Marsh Wren	R	1	0	0
830104	Long-billed Marsh Wren	R	0	1	0
830113	Long-billed Marsh Wren	R	0	1	0
830113	Long-billed Marsh Wren	R	1	0	0
830113	Long-billed Marsh Wren	R	0	1	0
830113	Long-billed Marsh Wren	R	0	1	0
830113	Long-billed Marsh Wren	R	1	0	0
830123	Long-billed Marsh Wren	R	0	1	0
830123	Long-billed Marsh Wren	R	1	0	0
830123	Long-billed Marsh Wren	R	0	1	0
830123	Long-billed Marsh Wren	R	1	0	0
** SUBTOTAL **			21	29	8
* SPECIES: Mallard					
821228	Mallard	F	0	0	2
830104	Mallard	R	0	0	3
830104	Mallard	F	2	0	0
830113	Mallard	F	0	0	2
** SUBTOTAL **			2	0	7
* SPECIES: Marbled Godwit					
820805	Marbled Godwit	F	1	0	0
830113	Marbled Godwit	F	3	0	0
** SUBTOTAL **			4	0	0
* SPECIES: Northern Harrier					
820805	Northern Harrier	F	1	0	0
820831	Northern Harrier	F	1	0	0
820909	Northern Harrier	F	2	0	0
820925	Northern Harrier	F	1	0	0
821017	Northern Harrier	F	1	0	0
821218	Northern Harrier	F	1	0	0
830113	Northern Harrier	F	1	0	0
** SUBTOTAL **			8	0	0
* SPECIES: Pied-billed Grebe					
821017	Pied-billed Grebe	R	1	0	0
821108	Pied-billed Grebe	R	1	0	0

02/18/83

SLOUGH SIDE

DATE	SPECIES	RF/OF	# SEEN	# CALL	# FLUSH
* SPECIES: Long-billed Marsh Wren					
830104	Long-billed Marsh Wren	R	0	1	0
830104	Long-billed Marsh Wren	R	0	0	1
830104	Long-billed Marsh Wren	R	1	0	0
830104	Long-billed Marsh Wren	R	0	1	0
830113	Long-billed Marsh Wren	R	0	1	0
830113	Long-billed Marsh Wren	R	1	0	0
830113	Long-billed Marsh Wren	R	0	1	0
830113	Long-billed Marsh Wren	R	0	1	0
830113	Long-billed Marsh Wren	R	1	0	0
830123	Long-billed Marsh Wren	R	0	1	0
830123	Long-billed Marsh Wren	R	1	0	0
830123	Long-billed Marsh Wren	R	0	1	0
830123	Long-billed Marsh Wren	R	1	0	0
** SUBTOTAL **			21	29	8
* SPECIES: Mallard					
821228	Mallard	F	0	0	2
830104	Mallard	R	0	0	3
830104	Mallard	F	2	0	0
830113	Mallard	F	0	0	2
** SUBTOTAL **			2	0	7
* SPECIES: Marbled Godwit					
820805	Marbled Godwit	F	1	0	0
830113	Marbled Godwit	F	3	0	0
** SUBTOTAL **			4	0	0
* SPECIES: Northern Harrier					
820805	Northern Harrier	F	1	0	0
820831	Northern Harrier	F	1	0	0
820909	Northern Harrier	F	2	0	0
820925	Northern Harrier	F	1	0	0
821017	Northern Harrier	F	1	0	0
821218	Northern Harrier	F	1	0	0
830113	Northern Harrier	F	1	0	0
** SUBTOTAL **			8	0	0
* SPECIES: Pied-billed Grebe					
821017	Pied-billed Grebe	R	1	0	0
821108	Pied-billed Grebe	R	1	0	0

02/18/83

SLOUGH SIDE

DATE	SPECIES	RF/OF	# SEEN	# CALL	# FLUSH
* SPECIES: Great Blue Heron					
821108	Great Blue Heron	R	1	0	0
821117	Great Blue Heron	R	1	0	0
821117	Great Blue Heron	R	1	0	0
821208	Great Blue Heron	R	0	0	1
821208	Great Blue Heron	F	0	0	1
821218	Great Blue Heron	R	1	0	0
830104	Great Blue Heron	F	0	0	1
830113	Great Blue Heron	F	1	0	0
830123	Great Blue Heron	R	0	1	0
830123	Great Blue Heron	R	1	0	0
830123	Great Blue Heron	R	0	0	1
** SUBTOTAL **			17	1	5
* SPECIES: Great Egret					
820805	Great Egret	F	1	0	0
820831	Great Egret	R	5	0	0
820909	Great Egret	R	2	0	0
821108	Great Egret	R	2	0	0
821108	Great Egret	F	1	0	0
821128	Great Egret	R	1	0	0
821208	Great Egret	F	0	0	1
821218	Great Egret	R	1	0	0
821228	Great Egret	F	1	0	0
830113	Great Egret	R	1	0	0
830123	Great Egret	R	0	1	0
** SUBTOTAL **			15	1	1
* SPECIES: Green-winged Teal					
821128	Green-winged Teal	F	0	0	4
821208	Green-winged Teal	R	4	0	0
821218	Green-winged Teal	R	5	0	0
** SUBTOTAL **			9	0	4
* SPECIES: Gull sp.					
820805	Gull sp.	F	32	0	0
820805	Gull sp.	F	31	0	0
820831	Gull sp.	F	3	0	0
821017	Gull sp.	F	6	0	0
** SUBTOTAL **			72	0	0
* SPECIES: Long-billed Curlew					

02/18/83

SLOUGH SIDE

DATE	SPECIES	RF/OF	# SEEN	# CALL	# FLUSH
* SPECIES: Great Blue Heron					
821108	Great Blue Heron	R	1	0	0
821117	Great Blue Heron	R	1	0	0
821117	Great Blue Heron	R	1	0	0
821208	Great Blue Heron	R	0	0	1
821208	Great Blue Heron	F	0	0	1
821218	Great Blue Heron	R	1	0	0
830104	Great Blue Heron	F	0	0	1
830113	Great Blue Heron	F	1	0	0
830123	Great Blue Heron	R	0	1	0
830123	Great Blue Heron	R	1	0	0
830123	Great Blue Heron	R	0	0	1
** SUBTOTAL **			17	1	5
* SPECIES: Great Egret					
820805	Great Egret	F	1	0	0
820831	Great Egret	R	5	0	0
820909	Great Egret	R	2	0	0
821108	Great Egret	R	2	0	0
821108	Great Egret	F	1	0	0
821128	Great Egret	R	1	0	0
821208	Great Egret	F	0	0	1
821218	Great Egret	R	1	0	0
821228	Great Egret	F	1	0	0
830113	Great Egret	R	1	0	0
830123	Great Egret	R	0	1	0
** SUBTOTAL **			15	1	1
* SPECIES: Green-winged Teal					
821128	Green-winged Teal	F	0	0	4
821208	Green-winged Teal	R	4	0	0
821218	Green-winged Teal	R	5	0	0
** SUBTOTAL **			9	0	4
* SPECIES: Gull sp.					
820805	Gull sp.	F	32	0	0
820805	Gull sp.	F	31	0	0
820831	Gull sp.	F	3	0	0
821017	Gull sp.	F	6	0	0
** SUBTOTAL **			72	0	0
* SPECIES: Long-billed Curlew					

02/18/83

SLOUGH SIDE

DATE	SPECIES	RF/OF	# SEEN	# CALL	# FLUSH
* SPECIES: Black-crowned Night Heron					
821228	Black-crowned Night Heron	F	5	0	0
** SUBTOTAL **					
			5	0	0
* SPECIES: Blackbird sp.					
821030	Blackbird sp.	R	0	0	50
821030	Blackbird sp.	R	0	0	15
** SUBTOTAL **					
			0	0	65
* SPECIES: Brewer's Blackbird					
820909	Brewer's Blackbird	F	14	0	0
** SUBTOTAL **					
			14	0	0
* SPECIES: Cinnamon Teal					
820805	Cinnamon Teal	F	2	0	0
820817	Cinnamon Teal	F	3	0	0
821117	Cinnamon Teal	F	0	0	2
821208	Cinnamon Teal	R	5	0	0
821208	Cinnamon Teal	R	3	0	0
821218	Cinnamon Teal	R	3	0	0
830113	Cinnamon Teal	F	0	0	3
830113	Cinnamon Teal	F	0	0	2
** SUBTOTAL **					
			16	0	7
* SPECIES: Common Yellowthroat					
821117	Common Yellowthroat	F	1	0	0
821218	Common Yellowthroat	R	1	0	0
830113	Common Yellowthroat	R	1	0	0
** SUBTOTAL **					
			3	0	0
* SPECIES: Coot					
820805	Coot	R	7	0	0
820817	Coot	R	4	0	0
820909	Coot	R	3	0	0
821030	Coot	R	0	15	0
821030	Coot	R	0	5	0
821108	Coot	R	3	0	0
821108	Coot	R	5	0	0
821117	Coot	R	2	0	0

02/18/83

SLOUGH SIDE

DATE	SPECIES	RF/OF	# SEEN	# CALL	# FLUSH
* SPECIES: Black-crowned Night Heron					
821228	Black-crowned Night Heron	F	5	0	0
** SUBTOTAL **			5	0	0
* SPECIES: Blackbird sp.					
821030	Blackbird sp.	R	0	0	50
821030	Blackbird sp.	R	0	0	15
** SUBTOTAL **			0	0	65
* SPECIES: Brewer's Blackbird					
820909	Brewer's Blackbird	F	14	0	0
** SUBTOTAL **			14	0	0
* SPECIES: Cinnamon Teal					
820805	Cinnamon Teal	F	2	0	0
820817	Cinnamon Teal	F	3	0	0
821117	Cinnamon Teal	F	0	0	2
821208	Cinnamon Teal	R	5	0	0
821208	Cinnamon Teal	R	3	0	0
821218	Cinnamon Teal	R	3	0	0
830113	Cinnamon Teal	F	0	0	2
830113	Cinnamon Teal	F	0	0	2
** SUBTOTAL **			16	0	7
* SPECIES: Common Yellowthroat					
821117	Common Yellowthroat	F	1	0	0
821218	Common Yellowthroat	R	1	0	0
830113	Common Yellowthroat	R	1	0	0
** SUBTOTAL **			3	0	0
* SPECIES: Coot					
820805	Coot	R	7	0	0
820817	Coot	R	4	0	0
820909	Coot	R	3	0	0
821030	Coot	R	0	1	0
821030	Coot	R	0	0	0
821108	Coot	R	3	0	0
821108	Coot	R	3	0	0
821117	Coot	R	2	0	0

02/18/83

SLOUGH SIDE

DATE	SPECIES	RF/OF	# SEEN	# CALL	# FLUSH
* SPECIES: American Bittern					
820925	American Bittern	F	2	0	0
821117	American Bittern	F	0	0	1
** SUBTOTAL **			2	0	1
* SPECIES: American Wigeon					
821128	American Wigeon	F	9	0	0
** SUBTOTAL **			9	0	0
* SPECIES: Barn Swallow					
820805	Barn Swallow	F	11	0	0
820805	Barn Swallow	F	8	0	0
820805	Barn Swallow	F	6	0	0
820817	Barn Swallow	F	8	0	0
820831	Barn Swallow	F	7	0	0
820831	Barn Swallow	F	11	0	0
820831	Barn Swallow	F	8	0	0
820909	Barn Swallow	F	11	0	0
** SUBTOTAL **			70	0	0
* SPECIES: Belted Kingfisher					
821228	Belted Kingfisher	F	1	0	0
830113	Belted Kingfisher	F	0	1	0
** SUBTOTAL **			1	1	0
* SPECIES: Black Phoebe					
821218	Black Phoebe	R	1	0	0
830104	Black Phoebe	F	1	0	0
830113	Black Phoebe	R	1	0	0
830123	Black Phoebe	R	0	1	0
** SUBTOTAL **			3	1	0
* SPECIES: Black-bellied Plover					
820817	Black-bellied Plover	R	7	0	0
** SUBTOTAL **			7	0	0
* SPECIES: Black-crowned Night Heron					

02/18/83

SLOUGH SIDE

DATE	SPECIES	RF/OF	# SEEN	# CALL	# FLUSH
* SPECIES: Snowy Egret					
821128	Snowy Egret	F	0	0	1
821208	Snowy Egret	R	0	0	1
821208	Snowy Egret	F	1	0	0
821218	Snowy Egret	F	1	0	0
821228	Snowy Egret	F	1	0	0
830113	Snowy Egret	R	2	0	0
830123	Snowy Egret	R	1	0	0
** SUBTOTAL **			20	0	3
* SPECIES: Song Sparrow					
820805	Song Sparrow	R	1	1	0
820805	Song Sparrow	R	3	1	0
820805	Song Sparrow	F	1	0	0
820817	Song Sparrow	R	1	0	0
820817	Song Sparrow	R	2	0	0
820817	Song Sparrow	R	1	0	0
820817	Song Sparrow	R	0	1	0
820831	Song Sparrow	R	1	0	0
820831	Song Sparrow	F	1	0	0
820831	Song Sparrow	F	8	0	0
820909	Song Sparrow	R	0	1	0
820909	Song Sparrow	R	0	1	0
820925	Song Sparrow	R	0	1	0
820925	Song Sparrow	F	1	0	0
821004	Song Sparrow	R	2	0	0
821004	Song Sparrow	R	0	1	0
821004	Song Sparrow	F	1	0	0
821004	Song Sparrow	F	1	0	0
821017	Song Sparrow	R	1	0	0
821017	Song Sparrow	F	1	0	0
821017	Song Sparrow	F	1	0	0
821017	Song Sparrow	F	2	0	0
821017	Song Sparrow	F	1	0	0
821017	Song Sparrow	F	2	0	0
821017	Song Sparrow	F	1	0	0
821017	Song Sparrow	F	2	0	0
821108	Song Sparrow	R	0	1	0
821108	Song Sparrow	R	1	0	0
821108	Song Sparrow	F	2	0	0
821117	Song Sparrow	R	1	0	0
821128	Song Sparrow	R	1	0	0
821128	Song Sparrow	F	2	0	0
821208	Song Sparrow	R	2	0	0
821208	Song Sparrow	R	2	0	0
821208	Song Sparrow	R	0	0	2
821208	Song Sparrow	F	0	1	0

02/18/83

SLOUGH SIDE

DATE	SPECIES	RF/OF	# SEEN	# CALL	# FLUSH
* SPECIES: Song Sparrow					
821208	Song Sparrow	F	0	1	0
821218	Song Sparrow	R	0	2	0
821218	Song Sparrow	R	2	0	0
821218	Song Sparrow	R	0	2	0
821218	Song Sparrow	R	0	1	0
821228	Song Sparrow	R	0	2	0
821228	Song Sparrow	R	0	3	0
821228	Song Sparrow	R	1	0	0
830104	Song Sparrow	R	0	2	0
830104	Song Sparrow	R	3	0	0
830104	Song Sparrow	R	0	2	0
830104	Song Sparrow	R	0	2	0
830113	Song Sparrow	R	0	3	0
830113	Song Sparrow	R	0	3	0
830113	Song Sparrow	R	0	0	1
830113	Song Sparrow	F	0	3	0
830123	Song Sparrow	R	3	0	0
830123	Song Sparrow	R	0	3	0
830123	Song Sparrow	R	2	0	0
830123	Song Sparrow	R	0	3	0
830123	Song Sparrow	R	0	0	2
** SUBTOTAL **			57	41	5
* SPECIES: Sora					
821030	Sora	R	0	1	0
821208	Sora	R	0	1	0
821208	Sora	R	0	1	0
821228	Sora	R	0	1	0
** SUBTOTAL **			0	4	0
* SPECIES: Virginia Rail					
821128	Virginia Rail	R	0	0	1
830104	Virginia Rail	R	0	1	0
** SUBTOTAL **			0	1	1
* SPECIES: Western Grebe					
820805	Western Grebe	R	1	0	0
820817	Western Grebe	R	3	0	0
820831	Western Grebe	R	3	0	0
820909	Western Grebe	R	1	0	0
820925	Western Grebe	R	5	0	0
820925	Western Grebe	R	3	0	0

02/18/83

SLOUGH SIDE

DATE	SPECIES	RF/OF	# SEEN	# CALL	# FLUSH
* SPECIES: Western Grebe					
821108	Western Grebe	R	2	0	0
821108	Western Grebe	R	1	0	0
821117	Western Grebe	R	1	0	0
821117	Western Grebe	R	1	0	0
821128	Western Grebe	R	1	0	0
821128	Western Grebe	R	1	0	0
821208	Western Grebe	R	1	0	0
821208	Western Grebe	R	1	0	0
821208	Western Grebe	R	1	0	0
821218	Western Grebe	R	1	0	0
821218	Western Grebe	R	3	0	0
821228	Western Grebe	R	1	0	0
830104	Western Grebe	R	3	0	0
830104	Western Grebe	R	1	0	0
830113	Western Grebe	R	1	0	0
830113	Western Grebe	R	1	0	0
830113	Western Grebe	R	1	0	0
830123	Western Grebe	R	1	0	0
830123	Western Grebe	R	0	1	0
830123	Western Grebe	R	1	0	0
** SUBTOTAL **			40	1	0
* SPECIES: White-crowned Sparrow					
821004	White-crowned Sparrow	F	11	0	0
821017	White-crowned Sparrow	F	10	0	0
821108	White-crowned Sparrow	F	0	0	15
821108	White-crowned Sparrow	F	0	0	11
821108	White-crowned Sparrow	F	18	0	0
821117	White-crowned Sparrow	F	0	0	23
821117	White-crowned Sparrow	F	0	0	11
821128	White-crowned Sparrow	R	16	0	0
821128	White-crowned Sparrow	F	0	0	11
821208	White-crowned Sparrow	R	0	0	23
821208	White-crowned Sparrow	R	0	0	12
821208	White-crowned Sparrow	R	0	0	5
821208	White-crowned Sparrow	F	0	0	16
821218	White-crowned Sparrow	R	0	0	14
821218	White-crowned Sparrow	R	0	0	14
821228	White-crowned Sparrow	R	23	0	0
821228	White-crowned Sparrow	R	0	0	18
821228	White-crowned Sparrow	R	0	0	12
830104	White-crowned Sparrow	R	0	0	18
830104	White-crowned Sparrow	R	0	0	21
830104	White-crowned Sparrow	R	0	0	11
830113	White-crowned Sparrow	R	0	0	22
830113	White-crowned Sparrow	R	0	9	0

02/18/83

SLOUGH SIDE

DATE	SPECIES	RF/OF	# SEEN	# CALL	# FLUSH
* SPECIES: White-crowned Sparrow					
830113	White-crowned Sparrow	F	0	0	9
830123	White-crowned Sparrow	R	0	0	21
830123	White-crowned Sparrow	F	0	0	23
830123	White-crowned Sparrow	F	0	0	13
** SUBTOTAL **			78	9	323
* SPECIES: White-tailed Kite					
820831	White-tailed Kite	F	2	0	0
821004	White-tailed Kite	F	1	0	0
821208	White-tailed Kite	F	1	0	0
** SUBTOTAL **			4	0	0
* SPECIES: White/Golden-crowned Sparrow					
820925	White/Golden-crowned Sparrow	F	18	0	0
820925	White/Golden-crowned Sparrow	F	0	0	19
821004	White/Golden-crowned Sparrow	F	19	0	0
821004	White/Golden-crowned Sparrow	F	19	0	0
821004	White/Golden-crowned Sparrow	F	17	0	0
821017	White/Golden-crowned Sparrow	F	18	0	0
821017	White/Golden-crowned Sparrow	F	16	0	0
821017	White/Golden-crowned Sparrow	F	28	0	0
821017	White/Golden-crowned Sparrow	F	10	0	0
821017	White/Golden-crowned Sparrow	F	23	0	0
821017	White/Golden-crowned Sparrow	F	21	0	0
821030	White/Golden-crowned Sparrow	F	0	0	20
** SUBTOTAL **			189	0	39
* SPECIES: Willet					
820805	Willet	F	2	0	0
820817	Willet	F	2	0	0

02/18/83

SLOUGH SIDE

DATE	SPECIES	RF/OF	# SEEN	# CALL	# FLUSH
* SPECIES:	Willet		0	0	2
821117	Willet	F	3	0	0
821208	Willet	R	0	0	2
821218	Willet	R	0	0	2
821228	Willet	F	0	0	2
830104	Willet	R	0	0	2
830113	Willet	F	0	0	2
** SUBTOTAL **			7	0	10
** TOTAL **			1258	160	861

B-2. GROUND AVIAN TRANSECT DATA. |
SPECIES OBSERVED IN THE
FIELDS OF CULLINAN RANCH.

02/18/83

FIELD SIDE

DATE	SPECIES	RF/OF	# SEEN	# CALL	# FLUSH
* SPECIES:	American Kestrel				
820805	American Kestrel	F	1	0	0
820805	American Kestrel	F	1	0	0
820817	American Kestrel	F	1	0	0
820817	American Kestrel	F	1	0	0
820817	American Kestrel	F	1	0	0
820831	American Kestrel	R	1	0	0
820831	American Kestrel	R	1	0	0
820831	American Kestrel	F	0	0	1
820909	American Kestrel	F	0	0	1
820909	American Kestrel	F	0	1	0
820909	American Kestrel	F	0	0	1
820925	American Kestrel	F	1	0	0
820925	American Kestrel	F	1	0	0
820925	American Kestrel	F	1	0	0
821004	American Kestrel	R	0	0	1
821004	American Kestrel	R	0	0	1
821004	American Kestrel	F	1	0	0
821004	American Kestrel	F	0	0	1
821017	American Kestrel	R	1	0	0
821017	American Kestrel	F	1	0	0
821017	American Kestrel	F	1	0	0
821108	American Kestrel	F	1	0	0
821108	American Kestrel	F	1	0	0
821108	American Kestrel	F	1	0	0
821108	American Kestrel	F	1	0	0
821117	American Kestrel	F	1	0	0
821117	American Kestrel	F	1	0	0
821128	American Kestrel	F	1	0	0
821128	American Kestrel	F	0	0	1
821208	American Kestrel	R	1	0	0
821208	American Kestrel	F	0	0	1
821208	American Kestrel	F	0	0	1
821218	American Kestrel	F	1	0	0
821218	American Kestrel	F	1	0	0
821218	American Kestrel	F	1	0	0
821228	American Kestrel	F	0	1	0
821228	American Kestrel	F	0	0	1
821228	American Kestrel	F	1	0	0
830104	American Kestrel	F	1	0	0
830104	American Kestrel	F	1	0	0
830104	American Kestrel	F	1	0	0
830113	American Kestrel	F	0	1	0
830113	American Kestrel	F	1	0	0
830113	American Kestrel	F	1	0	0
830123	American Kestrel	F	1	0	0
830123	American Kestrel	F	1	0	0
830123	American Kestrel	F	1	0	0
830123	American Kestrel	F	1	0	0
** SUBTOTAL **			35	3	10

02/18/83

FIELD SIDE

DATE	SPECIES	RF/OF	# SEEN	# CALL	# FLUSH
* SPECIES: American Robin					
821218	American Robin	R	1	0	0
** SUBTOTAL **					
			1	0	0
* SPECIES: Barn Owl					
821030	Barn Owl	F	0	1	0
821030	Barn Owl	F	0	1	0
821030	Barn Owl	F	0	1	0
** SUBTOTAL **					
			0	3	0
* SPECIES: Barn Swallow					
820805	Barn Swallow	F	5	0	0
820817	Barn Swallow	F	11	0	0
820817	Barn Swallow	F	16	0	0
820831	Barn Swallow	F	8	0	0
** SUBTOTAL **					
			40	0	0
* SPECIES: Black Phoebe					
821218	Black Phoebe	R	1	0	0
821228	Black Phoebe	R	0	1	0
** SUBTOTAL **					
			1	1	0
* SPECIES: Black-bellied Plover					
820805	Black-bellied Plover	R	11	0	0
820805	Black-bellied Plover	R	8	0	0
820805	Black-bellied Plover	R	3	0	0
820805	Black-bellied Plover	R	5	0	0
820805	Black-bellied Plover	R	7	0	0
820817	Black-bellied Plover	R	6	0	0
820831	Black-bellied Plover	R	12	0	0
820831	Black-bellied Plover	R	5	0	0
820831	Black-bellied Plover	R	6	0	0
820909	Black-bellied Plover	R	5	0	0
820909	Black-bellied Plover	F	4	0	0
820925	Black-bellied Plover	R	0	4	0
820925	Black-bellied Plover	R	4	0	0
821004	Black-bellied Plover	R	4	0	0
821004	Black-bellied Plover	R	4	0	0
821017	Black-bellied Plover	F	4	0	0
821017	Black-bellied Plover	F	3	0	0
821108	Black-bellied Plover	R	27	0	0

02/18/83

FIELD SIDE

DATE	SPECIES	RF/OF	# SEEN	# CALL	# FLUSH
* SPECIES: Black-bellied Plover					
821108	Black-bellied Plover	R	11	0	0
821108	Black-bellied Plover	R	13	0	0
821117	Black-bellied Plover	R	10	0	0
821128	Black-bellied Plover	R	11	0	0
821128	Black-bellied Plover	F	21	0	0
821208	Black-bellied Plover	R	22	0	0
830113	Black-bellied Plover	R	13	0	0
** SUBTOTAL **			219	4	0
* SPECIES: Brewer's Blackbird					
820817	Brewer's Blackbird	F	15	0	0
820817	Brewer's Blackbird	F	21	0	0
820831	Brewer's Blackbird	R	25	0	0
820831	Brewer's Blackbird	R	3	1	0
820909	Brewer's Blackbird	F	22	0	0
** SUBTOTAL **			86	1	0
* SPECIES: California Gull					
821017	California Gull	R	8	0	0
830104	California Gull	F	7	0	0
** SUBTOTAL **			15	0	0
* SPECIES: Common Crow					
820805	Common Crow	F	9	0	0
820805	Common Crow	F	0	6	0
** SUBTOTAL **			9	6	0
* SPECIES: Common Flicker					
821108	Common Flicker	F	1	0	0
821208	Common Flicker	F	1	0	0
821218	Common Flicker	F	0	1	0
821228	Common Flicker	F	0	1	0
830113	Common Flicker	R	1	0	0
** SUBTOTAL **			3	2	0
* SPECIES: Common Snipe					
821218	Common Snipe	F	0	1	0
** SUBTOTAL **			0	1	0

02/18/83

FIELD SIDE

DATE	SPECIES	RF/OF	# SEEN	# CALL	# FLUSH
* SPECIES: Dark-eyed Junco					
820925	Dark-eyed Junco	R	8	0	0
820925	Dark-eyed Junco	F	6	0	0
821004	Dark-eyed Junco	R	8	0	0
821004	Dark-eyed Junco	R	5	0	0
821017	Dark-eyed Junco	F	8	0	0
821108	Dark-eyed Junco	F	0	0	6
821208	Dark-eyed Junco	R	7	0	0
821228	Dark-eyed Junco	R	0	0	8
** SUBTOTAL **			42	0	14
* SPECIES: Great Blue Heron					
821004	Great Blue Heron	R	0	0	1
830123	Great Blue Heron	R	1	0	0
** SUBTOTAL **			1	0	1
* SPECIES: Great Egret					
820805	Great Egret	F	1	0	0
820817	Great Egret	F	2	0	0
820817	Great Egret	F	1	0	0
820817	Great Egret	F	1	0	0
820831	Great Egret	F	1	0	0
820909	Great Egret	F	1	0	0
821208	Great Egret	F	1	0	0
821208	Great Egret	F	1	0	0
821208	Great Egret	F	1	0	0
821228	Great Egret	F	0	0	0
830113	Great Egret	R	1	0	0
830123	Great Egret	R	1	0	0
830123	Great Egret	R	0	0	1
** SUBTOTAL **			12	0	1
* SPECIES: Great Horned Owl					
821030	Great Horned Owl	R	0	1	0
821218	Great Horned Owl	F	0	0	1
** SUBTOTAL **			0	1	1
* SPECIES: Greater Yellowlegs					
821218	Greater Yellowlegs	R	0	0	1
** SUBTOTAL **			0	0	1
* SPECIES: Gull sp.					

02/18/83

FIELD SIDE

DATE	SPECIES	RF/OF	# SEEN	# CALL	# FLUSH
* SPECIES: Gull sp.					
820805	Gull sp.	F	23	0	0
820805	Gull sp.	F	25	0	0
820805	Gull sp.	F	18	0	0
820805	Gull sp.	F	27	0	0
820817	Gull sp.	F	7	0	0
820817	Gull sp.	F	27	0	0
820817	Gull sp.	F	8	0	0
820817	Gull sp.	F	31	0	0
820817	Gull sp.	F	9	0	0
820831	Gull sp.	F	28	0	0
821017	Gull sp.	F	2	0	0
821017	Gull sp.	F	10	0	0
821017	Gull sp.	F	6	0	0
821030	Gull sp.	F	0	9	0
821030	Gull sp.	F	3	0	0
821030	Gull sp.	F	2	0	0
821030	Gull sp.	F	7	0	0
821030	Gull sp.	F	8	0	0
** SUBTOTAL **			241	9	0

* SPECIES: Horned Lark					
820817	Horned Lark	R	0	8	0
820817	Horned Lark	R	5	0	0
820817	Horned Lark	R	4	0	0
820817	Horned Lark	R	5	0	0
820817	Horned Lark	R	0	2	0
820817	Horned Lark	F	6	0	0
820831	Horned Lark	R	5	0	0
820831	Horned Lark	R	4	0	0
820831	Horned Lark	R	0	2	0
820831	Horned Lark	R	0	1	0
820831	Horned Lark	F	7	0	0
820831	Horned Lark	F	6	0	0
820909	Horned Lark	R	2	0	0
820909	Horned Lark	R	2	0	0
820909	Horned Lark	R	0	3	0
820909	Horned Lark	R	0	0	0
820909	Horned Lark	F	8	0	0
820909	Horned Lark	F	7	0	0
820909	Horned Lark	F	0	0	0
820925	Horned Lark	R	3	0	0
820925	Horned Lark	R	4	0	0
820925	Horned Lark	R	3	0	0

02/18/83

FIELD SIDE

DATE	SPECIES	RF/OF	# SEEN	# CALL	# FLUSH
* SPECIES:	Horned Lark				
820925	Horned Lark	R	2	0	0
820925	Horned Lark	F	7	0	0
820925	Horned Lark	F	2	0	0
821004	Horned Lark	R	8	0	0
821004	Horned Lark	R	6	0	0
821004	Horned Lark	R	6	0	0
821004	Horned Lark	R	0	3	0
821004	Horned Lark	R	2	0	0
821004	Horned Lark	R	0	3	0
821004	Horned Lark	F	7	0	0
821004	Horned Lark	F	0	0	5
821004	Horned Lark	F	3	0	0
821004	Horned Lark	F	0	4	0
821004	Horned Lark	F	0	6	0
821004	Horned Lark	F	3	0	0
821017	Horned Lark	R	0	5	0
821017	Horned Lark	R	3	0	0
821017	Horned Lark	R	7	0	0
821017	Horned Lark	F	4	0	0
821017	Horned Lark	F	2	0	0
821017	Horned Lark	F	2	0	0
821017	Horned Lark	F	1	0	0
821030	Horned Lark	R	0	2	0
821108	Horned Lark	R	0	5	0
821108	Horned Lark	R	3	0	0
821108	Horned Lark	R	0	5	0
821108	Horned Lark	R	0	5	0
821108	Horned Lark	F	0	5	0
821108	Horned Lark	F	8	0	0
821108	Horned Lark	F	6	0	0
821117	Horned Lark	R	6	0	0
821117	Horned Lark	R	7	0	0
821117	Horned Lark	R	0	3	0
821117	Horned Lark	R	0	4	0
821117	Horned Lark	R	0	2	0
821128	Horned Lark	R	5	0	0
821128	Horned Lark	R	0	0	3
821128	Horned Lark	R	0	6	0
821128	Horned Lark	F	0	0	5
821128	Horned Lark	F	0	0	7
821128	Horned Lark	F	0	2	0
821128	Horned Lark	F	0	3	0
821208	Horned Lark	R	0	7	0
821208	Horned Lark	R	7	0	0
821208	Horned Lark	R	0	5	0
821208	Horned Lark	R	4	0	0
821208	Horned Lark	R	2	0	0
821208	Horned Lark	F	10	0	0

02/18/83

FIELD SIDE

DATE	SPECIES	RF/OF	# SEEN	# CALL	# FLUSH
* SPECIES:	Horned Lark				
821208	Horned Lark	F	6	0	0
821208	Horned Lark	F	3	0	0
821208	Horned Lark	F	7	0	0
821218	Horned Lark	R	0	6	0
821218	Horned Lark	F	5	0	0
821218	Horned Lark	F	7	0	0
821218	Horned Lark	F	7	0	0
821218	Horned Lark	F	0	6	0
821218	Horned Lark	F	6	0	0
821228	Horned Lark	R	11	0	0
821228	Horned Lark	R	0	3	0
821228	Horned Lark	R	0	6	0
821228	Horned Lark	R	0	5	0
821228	Horned Lark	R	0	4	0
821228	Horned Lark	F	6	0	0
821228	Horned Lark	F	0	9	0
821228	Horned Lark	R	9	0	0
830104	Horned Lark	R	0	6	0
830104	Horned Lark	R	0	6	0
830104	Horned Lark	R	0	5	0
830104	Horned Lark	F	6	0	0
830104	Horned Lark	F	8	0	0
830113	Horned Lark	R	0	3	0
830113	Horned Lark	R	0	7	0
830113	Horned Lark	R	0	0	5
830113	Horned Lark	F	12	0	0
830113	Horned Lark	F	6	0	0
830113	Horned Lark	F	0	3	0
830113	Horned Lark	F	7	0	0
830123	Horned Lark	R	0	3	0
830123	Horned Lark	R	0	3	0
830123	Horned Lark	R	0	3	0
830123	Horned Lark	F	0	6	0
830123	Horned Lark	F	0	3	0
** SUBTOTAL **			311	196	25

* SPECIES:	House Finch				
820805	House Finch	F	0	8	0
820805	House Finch	F	6	0	0
820805	House Finch	F	12	0	0
820805	House Finch	F	7	0	0
820805	House Finch	F	6	0	0
820805	House Finch	F	0	11	0
820805	House Finch	F	0	11	0
820805	House Finch	F	0	11	0
820817	House Finch	F	0	11	0
820817	House Finch	F	5	0	0

02/18/83

FIELD SIDE

DATE	SPECIES	RF/OF	# SEEN	# CALL	# FLUSH
* SPECIES:	House Finch		12	0	0
820817	House Finch	F	12	0	0
820831	House Finch	F	7	0	0
820831	House Finch	F	7	0	0
820831	House Finch	F	11	0	0
820909	House Finch	F	0	13	0
820909	House Finch	F	5	0	0
820909	House Finch	F	14	0	0
820925	House Finch	F	8	0	0
820925	House Finch	F	8	0	0
821004	House Finch	F	13	0	0
821004	House Finch	F	11	0	0
821004	House Finch	F	11	0	0
821017	House Finch	F	8	0	0
821108	House Finch	F	8	0	0
821228	House Finch	F	29	0	0
821228	House Finch	F	0	13	0
830113	House Finch	F	0	11	0
830113	House Finch	F	11	0	0
830123	House Finch	F	0	13	0
** SUBTOTAL **			211	91	0

* SPECIES:	Killdeer		5	0	0
820805	Killdeer	R	7	0	0
820805	Killdeer	R	0	5	0
820805	Killdeer	R	7	0	0
820817	Killdeer	R	3	0	0
820817	Killdeer	R	5	0	0
820817	Killdeer	F	5	0	0
820831	Killdeer	R	8	0	0
820831	Killdeer	R	0	3	0
820831	Killdeer	R	7	0	0
820925	Killdeer	F	3	0	0
820925	Killdeer	F	7	0	0
820925	Killdeer	R	0	4	0
821004	Killdeer	R	0	0	0
821004	Killdeer	R	0	0	0
821004	Killdeer	F	5	0	0
821004	Killdeer	F	0	3	0
821004	Killdeer	F	3	0	0
821017	Killdeer	R	6	0	0
821017	Killdeer	R	3	0	0
821017	Killdeer	F	13	0	0
821030	Killdeer	R	1	3	0
821030	Killdeer	R	0	4	0
821030	Killdeer	R	0	2	0
821030	Killdeer	R	0	3	0

02/18/83

FIELD SIDE

DATE	SPECIES	RF/OF	# SEEN	# CALL	# FLUSH
* SPECIES: Killdeer					
821030	Killdeer	R	0	3	0
821030	Killdeer	R	0	3	0
821108	Killdeer	R	6	0	0
821108	Killdeer	R	0	4	0
821108	Killdeer	F	7	0	0
821108	Killdeer	F	3	0	0
821117	Killdeer	R	3	0	0
821117	Killdeer	R	4	0	0
821117	Killdeer	R	0	0	3
821128	Killdeer	R	4	0	0
821128	Killdeer	R	1	0	0
821128	Killdeer	F	7	0	0
821208	Killdeer	R	6	0	0
821208	Killdeer	R	0	7	0
821208	Killdeer	R	3	0	0
821208	Killdeer	R	0	3	0
821218	Killdeer	R	3	0	0
821218	Killdeer	R	17	0	0
821228	Killdeer	R	7	0	0
821228	Killdeer	R	12	0	0
830104	Killdeer	R	0	8	0
830113	Killdeer	R	6	0	0
830113	Killdeer	R	0	0	7
830123	Killdeer	R	0	0	11
** SUBTOTAL **			172	55	24
* SPECIES: Lesser Goldfinch					
821218	Lesser Goldfinch	F	0	5	0
830113	Lesser Goldfinch	F	0	7	0
** SUBTOTAL **			0	12	0
* SPECIES: Loggerhead Shrike					
820805	Loggerhead Shrike	F	1	0	0
820817	Loggerhead Shrike	F	1	0	0
820817	Loggerhead Shrike	F	1	0	0
820831	Loggerhead Shrike	F	1	0	0
820909	Loggerhead Shrike	F	0	0	1
820909	Loggerhead Shrike	F	1	0	0
820925	Loggerhead Shrike	F	1	0	0
820925	Loggerhead Shrike	F	1	0	0
821218	Loggerhead Shrike	F	1	0	0
821228	Loggerhead Shrike	F	0	0	1
830104	Loggerhead Shrike	F	1	0	0
830113	Loggerhead Shrike	F	1	0	0

02/18/83

FIELD SIDE

DATE	SPECIES	RF/OF	# SEEN	# CALL	# FLUSH
* SPECIES: Loggerhead Shrike					
830123	Loggerhead Shrike	F	1	0	0
** SUBTOTAL **					
			11	0	2
* SPECIES: Long-billed Curlew					
820805	Long-billed Curlew	R	18	0	0
820805	Long-billed Curlew	R	12	0	0
820805	Long-billed Curlew	R	7	0	0
820805	Long-billed Curlew	R	23	0	0
820805	Long-billed Curlew	R	11	0	0
820805	Long-billed Curlew	R	7	0	0
820805	Long-billed Curlew	F	11	0	0
820805	Long-billed Curlew	F	8	0	0
820817	Long-billed Curlew	R	0	9	0
820817	Long-billed Curlew	R	13	0	0
820817	Long-billed Curlew	R	11	0	0
820817	Long-billed Curlew	R	5	0	0
820817	Long-billed Curlew	F	8	0	0
820831	Long-billed Curlew	R	11	0	0
820831	Long-billed Curlew	R	7	0	0
820831	Long-billed Curlew	R	7	0	0
820909	Long-billed Curlew	R	8	0	0
820909	Long-billed Curlew	R	3	0	0
820909	Long-billed Curlew	R	6	0	0
821017	Long-billed Curlew	F	8	0	0
821017	Long-billed Curlew	F	0	0	8
821030	Long-billed Curlew	R	0	10	0
821117	Long-billed Curlew	R	3	0	0
830113	Long-billed Curlew	R	0	3	0
** SUBTOTAL **					
			187	22	8
* SPECIES: Mallard					
821030	Mallard	F	0	6	0
** SUBTOTAL **					
			0	6	0
* SPECIES: Mockingbird					
820925	Mockingbird	F	1	0	0
** SUBTOTAL **					
			1	0	0
* SPECIES: Mourning Dove					
820805	Mourning Dove	R	5	0	0

AD-A128 699

DRAFT ENVIRONMENTAL IMPACT REPORT/ENVIRONMENTAL IMPACT
STATEMENT CULLINAN RANCH SPECIFIC PLAN APPENDICES(U)
TORREY AND TORREY INC SAN FRANCISCO CA MAY 83

56

UNCLASSIFIED

F/G 13/2

NL



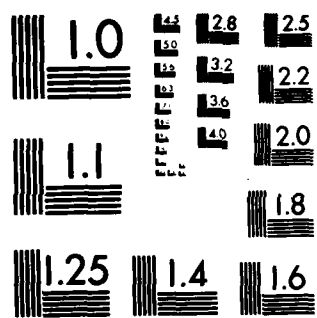

MICROCOPY RESOLUTION TEST CHART
NATIONAL BUREAU OF STANDARDS-1963-A

02/18/83

FIELD SIDE

DATE	SPECIES	RF/OF	# SEEN	# CALL	# FLUSH
* SPECIES: Mourning Dove					
820805	Mourning Dove	R	3	0	0
820805	Mourning Dove	F	4	0	0
820805	Mourning Dove	F	3	0	0
820805	Mourning Dove	F	5	0	0
820805	Mourning Dove	F	5	0	0
820805	Mourning Dove	F	4	0	0
820805	Mourning Dove	F	3	0	0
820805	Mourning Dove	F	2	0	0
820805	Mourning Dove	F	3	0	0
820817	Mourning Dove	R	6	0	0
820817	Mourning Dove	F	2	0	0
820817	Mourning Dove	F	5	0	0
820831	Mourning Dove	R	7	0	0
820831	Mourning Dove	R	5	0	0
820831	Mourning Dove	R	3	0	0
820909	Mourning Dove	R	7	0	0
820909	Mourning Dove	R	3	0	0
821004	Mourning Dove	F	5	0	0
821004	Mourning Dove	F	8	0	0
821017	Mourning Dove	R	7	0	0
821108	Mourning Dove	R	17	0	0
821108	Mourning Dove	R	3	0	0
821117	Mourning Dove	R	7	0	0
821128	Mourning Dove	F	7	0	0
821208	Mourning Dove	R	0	0	7
821208	Mourning Dove	R	0	0	5
821208	Mourning Dove	F	0	0	5
821208	Mourning Dove	F	0	0	5
821218	Mourning Dove	R	0	0	10
821218	Mourning Dove	R	0	0	11
821228	Mourning Dove	R	7	0	0
821228	Mourning Dove	R	0	0	6
821228	Mourning Dove	R	0	0	7
830113	Mourning Dove	R	0	0	13
830113	Mourning Dove	R	0	0	8
** SUBTOTAL **			136	0	77
* SPECIES: Northern Harrier					
820805	Northern Harrier	F	1	0	0
820805	Northern Harrier	F	1	0	0
820817	Northern Harrier	F	2	0	0
820817	Northern Harrier	F	1	0	0
820817	Northern Harrier	F	1	0	0
820831	Northern Harrier	F	1	0	0
820831	Northern Harrier	F	1	0	0
820831	Northern Harrier	F	1	0	0

02/18/83

FIELD SIDE

DATE	SPECIES	RF/OF	# SEEN	# CALL	# FLUSH
* SPECIES: Northern Harrier					
820909	Northern Harrier	F	17	0	0
820925	Northern Harrier	F	1	0	0
821004	Northern Harrier	F	1	0	0
821004	Northern Harrier	F	1	0	0
821017	Northern Harrier	F	1	0	0
821017	Northern Harrier	F	1	0	0
821017	Northern Harrier	F	1	0	0
821108	Northern Harrier	F	1	0	0
821108	Northern Harrier	F	1	0	0
821117	Northern Harrier	F	1	0	0
821117	Northern Harrier	F	1	0	0
821117	Northern Harrier	F	1	0	0
821128	Northern Harrier	F	1	0	0
821128	Northern Harrier	F	1	0	0
821128	Northern Harrier	F	1	0	0
821128	Northern Harrier	F	1	0	0
821128	Northern Harrier	F	1	0	0
821208	Northern Harrier	F	1	0	0
821208	Northern Harrier	F	1	0	0
821208	Northern Harrier	F	1	0	0
821208	Northern Harrier	F	1	0	0
821208	Northern Harrier	F	1	0	0
821218	Northern Harrier	F	1	0	0
821218	Northern Harrier	F	1	0	0
821218	Northern Harrier	F	1	0	0
821228	Northern Harrier	F	1	0	0
821228	Northern Harrier	F	1	0	0
821228	Northern Harrier	F	1	0	0
821228	Northern Harrier	F	1	0	0
821228	Northern Harrier	F	1	0	0
830104	Northern Harrier	F	1	0	0
830104	Northern Harrier	F	1	0	0
830104	Northern Harrier	F	1	0	0
830104	Northern Harrier	F	1	0	0
830113	Northern Harrier	F	1	0	0
830113	Northern Harrier	F	1	0	0
830113	Northern Harrier	F	1	0	0
830113	Northern Harrier	F	1	0	0
830123	Northern Harrier	F	0	1	0
830123	Northern Harrier	F	1	0	0
830123	Northern Harrier	F	1	0	0
830123	Northern Harrier	F	1	0	0
830123	Northern Harrier	F	1	0	0
830123	Northern Harrier	F	1	0	0
830123	Northern Harrier	F	1	0	0
** SUBTOTAL **			67	1	0

* SPECIES: Raven

02/18/83

FIELD SIDE

DATE	SPECIES	RF/OF	# SEEN	# CALL	# FLUSH
* SPECIES: Raven					
820925	Raven	R	3	0	0
821017	Raven	F	2	0	0
** SUBTOTAL **					
			5	0	0
* SPECIES: Red-tailed Hawk					
820805	Red-tailed Hawk	F	1	0	0
820805	Red-tailed Hawk	F	1	0	0
820817	Red-tailed Hawk	F	1	0	0
820831	Red-tailed Hawk	F	1	0	0
820831	Red-tailed Hawk	F	1	0	0
820831	Red-tailed Hawk	F	1	0	0
820909	Red-tailed Hawk	F	1	0	0
820925	Red-tailed Hawk	F	1	0	0
820925	Red-tailed Hawk	F	1	0	0
820925	Red-tailed Hawk	F	1	0	0
821004	Red-tailed Hawk	F	2	0	0
821004	Red-tailed Hawk	F	1	0	0
821004	Red-tailed Hawk	F	1	0	0
821017	Red-tailed Hawk	F	1	0	0
821017	Red-tailed Hawk	F	3	0	0
821017	Red-tailed Hawk	F	1	0	0
821017	Red-tailed Hawk	F	2	0	0
821017	Red-tailed Hawk	F	2	0	0
821017	Red-tailed Hawk	F	2	0	0
821017	Red-tailed Hawk	F	1	0	0
821017	Red-tailed Hawk	F	1	0	0
821108	Red-tailed Hawk	F	1	0	0
821108	Red-tailed Hawk	F	1	0	0
821117	Red-tailed Hawk	F	1	0	0
821117	Red-tailed Hawk	F	1	0	0
821128	Red-tailed Hawk	R	1	0	0
821128	Red-tailed Hawk	F	1	0	0
821208	Red-tailed Hawk	F	1	0	0
821208	Red-tailed Hawk	F	1	0	0
821208	Red-tailed Hawk	F	1	0	0
821208	Red-tailed Hawk	F	1	0	0
821218	Red-tailed Hawk	F	1	0	0
821218	Red-tailed Hawk	F	1	0	0
821228	Red-tailed Hawk	F	1	0	0
830104	Red-tailed Hawk	F	1	0	0
830104	Red-tailed Hawk	F	1	0	0
830113	Red-tailed Hawk	F	1	0	0
830113	Red-tailed Hawk	F	1	0	0
830123	Red-tailed Hawk	F	1	0	0
** SUBTOTAL **					
			47	0	0

* SPECIES: Red-winged Blackbird

02/18/83

FIELD SIDE

DATE	SPECIES	RF/OF	# SEEN	# CALL	# FLUSH
* SPECIES: Red-winged Blackbird					
820831	Red-winged Blackbird	R	38	0	0
821004	Red-winged Blackbird	R	23	0	0
** SUBTOTAL **			61	0	0
* SPECIES: Red-winged/Brewer's Blackbird					
820925	Red-winged/Brewer's Blackbird	R	75	0	0
820925	Red-winged/Brewer's Blackbird	F	50	0	0
821004	Red-winged/Brewer's Blackbird	R	32	0	0
821017	Red-winged/Brewer's Blackbird	F	51	0	0
821108	Red-winged/Brewer's Blackbird	F	50	0	0
821108	Red-winged/Brewer's Blackbird	F	200	0	0
821128	Red-winged/Brewer's Blackbird	F	23	0	0
821208	Red-winged/Brewer's Blackbird	R	50	0	0
821208	Red-winged/Brewer's Blackbird	F	150	0	0
821218	Red-winged/Brewer's Blackbird	R	55	0	0
821218	Red-winged/Brewer's Blackbird	R	42	0	0
830123	Red-winged/Brewer's Blackbird	R	50	0	0
** SUBTOTAL **			828	0	0
* SPECIES: Ring-necked Pheasant					
830104	Ring-necked Pheasant	F	0	0	↓
** SUBTOTAL **			0	0	↓
* SPECIES: Rock Dove					
820805	Rock Dove	F	5	0	0
821117	Rock Dove	R	23	0	0
821128	Rock Dove	R	23	0	0
821208	Rock Dove	R	23	0	0
821218	Rock Dove	R	23	0	0
821218	Rock Dove	R	28	0	0

02/18/83

FIELD SIDE

DATE	SPECIES	RF/OF	# SEEN	# CALL	# FLUSH
* SPECIES: Rock Dove					
821228	Rock Dove	R	25	0	0
830104	Rock Dove	R	23	0	0
830113	Rock Dove	R	230	0	0
** SUBTOTAL **			403	0	0
* SPECIES: Ruby-crowned Kinglet					
821218	Ruby-crowned Kinglet	F	1	0	0
** SUBTOTAL **			1	0	0
* SPECIES: Savannah Sparrow					
820805	Savannah Sparrow	R	0	2	0
820805	Savannah Sparrow	R	0	1	0
820805	Savannah Sparrow	R	2	0	0
820805	Savannah Sparrow	R	0	1	0
820805	Savannah Sparrow	F	3	0	0
820805	Savannah Sparrow	F	0	0	3
820805	Savannah Sparrow	F	0	0	3
820805	Savannah Sparrow	F	0	0	4
820805	Savannah Sparrow	F	0	0	4
820805	Savannah Sparrow	F	0	0	3
820805	Savannah Sparrow	F	0	0	2
820805	Savannah Sparrow	F	3	0	0
820805	Savannah Sparrow	F	0	0	2
820817	Savannah Sparrow	R	0	4	0
820817	Savannah Sparrow	R	5	0	0
820817	Savannah Sparrow	R	3	0	0
820817	Savannah Sparrow	R	2	0	0
820817	Savannah Sparrow	F	4	0	0
820817	Savannah Sparrow	F	3	0	0
820817	Savannah Sparrow	F	3	0	0
820817	Savannah Sparrow	F	3	0	0
820817	Savannah Sparrow	F	3	0	0
820817	Savannah Sparrow	F	5	0	0
820831	Savannah Sparrow	R	6	0	0
820831	Savannah Sparrow	R	3	0	0
820831	Savannah Sparrow	R	0	3	0
820831	Savannah Sparrow	R	0	0	6
820831	Savannah Sparrow	R	4	0	0
820831	Savannah Sparrow	R	0	2	0
820831	Savannah Sparrow	F	0	0	3
820831	Savannah Sparrow	F	0	0	6
820831	Savannah Sparrow	F	0	0	2
820831	Savannah Sparrow	F	0	0	1
820831	Savannah Sparrow	F	0	1	0

02/18/83

FIELD SIDE

DATE	SPECIES	RE/OF	# SEEN	# CALL	# FLUSH
* SPECIES:	Savannah Sparrow				
820831	Savannah Sparrow	F	3	0	0
820909	Savannah Sparrow	R	2	0	0
820909	Savannah Sparrow	F	0	0	4
820909	Savannah Sparrow	F	3	0	0
820909	Savannah Sparrow	F	0	0	2
820909	Savannah Sparrow	F	0	0	3
820909	Savannah Sparrow	F	3	0	0
820909	Savannah Sparrow	F	4	0	0
820909	Savannah Sparrow	F	0	0	2
820909	Savannah Sparrow	F	0	0	3
820925	Savannah Sparrow	R	0	3	0
820925	Savannah Sparrow	R	0	3	0
820925	Savannah Sparrow	R	0	2	0
820925	Savannah Sparrow	R	0	4	0
820925	Savannah Sparrow	R	0	3	0
820925	Savannah Sparrow	R	0	0	3
820925	Savannah Sparrow	R	0	0	3
820925	Savannah Sparrow	R	0	6	0
820925	Savannah Sparrow	F	6	0	0
820925	Savannah Sparrow	F	5	0	0
820925	Savannah Sparrow	F	0	0	2
820925	Savannah Sparrow	F	4	0	0
820925	Savannah Sparrow	F	5	0	0
820925	Savannah Sparrow	F	3	0	0
820925	Savannah Sparrow	F	0	0	4
820925	Savannah Sparrow	F	4	0	0
820925	Savannah Sparrow	F	0	2	0
820925	Savannah Sparrow	F	2	0	0
820925	Savannah Sparrow	F	0	0	4
820925	Savannah Sparrow	F	0	0	4
821004	Savannah Sparrow	R	7	0	0
821004	Savannah Sparrow	R	3	0	0
821004	Savannah Sparrow	R	3	0	0
821004	Savannah Sparrow	R	2	0	0
821004	Savannah Sparrow	R	0	0	5
821004	Savannah Sparrow	R	0	2	0
821004	Savannah Sparrow	R	0	0	6
821004	Savannah Sparrow	R	0	0	5
821004	Savannah Sparrow	R	0	2	0
821004	Savannah Sparrow	F	6	0	0
821004	Savannah Sparrow	F	3	0	0
821004	Savannah Sparrow	F	3	0	0
821004	Savannah Sparrow	F	3	0	0
821004	Savannah Sparrow	F	2	0	0
821004	Savannah Sparrow	F	0	3	0
821004	Savannah Sparrow	F	5	0	0
821004	Savannah Sparrow	F	0	0	4
821004	Savannah Sparrow	F	0	0	3

02/18/83

FIELD SIDE

DATE	SPECIES	RF/OF	# SEEN	# CALL	# FLUSH
* SPECIES:	Savannah Sparrow				
821017	Savannah Sparrow	R	0	7	0
821017	Savannah Sparrow	R	2	0	0
821017	Savannah Sparrow	R	1	0	0
821017	Savannah Sparrow	R	0	6	0
821017	Savannah Sparrow	F	6	0	0
821017	Savannah Sparrow	F	10	0	0
821017	Savannah Sparrow	F	3	0	0
821017	Savannah Sparrow	F	10	0	0
821017	Savannah Sparrow	F	3	0	0
821017	Savannah Sparrow	F	12	0	0
821017	Savannah Sparrow	F	6	0	0
821017	Savannah Sparrow	F	3	0	0
821030	Savannah Sparrow	R	0	0	3
821030	Savannah Sparrow	R	0	0	2
821108	Savannah Sparrow	R	6	0	0
821108	Savannah Sparrow	R	3	0	0
821108	Savannah Sparrow	R	5	0	0
821108	Savannah Sparrow	R	5	0	0
821108	Savannah Sparrow	R	1	0	0
821108	Savannah Sparrow	R	0	7	0
821108	Savannah Sparrow	F	7	0	0
821108	Savannah Sparrow	F	0	0	3
821108	Savannah Sparrow	F	0	0	4
821108	Savannah Sparrow	F	0	0	7
821108	Savannah Sparrow	F	0	0	2
821117	Savannah Sparrow	R	3	0	0
821117	Savannah Sparrow	R	0	2	0
821117	Savannah Sparrow	F	0	0	4
821117	Savannah Sparrow	F	2	0	0
821117	Savannah Sparrow	F	2	0	0
821117	Savannah Sparrow	F	0	0	2
821128	Savannah Sparrow	R	3	0	0
821128	Savannah Sparrow	R	0	4	0
821128	Savannah Sparrow	R	0	0	7
821128	Savannah Sparrow	F	7	0	0
821128	Savannah Sparrow	F	3	0	0
821128	Savannah Sparrow	F	7	0	0
821208	Savannah Sparrow	R	0	4	0
821208	Savannah Sparrow	R	3	0	0
821208	Savannah Sparrow	R	4	0	0
821208	Savannah Sparrow	R	7	0	0
821208	Savannah Sparrow	R	0	2	0
821208	Savannah Sparrow	R	5	0	0
821208	Savannah Sparrow	R	3	0	0
821208	Savannah Sparrow	F	5	0	0
821208	Savannah Sparrow	F	3	0	0
821208	Savannah Sparrow	F	0	2	0
821218	Savannah Sparrow	R	0	0	5

02/18/83

FIELD SIDE

DATE	SPECIES	RF/OF	# SEEN	# CALL	# FLUSH
* SPECIES: Savannah Sparrow					
821218	Savannah Sparrow	R	0	0	11
821218	Savannah Sparrow	R	8	0	0
821218	Savannah Sparrow	R	0	3	0
821218	Savannah Sparrow	R	5	0	0
821218	Savannah Sparrow	R	0	2	0
821218	Savannah Sparrow	F	6	0	0
821218	Savannah Sparrow	F	12	0	0
821218	Savannah Sparrow	F	6	0	0
821228	Savannah Sparrow	R	0	3	0
821228	Savannah Sparrow	R	0	2	0
821228	Savannah Sparrow	R	0	5	0
821228	Savannah Sparrow	F	12	0	0
830104	Savannah Sparrow	R	0	8	0
830104	Savannah Sparrow	R	0	7	0
830104	Savannah Sparrow	R	0	5	0
830104	Savannah Sparrow	R	0	3	0
830104	Savannah Sparrow	F	0	7	0
830104	Savannah Sparrow	F	8	0	0
830113	Savannah Sparrow	R	0	7	0
830113	Savannah Sparrow	R	0	12	0
830113	Savannah Sparrow	R	0	6	0
830113	Savannah Sparrow	R	3	0	0
830113	Savannah Sparrow	R	0	2	0
830113	Savannah Sparrow	F	0	11	0
830123	Savannah Sparrow	R	0	6	0
830123	Savannah Sparrow	R	0	7	0
830123	Savannah Sparrow	R	0	3	0
830123	Savannah Sparrow	R	5	0	0
830123	Savannah Sparrow	R	0	6	0
830123	Savannah Sparrow	F	0	0	7
** SUBTOTAL **			338	183	153
* SPECIES: Scrub Jay					
820925	Scrub Jay	R	1	0	0
** SUBTOTAL **			1	0	0
* SPECIES: Snowy Egret					
830104	Snowy Egret	F	1	0	0
** SUBTOTAL **			1	0	0
* SPECIES: Song Sparrow					
830104	Song Sparrow	R	0	3	0
** SUBTOTAL **			0	3	0

02/18/83

FIELD SIDE

DATE	SPECIES	RF/OF	# SEEN	# CALL	# FLUSH
* SPECIES: Starling					
821108	Starling	R	250	0	0
821108	Starling	R	125	0	0
821108	Starling	F	75	0	0
821117	Starling	R	75	0	0
821117	Starling	F	50	0	0
821128	Starling	R	20	0	0
821128	Starling	F	550	0	0
821208	Starling	R	500	0	0
821208	Starling	F	275	0	0
821208	Starling	F	500	0	0
821208	Starling	F	400	0	0
821218	Starling	R	700	0	0
821218	Starling	F	0	0	0
821218	Starling	F	250	0	0
821218	Starling	F	100	0	0
821218	Starling	F	50	0	0
821228	Starling	F	500	0	0
821228	Starling	F	250	0	0
821228	Starling	F	300	0	0
821228	Starling	F	200	0	0
830104	Starling	F	500	0	0
830104	Starling	F	300	0	0
830104	Starling	F	250	0	0
830104	Starling	F	500	0	0
830113	Starling	R	500	0	0
830113	Starling	R	500	0	0
830113	Starling	F	250	0	0
830113	Starling	F	500	0	0
830123	Starling	F	500	0	0
830123	Starling	F	250	0	0
830123	Starling	F	250	0	0
** SUBTOTAL **			9470	0	0
* SPECIES: Turkey Vulture					
820925	Turkey Vulture	R	2	0	0
820925	Turkey Vulture	F	1	0	0
820925	Turkey Vulture	F	3	0	0
820925	Turkey Vulture	F	1	0	0
821004	Turkey Vulture	F	1	0	0
821004	Turkey Vulture	F	3	0	0
821004	Turkey Vulture	F	2	0	0
821017	Turkey Vulture	F	2	0	0
821017	Turkey Vulture	F	1	0	0
821017	Turkey Vulture	F	4	0	0
821017	Turkey Vulture	F	2	0	0
821017	Turkey Vulture	F	1	0	0

02/18/83

FIELD SIDE

DATE	SPECIES	RF/OF	# SEEN	# CALL	# FLUSH
* SPECIES: Turkey Vulture					
821108	Turkey Vulture	F	2	0	0
821108	Turkey Vulture	F	1	0	0
821117	Turkey Vulture	F	1	0	0
821128	Turkey Vulture	F	1	0	0
821128	Turkey Vulture	F	1	0	0
821208	Turkey Vulture	F	1	0	0
821218	Turkey Vulture	F	1	0	0
821218	Turkey Vulture	F	1	0	0
821228	Turkey Vulture	F	1	0	0
821228	Turkey Vulture	F	3	0	0
830104	Turkey Vulture	F	1	0	0
830113	Turkey Vulture	F	3	0	0
830113	Turkey Vulture	F	3	0	0
830123	Turkey Vulture	F	3	0	0
** SUBTOTAL **			46	0	0
* SPECIES: Water Pipit					
821108	Water Pipit	R	0	0	4
821108	Water Pipit	R	4	0	0
821108	Water Pipit	R	6	0	0
821117	Water Pipit	R	3	0	0
821117	Water Pipit	R	6	0	0
821128	Water Pipit	R	5	0	0
821128	Water Pipit	R	3	0	0
821208	Water Pipit	R	9	0	0
821208	Water Pipit	R	6	0	0
821208	Water Pipit	R	5	0	0
821218	Water Pipit	R	9	0	0
821218	Water Pipit	F	22	0	0
821228	Water Pipit	R	5	0	0
821228	Water Pipit	R	3	0	0
821228	Water Pipit	R	0	0	3
821228	Water Pipit	F	0	11	0
821228	Water Pipit	F	3	0	0
830104	Water Pipit	R	0	6	0
830104	Water Pipit	R	0	0	8
830104	Water Pipit	R	0	0	8
830113	Water Pipit	R	0	0	5
830113	Water Pipit	R	0	0	5
830113	Water Pipit	R	0	0	7
830123	Water Pipit	R	0	0	5
830123	Water Pipit	R	0	0	6
** SUBTOTAL **			89	17	51

* SPECIES: Western Meadowlark

02/18/83

FIELD SIDE

DATE	SPECIES	RF/OF	# SEEN	# CALL	# FLUSH
* SPECIES:	Western Meadowlark				
820805	Western Meadowlark	R	6	3	0
820805	Western Meadowlark	R	9	0	3
820805	Western Meadowlark	R	0	3	0
820805	Western Meadowlark	R	0	2	0
820805	Western Meadowlark	R	0	2	0
820805	Western Meadowlark	R	0	1	0
820805	Western Meadowlark	R	0	3	0
820817	Western Meadowlark	R	0	2	0
820817	Western Meadowlark	R	0	1	0
820817	Western Meadowlark	R	0	2	0
820817	Western Meadowlark	R	0	1	0
820817	Western Meadowlark	R	0	1	0
820831	Western Meadowlark	R	0	1	0
820831	Western Meadowlark	R	0	1	0
820831	Western Meadowlark	R	8	0	0
820909	Western Meadowlark	R	0	3	0
820925	Western Meadowlark	R	0	3	0
820925	Western Meadowlark	R	0	3	0
820925	Western Meadowlark	R	6	0	0
820925	Western Meadowlark	R	0	2	0
820925	Western Meadowlark	R	0	3	0
820925	Western Meadowlark	R	0	6	0
820925	Western Meadowlark	F	3	0	0
820925	Western Meadowlark	F	3	0	0
820925	Western Meadowlark	F	3	0	0
820925	Western Meadowlark	F	1	0	0
820925	Western Meadowlark	F	3	0	0
820925	Western Meadowlark	F	3	0	0
821004	Western Meadowlark	R	2	0	0
821004	Western Meadowlark	R	3	0	0
821004	Western Meadowlark	R	1	0	0
821004	Western Meadowlark	R	0	3	0
821004	Western Meadowlark	R	0	8	0
821004	Western Meadowlark	R	2	0	0
821004	Western Meadowlark	R	0	0	1
821004	Western Meadowlark	R	0	2	0
821004	Western Meadowlark	R	0	1	0
821004	Western Meadowlark	R	3	0	0
821004	Western Meadowlark	R	0	0	2
821004	Western Meadowlark	F	0	0	5
821004	Western Meadowlark	F	1	0	0
821004	Western Meadowlark	F	3	0	0
821004	Western Meadowlark	F	2	0	0
821017	Western Meadowlark	R	7	0	0
821017	Western Meadowlark	R	6	0	0
821017	Western Meadowlark	R	0	6	0
821017	Western Meadowlark	R	2	0	0
821017	Western Meadowlark	R	3	0	0

02/18/83

FIELD SIDE

DATE	SPECIES	RF/OF	# SEEN	# CALL	# FLUSH
* SPECIES:	Western Meadowlark		8	0	0
821017	Western Meadowlark	F	2	0	0
821017	Western Meadowlark	F	4	0	0
821017	Western Meadowlark	F	1	0	0
821017	Western Meadowlark	F	3	0	0
821017	Western Meadowlark	F	6	0	0
821017	Western Meadowlark	F	3	0	0
821017	Western Meadowlark	F	7	0	0
821017	Western Meadowlark	F	4	0	0
821017	Western Meadowlark	F	3	0	0
821017	Western Meadowlark	F	6	0	0
821017	Western Meadowlark	F	6	0	0
821017	Western Meadowlark	F	1	0	0
821017	Western Meadowlark	R	0	0	1
821030	Western Meadowlark	R	7	0	0
821108	Western Meadowlark	R	2	0	0
821108	Western Meadowlark	R	6	0	0
821108	Western Meadowlark	R	0	15	0
821108	Western Meadowlark	F	6	0	0
821108	Western Meadowlark	R	4	0	0
821117	Western Meadowlark	R	0	3	0
821117	Western Meadowlark	R	1	0	0
821117	Western Meadowlark	F	6	0	0
821117	Western Meadowlark	R	0	3	0
821128	Western Meadowlark	R	12	0	0
821128	Western Meadowlark	R	0	5	0
821128	Western Meadowlark	R	9	0	0
821128	Western Meadowlark	F	7	0	0
821128	Western Meadowlark	F	5	0	0
821128	Western Meadowlark	R	0	21	0
821208	Western Meadowlark	R	3	0	0
821208	Western Meadowlark	R	10	0	0
821208	Western Meadowlark	R	3	0	0
821208	Western Meadowlark	R	0	1	0
821208	Western Meadowlark	R	2	0	0
821208	Western Meadowlark	F	18	0	0
821208	Western Meadowlark	F	11	0	0
821208	Western Meadowlark	F	3	0	0
821208	Western Meadowlark	F	6	0	0
821208	Western Meadowlark	R	0	6	0
821218	Western Meadowlark	R	9	0	0
821218	Western Meadowlark	R	3	0	0
821218	Western Meadowlark	R	0	11	0
821218	Western Meadowlark	F	35	0	0
821218	Western Meadowlark	F	28	0	0
821228	Western Meadowlark	R	21	0	0
821228	Western Meadowlark	R	0	3	0
821228	Western Meadowlark	R	0	3	0

02/18/83

FIELD SIDE

DATE	SPECIES	RF/OF	# SEEN	# CALL	# FLUSH
* SPECIES: Western Meadowlark					
821228	Western Meadowlark	R	0	3	0
821228	Western Meadowlark	F	23	0	0
821228	Western Meadowlark	F	0	7	0
830104	Western Meadowlark	R	0	9	0
830104	Western Meadowlark	F	23	0	0
830104	Western Meadowlark	F	36	0	0
830104	Western Meadowlark	F	21	0	0
830104	Western Meadowlark	F	22	0	0
830113	Western Meadowlark	R	0	31	0
830113	Western Meadowlark	R	12	0	0
830113	Western Meadowlark	R	0	3	0
830113	Western Meadowlark	R	0	3	0
830113	Western Meadowlark	F	21	0	0
830123	Western Meadowlark	R	0	0	0
830123	Western Meadowlark	R	0	11	0
830123	Western Meadowlark	R	0	7	0
830123	Western Meadowlark	R	0	5	0
830123	Western Meadowlark	R	0	25	0
** SUBTOTAL **			509	240	12
* SPECIES: White-tailed Kite					
820805	White-tailed Kite	F	2	0	0
820817	White-tailed Kite	F	2	0	0
820817	White-tailed Kite	F	2	0	0
820831	White-tailed Kite	F	2	0	0
820909	White-tailed Kite	F	2	0	0
820909	White-tailed Kite	F	2	0	0
820909	White-tailed Kite	F	1	0	0
820925	White-tailed Kite	R	2	0	0
821004	White-tailed Kite	R	1	0	0
821108	White-tailed Kite	F	1	0	0
821108	White-tailed Kite	F	1	0	0
821128	White-tailed Kite	F	2	0	0
821228	White-tailed Kite	F	1	0	0
830104	White-tailed Kite	F	1	0	0
830113	White-tailed Kite	F	1	0	0
830113	White-tailed Kite	F	1	0	0
830123	White-tailed Kite	F	1	0	0
830123	White-tailed Kite	F	1	0	0
** SUBTOTAL **			26	0	0
* SPECIES: Yellow-rumped Warbler					
820925	Yellow-rumped Warbler	R	9	0	0
821004	Yellow-rumped Warbler	F	7	0	0

FIELD SIDE

DATE	SPECIES	RF/OF	↑ SEEN	↑ CALL	↑ FLIGHT
* SPECIES:	Yellow-rumped Warbler				
821218	Yellow-rumped Warbler	R	0	4	0
821218	Yellow-rumped Warbler	R	0	3	0
821228	Yellow-rumped Warbler	R	0	5	0
821228	Yellow-rumped Warbler	R	0	3	0
830123	Yellow-rumped Warbler	F	5	0	0
** SUBTOTAL **			21	15	0
** TOTAL **			13647	878	381

B-3. GROUND AVIAN TRANSECTS
OVERFLIGHT HEIGHTS.

02/18/83

CULLINAN RANCH BIRD TRANSECTS
OVERFLIGHT HEIGHTS

STAT	SPECIES	DATE	# SEEN	# CALL	# FLUSH	COMP. DIR.
* OVERFLIGHTS FOR HEIGHT CLASS (IN METERS):			5			
3	Northern Harrier	821208	1	0	0	180
** SUBTOTAL **			1	0	0	
* OVERFLIGHTS FOR HEIGHT CLASS (IN METERS):			10			
11	Killdeer	821128	1	0	0	10
** SUBTOTAL **			1	0	0	
* OVERFLIGHTS FOR HEIGHT CLASS (IN METERS):			20			
4	Double-crested Cormorant	821108	1	0	0	300
7	Double-crested Cormorant	821108	1	0	0	30
10	Double-crested Cormorant	821108	3	0	0	180
** SUBTOTAL **			5	0	0	
* OVERFLIGHTS FOR HEIGHT CLASS (IN METERS):			25			
7	Great Blue Heron	820909	1	0	0	225
1	Double-crested Cormorant	821017	1	0	0	100
14	Great Blue Heron	821017	2	0	0	225
3	Western Gull	821108	7	0	0	270
3	Ruddy Duck	821108	7	0	0	115
6	California Gull	821108	3	0	0	240
7	Western Gull	821108	3	0	0	260
8	Pintail	821108	4	0	0	20
9	Green-winged Teal	821108	5	0	0	30
16	Long-billed Curlew	821108	3	0	0	250
19	Double-crested Cormorant	821108	1	0	0	200
20	Ring-billed Gull	821108	7	0	0	10
4	Double-crested Cormorant	821117	2	0	0	130
8	Ring-billed Gull	821128	9	0	0	210
6	Snowy Egret	821208	1	0	0	180
10	Common Crow	821218	0	3	0	200
15	Great Egret	821218	1	0	0	240
20	Raven	821218	0	2	0	180
13	Long-billed Curlew	821228	0	13	0	260
7	Snowy Egret	830104	1	0	0	180
13	Great Egret	830104	1	0	0	180
19	Snowy Egret	830113	1	0	0	260
** SUBTOTAL **			60	18	0	
* OVERFLIGHTS FOR HEIGHT CLASS (IN METERS):			50			

02/18/83

CULLINAN RANCH BIRD TRANSECTS
OVERFLIGHT HEIGHTS

STAT	SPECIES	DATE	# SEEN	# CALL	# FLUSH	COMP. DIR.
* OVERFLIGHTS FOR HEIGHT CLASS (IN METERS):			50			
1	Double-crested Cormorant	820805	7	0	0	0
6	Double-crested Cormorant	820805	14	0	0	0
10	Double-crested Cormorant	820805	7	0	0	0
2	Double-crested Cormorant	820817	5	0	0	0
4	Double-crested Cormorant	820817	7	0	0	0
19	Double-crested Cormorant	820817	5	0	0	0
2	Double-crested Cormorant	820831	7	0	0	0
14	Double-crested Cormorant	820831	11	0	0	0
11	Double-crested Cormorant	820909	6	0	0	225
13	Great Blue Heron	820909	1	0	0	225
16	Double-crested Cormorant	820909	4	0	0	210
20	Gull sp.	820909	19	0	0	210
6	Great Egret	820925	1	0	0	300
8	Long-billed Curlew	820925	22	0	0	225
18	Great Egret	820925	1	0	0	200
1	Double-crested Cormorant	821004	1	0	0	300
4	Pintail	821004	11	0	0	225
7	Green-winged Teal	821004	7	0	0	225
9	Double-crested Cormorant	821004	1	0	0	225
9	Great Egret	821004	1	0	0	225
9	Pintail	821004	9	0	0	225
12	Red-tailed Hawk	821004	1	0	0	225
1	Double-crested Cormorant	821017	1	0	0	100
2	Pintail	821017	8	0	0	100
3	White Pelican	821017	18	0	0	100
3	Great Egret	821017	1	0	0	330
3	Double-crested Cormorant	821017	1	0	0	225
4	Herring Gull	821017	9	0	0	110
5	Snowy Egret	821017	1	0	0	290
6	Snowy Egret	821017	1	0	0	290
6	White Pelican	821017	28	0	0	100
6	Gull sp.	821017	6	0	0	100
7	White Pelican	821017	21	0	0	100
9	White Pelican	821017	13	0	0	100
10	Double-crested Cormorant	821017	1	0	0	225
12	White Pelican	821017	3	0	0	100
13	White Pelican	821017	2	0	0	45
14	Great Egret	821017	1	0	0	225
3	Pintail	821108	5	0	0	50
3	White Pelican	821108	11	0	0	90
5	Marbled Godwit	821108	21	0	0	310
5	California Gull	821108	9	0	0	40
13	California Gull	821108	8	0	0	10
15	Ring-billed Gull	821108	1	0	0	25
2	White Pelican	821117	3	0	0	90
2	California Gull	821117	6	0	0	110
11	Common Crow	821117	4	0	0	160

02/18/83

CULLINAN RANCH BIRD TRANSECTS
OVERFLIGHT HEIGHTS

STAT	SPECIES	DATE	# SEEN	# CALL	# FLUSH	COMP. DIR.
* OVERFLIGHTS FOR HEIGHT CLASS (IN METERS):			50			
11	Double-crested Cormorant	821117	3	0	0	25
14	Western Gull	821117	2	0	0	10
15	Great Egret	821117	1	0	0	240
16	Double-crested Cormorant	821117	4	0	0	10
17	California Gull	821117	3	0	0	40
19	Pintail	821117	6	0	0	175
1	Pintail	821128	9	0	0	10
3	Mallard	821128	3	0	0	10
5	Raven	821128	1	0	0	240
6	Double-crested Cormorant	821128	1	0	0	20
12	California Gull	821128	1	0	0	10
16	Common Crow	821128	3	0	0	200
20	Ring-billed Gull	821128	15	0	0	360
2	Great Egret	821208	1	0	0	40
2	Great Egret	821208	1	0	0	40
5	Ring-billed Gull	821208	9	0	0	220
7	Common Crow	821208	3	0	0	200
19	Pintail	821208	7	0	0	20
8	Ring-billed Gull	821218	16	0	0	60
11	Snowy Egret	821228	1	0	0	245
18	Double-crested Cormorant	821228	3	0	0	210
12	Double-crested Cormorant	830104	1	0	0	10
18	Long-billed Curlew	830104	0	21	0	15
6	Common Crow	830123	0	2	0	200
** SUBTOTAL **			425	23	0	

* OVERFLIGHTS FOR HEIGHT CLASS (IN METERS):			75			
3	Double-crested Cormorant	820805	11	0	0	0
2	White Pelican	820817	33	0	0	0
6	Double-crested Cormorant	820817	5	0	0	0
13	Double-crested Cormorant	820817	6	0	0	0
4	White Pelican	820831	69	0	0	0
5	Double-crested Cormorant	820831	12	0	0	0
12	White Pelican	820831	18	0	0	0
3	White Pelican	820909	36	0	0	135
5	Double-crested Cormorant	820909	5	0	0	225
9	Double-crested Cormorant	820909	8	0	0	250
9	Duck sp.	820909	3	0	0	135
11	Gull sp.	820909	14	0	0	45
19	Double-crested Cormorant	820909	11	0	0	210
1	Double-crested Cormorant	820925	6	0	0	225
3	Great Egret	820925	1	0	0	300
9	Gull sp.	820925	11	0	0	60
12	Green-winged Teal	820925	8	0	0	45
12	Double-crested Cormorant	820925	1	0	0	225

02/18/83

CULLINAN RANCH BIRD TRANSECTS
OVERFLIGHT HEIGHTS

STAT	SPECIES	DATE	# SEEN	# CALL	# FLUSH	COMP. DIR.
* OVERFLIGHTS FOR HEIGHT CLASS (IN METERS):			75			
12	White Pelican	820925	53	0	0	120
15	Long-billed Curlew	820925	21	0	0	240
16	Double-crested Cormorant	820925	3	0	0	200
20	Gull sp.	820925	6	0	0	200
1	California Gull	821004	8	0	0	120
1	White Pelican	821004	29	0	0	120
1	Great Egret	821004	1	0	0	300
3	Gull sp.	821004	13	0	0	120
3	Red-tailed Hawk	821004	2	0	0	225
6	Gull sp.	821004	14	0	0	225
6	Double-crested Cormorant	821004	9	0	0	225
7	White Pelican	821004	39	0	0	120
7	Double-crested Cormorant	821004	4	0	0	225
9	White Pelican	821004	49	0	0	120
14	Double-crested Cormorant	821004	1	0	0	225
14	Great Egret	821004	1	0	0	225
15	Double-crested Cormorant	821004	2	0	0	225
18	Long-billed Curlew	821004	12	0	0	225
18	Double-crested Cormorant	821004	1	0	0	225
20	Double-crested Cormorant	821004	3	0	0	225
1	Herring Gull	821017	2	0	0	100
1	Long-billed Curlew	821017	28	0	0	100
2	Herring Gull	821017	3	0	0	100
7	Herring Gull	821017	6	0	0	45
8	White Pelican	821017	6	0	0	100
13	Gull sp.	821017	6	0	0	45
14	Long-billed Curlew	821017	13	0	0	225
16	Double-crested Cormorant	821017	3	0	0	225
18	Herring Gull	821017	1	0	0	225
1	Gull sp.	821030	3	0	0	45
3	Gull sp.	821030	10	0	0	210
15	Marbled Godwit	821117	13	0	0	220
16	Double-crested Cormorant	821117	8	0	0	25
18	Long-billed Curlew	821117	5	0	0	190
2	Black-bellied Plover	821128	75	0	0	240
8	Pintail	821128	3	0	0	150
8	Western Gull	821128	11	0	0	200
16	Double-crested Cormorant	821128	1	0	0	360
1	Sandpiper spp.	821208	75	0	0	200
2	Ring-billed Gull	821208	11	0	0	30
2	Double-crested Cormorant	821208	3	0	0	210
3	Glaucous-winged Gull	821208	2	0	0	200
3	Double-crested Cormorant	821208	1	0	0	40
4	California Gull	821208	7	0	0	210
4	Mallard	821208	3	0	0	210
5	Marbled Godwit	821208	28	0	0	220
6	Double-crested Cormorant	821208	3	0	0	350

02/18/83

CULLINAN RANCH BIRD TRANSECTS
OVERFLIGHT HEIGHTS

STAT	SPECIES	DATE	# SEEN	# CALL	# FLUSH	COMP. DIR.
* OVERFLIGHTS FOR HEIGHT CLASS (IN METERS):			75			
6	Long-billed Curlew	821208	1	0	0	360
7	California Gull	821208	5	0	0	200
7	Pintail	821208	5	0	0	40
7	Western Gull	821208	2	0	0	20
8	American Wigeon	821208	9	0	0	10
9	Marbled Godwit	821208	32	0	0	200
10	Pintail	821208	3	0	0	30
12	California Gull	821208	6	0	0	10
14	Glaucous-winged Gull	821208	2	0	0	20
16	California Gull	821208	3	0	0	20
18	Double-crested Cormorant	821208	3	0	0	360
19	Pintail	821208	4	0	0	10
2	California Gull	821218	8	0	0	50
2	Ring-billed Gull	821218	11	0	0	10
3	Pintail	821218	3	0	0	50
6	Marbled Godwit	821218	18	0	0	200
7	White Pelican	821218	3	0	0	50
10	Long-billed Curlew	821218	0	12	0	200
17	California Gull	821218	9	0	0	60
1	Ring-billed Gull	821228	5	0	0	50
4	Double-crested Cormorant	821228	1	0	0	200
4	Crow	821228	2	0	0	170
9	Pintail	821228	3	0	0	65
20	Ring-billed Gull	821228	8	0	0	25
1	Great Egret	830104	1	0	0	55
3	Pintail	830104	3	0	0	30
6	Marbled Godwit	830104	18	0	0	200
12	Pintail	830104	3	0	0	15
18	Mallard	830104	0	2	0	25
22	California Gull	830104	10	0	0	0
22	Ring-billed Gull	830104	15	0	0	0
3	California Gull	830113	8	0	0	30
4	Ring-billed Gull	830113	3	0	0	30
4	Pintail	830113	3	0	0	45
10	Common Crow	830113	0	2	0	160
16	Common Crow	830113	0	2	0	125
3	Long-billed Curlew	830123	0	1	0	275
9	Ring-billed Gull	830123	2	0	0	180
15	Double-crested Cormorant	830123	1	0	0	360
** SUBTOTAL **			1072	19	0	
* OVERFLIGHTS FOR HEIGHT CLASS (IN METERS):			85			
8	Mallard	821208	3	0	0	15
** SUBTOTAL **			3	0	0	
* OVERFLIGHTS FOR HEIGHT CLASS (IN METERS):			100			

02/18/83

CULLINAN RANCH BIRD TRANSECTS
OVERFLIGHT HEIGHTS

STAT	SPECIES	DATE	# SEEN	# CALL	# FLUSH	COMP. DIR.
* OVERFLIGHTS FOR HEIGHT CLASS (IN METERS):			100			
1	White Pelican	820805	28	0	0	0
8	Double-crested Cormorant	820805	9	0	0	0
15	Double-crested Cormorant	820805	8	0	0	0
18	Double-crested Cormorant	820805	12	0	0	0
20	Double-crested Cormorant	820805	7	0	0	0
1	White Pelican	820817	48	0	0	0
8	Double-crested Cormorant	820817	8	0	0	0
13	White Pelican	820817	68	0	0	0
10	Double-crested Cormorant	820831	1	0	0	0
1	White Pelican	820909	68	0	0	135
2	Double-crested Cormorant	820925	1	0	0	225
3	Herring Gull	820925	13	0	0	120
4	White Pelican	820925	48	0	0	120
6	White Pelican	820925	21	0	0	120
9	Double-crested Cormorant	820925	1	0	0	225
11	Double-crested Cormorant	820925	9	0	0	225
12	Gull sp.	820925	17	0	0	225
16	White Pelican	820925	58	0	0	90
17	Snowy Egret	820925	1	0	0	200
17	American Avocet	820925	11	0	0	200
18	Double-crested Cormorant	820925	1	0	0	200
20	Double-crested Cormorant	820925	7	0	0	200
2	Double-crested Cormorant	821004	3	0	0	225
3	Long-billed Curlew	821004	19	0	0	225
7	Long-billed Curlew	821004	16	0	0	45
9	Red-tailed Hawk	821004	1	0	0	225
11	Double-crested Cormorant	821004	6	0	0	225
12	Pintail	821004	8	0	0	225
12	Snowy Egret	821004	1	0	0	225
12	White Pelican	821004	66	0	0	135
13	Long-billed Curlew	821004	22	0	0	135
19	Turkey Vulture	821004	7	0	0	225
19	Long-billed Curlew	821004	21	0	0	225
15	Green-winged Teal	821017	8	0	0	180
18	Double-crested Cormorant	821017	1	0	0	225
20	Double-crested Cormorant	821017	1	0	0	225
20	Double-crested Cormorant	821017	3	0	0	225
1	Long-billed Curlew	821030	0	10	0	200
1	Double-crested Cormorant	821108	3	0	0	240
8	Marbled Godwit	821117	1	0	0	10
6	Mallard	821128	6	0	0	10
8	Double-crested Cormorant	821128	3	0	0	25
11	Pintail	821128	3	0	0	20
12	Great Blue Heron	821128	1	0	0	10
17	Black-bellied Plover	821128	50	0	0	220
17	Marbled Godwit	821128	21	0	0	220
20	Double-crested Cormorant	821128	7	0	0	15

02/18/83

CULLINAN RANCH BIRD TRANSECTS
OVERFLIGHT HEIGHTS

STAT	SPECIES	DATE	# SEEN	# CALL	# FLUSH	COMP. DIR.
* OVERFLIGHTS FOR HEIGHT CLASS (IN METERS):			100			
3	California Gull	821208	15	0	0	215
4	Pintail	821208	7	0	0	200
5	Black-bellied Plover	821208	40	0	0	20
8	Pintail	821208	3	0	0	20
8	Glaucous-winged Gull	821208	2	0	0	360
9	Black-bellied Plover	821208	25	0	0	200
10	Red-tailed Hawk	821208	1	0	0	180
12	Ring-billed Gull	821208	11	0	0	10
13	Double-crested Cormorant	821208	1	0	0	200
14	Long-billed Curlew	821208	1	0	0	200
2	Double-crested Cormorant	821218	3	0	0	40
4	Double-crested Cormorant	821218	14	0	0	10
5	Ring-billed Gull	821218	23	0	0	25
10	Double-crested Cormorant	821218	5	0	0	10
14	Double-crested Cormorant	821218	1	0	0	45
16	California Gull	821218	24	0	0	50
18	Ring-billed Gull	821218	2	0	0	10
20	Double-crested Cormorant	821218	5	0	0	25
1	Pintail	821228	0	9	0	0
9	California Gull	821228	11	0	0	35
9	Marbled Godwit	821228	18	0	0	50
10	Ring-billed Gull	821228	0	3	0	220
13	California Gull	821228	5	0	0	50
18	California Gull	821228	1	0	0	30
1	California Gull	830104	0	5	0	40
3	Double-crested Cormorant	830104	0	7	0	35
6	Ring-billed Gull	830104	21	0	0	50
6	Black-bellied Plover	830104	35	0	0	220
19	Double-crested Cormorant	830104	3	0	0	40
29	Double-crested Cormorant	830104	1	0	0	0
4	Double-crested Cormorant	830113	1	0	0	25
13	Pintail	830113	0	3	0	20
14	Ring-billed Gull	830113	6	0	0	270
14	Mallard	830113	0	2	0	360
15	Sandpiper spp.	830113	50	0	0	250
20	Great Blue Heron	830113	1	0	0	245
23	Ring-billed Gull	830113	8	0	0	280
3	California Gull	830123	3	0	0	200
4	Ring-billed Gull	830123	5	0	0	200
8	Pintail	830123	3	0	0	270
8	Mallard	830123	2	0	0	285
10	Long-billed Curlew	830123	1	0	0	280
15	Pintail	830123	0	3	0	180
17	Mallard	830123	0	2	0	190
19	Double-crested Cormorant	830123	1	0	0	180
20	Black-bellied Plover	830123	25	0	0	210
20	Ring-billed Gull	830123	1	0	0	220

02/18/83

CULLINAN RANCH BIRD TRANSECTS
OVERFLIGHT HEIGHTS

STAT	SPECIES	DATE	# SEEN	# CALL	# FLUSH	COMP. DIR.
* OVERFLIGHTS FOR HEIGHT CLASS (IN METERS):				100		
28	Ring-billed Gull	830123	7	0	0	360
** SUBTOTAL **			1115	44	0	
* OVERFLIGHTS FOR HEIGHT CLASS (IN METERS):				110		
13	Long-billed Curlew	821017	23	0	0	45
** SUBTOTAL **			23	0	0	
** TOTAL **			2705	104	0	

B-4. GROUND AVIAN TRANSECTS.
OVERFLIGHT DATA FOR
SELECTED SPECIES.

02/18/83

CULLINAN RANCH BIRD TRANSECTS
OVERFLIGHT HEIGHTS

STAT	SPECIES	DATE	# SEEN	# CALL	# FLUSH	COMP. DIR.
* OVERFLIGHTS FOR HEIGHT CLASS (IN METERS):			20			
4	Double-crested Cormorant	821108	1	0	0	300
7	Double-crested Cormorant	821108	1	0	0	30
10	Double-crested Cormorant	821108	3	0	0	180
** SUBTOTAL **			5	0	0	
* OVERFLIGHTS FOR HEIGHT CLASS (IN METERS):			25			
1	Double-crested Cormorant	821017	1	0	0	100
19	Double-crested Cormorant	821108	1	0	0	200
4	Double-crested Cormorant	821117	2	0	0	130
** SUBTOTAL **			4	0	0	
* OVERFLIGHTS FOR HEIGHT CLASS (IN METERS):			50			
1	Double-crested Cormorant	820805	7	0	0	0
6	Double-crested Cormorant	820805	14	0	0	0
10	Double-crested Cormorant	820805	7	0	0	0
2	Double-crested Cormorant	820817	5	0	0	0
4	Double-crested Cormorant	820817	7	0	0	0
19	Double-crested Cormorant	820817	5	0	0	0
2	Double-crested Cormorant	820831	7	0	0	0
14	Double-crested Cormorant	820831	11	0	0	0
11	Double-crested Cormorant	820909	6	0	0	225
16	Double-crested Cormorant	820909	4	0	0	210
1	Double-crested Cormorant	821004	1	0	0	300
9	Double-crested Cormorant	821004	1	0	0	225
1	Double-crested Cormorant	821017	1	0	0	100
3	Double-crested Cormorant	821017	1	0	0	225
10	Double-crested Cormorant	821017	1	0	0	225
11	Double-crested Cormorant	821117	3	0	0	25
16	Double-crested Cormorant	821117	4	0	0	10
6	Double-crested Cormorant	821128	1	0	0	20
18	Double-crested Cormorant	821228	3	0	0	210
12	Double-crested Cormorant	830104	1	0	0	10
** SUBTOTAL **			90	0	0	
* OVERFLIGHTS FOR HEIGHT CLASS (IN METERS):			75			
3	Double-crested Cormorant	820805	11	0	0	0
6	Double-crested Cormorant	820817	5	0	0	0
13	Double-crested Cormorant	820817	6	0	0	0
5	Double-crested Cormorant	820831	12	0	0	0
5	Double-crested Cormorant	820909	5	0	0	225
9	Double-crested Cormorant	820909	8	0	0	250

02/18/83

CULLINAN RANCH BIRD TRANSECTS
OVERFLIGHT HEIGHTS

STAT	SPECIES	DATE	# SEEN	# CALL	# FLUSH	COMP. DIR.
* OVERFLIGHTS FOR HEIGHT CLASS (IN METERS):			75			
19	Double-crested Cormorant	820909	11	0	0	210
1	Double-crested Cormorant	820925	6	0	0	225
12	Double-crested Cormorant	820925	1	0	0	225
16	Double-crested Cormorant	820925	3	0	0	200
6	Double-crested Cormorant	821004	9	0	0	225
7	Double-crested Cormorant	821004	4	0	0	225
14	Double-crested Cormorant	821004	1	0	0	225
15	Double-crested Cormorant	821004	2	0	0	225
18	Double-crested Cormorant	821004	1	0	0	225
20	Double-crested Cormorant	821004	3	0	0	225
16	Double-crested Cormorant	821017	3	0	0	225
16	Double-crested Cormorant	821117	8	0	0	25
16	Double-crested Cormorant	821128	1	0	0	360
2	Double-crested Cormorant	821208	3	0	0	210
3	Double-crested Cormorant	821208	1	0	0	40
6	Double-crested Cormorant	821208	3	0	0	350
18	Double-crested Cormorant	821208	3	0	0	360
4	Double-crested Cormorant	821228	1	0	0	200
15	Double-crested Cormorant	830123	1	0	0	360
** SUBTOTAL **			112	0	0	
* OVERFLIGHTS FOR HEIGHT CLASS (IN METERS):			85			
** SUBTOTAL **			0	0	0	
* OVERFLIGHTS FOR HEIGHT CLASS (IN METERS):			100			
8	Double-crested Cormorant	820805	9	0	0	0
15	Double-crested Cormorant	820805	8	0	0	0
18	Double-crested Cormorant	820805	12	0	0	0
20	Double-crested Cormorant	820805	7	0	0	0
8	Double-crested Cormorant	820817	8	0	0	0
10	Double-crested Cormorant	820831	1	0	0	0
2	Double-crested Cormorant	820925	1	0	0	225
9	Double-crested Cormorant	820925	1	0	0	225
11	Double-crested Cormorant	820925	9	0	0	225
18	Double-crested Cormorant	820925	1	0	0	200
20	Double-crested Cormorant	820925	7	0	0	200
2	Double-crested Cormorant	821004	3	0	0	225
11	Double-crested Cormorant	821004	6	0	0	225
18	Double-crested Cormorant	821017	1	0	0	225
20	Double-crested Cormorant	821017	1	0	0	225
20	Double-crested Cormorant	821017	3	0	0	225
1	Double-crested Cormorant	821108	3	0	0	240
8	Double-crested Cormorant	821128	3	0	0	25

02/18/83

CULLINAN RANCH BIRD TRANSECTS
OVERFLIGHT HEIGHTS

STAT	SPECIES	DATE	# SEEN	# CALL	# PLUSH	COMP. DIR.
* OVERFLIGHTS FOR HEIGHT CLASS (IN METERS):			100			
20	Double-crested Cormorant	821128	7	0	0	15
13	Double-crested Cormorant	821208	1	0	0	200
2	Double-crested Cormorant	821218	3	0	0	40
4	Double-crested Cormorant	821218	14	0	0	10
10	Double-crested Cormorant	821218	5	0	0	10
14	Double-crested Cormorant	821218	1	0	0	45
20	Double-crested Cormorant	821218	5	0	0	25
3	Double-crested Cormorant	830104	0	7	0	35
19	Double-crested Cormorant	830104	3	0	0	40
29	Double-crested Cormorant	830104	1	0	0	0
4	Double-crested Cormorant	830113	1	0	0	25
19	Double-crested Cormorant	830123	1	0	0	180
** SUBTOTAL **			126	7	0	
* OVERFLIGHTS FOR HEIGHT CLASS (IN METERS):			110			
** SUBTOTAL **			0	0	0	
** TOTAL **			337	7	0	

02/18/83

CULLINAN RANCH BIRD TRANSECTS
OVERFLIGHT HEIGHTS

STAT	SPECIES	DATE	# SEEN	# CALL	# FLUSH	COMP. DIR.
* OVERFLIGHTS FOR HEIGHT CLASS (IN METERS):			50			
3	White Pelican	821017	18	0	0	100
6	White Pelican	821017	28	0	0	100
7	White Pelican	821017	21	0	0	100
9	White Pelican	821017	13	0	0	100
12	White Pelican	821017	3	0	0	100
13	White Pelican	821017	2	0	0	45
3	White Pelican	821108	11	0	0	90
2	White Pelican	821117	3	0	0	90
** SUBTOTAL **			99	0	0	
* OVERFLIGHTS FOR HEIGHT CLASS (IN METERS):			75			
2	White Pelican	820817	33	0	0	0
4	White Pelican	820831	69	0	0	0
12	White Pelican	820831	18	0	0	0
3	White Pelican	820909	36	0	0	135
12	White Pelican	820925	53	0	0	120
1	White Pelican	821004	29	0	0	120
7	White Pelican	821004	39	0	0	120
9	White Pelican	821004	49	0	0	120
8	White Pelican	821017	6	0	0	100
7	White Pelican	821218	3	0	0	50
** SUBTOTAL **			315	0	0	
* OVERFLIGHTS FOR HEIGHT CLASS (IN METERS):			85			
** SUBTOTAL **			0	0	0	
* OVERFLIGHTS FOR HEIGHT CLASS (IN METERS):			100			
1	White Pelican	820805	28	0	0	0
1	White Pelican	820817	48	0	0	0
13	White Pelican	820817	68	0	0	0
1	White Pelican	820909	68	0	0	135
4	White Pelican	820925	48	0	0	120
6	White Pelican	820925	21	0	0	120
16	White Pelican	820925	58	0	0	90
12	White Pelican	821004	66	0	0	135
** SUBTOTAL **			405	0	0	
* OVERFLIGHTS FOR HEIGHT CLASS (IN METERS):			110			
** SUBTOTAL **			0	0	0	
** TOTAL **						

02/18/83

CULLINAN RANCH BIRD TRANSECTS
OVERFLIGHT HEIGHTS

STAT	SPECIES	DATE	# SEEN	# CALL	# FLUSH	COMP. DIR.
* OVERFLIGHTS FOR HEIGHT CLASS (IN METERS):			75			
2	Black-bellied Plover	821128	75	0	0	240
** SUBTOTAL **			75	0	0	
* OVERFLIGHTS FOR HEIGHT CLASS (IN METERS):			85			
** SUBTOTAL **			0	0	0	
* OVERFLIGHTS FOR HEIGHT CLASS (IN METERS):			100			
17	Black-bellied Plover	821128	50	0	0	220
5	Black-bellied Plover	821208	40	0	0	20
9	Black-bellied Plover	821208	25	0	0	200
6	Black-bellied Plover	830104	35	0	0	220
20	Black-bellied Plover	830123	25	0	0	210
** SUBTOTAL **			175	0	0	
* OVERFLIGHTS FOR HEIGHT CLASS (IN METERS):			110			
** SUBTOTAL **			0	0	0	
** TOTAL **			250	0	0	

02/18/83

CULLINAN RANCH BIRD TRANSECTS
OVERFLIGHT HEIGHTS

STAT	SPECIES	DATE	# SEEN	# CALL	# FLUSH	COMP. DIR.
* OVERFLIGHTS FOR HEIGHT CLASS (IN METERS):			25			
8	Pintail	821108	4	0	0	20
** SUBTOTAL **			4	0	0	
* OVERFLIGHTS FOR HEIGHT CLASS (IN METERS):			50			
4	Pintail	821004	11	0	0	225
9	Pintail	821004	9	0	0	225
2	Pintail	821017	8	0	0	100
3	Pintail	821108	5	0	0	50
19	Pintail	821117	6	0	0	175
1	Pintail	821128	9	0	0	10
19	Pintail	821208	7	0	0	20
** SUBTOTAL **			55	0	0	
* OVERFLIGHTS FOR HEIGHT CLASS (IN METERS):			75			
8	Pintail	821128	3	0	0	150
7	Pintail	821208	5	0	0	40
10	Pintail	821208	3	0	0	30
19	Pintail	821208	4	0	0	10
3	Pintail	821218	3	0	0	50
9	Pintail	821228	3	0	0	45
3	Pintail	830104	3	0	0	30
12	Pintail	830104	3	0	0	15
4	Pintail	830113	3	0	0	45
** SUBTOTAL **			30	0	0	
* OVERFLIGHTS FOR HEIGHT CLASS (IN METERS):			85			
** SUBTOTAL **			0	0	0	
* OVERFLIGHTS FOR HEIGHT CLASS (IN METERS):			100			
12	Pintail	821004	8	0	0	240
11	Pintail	821128	3	0	0	90
4	Pintail	821208	7	0	0	280
8	Pintail	821208	3	0	0	80
1	Pintail	821228	0	9	0	0
13	Pintail	830113	0	3	0	30
8	Pintail	830123	3	0	0	120
15	Pintail	830123	0	3	0	180
** SUBTOTAL **			24	15	0	
* OVERFLIGHTS FOR HEIGHT CLASS (IN METERS):			110			

02/18/83

CULLINAN RANCH BIRD TRANSECTS
OVERFLIGHT HEIGHTS

STAT	SPECIES	DATE	# SEEN	# CALL	# FLUSH	COMP. DIR.
* OVERFLIGHTS FOR HEIGHT CLASS (IN METERS):			25			
16	Long-billed Curlew	821108	3	0	0	250
13	Long-billed Curlew	821228	0	13	0	260
** SUBTOTAL **			3	13	0	
* OVERFLIGHTS FOR HEIGHT CLASS (IN METERS):			50			
8	Long-billed Curlew	820925	22	0	0	225
18	Long-billed Curlew	830104	0	21	0	15
** SUBTOTAL **			22	21	0	
* OVERFLIGHTS FOR HEIGHT CLASS (IN METERS):			75			
15	Long-billed Curlew	820925	21	0	0	240
18	Long-billed Curlew	821004	12	0	0	225
1	Long-billed Curlew	821017	28	0	0	100
14	Long-billed Curlew	821017	13	0	0	225
18	Long-billed Curlew	821117	5	0	0	190
6	Long-billed Curlew	821208	1	0	0	360
10	Long-billed Curlew	821218	0	12	0	200
3	Long-billed Curlew	830123	0	1	0	275
** SUBTOTAL **			80	13	0	
* OVERFLIGHTS FOR HEIGHT CLASS (IN METERS):			85			
** SUBTOTAL **			0	0	0	
* OVERFLIGHTS FOR HEIGHT CLASS (IN METERS):			100			
3	Long-billed Curlew	821004	19	0	0	225
7	Long-billed Curlew	821004	16	0	0	45
13	Long-billed Curlew	821004	22	0	0	135
19	Long-billed Curlew	821004	21	0	0	225
1	Long-billed Curlew	821030	0	10	0	200
14	Long-billed Curlew	821208	1	0	0	200
10	Long-billed Curlew	830123	1	0	0	280
** SUBTOTAL **			80	10	0	
* OVERFLIGHTS FOR HEIGHT CLASS (IN METERS):			110			
13	Long-billed Curlew	821017	23	0	0	45
** SUBTOTAL **			23	0	0	
** TOTAL **			208	57	0	

B-5. GROUND AVIAN TRANSECTS.
COMPASS DIRECTION OF
OVERFLIGHT BY STATION.

02/18/83

COMPASS DIRECTION OF OVERFLIGHTS

DATE	SPECIES	# SEEN	# CALL	# FLUSH	COMP. DIR.
* STATION # 1					
820805	Double-crested Cormorant	7	0	0	0
820805	White Pelican	28	0	0	0
820817	White Pelican	48	0	0	0
821228	Pintail	0	9	0	0
821128	Pintail	9	0	0	10
830104	California Gull	0	5	0	40
821030	Gull sp.	3	0	0	45
821228	Ring-billed Gull	5	0	0	50
830104	Great Egret	1	0	0	55
821017	Double-crested Cormorant	1	0	0	100
821017	Herring Gull	2	0	0	100
821017	Double-crested Cormorant	1	0	0	100
821017	Long-billed Curlew	28	0	0	100
821004	California Gull	8	0	0	120
821004	White Pelican	29	0	0	120
820909	White Pelican	68	0	0	135
821030	Long-billed Curlew	0	10	0	200
821208	Sandpiper spp.	75	0	0	200
820925	Double-crested Cormorant	6	0	0	225
821108	Double-crested Cormorant	3	0	0	240
821004	Double-crested Cormorant	1	0	0	300
821004	Great Egret	1	0	0	300
** SUBTOTAL **		324	24	0	

* STATION # 2					
820817	Double-crested Cormorant	5	0	0	0
820817	White Pelican	33	0	0	0
820831	Double-crested Cormorant	7	0	0	0
821218	Ring-billed Gull	11	0	0	10
821208	Ring-billed Gull	11	0	0	20
821208	Great Egret	1	0	0	40
821208	Great Egret	1	0	0	60
821218	Double-crested Cormorant	3	0	0	40
821218	California Gull	8	0	0	50
821117	White Pelican	3	0	0	60
821017	Pintail	8	0	0	100
821017	Herring Gull	3	0	0	100
821117	California Gull	6	0	0	110
821208	Double-crested Cormorant	3	0	0	110
820925	Double-crested Cormorant	1	0	0	110
821004	Double-crested Cormorant	3	0	0	110
821128	Black-bellied Plover	75	0	0	240
** SUBTOTAL **		182	0	0	

* STATION # 3

02/18/83

COMPASS DIRECTION OF OVERFLIGHTS

DATE	SPECIES	# SEEN	# CALL	# FLUSH	COMP. DIR.
* STATION # 3					
820805	Double-crested Cormorant	11	0	0	0
821128	Mallard	3	0	0	10
830104	Pintail	3	0	0	30
830113	California Gull	8	0	0	30
830104	Double-crested Cormorant	0	7	0	35
821208	Double-crested Cormorant	1	0	0	40
821108	Pintail	5	0	0	50
821218	Pintail	3	0	0	50
821108	White Pelican	11	0	0	90
821017	White Pelican	18	0	0	100
821108	Ruddy Duck	7	0	0	115
820925	Herring Gull	13	0	0	120
821004	Gull sp.	13	0	0	120
820909	White Pelican	36	0	0	135
821208	Northern Harrier	1	0	0	180
821208	Glaucous-winged Gull	2	0	0	200
830123	California Gull	3	0	0	200
821030	Gull sp.	10	0	0	210
821208	California Gull	15	0	0	215
821004	Red-tailed Hawk	2	0	0	225
821004	Long-billed Curlew	19	0	0	225
821017	Double-crested Cormorant	1	0	0	225
821108	Western Gull	7	0	0	270
830123	Long-billed Curlew	0	1	0	275
820925	Great Egret	1	0	0	300
821017	Great Egret	1	0	0	330
** SUBTOTAL **		194	8	0	***
* STATION # 4					
820817	Double-crested Cormorant	7	0	0	0
820831	White Pelican	69	0	0	0
821218	Double-crested Cormorant	14	0	0	0
830113	Double-crested Cormorant	1	0	0	0
830113	Ring-billed Gull	3	0	0	0
830113	Pintail	3	0	0	0
821017	Herring Gull	9	0	0	0
820925	White Pelican	48	0	0	0
821117	Double-crested Cormorant	2	0	0	0
821228	Crow	2	0	0	0
821208	Pintail	7	0	0	0
821228	Double-crested Cormorant	1	0	0	0
830123	Ring-billed Gull	5	0	0	0
821208	California Gull	7	0	0	0
821208	Mallard	3	0	0	0
821004	Pintail	11	0	0	0
821108	Double-crested Cormorant	1	0	0	0
** SUBTOTAL **		193	0	0	0
* STATION # 5					

02/18/83

COMPASS DIRECTION OF OVERFLIGHTS

DATE	SPECIES	# SEEN	# CALL	# FLUSH	COMP. DIR.
* STATION # 5					
820831	Double-crested Cormorant	12	0	0	0
821208	Black-bellied Plover	40	0	0	20
821218	Ring-billed Gull	23	0	0	25
821108	California Gull	9	0	0	40
821208	Ring-billed Gull	9	0	0	220
821208	Marbled Godwit	28	0	0	220
820909	Double-crested Cormorant	5	0	0	225
821128	Raven	1	0	0	240
821017	Snowy Egret	1	0	0	290
821108	Marbled Godwit	21	0	0	310
** SUBTOTAL **		149	0	0	
* STATION # 6					
820805	Double-crested Cormorant	14	0	0	0
820817	Double-crested Cormorant	5	0	0	0
821128	Mallard	6	0	0	10
821128	Double-crested Cormorant	1	0	0	20
830104	Ring-billed Gull	21	0	0	50
821017	White Pelican	28	0	0	100
821017	Gull sp.	6	0	0	100
820925	White Pelican	21	0	0	120
821208	Snowy Egret	1	0	0	180
821218	Marbled Godwit	18	0	0	200
830104	Marbled Godwit	18	0	0	200
830123	Common Crow	0	2	0	200
830104	Black-bellied Plover	35	0	0	220
821004	Gull sp.	14	0	0	225
821004	Double-crested Cormorant	9	0	0	225
821108	California Gull	3	0	0	240
821017	Snowy Egret	1	0	0	290
820925	Great Egret	1	0	0	300
821208	Double-crested Cormorant	3	0	0	350
821208	Long-billed Curlew	1	0	0	360
** SUBTOTAL **		206	2	0	
* STATION # 7					
821208	Western Gull	2	0	0	20
821108	Double-crested Cormorant	1	0	0	30
821208	Pintail	5	0	0	40
821004	Long-billed Curlew	16	0	0	45
821017	Herring Gull	6	0	0	45
821218	White Pelican	3	0	0	50
821017	White Pelican	21	0	0	100
821004	White Pelican	39	0	0	120
830104	Snowy Egret	1	0	0	180

02/18/83

COMPASS DIRECTION OF OVERFLIGHTS

DATE	SPECIES	# SEEN	# CALL	# FLUSH	COMP. DIR.
* STATION # 7					
821208	California Gull	5	0	0	200
821208	Common Crow	3	0	0	200
820909	Great Blue Heron	1	0	0	225
821004	Green-winged Teal	7	0	0	225
821004	Double-crested Cormorant	4	0	0	225
821108	Western Gull	3	0	0	260
** SUBTOTAL **		117	0	0	
* STATION # 8					
820805	Double-crested Cormorant	9	0	0	0
820817	Double-crested Cormorant	8	0	0	0
821117	Marbled Godwit	1	0	0	10
821208	American Wigeon	9	0	0	10
821208	Mallard	3	0	0	15
821108	Pintail	4	0	0	20
821208	Pintail	3	0	0	20
821128	Double-crested Cormorant	3	0	0	25
821218	Ring-billed Gull	16	0	0	60
821017	White Pelican	6	0	0	100
821128	Pintail	3	0	0	150
821128	Western Gull	11	0	0	200
821128	Ring-billed Gull	9	0	0	210
820925	Long-billed Curlew	22	0	0	225
830123	Pintail	3	0	0	270
830123	Mallard	2	0	0	285
821208	Glaucous-winged Gull	2	0	0	300
** SUBTOTAL **		114	0	0	
* STATION # 9					
821108	Green-winged Teal	5	0	0	30
821228	California Gull	11	0	0	35
821228	Marbled Godwit	18	0	0	50
820925	Gull sp.	11	0	0	60
821228	Pintail	3	0	0	65
821017	White Pelican	13	0	0	100
821004	White Pelican	49	0	0	120
820909	Duck sp.	3	0	0	135
830123	Ring-billed Gull	2	0	0	180
821208	Black-bellied Plover	25	0	0	200
821208	Marbled Godwit	32	0	0	200
820925	Double-crested Cormorant	1	0	0	225
821004	Double-crested Cormorant	1	0	0	225
821004	Red-tailed Hawk	1	0	0	225
821004	Great Egret	1	0	0	225
821004	Pintail	9	0	0	225

02/18/83

COMPASS DIRECTION OF OVERFLIGHTS

DATE	SPECIES	# SEEN	# CALL	# FLUSH	COMP. DIR.
* STATION # 9					
820909	Double-crested Cormorant	8	0	0	250
** SUBTOTAL **					
		193	0	0	
* STATION # 10					
820805	Double-crested Cormorant	7	0	0	0
820831	Double-crested Cormorant	1	0	0	0
821218	Double-crested Cormorant	5	0	0	10
821208	Pintail	3	0	0	30
830113	Common Crow	0	2	0	160
821108	Double-crested Cormorant	3	0	0	180
821208	Red-tailed Hawk	1	0	0	180
821218	Long-billed Curlew	0	12	0	200
821218	Common Crow	0	3	0	200
821228	Ring-billed Gull	0	3	0	220
821017	Double-crested Cormorant	1	0	0	225
830123	Long-billed Curlew	1	0	0	280
** SUBTOTAL **					
		22	20	0	
* STATION # 11					
821128	Killdeer	1	0	0	10
821128	Pintail	3	0	0	20
821117	Double-crested Cormorant	3	0	0	25
820909	Gull sp.	14	0	0	45
821117	Common Crow	4	0	0	160
820909	Double-crested Cormorant	6	0	0	225
820925	Double-crested Cormorant	9	0	0	225
821004	Double-crested Cormorant	6	0	0	225
821228	Snowy Egret	1	0	0	245
** SUBTOTAL **					
		47	0	0	
* STATION # 12					
820831	White Pelican	18	0	0	0
821128	Great Blue Heron	1	0	0	10
821128	California Gull	1	0	0	10
821208	California Gull	6	0	0	10
821208	Ring-billed Gull	11	0	0	10
830104	Double-crested Cormorant	1	0	0	10
830104	Pintail	3	0	0	15
820925	Green-winged Teal	8	0	0	45
821017	White Pelican	3	0	0	100
820925	White Pelican	53	0	0	120
821004	White Pelican	66	0	0	135
820925	Double-crested Cormorant	1	0	0	225

02/18/83

COMPASS DIRECTION OF OVERFLIGHTS

DATE	SPECIES	# SEEN	# CALL	# FLUSH	COMP. DIR.
* STATION # 12					
820925	Gull sp.	17	0	0	225
821004	Pintail	8	0	0	225
821004	Snowy Egret	1	0	0	225
821004	Red-tailed Hawk	1	0	0	225
** SUBTOTAL **		199	0	0	
* STATION # 13					
820817	Double-crested Cormorant	6	0	0	0
820817	White Pelican	68	0	0	0
821108	California Gull	8	0	0	10
830113	Pintail	0	3	0	20
821017	Gull sp.	6	0	0	45
821017	Long-billed Curlew	23	0	0	45
821017	White Pelican	2	0	0	45
821228	California Gull	5	0	0	50
821004	Long-billed Curlew	22	0	0	135
830104	Great Egret	1	0	0	190
821208	Double-crested Cormorant	1	0	0	200
820909	Great Blue Heron	1	0	0	225
821228	Long-billed Curlew	0	13	0	260
** SUBTOTAL **		143	16	0	
* STATION # 14					
820831	Double-crested Cormorant	11	0	0	0
821117	Western Gull	2	0	0	10
821208	Glaucous-winged Gull	2	0	0	20
821218	Double-crested Cormorant	1	0	0	45
821208	Long-billed Curlew	1	0	0	200
821004	Double-crested Cormorant	1	0	0	225
821004	Great Egret	1	0	0	225
821017	Great Egret	1	0	0	225
821017	Long-billed Curlew	13	0	0	225
821017	Great Blue Heron	2	0	0	225
830113	Ring-billed Gull	6	0	0	270
830113	Mallard	0	2	0	360
** SUBTOTAL **		41	2	0	
* STATION # 15					
820805	Double-crested Cormorant	8	0	0	0
821108	Ring-billed Gull	1	0	0	25
821017	Green-winged Teal	8	0	0	100
830123	Pintail	0	3	0	100
821117	Marbled Godwit	13	0	0	220

02/18/83

COMPASS DIRECTION OF OVERFLIGHTS

DATE	SPECIES	# SEEN	# CALL	# FLUSH	COMP. DIR.
* STATION # 18					
821004	Long-billed Curlew	12	0	0	225
821004	Double-crested Cormorant	1	0	0	225
821017	Double-crested Cormorant	1	0	0	225
821017	Herring Gull	1	0	0	225
821208	Double-crested Cormorant	3	0	0	360
** SUBTOTAL **		43	23	0	
* STATION # 19					
820817	Double-crested Cormorant	5	0	0	0
821208	Pintail	4	0	0	10
821208	Pintail	7	0	0	20
830104	Double-crested Cormorant	3	0	0	40
821117	Pintail	6	0	0	175
830123	Double-crested Cormorant	1	0	0	180
821108	Double-crested Cormorant	1	0	0	200
820909	Double-crested Cormorant	11	0	0	210
821004	Turkey Vulture	7	0	0	225
821004	Long-billed Curlew	21	0	0	225
830113	Snowy Egret	1	0	0	260
** SUBTOTAL **		67	0	0	
* STATION # 20					
820805	Double-crested Cormorant	7	0	0	0
821108	Ring-billed Gull	7	0	0	10
821128	Double-crested Cormorant	7	0	0	15
821218	Double-crested Cormorant	5	0	0	25
821228	Ring-billed Gull	8	0	0	25
821218	Raven	0	2	0	180
820925	Gull sp.	6	0	0	200
820925	Double-crested Cormorant	7	0	0	200
820909	Gull sp.	19	0	0	210
830123	Black-bellied Plover	25	0	0	210
830123	Ring-billed Gull	1	0	0	220
821004	Double-crested Cormorant	3	0	0	225
821017	Double-crested Cormorant	1	0	0	225
821017	Double-crested Cormorant	3	0	0	225
830113	Great Blue Heron	1	0	0	245
821128	Ring-billed Gull	15	0	0	360
** SUBTOTAL **		115	2	0	
* STATION # 22					
830104	California Gull	10	0	0	0
830104	Ring-billed Gull	15	0	0	0
** SUBTOTAL **		25	0	0	
* STATION # 23					

02/18/83

COMPASS DIRECTION OF OVERFLIGHTS

DATE	SPECIES	# SEEN	# CALL	# FLUSH	COMP. DIR.
* STATION # 23					
830113	Ring-billed Gull	8	0	0	200
** SUBTOTAL **		8	0	0	
* STATION # 28					
830123	Ring-billed Gull	7	0	0	360
** SUBTOTAL **		7	0	0	
* STATION # 29					
830104	Double-crested Cormorant	1	0	0	0
** SUBTOTAL **		1	0	0	
** TOTAL **		2705	104	0	

APPENDIX C. AERIAL SURVEY DATA.

C-1. DATA FOR AERIAL SURVEY
BY LOCATIONS.

7/16/83

AERIAL SURVEY DATA BY LOCATION

NOTE CANY LBSC PINT NWMI WALL HOBB CITY SBSC HBBS ANCO DRSP WIPS DCCO WBER GBSC SWIG DRPL LBCH LBDO WILL BURL MAGO AMV SAND NARA COLL OTHER OTHER OTHER

Table with columns for various survey locations and counts. Includes sub-section 'AERIAL COUNTS FOR LOCATION SP6' with rows 21111, 21116, 21201, 21215, 21224, 30120, 30125, 30201, and a 'SUBTOTAL**' row.

AERIAL COUNTS FOR LOCATION SP7

Table with columns for various survey locations and counts. Includes sub-section 'AERIAL COUNTS FOR LOCATION SP7' with rows 21111, 21116, 21201, 21215, 21224, 30120, 30125, 30201, and a 'SUBTOTAL**' row.

AERIAL COUNTS FOR LOCATION SP9

Table with columns for various survey locations and counts. Includes sub-section 'AERIAL COUNTS FOR LOCATION SP9' with rows 21111, 21116, 21201, 21215, 21224, 30120, 30125, 30201, and a 'SUBTOTAL**' row.

AERIAL COUNTS FOR LOCATION SP7

Table with columns for various survey locations and counts. Includes sub-section 'AERIAL COUNTS FOR LOCATION SP7' with rows 21111, 21116, 21201, 21215, 21224, 30120, 30125, 30201, and a 'SUBTOTAL**' row.

AERIAL COUNTS FOR LOCATION SP7

Table with columns for various survey locations and counts. Includes sub-section 'AERIAL COUNTS FOR LOCATION SP7' with rows 21111, 21116, 21201, 21215, 21224, 30120, 30125, 30201, and a 'SUBTOTAL**' row.

I

C-2. LISTING OF ABBREVIATIONS FOR
AERIAL SURVEY WORK.

I
I
I

CODES USED FOR
AERIAL SURVEY DATA

<u>Code</u>	<u>Common Name</u>	<u>Scientific Name</u>
AMAV	American Avocet	<u>Recurvirostra americana</u>
AMCO	American Coot	<u>Fulica americana</u>
AMWI	American Wigeon	<u>Anas americana</u>
BBPL	Black-bellied Plover	<u>Pluvialis squatarola</u>
BNST	Black-necked Stilt	<u>Himantopus mexicanus</u>
BOGU	Bonaparte's Gull	<u>Larus philadelphia</u>
BRBL	Blackbird	
	Brewer's Blackbird	<u>Euphagus cyanocephalus</u>
	Red-winged Blackbird	<u>Agelaius phoeniceus</u>
BRPE	Brown Pelican	<u>Pelecanus occidentalis</u>
		<u>californicus</u>
BUFF	Bufflehead	<u>Bucephala albeola</u>
CAGU	California Gull	<u>Larus californicus</u>
CANV	Canvasback	<u>Aythya valisineria</u>
CATE	Caspian Tern	<u>Sterna caspia</u>
CITE	Cinnamon Teal	<u>Anas cyanoptera</u>
COCR	American Crow	<u>Corvus brachyrhynchos</u>
COLO	Common Loon	<u>Gavia immer</u>
DCCO	Double-crested Cormorant	<u>Phalacrocorax auritus</u>
DUNL	Dunlin	<u>Calidris alpina</u>
DUSP	Duck sp.	
EAGR	Eared Grebe	<u>Podiceps nigricollis</u>
FLAM	Flamingo	<u>Phoenicopterus ruber</u>
FOTE	Forester's Tern	<u>Sterna forsteri</u>
GBHE	Great Blue Heron	<u>Ardea herodias</u>
GOLD	Common Goldeneye	<u>Bucephala clangula</u>
GREG	Great Egret	<u>Casmerodius albus</u>
GRWT	Green-winged Teal	<u>Anas crecca</u>
GRYE	Greater Yellowlegs	<u>Tringa melanoleuca</u>
GULL	Gull species	
HOLA	Horned Lark	<u>Eremophila alpestris</u>
LESC	Scaup	
	Lesser Scaup	<u>Aythya affinis</u>
	Greater Scaup	<u>Aythya marila</u>
LBDO	Dowitcher	
	Long-billed Dowitcher	<u>Limnodromus scolopaceus</u>
	Short-billed Dowitcher	<u>Limnodromus griseus</u>
MAGO	Marbled Godwit	<u>Limosa fedoa</u>
MABA	Northern Harrier	<u>Circus cyaneus</u>
MALL	Mallard	<u>Anas platyrhynchos</u>

NOSH	Northern Shoveler	<u>Anas clypeata</u>
PINT	Northern Pintail	<u>Anas acuta</u>
RBGU	Ring-billed Gull	<u>Larus delewarensis</u>
RODO	Rock Dove	<u>Columba livia</u>
RTHA	Red-tailed Hawk	<u>Buteo jamaicensis</u>
RUDU	Ruddy Duck	<u>Oxyura jamaicensis</u>
SAND	Sandpiper species	
SNEG	Snowy Egret	<u>Egretta thula</u>
SNGO	Snow Goose	<u>Chen caerulescens</u>
STAR	European Starling	<u>Sturnus vulgaris</u>
SUSC	Scoter	
	Surf Scoter	<u>Melanitta perspicillata</u>
	White-winged Scoter	<u>Melanitta fusca</u>
UNSH	Unidentified Shorebirds	
WEGR	Western Grebe	<u>Aechmophorus occidentalis</u>
WEGU	Western Gull	<u>Larus occidentalis</u>
WEME	Western Meadowlark	<u>Sturnella neglecta</u>
WFGO	Greater White-fronted Goose	<u>Anse albifrons</u>
WHPE	American White Pelican	<u>Pelecanus erythrorhynchos</u>
WTKI	Black-shouldered Kite	<u>Elanus caeruleus</u>
WILL	Willet	<u>Catoptrophorus semipalmatus</u>
WWE	White-winged Scoter	<u>Melanitta fusca</u>

APPENDIX D. ALTERNATE MARINA SURVEYS.

D-1. UTILIZATION OF ALTERNATE
MARINAS.

02/18/83

CULLINAN RANCH MONITORING PROGRAM

UTILIZATION OF ALTERNATE MARINAS

DATE	MARINA	STA	# SEEN	# FLUSH	FLUSH DIST.	FLUSH AGENT	RFOF	OF HT.
* UTILIZATION OF ALTERNATE MARINAS BY: American Coot								
821113	Redwood	1	2	0	0		R	0
821113	Redwood	1	40	40	20 Foot		R	0
821113	Redwood	1	54	0	0		R	0
821113	Redwood	2	5	0	0		R	0
821113	Redwood	2	0	1	10 Cat			0
821113	Redwood	2	5	0	0		R	0
821113	Redwood	2	0	1	10 Foot			0
821113	Redwood	2	8	0	0		R	0
821113	Redwood	3	1	0	0		R	0
821113	Redwood	3	34	0	0		R	0
821113	Redwood	3	16	0	0		R	0
821113	Redwood	4	40	0	0		R	0
821113	Redwood	4	8	0	0		R	0
821113	Redwood	4	6	0	0		R	0
821113	Redwood	5	4	0	0		R	0
821113	Redwood	5	10	0	0		R	0
821113	Redwood	5	10	0	0		R	0
821127	Redwood	1	0	60	20 Foot			0
821127	Redwood	1	12	0	0		R	0
821127	Redwood	1	15	0	0		R	0
821127	Redwood	1	0	25	20 Foot			0
821127	Redwood	2	0	25	15 Foot			0
821127	Redwood	2	0	3	15 Foot			0
821127	Redwood	2	2	0	0		R	0
821127	Redwood	2	0	6	40 Foot			0
821127	Redwood	3	0	11	100 Foot		R	0
821127	Redwood	3	0	25	50 Foot			0
821127	Redwood	3	0	12	50 Foot			0
821127	Redwood	3	0	6	50 Foot		R	0
821127	Redwood	4	14	0	0		R	0
821127	Redwood	4	6	0	0		R	0
821127	Redwood	4	2	0	0		R	0
821127	Redwood	4	1	0	0		R	0
821127	Redwood	4	0	1	20 Foot			0
821127	Redwood	4	10	0	0		R	0
821127	Redwood	4	0	25	50 Boat			0
821127	Redwood	4	0	25	25 Foot			0
821127	Redwood	4	0	3	15 Foot			0
821127	Redwood	4	1	0	0		R	0
821127	Redwood	5	0	5	25 Foot			0
821127	Redwood	5	0	21	20 Foot			0
821127	Redwood	5	6	0	0			0
821127	Redwood	5	15	0	0		R	0
821127	Redwood	6	0	3	40 Foot			0
821127	Redwood	6	25	0	0		R	0
821127	Redwood	6	3	0	0		R	0

02/18/83

CULLINAN RANCH MONITORING PROGRAM

UTILIZATION OF ALTERNATE MARINAS

DATE	MARINA	STA	#	#	FLUSH	FLUSH	RFOF	OF
			SEEN	FLUSH	DIST.	AGENT		HT.

* UTILIZATION OF ALTERNATE MARINAS BY: American Coot

821127	Redwood	6	20	0	0		R	0
821212	Bell Marin	Dow	10	0	0		R	0
821212	Bell Marin	Dow	10	0	0		R	0
821212	Bell Marin	Doe	3	0	0		R	0
830116	Redwood	1	2	0	0		R	0
830116	Redwood	1	0	2	15 Foot			0
830116	Redwood	1	45	0	0		R	0
830116	Redwood	1	0	1	15 Foot			0
830116	Redwood	1	0	1	10 Foot			0
830116	Redwood	2	0	15	25 Foot			0
830116	Redwood	2	0	16	15 Foot			0
830116	Redwood	3	0	1	50 Foot			0
830116	Redwood	3	0	2	15 Foot			0
830116	Redwood	2	0	2	20 Foot			0
830116	Redwood	3	0	7	15 Foot			0
830116	Redwood	4	30	0	0		R	0
830116	Redwood	4	0	4	15 Foot			0
830116	Redwood	4	3	0	0		R	0
830116	Redwood	5	35	0	0		R	0
830116	Redwood	6	2	0	0		R	0
830116	Redwood	6	0	1	15 Foot			0
830116	Redwood	6	0	50	20 Foot			0
**	SUBTOTAL	**		515	400	825		

* UTILIZATION OF ALTERNATE MARINAS BY: American Kestrel

820826	Bell Marin	1	1	0	0		R	0
**	SUBTOTAL	**		1	0	0		

* UTILIZATION OF ALTERNATE MARINAS BY: Avocet

820826	Bell Marin	3	15	0	0		F	10
820923	Bell Marin	1	5	0	0		F	10
820923	Bell Marin	3	25	0	0		R	0
820923	Bell Marin	4	5	0	0		R	0
820923	Bell Marin	4	2	0	0		R	0
**	SUBTOTAL	**		52	0	0		

* UTILIZATION OF ALTERNATE MARINAS BY: Barn Swallow

820923	Bell Marin	1	3	0	0		F	5
820923	Bell Marin	1	2	0	0		F	10
820923	Bell Marin	4	3	0	0		F	10
**	SUBTOTAL	**		8	0	0		

* UTILIZATION OF ALTERNATE MARINAS BY: Brown Pelican

02/18/83

CULLINAN RANCH MONITORING PROGRAM

UTILIZATION OF ALTERNATE MARINAS

DATE	MARINA	STA	#	#	FLUSH	FLUSH	RFOF	OF
			SEEN	FLUSH	DIST.	AGENT		HT.
* UTILIZATION OF ALTERNATE MARINAS BY: Brown Pelican								
821127	Redwood	2	1	1	20 Foot			0
821127	Redwood	3	1	0	0		OF	35
** SUBTOTAL **			2	1	20			
* UTILIZATION OF ALTERNATE MARINAS BY: Brown-headed Cowbird								
820923	Bell Marin	3	2	0	0		R	0
** SUBTOTAL **			2	0	0			
* UTILIZATION OF ALTERNATE MARINAS BY: Bufflehead								
821113	Redwood	3	0	5	40 Foot			0
830116	Redwood	3	2	0	0		R	0
830116	Redwood	3	0	4	40 Foot			0
** SUBTOTAL **			2	9	80			
* UTILIZATION OF ALTERNATE MARINAS BY: Canvasback								
821212	Bell Marin Doe	52	0	0	0		R	0
830116	Redwood	1	1	0	0		R	0
830116	Redwood	6	1	0	0		R	0
** SUBTOTAL **			54	0	0			
* UTILIZATION OF ALTERNATE MARINAS BY: Common Goldeneye								
821113	Redwood	3	0	20	40 Foot			0
821127	Redwood	1	0	21	30 Foot		R	0
821127	Redwood	1	1	0	0			0
821127	Redwood	2	1	0	0		R	0
821127	Redwood	2	0	4	100		R	0
821127	Redwood	3	4	0	0		R	0
821127	Redwood	3	0	5	100 Foot			0
821127	Redwood	3	0	1	50 Foot			0
821127	Redwood	3	4	0	0		R	0
821127	Redwood	3	5	0	0		OF	25
821127	Redwood	3	1	0	0		R	0
821127	Redwood	4	2	0	0		R	0
821127	Redwood	4	4	0	0		R	0
821127	Redwood	4	6	0	0		R	0
821127	Redwood	4	0	6	75 Foot			0
821127	Redwood	4	0	13	50 Boat			0
821127	Redwood	4	0	3	70 Boat			0

02/18/83

CULLINAN RANCH MONITORING PROGRAM

UTILIZATION OF ALTERNATE MARINAS

DATE	MARINA	STA	# SEEN	# FLUSH	FLUSH DIST.	FLUSH AGENT	RFOF	OF HT.
* UTILIZATION OF ALTERNATE MARINAS BY: Common Goldeneye								
821127	Redwood	6	2	0	0		R	0
821127	Redwood	6	2	0	0		R	0
821127	Redwood	6	28	0	0		R	0
821127	Redwood	6	7	0	0		R	0
821212	Bell Marin	Dow	1	0	0		R	0
821212	Bell Marin	Dow	4	0	0		R	0
830116	Redwood	1	1	1	50	Foot		0
830116	Redwood	1	6	6	20		R	0
830116	Redwood	2	0	3	30	Foot		0
830116	Redwood	2	0	1	15	Foot		0
830116	Redwood	2	1	0	0		R	0
830116	Redwood	3	0	1	5	Foot		0
830116	Redwood	3	0	1	75	Foot		0
830116	Redwood	3	4	0	0		OF	10
830116	Redwood	3	2	0	0		R	0
830116	Redwood	3	0	1	30	Foot		0
830116	Redwood	4	4	0	0		R	0
830116	Redwood	6	0	1	10	Foot		0
830116	Redwood	6	8	0	0		R	0
830116	Redwood	6	1	0	0		R	0
830116	Redwood	6	3	0	0		R	0
830116	Redwood	6	6	0	0		R	0
830116	Redwood	6	1	0	0		R	0
** SUBTOTAL **			109	88	750			

* UTILIZATION OF ALTERNATE MARINAS BY: Double-Crested Cormorant								
821212	Bell Marin	Dow	1	0	0		OF	18
** SUBTOTAL **			1	0	0			

* UTILIZATION OF ALTERNATE MARINAS BY: Double-crested Cormorant								
820826	Bell Marin	2	19	0	0		R	0
820923	Bell Marin	1	3	0	0		F	50
820923	Bell Marin	2	30	0	0		R	0
820923	Bell Marin	2	1	0	0		OF	30
821113	Redwood	1	2	0	0		OF	30
821113	Redwood	1	6	0	0		OF	30
821113	Redwood	1	1	0	0		R	0
821113	Redwood	1	12	0	0		F	10
821113	Redwood	1	73	0	0		F	10
821113	Redwood	2	14	0	0		OF	30
821113	Redwood	2	0	1	30	Foot		0
821113	Redwood	2	2	0	0		R	0

02/18/83

CULLINAN RANCH MONITORING PROGRAM

UTILIZATION OF ALTERNATE MARINAS

DATE	MARINA	STA	#	#	FLUSH	FLUSH	RFOF	OF
			SEEN	FLUSH	DIST.	AGENT		HT.
* UTILIZATION OF ALTERNATE MARINAS BY: Double-crested Cormorant								
821113	Redwood	2	0	1	20	Foot		0
821113	Redwood	3	0	4	30	Foot		0
821113	Redwood	3	0	1	50	Foot		0
821113	Redwood	3	5	0	0		R	0
821113	Redwood	4	2	0	0		R	0
821113	Redwood	4	0	0	0		F	10
821127	Redwood	1	1	0	0		OF	10
821127	Redwood	2	1	0	0		R	0
821127	Redwood	2	0	2	45	Foot		0
821127	Redwood	2	0	2	75	Foot		0
821127	Redwood	2	2	0	0		R	0
821127	Redwood	2	0	1	50	Foot		0
821127	Redwood	3	0	3	100	Foot		0
821127	Redwood	3	0	2	100	Foot		0
821127	Redwood	3	0	1	100	Foot		0
821127	Redwood	3	2	0	0		OF	75
821127	Redwood	3	1	0	0		OF	25
821127	Redwood	3	3	0	0		R	0
821127	Redwood	3	1	0	0		OF	50
821127	Redwood	3	3	0	0		OF	25
821127	Redwood	3	0	1	100	Foot		0
821127	Redwood	3	2	0	0		OF	25
821127	Redwood	3	2	0	0			25
821127	Redwood	4	1	0	0		R	0
821127	Redwood	4	0	1	20	Foot		0
821127	Redwood	4	1	0	0		R	0
821127	Redwood	5	1	0	0		OF	50
821127	Redwood	5	1	0	0			0
821127	Redwood	5	0	1	20	Foot	F	0
821127	Redwood	5	3	0	0		R	0
821127	Redwood	6	0	1	50	Foot		0
821127	Redwood	6	1	0	0		OF	1
821127	Redwood	6	1	0	0		R	0
821127	Redwood	6	2	0	0		R	0
821127	Redwood	6	4	0	0		OF	10
821127	Redwood	6	1	0	0		OF	25
821127	Redwood	5	3	0	0		R	0
821127	Redwood	6	1	0	0		R	0
821127	Redwood	6	0	1	75		F	0
821127	Redwood	6	2	0	0		R	0
821212	Bell Marin Dow	1	0	0	0		R	0
821212	Bell Marin Doe	0	5	5	20	Foot		0
821212	Bell Marin PdA	1	0	0	0		R	0
830116	Redwood	1	1	0	0		R	0
830116	Redwood	2	1	0	0			0
830116	Redwood	2	0	0	0		F	7

02/18/83

CULLINAN RANCH MONITORING PROGRAM

UTILIZATION OF ALTERNATE MARINAS

DATE	MARINA	STA	#	#	FLUSH	FLUSH	RFOF	OF
			SEEN	FLUSH	DIST.	AGENT		HT.
* UTILIZATION OF ALTERNATE MARINAS BY: Double-crested Cormorant								
830116	Redwood	3	1	0	0		R	0
830116	Redwood	6	2	0	0		R	0
** SUBTOTAL **			217	28	885			
* UTILIZATION OF ALTERNATE MARINAS BY: Double-crested Cormorant								
821127	Redwood	3	1	0	0		OF	10
** SUBTOTAL **			1	0	0			
* UTILIZATION OF ALTERNATE MARINAS BY: Duck sp.								
820826	Bell Marin	1	8	0	0		R	0
821113	Redwood	3	0	10	40	Foot		0
821127	Redwood	1	2	0	0		R	0
** SUBTOTAL **			10	10	40			
* UTILIZATION OF ALTERNATE MARINAS BY: Eared Grebe								
821113	Redwood	6	1	0	0		R	0
821127	Redwood	6	1	1	25	Foot	R	0
821127	Redwood	6	7	0	0		R	0
821212	Bell Marin Dow	1	0	0	0		R	0
** SUBTOTAL **			10	1	25			
* UTILIZATION OF ALTERNATE MARINAS BY: Forster's Tern								
821113	Redwood	1	1	0	0		F	20
821113	Redwood	3	3	0	0		F	0
821113	Redwood	4	1	0	0		F	20
** SUBTOTAL **			5	0	0			
* UTILIZATION OF ALTERNATE MARINAS BY: Great Blue Heron								
820826	Bell Marin	4	1	0	0		R	0
820923	Bell Marin	2	1	0	0		R	0
821212	Bell Marin Doe	1	0	0	0		OF	30
** SUBTOTAL **			3	0	0			
* UTILIZATION OF ALTERNATE MARINAS BY: Great Egret								

02/18/83

CULLINAN RANCH MONITORING PROGRAM

UTILIZATION OF ALTERNATE MARINAS

DATE	MARINA	STA	#	#	FLUSH	FLUSH	RFOF	OF
			SEEN	FLUSH	DIST.	AGENT		HT.

* UTILIZATION OF ALTERNATE MARINAS BY: Great Egret

820826	Bell Marin	2	1	0	0		R	0
820826	Bell Marin	4	2	2	40 Foot		R	0
820923	Bell Marin	2	1	0	0		R	0
820923	Bell Marin	3	1	0	0		R	0
820923	Bell Marin	4	1	0	0		R	0
821127	Redwood	2	1	0	0		OF	50
821127	Redwood	5	1	0	0		R	0
821212	Bell Marin	Doe	0	1	10 Foot			0
821212	Bell Marin	Doe	0	1	10 Motorcycle			0
830116	Redwood	3	0	1	30 Foot			0
** SUBTOTAL **			8	5	90			

* UTILIZATION OF ALTERNATE MARINAS BY: Greater Yellowlegs

820923	Bell Marin	3	1	0	0		R	0
820923	Bell Marin	4	1	0	0		R	0
821113	Redwood	5	0	1	12 Foot			0
** SUBTOTAL **			2	1	12			

* UTILIZATION OF ALTERNATE MARINAS BY: Gull Sp.

821113	Redwood	3	1	0	0		R	0
** SUBTOTAL **			1	0	0			

* UTILIZATION OF ALTERNATE MARINAS BY: Gull sp.

820826	Bell Marin	4	1	0	0		R	0
820923	Bell Marin	1	3	0	0		R	0
821113	Redwood	1	1	0	0		OF	10
821113	Redwood	3	5	0	0		R	0
821113	Redwood	4	9	0	0		R	0
821113	Redwood	5	13	0	0		R	0
821113	Redwood	6	4	0	0		R	0
821127	Redwood	1	2	0	0		R	0
821127	Redwood	3	10	0	0		OF	30
821127	Redwood	6	12	0	0		R	0
** SUBTOTAL **			60	0	0			

* UTILIZATION OF ALTERNATE MARINAS BY: Horned Grebe

821127	Redwood	2	0	1	75 Foot			0
** SUBTOTAL **			0	1	75			

* UTILIZATION OF ALTERNATE MARINAS BY: Killdeer

02/18/83

CULLINAN RANCH MONITORING PROGRAM

UTILIZATION OF ALTERNATE MARINAS

DATE	MARINA	STA	#	#	FLUSH	FLUSH	RFOF	OF
			SEEN	FLUSH	DIST.	AGENT		HT.
* UTILIZATION OF ALTERNATE MARINAS BY: Mallard								
821113	Redwood	3	4	0	0		R	0
821113	Redwood	4	21	0	0		R	0
821113	Redwood	4	34	0	0		R	0
821113	Redwood	5	17	0	0		R	0
821113	Redwood	5	6	0	0		R	0
821113	Redwood	5	9	0	0		R	0
821127	Redwood	1	6	0	0		R	0
821127	Redwood	1	0	3	10	Foot		0
821127	Redwood	1	21	0	0			0
821127	Redwood	2	1	0	0		R	0
821127	Redwood	2	20	0	0		R	0
821127	Redwood	2	0	6	25	Foot		0
821127	Redwood	2	5	0	0		R	0
821127	Redwood	2	0	3	10	Foot		0
821127	Redwood	2	2	0	0		R	0
821127	Redwood	3	6	0	0		OF	50
821127	Redwood	3	3	0	0		R	0
821127	Redwood	3	2	0	0		OF	25
821127	Redwood	4	5	0	0		R	0
821127	Redwood	4	6	0	0		R	0
821127	Redwood	4	9	0	0		R	0
821127	Redwood	4	12	0	0		R	0
821127	Redwood	4	11	0	0		R	0
821127	Redwood	4	30	0	0		R	0
821127	Redwood	4	13	0	0		R	0
821127	Redwood	4	30	0	0		R	0
821127	Redwood	4	11	0	0		R	0
821127	Redwood	4	10	0	0		R	0
821127	Redwood	4	0	10	30	Boat		0
821127	Redwood	4	0	15	15	Boat		0
821127	Redwood	4	0	2	5	Foot		0
821127	Redwood	4	1	0	0		R	0
821127	Redwood	5	10	20	0		R	0
821127	Redwood	5	8	0	0		R	0
821127	Redwood	5	2	0	0		OF	5
821127	Redwood	5	15	0	0		R	0
821127	Redwood	5	10	0	0			0
821127	Redwood	5	6	0	0			0
821127	Redwood	5	5	0	0		R	0
821127	Redwood	6	15	0	0		OF	5
821127	Redwood	6	10	0	0		OF	5
830116	Redwood	1	2	0	0		OF	30
830116	Redwood	1	3	0	0		R	0
830116	Redwood	1	5	0	0		R	0
830116	Redwood	1	3	0	0		R	0
830116	Redwood	2	0	1	20	Foot		0

02/18/83

CULLINAN RANCH MONITORING PROGRAM

UTILIZATION OF ALTERNATE MARINAS

DATE	MARINA	STA	# SEEN	# FLUSH	FLUSH DIST.	FLUSH AGENT	RPOF	OF HT.
* UTILIZATION OF ALTERNATE MARINAS BY: Mallard								
830116	Redwood	2	13	0	0		R	0
830116	Redwood	3	6	0	0		OF	10
830116	Redwood	3	2	0	0		OF	10
830116	Redwood	3	3	0	0		OF	10
830116	Redwood	3	3	0	0		R	0
830116	Redwood	3	2	0	0		OF	5
830116	Redwood	3	3	0	0			0
830116	Redwood	3	0	2	5	Foot		0
830116	Redwood	4	80	0	0		R	0
830116	Redwood	5	0	12	5	Foot		0
830116	Redwood	5	15	0	0		R	0
830116	Redwood	6	5	0	0		R	0
** SUBTOTAL **			546	89	280			

* UTILIZATION OF ALTERNATE MARINAS BY: Meadowlark								
821127	Redwood	2	0	2	25	Foot		0
** SUBTOTAL **			0	2	25			

* UTILIZATION OF ALTERNATE MARINAS BY: Mute Swan								
821127	Redwood	4	2	0	0		R	0
830116	Redwood	5	2	0	0		R	0
** SUBTOTAL **			4	0	0			

* UTILIZATION OF ALTERNATE MARINAS BY: Pied-billed Grebe								
821113	Redwood	6	2	2	20	Foot	R	0
821127	Redwood	1	2	0	0			0
821127	Redwood	1	1	0	0			0
821127	Redwood	2	1	0	0		R	0
821127	Redwood	2	1	0	0		R	0
821127	Redwood	2	0	2	100	Foot		0
821127	Redwood	3	0	2	75	Foot		0
821127	Redwood	3	1	0	0		R	0
821127	Redwood	4	4	0	0		R	0
821127	Redwood	4	2	0	0		R	0
821127	Redwood	4	7	0	0		R	0
821127	Redwood	4	0	1	10	Foot		0
821127	Redwood	5	0	1	15	Foot		0
821127	Redwood	5	0	5	25	Foot		0
821127	Redwood	5	4	0	0			0
821127	Redwood	6	1	0	0		R	0

02/18/83

CULLINAN RANCH MONITORING PROGRAM

UTILIZATION OF ALTERNATE MARINAS

DATE	MARINA	STA	# SEEN	# FLUSH	FLUSH DIST.	FLUSH AGENT	RFOF	OF HT.
* UTILIZATION OF ALTERNATE MARINAS BY: Pied-billed Grebe								
821127	Redwood	6	1	0	0		R	0
821127	Redwood	6	0	1	20 Foot			0
821127	Redwood	6	2	0	0		R	0
821127	Redwood	6	5	0	0		R	0
821212	Bell Marin Dow	5	0	0	0		R	0
830116	Redwood	1	2	0	0		R	0
830116	Redwood	1	1	0	0		R	0
830116	Redwood	5	0	1	5 Foot			0
** SUBTOTAL **			42	15	270			
* UTILIZATION OF ALTERNATE MARINAS BY: Pintail								
821212	Bell Marin Doe	1	1	0	0		R	0
** SUBTOTAL **			1	0	0			
* UTILIZATION OF ALTERNATE MARINAS BY: Rock Dove								
820923	Bell Marin	1	40	0	0		F	10
** SUBTOTAL **			40	0	0			
* UTILIZATION OF ALTERNATE MARINAS BY: Ruddy Duck								
821113	Redwood	3	16	16	15 Foot		R	0
821113	Redwood	5	1	0	0		R	0
821127	Redwood	3	9	0	0		R	0
821127	Redwood	4	3	0	0		R	0
821127	Redwood	5	4	0	0		R	0
821127	Redwood	6	6	0	0		R	0
821212	Bell Marin Doe	1	0	0	0		R	0
821212	Bell Marin Doe	10	0	0	0		R	0
821212	Bell Marin PdA	32	0	0	0		R	0
830116	Redwood	1	10	0	0		R	0
830116	Redwood	1	3	0	0		R	0
830116	Redwood	2	27	27	30 Foot		R	0
830116	Redwood	2	0	1	20 Foot			0
830116	Redwood	3	0	30	75 Foot			0
830116	Redwood	3	0	1	15 Foot			0
830116	Redwood	3	4	4	15		R	0
830116	Redwood	4	40	0	0		R	0
830116	Redwood	4	1	0	0		R	0
830116	Redwood	5	3	0	0		R	0
830116	Redwood	6	0	1	15 Foot			0
830116	Redwood	6	11	0	0		R	0

02/18/83

CULLINAN RANCH MONITORING PROGRAM

UTILIZATION OF ALTERNATE MARINAS

DATE	MARINA	STA	#	#	FLUSH	FLUSH	RFOF	OF
			SEEN	FLUSH	DIST.	AGENT		HT.
* UTILIZATION OF ALTERNATE MARINAS BY: Ruddy Duck								
830116	Redwood	6	0	10	15	Foot		0
830116	Redwood	6	9	0	0		R	0
830116	Redwood	6	8	0	0		R	0
** SUBTOTAL **								
			198	90	200			
* UTILIZATION OF ALTERNATE MARINAS BY: Sandpiper sp.								
820923	Bell Marin	1	35	0	0		R	0
820923	Bell Marin	2	1	0	0		F	20
820923	Bell Marin	3	5	0	0		R	0
821212	Bell Marin Dow	2	0	0	0		R	0
** SUBTOTAL **								
			43	0	0			
* UTILIZATION OF ALTERNATE MARINAS BY: Savannah Sparrow								
820826	Bell Marin	1	1	0	0		R	0
** SUBTOTAL **								
			1	0	0			
* UTILIZATION OF ALTERNATE MARINAS BY: Snowy Egret								
820826	Bell Marin	4	15	0	0		R	0
820923	Bell Marin	2	47	0	0		R	0
820923	Bell Marin	3	14	0	0		R	0
820923	Bell Marin	4	0	1	30	Foot		0
820923	Bell Marin	4	9	0	0		R	0
820923	Bell Marin	4	0	1	50	Foot		0
820923	Bell Marin	4	18	0	0		R	0
821113	Redwood	1	1	0	0		OF	20
821113	Redwood	1	1	0	0		R	0
821113	Redwood	2	1	0	0		R	0
821113	Redwood	2	1	0	0		R	0
821113	Redwood	5	0	1	5	Foot		0
821113	Redwood	6	7	0	0		R	0
821212	Bell Marin Dow	0	1	1	15	Foot		0
830116	Redwood	1	1	0	0		R	0
830116	Redwood	1	1	0	0		R	0
830116	Redwood	2	1	0	0		R	0
830116	Redwood	5	1	0	0		R	0
830116	Redwood	6	0	1	15	Foot		0
** SUBTOTAL **								
			118	5	115			

* UTILIZATION OF ALTERNATE MARINAS BY: Starling

02/18/83

CULLINAN RANCH MONITORING PROGRAM

UTILIZATION OF ALTERNATE MARINAS

DATE	MARINA	STA	#	#	FLUSH	FLUSH	RFOF	OF
			SEEN	FLUSH	DIST.	AGENT		HT.
* UTILIZATION OF ALTERNATE MARINAS BY: Starling								
820826	Bell Marin	1	15	0	0		F	15
820923	Bell Marin	2	1	0	0		F	1
** SUBTOTAL **			16	0	0			
* UTILIZATION OF ALTERNATE MARINAS BY: Western Grebe								
821113	Redwood	1	100	0	0		R	0
821113	Redwood	6	1	1	20 Foot		R	0
821127	Redwood	1	2	0	0		R	0
821127	Redwood	1	1	0	0		R	0
821127	Redwood	6	10	0	0		R	0
821212	Bell Marin Dow	1	1	0	0		R	0
821212	Bell Marin Doe	5	5	0	0		R	0
830116	Redwood	6	13	13	15 Foot		R	0
** SUBTOTAL **			133	14	35			
* UTILIZATION OF ALTERNATE MARINAS BY: Willet								
830116	Redwood	1	0	1	15 Foot			0
830116	Redwood	4	0	1	3 Foot			0
** SUBTOTAL **			0	2	18			
** TOTAL **			2244	788	3855			

D-2. FLUSHING DISTANCES AT
ALTERNATE MARINAS.

02/18/83

CULLINAN RANCH MONITORING PROGRAM

DATE	MARINA	#	FLUSH	FLUSH
		FLUSH	DIST.	AGENT

* NUMBERS OF BIRDS FLUSHED AND FLUSHING DISTANCES FOR: American Coot

821113	Redwood	1	10	Cat
821113	Redwood	1	10	Foot
830116	Redwood	1	10	Foot
821127	Redwood	25	15	Foot
821127	Redwood	3	15	Foot
821127	Redwood	3	15	Foot
830116	Redwood	2	15	Foot
830116	Redwood	1	15	Foot
830116	Redwood	16	15	Foot
830116	Redwood	2	15	Foot
830116	Redwood	7	15	Foot
830116	Redwood	4	15	Foot
830116	Redwood	1	15	Foot
821113	Redwood	40	20	Foot
821127	Redwood	60	20	Foot
821127	Redwood	25	20	Foot
821127	Redwood	1	20	Foot
821127	Redwood	21	20	Foot
830116	Redwood	2	20	Foot
830116	Redwood	50	20	Foot
821127	Redwood	25	25	Foot
821127	Redwood	5	25	Foot
830116	Redwood	15	25	Foot
821127	Redwood	6	40	Foot
821127	Redwood	3	40	Foot
821127	Redwood	25	50	Foot
821127	Redwood	12	50	Foot
821127	Redwood	6	50	Foot
821127	Redwood	25	50	Boat
830116	Redwood	1	50	Foot
821127	Redwood	11	100	Foot
**	SUBTOTAL	**		
		400	825	

* NUMBERS OF BIRDS FLUSHED AND FLUSHING DISTANCES FOR: Brown Pelican

821127	Redwood	1	20	Foot
**	SUBTOTAL	**		
		1	20	

* NUMBERS OF BIRDS FLUSHED AND FLUSHING DISTANCES FOR: Sufflehead

821113	Redwood	5	40	Foot
830116	Redwood	4	40	Foot
**	SUBTOTAL	**		
		9	80	

* NUMBERS OF BIRDS FLUSHED AND FLUSHING DISTANCES FOR: Common Goldeneye

02/18/83

CULLINAN RANCH MONITORING PROGRAM

DATE MARINA # FLUSH FLUSH
FLUSH DIST. AGENT

* NUMBERS OF BIRDS FLUSHED AND FLUSHING DISTANCES FOR: Common Goldeneye

830116	Redwood	1	5	Foot
830116	Redwood	1	10	Foot
830116	Redwood	1	15	Foot
830116	Redwood	6	20	
821127	Redwood	21	30	Foot
830116	Redwood	3	30	Foot
830116	Redwood	1	30	Foot
821113	Redwood	20	40	Foot
821127	Redwood	1	50	Foot
821127	Redwood	13	50	Boat
830116	Redwood	1	50	Foot
821127	Redwood	3	70	Boat
821127	Redwood	6	75	Foot
830116	Redwood	1	75	Foot
821127	Redwood	4	100	
821127	Redwood	5	100	Foot

** SUBTOTAL **

88 750

* NUMBERS OF BIRDS FLUSHED AND FLUSHING DISTANCES FOR: Double-crested Cormorant

821113	Redwood	1	20	Foot
821127	Redwood	1	20	Foot
821127	Redwood	1	20	Foot
821212	Ball Marin	5	20	Foot
821113	Redwood	1	30	Foot
821113	Redwood	4	30	Foot
821127	Redwood	2	45	Foot
821113	Redwood	1	50	Foot
821127	Redwood	1	50	Foot
821127	Redwood	1	50	Foot
821127	Redwood	2	75	Foot
821127	Redwood	1	75	
821127	Redwood	3	100	Foot
821127	Redwood	2	100	Foot
821127	Redwood	1	100	Foot
821127	Redwood	1	100	Foot

** SUBTOTAL **

28 885

* NUMBERS OF BIRDS FLUSHED AND FLUSHING DISTANCES FOR: Duck sp.

821113	Redwood	10	40	Foot
--------	---------	----	----	------

** SUBTOTAL **

10 40

* NUMBERS OF BIRDS FLUSHED AND FLUSHING DISTANCES FOR: Hared Grebe

02/18/83

CULLINAN RANCH MONITORING PROGRAM

DATE	MARINA	#	FLUSH	FLUSH
			FLUSH DIST.	AGENT
* NUMBERS OF BIRDS FLUSHED AND FLUSHING DISTANCES FOR: Eared Grebe				
821127	Redwood	1	25	Foot
** SUBTOTAL **		1	25	
* NUMBERS OF BIRDS FLUSHED AND FLUSHING DISTANCES FOR: Great Egret				
821212	Bell Marin	1	10	Foot
821212	Bell Marin	1	10	Motorcycle
830116	Redwood	1	30	Foot
820826	Bell Marin	2	40	Foot
** SUBTOTAL **		5	90	
* NUMBERS OF BIRDS FLUSHED AND FLUSHING DISTANCES FOR: Greater Yellowlegs				
821113	Redwood	1	12	Foot
** SUBTOTAL **		1	12	
* NUMBERS OF BIRDS FLUSHED AND FLUSHING DISTANCES FOR: Horned Grebe				
821127	Redwood	1	75	Foot
** SUBTOTAL **		1	75	
* NUMBERS OF BIRDS FLUSHED AND FLUSHING DISTANCES FOR: Killdeer				
821212	Bell Marin	1	10	Foot
821212	Bell Marin	3	10	Foot
820923	Bell Marin	6	30	Foot
** SUBTOTAL **		10	50	
* NUMBERS OF BIRDS FLUSHED AND FLUSHING DISTANCES FOR: Lesser Scaup				
821127	Redwood	2	50	Foot
** SUBTOTAL **		2	50	
* NUMBERS OF BIRDS FLUSHED AND FLUSHING DISTANCES FOR: Long-billed Curlew				
820826	Bell Marin	15	10	Foot
** SUBTOTAL **		15	10	
* NUMBERS OF BIRDS FLUSHED AND FLUSHING DISTANCES FOR: Mallard				
821127	Redwood	20	0	

02/18/83

CULLINAN RANCH MONITORING PROGRAM

DATE	MARINA	#	FLUSH	FLUSH
		FLUSH	DIST.	AGENT

* NUMBERS OF BIRDS FLUSHED AND FLUSHING DISTANCES FOR: Snowy Egret

821113	Redwood	1	5	Foot
821212	Bell Marin	1	15	Foot
830116	Redwood	1	15	Foot
820923	Bell Marin	1	30	Foot
820923	Bell Marin	1	50	Foot

** SUBTOTAL **

5 115

* NUMBERS OF BIRDS FLUSHED AND FLUSHING DISTANCES FOR: Western Grebe

830116	Redwood	13	15	Foot
821113	Redwood	1	20	Foot

** SUBTOTAL **

14 35

* NUMBERS OF BIRDS FLUSHED AND FLUSHING DISTANCES FOR: Willet

830116	Redwood	1	3	Foot
830116	Redwood	1	15	Foot

** SUBTOTAL **

2 18

** TOTAL **

788 3855

02/18/83

CULLINAN RANCH MONITORING PROGRAM

DATE	MARINA	#	FLUSH	FLUSH
		FLUSH	DIST.	AGENT
* NUMBERS OF BIRDS FLUSHED AND FLUSHING DISTANCES FOR: Mallard				
821127	Redwood	2	5	Foot
830116	Redwood	2	5	Foot
830116	Redwood	12	5	Foot
821127	Redwood	3	10	Foot
821127	Redwood	3	10	Foot
821113	Redwood	4	15	Foot
821127	Redwood	15	15	Boat
830116	Redwood	1	20	Foot
821127	Redwood	6	25	Foot
821127	Redwood	10	30	Boat
820826	Bell Marin	6	40	Foot
820923	Bell Marin	5	100	Foot
** SUBTOTAL **		89	280	

* NUMBERS OF BIRDS FLUSHED AND FLUSHING DISTANCES FOR: Meadowlark				
821127	Redwood	2	25	Foot
** SUBTOTAL **		2	25	

* NUMBERS OF BIRDS FLUSHED AND FLUSHING DISTANCES FOR: Pied-billed Grebe				
830116	Redwood	1	5	Foot
821127	Redwood	1	10	Foot
821127	Redwood	1	15	Foot
821113	Redwood	2	20	Foot
821127	Redwood	1	20	Foot
821127	Redwood	5	25	Foot
821127	Redwood	2	75	Foot
821127	Redwood	2	100	Foot
** SUBTOTAL **		15	270	

* NUMBERS OF BIRDS FLUSHED AND FLUSHING DISTANCES FOR: Ruddy Duck				
821113	Redwood	16	15	Foot
830116	Redwood	1	15	Foot
830116	Redwood	4	15	
830116	Redwood	1	15	Foot
830116	Redwood	10	15	Foot
830116	Redwood	1	20	Foot
830116	Redwood	27	30	Foot
830116	Redwood	30	75	Foot
** SUBTOTAL **		90	200	

* NUMBERS OF BIRDS FLUSHED AND FLUSHING DISTANCES FOR: Snowy Egret

APPENDIX E. DUTCHMAN SLOUGH.
FISH SAMPLING DATA.

02/18/83

CULLINAN RANCH FISH MONITORING
RESULTS OF SAMPLING

SPECIES	HAUL NO.	STATION	LENGTH (CM)	NO. CAU GHT	DATE
* SAMPLING RESULTS FOR: American shad					
American shad	1	SB	8	1	821009
American shad	1	SB	10	1	821120
** SUBTOTAL **				2	
* SAMPLING RESULTS FOR: Inland silverside					
Inland silverside	1	SB	8	1	821211
** SUBTOTAL **				1	
* SAMPLING RESULTS FOR: Longfin smelt					
Longfin smelt	1	SB	9	1	821211
Longfin smelt	1	OH	9	1	830129
** SUBTOTAL **				2	
* SAMPLING RESULTS FOR: Pacific staghorn					
Pacific staghorn	1	SB	13	2	821211
** SUBTOTAL **				2	
* SAMPLING RESULTS FOR: Shiner perch					
Shiner perch	2	SB	9	1	821009
Shiner perch	2	SB	10	1	821009
Shiner perch	1	SB	13	1	821211
** SUBTOTAL **				3	
* SAMPLING RESULTS FOR: Splittail					
Splittail	1	OH	8	1	821009
Splittail	2	OH	10	2	821009
Splittail	1	SB	8	3	821009
Splittail	1	SB	10	5	821009
Splittail	1	SB	11	10	821009
Splittail	1	SB	13	2	821009
Splittail	1	SB	12	3	821120
Splittail	1	SB	13	3	821120
Splittail	1	SB	15	1	821120
Splittail	2	SB	12	2	821120
Splittail	2	SB	13	6	821120
Splittail	2	SB	14	2	821120
Splittail	2	SB	15	2	821120

02/18/83

CULLINAN RANCH FISH MONITORING
RESULTS OF SAMPLING

SPECIES	HAUL NO.	STATION	LENGTH (CM)	NO. CAU GHT	DATE
* SAMPLING RESULTS FOR: Splittail					
Splittail	2	SB	16	2	821120
Splittail	2	SB	19	1	821120
Splittail	1	SB	35	1	821211
Splittail	1	SB	36	1	821211
Splittail	1	SB	37	1	821211
Splittail	1	SB	12	1	821211
Splittail	1	SB	13	3	821211
Splittail	1	SB	14	4	821211
Splittail	1	SB	15	1	821211
Splittail	1	SB	16	1	821211
** SUBTOTAL **					
				58	
* SAMPLING RESULTS FOR: Starry flounder					
Starry flounder	1	SB	10	1	821009
Starry flounder	1	SB	11	2	821120
Starry flounder	1	SB	12	1	821120
Starry flounder	1	SB	9	1	821211
** SUBTOTAL **					
				5	
* SAMPLING RESULTS FOR: Striped bass					
Striped bass	1	OH	5	2	821009
Striped bass	2	OH	8	2	821009
Striped bass	3	OH	8	2	821009
Striped bass	1	SB	5	2	821009
Striped bass	1	SB	9	10	821009
Striped bass	1	SB	20	1	821009
Striped bass	1	SB	23	1	821009
Striped bass	1	SB	25	1	821009
Striped bass	1	SB	35	1	821009
Striped bass	1	SB	37	1	821009
Striped bass	2	SB	9	13	821009
Striped bass	2	SB	10	3	821009
Striped bass	2	SB	23	3	821009
Striped bass	1	SB	8	1	821120
Striped bass	1	SB	9	1	821120
Striped bass	1	SB	11	1	821120
Striped bass	1	SB	12	1	821120
Striped bass	2	SB	9	1	821120
Striped bass	2	SB	10	1	821120
Striped bass	1	SB	8	1	821211
Striped bass	1	SB	9	1	821211
Striped bass	1	SB	10	3	821211
Striped bass	1	SB	11	4	821211

02/18/83

CULLINAN RANCH FISH MONITORING
RESULTS OF SAMPLING

SPECIES	HAUL NO.	STATION	LENGTH (CM)	NO. CAU GHT	DATE
* SAMPLING RESULTS FOR: Yellowfin goby					
Yellowfin goby	1	SB	17	1	821120
Yellowfin goby	1	SB	20	1	821120
Yellowfin goby	2	SB	14	1	821120
Yellowfin goby	2	SB	15	2	821120
Yellowfin goby	2	SB	16	2	821120
Yellowfin goby	1	SB	15	3	821211
Yellowfin goby	1	SB	16	1	821211
Yellowfin goby	1	SB	17	1	821211
** SUBTOTAL **				47	
** TOTAL **				270	

02/18/83

CULLINAN RANCH FISH MONITORING
RESULTS OF SAMPLING

SPECIES	HAUL NO.	STATION	LENGTH (CM)	NO. CAU GHT	DATE
* SAMPLING RESULTS FOR: Striped bass					
Striped bass	1	OH	8	1	830129
** SUBTOTAL **				58	

* SAMPLING RESULTS FOR: Threadfin shad					
Threadfin shad	1	OH	3	1	821009
Threadfin shad	1	OH	8	4	821009
Threadfin shad	2	OH	3	2	821009
Threadfin shad	3	OH	3	3	821009
Threadfin shad	1	SB	8	31	821009
Threadfin shad	1	SB	10	10	821009
Threadfin shad	1	SB	11	10	821009
Threadfin shad	1	SB	8	1	821120
Threadfin shad	1	SB	9	2	821120
Threadfin shad	1	SB	10	5	821120
Threadfin shad	1	SB	11	1	821120
Threadfin shad	1	SB	13	1	821120
Threadfin shad	2	SB	9	3	821120
Threadfin shad	2	SB	10	4	821120
Threadfin shad	2	SB	11	6	821120
Threadfin shad	2	SB	12	2	821120
Threadfin shad	1	SB	8	1	821211
** SUBTOTAL **				87	

* SAMPLING RESULTS FOR: Tule perch					
Tule perch	1	SB	11	2	821009
Tule perch	1	SB	13	1	821009
Tule perch	1	SB	18	1	821211
Tule perch	1	OH	4	1	830129
** SUBTOTAL **				5	

* SAMPLING RESULTS FOR: Yellowfin goby					
Yellowfin goby	1	OH	13	3	821009
Yellowfin goby	2	OH	10	1	821009
Yellowfin goby	2	OH	13	5	821009
Yellowfin goby	1	SB	14	3	821009
Yellowfin goby	2	SB	13	8	821009
Yellowfin goby	2	SB	18	1	821009
Yellowfin goby	1	SB	13	4	821120
Yellowfin goby	1	SB	14	3	821120
Yellowfin goby	1	SB	18	5	821120
Yellowfin goby	1	SB	16	2	821120

I
I
I
I

APPENDIX F. SCIENTIFIC AND COMMON NAMES OF
SPECIES PRESENTED.

BIRDS

Horned Grebe	<u>Podiceps auritus</u>
Eared Grebe	<u>Podiceps nigricollis</u>
Western Grebe	<u>Aechmophorus occidentalis</u>
Pied-billed Grebe	<u>Podilymbus podiceps</u>
American White Pelican	<u>Pelecanus erythrorhynchos</u>
Brown Pelican	<u>Pelecanus occidentalis</u>
Double-crested Cormorant	<u>Phalacrocorax auritus</u>
Great Blue Heron	<u>Ardea herodias</u>
Great Egret	<u>Casmerodius albus</u>
Snowy Egret	<u>Egretta thula</u>
Black-crowned Night Heron	<u>Nycticorax nycticorax</u>
American Bittern	<u>Botaurus lentiginosus</u>
Greater White-fronted Goose	<u>Anser albifrons</u>
Snow Goose	<u>Chen caerulescens</u>
Mallard	<u>Anas platyrhynchos</u>
Gadwall	<u>Anas strepera</u>
Pintail	<u>Anas acuta</u>
Green-winged Teal	<u>Anas crecca</u>
Blue-winged Teal	<u>Anas discors</u>
Cinnamon Teal	<u>Anas cyanoptera</u>
American Wigeon	<u>Anas americana</u>
Northern Shoveler	<u>Anas clypeata</u>
Redhead	<u>Aythya americana</u>
Canvasback	<u>Aythya valisineria</u>
Lesser Scaup	<u>Aythya affinis</u>
Greater Scaup	<u>Aythya marila</u>
Surf Scoter	<u>Melanitta perspicillata</u>
White-winged Scoter	<u>Melanitta fusca</u>
Common Goldeneye	<u>Bucephala clangula</u>
Bufflehead	<u>Bucephala albeola</u>
Common Merganser	<u>Mergus merganser</u>
Red-breasted Merganser	<u>Mergus serrator</u>
Ruddy Duck	<u>Oxyura jamaicensis</u>
Black-shouldered Kite	<u>Elanus caeruleus</u>
Sharp-shinned Hawk	<u>Accipiter striatus</u>
Cooper's Hawk	<u>Accipiter cooperii</u>
Red-tailed Hawk	<u>Buteo jamaicensis</u>
Bald Eagle	<u>Haliaeetus leucocephalus</u>
Northern Harrier	<u>Circus cyaneus</u>
Osprey	<u>Pandion haliaetus</u>
Peregrine Falcon	<u>Falco peregrinus</u>
Merlin	<u>Falco columbarius</u>
American Kestrel	<u>Falco sparverius</u>
California Quail	<u>Callipepla californica</u>
Ring-necked Pheasant	<u>Phasianus colchicus</u>
Clapper Rail	<u>Rallus longirostris</u>
Virginia Rail	<u>Rallus limicola</u>
Sora	<u>Porzana carolina</u>
Black Rail	<u>Laterallus jamaicensis</u>
Common Moorhen	<u>Gallinula chloropus</u>
American Coot	<u>Fulica americana</u>

Semipalmated Plover
Snowy Plover
Killdeer
Lesser Golden Plover
Black-bellied Plover
American Avocet
Black-necked Stilt
Long-billed Curlew
Whimbrel
Greater yellowlegs
Willet
Least Sandpiper
Dunlin
Western Sandpiper
Short-billed Dowitcher
Long-billed Dowitcher
Marbled Godwit
Common Snipe
Western Gull
Herring Gull
California Gull
Ring-billed Gull
Bonaparte's Gull
Forster's Tern
Caspian Tern
Rock Dove
Mourning Dove
Barn owl
Burrowing Owl
Short-eared Owl
Belted Kingfisher
Northern Flicker
Black Phoebe
Say's Phoebe
Horned Lark
Violet-green Swallow
Barn Swallow
Cliff Swallow
Scrub Jay
American Crow
Plain Titmouse
Bushtit
Marsh Wren
American Robin
Mockingbird
Water Pipit
Loggerhead Shrike
Starling
Yellow-rumped Warbler
Common Yellowthroat
Brown Towhee
Savannah Sparrow
Dark-eyed Junco
White-crowned Sparrow
Golden-crowned Sparrow

Charadrius semipalmatus
Charadrius alexandrinus
Charadrius vociferus
Pluvialis dominica
Pluvialis squatarola
Recurvirostra americana
Himantopus mexicanus
Numenius americanus
Numenius phaeopus
Tringa melanoleuca
Catoptrophorus semipalmatus
Calidris minutilla
Calidris alpina
Calidris mauri
Limnodromus griseus
Limnodromus scolopaceus
Limosa fedoa
Gallinago gallinago
Larus occidentalis
Larus argentatus
Larus californicus
Larus delawarensis
Larus philadelphia
Sterna forsteri
Sterna caspia
Columba livia
Zenaida macroura
Tyto alba
Athene cunicularia
Asio flammeus
Ceryle alcyon
Colaptes auratus
Sayornis nigricans
Sayornis saya
Eremophila alpestris
Tachycineta thalassina
Hirundo rustica
Hirundo pyrrhonota
Aphelocoma coerulescens
Corvus brachyrhynchos
Parus inornatus
Psaltriparus minimus
Cistothorus palustris
Turdus migratorius
Mimus polyglottos
Anthus spinoletta
Lanius ludovicianus
Sturnus vulgaris
Dendroica coronata
Geothlypis trichas
Pipilo fuscus
Passerculus sandwichensis
Junco hyemalis
Zonotrichia leucophrys
Zonotrichia atricapilla

Song Sparrow
Western Meadowlark
Red-winged Blackbird
Brewer's Blackbird
Brown-headed Cowbird
House Finch
Lesser Goldfinch
House Sparrow

Melospiza melodia
Sturnella neglecta
Agelaius phoeniceus
Euphagus cyanocephalus
Molothrus ater
Carpodacus mexicanus
Carduelis psaltria
Passer domesticus

MAMMALS

Common Opossum
Vagrant Shrew
Ornate Shrew
Suisun Shrew
Big Brown Bat
Pallid Bat
Brazilian Free-tailed Bat
Black-tailed hare
Beechy Ground Squirrel
Botta's pocket Gopher
Western Harvest Mouse
Salt Marsh Harvest Mouse
Deer Mouse
California Vole
Muskrat
Norway Rat
House Mouse

Didelphis virginiana
Sorex vagrans
Sorex ornatus
Sorex sinuosus
Eptesicus fuscus
Antrozous pallidus
Tadarida brasiliensis
Lepus californicus
Spermophilus beecheyi
Thomomys bottae
Reithrodontomys megalotis
Reithrodontomys raviventris
Peromyscus maniculatus
Microtus californicus
Ondatra zibethicus
Rattus norvegicus
Mus musculus

Feral Dog
Raccoon
Long-tailed Weasel
Mink
Striped Skunk
River Otter
Feral Cat
Harbor Seal

Canis familiaris
Procyon lotor
Mustela frenata
Mustela vison
Mephitis mephitis
Lutra canadensis
Felis cattus
Phoca vitulina

CULLINAN RANCH MONITORING PROGRAM
DUTCHMAN'S SLOUGH FISH SAMPLING

Species Represented in Sampling Data:

American shad	<u>Alosa sapidissima</u>
Threadfin shad	<u>Dorosoma petenense</u>
Longfin smelt	<u>Spirinchus thaleichthys</u>
Splittail	<u>Pogonichthys macrolepidotus</u>
Inland silversides	<u>Menidia beryllina</u>
Pacific staghorn sculpin	<u>Leptocottus armatus</u>
Striped bass	<u>Morone saxatilis</u>
Shiner perch	<u>Cymatogaster aggregata</u>
Tule perch	<u>Hysterocarpus traski</u>
Yellowfin goby	<u>Acanthogobius flavimanus</u>
Starry flounder	<u>Platichthys stellatus</u>

AGRIDEVELOPMENT COMPANY

3 FLEETWOOD COURT

ORINDA, CALIFORNIA 94563

CONSULTANTS - APPRAISERS

(415) 284-0789

AGRICULTURE - CHEMICALS - FOREST
MARKETING & FEASIBILITY STUDIES
RESEARCH & INVESTIGATIONS
LAND USE ECONOMICS

**TECHNICAL AND ECONOMIC EVALUATION
OF THE CULLINAN RANCH PROPERTY
FOR AGRICULTURAL PRODUCTION**

FOR

W. R. WILLIAMS & ASSOCIATES, INC.

HUNTINGTON BEACH, CALIFORNIA

By

**Richard B. Bohme, Ph.D., P.Ag.
Agricultural Consultant
Orinda, California**

August, 1982

TABLE OF CONTENTS

SUMMARY AND CONCLUSIONS

I.	PURPOSE OF STUDY	1
II.	BACKGROUND, LOCATION AND PRESENT USE	1
	A. Background	1
	B. Location	1
	C. Present Use	2
III.	SOIL CAPABILITIES	4
	A. Physical Characteristics	4
	B. Chemical Aspects	4
IV.	SEEPAGE AND FLOODING - DRAINAGE REQUIREMENTS	6
V.	LIMITATIONS OF DRYLAND FARMING - CROP ADAPTABILITY	7
VI.	PRODUCTION COSTS, YIELDS AND RETURNS	10
	A. Hay Production	10
	B. Seed Oat Production	10
	C. Lessee Net Crop Return	11
VII.	CRITIQUE OF REPORT - "Agricultural Values of Diked Historic Baylands", SFB CDC, April, 1982	12
	A. Introduction	12
	B. Location of Diked Agricultural Lands	13
	C. Physical Factors Influencing Crops Grown on Diked Baylands	13
	D. Economics of Hay and Oat Farming	13
	E. Interdependence of Local Feed and North Bay Dairy Industry	14
	F. Pressures on Continued Agricultural Use	14

EXHIBITS

1. Soil Survey of Solano County, California, USDA
Soil Conservation Service, University of California
Agricultural Experiment Station, May, 1977.
2. Sonoma County Agricultural Crop Report, 1981.
3. Solano County Agricultural Crop Report, 1981.
4. Napa County Agricultural Crop Report, 1981.
5. "Gross Farm Income Determines Operation Success",
California-Arizona Farm Press, July 31, 1982.

SUMMARY AND CONCLUSIONS

Summary

1. Background and Location

The Cullinan Ranch has been reclaimed from the Napa River-Petaluma-Sonoma Creek Delta as dry land since the late 1890's. It is designated on official maps as "Island No. 1". These lands lie westerly of the City of Vallejo and border Mare Island Naval Base on Route 37. The southerly border is about one-half mile north of San Pablo Bay.

2. Agricultural Use

The Grade 4, acidic-saline clay soils severely limit the adaptability of these lands for successful agricultural production; hence, the dryfarming of low value pastures and hay.

3. Soil Capabilities

The SCS has classified this property in the lowest category of farm land suitable for planting to cultivated crops: Land Capability Class IVw9 with severe limitations on choice of crops. The Storie Index (SI) productivity rating for these low Grade 4 soils is only 25-37 out of a possible 100.

4. Seepage and Drainage Requirements

The seepage of brackish-saline water from the bordering sloughs through the levees is intercepted by a network of open ditch drains. The high water table fluctuates between 2 to 5 feet below the soil surface and is discharged periodically by drain pump back into the slough. The excessive salinity and moisture in these waterlogged soils prevents the production of most crops. Deep rooted crops are damaged by the fluctuating water table.

5. Dryfarming - Crop Adaptability

Lack of good quality water in sufficient volume to permit irrigated crop production severely limits the choice of crops and productivity. Only low value pasture and hay have been produced because of the combination of factors limiting growth of crops; such as, strongly acidic-saline soils, high water table, heavy clay subsoil texture, waterlogging, lack of irrigation water.

6. Production Costs, Yields and Returns

Low average crop yields and returns from pasture and hay grown on the Cullinan Ranch will barely pay the costs of production. Occasional good yields of seed oats on about 230 acres of the better soils may produce a profit in some years. Considering the large investment needed for farming equipment, the Cullinan Ranch does not generate sufficient net spendable income to support an average family. The enterprise does not generate a fair return to management and the capital invested.

Conclusions

1. It is not technically or economically feasible to farm the Cullinan Ranch under present or foreseeable future conditions as a profitable agricultural enterprise because of limiting factors.
2. In the opinion of this consultant, the "agricultural land-use classification" of the Cullinan property does not realistically represent the highest and best use of this land in view of today's economic environment.

I. PURPOSE OF STUDY

The object of this study is to appraise the technical and economic feasibility of operating the Cullinan Ranch property as a viable and profitable agricultural enterprise. The land-use classification of the Cullinan Ranch will be re-evaluated in view of the limitations encountered for agricultural use.

II. BACKGROUND, LOCATION AND PRESENT USE

A. Background

The Cullinan Ranch was reported to be reclaimed from the Napa River Delta complex during the late eighteen hundreds (c. 1890). Over a period of many years, up to the present, the protective levees along Dutchman and South Sloughs were constructed, improved and maintained to prevent flooding and to facilitate drainage of the property, known as Island No. 1. Therefore, the Cullinan Ranch has been kept as a "dryland" for about 90 years for production of pasture and hay.

B. Location

The Cullinan Ranch is located in portions of Sections 4, 5 and 6, T3N, R4W; and portions of Sections 31 and 32, T4N, R4W, immediately south of the Napa County boundary in Solano County. The property lies northerly of State Route #37 westerly of the remains of Guadalcanal Village, a part of Mare Island Naval Base. Dutchman and South Sloughs of the Napa River form the northerly boundaries. Levees extending N-S form the west boundary and separate the property from a large salt pond. The southerly boundary is approximately 2500 feet north of the San Francisco Bay.

The 1493 acre, irregular parcel is dissected by swales and intermittent old water courses and lies west of the City of Vallejo within the

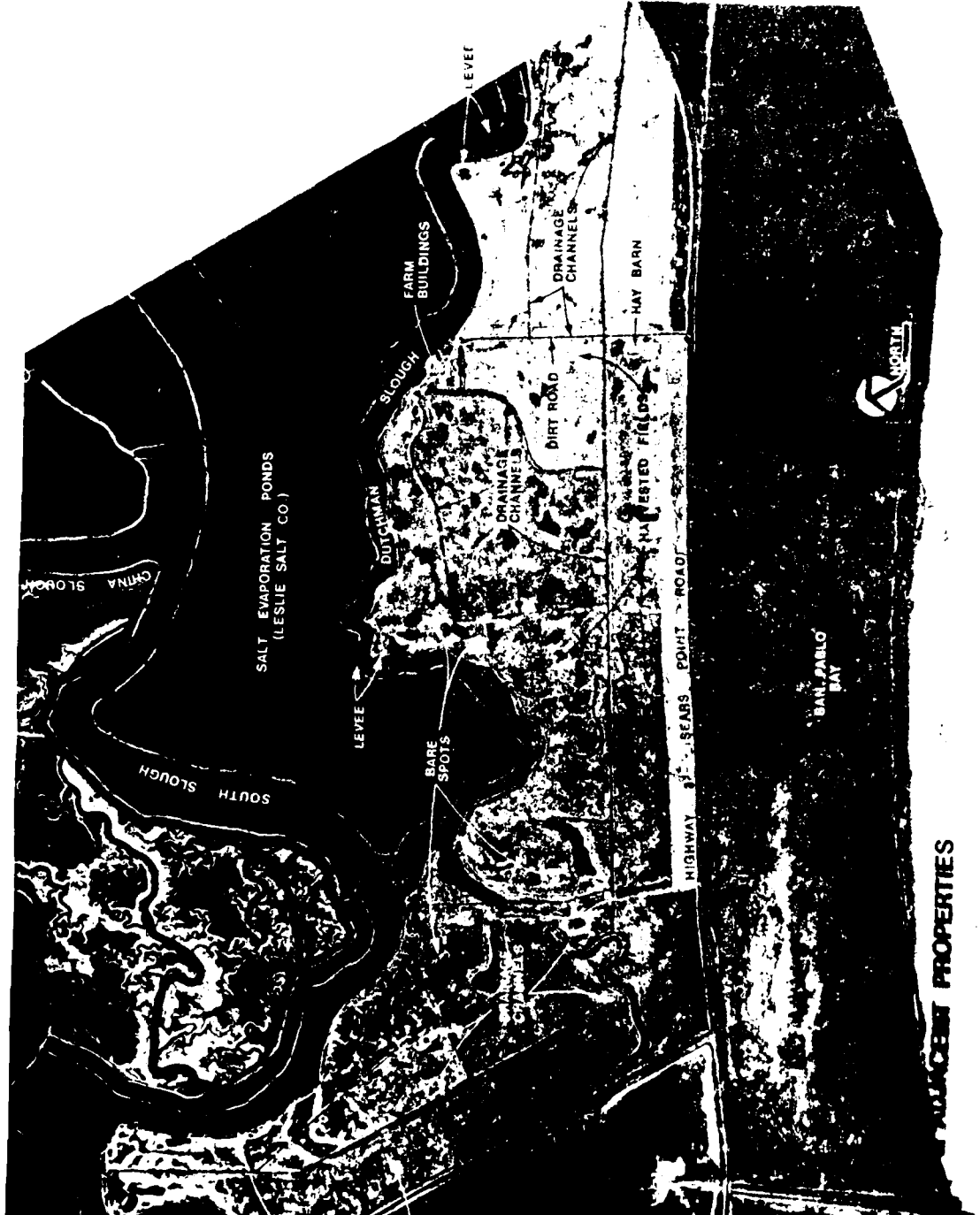

ADJACENT PROPERTIES

city's area of possible expansion and development influence.

C. Present Use

For the past 25-30 years the present lessee operators have grown dry farmed oats for grain, hay and straw on the better-drained soils of the Cullinan Ranch. Because of soil limitations and lack of irrigation, production has been restricted, yielding on average about 2½ tons per acre of dry hay and 1 ton per acre of oat grain. Oat straw may be baled in years when prices are favorable. For comparison, the Agricultural Crop Report - 1981, Solano County Department of Agriculture, shows the following data:

<u>Crop</u>	<u>Acres</u>	<u>Average Tons/A.</u>	<u>Average Value</u>
Hay (Grain)	6,400	2.60	\$55/Ton
Hay (Grass)	4,400	2.10	\$42/Ton
Pasture (Irrigated)	24,600	-	\$90/Acre
Pasture (Dry)	147,550	-	\$12/Acre
Oats (Grain)	3,500	0.98	\$150/Ton

These countywide averages compare closely to the data supplied by the lessee. Farmers must produce in excess of the county averages to receive fair wages and a suitable rate of return on investment. Note the higher return from irrigated pasture (\$90/acre/year) as compared with the forage value from dry pasture (\$12/acre/year) as found on the Cullinan Ranch. Lack of irrigation water severely limits productivity and income on the Cullinan Ranch. Hay (grain and grass) and pasture constitute the largest single land use classification in Solano County, totaling 183,000 acres in 1981. In addition, there are about 70,000 acres of irrigated alfalfa hay with average yields of 6-7 tons per acre per year; and alfalfa hay sells for \$80-90 per ton fieldside. Alfalfa is not adapted to the saline-sodic soils on the Cullinan Ranch and could not survive the fluctuating high water table.

The production of dryland pasture and hay shows that the Cullinan Ranch property is limited to a very low level of agricultural productivity and approaches the breakeven point of return many years.

Agricultural operations, such as tillage and planting, may be hampered or prevented by early and excessive rainfall which, combined with a high water table, restricts the use of the land. During low rainfall and drouth years, the increase in soil salinity and moisture stress results in poor hay and grain yields.

For a lessee to rely on the Cullinan Ranch for his sole source of income is economically infeasible. After land rent and equipment and labor costs are deducted from gross income little, if any, net spendable income remains for family living expenses. Equipment costs for land preparation, seeding, harvesting, hauling and storage are estimated to range between \$150,000-\$200,000 for tractors (2-3), disk, plough, harrow, seeder, mower-sweeper, bailer, loader, trucks and storage sheds. The present lessees already possess this equipment for their use on other property. The lessees operate the Cullinan Ranch as an adjunct to their primary farming operations on other, more productive lands. This property does not provide sufficient income to support a family because of low yields, high costs of operation and low hay-grain prices.

The net farmable acres are estimated as follows:

Total land area	1493 Acres
Less drains, levees, roads, farm sites (15%)	<u>(225)</u>
Net Farmable	1268 Acres

Contained in the net farmable acreage are many irregular saline areas and wet swales which further reduce the productivity of this unlevel property. These non-productive saline areas show up as irregular white spots on the attached aerial photo taken from the SCS Soil Survey of Solano County and

on the large scale aerial photograph provided by W. R. Williams & Associates, Inc. The irregular shape of the property makes it more difficult and expensive to farm.

III. SOIL CAPABILITIES

A. Physical Characteristics

The 1977 Soil Survey of Solano County, published by the Soil Conservation Service, USDA, in cooperation with the University of California classifies the soil type as Reyes silty clay loam, drained (Rd). The Reyes series consist of gray, poorly drained alluvial soils that are very strongly acid and saline. Below the surface 8-10 inches of silty clay loam lies a moist, gray, plastic silty clay that has reddish brown iron mottles. The dense clay subsoil is slowly permeable to water and air, which impedes root penetration and growth. Included with this soil in mapping are numerous small, bare areas of high salinity and more dense Reyes silty clay (Re) (see Soil Photo Map No. 39, Solano County). The high salinity areas contain dispersed and sealed silty clay which supports only limited growth of halophytic weeds. All of the work and expense involved in tilling and planting these interspersed, non-productive areas are a burden and loss to the entire enterprise. It is estimated that 10-15% of the farmable land is highly saline-acidic, non-productive Reyes silty clay.

The Cullinan Ranch property has been placed by the SCS in Capability Class IVv9, the lowest rating for cultivable agricultural land with very severe limitations on choice of crops, requiring very careful management. A field survey verified this classification.

B. Chemical Aspects

The Reyes silty clay loam and silty clay soils are extremely acid and contain a large amount of sulfic acid-forming derivatives. The

organic matter content is high in places but averages less than 15%. No peat deposits were found on the Cullinan Ranch, though local spots may be found at deep depths. Deep soil borings by Harding & Lawson, Soil Engineers, show localized deposits of peat. These deposits are limited in extent and thin, occurring in lenses or strata about 2-3 feet thick within the top 20 feet of soil.

Chemical analyses of the Cullinan Ranch soil conducted by the University of California showed the following acidic (pH) and saline characteristics.

Soil Type	Reaction (pH)	Salinity (E.C. - μ mhos/cm)	Sodium % (S.P.)
Bare Spots			
Reyes Si Cl L, drained (Rd)			
Depth 0-6"	3.8	7.4	67
6-16"	3.8	7.5	83
Best Spots			
Depth 0-6"	4.5	.77	77
6-16"	4.4	1.10	93

Relative acidity is expressed as pH which ranges from 1, strongly acid, to 7 which is neutral. Soil reactions of pH 3.8-4.5 are considered highly acid and inhibit nutrient availability and plant growth. Soil salinity is measured by the electrical conductance of the saturation extract of soil solution. Electrical conductivity (E.C.) measurements which exceed 4 indicate a saline soil which decreases the yields of crops. An E.C. of 4 reduces the yields of salt-sensitive crops by 50% or more and the yields of salt-tolerant crops by 5-10%. From the accompanying table it is readily seen that all plants growing on the Cullinan Ranch were unable to survive an E.C.-salinity of 7.4 μ mhos/cm. because the soil was barren (bare spots on SCS aerial photo).

The Storie Index (SI), a soil productivity rating which integrates soil texture, profile-rooting depth, slope and chemical factors, is a low 37 for Reyes Silty Clay Loam, drained (Rd). This indicates a poor soil - Grade 4 - with severe limitations for crops. The bare areas of Reyes Silty Clay (Re) included in the Cullinan Ranch are given a very low SI rating of 25, on a scale of 0 (Grade 6) to 100 (Grade 1).

Due to these factors limiting growth, attempts to grow other higher value crops have not been successful, and the Cullinan Ranch has been able to grow only oats for hay and, occasionally, for seed.

IV. SEEPAGE AND FLOODING - DRAINAGE REQUIREMENTS

The Cullinan Ranch property lies below sea level except for the protective levees, which have un surfaced roadways on top. These levees and the network of open drains crisscrossing the property, in combination with a large 60 h. p. drainage pump, are essential to maintaining the soil water table at a depth of 4-5 feet during the rainy season. When rainfall is adequate, the level of harmful salts may be reduced by leaching from the surface layer through the subsoil into the drains and thence by pumping into Dutchman Slough, which drains into the Napa River and the Bay. During the dry summer months evaporation of saline subsoil water occurs from the soil surface, increasing the soil salinity. Soil E.C. fluctuates between about 0.7 to 8 mhos/cm. The recurring high salinity is a perennial cause of reduced crop yields.

The leasees have had to operate the large drainage pumping plant generally from December through March-April most rainy seasons in order to keep the water table sufficiently low to permit hay growth and heavy equipment operations on the land. With higher electricity rates the power costs for drainage pumping, averaging about \$2,000 per month, have become a heavy burden on economic feasibility.

Levee and drain ditch maintenance and improvement costs are incurred periodically, especially during extremely wet seasons with high tides. Dutchman and South Sloughs are subject to tidal influence, and seepage of salt or brackish water into the soil of Cullinan Ranch occurs. Low swales and old channels may contain surface water during the wet season, and temporary ponding may occur in other low areas during the winter. This is normal in wet winters for low-lying flatlands with impaired soil drainage wherever they occur; however, the surface ponding may drown the pasture or oat crop, contributing to loss of yield.

Cullinan Ranch is part of the Napa River Delta, and Island No. 1 was formed by natural levees that were deposited by overflows of the sloughs which carry floodwaters from Sonoma and Petaluma Creeks also. The alluvium deposited as natural levees is mostly moderately coarse textured (sand) to moderately fine textured (silt and clay) sediments. Man-made artificial levees have increased the protection from flooding, creating relatively dry lands of low agricultural value. Certain drylands, such as Cullinan Ranch, consist mostly of clay and silt that settled out of suspension from slack water left after historic floods.

V. LIMITATIONS OF DRYLAND FARMING - CROP ADAPTABILITY

Lack of suitable water for irrigation has severely limited the cropping potential on the Cullinan Ranch for many years. The wells which have been bored on the Cullinan Ranch and nearby have produced saline or brackish water unsuitable for crop production and for leaching harmful salts from the soil profile. Only one small domestic-type water well out of several bored on the property has produced water of suitable quality for livestock. A recent sample from this well was analyzed and showed a pH of 7.8 and Electrical Conductivity (E.C.), a measure of salinity, of 1.75 mmhos per cm. This water has a brackish taste.

Even if irrigation were possible, the application of water combined with the existing high water table would necessitate the installation of expensive tile drains and sump pumping plants to remove the saline leach water. The large investment required to attempt reclamation of this marginal agricultural land would involve high risk, especially because the soil is low grade and would still be very limiting after the salinity and water table conditions had been improved.

Good quality surface and/or well water is not available for reclamation and irrigation, which very severely reduces the choice of crops adaptable to the Cullinan Ranch. Therefore, because of very severe soil and water limitations, this dryfarm land has produced only pasture, hay and oats which yield a low return. For use as pasture, the livestock carrying capacity is 1/3 to 1/2 the animal unit months (AUM) of productive grazing lands.

Referring to the Solano County Agricultural Report, the value of dry pasture varies between \$8 and \$12 per acre, as compared with \$80 to \$90 per acre for irrigated pasture. According to the SCS Soil Survey of Solano County, the Reyes silty clay loam soils when drained yield only 2 animal unit months (AUM) of grazing as dry pasture, but with irrigation grazing may be increased to provide 6 AUM of livestock carrying capacity. Other more productive soils provide 10 to 20 AUM of grazing as irrigated pasture. An animal unit month (AUM) is a measure of livestock carrying capacity of pasture. It is the number of animal units, or 1,000 pounds of live weight, that can be grazed on an acre of pasture for 30 days.

The Reyes soils are affected by varying amounts of salts, and intensive pasture management is not economically feasible.



MICROCOPY RESOLUTION TEST CHART
NATIONAL BUREAU OF STANDARDS-1963-A

Irrigation exploration, well development and land reclamation would be extremely expensive and risky, considering the Grade 4 soils on the Cullinan Ranch. Wells drilled in the area in the past have produced saline and brackish water barely suitable for livestock.

Assuming a large quantity of good quality water could be found, it would require at least two deep wells of large size to produce sufficient water to irrigate 1,000 acres of the most promising areas for reclamation and irrigation development. Before leaching to remove harmful salts could begin, installation of tile drains would require investment of \$300 to \$500 per acre on approximately 1,000 acres. Land grading and leveling costs preliminary to ponding and leaching with water would cost another \$200 to \$300 per acre. Assuming water of suitable quantity and quality could be found, land reclamation would require a highly speculative investment, as follows:

ESTIMATED LAND RECLAMATION COSTS

Irrigation Well Development - 2 each: 500 ft. @ \$50/ft. (Contract basis)	\$ 50,000
Deep Well Turbine Pumps - 2 @ \$20,000 (Includes electrical service and controls)	40,000
Land Grading and Leveling - 1,000 A. @ \$250/A. (Contract basis)	250,000
Installation of Tile Drains - 1,000 A. @ \$400/A. (Includes collector drains and sump pumps)	400,000
Leaching Costs - 1,000 A. @ \$100/A. (Includes 3 times ridging, ponding, leaching)	100,000
	<hr/>
Total Land Reclamation Costs	\$840,000

In view of the restricted crop adaptability of the low productivity soils on the Cullinan Ranch, the production potential does not justify the further investment of \$800,000 to \$900,000 to attempt to develop this property into a profitable agricultural enterprise.

VI. PRODUCTION COSTS, YIELDS AND RETURNS

A. Hay Production

According to the operators, the Cullinan Ranch produces on average about 2½ tons/acre of mixed oat hay per season. In 1982 hay is expected to bring \$50 per ton at the field, down somewhat from 1981 because of the large supply in the marketing area. Production costs (tillage, seed, planting, pesticides and harvesting) have been computed at \$80-\$100 per acre. Net return to the grower is estimated as follows:

<u>Hay Economics</u>	<u>Per Acre</u>	<u>Grower Share</u>	<u>Landlord Share</u>
		70%	30%
Average Yield	2½ T		
Crop Return @ \$50/T	\$125	\$87.50	\$37.50
Production Costs	87	(87.00)	-
Landlord's Taxes			(6.00)
Net Crop Return (Before Inc. Tax)		\$ 0.50	\$31.50

The operator must realize a sizable net profit in good crop years in order to survive. Because of the large hay supply most years (960,000 acres of alfalfa; 530,000 acres of other hay in California), large, irrigated, productive acreage is required to justify the heavy equipment investment needed to farm profitably. With farming costs on the increase, hay growing is coming very close to a breakeven enterprise, especially under Cullinan Ranch conditions.

B. Seed Oat Production

In good rainfall years the better soil areas on the Cullinan Ranch will produce clean oats suitable for seed and threshing. The lessees obtain about 1 ton per acre of oats on about 230 acres. Only 18½ (230 A/1268 A) of the farmable land produces a good crop of oat seed. At the recent price of 11-12¢ per lb. (\$230-\$240/T), gross return is estimated at \$230 per acre for oat seed.

<u>Seed Oat Economics</u>	<u>Per Acre</u>	<u>Grower Share</u> 70%	<u>Landlord Share</u> 30%
Average Yield	1 Ton		
Crop Return @ \$230/T	\$230	\$161	\$69
Production Costs*	(113)	(113)	-
Landlord's Taxes			(6)
Net Crop Return (Before Inc. Tax)		\$ 48	\$63

* Includes drainage pump costs @ \$12/acre, threshing @ \$15/T and hauling @ \$6/T.

C. Lessee Net Crop Return

From the above, the Lessee net crop return received from 1493 gross acres (1268 A. net farmable; 230 A. suitable for seed oats) contained in the Cullinan Ranch is estimated:

Lessee Net Crop Return

Hay - 1268 A. x \$0.50	\$ 634
Oat Seed - 230 A. x \$48	<u>11,040</u>
<u>Total Crop Return</u>	\$11,674

This is a very poor return to management for efforts expended on this agricultural enterprise, especially in view of an estimated \$150,000 investment in farming equipment required for operation. More intensive management and investment would be severely limited by the lack of irrigation water and the unproductive soils on the Cullinan Ranch.

On the Cullinan Ranch a farm operator is squeezed between high production costs and low commodity prices, combined with limited crop production and small gross income. With inflation in 1982 an average operator will need a gross income of \$150,000, of which he can expect to use 75 to 80% for operating expenses. At the 80% level, he will have \$30,000 net income. He will spend about \$15,000 for family living, \$4,000 for taxes and Social Security, leaving \$10,000 for principal payments on operating, equipment and land loans (or rent). See attached article - "Gross Income Determines

Farm Operation Success", California-Arizona Farm Press, July 31, 1982.

The Cullinan Ranch does not have the potential to generate sufficient gross income to be a profitable enterprise.

VII. CRITIQUE OF REPORT - "Agricultural Values of Diked Historic Baylands", SFBCDC, April, 1982

A. Introduction

The magnitude of importance of the hay and oats produced by the diked baylands to the economies of Marin, Napa, Sonoma and Solano Counties (32,000 acres x \$125/A. = \$4,000,000) is relatively small for these low value crops when compared with the total gross value for all agricultural products:

Solano County	\$151,097,700
Sonoma County	229,013,200
Napa County	74,725,000

Contrary to the claim of BCDC, these low productivity baylands are of even less relative importance to the economy of the entire Bay Area.

Furthermore, North Bay dairymen do not in particular rely on the forage produced on diked baylands for cow feed, since the bulk of the hay purchased by dairymen is produced in the Sacramento and San Joaquin Valleys where about 1.5 million acres of alfalfa and grain hays are grown. With average yields of hay estimated at 5 tons per acre, total hay production available in the Valleys is 7,500,000 tons annually. Additional loads of hay are trucked into Northern California from Nevada.

According to the California Department of Food and Agriculture, California ranks No. 2 nationally in milk and cream production (9.3% of U.S.). The leading counties for milk production in California are:

- | | |
|-------------------|----------------|
| 1) San Bernardino | 6) San Joaquin |
| 2) Tulare | 7) Fresno |
| 3) Stanislaus | 8) Sonoma |
| 4) Riverside | 9) Marin |
| 5) Merced | 10) Madera |

1982 data received from the Milk Pooling Section, Marketing Service Division, CDFA, Sacramento, show that 65-70% of the milk and milk products sold in the Bay Area are produced in the Central Valley. The BCDC staff report claimed half (50%) of the milk and milk products consumed in the Bay Area were produced by North Bay dairymen. Fresno and valley counties to the north supply 65-70% of the milk to the Bay Area.

B. Location of Diked Agricultural Lands

The fact that only 103 acres (0.4%) of diked lands are in higher value crops, out of 32,000 acres total, confirms the baylands are limited to relatively low value crops. The bulk of the baylands (84%) is in Marin and Sonoma Counties (27,000 acres).

C. Physical Factors Influencing Crops Grown on Diked Baylands

The staff states that climate and soil conditions are major physical factors determining crop adaptability on diked baylands, but the availability of irrigation water is as important as the soil capability and should not have been omitted as a primary factor limiting crop production.

The Cullinan Ranch has an earlier and longer growing season than other baylands. Rather than planting oats in the late spring as stated in the report, the Cullinan Ranch seeds oats in the fall and early winter.

Contrary to the report, alfalfa does not produce abundantly on acidic, saline and poorly drained clay soils. It is deep-rooted and commonly drowns or dies from disease when grown over a high and fluctuating water table.

D. Economics of Hay and Oat Farming

The example given in the report is distorted because the staff has used the best case values of 3 tons of hay per acre sold at \$55 per ton for \$165 per acre gross income. From this gross income is deducted \$100 for operating expenses, but they have omitted capital costs for land

and equipment, overhead and taxes - which result in a much lower net. The present lessee has provided data which show that hay production is about a breakeven business. Further in the report the staff admits (Page 4) that "hay and oat farms are not very profitable".

E. Interdependence of Local Feed and North Bay Dairy Industry

The staff report claims that diked wetlands are a major source of relatively inexpensive feed for North Bay dairymen and estimate that 40% of the forage is produced on diked baylands. However, the major portion (60%) is produced in the Central Valleys and Nevada. The latter may be greater than 60% in view of the 1,500,000 acres of hay in the Central Valleys compared with 32,000 acres total diked baylands.

~~The report infers that a change in use of diked baylands from forage production to other crops or uses would cause a loss of Bay Area dairies and a serious effect on the economy. There is no reason to believe dairies would close because bayland forage was not available. The dairies now obtain 60% or more of the hay required from outside the Bay Area, and more could be imported.~~

The claim is made that diked baylands in agricultural use help the regional economy by supplying milk products inexpensively. The prices of milk and other milk products are not influenced by forage from diked baylands, but by competition and marketing controls.

F. Pressures on Continued Agricultural Use

The report states that North Bay agricultural lands are threatened by urbanization because hay and oat farms are not profitable, urban areas are nearby, and there is little regulatory protection to assure continued agriculture. This indicates that the economic forces of supply and demand are working and that the land is subject to the rule of highest and best

use. The report sums up the situation for the urban fringe baylands by stating "since the farmer cannot increase his earnings by changing crops or expanding his holdings, urban development becomes an ever more attractive option".

Gross Income Determines Farm Operation Success

Farmers and ranchers are in the worst financial shape they've been in in a quarter of a century.

Many are pinched by high production costs on one side and low commodity prices on the other, notes Don Pretzer, farm management specialist for the Kansas Cooperative Extension Service.

In hard times or prosperous, the life blood of the farm business is gross income, the economist said. Without enough income, the business has little chance of succeeding.

Too low a level of gross sales results in lack of net income, from which the operator must meet some critical expenses. Twenty years ago, a farmer or rancher needed an annual gross income of \$100,000 to maintain and improve his farm.

Income Percentage

"Then — as now — the average need about 75 percent of his gross income to cover his operating expenses. The need for this amount is the same now as it was then, but the gross income needed to cover it has risen to \$200,000 or more."

Today, he believes that figure is \$300,000. "The average farmer or rancher needs to have \$300,000 in gross income to cover his operating expenses."

"He will spend \$100,000 for family living, \$50,000 for taxes and other expenses, \$100,000 for operating expenses, and \$50,000 for interest on operating expenses. The \$100,000 will service only \$200,000 for 20 years."

"Commercial" Farms

The old saw that it takes money to make money applies to production agriculture more

"In hard times or prosperous, the life blood of the farm business is gross income."

strongly than ever: Producing \$100,000 in gross income requires owning or renting at least \$1 million worth of assets. Of the 70,000 or so farms in Kansas, only some 11,000 are large enough to be so-called commercial farms.

"By commercial farms, we mean those units that have a large enough volume to provide income for the operator's family living expenses (including income taxes), income for debt servicing and enough growth to stay ahead of inflation," Pretzer explained.

If an operator doesn't have adequate business

"All of these are things most producers can actually do," Pretzer commented.

Calculating gross income involves more than just adding up the receipts for a certain year's sales of crops and livestock, the economist pointed out. "To come to grips with your gross income for any year, you need to establish the value of the inventories you have on hand."

"Suppose you have a cash grain farm and have normally carried over 40,000 bu. of wheat each year. Cash basis tax returns indicate that 1961 wheat sales of 60,000 bu. at \$3.50 would bring in a total of \$210,000. That would make 1961 a pretty good income year, right? Wrong!"

Pretzer explained that \$140,000 was in sales from the previous year's production. Using inventories will give you a correct measure of the current year's income. To illustrate, the beginning inventory of 40,000 bushels was valued at \$140,000, which should be recorded as 1960 income. Because of this, 1961 was \$70,000 rather than the total cash sales of \$210,000.

Capital Needs Up

Capital requirements have been climbing upward as gross income needs have been rising. Today the minimum average of \$250,000 in capital or assets is needed to operate a farm, the economist said.

"That is to say, \$250,000 in gross income requires \$250,000 in capital," he said. "The average farmer rents land valued at \$200,000, uses \$50,000 of his own funds and borrows \$50,000 to finance the purchase of land and/or obtain operating money."

Traditionally, hog and dairy farms have produced more gross income from capital used. In other words, \$4 or \$5 invested in a hog or dairy operation typically produces \$1 gross per year. This means \$750,000 in capital can provide a hog farmer or a dairyman the minimum gross income of \$200,000 instead of \$1 million.

"On the other hand, stock ranch cow herds are heavy users of capital relative to income produced," Pretzer added. "These operations will average \$25 to \$30 capital required to produce \$1 gross income. At the mid-range of \$25, producers need \$2.75 million to generate the minimum gross income needed."

To compare your operation with these examples, calculate the total capital you manage by adding up the fair market values for your land and building, machinery, livestock, average inventory of livestock and harvested crops and the fair market value of rented land, the economist suggested.

Use As Benchmark

"To calculate your capital use efficiency, divide the total capital you manage by your annual gross income. Compare the results with the figures cited for your type of operation," he added.

"If your figures are outside of the quoted averages, start looking for low crop yields, marginal livestock production factors and money tied up in nonproductive assets such as excess mach-

SOIL SURVEY OF
Solano County, California



United States Department of Agriculture
Soil Conservation Service
In cooperation with
University of California
Agricultural Experiment Station

AGRICULTURAL CROP REPORT 1981



Solano County Department of Agriculture

100 Years

Protecting Solano County Agriculture

FIELD CROPS: ACREAGE, PRODUCTION, AND VALUE

Crop	Year	Bearing Acreage	Production		Unit	Value	
			Per Acre	Total		Per Unit	Total
Barley	1981	7,500	1.45	10,875	Ton	120.00	1,305,000
	1980	8,300	1.40	11,620	Ton	135.00	1,568,700
Beans (Dry)	1981	15,372	.94	14,450	Ton	520.00	7,514,000
	1980	12,250	.95	11,638	Ton	584.04	6,797,000
Field Corn	1981	32,366	3.92	126,875	Ton	118.00	14,971,300
	1980	25,300	3.90	98,670	Ton	140.00	13,813,800
Hay (Alfalfa)	1981	10,800	6.50	70,200	Ton	80.00	5,616,000
	1980	12,600	6.40	80,640	Ton	98.00	7,902,700
<u>Hay (Grain)</u>	1981	<u>6,400</u>	<u>2.60</u>	<u>16,640</u>	Ton	<u>55.00</u>	<u>915,200</u>
	1980	<u>7,200</u>	<u>2.50</u>	<u>18,000</u>	Ton	<u>72.00</u>	<u>796,000</u>
<u>Hay (Grass)</u>	1981	<u>4,400</u>	<u>2.10</u>	<u>9,240</u>	Ton	<u>42.00</u>	<u>388,100</u>
	1980	<u>4,300</u>	<u>2.00</u>	<u>8,600</u>	Ton	<u>55.00</u>	<u>473,000</u>
Milo	1981	1,900	2.35	4,465	Ton	105.00	1,800
	1980	2,100	2.40	5,040	Ton	132.00	5,300
Nursery Stock	1981	1,210	---	---	---	---	5,924,400
	1980	1,210	---	---	---	---	5,048,000
<u>Oats</u>	1981	<u>3,500</u>	<u>.98</u>	<u>3,430</u>	Ton	<u>150.00</u>	<u>514,500</u>
	1980	<u>4,300</u>	<u>.99</u>	<u>4,257</u>	Ton	<u>154.99</u>	<u>659,800</u>
<u>Pasture (Irrigated)</u>	1981	<u>24,600</u>	---	---	Acre	<u>90.00</u>	<u>2,221,400</u>
	1980	<u>24,600</u>	---	---	Acre	<u>80.00</u>	<u>1,968,000</u>
<u>Pasture (other)</u>	1981	<u>147,550</u>	---	---	Acre	<u>12.00</u>	<u>1,770,600</u>
	1980	<u>147,600</u>	---	---	Acre	<u>8.00</u>	<u>1,180,800</u>
Safflower	1981	4,800	.95	4,560	Ton	370.00	1,687,200
	1980	5,200	1.30	6,760	Ton	285.00	1,926,600
Sugar Beets	1981	25,379	25.68	651,733	Ton	33.00	21,507,200
	1980	20,111	23.04	463,266	Ton	49.79	23,066,000
Sunflower	1981	2,661	.78	2,076	Ton	230.00	477,500
	1980	---	---	---	---	---	---
Wheat	1981	55,600	2.83	157,348	Ton	128.00	20,140,500
	1980	49,800	2.85	141,930	Ton	140.00	19,870,200
Miscellaneous	1981						673,000
	1980	(Silage, Straw, Screenings etc.)					520,000
TOTAL FIELD CROPS	1981	344,038					\$86,094,700
	1980	323,661					\$86,755,900

S U M M A R Y

<u>Year</u>	<u>Field Crops</u>	<u>Fruit & Nut Crops</u>	<u>Seed Crops</u>	<u>Truck Crops</u>	<u>Animal Production</u>	<u>Totals</u>
1971	\$25,002,100	\$ 7,890,100	\$ 723,800	\$10,653,200	\$ 8,292,100	\$ 52,561,300
1972	26,602,000	9,142,800	730,000	11,636,900	9,253,000	57,364,700
1973	33,326,300	12,411,000	741,600	16,899,900	10,681,900	74,060,700
1974	57,924,800	11,484,200	1,636,200	28,833,900	10,034,900	109,914,000
1975	47,184,500	10,762,700	1,847,900	28,784,300	10,643,100	99,222,500
1976	45,439,000	10,951,600	1,639,000	18,798,000	11,666,600	88,494,200
1977	43,710,700	11,676,100	1,639,400	32,552,300	10,616,900	100,195,400
1978	45,593,000	14,212,200	2,689,900	22,910,800	12,898,100	98,304,000
1979	66,117,700	16,865,700	4,993,100	30,092,400	16,123,200	134,192,100
1980	86,755,900	15,781,400	6,527,200	25,532,900	18,398,100	152,995,500
1981	86,094,700	17,875,900	3,685,000	24,753,300	18,688,800	151,097,700

CLASSIFICATION OF ACREAGE

Field Crops	171,888
Fruit & Nut Crops	13,977
Pasture Land.	172,150
Seed Crops	5,093
Truck Crops	19,560

TOTAL AREA

Square Miles - 827

Estimated Total County Population - 242,900

JANUARY 1, 1982 INVENTORY OF LIVESTOCK AND POULTRY

<u>Item</u>	<u>No. of Head</u>
Cattle & Calves	
All	47,000
Milk Cows (two years and older)	1,100
Hens & Pullets (of laying age).	76,000
Hogs & Pigs	200
Horses & Mules	3,550
Stock Sheep	55,000

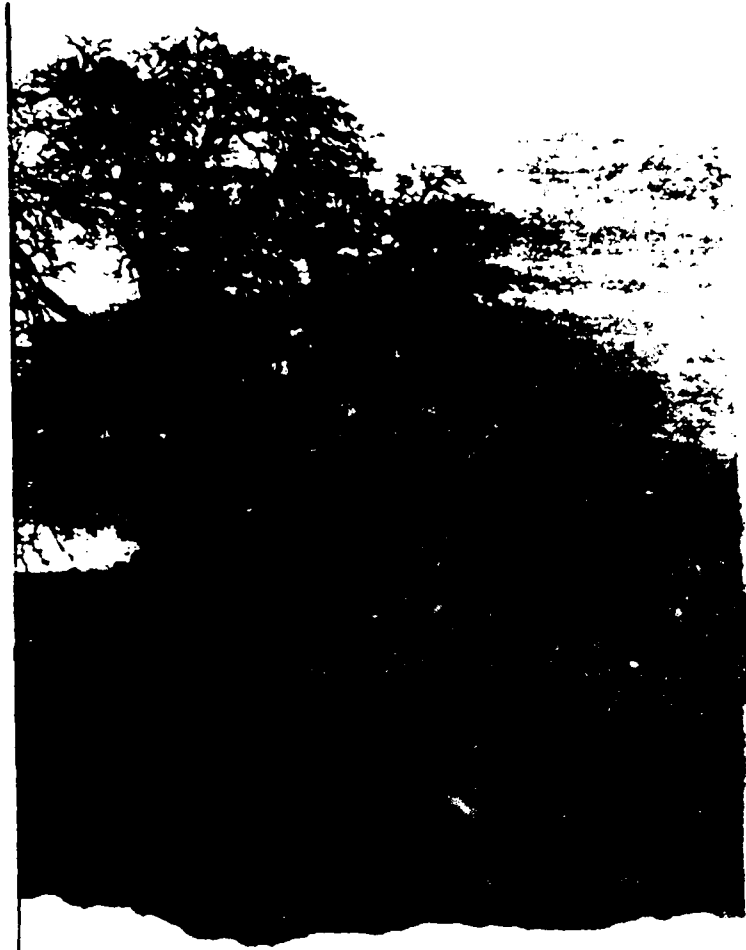

1981
Napa County Agricultural
Crop Report

FIELD CROPS: ACREAGE, PRODUCTION, AND VALUE

Crop	Year	Bearing Acreage	Production		Unit	Value	
			Per Acre	Total		Per Unit	Total
Barley	1981	7,500	1.45	10,875	Ton	120.00	1,305,000
	1980	8,300	1.40	11,620	Ton	135.00	1,568,700
Beans (Dry)	1981	15,372	.94	14,450	Ton	520.00	7,514,000
	1980	12,250	.95	11,638	Ton	584.04	6,797,000
Field Corn	1981	32,366	3.92	126,875	Ton	118.00	14,971,300
	1980	25,300	3.90	98,670	Ton	140.00	13,813,800
Hay (Alfalfa)	1981	10,800	6.50	70,200	Ton	80.00	5,616,000
	1980	12,600	6.40	80,640	Ton	98.00	7,902,700
<u>Hay (Grain)</u>	1981	6,400	2.60	16,640	Ton	55.00	915,200
	1980	7,200	2.50	18,000	Ton	72.00	1,296,000
<u>Hay (Grass)</u>	1981	4,400	2.10	9,240	Ton	42.00	388,100
	1980	4,300	2.00	8,600	Ton	55.00	473,000
Milo	1981	1,900	2.35	4,465	Ton	105.00	468,800
	1980	2,100	2.40	5,040	Ton	132.00	665,300
Nursery Stock	1981	1,210	---	---	---	---	5,924,400
	1980	1,210	---	---	---	---	5,048,000
<u>Oats</u>	1981	3,500	.98	3,430	Ton	150.00	514,500
	1980	4,300	.99	4,257	Ton	154.99	659,800
Pasture (Irrigated)	1981	24,600	---	---	Acre	90.00	2,221,400
	1980	24,600	---	---	Acre	80.00	1,968,000
Pasture (other)	1981	147,550	---	---	Acre	12.00	1,770,600
	1980	147,600	---	---	Acre	8.00	1,180,800
Safflower	1981	4,800	.95	4,560	Ton	370.00	1,687,200
	1980	5,200	1.30	6,760	Ton	285.00	1,926,600
Sugar Beets	1981	25,379	25.68	651,733	Ton	33.00	21,507,200
	1980	20,111	23.04	463,266	Ton	49.79	23,066,000
Sunflower	1981	2,661	.78	2,076	Ton	230.00	477,500
	1980	---	---	---	---	---	---
Wheat	1981	55,600	2.83	157,348	Ton	128.00	20,140,500
	1980	49,800	2.85	141,930	Ton	140.00	19,870,800
Miscellaneous	1981	(Silage, Straw, Screenings etc.)					673,000
	1980						520,000
TOTAL FIELD CROPS	1981	344,038					\$86,094,700
	1980	323,661					\$86,755,900



**SONOMA COUNTY
AGRICULTURAL COMMISSION
2555 Mendocino Avenue
Santa Rosa, CA 95401**

SONOMA COUNTY

FIELD CROPS

1989-1991

CROP	YEAR	PRODUCTIONS				GROSS VALUE	
		HARVESTED ACREAGE	PER ACRE	TOTAL	UNIT	PER UNIT	TOTAL
HAY	1981	16,800	2.83	47,900	Ton	118.00	\$2,778,200
	1980	11,540	2.51	29,000	Ton	83.00	2,465,000
WILD	1981	1,400	2.36	3,300	Ton	38.67	127,600
	1980	1,200	2.23	2,700	Ton	56.67	153,000
GREEN CHOP	1981	900	9.44	8,500	Ton	19.29(a)	164,000
	1980	640	16.09	10,300	Ton	28.35(a)	292,000
OATS, GRAIN	1981	2,200	1.00	2,200	Ton	175.00	385,000
	1980	1,770	1.64	2,900	Ton	280.00	812,000
PASTURE IRRIGATED	1981	6,400			Acre	93.90	598,400
	1980	6,400			Acre	92.97	595,000
GRASSLAND	1981	215,000			Acre	4.50	967,500
	1980	216,000			Acre	4.50	972,000
WOODLAND	1981	182,000			Acre	.50	91,000
	1980	184,000			Acre	.50	92,000
ENSIAGE CORN	1981	420	17.38	7,300	Ton	41.67(a)	304,200
	1980	1,116	19.18	21,400	Ton	47.01(a)	1,006,000
OATS Fresh	1981	5,700	10.07	57,400	Ton	36.67(a)	2,104,900
	1980	6,500	10.17	66,100	Ton	42.00(a)	2,776,000
STRAW	1981			782	Ton	27.49	21,500
	1980			352	Ton	31.25	11,000
MISCELLANEOUS(b)	1981	345					48,000
	1980	497					138,000
TOTAL	1981						\$7,382,300
	1980						\$8,388,000

(a) - Much of the gross of pastures and hay is not sold, but used on the farm. The value is determined by its feed equivalent of hay after it is cut, loaded and baled.
 (b) - Includes alfalfa, hay, vetch, timothy and wheat.

WOODS
 BOARD FEET (b)
 VALUE (c)

TOTAL
 \$ 3,000,000

(a) 1989 Harvest
 (b) Board feet is the quantity of timber cut and scaled.
 (c) Value of the timber immediately before cutting (International only)

VEGETABLE CROPS

CROP	YEAR	HARVESTED ACREAGE	TOTAL
MISCELLANEOUS TRUCK FARMS(a)	1981	311	\$6,305,000
	1980	191	\$8,371,000

(a) Includes melons, mushrooms, potatoes, pumpkins, squash, tomatoes, etc.

APIARY PRODUCTS

ITEM	YEAR	PRODUCTION		GROSS VALUE	
		TOTAL	UNIT	PER UNIT	TOTAL
HONEY	1981	31,000	lb.	.44	\$13,600
	1980	29,300	lb.	1.03	\$30,180
WAX	1981	300	lb.	3.30	990
	1980	900	lb.	3.22	2,898
MESSAGE BEES	1981	2,000	lb.	3.60	7,200
	1980	3,100	lb.	4.10	12,810
POLLINATION	1981				12,100
	1980				13,200
TOTAL	1981				\$37,500
	1980				\$49,488

**ECONOMIC FEASIBILITY
OF THE
CULLINAN RANCH
FOR
AGRICULTURAL PRODUCTION**

Prepared for
W. R. Williams & Associates, Inc.
Huntington Beach, California

By
A. Doyle Reed
Agricultural Economist
Davis, California

October 1982

RECEIVED OCT 25 1982

Contents

	<u>Page</u>
Summary	1
Purpose	2
General Description of Property	2
Location	2
Legal Description	2
Elevation	2
Topography	2
Climate	3
Soils	3
Drainage	4
Salinity	4
Irrigation Water	5
Farming in the Area	5
Present Farming on the Ranch	5
Future Agriculture on the Property	5
Economic Feasibility of Agricultural Production	6
Critique of Report - "Agricultural Values of Diked Historic Baylands"	9
Hay for North Bay Dairies	9
Economics of a 200 Acre Farm	10

Summary

This economic feasibility study analyzes the Cullinan Ranch located northwest of Vallejo in Solano County, California.

The ranch consists of 1493 acres of which 1,268 acres are farmable.

The soils are Class IV, the lowest class which can normally be cultivated. They are poorly drained, acid, and saline.

The ranch is presently rented to a farmer at Sonoma who farms it in conjunction with a like acreage of his own land.

Crops are limited to grain hay with occasional small acreages of oats for grain.

To farm this property as a separate unit would require an investment of about \$1,500,000 for the ranch and \$205,000 for machinery.

The potential net income for labor and land is about \$14,000.

The annual payment on a 7%, 30 year loan would be about \$200,000.

The return to land is a minus.

The ranch produces about 1.5 percent of the hay used by dairies in the north bay area.

A 200 acre grain hay farm on the Diked Historic Baylands would require an investment of over \$300,000 and would make a net loss of about \$150.

Economic Feasibility of the Cullinan Ranch
for Agricultural Production

Purpose

The object of this study is to analyze the economic feasibility of using the Cullinan Ranch for continued agricultural production.

General Description

Location

The Cullinan Ranch is located in western Solano County immediately south of the Napa County boundary and northwest of the City of Vallejo. The property lies north of State Route 37 and west of the remains of Guadalcanal Village which was a part of the Mare Island Naval Base. Dutchman and South Sloughs of the Napa River form the northern boundary. Levees separating this property from a salt pond form the western boundary. The southern boundary is the northern edge of Highway 37. The east boundary is the line between this property and Guadalcanal Village.

The property is designated on maps as "Island No. 1."

Legal Description

The property is located in portions of Section 3, 5, and 6, T3N, R4W and portions of Sections 31 and 32, T4N, R4W all on Mt. Diablo Base and Meridian.

Elevation

The property lies below sea level except for the protective levees.

Topography

The topography is very gently rolling with swales, ditches, and saline areas.

Climate

The area has a Mediterranean type climate with cool dry summers and moderate rainy winters. Fogs are common during the summer.

The rainfall averages about 25 inches per year, but varies from 15 to 45. The seasonal distribution is as follows:

Jan	5.5
Feb	4.8
Mar	3.3
Apr	1.7
May	.5
Jun	.1
Jul	Trace
Aug	Trace
Sep	.2
Oct	1.2
Nov	2.6
Dec	5.1

Temperatures average 58° for the year. July average temperatures are 66° and January is 47°. Temperatures have varied from 17° to 110°.

The frost free season is about 260 days extending from March 10 to November 25.

Soils

The two types of soil on the ranch are classed as Reyes silty clay loam, drained, and Reyes silty clay. The distribution of these soils is

Reyes silty clay loam - 85-905
Reyes silty clay - 10-105

The Reyes soils are gray, poorly drained alluvial soils that are strongly acid and saline. The dense clay subsoil is slowly permeable to water and air, and impedes root penetration and growth.

The Reyes silty clay are dense, highly saline, and with little or no plant growth.

These soils are Class IV under the Soil Conservation Service classification system. These are the lowest rated soils for cultivable agriculture and have very severe limitations on crop choice and require very careful management.

The Storie Index of soil productivity are:

Reyes silty clay loam 37

Reyes silty clay 25

The Stories Index rates soils from poor to good on a scale of 0 to 100. These soils are near the lower end of the scale.

Drainage

Since the property is below sea level, drainage is a constant problem. The area is criss-crossed with open drains and has a 60 HP drainage pump for raising the water into Dutchman Slough which empties into the Napa River. The pump has to operate from December through March or April in order to keep the water table sufficiently low to permit hay growth. Energy costs are averaging about \$2,000 per month.

Salinity

The Reyes soils are saline and the problem is aggravated by the saline subsoil water which moves to the surface during the summer and increases the salinity of the topsoil. Winter rains leach the salinity downward so plants can sprout and mature a crop.

Irrigation Water

Wells drilled on the property have all produced brackish water unsuitable for irrigation use. There is no present supply of suitable water at an economical price. With the increasing water needs in California, it is very doubtful water will ever be available for irrigation on this farm.

Farming in the Area

All of the Reyes and associated soils along the north shore of San Francisco Bay are used for producing dry land grain hay with occasionally small acreages of oats for grain. Uncultivated areas are used for pasture and some fields may be grazed after removing the hay. Pasturing has decreased during the past few years due to increased trucking costs.

Present Farming on the Ranch

The ranch is presently leased to a farmer who lives at Sonoma, and he operates this ranch in conjunction with a similar sized ranch at his home site.

The leasee has primarily grown grain hay, but with small acreages of oats for grain when prices and climatic conditions are satisfactory.

Future Agriculture on the Property

All conditions - soil, climate, markets, prices, costs, and technology all point toward grain hay as the primary agricultural use for the property. Many studies have been made of alternative uses for these lands, but none to date have come up with higher profit crops for the area.

Economic Feasibility of Agricultural Production

The economic potential of farming the Cullinan Ranch as a separate unit is as follows.

Investment

Ranch	\$1,500,000
Machinery	<u>205,000</u>
Total Investment	\$1,705,000

Income and Expense

Total

Income - 1268 acres @ 2.5 tons @\$55

\$174,350

Expense

Seed

\$ 27,900

Herbicides

11,400

Drainage pump energy

8,000

Fuel & repairs for equipment

14,000

Labor - hired

15,000

Interest on operating capital

4,100

Total cultural cost

\$ 80,400

Swath

5,300

Rake

2,400

Bale

1,100

Wire

19,000

Pickup bales

2,500

Harvest cost

\$ 30,300

Taxes

7,000

Misc cash overhead

12,000

Interest on equipment

10,240

Total overhead

\$ 49,740

Total cost

\$160,440

Net

\$ 13,910

Less value
family labor16,000

Return to Land

\$ -2,090

Percent return

Minus

A 70 percent, 30 year loan on the property would require the following annual payment.

<u>Interest rate</u>	<u>Annual payment</u>
8%	\$133,241
9	146,004
10	159,117
11	172,536
12	186,215
13	200,115
14	214,204
15	228,450

Conclusion

The property earns no returns on the investment and it would be impossible for the earnings from the farm to pay off a loan, even at relatively low interest rates.

Critique of Report - "Agricultural Values of Diked Historic Baylands"

Correction of a few statements is in order.

1. "...only crops that can be planted in the late spring for harvesting in the early fall are successful." Most of the crops in the area are planted in the fall. Farmers have a problem of drying the soil in the spring so they can get machinery on it. Grain hay fits this pattern because it can be planted in the fall and harvested in the late spring.

2. "The most successful crops on baylands are forage crops consisting of alfalfa..." Alfalfa cannot be grown on these soils because of the high and fluctuating water table.

Hay for North Bay Dairies

The report claims that this area is a major source of feed for the north bay dairies. There are no official statistics on feed shipments into the north bay area, but close estimates can be made.

The Agricultural Commissioner's report 36,000 dairy cows in Sonoma County and 15,000 in Marin County as of January 1, 1982. This is a total of 51,000 dairy cows in the area. It is important to note that these numbers have decreased 20 percent since 1972.

Modern dairy cows will consume about 4 tons of hay per year plus silage, maybe some green chop, grain and some pasture. The 51,000 cows in the area will use over 200,000 tons of hay in a year.

According to the Agricultural Commissioners, Sonoma and Marin Counties produce about 47,000 tons of hay a year.

Cullinan Ranch produces about 3,170 tons per year.

To summarize -

51,000 cows x 4 tons hay = 204,000 tons

Produced locally 47,000

Shipped in 157,000

Over 75 percent of the hay used for dairy cows in Sonoma and Marin Counties is shipped in. Cullinan Ranch produces 1.5 percent of the hay needed. The Historic Baylands of the North Bay produce about 30 percent of the hay used by the dairies. The bulk of the hay shipped into the north bay dairy area comes from the lower Sacramento and San Joaquin Valleys, although some usually comes from Nevada.

Economics of a 200 acre farm

The report states that a 200 acre farm could make a net profit of \$13,000 per year. This estimate is very unrealistic.

There can be wide differences between farmers, but if we assume:

the family purchased the farm with a 70 percent loan,

purchased used equipment of about 50 percent of new prices,

and

the family supplies essentially all the labor.

These assumptions are realistic for most people entering small scale agriculture.

The economic situation is as follows:

Investment

Land 200 acres @ \$1,000	\$200,000
Buildings	50,000
Machinery	<u>60,000</u>
Total	\$310,000

Income - 170 acres cultivated	<u>Total</u>
Hay 2.5 ton per acre @ \$55	\$23,375
Expenses	
Seed	\$ 3,740
Herbicide	1,530
Power for drainage pumps	1,070
Fuel and Repairs	1,870
Interest on operating capital	<u>325</u>
Total cultural cost	\$ 8,535
Swath	550
Rake	325
Bale \$220 plus wire @ 2,550	2,770
Pickup bales	<u>330</u>
Total harvest cost	\$ 3,975
Property tax	800
Misc. cash overhead	<u>1,650</u>
Total overhead	\$11,920
Total cost	\$23,530
Net	\$ -155
Loan payment on \$140,000 loan @ 12.5% for 30 years	\$18,026

Conclusion

It is impossible for a farmer to make a satisfactory living on 200 acres of Diked Historic Baylands even if there is no debt outstanding. Trying to pay off a mortgage is out of the question.

Qualifications

A. Doyle Reed
328 12th Street
Davis, CA 95616
916-753-2759

Education

Lawrence (Kansas) High School, 1930-34
Kansas State University, 1934-38, B.S., Agricultural Economics
Kansas State University, 1938-40, M.S. Agricultural Economics
University of California, Berkeley, 1946-48, Ph.D., (Conferred
1951), Agricultural Economics

Employment Record

January 1980 to date: Senior Lecturer in Agricultural Economics,
University of California, Davis. Teaching Farm Management
and Rural Appraisal.
1948-1979: Extension Economist specializing in Farm Management,
University of California, Davis. Worked throughout California
on all types of farm management problems. Included
were cost of production studies, enterprise selection,
leasing arrangements, economics of scale, labor management,
machinery management, feasibility studies, financing, income
tax, and estate planning.
1946-48: Research Assistant and Graduate Student, University of
California, Berkeley.
1941-45: Personnel Officer, U.S. Army.
1940-41: Instructor, Texas A & M College.

Activities in North Bay Area

1980 Koretsky King/Lee, Strangio & Associates. "Sonoma County
Wastewater Reclamation Project." Prepared the economic
analysis.
1976 Coleman Williams, Inc. "Route 37 Corridor." Helped with
the economic analysis of agriculture in Southern Sonoma
County.

PRELIMINARY FISCAL IMPACT EVALUATION - CULLINAN RANCH DEVELOPMENT
VALLEJO, CALIFORNIA

Prepared For:
W. R. WILLIAMS AND ASSOCIATES

September 1982



ALFRED GOBAR ASSOCIATES, INC.

207 South Brea Boulevard, Brea, California 92621 / Telephone (714) 529-9411

TABLE OF CONTENTS

CHAPTER		PAGE
I	INTRODUCTION	1
II	SUMMARY AND CONCLUSIONS	4
III	IMPACT ON THE CITY OF VALLEJO	8
	Revenues	8
	Property Tax	8
	Sales Tax	10
	Utility Users Tax	11
	Business License Revenue	12
	Utility Franchise Tax	13
	Property Transfer Tax	13
	Per Capita Revenues	14
	Costs	15
	Police Protection	15
	Fire Costs	16
	Street Maintenance	17
	Library	19
	Other Costs	19
	Overhead Costs	20
	Costs Summary	21
IV	SCHOOL IMPACT	23
V	PARKS AND RECREATION IMPACTS	25
VI	IMPACT ON SOLANO COUNTY	30
	Revenue	30
	Costs	31
	Summary	33
EXHIBIT		
II-1	Summary of City of Vallejo Revenue and Cost Estimates Cullinan Ranch Project	7
APPENDIX		
A	Police Department Cost Estimate	34

CHAPTER I
INTRODUCTION

The purpose of this report is to establish some perspective with regard to the fiscal consequences to the city of Vallejo , Solano County, and various other agencies of annexation and development of the Cullinan Ranch as planned. Plans for development of the Cullinan Ranch are still tentative; as a result, this document is not precise in terms of the fiscal consequences of its annexation and development. The purpose of this report primarily is to establish perspective about the probable impact on revenues and costs of the annexation and development of the project on the basis of the current tentative development plan.

Subsequently, when the planning process is more refined, a more precise interpretation of the costs and revenues implicit in the development of the Cullinan Ranch can be made.

Also influencing the tentative nature of these estimates is the potential for negotiation between the developer and City and other public agencies with regard to fees; provision of parks and school sites; the degree to which private streets will be included in the project and, therefore, maintained by a homeowners' association; and other matters which will eventually affect the overall allocation of costs and revenues as between the developer and public agencies affected by the Cullinan Ranch.

Generally, new developments add more to City revenues and other public agency revenues than they do to costs because of the high value

of new construction per capita of new population; i.e., if the assessed value and sales tax revenues per capita derivative of an increase in the population exceed the average for the existing population, it can be reasonably anticipated that public agency revenues will exceed costs. If this were not the case, the existing population base and the affected jurisdictions with a lower per capita revenue contribution would not be self-supporting.

Analysis of city budgets and other public agency budgets is a technique that is still in its infancy. Restricted availabilities of revenues are increasingly putting pressures on local agencies to engage in cost accounting analyses primarily for the purpose of improving the efficiency of providing city services. Application of cost accounting techniques to city fiscal planning, however, is still a relatively immature technique. For example, many local government costs are capacity costs. They imply the ability to respond, rather than a direct cost that is an ongoing function of direct services. Fire protection is a prime example of this type of cost. To the degree that increased development can be accommodated with an existing capacity, there is an argument to suggest that new development, therefore, does not constitute a basis for increasing direct costs. A counter argument is that new development should carry its prorata share of costs, not only the increased costs derivative of the development itself, but also of the ongoing costs, thereby representing financial benefit to the existing constituency of the city or other agency, and a valid reason to justify new development. Another important argument with regard to fiscal

impact is a tendency for cities, in particular, to experience higher costs per capita with an increase in the city's population rather than a decreasing cost per capita. This is something of an anomaly in that it implies diseconomies of scale. It can be argued, therefore, that new development which expands the population base of the city raises the cost of providing city services to all citizens because of the scale factor; i.e., per capita costs of city services for cities of 100,000 population tend to be generally greater than the per capita costs of providing city services to cities with a population of 50,000. To some extent, this may be a reflection of historical city management policies, which limited budgets primarily to the revenues that were generated. Larger cities generate more revenue per capita because of a broader base of revenue sources and, therefore, can justify higher budgets because of increased revenues. Constraints on the revenue flows to public agencies in recent years, however, suggest that the cost functions of city government may become more responsive to need to provide services and less responsive to the availability of revenues. It is not the purpose of this report to investigate these philosophical relationships, but assumptions regarding these relationships are important in critiquing technical presentations, such as that embodied in this report.

CHAPTER II
SUMMARY AND CONCLUSIONS

1. Because of the high value of development planned for the Cullinan Ranch, the inclusion of a disproportionate amount of retail space, and the anticipated high income level of Cullinan Ranch residents, the projected revenue to the city of Vallejo from the full development and occupancy of the project as currently planned is expected to amount to \$4.2 to \$5.4 million a year. Projected costs of providing City services to the expanded population of Vallejo implicit in the annexation, development, and occupancy of the Cullinan Ranch are projected in 1982 dollars to amount to \$0.7 to \$2.1 million a year (Exhibit II-1).
2. Net revenues are expected to be \$3.1 to \$4.6 million per year, for a benefit-to-cost ratio of 2.45 to 7.60:1.
3. Because of the preliminary nature of this investigation, revenues could be reduced by as much as \$500,000 a year and operating costs increased by as much as \$500,000 a year, causing a net shift in the surplus revenues of \$1,000,000 a year, reducing the estimate of the potential surplus cash flow to something on the order of \$2.1 to \$3.6 million a year. This represents a significant net contribution to City revenues.
4. In a subsequent report which will embody the results of a more refined hypothesis regarding the development plan, phasing, etc., the impact of phasing will be considered to ascertain the degree to

which commitments for City costs may be incurred before the materialization of the revenues implicit in the development program. The figures above are based on the full-horizon, build-out concept which currently appears to be from 15 to 20 years in the future. The treatment of all costs in terms of 1982 dollars obviously misstates the actual dollar amounts but should have relatively little effect on the fundamental relationships that imply significantly more revenue from the project than is likely to be necessary to cover the cost of providing City services.

5. A major unresolved problem with regard to the implications of the project relates to the schools. School construction funds are not available under current law as a result of the passage of Proposition 13. In terms of 1982 dollars, there is requirement for about \$9.0 million in construction costs to provide the number of schools anticipated to be needed by the population of the Cullinan Ranch. These construction funds may be available through State agencies or it may be necessary to investigate alternative avenues of generating the necessary construction funds. Under current statutes, operating costs of schools are provided through State allocations if local sources are not adequate. The immediate impact of the anticipated shortfall in construction funds is not severe because of the long-term nature of the development scheme for the Cullinan Ranch. One purpose of studies of these types, however, is to anticipate potential fiscal problems prior to their becoming imminent and, therefore, allow adequate time to devise

means of mitigating potential problems. That is, in fact, one of the purposes of this evaluation.

6. The cost of providing, maintaining, and operating parks cannot yet be defined accurately pending the conclusion of negotiations between the developer and the affected public agencies. This element, however, appears to be more than adequately covered by anticipated revenues as described in Chapter V, generating a benefit/cost ratio of something on the order of 3 to 4:1.
7. Solano County is expected to receive increased revenues of almost \$3.6 million a year against increased costs of slightly over \$0.6 million a year. Net revenues will be close to \$3.0 million annually for a benefit/cost ratio of 5.6:1. This is only slightly below the range of net revenues expected to be received by the city of Vallejo. Combined, net revenues to the City and County could total between \$5.0 and \$7.5 million a year.

EXHIBIT II-1
SUMMARY OF CITY OF VALLEJO REVENUE AND COST ESTIMATES
CULLINAN RANCH PROJECT

Revenues:

Property Tax	\$ 3,210,624
Sales Tax	1,067,220
Utility Users Tax	493,245
Business License Tax	66,388
Franchise Tax	61,605
Property Transfer Tax	204,468
Per Capita Revenues	<u>120,840- 247,266</u>

Total Revenue \$5,224,390-5,350,816

Costs:

Police Protection	\$ 300,000- 836,190
Fire Protection	156,439- 602,851
Public Works - Streets	41,123- 198,628
Library	63,384
Overhead Costs	<u>143,378- 434,789</u>

Total Costs \$ 704,324-2,135,842

Range of Net Revenues \$3,088,548-4,646,492

Range of Benefit:Cost Ratios 2.45 - 7.60:1

Source: Alfred Gobar Associates, Inc.

CHAPTER III
IMPACT ON THE CITY OF VALLEJO

Annexation and development of the Cullinan Ranch will contribute substantially to an increased tax base in the city of Vallejo. City revenues are generally derived from their proportionate share of the ad valorem property tax collected on new development, sales tax revenues supported by increased consumer expenditure derivative of an increased population, business license revenues related to new businesses to serve the expanding consumer base, utility users taxes, utility franchise taxes, and subventions from other agencies.

A. Revenues

1. Property Tax. In the 1981-1982 Budget for the city of Vallejo, total revenues of property taxes and related sources, including homeowners' exemption and business inventory exemption rebates from the State, amount to \$3,553,340. Excluding the reimbursements, the 1981-1982 projected revenues from property tax-related sources for the city of Vallejo is expected to amount to \$3,105,050.

The 1981-1982 tax base for the city of Vallejo is represented by an assessed value of \$316,775,000, or a market value equivalent to four times that amount - \$1,267,100,000.

Total tax revenues from taxable values, as noted above, are projected to be \$3,553,340.

This is equivalent to an effective tax rate for the city of Vallejo applied to market value of 0.0028043.

The market value of the total development plan for the Cullinan Ranch when fully developed can be estimated on the basis of assumptions regarding the development as it currently stands.

The plan currently allows for 3,000 single family units and 1,500 multi-family units for a total of 4,500 units. The average market value of the detached houses is expected to be \$214,500 a unit - a total market value on completion is therefore projected to be \$643,500,000.

The average value of the attached housing to be sold at the Cullinan Ranch is expected to \$144,000 per unit, implying a total market value of completed units on the basis of the current planning hypothesis of \$216,000,000. Total market value of residential planned for the Cullinan Ranch (expressed in 1982 dollars) is \$859,500,000.

The plan also includes allowance for significant commercial development, including a 10.5-acre neighborhood center and 55 acres of speciality shopping centers, and a 200-room hotel. The implicit market value of the retail commercial development - a total of 65.5 acres - will amount to \$60,000,000. The 200-room hotel, at an average value of \$75,000 a room, implies a market value of \$15,000,000.

Total market value of the commercial development will, therefore, amount to \$75,000,000.

Included in the plans currently is allowance for two marinas - one with 500 slips and one with 200 slips. These are expected to have a market value amounting to \$12,000 a slip or \$8.4 million.

The sum of the market values delineated above is \$942,900,000.

In addition to the secured property, personal property excluding boats maintained at the marina and in moorings will constitute another \$48,993,084 of market value subject to property tax assessment.

Exclusive of taxable value implied by boats associated with the marinas and other marine facilities related to the projects, the total market value amounts to \$991,893,084.

It is expected that a total of 1,700 boats will be located in Vallejo and, therefore, subject to property taxes. At an average value of \$90,000 each, these constitute a tax base value of \$153,000,000.

Total market value of assessable property resulting from the development of the Cullinan Ranch for residential purposes and the inclusion of substantial marina facilities will, therefore, be \$1,144,893,084.

Application of the implicit tax rate of 0.0028043 to this estimate of market value produces a projected revenue from property taxes to the city of Vallejo of \$3,210,624 a year. (Note that these are expressed in terms of 1982 prices.)

2. Sales Tax. Development plans for the project allow for a 10-acre neighborhood shopping center and 60 acres of other commercial development, including a hotel. Total commercial acreage, therefore, is anticipated to be 70 acres, which at a 25.0 percent lot coverage, implies 762,300 square feet of retail area. Assuming that taxable retail sales in this retail area amount to \$140 per square foot of sales area per year, total taxable sales will be \$106,722,000.

Cities are entitled to receive one percentage point of the sales taxes collected from merchants located within the city, or in this case annual revenues of \$1,067,220 a year. For comparison purposes, the 1981-1982 Budget estimates that sales tax collections for the city of Vallejo

will be \$3,679,000. This is equivalent to \$44.33 per capita for the existing population of Vallejo. The estimated sales tax revenue of \$1,067,220 a year derivative from the project is equivalent to an annual per capita revenue from this source of \$93.62 per capita for the estimated increased population of 11,400 associated with the Cullinan Ranch. It could be argued, therefore, that the sales tax revenues quoted above could be reduced by 52.48 percent if the revenue potential per capita for the Cullinan Ranch residents were equivalent to the existing revenue per capita from sales taxes for the current population of the city of Vallejo.

Note also, that included in the estimates above was the five acres of commercial property that may eventually be used for a hotel. To that extent, this parcel would not generate sales tax revenues. Offsetting this, however, would be the potential for City revenues from the imposition of a room tax.

The projected sales tax revenue of \$1,067,220 a year is equivalent to \$15,246 per acre per year on 70 acres of developed commercial facilities. A 6.0 percent bed tax on an assumed average rental rate of \$40 per night with 60.0 percent occupancy will generate room tax revenues of \$525.60 per room per year. Assuming that a 200-room hotel requires five acres of commercial land for its development, this is an effective city revenue of \$21,024 per acre per year - somewhat above the revenue potential for conventional retail facilities.

3. Utility Users Tax. The city of Vallejo collects a 7.5 percent tax on utility bills for gas and electric service, long-distance telephone

charges, and cable TV billings. Since the Cullinan Ranch development will be reasonably balanced in terms of land use patterns - residential and commercial - it is defensible to allocate revenue from this source on a per household basis; i.e., the mix of land uses in the Cullinan Ranch will be comparable to the mix Citywide. Therefore, the 4,500 units planned for the Cullinan Ranch represents the potential for utility users tax revenues per dwelling unit at least equivalent to that currently being realized by the City. Currently, utility users' taxes expressed on a per household basis are as follows:

	<u>Per Household*</u>
Gas and Electric	\$73.37
Telephone	30.92
Cable TV	<u>5.32</u>
Total	\$109.61

With total development of 4,500 households, the Cullinan Ranch population constitutes a revenue source from this category amounting to \$493,245 a year.

Because of the anticipated higher income profile of residents in the Cullinan Ranch, it is likely that utility users' tax from long-distance calls may be significantly greater on a per household basis than is typical of Vallejo at the present time.

4. Business License Revenue. In the 1981-1982 Budget, business license revenues for the City are projected to be \$248,000. Development

*Using average 1980 Census household size of 2.68 persons per household in the city of Vallejo and applying this to the Consultants' January 1, 1982 estimate of 83,000 population produces an estimate of 29,984 households in the city of Vallejo as of January 1, 1982.

of the Cullinan Ranch is expected to add about 26.0 percent to business license revenue for the city of Vallejo. This was calculated on the basis of a distribution of anticipated sales levels for merchants in the commercial sectors of the Cullinan Ranch and the application of the current business license fee schedule applicable in the city of Vallejo. The result of this analysis produced an estimate of business license revenue increases derivative of the development's plan for the Cullinan Ranch of \$64,388 a year.

5. Utility Franchise Tax. All utilities operating in the city of Vallejo contribute to City revenues via a franchise tax, the total of which for the 1981-1982 Budget is expected to be \$410,472 a year, or \$13.69 per household.

Applying an estimate of \$13.69 per household per year to the 4,500 households projected for the Cullinan Ranch produces a revenue estimate from this source of \$61,605 a year.

6. Property Transfer Tax. The city of Vallejo imposes a property transfer tax on real estate transactions within the City. The amount of these tax collections is a direct function of the value of property transferred. Projected City revenues in the 1981-1982 Budget from this source are \$254,000. The market value of secured property in the city of Vallejo, estimated on the basis of the assessed value figures from the 1981-1982 Budget, is \$1,160,740,000. The relationship between property transfer tax collections and market value of all secured property in the city of Vallejo is, therefore, \$0.2188 per \$1,000 of market value. The market value of the proposed project, excluding the

marina, will be \$934,500,000.

Applying a property transfer tax coefficient of \$0.2188 per \$1,000 of market value to this estimate for the Cullinan Ranch suggests a long-term revenue potential (in 1981 dollars) of \$0.2188 times \$934,500,000 times .001, equals \$204,468 a year.

Actually, this estimate may be somewhat high. It is based on a coefficient applied to market value. The coefficient, however, was derived from an arbitrary definition of market value that probably understates the true market value because of the assessment relationships stipulated by Proposition 13. The property transfer tax revenue potential estimated for this project, therefore, may be subject to some revision at a future date.

7. Per Capita Revenues. A variety of city revenues can be estimated on a per capita basis. Among the more important of these are the following: fines, forfeitures, and penalties; motor vehicle fees, cigarette taxes, off-highway vehicle fees; weed abatement fees, gas taxes (the portion transferred to the general fund only); traffic fines and fees; etc. Some of these sources of revenue are subject to rather substantial change. The State of California has shown a strong tendency in recent years to reduce subventions for motor vehicle fees, alcoholic beverage fees, etc., as the State attempts to transfer more revenue to State functions, providing less for local government.

In total, for the 1981-1982 Budget, however, revenues from these sources are projected to be \$880,061 to \$1,800,061, or equivalent to revenue per capita for the existing population of 83,000 persons of

\$10.60 to \$21.69. Applying this coefficient to a population estimate for the Cullinan Ranch of 11,400 suggests a revenue potential from per capita revenues of these types of \$120,840 to \$247,266 per year.

Total revenues derivative of the individual projections described above, therefore, are as follows:

Property Tax	\$3,210,624
Sales Tax	1,067,220
Utility Users Tax	493,245
Business License Revenue	66,388
Franchise Tax	61,605
Property Transfer Tax Revenue	204,468
Per Capita Revenues	<u>120,840- 247,266</u>

Total Revenue \$5,224,390-5,350,816

As discussed above, some of these revenue estimates may be subject to downward adjustments by perhaps as much as a total of \$500,000. This nonetheless justifies an estimate of City revenues from the development and annexation of the Cullinan Ranch as planned on the order of \$4.7 to \$4.9 million a year.

B. Costs

As noted in the introduction to this report, municipal cost accounting is still somewhat in its infancy. As a result, estimates of the costs allocable to a new project must be made on a variety of bases, some of which will be subject to review and adjustment.

1. Police Protection. The police department of the city of Vallejo reviewed the overall plans for the Cullinan Ranch development and based on the size of the project, diversity of uses and the fact that it is a contiguous area as opposed to fill, has estimated that one patrol unit, 24 hours a day will be required. The costs for this are estimated to be

\$300,000 per year in terms of 1982 dollars. The cost estimate covers the personnel costs for the five officers necessary to staff the patrol, equipment purchase, maintenance and operation and administrative overhead costs (See Appendix A).

In the 1981-1982 Budget, police costs for the city of Vallejo are projected to be \$6,088,189. This is equivalent to police costs per capita of \$73.35 per year. Since the Cullinan Ranch development proposal includes nonresidential as well as residential development, it could be argued that police costs per capita for the Cullinan Ranch population of 11,400 persons will be comparable to the per capita police costs for the city of Vallejo currently. Using this simplified assumption, the assignable costs for police projection for the Cullinan Ranch are \$836,190 per year.

While the estimate made by the police department is probably more nearly correct in terms of the incremental cost of the proposed development, the Consultants have shown a range in the calculation, using the per capita cost as a high-end estimate, in order to present a worst case picture of the possible costs involved.

2. Fire Costs. The cost of providing fire protection is essentially a capacity cost - the ongoing costs of maintaining ability to respond. Interviews with the fire department in Vallejo suggest that a separate fire station will be necessary to provide adequate protection to the Cullinan Ranch. Capital costs for a fire station have been estimated by the fire department at \$200,000 for the structure and necessary apparatus and equipment, including a boat to service the waterfront areas.

Amortizing \$200,000 over 25 years at a 13.0 percent interest rate indicates an annual cost for facilities of \$27,285 a year. Operating costs for manning a facility with a three-man engine company are projected by the fire department to total \$116,500 a year. Other departmental costs for weed abatement and civil defense - both related to the fire department operations - currently amount to \$1.11 per capita per year for the existing population in the city of Vallejo. The new population anticipated for the Cullinan Ranch (11,400) would, therefore, result in a cost factor for this category of \$12,654 a year.

Total fire department costs for the new station, its maintenance and operation, and for other departmental costs that are reasonably assignable to the Cullinan Ranch, therefore, amount to \$156,439 a year.

As is the case with police protection, the incremental cost of providing fire services to the Cullinan Ranch is significantly lower on a per capita basis than the average cost of providing fire protection throughout the city of Vallejo currently. The fire department budget for 1981-1982 for the city of Vallejo is \$4,297,224, or \$52.88 per capita for the existing population. Using a per capita coefficient to estimate the cost of fire projection for the Cullinan Ranch produces a much higher estimate of total fire costs assignable to the Cullinan Ranch project - \$602,851 a year.

3. Street Maintenance. The 1981-1982 City of Vallejo Budget allocates \$1,541,692 as a cost of maintaining 221.2 miles of streets within the City. This is equivalent to an average maintenance of \$6,970 per mile per year.

There is some ambiguity in the plan currently concerning the arrangements for maintaining streets within the Cullinan Ranch. There will be at least 5.9 miles of public streets - major collectors, frontage road, etc.

Local roads within the project may be maintained either by homeowners' association assessments or dedicated and maintained by public agencies. It is assumed that all local streets within the multi-family housing sectors of the Cullinan Ranch project will be privately maintained. If all local roads and streets within the single family housing sector of the Cullinan Ranch are eventually dedicated and maintained by the public, maximum street mileage to be maintained by public agencies will be 22.4 miles.

Based on current costs per mile of street maintenance, costs for the project, assuming 5.9 miles of public streets, will be \$41,123 a year.

Assuming that public agencies maintain 22.4 miles of public streets within the Cullinan Ranch area, street maintenance and street tree maintenance costs could be as much as \$156,128 a year.

There are 8.5 linear miles of pedestrian and bicycle paths proposed for the project, covering a total of 37 acres. There is a possibility that these may be dedicated to the City to be maintained by the street department. No estimates of the costs of such maintenance are available, however, City personnel agreed that such costs would be somewhat less than that of maintaining public streets. The Consultants are therefore using an estimate of \$5,000 per mile per year to maintain

the bicycle trails for a total annual cost of \$42,500. As an alternative, the bicycle/pedestrian corridor may be maintained privately with homeowners' association fees or through some other assessment vehicle, thereby representing no cost to the City.

Total public works costs are therefore estimated to range from a low of \$41,123 to \$198,628 annually.

A more specific cost analysis should be carried out when planning for the project is advanced and the ambiguities regarding the responsibility of maintaining internal streets have been resolved.

4. Library. Libraries in Vallejo are operated by Solano County agencies but are partially funded by City revenues. City expenditures for the library functions in the 1981-1982 Budget total \$497,610. Also in the 1981-1982 Budget, however, are projected revenues from library operations of \$36,000, producing a net cost to the City for library services of \$461,610 a year, or \$5.56 per capita.

Applying this cost factor to the projected population of 11,400 persons for the Cullinan Ranch project produces an estimate of library costs assignable to the project of \$63,384 a year.

5. Other Costs. The Water Department will be required to extend service to the Cullinan Ranch project. The developer, however, will pay all capital costs of providing water service to the property. Operating costs for the Water Department are covered from user charges with the result that there is expected to be no net fiscal impact to the City for capital improvements or operating costs associated with providing water utilities to the project.

Street lighting represents a potential cost for which sources of revenue have not yet been provided. It is anticipated that a special assessment district will be established in the Cullinan Ranch to cover these costs with the result there will be no net impact on the City.

Cost of maintaining waterways represents a substantial potential expense. The boating channels and the wetland area south of the centerline of the levee could possibly be dedicated to the City or other public jurisdiction. For example, a port authority could be established to maintain the waterways. It is projected now that an assessment of wharfage areas, or surcharges on boat slips, possibly together with maintenance fees paid by homeowners in the project will generate revenue to maintain the waterways, resulting in no net cost to the City or other agency involved.

6. Overhead Costs. The cost estimates above are direct costs and make no allowance for local government overhead functions such as general government, public building maintenance, public works, overhead, and other nonallocated costs. In the 1981-1982 Budget, the overhead costs as estimated by the Consultants are as follows:

General Government (Excluding Planning and Building Inspections)	\$1,417,753
Public Buildings Maintenance	370,913
Public Works Maintenance (Admin-Part)	44,042
Electrical/Communications	95,905
Electrial/Maintenance	309,184
Fixed Charges	778,557
Planning, Building, and Engineering (Net Cost)*	<u>568,556</u>
Total Overhead	\$3,584,910
Total Budget	\$17,608,122

*In the 1981-1982 Budget, revenues for the planning, building, and engineering functions are projected at \$553,825 against projected costs of \$1,122,381, or a net cost of \$568,556 for providing this overhead function.

These unassigned or unallocated costs amount to \$3,584,910 out of a total budget of \$17,608,122. Overhead, therefore, amounts to 20.36 percent of the total budget or 25.56 percent of direct costs. The direct costs projected above, therefore, have been burdened by the same proportion to reflect the allocation of overhead costs to the new population of the Cullinan Ranch project.

6. Costs Summary

Direct Costs:	
Police	\$300,000- 836,190
Fire	156,439- 602,851
Street Maintenance	41,123- 198,628
Library	63,384
	<hr/>
Total	\$560,946-1,701,053
Overhead Costs	143,378- 434,789
	<hr/>
Total Costs	\$704,324-2,135,842

Total costs are projected to range from \$704,324 a year to \$2,135,842 a year. It could be argued that these costs should be adjusted upwards to reflect some of the uncertainties described above. Adding \$500,000 to either estimate of City costs suggests a total projected increase in City Budget attributable to the Cullinan Ranch project of \$1.2 million to \$2.6 million a year.

In either case, the projected revenues substantially exceed the projected costs. It would require more than an 80.0 percent increase in the upper end estimate of projected City costs to result in the project representing a net breakeven to the City. It is unlikely that the cost estimates are in error by this magnitude.

In addition to the ongoing revenues described above which were placed in perspective as against the estimates of ongoing cost,

development of the Cullinan Ranch also implies a one-time revenue event related to real property development taxes and fees. The tax structure for this source of revenue is based on \$542 per unit for residential units which, for a total of 4,500 units, would generate one-time revenues of \$2,439,000. The real property development tax for commercial development was calculated on the basis of \$542 per unit or \$0.15 per square foot whichever is greater. It is estimated that there will be 241 commercial units in the 70.5 acres of commercial development planned for the project, generating additional real property development tax revenues of \$130,622.

Total real property development tax revenues, therefore, will be \$2,569,622 in terms of 1982 prices and tax structures.

Since this is a one-time event, it cannot be compared efficiently with the other revenues which are of a continuous and ongoing nature. Assuming, however, that the \$2,569,622 were to be invested at a 13.0 percent yield - approximately the City's cost of capital at the present time - the one-time revenue potential can be converted to an ongoing income stream of \$334,051 a year, improving even more the benefit/cost ratio implicit in the development and occupancy of the Cullinan Ranch as planned.

CHAPTER IV
SCHOOL IMPACT

Because of recent changes in California law, school budgets are particularly stressed by revenue restrictions. This represents a major consideration with regard to the Cullinan Ranch project. There is some ambiguity regarding the demand for schools derivative of the development and occupancy of the Cullinan Ranch project.

The Vallejo School District currently uses an estimate of 0.7 school-age children per household for determining school requirements for expanding population. Studies of schools in Foster City show a student population of 0.5 per household, suggesting that the Vallejo School District's estimate may be 40.0 percent higher than is necessary in light of experience elsewhere. More research is now being applied to this uncertainty.

Ranges of estimates of the number of schools required include provision for one junior high school and two elementary schools. Reasonable cost estimates for developing schools are \$7.0 million for a junior high school and \$3.3 million for an elementary school. This suggests the total potential cost of school construction (in 1982 dollars) of \$13.6 million dollars. Development fees are unlikely to generate significantly more than \$5.0 million available for school construction. The difference of about \$9.0 million of construction costs represents a major consideration for the project's total impact on the public sector. The importance of this factor cannot be diminished,

but at this stage in the project's planning and evolution, no definitive analysis can be made.

Current school funding in the State of California is based on formulas which in essence imply a null effect with regard to the operating expenses of schools.

CHAPTER V
PARKS AND RECREATION IMPACTS

At the current stage of the planning for the Cullinan Ranch project development, there is provision in the land plan for 95.5 acres of park-like development, including two neighborhood parks adjacent to school sites totaling 13 acres, one community park adjacent to a school site totalling 20 acres, a marina park of 10 acres, private view parks of 15.5 acres, and a bicycle and pedestrian corridor with 37 acres. This totals 95.5 acres of recreation development of this type.

In addition, the plan provides for open space area for which specific plans have not yet been prepared. Open space wetlands area include 78 acres of levee area, an 88-acre dredge spoils site and 86.5 acres of inter-tidal area.

The park district standards in the area call for 4.25 acres of park per 1,000 population. Applying this standard to the estimated population of the Cullinan Ranch project when developed (11,400 persons) suggests that the facility should incorporate 48.45 acres of park. The planned park development described above substantially exceeds the planning standards employed by the park district.

Estimated development costs for neighborhood parks exclusive of the land cost are \$50,000 an acre. For the 8.5 and 4.5-acre neighborhood parks being planned, this implies total development costs of \$650,000 for neighborhood parks.

Community parks cost about the same to develop, but are somewhat larger than neighborhood parks. The 20-acre community park included in

the plan will cost \$1,000,000 to develop plus additional development costs related to special amenities such as night-lighted ballparks, night-lighted tennis courts, etc. These figures do not include an allowance for land acquisition as the developer intends to dedicate the land area for these parks.

It is impossible at this stage in the planning process to determine the impact of park operations. The recreation district and the project developers have not yet reached agreement as to the allocation of costs for construction and operation of the recreation facilities that will be provided. The 15.5 acres of private view parks will most likely be owned and maintained by a homeowners' or improvement association, using funds obtained by assessing the low density homeowners. The 37 acres of bicycle and pedestrian corridors may possibly be dedicated to the city of Vallejo and have been discussed previously. The entire levee and wetlands areas might be offered to the State for public use and maintenance, or become part of the responsibility of a port authority, which would also have responsibility for maintaining the open water areas. This leaves a total of 43 acres of developed park lands which will probably be dedicated to and maintained by the Greater Vallejo Recreation District.

At this stage in the planning process, therefore, the major contribution that can be made is a tentative definition of the financial variables that are implicit in providing for recreation facilities.

Part of the capital costs for developing parks is accommodated by fees which are paid when permits are drawn. The fee structure applicable to the park district currently is as follows:

	<u>Cost Per Unit</u>
One Bedroom or Efficiency	\$ 450
Two Bedroom	602
Three Bedroom	748
Four Bedroom	1,051
Five Bedroom	1,350

These fees are designed to cover development costs of \$65,000 per acre including land acquisition at \$15,000 per acre for the appropriate level of park development associated with the probable population distribution dictated by the bedroom counts above. Developers can receive credits against the fees by donating land to the park district. Another offset to the fees is the possibility that the developer can construct a complete turn-key park to park district standards and dedicate it to the park district in lieu of fees. The turn-key parks dedicated in this manner will be valued at \$65,000 an acre as an offset to the development fees quoted above.

Since the actual level of park development is still ambiguous in the planning processes, it is difficult to estimate the operating cost for recreation facilities in this area.

In the 1981-1982 Greater Vallejo Recreation District Budget, total costs for recreation and parks amount to \$1,379,380, composed of the following:

Projected 1981-1982 Operating Expenditures:

Administration	\$ 252,460
Recreation	411,990
Parks	<u>590,625</u>
Total	\$1,255,075

Additional Costs:

Policy Items	66,505
Priority Allocations	40,000
Capital Outlay - Equipment	<u>17,800</u>
Total	\$124,305

Overall Total \$1,379,380

This is equivalent to park and recreation costs of \$16.62 per capita. Applying this coefficient to the estimated population of the Cullinan Ranch at buildout (11,400 persons) suggests annual costs of \$189,468 a year. Note, however, that the type of park development implied for the Cullinan Ranch may differ significantly from that now provided throughout the district. As a result, the total operational costs for recreation and parks for the Cullinan Ranch might be higher than the figure estimated by this technique. In recent studies conducted in Southern California, costs of park maintenance for the types of parks planned for the Cullinan Ranch averaged about \$6,000 per acre per year. Applying this standard to the 43 acres to be maintained by the park district produces an annual cost estimate of \$258,000.

Offsetting the costs to some extent are some revenue sources. Park operations generate some revenue directly from fees. In the 1981-1982 Greater Vallejo Recreation District Budget, income from fees and charges is estimated to be \$540,000 a year or \$6.51 per capita. This includes \$400,000 in fees collected at City-owned facilities which are passed on to the district which operates these facilities. Applying this revenue potential to the anticipated population at the Cullinan Ranch project

(11,400 persons) suggests revenue potential from this source of \$74,214 a year in terms of 1982 prices.

Another source of revenue is special district revenue related to property tax collections. Property tax revenue for the Greater Vallejo Recreation District for 1981-1982 is forecasted to be \$769,000. On a tax base with a market value of \$1.3 billion in the City of Vallejo, this implies a tax rate of \$0.60680 per \$1,000 of market value.

The projected market value of the Cullinan Ranch project in 1982 prices is expected to be \$1,144,893,084. Applying this tax rate formula to the base suggests that the property tax revenue from the Cullinan Ranch available to the recreation district operations would amount to \$694,836 a year.

These comparisons suggest that financing the development and operation of the appropriate level of park and recreation facilities for the Cullinan Ranch project does not represent a major obstacle to its successful pursuit.

A tentative summary of the revenues and costs associated with the park operations on the basis of the information that is currently available is as shown below:

Revenues:

Fees & Charges	\$ 74,214
Property Tax Revenue	<u>694,836</u>
Total Revenue:	\$769,050

Operating Costs: 189,468-258,000

Net Revenue: \$511,050-579,582

Benefit/Cost Ratio: 2.98-4.06:1

CHAPTER VI
IMPACT ON SOLANO COUNTY

Prior to annexation of the Cullinan Ranch into the city of Vallejo, Solano County receives the major share of tax revenues generated by the property. In its current undeveloped state, such revenues are minimal, consisting primarily of property taxes. Once developed, even though the property will no longer be unincorporated, the County's revenue will increase substantially.

Revenue

The only source of revenue to Solano County from the Cullinan Ranch property, once it is incorporated into the city of Vallejo, is derived from the County's portion of the property tax. The distribution of the total property tax of 1.0 percent of market value among the various taxing districts is difficult to determine on a parcel-by-parcel basis. However, the County Auditor has calculated the current ratio of the tax received by the County for an existing tax code area with the city of Vallejo. The County receives 31.3 percent of the 1.0 percent property tax for an implied tax rate of 0.00313 as applied to market value. This will be used to approximate the property tax revenue to the County once the property is annexed and developed.

The market value of the total development plan for the Cullinan Ranch when fully developed has been determined to be \$1,144,893,084. Applying the tax rate of 0.00313 to this estimate produces a projected property tax revenue to the County of \$3,583,515 (expressed in 1982 dollars).

The property presently generates revenue to the County based on its current assessed value of \$822,369. The County now receives 41.51 percent of the 1.0837 percent tax rate which applies to the property. Based on these rates, the current tax revenue to the County of Solano is approximately \$3,700. Therefore, the County will increase its revenues upon development of the property by a factor close to 1,000. The County's net revenue increase over that currently received is estimated to be \$3,579,815.

Costs

While the city of Vallejo will incur the costs of providing police and fire services, etc., to the Cullinan Ranch property once it is incorporated into the City, Solano County's operating costs also will be impacted by development of the property, primarily in the category of criminal justice. A review of the budget items in Solano County's 1981-1982 Budget identified the following cost items which will be affected by the development.

<u>Expenditure Classification</u>	<u>1981-1982 Budget Expenditure Estimate</u>
Judicial	\$ 6,474,304
District Attorney	50,500
Constables, Marshall	251,606
Detention and Correction	3,969,600
Protective Inspection	910,478
Other Protection	
Office Emergency Services	34,218
Coroner	283,430
Animal Control	449,769
Fish and Game	14,779
Local Agency Formation	14,929
Recorder	194,597
Veterans Services	<u>172,945</u>
	Total Costs \$12,821,155
Less Fees for Court Costs, Probation Services, Recording Fees, etc.	<u>-668,400</u>
	Net Cost \$12,152,755

Based on an estimated population as of January 1, 1982 of 250,000 in the County, the expenditures itemized above represent costs of \$48.61 per capita.

Applying this per capita cost factor to the projected population of 11,400 for the Cullinan Ranch yields a cost estimate to provide these services to the new development of \$554,154 per year.

None of the costs that the County incurs for welfare services and health and sanitation services were included in the analysis. In discussions with County officials, it was concluded that these costs were not applicable based on the demographic profile of the population base expected to reside in the Cullinan Ranch project.

The costs listed above are direct costs and do not allow for any general government overhead functions. In the 1981-1982 County Budget the overhead costs are estimated as follows:

Legislative and Administration	\$ 1,373,358
Finance	3,065,537
Counsel	366,888
Personnel	482,833
Elections	378,547
Property Management	2,281,531
Promotion	51,143
Planning*	535,928
Engineering*	1,205,311
Other General Costs	<u>2,512,138</u>
Total	\$12,253,214

*Net of Revenues from Permits and Fees

This represents 13.39 percent of the total expenditure requirements of the County which were \$91,524,350 in the 1981-1982 Budget. As a percent of direct costs, the 1981-1982 overhead represented 15.46

percent. This overhead burden was applied to the County's estimated direct costs of \$554,154 for the fully developed Cullinan Ranch project to arrive at a total annual County cost of \$639,826 to service the new population in the project.

Summary

The county of Solano is expected to receive annual revenues totaling \$3,579,815 and incur annual costs of \$639,826 upon full development of the proposed Cullinan Ranch project. The annual revenue net of costs is, therefore, estimated to be \$2,939,989. The derivative benefit/cost ratio is 5.6:1.

APPENDIX A
POLICE DEPARTMENT COST ESTIMATE



APPENDIX A

CITY OF VALLEJO

POLICE DEPARTMENT
ROLAND C. DART III
CHIEF OF POLICE

May 27, 1982

Mrs. Christine Coman
Senior Vice President
Alfred Gobar Associates, Inc.
207 South Brea Boulevard
Brea, CA 92621

Dear Mrs. Coman:

Mr. Don Patterson had briefed us on the preliminary long-range plans for the Cullinan Ranch development project several weeks ago. Based upon the information contained in your letter, I would estimate fiscal impact to the Police Department to be approximately \$300,000 per year. This does not include any inflationary influences or economic shifts but rather is computed on today's economy.

Based upon the size of the project, diversity of usages, and that it is a contiguous area as opposed to fill, one patrol unit, 24 hours a day would be required. Five officers are necessary to staff this type of patrol requirement. My estimate includes personnel costs, equipment purchase, maintenance and operation, and administrative overhead costs.

If you have any questions in this regard, please let me know.

Sincerely,

ROLAND C. DART, III
Chief of Police

/ss

MED

8