

AD A 128664

DCA CIRCULAR
600-60-1*



DEFENSE COMMUNICATIONS AGENCY

**DEFENSE COMMUNICATIONS AGENCY
COST AND PLANNING FACTORS
MANUAL**

DTIC
ELECTE
MAY 27 1983

D

MARCH 1983

THIS CIRCULAR CANCELS DCAC 600-60-1,
20 MAY 1976

DISTRIBUTION STATEMENT A
Approved for public release;
Distribution Unlimited



DEFENSE COMMUNICATIONS AGENCY
 WASHINGTON, D. C. 20305

IN REPLY REFER TO 690

21 April 1983

MEMORANDUM FOR DISTRIBUTION

SUBJECT: DCA Circular 600-60-1 (Cost Manual)

1. The DCA Cost and Planning Factors Manual has been revised and previous Changes consolidated. Addressee is on distribution for the enclosed number of copies. If either the address or the number of copies is incorrect, request notification be made to DCA, Code 690, Washington, D.C. 20305.
2. In an effort to maintain maximum currency, the attached updates to tables 38-2 and 38-3 supercede those included in the published circular and may be substituted therein.
3. Suggestions for improvement of the Cost Manual are solicited. Please contact DCA, Code 690, Washington, D.C.

IRWIN L. SEIDEL
 Chief, Cost and Economic
 Analysis Division

2 Enclosures

Accession For	
NTIS GRA&I	<input checked="" type="checkbox"/>
DTIC TAB	<input type="checkbox"/>
Unannounced	<input type="checkbox"/>
Justification	
By <u>Per Lt. on file</u>	
Distribution/	
Availability Codes	
Dist	Avail and/or Special
A	





DEFENSE COMMUNICATIONS AGENCY
WASHINGTON, D. C. 20305

DCA CIRCULAR 600-60-1*

4 March 1983

ANALYSIS

Defense Communications Agency
Cost and Planning Factors Manual

1. Purpose. This Circular provides a guide for personnel who prepare and review cost estimates and economic analyses of DCA-managed systems, programs, and projects. It presents DCA cost data, planning factors, estimating procedures, methods, and formats related to communications systems planning, programing, budgeting, and program evaluation.
2. Applicability. This Circular applies to Headquarters, DCA, and DCA field activities preparing and reviewing estimates of costs for DCA-managed systems, programs, and projects. This Circular does not apply to DECCO and DECCO field activities' normal Inquiry Quote procedures for obtaining contractor cost data except as an additional basis for comparing costs of alternative programs and equipment. It is provided to other addressees for general information and suggested guidance.
3. Contents. To facilitate the use, updating, and expansion of the material covered, the Circular has been organized in six sections. Within these sections, groupings of related subjects are divided into chapters which contain guidance, definitions, examples, and blank reproducible worksheets, where appropriate, for the application of the data.
 - a. Section A provides the DCA systems cost-estimating procedures applicable to major transmission and switching systems programs. It is the overall guide and reference in preparing cost estimates for major DCA programs. Generally, an analyst ready to conduct a cost analysis should start with the appropriate chapter in this section. Accordingly, these chapters include general systems descriptions and specific references to other sections and chapters of the Circular where the required cost data tables, graphs, relationships, and detailed procedures can be found.
 - b. Section B provides specific tables of cost and pricing data and cost-estimating relationships (CER's) for the communication equipment covered by this Circular. These tables reflect the experience of the military departments and staff elements within DCA. The data presented in these tables support the structure outlined in section A specifically related to the prime mission and auxiliary equipment.

*This Circular cancels DCAC 600-60-1, 28 May 1976. (For summary of significant changes, see signature page.)

OPR: 690

DISTRIBUTION: Special

c. Section C presents detailed guidance, methods, and appropriate factors and percentages for preparing estimates of communications systems integration, training, testing, management, data, site activation, and other support cost elements. These total system support costs, when added to those covered in section B, constitute the acquisition costs of the system (with the exception of transportation).

d. Section D presents guidance, methods, and factors for preparing estimates of system annual recurring operating and maintenance costs. These cost factors and procedures will also be useful in preparing project and subsystem cost estimates involving such individual or often separately examined areas as personnel pay and allowances.

e. Section E includes estimating procedures, definitions, and charges and rates for use in estimating leased communications costs. Examples have also been provided to assure proper use of the data.

f. Section F covers supplementary cost considerations related to the overall general area of cost and economic analysis--as opposed to individual communications systems or other acquisitions programs covered elsewhere. Since these general considerations affect almost everything from the way in which an individual cost estimate may be prepared to the overall approach to system or program cost estimating, the reader is encouraged to become familiar with the topics covered.

g. Supplement 1 contains a detailed work breakdown structure appropriate for costing complex communications systems.

4. Procedures and Use of the Circular. This Circular has been developed using the "building block concept" of cost estimating. The building blocks which have been specifically identified in this Circular are designed to serve as a guide for planning, estimating, and reporting the costs of communications projects. They are consistent with the triservice weapon and support systems work breakdown structure contained in MIL-STD-881 for the acquisition cost of DoD projects. Figure 1 illustrates 11 building blocks or major cost areas for estimating acquisition costs, and figure 2 illustrates the four major building blocks in estimating annual operating costs. Each building block indicates the chapter in the Circular where the cost elements for that block are defined and discussed. This approach is designed to encourage and facilitate an orderly estimating sequence. This estimating sequence may be viewed as eight independent operations applicable to most analyses of communications projects. These eight steps are to:

a. Prepare the System Description. The system prime mission equipment should be described in as much detail as possible by configuration and technical parameters; i.e., purpose, location, number, and type of terminals, number of channels, and frequency.

b. Determine Operational and Support Requirements. Estimate appropriate personnel levels and types, identify logistics and provisioning plans and concepts, training needs, operating support equipment requirements, etc.

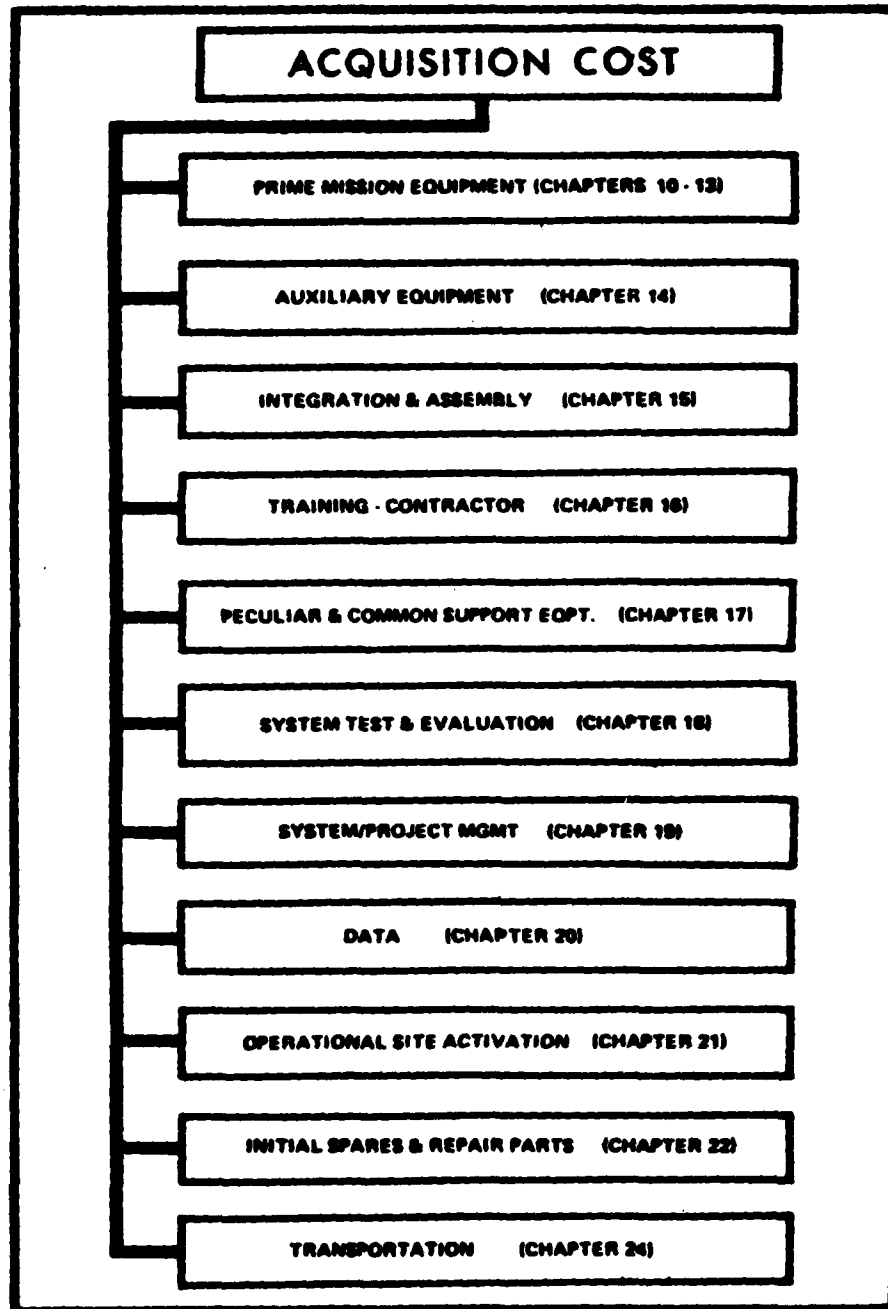

FIGURE 1. ACQUISITION COST - BUILDING BLOCK CONCEPT

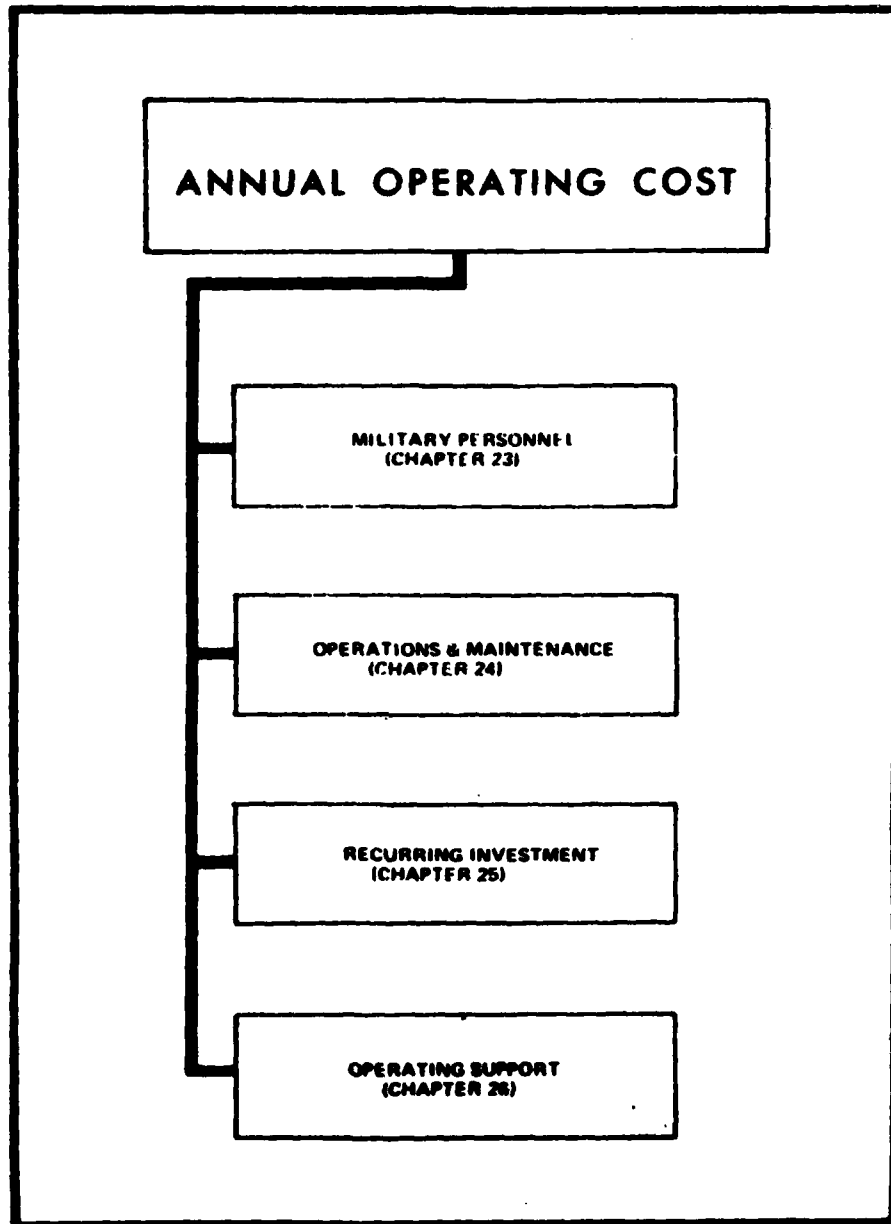

FIGURE 2. ANNUAL OPERATING COST BUILDING BLOCK CONCEPT

c. Establish a Time-Phased Master Plan. Develop a milestone schedule for design and test, procurement, assembly, construction of facilities, site activation, and the phasing-in and initial operations of sites. Select and identify those milestones which relate to different types of activities.

d. Identify Specific Cost Elements to be Estimated. List the cost building blocks applicable to the proposed system as shown in figures 1 and 2 on the appropriate cost formats from chapters 1 through 9. The lowest level of detail should correspond to the depth attainable from paragraphs a and b above.

e. Estimate Costs for the "Building Blocks." Using the most current cost information (this Circular, vendors' catalogs, and quotations, etc.), apply the unit equipment costs and planning factors to the individual building blocks for the system acquisition and annual operations cost identifying and documenting, as appropriate, sources of data, data adjustment made, and other computations.

f. Prepare the Time-Phased Fiscal Year Funding Schedule. Using estimated leadtimes required for each identifiable milestone, estimate the funding to be incurred for each fiscal year, making sure to back off the time required for the conceptual phase, the procurement phase, and the training and operational phases. The funding is required prior to the placement of contracts.

g. Consider Economic Escalation Impact. On the basis of the anticipated funding schedule, apply the guidance provided for economic escalation. (See chapter 38.)

h. Conduct an Economic Analysis of the Alternatives. In accordance with DCAI 600-60-1, investigate other program investment alternatives, (configurations and other system and equipment trade-offs) and apply techniques and procedures for economic analysis.

5. Revisions. All information contained in this Circular is continually reviewed, updated, and expanded by DCA. Appropriate changes, addendums, and additional material, reflecting the most current information available at the time of publication, will be published semiannually. As new data serving as the basis for changes to published costs are obtained or as more suitable or accurate procedures and techniques regarding cost and economic analysis are adopted, the Circular will be updated accordingly.

6. Source of Data. Every effort has been made to obtain cost data which are both reliable and representative of what one might expect to ultimately pay. Equipment costs have been obtained from vendors, the military departments, and recent contracts between the Government and suppliers. Where wide variations occurred, high and low values were disregarded and median prices computed. Support costs have been assembled both from historical data and from application of judgment factors. Their validity is under continuous review. Leased equipment cost information has been extracted from various tariffs, international agreements, Government quotations, and similar

sources. While every effort has been made to include all relevant costs, the user should not expect to be able to compute a completely accurate estimate of future expenditures working entirely from the data in this Circular. In a cost and planning factors manual such as this one, only generalized data and procedures can be addressed. When a cost estimate or economic analysis is prepared, the estimator must examine the individual situation and the information currently available to determine its relevance to the estimate. In certain instances that information will be more appropriate for use than the equipment or services prices contained in this Circular.

7. Additional Factors. When assistance in using or interpreting this Circular is necessary or a requirement exists for specific individual planning and cost factors or estimating procedures not currently contained in this Circular, send a request to the address shown in paragraph 8 or telephone 692-2873 or 692-2923 (AUTOVON 22 plus the last five digits listed).

8. Recommendations. Comments, recommendations, and data from DCA offices and all DoD components are encouraged and solicited. Certain information maintained by field activities may be more current or accurate than that presented herein. In addition, some activities will have requirements for cost data or procedures not presently contained in this Circular. In both of these cases, direct communication with Headquarters, DCA, Code 690, is encouraged. Corrections, additions, deletions, and all other suggestions for improvement are welcome and will be researched for incorporation into the Circular.

FOR THE DIRECTOR:

OFFICIAL:

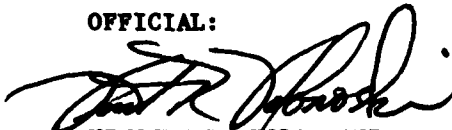

VINCENT R. VOLONOSKI
Chief, Administrative Support Division

F. LEE MAYBAUM
Colonel, USAF
Chief of Staff

SUMMARY OF SIGNIFICANT CHANGES. This revision updates planning rates and factors, notably operational site activation factors (chapter 21), personnel cost rates (chapters 23 and 24), other operating and support factors (chapter 24 and 26), CSIF subscriber rates (chapter 28), monetary rates of exchange (chapter 35), construction price indexes (chapter 36), and economic escalation indexes (chapter 38). New material is added in the areas of auxiliary equipment (chapter 14), site construction (chapter 21), and FOI rates (chapter 42).

CONTENTS

	<u>Paragraph</u>	<u>Page</u>
BASIC CIRCULAR		
Purpose.....	1	1
Applicability.....	2	1
Contents.....	3	1
Procedures and Use of the Circular.....	4	11
Revisions.....	5	v
Source of Data.....	6	v
Additional Factors.....	7	vi
Recommendations.....	8	vi
Contents.....		vii
Illustrations.....		xiv
Definitions and Glossary of Terms.....		xx
Abbreviations and Acronyms.....		xxvi

SECTION A. COST-ESTIMATING PROCEDURES

<u>Chapter</u>	<u>Paragraph</u>	<u>Page</u>
1. LOS MICROWAVE SYSTEMS		
Introduction.....	1	1-1
Project Description.....	2	1-1
Project Cost Estimate.....	3	1-2
Cost Model.....	4	1-2
2. TROPOSPHERIC SCATTER SYSTEMS.....		
Introduction.....	1	2-1
Project Description.....	2	2-1
3. HIGH FREQUENCY RADIO SYSTEMS..... (To be published later)		
4. SATELLITE COMMUNICATIONS SYSTEMS.....		
Introduction.....	1	4-1
Project Description.....	2	4-1
Estimating Procedure.....	3	4-1
5. CABLE SYSTEMS		
Introduction.....	1	5-1
Submarine Cable Systems.....	2	5-1
Land Cable Systems.....	3	5-16
6. FIBER OPTIC SYSTEMS..... (To be published later)		

CONTENTS (CON.)

<u>Chapter</u>	<u>Paragraph</u>	<u>Page</u>
7. (Reserved for future use).....		7-1
8. (Reserved for future use).....		8-1
9. ADVANCED CONCEPTS..... (To be published later)		9-1
SECTION B. COMMUNICATIONS PRIME MISSION EQUIPMENT		
10. TRANSMISSION SYSTEMS EQUIPMENT		
General.....	1	10-1
LOS Microwave Equipment.....	2	10-1
Tropospheric Scatter Systems Equipment.....	3	10-12
High-Frequency Radio Equipment.....	4	10-14
Satellite Systems.....	5	10-14
Cable Systems Equipment.....	6	10-21
11. MULTIPLEX EQUIPMENT		
Digital Multiplex	1	11-1
Frequency Division Multiplex (FDM).....	2	11-5
12. SWITCHED SYSTEMS EQUIPMENT..... (To be published later)		
13. CONTROL SYSTEM EQUIPMENT		
General.....	1	13-1
Technical Control Facility (TCF) and Patch and Test Facility (PTF).....	2	13-1
Orderwire and Intercom Equipment.....	3	13-1
Alarm System Equipment.....	4	13-1
Use of Tables.....	5	13-1
14. AUXILIARY EQUIPMENT		
General.....	1	14-1
Electric Power.....	2	14-1
Heating and Air-Conditioning.....	3	14-7
Modems.....	4	14-10
Voice Terminals.....	5	14-13
Data Terminals.....	6	14-16

CONTENTS (CON.)

<u>Chapter</u>	<u>Paragraph</u>	<u>Page</u>
SECTION C. COMMUNICATIONS SYSTEMS SUPPORT COSTS		
15. INTEGRATION AND ASSEMBLY		
General.....	1	15-1
Estimating Procedure.....	2	15-2
16. CONTRACTOR TRAINING		
General.....	1	16-1
Derivation of Factors.....	2	16-1
Use of Tables.....	3	16-2
Estimating Procedure.....	4	16-2
17. TEST, PECULIAR, AND COMMON SUPPORT EQUIPMENT		
General.....	1	17-1
Derivation of Factors.....	2	17-1
Use of Table.....	3	17-2
Estimating Procedure.....	4	17-3
18. SYSTEM TEST AND EVALUATION		
General.....	1	18-1
Estimating Procedure.....	2	18-1
19. SYSTEM/PROJECT MANAGEMENT		
General.....	1	19-1
System Engineering.....	2	19-1
Project Management Support.....	3	19-3
20. DATA - TECHNICAL SUPPORT DOCUMENTATION		
General.....	1	20-1
Derivation of Factors.....	2	20-1
Use of Table.....	3	20-1
Estimating Procedure.....	4	20-2
21. OPERATIONAL SITE ACTIVATION		
Introduction.....	1	21-1
Contractor Technical Support.....	2	21-1
Site Construction.....	3	21-2
Assembly, Installation, and Checkout On Site.....	4	21-8

CONTENTS (CON.)

<u>Chapter</u>	<u>Paragraph</u>	<u>Page</u>
22. INITIAL SPARES AND REPAIR PARTS		
General.....	1	22-1
Derivation of Factors.....	2	22-1
Use of Table.....	3	22-1
Estimating Procedure.....	4	22-1
SECTION D. ANNUAL OPERATING COSTS		
23. MILITARY PERSONNEL RATES		
General.....	1	23-1
Derivation of Factors.....	2	23-1
Use of Tables.....	3	23-3
24. OPERATIONS AND MAINTENANCE		
Civilian Personnel.....	1	24-1
TDY and Civilian Permanent		
Change of Station Cost.....	2	24-17
Transportation of Things.....	3	24-22
Utilities and POL.....	4	24-30
Contractor Employees.....	5	24-37
Security Clearances.....	6	24-52
Miscellaneous O&M Factors.....	7	24-53
25. RECURRING INVESTMENT		
General.....	1	25-1
Replacement Factor.....	2	25-1
Derivation of Factors.....	3	25-1
Estimating Procedure.....	4	25-1
26. OPERATING SUPPORT		
Introduction.....	1	26-1
Base Operations.....	2	26-2
Depot Maintenance.....	3	26-4
Recruitment, Basic Training, and		
Specialty Training.....	4	26-6
Hospitals.....	5	26-10
Military PCS Travel.....	6	26-11

CONTENTS (CON.)

<u>Chapter</u>	<u>Paragraph</u>	<u>Page</u>
SECTION E. LEASED COMMUNICATIONS COSTS AND SUBSCRIBER RATES		
27. PLANNING FOR LEASED SERVICES		
Content.....	1	27-1
Domestic or International.....	2	27-1
Analog or Digital.....	3	27-1
Dedicated or Shared.....	4	27-3
Government or Commercial.....	5	27-5
28. COMMUNICATIONS SERVICES INDUSTRIAL FUND (CSIF) SUBSCRIBER RATES		
General.....	1	28-1
Derivation of Factors.....	2	28-1
AUTOVON.....	3	28-1
AUTODIN.....	4	28-3
ARPANET.....	5	28-4
Defense Data Network (DDN).....	6	28-6
Multiplexed and Bulk Systems.....	7	28-7
CONUS Commercial Satellite Communications System (COMSATCOM).....	8	28-13
Terminal Equipment.....	9	28-14
29. INTERNATIONAL COMMERCIAL SERVICE		
General.....	1	29-1
Currency Conversion Factors.....	2	29-2
Use of Tables.....	3	29-2
30. DOMESTIC COMMERCIAL SERVICE		
General.....	1	30-1
Dedicated Systems	2	30-1
Shared Services.....	3	30-3
SECTION F. GENERAL COST CONSIDERATIONS		
31. ADP COST ESTIMATING		
Introduction.....	1	31-1
ADP Cost-Estimating Worksheets.....	2	31-1
Lease vs. Buy Analysis.....	3	31-15
32. RESIDUAL VALUE		
General.....	1	32-1
Guidelines and Procedures.....	2	32-1

CONTENTS (CON.)

<u>Chapter</u>	<u>Paragraph</u>	<u>Page</u>
33. MANPOWER/EQUIPMENT RATIOS..... (To be published later)		33-1
34. EQUIPMENT INSTALLATION SCHEDULE FACTORS..... (To be published later)		34-1
35. INTERNATIONAL MONETARY RATES OF EXCHANGE		
General.....	1	35-1
Use of Table.....	1	35-1
36. CONSTRUCTION PRICE INDEXES		
General.....	1	36-1
Derivation of Factors.....	2	36-1
Use of Tables.....	3	36-1
37. COST QUANTITY RELATIONSHIPS.....		
General.....	1	37-1
Derivation of Factors.....	2	37-1
Use of Tables.....	3	37-3
38. ECONOMIC ESCALATION		
General.....	1	38-1
Use of Tables.....	2	38-2
39. EQUIPMENT LEASE FACTORS..... (To be published later)		39-1
40. FISCAL-YEAR TIME PHASING OF COST ESTIMATE..... (To be published later)		40-1
41. DISCOUNTING		
General.....	1	41-1
Background.....	2	41-1
Guidelines and Procedures.....	3	41-2
Use of Tables.....	4	41-5
42. REPORT COSTING AND FREEDOM OF INFORMATION REQUESTS		
General.....	1	42-1
Derivation of Factors for Tables 42-1 and 42-2...	2	42-1
Use of Tables 42-1 and 42-2.....	3	42-3
Estimating Procedure.....	4	42-3
Derivation of Factors for Table 42-3.....	5	42-12
Use of Table 42-3.....	6	42-12

CONTENTS (CON.)

<u>Chapter</u>	<u>Paragraph</u>	<u>Page</u>
43. ANALYSIS OF COMMERCIAL ACTIVITIES..... (To be republished later)		43-1
44. DCS CAPITAL EQUIPMENT COSTS		
General.....	1	44-1
Derivation of Factors.....	2	44-2
Use of Tables.....	3	44-2
45. TRANSPORTABLE COMMUNICATIONS UNITS		
General.....	1	45-1
Development of Transportable Facilities.....	2	45-1
Considerations in Analyses.....	3	45-1
Costs of Transportable Units.....	4	45-3
INDEX.....		I-1
 SUPPLEMENT		
1. Work Breakdown Structure		

ILLUSTRATIONS

BASIC CIRCULAR

<u>Figure</u>		<u>Page</u>
1	Acquisition Cost - Building Block Concept.....	111
2	Annual Operating Cost - Building Block Concept.....	iv
SECTION A. COST ESTIMATING PROCEDURES		
1-1	LOS Microwave System - Example System Configuration.....	1-4
1-2	LOS Microwave Prime Mission Equipment Building Block.....	1-5
1-3	LOS Terminal Layout - Building Block Concept.....	1-6
1-4	LOS Relay Layout - Building Block Concept.....	1-7
1-5	LOS Node Layout - Building Block Concept.....	1-8
1-6	Cost Estimate Worksheet - Microwave System/Site.....	1-13
2-1	Tropospheric Scatter System - Example Configuration.....	2-4
2-2	Tropo Prime Mission Equipment Building Block.....	2-5
2-3	Tropo Terminal Layout - Building Block Concept.....	2-6
4-1	Proposed Satellite System Launch Schedule.....	4-4
5-1	Submarine Cable System - Example System Configuration.....	5-4
5-2	Submarine Cable System Prime Mission Equipment Building Block.....	5-5
5-3	Submarine Cable System Terminal Layout Building Block Concept.....	5-6
5-4	Submarine Cable System Terminal Layout Building Block Concept.....	5-7
SECTION B. COMMUNICATIONS PRIME MISSION EQUIPMENT COSTS		
11-1	Digital Multiplex Block Diagram.....	11-3
11-2	Example Site Configuration.....	11-4
14-1	MODEM Block Diagram.....	14-11
14-2	Voice Terminal Block Diagram.....	14-14
SECTION C. COMMUNICATIONS SYSTEMS SUPPORT COSTS		
21-1	Size/Unit Cost Adjustment Chart.....	21-7
SECTION D. ANNUAL OPERATING COSTS		
23-1	Military Labor Rates.....	23-3
24-1	Civilian Rates.....	24-2
24-2	Hazardous Duty Differentials at 25 Percent.....	24-15
24-3	Independent Cost Estimate Worksheet.....	24-47
24-4	Hardened Cable Example.....	24-50
SECTION E. LEASED COMMUNICATIONS COSTS AND SUBSCRIBER RATES		
27-1	Organization of Section E.....	27-7
28-1	Illustration of AUTOVON Cost Elements.....	28-4

ILLUSTRATIONS (CON.)

FigurePage

SECTION F. GENERAL COST CONSIDERATIONS

31-1	Equipment Purchase and Maintenance Costs.....	31-4
31-2	Equipment Lease and Maintenance Costs.....	31-7
31-3	Vendor Software and Services Costs.....	31-9
31-4	Nonequipment Costs.....	31-12
31-5	Time-Phased Cost Summary.....	31-14
32-1	Residual Value.....	32-2
37-1	Eighty-Percent Learning Curve on Linear Graph.....	37-2
37-2	Eighty-Percent Learning Curve on Log-Log Graph.....	37-2
42-1	Example of Summary Worksheet for Estimating Reporting Costs.....	42-8

SECTION A. COST ESTIMATING PROCEDURES

TablePage

1-1	Subsystem Description - LOS Microwave System.....	1-3
1-2	Acquisition Cost - Proposed Subsystem/Project Plan X-7X LOS Microwave System.....	1-9
1-3	Annual Operating Cost - Proposed Subsystem/Project Plan X-7X LOS Microwave System.....	1-11
1-4	Time-Phased Cost Estimate - Proposed Project Plan X-7X LOS Microwave System.....	1-12
2-1	Tropo Transmission Capabilities.....	2-2
2-2	Subsystem Description - Tropo System.....	2-3
2-3	Acquisition Cost - Subsystem Project Plan X-8X Tropo System 1GHz.....	2-7
2-4	Annual Operating Cost - Subsystem Project Plan X-8X Tropo System 1GHz.....	2-11
4-1	Subsystem Description - Satellite Subsystem Project Plan X-7X.....	4-2
4-2	Satellite Estimating Equations.....	4-3
4-3	Acquisition Cost of Proposed Subsystem Project Plan X-7X Satellite System.....	4-5
4-4	Operating and Support Costs of Proposed Subsystem/ Project Plan X-7X Satellite System.....	4-10
5-1	Subsystem Description Submarine Cable.....	5-3
5-2	Acquisition Cost Proposed Subsystem/Project Plan X-8X Submarine Cable System.....	5-8
5-3	Annual Operating Cost Proposed Subsystem/Project Plan X-8X Submarine Cable System.....	5-14
5-4	Time-Phased Cost Estimate - Proposed Project Plan X-8X Submarine Cable System.....	5-15

ILLUSTRATIONS (CON.)

<u>Table</u>	<u>Page</u>
5-5 Acquisition Cost-Proposed Subsystem/Project Plan X-8X Land Cable System.....	5-18
SECTION B. COMMUNICATIONS PRIME MISSION EQUIPMENT COSTS	
10-1 LOS Radio Equipment.....	10-3
10-2 LOS Microwave Antennas.....	10-5
10-3 Transmission Line Systems.....	10-7
10-4 Towers.....	10-9
10-5 Passive Reflectors.....	10-11
10-6 Tropo Radio Equipment.....	10-13
10-7 Tropo Antenna Equipment.....	10-13
10-8 Feed Subsystem Cost.....	10-14
10-9 Communications Satellite CER's (Nonrecurring Cost).....	10-16
10-10 Communications Satellite CER's (Cost of First Production Unit).....	10-17
10-11 Computation of Satellite Costs.....	10-18
10-12 Launch Vehicle Costs.....	10-19
10-13 SHF Earth Terminal CER.....	10-20
10-14 Submarine Cable Systems Equipment.....	10-22
10-15 Installed Telephone Cable Costs.....	10-24
11-1 PCM/TDM Equipment.....	11-7
11-2 FDM (AN/UCC-4) Rack Capacities.....	11-8
11-3 FDM Equipment Terminal Cost.....	11-9
11-4 FDM Equipment, Rack Costs.....	11-10
13-1 TCF/PTF Circuit Conditioning.....	13-3
13-2 TCF/PTF Circuit Control Equipment.....	13-3
13-3 TCF/PTF Circuit Conditioning Equipment.....	13-4
13-4 Orderwire and Intercom Equipment.....	13-5
13-5 Alarm System Equipment.....	13-6
14-1 Typical Station Power Requirements.....	14-5
14-2 Electrical Generation Costs.....	14-6
14-3 Electrical Distribution Costs.....	14-7
14-4 Heating Equipment Costs.....	14-8
14-5 Air-Conditioning Costs.....	14-9
14-6 MODEM Costs.....	14-13
14-7 Voice Terminal Costs.....	14-16
14-8 Facsimile Characteristics.....	14-19
14-9 Data Terminal Costs.....	14-20
SECTION C. COMMUNICATIONS SYSTEMS SUPPORT COSTS	
16-1 Contractor Training.....	16-3
17-1 Test, Peculiar, and Common Support Equipment.....	17-3
19-1 System/Project Management.....	19-4
20-1 Data-Technical Support Documentation.....	20-3
21-1 Contractor Technical Support.....	21-1

ILLUSTRATIONS (CON.)

<u>Table</u>	<u>Page</u>
21-2 Site Construction.....	21-3
21-3 Liquid Storage CERS.....	21-5
21-4 Permanent Buildings.....	21-6
21-5 Assembly, Installation, and Checkout.....	21-8
22-1 Initial Spares and Repair Parts.....	22-2

SECTION D. ANNUAL OPERATING COSTS

23-1 Military Personnel Standard Rates.....	23-5
23-2 DCA Military Labor Rates.....	23-6
23-3 DCA Military Labor Rates-Major.....	23-7
24-1 DCA Civilian Labor Rates.....	24-4
24-2 DCA Civilian Labor Rates-GS 13	24-5
24-3 Median Grades for Federal White-Collar Workers.....	24-6
24-4 Civilian Differentials and Allowances.....	24-10
24-5 Foreign National Pay Rate (Direct Hire, Except Where Indicated).....	24-16
24-6 Temporary Duty Travel Costs.....	24-19
24-7 Civilian Personnel PCS Cost.....	24-21
24-8 Transportation Costs as a Percentage of Equipment Costs.....	24-23
24-9 Transportation Cost Factors for Items Having Unit Value of Less Than \$10,000.....	24-25
24-10 Military Air Cargo Rates.....	24-27
24-11 Ocean Freight Rates.....	24-29
24-12 Vehicle Operating and Maintenance Costs.....	24-30
24-13 Utilities and POL.....	24-33
24-14 Annual Requirements for #2 Fuel Oil for Heating.....	24-36
24-15 Contractor Labor Costs (U.S. Nationals) - R&D Studies.....	24-40
24-16 Contractor Labor Costs (U.S. Nationals) - Contracts to Engineer, Furnish, Install Communications Systems.....	24-41
24-17 Contractor Labor Costs (U.S. Nationals) Contracts for Manufacture of Communications Equipment.....	24-42
24-18 Contractor Monthly Salaries Scientific, Engineering, and Technical Support Contracts.....	24-45
24-19 ILC Factors for Scientific, Engineering, and Technical Support Contracts.....	24-46
24-20 Federal Contract Research Centers.....	24-52
24-21 Security Clearance Costs.....	24-52
24-22 Miscellaneous O&M Factors.....	24-56
25-1 Annual Replacement Spares.....	25-1
26-1 Annual Base Operations Cost Per Individual.....	26-3
26-2 Education of Dependent Children.....	26-4
26-3 Depot Maintenance Cost Factors.....	26-5
26-4 Annual Training Costs.....	26-8
26-5 Composite Training Costs.....	26-10
26-6 Annual Medical Support Cost Per Individual.....	26-11
26-7 PCS Travel.....	26-13

ILLUSTRATIONS (CON.)

<u>Table</u>	<u>Page</u>
SECTION E. LEASED COMMUNICATIONS COSTS AND SUBSCRIBER RATES	
28-1 AUTOVON CSIF Planning Rates.....	28-5
28-2 AUTODIN CSIF Planning Rates.....	28-6
28-3 Transoceanic Multiplex Service CSIF Planning Rates.....	28-8
28-4 CONUS VFCT Links.....	28-9
28-5 CONUS Channel Packing Links.....	28-10
28-6 European Channel Packing Service CSIF Planning Rates.....	28-11
28-7 Intra-Europe Links of European Channel Packing Service....	28-11
28-8 1.544 MB/S CSIF Planning Rates.....	28-12
28-9 WAWS CSIF Planning Rates.....	28-15
28-10 COMSATCOM CSIF Planning Rates.....	28-16
28-11 Planned COMSATCOM Earth Terminal Locations.....	28-17
28-12 Cost for Terminal Equipment and Termination.....	28-18
29-1 List of CONUS Gateways.....	29-5
29-2 Leased Service Charges for Transoceanic Circuits.....	29-5
29-3 Leased Service Charges for Transoceanic Digital Service, Monthly Rates.....	29-9
29-4 Leased Service Charges for International Circuits - Europe.....	29-10
29-5 Monthly Leased Service Charges for Intracountry a thru Circuits in Europe.....	29-13
j	
29-6 Monthly Leased Service Charges for Intracountry Circuits - Hawaii.....	29-23
30-1 Rates for Voice Grade Service	30-6
30-2 Areas on the DDS Network.....	30-7
30-3 DDS Rates.....	30-8
30-4 Private Line Service.....	30-9
30-5 Minimum Single Voice Grade Satellite Channel Rate.....	30-10
30-6 DDS Per Minute Prices.....	30-11
30-7 WATS Rates.....	30-12
30-8 Monthly Rates for Low-Speed Public Access.....	30-13
SECTION F. GENERAL COST CONSIDERATIONS	
31-1 Number of Months to Breakeven.....	31-17
32-1 Economic Lives.....	32-3
35-1 Foreign Currency Budget Exchange Rates.....	35-2
36-1 Construction Price Indexes-States.....	36-1
36-2 Construction Price Indexes-Territories and Possessions of the United States.....	36-4
36-3 Construction Price Indexes-Foreign Countries.....	36-5
37-1 Estimated Improvement Curve Ranges in the Electronics Industry.....	37-5
37-2 Estimated Improvement Curve Slopes Based on Combinations of Manual and Machine Efforts.....	37-5
37-3 Learning Curve Factors.....	37-6
37-4 Unit Cost to Cumulative Average Conversion Factors.....	37-6
37-5 Production Cost Improvement Curve Slopes.....	37-7

ILLUSTRATIONS (CON.)

<u>Table</u>	<u>Page</u>
38-1 Price Level Indexes.....	38-3
38-2 Program Expenditure Rates.....	38-4
38-3 Weighted (TOA) Price Level Indexes.....	38-6
41-1 Annual Discount Factors.....	41-10
41-2 Individual Project Discounting Example.....	41-11
41-3 Differential Cost Discounting Example.....	41-12
41-4 Monthly Discount Factors.....	41-13
41-5 Combined Economic Escalation and 10-Percent Discount Factors (Annual Factors).....	41-17
41-6 Combined Economic Escalation and 10-Percent Discount Factors (Monthly Factors).....	41-19
41-7 Individual Project Example Based Upon Combined Escalation/Discount Factors.....	41-27
42-1 Report Cost Factors.....	42-6
42-2 Average Personnel Grade Levels.....	42-7
42-3 Freedom of Information Fees.....	42-12
44-1 Amplifier Costs.....	44-3
44-2 Antenna Costs.....	44-4
44-3 MODEM Costs.....	44-10
44-4 Multiplex Costs.....	44-11
44-5 Power Costs.....	44-15
44-6 Radio Costs.....	44-20
44-7 SEVOCOM Costs.....	44-24
44-8 Satellite Costs.....	44-25
44-9 Traffic Data Collection Systems Costs.....	44-26
44-10 Telephone Switching Costs.....	44-26
44-11 Teletype Costs.....	44-27

DEFINITIONS AND GLOSSARY OF TERMS

Antenna Systems (Line of Sight). Parabolic reflectors and feed horns (usually quoted as one item), radomes, antenna mounts, and passive reflectors, if used.

Assembler. Employee whose primary duty is to convert individual components to make an assembly or subassembly. Works with preformed jigs, harnesses, and fixtures. Manual dexterity is required.

Associate Engineer. An action officer working under supervision in a professional capacity but making only minor decisions which are subject to review.

Commercial Documentation. Documentation based upon the DoD Authorized Data List (referred to as TD-3) required to manage and develop a capability to support equipment of a commercial nature, with contractor assistance in some cases. Verified contractor publications overhaul, etc., are included.

Computer Programers I, II, and III. Computer Programer III is a fully qualified journeyman performing the same functions as the Senior Computer Programer, but with no supervisory responsibilities. Computer Programers I and II are of a less skilled classification and are closely supervised.

Computer Systems Specialist. Technically trained employee specializing in the selection and integration of computer components to match the operating characteristics and capabilities of the operating system.

Constant Dollars. Costs expressed in terms of the value of a dollar in a specified base year.

Cost-of-Living Allowance. This allowance is made to compensate for the difference existing between the adjusted annual pay rate and the prevailing standard of living in a particular geographical area.

Current Year Dollars. (Also "then year" or "inflated dollars.") Costs expressed in actual amounts, including any amounts due to economic price level changes.

Degree-day. A unit of heat measurement equal to 1° of variation below a standard temperature of the average temperature of 1 day.

Development Tests. The test planning and use of prototype equipment to acquire engineering data and confirm engineering hypotheses.

Direct-Hire Foreign National Personnel. Non-U.S. citizen personnel employed by the U.S. Forces overseas. Pay rates determined by the U.S. Forces are

usually aligned to the prevailing rates paid for comparable work in the particular geographical location. The U.S. Forces overseas are directly responsible for administration of management functions for direct hire foreign national personnel; and indirectly responsible for indirect hire foreign nationals.

Discounting. An adjustment to cash flow to account for the cost of capital. See "present value."

Diversity. The method of transmission or reception whereby, to reduce the effects of fading, a single received information signal is derived from a combination of, or selections from, signals containing the same information (MIL-STD-188-100).

Diversity, Frequency. The method of transmission or reception wherein the same information signal is transmitted and received simultaneously on two or more frequencies (MIL-STD-188-100).

Diversity, Space. The method of transmission or reception which employs antennas having spatial separations (MIL-STD-188-100).

Economic Life. The period of time during which a system or equipment will perform its function at a cost equal to or less than the cost of any alternative method of operation, or as long as the benefits received are greater than the cost. Economic life is sometimes equated to useful life, but may differ substantially from physical life.

Electronic Module. A combination of components contained in one or more packages and so arranged that they are common to one mounting which receives and delivers electrons to provide a complete function or functions for the subsystem in which they operate. Also, an interchangeable plug-in item containing components.

Electronics Technician. Technical personnel involved in the installation and maintenance of electronics equipment. Senior technicians are fully qualified journeymen. Junior technicians have fewer skills and experience and more limited capabilities.

Engineering Data. Drawings, associated lists, specifications, and other documentation pertaining to systems, subsystems, component engineering, and testing.

Engineering Manager. An engineer with responsibility for planning, organizing, and directing engineering activities of outstanding importance usually in a production facility.

Engineering Specialist. A highly skilled engineer engaged in the solution of engineering problems and manufacturing techniques of great difficulty but confined to a specialized area of expertise.

Fabrication Plant Employee. Employee with skills to assemble structural components who works from blueprints, drawings, or sketches. An accomplished metalsmith and welder.

Feed System. Waveguide (transmission line), circulators, dehydrators and pressure systems, and the mounting hardware to carry signals between the radio set and the antennas.

Frequency Division Multiplex (FDM). A method of deriving two or more simultaneous, continuous channels from a transmission medium connecting two points by assigning separate portions of the available frequency spectrum to each of the individual channels.

Full Support Documentation. That documentation based upon TD-3 required to manage and develop complete in-house Government capability for life-cycle support. Documentation at this level is normally procured for large quantities of equipment with a life cycle longer than 5 years.

Hazardous Duty. Duty performed under circumstances in which an accident could result in serious injury or death, such as duty performed on an open structure where adverse conditions exist such as darkness, lightning, steady rain, or high wind velocity.

Indirect-Hire Foreign National Personnel. Non-U.S. citizen personnel, employed by the host government to accommodate needs of U.S. Forces for local national personnel. Responsibilities for administrative management functions are assumed by the host government, and wages are usually aligned with those paid for comparable work in the particular geographical location.

Industrial Engineer. A person responsible for planning manufacturing processes to optimize efficiency. Is responsible for human factors and safety aspects of manufacturing.

Installation Supervisor. May be either an engineer or highly skilled technician who supervises technicians in the installation of components in their operating environment.

Life Cycle Costs (LCC). The total cost to the Government for a system over its full life, including the cost of development, procurement, operation, support, and where applicable, disposal.

Line of Sight (LOS). A direct propagation path that does not go below the radio horizon. Distance to the horizon from an elevated point. This path is affected by atmospheric refraction.

Management Data. Data necessary for configuration management, cost, schedule, and contractual data management and other program management.

Model Shop Wireman. Technician engaged in using schematics to wire components without the benefit of premanufactured harnesses. Often designs special jigs and fixtures.

Node. (Also called Junction Point, Branch Point, or Vertex.) Terminal of any branch of a network or terminal common to two or more branches of a network (MIL-STD-188-100).

Operating Life. That period of time when, through maintenance and repair, a system or equipment will continue to operate. Cost is not a consideration in its determination.

Operational Evaluation. Production hardware evaluation by the ultimate using command, demonstrating the system performance and tactical use under operational conditions.

Patch and Test. The function of quality control, equipment or channel substitution for maintenance or isolation of communications faults, accomplished under the technical supervision of a designated technical control facility.

Physical Hardship Duty. A duty which of itself may not be hazardous but which causes extreme physical discomfort or distress and is not adequately alleviated by protective or mechanical devices. Examples are duty requiring exposure to extreme temperatures for a long period of time; duty performed in cramped conditions; duty involving exposure to fumes, dust, and noise, which causes nausea, skin, eye, ear, or nose irritation.

Piece Parts. Those bits and pieces; i.e., nuts, bolts, transistors, resistors, etc., required for maintenance and repair of equipment or modules.

Post Differentials in Foreign Areas. The payment of post differentials provides a method of enhancing recruitment or incentive pay for a geographical area which may be remote or in a hazardous location.

Present Value. The present worth of past or future benefits and costs determined by multiplying each year's actual or expected cost by its discount factor and summed over all years of the planning period to make alternative programs and actions comparable regardless of time differences in the money flows.

Principal Engineer. A consultant and an outstanding contributor to the solution of complex problems; their solution often extends the existing state of the art.

Project Engineer. A supervisory communications engineer responsible for all engineering efforts required of the project.

Project Manager/Senior Official. An employee who by demonstrating excellence in technical and managerial positions has assumed a position of leadership within the company and is assigned to direct projects of major importance to the customer and company.

Pulse Code Modulation (PCM). A modulation process for the conversion of a waveform from analog to digital form by quantizing the analog information into a series of pulse codes.

Radio Set. Equipment used to transmit and receive the R.F. signals, including the transmitters, receivers, power supplies, and combiners.

Repeater Station, Radio. An intermediate station in a microwave system arranged to receive a signal from a distant station, and amplify and retransmit the signal to another distant station. The repeater usually performs this function in both directions simultaneously.

Replacement Factor. The estimated percentage of equipment or repair parts in use that will require replacement during a given period due to the equipment wearing out beyond repair, enemy action, abandonment, pilferage, and other causes except major catastrophes.

Reprocurement Documentation. That documentation required to assure that equipment procured on a "more of the same" basis is identical to equipment previously procured and satisfactorily supported.

Residual Value. The value assigned to a system at a given time prior to the end of its economic life.

Senior Computer Programmer. Technically trained employee having the knowledge required to translate instructions into machine-understandable language. Capable of writing complex programs and supervising and instructing those with less developed skills.

Senior Engineer. Often an action officer who may work on problems with little or no historical precedents and who may supervise less experienced technical and support personnel. Has no line supervisory responsibilities.

Senior Supervisory Systems Analyst. A manager skilled in directing analysis of problems so as to design a computer program for use in this resolution.

Support Documentation. Recorded data and information necessary to operate, maintain, and manage.

Systems Analyst. Technically and scientifically trained employee with qualifications similar to those of a Senior Supervisory Systems Analyst but with no managerial or supervisory duties.

Systems Engineer. An engineer with skills required to interface the individual subsystems of a communications system into an integrated whole. Must know different transmission media and modulation techniques.

Tailored Support Documentation. That documentation based upon TD-3 required to manage and develop limited Government in-house and contractor capability to support a limited number of equipment with a short useful life cycle. It can also include changes or improvement to documentation previously procured.

Technical Control. The functions of technical direction, coordination, technical supervision of transmission media and equipment, quality control, communications service restoral, and status reporting required to provide effective communications to the users. This includes direction of activities in any work area of the communications station containing distribution frames and associated jacks or switches through which equipment and facilities are patched or switched to provide the required transmission path. The work areas also include any test equipment or testing capability.

Technical Evaluation. The evaluation of performance characteristics of production (or near production) configured hardware, culminating in Government acceptance of contractual performance requirements.

Technical Orders and Manuals. Handbooks, technical manuals, technical orders, technical data sheets, and other like documentation required by DoD.

Technological Life. The period of time that the equipment will represent current technology. New technology may represent faster, more sophisticated systems; however, current technology may still adequately and economically meet the system requirements.

Terminal Value. The value of a system or equipment at the end of either the project life or the end of the economic life, whichever occurs first.

Test and Evaluation Support. All support elements necessary to operate and maintain systems and subsystems during testing and evaluation which are not consumed during a particular phase of testing; for example, reparable spares, repair parts, and contractor technical support not assigned to and costed within a particular phase of testing.

Test Facilities. Special test facilities required for performance of various developmental tests necessary for proof of design and reliability of the system or subsystem, such as white rooms, test chambers, etc.

Time Division Multiplex (TDM). Multiplex arrangement where several message channels share a single transmission facility, each having its own time slot.

Tropical Differential. Additional pay applicable to the Panama Canal Zone that is paid to one member of a household who may be employed by the DoD in that location.

ABBREVIATIONS AND ACRONYMS

A&E	architectural & engineering
A/C	air-conditioning
Add.	additional
Adm.	administrative
ADP	automatic data processing
ADPE	automatic data processing equipment
°F	degree(s) Fahrenheit
AFB	Air Force base
AFM	Air Force manual
AMT	AUTODIN multimedia terminal
ARPANET	Advanced Research Projects Agency Network
ASCII	American Standard Code for Information Interexchange
ASIF	Airlift Service Industrial Fund
ASR	automatic send/receive
AT&T	American Telephone and Telegraph
AUTODIN	Automatic Digital Network
AUTOSEVOCOM	Automatic Secure Voice Communications
AUTOVON	Automatic Voice Network
b/s	bits per second
B/T	berth term (shipping)
BD	baud(s)
Bldgs	buildings
BLS	Bureau of Labor & Statistics
BOQ	bachelor officer's quarters
Btu	British thermal units
C/M	card(s) per minute
CADIN	Continental Air Defense Integration North
CAU	CRYPTO ancillary unit
CCT	computer communications terminal
CCTC	Command and Control Technical Center
CCU	common control unit
CDRL	Contract Data Requirements List
CER	Cost-Estimating Relationship
Ch.	chapter(s)
Civ.	civilian
COMSATCOM	Commercial Satellite Communications System
CON.	continued
CONUS	contiguous United States
COTR	contracting officer's technical representative
CSIF	Communications Services Industrial Fund
CSM	circuit switch module
CTL	contingent termination liability
cu	cubic (measure of volume)
DA	Department of Army
DCA	Defense Communications Agency
DCAC	DCA circular

DCAI	DCA instruction
DCAOC	Defense Communications Agency Operations Center
DCEC	Defense Communications Engineering Center
DCP	Decision concept paper
DCS	Defense Communications System
DCT	data communications terminal
DDN	Defense Data Network
DEB	Digital European Backbone
DECCO	Defense Commercial Communications Office
Demod.	demodulation
DFSC	Defense Fuel Supply Center
diam.	diameter
DLC	direct labor costs
DLT	data line terminal
DoD	Department of Defense
DSCS	Defense Satellite Communications System
DSM	device switching module
DSTE	digital subscriber terminal equipment
EAM	electric accounting machines
EHF	extremely high frequency
Enl.	enlisted
Equip.	equipment
F/I	free in (Shipping)
FCC	Federal Communications Commission
FCRC	Federal contract research center
FDM	frequency division multiplex
FDX	full duplex
Fig.	figure
FIO	free in (shipping), free out
FOIA	Freedom of Information Act
ft	foot (feet)
ft ²	square foot (feet)
ft ³	cubic foot (feet)
ft ³ /min	cubic foot (feet) per minute
FY	fiscal year
FYDP	Five Year Defense Program
FYP	Five Year Program
G&A	general & administrative
gal	gallon(s)
GFM	Government furnished material
GHz	Gigahertz - one thousand million Hertz
GS	General Service (civilian employee)
GSA	General Services Administration
H.T.	heavy terminal
HDBK	handbook
HDX	half duplex
HEMP	high altitude electromagnetic pulse
HF	high frequency
hr	hours(s)

H SCT	high speed compound terminal
I/O	input/output
IF	intermediate frequency - usually 70 megahertz
ILC	indirect labor costs
IMP	interface message processor
Incl.	includes
Init.	initial
Instl.	installation
IRC	international record carrier
Is.	island(s)
ITA	International Telegraph Association
IUS	Interim upper stage
JTR	Joint Travel Regulations
K	one thousand (1×10^3)
kVA	kilovoltampere
kW	kilowatt - one thousand watts
kw	kilowatt
kWh	kilowatt hours
L.T.	light terminal
Lat.	latitude
lb	pound(s)
lb/ft ²	pounds of force per square foot
LCC	life cycle costs
lin.	linear
LOS	line-of-sight
L SCT	low-speed compound terminal
LT	long ton (shipping weight of 2,240 pounds)
M	one million (1×10^6)
M.T.	medium terminal
MAC	Military Airlift Command
MAG	magnetic
Maint.	maintenance
MCA	maximum calling area
MCP	military construction price
MEP	Management Engineering Plan
Mgmt.	management
Mi.	mile
MIL	military
MINET	Movements Information Network
Misc.	miscellaneous
MLPP	multilevel precedence preemption
Mod.	modulation
MODEM	modulator-demodulator
MOS	military occupational specialty
MSTS	Military Sea Transport Service
MT	measured ton
MTMC	Military Traffic Management Command
MUX	multiplex(or)
MW	microwave
N.	north

N/R	not required
NARS	National Archives & Records Service
NAV	Naval, Department of the Navy
NAV FAC P	naval facilities pamphlet
No.	number
O&M	operations and maintenance appropriation
O/S	overseas
OCS	Officer Candidate School
ODC	other direct charges
Off.	officers
OJT	on-the-job training
OMB	Office of Management & Budget
OPR	office of primary responsibility
OSD	Office, Secretary of Defense
OTP	Office of Telecommunications Policy
OW	orderwire
P&T	patch & test
Pam.	pamphlet
Para.	paragraph
PBX	private branch exchange
PCAM	punch card accounting machine
PCB	printed circuit board
PCM	pulse code modulation
PCS	permanent change of station
PEC	program element code
Pers.	personnel
PNB	precise-no-break
POL	petroleum, oil, and lubricant
POV	privately owned vehicle
PPM	principal period maintenance
PTT	post telephone and telegraph
Pwr.	power
Qtrs.	quarters
R&D	research and development
r/m	revolutions per minute
RDT&E	research, development, test, and evaluation
Refl.	reflector
Reimb.	reimbursements
RF	radio frequency
Sat.	satellite
SECORD	secure voice cord board
SG	supergroup
SHF	super high frequency
SOW	statement of work
Spec.	specialist
Spt.	support
sq	square (measure of area)
ST	short ton (2,000 pound avoirdupois)
Sta.	station
Str.	strand
T	ton
TCF	technical control facility

xxx

DCAC 600-60-1

TD-3	DoD Authorized Data List
TDM	time division multiplex
TDY	temporary duty
Tech.	technical or technician
TIP	terminal interface processor
TM	training manual
TO	technical order
TOA	total obligation authority
TSM	technical staff month
U.S.	United States
UHF	ultra high frequency
UPS	uninterruptible power supply
VDC	volts direct current
VF	voice frequency
VFCT	voice frequency carrier telegraph
VHF	very high frequency
w/m	words per minute
W/O	without
WB	Wage Board (civilian employee)
WAWS	Washington Area Wideband Service
WIN	WWMCCS Intercomputer Network
WWMCCS	Worldwide Military Command and Control System
xmtr	transmitter
yd	yard
yd ²	square yard(s)
yd ³	cubic yard(s)

SECTION A. COST-ESTIMATING PROCEDURES

CHAPTER 1. LOS MICROWAVE SYSTEMS

1. Introduction.

a. Line-of-sight (LOS) microwave systems normally use the frequency spectrum from 2 to 10 gigahertz (GHz). The LOS path lengths range from 1 to 100 miles depending upon propagation, terrain, frequency, and tower height, among other engineering considerations. The average system consists of path lengths of about 30 miles. The total microwave system consists of terminals, relays, and the normal support functions required for any communications system, such as technical control, multiplex, utilities, land, and buildings.

b. LOS microwave transmission is usually dual diversity, using either frequency, space, or polarization diversity. The transmission system will generally contain dual receive and transmit equipment at all locations for use as either frequency diversity systems or "hot standby" systems for redundancy.

c. Two techniques may be employed for the transmission and multiplexing of communications circuits. The current DCS uses frequency modulation transmission and frequency division multiplex (FDM), also called "analog systems." The future DCS will use digital transmission and time division multiplex (TDM), referred to as "digital systems." Both analog and digital systems use the same antennas, waveguide, towers, power, etc., with the basic equipment differences being in the radios, the multiplex, and the peculiar test equipment. The costing example shown in this chapter will cover "digital systems" through the substitution of costs for digital radios (chapter 10) and TDM (chapter 11) for the comparable analog radios and multiplex.

d. LOS microwave stations contain such equipment as radio sets, towers, antennas, feed systems, power supplies, orderwire, alarm systems, patch and test facilities, distribution frames, and multiplexers.

2. Project Description. Proposed hypothetical subsystem project plan K-7X requires the installation of a fixed LOS microwave system in Germany. The overall subsystem description is presented in table 1-1, and the configuration is portrayed in figure 1-1. The new system is designed to operate through a nodal station (part of the DCS). The area is in the temperate zone with moderate environmental conditions. There are no unduly restrictive local conditions or requirements that will affect the system planning. The system will contain three terminal or end locations (see figure 1-3), two relays (see figure 1-4), and a nodal station (figure 1-5). The system is to be operational in 2 years, and the schedule calls for terminal number 1, relay number 1, and the equipment for this link

at the nodal point to be under contract by fiscal year 1 of the subsystem project plan. The remainder of the equipment and buildings, and the training, are to be contracted for and the system turned over at the end of fiscal year 2. Operations will begin with fiscal year 3. All system equipment (see figure 1-2) is envisioned as being new to the Government and requires full support documentation with the exception of the microwave radio, multiplex, power, and test equipment which should be considered reprourement.

3. Project Cost Estimate. Tables 1-2 and 1-3 present completed cost estimate worksheets, and table 1-4 presents a time-phased funding schedule for this example system.

4. Cost Model. To be published later.

TABLE 1-1. SUBSYSTEM DESCRIPTION-LOS MICROWAVE SYSTEM						
Equipment & Facilities	Terminal			Relay		Nodal Point
	1	2	3	1	2	
VF Channel (equipped)	60	60	24	0	0	144
VF Channel Conditioned for Data	10	10	4	0	0	24
Towers Required (guyed) (ft)	1@ 100	1@ 100	1@ 100	1@ 100	1@ 100	1@ 200
Adequate Power Available	Yes	Yes	Yes	No	No	No
Buildings Available	No	No	No	No	No	No
Security Fence Required	No	No	No	Yes	Yes	No
Additional Land Required (Acre)	No	No	No	1/2	1/2	No
Access Road Required (mi)	No	No	No	1/2	1/2	No
Manpower Required						
Officer in Charge				Unmanned		1
Shift Supervisors (Enlisted)	2	2	2			2
Radio						
Enlisted	3	3	3			5
Civilian	1	1	1			1
MUX						
Enlisted	2	2	2			4
Civilian	1	1	1			1
Tech Control (Enlisted)						5
Power Tech (Enlisted)	—	—	—	—	—	2
TOTAL	9	9	9	0	0	21

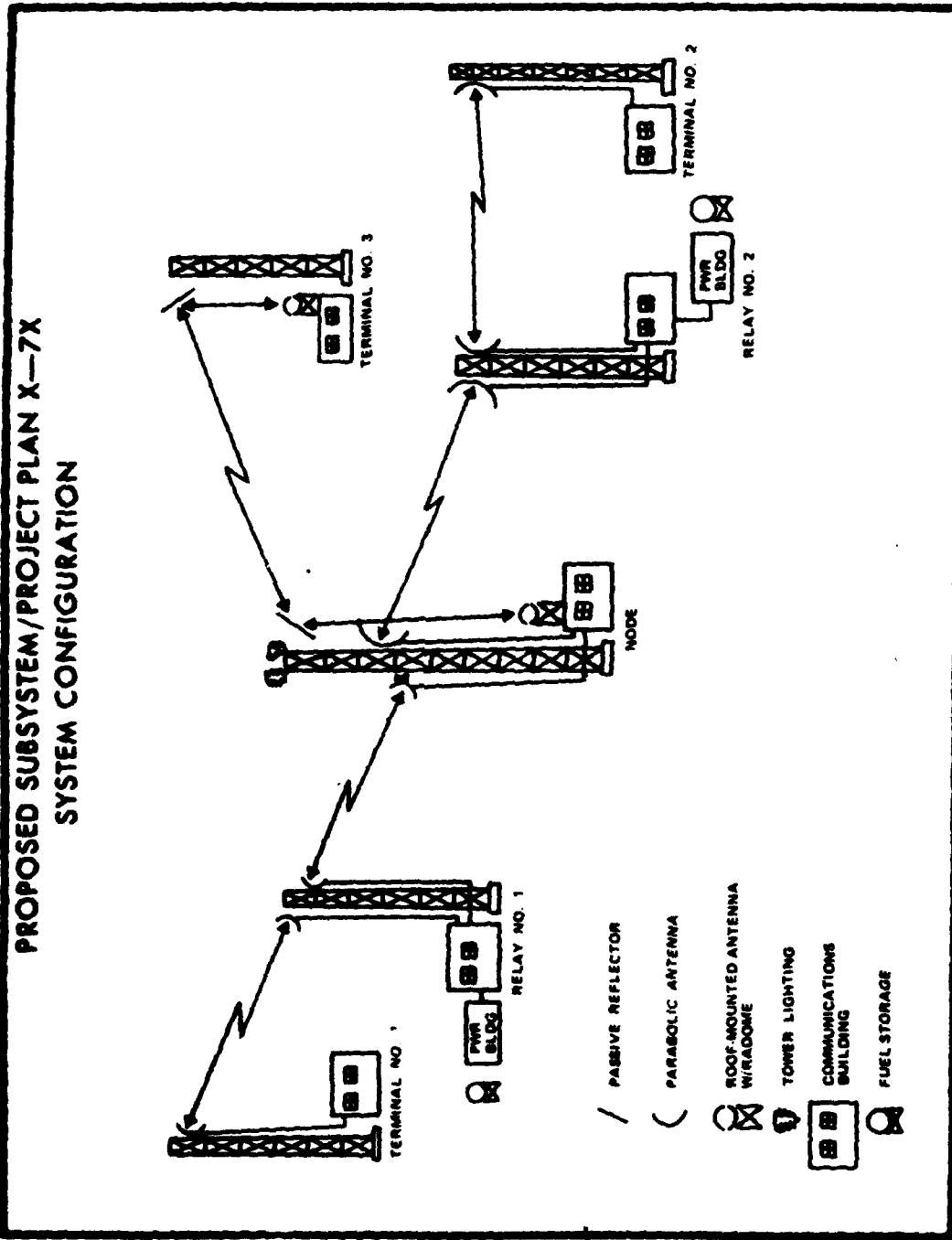

FIGURE 1-1. LOS MICROWAVE SYSTEM - EXAMPLE SYSTEM CONFIGURATION

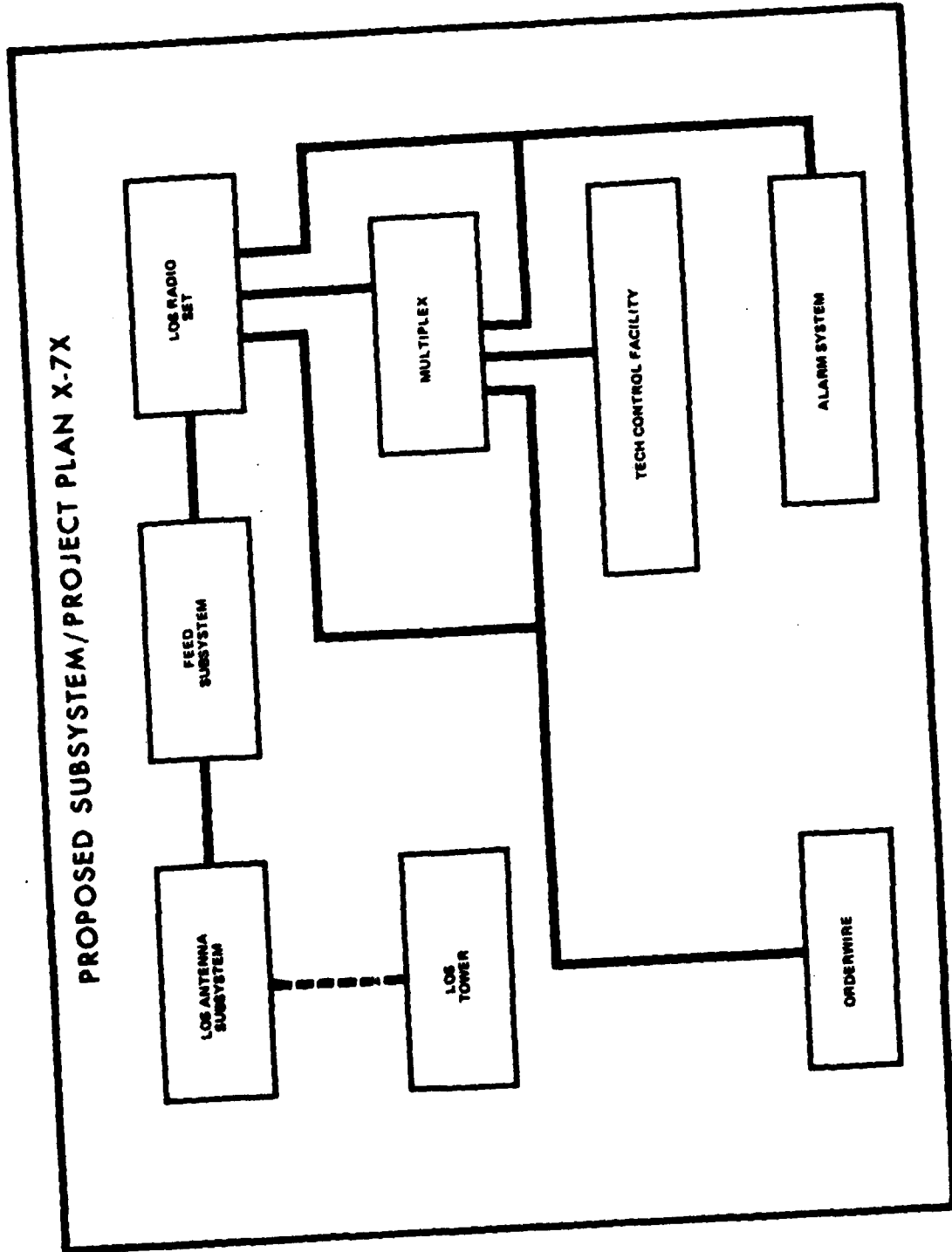

FIGURE 1-2. LOS MICROWAVE PRIME MISSION EQUIPMENT BUILDING BLOCK

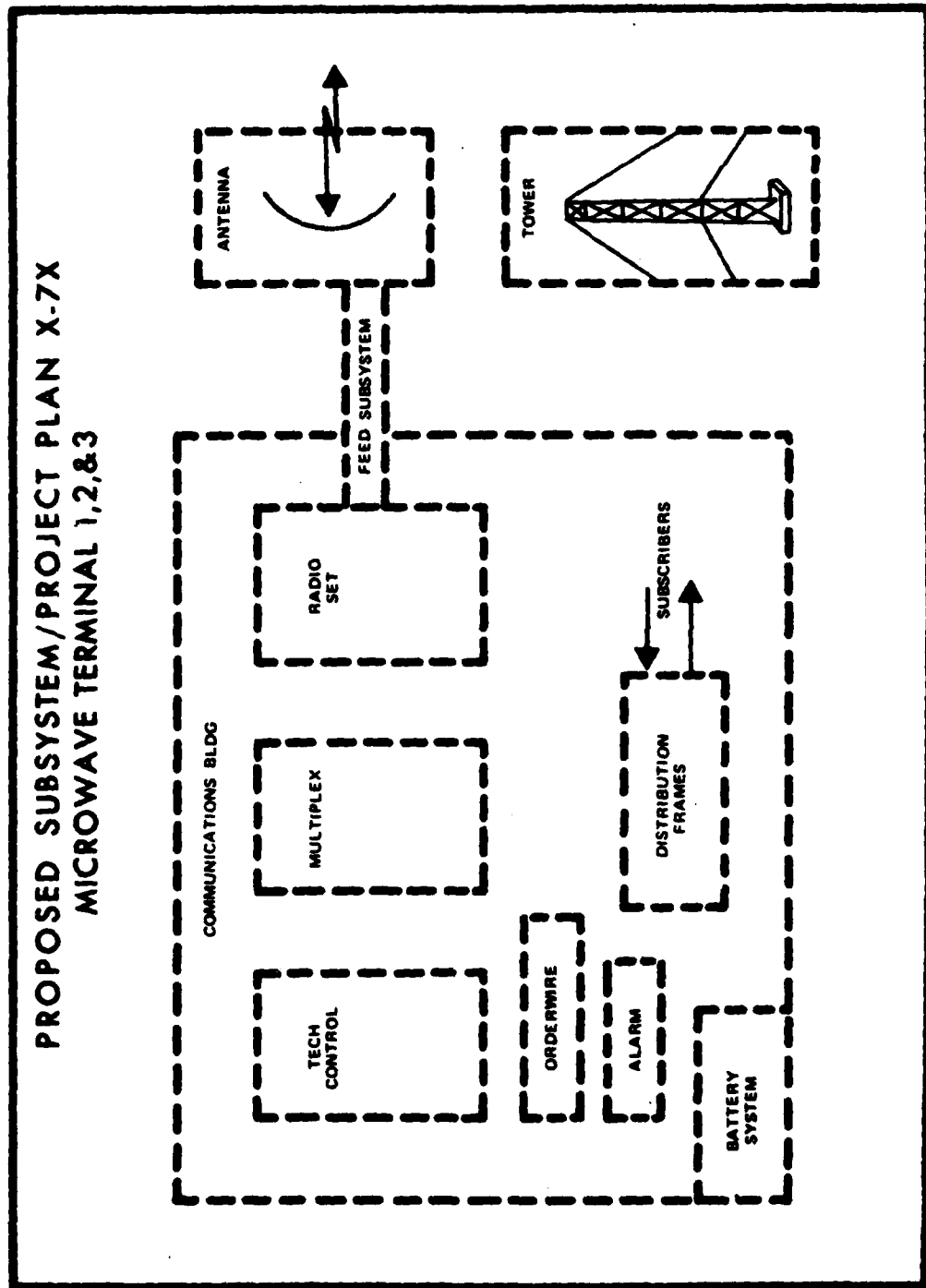

FIGURE 1-3. LOS TERMINAL LAYOUT - BUILDING BLOCK CONCEPT

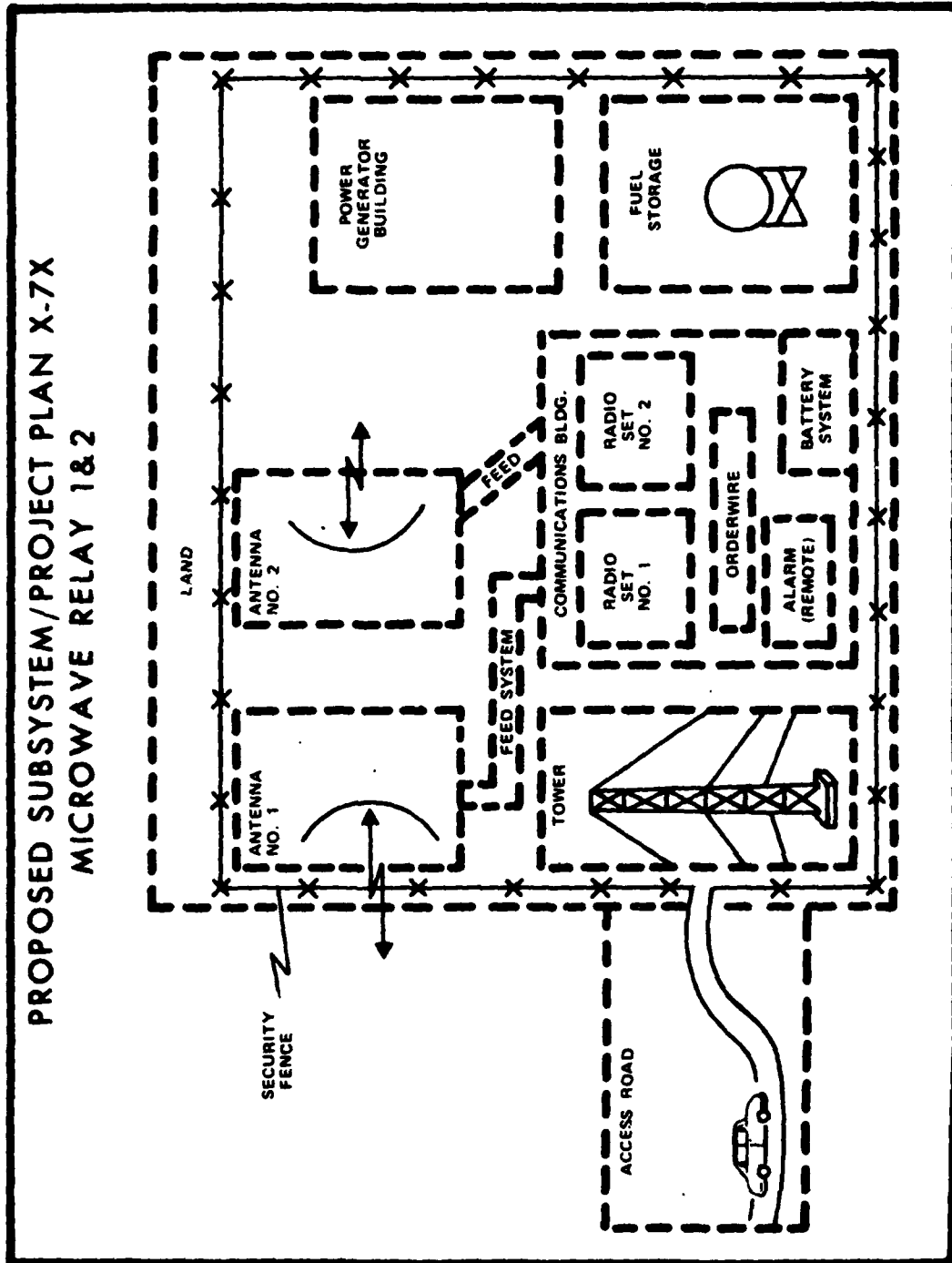

FIGURE 1-4. LOS RELAY LAYOUT - BUILDING BLOCK CONCEPT

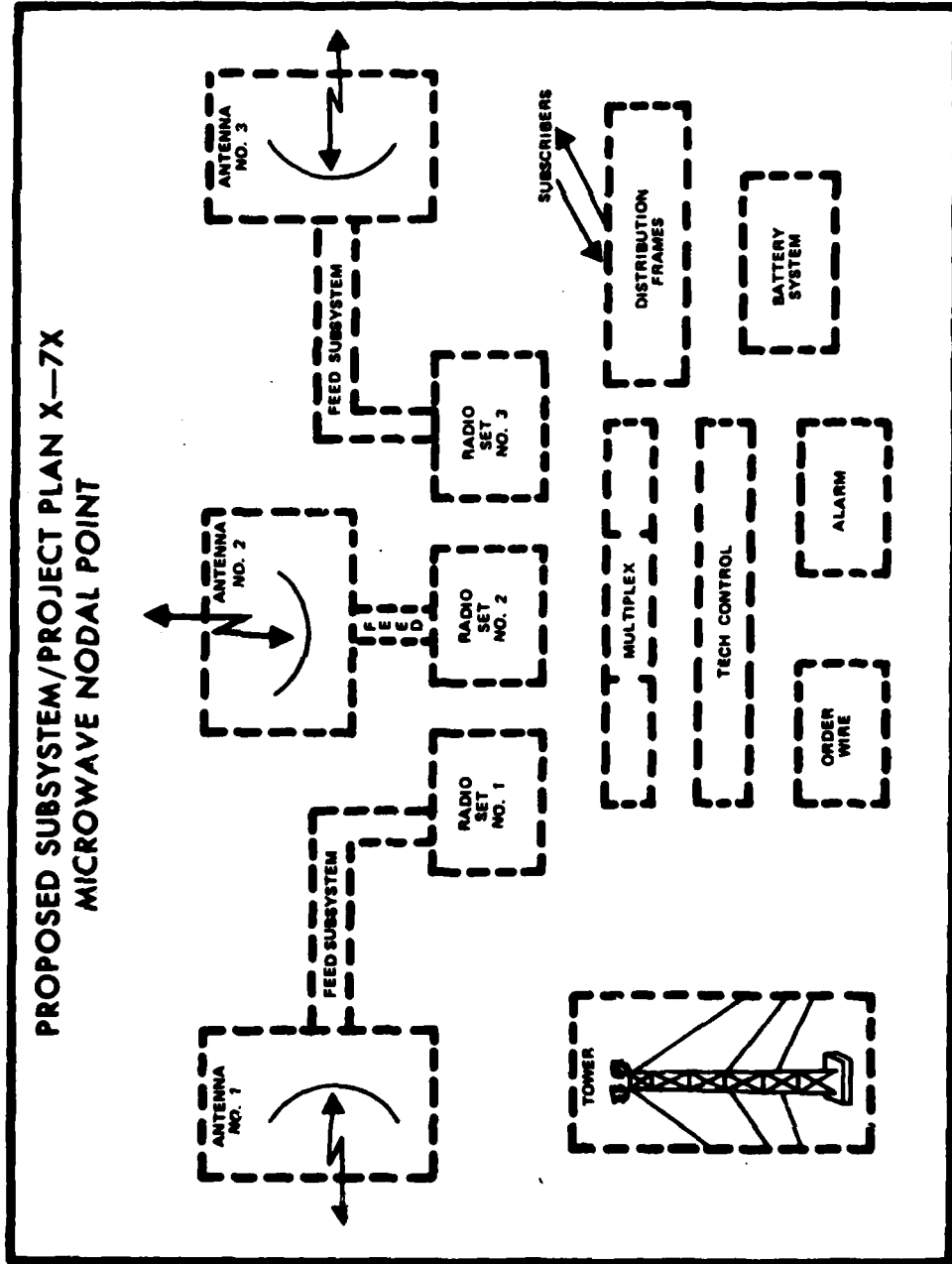

FIGURE 1-5. LOS NODE LAYOUT - BUILDING BLOCK CONCEPT

TABLE 1-2. ACQUISITION COST - PROPOSED SUBSYSTEM/PROJECT PLAN X-7X LOS MICROWAVE SYSTEM			
Cost-Estimating Structure	Reference Chap Table	Value/Computations	Total (\$000)
Communications Prime Mission Equipment			
LOS Microwave Equipment	10		
Radio Set Terminal	1	6 @ \$23,000	\$138.0
Radio Set Relay (Hetrodyne)		2 @ \$41,000	82.0
Antenna System			
Reflector (Parabolic)	2	10 4' @ \$2,630	26.3
Reflector (Flat)	5	2 4' X 6' @ \$665	1.3
Radome	2	2 4' @ \$300	.6
Feed System	3	10 @ \$1,409	14.1
Tower	4	5 100' Guyed @ \$2,300	11.5
		1 200' Guyed @ \$4,000	4.0
Multiplex	11	2 60 Channel @ \$75,100	150.2
		1 24 Channel @ \$53,800	53.8
	3	1 144 Channel @ \$165,200	165.2
Control Systems Equipment	13		
Tech Control & Patch & Test	1	240 Terminating Circuits @ \$175	42.0
		48 Data Conditioned Circuits @ \$1,150	55.2
	2	4 Circuit Control Equip. @ \$85,700	342.8
Orderwire/Intercom	4	4 Type A Configuration @ \$10,700	42.8
Alarm System	5	4 Type A Common Alarm Unit @ \$370	1.5
		1 Type II Master Station @ \$2,900	2.9
		5 Type I Remote Stations @ \$1,900	9.5
Auxiliary Equipment	14		
Electric Power			
Primary Power	2	3 15 kW @ \$16,300 X 2 Relays	97.8
Auxiliary Power	2	6 15 kW (Static) @ \$15,000	90.0
Subtotal: (Comm. Equip.)			\$1,331.5

Example costs presented above are not updated. Refer to appropriate chapters for all cost data.

TABLE 1-2. ACQUISITION COST - PROPOSED SUBSYSTEM/PROJECT PLAN X-7X LOS MICROWAVE SYSTEM (CON.)			
Cost-Estimating Structure	Reference Chp Table	Value/Computations	Total (\$000)
Integration & Assembly	15	5% of Comm. Equip.	66.6
Contractor Training	16	1 Course Prep. Cost 5 2-week classes	17.5 30.0
Test & Support Equip.	17	10% of Comm. Equip.	133.2
Test & Common Equip.			
Peculiar Support Equip.		5% of Comm. Equip.	66.6
System Test & Evaluation	18	5% of Comm. Equip.	66.6
System/Project Management	19		
System Engineering			
Contractor		10% of Comm. Equip.	133.2
F.C.R.C.		5 Man-years @ \$75K/Man-year	275.0
Project Management		10% of Comm. Equip.	133.2
Data	20	1 Reprourement - Tailored Support	
		Radio \$ 23,000	
		Radio 41,000	
		Antenna 3,595	
		Tower 6,300	
		Feed 1,409	
		MK 53,800	
		TCP & PTP 67,025	
		Orderwire 11,070	
		Alarms 4,800	
		Power 31,300	
		Test Equip. 133,200	
		\$396,499 X .5	198.2
		New Procurement-Unit-Tailored Support	
		Peculiar Support Equip. \$66.6 + 6 X 7	77.7
Operational Site Activation	21		
Contractor Tech. Support		1 7% X Comm. & Aux. Equip.	\$ 93.2
Site Construction			
Land Acquisition	2	2 1/2 Acre Lots @ \$3,000/Acre	\$ 3.0
Site Survey/Preparation	2	2 1/2 Acre Lots @ \$3,300/Acre	3.3
Buildings/Shelters	4	3 X 800 ft ² (Terminals) 1 X 1,600 ft ² (Node) 2 X 300 ft ² (Relays) 4,600 ft ² X \$62/ft ²	285.2
Foundations, Stands, Pads	2	5 Foundations @ \$720 1 Foundation @ \$1,080 6 Pads @ 280 yd ² X \$2.90/yd ²	3.6 1.1 4.9
Fences	2	2 X 625 lin.ft. X \$7.45/lin.ft.	9.3
Access Roads	2	2 X 1/2 mile X \$23,500/Mile	23.5
Fuel Storage Facilities	3	2 1,500 Gal Tanks @ \$1,500	3.0
(Construction Index)	36	1 Area Factor (1.2) X	\$335.9
404.3			
Assembly, Install & Check-out on Site	21	5 40% of Comm. Equip.	532.6
Initial Spares & Repair Parts	22	1 Reprourement (Comm. equip. & test equip.)	
		Piece Parts .05 X 1,464.7 X .3	22.0
		Elec. Modules .50 X 1,464.7 X .5	366.2
		Electro-Mech .45 X 1,464.7 X .7	461.4
		New Procurement (Peculiar spt. equip.)	
		Piece Parts .05 X 66.6 X .4	1.3
		Elec. Modules .50 X 66.6 X .75	25.0
		Electro-Mech. .45 X 66.6 X .75	22.5
		898.4	

Example costs presented above are not updated. Refer to appropriate chapters for all cost data.

TABLE 1-2. ACQUISITION COST - PROPOSED SUBSYSTEM/PROJECT PLAN X-7X LOS MICROWAVE SYSTEM (CON.)			
Cost-Estimating Structure	Reference Chap Table	Value/Computations	Total (\$000)
Transportation	24 8	Electronics Equipment Radio, MUX, Tech Control, Orderwire, Alarm, Test & Peculiar Support Equip., Spares & Repair Parts. $\$2,184.1 \times .09$	\$196.6
		Antennas, Towers, Power, Feed System, Fences, Fuel Storage Facilities $\$257.9 \times .14$	36.1
		Data (VIA Parcel Post) $\$275.9 \times .01$	2.8
			<u>235.5</u>
TOTAL ACQUISITION COST			<u>\$4,693.3</u>

Example costs presented above are not updated. Refer to appropriate chapters for all cost data.

TABLE 1-3. ANNUAL OPERATING COST - PROPOSED SUBSYSTEM/PROJECT PLAN X-7X LOS MICROWAVE SYSTEM			
Cost-Estimating Structure	Reference Chap Table	Value/Computation	Total (\$000)
Military Personnel - Pay and Allowances	23		
Officers	1	1 O-3 @ \$15,465	\$ 15.5
Enlisted Men	1	39 E-5 @ \$7,500	292.5
Operations and Maintenance	24		
Civilian Personnel - U.S.	1	8 GS-11 @ \$15,877	127.0
TDY - per diem	9	40 days @ \$25	1.0
TDY - transportation	6	4 MAC trips @ \$276	1.1
Civilian PCS	7	8 @ \$1,150	9.2
Transportation of Things	8	14% of O&M Mat'ls (\$153.1)	21.4
Utilities & FOL	13	11 K Gals Fuel @ \$.25/Gal X 2 Relays	5.5
Building Maintenance		.05 X \$342,224	17.1
Supplies & Equipment		.03 X (Comm. Equip. + Supt. Equip.)	45.9
Misc. Support	22	.003 X (Comm. Equip. + Supt. Equip.)	4.6
Recurring Investment	25		
Replacement Spares		.07 X (Comm. Equip. + Supt. Equip.)	107.2
Operating Support	26		
Base Operations	1	1 officer @ \$361, 39 enlisted @ \$317	12.7
Depot Maintenance	3	.005 X (Comm. Equip. + Supt. Equip.)	7.7
Replacement Training	5	1 @ \$5,230, 39 @ \$2,119	87.9
Hospitals	6	1 @ \$326, 39 @ \$303, 8 @ \$310	14.6
PCS Travel	7	40 @ \$800	32.0
TOTAL Annual Operating Cost			<u>\$802.9</u>

Example costs presented above are not updated. Refer to appropriate chapters for all cost data.

TABLE 1-4. TIME-PHASED COST ESTIMATE - PROPOSED PROJECT PLAN X-7X LOS MICROWAVE SYSTEM				
Cost Element	FY 1	FY 2	FY 3 to 12	Total Cost (\$000)
RDT&E	0	0	0	0
Investment				
Procurement				
Microwave Equip.	\$ 111.8	\$ 166.0		\$ 277.8
Multiplex	150.2	219.0		369.2
Tech Control & P&T	192.4	247.6		440.0
Orderwire	21.4	21.4		42.8
Alarm System	7.4	6.5		13.9
Electric Power	93.9	93.9		187.8
Integration & Assembly	28.8	37.8		66.6
Training	17.5	30.0		47.5
Test Equipment	86.5	113.3		199.8
System Test & Evaluation	28.8	37.8		66.6
System Engineering	231.4	176.8		408.2
Project Management	75.5	57.7		133.2
Data	119.5	156.4		275.9
Contractor Tech Supt. Assembly, Instl. & Checkout @ Site	53.4	39.8		93.2
Initial Spares & Repair Parts	230.6	302.0		532.6
Transportation	389.2	509.2		898.4
Military Construction Site Activation	102.0	133.5		235.5
Annual Operating Military Personnel	232.0	172.3	\$ 308.0	404.3
Operations & Maint.			232.8	3,080.0
Recurring Investment			107.2	2,328.0
Operating Support			154.9	1,072.0
				1,549.0
Total Including 10-Year System Cost	\$2,172.3	\$2,521.0	\$8,029.0	\$12,722.3

MICROWAVE SYSTEM/SITE COST ESTIMATE			
Proposed Subsystem Project Plan # _____		Date _____	
Project Name _____		Prepared by (Org.) _____	
System Description _____			
Operational Capabilities _____			
Time Frame: Acquisition _____		Operations _____	
Location _____			
ACQUISITION COST			
Cost Element Identification	Reference Chap Table	Value/ Computation	Total Cost (\$000)
Prime Mission Equipment			
Communications Equipment	10		
Radio Equipment		1	
Antenna System		2	
Refl., Radome, Mounts		5	
Feed System		3	
Towers		4	
Multiplex	11	2	
Tech Control & P&T Equip.	13	1	
Orderwire		4	
Alarm System		5	
Auxiliary Equipment			
Electric Power	14		
Primary Power		1	
Auxiliary Power		1	
Subtotal Prime Mission Equipment and Auxiliary Equipment			\$ _____
Integration & Assembly	15		
Contractor Training	16		
Test & Spt. Equip.	17		
Test & Common Equip.		1	
Peculiar Spt. Equip.		1	

FIGURE 1-6. COST ESTIMATE WORKSHEET - MICROWAVE SYSTEM/SITE

MICROWAVE SYSTEM/SITE COST ESTIMATE (CON.)			
Cost Element Identification	Reference Chap Table	Value/ Computation	Total Cost (\$000)
System Test & Evaluation	18		
System/Project Mgmt	19		
System Engineering		1	
Contractor			
FCRC			
Project Management		Par. 3	
Data	20	1	
Operational/Site Activation	21		
Contractor Tech Support		1	
Site Construction			
Land Acquisition		2	
Site Survey/Prep.		2	
Buildings, Shelters		4	
Foundations, Stands/Pads			
(Concrete, Misc.)		2	
Sewage Facilities			
Water Tanks		3	
(Construction Index)	36	1	
Assembly, Instl & Checkout			
On Site	21	5	
Init. Spares & Repair Parts	22	1	
Transportation	24	8	
Total Acquisition Cost			\$

FIGURE 1-6. COST ESTIMATE WORKSHEET - MICROWAVE SYSTEM/SITE (CON.)

MICROWAVE SYSTEM/SITE COST ESTIMATE (CON.)			
ANNUAL O&M COSTS			
Cost Element Identification	Reference Chap Table	Value/ Computation	Total Cost (\$000)
Military Personnel			
Pay and Allowances	23	1	
Operations and Maintenance	24		
Civilian Personnel -			
Pay and Allowances		1	
TDY		6	
Civilian PCS		7	
Transportation		8	
Utilities and POL -			
Electric Power		13	
Heat		14	
Contractor Employees		18	
Building Maintenance			
Supplies and Equipment			
Misc. Support		22	
Leased Services			
DCS Subscriber Rates	28		
Private Line - CONUS	30		
Private Line -			
International	29		
Recurring Investment	25		
Operating Support	26		
Base Operations		1	
Depot Maintenance		3	
Replacement Training		4	
Hospitals		6	
PCS Travel		7	
Other Indirect Costs			
Total Annual Operating Cost			\$

FIGURE 1-6. COST ESTIMATE WORKSHEET - MICROWAVE SYSTEM/SITE (CON.)

CHAPTER 2. TROPOSPHERIC SCATTER SYSTEMS

1. Introduction.

a. Tropospheric Scatter Systems (Tropo) are generally used for path lengths of 75 to 400 miles where terrain, geographic, or other factors dictate their use. Tropo normally uses that portion of the frequency spectrum from 450 MHz to 2 GHz, although some 4 GHz systems are in use. Tropo systems use a "bounce" technique, echoing the signals off the tropospheric layer of the atmosphere. The microwave signal leaves the earth at a very low takeoff angle, is forward-scattered by the troposphere (with some of the signal passing through the atmosphere) and returns to the earth via diverse paths. Tropo, as opposed to line-of-sight systems, uses higher transmitter power output (up to 50 kW), larger antennas (up to 120 ft), and has lower bandwidth availability (as low as 12 equivalent voice channels) dependent upon the path length, propagation, etc.

b. Tropo transmission is generally quadruple diversity, using space and frequency diversity. Some systems need only dual diversity, and there are systems using octuple diversity. There are some engineering "trade-offs" possible with tropo systems to meet the required propagation, such as higher transmitter power output with smaller antennas, multiple diversity, and combinations of the above. Transmission path requirements can be determined only by an engineering analysis of the individual paths involved.

c. Because of the economic and technical factors involved, only in certain situations would tropo be chosen over other methods of transmission. When sufficient engineering data exist to permit an analysis of the various transmission media for the same path, an engineering and economic analysis must be performed to determine the suitable method.

d. Table 2-1 may be used for very rough planning estimates to approximate the required transmitter and antenna combinations.

2. Project Description. Proposed subsystem project plan X-8X requires the installation of a fixed tropo system for the Navy in the north coastal area of Australia. The overall subsystem description is presented in table 2-2 and the configuration is portrayed in figure 2-1. The new system will be designed to operate in conjunction with an existing DCS station. The area is in a hot dry zone in a subtropic area. The tropo transmission medium was chosen because of the terrain and the logistics problems involved in supporting a LOS microwave system. The system will consist of three stations, with all channels capable of being dropped at the intermediate station and reinserted by the technical controllers. Figure 2-2 presents a block diagram of the equipment involved at all terminals.

TABLE 2-1. TROPO TRANSMISSION CAPABILITIES

Equivalent Voice Channels	Path Length (in miles)	Equipment Required	
		XMTR Output (in kW)	Antenna Height (in feet)
12	125	1	30
	325	10	60
	400	10	120
60	100	1	30
	175	1	120
	260	10	120
120	100	1	60
	225	10	120
240	100	10	120

NOTE: Transmission capabilities can be determined only by an analysis of the paths involved.

TABLE 2-2. SUBSYSTEM DESCRIPTION - TROPO SYSTEM			
Equipment and Facilities	Terminal Number		
	1	2	3
Transmitter Power Output	1kW	1kW	1kW
Frequency	1GHz	1GHz	1GHz
Antenna Size	60 ft	60 ft	60 ft
VF Channel (equipped)	12	24	12
VF Channel (conditioned for data)	4	8	4
Adequate Prime Power Available	yes	yes	yes
Auxiliary Power Available	no	no	no
Buildings Available	no	no	no
Security Fence Required	no	no	no
Additional Land Required	no	no	no
Access Road Required	no	no	no
Manpower			
Officer in Charge	-	1	-
NCOIC	1	1	1
Tropo Repair Technician	10	15	10
Total	11	17	11

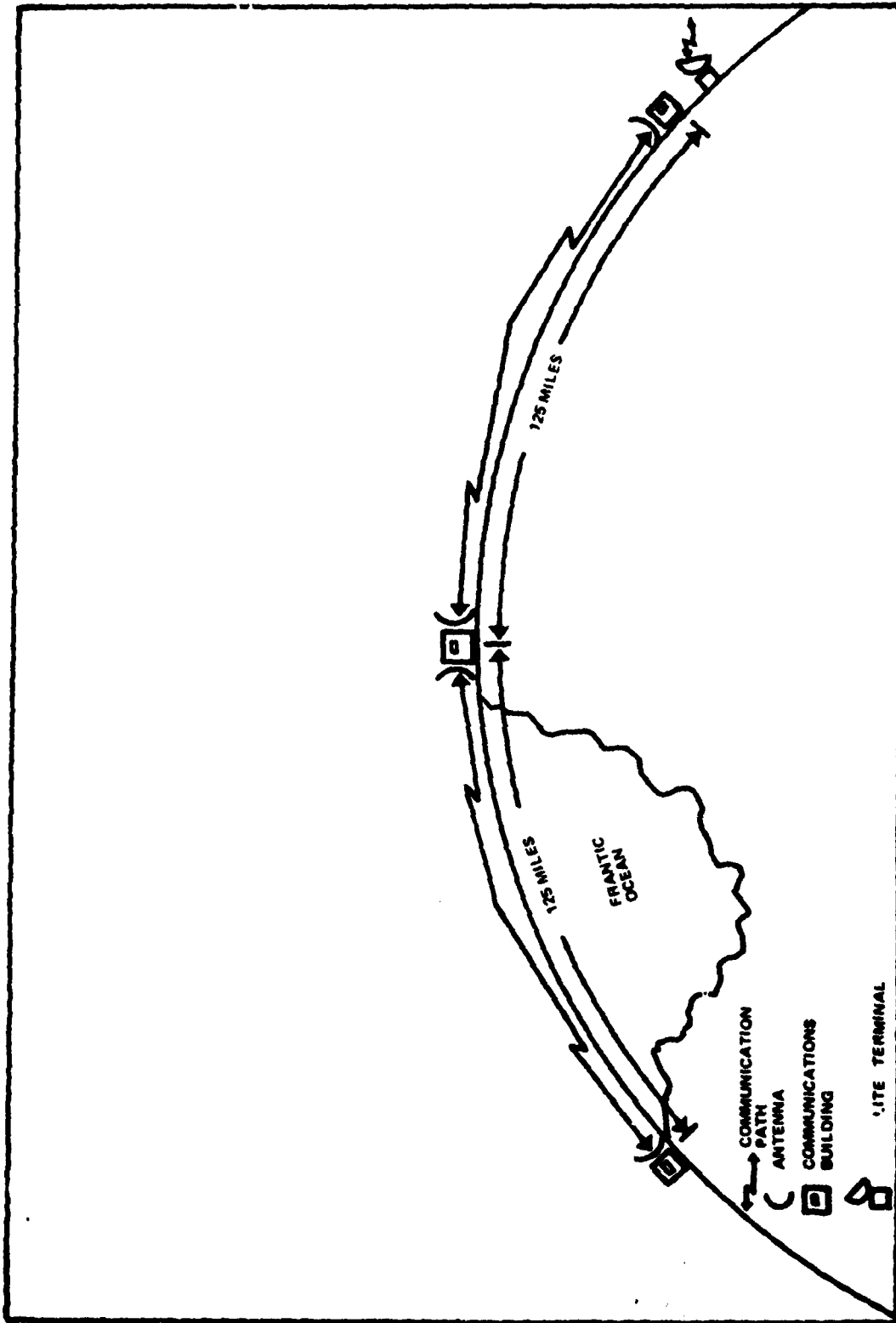

FIGURE 2-1. TROPOSPHERIC SCATTER SYSTEM - EXAMPLE CONFIGURATION

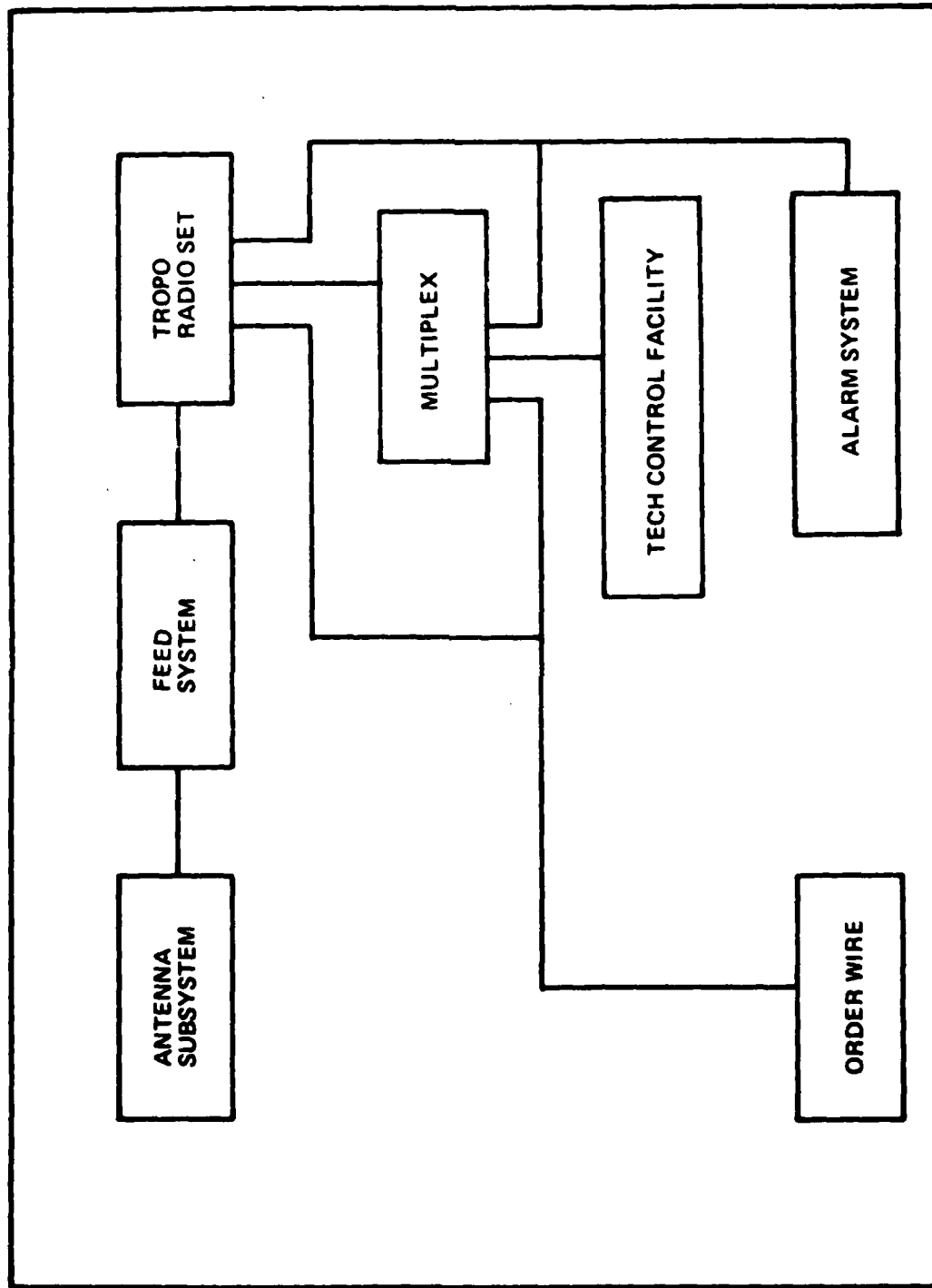

FIGURE 2-2. TROPO PRIME MISSION EQUIPMENT BUILDING BLOCK

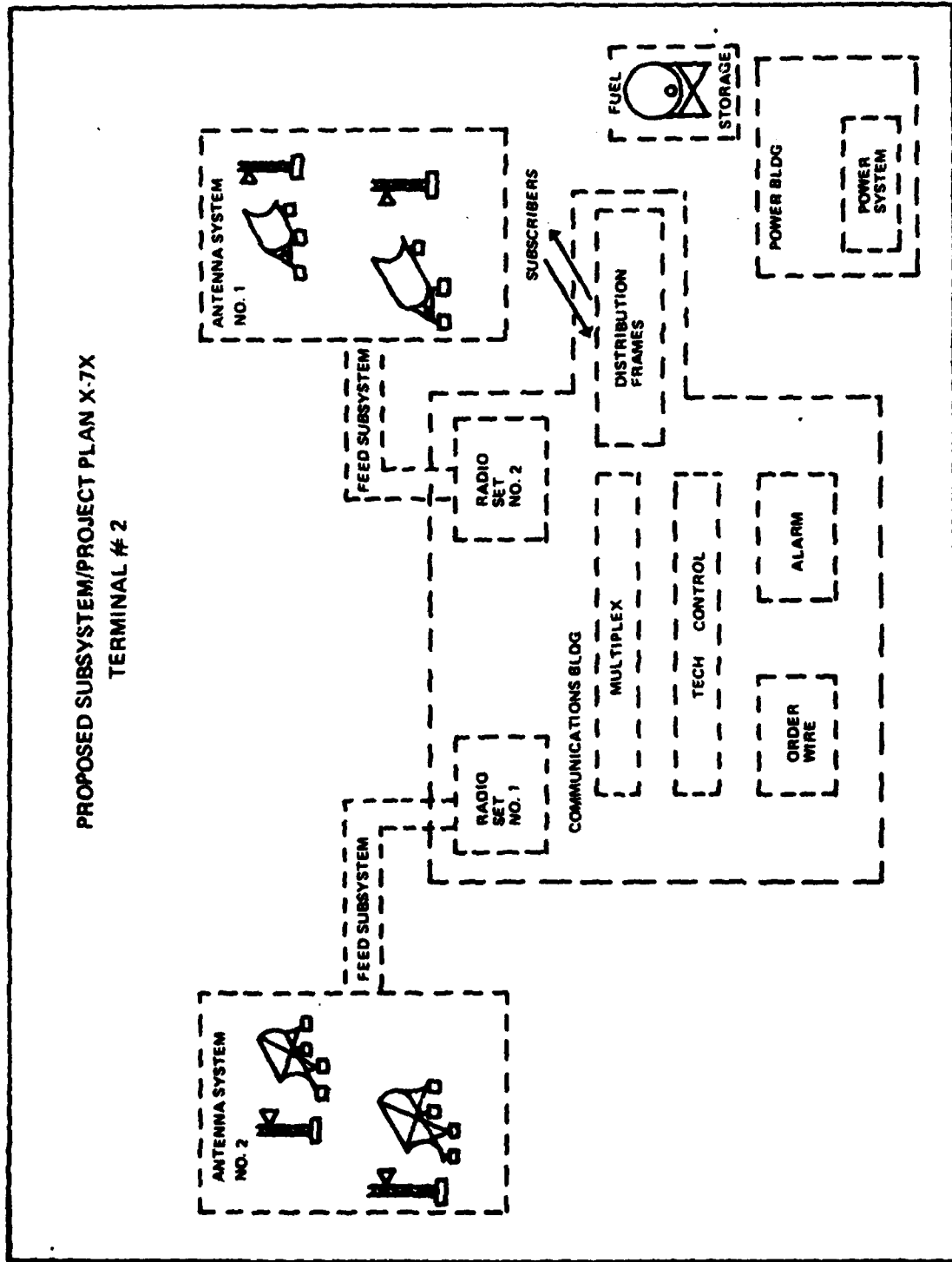

FIGURE 2-3. TROPO TERMINAL LAYOUT - BUILDING BLOCK CONCEPT

TABLE 2-3. ACQUISITION COST - SUBSYSTEM PROJECT PLAN X-8X
TROPO SYSTEM 1GHz

Cost-Estimating Structure	Reference Chap Table	Value/Computations	Total (\$000)
Comm. Prime Mission Equipment	10		
Tropo Radio Equip.	10		
Radio Set	6	1GHz, 1kW, 4 @ \$243,000	\$ 972.0
Antenna System	7	60 ft, 8 @ \$37,200	297.6
Feed System	8	4 @ \$11,345	45.4
Multiplex Equip.	11 3	12 Channel Set, 2 @ \$46,700 24 Channel Set, 1 @ \$53,800	93.4 53.8
Control Systems Equip.	13		
Tech Control & Patch & Test	1	Terminating Ckts., 48 @ \$175 Data Condt'd Ckts., 16 @ \$1,150	8.4 18.4
Orderwire/Intercom	2 4	Ckt. Control Equip., 3 @ \$85,700 Type A Configuration, 3 @ \$10,700	257.1 32.1
Alarm System	5	Type A Common Unit, 3 @ \$370	1.1
Auxiliary Equipment	14		
Electric Power			
Primary Power		Host-Provided	--
Auxiliary Power		100kW Rotary, 2 @ \$60,000 200kW Rotary, 1 @ \$88,000	120.0 88.0
Subtotal (Comm. Equip.)			\$1,987.3

NOTE: Example costs presented above are not updated. Refer to appropriate chapters for all cost data.

TABLE 2-3. ACQUISITION COST - SUBSYSTEM PROJECT PLAN X-8X
TROPO SYSTEM 1GHZ (CON.)

Cost-Estimating Structure	Reference Chap Table	Value/Computations	Total (\$000)
Integration & Assembly	15	5% of Comm. Equip.	\$ 99.4
Contractor Training	16 1	Course Preparation. 2-Week Class, 10 Students, 4 @ \$9,000	20.0 36.0
Test & Support Equip.	17		
Test & Common Equip.	1	10% of Comm. Equip.	198.7
Peculiar Support Equipment		5% of Comm. Equip.	99.4
System Test & Eval.	18	5% of Comm. Equip.	99.4
System Project Management	19		
System Engineering Contractor FCRC	1	10% of Comm. Equip. \$55,000/Man-Year, 5 @ \$55,000	198.7 275.0
Project Mgmt.		10% of Comm. Equip.	198.7
Data	20 1	Reprocurement-Tailored Support	
		Radio \$243,000	
		Antenna 37,200	
		Feed 11,345	
		MUX 46,700	
		TCF & PTF 87,025	
		Orderwire 10,700	
		Alarm 370	
		Power 148,000	
		Test Equip. 198,700	
		.5 X \$783,040	391.5
		New Procurement, Unit-Tailored Support Peculiar Support Equip. \$99.4 - 4 X 7	174.0

NOTE: Example costs presented above are not updated. Refer to appropriate chapters for all cost data.

TABLE 2-3. ACQUISITION COST - SUBSYSTEM PROJECT PLAN X-8X
TROPO SYSTEM 1GHz (CON.)

Cost-Estimating Structure	Reference Chap Table	Value/Computations	Total (\$000)
Operational Site Activation	21		
Contractor Tech Support	1	7% X Comm. Equip.	\$ 139.1
Site Construction			
Land Acquisition		Not Required	
Site Survey/Site Preparation	2	Not Required	
Buildings/Shelters	4	Base Comm., 6,880 ft. ² , 2 @ \$221,500 = \$443.0 Base Comm., 10,410 ft. ² , 1 @ \$312,300 = \$312.3 Pwr. Bldg., 1,000 ft. ² , 3 @ \$44,250 = \$132.8	
Foundations, Stands & Pads	10 7	Foundations, 8 @ \$11,200 = \$ 89.6	
Fences	21 2	Not Required	
Access Roads		Not Required	
Fuel Storage	3	5,000 Gal Tank, 3 @ \$4,000 = \$ 12.0	
	36 1	Construction Price Index = 2.3	
Subtotal		2.3 X \$989.7	2,276.3
Assembly, Install. & Check-out On Site	21 3	40% of Comm. Equip.	794.9

NOTE: Example costs presented above are not updated. Refer to appropriate chapters for all cost data.

TABLE 2-3. ACQUISITION COST - SUBSYSTEM PROJECT PLAN X-8X TROPO SYSTEM 1GHz (CON.)			
Cost-Estimating Structure	Reference Chap Table	Value/Computations	Total (\$000)
Initial Spares & Repair Parts	22 1	Reprourement (Comm. & Test Equipment) Piece Parts, $.05 \times .3 = .015$ Elec. Modules, $.50 \times .5 = .250$ Electro-Mech., $.45 \times .7 = .315$ $\$2,186,000 \times .580$	\$1,267.9
		New Procurement (Peculiar Support Equip.) Piece Parts, $.05 \times .4 = .0200$ Elec. Modules, $.50 \times .75 = .3750$ Electro-Mech., $.45 \times .75 = .3375$ $\$99,400 \times .7325$	72.8
Transportation	24 8	Electronics Equip.: Radio, MUX, TCF, Orderwire, Alarm, Test, & Peculiar Support Equip., Spares & Repair Parts $\$3,075.1 \times .10 = \307.5 Antennas, Power, Feed System $\$551.0 \times .16 = 88.2$ Data (via Parcel Post) $\$565.5 \times .01 = 5.7$	401.4
Total Acquisition Cost			<u>\$8,730.5</u>
NOTE: Example costs presented above are not updated. Refer to appropriate chapters for all cost data.			

TABLE 2-4. ANNUAL OPERATING COST - SUBSYSTEM PROJECT PLAN X-8X
TROPO SYSTEM 1GHz

Cost-Estimating Structure	Reference Chap Table	Value/Computations	Total (\$000)
Military Personnel, Pay & Allowances			
Officers	23 1	1 O-3 @ \$18,695	\$ 18.7
Enlisted Men	1	3 E-6 @ \$11,076	33.2
		35 E-5 @ \$9,130	319.6
Operations & Maintenance			
Civilian Personnel TDY, Per Diem	24 1 6	Per Diem, Worldwide, No Quarters, 35 days @ \$30/Day	- -
		Per Diem, Foreign Travel, 100 days @ \$22/Day	1.1
TDY, Transportation	24 6	Commercial Air (Cat 2) 20/O/W Trips @ \$275	2.2
Civilian PCS Transportation of Things	24 7 8	O&M, Supplies \$ 68,000 Spares \$160,000 16% X \$228,600	- -
Utilities & POL	24 13	400kW X 400 hr X .0833 = 13.3Gal. @ \$.35	36.6
Building Maint.	24 Par. 6b	\$888.2 X Area Factor (2.3) X .05	4.7
Supplies & Equip.	24 7c 7c	Comm. Equip. \$1,987.3 Supt. Equip. 298.1 .03 X \$2,285.4	102.1
Misc. Support	24 22	Comm. & Support Equip., \$2,285.4 X .003	68.6
			6.9

NOTE: Example costs presented above are not updated. Refer to appropriate chapters for all cost data.

TABLE 2-4. ANNUAL OPERATING COST - SUBSYSTEM PROJECT PLAN X-8X
TROPO SYSTEM 1GHz (CON.)

Cost-Estimating Structure	Reference Chap Table	Value/Computations	Total (\$000)
Recurring Investment	25		
Replacement Spares	Par. 4.	Comm. & Support Equip. \$2,285.4 X .07	\$ 160.0
Operating Support	26		
Base Operations	1	Navy Personnel, 39 @ \$580	22.6
Depot Maintenance	3	Comm. & Support Equip. \$2,285.4 X .005	11.4
Replacement Training	4	1 @ \$6,150 + 38 @ \$2,770	111.4
Hospitals	6	39 @ \$606	23.6
PCS Travel	7	1 @ \$1,346 + 38 @ \$567	<u>22.9</u>
Total Annual Operating Cost			<u>\$951.1</u>

NOTE: Example costs presented above are not updated. Refer to appropriate chapters for all cost data.

DCAC 600-60-1
SECTION A

3-1

CHAPTER 3. HIGH FREQUENCY RADIO SYSTEMS

(To be published later.)

CHAPTER 4. SATELLITE COMMUNICATIONS SYSTEMS

1. Introduction.

a. Communications satellites serve as relay stations for long-distance communications systems. Such systems can cover large portions of the earth's surface, while requiring only a single repeater to connect remote sites. They are particularly suited for long-distance, wideband requirements, and provide the capacity for transoceanic, high-rate data circuits that are not practical by undersea cable or terrestrial radio.

b. Generally, satellite communications systems have utilized the SHF and UHF portions of the spectrum. The following text pertains to only the former and includes satellites, launch vehicles, and earth terminals.

2. Project Description.

a. Proposed subsystem project plan X-7X (hypothetical) requires the orbiting of four synchronous altitude (22,300 statute miles) communications satellites, plus two in-orbit spares. The satellites will be cylindrical, with body-mounted solar cells having a maximum array output of 600 watts. The designed in-orbit life expectancy of the satellites will be 2 years, and the communication requirement will exist for 10 years. To provide the required capability, the satellites will weigh 1500 pounds each, with subsystem weights distributed approximately as follows:

<u>Item</u>	<u>Weight</u>
Structure, Temperature Control, and Interstage	300 lb
Electrical Power Supply	200
Altitude Control System	300
Telemetry, Tracking, and Control	200
Communications	300
Dispenser	200
Total	1500 lb

b. The satellites will be launched two at a time by the Titan IIIC launch vehicle which has been successful in 75 percent of its attempts. Twenty 5-kw transportable earth terminals, each with a 24-foot parabolic antenna, will also be required for European deployment. Each will require 20 enlisted men for operation and maintenance. All earth terminals and the satellite control facility will be located at existing installations, so that access lines, base housing and messing, utilities, and other support functions will be available at no additional cost. In addition, 12 officers and 30 enlisted men will be required to monitor and control the system from an existing satellite control facility (SCF) located in CONUS. These requirements are summarized in table 4-1.

3. Estimating Procedure.

a. First determine, either mathematically or graphically, the number of satellites and launch vehicles which will be required during the lifetime

of the project. The mathematical approach is shown in table 4-2, and both approaches are used in figure 4-1 for the hypothetical system described in paragraph 2. Note that both predict a requirement for 40 satellites with a 6-month interval between launches. The graphic approach has the advantage of being able to determine future requirements for an irregular launch schedule.

b. Tables 4-3 and 4-4 represent completed cost-estimating worksheets for proposed subsystem X-7X. The costs shown are adjusted where necessary to a FY 1977 base in accordance with the appropriate indexes from chapter 38.

TABLE 4-1. SUBSYSTEM DESCRIPTION - SATELLITE SUBSYSTEM/
PROJECT PLAN X-7X

Description	Requirement
<u>Space Segment:</u>	
Number of Satellites in Orbit	6 (4 Operational Plus 2 Standby)
Altitude	22,300 statute miles
Weight	1,500 pounds
<u>Weight Distribution:</u>	
Structure, Temperature Control & Interface	300 pounds
Electrical Power Supply	200 pounds
Attitude Control System	300 pounds
Telemetry, Tracking, & Control Communications	200 pounds
Dispenser	300 pounds
Maximum Solar Cell Array Output	200 pounds
Design Life Expectancy in Orbit	600 watts
System Operational Requirement	24 months
Single Launch Success Probability	10 years
	0.75
<u>Ground Segment:</u>	
Earth Terminals	20
Earth Terminal Transmitter Power	5 kW
Earth Terminal Antenna Diameter	24 feet
Earth Terminal Manning, Each	20 enlisted
Satellite Control Facility Manning	12 officers, 30 enlisted

TABLE 4-2. SATELLITE ESTIMATING EQUATIONS

TO ESTIMATE:	USE THIS EQUATION ¹
Launch interval to maintain a fixed number of satellites in orbit (in months)	$I = \frac{npe}{s}$
Number of launches required per year to maintain a fixed number of orbiting satellites	$L = \frac{12s}{npe}$
Number of satellites to be launched per year	$N = \frac{12s}{pe}$
Number of satellites required during system lifetime	$T = \frac{12sy}{pe}$
Total number of launch vehicles required during system lifetime	$B = \frac{12sy}{npe}$
<p>¹Letters used in equations are defined as follows:</p> <ul style="list-style-type: none"> B = Total lifetime launch vehicle requirement. e = Satellite life expectancy, in months. I = Launch interval, in months. L = Number of launches required per year. N = Number of satellites to be launched per year. n = Number of satellites per launch. p = Probability of a successful launch. s = Desired number of orbiting satellites. T = Number of satellites required during system lifetime. y = System life expectancy, in years. 	
<p>Source: DCA, Code 690.</p>	

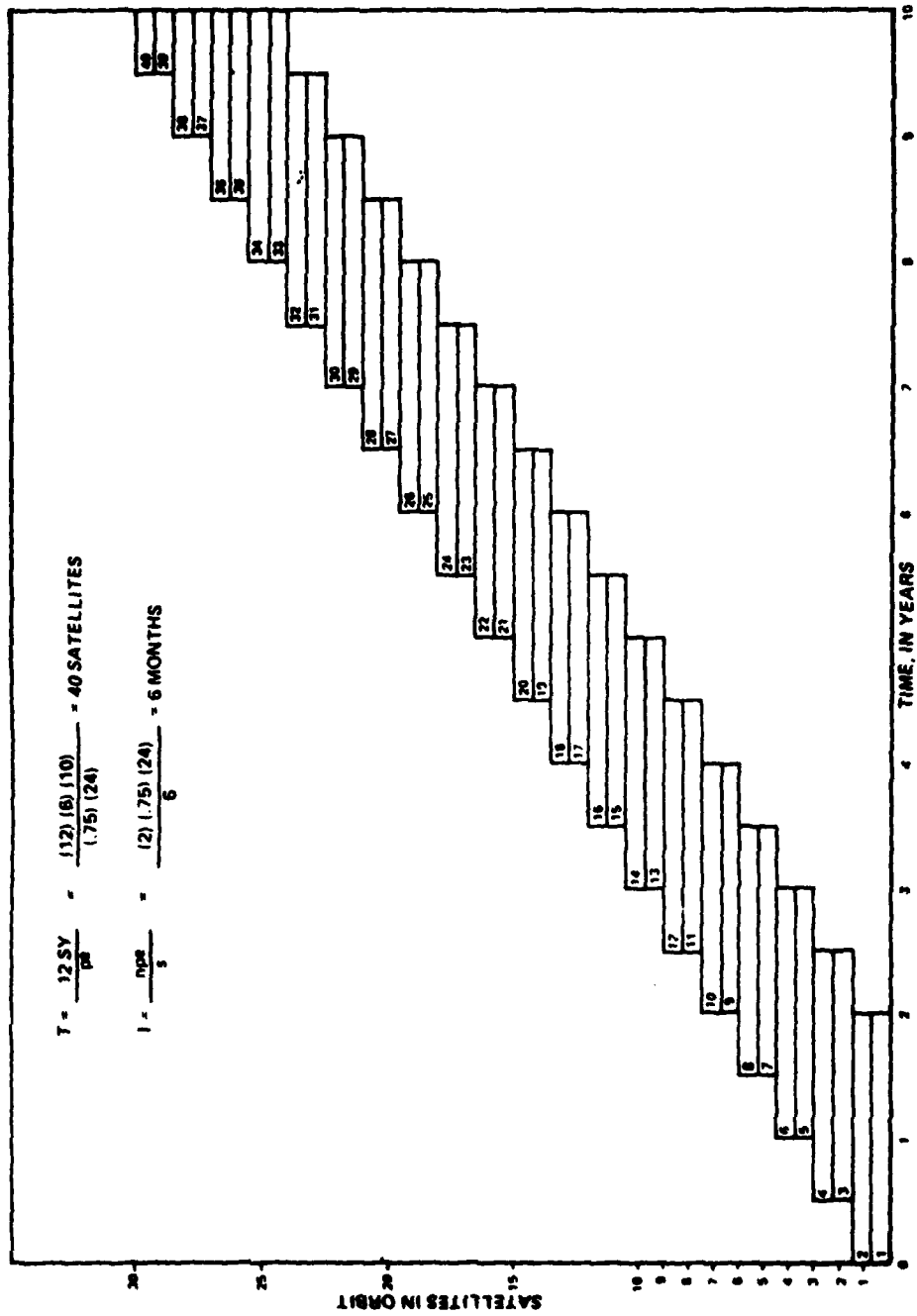

FIGURE 4-1. PROPOSED SATELLITE SYSTEM LAUNCH SCHEDULE

TABLE 4-3. ACQUISITION COST OF PROPOSED SUBSYSTEM/
PROJECT PLAN X-7X SATELLITE SYSTEM

Cost-Estimating Structure	Reference Chap Table	Value/Computations	Totals (\$000)
Research & Development			
Satellites			
Structure, Temp Control & Interface	10 10-9	847.7 + 166.4X(300 lb)·54x	4,468
Electrical Power Supply	10 10-9	238X(600 watts)·4785	5,081
Attitude Control System	10 10-9	515.3X(300 lb)·5194	9,970
Telemetry, Tracking, & Control	10 10-9	1058.7 + 34.92X(200 lb)	8,043
Communications	10 10-9	2527.2 + 16.13X(300 lb X 600 watts)·50	9,371
Dispenser	10 10-9	-150.6 + 6.572X(200 lb)	1,164
Subtotal, Hardware (FY 1974\$)			<u>38,097</u>
Program Level	10 10-9	.3546X(\$38,097)	13,509
Total, Satellite (FY 1974\$)			<u>(51,606)</u>
Total, Satellite (FY 1977\$)	38 38-1	\$51,606X(100.0/79.3)	65,077
Earth Terminals (FY 1976\$)	10 10-13	10 @ \$2,725	(27,250)
Earth Terminals (FY 1977\$)		\$27,250 (100.0/93.3)	<u>29,207</u>
Total Research & Development			94,284

TABLE 4-3. ACQUISITION COST OF PROPOSED SUBSYSTEM/
PROJECT PLAN X-7X SATELLITE SYSTEM (CON.)

Cost-Estimating Structure	Reference Chap Table	Value/Computations	Totals (\$000)
Initial Investment			
Contractor			
Prime Mission Equip.			
Satellite Unit Cost			
Structure, Temp Control & Interface	10 10-10	$-47.48 + 12.49X(300 \text{ lb}) \cdot 72$	711
Electrical Power Supply	10 10-10	$18.42X(600 \text{ watts}) \cdot 7237$	1,887
Attitude Control System	10 10-10	$21.49X(300 \text{ lb}) \cdot 8569$	2,850
Telemetry, Tracking, & Control Communications	10 10-10	$80.39 + 20.25X(200 \text{ lb})$	4,130
	10 10-10	$903.4 + .0166X(300 \text{ lb X}$ $600 \text{ watts})$	3,891
Dispenser	10 10-10	$-78.49 + 3.36X(200 \text{ lb})$	594
Subtotal, Hardware (FY 1974\$)			14,063
Program Level	10 10-10	$.3868X(\$14,063)$	5,440
Total, Satellite Unit Cost (FY 1974\$)			(19,503)
Total, Satellite Unit Cost (FY 1977\$)	38 38-1	$\$19,503X(100.0/75.3)$	25,900
Total Satellites Required=40	4 4-2	$(12)X(6 \text{ satellites})X(10 \text{ yr})$ ----- $(.75 \text{ probability})X(24 \text{ mo})$	
Total Satellite Cost (FY 1977\$)		40 X \$25,900	1,036,000

TABLE 4-3. ACQUISITION COST OF PROPOSED SUBSYSTEM/
PROJECT PLAN X-7X SATELLITE SYSTEM (CON.)

Cost-Estimating Structure	Reference Chap Table	Value/Computations	Totals (\$000)
Launch Vehicle Unit Cost (FY 1975\$)	10 10-12		36,500
Total Launch Vehicles=20	4 4-2	(12)X(6 satellites)X(10 yr) ----- (2 satellites)X(.75 prob.)X(24 mo)	
Total Launch Vehicle Cost (FY 1977\$)	38 38-1	20X(36,500)X(100.0/87.5)	834,386
Earth Terminal Unit Cost (FY 1976\$)	10 10-13	.0805X(24)+.163(5)-.0216	<u>2,725</u>
Earth Terminal Unit Cost (FY 1977\$)	38 38-1	\$2,725 X (100.0/93/3)	<u>2,921</u>
Total Earth Terminal Cost (FY 1977\$)		20 X \$2,921	<u>58,420</u>
Total Prime Mission Equip.			1,928,706
Auxiliary Equip. Integration & Assembly		Included above	
Training	16 16-1	Included above 2 courses, 2 wk ea.; 10 classes, 15 students ea.	366

TABLE 4-3. ACQUISITION COST OF PROPOSED SUBSYSTEM/
PROJECT PLAN X-7X SATELLITE SYSTEM (CON.)

Cost-Estimating Structure	Reference Chap Table	Value/Computations	Totals (\$000)
Test & Supt. Equip.			
Earth Terminals (Common)	17 17-1	.10X\$58,420	5,842
Earth Terminals (Peculiar)	17 17-1	.05X\$58,420	2,921
Satellite (Common) ¹	17 17-1	.10X\$25,900	2,590
Satellite (Peculiar) ¹	17 17-1	.05X\$25,900	<u>1,295</u>
Total, Test & Supt. Equip			12,648
System Test & Evaluation	18	.05X\$58,420	2,921
System Mgmt.	19 19-1	.20X\$58,420	11,684
Documentation			
Earth Terminals ²	20 20-1	(5) X (1/2) X \$2,921	7,302
Satellites ²	20 20-1	(5) X (1/2) X \$25,900	<u>60,750</u>
Total Documentation			68,052
Operational Site Activation	21 21-1	.07X\$58,420	4,089
¹ Use unit cost, vice total cost, since the same items are used for all satellites. ² (1/2) = Redundancy factor - all satellites and earth terminals are redundant.			

TABLE 4-3. ACQUISITION COST OF PROPOSED SUBSYSTEM/
PROJECT PLAN X-7X SATELLITE SYSTEM (CON.)

Cost-Estimating Structure	Reference Chap Table	Value/Computations	Totals (\$000)
Initial Spares & Repair Parts			
Earth Terminals	22 22-1	.18X\$58,420	10,516
Satellites ¹	22 22-1	.18X\$25,900	4,662
Total, Initial Spares & Repair Parts			<u>15,178</u>
Total Contractor			2,043,644
Government			
Transportation			
Earth Terminals	24 24-8	.10X\$58,420	5,842
Satellites	24 24-8	.01X\$1,036,000	10,360
Test & Supt. Equip. (Earth Terminals)	24 24-8	.14X(\$5,842 + \$2,921)	1,227
Test & Supt. Equip. (Satellites)	24 24-8	.03X(\$2,590 + \$1,295)	117
Total Transportation			<u>17,546</u>
Total Government			<u>17,546</u>
Total Initial Investment Cost			<u>2,061,190</u>
Total Acquisition Cost			2,155,474

¹See footnote 1, page 4-8.

TABLE 4-4. OPERATING & SUPPORT COSTS OF PROPOSED SUBSYSTEM/
PROJECT PLAN X-7X SATELLITE SYSTEM

Cost-Estimating Structure	Reference Chap Table	Value/Computations	Totals (\$000)
Military Pay & Allowances			
Officers (O-3)	23 23-1	12 @ \$32,543	391
Enlisted (E-5)	23 23-1	430 @ \$17,623	7,578
Total Military Pay & Allowances			<u>7,969</u>
Operations & Maintenance			
TDY-Per Diem	24 24-6	100 days @ \$.046	5
TDY-Travel	24 24-6	10 MAC trips @ \$.388	4
Transp. of Things	24 24-8	.14X(\$4,641 recurring investment)	650
Utilities & Fuel	24 24-13	(\$\$.03)X(100 kW)X(8760 hr)X (20 terminals)	526
Misc. Supt.	24 24-22	.003X\$58,420	175
Total Operations & Maintenance			<u>1,360</u>
Recurring Investment			
Replacement Spares & Repair Parts, Earth Terminals	25	.07X\$58,420	4,089
Test & Supt. Equip.	25	.07X\$12,648	885
Total Recurring Investment			<u>4,974</u>
Other Supt. Costs			
Base Operations	26 26-1	442 @ \$625	276
Depot Maintenance & Supply	26 26-3	.025X\$58,420	1,460
Replacement Training			
Officers	26 26-4	12 @ \$5,710	69
Enlisted	26 26-4	430 @ \$4,035	1,735
Hospitals	26 26-6	442 @ \$540	239
PCS Travel	26 26-7	442 @ \$1,713	757
Total Other Supt.			<u>4,536</u>
Total Operating & Support Costs			<u>18,839</u>

CHAPTER 5. CABLE SYSTEMS

1. Introduction. Cable systems may be classified as land or underwater, and may use either coaxial cable or paired cable. Cable systems are generally used for one of three purposes: on-base local (short-haul) distribution systems; limited medium- and long-haul communications; and underwater (long-haul) transmission. Coaxial cable is generally used for long-haul transmission (between distant exchanges) and paired cable is used for the short-haul transmission (between nearby exchanges). Land cable systems may be pole mounted (aerial) or buried (direct burial or in ducts).

2. Submarine Cable Systems.

a. General.

(1) Submarine cable systems are used for transmission across bodies of water that are too wide to be bridged by LOS microwave or tropospheric scatter systems. Satellite systems are highly competitive with subcable systems, especially over large bodies of water or where a high volume of traffic is generated. Military subcable systems are generally planned for 60 or 120 voice channels, although commercial systems currently are capable of approximately 2,000 voice channels, and future systems are being planned to accommodate up to 4,000 voice channels.

(2) Submarine cable systems can be divided into two portions: underwater (coaxial cable, repeaters, and equalizers); and on-land (terminal bays, power feed; multiplex, etc.). The land portion of a subcable system is a relatively fixed cost, while the underwater portion varies directly with the distance to be spanned. Repeaters are spaced approximately 17 nautical miles (nmi) apart for 60-channel systems and 12 nmi for 120-channel systems. The repeater spacing is a function of frequency and bandwidth, with the larger bandwidth systems requiring repeaters each 4 to 7 nmi. An equalizer is required for cable spans exceeding 200 nmi; additional equalizers are required for each 200 nmi increment thereafter, generally averaging about one equalizer for every 10 to 12 repeaters. The exact number of equalizers required depends, of course, on the particular bandwidth selected. Power for the system is fed from both terminals when the cable span exceeds 400 nmi.

(3) A major consideration in evaluating and costing cable systems is the mean time to repair a break in the cable. Experience has shown that breaks are frequent and that the time required to repair is measured in days and weeks. A cable guard ship is generally contracted for on an annual basis to stand by in a nearby port in the event of a break in the cable. Where feasible, two or more cable systems may share the protection of one cable guard ship. The cost of this ship may well exceed 50 percent of the total O&M fund requirement for the system.

b. Project Description. Proposed Subsystem Project Plan X-8X requires the installation of a submarine cable system near Iceland, spanning three

hypothetical sites: A, B, and C. Site B is an island with only a small service detachment. The cable will span sites A to B and B to C. The system will be a 60-channel system with existing interconnect media at sites A and C. A brief system description is listed in table 5-1, and a pictorial configuration is shown in figure 5-1. Figures 5-2 through 5-4 portray the building block concept of the equipment and materials required for the project. The system is to be operational in 1 year, and operations will begin in project year 2. The cable, repeaters, equalizers, multiplexers, control equipment, power generators, and test equipment are considered procurement items for purposes of costing documentation. The balance of the system equipment is envisioned as being new to the Government; the costs should therefore reflect full support documentation. Because of the remoteness of the location, a cable guard ship has been included in the O&M costs. The proposed routes must be surveyed prior to the engineering of the cable system to determine water depths and temperatures, bottom characteristics, topography, etc.

TABLE 5-1. SUBSYSTEM DESCRIPTION SUBMARINE CABLE

Equipment and Facilities	Site A	Site B	Site C
VF Channels (equipped with MUX)	60	120	60
VF Channels Terminating	50	100	50
VF Channels Terminating (data cond.)	10	20	10
Power Required	Yes	Yes	Yes
Buildings Required	Yes	Yes	Yes
Security Fence Required	Yes	Yes	Yes
Land Required	Yes	Yes	Yes
Access Roads Required	Yes	Yes	Yes
Personnel Quarters Required	Yes	Yes	Yes
Manpower Required			
NCOIC (Enlisted)	1	1	1
MUX			
Enlisted	5	5	5
Civilian	0	0	0
Tech Control (Enlisted)	7	7	7
Power Tech (Enlisted)	2	2	2
	—	—	—
Total	15	15	15

PROPOSED SUBSYSTEM/PROJECT PLAN X-7 X
SYSTEM CONFIGURATION

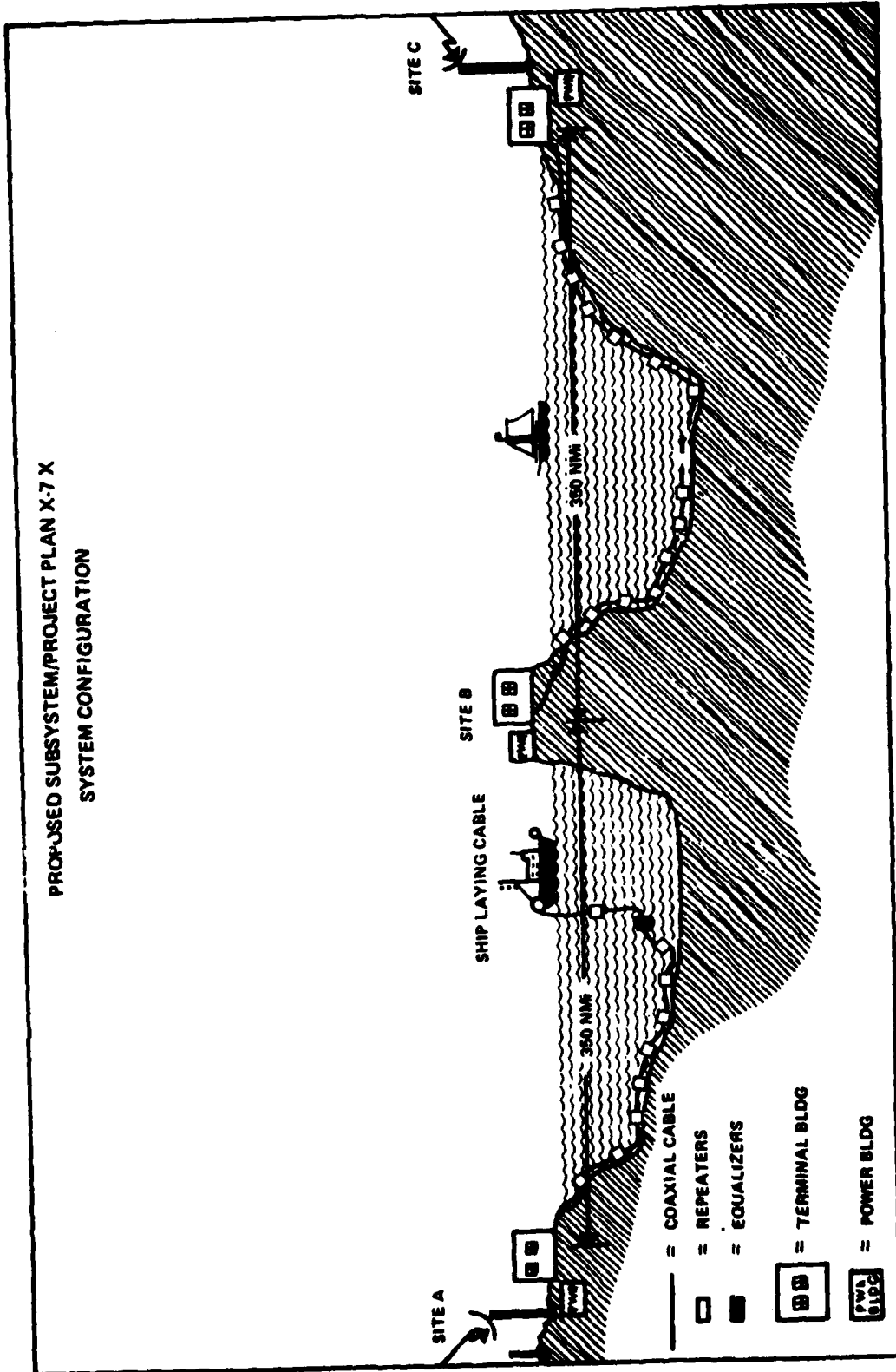

FIGURE 5-1. SUBMARINE CABLE SYSTEM-EXAMPLE SYSTEM CONFIGURATION

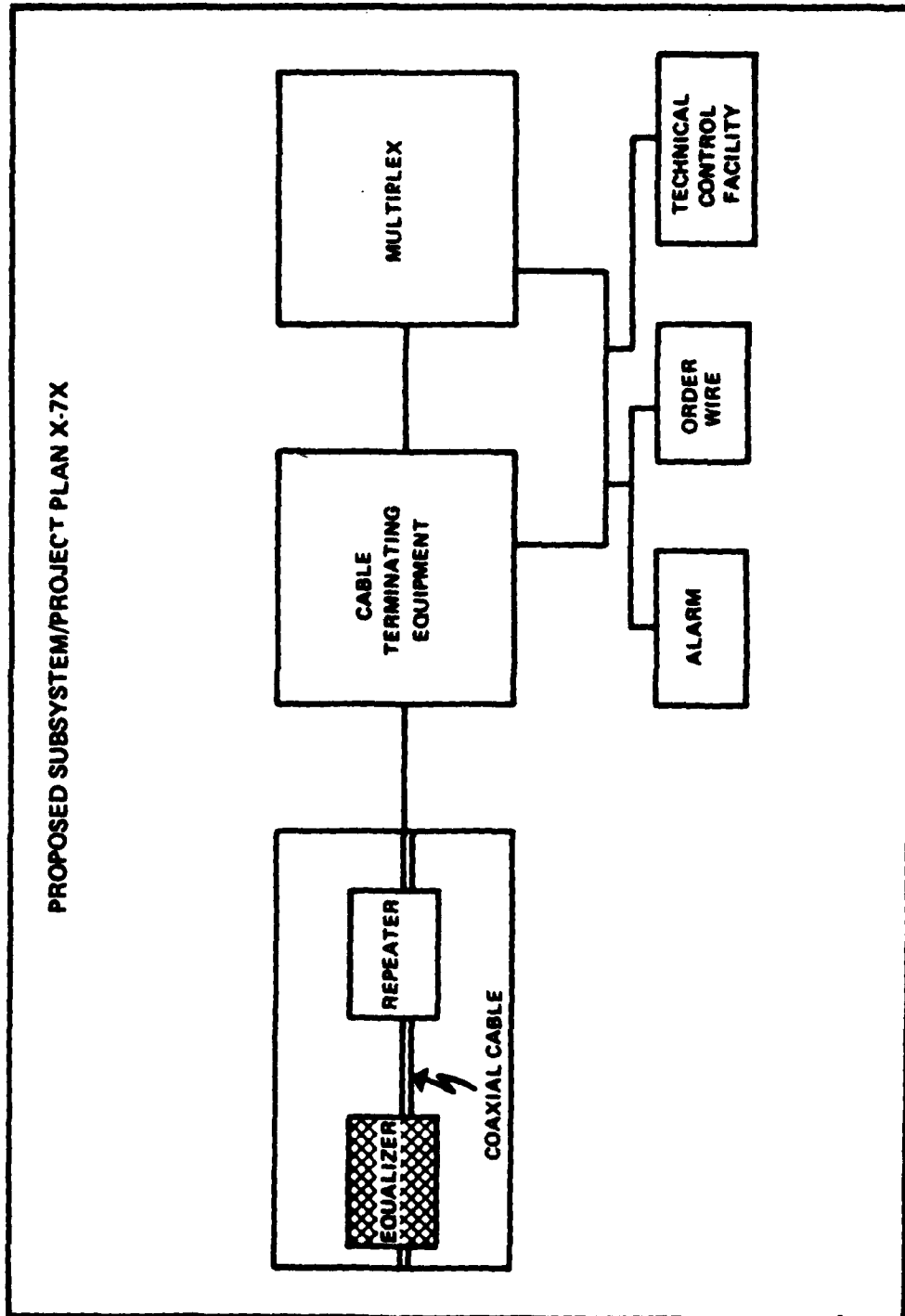

FIGURE 5-2. SUBMARINE CABLE SYSTEM PRIME MISSION EQUIPMENT BUILDING BLOCK

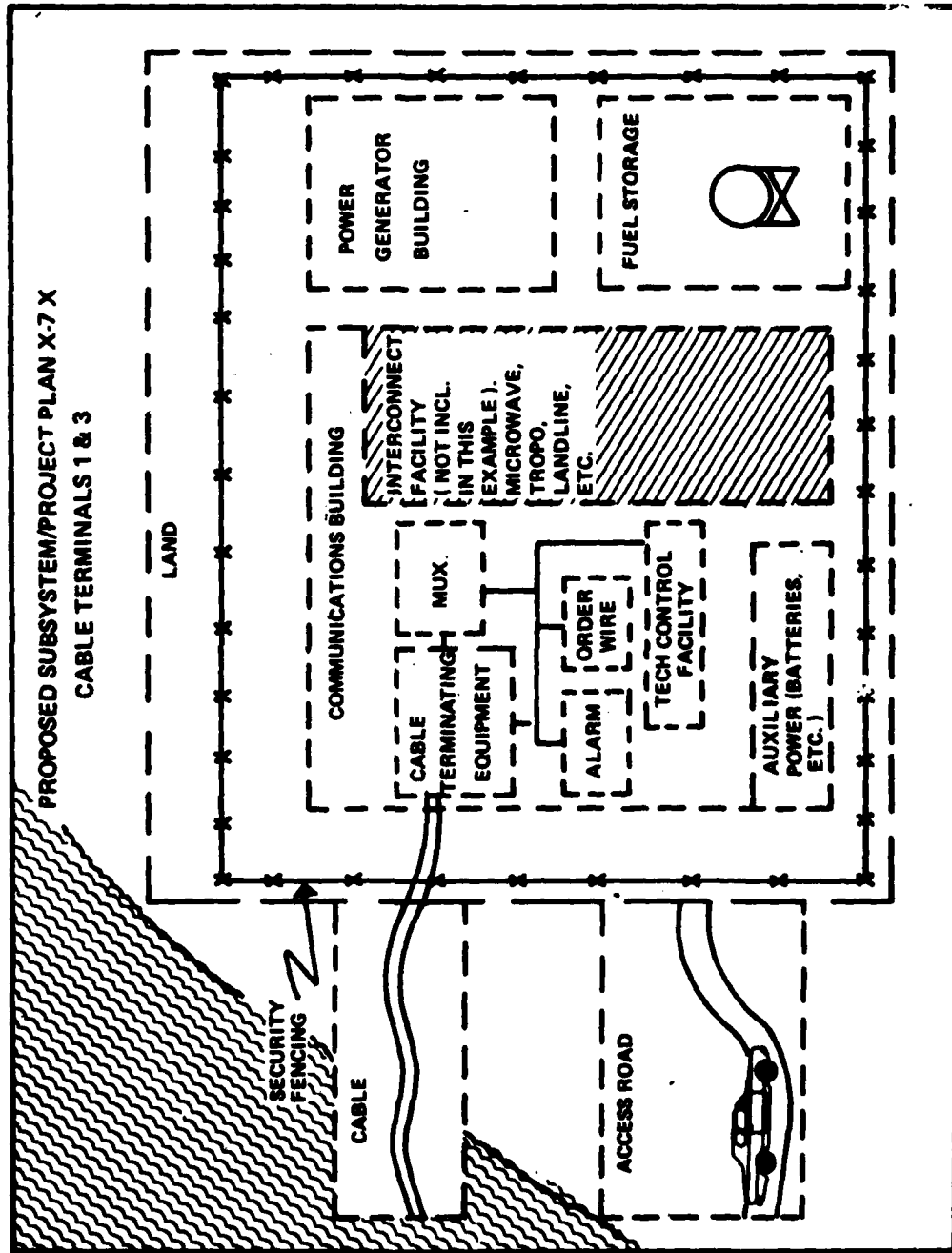

FIGURE 5-3. SUBMARINE CABLE SYSTEM TERMINAL LAYOUT BUILDING BLOCK CONCEPT

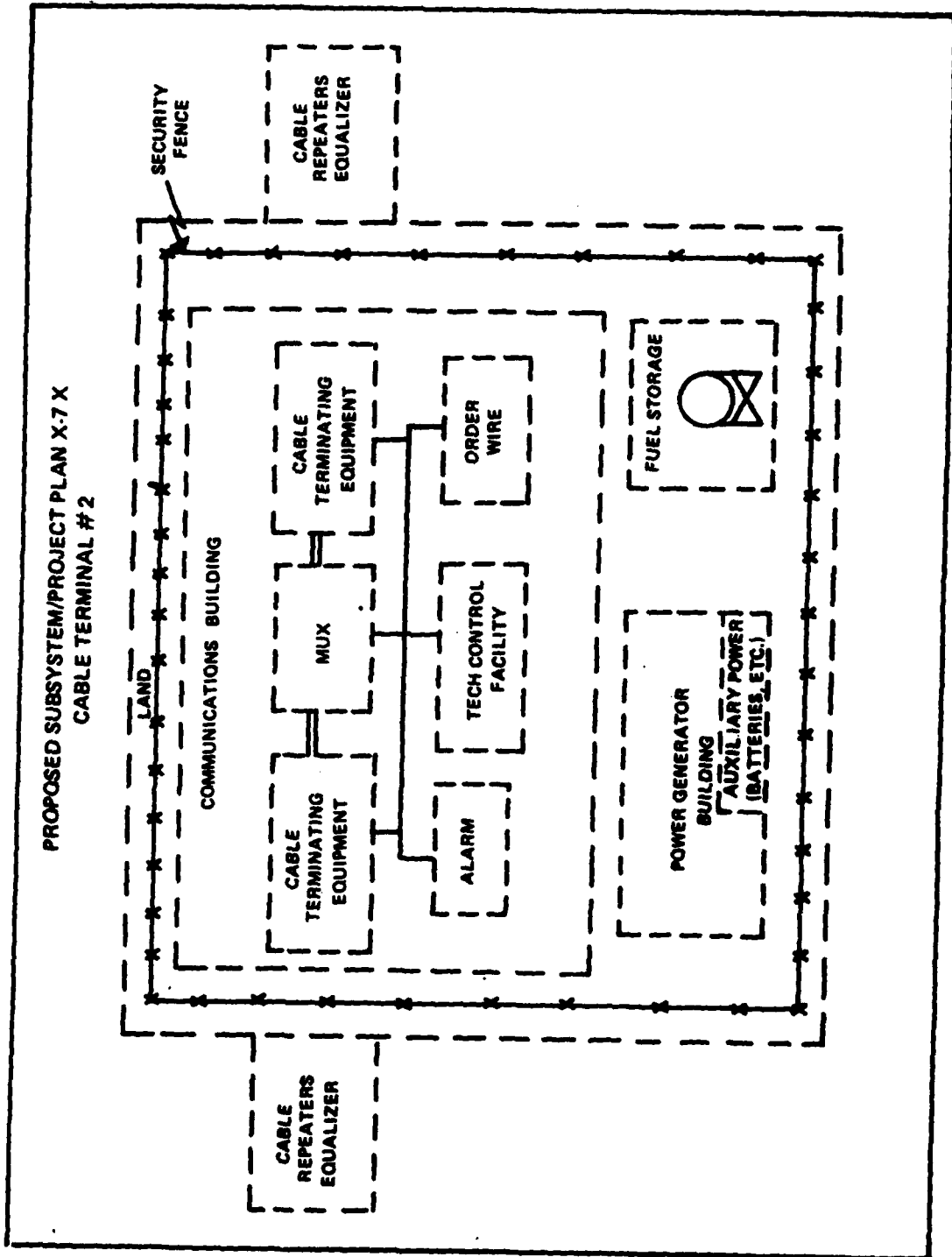

FIGURE 5-4. SUBMARINE CABLE SYSTEM TERMINAL LAYOUT BUILDING BLOCK CONCEPT

**TABLE 5-2. ACQUISITION COST PROPOSED SUBSYSTEM/PROJECT
PLAN X-8X
SUBMARINE CABLE SYSTEM**

Cost-Estimating Structure	Reference Chap Table	Value/Computations	Total (\$000)
Communications Prime			
Mission Equipment			
Underwater			
Coaxial Submarine			
Cable			
Link A-B	10 10-14	.3 nmi LP-10 @ \$33,000 X 2 ends	\$ 19.8
		1.6 nmi LPA @ \$27,500 X 2 ends	88.0
		.8 nmi A @ \$10,600 X 2 ends	17.0
		(344.6 nmi D + 10% @ \$5,700	2,160.6
			<u>2,285.4</u>
Link B-C		(same as total A-B)	2,285.4
			<u>4,570.8</u>
Repeaters	10 10-14	(350 X 1.1 nmi - 17 nmi) - 1 = 21.6 22 repeaters @ \$36,000 X 2 links	1,584.0
Equalizers	10 10-14	1/link @ \$35,400 X 2 links	<u>70.8</u>
		Subtotal Underwater Equipment	6,225.6
Cablehead			
Terminal Equipment			
Sites A & C	10 10-14	2 @ \$ 85,000	170.0
Site B		1 @ \$132,000	132.0
Multiplex	11 11-3	2 60 channel @ \$75,100	150.2
		1 120 channel @ \$121,900	121.9
NOTE: Example costs presented above are not updated. Refer to appropriate chapters for all cost data.			

TABLE 5-2. ACQUISITION COST PROPOSED SUBSYSTEM/PROJECT
PLAN X-8X
SUBMARINE CABLE SYSTEM (CON.)

Cost-Estimating Structure	Reference Chap Table	Value/Computations	Total (\$000)
Control Systems Equipment	13		
Tech Control & Patch & Test	13-1	240 Terminating Circuits @ \$175	\$ 42.0
		40 Data Conditioned Circuits @ \$1,150	46.0
	13-2	3 Circuit Control Equipment @ \$85,700	257.1
Orderwire/Intercom	13-4	3 Type A Configuration @ \$10,700	32.1
Alarm System	13-5	3 Type A Common Alarm Unit @ \$370	1.1
Auxiliary Equipment			
Electric Power	14 14-2	4 60kW @ \$19,100 X 3 sites	<u>229.2</u>
		Subtotal Cablehead Equipment	<u>1,181.6</u>
Subtotal Comm. Equip			<u>7,407.2</u>
Integration & Assembly	15	5% of Cablehead Equip.	59.1
Training-Contractor	16 16-1	1 Course Prep. Cost (1 wk course) 3 Classes of 15 students	11.0 19.0
Test & Sprt Equip.	17		
Test & Common Equip.	16-1	10% of Cablehead Equip.	118.2
Peculiar Sprt Equip.		5% of Cablehead	59.1
System Test & Eval.	18	5% of Cablehead Equip.	59.1

NOTE: Example costs presented above are not updated. Refer to appropriate chapters for all cost data.

TABLE 5-2. ACQUISITION COST PROPOSED SUBSYSTEM/PROJECT
PLAN X-8X
SUBMARINE CABLE SYSTEM (CON.)

Cost-Estimating Structure	Reference Chap Table	Value/Computations	Total (\$000)
System/Project Mgmt.	19		
Sys. Engr.-Contractor	19-1	10% of Comm. Equip.	\$ 740.7
Project Mgmt		10% of Comm. Equip.	740.7
Data	20 20-1	<u>Underwater Equip.</u>	
		Only Production & Test Data Required	
		Cost incl. in System/Project Mgmt.	0.0
		<u>Cablehead Equipment</u>	
		Term Equip.	
		Reprocurement-Full Sprt.	
		\$85,000 X 50% X 0	0.0
		New Procurement-System-Full Sprt	
		\$85,000 X 25% X 10.0	212.5
		Reprocurement-Comm. Sprt.	
		\$85,000 X 25% X 0	0.0
		Multiplex	
		Reprocurement-Full Sprt.	
		\$75,100 X 0	0.0
		Control Systems	
		Reprocurement-Full Sprt.	
		(378,000 - 4 lots) X 0	0.0
		Electric Power	
		Reprocurement-Full Sprt.	
		\$19,100 X 0	0.0
		Peculiar & Common Sprt. Equip.	
		Reprocurement-Full Sprt.	
		(\$177,400 - 4 lots) x 25% X 0	0.0

NOTE: Example costs presented above are not updated. Refer to appropriate chapters for all cost data.

TABLE 5-2. ACQUISITION COST PROPOSED SUBSYSTEM/PROJECT
PLAN X-8X
SUBMARINE CABLE SYSTEM (CON.)

Cost-Estimating Structure	Reference Chap Table	Value/Computations	Total (\$000)
		New Procurement-Unit Full Support (\$177,400 - 4 lots) X 25% X 9	\$ 99.8
		Reprocurement-Comm. Sprt. (\$177,400 4 lots) X 50% X 0	0.0
		Subtotal Data	312.3
Operational Site Activation	21		
Contractor Tech. Sprt	21-1	7% of Cablehead Equipment	82.7
Site Construction	21-2		
Land Acquisition		3 1 Acre Lots @\$3,000/Acre	9.0
Site Survey/Prep.	21-2	3 1 Acre Lots @\$3,300/Acre	9.9
Bldgs./Shelters	21-4	3 X 1,260 ft ² @\$14.40/ft ²	
		(Power)	54.5
		2 X 3,000 ft ² @\$18.20/ft ²	
		(Equipment)	109.2
		1 X 3,500 ft ² @\$18.20/ft ²	
		(Equipment)	63.7
		3 X 4,500 ft ² @\$20.00/ft ²	
		(Personnel)	270.0
Sewage Facilities	21-2	3 X \$3,500	10.5
Water Facilities	21-3	3 X \$4,000	12.0
Foundation, Stands, Pads	21-2	3 Pads @2500 ft ² @\$.70/ft ²	5.3
Fences		3 Lots @840 feet @\$7.45/foot	18.8
Access Roads	21-2	3 @ 1 mi @\$23,500/mi	70.5
Fuel Storage Facilities	21-3	3 @4,000 gal @\$1/gal	12.0
Subtotal Site Construction			645.4
Area Factor		(3.0) X \$645.4	1,936.2
NOTE: Example costs presented above are not updated. Refer to appropriate chapters for all cost data.			

TABLE 5-2. ACQUISITION COST PROPOSED SUBSYSTEM/PROJECT
PLAN X-8X
SUBMARINE CABLE SYSTEM (CON.)

Cost-Estimating Structure	Reference Chap Table	Value/Computations	Total (\$000)
Cable Ship Operations	10 10-15		
Cable Loading		770 nmi - 1.9 nmi/hr 406 hr	
Sailing Time (To Location)		24,000 nmi Roundtrip - 12 nmi/hr 2,000	
Laying of Shore Ends		4 Ends @12 hr/end 48	
Cable Laying		(350 X 1.1X2) nmi - 2.75 nmi/hr 280	
Contingencies (Foul weather, breaks, equip. breakdowns)		10% X 2,734 hr 273	
Subtotal Cable Ship Ops.		3,007 hr - 24 hr/day @ \$8,100/day	\$1,014.9
Assembly, Install & Check-out On Site	21 21-5	60% of Cablehead Equip.	709.0
Initial Spares and Repair Parts	22 22-1	Piece Parts .05 X .3 = .015 Elect. Modules .50 X .5 = .250 Electro-Mech .45 X .7 = .315 Subtotal Cablehead .580 X \$1,181,600 = 685.3 700 nmi @.03 @\$5,700/nmi (type D cable) 119.7 2 Repeaters @\$36,000 72.0 1 Equalizer @35.4 35.4	912.4
NOTE: Example costs presented above are not updated. Refer to appropriate chapters for all cost data.			

TABLE 5-2. ACQUISITION COST PROPOSED SUBSYSTEM/PROJECT PLAN X-8X SUBMARINE CABLE SYSTEM (CON.)			
Cost-Estimating Structure	Reference Chap Table	Value/Computations	Total (\$000)
Transportation	24 24-8	Electronics Equipment Term, Mux, Control System \$ 952,400 Peculiar & Common Spt. Equip. \$ 177,300 Initial Spares & Repair Parts (less spare cable) 792,700 \$1,922,400 X .10	\$192.2
		Electric Power & Prefab Bldgs. 726,600 X .16	116.3
		Sewer & Water Facilities, Pads, Fences, and Fuel Storage (50% procured locally) 29,300 X .16 4.7 Data (via Parcel Post) 312,300 X .01 3.1	316.3
Total Acquisition Cost			<u>\$14,497.9</u>
NOTE: Example costs presented above are not updated. Refer to appropriate chapters for all cost data.			

TABLE 5-3. ANNUAL OPERATING COST PROPOSED SUBSYSTEM/PROJECT
PLAN X-8X SUBMARINE CABLE SYSTEM

Cost-Estimating Structure	Reference Chap Table	Value/Computations	Total (\$000)
Military Personnel -			
Pay and Allowances	23 23-1		
Officers		-0-	\$ 0.0
Enlisted Men		15 E-5's X 3 sites @ \$8,839	397.8
O&M	24		
TDY	24-6	25 days @ \$25 plus transp.	1.0
Contractor Sprt.	10 10-15	(@ \$2,800/day X 355) + (10 days @ \$3,000 (1 break))	1,024.0
Cable Guard Ship			
Transp. of Things	24 24-8	.16 X (Supplies \$40,800 + Spares \$95,100)	21.7
O&M Materials			
Utilities & POL	24-13	78,000 Gals Fuel @ \$.25/gal X 3 sites	58.5
Building Maintenance		.05 X \$497,700 X 3.0 Area Factor	74.7
Supplies & Equip.		.03 X (Cablehead + Support Equipment)	40.8
Misc. Support	24-22	.003 X (Cablehead + Support Equipment)	4.1
Recurring Investment	25		
Replacement Spares		.07 X (Cablehead + Support Equipment)	95.1
Operating Support	26		
Base Operations			
Personnel	26-1	45 X \$764	34.4
Depot Maintenance	26-3	.005 X (Cablehead & Support Equipment)	6.8
Replacement Training	26-4	45 @ \$2,750	123.8
Medical	26-6	45 @ \$394	17.7
PCS Travel Costs	26-7	45 @ \$1,345	60.5
			<u>\$1,960.9</u>

NOTE: If cable guard ship is available from nearby system, costs should be prorated among the systems served. If none is required, costs should be deleted. Only costs for repair of one break @ \$30,000 (10 days @ \$3,000 day) are included. Example costs presented above are not updated. Refer to appropriate chapters for all cost data.

TABLE 5-4. TIME-PHASED COST ESTIMATE - PROPOSED PROJECT
PLAN X-8X
SUBMARINE CABLE SYSTEM

	FY 1	FY 2	FY 3 to 11	Total
RDT&E	0	0	0	0
Investment				
Procurement				
Cable & Terminal Equip.	\$ 6,527.6			\$ 6,527.6
Multiplex	272.1			272.1
Tech Control & P&T	345.1			345.1
Orderwire	32.1			32.1
Alarm System	1.1			1.1
Electric Power	229.2			229.2
Integration & Assembly	59.1			59.1
Training	30.0			30.0
Test Equipment	177.3			177.3
System Test & Evaluation	59.1			59.1
System Engineering	740.7			740.7
Project Management	740.7			740.7
Data	312.3			312.3
Contractor Tech Support	82.7			82.7
Assembly, Instal., & Checkout @ Site	709.0			709.0
Cable Ship Operations	1,014.9			1,014.9
Initial Spares & Repair Parts	912.4			912.4
Transportation	316.3			316.3
Military Construction				
Site Activation	1,936.2			1,936.2
Annual Operating				
Military Personnel		\$ 397.8	\$ 3,580.2	3,978.0
Operations & Maintenance		1,224.8	11,023.2	12,248.0
Recurring Investment		95.1	855.9	951.0
Operating Support		243.2	2,188.8	2,432.0
Total 10-Year System Cost	\$14,497.9	\$1,960.9	\$17,648.1	\$34,106.9

3. Land Cable Systems.

a. General.

(1) Land cable systems may be simple (voice frequency to voice frequency), short, with as little as a single pair connecting two main distribution frames; or very complex systems consisting of multipair cable (up to 2,400 pair in a single cable), repeaters, equalizers, and other line-conditioning equipment, connecting through a carrier to the main distribution frame. The carrier performs a multiplexing function and permits many users to be served over one cable.

(2) The systems are generally referred to as being either "inside or outside plant." Inside plant includes the central office functions, such as switching, control, etc. Outside plant refers to the interconnecting transmission media, such as the cables, poles, manholes, ducts, etc., between exchanges or between an exchange and a subscriber. Outside plant equipment may be pole mounted (aerial), open wire or insulated, or direct burial or buried in ducts. This chapter will not discuss inside plant functions and equipment.

(3) Although there are a few facilities providing long-distance transmission to the DCS using land cable systems, the primary transmission system is radio. Generally, the military land cable systems are short (5 miles or less) and simple (handset to handset). When use of a land cable system is proposed, a cost-effectiveness study must be made to determine the tradeoffs among a large multipair cable, a cable carrier system, and radio systems.

(4) Cable systems generally are placed in public rights-of-way; however, in some instances right-of-way and access to private land must be acquired.

(5) Cable carrier systems require repeaters for amplification of the signal and line build-out-networks at intervals determined by the characteristics of the line. The different types of cables and their characteristics determine the maximum span length, which in no case exceeds 14,000 feet, with an average span length in the 4,000- to 5,000-foot range. Repeater section lengths (spans) are a function of the type of cable used, pair separation in the cable, the number of systems in the cable, and number in use (one- or two-cable operation).

(6) In addition to open wire and twisted pair cable, coaxial cable may also be used for land cable systems. The cable may have from two to twenty 1/4-inch cables in one tube, the rest of the tube being filled with twisted pair cable. These cable systems use a carrier to multiplex the channels and require repeaters and equalization. Two coaxial cables one-fourth of an inch in diameter can be multiplexed to carry from 12 to 240 channels; however, the systems will not likely prove to be economically

efficient for the lower channel requirements. Because of the relatively small use of cable carrier systems in the DCS, no costs or further information will be included in this Circular.

b. Project Description.

(1) Subsystem Project Plan X-9X requires the establishment of six cable pairs from an existing service to a new location 1 mile away at a base near Norfolk, Virginia. The new location is on a Government post; therefore, no problems exist regarding rights-of-way.

(2) It is decided to use an underground system. Since all utilities are buried on the station, the topography and soil require the use of an underground concrete conduit; there are no streets to cross or utilities to move. The cable will be connected to an existing main distribution frame and a PBX (to be provided and maintained by subscriber) at the new location. There are existing cable plants at the station which will provide maintenance. There are no requirements for operational personnel, training, documentation, additional test equipment, or auxiliary equipment. The project cost estimate is given in table 5-5.

TABLE 5-5. ACQUISITION COST - PROPOSED SUBSYSTEM/PROJECT
PLAN X-8X
LAND CABLE SYSTEM

Cost-Estimating Structure	Reference Chap Table	Value/Computations	Total (\$000)
Communications Prime Mission Equipment Cable in Duct (6 pair)	10 10-10	5,280 ft @ \$13.50/ft (installed)	\$71.3
Integration & Assembly	15	Included in cable cost/ft	-
Contractor Training	16 16-1	Included in cable cost/ft	-
Test & Sprt Equip. System Test & Evaluation	17 17-1	Included in cable cost/ft	-
System/Project Mgmt	18	Included in cable cost/ft	-
System Engineering	19	Included in cable cost/ft	-
Project Management	19-1	Included in cable cost/ft	-
Data	20 20-1	Not Required	-
Operational Site Activation	21	Not Required	-
Initial Spares & Repair Parts	22	Not Required	-
Transportation	24 24-8	3% of Comm. Equip.	<u>2.1</u>
Total Acquisition Cost			<u>\$73.4</u>

NOTE: Example costs presented above are not updated. Refer to appropriate chapters for all cost data.

DCAC 600-60-1
SECTION A

CHAPTER 6. FIBER OPTIC SYSTEMS

(To be published later)

DCAC 600-60-1
SECTION A

7-1

CHAPTER 7

(Reserved for future use.)

DCAC 600-60-1
SECTION A

8-1

CHAPTER 8

(Reserved for future use.)

DCAC 600-60-1
SECTION A

CHAPTER 9. ADVANCED CONCEPTS

(To be published later.)

SECTION B. COMMUNICATIONS PRIME MISSION EQUIPMENT

CHAPTER 10. TRANSMISSION SYSTEMS EQUIPMENT

1. General. This chapter discusses "building block" costs for transmission systems. The chapter is divided by transmission medium into five major paragraphs and also includes tables and figures presenting the major equipment of the individual transmission systems. The cost data in the tables and figures are self-explanatory given the procedures and costing guidelines in section A of this Circular. The prices represent acquisition costs exclusive of transportation costs and site installation costs.

2. LOS Microwave Equipment. This paragraph contains tables of equipment costs and cost-estimating relationships (CER's) for LOS radio sets, antennas and radomes, transmission line systems, towers, and passive reflectors. In some geographical areas, the saturation of the frequency spectrum (normally 2-10 GHz) will dictate the frequencies, the transmitter power output, and the method of diversity. Local conditions may restrict tower height and design. In planning and costing subsystems, note that space diversity requires twice the number of antennas and transmission lines as frequency diversity. The transmission line subsystems for the lower frequencies are more expensive than those for the higher frequencies. Also, lower tower heights may result in an increased number of relays. Another cost consideration for tower selection is the cost and availability of land for guyed towers versus the higher cost of self-supporting towers. A simple formula for calculating the approximate land requirements of a guyed tower is:

$$A = \frac{(T \times 1.2 + 20)(T \times 1.4 + 20)}{43,560}$$

Where:

A = Land required in acres

T = Tower height in feet

a. Radio Equipment.

(1) Analog Radio Sets. Analog radio sets are divided into FDM/FM and PCM/TDM/FM subclasses. An FDM/FM radio set accepts analog baseband signals and transmits them, using frequency division multiplexing (FDM), over an FM radio. A PCM/TDM/FM radio set transmits pulse code modulation (PCM) signals, using time division multiplexing (TDM), over an FM radio. Each type of radio set is defined to contain a transmitter, receiver, orderwire (OW), duplexer, and power supply. The OW establishes link alignment and maintenance communications over channels which are separate from the channels carrying mission traffic; the duplexer provides isolation between the transmitter and receiver to prevent desensitization of the receiver when signals are transmitted and received simultaneously; the power supply provides required operating voltages to the radio set.

Normally, the OW and duplexer are not included with the radio set and are purchased as options. However, in some instances, radio sets include as built-in features the OW and duplexer as well as all required equipment to operate as either a hot-standby, repeater, or diversity terminal. When these features are not included, equipment must be added as necessary to complete the installation.

(2) Digital Radio Sets. Digital radio sets are divided into TDM/PSK and TDM/PRS modulation subclasses. The digital radio sets costed employ quadrature phase shift keying (QPSK) or 8-PSK signals. Radio sets employing quadrature partial response signal (QPRS) modulation are also included. Digital radio sets accept only digital baseband signals from TDM multiplexers. Like the analog radio set, the digital radio set contains a transmitter, receiver, OW, duplexer, and power supply. The OW and duplexer are not usually included as part of the radio set and must be purchased separately. Digital radio sets can be purchased to include as built-in features the OW and duplexer as well as all required equipment to be configured as a hot-standby, repeater, or diversity terminal. The Digital Radio and Multiplex Acquisition Program (DRAMA) family of digital radios is attaining widespread usage within the DCS. They use QPR or QPSK modulation (one of two bits/Hz) and accept one or two data streams each with rates from 3.2 to 12.9 Mb/s. Emission bandwidths of 3.5 MHz, 7 MHz, and 14 MHz are available. Each DRAMA radio also multiplexes a 192 Kb/s orderwire channel with the one or two data streams. Radios are distinguished by output frequencies and methods of diversity.

(3) Use of Table 10-1. This table, containing CER's and prices for LOS radio sets of the types currently on procurement for the DCS, is used to determine the number and type (analog/digital) of radio equipment desired. For digital radios, the distinguishing features, nomenclature, and costs of the DRAMA radios are listed. For analog radios the number of voice channels and the frequency are required as well as information on whether the radios have built-in hot-standby, diversity, and/or digital interface capabilities. After the correct radio is selected, calculate or locate in the table the unit cost and multiply by the quantity of radio equipment. To adjust the cost to a later base year, apply the technology cost multiplier shown in the table and inflate according to chapter 38.

TABLE 10-1. LOS RADIO EQUIPMENT

Cost Category	CER			Range	
(1) Analog	6578 x e ^{(.0001 x (3.94 x N + 208 x F))} x 2.64 for hot standby x 2.64 for diversity x 1.72 for digital interface			6 ≤ N ≤ 3600	.96 ≤ F ≤ 15.3
(2) 4-PSK Digital	12,500			48 ≤ N ≤ 300	
	12,500 + 93.75 x (N-300)			300 ≤ N ≤ 672	
(3) 8-PSK/PR Digital	12,500			96 ≤ N ≤ 600	
	12,500 + 46.9 x (N-600)			600 ≤ N ≤ 1344	
(4) DRAMA	See table below.				

N	Analog (1)**						Digital	
	Basic			W/Digital Interface			(2)	(3)
	F=1	F=5	F=12	F=1	F=5	F=12	4-PSK	8-PSK/PR
12	\$6,750	\$7,330	\$8,480	\$11,600	\$12,600	\$14,600		
60	6,880	7,470	8,640	11,800	12,900	14,900	\$12,500	
120	7,040	7,650	8,850	12,100	13,200	15,200	12,500	\$12,500
300	7,560	8,210	9,500	13,000	14,100	16,300	12,500	12,500
600	8,510	9,250	10,700	14,600	15,900	18,400	40,600	12,500
1200	10,800	11,700	13,500	18,500	20,100	23,300		40,600
2400	17,300	18,800	21,700	29,700	32,300	37,400		
3600	27,700	30,100	34,900	47,700	51,900	60,000		

DRAMA			
Nomenclature	Frequency	Diversity	Cost
AN/FRC-170(V)	4 GHz	Space	\$37,593
AN/FRC-171(V)	8 GHz	Space	38,512
AN/FRC-172(V)	4 GHz	Frequency	37,143
AN/FRC-173(V)	8 GHz	Frequency	37,158

NOTES: Base year is FY 1977.
N = no. of voicegrade channels, F = frequency in GHz.
Technology weighting factor is 1-.132 x (Y-1977), Y = fiscal year
** Use multipliers for hot standby and/or diversity when appropriate.

Source: Booz-Allen Applied Research, Contract No. 100-76-C-0049,
Jul 77; USACSA, Ft. Monmouth, 1977 contract; DCA, Code 690.

(a) Example 1. A digital subsystem requires 12 4 GHz space diversity DRAMA radios.

12 radios @ \$37,593 = \$451,116

(b) Example 2. An analog subsystem carrying 600 channels requires four terminals and four relays at 5 GHz with frequency diversity. Estimated costs for this equipment would be:

4 terminals @ \$24,420	\$ 97,680
4 relays @ (\$24,420 x 2)	195,360
Total	<u>\$293,040</u>

b. LOS Microwave Antennas.

(1) Antennas. Table 10-2 presents CER's and prices for high performance parabolic dish antennas. Typical halfpower beamwidths are 6 degrees or less with a maximum front-to-back ratio of 70 dB.

(2) Radomes. Also included in table 10-2 are CER's and prices for radomes, both heated and unheated, in sizes to fit the above antennas.

(3) Use of Table 10-2. Use one antenna system per terminal and two antennas per relay. From table 10-2 select the antenna size (based upon the desired gain) which matches the frequency selected from table 10-1. For example, dual polarized antennas with heated radomes would be costed as follows:

12 8-foot antennas @ \$9,200 = \$110,400

c. Transmission Line Systems. In microwave transmission systems, coaxial cable, elliptical waveguide, circular waveguide, and rectangular waveguide are used to provide the RF connection between the microwave radio set and antenna. Selection of the proper feed is primarily based on loss characteristics and the following general guidelines, which are established operating practices of microwave communication engineers.

TABLE 10-2. LOS MICROWAVE ANTENNAS

<u>Cost Category</u>		<u>CER</u>		<u>Range</u>
(1)	Parabolic Dish Antenna	65.9 x D ² + 2317 (+ 890 if Dual Polarized)		6 ≤ D ≤ 15
(2)	Unheated Radome	13.9 x D ² + 86		2 ≤ D ≤ 12
(3)	Heated Radome	18.45 x D ² + 357		2 ≤ D ≤ 12

<u>D</u>	<u>(1)Antenna</u>		<u>Radome</u>		<u>Total</u>			
	<u>Plane</u>	<u>Dual</u>	<u>(2)Unhtd</u>	<u>(3)Htd</u>	<u>Plane Unhtd</u>	<u>Plane Htd.</u>	<u>Dual Unhtd.</u>	<u>Dual Htd.</u>
2			\$ 160	\$ 400				
4			350	725				
6	\$ 5,000	\$ 5,700	540	960	\$ 5,540	\$ 5,960	\$ 6,240	\$ 6,660
8	6,600	7,600	950	1,600	7,550	8,200	8,550	9,200
10	8,400	9,300	1,460	2,120	9,860	10,520	10,760	11,420
12	11,800	12,800	2,120	3,050	13,920	14,850	14,920	15,850
15	17,300	18,150						

NOTES: Base Year is FY 1981.
D = antenna diameter in ft.
Antennas are high performance, .9-15 GHz, and include mounts.
Radomes are standard series, fiberglass.

Source: Catalog Price Lists; DCA, Code 690.

(1) Coaxial Cable. Usually used for systems operating below 3 GHz, coaxial cable is available in various diameter sizes, dielectric materials, and loss characteristics. For pressurized feed systems air dielectric cable is used; foam dielectric cable is suitable only for nonpressurized feeds. Coaxial cable is provided in one single continuous run.

(2) Elliptical Waveguide. The most commonly employed feed for systems operating above 3 GHz, this waveguide is semiflexible and available in various sizes and loss characteristics. Like coaxial cable, elliptical waveguide is provided and installed as a single continuous run, which eliminates the need for intermediate connecting flanges. Elliptical waveguide can be used for both pressurized and nonpressurized feed systems.

(3) Circular Waveguide. The primary advantage is its low rate of attenuation. Where long vertical tower runs are required, circular waveguide is normally selected since other waveguides cannot be used because of excessive attenuation. In addition to low loss, it can support two orthogonal polarizations within a single waveguide. Disadvantages include high cost, rigidity (which makes it practical only for straight runs), and moding problems that occur when the guide is large enough to support more than one mode for the frequency range in operation.

(4) Rectangular Waveguide. This waveguide is generally used to provide the end connections with the antenna and radio since they are normally terminated with rectangular feed flanges. Rectangular waveguide components such as elbows, twist sections, pressure windows, and transition elements are used in elliptical and circular waveguide systems for the end connections. Rectangular waveguide is available for long tower run application, but elliptical waveguide is normally selected over long rectangular waveguide runs because it is provided and installed as a single continuous run, eliminating the need for intermediate flanges. In addition, elliptical waveguide offers a slight improvement in the rate of attenuation.

(5) Use of Table 10-3. This table provides CER's and prices for various types of transmission line equipment. Costs for cables and waveguides include mounting hardware (based on 150-foot runs). Determine the type of transmission line to be used and apply the corresponding CER. Add dehydration equipment if appropriate. A single dehydrator can service up to four parallel runs of transmission line. For example, the cost of six elliptical waveguides, 300 feet in length, with two dehydrators, would be calculated as follows:

6 300-foot elliptical waveguides @ \$3,285	=	\$19,710
2 automatic dehydrators @ \$990	=	1,980
Total		<u>\$21,690</u>

TABLE 10-3. TRANSMISSION LINE SYSTEMS

<u>Cost Category</u>	<u>CER</u>	<u>150 Ft Run Cost</u>
Coaxial Cable	15.75 x L	\$2,363
Circular Waveguide*	29.65 x L	4,447
Elliptical Waveguide	10.95 x L	1,643
Automatic Dehydrator**	990	990

NOTES: Base year is FY 1977.
L = linear ft.
Based on 150-foot lengths including mounting hardware.
*Assumes 100 vertical feet of circular waveguide and 50 horizontal feet of elliptical waveguide.
**One dehydrator can service up to four parallel runs of transmission line.

Source: Booz-Allen Applied Research, Contract No. 100-76-C-0049, Jul 77; DCA, Code 690.

d. Towers. Table 10-4 contains CER's and prices, obtained from contracts and vendors' catalogs, for guyed, self-supporting, and wood pole towers, including concrete foundation and construction costs.

(1) Antenna Towers. Towers are used in microwave communications systems to achieve adequate line-of-sight (LOS) clearance based on path engineering data. Basically, the tower must be selected to withstand system design and operational loading requirements. Design loading refers primarily to the wind loading caused by antennas, waveguides, and other equipment mounted on the tower. Operational loading accounts for the tower twist and sway effect when very high wind is encountered. EIA Standard RS-222C is a commercial standard developed to aid tower designers account for various loading effects. The standard defines twist and sway limits as a function of antenna beamwidth so that the signal will not be degraded more than 10 dB. The United States is divided into three wind-loading zones, A, B, and C, with the following recommended minimum loading requirements:

(a) Zone A - 30 lb/ft² (approximately 86.0 mi/h).

(b) Zone B - 40 lb/ft² (approximately 100.0 mi/h).

(c) Zone C - 50 lb/ft² (approximately 112.5 mi/h). Zone C has the most stringent requirements and allows for tower usage in hurricane weather areas.

(2) Wood Poles. Land line cables and utility wires are usually carried on wood poles.

(3) Erection. Tower height, painting, lighting, and obstruction marking are regulated within the United States by the FAA and FCC. Generally, foreign countries impose similar regulations, usually in accordance with International Civil Aviation Organization (ICAO) recommendations.

(4) Use of Table 10-4. Determine tower height (from path profile) and type (guyed, self-supporting, or wood pole). Use one tower per terminal or relay. The table contains separate costs for tower structures (including painting and lighting), erection, and foundations. The erection costs are normally included in a total subsystem project plan in the factor for assembly, installation, and checkout on site. The foundation costs represent site activation costs and are subject to adjustment by construction price indexes to reflect geographical differences in cost. As an example, the structure cost of eight 200-foot self-supported towers can be calculated using CER (1) or can be located in the table:

8 200-foot self-supported towers @ \$129,000 = \$1,032,000

e. Passive Reflectors.

(1) Reflectors may be used to change the direction of a signal or to pass the signal on in the same direction. Tower-mounted reflectors are not generally used in an area where there are a large number of frequencies causing radio frequency interference (RFI) problems. Large ground-mounted reflectors are generally used as passive repeaters. They are usually remote from the manned site, and may present a security problem.

(2) Use of Table 10-5. This table contains CER's and prices obtained from vendors' catalogs for billboard type passive reflectors. Costs are included for tower mounted reflectors up to a size of 12 feet by 17 feet and groundmounted reflectors as large as 40 feet by 60 feet. After a survey has determined the feasibility of using passive repeaters (reflectors) and the number and size required, the appropriate cost for the size should be selected or derived from the table.

TABLE 10-4. TOWERS

<u>Cost Category</u>	<u>CER</u>	<u>Range</u>
Tower Structure		
(1) Self-Supported	$5.37 \times T^{1.8} + 296^*$ $3.23 \times T^2 - 559$	8 \angle T \angle 30 33 \angle T \angle 350
(2) Guyed	$85.6 \times T^{.969^*}$	50 \angle T \angle 500
(3) Wood Pole	$.00270 \times T^{2.89}$ $-6.34 \times 10^6 \times T^{-2} + 1809$	25 \angle T \angle 65 75 \angle T \angle 105
Erection		
(4) Self-Supported & Guyed	$.75 \times (\text{Structure Cost})$	
(5) Wood Pole	$3.69 \times 10^{-8} \times T^{5.77} + 151$ 622	25 \angle T \angle 45 50 \angle T \angle 100
Foundation		
(6) Self-Supported	$31.1 \times T^{1.18}$ $.937 \times T^{1.6} + 2943$	4 \angle T \angle 40 45 \angle T \angle 310.
(7) Guyed	$.0055 \times T^2 + 368$	80 \angle T \angle 400
<p>NOTES: Base year is FY 1977. T = Tower height in ft. *Rated at 40 lb/ft² with three 8-foot parabolic antennas.</p> <p>Source: AFCS; Booz-Allen Contract No. 100-76-C-0049, Jul 77; catalog price lists; DCA, Code 690.</p>		

TABLE 10-4. TOWERS (CON.)

HT	TOWER STRUCTURE		ERECTION		FOUNDATION		TOTAL COST		
	(1)SELF: SPRTD	(2) GUYED	(3)WOOD: POLE	(4) SELF: SPRTD	(5)WOOD: POLE	(6)SELF: SPRTD	(7) GUYED	SELF: SPRTD	WOOD POLE
8	\$ 520			\$ 390		\$ 360		\$ 1280	
12	770			570		580		1920	
20	1460			1110		1070		3650	
30	2740		\$ 50	2060		1720		6520	
40	4600		120	3450		2420		10500	\$ 210
50	7510	\$ 3790	220	5630	\$ 2840	3430	\$ 380	16600	330
60	11100	4520	370	8290	3390	3600	390	22900	840
70	15200	5250	520	11400	3940	3780	390	30500	990
80	20100	5980	820	15100	4480	3980	400	39100	1140
90	25600	6700	1030	19200	5030	4200	410	49000	1440
100	31700	7420	1180	23800	5570	4430	420	59900	1650
120	45900	8860		34400	6640	4930	440	85300	1800
140	62700	10300		47000	7710	5490	470	115000	
160	82000	11700		61500	8780	6090	500	150000	
180	104000	13100		78000	9840	6750	530	189000	
200	128000	14500		96400	10900	7440	570	232000	
220	156000	15900		117000	11900	8190	610	280000	
260	218000	16700		163000	14000	9790	710	390000	
300	290000	21500		217000	16100	11600	830	519000	
340	372000	24300		279000	18200		960	835000	
380		27100			20300		1100	1100000	
420		24800			22400		1270	1450000	
460		32600			24400		1450	1840000	
500		35300			26500		1640	2340000	

NOTE: BASE - FISCAL YEAR 1977

TABLE 10-5. PASSIVE REFLECTORS

<u>Cost Category</u>	<u>CER</u>	<u>Range</u>
(1) Tower Mounted	$20.5 \times A^{.835} + 419$	$24 \leq A \leq 204$
(2) Ground Mounted	$10.5 \times A^{1.09} + 317$	$80 \leq A \leq 2,400$

<u>Size</u>	<u>(1) Tower Mounted</u>	<u>(2) Ground Mounted</u>	
		<u>Reflector*</u>	<u>Mounts**</u>
4x6	\$ 710		
6x8	940		
8x10	1,210	\$ 1,560	\$450
8x12	1,350	1,840	450
10x15	1,760	2,790	450
10x16	1,840	2,970	450
12x16	2,070	3,550	450
12x17	2,160	3,770	450
14x16		4,140	450
16x20		5,960	450
16x24		7,210	450
20x24		9,100	450
20x32		12,300	450
24x30		14,000	450
30x32		19,000	450
30x40		24,200	900
30x48		29,400	900
40x50		41,900	900
40x60		51,100	900

NOTES: Base year is FY 1977.
A = area in sq ft.
Estimated costs for materials only.
*With 15-ft ground clearance.
**Concrete ground mounts in place 6 ft deep by 2 ft by 2 ft (should be included as a site activation cost).

Source: 1975 catalog price lists; DCA, Code 690.

3. Tropospheric Scatter Systems Equipment. This paragraph contains tables of equipment costs for tropo radio sets, antennas, and feed subsystems.

a. Cost Considerations. All equipment costs in this paragraph are based upon a quad-diversity configuration. For a gross estimate of costs, it is impracticable to use dual-diversity and low-power transmitters or small antennas. Accurate cost figures cannot be obtained without a complete engineering path analysis. In planning a tropo system, particular attention must be given to land requirements, site access, military construction, and all of the support functions which have a large impact on cost.

b. Equipment Tables.

- (1) Table 10-6 contains prices of radio equipment.
- (2) Table 10-7 contains prices for antennas, including foundations.
- (3) Table 10-8 contains the prices for complete feed subsystems.

c. Use of Tables.

(1) Table 10-6. Estimate the number and type of radios at the desired frequency. Select the power output for the transmitter, then multiply the unit cost by the quantity of radio equipment.

Example. A subsystem requires two terminals and one repeater at 2 GHz. The transmitter power output is 1 kW. Estimated costs for this equipment would be:

2 terminals @ \$245,000	\$490,000
1 repeater = 2 terminals @ \$490,000	<u>490,000</u>
Total	\$980,000

(2) Table 10-7. Use two antennas per terminal and two antennas per link at a relay (space diversity is assumed). Select the antenna size (based upon the assumed path parameters).

(3) Table 10-8. Select the feed subsystem of the appropriate frequency. The feed subsystem in the table includes all of the required equipment for two antennas located at a distance of 100 feet from the electronics building.

TABLE 10-6. TROPO RADIO EQUIPMENT

<u>Frequency</u> (GHz)	<u>XMITR Output</u> (kW)	<u>Cost</u>
1	1	\$243,000
	10	303,000
2	1	245,000
	10	309,000
4	1	249,000
	10	319,000

NOTES: Base year is pre-1970.
Includes 2 power amplifiers, 2 exciters, 4 receivers with combiners, 4 parametric amplifiers, 1 fault indicator, and 1 performance monitor.

TABLE 10-7. TROPO ANTENNA EQUIPMENT

<u>Antenna Size</u>	<u>Concrete Foundations*</u>	<u>Cost Per Antenna**</u>
15-ft dia. w/50-ft tower	\$ 700	\$ 12,100
30-ft dia. w/ground mount	2,800	20,800
60-ft dia. w/ground mount	11,200	37,200
85-ft dia. w/ground mount	23,600	74,300
120-ft dia. w/ground mount	36,000	143,300

NOTES: Base year is pre-1970.
*Concrete ground mounts in place. This cost should be included in site activation.
**Feed horn and mounting are included in cost.

TABLE 10-8. FEED SUBSYSTEM COST

<u>Frequency</u> (GHz)	<u>Antenna Size</u>		
	15 ft & 30 ft	60 ft & 85 ft	120 ft
1	\$9,075	\$11,345	\$14,040
2	6,725	9,065	12,580
4	4,980	7,250	11,190

NOTES: Base year is pre-1970.
Costs are for 2 antennas @ 100 ft from radio building. Feed horn and mounting are included in antenna subsystem (table 10-7). Feed subsystem prices include waveguide, waveguide bridge (supports), pressurization/dehydration equipment and hardware.

4. High-Frequency Radio Equipment. (Tables to be published at a later date.)

5. Satellite Systems. This paragraph contains tables of equipment costs and cost-estimating relationships for satellite communications systems. They are presented in three subparagraphs: satellites, launch vehicles, and earth terminals.

a. Satellites.

(1) Cost Considerations. The difficulty of deriving a single relationship or a single set of relationships for accurately estimating the cost of future satellite systems should be apparent. While many satellite systems exist, more complex military and commercial satellites are currently being orbited. The method proposed herein has been developed by the Space Division of the U.S. Air Force Systems Command, based on the historical costs of previous satellite programs. It is described in SAMSO Technical Report TR 78-61 of February 1978 entitled, "SAMSO Unmanned Spacecraft Cost Model" (fourth edition), which should be consulted if this cost-estimating technique is to be employed. The Space Division developed separate CER's for the nonrecurring cost (mainly RDT&E) and for the first unit of the production run. Costs of second and subsequent units may be derived from the first unit by application of an appropriate learning curve. (See chapter 37 for a discussion of learning curves.). The subsystems for which the Space Division developed CER's are:

(a) Structure, Thermal Control, and Interstage.

(b) Tracking, Telemetry, and Command (TT&C). (Separate CER's have been developed for communications and noncommunications satellites.)

(c) Communications. (Separate CER's have been developed for the antenna only, electronics only, and combined communications package.)

(d) Combined TT&C and Total Communications Subsystem.

(e) Attitude Control System (ACS).

(f) Electrical Power Supply (EPS). (Separate CER's have been developed for subsynchronous and synchronous satellites.)

(g) Apogee Kick Motor (AKM). (Separate CER's have been developed for satellites with and without an AKM.)

(h) Program Level.

(i) Combined Spacecraft Platform.

(j) Dispenser.

(k) Launch and Orbital Operations Support (LOOS).

(2) Cost-Estimating Relationships (CER's). The CER's usually relate the subsystem weight in pounds to the subsystem cost in thousands. Appropriate factors from chapter 38 must be applied to obtain cost estimates for years other than the base year stated. Selected CER's are given in table 10-9 and table 10-10. The Space Division has also normalized some of the CER's by subjective correction for technology carryover and complexity of design. (For a complete description, see the SAMSO manual on file in Code 690.)

Table 10-9. COMMUNICATIONS SATELLITE CER's
(Nonrecurring Cost)

<u>Subsystem</u>	<u>CER (\$K)</u> (W=weight, lb) (P=BOL power, watts)	<u>Range</u>
Structure, Thermal Control, and Interstage	$504 + 196 \times W^{.54}$	15 \angle W \angle 942
TT&C	$456 + 35.5 \times W$	8 \angle W \angle 119
Communications	$490 + 631 \times W^{.51}$	13 \angle W \angle 508
Combined Communi- cations and TTAC	$2,524 + 137 \times W^{.75}$	26 \angle W \angle 613
Attitude Control	$434 + 97.8 \times W^{.9}$	3 \angle W \angle 308
Electrical Power Supply	$166 \times P^{.501}$	25 \angle P \angle 980

NOTE: Base year is FY 1976.

Source: SAMSO TR 78-61, "SAMSO Unmanned Spacecraft Cost Model," fourth edition, Feb 78.

TABLE 10-10. COMMUNICATIONS SATELLITE CER'S
(Cost of First Production Unit)

<u>Subsystem</u>	<u>CER (\$K)</u> (W=weight, lb) (P=BOL power, watts)	<u>Range</u>
Structure, Thermal Control and Interstage	$91 + 9.89 \times W^{.75}$	15 \angle W \angle 1,710
TT&C	$145 + 16.3 \times W$	8 \angle W \angle 119
Communications	$86.6 + 35.85 \times W^{.87}$	13 \angle W \angle 508
Combined Communi- cations and TTAC	$123 + 45.6 \times W^{.84}$	26 \angle W \angle 613
Attitude Control	$-103 + 52.8 \times W^{.8}$	3 \angle W \angle 435
Electrical Power Supply	$134 \times (W \times P)^{.196}$	228 \angle (W X P) \angle 467,533

NOTE: Base year is FY 1976.

Source: SAMSO TR 78-61, "SAMSO Unmanned Spacecraft Cost Model," fourth edition, February 1978.

(3) Use of the Tables. To obtain a cost estimate using the relationships in either table 10-9 or table 10-10, first obtain an estimate of the independent variable. If the value of the independent variable is outside the stated allowable range, the CER may produce incorrect results. Enter the value of the independent variable in the expression for the estimated cost of that subsystem. The result is the estimated cost in thousands of dollars. Estimates must be secured for each of the subsystems in the satellite. To obtain the total cost of the program, an estimate must be obtained for both the fixed (nonrecurring) and variable (production costs). The estimated fixed cost is the sum of the nonrecurring cost estimates of the subsystems. The estimated cost of the first production unit is the sum of the first unit cost estimates of the subsystems. Subsequent production units are costed from the first unit by learning curves (chapter 37). These costs must be translated to the appropriate year as explained in chapter 38.

(4) Example. The following example is abstracted from SAMSO's manual to indicate how the technique may be applied. The SAMSO manual should be used for actual cost estimation.

(a) Assume a communications satellite with design weight as follows:

<u>Item</u>	<u>Pounds</u>
Structure and Interstage	200
Thermal Control	30
Communications	240
TT&C	80
EPS	310
Attitude Control (dry)	150
Contingency	20

(b) The beginning of life (BOL) output of the solar array is 540 watts. The production run will be for six satellites. Costs are desired in constant FY 1980 dollars. Thermal control is added to structure and interstage to obtain a total of 230 pounds for the S, TC, and I subsystem. In the absence of other data, the contingency weight is spread over the designed weights proportionally. The combined CER is used for communications and TT&C. The calculations are shown in table 10-11.

TABLE 10-11. COMPUTATION OF SATELLITE COSTS

<u>Category</u>	<u>Parameters</u>			<u>Cost (\$K)</u>	
	<u>Lb</u>	<u>Watts</u>	<u>Lb-Watts</u>	<u>Non-Recurring</u>	<u>First Unit</u>
S, TC, & I	235			\$ 4,242	\$ 685
Commun. & TTAC & TT&C	326			13,035	6,012
ACS	153			9,482	2,851
<u>EPS</u>	<u>316</u>	540	170,640	<u>3,882</u>	<u>1,421</u>
Total	1030			\$30,641	\$10,969

NOTE: Base year is FY 1977.

(c) Production cost for six units assuming 95-percent cumulative average learning curve = $6 \times .876 = 5.256$
Total Cost = Nonrecurring Cost + Production Cost
= \$30,641 + (5.256 X \$10,969)
= \$88,294K

To convert from FY 1976 to FY 1983 dollars divide by .556 (see chapter 38).
Total cost of program in constant FY 1983 dollars = \$158,800,000.

b. Launch Vehicles.

(1) Cost Considerations. In addition to the cost of the satellite itself, the large cost of the launch vehicle must be estimated. To date, three primary vehicles have been used to launch military communications satellites: Thor-Delta, Titan IIIC, and Atlas-Centaur. While the larger vehicles are more expensive, they generally have the capability to orbit several smaller payloads simultaneously. It then may be more economical to select a large launch vehicle for satellite programs in which multiple launches are feasible. As a result of this and other considerations, the calculation of space segment requirements and costs may become complex. The equations shown in table 4-2 may be of assistance to the analyst in making such calculations.

(2) Equipment Tables. Table 10-12 shows the costs of the launch vehicles, launch services, and pad use for various satellite programs.

TABLE 10-12. LAUNCH VEHICLE COSTS	
<u>Launch Vehicle</u>	<u>Cost (\$M)</u>
Thor-Delta	\$10.0
Straight-Eight Delta	14.0
Atlas-Centaur*	23.5
Titan IIIC*	36.5
Space Shuttle*	18.5
Space Shuttle IUS (Interim Upper Stage)	5.3

NOTES: Base year is FY 1975.
*Includes \$5.0M launch support costs.

Source: MILSATCOM Systems Architecture, DCA 25112, Mar 76; Straight-Eight Delta from COMSAT General Corporation.

(3) Use of the Table. Table 10-12 shows the total costs for placing payloads in orbit (not just the procurement costs for one launch vehicle). These costs should be used in conjunction with the appropriate relationships from table 4-2 to calculate space segment costs.

c. Earth Terminals.

(1) Cost Considerations. There are large variations in the complements of equipment involved in earth terminals. However, preliminary analyses with limited data do indicate some correlation between procurement cost and earth terminal transmitter power and antenna diameter for SHF earth terminals. (UHF earth terminals are not covered, since no UHF systems are currently part of the DCS.) RDT&E costs are estimated to be approximately 10 times the unit procurement cost.

(2) Equipment Table. The cost-estimating relationship shown in table 10-13 has been derived for SHF earth terminals, based on the historical costs of 13 ground- and air-based systems.

(3) Use of the Table. To use table 10-13, estimate the antenna diameter in feet (D) and the transmitter power requirement in kW (P). Enter these into the CER to calculate cost. Actual costs taken from recent procurement, restated in FY 1980\$ are: AN/TSC-86, \$2.8M and AN/GSC-39, \$5.2M. These higher costs should be used for a conservative estimate.

TABLE 10-13. SHF EARTH TERMINAL CER	
CER (\$M)	Independent Variables
$.0835 \times D + .157 \times P + .679$	D = Antenna Diameter in ft P = Transmitter Power in kW
NOTE: Base year is FY 1980.	
Source: DCA, Code 690, Mar 79.	

(4) Example. Estimate the procurement costs of two DSCS III earth terminals. Their D and P values are as follows:

<u>Terminal Type</u>	<u>D(Antenna Diameter)</u>	<u>P(Transmitter kW)</u>
AN/TSC-86	20	1
AN/GSC-39	40	5
AN/TSC-86:	$.0835(20 \text{ ft}) + .157(1 \text{ kW}) + .679$	= \$2.5M
AN/GSC 39:	$.0835(40 \text{ ft}) + .157(5 \text{ kW}) + .679$	= 4.8M

6. Cable Systems Equipment. This paragraph contains tables of equipment costs for submarine cable equipment and installed land cable systems.

a. Submarine Cable Equipment.

(1) Cost Considerations. Underwater systems equipment is not a shelf item and is produced individually for each system. Therefore, care must be exercised in using any cost figures from previous system installations. Prior to engineering the cable installation, a survey ship must survey the route. For cable planning purposes, 10 percent must be added to the distance between the shore terminals to allow for deviations in the cable route and variations in ocean floor topography. The cost of the terminal equipment varies with the number of cables terminated.

(2) Equipment Table. Table 10-11 contains prices of coaxial cable, repeaters, equalizers, and terminal equipment. Costs for primary power, multiplex, military construction, etc., may be found in the appropriate chapters.

(3) Use of Tables. Estimate the approximate distance between the cableheads in nautical miles and add 10 percent. At the cableheads, the cable must be heavily armored (type LPAA or LPA-10) until deep water is reached. Where the cable is subjected to tidal currents and a rough bottom (such as coral), LPA or type A (lighter armor) cable is used. The balance of the cable may be type D. Estimate the number of repeaters required by dividing the total distance by 17 nmi for 60-channel systems or 12 nmi for 120-channel systems, then subtracting one repeater from the result. Add one equalizer for every 10 to 12 repeaters. One lot of terminal equipment is required at each shore end installation. Estimate the cable and survey ship operations by multiplying and dividing the total cable length by the appropriate factors. For example, to load 1,900 nmi of cable, divide 1,900 nmi by 1.9 knots and the result is 1,000 hours.

TABLE 10-14. SUBMARINE CABLE SYSTEMS EQUIPMENT

<u>Factor</u>	<u>Cost</u>
Cable	
Type LPAA	\$43,600/nmi
Type LPA-10	33,000/nmi
Type LPA	27,500/nmi
Type A	10,600/nmi
Type D	5,700/nmi
Repeaters (tube-type)	
60 or 120 Channels	\$36,000/each
Equalizers (tube-type)	
60 or 120 Channels	\$35,400/each
Terminal Equipment	
60-channel terminal equipment consisting of d.c. power feed equipment containing 2 rectifier bays, 1 supervisory bay, 1 cable terminating bay, and 1 terminal bay containing pads, equalizers, and regulators.	\$85,000/each
120-channel terminal equipment consisting of d.c. power feed equipment containing 2 rectifier bays, 1 supervisory bay, 1 cable terminating bay, and 1 terminal bay containing pads, equalizers, and regulators.	\$132,000/each
Survey and Cable-Laying Ship Operations	\$8,100/day
Ship Operations	
Survey Ship Operations	80 nmi/day
Cable Loading	1.9 nmi/hour
Sailing Time	12 nmi/hour
Cable Laying	2.75 nmi/hour
Laying Shore Ends	12 hours/end

TABLE 10-14. SUBMARINE CABLE SYSTEMS EQUIPMENT (CON.)	
Contingencies (foul weather, breaks, equipment breakdown)	10% of total cable ship time
Cable Guard (long-term contract)	
In Port	\$2,800/day
At Sea	3,000/day
Source: Cable ship operations costs based on FY 1972 contract prices; cable systems equipment costs based on FY 1968 contract prices; DCA, Code 690.	

b. Land Cable Systems.

(1) Cost Considerations. Land cable systems may require a wide variety of equipment. The engineering required to provide simple block diagrams for the many configurations possible in one subsystem is beyond the scope of this manual. Some publications, such as the Rural Electrification Administration's "Report No. 30, United States Average Bid Cost for Outside Plant Assembly Units" and associated reports, may assist the engineer in detailed costing of a land cable subsystem.

(2) Equipment Table. Table 10-12 contains costs for installation of land cables. Column 1 includes the costs for cable, conduit, and concrete, and installation of all materials. Column 2 includes only the costs for the cable and cable installation. The costs for the conduit and the conduit installation are not included. Column 3 includes the cable, wood poles, crossarms, guys, etc., and installation of all materials.

TABLE 10-15. INSTALLED TELEPHONE CABLE COSTS

Number Of Pairs	Cost Per Linear Foot		
	Underground In Concrete- Encased Conduit (1)	Underground Cable For Conduit Installations (2)	Cable Elevated On Wood Poles (3)
6	\$13.53	\$ 1.05	\$1.29
11	13.91	1.21	1.50
26	14.39	-	1.84
51	15.72	1.80	2.22
76	16.85	2.11	2.60
101	17.87	5.03	3.30
202	21.94	8.85	4.79
303	25.16	11.87	6.24
404	28.38	15.10	-

Source: NAVFAC DM-10, Jun 71.

CHAPTER 11. MULTIPLEX EQUIPMENT

1. Digital Multiplex.

a. General. The DCS currently uses two main levels of digital multiplex equipment, the AN/FCC-98(V) (level 1) and the AN/FCC-99 (level 2). The level 1 multiplexer will accept up to 24 VF analog channels and produce one 1.544 Mb/s bit stream. The level 2 multiplexer will accept from two to eight 1.544 Mb/s bit streams from the level 1 multiplexer for input to the digital radio. The digital radios will accommodate either one or two level 2 output bit streams plus an optional 192 Kb/s service channel bit stream.

b. Level 1 Multiplexer. The AN/FCC-98(V) (formerly TD-1192) is the standard DCS level 1 multiplex. The AN/FCC-98(V) consists of a basic unit that has 24 ports, each of which will accept a VF card, and pulse code modulates and time division multiplexes (PCM/TDM) the 24 ports into one bit stream up to 1.544 Mb/s. Up to 12 of the ports can be configured into various combinations of digital data channels. The digital data channels cannot together exceed a total bit rate of 768 Kb/s. Cards are available to provide synchronous 56, 64, 128, and 512 Kb/s channels. Lower bit rate cards are available for asynchronous 0 to 20 and 50 Kb/s channels; however, each of these cards uses a full port.

c. Level 2 Multiplex. The AN/FCC-99 (formerly TD-1193) is the standard DCS level 2 TDM multiplexer. The AN/FCC-99 has eight input ports each capable of accepting 1.544 Mb/s. Two 1.544 Mb/s ports may be strapped to yield a single 3.088 Mb/s port, and four 1.544 Mb/s ports may be strapped to yield a single 6.176 Mb/s port. The input bit streams are combined into a single output bit stream of 3.232, 6.464, 9.696, or 12.928 Mb/s.

d. Service Channel Multiplexer. The service channel multiplexer provides two voice channels (64 Kb/s) and one telemetry channel (64 Kb/s) combined into one 192 Kb/s digital bit stream. The service channel connects directly to the digital radio and provides all the supervisory and telemetry functions for the O&M of the system. One service channel multiplexer is required for each digital radio. The AN/FCC-99(V) can be configured to function as a service channel mux.

e. Sublevel Multiplexer. To allow low speed DC devices, such as TTY terminals, to interface efficiently, a Low Speed Time Division Multiplexer (LSTDM) is used. The LSTDM is now designated AN/SCC-100. The LSTDM accommodates up to 16 low speed DC users with input speeds per port of up to 2400 b/s asynchronous and from 75 b/s to 64 Kb/s synchronous. The LSTDM combines the inputs and produces an output bit stream at rates from 1.2 Kb/s to 256 Kb/s.

f. Use of Tables. Figure 11-2 shows the connectivity of the AN/FCC-98(V) and the AN/FCC-99 to the digital radio. Table 11-1 contains the unit costs of the components of the AN/FCC-98(V) and the AN/FCC-99. These costs may be aggregated to estimate the costs of a complete new site or to add voice or data channels to an existing PCM/TDM multiplex. For example,

the site shown in figure 11-2 will provide channel breakouts at the voice level for 192 analog voice channels. This site also receives, regenerates, and "thru-groups" a combined bit stream of 12.928 Mb/s. (No multiplex costs are required for the "thru" digital bit stream @ 12.928 Mb/s.) Figure 11-2 presents a schematic drawing of the site. Costs for the digital multiplex at this site will be estimated as follows:

AN/FCC-98(V)

Basic Unit	16 ea @ \$ 7,600 =	\$121,600
VF Channel Cards	384 ea @ \$ 285 =	109,440

AN/FCC-99

Basic Unit	2 ea @ \$11,319 =	22,638
1.544 Mb/s Channel Cards	32 ea @ \$ 640 =	20,480

Service Channel Multiplex

	2 ea @ \$ 9,840 =	<u>19,680</u>
--	-------------------	---------------

Total Site Digital Multiplex \$293,838

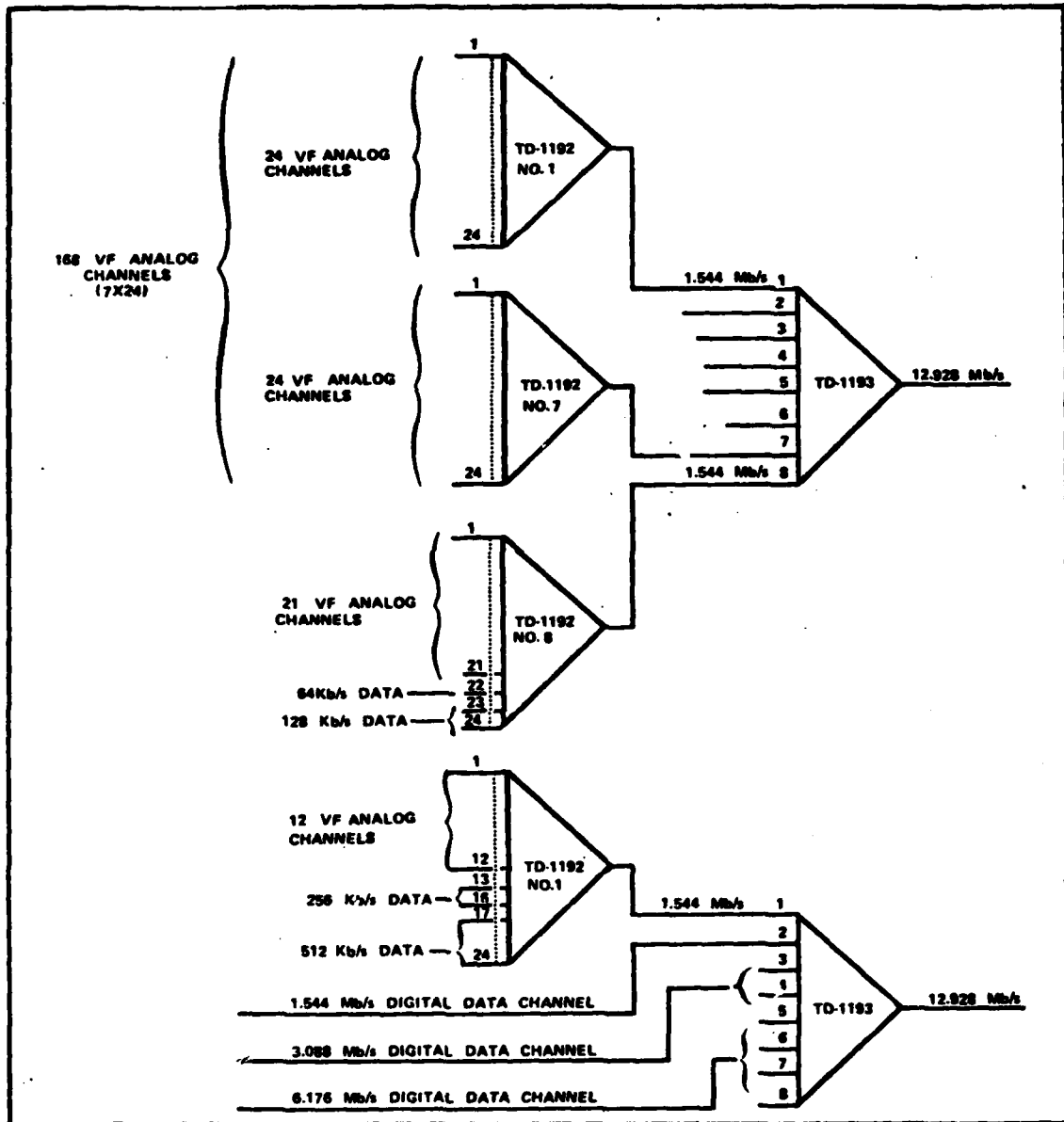

NOTE: NOT A TYPICAL OR APPROVED CONFIGURATION. DRAW: ONLY TO ILLUSTRATE POSSIBLE DATA BIT RATES AND THEIR REQUIRED PORT STRAPPING.

FIGURE 11-1. DIGITAL MULTIPLEX BLOCK DIAGRAM

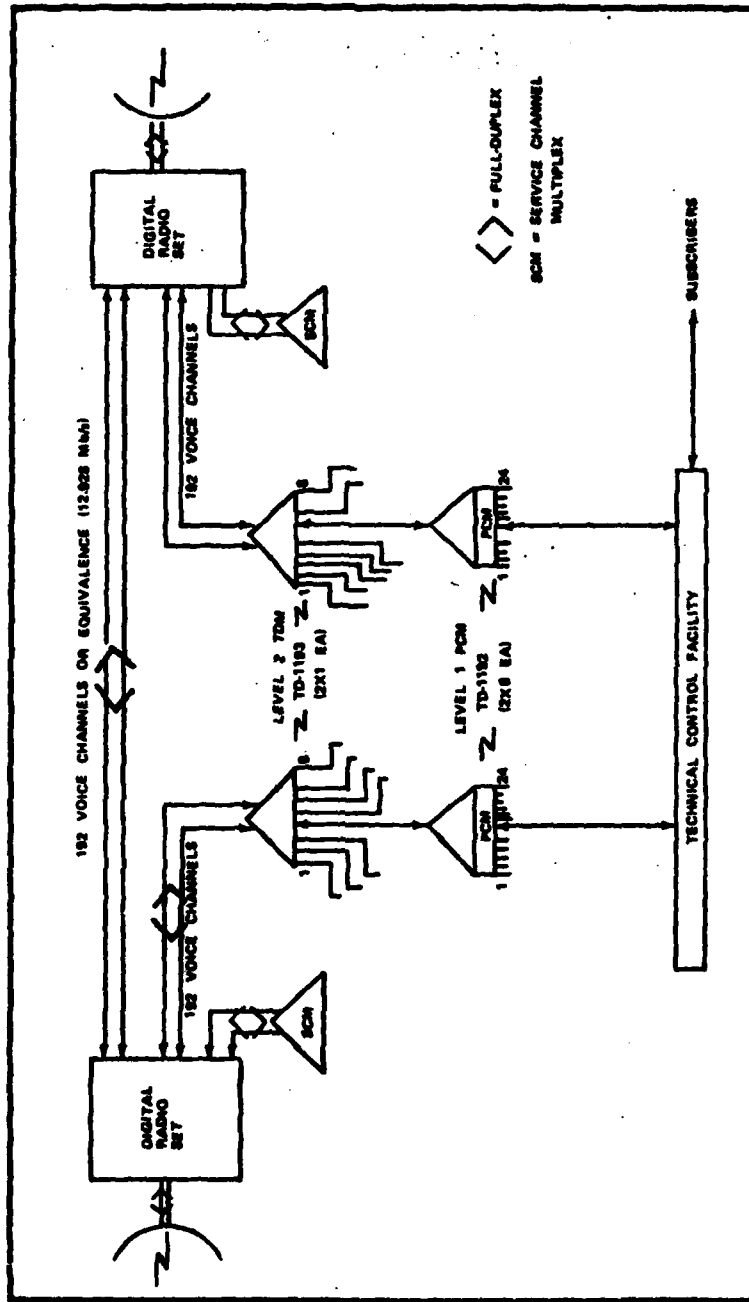

FIGURE 11-2. EXAMPLE SITE CONFIGURATION

2. Frequency Division Multiplex (FDM).

a. General. The standard DCS frequency division multiplexer is the AN/UCC-4 which has standard configurations for the various racks by function and terminal capacity, and may be configured to provide from 12 to 600 VF channels in 12-channel increments.

(1) The AN/UCC-4 has been developed in a modular concept with the basic unit or smallest part representing 12 VF channels combined to make one group. Five groups are combined to make one supergroup capable of handling 60 VF channels. Ten supergroups (termed a "master group") may be combined to place up to 600 channels on one RF carrier. There are nine different rack configurations which are used to make up a terminal. The following five racks are required for a basic terminal:

- (a) Common equipment rack.
- (b) Supergroup-group multiplexer-demultiplexer rack.
- (c) Channel MODEM rack.
- (d) Delay equalizer rack.
- (e) Group regulator rack.

(2) A multiplex terminal is required at any station where the channels are terminated, and two terminals are required for each complete communications link. When a station has two or more links, it will most likely not terminate all channels. Instead, some channels will be passed through at the group or supergroup level. When this occurs, interconnecting supergroup-group racks are required.

b. Use of Tables.

(1) Table 11-2 displays the AN/UCC-4 rack capacities in terms of VF channels and the number of racks required to make a terminal of a given channel capacity. This table lists the five basic racks required for a terminal to show how the costs are derived. The numbers in the "Rack Designator" column correspond to those contained in table 11-4.

(2) Table 11-3 contains pricing information for single terminals with no supergroup-group interconnecting equipment. It provides an estimate of equipment costs for multiplex installations based upon the number of voice channel terminations (channel ends) per site. As an example, the cost for a link consisting of two 60-channel terminals would be calculated: $2 \times \$75,100 = \$150,200$.

(3) Table 11-4 contains a list of equipment which may be used when detailed requirements are known regarding new installations or modifications to existing systems. For example, to modify an existing link from 48 to 60 VF channels, the costs shown under item 3, table 11-4, should be used. Each

from 48 to 60 VF channels, the costs shown under item 3, table 11-4, should be used. Each additional installation of 12 VF channels is costed by multiplying 2 by \$4,300 = \$8,600. Note that the equipment is required at both ends of the link. If the modification were to expand the link from 120 to 132 VF channels, an additional supergroup carrier generator and supply (item 1), an additional supergroup-group multiplexer-demultiplexer (item 2), an additional channel MODEM rack and a channel carrier amplifier (item 3), an additional equalizer group (item 4), and an additional group regulator (item 5) may be required. This requirement, of course, must be determined after considering the equipment already in the link. This example, assuming none of the above equipment is available, would be costed as follows:

Item 1. Basic rack (not required)	\$ 0
Add one supergroup carrier generator and supply	5,500
Item 2. Basic rack (not required)	0
Each additional supergroup and five groups	3,700
Item 3. Basic rack equipped for 12 VF channels	11,900
Channel carrier amplifier (pair)	3,200
Item 4. Basic rack equipped for 12 VF channels	5,300
Item 5. Basic rack (not required)	0
Each additional group regulator	<u>1,000</u>
Total per site	\$30,600
	X 2
Total per communications link	<u>\$61,200</u>

TABLE 11-1. PCM/TDM EQUIPMENT			
	Unit Cost	Maximum Configuration Voice Channels (384 ea)	
		Qty	Cost
<u>AN/FCC-99</u>			
Basic Unit	\$11,319	2	\$ 22,638
Cards			
1.544 Mb/s	640	32*	20,480
3.088 Mb/s	640	--	
6.176 Mb/s	640	--	
			<u>\$ 43,118</u>
<u>AN/FCC-98(V)</u>			
Basic Unit	7,600	16	121,600
Single Channel Unit Cards			
0-20 Kb/s	1,129	--	
50 Kb/s	919	--	
56/64/128/256/512 Kb/s	1,670	--	
Voice Frequency	285	384	<u>109,440</u>
			<u>\$231,040</u>
<u>Service Channel Multiplexer</u>			
Basic Unit with 2 VF and 1 data channel	9,840	1	<u>\$ 9,840</u>
	Total		\$283,998
<p>NOTES: Base year FY 1977. *Redundant cards are required for each port.</p> <p>Source: TD-1193--Contract #DAAB07-77-D-6501, Apr 77. TD-1192--Contract #DAAB07-76-R-0366, Dec 76.</p>			

TABLE 11-2. FDM (AN/UCC-4) RACK CAPACITIES

<u>Rack Designator</u>	<u>Number of Channels</u>				
	<u>1-60</u>	<u>61-120</u>	<u>121-180</u>	<u>181-240</u>	<u>241-300</u>
1- OA-8373(V)/UCC-4	x	x	x	x	x
2- OB-26(V)/UCC-4	x	x	x	x	
3- OB-31(V)/UCC-4	x	xx	xxx	xxxx	xxxxx
4- OA-8370(V)/UCC-4	x	x	xx	xx	xxx
5- OA-8367(V)/UCC-4	x	x	x	xx	xx
6- OB-29(V)/UCC-4					x
7- OB-30(V)/UCC-4					x

Each rack identified (x) is equipped at its basic or lowest level, and incremental equipment must be added to increase its capacity as shown in table 11-4. Table 11-3 presents the cost for some basic terminals.

Source: DCEO Standard Rack Configuration, 19/2; DCA, Code 690.

TABLE 11-3. FDM EQUIPMENT TERMINAL COST					
Basic Rack Configuration	Number of Channels				
	12	60	120	180	240
Frequency/Power Supply Group OA 8373(V)/UCC-4(V)					
Basic Rack	\$14,800	\$14,800	\$ 14,800	\$ 14,800	\$ 14,800
Add. Supergroup Carrier Generator	N/R	N/R	N/R	5,500	5,500
Multiplexer Group OB 26(V)/UCC-4(V)					
Basic Rack	8,700	8,700	8,700	8,700	8,700
Add. Supergroup	N/R	N/R	3,700	7,400	11,100
Channel MODEM- OB-31(V)/UCC-4(V)					
Basic Rack	11,900	11,900	23,800	35,700	47,600
Add. 12 VF Channels	N/R	17,200	34,400	51,600	68,800
Equalizer Group OA 8370(V)/UCC-4(V)					
Basic Rack	5,300	5,300	5,300	10,600	10,600
Add. 12 VF Channels	N/R	7,200	16,200	23,400	32,400
Amplifier/Pilot Regulator Group OA 8367(V)/UCC-4(V)					
Basic Rack	6,000	6,000	6,000	6,000	12,000
Add. Group Regulator	N/R	4,000	9,000	14,000	18,000
Basic Terminal	\$46,700	\$75,100	\$121,900	\$177,700	\$229,500
N/R - Not Required. Basic rack equipped as shown in table 11-4.					
NOTE: The standard FDM multiplex contract has expired. These costs are only included as reference information. The costs for new FDM multiplex equipment will depend upon the quantity required and whether DCS standard or commercial multiplex is procured.					
Source: AN/UCC-4(V) Contract Order Requirements for FY 1972; DCA, Code 690.					

TABLE 11-4. FDM EQUIPMENT, RACK COSTS
(Rack Assemblies of AN/UCC-4(V))

<u>Item</u>	<u>Cost</u>
1. <u>Frequency-Power Supply Group OA-8373(V)/UCC-4(V):</u> (Common Equipment Rack)	
Basic rack equipped to support up to 120 VF channels (supergroups 01 and 02 and up to 25 groups)	\$ 14,800
For additional supergroups (SG-03 through 10), add one Supergroup Carrier Generator and Supply	5,500
For additional groups (26 through 50), add one Group Carrier Amplifier	1,300
Supergroup Carrier Amplifier¹	
Basic unit equipped for one SG carrier output	1,300
Modules for one additional output (maximum of six channels per Amplifier Shelf)	2,600
a.c. Power Supply Unit ² (Two units for 1 to 4 supergroups) (Three units for 5 to 10 supergroups)	2,500
2. <u>Multiplexer Group OB-26(V)/UCC-4(V):³</u> (Supergroup-Group Multiplexer-Demultiplexer Rack)	
Basic rack equipped for 1 supergroup and 5 groups	8,700
Each additional supergroup and 5 groups (maximum 4 SG, 20 groups per rack)	3,700
¹ If the common equipment supports more than one link multiplex terminal, add a Supergroup Carrier Amplifier and appropriate modules for each additional supergroup requiring carrier supply. ² Add costs for a.c. Power Supply Units based on criteria indicated when d.c. Power Supply is not available. ³ Use items 6 and 7 when there are, or will be, more than four supergroups in the installation. Otherwise, use item 2.	

TABLE 11-4. FDM EQUIPMENT, RACK COSTS (CON.)

<u>Item</u>	<u>Cost</u>
3. <u>Channel MODEM</u>	
<u>Multiplexer Group OB-31(V)/UCC-4(V):</u>	
Basic rack equipped for 12 VF channels	\$ 11,900
Each additional 12 VF channels (maximum 60 per rack)	4,300
Channel Carrier Amplifiers (pair) for even-numbered racks after first rack	3,200
a.c. Power Supply Unit (one per rack) ²	2,500
4. <u>Equalizer Group, Envelope Delay OA-8370(V)/UCC-4(V):</u>	
(Group Regulator Rack)	
Basic rack equipped with one group regulator	5,300
Each additional group regulator (maximum 15 per rack)	1,000
a.c. Power Supply Units ² (One unit for 1 to 5 regulators) (Two units for 6 to 10 regulators) (Three units for 11 to 15 regulators)	2,500
5. <u>Amplifier/Pilot Regulator Group OA-8367(V)/UCC-4(V):</u>	
(Group Regulator Rack)	
Basic rack equipped with one group regulator	6,000
Each additional group regulator (maximum 15 per rack)	1,000
a.c. Power Supply Units ² (One unit for 1 to 5 regulators) (Two units for 6 to 10 regulators) (Three units for 11 to 15 regulators)	2,500
² See footnote 2, page 11-10.	

TABLE 11-4. FDM EQUIPMENT, RACK COSTS (CON.)

<u>Item</u>	<u>Cost</u>
6. <u>Multiplexer Group OB-29(V)/UCC-4(V):³</u> (Supergroup-Group Multiplexer Rack)	
Basic rack equipped for 1 supergroup and 5 groups	\$ 9,000
Each additional supergroup and 5 groups (maximum 10 SG, 50 groups per rack)	1,900
7. <u>Demultiplexer Group OB-30(V)/UCC-4(V):³</u> (Supergroup-Group Demultiplexer Rack)	
Basic rack equipped for 1 supergroup and 5 groups	13,100
Each additional supergroup and 5 groups (maximum 10 SG, 50 groups per rack)	2,600
8. <u>Interconnecting Group ON-82(V)/UCC-4(V):</u> (Supergroup-Group Interconnecting Rack)	
Basic rack equipped for one supergroup interconnec- tion (two interconnect units)	4,600
One additional supergroup interconnection (two interconnect units) (maximum 4 units per rack)	2,600
Each group interconnection (two group interconnect units) (maximum 10 units per rack)	900
9. <u>Interconnecting Group ON-89(V)/UCC-4(V):</u> (Group Interconnecting Rack)	
Basic rack equipped for one group interconnection (2 Group interconnect units)	1,700
Each additional group interconnection (two group interconnect units) (maximum 14 units per rack)	900
10. <u>Test Set, Telephone, AN/UCM-1:</u> (Transmission Test Set)	4,200

³See footnote 3, page 11-10.

Source: AN/UCC-4(V) Contract Order Requirements for FY 1972; DCA,
Code 690.

CHAPTER 12. SWITCHED SYSTEMS EQUIPMENT

(To be published later.)

CHAPTER 13. CONTROL SYSTEM EQUIPMENT

1. General. This chapter divides control systems equipment by function. Paragraph 2 presents the functions of technical control and patch and test facilities. Paragraph 3 covers orderwire and intercom for voice and data communications between technical controllers and maintenance personnel. Paragraph 4 discusses equipment for sensing and switching functions, and visual and audible notification of system or component failure or degradation.

2. Technical Control Facility (TCF) and Patch and Test Facility (PTF). The TCF is an organizational element of a DCS station which functions as the point of interface between the transmission elements of the system and interfaces users with the system. The PTF is an organizational element of a DCS station or user/subscriber terminal facility which functions as a supporting activity under the technical supervision of a designated TCF. Both the TCF and the PTF have the physical, electrical, and manpower capabilities to perform their respective functions.

3. Orderwire and Intercom Equipment. Orderwire circuits are intended for the exclusive use of technical controller and maintenance personnel exercising technical control of the DCS (TCF) and executing the functions of technical control (PTF). The major functions of voice and data orderwires in the technical control and maintenance of the DCS are described in DCA Circular 310-50-6, Defense Communications System Orderwire. Orderwire types are express, link, and local. The express and link orderwires use dial equipment while the local uses ringdown equipment.

4. Alarm System Equipment. The function of this equipment depends upon its location. Station common alarm units provide remote indication of failures of major equipment located at the same facility, and fault alarm-reporting system equipment provides remote monitoring of fault alarms at unattended microwave repeater stations as well as remote control of switching functions at the repeater stations.

5. Use of Tables.

a. To determine the cost for establishing a TCF, add the circuit cost (table 13-1) and the one-time equipment cost (table 13-2) to the orderwire and intercom cost (table 13-4) and the alarm system cost (table 13-5). To determine the cost for circuit expansion at a TCF now meeting DCA standards, multiply the quantity of added circuits, by type, by the average cost per circuit shown in table 13-1. When upgrading an existing TCF not presently meeting DCA standards, reuse those items listed in the one-time equipment cost which meet the DCA standards, and add the cost for the items required for the upgrade. For example, a TCF is to be expanded by 50 through circuits, 120 terminating circuits (analog), and 10 terminating circuits conditioned for data. The station has to be upgraded by the

addition of a digital frequency clock and a station digital read-out clock. The costs would be estimated as follows:

50 Through Circuits	@	\$ 85.00	=	\$ 4,250
120 Terminating Circuits	@	\$ 175.00	=	21,000
10 Terminating Circuits, Data Conditioned	@	\$ 1,150.00	=	<u>11,500</u>
Total Circuit Costs				\$36,750
1 Digital Frequency Clock	@	\$ 2,900.00	=	2,900
1 Station Digital Read-Out Clock	@	\$ 11,000.00	=	<u>11,000</u>
Total Cost				\$50,650

b. The procedure described in paragraph 5a may also be used to determine the following costs at a DCS or subscriber station:

- (1) PTF.
- (2) Orderwire or intercom system for a PTF.
- (3) Alarm reporting system for a PTF.

c. When actual circuit configurations as described in MIL-STD-188-310, Subsystem Design and Engineering Standards for Technical Control Facilities, are available, the list of VF and digital data circuit conditioning and VF signaling equipment contained in table 13-3 may be used.

d. Costs of orderwire and intercom equipment can be estimated using four types of size configurations as shown in table 13-4. These configurations are sized on the basis of the number of circuits controlled by the TCF. For example, if the technical control facility has the capability of controlling 900 circuits (VF and d.c.), then the cost for a type C configuration would be selected. For a TCF controlling 1,600 circuits, combine the costs for one type D and one type A.

e. Costs for the station common alarm unit can be estimated using four types of size configuration, as shown in table 13-5. If the technical control facility has the capability of controlling up to 500 circuits, for example, the cost of a type B configuration would be selected. For a TCF controlling 1,600 circuits, combine the costs for a type D and a type A.

f. Costs of a control and fault alarm-reporting system depend on the number of remote stations. If there are 10 remote stations reporting to the TCF, for example, the cost will be 10 times the cost for a type I plus the cost for one type II.

TABLE 13-1. TCF/PTF CIRCUIT CONDITIONING

<u>Type of Circuit</u>	<u>Average Cost Per Circuit¹</u>
Through	\$ 85
Terminating (includes pad, amplifier, and single-frequency supply unit)	175
Terminating, conditioned for data (includes cost for delay equalizer and amplitude equalizer)	1,150

¹If an echo suppressor is required, add \$100.

Source: 1972 contract prices; DCA, Code 690.

TABLE 13-2. TCF/PTF CIRCUIT CONTROL EQUIPMENT

<u>Equipment</u>	<u>One-Time Equipment Costs</u> <u>Cost</u>
20 Hz Ringing Supply	\$ 600
Quality Assurance Test Center	24,000
Cable Test Bay	3,700
Pattern Generator	1,400
Multiplier Unit	600
Digital Data Test Cabinet	2,200
Channel Breakout Monitor	11,400
48 V d.c. Power Supply	25,100
6 V d.c. Signal Power Supply	2,800
Digital Frequency Clock	2,900
Station Digital Read-Out Clock	<u>11,000</u>
Total One-Time Equipment Cost	\$85,700

Source: 1972 contract prices; DCA, Code 690.

TABLE 13-3. TCF/PTF CIRCUIT CONDITIONING EQUIPMENT

<u>Equipment</u>	<u>Cost</u>
<u>VF Circuit Conditioning and Signaling</u>	
Pad	\$ 8
Line Amplifier	19
Echo Suppressor	81
Delay Equalizer	564
Amplitude Equalizer	256
Four-Wire Terminating Set/Repeat Coil	46
Six-Way, Four-Wire Bridge	110
Pilot Make-Busy Extension Relay Unit	12
DX-1 Signaling Unit	18
DX-2 Signaling Unit	18
E&M to 20 Hz Ringing Converter	18
d.c. to E&M Converter	18
Single Frequency Signaling Unit	44
Pulse Link Repeater	18
Station 20 Hz Ringing Supply	600
<u>Digital Data Circuit</u>	
Digital Line Level Converter	40
Regenerative Repeater	54

Source: 1972 contract prices; DCA, Code 690.

TABLE 13-4. ORDERWIRE AND INTERCOM EQUIPMENT

<u>Type</u>	<u>Maximum Number of Circuits Controlled by TCF</u>	<u>Cost</u>	<u>Configuration</u>
A	200	\$10,700	5 Ringdown OW Positions 5 Dial OW Positions 20 Intercom Positions
B	500	17,400	10 Ringdown OW Positions 10 Dial OW Positions 30 Intercom Positions
C	900	30,600	15 Ringdown OW Positions 15 Dial OW Positions 40 Intercom Positions
D	1,400	42,000	20 Ringdown OW Positions 20 Dial OW Positions 50 Intercom Positions

Source: 1972 contract prices; DCA, Code 690.

TABLE 13-5. ALARM SYSTEM EQUIPMENT

<u>Station Common Alarm Unit</u>			
<u>Type</u>	<u>Maximum Number of Circuits Controlled by TCF</u>	<u>No. of Units¹</u>	<u>Cost</u>
A	200	1	\$ 370
B	500	2	680
C	900	3	990
D	1,400	4	1,300
<u>Control and Fault Alarm Reporting System</u>			
<u>Type</u>	<u>Description</u>	<u>Cost</u>	
I	Remote Station - One Per Remote Site; Monitors Up To 36 Fault Alarm Points	\$1,900	
II	Master Station - Controls and Monitors Up To 14 Remote (Type I) Stations	2,900	

¹One unit contains 24 alarm indicators.

Source: 1972 contract prices; DCA, Code 690.

CHAPTER 14. AUXILIARY EQUIPMENT

1. General. The auxiliary equipment discussed in this chapter may be used with any type of transmission or switch facility, as well as with subscriber terminals. The chapter is organized as follows:

- a. Electric power.
- b. Heating and air-conditioning.
- c. Modems.
- d. Voice terminals.
- e. Data terminals.
- f. Cryptographic equipment (to be published later).

2. Electric Power.

a. The source of power may be a Government-owned, independent generating plant, a commercial utility system, or a combination of the two. Communications stations seldom have identical power requirements; therefore, each power plant must be engineered and designed for a specific communications station. The types of power plants and the costs associated with procuring Government-owned power plants are discussed herein. A table of estimates of power requirements for typical communications facilities is included also.

b. The "Military Standardization Handbook" (MIL-HDBK-411) divides power plants into four classes:

(1) Primary Power, Class A. A primary power plant which provides an assurance of essentially continuous supply.

(a) Off-Facility Source. Commercial utilities or Government-owned power plants may be utilized as a primary power source after study has determined the supplier's ability to serve the projected 5-year load, system short circuit characteristics, voltage, and frequency, and has evaluated the system outages for the past 5 years.

(b) On-Facility Source. This category of primary power is a Government-owned power plant, collocated with the communications facility. These power plants include, in addition to the online generators, one spare generator and one generator for scheduled maintenance. The total number of generators (three or more) is determined by the required station reliability. Also included in the on-facility power plant are switchgear, automatic transfer switches, distribution panels, wire, cable, etc.

(2) Auxiliary Power, Class B. A standby power plant to cover extended outages (days) of primary power. The plant is essentially the same as class A, except that a maintenance generator is not required. This power plant is used where multiple sources of power are not available or the power sources are deemed susceptible to failure.

(3) Auxiliary Power, Class C. A quick start (10-60 seconds) unit to cover short-term outages (hours) of primary power. This power plant consists of an automatic start unit or units for each generator, and is primarily used in conjunction with multiple commercial power sources and a class D system for fixed plant facilities.

(4) Auxiliary Power, Class D. An uninterruptible power unit using stored energy to provide continuous power within specified voltage and frequency tolerances. Class D power plants are used to provide continuous precise power and to isolate power sensitive equipment from harmful transients and power surges. Uninterruptible power systems (UPS), also referred to as "precise-no-break systems (PNB)," consist of two types of power plants as follows:

(a) Static. A static power plant is a solid state power system sized to furnish full power to the critical technical load for short periods of time. It consists of batteries (reserve power), a rectifier/charger, inverters, and control panels.

(b) Rotating Flywheel. This plant consists of a motor driving a flywheel, an alternator, and a diesel engine to assume the load upon failure of primary power. An eddy current coupling is used to start the diesel engine automatically.

c. Use of Tables.

(1) Table 14-1 contains approximate power requirements for different types of communications stations, primarily for the communications/electronics requirements (operational load), and does not include other base functions.

(2) A planning figure for nonoperational load can be approximated by multiplying the number of operations and maintenance personnel by .5 kW per person.

(3) The normal procedure for estimating power requirements may be expressed in four steps as follows:

(a) Survey for Power Source. Available data or a site survey will disclose the availability or lack of adequate power. When no data are available, it must be assumed that the communications systems will require additional power.

(b) Determine Power Requirements. The power budget (load) for a station can be calculated by the power engineer when the list of equipment

and civil requirements are provided. In the absence of the calculated power budget, the planner can use table 14-1 to approximate the operational load and add .5 kW per person for the nonoperational load.

(c) Select Power Sources. Both primary and auxiliary power must be available for all communications stations. The selection of power sources will be based upon the survey mentioned in step (a) and MIL-HDBK-411.

(d) Estimate Power Plant Costs. Costs from the tables or other commercial catalogs and sources are applied to the power plants and switchgear requirements identified previously.

(4) Table 14-2 contains costs and cost-estimating relationships (CER's) for power plants consisting of the appropriate contingent of generators and other associated equipment, by kW ratings, of the standard DoD generator family (MIL-STD-633C). The number of generating units in a power plant is determined by the required station reliability. A station with a 45-kW class A requirement might consist of two 30-kW generators on line, one 30-kW unit as a spare, and one 30-kW unit for maintenance. The same station with a class B requirement might have one 60-kW unit on line and one 60-kW unit as a spare. For a class C requirement, one 60-kW auto-start might be used.

(5) Table 14-2 also contains CER's and costs of UPS systems by kVA ratings.

(6) For preliminary planning purposes, when no data are available, use the cost of a Government-owned class A power plant (four-generator configuration) with a class D (static) power plant, switchgear, and fuel system. For fuel transfer and storage systems costs use the costs shown in table 21-3. The storage system must be sized to provide an adequate supply for the replenishment cycle. To determine the amount of storage required, use the consumption rate shown in table 24-13 and assume a 30-day (720-hour) replenishment cycle. If a station survey is available and discloses an adequate off-facility power source (see paragraph 2b(1)(a)), use the costs shown in table 14-3 for a commercial power installation and add a class B power plant (two-generator configuration), a class D (static) power plant, where required, and a fuel system. Primary power is used to recharge the batteries so no additional requirements are added. Two examples of this procedure are given below.

(a) Example 1. Satellite Earth terminal (M.T.).

1. Survey for Power Source. Survey discloses no power available from other sources.

2. Determine Power Requirements.

Primary power:

Operational load (equipment) (table 14-1)	180kW
Nonoperational load (personnel)	
20 men @ 0.5 kW	10kW
Total Primary Power	<u>190kW</u>
Auxiliary power - (table 14-1)	120kW

3. Select Power Sources.

Government-owned, Class A and Class D.

4. Estimate Power Plant Costs.

Primary power (table 14-2): 190 kW @ \$1,500	\$285,000
Auxiliary power (table 14-2): 1 UPS - 96kVA	193,000
Fuel storage system (table 24-13)	
190 kW x .0833 gal/kWh x 720 hr/yr	
x 2 generators = 22,800 gals	
25,000 gal tank (table 21-3)	<u>51,000</u>
Total (FY 1985\$)	\$529,000

(b) Example 2. Satellite Earth Terminal (M.T.).1. Survey for Power Source. Survey discloses one source of adequate commercial power 1 mile distant.2. Determine Power Requirements. Same as example 1 (190 kW).3. Select Power Sources.

Primary power: commercial source.

Auxiliary power: Government-owned, Class B and Class D.

4. Estimate Power Plant Costs.

Primary power (table 14-3):	
Transmission line	\$ 50,000
Transformer	5,300
Substation	13,200
Subtotal Primary Power	<u>\$ 68,500</u>
Auxiliary power (table 14-2)	
Class B	171,000
Class D	193,000
Subtotal Auxiliary Power	<u>\$364,000</u>
Fuel Storage System (table 24-13)	
190 kW x .0833 gal/kWh x 720 hr/yr = 11,400 gal	
12,000 gal tank (table 21-3)	<u>25,000</u>
Total (FY 1985\$)	\$389,000

TABLE 14-1. TYPICAL STATION POWER REQUIREMENTS

Station	Operational kW Load Required	
	Class A/B	Class D
LOS		
Terminal	25	10
Relay	12.5	5
Transportable	25	10
TROPO (10 kW)		
Terminal	200	100
Relay	300	200
HF (0.1 kW)		
Transmitter	30	10
Receiver	30	10
Satellite Earth Terminal		
H.T. (8 kW)	600	300
M.T. (8 kW)	180	120
L.T. (1 kW)	30	0
<p>NOTE: For nonoperational load, add 0.5 kW times the number of operations and maintenance personnel.</p>		
<p>Source: DCA, Code 690, Jan 76.</p>		

TABLE 14-2. ELECTRICAL GENERATION COSTS

<u>Cost Category</u>	<u>CER</u>	<u>Range</u>
Class A		
Diesel Prime Mover	1,500 x P	
Combustion Gas Turbine	1,900 x P	
Class B		
Diesel Prime Mover	900 x P	
Combustion Gas Turbine	1,300 x P	
Class C		
Diesel Prime Mover	500 x P	
Class D		
Uninterruptible Power Supply ¹	$30,900 \times V^{0.4} + 1424$	50 ≤ V ≤ 500
<p>NOTES: Base year is FY 1985. P = power in kW V = power in kVA (equals roughly 1.25 kW) ¹Solid State; incl. lead calcium batteries, EMH, static transfer switch, input/output fuses, 15 days mfgs Tech Rep, installation.</p>		
<p>Source: "HQ USAF, Annual Construction Pricing Guide for FY 85 thru 89 Programs," Jun 82; DCA, Code 690.</p>		

TABLE 14-3. ELECTRICAL DISTRIBUTION COSTS

<u>Cost Category</u>	<u>CER (\$K)</u>	<u>Range</u>
Distribution & Transmission (per lin ft)		
Overhead (3 Phase)	$3.608 \times v^{0.6} - 8.879$	15 \angle v \angle 230
Underground Ducts ¹	$13.05 \times w^{0.5} - 4.23$	1 \angle w \angle 6
Underground Direct Burial (V=15)		
1 Phase, 1/0 Aluminum	13	
3 Phase, 1/0 Aluminum	30	
3 Phase, 750 MCM	60	
Transformers		
Single Phase, Oil, Pole	$21.84 \times A + 2004$	10 \angle A \angle 500
Single Phase, Dry	$50.80 \times A + 1495$	10 \angle A \angle 167
Three Phase, Oil, Pad	$21.78 \times A + 6347$	75 \angle A \angle 1500
Substation	$87 \times A$	
<p>NOTES: Base Year is FY 1985. V = kilovolts. W = number of passage ways. A = kVA = kilovolt-amperes (equals roughly 1.24 kW). ¹Type II fiber, Concrete encased 3 in. each way, excav. to 3-ft deep, backfill.</p>		
<p>Source: "HQ USAF Annual Construction Pricing Guide for FY 85 thru 89 Programs," June 1982; DCA, Code 690.</p>		

3. Heating and Air-Conditioning. Costs for heating and air-conditioning plant equipment may be estimated from the cost-estimating relationships (CER's) shown in tables 14-4 and 14-5, respectively. Associated recurring costs are discussed in paragraph 24-4.

TABLE 14-4. HEATING EQUIPMENT COSTS

<u>Cost Category</u>	<u>CER (\$K)</u>	<u>Range</u>
Central Heating Plant		
Coal-Fired Steam ¹	$35.08 \times B + 565$	50 \angle B \angle 200
Oil-Fired Steam ²	$41.76 \times B^{0.9} + 42.8$	10 \angle B \angle 200
Coal-Fired Hot Water ¹	$80.75 \times B^{0.8} + 274.9$	50 \angle B \angle 200
Oil-Fired Hot Water ²	$37.55 \times B^{0.9} + 45.8$	10 \angle B \angle 200
Self Contained Boilers		
Marine Type ³	$3.494 \times H^{0.5} - 2.18$	100 \angle H \angle 600
Steel Fired Box ⁴	$15.63 \times H^{0.3} - 27.5$	100 \angle H \angle 500
Cast Iron Sectional ⁵	$0.1884 \times H + 14.95$	60 \angle H \angle 200
Steel Packaged Water Tube ⁶	$0.0729 \times H + 82.1$	1000 \angle H \angle 3000
Piping (per lin ft) ⁷	$15.05 \times D + 26.6$	1.25 \angle D \angle 6
<p>NOTES: Base Year is FY 1985. B = millions of Btu/hr. H = horsepower = Btu/971.7 D = diameter in inches ¹Includes fuel and ash handling facilities ²Includes plant equipment and oil handling facilities ³IAW MIL-B-17452, combination gas/oil burner, steam/HW max. pressure 150 psi; installation included ⁴HP steam and HW boiler IAW ASME section IV; installation included ⁵LP steam and HW boiler IAW ASME section IV; installation included ⁶HP boiler IAW MIL-B-17095, combination oil/gas burner, wind box forced draft fan; max. steam pressure 100-250 psi ⁷Insulated steam or high temp. hot water pipe (supply or return) in single underground conduit; includes fitting accessories, 3-foot excavation, backfill, and testing</p>		
<p>Source: "HQ USAF Annual Construction Pricing Guide for FY 85 thru 89 Programs," Jun 82; DCA, Code 690.</p>		

TABLE 14-5. AIR-CONDITIONING COSTS

<u>Air-Conditioning (\$/ton)</u>	<u>New Construction</u>	<u>Existings Buildings</u>
Clean rooms	\$4,600	\$5,190
Communications, electronics, & data processing	3,530	3,950
Laboratories & medical facilities	3,640	4,100
OQ's, dorms, admin, morale, recreation, & other	3,420	3,875
<u>Evaporative (\$/cfm)</u>		
Single stage - 4 to 5 cfm/sq ft		
Warehouse ¹		\$ 0.60/cfm
Admin ²		0.90
Two stage - 1 to 2 cfm/sq ft		2.50
<u>Mechanical Ventilation (\$/cfm): 4 to 5 cfm/sq ft</u>		
Warehouse ¹		\$ 0.65/cfm
Admin ²		1.20
<p>NOTES: Base year is FY 1985. Costs are for a complete air-conditioning system including refrigeration cycle (if applicable) air-handling equipment, water saving device, ductwork, piping, controls, cutting and patching, electrical work, supervision, inspection, and overhead. Electrical work does not include transformers, but assumes a power supply with sufficient capacity and/or proper voltage within 5 feet of buildings. ¹Minimum ductwork. ²Extensive ductwork.</p>		
<p>Source: "HQ USAF Annual Construction Pricing Guide for FY 85 thru 89 Programs," Jun 82; DCA, Code 690.</p>		

4. Modems. Modems are often used as separate interface devices between data terminals or multiplexer equipment and the transmission media. The modem translates (modulates) the digital bit stream received from the terminal into a quasi-analog signal suitable for transmission over analog transmission facilities, such as 4-kHz voice grade telephone lines and retransforming (demodulating) the quasi-analog signal received into a digital bit stream. In addition to these basic functions, modems perform control functions that coordinate the flow of data in a data communications network.

a. Modems are designed to operate over networks with and without line conditioning. Line conditioning refers to special filtering and adjustments made at the switch for data circuits to improve transmission quality. In particular, group delay is controlled to reasonable levels with line conditioning. Both conditioned and unconditioned networks are available from common carriers. The maximum achievable bit rate on unconditioned lines is about 2.4 kb/s; on conditioned lines, it is about 9.6 kb/s. The Direct Distance Dial (DDD) network is an example of a network without conditioning.

b. As illustrated in figure 14-1, a modem consists of a modulator, a demodulator, a line equalizer, a timing unit, and an interface.

(1) The modulation section of the modem converts the received digital bit stream into an analog signal appropriate for transmission. The modulation techniques employed in modems fall into three general categories: frequency modulation (FM), phase modulation (PM), and amplitude modulation (AM). The type of modulation used depends on the specific modem application.

(a) Modems used for low-speed, asynchronous transmissions normally employ FM. The typical form of binary FM used is frequency-shift keying (FSK). Transmission rates on the order of 1800 kb/s are the present maximum rates available on voicegrade lines using FSK modulation techniques.

(b) The type of PM used in modems operating at medium transmission rates (1800-4800 b/s) is phase-shift keying (PSK), usually differential PSK (DPSK). Four phase shifts (4 PSK) permits a satisfactory operating speed of 2400 b/s over unconditioned (switched) voice networks. Increasing the number of phase shifts to eight permits a speed of 4800 b/s to be achieved over most channels. The number of levels achievable, however, is constrained by the characteristics of the communications channel.

(c) AM is used primarily in high-speed transmissions. Modems employing this type of modulation typically transmit four- or eight-level vestigial sideband (VSB) signals. These modems can achieve transmission rates up to 9600 b/s over conditioned voice channels. Signal power constraints and channel impairments (noise) are the limiting factors on the maximum obtainable transmission speed.

(2) The demodulation section of a modem detects and reconverts the received analog signal back to its digital form.

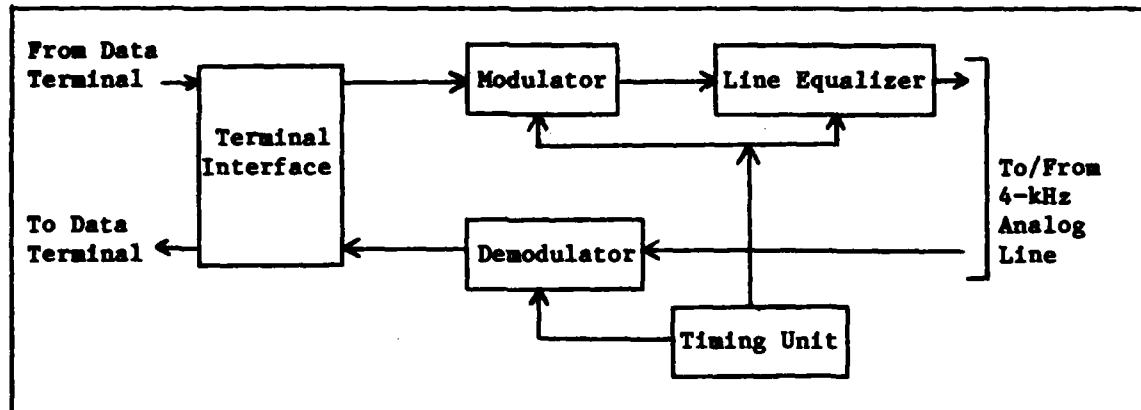

FIGURE 14-1. MODEM BLOCK DIAGRAM

(3) Line equalizers (either fixed, manual, or automatic) are provided within the modem to improve transmission quality by compensating for any distortions (in particular, intersymbol interference) on the transmission line. The type of equalization incorporated depends upon the modem's application and transmission rate. A fixed compromise equalizer, the simplest of the three equalizer types, is incorporated within modems operating up to 2000 b/s. Medium-speed modems normally contain equalizers that can be normally adjusted to variations in the channel measured at some point in time. They are most frequently used on conditioned circuits. Automatic adaptive equalizers are used in high-speed modems and are continually adjusted to compensate for channel variations.

(4) In synchronous transmissions, timing information is transmitted in addition to symbol information. The timing information recovered at the demodulator is used by the modem and the data terminal to properly sample the demodulated signal at the center of the symbol and to correctly interpret the received symbol, respectively.

(5) The external interfacing device at the modem/terminal I/O ports is either a commercial Electronic Industries Association (EIA) RS-232B/C or military MIL-STD-188-100 interconnecting cable. These 25-pin cables are serial interface standards and are used for data throughout rates up to 20 kb/s.

c. In many applications, modems are stand-alone devices and are not integral parts of the terminal; therefore, separate CER's have been developed for them. Modems are divided into two subclasses: acoustic couplers and data sets.

(1) Acoustic Coupler Modem. Acoustic couplers (AC) are low-speed transmission modems. Their nominal transmission rates range from 300 to 600 b/s; a few are capable of operating at 1200 b/s. AC's are synchronous, simplex, or half-duplex modems. They employ fixed compromise equalizers and use FSK modulation techniques. The interface between the modem and the voicegrade line is acoustic or inductive.

(2) Data Set Modems. Data sets are modems that have a hardwired, rather than an acoustic, interface to the telephone system. When operating over the public telephone system, this connection is accomplished via the Bell System's Data Access Arrangement (DAA). These modems operate over a transmission rate range of 300 to 9600 b/s (the maximum capacity rating of a 4-kHz line); the rates are switch-selectable. The modems are capable of both asynchronous and synchronous operation; synchronous transmission is provided on modems operating at transmission speeds of 1200 b/s and above. They are designed to operate in three modes: simplex, and half- and full-duplex. As with AC's, the modulation technique used in low-speed (300 to 1200 b/s) data sets is FSK. However, various types of modulation are employed in the medium- to high-speed (2000 to 9600 b/s) range. The more commonly used techniques include variations of PSK and AM.

d. Use of Table. Table 14-6 contains parametric cost-estimating relationships and costs for modems as described in this chapter. Solving the equations or reading directly from table 14-6 will result in costs expressed in constant FY 1981 dollars. A factor is provided to convert costs to those that could be expected if the item were to be militarized. To convert to program year dollars, see chapter 38 for instructions.

TABLE 14-6. MODEM COSTS		
<u>CER</u>	<u>Range</u>	<u>Militarization Factor</u>
494 x e.252 x R (x 2.18 if synchronous)	0.3 \leq R \leq 9.6	1.9
<u>Cost</u>		
<u>R</u>	<u>Synchronous</u>	<u>Asynchronous</u>
0.3	\$ 1,160	\$ 530
0.6	1,250	570
1.2	1,460	670
2.4	1,970	900
4.8	3,610	1,660
9.6	12,100	5,550
NOTES: Base year is FY 1981. R = transmission rate in kb/sec.		
Source: Booz-Allen Contract No. 100-76-C-0049, Jul 77; DCA, Code 690, Feb 81.		

5. Voice Terminals. Voice terminals convert analog speech signals into digital signals, primarily for secure speech application. However, in the all-digital DCS of the late 1980's, nonsecure digital voice capability will also be provided at the user level.

a. General. Voiceterminals are classified as NB, WB, and transitional. NB voice terminals operate at 9.6 kb/s or less over narrowband, 4-kHz analog facilities. WB voice terminals operate over a transmission media with a bandwidth greater than a 4-kHz, including pairs of voicegrade lines, 48-kHz FDM analog channels, and digital lines. WB voice terminals operate at bit rates greater than 9.6 kb/s - typically, 16 to 64 kb/s. Transitional voice terminals may operate over either NB or WB facilities. The above distinction assumes that 9.6 kb/s is the maximum bit rate achievable over voicegrade lines. Capability to operate at higher rates (for example, 16 kb/s, would modify the above distinction.

b. Composition. As shown in figure 14-2, a voice terminal is composed of three distinct elements: a signal processor, a COMSEC module, and a line interface.

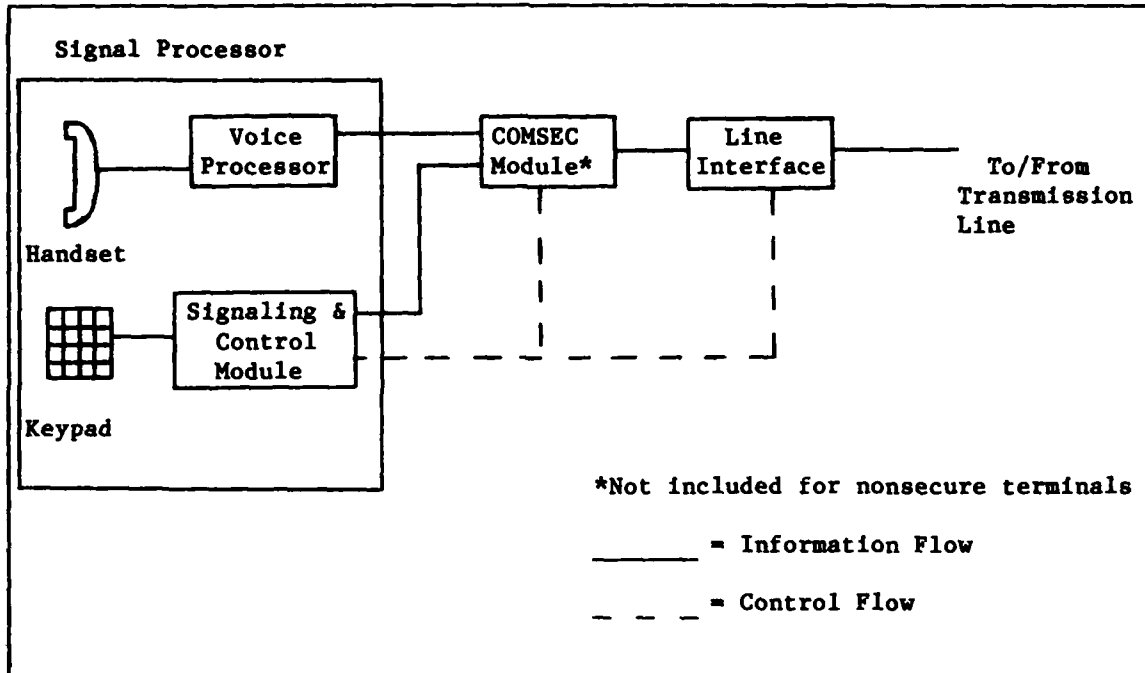

FIGURE 14-2. VOICE TERMINAL BLOCK DIAGRAM

c. Signal Processor.

(1) The signal processor is composed of two main elements: a voice processor and a signaling and control module. The voice processor converts analog speech to a digital signal and vice versa. Voice processors may also remove redundancy from the speech signal to lower the bit rate required for high-quality speech. The signaling and control module sends and receives the required signaling/supervisory information and coordinates or controls the operations of the other modules. The signal processor also provides a user interface via the handset, keypad, and various controls.

(2) All signal processors addressed in this chapter have a similar structure. They are characterized by the type of voice processor used. NB voice terminals include the following voice processing types; linear predictive coders (LPC); adaptive predictive coders (APC); and channel vocoders (CV). One voice processor type is identified as transitional: adaptive residual coders (ARC). Wideband voice terminals include pulse code modulation (PCM) and continuously variable slope delta modulation (CVSD) voice processor types. The circuits used for signaling and control are similar and the cost of implementing these circuits has been added to the cost of the voice processor in each case to arrive at the total cost of the signal processor.

d. COMSEC Module.

(1) The COMSEC module provides for encryption and decryption of digital voice traffic and signaling information of the voice terminal. The basic COMSEC module characteristics applicable to AUTOSEVOCOM and SVIP and to future DCS secure networks are similar to those of the KG-82 and KG-84 TENLEY/SEELEY COMSEC equipment which will be used in the TRI-TAC Program for encryption of digital loop traffic. The COMSEC module is required to function with dedicated or switched 4-wire lines in a half or full-duplex mode. The COMSEC and signaling characteristics are compatible with those of AUTOSEVOCOM II and TRI-TAC. The bit rate range indicated in the table is that required by any of the voice processors under study; hence, this COMSEC module is considered capable of supporting any of the voice processors discussed previously. The other numerical characteristics were derived from the KG-82 and KG-84 specifications. It is assumed that the COMSEC module would be a completely self-contained device, including power supply, timing source, and cabinet and mechanical assembly.

(2) The COMSEC module could also provide secure transmission capability for data terminals. To cover the types of data terminals considered in this study, the COMSEC module should operate at bit rates as low as 100 b/s. The modes of transmission should be both synchronous and asynchronous. These capabilities could be provided by a single COMSEC module as described; however, providing both a voice and data secure capability increases options and cost.

e. Line Interface. The line interface converts the digital signals to an appropriate format for transmission. The functions performed are similar to the modems previously described. The line interface is characterized by the transmission line type in use: narrowband (4-kHz) analog, wideband (48-kHz) analog, or wideband digital.

(1) For NB analog transmission lines, a synchronous modem is used as the line interface for normal applications. Operation at 16 kb/s over NB analog lines could be achieved in one of two ways with either a single synchronous modem operating at 16 kb/s or with two modems in a biplerex configuration.

(2) For WB analog transmission lines, line interfaces, available for some time, will interface digital signals at rates up to 64 kb/s to standard FDM analog trunk group bandwidth of 48 kHz.

(3) For digital transmission lines, a relatively inexpensive line interface is used to convert the digital bit stream to a format compatible with the transmission media. In addition to the modulation and demodulation functions, the digital line interface extracts received timing information and performs equalization and filtering on the received signal. A single digital line interface type should handle all bit rates of interest, from 2.4 to 64 kb/s, using a single modulation scheme (conditioned diphase).

TABLE 14-7. VOICE TERMINAL COSTS

<u>Component</u>	<u>Cost</u>	<u>Range</u>	<u>Militarization Factor</u>
Signal Processors			
LPC	\$ 4,570	R \angle 2.4	1.94
CV	4,420	R \angle 2.4	1.88
APC	3,650	R \angle 8.0	1.71
ARC	890	9.6 \angle R \angle 16	2.00
CVSD	670	R \angle 16	1.88
PCM	680	R \angle 48	2.15
COMSEC Modules	2,480	0.4 \angle R \angle 64	1.18
Line Interface Units			
Digital	1,110	-	2.0
Analog	1,750	R \angle 2.4	2.0
	7,740	R \angle 8.0	2.0
	8,090	9.6 \angle R \angle 16	2.0
	20,800	R \angle 16*	2.0
	3,630	R \angle 48	2.0
NOTES: Base year is FY 1981. R = transmission rate in kb/sec. *in biplerex configuration.			
Source: Booz-Allen Contract No. 100-76-C-0049, Jul 77; DCA, Code 690, Feb 81.			

f. Use of Table. Table 14-7 contains costs for voice terminal components as described above. The cost of one voice terminal, expressed in constant FY 1981 dollars, is the sum of the appropriate components. A factor is provided to convert costs to those that could be expected if the item were to be militarized.

6. Data Terminals. Data terminals are input/output (I/O) devices to a centrally located processing unit. They convert keyboarded or optically scanned messages into coded data streams for transmission to other terminals or computers over NB or WB transmission lines. This chapter is limited to examining three data terminal types: teleprinters, CRT display terminals, and facsimile equipment.

a. Teleprinters. Teleprinters provide hard copy of alphanumeric data and are configured as follows:

- (1) Receive-only (RO) terminal - includes printer only to receive data.
- (2) Keyboard send/receive (KSR) terminal - includes I/O printer and keyboard to enter data.
- (3) Automatic send/receive (ASR) terminal - includes printer, keyboard, and storage medium.

b. CRT Display Terminals. The primary functional difference between teleprinters and cathode ray tube (CRT) terminals is that the former uses a hardcopy printer to display, transmit, and receive data and the latter uses a CRT terminal as the display device. Only alphanumeric display CRT's are addressed here. CRT terminals are divided into three subclasses:

- (1) Simple CRT terminal - includes display capability only.
- (2) Buffered CRT terminal - includes display plus read-only memory (ROM) storage of vendor-provided software.
- (3) Programmable CRT terminal - includes the above plus random-access memory (RAM) storage of user-provided software.

c. Facsimile Terminals.

(1) Facsimile (FAX) terminals are analog and digital devices that transmit and receive copies of alphanumeric or graphic material (usually in standard 8 1/2 x 11 inches page format) over NB 4kHz telephone lines or WB transmission facilities. Unlike the previously discussed data terminals in which data to be transmitted must be keyed into the terminal or "read" from punched cards, FAX terminals contain scanning devices that convert the information content of the source material into electrical signals. The signals are transmitted to a remote site at which the source material is copied. FAX terminals are used as a means of relaying interoffice message traffic and transmitting graphical material such as topographic maps. Characteristics of facsimile equipment are contained in table 14-8.

(2) FAX terminals are heavily employed in DCA's AUTOVON and AUTODIN networks. A typical DCS application would be to transmit a weather map from a remote site (where the data may have been collected) to a central site for continental or worldwide weather forecasting. In such an application, a transmitter would be required at the remote site and a receiver at the central site; two-way transmitting and receiving (transceiving) capability may be unnecessary.

(3) Although these represent the primary applications of FAX terminals, the current trend is to employ digital FAX's as I/O terminals to data processing systems. A digitized copy of the graphic material is made for computer storage and processing (e.g., pattern recognition, etc.); a hard copy then can be made of the computer-stored information with the digital FAX.

(4) FAX terminals are used in any of the three basic configurations: transmitters, receivers, or transceivers.

d. Use of Table. Table 14-9 contains parametric cost estimating relationships and costs for data terminals as described in this chapter. Solving the equation, or reading directly from table 14-9 will result in costs expressed in constant FY 1981 dollars. A factor is provided to convert costs to those that could be expected if the item were to be militarized. To convert to program year dollars, follow instructions in chapter 38.

TABLE 14-8. FACSIMILE CHARACTERISTICS

Nonnumerical Transmission

Modulation technique	Analog (AM or FM) or digital
Mode of operation	Half-duplex
Scanning technique	Rotating drum or flatbed
Recording technique	Photographic, electrothermal, or electrolytic
Information type	Alphanumeric or graphic
Transmission line	
Analog	4-kHz voicegrade typical; 48kHz - wideband for special cases (large amount of information)
Digital	4800-9600 b/s voicegrade typical; 1-2 Mb/s may be required for receiving image from computer
Modem	Usually built-in for AM and FM facsimilies; not built-in for digital facsimiles

Numerical Transmission

Transmission time	2-12 minutes per page
Resolution rate	62-200 lines per inch

Source: Booz-Allen Contract No. 100-76-C-049, Jul 77.

TABLE 14-9. DATA TERMINAL COSTS

<u>Terminal Type</u>	<u>CER</u>	<u>Range</u>	<u>Militarization Factor</u>
Teleprinters			
R.O.	\$ 2,520	0.11 \angle R \angle 0.3	1.0
KSR	3,050	0.11 \angle R \angle 0.3	1.0
ASR	3,840	0.11 \angle R \angle 0.3	1.0
CRT Terminals			
Simple	1,890	R \angle 9.6	2.0
Buffered	2,560 x M-199	R \angle 9.6	2.0
		1 \angle M \angle 6	
Programmable	4,770 + 514 x M	R \angle 50	2.0
		4 \angle M \angle 72	
Facsimile Terminals			
Transceivers	203 x T-931 x S-874	1 \angle T \angle 12	
Receivers	0.5 x Transceiver	62 \angle S \angle 200	2.5
Transmitters	0.6 x Transceiver		

CRT Terminal Costs						
	M					
	1	2	3	4	5	6
Buffered	\$2,560	\$2,940	\$3,190	\$3,370	\$3,530	\$3,660
	12	24	36	48	60	72
Programmable	\$10,900	\$17,100	\$23,300	\$29,400	\$35,600	\$41,800

Facsimile Terminal Costs								
	S							
T	62	80	100	120	140	160	180	200
1	\$7,480	\$9,350	\$11,400	\$13,300	\$15,200	\$17,100	\$19,000	\$20,800
2	3,920	4,900	5,960	6,990	8,000	8,990	9,960	10,900
4	2,060	2,570	3,130	3,670	4,190	4,710	5,225	5,730
6	1,410	1,760	2,140	2,510	2,880	3,230	3,580	3,930
8	1,080	1,350	1,640	1,920	2,200	2,470	2,740	3,000
10	880	1,100	1,330	1,560	1,790	2,010	2,230	2,440
12	740	920	1,120	1,320	1,510	1,700	1,880	2,060

NOTES: Base year is FY 1981.
R = transmission rate in kb/sec.
M = memory in k bytes.
T = transmission time in min/page.
S = resolution in lines/in.

Source: Booz-Allen Contract No. 100-76-C-0049, Jul 77, DCA, Code 690, Feb 81.

SECTION C. COMMUNICATIONS SYSTEMS SUPPORT COSTS

CHAPTER 15. INTEGRATION AND ASSEMBLY

1. General.

a. The integration and assembly cost element refers to all efforts of the prime system or project contractor regarding technical and functional activities associated with the design, development, and production of mating surfaces, structures, equipment, parts, and materials required to assemble all major equipment and subsystems into an installed, operational system. This element includes all materials and parts and other mating equipment furnished by or to an integrating contractor.

b. Integration and assembly cost includes effort performed by the prime contractor related to:

- (1) Development of engineering layouts.
- (2) Determination of overall design characteristics.
- (3) Determination of requirements of design review.
- (4) Arrangement, conduct, and review of the testing of assembled components or subsystems prior to installation.
- (5) Detail production designing.
- (6) Inspection activities related to receiving, factory, and vendor liaison.
- (7) Design maintenance effort.
- (8) Quality planning and control.
- (9) Tooling (planning, design, and fabrication).
- (10) Administrative engineering.
- (11) Any cables, conduits, and connectors not covered elsewhere.
- (12) Assembly, joining, or mating in support of acceptance testing at the manufacturing facility.

c. All system and project management (including system engineering management and system engineering and supporting project management activities) and system test and evaluation which are associated with the overall system are excluded. When integration and assembly efforts described previously are included in other cost elements in the work breakdown structure estimate, the costs for these efforts should not be summarized into the integration and assembly cost element.

2. Estimating Procedure.

a. Integration and assembly costs are currently estimated as ranging from 5 percent to 20 percent of the total prime mission and auxiliary equipment acquisition cost. For routine systems using standard equipment, use the 5-percent factor. For new systems using equipment developed by many different manufacturers and of unusual complexity, the 20-percent factor would be more appropriate.

b. The planner should generally use a factor within this range unless the uniqueness of the project or other information dictates the use of another, more accurate relationship or estimating procedure, such as man-years and material expenses.

c. Sufficient data to develop more specific planning factors for this element have not been researched. As additional data are collected in accordance with the work breakdown structure in MIL-STD-881, relationships will be developed and tested to update the current estimating procedures.

CHAPTER 16. CONTRACTOR TRAINING

1. General.

a. Contractor training refers to the training services used to facilitate instruction through which personnel acquire sufficient concepts, skills, and aptitudes to operate and maintain the system with maximum efficiency. It includes those efforts associated with the design and production of training equipment and course preparation as well as the execution of training services. Costs for the development and acquisition of training equipment are an integral portion of this element and may, for certain programs, constitute the bulk of the cost for the element; however, the procedures for costing these items are currently excluded from the training course costs contained in this chapter. Separate investigation of these costs will have to be made by the analyst. Costs of training equipment setup and support, such as Government-furnished facilities, base support, and TDY for students, are excluded from contractor training course costs.

b. Contractor training of DCS personnel may be required for new and modified DCS equipment entering the inventory. Training on existing equipment (recurring proficiency training) is provided on a recurring basis by the military departments and is treated as an operating cost. Training costs for formal courses taught in military service schools are estimated in accordance with the military departments' publications referenced as source information for table 26-4.

c. On-the-job training at any time during the system or project life is an operational function not separately identified and costed in a system or program cost estimate.

d. Those students designated to attend contractor-conducted classes will be qualified at the journeyman level in their speciality.

2. Derivation of Factors.

a. Contractor training costs were developed to allow one instructor for classroom training and a second instructor to provide hands-on training, with a minimum of two instructors for fewer than 11 students.

b. Training costs are separated to indicate course preparation cost and cost associated with the instruction. Costs are based upon prior year experience updated to the fiscal year indicated by the table source.

(1) The dollars indicated for course preparation include costs for training aids, training documentation, instructor preparation and training, material, and reproduction of technical data. Contractor technical data utilized to develop the course material are purchased through initial procurement action, as described in chapter 20, in the form of preliminary technical orders which may be obtained in advance of the formal technical documentation.

(2) Instructor costs are based upon personnel pay, per diem, continental U.S. transportation, and miscellaneous expense associated with preparation of classrooms and removal of instructional material, but not upon the communications equipment utilized for hands-on training.

3. Use of Table. Table 16-1 represents data for estimating contractor cost for course preparation and instruction to be provided on a military facility when specific data applicable to the particular training program are not available.

4. Estimating Procedure.

a. Review the equipment specifications and other available information, including prior training requirements or related equipment. Then estimate the number of personnel to be trained, the number of weeks each trainee requires for training, and the maximum number of students per class who can be trained on available equipment.

b. Select the appropriate course preparation costs for the number of weeks each course is to be conducted. This is a single cost which does not increase for additional classes covering the same course material.

c. Determine the number of times the course must be repeated by dividing the number of students to be trained by the number of students who can be taught in each class. The limiting factors are the hours of hands-on training required by each student, the training hours available for the equipment, and the complexity of the classroom training to be provided as related to hands-on training. For example, where hands-on training requirements are equal to classroom training, and the equipment will accommodate only 5 students during available equipment hours, the maximum students per class should be 10. When classroom training requires twice the time for hands-on training, the class size would be 3 times the number who could receive hands-on training; or, when 5 students could receive hands-on training, the total number of students would be 15.

d. Select the appropriate instructor cost for the number of students in each class as determined by the course length in weeks. Multiply this cost by the number of times the course must be repeated; then add this total to the one-time charge for the course preparation cost.

e. Examples:

(1) Estimate the cost of a 3-week course to train 15 students.

Course Preparation Cost	\$33,000
Instructor Cost	<u>23,000</u>
Total	\$56,000

(2) Estimate the cost of a 3-week course to train 2 consecutive classes of 15 students each.

Course Preparation Cost	\$33,000
Instructor Cost 2 X \$23,000 =	<u>46,000</u>
Total	\$79,000

(3) Estimate the cost of a 6-week course to train 4 consecutive classes of 22 students each.

Course Preparation Cost	\$ 54,000
Instructor Cost 4 X \$70,000 =	<u>280,000</u>
Total	\$334,000

TABLE 16-1. CONTRACTOR TRAINING
(Thousands of Dollars)

Course Length (Weeks)	Course Preparation Cost	Instructor Cost Per Number of Students in Each Class			
		10 or fewer	11-15	16-20	21-25
1	\$13	\$ 7	\$10	\$13	\$16
2	23	11	16	22	27
3	33	15	23	31	39
4	40	19	30	40	50
5	47	23	36	48	60
6	54	27	42	56	70

Source: Contractor Cost Data updated to FY 1976; DCA, Code 690.

CHAPTER 17. TEST, PECULIAR, AND COMMON SUPPORT EQUIPMENT

1. General. The support equipment covered in this chapter includes organizational, intermediate (field), and depot requirements. The equipment requirements include system peculiar, test, and calibration items and equipment common to the support of more than one support system. All effort associated with the design, development, and production of the support equipment itself is also included as an integral part of the equipment costs.

a. Peculiar support equipment includes tools which are required for the maintenance and care of a system or portion thereof, but which are not directly engaged in the performance of the mission of the system. This category of support equipment generally involves unique or special-purpose vehicles, equipment, and tools used to:

- (1) Service.
- (2) Transport and hoist.
- (3) Repair.
- (4) Overhaul.
- (5) Assemble.
- (6) Disassemble.
- (7) Test.
- (8) Inspect.
- (9) Perform other maintenance of mission equipment.

b. Common support equipment includes tools required for maintenance and care of a system or portion thereof. While not engaged in the performance of its mission, this equipment is in the DoD inventory for the support of several systems other than the one currently being considered. Also considered a portion of the common support equipment cost is all effort required to ensure availability of this equipment for support of a particular defense material item. Equipment costs represented include acquisition of additional quantities of this common equipment currently in inventory caused by the introduction of the new defense material item being considered.

2. Derivation of Factors.

a. Test and Common Support Equipment. Review of available contract information indicated that a single factor is appropriate for test and common support equipment. This factor is applicable to the cost of

communications prime mission equipment and auxiliary equipment (table 1-2, subtotal I, for example).

b. Peculiar (Unique) Support Equipment. This cost varies with the equipment design. The cost can be controlled by having the contract require that equipment design emphasize the use of common test equipment. In research and development (R&D) projects, the cost for peculiar support equipment will be lower than when the hardware is actually provided, such as R&D with subsequent deployment procurement. For costing purposes, the appropriate cost factor to be used depends upon the type of procurement contemplated. The types of procurement which should be considered in selecting an appropriate factor are as follows:

(1) Reprocurement. The purchase of additional quantities exactly duplicating an item or items currently in use and afforded adequate support documentation.

(2) Research and Development. A project requiring research, exploratory development, advance development, engineering development, management, and support, but not yet approved for procurement and operation. The contractor has the entire operating, test, and support responsibility.

(3) Research and Development with Test and Deployment. An operational systems development approved for production and service employment, wherein a device is developed for use in a Government test or for use in a Government-deployed or field-test environment subsequent to inplant acceptance, with the contractor providing tailored support to effectively ensure that technical publications, repair parts, tools, test equipment, and training requirements match all planned usage requirements.

(4) Unit Procurement. The procurement of one or a few communications devices not in themselves constituting a total communications subsystem. This procurement may be utilized to augment a current operational system as well as to satisfy a single new mission requirement.

(5) System Procurement. The procurement of a segment of the DCS, such as a switching complex or a transmission subsystem, capable of performing or supporting an operational role.

3. Use of Table. The combined cost for test and common support equipment, including tools, is obtained by multiplying the estimated acquisition costs of the communications prime mission and auxiliary equipment by the percentage (10 percent) in table 17-1. Peculiar support equipment costs are computed by multiplying the total cost by the appropriate percentage factor shown in table 17-1 for the expected type of procurement involved. This cost is additive to the costs for test and common support equipment.

4. Estimating Procedure. For example, communications system prime mission equipment and auxiliary equipment estimated at a total cost of \$5,000,000 for the system procurement.

	<u>Cost Base</u>	<u>Factor</u>	<u>Total</u>
Test and common support equip.	\$5,000,000	.10	\$ 500,000
Peculiar support equip. (for system)	\$5,000,000	.10	<u>500,000</u>
			\$1,000,000

TABLE 17-1. TEST, PECULIAR, AND COMMON SUPPORT EQUIPMENT

Type	Factor
Test and Common Support Equipment	.10
Peculiar (unique) Support Equipment	
Reprocurement	.05
Research & Development	.10
R&D with Test & Deployment	.20
Unit Procurement	.05
System Procurement	.10

Source: Feb 72 update of FY 1970/FY 1971 factors; DCA, Code 690.

17-4

DCAC 600-60-1
SECTION C

(Blank)

CHAPTER 18. SYSTEM TEST AND EVALUATION

1. General. This chapter refers to the use of prototype, production, or specifically fabricated hardware to obtain or validate engineering data on the performance of the communication system and all effort associated with design and production of models, etc., in support of the test program.

a. The following are included:

(1) All detailed planning, support data reduction, and reports from such operations.

(2) All hardware items consumed or planned to be consumed in the conduct of such operations.

(3) Effort associated with models, specimens, fixtures, and instrumentation in support of the test program.

b. Excluded from this element are:

(1) Test articles which are complete units; i.e., functionally configured as required by the mission equipment.

(2) Development, component, acceptance, and other testing specifically associated with the hardware element, unless these tests are of special contractual significance and, as a result, are individually identified and separately costed.

2. Estimating Procedure.

a. System test and evaluation costs are currently estimated at a range of 5 percent to 10 percent of the acquisition cost of prime mission and auxiliary equipment for systems-type contracts.

b. Sufficient data to develop more specific procedures and relationships for this element are not currently available. As additional data are collected in accordance with the work breakdown structure in MIL-STD-881, factors will be tested and developed to update and expand these estimating procedures.

CHAPTER 19. SYSTEM/PROJECT MANAGEMENT

1. General. This chapter is organized into individual paragraphs covering contractually performed system engineering and project management support. These efforts include that administrative and technical management effort exclusive of the DoD system or program management office. The efforts are associated with the individual communications systems and projects related to:

- a. Planning.
- b. Directing.
- c. Controlling.
- d. Developing.
- e. Producing.

f. Ensuring that planning is accomplished by the organizations responsible for the complementary functions of logistics and maintenance support, personnel training, and operational testing, activation, and deployment of a system.

2. System Engineering.

a. This element covers the system management engineering endeavor which involves the direction and control of a totally integrated engineering effort; e.g., design engineering, support engineering, production engineering, and such specialty fields as reliability, maintainability, safety, system effectiveness, human factors, etc. System engineering also includes the effort to transform a stated requirement or need into an appropriate functional description and systems delineation through a repetitious process of definition, synthesis, and design, as well as the integration of special technical effort into engineering.

b. System engineering includes the following activities:

- (1) System definition.
- (2) Overall system design.
- (3) Design integrity analyses.
- (4) Cost-effectiveness analyses.
- (5) Weight and balance analyses.
- (6) Intrasystem and intersystem compatibility.

- (7) Reliability.
- (8) Maintainability.
- (9) Safety and survivability program requirements.
- (10) Human engineering and manpower factors program.
- (11) Preparation of equipment and component performance specifications.
- (12) Security requirements.
- (13) Logistics support integration.
- (14) Design of test and demonstration plans.

c. System management engineering may be accomplished by any one or all of the following three sources:

- (1) Hardware contractor or vendor.
- (2) Federal contracted research centers (FCRC's); e.g., MITRE, General Research Corp., CSC.
- (3) Independent architectural and engineering (A&E) firms.

d. The costs for this element may be estimated using the following guidelines:

- (1) Estimate the cost for the contractor by using a factor of 10 percent of the communication equipment acquisition cost.
- (2) When it is determined that an FCRC will be required for system engineering activities, estimate the cost for the FCRC by using 2 1/2 technical staff years for each year of the system acquisition contract. The cost per technical staff year may be determined from table 24-20.
- (3) Independent A&F firms may also be used in selected programs. They are generally limited to a fee of 8 percent of their portion of system acquisition cost. Use this factor of 8 percent only in the absence of particular quotes or more specific program information. It should be applied to only that portion of the acquisition cost with which the A&E firm will be concerned.

e. As a minimum, always include the systems contractor's effort (the major hardware supplier) in a systems estimate.

f. Sufficient data to develop more specific estimating procedures for this element are not currently available. As additional data are collected in accordance with the work breakdown structure in MIL-STD-881, procedures will be tested and developed to update the current factors. Currently, use the factors presented in table 19-1 unless other more specific information is available which dictates the use of different procedures.

3. Project Management Support.

a. This element refers to the technical and administrative activities relative to the overall project planning, organizing, directing, coordinating, controlling, and approving of actions designed to accomplish general project objectives.

b. Project management support should include the following functions:

- (1) Configuration management.
- (2) Cost and schedule management.
- (3) Data management.
- (4) Contract management.
- (5) Transportation and packaging management.
- (6) Program vendor liaison.
- (7) Value engineering.
- (8) Quality assurance.

c. Estimate project management support costs by using a factor of 10 percent of the communication equipment acquisition costs. This factor applies to all of the planning required to accomplish the objectives in paragraphs 3b(1) through (8). Actual cost factors for transportation and packaging (the costs of handling and shipping the materials) are contained in chapter 24, table 24-8. These costs are not included within this cost element.

d. Sufficient data to develop a more specific estimating procedure for this element are not currently available. As additional data are collected in accordance with the work breakdown structure in MIL-STD-881, relationships will be tested and developed to update or replace the current factor. Currently, use the factor of 10 percent unless other information is available which dictates the use of different factors, relationships, or procedures.

TABLE 19-1. SYSTEM/PROJECT MANAGEMENT

Type	Cost-Estimating Factor
System Management/ Engineering	
Contractor	10 percent of Communication Equipment Acquisition Costs
FCRC	2 1/2 Staff-Years* for Each Project Year
A&E Firm	8 percent of Appropriate Acquisition Costs
Project Management	10 percent of Communication Equipment Acquisition Costs
*See table 24-20 for staff-year costs	
Source: DCA, Code 690.	

CHAPTER 20. DATA - TECHNICAL SUPPORT DOCUMENTATION

1. General. There are 11 functional categories of technical data which are applied to contracts by an entry on DD Form 1423: Contract Data Requirements List. The data element refers to all deliverable data required, but such data includes only that Government-required data which will not be prepared if the data item is eliminated by the Government. Data costs also include the efforts for conversion into the Government format if data are identical to those used by the contractor but require a different format. Additional data requirements for test and evaluation, systems engineering, and project management support beyond that discussed below are addressed as overhead in chapters 18 and 19. The technical data functional categories are:

- a. A Administrative/Management.
- b. E Engineering and Configuration Documentation.
- c. F Financial.
- d. H Human Factors.
- e. L Logistic Support.
- f. M Technical Publications.
- g. P Procurement/Production.
- h. R Related Design Requirements.
- i. S System/Subsystem Analysis.
- j. T Test.
- k. V Provisioning.

2. Derivation of Factors. Contractor data available to DCA during FY 1970 and FY 1971 were reviewed and analyzed to determine factors appropriate to the level of support documentation desired within the category of procurement being costed.

3. Use of Table.

a. The cost for reprourement (items currently in use and fully supported in the Government system) does not require additional technical support documentation, except for specially tailored procurement.

b. Computations are a percent of the acquisition cost of a single unit of equipment or a unit mix of equipment. Purchase of more than one unit of the same type and configuration does not materially increase the documentation cost.

c. Purchase of a complete new system is reflected by the higher system support cost, inclusive of all R&D effort involved.

4. Estimating Procedure.

a. Determine the source and status of equipment.

b. Segregate equipment currently in the Government inventory and fully supported, then review the items to determine hardware cost for modified or updated items requiring current tailored documentation.

c. Review new equipment hardware (not current Government inventory) to determine the unit mix of new items which, when assembled, constitute an end item of equipment. Determine the cost of the unit mix of hardware for application of the "New Procurement Unit" factor in table 20-1.

d. Where a new type of equipment is to be procured, utilize the estimated cost of the hardware under development against the applicable level of support desired and the degree of development contracted. Technical support for R&D is less when R&D does not include test and deployment. The largest cost is incurred when technical support documentation is desired for the entire system.

e. For example, procurement of a LOS microwave system which contains equipment currently in Government inventory covers modified multiplex and new test equipment. Where the equipment cost is not applicable, the example shows \$XXX.

<u>LOS Microwave Equipment</u>	<u>Unit Value/Computation</u>	<u>Cost</u>
Radio Set Terminal	\$ XXX	
Radio Set Relay	XXX	
Antenna System	XXX	
Feed System	XXX	
Tower	XXX	
Multiplex - AN-UCC/4(V)	60-Channel @ \$72,600 x 0.5 (Tailored Reprocurement)	\$ 36,300
	Other \$ XXX	
Tech Control/Patch and Test	\$76,515 x 9.0 (Unit new procurement)	688,635
	Other \$ XXX	
Orderwire/Intercom	XXX	
Alarm System	XXX	
Auxiliary Equipment - Electric Power		
Primary Power	\$ XXX	
Other Auxiliary Equipment	XXX	
Total (Rounded)		\$725,000

TABLE 20-1. DATA - TECHNICAL SUPPORT DOCUMENTATION					
Level of Support	Reprocurement	Research and Development	R&D with Test and Deployment	<u>New Procurement Unit/System</u>	
Full	0	2.0	6.0	9.0	10.0
Tailored	0.5	1.5	5.0	7.0	9.0
Commercial	0	1.5	4.0	5.0	7.0

NOTE: Factors are multiplied against cost for one item of each type of new equipment.
Source: FY 1970/1971 cost data as updated to FY 1976 by DCA, Code 420.

CHAPTER 21. OPERATIONAL SITE ACTIVATION

1. Introduction. This chapter has been organized into three major areas which reflect the contractor activities related to the provision of technical support at the site, the construction of buildings and other supporting facilities, and the effort associated with assembly, installation, and checkout of the equipment at the site. This chapter addresses real estate, construction, building conversion, utilities, and other equipment used for housing and servicing communications equipment at the site.

2. Contractor Technical Support.

a. General. The contractor technical support discussed herein refers to all materials and services related to activation, such as final turnover and standby services, provided by the contractor.

b. Estimating Procedure.

(1) Estimate contractor technical support based on the number of man-years of technical support required to complete the site activation task and upon the cost-per-man-year factors presented in chapter 24, table 24-15, for lead and field system engineers, technicians, and clerical support personnel. The appropriate mix of personnel required and the number of personnel per system depend upon unique factors related to the individual system or program.

(2) In the absence of specific cost information, use the factor shown in table 21-1 for the percentage of the prime mission and auxiliary equipment acquisition costs.

(3) Sufficient data to develop manpower requirement factors by type of procurement for this element are unavailable. As additional data are collected in accordance with the work breakdown structure in MIL-STD-881, these estimating procedures will be updated and published in this Circular.

TABLE 21-1. CONTRACTOR TECHNICAL SUPPORT

7X X Prime Mission and Auxiliary Equipment Acquisition Cost

3. Site Construction.

a. General. This element covers the special-purpose facilities necessary to achieve system operational status. It includes real estate, site preparation, and construction of such items as access roads, foundations, buildings, shelters, and supporting facilities. Utilities and other support items are also required at almost all remote communications sites and frequently at sites located on military bases. All of the costs included herein are subject to adjustments for geographical cost differences, covered in chapter 36, table 36-1.

b. Use of Tables.

(1) Table 21-2 presents cost and planning factors for site construction. It reflects costs per unit of specified measurement. Since unit costs for certain construction items reflect both fixed and variable costs, they are sensitive to the total quantity on which they were based. As a result, the unit costs presented may not be valid for items of significantly different total quantity than that presented in the table.

(2) Table 21-3 shows cost-estimating relationships for liquid storage facilities. Costs for POL systems and for water tanks may be calculated by substituting the appropriate value of the relevant parameter into the equation representing the type of storage required.

(3) Table 21-4 contains building costs for the Washington metropolitan area for sizes as indicated. Variance in costs due to size differences may be determined by referring to figure 21-1. For building outside the Washington metropolitan area refer to chapter 36 and multiply the adjusted Washington, D.C., costs by the appropriate area factor to find the unit costs for the specified location.

c. Examples.

(1) POL System. A 5,000 gallon per minute hydrant fueling system is required. Using the CER found in table 21-3, the cost is estimated to be $(\$1,028 \times 5 + \$3,555 =)$ \$8,695K or \$8.7 million.

(2) Building. A 100,000 square foot data processing center is to be built in Billings, Montana. Table 21-4 shows costs for a 33,000 sq ft center to be \$96 per sq ft. The proposed center is three times as large as the typical center. Figure 21-1 shows costs of a building three times as large of the typical size as being 93 percent of the costs of the typical size (per square foot). The adjusted cost per square foot is thus: $.93 \times \$96 = \89 . The area factor from table 36-1 is .95; therefore, the cost of the building will be $.95 \times \$89 \times 100,000 = \$8.455M$.

TABLE 21-2. SITE CONSTRUCTION

<u>Construction Item</u>	<u>Unit</u>	<u>Unit Price</u>
Land Acquisition	acre	\$ 3,000
Site Preparation		
Clearing, 6" Trees, Cut & Chip	acre	2,520
Grading (Rough)	yd ²	3.10
Grading (Fine), 3 Passes, w/Roller	yd ²	0.85
Landscaping		
Topsoil - 6" Haul & Spread	yd ³	3.45
Topsoil - 6" Strip & Stockpile	yd ²	0.40
Grass Seeding, Hydraulic, w/Fertilizer	yd ²	0.70
Grass Sodding	yd ²	4.90
Mulching, Wood Chips	yd ²	1.40
Roads, Streets, Parking Areas		
Rigid: 12"	yd ²	50.00
10"		40.00
8"		31.50
6"		24.50
Flexible		12.04
Concrete Curb & Gutter	ft	18.50
6" Crushed Stone, Gravel	yd ²	5.50
Sidewalks - 4" Concrete	ft ²	3.80
Foundations - Pilings		
Wood (13" diam)	ft	12.90
Concrete (12" or 14" sq)		21.60
" (16" diam)		34.20
" (18" diam)		39.50
Buildings: See table 21-4.		
Towers: See table 10-4.		
Air-Conditioning: See table 14-8.		

TABLE 21-2. SITE CONSTRUCTION (CON.)

<u>Construction Item</u>	<u>Unit</u>	<u>Unit Price</u>
Chain Link Fence (type A, 9 Ga) (incl 3 Str Barbed Wire)	ft	
6'		\$14.00
8'		16.30
10'		21.10
Gate-Roadway	ea	
24', Swinging, Pair		4,800
36', Sliding		2,500
Demolition		
Building-Concrete	ft	3.10
Pavement - 6"		7.85
Water Storage Facilities: See table 21-3.		
Fuel Storage Facilities: See table 21-3.		
Sewage Facilities	site	
2,000 gal Septic System		720
5,000 gal Septic System		2,249
Electrical Facilities: See table 14-2.		
SOURCE: "HQ USAF Annual Construction Pricing Guide for FY 85 thru 89 Programs," Jun 82; NAVFAC DM-10, "Cost Engineering Criteria & Cost Data," May 82; DCA, Code 690.		

TABLE 21-3. LIQUID STORAGE CERS

<u>Cost Category</u>	<u>CER (\$K)</u>	<u>Range</u>
POL Systems (B = K barrels, G = K gallons, P = K gallons/min)		
Aboveground ¹	46.21 x B ^{0.8} + 79.4 or 18.01 x B + 236	2.5 \angle B \angle 100 25 \angle B \angle 250
Aboveground, w/Floating Pans ²	53.2 x B ^{0.85} + 112 or 27.46 x B + 138	2.5 \angle B \angle 100 50 \angle B \angle 250
Underground ³	1,712 x B ^{0.3} - 2,704 or 2.016 x G + 0.359	10 \angle B \angle 100 1 \angle G \angle 30
Hydrant Fueling/ Automatic Pressurized ⁴	1,028 x P + 3,555	1.2 \angle P \angle 5.4
Water Storage (G = M gallons)		
Steel, Stand Pipe ⁵	-5,311 x G ^{-0.1} + 6,277	0.5 \angle G \angle 2
Steel, Elevated ⁶	1,573 x G + 213	0.05 \angle G \angle 0.75
Concrete, Ground ⁷	-195.1 x G ^{-0.4} + 630	0.1 \angle G \angle 1
Concrete, Reservoir Cavity ⁸	285 x G + 214	0.25 \angle G \angle 2
<p>NOTES: Base Year - FY 1985. 1 barrel = 42 U.S. gallons.</p> <p>¹ Cone roof steel tank; incl. found., dike, & ext. coating.</p> <p>² Cone roof steel tank; w/o columns; inc. found., dike, int. epoxy lining, & ext. coating.</p> <p>³ Verticle steel tank; incl. found., excav., backfill, & epoxy lining.</p> <p>⁴ Includes 2 aboveground operational storage tanks.</p> <p>⁵ Tank w/found.; excl. ext. piping, pumping, & cathodic protection.</p> <p>⁶ Tank, standpipe, 125' tower, valves, w/found.; excl. pump house, pumps, & cathodic protection.</p> <p>⁷ Tank w/found.; excl. ext. piping & pumping.</p> <p>⁸ Incl. 6" concr. floor slab, ordinary excav., & piping w/in reservoir.</p>		
<p>Source: "HQ USAF Annual Construction Pricing Guide for FY 85 thru 89 Programs," Jun 82; DCA, Code 690.</p>		

TABLE 21-4. PERMANENT BUILDINGS

<u>Type</u>	<u>Typical Size</u>	<u>Cost Per Ft²</u>	<u>Total Cost</u>
Administration Office	44,000	\$ 80	\$3,520,000
Barrack Dormitory	115,000	64	7,360,000
Power Building	1,000	360	360,000
Communications Center	17,000	75	1,275,000
Sat Comm Grd Terminal	7,100	145	1,029,500
Communications Building	1,300	147	191,100
Telephone Exchange Bldg	5,700	99	564,300
Communications/ADP Ctr	22,000	121	2,662,000
Data Processing Center	33,000	96	3,168,000

NOTE: Base year is FY 1984.

Source: NAVFAC DM-10, "Cost Engineering Criteria & Cost Data," May 82;
DCA, Code 690.

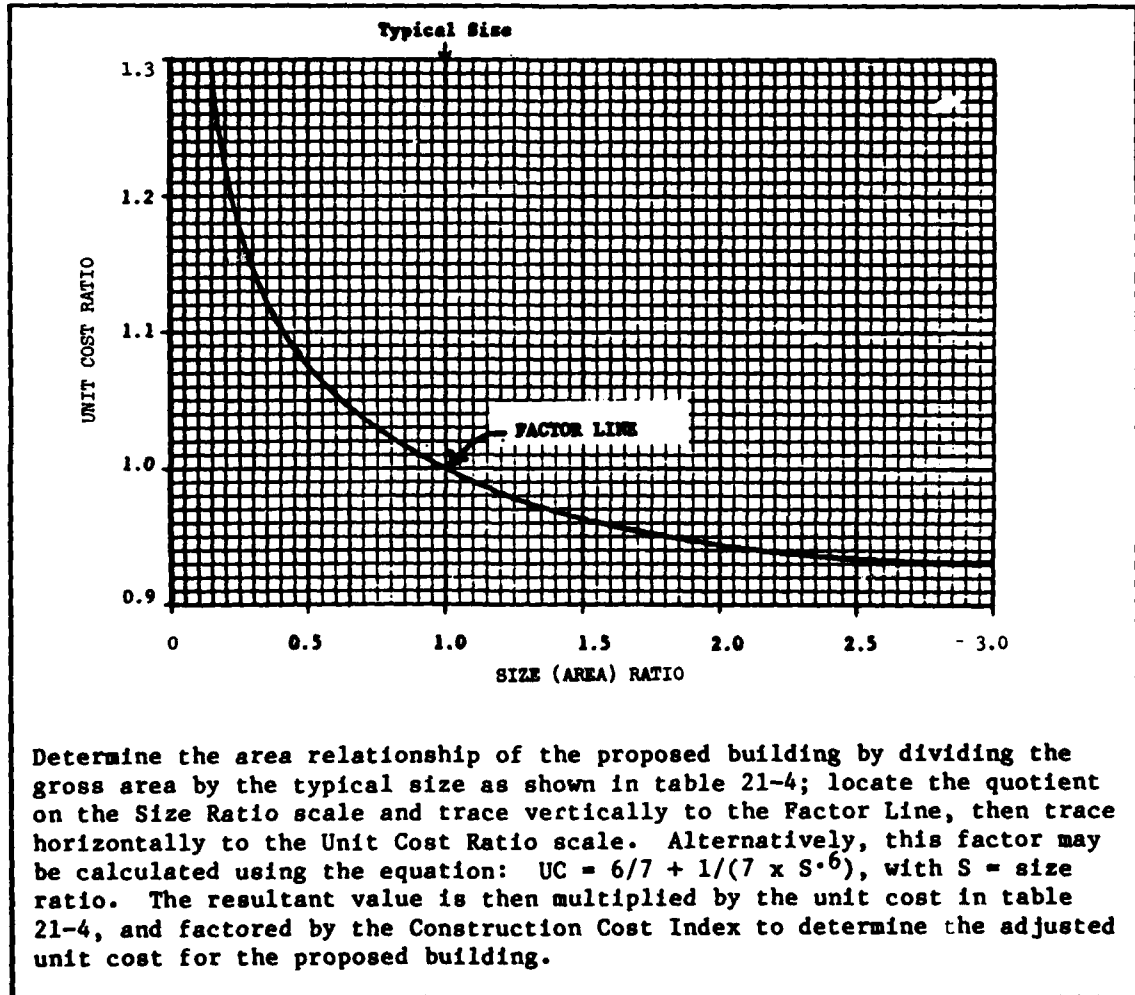

FIGURE 21-1. SIZE/UNIT COST ADJUSTMENT CHART

4. Assembly, Installation, and Checkout On Site.

a. General. The element comprising assembly, installation, and checkout at the site encompasses all materials and services required for assembly of mission equipment in the operations and support facility, and complete checkout of the equipment to ensure its achievement of operational status.

b. Estimating Procedure.

(1) The assembly, installation, and checkout of equipment on site may be estimated as a percentage of the total acquisition cost of the prime mission and auxiliary equipment. This factor is shown in table 21-5. Its broad range reflects the possible variations in the location of the effort and the complexity of the individual project. For example, a transportable system being totally assembled at the vendor's plant will cost about one-third as much to assemble as a system being completely assembled from components at a remote, hazardous location.

(2) Estimate within this range of factors, selecting a factor to fit the particular situation.

(3) Sufficient data to develop a more specific estimating procedure for this element are not currently available. As additional data are collected in accordance with the work-breakdown structure in MIL-STD-881, procedures will be developed to update and expand the current factors shown below.

TABLE 21-5. ASSEMBLY, INSTALLATION, AND CHECKOUT	
<u>Location of Assembly</u>	<u>Percentage of Prime and Auxiliary Equipment</u>
Vendor's Plant	20
Normal, Easily Accessible Site	40
Remote, Hazardous Site	60
Source: DCA, Code 690.	

CHAPTER 22. INITIAL SPARES AND REPAIR PARTS

1. General. The initial spares and repair parts covered in this chapter are a part of the initial equipment procurement, and include modules, spare components, and assemblies used for replacement purposes in major end items of equipment. Initial spares and repair parts are in addition to and are separately costed from parts procured annually to replace the initial spares or repair parts. The annual purchase of recurring spares and repair parts is covered in chapter 25 for recurring investment replacement spares and chapter 24 for expense-type (supplies and equipment) spare parts.

2. Derivation of Factors. Cost-estimating factors are based on contract data accumulated during prior fiscal years. Factors are stated as coefficients to be applied to the total cost of equipment. Separate factors were derived for piece parts, electronic modules, and electromechanical devices.

3. Use of Table. To use the factors presented in table 22-1:

a. Review the system or project equipment specifications and estimate the percentage of initial spares and repair parts which could be categorized as piece parts, electronic modules, and electromechanical devices. Any one or more of these categories could equal 100 percent, but the total cannot exceed 100 percent.

b. Determine the category of procurement which best applies; i.e., re-procurement, R&D, R&D with test and deployment, or new procurement. Cost variation are indicated for modules and transducers as determined by the deployment policy. When the majority of equipment being procured is deployed in groups; for example, 10 at each communications center, the lower percentage factor should be used. However, when the deployment is less than 3 units, the higher figure applies.

4. Estimating Procedure.

a. Determine the total cost for the equipment and the appropriate percentage of initial spares and repair parts for each of the three categories.

b. Determine the type of procurement and select an appropriate factor for each of the three categories which represent the deployment policy; i.e., procurement by units, two's, three's, etc., to determine high or low factor within the range.

c. For example, a review of the composition of proposed new equipment costs of \$200,000 indicated 5 percent of the initial repair items are piece parts, 50 percent are electronic modules, and 45 percent are electro-mechanical devices. Unit equipment prices apply.

<u>Estimated Price</u>		<u>Percentage Categorization</u>	<u>Unit Factor</u>	<u>Estimated Cost Range</u>
<u>Piece Parts</u>				
\$200,000	X	.05	X .3	= \$ 3,000
<u>Electronic Modules</u>				
\$200,000	X	.50	X .75-1.0	= 75,000-100,000
<u>Electromechanical Devices</u>				
\$200,000	X	.45	X .75-1.1	= 67,500- 99,000
TOTALS		1.00		\$145,500-202,000

TABLE 22-1. INITIAL SPARES AND REPAIR PARTS

	Reprocurement	R&D	R&D with Test and Deployment	New Procurement Unit	System
Piece Parts	.3	.2	.4	.3	.4
Electronic Modules	.5-.75	.5	1.2-2.0	.75-1.0	.75-1.0
Electromechanical Devices	.7	.5	.8	.75-1.1	.75-1.2

Source: FY 1970/1971 cost data; DCA, Code 420.

SECTION D. ANNUAL OPERATING COSTS

CHAPTER 23. MILITARY PERSONNEL RATES

1. General. This chapter provides rates for use in planning, programing, budgeting, accounting, cost analyses, economic analyses, program evaluations, reports (discussed more fully in chapter 42); and for computing reimbursements from other organizations (Federal and non-Federal). It does not include fees for Freedom of Information Act (FOIA) requests (discussed in chapter 42), or civilian personnel rates (discussed in chapter 24).

2. Derivation of Factors.

a. Table 23-1.

(1) Table 23-1 reflects annual standard rates which include for each military department the basic pay (at an average longevity increment), basic allowance for quarters, miscellaneous expense (an average cost for subsistence, station allowances overseas, uniform and clothing allowances, family separation allowances, separation payments, social security tax, death gratuities, servicemen's life insurance, reenlistment and enlistment bonus, and apprehension of military deserters), permanent change of station (PCS) expense, and incentive and special pay.

(2) The "DCS Composite" rate in table 23-1 and column 1 of table 23-2 is a weighted average of authorized strengths within the Defense Communications System (DCS).

b. Tables 23-2 and 23-3.

(1) The rates in table 23-2 were developed as shown in table 23-3 and depicted graphically in figure 23-1. The annual rate for planning, programing, budgeting, and accounting (column 1) is the DCS composite standard rate from table 23-1.

(2) The annual rates to be used for cost analyses, economic analyses, and program evaluations in accordance with DCAI 600-60-1 (column 2) include the DCS composite standard rate, retirement (26.5 percent of the standard rate), hospital costs from table 26-6, base operations costs from table 26-1, annual recruiting and accession travel costs, basic combat training, advanced individual training, communications specialty training costs (annualized) from table 26-5, and per capita temporary duty (TDY) travel costs from table 24-6. Prorated costs for supplies, utilities, contract services, supervision, clerical support, and other administrative overhead should be added where appropriate to the analysis.

(3) Hourly rates for the preparation of reports in accordance with DCAI 630-225-2 are given in column 3. These rates include the DCS composite

standard rate, retirement (26.5 percent), overhead (a 25.0 percent increase covering supervision, space, and administrative support), and an adjustment for leave and holiday costs (an 18.0 percent increase). These costs are divided by 2080 to give an hourly rate.

(4) Hourly rates for reimbursements from organizations outside the Federal Government are given in column 4. These rates include the DCS composite standard rate, retirement (26.5 percent of the standard rate), other personnel costs (8.0 percent of the standard rate for officers and 23.0 percent for enlisted personnel, covering the portion of the quarters, subsistence, medical, and other costs not included in the standard rates), and an adjustment for leave and holiday costs (18.0 percent). These costs are divided by 2080 to give an hourly rate.

(5) Hourly rates for reimbursements from Federal agencies are given in column 5. These rates are calculated as in column 4, except that retirement costs have been excluded in accordance with OSD guidance.

c. Figure 23-1.

(1) This pyramidal display graphically shows the composition of the rates in tables 23-2 and 23-3. Under each column heading are the elements included.

(2) The DCS composite standard rate is used for the foundation of all rates.

(3) Retirement costs are added for cost analyses, economic analyses, program evaluations, reports, and reimbursements from organizations outside the Federal Government. Retirement costs are not added for programing, budgeting, and accounting or for reimbursements from Federal agencies.

(4) Hospitalization, base operations, recruiting and accession, training, and TDY costs are added for cost analyses, economic analyses, and for program evaluations.

(5) Other personnel costs are included for reimbursements (both Government and non-Government).

(6) Overhead costs are included only for reports.

(7) The factor covering the accrual of leave and holiday costs is applicable only when the estimated amount of labor is based on time actually worked; i.e., when the reimbursing activity does not otherwise pay for the personnel costs incurred by DoD during nonproductive time, such as leave and holiday periods. Hourly rates for reports and reimbursements (both Government and non-Government), such as those in tables 23-2 and 23-3, include leave and holiday costs. When the estimated amount of labor includes time for leave and holidays; e.g., when an annual approach is used, the leave and holiday accrual factor should not be included.

PROGRAM, BUDGET, ACCOUNTING (ANNUAL) (1)	ECONOMIC ANALYSIS (ANNUAL) (2)	REPORTS (HOURLY) (3)	REIMBURSEMENTS FROM ORGANIZA- TIONS OUTSIDE THE FED GOV'T. (HOURLY) (4)	REIMBURSEMENTS FROM FEDERAL AGENCIES (HOURLY) (5)	
		LEAVE AND HOLIDAY COSTS			
		OVERHEAD			
		HOSP, BASE OPNS, ACCES- SION AND TRAINING, TDY			OTHER PERSONNEL COSTS
		RETIREMENT ALLOWANCES			
		DCS COMPOSITE STANDARD RATE (BASIC PAY, BASIC ALLOWANCE FOR QUARTERS, MISCELLANEOUS EXPENSE, PERMANENT CHANGE OF STATION, INCENTIVE AND SPECIAL PAY).			

FIGURE 23-1. MILITARY LABOR RATES

(8) The reference for column 1 is DoD 7220.9-H, DoD Accounting Guidance Handbook, sections 230 and 252, 1 February 1978.

(9) The references for column 3 are DoDI 5000.22, Guide to Estimating Costs of Information Requirements, 17 October 1974, and DCAI 630-225-2, Management and Control of Information Requirements, 4 October 1976, as amended.

(10) The reference for columns 4 and 5 is OASD(C) Memorandum, subject: Reimbursement Rates for Personnel Services, 24 September 1980.

3. Use of Tables.

a. Table 23-1. This table presents the standard rates for DoD military personnel. These rates are used for planning, programing, budgeting, and accounting. These rates should be used in preparing estimates of fiscal year fund requirements for the military personnel appropriations. They do not, however, reflect the total costs to the Government for military personnel. If service and rank are known, select the rate from the appropriate service

column. If the service is unknown, use the column headed "DCS Composite." The DCS Composite rates are also used as the standard rates in the first column in table 23-2. If the rank is unknown, use O-3 for officers and E-5 for enlisted personnel.

b. Table 23-2. This table presents a compilation of military personnel rates for most applications.

(1) If the rank is unknown, use O-3 for officers and E-5 for enlisted personnel.

(2) Column 1 is used for programing, budgeting, and accounting when the service is unknown.

(3) Column 2 is used for cost analyses, economic analyses, and program evaluations done under OMB Circular A-94, DoDI 7041.3, or DCAI 600-60-1.

(4) Column 3 is used for estimating the labor costs of reports covered by OMB Circular A-40, DoDI 5000.22, or DCAI 630-225-2. The term "report" refers to data, information, or reports used for specified and authorized Government functions. Column 3 is not used for Freedom of Information Act (FOIA) requests, which always involve a requestor outside the Government, and fees for which cover direct costs only (see chapter 42 for FOIA fees, and for a more complete discussion of report cost estimating).

(5) Column 4 gives an hourly rate to calculate reimbursements from organizations outside the Federal Government, and column 5 gives an hourly rate to calculate reimbursements from Federal agencies.

(6) Columns 3, 4, and 5 (hourly rates) are to be used when the estimated amount of labor is based on time actually worked; i.e., when the reimbursing activity does not otherwise pay for the personnel costs incurred by DoD during leave and holiday periods. When the amount of labor estimated includes time for leave and holidays; e.g., when an annual approach is used, then the rates in columns 3, 4, or 5 should be adjusted to eliminate leave and holiday costs (by dividing the hourly rate shown by 1.18), and to express the result on an annual basis (by multiplying by 2080). An annual rate derived in this way may be divided by 4 to determine a quarterly rate or by 12 to determine a monthly rate.

c. Table 23-3. This table gives an example of the calculations used in this chapter, using the grade of O-4 (major).

TABLE 23-1. MILITARY PERSONNEL STANDARD RATES					
RANK	ARMY	NAVY	MARINE CORPS	AIR FORCE	DCS COMPOSITE
O-10	\$74204	\$75143	\$75616	\$75514	
O-9	75182	76079	78330	73748	
O-8	78787	78966	76838	73898	
O-7	67166	68212	68374	65898	
O-6	62231	64374	61428	60329	\$61765
O-5	51465	53917	52380	52507	51865
O-4	43290	46163	44257	45175	43952
O-3	34890	39097	38295	37725	35980
O-2	26844	30142	32101	28999	27572
O-1	21457	23813	23984	22531	21863
W-4	40196	42033	42629		40692
W-3	33154	35308	33872		33412
W-2	23630	31848	30511		29016
W-1	25312		26900		25312
E-9	34579	36511	35916	34448	34713
E-8	29229	31350	29853	29499	29563
E-7	24633	27172	24951	25524	25283
E-6	20930	22860	21171	22389	21780
E-5	17884	18868	18693	18717	18357
E-4	15214	15930	15732	16055	15664
E-3	13364	13465	13026	13713	13531
E-2	12199	12277	11761	12476	12331
E-1	12921	11109	10721	11277	12000

NOTE: FY 1983 RATE; BASIC PAY LIMITED TO \$63,800 FOR O-8 THRU O-10.

SOURCE: DOD 7220.9-H, SEC. 23003.F, TABLES 1-4, OSD(C), 1 DEC 82; DCA CODE 690, JAN 83.

TABLE 23-2. DCA MILITARY LABOR RATES					
ANNUAL RATES			HOURLY RATES		
RANK	PROGRAM, BUDGET, ACCTNG	ECONOMIC ANALYSIS	REPORTS	REIMBURS- MNTS FROM ORGNIZTNS OUTSIDE PED GOVT	REIMBURS- MNTS FROM FEDERAL AGENCIES
(1)	(2)	(3)	(4)	(5)	
O-6	\$61765	\$87513			
O-5	51865	74989	\$46.53	\$39.57	\$31.78
O-4	43952	64979	39.43	33.54	26.93
O-3	35880	54768	32.19	27.38	21.98
O-2	27572	44259	24.73	21.04	16.89
O-1	21863	37037	19.61	16.68	13.40
W-4	40692	60855	36.50	31.05	24.93
W-3	33412	51646	29.97	25.49	20.47
W-2	29016	46085	26.03	22.14	17.78
W-1	25312	41400	22.71	19.31	15.51
E-9	34713	53292	31.14	29.44	24.22
E-8	29563	46777	26.52	25.07	20.63
E-7	25288	41369	22.68	21.45	17.65
E-6	21780	36932	19.54	18.47	15.20
E-5	18357	32602	16.47	15.57	12.81
E-4	15664	29195	14.05	13.29	10.93
E-3	13531	26497	12.14	11.48	9.44
E-2	12331	24979	11.06	10.46	8.60
E-1	12000	24560	10.76	10.18	8.37

NOTE: FY 83 RATES.

SOURCE: TABLE 23-1; DCA CODE 690, DEC 82.

TABLE 23-3. DCA MILITARY LABOR RATES - MAJOR					
COST ELEMENT	ANNUAL RATES		HOURLY RATES		
	PROGRAM, BUDGET, ACCNTNG	ECONOMIC ANALYSIS	REPORTS	REIMBURS- MNTS FROM ORGNIZTNS OUTSIDE FED GOVT	REIMBURS- MNTS FROM FEDERAL AGENCIES
	(1)	(2)	(3)	(4)	(5)
STANDRD RATE	\$ 43952	\$ 43952	\$ 43952	\$ 43952	\$ 43952
RETIREMENT		11647	11647	11647	
HOSPITAL		500			
BASE OPNS		2140			
TRAINING		5550			
TDY		1190			
OTHER PERS			13899	3516	3516
OVERHEAD			12510	10641	8544
LV/HOLIDAY					
ANNUAL RATE	\$ 83	\$ 64979			
HOURLY RATE			\$ 39.43	\$ 33.54	\$ 26.93

NOTE: FY 83 RATES.
SOURCE: DCA CODE 690, DEC 82.

CHAPTER 24. OPERATIONS AND MAINTENANCE

1. Civilian Personnel.

a. Federal Salaried Civilian Labor Rates. This paragraph provides labor rates associated with Federal salaried civilian personnel. It also contains information to assist in costing civilian personnel under special circumstances and in the absence of specific data concerning grade structures.

(1) General. The rates in this paragraph are for use in planning, programing, budgeting, accounting, cost analyses, economic analyses, program evaluations, reports (discussed in chapter 42), and for computing reimbursements from other organizations (Federal and non-Federal). This paragraph does not include fees for Freedom of Information Act (FOIA) requests (discussed in chapter 42), or military personnel rates (discussed in chapter 23).

(2) Derivation of Factors.

(a) The compensation rates in column 1 of tables 24-1 and 24-2 include the payroll rate (using step 5), and fringe benefits. These benefits are calculated as percentages of the payroll rate and consist of funded retirement (7.0 percent), health benefits (3.4 percent), life insurance (0.3 percent), bonuses, awards, and unemployment programs (1.9 percent), and the Government's contribution to Medicare (1.3 percent up to a maximum of \$464.10).

(b) The economic analysis rates in column 2 are based on the compensation rates in column 1 increased to cover the full retirement increment (13.4 percent of the payroll rate) and to cover training and temporary duty (TDY) travel costs (total DCA average rate).

(c) Hourly rates for the preparation of reports in accordance with DCAI 630-225-2 are given in column 3. These rates include compensation, the full retirement increment, overhead (a 25.0 percent increase covering supervision, space, and administrative support), and an adjustment for leave and holiday costs (an 18.0 percent increase). These costs are divided by 2080 to give hourly rates.

(d) Hourly rates for reimbursements from organizations outside the Federal Government are given in column 4. These rates include compensation, the full retirement increment, and the adjustment for leave and holiday costs. Costs are divided by 2080 to give hourly rates.

(e) Hourly rates for reimbursements from Federal agencies are given in column 5. These rates are calculated as in column 4, except that the full retirement increment has been excluded in accordance with DoD guidance. Funded retirement (see compensation) is included. Costs are divided by 2080 to give hourly rates.

(3) Figure 24-1.

(a) This pyramidal display graphically shows the composition of the rates in table 24-1. Under each column heading are the elements included.

(b) Civilian compensation is used for the foundation of all rates.

(c) The full retirement increment is added to compensation for cost analyses, economic analyses, program evaluations, reports, and reimbursements from organizations outside the Federal Government. The full retirement increment is not added for reimbursements from Federal agencies, but funded retirement (see compensation) is included.

(d) Training and TDY costs are added only for cost analyses, economic analyses, and program evaluations.

(e) Overhead costs are included only for reports.

(f) The factor covering the accrual of leave and holiday costs is applicable only when the estimated amount of labor is based on time actually worked; i.e., when the reimbursing activity does not otherwise pay for the personnel costs incurred by DoD during nonproductive time, such as leave and holiday periods. Hourly rates for reports and reimbursements (both

PROGRAM BUDGET, ACCOUNTING (ANNUAL) (1)	ECONOMIC ANALYSIS (ANNUAL) (2)	REPORTS (HOURLY) (3)	REIMBURSEMENT FROM ORGANIZA- TIONS OUTSIDE THE FED GOV'T (HOURLY) (4)	REIMBURSEMENT FROM FEDERAL AGENCIES (HOURLY) (5)
		LEAVE AND HOLIDAY COSTS		
		OVERHEAD		
		TRAINING, TDY		
		FULL RETIREMENT INCREMENT		
COMPENSATION: PAYROLL RATES, FRINGE BENEFITS (FUNDED RETIREMENT, HEALTH BENEFITS, LIFE INSURANCE, OTHER.)				

FIGURE 24-1. CIVILIAN RATES

Government and non-Government); such as those in tables 24-1 and 24-2, include leave and holiday costs. When the estimated amount of labor includes time for leave and holidays; e.g., when an annual approach is used, the leave and holiday accrual factor should not be included.

(g) The reference for column 1 is DoD 7220.9-H, DoD Accounting Guidance Handbook, sections 230 and 252, 1 February 1978.

(h) The references for column 3 are DoDI 5000.22, Guide to Estimating Costs of Information Requirements, 17 October 1974, and DCAI 630-225-2, Management and Control of Information Requirements, 4 October 1976, as amended.

(i) The reference for columns 4 and 5 is OASD(C) Memorandum, subject: Reimbursement Rates for Personnel Services, 24 September 1980.

(4) Use of Table 24-1.

(a) This table presents a compilation of civilian personnel rates for most applications.

(b) When the grade is known, locate the grade level on the table and select the appropriate subheading for the type of study being conducted. When the specific grade is unknown, see table 24-3 for examples of specific occupational series. Alternatively, use GS-9 for systems studies as an estimate of station or site operations personnel, and use GS-13 for Headquarters, DCA, and field activities personnel.

(c) Column 1 is used for programing, budgeting, and accounting.

(d) Column 2 is used for cost analyses, economic analyses, and program evaluations done under OMB Circular A-94, DoDI 7041.3, or DCAI 600-60-1. If appropriate, costs should be added for civilian differential allowances (table 24-4), civilian hazardous duty allowances (figure 24-2), permanent change of station (table 24-7), and for education of dependent children overseas (table 26-2). The following, while not normally included in an economic analysis, should be added if appropriate to the specific analysis being conducted: prorated costs for rent, building maintenance, utilities, supplies, transportation, and contractual services.

(e) Column 3 is used for reports covered by DCAI 630-225-2. The term "report" refers to data, information, or reports which carry out specified and authorized Government functions. Column 3 is not used for Freedom of Information Act (FOIA) requests, which always involve a requestor outside the Government, and fees which cover direct costs only (see chapter 42 for FOIA fees, and for a more complete discussion of report cost estimating).

(f) Column 4 gives an hourly rate to calculate reimbursements from organizations outside the Federal Government, and column 5 gives an hourly rate to calculate reimbursements from Federal agencies.

(g) Columns 3, 4, and 5 (hourly rates) are to be used when the estimated amount of labor is based on time actually worked; i.e., when the reimbursing activity does not otherwise pay for the personnel costs incurred by DoD during leave and holiday periods. When the amount of labor estimated includes time for leave and holidays; e.g., when an annual approach is used, then the rates in columns 3, 4, or 5 should be adjusted to eliminate leave and holiday costs (by dividing by 1.18), and to express the result on an annual basis (by multiplying by 2080). An annual rate derived in this way may be divided by four to determine a quarterly rate or by twelve to determine a monthly rate.

(5) Table 24-2. This table gives an example of the calculations used in this paragraph, using the grade of GS-13, step 5.

TABLE 24-1. DCA CIVILIAN LABOR RATES						
PROGRAM, BUDGET, ACCNTNG	ANNUAL RATES			HOURLY RATES		
	ECONOMIC ANALYSIS	REPORTS	REIMBURS- MNTS FROM: ORGNIZTNS: OUTSIDE FED GOVT	REIMBURS- MNTS FROM: FEDERAL AGENCIES		
GRADE:	(1)	(2)	(3)	(4)	(5)	
SES	\$ 72303	\$ 82532				
15	62422	71475	\$ 49.49	\$ 39.60	\$ 35.41	
14	53139	61088	42.13	33.70	30.15	
13	45038	52022	35.70	28.56	25.55	
12	37917	44057	30.05	24.04	21.51	
11	31637	37039	25.07	20.06	17.95	
10	28797	33865	22.82	18.26	16.34	
9	26146	30903	20.72	16.58	14.83	
8	23672	28137	18.76	15.01	13.43	
7	21375	25569	16.94	13.55	12.13	
6	19236	23179	15.25	12.20	10.91	
5	17258	20969	13.68	10.94	9.79	
4	15423	18918	12.22	9.78	8.75	
3	13741	17038	10.89	8.71	7.80	
2	12191	15305	9.65	7.73	6.92	
1	11197	14194	8.87	7.10	6.35	

NOTE: FY 1983 RATES; SES CALCULATED AT \$ 63800.

SOURCE: DCA, CODE 690, JAN 83.

TABLE 24-2. DCA CIVILIAN LABOR RATES - GS 13					
ANNUAL RATES			HOURLY RATES		
PROGRAM, BUDGET, ACCTNG	ECONOMIC ANALYSIS	REPORTS	REIMBURS- MNTS FROM: ORGNIZTNS: OUTSIDE FED GOVT	REIMBURS- MNTS FROM: FEDERAL AGENCIES	
CDST ELEMENT:	(1)	(2)	(3)	(4)	(5)
PAYROLL RATE:	\$ 39586	\$ 39586	\$ 39586	\$ 39586	\$ 39586
BENEFITS	5452	5452	5452	5452	5452
FULL RET INC:		5305	5305	5305	
TRAINING		490			
TDY		1190			
OVERHEAD			12585		
LV/HOLIDAY			11327	9062	8107
ANNUAL RATE :	\$ 45038	\$ 52022			
HOURLY RATE :			\$ 35.70	\$ 28.56	\$ 25.55
NOTES : FY 1983 RATES. SEE PARAGRAPH 1.A.(4)(D) FOR COSTS THAT ARE POTENTIALLY ADDITIVE FOR ECONOMIC ANALYSES.					
SOURCE: DCA, CODE 690, JAN 83.					

b. Median Grades for Federal White-Collar Workers.

(1) General. In the absence of a specific grade structure, table 24-3 provides assistance in determining the median grade for a given occupation. While not all inclusive, this table contains median grades for occupations most often associated with communications. For median grades in occupations not included in this table, contact the Director, DCA, ATTN: Code 690.

(2) Use of Table. The data shown in this table are grouped by types of occupations and listed by occupational category and series. The median grade for each occupation can be found by reading across the table.

TABLE 24-3. MEDIAN GRADES FOR FEDERAL WHITE-COLLAR WORKERS	
Occupational Category & Series	Median Grade
<u>Data Processing</u>	
Computer Specialist, 334	12
Computer Systems Operator, 332	7
Electronic Accounting Machine Project Planner, 362	7
Computer Aide and Technician, 335	5
Electronic Accounting Machine Operator, 359	4
Coding Clerk, 357	4
<u>Communications-Electronics</u>	
Engineer, Electronics, 855	12
Communications Specialist, 393	11
Electronics Technician, 856	11
Communications Manager, 391	11
Communications Relay Equipment Operator, 390	7
General Communications Clerk, 392	6
Cryptographic Equipment Operator, 388	6
Radio Operator, 389	4
Teletypist, 385	4
Communications Clerk, 394	4
Telephone Operator, 382	3

TABLE 24-3. MEDIAN GRADES FOR FEDERAL WHITE-COLLAR WORKERS (CON.)	
Occupational Category & Series	Median Grade
<u>Other Professional</u>	
Program Manager, 340	15
Engineer, Nuclear, 840	13
Operations Research Analyst, 1515	13
Engineer, General, 801	13
Program Analyst, 345	12
Engineer, Architectural, 808	12
Engineer, Civil, 810	12
Engineer, Mechanical, 830	12
Engineer, Electrical, 850	12
Mathematician, 1520	12
Construction Control Specialist, 809	9
Engineer, Drafting, 818	5
Surveying Technician, 817	4
<u>Administrative</u>	
Personnel Manager, 201	12
Budget and Accounting Analyst, 504	11
Secretary, 318	6
Correspondence Clerk, 309	5
Clerk Steno & Reporter, 312	4
Clerk Typist, 322	3
Mail & File Clerk, 305	3
<p>Source: "Distribution of Occupations by Grade," Table D-1, Office of Personnel Management, as of 31 Oct 77; DCA, Code 690.</p>	

c. Differentials and Allowances.

(1) General. Title 5, United States Code, authorizes payment of certain differentials and allowances to U.S. citizens who are employed at DoD installations located in foreign areas or who perform irregular or intermittent duty involving unusual physical hardship or hazard. The differentials and allowances are paid in addition to the basic annual pay rates shown in table 24-1.

(a) Nonforeign Area Allowances. The Office of Personnel Management established cost-of-living allowances and post differentials, based upon salary, which are paid to statutory-salaried employees in non-foreign areas under 5 U.S.C. 5941 and Executive Order 10000. The allowance for the Panama Canal Zone is separately established by State Department regulations.

(b) Foreign Area Allowances. "Department of State Standardized Regulations (Government Civilians, Foreign Areas)" establishes the allowances for statutory-salaried employees in foreign countries.

1. Post differential allowances are based upon the employee's salary.

2. Cost-of-living allowances for quarters, post allowances for family, and additional post allowances for children are based upon the family status (accompanied or unaccompanied), number of children, and salary level of the employee.

(c) Other Allowances. Education, transfer, home service, and separate maintenance allowances, as designated in Department of State Standardized Regulations, are not payable to DoD personnel. However, in lieu of an allowance, education for eligible dependent children is furnished through the military departments' dependent school programs in existing post schools or in contract-operated schools. The average cost per student is shown in table 26-2.

(2) Derivation of Factors.

(a) Nonforeign area cost-of-living and post differential allowances are stated as the authorized percentage of the basic salary.

(b) Foreign area post differential allowances are stated as the percentage of the basic salary authorized by the State Department.

(c) Foreign area cost-of-living allowances are stated in dollars based upon the salary for a GS-13 (step 4) employee accompanied by spouse and two children. Additional children or grades other than GS-13 would vary the cost slightly. These allowances are in addition to area cost-of-living and post differentials and, although reflecting family conditions, exclude education costs for children of military personnel (table 26-2).

(3) Use of Table. Table 24-4 is arranged alphabetically by country to show applicable allowances. When a specific location within the country is not shown, interpolate using a nearby city rate or the rate identified as for that country. Read across the table to determine the applicable allowances. Multiply the percentage factor by the basic salary in table 24-1, column 1. Add this amount to the appropriate salary and, where authorized, cost-of-living allowance. The education allowance (table 26-2) should be

added separately for overseas personnel for cost-effectiveness or cost-benefit studies and comparisons of commercial activities. Example costs and factors should be updated to current referenced table rates.

Example 1. From table 24-4, a GS-13, who is located in the Canal Zone, is entitled to a 15-percent post differential. Salary is computed as follows:

\$30,198 - Basic pay rate, from table 24-1, column 1
4,530 - Differential, from table 24-4,
(salary X .15 = differential cost)
\$34,728 - Salary adjusted to include only differential

Example 2. An individual is a GS-13, married, has two school-age children, and is located at Brussels, Belgium. From table 24-4, it is found that the foreign post differential is zero; however, cost-of-living allowances are payable.

(a) For an economic analysis or program evaluation, the cost for 1 person-year of this individual's time is computed to include the indirect cost for overseas education as follows:

\$38,939 - Total cost for 1 person-year, table 24-1 column 2
8,500 - Cost-of-living in Brussels, table 24-4
0 - Postdifferential, table 24-4
1,770 - Recurring overseas PCS, table 24-7
2,766 - Education cost of two children, table 26-2
\$51,975 - Total cost for 1 person-year

(b) For a study involving comparisons of commercial or industrial activities, computation of the total cost for 1 GS-13 person-year includes deducting the DCAI 600-60-1 cost (table 24-2, column 4), then adding back the DCAI 600-70-1 cost from table 24-2 (column 5), as follows:

\$51,975 - From (a) above
-38,939
\$13,036 - Subtotal for cost-of-living allowances, PCS,
and education
\$48,349 - Cost for 1 person-year, table 24-2, column 5
\$61,385 - Total cost for 1 person-year

TABLE 24-4. CIVILIAN DIFFERENTIALS AND ALLOWANCES

Area	Nonforeign Area	Foreign Area	
	Cost-of-Living & Post Differential	Post Differential	Cost-of-Living
	Percent		Dollars
Anchorage, Alaska	22.5		
Alaska (except Anchorage)	25		
Antarctic Region		25	900
Australia (unlisted)		0	1,300
" (N.W. Cape)		10	2,300
" (Woomera)		0	2,000
Azores (Lajes Field)		10	1,900
Bahamas (Andros Island)		0	3,800
" (Nicolls Town)		10	6,400
Bahrain		10	13,100
Belgium (Brussels)		0	8,500
" (Shape/Chievres)		0	5,200
Bermuda		0	4,900
British West Indies (Antigua)		0	1,900
Canada (other except N.W.)		0	500
" (Argentia)		0	1,700
" (Goose Bay)		10	500
" (Montreal)		0	5,000
" (Quebec)		0	5,100
" (Vancouver)		0	7,200
Canal Zone	15		
China (unlisted)		15	1,000
" (Tainan)		10	2,200
" (Taipei)		0	3,200
Columbia (Bogata)		0	4,900
" (Popayan)		10	1,600
Cuba (Guantanamo Bay)		10	700
El Salvador (San Salvador)		0	4,400
Ethiopia (unlisted)		25	1,100
" (Addis Ababa)		15	5,400
" (Asmara, Eritrea)		25	2,400

TABLE 24-4. CIVILIAN DIFFERENTIALS AND ALLOWANCES (CON.)

Area	Nonforeign Area Cost-of-Living & Post Differential	Foreign Area	
		Post Differential	Cost-of-Living
	Percent		Dollars
Germany (unlisted)		0	3,500
" (Augsburg)		0	3,900
" (Berlin, Frankfurt)		0	4,300
" (Bonn, Wahn)		0	7,000
" (Bremen)		0	5,300
" (Heidelberg, Schwetzingen)		0	4,200
" (Kaiserslautern, Landkreis)		0	3,600
" (Karlsruhe)		0	3,700
" (Worms)		0	3,500
" (Zweibrucken)		0	3,600
Greece (Unlisted)		0	1,800
" (Athens)		0	5,400
" (Iraklion - Crete)		0	1,800
" (Kavala)		10	1,300
" (Rhodes, Is. of)		0	1,700
Greenland		25	600
Guam	15		
Guatemala (City)		0	5,800
Hawaii	17.5		
Iceland (Keflavik - Grindavik)		10	2,700
Iran (unlisted)		20	1,600
" (Teheran)		10	7,400
Italy (unlisted)		0	1,400
" (Catania, Sigonella)		0	2,700
" (Naples)		0	5,500
" (Rome)		0	7,200
" (Vicenza)		0	2,700
Japan (unlisted)		0	2,700
" (Chitose)		0	1,900
" (Fukuoka, Itazuke AFB)		0	2,800

TABLE 24-4. CIVILIAN DIFFERENTIALS AND ALLOWANCES (CON.)

Area	Nonforeign Area	Foreign Area	
	Cost-of-Living & Post Differential	Post Differential	Cost-of-Living
	Percent		Dollars
Japan (Iwakuni)		0	2,800
(Misawa)		0	2,700
(Tokyo)		0	4,500
(Tokyo-To)		0	3,000
(Yokohama)		0	3,600
(Yokosuka)		0	4,000
Johnston Island	25		
Korea (unlisted S. of lat. 37°40' N.)		15	2,700
(unlisted N. of lat. 37°40' N.)		15	3,800
Korea (Osan, Pyongtaek, Seoul)		10	4,200
(Pusan)		10	3,700
(Taegu)		15	4,000
Malta		0	3,200
Midway	25	0	900
Morocco (Kenitra, Sidi Yahira)		0	3,100
(Rabat, Sale)		0	5,600
New Zealand (unlisted)		0	1,400
(Auckland, Wellington)		0	3,300
Panama (unlisted)		15	500
(Panama City)		0	6,500
Philippines (unlisted)		20	600
(Angeles, Tinang)		15	1,900
(Baguio City)		0	2,100
(Camp O'Donnell)		15	900
(Manila, Cavite)		10	3,800
(San Fernando, La Union)		10	2,100
(San Miguel, Zambales)		10	1,700
(Subic Bay, Cubi Point)		15	2,300
Portugal (Lisbon)		0	6,200
Puerto Rico	7.5		

TABLE 24-4. CIVILIAN DIFFERENTIALS AND ALLOWANCES (CON.)

Area	Nonforeign Area	Foreign Area	
	Cost-of-Living & Post Differential	Post Differential	Cost-of-Living
	Percent		Dollars
Ryukyus (unlisted post areas)		20	1,000
" (Okuma, Yaetake - Site 18)		10	1,800
" (Okinawa Island, except Okuma, Yaetake-Site 18, Fukuji)		10	2,600
Saudi Arabia (Dhahran)		20	9,000
Singapore		0	6,100
Spain (unlisted)		0	1,900
" (Madrid and Province)		0	6,500
" (Rota)		0	3,000
" (Zaragoza)		0	3,000
Thailand (unlisted)		25	2,900
" (Bangkok)		10	4,400
" (Chiang Mai)		15	2,300
" (Korat)		20	2,500
Thailand (Sattahip, U-Tapao)		15	3,400
" (Songkhla)		25	2,600
" (Udon)		25	3,400
Trust Territory of the Pacific			
Island (unlisted)		15	600
" (Kwajalein)		15	1,000
Turkey (unlisted)		10	1,700
" (Adana, Incirlik, Karatas)		0	2,500
Turkey (Ankara, Elmadag, Manzarali)		10	3,300
" (Diyarbakir - Pirinlik)		15	2,300
" (Istanbul)		0	4,700

TABLE 24-4. CIVILIAN DIFFERENTIALS AND ALLOWANCES (CON.)

Area	Nonforeign Area	Foreign Area	
	Cost-of-Living & Post Differential	Post Differential	Cost-of-Living
	Percent		Dollars
Turkey (Izmir-Cigli, Yamanlar)		0	2,800
" (Karamursel - Yalova, Golcuk)		0	2,400
United Kingdom (unlisted)		0	2,800
United Kingdom (Belfast)		20	1,900
" (Cheltenham)		0	2,500
" (Edinburgh)		0	3,400
" (Edzell)		0	2,100
" (Lakenheath, Mildenhall)		0	2,800
" (London, High Wycombe)		0	5,100
" (Londonderry)		20	1,400
" (Woodbridge, Bentwaters)		0	2,500
Virgin Islands	10		
Wake Island	25		

Source: Department of State Standardized Regulations (Government Civilians, Foreign Areas), TL: SR-252, chapter 900, dated 23 Nov 75; Code 690, base for GS-13 civilians with family; Federal Personnel Manual LTR No. 591-15, dated 31 Dec 75.

d. Hazardous Duty Differentials.

(1) General. An employee who is assigned and performs any irregular or intermittent duty specified in figure 24-2, when that duty is not usually one of the duties of the position, is entitled to this additional pay. The differential is authorized for employees who perform duties involving physical hardship and is not subject to the limitation placed on premium pay. It is in addition to any other pay or allowance discussed elsewhere in this Circular.

(2) Use of Figure 24-2 and Percentage Differential. Figure 24-2 lists situations or duties which meet the criteria established for payment of the 25-percent differential. Using the previous example, a GS-13 in the Canal Zone performs hazardous duty for 1 hour during each regular 8-hour workday. The salary is computed for a cost-effectiveness study as follows:

Annual rate (table 24-1, column 1)	\$38,939
Tropical differential (table 24-4) (Basic pay \$30,198 X .15) =	4,530
Hazardous duty differential (figure 24-2) (1/8 X .25 = .03125); (\$30,198 X .03125) =	944
Total annual cost to Government	\$44,413

Exposure to hazardous weather or terrain:

Work or travel on ice floes or in isolated or sparsely settled areas.

Work in rough terrain (cliffs, ledges, slopes, etc.).

Traveling under hazardous conditions (to remote sites at night, on bad roads, in rain, snow, or traveling where there is a danger of avalanches or whiteout phenomenon.

Participating in snow removal operations where there is a danger of avalanche.

Water search and rescue operations.

Hazardous boarding or leaving of vessel (performed under adverse conditions: ice, snow, fog, etc.); at sea, offshore, or transferring equipment.

Firefighting as a crew or team member in fighting:

Equipment, installation, or building fires.

Work in open trenches (15 ft or deeper).

High work (on structure 50 ft or more above base level, under open conditions).

Ground work beneath hovering helicopter.

Source: Civil Service Commission Federal Personnel Manual, Supplement 990-2, subchapter S9, pages 550-64, 565, and 572, 15 Mar 73; Code 690, 7 Nov 75.

FIGURE 24-2. HAZARDOUS DUTY DIFFERENTIALS @ 25 PERCENT

e. Foreign National Pay Rates.

(1) General. Table 24-5 displays foreign national personnel annual pay rates derived from military command budget factors, by geographical location, for personnel in the communications field.

(2) Use of Table 24-5.

(a) When both the geographical location and military department are known, multiply the required number of personnel by the annual pay factor from the appropriate column.

(b) When the military department employing a foreign national is unknown, multiply the required number of personnel by the annual pay factor in the column identified as "DCA Costing Standard."

TABLE 24-5. FOREIGN NATIONAL PAY RATE (DIRECT-HIRE, EXCEPT WHERE INDICATED)				
Geographical Location	Army FY 1975	Navy FY 1975	Air Force FY 1976	DCA Costing Standard FY 1976
Australia	-	\$16,291	-	\$16,500
Azores	-	8,495	-	9,500
Belgium	-	-	-	-
Bermuda	-	-	-	9,500
Canada	-	-	\$13,609	13,700
Canal Zone	\$10,008	8,297	12,026	12,000
Caroline Islands	-	-	-	-
Colombia	-	-	-	-
Crete	-	-	7,685	7,700
Cuba	-	-	-	7,400
Dhahran	-	-	-	-
Dominican Republic	-	-	-	-
Ethiopia	-	-	-	4,400
Germany*	11,700	-	12,169	12,200
Greenland	-	-	-	-
Greece	-	5,382	7,685	7,700
Guam	-	-	-	-
Guatemala	-	-	-	-
Iceland	10,440	10,823	-	10,900
Iran	-	-	-	-
Ireland	-	8,044	-	8,300
Italy	-	6,974	11,729	11,800
Japan*	8,002	11,695	12,025	12,100
Korea	3,008	-	3,261	3,300
Malta	-	-	-	-
Morocco	-	3,400	-	3,700
Netherlands	-	-	15,845	15,900
New Zealand	-	-	-	7,900
Okinawa	-	-	-	7,000
Pakistan	-	-	-	-

TABLE 24-5. FOREIGN NATIONAL PAY RATE
(DIRECT-HIRE, EXCEPT WHERE INDICATED) (CON.)

Geographical Location	Army FY 1975	Navy FY 1975	Air Force FY 1976	DCA Costing Standard FY 1976
Portugal	-	-	5,291	5,130
Philippines	-	-	2,093	2,100
Republic of China	-	-	-	4,300
San Salvador	-	-	-	-
Scotland	-	6,783	-	6,800
Singapore	-	-	-	4,200
South Africa	-	-	-	-
Spain*	-	5,589	8,450	8,500
Taiwan	-	-	4,227	4,300
Thailand	2,004	-	2,562	2,600
Trinidad	-	-	-	-
Turkey	-	-	7,997	8,000
United Kingdom*	-	6,891	8,265	8,300

*Indicates indirect hire.

Source: FY 1976 Budget Submissions of Air Force Communications Service;
FY 1975 experience for Army and Navy Communication Commands;
DCA, FY 1976 costing standard by Code 690, as of 14 Nov 75.

2. TDY and Civilian Permanent Change of Station Cost.

a. General. Operations and maintenance funds support the temporary duty (TDY) travel cost of assigned military and civilian personnel and the permanent change of station (PCS) travel of assigned civilian personnel. TDY and civilian personnel travel costs include transportation of individuals authorized to travel, payment of per diem allowances, rental of passenger-carrying vehicles or use of privately owned vehicles, transportation of baggage, official documents or household goods (PCS), and incidental expenses pertinent to the type of orders issued, including storage of household goods for civilian PCS moves.

b. Military and Civilian Temporary Duty.

(1) General. Accurate estimates for TDY costs require knowledge of the geographical area; available routes of transportation; operational requirements for local travel and visits to alternate locations; and

information on the distance from populated areas to the overseas sites for consideration of administrative, recreational, and welfare travel requirements. Operational travel requirements include visits to relay stations and remote sites and attendance at meetings or conferences.

(2) Derivation of Factors. In terms of overall cost of station operation and maintenance costs, the percentage of travel funds has the widest variation. Travel costs are influenced by such considerations as the scope of operations, geographical location, command and local policies concerning personnel allocation, authorized strength level, and the need for additional training other than formal training. (See chapter 26.) Average costs for per diem and trips between overseas areas and the continental United States (CONUS) were derived; however, rates vary widely by area depending on the cost-of-living. Specific allowances for TDY travel are available from the Joint Travel Regulation (J.T.R.) by city or area.

(3) Use of Table and Figure.

(a) Table 24-6 provides passenger rates for Airlift Service Industrial Fund (ASIF) and commercial air travel to Europe or Asia. The rate table includes cost of in-flight meals and 66 pounds of baggage.

(b) Hotel and other incidental expenses can be approximated using per diem cost factors from table 24-6.

(4) Estimating Procedures. (Example) A communication station, supporting six remote sites in mountainous terrain, is to be located in Europe. It is authorized 21 military and civilian personnel, has higher headquarters at Germany, and has operational requirements for visits to stations in Europe and CONUS. Two round trips are programed to CONUS.

<u>Per diem estimate</u>	<u>Amount</u>
Foreign country travel (no Government quarters) - 140 days @ \$50	\$7,000
TDY location (base facilities provided) - 100 days @ \$50 X .36	<u>1,800</u>
Total per diem	\$8,800
<u>Transportation</u>	
In-country. Government vehicles utilized, mileage is not payable.	
Military Airlift Command airlift estimate (one round trip @ \$200 each way)	\$ 440
Commercial airlift estimate (round trip @ \$400 each way)	800
Total transportation	<u>\$ 1,240</u>
Annual station TDY travel costs (military or civilian)	\$10,040

TABLE 24-6. TEMPORARY DUTY TRAVEL COSTS

	<u>CONUS</u>	<u>Overseas</u>
POV Mileage (Nonlocal)		
Civilian		
Driver	\$.20/mi	-
Passenger	0	-
Military		
Driver	\$.07/mi	-
Passenger	\$.07/mi	-
Car Rental (Compact)	\$22-27/day	\$40/day
Per Diem*		
Major Cities	\$56-75/day	\$50-130/day
Other	\$35/day	\$50/day
Miscellaneous Expenses	\$20/round trip	\$50/round trip
<u>Commercial Air (Category Z)</u>	<u>From or to Washington, DC</u>	
Europe		\$400
Near East		500
Africa		900
Alaska		400
Caribbean		130
Hawaii		285
Far East		800
CONUS cities		29-279
MAC travel to Europe		220
<p>*Reimbursement is reduced 50 percent when Government quarters are available and 14 percent when Government mess is available and increased by the amount of charges.</p> <p>Source: DCA Travel Office, 28 Jun 82.</p>		

c. Civilian Personnel PCS Cost.(1) General.

(a) Civilian PCS costs are incurred when individuals and their authorized dependents are permanently moved to an overseas location. U.S. civilians so assigned are authorized to move or store their household goods and personal effects, and to receive transportation, per diem, and mileage for themselves and authorized dependents for the trip to the overseas location and, upon satisfactory completion of their contract, for the return trip.

(b) Upon completion of each scheduled (2-year) tour, reemployment travel is authorized for the incumbent and family to the CONUS and return. The reemployment leave travel does not allow movement of household goods.

(2) Derivation of Factors. Factors for civilian PCS transportation and per diem costs can be utilized when the specific overseas area is unknown. They include transportation by commercial means or privately owned vehicle (POV) between home and a CONUS port or air terminal, per diem, and transportation to or from the overseas location. These factors also include costs for transporting household goods and one POV.

(a) These factors exclude cost-of-living allowances, quarters allowances, and other specific allowances which may be appropriate to a given country or overseas location.

(b) The factors are based on a family of four, with household goods weighing 10,000 pounds. Storage fees for household goods not shipped overseas are not considered, since offsetting costs are involved for the lighter shipment which occurs when a portion of the household goods is placed in storage. The annual recurring PCS factor reflects the average annual cost per U.S. civilian employee authorized overseas for initial or replacement PCS and rotational leave necessary to maintain the authorized space without regard to marital status of the employee.

(c) This annual factor should be used only when information as to the type of civilian PCS move is not available.

(3) Use of Table 24-7. Determine the estimated number and grade level of civilian personnel. Multiply by the appropriate factor from table 24-7. Civilian personnel with the grade of GS-7 or lower are not generally assigned to overseas communication sites; however, in those cases where GS-7 or a lower grade is known to be authorized, use the factor for "without dependents."

(a) Example 1. A communication station in Europe is authorized three U.S. civilian engineers. One of these is a GS-7 or lower grade upon initial assignment. Initial PCS cost would be determined as follows:

2 X \$3,710 = \$7,420 (accompanied)
1 X \$2,040 = 2,040 (w/o dependents)

Total PCS cost \$9,460

(b) Example 2. An overseas communications network is authorized 10 U.S. civilians. The annual recurring PCS cost would be computed as follows:

10 X \$1,770 = \$17,700 per year annual PCS cost

TABLE 24-7. CIVILIAN PERSONNEL PCS COST (OVERSEAS LOCATIONS)	
Type of Travel	Cost
Initial PCS Overseas Worldwide (one way) (or return to CONUS)	
With Dependents	\$3,710
Without Dependents	2,040
Reemployment Leave (round trip)	
With Dependents	1,630
Without Dependents	410
Annual Recurring Overseas PCS Factor and/or Reemployment Leave	1,770
NOTE: Base year is FY 1977.	
Source: DCA, Code 690, Apr 77.	

3. Transportation of Things.

a. General. Transportation of things involves movement of supplies, equipment, tools, and material to or from the base or construction site. The factors presented in this paragraph are for relocation of material when considerable distance between areas is involved. When specifics as to size and weight are not available, transportation costs can be computed as a percentage of equipment cost. (See tables 24-8 and 9.) When more specific details are available to the cost estimator, transportation costs can be determined from the rate tables for air, water, and land transportation. (See tables 24-10, 11, and 12.)

b. Derivation of Factors.

(1) Transportation factors as a percentage of equipment costs are based on prior year cost experience for Department of Defense material shipped to or from overseas on a worldwide basis.

(2) Aircraft cargo rates were derived from Airlift Service Industrial Fund (ASIF) rates. Airlift procured through the ASIF includes commercial service contracted by the Military Airlift Command.

(3) Ocean freight rates are based on port-handling charges and ocean freight transportation costs from east or west coast port terminals using a minimum of 40 cubic feet per measurement ton. CONUS and overseas port-handling costs are included.

(4) Vehicle-operating costs were developed from the military cost accounting system for motor vehicles.

c. Use of Tables.

(1) Tables 24-8 and 9, Transportation. In cases where the planner has insufficient information to base an estimate upon the equipment size and weight, relatively accurate overall estimates may be obtained by using factors representing a percentage of the equipment costs. This percentage covers the costs associated with forwarding equipment to the U.S. port, port-loading charges, costs for ocean transportation to the foreign port, and unloading charges (forwarding to final destination not included).

(a) Costing Considerations.

1. Administrative costs, such as general overhead expense and associated contractor personnel costs, are not included. See table 24-9 for contractor-operated base cost factors pertinent to processing and handling equipment.

2. The parcel post factor should be used for shipment of data or small parts.

3. Electronics equipment, transportable communications units, and containers prepackaged prior to shipment to the U.S. port have a higher value in proportion to their weight and volume than normal depot items, antennas, and required supplies; therefore, individual percentage factors applicable to the estimated costs of electronics equipment and transportable units should be used.

4. A separate higher percentage factor should be applied to the cost of all other items, such as antennas, supplies, and items having a unit value less than \$10,000.

5. The various basic factors in table 24-9 were used to determine the percentages shown in table 24-8 for items having a unit value less than \$10,000.

6. Use the cost-estimating structure for acquisition costs to determine the total cost of equipment by category (antennas, electronics, other) to be shipped.

TABLE 24-8. TRANSPORTATION COSTS AS A PERCENTAGE OF EQUIPMENT COSTS			
FROM CONUS DEPOT OR CONTRACTOR'S PLANTS TO:			
Category	CONUS	Europe, Alaska, Hawaii, Latin America, and Mediterranean ports	Far East, Near East, North Atlantic, South America, and Africa except Mediterranean ports
Electronic Equipment	1%	9%	10%
Transportable Units	2	10	11
Antennas, Supplies, Cable, and Misc. Parts (items having a unit value of less than \$10,000)	3	14	16
New Fixed Sites-Cost Model	1.04	9.1	10.12

Source: DoDI 7510.4, Change 4, dated 22 Jan 73; DCA, Code 690, 16 Jan 76.

(b) Example. Six LOS microwave terminals and two repeaters are being shipped to a deepwater port in southern Asia, location not specified. The costs (in thousands of dollars) for transportation are calculated as follows:

<u>Equipment</u>	<u>Estimated Cost of Equipment</u>	<u>Cost Factor (from table 24-8)</u>	<u>Transportation Cost</u>
Antennas	\$ 6.3		
Towers	19.4		
Auxiliary power	<u>47.9</u>		
Subtotal	\$ 73.6	.16	\$ 11.78
Electronics	680.6	.10	68.06
Test equipment	75.4	.10	7.54
Spare parts	75.4	.16	12.06
Support equipment	37.7	.16	6.03
Fences and tanks*	\$ 5.7		
Spares	75.4		
Buildings and construction material*	<u>0</u>		
	\$ 81.1	.16	\$ 12.98
Data (via Parcel Post)	52.7	.01	<u>53</u>
			\$118.98 (use \$120)

*Value for buildings, construction material, fencing, etc., should include the cost of what is to be shipped from the United States for the specific project. In this example, local procurement, except for fencing and tanks, is assumed.

TABLE 24-9. TRANSPORTATION COST FACTORS FOR ITEMS
HAVING UNIT VALUE OF LESS THAN \$10,000

Transportation Cost Element	Percentage
Packing, Handling, and Crating	3.5
CONUS Transportation to Port	3
CONUS Port Loading and Handling	2.5
Overseas Port Unloading and Handling	1
Overseas Transportation to:	
Europe, Alaska, Hawaii, Latin America, and Mediterranean Ports	4
Far East, Near East, Newfoundland, Labrador, Thule, Iceland, South America, African Ports (other than Mediterranean)	6
Parcel Post	1

Source: Parts C and D, DoDI 7510.4, Change 4, dated 22 Jan 73. Current as of 16 Jan 76, Code 690.

(2) Table 24-10, Military Air Cargo Rates.

(a) Costing Considerations.

1. Air freight rates are expressed in cents per pound, with a minimum weight of 12.5 pounds per cubic foot, including packaging.

2. Rates vary by geographical location and the amount of traffic flowing to specified locations. Transportation category priority nine (AFCS TP-9) can be designated to obtain a reduced ASIF rate for cargo inbound to CONUS when priority airlift is not required, which amounts to a 12-percent reduction in the normal military air rate shown on the table.

3. Rates to locations not listed may be estimated in accordance with the footnote of table 24-10, or by consulting AFR 76-11.

4. Packing and crating for protection from the elements, in addition to that provided by the contractor, is normally not required for shipment of communication equipment by military air.

(b) Example. Electronic equipment, racks, auxiliary power, a prefabricated tower in 20-foot sections, miscellaneous parts, supplies, and necessary tools for assembly. Excludes equipment necessary for erection and assembly at site near Athens, Greece. The rate per pound from east coast to Athens, Greece, is \$0.698 (table 24-10).

<u>Category</u>	<u>Weight (pounds)</u>	<u>Cubic Feet</u>	<u>Minimum Costing Weight (pounds)</u>	<u>Total Cost of Equipment</u>
Electronic gear*	6,000	600	7,500	
Tower* and aux. power	7,000	750	9,375	
Miscellaneous parts	1,000	60	1,000	
Hand tools	5,000	30	5,000	
Total pounds for shipment including packaging			<u>22,875</u>	\$110,000

1. Formula. Multiply the transportation rate in cents per pound by the computed minimum costing weight: $\$0.698 \times 22,875 = \$15,967$.

2. Additional Costs. When military aircraft and other methods of transportation are desired, use table 24-9 for transportation to the port and table 24-10 for foreign country destination costs. Similarly, ground-mile distance from the foreign airport to the site is used to compute transportation costs from table 24-12 data. These transportation costs are additive.

<u>Transportation</u>	<u>Cost</u>
Military air from east coast to Greece	\$15,967
Transportation from manufacturers to east coast (3% times equipment cost - table 24-9)	3,300
Transportation from Athens to site (four 3-ton truckloads at 200-mile round trip - table 24-12)	<u>128</u>
Total transportation cost	\$19,395

*Minimum weight factor of 12.5 pounds per measured cubic foot exceeds the actual weight.

TABLE 24-10. MILITARY AIR CARGO RATES
(Dollars per Pound)

Destination	From	
	Philadelphia/ Dover AFB	San Francisco/ Travis AFB
Alaska, Anchorage (Elmendorf AFB)	\$ 0.992	\$ 0.603
Australia, Woomera	3.153	2.429
Azores, Lajes	0.755	
Bermuda, Kindley AFB	0.223	
Canada, Goose Bay	0.353	
Germany, Frankfurt (Rhein-Main AB)	1.163	1.646
Greece, Athens	1.491	2.664
Guam (Andersen AFB)	3.015	1.814
Hawaii (Hickam AFB)	1.433	0.709
Iceland, Keflavik	0.795	
Italy, Naples	1.355	
Japan, Tokyo (Yokota AB)	2.005	1.506
Johnston Island	1.673	0.949
Korea, Osan	2.206	1.707
New Zealand, Christ Church	2.847	2.123
Norway, Oslo	1.371	1.878
Okinawa (Kadena AB)	2.279	1.780
Panama, Canal Zone (Howard AFB)	0.626	
Peru, Lima	1.049	
Philippines, Manila (Clark AB)	2.539	2.040
Puerto Rico, Roosevelt Roads	0.466	
South Africa, Johannesburg	2.538	
Spain, Madrid	1.074	
Thailand, Bangkok	3.354	2.630
Turkey, Adana	1.677	
United Kingdom, London, England	1.033	1.759
Wake Island		1,379

NOTE: For military cargo rates between points not shown, multiply cargo weight in pounds times \$0.000335 per pound per nautical air mile. Twelve and one-half (12.5) pounds per measured cubic foot is the minimum weight factor.

Source: U.S. Government Airlift Rates (AFR 76-11), 2 Aug 82.

(3) Table 24-11, Military Sealift and MTMTS Rates for Ocean Freight.(a) Costing Considerations.

1. This rate table is used to estimate the cost of port-handling charges and ocean freight transportation from east or west coast port terminals. Structural steel, prefabricated towers, and heavy, bulky material may be forwarded by water to the site in anticipation of later delivery of the electronics gear. In some instances, the only access to the location may be by deepwater port facilities because of the lack of airstrips of adequate size to handle transport aircraft.

2. Costs do vary between structural steel and other equipment, transportable vans, and containers. Determine the weight which meets the separate rate variances.

3. For shipments by water, 1 measurement ton is a unit of volume equal to 40 cubic feet.

4. Military vans fully or partially loaded are billed on the basis of 80 percent of the 1,100 cubic feet of interior capacity, or a costing weight of 22 measurement tons (22 M/T).

(b) Example. Two LOS microwave 15-rack sets, electronics and parts, put into three military vans at the factory and occupying 3,000 cubic feet of space; supplies and miscellaneous tools boxed into 240 cubic feet; and a structural steel tower measured at 1,200 cubic feet, are to be shipped from the CONUS east coast to the east Mediterranean. The transportation cost is estimated as follows:

<u>Description</u>	<u>Cubic Measurement</u>		<u>Rate</u>	<u>Cost</u>
	<u>Feet</u>	<u>Tons</u>		
Electronic gear (3 military vans)	3,300	66	\$58	\$3,828
Supplies and tools*	240	--	--	--
Structural steel (general cargo)	1,200	30	88	2,640
Estimated ocean freight cost				<u>\$6,468</u>

*Shipped in vans at no additional cost.

TABLE 24-11. OCEAN FREIGHT RATES

East Coast to:	General Cargo	Military Vans	Wheeled Vehicles
Panama Lant	\$ 67	\$42	\$46
Europe	81	52	56
British Isles	79	51	55
East Mediterranean	88	58	62
South & East Africa	97	65	69
West Coast, S. America	78	50	54
East Coast, S. America	87	57	61
Rhine River	82	53	57
<u>West Coast to:</u>			
Panama Lant	86	51	57
Europe	108	68	74
British Isles	107	67	73
East Alaska	73	41	48
West Alaska	77	45	51
Hawaiian Islands	80	45	51
Taiwan	98	60	67
Philippine Islands	102	63	69
Thailand	108	67	74
South Pacific	89	53	60
West Coast, S. America	91	55	61
East Coast, S. America	106	66	73
Vietnam	112	71	77
Ryuku Islands	98	60	67
Korea	96	59	65
Japan	95	58	64
<p>NOTE: These measurement-ton rates include transportation, port handling, and documentation cost for containers already packed. If sea vans are stuffed (packed) at port, add \$18.88 per ton at east coast or \$11.00 per ton at west coast.</p> <p>Source: Military Sealift Command Billing Rates, COMSCTRST 7600.3F, dated 15 July 75; MTMC Port Handling Billing Rates, DA Pamphlet 55-3, dated Sep 78; DCA, Code 690, as of 4 Nov 75.</p>			

(4) Table 24-12, Vehicle Operating and Maintenance Costs. An estimate of the average annual operating and maintenance costs (except for costs of the vehicle operator) of Government-owned and Government-operated vehicles can be obtained from the following table by multiplying the number of vehicles by the estimated mileage (or average mileage) for each vehicle of a similar type, then multiplying this product by the appropriate O&M cost.

TABLE 24-12. VEHICLE OPERATING AND MAINTENANCE COSTS

Type of Vehicle	Average Annual Mileage Per Vehicle	Miles Per Gallon of Fuel Issued	Total Operation and Maintenance Cost Per Mile*
Sedan			
Compact	8,800	17.0	\$0.23
Standard	6,800	13.5	.38
Station Wagon			
Compact	11,200	15.9	.23
Standard	7,200	13.9	.35
Ambulance	3,400	9.0	.65
Bus	10,000	7.0	.59
Truck			
Compact	7,700	17.2	.21
Up to 4.25 Tons			
4 X 2	8,400	9.6	.38
4 X 4	8,100	9.6	.41
4.25-6.25 Tons			
4 X 2	9,600		
4 X 4	4,300		
6.25-12 Tons	4,800	8.3	.49
Over 12 Tons	4,900	6.2	.73

*Excludes vehicle operator salary.
Source: AFR 173-13, table 2-8, 1 February 1982.

4. Utilities and POL.

a. General. The annual recurring costs of petroleum, oils, and lubricants (POL), heat, light, and other related utility services, except transportation and communications services (post, camp, or station communications), are discussed herein.

(1) The cost for operating well pumps for onsite water and sewage systems, except for personnel cost, is contained in the cost factors for electricity, POL (fuel) supplies, and miscellaneous costs.

(2) The use of POL products is addressed in terms of operating power units for generators and necessary heating of buildings. Vehicle fuel requirements are addressed in paragraph 3.

(3) Cost estimates should generally be based upon the site's operating 24 hours a day, 7 days a week (8760 hours for a 365-day year).

(4) The cost of number two fuel oil or grade 2-D diesel fuel contains the cost for delivery of fuel, lubricating oil consumed by the diesel engine per gallon of fuel, and transportation costs. Sites remote from military bases or populated areas may incur additional trucking costs.

(5) Use the price for number two fuel oil or grade 2-D diesel oil for estimating both power and heating costs when another type of fuel is not specified.

(6) Factors apply to locations in similar latitudes or weather conditions. For specific locations, weather data are obtainable from the Engineering Weather Data handbooks, AFM 88-8, chapter 6, TM 5-785, and NAV FAC P-89. Using the standard temperatures of 55° for unoccupied buildings and 65° for occupied buildings, one can determine from weather data the number of degrees below the standard in terms of degree-days.

b. Electricity.

(1) Fuel Costs for Auxiliary Power-Generating Equipment.

(a) General.

1. Fuel consumption requirements for communications power-generating equipment are based upon the kilowatt hours (kWh) of power required to operate each station, terminal, or relay site, plus the fuel necessary to test and exercise backup or no-break power units.

2. Commercial electricity is the primary source of DCS power; however, backup power other than commercial is normally required at the sites. The operating hours of generator sets are dependent upon the reliability of commercial power available during emergency conditions. (See chapter 14.)

(b) Estimating Procedure.

1. Determine the kW power requirement by computing the kW requirement of the equipment and a kW factor to support necessary utilities. (Utilities are generally considered an operational load related to the number of authorized personnel and the climatic conditions at the site.)

2. Determine the product of the consumption factor for fuel, the required kWh factor, the price of fuel (including delivery), and the annual operating hours for the diesel electric sets to obtain annual operating costs for fuel. Expressed as an equation:

$$\text{Annual fuel costs} = H \times C \times K \times F$$

Where:

H = Number of operating hours per year
 C = Cost of the fuel being used
 K = Kilowatt power requirement
 F = Consumption rate of gallons of fuel per kWh, .0833

(2) Commercial Electricity Costs. These costs are estimated using the local prevailing rate per kWh. It is necessary to coordinate the use of commercial electricity with emergency requirements, such as battery banks or fuel for standby generators. The cost of fuel to operate generators is equal to or slightly less than the price for commercial electricity costs, dependent upon the fuel consumption factor. See table 24-13.

(3) Example 1. A manned LOS microwave terminal (10 men) in CONUS with a commercial primary power source requires a class B power plant consisting of two 30-kW generators and an auxiliary class D static system to ensure uninterrupted power. Table 24-13 factors are applicable.

(a) Commercial Prime Power Requirements. See chapter 14.

	<u>Average kW Load</u>
Operational load (equipment)	25
Nonoperational load (personnel) $10 \times .5 =$	<u>5</u>
Total	30

(b) Auxiliary Power Requirements.

	<u>Hours</u>
Two 30-kW generators, each exercised for 2 hours every 2 weeks	104
Estimate for emergency operations per year (due to weather, etc.)	<u>296</u>
Annual hours	400

(c) Annual Utilities Cost.

	<u>Cost</u>
Prime: $8760 \text{ hr} \times 30 \text{ kW} \times \$0.05/\text{kWh}$	\$13,140
Auxiliary: $400 \text{ hr} \times 30 \text{ kW} \times$ $\$0.45/\text{gal} \times .0833 \text{ gal}/\text{kWh}$	<u>450</u>
Annual cost	\$13,590

(4) Example 2. An LOS microwave site without commercial power requires a class A power plant consisting of three 30-kW generators (prime, backup, and scheduled maintenance) plus an auxiliary class D static system to ensure uninterrupted power. The average load is 25 kW. Factors appear in table 24-13.

Annual utilities cost:

$$8760 \text{ hr} \times 25 \text{ kW} \times \$0.45/\text{gal}^* \times .0833 \text{ gal/kWh} = \$8,209$$

TABLE 24-13. UTILITIES AND POL

<u>Item</u>	<u>Factor</u>
Annual Operating Hours	8760
Fuel Consumption (gallon #2 fuel oil or grade DF-2 diesel oil per kWh)	.0833
Price DF-2 Fuel Oil (delivered) per Gallon	\$ 1.22
Commercial Electricity (cost per kWh on large military base in CONUS)	
Reimbursable rate	\$ 0.050
Government rate	.045

Source: DFSC Price Bulletin; Andrews AFB; DCA, Code 690, Jul 82.

c. Heating.

(1) General.

(a) To estimate operating fuel requirements for heating equipment, it is necessary to consider type of construction, season, zone, and other climatic factors, cubic footage of area to be heated, gross loss of heat, equipment and lighting heat input, and efficiency ratings of heating equipment.

*Current prices may be used because of rapidly changing fuel cost; however, the date and source of current prices should be included as a footnote.

(b) Basic guidelines used by civil engineers in computing heating cost estimates are as follows:

1. The building heating equipment is designed to maintain 75 degrees indoor temperature during daily operating conditions at outdoor winter design conditions established for the geographical area. In addition, the heating system should have a minimum capacity to maintain 50 degrees indoor temperature without operation of communications equipment or lights at outdoor winter design conditions. Heating equipment generally operates at 80-percent efficiency, and may use one or more fuels.

2. When diesel generators are in use, heating equipment normally will use the same type of fuel; i.e., number two fuel oil or grade 2-D diesel fuel. British thermal unit (Btu) output increases in proportion to the weight of the fuel.

(2) Use of Table. To estimate costs where only general seasonal, climatic, and geographical factors are known, assume the building will be designed to meet the minimum temperature standard (50 to 65 degrees) for the building area where heating is absolutely essential. Consider the location required (e.g., mountainous or windy) and multiply the cubic footage of the building to be heated by the appropriate factor from table 24-14 for gallons per cubic foot of space. Utilize the 55-degree-day table for buildings not normally occupied and the 65-degree-day table for occupied buildings. Adequate heat to maintain 65 degrees plus gains from equipment and lights will provide necessary working and living conditions for communications maintenance and operational personnel.

(3) Estimating Procedures.

(a) Multiply cubic feet of building space by the appropriate factors from table 24-14.

(b) Multiply total gallons of heating fuel obtained by the cost factor in table 24-13 for number two fuel oil to obtain the annual cost for heating.

(4) Example. Heating costs are to be estimated for a remote LOS microwave site located within 60 miles of Olathe, Kansas. The building complex will be insulated, with a ceiling height of 10 feet, and will contain barracks, mess, recreation, and support facilities for 15 communications and 6 support personnel (military) in addition to operational communications equipment. Required square footage is shown below.

(a) Building Volume Calculations.

<u>Type</u>	<u>Square Footage</u>	<u>Cubic Feet</u>
Operations	1,050	10,500
Barracks, mess, recreation	4,000	<u>40,000</u>
Total occupied space (insulated 65 degrees)		50,500
Generator building	150	1,500
Storage, garage, and hobby shop	550	<u>5,500</u>
Total unoccupied space (insulated 55 degrees)		7,000

(b) Cost Calculations.

	<u>Cost</u>
50,500 ft ³ X .0891 gal/ft ³ X \$0.45/gal*	\$2,025
7,000 ft ³ X .0180 gal/ft ³ X \$0.45/gal*	<u>57</u>
Estimated annual cost	\$2,082

*The current price may be used because of rapidly changing fuel costs; however, the date and source of current prices should be included as a footnote when the cost per gallon varies from table 24-13 price.

TABLE 24-14. ANNUAL REQUIREMENTS FOR #2 FUEL OIL FOR HEATING

<u>Location</u>	<u>Number of Gallons Per Year Per Cubic Foot</u>		
	<u>Unoccupied Space (55°)</u>	<u>Occupied Space (65°)</u>	
	<u>Not Insulated</u>	<u>Fully Insulated</u>	<u>Fully Insulated</u>
Tropics (except high altitudes)	0	0	0
Southern United States, near coastal areas	.0024	.0016	.0177
Gulf Coast States, coastal States from VA South, and CA; Tokyo, Japan, and Southern Japan; Mediterranean coastal areas in Europe; and Southern England	.0222	.0131	.0791
Northern England, Germany and Southern Europe, Northern Japan (except mountainous terrain in all locations); Continental U.S. south of and including RI, PA, IN, KS, NM, AZ.	.0297	.0180	.0891
Southern Canada and Northern U.S. except Rocky Mtn. areas; Scandinavian Countries; European mountainous areas except U.S.S.R. and Swiss Alps	.0521	.0335	.1337
Point Barrow, AK, and extremely mountainous areas		.0965	.2954

Source: DCA Code 690/NAV Docks MO-303 Exhibit 4-4 and V, dated 23 Aug 71; current as of 16 Jan 76, DCA, Code 690.

5. Contractor Employees.

a. General.

(1) Guidance for costing contractor-furnished employees is provided herein. These employees fill key positions as professional engineers and consultants as well as provide site supervision and administrative and technical services. Tables 24-15 through 24-17 contain costs for their services, which include the following:

- (a) Salary.
- (b) Overhead and general and administrative expenses.
- (c) Profit or fee.

(2) An additional consideration for subsistence is made for those employees serving in overseas areas.

(3) Travel costs are additive.

(4) The three general classes of service of contractor-furnished employees for which cost factors have been developed are as follows:

- (a) R&D to include studies and reports.
- (b) Manufacturing.
- (c) Engineering, furnishing, and installing of communications equipment/systems.

b. Job classification is not standardized throughout industry; what is called an engineer in one company may be a junior engineer, engineering aide, or engineering technician in other companies. Because of this lack of standardization, a job title is somewhat meaningless unless the duties and qualifications for that job are known. For this reason brief job descriptions of the duties associated with job titles have been included in the Glossary of Terms. These job descriptions should be used as an aid in the determination of the labor classifications to be priced when job titles are not self-explanatory.

c. Salaries are affected by the geographical areas where work is to be done and by union activities. These differences may be significant; therefore, salaries contained herein should be used only when actual rates for the area concerned are not known.

d. Derivation of Factors.

(1) A review of existing contracts indicates that the contractual effort takes place in the home plant, at the field location in the CONUS,

or in the overseas area. For example, a lead engineer may be utilized at any of these locations. The additional costs for this individual away from the home plant, such as lodging, subsistence, and overhead, are included in the annual pay rates for field and overseas factors.

(2) Field systems engineers usually operate away from the home plant, while planning and installation or systems service and support engineers complete their assignment using in-house facilities and staff, with only minimal travel required.

(3) Transportation costs for contractor personnel are not contained in the annual pay rate. Estimates can be prepared using tables 24-6 and 24-7.

e. Use of Tables.

(1) Determine the number and type of personnel required to perform necessary functions in terms of person-years, then perform the required multiplication.

(2) Pay rates for engineers, technicians, and civilian clerical support in the field are contained in table 24-16.

(3) Table 24-2, "DCA Civilian Personnel Pay Rates CONUS," may be used as a guide for clerical support in the home plant, and table 24-5, "Foreign National Pay Rate," provides salaries for clerical personnel overseas.

f. Estimating Procedures.

(1) Determine from the specifications contained in the work statement or contract the specific parameters of the contractual effort to be performed at the contractor's plant and on location (field or overseas). The degree of sophistication of the equipment, the state of the research and development effort, and the physical and political situation at the overseas location must be considered. These intangible factors could require complete assembly and testing at the home plant prior to disassembly and shipment of the communications gear; or, in the case of less sophisticated equipment in the inventory, the contractor might work solely at the overseas location. In other situations, the contractor may be operating and maintaining communications equipment already in place at remote locations, or in countries where military personnel are not allowed.

(2) After determining personnel requirements in person-years, segregate by type (engineers, technicians, and clerical support) and by nationality, keeping U.S. nationals in key jobs where security requirements dictate foreign personnel cannot be used. Normally, clerical positions overseas may be filled by foreign personnel. Compute pay cost using table 24-2 and the next lower grade for skill required. Table 24-5

indicates variances in salaries between countries for communications technicians.

g. Example.

(1) There is a requirement to estimate the costs of the development of a very sophisticated computer program which will be associated with a new switched communications system. It is estimated that the development of the program will require 120 person-years of effort. One programmer will be stationed in Europe, the rest of the work will be done in CONUS.

(2) The first step in making the estimate is to determine the time and skills needed for each phase of the requirement. This can be done as follows:

Analysis (40%):

Program Manager	1
Sr Supervisory Systems Analyst	4
Computer Systems Analyst	3
Sr Computer Programmer	3
Computer Programmer I	12
Computer Programmer II	12
Computer Programmer III	13
	<u>48</u> Person-years

Coding (20%):

Program Manager	.5
Sr Supervisory Systems Analyst	3
Sr Computer Programmer	6
Computer Programmer II	14.5
	<u>24</u> Person-years

Task (40%):

Program Manager	1
Sr Supervisory Systems Analyst	4*
Sr Computer Programmer	4
Computer Programmer II	39
	<u>48</u> Person-years

(3) Cost estimate using the time shown above and labor rates in tables 24-15, 16, and 17 will be:

*Two person-years (one analyst) effort in Europe.

Labor:

Program Manager	2.5 @ \$93,400 =	\$ 233,500
Sr Supervisory Systems Analyst	11 @ 66,200 =	728,200
Computer Systems Analyst	3 @ 66,200 =	198,600
Sr Computer Programmer	13 @ 46,300 =	601,900
Computer Programmer I	12 @ 26,900 =	322,800
Computer Programmer II	65.5 @ 32,200 =	2,109,100
Computer Programmer III	13 @ 39,100 =	508,300
Cost of Labor		<u>\$4,702,400</u>

Other Costs:

Transportation 1 round trip to Europe @ \$3,600	7,200
Overseas Bonus and Extended Workweek @ 40% X \$46,300	18,520
Total Other Costs	<u>25,720</u>

Total

\$4,728,120

TABLE 24-15. CONTRACTOR LABOR COSTS (U.S. NATIONALS) -
R&D STUDIES

Occupational Category	Hourly Rate	Annual Rate	Annual Cost To User
Prog Mgr/Sr Official	\$ 18.70	\$ 38,900	\$ 93,400
Engineers			
Principal Engineer	16.68	34,700	83,300
Senior Engineer	10.00	20,800	49,900
Associate Engineer	6.92	14,400	34,600
Computer Systems Operations			
Sr Supervisory Systems Analyst	13.27	27,600	66,200
Computer Systems Analyst Specialist	13.27	27,600	66,200
Systems Analyst	11.15	23,200	55,700
Sr Computer Programmer	9.28	19,300	46,300
Computer Programmer I	5.38	11,200	26,900
Computer Programmer II	6.44	13,400	32,200
Computer Programmer III	7.84	16,300	39,100
Electronic Technician			
Electronic Tech Jr	5.14	10,700	25,700
Electronic Tech Sr	7.26	15,100	36,200

TABLE 24-15. CONTRACTOR LABOR COSTS (U.S. NATIONALS) -
R&D STUDIES (CON.)

Occupational Category	Hourly Rate	Annual Rate	Annual Cost To User
Support			
Secretarial/Tech Typing	5.19	10,800	25,900
Clerical	3.70	7,700	18,500

Source: 1977/78 Contract Data

TABLE 24-16. CONTRACTOR LABOR COSTS (U.S. NATIONALS) -
CONTRACTS TO ENGINEER, FURNISH, INSTALL COMMUNICATION SYSTEMS

Occupational Category	Hourly Rate	Annual Rate	Annual Cost To User	
			CONUS	Overseas*
<u>CONUS</u>				
Systems Engineer	\$ 9.30	\$19,300	\$45,700	-
Senior Engineer	11.67	24,300	57,600	-
Project Engineer	8.96	18,600	44,100	-
Draftsman	7.36	15,300	36,300	-
Clerical	4.14	8,600	20,500	-
Project Manager	20.40	42,400	100,500	-
<u>OVERSEAS*</u>				
Senior Field Engineer	8.35	17,400	-	\$28,800
Field Engineer	6.83	14,200	-	23,500
Installation Supervisor	10.80	22,500	-	37,200
Test & Acceptance Supervisor	9.89	20,600	-	34,100
Technician	5.35	11,100	-	18,400

*Overseas costs to user are lower than CONUS rates because most corporations have their field activities in a separate overhead pool which has a lower departmental burden. However, workers overseas are usually paid for a 48-hour week, and incentives are paid to personnel who remain overseas for a specified period. These incentives are additional to labor costs shown above, and they range in value from approximately 20 percent in Europe to 20 to 30 percent in the Middle East and the Pacific and up to 70 percent for hazardous and extreme climatic conditions.

Source: 1977/78 contract data.

TABLE 24-17. CONTRACTOR LABOR COSTS (U.S. NATIONALS) -
CONTRACTS FOR MANUFACTURE OF COMMUNICATIONS EQUIPMENT

Occupational Category	Hourly Rate	Annual Rate	Annual Cost To User
Engineering Manager	\$14.97	\$31,100	\$79,000
Industrial Engineer	9.81	20,400	51,800
Engineering Specialist	13.95	29,000	73,700
Sr Engineering Specialist	15.95	33,200	84,300
Technician	7.84	16,300	56,400
Fabrication Plant	6.12	12,700	43,900
Model Shop Wireman	5.93	12,300	42,600
Assembler	4.75	9,880	38,200
Quality Control	8.79	18,300	63,300

Source: 1977/78 contract data.

h. Independent Government Cost Estimate for Scientific, Engineering, and Technical Support Contracts.

(1) General.

(a) This paragraph provides guidance for the preparation of independent Government estimates for planning and budget purposes, for contracts providing management and scientific analysis, and engineering and technical support. The use of the suggested formats is not a mandatory requirement, unless stated by other DCA documents. These contracts are labor-intensive and usually involve only small amounts of material and equipment. This paragraph does not apply to contracts for the acquisition of hardware, for the operation of communications systems, or for the maintenance of these systems.

(b) The cost estimate is based on the Statement of Work (SOW) which describes the work (tasks, materials, and services) to be performed (see DCAI 260-70-3, Project Monitor's Handbook for the Preparation and Processing of Acquisition Actions, chapter 6). The

SOW provides the link between the Government's requirement and the corresponding cost to the Government. First, the total contract price is estimated, using the categories: Direct Labor Charges (DLC), Indirect Labor Charges (ILC), Other Direct Charges (ODC), General and Administrative (G&A), and Fee, described in paragraph (3). These costs are then spread over the performance years of the proposed contract. Finally, the time-phased costs are adjusted to include the effects of inflation on budget estimates.

(c) Cost estimating for these contracts begins with an analysis of the stated requirements to determine the categories of effort the project tasks will require and the amount of each category of effort. The office preparing the SOW must describe the requirement as specifically as possible (without necessarily specifying the details of the contractor's approach to the tasks). The requirement should be divided into well-defined tasks and an end product described for each. Examples of end products include milestone schedules, literature reviews, block diagrams of computer programs, functional specifications for switching devices, and working prototypes of an item. Some suggestions are provided below on relating the tasks identified above to the corresponding labor requirements.

1. Decide whether the tasks and their interrelationships are simple or complex. Decide also whether the tasks are state-of-the-art or routine. A literature review or interviews may be required.

2. Decide on a unit of measure for labor. For estimating purposes the concept of a Technical Staff Month (TSM) is suggested. A TSM is defined as 1 month of a professional, technical, or scientific person's time directed to the performance of the tasks in the SOW. TSM should not include general management or supervision unless the supervisor or manager is assigned and identified to the individual project; nonproductive time, such as leave and holidays; and administrative, secretarial, clerical, and graphics support personnel. The costs for these items are included in ILC (see paragraph (3)(b)).

3. Meet with previous Contracting Officer's Technical Representatives (COTR's) experienced in similar work and review the contracts to help quantify the relationship between the level of contractor staffing and the corresponding outputs for the proposed tasks. Review of this historical data is easier to accomplish and provides a more accurate estimate of TSM if the project has been divided into well-defined tasks. Exercise caution when using historical data to estimate TSM, especially when contracts are not very similar or the tasks are state-of-the-art R&D efforts. Consider also that the relationship between the number of TSM required and project size is not a linear one. Large projects require additional TSM for integration and coordination requirements.

4. Reference texts that address requirements definition and methods for estimating TSM requirements are available in the DCA Technical Library and the DCEC Technical Library. However, regardless of the method used to estimate the TSM, the estimate still relies heavily on expert judgment.

5. At the end of this phase, the project monitor should have a planning estimate for the categories and amounts of TSM required and also a preliminary project schedule. The Independent Cost Estimate Worksheet can now be completed.

(d) Instructions for preparation of independent cost estimates when the contract is to be let to a Federal Contract Research Center (FCRC) are discussed under paragraph (6) below.

(2) Derivation of Factors.

(a) The occupational categories and the narrative descriptions in table 24-18 were developed from a study of FY 1980 DCA contracts. The monthly salaries in this table were compiled from the contracts, Bureau of Labor Statistics, and a variety of articles and association reports. These salary figures were then updated to FY 1981 price levels. The use of more recent salary data, when available, is encouraged.

(b) The loading factors below for Indirect Labor Charges, G&A, and Fee were developed from a study of task order contracts.

TABLE 24-18. CONTRACTOR MONTHLY SALARIES
SCIENTIFIC, ENGINEERING, AND TECHNICAL SUPPORT CONTRACTS

<u>Management Staff/Advisers</u>	Years' Experience				
	Under 5	5	10	15	20+
High-level Executives/Supervisors	-	-	-	\$4500	\$4500
- Director of Engineering					
- Manager of a large project					
Director of Research					
Mid- to High-level Executives/Supervisors					
- Program Manager for a medium-sized project	-	-	\$3600	3600	-
- Manager of a medium-sized division					
Senior Technical Advisers				4500	4500
- Ph. D.					
Widely recognized in their field					
Consultants	-	-	-	4500	4500
<u>Engineers</u>					
Senior Engineers	-	-	-	3600	3600
- Usually Electrical Engineers					
- Ph. D. Level, MSEE Level					
Mid-level Engineers--with advanced degree	-	\$3100	3100	-	-
--without advanced degree	-	-	-	3100	3100
- Branch Chief					
- Senior Engineer on a small project					
Member of technical staff					
Entry-level to Mid-level Engineers	\$2550	2550	-	-	-
Undergraduate degree in Engineering					
<u>ADP Personnel</u>					
Senior ADP Personnel	-	-	-	2700	2700
- Often has advanced degree					
- Program Manager					
Mid-level ADP Personnel	-	1600	200	-	-
Entry-level ADP Personnel	1250	-	-	-	-
Source: DCA FY 1980 Contracts updated to FY 1981 price levels, Bureau of Labor Statistics, and various professional journals.					

(3) Preparation of Independent Government Estimates. The Independent Cost Estimate Worksheet (figure 24-3) is used to prepare independent estimates. It provides guidance for calculating Direct Labor Costs (DLC), Indirect Labor Costs (ILC), Other Direct Costs (ODC), G&A, Contractors' Fee, and Total Cost. Other quantities, specifically the average cost per TSM and the comparison ratio, are also calculated on this worksheet to allow convenient comparison to other contractual efforts.

(a) To calculate Direct Labor Charges (DLC), enter the number of Technical Staff Months required for each category of effort identified. Using table 24-18, determine the monthly salary level for each category of effort identified. Multiply the TSM by the monthly salary and sum the results to arrive at the DLC.

(b) Indirect Labor Charges (ILC) include all labor costs chargeable to the contract other than the salaries of the professional, technical, and scientific persons included under DLC above. ILC covers the salaries of the administrative, secretarial, clerical, and graphics support personnel. ILC also covers the employee benefits, social security, workmen's compensation, and an amount for nonproductive time for all persons charged to this contract. An analysis of recent DCA contracts showed that ILC, using this definition, ranged from 87 percent to 211 percent of DLC with an average value of 150 percent. Table 24-19 shows how the ILC rate varied for different categories of tasks. For planning purposes, unless better information is available (e.g., prior contracts for very similar work) or if the task falls into one of the categories identified in table 24-19, use the formula:

$$ILC = 1.5 \times DLC$$

TABLE 24-19. ILC FACTORS FOR SCIENTIFIC, ENGINEERING,
AND TECHNICAL SUPPORT CONTRACTS

<u>Category</u>	<u>ILC Factor</u>
Management Analysis, Math Modeling, Operations Research	1.75 - 2.00
Test Design and Implementation, Technical Assistance, Computer Programing	1.25 - 1.75
Engineering Support, Data Collection, Update Previous Studies	.90 - 1.25

Source: Code 690 study of DCA contracts, 1980.

FOR OFFICIAL USE ONLY (WHEN FILLED IN)

INDEPENDENT GOVERNMENT COST ESTIMATE			
CONTRACT NUMBER		TASK ORDER	
		AMENDMENT	
1. DIRECT LABOR CHARGES			
<u>CATEGORY OF EFFORT</u>	<u>NUMBER OF MONTHS</u>	<u>MONTHLY SALARY*</u>	
_____	X	_____	•
_____	X	_____	•
_____	X	_____	•
_____	X	_____	•
_____	X	_____	•
TOTALS	(TSM)		(DLC)
AVERAGE COST PER TSM = DLC/TSM = _____			
2. INDIRECT LABOR CHARGES			
ILC = (DLC) X (LOADING FACTOR) = _____ X _____ = _____ (ILC)			
COMPARISON RATIO = (DLC + ILC)/TSM = _____			
3. OTHER DIRECT CHARGES			
	TRAVEL	•	
	MATERIAL	•	
	EQUIPMENT	•	
	ADP	•	
	SUBCONTRACT	•	
	OTHER (Specify)	•	
SUBTOTAL A = (DLC) + (ILC) + (ODC) = _____ (A)		TOTAL = _____	(ODC)
4. GENERAL AND ADMINISTRATIVE (G&A)			
G&A = (A) X (G&A LOADING FACTOR) = _____ X _____ = _____ (G&A)			
SUBTOTAL B = (DLC) + (ILC) + (ODC) + (G&A) = _____ (B)			
5. FEE			
FEE = (B) X (Fee Rate) = _____ X _____ = _____ (FEE)			
6. TOTAL COST			
TOTAL = (DLC) + (ILC) + (ODC) + (G&A) + (FEE) = _____ (TOTAL)			
*Note—Costs are estimated in constant FY _____ dollars.			

DCA FORM 782 FEB 81

FOR OFFICIAL USE ONLY (WHEN FILLED IN)

FIGURE 24-3. INDEPENDENT COST ESTIMATE WORKSHEET

(c) Other Direct Charges (ODC) cover travel (including transportation, per diem, and rental cars), material, equipment, ADP, consulting, subcontracts, and other items. These items can only be identified and priced after development of a more specific knowledge of the required tasks. Many of these items can be priced by using readily available sources (e.g., airline fares, equipment catalog prices, rental car schedules). ADP equipment prices can be found in Auerbach Computer Technology reports, or other reference sources.

(d) General and Administrative (G&A) charges cover companywide costs (for example, office space and insurance) that the contractor will allocate to the contract. G&A in recent contracts has usually ranged from 14 percent to 18 percent of the total of DLC, ILC, and ODC. However, values outside this range were also observed. For planning, unless better information is available, use the formula:

$$\text{G\&A} = .16 \times (\text{DLC} + \text{ILC} + \text{ODC})$$

(e) The element Fee covers the profit or fee to the contractor. The amount for fee is subject to negotiation and depends on the degree of contractor risk, the value of contractor facilities, and other factors. The DCA contracts researched were of the cost-plus-fixed-fee type (low risk to the contractor), and the fee ranged in the area of 10 percent of the total cost of DLC, ILC, ODC, and G&A. For planning, unless better information is available, use the formula:

$$\text{Fee} = .10 \times (\text{DLC} + \text{ILC} + \text{ODC} + \text{G\&A})$$

(4) Time-Phasing the Planning Estimate. For budget purposes the cost figures derived above on the Independent Cost Estimate worksheet must be spread out over the duration of the contract and also adjusted for inflation. Paragraph (a) below shows how to spread these constant dollars over the duration of contract performance, and paragraph (b) below shows how to adjust the time-phased, constant-dollar costs to include the effects of inflation during the contract period.

(a) First, spread the total constant-dollar amount into specific amounts for each fiscal year. For DLC and ILC, use proportions. Allocate the dollars for these elements in each fiscal year proportional to the number of TSM expended in that year. Projects that take place entirely in 1 fiscal year do not have to be time phased. The SOW may suggest how quickly the tasks are to be performed (for example, a surge effort with minimal follow-on, or alternatively, an even level of effort throughout). For ODC, the time phasing requires a knowledge of each of the items and when they are required. The time phasing of G&A and Fee can be based on the same proportions as were used for DLC, ILC, and ODC, above. After spreading these costs over the fiscal years of the contract (i.e., before adjusting to include the effects of inflation) the total amount should be the same as the total constant-dollar amount originally developed.

(b) For budget purposes it is necessary to calculate the Total Obligation Authority (TOA) required in each fiscal year. The TOA figures are developed from the time-phased, constant-dollar costs developed in paragraph (a), by adjusting for the effects of price level changes and outlay rates. Table 38-3 (Weighted Price Level Indexes) gives a specific index for each fiscal year. The following formula is used:

$$\frac{\text{Index}}{100} \times \text{Constant Dollar Costs} = \text{TOA}$$

Chapter 38 provides further discussion on how to use these indexes.

(5) Example, Using Worksheet to Prepare Planning Estimate.

(a) Using data and scenarios prepared by DCA, the contractor will analyze the capability of a proposed hardened cable communications network to endure several types of natural disasters, such as earthquake and fire. Several types of cable will be provided as Government Furnished Material (GFM), and the contractor will perform testing at the contractor's own facility, assumed in this example to be a local one. It is not possible to specify exactly how many tests will be run, because the plan requires that the contractor use an iterative search procedure in which the results of each stage are analyzed before deciding how to continue. There will be, however, not fewer than 12 and not more than 36 tests. The contract will start at the beginning of the third quarter of FY 1981 and run for 2 years. Costs for this example will be estimated first in constant FY 1981 dollars. Then the TOA will be calculated.

(b) On the basis of the Statement of Work and a knowledge of similar projects, it is estimated that a contractor might assign four professionals, each devoting half his or her time to this project (the other half to another, unrelated project). There might be a senior engineer, two members of the technical staff, and an engineering aide. Figure 24-4 shows under Direct Labor the types of effort and the number of months for each. Enter the monthly salaries under Direct Labor Charges. The ILC loading factor (from table 24-19) is estimated to be 1.5, and is entered under Indirect Labor Charges. Since the contractor will use GFM at the local facility, the contract should have no material or travel. The contractor should already have any necessary test equipment. Other Direct Charges, then, are estimated at zero. The suggested G&A loading factor of .16 is considered appropriate, and is entered on line 4 of the worksheet. Likewise, a Fee rate of .10 is entered on line 5. The total contract cost estimate, in constant dollars, is then \$453,618, as shown on line 6 of figure 24-4.

INDEPENDENT GOVERNMENT COST ESTIMATE				
CONTRACT <u>Hardened Cable Example</u>			TASK ORDER	
			AMENDMENT	
1. DIRECT LABOR CHARGES				
<u>CATEGORY OF EFFORT</u>	<u>NUMBER OF MONTHS</u>		<u>MONTHLY SALARY*</u>	
Senior Engineer	12	X	\$3,100	= \$37,200
Tech Staff Member	24	X	3,100	= 74,400
Engineering Aide	12	X	2,550	= 30,600
		X		=
		X		=
TOTALS	48	(TSM)		<u>142,200 (DLC)</u>
AVERAGE COST PER TSM = DLC/TSM = <u>\$2,962</u>				
2. INDIRECT LABOR CHARGES				
ILC = (DLC)X(LOADING FACTOR) = <u>142,200</u> X <u>1.5</u> = <u>213,300 (ILC)</u>				
COMPARISON RATIO = (DLC + ILC)/TSM = <u>\$7,406</u>				
3. OTHER DIRECT CHARGES				
	TRAVEL	-	-	=
	MATERIAL	-	-	=
	EQUIPMENT	-	-	=
	ADP	-	-	=
	SUBCONTRACT	-	-	=
	OTHER (Specify)	-	-	=
	TOTAL			<u>0 (ODC)</u>
SUBTOTAL A = (DLC) + (ILC) + (ODC) = <u>\$355,500 (A)</u>				
4. GENERAL AND ADMINISTRATIVE (G&A)				
G&A = (A) X (G&A LOADING FACTOR) = <u>355,500</u> X <u>.16</u> = <u>56,880 (G&A)</u>				
SUBTOTAL B = (DLC) + (ILC) + (ODC) + (G&A) = <u>\$412,380 (B)</u>				
5. FEE				
FEE = (B) X (Fee Rate) = <u>\$412,380</u> X <u>.10</u> = <u>41,238 (FEE)</u>				
6. TOTAL COST				
TOTAL = (DLC) + (ILC) + (ODC) + (G&A) + (FEE) = <u>\$453,618 (TOTAL)</u>				
Note--Costs are estimated in constant FY <u>81</u> dollars.				

FIGURE 24-4. HARDENED CABLE EXAMPLE

(c) A constant level of effort is assumed for this contract, which runs for eight quarters -- two in FY 1981, four in FY 1982, and two in FY 1983. The use of proportions (one-eighth of the constant-dollar total in each quarter) gives time-phased constant-dollar costs as follows:

Fiscal Year	FY 1981	FY 1982	FY 1983	Total
Cost (Constant FY 1981 \$)	113,404	226,810	113,404	453,618

(d) The Total Obligation Authority for this example is calculated by using the RDTE indexes from table 38-3 of this manual. First divide these indexes by 100, and then multiply the constant-dollar costs above as follows:

Fiscal Year	FY 1981	FY 1982	FY 1983	Total
Cost (Constant FY 1981 \$)	113,404	226,810	113,404	
Index	1.049	1.137	1.222	
TOA (Current \$)	<u>118,961</u>	<u>257,883</u>	<u>138,580</u>	<u>515,424</u>

The Total Obligation Authority is presented on DCA Form 9: Summary Sheet.

(6) Federal Contract Research Centers. There are six Federal Contract Research Centers (FCRC's), three of which are used by DCA as shown in table 24-20. These are nonprofit organizations primarily engaged in providing independent specialized technical and scientific support to DoD. FCRC's charge a fixed fee per TSM (table 24-20). This is a loaded fee that includes ILC, G&A, and Fee discussed previously.

(a) To prepare an independent estimate for an FCRC contract effort, the types and amounts of effort required to perform the tasks are identified in the SOW as described in paragraph (1)(c) above.

(b) Multiply the total number of TSM required by the cost per TSM from table 24-20.

(c) Use the Independent Cost Estimate Worksheet to complete the estimate. Do not, however, complete section 2 (Indirect Labor Charges), section 4 (G&A), or 5 (Fee), as the costs for these items are included in table 24-20.

(d) Time phasing of planning estimates for FCRC's is accomplished as described in paragraph (4).

TABLE 24-20. FEDERAL CONTRACT RESEARCH CENTERS

<u>FCRC</u>	<u>Fee per TSM (FY 1983)</u>
Institute for Defense Analysis (IDA)	\$10,400
Lincoln Labs	11,150
MITRE	
CONUS	9,200
Europe	15,400
Pacific	13,750

Source: Code 690, Sep 82.

6. Security Clearances.

a. General. The U.S. Government incurs expenses for investigations of all personnel who require access to information which has been classified in the interests of national security. Investigations of employees of, and contractors for, the military departments and defense agencies are conducted by the Defense Investigative Service (DIS).

b. Derivation of Costs. Table 24-18 presents average costs for background investigations ("BI") and BI Bring-ups on DCA personnel. Included are costs of "full field" DIS investigations and National Agency Checks, as well as Security Division costs associated with converting investigations into clearances. BI Bring-ups are updates conducted on individuals at 5-year intervals. To determine a recurring annual cost, divide the tabled cost by 5. When an overseas check is required for military personnel, it is conducted by the applicable military department.

TABLE 24-21. SECURITY CLEARANCE COSTS

<u>Item</u>	<u>Cost</u>
Background Investigation	\$330
BI Bring-up (every 5 years)	75
Overseas Check	30

Source: DIS, DCA Code 240, and DCA Code 690 as of Jun 78.

7. Miscellaneous O&M Factors.

a. Building Maintenance.

(1) General. This paragraph covers the recurring annual costs for building maintenance normally funded from the O&M appropriation. These costs include recurring supplies, materials, and other minor equipment items for the repair and maintenance of buildings and other structures, grounds, roadways, parking lots, and foundations. Also included are support for custodial and protective services, fire reporting, and security alarm system maintenance. Excluded are military and civilian U.S. employees' pay and allowances. Minor construction projects costing \$25,000 or less funded from the operations and maintenance funds are included; however, DoD policy forbids the military departments to augment major communication construction projects with O&M project funds. Storage and supply buildings supporting communication facilities should be included in the basic construction costs, even though costing \$25,000 or less.

(2) Use of Table. A cost factor found in table 24-22 should be applied to the estimated initial cost of communications buildings and facilities to estimate the annual cost of building maintenance. The analyst must determine if the construction index should be applied to adjust the estimated costs selected for the geographical area. Construction cost indexes are contained in chapter 36.

(3) Example 1. The buildings and facilities of an LOS microwave system to be built in the northern area of Michigan are estimated to cost \$285,200.

$\$285,200 \times .05 \times 1.15 = \$16,399$ per year building maintenance.

(4) Example 2. The buildings in an existing microwave system actually cost \$300,000 to construct. (When actual cost is available, the construction index factor does not apply.)

$\$300,000 \times .05 = \$15,000$ per year building maintenance.

b. Supplies and Equipment.

(1) General. This topic addresses the recurring annual costs for supplies and equipment normally funded from the O&M appropriation. More specifically, this element includes the cost of supplies, material, repair parts, equipment assemblies, and clothing or other expendable equipment consumed in the operation and maintenance of communications mission equipment. Excluded are "investment" type items contained in chapter 25 or spares costing over \$1,000 per item of issue; POL products costed in this chapter, paragraph 4, "Utilities and POL"; and supplies or equipment utilized by the host base in performing support functions, such as building and grounds maintenance and operation and maintenance of vehicles covered in paragraphs a and c. The supplies and equipment costed in this element are the recurring

annual costs funded in the communications organization budgets, to include the base communication applicable costs. The supplies and equipment encompass associated supplies, material, clothing, furniture, fixtures (not affixed), safety items, tools, machinery, chemicals, instruments, and apparatus.

(2) Use of Table. Determine the costs of mission, auxiliary, test, peculiar, and common support equipment. Add together and multiply by the factor found in table 24-22.

(3) Example. LOS communication, auxiliary, test, and support equipment at a site are estimated to cost \$857,000.

$\$857,000 \times .03 = \$25,710$ per year recurring O&M cost.

c. Military Base Contractual Services. These services exclude DECCO leases, depot level maintenance, and contractor-operated bases or sites.

(1) General.

(a) Costs reviewed encompassed the following:

1. Data processing (PCAM, EAM) and computer equipment leases not obtained through DECCO.
2. Rental of reproducing equipment.
3. Communication contract services, such as service contracts, telephone ringers, and alarms, unless obtained through DECCO.
4. Other leased equipment, such as cranes.
5. Postage and post office boxes.
6. Purchased equipment maintenance.
7. Printing and reproduction.

(b) A factor has been developed for those portions of the above services, such as crane leases and repair of air conditioners, pertinent to an LOS site supported by a host base. If normal base support is not available, the percentage will increase.

(2) Use of Table. Multiply the appropriate factor in table 24-22 by the estimated cost of the equipment. Communication units, detachments, and squadrons receive base support from the closest military installation.

(3) Estimating Procedure. Determine the cost of the prime mission, auxiliary, test, and support equipment and estimate the availability of base support.

(4) Example. LOS total equipment costing \$857,000 requires contractual support available from a host base.

$$\$857,000 \times .003 = \$2,571 \text{ annual cost}$$

d. Contractor-Operated Base Markups.

(1) General. A review of current contracts revealed a wide range of contractual support costs. It is necessary to apply the personnel costs of the local country as shown by table 24-5 to the technical and clerical personnel costs of the U.S. contractor. Costs in table 24-15 for engineering and key personnel of the contractor already incorporate these support costs.

(2) Use of Table. Table 24-22 contains cost factors and instructions as to application of the markup to cost estimates developed in accordance with other parts of this Circular; e.g., cost markup on salaries or material purchase prices. These factors should be used only when the salaries of personnel or material purchase prices exclude overhead and miscellaneous support costs.

(3) Estimating Procedure.

(a) Consider the type of personnel trained to operate the transmission media as well as the climatic factors, the geographical area, and the political situation of the foreign country. When adequate personnel are available from a nearby city, the amount of required personnel housing and other support will decrease. Conversely, if the base is to be operated in a remote desert, all personnel support must be included in the base facility complex. The estimate must incorporate the contractor's cost and overhead and profit. Contractor costs are subject to, and directly affected by, the foreign country's political situation and customs, a factor difficult to evaluate but necessary to consider.

(b) Use the basic factors and block diagrams available in this Circular for estimating equipment, supplies, spare parts, other material, transportation, etc., anticipated to be furnished by contract. Separately identify the subtotals of the various categories of cost; apply the overhead factors to the categories; compute the direct costs which include personnel overhead; apply the additional factor for overhead, taxes and profits; and total. Determine the appropriate totals and apply the factors in table 24-22.

TABLE 24-22. MISCELLANEOUS O&M FACTORS

Item	Percentage
<u>Annual Costs</u>	
Maintenance and Acquisition of Buildings	.05
Supplies and Equipment	.03
<u>Military Base Contractual Services</u> (excludes DECCO and contractor-operated base)	
Host-Tenant Support Available	.3
Host-Tenant Support Not Available	1.0
<u>Contractor-Operated Base Markups</u>	
Personnel Overhead: Increase Salaries for Civilians (U.S. or foreign)	25.0
Processing and Handling of Materials: Increase Total Purchase Price	6.0
Other Overhead: Increase Total for Direct Cost Plus Above Percentage Markups	5.0
U.S. Taxes and Profit: Increase All Costs and Prior Markups	10.0
Source: DCA, Code 690, current as of Feb 76.	

CHAPTER 25. RECURRING INVESTMENT

1. General. Recurring investment primarily encompasses spare parts (costing over \$1,000), other high-value items, replacement equipment, and communications devices (not in themselves a communications subsystem) required on an annual basis to support an existing communications system. Research and development costs are not treated in this chapter as recurring investment, even though the R&D effort may be continued after the communication system is operational. Ongoing R&D effort should be separately costed to indicate annual requirements.

2. Replacement Factor. The estimated percentage of equipment or repair parts in use that will require replacement during a given period because of equipment wearing out beyond repair, enemy action, abandonment, pilferage, and other causes except natural disasters.

3. Derivation of Factors. Data available over the past years and special studies made at operational communications sites were reviewed for the amount of spare parts, other high-value items, and replacement spares requisitioned annually to replace initial spares, spare parts, and wornout equipment. When the cost was compared with the initial equipment cost, including peculiar and support test equipment, a replacement factor was developed for recurring investment items. Spare parts and supplies of a lower value (under \$1,000) and readily expendable items are discussed in chapter 24.

4. Estimating Procedure. Determine the estimated value of communications equipment, then multiply the equipment cost by 7 percent to obtain the recurring investment cost for replacement spares. For example, the acquisition cost for proposed LOS microwave system is estimated to be:

Communications prime mission equipment and auxiliary electric power	\$5,000,000
Test, peculiar, and common support equipment	750,000
Total value of equipment	\$5,750,000
\$5,750,000 X .07 = \$402,500 annual recurring investment cost.	

TABLE 25-1. ANNUAL REPLACEMENT SPARES

7% X Acquisition Cost of Equipment

CHAPTER 26. OPERATING SUPPORT

1. Introduction. To facilitate complete coverage of applicable costs, this chapter highlights program or systems costs generally excluded from planning, programing, and budget estimates. Operating support costs require an expenditure of Government resources either directly or, as is more often the case, in an indirect manner not easily associated with individual projects. Funding for these items, therefore, is generally provided for by overall military department requirements rather than by the accumulation of individual project cost estimates in the budget. These hidden costs are required to support all communications installations regardless of the cognizant military department providing the support or funding the system. Therefore, these costs should be considered in the conduct of cost-benefit and cost-effectiveness studies, although they are not generally included in formal program budget estimates for individual projects such as those for the FYP, S/SP, MEP, DCF, and others.

a. Operating support costs are generally associated with personnel when the site is located on or adjacent to a military installation. The support provided includes housing, recreational, welfare, and medical facilities.

b. The military departments provide supply and equipment support, depot maintenance of equipment, replacement training, and costs of moving military personnel, their dependents and household goods (military PCS travel).

c. U.S. civilians employed by the U.S. Government in overseas locations are provided additional support because of their status as representatives of the United States in a foreign land. This support may include:

- (1) Medical and dental care and hospitalization.
- (2) Government transportation.
- (3) Messing, housing, recreational, welfare, and other related facilities.
- (4) Schools for dependents.

d. This chapter is organized to highlight estimating procedures for six major operating support costs.

- (1) Base operations.
- (2) Depot mainterance.
- (3) Recruiting, accession travel, basic training, and communications specialty training.
- (4) Hospitals.

(5) Military PCS travel.

(6) Other indirect costs.

2. Base Operations.

a. General. Base operations costs are incurred by the host organization or command in providing post, camp, station, or base-level support to communications sites or stations. This support may be control, supervision, or administration of the authorized military and civilian personnel. This involves those supplies, equipment, and personnel services made available through funds budgeted for and available to the host organization to operate the base, the base communications distribution system, and tactical communications. Costs above the installation level for services such as the accounting and finance centers, centralized departmental personnel, and legal administration are addressed in paragraph 7, "Other Indirect Costs."

b. Derivation of Factors. Base operations costs in the FYDP were utilized to provide a costing factor for personnel, supplies, equipment, and facilities related to the performance of the following functions: command (post, camp, or base level only), Judge Advocate, information, chaplain, safety, material operations, plans and programs, personnel, civil engineering, telecommunications (non-DCS), administrative services, base procurement, comptroller, fuel, transportation, security (military police), audiovisual laboratory, bands, dispensaries/clinics, schools for dependents, food service, and Navy/fleet shore stations.

c. Use of Tables.

(1) Table 26-1. The current cost-per-person-year factors for estimating base operations for communications programs are presented in table 26-1. When the supporting military department is not known, or the program is a joint military function, utilize the factor in the column "Service Unknown." Civilian personnel, even though performing full-time maintenance or operating functions, are not included in the calculation. As a result, base operations costs are not to be applied to civilian positions.

(2) Table 26-2. The annual overseas cost for education of civilian and military dependent children is used for costing civilian and military personnel in system studies, economic analyses, and comparisons of commercial or industrial activities. This factor represents the average cost incurred by the responsible military department for providing service-operated or contract schools for dependent children accompanying DoD personnel assigned to U.S. territories, possessions, or foreign countries. When the actual number of school age children is unknown, use an estimate of two school-age children for each authorized U.S. civilian position above GS-7 and for each authorized military position above the equivalent ranks of O-2, W-1, and E-5.

d. Estimating Procedure.

(1) To estimate the base operations support required by a proposed communications site or station, multiply the total number of officers and enlisted personnel authorized for the organization by the appropriate cost-per-person-year factor, then escalate the cost to the appropriate year in accordance with chapter 38, table 38-4 ("Federal Purchase of Goods and Services") or table 38-1 ("O&M").

Example 1: Authorization is for 30 officers and enlisted personnel at an overseas location. Support is to be provided by the Army in FY 1978. The O&M cost in FY 1978 dollars is calculated as follows:

$$30 \times \$570 \times (107.1/100.0) = \$18,314$$

Example 2: Authorization is for 1 officer, 20 enlisted personnel, and 3 civilians in FY 1977. Service and location are unknown.

$$21 \text{ (military)} \times \$520 = \$10,920$$

$$3 \text{ (civilian)} \times \$ 0 = 0$$

$$\text{Total} = \$11,340 \text{ in FY 1977 dollars}$$

TABLE 26-1. ANNUAL BASE OPERATIONS COST PER INDIVIDUAL

<u>Location</u>	<u>Army</u>	<u>Navy</u>	<u>Air Force</u>	<u>DCS Composite</u>
Worldwide		Unknown	\$1,080	\$1,400
CONUS	\$1,588			
Europe	2,099			
Pacific	2,970			
Alaska	2,592			
Korea	4,038			
Panama	3,361			

NOTE: Base Year is FY 81.

Source: AFR 173-13, Figure 7-1, 1 Feb 81; "Army DACA-CAC, Nov 82; DCA, Code 690.

(2) Determine whether dependents are authorized at the site or station. Use the product of the geographical area factor, the number of accompanied civilian personnel, and the number of children per family. School-age children of military personnel are covered by base operations cost (table 26-1).

Example: Organization assigned to Italy.

<u>Grade</u>	<u>Number Authorized</u>	<u>Accompanied by Dependents</u>
GS-13	1	1
GS-10	1	1
GS-7	1	<u>0</u>
		2 total families

When incremental costing is required, multiply:

2 (families) x 2 (children per family) x \$1,383 (Europe) = \$5,532 for FY 1976.

TABLE 26-2. EDUCATION OF DEPENDENT CHILDREN

Location	Annual Cost Per Student
Atlantic and Countries South of U.S.	\$1,998
Europe, Africa, and Asia to 90° Longitude East	1,383
Pacific and Asia from 90° Longitude East	1,531
DoD Worldwide	1,500

NOTE: Base Year is FY 1976.

Source: DoD and departmental education offices as of Oct 75.

3. Depot Maintenance.

a. General. The military department operating the communications electronics maintenance depots incurs the cost for the repair, modification, testing, storage, and rehabilitation of communications equipment.

Neither DCA nor the commands charged with operating and maintaining the C/E equipment are generally required to account or budget for these costs; however, it is important, even if these costs are excluded from budget estimates, that they be specifically considered in cost-benefit and cost-effectiveness studies for communications projects. The maintenance costs of work performed at depots are charged to program VII in the Five Year Defense Program. Depot costs are not reflected in the prices of the replacement of replenishment spares or repair parts.

b. Derivation of Factors. The factors presented reflect the fact that the environment in which the equipment is operated plays a major role in the frequency and magnitude of depot repair. Transportable communications equipment is subject to combat damage, movement stress, and environmental conditions such as salt air, dust, and dampness. DCS equipment, however, is generally installed in permanent facilities under controlled environmental conditions; consequently, the majority of depot maintenance for DCS communications equipment does not involve major repair of hardware items. Instead, it generally consists of replacement of moving parts and modules. This environment results in a lower cost factor than that for equipment operated under field conditions. Cost factors for specified items of communications equipment for which overhaul data were available from Army depots were derived by converting unit costs for their repair to an annual basis.

c. Use of Table 26-3. Multiply the acquisition cost of the prime mission, auxiliary, and test equipment by the appropriate factor in the table to obtain annual recurring depot maintenance costs. For example, assume that the DCS communications prime mission, auxiliary, and support equipment cost for a fixed site system is \$2 million.

$$\$2,000,000 \times .005 = \$10,000 \text{ annual depot maintenance.}$$

TABLE 26-3. DEPOT MAINTENANCE COST FACTORS	
<u>Equipment Type</u>	<u>Annual Cost Factor</u>
DCS Fixed Site	0.005
Transportable	0.025

Source: DCA, Code 690, 1 Oct 75.

4. Recruitment, Basic Training, and Specialty Training.

a. General. The basic methodology and data for estimating the training and associated costs incurred in training recruits to ensure the presence of trained technicians over a period of years is provided herein. Costs are displayed for individual training and are then converted to an annual cost to account for personnel losses that will be incurred over a period of time.

(1) The costs shown in tables 26-4 and 26-5 provide for the following:

(a) Force maintenance costs to recruit, transport, indoctrinate, examine, and clothe recruits.

(b) Personnel, equipment, and facility costs associated with the operations of basic and technical training centers.

(c) Transportation and salaries for students attending schools.

(d) Education of officers at service academies, college level ROTC, and officers training schools.

(2) Costs excluded from those shown in tables 26-4 and 26-5 are:

(a) Costs of contractor-conducted training procured as part of a contract for equipment. Such training is considered an investment cost and will be estimated and priced separately in accordance with instructions contained in chapter 16.

(b) Costs have not been adjusted for the small number of recruits who will, by virtue of previous military service or civilian education, perform in a technical speciality without further training.

(3) The costs contained herein are a composite of funding for several budget appropriations; therefore, they should not be used to estimate the annual requirements for any one budget appropriation or classification.

b. Computation of Annual Training Costs.

(1) The annual training costs are the product of the training costs and the annual attrition factor.

(2) The annual attrition rate is derived from the retention rate ($1 - \text{retention rate} = \text{attrition rate}$). Total losses for a period are computed and added to the initial requirements to obtain total training requirements ($1 + \text{losses} = \text{total requirements}$). This quantity is then divided by the number of years for which losses were determined. The decimal fraction resulting from the conversion of this total to a percentage is the Annual Attrition Factor. Expressed mathematically:

$$\text{Annual Attrition Factor} = \frac{1+(1-RF_1)+(1-RF_2)+(1-RF_n)}{100Y}$$

Where: RF_1 , RF_2 , and RF_n = Retention Factors for a term
or period of years

y = The total number of years
used to compute RF_1 ,
 RF_2 , and RF_n

100 = Constant used to convert
results to a percentage

c. Use of Tables:

(1) Table 26-4 contains the training costs and annual attrition factors for specialties employed within the DCS. In estimating the training costs for a facility, the staffing, if not given, must be estimated or extracted from published standards. The number to be trained in each specialty will be multiplied by the training costs and the annual attrition factor. The sum of the products so obtained will be the annual training costs.

(2) It will frequently be necessary to estimate the training costs when it has not been determined which military service is to have operations and maintenance responsibility. In such instances costs should be computed for each service, and a composite DCS costs be computed by multiplying the Army's costs by 41 percent, the Navy's cost by 12 percent, and the Air Force's cost by 47 percent. This procedure is illustrated in table 26-5.

TABLE 26-4. ANNUAL TRAINING COSTS

Service	MOS NEC AFSC	Training Costs	Annual Attrition	Annual Costs
<u>Army</u>				
	26R	\$ 46,160	.174	\$ 8,032
	26Y	38,304	.170	6,512
	26Z	48,050	.193	9,274
	32D	37,704	.192	7,239
	32E	49,419	.173	8,549
	32F	46,642	.193	9,002
	32G	25,418	.203	5,160
	32H	19,067	.136	2,593
	34F	55,215	.147	8,117
	34H	55,215	.173	9,552
	34L	24,800	.208	5,158
	36H	30,468	.184	5,606
	52B	16,395	.193	3,164
	52D	21,176	.215	4,553
	71B	18,087	.173	3,129
	76U	14,236	.160	2,278
			Average	\$ 6,120
<u>Navy</u>				
	CE(E6)	\$ 18,718	.167	\$ 3,126
	DS 1666	32,272	.175	5,648
	ET 1404	21,982	.231	3,398
	ET 1415	22,041	.161	3,549
	ET 1434	29,078	.149	4,333
	ET 1462	29,078	.184	5,350
	RM 2318	15,292	.207	3,165
	RM 2361	27,478	.214	5,880
	IC 4713	7,204	.151	1,088
	EM 5632	15,466	.131	2,026
			Average	\$ 3,876

TABLE 26-4. ANNUAL TRAINING COSTS (CON.)

Service	MOS NEC AFSC	Training Costs	Annual Attrition	Annual Costs
Air Force	291XX	\$ 8,596	.183	\$ 1,573
	295XX	3,757	.205	770
	304XX	1,776	.191	2,249
	306XX	17,774	.178	3,164
	307XX	15,479	.191	2,960
	361XX	12,018	.198	2,380
	362XX	16,236	.165	2,679
	542XX	9,405	.177	1,665
	645XX	6,954	.186	1,293
				Average

Sources: Actual FY 1978 training costs for Army and Navy supplied by services. FY 1983 Air Force costs from AFP 173-13, 1 Feb 82. Actual retention rates for all three services are given for 1978.

TABLE 26-5. COMPOSITE TRAINING COSTS
(Communications Terminal)

<u>Organization</u>	<u>Classification</u>	<u>Qty</u>	<u>Training Costs</u>	<u>Attr. Rates</u>	<u>Annual Costs</u>
<u>Army</u>	26R	2	\$46,160	.174	\$16,064
	32H	3	19,067	.136	7,779
	52B	1	16,395	.193	3,164
Total Training Costs - Army					\$27,007
<u>Navy</u>	ET1404	1	\$21,982	.231	\$ 5,078
	ET1411	4	22,805	.149	13,592
	CE(E6)	1	18,718	.167	3,126
Total Training Costs - Navy					\$21,796
<u>Air Force</u>	29530	1	\$ 4,894	.205	\$ 1,003
	30430	3	19,238	.191	11,023
	30630	2	19,648	.178	6 995
Total Training Costs - Air Force					\$19,021
<u>Composition</u>			<u>Annual Cost</u>	<u>Econ. Escal.*</u>	
Army:	41% x		\$27,007	- .639	\$17,328
Navy:	12% x		\$21,796	- .639	4,093
Air Force:	47% x		\$19,021	- 1.000	8,940
FY 1983 DCS Composite Rate					\$20,196
*Economic escalation factors from table 38-1 are applied to obtain FY 1983 costs.					
Source: Costs from table 26-4. Composition percentages, FY 1979, DCA, Code 690.					

5. Hospitals.

a. General. This element encompasses the medical costs for operation of the military hospitals and Government-paid costs for civilian hospitals associated with care of military personnel and their dependents. Also

included are authorized hospital costs applicable to civilian personnel and their dependents located in overseas areas. Excluded are the operating costs for base dispensaries, and medical and dental clinics included in base operations. (See paragraph 2.)

b. Use of Tables. An annual cost has been derived and is shown in table 26-6 for the military departments. These factors are to be multiplied by the expected authorized organizational strength.

TABLE 26-6. ANNUAL MEDICAL SUPPORT COST PER INDIVIDUAL				
<u>Location</u>	<u>Army</u>	<u>Navy</u>	<u>Air Force</u>	<u>DCS Composite</u>
Worldwide		Unknown	\$500	\$465
CONUS	\$410			
Alaska	410			
Pacific	410			
Korea	465			
Europe	460			

NOTE: Base Year FY 1982.

Source: "Army Force Planning Cost Handbook," May 81; AFR 173-13, Chapter 7, 1 Feb 82; DCA, Code 690.

6. Military PCS Travel.

a. General. The military departments centrally fund and budget for PCS travel requirements; however, this expense is a necessary operating support cost to individual program and project cost estimates. The estimated cost to the military departments has been stated on an annual basis and on an individual-move basis to provide easily calculated estimates of the total PCS travel costs involved in a project. The annual cost is included in the composite standard rates of chapter 23.

b. Derivation of Factors. The PCS travel cost factors shown in table 26-7 were obtained from the military departments.

c. Use of Table 26-7. In the absence of specific data, the factor "Annual Cost per Personnel Authorization" may be used to estimate the

annual recurring costs by multiplying the respective numbers of authorized officers and enlisted men by the factors shown for the service involved. Factors for cost per move may be used when specific data are available for estimating initial costs for a particular budget year; however, for estimates covering the life cycle of a system, the annual cost should be utilized. When the service or grade composition is not known, the DCS composite may be used.

d. Estimating Procedure.

(1) Example 1. Twenty military personnel are required at a communications site at an overseas location. Composition and grades are unknown.

20 X \$1,065 = \$21,300 annual PCS cost.

(2) Example 2. An Air Force communications unit of 3 officers and 28 airmen is being returned to CONUS from Okinawa. Cost for return PCS travel is desired.

3 X \$9,481 = \$ 28,443
28 X \$3,667 = \$102,676

TOTAL: \$131,119 PCS cost for return trip.

TABLE 26-7. PCS TRAVEL

	<u>Army</u>	<u>Navy</u>	<u>Air Force</u>	<u>USMC</u>	<u>DCS Composite</u>
Annual Cost Per Personnel Authorization					
Officer	\$5,030	\$2,447	\$ 2,522	\$3,151	\$4,200
Enlisted	2,030	998	1,354	1,008	1,620
DCS Composite	2,290	1,030	1,400	-	1,770
Cost Per Move					
Within CONUS or Overseas Area					
Officer	\$5,868	\$7,900	\$5,034		\$5,710
Enlisted	1,587	3,500	2,939		2,390
DCS Composite	1,955	3,590	3,020		2,590
CONUS to/from Overseas					
Officer	\$9,461	\$7,900	\$12,632		\$10,320
Enlisted	3,084	3,500	5,420		4,180
DCS Composite	3,630	3,590	5,700		4,540
Worldwide Average					
Officer			\$ 5,890		
Enlisted			2,604		
DCS Composite			2,730		
NOTE: Base Year FY 1983.					
Source: FYDP, Part I, OASD(C), 19 Oct 82; AFR 173-13, "USAF Cost and Planning Factors," table 3-6, 1 Feb 82; Army DAPE-MBB, Nov 82; Navy NCB 14, Nov 82; DCA, Code 690, Nov 82					

SECTION E. LEASED COMMUNICATIONS COSTS AND SUBSCRIBER RATES

CHAPTER 27. PLANNING FOR LEASED SERVICES

1. Content. Section E is divided into four chapters as outlined in figure 27-1.

a. This chapter is a guide to the use of the remaining three chapters and details some considerations in determining the type of leased service to obtain. Communications services which the user obtains by means other than procurement are considered "leased services." This term encompasses both Government services and common carrier services. These are domestic or international service; analog or digital service; dedicated or shared service; and Government or commercial supply.

b. The three remaining chapters contain the cost data. Chapter 28 catalogs the leased services of the Government. The remaining two chapters present the commercial sector. International services are presented in chapter 29; domestic services are presented in chapter 30.

2. Domestic or International.

a. For commercial service the user must determine whether the required service is domestic or international in order to determine the vendor and pricing options. For historical reasons "international" means "overseas." Mexico and Canada are considered to be domestic, while Hawaii, Alaska, Puerto Rico, and the Virgin Islands are international.

b. Again, for historical reasons the commercial vendors are divided between the International Record Carriers (IRC's) and AT&T. The IRC's are authorized to provide service between international points and selected domestic locations known as "gateways." At present the rates are such that it is cheaper to lease connecting links ("tails") to the coastal gateways than to use a midcontinent gateway. If service is required to a location other than a gateway, connecting links must be obtained at domestic rates from a domestic carrier. AT&T can provide service from any domestic point to any overseas point.

c. Commercial overseas circuits are provided over either satellite or undersea cable. The same rate is charged for the international circuit regardless of the medium used. The rates between nations vary widely because a portion of the rate is set by each nation.

d. Domestic private line service can be obtained through DECCO. AUTOVON and AUTODIN provide worldwide switched service.

3. Analog or Digital.

a. It is usually cheaper to secure analog service for voice requirements and digital service for nonvoice requirements. Service over all-digital

plant is of higher quality. This improvement in quality is important only for digital service.

(1) Analog service is provided by AUTOVON or by private line. Secure voice is obtained by use of special terminal equipment.

(2) Nonvoice service is provided by AUTODIN or by private line. The basic AUTODIN service is similar for all types of nonvoice communications. The user obtains the particular service required--teletypewriter, data transmission, or facsimile--by selection of appropriate terminal equipment.

b. Transmission facilities can be constructed to carry either analog or digital signals. Furthermore, through the use of appropriate interface devices, analog signals can be carried on digital facilities and digital signals can be carried on analog facilities. Most of the demand is for voice (analog) service. The carriers, therefore, usually accept and deliver analog signals regardless of the nature of their transmission plant. All-digital service is offered by some carriers between specific domestic major metropolitan areas. Digital service sometimes can be obtained outside the major metropolitan areas by special arrangements with the carriers. The DoD common user systems are converting to all-digital.

c. Due to the general lack of availability of digital service, the current custom is for data users to lease voice-grade (nominal 4 kHz) circuits and obtain digital service by use of analog-to-digital conversion units (modems). The user must place a modem at each end of the analog circuit. Data line speeds up to 0.300 kb/s can be obtained using ordinary dial-up lines. Higher speed usually requires dedicated circuits. Speeds of 1.2 kb/s, 2.4 kb/s, 4.8 kb/s, or 9.6 kb/s sometimes require the circuits to be specially conditioned (at extra cost). Either two or six lines can be used for 19.2 kb/s service. The two-line configuration employs more expensive termination equipment; therefore, the six-line system is used except for applications over long distances. Some carriers offer special rates for the 48 khz (12 voice-grade lines) needed for 56.0 kb/s. When estimating charges, assume 1 line for speeds up to 9.6 kb/s, 6 lines for 19.2 kb/s, and 12 lines for 56 kb/s. Vocoders are used to carry voice over digital circuits. With appropriate encoding devices intelligible voice signals can be sent over line speeds as low as 2.4 kb/s. However, to obtain customary voice quality a line speed of 64 kb/s is required.

d. One form of digital service is known as packet switching. In packet switching the user's input is divided into short messages or "packets." The vendors perform error detection tests and will correct any errors which have been introduced into the message. In addition, they will perform the conversions required for dissimilar machines to communicate with each other. Packet switching systems are operated by both commercial vendors and the Government.

4. Dedicated or Shared.

a. Definition. A dedicated system is one which serves a single entity (private line network). A shared or common user system serves many users and hence usually is a switched network.

(1) The primary reason to join a shared network such as AUTOVON is to have access to the other users. Indeed, the more entities connected to a network, the more valuable the network is to each individual user. A secondary reason for choosing a shared system is economic. The more users on a system, the higher the level of aggregation and utilization, the larger the base over which the cost is spread, the lower the per unit cost which must be borne by each user.

(2) The primary reason for choosing a dedicated system is responsiveness. Dedicated systems will not, however, have the extensive reroute capability and the ability to handle variable demand which are inherent in a shared system. The DoD shared user systems accommodate the responsiveness issue through use of a priority system.

b. Government Shared User Systems.

(1) DoD policy (cf. ASD(C³I) Memorandum, subject: DoD Long-Haul Telecommunications Service Acquisition and Management, 29 August 1979; JCS Memorandum of Policy No. 165, AUTODIN and Associated Message Processing Systems, 5 May 1976; and JCS Memorandum of Policy No. 151, AUTOVON and AUTOSEVOCOM Service) favors the use of Government common user systems (chapter 28).

(2) AUTOVON can be used for worldwide military access. Established policy for the use of AUTOVON sets 5 minutes as the approximate upper limit on voice call length. The AUTOVON policy for data or facsimile traffic is for a maximum connect time of 18 minutes, provided the precedence is routine. AUTOSEVOCOM is a secure voice capability which can be acquired through AUTOVON. In Alaska, service is obtained from the ATSS (Alaska Telephone Switching System). Current planning calls for the replacement of ATSS by AUTOVON in FY 1982. The General Services Administration (GSA) operates a CONUS network known as Federal Telecommunications Service (FTS). If a sufficient number of long-distance calls are made to non-AUTOVON locations, FTS may be economical.

(3) AUTODIN can be used for worldwide record traffic and can also provide inquiry-response service to host computers. By use of appropriate terminal devices, AUTODIN can provide facsimile service and process magnetic tape, OCR format, or other machine-readable formats. AUTODIN provides a gateway to the commercial Telex/TWX common user networks by means of "commercial refile." The currently operational DoD packet switched network is the ARPANET. The plans for AUTODIN II envision the extension of packet switching capability throughout the AUTODIN community. Data users in the Washington, D.C., area can use the Washington Area Wideband System (WAWS)

digital network. For additional data regarding future capabilities of AUTODIN and AUTOVON see MIL-STD-187-310, "Standards for Long Haul Communications, Switching Planning Standards for the Defense Communications Systems."

(4) DoD also operates cost-sharing arrangements for dedicated networks. Communications channels are multiplexed down to the circuit sizes needed by the shared or dedicated networks (chapter 28).

c. Commercial Shared User Systems. Commercial common user systems include ordinary dial telephone service which can connect worldwide. Volume discounts for CONUS traffic can be obtained through the use of Wide Area Telephone Service (WATS). In addition to the network provided by the traditional carriers, more limited switched services are provided by the Specialized Common Carriers (SCC). For data communications there are packet switched services available with access by private line, local dial-up, or carrier-provided IN-WATS.

d. Dedicated Systems.

(1) Commercial domestic dedicated circuit rates are found in chapter 30. The user should also check the cost-sharing arrangements for multiplexed and bulk systems (chapter 28) for dedicated networks.

(2) The established carriers provide terrestrial private line service to most CONUS locations. The Specialized Common Carriers (SCC) provide service to selected metropolitan areas. Packet carriers offer "hot line service" for traffic between fixed locations and perform their usual speed or code conversion and error correction functions.

(3) The satellite carriers have placed earth stations on the east, west, and gulf coasts and secured terrestrial distribution facilities to major population centers. The rates stated for service between these centers tend to follow the terrestrial rates. If the user desires service beyond the boundaries of a satellite service area, terrestrial distribution lines must be secured at additional expense. At present there are three satellite carriers offering service to 29 major metropolitan areas. Satellite carriers may be less expensive for requirements with one or more of the following characteristics: multipoint broadcast, wideband, extreme distances, or asymmetrical demand. For some data transmission applications the 270 ms propagation delay may create response time or error control problems. The carriers will supply dedicated earth stations for use with their satellites at negotiated rates. At some locations a dedicated earth terminal is the least costly commercial alternative for a single 56 kb/s duplex circuit. As satellites operating at higher frequencies to roof-mounted earth terminals become available; e.g., the service proposed by Satellite Business Systems (SBS), dedicated earth terminals will prove in at lower traffic densities. The carriers will also lease transponder space for use with user-provided earth stations. Direct contact with the vendors is required for quotation of rates for these customized services.

5. Government or Commercial.

a. The U.S. Government has a policy of depending upon the private sector for communications services. However, this does not mean that the use of commercial long distance is preferred over AUTOVON. Such policy considerations have been addressed in the architecture decisions of the Government systems. Users should select between the employment of Government-owned or -leased facilities and the construction or lease of additional facilities on the basis of the least costly alternative. Unfortunately, "cost" is a concept which changes depending upon the purpose and viewpoint in mind. At least three different cost views are commonly used in the analysis of communications systems: commercial/industrial activities cost comparisons, economic cost-to-the-Government, and budgetary cost-to-the-user.

b. A special study must be conducted to determine the commercial/industrial activities cost comparisons, or "A-76 costs." These studies consider the long-run total cost (in a cost accounting sense) the Government would have to bear to provide the service. Guidance for analyses of this type is given in chapter 43. Prospective or existing users of existing DoD common user networks or the multiplex and bulk transmission media offerings of DECCO (chapter 28) are not required to prepare analyses of this type.

c. The distinction between the other two, cost-to-the-Government and cost-to-the-user, is most easily seen by an example. Assume there is a user with a need for a message switching service.

(1) What would be the cost-to-the-Government if this requirement were to be placed upon an existing switching center? The cost-to-the-Government depends upon whether there is spare capacity at the switching center. If the new load could be absorbed within existing resources, then the Government could meet the new requirement at no additional cost. If additional resources had to be procured to meet the new demand, then the cost-to-the-Government would be the price of those new resources. If an existing user had to be displaced to make room for the new requirement, then the cost-to-the Government would be the cost of placing the uprooted user's requirement on some other system. This cost-to-the-Government is the true economic penalty which DoD must absorb in order to meet the requirement.

(2) What is the impact upon the user's budget? Again, the answer depends upon the circumstances. The switching center may be provided by another military department. In this case there is no impact upon the user's budget even if there were a positive cost-to-the-Government. On the other hand, the center may be industrially funded. In this case the user would be charged a pro rata share of the costs even if the center had spare capacity and the cost-to-the-Government were zero.

d. These three cost concepts have different uses. The commercial/industrial or "A-76" comparisons are used for the "make or buy" decision.

The cost-to-the-Government is used in economic analyses to determine which of several alternative methods of meeting a requirement is the least costly. The cost-to-the-user is needed for budgetary planning purposes. The remaining chapters in this section contain both cost-to-the-user and cost-to-the-Government data.

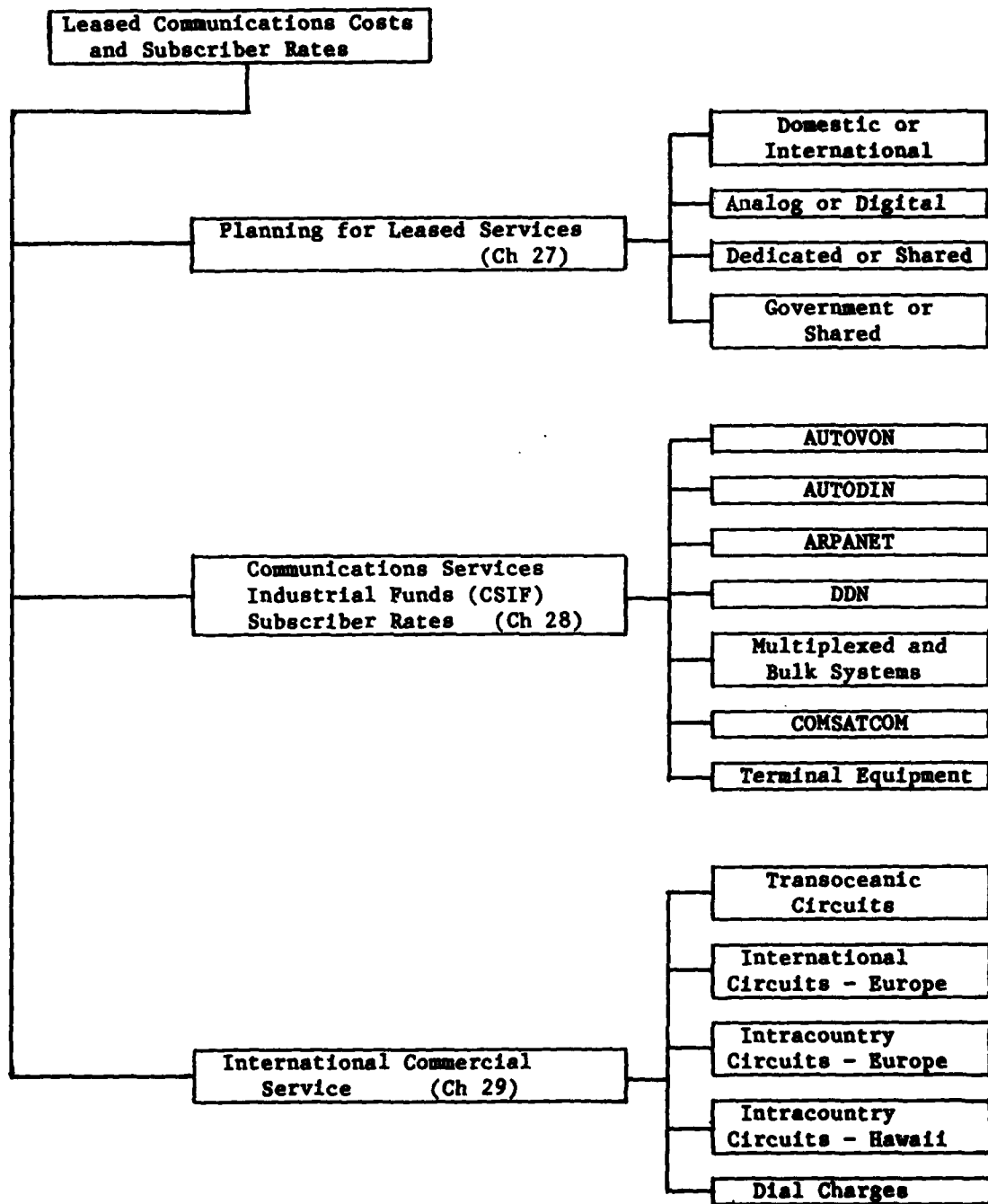

FIGURE 27-1. ORGANIZATION OF SECTION E

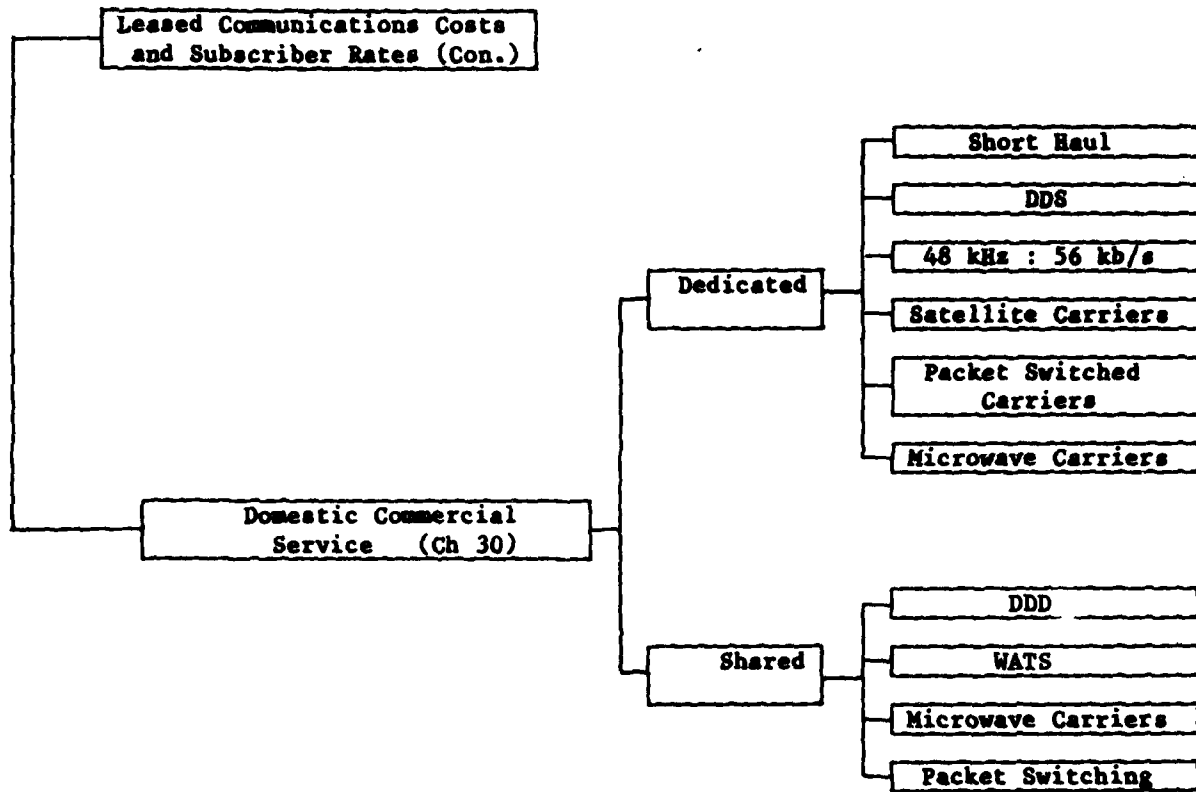

FIGURE 27-1. ORGANIZATION OF SECTION E (CON.)

**CHAPTER 28. COMMUNICATIONS SERVICES INDUSTRIAL FUND (CSIF)
SUBSCRIBER RATES**

1. General.

a. Currently, within DoD, an activity may be either funded directly from an appropriation or funded through a revolving fund such as an industrial fund. Where an industrial fund is used, operating costs are paid initially from a segregated fund or corpus which is set up to finance the costs of a cycle of operations that are subsequently reimbursed to the fund by the customers of the activity. The Communications Services Industrial Fund (CSIF) is a DoD revolving fund used to centrally procure communications services from commercial carriers for DoD and for authorized non-DoD departments and agencies. Customers place their orders for service with DECCO. In turn DECCO orders commercial services from commercial companies to satisfy user's requests. The services are provided by commercial companies for the customers. The commercial companies then bill DECCO. DECCO verifies the bills then pays the commercial companies from the corpus of the CSIF. The customers who were provided service are then billed by DECCO. The funds collected from the customers are returned to the CSIF working capital corpus.

b. This chapter covers the standard services and equipment which may be secured through the CSIF. The charges for each service cover the expenses of that service. The rates are designed to assure that the CSIF operates at a "break-even" level. In general, the CSIF rates cover only the "backbone" charges associated with the switches and leased interswitch trunks. The user must separately secure terminal equipment, access lines to the switch, and attachment to the switch. In addition to the rates for the backbone and terminal equipment (listed in this chapter), subscribers must pay for all leased access lines or other private line services (contained in chapters 29 and 30), as well as any other charges which may be unique to their service. Unless noted otherwise, the charges tabled are budgetary cost-to-the-user. Instructions for calculation of cost-to-the-Government are presented at the end of the sections.

c. Planning rates are published each summer for the second fiscal year in the future (the rates published in August 1982 were for FY 1984). During the OSD budget review cycle, changes may be made in either the estimated demand for services or the estimated costs. Revised planning rates which reflect these changes are published in the winter.

2. Derivation of Factors. Subscriber rates for CSIF-financed systems were developed by the DCA Communications Services Industrial Fund Division (Code 670). Average charges for termination on the user's site and attachment to the switch were computed based on current FCC approved tariffs. All rates are subject to change.

3. AUTOVON.

a. General. AUTOVON is the common user automatic switched voice network for DoD and authorized non-DoD users. AUTOVON subscribers are

responsible for the payment of costs associated with access lines, terminal equipment, and termination charges (paragraph 8 and chapters 29 and 30), and for termination charges as well as a share of the cost of the backbone network of lines and switches (this paragraph). Narrowband secure voice (AUTOSEVOCOM) is obtained by use of appropriate terminal equipment. See Pricing and Availability Information for COMSEC Equipment, KAG-25/TSEC. Three types of service are available: send-and-receive, send-only, and receive-only. The subscriber rates (backbone charges) are not levied against users of receive-only service, but such users must pay for the required termination and terminal equipment and the access lines.

b. Subscriber Rates for AUTOVON Backbone Service. The subscriber rate structure is based upon the type of service provided, preemption capability, and the Maximum Calling Area (MCA). The following MCA's are authorized:

(1) Local MCA. In Europe and the Pacific the local MCA provides access to users attached to the same switch.

(2) Area MCA. Area MCA subscribers in the four major geographical areas (CONUS, Europe, Pacific, and the Caribbean) may communicate with other customers located in the same major geographical area.

(3) Area Plus. The (overseas) Area Plus (CONUS) MCA permits transoceanic communications by providing communications between the overseas MCA and CONUS. It also permits communications between CONUS Air Force subscribers and the Canadian Network (CADIN - Continental Air Defense Integration North).

(4) Global MCA. The Global MCA permits communications between an AUTOVON subscriber and any other AUTOVON subscriber regardless of geographical area.

c. Use of Tables. Table 28-1 provides the cost-to-the-user planning rates for send-and-receive service. When other than Routine service is required, multiply the rates by the appropriate weight shown. For send-only or phone/data service, the rate should be doubled.

d. Example. To compute the cost for AUTOVON service, the termination and access fees must be added to the backbone charges (figure 28-1). As an example, assume a subscriber in CONUS requires service with Immediate precedence to subscribers in the United Kingdom. A 110-mile access line is needed to reach the telephone exchange of the servicing AUTOVON switch.

<u>Item</u>	<u>Monthly Charge</u>
Terminal Equipment and Termination Charge:	
Termination to a nonsecure location and access to the switch in a remote exchange (table 28-13)	\$ 215

Access Line (assume A - B rates):

Fixed fee	\$341.27	
10 miles @ \$0.93	<u>9.30</u>	
Total Cost (chapter 30, table 30-1)		351

Backbone Service (table 28-1):

Europe + CONUS service with Immediate precedence	\$1,055 x <u>3</u>	
		<u>3,165</u>

Total Budgetary Cost-to-the-User (per month) \$ 3,731

e. Cost-to-the-Government. The CSIF charges for the AUTOVON backbone are not included in the calculation of the economic cost-to-the-Government. In the example above, delete the \$3,165 for the backbone. The cost-to-the-Government is the termination and access line cost.

4. AUTODIN.

a. General.

(1) AUTODIN subscriber charges are based upon the category and speed of service. AUTODIN services were designed with narrative record service as the primary application. Subsequent modifications have added query/response service for data base transactions and sequential delivery service for applications, such as facsimile, where the order of arrival is important. Reference material for the AUTODIN services are DCAC 310-D70-60, Operating Procedures for Query/Response Service, and DCAC 310-D70-63, Operating Procedures for Sequential Delivery Service. These describe the basic AUTODIN transmission service (secure message switched service at speeds up to 4800 b/s). Many kinds of communications can be obtained through AUTODIN depending upon the terminal equipment. Examples include teletype, facsimile, or computer magnetic tape transfer. The number of approved terminal devices is too large for inclusion here; cf. DCAC 310-D130-3, Approved DCS AUTODIN Terminal (Hardware and Software) Systems.

(2) In addition to the monthly rates for the backbone service, the users must pay the cost of leased access lines (paragraph 7, chapters 29 and 30) and any other charges imposed by the carriers in their area. The charge for termination of the access line at the user's site and the switch is given in paragraph 9. The terminal equipment itself is additional. Further information on modes of operation, speed of service, terminal equipment, etc., may be obtained from the references cited above.

b. Use of Tables. Table 28-2 presents backbone rates for regular and query/response AUTODIN services. For example, a user wanting low-speed regular AUTODIN service should plan upon a budgetary expense for backbone charges of (\$795 x 2 =) \$1,590 during FY 1984. The computations for AUTODIN service are similar to those required for AUTOVON. See paragraph 3d.

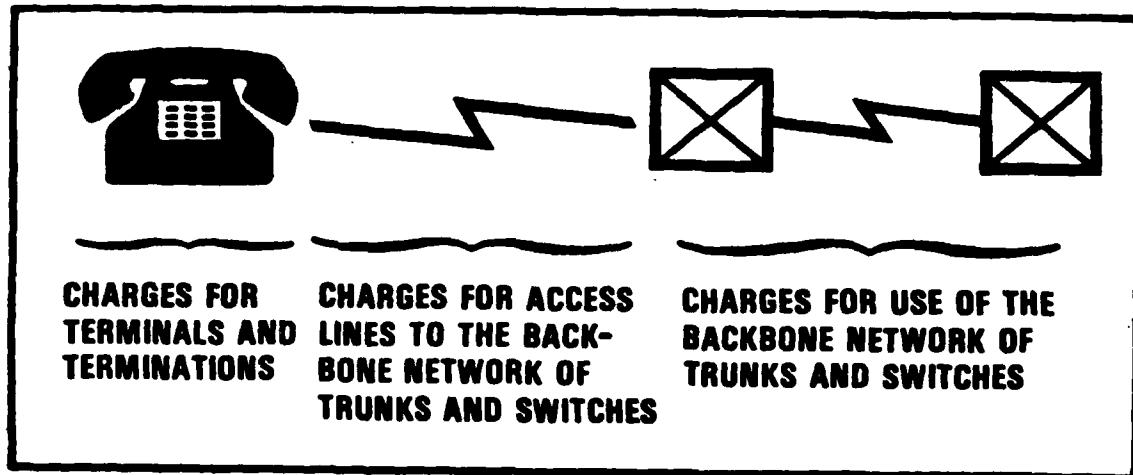

FIGURE 28-1. ILLUSTRATION OF AUTOVON COST ELEMENTS

c. Cost-to-the-Government. Adequate capacity exists within the store-and-forward switches and interswitch trunks to accommodate reasonable increases in demand without additional expenditure for resources. Thus, there is no out-of-pocket cost for added load on the backbone AUTODIN network. Such costs may be incurred for access lines and terminal equipment. In the case of a user leaving a dedicated network and substituting AUTODIN service, there will usually be a savings to the Government as the access lines will be cheaper than the displaced network.

5. ARPANET. The ARPANET is an intercomputer packet-switched network linking DoD sponsored research centers and activities in CONUS, Hawaii, Norway, and the United Kingdom. The network can process bulk and interactive data communications. The transit time of a message is normally less than 250 ms. The CSIF fee for the ARPANET is computed on a node (TIP/IMP) basis regardless of the amount of traffic which enters or exits the network through the node. The FY 1984 planning rate per ARPANET node is \$9,200 per month (source: DCA Code 670, August 1982). An existing node may be expanded by means of a BBN C/30 IMP to accommodate additional hosts. The fee for an augmented node is an additional \$2,300 per month for a total of \$11,500 per month (source: DCA Code 670, August 1982). The user must pay for access to the node and for the termination charges.

TABLE 28-1. AUTOVON CSIF PLANNING RATES

<u>Maximum Calling Area (MCA)</u>	<u>FY 1984 Monthly Rate Per Weighted Unit</u>
Local	
Europe	\$ 28
Pacific	202
Area	
CONUS	710
Europe	55
Pacific	405
CADIN	702
Area Plus	
CONUS & Europe	1,055
CONUS & Pacific	1,290
CONUS & Caribbean	851
Global	1,776
<u>Preemption Capability</u>	<u>No. of Weighted Units</u>
Flash	4
Immediate	3
Priority	2
Routine	1
NOTE: For Phone/Data and PBX (Send Only) Service, double the charge shown.	
Source: "FY 1984 Communications Services Industrial Fund (CSIF) Planning Rates," 11 Aug 82, DCA, Code 670; DCA, Code 690.	

TABLE 28-2. AUTODIN CSIF PLANNING RATES

FY 1984 Monthly Rates					
Speed of Service	Regular Service		Query/Response ²		
	No. of Weighted Units	Rate Per Access Line ¹	Area	Area Plus	Worldwide
High Speed			\$2,500	\$3,500	\$4,500
4.8 kb/s	12	\$9,540			
2.4	8	6,360			
Medium Speed			1,300	1,900	2,500
1.2	6	4,770			
0.6	4	3,180			
Low Speed			600	800	1,000
0.3 or less	2	1,590			

NOTES: ¹Charge per Weighted Unit is \$795.
²Charges include access to one terminal or host. Add \$100 for each additional terminal/host accessed.

Source: "FY 1984 Communications Services Industrial Fund (CSIF) Planning Rates," 11 Aug 82; DCA, Code 670; DCA, Code 690.

6. Defense Data Network (DDN). The DDN is projected to be operational during FY 1984. However, sufficient firm backbone cost and access line data (number by speed, by customer activity) is not currently available to develop and publish FY 1984 planning rates. Current projections indicate that during FY 1984, only the WIN backbone, the MILNET portion of the ARPANET backbone, and possibly the MINET (not currently funded via the CSIF) will be operational as the initial segment of the DDN. The FY 1984 backbone O&M program is projected at \$37.2 million, which includes \$3.7 million for the CSIF funded WIN backbone and \$2.2 million for that portion of the ARPANET backbone to be incorporated into the DDN.

7. Multiplexed and Bulk Systems.

a. General. DCA operates several multiplex and bulk encrypted circuit systems to reduce the total cost of communications. The costs of the multiplexers and trunks are shared by the users. A DECCO management fee of 1.25 percent must be added to the stated rates. The decision as to the type and location of multiplex services is determined by an economic analysis. The guidelines for analysis and funding of multiplex systems are found in DCAC 310-70-59, DCA Management of DoD Multiplex Systems. The economic analysis examines whether a multiplex system should be installed in a particular area. A different economic analysis would be required to determine whether it would be cost effective to activate another circuit over an existing route. As in all systems operated by the CSIF, the user must fund any access lines needed to reach the multiplex network.

b. Transoceanic Service. Table 28-3 lists the routes and rates for transoceanic channel packing and voice frequency carrier telegraph (VFCT) service. If 1200 b/s service is desired, it can be obtained at half the 2400 b/s rate. Speeds less than 1200 can be obtained as multiples of the 75 b/s rate; e.g., 300 b/s would cost four times the 75 b/s rate. Non-standard expenses, such as connection to a circuit not compatible with the DCS multiplex or special routing expenses, will be charged to the user. Costs of a circuit to other areas will be prorated among all users of the circuit until a standard rate can be established for the circuit.

c. CONUS Voice Frequency Carrier Telegraph (VFCT). Table 28-4 lists the current location of VFCT nodes and the per mile charge.

d. CONUS Channel Packing. CONUS channel packing provides for service at 1200 b/s, 2400 b/s, and higher speeds. Table 28-5 lists the current locations of and per mile charges for 2.4 Kb/s CONUS channel packing nodes. Other speeds are charged as multiples of 2400 b/s.

e. European Channel Packing. European channel packing provides service from Fort Meade, MD, to Chicksands, United Kingdom, and within Europe. Table 28-6 gives the speeds and rates. Table 28-7 lists the current locations of European channel packing nodes.

f. Bulk Encrypted Circuits. 1.544 Mb/s systems are charged at the rates contained in table 28-8.

g. Washington Area Wideband Service (WAWS). The Washington Area Wideband Service (WAWS) is an all-digital, bulk-encrypted service which can go up to 90 mb/s. In addition to the security offered by bulk encryption, the WAWS hardware provides for high reliability and low bit error rate. Table 28-9 lists the WAWS service points and rates. The DECCO administration fee of 1.25 percent must be added to the WAWS charges.

TABLE 28-3. TRANSOCEANIC MULTIPLEX SERVICE CSIF PLANNING RATES

		FY 1984 Monthly Rates		
		<u>75 b/s</u>	<u>2,400 b/s</u>	
CONUS	- Europe	\$ 690	\$7,910	
	- Puerto Rico	330	N/A	
	- Bermuda	430	N/A	
	- Canal Zone	670	N/A	
	- Japan	N/A	9,310	
East Coast	- Hawaii	390	N/A	
	- Guam	730	N/A	
	- Australia	1,190	N/A	
West Coast	- Hawaii	500	2,300	
	- Guam	840	N/A	
	- Japan	470	N/A	
	- Australia	1,300	N/A	
Hawaii	- Guam	340	4,230	
	- Philippines	460	5,510	
	- Japan	480	9,200	
	- Australia	800	6,300	
Guam	- Philippines	470	7,560	
	- Japan	690	8,300	
	- Australia	1,140	N/A	
Philippines	- Japan	2,030	14,490	
	- Australia	1,260	N/A	
		<u>600 b/s</u>	<u>1,200 b/s</u>	<u>4,800 b/s</u>
East Coast	- Hawaii	\$1,580	\$ 1,920	\$3,830

Source: "FY 1984 Communications Services Industrial Fund (CSIF) Planning Rates," 11 Aug 82; DCA, Code 670.

TABLE 28-4. CONUS VFCT LINKS

	<u>End Points</u>	<u>Airline Miles</u>
Andrews AFB, MD	Ft. Detrick, MD	46
	Ft. Meade, MD	18
	Ft. Ritchie, MD	65
	Kelly, TX	1,389
	McClellan, CA	2,376
	Norfolk, VA	145
	Patrick, FL	761
	Pentagon, VA	10
	Stockton, CA	2,377
	W. Sweetgrass, MT	1,860
Boca Chica, FL	Homestead, FL	105
Cape Canaveral, FL	Vandenberg, CA	2,376
Ft. Detrick, MD	Ft. Leavenworth, KS	933
	Ft. Meade, MD	45
	Ft. Ritchie, MD	22
	McClellan, CA	2,342
	Norfolk, VA	188
	Patrick, FL	789
	Pentagon, VA	41
	Stockton, CA	2,343
Ft. Leavenworth, KS	Ft. Ritchie, MD	927
	Kelly, TX	705
	McClellan, CA	1,423
	Point Reyes, CA	1,500
	Offutt, NE	145
Ft. Ritchie, MD	Carlisle Barracks, PA	38
	McClellan, CA	2,334
	Pentagon, VA	62
	Stockton, CA	2,335
	Ft. Meade, MD	60
Norfolk, VA	Arlington, VA	62
	Boca Chica, FL	912
	Cutter, ME	716
	Pentagon, VA	148

TABLE 28-4. CONUS VFCT LINKS (CON.)

San Diego, CA	Long Beach, CA	96
	Stockton, CA	435
Whidbey Island, WA	Stockton, CA	723
NOTE: FY 1984 CSIF planning rate is \$0.143 per airline mile.		
Source: "FY 1984 Communications Services Industrial Fund (CSIF) Planning Rates," 11 Aug 82; DCA, Code 670.		

TABLE 28-5. CONUS CHANNEL PACKING LINKS

	<u>End Points</u>	<u>Airline Miles</u>
Alexandria, VA	Los Angeles, CA	2,292
	San Diego, CA	2,255
Cameron Station, VA	Kirtland, NM	1,643
	Wright-Patterson, OH	381
Ft. Ritchie	Offutt, NE	1,311
NOTE: FY 1984 CSIF planning rate for 2.4 kb/s service is \$0.41 per airline mile. Speeds over 2.4 kb/s are charged as multiples of that rate.		
Source: DECCO Code D650, 5 Jul 79; "FY 1984 Communications Services Industrial Fund (CSIF) Planning Rates," 11 Aug 82; DCA, Code 670.		

TABLE 28-6. EUROPEAN CHANNEL PACKING SERVICE CSIF PLANNING RATES				
Locations	FY 1984 Monthly Rates by Speed of Service (kb/s)			
	1.2	2.4	4.8	7.2
Ft. Meade - Chicksands	\$ 5,310	N/A	N/A	N/A
Intra-Europe (per link)	1,540	\$3,080	\$6,160	\$9,240

Source: "FY 1984 Communications Services Industrial Fund (CSIF) Planning Rates," 11 Aug 82; DCA, Code 670.

TABLE 28-7. INTRA-EUROPE LINKS OF EUROPEAN CHANNEL PACKING SERVICE			
San Vito, Italy	Hellenikon, Greece Iraklion, Greece	Boerfink, FRG	Gablingen, FRG
Croughton, UK	Coltano, Italy London, UK Pirmasens, FRG Rota, Spain Vaihingen, FRG	Pirmasens, FRG Ft. Meade, MD	Coltano, Italy Vaihingen, FRG London, UK Chicksands, UK

Source: DCA, Code 670, Oct 82.

TABLE 28-8. 1.544 MB/S CSIF PLANNING RATES

<u>System</u>	<u>FY 1984 Monthly Per Channel Charge</u>
Ft. Leavenworth - Halls Beach	\$1,720
West Coast - Hawaii	1,790
McClellan AFB - Neklason Lake	1,050

Source: "FY 1984 Communications Services Industrial Fund (CSIF) Planning Rates," 11 Aug 82, DCA, Code 670

h. Defense Satellite Communications System (DSCS). DSCS provides worldwide communications to both tactical (mobile) and fixed locations of DoD and other authorized users. Congress has directed that a user charge system be established for the use of the DSCS. DCA has proposed that the user charge be administered as part of the CSIF. Users procuring their entire service (space plus ground) will be charged a monthly rate for each simplex (one-way) circuit depending upon the b/s requirement of the circuit. Two-way service is obtained by two one-way circuits. Users supplying their own earth terminals will pay only the space segment charges. The space segment charge will be based upon the line speed of each simplex circuit, but an adjustment will be required to reflect the operating characteristics of the user's earth terminal. Users obtaining an entire transponder will be charged in accordance with the percentage of the satellite's power and bandwidth contained in that transponder. As the exact rate structure has not yet obtained OSD approval, no rates can be presented at this time.

8. CONUS Commercial Satellite Communications System (COMSATCOM). Table 28-10 provides CSIF planning rates for the proposed services described below. Earth terminals are planned for the locations listed in table 28-11.

a. Voice Services.

(1) Switched Voice. Switched voice service provides the means for vocal communications between users interconnected by full duplex switched facilities. The service quality will be (approximate) toll grade and the switched facilities will be provided to users on an as available first-come, first-served basis with Grade-of-Service objectives as specified in the COMSATCOM RFP.

(2) Switched Voice with Off-Net Capability. Switched voice service with off-net capability provides users with switched voice network services and also with the capability to access users not provided with COMSATCOM switched voice service through the commercial DDD network. Users of this service will be billed for the off-net portion of their calls.

(3) Full Period. Full period voice service provides a dedicated (nonswitched) full duplex voice capability between pairs of users. The service quality will be equivalent to commercial "toll quality."

(4) Alternate Voice and Data. Alternate voice and data service provides switched voice service with the additional capability of using the channel for transfer of quasi-analog data between the connected users when not being used for voice communications. Two levels of alternate voice/data service are available, one for data transmission rates not to exceed 2.4 kb/s, and one for data rates up to 4.8 kb/s. The modems required for the data transmission in this service are not included as part of the COMSATCOM service.

b. Full Period Data Services. Full period data services provide for the transmission of digital data over simplex, nonswitched, full period channels at the data rates specified. Digital data services do not include a transmission channel for control signaling sent to the data source by the data recipient. Users requiring a return channel for control signals, acknowledgements, echo back, or other purposes will have to lease a simplex channel service for that purpose in addition to the channel used for the data transmission.

c. Full Period Video Service. Video nonswitched services will include: Telebroadcast, Teleseminar, Teleconference, Freeze-frame video connections, and Voice and Graphics Conferencing.

(1) Telebroadcast. A near full motion video broadcast service using 1.544 mb/s in an arrangement where only one station transmits a video signal (1 uplink only) while all others are in the receive only mode. The receiving stations are completely passive; i.e., they do not transmit either video or audio.

(2) Teleseminar. A near full motion video broadcast service using 1.544 mb/s in an arrangement where only one station transmits a video signal (1 uplink only) while all others are in the receive only mode. The receiving stations are completely passive; i.e., they do not transmit either video or audio.

(3) Teleconferencing. A near full motion video service arrangement requiring two 1.544 mb/s channels (2 uplinks), where one station, usually referred to as the conference chairman, has undivided use of a video uplink while another video uplink is rotated among the other stations for each conferee speaking. For audio communication, full audio conference bridging shall be provided. Conference participants who are not subscribers to COMSATCOM switched voice services will require a COMSATCOM voice service connection.

(4) Freeze-frame Video. Connection service that provides two nonswitched 56 kb/s channels between users with the slow scan video transmitted over on 56 kb/s channel and broadcast quality audio transmitted over the other channel.

(5) Voice and Graphics Conferencing. A nonswitched service providing two 56 kb/s channels for the undivided use of the conference chairman and two 56 kb/s channels which are rotated among the other stations for each conferee speaking.

9. Terminal Equipment. The complete list of terminal equipment which may be attached to AUTOVON, AUTODIN, or dedicated circuits is too large for presentation here. Table 28-12 gives average prices for attachment to the access line and attachment of the access line to the switch. The cost of the terminal equipment is additional. Much of the equipment located in CONUS is leased from the carriers under tariff. Overseas the equipment is usually Government owned. Lease charges for specific locations can be obtained from the servicing telephone and telegraph companies. For equipment which is to be purchased or leased from noncarriers, users are directed to GSA schedules, vendor price lists, or other chapters of this manual; e.g., chapter 11, Multiplex Equipment. For leased equipment the cost-to-the-Government is the fee stated in the tariff. The cost-to-the-user is the fee plus the 1.25 percent DECCO administration charge. For Government-owned equipment, such as COMSEC, the cost-to-the-Government is either zero for equipment which would otherwise go unused, or it is the procurement cost of the additional equipment.

TABLE 28-9. WAWS CSIF PLANNING RATES

<u>Point-to-Point</u>	<u>FY 1984 Monthly Rates</u>			
	<u>1.544 mb/s</u>	<u>40.8-56.0 kb/s</u>	<u>9.7-40.0 kb/s</u>	<u>.150-9.6 kb/s & Voice</u>
Andrews - Site R	\$10,595	\$1,990	\$535	\$175
Andrews - Ft. Detrick	1,825	1,780	430	150
Andrews - Ft. Meade	996	890	220	80
Andrews - Naval Security Sta	875	700	445	32
Andrews - Pentagon	1,045	780	140	25
Site R - Ft. Belvoir	12,405	2,010	560	170
Site R - Ft. Detrick	11,225	1,790	325	160
Site R - Ft. Meade	9,185	1,100	315	90
Site R - Naval Security Sta	8,325	1,040	200	95
Site R - Pentagon	7,545	795	170	80
Friendship Annex - Ft. Meade	1,755	-	-	-
Ft. Belvoir - Ft. Detrick	5,260	1,800	450	150
Ft. Belvoir - Ft. Meade	3,000	910	240	80
Ft. Belvoir - Naval Secur Sta	874	975	300	155
Ft. Belvoir - Pentagon	996	955	300	160
Ft. Detrick - Ft. Meade	2,040	890	210	70
Ft. Detrick - Naval Secur Sta	2,175	1,230	290	95
Ft. Detrick - Pentagon	3,755	1,075	240	80
Ft. Meade - Naval Secur Sta	787	920	225	75
Ft. Meade - Pentagon	874	835	240	80
Naval Secur Sta - Pentagon	785	245	50	15

NOTE: Color TV is offered at \$102,000 per month which includes associated A/D convertors necessary for interfacing the video with the WAWS Transmission Media. Service at speeds above 1.544 mb/s is priced as multiples of the 1.544 mb/s rate.

Source: "FY 1984 Communications Services Industrial Fund (CSIF) Planning Rates," 11 Aug 82, DCA, Code 670.

TABLE 28-10. COMSATCOM CSIF PLANNING RATES

<u>Type of Service</u>	<u>FY 1984 Monthly Fee</u>
<u>Voice</u>	
One switched voice circuit	\$ 512
One switched voice circuit with off-net capability	1,013
One full period voice circuit (dedicated)	757
One switched Voice-Data (data not to exceed 2.4 kb/s)	757
One switched Voice-Data (data not to exceed 4.8 kb/s)	1,516
<u>Full Period Data Port (Simplex)</u>	
1.2 kb/s	\$ 347
2.4	389
4.8	533
9.6	694
19.2	1,216
56.0	1,975
112.0	3,308
224.0	5,335
448.0	9,176
1.344 mbps	29,235
1.544	29,235
3.088	58,470
<u>Full Period Video Service</u>	
Telebroadcast: Originator	\$ 29,235
Receive Only	8,322
Teleseminar: Originator	\$ 29,235
Video Receive-Audio Send	8,963
Teleconference: Originator (Chairman)	\$ 29,235
Other Participants	$8,150 + \frac{20,000}{N-1}$ (N = # of conferees)
Freeze Frame	\$ 3,948
Voice and Graphics Conferencing	\$ 3,948
Source: "FY 1984 Communications Services Industrial Fund (CSIF) Planning Rates," 11 Aug 82, DCA, Code 670.	

TABLE 28-11. PLANNED COMSATCOM EARTH TERMINAL LOCATIONS

Washington, D.C.
Sacramento, California
San Diego, California
Los Angeles, California
San Francisco, California
San Antonio, Texas
Oklahoma City, Oklahoma
Ft Huachuca, Arizona
Dayton, Ohio
Salt Lake City, Utah
Atlanta, Georgia
Warren, Michigan
Chambersburg, Pennsylvania
Huntsville, Alabama
Red Bank, New Jersey
Rock Island, Illinois
St. Louis, Missouri
Aberdeen, Maryland
Norfolk, Virginia

Source: "FY 1984 Communications Services Industrial Fund (CSIF) Planning Rates," 11 Aug 82, DCA, Code 670.

TABLE 28-12. COST FOR TERMINAL EQUIPMENT AND TERMINATION

<u>AUTOVON</u>		
<u>Termination and First Terminal</u>	<u>Monthly</u>	<u>Installation</u>
Switch in Local Exchange	\$157	\$ 125
Switch in Remote Exchange	215	154
<u>Surcharge for Secure Termination</u>		
Switch in Local Exchange	5	
Switch in Remote Exchange	42	
<u>Extensions</u>	8	77
<u>AUTODIN</u>		
<u>Termination Charges</u>	<u>Monthly</u>	<u>Installation</u>
Speed (b/s)		
75-300	\$460	\$1,150
600-1200	473	1,386
2400	532	1,386
4800	620	1,386
9600	940	2,010
Source: DCA, Code 690, Jul 81.		

CHAPTER 29. INTERNATIONAL COMMERCIAL SERVICE

1. General.

a. Content. This chapter provides leasing charges for single channel services offered by foreign carriers and, in the case of transoceanic service, consolidated rates for the international record carriers (IRC's) and foreign carriers. The leasing charges are provided for use in estimating costs and projecting monetary requirements for international services. Charges and regulations will vary from country to country and within countries; therefore, completely accurate costing can be obtained only from the appropriate leasing entity.

b. Provision of Private Line Service. Private line service is provided in most of the countries in the world. In most countries the telephone system is Government-owned with the management and operations under the control of the Ministry of Post, Telecommunications, and Telegraph (PT&T). International service is provided through agreements between the international common carriers and the INTELSAT and NATO Allied Long Lines Agency (ALLA) agreements. All services transiting or terminating in any country are provided in accordance with the capabilities and regulations of that country, and any special services must be the subject of special agreements with that country.

c. Voice Services. Ordinary local voice service is usually provided over a "two-wire" circuit (one wire-pair). Long-distance service is usually provided over a "four-wire" circuit (two wire-pairs) between the switching centers. Some data transmission applications require four-wire circuits terminal to terminal. In such cases, and where four-wire charges are not shown, the rates may be estimated as twice the two-wire charge.

d. Planned Services. Many new services are currently being planned, such as high-speed digital services and packet switching services. INTELSAT, as an example, has an experimental 50 kb/s circuit that uses the same bandwidth as one voice circuit. Information concerning these new services will be included in this publication as it becomes available.

e. DECCO-Leased Services. In addition to the charges (cost-to-the-Government) contained herein, an overhead charge of 1.25 percent (cost-to-the-user) will be assessed for services leased through DECCO.

f. Media. Private line circuits are provided through all forms of transmission media such as HF radio, satellite, submarine cable (subcable). The carriers diversify the circuits (where possible) among the various media and automatically reroute circuits when an uncorrected degradation of one of the circuits occurs. The selection of the transmission medium is generally at the carriers' discretion. The circuits are suitable for voice and data (up to the bandwidth of the standard telephone-type circuit) and may be submultiplexed in most cases. Digital service often is available on transoceanic circuits and within many countries. Direct contact with the vendor is required for services not listed herein.

g. Charges. Charges for most private line services are based on distance. The charge may be stated as a rate per mile (or kilometer), a fixed rate for a maximum number of miles (or kilometers) or a rate per zone. In addition to the international zone charges between countries, some countries are subdivided into zone center exchange areas for intracountry services. Most countries have a one-time installation charge and a flat monthly "service" charge in addition to the distance-related charges.

2. Currency Conversion Factors. The charges of the carrier have been converted to U.S. dollars using the rates of exchange given in table 35-1 except when a different value is specified. For additional information on monetary rates of exchange, see chapter 35.

3. Use of Tables.

a. General. Information on leasing charges is found in tables 29-1 through 29-7. Only selected leased services charges are presented in the tables; however, additional information may be obtained from DCA, Code 690, or DECCO, Code D650.

b. List of CONUS Gateways. The international record carriers (IRC's) provide service between overseas points and selected entry points, known as gateways, in CONUS. There are four sets of gateways (table 29-1). The rate from an overseas point to the gateway is the same for each city in a set. Connecting links, or "tails," must be obtained from the user's location to the gateway. It is generally cheaper to secure service through a coastal gateway, as the cost of tail circuit is usually less than the surcharge imposed for use of midcontinent gateways. No discount is available for multiple channel lease.

c. International Rates. International analog circuits are suitable for voice or data and may be "channel packed." (See chapter 28 for information on channel packing.) In addition to the transoceanic channel, tails must be secured from the local carrier. When both ends of a circuit are located outside CONUS, the connection charges must be determined on a case-by-case basis due to the large variations in charges by foreign jurisdictions. Table 29-2, Leased Service Charges for Transoceanic Circuits, and table 29-3, Leased Service Charges for Transoceanic Digital Service, contain the basic service charges. A DECCO service fee of 1.25 percent must be added to the charges. When one end of the circuit is located in CONUS, the tables can be used to estimate the total cost by either of two methods.

(1) One estimate can be obtained by adding a fee of \$500 for the tail segments. For example, to estimate the cost of a full-period voice circuit between Maryland and Japan, add \$500 to the West Coast - Japan charge of \$18,370 for an estimated fee of \$18,870.

(2) An alternative method is to select a circuit from the list of representative charges. The circuit should be as similar to the desired circuit, as possible. The estimate for the new circuit is the actual fee for

the representative circuit. In our example, an appropriate choice would be Tinker AFB, OK, to Fuchu, Japan--a fee of \$18,510.

d. Leased Service Charges for International Circuits - Europe. Table 29-4 presents rates between European countries.

(1) Telephone Circuits. The NATO Allied Long Lines Agency (ALLA) negotiates agreements with the European telecommunications authorities to secure discounts for military circuits. The terms for discount are currently under negotiation. Information can be obtained from DECCO-Europe.

(2) Telegraph Circuits. Telegraph circuits are priced on the basis of a 8,000-minute-per-month, 50-baud circuit except where otherwise noted. The terms for discounts are currently under negotiation. Information can be obtained from DECCO-Europe.

(3) Data Circuits. If the traffic is in excess of 300 b/s, a data circuit should be used. Some jurisdictions require data circuits for all nonvoice, nontelegraph applications.

(4) Zone Rates. As a general rule all countries are considered to be one "zone" for intercountry traffic except for Germany and countries adjacent to Germany. It is suggested that planners who do not have ready access to zone data use the higher of the zone rates. For example, for traffic between Belgium and Germany, assume the German location is in zone two. In addition, there are certain border zone areas where traffic is charged at intranational vice international rates. Information concerning zones may be obtained from the compendium published by ALLA or from the carrier.

(5) DECCO Service Charge. The DECCO service charge of 1.25 percent must be added to the circuit charge.

e. Leased Service Charges for Intracountry Circuits - Europe.

(1) This table provides selected rates for intracountry services available in Europe. Each country establishes its own system for internal charges, as in the following examples:

(a) Belgium is divided into adjoining and nonadjoining zones. If the service points are within the same zone, or adjoining zones, the adjoining zone rate applies. If the service points are separated by a third zone, the nonadjoining zone rate applies. The rate is a fixed amount per month.

(b) Other countries have a charge per kilometer. A 15-km preferential rate telephone circuit in Germany would cost $(7)(15) = \$105/\text{mo}$. France has two parts to its charges. If a 15-km circuit were required in France, the fixed fee would be \$49, because the largest minimum distance less than 15 km is 11 km and the fixed fee for circuits in the 11-50 km band is

\$49. The distance fee for this circuit would be \$7 per km for all in excess of 11 km or (4)(7) = \$28. The total fee is the sum of \$28 and \$49 or \$77 per month.

(c) Still other countries, such as Greece, Italy, and the Netherlands, have a flat charge for a given number of kilometers, with the charge increasing at each new incremental step. The fee for a 40-km telephone circuit in Greece would be priced at the 46-km rate, \$1,123. In the United Kingdom, the installation fee also varies by a minimum distance band schedule.

(2) The DECCO service charge of 1.25 percent must be added to the circuit charge.

f. Leased Service Charges for Intracountry Circuits - Hawaii.

(1) Except for Hawaii, table 29-6, available information on intracountry circuits in the Pacific/Asia region is insufficient to permit analysis and the preparation of planning factors. Rates must be obtained from the local jurisdiction.

(2) The DECCO service charge of 1.25 percent must be added to the circuit charge.

g. Dial Charges. Rates are lowest for dialed station-to-station calls. These rates also apply to areas where operator assistance is required due to absence of provision for international direct distance dialing. The rates are usually lower on calls from the U.S. to overseas. If a call must be placed from overseas, it may be cheaper to either call collect or have the CONUS party call back after the initial period. Rates are for the initial 3 minutes of calling. Rates to the Caribbean, Central America, and South America vary by the actual distance of the call. Rates to all other points are the same regardless of where in CONUS the call originates. The local telephone company will provide upon request a booklet which gives more detailed rate information.

TABLE 29-1. LIST OF CONUS GATEWAYS

<u>EAST COAST</u>	<u>MIDEAST</u>
Atlanta, GA	Chicago, IL
Baltimore, MD	Cincinnati, OH
Boston, MA	Cleveland, OH
Hicksville, NY	Dallas, TX
Miami, FL	Detroit, MI
Newark, NJ	Houston, TX
New York, NY	Memphis, TN
Philadelphia, PA	Milwaukee, WI
Pittsburgh, PA	Minneapolis, MN
Stanford, CT	New Orleans, LA
Washington, DC	St. Louis, MO
<u>WEST COAST</u>	<u>MIDWEST</u>
Los Angeles, CA	Denver, CO
San Francisco, CA	
Seattle, WA	

Source: DECCO, Sep 80.

TABLE 29-2. LEASED SERVICE CHARGES FOR TRANSOCEANIC CIRCUITS

Full Period Voice/Data Service Subcable/Satellite/Composite Monthly Rates		
<u>From Gateway</u>	<u>To Gateway</u>	<u>Channel Charge</u>
West Coast	Australia	\$19,264
	Guam	7,500
	Hawaii	2,313
	Japan	18,370
	Midway	11,500
	Philippines	14,150
	Thailand	18,580

TABLE 29-2. LEASED SERVICE CHARGES FOR TRANSOCEANIC CIRCUITS (CON.)

Full Period Voice/Data Service
Subcable/Satellite/Composite Monthly Rates

<u>From Gateway</u>	<u>To Gateway</u>	<u>Channel Charge</u>
East Coast	Bahamas	\$ 4,900
	Bermuda	5,840
	Cuba	2,000
	France	9,295
	Germany	12,300
	Italy	11,019
	Jamaica	5,879
	Panama Canal	7,525
	Puerto Rico	2,680
	Spain	10,740
	United Kingdom	9,707
Philippines	Guam	8,450
	Japan	12,707
	Thailand	14,875
Guam	Japan	10,669
	Thailand	13,800
Hawaii	Alaska (via San Fran.)	5,170
	Australia	10,430
	Guam	4,075
	Japan	14,547
	Korea	15,507
	Philippines	12,707
	Thailand	14,375

Representative Charges for Terminal-to-Terminal Leased Services

<u>From</u>	<u>To</u>	<u>CONUS Tail</u>	<u>Inter'l Channel</u>	<u>Foreign Tail</u>	<u>Monthly Total</u>
Offutt, AFB, Nebraska	Andersen, Guam	\$160	\$ 7,500	-	\$ 7,660
Arlington, Virginia	Honolulu, Hawaii	140	2,313	\$180	2,633
Lodi, California	Honolulu, Hawaii	230	2,313	237	2,780

TABLE 29-2. LEASED SERVICE CHARGES FOR TRANSOCEANIC CIRCUITS (CON.)

Full Period Voice/Data Service
Subcable/Satellite/Composite Monthly Rates

Representative Charges for Terminal-to-Terminal Leased Services

<u>From</u>	<u>To</u>	<u>CONUS Tail</u>	<u>Inter'l Channel</u>	<u>Foreign Tail</u>	<u>Monthly Total</u>
Offutt, AFB, Nebraska	Tokyo, Japan	\$240	\$18,370	-	\$18,610
McClellan, California	Thule, Greenland	140	1,989	-	2,129
Ent, Colorado	Pearl Harbor, Hawaii	140	2,313	\$249	2,702
Lodi, California	Clark AB, Philippines	230	14,150	-	14,380
Tinker AFB, Oklahoma	Fuchu, Japan	140	18,370	-	18,510
Fort Detrick, Maryland	Honolulu, Hawaii	140	2,313	249	2,702
Carswell AFB, Texas	Clark AB, Philippines	160	14,150	-	14,310
Andrews AFB, Maryland	London, United Kingdom	115	9,707	157	9,979
Arlington, Virginia	London, United Kingdom	85	9,707	157	9,949
Cheyenne Mt Complex, CO	London, United Kingdom	235	9,707	157	10,099
Offutt AFB, Nebraska	Mildenhall, United Kingdom	162	9,707	157	10,026
Berryville, Virginia	Riyadh, Saudi Arabia	399	18,482	291	19,172

TABLE 29-2. LEASED SERVICE CHARGES FOR TRANSOCEANIC CIRCUITS (CON.)

Full Period Voice/Data Service Subcable/Satellite/Composite Monthly Rates					
<u>From</u>	<u>To</u>	<u>CONUS Tail</u>	<u>Inter'l Channel</u>	<u>Foreign Tail</u>	<u>Monthly Total</u>
Pentagon, Virginia	Helsinki, Finland	\$ 85	\$11,120	-	\$11,205
Washington, DC	London, United Kingdom	67	9,707	157	9,931
Cheyenne Mt. Complex, CO	Athens, Greece	240	11,234	261	11,735
Norfolk, Virginia	Buitrage, Spain	161	10,740	212	11,113
Pottstown, Pennsylvania	Feldberg, Germany	230	12,300	407	12,937
Washington, DC	Kjeller, Norway	67	9,815	240	10,122
Colorado Springs, CO	Aviano, Italy	240	11,019	225	11,484
Gentile, Ohio	Leghorn, Italy	96	11,019	222	11,337
Pottstown, Pennsylvania	Monte Vergine, Italy	230	11,019	222	11,471
Cheyenne Mt. Complex, CO	Aviano, Italy	240	11,019	225	11,484
Fort Detrick, Maryland	Flatts, Bermuda	96	5,840	-	5,936

TABLE 29-2. LEASED SERVICE CHARGES FOR TRANSOCEANIC CIRCUITS (CON.)

Leased Telegraph Monthly Rates		
From U.S. Coastal Gateway to:	baud	
	75	50
Australia	\$6,080	\$5,528
Austria	4,056	3,688
Belgium	4,047	3,680
Denmark	4,047	3,680
France	3,726	3,388
Germany	4,036	3,668
Guam	3,300	3,000
Hawaii	—	225
Ireland	4,024	3,659
Italy	4,036	3,668
Japan	6,447	5,770
Luxembourg	4,047	3,680
Netherlands	3,883	3,531
Norway	4,047	3,680
Sweden	4,047	3,680
Switzerland	4,056	3,688
United Kingdom	4,045	3,678

Source: DECCO, Sep 80.

TABLE 29-3. LEASED SERVICE CHARGES FOR TRANSOCEANIC DIGITAL SERVICE, MONTHLY RATES

<u>From Gateway</u>	<u>To Gateway</u>	<u>b/s</u>	<u>Channel Charge</u>
West Coast	Hawaii	75	\$ 225
		150	260
		300	425
		1200	1,000
		2400	1,755
		4800	1,995

TABLE 29-3. LEASED SERVICE CHARGES FOR TRANSOCEANIC DIGITAL SERVICE,
MONTHLY RATES (CON.)

<u>From Gateway</u>	<u>To Gateway</u>	<u>b/s</u>	<u>Channel Charge</u>		
East Coast	Germany	1200	6,200		
	or	2400	7,500		
	United Kingdom	4800	9,000		
		7200	10,500		
		9600	12,300		
East Coast	Spain	2400	7,300		
		4800	8,900		
		7200	10,390		
		9600	12,000		
REPRESENTATIVE CHARGES FOR DIGITAL TERMINAL-TO-TERMINAL LEASED SERVICES					
<u>From</u>	<u>To</u>	<u>CONUS Tail</u>	<u>International Channel</u>	<u>Foreign Tail</u>	<u>Monthly Total</u>
Norfolk, VA	Rota, Spain	\$180	\$ 10,390	\$112	\$ 10,682
Randolph TX	Ramstein, Germany	385	12,300	215	12,900
Source: DECCO, Sep 80.					

TABLE 29-4. LEASED SERVICE CHARGES FOR INTERNATIONAL CIRCUITS -
EUROPE

<u>From</u>	<u>To</u>	<u>Fixed Fee</u>		
		<u>Voice</u>	<u>50-baud Telegraph</u>	<u>Data</u>
Belgium	Denmark	\$2,246	\$842	\$3,052
	France Zone 1	1,796	674	2,244

TABLE 29-4. LEASED SERVICE CHARGES FOR INTERNATIONAL CIRCUITS - EUROPE (CON.)

From	To	Fixed Fee			
		Voice	50-baud Telegraph	Data	
Belgium	France Zone 2	\$2,096	\$ 786	\$2,619	
	Germany Zone 1	2,176	814	2,719	
	Germany Zone 2	2,381	895	2,978	
	Netherlands	1,574	590	1,967	
	Luxembourg	1,615	606	2,018	
	Norway	3,056	1,146	3,819	
	United Kingdom	1,776	666	2,219	
Denmark	France	2,477	929	3,355	
	Germany Zone 1	1,901	711	2,564	
	Germany Zone 2	2,107	792	2,823	
	Netherlands	1,794	674	2,464	
	Luxembourg	2,109	791	2,875	
	Norway	1,022	383	1,377	
	United Kingdom	1,892	710	2,629	
France Zone 1	Germany Zone 1	1,915	717	2,392	
	Zone 2	Germany Zone 1	2,215	829	2,766
	Zone 1	Germany Zone 2	2,120	797	2,651
	Zone 2	Germany Zone 2	2,420	909	3,025
France Zone 1	Luxembourg	1,647	618	2,059	
France Zone 2	Luxembourg	1,947	730	1,433	
Single Zone	Norway	n/a	n/a	n/a	
Single Zone	Portugal	1,562	586	1,951	
Single Zone	United Kingdom	1,771	664	2,213	
Germany Single Zone	Italy	3,011	1,127	3,762	
	Zone 1	Luxembourg	2,027	758	2,533
	Zone 2	Luxembourg	2,232	839	2,792
	Zone 1	Netherlands	1,901	712	2,375
	Zone 2	Netherlands	2,107	792	2,634
	Zone 1	Norway	2,642	989	3,301
	Zone 2	Norway	2,847	1,070	3,560
	Single Zone	United Kingdom	2,637	1,003	3,204
Greece	Italy	3,951	1,481	4,934	

TABLE 29-4. LEASED SERVICE CHARGES FOR INTERNATIONAL CIRCUITS -
EUROPE (CON.)

From	To	Fixed Fee		
		Voice	50-baud Telegraph	Data
Greece	Turkey	\$7,650	\$2,867	\$9,554
	United Kingdom	3,812	1,429	4,761
Italy	Turkey	8,538	3,200	10,663
	United Kingdom	2,489	933	3,109
Netherlands	Norway	2,616	983	3,270
	Luxembourg	1,801	676	2,249
	United Kingdom	1,423	536	1,778
Norway	United Kingdom	2,697	1,735	2,646
Portugal	United Kingdom	984	369	1,229
<u>Representative Circuit Charges</u>				
<u>From</u>	<u>To</u>	<u>Monthly Rates</u>		
		<u>Voice</u>		
Coltano, Italy	Langerkopf, Germany	\$3,100		
	Donnersberg, Germany	Humosa, Spain	4,271	
	Athens, Greece	3,842		
	Naples, Italy	3,100		
	Coltano, Italy	3,100		
Feldberg, Germany	Martlesham-Heath, U.K.	2,726		
	Martlesham-Heath, U.K.	2,726		
	Hillingdon, U.K.	2,726		
	Coltano, Italy	3,100		
	Naples, Italy	3,100		
Hillingdon, U.K.	Athens, Greece	3,842		
	Martlesham-Heath, U.K.	255		
	Schoenfeld, Germany	2,726		
	Langerkopf, Germany	2,726		
Humosa, Spain	Naples, Italy	2,489		
	Langerkopf, Germany	4,270		
	Naples, Italy	3,193		

TABLE 29-4. LEASED SERVICE CHARGES FOR INTERNATIONAL CIRCUITS - EUROPE (CON.)

<u>Representative Circuit Charges</u>		
<u>From</u>	<u>To</u>	<u>Monthly Rates Voice</u>
Naples, Italy	Coltano, Italy	940
	Stuttgart, Germany	3,100
	Athens, Greece	3,950
	Langerkopf, Germany	3,100
Schoenfeld, Germany	Martlesham-Heath, U.K.	2,726

Source: DECCO/EUR, Dec 79.

TABLE 29-5a. MONTHLY LEASED SERVICE CHARGES FOR INTRACOUNTRY CIRCUITS IN EUROPE: BELGIUM (Exchange Rate \$1 = 28.88)

<u>Telephone (2-or 4-wire)¹</u>		
<u>Zones</u>		<u>Fixed Fee</u>
Adjoining Zones		\$225
Nonadjoining		450

<u>Telegraph</u>		
<u>Zones</u>		<u>Fixed Fee</u>
Adjoining		\$225
Nonadjoining		
50-baud		113
100-baud		135
200-baud		158

¹Multiply by 1.25 if use is for data transmission.

NOTE: Installation fee: \$87 per circuit, double for 4-wire.
Conditioning for data circuits: Zone circuits \$108, Interzone \$152.

TABLE 29-5b. MONTHLY LEASED SERVICE CHARGES FOR INTRACOUNTRY CIRCUITS
IN EUROPE: FRANCE (Exchange Rate \$1 = 4.18)

<u>Telephone (2-wire)</u>		
<u>Minimum Distance (km)</u>	<u>Per km Over minimum</u>	<u>Fixed Fee</u>
0	\$9	\$ 33
11	7	49
51	5	150
<u>Distance (km)</u>	<u>Telephone (4-wire)</u>	
0-30	2 X 2-wire fee	
Over 30	\$134 + (2 X 2-wire fee)	
<u>Telephone (M-102 Data Conditioning)</u>		
0-30	2-wire fee X 2.2	
Over 30	\$180 + (1.2 X 2-wire fee)	
<u>50-baud Telegraph</u>		
<u>Minimum Distance (km)</u>	<u>Per km Over minimum</u>	<u>Fixed Fee</u>
0	\$9	\$ 33
11	7	49
51	2	336
<u>Up to 200-baud Telegraph</u>		
0	\$9	\$ 33
11	7	49
51	3	282
<p>NOTES: Maximum total monthly fee for a 50-baud telegraph circuit is \$724; maximum for a telegraph circuit up to 200 baud is \$940.</p> <p>The maximum total monthly fee is \$1,718 per 2-wire telephone circuit. Installation fee: \$120 per terminal.</p>		

TABLE 29-5c. MONTHLY LEASED SERVICE CHARGES FOR INTRACOUNTRY
CIRCUITS IN EUROPE: GERMANY (Exchange Rate \$1 = 1.78)

<u>Telephone</u>	
<u>2-Wire Circuit</u>	<u>Rate per km</u>
With preferential rates ¹	\$7
Other	11
4-wire surcharge \$112 per terminal; however the monthly surcharge for the two terminals shall not exceed the monthly fee for the circuit itself.	
<u>Telegraph</u>	
<u>2-Wire Circuit</u>	<u>Rate per km</u>
50 baud ¹	\$3
Over 50 baud	5
4-wire surcharge, \$84 per terminal; however, the monthly surcharge for the two terminals shall not exceed the monthly fee for the circuit itself.	
Installation charge: \$225, double for 4 wire	
Data conditioning: \$270	
¹ Telephone out-of-area tieline circuits connected at both terminals to administrative switchboards or dial central offices having access to the Deutsche Bundespost civil network and all 50-baud telegraph circuits are accorded preferential rates under the NATO Status of Forces Agreement.	

TABLE 29-5d. MONTHLY LEASED SERVICE CHARGES FOR INTRACOUNTRY CIRCUITS
IN EUROPE: GREECE (Exchange Rate \$1 = 35.21)

<u>Telephone (2-wire)</u>					
<u>Minimum Distance (km)</u>	<u>Fixed Fee</u>				
0	\$ 241				
21	481				
31	722				
46	1,123				
81	1,604				
161	2,086				
241	2,567				

<u>Telegraph</u>					
<u>Minimum Distance (km)</u>	<u>Fixed Fee</u>				
	<u>baud</u>				
	<u>50</u>	<u>75</u>	<u>100</u>	<u>200</u>	
0	\$ 90	\$ 99	\$ 198	\$ 144	
21	180	199	217	289	
31	271	298	325	433	
46	421	463	505	674	
81	601	662	722	963	
161	782	860	939	1,251	
241	963	1,058	1,155	1,540	

NOTE: Installation fee: \$85 per terminal.
Data conditioning: 15% surcharge.

TABLE 29-5e. MONTHLY LEASED SERVICE CHARGES FOR INTRACOUNTRY CIRCUITS
IN EUROPE: ITALY (Exchange Rate \$ = \$28.71)

<u>Telephone</u>				
<u>Minimum Distance (km)</u>				<u>Fixed Fee</u>
0				\$159
16				299
31				528
61				677
121				806
241				996

<u>Telegraph</u>				
<u>Minimum Distance (km)</u>	<u>Per km Over minimum</u>		<u>Fixed Fee</u>	
	<u>baud</u>		<u>baud</u>	
	<u>50</u>	<u>over 50</u>	<u>50</u>	<u>over 50</u>
0	\$1	\$2	\$0	\$0
401	1	2	8	8

NOTE: Installation fee: \$109 per circuit.
Data conditioning: \$42.

**TABLE 29-5f. MONTHLY LEASED SERVICE CHARGES FOR INTRACOUNTRY CIRCUITS
IN EUROPE: NETHERLANDS (Exchange Rate \$1 = 1.98)**

<u>Telephone (2-wire)¹</u>			
<u>Minimum Distance (km)</u>	<u>Fixed Fee</u>		
0	\$ 88		
11	126		
26	202		
51	253		
101	278		

<u>Telegraph</u>			
<u>Minimum Distance (km)</u>	<u>Fixed Fee</u>		
	<u>50</u>	<u>100</u>	<u>200</u>
0	\$ 88	\$110	\$133
11	114	142	170
26	139	174	208
51	152	189	227
101	164	205	246

¹For 4-wire circuits multiply fixed fee by 1.2.
Data conditioning: \$61.

TABLE 29-5g. MONTHLY LEASED SERVICE CHARGES FOR INTRACOUNTRY CIRCUITS
IN EUROPE: NORWAY (Exchange rate: \$1 = 5.30)

<u>Telephone (2- or 4-wire)</u>			
<u>Minimum Distance (km)</u>	<u>Fixed Fee</u>	<u>Minimum Distance (km)</u>	<u>Fixed Fee</u>
0	50	121	313
11	79	151	370
21	104	201	423
31	131	251	476
41	168	301	550
61	204	401	630
81	239	601	747
101	274		

<u>Telegraph Circuits - Fixed Fees</u>			
<u>Minimum Distance (km)</u>	<u>50 Baud</u>	<u>100 Baud</u>	<u>200 Baud</u>
0	\$ 50	\$ 63	\$ 75
11	69	86	104
21	83	104	124
31	94	118	142
41	113	142	162
61	131	164	197
81	149	186	223
101	165	206	248
121	182	226	272
151	209	261	313
201	236	296	354
251	263	327	393
301	297	371	447
401	352	439	527
601	414	517	621

Installation fee: \$79 per terminal.
Data Conditioning: \$102.

**TABLE 29-5h. MONTHLY LEASED SERVICE CHARGES FOR INTRACOUNTRY CIRCUITS
IN EUROPE: SPAIN (Exchange Rate \$ = 66.56)**

<u>Telephone</u>						
<u>Fixed Fee¹</u>						
<u>Minimum Distance (km)</u>	<u>Voice 2-Wire</u>	<u>Voice 4-Wire</u>	<u>Data 2-Wire</u>	<u>Data 2-Wire Cond.</u>	<u>Data 4-Wire</u>	<u>Data 4-Wire Cond.</u>
0	\$413	\$ 434	\$ 671	\$1,007	\$ 767	\$1,151
21	517	539	841	1,261	937	1,405
101	692	713	1,125	1,688	1,221	1,832
201	825	846	1,342	2,014	1,438	2,158
401	1034	1,055	1,682	2,522	1,778	2,667

<u>Telegraph</u>				
<u>Fixed Fee</u>				
<u>Minimum Distance (km)</u>	<u>baud</u>			
	<u>50</u>	<u>75</u>	<u>200 2-wire</u>	<u>200 4 wire</u>
0	\$201	\$252	\$302	\$345
21	252	315	378	422
101	338	422	506	549
201	403	505	604	647
401	504	631	757	800

Second circuit is discounted by 20%. Third circuit is discounted by 30%.
Fourth and subsequent circuits are discounted by 40%.

¹Multiply voice 2-wire rate by 2.5 for VFCT fee.

NOTE: Installation fee: Telephone (voice) and telegraph
\$421 per circuit; all others, \$572 per circuit.
Surcharges of up to 40% may be applied for all circuits other than simple
point-to-point depending upon the characteristics of the network.

TABLE 29-51. MONTHLY LEASED SERVICE CHARGES FOR INTRACOUNTRY CIRCUITS
IN EUROPE: TURKEY (Exchange Rate \$1 = 47.10)

<u>Telephone</u>	
<u>Minimum Distance (km)</u>	<u>Fixed Fee</u>
0	\$1,536
41	1,708
101	2,501
201	3,201
301	3,841

<u>Telegraph</u>	
<u>Minimum Distance (km)</u>	<u>Fixed Fee</u>
0	\$256
41	352
101	512
201	640
301	768

Installation charge: \$ 6.37 per terminal.

TABLE 29-5j. MONTHLY LEASED SERVICE CHARGES FOR INTRACOUNTRY
CIRCUITS IN EUROPE: UNITED KINGDOM

The telephone and telegraph monthly fixed fees and the installation charges vary by distance. There is no per km fee. Telegraph circuits may be secured from the Defense Telegraph Network for a monthly fixed fee of \$33 for 50 baud and \$52 for 110 baud. The installation fee for Defense Telegraph Network circuits is the same as for commercial circuits.

Minimum Distance (km)	Telephone			Telegraph		
	Voice	Data	Install.	50 baud	110 baud	Install.
16	\$184	\$195	\$298	\$124	\$124	\$255
32	204	216	298	131	131	255
48	217	238	298	135	156	255
64	242	266	298	136	182	255
80	262	294	340	139	188	298
96	288	323	340	142	191	298
112	316	362	340	145	194	298
128	355	394	340	149	197	298
144	372	418	340	152	200	298
160	452	491	383	158	222	340
240	532	578	383	163	234	340
320	606	629	383	170	240	340
400	674	713	383	179	252	340
481	771	798	383	184	259	340

NOTE: Circuit fees may be increased by 15-30 percent and installation fees by 50 to 100 percent depending upon network characteristics. Contact DECCO/Europe for specifics.

Source: DECCO/EUR Nov 80.

TABLE 29-6. MONTHLY LEASED SERVICE CHARGES FOR INTRACOUNTRY CIRCUITS -
HAWAII

<u>Location</u>	<u>Rate</u>		
	<u>75-baud Telegraph</u>		
	<u>Telephone</u>	<u>Half Duplex</u>	<u>Full Duplex</u>
Intra-Oahu (per mile)	\$ 5	\$ 4	\$ 5
Oahu-Hawaii	425	90	100
Oahu-Molokai	130	75	83
Oahu-Kauai or Maui	250	75	83

Source: DECCO, Sep 80.

CHAPTER 30. DOMESTIC COMMERCIAL SERVICE

1. General. DECCO can obtain other services from a common carrier when the usual services obtained through the CSIF (chapter 28) do not satisfy special user requirements. These other services are outlined in this chapter. In addition to the cost-to-the-Government fees listed here, the user must pay for terminal equipment and a 1.25 percent DECCO administration fee. (Terminal equipment costs are found in chapter 28, paragraph 7.) The domestic commercial communications market is currently adjusting to the withdrawal of TELPAK by AT&T and the maturation of the other common carriers. Thus, service offerings and rates are expected to be highly volatile for the foreseeable future.

2. Dedicated Systems.

a. General. If the standard offerings of the carriers are inadequate, special construction may be required. The rates for special construction are negotiated with the carrier. Dedicated channels can be obtained either from the established carriers (AT&T, Western Union) or from the other common carriers. The established carriers offer services throughout CONUS; the service areas of the other carriers are restricted to those locations where they have facilities.

b. Established Terrestrial Carriers.

(1) Voice Grade Service. The terrestrial service rates of AT&T and Western Union are essentially equal. The rates are given in table 30-1. The rates are based upon airline mileage and the classification of the served points. Roughly 400 rate centers have been "listed" as "category A" locations. All others are "unlisted" or "category B" locations. Category A locations are served by high-capacity, low-cost-per-circuit-mile facilities; therefore, rates associated with them are lower. The lowest rate is between two listed areas, the highest between two unlisted areas. The first 100 miles of a 300-mile circuit between two listed cities would cost \$248.64 per month. The remaining 200 miles would be billed at the rate of 0.93 per mile or \$186 per month, for a total of \$434.64 per month.

(2) DDS. AT&T offers an all-digital service called DDS (Dataphone Digital Service). This service is currently authorized to 96 metropolitan areas (Digital Service Areas - DSA) in the United States (table 30-2). Service is not yet available to all authorized areas. Analog facilities can be used to extend DDS beyond these areas. Service is offered at speeds of 2.4, 4.8, 9.6, 56 and 1,544 kb/s. Service at 2.4 kb/s, 4.8 kb/s or 9.6 kb/s is charged at the same rate. The rates of service at 56 kb/s and below are given in table 30-3. Service at 1.544 mb/s has a fixed fee of \$2,838 per month plus mileage charges. The mileage fee for the first 200 miles (1-200) is \$90.84 a mile per month. The fee for the next 300 miles (201-500) is \$70.97 a mile per month. All miles over 500 are charged at \$56.78 a mile per month. In addition, the user will be required to secure an access line from the user premises and the serving central office. This access line has a

fixed charge of \$710 per month and a mileage charge of \$85.13 a mile per month. The access line has an installation charge of \$355. The termination fee for 1.544 service is \$567 per month with an installation fee of \$142.

(3) 48 kHz : 56 kb/s. AT&T offers a 48 kHz service suitable for transmission at 56 kb/s. The rates are given in table 30-4. This offering can be used to extend DDS beyond its service areas.

(4) Other. The established carriers offer other private-line services suitable for purposes such as low-speed data, wideband data, radio, or television. These can provide service ranging from 75 b/s to 1.544 mb/s or from voice-grade to television bandwidths. Rates for these services can be obtained from Code 690.

c. Satellite Carriers.

(1) General. Satellite carriers may be less expensive for requirements with one or more of the following characteristics: multipoint broadcast, wideband, extreme distances, or asymmetrical demand. For some data transmission applications the 275-ms propagation delay may create response-time problems. Furthermore, the error control procedures may be different from those appropriate for use with terrestrial facilities. Some vendors have developed equipment to compensate for the delay and hence permit the use of terrestrial protocols over satellites.

(2) Special Construction. The carriers will supply dedicated earth stations for use with their satellites at negotiated rates. At some locations a dedicated 15m earth terminal is the least costly commercial alternative for even a single 56 kb/s duplex circuit. Broadcast applications which can use the less expensive receive-only earth stations are also candidates for dedicated earth stations. As satellites operating at higher frequencies to roof-mounted earth terminals become available; e.g., the service proposed by Satellite Business Systems (SBS), dedicated earth terminals will prove in at lower traffic densities. The carriers will also lease transponder space for use with user-provided earth stations. Direct contact with the vendors is required for quotation of rates for customized service.

(3) Private Line Service.

(a) The satellite carriers have placed earth stations on the east, west, and gulf coasts and secured terrestrial distribution facilities to major population centers. The rates stated for service between the centers tend to follow the rates of their terrestrial competitors. Thus, while satellite technology is distance insensitive, the pricing of individual satellite circuits is not. If the user desires service beyond the boundaries of a satellite service area, terrestrial distribution lines must be secured at additional expense. These can be obtained directly from a landline carrier or through the satellite carrier at the user's option.

(b) At present there are three satellite carriers offering private line services. They are American Satellite Corporation (ASC or AmSat), R.C.A. Americom (RCA), and Western Union Telegraph Company (WU).

(c) The rates charged by the carriers for single-voice grade channels tend to be similar. Sample monthly rates are short haul (New York-Chicago), \$500; medium haul (Houston-Los Angeles), \$700; long haul (San Francisco-Atlanta), \$1,000. Some vendors offer discounts to users who lease multiple circuits. The discount schemes differ by carrier and range from a low of a 10-percent discount for 6 to 11 channels to a high of a 40-percent discount for over 240 channels. The carriers have different schedules and formulas for the discounts, but in general the discount is determined by the total number of voice grade circuits leased without regard to end-points. The minimum rate single circuit for the several city pairs is given in table 30-5. Rate changes for satellite service have been frequent. It is advisable to verify all rates. In addition to voice grade (4 kHz) circuits, wideband and data service is available.

(d) The rate in dollars per month is given at the intersection. For example, a Dallas, Texas, to Buffalo, New York, circuit can be obtained for \$750 per month. A Los Angeles, California, to Atlanta, Georgia, voice-grade line costs \$1,000 per month. In addition to the recurring fees for the circuit, there may be additional fees for termination equipment or installation, or both.

(e) Organizations considering use of satellite private line services should contact Code 690 or the vendors for current price and discount quotations.

d. Packet Switched Carriers. Packet switching is inherently a switched service. However, if service is needed between only two points, Telenet offers a private line style of service (no routing data are required). The access (termination) fees are the same as those given in table 30-3 for the switched service, but the traffic fee is at a flat rate. The monthly traffic fees are \$25 for 75-110 b/s, \$50 for 134.5-300 b/s, and \$75 for 1.2 kb/s (source: Code 690, March 1981).

e. Microwave Carriers. Several vendors; e.g., MCI, offer service to selected locations by means of microwave. Connecting trunks or local loops or both must be obtained from the established carriers. The rates of the microwave carriers tend to be less than those of the established carriers for similar service. The rates and service locations are too varied for presentation here. Direct contact with the vendor is required for quotations.

3. Shared Services.

a. General. AUTOVON and AUTODIN (chapter 28) will meet most of the communications needs of DoD users. For some applications, however, commercial service may be required.

b. Dial-up.

(1) General. Full-time private line service is too expensive for occasional use. Ordinary dial-up service should be considered for applications with geographically dispersed, occasional access users. Three alternatives are available, Direct Distance Dialing (DDD), Wide Area Telecommunications Service (WATS), and switched services available from Specialized Common Carriers.

(2) DDD. Ordinary long-distance service is part of AT&T's Message Telecommunications Service (MTS). The minimum billing period for MTS is 1 minute. Additional usage is also charged on 1-minute intervals. The least expensive MTS mode is DDD (station-to-station service without operator assistance). CONUS rates provide for two discount periods. Sunday through Friday evenings (1700-2300 hours local time) are discounted 35 percent. Night (2300-0800) hours and Saturday and Sunday (except evening hours) are discounted 60 percent. Calls to Alaska and Hawaii are discounted at 30 percent for evening hours and 55 percent at night. Calls to Puerto Rico and the Virgin Islands follow the CONUS discount schedule. Rates for stations within CONUS and between CONUS and Alaska are on the basis of rate bands based on mileage. Rates between Hawaii and Puerto Rico-Virgin Islands and CONUS are on the basis of rate bands based on states. Roughly stated, band 1 contains the states located on the near coast, band 2 those in central CONUS, and band 3 the far coast. The precise composition of the bands can be obtained from either the local telephone company or Code 690. The rates in table 30-6 are for station-to-station dialed calls (DDD).

(3) WATS.

(a) Wide Area Telephone Service (WATS) is a bulk discount offering for users who make large numbers of long-distance calls. Recent changes in the price structure of WATS have removed the flat-rate features formerly associated with this offering. Billings for WATS follow the same business day, evening, and night/weekend periods as DDD. While exact comparisons cannot be made, WATS tends to have a higher discount than DDD for the night and evening periods. The rates also decrease with usage.

(b) WATS service is either send-only (outward WATS) or receive-only (800 service or inward WATS). If both send and receive services are desired, they must be procured separately. While a single outward access line may be procured, the minimum purchase of inward WATS is two access lines connected to a hunting arrangement. (The fees for the hunting arrangement and any terminal equipment attached to the access line are established by the local telephone company.)

(c) Both intrastate WATS and interstate WATS are available, but different access lines and telephone numbers must be used. The local telephone company must be contacted for rates and terms for intrastate WATS. Interstate WATS cannot be used to place calls to or from locations in the same state where the access line is terminated.

(d) WATS rates are based on service areas. The service areas form concentric "circles" around the states (area codes) where the line is terminated. The service areas are different for each state and are constructed using area codes. The goal is to provide access to percentages of the telephones in the United States. The goal of service area 1 is to provide access to roughly 10 percent of the telephones; service area 2, 20 percent; service area 3, 40 percent; service area 4, 60 percent; service area 5, all of CONUS, Puerto Rico, and the U.S. Virgin Islands; and service area 6, all of area 5, Hawaii, and Alaska. In practice, service area 1 includes adjacent and nearby states. Higher numbered service areas add more distant states. For rate purposes, Puerto Rico and the U.S. Virgin Islands are considered to be part of CONUS; e.g., they are included in Florida's service area 4. Alaska and Hawaii are found only in service area 6.

(e) As a rule of thumb, outward WATS becomes the least costly alternative when toll calls reach 12-14 hours per month and 800 service at 5 hours per month. The WATS rates have two components, a fixed fee per access line per month and a variable fee based on the average usage of the access lines for the month. Rates for business day and evening periods change at 15, 40, and 80 hours of use. A single rate applies to all night calls. The usage fee varies by service area and state. Precise rates and service area definitions are available from the telephone company. Table 30-7 gives average fees for service areas 1, 5, and 6 (SA-1, SA-5, SA-6). As an example of the use of the table to obtain a cost estimate, assume a single service area 1 outward WATS line with one extension to a nearby building has an estimated monthly usage of 50 hours of business day, 20 hours of evening, and 20 hours of night periods. The estimated one-time fee total is \$168 for the service order and installation of the access line. The service order and installation for the extension cost \$203. The total one-time charge for this service is \$371. The fixed monthly fees are \$30 for the access line plus \$24 for the extension or a total of \$54. The usage charge must be computed by rate period. For business day, the calculation is $(15)(18) + (40 - 15)(16) + (50 - 40)(14) = \810 . Evening charges are estimated as $(15)(12) + (10 - 15)(10) = \230 . Night charges are $20(6) = \$120$. The total estimated usage charges are \$1,160. Thus, the estimated monthly fee is \$1,214 per month.

(4) Microwave Carriers. Several of the specialized carriers offer a WATS-like service to many major metropolitan areas. The rates lie between \$0.21 and \$0.40 per minute depending upon the city pairs involved (source: Code 690, March 1981). These offerings are subject to minimum monthly bills. Rates can be obtained from the carriers or from Code 690.

c. Packet Switching.

(1) Tymnet and Telenet offer domestic packet switched service and can arrange for connections to Mexico, Canada, and many overseas points. Connection can be made to the packet networks on either a dedicated or a demand basis. Computers are usually connected on a dedicated basis, while terminals may be either demand or dedicated depending upon usage. Therefore, interface equipment at a computer site varies widely depending upon the

capability sought. The monthly charge for the equipment needed for a dedicated port may be as low as a few hundred dollars for low-speed lines to several thousand dollars for a front-end processor capable of handling multiple terminals at varying or high speeds. Demand access is by ordinary dial telephone service to either the vendor's local telephone number or to a WATS (800) number. The terminal and associated modem are separately secured by the demand access user.

(2) The variables in packet switching fees are type of access (demand or dedicated), speed of access, volume of traffic, and the length of time connected to a demand access port. In addition there may be minimum service charges or volume discounts available. The rates given in table 30-8 are for measured volume, demand access by low-speed (110-300 b/s), user-provided terminals. These may be used to estimate the per terminal fee using public access. Unlimited volume and unlimited time rates are also available. Tymnet also offers data storage at \$0.03 per thousand characters per day (source: Code 690, March 1981).

(3) Information regarding specific dedicated equipment and services can be obtained from Code 690 or the vendors.

TABLE 30-1. RATES FOR VOICE GRADE SERVICE (\$/MO)

Class Mark	Fixed Fee			Per Mile Over Class Mark		
	A-A	A-B	B-B	A-A	A-B	B-B
1	\$ 72.39	\$ 73.81	\$ 75.22	\$2.55	\$4.69	\$6.25
15	108.09	139.47	162.72	2.13	4.40	5.39
25	129.39	183.47	216.62	1.59	2.84	3.97
40	153.24	226.07	276.17	1.59	1.92	2.98
60	185.04	264.47	335.77	1.59	1.92	2.27
80	216.84	302.87	381.17	1.59	1.92	1.92
100	248.64	341.27	419.57	0.93	0.93	0.95
1,000	1,085.64	1,178.27	1,274.57	0.57	0.57	0.57

Source: AT&T Tariff 260, Aug 81.

TABLE 30-2. AREAS ON THE DDS NETWORK

Akron, OH	Hartford, CT	Omaha, NE
Allentown, PA	Houston, TX	Orlando, FL
Anaheim, CA	Indianapolis, IN	Philadelphia, PA
Atlanta, GA	Inglewood, CA	Phoenix, AZ
Baltimore, MD	Jacksonville, FL	Pittsburgh, PA
Boston, MA	Kansas City, MO	Portland, OR
Buffalo, NY	Los Angeles, CA	Raleigh, NC
Camden, NJ	Louisville, KY	Rochester, NY
Carlisle, PA*	Madison, WI	Sacramento, CA
Charlotte, NC	Memphis, TN	Salt Lake City, UT
Chicago, IL	Miami, FL	San Diego, CA
Cincinnati, OH	Milwaukee, WI	San Francisco, CA
Cleveland, OH	Minneapolis, MN	Seattle, WA
Columbus, OH	Mountain View, CA	St. Louis, MO
Dallas, TX	Nashville, TN	Syracuse, NY
Dayton, OH	Newark, NJ	Toledo, OH
Denver, CO	New Haven, CT	Tulsa, OK
Detroit, MI	New Orleans, LA	Washington, DC
Greensboro, NC	New York, NY	Worcester, MA
Harrisburg, PA	Oakland, CA	White Plains, NY
	Oklahoma City, OK	Wichita, KS
		Wilmington, DE

*U.S. Government only - 1.544 Mb/s for Blue Ridge Summit

Source: DECCO, Sep 80.

TABLE 30-3. DDS RATES

<u>Monthly Fixed Fee (\$/mo)</u>					
<u>Transmission Speed</u>	<u>Class Mark (miles)</u>				
	<u>1</u>	<u>15</u>	<u>25</u>	<u>100</u>	<u>1,000</u>
2.4 - 9.6 kb/s	\$72.39	\$108.09	\$129.39	\$248.64	\$1,085.64
56 kb/s	361.95	540.45	646.95	1,243.20	5,428.20
<u>Per Mile Over Class Mark (\$/mi/mo)</u>					
<u>Transmission Speed</u>	<u>Class Mark (miles)</u>				
	<u>1</u>	<u>15</u>	<u>25</u>	<u>100</u>	<u>1,000</u>
2.4 - 9.6 kb/s	\$2.55	\$2.13	\$1.59	\$0.93	\$0.57
56 kb/s	12.75	10.65	7.95	4.65	2.85
<u>Termination Charges (\$)</u>					
<u>Transmission Speed</u>	<u>Installation Charge</u>		<u>Monthly Fee</u>		
2.4 kb/s	\$183.00		\$120.00		
4.8 kb/s	183.00		227.00		
9.6 kb/s	183.00		399.00		
56.0 kb/s	256.00		922.00		
Source: AT&T Tariff FCC No. 267. Current as of Aug 81.					

TABLE 30-4. PRIVATE LINE SERVICE (48 khz: 56 kb/s) (\$/mo)	
<u>Mileage Band</u>	<u>Rate Per Airline Mile</u>
First 250 (1-100)	\$23.05
Next 100 - 250 (251-500)	16.20
Each additional mile (501 and over)	11.50
Monthly termination fee	\$653
Installation charge	\$306
Source: AT&T Tariff FCC 260, current as of Aug 81.	

TABLE 30-5. MINIMUM SINGLE VOICE GRADE SATELLITE CHANNEL RATE (\$00)

	1	2	3	4	5	6	7	8	9	10	11	12	13	14	15	16	17	18	19	20	21	22	23	24	25
1. Atlanta																									
2. Baltimore	5																								
3. Boston	5																								
4. Buffalo																									
5. Camden																									
6. Chicago	5	5	5	5																					
7. Cincinnati	5																								
8. Cleveland	5																								
9. Columbus	5																								
10. Dallas	5	7.5	7.5	7.5	5	5	5	5																	
11. Dayton	5																								
12. Detroit	5																								
13. Houston	5	7.5	7.5	7.5	5	7.5	7.5	5																	
14. Indianapolis*	5																								
15. Kansas City	5																								
16. L. A.*	10	10	10	10	10	7.5	10	10	6	10	10	7	7.5	7.5											
17. Milwaukee	5	5	5																						
18. Minneapolis	5																								
19. New York	5																								
20. Phila.	5																								
21. Phoenix	10																								
22. Pittsburgh																									
23. St. Louis	5	5																							
24. San Fran.*	10	10	10	10	10	7.5	10	10	10	7	10	10	7	7.5	7.5										
25. Seattle	10																								
26. Wash., D.C.	5																								
27. Wilmington	5																								

Indianapolis, L. A. Los Angeles, San Fran.* San Francisco

Source: American Satellite Corporation Tariff FCC No. 1 RCA American Communications, Inc.
Tariff FCC No. 1 Western Union Telegraph Co. Tariff FCC No. 261

TABLE 30-6. DDD PER MINUTE PRICES
(\$/min)

Miles/bands	CONUS		Alaska		Hawaii		P.R./V.I.	
	init. min	add. min	init. min	add. min	init. min	add. min	init. min	add. min
1-10	\$0.20	\$0.09						
11-16	0.24	0.13						
17-22	0.28	0.15						
23-30	0.33	0.19						
31-40	0.37	0.22						
41-45	0.41	0.26						
56-70	0.43	0.28						
71-124	0.45	0.30						
125-196	0.46	0.32						
197-292	0.48	0.34						
292-430	0.50	0.36						
431-925	0.53	0.36	\$0.61	\$0.43				
926-1910	0.55	0.38	0.64	0.46				
1911-3000	0.57	0.40	0.71	0.54				
3001-4250	0.59	0.42	0.79	0.62				
4251-5750	0.61	0.44	0.87	0.70				
band 1					\$0.66	\$0.48	\$0.89	\$0.85
band 2					0.70	0.53	0.96	0.92
band 3					0.73	0.55	1.02	0.98

Source: AT&T Tariff FCC No. 263, current as of Jul 81.

TABLE 30-7. WATS RATES

<u>Outward WATS</u>					
Service order for access line, per order					\$ 50
Installation, per access line					118
Monthly charge, per access line					30
<u>Average Rate Per Hour of Use Per Rate Period Per Access Line (\$)</u>					
<u>Hours</u>	<u>0-15</u>	<u>Business Day</u>		<u>81</u>	
		<u>16-40</u>	<u>41-80</u>		
SA-1	18	16	14	12	
SA-5	21	19	17	14	
SA-6	27	24	21	17	
<u>Hours</u>	<u>0-15</u>	<u>Evening</u>		<u>81</u>	<u>Night</u>
		<u>16-40</u>	<u>41-80</u>		
SA-1	12	10	9	8	6
SA-5	14	12	11	9	7
SA-6	17	15	13	11	9
<u>800 Service</u>					
Service order for access line, per order					\$ 59
Installation, per access line					147
Monthly charge, per access line					35
<u>Average Rate Per Hour of Use Per Rate Period Per Access Line (\$)</u>					
<u>Hours</u>	<u>0-15</u>	<u>Business Day</u>		<u>81</u>	
		<u>16-40</u>	<u>41-80</u>		
SA-1	18	16	14	13	
SA-5	19	18	16	14	
SA-6	24	22	20	17	
<u>Hours</u>	<u>0-15</u>	<u>Evening</u>		<u>81</u>	<u>Night</u>
		<u>16-40</u>	<u>41-80</u>		
SA-1	13	12	10	9	8
SA-5	14	13	12	10	9
SA-6	17	16	14	13	11

TABLE 30-7. WATS RATES (CON.)

<u>Other</u>	
<u>Extensions</u>	
Service order for extensions, per order	\$ 77
Installation, same building, per extension	20
Installation, different building, per extension	126
Monthly rate for first extension on access line	24
Monthly rate for subsequent extensions on access line	7
<u>Surcharge for 4-Wire Service</u>	
Installation	52
Monthly rate per access line	16

Source: AT&T Tariff, Jul 81.

TABLE 30-8. MONTHLY RATES FOR LOW-SPEED PUBLIC ACCESS
(Per Minute of Connect Time)

<u>Access Location</u>	<u>Tymnet</u>	<u>Telenet</u>
High Density	\$0.04	\$0.05
Low Density	0.08	0.05
WATS	0.25	0.25
Per Packet Transmitted	0.05	0.05

Source: Tymnet and Telenet marketing literature, as of Mar 81.

SECTION F. GENERAL COST CONSIDERATIONS

CHAPTER 31. ADP COST ESTIMATING

1. Introduction. This chapter consists of worksheets or formats used in preparing estimates of costs of proposed ADP systems and also used as cost formats by vendors responding to requests for proposals. Detailed instructions are provided for using the worksheets in making lease versus buy comparisons.

2. ADP Cost-Estimating Worksheets.

a. General. This paragraph contains cost tables and instructions to assist in supplying necessary cost data for determining the total life-cycle costs to the Government for proposed ADP systems. The data presented in this manner should be particularly suitable for evaluation during system source selection proceedings. The figures presented are:

- (1) Figure 31-1: "Equipment Purchase and Maintenance Costs."
- (2) Figure 31-2: "Equipment Lease and Maintenance Costs."
- (3) Figure 31-3: "Vendor Software and Services Costs."
- (4) Figure 31-4: "Nonequipment Costs."
- (5) Figure 31-5: "Time-Phased Cost Summary."

b. Use of Worksheets. These figures are designed to give consideration to all procurement, installation, operating, maintenance, site preparation, and expendable supplies costs to be incurred in the ADP system operation. Each system being evaluated may require different combinations of these five worksheets. Only those appropriate to each situation should be used in requests for proposals. Any supplementary explanations which will ensure clarity of entries should also be included. All special or additional features attached to a component to complete the requirement should also be listed and priced beneath the component concerned. Although figures 31-4 and 31-5 have been prepared to accommodate 8 years of annual fund requirements, specific ADPE applications may require either fewer or more years for the expected system or equipment economic life. These figures should be adjusted, therefore, to accurately reflect the envisioned program.

c. Instructions for Figure 31-1: Equipment Purchase and Maintenance Costs.

(1) Column 1: Equipment (Hardware) Item Description. Enter a brief descriptive title for each type of equipment. Equipment is to be grouped as follows, with subtotals for each:

(a) Central Processor and Main Storage. List all devices and equipment directly associated with the functioning of the central processor.

(b) Input/Output (I/O) and Control. List all I/O components and magnetic tape units, including related control units and devices.

(c) Auxiliary Storage. List proposed equipment providing immediate or random access storage, including related special devices.

(d) Remote Terminals. List proposed remote access equipment, including required interface components or special devices.

(e) Other. List other proposed components and special feature equipment not identified above.

(2) Column 2: Model Number/Group. Enter the current model number for each equipment item listed.

(3) Column 3: Equipment Condition Code. Indicate by symbol whether the equipment is either refurbished under warranty as new equipment (R), new (N), or refurbished equipment not under warranty as new equipment (R-NW).

(4) Column 4: Quantity. Indicate the number of units of each type of equipment proposed.

(5) Column 5: Unit Purchase Price. Enter the proposed unit purchase price. In evaluating bids enter the price as contained in the bid or proposal. When the worksheet is being used to estimate the costs of a proposed ADP system, enter the amount that is expected to be charged by the vendor. Many prices may be obtained from Federal Supply Schedules or from the manufacturer's price lists; however, these prices are often discounted by 20-50 percent when a sizable order is placed. The estimate must consider these discounts.

(6) Column 6: Total Purchase Price. Multiply column 4, "Quantity," by column 5, "Unit Purchase Price," and enter the result in column 6.

(7) Column 7: Maintenance Charges (Prime Shift Operation).¹ Enter the basic monthly charge for maintenance during the principal period of maintenance (PPM) for each type of equipment. If maintenance is to be provided during weekends, that cost should also be included and noted. (See page 31-11, paragraph 2g(2).)

¹If the maintenance charges appear to be excessive, or their fairness cannot be determined; Government-provided maintenance costs will be estimated in accordance with DCAI 600-70-1 and chapter 43, this Circular. Use the most favorable costs in the comparisons made in accordance with paragraph 3, this chapter.

(8) Column 8: Maintenance Charges (Two-Shift Operation).¹ Enter the basic monthly maintenance charges for each type of equipment for both shifts during a two-shift system operation.

(9) Column 9: Maintenance Charges (Three-Shift Operation).¹ Enter the basic monthly maintenance charges for each type of equipment for all shifts during a three-shift system operation.

¹See footnote 1, page 31-2.

Equipment (Hardware) Item Description (1)	Model Number/ Group (2)	Equip. Condition Code (3)	Quantity (4)	Unit Purchase Price (5)	Total Purchase Price (4)X(5) (6)	Maintenance Charges		
						Prime Shift Operation (7)	2-Shift Operation (8)	3-Shift Operation (9)
TOTALS:								
Purchase								
Monthly Maintenance								

FIGURE 31-1. EQUIPMENT PURCHASE AND MAINTENANCE COSTS

d. Instructions for Figure 31-2: Equipment Lease and Maintenance Costs.

(1) Column 1: Equipment (Hardware) Item Description. Enter a brief descriptive title for each type of equipment. Equipment is to be grouped as follows, with subtotals for each:

(a) Central Processor and Main Storage. List all devices and equipment directly associated with the functioning of the central processor.

(b) Input or Output and Control. List all I/O components and magnetic tape units, including related control units and devices.

(c) Auxiliary Storage. List proposed equipment providing immediate or random access storage, including related special devices.

(d) Remote Terminals. List proposed remote access equipment, including required interface components or special devices.

(e) Other. List other proposed components and special feature equipment not identified above.

(2) Column 2: Model Number/Group. Enter the model number corresponding to each equipment item identified. This model number should be the same as that used in the most recent Authorized Federal Supply Schedule Price List.

(3) Column 3: Equipment Condition Code. Indicate by symbol whether the equipment is either refurbished under warranty as new equipment (R), new (N), or refurbished without warranty (R-NW).

(4) Column 4: Quantity. Indicate the number of units of each type of equipment proposed.

(5) Column 5: Monthly Lease Cost. Enter the proposed monthly lease cost for each component proposed.

(6) Column 6: Total Lease Cost. Multiply column 4, "Quantity," by column 5, "Monthly Lease Cost," and enter the result in column 6.

(7) Column 7: Extra-Use Hourly Rate. If applicable, enter the extra-use hourly rate for each component.

(8) Column 8: Maintenance Charges (Prime Shift Operation). Enter the basic monthly maintenance charge for the total proposed quantities of each type of equipment during the principal period of maintenance (PPM).

(9) Column 9: Maintenance Charges (Two-Shift Operation). Enter the basic monthly maintenance charges for the total proposed quantities of each type of equipment for both shifts during two-shift system operation.

(10) Column 10: Maintenance Charges (Three-Shift Operation). Enter the basic monthly maintenance charges for the total proposed quantities of each type of equipment for all shifts during three-shift system operation.

e. Instructions for Figure 31-3: Vendor Software and Services Costs.

(1) Column 1: Software and Services Item Description. Enter a brief description of each of the proposed software items and services. Requirements are to be grouped as follows, with subtotals for each:

(a) Programing Aids (Software). List the proposed computer programs, routines, subroutines, languages, translation compilers, and related items to be provided either at the time of installation of the system or at any time during the system life.

(b) Technical and Programing Services. Identify the costs incurred to provide the programs.

(c) Training Services. Identify the costs associated with contractor-provided executive orientation; analyst, programmer, and operator training; and other proposed training services. The proposed use of Government-furnished equipment, facilities, or personnel in support of training should be identified specifically and applicable costs shown.

(d) Documentation. Identify the total cost associated with the proposed quantities of manuals, programing routine descriptions, and programing aids to be provided.

(e) Preinstallation Compilation and Test Time. Identify total costs for the requirement.

(f) Other. Identify other proposed service or software items not included above, and provide an explanation on the basis of these costs in the general costing considerations narrative. (See page 31-11, paragraph 2g(6).) Costs for installing the system, consisting of components listed on worksheets illustrated in figures 31-1 and 31-2, will be entered in this column. In estimating these costs, assume that all site preparation work (reference figure 31-4) has been completed.

(2) Column 2: Total Proposed Quantity. Indicate, where meaningful, quantities and measurement of units for each service or software item identified.

(3) Column 3: Unit Purchase Price. Enter the proposed purchase price for one unit of the service or software item. Where not appropriate, leave blank.

(4) Column 4: Total Purchase Price. Multiply column 2, "Quantity," by column 3, "Unit Purchase Price," and enter the product in this column; or enter the total proposed price for the Government to acquire ownership of the item. Where not appropriate, leave blank.

Equipment (Hardware) Item Description (1)	Model Number (2)	Equip. Condition Code (3)	Quantity (4)	Monthly Lease Cost (5)	Total Lease Cost (4)X(5) (6)	Extra-Use Hourly Rate (7)	Maintenance Charges		
							Prime Shift Operation (8)	2-Shift Operation (9)	3-Shift Operation (10)
TOTALS									
Monthly Lease									
Hourly Usage Charges									
Monthly Maintenance									

FIGURE 31-2. EQUIPMENT LEASE AND MAINTENANCE COSTS

(5) Column 5: Description (Monthly Charges). Identify the basis for charges which will be incurred on a recurring monthly basis; e.g., rental, lease, user charges, royalties, etc.

(6) Column 6: Unit Price (Monthly Charges). Indicate the cost per unit for items described in column 5; e.g., cost per work-month, cost per hour used, etc. Where not appropriate, leave blank.

(7) Column 7: Total (Monthly Charges). Enter the total monthly charges for the items described in column 5. Note that the respective quantities for these items are not required. Where not appropriate, leave blank.

(8) Column 8: Total Annual Charges. For the items described in column 5 which represent charges during system operation, enter the product obtained by multiplying the appropriate entries in column 7 by 12 (months/year). Where not appropriate, leave blank.

f. Instructions for Figure 31-4: Nonequipment Costs.

(1) Column 1: Cost Element. List all costs for items other than equipment in the following structure:

(a) Site Preparation. List costs to be incurred for the following:

1. Building Requirements.

a. Floor Construction. Enter costs for construction of raised floors or treatment of floors, including carpeting, for resistance to static electricity.

b. Acoustical Treatment. Enter costs for acoustical treatment of doors, ceilings, and walls to prevent transmission of noise.

c. Lighting. Show costs involved to ensure adequate lighting.

d. Safety Equipment. Include all costs for fire extinguishers, sprinkler systems, etc.

e. Air-Conditioning. Show costs incurred for air-conditioning the building.

f. Space for Contractor Use. Furnish costs incurred in providing or preparing an area for use by the contractor for offices, storage of miscellaneous spare parts, etc.

Software and Services Item Description (1)	Total Proposed Quantity (2)	Unit Purchase Price (3)	Total Purchase Price (2)X(3) (4)	Monthly Charges			Total Annual Charges 12X(7) (8)
				Description (5)	Unit Price (6)	Total (2)X(6) (7)	
TOTALS:							
Purchase							
Annual Charges							

FIGURE 31-3. VENDOR SOFTWARE AND SERVICES COSTS

g. Other. List and separately identify any other costs related to site preparation not shown above.

2. Cables. Indicate costs for cables other than those furnished without separate charge by the contractor for the initial installation (including costs for special cable lengths) or external cables required for a unit to be installed through walls, doors, or floors.

3. Subtotal Site Preparation. Show a subtotal for site preparation for each fiscal year involved. Enter the total of columns 2-9 in column 10.

(b) Utilities.

1. Temperature and Humidity Control. List costs for air-conditioning and other air-filtering systems necessary for maintaining proper temperature and relative humidity levels.

2. Power Requirements. Enter costs for principal power requirements and other associated requirements. (See chapter 24, table 24-13.)

3. Subtotal Utilities. Enter subtotals for utilities for each fiscal year. Enter the total of columns 2-9 in column 10.

(c) Government Personnel. Enter the costs for military and civilian personnel required to operate the system per year. Both rates should reflect those used in conducting economic analyses.

1. Military Pay and Allowances. For costs of military personnel, see chapter 23, table 23-2.

2. Civilian Salaries and Overtime. For costs of civilian personnel, see chapter 24, table 24-1.

3. Subtotal Government Personnel. Enter the total of columns 2-9 in column 10.

(d) Operating Supplies. Enter costs for operating supplies; e.g., paper, tapes and tape reels, disks, etc.

(e) Total Nonequipment Costs. Enter the total of (a) through (d) in columns 2 through 10.

g. Instructions for General Costing Considerations Narrative. The following considerations are addressed to selected aspects of the cost data supporting the ADP cost estimate. Response to these items should be in narrative form, keyed to each of the points identified below.

(1) Basic and Extra Use Costs.

(a) State the number of hours per month constituting the basic shift, and explain in detail how operational use time is measured and costed.

(b) If extra-shift use of one component or one category of components creates costs associated with other components or categories of components, explain the details of such costs.

(2) Maintenance Proposed. Explain maintenance contract terms, conditions, and prices as they relate to the proposed equipment for either onsite maintenance or oncall maintenance both during and outside the PPM. Provide the specific GSA Federal Supply Schedule Price List, if applicable, or other official source documentation covering the proposed maintenance plan.

(3) Training Services. Indicate in figure 31-3 the specific items of Government-furnished equipment, facilities, or personnel required to support the proposed training, and the basis for the costing of these items.

(4) Transportation. Explain the provisions for transporting the equipment to the site where it is to be installed, identifying the total cost expected to be incurred. If Government-furnished transportation services or equipment is required, include estimated costs for these services in the total systems cost and explain the rates or other basis for the derivation of these costs.

(5) Installation. Explain the provisions for installing the equipment and indicate the expected cost necessary for the equipment installation. If Government-furnished installation services or equipment is required, include the estimated costs for these items in the total systems cost and explain the basis for the derivation of these costs.

(6) Other Costs. Explain any other costs used in preparing this system estimate not covered in the preceding categories, or other costing considerations which would serve to clarify the estimate.

h. Instructions for Figure 31-5: Time-Phased Cost Summary.

(1) Column 1: Cost Element. This column is a consolidation of major items detailed in previous figures. The sum of the identified items should reflect the total ADPE acquisition being costed. Note that costs for elements 8, 9, 10, and 11 must be converted to annual charges for this summary.

(2) Column 2: Reference Figure. This column indicates the specific format from which the items indicated in column 1 were extracted.

(3) Column 3: Explanation. This column is provided for noting the derivation of any reference used to assist in calculations, sources for evaluations, documentation, procedures, factors, etc.

COST ELEMENT (1)	FY-1 (2)	FY-2 (3)	FY-3 (4)	FY-4 (5)	FY-5 (6)	FY-6 (7)	FY-7 (8)	FY-8 (9)	TOTAL OF COLUMNS 2-9 (10)
1. Site Preparation									
a. Building Requirements									
(1) Floor Construction									
(2) Acoustical Treatment									
(3) Lighting									
(4) Safety Equipment									
(5) Air-Conditioning									
(6) Space Requirements									
(7) Other									
b. Cables									
c. Subtotal Site Preparation									
2. Utilities									
a. Temperature and Humidity Control									
b. Power Requirements									
c. Subtotal Utilities									
3. Government Personnel									
a. Military Pay and Allowances									
b. Civilian Salaries and Overtime									
c. Subtotal Govt Personnel									
4. Operating Supplies									
5. Total Nonequipment Costs									

FIGURE 31-4. NONEQUIPMENT COSTS

(4) Columns 4-11: Fiscal Years 1-8. All annual funds should be shown in the applicable column for the fiscal year when they will be required. FY 1 should represent the first project fiscal year in which funds are required. The discount factors shown for each fiscal year in row 18 should be multiplied by the Total System Costs in row 17 to calculate Total System Discounted Costs for row 19.

(5) Column 12: Sum (4-11). Enter the total annual fund requirements for the project. There is no entry in row 18 for this column.

1. Cost Factors for Utilities and Operating Personnel.

(1) The costing procedure which can be used to estimate the annual cost of utilities is as follows:

$$\text{Annual Cost of Utilities} = 12 \times H \times (KE + KA) \times EC.$$

Where,

H = Monthly operational hours based on extrapolated live test demonstration timing.

KE = Number of kilowatts of power used by the proposed equipment items.

KA = Number of kilowatts of power used for air-conditioning. A conversion factor of 1.5 kilowatts per 12,000 Btu's will be used to convert Btu's to kilowatts for determination of KA.

EC = Cost of commercial electricity per kilowatt hour from table 24-13.

(2) The method for estimating the costs of Government operation and maintenance personnel is as follows:

$$\text{Cost of Personnel/Year} = A \times B \times C$$

A = Pay and allowances of computer operators (see chapters 23 and 24).

B = Number of computer center personnel required per shift. Specify the number and function of these persons. Personnel requirements are to be based on the proposed equipment. Normally an extrapolated live test demonstration timing of benchmark programs determines the number of required operational hours.

Cost Element (1)	Reference Figure (Column) (2)	Explanation (3)	Annual Fund Requirements								SUM(4-11) (12)			
			FY-1 (4)	FY-2 (5)	FY-3 (6)	FY-4 (7)	FY-5 (8)	FY-6 (9)	FY-7 (10)	FY-8 (11)				
1. Equipment Purchase	31-1(6)	DCAC 600-60-1												
2. Site Preparation	31-4-(1)c													
3. Transportation (From Page 31-14, par. f(4))														
4. Installation (From Page 31-14, par. f(5))														
5. Software/Services Purchases	31-3(4)													
6. Other Nonrecurring Charges (From P. 31-15, par. f(6))														
7. Subtotal Nonrecurring Charges (1 thru 6) above														
8. Equipment Lease Charges	31-2(6)													
9. Basic Equipment Maintenance (Purchase Equipment)	31-1(7-9)													
10. Basic Equipment Maintenance (Leased Equipment)	31-2(8-10)													
11. Extra Use Charges	31-2(7)													
12. Utilization	31-4-(2)c													
13. Government Personnel	31-4-(3)c													
14. Operation Supplies	31-4-4													
15. Software/Serv Annual Charges	31-3(8)													
16. Subtotal Recurring Charges (8 thru 15) above														
17. Total System Costs (7-16) above														
18. Discount Factor														
19. Total System Discounted Cost														

FIGURE 31-5. TIME-PHASED COST SUMMARY

C = Number of shifts proposed for each category
of personnel.

(3) Personnel requirements for operation of remote terminals should be excluded. If a different method of arriving at personnel costs is used, or any different factors are used, substantiating data should be submitted in the general costing consideration narrative.

(4) The personnel costs will include the cost of personnel required to operate the computer per shift.

3. Lease vs. Buy Analysis.

a. General. This paragraph assists in the determination of a lease versus buy breakeven point within the economic life of the equipment. This point reflects that time when cumulative discounted lease charges are equivalent to cumulative discounted purchase costs less the discounted residual value. If the equipment is likely to remain in use after this breakeven or crossover point, the economic advantage shifts from leasing to purchasing. Table 31-1 can be used with a ratio representing monthly lease cost as a fraction of equipment purchase cost and estimates regarding terminal value and inflation rate in determining a breakeven period. The table takes into consideration the annual 10-percent discount rate, adjusted to a monthly rate. Complex alternatives combining lease and purchase, such as the various forms of lease-with-option-to-buy, or contracts requiring basic termination liability payments, are not treated in this paragraph.

b. Use of Table. Table 31-1 is based on the ratio of differential recurring costs to differential investment costs. When the lease charge does not include maintenance, this ratio will usually be the monthly lease charge divided by the purchase price. If maintenance is included in the lease option, the maintenance charge for the purchase case should be subtracted from the lease charge before dividing. After the ratio has been determined, assumptions must be made as to the most likely economic life (see chapter 32) and terminal value of the equipment (salvage value as a percentage of original purchase price) and the economic escalation rate. The table, which is based on accelerated depreciation, can then be used to determine the number of months to the breakeven point.

c. Estimating Procedure. Monthly lease-to-purchase ratios from .008 to .027 are indicated down the left-hand column of the table. For smaller ratios, lease is usually preferred; for larger ratios, purchase is preferred. Locate the correct ratio and read across to the column for the appropriate economic life, terminal value, and inflation percentages. The number located will be the number of months after purchase it will take for the cumulative discounted expenditures for leasing to equal the cumulative discounted expenditures for purchasing the equipment. This number may be adjusted to account for a 3-month warranty, when applicable, by subtracting 80 times the monthly maintenance charge to purchase price ratio times the economic life (in years).

(1) Example 1. An item of equipment, with an estimated economic life of 8 years, has a purchase price of \$50,000 and a monthly lease charge of \$1,000, which does not include maintenance. There is no warranty. The equipment is assumed to have no terminal value, and the annual inflation rate is estimated at 4 percent. The lease-to-purchase ratio is calculated to be $\$1,000/\$50,000 = .020$. Locating this ratio on the left side of the table in the 8-year life section and following the row across to the 0 percent terminal value, 4 percent inflation column, the breakeven point is found to be the 38th month. It would therefore be more economical to purchase this equipment if it is to be in use longer than 38 months.

(2) Example 2.

Purchase Price of Equipment	= \$189,000
Monthly Lease Charge (including maintenance)	= \$3,212
Monthly Maintenance Charge (if purchased)	= \$850
Warranty Period (if purchased)	= 3 months
Estimated Economic Life	= 12 years
Estimated Terminal Value (in today's dollars)	= \$20,000
Estimated Inflation Rate	= 6%

Since lease includes maintenance, the differential cost is calculated:

$$\text{Lease-to-Purchase Ratio} = \frac{\$3,212 - \$850}{\$189,000} = .0125$$

The terminal value is approximately 10 percent ($\$20,000/\$189,000 = .106$).

(a) Locate the lease/purchase ratio (.0125) on the table. This ratio is between .012 and .013.

(b) Locate the 4 percent and 8 percent inflation rate columns under 12-year life, 10 percent terminal value.

(c) The relevant section of the table is:

	<u>4%</u>	<u>6%</u>	<u>8%</u>
.012	81		41
.0125		(?)	
.013	63		23

Since both coordinates are midway between the values shown on the table, the result may be approximated by averaging the four values shown above, $(81 + 41 + 63 + 23)/4 = 52$.

(d) To account for the warranty, subtract
 $(80 \times \frac{\$850}{\$189,000} \times 12) = 4.3$ from 52 to get a breakeven point
of 47.7 or 48 months.

TABLE 31-1. NUMBER OF MONTHS TO BREAKEVEN												
MTHLY LS* / PURCH	8-YEAR LIFE						12-YEAR LIFE					
	0% TERM VALUE			10% TERM VALUE			0% TERM VALUE			10% TERM VALUE		
	0 %	4 %	8 %	0 %	4 %	8 %	0 %	4 %	8 %	0 %	4 %	8 %
.008	96	96	96	96	96	96	144	144	138	144	144	124
.009	96	96	96	96	96	96	144	144	118	144	144	101
.010	96	96	96	96	96	96	144	134	98	144	122	79
.011	96	96	96	96	96	88	144	114	78	144	101	58
.012	96	96	88	96	96	78	135	95	59	126	81	41
.013	96	95	79	96	86	68	115	78	43	104	63	23
.014	96	86	70	96	76	58	97	61	27	86	48	18
.015	94	77	61	87	67	48	88	48	14	69	33	4
.016	85	68	52	77	58	40	66	34	6	53	19	2
.017	76	60	45	68	48	31	52	22	3	41	16	2
.018	68	52	37	59	41	22	41	12	2	29	5	1
.019	60	45	29	51	34	15	38	6	1	18	3	1
.020	52	38	21	44	26	9	28	4	1	10	2	1
.021	46	31	15	37	19	6	12	2	1	5	1	1
.022	40	24	9	30	13	4	7	2	1	3	1	1
.023	33	18	6	23	8	3	3	1	1	2	1	0
.024	27	13	4	17	5	2	3	1	1	2	1	1
.025	22	9	3	12	4	2	2	1	0	1	1	0
.026	17	6	2	8	3	1	1	1	1	1	0	0
.027	12	4	2	6	2	1	1	1	0	1	1	0
	16-YEAR LIFE						20-YEAR LIFE					
MTHLY LS* / PURCH	0% TERM VALUE			10% TERM VALUE			0% TERM VALUE			10% TERM VALUE		
	0 %	4 %	8 %	0 %	4 %	8 %	0 %	4 %	8 %	0 %	4 %	8 %
	.008	192	187	121	192	173	97	240	179	88	240	161
.009	192	151	87	192	135	61	240	132	48	240	113	13
.010	192	119	55	187	102	32	193	92	18	188	71	3
.011	157	91	38	145	72	18	144	57	3	131	39	2
.012	125	65	18	112	48	3	107	38	2	92	12	1
.013	98	44	4	84	26	2	75	18	1	59	4	1
.014	75	24	2	60	9	1	48	3	1	34	2	1
.015	54	18	1	41	4	1	28	2	1	14	1	1
.016	38	4	1	24	2	1	11	1	0	4	1	0
.017	22	2	1	18	1	1	4	1	0	2	1	0
.018	18	2	1	4	1	0	2	1	0	1	1	0

* LEASE EXCLUDING MAINTENANCE (I.E., DIFFERENCE IN RECURRING COSTS BETWEEN LEASE AND PURCHASE OPTIONS)

NOTE: TO ACCOUNT FOR A 3-MONTH WARRANTY, USE THE TABLE VALUE LESS $(80 \times \text{MTCR/PURCH} \times \text{ECON LIFE IN YRS})$

CHAPTER 32. RESIDUAL VALUE

1. General.

a. This chapter discusses economic life, depreciation, and terminal value of communications equipment. The three subjects are closely related and are used in determining life cycle costs, comparative analyses of alternate systems, and system and equipment replacement studies.

b. Residual value is the net funds or cash value which would be obtained by selling an investment during its useful life after allowing for a reduction in value to account for estimated removal costs. At the end of the useful or "economic" life, residual value is the terminal value.

c. The residual value of communications equipment decreases with time (disregarding the effects of inflation, which is covered in chapter 38). As illustrated in figure 32-1, this value is determined by the way the equipment depreciates, its terminal value, and its economic life. If the equipment is sold, the fair market value is the exact amount to be used for residual value, and the receipts for the sale must be turned in to the Treasury as miscellaneous receipts. In preparing a replacement analysis, show the proceeds from the sale as a reduction in the investment cost of the new system, even though they will not be used in the funding schedule.

2. Guidelines and Procedures.

a. Economic Lives. Economic lives have been established for various categories of equipment. These lives have been estimated or forecasted based upon military environments, experience, and the expected technological cycle. When the system or equipment is being overtaken by technology, there may be a resultant reduction in the economic life of the system. The economic lives shown in table 32-1 should be considered as average or general. They will vary for identical facilities with differing environments and operational requirements. In the selection of an appropriate economic life, the category of communication equipment which represents the largest part of a single, integrated facility may be used to estimate the life of the complete facility. For example, a microwave radio relay has a 13-year economic life even though a microwave antenna may have a longer life. In an analysis of the facility, a 13-year life would be more appropriate for the entire facility.

b. Terminal Value. Excess equipment may be either sold as scrap, sold as an operating system, reutilized, stored for reutilization, or abandoned in place. The salvage value of the equipment and current need will likely determine which option is chosen. Terminal value is often expressed as a fraction of original purchase price (e.g., 10%).

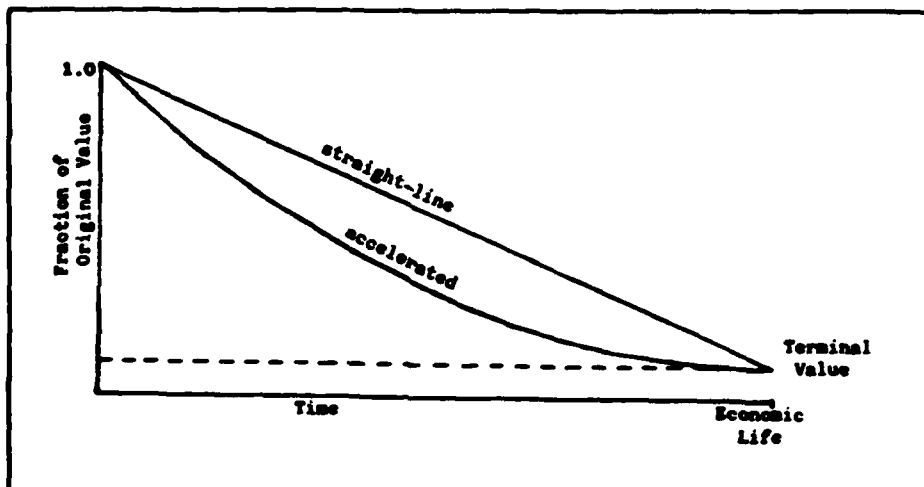

FIGURE 32-1. RESIDUAL VALUE

c. Depreciation. Graphic representations of the decrease in residual value over time are generally in one of two forms, as depicted in figure 32-1. The upper line shows "straight-line" depreciation while the one below it shows "accelerated" depreciation.

(1) Under straight-line depreciation, residual value during the economic life may be calculated using the following formula:

$$R = P \times \left[S + (1 - S) \times \left(\frac{L - T}{L} \right) \right]$$

Where: R = residual value
P = original purchase price
L = economic life
S = terminal value as a fraction of P
T = time in use to date

(2) Accelerated depreciation is considered to be more applicable to communications equipment. The two most common types are "double declining balance" and "sum-of-the-digits," which can be approximated with the following formula:

$$R = P \times \left[S + (1 - S) \times \left(\frac{L - T}{L} \right)^2 \right]$$

Where: R, P, S, L and T as above.

(3) After the economic life, residual value equals terminal value:

$$R = P \times S \quad \text{for } T \geq L$$

TABLE 32-1. ECONOMIC LIVES

Category of Facilities	Economic Life (years)
ADPE	
Control Units	16
Core Storage	12
CPU's (large scale)	10
Data Sets & Modems	8
Drives (Disk & Tape)	14
I/O (Card Punch/Readers & Printers)	18
Terminals (CRT & Typewriter)	10
Auxiliary Equipment	
Power	19
System Test	16.5
Site Activation	
Buildings	30
Furniture & Office Equipment	8
Roads	32
Switching	
Central Office Equipment	20
Private Branch Exchange	15
Transmission Systems	
Cable	26.5
Cable Carrier (Mux)	8
HF	13
LOS Microwave	13
Multiplex	8
Satellite	
Ground Segment	10
Space Segment	
DSCS II	3.2
DSCS III	6.2
Tropo	8

Source: IRS Pub 534, Tax Information on Depreciation, 1977
GSA, May 77; DCA, Code 690, Apr 79.

CHAPTER 33. MANPOWER/EQUIPMENT RATIOS

(To be published later.)

DCAC 600-60-1
SECTION F

34-1

CHAPTER 34. EQUIPMENT INSTALLATION SCHEDULE FACTORS

(To be published later.)

CHAPTER 35. INTERNATIONAL MONETARY RATES OF EXCHANGE

1. General. This chapter contains monetary exchange rates for budgetary and planning purposes. Actual rates are subject to day-to-day fluctuations; however, OSD(C) has directed that rates contained herein be used for the purposes stated. Paying offices will record variations from the designated rates by entering the value of the variations in special accounts established for this purpose.

2. Use of Table. Table 35-1 lists the exchange factors by budget year. To determine the (United States) cost of a contract or lease, first obtain the price in the foreign currency and then convert to U.S. dollars.

a. Example 1. The FY 1983 cost of contract is 2,744,100 yen (Japan). The rate of exchange for Japan is 298.89 yen to the U.S. dollar.

$$2,744,100 \text{ yen} / 298.89 = \$9,181$$

b. Example 2. The FY 1983 cost of a lease is 3,831 British pounds sterling (United Kingdom). The rate of exchange for the United Kingdom is 0.68 pounds to the dollar.

$$3,831 \text{ pounds} / 0.68 = \$5,634$$

c. Example 3. These factors can also be used to convert from dollars to local currency. If the amount to be received is \$1,000 FY 1983\$ with payment to be made in Deutsch marks,, the calculation is:

$$\$1,000 \times 2.95 = 2,950 \text{ DM}$$

TABLE 35-1. FOREIGN CURRENCY BUDGET EXCHANGE RATES

<u>Country</u>	<u>Monetary Unit</u>	<u>Foreign Currency Per U.S. \$</u>	
		<u>FY 1983</u>	<u>FY 1984</u>
Belgium	Franc	55.62	48.05
Canada	Dollar	1.50	1.30
Denmark	Krone	10.07	8.70
Fed Rep of Germany	Mark	2.95	2.52
France	Franc	7.72	6.99
Greece	Drachma	78.23	69.80
Italy	Lira	1,622.59	1,409.00
Japan	Yen	298.89	259.45
Netherlands	Guilder	3.27	2.76
Norway	Krone	7.47	6.40
Portugal	Escudo	89.18	84.75
Spain	Peseta	130.06	113.19
Turkey	Lira	177.55	160.65
United Kingdom	Pound	0.68	0.59

Source: "Revised FY 1983 Foreign Currency Execution Rates," OSD(C),
8 Oct 82; FY 1984 Rates from OSD(C) Memorandum, 23 Jul 82.

CHAPTER 36. CONSTRUCTION PRICE INDEXES

1. General. The cost indexes given in tables 36-1 through 36-3 represent approximate geographical adjustment factors for construction of repetitive type (not unique or unusual with regard to design or construction techniques used) facilities. For construction of more complex facilities or under extremely abnormal conditions, the indexes should be increased appropriately. The indexes are given for use in review or for broad preliminary planning. They are not intended to be a substitute for local surveys or specific experience.

2. Derivation of Factors. The construction price factors were derived from military department guidance documents as annotated in the sources, using Washington, D.C., as the standard, with an index of 1.00.

3. Use of Tables. Multiply the complete site construction costs, as estimated from chapter 21, paragraph 3, by the index factor from the applicable table. For example, if the construction costs from chapter 21, paragraph 3, are \$300,000 and the location is Point Barrow, Alaska, a factor of 3.5 will be applied. If the location is Mountain Home, AFB, Idaho, a factor of 1.2 will be applied.

Point Barrow \$300,000 X 3.5 = \$1,050,000
Mountain Home \$300,000 X 1.2 = \$360,000

TABLE 36-1. CONSTRUCTION PRICE INDEXES	
STATES (FOLLOWED BY EXCEPTIONS)	INDEX
ALABAMA.....	0.89
GULF COAST AREA.....	1.00
ALASKA (ALEUTIAN IS.).....	3.80
CLEAR AFB.....	2.20
EIELSON AFB.....	2.10
ELMENDORF AFB.....	1.90
KODIAK.....	2.50
KING SALMON.....	2.60
NOME.....	2.30
POINT BARROW.....	3.50
ARIZONA.....	1.01
YUMA & DAVIS-MONTHAN.....	1.10
FORT HUACHUCA.....	1.20
GILA BEND AFS.....	1.15

TABLE 36-1. CONSTRUCTION PRICE INDEXES (CON.)

STATES (FOLLOWED BY EXCEPTIONS)	INDEX
ARKANSAS.....	0.87
CALIFORNIA.....	1.11
MCCLELLAN & NORTON.....	1.15
S.F. BAY AREA.....	1.20
COLORADO.....	0.98
DENVER.....	1.10
CONNECTICUT.....	1.03
NEW LONDON.....	1.20
DELAWARE.....	0.99
DISTRICT OF COLUMBIA AREA.....	1.00
FLORIDA.....	0.95
KEY WEST.....	1.20
GULF COAST.....	1.00
MIAMI & ATLANTIC COAST.....	1.15
GEORGIA.....	0.86
ATLANTA.....	1.00
HAWAII (OAHU).....	1.20
KAUAI.....	1.80
IDAHO.....	0.96
MOUNTAIN HOME AFB.....	1.20
ILLINOIS.....	1.04
SCOTT AFB.....	1.20
INDIANA.....	0.97
GARY & INDIANAPOLIS.....	1.05
GRISSOM AFB.....	1.10
IOWA.....	0.97
KANSAS.....	0.96
KENTUCKY.....	0.94
LOUISIANA.....	0.92
FORT POLK & ENGLAND AFB.....	1.05
NEW ORLEANS.....	1.10
MAINE.....	0.90
NORTHERN AREA.....	1.14
MARYLAND.....	0.96
FORT RITCHIE & PATUXENT.....	1.10
MASSACHUSETTS.....	1.02
BOSTON.....	1.11
FORT DEVENS.....	1.15
MICHIGAN.....	1.02
NORTHERN AREA.....	1.15
MINNESOTA.....	0.99
NORTHERN AREA.....	1.15

TABLE 36-1. CONSTRUCTION PRICE INDEXES (CON.)

STATES (FOLLOWED BY EXCEPTIONS)	INDEX
MISSISSIPPI.....	0.99
KEESLER AFB.....	1.00
MISSOURI.....	0.98
ST. LOUIS.....	1.02
FORT LEONARD WOOD.....	1.20
MONTANA.....	0.95
NORTHERN AREA & MALSTROM.....	1.15
NEBRASKA.....	0.94
NEVADA.....	1.05
FALLON NAS.....	1.20
NELLIS AFB.....	1.15
TONOPAH.....	1.60
NEW HAMPSHIRE.....	0.92
PORTSMOUTH.....	0.97
NEW JERSEY.....	1.04
NEW MEXICO.....	0.96
HOLLOMAN AFB.....	1.05
NEW YORK.....	1.03
GRIFFISS & HANCOCK.....	1.06
NYC & LONG ISLAND.....	1.17
NORTH CAROLINA.....	0.84
CHERRY POINT & CP LEJEUNE.....	0.95
S. JOHNSON, FT BRAGG, & POPE.....	1.00
NORTH DAKOTA.....	0.91
NORTHERN AREA.....	1.15
OHIO.....	1.02
WRIGHT-PATTERSON AFB.....	1.10
OKLAHOMA.....	0.94
TINKER AFB.....	1.00
OREGON.....	1.02
PENNSYLVANIA.....	1.01
RHODE ISLAND.....	1.00
SOUTH CAROLINA.....	1.00
SOUTH DAKOTA.....	0.92
ELLSWORTH AFB.....	1.15
TENNESSEE.....	0.88
NAS MEMPHIS.....	1.00
TEXAS.....	0.98
DALLAS & CARSWELL.....	1.10
UTAH.....	0.98
DUGWAY PROVING GROUND.....	1.30
HILL AFB.....	1.20

TABLE 36-1. CONSTRUCTION PRICE INDEXES (CON.)

STATES (FOLLOWED BY EXCEPTIONS)	INDEX
VERMONT.....	0.91
NORTHERN AREA.....	1.07
VIRGINIA.....	0.91
NO. VA. & TIDEWATER.....	1.00
WASHINGTON (STATE).....	1.01
PUGET SOUND AREA.....	1.15
WEST VIRGINIA.....	0.96
WISCONSIN.....	0.98
WYOMING.....	0.91

Source: DoD 4270.1-CG, "Military Construction Cost Review Guide, Fiscal Year 1984," Jul 82.

TABLE 36-2. CONSTRUCTION PRICE INDEXES

TERRITORIES AND POSSESSIONS OF THE UNITED STATES	INDEX
CANAL ZONE.....	1.5
CAROLINA ISLANDS (TRUK).....	2.0
JOHNSTON ISLANDS.....	2.4
LINE ISLANDS (PALMYRA).....	2.0
MARIANA ISLANDS (GUAM).....	1.5
MARSHALL ISLANDS.....	2.4
MIDWAY ISLAND.....	2.4
PUERTO RICO (SAN JUAN).....	1.4
ROOSEVELT ISLANDS.....	1.5
SAMOA.....	2.4
VIRGIN ISLANDS.....	1.3
WAKE ISLAND.....	2.2

Source: "HQ USAF Annual Construction Pricing Guide for FY 85 thru 89 Programs," Jun 82.

TABLE 36-3. CONSTRUCTION PRICE INDEXES

FOREIGN COUNTRIES	INDEX
ADMIRALTY ISLANDS.....	2.2
ALGERIA.....	1.3
ARGENTINA.....	1.9
ASCENSION ISLAND.....	2.5
AUSTRALIA	
NORTH COASTAL AREAS.....	2.3
SOUTH COASTAL AREAS.....	1.1
AZORES.....	1.3
BAHAMA ISLANDS.....	1.5
BELGIUM.....	1.5
BERMUDA.....	1.6
BOLIVIA.....	1.7
BRAZIL.....	1.5
BRITISH GUIANA.....	1.2
BRITISH HONDURAS.....	1.0
BRITISH WEST INDIES	
ANTIGUA.....	1.4
BARBADOS.....	1.2
TRINIDAD.....	1.2
BURMA.....	1.4
CANADA	
LABRADOR.....	1.4
NEWFOUNDLAND	
ARGENTIA.....	1.8
INLAND AREAS.....	2.2
NORTH INLAND AREAS (DEW LINE).....	4.2
SOUTH INLAND AREAS.....	1.6
CHILI.....	1.5
CHRISTMAS ISLANDS.....	2.2
COLUMBIA.....	1.3
COSTA RICA.....	1.0
CUBA (GUANTANAMO BAY).....	1.6
DENMARK.....	1.15
DIEGO GARCIA.....	3.0
ECUADOR.....	1.5
EGYPT.....	2.5
EL SALVADOR.....	1.0
FRENCH GUIANA.....	1.2
GERMANY, WEST.....	1.5
GREECE.....	1.4

TABLE 36-3. CONSTRUCTION PRICE INDEXES (CON.)

FOREIGN COUNTRIES	INDEX
GREENLAND	
ICE CAP.....	4.0
NARSARSSUAK.....	4.2
SONDRESTROM AFB.....	3.1
THULE.....	3.5
GUATEMALA	1.0
ICELAND	3.0
INDIA (BOMBAY)	0.9
ISRAEL	1.1
ITALY	1.1
JAMAICA	1.2
JAPAN	
NORTHERN AREA.....	1.7
OKINAWA.....	1.6
SOUTHERN AREA.....	1.6
WAKKANAI.....	1.8
KOREA	1.05
LIBERIA	0.8
MEXICO (MEXICO CITY)	1.0
MOROCCO	1.0
NETHERLANDS	1.6
NEW ZEALAND	0.8
NICARAGUA	1.0
NORWAY	1.4
OMAN	2.25
PAKISTAN (WEST KARACHI)	1.2
PARAGUAY	1.6
PHILIPPINE ISLANDS	1.0
PHOENIX ISLANDS (CANTON ISLAND)	2.4
SAUDI ARABIA (DHARRAN)	2.25
SPAIN	1.3
SRI LANKA	1.1
SWEDEN	1.2
TAIWAN	0.8
THAILAND	1.0
TURKEY	1.6
UNITED KINGDOM	1.5
URUGUAY	1.6
VENEZUELA	1.3

Source: "HQ USAF Annual Construction Pricing Guide for FY 85 thru 89 Programs," Jun 82.

CHAPTER 37. COST-QUANTITY RELATIONSHIPS

1. General. Three separate and distinct factors influence the behavior of costs over time. Technological improvements and productivity gains tend to reduce costs. Forces in the economy impact costs in the form of inflation (see chapter 38). The third factor involves the economies of scale that are realized as production quantities increase. This chapter deals with this "learning curve" relationship between costs and quantities.

a. The fundamental concept of learning (or "improvement") curves was derived from the observation that execution improves with repetition. There is less total effort and less waste involved in subsequent repetitive performances. This concept applies to processes ranging from manual crafts and mental exercises to management innovations in large production lines. Figure 37-1 graphically depicts the relationship between units and resources required per unit.

b. Learning curve calculations are based on the premise that production cost is reduced by some constant percentage each time production quantity doubles. For example, for an 80-percent cost curve, the cost to produce the 400th unit would be only 80 percent of the cost to produce the 200th unit. Such a curve is said to have an 80-percent "slope." This cost generally refers to the unit cost but it also may, in unusual situations, represent the cumulative average ("cum avg.") cost. When costs are plotted against quantities on logarithmic graph paper, as in figure 37-2, the cost curve (unit or cum avg.) will appear as a straight line. Figure 37-2 shows the curve of figure 37-1 plotted on "log-log" graph paper. The curve now appears as a straight line with an 80-percent slope.

c. Changes in the production process or in the product itself may necessitate an adjustment in the learning curve. A product design change would likely cause an upward jog in the curve, while an innovation in the production chain might advance the curve downward. Such an improvement would characterize a technological change. Technological improvements (e.g., vacuum tubes to solid state to microelectronics) generally result in a step function on the cost improvement curves. The slope of the curve, after the step function, will depend on the processes used to fabricate the new item.

2. Derivation of Factors. The basic learning curve cost multiplier at n units (as tabulated in table 37-3) is n^B , where $B = \ln S / \ln 2$ and $S =$ learning curve slope.

a. Tables 37-1 and 37-2. These tables report learning curve slopes based on research in the electronics industry. When actual data are available, the slope may be calculated by a logarithmic transformation on a linear least squares regression. The curve to be fit, $C_n = C_1 X n^B$ (where $C_n =$ cost at the n th unit and $C_1 =$ first unit cost) is computed in the form $\ln C_n = \ln C_1 + B X \ln n$.

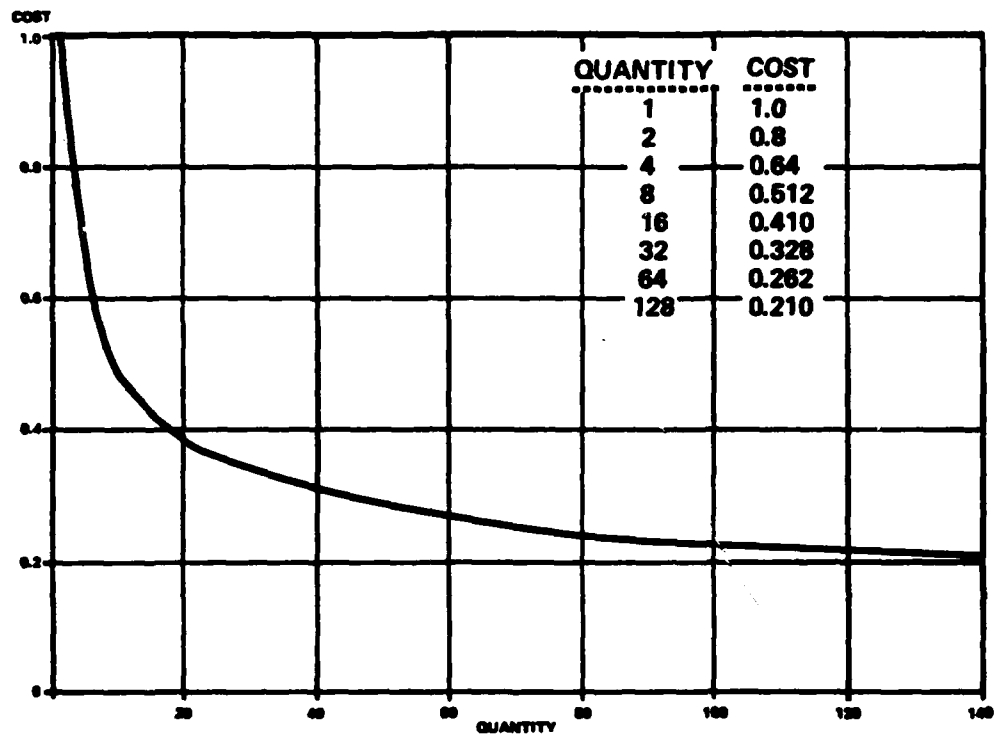

FIGURE 37-1. 80% LEARNING CURVE ON LINEAR GRAPH

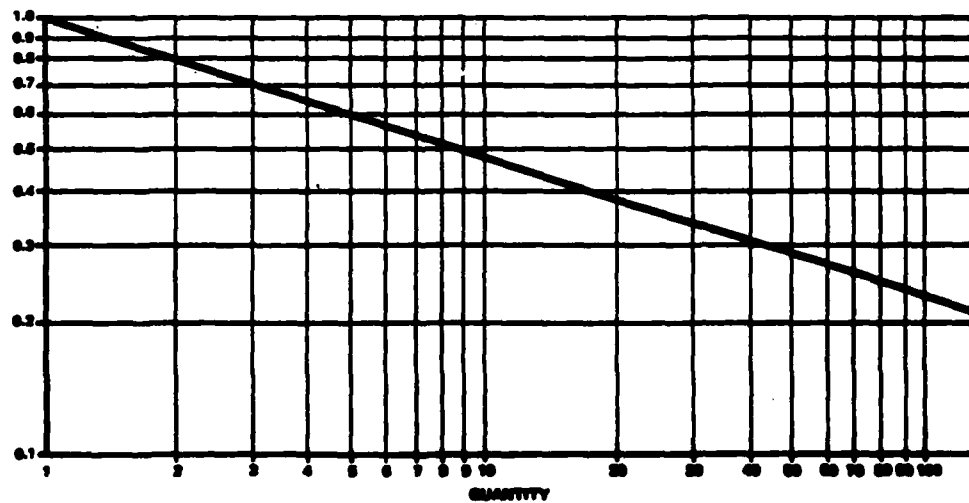

FIGURE 37-2. 80% LEARNING CURVE ON LOG-LOG GRAPH

b. Table 37-4.

(1) If a unit cost curve is used, the cum avg. cost for n units may be found by multiplying the unit cost by the factor: $\sum_{i=1}^n i^{B/n^{B+1}}$. This number, as displayed in table 37-4, converges toward $1/(B+1)$.

(2) If a cum avg. curve is used, the nth unit cost is calculated by multiplying the cum avg. cost by the factor: $n - (n-1) \times \frac{n-1}{n} B$. Alternatively, the conversion can be approximated by dividing by the factor in table 37-4.

3. Use of Tables. The tables can be used to determine the cost to buy various quantities of equipment. If the slope of the cost curve is not known, it must be estimated.

a. Tables 37-1 and 36-2 show typical learning curve slopes for use when there are not sufficient data on which to base a learning curve slope calculation. For instance, if a new product is to be manufactured using an established process, table 37-1 suggests using a slope in the 80-85 percent range. Where a manufacturing effort is to be half assembly work and half machine work, table 37-2 suggests an 85 percent slope might be appropriate.

b. Table 37-3 contains learning curve factors for selected slopes at selected quantities. To calculate the factor for a quantity not found, either multiply the factor for half the quantity by the slope, or divide the factor for twice the quantity by the slope, or use linear interpolation. To find the cost for a given quantity, multiply the first unit cost by the appropriate factor shown. If the cost for some quantity is cum avg., the cumulative total cost is found by multiplying the cum avg. cost by the quantity. The average cost of any quantity will always be greater than the incremental cost of the last unit of the quantity.

(1) Example 1. If the first unit cost is \$5,000 and the learning curve slope is assumed to be 85 percent, the cost at the 600th unit is $\$5,000 \times .223 = \$1,115$. If the curve is cum avg., the cumulative cost for 600 units is $600 \times \$1,115 = \$669,000$.

(2) Example 2. If the cost at the 40th unit is \$200 and the learning curve slope is 90 percent, then the cost at the 300th unit is found by deriving the first unit cost and then the 600-unit cost (since the quantity of 300 is not in the table) and dividing by .9. Since the cost at the 40th unit is \$200, the first unit cost is $\$200 / .571 = \350 , the cost at the 600th unit is $\$350 \times .378 = \132 , and the cost at the 300th unit is $\$132 / .9 = \147 .

c. Table 37-4 contains ratios of cumulative average costs to unit costs. If a unit cost is known, then the cum avg. cost is obtained by multiplying by the factor in table 37-4. If a cum avg. cost is known, the unit cost is obtained by dividing by the factor in table 37-4.

(1) Example 3. Suppose that in example 1 above the learning curve is of the unit cost variety and we wish to find the cost for the first 600 units. The unit cost for the 600th unit is multiplied by the factor for 600 units at 85 percent slope from table 37-4 to get a cum avg. cost of $600 \times \$1,450 = \$870,000$. The sensitivity of these calculations to the slope is demonstrated by the fact that the cost would be more than 50 percent higher if a 90-percent slope were used instead of an 85-percent slope.

(2) Example 4. In this case, the unit cost curve slope is estimated to be 80 percent with the first unit cost quoted at \$20,000 and the acquisition planned to be in lots of 10, 50, and 40 units. The cost of the first lot, found by following the procedure in example 3, is $\$20,000 \times .477 \times 1.325 \times 10 = \$126,405$. The cumulative cost for the first two lots (60 units) is $\$20,000 \times .268 \times 1.424 \times 60 = \$457,958$. The cumulative cost for all three lots (100 units) is $\$20,000 \times .227 \times 1.438 \times 100 = \$652,852$. After subtraction, the second lot is found to cost \$331,553 and the third \$194,894.

d. In a production facility each activity has a representative slope or range of slopes. The reason for the wide ranges is that within each type of operation the slope depends on the specific processes and the complexity of the item. In general, the cost improvement curve slope will increase as product complexity increases. The ranges for each type of activity and the average are presented in table 37-5. Purchased materials have shallower slopes than labor. Some of the reasons are that vendors supplying the materials are usually on the shallow portion of their cost improvement curves, therefore, the purchaser does not experience large changes. Purchased materials also have loadings (over-head, fee, etc.,) which do not follow the cost improvement curve effect.

TABLE 37-1. ESTIMATED IMPROVEMENT CURVE RANGES
IN THE ELECTRONICS INDUSTRY

<u>Product</u>	<u>Manufacturing Method</u>	<u>Improvement Curve Range (percent)</u>
New	New	75-80
New	Standard (Old)	80-85
Variation of old	Standard (Old)	85-90
Mass production item	Standard (Old)	90-95

Source: Electronics Industry Cost Estimating Data, by Fred C. Hartmeyer, Ronald Press, 1964.

TABLE 37-2. ESTIMATED IMPROVEMENT CURVE SLOPES BASED ON
COMBINATIONS OF MANUAL AND MACHINE EFFORTS

<u>Assembly Work (percent)</u>	<u>Machine Work (percent)</u>	<u>Improvement Curve Slope (percent)</u>
75	25	80
50	50	85
25	75	90

Source: U.S. Army Electronics Command

TABLE 37-3. LEARNING CURVE FACTORS						
QUANTITY	SLOPE					
	95%	90%	85%	80%	75%	70%
2	.950	.900	.850	.800	.750	.700
4	.903	.810	.723	.640	.563	.490
6	.876	.762	.657	.562	.475	.390
8	.857	.729	.614	.512	.422	.343
10	.843	.705	.583	.477	.385	.306
20	.801	.634	.495	.381	.288	.214
40	.761	.571	.421	.305	.216	.150
60	.739	.537	.383	.268	.183	.122
80	.723	.514	.358	.244	.162	.105
100	.711	.497	.340	.227	.148	.094
200	.676	.447	.289	.182	.111	.065
400	.642	.402	.245	.145	.083	.046
600	.623	.378	.223	.128	.070	.037
800	.610	.362	.209	.116	.062	.032
1000	.600	.350	.198	.108	.057	.029
2000	.570	.315	.168	.087	.043	.020
4000	.541	.283	.143	.069	.032	.014
6000	.525	.267	.130	.061	.027	.011
8000	.514	.255	.122	.055	.024	.010
10000	.506	.247	.115	.052	.022	.009

TABLE 37-4. UNIT COST TO CUM AVG CONVERSION FACTORS						
QUANTITY	SLOPE					
	95%	90%	85%	80%	75%	70%
2	1.026	1.056	1.088	1.125	1.167	1.214
4	1.046	1.098	1.158	1.227	1.309	1.407
6	1.054	1.116	1.189	1.276	1.379	1.506
8	1.059	1.127	1.208	1.305	1.423	1.568
10	1.062	1.134	1.221	1.325	1.453	1.613
20	1.069	1.152	1.252	1.375	1.530	1.730
40	1.074	1.163	1.272	1.409	1.586	1.819
60	1.075	1.167	1.280	1.424	1.611	1.860
80	1.076	1.169	1.285	1.432	1.625	1.885
100	1.077	1.171	1.288	1.438	1.635	1.903
200	1.078	1.174	1.295	1.451	1.659	1.946
400	1.079	1.176	1.299	1.460	1.675	1.978
600	1.079	1.177	1.301	1.463	1.682	1.993
800	1.079	1.177	1.302	1.465	1.686	2.001
1000	1.079	1.178	1.303	1.466	1.689	2.007
2000	1.079	1.178	1.304	1.469	1.696	2.022
4000	1.080	1.178	1.304	1.471	1.700	2.033
6000	1.080	1.178	1.305	1.471	1.702	2.037
8000	1.079	1.179	1.305	1.471	1.702	2.040
10000	1.079	1.179	1.305	1.471	1.701	2.042

TABLE 37-5. PRODUCTION COST IMPROVEMENT CURVE SLOPES

Operation	Average Slope	Range of Slopes
Machine Shop	90	75 - 95
Numerical Control	95	90 - 100
Sheet Metal	87	75 - 95
PCB Fabrication	91	80 - 100
PCB Assembly	88	80 - 100
Optical Fabrication	85	75 - 95
Electrical Assembly	85	75 - 98
Mechanical Assembly	86	75 - 95
Opto-Mech Assembly	86	80 - 95

Source: "A Survey of Cost Improvement Curves," Working Committee on Air Launched Weapons Systems Costs, Jul 79.

CHAPTER 38. ECONOMIC ESCALATION

1. General. The preparation of cost estimates for systems and programs involving the acquisition of major communications equipment potentially serves three distinct purposes. These purposes are economic analysis and program evaluation conducted to assist managers in identifying the best new programs and projects to be adopted; comparative cost analysis in a commercial or industrial activities study to determine the relative costs of obtaining products and services from in-house Government and private commercial sources; and estimates of resource requirements included by DoD components in program and budget documentation and requests.

a. The cost estimates used in responding to each of these three purposes are usually unique. An estimate prepared for one purpose cannot, as a general rule, be used without adjustment for other purposes.

(1) Economic analyses and program evaluations accomplished in accordance with DCAI 600-60-1 (DoDI 7041.3 and OMB Circular A-94) are based upon total life cycle program costs, which are discounted (see chapter 41) and which reflect the consideration of economic escalation in all dollar costs included in the estimate.

(2) In the case of comparative cost analyses of commercial or industrial activities accomplished in accordance with DCAI 600-70-1 (DoDI 4100.33 and associated Cost Comparison Handbook, OMB Circular A-76, and OTP Circular 13), costs are converted to the dollars of each performance year (prorated over appropriate fiscal years) using the escalation factors contained in this chapter, in accordance with annex D to the Handbook.

(3) Program and budget cost estimates which identify future total obligation authority (TOA) for the DoD components within the Five Year Defense Program (FYDP), President's budget, and congressional appropriation acts require special procedures. Costs for all years covered by the program or budget (not necessarily the total life cycle) should initially be based upon prices and price levels prevailing during the fiscal year in which the estimate is prepared. All procurement, R&D and military construction costs, and O&M costs exclusive of civilian personnel should be adjusted to include estimates of economic escalation for all years being considered. In accordance with current Office of Management and Budget (OMB) and DoD policy, military and civilian pay and allowances are not adjusted for economic escalation, but reflect the price level costs in effect during the budget year. None of the budget estimate costs for any of the appropriations are discounted. Also, the costs being considered in the budget estimate prepared to support the DCS are limited to those reflected in the program elements of the FYDP Telecommunications Subsystem.

b. In accordance with current DoD budget guidance, estimates of price level changes affecting program acquisition costs will be based upon the index presented in table 38-3. The only exception to this rule will be the

case where an individual program manager has specific contractual arrangements with the prime contractor through contract options or multiyear contracts.

c. The TOA estimated for a particular year should reflect the price level changes over the total span of years that procurement will be affected by these changes. For example, the estimated cost in FY 1984 for a procurement of microwave terminals might actually cover contractor effort which will take place through FY 1984. The time delay in the actual expenditure of the funds for the terminals provides for the phasing of outlays and successive contracts for the equipment and other procurement-related services involved. In the budgetary sense, the TOA would reflect FY 1982 as the year the funds were required, but the economic escalation included in those funds would reflect expected price level changes through FY 1986.

d. As with the determination of the expected price levels themselves, estimates of the time phasing of actual expenditures should be based on the data presented in table 38-2 except when expected contractor payment patterns of specific programs are known. Unless neither the projected price levels nor the time phasing of the expenditures can be based on specific contractual data, table 38-3 should be used. This table is based upon the general price levels presented in table 38-1 and the expenditure rates of table 38-2.

2. Use of Tables.

a. Table 38-1 presents estimates of past and future price levels for nonrecurring development and procurement of equipment items and services, military construction, recurring operating and maintenance costs excluding civilian personnel pay and benefits, pay and allowances for military personnel, and basic pay and benefits for GS civilian personnel. If indexes are required beyond the last year shown in the table, they may be derived by compounding the rate shown in the table. For a technique incorporating both economic escalation and discounting, refer to chapter 41.

(1) The use of these indexes in preparing final program budgets involves special treatment of the estimates. (See paragraph 1a.)

(2) The FY 1976 index should be considered the price level prevailing during December 1975. August 1976 is considered the price level midpoint for FY 1976 (the Transition Quarter representing 1 July through 30 September 1976), and March 1977 is the prevailing price level period for FY 1977. These months are the measure of the average price level prevailing during those fiscal years.

(3) Table 38-1 should be used for adjusting procurement, RDT&E, construction, and O&M (exclusive of civilian personnel) dollars to constant

TABLE 38-1. PRICE LEVEL INDEXES						
FISCAL YEAR	PURCHASES				PAY & ALLOW	
	PROC	RDTE	MILCON	OGM	CIV	MIL
1973	47.3	46.4	43.0	43.7	49.3	47.5
1974	50.0	50.1	49.0	46.3	53.8	50.8
1975	54.4	55.5	58.2	53.2	58.2	54.1
1976	58.0	59.2	59.2	57.2	63.0	56.9
1977	62.3	62.5	61.1	61.9	68.6	60.1
1978	66.6	66.7	66.0	66.3	73.9	64.3
1979	72.4	72.4	72.4	72.4	78.4	68.1
1980	80.0	80.0	80.0	80.0	83.7	73.0
1981	88.5	88.5	88.5	88.5	91.0	84.6
1982	95.2	95.2	95.2	95.2	96.0	96.1
1983	100.0	100.0	100.0	100.0	100.0	100.0
1984	105.3	105.3	105.3	105.3	100.5	100.0
1985	110.5	110.5	110.5	110.5	106.6	110.9
1986	115.6	115.6	115.6	115.6	113.1	116.4
1987	120.8	120.8	120.8	120.8	119.6	122.8
1988	126.3	126.3	126.3	126.3	126.4	129.6
1989	132.0	132.0	132.0	132.0	133.5	136.7
1990	137.9	137.9	137.9	137.9	141.1	144.3
1991	144.1	144.1	144.1	144.1	149.1	152.2
1992	150.6	150.6	150.6	150.6	157.5	160.6
1993	157.4	157.4	157.4	157.4	166.5	169.4
1994	164.5	164.5	164.5	164.5	175.9	178.7
1995	171.9	171.9	171.9	171.9	185.9	188.5
1996	179.6	179.6	179.6	179.6	196.4	198.9
1997	187.7	187.7	187.7	187.7	207.6	209.8
1998	196.1	196.1	196.1	196.1	219.3	221.4
RATE	4.5	4.5	4.5	4.5	5.7	5.5

NOTES: BASE - FISCAL YEAR 1983.
OGM EXCLUDES FUEL AND CIVILIAN PERSONNEL PAY & ALLOWANCES.

SOURCE: PURCHASES INDEXES BEYOND BASE YEAR FROM OASD(C) MEMO, "PRICE ESCALATION INDICES," 17 JAN 83; PRE-BASE YEAR AND PERSONNEL INDEXES FROM "DDO DEFLATORS (OLTLAYS)," 27 JAN 83; DCA, CODE 690.

dollars for budgetary purposes. When current estimating factors are not available and a prior year is used as the base year, use the indexes to increase the base year costs to budget year costs. For example, current year FY 79 RDT&E costs are translated to current year 1983 costs by multiplying by (100.0/72.3).

b. Table 38-2 should be used to estimate the rates of outlay or expenditure by type of budget appropriation so that, in projecting future prices, the estimated program cost will reflect the estimated price escalation over the time period during which the outlay will be expended. The rows indicate the part of the appropriation which is expended in the first, second, and successive years. The columns under each appropriation refer to the initial fiscal year of the outlay, and the row values under each column indicate the fraction of expenditure in that and subsequent fiscal years. For example, procurement funds will be outlaid as follows: 16 percent in the first year, 40 percent in the second, 27 percent in the third, etc. This procedure of recognizing the timelag in expenditure rates generally has the effect of materially increasing the price level rate of change identified for a given year. For example, a cost estimate made in FY 1983 for RDT&E funds in the amount of \$2,800 in an FY 1984 program with price level increases estimated at 6 percent per year would result in program costs as follows:

<u>FY</u>	<u>Dollars</u>		<u>Percent of Outlay</u>		<u>Inflation Rate</u>		<u>Adj Dollars</u>
1983	-		-		1		
1984	\$2,800	X	.54	X	1+.05	=	\$1,588
1985	2,800	X	.39	X	(1+.05) ²	=	1,204
1986	2,800	X	.07	X	(1+.05) ³	=	227
							<u>\$3,019</u>
							FY 1983 Adjusted Estimate

Percent Inflation [$(\$3,019 - \$2,800)/\$2,800$] = 7.8%

TABLE 3A-2. PROGRAM EXPENDITURE RATES					
APPROPRIATION					
FISCAL YEAR	PROCUREMENT	RDT&E	MIL. CONSTR.	P&M	MIL. & CIV. PAY & ALLOW.
FIRST	.18	.53	.15	.77	1.00
SECOND	.40	.39	.38	.20	
THIRD	.27	.07	.18	.03	
FOURTH	.10	.01	.14		
FIFTH	.05		.08		
SIXTH			.07		

SOURCE: OUTLAY RATES - DEFENSE AGENCIES, POM PREPARATION INSTRUCTIONS, OASD(P&E), 23 MAR 83.

c. Table 38-3 reflects a combination of the information presented in tables 38-1 and 38-2. This table is appropriate for use when both the expected economic escalation and the anticipated rate of expenditure are to be included in the estimate, unless specific program contractual data for either are available.

(1) The price level indexes presented in table 38-1 have been adjusted by the appropriate outlay time-phasing factors from table 38-2. The adjusted indexes presented in this table should be used as the basis for adjusting program and budget cost estimates for each fiscal year to account for economic escalation.

(2) For example, a program and budget cost estimate for procurement of communications equipment based on constant year FY 1983 price levels would be adjusted for economic escalation for FY 1984 through FY 1986 using table 38-3 as follows:

	<u>FY 1984</u>	<u>FY 1985</u>	<u>FY 1986</u>	<u>Total</u>
Comm. Equipment (FY 1983)	\$26,500	\$ 8,200	\$12,500	\$47,200
Economic Escalation Adjustment Factor	X <u>1.131</u>	X <u>1.183</u>	X <u>1.237</u>	<u> </u>
Total Comm. Equip.	\$29,972	+ \$9,701	+ \$15,462	= \$55,135
Inflation (included)	\$3,472	+ \$1,501	+ \$2,962	= \$7,935

TABLE 3A-3. WEIGHTED (TON) PRICE LEVEL INDEXES						
FISCAL YEAR	PURCHASES				PAY & ALLOW	
	PRNC	RDTF	MILCON	O&M	CIV	MIL
1973	52.1	48.6	53.3	44.5	49.3	47.5
1974	56.0	53.0	59.0	48.0	53.8	50.8
1975	60.1	57.6	62.8	54.3	58.2	54.1
1976	64.6	61.2	66.7	58.4	63.0	56.9
1977	69.8	65.0	72.2	63.1	68.6	60.1
1978	76.1	70.1	78.8	67.9	73.9	64.3
1979	83.5	76.7	85.9	74.4	78.4	68.1
1980	90.8	84.6	92.9	82.2	83.7	73.0
1981	97.1	92.1	99.1	90.2	91.0	84.6
1982	102.4	97.9	104.4	96.5	96.0	96.1
1983	107.5	105.0	109.6	101.4	100.0	100.0
1984	112.8	108.2	114.8	106.6	100.5	100.0
1985	118.0	113.4	120.2	111.8	106.6	110.9
1986	123.3	118.6	125.6	117.0	113.1	116.4
1987	128.9	123.9	131.3	122.3	119.6	122.8
1988	134.7	129.5	137.2	127.8	126.4	129.6
1989	140.8	135.3	143.3	133.5	133.5	136.7
1990	147.1	141.4	149.8	139.5	141.1	144.3
1991	153.7	147.8	156.5	145.8	149.1	152.2
1992	160.6	154.4	163.6	152.4	157.5	160.6
1993	167.9	161.4	170.9	159.2	166.5	169.4
1994	175.4	168.6	178.6	166.4	175.9	178.7
1995	183.3	176.2	186.7	173.9	185.9	188.5
1996	191.6	184.2	195.1	181.7	196.4	198.9
1997	200.2	192.4	203.8	189.9	207.6	209.8
1998	209.2	201.1	213.0	198.4	219.3	221.4

NOTE: BASE - FISCAL YEAR 1983.

SOURCE: TABLES 3A-1 AND 3A-2 DCA CODE 690, MAR 83.

CHAPTER 39. EQUIPMENT LEASE FACTORS

(To be published later.)

DCAC 600-60-1
SECTION F

40-1

CHAPTER 40. FISCAL-YEAR TIME PHASING OF COST ESTIMATE

(To be published later.)

CHAPTER 41. DISCOUNTING

1. General.

a. This chapter addresses the subject of discounting: the determination of the present value of future cash flows. Discounting is applied to cost estimates of DCA-managed systems and programs being evaluated in cost-effectiveness or cost-benefit type trade-off studies. Both economic analyses and comparison studies representing proposals for commercial and industrial activities will consider total life cycle discounted program costs in the decision process to determine the least costly alternative.

b. The tables in this chapter have been organized into two separate groups, depending on the identified time interval of the expenditures. Tables 41-1, 41-2, 41-3, and 41-5 apply to discounting costs on an annual basis, which means that the estimates of costs can be identified in terms of specific years of expenditure, either calendar or fiscal. Tables 41-4 and 41-6 address costs which are expected to be expended and can be identified on a monthly basis throughout the program life cycle. These latter procedures apply particularly to equipment rental, maintenance, and purchase trade-offs such as those routinely done for automatic data processing equipment.

2. Background.

a. Discounting refers to the use of a percentage factor to adjust cash flows or expenditures which are expected to occur during a future time interval to a *common denominator* or base, namely, funding equivalents in terms of the value of dollars today. This calculation of a present value for proposed expenditures takes into consideration the fact that money expended today is more valuable than that expended in the future, even if price levels do not change. The use of the percentage factor, therefore, serves the purpose of adjusting dollars to be expended in future years to a value comparable to the dollar of today, excluding the effects of inflation. The sum of the dollars adjusted to today's dollar using this procedure throughout the total expected life of a program represents the estimated total program life cycle discounted costs (see also chapter 32).

b. The procedures for discounting are used in conducting economic analyses and other system, program, and project investment studies when the costs of alternative courses of action are examined. The intent is to compare these individual competing alternatives in terms of their respective total life cycle discounted costs. Discounting (or the use of discounted dollars), however, is not appropriate in preparing program budget estimates or fund requests. For budgeting, undiscounted dollars are appropriate (see also chapter 38).

c. The policy of discounting proposals for defense expenditures has been established essentially as a basis for reflecting the effects of opportunity costs so that proposals for DoD investment will not be approved on the basis

of cost savings which earn a return amounting to less than the return on an alternative use of the funds in the private sector. This approach to discounting, therefore, equates the value of DoD funds to the value which they would have earned in private capital markets if they were invested in the private sector.

d. The discount factors presented in the tables in this chapter have been mathematically derived on the basis of an integral equation. This equation considers the progressive reduction in the values of future dollars as a continuous and cumulative function of the time interval involved. Each of the annual intervals represents values accumulated and summed throughout the interval of each successful year rather than at yearend points, used in most conventional present value tables. The rationale for this somewhat unusual approach is that the forecasted expenditures being treated are more likely to occur randomly throughout the identified time interval than to be fully expended in a lump sum at the end of the interval or at some other selected point within the interval. The net effect of the differences in these approaches is that the discount factors presented here for a given interval are approximately equal to the mean average of the two conventional present-value factors representing the beginning and the end of the intervals considered. Mathematically, the discounting equation used in the calculation of all the discount factors presented in this chapter is expressed as follows:

$$\int_{t-1}^t Q_t dt = \frac{R}{(1+R)^t \text{Ln}(1+R)}$$

Where,

t = time period; i.e., 1, 2, ..., T

$Q_t = (1 + R)^{-t}$

R = discount rate; i.e., .075, .10, or .125

Ln = natural logarithm

3. Guidelines and Procedures.

a. Discounting should be used in all investment proposals in the comparison of alternative courses of action with the following exceptions:

(1) When it can be shown that the minimum level of effort required to do the analysis would not be worth the benefits to be gained from such an analysis.

(2) When other DoD instructions and issuances prescribe equipment age or condition replacement criteria, labor and equipment trade-off standards, or requirements computations which in turn have been based on economic analyses.

(3) When proposed actions are specifically directed by legislation or prior irrevocable management decisions which preclude any choice or trade-off among alternatives, including alternative ways to accomplish a program or project.

b. Discounting is not appropriate in the preparation of program budget estimates where alternative courses of action are not being considered. If there are no alternative proposals being compared and analyzed, there is no need for discounting.

c. The standard discount rate or factor to be applied to cost estimates has been established by OSD(C) as 10 percent per year compounded annually. This specific factor must be used in conducting planning studies, making trade-offs among program alternatives, and preparing and evaluating proposed program changes to effect cost reductions. To enhance the analysis of the alternatives by evaluating the impact of the use of discounting in these studies; however, it is recommended that other rates such as 7 1/2 percent and 12 1/2 percent also be used in comparing the alternatives. The use of these higher and lower discounting factors serves to demonstrate the sensitivity in the preference for the lowest cost alternative to the use of the discount rate. Variations in the identification of the lowest cost alternative which occur solely as a result of varying the discount rate from 10 percent should be discussed in the project narrative justification and the impact of the discount rate on the preferred alternative addressed.

d. The 10-percent discount rate is considered to be independent from and does not reflect or otherwise consider inflation or other economic and price level changes in any way. Further, the specific considerations of the treatment of future price level changes should be independent from and not based upon this 10-percent discount rate. (See also chapter 38.) Considerations of economic escalation should precede the application of discounting factors in determining the total life cycle discounted costs for the alternatives. For a simultaneous application procedure, see paragraph k, this chapter, and table 41-5.

e. The discount factor does not consider, adjust, or otherwise account for differences or variations in the risk or uncertainty associated with either the cost estimate of a program or any other factors concerning the program itself. Treatment of program risk and uncertainty should be done in terms of a narrative explanation or, if possible, described quantitatively elsewhere in the study.

f. Discounting is not applicable to expenditures which have already been made (sunk costs) and cannot be recovered. Sunk costs are not considered relevant and are not to be included in the cost estimates of future investment proposals.

g. The economic lives of all alternatives (see chapter 32) need not be the same to compare the discounted costs of alternative proposals. Certain alternatives are likely to differ in terms of their initial operational capability date and, possibly, total economic lifespan. The comparison of the costs of these alternatives, therefore, should not be constrained by artificially and inaccurately assuming the same life cycle for all of the alternatives. Since there may be inherent advantages or disadvantages linked to schedule or operational dissimilarities among the alternatives, the total life cycle discounted costs need only be adjusted to an annual basis for comparison; that is, a uniform annual discounted cost. This cost is calculated by dividing the total discounted costs accumulated over the life of the project by the sum of the discount factors for only those years in which the alternative yields benefits.

h. In applying the discount factor, the year in which the discounting begins is determined by the year in which the first investment will be made for any of the alternatives. This first investment year is referred to as the base year for the discounting, and it is the same base year for all of the alternatives even though it may be the first year of expenditures for only one of the alternatives being considered. The discount factors for all alternatives for all subsequent years, however, are determined by counting from this base year.

i. In the absence of specific program or equipment data to the contrary, communications systems equipment generally will be assumed to have no residual value (see also chapter 32) at the end of the expected program or project life cycle. If there is an expected terminal value, however, that value should be shown in the analysis for the calculation of the total program discounted life cycle costs as follows:

(1) Individual project discounting, as shown in the example in table 41-2, is a negative entry in the project year following the last operational year in the "Nonrecurring Investment" column and discounted negative entry in the "Discounted Annual Cost" column.

(2) Differential cost discounting, although not shown in the example in table 41-3, is a negative entry in the project year following the last operational year in the "Annual Costs/Present Alternative" or the "Annual Costs/Proposed Alternative" column, and in the "Differential Annual Cost" column, which will be the basis for applying the discounting factors.

j. The discounting of the cost estimate is addressed after all of the costs of the project have been estimated (section A) and time-phased, anticipated economic escalation has been considered (chapters 40 and 38), and appropriate adjustments to the costs have been made.

k. It is possible to incorporate discounting and anticipated economic escalation into one process if the escalation rate is estimated to continue at a consistent rate. Table 41-5 has been derived to present the results of

this combined process. The factors used are derived by multiplying the individual discount factor by $(1+E)^{t-1}$, where E=economic escalation rate.

4. Use of Tables.

a. Table 41-1. This table contains the annual discount factors presented in DoDI 7041.3, "Economic Analysis and Program Evaluation for Resource Management," 18 October 1972. Three separate discount rates are shown: the 12 1/2 percent and 7 1/2 percent to be used in sensitivity analyses and the standard OSD-required 10 percent. Columns 2 through 4 on this table represent the factors used when the cash flow of a project accrues at different amounts for each year. In discounting annual expenditures, these factors are multiplied by the respective projected annual expenditures for each of the project years to obtain the total discounted or present value dollars (see the example presented in table 41-2 for the use of the 10-percent rate). The rates in columns 5 through 7 represent the cumulative amounts for these three factors. These are useful for two purposes: when expenditures are expected to occur in the same amount each year, and in calculating the uniform annual costs described in paragraph 3g above.

(1) For the recurring annual expenditures, if the same amount were expended during the first 5 years of a project being discounted at 10 percent, a single calculation of 3.977 times the annual expenditure rate provides the same result as multiplying and summing the five products of each of the factors and the annual expenditure for the first 5 years, since:

$$.954 + .867 + .788 + .717 + .651 = 3.977$$

If the annual expenditures were constant during the 5th through 12th years, the difference between the cumulative factors for the 12th and 4th years would be appropriate. This factor difference would then be multiplied by the annual expenditure rate as follows:

$$\begin{aligned} \text{Total discounted costs} &= \\ &(7.148 - 3.326) \times \text{annual expenditures.} \end{aligned}$$

(2) In the case of each of the uniform annual costs, the total discounted costs of each of the projects are divided by the cumulative discount factors for those years during which benefits are received. This, in effect, translates the total project costs into the present value of an amount which, if expended annually for the useful life of the project, would equal the total project discounted costs. This amount, the uniform annual cost, serves as the basis for determining the least costly alternative. For example, if costs of a project were assumed to begin during the third year for this alternative and benefits were to be received only the fourth and fifth years:

<u>Project Year</u>	<u>Total Annual Cost</u>	<u>Discount Factor</u>	<u>Discounted Annual Cost</u>
1 (Base Year)	-	.954	-
2	-	.867	-
3	\$ 50,000	.788	\$39,400
4	45,000	.717	32,265
5	40,000	.651	26,040
Totals	\$135,000	3.977	\$97,705

Uniform Annual Cost (\$97,705 divided by (.717 + .651)) = \$71,422.

b. Table 41-2. This table presents an example of the use of the 10-percent discount factors presented in table 41-1 in discounting the costs of a hypothetical individual project requiring \$25,000 for R&D, \$365,000 in procurement funds, and an operating and maintenance cost of \$40,000 per year when fully operational for a 7-year life during which the alternative yields benefits. There is also an expected residual value of \$35,000 at the project termination. (See chapter 32 for further discussion regarding residual value.)

c. Table 41-3. This table presents an example of discounting the marginal or differential costs between two competing alternatives with benefits realized during the entire program or project life cycle. This case is similar to most cost savings proposals in that it offers a comparison with an alternative which involves an increased expenditure in the next few years in anticipation of reducing the present operating expenses thereafter. In this example, \$85,000 of investment is spent during the first 2 years to buy equipment for replacing the present system which continues to operate during this period. The proposed alternative operates for years 3-10. The current system is phased out without residual value at the beginning of the third year. (If there were to be a residual value, it would be shown in the third year.) It should be noted that benefits are received from both alternatives throughout the full 10 years of comparison; therefore, the basis for uniform annual costs for both alternatives is 10 years.

d. Table 41-4. This table contains monthly discount factors which are based on the same three annual rates used in table 41-1: 10 percent as required by DoD, and 7 1/2 percent and 12 1/2 percent for use in performing sensitivity analyses. Each of the discount factors is presented for periods of 1 through 96 months. If additional monthly factors or different discount rates are required, they may be calculated using the general equation presented in paragraph 2d, or will be provided upon a request sent to the Director, DCA, ATTN: Code 690, Washington, D.C. 20305.

(1) If cash flows are the same in each month (e.g., in a situation where equipment is leased on a monthly basis), the discounted lease costs should be calculated by using the appropriate cumulative discount factors. If cash flows are different each month (e.g., when equipment is purchased and

maintenance is a separate item), discounted purchase costs would be calculated by using the appropriate individual discount factors. The presentation of the results of an analysis conducted on a monthly rather than an annual basis should be essentially the same and follow the general format presented in tables 41-2 and 41-3, except that the intervals, funds, and discount factors would be quoted on a monthly basis.

(2) Table 41-4 can also be used to find the break-even period for differential cost discounting type proposals provided that the differential annual cost is constant and the effects of inflation and residual value are irrelevant. The break-even period is that time when discounted investment costs equal cumulative discounted savings.

(a) This can be shown mathematically as follows:

$$\sum_{k=1}^m (I_k \times d_k) = S \times (D_n - D_m)$$

Where,

- n = break-even period (unknown)
- m = periods of investment
- I_k = investment in period k
- S = amount saved during each period
- d_k = discount factor for period k
- D_k = cumulative discount factor through period k (d_k and D_k are supplied in tables 41-1 for annual factors; 41-4 for monthly factors; 41-5, annual factors including escalation; and 41-6, monthly factors including escalation.)

Hence,

$$D_n = \frac{\sum_{k=1}^m (I_k \times d_k)}{S} + D_m$$

(b) For example, investments are made for 3 months in the amounts of \$30,000, \$20,000 and \$10,000. Operating expenses are \$5,000 per month for the present system and \$2,000 per month for the proposed investment alternative, which begins full operations in month 4.

Therefore,

$$m = 3, I_1 = \$30,000, I_2 = \$20,000, I_3 = \$10,000,$$

$$S = \$5,000 - \$2,000 = \$3,000$$

From the 10 percent column of table 41-4,

$d_1 = .996$, $d_2 = .988$, $d_3 = .980$, $D_3 = 2.965$
Using the formula,

$$D_n = \frac{(I_1 \times d_1) + (I_2 \times d_2) + (I_3 \times d_3)}{S} + D_3$$

$$= \frac{59,440}{3,000} + 2.965$$

$$= 22.778$$

(c) For a cumulative discount factor of 22.8, the equivalent number of months in table 41-4 in the 10-percent column would be slightly more than 25 or 26 months. This is the number of months from project initiation necessary to offset the investment costs.

e. Table 41-5. This table contains the annual and cumulative factors to be used for various economic escalation rates coupled with the 10-percent discount rate. (Table 41-1 reflects the zero-percent annual economic escalation rate.) In the absence of more specific information, recent average rates have been 6.5 percent for military pay and allowances and civilian pay, and 3.6 percent for Federal purchase of goods and services. (See also table 38-4.)

(1) The initial step must be the escalation of all costs prior to the base year up to the base year so that all costs are expressed in constant base-year dollars. For instance, if the base year is 3 years in the future, escalate this year's costs by the appropriate rate three times, next year's twice, and the following year's once.

(2) Investment and recurring costs are then multiplied by the appropriate annual or cumulative factors, or both, as in paragraph 4a(1), this chapter.

f. Table 41-6. This table presents the monthly and cumulative factors to be used with various economic escalation rates coupled with the 10-percent discount rate. The annual escalation and discount rates have been converted to equivalent monthly rates: if R is the yearly discount rate (e.g., .10), then the equivalent monthly discount rate, R_m , can be found using the formula: $R_m = (1 + R)^{1/12} - 1$.

(1) The mathematical equation shown in paragraph d(2)(a) can be used to determine the approximate monthly breakeven period for differential cost discounting type proposals wherein all costs are stated in current dollars (excluding inflation) for each of the years evaluated. The investment cost discount and inflation factors, however, should represent the anticipated

escalation rate for the investment portion, and the break-even period calculation, using the cumulative discount and inflation factors considered appropriate, should be based on expected rates of escalation for the annual recurring costs of the proposals.

(2) For example, assume investments are proposed for the first 2 project months in the amounts of \$5,000 and \$10,000 to reduce annual operating costs from \$3,000 to \$2,000 per month beginning in the third month. Assume also that annual inflation rates for investment and annual operating costs are anticipated at 8 percent and 4 percent, respectively. Note that d_1 and d_2 should be based on the 8-percent rate and D_2 on the 4-percent rate.

$$D_n = \frac{(5,000 \times .996) + (10,000 \times .995)}{1,000} + (1.987)$$

$$D_n = 16.917$$

In table 41-6 in the 4-percent (for annual operating costs) column, the closest cumulative discount and inflation factor is 17.235, resulting in a break-even period of 18 months.

g. Table 41-7. This table presents an example of the use of escalation factors found in table 41-5. In this case, \$100,000 in current FY 1975 dollars is to be invested in procurement funds (with a 3-percent escalation rate) in both 1977 and 1978, and operating expenses of \$10,000 are scheduled for civilian pay annually from 1979 through 1983. These are adjusted from 1975 to 1977 dollars by using 5.5 percent per year, and the investment funds are adjusted by using 3 percent per year for 2 years. All costs will then be expressed in FY 1977 constant dollars.

.....
: **TABLE 41-1. ANNUAL DISCOUNT FACTORS** :
:

YEAR:	INDIVIDUAL			CUMULATIVE		
	7 1/2%	10%	12 1/2%	7 1/2%	10%	12 1/2%
1	0.965	0.954	0.943	0.965	0.954	0.943
2	0.897	0.867	0.839	1.862	1.821	1.782
3	0.835	0.788	0.745	2.697	2.609	2.527
4	0.777	0.717	0.663	3.474	3.326	3.190
5	0.722	0.651	0.589	4.196	3.977	3.779
6	0.672	0.592	0.523	4.868	4.569	4.302
7	0.625	0.538	0.465	5.493	5.107	4.767
8	0.581	0.489	0.414	6.074	5.596	5.181
9	0.541	0.445	0.368	6.615	6.041	5.549
10	0.503	0.405	0.327	7.118	6.446	5.876
11	0.468	0.368	0.291	7.586	6.814	6.167
12	0.435	0.334	0.258	8.021	7.148	6.425
13	0.405	0.304	0.230	8.426	7.452	6.655
14	0.377	0.276	0.204	8.803	7.728	6.859
15	0.350	0.251	0.181	9.153	7.979	7.040
16	0.326	0.228	0.161	9.479	8.207	7.201
17	0.303	0.208	0.143	9.782	8.415	7.344
18	0.282	0.189	0.127	10.064	8.604	7.471
19	0.262	0.172	0.113	10.326	8.776	7.584
20	0.244	0.156	0.101	10.570	8.932	7.685
21	0.227	0.142	0.089	10.797	9.074	7.774
22	0.211	0.129	0.080	11.008	9.203	7.854
23	0.197	0.117	0.071	11.205	9.320	7.925
24	0.183	0.107	0.063	11.388	9.427	7.988
25	0.170	0.097	0.056	11.553	9.524	8.044

.....
: **Source: DCA, CODE 690.** :
:

TABLE 41-2. INDIVIDUAL PROJECT DISCOUNTING EXAMPLE

Project Year	Nonrecurring		Recurring Operations	Annual Cost	10-Percent Discount Factor	Dis-counted Annual Cost
	R&D	Investment				
1	\$25,000	\$ 5,000		\$ 30,000	.954	\$ 28,620
2		275,000		275,000	.867	238,425
3		85,000	\$ 5,000	90,000	.788	70,920
4			28,000	28,000	.717	20,076
5			40,000			
6			40,000			
7			40,000			
8			40,000	40,000	3.488 ¹	139,520
9			40,000			
10			40,000			
11			40,000			
12		-35,000 ²		-35,000	.334	-11,690
Totals	\$25,000	\$330,000	\$313,000	\$668,000		\$485,871

Uniform Annual Cost (7 years) \$139,298.

¹The cumulative discount factor for the 11th year less the cumulative discount factor for the 4th year is the sum of the individual factors for years 5 through 11.

²Reflects the terminal value of the investment at the end of the program life cycle (the year following the last year operation).

Source: DCA, Code 690.

TABLE 41-3. DIFFERENTIAL COST DISCOUNTING EXAMPLE

Project Year	Annual Costs		Differen- tial Annual Cost	10-Percent Discount Factor	Discounted Differen- tial Annual Cost
	Present Alternative	Proposed Alternative			
1	\$ 45,000	\$105,000	-\$60,000	.954	-\$57,240
2	45,000	70,000	-25,000	.867	-21,675
3	45,000	20,000	25,000	4.626*	115,650
4	45,000	20,000			
5	45,000	20,000			
6	45,000	20,000			
7	45,000	20,000			
8	45,000	20,000			
9	45,000	20,000			
10	45,000	20,000			
Totals	\$450,000	\$335,000	\$115,000	6.446	\$ 36,735
SUMMARY OF COSTS					
Present Value of New Investment:					
ADPE (\$60,000 X .954)					\$57,240
Software (\$25,000 X .867)					21,675
					78,915
Present Value of Savings (\$25,000 X 4.626)					\$115,650
Savings/Investment Ratio (\$115,650 divided by \$78,915)					1.46:1
Uniform Annual Savings (\$36,735 divided by 6.446)					\$5,699
*The cumulative discount factor for the 10th year less the cumulative discount factor for the 2nd year.					
Source: DCA, Code 690.					

SECTION F

TABLE 41-4. MONTHLY DISCOUNT FACTORS

INDIVIDUAL			CUMULATIVE			
MO	7 1/2%	10%	12 1/2%	7 1/2%	10%	12 1/2%
1	0.997	0.996	0.995	0.997	0.996	0.995
2	0.991	0.988	0.985	1.988	1.984	1.980
3	0.985	0.980	0.976	2.973	2.965	2.956
4	0.979	0.973	0.966	3.952	3.937	3.922
5	0.973	0.965	0.957	4.925	4.902	4.879
6	0.967	0.957	0.947	5.893	5.859	5.827
7	0.962	0.950	0.938	6.854	6.809	6.765
8	0.956	0.942	0.929	7.810	7.751	7.694
9	0.950	0.935	0.920	8.760	8.686	8.614
10	0.944	0.927	0.911	9.705	9.613	9.525
11	0.939	0.920	0.902	10.643	10.533	10.427
12	0.933	0.913	0.893	11.576	11.446	11.320
13	0.927	0.905	0.885	12.504	12.351	12.205
14	0.922	0.898	0.876	13.426	13.250	13.081
15	0.916	0.891	0.867	14.342	14.141	13.948
16	0.911	0.884	0.859	15.253	15.025	14.807
17	0.905	0.877	0.850	16.158	15.902	15.657
18	0.900	0.870	0.842	17.058	16.772	16.500
19	0.894	0.863	0.834	17.953	17.636	17.334
20	0.889	0.857	0.826	18.842	18.492	18.159
21	0.884	0.850	0.818	19.725	19.342	18.977
22	0.878	0.843	0.810	20.604	20.185	19.787
23	0.873	0.836	0.802	21.477	21.021	20.589
24	0.868	0.830	0.794	22.345	21.851	21.383

TABLE 41-4. MONTHLY DISCOUNT FACTORS (CON.)						
MO	INDIVIDUAL			CUMULATIVE		
	7 1/2%	10%	12 1/2%	7 1/2%	10%	12 1/2%
25	0.863	0.823	0.786	23.208	22.674	22.169
26	0.858	0.817	0.779	24.065	23.491	22.943
27	0.852	0.810	0.771	24.918	24.301	23.719
28	0.847	0.804	0.763	25.765	25.105	24.482
29	0.842	0.797	0.756	26.607	25.902	25.233
30	0.837	0.791	0.749	27.444	26.694	25.937
31	0.832	0.785	0.741	28.276	27.478	26.728
32	0.827	0.779	0.734	29.103	28.257	27.462
33	0.822	0.772	0.727	29.926	29.030	28.189
34	0.817	0.766	0.720	30.743	29.796	28.909
35	0.812	0.760	0.713	31.555	30.556	29.621
36	0.807	0.754	0.706	32.362	31.311	30.327
37	0.803	0.748	0.699	33.165	32.059	31.026
38	0.798	0.742	0.692	33.963	32.801	31.718
39	0.793	0.737	0.685	34.756	33.538	32.403
40	0.788	0.731	0.679	35.544	34.269	33.082
41	0.783	0.725	0.672	36.327	34.994	33.754
42	0.779	0.719	0.665	37.106	35.713	34.419
43	0.774	0.714	0.659	37.880	36.426	35.078
44	0.769	0.708	0.652	38.649	37.134	35.731
45	0.765	0.702	0.646	39.414	37.836	36.377
46	0.760	0.697	0.640	40.174	38.533	37.017
47	0.756	0.691	0.634	40.930	39.224	37.650
48	0.751	0.686	0.627	41.681	39.910	38.278

.....

:

: TABLE 41-4. MONTHLY DISCOUNT FACTORS (CON.) :

:

.....

	INDIVIDUAL			:	CUMULATIVE			:
MO	7 1/2%	10%	12 1/2%	:	7 1/2%	10%	12 1/2%	:
49	0.747	0.680	0.621	:	42.427	40.590	38.899	:
50	0.742	0.675	0.615	:	43.170	41.265	39.514	:
51	0.738	0.670	0.609	:	43.907	41.935	40.123	:
52	0.733	0.664	0.603	:	44.640	42.599	40.726	:
53	0.729	0.659	0.597	:	45.369	43.258	41.324	:
54	0.724	0.654	0.591	:	46.093	43.912	41.915	:
55	0.720	0.649	0.586	:	46.814	44.561	42.501	:
56	0.716	0.644	0.580	:	47.529	45.204	43.081	:
57	0.711	0.638	0.574	:	48.241	45.843	43.655	:
58	0.707	0.633	0.569	:	48.948	46.476	44.224	:
59	0.703	0.628	0.563	:	49.651	47.104	44.787	:
60	0.699	0.623	0.558	:	50.349	47.728	45.345	:
61	0.694	0.618	0.552	:	51.044	48.346	45.897	:
62	0.690	0.614	0.547	:	51.734	48.960	46.444	:
63	0.686	0.609	0.541	:	52.420	49.569	46.985	:
64	0.682	0.604	0.536	:	53.102	50.172	47.522	:
65	0.678	0.599	0.531	:	53.780	50.772	48.052	:
66	0.674	0.594	0.526	:	54.454	51.366	48.578	:
67	0.670	0.590	0.521	:	55.124	51.956	49.099	:
68	0.666	0.585	0.516	:	55.790	52.541	49.614	:
69	0.662	0.580	0.511	:	56.451	53.121	50.125	:
70	0.658	0.576	0.506	:	57.109	53.697	50.630	:
71	0.654	0.571	0.501	:	57.763	54.268	51.131	:
72	0.650	0.567	0.496	:	58.413	54.835	51.627	:

.....

TABLE 41-4. MONTHLY DISCOUNT FACTORS (CON.)						
MO	INDIVIDUAL			CUMULATIVE		
	7 1/2%	10%	12 1/2%	7 1/2%	10%	12 1/2%
73	0.646	0.562	0.491	59.059	55.397	52.118
74	0.642	0.558	0.486	59.701	55.955	52.604
75	0.638	0.553	0.481	60.339	56.508	53.035
76	0.634	0.549	0.477	60.974	57.057	53.562
77	0.631	0.545	0.472	61.604	57.602	54.034
78	0.627	0.540	0.467	62.231	58.142	54.501
79	0.623	0.536	0.463	62.854	58.673	54.964
80	0.619	0.532	0.458	63.474	59.210	55.422
81	0.616	0.528	0.454	64.099	59.739	55.876
82	0.612	0.523	0.449	64.701	60.261	56.325
83	0.608	0.519	0.445	65.309	60.780	56.770
84	0.605	0.515	0.441	65.914	61.296	57.211
85	0.601	0.511	0.436	66.515	61.807	57.647
86	0.597	0.507	0.432	67.112	62.314	58.079
87	0.594	0.503	0.428	67.706	62.817	58.507
88	0.590	0.499	0.424	68.296	63.316	58.931
89	0.587	0.495	0.420	68.883	63.811	59.350
90	0.583	0.491	0.415	69.466	64.302	59.766
91	0.580	0.487	0.411	70.045	64.790	60.177
92	0.576	0.483	0.407	70.622	65.273	60.584
93	0.573	0.480	0.403	71.194	65.753	60.988
94	0.569	0.476	0.399	71.763	66.229	61.387
95	0.566	0.472	0.396	72.329	66.701	61.783
96	0.562	0.468	0.392	72.892	67.169	62.174

Source: DCA, CCDE 690

TABLE 41-5. COMBINED ECONOMIC ESCALATION
AND 10 % DISCOUNT FACTORS
(ANNUAL FACTORS)

ANNUAL INFLATION RATES

YEAR:	INDIVIDUAL				CUMULATIVE			
	2%	4%	6%	8%	2%	4%	6%	8%
1	.954	.954	.954	.954	0.954	0.954	0.954	0.954
2	.884	.902	.919	.936	1.838	1.856	1.873	1.890
3	.820	.853	.886	.919	2.658	2.708	2.759	2.810
4	.760	.806	.854	.903	3.419	3.514	3.612	3.713
5	.705	.762	.822	.886	4.124	4.276	4.435	4.599
6	.654	.721	.793	.870	4.778	4.997	5.227	5.469
7	.606	.681	.764	.854	5.384	5.678	5.991	6.323
8	.562	.644	.736	.839	5.947	6.322	6.727	7.162
9	.521	.609	.709	.824	6.468	6.931	7.436	7.986
10	.483	.576	.683	.809	6.951	7.507	8.120	8.795
11	.448	.544	.659	.794	7.400	8.052	8.778	9.588
12	.416	.515	.635	.779	7.815	8.566	9.413	10.368
13	.385	.487	.612	.765	8.201	9.053	10.024	11.133
14	.357	.460	.589	.751	8.558	9.513	10.614	11.885
15	.331	.435	.568	.738	8.890	9.948	11.182	12.622
16	.307	.411	.547	.724	9.197	10.359	11.729	13.347
17	.285	.389	.527	.711	9.482	10.748	12.256	14.058
18	.264	.368	.508	.698	9.746	11.115	12.764	14.756
19	.245	.348	.490	.686	9.991	11.463	13.254	15.442
20	.227	.329	.472	.673	10.218	11.791	13.726	16.115
21	.211	.311	.455	.661	10.429	12.102	14.180	16.776
22	.195	.294	.438	.649	10.624	12.396	14.619	17.424
23	.181	.278	.422	.637	10.806	12.674	15.041	18.061
24	.168	.263	.407	.625	10.973	12.936	15.448	18.687
25	.156	.248	.392	.614	11.129	13.184	15.840	19.301

TABLE 41-5. COMBINED ECONOMIC ESCALATION
AND 10 % DISCOUNT FACTORS
(ANNUAL FACTORS) (CON.)

ANNUAL INFLATION RATES									
	INDIVIDUAL				CUMULATIVE				
YEAR:	10%	12%	14%	16%	10%	12%	14%	16%	
1	0.954	0.954	0.954	0.954	0.954	0.954	0.954	0.954	0.954
2	0.954	0.971	0.989	1.006	1.908	1.925	1.942	1.960	
3	0.954	0.989	1.024	1.061	2.861	2.914	2.967	3.020	
4	0.954	1.007	1.062	1.119	3.815	3.921	4.029	4.139	
5	0.954	1.025	1.100	1.180	4.769	4.946	5.129	5.319	
6	0.954	1.044	1.140	1.244	5.723	5.990	6.269	6.563	
7	0.954	1.063	1.182	1.312	6.677	7.052	7.451	7.874	
8	0.954	1.082	1.225	1.383	7.631	8.134	8.676	9.258	
9	0.954	1.102	1.269	1.459	8.584	9.236	9.945	10.716	
10	0.954	1.122	1.315	1.538	9.538	10.358	11.261	12.255	
11	0.954	1.142	1.363	1.622	10.492	11.500	12.624	13.877	
12	0.954	1.163	1.413	1.711	11.446	12.663	14.037	15.588	
13	0.954	1.184	1.464	1.804	12.400	13.847	15.501	17.392	
14	0.954	1.206	1.517	1.902	13.354	15.053	17.018	19.294	
15	0.954	1.228	1.573	2.006	14.307	16.280	18.591	21.301	
16	0.954	1.250	1.630	2.116	15.261	17.530	20.221	23.416	
17	0.954	1.273	1.689	2.231	16.215	18.802	21.910	25.647	
18	0.954	1.296	1.751	2.353	17.169	20.098	23.661	28.000	
19	0.954	1.319	1.814	2.481	18.123	21.417	25.475	30.481	
20	0.954	1.343	1.880	2.616	19.077	22.761	27.355	33.098	
21	0.954	1.368	1.949	2.759	20.030	24.128	29.304	35.857	
22	0.954	1.393	2.019	2.910	20.984	25.521	31.323	38.767	
23	0.954	1.418	2.093	3.068	21.938	26.939	33.416	41.835	
24	0.954	1.444	2.169	3.236	22.892	28.382	35.585	45.071	
25	0.954	1.470	2.248	3.412	23.846	29.852	37.833	48.483	

Source: DCA, CCDE 690

:A..... :
: :
: **TABLE 41-6. COMBINED ECONOMIC ESCALATION** :
: **AND 10 % DISCOUNT FACTORS** :
: **(MONTHLY FACTORS)** :
: :
: :
: **ANNUAL INFLATION RATES** :
: :
: **INDIVIDUAL** : **CUMULATIVE** :
: :
: MO : 2% 4% 6% 8% : 2% 4% 6% 8% :
: :
: : : : : : : : : : :
: 1 : .996 .996 .996 .996 : 0.996 0.996 0.996 0.996 :
: 2 : .990 .991 .993 .995 : 1.986 1.987 1.989 1.991 :
: 3 : .984 .987 .990 .993 : 2.969 2.974 2.979 2.984 :
: 4 : .977 .982 .987 .991 : 3.947 3.956 3.966 3.975 :
: 5 : .971 .978 .984 .990 : 4.918 4.934 4.950 4.965 :
: 6 : .965 .973 .981 .988 : 5.883 5.907 5.930 5.953 :
: : : : : : : : : : :
: 7 : .959 .968 .978 .987 : 6.842 6.875 6.908 6.940 :
: 8 : .953 .964 .975 .985 : 7.796 7.839 7.883 7.926 :
: 9 : .947 .959 .972 .984 : 8.743 8.790 8.855 8.910 :
: 10 : .941 .955 .969 .982 : 9.684 9.754 9.823 9.892 :
: 11 : .935 .951 .966 .981 : 10.619 10.705 10.789 10.873 :
: 12 : .929 .946 .963 .979 : 11.549 11.651 11.752 11.853 :
: : : : : : : : : : :
: 13 : .924 .942 .960 .978 : 12.472 12.592 12.712 12.830 :
: 14 : .918 .937 .957 .976 : 13.390 13.530 13.669 13.807 :
: 15 : .912 .933 .954 .975 : 14.302 14.463 14.622 14.782 :
: 16 : .906 .929 .951 .973 : 15.208 15.391 15.573 15.755 :
: 17 : .901 .924 .948 .972 : 16.109 16.315 16.521 16.727 :
: 18 : .895 .920 .945 .970 : 17.004 17.235 17.467 17.698 :
: : : : : : : : : : :
: 19 : .889 .916 .942 .969 : 17.893 18.151 18.409 18.667 :
: 20 : .884 .911 .939 .968 : 18.777 19.062 19.348 19.634 :
: 21 : .878 .907 .936 .966 : 19.655 19.970 20.284 20.600 :
: 22 : .873 .903 .934 .965 : 20.528 20.873 21.218 21.565 :
: 23 : .867 .899 .931 .963 : 21.395 21.771 22.149 22.528 :
: 24 : .862 .895 .928 .962 : 22.257 22.666 23.076 23.490 :
: : : : : : : : : : :
: :
: : : : : : : : : : :
: :
: : : : : : : : : : :
: :
: : : : : : : : : : :
: :

TABLE 41-6. COMBINED ECONOMIC ESCALATION
AND 10 % DISCOUNT FACTORS
(MONTHLY FACTORS) (CON)

ANNUAL INFLATION RATES									
	INDIVIDUAL				CUMULATIVE				
MO	2%	4%	6%	8%	2%	4%	6%	8%	
25	.856	.890	.925	.960	23.114	23.556	24.001	24.450	
26	.851	.886	.922	.959	23.965	24.442	24.923	25.408	
27	.846	.882	.919	.957	24.810	25.324	25.842	26.366	
28	.840	.878	.916	.956	25.651	26.202	26.759	27.321	
29	.835	.874	.914	.954	26.486	27.076	27.672	28.276	
30	.830	.870	.911	.953	27.316	27.946	28.583	29.228	
31	.825	.866	.908	.951	28.140	28.812	29.491	30.180	
32	.820	.862	.905	.950	28.960	29.673	30.396	31.130	
33	.814	.858	.902	.948	29.774	30.531	31.298	32.078	
34	.809	.854	.900	.947	30.584	31.385	32.198	33.025	
35	.804	.850	.897	.946	31.388	32.234	33.095	33.971	
36	.799	.846	.894	.944	32.187	33.080	33.989	34.915	
37	.794	.842	.891	.943	32.981	33.922	34.880	35.858	
38	.789	.838	.889	.941	33.770	34.760	35.769	36.799	
39	.784	.834	.886	.940	34.554	35.594	36.654	37.739	
40	.779	.830	.883	.938	35.334	36.424	37.537	38.677	
41	.774	.826	.880	.937	36.108	37.250	38.418	39.614	
42	.770	.822	.878	.936	36.878	38.072	39.295	40.549	
43	.765	.819	.875	.934	37.642	38.891	40.170	41.484	
44	.760	.815	.872	.933	38.402	39.705	41.042	42.416	
45	.755	.811	.870	.931	39.157	40.516	41.912	43.347	
46	.750	.807	.867	.930	39.908	41.323	42.779	44.277	
47	.746	.803	.864	.928	40.653	42.127	43.643	45.206	
48	.741	.800	.862	.927	41.394	42.926	44.504	46.133	

TABLE 41-6. COMBINED ECONOMIC ESCALATION
AND 10 % DISCOUNT FACTORS
(MONTHLY FACTORS) (CON)

ANNUAL INFLATION RATES									
INDIVIDUAL					CUMULATIVE				
MO	2%	4%	6%	8%	2%	4%	6%	8%	
49	.736	.796	.859	.926	42.131	43.722	45.363	47.058	
50	.732	.792	.856	.924	42.863	44.514	46.220	47.982	
51	.727	.788	.854	.923	43.590	45.303	47.073	48.905	
52	.723	.785	.851	.921	44.312	46.087	47.924	49.826	
53	.718	.781	.848	.920	45.030	46.869	48.772	50.746	
54	.714	.777	.846	.919	45.744	47.646	49.618	51.665	
55	.709	.774	.843	.917	46.453	48.420	50.461	52.582	
56	.705	.770	.840	.916	47.158	49.190	51.302	53.498	
57	.700	.767	.838	.914	47.858	49.957	52.139	54.412	
58	.696	.763	.835	.913	48.554	50.720	52.975	55.325	
59	.691	.760	.833	.912	49.245	51.479	53.807	56.236	
60	.687	.756	.830	.910	49.932	52.235	54.638	57.146	
61	.683	.752	.828	.909	50.615	52.988	55.465	58.055	
62	.679	.749	.825	.907	51.294	53.737	56.290	58.962	
63	.674	.745	.823	.906	51.968	54.482	57.113	59.868	
64	.670	.742	.820	.905	52.638	55.224	57.933	60.773	
65	.666	.739	.817	.903	53.304	55.963	58.750	61.676	
66	.662	.735	.815	.902	53.965	56.698	59.565	62.578	
67	.658	.732	.812	.900	54.623	57.429	60.378	63.478	
68	.653	.728	.810	.899	55.276	58.158	61.188	64.377	
69	.649	.725	.807	.898	55.926	58.882	61.995	65.275	
70	.645	.721	.805	.896	56.571	59.604	62.800	66.171	
71	.641	.718	.802	.895	57.212	60.322	63.602	67.066	
72	.637	.715	.800	.894	57.849	61.037	64.402	67.960	

TABLE 41-6. COMBINED ECONOMIC ESCALATION
AND 10 % DISCOUNT FACTORS
(MONTHLY FACTORS) (CON)

ANNUAL INFLATION RATES									
INDIVIDUAL					CUMULATIVE				
MO	2%	4%	6%	8%	2%	4%	6%	8%	
73	.633	.711	.798	.892	58.482	61.748	65.200	68.852	
74	.629	.708	.795	.891	59.112	62.456	65.995	69.743	
75	.625	.705	.793	.889	59.737	63.161	66.787	70.632	
76	.621	.702	.790	.888	60.358	63.863	67.578	71.521	
77	.617	.698	.788	.887	60.975	64.561	68.365	72.407	
78	.614	.695	.785	.885	61.589	65.256	69.151	73.293	
79	.610	.692	.783	.884	62.199	65.948	69.933	74.177	
80	.606	.689	.780	.883	62.805	66.636	70.714	75.059	
81	.602	.685	.778	.881	63.407	67.321	71.492	75.941	
82	.598	.682	.776	.880	64.005	68.003	72.268	76.821	
83	.595	.679	.773	.879	64.599	68.682	73.041	77.699	
84	.591	.676	.771	.877	65.190	69.358	73.812	78.577	
85	.587	.673	.769	.876	65.777	70.031	74.580	79.453	
86	.583	.669	.766	.875	66.361	70.700	75.346	80.327	
87	.580	.666	.764	.873	66.941	71.367	76.110	81.201	
88	.576	.663	.761	.872	67.517	72.030	76.872	82.073	
89	.573	.660	.759	.871	68.089	72.690	77.631	82.943	
90	.569	.657	.757	.869	68.658	73.347	78.387	83.813	
91	.565	.654	.754	.868	69.223	74.001	79.142	84.681	
92	.562	.651	.752	.867	69.785	74.652	79.894	85.547	
93	.558	.648	.750	.865	70.343	75.300	80.644	86.413	
94	.555	.645	.747	.864	70.898	75.945	81.391	87.277	
95	.551	.642	.745	.863	71.450	76.587	82.136	88.139	
96	.548	.639	.743	.861	71.997	77.226	82.879	89.001	

TABLE 41-6. COMBINED ECONOMIC ESCALATION
AND 10 % DISCOUNT FACTORS
(MONTHLY FACTORS) (CON)

ANNUAL INFLATION RATES									
	INDIVIDUAL				CUMULATIVE				
MO	10%	12%	14%	16%	10%	12%	14%	16%	
1	0.996	0.996	0.996	0.996	0.996	0.996	0.996	0.996	0.996
2	0.996	0.998	0.999	1.000	1.992	1.994	1.995	1.996	
3	0.996	0.999	1.002	1.005	2.988	2.993	2.997	3.001	
4	0.996	1.001	1.005	1.009	3.984	3.993	4.002	4.011	
5	0.996	1.002	1.008	1.014	4.980	4.995	5.010	5.025	
6	0.996	1.004	1.011	1.018	5.976	5.999	6.021	6.043	
7	0.996	1.005	1.014	1.023	6.972	7.004	7.035	7.066	
8	0.996	1.007	1.017	1.027	7.968	8.010	8.052	8.093	
9	0.996	1.008	1.020	1.032	8.964	9.018	9.072	9.125	
10	0.996	1.010	1.023	1.037	9.960	10.028	10.095	10.162	
11	0.996	1.011	1.026	1.041	10.956	11.039	11.121	11.203	
12	0.996	1.013	1.029	1.046	11.952	12.052	12.150	12.248	
13	0.996	1.014	1.032	1.050	12.948	13.066	13.183	13.299	
14	0.996	1.016	1.035	1.055	13.944	14.082	14.218	14.354	
15	0.996	1.017	1.038	1.060	14.940	15.099	15.256	15.414	
16	0.996	1.019	1.042	1.064	15.937	16.117	16.298	16.478	
17	0.996	1.020	1.045	1.069	16.933	17.138	17.342	17.547	
18	0.996	1.022	1.048	1.074	17.929	18.160	18.390	18.621	
19	0.996	1.023	1.051	1.079	18.925	19.183	19.441	19.700	
20	0.996	1.025	1.054	1.083	19.921	20.208	20.495	20.783	
21	0.996	1.026	1.057	1.088	20.917	21.234	21.552	21.871	
22	0.996	1.028	1.060	1.093	21.913	22.262	22.612	22.964	
23	0.996	1.029	1.063	1.098	22.909	23.292	23.676	24.062	
24	0.996	1.031	1.067	1.103	23.905	24.323	24.742	25.165	

TABLE 41-6. COMBINED ECONOMIC ESCALATION
AND 10 % DISCOUNT FACTORS
(MONTHLY FACTORS) (CON)

ANNUAL INFLATION RATES									
INDIVIDUAL					CUMULATIVE				
MO	10%	12%	14%	16%	10%	12%	14%	16%	
25	0.996	1.033	1.070	1.108	24.901	25.355	25.812	26.273	
26	0.996	1.034	1.073	1.113	25.897	26.389	26.885	27.385	
27	0.996	1.036	1.076	1.118	26.893	27.425	27.961	28.503	
28	0.996	1.037	1.079	1.122	27.889	28.462	29.041	29.625	
29	0.996	1.039	1.083	1.127	28.885	29.501	30.123	30.752	
30	0.996	1.040	1.086	1.132	29.881	30.541	31.209	31.885	
31	0.996	1.042	1.089	1.137	30.877	31.583	32.298	33.022	
32	0.996	1.044	1.092	1.143	31.873	32.627	33.391	34.165	
33	0.996	1.045	1.096	1.148	32.869	33.672	34.486	35.312	
34	0.996	1.047	1.099	1.153	33.865	34.718	35.585	36.465	
35	0.996	1.048	1.102	1.158	34.861	35.767	36.687	37.623	
36	0.996	1.050	1.105	1.163	35.857	36.816	37.792	38.786	
37	0.996	1.051	1.109	1.168	36.853	37.868	38.901	39.954	
38	0.996	1.053	1.112	1.173	37.849	38.921	40.013	41.127	
39	0.996	1.055	1.115	1.178	38.845	39.975	41.128	42.306	
40	0.996	1.056	1.119	1.184	39.841	41.031	42.247	43.489	
41	0.996	1.058	1.122	1.189	40.837	42.089	43.369	44.678	
42	0.996	1.059	1.125	1.194	41.833	43.148	44.494	45.872	
43	0.996	1.061	1.129	1.200	42.829	44.209	45.623	47.072	
44	0.996	1.062	1.132	1.205	43.825	45.272	46.755	48.277	
45	0.996	1.064	1.135	1.210	44.821	46.336	47.890	49.487	
46	0.996	1.066	1.139	1.216	45.817	47.401	49.029	50.703	
47	0.996	1.067	1.142	1.221	46.813	48.469	50.171	51.923	
48	0.996	1.069	1.146	1.226	47.809	49.538	51.317	53.150	

TABLE 41-6. COMBINED ECONOMIC ESCALATION
AND 10 % DISCOUNT FACTORS
(MONTHLY FACTORS) (CON)

		ANNUAL INFLATION RATES							
		INDIVIDUAL				CUMULATIVE			
MO		10%	12%	14%	16%	10%	12%	14%	16%
49		0.996	1.070	1.149	1.232	48.805	50.603	52.466	54.382
50		0.996	1.072	1.152	1.237	49.801	51.680	53.618	55.619
51		0.996	1.074	1.156	1.243	50.797	52.754	54.774	56.862
52		0.996	1.075	1.159	1.248	51.793	53.829	55.933	58.110
53		0.996	1.077	1.163	1.254	52.789	54.906	57.096	59.364
54		0.996	1.079	1.166	1.259	53.785	55.985	58.262	60.623
55		0.996	1.080	1.170	1.265	54.781	57.065	59.432	61.888
56		0.996	1.082	1.173	1.271	55.777	58.147	60.605	63.158
57		0.996	1.083	1.177	1.276	56.773	59.230	61.782	64.435
58		0.996	1.085	1.180	1.282	57.769	60.315	62.962	65.716
59		0.996	1.087	1.184	1.288	58.765	61.402	64.146	67.004
60		0.996	1.088	1.187	1.293	59.760	62.490	65.333	68.297
61		0.996	1.090	1.191	1.299	60.756	63.580	66.524	69.596
62		0.996	1.092	1.194	1.305	61.752	64.672	67.718	70.901
63		0.996	1.093	1.198	1.311	62.748	65.765	68.916	72.211
64		0.996	1.095	1.201	1.316	63.744	66.860	70.117	73.528
65		0.996	1.097	1.205	1.322	64.740	67.956	71.322	74.850
66		0.996	1.098	1.209	1.328	65.736	69.054	72.531	76.178
67		0.996	1.100	1.212	1.334	66.732	70.154	73.743	77.512
68		0.996	1.101	1.216	1.340	67.728	71.256	74.959	78.852
69		0.996	1.103	1.219	1.346	68.724	72.359	76.178	80.198
70		0.996	1.105	1.223	1.352	69.720	73.463	77.402	81.549
71		0.996	1.106	1.227	1.358	70.716	74.570	78.628	82.907
72		0.996	1.108	1.230	1.364	71.712	75.678	79.859	84.271

TABLE 41-6. COMBINED ECONOMIC ESCALATION
AND 10 % DISCOUNT FACTORS
(MONTHLY FACTORS) (CON)

ANNUAL INFLATION RATES									
INDIVIDUAL					CUMULATIVE				
MO	10%	12%	14%	16%	10%	12%	14%	16%	
73	0.996	1.110	1.234	1.370	72.708	76.788	81.093	85.641	
74	0.996	1.111	1.238	1.376	73.704	77.899	82.331	87.017	
75	0.996	1.113	1.241	1.382	74.700	79.012	83.572	88.399	
76	0.996	1.115	1.245	1.388	75.696	80.127	84.817	89.787	
77	0.996	1.116	1.249	1.394	76.692	81.244	86.066	91.181	
78	0.996	1.118	1.253	1.400	77.688	82.362	87.319	92.582	
79	0.996	1.120	1.256	1.407	78.684	83.481	88.575	93.988	
80	0.996	1.121	1.260	1.413	79.680	84.603	89.835	95.401	
81	0.996	1.123	1.264	1.419	80.676	85.726	91.099	96.820	
82	0.996	1.125	1.268	1.426	81.672	86.851	92.366	98.246	
83	0.996	1.127	1.271	1.432	82.668	87.978	93.638	99.678	
84	0.996	1.128	1.275	1.438	83.664	89.106	94.913	101.116	
85	0.996	1.130	1.279	1.445	84.660	90.236	96.192	102.560	
86	0.996	1.132	1.283	1.451	85.656	91.367	97.474	104.011	
87	0.996	1.133	1.287	1.457	86.652	92.501	98.761	105.469	
88	0.996	1.135	1.290	1.464	87.648	93.636	100.051	106.933	
89	0.996	1.137	1.294	1.470	88.644	94.773	101.346	108.403	
90	0.996	1.138	1.298	1.477	89.639	95.911	102.644	109.880	
91	0.996	1.140	1.302	1.483	90.635	97.051	103.946	111.363	
92	0.996	1.142	1.306	1.490	91.631	98.193	105.252	112.853	
93	0.996	1.144	1.310	1.497	92.627	99.337	106.561	114.350	
94	0.996	1.145	1.314	1.503	93.623	100.482	107.875	115.853	
95	0.996	1.147	1.318	1.510	94.619	101.629	109.193	117.363	
96	0.996	1.149	1.322	1.517	95.615	102.778	110.514	118.880	

Source: DCA, CODE 690

TABLE 41-7. INDIVIDUAL PROJECT EXAMPLE BASED UPON
COMBINED ESCALATION/DISCOUNT FACTORS

Project Year	Annual Costs		Base Year Total	Escalation/ Discount Factor	Adjusted Discounted Cost
	Inv.	O&M			
1 (1977)	\$100,000		\$106,090 ¹	.954 ³	\$101,210
2	100,000		106,090	.893	94,738
3		\$10,000	11,130 ²	4.044 ⁴	45,010
4		10,000			
5		10,000			
6		10,000			
7		10,000			
Totals	\$200,000	\$50,000	\$267,830		\$240,958

¹The investment must be inflated from 1975 dollars to 1977 dollars,
 $\$100,000 \times (1.03)^2 = \$106,090$.

²The annual operating costs are inflated to 1977 dollars,
 $\$10,000 \times (1.055)^2 = \$11,130$.

³These factors for 3% are the average of the factors in table 41-5 for
 2% and 4%.

⁴The cumulative factor for years 3 through 7 is the 7th year less the
 2d year cumulative in table 41-5 for the 5.5% rate. The appropriate factor
 for 5.5% is 3/4 of the way between the factors for 4% and 6%:

4% factor = 5.678 - 1.856 = 3.822

6% factor = 5.991 - 1.873 = 4.118

5.5% factor = 3.822 + (3/4) X (4.118 - 3.822) = 4.044

CHAPTER 42. REPORT COSTING AND FREEDOM OF INFORMATION REQUESTS

1. General. This chapter discusses procedures and rates for use in estimating the cost of reports submitted in accordance with DCAI 630-225-2, Management and Control of Information Requirements, and fees to be charged for Freedom of Information Act (FOIA) requests made in accordance with DCAI 210-225-1, DCA Freedom of Information Act Program. The term "report" refers to data, information, or reports which are used for specified and authorized Government functions. A report then is used primarily by the Federal Government. FOIA requests, on the other hand, always involve a requestor outside the Government who is the primary user. Procedures used to calculate labor costs for reports are different from the ones for FOIA requests. Reports are covered in paragraphs 2 through 4 of this chapter and FOIA requests are covered in paragraphs 5 and 6.

a. The cost of a reporting requirement is the total of nonrecurring and recurring expenses incurred by the Government throughout the life cycle of the report. The cost rates contained in this chapter and in chapters 23 and 24 are used in cost estimation and in the accumulation of actual cost data. Estimated costs are refined or replaced by actual cost data when the reporting requirement is implemented.

b. The factors outlined in this chapter provide a basis for costing either a manual or an automated individual report or reporting system. All of the factors may not apply to a particular report, and there may be additional factors which apply to a specific costing situation.

c. There are three separate stages or times when report costing is required:

(1) Submitted with the request for the institution of a report (estimated cost).

(2) Following the first reporting cycle (week, month, quarter, etc.) during which the reporting requirement was implemented (actual cost).

(3) Annually, at the time all reporting requirements are reviewed for essentiality and continued effective benefits (actual cost versus value).

d. In transactions with non-Government activities when full reimbursement is appropriate, the standard rates must be increased in order to cover additional appropriate costs. These rates are identified as "Non-Government."

2. Derivation of Factors for Tables 42-1 and 42-2.

a. Personnel Costs.

(1) Hourly personnel rates were developed as described in chapters 23 and 24.

(2) Average grades for professional, administrative, and clerical personnel were determined by examining the authorized manning tables.

(3) Average grades for ADP personnel were based on actual personnel assigned.

b. ADP Costs. ADP costs, as stated in terms of Computer Resource Units (CRU's), consist of the costs of operating the ADP facility. The formula for CRU charging, as installed on the CCTC machine accounting system (MACUA), allows calculation of a user charge that is equitable regardless of the system used, whether terminal or batch input. The CRU costs were determined by adding the costs of computer lease and maintenance, supplies, operations personnel, and overhead, and dividing the sum by the average annual use of computer resources, such as core storage, processor time, and input-output time. CRU's utilized are reported to the user or estimated by the ADP machine room personnel.

c. Associated Costs.

(1) General Services Administration (GSA) schedules, National Archives Records Service (NARS) and OMB documents, and DoD directives were sources of information in compiling rates.

(2) Dry reproduction and paper costs were determined from a review of current billings and of charges given in Change 3 to DoD Directive 5400.7. Cost per page excludes clerical time required for personnel to operate the machine.

(3) Mailing costs include U.S. Postage Service charges and pouch handling and personnel costs other than those incurred in the office preparing or receiving the report; mailing costs are found in GSA studies and current FY pay tables.

(4) DoD CONUS AUTODIN cost per message was developed from current reported message volume, related AUTODIN backbone costs, salaries of personnel performing the message-handling service, headquarters supervision costs, and estimated terminal operation and maintenance costs incurred by the military departments.

(a) The per-message rate was determined from outgoing message traffic; therefore, reports forwarded by two separate locations should be costed as two messages, and one outgoing report to two or more receiving locations is costed as one message.

(b) Generally, a single AUTODIN message is equivalent to approximately 21 typed lines of report data or, when punch card input of 80 characters or less is used, 67 lines of punch card data.

(5) Manual file storage costs were developed from GSA factors. Fifteen percent of the total dollar cost is filing equipment cost amortization, and 85 percent of the total is space and maintenance cost.

(6) Specific contract prices and GSA schedules may be used to obtain fixed costs, such as contract printing, equipment purchases, tape, cards, and other supplies.

3. Use of Tables 42-1 and 42-2. In costing reports, use tables available in chapters 23 and 24 to assist in determining both military and civilian hourly costs. In addition, table 42-1 reflects other factors and rates to be used in costing other aspects of reporting. The following explains, in general terms, how the various tables can be used.

a. Table 23-2. When military grade is known, use the appropriate hourly rate for report costs in table 23-2. When grade is unknown, see table 42-2 or use O-3 for officers and E-5 for enlisted personnel.

b. Table 24-1. Use table 24-1 for Government reports when the civilian grade is known. When grade is unknown but occupational series is known, use table 24-3 to determine grade. Alternatively, see table 42-2 for average grade levels.

c. Table 42-1. The list of cost factors in this table is not all-inclusive, but represents items for consideration in costing of reports. The use of these factors is self-explanatory.

4. Estimating Procedure.

a. An estimate of the annual cost is prepared when an office is requesting approval of a new or revised report. Generally, the annual cost can be obtained by determining the cost of one full reporting cycle (day, month, quarter) and projecting this figure to obtain the annual cost. Figure 42-1, Summary Worksheet for Estimating Reporting Costs, is followed by an example which demonstrates how report costs are compiled.

b. Feeder report costs incurred by responding organizations solely for submitting data for a single report must be included in the estimated and actual report costs. If feeder reports already exist or will have multiple uses, only that portion of the costs required to collect and modify or manipulate the data exclusively for the new report need be included.

c. ADP personnel and equipment costs are normally provided by the ADP facility to the Office of Primary Responsibility (OPR) for each report, using DCA Form 319, Request for ADP Services. In some cases the monthly or weekly mechanized listing indicates customer services provided in terms of computer resource units (CRU). Table 42-1 indicates the cost per CRU for use where an accurate machine hour cost from the processing organization is not available.

d. To facilitate the gathering and evaluation of data necessary to implement OMB Circular A-40 (revised 3 May 1973), cost elements have been separated into three functions: developmental costs, operational costs, and user costs. All of these functions and their related subelements must be included in the cost estimate and the reporting of actual costs.

(1) Developmental Costs. Developmental costs result from those activities necessary for establishing a new requirement or modifying an existing reporting requirement. Developmental costs may include:

(a) Specification of Reporting Requirement. Preliminary activities, including:

1. Determining the specific reporting need.
2. Identifying the scope and objectives of the reporting system.
3. Appraising the interface and impact on other planned and existing reporting systems.
4. Determining benefits to be derived from the proposed reporting requirement.
5. Developing a working agreement among organizational components involved with designing the reporting system.

(b) Analysis of Reporting Requirement. The determination of the information to be provided by the reporting system, including:

1. Certifying the need.
2. Discussing and determining the needed information.
3. Selecting available or appropriate data sources, media, and processing requirements.
4. Developing reporting system output requirements and specifications.

(c) Design of Reporting System. The preparation of the written description of the proposed system, including:

1. Determining needed processing of input documents.
2. Developing input and output documents, to include standard data elements as applicable.
3. Establishing data files and other related documentation.

(d) Installation of Reporting System. The conversion of the written instruction, or plan, to an operable ongoing reporting system, including:

1. Programing and debugging a computer-oriented reporting system.

2. Acquiring and installing new equipment or modifying existing equipment.
3. Developing, writing, and issuing implementing directives and other instructions.
4. Scheduling and performing tests of the reporting system during installation.
5. Scheduling and conducting training and orientation.
6. Preparing the ADPE site.

(2) Operational Costs. Operational costs result from those continuing activities necessary to prepare and transmit a report. Operational costs include:

(a) Data Collection. The activity necessary to acquire, record, and make available data at some other location or time, including:

1. Assembling and recording source data by the various preparing units.
2. Controlling the accuracy of source data.
3. Forwarding source data to a processing unit.
4. Storing source data for future reference.

(b) Data Processing. The manipulation of data into the desired structure or format for evaluation and analysis, including:

1. Receiving, controlling, and editing source documents at the processing unit.
2. Summarizing source data and converting it to machine-readable data.
3. Updating the data base file.
4. Extracting and compiling data in the desired report media and format.
5. Posting data on worksheets and developing narrative, statistical, or graphic displays.

(c) Data Transmission. This includes reproduction and distribution of completed reports from processing units.

(3) User Costs. User costs result from those normal operations performed on the transmitted information by the requiring office. User costs include:

- (a) Refining, interpreting, and analyzing the information received.
- (b) Reading, reviewing, discussing, and documenting information presented; e.g., hard copy report, briefing sessions, remote terminal response.
- (c) Local filing and remote storage in records repository for future reference.
- (d) Destruction of records.

TABLE 42-1. REPORT COST FACTORS¹

<u>Cost Factor</u>	<u>Government</u>	<u>Non-Government</u>
ADP (per Computer Resource Unit)	\$71.00	
Mailing (per report) (includes U.S. Postal Service charges)	2.75	\$3.30
DoD CONUS AUTODIN (per message)	1.75	2.45
File Storage Costs - Manual		
Secure (per classified document)	8.75	8.95
Nonsecure (per cubic foot)	5.10	5.20
Dry Reproduction (per page) (includes paper)	.05	.05
Existing Publications (per printed page)	.01	.01
Microfiche, per fiche in stock	.06	.06
Microfiche, Reproduction, first fiche	N/A	5.00
Microfiche, Reproduction, additional fiche	N/A	.10
Printing Reports (per page)	.05	.05
Reading Cost at Professional Level/Professional Search/Computer Programmer	GS-11 Rate	GS-11 Rate

¹Cost based on FY 1977 salaries unless otherwise dictated by OSD.

TABLE 42-2. AVERAGE PERSONNEL GRADE LEVELS

	Overhead		Automatic Data Processing			
	Professional	Admin/ Clerical	Analyst	Programmer	Specialist	Computer Operator
<u>DCA HQ</u>						
Officer	(05+04)/2	-	-	0-4	-	-
Enlisted	E-7	E-4	-	-	-	-
Civilian	GS-13	GS-6	GS-13	-	GS-13	-
<u>DCA Field</u>						
Wash, D.C. Area						
Officer	0-4	0-2	0-3	0-4	-	0-2
Enlisted	E-7	E-4	E-7	E-6	E-8	E-6
Civilian	GS-13	GS-6	GS-13	GS-12	GS-9	GS-9
<u>DCA Field</u>						
Outside Va, Md, D.C.						
Officer	0-4	0-2	-	-	-	-
Enlisted	E-7	E-3	E-6	E-6	-	E-5
Civilian	GS-13	GS-5	GS-13	GS-13	GS-12	GS-5
Source: DCA, Code 690, based on 9 Dec 77 PERMIS report data.						

SUMMARY WORKSHEET FOR ESTIMATING REPORTING COSTS												
REPORT SYMBOL	REPORT TITLE	ESTIMATE PREPARED BY			DATE							
DCA(SA) 630-02	Estimating Reporting Costs	A.T. BENTON			1 September 1977							
FACTORS		COSTS (\$)										
REPORTING CATEGORIES	REPORTING ACTIVITIES	DIRECT PERSONNEL (a)	OVERHEAD (% of column (a)) (b)	DIRECT EQUIPMENT (c)	DIRECT MATERIAL (d)	OTHER DIRECT COSTS (e)	TOTAL (a+b+c+d+e) (f)					
DEVELOPMENTAL COSTS	1. Specification of Reporting Requirement	\$ 607	INCLUDED				\$ 607					
	2. Analysis of Reporting Requirement	180					180					
	3. Design of Reporting System	477				110,066	\$110,543					
	4. Installation of Reporting System	314	IN	284			598					
5. DEVELOPMENTAL COSTS		(Add totals in column f)								111,928		
OPERATIONAL COSTS	6. Data Collection	702	COLUMN				702					
	7. Data Processing			178			178					
	8. Data Transmission		(A)	5		24	29					
9. OPERATIONAL COSTS FOR ONE REPORT		(Add totals in column f)								909		
10. ANNUAL OPERATIONAL COSTS		(Cost for one report multiplied by frequency per year)								1,818		
USER COSTS	11. Refining, Interpreting, and Analyzing Information Received	657	COSTS	142			799					
	12. Reading, Reviewing, Discussing, and Documenting Information Presented	714				10	724					
13. USER COSTS FOR ONE REPORT		(Add totals in column f)								1,523		
14. ANNUAL USER COSTS		(Cost for one report multiplied by frequency per year)								3,046		

NOTE: (Estimates of reporting costs should be prepared in accordance with GUIDE TO ESTIMATING REPORTING COSTS which is issued by CSA/NARS/NR)

OPTIONAL FORM NO. 101
MAY 1962 EDITION
GSA FPMR (41 CFR) 101-11.6

GENERAL SERVICES ADMINISTRATION

FIGURE 42-1. EXAMPLE OF SUMMARY WORKSHEET FOR ESTIMATING REPORTING COSTS

Example for Government-Required Report¹

<u>Cost Element</u>		<u>Personnel</u> (Including Retirement, Hosp. & Ins.)	<u>Equipment</u>	<u>Other</u>	<u>Total</u>
<u>Developmental</u>					
Specification:					
20 hr @ (GS-13)	\$18.04	= \$361			
10 hr @ (GS-5)	6.91	= 69			
10 hr @ (O-3)	15.00	= 152			
1 hr @ (GS-15)	25.08	= 25			
Subtotal		607		\$	607
Analysis:					
10 hr @ (GS-13)	\$18.04	= 180			180
Design:					
Program Management:					
10 hr @ (GS-14)	\$21.32	=			213
Contractor R&D Effort:					
2-staff-years @ \$55,000		=		\$110,000	
Programming:					
10 hr @ (GS-12)	\$15.17	= 152			
Review:					
2 hr @ (GS-13)	\$18.04	= 36			
Coordinations:					
1 hr @ (GS-14)	\$21.32	= 21			
Clerical:					
10 hr @ (GS-3)	\$ 5.50	= 55			
Mailing Cost: 12 Sets					
X 2 reports @ \$2.75		=		66	
Subtotal		\$477	0	\$110,066	\$110,543

¹Example costs are presented above. To obtain current costs, refer to tables 23-2, 24-1, 42-1, and 42-2, other appropriate chapters, and existing contract prices for material, equipment, and contractual services.

42-10

DCAC 600-60-1
SECTION F

<u>Cost Element</u>	<u>Personnel</u>	<u>Equipment</u>	<u>Other</u>	<u>Total</u>
Installation:				
Prepare Inst.:				
20 hr @ (GS-12)	\$15.17	-		\$ 303
Clerical:				
2 hr @ (GS-3)	\$ 5.50	-		11
Test Run				
4 CRU @ \$71	-		\$284	
Subtotal	314	284	0	\$ 598
Total Developmental Cost	\$1,578	\$284	\$110,066	\$111,928
Operational				
Data Collection:				
Feeder Reports: (manual processing)				
8 regions X 3 hr @ (E-7) \$10.46	-	\$251		
8 regions X 1 hr @ (E-9) \$14.22	-	114		
Review (area and hq):				
3 areas X 3 hr @ (E-9) \$14.22	-	128		
20 hr @ (GS-9) \$10.46	-	209		
Subtotal	\$702	0	0	\$ 702
Data Processing:				
3 areas X .5 CRU each + hq 1 hr = 2.5 CRU X \$71	-	\$178		\$ 178
Data Transmission:				
Xerox: (50 pages X 2 copies) = 100 X \$.05	-	\$ 5		
10 Messages (AUTODIN) X \$1.75			\$ 18	
Mailing: 2 (reports) X \$2.75	-		6	
Subtotal	0	\$ 5	\$ 24	\$ 29

<u>Cost Element</u>	<u>Personnel</u>	<u>Equipment</u>	<u>Other</u>	<u>Total</u>
Operational Cost for One Report:	<u>\$702</u>	<u>\$183</u>	<u>\$24</u>	<u>\$ 909</u>

Annual Operating Cost:
2 (semiannual reports) X \$909 = \$ 1,818

User

Refining, Interpreting, and Analyzing:

10 hr @ (GS-14) \$21.32	=	\$213		
10 hr @ (GS-13) \$18.04	=	180		
20 hr @ (GS-9) \$10.46	=	209		
ADP: 2 CRU X \$71.00	=		\$142	
10 hr @ (GS-3) \$5.50	=	<u>55</u>		
Subtotal		\$657	\$142	0
				\$ 799

Reading, Reviewing, Discussing, and Documentation:

20 hr @ (GS-13) \$18.04	=	361		
10 hr @ (GS-14) \$21.32	=	213		
2 hr @ (GS-15) \$25.08	=	50		
1 hr @ (O-6) \$25.70	=	26		
1 hr @ (GS-16) \$29.41	=	29		
5 hr @ (GS-5) \$ 6.91	=	35		
Storage (unclassified) 2 X \$5.10	=			<u>\$10</u>
Subtotal		<u>\$ 714</u>	<u>0</u>	<u>\$10</u>
				<u>\$ 724</u>

User Cost for One Report: \$1,371 \$142 \$10 \$1,523

Annual User Cost:
2 (semiannual report) x \$1,523 \$3,046

5. Derivation of Factors for Table 42-3. Factors for manual search and duplication are from DCAI 210-225-1. Other cost factors are found elsewhere herein, as referenced in table 42-3.

6. Use of Table 42-3. Only direct costs are charged for FOIA requests. Retirement, leave and holiday, and overhead costs should not be included in the charges. Search fees are to be based on time actually spent. Establishment of a minimum fee is not allowed, and when direct costs for a single FOIA request total less than \$30, the fee should be waived in most cases (see DCAI 210-225-1). Table 42-3 provides or references factors for use in FOIA requests.

TABLE 42-3. FREEDOM OF INFORMATION FEES

<u>Cost Element</u>	<u>Factor</u>
Manual Search	
Clerical (E-9, GS-8, and below)	\$ 8/hour
Executive (O-7, GS-16, and above)	26/hour
Professional (all other)	16/hour
Computer Search	see table 42-1
Transportation	
Records	see table 24-9
Personnel	see table 24-6
Duplication	
Office Copy	0.10/page
Microfiche	0.25/page
Printed Material	0.01/page
Source: DCAI 210-225-1, 19 Dec 80.	

DCAC 600-60-1
SECTION F

43-1

CHAPTER 43. ANALYSIS OF COMMERCIAL ACTIVITIES

(To be published later.)

CHAPTER 44. DCS CAPITAL EQUIPMENT COSTS

1. General.

a. This chapter presents a listing of equipment purchased to support the functions of the Defense Communications System.

b. The unit costs in the tables are historical and may be used for planning and programming purposes. Each cost shown is appropriate for the year specified. That cost, then, may be different from the cost expended for any single equipment item.

c. All items of equipment have been identified by the military departments as being allocated to a DCS function. The list contains those items with a minimum quantity of two owned and a minimum cost of \$100. Also, specifically excluded items of equipment are towers, since there is little standardization among them (see chapter 10 for unit costs); technical control patch and test equipment, for which costs have been calculated by a CER (see chapter 13); and ADP equipment (use Authorized ADP Schedule Price Lists from GSA).

d. The sources from which the unit costs were extracted are coded as follows:

- A "USA Signal Center & School-Reference Data"
- B Electronics Systems Division, AFSC (Hanscom AFB)
- C "CSI Cost Factors & Estimates for Point-to-Point Transmission Systems"
- E USA Electronics Command (Fort Monmouth)
- F AF Communications Command (Andrews AFB)
- G Engineering Estimate
- I Code 690 Cost-Estimating Relationship (see paragraph 2)
- J Joint Electronics Type Designation System
- K Estimate
- L Catalog Management Data, Defense Logistics Supply Center (1979)
- M Master Equipment Reference List
- N Fiscal & Supply Department (Washington Naval Yard)
- P DCA Code 280
- Q MILSATCOM Systems Architecture (1976)
- R Code 690 Cost-Estimating Relationship (see paragraph 2)
- S DCAC 600-60-1 (May 1976)
- T DCA Code 312
- U USA Communications Command (Fort Huachuca)
- V Vendor
- W AF Communications Command (Scott AFB, IL)
- Z USA Communications Systems Agency (Fort Monmouth)

2. Derivation of Factors.

a. For some items, no cost has been found. However, the costs of similar items were available, and statistical regression analysis was used to estimate the missing costs as a function of an appropriate variable. These cost-estimating relationships (CER's) have been given a source code of "R" or "I."

b. In the case of variable-configuration multiplexers, an "I" is used to indicate that the number entered as a cost refers to a particular CER (E = channel terminations):

(1) 1500 X E	General (1966)
(2) 5774 + 608.6 X E	MX-106 (1966)
(3) 1200 X E	MX-103 (1965)
(4) 8641 + 533.4 X E	AN/FCC-18 (1966)
(5) 30,421 + 813.7 X E	AN/UCC-4 (1972)
(6) $\frac{E \times 10^6}{141 + 6.42 X E}$	AN/FCC-32 (1966)
(7) 5315 + 507.8 X E	AN/FCC-55 (1966)
(8) 6198 + 1122 X E	MC-50 (1966)
(9) 1100 X E	L1 Carrier (1966)
(10) 825.5 X E-9989	(Voice - General) (1966)

c. As an example of a CER coded "I," for a 60-channel AN/FCC-18 with CER number 4, the cost would be \$40,645, or \$8,641 + \$533.4 X 60.

3. Use of Tables.

a. The equipment, which is listed in the following tables, is divided into 11 major categories for easy reference: amplifiers, antennas, MODEMS, mux, power, radios, AUTOSEVOCOM, satellite, traffic data collection systems, telephone switching, and teletype.

b. The submission of more recent cost data than that presented in these tables is encouraged and solicited. Please present such information to the Director, DCA, ATTN: Code 690, Washington, D.C. 20305.

TABLE 44-1. AMPLIFIER COSTS

DESCRIPTION	DESIGNATION	SOURCE	
		YEAR	UNIT COST
TVLG WAVE TUBE AMP	EM1184E	78 L \$	10150
LINEAR POWER AMP	205J-1A	78 L	53353
TVLG WAVE TUBE AMPLFR	767H/MSC-46	79 L	21250
TVLG WAVE TUBE AMPLFR	792H/FSC-78	80 K	20000

SOURCE: DCA, CODE 690, MAY 81.

TABLE 44-2. ANTENNA COSTS

DESCRIPTION	DESIGNATION	SOURCE		UNIT COST
		YEAR		
ANT SUPPORT 73.7FT	AB-105C/FRC.	80	W \$	786
ANT GP PARA DISH 30FT	AN/FRA-100	74	F	18000
ANT GP BBD 60FT	AN/FRA-21	71	V	50000
ANT GP PARA DISH 30FT	AN/FRA-26	65	J	35000
ANT GROUP	AN/GRA-77	74	L	400
ANT GROUP	AN/GRA-78	73	M	410
ANT PHASED ARRAY	AN/TRA-40	74	L	1063690
ANT SHF	AN/TRC-42	73	L	3500
ANT GP PARA DISH 52FT	AP-2FG-1603B	74	V	129900
ANT GP PARA DISH 33FT	AP-2FM-1003B	74	V	51600
ANT GP PARA DISH 62FT	AP-2FM-1603A	74	V	156600
ANT GP PARA DISH 62FT	AP-2FM-1803	74	V	156600
ANT GP PARA DISH 6FT	AP-2FS-K84B	73	M	1500
ANT PARA DISH 3.9FT	AP-7FS-121-122A	71	V	360
ANT PARA DISH	AP-7FS-121-7A	74	V	2540
ANT PARA DISH	AP-7FS-1211227A	74	V	2540
ANT PARA DISH 5.9FT	AP-7FS-181-182A	71	V	430
ANT PARA DISH 6FT	AP-7FS-181-3A	71	V	430
ANT PARA DISH 12FT	AP-7FS-182-3A	71	V	2360
ANT PARA DISH 6FT	AP-7FS-182B	71	V	430
ANT GP PARA DISH 10FT	AP-7FS-304B	73	M	1235
ANT GP PARA DISH 20FT	AP-7FS-604B	74	V	28400
ANT PARA DISH 6FT	APC-20FS-182-2A	71	V	430
ANT PARA DISH 4FT	APC-7FS-122-7A	71	V	360
ANT PARA DISH 6FT	AQ74-25B	78	L	388
REFLECTOR PASSV-	AR-3PRD-2A	72	K	1200
ANT PARA DISH	AS-1018/URC	71	N	450
ANT PARA DISH 4FT	AS-1452	71	L	1794
ANT REFLECTOR	AS-1761/FSC-23	73	L	500
ANT LPA ROTABLE	AS-1862/FRC	72	K	2800
ANT PARA DISH 40FT	AS-1920/MSC-46	79	L	1200
ANT REFLECTOR	AS-1921/MSC-46	73	L	1500
ANT	AS-2187/FRC	79	L	26640
ANT INVERTED CONE HF	AS-2212/FRC	77	L	1020
ANT VERT LOG PER	AS-2224/FRC	69	K	2500

TABLE 44-2. ANTENNA COSTS (CON.)

DESCRIPTION	DESIGNATION	SOURCE YEAR	UNIT COST
ANT SHROUDOME 12FT	AS-2489/E	73 L \$	1850
ANT SHROUDOME 6FT	AS-2491/F	73 L	1100
ANT SHROUDOME 8FT	AS-2492/F	73 L	1350
ANT PARA DISH 8FT	AS-4040/FSC	78 L	4212
ANT PARA DISH 6FT	AS-4041/FSC	79 L	2500
ANT PARA DISH 10FT	AS-4043/FSC	79 L	5160
ANT PARA DISH 12FT	AS-4044/FSC	79 L	5800
ANT DIPOLE 50FT	AS-640/TRC	69 K	2000
ANT DIPOLE 6FT	AS-640/TRC	69 K	240
ANT DIPOLE 4.8FT	AT-413/TRC	79 L	699
ANT DIPOLE 70FT	AT-413/TRC	69 K	500
ANT DIPOLE 4.8FT	AT-414/TRC	79 L	414
ANT VHF	AT-414/TRC	79 L	226
ANT TORUS	A2338527	68 K	3000
ANT DIPOLE ARRAY	CA-4001	68 K	1000
ANT DIPOLE 7FT	CA-4001	68 K	1000
ANT PARA DISH	CA-7732/FSC-19	72 K	3000
ANT WULLENWEBER	CDA A	69 K	20000
ANT CONICAL MONOPOL HF	CM-1	72 K	2800
ANT CONICAL MONOPOL HF	CM-2	72 K	2800
ANT CONICAL MONOPOL	CM-2006	72 K	2800
ANT CONICAL MONOPOL HF	CM-4	72 K	2800
ANT WHIP 50FT	C67047	69 K	500
ANT PARA DISH 6FT	DP6C-2J44	71 V	430
ANT PARA DISH 4FT	DX-4	71 V	360
ANT PARA DISH 8FT	D1944M	71 V	860
ANT PARA DISH 10FT	D1945M	71 V	1290
ANT PARA DISH	FRA-100	74 T	18000
ANT GP BBD 60FT	GS-18705	74 F	145000
ANT MONOPOLE OMNI 20KW	HA-47/100	72 K	7000
ANT PARA DISH 10FT	HP-10-71G	80 V	7700
ANT PARA DISH 10FT	HP-10-71GD	80 V	7700
ANT PARA DISH 12FT	HP-12-77GF	80 V	11000
ANT PARA DISH 6FT	HP-6-44P	80 V	4600
ANT PARA DISH 6FT	HP-6-71G	80 V	4600

TABLE 44-2. ANTENNA COSTS (CONT.)

DESCRIPTION	DESIGNATION	SOURCE		UNIT COST
		YEAR		
ANT PARA DISH 6FT	HP-6-71GD	80	V \$	4600
ANT PARA DISH 6FT	HP-6-77GD	80	V	4600
ANT PARA DISH 8FT	HP-8-44D	80	V	6200
ANT PARA DISH 8FT	HP-8-71G	80	V	6200
ANT PARA DISH 8FT	HP-8-71GD	79	V	5400
ANT PARA DISH 8FT	HP-8-77GD	80	V	6200
ANT PARA DISH 6FT	HPX-6-71D	80	V	5400
ANT LP ROTATABLE	LPA-10	72	K	4000
ANT PARA DISHW/RDM 4FT	L4404W	71	V	360
ANT PARA DISHW/RDM 6FT	L4406W	71	V	430
ANT PARA DISHW/RDM 8FT	L4408W	71	V	860
ANT MT PARA 6FT	M4	72	K	1200
ANT GRP P/N3030	NUS 8410-G1	72	K	5000
REFLECTOR PASSV 4X8	OA-1389/GRC	79	L	414
ANT GP BBD 60FT	OA-3438/FRC39AV	79	L	2000
ANT GP PARA DISH 30FT	OA-7075/FRC102V	74	L	54200
ANT GP BBD 60FT	OA-7077/FRC102V	73	M	50000
ANT GP BBD 60FT	OA-7389/FRC-96	78	L	31000
ANT GP 18FT	OA-8244/TSC-54	79	L	5000
ANT PARA DISH	OE-118	72	K	3000
ANT PARA DISH 6FT	OP-6C-2-J44	71	V	2570
ANT PARA DISH 10FT	P-10-71G	74	V	1610
ANT PARA DISH 10FT	P-70120	71	V	3900
ANT PARA DISH 4FT	P-7048TB	71	V	320
ANT PARA DISH 4FT	P-7048TC	71	V	320
ANT PARA DISH 6FT	P-7072C	71	V	2570
ANT PARA DISH 8FT	P-7096TB	71	V	3280
ANT PARA DISH 4FT	P-8048-TC	71	V	320
ANT PARA DISH 12FT	PL12-21G	74	V	3630
ANT PARA DISH 12FT	PL12-71G	80	V	5400
ANT PARA DISH 12FT	PL12-77G	80	V	5450
ANT PARA DISH 6FT	PL6-17C	80	V	1200
ANT PARA DISH 6FT	PL6-71GD	80	V	1070
ANT PARA DISH 10FT	PXL10-44	80	V	2480
ANT PARA DISH 12FT	PXL12-71G/S	80	V	5400

TABLE 44-2. ANTENNA COSTS - (CON.)

DESCRIPTION	DESIGNATION	SOURCE	
		YEAR	UNIT COST
ANT PARA DISH 8FT	PXL8-44	74 V \$	1520
ANT PARA DISH 10FT	P10-71GC	78 L	4990
ANT PARA DISH 4FT	P4-44 -	74 V	370
ANT PARA DISH 30FT	P4-71	79 V	620
ANT PARA DISH 4FT	P4-71G	79 V	670
ANT PARA DISH 4FT	P4-71GC	79 V	670
ANT PARA DISH 6FT	P6-59	74 V	510
ANT PARA DISH 6FT	P6-71G	80 V	900
ANT PARA DISH 4FT	P7048T	71 V	360
ANT PARA DISH 8FT	P8-71G	80 V	1580
ANT PARA DISH 10FT	P80120T-B	71 V	3900
REFLECTOR PASSV	P80120T-C	72 K	1200
ANT PARA DISH 10FT	P8020T	71 V	2000
ANT PARA DISH 6FT	P8072T-TC	71 V	2570
ANT DUAL HELICAL	REL 137P1	72 K	900
ANT GP DIPOLE ARRAY	REL 837P3A1A	72 K	2000
ANT PARA DISH 6FT	REL 848 P13A	71 V	430
ANT PARA DISH 6.55FT	RESK 848 P13A	71 V	1764
ANT PARA DISH 10FT	RF 10P-J2	71 V	1290
ANT PARA DISH 4FT	RF 4P-J	71 V	290
ANT PARA DISH 6FT	RF 6P	71 V	430
ANT PARA DISH 8FT	RF 8P-J12	71 V	860
ANT SWC MATRIX	SA-1551V2/GRT	74 L	6534
ANT SECTOR ARRAY HF	SA5-6	68 K	5000
ANT GP PARA DISH 4FT	SK484P12A	71 V	290
ANT PARA DISH 10FT	SP-80120T	71 V	3900
ANT PARA REFLECTOR	SP-80144	72 K	1200
ANT PARA W/SHROU 12FT	SP-80144T	71 V	5130
ANT PARA DISH 12FT	SP-80144TC	73 L	1850
ANT PARA DISH 12FT	SP-80144TDP	73 L	1850
ANT PARA DISH 6FT	SP-8072T	71 V	2570
ANT PARA DISH 8FT	SP-8096T	71 V	3280
ANT DIPOLE ARRAY	T2FD	69 K	800
ANT VERT LOG PERIODIC	UMODEL 503	68 K	5000
ANT VERT LOG PERIODIC	UMODEL 513	68 K	5000

TABLE 44-2. ANTENNA COSTS (CON.)

DESCRIPTION	DESIGNATION	SOURCE	
		YEAR	UNIT COST
ANT YAGI 10 ELEMENT	Y102B	71 K \$	266
ANT PARA DISH	1244	77 K	5600
ANT PARA DISH	2336831G1	74 L	1794
ANT LP ROTATABLE	237A-1A	79 L	12019
ANT LP ROTATABLE	237B-1	68 H	11800
ANT LP ROTATABLE	237B-3	68 H	10000
ANT RHOMBIC HF	262-507-192	68 S	7176
ANT RHOMBIC HF	303-589-200	68 S	7176
ANT RHOMBIC HF	307-600-203	68 S	7176
ANT RHOMBIC HF	316-600-200	68 S	7176
ANT RHOMBIC HF	320-600-219	68 S	7176
ANT RHOMBIC HF	321-468-116	68 S	7176
ANT RHOMBIC HF	321-610-166	68 S	7176
ANT RHOMBIC HF	321-618-166	68 S	7176
ANT RHOMBIC HF	321-618-186	68 S	7176
ANT RHOMBIC HF	350-657-240	68 S	7176
ANT RHOMBIC HF	350-704-256	68 S	7176
ANT PARA DISH 4FT	368-1851-15	74 L	425
ANT PARA DISH 6FT	368-1852-3	71 V	430
ANT RHOMBIC HF	375-705-256	68 S	7176
ANT PARA DISH	41344-1	72 K	1200
ANT RHOMBIC HF	420-780-301	68 S	7176
ANT RHOMBIC HF	440-856-198	68 S	7176
ANT RHOMBIC HF	450-854-278	68 S	7176
ANT RHOMBIC HF	450-860-286	68 S	7176
REFLECTOR PASSV	463-2474-1	74 L	600
ANT RHOMBIC HF	486-964-212	68 S	7176
ANT RHOMBIC HF	492-899-444	68 S	7176
ANT RHOMBIC HF	498-937-390	68 S	7176
ANT LP ROTATABLE	5002	75 E	15000
ANT RHOMBIC HF	520-1000-343	68 S	7176
ANT PARA DISH	537E-1	72 K	3000
ANT RHOMBIC HF	598-1100-468	68 S	7176
ANT RHOMBIC HF	598-1100-688	68 S	7176
ANT RHOMBIC HF	600-1070-544	68 S	7176

TABLE 44-2. ANTENNA COSTS (CON.)

DESCRIPTION	DESIGNATION	SOURCE		UNIT COST
		YEAR		
ANT RHOMBIC HF	600-1100-468	68	S \$	7176
ANT RHOMBIC HF	600-1104-468	68	S	7176
ANT RHOMBIC HF	600-1104-610	68	S	7176
ANT RHOMBIC HF	600-1110-476	68	S	7176
ANT 15FT	63-9G1	74	L	6500
ANT PARA DISH	6324-1ZD044-003	72	K	1800
ANT PARA DISH	75052-2	72	K	2000
REFLECTOR PASSV	81-KDSA	75	K	6000
ANT 4 FIELD 8 DIPOLE	837P3A	71	V	1000
REFLECTOR PASSV	8889-PR	72	K	1200

SOURCE: DCA, CODE 696, MAY 81

TABLE 44-3. MODEM COSTS

DESCRIPTION	DESIGNATION	SOURCE	
		YEAR	UNIT COST
MODEM DIGITAL DATA	AN/USC-26	74 K \$	30000
MODEM DIGITAL DATA	DS-2400	75 V	1500
MODEM RIXON DIGITAL	DS-9600	75 K	9000
MODEM LOW SPEED 1CH	MD-674(P)/G	80 D	710
MODULATOR	MD-777/FRT	74 K	15000
MODEM DIGITAL DATA	MD-823/G	80 W	15450
DIG TROPO MODEM	MD-918/GRC	81 E	220000
MODEM DIGITAL DATA	MD-920/G	74 K	15000
MODEM DIGITAL DATA	MD-921/G	74 K	15000
DIG SAT MODEM	MD-1002/G	81 E	34000
MODEM DATA 4800BD	MSCIT	72 K	5400
MODEM LOW/HIGH SPEED	207C	76 W	12000
MODEM DIGITAL DATA	26C	76 W	3809
MODEM CARRIER	420R	72 K	8000
HI SPD COMM INTRFC TER	9600	75 K	9000

SOURCE: DCA, CODE 690, MAY 81.

TABLE 44-4. MULTIPLEX COSTS

DESCRIPTION	DESIGNATION	SOURCE		UNIT COST
		YEAR		
MUX VOICE	AN/ACC-1	74	L \$	3186
MUX VOICE	AN/ACC-3	74	L	94200
MUX VOICE 45CH	AN/FCC-15	74	L	23000
MUX VOICE	AN/FCC-17	11	I	1
MUX VOICE LVL2	AN/FCC-18TCS600	4	I	1
MUX TTY 16CH	AN/FCC-19	66	H	10000
MUX VOICE 12CH	AN/FCC-21	80	W	50000
MUX VOICE 12CH	AN/FCC-22	80	W	125000
MUX TTY 32CH	AN/FCC-25	74	E	17500
MUX TTY	AN/FCC-31	74	L	14651
MUX VOICE LVL2	AN/FCC-32	6	I	1
MUX VOICE LVL2 12CH	AN/FCC-32(V)	6	I	1
MUX V LVL2 120CH	AN/FCC-32(V) 4	6	I	1
MUX VOICE LVL2 4CH	AN/FCC-32(V)19	6	I	1
MUX VOICE LVL2 4CH	AN/FCC-32(V)24	6	I	1
MUX VOICE LVL2 4CH	AN/FCC-32(V)26	74	L	21800
MUX TTY HF 16CH	AN/FCC-37	66	J	10000
MUX TTY 16CH	AN/FCC-38	68	J	6600
MUX V 46A 120CH	AN/FCC-55(V)	66	H	66000
MUX TTY 16CH	AN/FCC-56	68	J	10000
MUX VOICE 24CH	AN/FCC-58	73	M	75000
MUX TTY 16CH	AN/FCC-66	74	L	9500
MUX TTY 16CH	AN/FCC-67	79	L	8320
MUX TTY	AN/FCC-68	77	L	7886
MUX TTY	AN/FCC-69	74	L	4540
MUX TTY	AN/FCC-70	74	L	2793
TERM TELEPHONE PCM	AN/FCC-95	68	K	12000
MUX VOICE	AN/FCC-97 DB-84	77	L	6200
MUX DIG PCM LVL1	AN/FCC-98TD1192	76	E	16000
MUX DIG LVL2	AN/FCC-99TD1193	80	E	14000
MUX TTY 1CH	AN/FGC-125	67	K	2700
MUX TTY 16CH	AN/FGC-135	76	L	14000
MUX TTY 36CH	AN/FGC-136	74	L	14000
MUX TTY	AN/FGC-60	75	T	27000
MUX TTY 16CH	AN/FGC-60(V)	75	T	27000

TABLE 44-4. MULTIPLEX COSTS (CON.)

DESCRIPTION	DESIGNATION	SOURCE		UNIT COST
		YEAR		
MUX TTY	AN/FGC-61	66	H \$	17600
MUX VOICE	AN/GCC-19	74	K	20000
MUX TTY 229	AN/GGA-10	68	H	7500
TERMINAL TELEPHONE MUX	AN/GGC-19	74	K	20000
MUX VOICE	AN/MCC-12	66	H	95000
MUX TTY	AN/SGC-1A	73	N	850
MUX VOICE	AN/TCC-13	68	H	10000
MUX VOICE 4CH	AN/TCC-3	76	T	1991
MUX VOICE 12CH	AN/TCC-50	68	H	5800
MUX VOICE 12CH	AN/TCC-7	76	T	10503
COMM SUB SYSTEM	AN/TCC-78	74	F	165000
MUX VOICE	AN/TCC-79	74	F	165000
MUX VOICE	AN/UCC-2	74	L	38000
MUX VOICE	AN/UCC-4	5	I	1
MUX VOICE	AN/UCC-4(V)	5	I	1
CABLE SYSTEM PCM	B310	68	K	24000
MUX VOICE	CT-12C	75	V	12160
MUX VOICE DIG LVL1	CY-104	73	K	12000
MUX TTY VF	K65	68	K	16000
MUX VOICE	L CARRIER	9	I	1
MUX VOICE L1	L CARRIER	9	I	1
MUX T/DIV LS	LSTDN	81	B	4750
MUX VOICE	L1 CARRIER	9	I	1
MUX VOICE	MC-50	8	I	1
MUX VOICE SEND	MODEL 123	74	L	300
MUX VOICE	MX-103	3	I	1
MUX VOICE	MX-106	2	I	1
MUX	NCM-12A	75	V	12900
CHANNEL TRANSLATING	NVT-60CA	73	K	20000
MUX VOICE SEND GP	OA-6569/FGC-60V	68	M	5000
DEMUX GROUP	OA-7370V12UCC4V	5	I	1
MUX GROUP	OA-7371V12UCC4V	5	I	1
DEMUX GROUP	OB-27 V1 UCC4V	5	I	1
MUX GROUP/1	OB-28(V) UCC4V	5	I	1
MUX VOICE	OB-79(V)/FSC	73	K	20000

TABLE 44-4. MULTIPLEX COSTS (CON.)

DESCRIPTION	DESIGNATION	SOURCE	
		YEAR	UNIT COST
MUX VOICE	DB-79(V)1/FSC	73 K	\$ 20000
MUX VOICE	R-240	10 I	1
MUX TERM BAY	REL 13C39	73 M	43000
MUX MOD VOICE	GP REL 13C41	71 V	24880
MUX VOICE	120CH REL 13C43 V120	66 H	60000
MUX VOICE	60CH REL 13C43 V60	66 H	30000
MUX VOICE	RS-1	10 I	1
MUX TTY	VF T-240-3	72 K	11000
MUX VOICE	TCS-600/FCC-18	4 I	1
MUX V SEND	123 TD-410/UGC	80 W	306
DEMUX VOICE	TD-411/UGC	73 M	629
MUX VOICE	TD-908/UG	74 L	1620
DEMUX VOICE	TD-909/UG	74 L	1620
MUX VOICE SEND	TD-97/FGT-2	66 H	1932
TELEGRAPH CONV	TH-5/TG	73 M	178
MUX DIG LVL1	T1-4000	10 I	1
MUX VOICE	120CH V-120FU	66 H	60000
MUX VOICE	60CH V-60FU REL13C43	68 H	30000
MUX TTY LVL1	VFCT-30	68 K	7000
MUX VOICE	12CH VZ-12	66 H	8500
MUX TTY	2002-22	74 L	16884
MUX TTY 22CH	2002-22H	68 H	17000
MUX TTY	2087	70 K	12000
MUX DIGITAL	2150A	74 L	23288
MUX DIGITAL	2150B	74 F	23288
MUX DIGITAL	2151C	74 L	11874
MUX DIGITAL	2151E	74 L	14920
MUX DIGITAL	2152A	74 L	21431
MUX DIGITAL	2152B	74 L	34000
MUX DIGITAL	2152C	74 L	31200
MUX DIGITAL	2152F	74 L	24605
MUX DIGITAL	2152G	73 M	32905
MUX	400-8	73 K	20000
MUX TTY	43A1 J70112	74 L	8690
MUX VOICE	72CH 45BX	74 L	44577

TABLE 44-4. MULTIPLEX COSTS (CON.)

DESCRIPTION	DESIGNATION	SOURCE	
		YEAR	UNIT COST
MUX VOICE	96CH 45BX	74 L	\$ 61215
MUX VOICE	24CH 45BXT2	66 H	16500

SOURCE: DCA, CODE 690, MAY 81.

TABLE 44-5. POWER COSTS			
DESCRIPTION	DESIGNATION	SOURCE YEAR	UNIT COST
POWER SPLY INVERTER	AC1000	75 L \$	9296
RECTIFIER	AED48TFR100T	74 K	3000
RECTIFIER	AE48TFR200T	74 K	3000
RECTIFIER	ARR-48-AC-150	73 K	3000
RECTIFIER	ARR-48-AC-30	73 K	3000
BATTERY CHARGER	ARR-48-AC-35-F3	74 U	826
RECTIFIER	AS210401-A	73 K	3000
INVERTER	AS210414-A	73 K	600
RECTIFIER	A12B-100-48V	73 K	3000
RECTIFIER	A12B-50	73 K	3000
RECTIFIER	A48-TFR-400T	73 K	3000
RECTIFIER FLOAT	B48TFR75S	73 K	3600
INVERTER	C-9362/FYQ	72 K	600
INVERTER	C-9363/FYQ	72 K	600
BATTERY CHARGER	CAT 4234 FORM A	73 K	2000
INVERTER	CAT 4241 FORM A	73 K	600
BATTERY CHARGER	CAT 4243 FORM A	73 K	2000
GEN SET DSL 60KW	CE-600-AC/EG	74 L	9120
BATTERY CHARGER	CGR-35A-10	79 L	1653
BATTERY CHARGER	CGR-50A-10	79 L	1994
BATTERY CHARGER	CGR-75A-10	79 L	2475
GEN SET DSL 30KW	CLED-I	74 L	2970
BATTERY CELLS	CS1200	75 K	207
RECTIFIER	C48 FB 100	72 K	2400
INVERTER	C9363/FYQ	73 K	600
RECTIFIER	DC 1000	73 K	3000
GEN SET DSL 100KW	D17000	74 L	14060
GEN SET DSL 20KW	D298ERX7	74 L	2080
GEN SET DSL 170KW	D342-C	74 L	10910
GEN SET DSL 1000KW	D397	74 L	39652
BATTERY 2VDC	ECH-15	72 K	150
BATTERY 2.2VDC 425AH	EHC-11 (MXC425)	75 V	130
BATTERY 2VDC 220AH	EHGS-7	75 V	151
GEN SET DSL 100KW	EMU-17/E	74 L	20180
BATTERY CELLS	ETA- 5	75 K	100

TABLE 44-5. POWER COSTS (CON.)				
DESCRIPTION	DESIGNATION	SOURCE YEAR	UNIT	COST
BATTERY CELLS	ETA- 7 (2)	79 K	\$	200
BATTERY 2VDC 255AH	ETA- 9(2MAX255)	75 V		160
BATTERY 2VDC 340AH	ETA-11 (MAX340)	75 V		100
BATTERY 2VDC	ETC-11	76 L		14000
BATTERY 24X2VDC 490AH	ETC-13	75 V		2784
BATTERY 2VDC 190AH	ETC-76(2MAX190)	75 V		129
BATTERY 2VDC 475AH	EWT-17 (MAX475)	75 V		118
BATTERY CELLS	EWT-21	75 K		120
BATTERY CELLS	EWT-23	75 K		120
GEN SET DSL	E5239RN	75 R		8899
BATTERY CHARGER	FD4000AP14	75 K		2000
RECTIFIER	FEC-29674	74 K		3000
BATTERY CELLS 750AH	FHC-11	75 V		222
BATTERY 2VDC 900AH	FHC-13	75 V		258
BATTERY CELLS 1050AH	FHC-15	75 V		278
BATTERY CELLS 1350AH	FHC-19	75 V		318
BATTERY CELLS 1500AH	FHC-21	75 V		338
BATTERY 2VDC 1650AH	FHC-23	75 V		357
GEN SET DSL 1400KW	FS-138-HSC	68 H		186000
BATTERY CELLS 1180AH	FTA-15	75 V		263
BATTERY CELLS	FTC- 5	75 K		150
BATTERY CELLS 1010AH	FTC-13	75 V		258
BATTERY CELLS 1340AH	FTC-17	75 V		298
BATTERY 2VDC 1680AH	FTC-21	75 V		338
RECTIFIER FLOTRL 48V	F100D50	79 L		3119
RECTIFIER	F37D37	73 K		2800
RECTIFIER FLOTRL130V	F50D140	74 L		2819
RECTIFIER	GRL-48-T-200F	73 K		2700
RECTIFIER	G24/TFR/25-SE	73 K		2700
RECTIFIER 100 AMP	HM100D50	68 K		2000
RECTIFIER 100 AMP	HM100K50	68 K		2000
RECTIFIER 200 AMP	HM200D50	68 K		3000
RECTIFIER 400 AMP	HM400D50	68 K		4000
INVERTER	INV1048	73 K		600
GEN SET DSL 20KW	J-108	74 T		10200

TABLE 44-5. POWER COSTS (CON.)			
DESCRIPTION	DESIGNATION	SOURCE YEAR	UNIT COST
GEN SET DSL 60KW	JS-6-G60KW	74 L \$	5460
RECTIFIER	J50B50442-00	73 K	2700
RECTIFIER	J86494	73 K	2700
BATTERY CELLS 250AH	KC-7	79 V	121
BATTERY 2VDC 300AH	KCT-300	79 V	107
BATTERY 2VDC 450AH	KCT-450	79 V	141
BATTERY 2VDC 660AH	KCT-660	79 V	195
BATTERY CELLS	KCU-17	73 V	153
BATTERY CELLS	KCU-21	73 K	150
BATTERY CELLS	KG-34-3	73 K	150
BATTERY 2VDC 660AH	KT-660A	79 V	195
BATTERY CELLS	LC-15	79 K	300
BATTERY CELLS	LC-17	79 K	300
BATTERY CELLS 1008AH	LCT-1008	79 V	319
BATTERY CELLS 1176AH	LCT-1176	79 V	348
BATTERY CELLS 840AH	LCT-840	79 V	279
BATTERY CELLS	LCU-21	79 K	300
BATTERY CELLS	LCU-27	79 K	300
GEN SET DSL 100KW	LGA601-100	74 L	12079
BATTERY 2VDC 1344AH	LT-1344A	79 V	373
RECTIFIER	L50F50	73 K	2700
BATTERY CELLS 285AH	MAX-285	79 K	190
GEN SET DSL 100KW	MB-16	74 L	9690
GEN SET DSL 45KW	MB-17	74 L	8990
BATTERY CELLS 510AH	MCX-510	79 V	188
GEN SET DSL 15KW	MD-1518 15W	74 L	2440
RECTIFIER/INVERTER	MODEL 37	73 K	3000
GEN SET DSL UPS	MODEL 6025	72 K	60000
RECTIFIER	MODEL 48-100BCSM	73 K	3000
GEN SET DSL DELCO	MODTE 4821	72 K	18000
GEN SET DSL 100KW	M100DM6	74 L	5900
RECTIFIER 100 AMP	M100F50	73 K	2700
RECTIFIER 200 AMP	M200D50	73 K	2700
RECTIFIER 25 AMP	M25F50	73 K	2700
RECTIFIER 30 AMP	M30F50	68 K	2700

TABLE 44-5. POWER COSTS (CON.)

DESCRIPTION	DESIGNATION	SOURCE YEAR	UNIT COST
RECTIFIER 30 AMP	M30F50	68 K \$	2700
BATTERY 2VDC 1008AH	NCX-1008	79 V	301
BATTERY CELLS 1344AH	NCX-1344	79 V	366
BATTERY CELLS 1680AH	NCX-1680	79 V	430
BATTERY CELLS 1848AH	NCX-1848	79 V	462
BATTERY CELLS 2016AH	NCX-2016	79 V	495
RECTIFIER	PEC-3174	73 K	3000
POWER SUPPLY(RECTIFIER)	PP-4862/FJQ	74 L	1500
BATTERY CHARGER	PP-6936/FYQ	73 K	2000
BATTERY CHARGER	PP-7024/FSC	73 K	2000
GEN SET DSL 100KW	PU-495	73 L	30000
GEN SET DSL 100KW	PU-495/G	74 L	30000
GEN SET DSL	PU-619M	74 K	31800
GEN SET MOTOR 100KW	PU-682/FJQ	74 L	5000
GEN SET DSL	R8V 16/18	72 K	18000
RECTIFIER	S AND H	73 K	3000
CONVERTER	SCPF-3	73 K	3000
GEN SET DSL 30KW	SF-30-MD/CIED	75 T	13110
GEN SET DSL 60KW	SF-60-MD/CIED	74 L	10524
INVERTER	SPEC INVERT-1	73 K	600
RECTIFIER	TFR-37T-230	73 K	3000
RECTIFIER	TYPE 1226	73 K	3000
RECTIFIER/INVERTER	UPS-500	73 K	2000
KLYSTRON TUBE HPA	VA925/TSC-54	66 K	12000
KLYSTRON TUBE HPA	VKX7753B/MSC-46	66 K	12000
KLYSTRON TUBE LPA	VKX7780E1/TSC54	66 K	12000
INVERTER 48-120.1KVA	WAA1028	68 K	2900
RECTIFIER	ZTT-48-2X50V	73 K	2700
BATTERY 25X2VDC 250AH	1/2YP-250A-25	75 V	1275
BATTERY 25X2VDC 400AH	1YP-400A	75 V	1800
BATTERY 25X2VDC 400AH	1YP-400A-25	75 V	1800
BATTERY 25X2VDC 600AH	1YP-600A-25	75 V	2700
BATTERY 25X2VDC 700AH	1YP-700A-25	75 V	3350
BATTERY 25X2VDC 800AH	1YP-800A-25	75 V	3725
BATTERY 25X2VDC 900AH	1YP-900A-25	75 V	3925

TABLE 44-5. POWER COSTS (CON.)

DESCRIPTION	DESIGNATION	SOURCE	
		YEAR	UNIT COST
STATIC INV 1KVA/.8KW	101610501	73 K	\$ 600
GEN SET DSL 12.5KW	15-US 10827 B8	74 L	3310
GEN SET DSL	16-5678	75 R	323785
GEN SET DSL	16YHX	75 R	12540
RECTIFIER	18587	73 K	3000
BATTERY CELLS 170AH	2-MCX-170	79 V	160
BATTERY CELLS 255AH	2-MCX-255	79 V	215
BATTERY 25X2VDC 1200AH	2YP-1200A-25	75 V	6850
RECTIFIER	200A	73 K	3000
INVERTER	200T006H01	73 K	600
RECTIFIER-INVERTER	28283	73 K	3000
RECTIFIER	31795	73 K	3000
TRANS FLOAT RECTIFIER	3925	73 K	3000
INVERTER	4-GX-48-50-115	73 K	600
GEN SET DSL 300KW	40-SX-6	74 L	55000
GEN SET DSL 200KW	40-SX-6SHEB	74 L	42000
GEN SET DSL 400KW	40-SX-8	74 L	65000
GEN SET DSL 440KW	40-SX-8	74 L	75000
GEN SET DSL 500KW	40-SX-8	74 L	75000
GEN SET DSL 60KW	6-71	74 L	2900
RECTIFIER	6130L5089435250	73 K	3000
RECTIFIER	7SD50	73 K	3000
BATTERY 2VDC 1650AH	76196	75 V	236
GEN SET MOTOR	8-5100	77 K	15000

SOURCE: DCA, CODE 690, MAY 81.

TABLE 44-6. RADIO COSTS

DESCRIPTION	DESIGNATION	SOURCE		UNIT COST
		YEAR		
RADIO SET	AN/ARC-89V	74	L \$	97700
RADIO REC ABNE AM/FM	AN/ARR-68	74	F	6884
TRNSMTTR SET AM/FM	AN/ART-42	74	F	16280
RADIO SET SHF 74A	AN/FRA-90	74	L	30000
RADIO SET UHF 100KW	AN/FRC-101(V)	66	J	325000
RADIO SET UHF	AN/FRC-102(V)	73	M	30000
RADIO SET SHF	AN/FRC-109	74	E	14000
RADIO SET SHF	AN/FRC-113(V)12	74	B	25000
RADIO SET SHF	AN/FRC-113(V)15	74	B	25000
RADIO SET SHF	AN/FRC-113(V)19	74	B	25000
RADIO SET SHF	AN/FRC-113(V)2	74	B	25000
RADIO SET SHF	AN/FRC-113(V)21	74	B	25000
RADIO SET SHF	AN/FRC-113(V)3	74	B	25000
RADIO SET SHF	AN/FRC-113(V)4	74	B	25000
RADIO SET SHF	AN/FRC-113(V)5	74	B	25000
RADIO SET SHF	AN/FRC-113(V)6	74	B	25000
RADIO SET SHF	AN/FRC-113(V)9	74	B	25000
RADIO SET UHF	AN/FRC-114	66	J	120000
RADIO SET	AN/FRC-127	73	M	350000
RADIO SET SHF	AN/FRC-148(V)	73	M	50000
RADIO SET SHF 1W	AN/FRC-149(V)	74	T	1460
RADIO SET 1W	AN/FRC-154(V)1	74	L	10000
RADIO SET 1W FR DIV	AN/FRC-155	80	W	31114
RADIO SET 5W FR DIV	AN/FRC-157	80	W	45181
RADIO SET 5W FR DIV	AN/FRC-157	80	W	45181
RADIO SET 1W SP DIV	AN/FRC-158(V)1	80	W	26500
RADIO SET 1W SP DIV	AN/FRC-158(V)3	80	W	28000
RADIO SET 1W SP DIV	AN/FRC-158(V)6	80	W	28000
RADIO SET SHF 1W SP DV	AN/FRC-159	80	U	29746
RADIO SET SHF 1W SP DV	AN/FRC-159(V)5	80	U	28000
RADIO SET SHF 1W SP DV	AN/FRC-159(V)8	80	U	28000
RADIO SET SHF	AN/FRC-159(V)9	76	M	50000
RADIO SET DIG SP DIV	AN/FRC-162(V)5	80	W	30000
RADIO SET DIG 5W SP DV	AN/FRC-165	80	K	40000
RADIO SET DIG 5W SP DV	AN/FRC-165(V)1	80	W	36000

TABLE 44-6. RADIO COSTS (CON.)

DESCRIPTION	DESIGNATION	SOURCE		UNIT COST
		YEAR		
RADIO SET DIG 4G SP DV	AN/FRC-170	80	E \$	37593
RADIO SET DIG 4G FR DV	AN/FRC-171	80	E	37143
RADIO SET DIG 8G SP DV	AN/FRC-172	80	E	38512
RADIO SET DIG 8G FR DV	AN/FRC-173	80	E	37158
RADIO SET UHF	AN/FRC-26	68	J	15200
RADIO SET UHF	AN/FRC-37	73	M	19000
RADIO SET UHF 10KW	AN/FRC-39A(V)	76	W	400000
RADIO SET UHF	AN/FRC-58A	73	M	400000
RADIO SET UHF 10KW	AN/FRC-75	66	H	200000
RADIO SET SHF MR-300	AN/FRC-80	74	L	22500
RADIO SET SHF MR-300	AN/FRC-80(V)1	74	L	22500
RADIO SET SHF MR-300	AN/FRC-80(V)2	74	V	22500
RADIO SET SHF 1W	AN/FRC-84	73	M	10882
RADIO SET UHF 10KW	AN/FRC-96	66	J	325000
RADIO SET UHF 1KW	AN/FRC-97	66	J	235000
RECEIVER SET HF	AN/FRR-60(V)	75	T	23420
RECEIVER SET HF	AN/FRR-73	72	K	12000
RECEIVER SET	AN/FRR-79	74	L	34299
TRNSMTR SET HF 10KW	AN/FRT-39A	65	C	30000
TRNSMTR SET HF 10KW	AN/FRT-39B	66	H	31700
TRNSMTR SET HF 5KW	AN/FRT-39D	70	X	25000
TRNSMTR SET HF	AN/FRT-39E	66	H	31700
TRNSMTR SET HF 40KW	AN/FRT-40	66	H	69700
TRNSMTR SET HF 40KW	AN/FRT-40A	66	H	71900
TRNSMTR SET HF 40KW	AN/FRT-40B	65	H	62300
TRNSMTR SET HF	AN/FRT-40C	74	L	52000
TRNSMTR SET HF 10KW	AN/FRT-52A	66	H	31600
TRNSMTR SET HF 40KW	AN/FRT-54A	68	J	70000
TRANSMITTER SET HF	AN/FRT-76	73	L	54440
TRNSMTR SET HF	AN/FRT-85	74	L	62520
RADIO SET SHF 10W	AN/GRC-169(V)	72	K	9000
TRNSMTR SET SHF 5W	AN/GRC-169(V)	66	R	17620
RADIO SET .5W	AN/GRC-182	73	K	20000
RADIO SET SHF 1W	AN/GRC-66(V)3	73	M	60000
RADIO SET SHF 1KW	AN/GRC-66(V)5	66	O	127768

TABLE 44-6. RADIO COSTS (CON.)

DESCRIPTION	DESIGNATION	SOURCE		UNIT COST
		YEAR		
RECEIVER VHF	AN/GRR-23	80	W \$	2515
TRNSMTTR SET VHF 50W	AN/GRT-21/T1108	80	W	2720
TRANSMITTER HF 10KW	AN/GRT-33	78	L	35600
RADIO SET SHF	AN/MRC-114(V)1	73	L	25000
RADIO SET SHF	AN/MRC-114(V)2	73	L	25000
RADIO SET SHF	AN/MRC-114(V)4	74	L	25000
RADIO SET UHF 1KW	AN/MRC-80	66	C	140000
RADIO SET VHF FM	AN/MSC-54	74	L	120000
RADIO SET SHF	AN/TRC-150	74	L	15000
RADIO SET VHF/UHF 120W	AN/TRC-24	66	H	14000
RADIO SET UHF 4-10 W	AN/TRC-29	75	T	9410
RADIO SET VHF/UHF 120W	AN/TRC-35	66	H	23000
TRANSCEIVER	AN/URC-32A	68	H	7000
RADIO SET	AN/URC-55	74	L	122108
RADIO SET UHF 50W	EM 120/400	66	H	32500
RADIO SET SHF .5W	FM 120/7000	72	K	11000
RADIO SET UHF 10W	FM 120/800	75	V	26840
RADIO SET SHF	FM 120/8000	72	K	11000
TRNSMTTR SET HF 4KW	GA-11038	74	L	55126
RECEIVER SET HF	HC-150	74	L	37700
RADIO SET SHF 20W	HM-510	66	H	21500
RADIO REPEATER SHF 20W	HM-560	66	H	29100
RADIO SET SHF FRC148V	LC-4	74	U	29000
RADIO SET SHF	LC-4D	72	K	11500
RADIO SHF 4.5-5.0GHZ	LC-4E	69	E	15000
RADIO SET SHF	LC-4G	72	K	11500
RADIO SET SHF	LC-4K	72	K	11500
RADIO SET	LC-4N	72	K	11500
RADIO SET SHF	LC-4SC	72	K	11500
RADIO SET	LC-8	72	K	11500
RADIO SET	LC-8D	72	K	11500
RADIO SET SHF	LC-8D-5	72	K	11500
RADIO SET SHF	LC-8G	72	K	11500
RADIO SET SHF	M-228-2A	74	V	42000
RADIO SET SHF	M-228-3C	74	K	42000

TABLE 44-6.		RADIO COSTS (CON.)	
DESCRIPTION	DESIGNATION	SOURCE YEAR	UNIT COST
RADIO SET SHF	MR-300 (FRC-80)	74 L \$	22500
RADIO SET SHF	MW-502	66 H	10120
RADIO SET SHF 1W	MW-503A	66 H	20082
RADIO SET SHF	MW-508D	74 L	29788
RADIO SET SHF	MW-509A	75 Z	25200
RADIO SET SHF	MW-608D	75 E	17475
RADIO SET GP	0A-1389/GRC	80 W	414
MODULATOR OSCILLATOR GP	0A-2180/FRT-51	66 K	700
RADIO SET VHF	Q2041A	73 K	20000
RECEIVER HF	R-1051/URR	74 L	4320
RECEIVER HF	R-1051B/URR	74 L	5770
RECEIVER HF	R-1051D/URR	74 L	4320
RECEIVER HF	R-1051E/URR	74 L	4540
RECEIVER HF	R-390A/URR	80 W	976
RDO SET SHF FM120/2000	REL 138Y3B	72 K	11000
RADIO SET VHF	RML-4	74 L	300000
RECEIVER	RO-2GA120-2A	74 V	23300
RECEIVER	RO-2GA120-2B	74 V	23300
RECEIVER	RO-2GA60-1A	74 V	21400
RECEIVER	RO-2GA60-1B	74 V	21400
TRNSMTTR SET SHF	TO-2G120-2A	74 V	19000
RADIO SET SHF	TR-2GD-300-1A	74 V	52250
RADIO SET UHF	TR-450-03	72 K	11500
RADIO SET SHF	TR-7GD-300-9A	74 V	52250
RADIO SET SHF	TR-7GD-600	74 V	52250
RADIO SET SHF	TR-7GD-600-5A	74 V	52250
RADIO TRNSMTTR SET	URG-208-U-10	74 L	345
RADIO SET UHF	14A/W	75 Z	2400
TRNSMTTR SET SHF 10KW	2GD-300	72 K	106000
TRANSMITTER SET HF	205J	73 K	3000
TRANSMITTER SET HF	208-U10	74 K	345
RADIO SET UHF 1KW	2600SERIESIWCS	72 K	125200
EXCITER HF	310V-1	66 H	10000
RECEIVER SUBSYSTEM	597-7020-001	68 K	35000
RECEIVER SET	651F-1	66 H	9500

TABLE 44-6. RADIO COSTS (CON.)

DESCRIPTION	DESIGNATION	SOURCE	
		YEAR	UNIT COST
RADIO REC SHF 2EA	7GD-600	68 K \$	16000
RADIO SET SHF FRC90	74A2-25556	74 L	30000
RECEIVER HF	905	74 L	650

SOURCE: DCA, CODE 690, MAY 81.

TABLE 44-7. SEVOCOM COSTS

DESCRIPTION	DESIGNATION	SOURCE	
		YEAR	UNIT COST
SW AUTOSEVOCOM 25LINE	AN/FTC-31(V)	66 U \$	160000
SW AUTOSEVOCOM 50LINE	AN/FTC-31(V)	66 U	200000
SWBD SEVOCOM MANUAL	SECORD	68 V	7070
SWBD SEVOCOM MANUAL	758A	72 V	127434

SOURCE: DCA, CODE 690, MAY 81.

TABLE 44-8. SATELLITE COSTS-

DESCRIPTION	DESIGNATION	SOURCE	
		YEAR	UNIT COST
EARTH TERM SATELLITE	AN/FSC-78	76 P	\$ 5872000
EARTH TERM SAT 60 FT	AN/FSC-78 (HT)	76 P	5872000
EARTH TERM SAT 60 FT	AN/FSC-9	68 Q	8000000
EARTH TERM SAT 40 FT	AN/MSC-46	75 Q	4700000
EARTH TERM SATELLITE	AN/MSC-59	76 Q	356000
EARTH TERM SAT 38 FT	AN/MSC-61 (MT)	76 P	4680000
EARTH TERM SAT TRUCK	AN/MSC-66	69 K	700000
EARTH TERM SATELLITE	AN/MSC-85 V1	76 Q	615000
EARTH TERM SATELLITE	AN/MSC-85 V2	76 Q	834000
EARTH TERM SAT 18 FT	AN/TSC-54	75 Q	1800000
EARTH TERM SAT 8 FT	AN/TSC-86	76 Q	976000
EARTH TERM SAT 20 FT	AN/TSC-86(LT-2)	76 P	2089000
SATELLITE (W/O LAUNCH) PHASE II		76 P	16150000

SOURCE: DCA, CODE 690, MAY 81.

TABLE 44-9. TRAFFIC DATA COLLECTION SYSTEMS COSTS

DESCRIPTION	DESIGNATION	SOURCE	
		YEAR	UNIT COST
TRAFFIC DATA COL SYS	EB/DATA MISC	75 V \$	86700
TRAFFIC DATA COL SYS	122/G	75 V	35000
TRAFFIC DATA COL SYS	122/GA	75 V	33000
TRAFFIC DATA COL SYS	123/G	75 V	50600

SOURCE: DCA, CODE 690, MAY 81.

TABLE 44-10. TELEPHONE SWITCHING COSTS

DESCRIPTION	DESIGNATION	SOURCE	
		YEAR	UNIT COST
BOARD TOLL	C5-3A	72 K \$	34000
SWBD TELEPHONE	F-36	72 K	4000
VF DIAL	S/H 1773001	66 K	5000
SW/CONT SUBSYSTEM	SA-1704/G	73 M	2600
SWBD SECORD MANUAL	SB-3259/G	73 M	4800
TERM SET 2W/4W	TYPE 403	68 K	150

SOURCE: DCA, CODE 690, MAY 81.

TABLE 44-11. TELETYPE COSTS

DESCRIPTION	DESIGNATION	SOURCE	
		YEAR	UNIT COST
TELEPRINTER SET	AN/FGC-100	74 L \$	7220
TTY SET	AN/FGC-144	80 W	2250
TTY SET	AN/FGC-161X	66 K	4000
TTY SET	AN/FGC-20	80 W	2180
TTY SET	AN/FGC-20X	80 W	1480
TTY SET	AN/FGC-25X	80 W	3605
TTY SET	AN/FGC-58	74 E	3275
TTY SET	AN/FGC-59	66 H	21000
TTY SET	AN/FGC-67	80 W	1681
TTY SET	AN/FGC-69	74 E	4180
TTY SET	AN/FGC-79	74 E	4168
TTY SET	AN/FGC-79A	73 M	5000
TTY SET	AN/FGC-80	68 H	3800
TTY SET	AN/FGC-97X	80 W	1587
KEYBOARD PRINTER	AN/GGC-57A(V)4	80 W	7956
KEYBOARD DISPLAY	AN/GGC-62	80 K	7900
RO PRINTER 80 COL.	AN/GGR-3A(V)4	80 W	7097
TTY SET	AN/UGC-13	80 W	4000
TTY SET MOD 28/32	AN/UGC-20	73 M	1235
TTY SET	AN/UGC-32X	80 W	4035
TTY SET	AN/UGC-4	69 M	1518
TTY SET	AN/UGC-47	75 L	2300
TTY SET	AN/UGC-48	74 L	5510
TTY SET	AN/UGC-49	74 L	5520
TTY SET	AN/UGC-51	80 W	1944
TTY SET	AN/UGC-57A	80 L	4930
TTY SET	AN/UGC-88B	73 K	1500
TTY SET	AN/UGR-10	74 L	7850
TELEPRINTER	AN/UGR-9	74 L	1830
COMMON CONTROL GP	C8120 PG	80 K	25000
HIGH SPEED CARD PUNCH	DSTE	80 K	21000
HIGH SPEED TAPE PUNCH	DSTE	80 K	21000
LOW PUNCH TAPE REPERF	DSTE	80 K	21000
LOW SPEED CARD PUNCH	DSTE	80 K	21000
LOW SPEED TAPE PUNCH	DSTE	80 K	15000

TABLE 44-11. TELETYPE COSTS (CON.)

DESCRIPTION	DESIGNATION	SOURCE	
		YEAR	UNIT COST
PAGE PRINTER	DSTE	80 K \$	32000
READER	DSTE	80 K	21000
READER PAPER TAPE/DUAL	DSTE	80 K	21000
TTY SET	MODEL NO 28ASR	73 V	4415
TTY DISTRIBUTOR-XMTR	TT-123A/FG	73 M	403
TTY SET	TT-171/UG	73 M	1050
TTY SET	TT-171C/UG	73 M	1140
TTY REPERFORATOR	TT-192A/UG	74 L	268
TTY SET	TT-243/FG	74 L	1710
TTY DISTRIBUTOR-XMTR	TT-273/FG	74 L	3594
TTY REPERFORATOR	TT-274/FG	74 L	824
TTY /REC. ONLY/	TT-306A/UG	76 W	1287
TTY REPERFORATOR	TT-329/UG	74 L	765
TTY REPERFORATOR	TT-331/UG	74 L	4000
TTY REPERFORATOR	TT-331A/UG	68 M	6200
TTY REPERFORATOR	TT-332/UG	74 L	5400
TTY DISTRIBUTOR-XMTR	TT-333A/UG	73 M	8635
TTY REPERFORATOR	TT-346/UG	69 M	1000
TTY SET	TT-47C/UG	73 M	1490
TTY SET	TT-47J/UG	68 M	1305
TTY REPERFORATOR	TT-575/UG	74 L	717
TTY SET	2002-166	74 L	16884

SOURCE: DCA, CODE 690, MAY 81.

CHAPTER 45. TRANSPORTABLE COMMUNICATIONS UNITS

1. General. Although the vast majority of the facilities of the DCS are installed as fixed plant installations, certain applications require that transportable units be used. The Joint Strategic Operations Plan (JSOP) requires transportable units for Joint Communications Contingency Station Assets (JCCSA). DCA has also been directed to consider the use of transportable units for all new requirements and for the extension or restoral of the DCS. This chapter provides guidance in the preparation of cost estimates for transportable communications facilities.

2. Development of Transportable Facilities. The transportable units of the DCS, to preserve system integrity, must interface and be compatible with both the fixed plant portion of the DCS and tactical equipments. This need for interoperability and compatibility makes it extremely improbable that we will be faced with the task of developing major components for transportable applications--most of the development effort has been completed by programs such as TRI-TAC; therefore, it can be expected that future transportable units of the DCS will utilize major components that have gone through the R and D phase and are now or have been in production. The major difference between the fixed plant and transportable units will be the packaging.

3. Considerations in Analyses. The choice between fixed and transportable facilities will be made in compliance with the Defense Consolidated Guidance (CG) and will support the objectives of the Joint Strategic Planning System (JSPS). Comparative cost is not the determining factor in selecting fixed plant over transportable units or vice versa. Each has operational advantages over the other, and the value of the advantages (or cost of disadvantages) must be considered together with the costs. The most apparent advantages and disadvantages of transportable units are as follows:

a. Advantages.

(1) Assembly at a CONUS plant reduces costs by the elimination of incentives for contractor personnel to work in overseas locations and usually results in a more rapid delivery of an operational system.

(2) Use of one engineering design for a number of units will help to reduce costs.

(3) Production of a number of like units will reduce costs because of the learning curve effects.

(4) Standardization tends to reduce training costs.

(5) Overseas expenditures favorable to our Balance of International Payment position will be reduced.

- (6) Maintainability and reliability can be more consistently engineered into a standard facility.
- (7) Flexibility can be realized by use of modular blocks.
- (8) Standard one-time documentation is possible.
- (9) Amenability to stockpiling will permit establishment of communications in less time, with less misidentification, damage, and loss of parts in storage or in transit.
- (10) Operational status is not delayed because of allied building construction.
- (11) Spare parts provisioning is simplified and often eliminated when major components, now in the inventory, are used.
- (12) Transportability enhances survivability, since units can be readily replaced if destroyed or moved if endangered, instead of being abandoned.

b. Disadvantages.

- (1) Fixed plant installations are usually tailored to meet the requirement of a specific path or set of conditions. The use of transportable units, because equipment selection, channel capacity, and other technical parameters are predetermined, requires that the path be tailored to the equipment. This may either degrade operations or result in the providing of capabilities which exceed requirements.
- (2) Lack of similarities between common equipment (i.e., technical control) requirements at nodal points complicates the development and production of standard units for such use.
- (3) Use of transportable power plants for electrical power production will result in a large number of power plants being operated at some locations with transportable facilities. Economies that could be realized with centralized power plants are not achieved.
- (4) Transportability is often achieved at the expense of operator comfort.
- (5) Transportable units must rely upon antenna systems that are easily and readily assembled and erected. Rigidity, such as that achieved with fixed plant installations using antennas securely anchored in a concrete base, is not achieved. Also, the inability to use the larger antennas in a transportable mode often limits the maximum utilization of the RF capabilities.

(6) The manning of each unit as if it were the only one operating at a given site increases O&M costs.

(7) Transportable shelters do not last as long as permanent buildings.

(8) Future expansion is restricted.

(9) Size of some facilities makes it impractical to manufacture them as transportable units.

4. Cost of Transportable Units.¹

a. The requirement for pricing a transportable facility using already developed components indicates that the requirements for major components and parts are known. A review of past contracts reveals that there is a stable relationship between the cost of parts and the total contract price. The relationship is:

Cost of parts X 1.55 = total cost

b. Without detailed engineering the total equipment requirements will not be known; however, the major components will in all likelihood be identifiable. As a general rule the major components will make up 80 percent of the costs of the total parts. The relationship between the cost of major components and the total facility cost then becomes:

Costs of major components² X 1.95 = total cost

¹Costs do not include costs of data required of a development contract. They do, however, contain costs for copies of commercial and military manuals for the equipment items and a commercial grade manual required to explain the system's operations and maintenance. A limited supply of spare parts and test equipment is included in the costs.

²Major components consist of necessary receivers, transmitters, antennas, power equipment, concentrators, switches, manuals, multiplexing equipment, and shelters as obtained from a manufacturer.

WORK BREAKDOWN STRUCTURE

	<u>Reference Chap Table</u>	<u>Budget Est.</u>	<u>DCAI</u>	
			<u>600- 60-1</u>	<u>600- 70-1</u>
1. Program Acquisition Costs		x	x	x
a. Research and Development		x	x	x
(1) Contractor		x	x	x
(a) Program Initiation, Demonstration and Validation		x	x	x
(b) Full-Scale Engineering Development		x	x	x
1. Program Management		x	x	x
2. Engineering		x	x	x
3. Fabrication, Mock- ups, Models		x	x	x
4. Test and Evaluation		x	x	x
5. Documentation		x	x	x
a. Technical Orders and Manuals		x	x	x
b. Engineering Data		x	x	x
c. Management Data		x	x	x
d. Data Repository		x	x	x
6. Peculiar Support Equipment		x	x	x
a. Organization		x	x	x
b. Intermediate		x	x	x
c. Depot		x	x	x
(2) Government				
(a) Program Initiation, Demonstration, and Validation				x
1. Requirements Determination				x
2. Advance Planning Studies				x
3. Request for Proposal and Work Statement Preparation				x
4. Source Selection Evaluation				x
5. Project Management Office				x
6. Travel				x
7. Test and Evaluation			x	
(b) Full-Scale Engineering Development		x	x	x
1. Program Management				x
2. Test and Evaluation				x
3. Documentation				x
4. Industrial Facilities		x	x	x
5. Government-Furnished Equipment		x	x	x

WORK BREAKDOWN STRUCTURE

	Reference Chap Table	Budget Est.	DCAI		
			600- 60-1	600- 70-1	
b. Procurement			x	x	x
(1) Contractor			x	x	x
(a) Prime Mission Equipment			x	x	x
<u>1.</u> Terrestrial					
Communications	10-13	x	x	x	
<u>2.</u> ADPE	31	x	x	x	
<u>3.</u> Computer Programs		x	x	x	
<u>4.</u> Space	10				
<u>a.</u> Launch Vehicle	10 11	x	x	x	
<u>b.</u> Stage Vehicle		x	x	x	
<u>c.</u> Space Vehicle		x	x	x	
<u>d.</u> Ground Equipment	10 12	x	x	x	
(b) Auxiliary Equipment	14	x	x	x	
<u>1.</u> Electric Power		x	x	x	
<u>a.</u> Primary		x	x	x	
<u>b.</u> Secondary		x	x	x	
<u>2.</u> Air-Conditioning Equipment		x	x	x	
<u>3.</u> Heating Equipment		x	x	x	
<u>4.</u> Modems		x	x	x	
<u>5.</u> Terminals		x	x	x	
(c) Integration and Assembly	15	x	x	x	
<u>1.</u> Assembly and Mating		x	x	x	
<u>2.</u> Vans, Storage, Trans- portation Devices		x	x	x	
<u>3.</u> Cables, Conduits, Connectors		x	x	x	
(d) Training (Contractor)	16	x	x	x	
<u>1.</u> Facilities		x	x	x	
<u>2.</u> Devices and Equipment		x	x	x	
<u>3.</u> Initial Student Training		x	x	x	
<u>a.</u> Instructors		x	x	x	
<u>b.</u> Operators		x	x	x	
<u>c.</u> Maintenance Personnel		x	x	x	
(e) Peculiar Support Equipment	17	x	x	x	
(f) System Test and Evaluation	18	x	x	x	
(g) System Project Management	19	x	x	x	
<u>1.</u> Systems Engineering	19 1	x	x	x	
<u>2.</u> Project Management	19 1	x	x	x	
(h) Documentation	20	x	x	x	
<u>1.</u> Technical Orders and Manuals	20 1	x	x	x	
<u>2.</u> Engineering Data	20	x	x	x	

WORK BREAKDOWN STRUCTURE

	Reference Chap Table	Budget Est.	DCAI	
			600- 60-1	600- 70-1
3. Management Data	20 1	x	x	x
4. Data Repository		x	x	x
(1) Operational/Site Activation	21	x	x	x
1. Contractor Technical Support	21 1	x	x	x
2. Site Construction	21	x	x	x
a. Rights of Way and Easements	2	x	x	x
b. Land Acquisition	2	x	x	x
c. Site Survey/ Preparation	2	x	x	x
d. Buildings and Shelters	3	x	x	x
e. Foundations, Stands, Pads	2	x	x	x
f. Fences	2	x	x	x
g. Access Roads	2	x	x	x
h. Fuel Storage Facilities	4	x	x	x
i. Sewage Facilities	2	x	x	x
j. Water Tanks	4	x	x	x
k. Administrative Communications	2	x	x	x
3. Flight Support Opera- tions and Services	10	x	x	x
a. Launch Operations		x	x	x
b. Flight Operations		x	x	x
c. Recovery Operations		x	x	x
4. Site/Ship/Vehicle Conversion		x	x	x
5. Assembly, Installation Checkout On Site	21 4	x	x	x
6. Cable Ship Operations	10 9	x	x	x
(j) Initial Spares and Initial Repair Parts	22 1	x	x	x
(2) Government		x	x	x
(a) Program Management/ Systems Engineering		x	x	x
1. In-house System Project Management Office				x
2. Federally Contracted Research Center	19 1	x	x	x
3. Architectural and Engineering Services	19 1	x	x	x

WORK BREAKDOWN STRUCTURE

	Reference Chap Table	Budget Est.	DCAI	
			600- 60-1	600- 70-1
(b) Initial Training		x	x	x
(c) Test and Evaluation	18		x	x
1. Production Acceptance (PAT&E)			x	x
2. Operational (OT&E)			x	x
(d) Industrial Facilities		x	x	x
(e) Common Support Equipment	17	x	x	x
(f) Government-Furnished Equipment		x	x	x
(g) Transportation	24		x	x
1. Shipping and Packaging	24 8-11		x	x
2. First Destination Transportation		x	x	x
3. Vehicles	24 12		x	x
(h) Communications-Initial Service Charge		x	x	x
1. Terminals		x	x	x
2. Switch Connections		x	x	x
2. Operating and Support Costs (Ownership)				
a. Military Personnel-Basic Pay and Allowances	23 1	x	x	x
(1) Officers		x	x	x
(2) Enlisted Men		x	x	x
b. Military Personnel Retirement	23		x	x
(1) Officers			x	x
(2) Enlisted Men			x	x
c. Operations and Maintenance		x	x	x
(1) Civilian Personnel (U.S. Civilian and Foreign National)	24	x	x	x
(a) Civilian Pay and Benefits	24 1,5	x	x	x
(b) Special Differentials and Allowances	24 4		x	x
1. Nonforeign Allowance			x	x
2. Foreign Area Allowance			x	x
a. Post Differential			x	x
b. Cost-of-Living Allowance (COLA)			x	x
3. Dependent Education	26 2		x	x
4. Hazardous Duty Differential	24 4		x	x
(2) TDY Travel (Per Diem and Transportation)	24 6		x	x

WORK BREAKDOWN STRUCTURE

	Reference Chap Table	Budget Est.	DCAI	
			600- 60-1	600- 70-1
(3) PCS-U.S. Civilians	24	7	x	x
(4) Transportation of Things	24		x	x
(a) Shipping and Packaging	24	8-11	x	x
(b) First and Second Destination Transportation			x	x
(c) Vehicles	24	12	x	x
(5) Utilities and Fuel	24	13	x	x
(a) Electricity			x	x
(b) Sewage			x	x
(c) Fuel			x	x
(d) Water			x	x
(6) Building Maintenance	24		x	x
(7) Supplies and Equipment	24		x	x
(8) Miscellaneous Support	24	16	x	x
(9) Contractual Operations and Maintenance Services			x	x
(10) Leased Communications	27-31		x	x
(a) Access Lines			x	x
(b) Trunks			x	x
(c) Terminals and MODEMS			x	x
(d) Other Communication Service Leases/Rentals			x	x
d. Recurring Investment	25		x	x
(1) Replacement Spares and Repair Parts	25		x	x
e. Operating Support Costs			x	x
(1) Base Operations	26	1	x	x
(2) Depot Maintenance and Supply	26	3	x	x
(a) Personnel			x	x
(b) Facilities			x	x
(c) Test and Support Equipment			x	x
(3) Replacement Training	26	4	x	x
(4) Hospitals	26	5	x	x
(5) PCS-Military	26	6	x	x
(6) Other Indirect Costs	26	7	x	x
3. Other Cost Considerations	26			x
a. Federal Taxes	26	7		x
b. Depreciation in Facil- ities and Equipment	32	1		x
c. Interest on New Capital Investment	26	7		x

WORK BREAKDOWN STRUCTURE

	Reference Chap Table		DCAI	
			Budget Est.	600- 60-1
d. Insurance (Property and Employee Liability)	26	7		x
e. Other Indirect Costs Above Installation Level	26	7		x
4. Termination Liabilities			x	x
a. Termination Charges			x	x
b. Restoration Costs			x	x
c. Personnel Relocation Costs	24	6	x	x
d. Other	26	6	x	x
5. Residual Value Credit	32		x	
a. Land			x	
b. Buildings	32	1	x	
c. Equipment	32	1	x	
d. Other			x	

INDEX

<u>Subject</u>	<u>Chapter/Page</u>
A&E firm costs.....	19-4
Abbreviations.....	xxvi
Access lines.....	28-2, 28-14
Acoustic couplers.....	14-12
Activation.....	21
ADP (automatic data processing)	
Computer Resource Unit Costs.....	42-2
Cost estimating.....	31
Equipment lease costs.....	31-5
Equipment purchase costs.....	31-2
Grade level averages (DCA).....	42-7
Non-equipment costs.....	31-8
Operating personnel costs.....	24-40, 24-45, 31-13, 42-1, 42-3
Software.....	31-6
Time-phased cost summary.....	31-11
Vendor costs.....	31-6
Air cargo rates.....	24-25
Air-conditioning.....	14-7
Air passenger rates.....	24-19
Airlift Service Industrial Fund.....	24-18
Alarm system equipment costs.....	13-1, 13-6
Allowances	
Civilian personnel.....	24-7
Military personnel.....	23-1
Amplifier equipment costs.....	44-3
Analog lines.....	14-10
Analog radio.....	10-1
Analog service.....	27-1
Annual operating costs.....	23, 24, 25, 26
Annual pay rates.....	23-1, 24-1
Antenna costs.....	10-4, 10-12, 44-4
Appropriations.....	38
Area MCA, Area Plus.....	28-2
ARPANET.....	28-4
Assembly, installation and checkout.....	21-8
Atlas Centaur costs.....	10-19
Attrition rates.....	26-6
AUTODIN.....	27, 28-3
AUTODIN message costs.....	42-2, 42-6
AUTOVON.....	27, 28-1
Auxiliary equipment.....	14, 24-31
Base operations (BOS).....	26-2
Basic training.....	26-6
Boilers.....	14-8
Building, shelter.....	21-2, 21-7
Building blocks.....	11

INDEX (CON.)

<u>Subject</u>	<u>Chapter/Page</u>
Building maintenance.....	24-50
Bulk encrypted circuits.....	28-7
Cable systems.....	5,10-23
Land.....	5-16,10-23
Submarine.....	5-1,10-21
CADIN monthly subscriber rates.....	28
Capital equipment costs.....	44
Cash flows.....	41-1
Change of station costs.....	24-20,26-12
Channel packing.....	28-7
Checkout, onsite.....	21-8
Children, education of.....	26-2
Circuit conditioning.....	13-4
Circuit conditioning equipment.....	13-3
Circuit control equipment.....	13-3
Circuit rental costs.....	29-12
Civilian differentials.....	24-7
Civilian pay.....	24-1
Civilian PCS costs.....	24-20
Civilian temporary duty travel.....	24-19
Clerical support personnel.....	24-46
Commercial rates	
Air transportation.....	24-25
Electricity.....	24-31
Ocean freight.....	24-28
Commercial activities.....	43
Common control unit.....	30-2
Common support equipment.....	17
Communications specialty training.....	26-6
COMSATCOM.....	28-13
COMSEC modules.....	14-14,14-15
Conditioning equipment costs.....	13-4
Construction price indexes.....	36
Contract Data Requirements List.....	20-1
Contractor employees.....	24-37
Contractor technical support.....	21-1
Contractor training.....	16
Control system equipment.....	13
Cost elements.....	iii,v, Supplement 1
Cost estimating procedures.....	1,2,4,5
Cost-of-living allowance.....	24-7
Cost-quantity relationships.....	37
Costs, DCS capital equipment.....	44-1
CRT display terminals.....	14-17
CSIF subscriber rates.....	28
ARPANET.....	28-4
AUTODIN.....	28-3
AUTOVON.....	28-1

INDEX (CON.)

<u>Subject</u>	<u>Chapter/Page</u>
Currency conversion factors.....	35
Data.....	20
Data processing.....	see ADP
Data set modems.....	14-12
Dataphone digital service.....	30-1
DDD.....	30-4
DDN.....	28-6
DDS.....	30-1
Dedicated services.....	27-3
Definitions.....	xx
Dehydration equipment.....	10-6,10-7,10-14
Demodulators.....	14-11
Dependents.....	26-2
Depot maintenance cost factors.....	26-4
Depreciation.....	32-1
Dial-up service.....	30-4
Diesel generator costs.....	14-6,44-18
Differential costing.....	41-7,41-14
Differentials and allowances.....	24-7
Digital multiplex.....	11-1
Digital radio.....	10-2
Digital service.....	27-1
Discount factors.....	41
Discount rate.....	41
Discounting.....	41
Dispenser costs (satellite).....	10-15
Documentation.....	20
Domestic service.....	27-1
DSCS.....	28-12
Earth terminals.....	10-9
Economic analysis.....	v,23-1,24-1,,38-1
Economic escalation.....	v,38,41-4
Economic life.....	32-1
Education allowance.....	24-8
Education of dependent children (costs).....	26-4
Electricity.....	14-1
Commercial costs.....	24-31
Distribution.....	14-7
Generation.....	14-3
Engineering Costs.....	24-40
Engineering, system.....	19-1
Enlisted replacement rate.....	26-6
Escalation, economic.....	38,41-5,41-20
Evaporative systems.....	14-9
Exchange rates.....	35
Expenditure rates.....	38-2

INDEX (CON.)

<u>Subject</u>	<u>Chapter/Page</u>
Facsimile terminals.....	14-17
FCRC costs.....	24-52
Federal white collar workers.....	24-6
Feed subsystem.....	10-4,10-6,10-12
Fences.....	21-4
Foreign national pay rates.....	24-16
Foundations.....	21-3
Freedom of Information search cost.....	42
Freeze-frame video.....	28-14
Freight rates, ocean.....	24-28
Frequency division multiplex (FDM).....	11-5
Fuel oil	
Consumption rates.....	24-31
Costs.....	24-31
Requirements.....	24-33
Storage.....	21-6
Funding schedule.....	v
Gateways to CONUS.....	29-2
Generator costs.....	14-6
Global MCA.....	28-2
Glossary of terms.....	xx
Grade levels, average.....	24-6,42-7
Hazardous duty differential.....	24-14
Heating costs.....	14-7,24-31
High frequency radio equipment.....	10-14
Hospitals, annual costs.....	26-11
Hourly pay rates.....	23-1,24-1
Improvement curves.....	37
Independent Government cost estimate.....	24-49
Index, price.....	36,38
Industrial activities.....	43
Inflation rate.....	38,41-5
Initial spares and repair parts.....	22
Installation and checkout.....	21-8
Insurance.....	24-1
Integration and assembly.....	15
Intercom equipment.....	13-1,13-5
International monetary rates of exchange.....	35
International service.....	27-1
Investment costs, recurring.....	25
Land cable systems.....	5-16
Land requirements.....	10-1
Landscaping.....	21-3

INDEX (CON.)

<u>Subject</u>	<u>Chapter/Page</u>
Launch vehicle costs.....	10-19
Learning curves.....	37
Lease-versus-buy analysis.....	31-15
Leased communications costs.....	27
Leased service charges.....	29
Life cycle costs.....	41-1
Line equalizers.....	14-11
Line interface.....	14-14,14-15
Liquid storage costs.....	21-6
Local MCA.....	28-2
LOS microwave systems.....	1,10-1,20-3
Mail costs.....	42-2,42-6
Maintenance, ADP.....	31-2,31-5,31-11
Maintenance, depot.....	26-4
Maintenance, operations and.....	24
Management engineering.....	19-1
Management support.....	19-3
Master plan.....	v
Maximum calling area.....	28-2
Median grades, Federal workers.....	24-6
Medical support costs.....	26-11
Microwave carriers.....	30-3,30-5
Microwave systems.....	1
Military air cargo rates.....	24-28
Military pay rates.....	23
Military sealift rates.....	24-28
Military temporary duty.....	24-17
MINET.....	28-6
Modems.....	14-10,44-10
Modulators.....	44-11
Monetary rates of exchange.....	35
Multiplex	
Equipment costs.....	11,44-11
Estimating relationships.....	44-2
Ocean freight rates.....	24-28
Operating support costs.....	26
Operational site activation.....	21
Operational support requirements.....	11
Operations and maintenance.....	24
Operations and maintenance, vehicle.....	24-29
Orderwire equipment.....	13-1,13-6
Outlay rates.....	38-4

INDEX (CON.)

<u>Subject</u>	<u>Chapter/Page</u>
Packet switched carriers.....	30-3,30-5
Passive reflectors.....	10-8
Patch and test facility.....	13-1
Pay and allowances, military personnel.....	23
Pay rates, foreign nationals.....	24-16
Pay, civilian.....	24-1
Peculiar support equipment.....	17
Per diem rates.....	24-17
Permanent change of station costs.....	24-20,26-2
Personnel costs, ADP.....	42-1
Personnel, military, pay and allowances.....	23
Phasing factors, escalation.....	38-2
POL costs.....	21-2,21-6,24-31
Post differential.....	24-7
Power plants	
Auxiliary.....	14-2
Costs.....	14,44-15
Primary.....	14-1
Rotating flywheel.....	14-2
Static.....	14-2
Power requirements (typical stations).....	14-5
Power sources.....	14-1
Present value computations.....	41-12
Pressurization/dehydration equipment.....	10-6,10-7,10-14
Private line service	
CONUS.....	30
International.....	29
Program evaluation.....	23-1,24-1,38-1
Project management.....	19
Project management support.....	19-3
Pulse Code Modulation (PCM).....	11-1
Radio costs.....	10-1,10-2,10-3,10-12,10-13,44-20
Rates of exchange.....	35
Rates, subscriber.....	27,28
Recruiting costs.....	26-6
Recurring investment costs.....	25
Reflector costs.....	10-8
Reimbursement rates.....	23-1
Repair parts	
Initial.....	22
Recurring.....	25
Replacement rate, enlisted.....	26-6
Report costing procedures.....	42
Reprocurement.....	17-2
Research and development.....	17-2,20-3,38-1

INDEX (CON.)

<u>Subject</u>	<u>Chapter/Page</u>
Residual value.....	32
Revisions.....	vi
Roads, streets, parking area costs.....	21-3
 Satellites	
Carriers.....	30-2
CER's.....	10-15
Communications systems.....	4, 10-14
Costs.....	44-25
Earth terminal costs.....	10-20
Service terminals.....	44-32
Sewage.....	21-4
SEVOCOM costs.....	44-24
Shared services.....	30-3
Shared user systems.....	27-3
Signal processors.....	14-14
Site activation.....	21-1
Site construction.....	21-2
Space shuttle costs.....	10-19
Spare parts	
Initial.....	22
Recurring.....	25
Station power requirements.....	14-5
Submarine cable systems.....	5-1, 10-21
Subscriber rates.....	27, 28
Support equipment.....	17
Support personnel.....	24-38, 24-46
Support requirements.....	11
System description.....	11
System engineering.....	19-1
System management.....	19
System procurement.....	17-2
System test and evaluation.....	18
Systems support.....	15, 16, 17, 18, 19, 20, 21, 22
Tariffs.....	29, 30
Technical Control Facility (TCF).....	13-1
Technical orders and manuals.....	20
Technical support.....	21-1
Technical support documentation.....	20
Technicians.....	24-38
Telebroadcast.....	28-13
Telaconferencing.....	28-14
Telephone cable costs.....	10-21
Telephone switching costs.....	44-26
Teleprinters.....	14-17

INDEX (CON.)

<u>Subject</u>	<u>Chapter/Page</u>
Teleseminar.....	28-14
Teletype equipment costs.....	44-27
Temporary duty travel costs.....	24-22
Terminals.....	10-19, 11-5, 14-13, 14-16, 30
Terminal interface.....	14-11
Terminal value.....	32-1
Termination.....	28-14, 29, 30
Terrestrial carriers.....	30-1
Test and Evaluation.....	18
Test, peculiar and common support equipment.....	17
Time Division Multiplex (TDM).....	11-1
Time-phasing.....	v, 24-48, 38-4
Timing units.....	14-11
Titan III C costs.....	10-19
Towers.....	10-1, 10-7
Traffic data collection system costs.....	44-27
Training	
Basic.....	26-6
Communications specialty.....	26-6
Contractor.....	16
Transmission lines.....	10-4
Transmission systems equipment.....	10
Transoceanic service.....	28-7
Transportable communications units.....	45
Transportation costs of things.....	24-22
Travel	
Military PCS.....	26-12
Temporary duty.....	24-17
Tropospheric scatter systems.....	2, 10-2
Trunks.....	28-4
TT&C (satellites).....	10-14
Uniform annual costs.....	41-6, 41-12
Uninterruptible power supplies.....	14-2
Unit procurement.....	17-2
Utilities and POL costs.....	24-31, 31-13
Vehicle operating and maintenance costs.....	24-29
Ventilation.....	14-9
Video.....	14-17, 28-14
Voice Frequency Carrier Telegraph (VFCT).....	28-7
Voice services.....	30-1
Voice terminals.....	14-13

INDEX (CON.)

<u>Subject</u>	<u>Chapter/Page</u>
Water storage.....	21-6
WATS.....	30-4
Waveguides.....	10-6
WAWS.....	28-7
Wideband switching.....	28-7
WIN.....	28-6
Work Breakdown Structure.....	Supplement 1
Zone rates.....	29-3