

MICROCOPY RESOLUTION TEST CHART  
NATIONAL BUREAU OF STANDARDS-1963-A

AD A127158

BY THE COMPTROLLER GENERAL

Report To The Congress

OF THE UNITED STATES

# Evaluation Of Defense Attempts To Manage Battlefield Intelligence Data

↙ The Department of Defense undertook the Battlefield Exploitation and Target Acquisition project 3 years ago to develop new technology for automated information management of battlefield intelligence data.

After reviewing project development efforts, GAO recommended that Defense redirect the project to better utilize technology benefits in fielding operational systems. ↘

DTIC ELECTE  
S APR 25 1983 D  
A

DTIC FILE COPY



This document has been approved for public release and sale; its distribution is unlimited.

GAO/IGD-81-23  
FEBRUARY 24, 1981

83 04 22 091



COMPTROLLER GENERAL OF THE UNITED STATES  
WASHINGTON, D.C. 20548

B-197731

To the President of the Senate and the  
Speaker of the House of Representatives

This report points out problems in Department of Defense management of the Battlefield Exploitation and Target Acquisition project. We made the review to determine if technology development objectives were being achieved. We are recommending that the Secretary of Defense modify planned development efforts to make the project cost effective.

We are sending copies of this report to the Chairmen, House and Senate Committees on Intelligence and on Defense Appropriations; the Secretary of Defense; the Secretaries of the Army, Air Force, and Navy; and the Director, Office of Management and Budget.

*James B. Stacks*  
Comptroller General  
of the United States

Accession for

1977-78

1977-78

1977-78

1977-78

1977-78

1977-78

1977-78

1977-78

1977-78

1977-78

1977-78

1977-78

1977-78

1977-78

1977-78

1977-78

COMPTROLLER GENERAL'S  
REPORT TO THE CONGRESS

EVALUATION OF DEFENSE  
ATTEMPTS TO MANAGE  
BATTLEFIELD INTELLIGENCE DATA

D I G E S T

The Battlefield Exploitation and Target Acquisition (BETA) project was initiated in September 1977 as a joint service experiment to develop a test bed for automated collection, analysis, correlation, and dissemination of tactical intelligence data. The BETA test bed includes ground stations which receive sensor messages, correlation centers that automatically process the sensor data, operator terminals for displaying correlation center output, and communications equipment to route sensor messages and distribute reports.

The experiment was estimated to cost \$98 million through completion in fiscal year 1984. However, in June 1980 congressional committees redirected the project after learning of BETA's development schedule slippage, inordinate cost increases, reduced capabilities, and poor performance during testing. The committees asked that current project funding be used to complete software development and to correct test bed deficiencies. Instead of continuing with a technology demonstration project, the Secretary of Defense was to provide the Congress with an acquisition plan by September 30, 1980, for joint service development and acquisition of a fielded system. This system was to build on BETA software already developed and make maximum use of common hardware.

GAO reviewed the status of the BETA project and concluded that:

--Its capabilities were not sufficiently developed and tested to provide a baseline for the early fielding of an operational system, and considerable corrective action is needed to achieve this goal. For example, it does not process the required volume of sensor data or process

the data within required response times. The current test phase needs to be completed to provide sufficient technical information for the engineering development effort directed by the Congress. (See pp. 13 and 24.)

- Pressure from Department of Defense management to test BETA in a September 1980 European demonstration contributed significantly to project development problems such as cost growth and reduced performance requirements. (See p. 24.)
- Prior to congressional direction to form a joint service project, the Air Force was the only service committed to using the BETA design and software to facilitate the early fielding of an operational correlation system. (See p. 5.)
- The Army, which requires functions in addition to those provided by BETA, planned further test bed experiments while it continued analyzing its correlation system requirements. The Navy and Marine Corps foresee very limited application of present BETA technology to their projects. (See pp. 7, 9, and 11.)

#### RECOMMENDATIONS

In view of development problems experienced by the BETA project, GAO recommends that the Secretary of Defense include the following provisions in the revised project plan requested by the Congress:

- The principal objective of future BETA efforts should be to support the early fielding of a joint service tactical echelon correlation system to meet Army and Air Force operational requirements for the 1980s.
- An overall schedule for system engineering development and early fielding, as well as corresponding funding requirements.

- An orderly, well-planned, software development process that progresses based on achievement of performance goals instead of a time schedule. This process should start with a 6 to 8 month "find-and-fix" phase to correct major software discrepancies in the test bed.
- A firm Army commitment to utilize the BETA system architecture to fulfill a portion of its tactical fusion requirements, so that a joint project can make maximum use of existing software and common hardware.
- Navy definition of a technical approach for integrating BETA's ground target nominations into shipboard command and control systems.
- Marine Corps analyses comparing its correlation system requirements with planned BETA capabilities, and subsequently, a plan that defines how BETA can be used to satisfy these requirements.
- An acquisition strategy that will maximize use of BETA software to the extent technically feasible. (See p. 25.)

#### AGENCY COMMENTS

The Department of Defense suggested that GAO clarify statements concerning the services' intended use of BETA technology:

- The Army intends to use BETA technology where appropriate. However, it declined to make a commitment at this time to use the BETA system architecture, and it wishes to consider the applicability of another system under development.
- The Navy agrees with the need to define a technical approach for providing information on ground targets to its forces, but believes that it is premature to assume that BETA's ground target nominations should be integrated into shipboard command and control systems.

--The Marine Corps advised that it will evaluate the applicability of BETA technology to a system currently under development. (See p. 26.)

CONTRACTOR COMMENTS

TRW, Inc., considers this report to be objective and constructive and advises that the "find-and-fix" phase is being conducted and progress has been made in correcting the technical problems which existed during GAO's review. (See p. 19.)



C o n t e n t s

		<u>Page</u>
DIGEST		i
CHAPTER		
1	INTRODUCTION	1
	Development history and plans	2
	Objectives, scope, and methodology	3
2	SERVICES PLAN LIMITED UTILIZATION OF BETA TECHNOLOGY	5
	Benefits achievable through transfer of BETA technology	5
	Air Force planned use of BETA technology	6
	Army is uncertain about requirements	7
	Navy plans limited use of BETA technology	9
	Marine Corps foresees limited BETA application	11
3	BETA CAPABILITIES WERE NOT SUFFICIENTLY DEVELOPED FOR EUROPEAN TESTING IN 1980	13
	BETA capabilities reduced to meet self-imposed time schedule	13
	Laboratory testing disclosed performance problems	15
	Contractor comments	19
4	BETA PROJECT HAS SIGNIFICANT COST GROWTH	21
5	THE CONGRESS REDIRECTED THE BETA PROJECT	23
6	CONCLUSIONS, RECOMMENDATIONS, AND AGENCY COMMENTS	24
	Conclusions	24
	Recommendations	25
	Agency comments	26
APPENDIX		
I	Letter dated December 4, 1980, from Communications, Command, Control, and Intelligence, Assistant Sec- retary of Defense	28

		<u>Page</u>
<b>APPENDIX</b>		
II	Letter from the BETA Project Manager, Defense and Space Systems Group of TRW, Inc.	35
III	Schematic of BETA architecture	40
IV	Pictures of BETA test bed subsystems	41
V	Deletions in BETA system functional requirements	43
VI	Second phase of deletions in BETA system functional requirements	45

ABBREVIATIONS

ASAS	All Source Analysis System
BETA	Battlefield Exploitation and Target Acquisition
GAO	General Accounting Office
OSD	Office of the Secretary of Defense

## CHAPTER 1

### INTRODUCTION

Military commanders have a need to

- support near real-time targeting;
- identify enemy axes of advance and capabilities with sufficient detail and at sufficient range to allow the timely and effective deployment of friendly forces, at all tactical levels, and to support operations to intercept enemy forces; and
- rapidly determine high value targets, such as enemy command and control systems, to allow immediate exploitation by commands at all levels.

To help meet these requirements, the Battlefield Exploitation and Target Acquisition (BETA) test bed <sup>1</sup>/ project was conceived to demonstrate the feasibility and utility of prompt coupling of target acquisition sensors into tactical combat situation displays and firepower systems.

The BETA test bed is essentially composed of ground stations which receive sensor messages, correlation centers (sometimes referred to as fusion centers) that automatically process the sensor data, operator terminals for displaying and correlating the information, and communications equipment to route messages and distribute reports. The BETA project requires a complex arrangement of personnel and equipment, including computers and software, to handle the large volume of sensor data within established time frames.

Sensor messages provide intelligence data on potential ground threats, such as artillery sites, command posts, assembly areas, air defense sites, and tank formations. These messages include data on location of threat, time of detection, and identification of target type. After this data is passed to a BETA correlation center, it is automatically organized and correlated with intelligence data already on file to create an updated record on the threat entity.

---

<sup>1</sup>/A test bed is an experimental model of a military system which is used to develop and test new technology.

Alphanumeric or graphic data can then be displayed at operator terminals for intelligence analysts' use. (See app. III for schematic of BETA architecture and app. IV for pictures of test bed subsystems.)

Specifically, the BETA project was conceived on the premise that timely correlation and dissemination of near real-time sensor data can be used to enhance the selective application of firepower against a numerically superior force. The Office of the Secretary of Defense (OSD) believes that the projected enemy threat in a major conventional conflict requires a highly responsive command, control, communications, and intelligence system to allocate and maneuver forces effectively and to select and strike critical targets successfully. Also, successful combat requires air and ground forces to have a common perception of the battlefield and a highly responsive interaction. This requirement includes automating the correlation and dissemination of sensor reports to ensure timely battlefield use of intelligence data. When advanced sensor systems are fielded, they will accurately detect and identify enemy land targets at long ranges and may provide the continuous capability to see the battlefield and produce large volumes of precise data. Automation is required because this vast volume of data could not be assimilated, correlated, and displayed using manual methods.

#### DEVELOPMENT HISTORY AND PLANS

The need for an experimental system was identified after several years of study by the Defense Advanced Research Projects Agency. Based on the Agency's proposal, in May 1977 the Undersecretary of Defense, Research and Engineering directed the services to support the Agency in developing BETA. This system was to be tested during a European exercise scheduled for September 1980.

The Army and Air Force elected to carry out this direction and, with OSD approval, established a joint project office in September 1977. The Army was assigned to manage the project. In November 1977 a Request For Proposal was issued to obtain a system contractor. A letter contract was signed in March 1978 with TRW, Inc. The contractor's effort included developing software and integrating it with hardware obtained from subcontractors. The definitized contract was signed in August 1978 after congressional approval of additional project funding. This funding approval was conditional upon (1) active participation in the BETA project by the Navy,

the Marine Corps, and the national intelligence community so that BETA would be a Department of Defense-wide program and (2) development of a processing system which would handle sensor data from all services, including national intelligence systems.

In January 1980 OSD approved a plan for continuing the BETA technology development after the European demonstration. The objectives of this plan were to (1) complete development of software functions previously eliminated, (2) make software improvements which are necessary to support wartime data loads on the system, (3) develop a battlefield simulator to permit evaluation of BETA and follow-on service systems at expected combat data loads, and (4) participate in field exercises to support evaluation of evolving sensor and communications technologies while demonstrating interoperability with other command and control systems. The BETA project was estimated to cost \$98 million through completion in fiscal year 1984.

#### OBJECTIVES, SCOPE, AND METHODOLOGY

We evaluated the BETA project to determine if project objectives were being achieved and if it was cost effective to continue as planned with the test bed development. Accordingly, we reviewed (1) planned test bed capabilities to ascertain the extent of automation being provided, (2) results of tests and evaluations to determine if the current test bed configuration met contract specifications and was operationally effective, and (3) service plans for utilizing BETA technology to ascertain if the expected benefits justify project cost. We periodically discussed our findings in detail with staffmembers from the House Permanent Select Committee on Intelligence and the Subcommittee on Defense, House Committee on Appropriations.

We examined project plans, correspondence, contract specifications, test plans and reports, and cost estimates and observed BETA tests which were performed during the review. In addition, we interviewed project management officials responsible for BETA development and service officials who developed requirements for, or managed, related projects which were considering the application of BETA technology. Our review was principally conducted at the BETA Project Office, Harry Diamond Laboratories, Adelphi, Maryland. In addition, we visited the following contractor and service organizations:

--TRW, Inc., Redondo Beach, California.

- Department of the Army Headquarters, Washington, D.C.
- All Source Analysis System Project Office, U.S. Army Electronics Research and Development Command, Vint Hill Farms, Virginia.
- U.S. Army Training and Doctrine Command organizations at Fort Monroe, Virginia; Fort Huachuca, Arizona; and Fort Leavenworth, Kansas.
- Chief of Naval Operations, Washington, D.C.
- Air Force Systems Command, Washington, D.C.
- Air Force Tactical Air Command, Langley Air Force Base, Virginia.
- Tactical Fusion Division Project Office, Electronics System Division, Hanscom Field, Massachusetts.
- Marine Corps Director of Intelligence, Washington, D.C.

## CHAPTER 2

### SERVICES PLAN LIMITED UTILIZATION

#### OF BETA TECHNOLOGY

One of the principal objectives of the BETA project was to develop computer-based intelligence data processing technology that would facilitate interoperability and equipment standardization among the services for correlation center operations. However, significant research and development funds were invested in the BETA project without adequate service commitment to directly apply the technology to ongoing or planned correlation center developments. The Air Force was the only service committed to using the BETA test bed design and software to facilitate early fielding of an operational system. The Army was uncertain about its system requirements and was only committed to further BETA test bed experimentation. The Navy and Marine Corps are monitoring BETA project results and are considering participation in joint exercises, but these services foresee very limited application to their own projects at this time.

The BETA test bed is specifically designed to satisfy service requirements for fusing intelligence data involving ground targets. Recognizing that future BETA tests may disclose some service unique requirements, a joint service development effort, using the same intelligence data processing technology, fosters considerable interoperability in battle management as well as significant cost savings. The benefits to be realized by this approach should substantially outweigh the disadvantages.

#### BENEFITS ACHIEVABLE THROUGH TRANSFER OF BETA TECHNOLOGY

Specific benefits that could be realized by the BETA project include the following:

- Development of automated data correlation and situation display techniques for responsive dissemination and processing of sensor information.
- Identification of communication requirements to support multiservice sensor utilization.
- Assistance to the North Atlantic Treaty Organization in defining requirements for automated facilities at the tactical level.

--Provision of a suitable test bed for the services to validate functional requirements and develop software and procedures for effective command and control of joint tactical forces, particularly during a time of crisis.

--Development of software for direct transfer to correlation center projects, facilitating the early fielding of operational systems.

Some of these benefits have already been realized. For example, communications protocols, message standards and formats, and operational procedures for joint service utilization of sensor data have already been developed. Also, the BETA project has developed working interfaces with 12 separate sensor systems that formerly operated with their own message standards and computer architectures. Project officials have advised that if the technology lessons learned from BETA are adopted by our military, this would greatly facilitate interoperability and equipment standardization. This would provide a substantially improved capability for giving operational direction to our military, particularly during a time of crisis. Irrespective of these benefits, the services' planned use of BETA technology will be limited.

#### AIR FORCE PLANNED USE OF BETA TECHNOLOGY

The Air Force has a requirement for a mobile, real-time system that can process and correlate large volumes of intelligence data. This volume of data is expected to increase substantially in the 1980s. To meet this requirement, the Air Force planned the development of the Tactical Fusion Division System. Although a system feasibility study was completed in 1977, the Air Force deferred system development efforts because of the BETA project. Subsequently, the Air Force planned to start the engineering development of the Tactical Fusion Division System during fiscal year 1981, using BETA software and compatible computer equipment which meets military specifications. The Air Force planned to field an operational system in 1984.

The Air Force's plan is not without some technological risks. For example, although adequate for test bed purposes, commercial off-the-shelf computers and related equipment used for the BETA project are too large, heavy, and fragile to meet the Air Force's mobility requirements. Versions of computers used in the BETA correlation center which meet military specifications are available from vendors, but a



major effort will be needed to develop suitable operator terminals which can both meet mobility requirements and use BETA-developed software with minimal change. This will require specification of a terminal design that is compatible with the instruction set architecture of the terminals used in the BETA test bed. Air Force officials see this operator terminal development as a major risk.

Another major risk associated with the BETA project is software development. The Air Force has a mission requirement to process up to 4,000 sensor messages an hour. Although this requirement was included in BETA's contract specifications, to date the BETA test bed has not been tested at that message load. During initial system integration testing, BETA could not operate under a message load exceeding 1,300 messages an hour. In addition, the Air Force believes that future testing may identify some unique service requirements.

#### ARMY IS UNCERTAIN ABOUT REQUIREMENTS

The Army plans to field a partial All Source Analysis System (ASAS) capability by 1985 while it develops the full system capability it believes is required for the future. In addition to correlation and dissemination of sensor data, ASAS capability will include other intelligence management functions to support corps and division echelon commanders. The initial system, designated "Early Fielding ASAS," was to include automated input processing and data base retrieval and display, but automated analysis would have been limited. The Army intended to incorporate capabilities of existing programs, such as BETA, to the extent feasible. The Army is currently studying overall ASAS design and functional requirements. However, at the time of our review, the Army was uncertain to what extent BETA-like capabilities would be incorporated. Also, the Army wanted to analyze the results of BETA testing before it committed itself to direct software transfer to support an early fielding of ASAS. At the present time, the Army is committed to test bed experiments to validate ASAS requirements.

In July 1978 the U.S. Army Training and Doctrine Command proposed ASAS development. Army Headquarters approved this proposal in February 1979, with the condition that an indepth operational concept and functional description study be prepared. Further, initial efforts were limited to signal intelligence/electronic warfare functions, and BETA project results were to be assessed for applicability to the ASAS requirement.

A plan was formulated to concurrently test BETA with an automated files management system, called the Technical Control and Analysis Center, and an advanced development model of an ASAS subsystem for compartmented processing of special intelligence data. Test results were to be used for defining requirements for automated intelligence information processing at both corps and division echelons so that an ASAS engineering development program could start in fiscal year 1981. This evaluation was to be performed during fiscal year 1980 in both the United States and Europe. According to Army officials, this plan could not be implemented because Technical Control and Analysis Center development fell 18 months behind schedule due to a delay in reprogramming funds.

Under the Army's revised acquisition strategy, various system options were being considered to fulfill the requirement for early fielding of ASAS. These options included a version of BETA which meets military specifications, the Tactical Control and Analysis Center, an Interim Tactical Electronic Intelligence Processor, and an Intelligence Information Subsystem. According to Army officials, the choice was to be made by the end of 1980, after completion of a study to define functional requirements.

Requirements definition for the advanced ASAS is scheduled for completion in September 1982, after the Army assesses BETA test results and conducts experiments with the test bed to further develop functional system descriptions, operational concepts, and doctrine. Like the Air Force, the Army requires the capability to process several thousand messages an hour. Therefore, the Army faces the same problem in evaluating current BETA test results to determine if its design will provide adequate communications processing capability.

#### Army comments

In commenting on a draft of this report, the Army (1) disagreed that it should be committed to using BETA to fulfill its requirements, (2) disagreed that it was uncertain about its system requirements, and (3) objected to calling the Technical Control and Analysis Center an automated files management system.

The Army advised that ASAS requires functions in addition to those planned for the Tactical Fusion Division System, and that these functions are not within the scope of

the BETA development. Therefore, BETA cannot fulfill the total ASAS requirement, which includes processing, special compartmented information, control of sensors, and other intelligence functions. However, the Army stated that it intends to use BETA technology and methodology for the subset of ASAS, which is called collateral processing, where appropriate. The Army declined to use the currently configured test bed as the total baseline hardware architecture, noting hardware development for the Technical Control and Analysis Center and the ASAS Signal Intelligence and Electronic Warfare Subsystem programs. However, we observed that failure to use the BETA system architecture for the collateral processing subset will preclude using major portions of the BETA software which has already been developed over the past 2 years and will further preclude the early fielding of an operational system. For example, we noted there would be changes in software for input and processing of sensor messages and correlating data and for presenting target nominations at the operator terminal.

The Army advised that a version of the Technical Control and Analysis Center will process special compartmented information. Further, the Center will provide for automatic record traffic message inputting, automatic extraction of data from selected record traffic and manually inputted messages, correlation of parametric data, automated analysis routines, and automated support to mission management. We reviewed the status of the Center's development and found that while previously described functions have been specified and designed, only a small portion of the software has been developed. Completion of Center development is scheduled for mid-1982. Subsequently, an upgrade program is scheduled to add color graphics for the operator consoles, which is similar in capability to the BETA operator terminals.

NAVY PLANS LIMITED USE  
OF BETA TECHNOLOGY

The Navy's involvement in the BETA project was limited to providing a sensor system for the planned European demonstration and investigating methods of communicating correlation center data between maritime and land-based forces. The Navy believes there is a significant difference in correlation system capabilities required to track highly mobile naval targets versus static ground targets in a land battle. Therefore, the Navy believes that large scale application of BETA to support the Navy's requirement is not feasible and

there is no plan to utilize present BETA-like hardware or software in Navy correlation systems. Navy involvement in future BETA efforts will include participation in a planned joint service exercise. The BETA post-1980 development plan states several potential scenarios in which a land-based BETA-like correlation center could be useful to Navy operations:

- In an amphibious operation during a land battle, the Navy could use the land-based correlation center information to coordinate air support and targeting. By providing a ground situation display, the center would support the command and control of the amphibious operation.
- A land-based correlation center could help direct naval gunfire support through ground displays through its target nomination capability. The ability to link target acquisition sensors to gunfire support ships would enhance all-weather, day/night, standoff targeting.
- A land-based correlation center could provide targeting support for ship-launched missiles against land targets.

If the above requirements are to be supported, ground target nominations must be integrated into shipboard command and control systems. At the time of our review, the Navy had not developed a technical approach to accomplish this integration.

Although the Navy was scheduled to participate in the 1980 BETA European demonstration, this testing would not have included the above scenarios because of the demonstration's location in central Europe. Therefore, BETA's ability to support the Navy's involvement in joint operations would not have been evaluated.

#### Navy comments

In commenting on a draft of this report, the Navy advised that present BETA hardware and software are similar to a current Navy operational correlation system tailored to maritime target data processing. Thus, present BETA technology does not significantly improve current Navy operational capabilities.

The Navy agrees that BETA-derived information on ground targets should support naval forces, but believes that it is premature to assume that BETA's ground target nominations should be integrated into shipboard command and control systems. The Navy agrees with the need to define a technical approach for providing BETA-derived information to its forces and advises that it will consider the possible use of graphic display terminals already in the Navy's inventory.

MARINE CORPS FORESEES  
LIMITED BETA APPLICATION

Current Marine Corps participation in the BETA project consists of observing the test program. Following the June 1978 congressional direction to include Marine Corps participation in the BETA project, it was determined that the Marine Corps had no real-time sensor system to interface with the BETA test bed during the planned European demonstration. Results of this demonstration were to determine potential BETA application in developing related Marine Corps systems. We found that there was no detailed analysis of BETA's ability to satisfy Marine Corps intelligence processing requirements. Nevertheless, Marine Corps officials advised that a system under development, called the Intelligence Analysis Center, will satisfy its requirements, and there is no plan to implement BETA. The Marine Corps plans to participate in a joint service exercise to evaluate communications interoperability with BETA and other command and control systems.

The similarity of intelligence needs in land warfare raises a question whether any substantive difference exists between Army and Marine Corps information requirements, and the need for the Marine Corps to continue development of systems having functions similar to those included in BETA. Therefore, the Marine Corps effort may nearly duplicate the BETA effort and continued development of the Intelligence Analysis Center could compound the existing problem of software and equipment compatibility and interoperability among and between the services. Compatibility and interoperability of equipment and software become extremely important during crisis management and periods of armed conflict.

Marine Corps comments

In commenting on a draft of this report, the Marine Corps advised that it has informally analyzed its correlation system requirements and determined that there is no current requirement for BETA capabilities. However, it will continue to

monitor results of the BETA project and will consider using developed technology to meet future requirements.

The Marine Corps believes that there are substantive differences between Army and Marine Corps information requirements and the methods of handling information. This is because it operates in an amphibious warfare environment and it manages information at a different organizational level than the Army.

The Marine Corps disagreed that development of the Intelligence Analysis Center was redundant to a BETA-like system. The Center's function is to provide a detailed, comprehensive intelligence data base and is not intended to handle raw sensor data. Instead, sensor data processing and correlation will be performed by the Marine Tactical Combat Operations System, currently under development. We were advised that a test bed for this system is being developed and BETA software has been requested for use in this effort. Using the test bed, the Marine Corps intends to determine the applicability of BETA-derived technology to Marine Corps automated data processing systems.

### CHAPTER 3

#### BETA CAPABILITIES WERE NOT SUFFICIENTLY

#### DEVELOPED FOR EUROPEAN TESTING IN 1980

BETA test bed capabilities have not been sufficiently developed to warrant field testing in Europe. Although BETA is heavily dependent on software to perform its functions, the software was not developed under an orderly process. We found that management actions taken to meet scheduled milestones violated sound software development practices. Further, there are serious technical problems and the test bed performance does not meet contract specifications.

As of July 1980, BETA had not successfully completed system integration tests. Laboratory testing has disclosed that the test bed does not (1) function correctly, (2) process the required volume of sensor messages, or (3) process the data within required response times. Further, testing was not sufficient to evaluate whether BETA's design could meet contractual requirements. Considerable corrective action will be needed before the BETA project can provide an acceptable software baseline for early fielding of an operational system.

#### BETA CAPABILITIES REDUCED TO MEET SELF-IMPOSED TIME SCHEDULE

BETA development requirements were initially defined in a Request For Proposal issued to industry in November 1977. Required automated capabilities were to include:

- Correlation centers established at three echelons:  
Air Force tactical air control, Army Corps, and Army division levels.
- A capability to simultaneously process the input from 15 sensors plus other reports to a maximum of 4,000 reports an hour.
- Specific system response times for performing major functions, such as correlating data, processing data through the system, and responding to operator requests for information. Data correlation involves comparing new sensor reports with previous reports on file to update target status, and associating and displaying data for specific areas of interest.

--A capability to generate color graphic and alphanumeric tactical situation displays on operator terminals and an ability to transmit displayed data to other operator terminals and between correlation centers.

On December 4, 1978, the system specification was revised to define functional capability requirements in more detail and to provide a plan for verifying that test bed performance complied with stated requirements. Project officials believe that this revised specification required more capability than the original Request For Proposal.

After the contractor revealed that the full test bed capability defined by the contract could not be accomplished within estimated program cost and time schedule milestones for the 1980 European demonstration, the BETA project was restructured to fit the schedule and available funds. Accordingly, the system specification was again revised on January 26, 1979, to reflect the reduced scope of the project. (See app. V for examples.) The test bed configuration represented by this specification was dubbed "Bare Bones BETA" by the project office.

In August 1979 the project office directed additional deletions in automated functional capabilities after determining this action was needed to keep the project on schedule. (See app. VI for examples.) The project office designated this configuration "Bare Bones BETA Minus." Project officials believed that these software functions were not required for the 1980 European demonstration.

Generally speaking, the changes in requirements occurred in three areas:

- Elimination of the Army division correlation center. Instead, remote display systems which are essentially operator terminals, were substituted to partially offset the loss of correlation center capability.
- Elimination of selected but necessary automated functions to assist in processing a large volume of sensor reports.
- Deletion of selected automated functions to assist system operators in managing sensors.

According to project plans, the deleted requirements were to be reinstated during the next project phase. As evidenced by a February 1979 BETA project director memorandum, the



changes in requirements which defined the Bare Bones BETA configuration were made primarily to meet the scheduled 1980 European demonstration time schedule as directed by OSD. Even with the changes, he considered that meeting the schedule presented a very high risk. He believed that deletion of the division correlation center was a major loss of planned capability and that some of the deleted software requirements were significant. Nevertheless, he considered the Bare Bones BETA configuration to have sufficient capability to support the European demonstration. This is because it would provide sensor interfaces, message handling procedures, multiuser sensor data distribution, a data base and displays to support manual analysis, and remote dissemination of information. He believed that, considering the low sensor message load expected during the European exercise, Bare Bones BETA would be capable of other-aided sensor data correlation, resulting in near realtime target location.

We discussed the impact of the deleted requirements with officials from Army and Air Force activities responsible for defining system requirements. They agreed that deleted hardware and software requirements were significant reductions in test bed capabilities and believed that it was desirable to include these requirements in the current configuration.

#### LABORATORY TESTING DISCLOSED PERFORMANCE PROBLEMS

The BETA project plan, dated May 8, 1979, established a series of major test, training, and evaluation milestones leading up to the 1980 European demonstration. After these events were held, BETA officials concluded that BETA failed major test phases and was not ready to proceed with the European demonstration. Overall, the test results showed that the Bare Bones BETA Minus test bed had serious software discrepancies which precluded it from functioning correctly. Further, it cannot process the specified volume of sensor data nor process the data within specified response times. Also, we found that adequate documentation was not prepared to validate test results, and system integration tests and training exercises were started before previous test phases were successfully completed. Further, configuration control was lost over software changes made to correct discrepancies disclosed by testing. The following sections describe the objectives and results of the three major testing milestones: correlation center integration, system integration, and command post exercises.

### Correlation center integration testing

This test phase consisted of integrating and testing the functional capabilities of the four major software segments: applications, communications, operator terminal, and system support. This integration activity consisted of introducing new software components into the software test configuration to verify that each computer processing mode could execute functional tasks without significant anomalies.

According to correlation center integration test plans, test results were to be documented to validate that system functional requirements were met. Further, discrepancies identified during this test phase were to be corrected before system integration testing was started. We found that the contractor did not meet either of these two conditions.

It should be noted that this test disclosed 1,258 software discrepancies, some of which were considered significant by the BETA Project Office. At the time of the system integration test, 216 of these discrepancies were unresolved, 17 were deferred for further study, 65 were logged pending classification, and the remaining 960 were closed.

Examples of significant software discrepancies noted during testing included the following:

- Communications segment. Heavy message traffic results in transmission errors, illegal message routing, and total system collapse. There are also frequent transmission errors and loss of synchronization when sending messages to the operator terminals.
- Operator terminal segment. Operator terminals frequently lockout and require reload. Operator cannot qualify a query by location error, target nomination status, or targetability. Also, a radio query cannot be qualified by frequency. Canceling an in-process query sometimes results in display of incorrect information. The same query at different terminals results in display of different information.
- Data storage and retrieval segment. Under heavy load conditions this segment fails to respond properly to open calls for information. This causes the entire BETA process to shut down.

### System integration tests

The objective of system integration testing is to verify that the test bed meets specified system performance requirements. This testing is being conducted at the contractor's facility in Redondo Beach, California. A demonstration was scheduled for May 29, 1980, to show top management that this phase was successfully completed.

We observed the May 29 demonstration and noted that BETA did not function properly. Project officials concurred with our observation. For example, half of the operator terminals were inoperable or appeared unable to communicate with the correlation centers. The terminals which were operable were unable to execute some of the basic information queries to the correlation centers. At the time of our visit, data could not be obtained on (1) system availability, (2) response time in executing functions, or (3) the capability to process and correlate the required volume of sensor messages. This was because this test phase was just starting instead of ending as scheduled and no data had been accumulated. The numerous hardware and software problems in getting the system to function resulted in only limited integration tests being performed. The project office now estimates that this test phase will not be completed until February 1981.

In addition to observing the demonstration, we asked the contractor to provide documentation showing the results of correlation center integration testing. We were advised that the required documentation had not been prepared in the haste to meet the schedule for European testing. Therefore, project officials were unable to verify that system functional requirements were met. However, we were shown raw test case data for several processing modes which indicated the testing was being performed.

Lack of complete documentation also created another problem. When the contractor's software test team modified the software to correct problems disclosed by testing, it did not fully document the changes. Therefore, the contractor cannot readily determine how this version is really designed. This makes it very difficult to identify the causes of new problems and to implement a design change. Project officials characterized this situation as "loss of configuration control" and believe that this problem must be corrected before the software can provide an acceptable baseline for engineering development.

### Command post exercise

The command post exercise was held on July 7, 1980. Test bed equipment was located both at TRW's laboratory facility and at Camp Pendleton, California. According to the project plan, the exercise objective was to provide an initial user evaluation of BETA in a field environment, test technical interfaces of BETA subsystems, and evaluate how well military personnel were trained to operate the system. However, in view of the problems experienced during system integration tests, specific criteria were developed by the project office which oriented the exercise objective toward determining if BETA had sufficient technical capability to participate in the European demonstration. The criteria described the functional capabilities that had to be demonstrated before project management would approve shipping the test bed to Europe. Essentially, BETA had to successfully complete system integration tests and demonstrate specified functional capabilities when processing 1,000 simulated sensor messages an hour (versus the specified rate of 4,000 messages an hour).

We also observed the command post exercise and found that test bed performance did not pass the criteria established by the project office. Many automated functions were unreliable and system hardware availability was not adequate. The project office believes that there are significant software problems affecting (1) capability to query the system for information, (2) operator terminal usability and availability, and (3) communications reliability.

After the exercise, the contractor was unable to provide test data showing that sensor reports processed during the exercise were properly correlated and file records were correctly updated. Therefore, project officials did not know if the tactical situation reports being displayed were accurate. Previous tests identified numerous correlation software discrepancies and data is needed to verify that software revisions have corrected the discrepancies.

We discussed the operator training program with training instructors and were advised that the test bed was too unstable to train military operators for the European demonstration. They believe that up to 4 additional weeks of training would have been needed before the operators could perform in the European demonstration. During June 1980, the project office attempted to train 53 terminal operators at TRW; however, the test bed did not operate well enough to provide

adequate terminal time for training until the last week in June. By that time, 41 of the 53 trainees had departed. The 12 remaining trainees were retained to participate in the exercise and, therefore, received additional training.

A project official advised that only limited performance testing was held before the exercise because the system did not work well enough to perform the tests required by the system integration test plan. Further, he advised that due to software problems, the test bed was unable to operate under a sensor message load exceeding 1,300 messages an hour.

Project officials believe that system integration tests must be continued to determine whether the test bed design can adequately process the required sensor load, and if not, to identify needed changes to achieve this capability. They believe that the effort will require 6 to 8 months of additional testing.

#### CONTRACTOR COMMENTS

TRW, Inc., has commented on a draft of this report and advised that it considers this report to be an objective and constructive review of a difficult technological undertaking. Further, the contractor believes that it has recently made progress in correcting some technical problems. The following detailed observations were also provided by TRW, Inc.

- The program objective of developing a highly technical system within 2-1/2 years was extremely ambitious, but achievable. Due to slow program start-up and delays in completing system design, significant schedule compression in later portions of the program resulted. Further, the program development activities were restructured to achieve the European testing milestone in September 1980. This caused development tasks to be performed in parallel rather than following a slower paced and less risky sequential procedure. Also, it became necessary to defer all tasks which were not essential to the European demonstration, including software documentation.
- The specified requirement to process 4,000 sensor reports an hour is questionable, particularly with tight cost and schedule restrictions.

--Examples cited as communication software discrepancies were also related to other factors, such as hardware design problems and operator errors.

--Standard configuration control procedures were maintained on all major segments except the application's software, which was approximately one-sixth of the total software developed. This problem has been corrected.

--Operator terminal availability was the most significant problem which prevented BETA from participating in the European exercise. Numerous design changes have been identified and tested, and now terminal operation is extremely stable.

We are presently monitoring contractor efforts to correct software and hardware technical problems. Completion of testing to verify correction of reported discrepancies is scheduled for February 1981.

## CHAPTER 4

### BETA PROJECT HAS SIGNIFICANT COST GROWTH

The BETA project was estimated to cost \$98 million through completion in fiscal year 1984. In June 1980 project officials estimated that the first project phase would cost \$59 million, including \$46.5 million for the system contractor's effort. The \$39 million for the post-1980 development phase included \$9.6 million for inflation. The schedule below shows estimated funding contributions from Defense agencies involved in the project.

<u>Agency</u>	<u>Funding contribution</u>		
	<u>Current phase</u>	<u>Post-1980</u>	<u>Total</u>
	----- (millions) -----		
Defense Advanced Research Projects Agency	\$10.80	\$ 0.00	\$10.80
Department of the Army	23.60	20.80	44.40
Department of the Navy	3.00	2.20	5.20
Department of the Air Force	21.10	14.50	35.60
Marine Corps	0.02	0.05	0.07
National Security Agency	0.30	0.00	0.30
Agency to be determined	<u>0.00</u>	<u>1.40</u>	<u>1.40</u>
Total	<u>\$58.82</u>	<u>\$38.95</u>	<u>\$97.77</u>

When the cost plus award fee contract was signed with TRW, Inc., in March 1978 to develop the test bed for a September 1980 European demonstration, the project office estimated the cost to be \$21.2 million. As of May 1980, estimated contract costs have grown \$25.3 million. <sup>1/</sup> This cost growth would have been even higher if development of various software functions and acquisition of hardware items had not been deferred until

<sup>1/</sup>Includes \$3 million in additional requirements added by the project office.

the next phase of the project. Project office personnel attributed most of the cost growth to the contractor's difficulty in (1) initially understanding functional requirements, (2) obtaining experienced computer professionals in California, and (3) obtaining acceptable hardware and software from subcontractors.

In our March 1980 report to the Chairman, Subcommittee on Defense, House Committee on Appropriations (LCD-80-38), we stated that the cost growth totaled \$20.1 million. About 2 months later, project officials estimated that the cost growth would total \$25.3 million. Project officials stated that the additional \$5.2 million would be needed to correct both hardware and software discrepancies disclosed during laboratory testing.



## CHAPTER 5

### THE CONGRESS REDIRECTED THE BETA PROJECT

In our March 3, 1980, report, we questioned the project's readiness for a European test and recommended that several options be considered before authorizing additional funds. These options included delaying the European test until more comprehensive field tests could be conducted, terminating the project, or deferring approval of additional funding until more current and reliable test results become available.

OSD subsequently requested the Congress to approve the reprogramming of \$6.7 million to cover known and anticipated cost growth for completing the initial, but degraded phase of the project. After the Congress questioned OSD about our concerns, in April 1980 the House Permanent Select Committee on Intelligence advised the Secretary of Defense that \$3.7 million of the requested \$6.7 million would be deferred until June 1980, when the results of the system integration tests could be assessed. Further, the Committee advised that continued funding of BETA would be contingent on the successful completion of the European demonstration or the presentation of an acceptable alternative test demonstration plan.

In June 1980 the House Committee on Appropriations and the House Permanent Select Committee on Intelligence learned that system integration test results were unsatisfactory. The reprogramming request was approved subject to certain conditions. The Committees noted BETA's development schedule slippage, inordinate cost increases, reduced capabilities, and poor performance during testing. Therefore, the Committees asked that the reprogramed money be used to complete the software effort and to correct system deficiencies. Further, future project efforts were directed toward acquiring a common fusion system for the Army and Air Force at the earliest date possible. Instead of continuing with a technology demonstration project, the Department of Defense was requested to provide the Congress with a plan <sup>1/</sup> showing milestones and funding requirements for joint service development of a fielded system, building on BETA software and making maximum use of common hardware.

---

<sup>1/</sup>The Secretary of Defense provided the plan to the Congress in October 1980. The Subcommittee on Defense, House Committee on Appropriations, asked us to thoroughly evaluate this plan following its submission to the Congress.

## CHAPTER 6

### CONCLUSIONS, RECOMMENDATIONS, AND AGENCY COMMENTS

#### CONCLUSIONS

Although the BETA project did not successfully meet its goals, time and money were heavily invested in developing the BETA technology. The services require intelligence correlation system capabilities, and we believe that the investment in BETA should be maximized. BETA capabilities have not been sufficiently developed and tested to provide a baseline for early fielding of an operational system. Therefore, we believe that several months of additional testing would be useful in achieving this goal. As a minimum, this testing would provide sufficient technical information for deciding on how to proceed with the engineering development effort directed by the Congress. For example, additional testing could identify fundamental changes needed in BETA's software to achieve acceptable performance or it could show that starting over with a different design is warranted. Testing conducted so far shows that:

- The test bed does not have the capability to process the required volume of sensor data. This capability is a critical element in the operational requirement defined by OSD. Problems with software precluded testing the system beyond 33 percent of the specified message load level. Therefore, the project office was unable to validate the test bed's ability to process specified sensor message loads.
- The software package has serious discrepancies which preclude the system from either functioning correctly or operating at specified design levels. Further, adequate software documentation was not prepared to validate test results, and the project proceeded into the system integration test phase before successfully completing previous test phases.
- While BETA is designed for automated correlation of sensor data inputs, some of the automated functions to assist system operators in controlling the high volume of data and managing sensors were deleted as requirements. Since these functions must be performed manually, it takes longer to nominate targets.

In addition to software development problems and reduced performance requirements, the project also experienced considerable cost growth--TRW's estimated development cost has more than doubled since the contract was awarded and now totals over \$46 million. We believe that pressure from OSD management to field test BETA in Europe by September 1980 contributed significantly to project development problems. In our opinion, a software-dependent system, such as BETA, should have been developed under an orderly process that is event-oriented, instead of driven by a time schedule.

The services have already invested almost \$60 million in BETA development to carry out a field exercise in Europe. If the project had proceeded to the next phase as planned, the total investment would soon approach the \$100 million threshold used by OSD for classifying projects as a major weapon system acquisition. Although the BETA project started out as a technology demonstration, the research and development effort now being performed to implement project objectives is characteristic of a weapon system's advanced development phase. Therefore, the services should resolve their basic requirement questions as early as possible so that management can effectively proceed with a joint service project.

In view of congressional direction to form a joint service correlation system project, we believe that the principal direction of BETA efforts in the immediate future should be to support the early fielding of a joint service tactical correlation system. Therefore, a reasonable attempt should be made to correct deficiencies which presently exist with BETA software so that, when combined with computer hardware that meets military specifications, it can be used to the maximum extent possible in an operational system.

#### RECOMMENDATIONS

We recommend that the Secretary of Defense include the following provisions in the BETA project plan:

- The principal objective of future BETA efforts should be to support the early fielding of a joint service tactical echelon correlation system to meet Army and Air Force operational requirements for the 1980s.
- An overall schedule for system engineering development and early fielding, as well as corresponding funding requirements. Further, this acquisition should

be managed by a single project office, responsible for accommodating both Army and Air Force requirements and for maintaining system configuration control.

- An orderly, well-planned, software development process with progress based on attainment of performance goals, instead of a time schedule. This process should start with a 6 to 8 month "find-and-fix" phase to (1) correct major software discrepancies and (2) attempt bringing the current test bed up to specified performance levels. After this phase is successfully completed, as evidenced by testing, service experimentation with the test bed should continue to identify and develop service-unique or advanced capabilities, which can be added during engineering development by future software/hardware upgrades.
- Firm Army commitment to utilize the BETA system architecture to fulfill a portion of its tactical fusion requirements so that the joint project can make maximum use of existing software and common hardware.
- Navy definition of a technical approach for integrating BETA's ground target designations into shipboard command and control systems.
- Marine Corps analysis comparing its correlation system requirements with planned BETA capabilities, and subsequently, a plan that defines how BETA can be used to satisfy those requirements.
- An acquisition strategy that will maximize use of BETA software in the engineering development model of the joint correlation system to the extent technically feasible. Essentially, this will require the contractor to provide computer hardware which meets military specifications and is compatible with BETA software.

#### AGENCY COMMENTS

The Department of Defense has suggested that we clarify statements concerning the services' intended use of BETA technology.

- The Army intends to use BETA technology where appropriate. However, it declined to make a commitment at this time to use the BETA system architecture, and it

wishes to consider the applicability of another system under development.

- The Navy agrees with the need to define a technical approach for providing information on ground targets to its forces, but believes that it is premature to assume that BETA's ground target nominations should be integrated into shipboard command and control systems.
- The Marine Corps advised that it will evaluate the applicability of BETA technology to a system currently under development.



COMMUNICATIONS,  
COMMAND. CONTROL,  
AND INTELLIGENCE

ASSISTANT SECRETARY OF DEFENSE

WASHINGTON, D.C. 20301

4 DEC 1980

Mr. R. W. Gutmann  
Director, Logistics and  
Communications Division  
U. S. General Accounting Office  
Washington, D. C. 20548

Dear Mr. Gutmann:

This letter is in reply to your letter dated October 20, 1980, to the Secretary of Defense regarding your report, "The BETA Project: An Evaluation of Defense Efforts to Develop an Automated System for Managing Battlefield Intelligence Data" (GAO Code 941192) (OSD Case #5395-A).

The Department of Defense has reviewed the draft of the subject report. A meeting was held with GAO in the Pentagon on November 6, 1980, to discuss comments and issues pertaining to the draft. Enclosed for your consideration are the appropriate comments which resulted from that meeting.

Sincerely,

A cursive handwritten signature in dark ink.

Gerald E. Dinnon

Enclosure

Comments on GAO Draft Report dated October 20, 1980, "The BETA Project: An Evaluation of Defense Efforts to Develop an Automated System for Managing Battlefield Intelligence Data" (GAO Code 941192) (OSD Case #5395-A)

1. Page iii, lines 14-22

- a. Draft - Prior to Congressional direction to form a joint service project, the Air Force was the only service committed to using the BETA design and software.....The Army planned further test bed experimentation while it continued analyzing its correlation system requirements.
- b. Comment: Paragraph is misleading in that comparability between the Army's All Source Analysis System (ASAS) and the Air Force's Automated Tactical Fusion Division (ATFD) is not as simple as implied. ATFD, as a collateral (non-compartmented) processing-only operation, can readily use BETA since it too relates to collateral processing and reporting. The Army has stated that it intends to use the BETA technology and methodology for that subset of the ASAS which pertains to the collateral process. However, it must be reiterated that the ASAS must also process special compartmented information, control organic sensors, and perform associated intelligence and OPSEC functions which were not within the scope of the BETA development.

2. Page iii, Last Sentence

- a. Draft - The Navy and Marine Corps foresee very limited application of BETA technology to their own projects.
- b. Comment: Future BETA correlation technology may have application to Navy systems. Present BETA technology does not significantly improve upon that utilized in operational Navy correlation systems tailored to processing of maritime target data.
- c. Recommendation: Insert "present" between "of" and "BETA."

3. Page iv, last sentence

- a. Draft - The plan should contain "a firm Army commitment that will use a militarized version of BETA to fulfill its requirements."
- b. Comment: Do not agree. BETA cannot fulfill all of the ASAS requirements as BETA project only encompassed collateral intelligence processing and reporting. Additionally, the term "Militarized version of BETA" connotes acceptance of the commercial hardware design ignoring our hardware development in the Technical Control and Analysis (TCAC) and ASAS SIGINT/EW subsystem programs. BETA technology will be evaluated and utilized where appropriate; however, we cannot agree to acceptance of a currently configured test bed as our total baseline hardware architecture. This can only be ascertained by the Program Manager in the evolution of the ASAS/ATFD systems.

4. Page V, First Paragraph/Page 35, Line 11
  - a. Draft - Navy definition of a technical approach for integrating BETA's ground target nominations into shipboard command and control systems.
  - b. Comment: Shipboard systems, not necessarily all available on a given ship, include those categorized as Command and Control, Combat Direction, and Intelligence Support. It is considered premature to assume BETA's ground target nominations should be integrated into shipboard command and control systems.
  - c. Recommendation: Replace sentence with: "Navy definition of a technical approach for providing BETA derived information to supporting Naval forces."
5. Page V, Recommendation
  - a. Draft - Marine Corps analyses comparing its correlation system requirements with planned BETA capabilities, and subsequently, a plan that defines how BETA can be used to satisfy these requirements.
  - b. Comment: The Marine Corps has informally accomplished this task. Technical advisors have determined that there is no present requirement for BETA capabilities, however, the technology continues to be monitored. The lack of the sensor assets which contribute to BETA make its use impractical by the Marine Corps.
  - c. Recommendation: Delete subject paragraph.
6. Page 7, lines 5-8
  - a. Draft - Significant research and development funds were invested in the BETA project without adequate Service commitment to directly apply the technology to ongoing or planned correlation center developments.
  - b. Comment: Statement is misleading. Both the BETA Project Plan and the Post 80 Addendum (which were concurred in by the services and approved by OSD) state that the BETA project will develop procedures and processes for the correlation of sensor inputs and target nominations. They further state that these software and procedures will be utilized to support fielding of service systems. The Army has supported these objectives throughout project evolution and fully intends to utilize the BETA technology along with ASAS SIGINT EW subsystem and Technical Control and Analysis Center (TCAC) technology, in the development of our ASAS program.



## 7. Pages 7, lines 11-13

- a. Draft - The Army was uncertain about its system requirements and was only committed to further test bed experimentation.
- b. Comment: Statement is misleading. The current Letter of Agreement (LOA) and the recently completed functional system description describe the All Source Analysis System (ASAS) requirements which will be formalized into a final ROC. Additionally, the ASAS requires both collateral (BETA) and special compartmented information processing as well as command and control functions, which dictates further experimentation with the "test bed" to ensure it meets Army requirements. Since the Air Force envisions its Automated Tactical Fusion Division (ATFD) as only a collateral processing operation, it can more readily "use the test bed design and software" as developed. Additionally, a review of the text in pages 11 through 13 portrays a logical strategy which does not equate to "uncertainty."

## 8. Page 7, lines 13-16

- a. Draft - The Navy and Marine Corps are monitoring BETA project results and are considering participation in joint exercises, both these services foresee very limited application to their own projects.
- b. Comment: Modify paragraph for accuracy.
- c. Recommendation: That the sentence be changed to read: "The Navy and Marine Corps are monitoring BETA project results and are considering participation in joint exercises, both these services foresee very limited application to their own projects at this time."

## 9. Page 12, first paragraph

- a. Draft - A plan was formulated to concurrently test BETA with an automated files management system, called the Technical Control and Analysis Center ...According to Army officials, this plan could not be implemented because Technical Control and Analysis Center development fell one year behind schedule.
- b. Comment: TCAC is not simply an "automated files management system." The TCAC provides for automatic record traffic message inputting, automatic extraction of data from selected record traffic and manually inputted messages, correlation of parametric data, automated analysis routines and automated support to mission management. The Advanced Development Model (Signal Electronics Warfare System) ADM (SEWS) and TCAC-D Division are identical in both hardware and software.

TCAC is approximately 18 months behind schedule due to delay in reprogramming of funds to accomplish the program. Funds were not approved for the program until November, 1979. Delivery of TCAD-D is now expected on or about 2D Qtr FY 82.

## 10. Page 13, line 21

- a. Draft - Therefore, the Navy believes that large scale application of BETA to support the Navy's requirement is not feasible and there is no plan to utilize BETA-like hardware or software in Navy correlation systems.
- b. Comment: Present BETA hardware and software is in fact similar to the Navy's currently operational correlation system tailored to maritime target data processing. Present BETA technology does not significantly improve upon current Navy operational capabilities.
- c. Recommendation: Change to read: "Therefore, the Navy believes that large scale application of BETA to support the Navy's requirement is not feasible and there is no plan to utilize present BETA developed hardware or software in Navy correlation systems."

## 11. Page 14, line 6

- a. Draft - By providing a ground situation display, the center would support the command and control of the amphibious operation.
- b. Comment: Clarification to recognize possible use of graphic display terminals already in Navy inventory.
- c. Recommendation: Change to read: "By providing ground situation information, the center would support the command and control of the amphibious operation."

## 12. Page 14, line 9

- a. Draft - A land-based correlation center could help direct Naval gunfire support through ground displays through its target nomination capability.
- b. Comment: Clarification to recognize possible use of graphic display terminals already in Navy inventory.
- c. Recommendation: Change to read: "A land-based correlation center could help direct Naval gunfire support by providing ground situation information to gunfire support ships."

## 13. Page 14, lines 18-22

- a. Draft - If the above requirements are to be supported, ground target nominations must be integrated into shipboard command and control systems. At the time of our review, the Navy had not developed a technical approach to accomplish this integration.
- b. Comment: Shipboard systems, not necessarily all available on a given ship, include those categorized as Command and Control, Combat Direction, and Intelligence Support. It is considered premature to assume BETA's ground target nominations should be integrated into shipboard command and control systems.

## 13. Page 14, line 18 (continued)

- a. Recommendation: Change to read: "If the above requirements are to be supported, BETA-derived information must be provided to supporting Naval Forces. At the time of our review, the Navy had not developed a technical approach to accomplish this."

## 14. Page 15, line 15

- a. Draft - The similarity of intelligence needs in land warfare raises a question whether any substantive differences exists between Army and Marine Corps information requirements, and the need for the Marine Corps to continue development of systems having functions similar to those included in BETA. Therefore, the Marine Corps effort may nearly duplicate the BETA effort and continued development of their IAC could compound the existing problem of software and equipment compatibility and interoperability of equipment and software becomes extremely important during crisis management and during periods of armed conflict.
- b. Comments: Differences do exist between Army and Marine Corps information requirements and the method of handling that information. The Marine Corps doctrinally operates in a different environment - amphibious warfare with primary support from the Navy - and will (probably) work the problem at a different level (the Army is concerned with Corps-level and higher including theater-level). A direct comparison of Army and Marine Corps requirements, with the assumption that these requirements are the same, is incorrect.

The Intelligence Analysis Center (IAC) does not duplicate ASAS functions. If anything, it should be compared with the Air Force Display Control/Storage Retrieval (DC/SR). The IAC, as does DC/SR, contains a detailed comprehensive intelligence data base. The IAC, through the Naval Intelligence Processing System (NIPS) digitized data base, provides the Landing Force Commander (MAGTF Commander) with his link to the Navy's intelligence system as well. It is not intended to handle rough combat information such as raw sensor reports, which may be used to develop near real time (NRT) targets. This follows the Air Force plan to have a Tactical Fusion Division (follow on to BETA) complement the DC/SR: the TFD will correlate NRT sensor reports, pass target nominations to the G-3 structure, this correlation would (probably) be performed in the Tactical Combat Operations (TCO) system, then passed to Marine Integrated Fire and Air Support System (MIFASS) for targeting, and the IAC for data base updates. The ASAS is intended to include the correlation capability, along with a very limited resident data base (at the division and corps levels), to support NRT targeting and tactical (combat) intelligence production only. The detailed intelligence data base, as duplicated by NIPS, is found at levels above Corps.

## 14. Page 15 (continued)

Interoperability. The IAC can accept JINTACCS formatted reports through the AUTODIN system. OSD has directed that selected service systems be fully interoperable with similar other-service systems. In the Marine Corps automated C<sup>3</sup>I program, this would be effected through the TCO system, our executive C<sup>2</sup> system, which would be expected to fully interoperate with equivalent service systems in the joint environment.

- c. Recommendation: That the paragraph concerning Army and Marine Corps information requirements and addressing the possible redundancy between the IAC and a BETA-like system be deleted in its entirety, and replaced with the following:

"Although many of the information requirements of the Army and the Marine Corps are similar on the surface, major differences exist in the environment in which the information is processed and the manner in which it is handled doctrinally. The Marine Corps is preparing to field its Intelligence Analysis Center which is functionally similar to the Air Force TIPI DC/SR and provides the Marine Air-Ground Task Force commander with a direct link to the Naval Intelligence Processing System. The Marine Tactical Combat Operations System (TCO), currently under development, will provide combat information and limited raw sensor data (to include target nominations for MIFASS) to the division level and below. A test bed for the TCO system is currently being fielded at Camp Pendleton, California. Personnel running this test bed have requested all BETA software deliverables to be utilized in further developmental work in order to determine the degree of applicability of BETA-derived technology to Marine Corps ADP systems. The TCO system eventually fielded in the 1990 time-frame will be fully interoperable with equivalent service C<sup>2</sup> systems, enhancing ease of joint service C<sup>2</sup>."

## 15. Page 27

- a. Draft - Department of the Navy funding line:

Current Phase	Post 1980	Total
1.00	2.20	3.20

- b. Comment: Clarification needed to include Navy funds provided in FY 79 as well as FY 80.

- c. Recommendation: Change to read:

Current Phase	Post 1980	Total
3.0	2.20	5.20

Mr. Richard W. Gutmann  
Director  
United States General Accounting Office  
Logistics and Communications Division  
Washington, D.C. 20548

Dear Mr. Gutmann:

We appreciate the opportunity to review and comment on your draft report on the BETA project. We consider the report to be an objective and constructive review of this difficult technological undertaking.

At the same time, we at TRW are proud of our performance on BETA and are pleased to provide the attached fact sheet which outlines the progress we have made since your review. In short, the BETA test bed is now in good shape. Full software documentation will be complete by 1 March 1981. The system has been stabilized and we feel it is now ready to serve as a vital technical cornerstone to the continuing development of a joint fusion capability.

Sincerely,

  
E. R. Mangold  
BETA Project Manager

Attach.

DEFENSE AND SPACE SYSTEMS GROUP OF TRW INC. • ONE SPACE PARK • REDWOOD BEACH, CA 94065 • (415) 339-4000

TRW COMMENTS ON SPECIFIC GAO CONCERNS

## INTRODUCTION/BACKGROUND

The BETA test bed program, a concept originally developed by DARPA, was initiated in March of 1978 under the management of a Joint Program Office. Its principal milestone was a European Demonstration in the Fall of 1980. The program to design and develop, within a 2-1/2 year period, a multi-service, high-technology system testing the feasibility of innovative state-of-the-art multi-sensor fusion/correlation concepts was extremely ambitious, but achievable. Due to a slow program start up and the January 1979 descoping which delayed the completion of system design phase, significant schedule compression was induced into the later portions of the program.

Subsequent to the successful Multi Center Demonstration in December 1979, it was emphasized to TRW by OSD&E that BETA was, in effect, a Quick Reaction Capability (QRC) program which had to achieve the European milestone in September 1980. To achieve this goal a major restructuring and prioritization of project activities was necessary. Major immediate effects of this redirection included the need to develop, integrate, test, and train in parallel rather than following slower-paced and less risky sequential procedures. It also became necessary to defer all tasks which were not essential to the European Demonstration. Key among those deferred tasks was software documentation.

Sensor Data Rate Processing/Response Time

Considerable attention has been focused on the BETA top level System Specification requirement to process 4000 reports/hour. This rate is predicated upon a hypothetical sensor suite collecting against a postulated 1990 Central European Front threat. Although it is a BETA requirement constraint, its validity is certainly questionable particularly with a tight cost and schedule restrictions.

In the European Certain Rampart FTX, a maximum data rate of from 200-500 reports/hour was predicted. To ensure success at this rate, BETA was required to demonstrate a processing capability of 1000 reports/hour during the CONUS

CPX. This rate was demonstrated consistently over the two-day CPX. Currently, BETA can process a sustained rate of 2400 reports/hour with peak rates of 4000 reports/hour over extended time periods. At these rates the correlation timeliness is less than two seconds per report against a specified requirement of five seconds.

#### DR Status

At the time of Correlation Center Integration Tests the Discrepancy Report (DR) status was as indicated, however, some amplification is warranted. The number of DR's is certainly reasonable and consistent with other software development efforts of this size and complexity. Many DR's were duplicate statements of the same problem, i.e., analysis and problem fixing simultaneously closes several DR's. In addition, the so-called deferred DR's represents a desired capability and "wouldn't it be nice if" instead of a legitimate specified system problem.

Examples cited as Communications Software discrepancies were, in fact, not always caused by software DR's, but by other factors such as:

1. Fibre optics hardware design problems which have been subsequently isolated and fixed, and
2. Operator error in affixing message routing indicators.

It is important to note that currently all DR's which were considered significant by the project office have been corrected.

#### Software Configuration Control

The GAO report indicates that Software Configuration Control was lost during the test and integration timeframe. This statement requires some discussion. The software developed, tested and integrated into the BETA system consists of several major packages, namely:

1. Communication software
2. Operator Terminal software
3. Data Base Management software
4. System Support software
5. RSX-11M Operating System software and
6. Applications software

Standard configuration control procedures were maintained on all major packages with the exception of the Applications software which comprised approximately one-sixth of the total software developed. The fast moving QRC pace of the integration phase during the last two months prior to the CPX overstressed the configuration management procedures that had been developed for the Application software. This resulted in a definite time lag between the integrated/ tested software and the appropriate official software documentation.

Subsequent to the CONUS CPX, this problem was corrected by baselining the Applications software and establishing a more responsive configuration control system.

#### Operator Terminal Availability

The single-most significant problem which prevented BETA from supporting the European exercise was specifically the Operator Terminal availability which at times has been improperly and erroneously described and measured.

The Operator Terminal (OT) is an advanced, state-of-the-art, microprocessor based computing system. These terminals were developed specifically in response to BETA's unique requirements for distributed processing. Numerous hardware design problems were discovered on the terminals as the terminal hardware and software were integrated. The principal manifestation of the hardware design deficiency was keyboard lockout, i.e., the OT would no longer respond to any operator actions causing the terminal to be totally inoperable until the entire terminal initialization process had been completed - this requiring about 15 minutes. It should be pointed out that despite numerous terminal lockout occurrences during the CPX demonstration; the correlated data base was never inaccurate nor destroyed. The significance of this is that upon reinitialization a terminal was again fully operational.

As a result of a determined and sustained effort by a combined TRM/Aydin Tiger Team numerous design changes have been identified and successfully tested yielding an extremely stable configuration. In addition and to provide further insurance, a fault tolerant warm start software fix has been identified and is being developed.



**SUMMARY**

The concerns illuminated by the GAO report were valid and were shared by TRM managers. Corrective action has been taken to the significant benefit of the BETA Test Bed Program.

APPENDIX III

APPENDIX III

SCHEMATIC OF BETA ARCHITECTURE

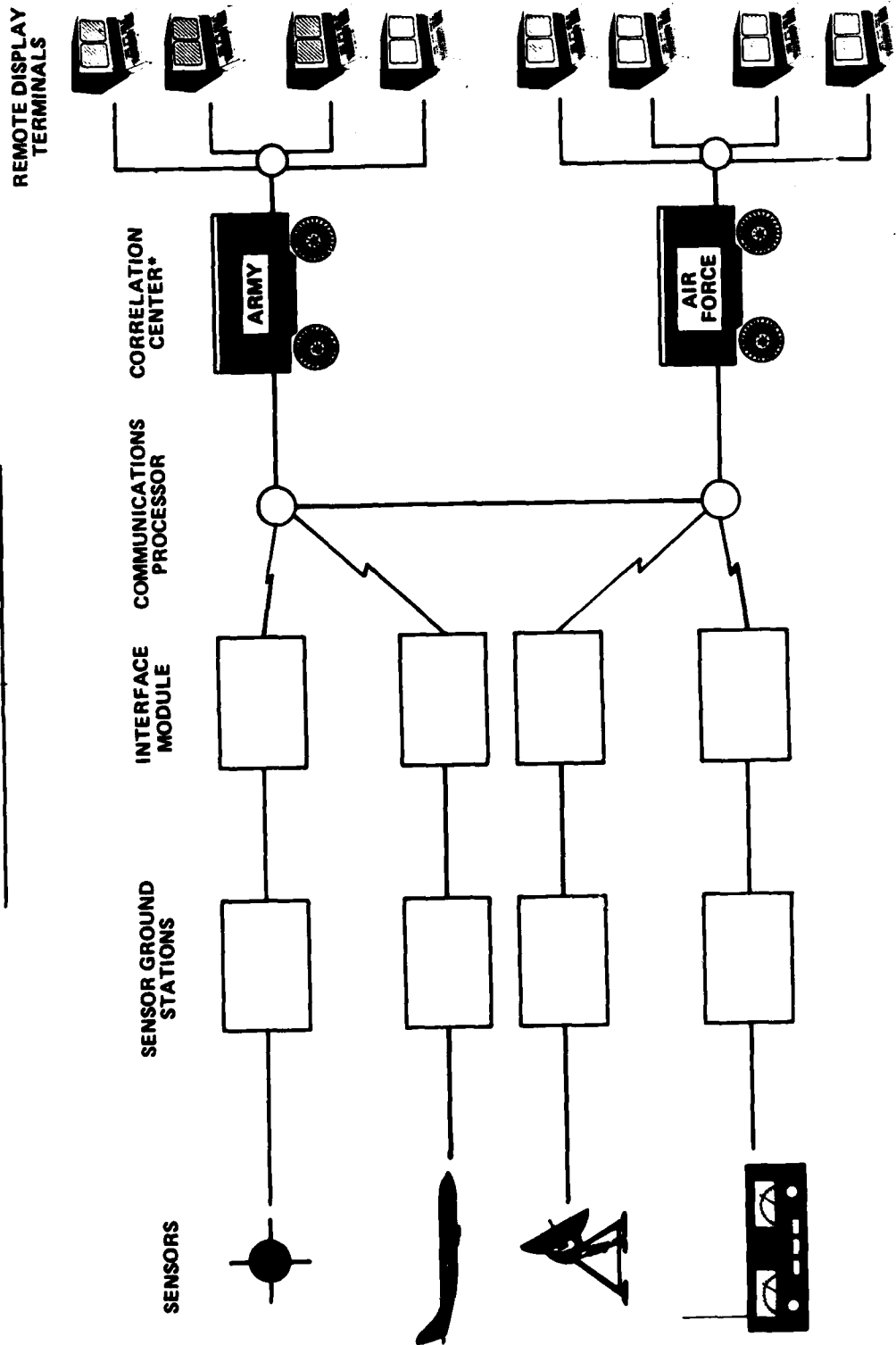

\* Each Correlation Center is comprised of three vans.



**ONE OF THREE VANS WHICH COMPRISE A BETA CORRELATION CENTER**  
PHOTO COURTESY OF THE BETA JOINT PROJECT OFFICE

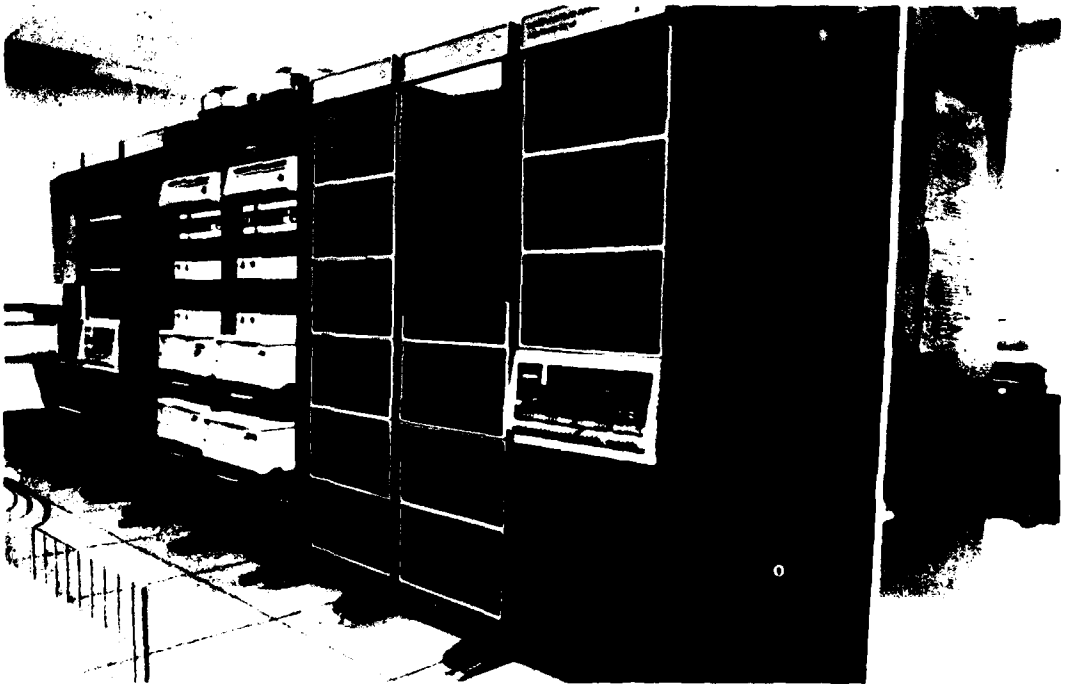

**BETA CENTRAL PROCESSING EQUIPMENT**  
PHOTO COURTESY OF THE BETA JOINT PROJECT OFFICE

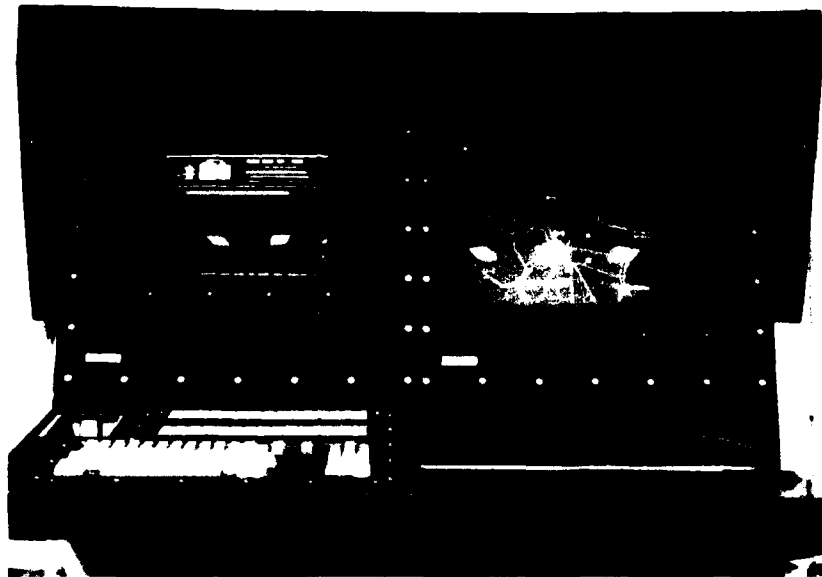

**BETA OPERATOR TERMINAL**  
PHOTO COURTESY OF THE BETA JOINT PROJECT OFFICE

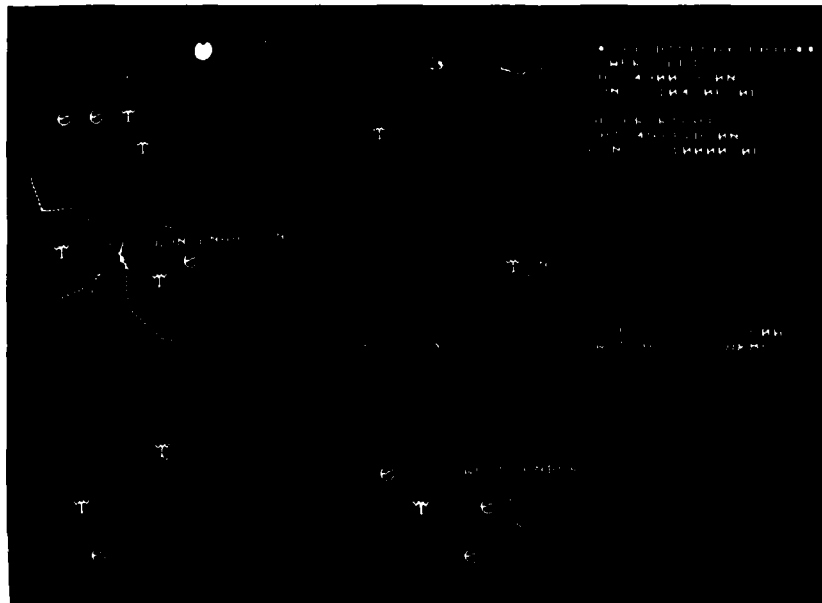

**BETA SITUATION DISPLAY**  
PHOTO COURTESY OF THE BETA JOINT PROJECT OFFICE

LEGEND:



UNKNOWN RADAR

SINGLE CHANNEL RADIO

SOLID AND DASHED LINES REPRESENT ROADS, URBAN-  
IZED AREAS AND MANEUVER CONTROL MEASURES

DELETIONS IN BETA SYSTEM  
FUNCTIONAL REQUIREMENTS (note a)  
(Bare Bones BETA Configuration)

<u>Deleted function</u>	<u>Impact</u>
Automated BETA interface module filtering	Reduced system capability to handle high message volume (for sensor ground stations without filtering capability).
Division correlation center	System no longer able to validate division level fusion requirements and corps/division level interoperability processes/activities.
Sensor bias correction	System no longer able to correct for location error in sensor input data. Location error correction cannot be manually performed by terminal operator.
Accounting for sensor cueing request	System no longer able to monitor status of operator requests to direct sensors to specific geographic areas. Operator must perform this task manually.
Automated correlation of mover reports	System no longer able to correlate reports of moving targets, e.g., a tank column. Function can be done by using query function and additional manual terminal operator functions.

---

a/Per system specification change in January 1979.

APPENDIX V

APPENDIX V

Deleted  
function

Impact

Sensor coordinated unique  
tools

System no longer able to  
aid sensor coordinator per-  
form such tasks as mission  
planning and sensor cover-  
age areas and times. Task  
must be done manually.

Hold capability

System no longer able to  
automatically prevent or  
inhibit purge of target  
sightings placed in status.

Terminal response time  
criteria

System response time  
specification changed from  
not to exceed to an average  
time for all responses.  
Could result in slower sys-  
tem response time.

Automatic data base  
update

System no longer able to  
automatically notify opera-  
tor of possible target  
aggregation. Additional  
manual steps required.

SECOND PHASE OFDELETIONS IN BETA SYSTEM FUNCTIONAL REQUIREMENTS (note a)(Bare Bones BETA Minus Configuration)

<u>Deleted function</u>	<u>Impact</u>
Correlation ambiguity	System no longer able to differentiate between possible correlation and noncorrelation of target. This differentiation must be done manually by operator.
Component collection	System no longer able to look at lower level entities in order to link with a higher entity. Replaced by additional manual linking operations and increased use of cross-correlation.
Automatic shared situation displays	System no longer able to automatically send snapshot of current situation to other correlation centers. Requires additional manual operations by terminal operator.
Automatic data base saturation maintenance	System no longer able to automatically purge data base. Operator-inhibit purge no longer needed. Manual purge must be used.
Dynamic filter maintenance for sensor reports	System no longer able to change filter requirements in response to changes in the target situation. Filtering will be done by static requirements which can be changed at each system startup.

---

a/These deletions were directed by the BETA project office in August 1979.

<u>Deleted function</u>	<u>Impact</u>
Saved displays	System no longer able to differentiate between messages and displays stored in terminal operator working file from routine messages and displays sent to operator for action. Additional manual sort operations required by terminal operator.
Boolean template processing	System no longer has factory preset unit identification parameters. Parameters must now be put into system by terminal operator as an additional manual step.



DATE  
FILMED

5-8