

AD-A126 110

PROCEEDINGS OF CONFERENCE ON LOCAL AREA MILITARY
NETWORKS GRIFFISS AFB NEW YORK 28-30 SEPTEMBER 1982(U)
ROME AIR DEVELOPMENT CENTER GRIFFISS AFB NY
D B WARNUTH ET AL. 1982

1/6

UNCLASSIFIED

F/G 17/2

NL

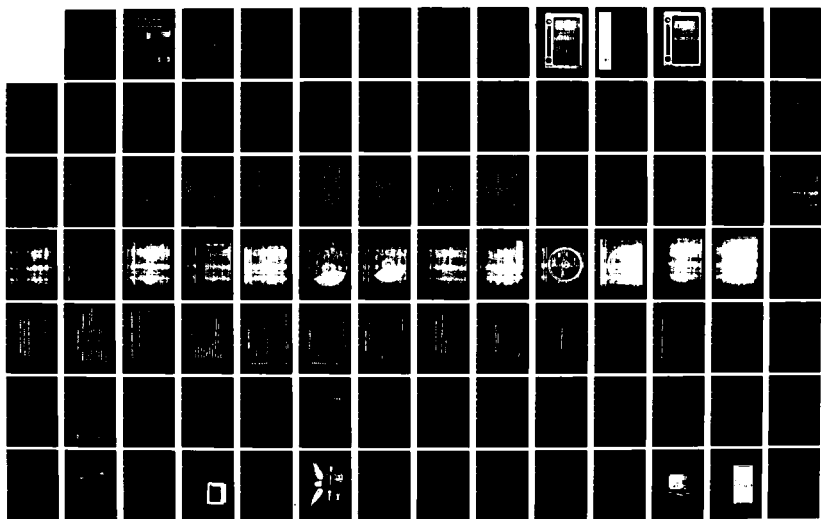

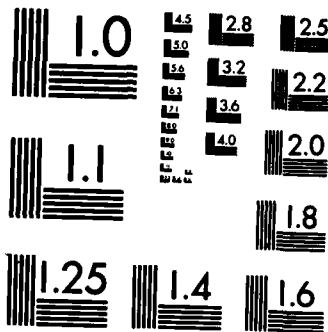

MICROCOPY RESOLUTION TEST CHART
NATIONAL BUREAU OF STANDARDS-1963-A

2

ADA 126110

PROCEEDINGS OF CONFERENCE ON LOCAL AREA MILITARY NETWORKS

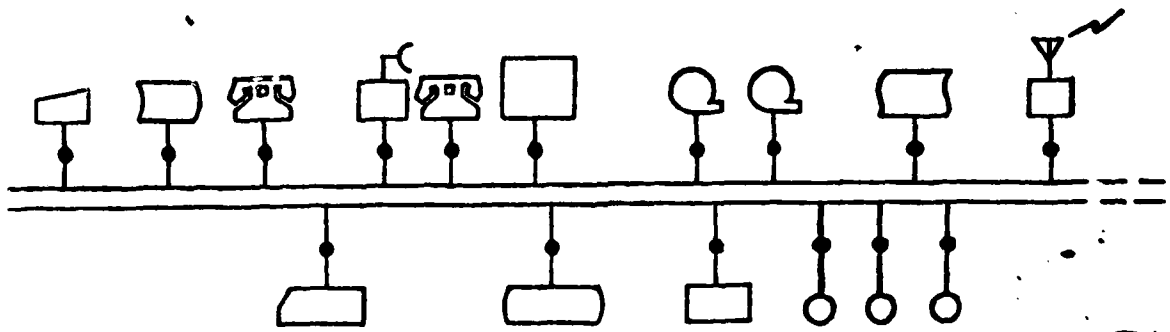
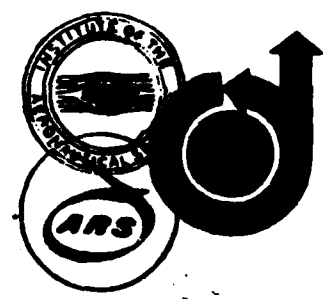

GRIFFISS AFB, New York

28 - 30 SEPT, 1982

S DTIC
ELECTE
MAR 28 1983
D
E

EDITED BY: DONALD B. WARMUTH & NEIL S. MARPLES

This document has been approved
for public release and sales in
distribution is unlimited.

DTIC FILE COPY

00 03 28 024

Approved for public release;
distribution unlimited.

LOCAL AREA MILITARY NETWORKS CONFERENCE
GRIFFISS AIR FORCE BASE, NY 28-30 SEPTEMBER 1982
AGENDA

27 SEP 82

1800-2000 Early Registration at the Officers Club

28 SEP 82

0800-0945 Registration at the Theater

0945-1000 Administrative Announcements

1000-1015 Welcome and Opening Remarks
By Col P. O. Bouchard
Commander, Rome Air Development Center

1015-1100 Keynote Address
By Charles C. Joyce
President, Network Strategies Inc.

1100-1230 Lunch

1230-1500 Local Area Network Requirements

Panel Chairman: Brig Gen John Paul Hyde - Commander, ECD 6
and USAFE/DC

Panel Members:

Dr. Joel S. Lawson, Chief Scientist, C3I Systems and Technology
Directorate, Naval Electronics Systems Command
Mr. Robert Puttcamp, US Army Communicative Technology Office,
Ft Eustis VA 10
Lt Col Jonathan Katz, AFCC, Chief of Telecommunications 25
Planning
Dr. Michael Muntner, President Contel Information Systems,
Government Systems Division 35
Mr. Clifford O'Dell, Space Command 39

1500-1530 Break

Accession For	
NTIS GRA&I	<input checked="" type="checkbox"/>
DTIC TAB	<input type="checkbox"/>
Unannounced	<input type="checkbox"/>
Justification	
By _____	
Distribution/	
Availability Codes	
Dist	Avail and/or Special
A	



5

28 SEP 1982 (Con't)

1530-1730 Technology I

Session Chairman: Lt Mark McCall - RADC/COTE

53

"Comparison of Coaxial Cable and Fibre Optics for Local Area Networks," Mr. Tom Reale and Mr. Charles Husbands, 54
MITRE Bedford Operations

"Multi Loop Optical Fiber Network," Mr. Gerd Keiser 62
and Mr. Raynor W. Taylor, GTE Systems, Communications Systems
Division

"Fiber Optic Data Bus Technology and Applications," 69
Mr. David R. Porter, ITT Electro-Optical Products Division

"Teleconferencing Fiber Optic Communication System," 101
Mr. Ralph Mednick and Mr. Raynor W. Taylor,
GTE Systems, Communications Systems Division

1730 Adjourn

1830 Cocktails at the Beeches Restaurant

2000 AFCEA Dinner Meeting at the Beeches Restaurant
Dinner Speaker - Brig Gen John Paul Hyde
Commander, European Communications Division

29 SEP 82

0800-1000 Technology II

Session Chairman: Dr. Andrew Yang - RADC/ES

133

"Components for Optical Fiber Net," Dr. Andrew Yang and 134
Mr. C Husbands, RADC and Mitre

"Manufacturing Technology for Fused Optical Couplers," 141
Mr. J.C. Williams and Mr. C. Villarruel, ITT EOPD and NRL

"Fiber Optic Couplers for Use in Local Area Military Network,"
Mr. A. R. Nelson, AETNA Telecommunications Laboratory 162

"Multimode Fiber Optic Switches," Mr. R. A. Soref, Sperry
Research Center 185

1000-1030 Break

29 SEP (Con't)

1030-1230 Local Network Issues

Session Chairman: Mr. Dick Metzger - RADC/COTD	204
"Layered Protocol Structures-the OSI Model," Dr. John Day, Micro Data Corp.	205
"Interneting Local Area Networks," Dr. David Clark, Massachusetts Institute of Technology	222
"Security Issues and Key Distributions in Local Area Networks," Dr. Deepinder Sidhu, Burroughs Corporation	232
"Design Trade-Offs for Survivable Local Packet Networks," James A. Keddie, Magnavox Data Systems Inc.	263

1230-1400 Lunch

1400-1545 Implementation I

Session Chairman: Mr. Brian Hendrickson - RADC/DCLW	294
"Flexible Interconnect Local Area Network," Mr. James L. Davis, Rome Air Development Center	295
"Local Area Network Design for Command Centers," Mr. Otis Gooding, Litton Amecom	326
"Application of Local Data Network to Navy Command Centers," Mr. Calvin Cornils, Naval Electronics Systems Engineering Center	343
"Fiber Optic Impact on Local Area Networks," Mr. Peter Steensma, ITT Defense Communications Division	353

1545-1600 Break

1600-1730 Implementation II

Session Chairman: Mr. John McNamara - RADC/OCDS	376
"Issues Influencing Tactical Local Area Network Implementation," Lt Gregory Swietek, Rome Air Development Center	377
"A Control System Architecture for Tactical Radar Networks," 383 Dr. G. Lucas and Mr. T. Burke, Decision Science Applications Inc.	
"Implementation of a Local Network for Tactical Systems," Mr. Ron Foss, Sperry Univac	426
"A Conceptual Local Area Communications Network for a Distributed, Modular Operations Center," Mr. Gerhard Pfister, ITT Gilfillan	447

1730 Adjourn

30 SEP 82

0800-1000 Standardization

Session Chairman: Mr. James L. Davis - RADC/DCLW 488

"Protocol Standardization," Dr. Rona Stillman, Hq USAF 489

"Implementation and Application of DoD Standard Protocols
in Local Area Networks," Mr. John K. Summers, MITRE Corp 500

"National Bureau of Standards Activities in LAN's," Mr. Dan
Stokesberry, National Bureau of Standards 514

"NATO Standardization for Local Area Networks," Mr. Steve
Anderson and Mr. Dennis Abbot, Sperry Univac

1000-1030 Break

1030-1230 Panel on Standardization

Panel Moderator: Mr. James L. Davis - RADC/DCLW

Panel Members:

Dr. Rona Stillman, USAF/ACD

Mr. John K. Summers, Mitre Corp

Mr. Dan Stokesberry, National Bureau of Standards

Mr. Steve Anderson, Sperry Univac

1230 Adjourn

BIOGRAPHY

Charles C. Joyce, Jr., President, Network Strategies Incorporated, Burke, Virginia. Mr. Joyce has extensive experience in data communications networks and information systems. He has directed a variety of projects including a study of Electronic Message System Policy for the U.S. Congress, and studies for government and commercial clients involving data communications network design, implementation and management. He teaches data communications seminars for Systems Technology Forum.

Prior to co-founding Network Strategies Incorporated, Mr. Joyce was Vice President of Richard L. Deal & Associates. Previously, he was Director of Information Technology and Policy at the MITRE Corporation, McLean, Virginia. He has also served as an Assistant Director in the Office of Telecommunications Policy, Executive Office of the President, and has exercised responsibility for planning, implementation, and review of communications and computer systems in the office of the Secretary of Defense and at the White House.

Mr. Joyce is active in the Armed Forces Communications and Electronics Association, and is a frequent speaker at technical conferences and seminars.

BIOGRAPHY

Brigadier General John Paul Hyde is the Deputy Chief of Staff for Communications and Air Traffic Control, HQ United States Air Forces in Europe and Commander, US Air Force European Communications Division, both located at Ramstein Air Base, Germany. In these positions he is responsible for fixed and mobile telecommunications and air traffic-control systems throughout Europe and the Middle East for Air Force, US Government and other North Atlantic Treaty Organization and civilian agencies.

General Hyde was born July 21, 1934 in Cincinnati, Ohio. He earned a Bachelor of Science Degree from the University of Cincinnati in 1957 and both Master of Science and PhD degrees from the University of Pittsburg in 1963 and 1965 respectively, all in the field of electrical engineering.

After completing graduate school in 1965 he was assigned to the VELA Seismological Center, a division of the Air Force Technical Applications Center in Alexandria VA. In June 1969, General Hyde became Director of Aerospace-Mechanics Sciences Research at the Frank J. Seiler Laboratory, Air Force Systems Command, US Air Force Academy, Colorado.

General Hyde was the Associate Director of the Defense Communications Engineering Center, Reston VA in 1974. In February 1977, he was named Deputy Chief of Staff for Communications and Electronics, HQ Tactical Air Command, and Commander of the Tactical Communications Area, Langley AFB VA. He assumed his present duties in August 1980.

His military decorations and awards include the Department of Defense Superior Service Medal, Legion of Merit, Bronze Star Medal, Meritorious Service Medal, Air Force Outstanding Unit Award ribbon with "V" device and three oak leaf clusters, Republic of Vietnam Armed Forces Honor Medal 1st Class and Republic of Vietnam Air Service Medal.



SPANGDAHLEM AIR BASE



- OPERATIONS: CAMPS, AFORMS
- LOGISTICS: MINET, ALCS, EDS
- SUPPLY/PERSONNEL: PHASEIV
- INTELLIGENCE: IITS
- WEATHER: EURMEDS
- CIVIL ENGINEER: USAFE CEINET
- COMPROLLER: SMALL COMPUTER FORMS
- MEDICAL: CLINICAL ACCOUNTING
- ADMINISTRATION: "CREEK EDIT" WORD PROCESSING
- COMMUNICATIONS: ETS, SRT



EIFEL 1	GEADGE	JAMPS (AMHS)
EIFEL FOLLOW-ON	TRT	AWDS
AFIRMS	IITS	EDS
WWMCCS	SCARS	MINET
CAMPS	RAPS	IDHS
AFORMS	MDTS	CAFMS

- TERMINALS TIED TO UNIQUE SYSTEMS
- MIXTURE OF HARDWARE TYPES
- REDUNDANT REPORTING, MANNING



SPANGDAHLEM AIR BASE



- OPERATIONS: CAMPS, AFORMS
- LOGISTICS: MINET, ALCS, MEDS
- SUPPLY/PERSONNEL: PHASE IV
- INTELLIGENCE: IITS
- WEATHER: EURMEDS
- CIVIL ENGINEER: USAFE CEINET
- COMPROLLER: SMALL COMPUTER FOR NET
- MEDICAL: CLINICAL ACCOUNTING
- ADMINISTRATION: "CREEKEDIT" WORD PROCESSORS
- COMMUNICATIONS: ETS, SRT



V CORPS
DISPERSED COMMAND POST

TRADOC PAM 525-5
DNIA



INTELL	INTELLIGENCE CELL
+ ASIC	ALL SOURCE INTELLIGENCE CENTER
CBC	CURRENT BATTLE CELL
PLANS	FUTURE BATTLE CELL
SPT	SUPPORT CELL
FSE	FIRE SUPPORT ELEMENT
CMD	COMMANDER, WHEN NOT AT TAC
ASOC	AIR SUPPORT OPERATIONS CENTER
RAOC	REAR AREA OPERATIONS CENTER
CAG	COMBAT AVIATION GROUP

STAFF PLANNING

AND

DECISION SUPPORT SYSTEM

SPADS

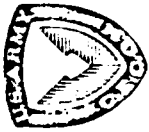



ACTO

DNA

CACDA

CATRADA

DARPA

FORSOM

BDM

PERCEPTRONICS

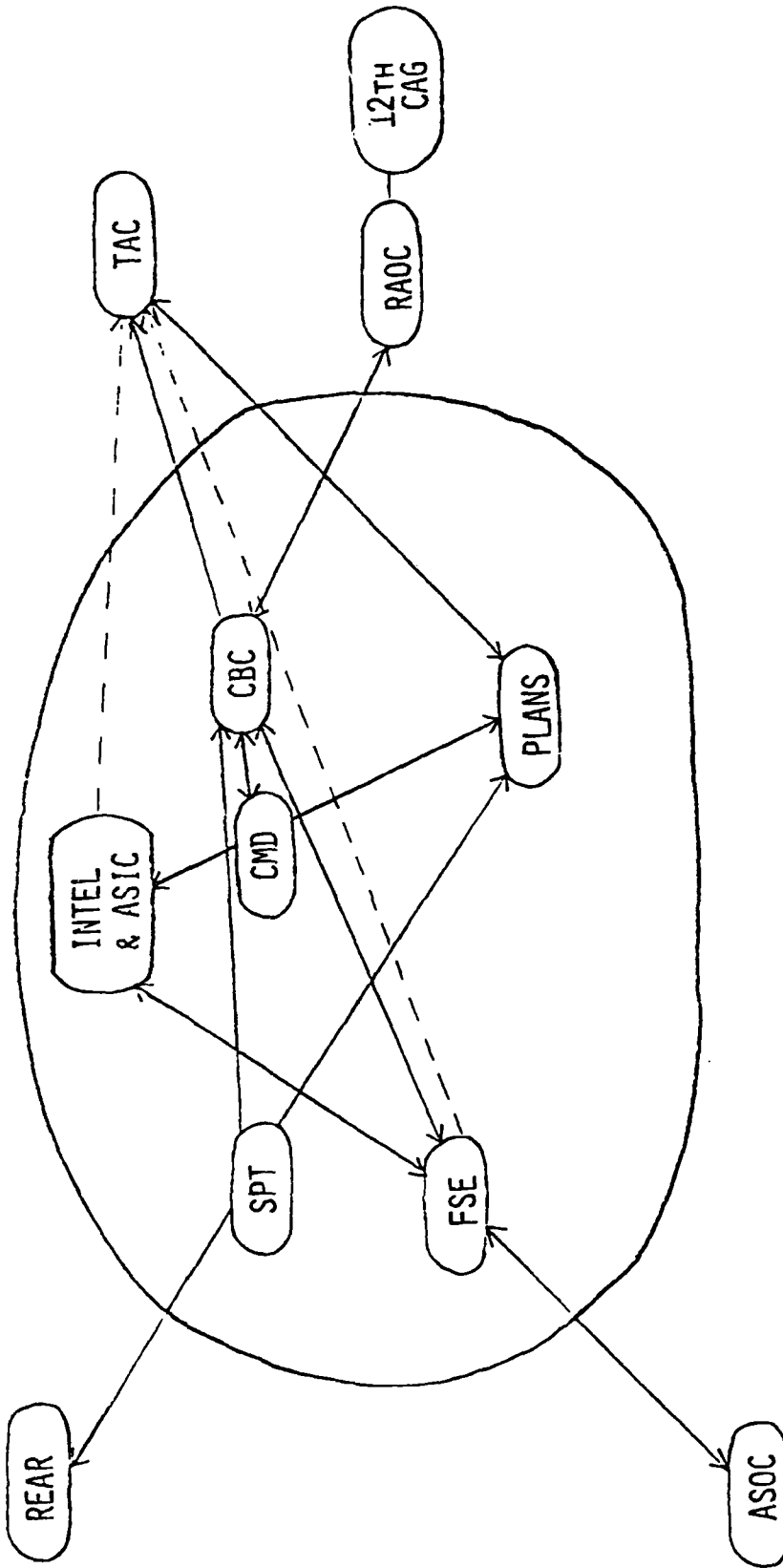

CURRENT DISPERSED MODE
 CONCEPT
 V CORPS



EQUIPMENT LIST

APPLE II MICRO COMPUTER

CORVUS HARD DISK

VIDEO DISC PLAYER

SYMTEC PROFESSIONAL GRAPHICS SYSTEM

CORVUS OMNINET SYSTEM

PRINTERS

MODEMS

(PLOTTERS)

FLOPPY DISK DRIVES



EACH CELL WILL BE A LOCAL NETWORK ON THE CORVUS OMNINET SYSTEM

EACH CELL WILL HAVE:

ONE OR MORE WORK STATIONS

COMMUNICATIONS GATEWAY

ELECTRONIC MAIL

AUTOMATED MESSAGE DELIVERY

PRINTER/PLOTTER GATEWAY

HARD DISK GATEWAY

ONE OR MORE VIDEO DISC PLAYERS



CRESTED EAGLE

62

63 OPS

ASIC

TAC CP



POWER PROBLEMS

AUTO TRANSFORMERS

3RD WIRE GROUND ON CONDUIT

V CORPS WILL RE-WIRE VANS

50 HZ NOT A PROBLEM



CARAVAN GUARD

MODULES HARDWIRED TOGETHER
CONNECTION TO OTHER MODULES THROUGH
TASS NETWORK
MAY TRY DBP FOR UNCLASSIFIED
COMMUNICATIONS



NOT SURE AT THIS TIME HOW MUCH EQUIPMENT WILL BE AVAILABLE
FOR CARAVAN GUARD

VIDEO DISC WILL NOT BE READY

VIDEO DISC WILL BE USED IN REFORGER 82 FOR FIRST TIME

V CORPS VANS WILL BE REWIRED FOR CARAVAN GUARD



REFORGER 82

8ID ACTIVE WITH DISPERSED DTOC
MODULE TO MODULE COMMUNICATION WITH
V CORPS
V CORPS MAINLY AS UMPIRES

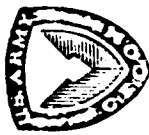

ABLE ARCHER 82

WIDER DISPERSION FOR BOTH V CORPS
AND 81D

COMMUNICATIONS OVER TASS NETWORK

UNCLASSIFIED OVER DBP

MESSAGE CENTER DISPERSED



WINTEX - 83

FULLY DISPERSED TEST

V CORPS

8 ID

MAY TRY SOME COMMUNICATION WITH

VII CORPS DISPERSED CP



POST WINTEX - 82

TESTS AS NECESSARY TO INSURE WE HAVE
A WORKING SYSTEM

INTEGRATION WITH VII CORPS

INTEGRATION WITH XVIII AIRBORN CORPS

**AIR FORCE
BASE LEVEL
NETWORKING REQUIREMENTS**

**HQ AFCC/XODX
27 SEP 82**

2 14171 AGC

BASE LEVEL NETWORKING

MENU

- **BASE TELECOMMUNICATIONS SYSTEM (BTS)**
 - **CURRENT ENVIRONMENT AND PROBLEM AREAS**
 - **ACTIONS UNDERWAY**
- **FUTURE NEEDS**
 - **QUANTITATIVE**
 - **QUALITATIVE**
- **ISSUES**
 - **INFORMATION ARCHITECTURE**
 - **INTEGRATION**
 - **STANDARDS**
- **AFCC STATEMENT OF NEED:**
 - **BASE LEVEL INFORMATION TRANSMISSION SYSTEM**

**BASE LEVEL NETWORKING
CURRENT PROGRAMS**

- TELEPHONE
 - SCOPE DIAL: REPLACE GOVERNMENT-OWNED SWITCHES
 - EUROPEAN TELEPHONE SYSTEM: MODERNIZE SWITCHES IN EUROPE
 - SCOPE EXCHANGE: REPLACE LEASED SWITCHES
- TELECOMM CENTERS
 - STANDARD REMOTE TERMINAL (SRT)
 - AIR FORCE AUTOMATED MESSAGE PROCESSING EQUIPMENT (AFAMPE)
- ADP - PHASE IV CAPITAL REPLACEMENT
- INTRA-BASE RADIO-VOICE PRIVACY
- ALARMS & SENSORS - COMPUTER DRIVEN SYSTEMS
- FACSIMILE/TELECONFERENCE: STANDARD FACSIMILE

**BASE LEVEL NETWORKING
BASE TELECOMMUNICATIONS SYSTEM
PRIMARY SUBSYSTEMS**

- BASE WIRE AND TELEPHONE SWITCHING SYSTEM
 - CENTRAL SWITCH
 - CABLE PLANT
- TELECOMMUNICATIONS CENTERS
 - AUTODIN TERMINAL
 - ANCILLARY PROCESSING
- BASE ADP AND REMOTES
 - B3500/B3700/UNIVAC 1050-II
- INTRA-BASE RADIO (IBR)
 - INDIVIDUAL NETS
- ALARM AND SENSOR SYSTEMS
- OTHER SYSTEMS-FACSIMILE, CCTV, TELECONFERENCING, SECURE VOICE.

**BASE LEVEL NETWORKING
BASE TELECOMMUNICATIONS SYSTEM
PROBLEMS**

- ACCELERATING DEMANDS
- SYSTEM/SUBSYSTEM/HARDWARE PROLIFERATION
- COMPLEX INTERFACES
- TRANSMISSION PLANT OBSOLESCENCE
- LOGISTIC SUPPORT
- NEED FLEXIBILITY
- CANNOT AFFORD DEDICATED OVERLAYS

**BASE LEVEL NETWORKING
WHERE WE'RE AT**

- MODERNIZATION DRIVEN BY LOGISTICS AND MANPOWER CONSIDERATIONS
- MOSTLY A ONE-FOR-ONE REPLACEMENT
- SYSTEM APPROACH REQUIRED
- BASIC TRANSMISSION SYSTEM NOT ADDRESSED
- LOCAL AND WIDE AREA NETWORKING & CONCEPTS
 - PROVIDE IMPROVED TRANSMISSION AND SERVICES
 - APPROACH UBIQUITOUS SERVICE

**BASE LEVEL NETWORKING
QUANTITATIVE REQUIREMENTS**

- RESOURCE GROWTH
 - TERMINAL DEVICE EXPLOSION: PROJECTED OVER 110,000 BY 1989
 - INTRODUCTION OF "OFFICE AUTOMATION", PERSONAL MICRO-COMPUTERS AND WORK STATIONS
 - FUNCTIONAL MANAGEMENT INFORMATION/DATA PROCESSING SYSTEMS
- CAPACITY LIMITATIONS
 - CURRENT BASE PLANTS SIZED FOR VOICE AND LIMITED DATA
 - CABLE PLANTS ENGINEERED FOR ANALOG VOICE - LIMITED BANDWIDTH

**BASE LEVEL NETWORKING
QUALITATIVE REQUIREMENTS**

- IMPROVED CONNECTIVITY
 - CONNECTION ORIENTED AND "CONNECTIONLESS"
 - TERMINAL-TO-TERMINAL AND TERMINAL TO HOST
- HANDLE INFORMATION TYPES: DATA, IMAGERY, VIDEO, SECURE VOICE, FACSIMILE
- IMPROVED SERVICES-HANDLE DATA ORIENTED PROTOCOLS
- IMPROVED TRANSMISSION QUALITY-END-TO-END TRANSPORT INTEGRITY
- FLEXIBILITY: RELOCATION, RESTORAL, INTERFACE, INTEGRATION
- ECONOMICAL GROWTH
- SYSTEM/NETWORK MANAGEMENT AND CONTROL

**BASE LEVEL NETWORKING
ISSUES**

- **INFORMATION ARCHITECTURES**
 - **DISTRIBUTION OF RESOURCES**
 - **PROCESSING VS COMMUNICATING**
 - **CHANGING ORGANIZATIONAL/FUNCTIONAL BOUNDRIES**
- **INTEGRATION**
 - **VERTICAL AND HORIZONTAL**
 - **TECHNICAL-GATEWAYS**
 - **INTERFACE WITH EXISTING SUBSYSTEMS**
 - **INTERFACE WITH EMERGING SYSTEMS**
- **STANDARDS**
 - **CHOOSE NOW**
 - **WAIT FOR ADOPTION**

**BASE LEVEL NETWORKING
AFCC STATEMENT OF NEED (SON)
MODERNIZING THE BASE LEVEL INFORMATION TRANSMISSION SYSTEM**

- **PURPOSE: ESTABLISH A PROGRAM TO DESIGN, ACQUIRE,
INSTALL, MANAGE, OPERATE AND MAINTAIN AN
INTEGRATED INFORMATION HIGHWAY SYSTEM
ON MOST AIR FORCE BASES**
- **SATISFY REQUIREMENTS**
- **MAKE PRUDENT CAPITAL INVESTMENTS AND RESOURCE
REALLOCATIONS**
- **EXPLOIT LOCAL AREA NETWORKING CONCEPTS AND
TECHNOLOGIES**
- **ESTABLISH AIR FORCE CORPORATE APPROACH TO INFORMATION
TRANSPORTATION**

OPERATIONAL LAN IMPLICATIONS

- INCREASE AVAILABILITY/MAINTAINABILITY
- MONITOR PERFORMANCE/DETECT PROBLEMS
- NEW SOFTWARE RELEASES
- RAM RESIDENT CODE
- RELIABLE NETWORK CONTROL CENTER (DLL/UJD)
- NETWORK ORGANIZATIONAL RESPONSIBILITY
 - OPERATE (INTEGRATE WITH TECH CONTROL)
 - ACCESS CONTROL (SECURITY OFFICE)
 - ADMINISTER (CONFIGURATION CONTROL)

REQUIREMENTS TRENDS (NON-OFFICE ENVIRONMENT)

- CABLE USE FOR MULTIPLE SERVICES
- HIGHER INTERFACE SPEEDS
- GATEWAYS TO OTHER NETWORKS
- FUNCTIONAL EXPANDIBILITY (NEW INTERFACES, SPEEDS, SERVICES)
- NOT A TOY!!

LAN APPLICATIONS

- OFFICE VS DATA PROCESSING VS PROCESS CONTROL
- COPPER REPLACEMENT
 - N TO 1 (MUX, STAT MUX)
 - N TO N (CLASSICAL NETWORK)
- DISTRIBUTED "MESSAGE" SWITCH
 - ROUTE TRAFFIC: SOURCE TO DESTINATION
 - FLOW CONTROL
 - ACCESS/SECURITY CONTROL
 - PERFORMANCE MONITORING & AUDIT TRAILS
 - DATA CONTENT ROUTING
- DISTRIBUTED FRONT END
 - OFF-LOAD COMM PROCESSING TO LAN
 - ACCESS TO GATEWAYS

LOCAL AREA NETWORK (LAN)
REQUIREMENTS & IMPLICATIONS

CONCEPTUAL APPLICATION OF SELECTED ARCHITECTURE

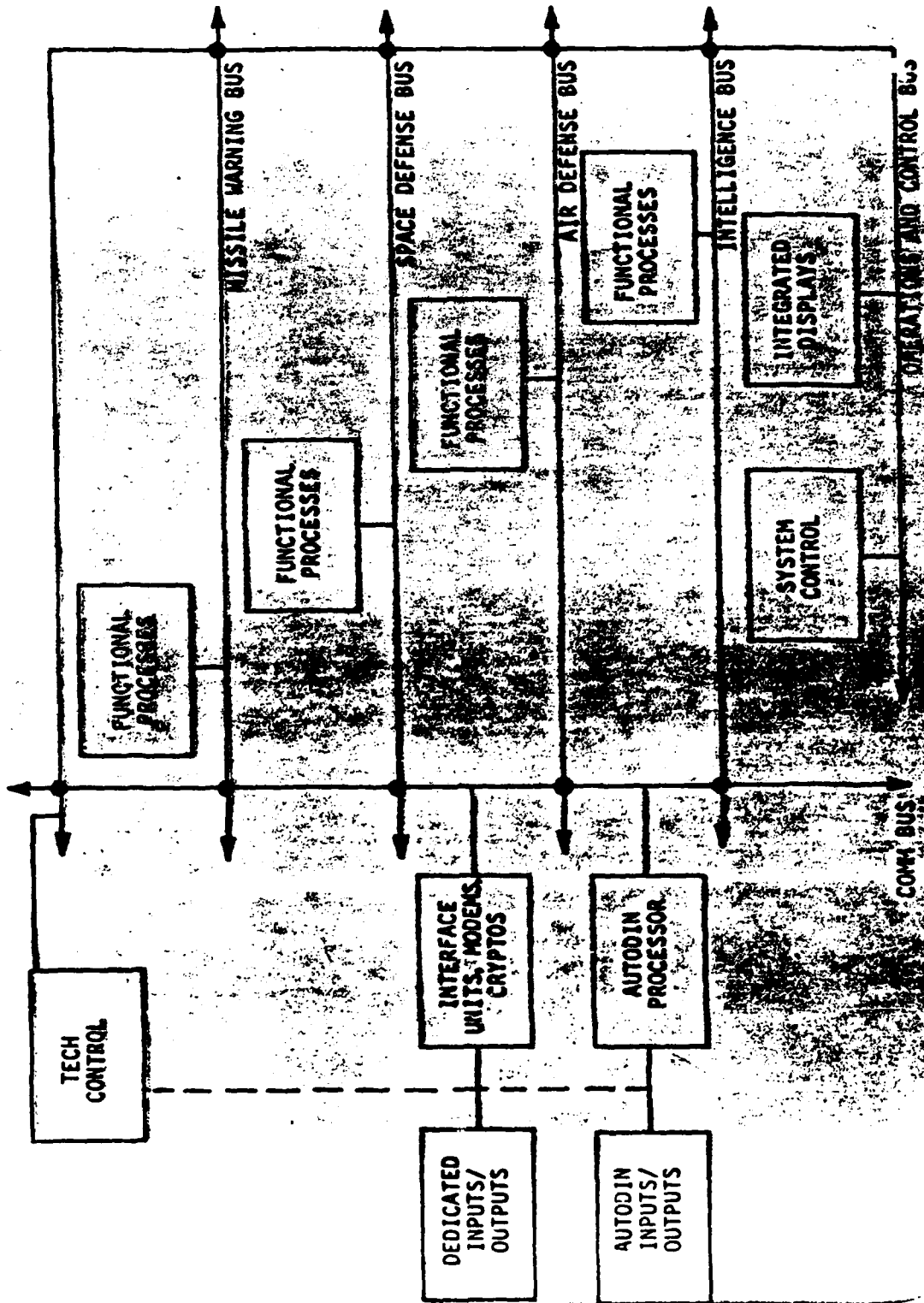

SUMMARY

ADP ARCHITECTURE WILL SATISFY THE
EVOLVING NORAD MISSIONS

TECHNICAL INTERCHANGE

ADVANCED INFORMATION AND DECISION SYSTEM

HARRIS CORPORATION

BETAC CORPORATION

HARVARD UNIVERSITY

BOLT BERANEK AND NEWMAN, INC.

HONEYWELL INCORPORATED

BURROUGHS CORPORATION

INTERNATIONAL TELEPHONE AND TELEGRAPH

CARNEGIE-MELLON UNIVERSITY

MARTIN-MARIETTA AEROSPACE

COMPUTER CORPORATION OF AMERICA

MITRE CORPORATION

CONTROL DATA CORPORATION

NATIONAL CENTER FOR ATMOSPHERIC RESEARCH

DIGITAL COMMUNICATIONS CORPORATION

NETWORK SYSTEMS CORPORATION

FORD AEROSPACE COMMUNICATIONS CORPORATION

ROME AIR DEVELOPMENT CENTER

GENERAL DYNAMICS

STATE UNIVERSITY OF NEW YORK AT BUFFALO

GENERAL ELECTRIC

UNIVERSITY OF MICHIGAN

ADP ARCHITECTURE WILL SATISFY THE
EVOLVING ADMINISTRATION

TRANSITION SCHEDULE



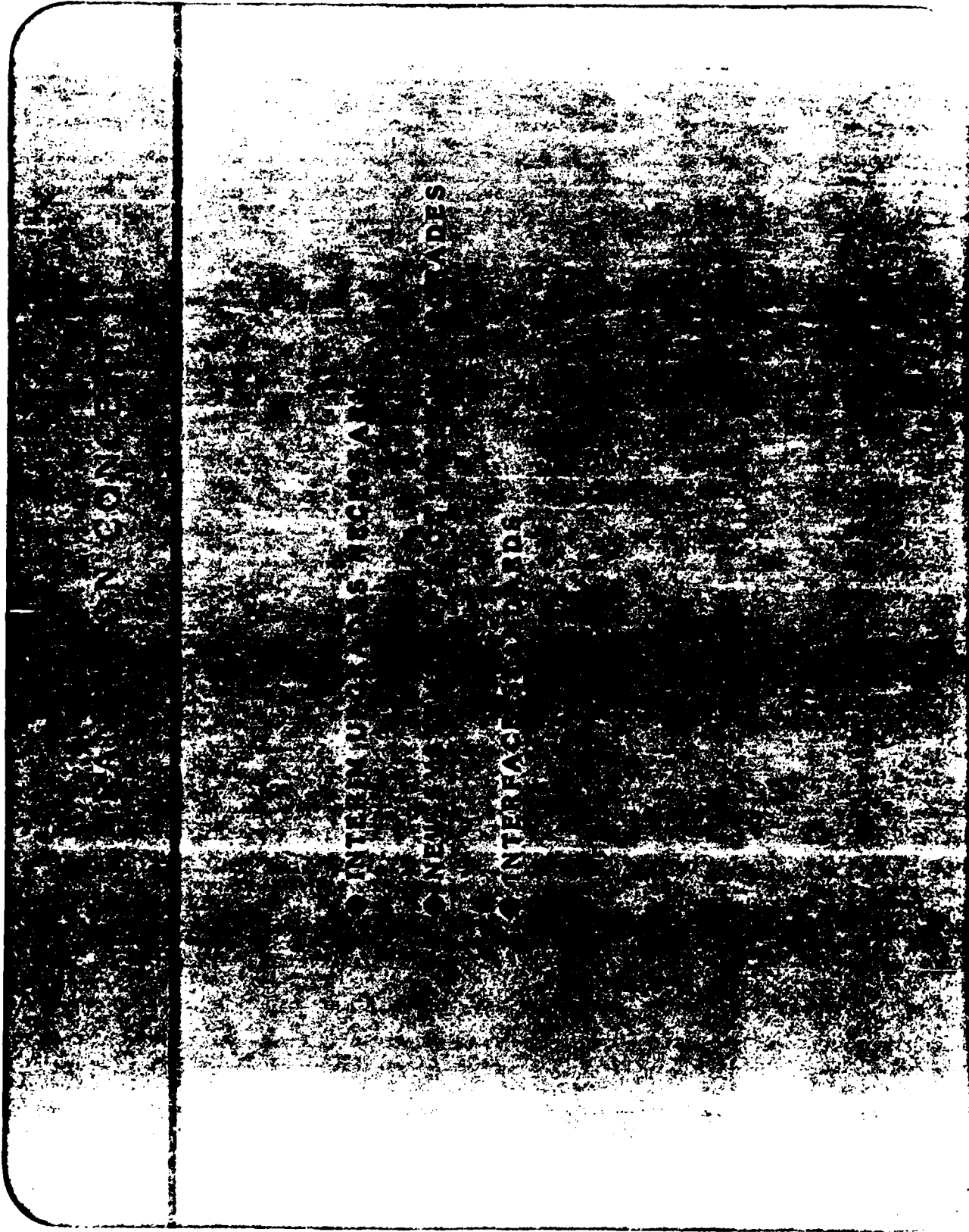

NCMC ADP ARCHITECTURE (EXPANDED)

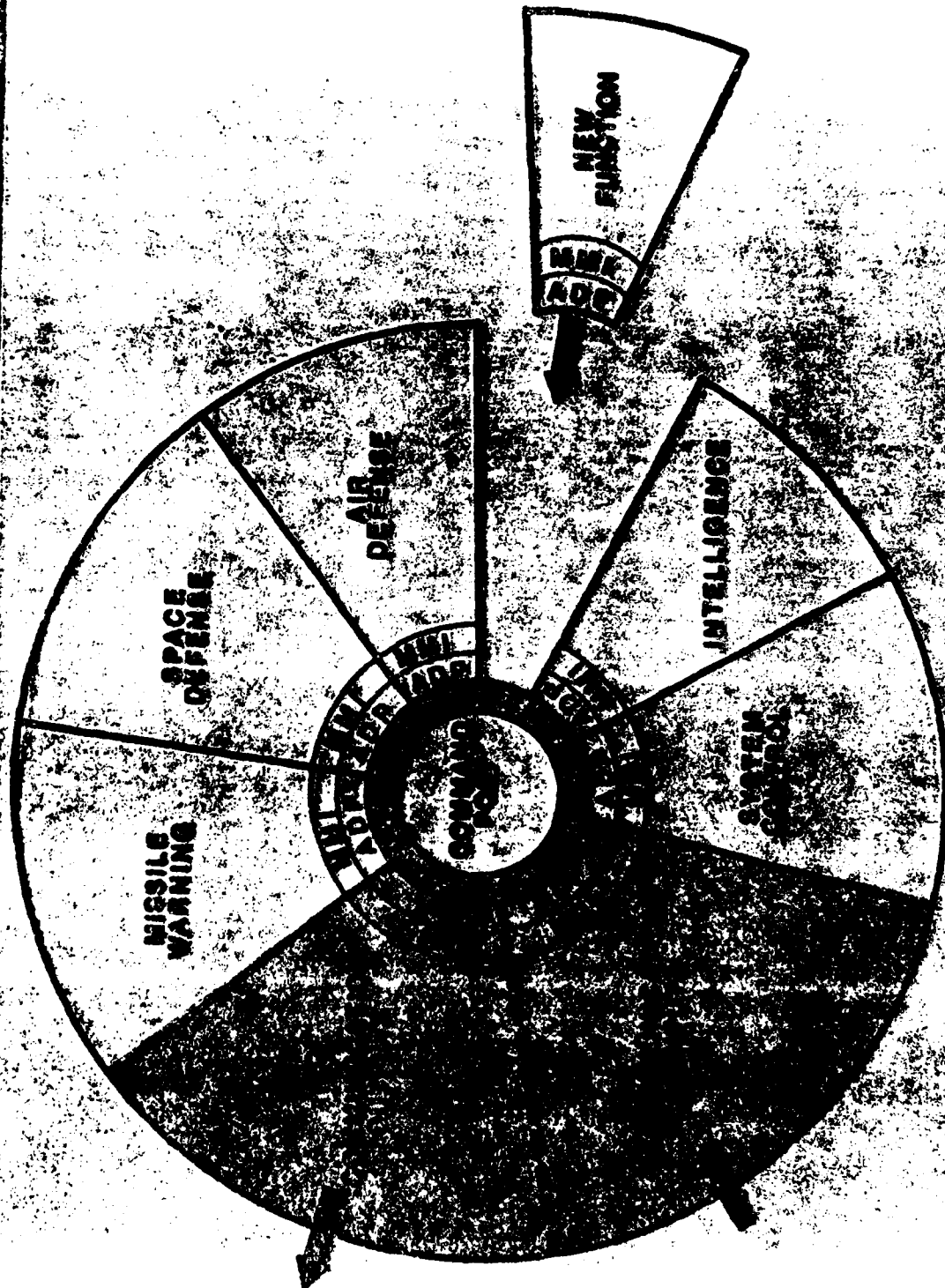

SELECTED ARCHITECTURE

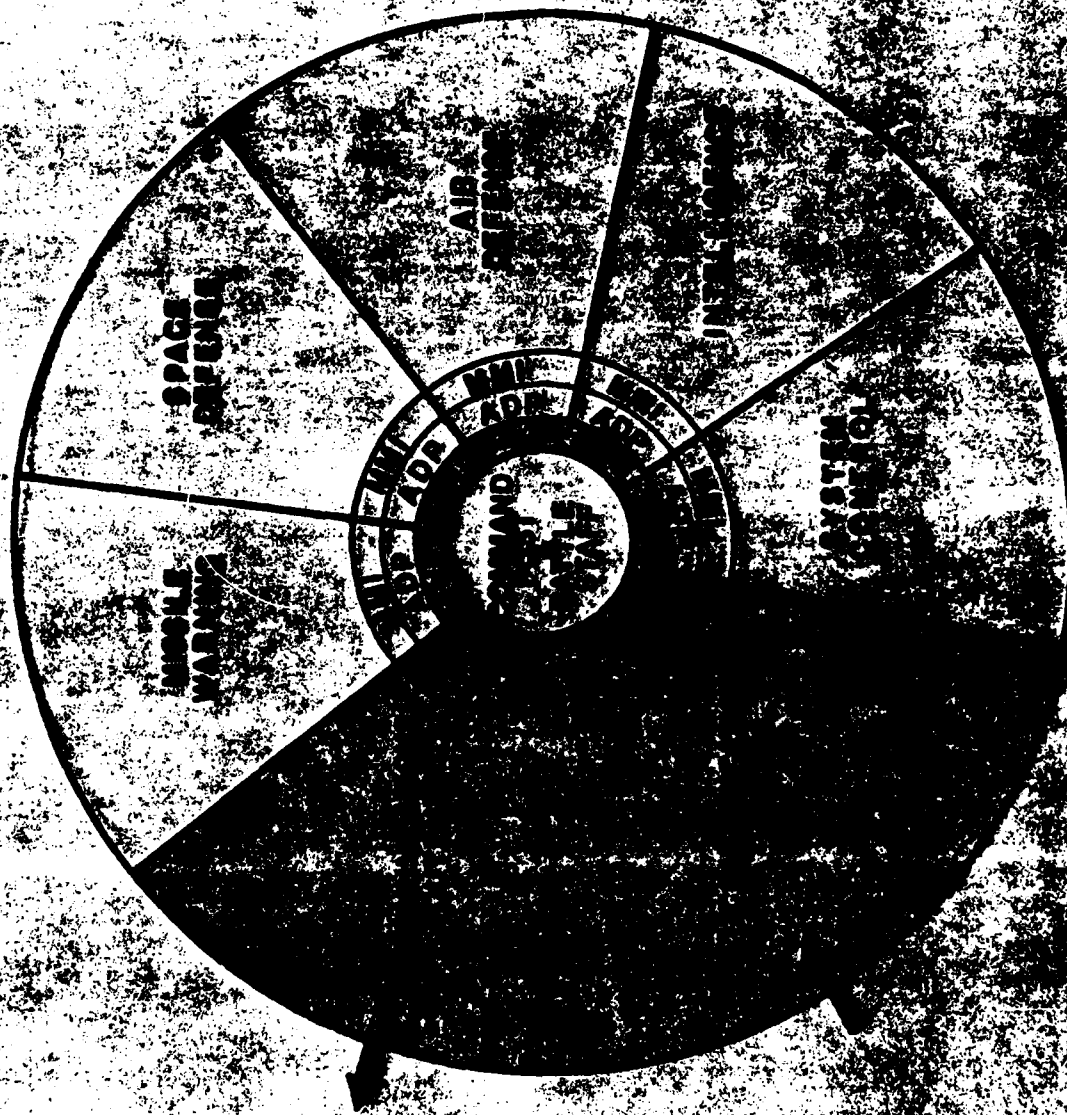

FEATURES OF SELECTED ARCHITECTURE

- SEPARATION OF MISSIONS
- CAN BE RECONFIGURED
- FLEXIBLE
- INTERFACED AND CARDS AVAILABLE

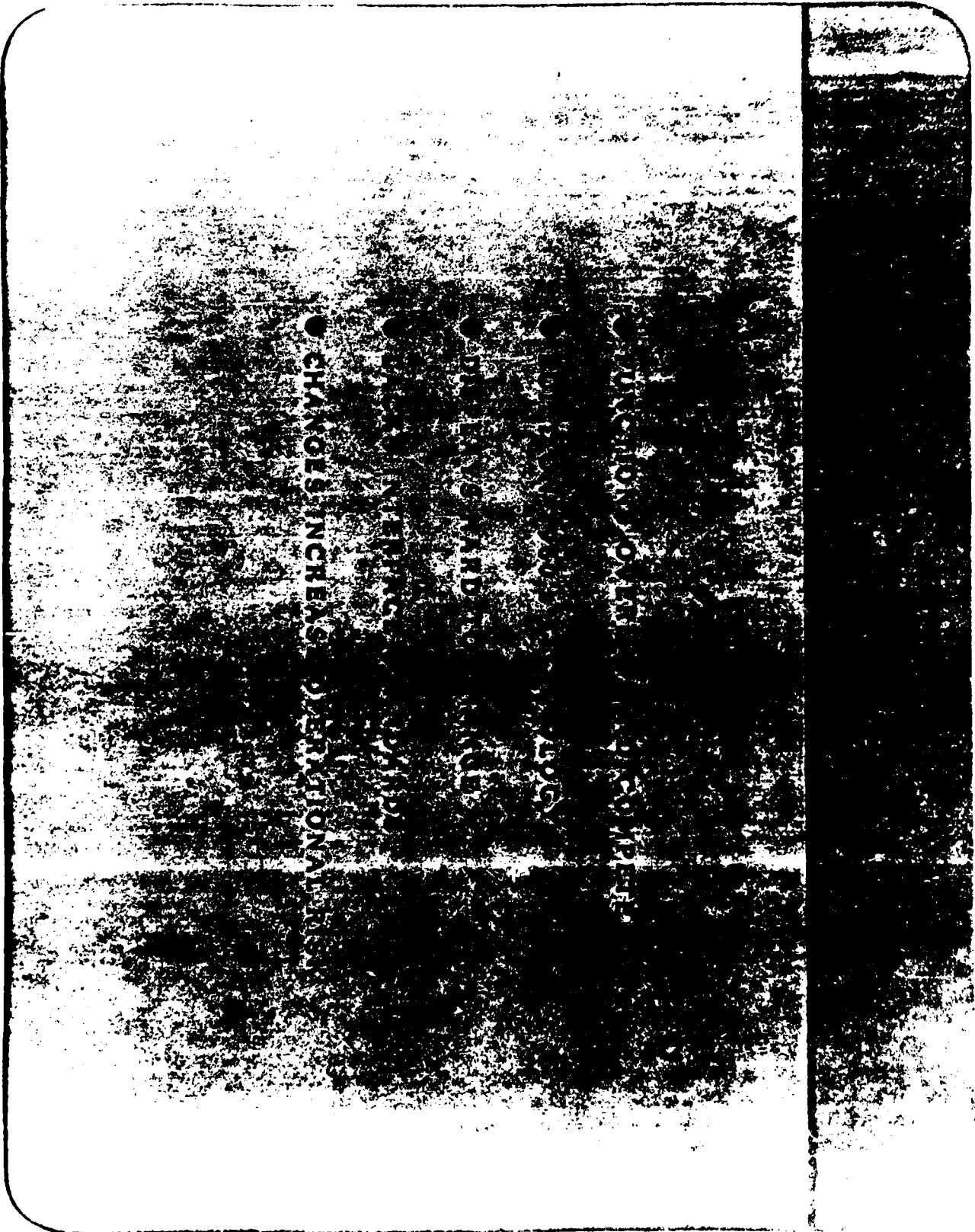

CONCURRENT ARCHITECTURE

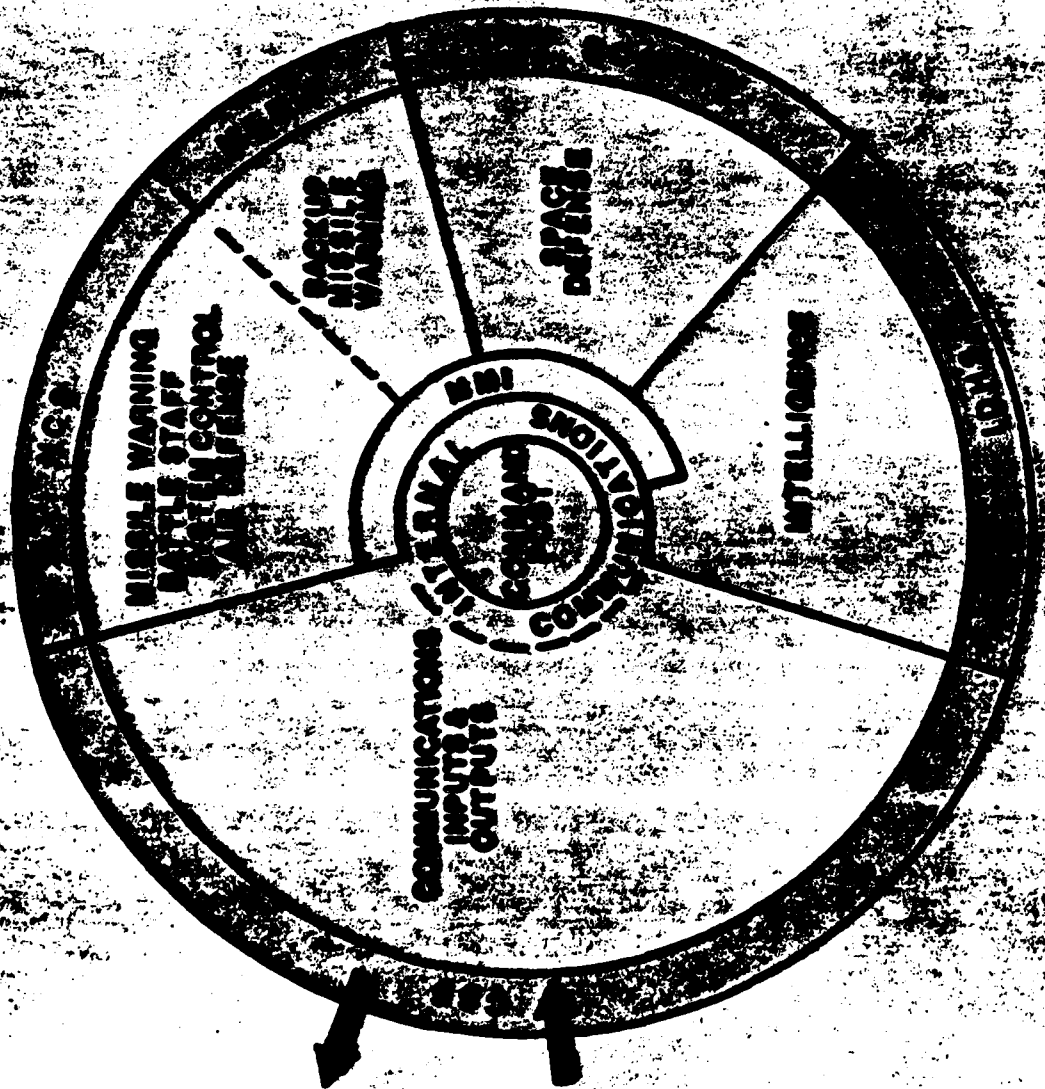

Copy available to DTIC does not permit fully legible reproduction

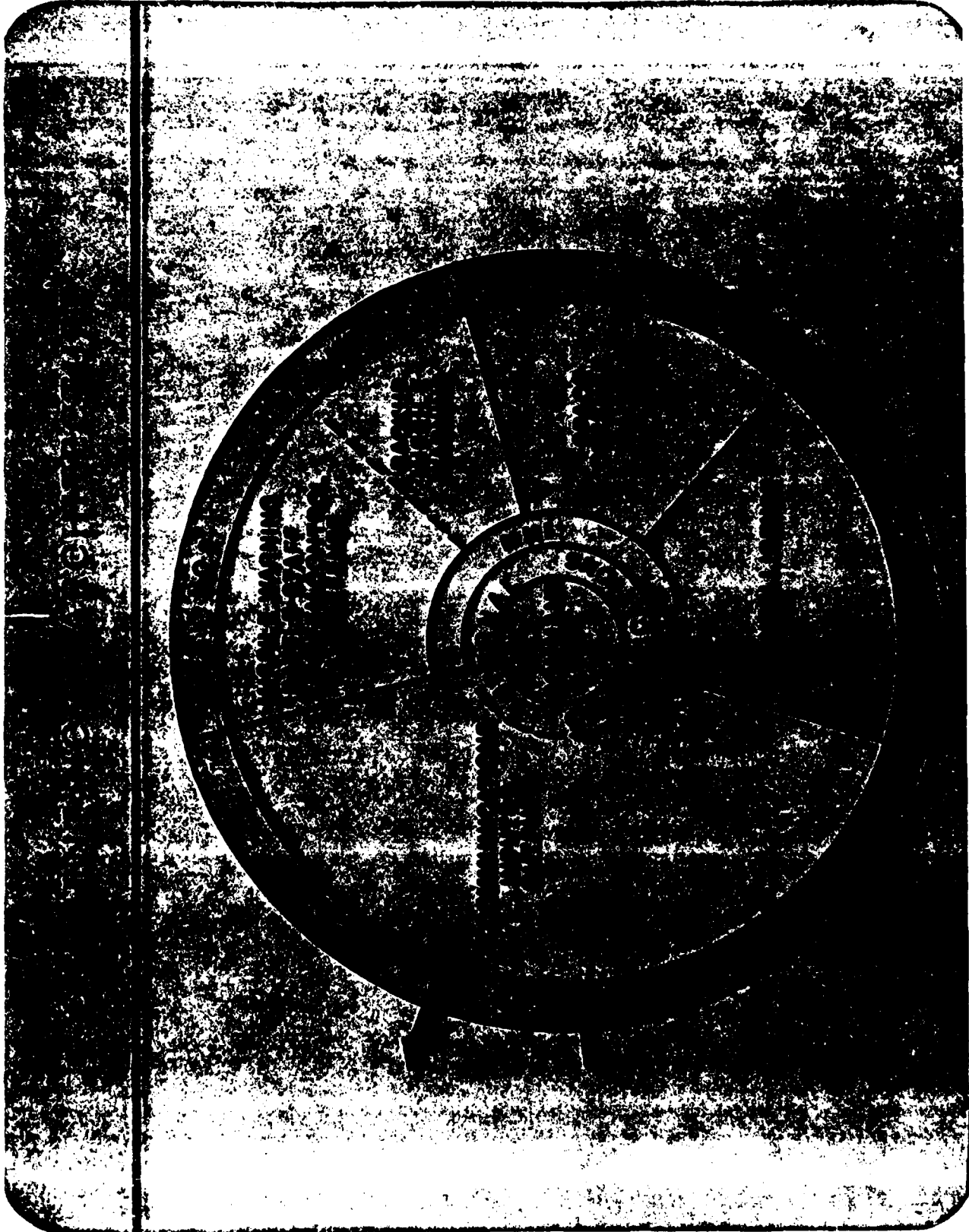

Copy available to DTIC does not permit fully legible reproduction

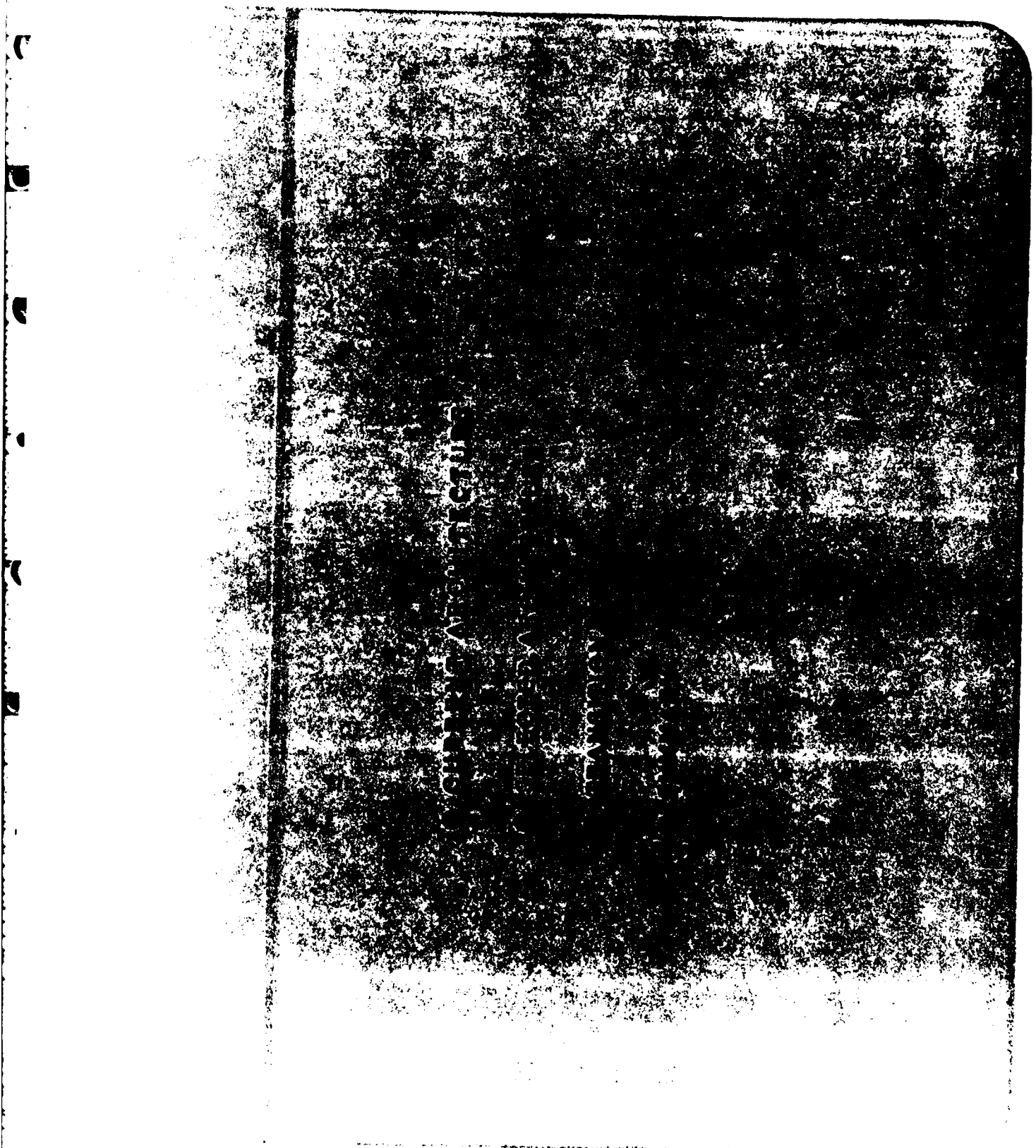

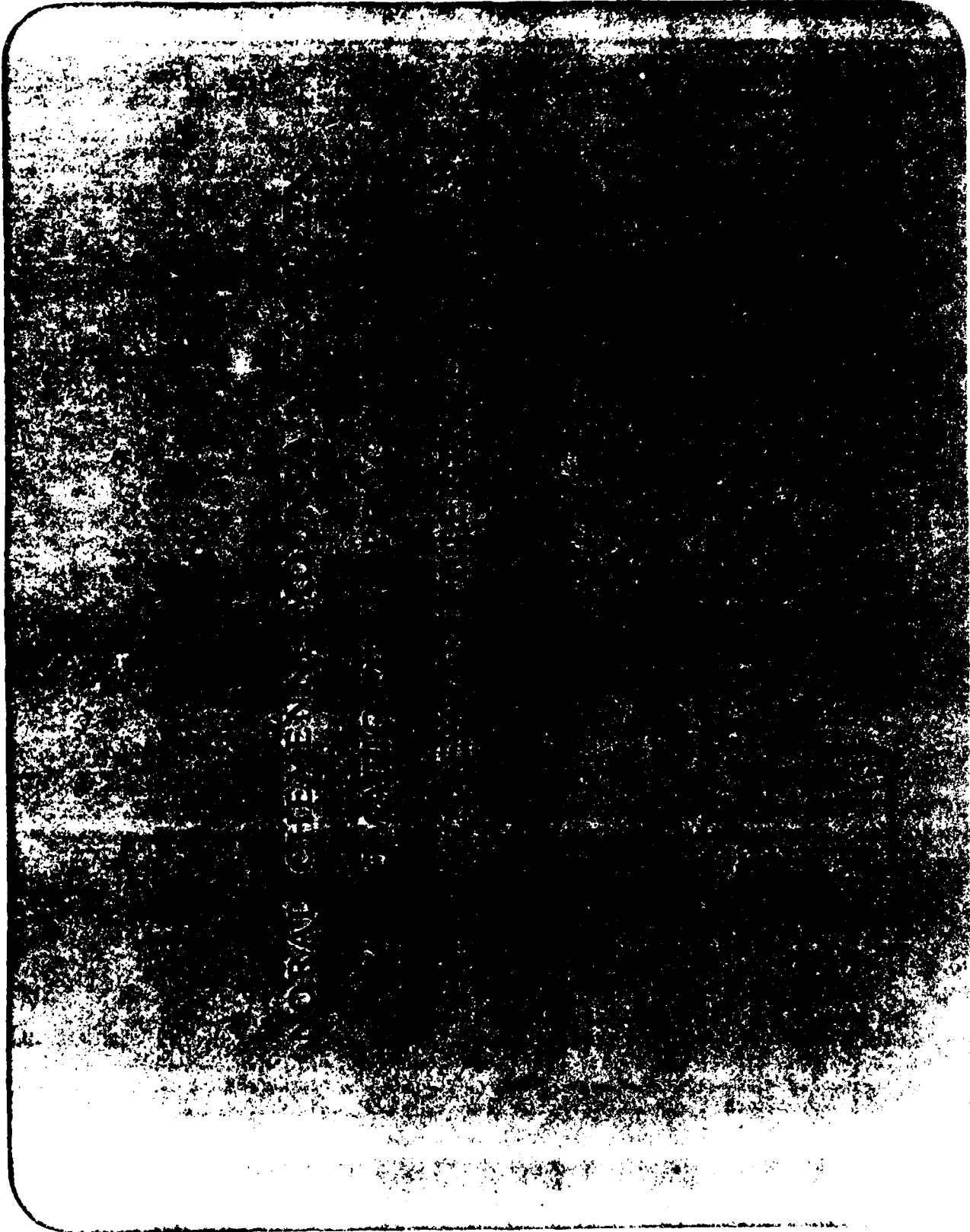

-52-
Copy available to DTIC does not
permit fully legible reproduction

Technology I (1530-1730 28 Sep)

Session Chairman: Lt Mark McCall - RADC/COTE

"Comparison of Coaxial Cable and Fiber Optics for Local Area Networks,"
Mr. Tom Reale and Mr. Charles Husbands, MITRE Bedford Operations

The technology for broadband local area networks has advanced rapidly over the last several years. Previous networks were constructed entirely of coaxial cable with fiber optics for point-to-point links. Recently hybrid systems are being designed and implemented. It is envisioned that as fiber optic technology progresses it will usurp coaxial cable as the communication medium. This paper will address some issues involved in the transition with particular emphasis on topology and protocol.

"Multi Loop Fiber Network," Mr. Gerd Keiser and Mr. Raynor W. Taylor,
GTE Systems, Communications Systems Division

A network using five full duplex optical fiber loops is being developed for local area data transmission. Each pair in a loop can maintain an effective data rate of 20 Mbs in opposite directions, thus giving a total system capacity of 200 Mbs. Each node is three simultaneous active network connections and supports up to 10 variable speed users. The nodes provide real-time actions and flow control while a network control center handles failures, monitors system performance, and provides long term management and network optimization.

"Fiber optic Data Bus Technology and Applications," Mr. David R. Porter,
ITT Electro-Optical Products Division

Fiber Optics technology has rapidly matured to a point where practical fiber optic data bus systems are now being demonstrated. Two systems will be described: (1) 1 Mbs MIL-STD 1553 compatible fiber optic bus and (2) 100 Mbs fiber optic bus. System function, architecture, key technological developments, performance and bus access protocol will be addressed.

"Teleconferencing Fiber Optic Communication System," Mr. Ralph Mednick
and Mr. Raynor W. Taylor, GTE Systems, Communications Systems Division

GTE has developed a wideband local area network system that provides full motion video conferencing, other voice, data, video, and audio services to military or civilian users. The system is a star network optic subscriber loop carrying all traffic. As many as 25 separate user locations can be connected in a single video conference; several conferences may take place simultaneously. Full screen video or split screen picture presentation as well as graphic modes are available. Other features of the system will be described as well.

**COMPARISON OF MEDIA
AND TOPOLOGIES FOR
LOCAL AREA NETWORKS**

**C. HUSBANDS
T. J. REALE**

THE MITRE CORPORATION

THE PROBLEM

MEDIA TOPOLOGIES

FIBER OPTICS

BASEBAND

BROADBAND



FULLY CONNECTED MESH

PARTIALLY CONNECTED MESH

STAR

COAXIAL CABLE

BASEBAND

BROADBAND



RING

BUS

TWISTED PAIR

CLASSICAL MEDIA COMPARISON

	FIBER OPTICS		COAXIAL CABLE		TWISTED PAIR
	BROADBAND 30MHZ-300MHZ	BASEBAND 16HZ	BROADBAND 450 MHZ	BASEBAND 20MHZ-50MHZ	
AVAILABLE BANDWIDTH	30MHZ-300MHZ	16HZ	450 MHZ	20MHZ-50MHZ	10MHZ
NO OF CARRIERS (VIDEO)	4 - 10	1	50	1	1
MAXIMUM SINGLE CHANNEL DATA RATE	5-10 MBPS	300 MHZ	5-10 MBPS	50MBPS	10MBPS
ERROR RATE (UNCORRECTED)	10^{-12}	10^{-12}	10^{-12}	10^{-12}	10^{-10}
SPACING BETWEEN TAPS	0	0	0	2 M	1 M
NO OF INSTALLED SYSTEMS	NO LAN'S 10 POINT TO POINT	$>10^2$	10^4	10^2	10^4

LAN FACTORS

AVAILABILITY

MAINTAINABILITY

SURVIVABILITY

FAIL SOFT

CONNECTIVITY

EXPANDABILITY

TRANSFER TIMES

SINGLE / MULTIPLE CARRIER REQUIREMENTS

ABILITY TO HANDLE MANY NODES

MOBILITY

FIBER OPTICS

- WELL SUITED TO RING AND STAR TOPOLOGIES
- PRIMARILY USED FOR POINT TO POINT BASEBAND COMMUNICATION
- CAN HANDLE LONG DISTANCES
- CAN HANDLE VERY HIGH DATA RATES
- EMI, RFI SUSCEPTABILITY VERY LOW
- WHEN USED WITH RING TOPOLOGIES FAULT TOLERANT ARCHITECTURE NEEDED

-58-

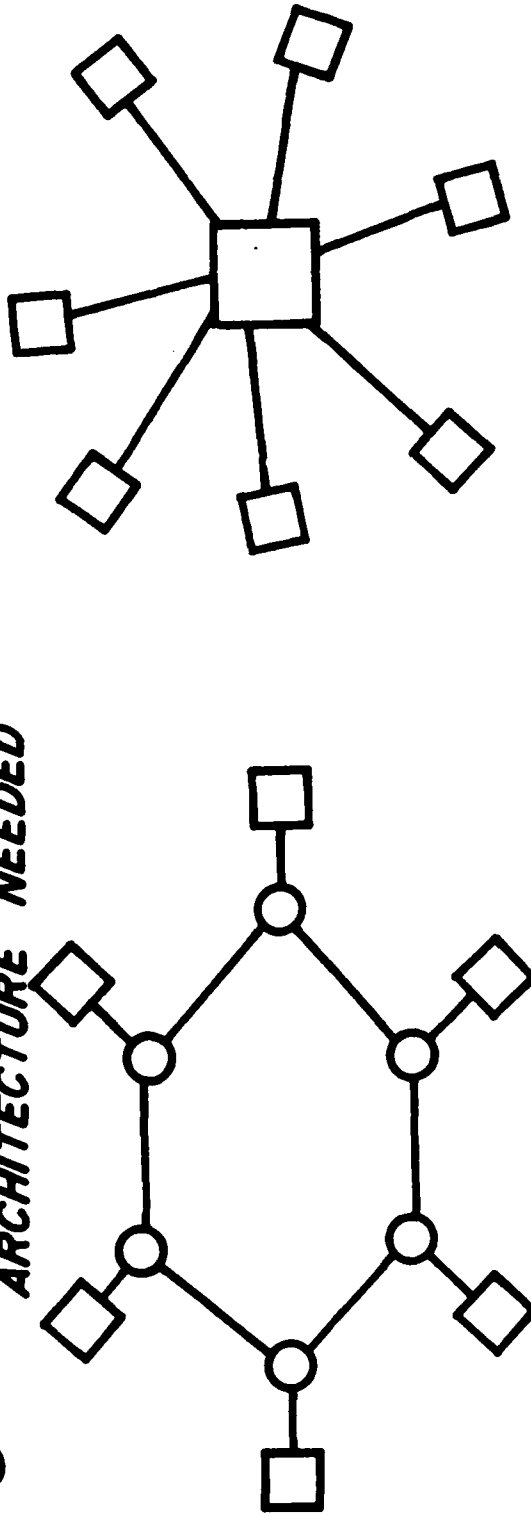

- EXAMPLES : FIBER CAMBRIDGE RING, GODDARD SPACE CENTER, FIBRENET, AFAL

COAX CABLE

- WELL SUITED TO BUS TOPOLOGIES
- CAN HANDLE A VERY LARGE NO OF USERS
- CAN SUPPORT MULTI-MEDIA COMMUNICATION
- VERY MATURE TECHNOLOGY
- LOW EMI, RFI SUSCEPTABILITY
- POWER CAN BE DISTRIBUTED ON SAME CABLE
- VERY LARGE THROUGHPUT WHEN AGGREGATED

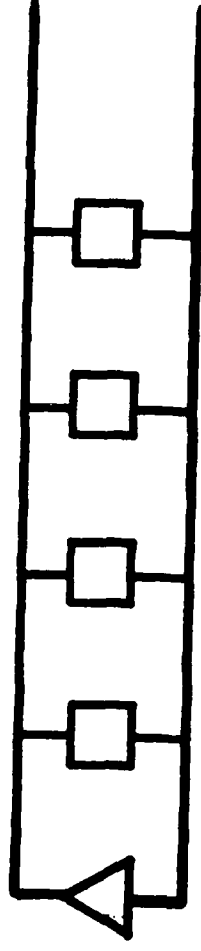

- SUPPORTS BURSTY USERS WELL

EXAMPLES: HTACC, WIS?, PENTAGON, ETHERNET,
MITRENET

TWISTED PAIR

SUITABLE FOR BUS, STAR AND MESH TOPOLOGIES

VERY INEXPENSIVE

LIGHT WEIGHT

CAN HANDLE MODERATE DATA RATES FOR SHORT DISTANCES

BANDWIDTH LIMITED

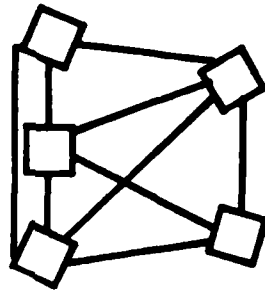
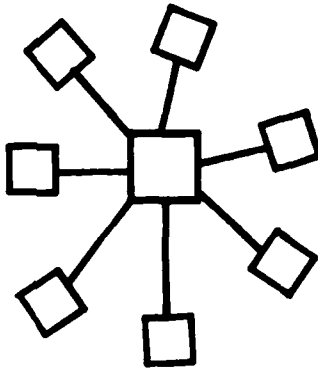
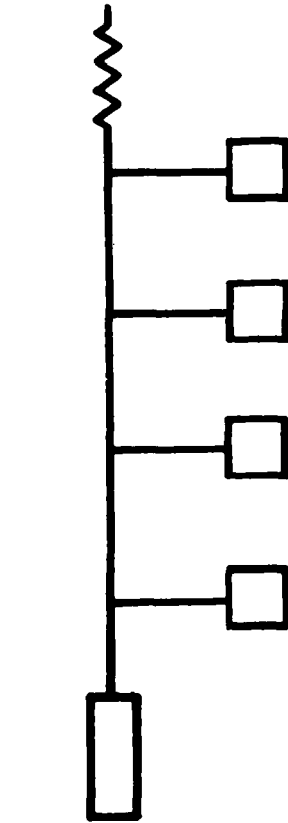

EXAMPLES : MIL - S - 1553, PABX, CAMBRIDGE RING

2 EXAMPLES OF AN ARCHITECTURE

FIBER OPTICS — GODDARD SPACE CENTER

COAXIAL CABLE — HTACC

A Multi-Loop Optical Fiber Network

Sylvania Systems Group
Communication Systems Division
GTE Products Corporation
77 A Street
Needham Heights, Mass. 02194 U.S.A.
Area Code 617 449-2000
TELEX: 92-2497



Systems

System Objective

To provide a high bandwidth system for Local Area Data Communications.

7870-02

NETWORK COMPONENTS

- OPTICAL FIBER CABLE
- BUS ACCESS UNIT
- MULTIPLEXER UNIT
- ADCCP UNIT
- NODAL PROCESSOR
- HOST INTERFACE
- NETWORK CONTROL CENTER

5795-80E

Multiloop Network Configuration

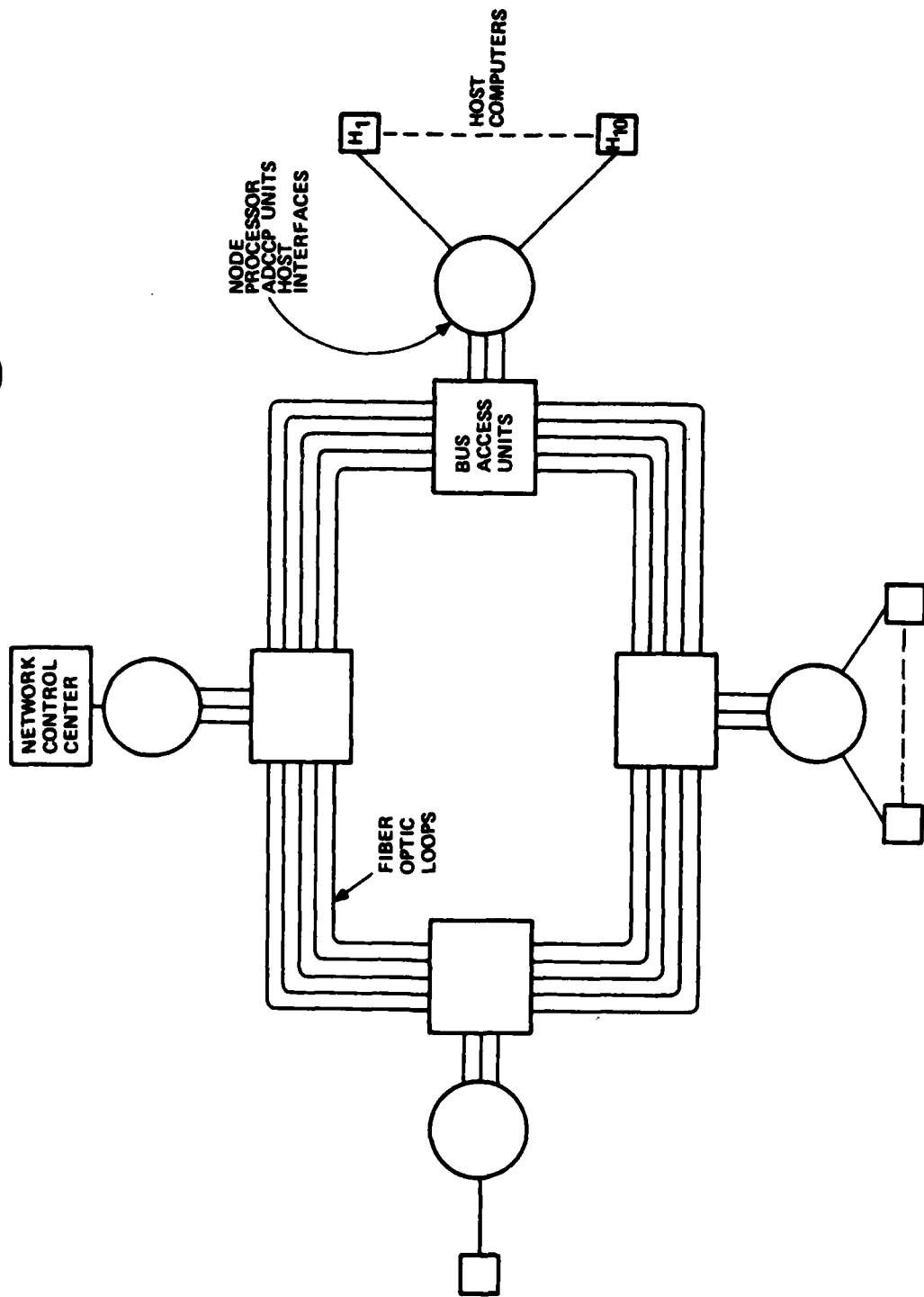

5754-90E (A)

MULTILOOP NETWORK NODE

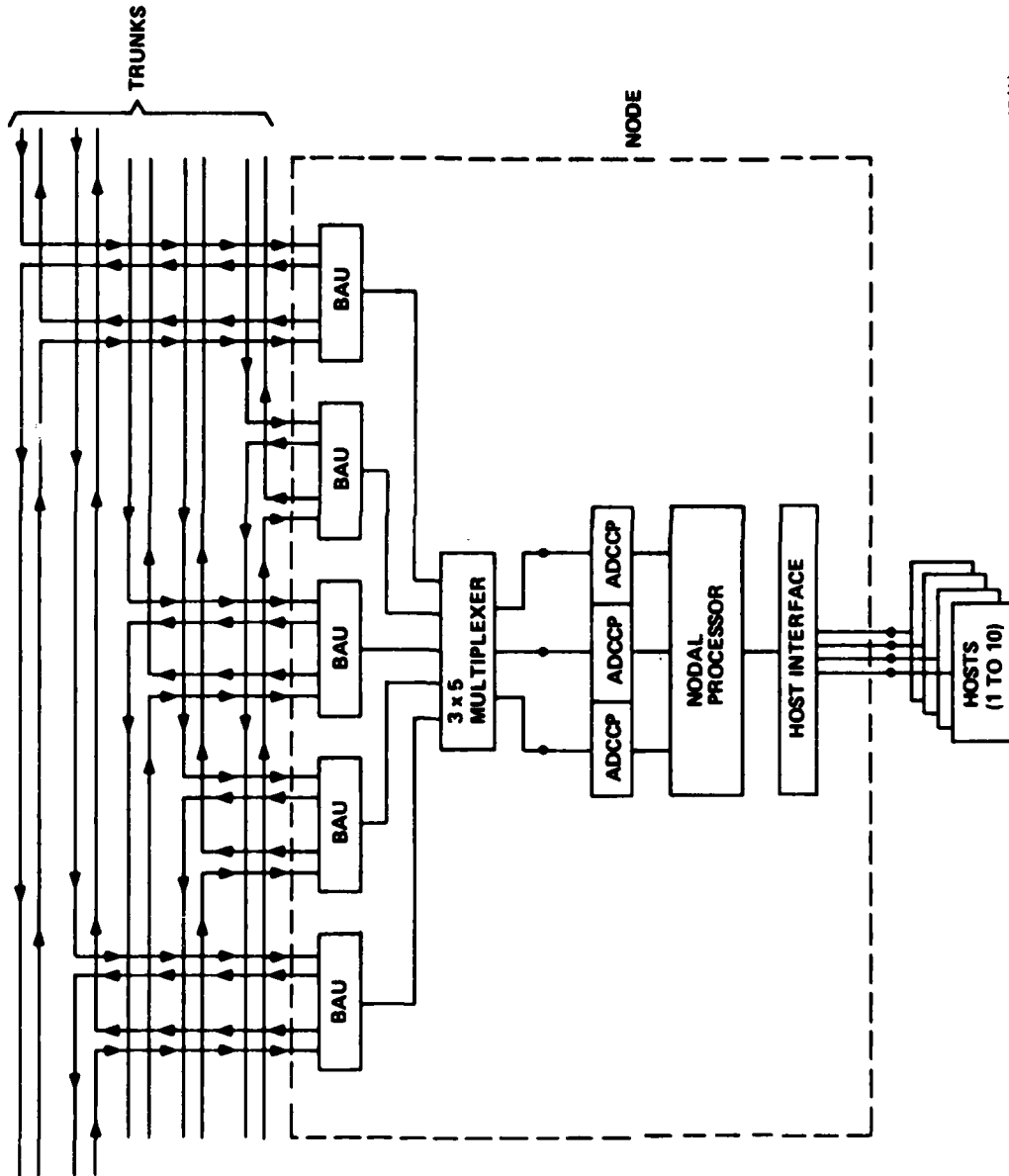

6737-80E (A)

MULTILOOP ARCHITECTURE KEY CONCEPTS

- USE OF MULTIPLE LOOPS
 - PROVIDES HIGH AGGREGATE BANDWIDTH
 - ALLOWS ACHIEVABLE (STATE-OF-THE-ART) MESSAGE-PROCESSING SPEEDS
- EFFICIENT BANDWIDTH SHARING THROUGH CONTENTION PROTOCOLS
- ABLE TO HANDLE LONG FILE TRANSFERS
- FULL-DUPLEX LOOPS PROVIDE FAIL-SOFT MODE OF OPERATION
- FIBER OPTIC TRANSMISSION MEDIA
 - RELATIVELY EASY TO INSTALL IN EXISTING DUCTS
 - IMMUNE TO EMI AND CROSSTALK
 - ELECTRICAL ISOLATION BETWEEN NODES
 - RELATIVELY SECURE MEDIUM
- EXISTING FIBER OPTIC SYSTEM ABLE TO MEET TRANSMISSION OBJECTIVES
- ABLE TO CARRY HIGH-BANDWIDTH SIGNALS OVER LONG DISTANCES UNREPEATED

SYSTEM PERFORMANCE OBJECTIVES

- 20 Mb/s EFFECTIVE DATA TRANSFER RATE BETWEEN NODES
- 200 Mb/s AGGREGATE TRUNK BANDWIDTH
- FULL-DUPLEX, BIT-ASYNCHRONOUS OPERATION AT INTERNODE DISTANCES UP TO 3000 FEET
- CONCURRENCY OF CONTROL AND DATA MESSAGES
- P (BE) < 10 (-9)
- ADCCP LINK-LAYER PROTOCOL ON NETWORK
- DYNAMIC ADDITION/DELETION OF HOSTS
- THREE NETWORK AND MULTIPLE HOST CONNECTIONS PER NODE
- INDIVIDUAL HOST CONNECTIONS FROM 9.6 kb/s THROUGH 20 Mb/s
- ADAPTIVE FLOW CONTROL OF HOST CHANNEL TRAFFIC

7972-92

FIBER OPTIC DATA BUS TECHNOLOGY AND APPLICATIONS

D. Porter
ITT Electro-Optical Products Division
7635 Plantation Road, N.W.
Roanoke, Virginia 24019

ABSTRACT

This paper is intended to provide a general background on fiber optic data buses; i.e., what they are; why they are beneficial; what they look like; how they work; and where they are being used.

I. INTRODUCTION

A data bus is a communication system which interconnects a number of physically dispersed users (often called terminals) over a common communication channel (the bus). In most digital data buses, the bus is cooperatively shared by time division multiplexing (tdm) data transmissions. Data buses using twisted wire pair and coaxial cable have already been implemented in airplanes, ships, land vehicles, military tactical centers, space vehicles, and computing centers to reduce wiring, achieve system flexibility, and provide growth potential. These systems have proven data buses to be the strongest tool for integration of large complex systems because the data bus establishes a common basis for communication between all terminals. Terminals may be dropped, replaced, or new

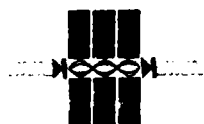

terminals may be added with minimum effort and without adversely affecting other operating terminals.

II. BENEFITS OF FIBER OPTICS

Fiber optics has many advantages over conventional wire which makes it a desirable transmission medium to consider for data buses. Some of these advantages are listed in Table 1. Fiber optic buses can do things that are impossible to do with wire while providing better performance, dramatic improvements in reliability, and reduced life cycle cost.

III. CONFIGURATIONS AND ARCHITECTURAL TRADEOFFS

A large variety of data bus configurations (topologies) and terminal architectures have been investigated for fiber optic data buses. Some very general representations of these configurations are illustrated in Figure 1. The most common fiber optic data bus configuration uses a single passive star coupler which distributes a signal from any one user to all users equally. The star configuration has the advantage of minimizing the number of couplers and connectors in the bus, thus minimizing optical loss. It also provides a relatively uniform range of signals at all receivers connected to the bus. The disadvantage of the star configuration is that it may require more cable than the tee configuration which is almost exclusively used in wire systems. The fiber optic tee configuration is typically limited to five to seven terminals

Table 1. Advantages of Fiber Optics.

Desirable Transmission Properties

- Greater bandwidth over longer distances; 200-1000 MHz·km typical for graded-index fibers
- Low signal attenuation; 3-5 dB/km at 0.85 μ m wavelength; less than 1 dB/km at 1.3 μ m wavelength
- Number of terminals is limited only by power considerations not signal distortion induced by taps on a wire bus

Enhanced Physical Characteristics

- Smaller
- Lighter weight
- More flexible and flexible over wide temperature range
- More elastic
- Not subject to flexural fatigue
- Corrosion resistant

Improved Reliability (Fewer Failure Mechanisms)

- Not electrically conductive, not a current path, electrically isolates terminals from each other, no shock hazard
- No possibility of short circuits or ground loops
- Intermittents are unlikely because intimate contact between fiber optic pins is not required to transmit the signal
- Safe in explosive environments
- Electrically isolates data bus terminals

Table 1. Advantages of Fiber Optics (continued).

Improved Channel Integrity

- Not affected by electromagnetic interference (emi) produced by power cables, switch closures, antennas, radiation from other signal wiring or electronic equipment, lightning, etc.
- Not affected by electromagnetic pulse (emp) associated with nuclear explosions. Electromagnetic pulse induced currents in wires connected to unprotected terminal equipment can result in equipment failure.
- Fiber optic cables do not radiate signals which might interfere with other systems.

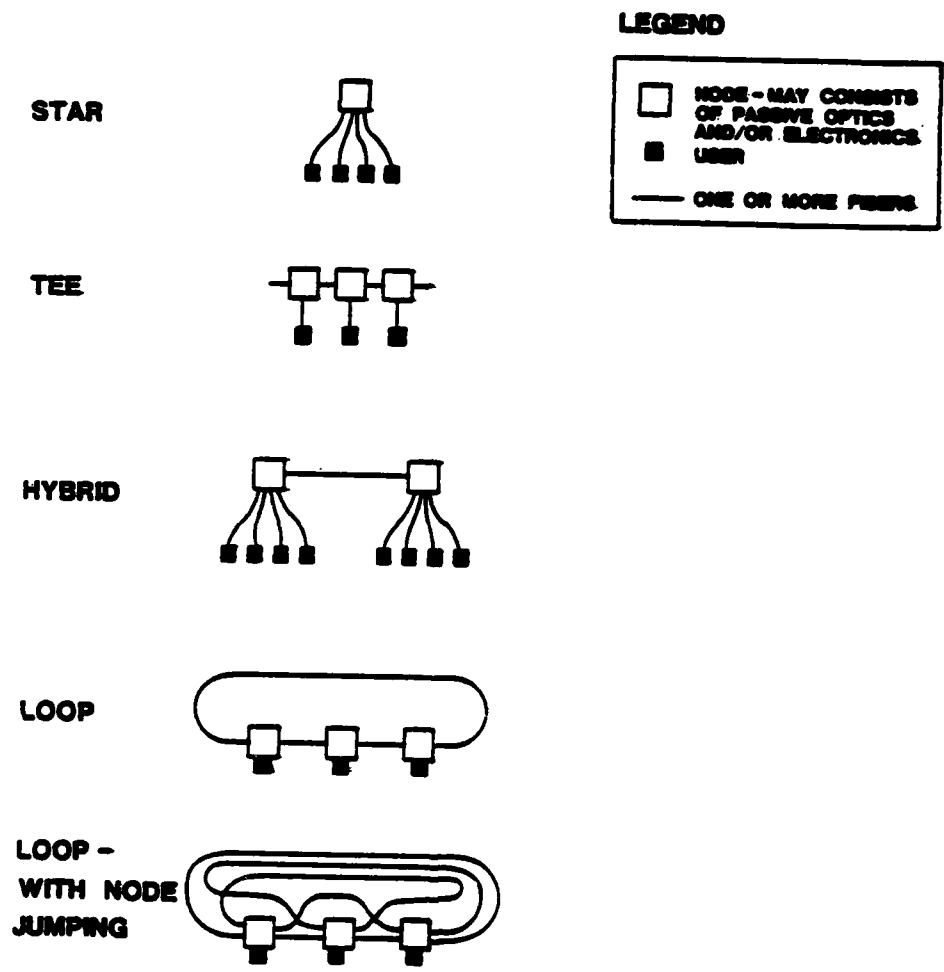

Figure 1. Data Bus Configurations.

unless repeaters are used because of the serial loss through connectors and tee couplers. Unfortunately, the equivalent of a high impedance tap analogous to wire bus couplers has not been developed for fiber optic systems.

Both passive and active (with repeaters) hybrid configurations have been developed which combine some of the advantages of the star and tee configurations. In the hybrid configuration couplers are located within clusters of users and only a few long cables are needed to interconnect between clusters.

Loop configurations have been devised which provide added redundancy over the basic tee configuration. If a break occurs; the bus reverts to a tee configuration. Since loop configurations are often based on use of repeaters at each node, passive node jumping is sometimes used to prevent failure of the loop bus due to repeater, connector, or fiber failure.

In all the configurations illustrated in Figure 1, nodes may consist of passive optical components and/or electronics; cables between nodes may consist of one or several fibers transmitting signals in one or both directions.

The bus configuration and terminal design selected for a specific application is typically based on a number of trade offs for a

given set of ground rules or basic system requirements. A list of some of the issues requiring a trade off analysis which are often encountered is given in Table 2.

IV. COMPONENTS

Optical Sources

Light emitting diodes (LED) composed of GaAlAs are presently the most suitable optical source for fiber optic data bus applications. Data rates of up to 150 Mb/s can be accommodated with LED sources. GaAlAs has good radiation resistance. Coupled powers of 100 μ W (at 100 mA junction current) are typical for stripe geometry GaAlAs double heterojunction light emitting diodes. Recently, devices became available in full military grade versions which have hermetic packages and operate from -55°C to $+125^{\circ}\text{C}$.

GaAlAs semiconductor laser diodes are useful at higher data rates, provide higher output powers than light emitting diodes and may also be suitable for some military applications in the near future. However, lasers generally require cooling and closed loop stabilization of the output power for operation over a wide temperature range and impose undesirable safety constraints.

Open loop stabilization and cooling above $+70^{\circ}\text{C}$ is desirable even for light emitting diodes. Variations in output power can occur due to the LED conversion efficiency's dependence on temperature

Table 2. Data Bus Issues.

Bus Design

- Topology
- Number of users
- Separation between users
- Number of fibers per cable
- Cable routing
- Cable type
- Connector type
- Growth potential

Terminal Design

- Encoding and decoding
- Synchronization
- Data detection (receiver design)
- Clock recovery
- Parallel to serial and serial to parallel conversion
- Data validation
- Built-in tests
- Data buffer
- Modularity
- Maintainability
- Safety

Table 2. Data Bus Issues (continued).

Transmission

- Source type
- Detector type
- Optical wavelength
- Modulation technique
- Data code
- Data format
- Link budget
- Rise time and dispersion

Performance

- Data rate
- Optical signal range (OSR)
- Receiver sensitivity and dynamic range
- Receiver intermessage dynamic range
- Bit error rate
- Data latency
- Bus loading efficiency
- Performance margins

Table 2. Data Bus Issues (continued).

Bus Control

- Bus access protocol
- Control protocol
- Failure modes

Environmental

- Temperature, etc.
- Hermetic sealing
- emi radiation and susceptibility (electronics)
- Nuclear radiation (electronics and optics)

Reliability

- Mean time between failures
- Mean time to repair
- Redundancy
- Availability

Cost

- Nonrecurring
- Recurring
- Cost of ownership

over the military temperature range. Above +70°C it is desirable to cool light emitting diodes to avoid degradation of device lifetime.

Optical Detectors

Silicon pin (p-type, intrinsic, n-type) photodiodes are presently the most common detectors for fiber optic data bus applications. The pin photodiodes are fast, efficient, low noise, and operate over a wide temperature range. Reversed biased pin diodes generate a photocurrent proportional to the optical signal power incident on the active area of the device.

Avalanche photodiode (APD) detectors provide greater sensitivity than pin photodiodes due to avalanche gain achieved in the device. However, a large reverse bias voltage (typically 300-400 V) is required. Avalanche photodiodes are used in a fixed gain configuration (rather than automatic gain control (agc)) to accommodate fast acquisition of data in data bus applications.

Fibers and Cable

Optical fibers which are recommended for data bus applications include the large core (100 μm) slightly graded-index fiber and the 50 μm core graded-index fiber (see Figure 2). Both fiber types have a borosilicate cladding and doped silica core to achieve the desired optical transmission characteristics. The

GRADED INDEX

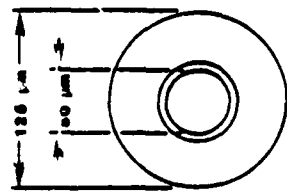

SEMI-GRADED INDEX

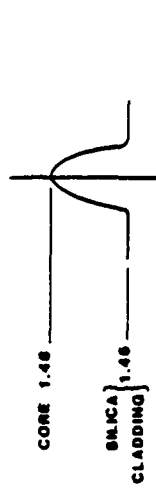
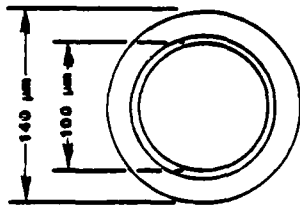

INDEX OF REFRACTION PROFILE

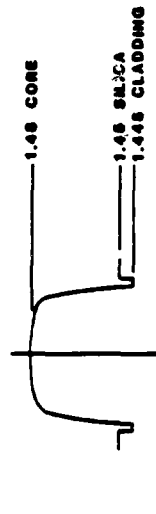

Figure 2. Optical Fibers.

large core slightly graded fiber is most suitable in short distance applications which have many connectors. The larger core results in lower loss connectors. However, fiber attenuation is 6-8 dB/km at 0.85 μm . The smaller core (50 μm) graded-index fiber has 3.5-5.0 dB/km attenuation at 0.85 μm and low dispersion which makes it more suitable for high data rate long distance applications. Both fibers are glass-glass constructions with a characteristically high mechanical strength. Fibers are typically tested to 100,000 psi during the manufacturing process. The glass cladding also provides a solid base for splice or connector installation.

Cables have been developed for surface tactical installations, underwater installations, aircraft installation, and a broad range of commercial direct burial, aerial mount, and duct installed applications (see Figure 3). The designs have proven adequate for wind buffeting and ice loading, installation pull, plowing under ground, and physical abuse under truck tires and armored vehicle tracks.

Couplers

A variety of directional, transmissive, reflective, and wavelength dependent optical couplers using either 50- μm or 100- μm core diameter all-glass fiber have been developed for use in fiber optic data bus systems. Samples are shown in Figure 4.

	TACTICAL	INTRA-BUILDING	AIRCRAFT
CROSS-SECTION			
JACKET MATERIAL:	POLYURETHANE	POLYURETHANE	TEFZIL
DIAMETER:	5.08 mm	3.05 mm (EA.)	2.5 mm
NUMBER OF FIBERS:	2, 4, 6	2	1
TENSILE STRENGTH:	67.0 Kgf	60.0 Kgf	67.0 Kgf
BEND RADIUS:	5.0 cm	3.5 cm	6.0 cm

Figure 3. Fiber Optic Cables.



TRANSMISSIVE STAR

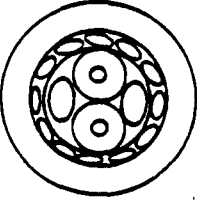
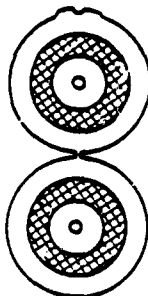
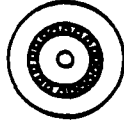
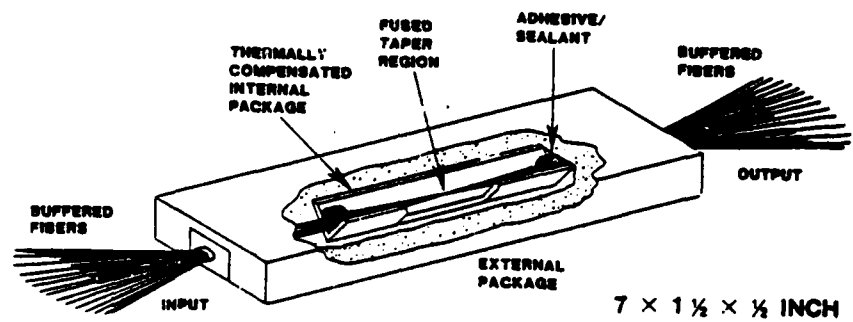
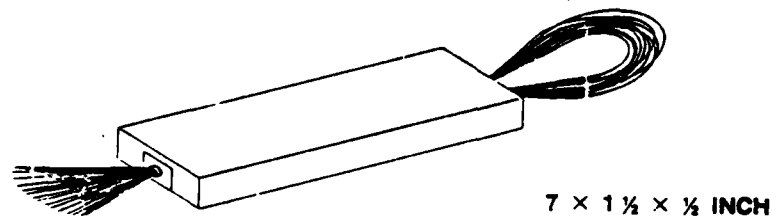

REFLECTIVE STAR

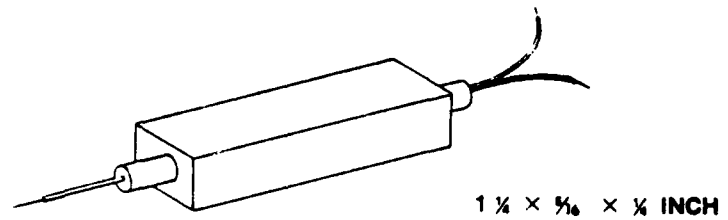

SPLITTER/COMBINER

Figure 4. Optical Couplers.

Optical performance and environmental stability of ITT EOPD couplers have been proven. The maximum excess loss of directional couplers with less than six ports is 2.0 dB. Larger directional couplers with up to 64 ports have less than 3 dB maximum excess loss. Reflection type couplers (used in systems to communicate bidirectionally over a single fiber) are specified to have less than 4.0 dB excess loss. Coupler uniformity, a measure of port-to-port output power variation, is specified to range from less than 10% to less than 40% depending on the number of coupler ports.

Environmental tests have been made on ITT couplers following a selected set of procedures from MIL-E-5400R and MIL-STD-810C. The tests have included high temperature, low temperature, temperature shock, humidity, vibration, and shock. The intent of the coupler test program is to fully comply with the requirements of MIL-E-5400R, Class 1A, for equipment to be used in piloted aircraft. Results of environmental testing to date have shown that the coupler designs can meet these requirements.

Optical couplers may be packaged with demountable connectors for easy replacement or spliced into the system as a permanent installation (see Figure 5). Modularity and mean time to repair (MTTR) are improved by providing connectorized couplers; however, often the connectors are more expensive than the coupler itself. This

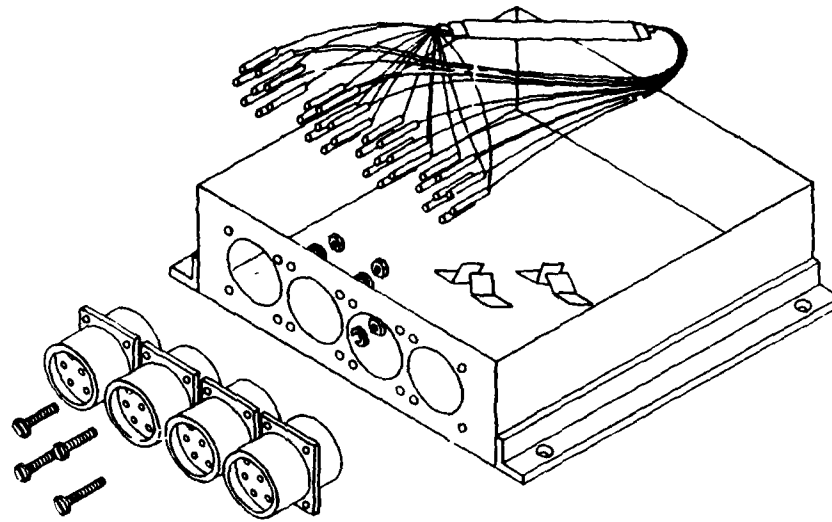

a. Packaged With Connectors

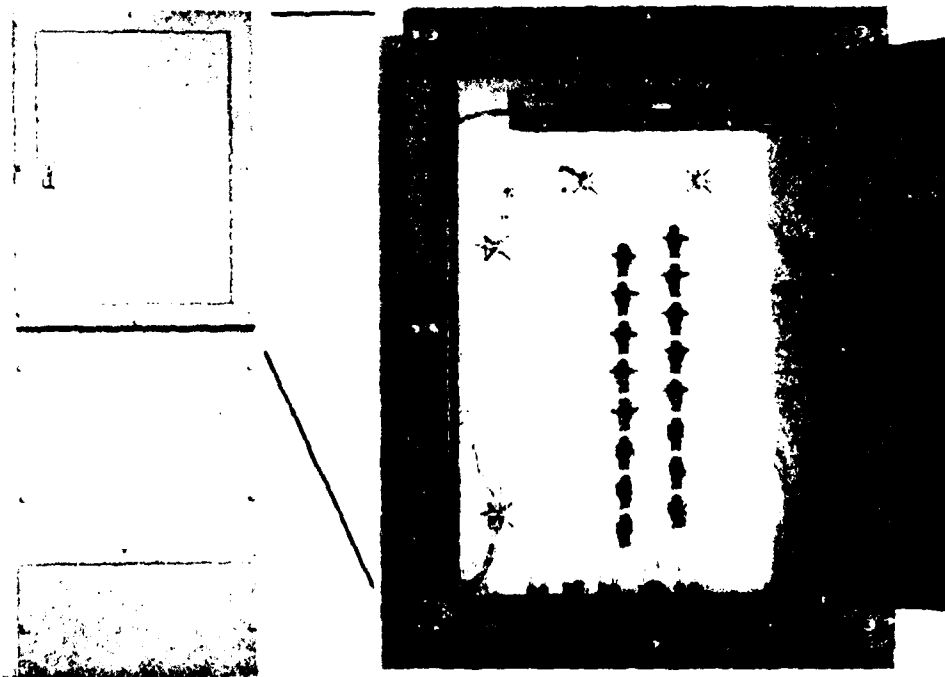

b. Wallmount Installation

Figure 5. Coupler Packaging and Installation.

cost can be avoided by permanently splicing couplers into the bus with the added advantage of reduced loss.

Connectors

Connectors are often required at fire walls, pressure bulkheads, production breaks, couplers, and equipment interfaces. Both simplex and multiway fiber optic connectors have been developed by numerous connector manufacturers based on styles which have already become standards for wire systems (see Figure 6).

Features desirable in an optical connector design include:

- a. Ease of termination
- b. Low insertion loss and repeatability
- c. Long term reliability
- d. Cable strain relief

Most fiber optic connectors to date use the butt joint alignment principle in which the fibers are aligned to each other by a precision metal, glass, ceramic, or plastic mechanical assembly. In these systems, the main cause of optical loss is radial (transverse) fiber offset which must be controlled to about $5 \mu\text{m}$ (0.0002 in) or less to achieve a low-loss connector.

The optical losses associated with end separation, angle mismatch, and Fresnel reflection are usually much lower than for radial offset. Commercially available multifiber connectors using the butt

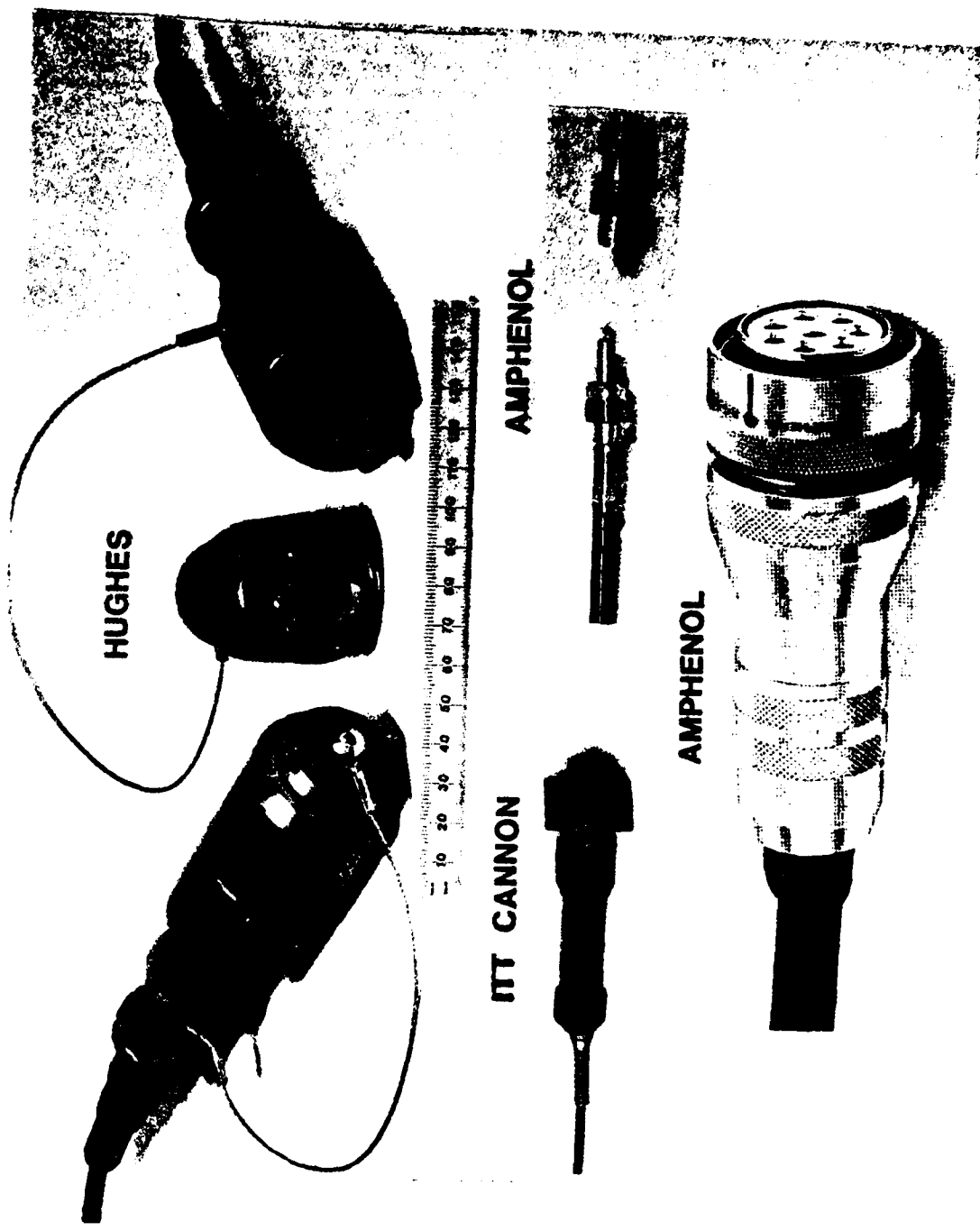

Figure 6. Fiber Optic Connectors.

joint technique have typical optical insertion losses of 0.5 dB to 3.0 dB. As connectors improve, connectors should become available with losses consistently below 1.0 dB.

V. DATA RECOVERY

Data transmissions in fiber optic data buses are typically bursty, asynchronous, varying in amplitude, closely spaced, and high speed. Recovery of data requires that the receiver, data detection scheme and clock recovery scheme take into account the unique characteristics of the received data bus transmissions.

Data Bus Receiver

A typical receiver for point-to-point applications uses a pin photodiode or an APD to convert a small intensity modulated optical signal into a signal photocurrent. A carefully designed low-noise amplifier is used as the first stage in a number of successive gain stages to amplify the signal to levels suitable for threshold detection.

In point-to-point links, agc is often used to adjust the signal to an optimum level for detection with a voltage comparator. The agc process used in point-to-point links generally has a long convergence time and is not suitable for data buses where data transmissions are short and change in amplitude between adjacent transmissions. Therefore, an optical data bus receiver is unique

in that it must accommodate a large range of input signal levels and have a very short acquisition time.

Unlike bipolar electrical signals, intensity modulated optical signals are unipolar and a change in the received signal amplitude results in a change in the average value (see Figure 7). The term optical signal range (OSR) has been used to describe the magnitude of this change and is defined as the ratio of the average or peak powers, expressed in decibels.

The term dynamic range has been traditionally used to refer to the total range over which a receiver can operate. The range is generally limited by saturation at one extreme and by noise at the other extreme. However, because of the short acquisition time requirement, the term dynamic range is not entirely adequate for characterizing optical data bus receivers. Therefore, the new term, intermessage dynamic range (IDR), has been defined for characterizing optical data bus receiver performance. IDR is defined as the maximum OSR that a receiver can accommodate when separated by a minimum intermessage gap, t_g . The challenge is to design an optical receiver for use in data bus applications which can tolerate a very large OSR for very small t_g .

Receiver designs may be divided into three types: switched, linear, and nonlinear (see Figure 8). Switched designs include

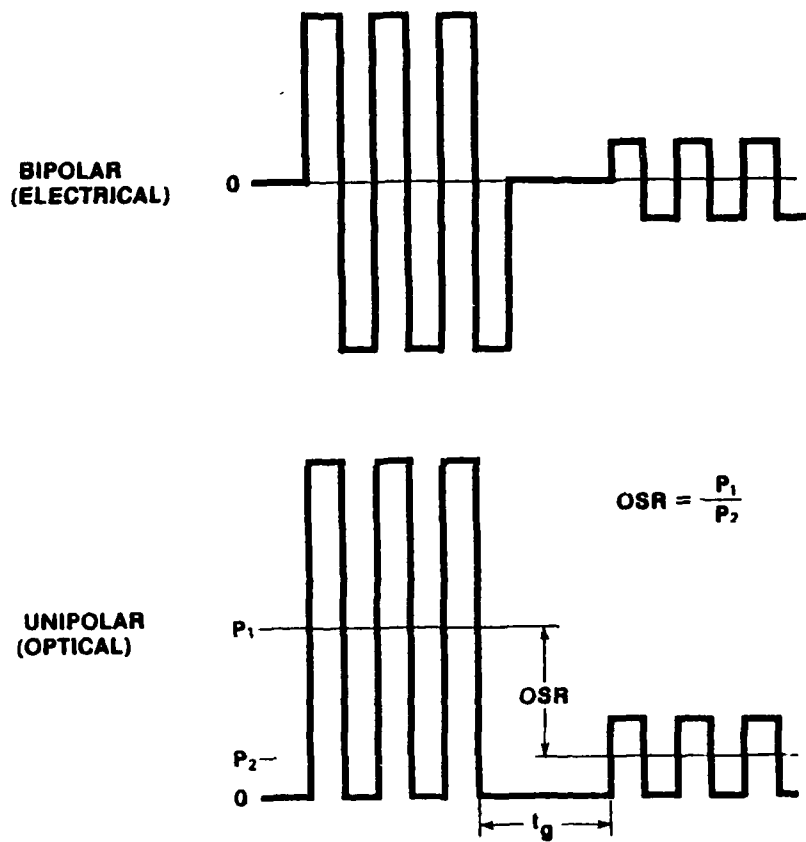

Figure 7. Intermessage Dynamic Range.

adaptive threshold and fast response agc. Linear designs can be used if additional interface electronics is provided between the transmitter/receiver and the host. Such schemes include narrow pulse Manchester, edge detection, three-state Manchester, and frequency shift keying (fsk). ITT's receiver design employs the non-linear approach.

The ITT symmetrical clamp receiver design was recently optimized for use on a 1 Mb/s transceiver card for MIL-STD-1553 (an aircraft multiplex bus standard) (see Figure 9). The design is architecturally more attractive than switched designs because it does not require a control signal from the data decoder to initialize the receiver prior to a message and is more reliable and economical than linear designs because additional interface electronics is not required. Waveforms for the symmetrical clamp receiver are shown in Figure 10. The waveforms represent a 23.0 dB (200:1) OSR for a 2 bit separation between transmission (as required by MIL-STD-1553). The sensitivity achieved with this design is -52.0 dBm (6 nW). A 16.0 Mb/s version of the receiver has also been developed by ITT for Litton Data Systems for use in the TAOC-85 program, U.S. Marine Corps.

Clock Recovery

Clock recovery is a key consideration in any asynchronous communication system. Poor timing can result in burst errors which can



SWITCHED RECEIVERS

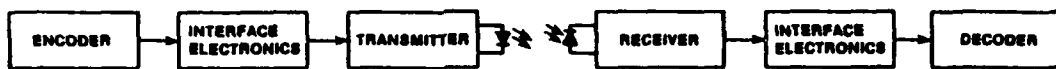

LINEAR RECEIVERS

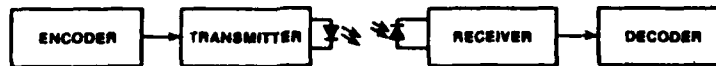

NONLINEAR RECEIVERS

Figure 8. Architectural Implications of Receiver Types.

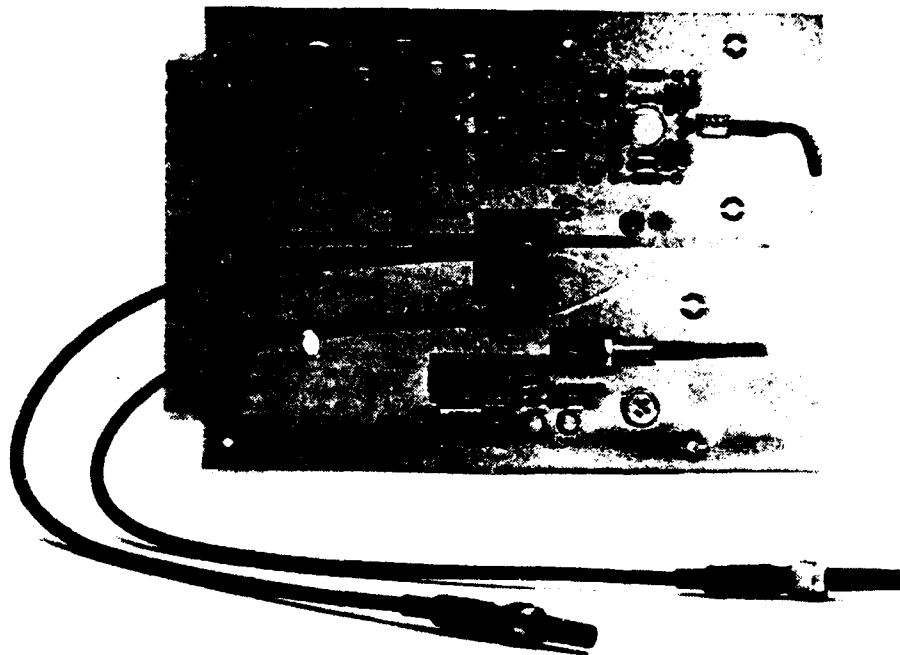

Figure 9. 1 Mb/s Data Bus Transmitter/Receiver Card.

PREAMPLIFIER
OUTPUT

SYMMETRICAL
CLAMP
OUTPUT

LOGIC LEVEL
OUTPUT

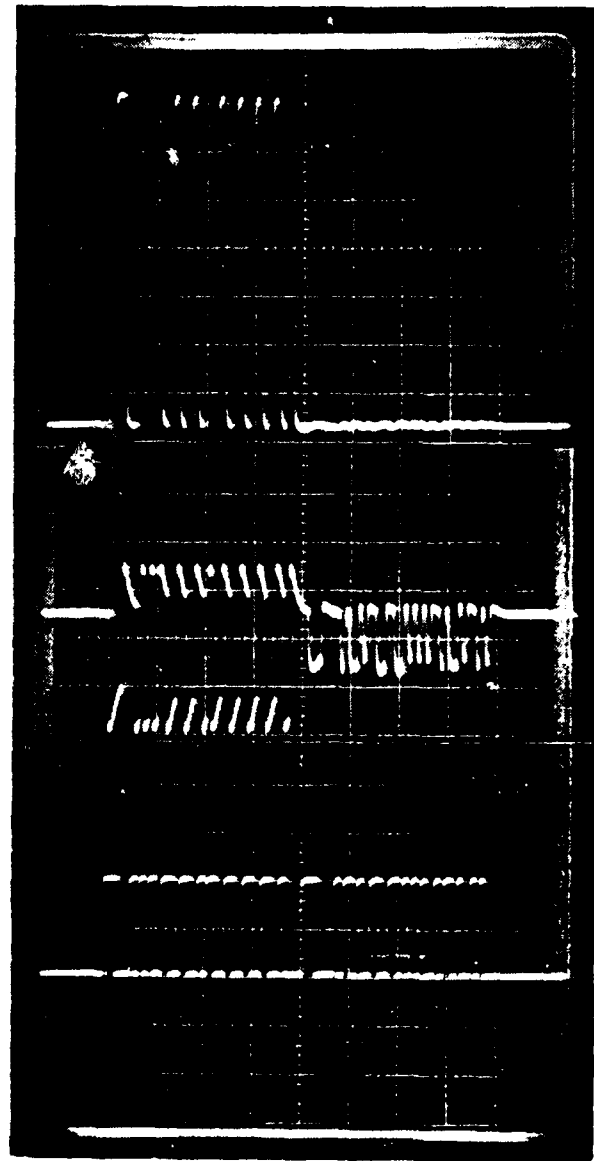

Figure 10. Data Bus Receiver Waveforms.

increase error rates by orders of magnitude over error rates resulting from purely additive noise. Clock recovery for data buses is generally more difficult than for continuous systems because data is bursty and asynchronous. In addition, clock must be acquired very quickly to maintain high bus loading efficiencies, especially when bursts of data are short.

Encoding (such as Manchester biphase) is often used to provide a strong frequency component from which clock can be easily derived. Manchester code guarantees a transition in the center of each bit. Both digital and analogue techniques are used to derive clock from the received data. At low data rates digital techniques are more common. Analogue techniques using tuned circuits become easier at higher data rates.

VI. DATA BUS PERFORMANCE

A summary of the performance of a 100 Mb/s fiber optic data bus system recently developed by ITT for NASA-Marshall Space Flight Center (see Figure 11) is graphically illustrated in Figure 12. The OSR of 5.6 dB (-24.6 dBm to -19.0 dBm) is derived from measured star coupler loss (including connectors) and a -3.7 ± 0.7 dBm coupler power. The 18.8 dB receiver dynamic range can be adjusted upward or downward by several decibels by adjusting receiver gain. All data bus terminals have been set for a sensitivity level (bit error rate (BER) $< 10^{-10}$) of -31.0 dBm and

AD-A126 110

PROCEEDINGS OF CONFERENCE ON LOCAL AREA MILITARY
NETWORKS GRIFFISS AFB NEW YORK 28-30 SEPTEMBER 1982(U)
ROME AIR DEVELOPMENT CENTER GRIFFISS AFB NY
D B WARMUTH ET AL. 1982

2/6

UNCLASSIFIED

F/G 17/2

NL

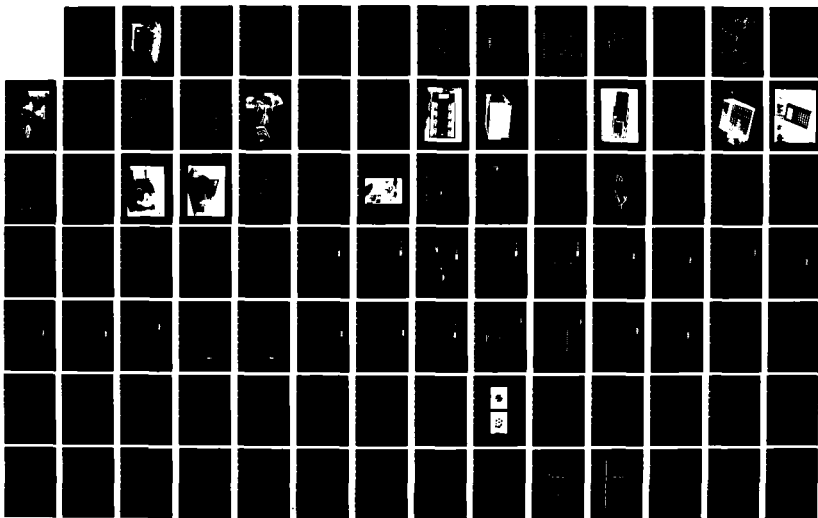

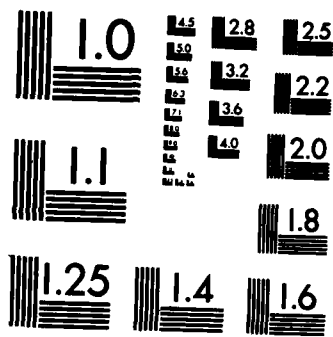

MICROCOPY RESOLUTION TEST CHART
NATIONAL BUREAU OF STANDARDS-1963-A

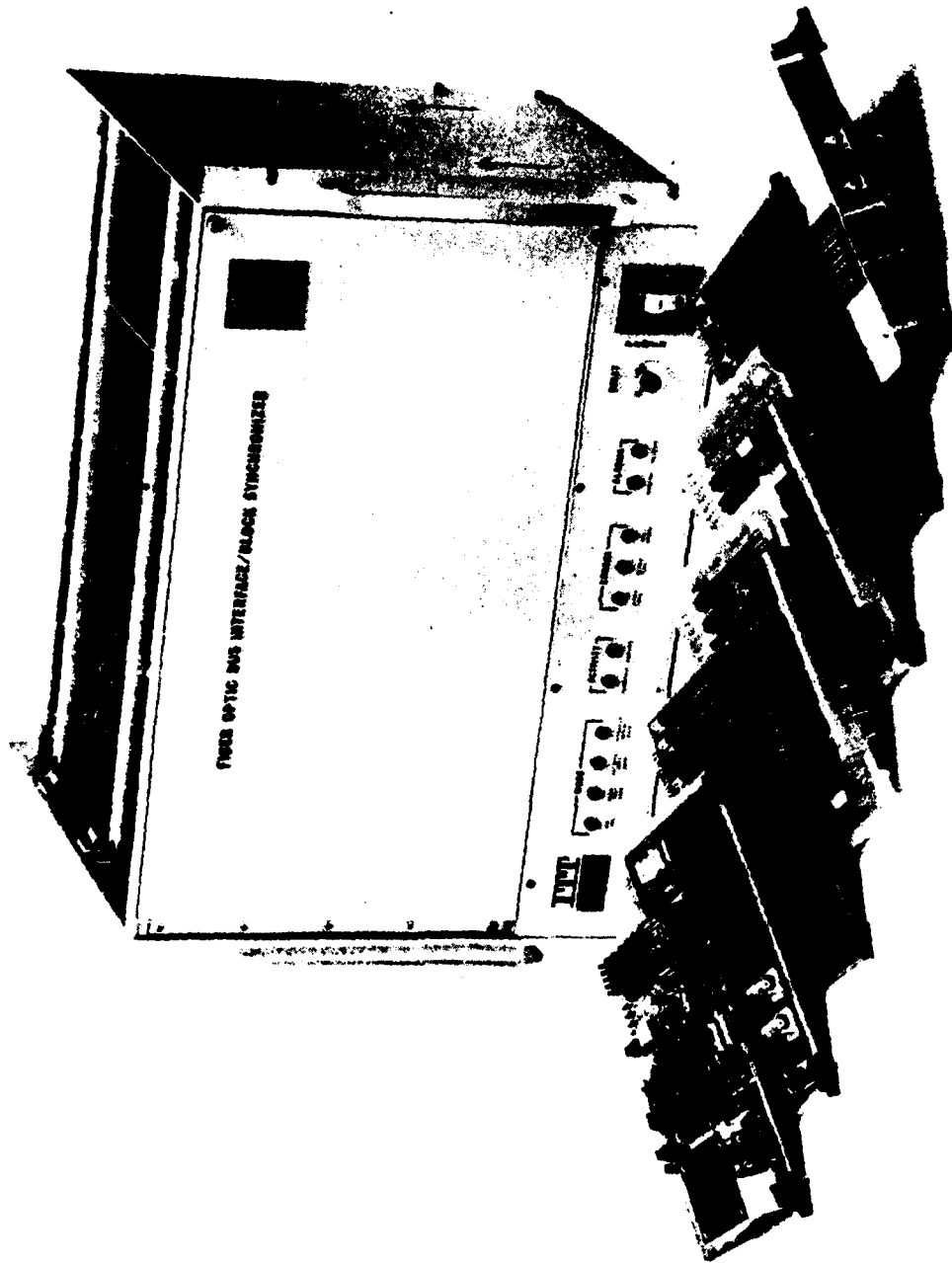

Figure 11. 100 Mb/s Data Bus Terminal.

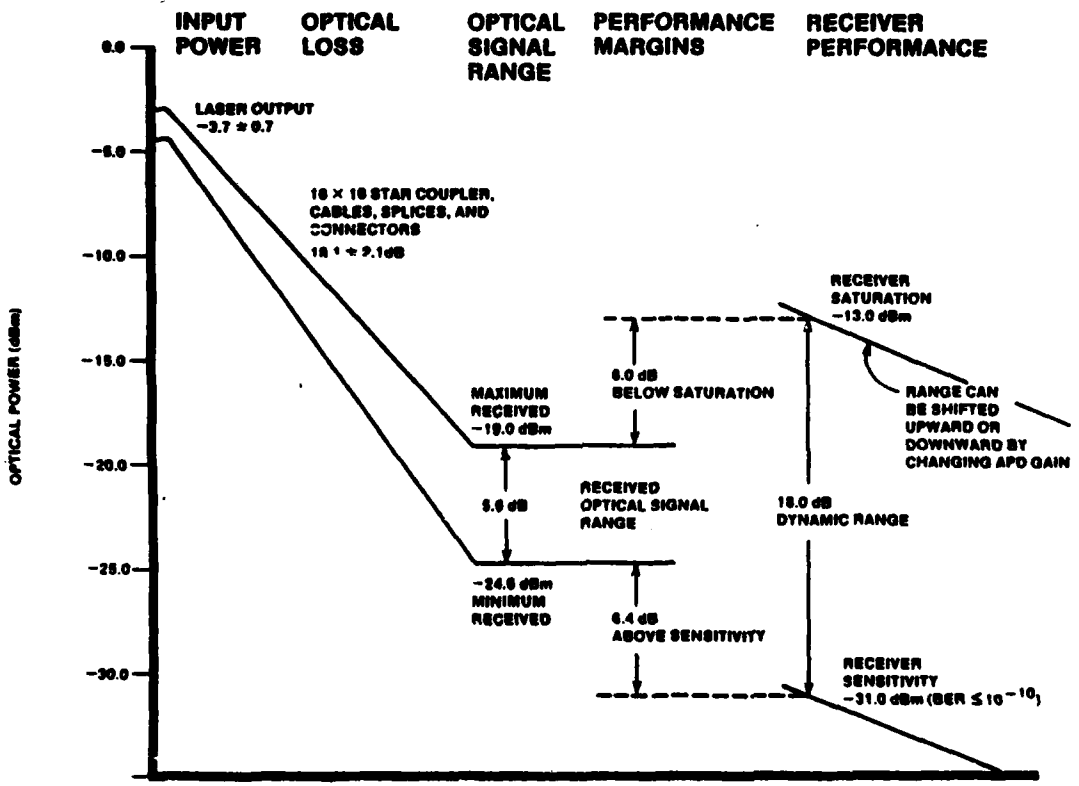

Figure 12. 100 Mb/s Data Bus Performance Summary.

a sensitivity level (bit error rate (BER) $<10^{-10}$) of -31.0 dBm and saturation level of -13.0 dBm. Therefore, the margin above the sensitivity level is 6.4 dB optical and below saturation is 6.0 dB optical.

VII. BUS ACCESS AND CONTROL

The resources of a data bus must be shared in an orderly fashion by all terminals to achieve high efficiency. For this reason a protocol for bus access (decision to transmit) and control of messages (content, origin, and destination) must be adopted.

The bus access protocol is the set of rules adopted by all data bus terminals to govern which terminal gains access to the bus at a given instant. The overall objective is to utilize the bus communications resource in the most efficient manner. Parameters of interest are bus loading efficiency, average wait time, and maximum wait time. No single bus access protocol has yet emerged which meets the needs of all applications equally well. There are presently a number of industry efforts to standardize on a bus access protocol. However until standards emerge, bus access protocol will continue as an issue of consideration for system designers. Popular bus access protocols include:

- a. Command/response (MIL-STD-1553)
- b. Time slot allocation
- c. Dynamic time slot allocation

- d. Carrier sensed multiple access with collision detection (CSMA/CD)
- e. Token passing

Even fewer standards exist for message control. Issues relating to control protocol include:

- a. Buffer sizes
- b. Message size and format
- c. Issuing commands
- d. Status reporting
- e. Message routing

VIII. DATA BUS APPLICATIONS

Data buses have gained acceptance in both commercial and military applications; in ground based, airborne, sea going, and spacecraft installations; and throughout almost every discipline; e.g., data base, strategic, tactical, medical, financial, control, etc. Data buses have been used to transmit digital data, analog data, digitized analog data, voice, video, and radar signals. Only imagination appears to limit the range of applications for data buses. Data bus technology began in the 1960's and rose to full prominence in the 1970's with wire technology as the principle transmission medium. The 1980's will see broad applications of data buses using both wire and fiber optics. Perhaps the 1990's will predominantly belong to fiber optics.

IX. CONCLUSIONS

Fiber optic data bus technology offers many tangible benefits over wire technology. These benefits have been noted earlier in this paper. Fiber optics technology has matured considerably in the last several years and the components and techniques are available today to take advantage of the benefits offered by fiber optic systems.

ITT ELECTRO-OPTICAL PRODUCTS DIVISION
7835 Plantation Rd., Roanoke, Va. 24019. Telephone (703) 563-0371

TELECONFERENCING

FIBER-OPTIC

COMMUNICATION SYSTEM

THEME

Ground Communications

Must Survive

Future Electronic/Physical Threats

PERCEIVED NEEDS

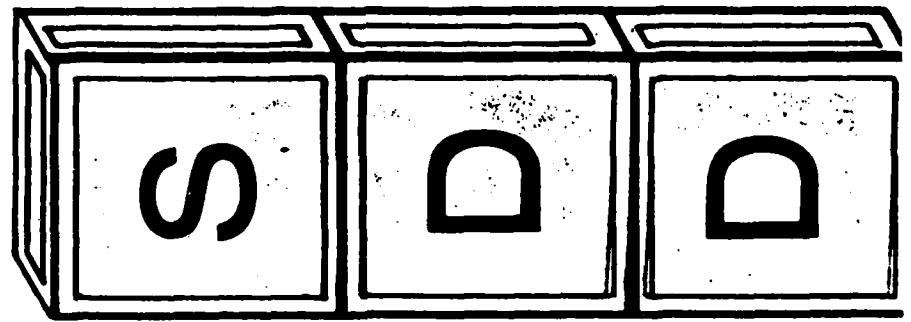

URVIVABLE

ECENTRALIZED

ISPERSION

ISSUES

- **Dispersion Enhances Survivability**
- **Dispersion Creates C² Problems**
- **Rapid Technology Changes Underway**

CELLULAR COMMAND POST CONCEPT

- **Small Functional Cells**
- **Common Structure Duplicated**
- **Highly Mobile**
- **5-10 km Apart**

AF DEPLOYMENT

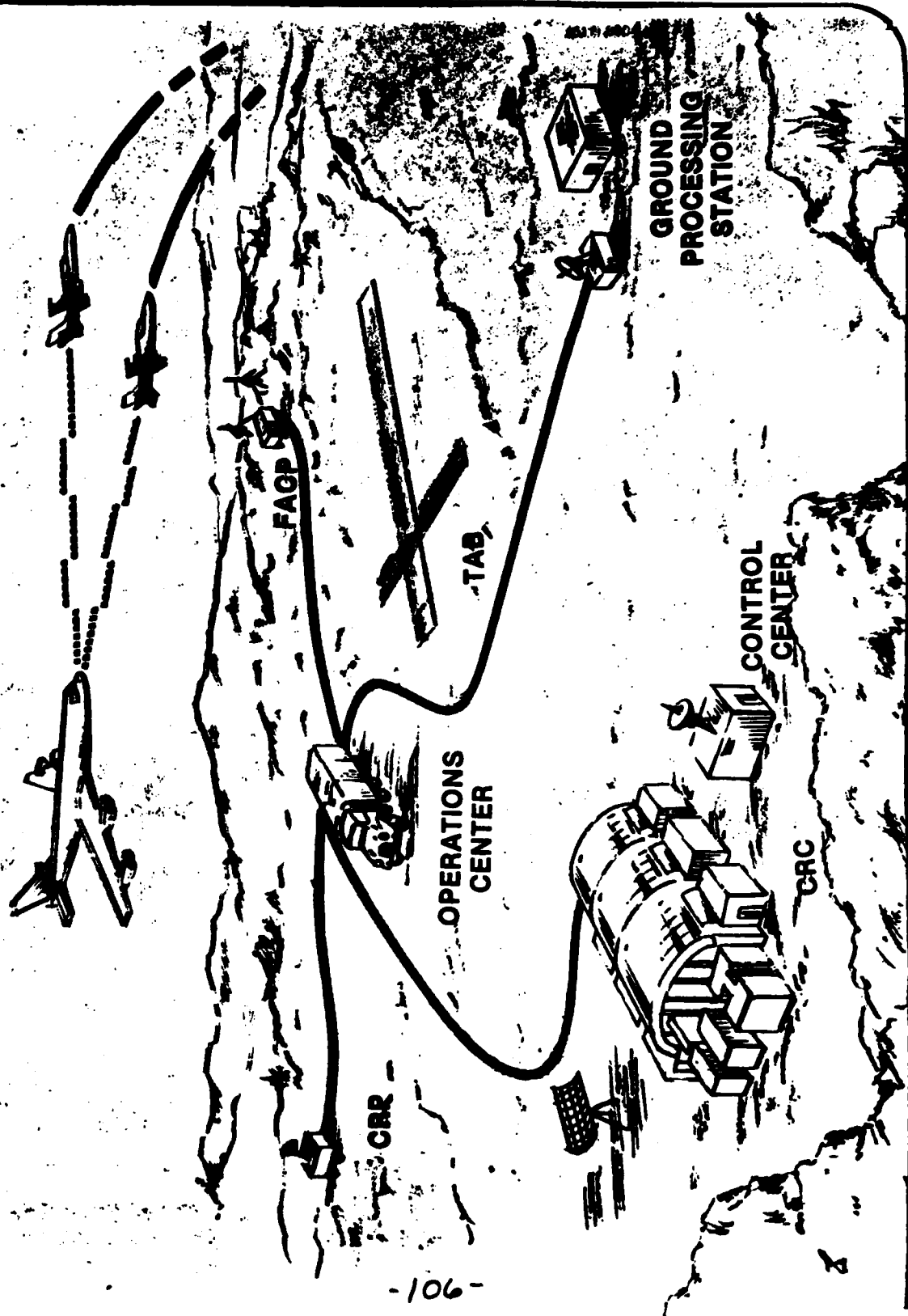

DECISION—MAKING UNDER STRESS

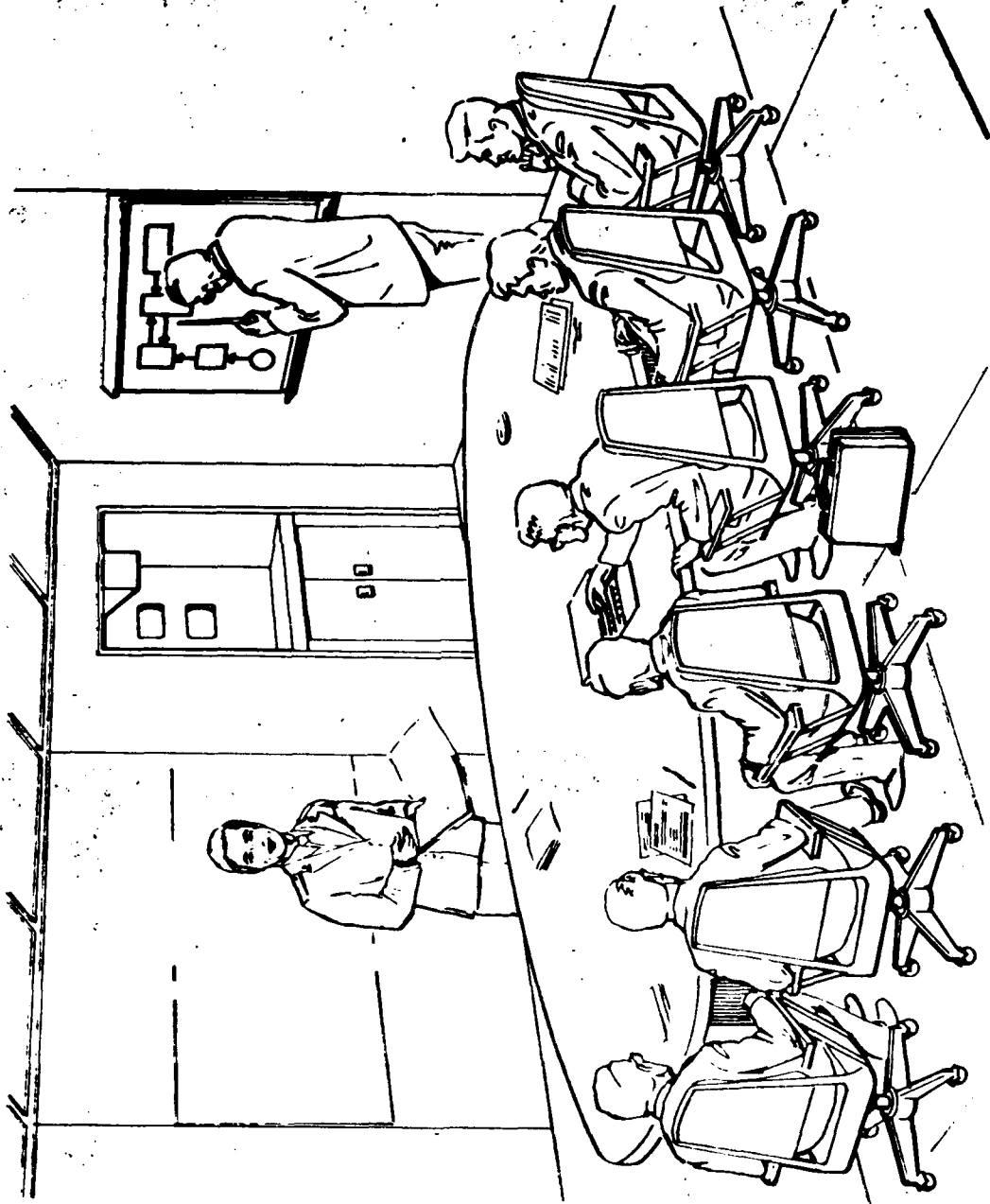

DECISIONMAKING UNDER STRESS



**VIDEO TELECONFERENCING
AS A SOLUTION**

VIDEO CONFERENCING FUNCTIONS

- Multi-Location
 - Picture Presentation
 - Full-Screen
 - Split-Screen
- Full-Motion
- Color
 - Picture Content
 - Person
 - Graphics/Document
- Location
 - Conference
 - Office
- Camera Control

VIDEO CONFERENCING APPROACH

- **Analog Optical Fiber Transmission**
- **Standard TV Set**
- **1 Standard Camera per Site**
- **Star Network**
- **Multiservice Flexibility**

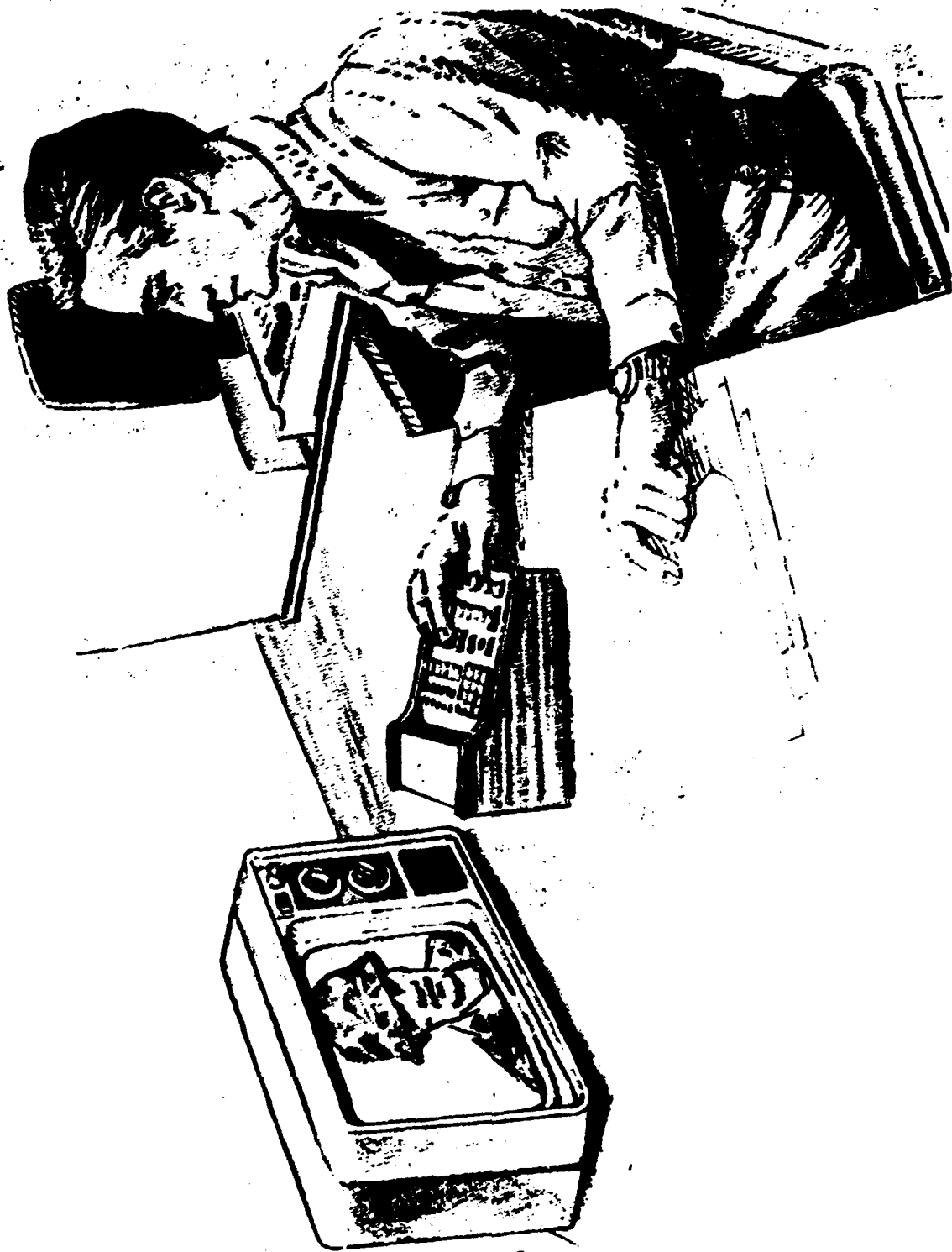

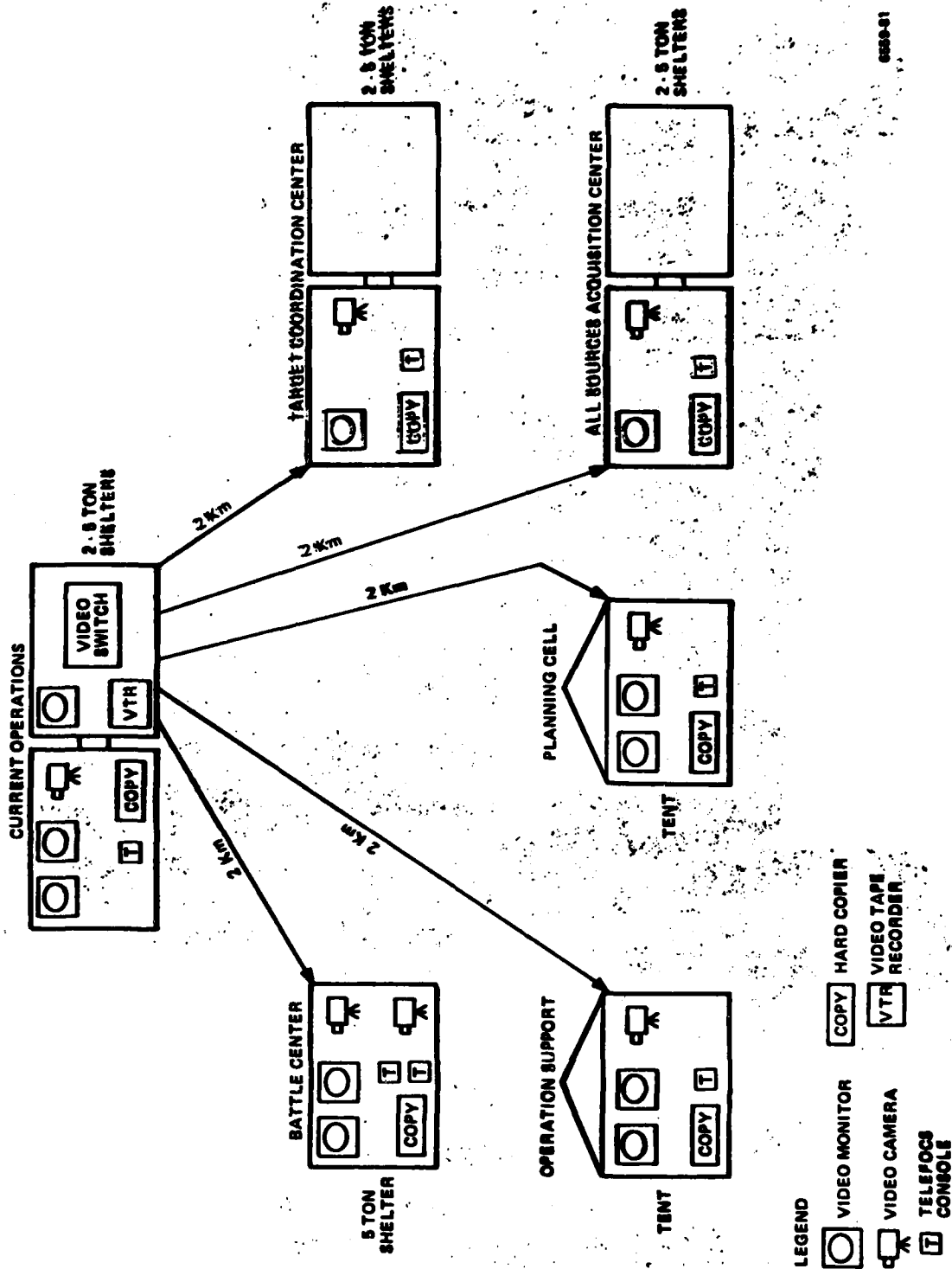

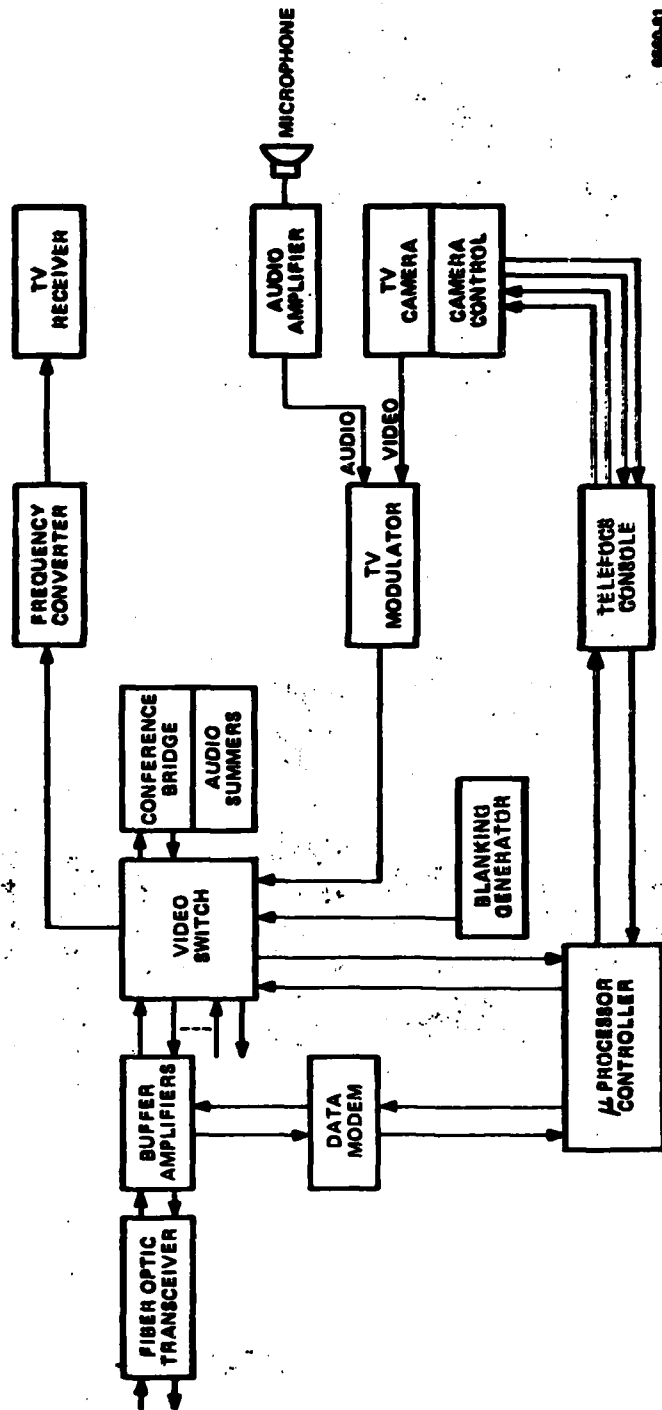

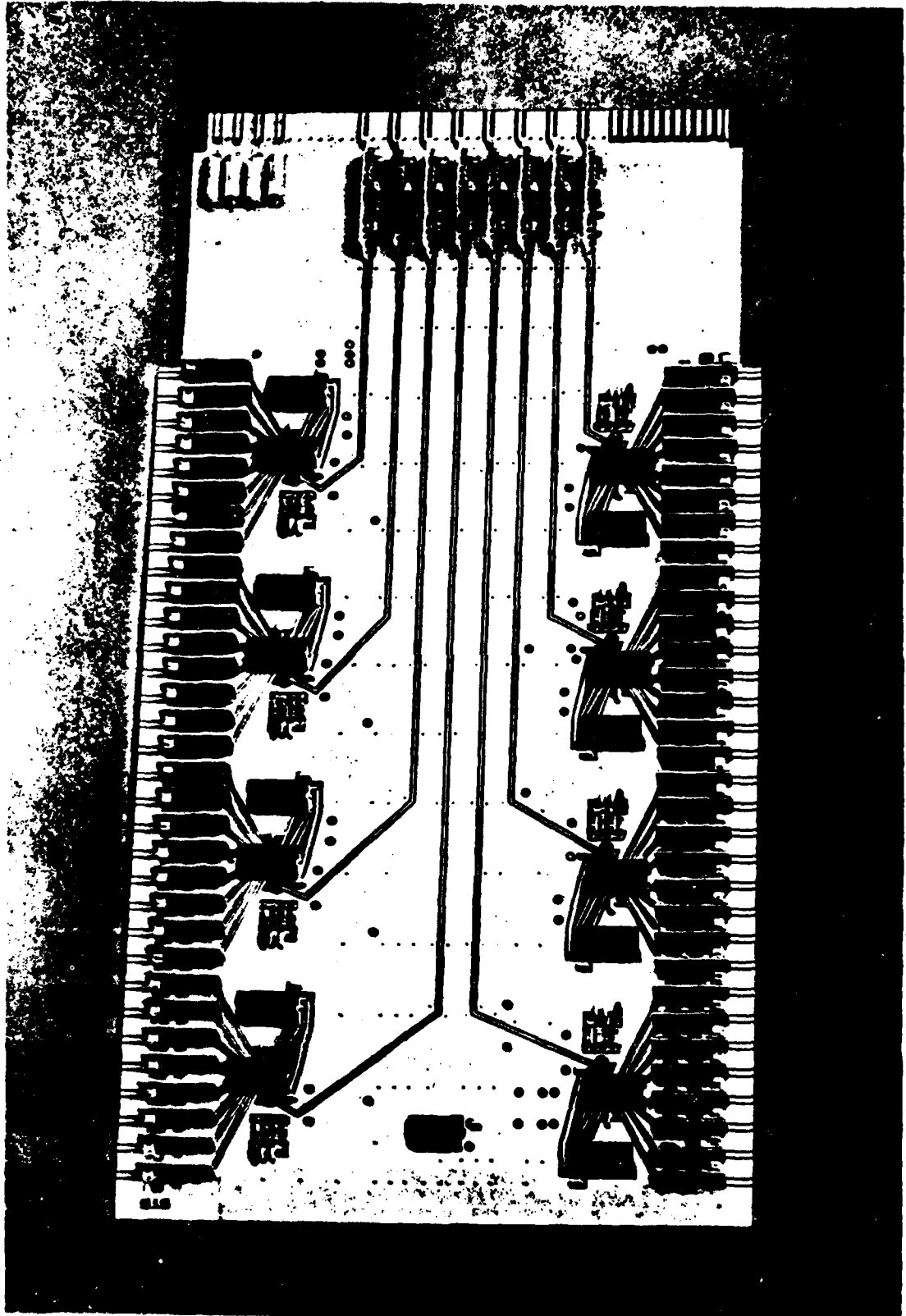

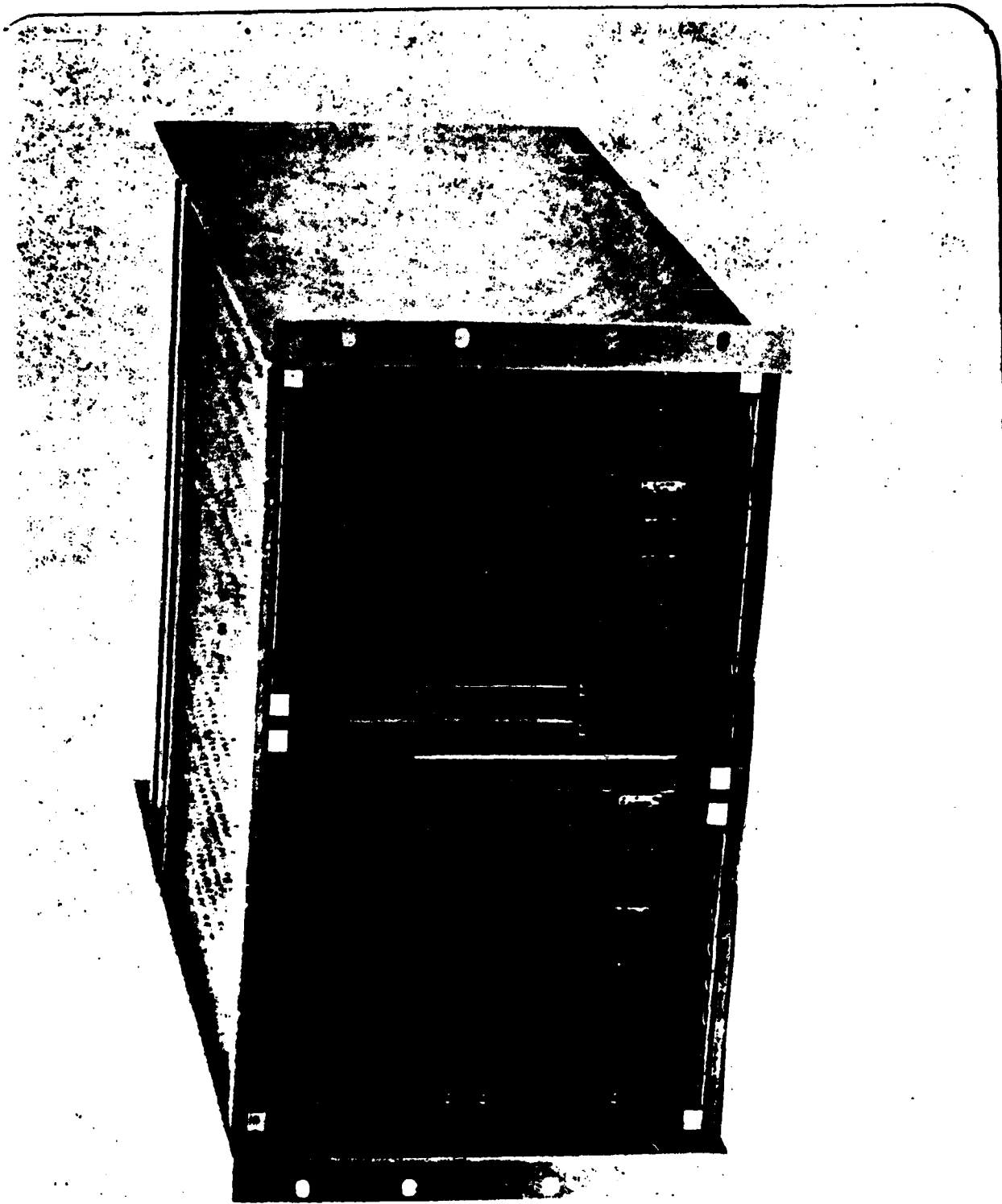

- 116 -

FREQUENCY PLAN

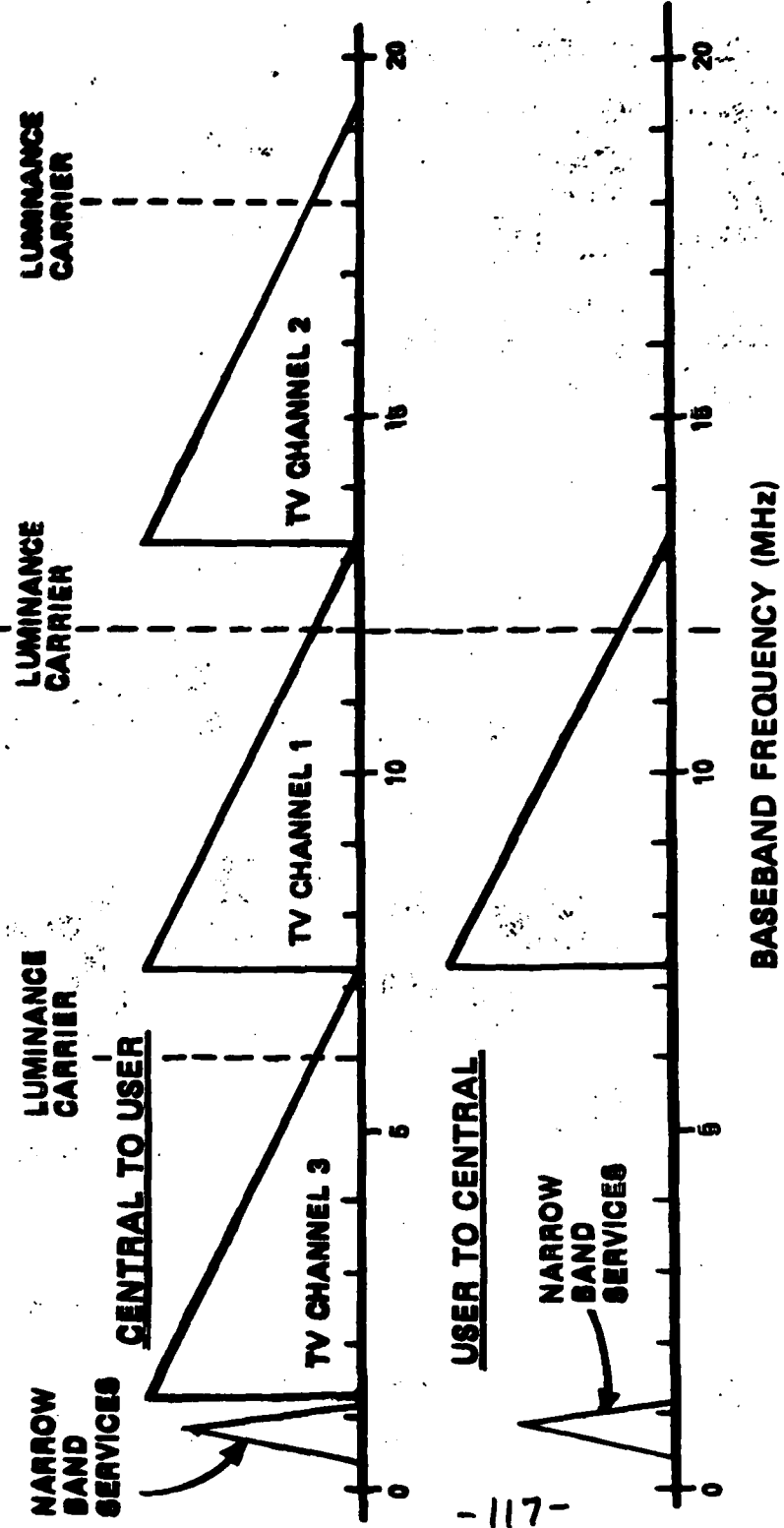

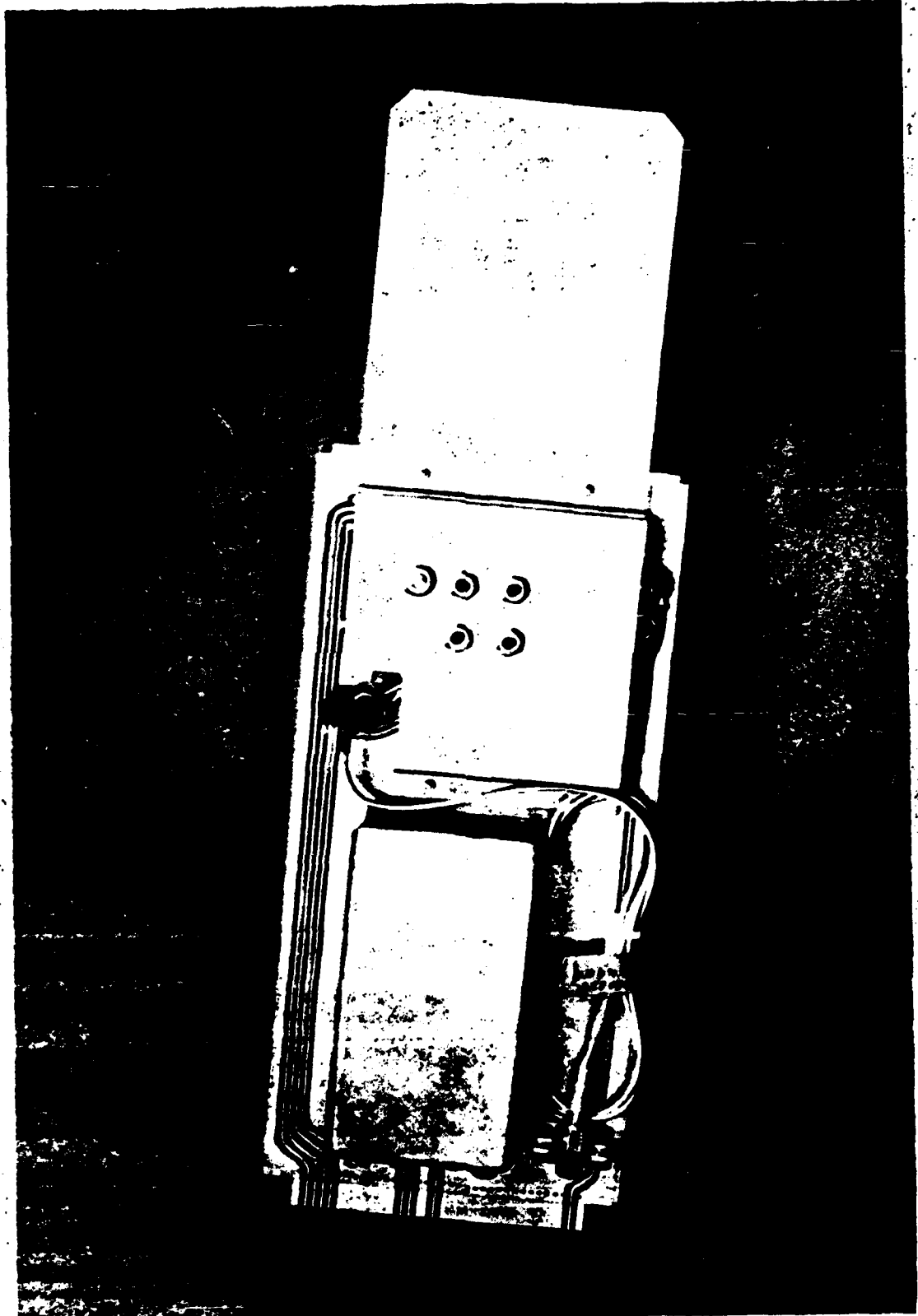

- 118 -

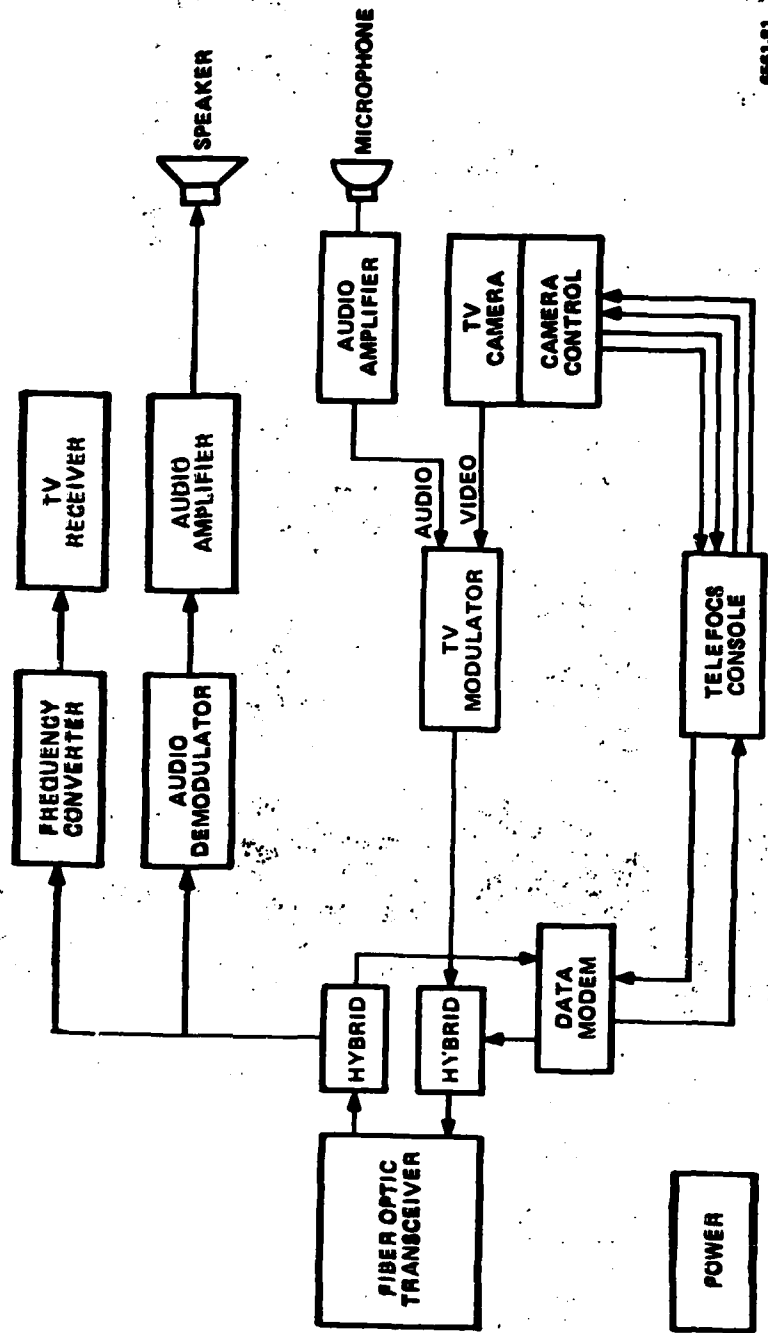

6561-81

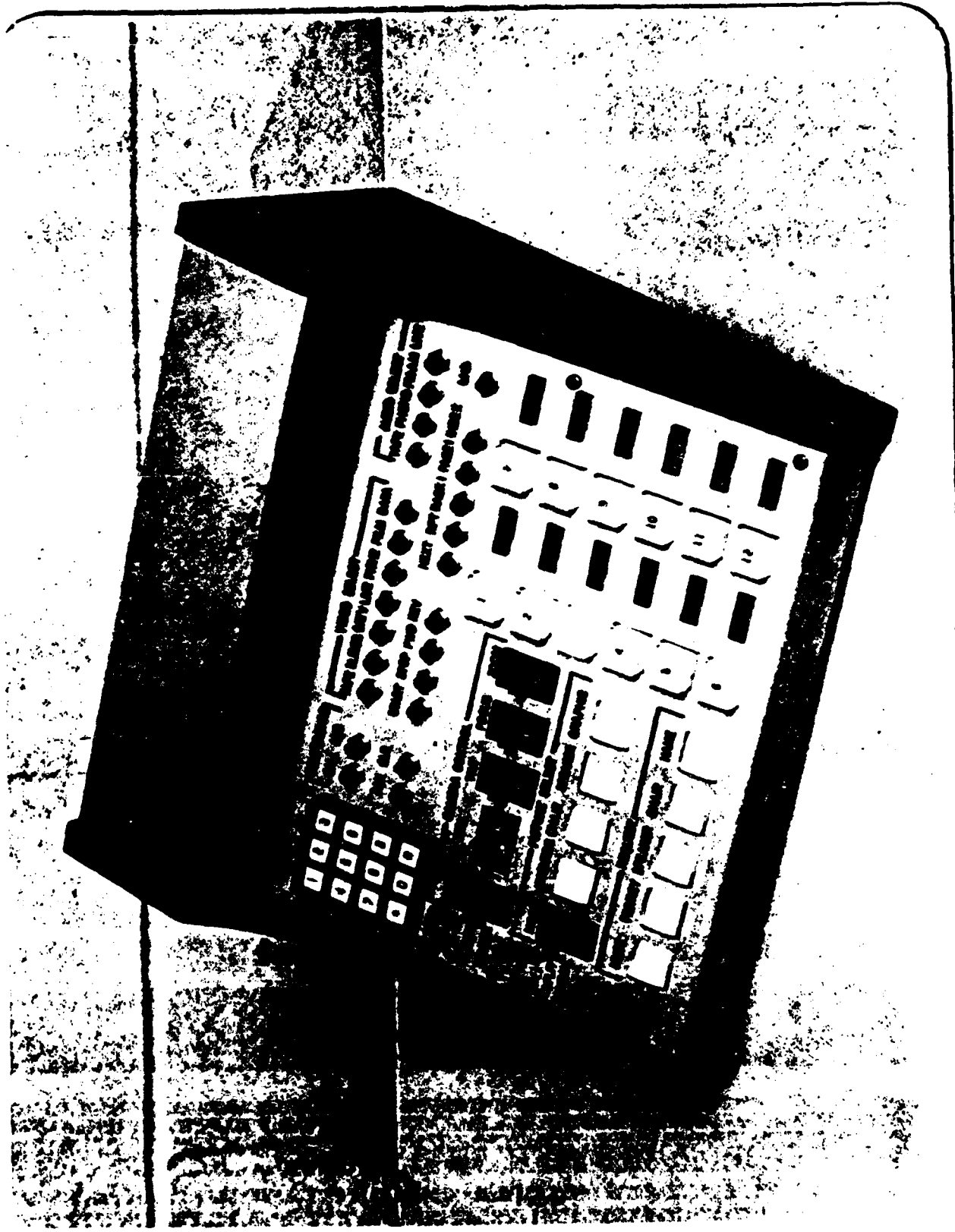



VIDEO CONTROLLER

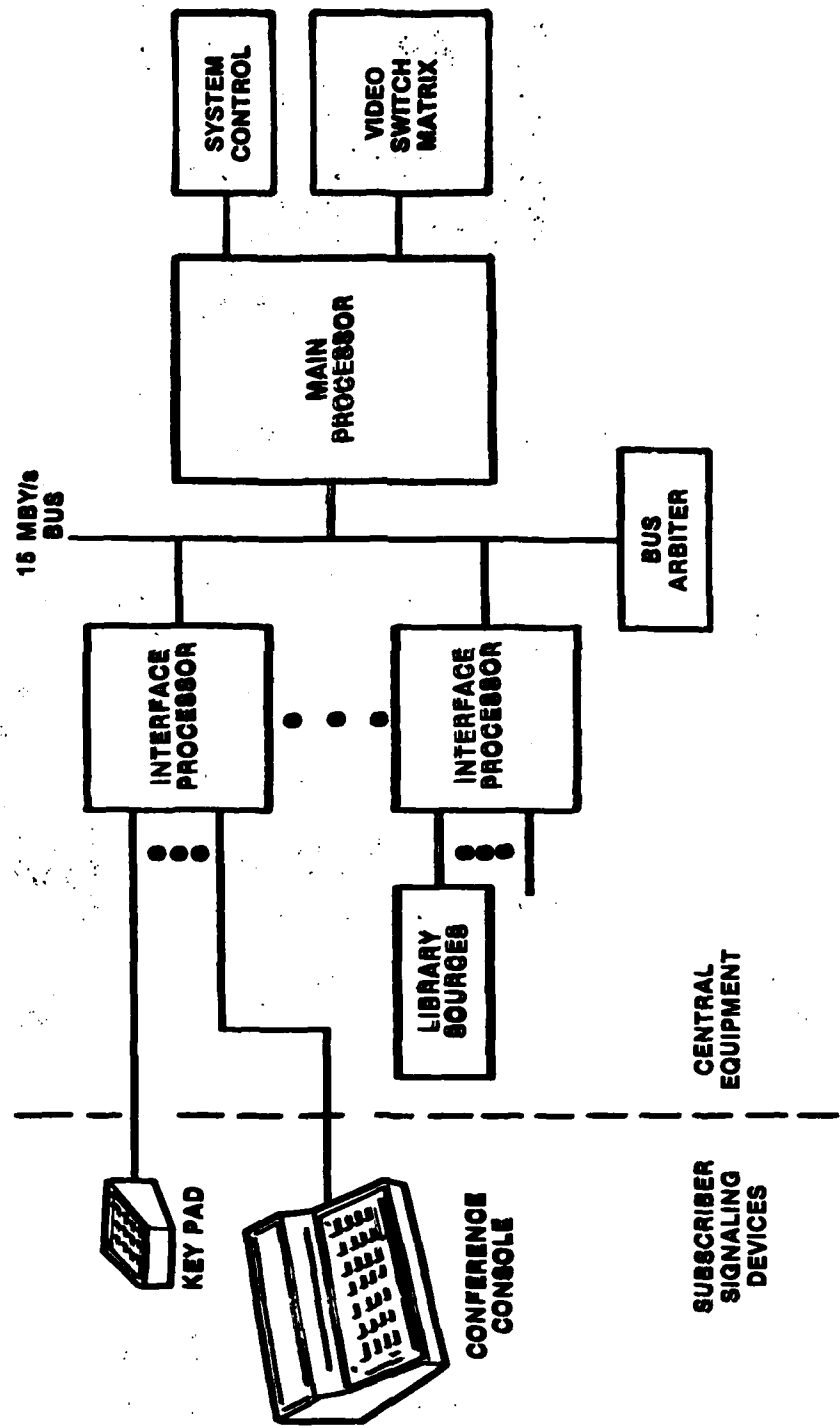

Video Teleconferencing System - Shelter Configuration

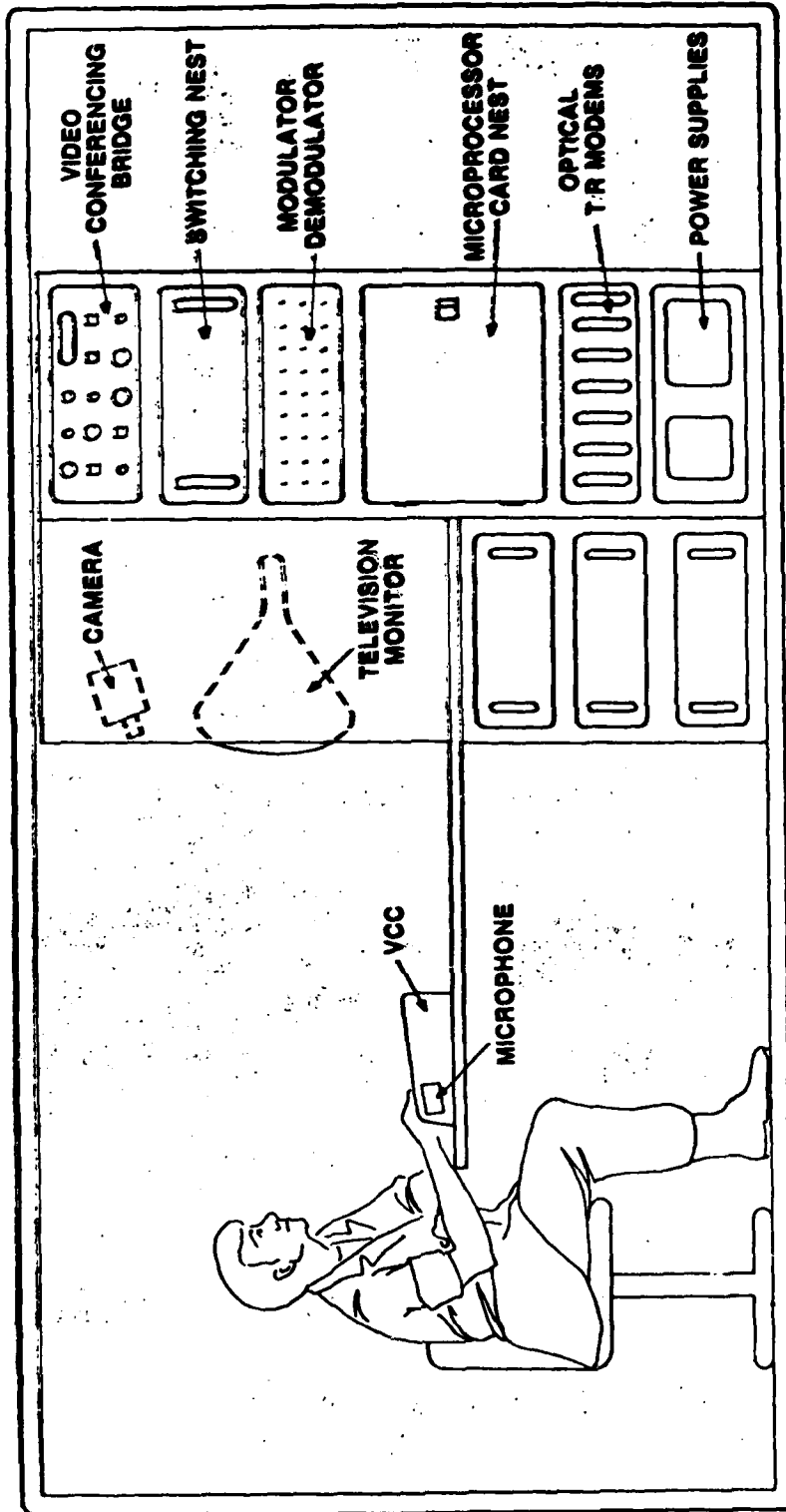

1400 01

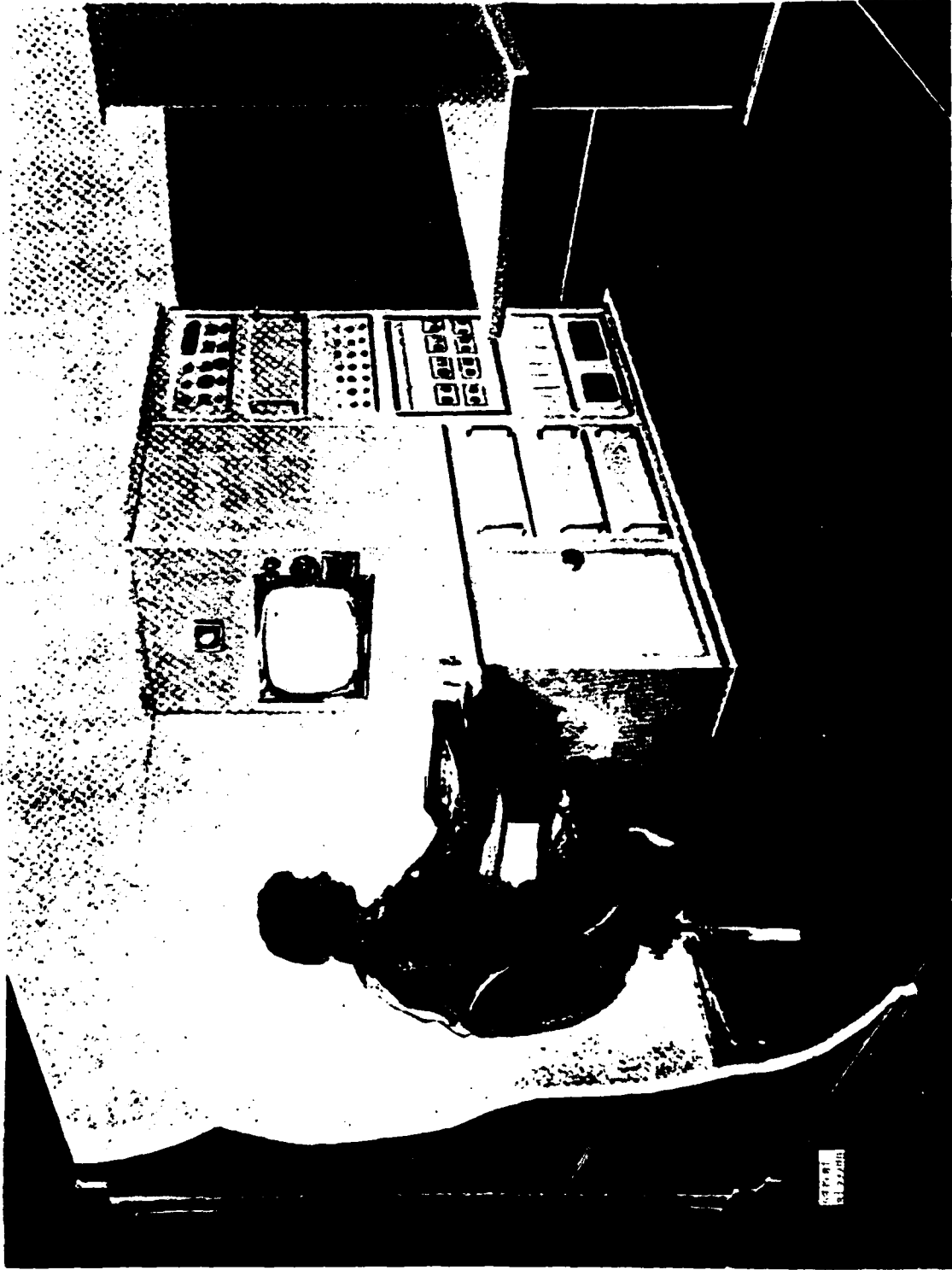

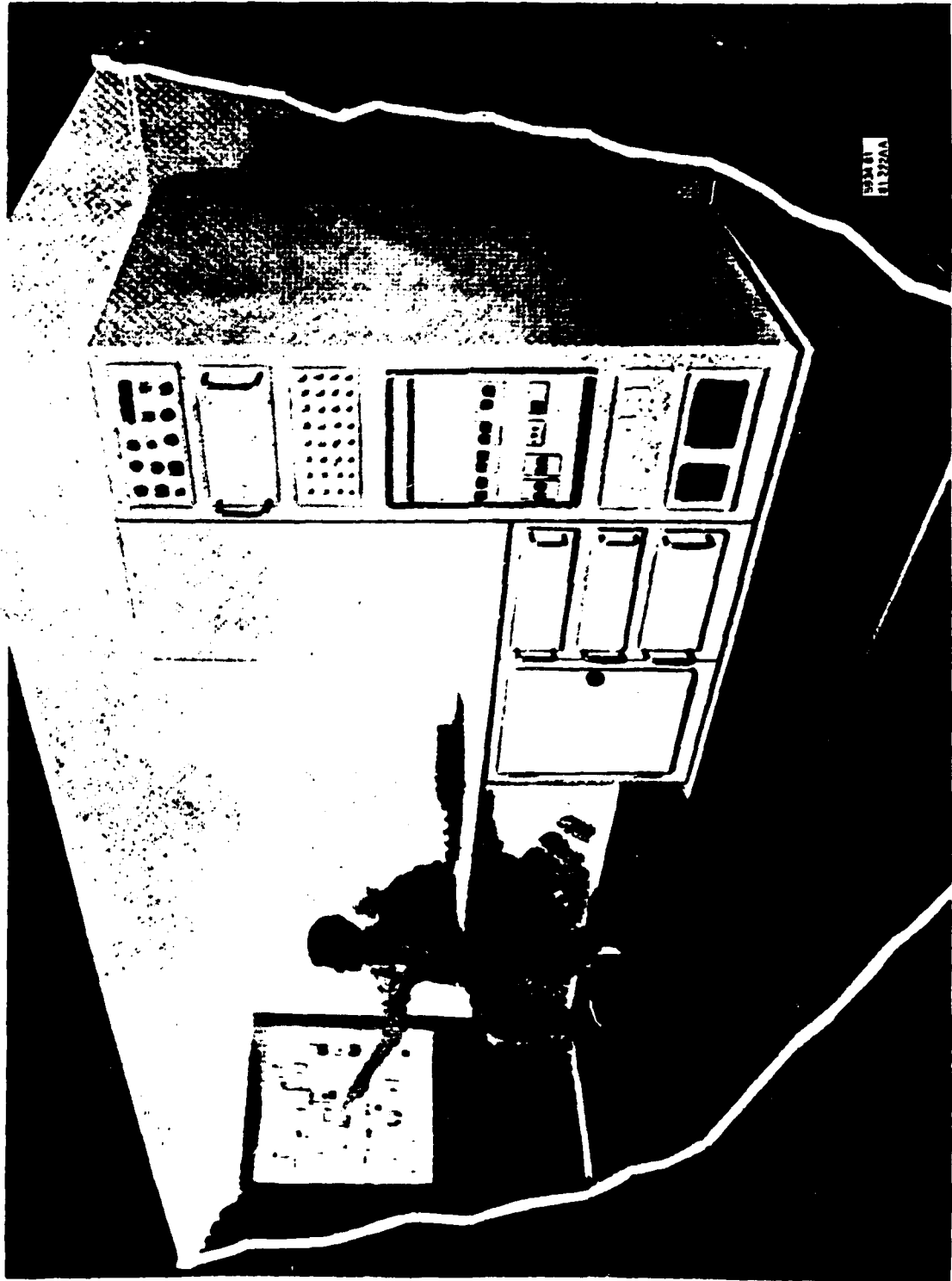

MSLS

Multiservice Local System

MSLS SERVICES

- **Video Conferencing**
- **Video Distribution**
- **Audio Distribution**
- **Data Switching**
- **Office Services**
- **Voice Telephone**
- **Remote Control and Monitoring**



SPLIT—SCREEN PRESENTATION

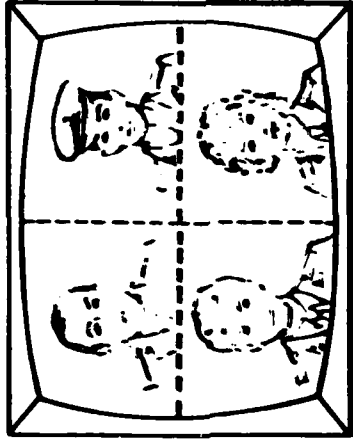
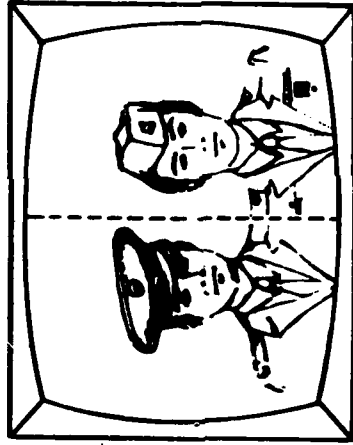
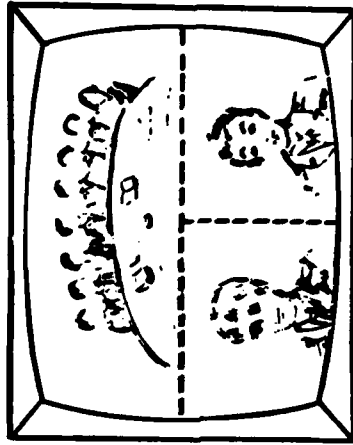

MSLB DATA SWITCH

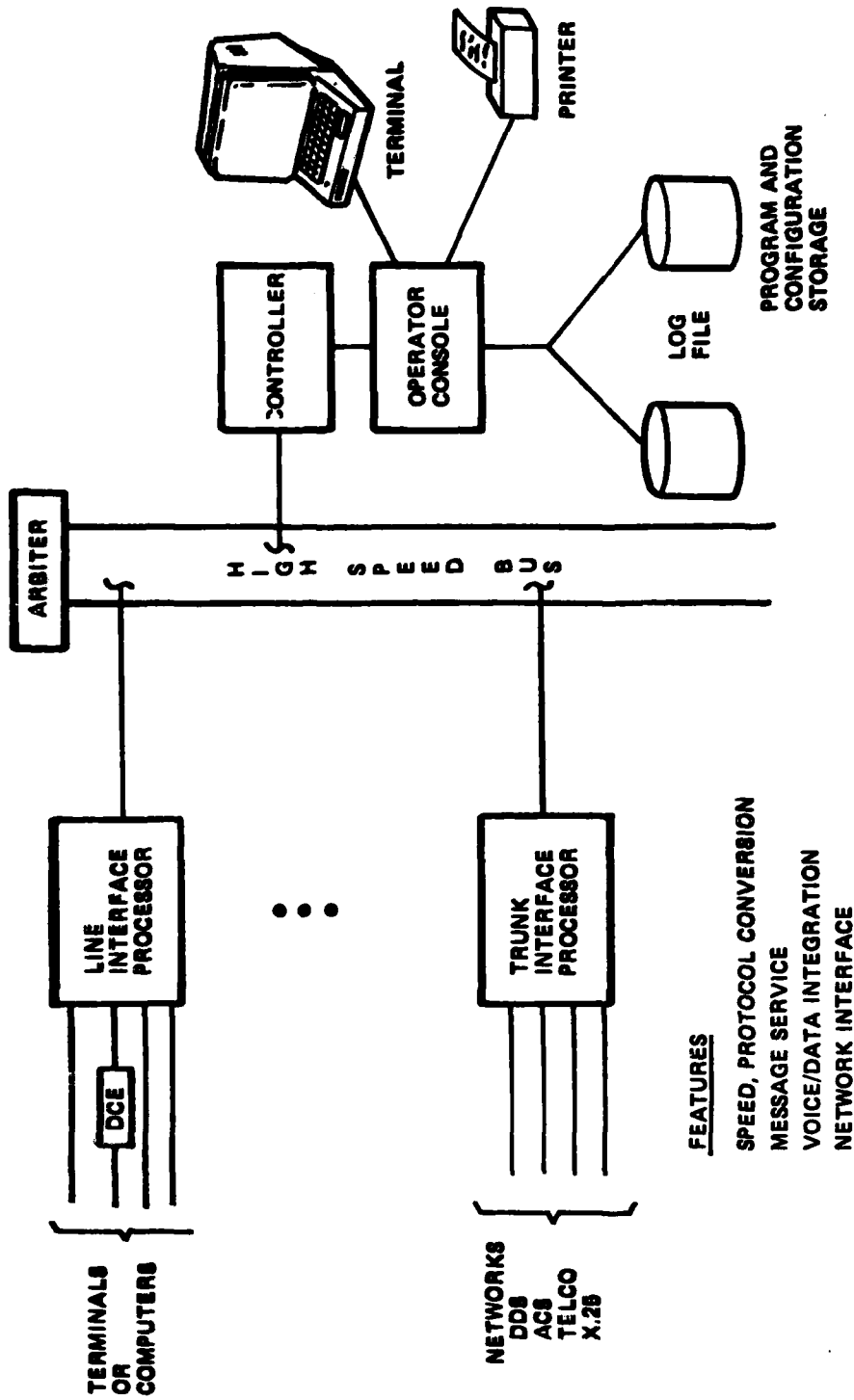

FEATURES

- SPEED, PROTOCOL CONVERSION
- MESSAGE SERVICE
- VOICE/DATA INTEGRATION
- NETWORK INTERFACE

EXTERNAL DIGITAL INTERFACE

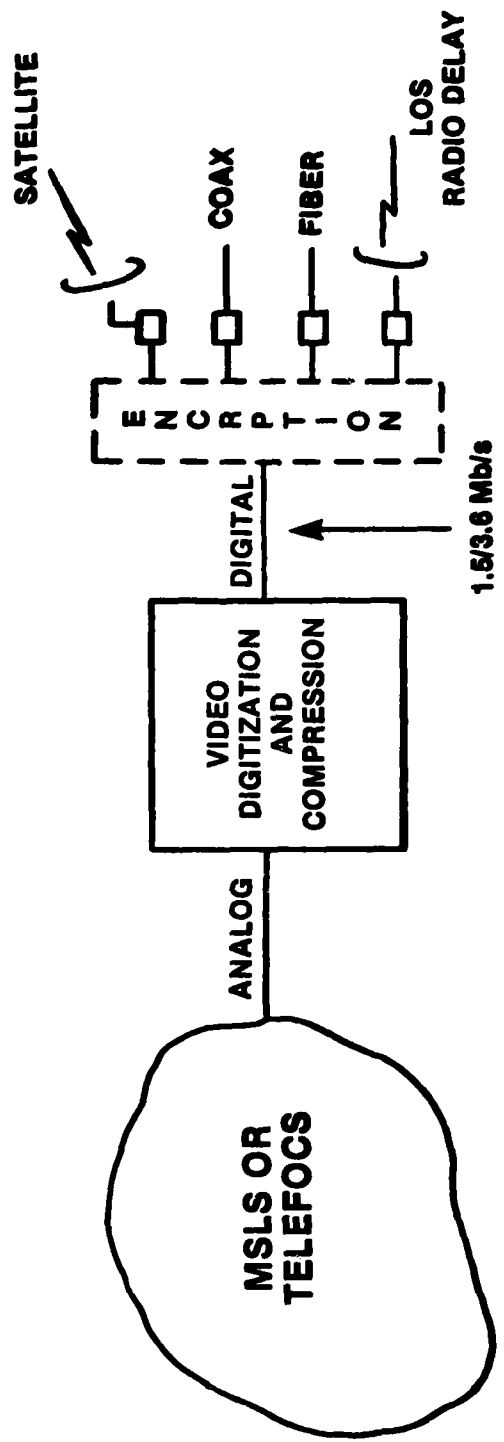

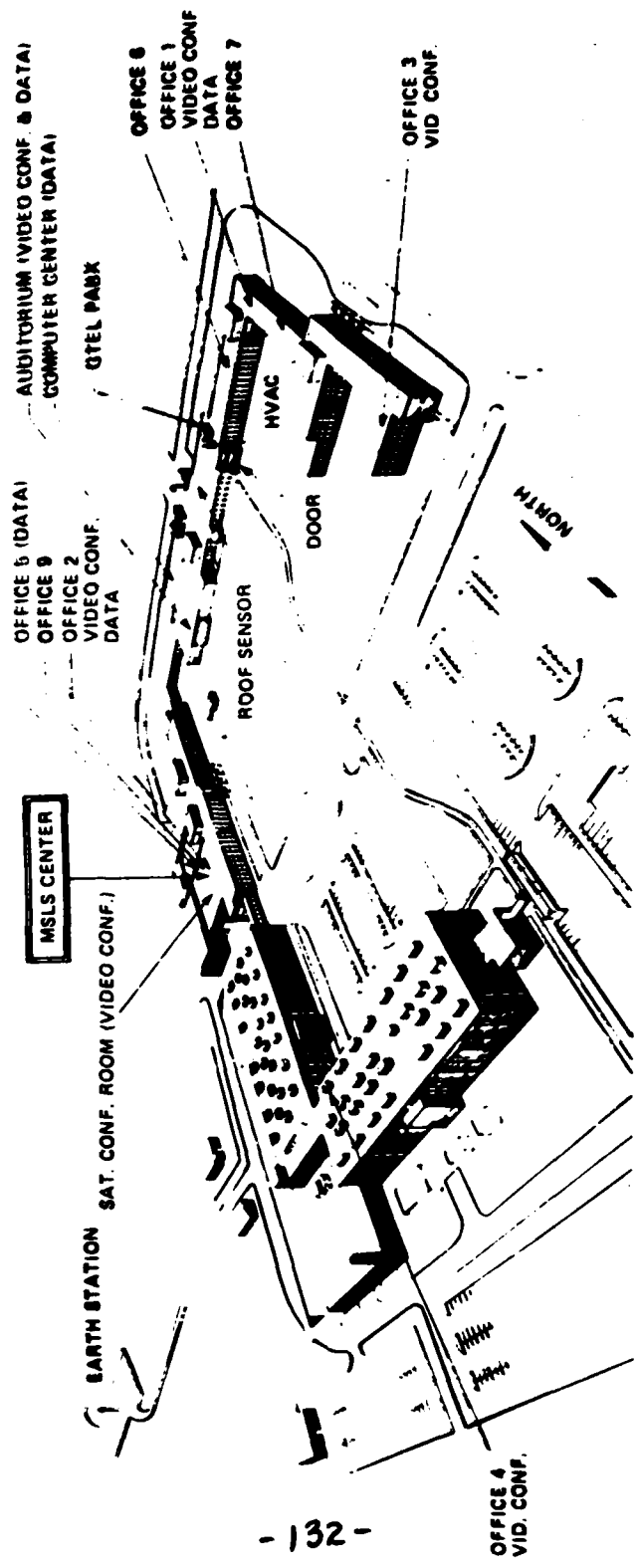

Demonstration System Configuration

Technology II (0800-1000 29 Sep)

Session Chairman: Dr. Andrew Yang - RADC/ES

"Components for Optical Fiber Net," Dr. Andrew Yang and Mr. Charles Husbands, RADC and MITRE Bedford Operations

The applications and the state of development of Fiber optic components such as couplers, wavelength multiplexers, switches, repeaters, etc. will be discussed.

"Manufacturing Technology for Fused Optical Couplers," Mr. J. C. Williams and Mr. C. Villarruel, ITT EOPD and NRL

Manufacturing Technology which was developed for star and tee multimode fiber optic couplers is presented. The couplers manufactured have advanced optical and environmental performance. Over 200 couplers of 13 different types were fabricated, optically tested and environmentally tested.

"Fiber Optic Couplers for Use in Local Area Military Networks," Mr. A. R. Nelson, AETNA Telecommunications Laboratory

A survey will be presented of fiber optic couplers suitable for use with local area military networks. The presentation will concentrate on low cost designs that are appropriate for mass production.

"Multimode Fiber Optic Switches," Mr. R. A. Soref, Sperry Research Center

Low loss fiber optic switches, especially 2x2 bypass switches are useful components in local area fiber networks. This paper will review several techniques for making such components, including the electro-mechanical, magneto-optic, and electro-optic liquid crystal techniques.

"COMPONENTS FOR FIBER OPTIC
MILITARY LOCAL AREA NETWORKS"

DR A.C. YANG - RADC / ESO

DR M.D. DRAKE - MITRE

MR C.R. HUSBANDS - MITRE

TACTICAL NETWORK CHARACTERISTICS

- 0 MOBILE
- 0 CONNECTORIZED
- 0 RUGGEDIZED
- 0 REDUNDANCY
- 0 MODULARLY EXPANDABLE
- 0 RADIATION RESISTANT

REQUIRED COMPONENTS

0 COUPLERS (TEE, STAR)

0 SWITCHES

0 TRANSMITTERS

0 RECEIVERS

0 REPEATERS

0 WAVELENGTH MULTIPLEXING

TRANSMITTER CONCERNS

0 MODAL NOISE

0 SUPER RADIANT LED'S

RECEIVER CONCERNS

O BURSTY DATA - SYNCHRONIZATION
D C RESTORATION

O IDLE CHANNEL - AGC DRIFTING

O DYNAMIC RANGE - AGC SETTLING TIME
VESTIGAL POWER

NETWORK CONSIDERATION

- 0 NETWORK ARCHITECTURE
- INTERCONNECTIVITY - MINIMUM AMOUNT OF CABLE
- REDUNDANCY
- 0 MULTI-MEDIA - WDM

CONCLUSION

O COMPONENTS ARE EMERGING FOR
LOCAL NETWORK IMPLEMENTATION

O HIGH COST

O FURTHER COMPONENT DEVELOPMENT NEEDED

FUSED OPTICAL COUPLER MANUFACTURING TECHNOLOGY

J. C. WILLIAMS
ITT EOPD
ROANOKE, VA

C. VILLARRUEL
NAVAL RESEARCH LABORATORY
WASHINGTON, DC

BASED ON WORK SPONSORED BY NRL CONTRACTS

N00173-80-C-0027
N00173-80-C-0047



ELECTRO-OPTICAL
PRODUCTS DIVISION

FUSED OPTICAL COUPLER MANUFACTURING TECHNOLOGY

- PHASE 1
 - PROCESS DESIGN AND DOCUMENTATION
 - "PILOT" PRODUCTION
 - 24 STAR COUPLERS
 - 70 TEE AND DUPLEX COUPLERS

- PHASE 2
 - PROCESS IMPROVEMENT
 - 12 STAR COUPLERS
 - 14 TEE AND DUPLEX COUPLERS
 - "FULL SCALE" PRODUCTION
 - 40 STAR COUPLERS
 - 105 TEE AND DUPLEX COUPLERS

- PHASE 3
 - ENVIRONMENTAL TESTING
 - 30 STAR COUPLERS
 - 70 TEE AND DUPLEX COUPLERS
 - WORK STILL IN PROGRESS



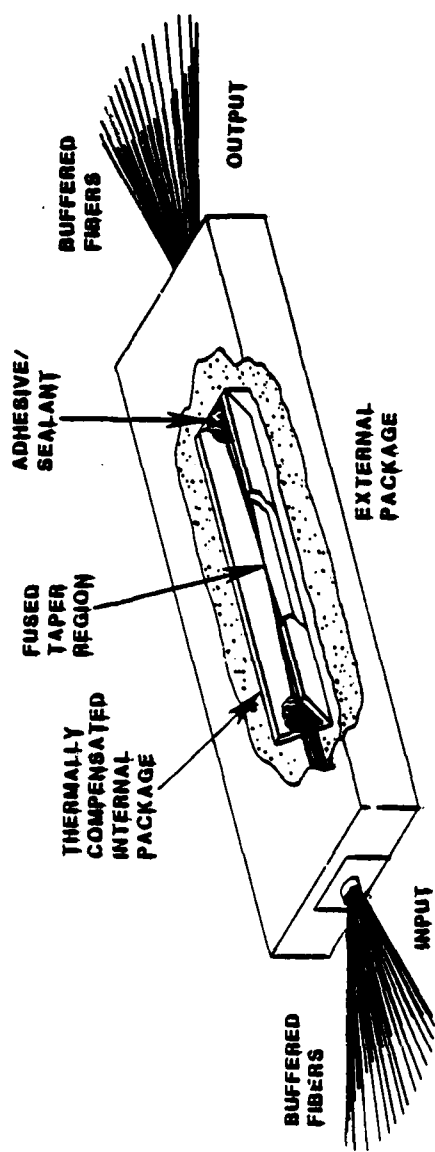

OPTICAL COUPLER PACKAGE CROSS SECTION



**ELECTRO-OPTICAL
PRODUCTS DIVISION**

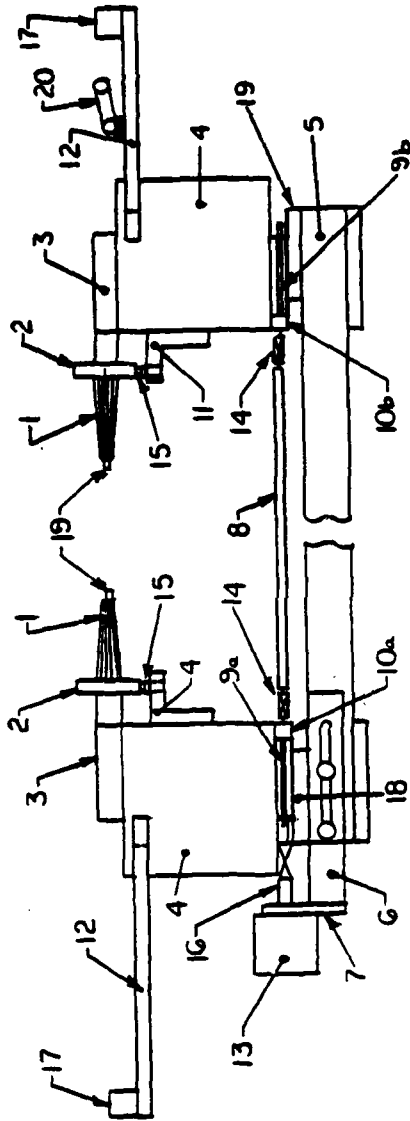

- | | | |
|------------------------|-----------------------------|--------------------------|
| 1. GUIDE SHAFT | 8. DRIVE SHAFT | 14. UNIVERSAL JOINTS |
| 2. GUIDE RING | 9a, b. THREADED DRIVE SHAFT | 15. BALL PLUNGER |
| 3. SUPPORT SHAFT | 10a, b. THREADED STOP | 16. FLEXIBLE SHAFT |
| 4. SUPPORT BRACKET | 11. BALL PLUNGER MOUNT | 17. FELT CLAMP |
| 5. BASE | 12. EXTENSION BRACKET | 18. TRANSLATION STAGE |
| 6. MOTOR MOUNT SUPPORT | 13. DC MOTOR | 19. GUIDE SHAFT ADAPTORS |
| | | 20. TENSION BAR |

ROTARY FUSION STATION
ASSEMBLY DRAWING



BEAMSPLITTER DETECTION - INJECTION
ASSEMBLY

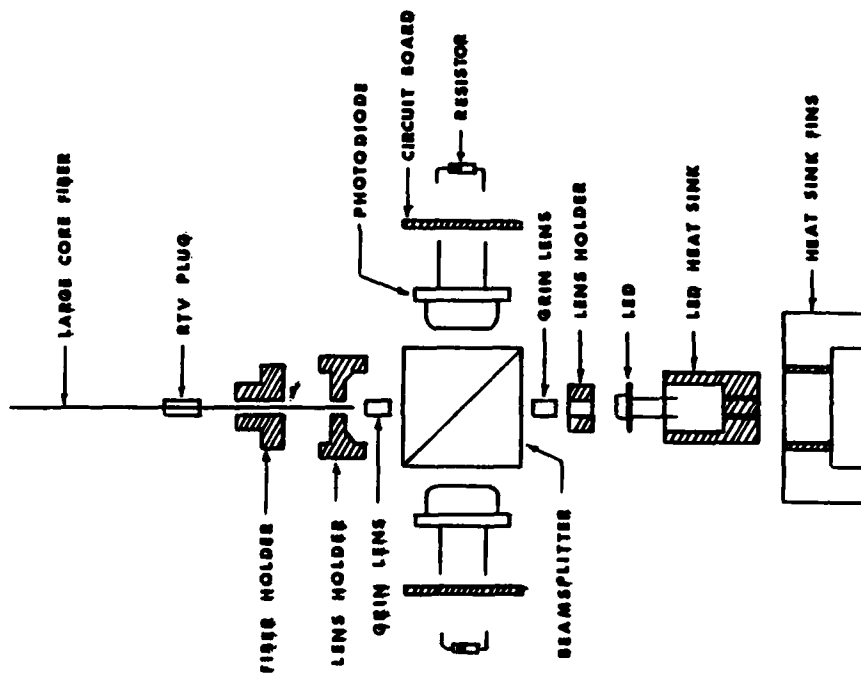

**ELECTRO-OPTICAL
PRODUCTS DIVISION**

FUSED OPTICAL COUPLER MANUFACTURING
TECHNOLOGY ADVANCES

- FABRICATION TECHNOLOGY
 - FIXED, WIDE TORCH FOR LOW LOSS
 - TENSION CONTROL FOR UNIFORMITY
 - PUSH-PULL AND SCRIBE AND BREAK TECHNIQUES FOR UNIFORMITY
- MEASUREMENT TECHNOLOGY
 - INSERTION LOSS MATRIX MEASUREMENTS
 - INJECTION - DETECTION STATIONS
- PACKAGING TECHNOLOGY
 - THERMALLY MATCHED INTERNAL PACKAGE



OPTICAL COUPLER SPECIFICATIONS

- INSERTION LOSS
- UNIFORMITY
- EXCESS LOSS
- BACKSCATTER
- MODAL UNIFORMITY



OPTICAL COUPLER TESTING DEFINITIONS

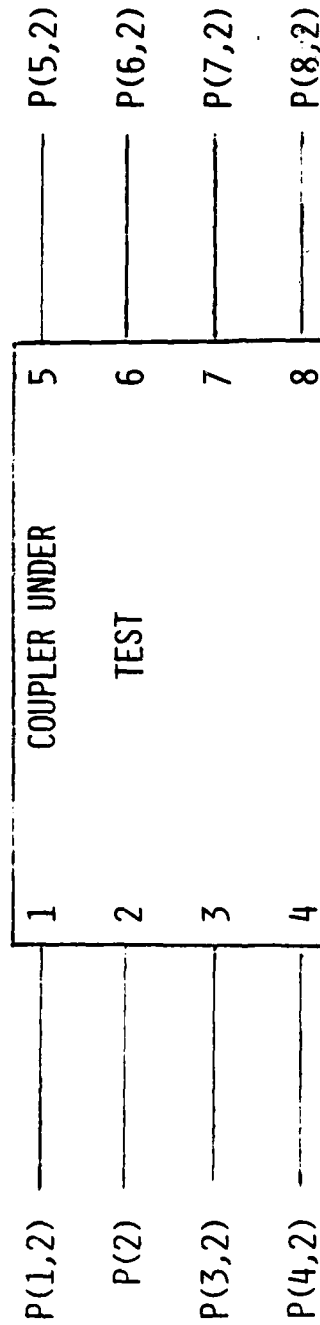

$P(J)$ = INPUT POWER LEVEL AT PORT J

$P(I, J)$ = POWER AT OUTPUT PORT I COUPLED FROM INPUT PORT J



ELECTRO-OPTICAL
PRODUCTS DIVISION

OPTICAL COUPLER INSERTION LOSS

IL (I, J) = INSERTION LOSS TO OUTPUT I FROM INPUT J AND COMPUTED FROM:

$$IL (I, J) = -10 \text{ Log } \frac{P (I, J)}{P (J)} \quad (\text{dB})$$

WHERE P (I, J) = POWER AT OUTPUT PORT I
COUPLED FROM INPUT PORT J

P (J) = INPUT POWER LEVEL AT PORT J



OPTICAL COUPLER EXCESS LOSS

$$EL (I, J) = IL (I, J) - 10 \text{ Log } M$$

WHERE M = NUMBER OF OUTPUT PORTS



OPTICAL COUPLER UNIFORMITY

- OSR = OPTICAL SIGNAL RANGE COMPUTED AS

$$\text{OSR} = \text{MAX} | \text{IL} (I, J) | - \text{MIN} | \text{IL} (I, J) | \quad (\text{dB})$$

- U (J) = UNIFORMITY OF ALL PORTS FOR INPUT J COMPUTED AS:

$$U (J) = \frac{\text{MAX P} (I, J) - \text{MIN P} (I, J)}{\text{MAX P} (I, J)} \quad (\%)$$

WHERE THE MAXIMA AND MINIMA CONSIDER ALL OUTPUTS, I



2 X 2 COUPLER PERFORMANCE MATRIX
 INSERTION LOSS IN DB

OUTPUT PORT I	INPUT J				A(I)
	<u>1</u>	<u>2</u>	<u>3</u>	<u>4</u>	
1	*	*	3.5	4.1	3.8
2	*	*	3.8	3.6	3.7
3	3.6	4.0	*	*	3.8
4	3.9	3.6	*	*	3.8
U(J)	8%	8%	7%	12%	0.8
E(J)	0.7	0.8	0.6	0.8	



U(J) = UNIFORMITY

E(J) = TOTAL EXCESS LOSS

A(I) = AVERAGE INSERTION LOSS

* = BACKSCATTER ELEMENT NOT MEASURED

**Coupler Insertion Loss Matrix Before
Modification of Mixing Region.**

16-Port (8 x 8) Transmission Coupler
 Coupler Type T-7014
 Coupler Number 8115-0004
 Fiber id 810114-12

Insertion Loss Matrix (dB)

Output Port I	Input J							
	<u>1</u>	<u>2</u>	<u>3</u>	<u>4</u>	<u>9</u>	<u>10</u>	<u>11</u>	<u>12</u>
1					9.4	10.5	10.1	10.6
2					11.0	9.8	10.5	10.9
3					10.9	10.6	9.9	10.8
4					10.7	10.5	10.2	9.8
5					10.9	10.9	10.5	10.9
6					10.5	10.5	10.2	10.6
7					10.7	10.7	10.4	10.8
8					11.0	10.8	10.5	10.8
9	9.5	10.8	10.9	10.4				
10	10.8	9.8	10.7	10.4				
11	10.5	10.5	10.2	10.1				
12	10.8	10.9	10.9	9.6				
13	10.6	10.7	10.7	10.3				
14	10.5	10.7	10.7	10.3				
15	10.6	10.8	10.8	10.4				
16	10.4	10.5	10.5	9.9				
Uniformity Factor	25%	22%	15%	17%	31%	21%	14%	23%



**Coupler Insertion Loss Matrix After Modification
of Mixing Region To Improve Uniformity.**

16-Port (8 x 8) Transmission Coupler
 Coupler Type T-7014
 Coupler Number 8115-0004
 Fiber id 810114-12

Insertion Loss Matrix (dB)

Output Port I	Input J							
	<u>1</u>	<u>2</u>	<u>3</u>	<u>4</u>	<u>9</u>	<u>10</u>	<u>11</u>	<u>12</u>
1					10.4	10.3	10.1	10.5
2					10.9	10.6	10.4	10.8
3					10.9	10.6	10.2	10.8
4					10.7	10.4	10.2	10.5
5					10.7	10.8	10.6	10.9
6					10.5	10.3	10.1	10.5
7					10.7	10.5	10.3	10.7
8					11.0	10.8	10.6	10.8
9	10.5	10.8	10.9	10.4				
10	10.6	10.6	10.7	10.3				
11	10.4	10.4	10.5	10.1				
12	10.7	10.8	10.9	10.4				
13	10.5	10.6	10.7	10.2				
14	10.4	10.5	10.7	10.2				
15	10.5	10.7	10.8	10.4				
16	10.3	10.4	10.5	10.0				
Uniformity Factor	8%	8%	9%	9%	11%	10%	10%	9%

Backscatter
Elements

Backscatter
Elements



8 PORT REFLECTION STAR PERFORMANCE MATRIX
 INSERTION THROUGHPUT IN DB

OUTPUT PORT I	INPUT J							
	1	2	3	4	5	6	7	8
1	*	-11.2	-11.5	-11.1	-11.5	-11.5	-10.9	-11.7
2	-11.3	*	-11.4	-11.3	-11.5	-11.4	-10.9	-11.7
3	-11.4	-11.4	*	-11.2	-11.7	-11.7	-10.8	-11.8
4	-11.2	-11.1	-11.3	*	-11.4	-11.4	-10.8	-11.4
5	-11.6	-11.6	-11.8	-11.5	*	-11.8	-11.3	-12.0
6	-11.6	-11.4	-11.7	-11.4	-11.8	*	-11.2	-11.9
7	-11.2	-11.1	-11.1	-11.0	-11.4	-11.3	*	-11.5
8	-11.5	-11.5	-11.7	-11.3	-11.7	-11.8	-11.2	*
U(1)	98	118	138	108	88	108	118	138
P(1)	98	118	98	108	88	108	118	138
A(1)	-11.4	-11.3	-11.5	-11.2	-11.6	-11.6	-11.0	-11.7
MIN(1)	-11.6	-11.6	-11.8	-11.5	-11.8	-11.8	-11.3	-12.0
MAX(1)	-11.2	-11.1	-11.1	-11.0	-11.4	-11.3	-10.8	-11.4



16 PORT TRANSMISSION STAR PERFORMANCE MATRIX

INSERTION THROUGHPUT IN DB

OUTPUT PORT I	INPUT J								
	17	18	19	20	21	22	23	24	A[I]
1	-13.3	-15.8	-15.6	-15.8	-15.3	-15.3	-15.6	-15.4	-15.2
2	-14.8	-13.9	-15.5	-15.7	-15.2	-15.0	-15.5	-15.3	-15.1
3	-15.0	-15.6	-14.3	-15.8	-15.4	-15.3	-15.7	-15.5	-15.3
4	-14.3	-14.8	-14.9	-14.3	-14.6	-14.5	-15.0	-14.8	-14.6
5	-14.1	-14.7	-14.7	-14.9	-13.5	-14.3	-14.8	-14.6	-14.4
6	-14.8	-15.4	-15.5	-15.6	-15.2	-14.6	-15.5	-15.3	-15.2
7	-14.6	-15.1	-15.2	-15.4	-14.9	-14.8	-14.4	-15.1	-14.9
8	-14.3	-14.8	-14.9	-15.1	-14.6	-14.5	-14.9	-14.3	-14.7
9	-14.5	-15.1	-15.2	-15.3	-14.9	-14.8	-15.2	-15.0	-15.0
10	-13.8	-14.5	-14.5	-14.6	-14.2	-14.0	-14.5	-14.3	-14.3
11	-13.6	-14.1	-14.2	-14.4	-13.9	-13.8	-14.3	-14.1	-14.1
12	-14.1	-14.7	-14.7	-14.9	-14.4	-14.3	-14.8	-14.6	-14.5
13	-14.1	-14.7	-14.8	-15.0	-14.5	-14.4	-14.8	-14.7	-14.6
14	-13.4	-14.0	-14.1	-14.2	-13.8	-13.6	-14.1	-13.9	-13.9
15	-14.2	-14.8	-14.8	-15.0	-14.5	-14.4	-14.9	-14.7	-14.6
16	-14.3	-14.8	-15.0	-15.0	-14.7	-14.5	-15.0	-14.9	-14.8
0[J]	338	368	298	318	358	328	318	318	
P[J]	318	358	298	318	318	328	318	318	
A[J]	-14.2	-14.8	-14.9	-15.0	-14.6	-14.5	-14.9	-14.8	-14.7
F[J]	-2.1	-2.7	-2.8	-3.0	-2.5	-2.4	-2.9	-2.7	-2.6
MIN[J]	-15.0	-15.8	-15.6	-15.8	-15.4	-15.3	-15.7	-15.5	
MAX[J]	-13.3	-13.9	-14.1	-14.2	-13.5	-13.6	-14.1	-13.9	



ELECTRO-OPTICAL
PRODUCTS DIVISION

SYSTEM DESIGN EXAMPLE

- 100 Mb/s DATA BUS
- STAR TYPOLOGY
- TRANSMISSION TYPE 16 x 16 COUPLER



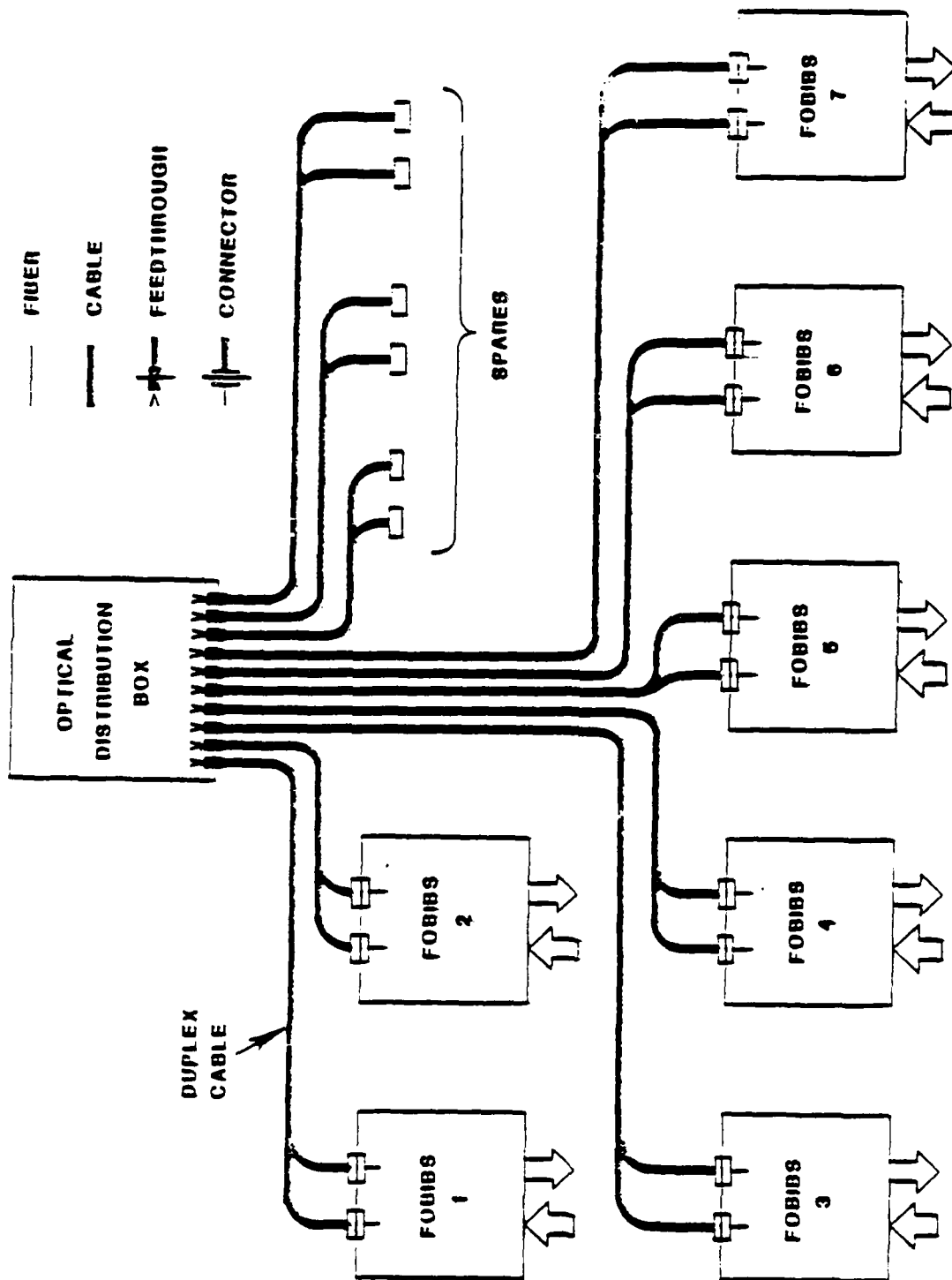

FIBER OPTIC DATA BUS

307 15190



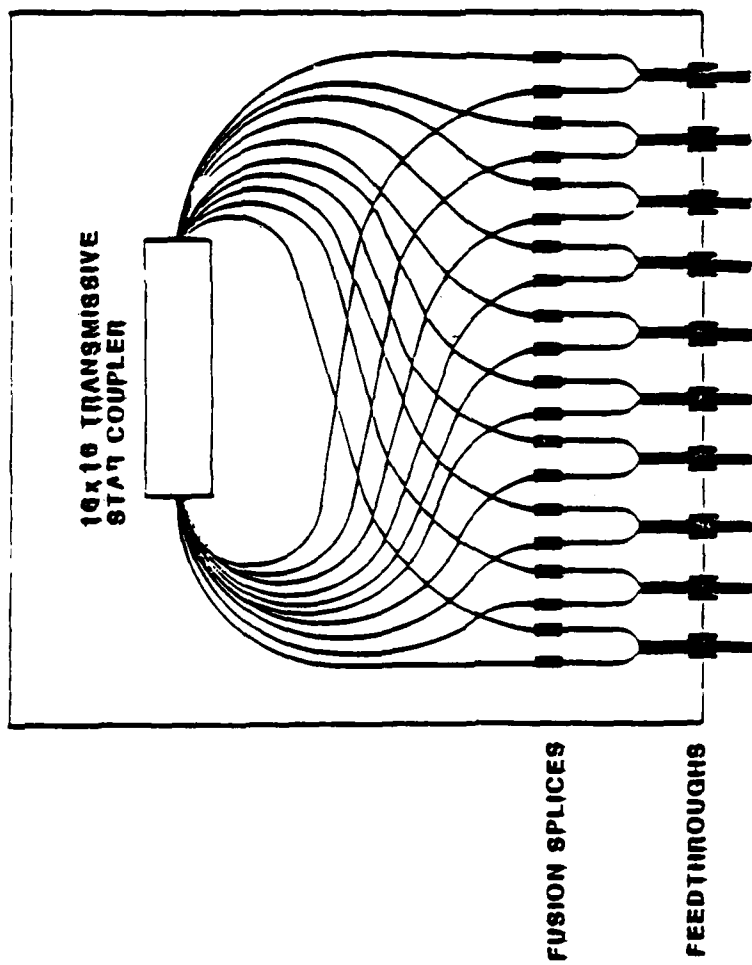

OPTICAL DISTRIBUTION BOX

100 15500



INPUT OPTICAL POWER LOSS OPTICAL SIGNAL RANGE OPTICAL PERFORMANCE MARGINS RECEIVER PERFORMANCE

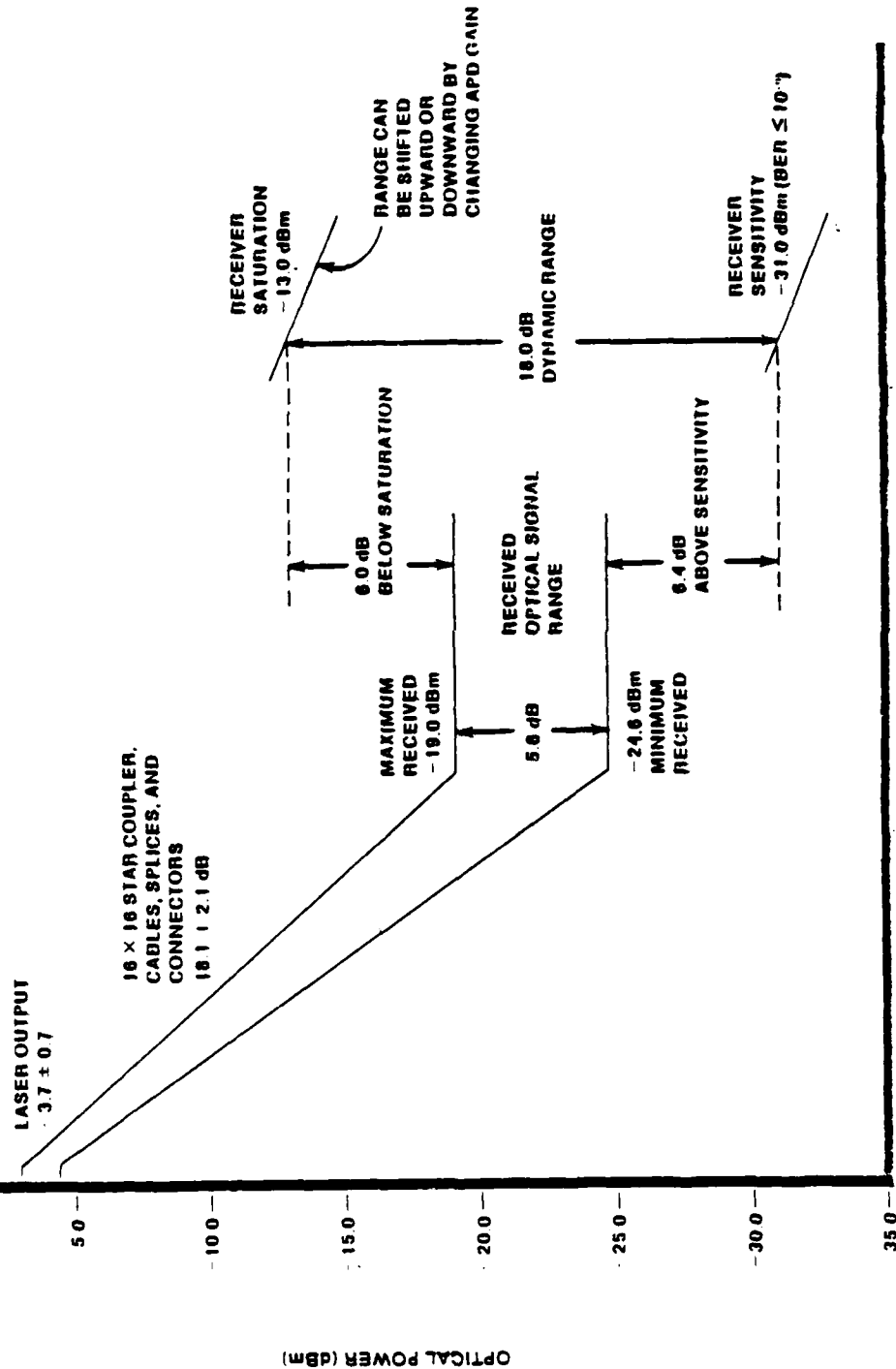

-160-

107 15590



CONCLUSIONS

- COUPLERS ARE AVAILABLE FOR A WIDE VARIETY OF SYSTEMS
- OPTICAL PERFORMANCE OF THE COUPLERS IS EXCELLENT
- ENVIRONMENTAL PERFORMANCE OF THE COUPLERS IS GOOD



Biography

Dr. Arthur R. Nelson is currently manager of the Fiber Optic Component Group at Aetna Telecommunications Laboratories in Westborough, Massachusetts. Responsibilities include the development of fiber optic couplers and sensors suitable for economical mass production. Previously, Dr. Nelson was a member of the technical staff at the Sperry Research Center in Sudbury, Massachusetts, working on fiber optic switches, sensors and multiplexing systems. From 1977 to 1979, he was supervisor of a fiber optic coupler group at ITT in Roanoke, Virginia. Dr. Nelson received the Ph.D. in Physics from Rensselaer Polytechnic Institute in 1973 and the M.S. in Physics from Cornell University in 1969.

FIBER OPTIC COUPLERS FOR USE IN
LOCAL AREA MILITARY NETWORKS

A.R. Nelson
Aetna Telecommunications Laboratories

Summary

A survey is presented of fiber optic couplers for use in local area military networks. In particular, a new active coupler is described that conveniently incorporates a source and detector in the coupler itself. This new coupler is low cost, extremely efficient, and easily mass produced. In addition,, the active coupler eliminates the need for several splices and/or connectors in a typical system as compared with present couplers.

FIBER OPTIC COUPLERS FOR USE IN
LOCAL AREA MILITARY NETWORKS

ARTHUR. R. NELSON
AETNA TELECOMMUNICATIONS LABORATORIES
WESTBOROUGH, MA 01581

- 164 -

AETNA TELECOMMUNICATIONS
LABORATORIES

FIBER OPTIC COUPLERS FOR USE IN
LOCAL AREA MILITARY NETWORKS

COUPLER TYPES

- STAR COUPLERS
- DIRECTIONAL COUPLERS
- BIDIRECTIONAL COUPLERS
- WDM COUPLERS
- SWITCHES

STAR COUPLERS - -PARALLEL CONFIGURATION NETWORK

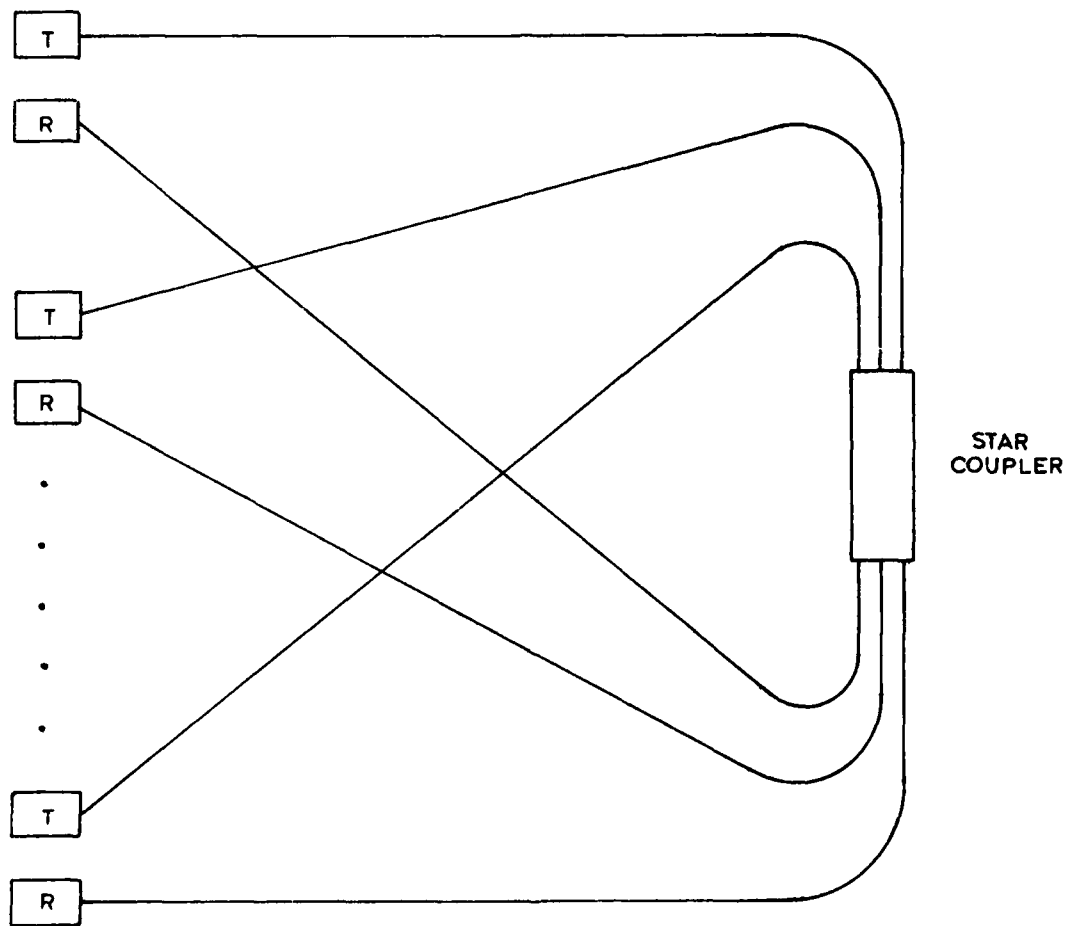

TRANSMISSION STAR

STAR COUPLERS -- FABRICATION METHODS

FUSED BICONICAL TAPER

- FIBERS FUSED AND TAPERED
- LOW LOSSES, GOOD UNIFORMITY
- DOES NOT LEND ITSELF WELL TO MASS PRODUCTION
- LONG TERM RELIABILITY IS NOT KNOWN

MIXER ROD APPROACH

- FIBERS ATTACHED TO A SEPARATE MIXING REGION
- RELATIVELY HIGHER LOSS, GOOD UNIFORMITY
- MODERATELY DIFFICULT TO MASS PRODUCE

DIFFUSED COUPLERS

- NEWLY DEVELOPED TECHNIQUES
- HIGH LOSS
- EXCELLENT FOR MASS PRODUCTION

FUSED TRANSMISSION STAR COUPLER

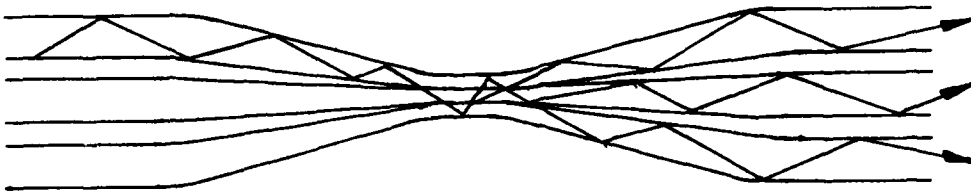

TYPICAL PERFORMANCE

NO. OF FIBERS	2 TO 100
EXCESS LOSS	~ 1dB
UNIFORMITY	± 10%
DIRECTIVITY	40dB MIN.

REFLECTION STAR COUPLER

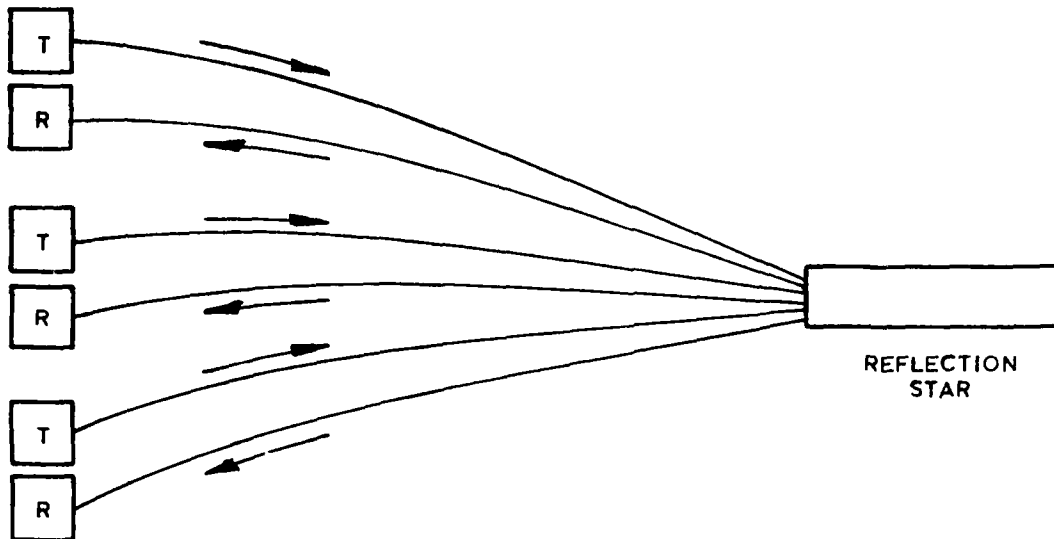

STAR WITH BIDIRECTIONAL TRANSMISSION

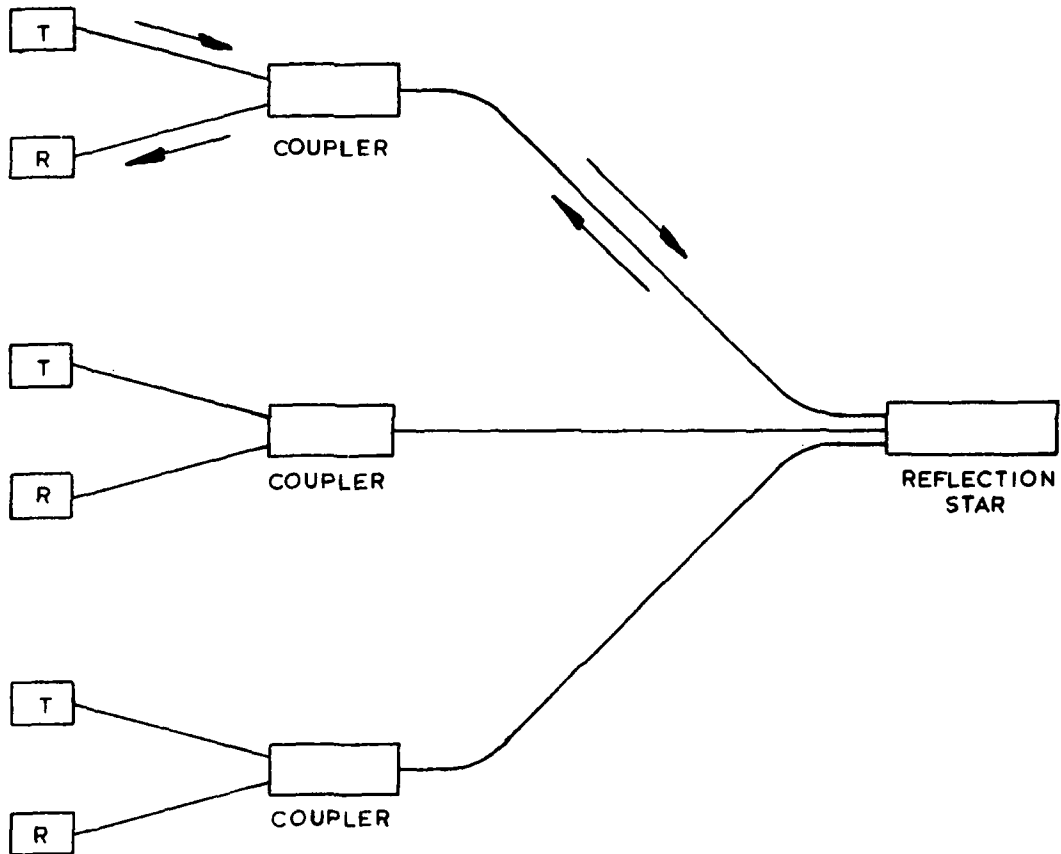

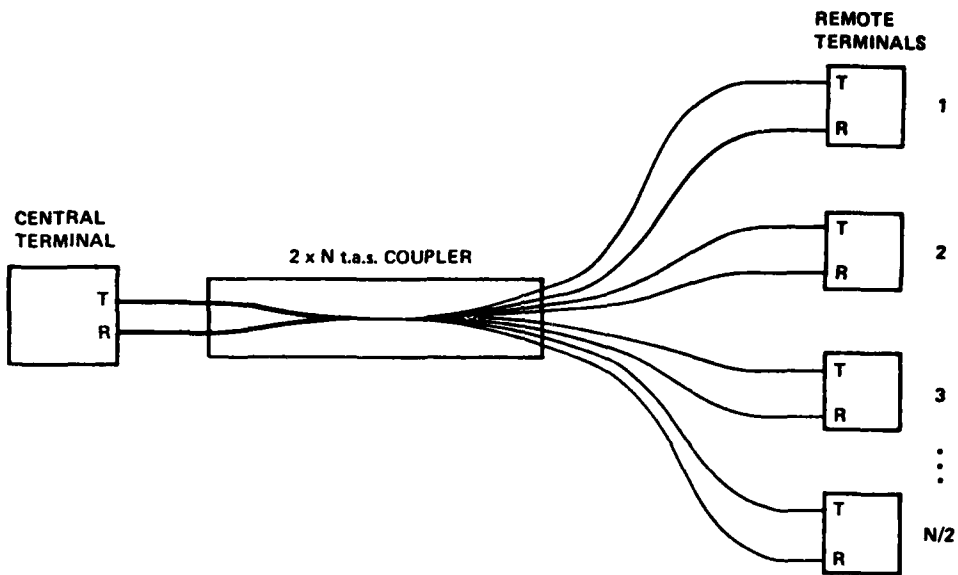

F.O. system using 2 x N t.a.s. coupler.

AETNA TELECOMMUNICATIONS
LABORATORIES

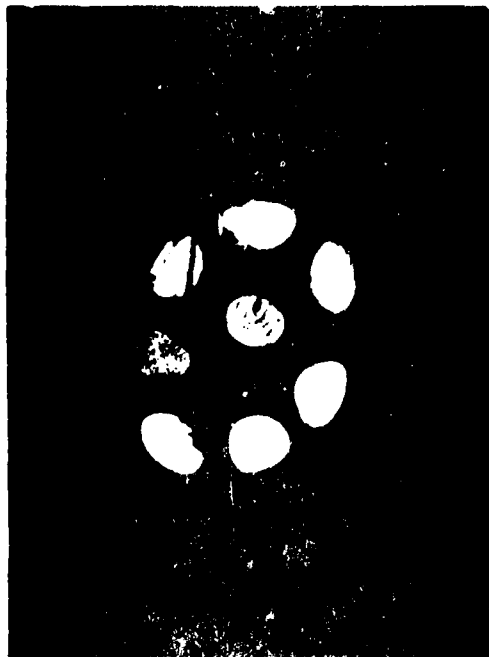

THREE PORT COUPLER TYPES

- FUSED BICONICAL TAPER
- FIBER BEAMSPLITTER
- LENSED BEAMSPLITTER
- "ACTIVE" COUPLER
INCORPORATING TX AND Rc IN
THE COUPLER ITSELF

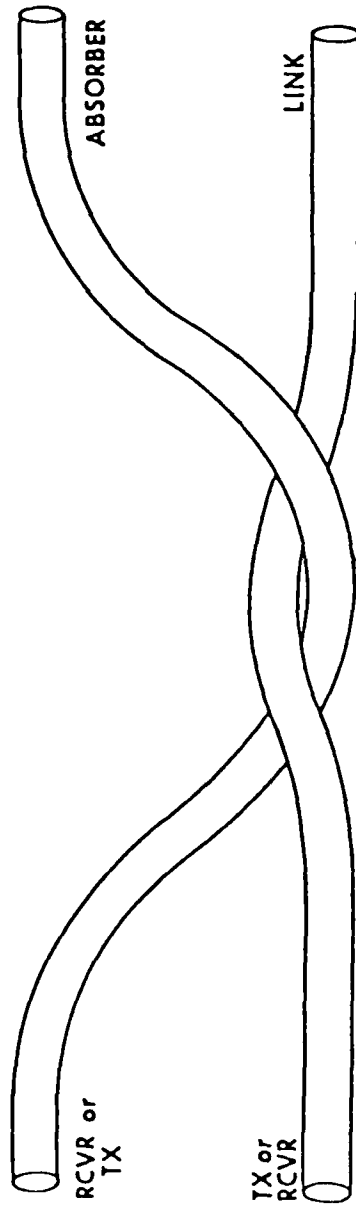

FUSED BICONICAL TAPER

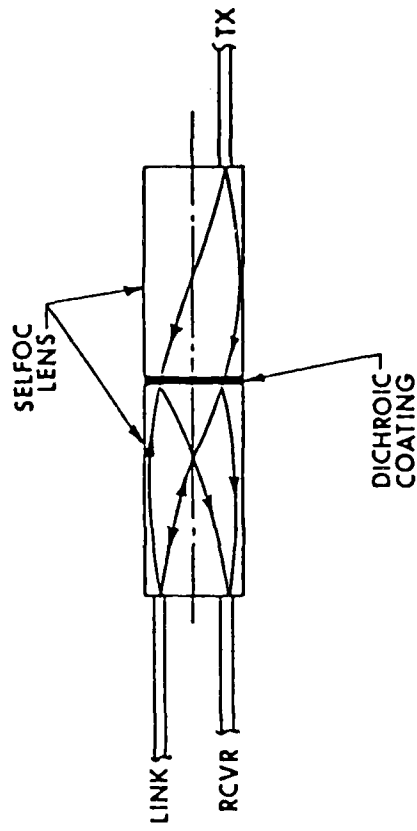

BI-DIRECTIONAL COUPLER USING SELFOC® LENSES

AETNA TELECOMMUNICATIONS
LABORATORIES

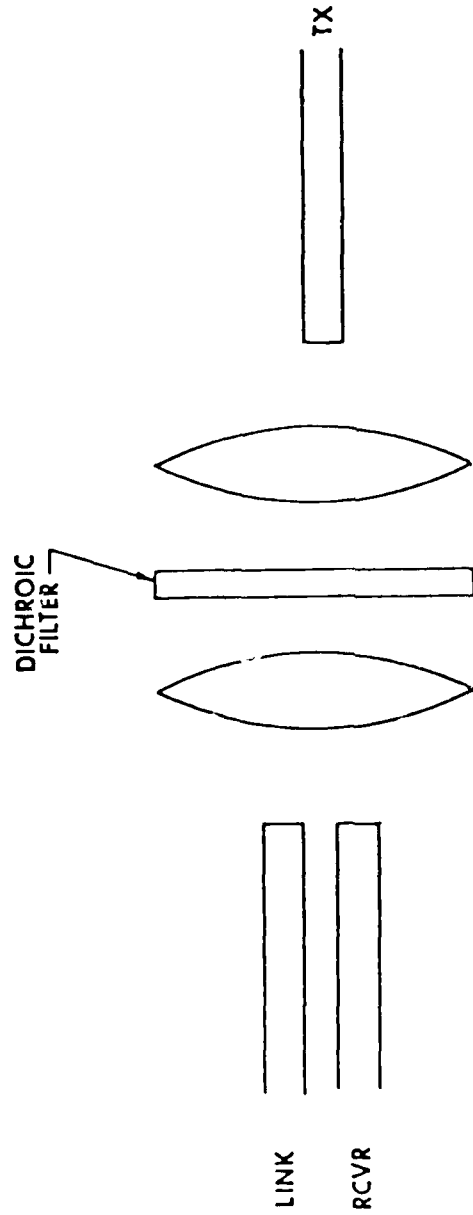

COMPACT BI-DIRECTIONAL COUPLER USING LENSES

AETNA TELECOMMUNICATIONS
LABORATORIES

RECEIVER

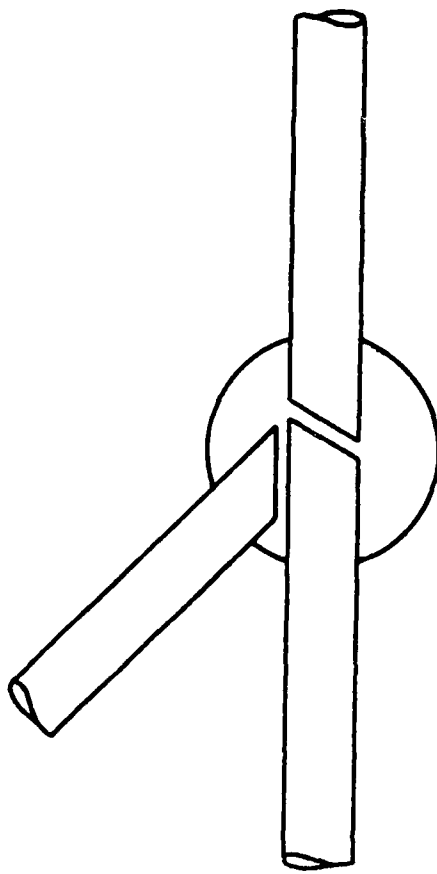

LINK

TRANSMITTER

FIBER BEAMSPLITTER COUPLER

AETNA TELECOMMUNICATIONS
LABORATORIES

ACTIVE COUPLERS

- INCORPORATE SOURCE AND/OR DETECTOR IN COUPLER BODY
- DESIGN CAN ELIMINATE NEED FOR MULTIPLE CONNECTORS OR SPLICES => LOWER COST, LOWER LOSS
- INEXPENSIVE MOLDED PLASTIC BODY LOWERS COST OF COUPLER AND LABOR
- USING SOURCE AND DETECTOR FOR COUPLING YIELDS LOWER NET LOSSES, HIGHER COUPLED POWER
- CAN ALSO BE DESIGNED AS A WDM COUPLER

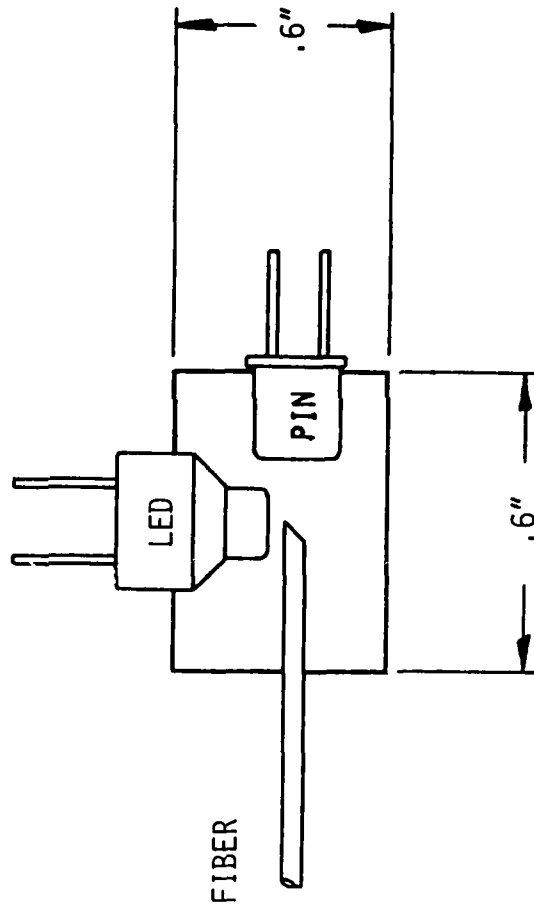
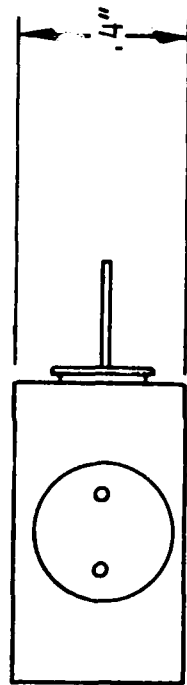

ACTIVE BIDIRECTIONAL COUPLER

TRANSCEIVER WITH F.B.T. COUPLER

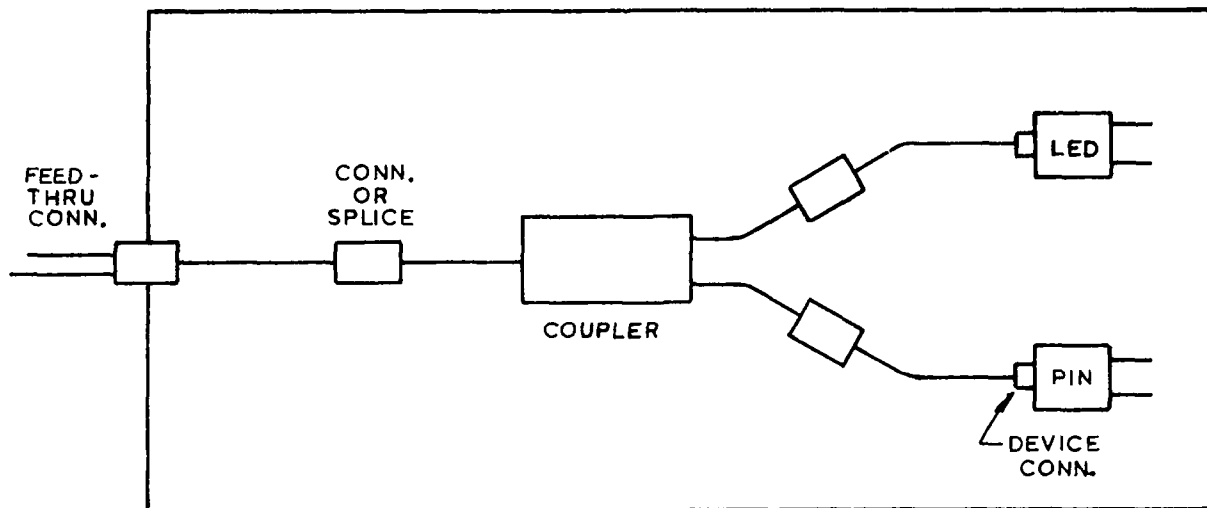

TRANSCEIVER WITH ACTIVE COUPLER

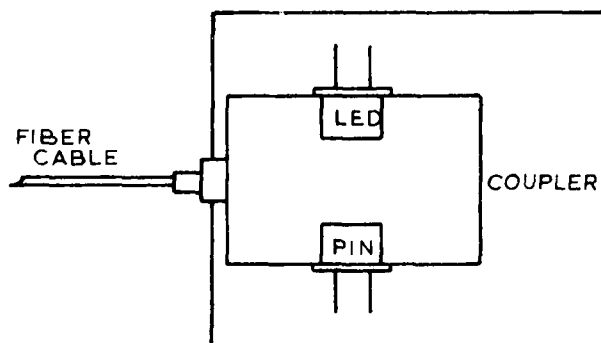

ADVANTAGES OF ACTIVE COUPLER DESIGN

- ELIMINATES SPLICES, CONNECTORS
- SAVES INSTALLATION TIME, COST,
MANPOWER
- LOWER COST
- HIGHER COUPLED POWER
- RUGGED DESIGN
- SMALL VOLUME
- USEFUL FOR λ MUX

FIBER OPTIC SENSORS

- COMPATIBLE WITH FIBER OPTIC TRANSMISSION SYSTEM

- MULTIMODE SENSORS ARE BEING DEVELOPED FOR MANY APPLICATIONS
 - TEMPERATURE,
 - PRESSURE,
 - ACOUSTIC,
 - MOTION,
 - AND MANY OTHERS

- COMPACT PASSIVE SENSORS ARE SUITABLE FOR IN-BUILDING USE WITH LANS;
FOR EXAMPLE, TEMPERATURE PROBES
FOR ENERGY MANAGEMENT

FIBER OPTIC SENSING SYSTEMS

UNIQUE ADVANTAGES OF FIBER OPTICS FOR SENSING:

- ALL THE USUAL ADVANTAGES OF FIBER OPTIC TRANSMISSION

- LIGHT WEIGHT, SMALL SIZE
- IMMUNITY TO EMI
- DOES NOT RADIATE
- NO SPARK OR SHOCK HAZARD
- NO GROUND LOOPS
- LARGE BANDWIDTH, LOW LOSS

- PLUS SPECIAL BENEFITS FOR SENSING

- FIBER OPTICS IS COMPATIBLE WITH UNIQUE OPTICAL SENSORS FOR PRESSURE, TEMPERATURE, SOUND, ETC.
- REMOTE SENSING USING FIBER OPTIC LINES
- PASSIVE SENSING: NO ELECTRICAL POWER REQUIRED AT THE SENSOR LOCATION
- PASSIVE MULTIPLEXING SYSTEMS EXIST FOR COMBINING LARGE NUMBERS OF SENSORS ON ONE LINE

COMPACT FIBER TEMPERATURE SENSOR

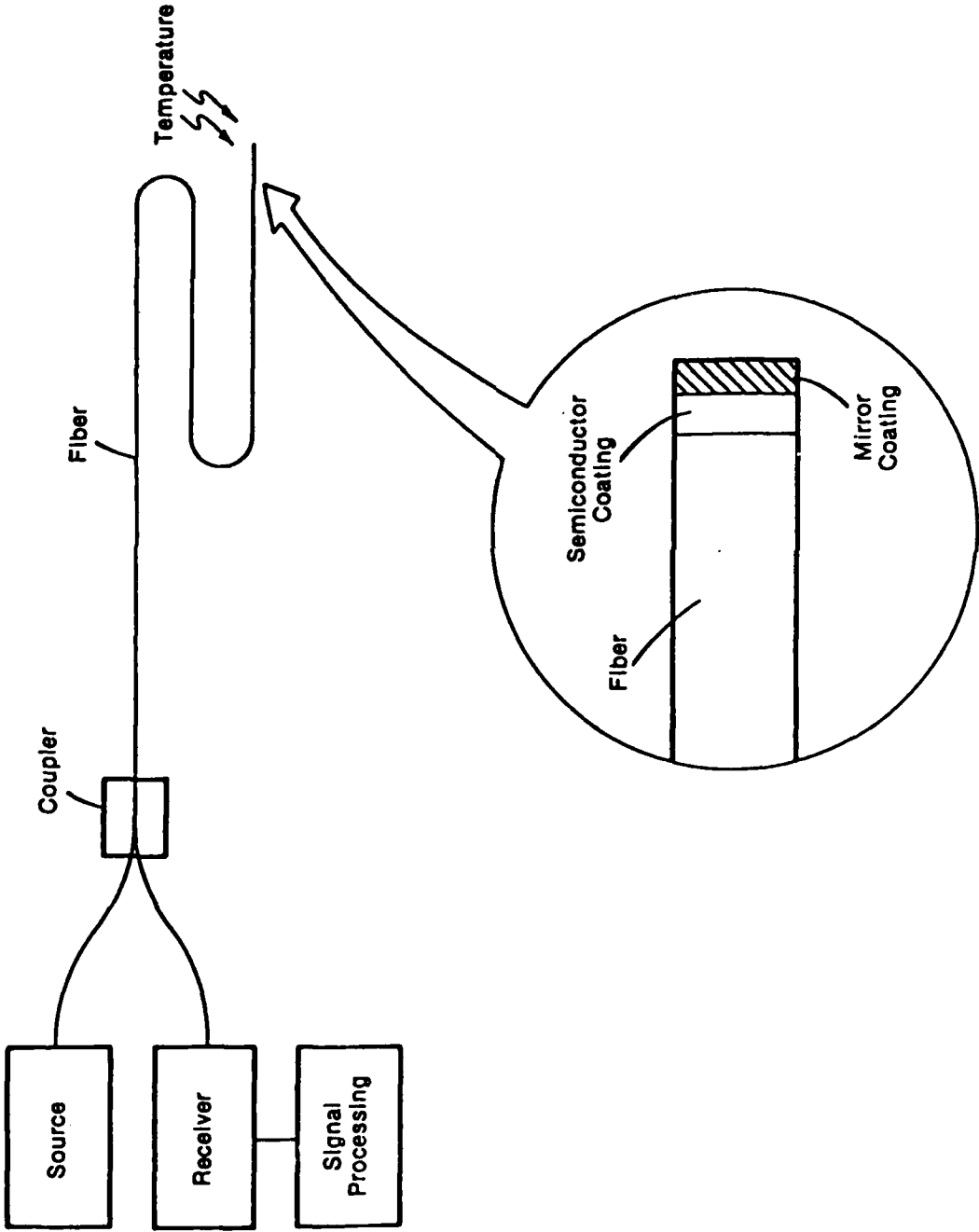

Enlarged View of End of Fiber

AETNA TELECOMMUNICATIONS
LABORATORIES

RICHARD SOREF received the Ph.D. degree in Electrical Engineering from Stanford University in 1964. He is currently a Member of the Technical Staff at Sperry Research Center in Sudbury, Massachusetts where he has conducted numerous research programs in electro-optics over the past 17 years. His current interests include fiber-optic sensors and optical switching.



100 NORTH ROAD
SUDBURY, MA. 01776
TELEPHONE (617) 388-4000

MULTIMODE FIBER-OPTICAL SWITCHES

Richard A. Soref
Sperry Research Center
Sudbury, Massachusetts 01776

Low-loss fiber optical switches, especially 2 x 2 bypass switches, are useful components in local area networks. This paper will survey several techniques for making such components, including the electro-mechanical, magneto-optical, and electro-optical liquid crystal techniques.

TRANSMIT/RECEIVE MODE

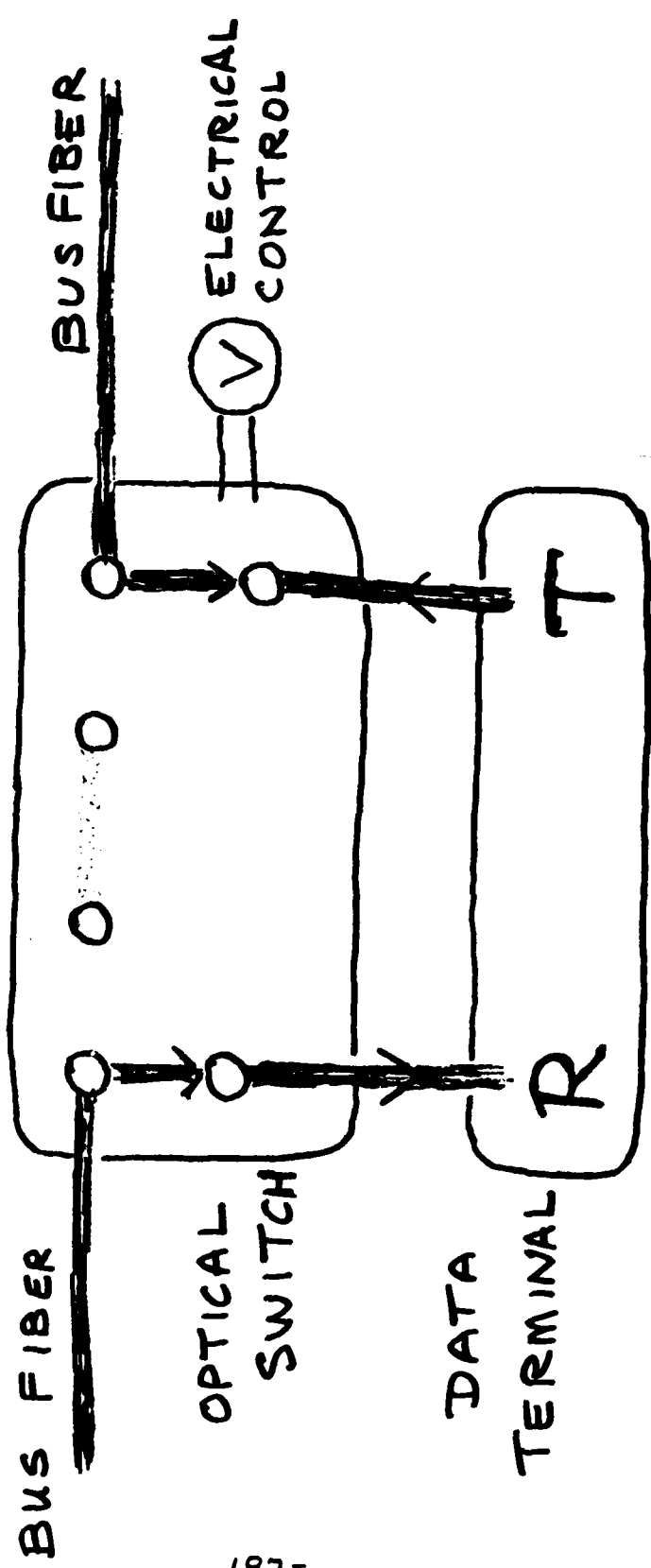

BYPASS MODE

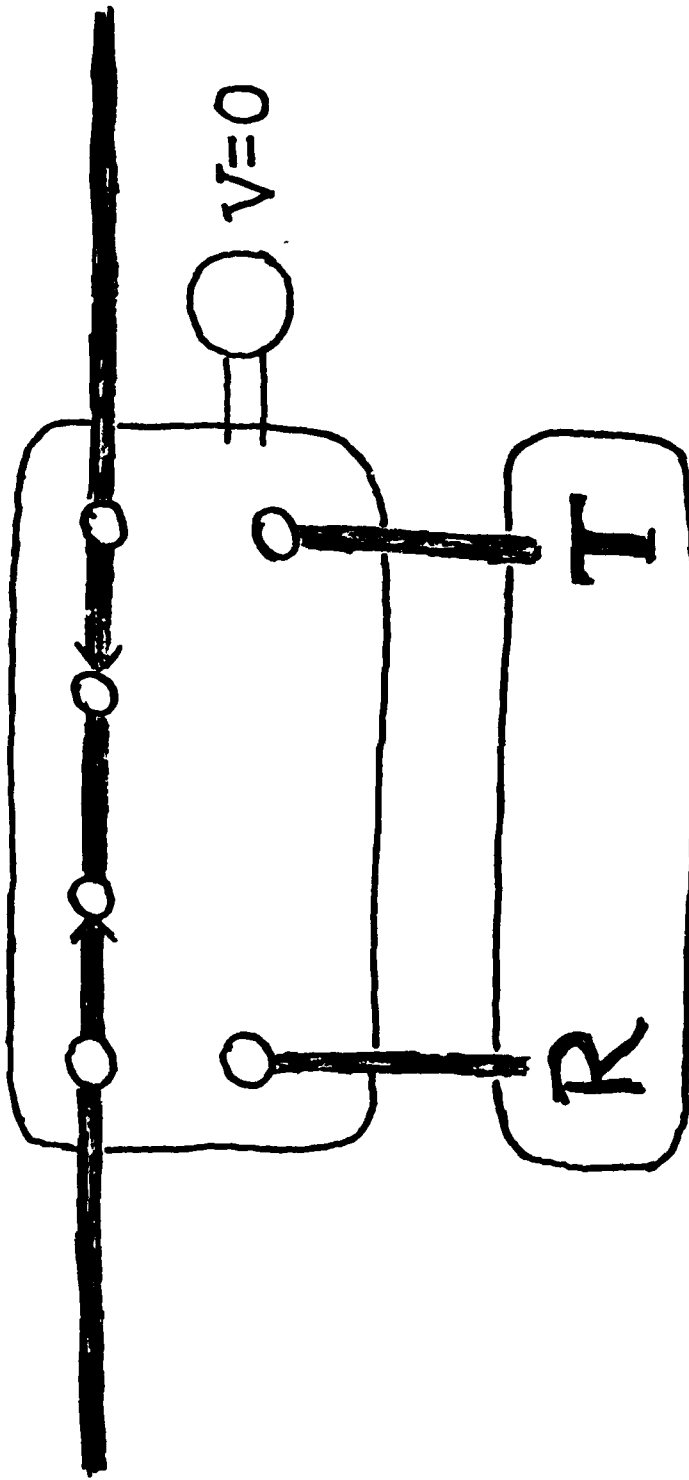

ELECTRO-MECHANICAL

- NIPPON ELECTRIC
- SIEMENS
- KAPTRON
- AMERICAN TIME
- BATTELLE-GENEVA

ELECTRO-OPTICAL

- SPERRY (LIQUID CRYSTAL)
- SPERRY (POCKEL'S EFFECT)
- BELL LABS (LIQUID CRYSTAL)
- HEWLETT PACKARD (LIQUID CRYSTAL)

MAGNETO-OPTICAL

- FUJITSU (FARADAY ROTATION)
- SPERRY (STRIPE DOMAIN)

AD-A126 118

PROCEEDINGS OF CONFERENCE ON LOCAL AREA MILITARY
NETWORKS GRIFFISS AFB NEW YORK 28-30 SEPTEMBER 1982(U)
ROME AIR DEVELOPMENT CENTER GRIFFISS AFB NY
D B WARMUTH ET AL. 1982

3/6

UNCLASSIFIED

F/G 17/2

NL

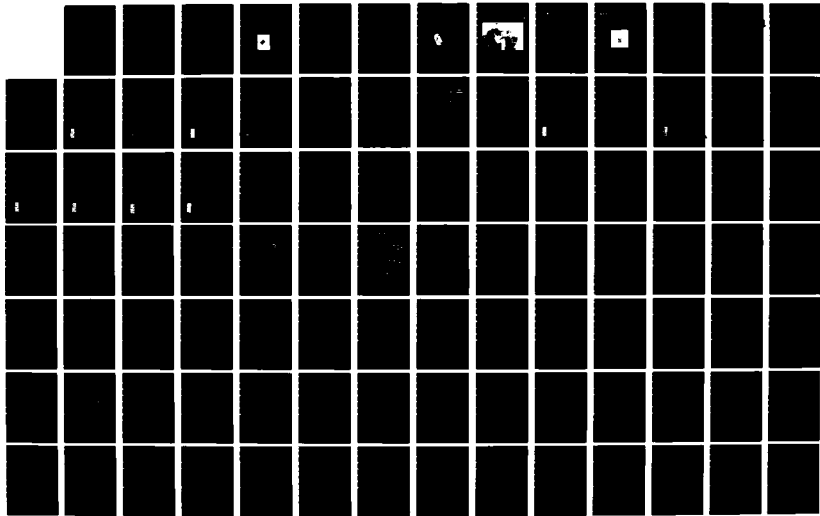

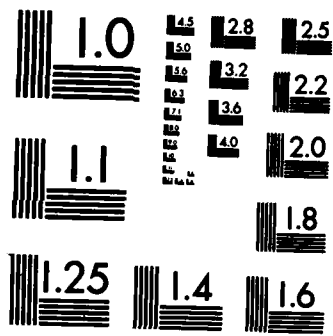

MICROCOPY RESOLUTION TEST CHART
NATIONAL BUREAU OF STANDARDS-1963-A

ELECTRO-WETTING

● BELL LABS

ACOUSTO-OPTICAL

PIEZO-ELECTRIC, ETC.

R.A.S./Sperry-7

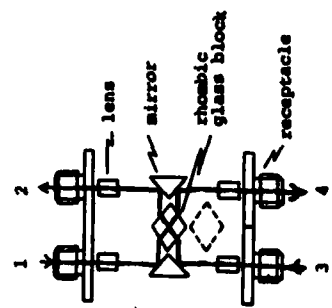

NIPPON
ELECTRIC
COMPANY
movable
rhomb

R.A.S./Sperry-B

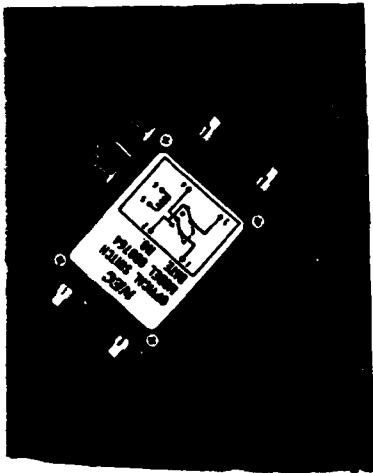

Magneto-optical switch (bi-stable)

(FUJITSU)

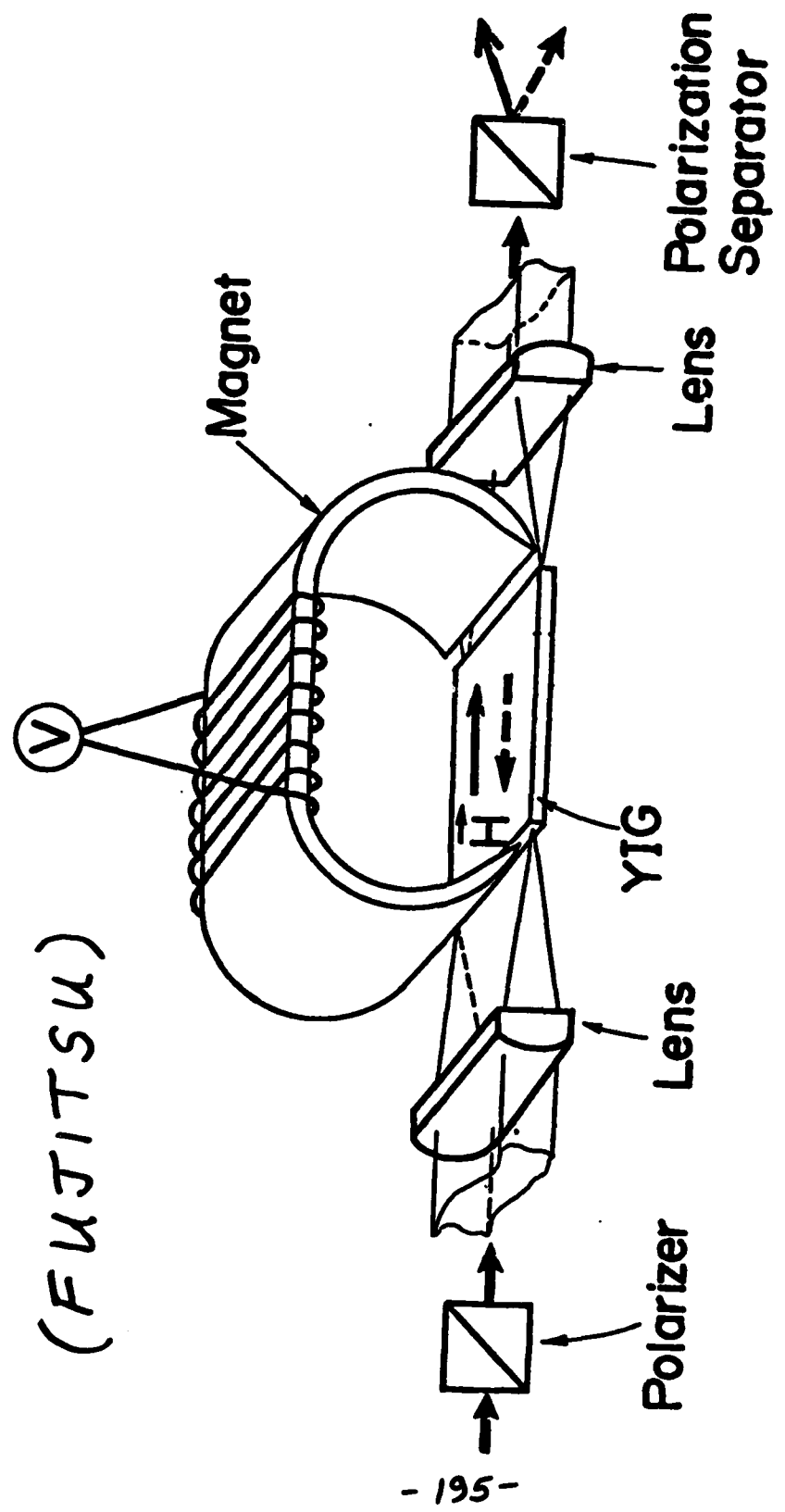

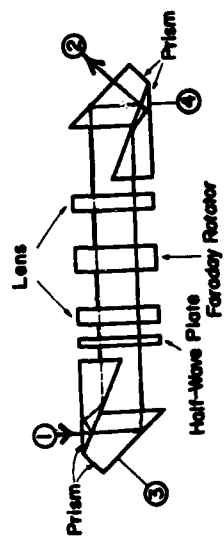

R.A.S./Sperry - 10

R.A.S/Sperry-11

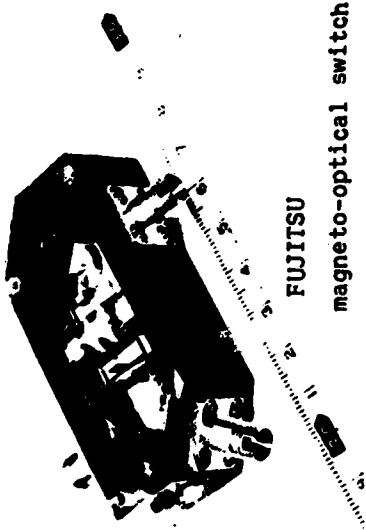

R.A. Stapp 12

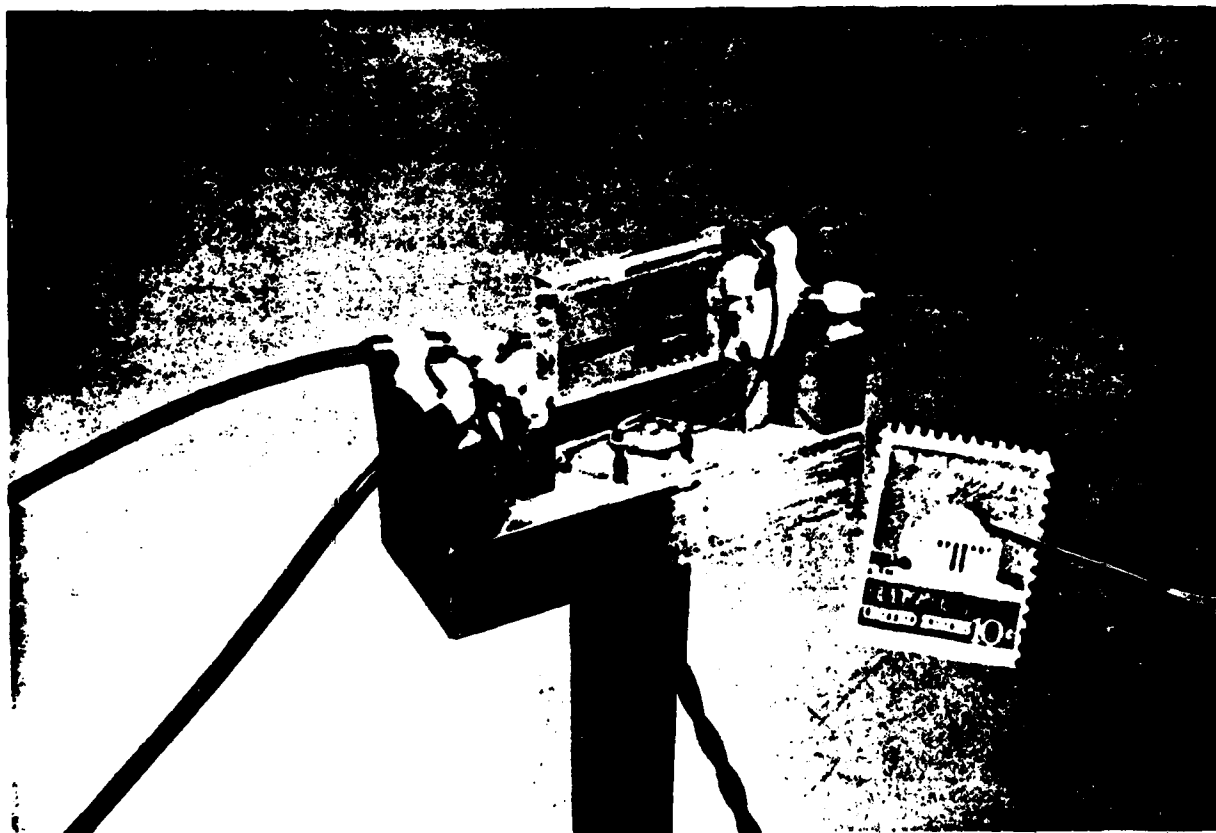
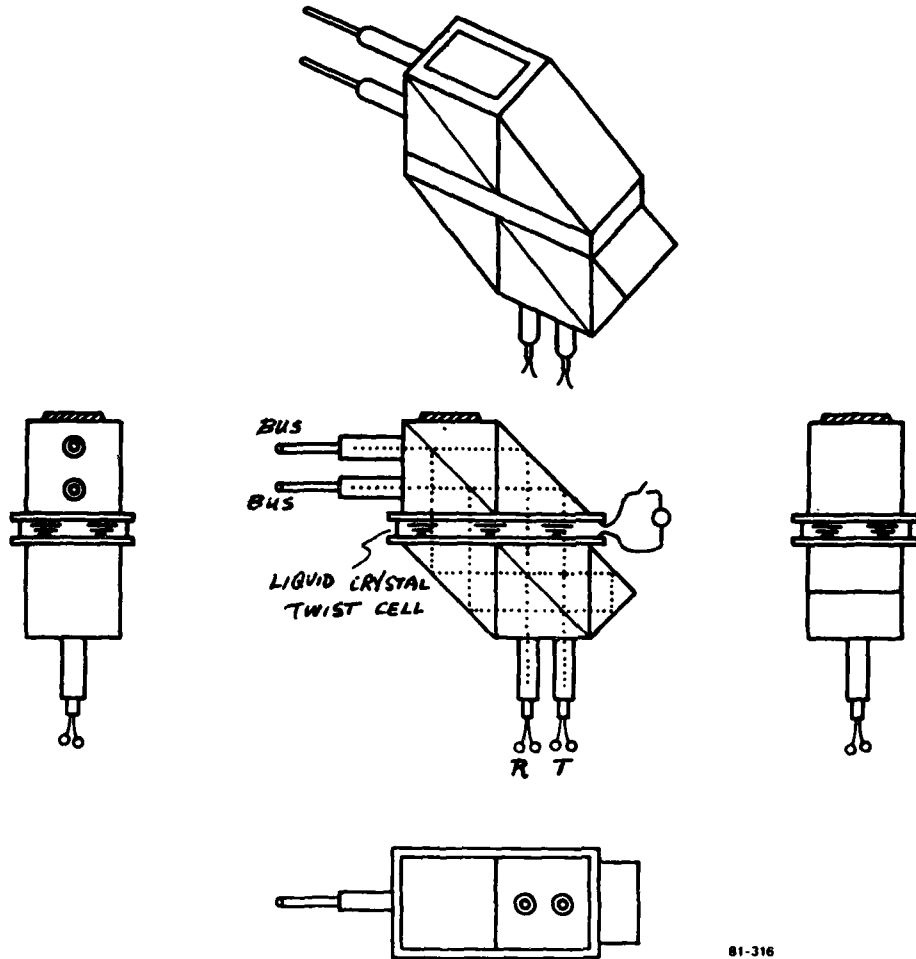

FIG. 2. Working model of 2 x 2 double-pass liquid-crystal fiber-optical switch.



81-316

FIG. 8 Fiber optical bypass switch: in-plane approach based on Figs. 2 and 4.



R.A.S./Sperry - 14



INS. LOSS: 1 to 2 dB

OPER. VOLTAGE: 3V

CROSSTALK: -30 dB (ON STATE)

CROSSTALK: -17 dB (OFF STATE)

SW. SPEED: 100 ms

R.A.S./Sperry-16

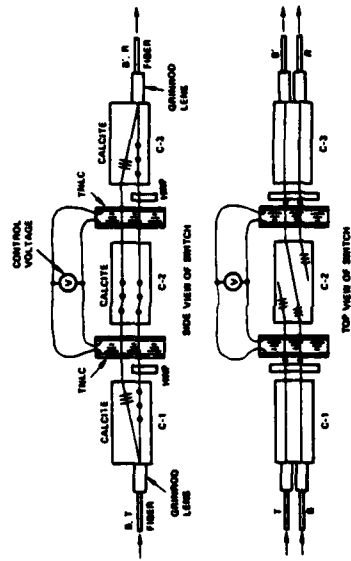

INS. LOSS: 1 to 2 dB

OPER. VOLTAGE: 5 V

CROSSTALK: -33 dB (ON STATE)

CROSSTALK: -35 dB (OFF STATE)

SW. SPEED: 100 ms

Local Network Issues (1030-1230 29 Sep)

Session Chairman: Mr. Dick Metzger - RADC/COTD

"Layered Protocol Structures - the OSI Model," Dr. John Day,
Micro Data Corp.

This presentation will discuss the use and applicability of layered protocol structures with emphasis on the current open system inter-connect (OSI) reference model currently being developed by the International Standards Organization. Its potential applicability to local area networks will be discussed.

"Internetting Local Area Networks," Dr. David Clark, Massachusetts
Institute of Technology

This presentation will discuss the technical issues involved in inter-connecting multiple local area networks. In addition, the MIT experience using TCP/IP as the internet protocol will be discussed.

"Security Issues and Key Distribution in Local Area Networks,"
Dr. Deepinder Sidhu, Burroughs Corporation

This presentation will discuss two sub topics. The first will present research that has been accomplished in developing key distribution protocols for secure network links. The second topic will address security issues related to the design of local area networks.

"Design Trade-Offs for Survivable Local Packet Networks," Mr. James
A. Keddle, Magnavox Data Systems Inc.

An approach to achieving a survivable network is to incorporate many of the currently used survivability design techniques directly into a top down systems approach. This presentation deals with some of the survivability issues which should be considered when designing, implementing, and operating a local area network for use within a command and control system.



LAYERED PROTOCOL ARCHITECTURE:

THE ISO REFERENCE MODEL OF OPEN SYSTEMS INTERCONNECTION

JOHN NEUMANN
Microdata
Chairman,
ANSI OSI Transport

and

RICHARD desJARDINS
Computer Technology Associates
Chairman,
ISO OSI

Presented to Local Area Military Networks Conference
Rome Air Development Center
28-30 September 1982



FUNCTIONAL ALLOCATION OF APPLICATION-PROCESSES IN DISTRIBUTED SYSTEMS: TERMINALS, COMPUTERS, PLANTS (SENSORS/EFFECTORS)

TYPICAL DISTRIBUTED SYSTEMS CONFIGURATION

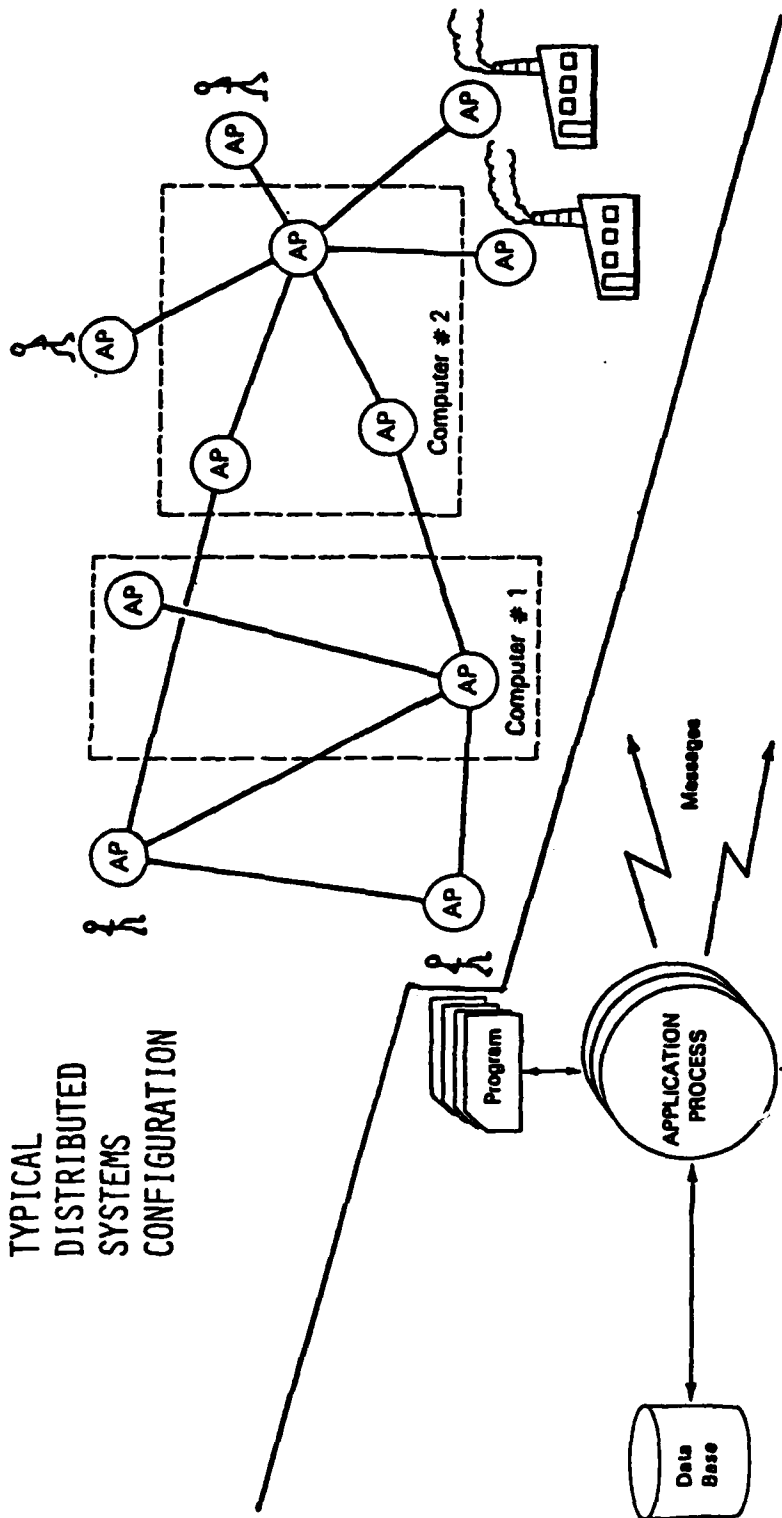

IMPLEMENTATION OF AN AUTOMATED APPLICATION-PROCESS ENVIRONMENT



SYSTEMS COMMUNICATE USING OSI PROTOCOLS

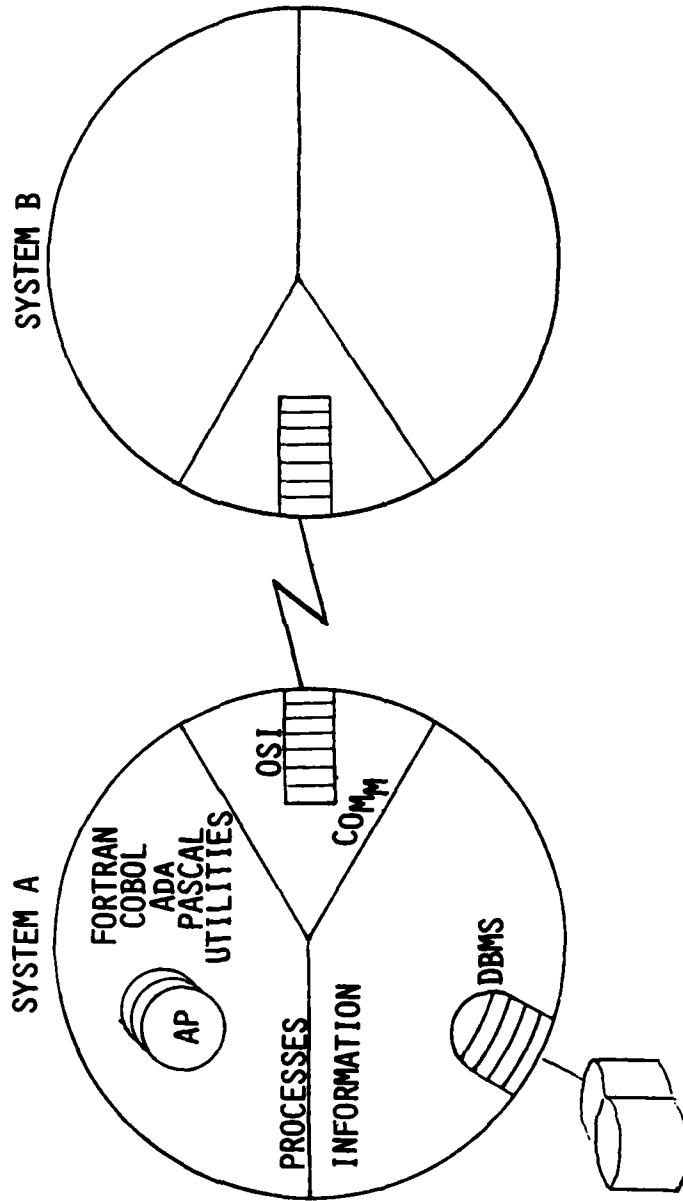



**REFERENCE MODEL OF OPEN SYSTEMS INTERCONNECTION (OSI)
PROTOCOL STANDARDIZATION**

- DEFINITION OF OSI: INTERCONNECTION OF SYSTEMS "OPEN" TO USE OSI STANDARD PROTOCOLS
- "REFERENCE MODEL": COMMON ARCHITECTURAL BASIS FOR COORDINATING OSI STANDARDS
- SECURE COMMUNICATIONS: BUILT USING OSI PROTOCOLS + SECURITY FEATURES
- ADVANTAGES OF USING OSI AS A DESIGN REFERENCE:
 - LAYERED ARCHITECTURE PROVIDES ENGINEERING STABILITY, ECONOMIC ADVANTAGES
 - WIDESPREAD ADOPTION OF OSI MODEL (ISO/ANSI/NBS) ASSURES COMMERCIAL AVAILABILITY
 - INTEROPERABILITY GREATLY ENHANCED
- DARPA/DOD/NCS/NBS STANDARD PROTOCOLS: COMPATIBLE WITH OSI MODEL

1-8081

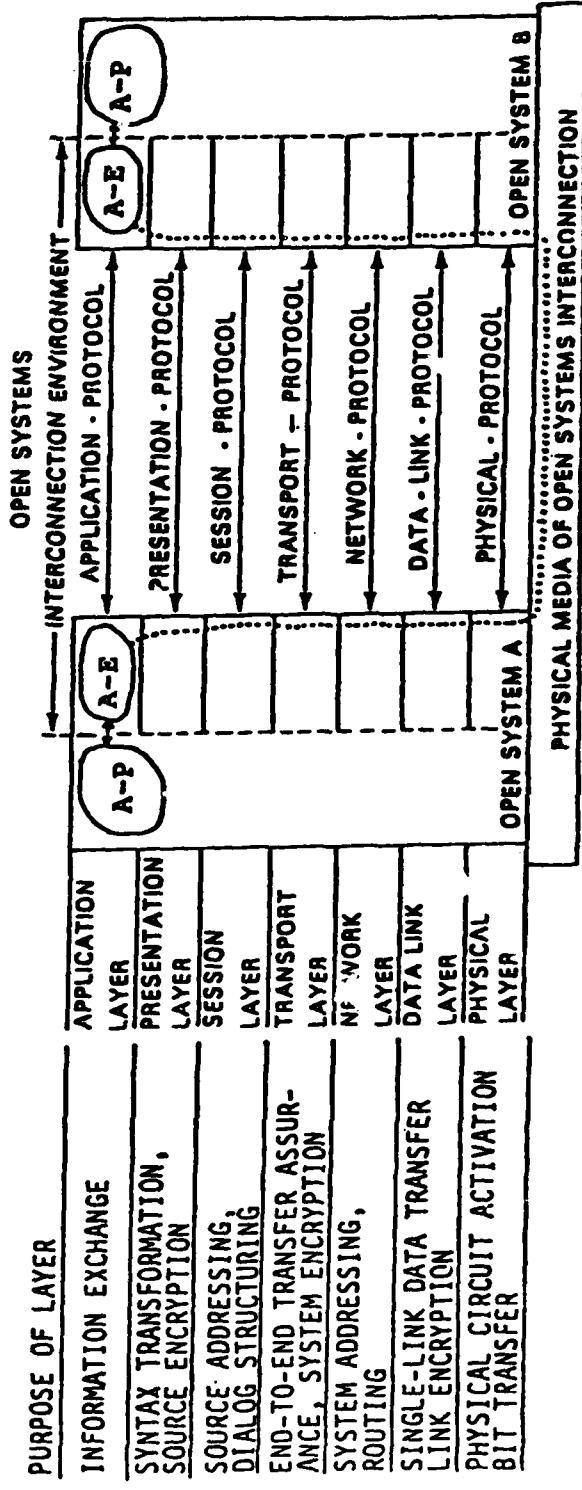

A-P = application-process, A-E = application-entity



ROLES OF STANDARDS BODIES

- **INTERNATIONAL ORGANIZATION FOR STANDARDIZATION (ISO) :**
 - TECHNICAL COMMITTEE 97- INFORMATION PROCESSING SYSTEMS
 - SUBCOMMITTEE 16 - OPEN SYSTEMS INTERCONNECTION
 - SUBCOMMITTEE 6 - DATA COMMUNICATIONS

- **AMERICAN NATIONAL STANDARDS INSTITUTE (ANSI) :**
 - TECHNICAL COMMITTEE X3 - INFORMATION PROCESSING SYSTEMS
 - TECHNICAL COMMITTEE X3T5 - OPEN SYSTEMS INTERCONNECTION
 - TECHNICAL COMMITTEE X3S3 - DATA COMMUNICATIONS

- **INTERNATIONAL TELEPHONE AND TELEGRAPH CONSULTATIVE COMMITTEE (CCITT)**



SERVICE AND PROTOCOL ARCHITECTURE OF EACH LAYER

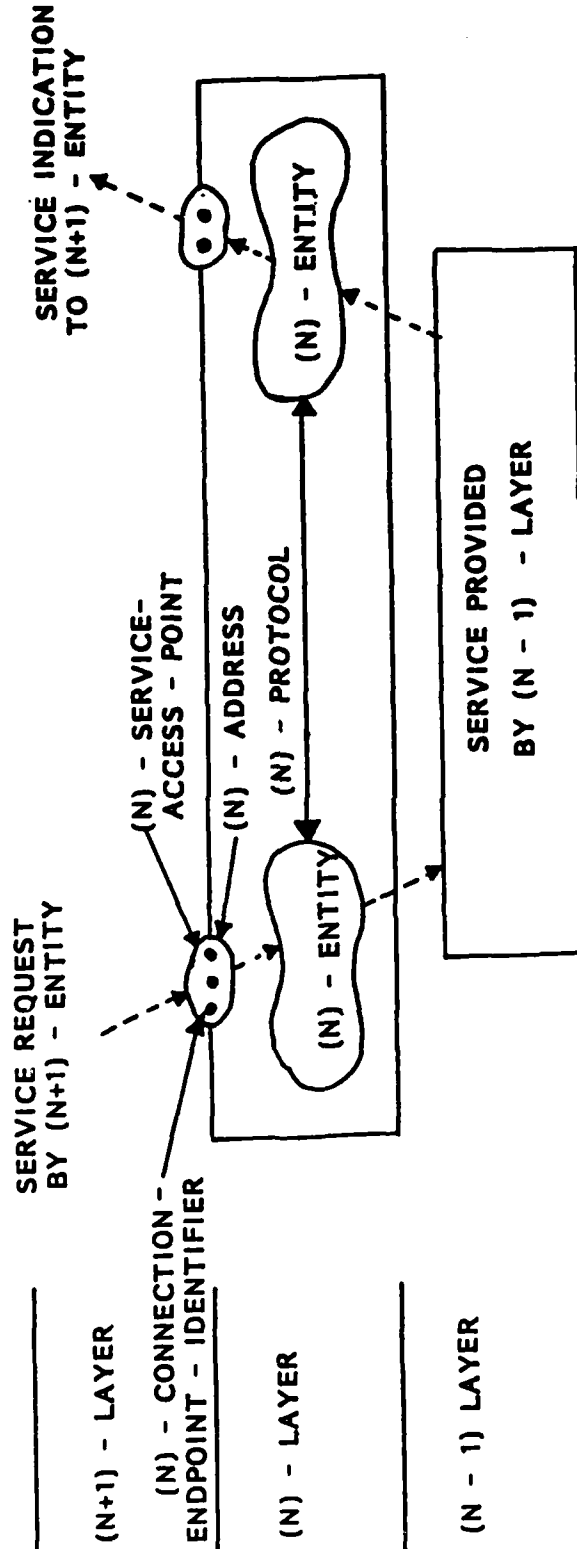

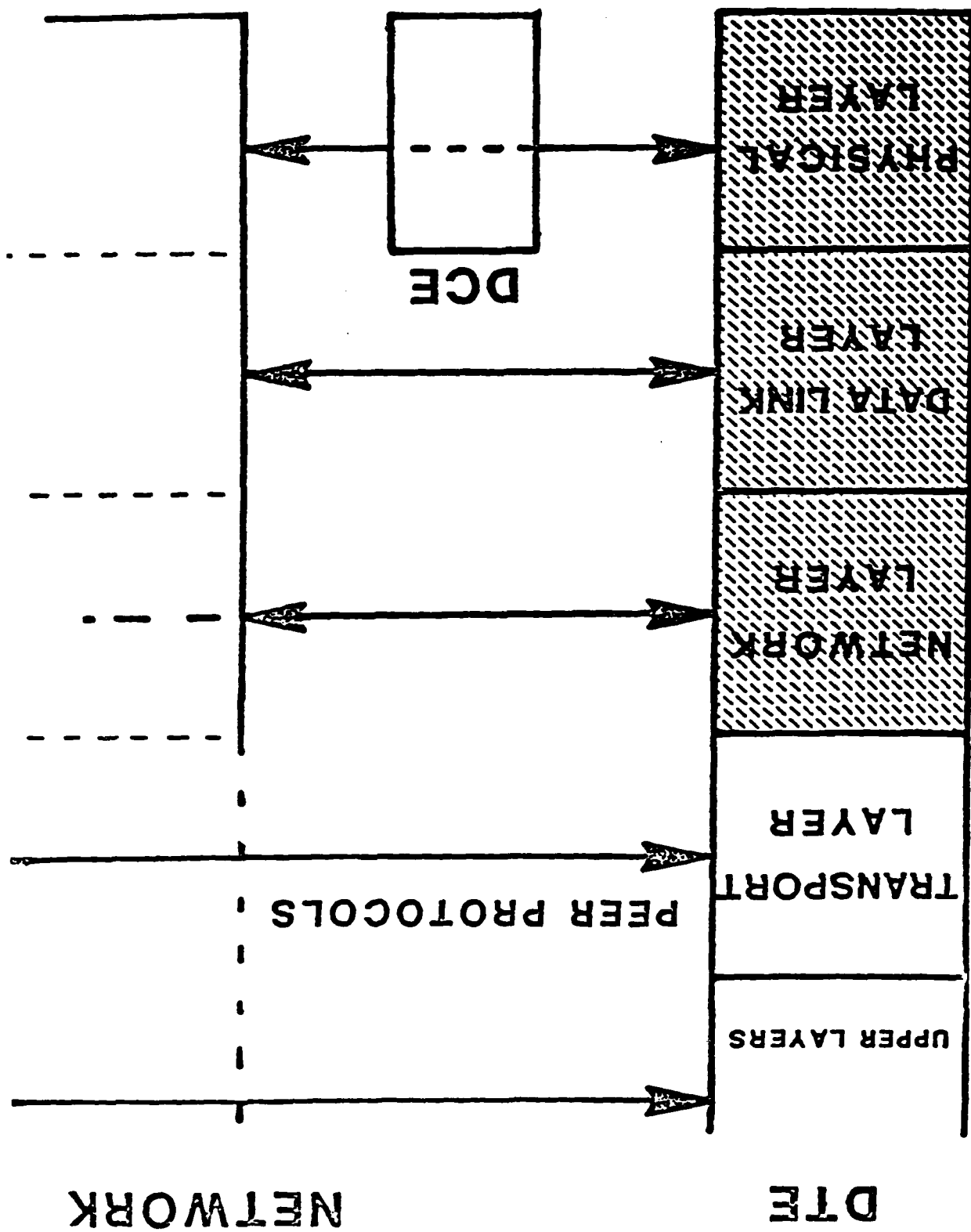



SERIAL NETWORKING TECHNOLOGIES

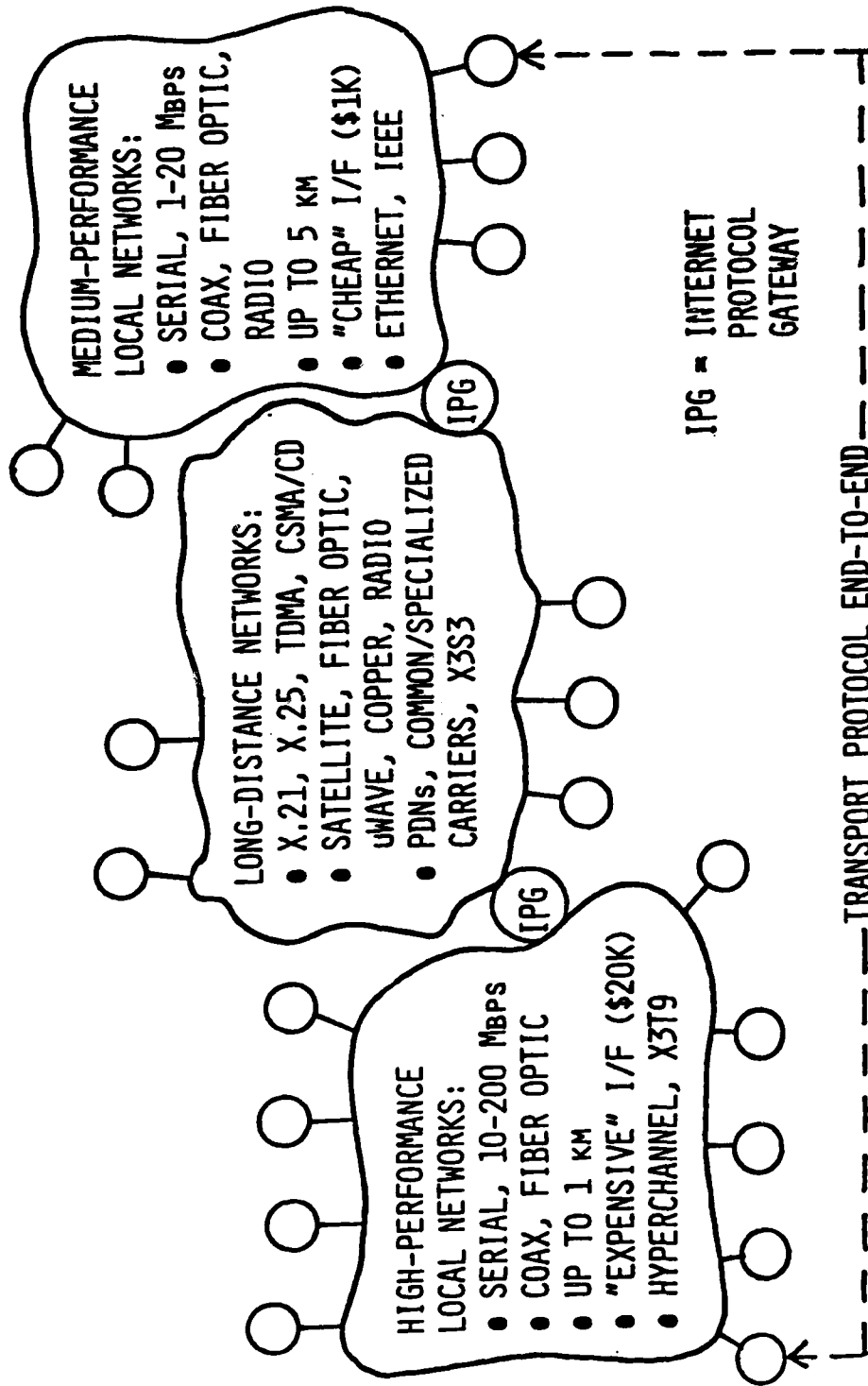



MIDDLE AND UPPER LAYERS

TRANSPORT LAYER: PROVIDE COST-EFFECTIVE, RELIABLE END-TO-END DATA TRANSFER

- CLASS 0 -- SIMPLE CLASS
- CLASS 1 -- BASIC ERROR RECOVERY CLASS
- CLASS 2 -- MULTIPLEXING CLASS
- CLASS 3 -- ERROR RECOVERY CLASS
- CLASS 4 -- ERROR DETECTION AND RECOVERY CLASS

WORLD TRANSPORT DRAFT SERVICE/PROTOCOL STANDARD ADOPTED IN JUNE 1982

SESSION LAYER: ESTABLISH AND CONTROL DIALOG

WORLD SESSION DRAFT SERVICE/PROTOCOL STANDARD NOT LIKELY UNTIL 1983

SESSION AND TRANSPORT STANDARDS LIKELY TO BE COMPATIBLE: ISO/CCITT/ANSI/ECMA/NBS

PRESENTATION LAYER: PROVIDE TRANSFORMATIONS OF SYNTAX

APPLICATION LAYER: PROVIDE STANDARD APPLICATION-PROCESS INTERCONNECTIONS

PRESENTATION AND APPLICATION LAYER ARCHITECTURE AND SERVICE DESCRIPTIONS MAY BE AGREED BY 1983, DRAFT STANDARDS FOR VIRTUAL TERMINAL/VIRTUAL FILE/JOB TRANSFER NOT LIKELY BEFORE 1984

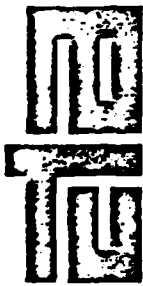

UPPER LAYER ARCHITECTURE

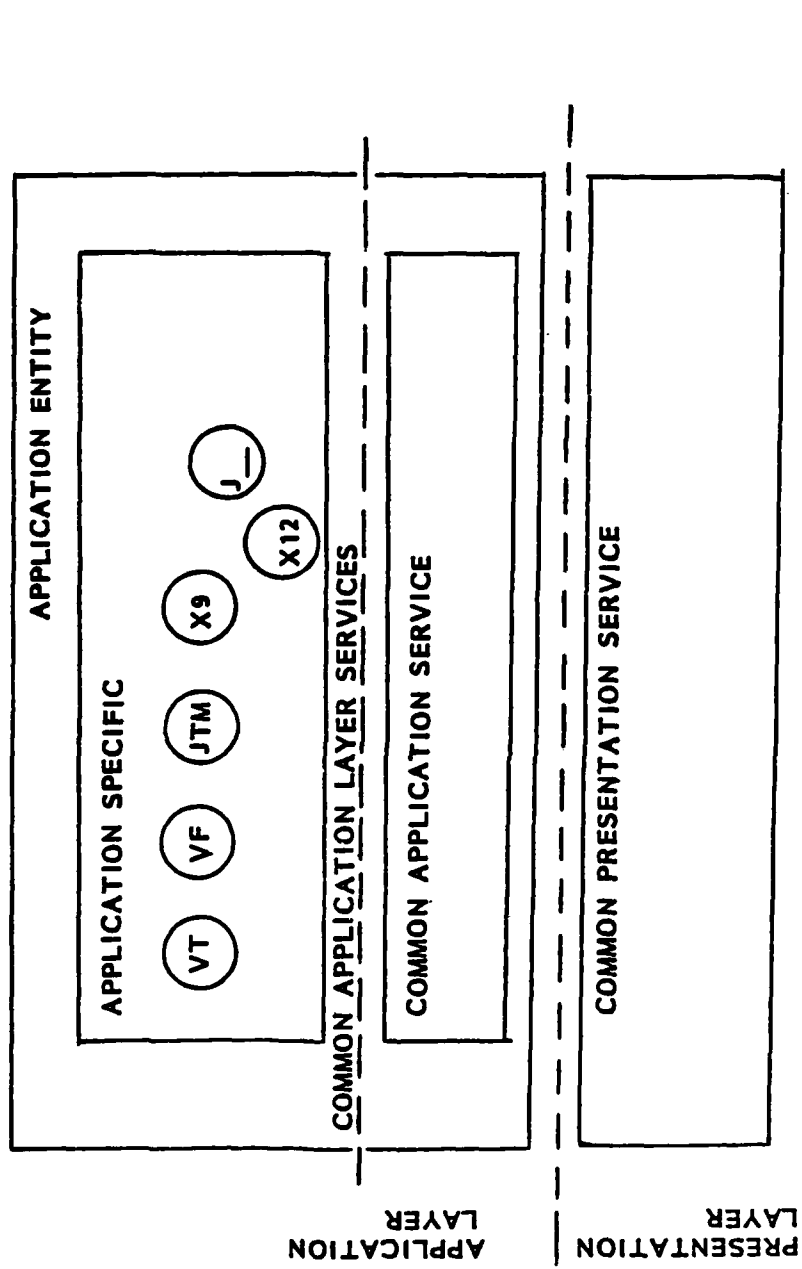



OPEN SYSTEMS INTERCONNECTION
TIME TABLE AS OF 8/82

- BASIC REFERENCE MODEL OF OSI IS CURRENTLY BEING PROCESSED AS WORLD STANDARD (ISO DRAFT INTERNATIONAL STANDARD 7498)
- LOWER LAYERS 1-3 ARE FAIRLY MATURE IN PUBLIC NETWORK APPLICATIONS (i.e., HDLC, X.25/X.75)
- LOCAL AREA NETWORKS (i.e., IEEE 802, SC13 LDDI) ARE RECEIVING GREAT ATTENTION, SHOULD HAVE DRAFT STANDARDS IN LATE 1982
- INTERNET STANDARDS FOR LANs, PUBLIC-TO-PRIVATE INTERFACE, ARE VERY ACTIVE IN X3S3 AND SC6, SHOULD GET DRAFTS IN 1983
- WORLD TRANSPORT STANDARD IS NOW ISO DRAFT PROPOSED STANDARD (ISO DP 8072/8073)
- WORLD SESSION STANDARD IS DUE AS DRAFT PROPOSED STANDARD IN 1983
- DRAFT MESSAGE STANDARDS (i.e., CCITT MESSAGE HANDLING SYSTEMS, NBS FIPS MESSAGE FORMAT STANDARD) WILL BE AVAILABLE IN 1982
- NORTH AMERICAN VIDEOTEX SPECIFICATION, CCITT TELETEXT DRAFT, WILL BE AVAILABLE IN 1982
- COMMON PRESENTATION AND APPLICATION PROTOCOLS (including FILE TRANSFER, VIRTUAL TERMINAL, JOB TRANSFER, SYSTEMS MANAGEMENT) WILL HAVE STABLE SERVICE DEFINITIONS IN 1983, DRAFT PROPOSED STANDARDS IN 1984

SC16 8-YEAR PLAN

PROJECTS MEETINGS	1982		1983		1984		1985		1986	
	Tokyo	Europe	Europe	Ottawa	(Scand.)	(Paris)	(USA)	(Eurasia)		
1. Ref. Model	DIS									
+ Connectionless	NWI	IS	DP		DIS					
2. Transport	DP	DIS			IS					
+ Connectionless			DP							
3. Session		DP		DIS						
4. VT			SS	DP						
5. FTAM		SS	DP							
6. JTM			SS	SS	DP					
7. Management			SS	SS						
(8) Presentation	NWI	SS		DP						
(7) C. Application		NWI								

LEGEND: P = WG/Plenary meetings, W = WG meetings only.
 NWI = Either NWI is prepared or need for NWI is denied.
 SS = Stable Service Definition.

NOTE: DP → DIS = 10 months,
 DIS → IS = 12 months.
 (best cases)
 Rdj 11 June 1982

LAN

LOCAL AREA NETWORK STANDARDS

DATA LINK + PHYSICAL LAYERS

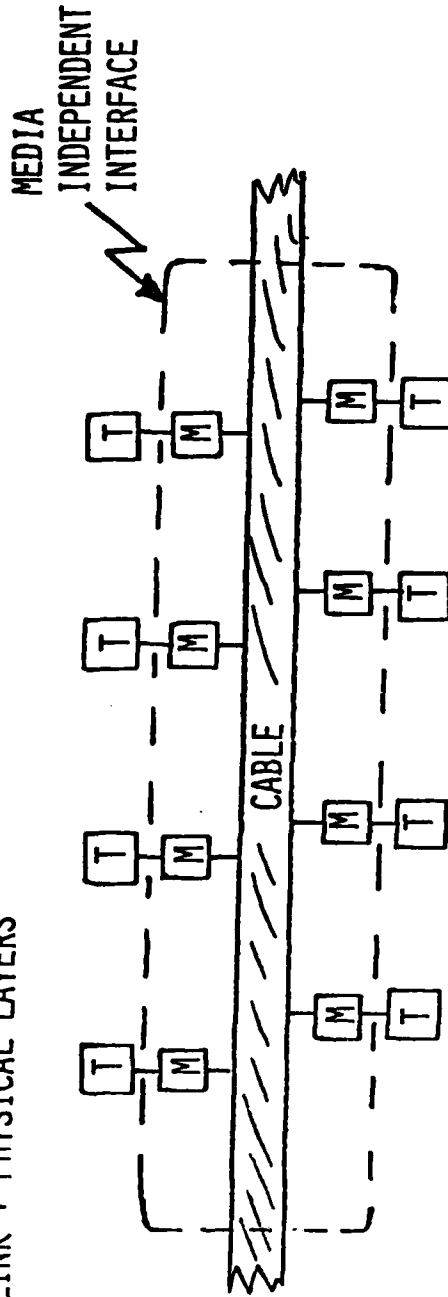

M = MEDIA ACCESS UNIT, T = DATA TERMINAL EQUIPMENT

PHYSICAL LAYER:

- SEVERAL TYPES OF MEDIA POSSIBLE: COAX, OPTICAL, RADIO
- BASEBAND OR BROADBAND POSSIBLE

DATA LINK LAYER:

- TWO TYPES OF MEDIA ACCESS: CSMA/CD, TOKEN PASSING
- FRAME STRUCTURE, ADDRESSING, ERROR/FLOW CONTROL

STANDARDS: IEEE 802, ETHERNET (PROPRIETARY), ANSI X3T9.5 (50 MBPS)



USE OF LAN AS INTERCONNECTING SUBNETWORK

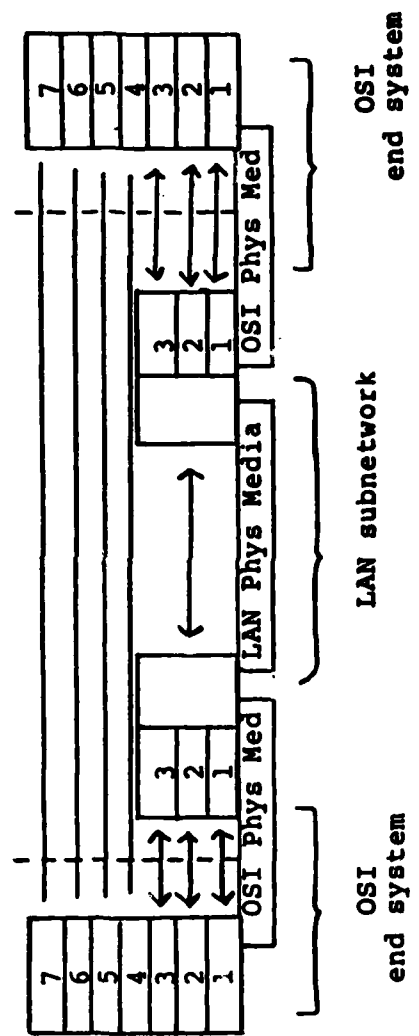



USE OF LAN TO CONSTRUCT COMPOSITE END-SYSTEMS

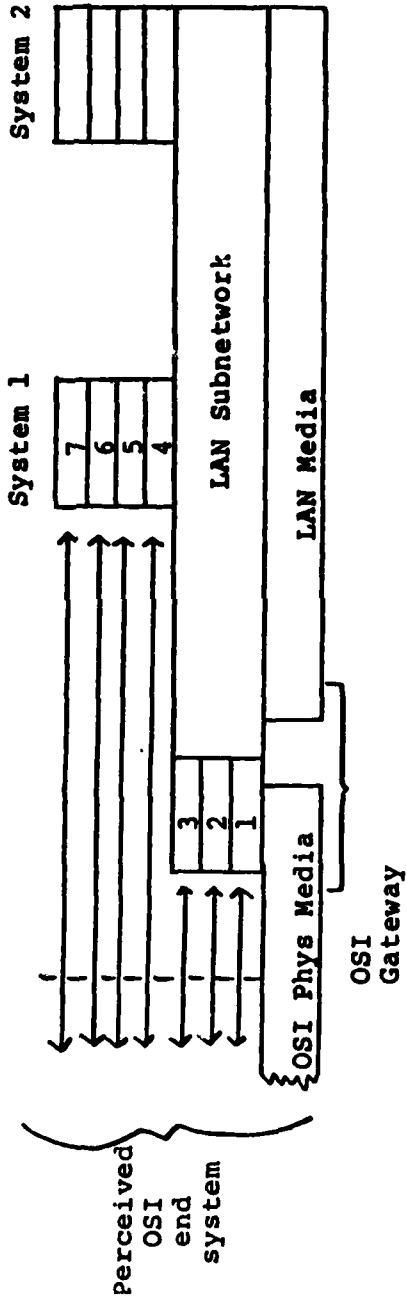



DIRECT USE OF LAN SYSTEMS AS OSI END-SYSTEMS

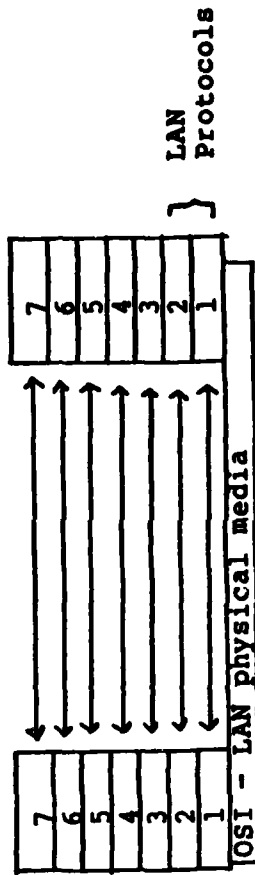



ENHANCEMENTS OF REFERENCE MODEL FOR LANs

SEVERAL PROPOSALS TO ENHANCE REFERENCE MODEL TO BETTER MEET REQUIREMENTS FOR LAN DEVELOPMENTS:

- **BROADCAST**
(Data Link Layer service, no acknowledgment)
- **ERROR DETECTION/CORRECTION**
(Data Link Layer function, may be unnecessary for LANs)
- **NETWORK LAYER MINIMAL FUNCTIONALITY**
(What is minimum set of functions for systems within an LAN?)
- **GATEWAYS**
(What interface functions required for LANs of various types, LANs to non-LAN networks?)
- **CONTENTION RESOLUTION**
(Should this service be assigned solely to Physical Layer?)
- **CHANNEL DERIVATION AND MODULATION**
(These functions should be assigned to Physical Layer)

Interconnection of Local Area Nets

David D. Clark
Laboratory for Computer Science
Massachusetts Institute of Technology

Abstract of talk

A local network is often installed as an isolated facility, but there are a number of reasons why it is desirable to connect several such networks together to form a larger facility. For example, the installation may grow too large physically to be spanned by one single link. This talk addresses the various problems that can arise when a gateway computer is used to join several local networks, with particular attention to the issues of protocol design. Local networks are very simple devices, and very simple protocols can be made to work on them. The concern is that addition of a gateway to the configuration will cause either increased complexity in the protocols or decreased performance of the network.

At the M.I.T. Lab for Computer Science there is a installation of several local networks joined together using gateways. Our experience with this facility is that good performance can be obtained, and that the problems with protocols are not serious. In fact, careful study of the protocols in use suggests that the actual problems experienced are not at all what we expected. The actual protocol implementation is not as large a task as integrating the protocol into the operating system and interfacing it to its client programs. This implies that the addition of gateways to the configuration was not an important factor in the complexity of the total task.

David D. Clark

**Biographical Note
August 1982**

David Clark graduated from Swarthmore College in 1966, and received his PhD from M.I.T in 1973. Since then, he has been employed at the Laboratory for Computer Science at M.I.T., where he is currently a Principal Research Scientist in the Computer Systems and Communication group.

Dr. Clark's research area is operating systems, computer networks, and the interaction of the two. He has worked on several operating systems, including the Multics system done at M.I.T. during the 1960s. He has been involved in computer networking since the early days of the ARPANet, and has designed and implemented a number of network protocols. Currently, he is Chief Protocol Architect for the DARPA Internet Protocol project.

Dr. Clark has been involved for several years in a project to develop a high-speed local net at M.I.T., one based on the ring concept. This net, which is now a commercial product, is in use at M.I.T., and is part of the network configuration on which he will report in this talk.

**INTERCONNECTION OF LOCAL AREA NETS
or
WHY PROTOCOLS RUN SLOWLY**

David D. Clark

**Laboratory for Computer Science
Massachusetts Institute of Technology**

Current Network/Gateway Plan M.I.T. Lab for Computer Science July 1982

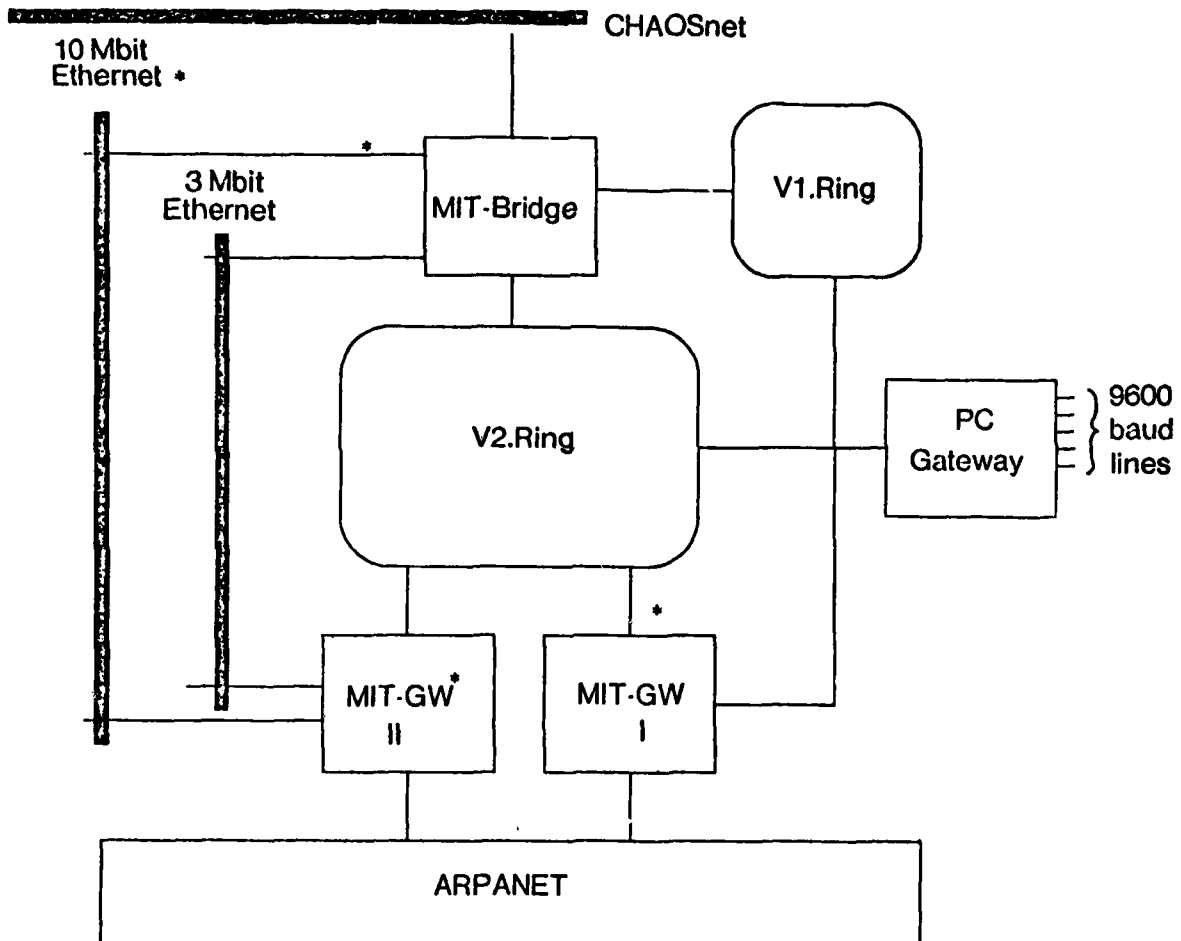

* not installed as of 7/1/82

Local Network Attributes

- * High performance:**
 - High throughput**
 - Low delay**

It would be nice if internetting did not degrade this performance.

- * Missing problems**
 - No routing**
 - No congestion**

It would be nice if internetting did not re-introduce the need to deal with these issues.

Gateway Performance

A gateway can be designed that has performance consistent with local networks.

Measurements of current M.I.T. gateway show 250-350 instructions per packet.

For a DEC 11/23, this is a per packet overhead of about 1 ms.

At 1 ms. per packet, a throughput of 10 mbps is achieved with a packet of 1250 bytes.

This analysis is much too simplistic.

Protocol complexity:

Gateways do raise the possibility of:

Increased delay -> multi-packet windows

Buffer overflow -> congestion control

Gateway failure -> dynamic routing

But:

Are these hard problems? (Not really.)

**Is it reasonable to ignore them under any
circumstances? (Its risky.)**

**What is hard about protocols?
or
Why do they run so slowly?**

Performance and complexity problems are usually found in:

**Interfacing to the operating system.
Interfacing to the client program.**

Protocols are unfamiliar, as well as difficult.

DARPA Internet Protocols

- * Intended for sophisticated internetworking.**
- * Permits 3 levels of host address.**
- * Supports several transport levels.**
- * Much experience with correct and effective implementations.**

The really hard problem: Using more than one protocol family.

This requires that the gateways be "multi-lingual".

DEEPINDER P. SIDHU

Deepinder P. Sidhu was born in Chachrari (Pb) India on 13 May 1944. He received his B.S. degree in Electrical Engineering from the University of Kansas, Lawrence, KN in 1966, Ph.D. in Theoretical Physics and M.S. in Computer Science from the State University Of New York at Stony Brook in 1973 and 1979 respectively.

He was Research Associate in Physics at Rutgers University from 1973 to 1975. From 1975 to 1980, he was member of the Scientific Staff at Brookhaven National Laboratory, Upton, NY and held the position of Assistant Physicist from 1975 to 1977 and Associate Physicist from 1977 to 1980. From 1980 to 1982, he was with the MITRE Corporation, Bedford, Mass. as a technical staff. Since March 1982, he has been with the the Burroughs Corporation, Paoli, PA where he is manager of the Secure and Distributed Systems department in the Research and Development Organization.

Dr. Sidhu has made several significant contributions to Theoretical Physics and has published more than 60 research papers in Physics. His notable contributions are to the development of Reggeon Field Theory for multiparticle amplitudes, development of Left-Right Symmetric Unified Gauge Theories of Electroweak Interactions, and model independent determination of the Weak Neutral Current Coupling of Quarks. The last work is considered one of the definitive pieces of work on the subject and for deciding the 1979 Nobel Prize in Physics. It was cited by S. Weinberg in his Nobel Prize acceptance speech.

Dr. Sidhu has given several invited talks at national and international conferences. Recently, his name was listed in the, "American Men and Women of Science."

Dr. Sidhu's current interests are in the area of Computer Science, particularly, computer network architectures and interconnections, protocols specification and verification, protocol standards, software development methodologies, distributed data bases, computer and network security, local area computer networks. He has written over 25 research papers in the area of protocol specification and verification, computer and network security, security verification, and design of local area computer networks. Some of these papers were presented at national and international conferences. At Burroughs, in addition to being department manager, Dr. Sidhu is a principle investigator for several IR&D projects in the area of local networks, network security, and design of high performance network front ends. Dr. Sidhu has reviewed papers for several national and international conferences and also for several journals which include IEEE Transactions on Communication, IEEE Transactions on Computers, and Computer Networks Journal.

SECURITY IN LOCAL AREA NETWORKS

Deepinder P. Sidhu
*Research and Development **
Burroughs Corporation
Paoli, PA 19301

(On January 1, 1983, Organization becomes part of
System Development Corporation – A Burroughs Company*

APPROACHES TO LOCAL NETWORK SECURITY

- *END-TO-END ENCRYPTION*
- *TRUSTED SOFTWARE*
(Subject of this talk)
- *ENCRYPTION AND TRUSTED SOFTWARE*

REFERENCES

D. P. Sidhu and M. Gasser, "Design for a Multilevel Secure Local Area Network", MITRE Corp., MTR-8702 (March 1982)

D. P. Sidhu and M. Gasser, "A Multilevel Secure Local Area Network", *Proc. of 1982 Security and Privacy Symposium*, Oakland, CA (26-28 April 1982)

D. P. Sidhu, "A Local Area Network Design for Military Applications", To be presented at the *7th Conference on Local Area Networks*, Minneapolis, MN (October 12-13, 1982)

D. P. Sidhu, "Security in Local Area Networks", Burroughs Corp. Report (1982), in preparation

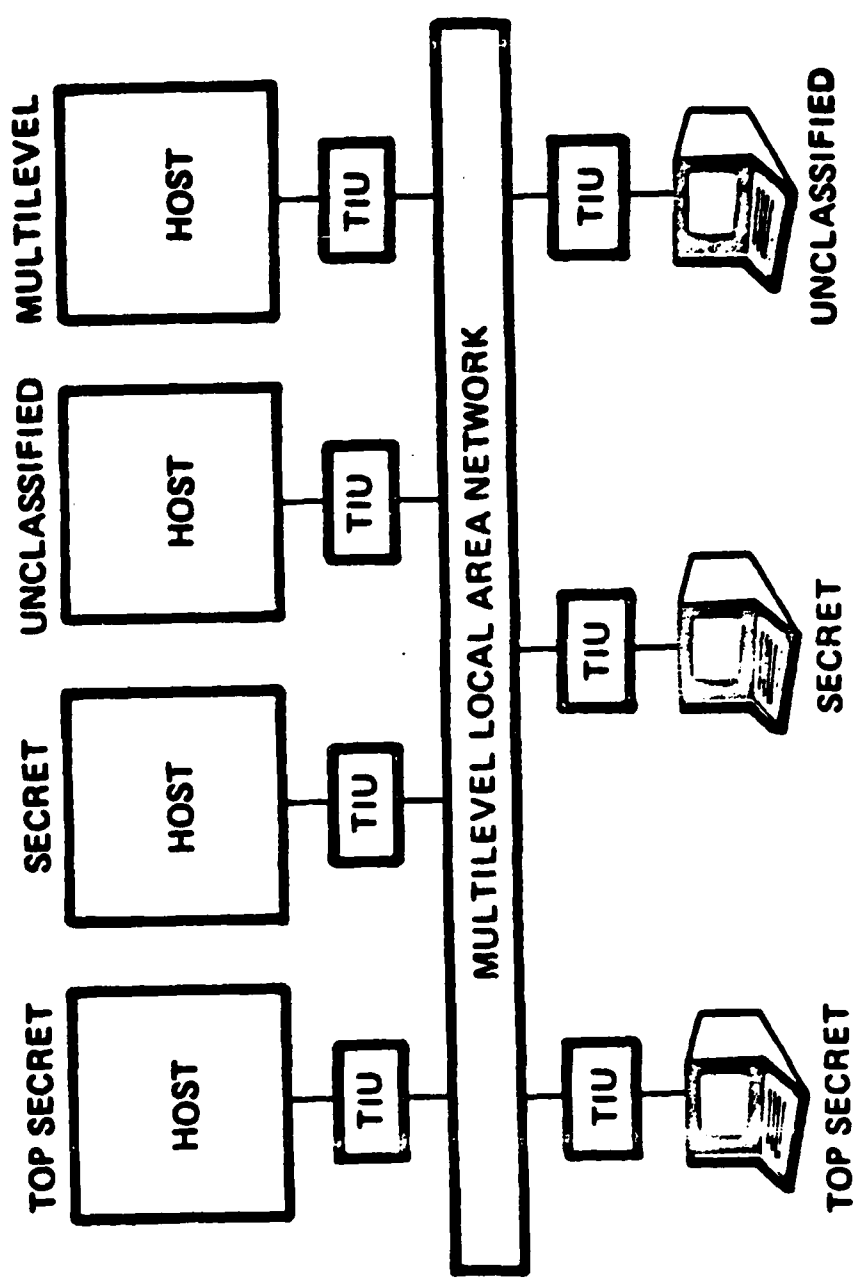

Figure Simple Multilevel Local Area Network

SECURE LAN REQUIREMENTS

Basic Requirement

LAN allows transmission of data at different security levels but with appropriate protection of data at each security level

Additional Requirements

- 1. Flexibility to meet different operational requirements*
- 2. Allows communication among subscribers fully consistent with DoD security policy*
- 3. Flexibility to allow evolutionary changes - advances in transmission technology, VLSI hardware, etc.*
- 4. Allows interconnection with wide-area networks*

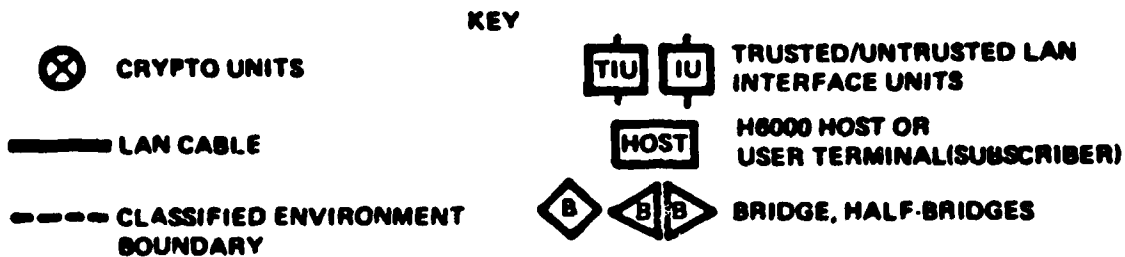
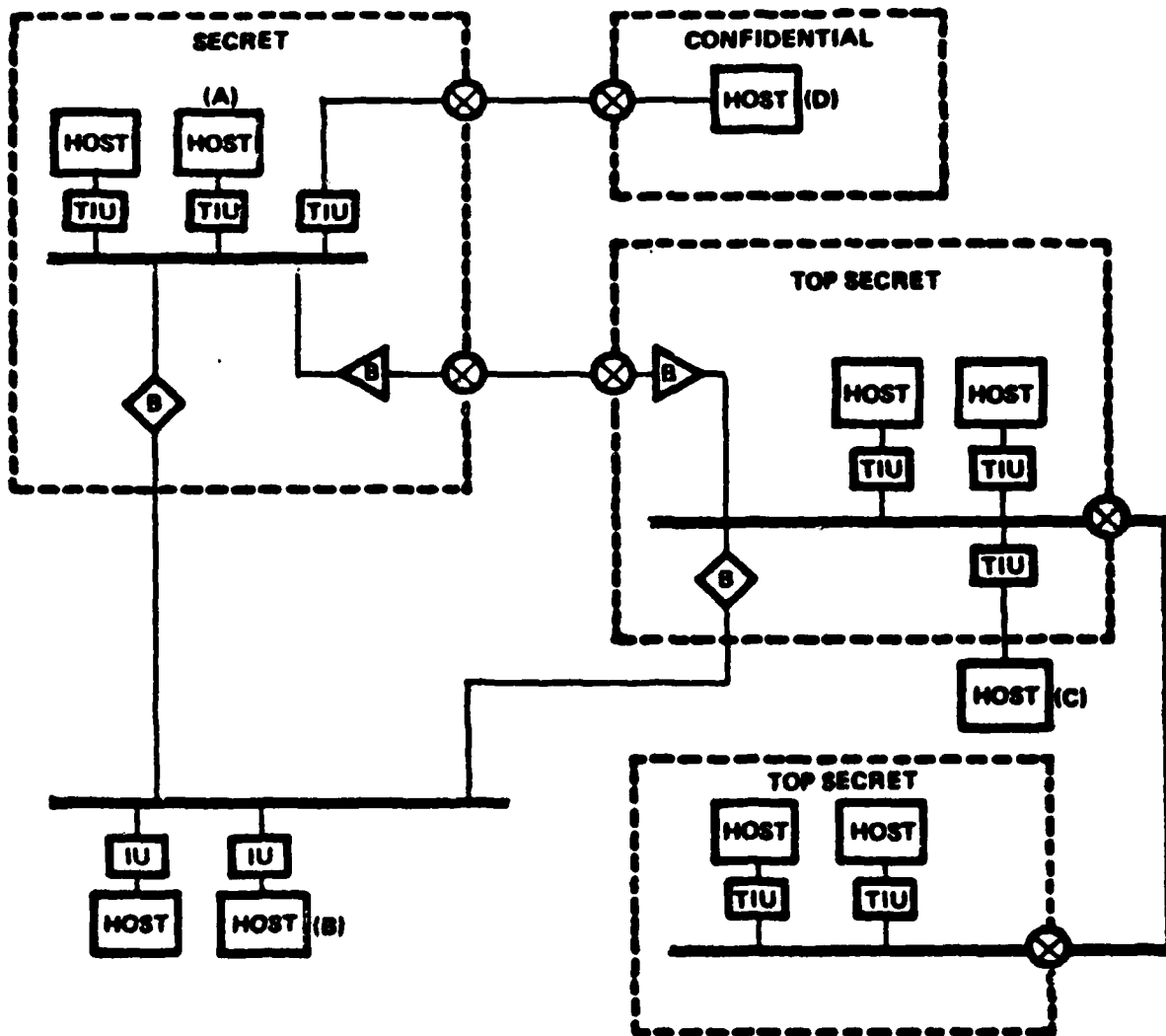

Figure Full Multilevel Local Area Network

BENEFITS OF SECURE LAN ARCHITECTURE

1. *It allows reconfiguration with minimum disruption of service within a fixed security environment.*
2. *It allows user separation by communities of interest and information flow, as well as by security levels.*
3. *It allows for data security by physical separation of data flow if desired.*
4. *It enhances reliability by limiting the effect of failures and denial-of-service attacks to a single subnetwork.*

SECURE LAN COMPONENTS

- *Subnetworks*

Parts of secure LAN that reside fully within protected security environments

- *Trusted Interface Units (TIUs)*

Provide subscribers connection to subnetworks and act as security filters

- *Bridges*

Provide links between subnetworks

- *Gateways*

Allow interconnection to wide-area networks

- *Guards*

Allow information to move from one security level to another in a controlled way

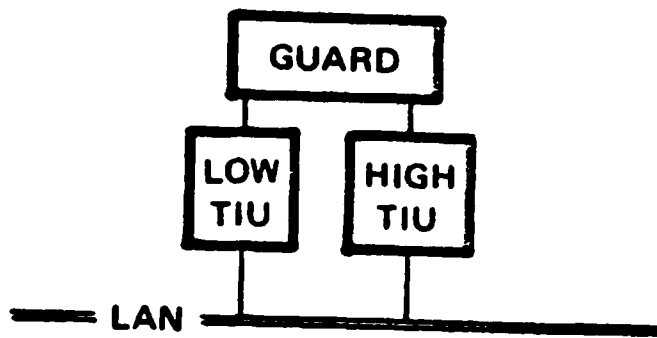

Figure **Guard on the Secure LAN**

SUBNETWORKS

- *TOPOLOGIES*

- Bus*
 - Star*
 - Ring*
 - Mesh*

- *ACCESS METHODS*

- Random Access Protocols (e.g. CSMA/CD)*
 - Broadcast Recognize Access Protocols*
 - Token Passing Protocols*
 - Dedicated Circuits*

- *TRANSMISSION TECHNIQUES*

- Baseband*
 - Broadband*

SIMPLIFYING ASSUMPTIONS FOR SUBSEQUENT DISCUSSION

- Subnetworks are bus networks*
 - Use identical protocols (IEEE 802 CSMA/CD)*

PROTOCOL DETAILS

Low Layer Protocols

Level 1: Physical (IEEE 802)
Level 2: Link (IEEE 802 CSMA/CD)
Level 3: Network

High Layer Protocols

Internet Protocol (IP)
Transmission Control Protocol (TCP)
(DoD Standard IP/TCP)

Ethernet Link Protocol

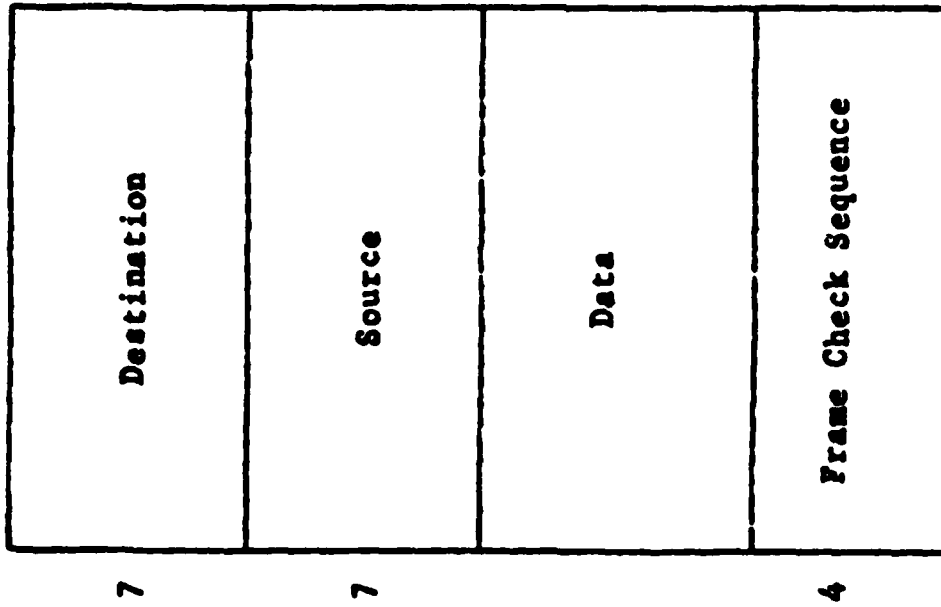

(a)

Secure LAN Link Protocol

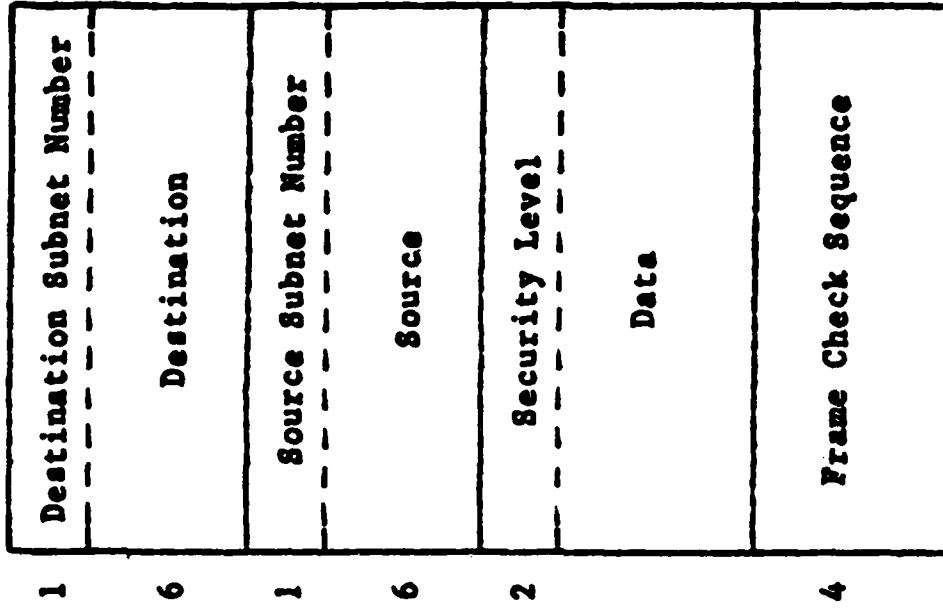

(b)

Figure Local Area Network Packet Format

FIELDS OF MODIFIED IEEE 802 CSMA/CD FRAME FORMAT

Destination Subnet Number: 1 octet

Destination local subnetwork number

Destination: 6 octets

Address on the subnetwork of the TIU receiving the frame

Source Subnet Number: 1 octet

Source local subnetwork number

Source: 6 octets

Address on the subnetwork of the TIU sending the frame

Security Level: 2 octets

Security level of the data part in the frame

Data: variable (up to some maximum) number of octets

Data in a fully transparent form, i.e., any bit sequence is allowed

Frame Check Sequence: 4 octets

Contains cyclic redundancy check (CRC) value computed over all the fields

CHANGES IN IEEE 802 FRAME FORMAT

- *Destination Subnet Number*
- *Source Subnet Number*
- *Security Level*
- *Use two-level hierarchical addressing scheme*
Address = (Subnet Number, TIU Number)
- *Security Level Processing Function*

```
function Recognize_Security_Level  
  (level: Security_Level_Value): Boolean  
  begin  
    Recognize_Security_Level :=  
    {Return true if the level is a  
    member of the set of secu-  
    rity levels associated with  
    the receiving unit}  
  end; {Recognize_Security_Level}
```

ENCODING OF SECURITY LEVELS

- *Can specify a number of security levels with 16 bits*
- *A scheme [Postel81/IP Spec] to use 16 bits to specify 16 security levels*

<i>00000000</i>	<i>00000000</i>	-	<i>Unclassified</i>
<i>11110001</i>	<i>00110101</i>	-	<i>Confidential</i>
<i>01111000</i>	<i>10011010</i>	-	<i>EFTO</i>
<i>10111100</i>	<i>01001101</i>	-	<i>MMMM</i>
<i>01011110</i>	<i>00100110</i>	-	<i>PROG</i>
<i>10101111</i>	<i>00010011</i>	-	<i>Restricted</i>
<i>11010111</i>	<i>10001000</i>	-	<i>Secret</i>
<i>01101011</i>	<i>11000101</i>	-	<i>Top Secret</i>
<i>00110101</i>	<i>11100010</i>	-	<i>(Reserved for future use)</i>
<i>10011010</i>	<i>11110001</i>	-	<i>(Reserved for future use)</i>
<i>01001101</i>	<i>01111000</i>	-	<i>(Reserved for future use)</i>
<i>00100100</i>	<i>10111101</i>	-	<i>(Reserved for future use)</i>
<i>00010011</i>	<i>01011110</i>	-	<i>(Reserved for future use)</i>
<i>10001001</i>	<i>10101111</i>	-	<i>(Reserved for future use)</i>
<i>11000100</i>	<i>11010110</i>	-	<i>(Reserved for future use)</i>
<i>11100010</i>	<i>01101011</i>	-	<i>(Reserved for future use)</i>

DoD STANDARD INTERNET PROTOCOL (IP)

- *Provide Datagram service in the "catenet" environment*
- *Provide fragmentation and reassembly of long datagrams*
- *Security label of the datagram data field can be sent through the "option field" in IP header*
- *IP Header Format*

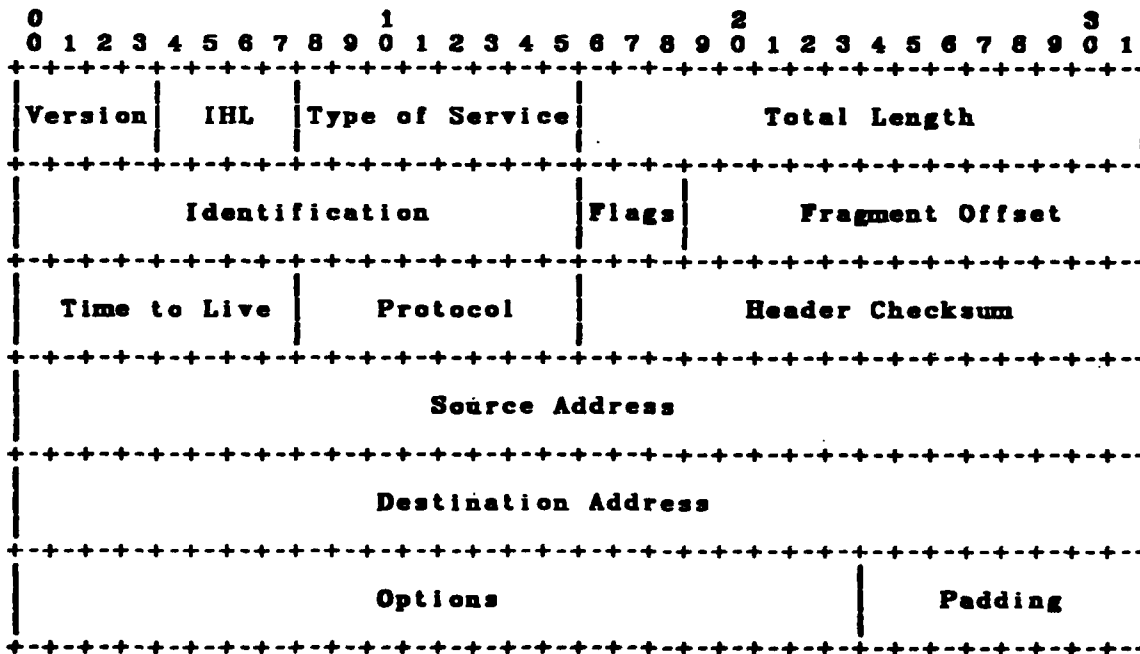

DoD STANDARD TRANSMISSION CONTROL PROTOCOL (TCP)

- *Connection oriented host-to-host protocol*
- *Provide reliability, flow control, multiplexing, ...*
- *Security label of data passed as parameter in TCP/IP interface calls (send and receive datagrams)*
- *TCP/User Connection "OPEN" Command*

OPEN (local port, foreign socket, active/passive [, timeout][, precedence][, security/compartments][, options] → local connection name

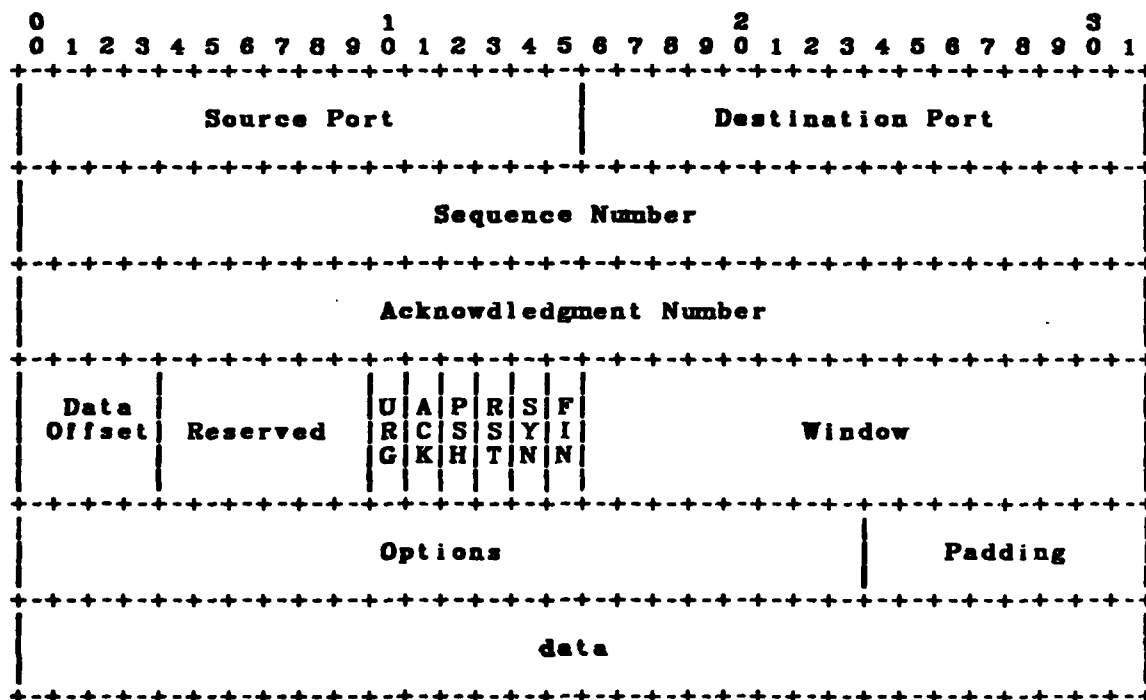

TRUSTED INTERFACE UNIT DESIGN

- *Single-Level TIU*
 - Figure*
 - "Red/Black" refer to multilevel/single-level*
 - Red Area*
 - LAN medium*
 - Interface*
 - CSMA/CD*
 - Security Processor*
 - Black Area*
 - CPU*
 - Memory*
 - I/O Ports*
- *Variable-Level TIU*
- *Multi-Level TIU*

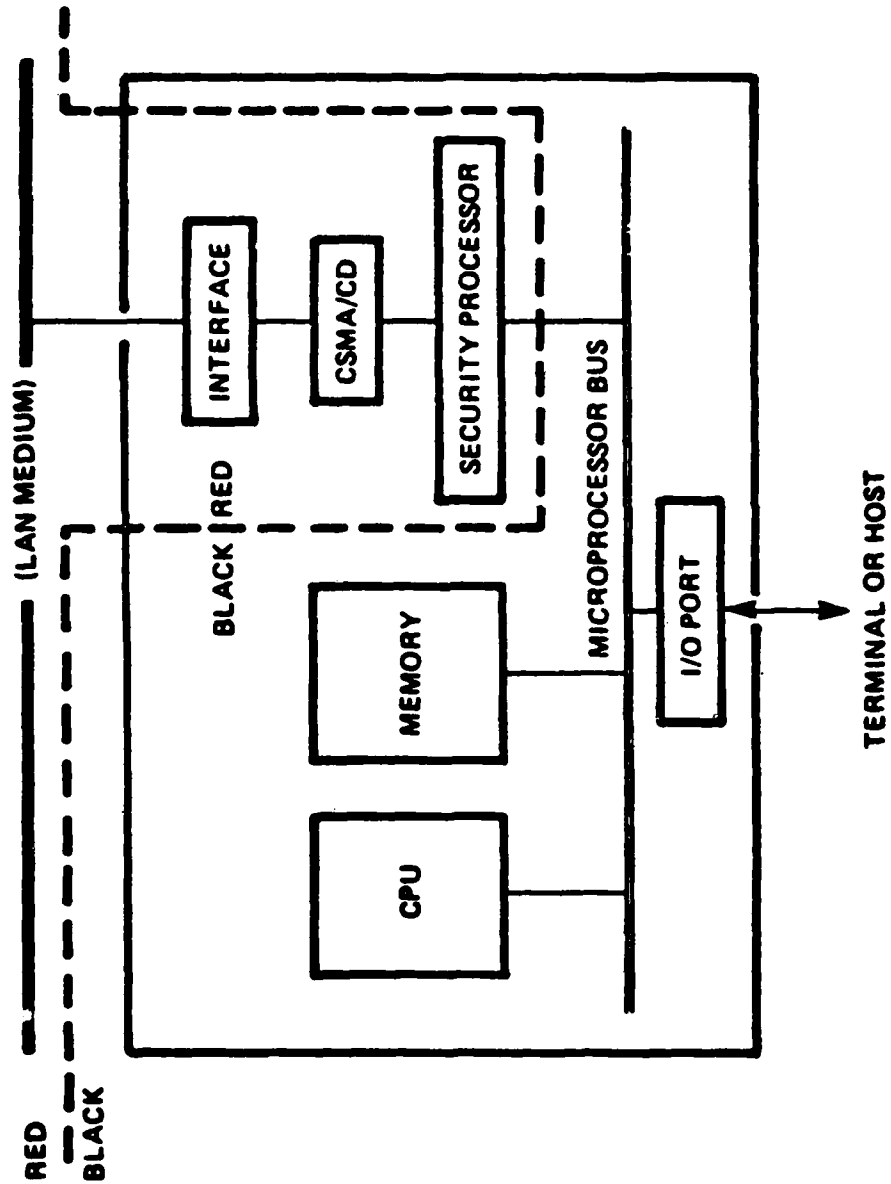

Figure Trusted Interface Unit (TIU) Architecture

SECURITY LABEL CHECKER FOR PACKETS

- *Feasible to implement hardware-validation mechanism for security labels on packets with a controlling state machine in the LAN interface*

BRIDGE CONCEPTS

- *Bridges pass in general multilevel data from one multilevel subnetwork to another which requires them to be trusted*
- *(Figure) shows logical structure of a bridge*
- *Bridges implement physical and link level protocols (also IP)*
- *Bridge Security Processing Function*
- *Bridges Implement Suitable Routing Strategy*
- *Bridge Provide Buffering Capability*
- *Half-Bridge Concept Useful*

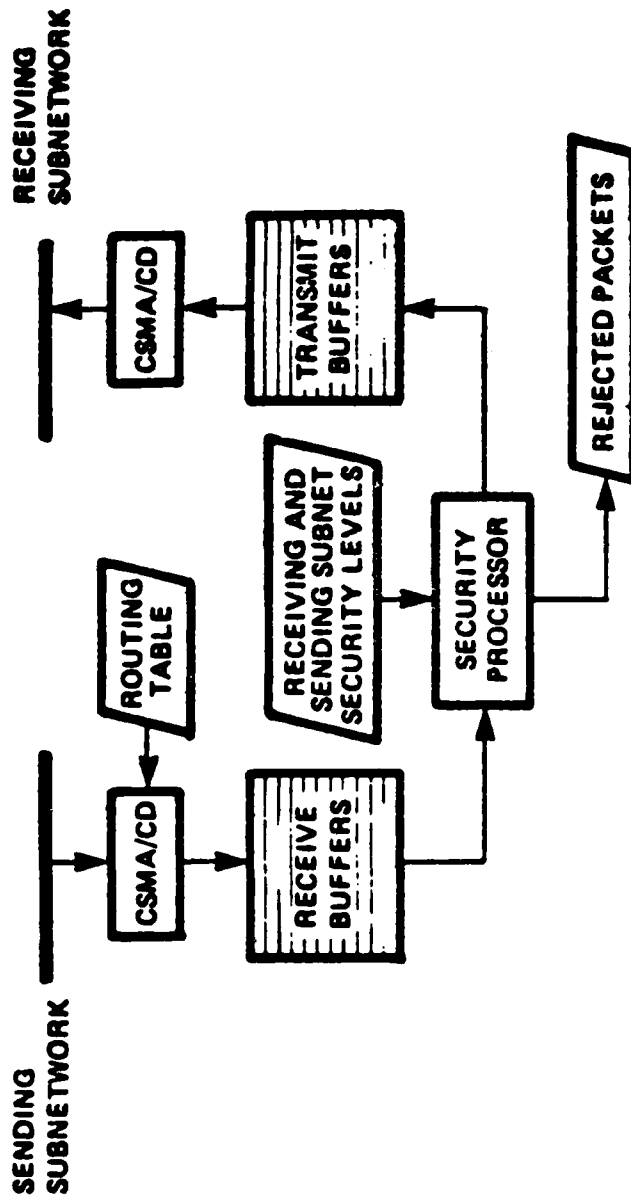

Figure Functional Bridge Architecture (Half-duplex)

LOCAL NETWORK #

1 2 3 4 5

1	1	0	1	0
---	---	---	---	---

(a)

1 (0) in column n means that bridge will (not) pick packets destined for subnetwork n.

LOCAL NETWORK #

1 2 3 4 5

1	1	1	0	0	0
2	1	0	1	1	1
3	0	1	1	1	1
4	1	1	1	1	1
5	1	1	1	1	1

B
R
I
D
G
E
#

(b)

Figure Fixed Routing Tables in Bridges

DESIGN ISSUES FOR FURTHER STUDY

- *Allowing multicast addressing make bridge design complex*
- *Bridges could become bottlenecks. IP in bridges could help alleviate congestion.*
- *Bridges introduce extra delay*
- *Alternatives to hierarchical addressing*
- *Mixing trusted software with end-to-end encryption*
- *Add security watch functions*
- *Allow one way communication*
- *Prevention of denial of service threats*
- *Distributed Operating System for LAN*
 - Provide resource sharing*
 - Provide administrative and maintenance functions*

LIMITATION AND RESTRICTIONS

- *Implementation of Need-to-Know protection will add considerable complexity to TIU in terms of trusted software*
- *TIU will require external databases to determine users identities (authentication)*
- *Overall security of data in the subnetwork depend on ability to physically protect the LAN medium*
- *Reconfiguration Difficult*

ALTERNATIVE APPROACHES TO LAN SECURITY

- *Use of Fixed Bandwidths*

Assign information of different security levels (on a broadband cable) to different channels or time slots

Disadvantages:

Puts small upper bound on the number of security levels

Requires cross channel bridges for upgrade to full multilevel

- *Use of End-to-End Encryption*

Key distribution problem

- *Use of Separate Physical LANs*

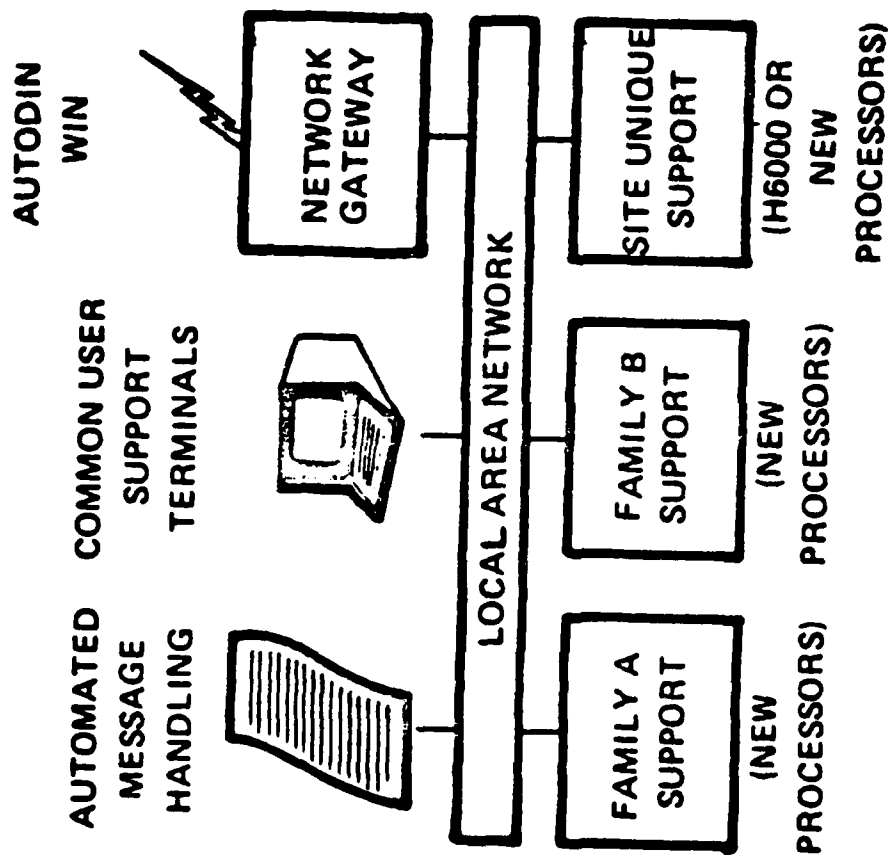

Figure Resources at a WIS Node

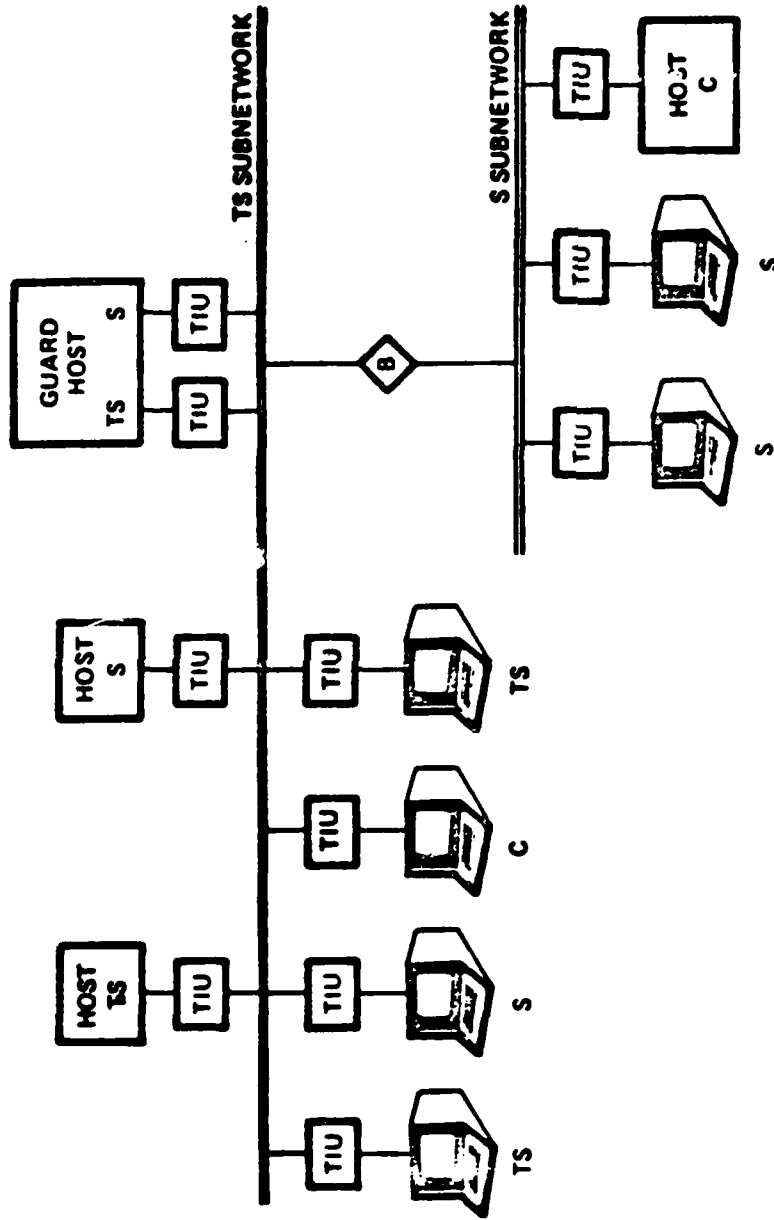

Figure Scenario #1: Single-level TIUs

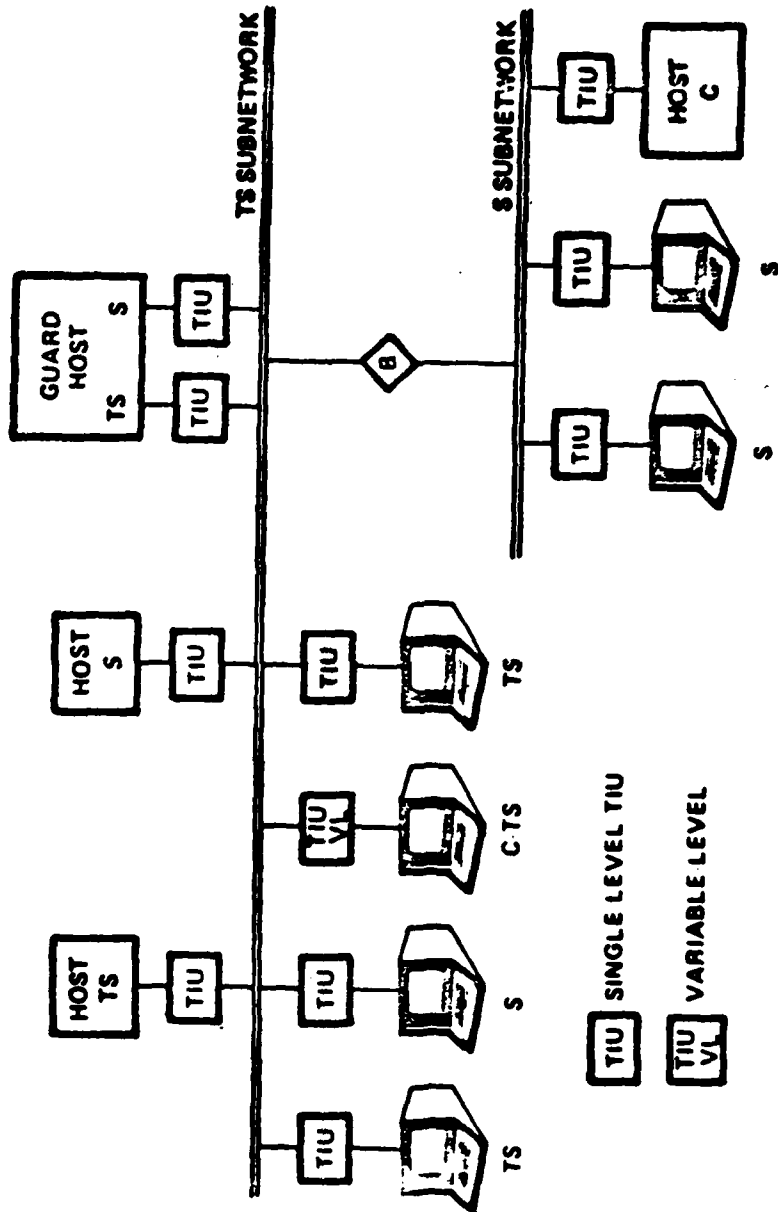

Figure Scenario #2: Variable-level TIUs

IA-64.894

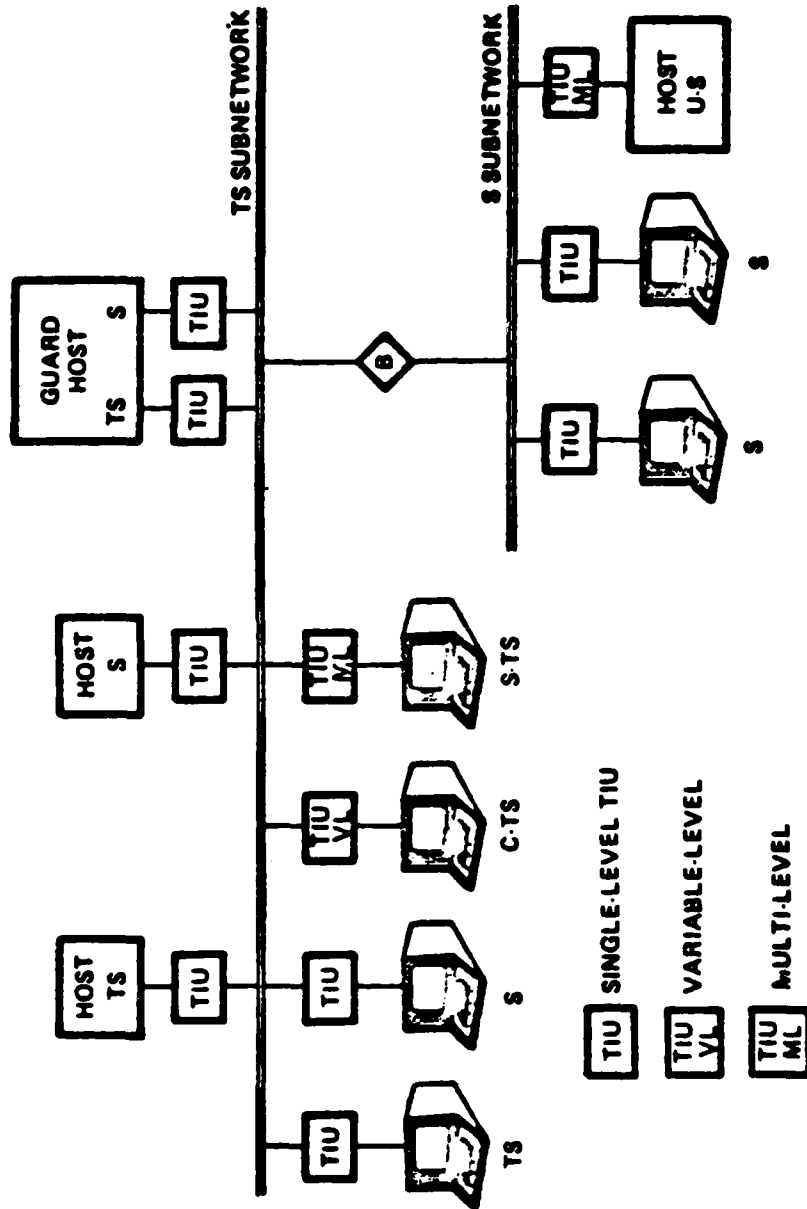

Figure Scenario #3: Variable and Multilevel TIUs

DESIGN TRADE-OFFS FOR
SURVIVABLE LOCAL PACKET NETWORKS

JAMES A. KEDDIE

WHAT THIS TALK IS ABOUT

- SURVIVABILITY DESIGN ISSUES
- TRADE-OFFS
- DESIGN PHILOSOPHY
- IMPLEMENTATION EXAMPLES

WHAT THIS TALK IS NOT ABOUT

- A SURVIVABLE DESIGN RECOMMENDATION
- AN ALL INCLUSIVE DISCUSSION
- A SECURITY DISCUSSION

DEFINITIONS

- SYSTEMS ENGINEERING
- LAYERED ARCHITECTURE
- LOCAL AREA NETWORK
- SURVIVABILITY

SYSTEMS ENGINEERING

- REQUIREMENTS DEFINITION
- ANALYSIS
- TRADE-OFFS/SELECTION
- DESIGN/SPECIFICATION
- IMPLEMENTATION
- VERIFICATION/VALIDATION

Protocol Hierarchical Structure

LAYER	LEVEL	PURPOSE	DATA UNIT
Application	7	To provide the means for applying distributed data communications/ processing resources to specific user requirements.	Message
Presentation	6	To provide means for transforming data including data compression, code conversion, file format conversion, and data terminal presentation changes.	Message
Session	5	To provide users the means to open and close connections, negotiate service options, and control data transmission.	Message
Transport	4	To provide the means for reliable communications between host processes including establishing, managing, and multiplexing connections and regulating data flow.	Message
Network	3	To provide the means to reliably exchange data and control information with the communications subnet.	Packet
Data Link	2	To define the means for exchanging data over a communications link, including error control and data flow regulation.	Frame
Physical	1	To define the physical, electrical, functional, and procedural characteristics to establish, maintain, and disconnect the physical communications link.	Bit

LOCAL AREA NETWORK

- TRANSMISSION MEDIA INEXPENSIVE
- HIGH DATA RATES
- HIGH CONNECTIVITY
- NODES CAN COMMUNICATE DIRECTLY
- DATA FORMATED IN PACKETS

SURVIVABILITY

PROVIDE SERVICE TO SURVIVING SUBSCRIBERS DURING
A DISASTER WHICH RENDERS SOME SWITCHING CENTERS
INOPERATIVE

THE CAPABILITY TO PERMIT CRITICAL MESSAGE TRAFFIC
TO FLOW IN SPITE OF THE SIMULTANEOUS DISABLEMENT
OF MULTIPLE LINKS AND NODES WITHIN THE NETWORK AND
THE INTRODUCTION OF JAMMING AND SPOOFING SIGNALS
BY AN ADVERSARY

SURVIVABILITY

THE ABILITY OF A NETWORK TO SUSTAIN DAMAGE AND
CONTINUE TO PROVIDE AN ACCEPTABLE LEVEL OF
SERVICE TO THE SUBSCRIBERS OF THE NETWORK

NETWORK SURVIVABILITY FEATURES

- MULTIPLE ROUTES
- ROUTING EFFICIENCY
- DISTRIBUTED INTELLIGENCE
- ENVIRONMENTAL RESISTANCE
- PROTOCOLS

MULTIPLE ROUTE FEATURES

- NUMBER OF LINKS TO EACH NODE
- DISPERSION OF LINKS
- TOPOLOGY OF TRANSMISSION MEDIA
- MULTIPLE TRANSMISSION MEDIAS

ROUTING EFFICIENCY FEATURES

- SELECTS SHORTEST ROUTE
- AUTOMATIC REROUTING
- AUTOMATIC DATA FORMAT CONVERSION
- CONGESTION CONTROL

DISTRIBUTED INTELLIGENCE FEATURES

- AUTONOMOUS NODE CONTROL
- AUTOMATIC RECOVERY/RECONFIGURATION
- MULTIPLE NETWORK MANAGERS
- REDUNDANT ACCESS CONTROL SITES
- REDUNDANT KEY DISTRIBUTION MANAGER SITES

ENVIRONMENTAL FEATURES

- RADIOACTIVE HARDENING
- TEMPEST TESTING
- MILITARIZED (SHAKE, RATTLE, & ROLL)
- SHIELDING

PROTOCOL SURVIVABILITY FEATURES

- ERROR CONTROL
- MESSAGE ACCOUNTABILITY
- MALFUNCTION DETECTION
- ADVERSARY DETECTION

SURVIVABILITY MUST BE DESIGNED IN

- THREATS DEFINED
- SURVIVABILITY AND EFFICIENCY GOALS DEFINED
- DESIGN TECHNIQUES EMPLOYED

THREAT DEFINITION YIELDS USER SURVIVABILITY REQUIREMENTS

- EXTERNAL THREATS
 - ELECTRONIC WARFARE
 - DIRECTED ENERGY
 - PHYSICAL

- INTERNAL THREATS
 - FAILURES
 - PROCEDURAL ERRORS
 - EMPLOYEE SABOTAGE

GOALS AND OBJECTIVES YIELD MEASUREABLE CONSTRAINTS

- ADDRESSING
- ROUTING
- EFFICIENCY
- PERSISTENCE
- AVAILABILITY
- RELIABILITY

DESIGN TECHNIQUES EMPLOYED DIRECTLY INTO
A SYSTEMS ENGINEERING APPROACH

- FAULT TOLERANCE
- FAIL SAFE
- ERROR DETECTION CORRECTION
- SECURITY FAULT ANALYSIS
- VERIFICATION AND VALIDATION
- DISTRIBUTED PROCESSING

DESIGN OPTIONS

FEATURES (GOALS)

IMPLEMENTATION

MULTIPLE ROUTES

ROUTING EFFICIENCY

DISTRIBUTED INTELLIGENCE

ENVIRONMENT HARDENING

PROTOCOLS

DOUBLE LOOP DESIGN

DECNET

TOKEN PASSING

PACKET RADIO NETWORK

MULTILEVEL SECURITY PACKET NETWORK

DESIGN TRADEOFFS ISSUES

- ROUTING ADAPTABILITY VS CAPABILITY
- ADDRESSING VS EXPANDABILITY
- SIMPLICITY VS CAPABILITY
- PERSISTENCE VS THROUGHPUT

DOUBLE LOOP ARCHITECTURE

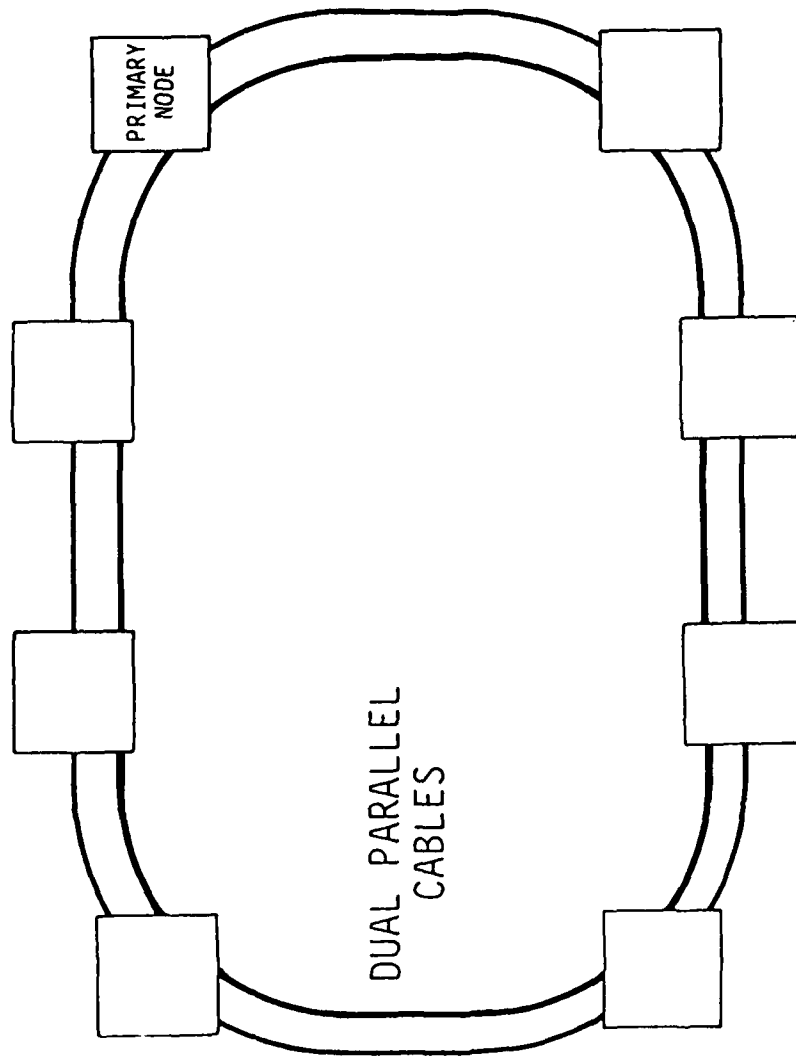

MULTIPLE DOUBLE LOOP ARCHITECTURE

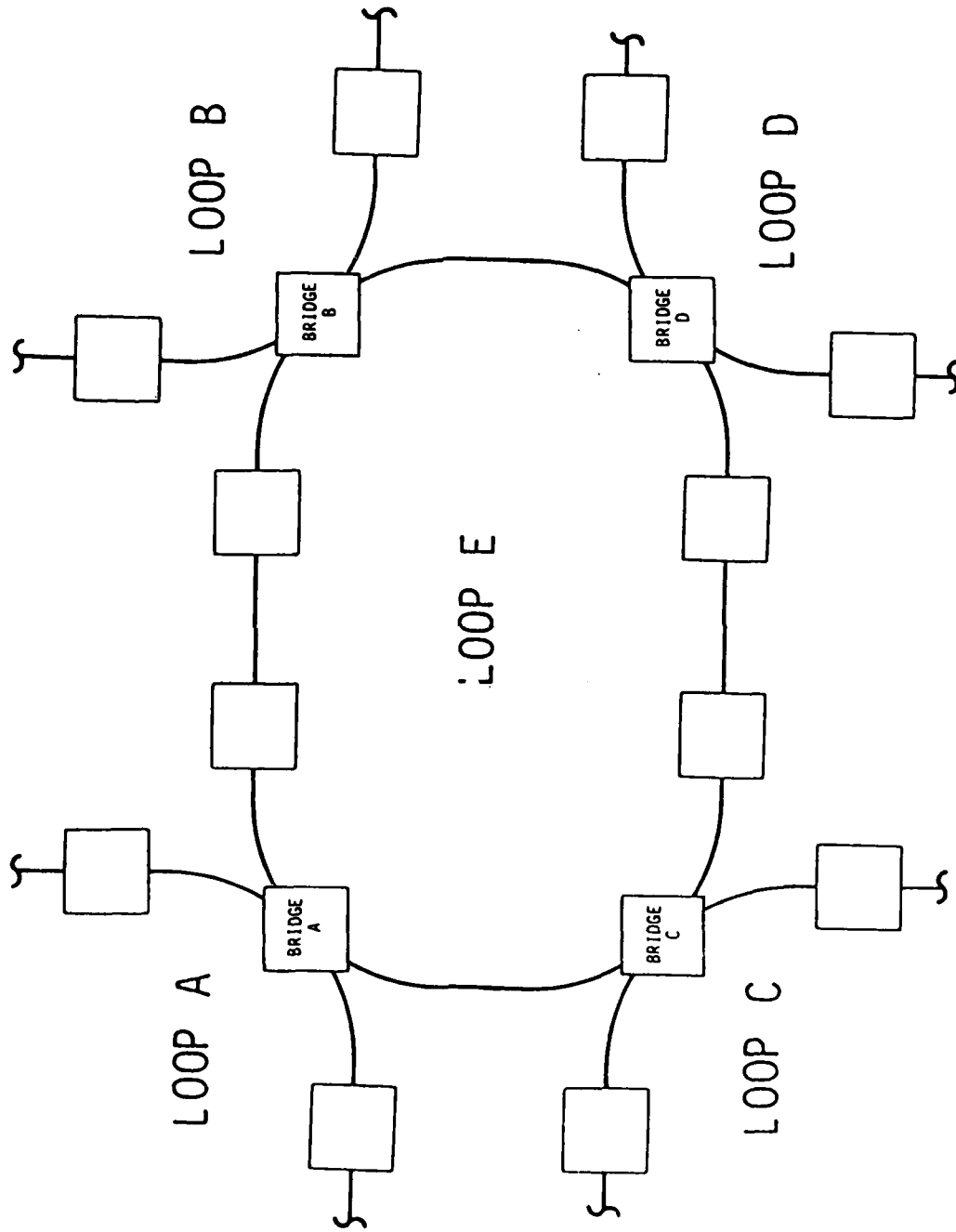

FLAT FOUR DOUBLE LOOP

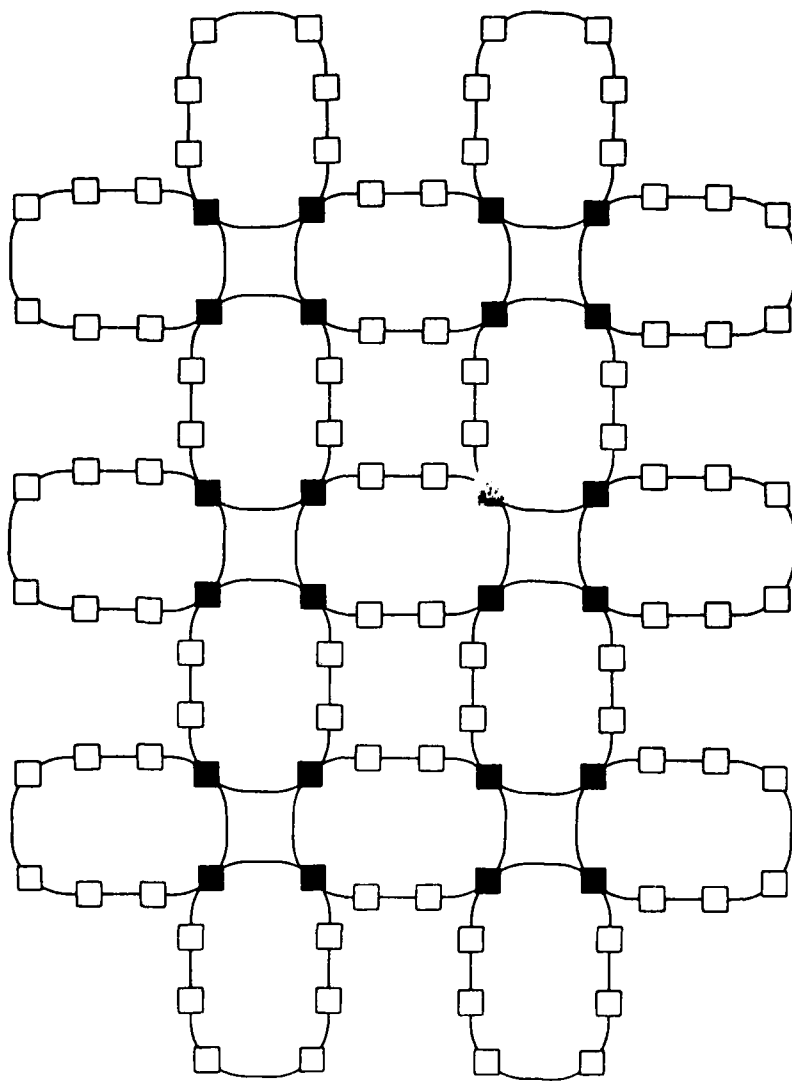

TOKEN PASSING

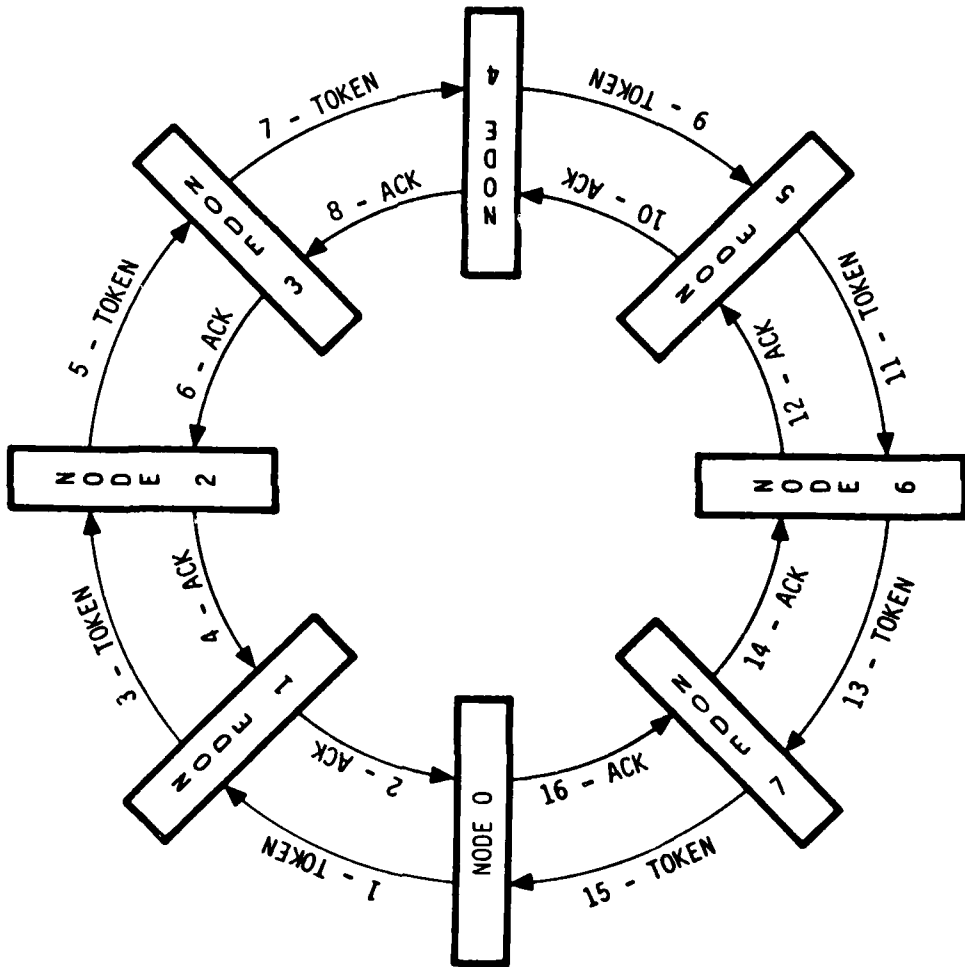

RD-A126 110

PROCEEDINGS OF CONFERENCE ON LOCAL AREA MILITARY
NETWORKS GRIFFISS AFB NEW YORK 28-30 SEPTEMBER 1982(U)
ROME AIR DEVELOPMENT CENTER GRIFFISS AFB NY
D B WARMUTH ET AL. 1982

4/6

UNCLASSIFIED

F/G 17/2

NL

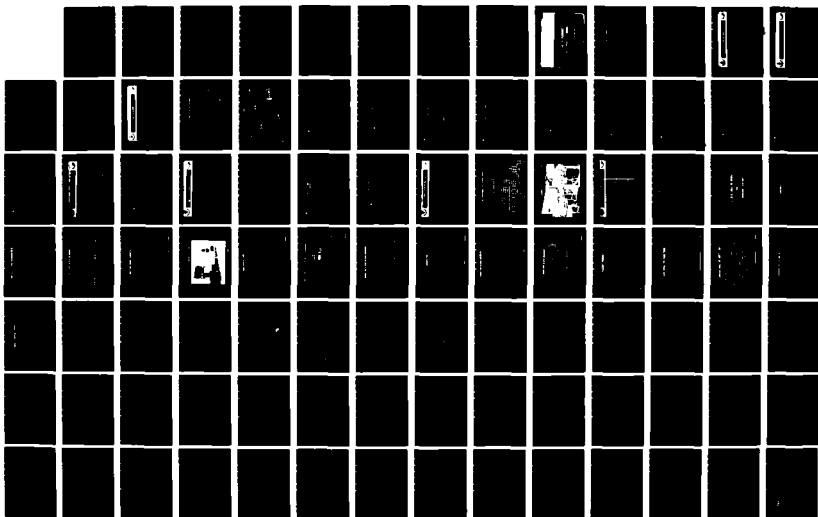

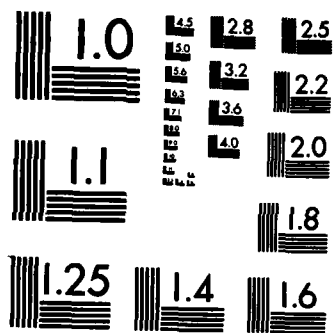

MICROCOPY RESOLUTION TEST CHART
NATIONAL BUREAU OF STANDARDS-1963-A

TOKEN PASSING

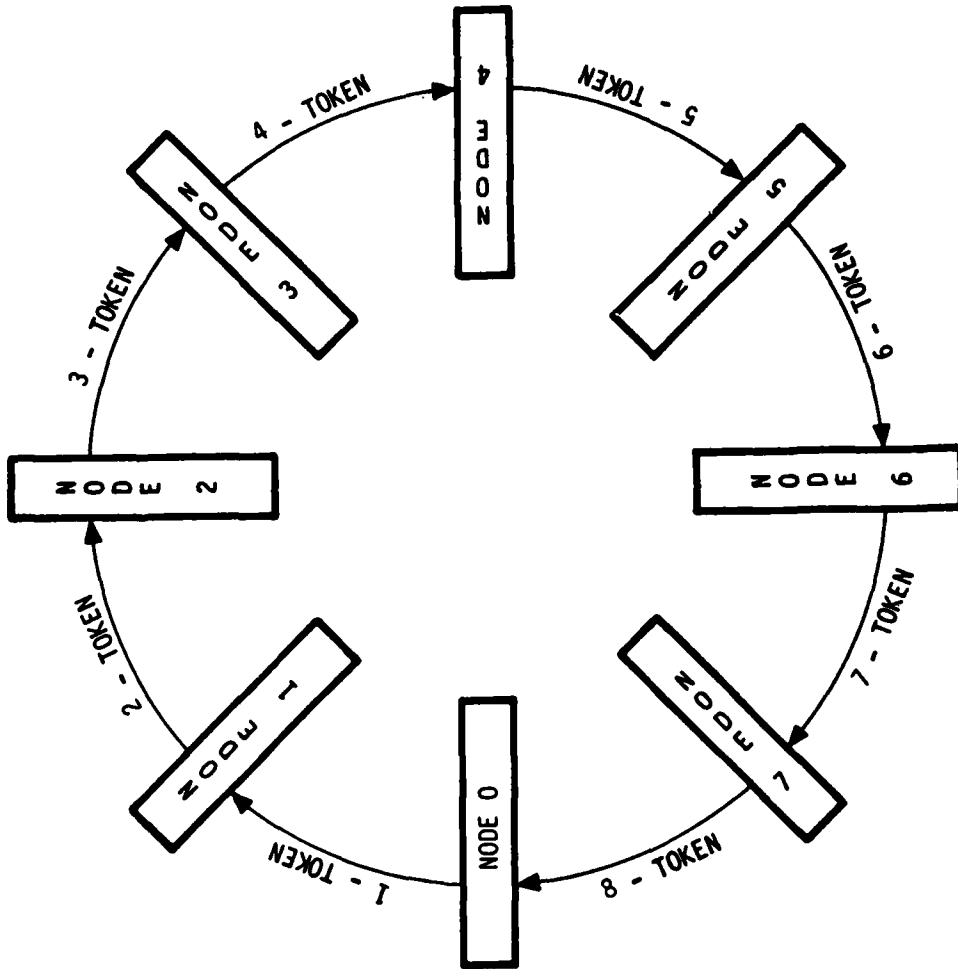

ADAPTABILITY VS EFFICIENCY

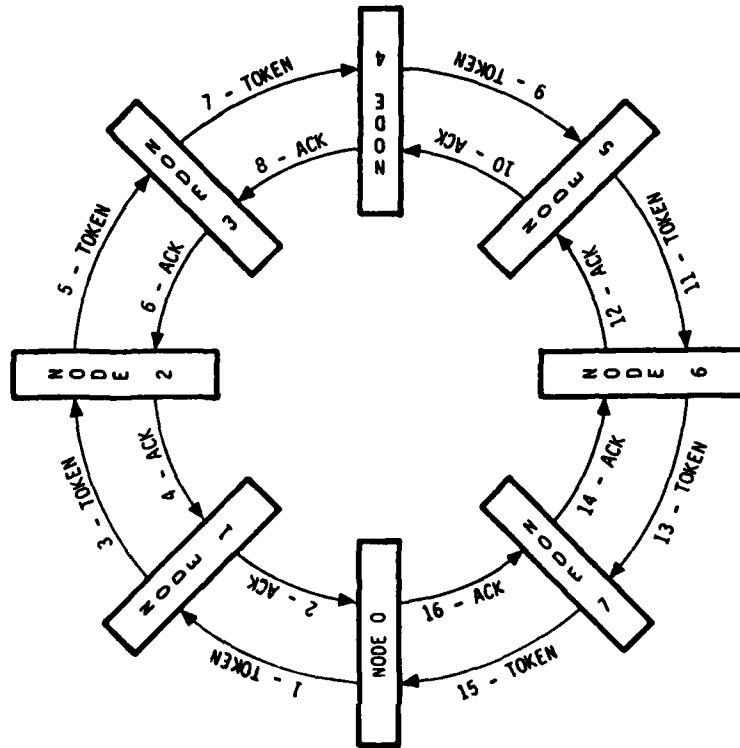
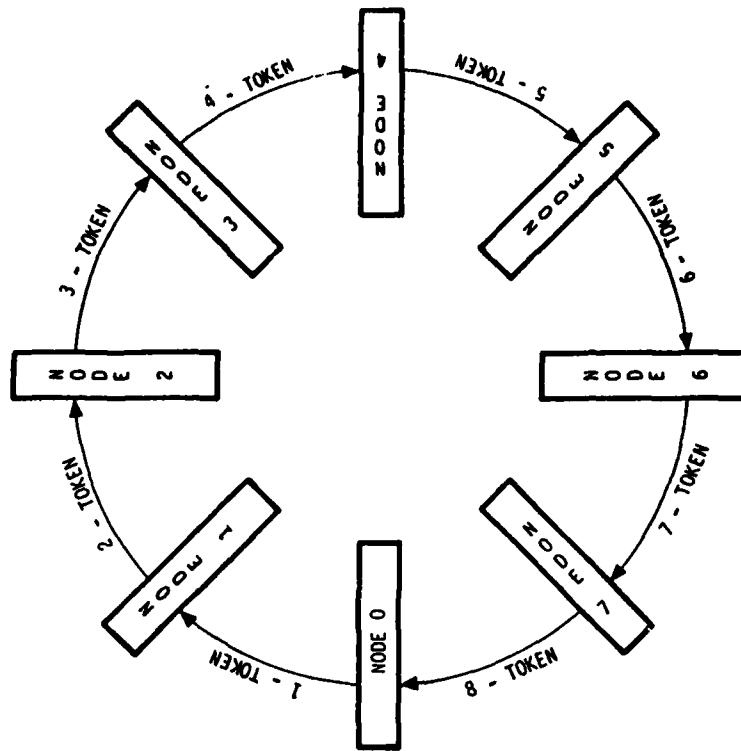

DISTRIBUTED MALFUNCTION AND TOKEN RECOVERY

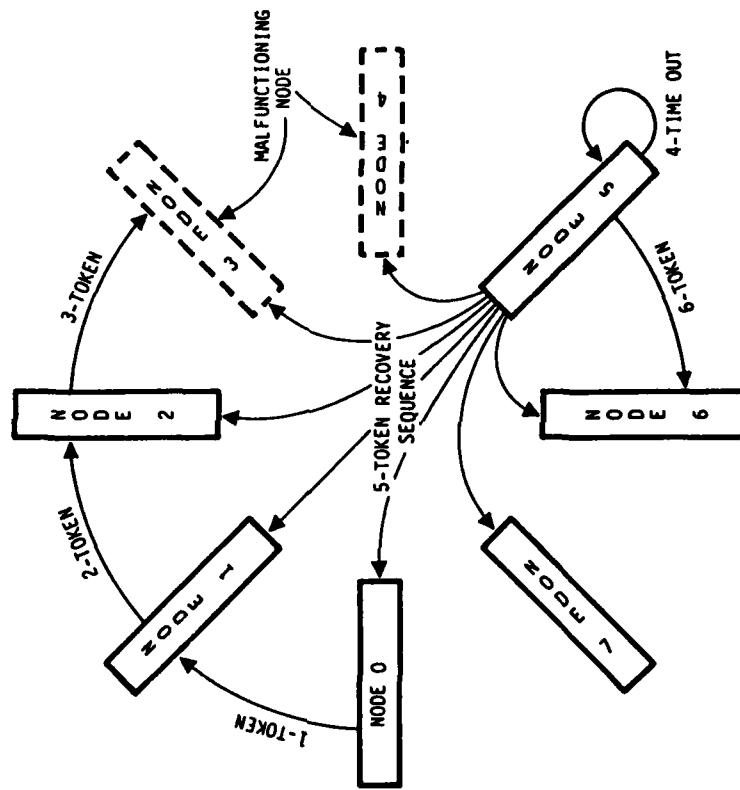

MISSING NODE RECOVERY

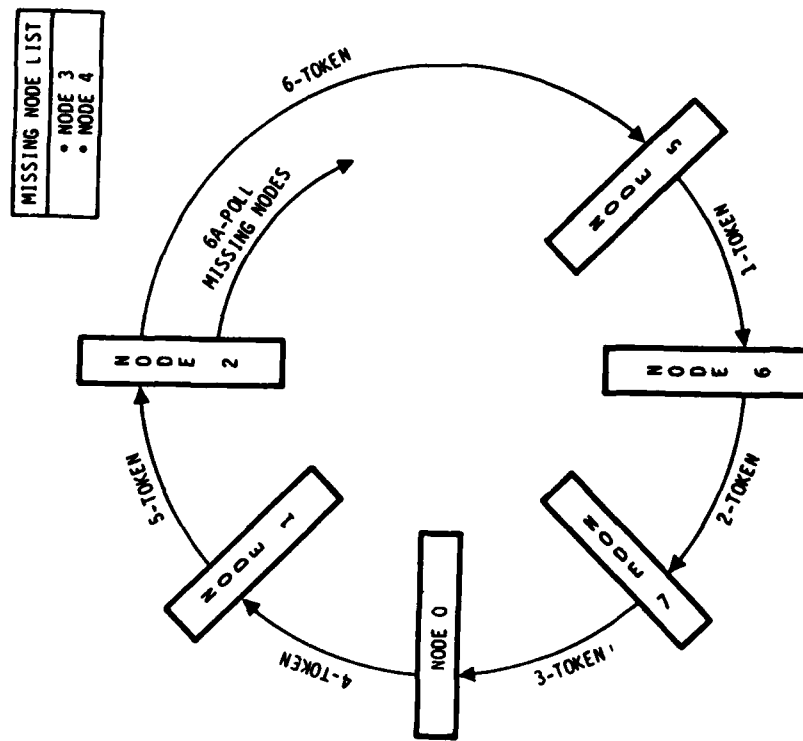

MEGALINK SYSTEM BLOCK DIAGRAM

LSI-11 1MBD COMMUNICATIONS INTERFACE

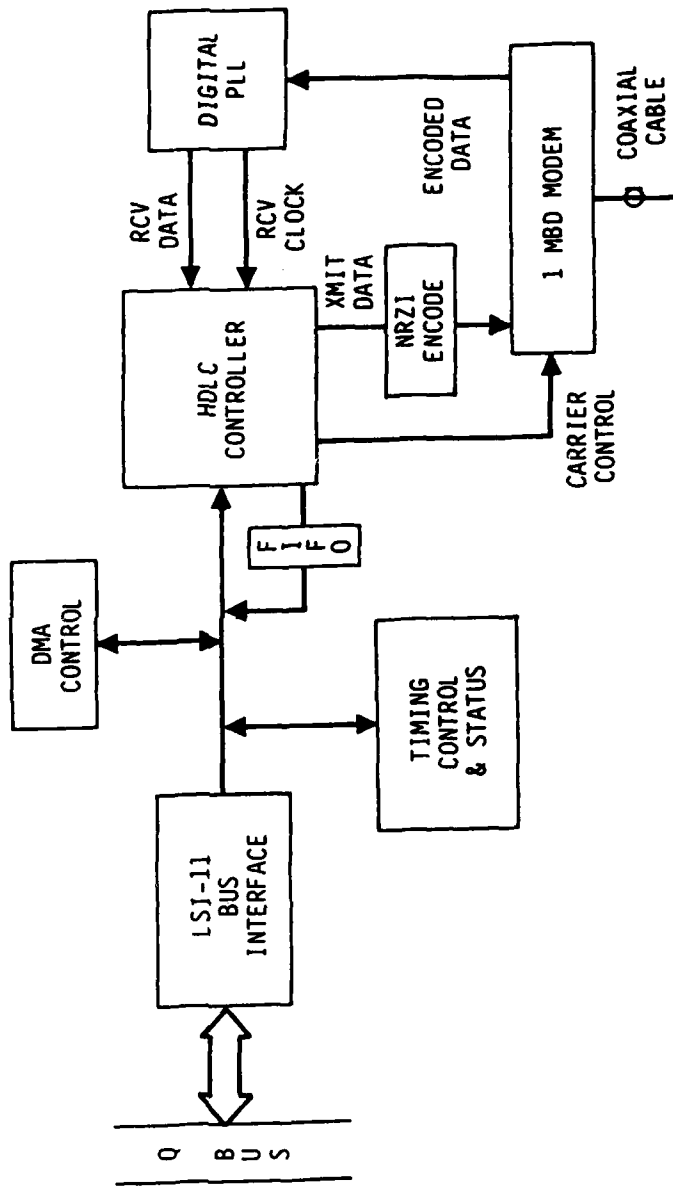

SURVIVABILITY MUST BE DESIGNED IN

- **THREATS DEFINED**
- **SURVIVABILITY AND EFFICIENCY GOALS DEFINED**
- **DESIGN TECHNIQUES EMPLOYED**

Implementation I (1400-1545 29 Sep)

Session Chairman: Mr. Brian Hendrickson - RADC/DCLW

"Flexible Interconnect Local Area Network," Mr. James L. Davis,
Rome Air Development Center

Development of a general purpose high performance local area network for C3I will be described. Technical characteristics and program status will be discussed.

"Local Area network Design for Command Centers," Mr. Otis Gooding,
Litton Amecom

Presentation describes the high speed LAN designed to meet the communication performance requirements of a command center complex. The LAN design provides an integrated communication network for voice, video, and data all combined into a single system. The system is capable of interconnecting a wide variety of telephone instruments, radio equipment, crypto devices, work stations, and other data devices. A highly transparent user interface and protocol inter connect is provided for maximum adaptation and flexibility. In addition to providing routine protocol handling, the interconnect architecture allows special processing of user information when required. Those features that best characterize the system performance are high throughput, high reliability, expandability and distributed network control.

"Application of Local Area Network to Navy Command Centers,"
Mr. Calvin Cornils, Naval Electronics System Engineering Center

The Navy (NAVELEX PME-120) is developing a prototype local data network for testing at its land based command and control test bed. Subsequent field testing in an operational environment is also planned. The network will be used to develop improvements in data exchange techniques (via gateways) to long haul communication circuits, and to demonstrate the applicability of local network technology to Naval command centers ashore.

"Fiber Optic Impact on Local Area Networks," Mr. Peter Steensma,
ITT Defense Communications Division

System impacts of speed ranges available by fiber optics utilization will be discussed. Protocol issues, bandwidth and physical (distance) implication will also be discussed.

E-1

**FLEXIBLE INTRACONNECT
NEW APPROACH TO C² CENTERS**

PRESENTED BY: JIM DAVIS, RABG/DGL

C³ ACQUISITION ENVIRONMENT

**LONG, INVOLVED PROCESS
TOO MUCH COST TO DEVELOP & TIME TO REALIZE
DYNAMIC REQUIREMENTS NOT SATISFIED
ACCELERATED TECHNOLOGICAL OBSOLESCENCE
INTENSE REAL-TIME OPERATIONAL SCENARIOS
LIMITED RECURRING OPERATIONAL EXPERIENCE**

GOAL: DEVELOP CONCEPT TO STREAMLINE PROCESS

FLEXIBLE INTRACONNECT CONCEPT

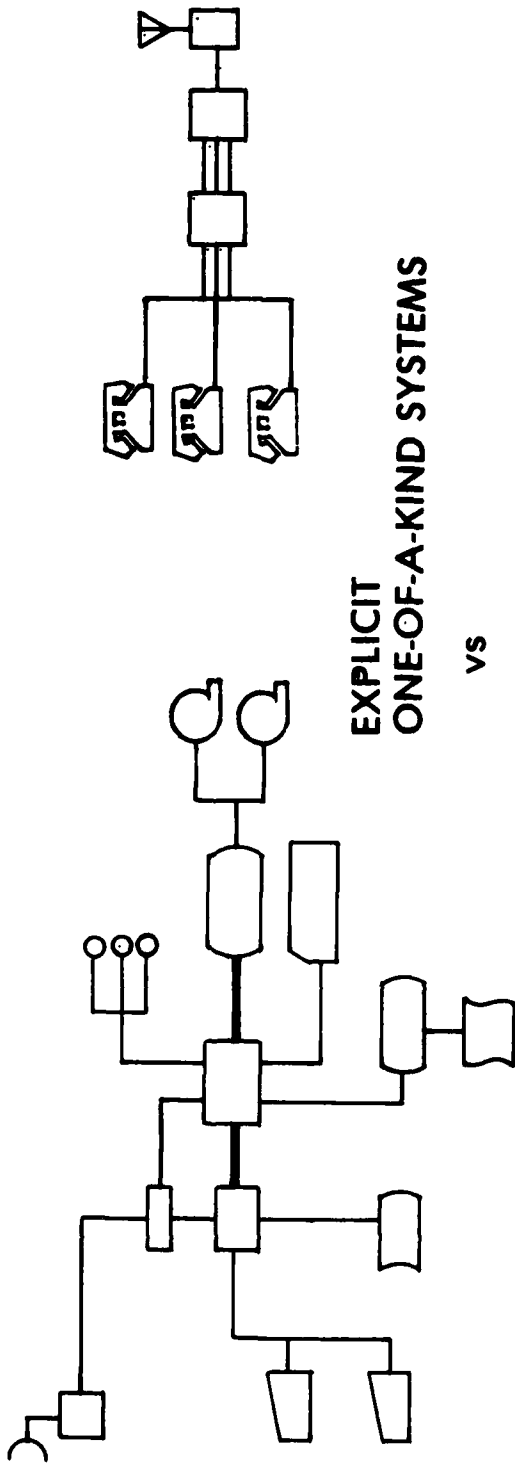

EXPLICIT
ONE-OF-A-KIND SYSTEMS

VS

GENERIC
MODULAR
ARCHITECTURE

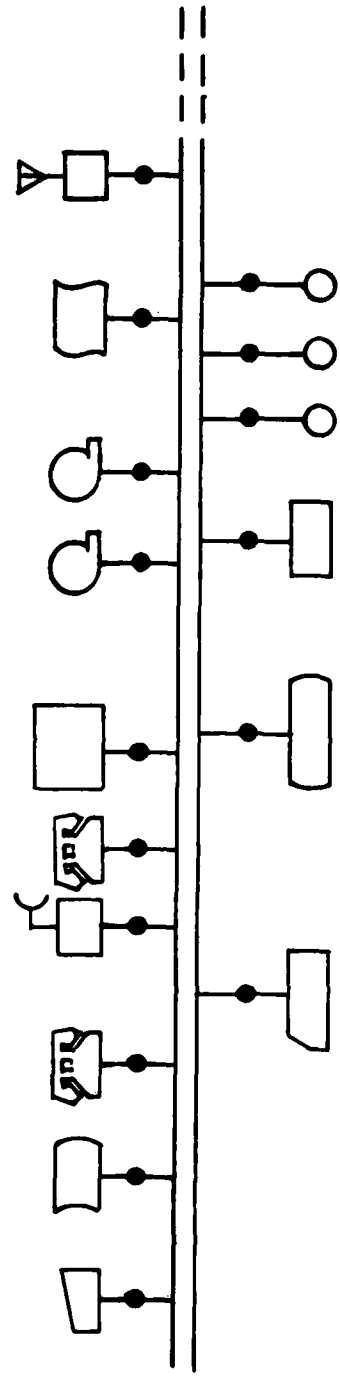

07 APR 1982/268



LOCAL AREA NETWORK



DEFINITION:

LOCAL 100 METERS TO 10 KM

AREA (EQUIPMENT) COMPUTERS, TERMINALS,
TELEPHONES, CRTS, WORK
STATIONS, INSTRUMENTATION

NETWORK CONNECTS 10 TO 10,000 STATIONS

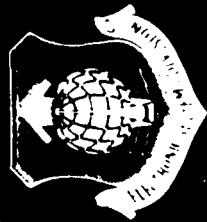

COMMUNICATION TECHNOLOGIES



LONG HAUL NETWORK

WIDE AREA, LOW BANDWIDTH

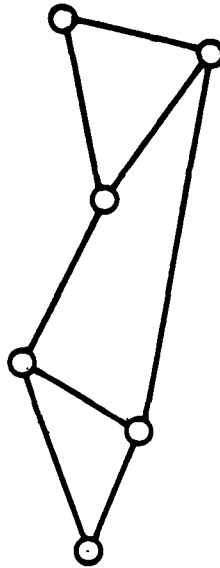

(2KB\S X 5000Km = 10,000,000)

LOCAL NETWORK

SMALL AREA, HIGH BANDWIDTH

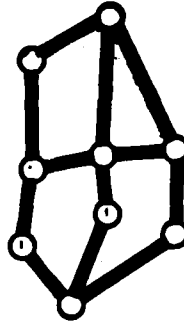

(2MB\S X 5Km = 10,000,000)

BANDWIDTH X DISTANCE = CONSTANT

LOCAL AREA NETWORKS

APPLICATION:	CHARACTERISTICS-ENVIRONMENT:
OFFICE AUTOMATION	TERMINAL ORIENTED-LIGHT INDUSTRY
PROCESS CONTROL	REAL TIME-HEAVY INDUSTRIAL
INSTRUMENTATION	PERIODIC SAMPLES-LABORATORY TESTING MIXED RATES
SPECIAL PURPOSE	IMBEDDED, CUSTOMIZED-VARIOUS (WEAPONS SYSTEMS)
<u>COMMAND & CONTROL</u>	<u>REAL TIME, SURVIVABLE, FAULT TOLERANT,</u> <u>FILE TRANSFERS-SEVERE UNPREDICTABLE</u> <u>MILITARY ENVIRONMENT, MULTIPLE VENDORS</u>

06 APR 1982 1268

LOCAL AREA NETWORKS

APPLICATIONS & SUGGESTED STANDARDS

<u>APPLICATION</u>	<u>STANDARD</u>
OFFICE AUTOMATION/PROCESS CONTROL	IEEE-802 (ETHERNET)
INSTRUMENTATION SYSTEMS	IEEE-488
AVIONICS, VEHICLE CONTROL	MIL-STD-1553B
COMMAND & CONTROL	FLEXIBLE INTRACONNECT

1982 APR 09 1268

1264



FLEXIBLE INTRACONNECT



LOCAL INFORMATION DISTRIBUTION SYSTEM

- **UNIFORM DIGITAL CONTROL**
- **GENERAL PURPOSE MILITARY APPLICATIONS**
- **HIGH CAPACITY**
- **HIGH INTEGRITY**
- **MODULAR & EXTENSIBLE**

FLEXIBLE INTRACONNECT LOCAL AREA NETWORK

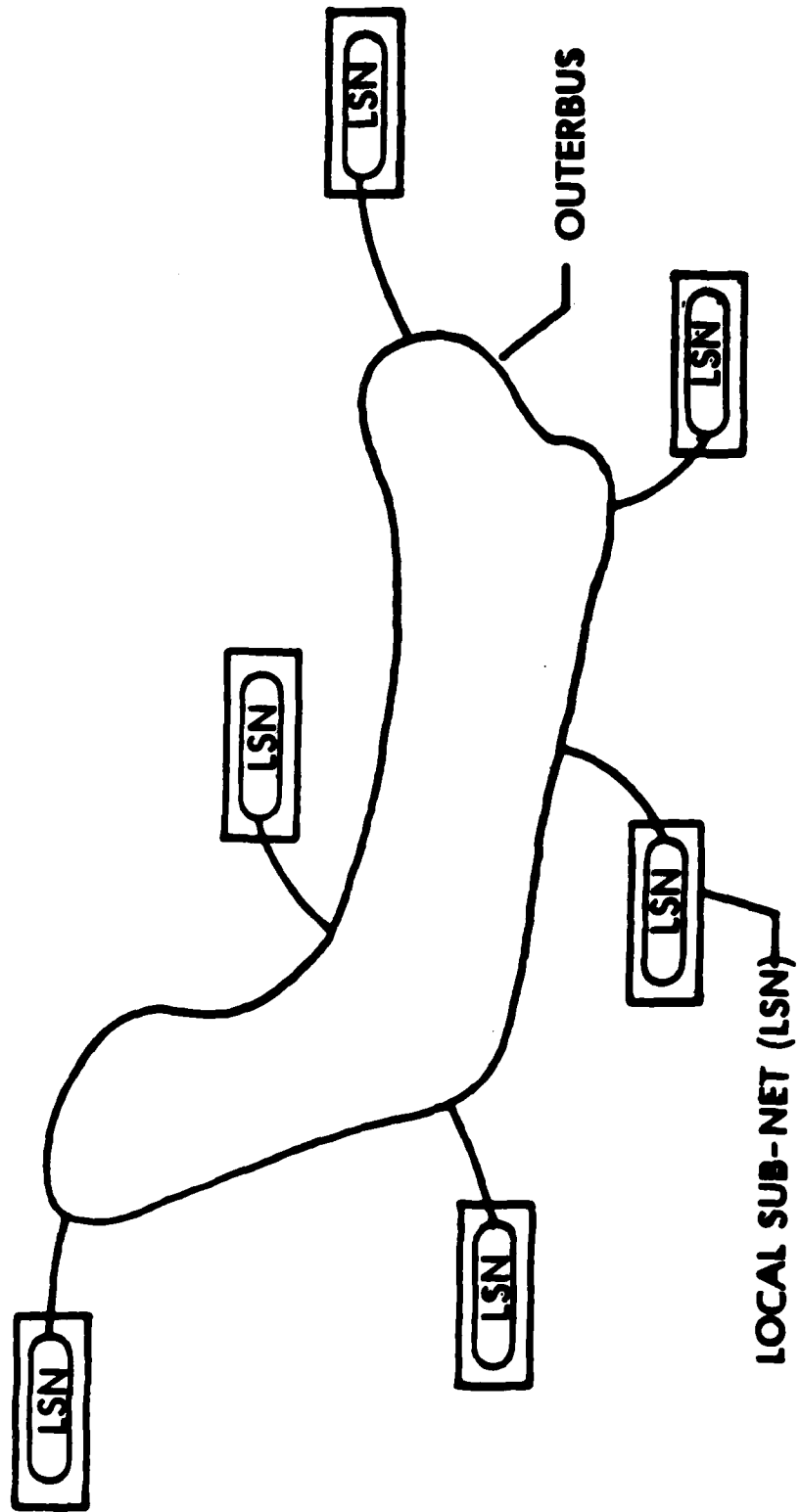

06 APR 82 1455

FLEXIBLE INTRACONNECT

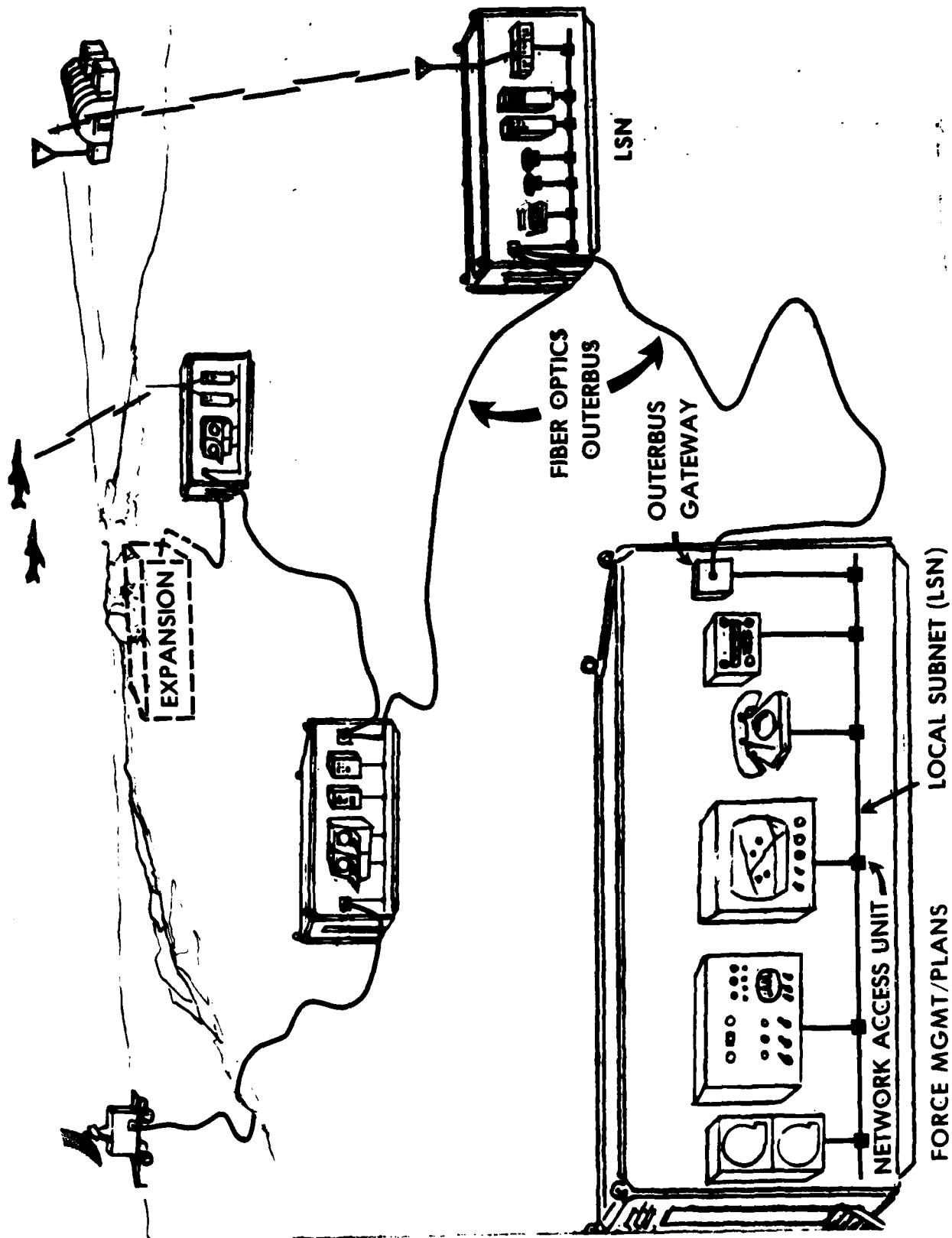

FI SERVICES & FEATURES



ADDRESSING
ERROR CONTROL
GUARANTEED MESSAGE DELIVERY
REAL TIME CIRCUIT AVAILABILITY
VENDOR INDEPENDENCE
LINK ENCRYPTION (OBS/EFTO)

06 APR 1982 1368

*Delete: Vendor
Independence?*

*Change: "Addressing" to:
"Flexible Addressing"*

FILAN ADDRESSING



**POINT-TO-POINT
BROADCAST
MULTICAST
VIRTUAL ADDRESSING
MOMCOM (MAN ON THE MOVE)**

06 APR 1982 1268

1268 07 APR 1982

FI ADDRESSING SERVICES



POINT TO POINT
(ONE TO ONE)

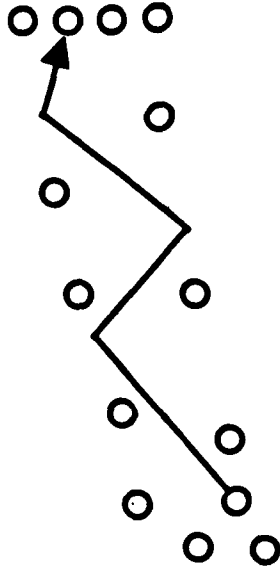

BROADCAST
(ONE TO ALL)

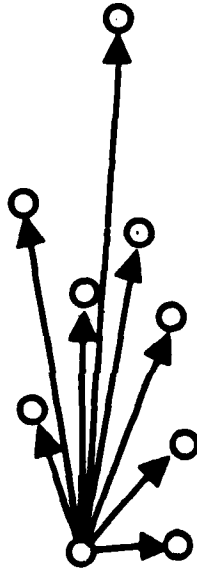

MULTICAST
(ONE TO SEVERAL)

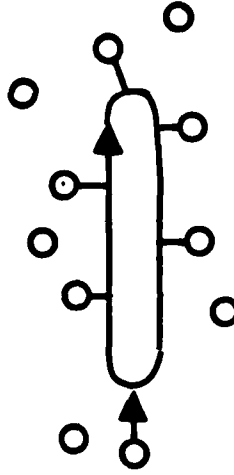

LAZY SUSAN
(SEQUENTIAL ROUTING)

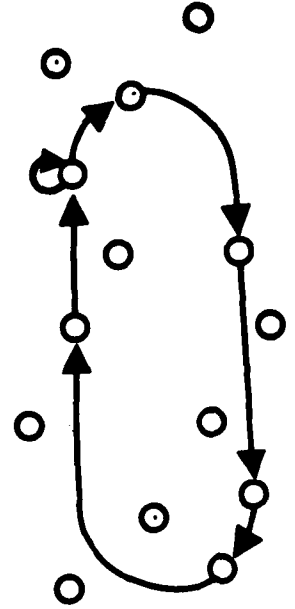



FI LAN VIRTUAL ADDRESSING

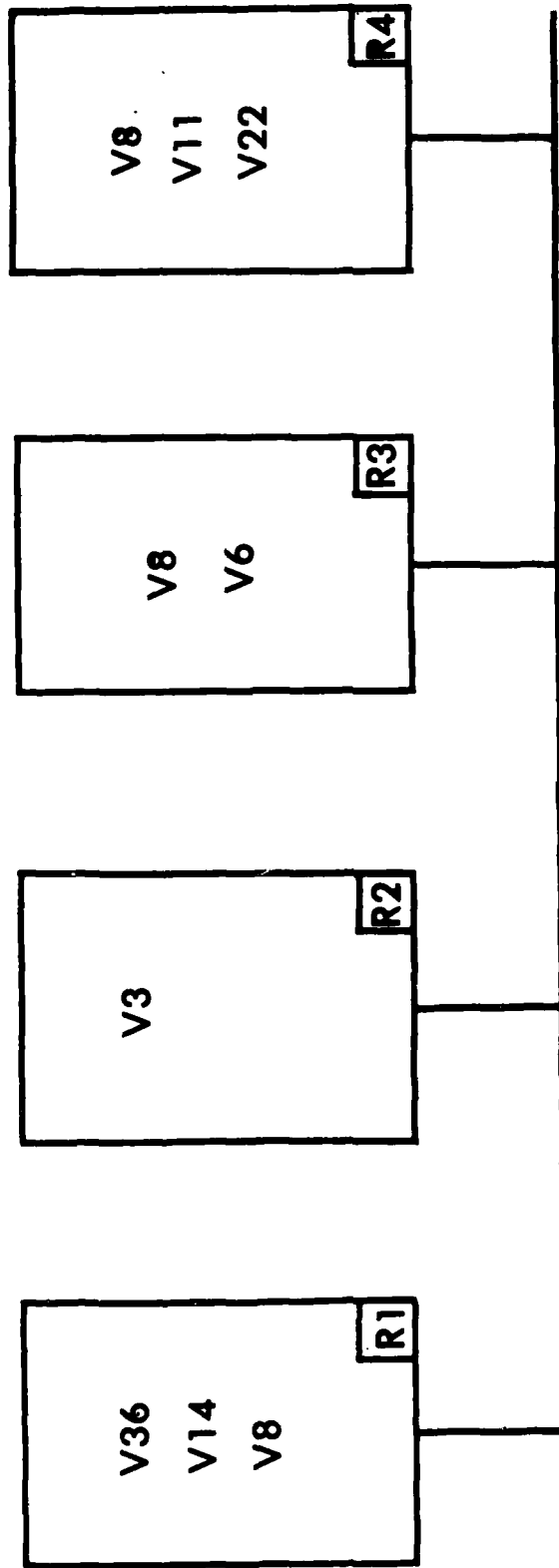

- REAL ADDRESSES (R)
- VIRTUAL ADDRESSES (V)
- MULTIPLE VIRTUAL ADDRESSES (PER HOST, SHARED)

FILAN ERROR CONTROL



MESSAGE SEQUENCE NUMBER
ELAPSED TIME CHECKS
SENDER RECEIVER AUTHORIZATION CHECK
MESSAGE TYPE CHECK
ON-LINE TESTING
HEADER PROTECTION

FI INTERFACES & INTEROPERABILITY



**RATE INDEPENDENCE
INTERFACE CONVERSION
MESSAGE BUFFERING
VARIABLE LENGTH MESSAGES
VENDOR INDEPENDENCE
PROGRAMMABLE INTERFACE CONVERTERS
STANDARD FILAN INTERFACE**



ISO REFERENCE MODEL FOR OPEN SYSTEMS INTERCONNECTION

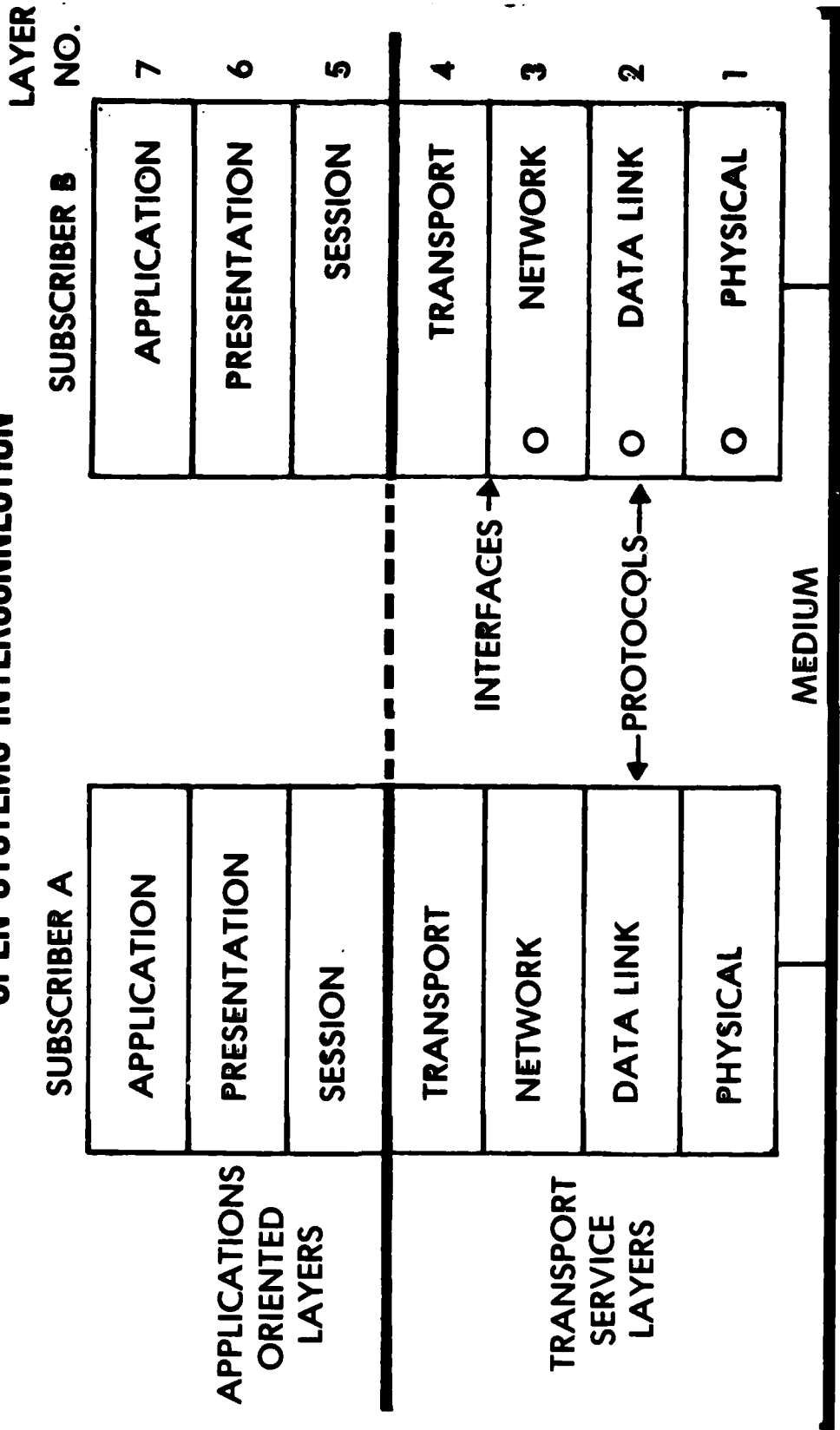

OPEN SYSTEMS INTERCONNECTION



<u>LAYER</u>	<u>PURPOSE</u>
7 APPLICATION	END USER SETS TRANSFER CONDITIONS
6 PRESENTATION	CODE, LANGUAGE, FORMAT TRANSLATIONS
5 SESSION	NETWORK TO NETWORK EXCHANGE
4 TRANSPORT	TRANSMISSION CONTROL
3 *NETWORK	MESSAGE ROUTING & DELIVERY
2 *LINK	PACKET ASSEMBLY, ERROR CONTROL
1 *PHYSICAL	ELECTRICAL, MECHANICAL CONNECTION

*FI LOCAL AREA NETWORK



USER INTERFACE

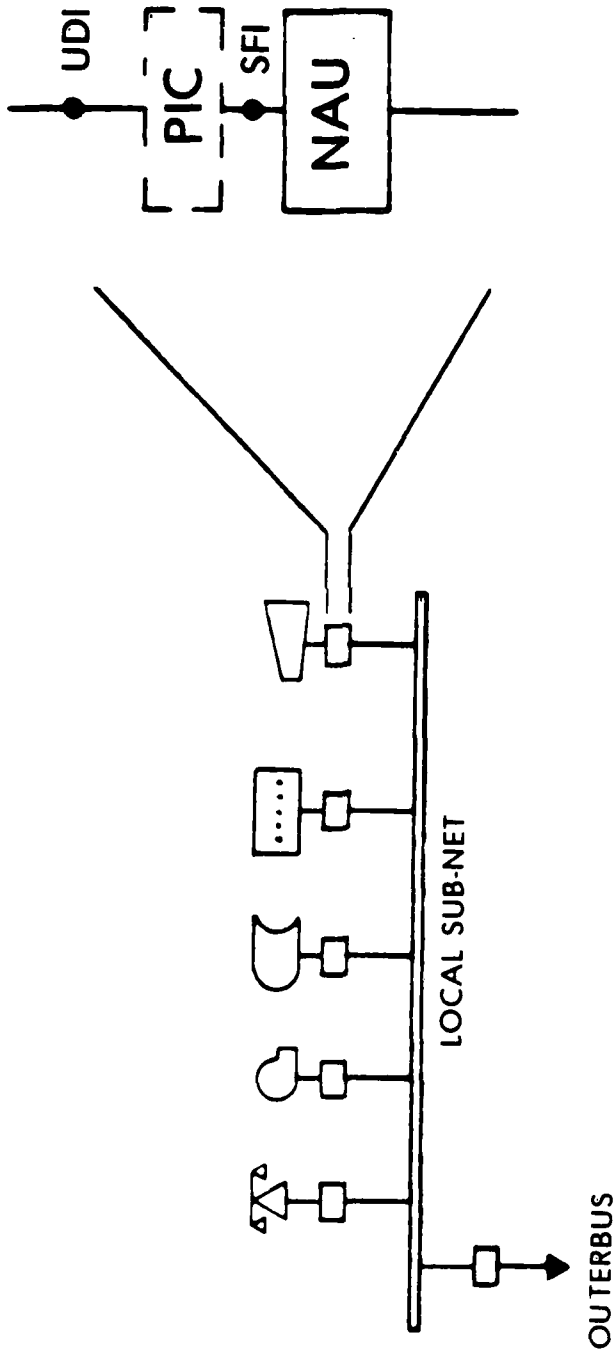

UDI - USER DEFINED INTERFACE

PIC - PROGRAMMABLE INTERFACE CONVERTER

SFI - STANDARD FI INTERFACE (MIL-STD-FI)

NAU - NETWORK ACCESS UNIT

1865

06 APR 1982



STANDARD FI INTERFACE (PHYSICAL LAYER)

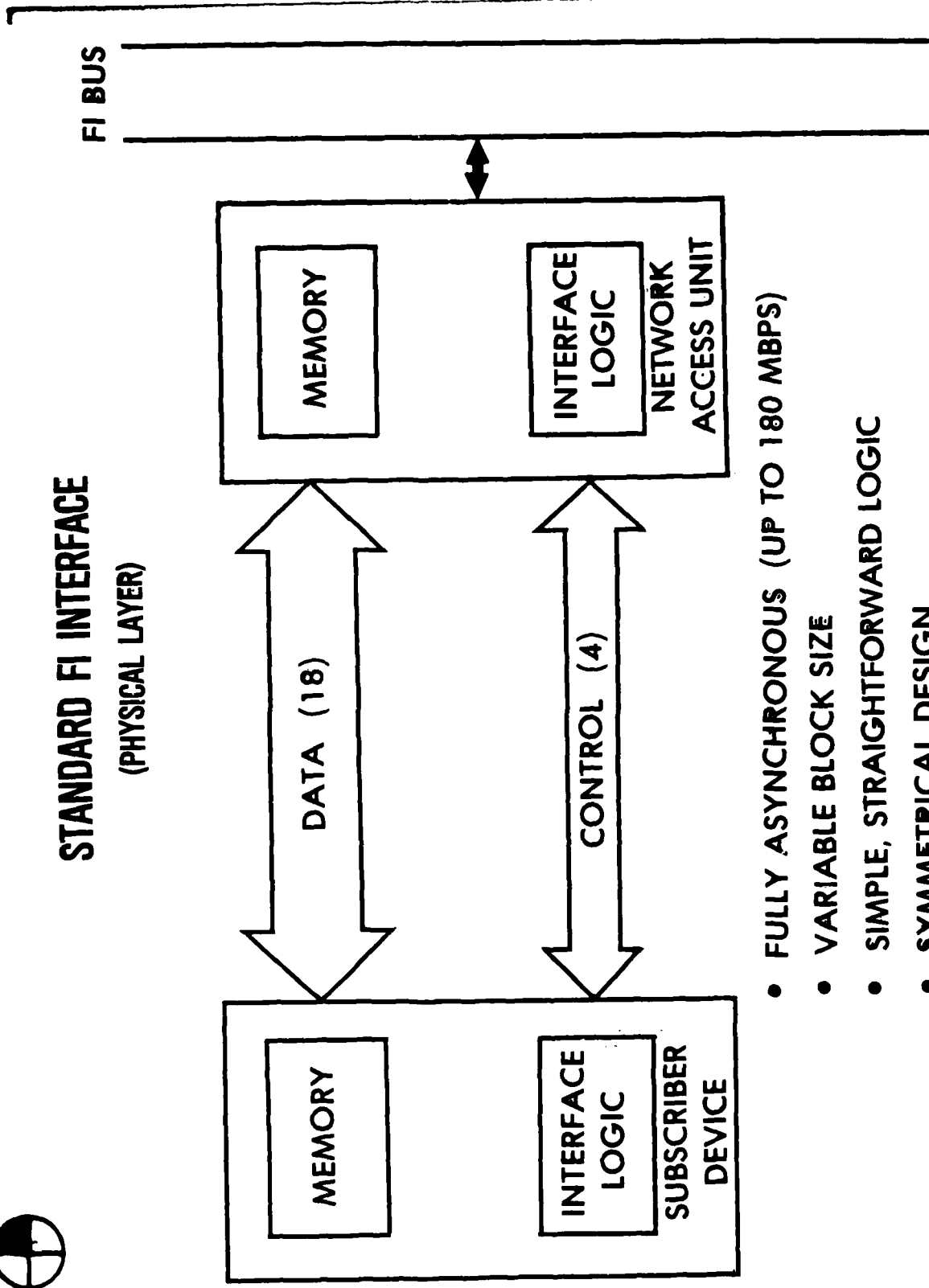

- FULLY ASYNCHRONOUS (UP TO 180 MBPS)
- VARIABLE BLOCK SIZE
- SIMPLE, STRAIGHTFORWARD LOGIC
- SYMMETRICAL DESIGN



FI STANDARD LINK LEVEL PROTOCOL



MSG TYPE	ACK/NAK	MODE
PRIORITY	SUBBUS ADDRESS	
DESTINATION VIRTUAL ADDRESS		
SOURCE VIRTUAL ADDRESS		
DESTINATION REAL ADDRESS		
SOURCE REAL ADDRESS		
WORD AND BIT COUNT		
MESSAGE NUMBER		
SUBBUS SEQUENCE NUMBER		
TRANSMIT TIME		
ERROR DETECTION		
DATA		

FI PROTOCOLS (BASED ON ISO MODEL)



NETWORK

NETWORK MANAGEMENT
PERFORMANCE MONITORING
TEST & DIAGNOSTICS

LINK

HEADER DEFINITION
MESSAGE FRAMING
ERROR CONTROL

PHYSICAL

MINITURE COAX
FIBER OPTICS



DESIGN CHARACTERISTICS



- TOPOLOGY: BUS (LOCAL SUBNET), STAR (OUTERBUS)
- PROTOCOL: DETERMINISTIC-SMART POLLING WITH REDUNDANT POLLERS
- MEDIA: MINITURE COAX (LSN) COAX OR FIBER OPTICS (OUTERBUS)
- ERROR RATES: DATA 10^{-12} , HEADERS 10^{-15}
- SUPPORTABLE STANDARD HARDWARE & SOFTWARE

FLEXIBLE NETWORK ARCHITECTURE

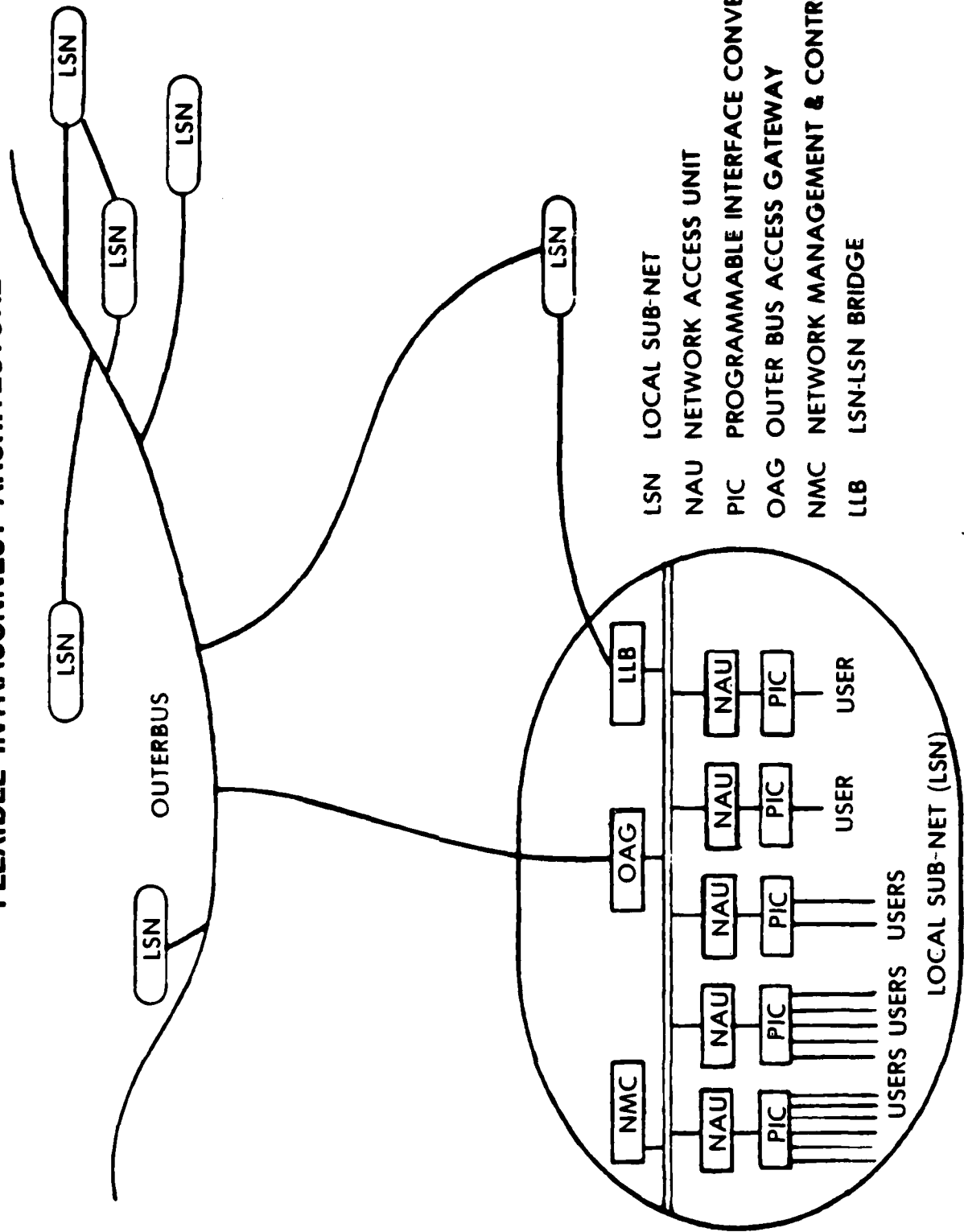

06 APR 1982 1268



FLEXIBLE INTRACONNECT DESIGN STANDARDS

PROTOCOLS	MIL-STD-(FI) ; PROGRAMMABLE INTERFACE CONVERTERS
HARDWARE	QPL JANTX PARTS (MRAP/SRAP) MIL-M-38510/530-01 (8086 MICROPROCESSOR) MIL-STD-454F (EQUIPMENT REQUIREMENTS)
SOFTWARE	MIL-STD-1753 FORTRAN MIL-STD-1815 ADA
SOFTWARE DEV'T	UNIX/PWB VAX 11/780
DOCUMENTATION	DOD-STD-7935.1-S (SOFTWARE/CPCIs) MIL-STD-490 (SYSTEM/CI SPECS) MIL-STD-483 (CONFIG. MGT)
BITE/BITF	IEEE-STD-488
ARCHITECTURE	ISO OPEN SYSTEMS INTERCONNECTION

FI OPERATING SYSTEM



MANAGEMENT & CONTROL
RESOURCE ALLOCATION
ACCESS CONTROL
CONFIGURATION MANAGEMENT
TRAFFIC STATISTICS
SERVICE AUTHORIZATIONS
PROGRAM DOWNLOAD
UNIVERSAL TEST & SERVICE PORTS



DEVELOPMENT PROGRAM OBJECTIVES



- PROVE ENGINEERING PERFORMANCE
- TEST/DEMONSTRATE CONCEPT
- PROVE/VERIFY STANDARDS
- TRANSFER TECHNOLOGY

FLEXIBLE INTRACONNECT DEVELOPMENT SYSTEM

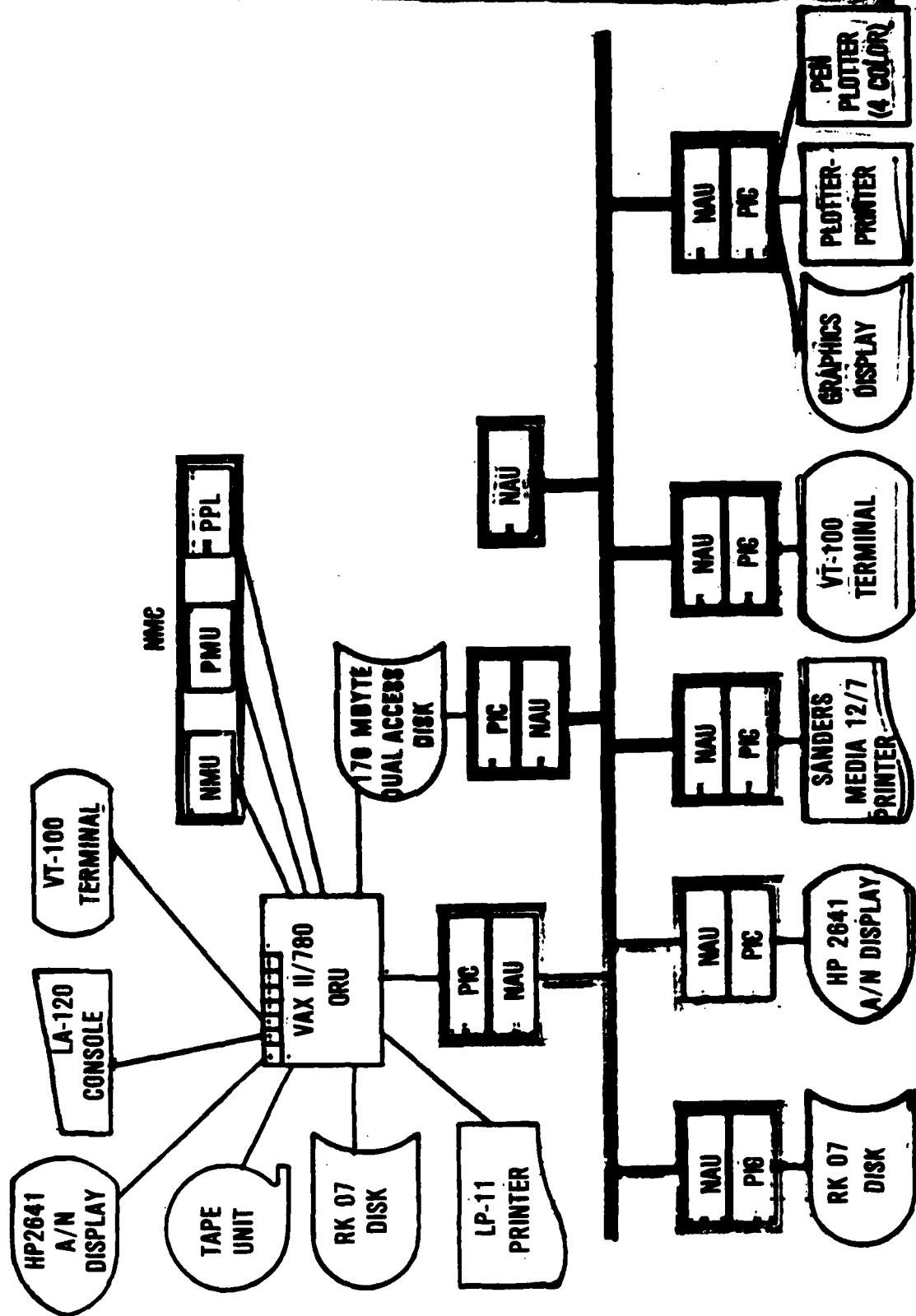

UNIT SERVICE PORT

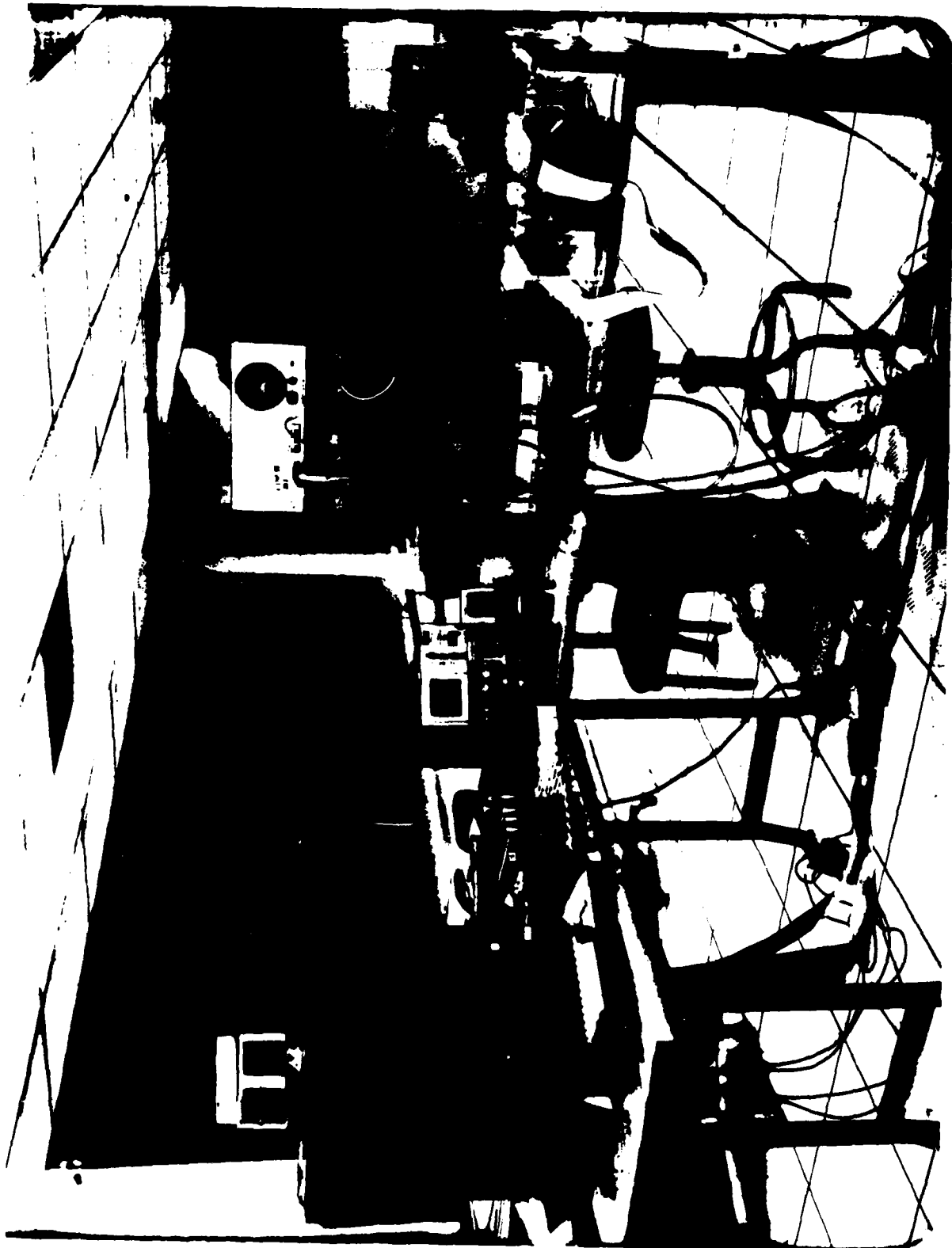

42.35-81

P2



FLEXIBLE INTRACONNECT SCHEDULE



67 | 70 | 73 | 76 | 79 | 82 | 85 | 88 | 91 | 94 | 97 | 00

HUGHES
MARTIN-MARIETTA

DEFINITION STUDIES

"A" SPEC
MIL-STD-(FI)

SPEC PREPARATION

SYSTEM DEVELOPMENT
(MARTIN-MARIETTA
F30602-81-C-0016)

LOCAL SUBNET

OUT BUS/INTEGRATION

VIDEO BUS



TESTS

"B" SPEC & CPCIS

DOCUMENTATION

TECHNOLOGY TRANSFER

C³ APPLICATIONS

NUKAD OFF SITE TEST FACILITY LOCAL AREA NETWORK DEMONSTRATION

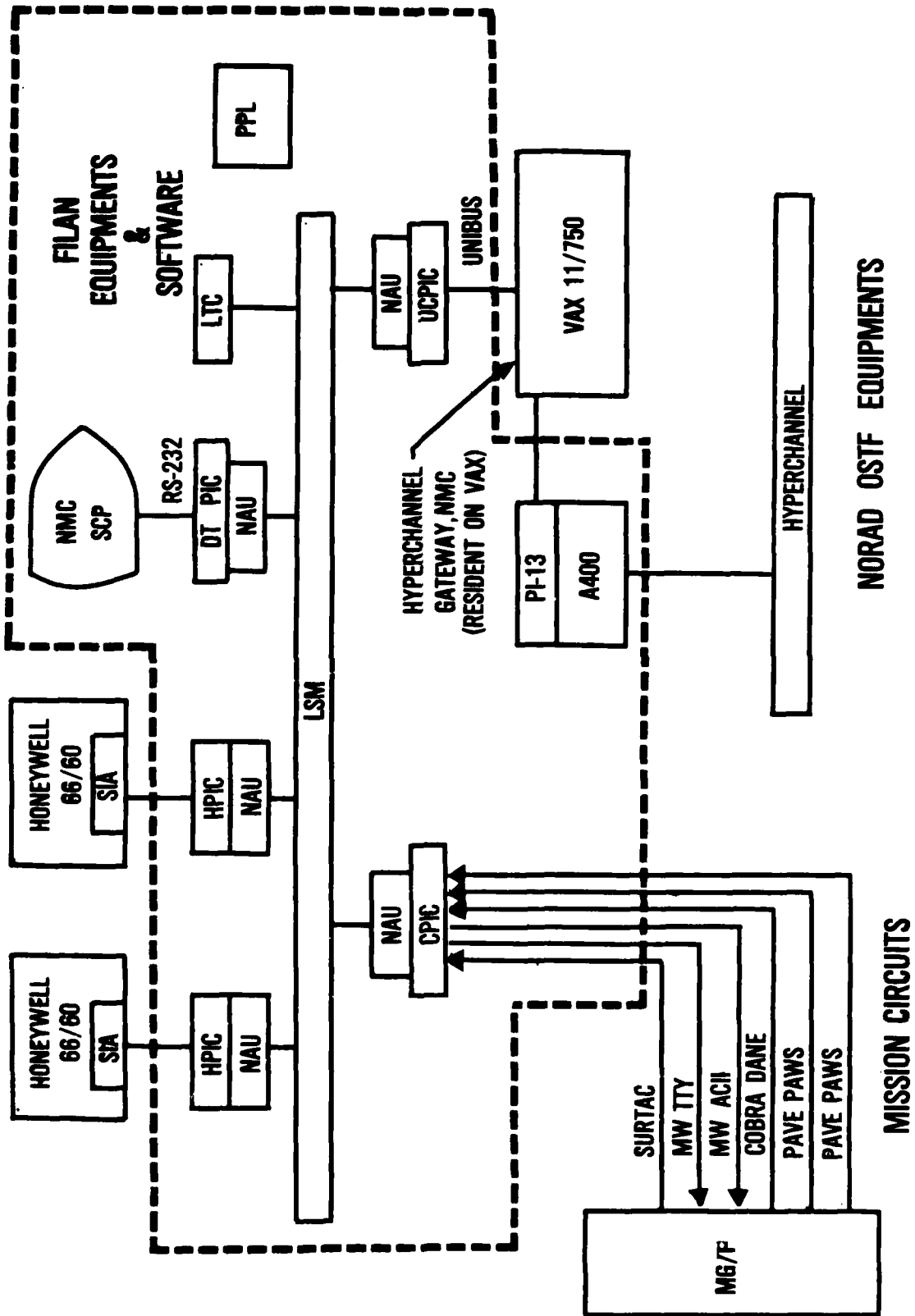

**A LOCAL AREA NETWORK
FOR
COMMAND CENTERS**



AMECOM

Litton

AGENDA

- UBITS/LAN
- REQUIREMENTS
- SYSTEM ARCHITECTURE
- ADVANTAGES AND CAPABILITIES
- ENHANCEMENTS
PLANNED



AMECOM

Litton

UBITS SYSTEM REQUIREMENTS

- **RAPID INTERCONNECT AND CONTROL OF DATA DEVICES**
- **AUTOMATED MESSAGE PREPROCESSING**
- **COMMUNICATIONS CONTROL TERMINAL**
- **INTEGRATED SERVICE FOR DATA, VOICE AND VIDEO**
- **SYSTEM CAPABILITY EXPANSION**
- **SYSTEM MODULARITY**



AMECOM



LOCAL BUS BLOCK DIAGRAM

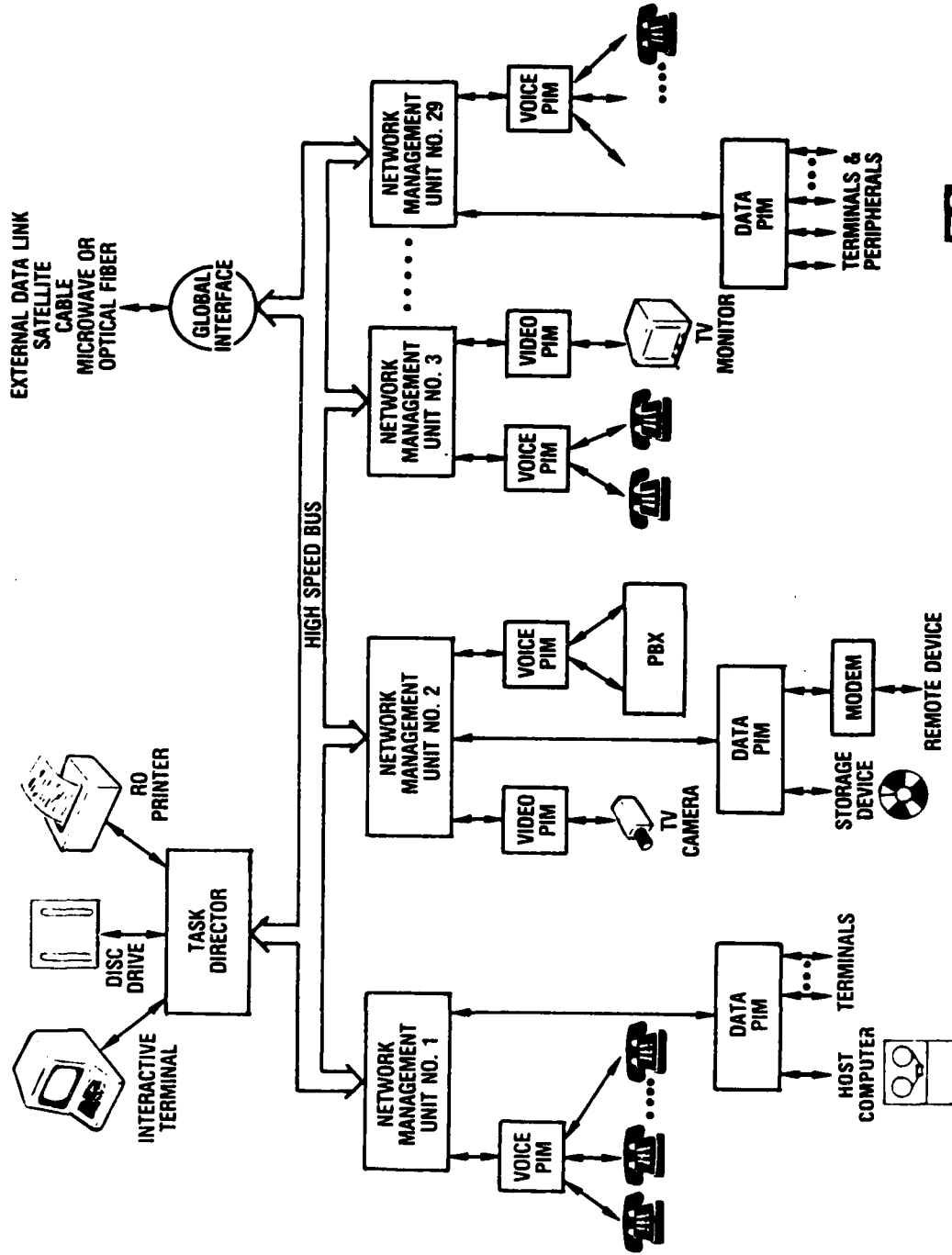

AMECOM

UBITS NETWORK EXAMPLE

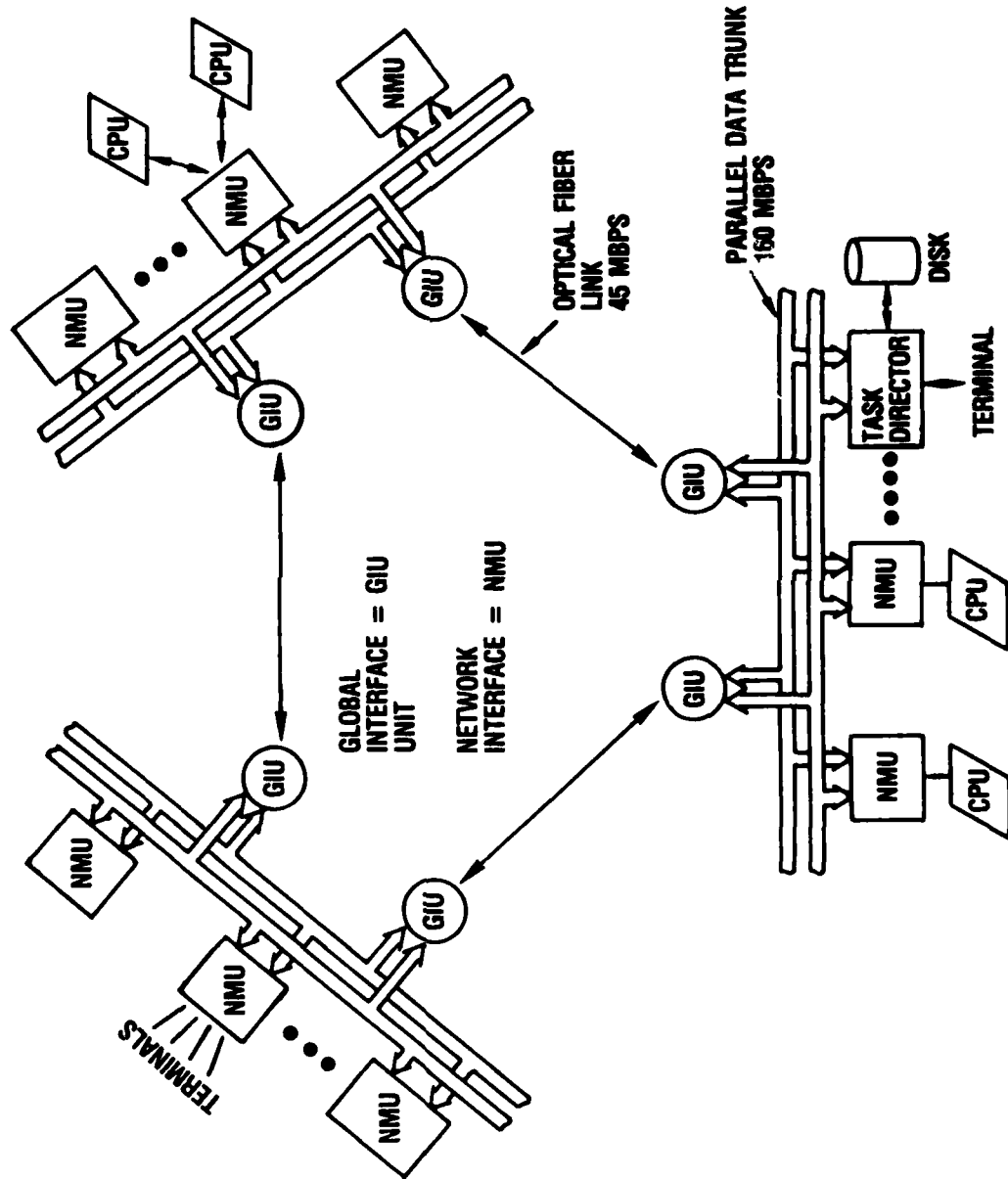

UBITS DEVELOPMENT SYSTEM

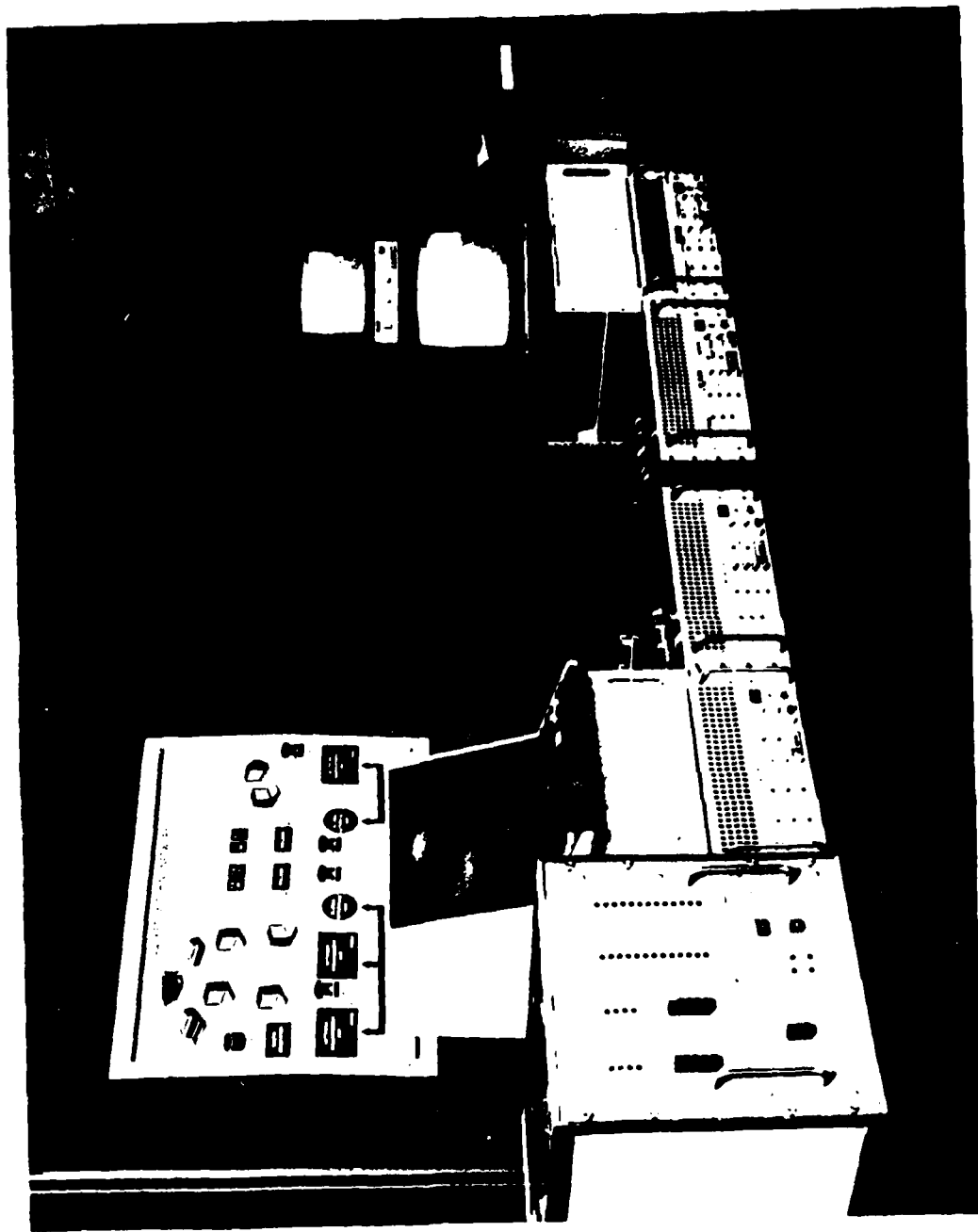

AMECOM

LITTON

NMU APPLICATION

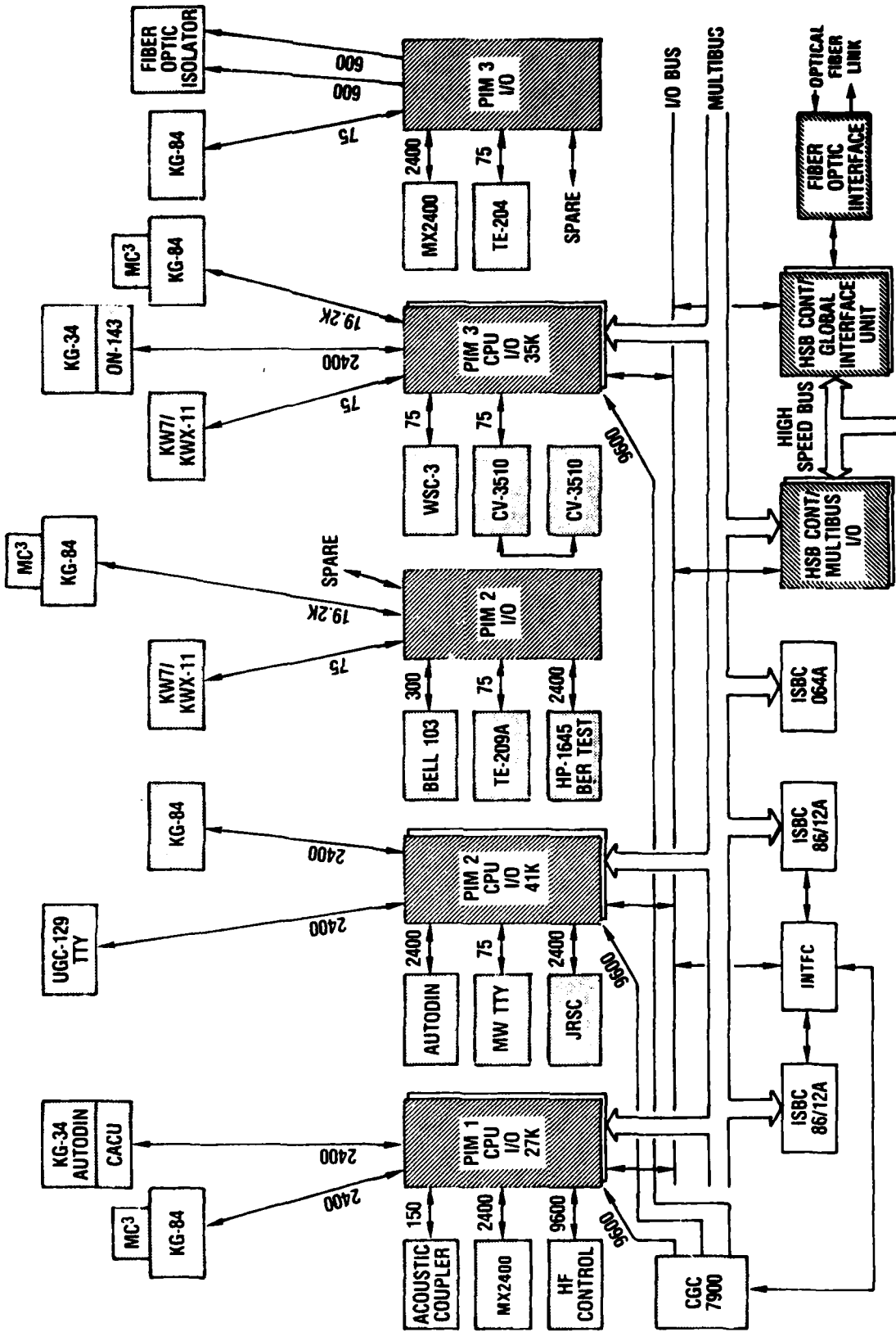

NMU CONFIGURATION BLOCK DIAGRAM

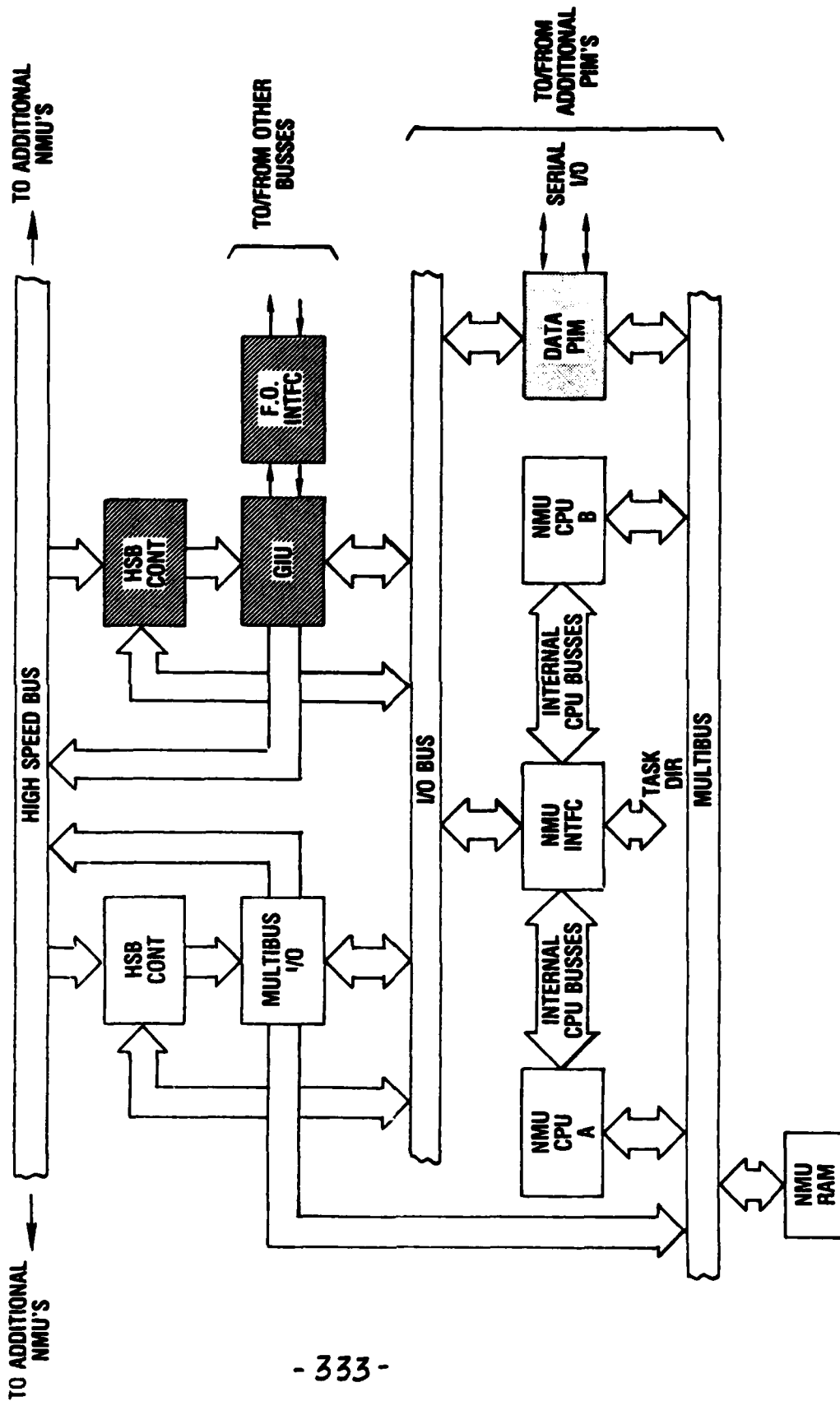

SERIAL DATA PIM BLOCK DIAGRAM

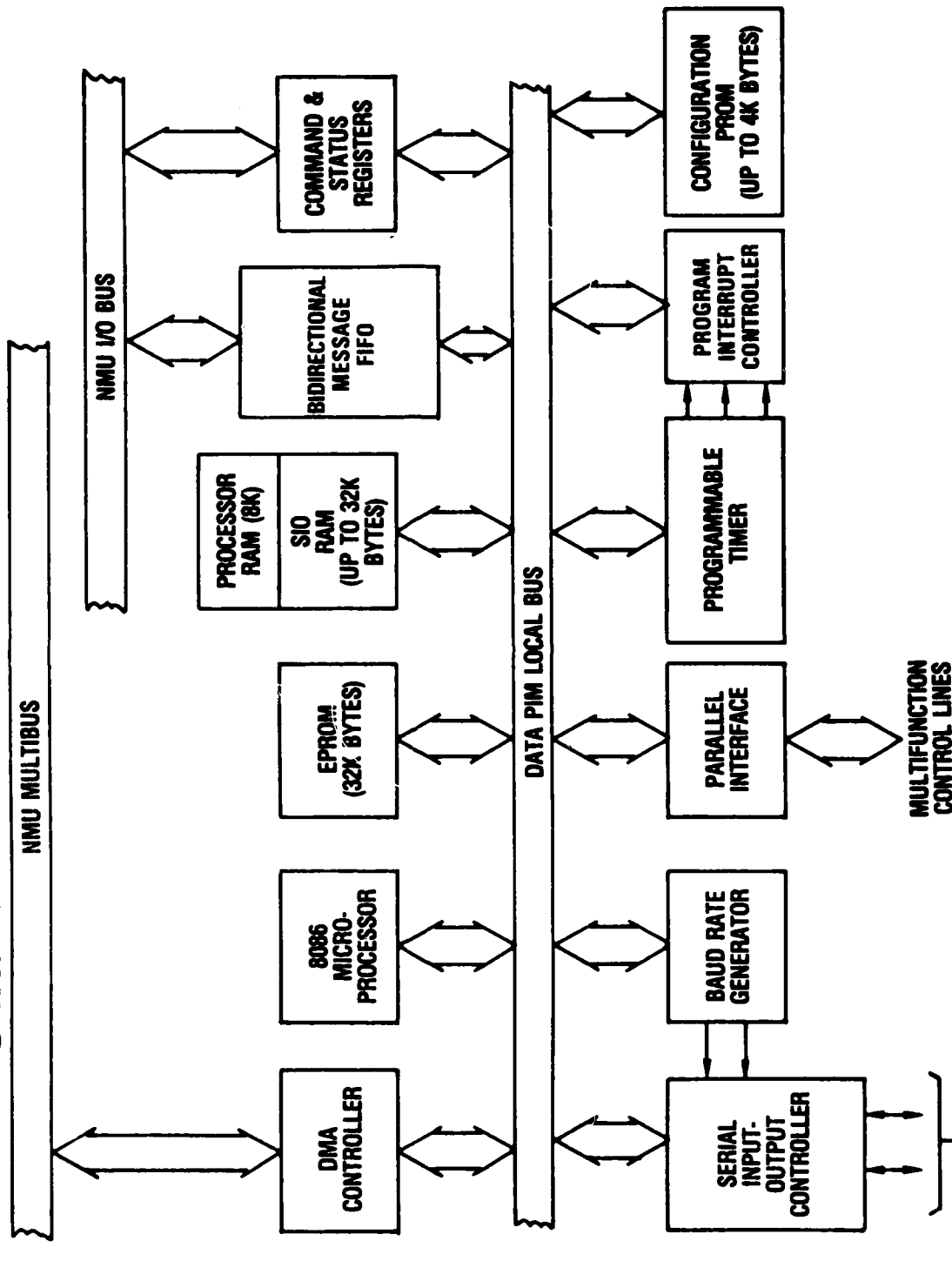

UP TO 24 SIGNAL I/O DEVICES



AMECOM

T1 CARRIER PIM

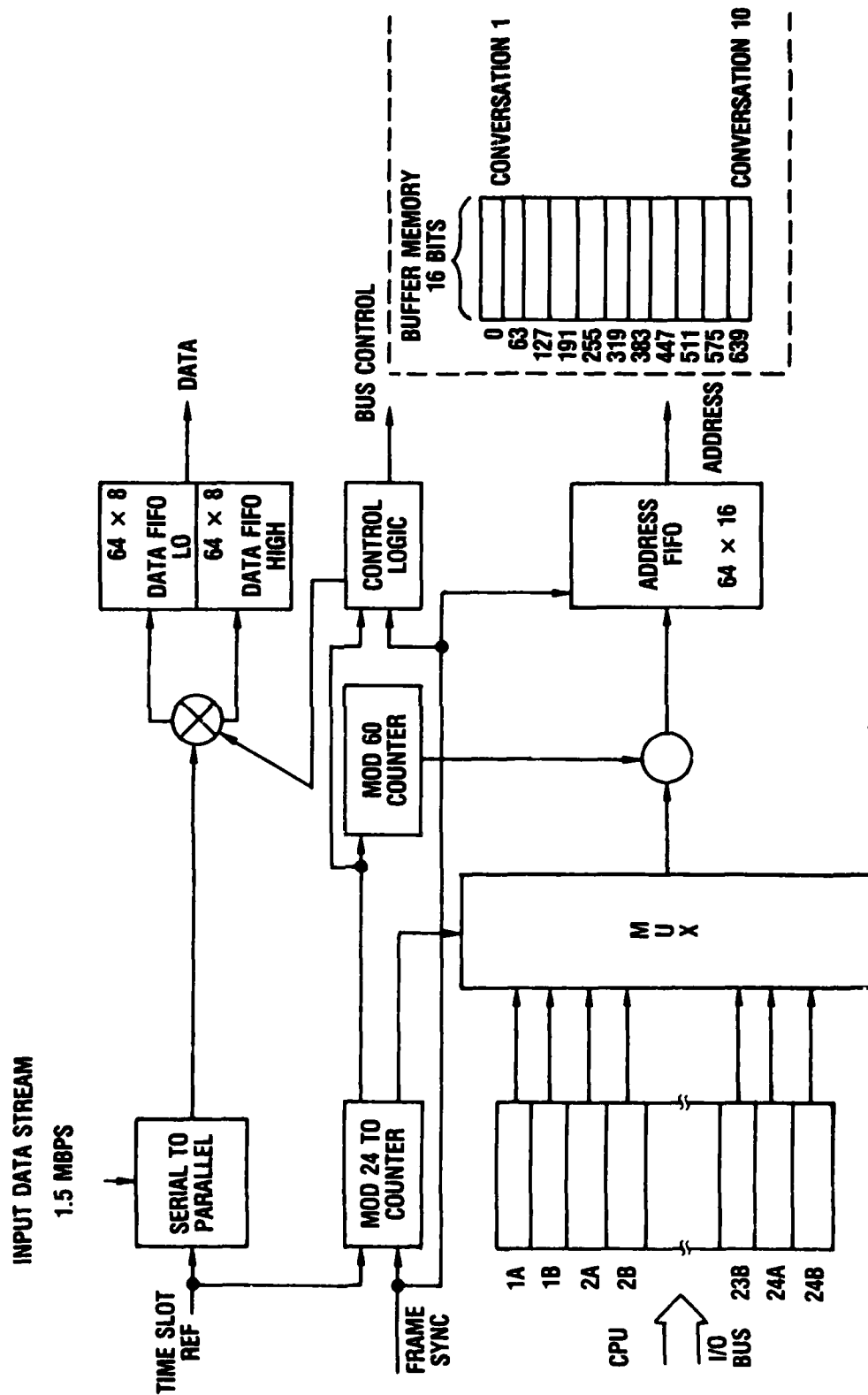

AMECOM

VOICE PIM BLOCK DIAGRAM

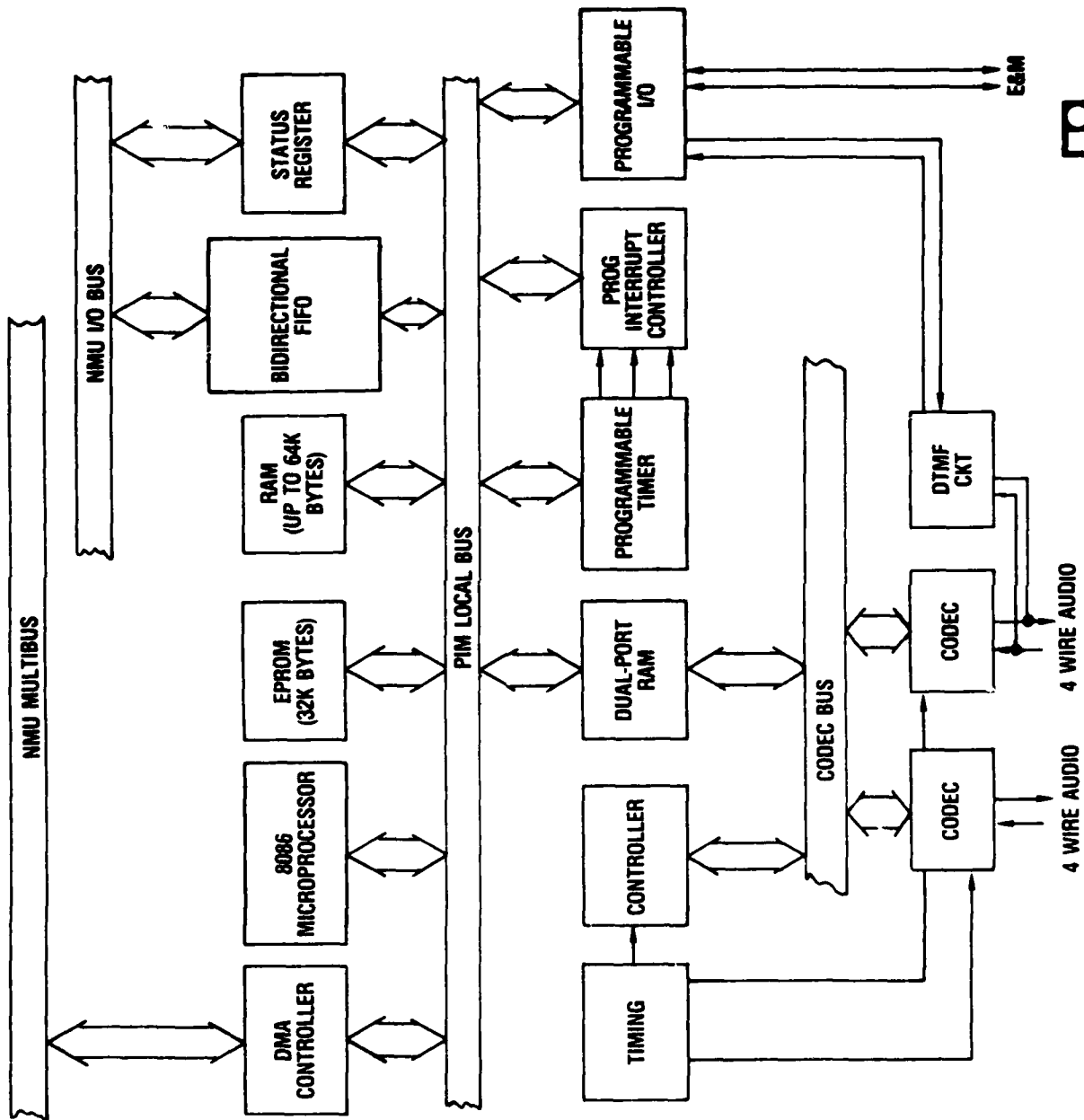

VIDEO PIM BLOCK DIAGRAM

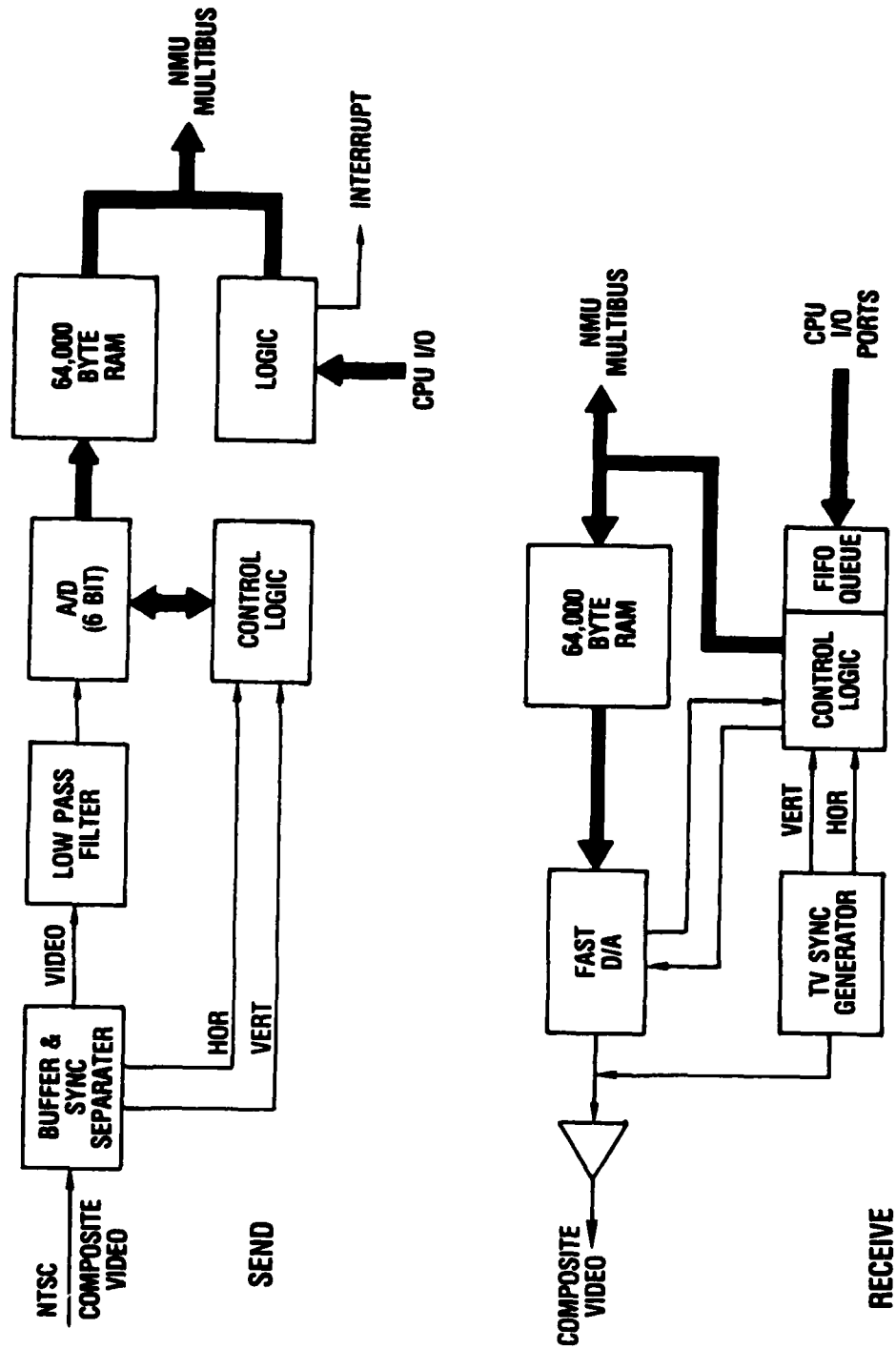

PACKET FORMAT

CONTROL

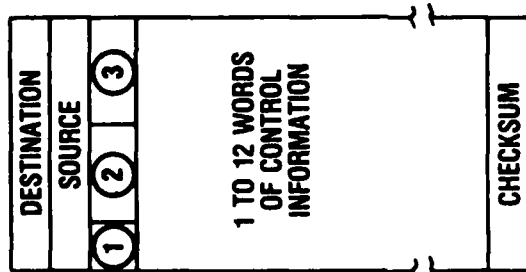

- ① PACKET TYPE — 2 BITS
 - ② LENGTH (WORDS) — 6 BITS
 - ③ CONTROL CODES — 8 BITS
- CHECKSUM FOR ENTIRE PACKET.

DATA

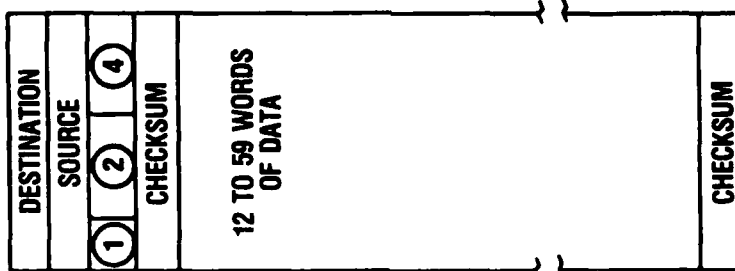

- ① PACKET TYPE — 2 BITS
- ② LENGTH (BYTES) — 7 BITS
- ④ SEQUENCE NO. — 7 BITS

VIDEO

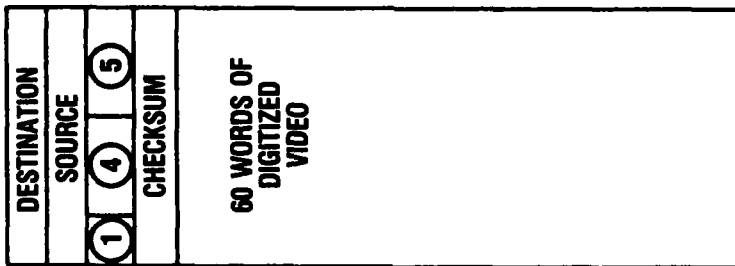

- ① PACKET TYPE — 2 BITS
 - ④ SEQUENCE NO. — 7 BITS
 - ⑤ UNUSED — 7 BITS
- CHECKSUM FOR HEADER ONLY.

VOICE

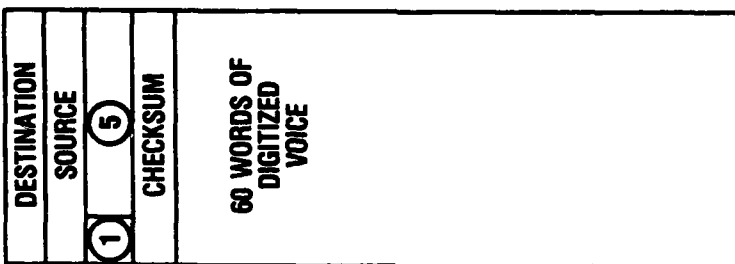

- ① PACKET TYPE — 2 BITS
 - ⑤ UNUSED — 14 BITS
- CHECKSUM FOR HEADER ONLY. SEPARATE CHECKSUM FOR HEADER AND DATA.



AMECOM

TASK DIRECTOR FUNCTIONS

- **INITIALIZATION**
- **RECONFIGURATIONS**
- **CALL CONTROL**
- **AUTOMATIC FAULT REPORTING/DIAGNOSTICS**
- **FAULT ISOLATION DIAGNOSTICS**



ADVANTAGES OF UBITS LAN

- **REAL TIME COMMUNICATIONS**
- **PROVIDES AUTOMATED CONTROL OF DEVICE CONNECTIVITY**
- **MATCHES ELECTRICAL INTERFACES OF DISIMILAR DEVICES**
- **PROVIDES CAPABILITY FOR SPEED CODE & PROTOCOL CONVERSION**
- **PROVIDES STATUS MONITORING AND REPORTING**
- **RECONFIGURABLE CLASSMARKING**
- **RECONFIGURATION TO SELECTED COMM. PLANS**
- **RELIABLE OPERATION THROUGH DISTRIBUTED CONTROL AND REDUNDANCY**

-340-



AMECOM

SUMMARY OF CAPABILITIES

SYSTEM COMPONENTS	CHARACTERISTICS	FUNCTION	PERFORMANCE	APPLICATION
GLOBAL INTERFACE UNIT (GIU)	HARDWIRED DESIGN.	HIGH SPEED SERIAL	45 MBPS OPERATION.	POINT TO POINT LINKS FOR PRIVATE NETWORKS
NETWORK MANAGEMENT UNIT (NMU)	16 BIT MICROPROCESSOR CONTROLLED (REDUNDANT) MULTIMASTER BUS ARCHITECTURE.	HIGH SPEED PARALLEL INTERFACE CONTENTION, ERROR, AND FLOW CONTROL	160 MBPS PARALLEL INTERFACE. 10 MBPS THROUGHPUT.	REAL TIME, INTEGRATED VOICE, VIDEO, AND DATA COMMUNICATIONS SYSTEMS.
VOICE PIM(S)	HARDWIRED DESIGN. MULTIBUS COMPATIBLE. MICROPROCESSOR CONTROLLED. MULTIBUS COMPATIBLE.	T1 MUX/DEMUX SINGLE ANALOG VOICE CHANNEL	24 CHANNELS AT 64 KBPS. 1.5 MBPS THROUGHPUT SINGLE CHANNEL AT 64KBPS	VOICE SWITCHING INTERFACES
VIDEO PIM	HARDWIRED DESIGN. MULTIBUS COMPATIBLE.	A/D, D/A CONVERSIONS. CCTV, CAMERA, TV MONITOR INTERFACES.	2 FRAMES/SEC. 1 MBPS THROUGHPUT.	VIDEO CONFERENCING. SECURITY SYSTEMS.
DATA PIM	16 BIT MICROPROCESSOR BASED. MULTIBUS COMPATIBLE. DMA CAPABILITY. SOFTWARE RECONFIGURABLE. OPTIONAL I/O PROCESSOR.	PACKET ASSEMBLY/DISASSEMBLY (PAD). PIM TO PIM PROTOCOL. ASYNCHRONOUS AND SYNCHRONOUS LINK PROTOCOLS.	SINGLE PROCESSOR CONFIG. 220 KBPS MAX THROUGHPUT. FOR SINGLE DEVICE. UP TO 24 FULL DUPLEX 9600 BAUD PORTS.	TERMINAL HANDLER. ASYNCH/SYNCH PORT. PUBLIC NETWORK GATEWAY. PROTOCOL CONVERSION. DATA CONCENTRATION. STATISTICAL MULTIPLEXING.



AMECOM

PLANNED ENHANCEMENTS

- **FIBER OPTIC BUS**
 - STAR TOPOLOGY**
 - LINEAR BUS**
- **MLS/LAN**
 - FORMAL MATHEMATICAL SECURITY MODEL**
 - OPERATIONAL COMMUNICATIONS REQUIREMENTS**
 - MLS/LAN ARCHITECTURE**
 - MLS/LAN DEVELOPMENT**



AMECOM

Litton

NAVAL

COMMAND

CENTERS

NETWORK

AN APPLICATION OF THE

INFORMATION SYSTEM PROTOTYPE

TO NAVAL COMMAND CENTERS

NESEC-V
AUGUST 1982

NAVAL COMMAND AND CONTROL SYSTEM PROFILE

- 34 OPERATIONAL ASHORE NODES WITHIN NCCS

NCC	1
NOSIC	1
FCC	3
FOSIC	3
FOSIF	2
ATCC	3
AOCC	5
ASWOC	16

- 1 ASHORE SYSTEM/SUBSYSTEM R&D NODE

C² ENGINEERING DEVELOPMENT AND
SYSTEM PROTOTYPE FACILITY

- 7 SYSTEMS/SUBSYSTEMS AMONG THE 35 ASHORE NODES

NWSS
FHLT
HLT
ID
ADS
OSIS BASELINE
OCPH

NESEC-V
CODE 343

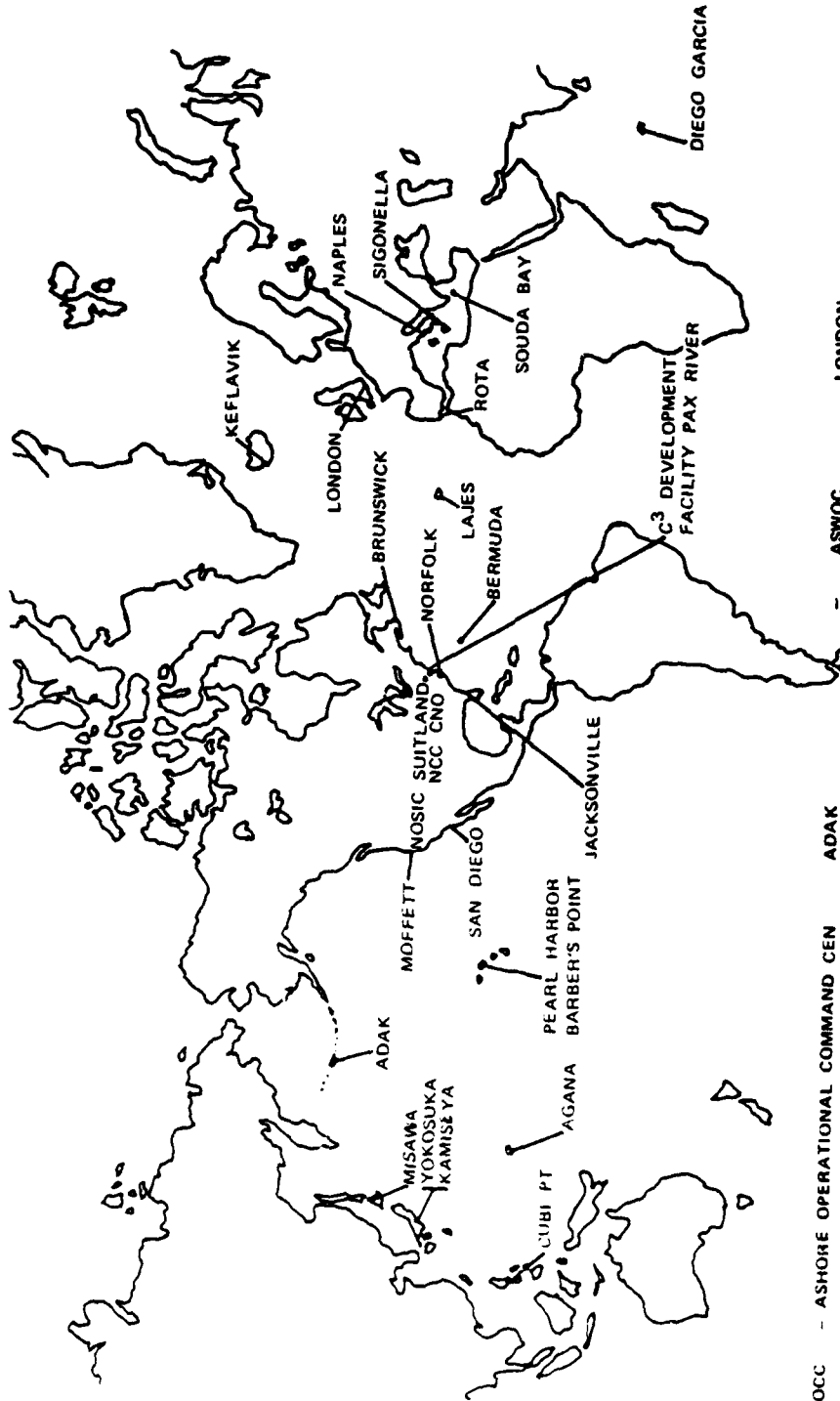

AOCC	-	ASHORE OPERATIONAL COMMAND CEN	ADAK	-	ASWOC	LONDON	-	FCC, FOSIC
ASWOC	-	ASW OPERATIONS CENTER	AGANA	-	ASWOC	MISAWA	-	ASWOC
ATCC	-	ASHORE TACTICAL COMMAND CENTER	BARBER'S POINT	-	ASWOC	MOFFETT	-	ASWOC
FOSIC	-	FLEET OCEAN SURVEILLANCE INFO CEN	BERMUDA	-	ASWOC	NAPLES	-	ATCC, AOCC
FOSIF	-	FLEET OCEAN SURVEILLANCE INFO FAC	BRUNSWICK	-	ASWOC	NORFOLK	-	AOCC, FCC, FOSIC
FCC	-	FLEET COMMAND CENTER	CUBI PT	-	ASWOC	PEARL HARBOR	-	AOCC, ATCC, FCC, FOSIC
NCC	-	NAVAL COMMAND CENTER	DIEGO GARCIA	-	ASWOC	ROTA	-	ASWOC, FOSIF
NUSIC	-	NAVAL OCEAN SURVEILLANCE INFO CEN	JACKSONVILLE	-	ASWOC	SAN DIEGO	-	AOCC
			KADENA	-	ASWOC	SIGONELLA	-	ASWOC
			KAMISEYA	-	ATCC, FOSIF	SOUDA BAY	-	ASWOC
			KEFLAVIK	-	ASWOC	YOKOSUKA	-	AOCC
			LAJES	-	ASWOC			

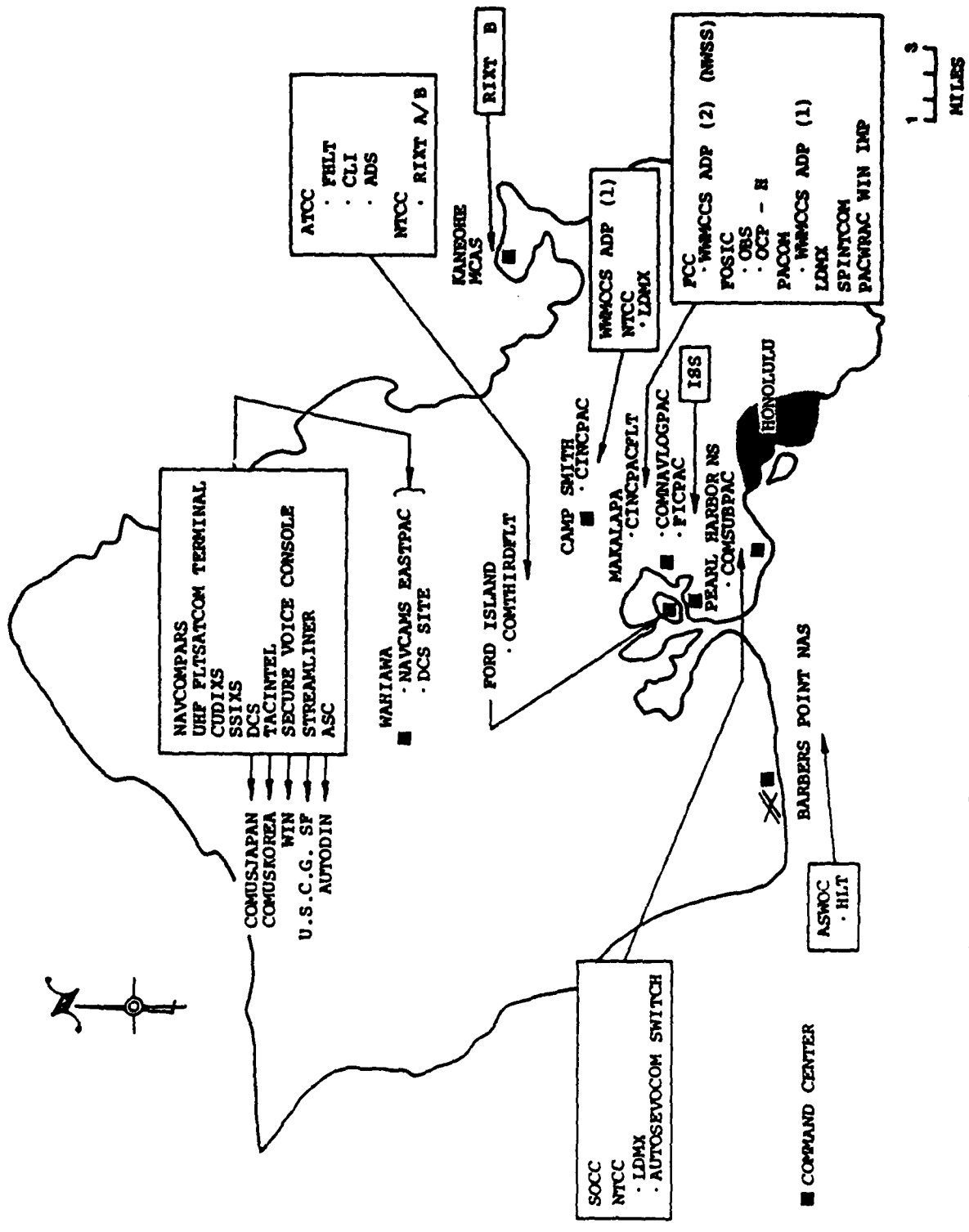

NAVAL COMMAND CENTERS (OAHU)

IID SYSTEM INTERFACES

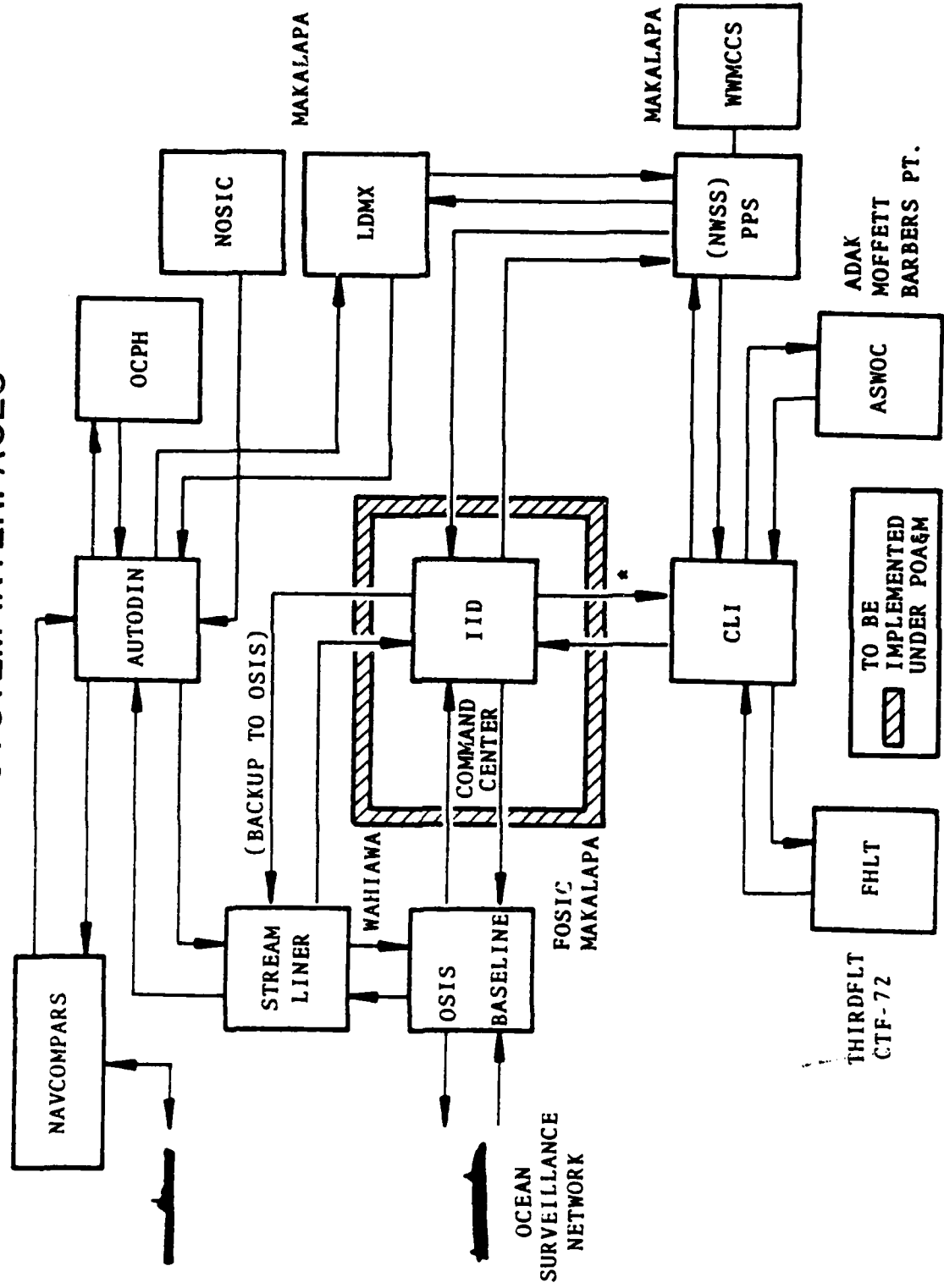

*LINK REQUIRES A SECURITY WAIVER MANUAL CONNECT/DISCONNECT

ISP DESIGN CONCEPT

- △ INTERNAL AND EXTERNAL NETWORK INTERFACE UNITS

- △ MULTIPLE EXTERNAL NIU CONFIGURATIONS

- △ DOD PROTOCOL STANDARDS (TCP/IP)

- △ PROTOCOL TECHNOLOGY TRANSITION

- △ VAX-11/730/750/780

- △ UNIX OPERATING SYSTEM

- △ ETHERNET (10 Mb/s)

(IF SUBSYSTEM IS COMPATIBLE,
FEP NIU MAY BE IMBEDDED)

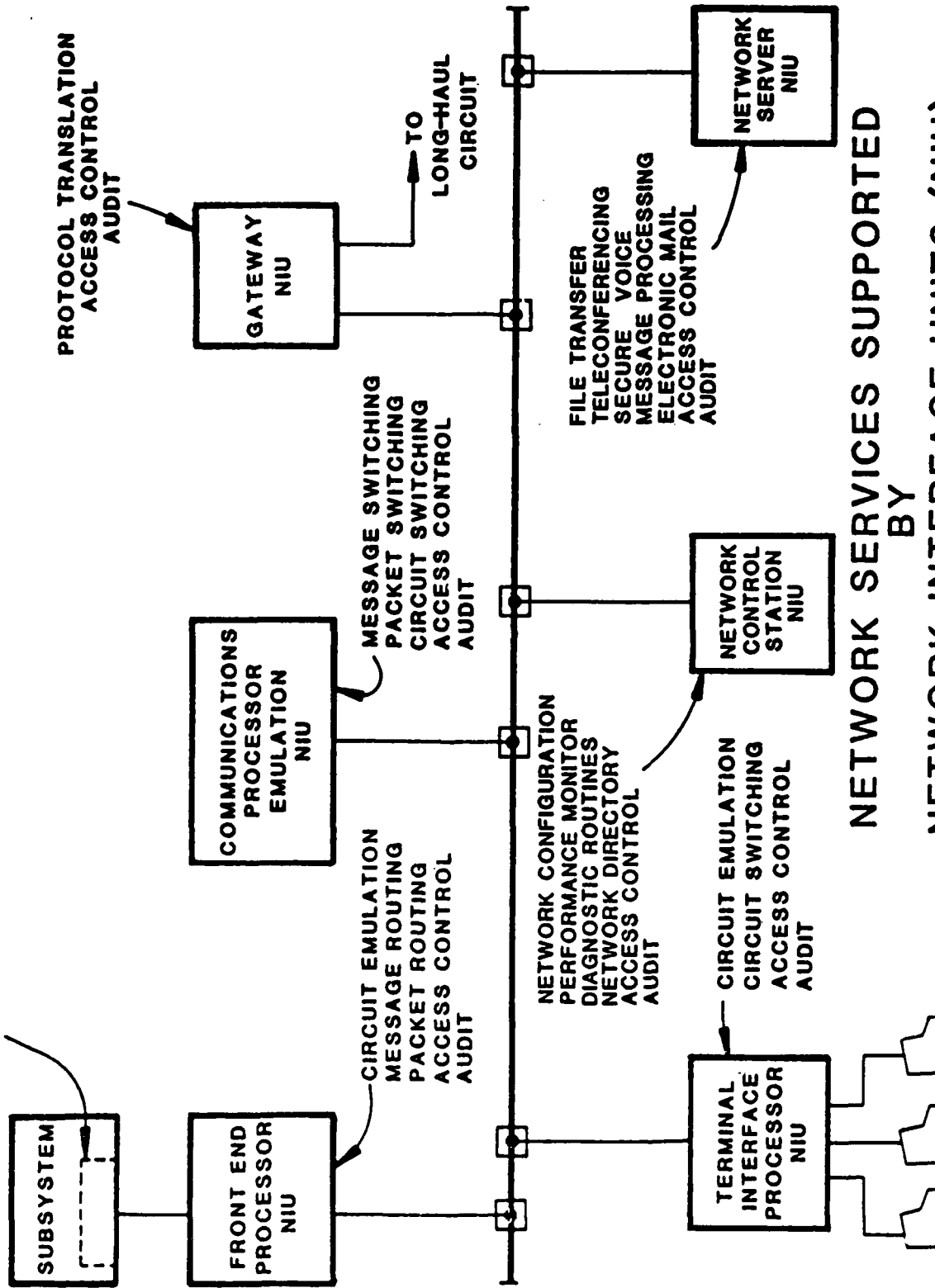

**NETWORK SERVICES SUPPORTED
BY
NETWORK INTERFACE UNITS (NIU)**

NOTE: TCP/IP AND ASSOCIATED PROTOCOLS ARE AVAILABLE FOR:
 DEC/UNIX
 DEC/VMS
 DEC/IAS

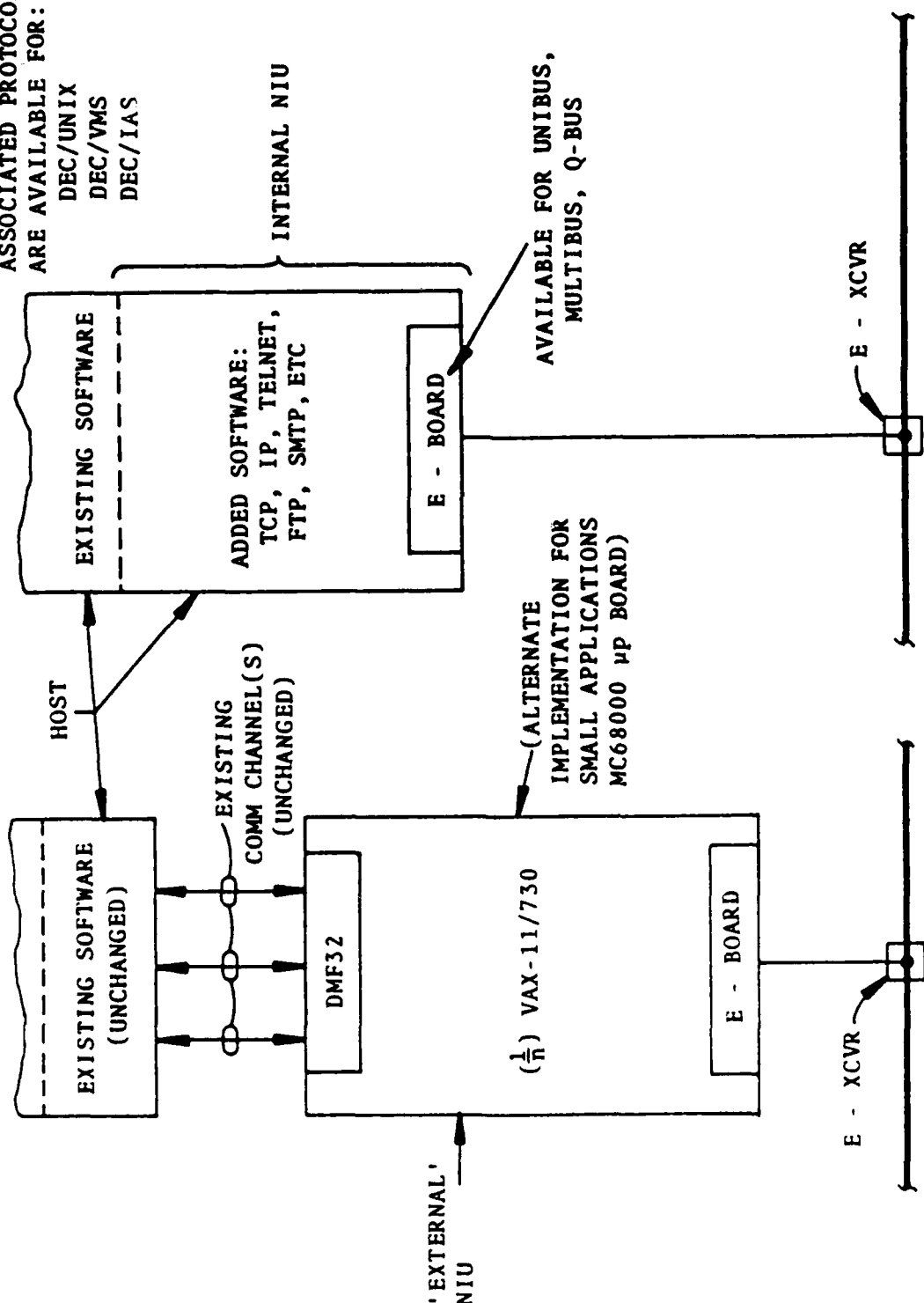

'INTERNAL' NIU
 (FOR COMPATIBLE AND COMPLIANT HOSTS)

'EXTERNAL' NIU
 (FOR NON-COMPATIBLE OR NON-COMPLIANT HOSTS)

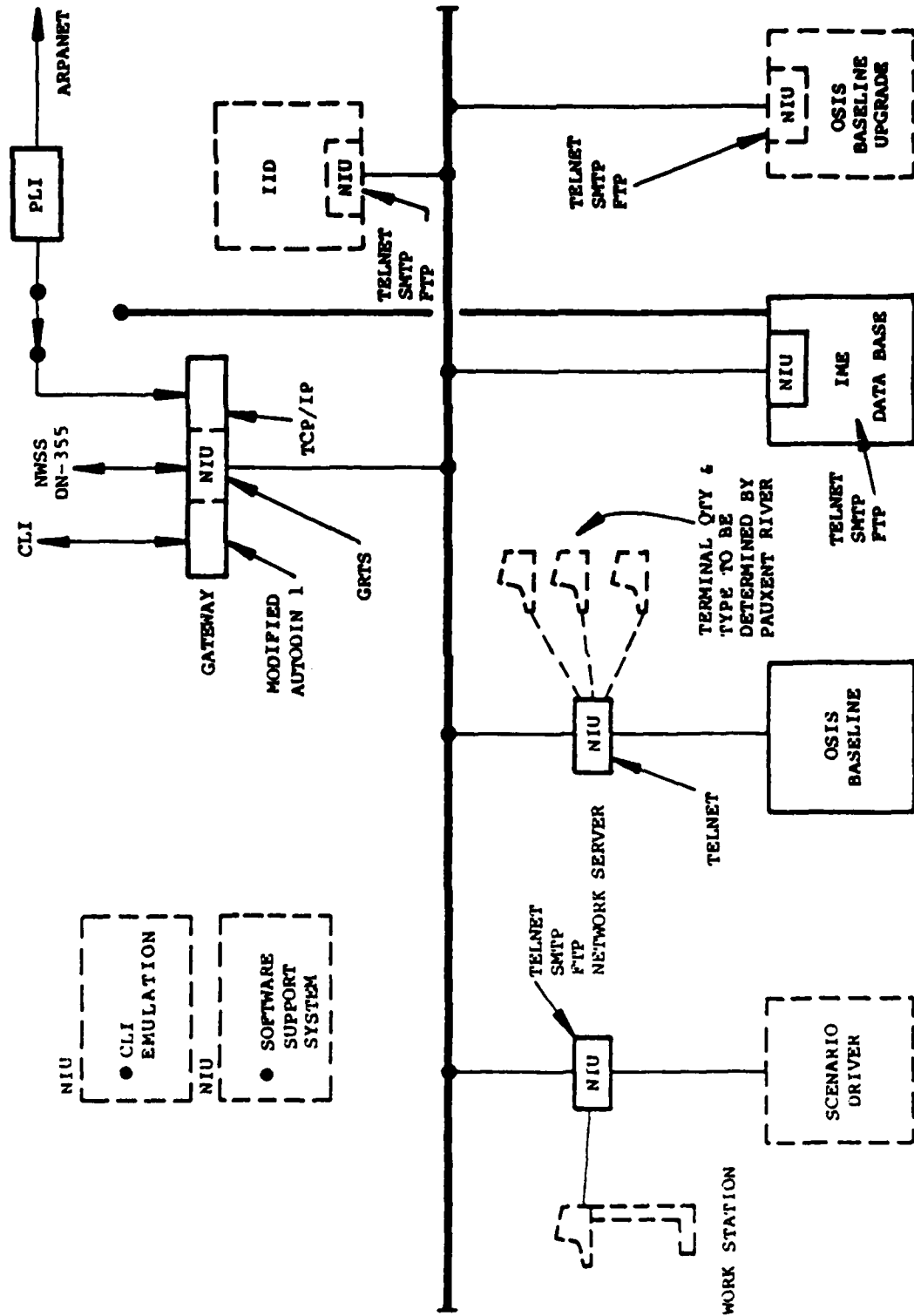

ISP TEST AND EVALUATION AT EDSPF PATUXENT RIVER

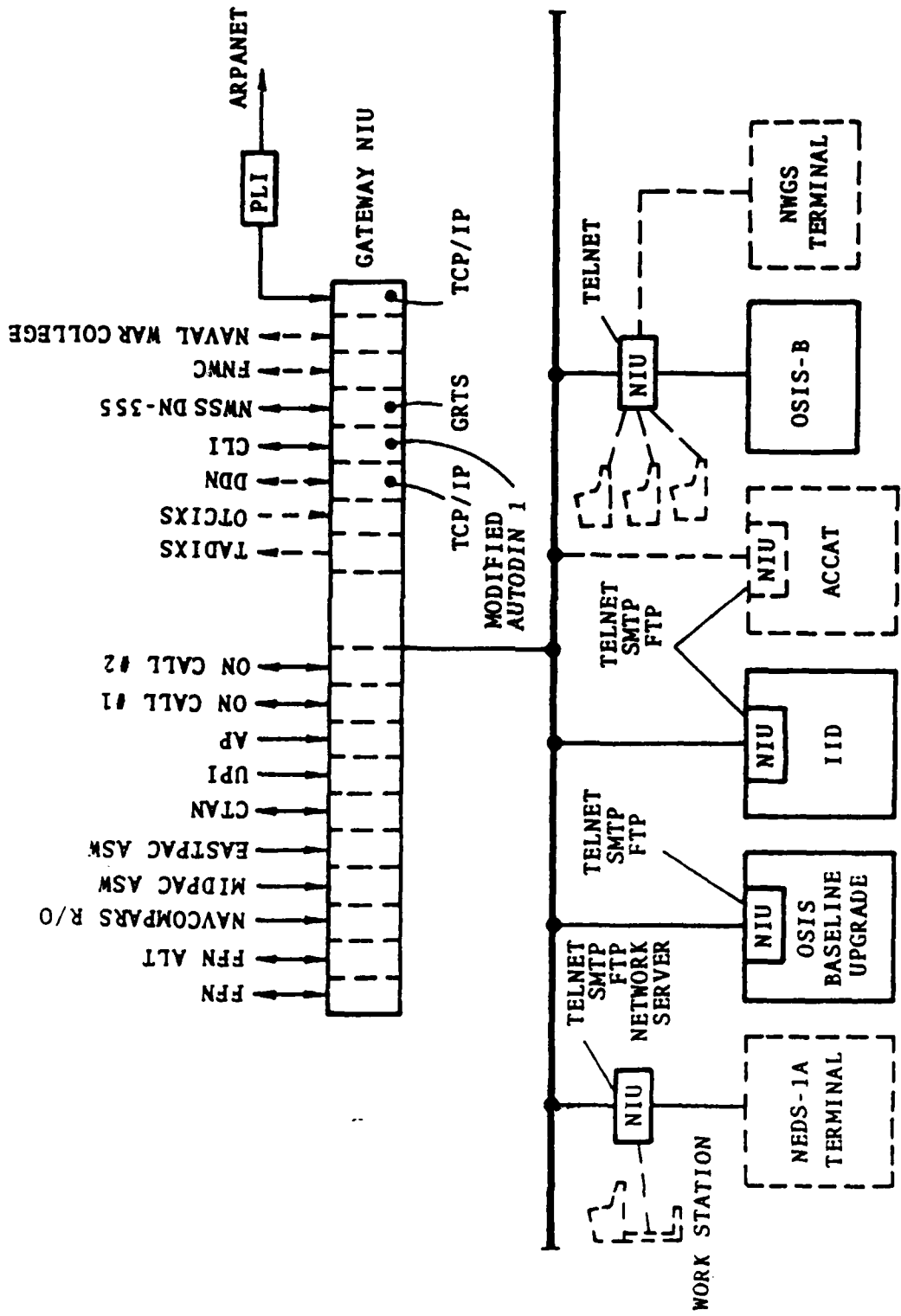

ISP TEST & EVALUATION AT CINCIPACFLT COMMAND CENTER

**IMPACT OF FIBER OPTICS
ON
LOCAL AREA NETWORKS**

S. BALSERA

P. STEENSMA

**ITT DEFENSE COMMUNICATIONS
NUTLEY, NEW JERSEY**

LAN DEFINING CHARACTERISTICS

- **SMALL AREA COVERED \sim 1KM**
- **HIGH DATA RATES $>$ 1 MBPS**
- **USER AUTONOMY AND INTELLIGENCE**

LONG HAUL VS LAN CHARACTERISTICS

PARAMETER	LONG HAUL	LAN
NETWORK OWNER	COMMON CARRIERS	USER
COVERAGE	TENS TO THOUS. KMS.	5 KM
TRANSMISSION BANDWIDTH	92 KBS	3200 MBS
NETWORK TRANSIT DELAY	0.3- 2 SEC.	25 SEC.
BIT ERROR RATE	$10^{-4} - 10^{-6}$	$10^{-6} - 10^{-9}$
NUMBER OF HOPS	3 - 6	1
NODE CONNECTIVITY	LIMITED	FULL
TRANSMISSION COST	VERY HIGH	VERY LOW

THE TRANSMISSION PIPELINING EFFECT OF PACKET SWITCHING

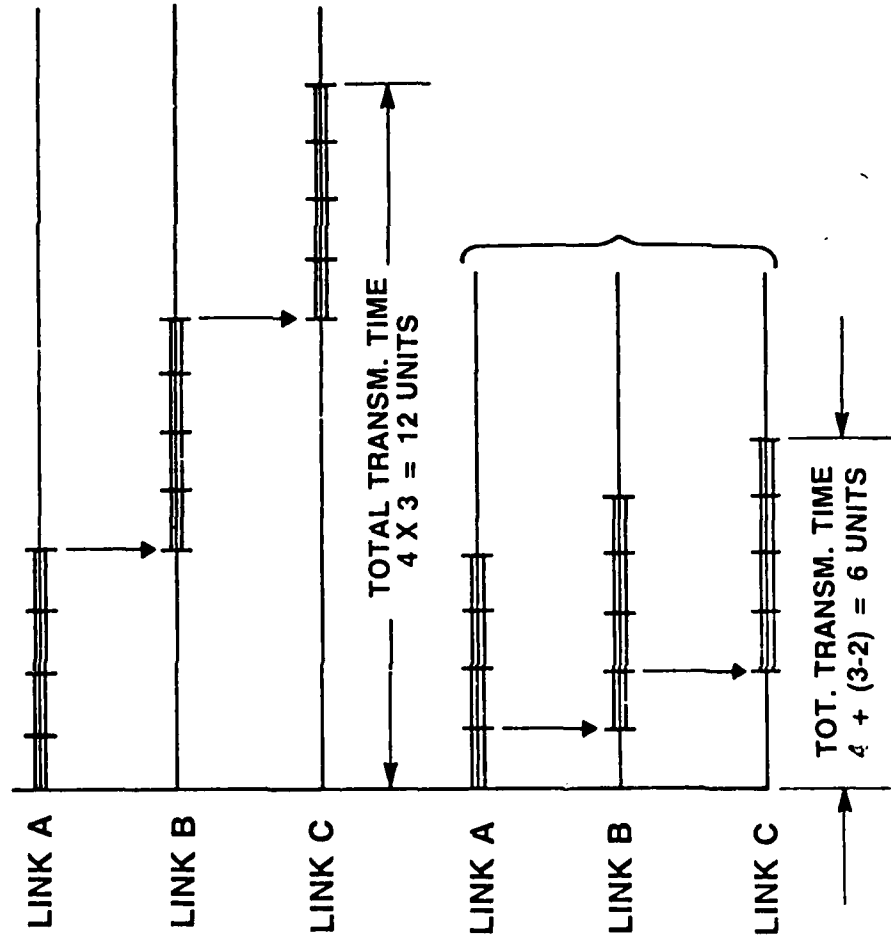
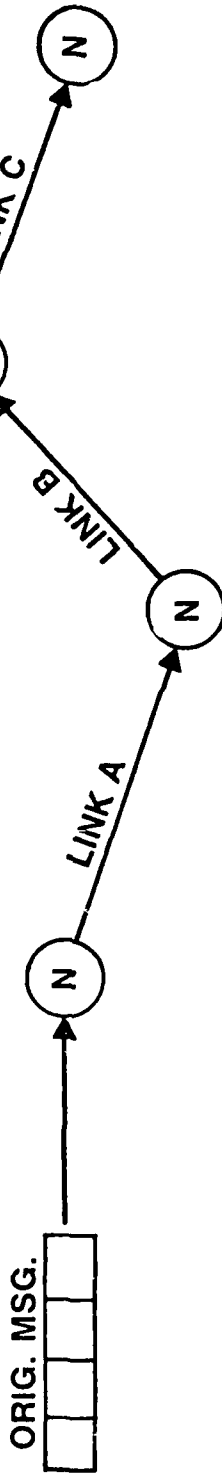

MESSAGE SWITCHING
(STORE FULL MSG.
AT EACH NODE
BEFORE COMMENCING
RETRANSMISSION)

PACKET SWITCHING
(SINGLE PACKETS
RETRANSMITTED
AFTER ACCUMULATION)

KEY CHARACTERISTICS OF FIBER OPTIC LAN ENVIRONMENT

- SIMPLE TOPOLOGY
 - POWER LIMITED
- ERRORS ARE
 - LOW
 - LOCALIZED IN TIME AND SPACE
- LOW INTERUSER DELAY
- ECONOMIC LARGE BANDWIDTH

METALLIC VS. FIBER OPTIC ERROR ENVIRONMENT

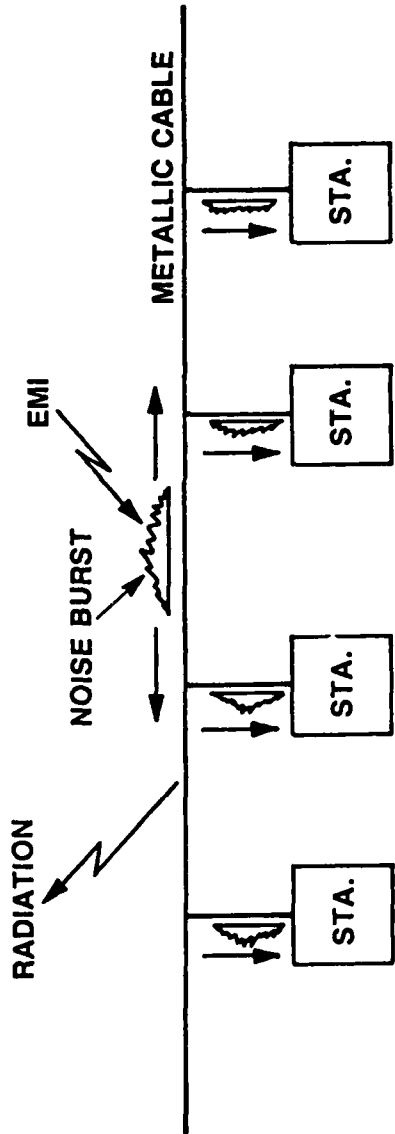

FEC INEFFECTIVE

- NOISE AFFECTS ALL STATION
- REQUIRES DOUBLE SPEED
- BURST ERRORS DIFFICULT TO CORRECT

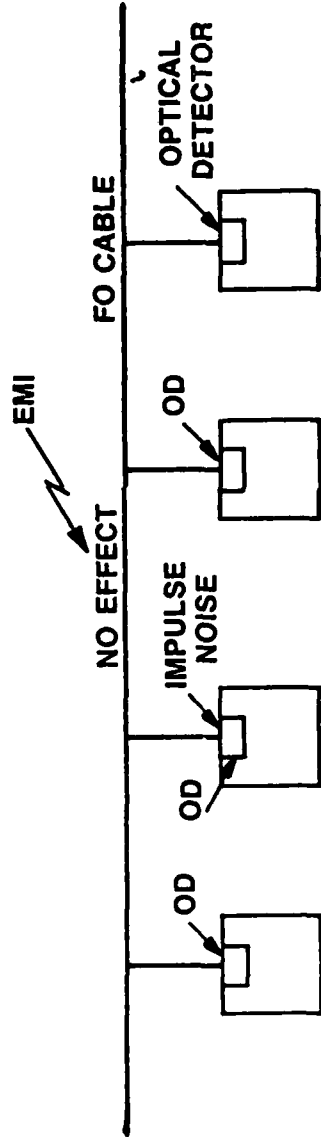

FEC EFFECTIVE

- NOISE AFFECTS ONLY ONE STATION
- BANDWIDTH AVAILABLE
- SINGLE BIT ERRORS
- LOW BER CHANNEL

ERROR CONTROL TECHNIQUES

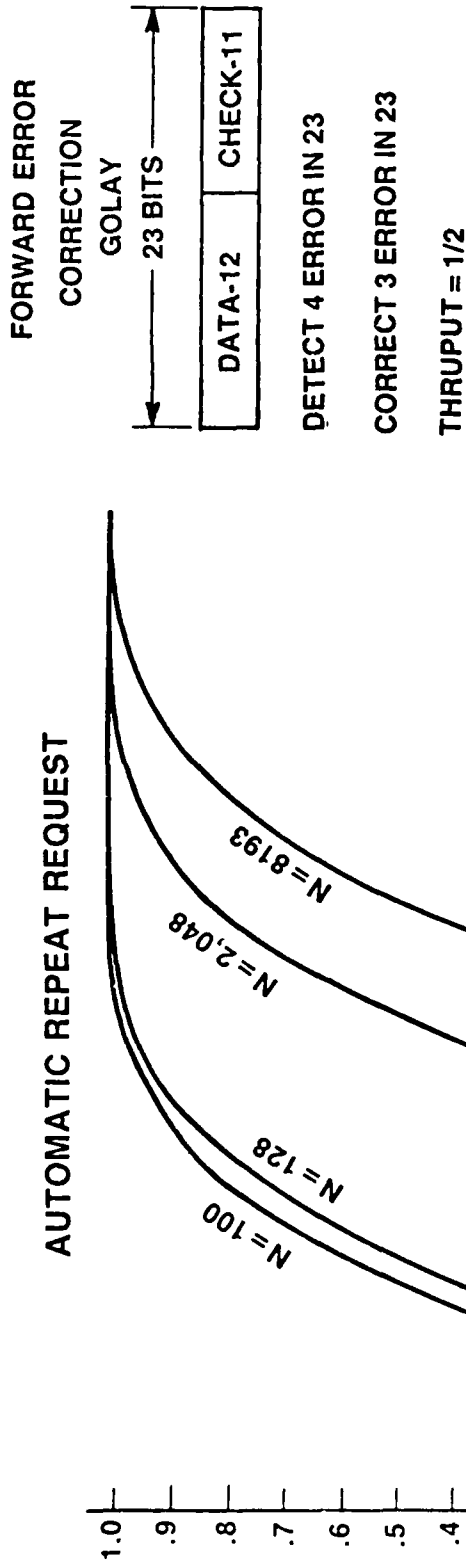

- 359 -

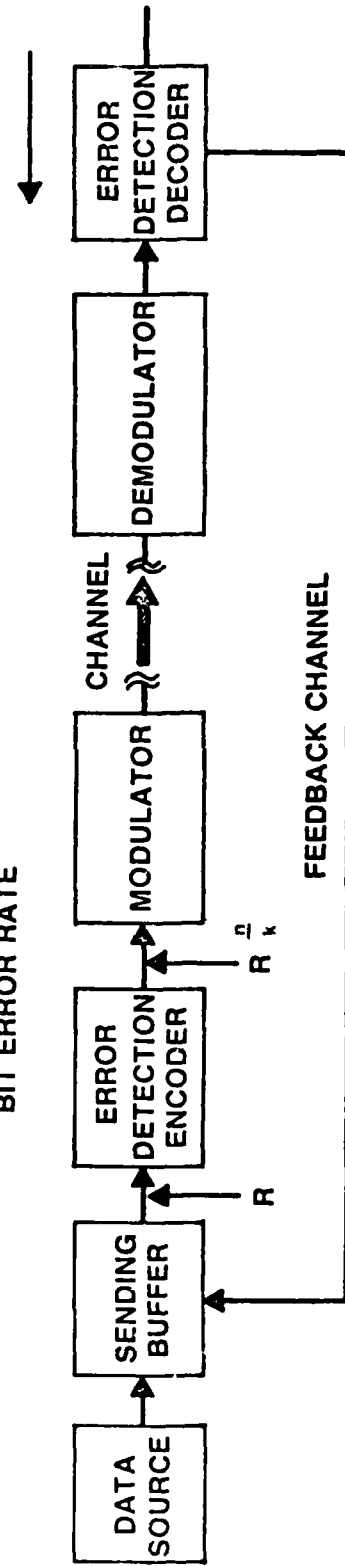

SIMPLIFICATIONS FROM FEC IN FO CABLES

- **SIMPLER LINK PROTOCOLS**
- **LOW BUFFER REQUIREMENTS (NO BUFFER HOLDING)**
- **ACK/NACK PROCESSING NOT REQUIRED**
- **PACKET SEQUENCE MAINTAINED**
- **MINIMUM DELAY VARIANCE**
- **CONVENIENT MULTI CAST**

TOPOLOGY ALTERNATIVES

STAR

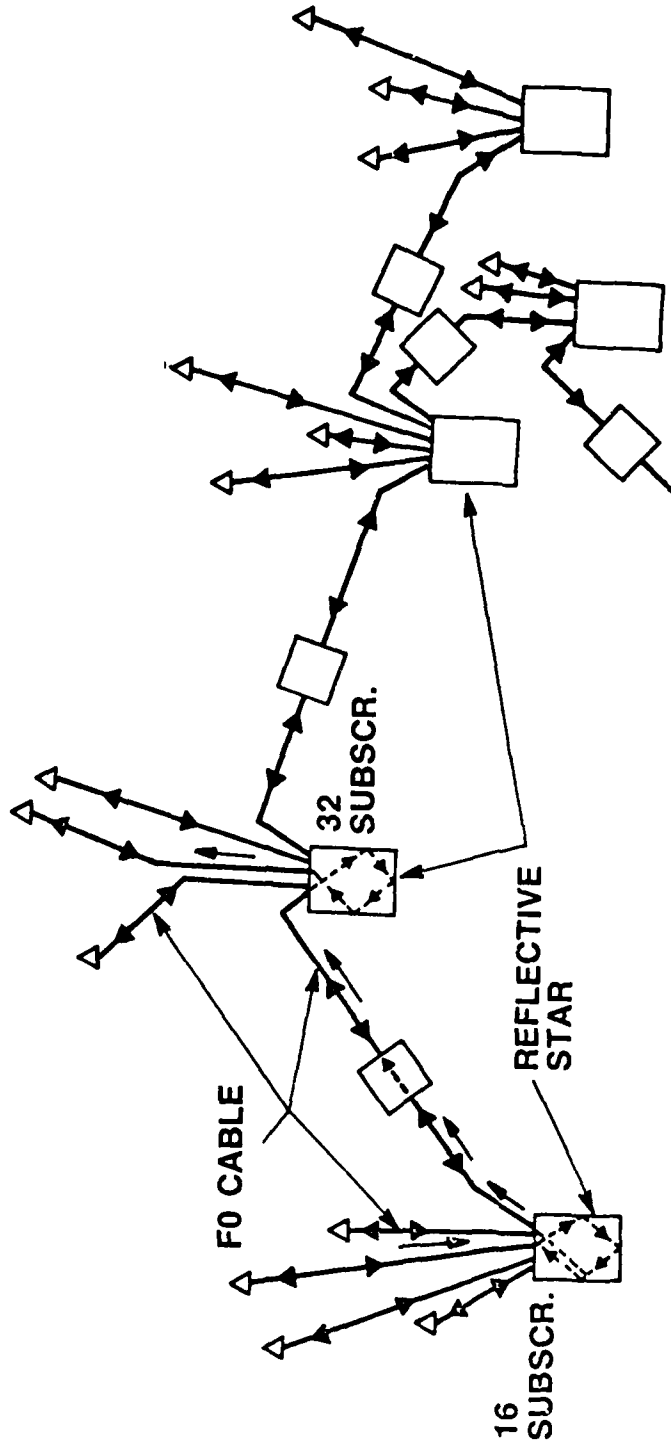

△ TERMINAL OR HOST
□ COUPLING AMPLIFIER

LINEAR RING

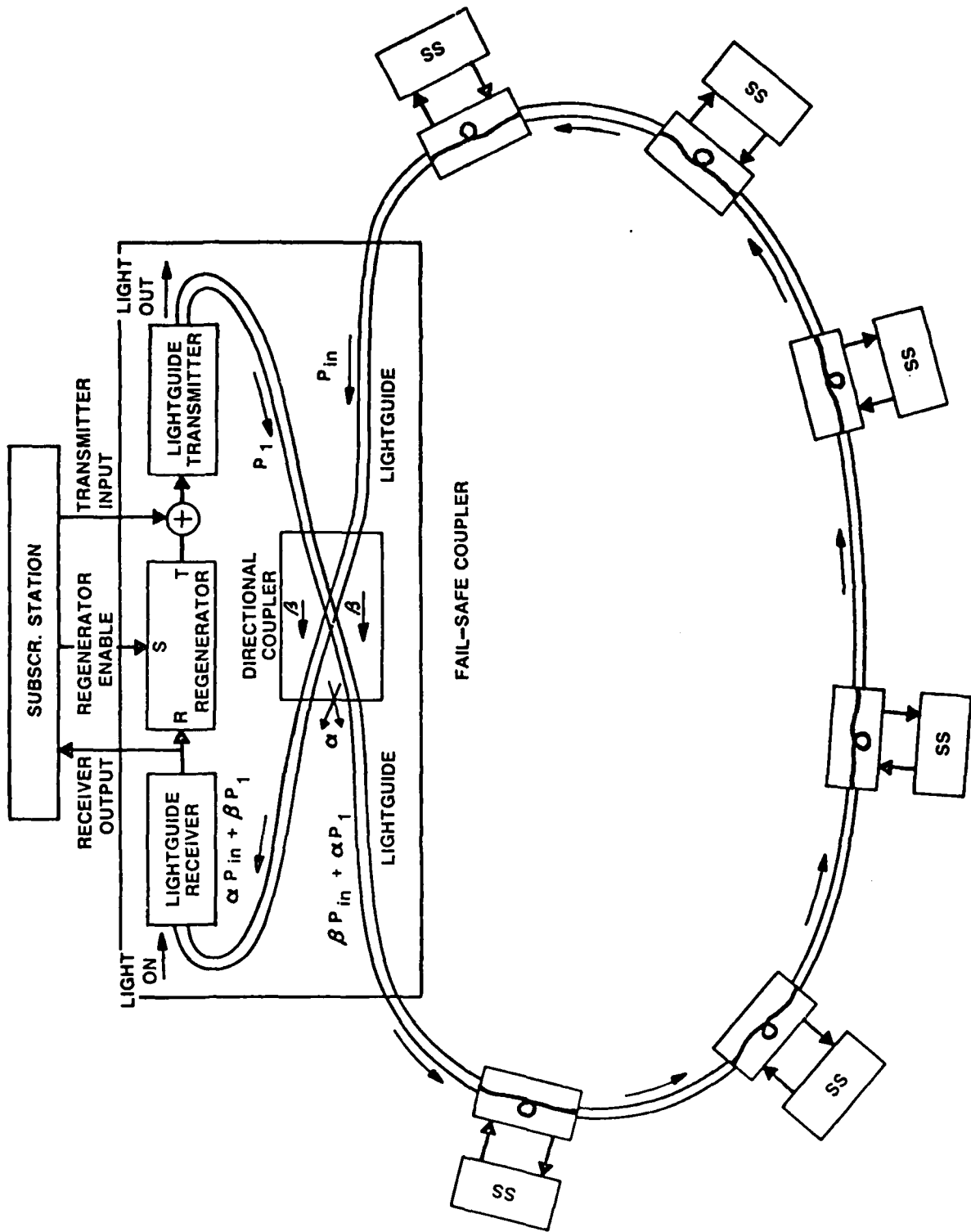

CAPABILITIES OF FIBER OPTIC MULTIPOINT DISTRIBUTION SYSTEMS

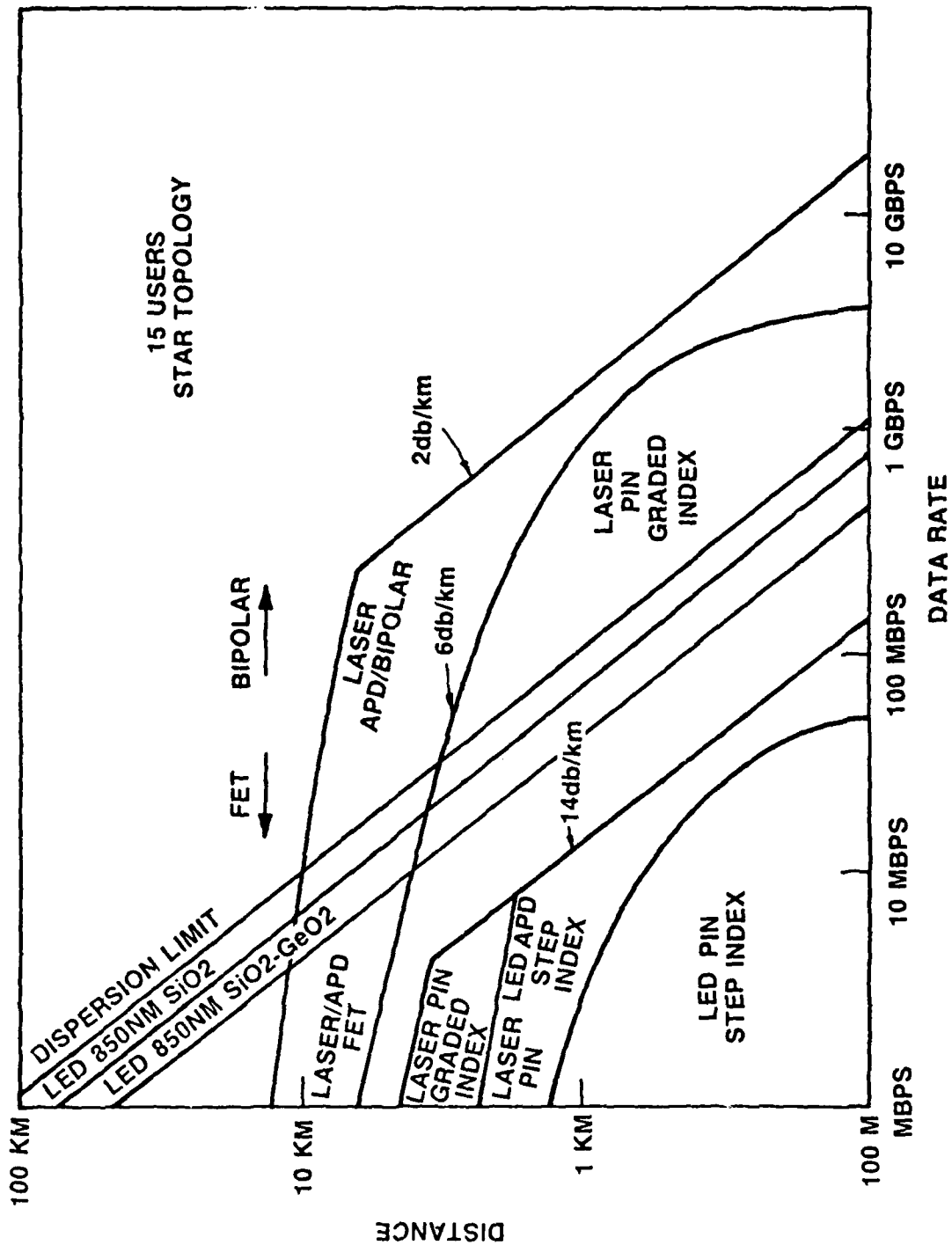

LOW DELAY IN FIBER OPTIC BUSES

- QUEUE WAIT TIME: ≈ 0
- TRANSMISSION TIME: 5-10 μ SEC
- TIME OF FLIGHT: 5 μ SEC/KM
- PACKET PROCESSING TIME: 5-10 MSEC
- NO STORE AND FORWARD
- NO QUEUE BUILDUP - HIGH SPEED BUS SERVER
NEAR REAL TIME CONTROL
- NO NEED FOR PRECEDENCES

CONTROL IMPACT OF LOW DELAY

CONVERSATIONAL VS. TELEGRAM INTERACTION FLOW CONTROL APPROACH

CONVENTIONAL

- WINDOW RESERVATION
- PROCESSING INTENSIVE
(MSG. RESEQUENCING)
- SLOW CONTROL ACTION
- LOW BUFFER EFFIC.
(BULK RESERVATION)

FIBER OPTIC

- START/STOP
- SIMPLE (AUTOMATIC SEQUENCE)
- FAST CONTROL
(SINGLE HOP + HI-SPEED)
- HIGH BUFFER EFFICIENCY
(SINGLE BUFFER RESERVATION)

BANDWIDTH IMPACT

- **ALLOWS HIGH CAPACITY APPLICATIONS**
 - "TELEPROCESSING"
 - TRUE MULTIPROCESSING - MOBILE SOFTWARE
 - VOICE
- **DIFFERENT MULTIPLE ACCESS CONSTRAINTS**
- **SPEED GAP AND PROCESSOR BLOCKING**

LIMITS ON CONTENTION BASED ACCESS

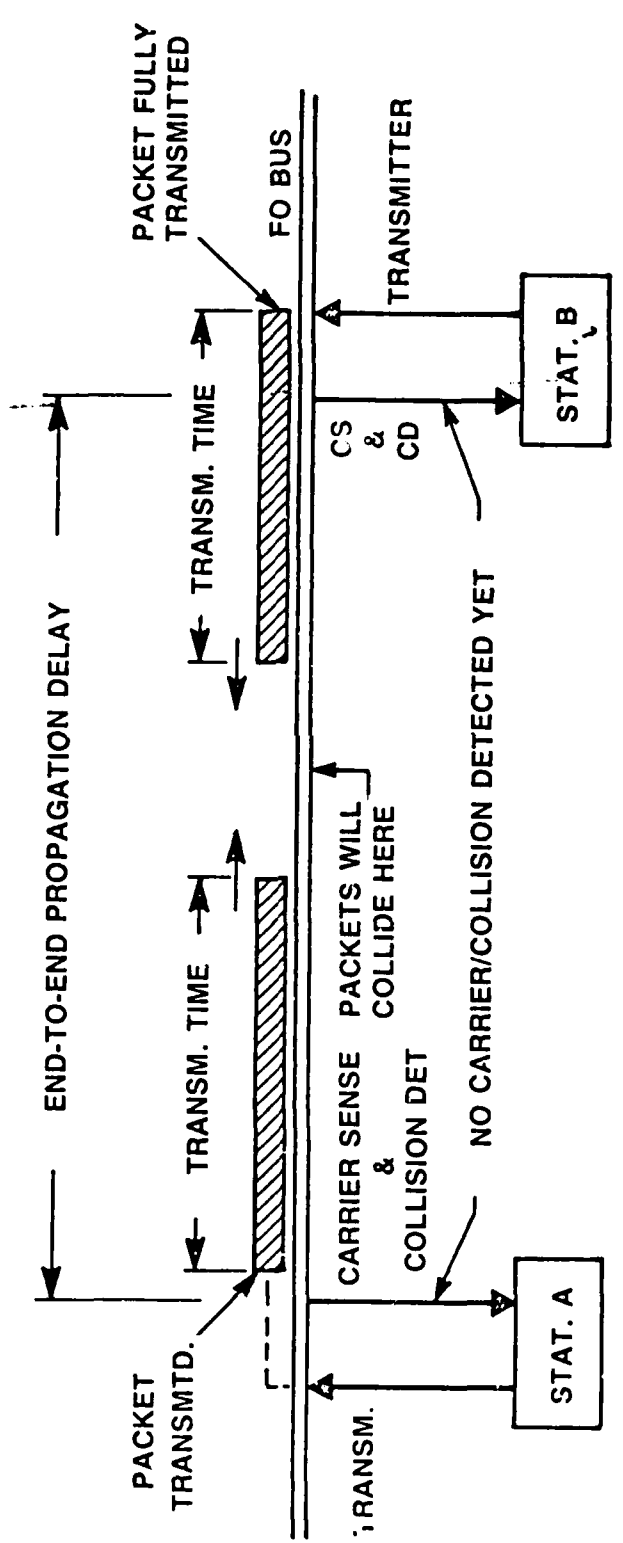

200 MB/S
 TRANSMISSION TIME FOR A 2000 BIT PACKET: $10 \mu\text{SEC}$
 PROPAGATION TIME FOR 1 KM CABLE: $5 \mu\text{SEC}$ } $a = 0.5$

$a =$ END TO END PROPAGATION DELAY
PACKET TRANSMISSION TIME

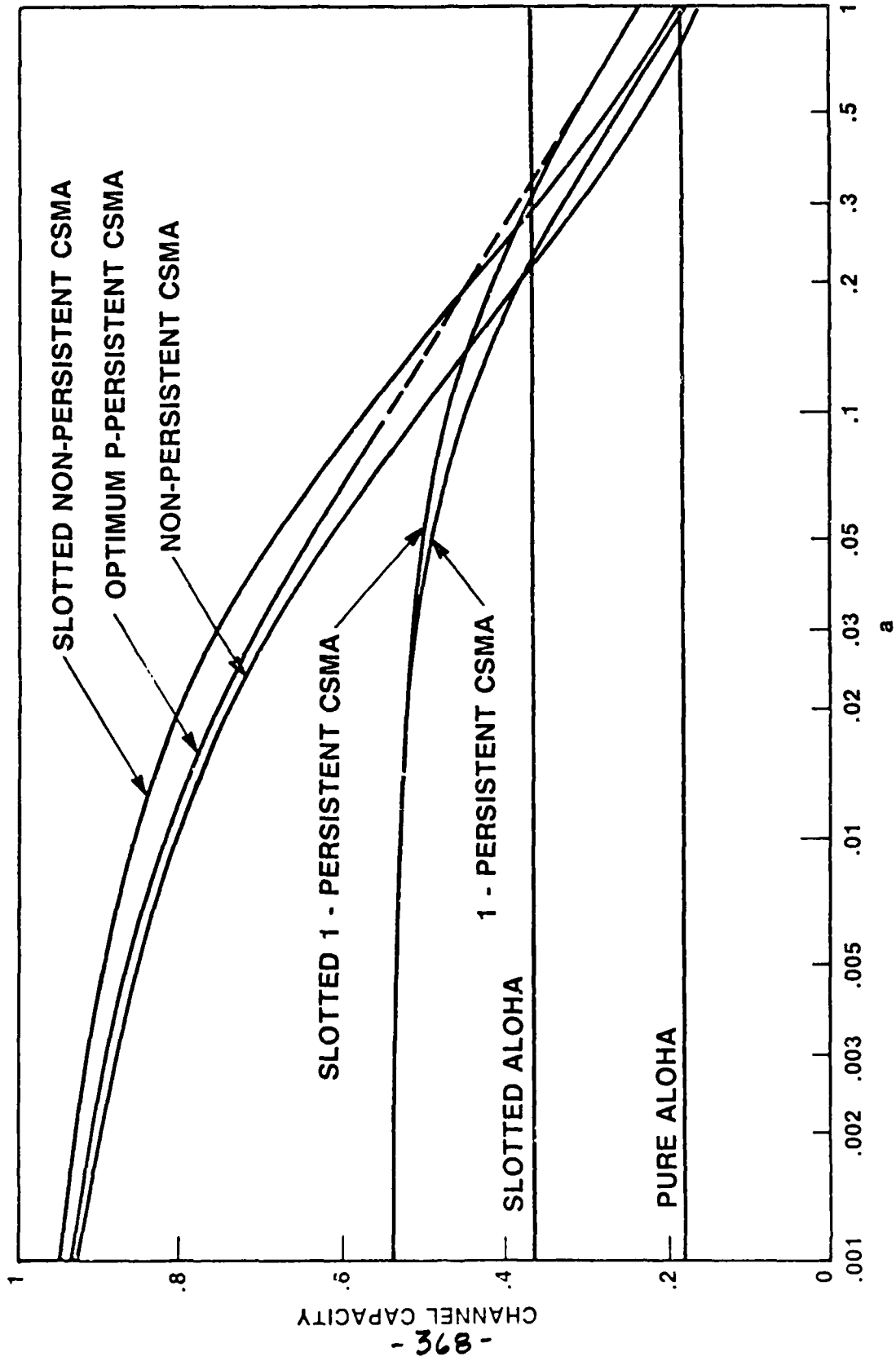

CHANNEL CAPACITY

a

LIMITS ON DETERMINISTIC ACCESS

POLLING CYCLE = N

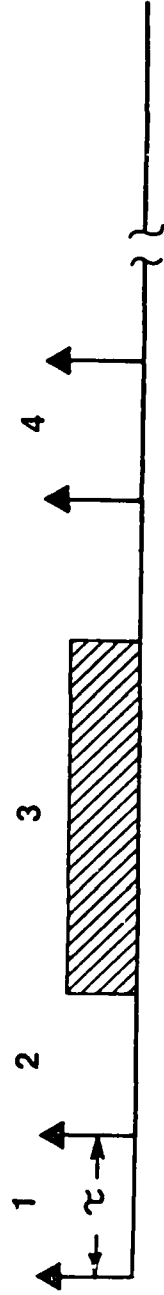

STAR $\tau = \frac{2 R n}{C}$

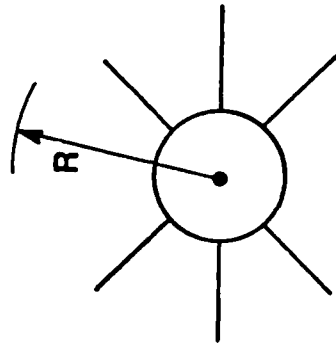

N = NO SUBSCRIBER
 C = SPEED OF LIGHT
 n = INDEX OF REFRACTION
 R = RADIUS

RING $\tau = \frac{2 d n}{C}$

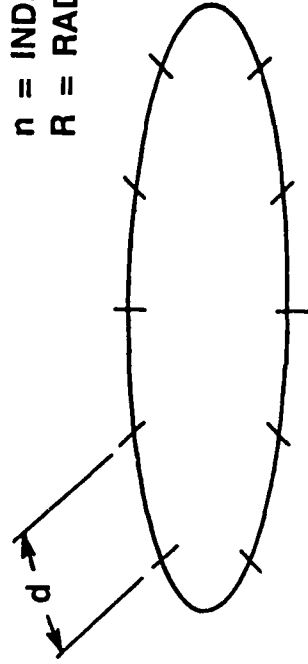

QUEUEING MODEL FOR SUBSCRIBER BLOCKING ANALYSIS

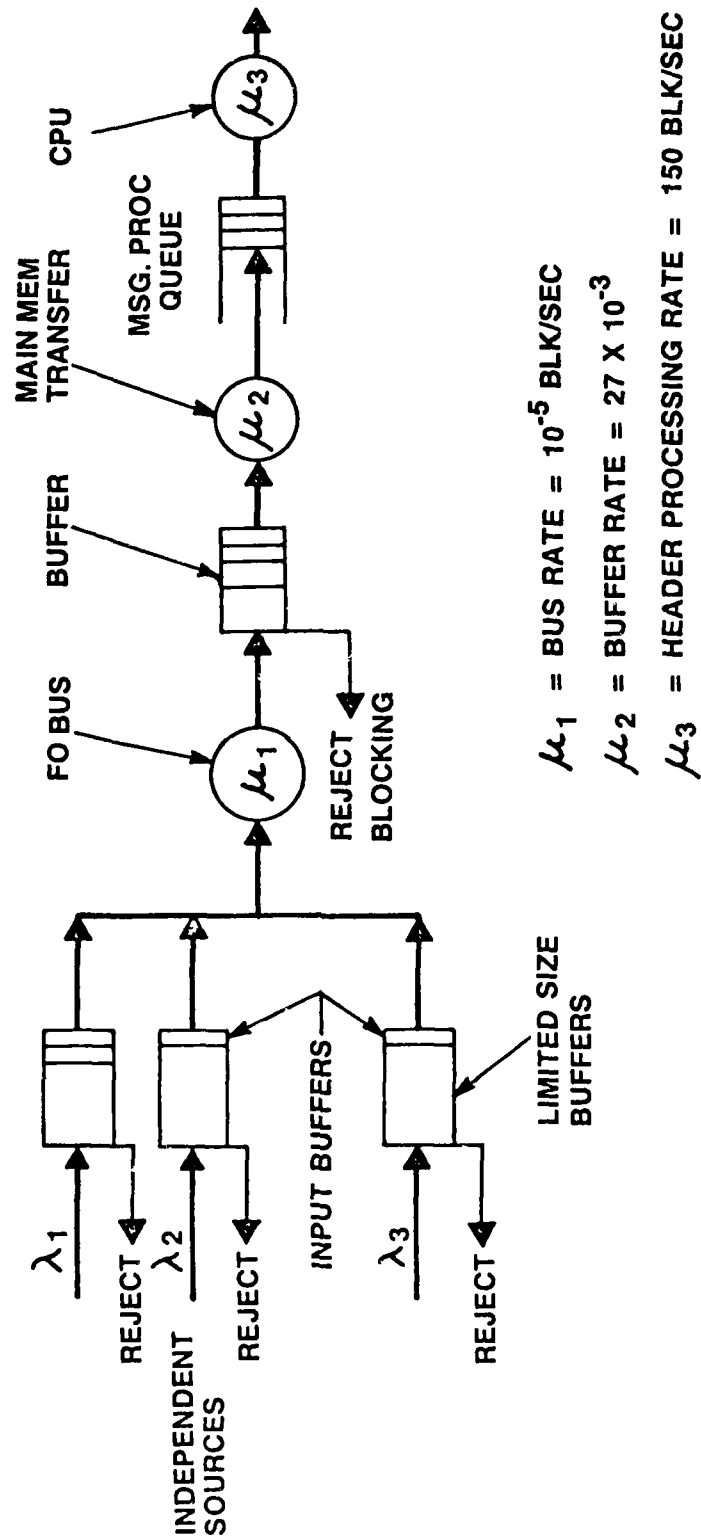

SUBSCRIBER BLOCKING IN VERY FAST BUSES

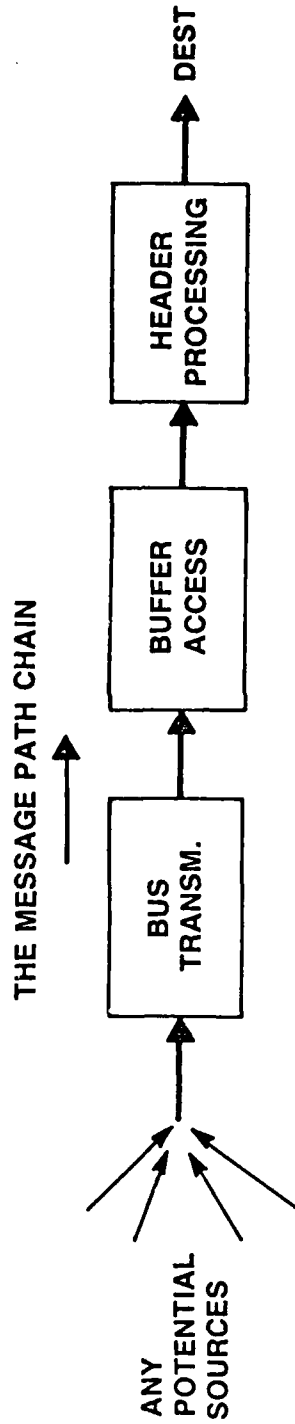

BUS RATE: $\frac{200 \text{ MBS}}{250 \times 8} = 100,000 \text{ BLOCKS/SEC}$

BUFFER RATE: $\frac{1}{250 \times 150 \times 10^{-9}} = 27,000 \text{ BLKS/SEC}$

PROCESSOR RATE: Z-80 $\approx 12 \text{ BLKS/SEC}$
 Z-8000 $\approx 150 \text{ BLKS/SEC}$

ASSUME

- 1 BLK = 250 BYTES
- MEM. SPEED = 150 NSEC.
- BUS SPEED = 200 MBS

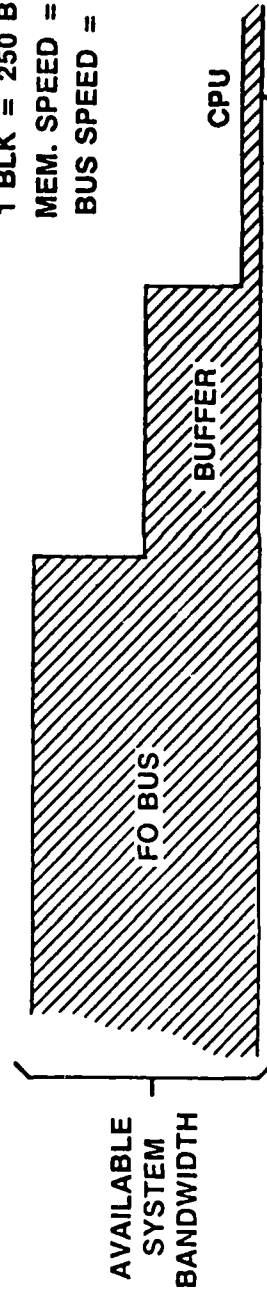

THE CPU IS THE BOTTLENECK

CLOSING THE SPEED GAP

- THROTTLE BUS NEEDS MORE PROCESSING
WASTES BANDWIDTH
INCREASES DELAY
- CHANNELIZE BUS
WAVELENGTH MULTIPLEXING TECHNOLOGY DEVELOPMENT
CARRIERS (BROADBAND) SHOT NOISE LOADING
WORD ORIENTED TDM AVAILABLE TECHNOLOGY
- SPECIAL PURPOSE PROCESSORS LIMITS PROTOCOL
(HIGH SPEED STATE MACHINE) SOPHISTICATION
- MESSAGE TRANSACTION VS. PACKET - FEWER HEADERS

STATE MACHINE APPROACH TO PROTOCOL

DETECTED CONDITIONS

- ① FOR ME - THIS BIU'S DESTINATION ADDRESS
- ② VDA - VALID DESTINATION ADDRESS
- ③ INV - INVALID DATA
- ④ VOA - VALID ORG ADR
- ⑤ CPA - CONNECTED PARTY ADDRESS
- ⑥ VAL DATA - VALID DATA
- ⑦ EOP - END OF PACKET
- ⑧ FROM ME - THIS BIU'S ORGINATION ADDRESS

OUTPUTS

- ENABLE BUFFER MEMORY - ENABLE DATA TO BE STORED IN BUFFER
- DUMP MEM BUF - CLEAR DATA PREVIOUSLY STORED FROM THIS PACKET
- LOAD CCWR - STORE CONTROL WORD AND NOTIFY CONTROLLER
- OK - NOTIFY COTROLLER NO ERRORS IN THIS BIU'S LAST TRANSMISSION
- OK - NOTIFY CONTROLLER ERRORS DETECTED IN THIS BIU'S LAST TRANSMISSION

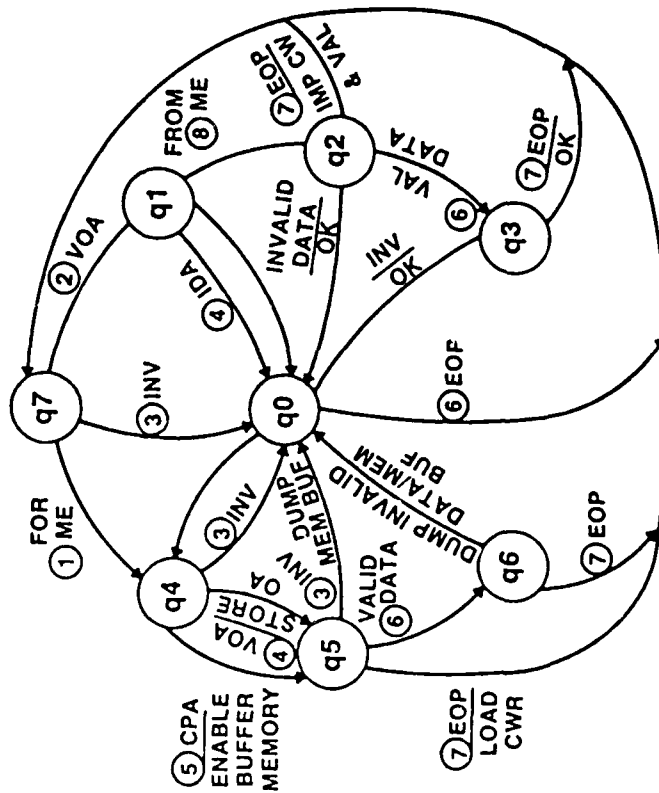

HIGH SPEED STATE MACHINE

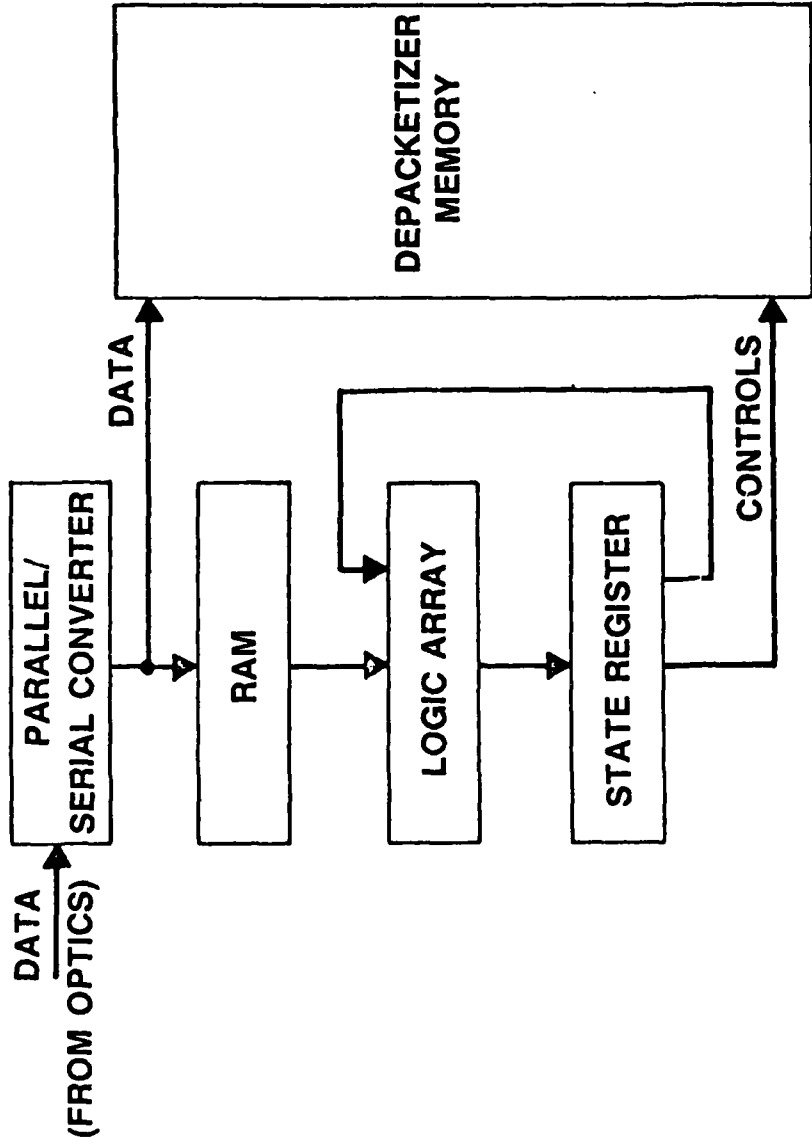

CONCLUSIONS

- FIBER OPTIC TECHNOLOGY PROVIDES A UNIQUE LAN COMMUNICATIONS ENVIRONMENT

- IMPLIES

 - SIMPLIFIED CONTROL PROTOCOLS

 - ERROR

 - FLOW

 - ACCESS

- PROCESSOR LIMITED SYSTEM:

 - REQUIRES CAREFUL SYSTEM DESIGN

Implementation II (1600-1730 29 Sep)

Session Chairman: Mr. John McNamara - RADC/OCDS

"Issues Influencing Tactical Local Area Network Implementation,"
Lt Gregory Swietek, Rome Air Development Center

Discussion of specific issues which must be addressed during the successful implementation of Local Area Networks in a tactical environment.

"A Control System Architecture for Tactical Radar Networks,"
Dr. G. Lucas and Mr. T. Burke, Decision Science Applications Inc.

A methodology and example of a user friendly network control concept will be presented.

"Implementation of a Local Network for Tactical Systems," Mr. Ron
Foss, Sperry Univac

Experience gained in building a local area network in the tactical environment will be presented.

"A Conceptual Local Area Communications Network for a Distributed,
Modular Operations Center," Mr. Gerhard Pfister, ITT Gilfillan

A practical application of a local area communicative network to a modular tactical system will be presented.

- 0 LAN REQUIREMENTS OF SURVEILLANCE INTERNETTING
- 0 ALLOCATION AND PRIORITIZATION OF RESOURCES
- 0 FORMAL AND INFORMAL INFORMATION FLOW
- 0 PHYSICAL SECURITY
- 0 USER ACCEPTANCE AND UTILIZATION

0 PRIORITIZATION OF RESOURCES, TARGETS, AREAS

0 NECESSARY FOR RESOURCE ALLOCATION

0 MAINTAIN "BEST POSSIBLE" LEVEL OF PERFORMANCE

0 CANDIDATE VALUE-DRIVEN ALGORITHM BY DSA

0 RESOURCE ALLOCATION RESPONSIVE TO ENVIRONMENT

0 SUPPORTS EMCON

0 CAPITALIZE ON OVERLAPPING COVERAGE

0 MAINTAIN PERFORMANCE IN A DEGRADED ENVIRONMENT

0 FORMAL AND INFORMAL INFORMATION REQUIREMENTS

0 TACS DEFINES FORMAL INFORMATION REQUIREMENTS

0 LAN MUST CAPTURE "BIG ROOM" ATMOSPHERE

0 INFORMAL INFORMATION FLOW IS IMPORTANT

0 PHYSICAL SECURITY REQUIREMENTS

0 RECONFIGURABILITY, REINITIALIZATION

0 REDUNDANCY

0 MINIMIZE EXPLOITABILITY

0 USER ACCEPTANCE AND UTILIZATION REQUIREMENTS

0 LAN MUST BE INTUITIVE TO USER

0 "FAILSAFE" TO HIGHEST POSSIBLE DEGREE

0 LAN MUST SUPPORT NOVICE AND SOPHISTICATE

0 FLEXIBILITY : TASK PROSECUTION

DSA

DSA 437

**A CONTROL SYSTEM ARCHITECTURE FOR
FUTURE TACTICAL RADAR NETWORKS**

T. E. BURKE

G. L. LUCAS

**DECISION-SCIENCE APPLICATIONS, INC.
1901 N. MOORE STREET, SUITE 1000
ARLINGTON, VA 22209**

SEPTEMBER 29, 1982

AD-A126 110

PROCEEDINGS OF CONFERENCE ON LOCAL AREA MILITARY
NETWORKS GRIFFISS AFB NEW YORK 28-30 SEPTEMBER 1982(U)
ROME AIR DEVELOPMENT CENTER GRIFFISS AFB NY
D B WARMUTH ET AL. 1982

5/6

UNCLASSIFIED

F/G 17/2

NL

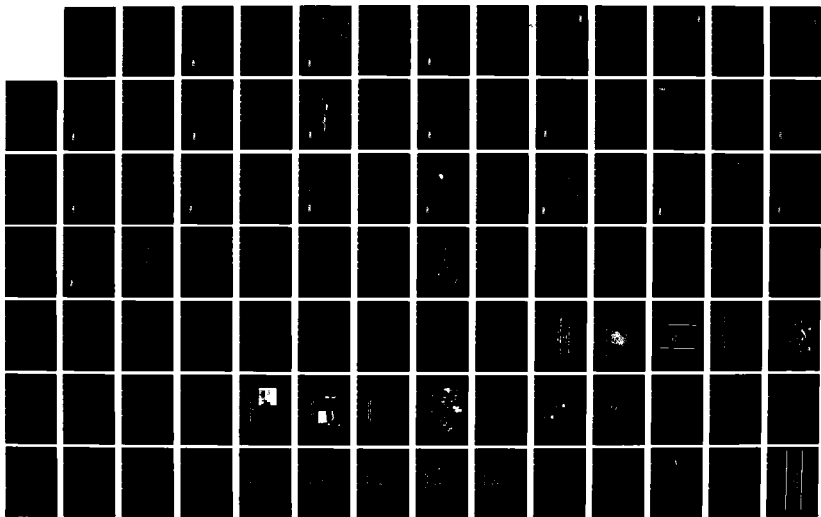

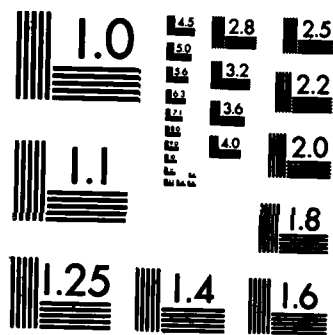

MICROCOPY RESOLUTION TEST CHART
NATIONAL BUREAU OF STANDARDS-1963-A

TITLE

MY PRESENTATION DISCUSSES OUR RECENT WORK IN DEVELOPING A CONTROL SYSTEM ARCHITECTURE FOR FUTURE TACTICAL RADAR NETWORKS. THIS WORK WAS PERFORMED FOR RADC AS PART OF THE SURVEILLANCE INTERNETTING AND IDENTIFICATION PROGRAM. FROM THE NUMBER OF PROGRAMS ADDRESSING THE ISSUE, ONE CAN CONCLUDE THAT THERE IS WIDESPREAD RECOGNITION OF NEED FOR MULTI-RADAR OPERATIONS -- BOTH TO COUNTER THE GROWING ELECTRONIC THREAT AND TO REALIZE THE FULL POTENTIAL OF THE CAPABILITIES WHICH WILL BE BUILT INTO ADVANCED TACTICAL RADARS.

THE CONTROL SYSTEM ARCHITECTURE WHICH WE HAVE DEVELOPED PROVIDES A METHODOLOGY FOR THE AUTONOMOUS CONTROL OF A NETWORK SUBJECT TO THE PRIORITIES OF THE OPERATORS.

I WILL OUTLINE OUR CONTROL SYSTEM ARCHITECTURE AND SHOW YOU SOME EXAMPLES OF THE CONTROL SYSTEM IN OPERATION ON OUR RADAR NETWORK SIMULATION.

DSA

DSA 437

**A CONTROL SYSTEM ARCHITECTURE FOR
FUTURE TACTICAL RADAR NETWORKS**

T. E. BURKE

G. L. LUCAS

**DECISION-SCIENCE APPLICATIONS, INC.
1901 N. MOORE STREET, SUITE 1000
ARLINGTON, VA 22209**

SEPTEMBER 29, 1982

SURVEILLANCE SYSTEM OVERVIEW

LOOKING AT THE SURVEILLANCE SYSTEM OF THE FUTURE IT IS APPARENT THAT EACH INDIVIDUAL SENSOR WILL POSSESS TREMENDOUS CAPABILITY TO GATHER, PROCESS, AND COMMUNICATE LARGE AMOUNTS OF INFORMATION. THE ADVANCED TACTICAL RADAR WITH ITS AGILE BEAM AND MULTIPLE WAVEFORMS WILL HAVE THE CAPABILITY TO PERFORM A MULTITUDE OF ACTIVITIES IN ESSENTIALLY ANY ORDER DESIRED. THESE CAPABILITIES PROVIDE US WITH THE OPPORTUNITY TO BUILD INTELLIGENCE INTO OUR NETWORKS OF THE FUTURE.

WHILE THE ENTIRE SYSTEM CONTAINS MANY ELEMENTS, OUR WORK HAS THUS FAR CONCENTRATED ON INTELLIGENT CONTROL OF ADVANCED TACTICAL RADARS. FROM THE SYSTEM CHARACTERISTICS AS SHOWN ON THIS SLIDE, WE DERIVED THE DESIGN OBJECTIVES OF OUR CONTROL SYSTEM ARCHITECTURE.

SYSTEM OVERVIEW

SYSTEM DESCRIPTION

- NETWORK OF SURVEILLANCE SYSTEMS
- OPERATED & CONTROLLED AS A SINGLE SYSTEM
- AUTOMATED & INTERACTIVE
- HIGHLY MOBILE & RELIABLE
- MODULAR WITH A MINIMUM OF UNIQUE HARDWARE
- USES NEW & EXISTING SENSORS
- AUTOMATED INTERFACE WITH OTHER SERVICES

SYSTEM FEATURES

- CONTINUOUS AUTOMATIC TRACKING
 - LOW LEVEL COVERAGE
- AUTOMATIC
 - SENIOR RESOURCE MANAGEMENT
 - DATA MANAGEMENT & DISPLAY
- MODULAR OPERATIONS CENTER
 - HIGHLY MOBILE
 - CBR PROTECTED
 - LOW POWER REQUIREMENTS

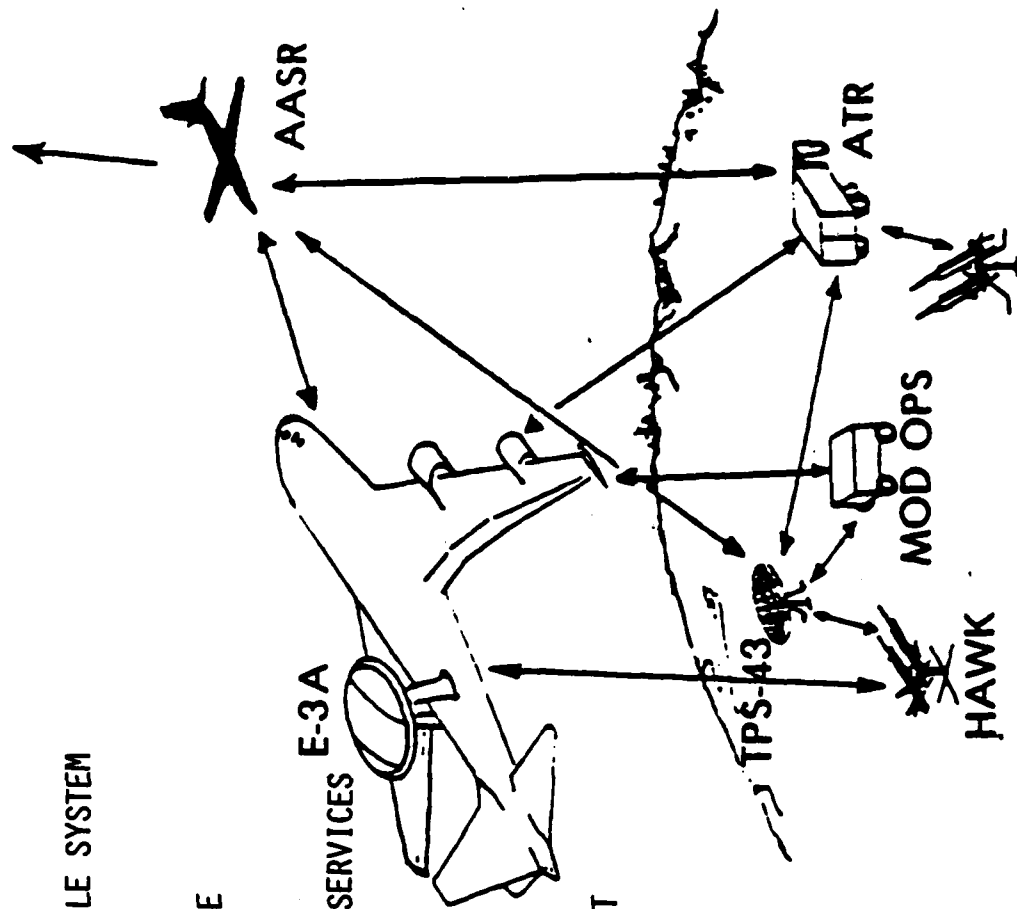

CONTROL SYSTEM DESIGN OBJECTIVES

THE PROJECTIONS OF THE THREAT WHICH WILL FACE THE ADVANCED TACTICAL RADAR ALL ENVISION A DENSE, RAPIDLY CHANGING ENVIRONMENT THAT WILL BE VIRTUALLY BEYOND THE CAPABILITIES OF HUMAN OPERATORS TO HANDLE. FOR THIS REASON, THE SYSTEM MUST OPERATE AUTONOMOUSLY, SUCH THAT WITHOUT HUMAN INTERVENTION IT WILL OPERATE IN A COMMON SENSE AND INTELLIGENT MANNER IN THE DENSE DYNAMIC ENVIRONMENT.

WHILE BEING CAPABLE OF OPERATING AUTOMATICALLY, THE CONTROL SYSTEM MUST BE RESPONSIVE TO OPERATOR PRIORITIES AND PREFERENCES. THE CAPABILITY MUST EXIST FOR THE OPERATOR TO ENTER NEW PRIORITIES IN AN EASY, STRAIGHTFORWARD, AND SIMPLE FASHION.

THE CONTROL SYSTEM DESIGN SHOULD MINIMIZE THE IMPACT UPON THE COMMUNICATIONS LOAD OF THE NETWORK.

SURVIVABILITY OF THE NETWORK FUNCTIONS IS A NECESSITY, AS IS THE CAPABILITY FOR GRACEFUL DEGRADATION AND GRACEFUL ENHANCEMENT OF THE FUNCTIONS AS ELEMENTS OF THE NETWORK BECOME INOPERATIVE OR REJOIN THE NETWORK.

NOT QUITE SO OBVIOUS IS OUR OBJECTIVE TO MAKE THE CONTROL SYSTEM CONCEPTUALLY SIMPLE AND INTUITIVE. WE BELIEVE THAT THE DEGREE OF ACCEPTANCE OF AUTOMATION CONCEPTS IS INVERSELY PROPORTIONAL TO THE COMPLEXITY OF THE CONCEPT.

FINALLY, STRONG EMPHASIS IS PLACED ON A PHILOSOPHY OF DESIGN WHICH COULD BE READILY GENERALIZED, EXTENDED, OR MODIFIED. GENERAL DESIGN PRINCIPLES WERE IDENTIFIED AND REAL OR ILLUSTRATIVE ALGORITHMS WERE DEVELOPED WHERE FEASIBLE. IN THIS WAY, WE BELIEVE THAT OUR CONTROL SYSTEM ARCHITECTURE CAN BE ADAPTED AS NECESSARY TO NEW AND DIFFERENT NETWORK CONCEPTS.

DSA CONTROL SYSTEM DESIGN OBJECTIVES

- OPERATES AUTONOMOUSLY
- RESPONSIVE TO OPERATOR PRIORITIES
- MINIMIZES COMMUNICATION LOAD
- ENHANCES SURVIVABILITY
- CONCEPTUALLY SIMPLE AND INTUITIVE
- READILY MODIFIED AND EXTENDED

IN DEVELOPING THE ARCHITECTURE FOR OUR CONTROL SYSTEM MANY ISSUES WERE CONSIDERED, THE MOST SIGNIFICANT OF WHICH ARE SHOWN ON THIS SLIDE.

MULTI-RADAR SEARCH AND TRACK, WHEREBY RADARS SHARE RESPONSIBILITIES, WAS TREATED IN DETAIL. RESPONSIBILITY FOR SEARCH AND TRACK WAS VARIED AUTOMATICALLY AMONG THE RADARS OF A NETWORK IN ORDER TO EQUALIZE THE LOAD OVER THE NETWORK. IDENTIFICATION WAS TREATED AS A SYSTEM-WIDE FUNCTION, SO THAT A TRACK ONCE IDENTIFIED BY ANY RADAR DID NOT HAVE TO BE RE-IDENTIFIED UNLESS THE TRACK LEFT THE COVERAGE OF THE ENTIRE NETWORK.

THE INTERFACING OF THE OPERATOR AND THE AUTOMATED NETWORK WAS EXAMINED IN DETAIL. PROCEDURES FOR EXPRESSING OPERATOR PREFERENCES CONVENIENTLY AND NATURALLY WERE DEVELOPED. THE ISSUE OF CONTENTION AMONG AN OPERATOR AT A CONTROL CENTER, AN OPERATOR AT AN INDIVIDUAL RADAR, AND THE AUTOMATED SYSTEM WAS EXAMINED.

WE LOOKED AT THE DIFFERENT TYPES OF CONTROL PARAMETERS WHICH ARE APPROPRIATE FOR THE CONTROL OF INDIVIDUAL RADARS AND FOR COMMUNICATION BETWEEN RADARS.

WE TREATED THE ISSUE OF WHERE INFORMATION SHOULD BE STORED, WHERE IT SHOULD BE SENT, WHEN IT SHOULD BE SENT, AND WHERE IT SHOULD BE COMBINED.

THE ISSUE OF CONTROL SYSTEM DESIGN TO INSURE GRACEFUL DEGRADATION WAS EXAMINED IN DETAIL. AUTOMATIC PROCEDURES FOR ENSURING APPROPRIATE NETWORK RESPONSE TO THE LOSS OF A RADAR WERE DEVELOPED, AND OUR CONTROL SYSTEM ALSO PROVIDES AUTOMATIC GRACEFUL ENHANCEMENT OF THE NETWORK FUNCTIONS WHEN RADARS COME BACK INTO THE SYSTEM.

IN ORDER TO CALCULATE THE RESPONSE OF THE NETWORK WE DEVELOPED MEASURES OF EFFECTIVENESS AS AN INTEGRAL PART OF OUR METHODOLOGY.

PERHAPS MOST IMPORTANTLY, WE FOUND THAT IN ORDER TO HAVE A LOOSELY-COUPLED, INTELLIGENT RADAR NETWORK, IT IS NECESSARY TO HAVE INTELLIGENCE BUILT INTO THE INDIVIDUAL RADAR NODES. THIS IS ESPECIALLY IMPORTANT IF THE GOAL OF MINIMUM COMMUNICATIONS IMPACT IS TO BE REALIZED. THEREFORE, WE DESIGNED IN GREAT DETAIL, THE CONTROL STRUCTURE THAT WOULD BE NECESSARY WITHIN AN INDIVIDUAL RADAR SITE.

DSA

CURRENT ACTIVITY CLASSES OF SCHEDULER

- SEARCH
- TRACK INITIATION
- TRACK MAINTENANCE
- IDENTIFICATION
- TRACK DROP

CONTROL SYSTEM ARCHITECTURE

THIS SLIDE ILLUSTRATES THE BASIC ARCHITECTURE FOR THE CONTROL SYSTEM. COMMUNICATION PROCESSORS AND OTHER PROCESSING ACTIVITIES NOT DIRECTLY RELATED TO THE CONTROL ARCHITECTURE ARE NOT SHOWN. THE COMMAND CENTER IS THE UPPER LEVEL CONTROL FOR THE SYSTEM. ITS FUNCTION, IN ESSENCE, IS TO CONTROL THOSE ACTIVITIES THAT REQUIRE DECISIONS AFFECTING MORE THAN ONE RADAR. IN OUR SCHEME, THE COMMAND CENTER SHOULD NOT NECESSARILY BE ASSOCIATED WITH ANY PARTICULAR ELEMENT OF OUR EXISTING TACTICAL AIR CONTROL SYSTEM (TACS). IT MAY BE LOCATED AT ANY RADAR NODE OR AT AN INDEPENDENT SITE, OR MAY EVEN BE MOVED DYNAMICALLY FROM SITE TO SITE. SYSTEM OPERATORS, HOWEVER, ARE ASSUMED TO BE LOCATED AT THE COMMAND CENTER.

THE DOTTED LINE ENCLOSSES THE TWO ELEMENTS WHICH COMPRISE EACH INDIVIDUAL RADAR SITE. THESE ARE THE LOCAL CONTROLLER AND THE SCHEDULER. THE SCHEDULER ON A DYNAMIC BASIS SELECTS FROM A LARGE NUMBER OF CANDIDATE ACTIVITIES THE ONE PARTICULAR ACTIVITY THAT THE RADAR WILL DO NEXT. ACTIVITIES ARE DRAWN FROM VARIOUS CLASSES SUCH AS: SEARCH, TRACK OR IDENTIFICATION. MATHEMATICALLY, THE SCHEDULER WORKS SIMPLY BY SELECTING THE MOST VALUABLE ACTIVITY AT EACH DECISION POINT AND ACTIVATING IT. THE VALUE OF EACH ACTIVITY IS DETERMINED BY THE USE OF VALUE-FUNCTIONS, THE BASIS OF OUR METHODOLOGY, WHICH UNFORTUNATELY I CANNOT COVER IN THIS PRESENTATION. I WILL BE GLAD TO MEET LATER WITH ANY OF YOU WHO WOULD LIKE TO KNOW THE DETAILS OF OUR VALUE FUNCTIONS.

THE LOCAL CONTROLLER HAS TWO PRINCIPLE FUNCTIONS. THE FIRST IS THE SELECTION OF CANDIDATE ACTIVITIES FOR INCLUSION IN OR DELETION FROM THE ACTIVITY SETS OF THE SCHEDULER. THE SECOND FUNCTION IS TO DYNAMICALLY ADJUST THE CONTROL PARAMETERS OF THE SCHEDULER IN RESPONSE TO CHANGES IN THE ENVIRONMENT OR TO INITIATIVES FROM THE COMMAND CENTER.

DSA

CONTROL SYSTEM ARCHITECTURE

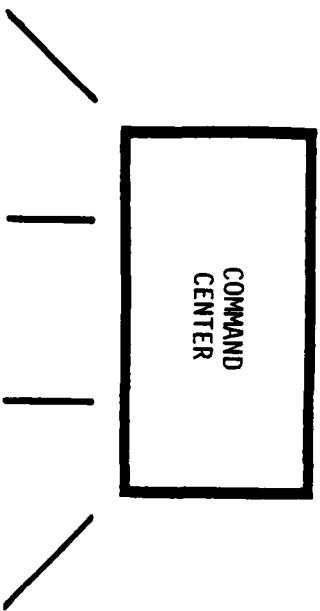

SETS SYSTEM OBJECTIVES, OBSERVES UNFOLDING AIR BATTLE, MODIFIES OBJECTIVES TO CORRESPOND TO CHANGING CONDITIONS, AND TRANSMITS OBJECTIVES TO INDIVIDUAL RADARS.

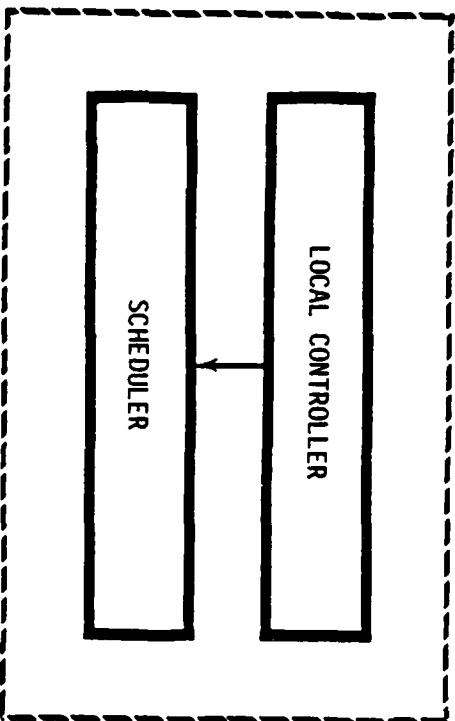

DETERMINE ACTIVITIES TO CONSIDER AS CANDIDATES FOR SCHEDULING AND ADJUSTS CONTROL PARAMETERS TO MEET SYSTEM OBJECTIVES.

SELECT ACTIVITIES TO OPTIMIZE SCHEDULE SUBJECT TO CONSTRAINTS ON RADAR.

CURRENT ACTIVITY CLASSES OF SCHEDULER

AT THE PRESENT TIME, THERE ARE FIVE ACTIVITY CLASSES FROM WHICH THE SCHEDULER CAN SELECT ACTIVITIES AS SHOWN ON THIS SLIDE. WITHIN SEARCH, EACH SECTOR IS SEPARATELY SCHEDULED; AND WITHIN THE TRACK CLASS, EACH TRACK IS SEPARATELY SCHEDULED. EVERY POSSIBLE ACTIVITY, REGARDLESS OF CLASS IS CONSIDERED FOR SCHEDULING AT EVERY DECISION POINT.

DSA

MAJOR AREAS, ADDRESSED

- NETWORK SEARCH, TRACK, IDENTIFICATION
- OPERATOR INTERFACE
- CONTROL PARAMETERS
- COMMUNICATION
- INFORMATION MANAGEMENT
- SURVIVABILITY
- MEASURES OF EFFECTIVENESS
- INDIVIDUAL RADAR CONTROL

FUNCTIONS OF LOCAL CONTROLLER

THE TWO PRINCIPLE FUNCTIONS OF THE LOCAL CONTROLLER ARE EXPANDED ON THIS SLIDE. IT IS THE ABILITY OF THE LOCAL CONTROLLER TO SELECT WHICH ACTIVITIES ARE TO BE CONSIDERED IN THE SCHEDULE BASED UPON THE DYNAMIC ENVIRONMENT OR DIRECTIVES OF THE COMMAND CENTER WHICH MAKES EACH RADAR NODE AN INTELLIGENT DECISION ENTITY.

ALSO, EACH RADAR SITE HAS A LOCAL OPERATOR WHO CAN OVERRIDE THE AUTOMATIC FUNCTIONS OF THE LOCAL CONTROLLER AS NECESSARY TO INSURE THAT THE SYSTEM IS RESPONSIVE TO HIS PREFERENCES.

DSA

FUNCTIONS OF LOCAL CONTROLLER

- SELECTS ACTIVITIES FOR INCLUSION IN SCHEDULER
CANDIDATE SET
- SELECTS ACTIVITIES FOR REMOVAL FROM SCHEDULER
CANDIDATE SET
- ADJUSTS PARAMETERS IN SCHEDULER'S VALUE FUNCTIONS
- RESPONDS TO DIRECTIONS FROM COMMAND CENTER

FUNCTIONS OF COMMAND CENTER

THE FUNCTIONS OF THE COMMAND CENTER ARE SHOWN ON THIS SLIDE. THE COMMAND CENTER, AS THE NAME IMPLIES, PROVIDES DIRECTION FOR THE NETWORK. SYSTEM OPERATORS ARE LOCATED AT THE COMMAND CENTER, WHERE THEY CAN OVERRIDE EVERY AUTOMATIC FUNCTION AND LOCAL OPERATOR IN THE SYSTEM.

OUR TREATMENT OF NETWORK SEARCH AND TRACK FOLLOWS QUITE NATURALLY ONCE INTELLIGENCE HAS BEEN BUILT INTO THE LOCAL DECISION NODES. ESSENTIALLY, THE ASSIGNMENT OF RESPONSIBILITY TO EACH RADAR VARIES SUCH THAT THE SYSTEM LOAD TENDS TO BE EVENLY DISTRIBUTED OVER THE INDIVIDUAL RADARS.

THE NETWORK EMPLOYS THE CONCEPT OF SYSTEM AND LOCAL TRACKS, IN WHICH EACH RADAR MAINTAINS ITS OWN LOCAL TRACKS AND THE COMMAND CENTER MAINTAINS SYSTEM TRACKS, WHICH ARE COMPOSITES OF THE LOCAL TRACKS.

DSA **FUNCTIONS OF COMMAND CENTER**

- CONTROL OF NETWORK ACTIVITIES THAT REQUIRE MORE THAN ONE RADAR
- CAN BE LOCATED AT INDEPENDENT SITE OR AT ONE OF THE RADAR SITES
- LOCATION OF SYSTEM OPERATORS WHO SET NETWORK OBJECTIVES AND WHO CAN OVERRIDE AUTOMATIC OPERATION ,
- OBSERVES AND RESPONDS TO DYNAMICALLY CHANGING ENVIRONMENT
- MODIFIES OBJECTIVES OF LOCAL CONTROLLERS TO ACHIEVE NETWORK GOALS

RNET-OPERATOR'S STATION

IN THE SHORT TIME REMAINING, I WILL TURN TO A DEMONSTRATION OF A FEW RESULTS WHICH WE HAVE OBTAINED USING OUR NETTED RADAR SIMULATION, RNET. I HAVE CHOSEN THREE SIMPLE CASES WHICH WILL ILLUSTRATE THE BEHAVIOR OF THE CONTROL SYSTEM IN RNET.

THE OPERATOR'S STATION IS DEPICTED ON THIS SLIDE. WE HAVE A TERMINAL, IN THE CENTER, FOR COMMUNICATING WITH THE COMPUTER. ON THE RIGHT IS A TEKTRONIX GRAPHICS DISPLAY WHICH ALLOWS THE OPERATOR TO VIEW ANY SCENARIO, AT ANY TIME, IN GREAT DETAIL. ON THE LEFT THERE IS A TEKTRONIX HARD COPY UNIT FOR PERMANENTLY RECORDING ANY OF THE GRAPHICS DISPLAYS.

THE COMMAND SCREEN WHICH COMES UP ON THE OPERATOR'S TERMINAL IS THE HEART OF THE INTERACTIVE SYSTEM.

RNET-OPERATOR'S STATION

DSA

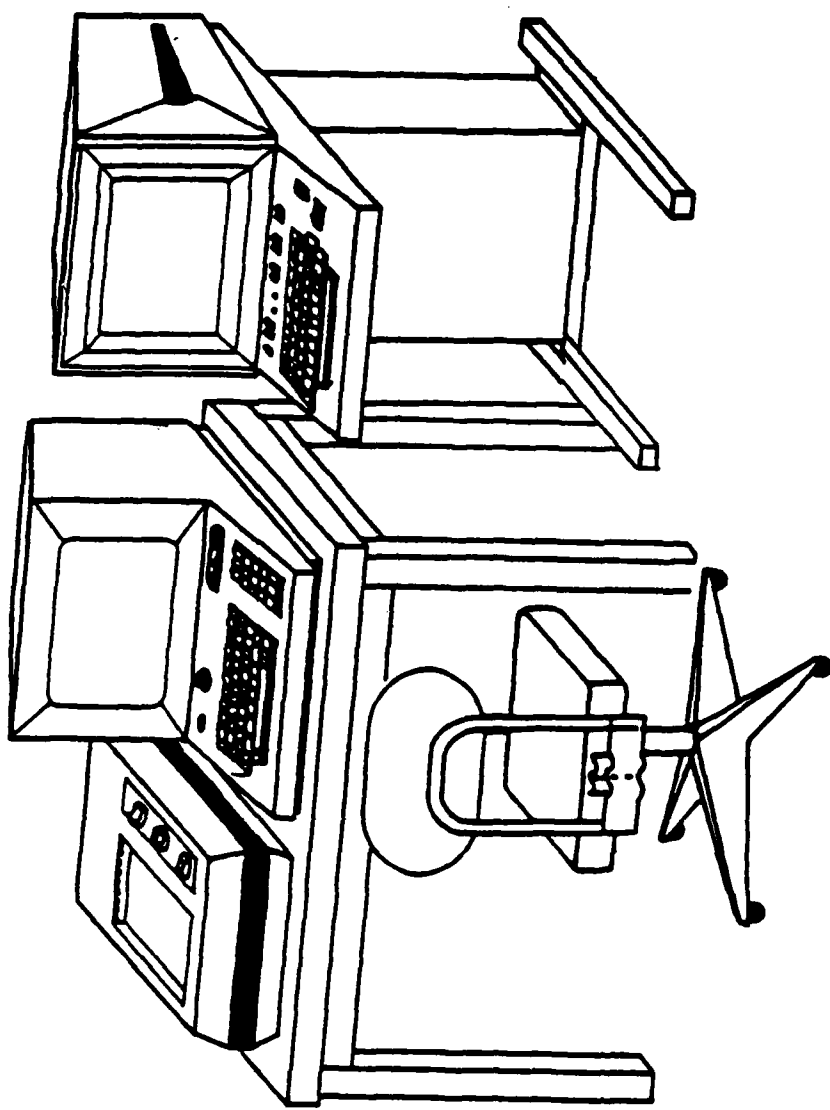

RNET

THE MAJOR FEATURES OF THE RNET SIMULATION ARE SHOWN HERE. WE HAVE USED THE SIMULATION TO DEVELOP THE RADAR AND RADAR NETWORK OF OUR CONTROL ARCHITECTURE.

IT IS HIGHLY INTERACTIVE WHICH PERMITS THE USER A WIDE VARIETY OF OPTIONS FOR ANALYZING SYSTEM PERFORMANCE.

THE GRAPHICS DISPLAYS PROVIDE A VISUAL AID IN THE ANALYSIS.

THE STRUCTURE OF RNET ALLOWS EXAMINATION OF SCENARIOS WHICH ARE OF THE COMPLEXITY AS USED IN THE SEEK SCREEN STUDY--SOMETHING THAT WE FEEL IS VERY IMPORTANT IN OBTAINING MEANINGFUL RESULTS.

IT IS VERY FAST RUNNING--ESSENTIALLY REAL TIME--AND EASILY MODIFIED TO ACCEPT DIFFERENT SCENARIOS OR NETWORK CONCEPTS.

DSA

RNET

- TEST-BED FOR DEVELOPING RADAR AND RADAR NETWORK
AUTOMATIC CONTROL ALGORITHMS
- MONTE-CARLO INTELLIGENT RADAR NETWORK SIMULATION
- ¹
HIGHLY INTERACTIVE
- GRAPHICS DISPLAYS ALLOW USER TO VIEW SCENARIO DEVELOPMENT
- SCENARIO OF DETAIL OF "SEEK SCREEN"
- FAST RUNNING
- EASILY MODIFIED

INTERFACE TO RNET AS SEEN ON THE OPERATOR'S CONSOLE

THE COMMAND SCREEN PERMITS THE OPERATOR TO SELECT ANY ONE OF 20 POSSIBLE ACTIONS AT EACH TIME STEP IN THE SIMULATION. TIME DOES NOT ALLOW ME TO DESCRIBE WHAT ACTION WILL RESULT FROM EACH SELECTION, BUT I DO WANT TO MENTION FOUR.

IN THE LEFT COLUMN, NO. 18 PERMITS THE OPERATOR TO SELECT THE TIME OF THE NEXT STOP IN THE SIMULATION RUN WHEN HE MAY EXAMINE IN DETAIL WHAT IS TRANSPIRING. IN THE RIGHT COLUMN, NO. 21 PERMITS THE OPERATOR TO SELECT THE SCALING OF THE DISPLAY ON THE TEKTRONIX GRAPHICS SCREEN SO THAT HE CAN OBTAIN AS MUCH DETAIL AS NEEDED. ALSO ON THE RIGHT, NO. 23 CHECKPOINT, PROVIDES ONE OF THE MOST USEFUL FEATURES AS IT WILL ALLOW THE OPERATOR TO SAVE THE CURRENT STATE OF THE SIMULATION. THEN, AT SOME TIME LATER HE CAN RESET THE SIMULATION TO THE POINT SAVED, CHANGE CONDITIONS IF DESIRED AND RERUN THE SIMULATION TO OBSERVE THE RESULT OF HIS CHANGE. NO. 20, AT THE TOP OF THE RIGHT COLUMN PROVIDES A DETAILED TRACE OF THE ACTION OF THE SCHEDULER WITHIN ANY RADAR. I WOULD LIKE TO SHOW YOU AN EXAMPLE OF A RADAR TRACE.



INTERACTIVE INTERFACE TO RNET AS SEEN ON THE OPERATOR'S CONSOLE

RNET USER INTERFACE TIME = 2.500

SELECT ACTION - -

- | | | | |
|-----|----------------|-----|--------------------|
| 10. | AIRCRAFT | 20. | RADAR TRACE |
| 11. | MISSILES | 21. | ZOOM |
| 12. | RADARS | 22. | DISPLAY LABELS |
| 13. | RADAR SECTORS | 23. | CHECKPOINT |
| 14. | RADAR TRACKS | 24. | PRINT OPTIONS |
| 15. | NETWORK SEARCH | 25. | CONTINUE |
| 16. | NETWORK TRACK | 26. | NON-STOP CONTINUE |
| 17. | RADAR KILL | 27. | HARD COPY |
| 18. | SNAPSHOT | 28. | HARD COPY NON-STOP |
| 19. | AIRCRAFT TRACE | 29. | ABORT |

OPERATION OF THE RADAR SCHEDULER

THIS SLIDE SHOWS A PRINTOUT OF THE OPERATION OF THE SCHEDULER OF ONE RADAR FOR ABOUT 30 SECONDS. NOTE THAT THE SECTOR SEARCH AND TRACK UPDATE ACTIVITIES ARE INTERMINGLED IN NO PRESET ORDER. WE HAVE ONLY ONE TRACK IN THE SYSTEM AT THIS TIME. THE SCHEDULER IS SELECTING EACH ACTIVITY ON A DYNAMIC BASIS TO MAXIMIZE ITS VALUE FUNCTION AND NOT TO FOLLOW AN ARBITRARY SCHEDULE.

IN THE MIDDLE OF THE PRINTOUT YOU WILL SEE A NOTE THAT THE AIRCRAFT IS MANEUVERING AND THE SCHEDULER SHOULD ADJUST THE REVISIT TIME. THIS NOTE COMES FROM THE LOCAL CONTROLLER IN THE FORM OF A CHANGE TO THE VALUE CONTROL PARAMETERS. THE RESULT IS, AS YOU CAN SEE IN THE BOTTOM OF THE PRINTOUT, THAT THE SCHEDULER UPDATES THE TRACK MUCH MORE FREQUENTLY.

WE CAN SEE THIS CHANGE IN TRACK UPDATE RATE MORE VIVIDLY IF WE PLOT THE REVISTS ON A TIME SCALE.



OPERATION OF THE RADAR SCHEDULER FOR MANEUVERING AIRCRAFT

TRACK UPDATE: TRK	1	RANGE	23.74	SECTOR 2	TRUE ID 600
SEARCH: SECTOR	9	TIME	4.642		
SEARCH: SECTOR	5	TIME	4.645		
SEARCH: SECTOR	1	TIME	4.648		
SEARCH: SECTOR	10	TIME	4.655		
SEARCH: SECTOR	6	TIME	4.683		
SEARCH: SECTOR	11	TIME	4.707		
SEARCH: SECTOR	10	TIME	4.725		
SEARCH: SECTOR	5	TIME	4.728		
SEARCH: SECTOR	1	TIME	4.731		
SEARCH: SECTOR	6	TIME	4.748		
TRACK UPDATE: TRK	1	RANGE	25.30	SECTOR 2	TRUE ID 600
SEARCH: SECTOR	4	TIME	4.750		
SEARCH: SECTOR	2	TIME	4.753		
SEARCH: SECTOR	3	TIME	4.755		
SEARCH: SECTOR	13	TIME	4.775		
SEARCH: SECTOR	10	TIME	4.793		
SEARCH: SECTOR	6	TIME	4.811		
SEARCH: SECTOR	5	TIME	4.813		
SEARCH: SECTOR	1	TIME	4.816		
SEARCH: SECTOR	7	TIME	4.841		
TRACK UPDATE: TRK	1	RANGE	26.30	SECTOR 2	TRUE ID 600
AIRCRAFT MANEUVERING: ADJUST		REVISIT	TIME		
SEARCH: SECTOR	10	TIME	4.858		
SEARCH: SECTOR	8	TIME	4.881		
SEARCH: SECTOR	6	TIME	4.899		
SEARCH: SECTOR	4	TIME	4.901		
SEARCH: SECTOR	5	TIME	4.904		
SEARCH: SECTOR	2	TIME	4.906		
SEARCH: SECTOR	1	TIME	4.909		
SEARCH: SECTOR	10	TIME	4.926		
SEARCH: SECTOR	3	TIME	4.928		
SEARCH: SECTOR	9	TIME	4.953		
TRACK UPDATE: TRK	1	RANGE	27.32	SECTOR 2	TRUE ID 600
SEARCH: SECTOR	6	TIME	4.970		
SEARCH: SECTOR	15	TIME	4.995		
SEARCH: SECTOR	10	TIME	5.012		
TRACK UPDATE: TRK	1	RANGE	27.32	SECTOR 2	TRUE ID 600
SEARCH: SECTOR	5	TIME	5.015		
SEARCH: SECTOR	1	TIME	5.018		
SEARCH: SECTOR	14	TIME	5.036		
SEARCH: SECTOR	6	TIME	5.054		
TRACK UPDATE: TRK	1	RANGE	27.32	SECTOR 2	TRUE ID 600

ADJUSTMENT OF TRACK REVIST TIME

HERE IS THE TIME PLOT FOR TWO MINUTES MARKING EACH TRACK UPDATE ACTIVITY. RECALL, THERE IS ONLY ONE TRACK. IT IS CLEAR THAT DURING THE FIRST MINUTE THE SCHEDULER UPDATED THE TRACK ABOUT ONCE EVERY 8 OR 9 SECONDS. WHEN THE AIRCRAFT MANEUVERS, THE UPDATE RATE INCREASES TO ABOUT ONCE EVERY 2 SECONDS UNTIL THE AIRCRAFT CEASES ITS MANEUVER.

THIS IS A SINGLE EXAMPLE OF THE INTELLIGENCE WHICH HAS BEEN BUILT INTO THE LOCAL RADAR NODES. I'LL TURN NOW TO A TWO RADAR NETWORK EXAMPLE

DSA

**ADJUSTMENT OF TRACK REVISIT
TIME FOR MANEUVERING AIRCRAFT**

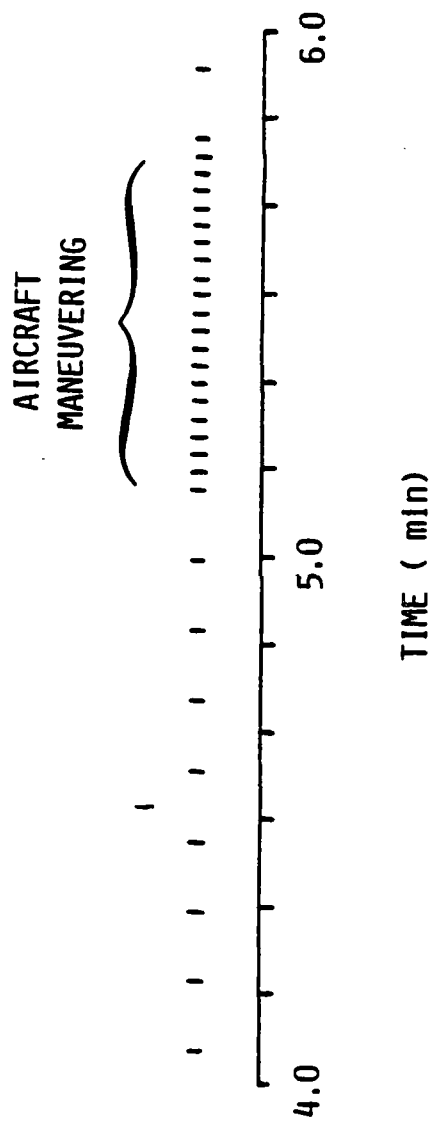

RADAR COVERAGE LIMITS, TWO RADARS

THE GEOMETRY OF A TWO RADAR CASE IS SHOWN ON THIS SLIDE. THE TWO RADARS ARE LOCATED ABOUT 45 NAUTICAL MILES APART. AIRCRAFT F6-0 WILL FLY THE COURSE AS SHOWN. THE COVERAGE LIMITS ILLUSTRATED ARE THOSE FOR AN AIRCRAFT AT 2000 FT., WHICH IS WHERE AIRCRAFT 6 IS FLYING. THE INPUT DATA HAS SPECIFIED THAT THE NETWORK IS TO TRACK THE AIRCRAFT AT AN ACCURACY OF 50 METERS. WE WISH TO OBSERVE HOW THE COMMAND CENTER--WHICH IS NOT SHOWN IN THE PICTURE--WILL ASSIGN RESPONSIBILITY, AND HOW THE RADARS WILL REACT TO THEIR ASSIGNMENTS.

DSA

RADAR COVERAGE, LIMITS, TWO RADARS

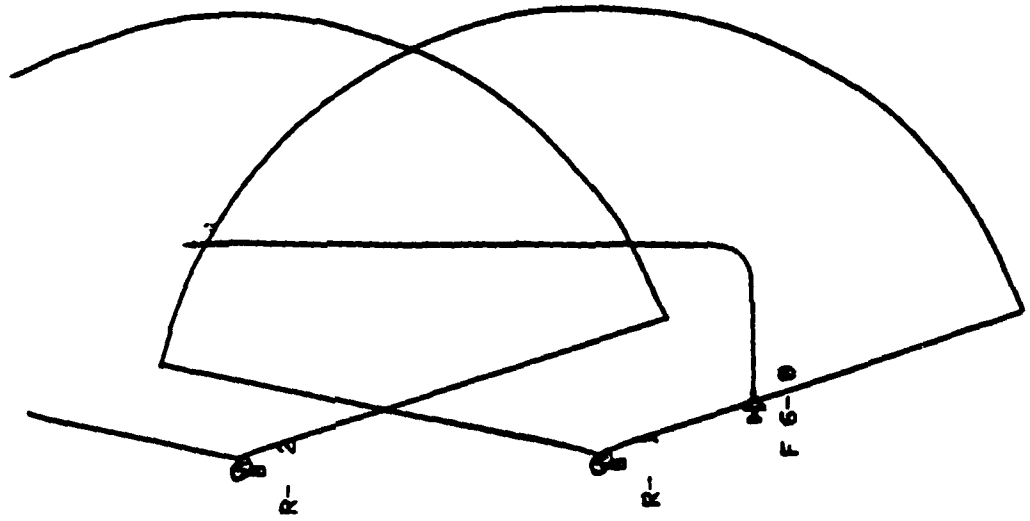

DIVISION OF RESPONSIBILITY FOR TRACKING ACCURACY

THIS PLOT SHOWS US HOW THE TWO RADARS COOPERATE TO TRACK AN AIRCRAFT TO THE DESIRED TRACKING ACCURACY. THE TWO RADARS ARE SHOWN AT THE BOTTOM OF THE PLOT. OUR AIRCRAFT F-6 FLIES FROM LEFT TO RIGHT. THE SOLID BLACK LINES SHOW THE ACCURACY WITH WHICH EACH RADAR MUST TRACK THE AIRCRAFT--THIS IS AUTOMATICALLY ASSIGNED BY THE COMMAND CENTER. THE DASHED BLACK LINES SHOW THE ACCURACY WITH WHICH THE RADAR IS ACTUALLY TRACKING AIRPLANE 6. NOTE THAT THE RADARS DO BETTER THAN ASKED. THIS IS A FEATURE OF OUR INTELLIGENT RADARS IN THAT THEY ALWAYS DO THEIR BEST--USUALLY BETTER THAN REQUIRED. THE RESULT OF THE COMBINED EFFORT IS A NETWORK TRACK MAINTAINED BY THE COMMAND CENTER WHICH KNOWS THE LOCATION OF THE AIRCRAFT WITH AN ACCURACY AS SHOWN BY THE BLUE LINE. SO, WE SEE THAT NETWORK TRACKING THE COMMAND CENTER IS CAPABLE OF DYNAMICALLY ASSIGNING RESPONSIBILITY AMONG THE VARIOUS RADARS IN ORDER TO ACHIEVE SYSTEM WIDE GOALS.

THIS PARTICULAR CASE ALSO PROVIDES A CHANCE TO EXAMINE THE GRACEFUL DEGRADATION FEATURE OF OUR SYSTEM. LET US SEE WHAT WOULD HAPPEN IF RADAR TWO WERE TO BECOME INOPERATIVE DURING THE RUN.

**DIVISION OF RESPONSIBILITY FOR
TRACKING ACCURACY BETWEEN TWO
NETTED RADARS WITH EQUAL LOADS**

DSA

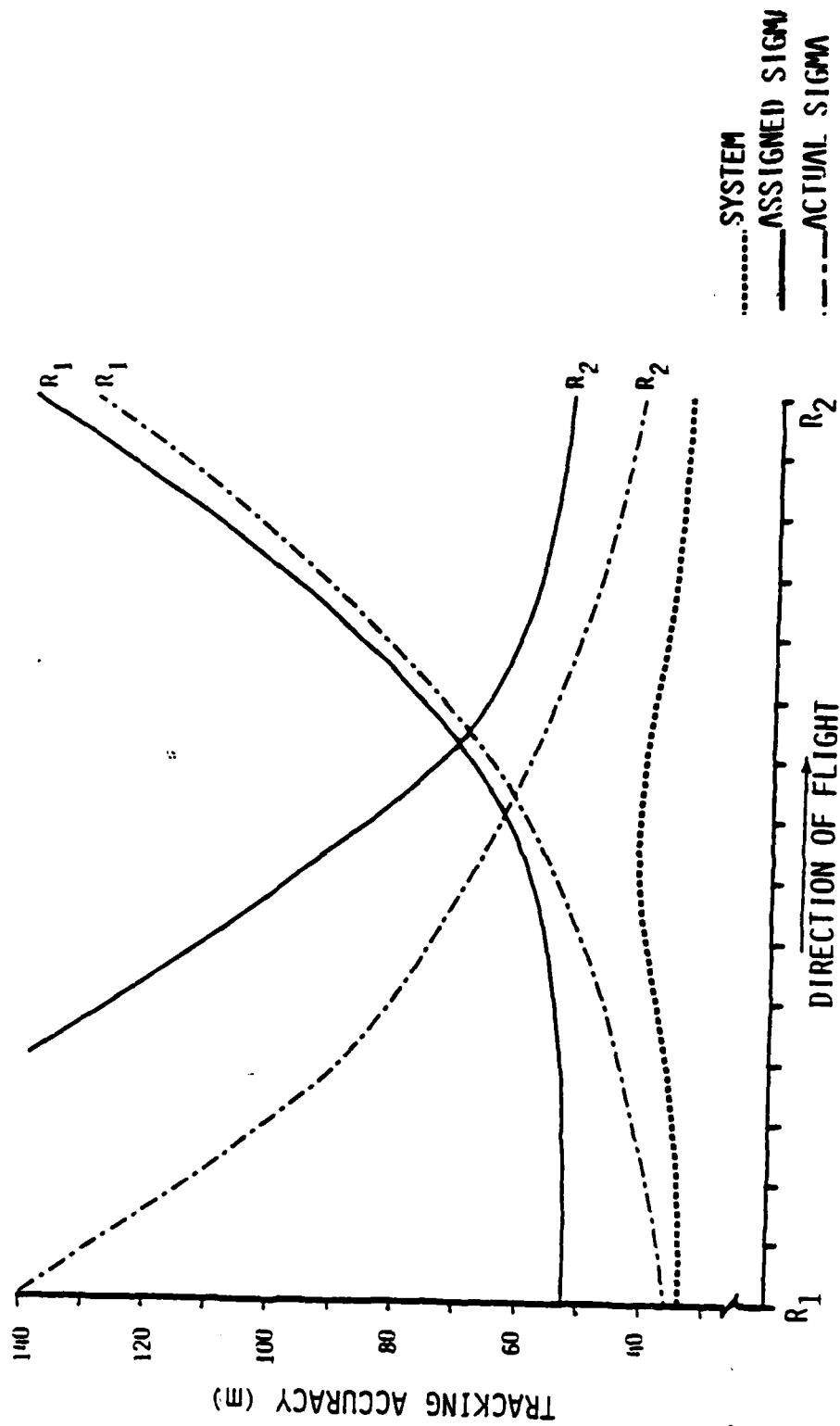

DIVISION OF RESPONSIBILITY WHEN ONE RADAR CEASES OPERATION

HERE WE SEE THE RESULTS OF THE NETWORK TRACKING FUNCTION WHEN RADAR TWO BECOMES INOPERATIVE AT ABOUT THE TIME OUR AIRCRAFT IS HALFWAY BETWEEN THE TWO RADARS. NOTE, THE COMMAND CENTER AUTOMATICALLY ADJUSTED THE ASSIGNED ACCURACY OF RADAR ONE TO ASSUME THE ENTIRE LOAD. NOTE, ALSO, RADAR ONE RESPONDED BY INCREASING ITS ACTUAL TRACKING ACCURACY TO MEET SYSTEM REQUIREMENTS. IN THIS PARTICULAR CASE, BECAUSE OF THE DISTANCE TO THE TARGET, RADAR ONE IS NOT ABLE TO ACHIEVE THE SYSTEM WIDE GOAL--IT DOES ITS BEST CONSISTENT WITH ALL OF ITS ASSIGNED RESPONSIBILITIES.

FINALLY, I'LL SHOW AN EXAMPLE OF A LARGER NETWORK SCENARIO.

DSA

**DIVISION OF RESPONSIBILITY FOR TRACKING
ACCURACY BETWEEN TWO NETTED RADARS
WHEN ONE CEASES OPERATION**

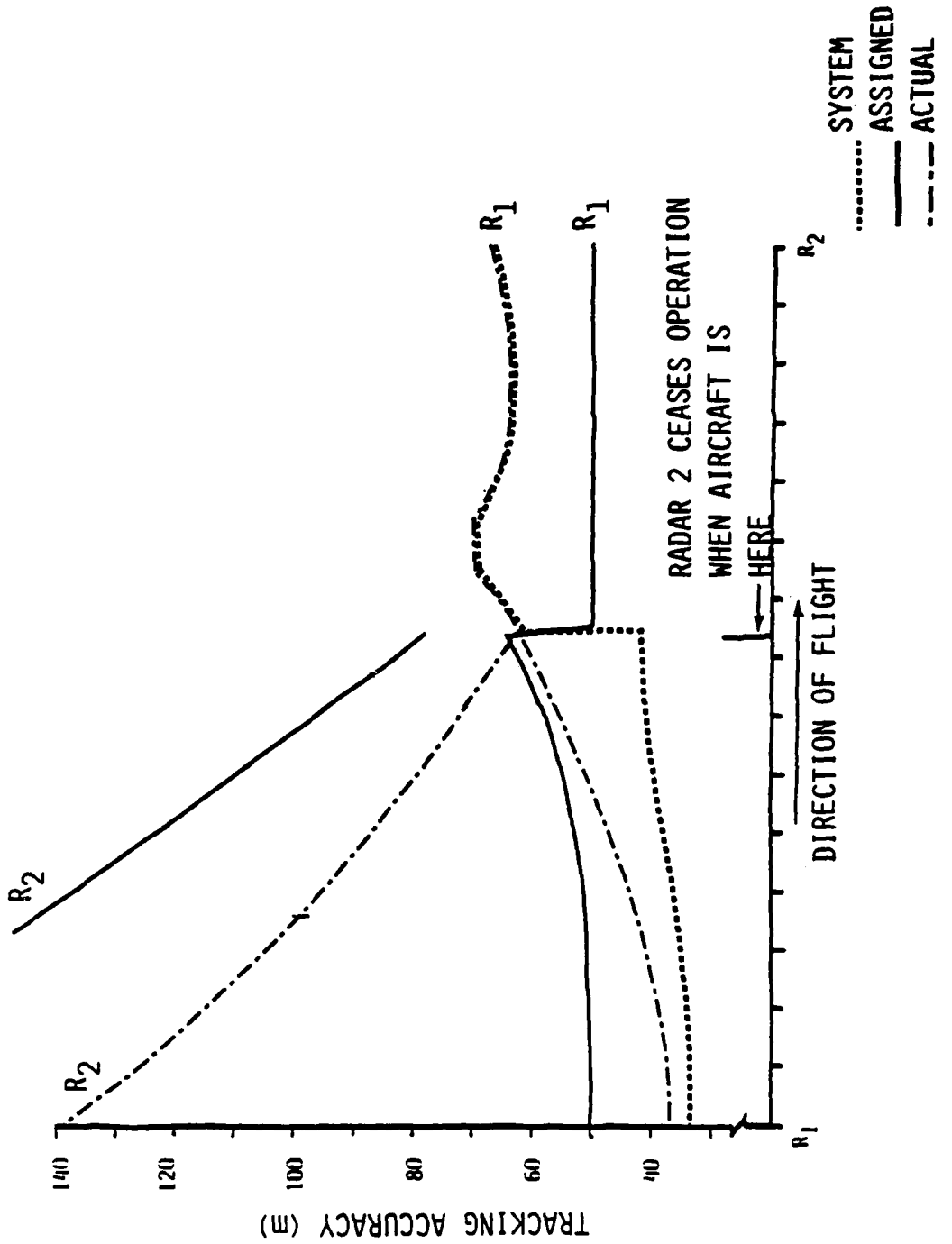

FIVE RADAR SCENARIO

THIS SLIDE IS MADE FROM THE TEKRONIX HARD COPY UNIT. WE HAVE FIVE RADARS NEAR THE CENTER OF THE PICTURE. A SEMI-CIRCLE OF AIRCRAFT BEHIND THE RADARS REPRESENT DEFENDING INTERCEPTORS. THE MASS TO THE RIGHT OF THE RADARS IS A LARGE FORMATION OF ATTACKING AIRCRAFT. THE AIRCRAFT IN THE UPPER LEFT REPRESENTS AN AWACS, AND THE ODD SHAPED OBJECTS POINTING TOWARD THE AWACS ARE THREE AIR-TO-AIR MISSILES WHICH HAVE BEEN FIRED AT THE AWACS. THESE MISSILES ARE OF VERY LOW CROSS SECTION, ARE TRAVELING AT ABOUT MACH 2, AND, ARE ABOUT 100 MILES FROM RADAR TWO. WE HAVE SPECIFIED THAT THE MISSILES ARE THE MOST IMPORTANT OBJECTS TO TRACK, AND THAT THEY BE TRACKED WITH AN ACCURACY OF 50 METERS. THIS TRACKING ACCURACY FOR THESE TARGETS IS ESSENTIALLY AN IMPOSSIBILITY FOR THE INDIVIDUAL RADARS. THIS SNAPSHOT LOOK IS TAKEN AFTER THE SCENARIO HAS BEEN DEVELOPING FOR 21 MINUTES.

I WANT TO SHOW YOU TWO SITUATIONS FOR THIS EXAMPLE. WE WILL LOOK AT ONE CASE WHERE THE RADARS ARE OPERATING INDEPENDENTLY AND AT A SECOND CASE WHERE THE RADARS ARE OPERATING WITH THE COMMAND CENTER DYNAMICALLY ASSIGNING AND REASSIGNING SEARCH AND TRACKING RESPONSIBILITIES. FIRST, - HOWEVER, LET ME SHOW YOU HOW WE CAN USE THE INTERACTIVE GRAPHICS TO EXAMINE IN MORE_DETAIL THE MASSIVE RAID WHICH IS JUST A 'BLOB' IN THIS PICTURE.

DSA

FIVE RADAR SCENARIO



12X EXPANSION OF RAID

THIS IS AN EXPANSION BY A FACTOR OF ABOUT TWELVE OF THE RAID. NOTE THE AIRCRAFT FORMATIONS. THE 'STAR' ON THE FRONT OF SOME AIRCRAFT INDICATE THAT THEY ARE ACTIVELY JAMMING.

NOW BACK TO THE LOADING ON THE RADARS WHEN THEY ARE NOT NETTED.

DSA

12 X EXPANSION OF RAID

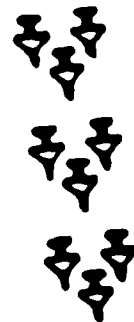
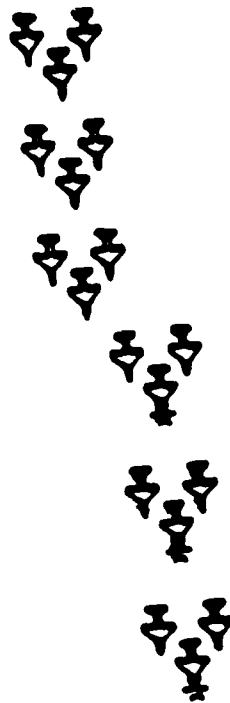

DYNAMIC LOADING--NO NETWORK

THIS PLOT SHOWS THE DYNAMIC LOADING OF THREE OF THE RADARS AS THE RAID PROGRESSES.. THE SPIKES IN THE DYNAMIC LOAD CORRESPOND TO THE FLIGHT OF THE AIR-TO-AIR MISSILES AT ABOUT THE 20 MINUTE TIME, AND AGAIN 10 MINUTES LATER. IN THIS CASE, THE RADARS ARE ACTING INDEPENDENTLY, EACH TRYING TO ACHIEVE THE REQUIRED 50 METER TRACKING ACCURACY. FOR RADAR 2, THE TASK IS IMPOSSIBLE AND THE RADAR BECOMES OVERLOADED. FOR RADARS FIVE AND NINE, THE TASK IS NOT QUITE IMPOSSIBLE, BUT DOES CAUSE A SEVERE STRAIN. THE DIFFERENCE IN THE EFFECT ON THE RADARS IS DUE TO THE DISTANCE FROM THE RADARS TO THE MISSILES.

DSA DYNAMIC LOADING OF SELECTED RADARS

DSA

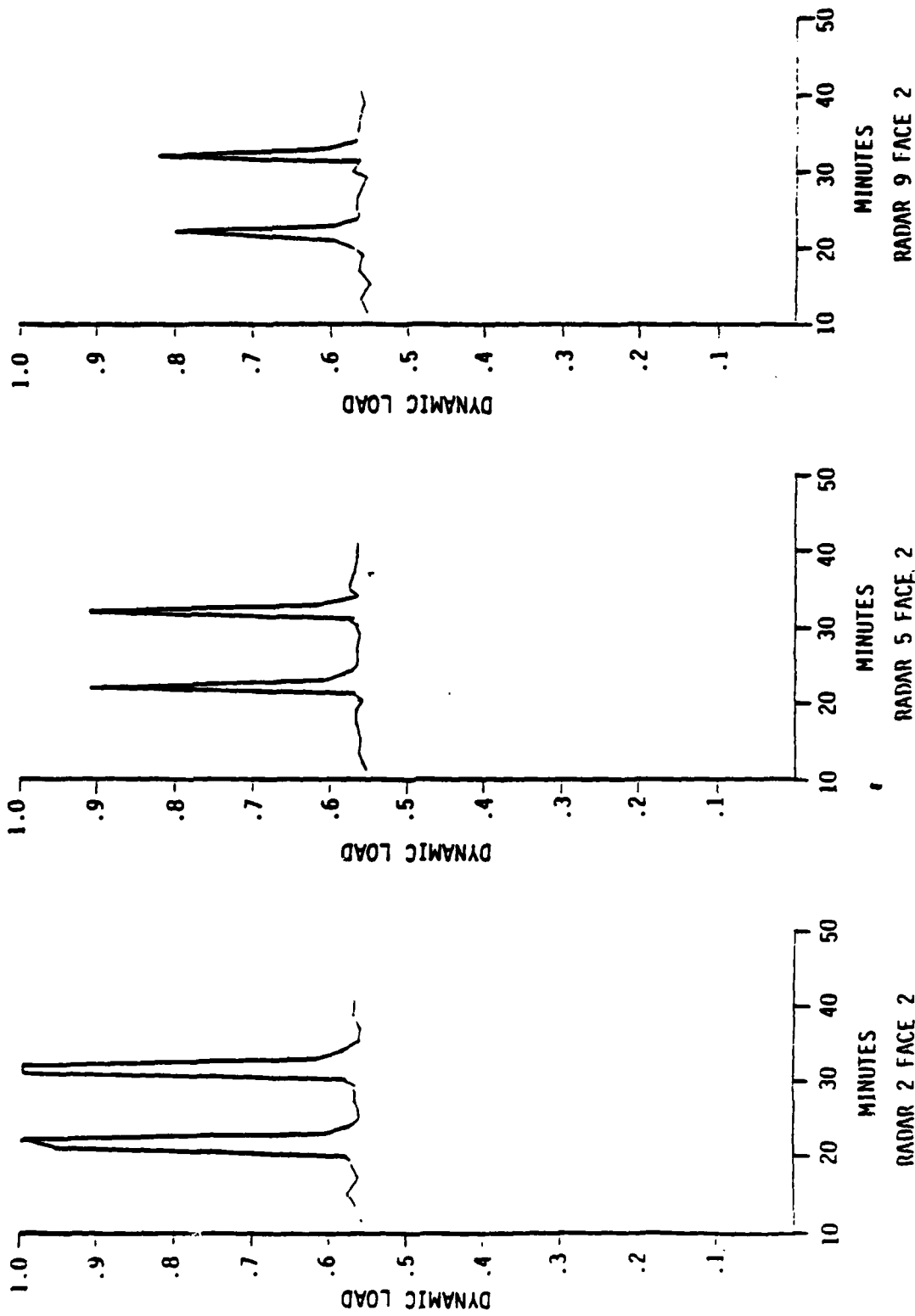

DYNAMIC LOADING--NETWORK ON

NOW LOOK AT WHAT HAPPENS WHEN WE LET THE COMMAND CENTER ACT AS AN INTELLIGENT NETWORK CONTROLLER. THE REQUIREMENT TO TRACK THE MISSILES REMAINS THE SAME, BUT NOW THE RADARS ARE COOPERATING AND AS A RESULT, NONE OF THEM BECOME OVERLOADED AND THE SYSTEM-WIDE GOAL IS MET. THIS IS RATHER DRAMATIC EVIDENCE OF THE VALUES TO BE GAINED BY AN INTERNETTING PROGRAM.

**COMPARISON OF DYNAMIC LOADING OF RADARS
WHEN NETTED AND NOT NETTED
(LOWER PLOT IN EACH INSTANCE IS FOR NETTED CASE)**

DSA

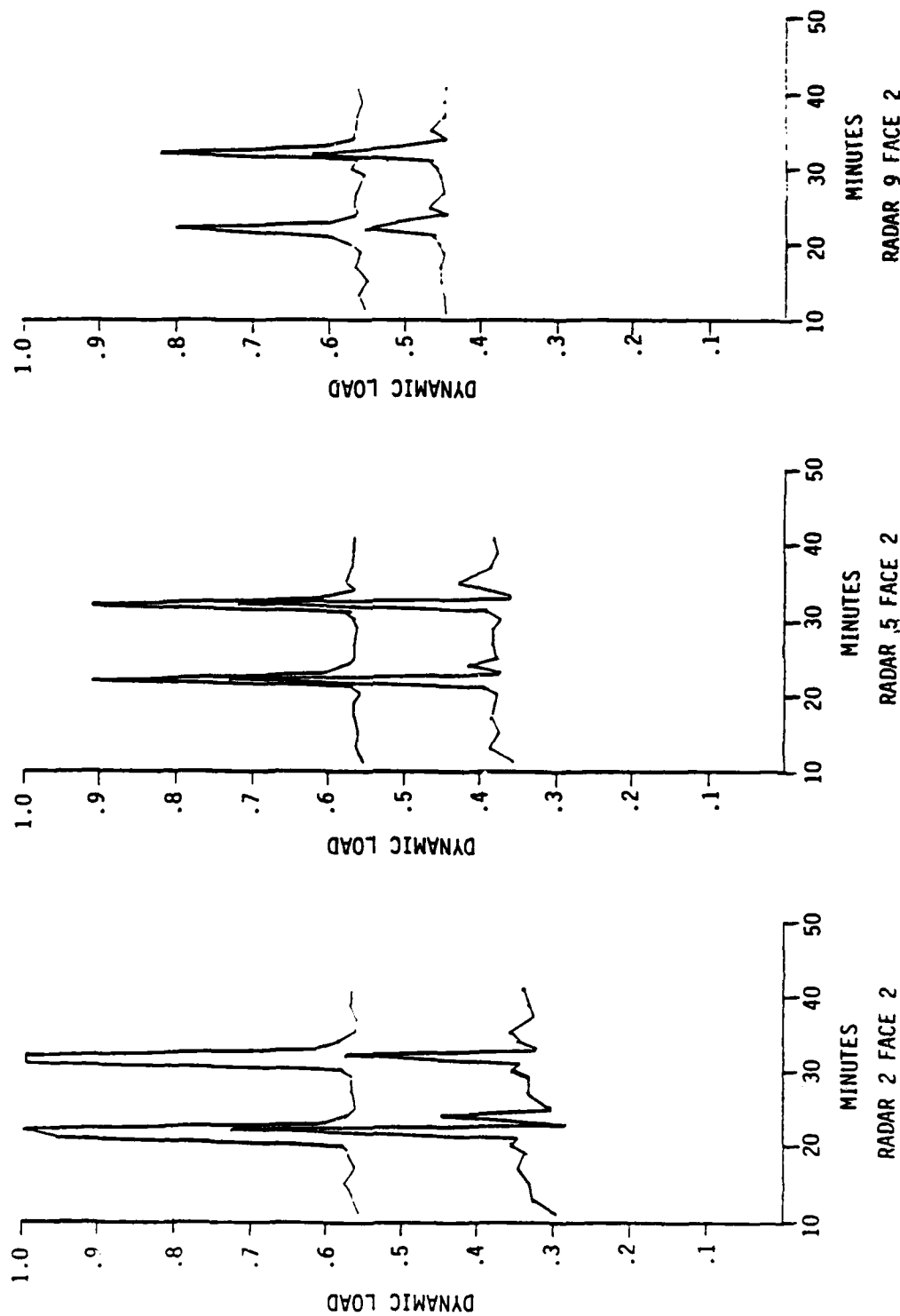

SUMMARY

IN SUMMARY, THERE SHOULD NOT BE MUCH DOUBT REMAINING THAT NETTING IS THE NEXT SIGNIFICANT STEP TO BE TAKEN IN IMPROVING THE PERFORMANCE OF OUR DISTRIBUTED SENSOR SYSTEMS.

OUR CONTROL SYSTEM ARCHITECTURE DOES PROVIDE AN AUTOMATIC CONTROL THAT IS SUBJECT TO USER PRIORITIES.

RNET, THE NETTED RADAR SIMULATION IS A TOOL FOR THE STUDY OF MANY NETWORKING ISSUES.

SUMMARY

- FUTURE TACTICAL RADARS REQUIRE NETTING TO REALIZE FULL POTENTIAL OF CAPABILITIES
- VALUE-DRIVEN CONTROL SYSTEM ARCHITECTURE PROVIDES AUTOMATIC CONTROL THAT IS RESPONSIVE TO USER PRIORITIES
 - SURVIVABLE
 - MINIMIZES COMMUNICATIONS
 - EASILY EXTENDED
- RNET IS A USER ORIENTED, INTERACTIVE SIMULATION OF AN INTELLIGENT RADAR NETWORK
 - TEST-BED FOR DEVELOPING CONTROL ALGORITHMS
 - PRIORITY CONTROL COMMUNICATIONS NETWORK
 - STUDY TOOL FOR OPERATOR INTERFACE ISSUES

IMPLEMENTATION OF A LOCAL NETWORK
FOR TACTICAL SYSTEMS

SPERRY UNIVAC

RONALD W. FOSS

SPERRY UNIVAC

SERIAL DATA BUS ENVIRONMENT

CRITICAL REAL TIME DATA

SURVIVE MULTIPLE FAULTS WITH MINIMUM LOSS OF
REAL TIME DATA

EQUIPMENTS FULLY QUALIFIED TO MIL-E-16400

FUNCTIONALLY TRANSPARENT TO EXISTING
SUBSYSTEM APPLICATION SOFTWARE



REQUIREMENTS

RESPONSE TIME

THROUGHPUT

FAULT TOLERANCE

COMPATIBILITY

DESIGN APPROACH

RESOURCE ALLOCATION

FAULT TOLERANCE

COMPATIBILITY

PERFORMANCE

SUMMARY

PRESENT STATUS

PLANS

- o SENSOR UPDATES
 - TRACKING RADAR - 4.8 MSEC
 - ACOUSTIC SENSORS - 4.8 MSEC
 - TRACK BASE - 300+ TRACKS/SEC
- o ATTITUDE UPDATES
 - TRACK PROCESSING - 1 MSEC
 - LASER TRACKING - 0.48 MSEC
- o WEAPON CONTROL
 - AREA WEAPONS - 4.8 MSEC
 - CLOSE-IN WEAPONS - 1 MSEC
- o NAVIGATION - 100 MSEC
- o OTHER UPDATE INTERVALS - ≤ 1 SEC
- o MULTIPLE DESTINATIONS FOR MOST MESSAGES

THROUGHPUT FUNDAMENTALLY DIFFERENT FROM NON-REAL TIME SYSTEMS

JITTER CRITICAL TO TRACKING, AIMING AND NAVIGATION
TRAFFIC GENERATORS ARE PREDOMINANTLY SYNCHRONOUS
TRAFFIC GENERATORS CAN BE MUTUALLY SYNCHRONOUS

REQUIRED INFORMATION RATES 2 MBPS NOMINAL
8 MBPS PEAK

AVERAGE MESSAGE LENGTH 9.9 16 BIT WORDS

SUPPORT BOOT LOADS OF ALL HOST PROCESSORS

DATA BUS FAILURE MODES

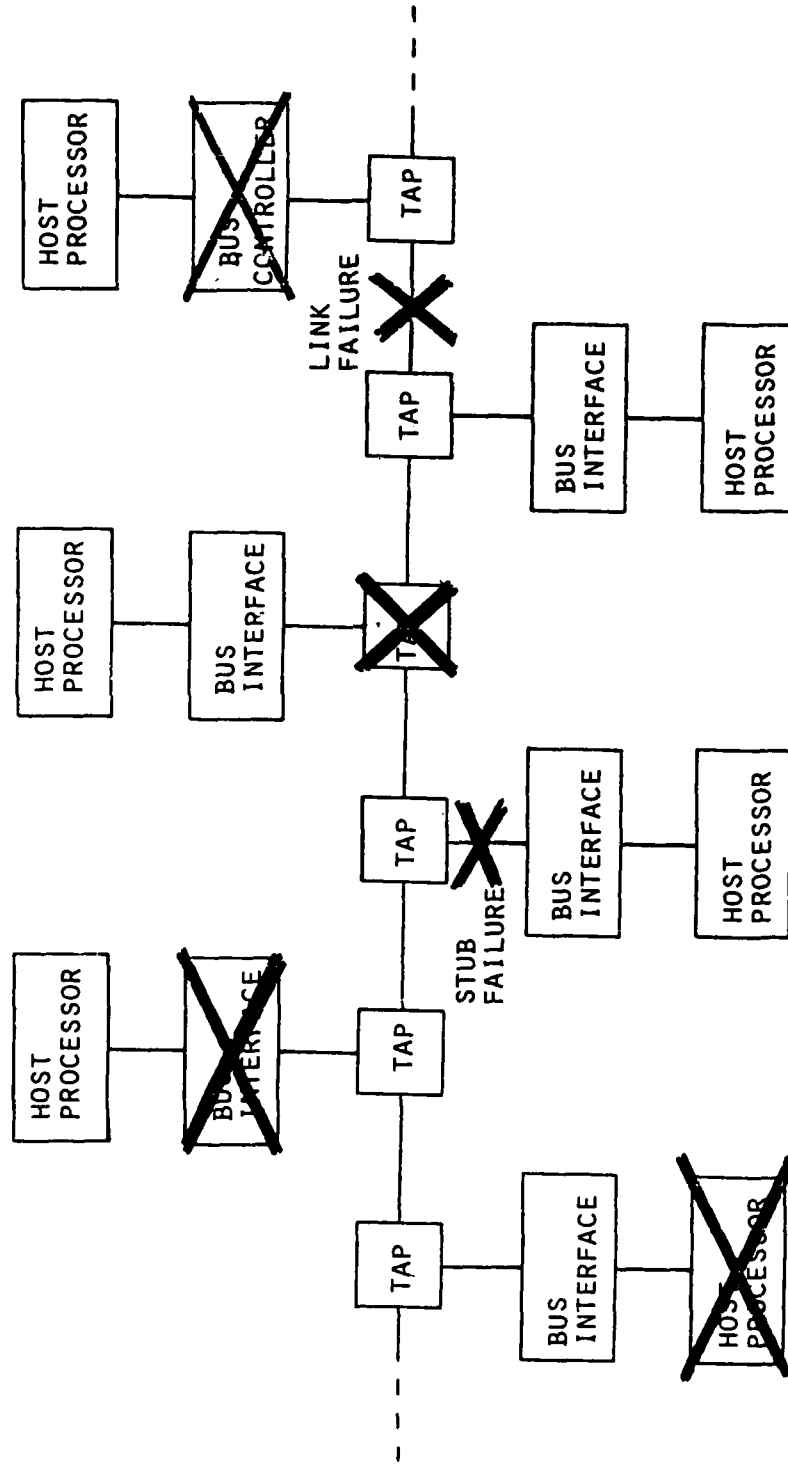

REQUIREMENTS

RESPONSE TIME

THROUGHPUT

FAULT TOLERANCE

COMPATIBILITY



DESIGN APPROACH

RESOURCE ALLOCATION

FAULT TOLERANCE

COMPATIBILITY

PERFORMANCE

SUMMARY

PRESENT STATUS

PLANS

BUS TRANSMISSION SYSTEM

SEPARATE DATA AND CONTROL CIRCUITS

UP TO FOUR SPARE CHANNELS

CHANNEL TRANSMISSIONS: 10 MHZ MANCHESTER

256 USERS OVER 300 METER BUS: 30 METER STUBS

SERIAL DATA BUS SYSTEM

POLLED BUS ARBITRATION DOES NOT INTERRUPT DATA FLOW

POLL SEQUENCE PROGRAMMABLE IN REAL TIME

DYNAMIC REASSIGNABLE BUS CONTROL

MULTIPLE PRIORITY LEVELS

BROADCAST & POINT-TO-POINT ADDRESSING

MESSAGE FILTER BY DEVICE ADDRESS OR BY MESSAGE CONTENT

500 USEC ACCESS TIME

VARIABLE MESSAGE LENGTH TO 127 - 32 BIT WORDS

MESSAGE BUFFERING PERFORMED IN BUS INTERFACE NODE

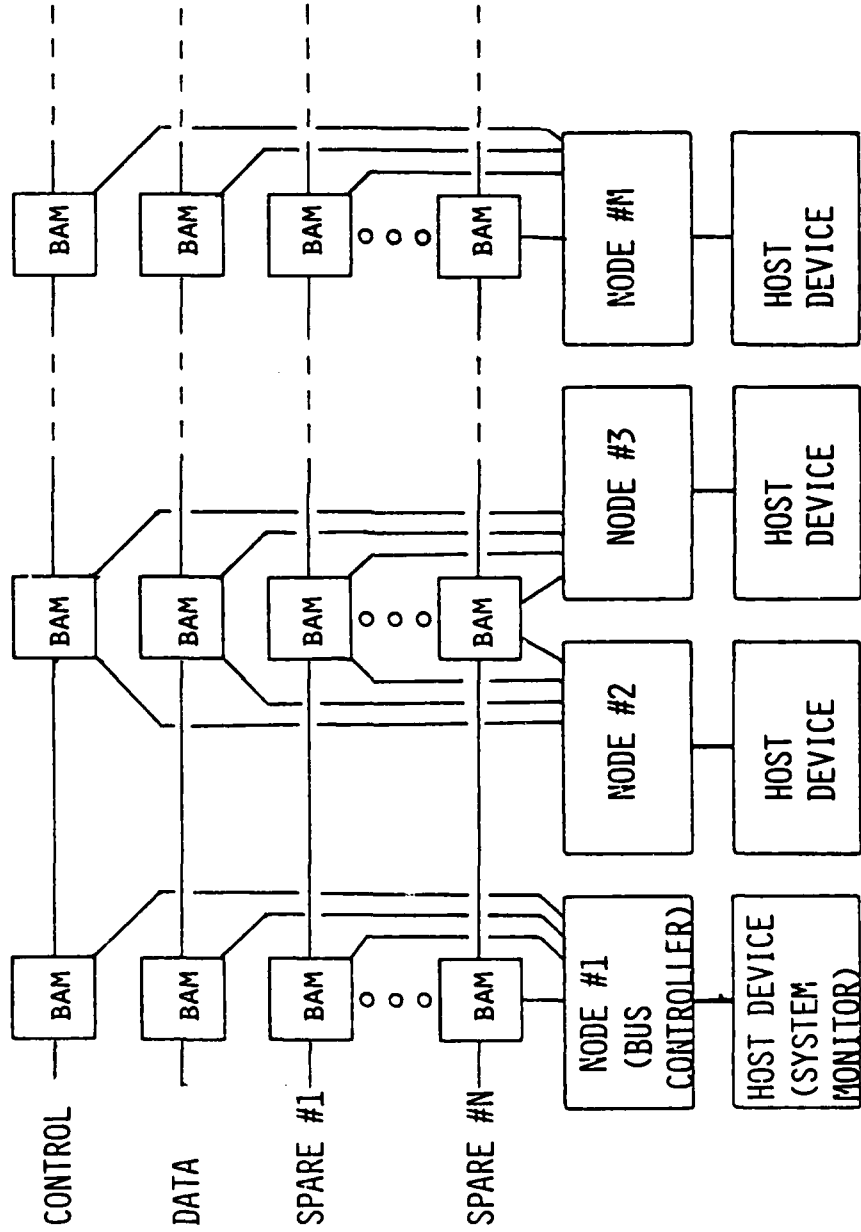

- | STEP | ACTIVITY |
|------|---|
| 1. | USER TRANSFERS MESSAGE TO NODE OUTPUT BUFFER |
| 2. | NODE REPLIES TO NEXT POLL WITH MESSAGE REQUEST WHICH CONTAINS PRIORITY FROM MESSAGE HEADER |
| 3. | NODE WAITS FOR SELECT COMMAND FROM BUS CONTROLLER |
| 4. | NODE TRANSMITS MESSAGE WHEN DATA CHANNEL IS QUIESCENT |
| 5. | IF A MESSAGE BEING TRANSMITTED IS INTERRUPTED FOR A PRIORITY 0 MESSAGE THE NODE RESTARTS AT STEP 2. |

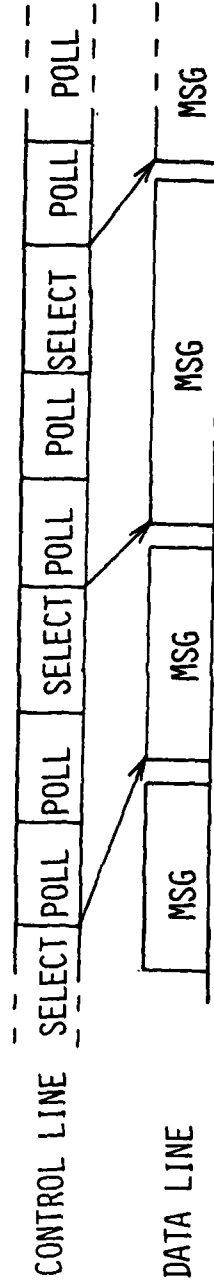

LEVEL I: POLL SEQUENCE

UP TO 16 HIGH PRIORITY NODES

UP TO 256 LOW PRIORITY NODES

LOW PRIORITY NODE SUBSETS POLLED AFTER EACH HIGH-PRIORITY POLL CYCLE

LEVEL II: MESSAGE QUEUEING AT EACH NODE

896 - 32 BIT WORD BUFFER FOR PRIORITY 1, 2, 3 MESSAGES

SEPARATE BUFFER FOR A PRIORITY ZERO MESSAGE

NODE TRANSMITS HIGHEST PRIORITY MESSAGE WHEN POLLED

NODE ABORTS TRANSMISSION IN FAVOR OF A PRIORITY ZERO MESSAGE.

ABORTED MESSAGE RETAINED IN XMIT QUEUE

FAILURE MODES	DESIGN FEATURE
BUS LINK	MULTIPLE PATHS, AUTOMATIC OUTAGE DETECTION
TAP, STUB	PASSIVE TAP WITH ACTIVE ISOLATION OF STUB
NODE	INTEGRAL TRANSMIT TIMEOUT TO AVOID CHATTERING SELECTIVE NODE DISABLE NODE RESPONSE TESTED EVERY 100 MSEC
HOST	PRE-PLANNED FALL-BACK PARTITIONING
BUS CONTROLLER	ANY NODE MAY BE CONFIGURED AS BACKUP CONTROLLER ALL CONTROLLER NODES MONITOR TRAFFIC FOR ERRORS - EACH ATTEMPTS RECOVERY IN PRE-PLANNED ORDER ACTIVE BUS CONTROLLER DEFERS TO CONTROL ACTIVITY ON NEW CHANNEL

- o ALL NODES CYCLICALLY SCAN ALL CHANNELS (500 USEC/CHANNEL)
- o A CONTROL CHANNEL CHANGE INITIATED BY THE USER CAUSES THE BUS CONTROLLER TO
 - CHANGE TO THE NEW CONTROL CHANNEL
 - TRANSMIT A CHANNEL CONTROL COMMAND EVERY 100 USEC FOR 5 MSEC
- o ANY NODE WHICH RECEIVES 3 CORRECTLY CODED CHANNEL CONTROL COMMANDS WITH NO INTERVENING ERRORS SWITCHES TO THE NEW CHANNEL
- o A BUS CONTROLLER WHICH OBSERVES THIS SEQUENCE WILL DROP THE BUS CONTROLLER MODE

SPERRY UNIVAC

SYSTEM COMPATIBILITY ACHIEVED BY PERFORMING
BUS OPERATIONS IN THE NODE

NODE COMMUNICATES WITH HOST PROCESSOR VIA STANDARD I/O CHANNEL

NODE PERFORMS ALL BUS FUNCTIONS

MESSAGE QUEUEING

TRANSMISSION CONTROL

RECEPTION CONTROL

MESSAGE ACKNOWLEDGEMENT

BUS ERROR MONITORING

BUS CONTROLLER NODE PERFORMS ALL POLLING

NODE PROVIDES STATUS REPORTS TO HOST UPON SYSTEM RECONFIGURATION

BUS CONTROLLER HOST CONTAINS STANDARD SYSTEM RECONFIGURATION TASK

REQUIREMENTS

RESPONSE TIME

THROUGHPUT

FAULT TOLERANCE

COMPATIBILITY

DESIGN APPROACH

RESOURCE ALLOCATION

FAULT TOLERANCE

COMPATIBILITY

PERFORMANCE



SUMMARY

PRESENT STATUS

PLANS

THROUGHPUT VS MESSAGE LENGTH

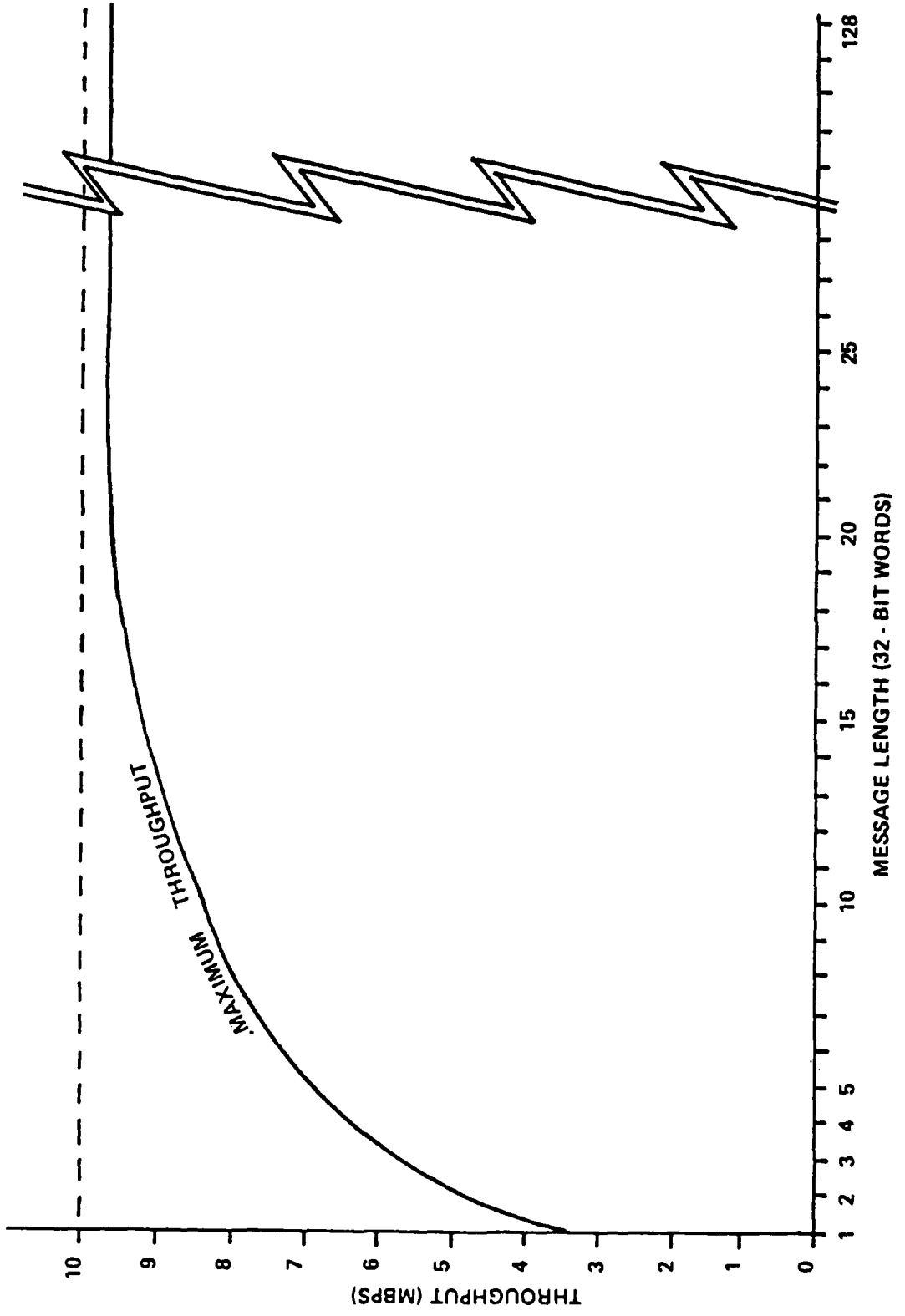

SPERRY UNIVAC MESSAGE END-TO-END DELAY HISTOGRAM

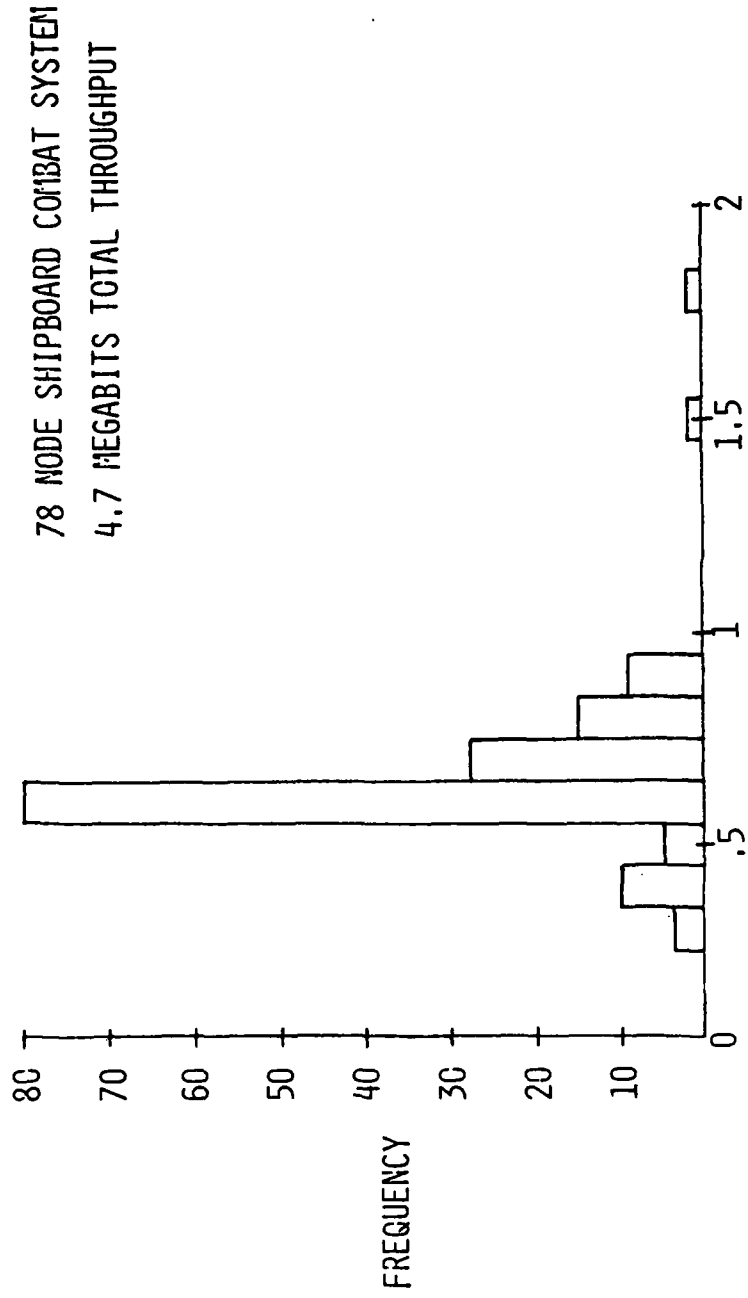

EXPECTED MESSAGE END-TO-END DELAY (MILLISECONDS)

REQUIREMENTS

RESPONSE TIME

THROUGHPUT

FAULT TOLERANCE

COMPATIBILITY

DESIGN APPROACH

RESOURCE ALLOCATION

FAULT TOLERANCE

COMPATIBILITY

PERFORMANCE

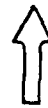

SUMMARY

PRESENT STATUS

PLANS

SYSTEM DEVELOPMENT STATUS

MILESTONE	1975	1976	1977	1978	1979	1980	1981	1982	1983	1984	1985
SYSTEM CONCEPT DEFINITION STUDY		▽	▽	▽							
SYSTEM MODELING			▽	▽							
SERIAL DATA BUS SPECIFICATION			▽	▽							
SERIAL DATA BUS BRASSBOARD DEVELOPMENT			▽	▽	▽						
SYSTEM CONTROL SOFTWARE DEVELOPMENT			▽	▽	▽	▽					
BRASSBOARD SYSTEM DEMONSTRATIONS			▽	▽	▽	▽	▽				
ADVANCED DEVELOPMENT MODEL			▽	▽	▽	▽	▽	▽			
FOREIGN WEAPONS EVALUATION PROGRAM			▽	▽	▽	▽	▽	▽	▽		
ENGINEERING DEVELOPMENT MODEL			▽	▽	▽	▽	▽	▽	▽	▽	
DISTRIBUTED OPERATING SYSTEM			▽	▽	▽	▽	▽	▽	▽	▽	▽
PRODUCTION										▽	---

FIBER OPTIC PRIMARY BUS LINK DEMONSTRATION SCHEDULED IN CY 82

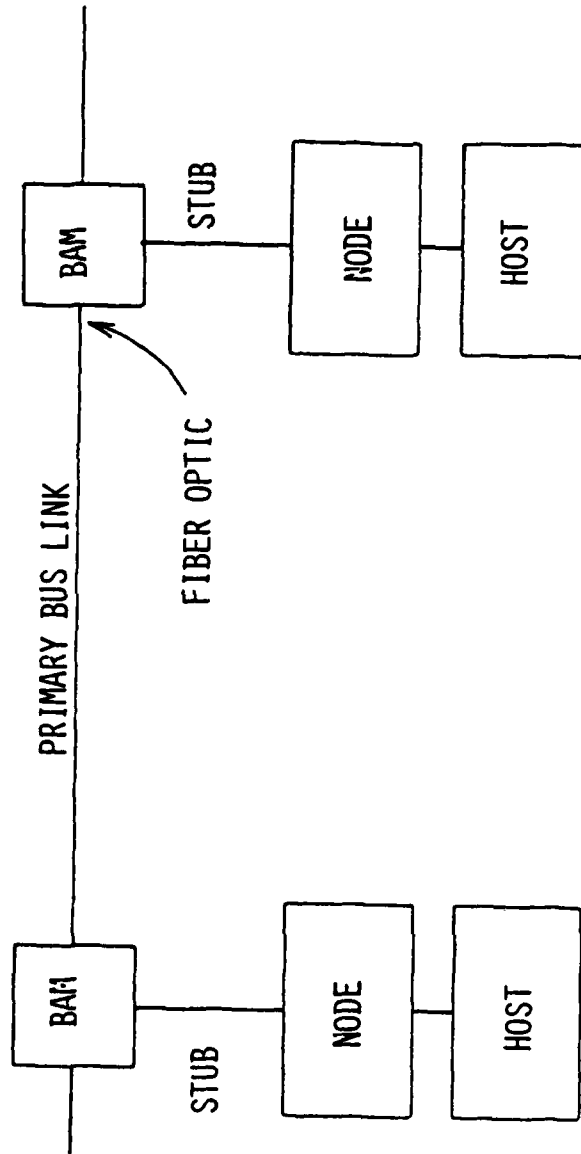

THE MILITARIZED TACTICAL SYSTEM MODULE WITH INTEGRAL SDB
NODE PROVIDES C³I SYSTEM MODULARITY AT EACH OPERATORS STATION

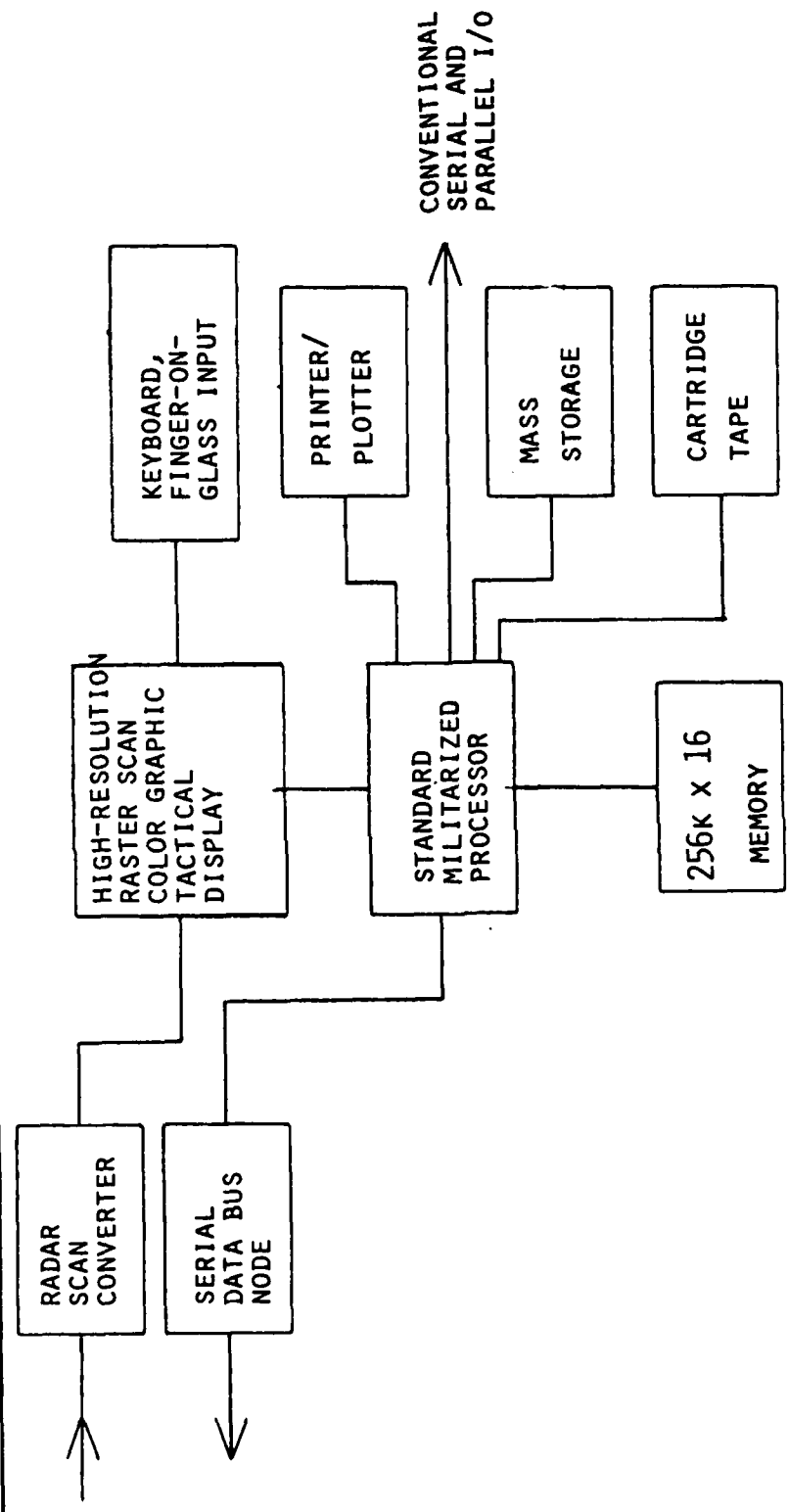

**A CONCEPTUAL
LOCAL AREA COMMUNICATIONS NETWORK
FOR
A DISTRIBUTED
MODULAR OPERATIONS CENTER**

- 447 -

2053-1

JTT GILFILLAN

MODULAR OPERATIONS CENTER CONCEPT STUDY

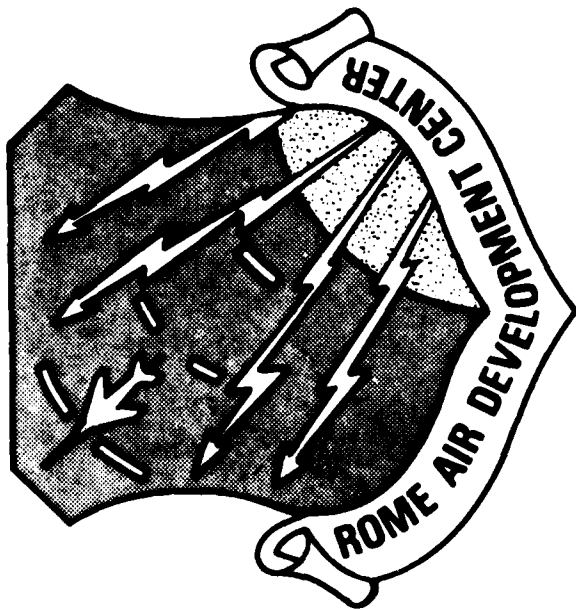

ITM GILFILLAN

2053-2

**MODULAR
DISTRIBUTED
C³**

JTT GILFILLAN

2053-3

**CURRENT EMPLOYMENT CONCEPT FOR
SURVEILLANCE AND AIRSPACE CONTROL FUNCTION**

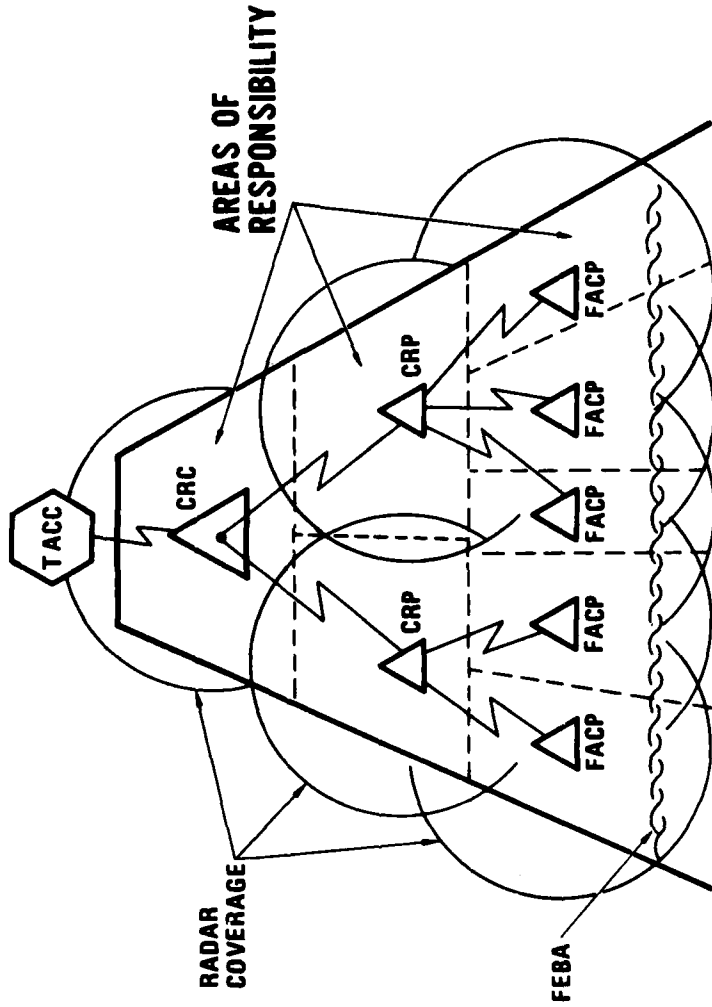

JTT GILFILLAN

2053-4

CONTROL AND REPORTING CENTER

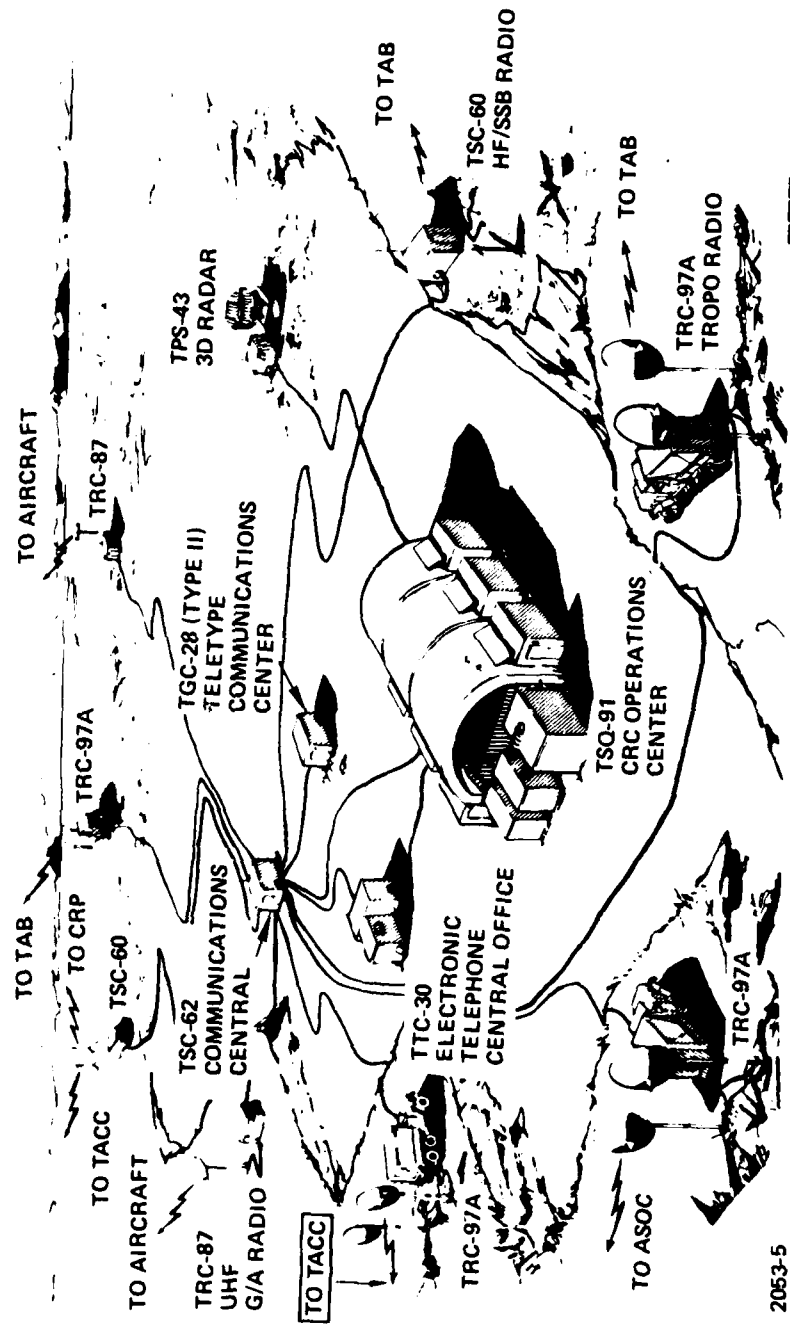

GILFILLAN

2053-5

KEY ARCHITECTURAL NEEDS

- NEW SURVEILLANCE/CONTROL CONCEPT
- MODULAR DISTRIBUTED C²
- NETTED SURVEILLANCE
- DISTRIBUTED COMMUNICATIONS
- CONNECTIVITY TO EXISTING AND FUTURE COMMUNICATIONS ASSETS

2053-6

ITT GILFILLAN

**NEW EMPLOYMENT CONCEPT FOR
SURVEILLANCE AND AIRSPACE CONTROL FUNCTION**

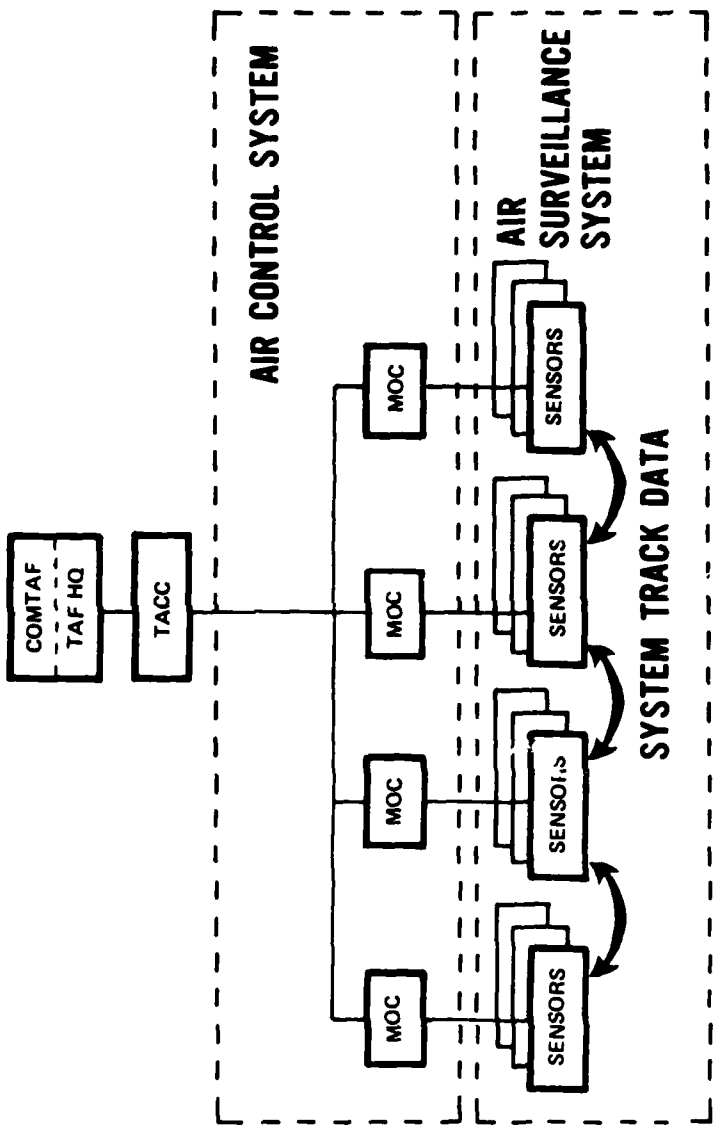

JTT GILFILLAN

2053-7

COMPOSITION OF THE MOC

- COMMAND AND CONTROL MODULES
- COMMUNICATIONS NODAL CONTROL ELEMENT
- CIRCUIT SWITCHES
- MESSAGE SWITCH
- REMOTED RADIO PARKS

2053-8

W. J. GILFILLAN

This page intentionally left blank.

**COMMAND AND CONTROL MODULE
(CCM)**

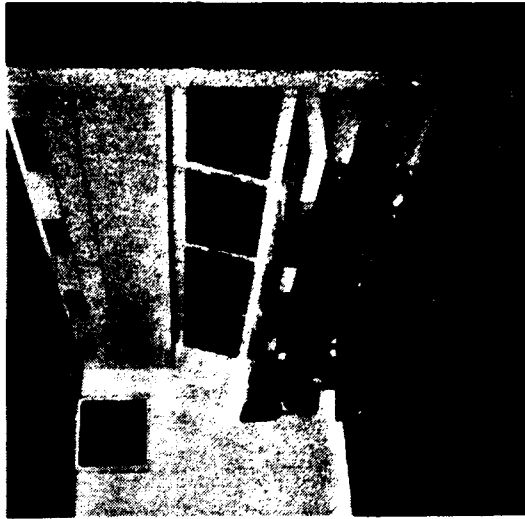

P-14342-11

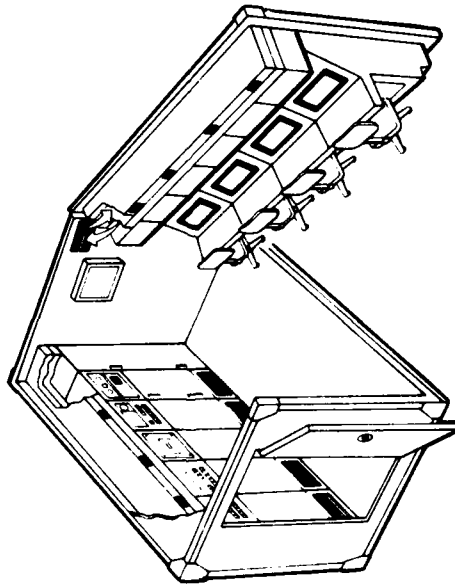

ITT GILFILLAN

2053-34

**HIGH RESOLUTION
FLAT PANEL DISPLAY CONSOLE**

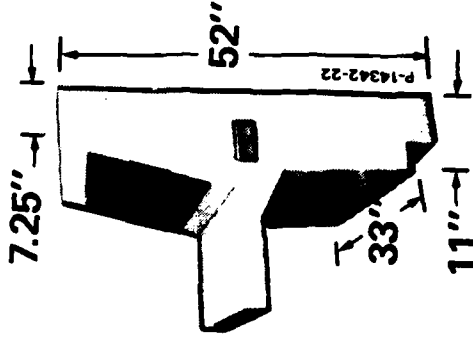
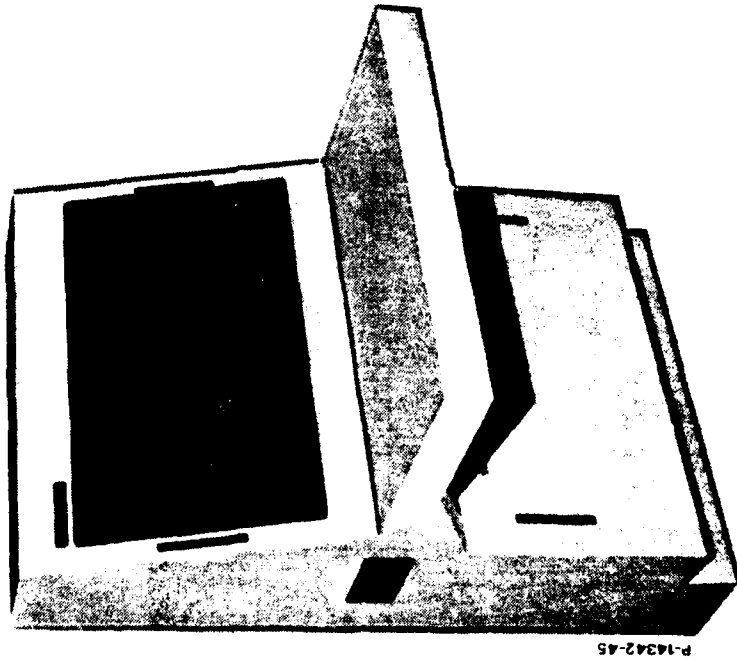

JUN GILLILLAN

2053-33

COMMAND AND CONTROL MODULE INTERNAL DIAGRAM

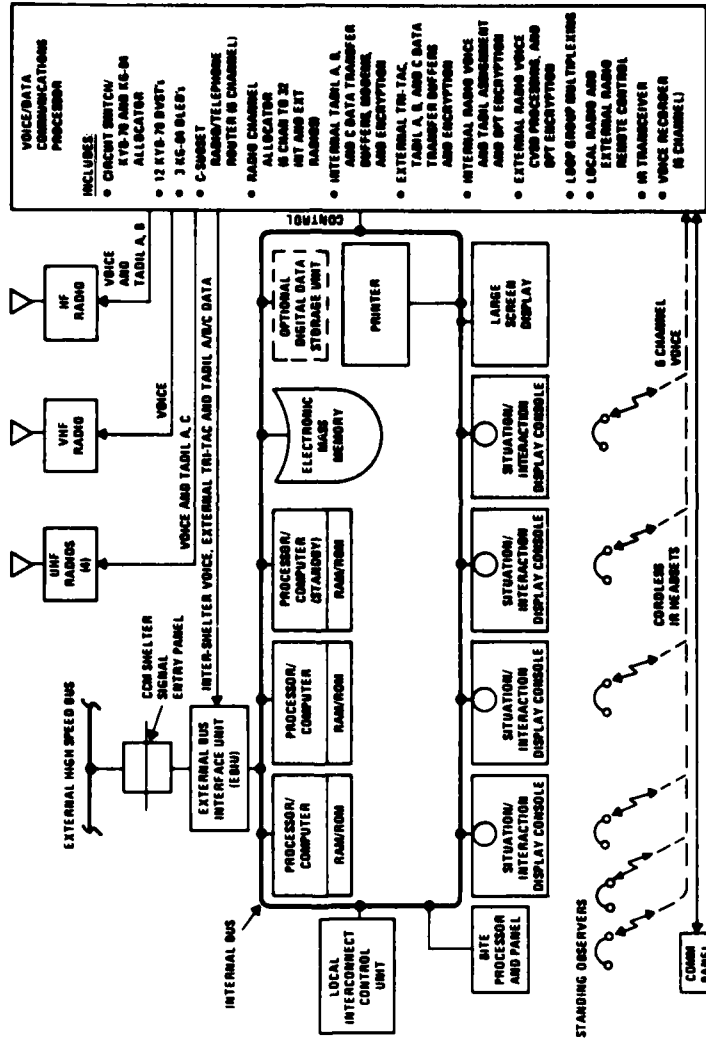

- VOICE/DATA COMMUNICATIONS PROCESSOR INCLUDE:**
- CIRCUIT SWITCH/KEY-TO AND 66-80 ALLOCATOR
 - 12 KYB-70 BYST'S
 - 3 KC-80 BLEP'S
 - C-SUBSET RADIO/TELEPHONE ROUTER (8 CHANNEL)
 - RADIO CHANNEL ALLOCATOR
 - 16 CHAN TO 32 INT AND EXT RADIOS
 - INTERNAL TABIL A, B AND C DATA TRANSFER BUFFER, SCHEDULE AND ENCRYPTION
 - EXTERNAL TR-TAC, TABIL A, B AND C DATA TRANSFER BUFFER AND ENCRYPTION
 - INTERNAL RADIO VOICE AND TABIL ASSIGNMENT AND OPT ENCRYPTION
 - EXTERNAL RADIO VOICE CYB PROCESSOR, AND OPT ENCRYPTION
 - LOOP GROUP MULTIPLEXING
 - LOCAL RADIO AND EXTERNAL RADIO REMOTE CONTROL
 - IN TRANSMITTER
 - VOICE RECORDER (8 CHANNEL)

2053-35

ITT GULFILLAN

MODULAR OPERATIONS CENTER DEPLOYMENT

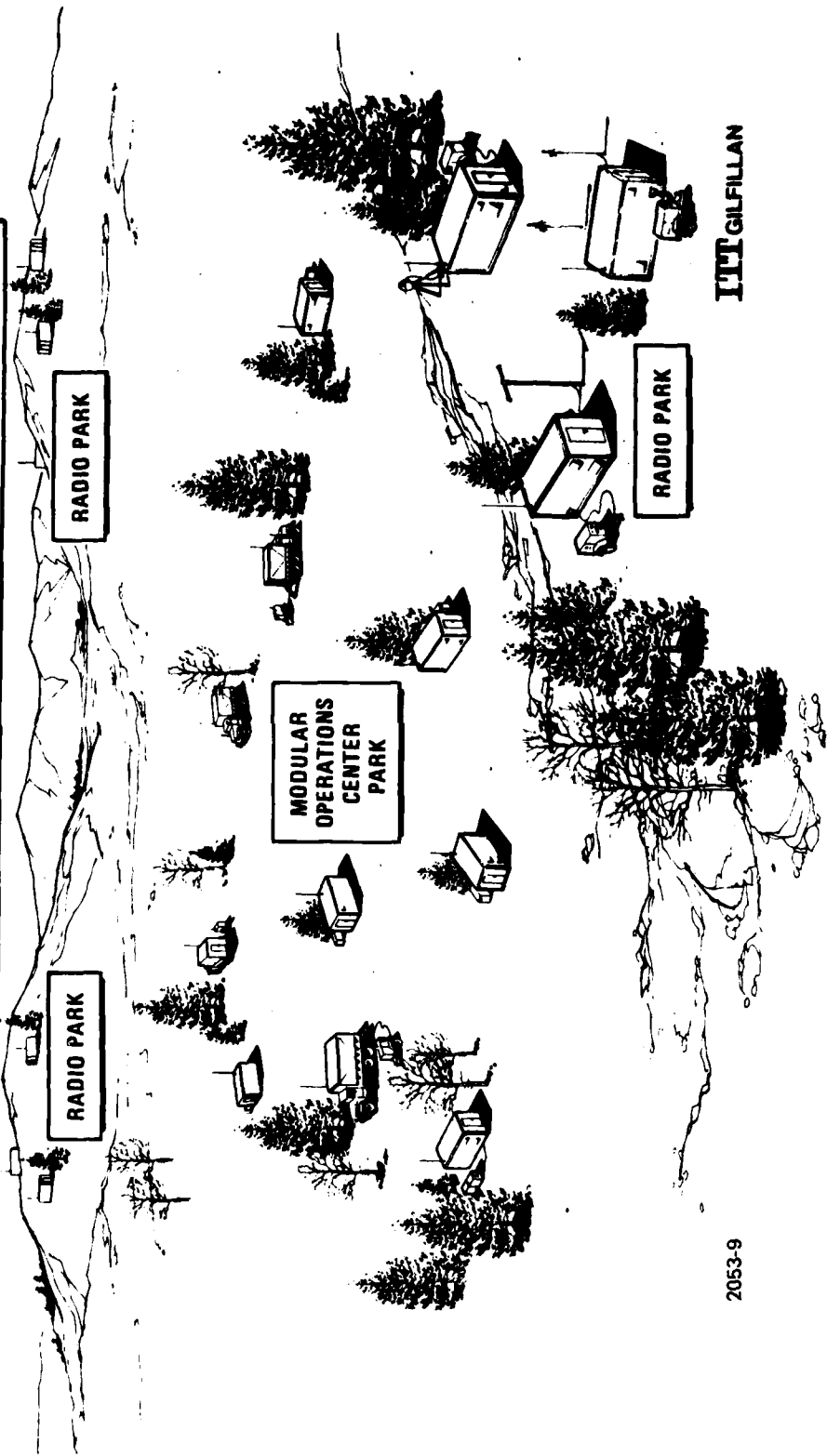

ITT GILFILLAN

2053-9

NETWORK DESIGN GOALS

- SURVIVABILITY
- RELIABILITY
- UNIFORM DISTRIBUTION OF NODE/LINK
SURVIVABILITY ACROSS THE NET
- DISTRIBUTED NETWORK MANAGEMENT AND CONTROL
- OPERATIONAL FLEXIBILITY
- UNIVERSAL CONNECTIVITY
- EASE OF USER ACCESS
- NO PROCESSING TO ROUTE OR TO REMOVE MESSAGES
- MAXIMUM TRAFFIC TRANSMISSION RATE –
200 MBITS/SEC

2053-10

ITT GILFILLAN

TRANSMIT / RECEIVE OR U-BUS

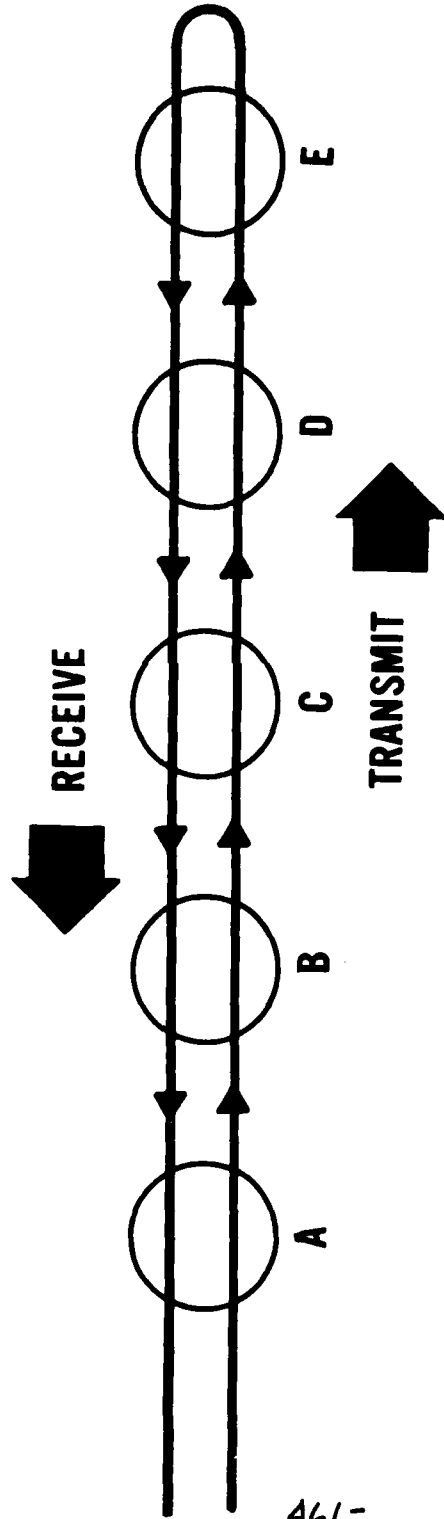

CLOSED U-BUS

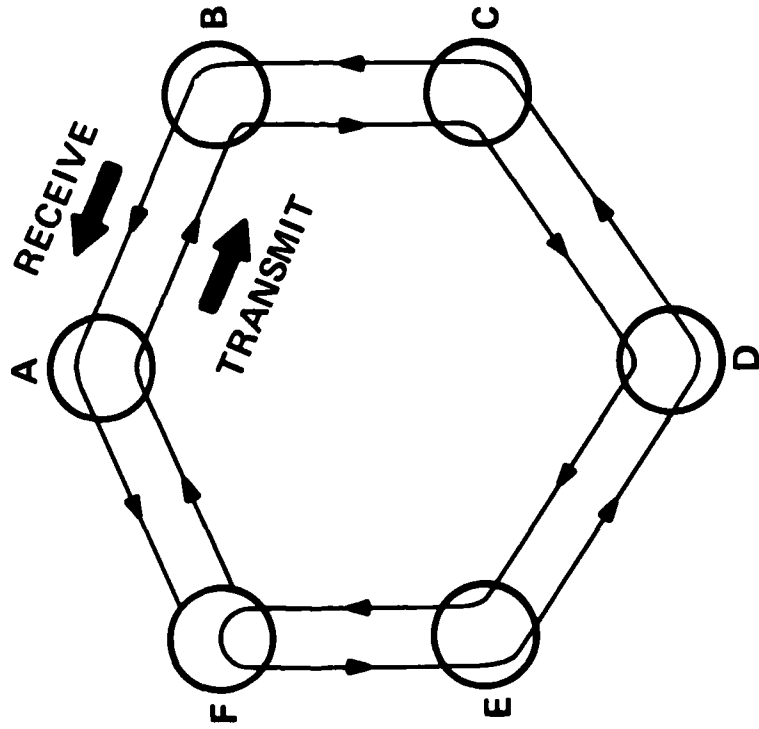

JIT GILFILLAN

2053-12

CLOSED U-BUS

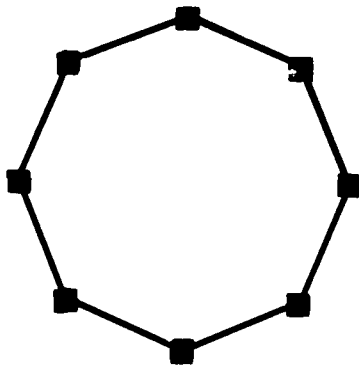

JIM GILFILLAN

2053-13

**CLOSED U-BUS
WITH SINGLE-SKIP BRAID**

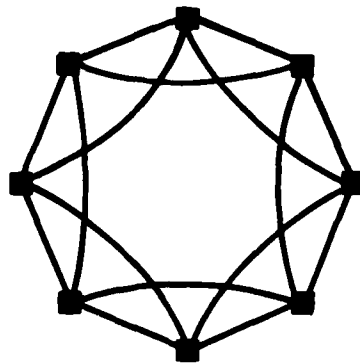

JTT GILFILLAN

2053-14

LINKED NETWORKS

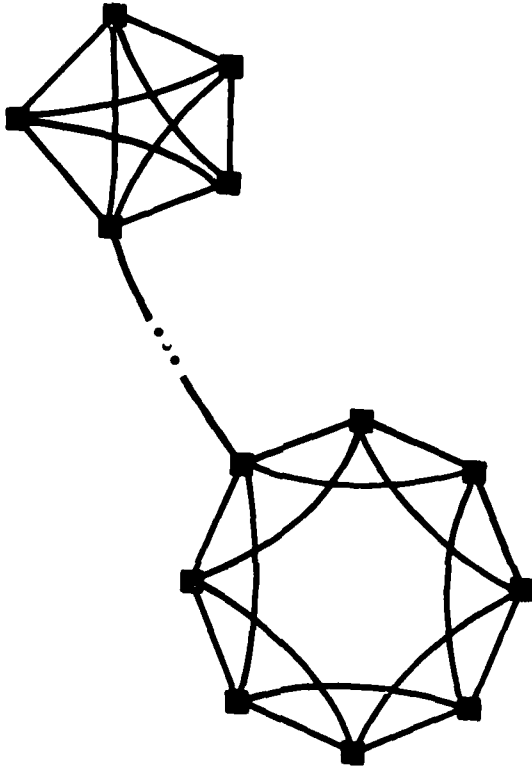

2053-15

JUN GILLILLAN

LINKED NETWORKS WITH REDUNDANT STRUCTURING

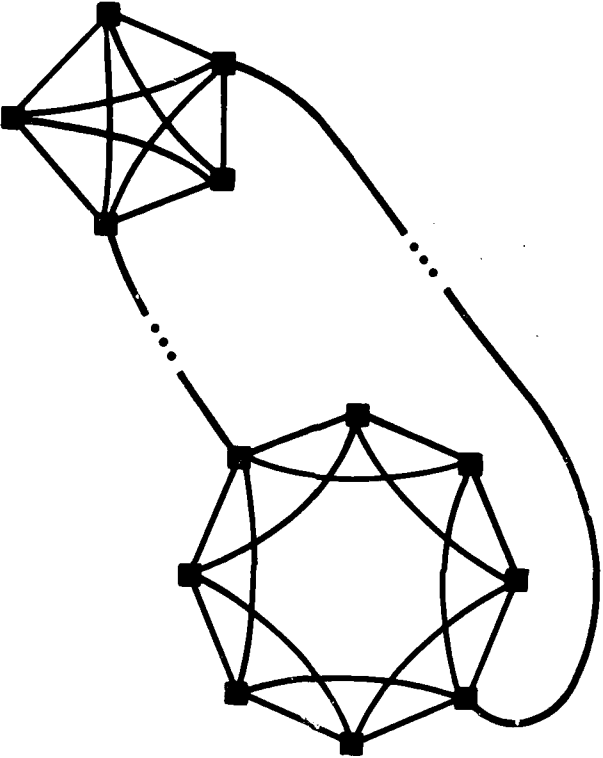

IJT GILLIAN

2053-16

**FULLY IMPLEMENTED
SYSTEM OF NETWORKS**

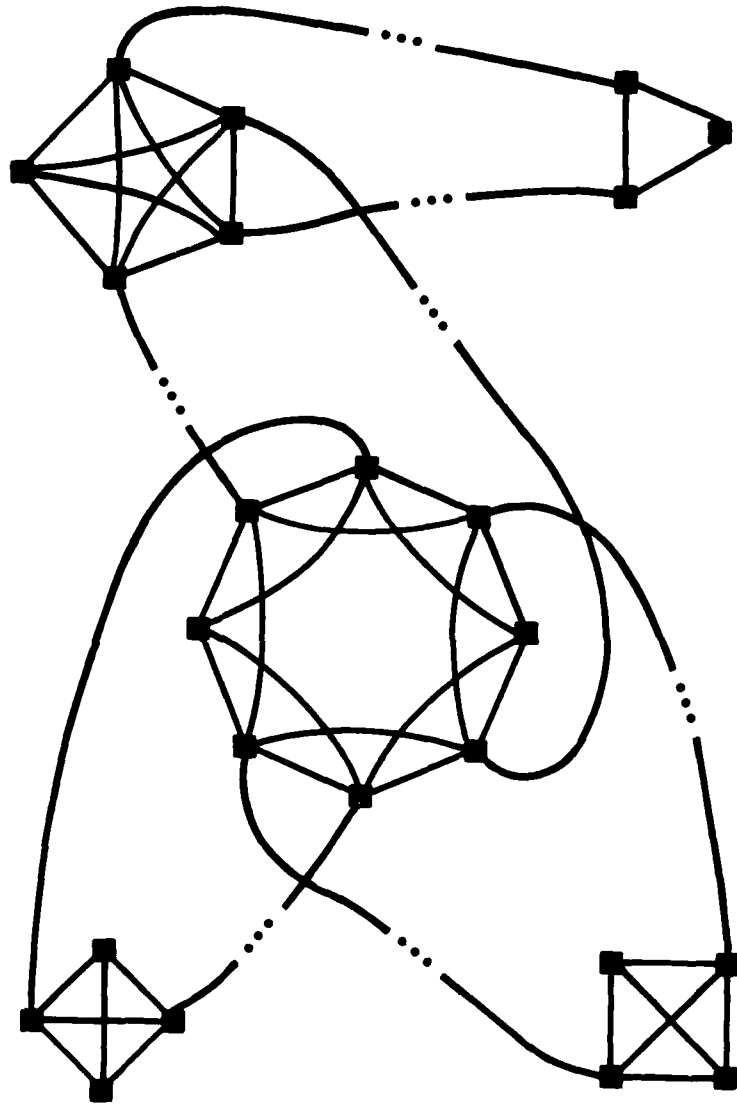

J.J. GILLILLAN

2053-17

MODULAR OPERATIONS CENTER

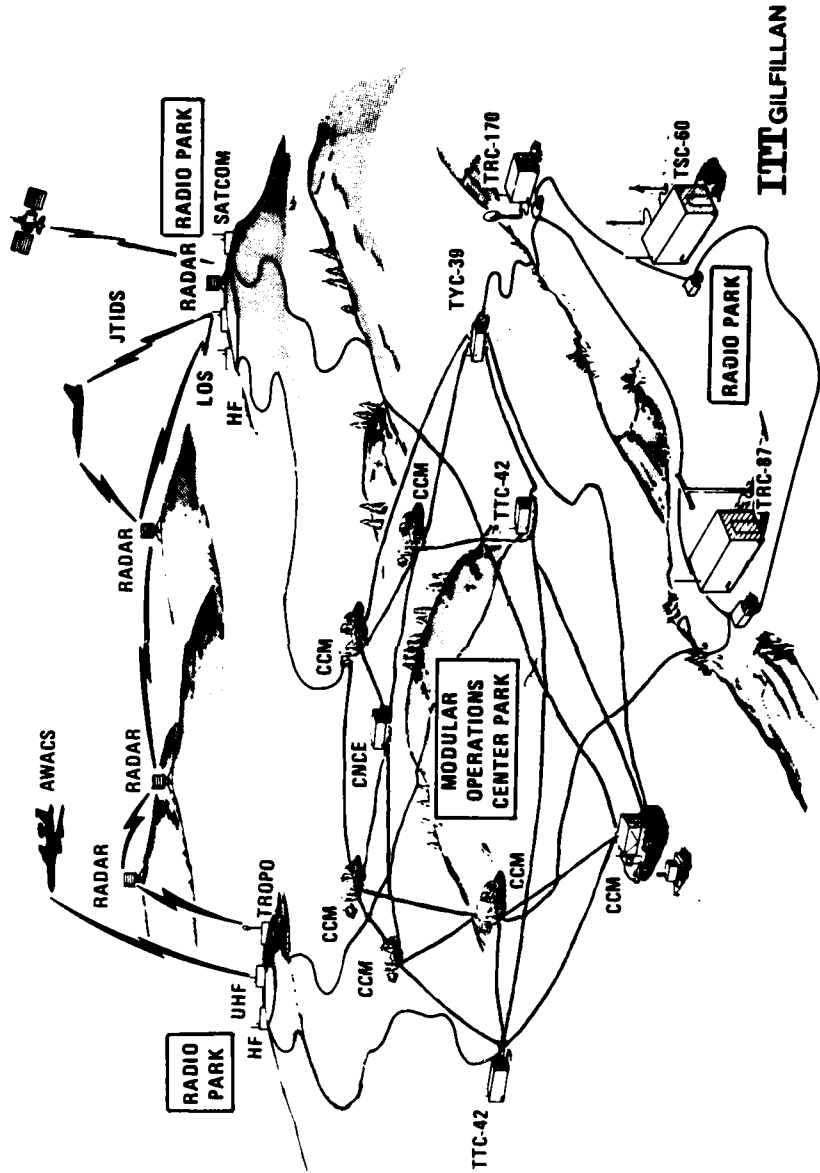

2053-18

**SWITCHING CONFIGURATION
PRIMARY PATH**

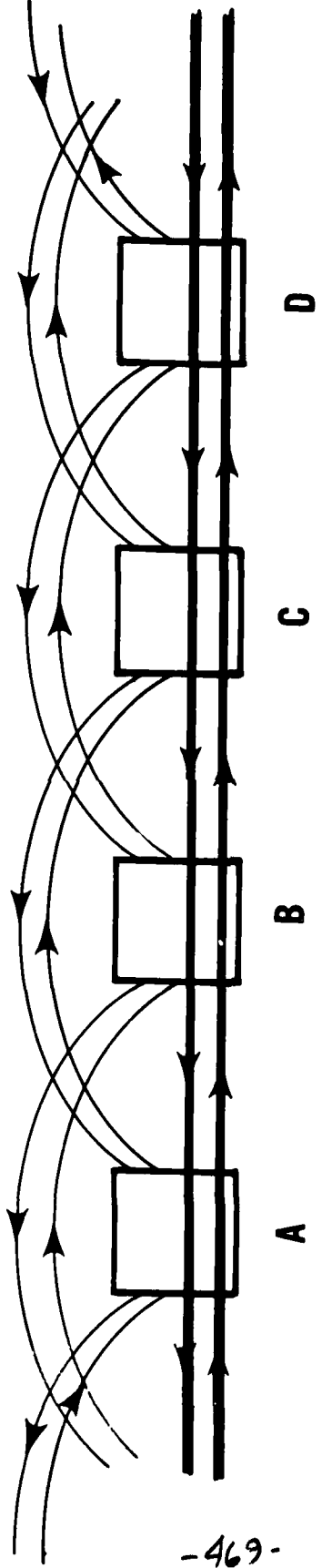

-469-

JIT GILLILLAN

2053-19

**SWITCHING CONFIGURATION
START/END NODE**

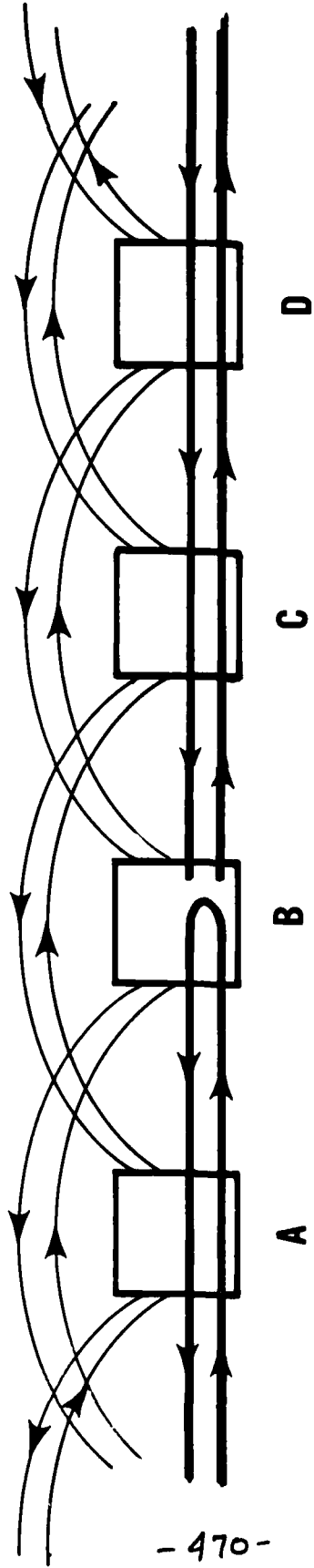

- 470 -

ITT GILFILLAN

2053-20

**SWITCHING CONFIGURATION
LOSS OF NODE**

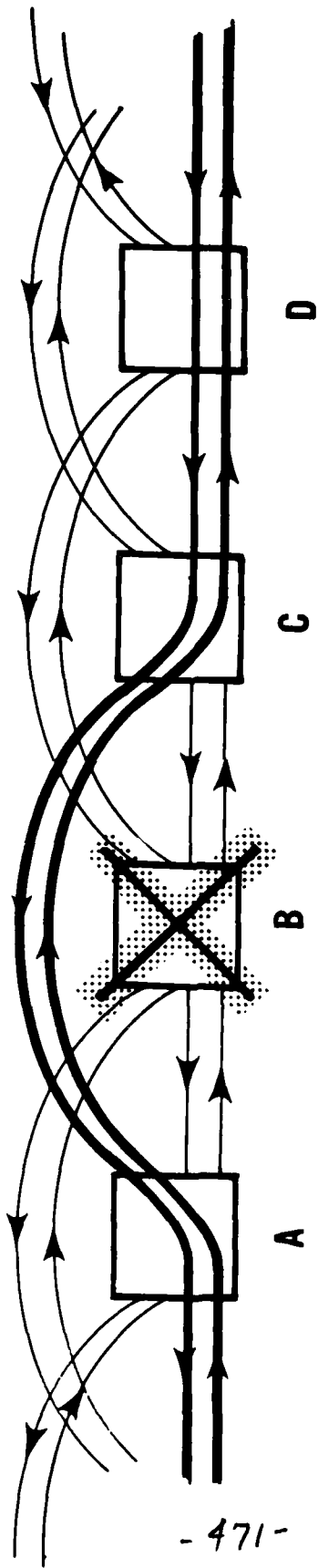

- 471 -

ITT GILFILLAN

2053-21

**SWITCHING CONFIGURATION
LOSS OF PRIMARY LINK**

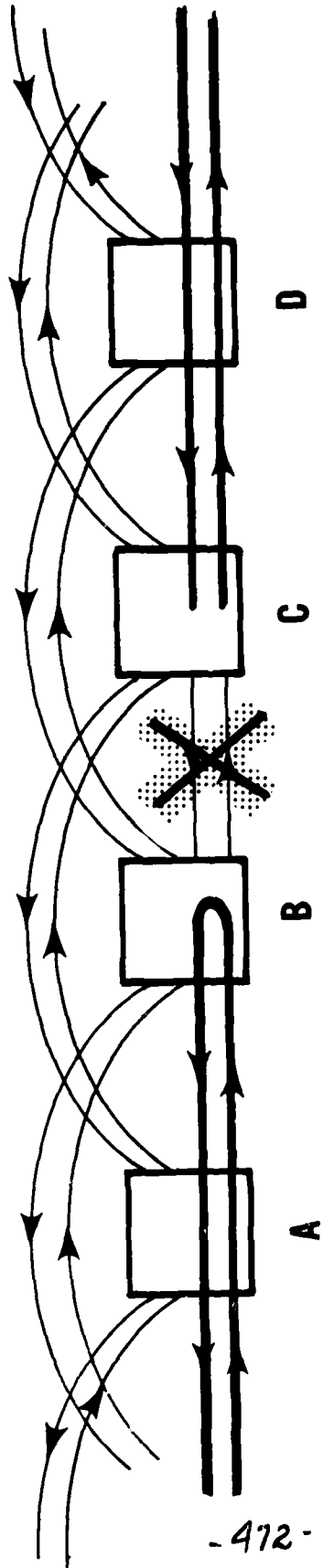

- 472 -

JTT GILFILLAN

2053-22

**SWITCHING CONFIGURATION
LOSS OF PRIMARY LINK**

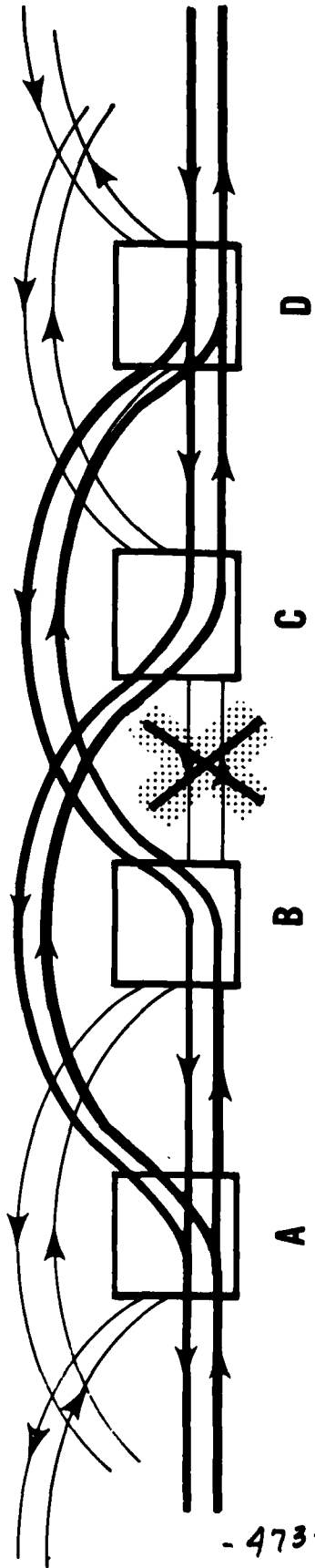

- 473 -

INAPPROPRIATE SOLUTION!

2053-23

JTG GILLILLAN

**SWITCHING CONFIGURATION
LOSS OF PRIMARY LINK**

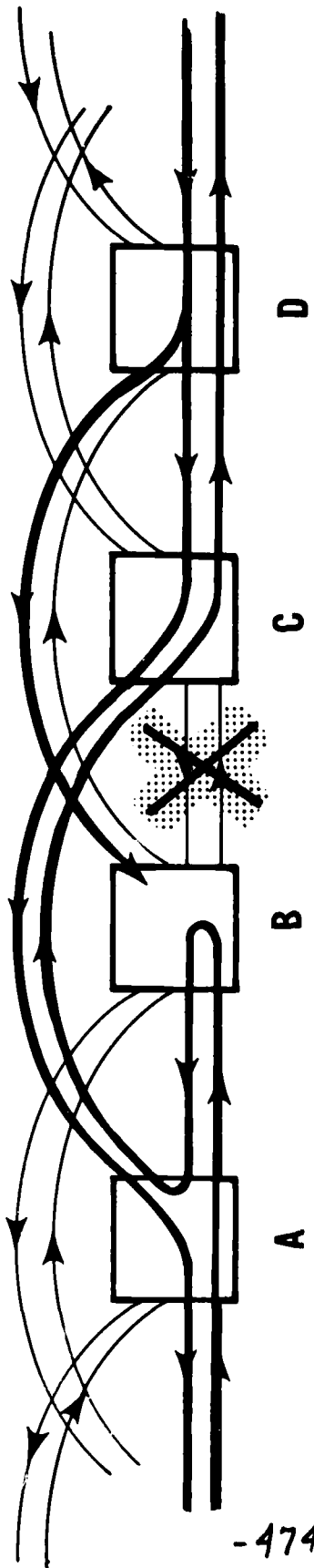

-474-

ITT GILFILLAN

2053-24

ADDITION OF NODE TO EXISTING NETWORK

STATE 1

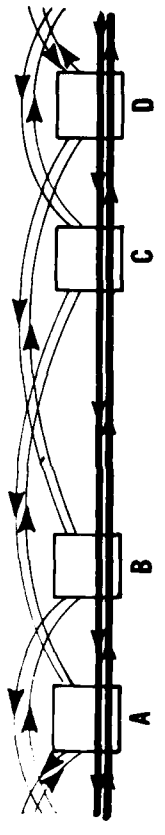

STATE 2

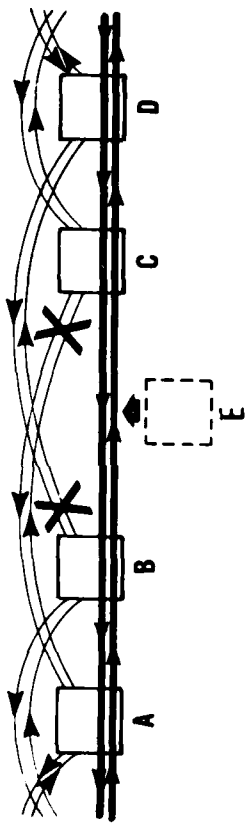

STATE 3

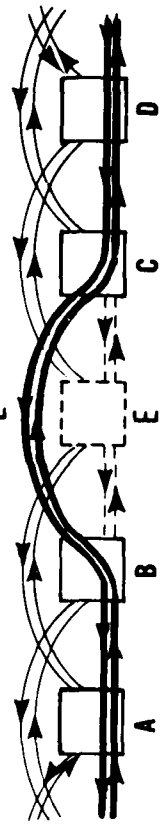

STATE 4

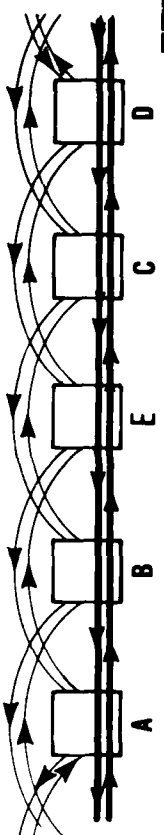

2053-40

ITT GILFILLAN

EXTERNAL BUS INTERFACE UNIT (EBIU)

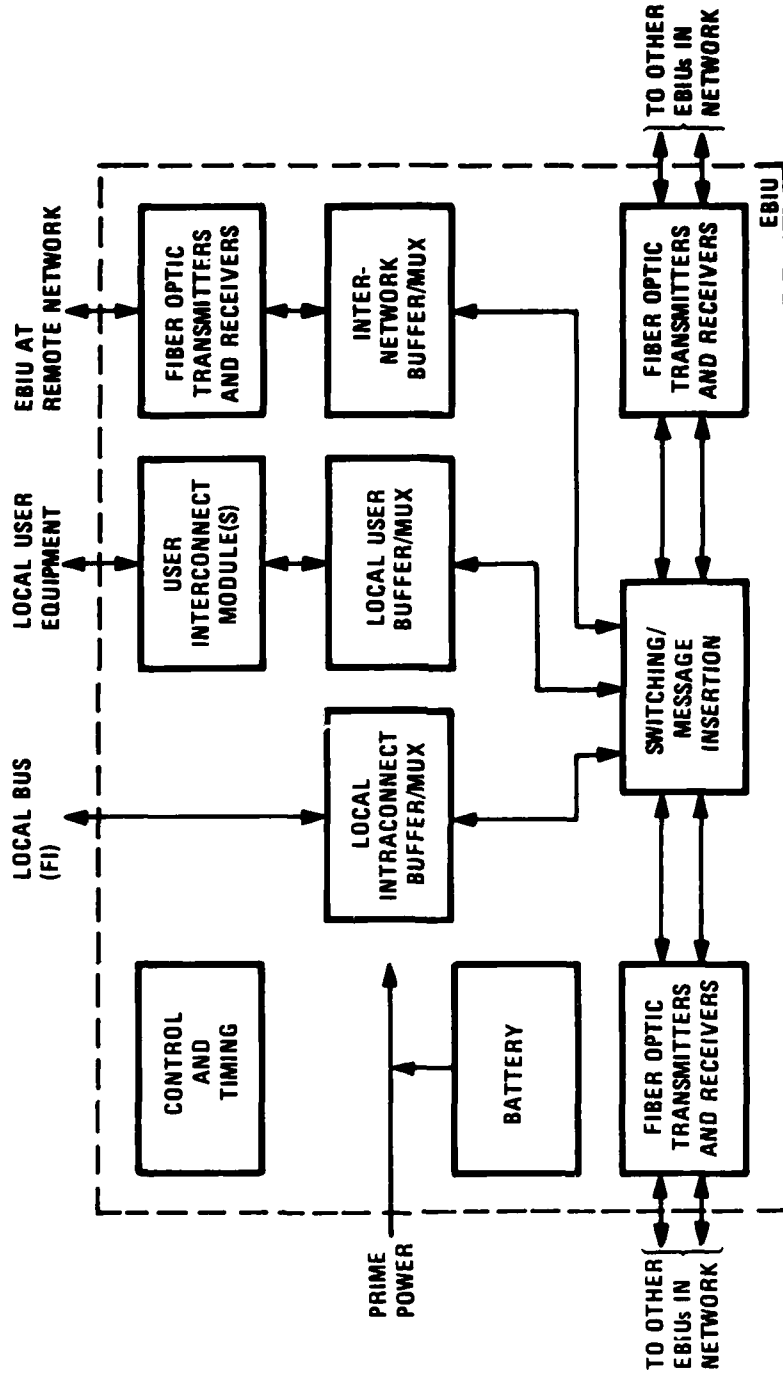

J. J. GILFILLAN

2053-25

OPTICAL DIRECTIONAL COUPLER/SWITCH

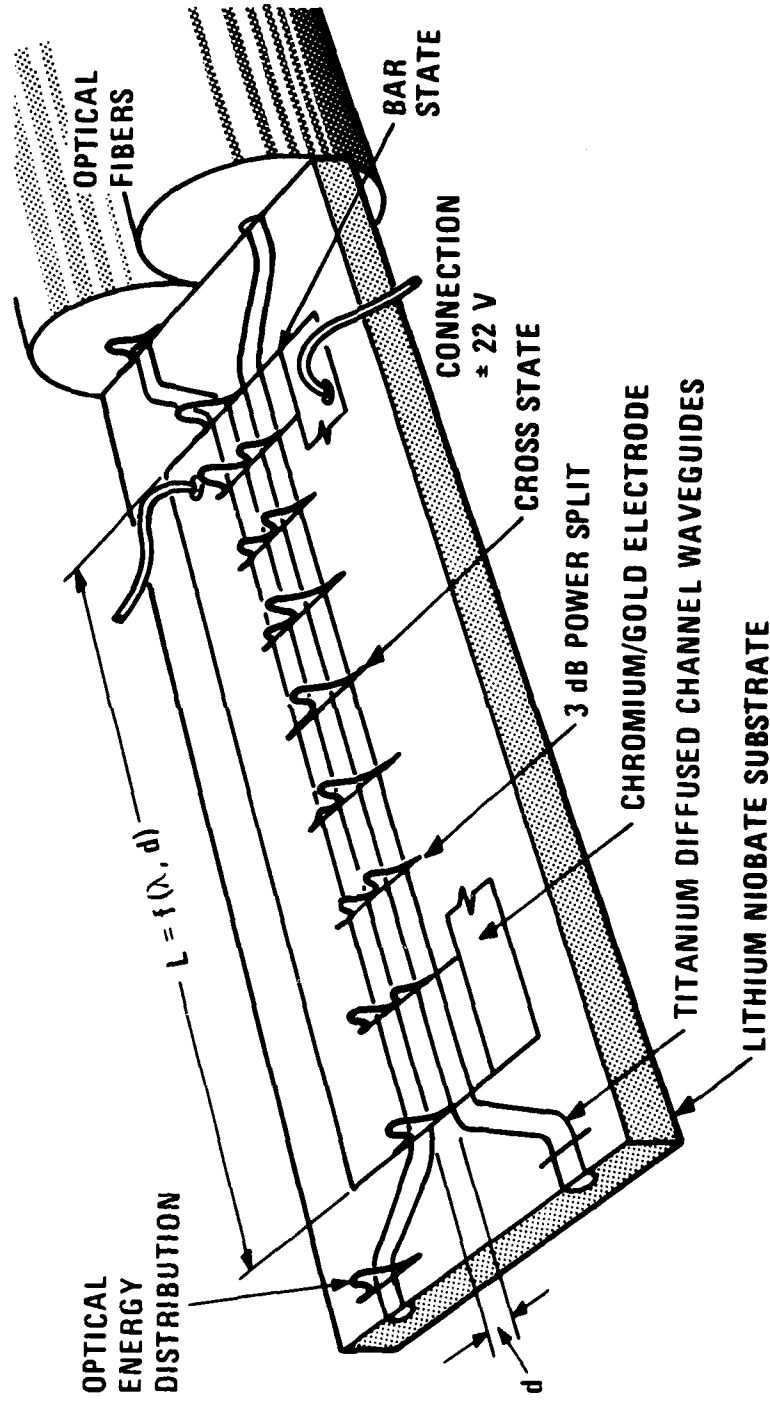

2053-26

ITT GILFILLAN

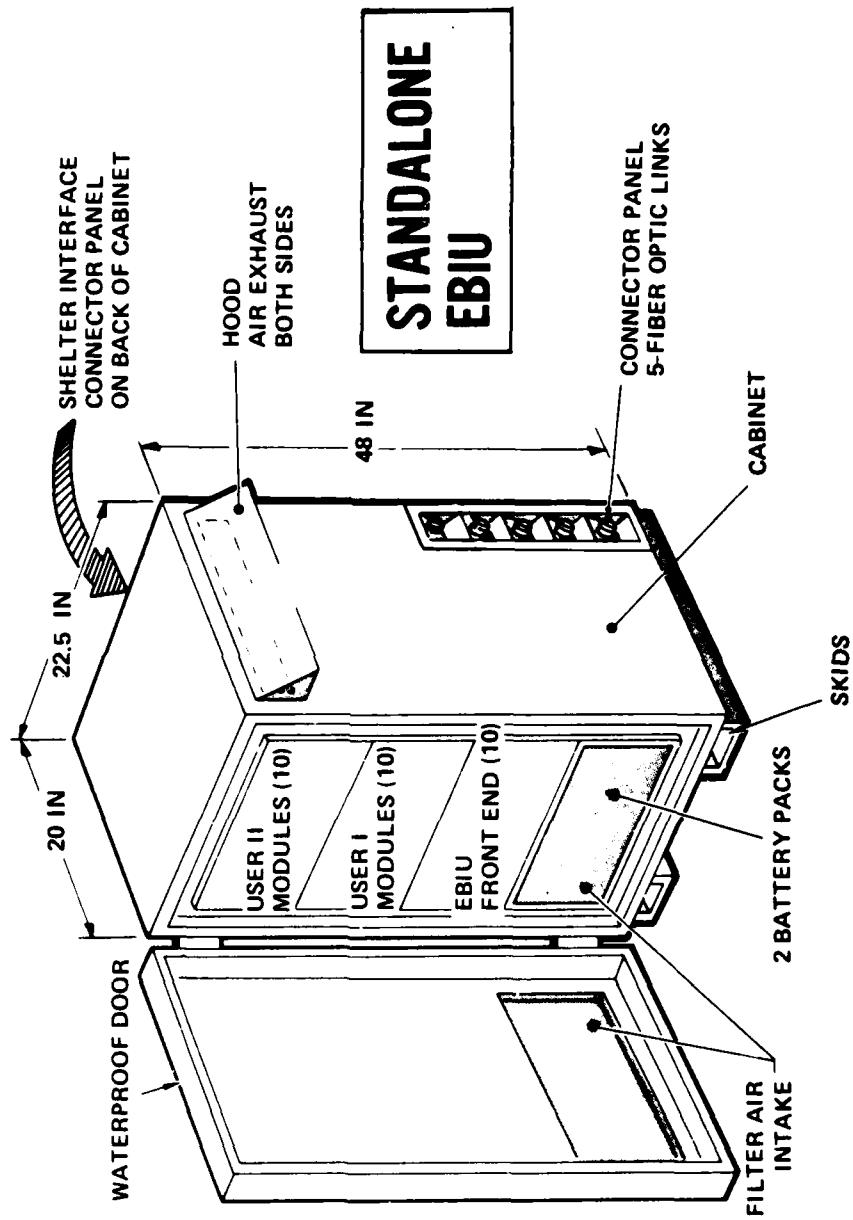

ITT GILFILLAN

2053-27

**IMPACT OF THE LAN
ON
COMMUNICATIONS**

-479-

2053 28

ITT GILFILLAN

AD-A126 110

PROCEEDINGS OF CONFERENCE ON LOCAL AREA MILITARY
NETWORKS GRIFFISS AFB NEW YORK 28-30 SEPTEMBER 1982(U)
ROME AIR DEVELOPMENT CENTER GRIFFISS AFB NY
D B WARNUTH ET AL. 1982

6/6

UNCLASSIFIED

F/G 17/2

NL

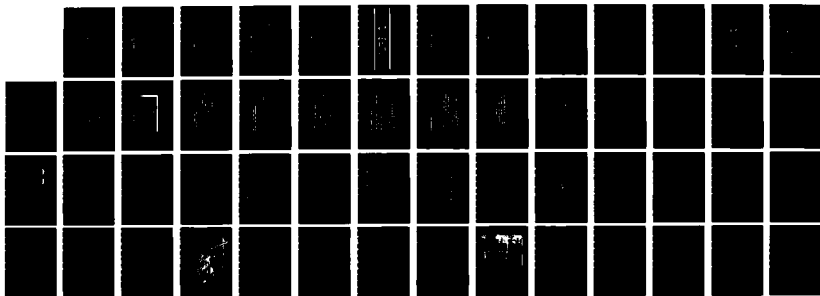

END

FILMED
24
DTIC

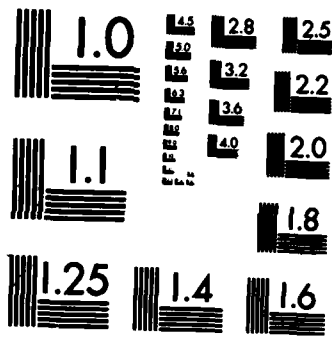

MICROCOPY RESOLUTION TEST CHART
NATIONAL BUREAU OF STANDARDS-1963-A

OBSOLETE ANALOG CRC/CRP COMMUNICATION STRUCTURES

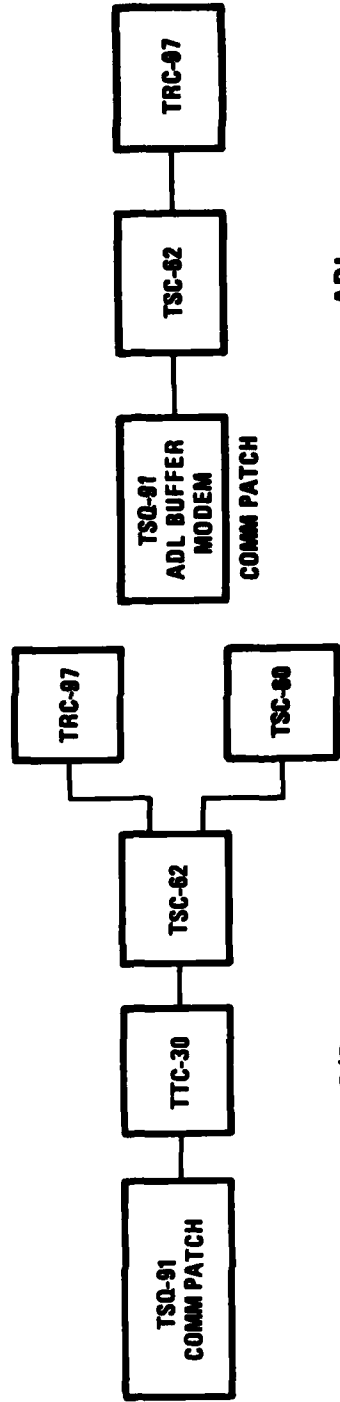

ADL

G/G

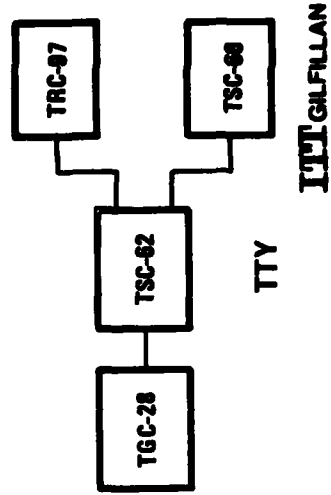

TTY

TTY GILFILLAN

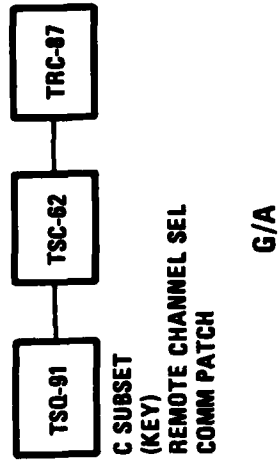

G/A

2053-29

TRI-TAC COMMUNICATION STRUCTURES

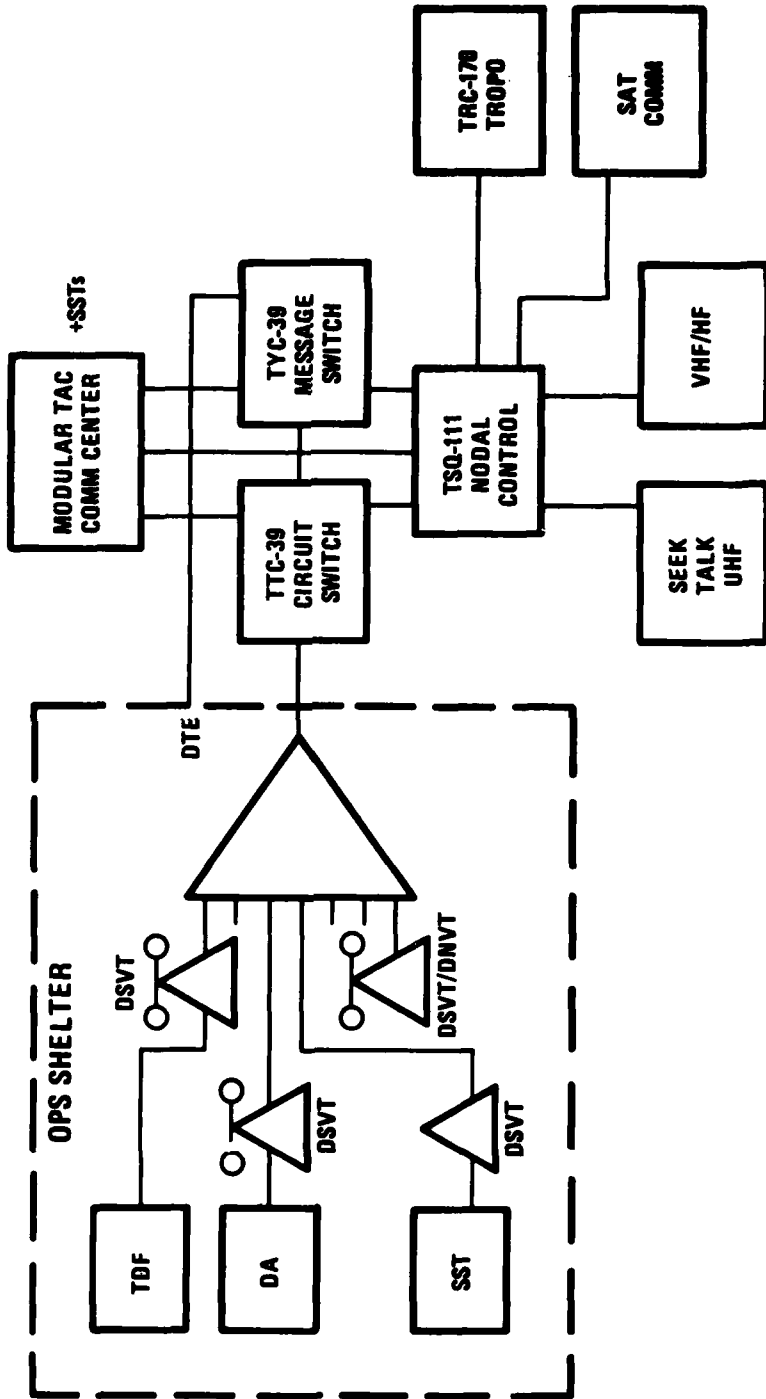

J. J. GILFILLAN

2053-30

MODULAR OPERATIONS CENTER

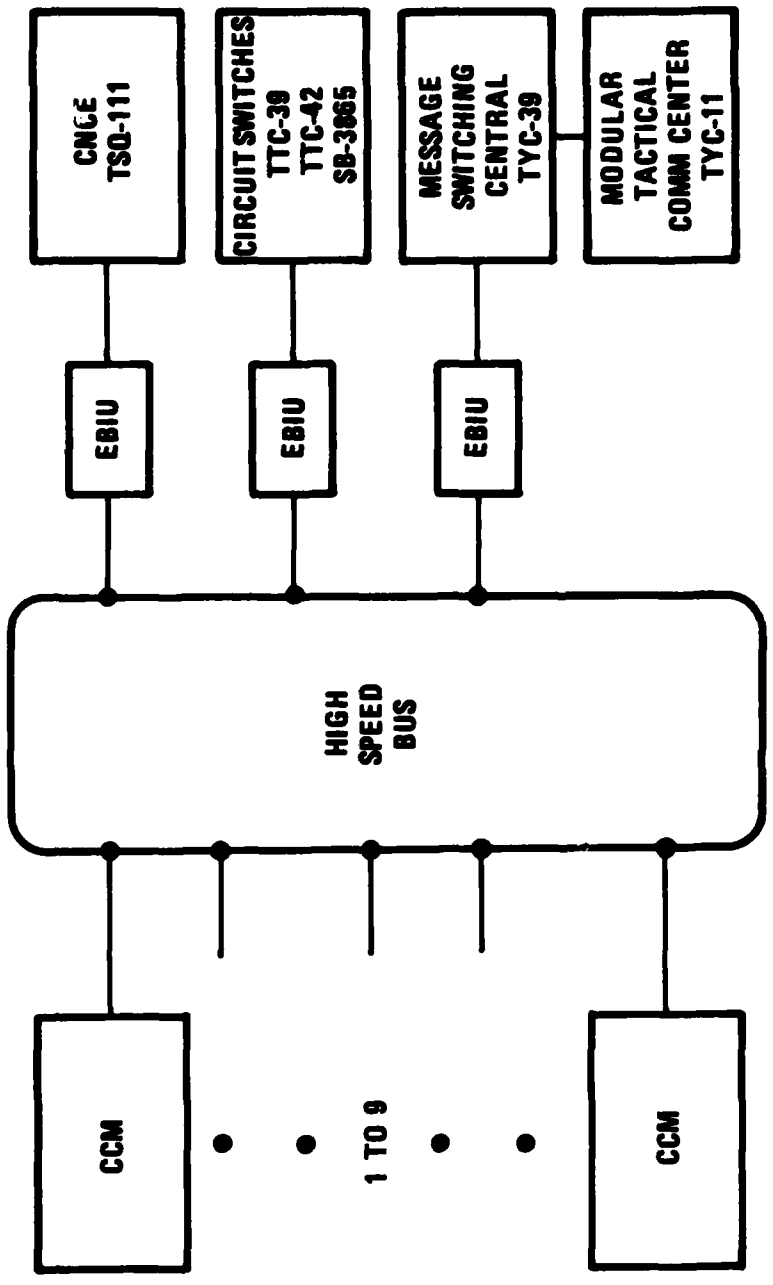

ITT GILFILLAN

2063-31

RADIO PARK

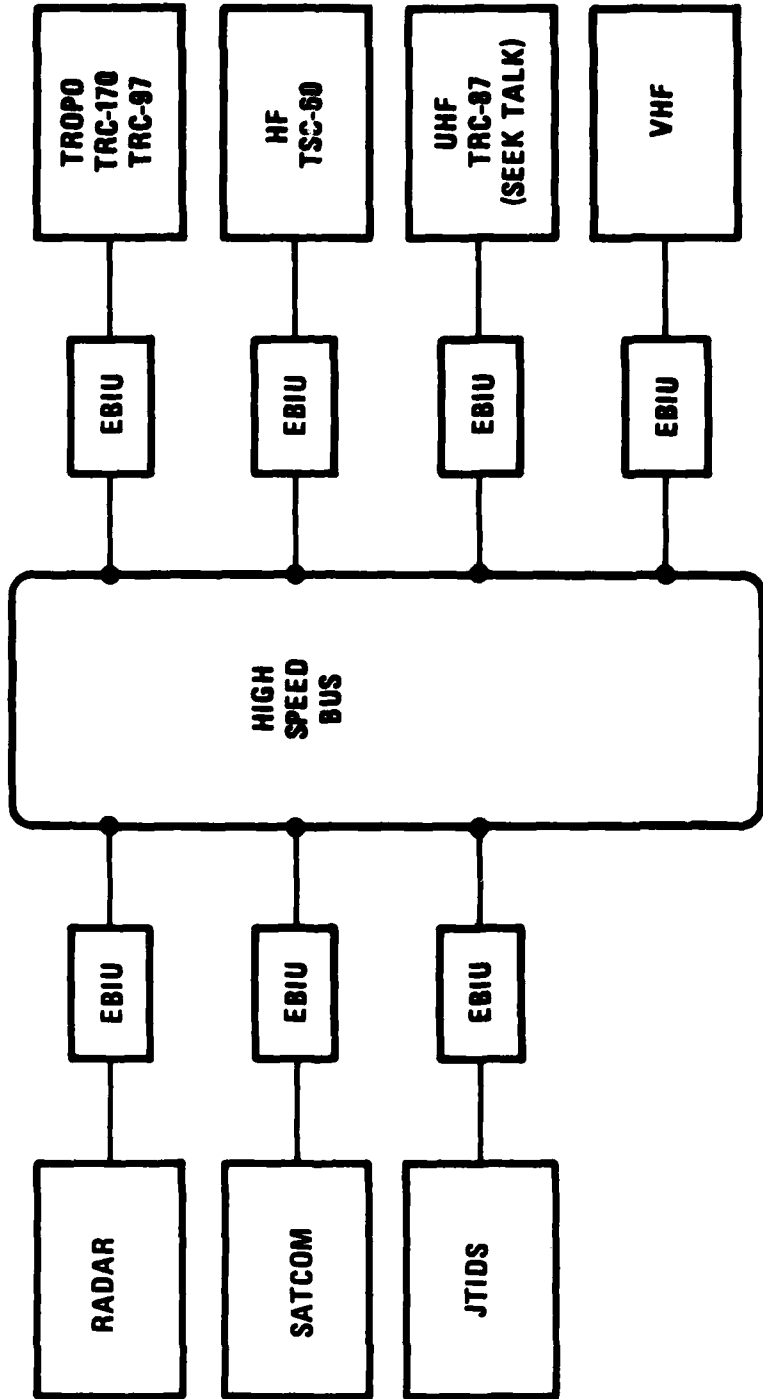

J. J. GILFILLAN

2053-32

**OPERATIONAL IMPLICATIONS
OF THE
DISTRIBUTED ARCHITECTURE**

- 484 -

JIT GILLIAN

2053-36

MAJOR CHALLENGES

- FUNCTIONAL INTEGRITY
- DEGRADED MODE CAPABILITY

2053-37

ITT GILFILLAN

SOLUTION

- REDEFINITION OF OPERATIONAL CONCEPTS
AND FUNCTIONS
- CREATION OF NEW ORGANIZATION
- OPERATOR TRAINING
- INFUSION OF NEW TECHNOLOGY
- EQUIPMENT UTILIZATION

JULI GULLAN

2053-38

CONCLUSION

TACTICAL UNITS CONSISTING OF MODULAR, DISTRIBUTED ELEMENTS THAT ARE INTERCONNECTED BY LOCAL AREA NETWORKS ARE MORE SURVIVABLE AND HAVE GREATER OPERATIONAL FLEXIBILITY THAN TACTICAL UNITS THAT ARE FUNCTIONALLY AND PHYSICALLY CENTRALIZED.

2053-39

ITT GILFILLAN

Standardization (0800-1000 30 Sep)

Session Chairman: Mr. James L. Davis - RADC/DCLW

"Protocol Standardization," Dr. Rona Stillman, Hq USAF/ACD

Protocol standards for local area networks with military applications.

"Implementation and Application of DoD Standard Protocols in Local Area Networks," Mr. John K. Summers, MITRE Corp.

Selection and implementation of DoD standard protocols in microprocessors; evolution strategies and performance results.

"National Bureau of Standards Activities in LAN's," Mr. Dan Stocksberry, National Bureau of Standards

Discussion of LAN selection criteria and performance measurements of LANs.

"NATO Standardization for Local Area Networks," Mr. Steve Anderson, and Mr. Dennis Abbot, Sperry Univac

Local Area Network Standardization activities in NATO will be discussed with emphasis on ship system integration.

PIVOTAL TECHNOLOGIES

- **INEXPENSIVE, POWERFUL MICROCOMPUTERS**
- **INEXPENSIVE, HIGH BANDWIDTH COMMUNICATIONS**
- **PROVEN EFFICIENCY OF PACKET SWITCHING FOR
BURSTY COMPUTER COMMUNICATIONS**

**OLD ARCHITECTURE MODEL:
CENTRALIZED MAINFRAME, DEDICATED COMMUNICATIONS**

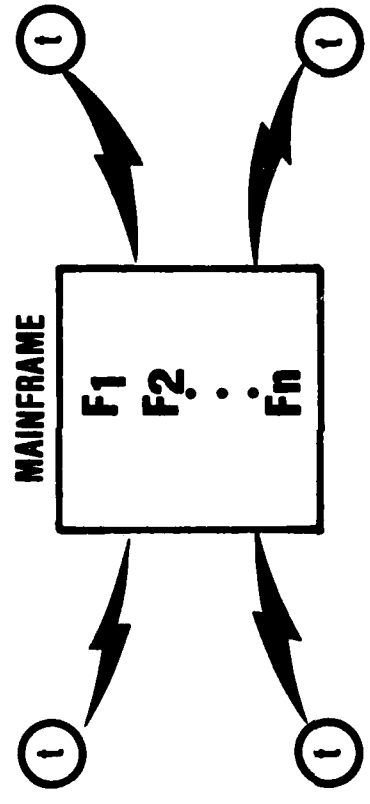

-
- EXPENSIVE MAINFRAME, COMMUNICATIONS
 - ALL HARDWARE FROM SINGLE VENDOR
 - NOT EASILY EXPANDED
 - MULTILEVEL SECURITY VIA KERNEL TECHNOLOGY
TOO DIFFICULT
 - "EVOLUTION" BY WHOLESAL REPLACEMENT

**NEW ARCHITECTURE MODEL:
LOCAL AREA NETWORK, CATENET**

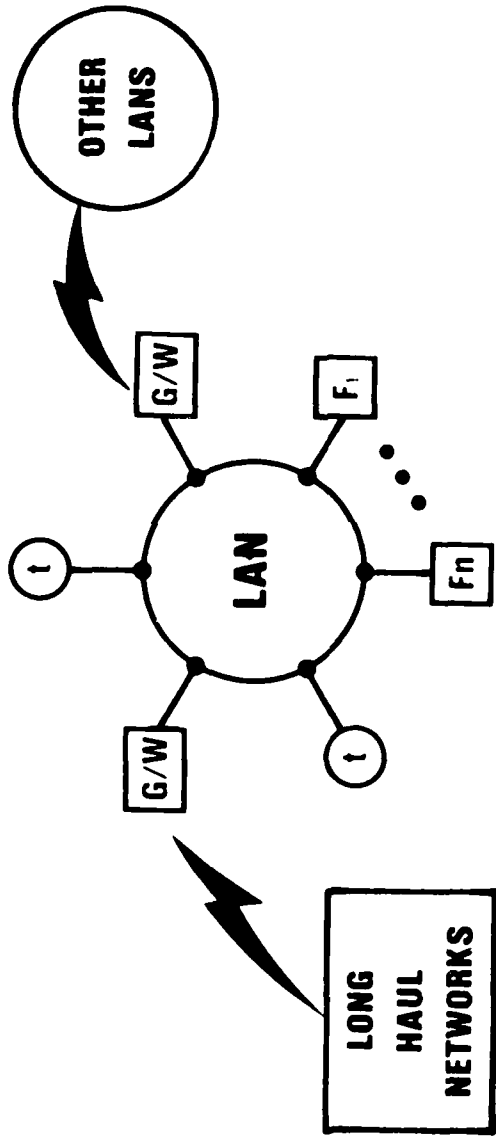

- FUNCTIONALLY DEDICATED PROCESSORS
- ECONOMICAL COMMON USER LONG HAUL COMMUNICATION
- EASILY EXPANDED TO ACCOMMODATE NEW USERS, SERVICES
- POTENTIAL EXISTS FOR
 - VENDOR INDEPENDENCE
 - GRACEFUL INCREMENTAL EVOLUTION
 - MULTILEVEL SECURITY VIA ENCRYPTION TECHNOLOGY
- TRUE RESOURCE SHARING

**KEY TO REALIZING LAN POTENTIAL:
LEARN FROM PAST HISTORY**

- MAJOR HARDWARE IMPROVEMENTS/NEW GENERATIONS
COME QUICKLY, CHEAPLY
- SOFTWARE IS THE PROBLEM
 - LATE
 - LONG TO MATURITY, STABILITY
 - EXPENSIVE TO BUILD, MAINTAIN, TRANSPORT
- MULTILEVEL SECURITY VIA SOFTWARE SEPARATION ALONE
IS TOO HARD, TOO EXPENSIVE, TOO SLOW
- GATEWAY TECHNOLOGY NEWER, LESS WELL DEVELOPED
THAN INTRANETWORK SWITCHING

STRATEGIC APPROACH

- **BUILD SOFTWARE TO SPAN GENERATIONS OF HARDWARE**
 - **MODULAR SOFTWARE**
 - **HIGH LEVEL STANDARD LANGUAGES**
 - **HARDWARE INSENSITIVE**
- **PLAN TO REPLACE HARDWARE BY NEWER HIGHER PERFORMANCE/PRICE OFFERINGS**
 - **MODULAR HARDWARE**
 - **VENDOR INDEPENDENCE AT LOGICAL INTERFACES**
- **BE WILLING TO PAY**
 - **SYSTEM PERFORMANCE**
 - **SOFTWARE NOT OPTIMIZED FOR SPEED, MEMORY UTILIZATION**
 - **INITIAL COST - BUY MORE HARDWARE**
- **MOUNT ALTERNATIVE ATTACK ON MULTILEVEL SECURITY BASED UPON ENCRYPTION, INTIMATELY RELATED TO PROTOCOLS**
- **SIMPLIFY GATEWAYS BY JUDICIOUS PROTOCOL MANAGEMENT**

**UNDERLYING REQUIREMENT:
STANDARD, LAYERED PROTOCOLS**

BASIC LEVEL	SUBLEVELS
APPLICATIONS FUNCTIONS	USER ORIENTED APPLICATIONS
END-TO-END TRANSPORT	HOST-TO-HOST
TRANSMISSION	INTERNETWORK
	NETWORK PACKET EXCHANGE
	FRAME TRANSFER
	PHYSICAL INTERFACE

**SOME LAN CHOICES ARE SECOND ORDER:
CHARACTERISTICS OF LAN**

- TOPOLOGY
 - RING
 - BUS
 - MESH
- MEDIUM
 - TWISTED PAIR
 - COAXIAL CABLE
 - FIBRE OPTICS
- ACCESS MECHANISM
 - CONTENTION (CSMA, CSMA/CD)
 - DETERMINISTIC
- MODULATION
 - BASEBAND
 - BROADBAND

**SOME CHOICES ARE FIRST ORDER:
PROTOCOLS AND THEIR MANAGEMENT**

- **LAYERED ARCHITECTURE OF VENDOR INDEPENDENT PROTOCOLS**
- **CHOICE OF PROTOCOLS, ESPECIALLY AT INTERNETWORK
LAYER AND ABOVE**
- **STANDARDIZATION AND EVOLUTION OF THESE PROTOCOLS**

PROTOCOLS ARE COMPLEX OBJECTS

- **SERVE ASYNCHRONOUS PROCESSES**
- **EXHIBIT TIME DEPENDENT, LOAD DEPENDENT BEHAVIOR**
- **EXPENSIVE TO DESIGN, SPECIFY, DEVELOP, TEST**
- **MATURE SLOWLY**
- **GENERALLY IMPLEMENTED IN SOFTWARE**

DOD STANDARD PROTOCOLS: TCP/IP

- **MOST WIDELY IMPLEMENTED, TESTED STANDARD TRANSPORT PROTOCOLS AVAILABLE TODAY**
- **MEET DOD REQUIREMENTS, SUPPORT HIGHER LEVEL USER ORIENTED SERVICE PROTOCOLS**
- **IMPLEMENTED SUCCESSFULLY ON LAN**
- **OPERATE WITH PLI's, WHICH PROVIDE END-TO-END SECURITY**
- **ARE THE CONTEXT FOR ONGOING RESEARCH IN MULTILEVEL SECURITY**

RECOMMENDATIONS

- IMPLEMENT TCP/IP ON LAN AS WELL AS DDN
 - TCP/IP IS "KNOWN QUANTITY"
 - SIMPLIFIES GATEWAY
 - PERMITS USE OF PLI's, APPLICATION OF MULTILEVEL SECURITY RESEARCH IN LAN's
 - NO ANALOGOUS INTERNATIONAL/NATIONAL STANDARDS
- PARTICIPATE IN INTERNATIONAL/NATIONAL STANDARDS ACTIVITIES
- SUPPORT RESEARCH
 - MULTILEVEL SECURITY ON LAN's
 - NEW APPLICATIONS PROTOCOLS (E.G., MULTIMEDIA CONFERENCING)
 - TRUE RESOURCE SHARING

**Use of
Transmission Control
Protocols/Internet Protocols
(TCP/IP) in Local Area Networks**

Background

- **Research Project Started in Washington in May 1978**
- **Project Objectives**
 - **To Investigate the Use of Local Networks as a Transition Strategy to the Next Generation Worldwide Command and Control Systems (WWMCCS)**
- **Approach**
 - **Connect H6000 to LAN**
 - **Connect Terminals to LAN**
 - **Connect New Computers to LAN**
 - **Use Terminals to Access Both the Old and the New Systems**

Requirements

- **Interconnection Between 100s of Terminals and 10s of Computers**
- **Terminal-to-Terminal Communications Up to 19.2 Kbps**
- **Virtualization of Terminal Characteristics**
- **Inexpensive Terminal Interfaces**
- **Computer-to-Computer Communication in the Megabit Range**
- **High Speed Computer Interfaces With Minimal Impact from Networking Software**
- **Internetworking**

Protocol Issues

- **TCP/IP is the DoD Long Haul Network Standard**
- **What Standard Should be Used on the LAN?**
- **What Kind of Gateway is Required Between LAN and Long-Haul?**
- **What is the Functionality of the Gateway?**
- **What Throughput/Performance Can be Attained on the Gateway**
- **Inboard vs. Outboard LAN Protocols**

Protocols for Use With Local Networks— The Choice

Layer	International Standards	DoD Standards	Vendor Unique
Application	ECMA Draft File Transfer	ARPANET Mail ARPANET FTP ARPANET Telnet	Vendor Specific
Presentation	CCITT X3/X28/X29		
Session	ISO Draft Std	TCP	
Transport	ISO Draft Std		
Network	CCITT X.25 Packet Level		
Data Link	IEEE 802 Proposed Standard	CSMA/CD or Token	
Physical		Baseband or Broadband	

Approach Investigated

- **Outboard TCP/IP**
- **Low Level Gateway Between LAN and Long-Haul Network**
- **TCP/IP Implemented in a Z8000 Microprocessor Which Functioned as a Bus Interface Unit (BIU)**
- **CSMA/CD Used as the Lower Level Protocols**
- **ARPANET Used to Functionally Simulate the DoD Long-Haul Network**

MITRE/Washington Cable Bus Configuration

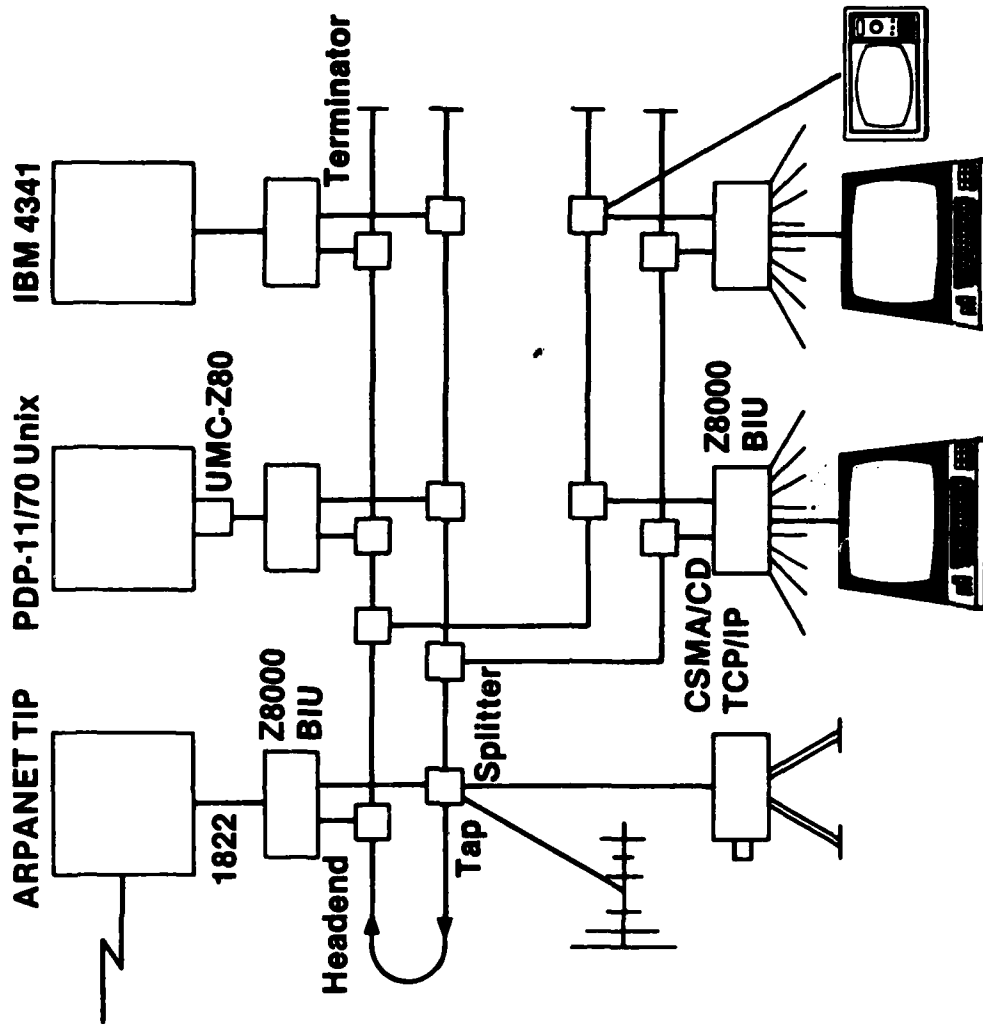

Performance Data

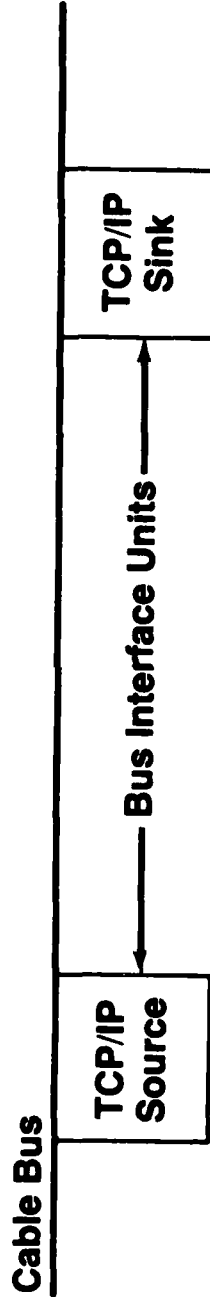

- Electrical Signaling Rate Was 890 KBPS
- Data Flow From Source to Sink Was 350 BITS Per Second With 512 Byte Data Messages
- Limiting Factor Was the S10 Chip Which Was Restricted to 890 KBPS

Test Results

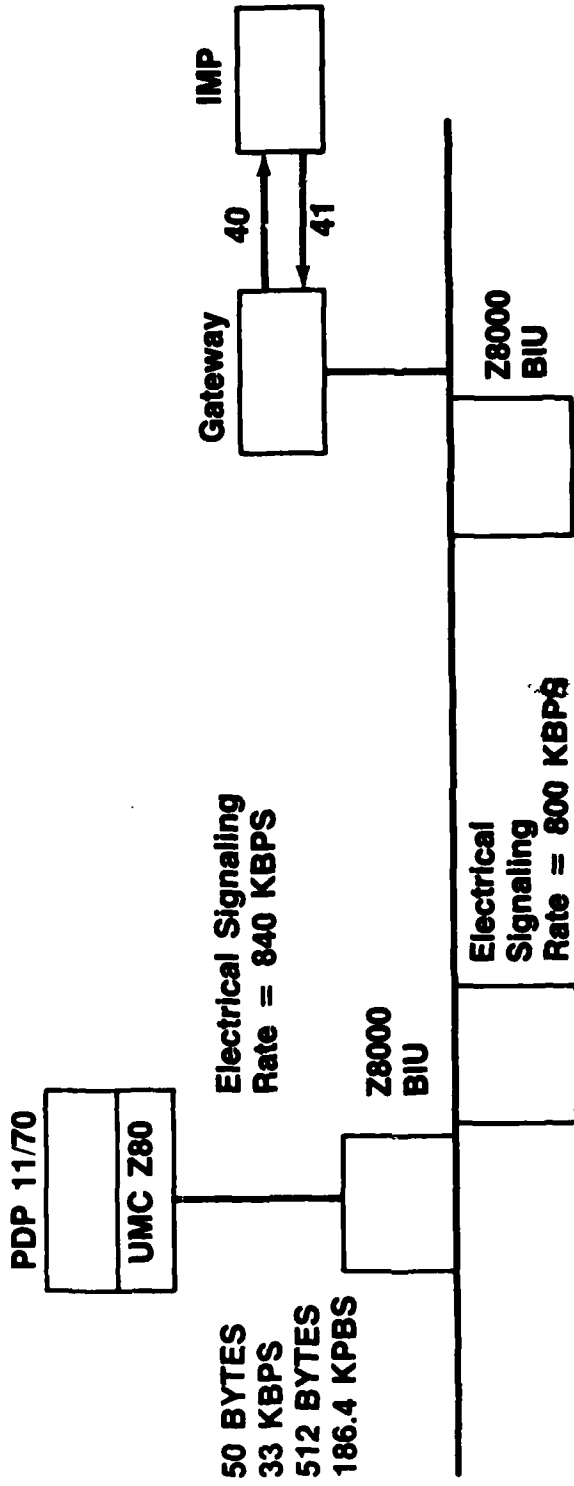

8 BYTE Packets - 200 Packets Per Second - 14.2 KBPS

8 K BYTE Packets - 6.9 Packets Per Second - 452 KBPS

Reston LAN Testbed

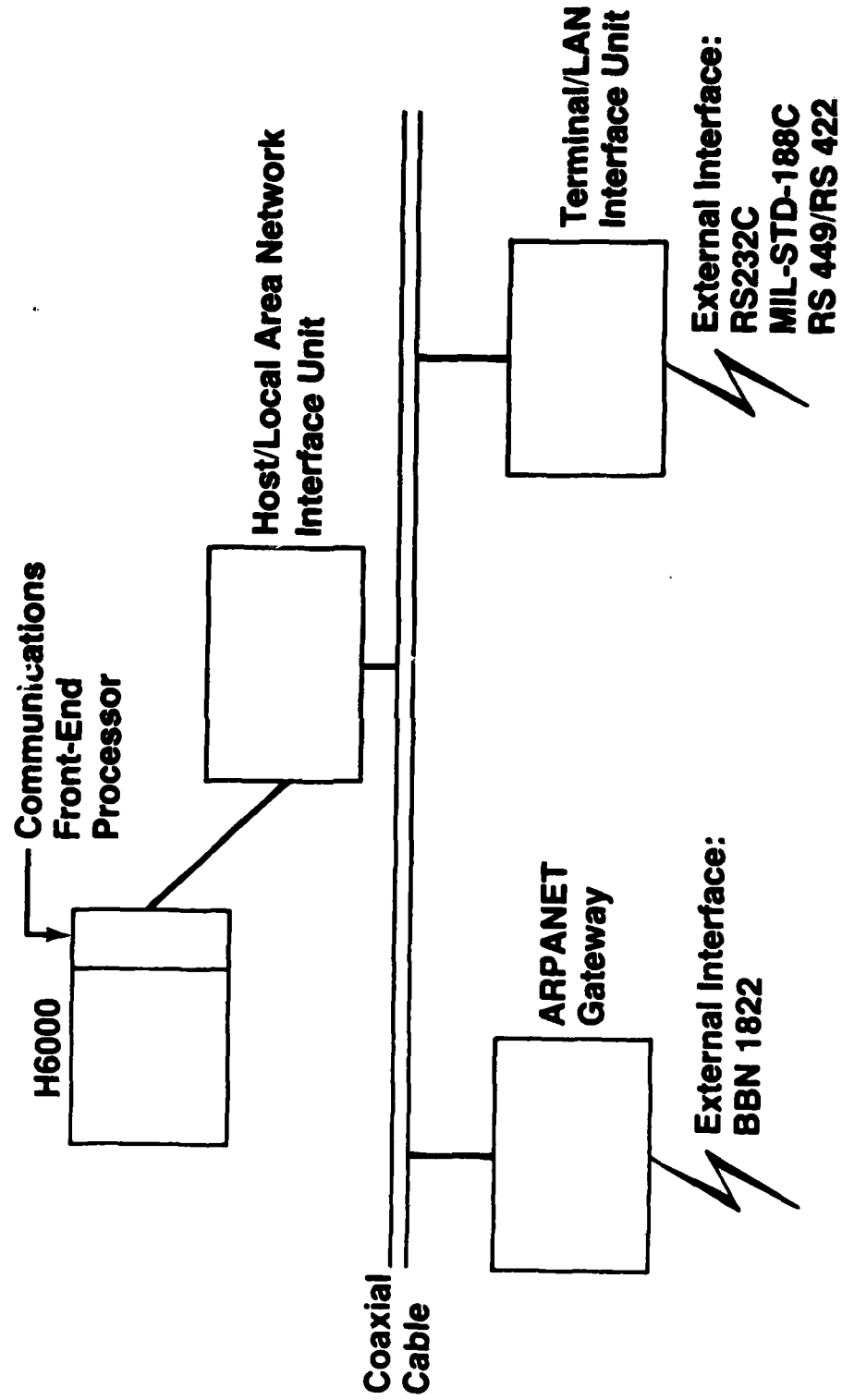

Multiprocessor System

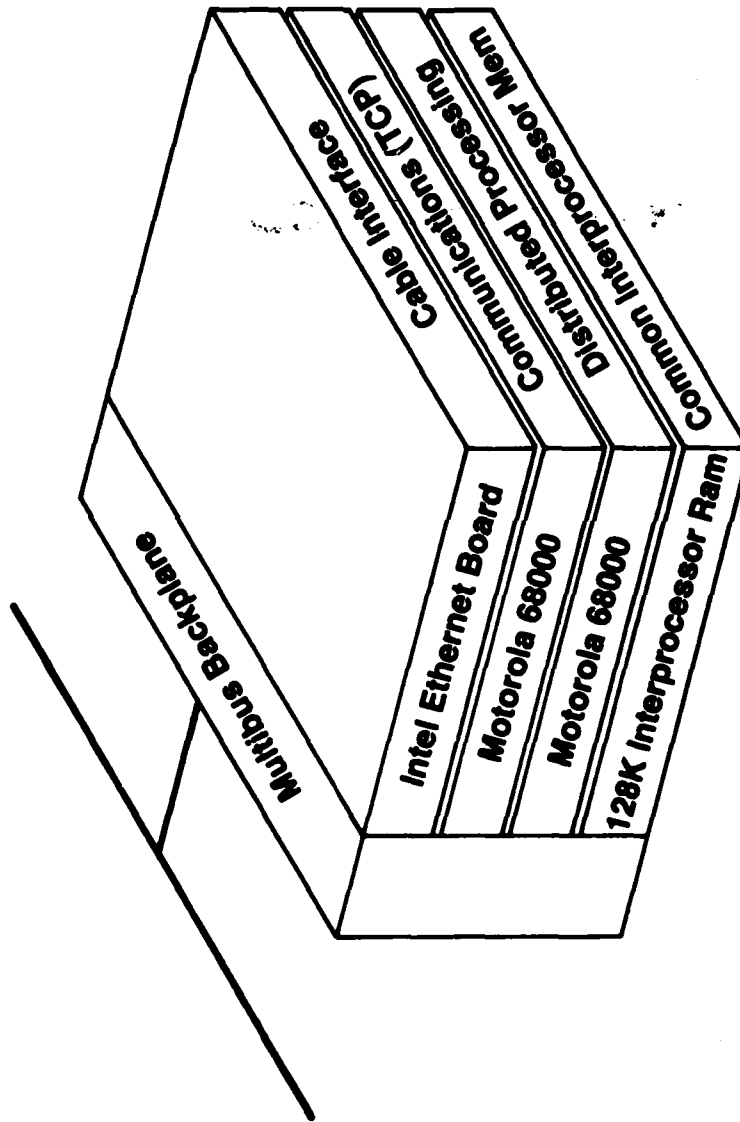

Distributed Processing Protocols

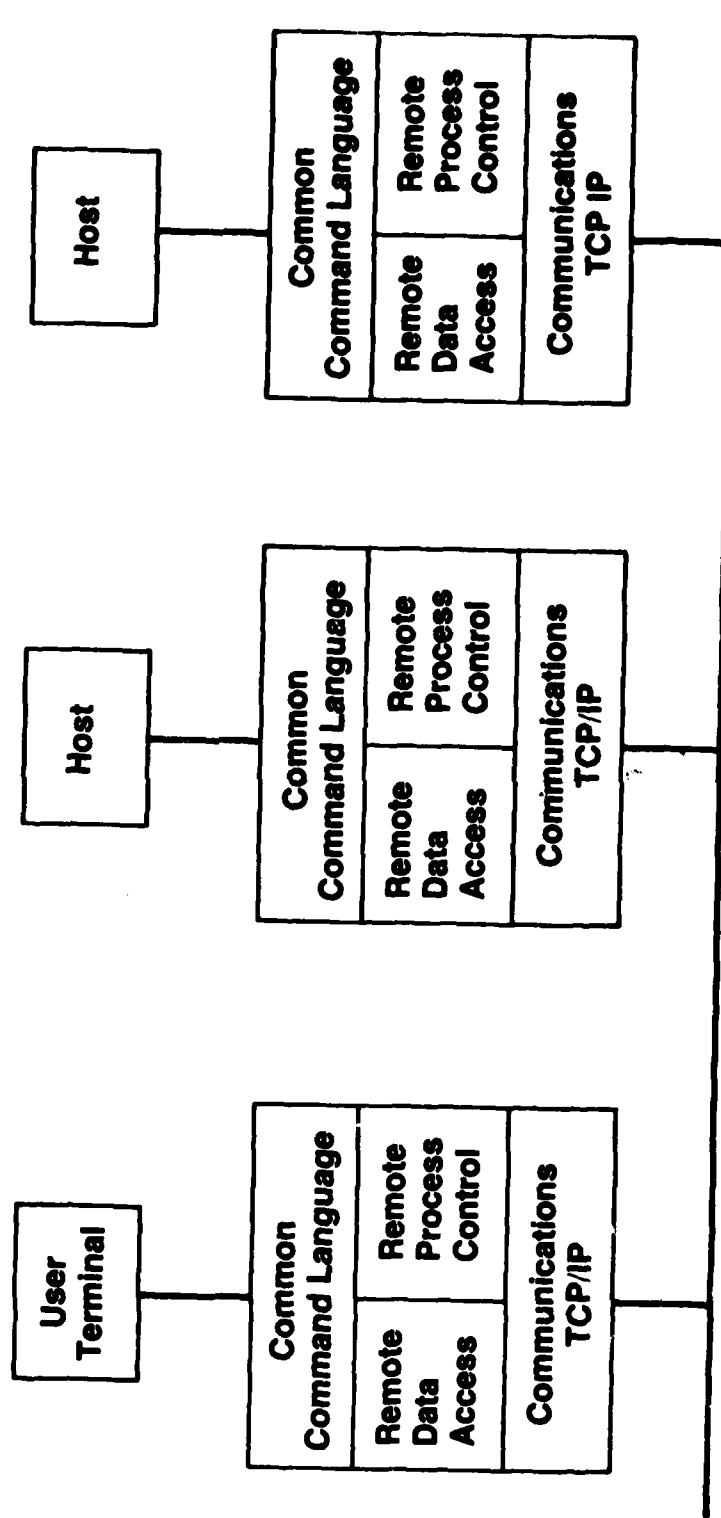

Long-Range Goals of Reston Experiments

- **Understanding the Distributed Environment**
 - **Security Issues**
 - **Performance Issues**
 - **Protocol Issues**
 - **Data Base Issues**
 - **Application Placement Issues**
 - **Workstation Issues**
 - **User Interface Issues**
 - **Internetworking Issues**
 - **Configuration Management Issues**

Conclusions

- **Performance of TCP/IP Is Good**
- **Number of Bytes of Overhead Is Not an Important Issue**
- **TCP/IP Has Built in Security Features Which Can be Exploited for E³**
- **1 MBPS Throughput Is Achievable With the Right Hardware**

NATIONAL BUREAU OF STANDARDS

ACTIVITIES IN LOCAL AREA NETWORKS

DAN STOKESBERRY

NETWORK STANDARDS MULTI-PLATFORM PROTOCOL

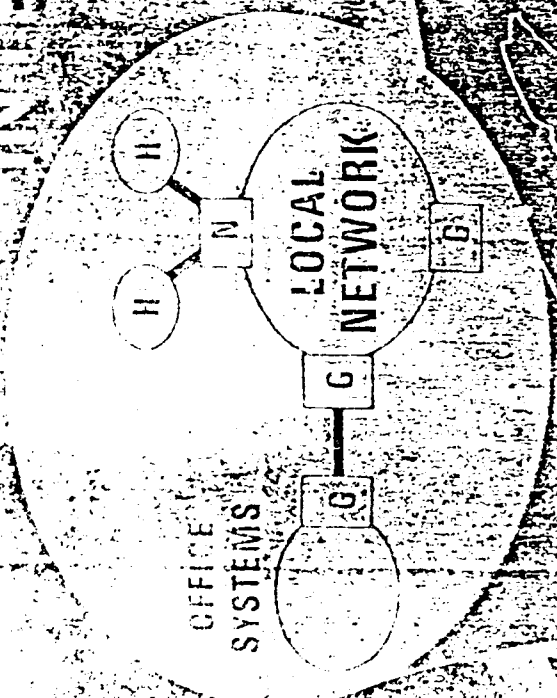

COMPUTER NETWORK PROTOCOL STANDARDS

OBJECTIVES:

- (1) TO MAKE POSSIBLE DISTRIBUTED COMPUTER NETWORKS IN THE FEDERAL GOVERNMENT
- (2) TO PROVIDE INTEROPERABILITY AND AVOID UNIQUE, EXPENSIVE SOLUTIONS
TO INTEROPERABILITY PROBLEMS
- (3) TO ENABLE THE INTERCONNECTION OF DIFFERENT NETWORK COMPONENTS
SELECTED ON COST AND PERFORMANCE CONSIDERATIONS

HIGH LEVEL
PROTOCOLS

LOCAL AREA
NETWORKS

OFFICE
AUTOMATION

- ACCESS NEEDS AND IMPACTS
- COORDINATE WITH FEDERAL AGENCIES
- MEET WITH ADVISORY PANELS
- MEET WITH MANUFACTURES
- PARTICIPATE IN STANDARDS ACTIVITIES
- INTERNATIONAL COORDINATION
- U.S. INDUSTRY COORDINATION
- PROVIDE DOCUMENTATION

NETWORK
STANDARDS AND SCHEDULE

1981

MESSAGE FORMAT

1982

TRANSPORT -- BASIC AND EXTENDED
SESSION

FILE TRANSFER AND DATA PRESENTATION

VIRTUAL DEVICE

LOCAL AREA NETWORK

INTERNET

1983

MESSAGE PROTOCOLS

JOB TRANSFER AND MANIPULATION

FUTURE

MANAGEMENT PROTOCOLS

DISTRIBUTED DATA PROTOCOLS

STANDARDS ORGANIZATIONS WITH LAN INTERESTS

ISO TC 97/SC 6

ECMA TG 24 LN

IEC PROWAY

ANSI X3.T9

EIA TR 40.1

IEEE 802

NBS FIPS

EVOLVING ARCHITECTURES

(JANUARY, 1982)

802

ISO

ECMA

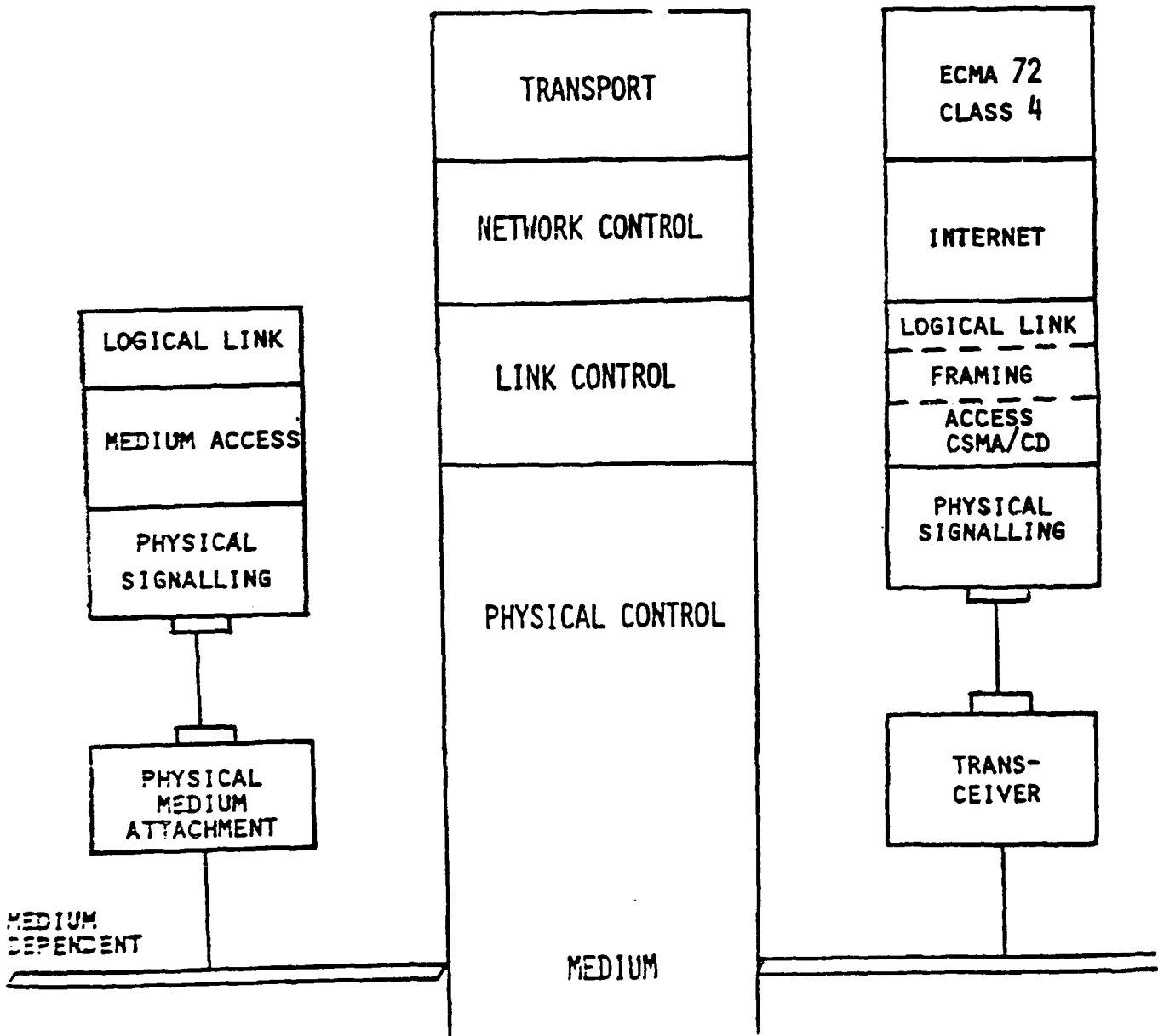

802 DOCUMENTATION

INTRODUCTION
2/3 SERVICE SPEC
LLC TYPE 1 & 2
LLC/MAC SERVICE SPEC

CSMA/CD MAC
1/2 SERV SPEC
PSS/ALL INTERFACE
BASEBAND COAX MAU

TOKEN BUS MAC
1/2 SERV SPEC
PSS/ALL INTERFACE
BROADBAND COAX MAU

TOKEN RING MAC
1/2 SERV SPEC
PSS/ALL INTERFACE
TWISTED PAIR MAU

SUPPLEMENTARY MATERIAL
- GLOSSARY
- MANAGEMENT
- INTERNET

FEDERAL INFORMATION PROCESSING STANDARDS

DECEMBER 1982	CSMA/CD	10 MEGABIT BASEBAND
1983	TOKEN RING	
1983	BROADBAND CSMA/CD	
1983	TOKEN BUS	

LOCAL NETWORKING LABORATORY

- PERFORMANCE MEASUREMENT
- TRAFFIC CHARACTERIZATION
- NETWORK MANAGEMENT
- ANALYTIC/SIMULATION MODELING
- RESEARCH

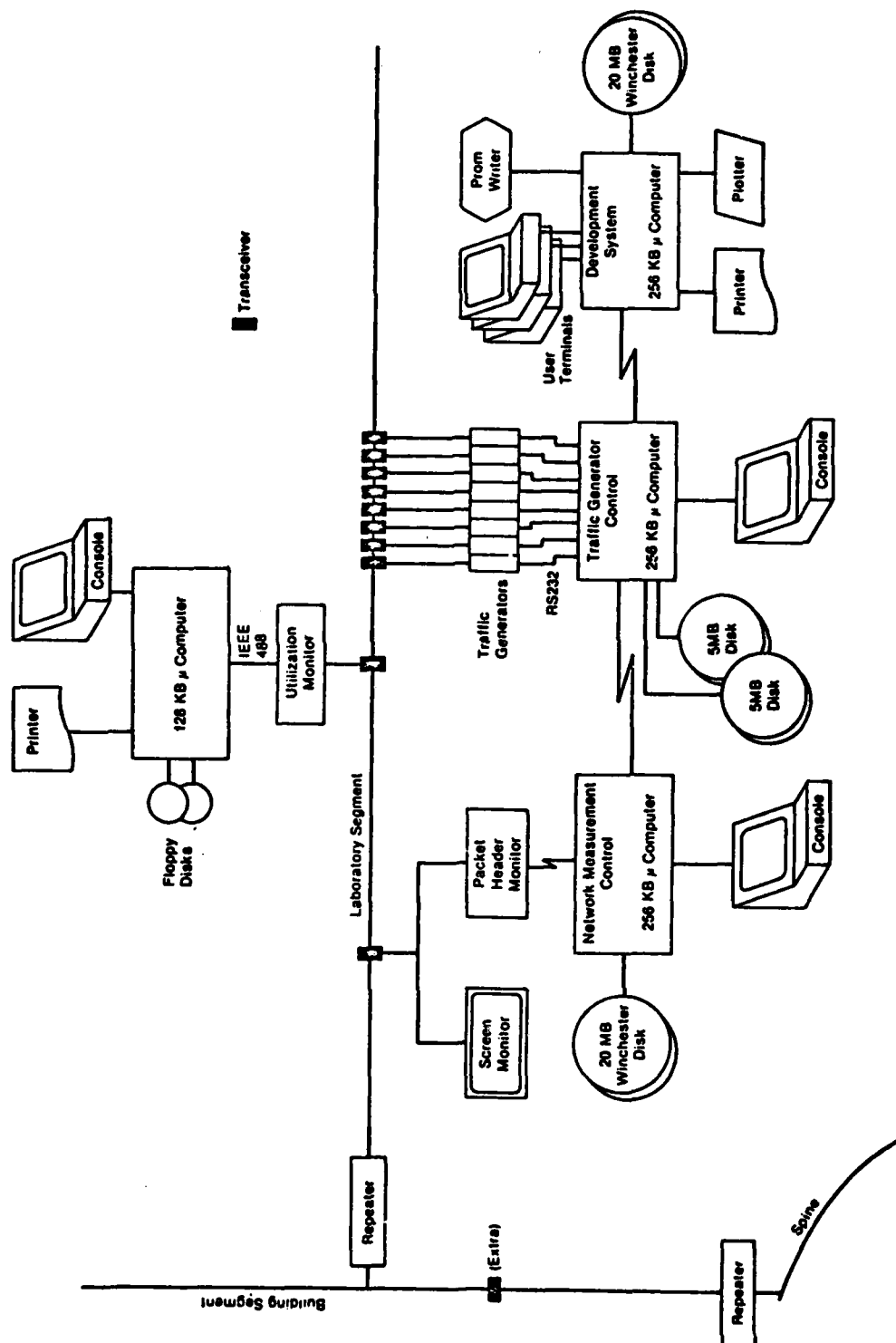

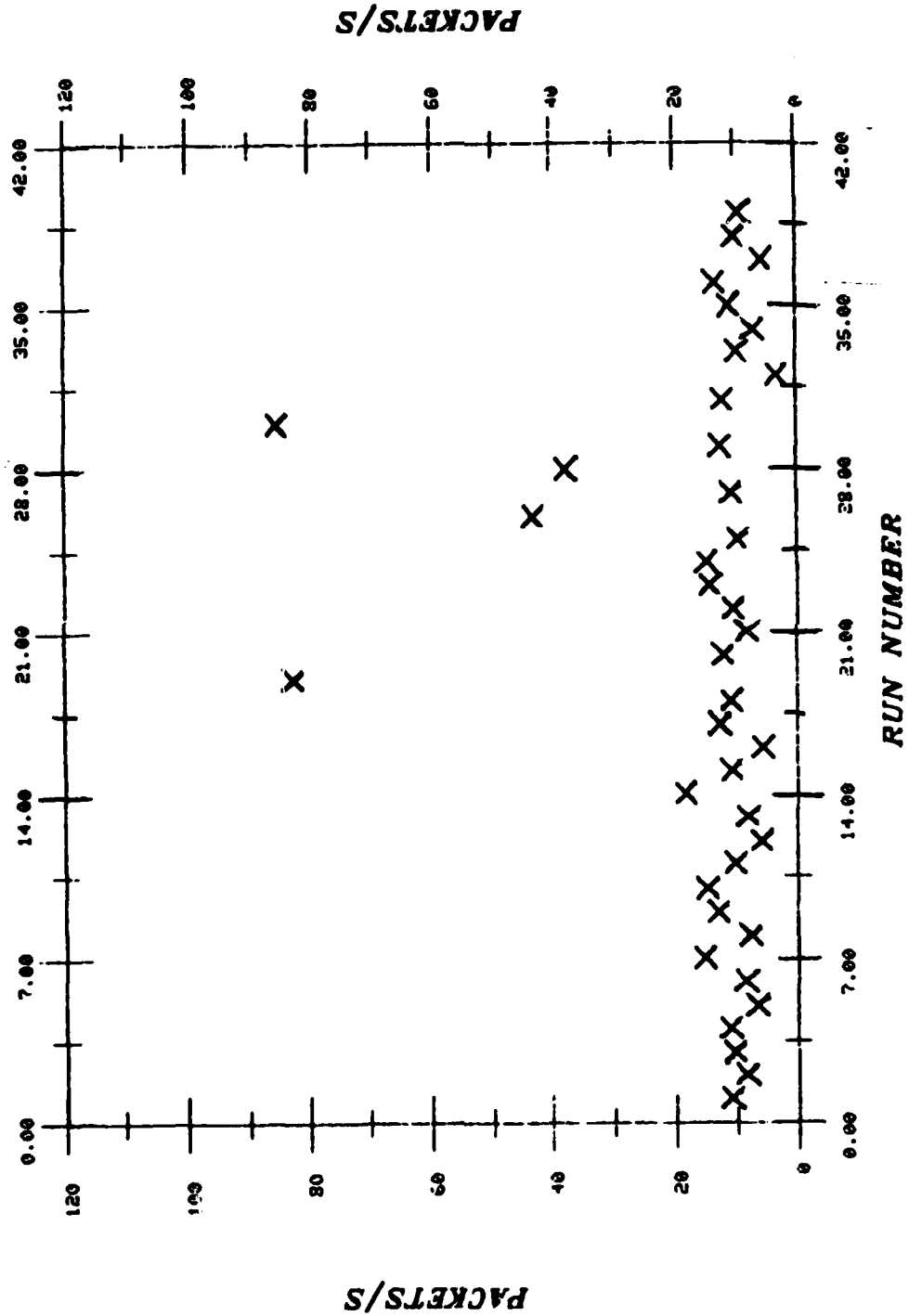

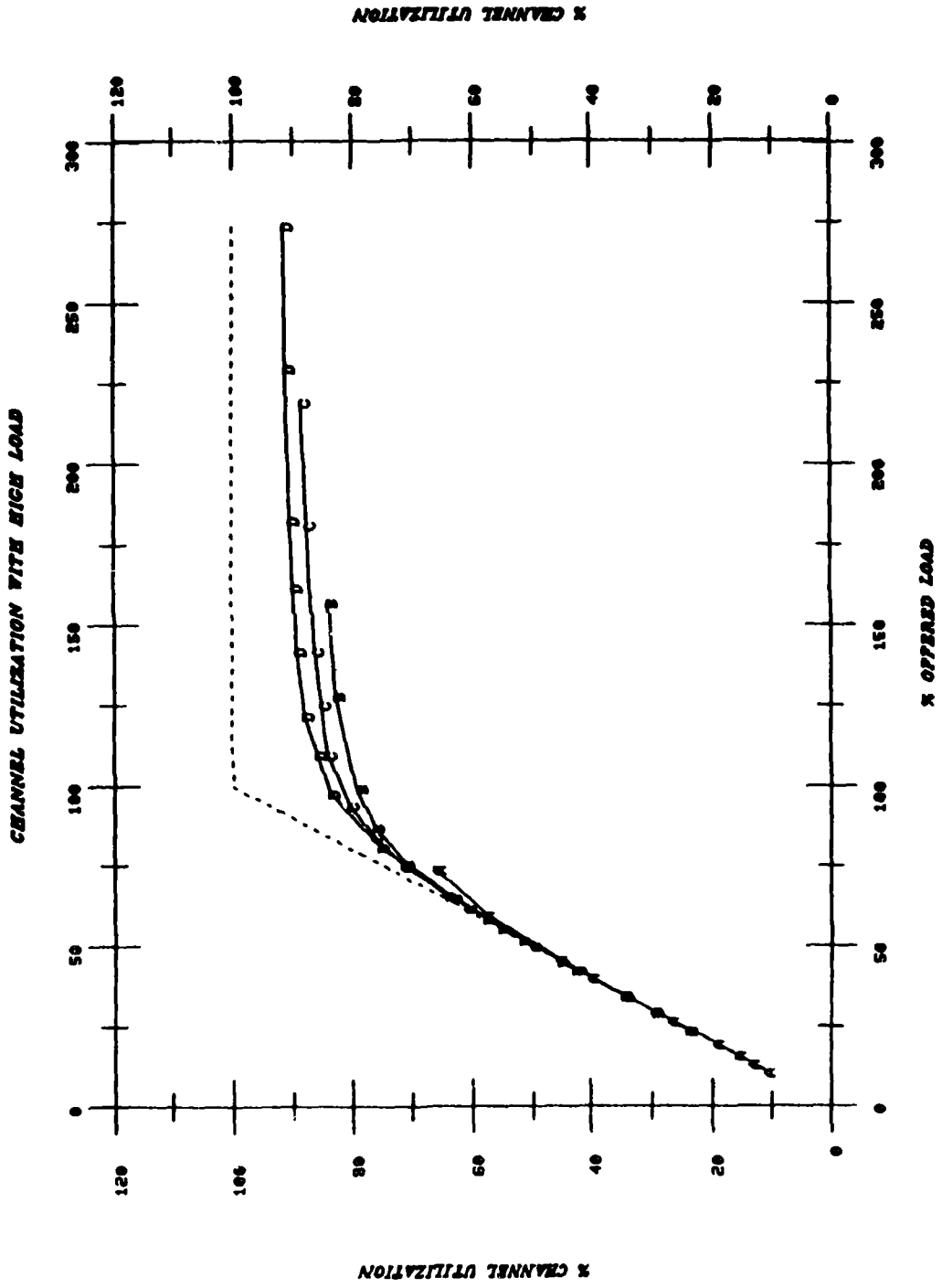

Average Acquisition Delay vs Utilization

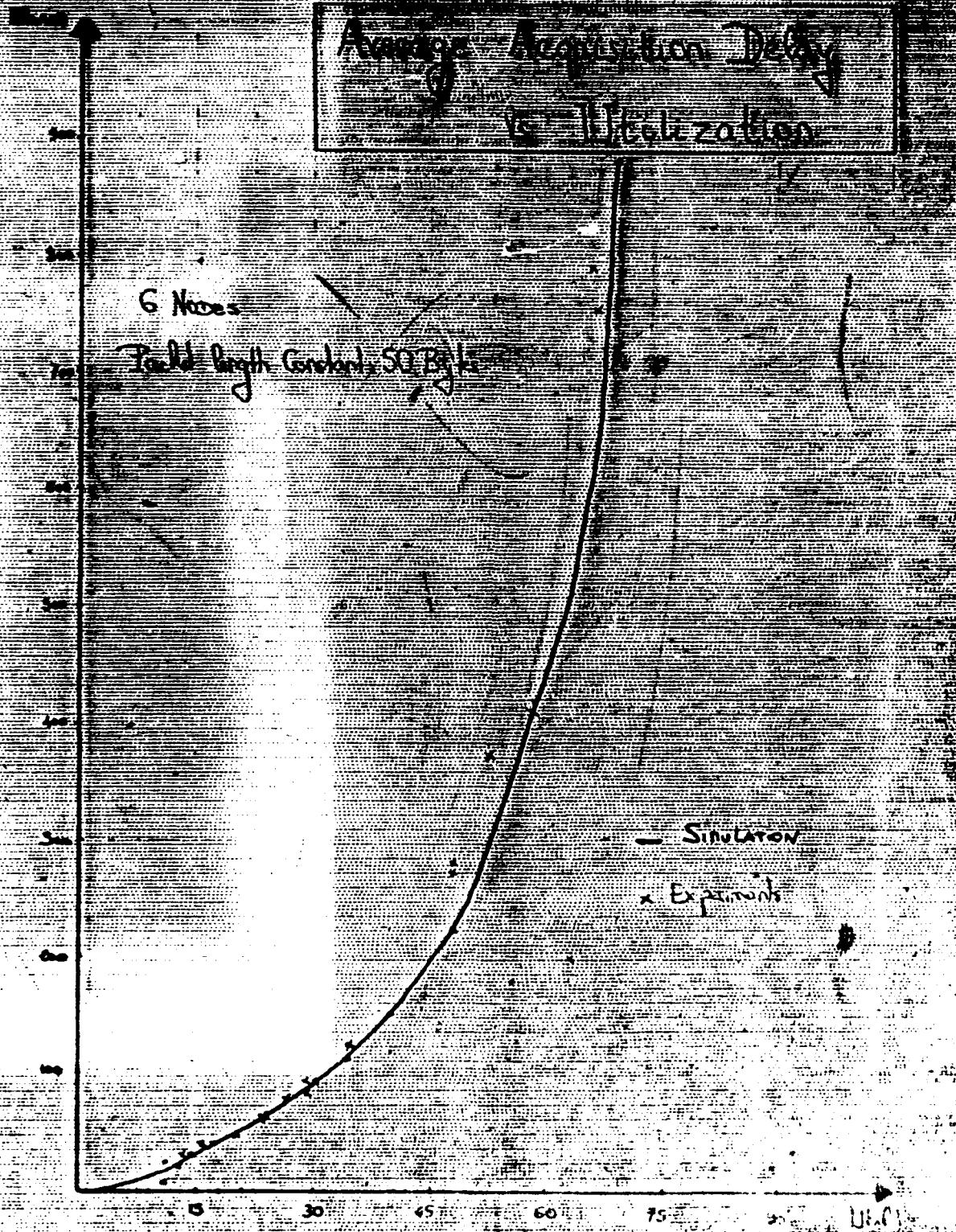

MAJOR POINTS IN PRESENTATION

- NBS NETWORK PROTOCOL STANDARDS PROGRAM INCLUDES LANs
- LANs ARE DIFFERENT FROM LONG HAUL NETWORKS
- IEEE IS ACCREDITED UNDER ANSI -- 802 HAS LAN ACTION
- LAN ARCHITECTURES ARE COMPATIBLE WITH OSI REFERENCE MODEL
- NBS FIPS INCLUDE CSMA/CD THIS YEAR

Revised 8/24/82
From 2/11/81

**CURRENT LIST OF DOCUMENTS AVAILABLE FROM
THE SYSTEMS AND NETWORK ARCHITECTURE DIVISION**

Address requests to: National Bureau of Standards
Systems & Network Architecture Division
B218/Technology Building
Washington, D. C. 20234

Federal Computer Network Protocol Standards Program: An Overview

NBSIR 80-2154	The NBS Computer Networking Program
ICST/HLNP-80-1	Features of the Transport and Session Protocols
ICST/HLNP-80-6	Features of the File Transfer Protocol (FTP) and the Data Presentation Protocol (DPP)
ICST/HLNP-80-8	Features of Internetwork Protocol
ICST/HLNP-80-9	Service Specification of the File Transfer Protocol (FTP) and the Data Presentation Protocol (DPP)
ICST/HLNP-80-12	Features of Network Interprocess Communication Protocols
ICST/HLNP-80-15	Service Specification of a Network Interprocess Communications Protocol
ICST/HLNP-81-2	Specification of the Session Protocol
ICST/HLNP-81-6	Specification of the Internet Protocol
ICST/HLNP-81-11	Specification of the Transport Protocol Vol. 1
ICST/HLNP-81-12	Specification of the Transport Protocol Vol. 2
ICST/HLNP-81-13	Specification of the Transport Protocol Vol. 3
ICST/HLNP-81-14	Specification of the Transport Protocol Vol. 4

ICST/HLNP-81-15	An Automated Formal Specification and Implementation Method for Protocols
ICST/HLNP-81-17	The Impact of Satellite Transmission on High-Level Computer Network Protocols
ICST/HLNP-81-18	The Effects of Satellite Technology on the ISO Model of Open Systems Interconnection
ICST/HLNP-81-19	Security in Higher Level Protocols: Approaches, Alternatives and Recommendations
ICST/HLNP-81-20	A Benchmark for Implementations of the NBS Transport Protocol
ICST/HLNP-82-4	Specification of the File Transfer Protocol
ICST/HLNP-82-5	Specification of the Data Presentation Protocol
NBS SP 500-81 (81)	A Survey of Standardization Efforts of Coded Character Sets for Text Processing
NBS SP 500-72 (80)	Guidance on Requirements Analysis for Office Automation Systems
NBS SP 500-69 (80)	An Analytic Study of Shared Devices Among Independent Computing Systems
NBS SP 500-63 (80)	A Testbed for Providing Uniformity to User-Computer Interaction Languages
NBSIR 80-2005 (80)	Computer Science and Technology: Investigation of Technology-Based Improvement of the Eric System
NBSIR 80-2187 (80)	Local Area Network Feasibility Study of the Naval Sea Systems Command
ICST/LANP-81-1	Specification and Analysis of Local Area Network Architecture Based on the ISO Reference Model
ICST/LANP-81-2	Feature Analysis of Local Area Computer Networks
ICST/LANP-81-3	Requirements Analysis of Local Area Computer Networks
ICST/LANP-81-4	Specification of Functional Requirements for Local Area Computer Networks
ICST/LANP-81-5	Guideline for the Selection of Local Area Computer Networks (Draft Report)
ICST/LANP-80-1	On the Impact of High Speed Local Networks Upon Distributed Computer Architectures

ICST/LANP-80-2	Standards for Local Computer Networks (Draft)
ICST/LANP-001 (80)	NBS Local Network Control and Interface Facility (Vol. 1 - CATV Cable System Design)
ICST/LANP-002 (80)	NBS Local Network Control and Interface Facility Project (Vol. 2 - Technical Control Hardware and Software Description)
ICST/LANP-003 (81)	NBS Network Control and Interface Facility Project (Vol. 3 - X.25 UNIX Host Interface Design and Implementation)
ICST/LANP-004 (81)	NBS Network Control and Interface Facility Project (Vol. 4 - Terminal BIU Software Description)
ICST/LANP-005 (80)	The Design and Engineering of a Performance Measurement Center for a Local Area Network
ICST/LANP-82-1 (82)	A Look at the Network Management
ICST/CBOS 80-2	Specification of a Draft Message Format Standard
ICST/CBOS-81-3	PhoneNet Metrics and Measurement Facility
ICST/CBOS-82-1	"Features of the Message Transfer Protocol"
*ICST/CBOS-82-3	Service Specification of a Message Transfer Protocol

Amer, Paul D., "A Measurement Center for the NBS Local Area Computer Network."

Article, "Status of the National Bureau of Standards' Computer Networking Program,"
The LocalNetter Newsletter, Vol. 1, No. 5, August, 1981.

Blumer, Thomas P. and John C. Burruss, "Specification and Implementation of
a Protocol Standard," to be presented at Compcon Spring 1982.

Dampier, Ingrid, K., and G. W. Dickamore, "Technology Assessment of Flexible
Disks as Used in Stand-Alone Text Processing Systems"

Deutsch, D., "Design of a Message Format Standard," submitted to IFIP Symposium
on Computer Message Systems - April 1980.

Dickamore, W., Gene, and I. K. Dampier, "Survey and Market Forecast of Flexible
Disks"

"Draft Office Automation Glossary", Dataflow Systems, Inc., Booz Allen and
Hamilton, Inc., and CBOS staff.

Heafner, John F. and R. P. Blanc, "The NBS Program in Computer Network Protocol
Standards", Fifth Interconational Conference on Computer Communication, October
27-30, 1980.

Heafner, J. and R. Blanc, "Summary of Current NBS Protocol Specifications," National Telecommunications Conference, November 29 - December 3, 1981.

Heafner, J. and B. Blanc, "Network Protocol Standards Development and Usage" February 1982, Data Communications.

Heafner, J. and R. Blanc, "Description of a Planned Federal Information Processing Standard for Transport Protocol," Seventh Data Communications Symposium - 1981, October 27-29, 1981.

Knoerdel, J., "A Survey of Standardization Efforts of Coded Character Sets for Text Processing."

McCoy, W., R. Colella and M. Wallace, "Assessing the Performance of High-Level Computer Network Protocols," National Physical Laboratory, Teddington, England, April 1981.

Mink, A., J. Knoerdel, and J. Brooks, "The Design and Implementation of an Office Application Using Existing High Level Tools."

Nielsen F., "Session Layer Protocols," Network Architecture, Pergammon Info Tech, February 1982.

Nielsen, F. and J. Heafner, "Description of a Planned Federal Information Processing Standard for the Session Protocol," INFOCOM 82, April, 1982.

Nielsen, F. and J. Moulton, "Description of a Planned Federal Information Processing Standard for the File Transfer Protocol," INFOCOM 82, April 1982.

Swanson, J. and S. Clopper, "Services and Protocol Mechanisms of a Data Presentation Protocol," INFOCOM 82, April 1982.

Tenney, R., et.a., "Impact of Satellite Technology on Transport Flow Control," Seventh Data Communications Symposium - 1981, October 27-29, 1981.

"The Integration of Facsimile Technology into Computer Based Office Information Systems," Richard L. Deal & Associates, Inc.

* indicates new document

4-8
DTI