

AD-A125 595

THE CONSTRAINT METHOD FOR SOLID FINITE ELEMENTS(U)  
WASHINGTON UNIV ST LOUIS MO DEPT OF SYSTEMS SCIENCE AND  
MATHEMATICS I N KATZ 38 NOV 82 AFOSR-TR-83-0888

1/1

UNCLASSIFIED

AFOSR-81-0252

F/G 12/1

NL

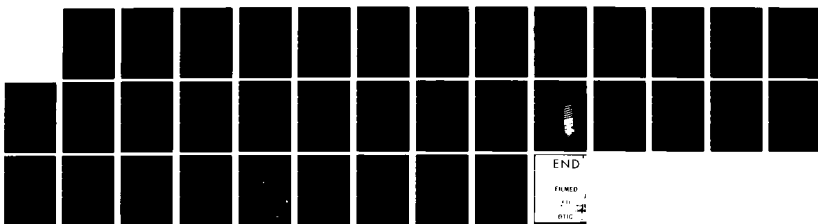

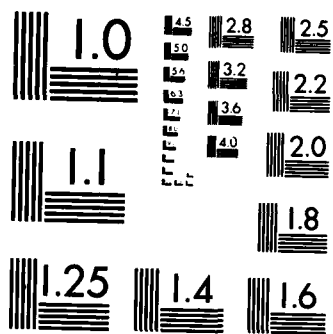

MICROCOPY RESOLUTION TEST CHART  
NATIONAL BUREAU OF STANDARDS-1963 A

AFOSR-TR- 83 - 0080

5

AD A125595

Final Scientific Report

Air Force Office of Scientific Research Grants , AFOSR-81-0252

Period: 1 October 1976 - 30 September 1982

Title of Research: The Constraint Method for Solid Finite Elements

Department of Systems Science and Mathematics

School of Engineering and Applied Science

Washington University - Box 1040

St. Louis, Missouri 63130

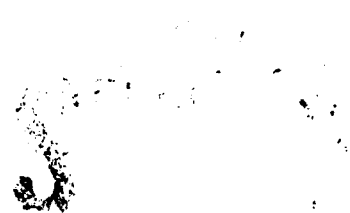

Approved for public release;  
distribution unlimited.

DTIC FILE COPY

83 CS 14 019

*unclassified*

UNCLASSIFIED

SECURITY CLASSIFICATION OF THIS PAGE (When Data Entered)

REPORT DOCUMENTATION PAGE		READ INSTRUCTIONS BEFORE COMPLETING FORM
1. REPORT NUMBER AFOSR-TR-88-0080 8218	2. GOVT ACCESSION NO. AD-A125595	3. RECIPIENT'S CATALOG NUMBER
4. TITLE (and Subtitle)  The Constraint Method for Solid Finite Elements	5. TYPE OF REPORT & PERIOD COVERED Final Scientific Report 1 Oct. 1976-30 Sep. 1982	
	6. PERFORMING ORG. REPORT NUMBER	
7. AUTHOR(s)  I. Norman Katz	8. CONTRACT OR GRANT NUMBER(s)  AFOSR 81-0252	
9. PERFORMING ORGANIZATION NAME AND ADDRESS Department of Systems Science and Mathematics Box 1040, Washington University St. Louis, MO 63130	10. PROGRAM ELEMENT, PROJECT, TASK AREA & WORK UNIT NUMBERS  6/102F 2304/A3	
11. CONTROLLING OFFICE NAME AND ADDRESS Air Force Office of Scientific Research (AFSC) Directorate of Math. and Information Sciences Bolling Air Force Base, DC 20332	12. REPORT DATE November 30, 1982	
	13. NUMBER OF PAGES 34	
14. MONITORING AGENCY NAME & ADDRESS (if different from Controlling Office)	15. SECURITY CLASS. (of this report)  Unclassified	
	15a. DECLASSIFICATION/DOWNGRADING SCHEDULE	
16. DISTRIBUTION STATEMENT (of this Report)  Approved for public release; distribution unlimited.		
17. DISTRIBUTION STATEMENT (of the abstract entered in Block 20, if different from Report)		
18. SUPPLEMENTARY NOTES		
19. KEY WORDS (Continue on reverse side if necessary and identify by block number)  Finite Element Analysis, Stress Analysis, Hierarchic Families of Finite Elements, P-version of Finite Element Method, Numerical Analysis		
20. ABSTRACT (Continue on reverse side if necessary and identify by block number)  The p-version of the finite element method is a new approach to finite element analysis which has been demonstrated to lead to significant computational savings, often by orders of magnitude (this approach was formerly called the constraint method; the new term p-version is more descriptive). Conventional approaches (called the h-version) generally employ low order polynomials as basis functions. Accuracy is achieved by suitably refining the approximating mesh. The p-version uses polynomials of arbitrary order $p \geq 2$ for problems in plane elasticity where $C_0$ continuity is required and polynomials of order $p \geq 5$ for problems in plate bending where $C_1$ continuity is required.		

UNCLASSIFIED

SECURITY CLASSIFICATION OF THIS PAGE(When Data Entered)

Hierarchic elements which implement the p-version efficiently are used together with precomputed arrays of elemental stiffness matrices.

Some important research results are:

1. In polygonal regions, under conditions usually satisfied in practice, if the h-version converges with order of error in energy norm  $O(1/N^{\alpha})$  then the p-version converges with order of error in energy norm  $O(1/N^{2\alpha})$ , where  $N$  is the number of degrees of freedom. This applies to planar problems which require either C0 or C1 global continuity.
2. Hierarchic C0 elements for triangles or rectangles have been developed and implemented for  $p \geq 2$ . Hierarchic C1 triangular elements have been developed and implemented for  $p \geq 5$ . Hierarchic C0 solid elements have been developed for  $p \geq 2$  for bricks, tetrahedra, triangular prisms, and rectangular pyramids.
3. Modified Bernstein polynomials have been constructed over triangles which provide a smooth approximation to functions in  $H_0^2$ . These polynomials are used to prove that the p-version of the finite element method converges in the C1 case (plate bending).
4. Explicit mappings have been constructed which map triangles with one curved side into the standard triangle. These mappings have the property that the resulting elemental stiffness matrices can be integrated in closed form. The need for numerical quadrature, which may be inefficient in the p-version, is thereby obviated. The curved side can be either parabolic or elliptic. The newly constructed mappings permit the p-version to be applied to domains with curved boundaries of specified shapes.
5. The p-version analysis of stresses in a rhombic plate was completed. The results compare very favorably with those of other codes.

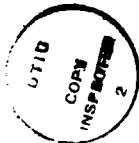

A

SECURITY CLASSIFICATION OF THIS PAGE(When Data Entered)

**REPORT OF INVENTIONS AND SUBCONTRACTS**

(Pursuant to "Patent Rights" Contract Clause) (See Instructions on Reverse Side)

FORM APPROVED  
OMH NO 2-7-74B

1 NAME AND ADDRESS OF CONTRACTOR (Include Zip Code)  
**I. Norman Katz**  
**Washington University, Box 1040**  
**St. Louis, MO 63130**

2 CONTRACT NUMBER  
**AFSOR 77-3122, AFOSR 81-0252**

3. TYPE OF REPORT (Check One)  
 a. INTERIM  b. FINAL

**SECTION I - INVENTIONS ("Subject Inventions")**

4. INVENTION DATA (Listed below are all inventions required to be reported) (If "None," so state)

(i) NAME OF INVENTOR(S)	(ii) TITLE OF INVENTION	(iii) CONTRACTOR DISCLOSURE IDENTIFICATION NUMBER OR PATENT APPLICATION SERIAL NUMBER	(iv) CONTRACTOR FILED U.S. PATENT APPLICATION		(v) CONFIRMATORY LICENSE OR ASSIGNMENT FORWARDING TO CONTRACTING OFFICER	
			YES	NO	YES	NO
None						

**SECTION II - SUBCONTRACTS (Containing a "Patent Rights" Clause)**

5. SUBCONTRACT DATA (Listed in information required but not previously reported for Subcontract) (If "None," so state)

(i) NAME AND ADDRESS OF SUBCONTRACTOR (Include Zip Code)	(ii) SUBCONTRACT NUMBER	(iii) SUBCONTRACT PATENT RIGHTS CLAUSE	(iv) WORK TO BE PERFORMED UNDER SUBCONTRACT	(v) SUBCONTRACT DATES	
				START	COMPLETION
None					

**SECTION III - CERTIFICATION**

CONTRACTOR CERTIFIES THAT PROMPT IDENTIFICATION AND TIMELY DISCLOSURE OF SUBJECT INVENTIONS PROCEDURES HAVE BEEN FOLLOWED

DATE: **11/30/82**

NAME AND TITLE OF AUTHORIZED OFFICIAL (Print or Type): **I. Norman Katz, Professor of Applied Mathematics & Systems Science**

SIGNATURE: *I. Norman Katz*

TABLE OF CONTENTS

	Page
1. INTRODUCTION .....	1
2. RESEARCH ACCOMPLISHMENTS .....	2
2.1 Rate of Convergence of the P-version .....	2
2.2 Hierarchic Families of Solid Finite Elements .....	6
2.3 P-version Analysis of a Rhombic Plate .....	14
2.4 Computer Implementation - COMET-X .....	16
2.5 A Sample Problem .....	17
3. REFERENCES .....	18
4. FIGURES .....	20
5. PAPERS PUBLISHED AND PRESENTED SINCE THE START OF THE PROJECT ....	27
5.1 Published Papers .....	27
5.2 Presented Papers .....	28
5.3 Seminars Presented at Government Laboratories .....	29

AIR FORCE OFFICE OF SCIENTIFIC AND TECHNICAL RESEARCH  
 WASHINGTON, D. C. 20330  
 REPORT NUMBER AFOSR-77-001  
 JANUARY 1977  
 UNIVERSITY OF CALIFORNIA, SAN DIEGO  
 CALIFORNIA RESEARCH CENTER  
 SAN DIEGO, CALIFORNIA 92162  
 DISTRIBUTION DIVISION

## 1. INTRODUCTION

Two approaches to finite element analysis are now widely recognized in the engineering and mathematical communities. In both approaches the domain  $\Omega$  is divided into simple convex subdomains (usually triangles or rectangles in two dimensions, and tetrahedra or bricks in three dimensions) and over each subdomain the unknown (displacement field) is approximated by a (local) basis function (usually a polynomial of degree  $p$ ). Basis functions are required to join continuously at boundaries of the subdomains in the case of planar or 3 dimensional elasticity, or smoothly in the case of plate bending. The difference between the two approaches lies in the manner in which convergence is achieved. These two approaches are:

1. The h-version of the finite element method. In this approach the degree  $p$  of the approximating polynomial is kept fixed, usually at some low number such as 2 or 3. Convergence is achieved by allowing  $h$ , the maximum diameter of the convex subdomains, to go to zero. Estimates for the error in energy have long been known [1, 2, 3]. In all of these estimates  $p$  is assumed to be fixed and the error estimate is asymptotic in  $h$ , as  $h$  goes to zero.
2. The p-version of the finite element method. In this approach the subdivision of the domain  $\Omega$  is kept fixed but  $p$  is allowed to increase until a desired accuracy is attained. The p-version is reminiscent of the Ritz method for solving partial differential equations but with a crucial distinction between the two methods. In the Ritz method a single polynomial approximation is used over the entire domain  $\Omega$  ( $\Omega$ , in general, is not convex). In the p-version of the finite element method polynomials are used as approximations over convex subdomains. This critical difference gives the p-version a much more rapid rate of convergence than either the Ritz method or the h-version as will be explained later.



The p-version of the finite element method requires families of polynomials of arbitrary degree  $p$  defined over different geometric shapes. Polynomials defined over neighboring elements join either continuously (are in  $C^0$ ) for planar or three dimensional elasticity, and smoothly (are in  $C^1$ ) for plate bending. In order to implement the p-version efficiently on the computer, these families should have the property that computations performed for an approximation of degree  $p$  are re-usable for computations performed for the next approximation of degree  $p + 1$ . We call families possessing this property hierarchic families of finite elements.

The h-version of the finite element method has been the subject of intensive study since the early 1950's and perhaps even earlier. Study of the p-version of the finite element method, on the other hand, began at Washington University in St. Louis in the early 1970's. Research in the p-version (formerly called The Constraint Method) has been supported in part of the Air Force Office of Scientific Research since 1976. In this report we review some of the more important accomplishments during this funding period, and describe the current status of the p-version of the finite element method.

## 2. RESEARCH ACCOMPLISHMENTS

### 2.1. Rate of convergence of the p-version

Extensive computational experiments have provided empirical evidence that the rate of convergence in the p-version is significantly higher than in the h-version. For example, a shell problem consisting of a circular cylindrical shell with symmetrically located cutouts was subjected to a uniform axial end shortening of known amount as shown below.

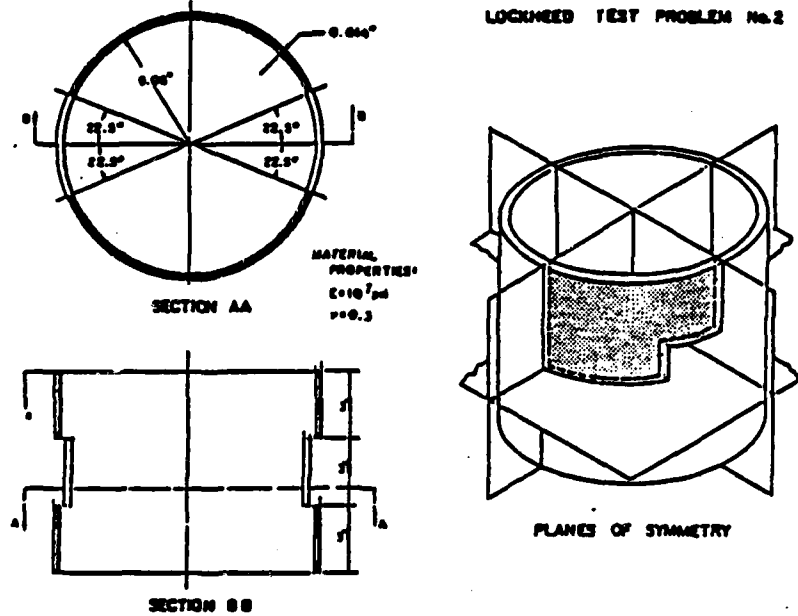

The boundary conditions at the ends of the shell are

$$w = v = \frac{\partial w}{\partial x} = 0 \quad u = \text{constant} = 0.2 \times 10^{-3} \text{ inches}$$

The solution to this problem using the p-version of the finite element was compared to the solution by other computer programs in [4]. The table shown below gives the number of degrees of freedom needed by the different computer codes to attain the same degree of accuracy.

It is clear that the p-version requires far fewer degrees of freedom than the next best code, TRISHL which was specifically altered to solve this problem.

COMPUTER CODE	SOURCE	NUMBER OF ELEMENTS	DEGREES OF FREEDOM
SHELL 9	GULF GENERAL ATOMIC, INC.	476	2457
STAGS	LOCKHEED MISSILES AND SPACE CORP.	342	1437
REXBAT	LOCKHEED MISSILES AND SPACE CORP.	241	APPROX 1125
TRISHL	NATIONAL AERONAUTICAL ESTABLISHMENT, CANADA	100	637
COMET-X	WASHINGTON UNIVERSITY	10	500 (6-6-7-CASE)

COMPARISON OF SOME COMPUTATIONAL PARAMETERS

In other sample problems the reduction of the number of degrees of freedom used by the p-version is even more striking. In [5], the p-version is applied to problems in elastic fracture mechanics with excellent results and in [6] the p-version is used to analyze an edge-cracked panel and a parabolically loaded panel. In Figures 1 and 2 the respective triangulations are shown and in Figures 3 and 4, the error in strain energy is plotted against the reciprocal of the number of degrees of freedom.

The following two theorems, which were recently proved, provide a rigorous explanation for the efficiency of the p-version. In both theorems  $\Omega$  is a bounded polygonal domain in the plane. In Theorem 1, a model problem for the  $C^0$  case is considered, and in Theorem 2, a model problem for the  $C^1$  case is considered. In both cases, the problems are singularity problems, that is the smoothness of the solutions are governed by the local behavior at the vertices  $A_i$  of the polygons. Suppose that  $\alpha_i$  is the angle at vertex  $A_i$ , and that polar coordinates  $(r_i, \phi_i)$  are used at  $A_i$ . The solution in the neighborhood of  $A_i$  is of the form

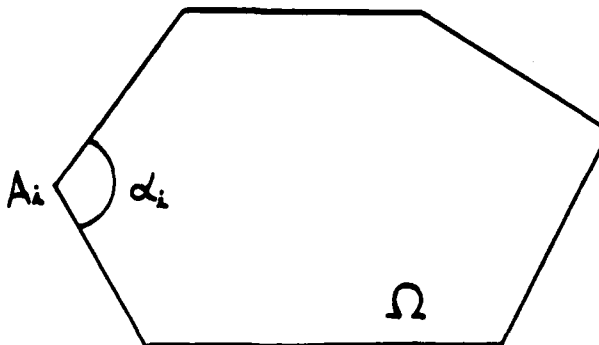

$$\rho_1(r_1) \theta_1(\phi_1)$$

$$\rho_1(r_1) = r_1^{\gamma_1} g_1(|\log r_1|), \quad \theta_1(\phi_1) \text{ is very smooth.}$$

$\gamma_1$  depends upon  $\alpha_1$ .

The domain  $\Omega$  is assumed to be triangulated in such a way that  $A_1$  coincides with a vertex of a triangle. The exact assumptions on  $g_1$  and  $\theta_1$  are given in [6].

Theorem 1 (model problem for  $C^0$  Case)

$$-\Delta u + u = f \quad \text{in } \Omega \quad (1)$$

$$u = 0 \quad \text{on } \partial\Omega$$

Let  $u$  be the solution to (1) in the weak sense, and let  $u_p$  be the finite element approximation to  $u$ , using polynomials of degree  $p$  with the triangulation  $S$  fixed (i.e.  $u_p$  is the solution to (1) using the  $p$ -version of the finite element method). If  $u \in H^k(\Omega)$ , with  $k > 1$ , then

$$\|u - u_p\|_{2,\Omega} \leq C p^{-\mu+\epsilon} \|u\|_k, \quad \mu = \min(k-1, 2\gamma_1), \quad \gamma_1 = \frac{\pi}{\alpha_1} \quad (2)$$

where  $\epsilon > 0$  is arbitrary.

Theorem 2 (model problem for  $C^1$  case)

$$\Delta^2 w = f \quad \text{in } \Omega \quad (3)$$

$$w = \frac{\partial w}{\partial n} = 0 \quad \text{on } \partial\Omega \quad (\text{clamped edge})$$

Let  $w$  be the solution to (2) in the weak sense, and let  $w_p$  be the solution to (3) using the  $p$ -version of the finite element method. If  $w \in H^k(\Omega)$  with  $k > 2$ , then

$$\|w - w_p\|_{2,\Omega} \leq c P^{-\mu+\epsilon} \|w\|_k, \quad \mu = \min(k-2, 2(\gamma_1 - 1)) \quad (4)$$

$\gamma_1(\alpha_1)$  = smallest positive root of the equation

$$\sin^2(\gamma_1 - 1)\alpha_1 - (\gamma_1 - 1)^2 \sin^2 \alpha_1 = 0$$

The error estimates in (2) and (4) can be compared with analogous estimates for  $u_h$  and  $w_h$ , the solutions by the h-version of the finite element method. Assume, for convenience that in (2)  $k - 1 \geq 2\gamma_1$ , and in (4)  $k - 2 \geq 2(\gamma_1 - 1)$ , that is convergence is determined by the nature of the singularities at corners. Then the analogous estimates are

$$\|u - u_h\|_{1,\Omega} \leq ch^\gamma \|u\|_k, \quad \gamma = \min \gamma_1 \quad (2')$$

$$\|w - w_h\|_{2,\Omega} \leq ch^{(\gamma-1)} \|w\|_k, \quad \gamma = \min \gamma_1. \quad (4')$$

If  $N$  is the number of degrees of freedom then  $p \sim N^{1/2}$ ,  $h \sim N^{-1/2}$  and

$$\|u - u_p\|_{1,\Omega} = O(N^{-\gamma}), \quad \|u - u_h\|_{1,\Omega} = O(N^{-\gamma/2})$$

$$\|w - w_p\|_{2,\Omega} = O(N^{-(\gamma-1)}), \quad \|w - w_h\|_{2,\Omega} = O(N^{-1/2(\gamma-1)})$$

Therefore, if the criterion used to compare methods is the number of degrees of freedom required to achieve a given error in energy, then the rate of convergence of the p-version is twice that of the h-version. This result provides a rigorous proof for the extensive computational evidence that has been gathered, and explains in part the efficiency of the p-version.

## 2.2. Hierarchic Families of Solid Finite Elements

In order to implement the p-version efficiently, families of finite elements are needed with the hierarchic property: computations performed for an approximation of order  $p$  should be re-usable when raising the order to  $p + 1$ . More

specifically, the stiffness matrix corresponding to the polynomial approximation of degree  $p$  should be a submatrix of the polynomial approximation of degree  $p + 1$ . In terms of basis functions, this implies that the basis functions for a  $p$ th order approximation should be a subset of the basis functions for a  $(p + 1)$ st order approximation.

Hierarchical families for triangles both in the  $C^0$  case and in the  $C^1$  case are described in detail in [7, 8, 9, 10, 11]. We now describe hierarchic families of polynomials for various three dimensional shapes. All of these families are globally in  $C^0$ .

tetrahedron. A hierarchic family for the tetrahedron can be constructed from the hierarchic family for the triangle by using natural coordinates. The linear element is:

	nodal variable	shape function
vertex nodes	$u(1)$	$L_1$
	$u(2)$	$L_2$
	$u(3)$	$L_3$
	$u(4)$	$L_4$

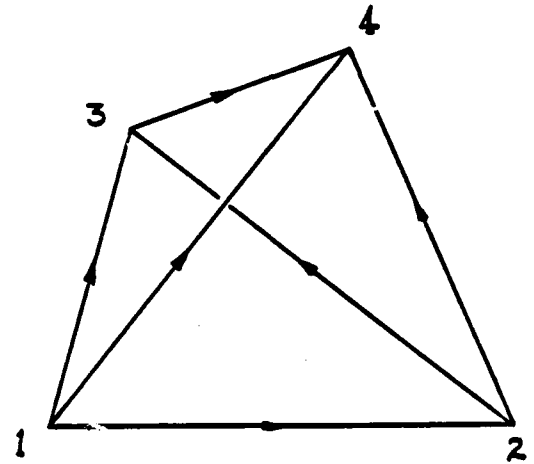

The quadratic element has the same nodal variables and shape functions as the linear element and the additional nodes:

	nodal variables	shape functions
edge nodes	$u_{ss}$ (12)	$-\frac{1}{2} L_1 L_2$
	$u_{ss}$ (23)	$-\frac{1}{2} L_2 L_3$
	$u_{ss}$ (31)	$-\frac{1}{2} L_1 L_3$
	$u_{ss}$ (14)	$-\frac{1}{2} L_1 L_4$
	$u_{ss}$ (34)	$-\frac{1}{2} L_3 L_4$
	$u_{ss}$ (24)	$-\frac{1}{2} L_2 L_4$

The hierarchic family for a tetrahedron up to the element of degree 4 is shown in Figure 5. Boundary nodal variables correspond to vertices, edges, and faces. Additional internal nodal variables are introduced to provide a basis for a complete polynomial of degree p. Complete details are given in [12].

brick A hierarchic family for the brick can be constructed from the hierarchic family for the rectangle. For convenience, we consider only the square and from it we construct a hierarchic family for the cube. The hierarchic family for the square is given as follows.

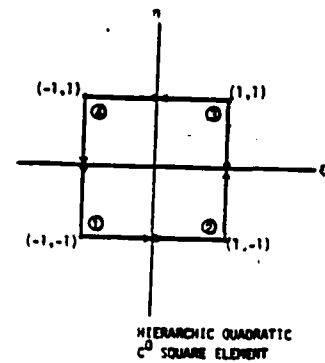

$$Q_j(\xi) = \begin{cases} \frac{1}{j!} (\xi^j - 1) & j \geq 2, \text{ even} \\ \frac{\xi}{j} Q_{j-1}(\xi) & j \geq 3, \text{ odd} \end{cases}$$

satisfies

$$Q_j^{(+1)} = 0 \quad Q_j^{(i)}(0) = 0 \quad i = 2, \dots, j-1$$

$$Q_j^{(j)}(0) = 1.$$

Now, consider the square of side 2 as shown in the figure. Basis functions  $N_{u(i)}$  corresponding to the nodal variables  $u(i)$   $i = 1, 2, 3, 4$  are

$$N_{u(1)} = \frac{1}{4} (1 - \xi)(1 - \eta) \quad N_{u(3)} = \frac{1}{4} (1 + \xi)(1 + \eta) \quad (5)$$

$$N_{u(2)} = \frac{1}{4} (1 + \xi)(1 - \eta) \quad N_{u(4)} = \frac{1}{4} (1 - \xi)(1 + \eta)$$

and it is easily seen that these basis functions span the same space as  $1, \xi, \eta, \xi\eta$  i.e. they contain the complete linear polynomial. Also these nodal variables enforce  $C^0$  continuity across sides. Now denoting by  $(ij)$  the mid-point of side  $ij$ , basis functions corresponding to the nodal variables  $u_{\xi\xi}(12)$ ,  $u_{\eta\eta}(23)$ ,  $u_{\xi\xi}(34)$ ,  $u_{\eta\eta}(41)$  are

$$N_{u_{\xi\xi}(12)} = Q_2(\xi)(1 - \eta) \quad N_{u_{\xi\xi}(34)} = Q_2(-\xi)(1 + \eta) \quad (6)$$

$$N_{u_{\eta\eta}(23)} = (1 + \xi)Q_2(\eta) \quad N_{u_{\eta\eta}(41)} = (1 - \xi)Q_2(-\eta)$$

and these basis functions added to the ones in (5) span the same space as  $1, \xi, \eta, \xi^2, \xi\eta, \eta^2, \xi^2\eta, \xi\eta^2$ , i.e. they contain a complete quadratic and they enforce  $C^0$  continuity along sides. The basis functions (5) are taken for the hierarchic rectangular  $C^0$  linear element, and those in (5) and (6) for the quadratic element.

For  $j \geq 3$ , we have

$$N_{u_{\xi^j}(12)} = Q_j(\xi)(1 - \eta) \quad N_{u_{\xi^j}(34)} = Q_j(-\xi)(1 + \eta)$$

$$N_{u_{\eta^j}(23)} = (1 + \xi)Q_j(\eta) \quad N_{u_{\eta^j}(41)} = (1 - \xi)Q_j(-\eta)$$



as the basis function for  $j$ th order tangential derivatives at midsides, and for  $j \geq 4$  we add the internal modes

$$(1 - \xi^2) (1 - \eta^2) \eta^{j-4-i} \xi^i \quad i = 0, \dots, j - 4.$$

These basis functions span the same space as a complete polynomial of degree  $j$  and the two monomials of degree  $j+1$ ,  $\xi^j \eta$ ,  $\xi \eta^j$ .

Thus, the hierarchic  $C^0$  square element of degree  $p \geq 2$  has  $(1/2)(p+1)(p+2)+2$  basis functions, two more than the dimension of the complete polynomial of degree  $p$ . The two extra terms correspond to  $\xi^p \eta$ ,  $\xi \eta^p$ . By scaling the sides of the square the elements are easily transformed into rectangular ones.

The hierarchic family for the brick can now be constructed. Linear element:

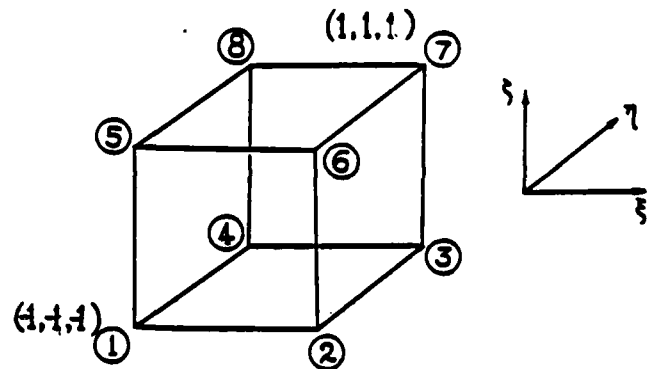

vertex nodes

nodal variable	shape function
$u(1)$	$\frac{1}{8} (1-\xi) (1-\eta) (1-\zeta)$
$u(2)$	$\frac{1}{8} (1+\xi) (1-\eta) (1-\zeta)$
$u(3)$	$\frac{1}{8} (1+\xi) (1+\eta) (1-\zeta)$
$u(4)$	$\frac{1}{8} (1-\xi) (1+\eta) (1-\zeta)$
$u(5)$	$\frac{1}{8} (1-\xi) (1-\eta) (1+\zeta)$
$u(6)$	$\frac{1}{8} (1+\xi) (1-\eta) (1+\zeta)$
$u(7)$	$\frac{1}{8} (1+\xi) (1+\eta) (1+\zeta)$
$u(8)$	$\frac{1}{8} (1-\xi) (1+\eta) (1+\zeta)$

The quadratic element adds the shape functions as follows:

nodal variables	shape functions
$u_{ss}$ (12)	$\frac{1}{4} Q_2(\xi)(1-\eta)(1-\zeta)$
$u_{ss}$ (23)	$\frac{1}{4} (1+\xi)Q_2(\eta)(1-\zeta)$
$u_{ss}$ (34)	$\frac{1}{4} Q_2(\xi)(1+\eta)(1-\zeta)$
$u_{ss}$ (41)	$\frac{1}{4} (1-\xi)Q_2(\eta)(1-\zeta)$
$u_{ss}$ (55)	$\frac{1}{4} (1-\xi)(1-\eta)Q_2(\zeta)$
$u_{ss}$ (26)	$\frac{1}{4} (1+\xi)(1-\eta)Q_2(\zeta)$
$u_{ss}$ (37)	$\frac{1}{4} (1+\xi)(1-\eta)Q_2(\zeta)$
$u_{ss}$ (48)	$\frac{1}{4} (1-\xi)(1+\eta)(1+\zeta)$
$u_{ss}$ (56)	$\frac{1}{4} Q_2(\xi)(1-\eta)(1+\zeta)$
$u_{ss}$ (67)	$\frac{1}{4} (1+\xi)Q_2(\eta)(1+\zeta)$
$u_{ss}$ (78)	$\frac{1}{4} Q_2(\xi)(1+\eta)(1+\zeta)$
$u_{ss}$ (81)	$\frac{1}{4} (1-\xi)Q_2(\eta)(1+\zeta)$

edge  
nodes

Higher degree elements add edge modes, face modes and internal modes. More details are given in [12, 13].

triangular prism A hierarchic family for the triangular prism can be constructed by combining the hierarchic families for the triangle (in natural coordinates) and for the square (in rectangular coordinates)

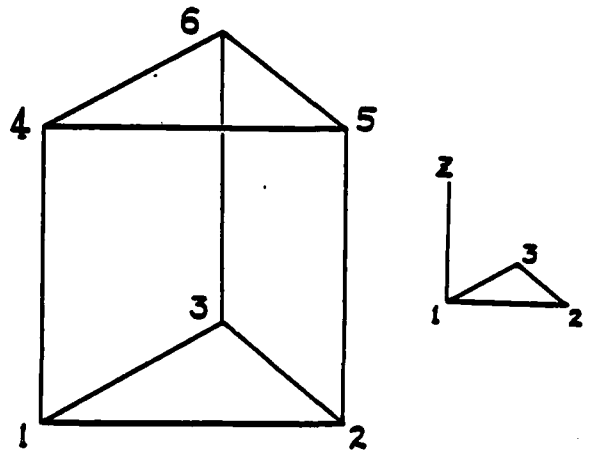

vertex  
modes

nodal variable	shape function
u (1)	$L_1 (1 - z)$
u (2)	$L_2 (1 - z)$
u (3)	$L_3 (1 - z)$
u (4)	$L_1 (1 + z)$
u (5)	$L_2 (1 + z)$
u (6)	$L_3 (1 + z)$

The quadratic element adds the following shape functions:

edge  
nodes

nodal variable	shape function
$u_{ss}$ (12)	$N_2(L_1, L_2)(1-z)$
$u_{ss}$ (23)	$N_2(L_2, L_3)(1-z)$
$u_{ss}$ (31)	$N_2(L_3, L_1)(1-z)$
$u_{ss}$ (45)	$N_2(L_1, L_2)z$
$u_{ss}$ (56)	$N_2(L_2, L_3)z$

	nodal variable	shape function
edge nodes	$u_{ss}$ (64)	$N_2 (L_3, L_1)z$
	$u_{ss}$ (14)	$L_1 Q_2(z)$
	$u_{ss}$ (25)	$L_2 Q_2(z)$
	$u_{ss}$ (36)	$L_3 Q_2(z)$

$$N_2(L_1, L_j) = -\frac{1}{2} L_1 L_j = \text{second edge mode for triangle}$$

$$Q_2(z) = \frac{1}{2} z(z - 1) = \text{second edge mode for rectangle.}$$

Higher degree elements add edge modes, face modes and internal modes. Further details are given in [12, 13].

square pyramid. It can be shown [13] that no hierarchic family exists which consists of polynomials alone. However it is possible to supplement certain rational functions in such a way that the element of degree  $p$  contains a complete polynomial of degree  $p$  and additional rational functions. Furthermore, because of the special form of these rational functions, integration of all shape functions which appear in the elemental stiffness matrix can be performed in closed form. No numerical quadrature is required. The linear element is:

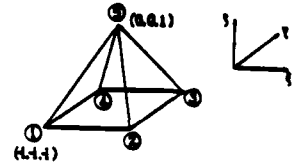

	nodal variable	shape function
vertex nodes	$u$ (1)	$\frac{1}{8} (1 - \frac{2\xi}{1-\zeta}) (1 - \frac{2\eta}{1-\zeta}) (1 - \zeta)$
	$u$ (2)	$\frac{1}{8} (1 + \frac{2\xi}{1-\zeta}) (1 - \frac{2\eta}{1-\zeta}) (1 - \zeta)$
	$u$ (3)	$\frac{1}{8} (1 + \frac{2\xi}{1-\zeta}) (1 + \frac{2\eta}{1-\zeta}) (1 - \zeta)$
	$u$ (4)	$\frac{1}{8} (1 - \frac{2\xi}{1-\zeta}) (1 + \frac{2\eta}{1-\zeta}) (1 - \zeta)$
	$u$ (5)	$\frac{1}{2} (1 + \zeta)$

Each of the vertex modes is a linear combination of  $1, \xi, \eta, \zeta, \frac{\xi\eta}{1-\zeta}$ .

Higher degree elements again add edge modes, face modes and internal modes.

Further details are given in [13].

### Combinations

Hierarchic families of the different shapes shown here have been constructed so that they join together continuously. Thus geometries such as the ones shown below can be modeled using as few elements as possible. In this way the subdivision of the polyhedral domain  $\Omega$  can be made very coarse and accuracy can be obtained by increasing  $p$ , without using added degrees of freedom to describe the geometry. As has been shown (at least for two dimensional problems) the rate of convergence in the  $p$ -version is twice that obtained for the  $h$ -version. Therefore subdividing

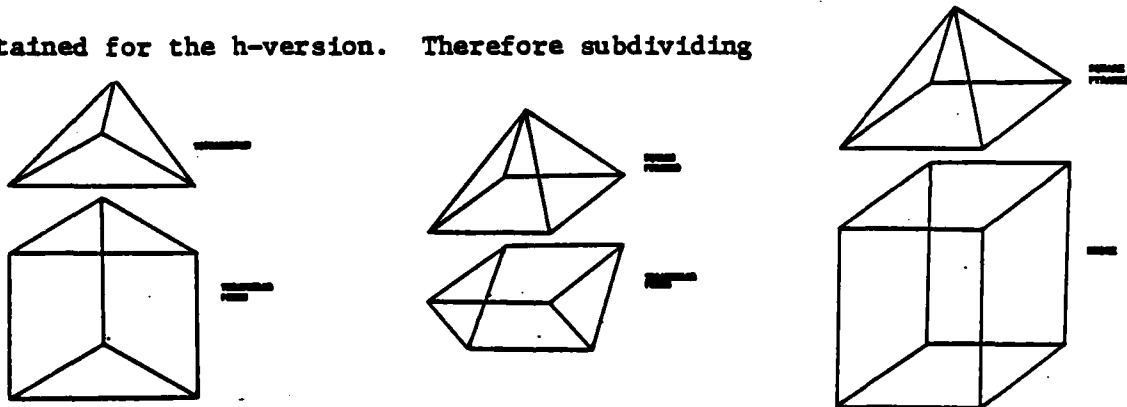

in this way leads to computational efficiency, since it makes maximum use of the  $p$ -version. It also requires significantly simpler input.

### 2.3 P-Version Analysis of a Rhombic Plate

The problem of the stress analysis of a rhombic plate is a difficult one which has attracted much attention [14, 15, 16, 17]. We consider the rhombic plate shown in Figure 6, which is simply supported, uniformly loaded and whose acute angles are 30 degrees. A very strong singularity occurs at the obtuse vertex when plate bending theory is applied to this problem, and this singularity leads to  $\mu = 0.4$  in Theorem 2, Equation (4). As a result many finite element

models of the rhombic plate either fail to converge or converge very slowly. The hierarchic  $C^1$  family used in the p-version contains corrective rational functions. These rational functions absorb the singularity very well and lead to the best results thus far obtained for this problem. Shown below are the values for the deflection at the central point,  $w_c$ , using the  $C^1$  p-version analysis, with  $p = 5$  and with different numbers of elements. These results are compared with results obtained by other methods

$C^1$  p-version

no. of elements	1	2	3	4	5	6	7
no of degrees of freedom	8	16	25	33	42	51	60
$w_c$	2.8938	3.1520	3.4651	3.8217	4.0049	4.0217	4.0824
% error	29.2	22.8	14.9	6.4	1.8	1.4	0.x

other codes

	no. of degrees of freedom	% error
Sander [14]	> 1000	24
Argyris [15]	$\approx$ 1300	2
Basu, Szabo et al [16]	$\approx$ 130	2
Basu, Szabo et al [16]	$\approx$ 180	1

Morley [17]

exact value (analytic expression) = 4.08

#### 2.4. Computer Implementation - COMET-X

COMET-X is an experimental computer code which implements the p-version of the finite element method by using the hierarchic families which have been constructed. COMET-X is maintained by the Center for Computational Mechanics at Washington University and it is the only computer code in existence which implements the p-version. COMET-X can be used as a code to implement the h-version as well simply by fixing the polynomial order  $p$  and refining the mesh.

COMET-X currently has the following capabilities:

- A. Element types: Stiffeners, triangular elements, triangular elements with one side curved, rectangular elements, solid elements of the shapes described earlier.
  - B. Types of Analysis: Laplace and Poisson equations, plane elasticity, elastic plate bending, stiffened elastic plates, 3-dimensional elasticity, temperature distribution in 3-dimensions.
  - C. Special Capabilities: non-uniform  $p$ -distribution, elastic fracture mechanics computations in two dimensions, nearly incompressible solids, linear boundary layer problems.
  - D. Pre- and Post processing capabilities including graphics and visual displays.
- The capabilities and usage of COMET-X are described in detail in [16].

2.5. A Sample Problem

As an example of a problem analyzed by the p-version using hierarchic solid finite elements, [18], consider the finite element model of a gear casing, shown below. The model on the right was used in COMET-X, the one on the left was used by NASTRAN. Stress contours shown in Figure 7 were obtained from COMET-X.

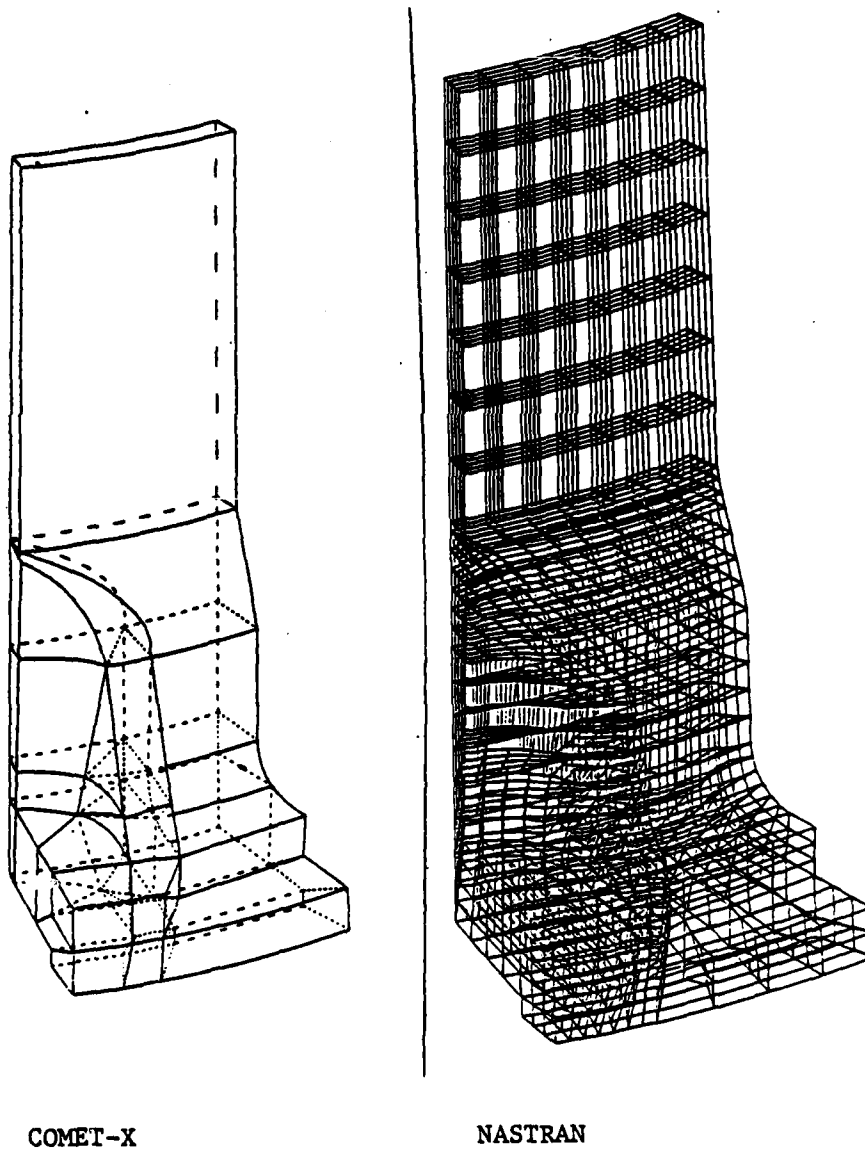

Finite Element Meshes for a Gear Casing



3. REFERENCES

- [1] J. R. Whiteman, The Mathematics of Finite Elements and Applications Academic Press Inc., London, (1973).
- [2] G. Strang and G. J. Fix, An Analysis of the Finite Element Method Prentice-Hall, New Jersey (1973).
- [3] P. G. Ciarlet, The Finite Element Method for Elliptic Problems North-Holland Publishing Company, New York (1978).
- [4] M. P. Rossow, K. C. Chen, and J. C. Lee, "Computer Implementation of the Constraint Method", *Computers and Structures*, Vol. 6, pp. 203-209 (1976).
- [5] B. A. Szabo and A. K. Mehta, "P-convergent Finite Element Approximation in Fracture Mechanics", *Int. J. Num. Methods in Engineering*, Vol. 12, pp. 551-560 (1978).
- [6] I. Babuska, B. A. Szabo, and I. N. Katz, "The p-version of the Finite Element Method", to appear in *SIAM J. Numerical Analysis* (June 1981).
- [7] I. N. Katz and M. P. Rossow, "Nodal Variables for Complete Conforming Finite Elements of Arbitrary Polynomial Order", *Computers and Mathematics with Applications*, Vol. 4, No. 2, pp. 85-112 (1978).
- [8] I. N. Katz, "Integration of Triangular Finite Elements Containing Corrective Rational Fractions", *Int. J. Num. Methods in Engineering*, Vol. 11, pp. 107-114 (1977).
- [9] I. N. Katz, A. G. Peano, M. P. Rossow and B. A. Szabo, "The Constraint Method for Finite Element Stress Analysis", *Proceedings of the World Congress on Finite Element Methods in Structural Mechanics*, Bournemouth, England, pp. 7.1-7.26 (1975).
- [10] M. P. Rossow and I. N. Katz, "Hierarchal Finite Elements and Pre-computed Arrays", *Int. J. Num. Methods in Engineering*, Vol. 12, No. 6, pp. 997-999 (1978).
- [11] A. G. Peano, "Hierarchies of Conforming Finite Elements for Plane Elasticity and Plate Bending", *Computers and Mathematics with Applications*, Vol. 2, pp. 211-224 (1976).
- [12] I. N. Katz, B. A. Szabo, and A. G. Peano, "Hierarchic Solid Elements for the p-version of the Finite Element Method", in preparation.
- [13] I. Babuska, I. N. Katz and B. A. Szabo, "Hierarchic Families for the p-version of the finite element method", Advances in Computer Methods for Partial Differential Equations III. Ed. by R. Vichnevetsky and R. S. Stepleman, IMACS, pp. 278-285 (1979).
- [14] G. Sander, "Application of Dual Analysis Principle", *Proceedings of Symposium on High Speed Computing of Elastic Structures*, University of Liege, pp. 167-207 (1971).

- [15] J. H. Argyis, et. al., "On the Application of the SHEBA Shear Element", Computational Methods in Applied Mech. Engr., Vol. 1, pp. 317-347 (1972).
- [16] P. K. Basu, B. A. Szabo, and B. D. Taylor, "Theoretical Manuel and User's Guide for Comet-XA", Center for Computational Mechanics, Washington University, St. Louis, Missouri 63130, CCM-79-2 (June 1979).
- [17] L. S. D. Morley, "Bending of a Simply Supported Rhombic Plate Under Uniform Normal Loading", Quarterly of Mech. and Applied Math, Vol. 15, Part 4, pp. 414-426 (1962).
- [18] A. G. Peano and J. Walker, paper presented at the Third World Congress on Finite Element Methods (1981).

4. FIGURES

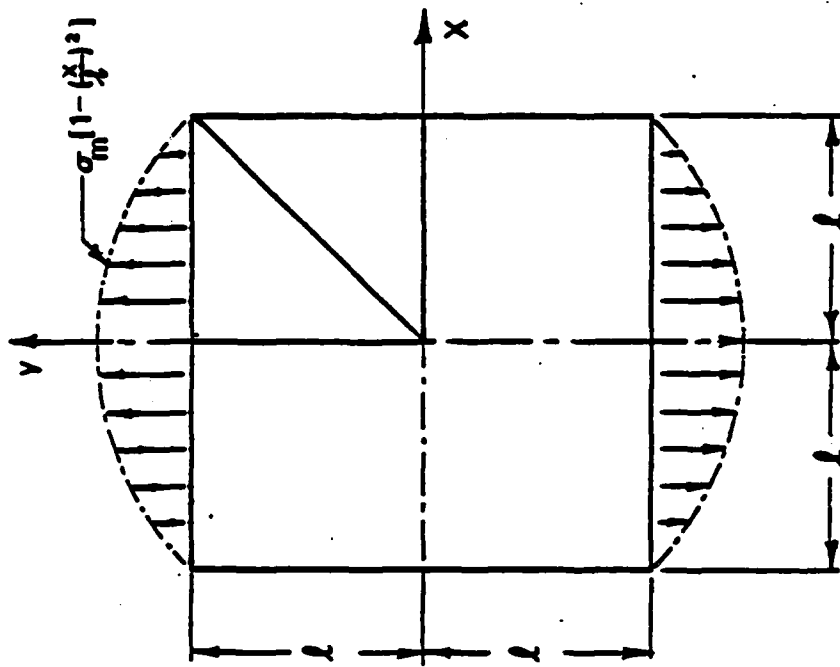

FIGURE 2

Parabolically loaded square panel and finite element triangulation

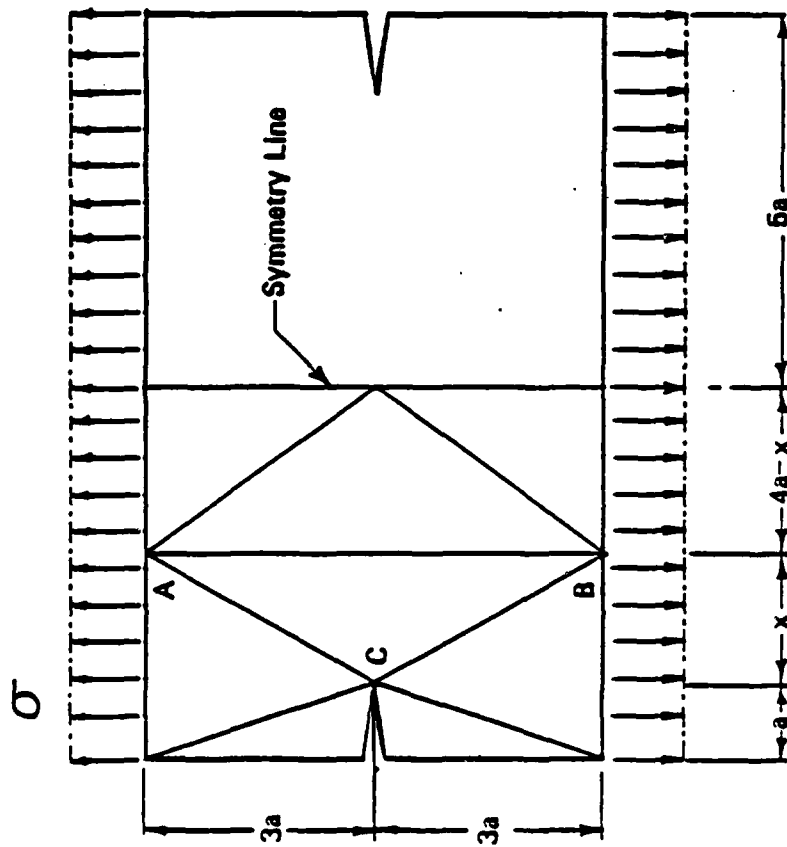

FIGURE 1

Edge cracked rectangular panel and finite element triangulation

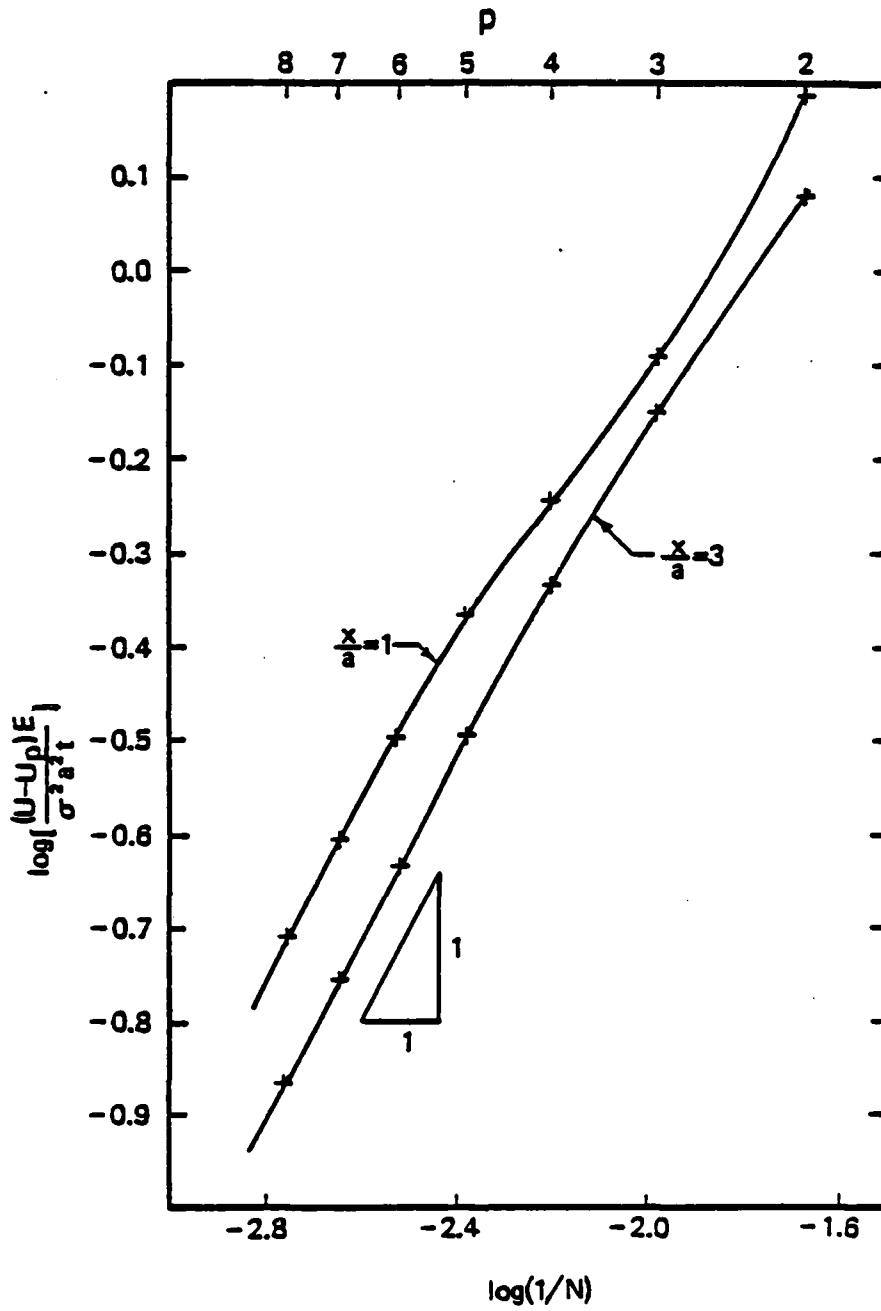

FIGURE 3

Edge cracked rectangular panel. Estimated error in strain energy vs. reciprocal of the number of degrees of freedom

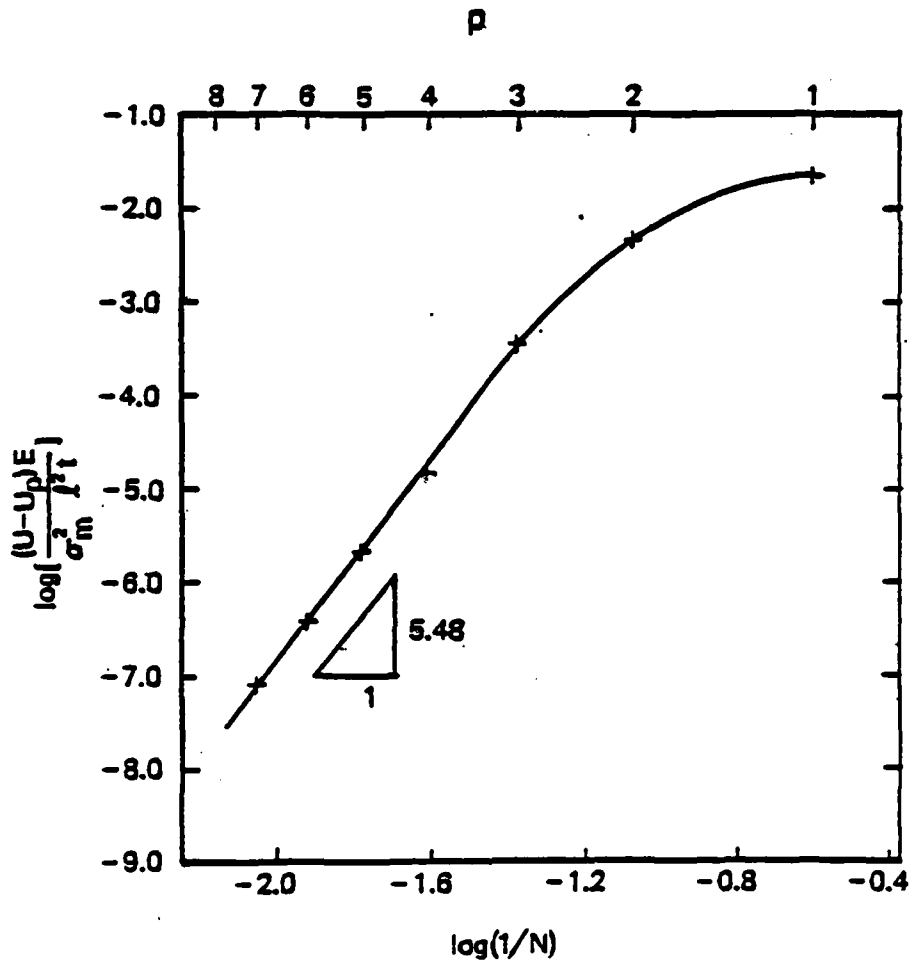
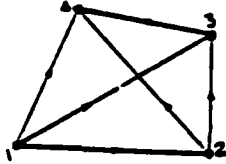

FIGURE 4

Parabolically loaded square panel. Error in strain energy vs. reciprocal of the number of degrees of freedom

Figure 5. Nodal variables and shape functions for the first four hierarchic tetrahedral  $C^0$  elements



1. Linear

4 terms: Values of the approximating function at the vertices.

$$N_1 = L_1, \quad N_2 = L_2, \quad N_3 = L_3, \quad N_4 = L_4$$

2. Quadratic

6 additional terms: Second derivatives at the midpoints of edges.

Normalizing factor:  $-1/2$

$$N_5 = L_1 L_2, \quad N_6 = L_2 L_3, \dots, \quad N_{10} = L_1 L_4$$

3. Cubic

10 additional terms: Six third derivatives at the midpoints of edges.

Normalizing factor:  $\frac{1}{12}$

$$N_{11} = L_1^2 L_2 - L_1 L_2^2, \quad N_{12} = L_1^2 L_3 - L_1 L_3^2, \quad \dots, \quad N_{16} = L_1^2 L_4 - L_1 L_4^2$$

Four face modes:

$$N_{17} = L_1 L_2 L_3, \quad N_{18} = L_1 L_2 L_4, \quad N_{19} = L_1 L_3 L_4, \quad N_{20} = L_2 L_3 L_4$$

4. Quartic

15 additional terms: Six fourth derivatives at the midpoints of edges.

Normalizing factor:  $-1/48$

$$N_{21} = L_1^3 L_2 + L_1 L_2^3, \quad N_{22} = L_1^3 L_3 + L_1 L_3^3, \quad \dots, \quad N_{26} = L_1^3 L_4 + L_1 L_4^3$$

Eight face modes:

$$N_{27} = L_1^2 L_2 L_3, \quad N_{28} = L_1 L_2^2 L_3, \quad N_{29} = L_1^2 L_3 L_4, \quad N_{30} = L_1 L_3^2 L_4$$

$$N_{31} = L_1^2 L_2 L_4, \quad N_{32} = L_1 L_2^2 L_4, \quad N_{33} = L_1^2 L_3 L_4, \quad N_{34} = L_1 L_3^2 L_4$$

One internal mode:

$$N_{35} = L_1 L_2 L_3 L_4$$

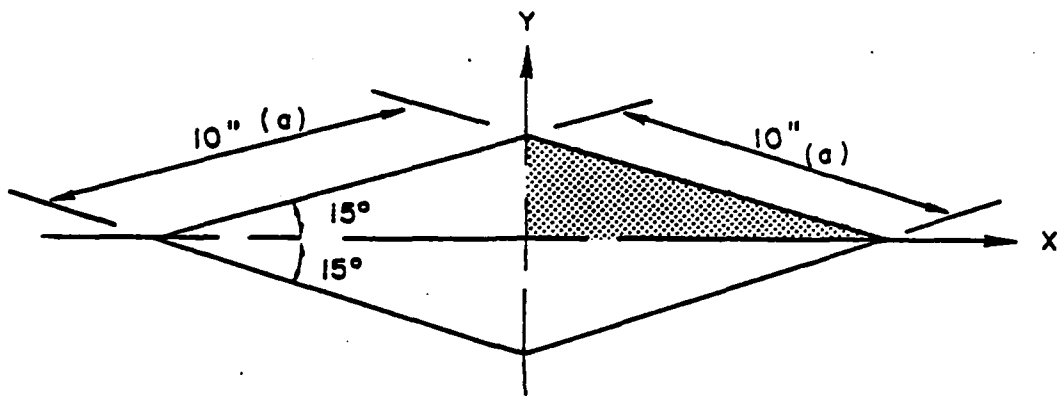

(  $h = 0.1$  ",  $E = 30,000$  ksi,  $\nu = 0.3$ ,  $\lambda = 5/6$  )

UNIFORM LATERAL LOAD = 0.1 ksi

60°-Skew Simply Supported Plate Under  
Uniformly Distributed Load

Figure 6. The Rhombic Plate Problem



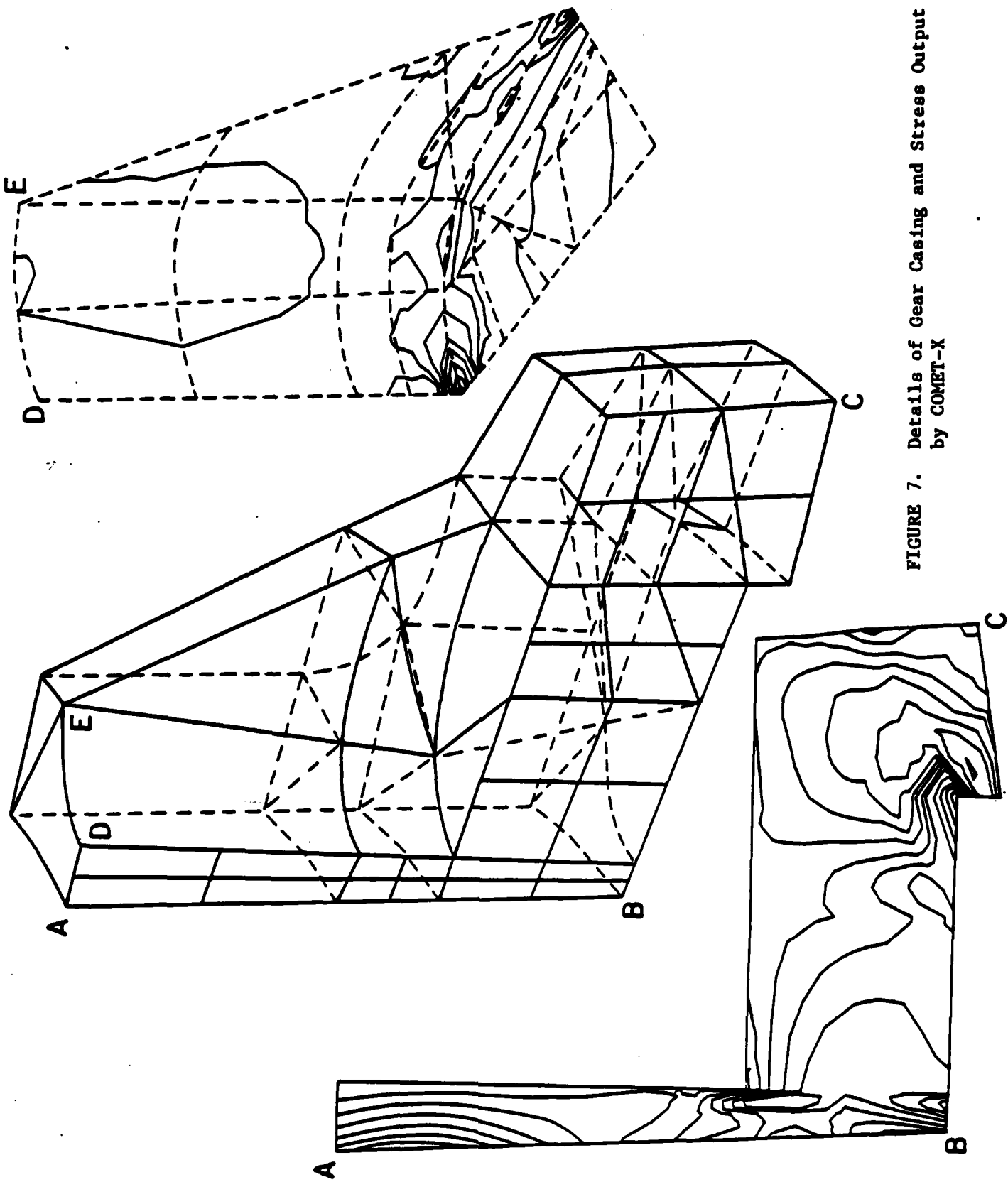

FIGURE 7. Details of Gear Casing and Stress Output by COMET-X

5. PAPERS PUBLISHED AND PRESENTED SINCE THE START OF THE PROJECT (1977)

5.1. Published Papers:

1. "Hierarchal Finite Elements and Precomputed Arrays", by Mark P. Rossow and I. Norman Katz, Int. J. for Num. Method in Engr., Vol. 13, No. 6 (1978) pp. 977-999.
2. "Nodal Variables for Complete Conforming Finite Elements of Arbitrary Polynomial Order", by I. Norman Katz, A. G. Peano, and Mark P. Rossow, Computers and Mathematics with Applications, Vol. 4, No. 2, (1978). pp. 85-112.
3. "A Hierarchic Family of Complete, Conforming  $C^1$  Triangular Elements, for Plate Bending", by I. Norman Katz and Barna Szabo, (in preparation).
4. "Hierarchic Solid Elements for the p-version of the Finite Element Method", by I. Norman Katz, B. A. Szabo and A. G. Peano (in preparation).
5. "P-convergent Finite Element Approximations in Linear Elastic Fracture Mechanics", by Anil K. Mehta (doctoral dissertation), Department of Civil Enigneering, Washington University (1978).
6. "An Improved p-version Finite Element Algorithm and a Convergence Result for the p-version" by Anthony G. Kassos, Jr. (doctoral dissertation) Department of Systems Science and Mathematics, Washington University, (August, 1979).
7. "Hierarchic Families for the p-version of the Finite Element Method", I. Babuska, I. N. Katz and B. A. Szabo, invited paper presented at the Third IMACS International Symposium on Computer Methods for Partial Differential Equations, published in Advances in Computer Methods for Partial Differential Equations - III (1979) pp. 278-286.
8. "The p-version of the Finite Element Method", I. Babuska, B. A. Szabo, and I. N. Katz, Technical Report No. WU/CCM-79/1, SIAM J. of Numerical Analysis (June 1981), pp. 515-545.
9. "Hierarchic Triangular Elements with one Curved Side for the p-version of the Finite Element Method", by I. Norman Katz (in preparation).
10. "Implementation of a  $C^1$  Triangular Element based on the p-version of the Finite Element Method", by I. Norman Katz, D. W. Wang and B. Szabo, Research in Structural and Solid Mechanics-1982, NASA Conference Publication 2245, pp. 153-170.
11. "The p-version of the Finite Element Method for Problems Requiring  $C^1$  Continuity", by Douglas W. Wang (Doctoral Dissertation), Department of Systems Science and Mathematics, Washington University (August 1982).

5.2. Presented Papers:

1. "Hierarchical Approximation in Finite Element Analysis", by I. Norman Katz, International Symposium on Innovative Numerical Analysis in Applied Engineering Science, Versailles, France, May 23-27, 1977.
2. "Efficient Generation of Hierarchical Finite Elements Through the Use of Precomputed Arrays", by M. P. Rossow and I. N. Katz, Second Annual ASCE Engineering Mechanics Division Speciality Conference, North Carolina State University, Raleigh, NC, May 23-25, 1977.
3. " $C^1$  Triangular Elements of Arbitrary Polynomial Order Containing Corrective Rational Functions", by I. Norman Katz, SIAM 1977 National Meeting, Philadelphia, PA, June 13-15, 1977.
4. "Hierarchical Complete Conforming Tetrahedral Elements of Arbitrary Polynomial Order", by I. Norman Katz, presented at SIAM 1977 Fall Meeting, Albuquerque, NM, October 31- November 2, 1977.
5. "A Hierarchical Family of Complete Conforming Prismatic Finite Elements of Arbitrary Polynomial Order", by I. Norman Katz, presented at SIAM 1978 National Meeting, Madison, WI, May 24-26, 1978.
6. "Comparative Rates of h- and p- Convergence in the Finite Element Analysis of a Model Bar Problem", by I. Norman Katz, presented at the SIAM 1978 Fall Meeting, Knoxville, Tennessee, October 20- November 1, 1978.
7. "Smooth Approximation to a Function in  $H_0^2(D)$  by Modified Bernstein Polynomials over Triangles" by A. G. Kassos, Jr. and I. N. Katz, presented at the SIAM 1979 Fall Meeting, Denver, Colorado, November 12-14, 1979.
8. "Triangles with one Curved Side for the p-version of the Finite Element Method" by I. Norman Katz, presented at the SIAM 1980 Spring Meeting, Alexandria, VA, June 5-7, 1980.
9. "Hierarchical Square Pyramidal Elements for the p-version of the Finite Element Method" by I. Norman Katz, presented at the SIAM 1980 Fall Meeting, Houston, TX, November 6-8, 1980.
10. "The Rate of Convergence of the p-version of the Finite Element Method for Plate Bending Problems", by Douglas W. Wang and I. Norman Katz, presented at SIAM 1981 Fall Meeting, October 6-8, 1981, Cincinnati, Ohio.
11. "The p-version of the Finite Element Method", by I. Norman Katz, presented at the 1982 Meeting of the Illinois Section of the Mathematical Association of America, Southern Illinois University at Edwardsville, April 30-May 1, 1982.
12. "Computer Implementation of a  $C^1$  Triangular Element based on the p-version of the Finite Element Method", by Douglas W. Wang and I. Norman Katz, presented at the SIAM 30th Anniversary Meeting, July 19-23, 1982, Stanford, California.

13. "Implementation of a  $C^1$  Triangular Element Based on the p-version of the Finite Element Method", presented at the Symposium on Advanced and Trends in Structural and Solid Mechanics, October 4-7, 1982, Washington, D.C.

### 5.3. Seminars Presented at Government Laboratories

1. "Advanced Stress Analysis Technology" BY B. A. Szabo and I. N. Katz, presented on September 8, 1977 at the Air Force Flight Dynamic Laboratory, Wright-Patterson Air Force Base.

#### abstract

With one exception, all finite element software systems have element libraries in which the approximation properties of elements are frozen. The user controls only the number and distribution of finite elements. The exception is an experimental software system, developed at Washington University. This system, called COMET-X, employs conforming elements based on complete polynomials of arbitrary order. The elements are hierarchic, i.e. the stiffness matrix of each element is embedded in the stiffness matrices of all higher order elements of the same kind. The user controls not only the number and distribution of finite elements but their approximation properties as well. Thus convergence can be achieved on fixed mesh. This provides for very efficient and highly accurate approximation and a new method for computing stress intensity factors in linear elastic fracture mechanics. The theoretical developments are outlined, numerical examples are given and the concept of an advanced self-adaptive finite element software system is presented.

2. "The Constraint Method for Finite Element Stress Analysis", by I. N. Katz, presented at the National Bureau of Standards, Applied Mathematics Division on October 19, 1977.

#### abstract

In conventional approaches to finite element stress analysis accuracy is obtained by fixing the degree  $p$  of the approximating polynomial and by allowing the maximum diameter  $h$  of elements in the triangulation to approach zero. An alternate approach is to fix the triangulation and to increase the degrees of approximating polynomials in those elements where more accuracy is required. In order to implement the second approach efficiently it is necessary to have a family of finite elements of arbitrary polynomial degree  $p$  with the property that as much information as possible can be retained from the  $p$ th degree approximation when computing the  $(p+1)$ st degree approximation. Such a HIERARCHIC family has been formulated with  $p \geq 2$  for problems in plane stress analysis and with  $p \geq 5$  for problems in plate bending. The family is described and numerical examples are presented which illustrate the efficiency of the new method.

3. "The p-version of the Finite Element Method", by I. N. Katz and B. A. Szabo, presented at Air-Force Flight Dynamics Laboratory Wright-Patterson Air Force Base on April 23, 1981.

abstract

The theoretical basis of the p-version of the finite element method has been established only quite recently. Nevertheless, the p-version is already seen to be the most promising approach for implementing adaptivity in practical computations. The main theorems establishing asymptotic rates of convergence for the p-version, some aspects of the algorithmic structure of p-version computer codes, numerical experience and a posteriori error estimation will be discussed from the mathematical and engineering points of view.

