

10

ADA 124713

AIR FORCE INSTITUTE OF TECHNOLOGY



AIR UNIVERSITY
UNITED STATES AIR FORCE

ACES II NEGATIVE Gz RESTRAINT INVESTIGATION

THESIS

AFIT GE/EE 82D-45

David G. Leupp
Capt USAF

SCHOOL OF ENGINEERING

DTIC
ELECTE
FEB 22 1983

WRIGHT-PATTERSON AIR FORCE BASE, OHIO

This document has been approved
for public release and sale; its
distribution is unlimited.

PII Redacted

88 02 022 148

DTIC Copy

AFIT/GE/EE/82D-45

ACES II NEGATIVE Gz RESTRAINT INVESTIGATION

·THESIS

AFIT/GE/EE/82D-45

David G. Leupp
Capt USAF

DTIC
ELECTE
FEB 22 1983
S D
A

Approved for public release; distribution unlimited

ACES II NEGATIVE Gz RESTRAINT INVESTIGATION

THESIS

Presented to the Faculty of the School of Engineering
of the Air Force Institute of Technology
Air University
in Partial Fulfillment of the
Requirements for the Degree of
Master of Science Electrical Engineering

by

David G. Leupp, B.S.E.E.

Capt USAF

Graduate Electrical Engineering

December 1982

Application For	
REPRODUCTION	<input type="checkbox"/>
FOR TAB	<input type="checkbox"/>
REPRODUCED	<input type="checkbox"/>
Justification	
Distribution/	
Availability Codes	
and/or	
Special	

A

Approved for public release; distribution unlimited.



Acknowledgements

I am indebted to the entire staff of the Acceleration Effects Branch of the Aerospace Medical Research Laboratory (AFAMRL/BBS). The support provided by the branch was outstanding, and made this project a great experience.

I must specifically thank some people who contributed in very special ways to the investigation. First, I thank Dr. Dana Rogers for introducing me to the project, and serving as a member of my thesis committee.

Thanks are due to my thesis advisor, Major Walt Seward, and to Dr. Matthew Kabrisky. The time and effort they spent reviewing my work greatly contributed to the quality of the final product.

I am particularly grateful to John Frazier of AMRL for providing the benefit of his wisdom and experience. His guidance added immeasurably to the success of the project, and helped to make it a true learning experience for me.

I would be remiss if I did not specifically thank Don McColler for his design and construction of the instrumentation amplifier, Marvin Roark for writing the centrifuge software, Karen Hudson for her invaluable assistance in the analysis of the data, and Bill Gruesbeck for his careful design and construction of the Displacement Transducer Assembly.

Finally, I thank my wife, Cindy, for her encouragement and patience throughout the project.

David G. Leupp

Contents

	Page
Acknowledgements	ii
List of Figures	v
List of Tables	vi
Abstract	vii
I. Introduction	1
Background	1
Problem	2
Scope	3
General Approach	3
Development	4
II. Technical Approach	5
Measurement Philosophy	5
Test Sequence	8
Summary	9
III. Equipment	11
Overview	11
Dynamic Environment Simulator	11
Test Items	13
Associated Hardware	18
Instrumentation	19
Tracking Task	23
Manikins	25
Data Acquisition and Analysis	26
Summary	27
IV. Human Subjects	28
Qualifications	28
Human Use Protocol	28
Subject Anthropometry	29
Summary	30
V. Procedures	31
Human Subject Test Procedures	31
Manikin Test Procedures	35
Summary	37

Contents

VI. Analysis and Results	38
Overview	38
Primary Human Subject Results	39
Secondary Human Subject Results	47
Manikin Results	49
Summary	54
VII. Conclusions and Recommendations	55
Review	55
Conclusions	55
Recommendations	57
Bibliography	59
Appendix A: Acceleration Vectors	61
Appendix B: Pilot Questionnaire and Summarized Responses	62
ACES II Negative-G Crew Member Questionnaire	62
Summarized Responses	63
Appendix C: Instrumentation Details	65
Displacement Transducer Assembly	65
Strap Strain Links	65
Seat Force Load Cells	65
Chest Accelerometer	65
Appendix D: Human Subject Primary Data	67
Appendix E: Post-run Questionnaires and Summarized Responses	83
Post-rollover Questionnaire	84
Post-rotation Questionnaire	86
Post-rollover Responses	88
Post-rotation Responses	90
Vita	92

List of Figures

Figure		Page
1	Dynamic Environment Simulator (DES)	11
2	DES Cab Interior	12
3	ACES II Restraint System	14
4	Standard ACES II Lap Belt	17
5	Test Lap Belt and Tiedown Strap	17
6	Displacement Transducer Assembly (DTA)	20
7	Accelerometer Belt	24
8	Typical Subject Gz Profile for Forward Rollover	33
9	Typical Subject Gz Profile for -1.5 Gz Rotation	33
10	Typical Subject Gz Profile for -2.0 Gz Rotation	33
11	Rollover Displacement Data for Human Subjects	41
12	Rotation Displacement Data for Human Subjects	41
13	5th Percentile Manikin Displacement Data	51
14	95th Percentile Manikin Displacement Data	52
15	Means of 5th and 95th Percentile Manikin Displacement Data, and Mean Human Displacements	54
16	Standard Acceleration Terminology	61
17	Strain Gage Bridge Configuration	66
18	Lap Belt and Tiedown Strap Strain Link	66

List of Tables

Table		Page
I	-1.0 Gz Test Matrix	10
II	-1.5 and -2.0 Gz Test Matrix	10
III	Manikin Data	25
IV	Human Subject Anthropometry	30
V	Human Subject Displacement Results	40
VI	Rollover Tracking Score Data	43
VII	Rotation Tracking Score Data	43
VIII	Ejection Delay Data Summary	44
IX	Human Subject Strap Force Data	48
X	5th and 95th Percentile Manikin Displacement Data for -1 Gz	50
XI	5th Percentile Manikin Displacement for -1 to -5 Gz Rotations	50
XII	95th Percentile Manikin Displacement Data for -1 to -5 Gz Rotations	51

Abstract

Seven human subjects, and 5th and 95th percentile male manikins were subjected to -Gz conditions on a man-rated centrifuge to test the restraint effectiveness of the ACES II restraint system used on the A-10, F-15, and F-16. The restraint was tested with shoulder straps locked, unlocked, and unlocked with the addition of a tiedown strap connected between the lap belt and the floor. A -1 Gz condition was created by inverting the centrifuge cab for 30 seconds. Human subjects were exposed to levels of -1.5 and -2 Gz for 20 and 10 seconds respectively by rotating the centrifuge arm. Manikins were similarly exposed to levels up to -5 Gz.

Off-seat displacement was measured directly by a unique spring-loaded transducer mounted in the seat pan. Lap belt and tiedown strap forces, and tracking and ejection task performance were also measured.

Average off-seat displacement for the human subjects using the unmodified restraint with shoulder straps unlocked was 3.2, 3.6, and 3.8 centimeters at -1, -1.5, and -2 Gz respectively. With the tiedown strap these figures were reduced to 2.1, 2.6, and 2.7 cm. Corresponding displacements with the unmodified restraint and locked shoulder straps were 2.9, 3.2, and 3.6 cm. Manikin data was consistent with that of the human subjects, indicating that the tiedown strap provided improved restraint at all levels up to -5.0 Gz. Tracking scores and ejection task data could not be correlated to restraint system.

ACES II NEGATIVE G RESTRAINT INVESTIGATION

I. Introduction

Background

The ACES (Advanced Concept Ejection Seat) II ejection seat is used in the newest generation of U.S. Air Force fighter aircraft, specifically the A-10, F-15, and F-16. Although advanced relative to earlier seats the ACES II is not perfect. Recent experiences such as loss of power to F-16 flight control hardware have highlighted one specific problem -- unsatisfactory restraint of crewmembers during negative Gz conditions (see Appendix A for definition of gravitational vectors). This lack of restraint hampers aircraft recovery attempts, as well as the performance of ejection procedures by crewmembers (Ref 1:Y-19, 2:U-2). Additionally, lack of restraint under such conditions, resulting in poor body positioning, contributes to crewmember injuries during ejection (Ref 2:Y-14). Although negative Gz conditions are very uncommon during normal flight (Refs 3,4), they are apparently typical of many aircraft emergency situations in which control of the aircraft is lost. Negative Gz levels for one representative aircraft mishap were estimated at "5 to 6 negative G's in the first seconds, with a duration of 6 seconds," (Ref 2:Y-13). Such an exposure is relatively extreme, and was apparently not anticipated during design of the ACES II system. The problem posed by body movement caused by a negative Gz acceleration component is compounded by the fact that, for upward travel greater than several centimeters, a crewmember is likely to find his helmet being pushed against the aircraft canopy. Canopy contact, body malpositioning, and

psychological discomfort due to off-seat travel all adversely affect the ability of a crewmember to maintain or regain control of an aircraft, or to successfully perform an ejection.

Relatively little work has been done in the field of negative Gz restraint evaluation. This is in spite of the fact that a recent study showed negative Gz acceleration to be one of the two components of a typical emergency situation that causes crewmembers the most difficulty (Ref 5:23). Early studies involving downward ejecting seats indicated that an inverted-V crotch, or lap belt tiedown strap, significantly reduced off-seat travel of crewmembers during ejection (Ref 6:16). Most subsequent studies (Refs 5,7,8), and current work being done by the Naval Air Development Center (Ref 9) have examined off-seat travel or head movement under static, -1 Gz conditions. Even under these relatively benign conditions, off-seat travel in the range of five centimeters is apparently typical. Evidence of studies examining restraint under dynamic conditions of negative acceleration, or at amplitudes greater than -1 Gz is lacking in the literature.

The above discussion clearly indicates the importance of acquiring negative Gz restraint data more extensive than that gathered in any previous effort. This report details an investigation aimed at providing data specific to the ACES II system, under dynamic negative Gz accelerations of amplitude up to -2.0 Gz.

Problem

The primary goal of this research effort was to design and test modifications to the existing ACES II system which will provide improved crewmember restraint under negative Gz conditions.

Secondarily, the effort sought to extend the relatively small body of knowledge relating to negative Gz restraint and restraint measurement for application to future Air Force systems.

Scope

This investigation is part of a larger study which will ultimately result in development of a completely new ejection system for future Air Force aircraft. As one interim measure, the Air Force Aeronautical Systems Division Life Support Systems Program Office (ASD/AES) requested development of a modification to the existing ACES II system which would provide improved negative Gz restraint (Ref 10). Basic requirements for any modification included easy installation on the existing fleet of ACES II seats, crewmember acceptability, and non-degradation of restraint characteristics for other (non -Gz) acceleration vectors.

In accordance with the ASD/AES requirements, this effort was limited to testing simple modifications to the existing ACES II system. Throughout the investigation emphasis was placed on the practicality of proposed solutions. As described later, efforts were made to determine crewmember practices with respect to the current ACES II seat, and these findings were incorporated in the test procedures.

The study was tailored to provide a specific recommendation to ASD/AES for modification of the ACES II system. No attempt was made to study all possible types of restraint or negative Gz protection systems.

General Approach

Primary data for this study was acquired by testing human subjects using various restraint configurations on the Dynamic Environment Simulator (DES) operated by the Acceleration Effects Branch of the Air

Force Aerospace Medical Research Laboratory (AFAMRL/BBS),
Wright-Patterson Air Force Base, Ohio. Human testing was conducted at
three levels; -1.0 Gz, -1.5 Gz, and -2.0 Gz. Various physical
measurements were supplemented by tracking performance data. Tests using
anthropomorphic manikins were conducted to extend results to negative Gz
levels beyond normal human tolerance.

Development

A detailed development of the experimental approach used in this
study is contained in Chapter II. Included is justification for the
definition of restraint used throughout the study.

Chapter III contains details of the equipment used during the
investigation, including the DES, test items, seat modifications,
instrumentation hardware, and data acquisition and analysis equipment.
The tracking task is also described, along with specifications for the
manikins used during testing.

Information specific to the use of human subjects is contained in
Chapter IV. Included is background information used to establish the
safety of the selected test conditions.

Details of the testing process, and results and analysis are
described in Chapters V and VI, respectively.

Finally, specific conclusions and recommendations are presented in
Chapter VII.

II. Technical Approach

Measurement Philosophy

It was necessary, for the purposes of this study, to go beyond the static, -1 Gz test conditions used in previous studies. Aircraft out-of-control situations typically produce extremely dynamic conditions of acceleration, with relatively high G levels, including those in the negative Gz direction (Ref 1:T-26, 2:Y-13). Although actual conditions are too extreme to duplicate routinely with human subjects, significant acceleration levels were produced during this investigation.

A fundamental requirement of this research was to measure the amount of crewmember restraint provided by several different restraint systems. Implied in the term restraint is the control of body movement to allow necessary crewmember activity. To allow quantitative study, a working definition of restraint was developed for the purposes of this investigation. Restraint is defined here as the degree to which the subject (neglecting limbs) and seat act together as a single object under an applied negative Gz acceleration vector. With perfect restraint, for example, no subject movement relative to the seat occurs. This condition is impossible in practice, due to the non-rigid nature of the human body. In one study, Bason and Etheredge found that a torso stretch of about four centimeters was typical for subjects exposed to -1.0 Gz for a short period (Ref 8:38). In addition to extension, considerable body movement occurs due to movement and "give" of the skin and musculature. Although perfect restraint was not an attainable goal, the definition used here allowed comparison of the restraint systems under test. Limb movement was not a primary consideration in this study since its control would

involve measure beyond simple restraint system modification. Additionally, it was believed that effective body restraint would contribute significantly to the ability of a crewmember to effectively control his limb movements.

With a working definition for restraint established, a number of parameters were considered for measurement. Among these were: acceleration of the subject relative to the seat, force exerted on the restraint system straps, force exerted on the seat pan, subject movement with respect to the seat, subject performance on physical tasks. These parameters have all been measured as part of one or more previous restraint investigations. Few studies specifically related to negative Gz restraint have been conducted, however, and these provided little guidance for the conduct of this study. The most extensive previous negative G restraint study (Ref 8) measured only body and head displacement off the seat, in a static (upside-down) position. The dynamic conditions produced during this investigation demanded more elegant measurements.

The parameters selected for measurement were:

1. force exerted on restraint system straps,
2. force exerted on the seat pan,
3. subject acceleration with respect to seat,
4. subject off-seat displacement, and
5. human subject task performance.

Parameters 1 through 4 were measurable for manikins as well as human subjects, allowing the possibility of extrapolation to G levels beyond human tolerance. The single most important parameter listed is off-seat displacement. This measure was regarded as primary since it closely

affects crewmember psychological distress under negative G conditions, crewmember access to controls, and problems related to contact with the canopy. Intuitively, a restraint system that holds a crewmember firmly on the seat pan during negative G acceleration would be ideal. Indeed, the U.S. Navy has adopted, as one requirement for an advanced ejection seat currently under development, "Firm restraint (zero clearance) of the crewman's buttocks to the seat lid for negative G accelerations up to -3G." (Ref 11:1).

The second parameter of major importance was subject performance on a physical task. A major effect of poor body positioning due to inadequate restraint in a negative G environment is impairment of crewmember ability to reach or operate controls. This was of primary interest in this study, and crewmember performance on a standardized task was hypothesized to be a good, albeit indirect, measure of restraint adequacy.

Parameters 1 through 3 listed above were regarded as measures of secondary importance. Strap forces were measured primarily to determine if forces were effectively distributed on the straps, and to establish strength requirements for the straps. Seat pan forces were measured in order to provide accurate data on seat loading before actual body displacement off the seat. Finally, subject acceleration relative to the seat was measured to help determine its future usefulness as a measure of restraint. Logically, perfect restraint could be characterized as a condition of identical seat and body acceleration. This parameter was not used as a primary restraint measure, however, due to anticipated accuracy and interpretation difficulties.

Test Sequence

Test was conducted in two basic phases, the first consisting of manikin runs, the second of runs with human subjects. For both manikin and human tests two types of acceleration conditions were produced. The first, a level of -1.0 Gz, was produced by simply turning the DES cab 360 degrees, through the inverted position. The second type of acceleration condition, necessary for levels above -1.0 Gz, was produced by movements of the DES fork and cab, and rotation of the centrifuge arm (further details of the DES are discussed in the following chapter).

Manikin testing was performed for two primary reasons. For tests duplicating the conditions of later human runs (at levels of -1.0, -1.5, and -2.0 Gz) the manikin tests provided evidence of safe equipment operation and test conditions. Additionally, the data obtained from these tests was subsequently compared to human tests under the same conditions to establish the validity of extending manikin test results to humans. Presuming this could be established, manikin tests were conducted at G levels beyond safe human exposure levels in order to allow extrapolations of human performance to those levels. Instrumentation for manikin tests was identical to that used for human subjects, and the manikin test sequence closely followed that described for the human subjects below. In addition to duplicating the human runs, manikin tests were conducted at levels up to -5.0 Gz.

Each of seven human subjects was submitted to a series of 15 test runs. Nine tests were conducted at the -1.0 Gz level; three for each of the three restraint configurations under test. Each restraint was tested by rolling the subject through one rotation forward, sideways right, and sideways left, each rotation being a separate run. Restraint

characteristics during rotation in the three different directions were tested to establish the range of body movement during negative Gz onsets from various directions. Rotation backwards was not tested, since it was felt that the support initially provided by the back of the seat would make that condition less severe than the three just described. In addition to the test runs at -1.0 Gz, each human subject participated in six runs at higher levels. One run with each restraint configuration was conducted at both -1.5 and -2.0 Gz. Tables I and II show typical test matrices for both -1.0 Gz and high level runs for the human subjects.

Summary

This chapter briefly discussed the concepts underlying the approach taken for this research effort. Previous related work was cited, and the key concept of restraint was defined. The test sequence followed during the project was described in general terms, and is more fully explained in Chapter V. Some of the project hardware was mentioned in passing in this chapter; the following chapter discusses it in detail.

Table I. -1.0 Gz Test Matrix

Run Number	Restraint System		
	1	2	3
1	FWD		
2	SIDER		
3	SIDEL		
4		FWD	
5		SIDER	
6		SIDEL	
7			FWD
8			SIDER
9			SIDEL

NOTE: FWD = roll forward
 SIDER = roll sideways right
 SIDEL = roll sideways left

Table II. -1.5 and -2.0 Gz Test Matrix

Run Number	Restraint System		
	1	2	3
1	-1.5		
2	-2.0		
3		-1.5	
4		-2.0	
5			-1.5
6			-2.0

Numbers represent test G level.

III. Equipment

Overview

This chapter will describe in detail the equipment used during the investigation. The project "testbed," the Dynamic Environment Simulator, or DES, will be described first. Discussion of the test items, associated hardware, instrumentation, tracking task, manikins, and data acquisition and analysis facilities will follow.

Dynamic Environment Simulator

The Dynamic Environment Simulator (DES), shown in Figure 1, is a three-axis, man-rated centrifuge, located in Building 33, Area B, Wright-Patterson Air Force Base, Ohio. A cab containing instrumentation, test items, and test subject is located at 19 feet from the center of

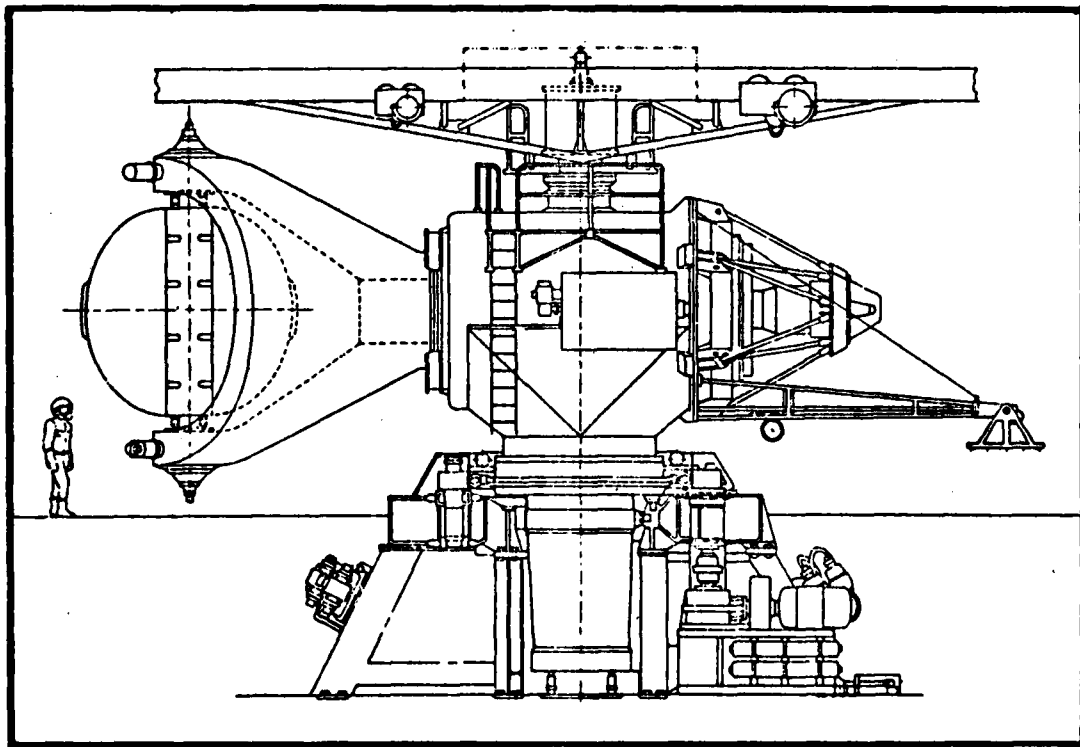

Figure 1. Dynamic Environment Simulator (DES) (Ref 12)

rotation. During the study described here, an ACES II seat, aircraft controls, cathode ray tube (CRT), and associated instrumentation were placed in the cab. Figure 2 illustrates the cab interior configured essentially the same as during the conduct of this study. Although manual control is possible, the DES was controlled by the PDP 11/40 "Primary Controller" computer during all conditions tested under this project. Such computer control is typical for most programs on the DES, for reasons of safety and consistency.

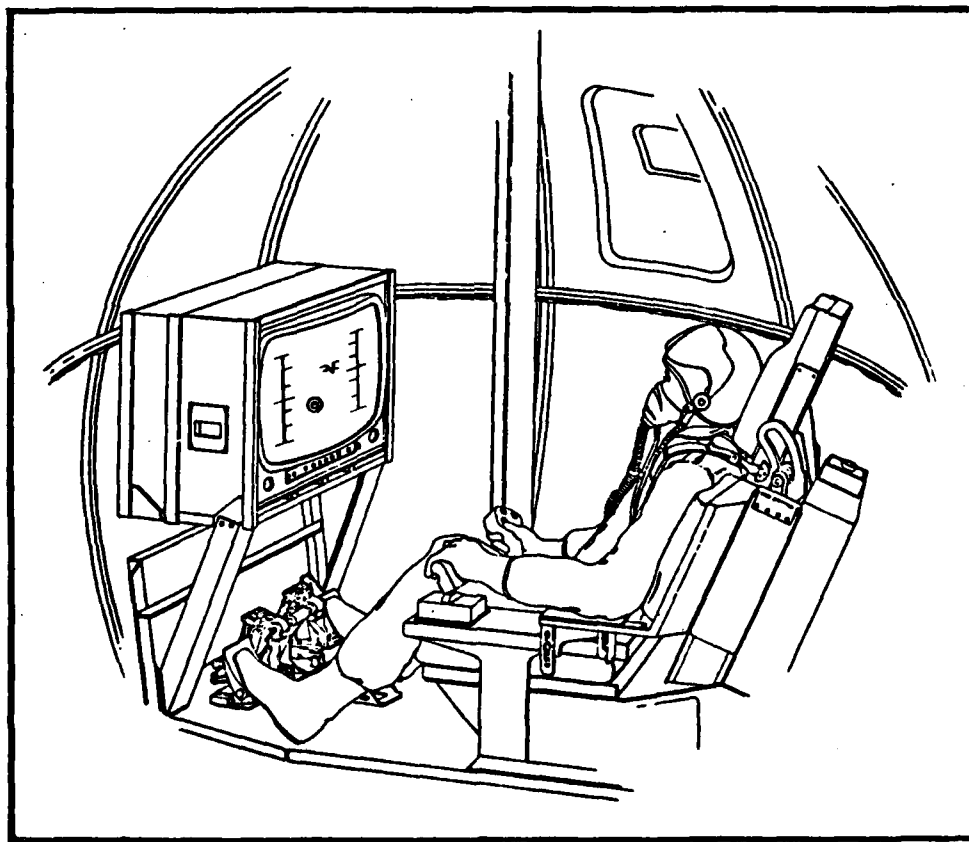

Figure 2. DES Cab Interior (Ref 12:1-9)

The CRT display in the cab was used to present information to the subject, and to display tracking task graphics. A hybrid computer,

composed of an SEL 32/77 digital computer and an EAI 680 analog computer, was used to generate target motions and collect subject performance data, while a PDP 11/34 was used as a display controller for display generation (Ref 12:1-1 to 1-5).

Test Items

The test items, as defined here, consist of the three restraint configurations tested during the study.

All three restraint configurations chosen for investigation were based on the standard ACES II system shown in Figure 3. That system consists of a lap belt, PCU/15-P harness with shoulder straps, and shoulder strap inertial reels in the ACES II seat. During use, the crewmember simply tightens the lap belt to the desired tension, while the inertial reels may act in one of two different modes. In the locked mode, the reels retract when slack occurs in the shoulder straps to which the reels are connected, and will not allow the crewmember to subsequently move forward. In the unlocked mode, on the other hand, the shoulder straps move forward and back as the crewmember does, allowing considerable mobility. During rapid acceleration onsets the inertial reels lock automatically, preventing excessive crewmember movement. During the ejection procedure the inertial reels automatically retract to hold the crewmember firmly in the seat.

The three restraint configurations tested were:

1. ACES II system, unlocked,
2. ACES II system, locked,
3. ACES II system, unlocked, with tiedown strap.

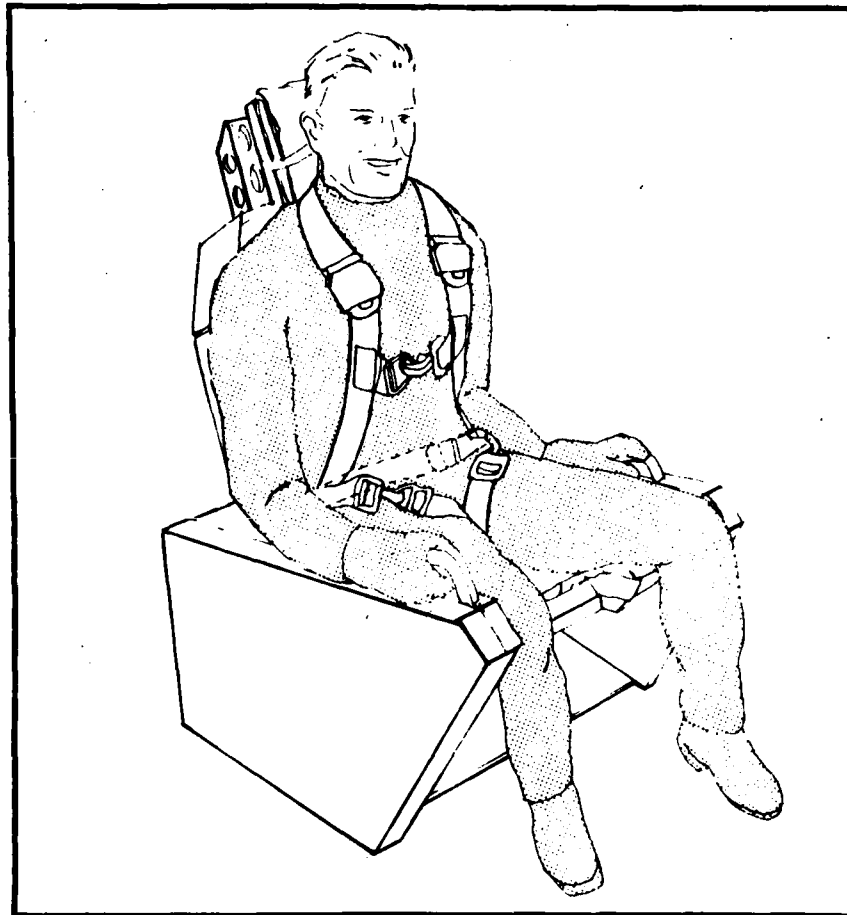

Figure 3. ACES II Restraint System

A questionnaire (a copy of which, with summarized responses, is contained in Appendix B) was administered to nine Air Force pilots, three in each of the aircraft presently using the ACES II system (A-10, F-15, F-16). Partially on the basis of responses to that questionnaire, configuration one was chosen as the baseline restraint condition. All nine pilots stated they fly almost entirely with the inertial reels unlocked, in order to provide maximum visibility and access to cockpit controls. This was confirmed by conversations with other active pilots, Navy test personnel (Ref 13), and the Bason-Etheredge report (Ref 8:131). The latter shows the results of a questionnaire administered to Navy

personnel flying in aircraft equipped with inertial reels similar to those in the ACES II system. Of the 982 responses, 75 percent reported that they lock the inertial reels only for takeoffs and landings.

Although the vast majority of pilots feel that the locked mode is too confining for normal flight conditions, it was chosen as the second restraint condition for a number of reasons. Primarily, enhanced safety under some flight conditions might be possible by specifying operation in the locked mode, should that mode actually provide improved restraint relative to the unlocked condition.

The third restraint configuration consisted of the unlocked ACES II system modified to include a "tiedown" strap. The added strap ran from the center of the lap belt to an attachment point on the floor immediately in front of the seat. This configuration was chosen on the basis of several factors. In early studies involving a downward ejecting seat for the B-47B aircraft, Hecht found that a tiedown strap (in the form of an inverted "V") reduced typical subject-seat displacement from 15.0 to 7.5 centimeters (Ref 6:16). The strap also reduced the magnitude of foot movement off the floor by about 50 percent (Ref 6:22). The reduction in subject motion was apparently achieved by preventing rotation of the lap belt around its attachment points at the side of the seat. From the standpoint of the goal of this study, the tiedown strap represents a relatively simple modification to the existing system. Additionally, the tiedown strap modification is practically unique in that it imposes no restriction on upper body movement required for visibility and control accessibility during normal flight. The unlocked mode was chosen to duplicate the configuration used most often in practice.

Although the standard ACES II restraint system formed the basis for all test items, a modified lap belt assembly was used during testing. The standard ACES II lap belt is shown in Figure 4, while the lap belt and tiedown strap used in this study are shown in Figure 5. Several differences are obvious. In the test item strain links have been sewn to each end of the belt; these allowed measurement of belt forces during the test exposures. The buckle assembly used in the test item was chosen to allow easy incorporation of the tiedown strap during test conditions requiring it; this was not possible with the standard ACES II buckle. Finally, adjusters were incorporated into the test item to allow proper fitting to each subject; in the standard ACES II lap belt facility for adjustment is integral to the buckle. Use of the non-ACES II lap belt was not expected to affect the applicability of test results to the ACES II system. The test item was the same width as the ACES II belt, and could be properly adjusted for flight conditions. The adjusters on the test item were viewed as a possible source of discomfort, but in preliminary runs subjects were not bothered by them.

The tiedown strap (see Figure 5) included a strain link identical to those sewn to the lap belt. The link was attached to the cab floor in front of the ACES II seat. A loop at the upper end of the strap could be slipped over the tongue on one end of the lap belt, which was then buckled. This arrangement allowed easy connection of the tiedown strap by the subject in the cab, eliminating any delay between restraint configuration changes. An adjuster was incorporated into the strap to allow adjustment for each subject. The single strap configuration was chosen for testing rather than the inverted-V strap tested by Hecht (Ref 6) because of the simplicity of only one seat attachment point. This

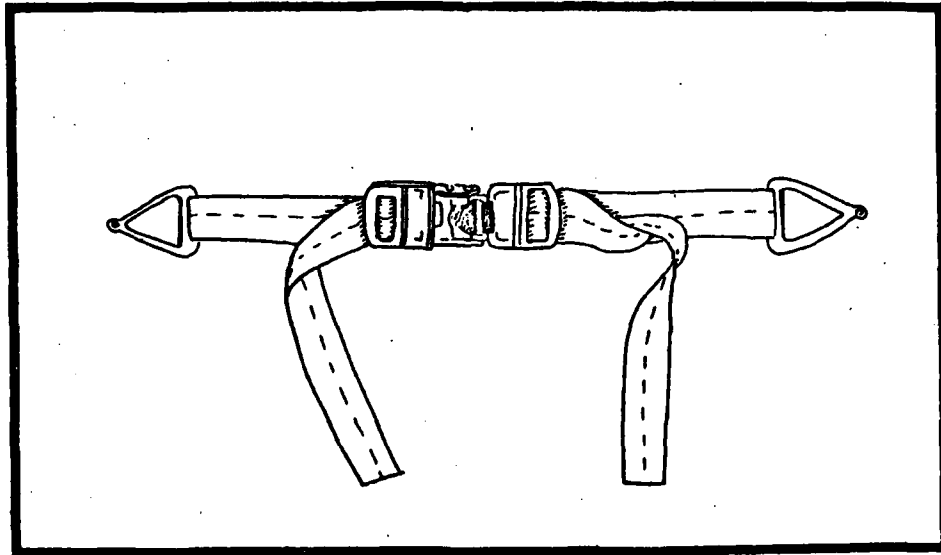

Figure 4. Standard ACES II Lap Belt

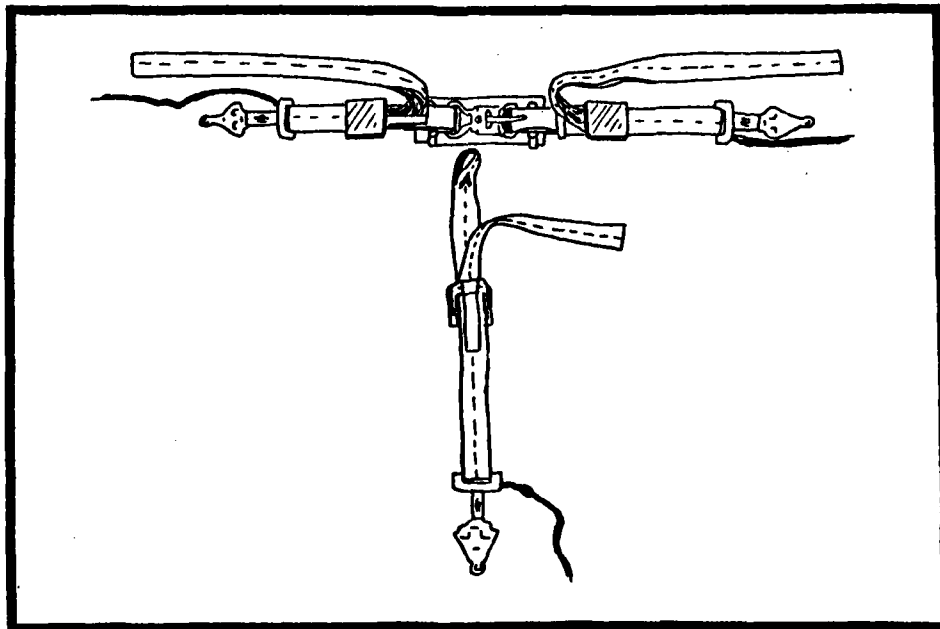

Figure 5. Test Lap Belt and Tiedown Strap

factor is of some importance, since operational use of the tiedown strap would require a mechanism for release of the strap from the seat for the purpose of emergency ground egress and man-seat separation during ejection. The single strap was assumed to function in the same manner as the inverted-V configuration in terms of reducing lap belt movement.

Associated Hardware

Associated hardware, the items used to simulate an aircraft cockpit environment in the DES cab, will be discussed in this section. Although the ACES II system is used in three aircraft, hybridization of the test configuration was avoided as much as possible. With minor exceptions noted below, an effort was made to simulate the restraint and controls of an F-16 aircraft.

An ACES II seat was installed in the DES cab, mounted with a 30 degree backangle to duplicate the configuration of the F-16. Rudder pedals, throttle (on the left side of the seat), and side-mounted (right side) force stick were installed to closely simulate those found in operational F-16's. The ejection handles represent the one major deviation from the F-16 layout. A-10 and F-15 aircraft are equipped with ejection handles on the sides of the seat, while the F-16 has a single ejection handle mounted in front of the seat. Because mounting both the ejection handle and the tie-down strap in front of the seat proved difficult, side ejection handles were used during the tests.

No effort was made to simulate the presence of a canopy over the seat. Although canopy contact represents an important aspect of negative Gz restraint, it was felt that the measure of off-seat displacement

provided adequate information for determination of the relative merit of the restraint configurations under test.

Instrumentation

The instrumentation developed for this study may be divided into two categories, based on conceived importance to the primary goal of the study. The measures necessary for determining the relative effectiveness of the three restraint configurations included displacement off the seat, ejection task performance, and tracking task performance. A number of measurements of secondary importance were made. In some cases the secondary instrumentation was included to provide data "just in case" proper interpretation of the primary measurements required it. Force measurements on the lap belt and tiedown strap, and seat load measurements fall into this category. Acceleration of the subject (or manikin) in the Gz direction was measured in the hope that it might prove to be an adequate measure of restraint. If such were the case, future studies of this type might dispense with the rather difficult problem of directly measuring off-seat displacement. This section will discuss both primary and secondary instrumentation. Justification of the chosen measurement techniques will be included. Details of the tracking task will be covered in the following section. Appendix C contains additional instrumentation details such as transducer manufacturers and model numbers, and available specifications.

Displacement off the seat was considered to be the most important measure of restraint. As mentioned in Chapter II, no previously published study has made such measurements under conditions of dynamic acceleration. After some consideration of the problem, it became obvious

that direct measurement of the displacement is not a trivial matter. Factors contributing to the problem include the difficulty of safely attaching any type of device to the subject, inaccessibility of the area between the subject and the seat, inevitable slack in any clothing subjects might be wearing, and so on. Indirect techniques, specifically photographic techniques, were rejected because of excessive data reduction requirements, and accuracy problems (camera positioning, reference point visibility, etc.). Measurement of head displacement, a somewhat easier task, was dismissed as inadequate because of the added effect of torso stretch under negative Gz exposure. The direct measurement approach was pursued, and resulted in the development of the Displacement Transducer Assembly (DTA). The DTA, shown in Figure 6, resembles a spring scale in many respects. In operation, a section of the seat pan was replaced by a metal plate which was spring-loaded from beneath the seat. When a subject (or manikin) sat in the seat, the plate was depressed by the subject's weight to the level of the seat pan. If the subject rose out of the seat for any reason, the spring-loaded plate remained in contact with the subject, rising up from the seat as

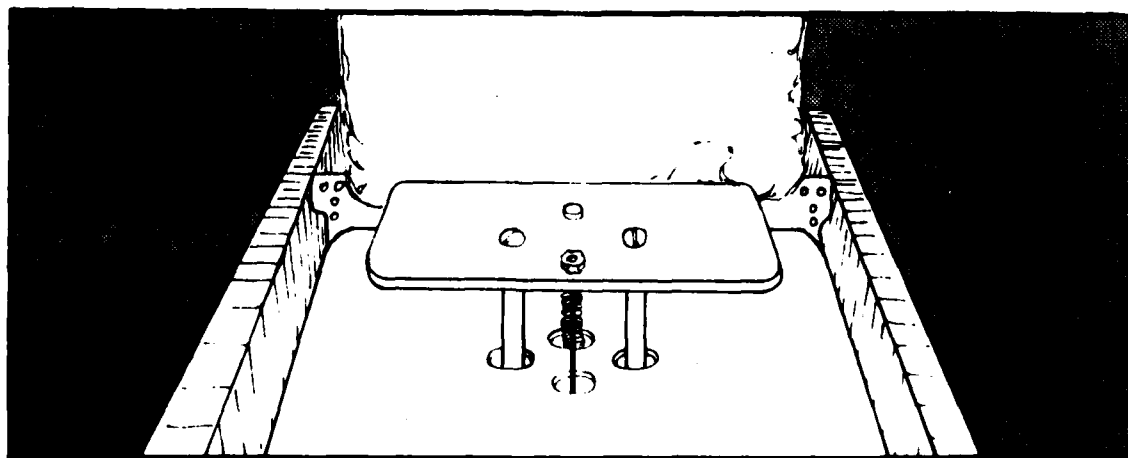

Figure 6. Displacement Transducer Assembly (DTA)

necessary. A potentiometer-type linear displacement transducer was attached to the plate, providing a resistance which varied proportionately to the off-seat displacement of the plate (and subject) over a range of approximately seventeen centimeters. A voltage was applied across the transducer potentiometer; calibration was achieved by measuring the voltage between the potentiometer wiper and the grounded end while the plate was at various levels above the seat.

Human subject performance of an ejection task was measured during each test run. Hardware modifications for these measurements consisted simply of two switches; one mounted on the control stick, and one mounted on the left ejection handle. Upon receiving an eject prompt on the cab CRT, each subject attempted to perform an ejection as quickly as possible. The ejection procedure involved simply releasing the control stick and pulling the ejection handles as quickly as possible. The instrumentation computer was programmed to detect and time the interval between control stick release and ejection handle activation. This interval was considered the ejection delay, and was assumed to be related to the amount of subject displacement in the seat. Secondly, the delay between the display of the eject prompt and subject response (control stick release) was also recorded, on the assumption that it is an indicator of subject stress due to the G environment rather than physical displacement.

Throughout the onset of negative Gz, each subject attempted to track a target on the CRT. Inputs on the rudder pedals, throttle, and control stick pitch and roll axis were all measured by the instrumentation computer during the tracking period. That period extended from the start of negative Gz onset to the moment the subject was prompted to eject.

Forces on the lap belt and tiedown straps were measured during all human and manikin runs. These measurements helped to establish the physical conditions experienced during the negative Gz exposures, helped to explain the way the body moves under the various onset conditions, and provided data on the effect of the tiedown strap. Force measurements were achieved by replacing some standard restraint system attachment hardware with specially designed strain links instrumented with bonded strain gages. Drawings of the basic link, and the gage arrangement are included in Appendix C. One link was sewn to each side of the lap belt, acting both as attachment hardware and instrumentation device. In the same manner, a link was sewn to the tiedown strap, and used to attach the strap to the floor. Each link was hinged to allow the instrumented portion to align with the direction of force exerted on the strap. All three strain gage bridges were supplied with plus and minus five volts; the gains of corresponding instrumentation amplifier channels were adjusted for outputs of approximately 110 millivolts per kilogram. Calibration was performed by measuring the actual amplifier output while suspending weights of two known values from each link. At the amplifier gain setting mentioned, the links provided measurements over a range from 0 to about 100 kilograms, being limited by the amplifier full-scale output of 11 volts.

Two load cells were mounted under the seat pan area beneath the ends of the displacement transducer assembly plate. Due to the geometry of the fiberglass seat pan, and the plate intervening between the subject and the load cells, exact measurements of load on the seat pan were not expected; rather, an accurate indication of the time that the weight of subject or manikin lifted off the seat was desired. Each cell was rated

by the manufacturer for a full-scale indication of 115 kilograms, and was calibrated in the same manner as the strain links.

The final instrumentation device consisted of an accelerometer attached to the chest of each human subject and manikin to provide data on acceleration of the upper body in the Gz direction. Figure 7 shows the accelerometer, mounted on a leather plate attached to a belt of elastic material. The belt was placed around the chest of each test subject, and was designed to allow easy chest expansion and contraction during breathing. With the accelerometer located over the sternum, the belt was tightened, then fastened in back with velcro. To further minimize movement of the device with respect to the subject, it was then taped to the subject's flight suit. Output of the instrumentation amplifier was measured at plus and minus one G to provide a calibrate value of 1.45 volts per G, over a range of plus six to minus six G's.

At several points in the above discussion reference has been made to an instrumentation amplifier. This piece of equipment, designed and built in-house, consisted of eight channels, providing variable gain and balance on each channel, with outputs capable of ranging from plus to minus eleven volts. Gain adjustment was performed by fixed resistors soldered into the circuitry. Balance adjustments were made with vernier-equipped potentiometers, and were checked before each series of tests.

Tracking Task

Although mentioned previously, the tracking task requires somewhat further explanation. Because it was assumed to be an indirect measure of subject restraint, an attempt was made to develop a task that would

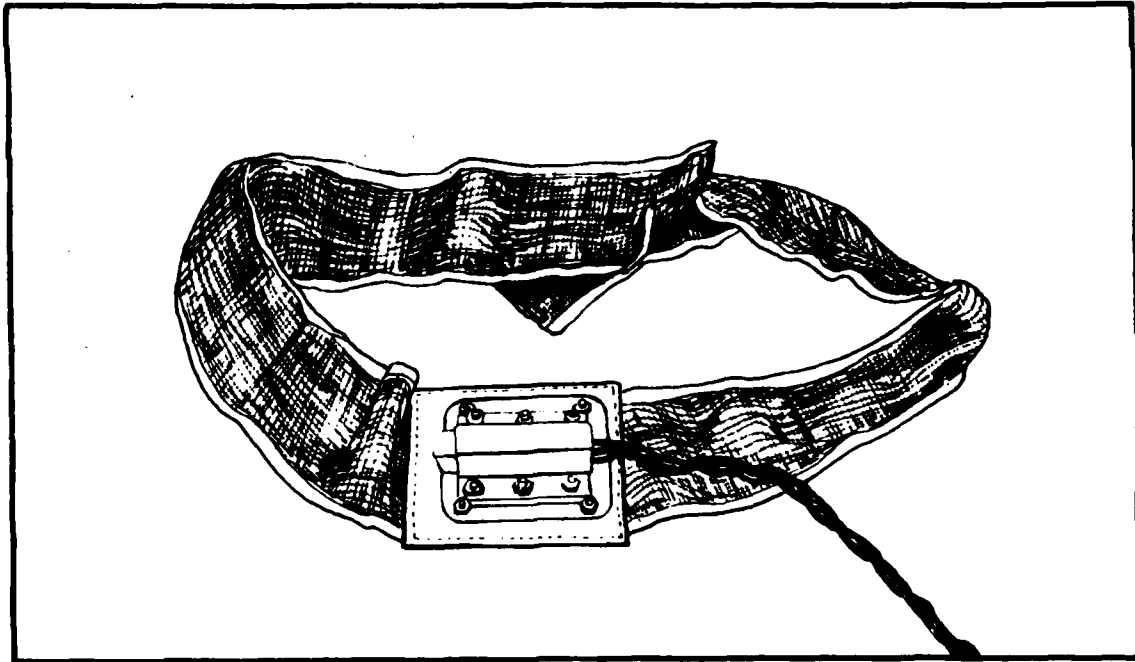

Figure 7. Accelerometer Belt

reflect inadvertant inputs caused by a number of different body motions. Tracking errors due to movement of the control stick (in both pitch and roll), rudder pedals (yaw), and throttle (speed) were used to calculate a tracking score. Due to time restraints, the task was based on one previously developed and used in a number of programs. The task required the subject to track a target on the CRT mounted in front of the ACES II seat in the DES cab. In previous studies, the target was moved in response to a combination of sine wave forcing functions in designated control axis; forcing functions applied to more than one axis resulted in a difficult task requiring considerable training to achieve asymptotic performance. In order to provide an appropriately difficult task, yet reduce required training time, no forcing functions were applied to any axis during this study. Instead, the task was modified to be unstable in

the pitch and roll axis. Ideally, yaw and speed control would also have been made unstable, but these proved impossible to modify in the time available. As a result, the tracking scores reflected predominately inadvertant inputs in roll and pitch; that is, the difficulty subjects experienced in maintaining control of the movement of their right hand. Despite this limitation, it was expected that this task would reflect the relative effectiveness of the restraint systems under test.

Manikins

Two anthropomorphic manikins were used during the study to establish their effectiveness for the extension of results to G levels beyond human tolerance. One manikin, an Alderson Model F-95, simulated a 95th percentile male subject, while the other was an Alderson C-5 5th percentile male manikin. Relevant instrumentation was identical to that used for the human subjects. Important data for the manikins is listed in Table III below.

Table III. Manikin Data

	5th Percentile	95th Percentile
Weight (kg)	60.2	91.1
Stature (cm)	165.6	185.7
Sitting height (cm)	85.1	96.5
Shoulder breadth (cm)	41.9	49.3

Data Acquisition and Analysis

Objective data was acquired by two primary means; computer interface with the instrumentation, and real-time strip chart output. The hybrid computer described in the DES section of this chapter gathered data from the seat pan load cells, strain links, DTA, ejection switches, and tracking task inputs using a sampling interval of forty milliseconds. Necessary calculations were performed (scaling, summation, etc.), and a summary printout produced soon after each series of runs. The printout contained a variety of tracking task scores (based on various control inputs and time intervals), the ejection delay, and instrumentation readings averaged over intervals of one second (for the -1.5 and -2.0 runs) or two seconds (for the -1 Gz rollovers). In addition to the printout, all data gathered by the computer during each run was stored as a record on magnetic tape.

A strip chart recorder was operated during every run, providing a subject electrocardiogram as well as a real-time plot of displacement, cab Gz acceleration, and tiedown and lap belt forces. Channels were also allotted to the control stick and ejection handle switches to allow immediate verification of their operation.

In order to simplify the data reduction process, an attempt was made to deal primarily with a relatively small number of discrete measurements made during each test. For example, the maximum displacement observed during a run was viewed as a discrete value of extreme importance. Following each run, the most important data was distilled from the printouts and strip charts by the investigator, then manually input to a small computer which produced a single sheet printout containing the condensed data in a convenient format. The data in this form was

ultimately used for most of the statistical analysis discussed in Chapter VI.

Summary

This chapter described in some detail the equipment used for this project, including the instrumentation, test items, dynamic environment simulator, computer control system, and so on. In the case of the instrumentation, some further details are contained in Appendix C. The system of data acquisition, and preliminary analysis was described. Details of the data analysis are covered in Chapter VI, "Analysis and Results." The following chapter discusses the human subjects used in this research effort.

IV. Human Subjects

Qualifications

All subjects tested during the program were members of the Acceleration Hazardous Duty Panel of the AFAMRL. Panel members undergo an initial physical examination similar to the USAF Class III flying physical, and are examined by a physician before and after every centrifuge exposure. Members receive hazardous duty pay during months for which they participate in at least one test run. The centrifuge experience of panel members involved in this study ranged from five to forty-six months of panel duty, with only one subject having less than twenty-one months. Although most subjects had extensive centrifuge experience, none had previously undergone significant exposure to negative Gz conditions.

All test subjects volunteered for participation in the project following a thorough briefing of the purpose, risks, and content of the investigation. A number expressed particular interest because of the rather unusual requirement for negative Gz exposure. At least one panel member declined to participate for the same reason. Subjects were encouraged to ask questions, and reminded that they could stop participation in the study at any time.

Human Use Protocol

Exposure levels were carefully chosen to provide useful data with minimal likelihood of subject injury. Although relatively little work has been done in the area of human tolerance to negative Gz acceleration, enough precedent existed to define safe exposures for this study. Kennealy, Kirkland, and Sneider report on four subjects exposed to

negative Gz accelerations on the centrifuge used for this investigation (Ref 14:483). In those runs, the cab was turned upside down for 10 seconds, the subjects were then accelerated to -1.5 Gz in 5 seconds, held at that level for 2 seconds, then decelerated to the inverted position in 5 seconds, held in that position for 10 more seconds, then returned to +1 Gz. After several minutes the same sequence was performed, this time to a level of -2.0 Gz. In those tests no subject lost consciousness or vision. Bradycardia was evident in all four subjects. Another reference cites tests showing no conjunctival hemorrhage or diminished vision for 20 subjects exposed to -2.0 Gz for 10 seconds. Both conditions were observed in 40 percent of subjects exposed to -3.0 Gz for 10 seconds (Ref 15:248). On the basis of these and other precedents, exposure limits of -1.0 Gz for 30 seconds, -1.5 Gz for 20 seconds, and -2.0 Gz for 10 seconds were established for this study. Exposure limits for this, as for all AFAMRL studies, were examined and approved by the Laboratory Human Use Review Committee.

Subject Anthropometry

This study dealt specifically with physical characteristics of restraint systems, with possible application of operational hardware. For this reason it was particularly desirable to test a group of physically diverse subjects. Subject standing height ranged from approximately 165 cm (5'5") to 185 cm (6'1"). The lightest subject weighed 63.5 Kg (140 lbs), while the heaviest weight 90.3 Kg (200 lbs). Complete subject anthropometry is shown in Table IV below.

Table IV. Human Subject Anthropometry

(Measurements in centimeters unless otherwise noted.)

Subject No.	1	2	3	4	5	6	7
Age (yrs)	32	26	26	39	31	31	26
Weight (Kg)	68.7	90.3	83.9	89.8	89.8	63.5	74.5
Stature	179.8	176.5	169.6	181.9	185.1	165.4	170.5
Sitting Height	95.9	92.3	87.9	98.9	96.1	86.2	88.5
Mid-shoulder height, sitting	64.7	66.3	61.4	70.8	64.0	60.7	63.5
Trochant. Height	93.3	92.2	89.1	92.8	97.9	87.6	92.2
Knee Height, sitting	56.9	54.9	54.3	56.5	59.1	51.7	54.6
Hip breadth, sitting	35.0	40.0	38.5	40.1	37.2	35.2	35.3
Aorta-eye length	N/A	29.6	27.9	31.0	N/A	28.7	N/A

Summary

Characteristics of the human subjects used during this investigation were discussed in this chapter. In the next chapter, details of the procedures used for testing both humans and manikins are described.

V. Procedures

Human Subject Test Procedures

As discussed in Chapter II, human subjects were subjected to two different types of acceleration exposure. The first type was achieved by turning the centrifuge cab or fork 180 degrees, so that the cab was upside down, with a resultant -1.0 Gz condition experienced by the subject. Following a period in the inverted position the cab was turned another 180 degrees, returning the subject to the upright position. The second type of exposure involved rotation of the centrifuge arm. Before arm rotation, the centrifuge fork was turned ninety degrees to place the subject on his back; the cab was then turned ninety degrees to position the head of the subject outward from the center of rotation. In this position, with back toward the floor and head out, rotation of the centrifuge arm produced an acceleration vector through the axis of the subject's body, with the subject experiencing an "eyeballs up," or negative Gz condition. This position was chosen with consideration to subject comfort before the run, and to help ensure that the subject would be safe and accessible to rescue personnel should a medical emergency or centrifuge malfunction occur. The alternatives, face down or side down, or cab and fork movement during arm rotation, were unacceptable in this respect. Although the chosen position provided a 1.0 G vector acting to push the subject's back into the seat, this had to be accepted in light of the alternatives. In any case, the Gz vector was assumed to predominate in terms of body displacement out of the seat. Negative Gz levels of -1.5 and -2.0 Gz were produced during the series of runs involving arm rotation, by simply rotating at the velocity necessary to

produce the desired acceleration level at the cab. Figures 8, 9, and 10 show profiles of typical subject Gz exposure during a forward rollover, -1.5 Gz run, and -2.0 Gz run. Note that the period of peak negative Gz exposure was approximately thirty, twenty, and ten seconds respectively.

Each run, regardless of type, required several operations to be performed by the subject. In all cases the subject began tracking a target on the cab CRT before the onset of the negative Gz acceleration. Tracking continued during the onset, and through a portion of the period spent at peak negative Gz. Approximately midway through the period of peak negative Gz exposure, a prompt ("EJECT") was displayed on the CRT. The subject was then required to release the control stick and pull the ejection handles as quickly as possible. Subjects then returned to the tracking task and continued tracking until completion of the run. A tracking score was calculated based on the tracking period before the prompt, and an ejection delay was calculated from the stick release and ejection handle activation times.

Each subject underwent testing on two separate days. The order of the two types of testing performed was chosen randomly for each subject. One day involved nine cab inversions; three with each restraint configuration. One rollover was forward (head first), one to the right, and one to the left, with a one minute delay between each rollover. After the three inversions the restraint configuration was changed (by the subject), and the process repeated. The final restraint system was tested in like manner. Restraint system order was selected at random, as was rollover direction for each restraint.

The second type of testing, rotation to levels of -1.5 and -2.0 Gz, was performed on a separate day. In this case restraint system order was

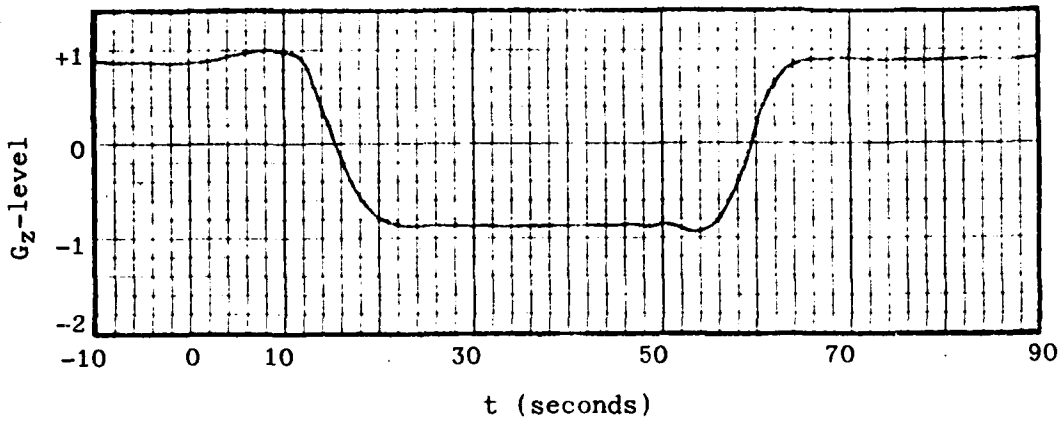

Figure 8. Typical Subject Gz Profile for Forward Rollover

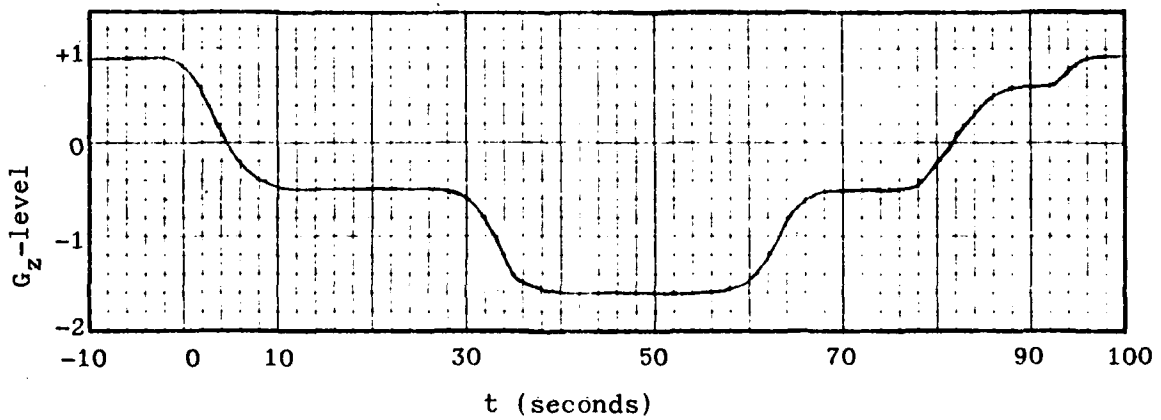

Figure 9. Typical Subject Gz Profile for -1.5 Gz Rotation

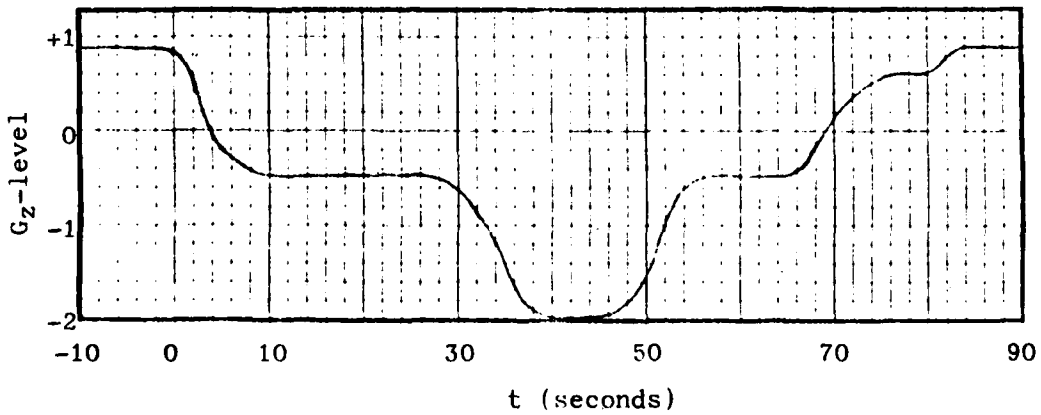

Figure 10. Typical Subject Gz Profile for -2.0 Gz Rotation

also determined randomly, as was the order of the G-level exposure. With each chosen harness one run was made to the first G-level, then a run was made to the remaining level. A five-minute rest period was observed between each test run. During this day of testing each subject participated in a total of six runs -- one to each G-level with each restraint system.

Before testing, the subject received a briefing on the exposures programmed for that day, tracking and ejection requirements, and equipment operation. The subject participated in five "dry" runs each day before data runs. Dry runs involved performing the tracking and ejection tasks with the DES cab stationary. Scores for these "static" runs were recorded to establish baseline performances.

During testing subjects wore typical flight equipment: flight suit, boots, anti-G suit, PCU-15/P harness, helmet, oxygen mask, and gloves. No cushion was used on the ACES II seat in order to avoid interference with operation of the Displacement Transducer Assembly. The ACES II seat cushion is quite thin and firm, and its omission is not believed to have significantly affected any of the data obtained. The accelerometer belt described in Chapter IV was worn by each subject over the flight suit but under the PCU-15 harness; the transducer was taped to the flight suit to minimize movement with respect to the subject.

After entry into the cab each subject adjusted rudder pedals and control stick for his own personal comfort. Subjects were also asked to adjust the restraint system straps as they would if they expected to fly. They were reminded that most pilots prefer to fly with a tight lap belt.

Following each day's test runs each subject was asked to complete a questionnaire to provide subjective data concerning severity of exposure,

comparison of restraint systems, and so on. These questionnaires and subject responses are discussed in detail in Chapter VI.

Manikin Test Procedures

Detailed manikin test procedures were developed after analyzing results of several series of test runs. The initial intent had been to tighten the lap belt and/or tiedown strap to a specified tension (based on real-time strip chart output) before each test run. The preliminary runs showed, however, that the belts had to be tightened after nearly every run as a result of the manikin shifting position in the seat; the manikin became more tightly bound in the seat with each adjustment, and after several adjustments began to behave very consistently in terms of displacement and belt forces during the runs. The initial runs with human subjects indicated that the manikin results after one readjustment most closely resembled those of the humans in terms of consistency. In light of this information a standard sequence was developed and followed during all manikin data runs. The manikin was strapped into the seat, with belt tensions adjusted to within one kilogram of those found typical for human subjects (5 Kg, for the lap belt, 3 Kg for the tiedown strap). Before actual data runs the manikin was rolled once in each of three directions (forward, right, and left), and the belts readjusted. A series of data runs then commenced. In addition to the restraint systems being tested, some additional restraint was necessary for the manikins in order to prevent uncontrolled movement of legs and arms. This was provided by wrapping one quarter inch "bungy" cord around each limb and adjacent hardware. In this manner each foot was attached to the rudder pedal it rested on, and each wrist was attached to the corresponding seat

ejection handle. The flexible cord allowed some movement of feet and arms, yet prevented limb displacement that would have required correction during the test sequence.

Test conditions duplicated these for the human subjects, and extended to higher G-levels during the rotational runs. All runs were performed using both a 95th percentile and a 5th percentile manikin. A series of nine rollovers was performed with each manikin and each restraint configuration, with the manikin being rolled forward, right, and left, in random order. During each rollover the cab was rolled to the inverted position, held there for approximately five seconds, then rolled back upright, completing a 360 degree roll. After a brief delay the next rollover was performed. The initial strap adjustment sequence was performed before each series of runs. The resulting data base consisted of eighteen displacement measurements (nine for each manikin) for each restraint system.

Testing at higher G-levels followed the same initial strap adjustment sequence. Before rotation, the manikin was positioned with the back of the seat toward the floor and head pointing out from the center of rotation, duplicating the position of the human subjects. The centrifuge was then run at increasing rotation speed through a series of G-levels, beginning at -1 Gz and extending to -5 Gz. During the series, levels of -1.0, -1.5, -2.0, -3.0, -4.0, and -5.0 were maintained for a period of approximately five seconds in order to allow the manikin to reach a stable position. This sequence was repeated six times with each manikin and each restraint configuration, with the initial strap adjustment performed following each restraint change.

During all manikin test runs lap and tiedown strap forces, manikin

and cab acceleration in the Gz direction, and displacement off the seat were measured. No seat cushion was used, as was the case during the human subject runs.

Summary

This chapter discussed the details of the procedures used during this investigation, elaborating on the general test sequence outlined in Chapter II. Manikin test procedures were described as generally duplicating those of the human subjects, with additional runs at higher G-levels. The next chapter discusses in detail the analysis and results of the data gathered according to these procedures.

VI. Analysis and Results

Overview

Significant results were obtained during the course of the project. The possibilities for analysis are seemingly endless, particularly with respect to comparison of human subject and manikin data. This chapter will present the results of the analysis made to this point; some suggestions for further analysis and research will be made in the following chapter.

The analysis of the data of primary importance will be presented first. Primary data was considered to be the displacement, tracking score and ejection delay data measured for the human subjects, and the subjective questionnaire responses of those subjects. Results derived from the secondary human subject data (i.e. strap forces, seat pan loads, and accelerometer data) will then be discussed. Condensed raw displacement, tracking, and ejection data for each subject is contained in Appendix D; a copy of the subject questionnaires and summarized responses are contained in Appendix E.

Data acquired during the manikin phase of the project will be covered after discussion of the human subject data. An attempt will be made to explain the relationship of the manikin data to the human subject data, and extension of the human results to higher G-levels will be discussed.

Throughout this chapter and the next, reference to the restraint systems under test will be by name or number, as follows:

1. ACES II, unmodified, shoulder straps unlocked;
2. ACES II, unmodified, shoulder straps locked;
3. ACES II, with tiedown strap, shoulder straps unlocked.

As discussed in Chapter 3, configuration 1 is that in normal operational use at the present. Restraint 2 was tested to establish the best restraint possible with the current system, despite operational unsuitability. Restraint 3 was considered a possible modification suitable for incorporation into the present system.

Primary Human Subject Results

Table V summarizes the mean maximum off-seat displacement results for the human subjects. The data for forward, left, and right rollovers (-1 Gz) for a single restraint configuration have been combined in the table for simplicity of representation. The variation in N (number of data values for each condition) is due to a number of cases in which additional data points (beyond those called for in the test plan) were acquired for one or more subjects. In no case was displacement data lost due to equipment malfunction.

Several features of the data are immediately apparent. Predictably, the mean displacement increased with each increase in G-level. The fact that this is true justifies to some extent the initial assumption that the resistance of the subject against the back of the seat would not be an important factor during the rotational runs. Comparing the data for the different restraint systems reveals that for all three G-levels, displacement was greatest for system 1, next largest for system 2, and smallest for system 3.

Table V. Human Subject Displacement Results

(N - Number of Trials)

G-Level:	-1 Gz	-1.5 Gz	-2.0 Gz
Restraint 1:			
Mean max. disp. (cm)	3.2	3.6	3.8
Standard Deviation	1.15	1.24	1.30
N	21	6	6
Restraint 2:			
Mean max. disp. (cm)	2.9	3.2	3.6
Standard Deviation	1.2	1.3	1.26
N	21	8	6
Restraint 3:			
Mean max. disp. (cm)	2.1	2.6	2.7
Standard Deviation	0.86	1.19	1.09
N	28	6	7

The standard deviation of the data for restraint number 3 is also smallest in all cases, indicating that there was less variability between subjects than for the other two systems. Displacement results were very consistent; with few exceptions every subject under every test condition showed the least displacement with restraint number 3. The displacement data for the rollovers and rotations is shown graphically in Figures 11 and 12 respectively.

Separate analysis of variance (ANOVA) procedures were performed on the rollover and rotation data. A model combining individual subject variability, restraint system, and direction (or G-level) proved effective, accounting for 92 and 96 percent of the observed variation for the rollover and rotation runs respectively. In both cases, the hypothesis that the mean displacement for all restraints was equal was rejected with a confidence of 99.9% ($p = .0001$). A Newman Keuls Multiple Comparison Procedure (Ref 17) was then conducted on each set of data in order to determine which restraint systems differed. At an alpha = 0.10

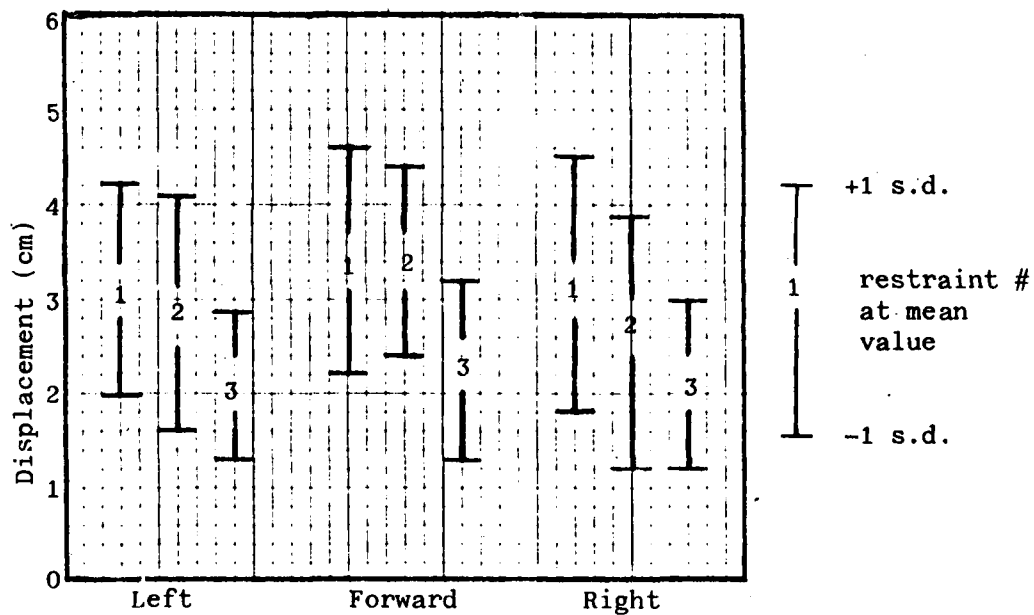

Figure 11. Rollover Displacement Data for Human Subjects

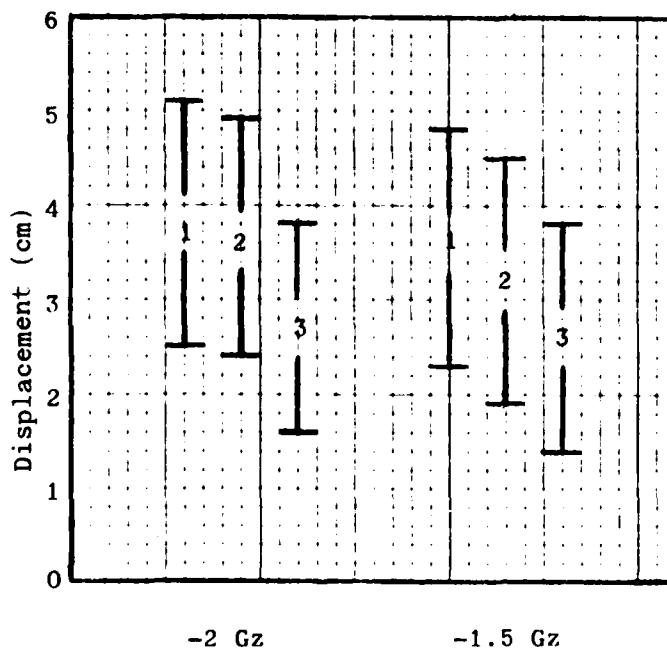

Figure 12. Rotation Displacement Data for Human Subjects

(90% confidence) level, the test showed that the differences observed between all three restraint configurations are significant. Thus, at the confidence levels specified, it can be stated that restraint 3 allowed significantly less off-seat displacement than either restraint 1 or 2. In the -1 Gz (rollover) case the decrease in displacement amounted to approximately 34 percent. For the -1.5 Gz and -2.0 Gz rotation runs, the decrease was 28 and 29 percent respectively. In all three cases the actual decrease in off-seat displacement was approximately 1 centimeter.

The ANOVA tests further showed that G-level and rotation direction, in addition to restraint configuration, were significant variables, although the F-values for these variables were considerably lower. For the rollover conditions, rolling forward produced slightly greater displacement than rolling to either side.

Tracking score data acquired during the investigation proved inconclusive. Tables VI and VII summarize the tracking data for rollover and rotation test conditions respectively. The values shown for the static condition are calculated from the static scores achieved by each subject on the second day of testing. Rollover scores for the first subject were not collected due to a software error.

The outstanding feature of the data is the very large standard deviation evident for all conditions. Although an analysis of variance was performed, the large variation between subjects, as well as for individual subjects, prevented any of the variation in the means from being ascribed to either restraint configuration or type of exposure.

Table VI. Rollover Tracking Score Data

(N = Number of Trials)

Condition:	Static	Forward	Right	Left
Restraint 1:				
Mean tracking score	139	371	326	267
Standard deviation	105	276	249	236
N	35	6	6	6
Restraint 2:				
Mean tracking score		275	245	303
Standard deviation		177	150	177
N		6	6	6
Restraint 3:				
Mean tracking score		350	383	388
Standard deviation		262	246	231
N		9	7	8

Table VII. Rotation Tracking Score Data

(N = Number of Trials)

Condition:	Static	-1.5 Gz	-2.0 Gz
Restraint 1:			
Mean tracking score	139	134	221
Standard deviation	105	81	196
N	35	7	7
Restraint 2:			
Mean tracking score		165	237
Standard deviation		126	202
N		8	7
Restraint 3:			
Mean tracking score		261	241
Standard deviation		237	232
N		7	7

Static tracking data for individual subjects shows a definite training effect, with scores becoming consistently lower as the subject gained experience (see Appendix D). Since most subjects had previous experience with a closely related tracking task, such a pronounced

learning effect was not anticipated, and certainly had an adverse effect on the usefulness of the data.

The mean tracking scores do appear to indicate that the rollover condition provided a more challenging tracking environment than the higher G-level rotations. This is probably due to the support provided by the back of the seat throughout the rotations.

As in the case of the tracking scores, the ejection data did not allow any conclusions to be made with respect to the relative merits of the restraint systems. The ejection delay data is summarized in Table VIII below.

Table VIII. Ejection Delay Data Summary

(N = Number of Trials)

Condition:	Static	-1 Gz	-1.5 Gz	-2.0 Gz
Restraint 1:				
Mean delay (secs.)	.51	.53	.74	.48
Standard deviation	.15	.19	.27	.18
N	25	20	6	6
Restraint 2:				
Mean delay (secs.)		.59	.55	.39
Standard deviation		.26	.27	.20
N		19	6	6
Restraint 3:				
Mean delay (secs.)		.55	.52	.45
Standard deviation		.26	.21	.16
N		28	6	6

A hardware malfunction resulted in the total loss of ejection delay data for one subject, resulting in N = 6 for the -1.5 and -2.0 Gz levels. In several other cases isolated malfunctions occurred, or subjects neglected either to reset the ejection handles between runs or to perform the ejection procedure during a run, resulting in a number of missing data

points. Data for all three rollover directions is combined in the table because the ejection procedure was performed after a stable inverted position had been reached.

An apparently surprising aspect of the data are the smaller delays achieved by the subjects at the -2.0 Gz level. This can probably be attributed to an oversight in the design of the experiment. The allowable human exposure was ten seconds at -2.0 Gz, versus twenty and thirty seconds at -1.5 Gz and -1.0 Gz, respectively. In all cases the ejection prompt was given at the midpoint of the exposure. As a result, subjects were probably better able to anticipate the prompt at -2.0 Gz (given only five seconds after the exposure began) than at the lower G levels.

A questionnaire was administered to each subject after each series of rotation and rollover exposures. In some cases, due to time constraints, subjects were allowed to take a questionnaire home with them, with instructions to complete all responses within several hours of the exposure. The questionnaires for post-rollover and post-rotation varied slightly, in that some questions specific to the applicable exposures were asked. A copy of each type of questionnaire, along with summarized responses are contained in Appendix E. Completed post-rollover questionnaires were received from all seven subjects; six subjects returned completed post-rotation questionnaires.

In response to a question concerning restraint effect on tracking and ejection performance, approximately half of the responses claimed that type of restraint did have an effect on performance. Restraint 3 was rated the best in four cases, restraint 2 was judged best in two cases. Four responses indicated that restraint 1 was the worst, in one

case restraint 3 was judged the worst. An almost identical distribution of responses was received for the question relating to restraint system affect on the ability of the subjects to keep their feet on the rudder pedals.

When asked to describe any sources of physical discomfort the subjects made a number of different responses, most related to pressure from the lap belt. In four cases, subjects reported that the two harness clips (one on each side of the pelvis) pressed uncomfortably into the pelvis. The pressure in these cases resulted from the clips being under the lap belt. In six more cases pressure from the lap belt itself was reported as a source of discomfort. In all but one of these cases the discomfort was reported as occurring with restraints 1 and/or 2, but not with restraint 3. One subject reporting uncomfortable lap belt pressure with restraint 1 mentioned that some abdominal discomfort existed even twelve to twenty-four hours after testing. In one case each the shoulder straps and the tiedown strap were reported as sources of discomfort. Although not mentioned on subject questionnaires, several subjects noted during testing that the flight helmet was extremely uncomfortable at the -1.5 and -2.0 Gz levels. This phenomena is apparently very dependent on individual adjustment, since some subjects reported no discomfort at all from the helmet.

One question asked for suggestions for improved negative Gz restraint. Most responses related to spreading the load that is currently taken by the lap belt alone. One response suggested widening the shoulder straps; two suggested widening or padding the lap belt. Two subjects thought that the present restraint allows too much slack in the shoulder straps, even when locked. One subject advised adding stirrups

for the rudder pedals, three subjects suggested incorporation of the tiedown strap as tested.

The last question on each questionnaire required the subject to estimate his maximum off-seat displacement during the testing sequence. This question was included to provide some idea of how accurate such subjective information might be. The responses following the rollover sequence were often extremely high. Although the maximum displacement never exceeded 4.85 cm, four of the seven responses ranged from approximately 6 cm to 20 cm. Responses to the same question following the rotation sequence were generally much closer to the measured value.

Secondary Human Subject Results

Measurements regarded as of secondary importance during the human subject runs were lap belt and tiedown strap forces, subject acceleration in the Gz direction, and seat pan loads. These will be discussed in turn.

Table IX summarizes the lap belt and tiedown strap force data acquired for the human subjects. The forces shown were calculated from those measured at the approximate midpoint of each G exposure. As explained in Chapter III, forces were measured by strain links attached to the right and left sides of the lap belt, and the floor end of the tiedown strap. As previously noted, a number of subjects listed the lap belt as the prime source of discomfort during negative Gz exposure. It seems logical that the discomfort would be related to the amount of force measured on the belt. In Table IX the sum of the right and left lap belt forces has been listed to represent the total force on the lap belt.

Table IX. Human Subject Strap Force Data

NOTE: R+L = Sum of right and left lap belt forces.
 Tie. = Tiedown strap force.
 N = Number of trials.

G-level: Strap:	-1.0 Gz		-1.5 Gz		-2.0 Gz	
	R+L	Tie.	R+L	Tie.	R+L	Tie.
Restraint 1:						
Mean force (Kg)	117.1	0	154.1	0	195.7	0
Standard deviation	7.4	0	11.9	0	15.2	0
N	21		7		7	
Restraint 2:						
Mean force (Kg)	113.2	0	149.6	0	191.8	0
Standard deviation	10.6	0	10.6	0	11.2	0
N	21		7		7	
Restraint 3:						
Mean force (Kg)	97.0	27.4	132.0	36.6	169.5	41.7
Standard deviation	9.2	5.1	10.7	15.6	14.2	18.6
N	28		7		7	

As expected, strap forces rise with increasing G exposure. Restraint 2 shows lap belt forces slightly lower than those for restraint 1, indicating that in the locked mode the shoulder straps (and hence the subject's shoulders) did take some load. The magnitude of the shoulder load is surprisingly small, however, amounting to only about four kilograms (the difference between the lap belt loads for restraints 1 and 2). Results for restraint 3 show a lap belt load significantly lower than for restraint 1. This is not surprising, since in this configuration the tiedown strap is picking up part of the load. The load averaged about twenty kilograms less than for restraint 1 under the same condition.

No conclusive results were obtained from comparison of measurements of cab and subject acceleration in the Gz direction. A possibility originally considered was that a well restrained subject would match the

acceleration profile of the cab more closely than a poorly restrained subject. Although this must certainly be true, it was impossible to detect any meaningful differences between plots of cab and subject Gz acceleration for the three difference restraint systems. Contributing to the interpretation difficulties were inaccuracies in cab and subject accelerometer scaling and zero levels, subject movement in the seat in directions other than Gz, and inaccuracies in placement of the accelerometer on the subject.

Seat pan load cell data was found to be unnecessary. These measurements were originally made in order to help interpret data at points where the load on the seat decreased, but displacement off the seat did not take place. In fact, such a case never occurred; displacement was measured on every run, and interpretation of the data never required use of seat pan loads.

Manikin Results

Testing with 95th and 5th percentile manikins duplicated the rollover sequence and -1.5 and -2.0 Gz rotations of the human subjects. In addition, data was collected during rotations at G-levels of -1.0, -3.0, -4.0, and -5.0 Gz. Tables X, XI, and XII summarize the displacement data for the manikins. Table X allows comparison of 5th and 95% percentile manikin data for the -1 Gz rollover and rotation conditions. Table XI summarizes the 5th percentile manikin data for all rotation test conditions, and Table XII does the same for the 95th percentile manikin data. In all cases the data shown was calculated from displacement measurements made at the midpoint of the G exposure, corresponding very closely to the maximum displacement at that G level.

Table X. 5th and 95th Percentile Manikin Displacement Data for -1 Gz

(N = Number of Trials)

Manikin: -1 Gz exposure:	5%		95%	
	Roll	Rotate	Roll	Rotate
Restraint 1:				
Mean disp. (cm)	1.9	2.1	2.7	2.6
Standard deviation	.19	.30	.42	.74
N	9	6	9	6
Restraint 2:				
Mean disp. (cm)	2.1	2.1	2.6	2.0
Standard deviation	.12	.23	.26	.29
N	9	6	9	6
Restraint 3:				
Mean disp. (cm)	1.8	1.7	2.0	1.8
Standard deviation	.10	.40	.10	.29
N	9	6	9	6

Table XI. 5th Percentile Manikin Displacement Data

for -1 to -5 Gz Rotations

(N = Number of Trials)

Gz Exposures:	-1	-1.5	-2	-3	-4	-5
Restraint 1:						
Mean disp. (cm)	2.1	2.7	3.4	4.5	5.2	5.5
Standard deviation	.30	.29	.22	.16	.16	.10
N	6	6	6	6	6	6
Restraint 2:						
Mean disp. (cm)	2.1	2.8	3.6	4.6	5.3	5.7
Standard deviation	.23	.26	.18	.12	.08	.08
N	6	6	6	6	6	6
Restraint 3:						
Mean disp. (cm)	1.7	2.3	3.0	4.0	4.7	5.2
Standard deviation	.40	.41	.44	.31	.22	.15
N	6	6	6	6	6	6

Table XII. Percentile Manikin Displacement Data
for -1 to -5 Gz Rotations

(N = Number of Trials)

Gz Exposure:	-1	-1.5	-2	-3	-4	-5
Restraint 1:						
Mean disp. (cm)	2.6	3.1	3.7	5.0	5.9	6.4
Standard deviation	.74	.69	.56	.39	.25	.17
N	6	6	6	6	6	6
Restraint 2:						
Mean disp. (cm)	2.0	2.3	2.8	3.6	4.2	4.7
Standard deviation	.29	.28	.26	.19	.11	.10
N	6	6	6	6	6	6
Restraint 3:						
Mean disp. (cm)	1.8	2.1	2.4	3.2	3.8	4.3
Standard deviation	.29	.24	.29	.19	.19	.12
N	6	6	6	6	6	6

The mean displacement data in Tables XI and XII is displayed graphically, along with best-fit straight lines, in Figures 13 and 14 respectively.

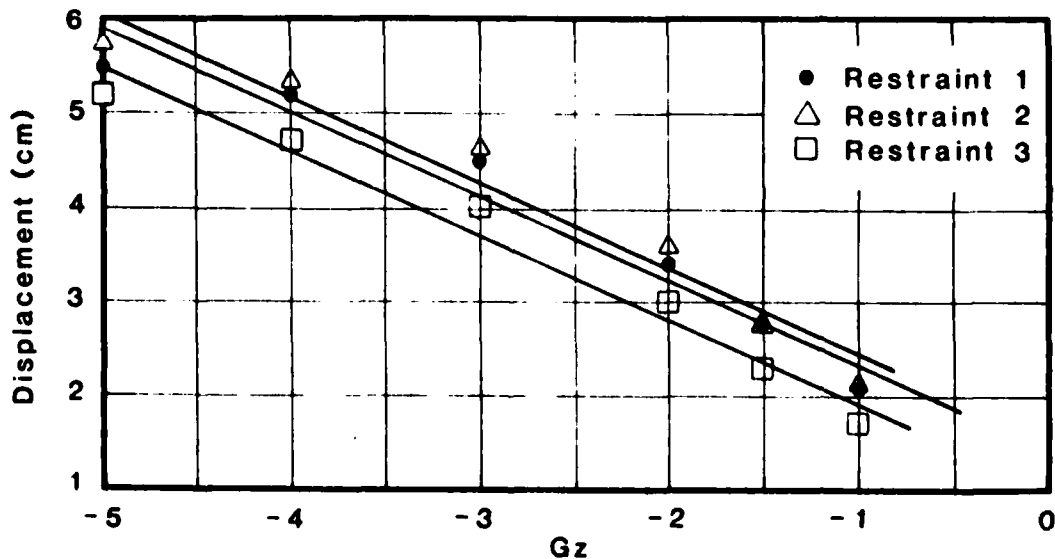

Figure 13. 5th Percentile Manikin Displacement Data

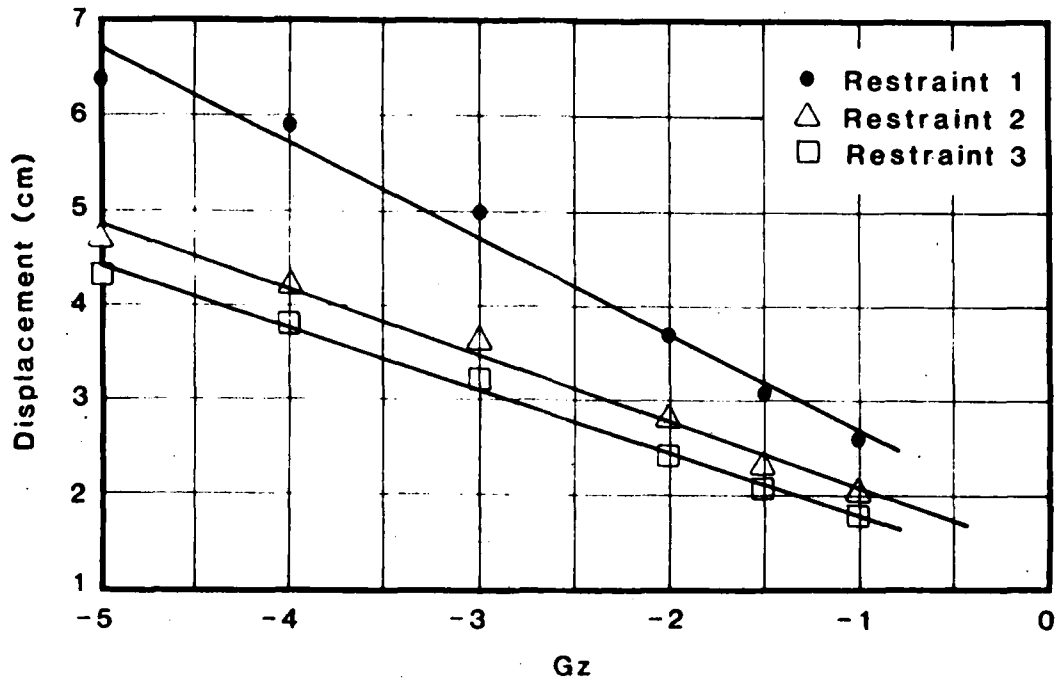

Figure 14. 95th Percentile Manikin Displacement Data

Examination of the data in Table X reveals that the mean displacements measured during -1 Gz rollovers were in most cases nearly identical to those measured during the -1 Gz rotational tests. The initial assumption that seat back friction during the rotational runs (due to Earth gravity acting on the subject) would have a minimal effect on displacement is therefore further validated.

It is immediately apparent from the manikin data that off-seat displacement tended to increase as the G exposure increased. Further, data for both manikins shows that restraint system 3 allowed the least amount of displacement at all levels of negative Gz acceleration. An ANOVA and Neuman Keuls Multiple Comparison analysis of the data confirmed that the observed difference is actually significant at a confidence level of 90%. For the 5th percentile manikin, restraint 3 demonstrated decreases in displacement ranging from 19% at -1 Gz to 5% at -5 Gz

compared to restraint system 1 during the rotations. Displacement reduction for the 95th percentile manikin more closely resembled that for the human subjects, remaining between 31% and 36% for all rotation conditions. For the -1 Gz rollovers, restraint 3 demonstrated a decrease in displacement amounting to 5% and 26% for the 5th and 95th percentile manikins respectively. For the 5th percentile manikin restraints 1 and 2 performed almost identically; in the case of the 95th percentile manikin, restraint 2 allowed significantly less displacement than did restraint 1.

It is clear that the two sizes of manikins provided data that varied considerably in several aspects. Specifically, the 5th percentile manikin data for all three restraints track very closely (i.e. best fit lines remain parallel) over the entire range of exposures. In contrast, displacement data for the 95th percentile manikin diverges as the G level increases, particularly for restraint 1. Another difference is the relative performance of restraints 1 and 2 already mentioned. A Newman Keuls Multiple Comparison revealed that the difference in mean values observed for restraints 1 and 2 on the 5th percentile manikin were not significant at the 90% confidence level. The same procedure showed that the performance of restraints 1 and 2 on the 95th percentile manikin did differ significantly.

Despite the differences, the data for both manikins is roughly similar in terms of slope and amplitude of displacement. Figure 15 shows data derived by taking the mean of the 5th and 95th percentile manikin data for each restraint configuration under the rotational test conditions. Also plotted is the mean human subject data for -1, -1.5, and -2 Gz. Note that the -1 Gz human data is that measured during the rollover sequence, since no -1 Gz rotations were conducted with the

humans. It is apparent that, although the manikin data does not exactly match the human data, it is at least similar in form. This is encouraging in terms of any conclusions that might be made based on the manikin data.

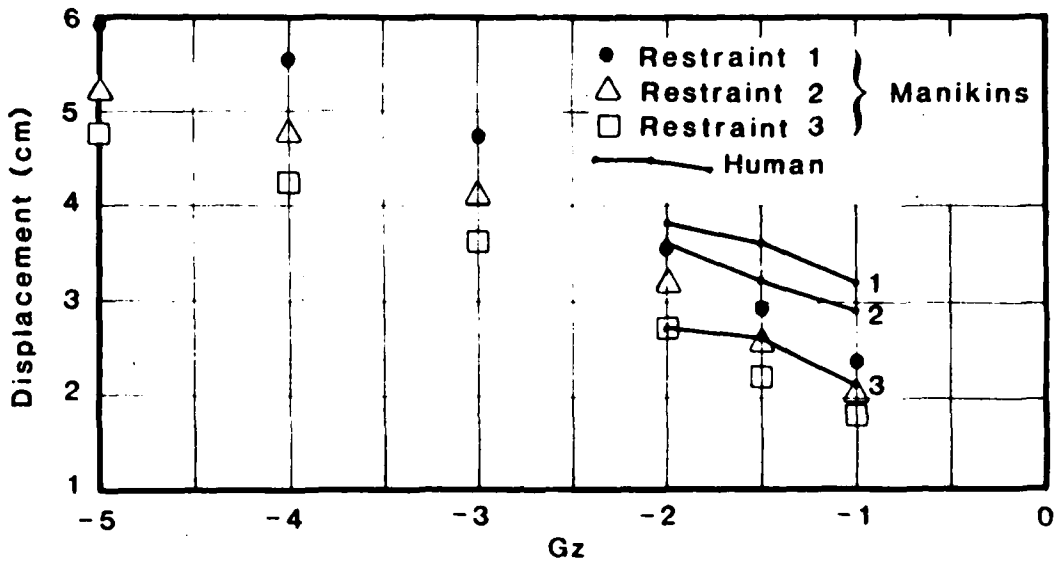

Figure 15. Means of 5th and 95th Percentile Manikin Displacement Data, and Mean Human Displacements

Summary

Human subject and manikin data were discussed at some length. Rather than summarize the important results here, they are listed as part of the conclusions and recommendations in the following chapter.

VII. Conclusions and Recommendations

Review

As stated in Chapter I, the primary goal of this investigation was to design and test modifications to the existing ACES II restraint system which would provide improved crewmember restraint under negative Gz conditions. The intent has been to provide specific recommendations to ASD/AES for modification of the existing system.

Restraint, for the purposes of this study, has been defined as the degree to which the subject (or manikin) and seat act together as a single object under an applied negative Gz acceleration vector. The primary measurement of restraint was off-seat displacement, measured directly by a spring-loaded transducer mechanism.

Conclusions

On the basis of the results obtained for seven human subjects, one 5th percentile, and one 95th percentile manikin, the following conclusions are drawn:

1. The addition of a single tiedown strap to the existing ACES II restraint system provides a significant improvement in crewmember restraint compared to the system as it is now used. The improvement amounts to approximately 30 percent as measured by off-seat displacement of the human test subjects.
2. Locking the shoulder straps of the existing ACES II configuration results in a slight improvement over the unlocked mode normally used by crewmembers. Resultant shoulder loads average only about four kilograms at G levels up to 2.0 Gz, and are not

considered uncomfortable by most subjects.

3. Test subjects feel restraint system 3 (incorporating the tiedown strap) to be preferable to the existing system in terms of comfort during negative Gz exposure.

4. With both 5th and 95th percentile manikins the addition of a tiedown strap reduced off-seat displacement significantly at all Gz levels tested (-1 Gz to -5 Gz).

5. The manikin results cannot be used to directly predict human performance at levels above human tolerance. Manikin data does, however, resemble the human subject data in general form and magnitude, providing confidence that the relative performance of the restraint systems at the higher G levels can be deduced from the manikin results.

6. Tracking scores and ejection delays could not be correlated to restraint system. In the case of the tracking task, complete training of the subjects was not achieved before conducting tests at negative Gz. Ejection delay data was biased due to unequal delays before the prompt at different G levels.

7. Restraint 2 did not provide significantly better restraint for the 5th percentile manikin than did restraint 1. This indicates that the locked shoulder straps did not provide any added restraint. This result is anomalous, in that lap belt data for these conditions implies that the shoulder straps did provide some support.

Examination of the data for the smaller human subjects shows that

restraint 2 apparently did provide them improved restraint compared to restraint 1. The possibility remains that, in the locked mode, the present configuration allows too much shoulder strap slack for very small crewmembers. This seems particularly likely in light of comments made by several subjects that there was too much slack in the shoulder straps.

Recommendations

Based on observations made during this investigation, the following recommendations are proposed for consideration:

1. Incorporate a single tiedown strap into the existing ACES II restraint system to improve restraint under negative Gz conditions.
2. Although the results of tracking and ejection tasks were inconclusive, the original rationale for these measurements remains, and future efforts of this type should include these measurements. More extensive subject training (to an asymptotic performance level) for the tracking task, and better control of the ejection task initiation could well result in data that correlates to restraint configuration. Such a correlation would provide two indications of restraint effectiveness in addition to off-seat displacement.
3. The Displacement Transducer Assembly (DTA) provided data of excellent quality throughout the study. As a method of providing direct off-seat displacement measurements it should be used in any future studies of this nature.
4. In this study, no attempt was made to simulate the presence of a

canopy over the subject. Canopy contact is frequent in operational situations, and presents a definite hazard during emergencies. Physical simulation of the canopy should be possible, even with the safety considerations necessary for experimentation with human subjects, and should be attempted in future efforts. Of particular interest would be the amount of canopy contact observed for various restraints, and its affect on tracking and ejection tasks.

5. The advisability of modifying the present restraint system to reduce the amount of shoulder strap slack when in the locked mode should be investigated.

6. This study investigated the performance of a single tiedown strap. A similar study of an inverted-V tiedown configuration should be conducted.

7. Only the case of simple Gz acceleration was addressed by this study. For a more complete understanding of restraint in the operational environment, this investigation should be extended to cover combined Gx, Gy, and Gz acceleration conditions.

Bibliography

1. USAF Class A Flight Mishap Report, F-15A No. 78-0046, 388 Tactical Fighter Wing, Hill AFB, Utah, 5 August 1981.
2. USAF Class A Flight Mishap Report, F-16A No. 79-0316, 388 Tactical Fighter Wing, Hill AFB, Utah, 10 April 1981.
3. Gillingham, K.K., MD. "G Stress on A-10 Pilots During JAWS II Exercises," Aviation Space and Environmental Medicine, 53:336-341 (April 1982).
4. Gillingham, K.K., MD. Telephone discussion of recent unpublished studies of F-15 and F-16 pilot stress. USAF School of Aerospace Medicine, Brooks AFB, Texas, 3 May 1982.
5. Fessenden, E. Acceleration Effects on the Ability to Activate Emergency Devices in F-4 Aircraft. ADC-77105-40. Warminster, Pa.: Crew Systems Department, Naval Air Development Center, 11 July 1977. (AD A042 281)
6. Hecht, K.F. Downward Crew Ejection Seat Tests from the B-47B Airplane. WADC Technical Report 53-443. Wright-Patterson AFB, Ohio; Wright Air Development Center, November 1953.
7. Guthrie, M.A. Effects of Gz and Gy Acceleration on Head and Helmet Displacement. MS Thesis. Wright State University, Dayton, Ohio 1982.
8. Bason, R. and J. Etheredge. Aircrew Personnel Restraint Subsystems Definition of Deficiencies and Requirements. NATC-SY-28R-78. Naval Air Station, Patuxent River, Ma.: Naval Air Test Center, 24 August 1978 (AD A058 995)
9. Lorch, D., Engineer. Telephone discussion of current negative Gz restraint work being done for the USN advanced ejection seat (MPES) project. Naval Air Development Center, Warminster, Pa., 7 April 1982.
10. "ACES II Improved Restraint System Development." Memorandum of Agreement between AFAMRL and ASD/AES, 21 August 1981.
11. Zenobi, T.J. MPES Negative G Restraint Strap Design Options. NADC-80232-60. Warminster, Pa.: Aircraft and Crew System Technology Directorate, Naval Air Development Center, February 1981. (AD A098 030)
12. Dynamic Environment Simulator (DES) User's Guide. Raytheon Service Company, Burlington, Mass., 1 April 1981.

13. Shope, Berry, Engineer. Telephone conversation. Naval Air Test Center, Aircrew Systems Branch, Survival Section, Naval Air Station, Patuxent River, Ma., 26 July 1982.
14. Kennealy, J.A, J.S. Kirkland, and R.E. Sneider, "Bradycardia Induced by Negative Acceleration," Aviation, Space, and Environmental Medicine. May 1976.
15. Environmental Biology. (AMLR-TR-66-194), November 1966.
16. Sharp, G.R. and J. Ernsting. "The Effects of Long Duration Acceleration," in Aviation Medicine. Edited by Air Marshal Sir Geoffrey Dhenin. London: Tri-Med Books, Ltd., 1981.
17. Miller, R.G., Jr. Simultaneous Statistical Inference. New York: McGraw-Hill Book Co., 1966.

APPENDIX A Acceleration Vectors

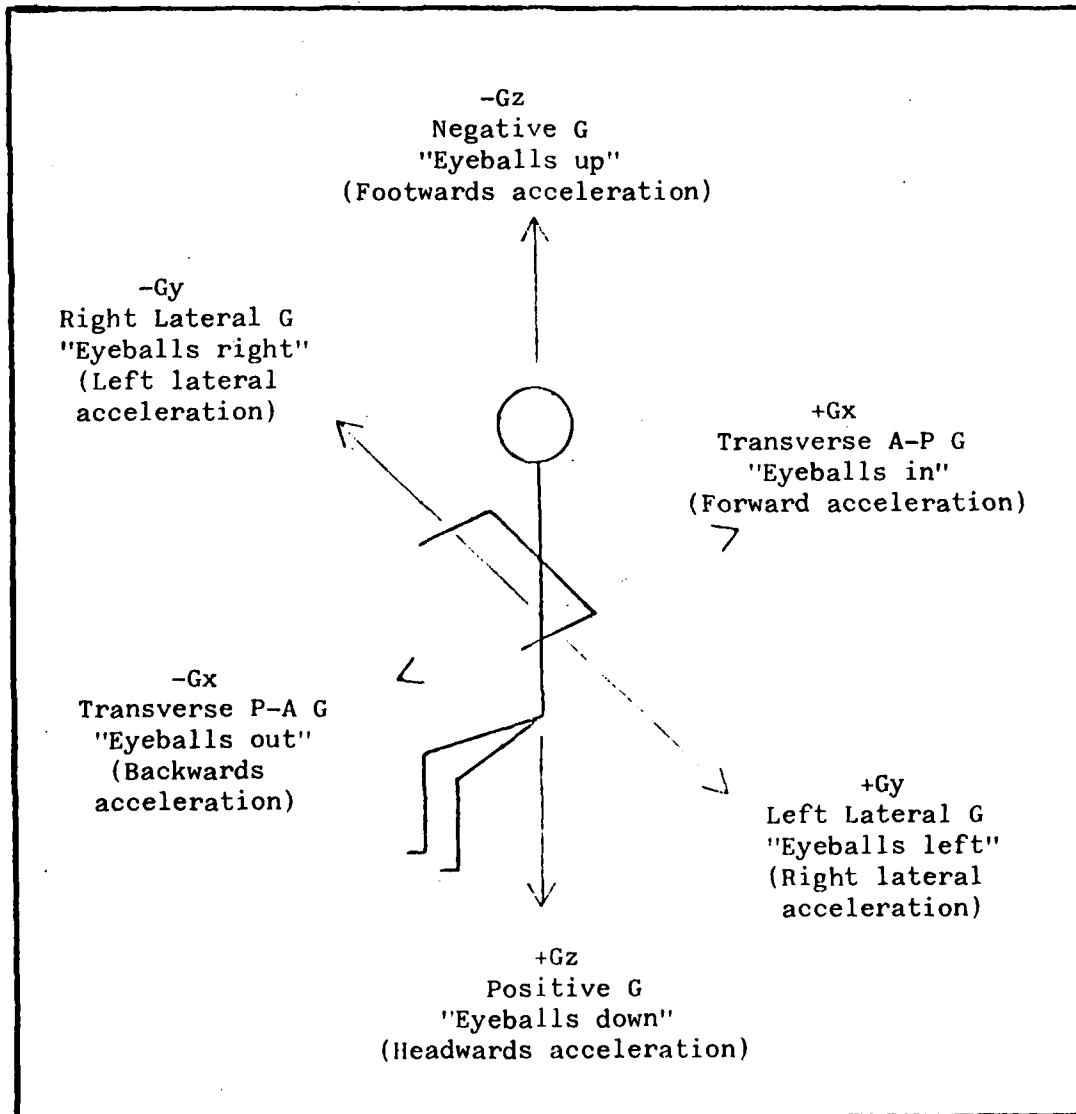

Figure 16. Diagram illustrating standard terminology for describing the direction of acceleration and inertial forces. The vector arrows indicate the direction of the resultant inertial forces (Ref 16:217).

Summarized Responses to Pilot Questionnaire

By question number:

1. 5 respondents were Captains, 4 were Majors.
2. All respondents were members of the 422 Test and Evaluation Squadron (AF Fighter Weapons School), Nellis AFB.
3. 3 pilots from each aircraft using the ACES II seat (A-10, F-15, and F-16) were selected as respondents.
4. Hours varied from 182 to 1000, with a mean of 656.
5. Unlocked in all cases.
6. Comfort, accessibility, visibility were all consistently mentioned.
7. N/A
8. Tight in all cases. Many mentioned that they tighten it as tight as they can get it.
9. Responses varied:

A-10: Less than 10 percent (1 response)
 Less than 5 percent (1 response)
 "infrequently" (1 response)

F-15: 30 seconds/flight (1)
 2-3 times/hour (1)
 "infrequently" (1)

F-16: less than 1/hour (2)
 1 per hour (1)

10.	<u>Yes</u>	<u>No</u>	
	0	3	A-10
	1	2	F-15
	0	3	F-16

11. The one yes respondent had previous experience in the F-4, and felt it's restraint was better than ACES II. Complained specifically of hitting canopy under -Gz.

12.	<u>Yes</u>	<u>No</u>	
	2	1	A-10
	2	1	F-15
	3	0	F-16

13. Man-seat separation under -Gz:

none	(2 respondents)
1/2"	(1)
3/4"	(1)
1"	(1)
1 to 2"	(1)
2 to 3"	(1)
3"	(1)
3 to 4"	(1)

14. Yes No

0	3	A-10
2	1	F-15
2	1	F-16

15. All responded that lack of leg restraint is not a problem.

16. 4 pilots responded that the straps sometimes lock under negative Gz conditions. 5 answered no.

17. 3 pilots made suggestions:

- the new Frost fitting on the lap belt is harder to use than the older Koch fitting - can't tighten lap belt as tightly.
- shoulder straps are too long - the amount left over has to be stuffed somewhere.
- study the "Thunderbird modification."

APPENDIX C Instrumentation Details

Displacement Transducer Assembly

Transducer: Research Incorporated
Box 24064
Minneapolis, Minn. 55424

Model 7100-8, Linear 1K ohm potentiometer,
20 cm (8 inch) maximum displacement

Strap Strain Links

Strain Gages: Micro-Measurements
Romulus, Michigan

Model CEA-06-125UT-350
350 ohm resistance, + or - .4%
gage factor = 2.08 + or - 1% at 75 deg. F.
gage length 1.57 mm
total length 2.90 mm
Gage width 1.57 mm

One of these double gages was bonded to each side of each link in the bridge configuration pictured in Figure C-1.

The links themselves were machined from 6061-T6 Aluminum to the form shown in Figure C-2. Some filing at the attachment ends of the lap belt links was subsequently necessary to ensure easy extraction of the links from the seat hardware during emergency ground egress.

Seat Force Load Cells

Load Cells: Strainsert
Union Hill Industrial Park
West Conahohocken, Pa. 19428

Model FLO25U-2SPKT
114 Kg (250 lb) capacity
2-mV/V, 350 ohms
non-linearity approx .05%

Load cells were of the strain-gage type, with the gages wired in the same configuration as that in Figure C-1.

Chest Accelerometer

Accelerometer: Statham Laboratories

Model F-6-340, + or - 6 G range
Strain-gage type

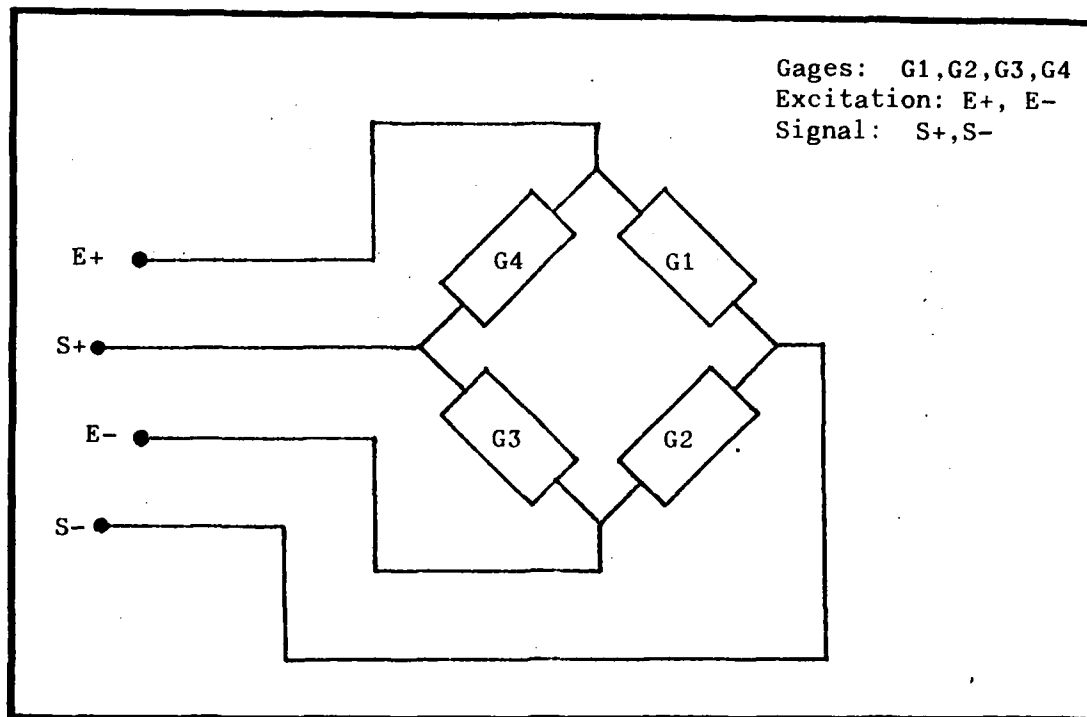

Figure 17. Strain Gage Bridge Configuration

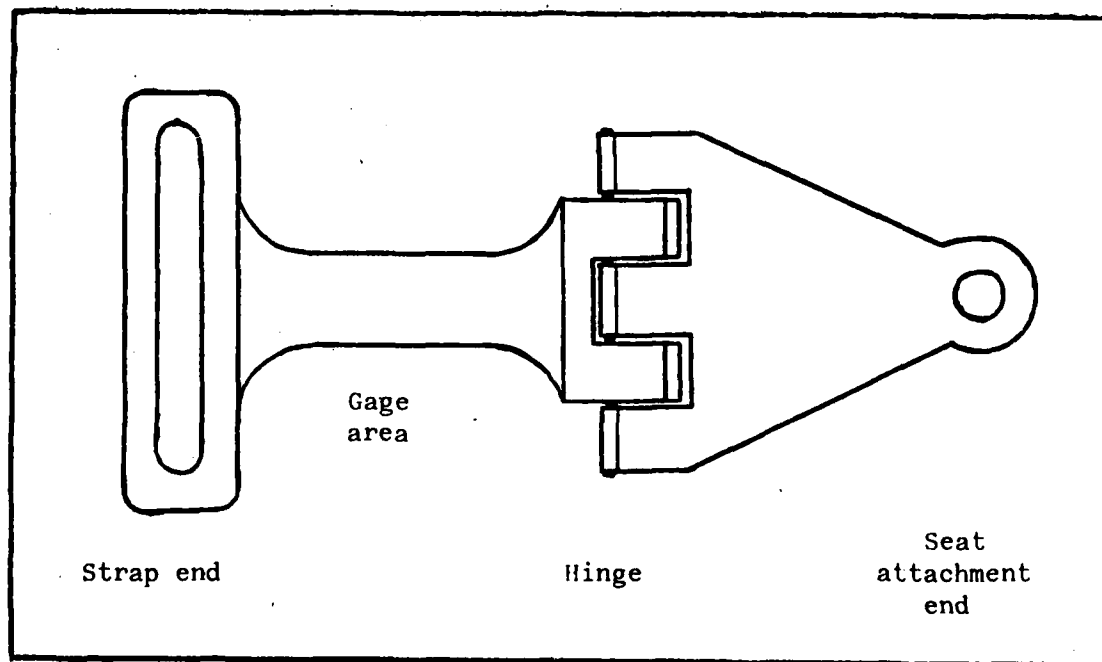

Figure 18. Lap Belt and Tiedown Strap Strain Link

APPENDIX D Human Subject Primary Data

The primary data for each human subject is listed on the following pages. Primary data includes maximum off-seat displacement, tracking score prior to the ejection prompt, and ejection delay (measured from stick release to ejection handle activation).

Data for the -1 Gz rollovers is listed first, one page for each subject (except subject six who participated in an extra series of runs with restraint 3). Data for the -1.5 and -2.0 Gz rotation test is then listed, also one page per subject.

In some cases the symbol "-" takes the place of a data value. In these cases the data value was not successfully measured. Reasons for missing data points include software and hardware malfunctions, and subject error.

Rollovers
 Subject # 1
 24 AUG 82

Run #	Dir.	Restraint System	Max. Disp. (cm)	Tracking Score	Eject Delay (secs)
1	Left	1	1.33	-	0.60
2	Fwd	1	1.76	-	0.68
3	Right	1	0.96	-	0.60
4	Right	2	1.10	-	0.56
5	Right	2	0.94	-	0.36
6	Left	2	0.85	-	0.48
7	Left	3	0.48	-	0.56
8	Right	3	0.29	-	0.52
9	Fwd	3	0.10	-	0.40

Static scores:	-	0.56
	-	0.64
	-	0.32
	-	-
	-	0.44

NOTE: Restraint # 1: unmodified, unlocked
 # 2: unmodified, locked
 # 3: tiedown, unlocked

Rollovers
Subject # 2
31 AUG 82

Run #	Dir.	Restraint System	Max. Disp. (cm)	Tracking Score	Eject Delay (secs)
1	Left	3	1.56	170	0.52
2	Fwd	3	1.92	101	0.60
3	Right	3	1.63	172	0.48
4	Fwd	2	3.16	110	0.48
5	Left	2	2.88	157	0.60
6	Right	2	2.31	151	0.44
7	Right	1	2.54	140	0.40
8	Left	1	2.70	110	0.44
9	Fwd	1	2.81	43	0.36

Static scores:

44	0.68
56	0.48
50	-
41	0.48
36	0.48

NOTE: Restraint # 1: unmodified, unlocked
2: unmodified, locked
3: tiedown, unlocked

Rollovers
Subject # 3
26 AUG 82

Run #	Dir.	Restraint System	Max. Disp. (cm)	Tracking Score	Eject Delay (secs)
1	Right	1	2.97	198	0.64
2	Left	1	3.18	85	0.68
3	Fwd	1	2.71	172	-
4	Right	3	1.29	150	0.56
5	Fwd	3	1.48	103	0.60
6	Left	3	1.52	172	0.72
7	Fwd	2	2.53	102	0.44
8	Right	2	2.14	119	-
9	Left	2	1.94	222	-

Static scores:	333	0.88
	293	-
	227	0.64
	156	-
	121	-

NOTE: Restraint # 1: unmodified, unlocked
2: unmodified, locked
3: tiedown, unlocked

Rollovers
Subject # 4
26 AUG 82

Run #	Dir.	Restraint System	Max. Disp. (cm)	Tracking Score	Eject Delay (secs)
1	Fwd	2	2.06	270	1.24
2	Right	2	1.78	147	0.96
3	Left	2	2.07	238	0.84
4	Right	3	1.79	110	0.84
5	Fwd	3	1.99	101	0.72
6	Left	3	1.92	205	0.72
7	Right	1	2.42	101	0.72
8	Left	1	2.72	134	0.84
9	Fwd	1	2.87	425	0.64

Static scores:

	97	0.80
	104	0.56
	74	0.84
	79	0.64
	99	0.64

NOTE: Restraint # 1: unmodified, unlocked
2: unmodified, locked
3: tiedown, unlocked

Rollovers
Subject # 5
28 SEP 82

Run #	Dir.	Restraint System	Max. Disp. (cm)	Tracking Score	Eject Delay (secs)
1	Left	3	2.13	160	0.52
2	Fwd	3	3.06	212	0.60
3	Right	3	3.06	-	0.12
4	Left	1	4.49	285	0.44
5	Right	1	4.54	234	0.44
6	Fwd	1	4.79	206	0.36
7	Fwd	2	4.38	189	0.48
8	Left	2	4.19	185	0.36
9	Right	2	4.15	184	0.44
10	Fwd	3	3.00	139	0.40
Static scores:				206	0.56
				104	-
				108	0.56
				87	0.52
				59	0.44

NOTE: Restraint # 1: unmodified, unlocked
2: unmodified, locked
3: tiedown, unlocked

Rollovers
Subject # 6
1 SEP 82

Run #	Dir.	Restraint System	Max. Disp. (cm)	Tracking Score	Eject Delay (secs)
1	Fwd	3	2.96	638	0.44
2	Right	3	2.81	579	0.44
3	Left	3	3.01	611	0.36
4	Left	3	3.09	569	0.36
5	Fwd	3	2.77	607	0.36
6	Right	3	2.67	362	0.44

Static scores:	137	0.44
	143	0.40
	177	0.28
	307	0.28
	263	0.32

NOTE: Restraint # 1: unmodified, unlocked
2: unmodified, locked
3: tiedown, unlocked

Rollovers
Subject # 6
9 SEP 82

Run #	Dir.	Restraint System	Max. Disp. (cm)	Tracking Score	Eject Delay (secs)
1	Left	2	3.76	394	0.36
2	Right	2	4.10	469	0.44
3	Fwd	2	4.22	456	0.28
4	Fwd	1	4.85	676	0.24
5	Right	1	4.51	611	0.16
6	Left	1	4.57	271	0.28
7	Left	3	2.61	697	0.28
8	Fwd	3	2.63	655	0.36
9	Right	3	2.70	706	0.36

Static scores:	266	1.08
	136	0.36
	252	0.32
	195	0.16
	118	0.32

NOTE: Restraint # 1: unmodified, unlocked
2: unmodified, locked
3: tiedown, unlocked

Rollovers
Subject # 7
14 SEP 82

Run #	Dir.	Restraint System	Max. Disp. (cm)	Tracking Score	Eject Delay (secs)
1	Left	1	2.69	717	0.80
2	Fwd	1	3.95	705	0.72
3	Right	1	4.06	670	0.60
4	Right	2	3.85	402	0.68
5	Fwd	2	3.97	520	1.08
6	Left	2	4.05	624	0.68
7	Left	3	2.36	516	0.76
8	Right	3	2.58	600	0.72
9	Fwd	3	2.59	593	1.56

Static scores:	304	0.72
	336	0.84
	445	0.36
	613	0.72
	642	0.88

NOTE: Restraint # 1: unmodified, unlocked
 # 2: unmodified, locked
 # 3: tiedown, unlocked

Rotations
Subject # 1
3 SEP 82

Run #	G-level	Restraint System	Max. Disp. (cm)	Tracking Score	Eject Delay (secs)
1	-2.0	2	1.91	153	0.36
2	-1.5	2	2.22	47	0.48
3	-1.5	1	2.44	39	0.56
4	-2.0	1	2.90	111	0.64
5	-1.5	3	1.44	37	0.56
6	-2.0	3	1.86	79	0.56

Static scores:	85	0.56
	107	0.48
	113	0.44
	56	0.44
	172	0.36

NOTE: Restraint # 1: unmodified, unlocked
 # 2: unmodified, locked
 # 3: tiedown, unlocked

Rotations
Subject # 2
25 AUG 82

Run #	G-level	Restraint System	Max. Disp. (cm)	Tracking Score	Eject Delay (secs)
1	-2.0	3	0.92	170	-
2	-1.5	3	0.74	109	-
3	-2.0	1	1.59	110	-
4	-1.5	1	1.50	94	-
5	-1.5	2	1.44	70	-
6	-1.5	2	1.57	81	-
7	-2.0	2	1.80	102	-

Static scores:

103 -
65 -
54 -
37 -
36 -

NOTE: Restraint # 1: unmodified, unlocked
2: unmodified, locked
3: tiedown, unlocked

Rotations
Subject # 3
1 SEP 82

Run #	G-level	Restraint System	Max. Disp. (cm)	Tracking Score	Eject Delay (secs)
1	-2.0	2	4.13	109	0.60
2	-1.5	2	3.43	90	0.48
3	-1.5	3	2.84	71	0.48
4	-2.0	3	2.61	78	0.40
5	-2.0	1	3.58	112	0.36
6	-1.5	1	3.60	97	0.64

Static scores:	167	-
	129	-
	77	0.48
	118	-
	92	0.52

NOTE: Restraint # 1: unmodified, unlocked
2: unmodified, locked
3: tiedown, unlocked

Rotations
Subject # 4
9 SEP 82

Run #	G-level	Restraint System	Max. Disp. (cm)	Tracking Score	Eject Delay (secs)
1	-1.5	1	3.81	169	0.80
2	-2.0	1	4.15	66	0.24
3	-2.0	2	4.05	69	0.20
4	-1.5	2	3.86	85	0.76
5	-1.5	3	2.54	82	0.68
6	-2.0	3	3.18	144	0.24

Static scores:

73	0.80
71	0.64
48	0.64
48	0.72
60	0.88

NOTE: Restraint # 1: unmodified, unlocked
 # 2: unmodified, locked
 # 3: tiedown, unlocked

Rotations
Subject # 5
31 AUG 82

Run #	G-level	Restraint System	Max. Disp. (cm)	Tracking Score	Eject Delay (secs)
1	-1.5	1	3.96	103	1.24
2	-2.0	1	4.24	181	0.64
3	-1.5	3	2.50	429	0.16
4	-2.0	3	2.71	114	0.28
5	-2.0	2	3.98	184	0.16
6	-1.5	2	3.71	304	0.08

Static scores:

	129	-
	100	0.68
	101	0.60
	114	0.48
	40	0.48

NOTE: Restraint # 1: unmodified, unlocked
2: unmodified, locked
3: tiedown, unlocked

Rotations
 Subject # 6
 31 AUG 82

Run #	G-level	Restraint System	Max. Disp. (cm)	Tracking Score	Eject Delay (secs)
1	-2.0	3	3.81	399	0.56
2	-1.5	3	4.24	575	0.48
3	-1.5	2	4.15	324	0.84
4	-2.0	2	4.56	447	0.40
5	-1.5	1	4.34	139	0.48
6	-2.0	1	4.56	357	0.36

Static scores:	
681	1.68
390	-
594	-
428	-
428	0.60
360	0.48
189	0.96

NOTE: Restraint # 1: unmodified, unlocked
 # 2: unmodified, locked
 # 3: tiedown, unlocked

Rotations
Subject # 7
23 SEP 82

Run #	G-level	Restraint System	Max. Disp. (cm)	Tracking Score	Eject Delay (secs)
1	-2.0	2	4.98	595	0.64
2	-1.5	2	5.06	321	0.68
3	-1.5	1	5.28	294	0.72
4	-2.0	1	5.66	607	0.64
5	-1.5	3	3.60	525	0.76
6	-2.0	3	4.03	705	0.64

Static scores:

365 -
238 -
430 -
406 -
182 -

NOTE: Restraint # 1: unmodified, unlocked
2: unmodified, locked
3: tiedown, unlocked

APPENDIX E Post-run Questionnaire and Summarized Responses

A questionnaire was given to each subject following each day of testing. The questionnaire given after the rollover sequence was slightly different than that given following the rotation sequence. A copy of each questionnaire is included here.

Following the questionnaires themselves is a summary of responses. This summary was condensed from the seven post-rollover and six post-rotation questionnaires received back from the subjects. The post-rollover and post-rotation questionnaires are summarized separately, and in that order.

Post-rollover Questionnaire

Subject _____ Date _____

Note: Please refer to specific restraint systems by name or number:

- 1 - unmodified ACES II, unlocked
- 2 - unmodified ACES II, locked
- 3 - ACES II, unlocked, with tiedown strap

1. Which rotation direction (right, left, forward) do you regard as the most severe in terms of upper body movement?

2. Did direction of rotation affect your ability to keep your feet positioned on the rudder pedals?

If yes, which direction presented the most difficulty in this regard?

3. In general, do you feel that your body movement during the rollovers caused significant unintentional input to the rudder controls?

to the control stick?

to the throttle?

4. Do you feel that the -1 Gz exposure made the ejection task more difficult (i.e. slower) than at +1 Gz?

5. Did restraint configuration (as opposed to direction of rotation) have a significant effect on your ability to perform the tracking and/or ejection task?

If yes, which restraint was best?

worst?

6. Did restraint configuration affect your ability to keep your feet on the rudder pedals?

If yes, which restraint was best?

worst?

7. With restraint number 2 (inertial reels locked), did the shoulder straps support any of your body weight during the -Gz exposure?

If yes, was the condition uncomfortable?

8. Did you experience "psychological discomfort" (e.g. disorientation, fear of falling, etc.) during the -Gz exposure?

If yes, do you think it (as opposed to physical displacement) contributed to tracking errors and/or ejection delay?

9. Describe any sources of physical discomfort (pressure points, binding, etc.) you noticed during the test sequence. Please specify restraint configuration and test condition (direction of rotation) if possible.
10. Describe any physical sensations you experienced during -Gz exposure (vertigo, headache, other pain, etc.).
11. Estimate your tolerance to -Gz exposure (for example, in terms of tolerable exposure time to -2 Gz), and describe what you feel might be limiting factors to -Gz tolerance.
12. Briefly compare your exposure at this level to those you experienced at -1.5 and -2.0 Gz (if applicable).
13. Describe any suggestions you might have for an improved -Gz restraint system.
14. Estimate the maximum distance your buttocks lifted off the seat during this series of runs:

Post-rotation Questionnaire

Subject _____ Date _____

Note: Please refer to specific restraint systems by name or number:

- 1 - unmodified ACES II, unlocked
- 2 - unmodified ACES II, locked
- 3 - ACES II, unlocked, with tiedown strap.

1. In general, between the exposure levels of -1.5 and -2.0 Gz, did you notice:
 - A significant difference in off-seat displacement?
 - A difference in ability to keep your feet on the rudder pedals?
 - A difference in ability to perform the tracking and/or ejection task?
2. Did restraint configuration have a significant effect on your ability to perform the tracking task and/or ejection task?
 - If yes, which restraint was best in this respect?
worst?
3. Did restraint configuration affect your ability to keep your feet on the rudder pedals?
 - If yes, which restraint was best?
worst?
4. With restraint number 2 (inertial reels unlocked), did the shoulder straps support any of your weight during the -Gz exposure?
 - If yes, was the condition uncomfortable?
5. Did you experience "psychological discomfort" (e.g. disorientation, fear of falling, etc.) during the -Gz exposure?
 - If yes, do you think it (as opposed to physical displacement) contributed to tracking errors and/or ejection delay?
6. Describe any sources of physical discomfort (pressure points, binding, etc.) you noticed during the test sequence. Please specify restraint configuration, and G level if possible.
7. Describe any physical sensations you experienced during -Gz exposure (vertigo, headache, other pain, etc.).

8. Estimate your tolerance to -Gz exposure (for example, in terms of tolerable exposure time at -2 Gz), and describe what you feel might be limiting factors to -Gz tolerance.
9. Briefly compare your exposure at these levels to those you experienced at -1 Gz (if applicable).
10. Describe any suggestions you might have for an improved -Gz restraint system.
11. Estimate the maximum distance your buttocks lifted off the seat during -1.5 Gz exposure:
-2.0 Gz exposure:

Summarized Responses to Post-rollover Questionnaire

NOTE: This is a summary of 7 completed questionnaires; numbers in the summary indicate the number of responses of each type.

By question number:

1. Right: 3
Left: 3
Forward: 3

2. Yes: 4 No: 3

For those answering "yes": Right: 2
Left: 2
Forward: 2

3.	Yes	No
Rudder	3	4
Control Stick	5	2
Throttle	6	1

4. Yes: 1 No: 6

5. Yes: 4 No: 3

For those answering "yes":

Best restraint: 0 answered restraint 1
2 answered restraint 2
2 answered restraint 3

Worst restraint: 2 answered restraint 1
0 answered restraint 2
1 answered restraint 3

6. Yes: 3 No: 3

For those answering "yes":

Best restraint: 0 answered restraint 1
1 answered restraint 2
3 answered restraint 3

Worst restraint: 2 answered restraint 1
0 answered restraint 2
1 answered restraint 3

7. Yes: 5 No: 0 "Not much": 2

For those answering "yes":

1 responded yes, it was uncomfortable
5 responded no, it was not uncomfortable

8. Yes: 1 No: 6

9. Sources of discomfort:

harness clips press into pelvis, all 3 restraints: 1
lap belt pressure, all 3 restraints: 1
lap belt pressure, restraints 1 and 2: 1
lap belt pressure, restraint 1: 2
shoulder straps: 1

10. None: 5

Slight vertigo at start of left and right rolls: 1

11. Tolerance estimates for -1 Gz ranged from 20 seconds to 10 to 15 minutes.

12. Lap belt pressure less severe: 1

13. Suggestions for improved negative Gz restraint:

incorporate tiedown: 2
spread support somehow: 2
widen shoulder straps: 1
add stirrups to rudder pedals: 1

14. Estimated maximum off-seat displacement:

2.5 cm: 2
5-7.5 cm: 1
6.5 cm: 1
10 cm: 1
15 cm: 1
20 cm: 1

Summarized Responses to Post-rotation Questionnaire

NOTE: This is a summary of 6 completed questionnaires; numbers indicate the number of responses of each type.

By question number:

	Yes	No
1. Off-seat displacement	3	3
Rudder pedals	2	4
Tracking/ejection	4	2

2. Yes: 2 No: 4

For those answering "yes":

Best restraint: 0 answered restraint 1
0 answered restraint 2
2 answered restraint 3

Worst restraint: 2 answered restraint 1
0 answered restraint 2
0 answered restraint 3

3. Yes: 1 No: 5

"Yes" response: Restraint 3 best
Restraint 1 worst

4. Yes: 2 No: 3

For those answering "yes", both said the condition was not uncomfortable.

5. Yes: 0 No: 5

6. Sources of discomfort:

harness clips pressed into legs: 3 responses
lap belt pressure, restraints 1 and/or 2: 1 response
tiedown strap uncomfortable: 1 response

7. Physical sensations:

none: 1 response
pressure in head and sinuses: 2 responses
headache during exposure: 2 responses
"eyes felt like they were going to pop": 1 response
face flushed: 1 response
difficulty keeping eyes focused: 1 response

8. Tolerance estimates for -1.5 Gz were 20 to 30 seconds.
Tolerance estimates for -2 Gz were from 10 to 70 seconds.
9. -1.5 and -2 Gz exposure was judged much more severe than -1 Gz exposure in terms of head pressure and lap belt pressure.
10. Suggestions for improved negative Gz restraint:

none: 1
let shoulder straps be tightened more tightly: 2
pad or widen lap belt: 2
incorporate tiedown: 1

11. Estimated maximum off-seat displacement:

-1.5 Gz		-2 Gz	
2 cm:	1 response	2.5 cm:	1 response
2.5 cm:	1 response	3.2 cm:	1 response
3.7-5 cm:	1 response	3.7-5 cm:	1 response
5 cm:	1 response	7.5 cm:	2 responses
7.5 cm:	1 response	15 cm:	1 response
15 cm:	1 response		

Vita

PII Redacted

David G. Leupp [REDACTED]

In

1972 he graduated from high school in Honolulu, Hawaii, then attended the United States Air Force Academy from which he received the degree of Bachelor of Science, Electrical Engineering in June 1976. Upon graduation he was assigned as Officer-in-Charge, Instrumentation Section, 6511th Parachute Test Squadron, at El Centro, California. In 1978 he joined the Technical Engineering Branch of the 351st Strategic Missile Wing at Whiteman AFB, Missouri, where he served until entering the School of Engineering, Air Force Institute of Technology, in June 1981.

PII Redacted [REDACTED]

PII Redacted [REDACTED]

Unclassified

SECURITY CLASSIFICATION OF THIS PAGE(When Data Entered)

20. Average off-seat displacement for the human subjects using the unmodified restraint with shoulder straps unlocked was 3.2, 3.6, and 3.8 centimeters at -1, -1.5, and -2 Gz respectively. With the tiedown strap these figures were reduced to 2.1, 2.6, and 2.7 cm. Corresponding displacements with the unmodified restraint and locked shoulder straps were 2.9, 3.2, and 3.6 cm. Manikin data was consistent with that of the human subjects, indicating that the tiedown strap provided improved restraint at all levels up to -5 Gz. Tracking and ejection task scores could not be correlated to restraint system.

Unclassified

SECURITY CLASSIFICATION OF THIS PAGE(When Data Entered)