

AD-A123 915

AIR DEMAND AND VIBRATION MEASUREMENTS WYNOOCHEE DAM  
WYNOOCHEE RIVER WASHINGTON(U) ARMY ENGINEER WATERWAYS  
EXPERIMENT STATION VICKSBURG MS HYDRA... E D HART

1/1

UNCLASSIFIED

DEC 82 WES/TR/HL-82-2

F/G 13/13

NL

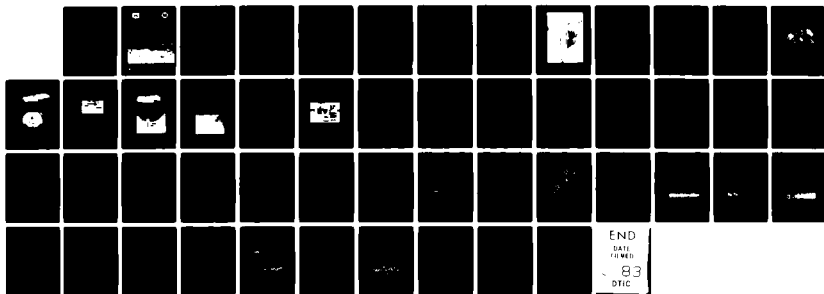

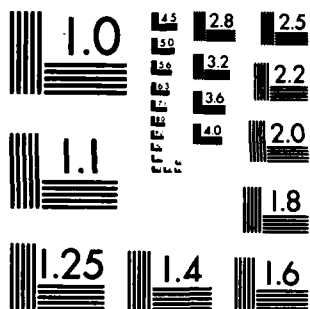

MICROCOPY RESOLUTION TEST CHART  
NATIONAL BUREAU OF STANDARDS-1963-A

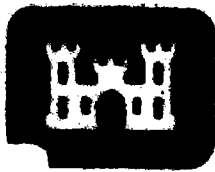

12



MISCELLANEOUS PAPER HL-82-2

ADA 123915

# AIR DEMAND AND VIBRATION MEASUREMENTS, WYNOOCHEE DAM WYNOOCHEE RIVER, WASHINGTON

by

E. Dale Hart

Hydraulics Laboratory

U. S. Army Engineer Waterways Experiment Station  
P. O. Box 631, Vicksburg, Miss. 39180

December 1982  
Final Report

DTIC  
SELECTED  
S JAN 28 1983 D

Approved For Public Release; Distribution Unlimited

A

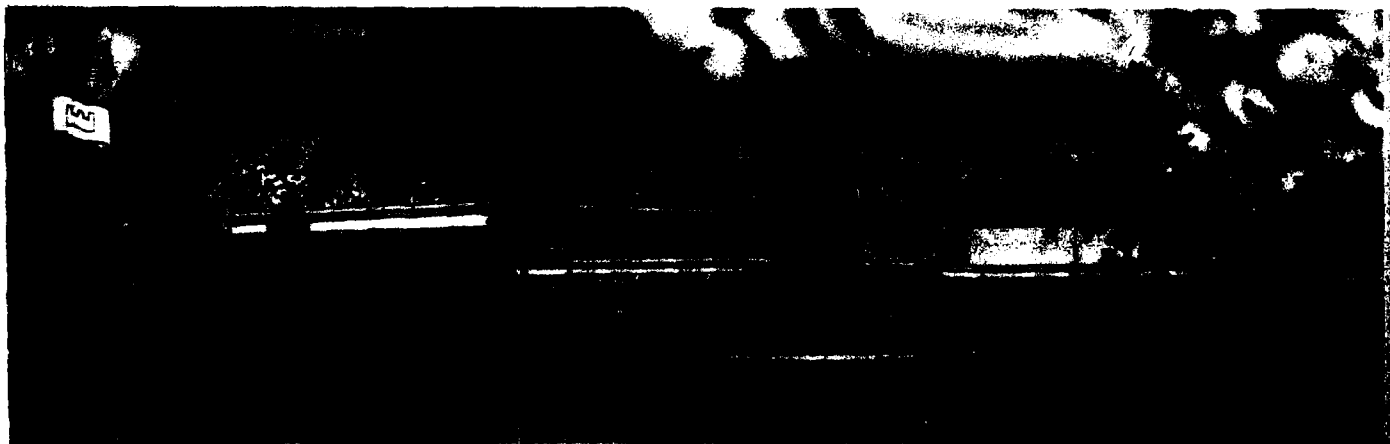

Prepared for U. S. Army Engineer District, Seattle  
Seattle, Washington 98124

DTIC FILE COPY

88 01 28 039

**Destroy this report when no longer needed. Do not return  
it to the originator.**

**The findings in this report are not to be construed as an official  
Department of the Army position unless so designated  
by other authorized documents.**

**The contents of this report are not to be used for  
advertising, publication, or promotional purposes.  
Citation of trade names does not constitute an  
official endorsement or approval of the use of  
such commercial products.**

Unclassified

SECURITY CLASSIFICATION OF THIS PAGE (When Data Entered)

REPORT DOCUMENTATION PAGE		READ INSTRUCTIONS BEFORE COMPLETING FORM
1. REPORT NUMBER Miscellaneous Paper HL-82-2	2. GOVT ACCESSION NO. AD-A123915	3. RECIPIENT'S CATALOG NUMBER
4. TITLE (and Subtitle) AIR DEMAND AND VIBRATION MEASUREMENTS, WYNOOCHEE DAM, WYNOOCHEE RIVER, WASHINGTON	5. TYPE OF REPORT & PERIOD COVERED Final report	
	6. PERFORMING ORG. REPORT NUMBER	
7. AUTHOR(s) E. Dale Hart	8. CONTRACT OR GRANT NUMBER(s)	
9. PERFORMING ORGANIZATION NAME AND ADDRESS U. S. Army Engineer Waterways Experiment Station Hydraulics Laboratory P. O. Box 631, Vicksburg, Miss. 39180	10. PROGRAM ELEMENT, PROJECT, TASK AREA & WORK UNIT NUMBERS	
11. CONTROLLING OFFICE NAME AND ADDRESS U. S. Army Engineer District, Seattle Seattle, Wash. 98124	12. REPORT DATE December 1982	
	13. NUMBER OF PAGES 45	
14. MONITORING AGENCY NAME & ADDRESS (if different from Controlling Office)	15. SECURITY CLASS. (of this report) Unclassified	
	15a. DECLASSIFICATION/DOWNGRADING SCHEDULE	
16. DISTRIBUTION STATEMENT (of this Report) Approved for public release; distribution unlimited.		
17. DISTRIBUTION STATEMENT (of the abstract entered in Block 20, if different from Report)		
18. SUPPLEMENTARY NOTES Available from National Technical Information Service, 5285 Port Royal Road, Springfield, Va. 22151		
19. KEY WORDS (Continue on reverse side if necessary and identify by block number) Air demand Gate vibrations Structure vibrations Vertical lift gates Wynoochee Dam		
20. ABSTRACT (Continue on reverse side if necessary and identify by block number) Tests were conducted to determine (a) the magnitude of vibrations occurring at the dam structure, Vista House, and sluice gate, (b) gate-lip pressure fluctuations, (c) airflow rates, and (d) if correlation existed between the gate and Vista House vibrations. The measurements were made for a full range of gate openings at 1-ft increments from 1 through 10 ft with essentially full pool (799+ ft msl). Data reduction and analysis by WES indicated a frequency correlation of (Continued)		

DD FORM 1473 EDITION OF 1 NOV 65 IS OBSOLETE

Unclassified

SECURITY CLASSIFICATION OF THIS PAGE (When Data Entered)

Unclassified

SECURITY CLASSIFICATION OF THIS PAGE(When Data Entered)

20. ABSTRACT (Continued)

small magnitude between the gate-lip pressures and Vista House vibrations during test 17 (gate opening 9 ft). The measured air vent velocities and head losses were within the limits suggested by EM 1110-2-1602. The maximum air vent flow occurred when the sluice gate was fully open.

Unclassified

SECURITY CLASSIFICATION OF THIS PAGE(When Data Entered)

PREFACE

The prototype tests described in this report were conducted during June 1981 by the U. S. Army Engineer Waterways Experiment Station (WES) under the sponsorship of the U. S. Army Engineer District, Seattle.

Acknowledgement is made to the personnel of the Seattle District for their assistance in the investigation. Mr. E. D. Hart, Chief, Prototype Evaluation Branch, Hydraulics Laboratory, was test coordinator for WES. This report was prepared by Mr. Hart with assistance from Mr. J. E. Hall and Dr. F. M. Neilson, under the general supervision of Mr. M. B. Boyd, Chief of the Hydraulic Analysis Division, and Mr. H. B. Simmons, Chief, Hydraulics Laboratory, WES.

Commander and Director of WES during the investigation and the preparation and publication of this report was COL Tilford C. Creel, CE. Technical Director was Mr. F. R. Brown.



Accession Number	
	<input checked="" type="checkbox"/>
	<input type="checkbox"/>
	<input type="checkbox"/>
	<input type="checkbox"/>
	<input type="checkbox"/>
	<input type="checkbox"/>
	<input type="checkbox"/>
	<input type="checkbox"/>
	<input type="checkbox"/>
	<input type="checkbox"/>

A

CONTENTS

	<u>Page</u>
PREFACE . . . . .	1
CONVERSION FACTORS, U. S. CUSTOMARY TO METRIC (SI)	
UNITS OF MEASUREMENT . . . . .	3
PART I: INTRODUCTION . . . . .	5
Pertinent Features of the Project . . . . .	5
Outlet Works . . . . .	5
Purpose and Scope of Tests . . . . .	7
PART II: TEST FACILITIES, EQUIPMENT, AND PROCEDURES . . . . .	8
Test Facilities . . . . .	8
Other Measurements . . . . .	13
Test Equipment . . . . .	13
Test Procedures . . . . .	14
PART III: TEST RESULTS AND ANALYSES . . . . .	16
Accelerations . . . . .	16
Gate Pressures . . . . .	18
Air Demand . . . . .	19
Differential Pressures . . . . .	22
PART IV: CONCLUSIONS . . . . .	23
REFERENCES . . . . .	24
TABLES 1-5	
PLATES 1-16	



CONVERSION FACTORS, U. S. CUSTOMARY TO METRIC (SI)  
UNITS OF MEASUREMENT

U. S. customary units of measurement used in this report can be converted to metric (SI) units as follows:

Multiply	By	To Obtain
acre-feet	1233.489	cubic metres
cubic feet per second	0.02831685	cubic metres per second
Fahrenheit degrees	*	Celsius degrees or Kelvins
feet	0.3048	metres
feet per second	0.3048	metres per second
feet per second per second	0.3048	metres per second per second
grams	0.002204622	pounds (mass)
inches	0.0254	metres
inches per second	25.4	millimetres per second
inches per second per second	25.4	millimetres per second per second
miles (U. S. statute)	1.609344	kilometres
pounds (force) per square inch	6894.757	pascals
square feet	0.0929	square metres

---

\* To obtain Celsius (C) temperature readings from Fahrenheit (F) readings, use the following formula:  $(5/9)(F - 32)$  to obtain Kelvin (K) readings, use:  $K = (5/9)(F - 32) + 273.15$ .

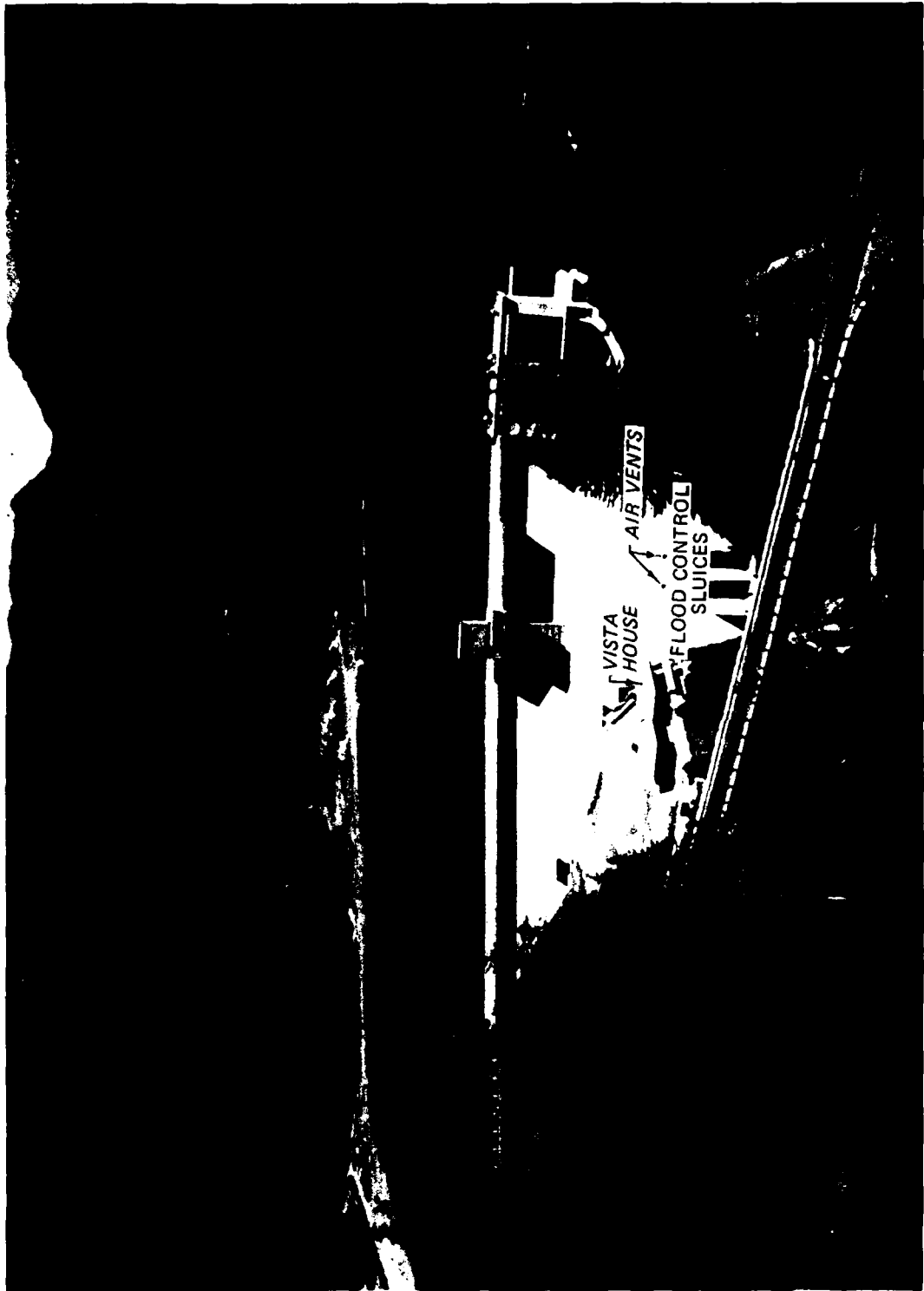

Figure 1. Wynoochee Dam

AIR DEMAND AND VIBRATION MEASUREMENTS, WYNOOCHEE DAM  
WYNOOCHEE RIVER, WASHINGTON

PART I: INTRODUCTION

Pertinent Features of the Project

1. Wynoochee Dam (Figure 1) is located on the Wynoochee River in northwestern Washington 51.8 miles\* upstream from the confluence with the Chehalis River and approximately 2 miles north of the town of Gris-dale, Washington (Figure 2). The multipurpose project provides industrial water supply, flood control, recreation, enhancement of fisheries, and irrigation. The feasibility of installing generators for hydroelectric power is currently being studied. Completed in 1972, the project consists of a concrete gravity-type dam with earth-fill extensions, a 4.4-mile-long lake at normal pool el 800.0\*\* which impounds 70,000 acre-feet of water, and fish facilities.

Outlet Works

2. Six individual 24-in.-diam steel outlet pipes are used to maintain low-flow multilevel withdrawal and to provide for downstream fish passage. The pipe intakes are located at various elevations from 690 to 780, as shown in Plate 1. The chute-type spillway is controlled by a two-bay, ogee-shaped crest structure with 32-ft-wide by 39-ft-high tainter gates. The chute is designed so that the flow will converge to the right and thereby be directed into the rock canyon below the dam. Flood-control releases are accomplished by two 6-ft-wide by 12-ft-high sluices, each having a 6-ft-wide by 10-ft-high control section which houses the upstream emergency gates and downstream service gates. The sluices are shown in Plate 1 and a sluice section is shown in Plate 2.

---

\* A table of factors for converting U. S. customary units of measurement to metric (SI) units is presented on page 3.

\*\* All elevations (el) cited herein are in feet above National Geodetic Vertical Datum (NGVD).

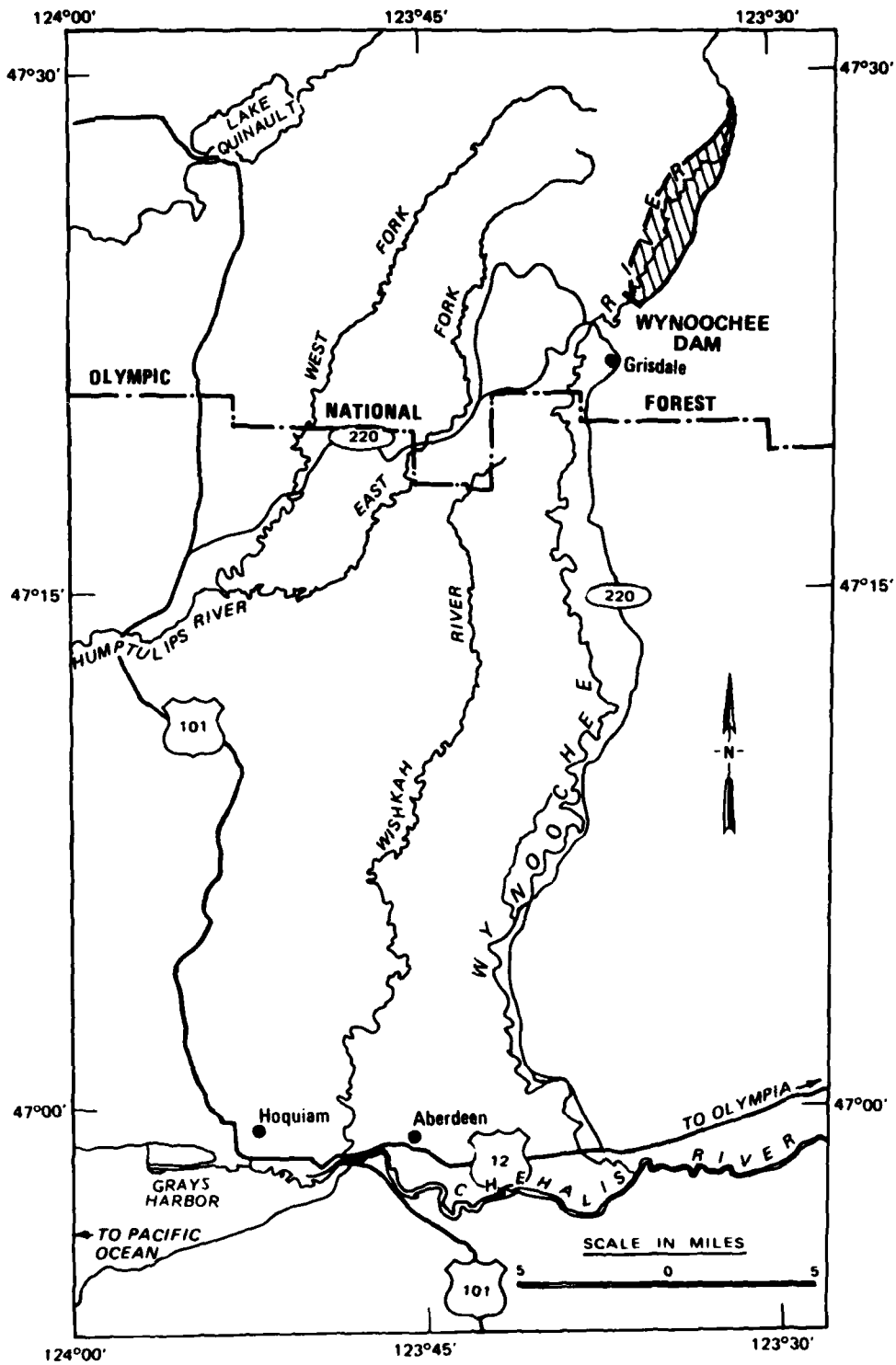

Figure 2. Vicinity map

## Purpose and Scope of Tests

### Background

3. After the project became operational, Seattle District personnel noted vibrations at or near the Vista House (Figure 1) during sluice discharges. Vibration tests were conducted by the Denver Mining Research Center, U. S. Bureau of Mines, in December 1975 (Stebly and Leighton, no date) to determine the intensity of the vibrations at the Vista House. All vibration levels were found to be well below the normally accepted safe levels. The Bureau of Mines report concluded that the principal source of vibrations was airflow through the canyon and dam. However, the Seattle District believed the source might be waterflow-induced vibrations. Therefore, the district requested the U. S. Army Engineer Waterways Experiment Station (WES) to conduct prototype tests to measure gate and structure vibrations and also the corresponding air demand.

### Purpose

4. The primary purpose of the test program was to determine the magnitude of vibrations occurring at the dam structure, sluice gate, and Vista House for a full range of gate openings under the maximum available head. In addition, it was desired to determine if a correlation existed between the gate and Vista House vibrations. Other information desired included gate-lip pressure fluctuations and airflow rates through the air vent and sluice.

### Scope

5. The WES test program included measurement of (a) vibrations at the Vista House, the dam, and the service gate, (b) gate-lip pressures, and (c) air demand. Pressure drops from the atmosphere to a station in the air vent, the access shaft, and the sluice gate were also measured. The tests were conducted utilizing the right (looking downstream) sluice with a full range of gate openings at 1-ft increments from 1 through 10 ft at an average pool elevation of 799.5. Measurements were also made at a 1/2-ft gate opening and during continuous closing, starting from full open.

## PART II: TEST FACILITIES, EQUIPMENT, AND PROCEDURES

### Test Facilities

6. The locations of the test instrumentation of the structure are shown in Plate 2. Details of the gate-lip pressure transducer are shown in Plate 3, and the different types of transducers used in the measurements described herein are shown in Figure 3. The specifics of each transducer are listed in Table 1.

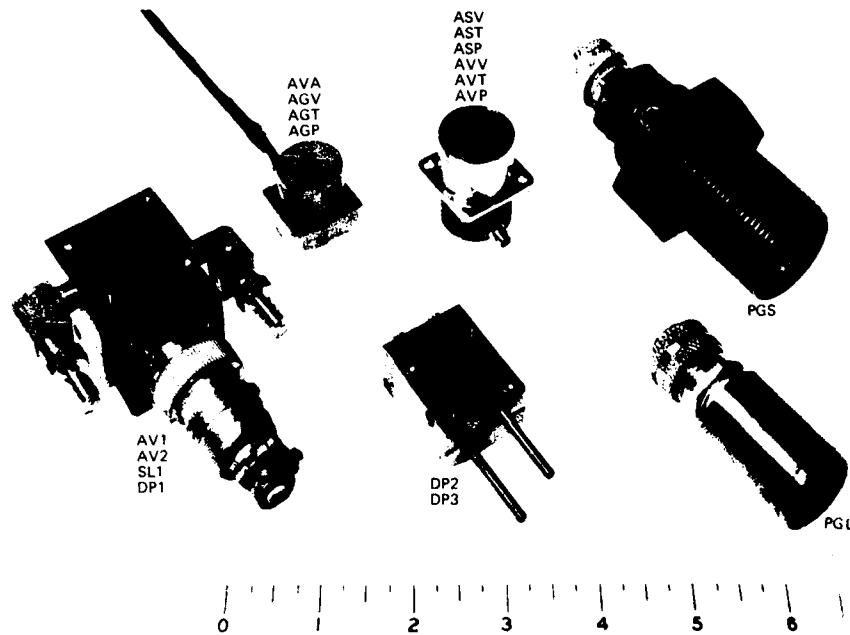
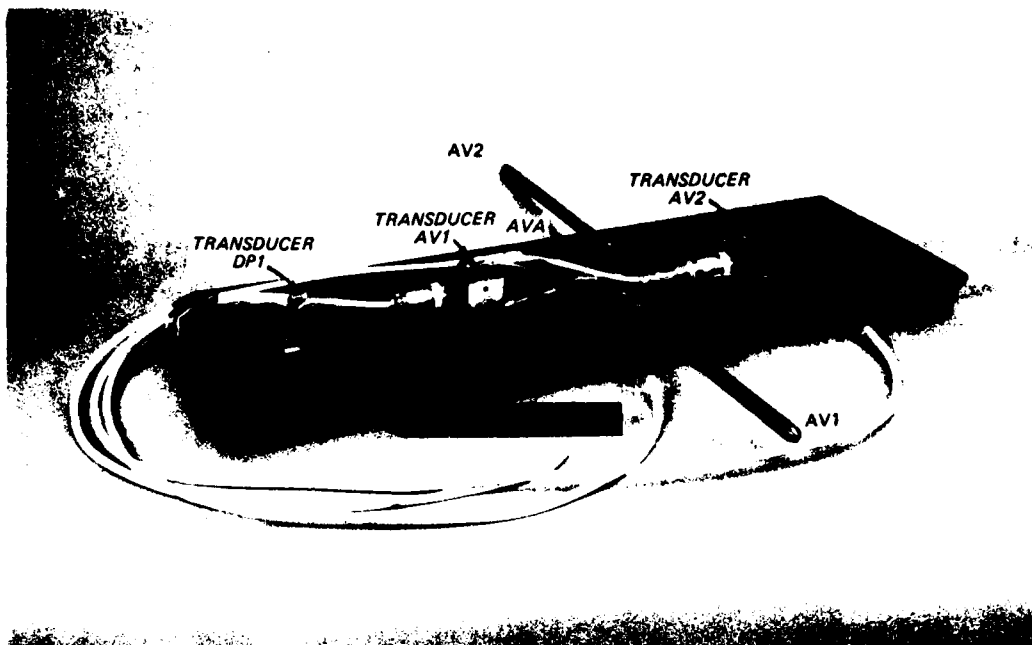

Figure 3. Test instrumentation (scale in inches)

### Pressure differential

7. Instrumentation was installed to record the pressure drop between the atmosphere and three locations within the test sluice-air vent system. Special housing for the differential-pressure transducers was fabricated at WES. The differential between the atmosphere and the location of the air-vent velocity strut (Plate 2) was measured with a differential pressure transducer (DP1) housed inside the strut as shown in Figure 4. A plastic tube led from one port of the transducer to the



a. Air-vent strut, open, exposing instrumentation

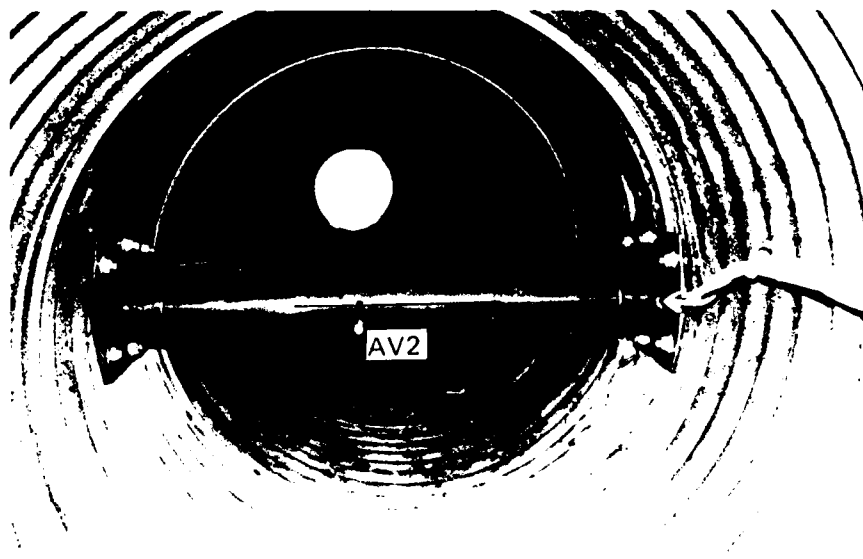

b. Air-vent strut installed (looking in direction of water flow)

Figure 4. Air-vent strut

atmosphere (recording area). A 1/8-in. hole was drilled in each side of the strut to the other open port of the transducer to admit the local pressure. Transducers for measuring the differential to the access shaft (DP2) and near the sluice gate (DP3) were housed in special containers as shown in Figure 5, which were epoxied to the access shaft wall. The transducers were isolated by packing the containers with foam rubber. Plastic tubing attached to the atmospheric port of each transducer terminated in the gate-control chamber which also served as the recording area.

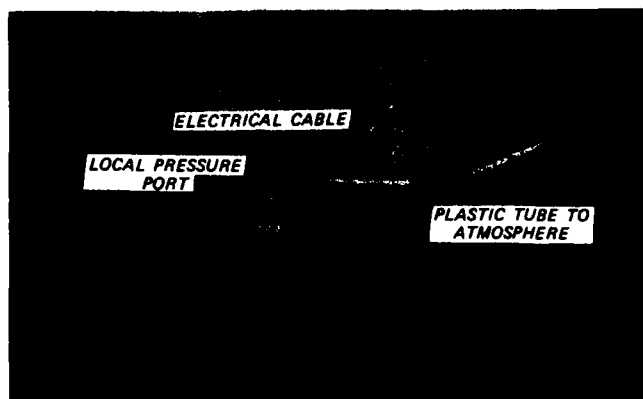

Figure 5. Differential pressure transducer DP2

#### Gate-lip pressures

8. Two pressure transducers (PGL and PGS) were mounted in the lip area of the test gate, as shown in Plates 2 and 3. The transducers were housed in special adapters and secured with either a locknut or setscrews.

#### Air velocity

9. Special struts (Plate 2 and Figures 4 and 6) were fabricated to house the instrumentation used in acquiring the data necessary for computing air velocities in the vent and the sluice. Pitot tubes extended downstream (AV1) and upstream (AV2) for detecting airflow into and out of the air vent, respectively. The sluice pitot tube (SL1) which was located 13.5 in. from the roof detected airflow into the exit portal of the sluice. The sluice strut and accompanying instrumentation are shown in Figure 6.



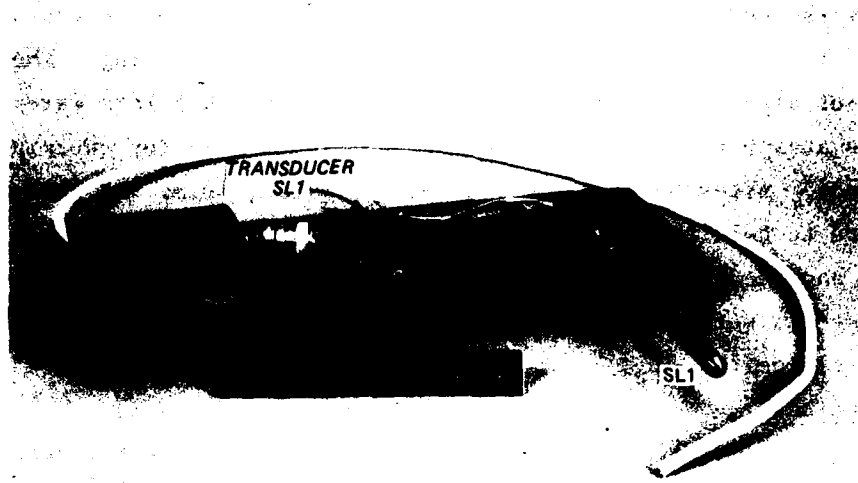

a. Sluce strut, open, exposing instrumentation

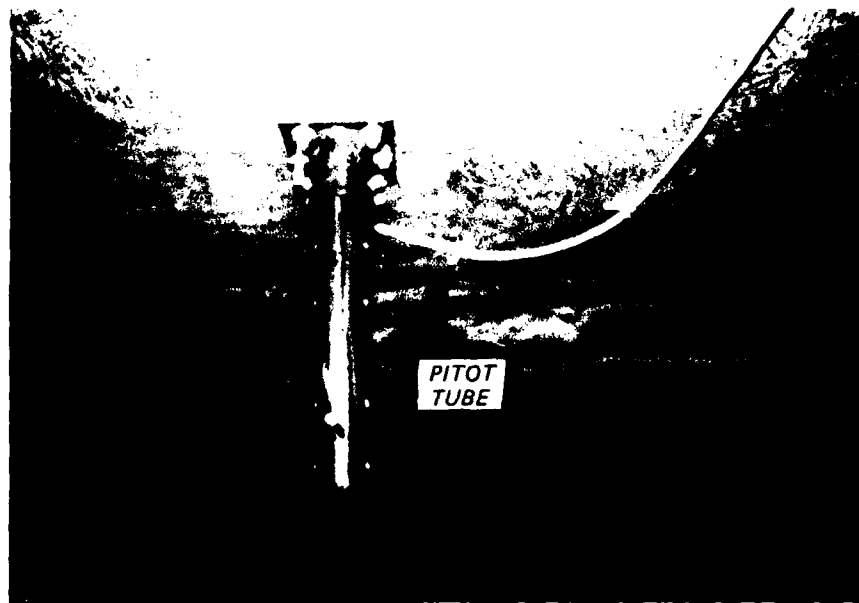

b. Sluce strut installed (looking upstream)

Figure 6. Sluce strut (SL1)

10. The struts consisted of two halves, bolted together, with sections removed from their inside to accommodate the pitot tubes, pressure transducers, electrical cables, and plastic tubing. The air-vent strut also contained an accelerometer. Strut brackets were fabricated to attach to the air-vent walls and sluice roof for encasing the strut ends. After bolting the brackets in place, shims and setscrews were used to hold the struts securely. The electrical cables (both struts) and the plastic tubing (air-vent strut) that exited from the end of the struts were attached to anchor bolts in the reach within the vent and the sluice.

#### Accelerations

11. A special accelerometer plate was welded to a horizontal brace on the downstream side of the test gate under the supervision of WES personnel, just prior to the tests. A cluster of three accelerometers (vertical, transverse, and parallel to flow) was then attached to the plate. In addition, special individual accelerometer mountings were expoxied to the floor of the gate-control chamber and Vista House. Plate 2 shows the location of the canister housing the gate accelerometers. The Vista House accelerometer configuration, shown in Figure 7,



Figure 7. Vista House accelerometers

is identical to that of the dam structure accelerometers. An accelerometer (AVA), shown in Figures 3 and 4, was installed in the air-vent strut to monitor the strut's vibrational amplitude and frequency during the tests.

#### Other Measurements

12. Other recorded data consisted of Wynoochee Lake elevation, air temperature, wind speed and direction, barometric pressure, and gate opening. Air temperature and wind speed and direction were continuously recorded on a Meteorology Research, Inc., portable weather station. Water discharge was determined from computed discharge rating curves provided by the Seattle District.

#### Test Equipment

13. The test equipment listed and described herein includes the transducers, cables, and recording equipment. Transducers used in the tests were as follows:

- a. Head differential: 0.20- to 0.50-psid pressure transducers.
- b. Gate-lip pressures: 50-psia pressure transducers.
- c. Air velocity (pitot tube pressure differential): 0.125- to 0.20-psid pressure transducers.
- d. Vibrations (accelerometers).
  - (1) Dam and Vista House: 1  $\mu$ g- to 25-g servo-accelerometers.
  - (2) Gate: 2.5-g accelerometers.
  - (3) Air-vent strut: 2.5-g accelerometers.

14. Cable lengths required for the test program were determined from contract drawings and actual measurements at the project. These cable lengths (listed in Table 1) were cut and used in the calibration of their corresponding transducers to account for line losses.

15. The recording equipment consisted of: (a) WES-fabricated

model 01 bridge-balance amplifiers with frequency response from DC to 10 kHz, (b) Validyne model CD15 carrier-demodulators with a frequency response of DC to 1 kHz, (c) WES-fabricated servo-accelerometer amplifiers, frequency response DC to 500 Hz, (d) a Sangamo model Sabre III, 32-track magnetic-tape recorder with a frequency response from DC to 40 kHz, (e) WES-fabricated galvanometer-driver amplifiers (to allow playback from magnetic tape to oscillograms), (f) CEC model 7-362 galvanometers, and (g) a CEC-5-119P4 direct-print oscillograph capable of reproducing up to 36 channels of data at paper speeds varying from 0.25 to 160 ips at a frequency response of DC to 40 kHz. Figure 8 shows the equipment setup at the recording station (gate control-chamber).

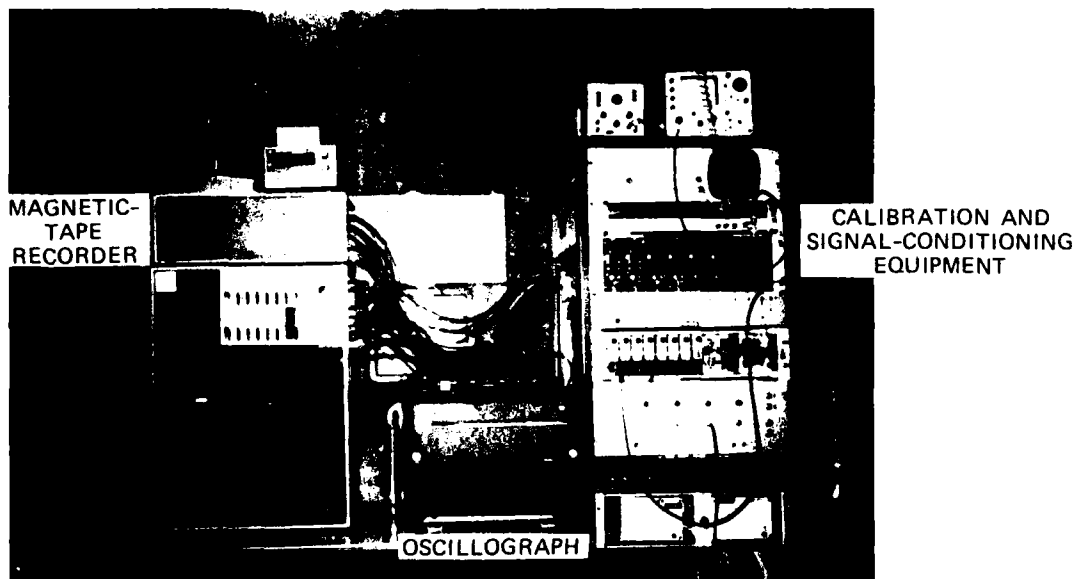

Figure 8. Recording equipment

#### Test Procedures

16. The tests, conducted on 11 June 1981, were recorded at a gate opening of 0.5 ft and then at 1-ft gate-opening increments from 1 ft to full open (10 ft). A continuous closing run was also recorded. Each individual gate-opening test was recorded on magnetic tape for 5 min.

A portion of the taped data was transferred to oscillograms to confirm that the data were being recorded and to make a visual check and some initial computations of results.

17. The procedure was the same for all tests and consisted of the following:

- a. Record test number, gate opening, date, time, and conditions.
- b. Record step calibrations.
- c. Raise gate to test position, allow flow to stabilize.
- d. Record data on tape and oscillograms.
- e. Record other test conditions.\*
- f. Repeat steps a, c-e for each gate opening.
- g. Record step calibrations.

18. Voice comments on the tapes and notes recorded on the oscillograms were made for later reference and assistance in data reduction. Where necessary, gain adjustments were made to improve the transducer signals' amplifier sensitivity.

---

\* Test conditions are listed in Table 2.

### PART III: TEST RESULTS AND ANALYSES

19. Test runs were conducted at gate openings of 0.5 and 1.0 ft and at 1-ft increments thereafter to full open (10.0 ft). The transducer types and locations used in this study are discussed in Part II and summarized in Table 1. The conditions of each test run are presented in Table 2.

20. Each data channel was digitized, from which 4-, 50-, and 200-sec time histories were developed. The digitized channels were transformed electronically from the time to the frequency domain in order to display the frequencies at which maximum energy was concentrated. This manipulation is the equivalent of a mathematical Fourier Transform (or Fast Fourier Transform, abbreviation FFT). The records were scanned for the maximum, minimum, average, and root-mean-square (RMS) values.

#### Accelerations

21. Three-directional acceleration measurements were made in the dam, the Vista House, and on the test sluice gate. The measurements were made to obtain their magnitudes at each gate opening and to determine if any correlation existed between the structure accelerations and gate vibrations.

#### Dam acceleration

22. A summary of the dam acceleration data is presented in Table 3. The peak-to-peak (pk to pk) and root mean square (RMS) accelerations and predominant frequencies were determined from the time histories and corresponding FFT's. The same procedure was used in determining the Vista House and sluice-gate acceleration data.

23. If the frequency  $f$  is known and is quasi-sinusoidal, the measured acceleration  $g$  can be used to approximate the structure displacement  $d$  in inches (Thomson 1972) with the equation:

$$d = \frac{386 \text{ g}}{(2\pi f)^2} \quad (1)$$

where 1 g equals 386 in./sec<sup>2</sup>. From Table 3, the largest recording of each dam accelerometer transducer was used with Equation 1 to approximate the corresponding displacements. These computations are listed below.

Transducer	Test No.	Gate Open. ft	Pk-pk Accel		Freq Hz	Pk-pk Displ in. × 10 <sup>-5</sup>
			g	ft/sec <sup>2</sup>		
ASV	15	7	0.010	0.32	92	1.2
AST	17	9	0.017	0.55	89	2.1
ASP	16	8	0.023	0.74	88	2.9

Plate 4 presents graphs of the effects of vibrations as they relate to persons and structures. The accelerations and displacements lie well within the region considered safe for structures.

#### Vista House accelerations

24. The acceleration data for the Vista House measurements are also listed in Table 3. The maximum acceleration given in the table is approximately 0.012 g or 0.39 ft/sec<sup>2</sup> (AVP, tests 9 and 11). The random frequency of these measurements could not be used to approximate the displacements. The acceleration value falls within the safe limits of the graph in Plate 4.

#### Gate accelerations

25. The measured gate accelerations were larger than those of the structures. Table 3 indicates that the largest accelerations occurred at the higher gate openings. The highest value recorded by each accelerometer is listed below.

Transducer	Test No.	Gate Open. ft	Pk-pk Accel		Freq Hz	Pk-pk Displ in. × 10 <sup>-5</sup>
			g	ft/sec <sup>2</sup>		
AGV	18	10	0.17	5.47	65	39
AGT	17	9	0.08	2.58	23	148
AGP	17	9	0.48	15.45	23	887

Plates 5-7 show typical gate acceleration time-history plots and FFT's (AGV, AGT, and AGP, respectively) recorded during test 15 (gate opening 7.0 ft).

#### Gate Pressures

26. Gate-pressure fluctuations were measured at the gate lip (PGL) and on the upstream skin plate (PGS). Transducer PGS was damaged and did not produce a signal during tests 16-18. Table 4 presents the measured values for these transducers. A typical time-history plot and an FFT for transducer PGL are shown in Plate 8.

27. The cross-spectral density function (CSDF) for two sets of random data describes the general dependence of the values of one set of data on the other (Bendat and Piersol 1958). The degree of dependence is expressed in the frequency domain. Basically, the degree of dependence is determined by individually frequency-filtering the two signals with narrow band-pass filters having identical bandwidths and the same center frequency, and multiplying the two filtered signals. If there is a high level of dependence between the two signals at a particular frequency, it will plot as a relatively discrete spike on an amplitude-frequency graph of the CSDF.

28. Cross-spectral density functions were derived to determine if correlation existed between the gate-lip pressure fluctuations (PGL) and the accelerations of the Vista House (AVV, AVT, AVP) and the gate (AGV, AGT, AGP). These functions were computed and plotted for each test. The resulting plots, excluding test 17, were random in frequency and low in amplitude. During test 17 (gate opening 9.0 ft), a frequency of approximately 23 Hz was dominant in the Vista House and gate accelerations. The correlation amplitudes were very small since the recorded accelerations were also very small (Table 3). Typical uncorrelated examples are shown for the gate-lip pressures and gate accelerations in Plate 9 and for the gate-lip pressures and Vista House accelerations in Plate 10. These plates were developed from data acquired during test 15 (gate opening 7.0 ft). Plate 11 shows the CSDF plots of the gate lip and also vertical accelerometers of the Vista House and the gate, test 17.



## Air Demand

29. Pitot tube differential pressures were measured at the locations shown in Plate 2 for determining the air demand in the air vent and the test sluice (AV1 and AV2 and SL1, respectively). Transducer AV2 recorded pressure differentials related to airflow downstream (left to right in Plate 2). Differential pressures from AV1 and SL1 were used to compute upstream flow.

30. Velocity at a point  $V_p$  is proportional to the recorded differential pressure when measured by a pitot tube (Rouse 1962). This relation shown in Figure 9 is given by the equation

$$V_p = k\sqrt{\Delta p} \quad (2)$$

where

$k$  = constant of proportionality

$\Delta p$  = differential pressure between points A and B (Figure 9)

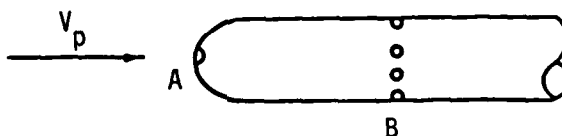

Figure 9. Pitot tube tip

The pitot tubes used in the Wynoochee Dam tests were calibrated by the National Space Technology Laboratories (NSTL), Bay St. Louis, Miss. (Hart 1981). The calibrated value of  $k$  was determined to be 351.90. The Mach number for all point velocities measured was less than unity; therefore, the compressibility of air was not considered in the data analysis (Vennard 1976).

### Air vent

31. Pitot tube measurements were made in both directions in the air vent at the location shown in Plate 2. The pitot tube support strut was located approximately 33.3 ft from the vent entrance (point A, Plate 2). This placed the strut approximately 13 equivalent diameters

( $D_e$ ) from the entrance. Rouse (1962) shows that for fully developed flow ( $D_e \approx 50$ ) the ratio of the maximum velocity  $V_p$  to the average value  $\bar{V}$  in terms of the friction coefficient  $f$  is

$$\frac{V_p}{\bar{V}} = (1 + 1.43\sqrt{f}) \quad (3)$$

Tullis and Wang (1974) found that this ratio is 6 percent smaller at  $D_e = 13$ . If this factor is applied to Equation 3, then  $\bar{V}$  can be computed as follows:

$$\bar{V} = \frac{V_p}{(1 + 1.43\sqrt{f})0.94} \quad (4)$$

32. The air vent at Wynoochee Dam is an embedded corrugated pipe 2.5 ft in diameter with a helix angle of 70 deg. The friction coefficient for these specifications is 0.034 (OCE 1980). Equation 4 was used to compute the average velocity which was multiplied by the vent area ( $4.91 \text{ ft}^2$ ) to determine the air discharge.

33. Table 5 presents the air-vent data which are based on the average and maximum point velocities. The maximum point velocities were determined from the maximum peak over the period of the time-history plot. A typical time history of differential pressures ( $\Delta p$  of equation 2) in the air vent (AV1) is shown in Plate 12. There was no recorded reversal of airflow in the air vent. Although there was a continuous signal from transducer AV2, it was due to air flowing in the direction opposite of that shown in Figure 9.

34. Others (Kalinske and Robertson 1943) have found the ratio of air demand to water discharge to be a function of the Froude number, minus one. The Corps of Engineers combined this information with field measurements and derived a suggested design curve. The Wynoochee air-vent discharges from Table 5 have been plotted on the Hydraulic Design Criteria (HDC) chart reproduced in Plate 13.

35. Corps field tests to determine air demand in regulated outlet

works have indicated two gate positions at which the air demand greatly exceeds that of the other openings. Large quantities of air are required when the gate is about 5 percent open and again at some gate position between 50 and 100 percent open. At small gate openings, the jet frays or breaks up and entrains large quantities of air. As the gate opens further, the airflow initially decreases and then increases to a maximum value which is caused by the drag force between the water surface and the air above. The average air-vent discharges recorded at Wynoochee are plotted on the HDC Chart in Plate 13. The second maximum occurred at full gate opening.

#### Sluice

36. The sluice air velocity was measured near the exit portal, as shown in Plate 2. Air was probably drawn primarily through the sluice-roof grating, as shown in Figure 10. Because of this and the reverse airflow occurring near the water surface, a velocity profile could not be predicted at transducer SL1. The assumed flow profile at the transducer is shown in the figure. The measured point velocities are listed in Table 5 and indicate that point velocities near the sluice roof were

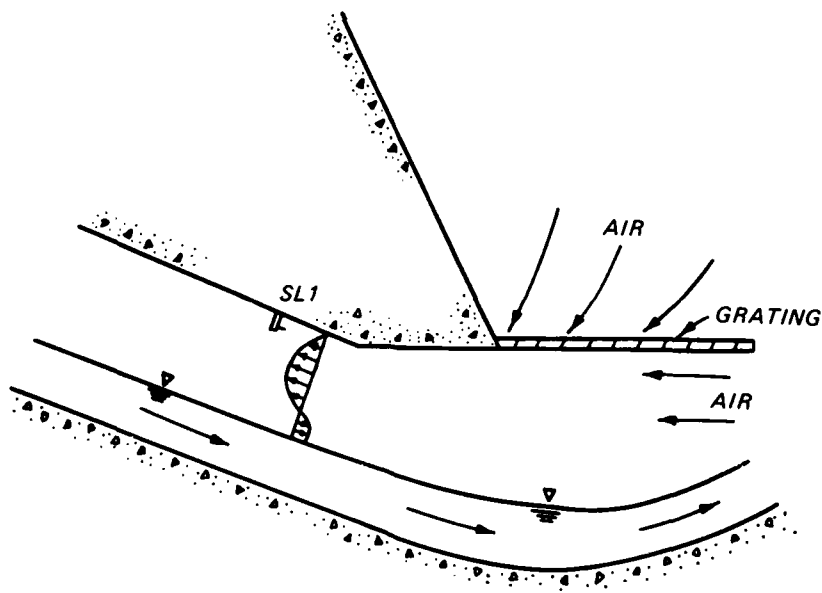

Figure 10. Exit portal-flow conditions

relatively high. However, due to the unknown velocity profile, the air-flow rate up the sluice was not estimated.

#### Differential Pressures

37. Differential pressures were measured between the atmosphere and three locations in the air vent and equipment shaft (DP1, DP2, DP3, Plate 2). The maximum and average differential pressures are listed in Table 5. Corps criteria (OCE 1980) suggest that the maximum air-vent velocity not exceed 150 fps and that head loss through the vent not exceed 0.5 to 1.0 ft of water. The maximum recorded differential pressure at Wynoochee was 0.9 ft of water (DP3, test 18) and the maximum recorded air-vent point velocity was 136 fps (AV1, test 18). A typical time-history plot and an FFT for differential pressure at transducer DP3 are shown in Plate 14.

38. Possible correlation between gate-lip pressures (PGL) and air-vent differential pressures (DP3) were analyzed using the previously described CSDF (paragraph 27). The analysis was made for all tests and showed, excluding test 17, that the frequencies were random and of very small amplitude. A dominant frequency of 23 Hz occurred in the (PGL)  $\times$  (DP3) analysis at a very small amplitude (Plate 15). Plate 16 presents a typical CSDF for PGL and DP3 taken from test 15 (gate open 7.0 ft).

#### PART IV: CONCLUSIONS

39. The following determinations resulted from field observations and analysis of the reduced Wynoochee Dam prototype data.

- a. Correlation occurred between the frequency of the gate-lip pressure fluctuations and both the accelerations of the Vista House and the air-vent pressure fluctuations during test 17 (gate opening 9 feet). The maximum recorded pk-pk acceleration during the test was 0.0008 g.
- b. The maximum recorded air-vent velocity and head loss were within the limits suggested in EM 1110-2-1602.
- c. The ratio of air discharge through the vent and water discharge in the sluice plots reasonably well on the Corps suggested design curve.
- d. Air-vent flow reaches a maximum when the sluice gate is full open.
- e. Air flowed into the sluice-exit portal at all gate openings for which measurements were made.

## REFERENCES

- Bendat, J. S., and Piersol, A. G. 1958. "Measurements and Analysis of Random Data," John Wiley and Sons, Inc., New York.
- Crandal, F. J. 1949 (Apr). "Ground Vibration Due to Blasting and Its Effect Upon Structures," Boston Society of Civil Engineers, Vol 36, No. 2.
- Hart, E. D. 1981. "Air Demand Tests, Libby Dam, Kootenai River, Montana," Miscellaneous Paper HL-81-6, U. S. Army Engineer Waterways Experiment Station, CE, Vicksburg, Miss.
- Kalinske, A. A., and Robertson, J. M. 1943. "Entrainment of Air in Flowing Water--Closed Conduit Flow," Transactions American Society of Civil Engineers, Vol 108.
- Office, Chief of Engineers. 1980. "Engineering and Design: Hydraulic Design of Reservoir Outlet Works," EM 1110-2-1602, Washington, D. C.
- Richart, F. E., Jr., Hall, J. R., and Woods, R. D. 1970. "Vibrations of Soils and Foundations," Prentice Hall, Inc., Englewood Cliffs, N. J.
- Rouse, H. 1962. "Elementary Mechanics of Fluids," John Wiley and Sons, Inc., New York.
- Smith, P. M., and Edmister, T. D. 1971. "Spillway Chute and Sluice Outlets, Wynoochee Dam and Reservoir, Wynoochee River, Washington," Bonneville Hydraulic Laboratory Report 134-1.
- Stebly, B. J., and Leighton, F. No date. "Vibration Analysis of the Wynoochee Dam Vista House," Denver Mining Research Center, U. S. Bureau of Mines, DMRC Report 10016.
- Thomson, W. T. 1972. "Theory of Vibration with Applications," Prentice-Hall, Inc., Englewood Cliffs, N. J.
- Tullis, J. P., and Wang, J. 1974. "Turbulent Flow in the Entry Region of a Rough Pipe," Transaction of the ASME, Journal of Fluid Engineering, March 1974.
- Vennard, J. K. 1976. "Elementary Fluid Mechanics," John Wiley and Sons, Inc., New York.
- Vierk, R. K. 1967. "Vibration Analysis," International Textbook Co., Scranton, Pa.

Table 1  
Instrumentation

Code*	Instrument		Location		Cable Length ft	Function
	Type	Range	Station**	Elevation		
AV1	Validyne DP15-22	0.20 psid	0+35.2	704.0	100	Air-vent inflow velocity
AV2	Validyne DP15-22	0.20 psid	0+35.2	704.0	100	Air-vent outflow velocity
SL1	Validyne DP15-20	0.125 psid	0+78.1	676.2	225	Sluice air-inflow velocity
DP1	Validyne DP15-22	0.20 psid	0+35.2	704.0	100	Pressure drop, atmosphere to strut
DP2	Validyne DP 9-26	0.50 psid	0+17.0	706.5	100	Pressure drop, atmosphere to access shaft
DP3	Validyne DP 9-26	0.50 psid	0+14.0	697.6	100	Pressure drop, atmosphere to sluice gate
PGL	CEC 4-312A	50 psia	0+10.0	687.5†	100	Gate-lip pressure fluctuations
PGS	CEC 4-312A	50 psia	0+10.0	688.0†	100	Gate-skinplate pressure fluctuations
AVA	Statham A73TC	2.5 g	0+35.2	704.0	100	Air-vent strut vibration
AGV	Statham A73TC	2.5 g	0+10.0	689.2†	100	Vertical gate vibration
AGT	Statham A73TC	2.5 g	0+10.0	689.2†	100	Transverse gate vibration††
AGP	Statham A73TC	2.5 g	0+10.0	689.2†	100	Parallel gate vibration††
ASV	Kistler QAll6-17	1 µg-25 g	0+00.0	711.0	20	Vertical structure vibration
AST	Kistler QAll6-17	1 µg-25 g	0+00.0	711.0	20	Transverse structure vibration††
ASP	Kistler QAll6-17	1 µg-25 g	0+00.0	711.0	20	Parallel structure vibration††
AVV	Kistler QAll6-17	1 µg-25 g	Vista House	753.25	425	Vertical Vista House vibration
AVT	Kistler QAll6-17	1 µg-25 g	Vista House	753.25	425	Transverse Vista House vibration††
AVP	Kistler QAl000-S3	1 µg-25 g	Vista House	753.25	425	Parallel Vista House vibration††

\* See also Figure 3 and Plates 2 and 3.

\*\* Relative to dam axis.

† With gate in closed position.

†† Relative to water flow direction.

Table 2  
Test Conditions

Test No.	Date 1981	Start Time hr	Gate Opening ft	Water Discharge cfs	Air Temp °F	Avg Wind Speed mph	Wind Direction	Barometric Pressure psi	Pool El ft NGVD	Comments
1	6/10	1715	Closed	0*						Tap test, dam
2	6/10	1730	Closed	0*						Tap test, Vista House
3	6/10	1740	Closed	0*						Tap test, air vent strut
4	6/10	1745	Closed	0*						Tap test, service gate
5	6/11	0930	1.0**	0*	47	2.8	SW		799.80	Tap test, service gate
6	6/11	1250	3.0	1110	53	2.9	SW	14.20		Trial run
7	6/11	1352	0.5	200	55	2.9	SW	14.18		
8	6/11	1428	0.5	200	55	2.9	SW			
9	6/11	1438	1.0	370	54	2.9	SW			
10	6/11	1458	2.0	740	55	3.4	S			
11	6/11	1519	3.0	1110	55	3.3	S		799.75	
12	6/11	1550	4.0	1490	57	3.3	S	14.17		
13	6/11	1622	5.0	1875	59	3.3	SW			
14	6/11	1650	6.0	2250	50	3.3	SW		799.62	
15	6/11	1745	7.0	2630	40	3.3	N	14.17		
16	6/11	1756	8.0	3050	40	3.3	NE		799.45	
17	6/11	1820	9.0	3430	41	3.3	NE			
18	6/11	1850	10.0	4530	42	3.3	NE	14.17	799.25	
19	6/11	1910	Closing	--	42	2.0	NE	14.14	799.05	Continuous closing from 10 ft

\* Water discharge through flow outlets only.

\*\* Emergency gate closed.



Table 3  
Dam, Vista House, and Gate Accelerations

Test No.	Gate Open ft	Dam								
		ASV			AST			ASP		
		Pk-Pk* g	RMS g	Freq Hz	Pk-Pk* g	RMS g	Freq Hz	Pk-Pk* g	RMS g	Freq Hz
8	0.5	0.0006	0.0002	78	0.0008	0.0002	55	0.0008	0.0002	57
9	1	0.0011	0.0005	60	0.0008	0.0002	57	0.0011	0.0004	55
10	2	0.0021	0.0007	87	0.0021	0.0004	93	0.0023	0.0004	87
11	3	0.0014	0.0005	65	0.0014	0.0003	79	0.0018	0.0003	88
12	4	0.0023	0.0004	77	0.0021	0.0004	79	0.0021	0.0004	86
13	5	0.0023	0.0005	78	0.0018	0.0003	74	0.0016	0.0003	69
14	6	0.0023	0.0005	89	0.0023	0.0004	94	0.0023	0.0004	67
15	7	0.0103	0.0008	92	0.0069	0.0008	92	0.0041	0.0008	93
16	8	0.0068	0.0015	88	0.0073	0.0014	94	0.0229	0.0016	88
17	9	0.0091	0.0024	85	0.0171	0.0019	89	0.0114	0.0024	70
18	10	0.0022	0.0025	40	0.0044	0.0009	86	0.0044	0.0012	89
		Vista House								
		AVV			AVT			AVP		
		Pk-Pk* g	RMS g	Freq Hz	Pk-Pk* g	RMS g	Freq Hz	Pk-Pk* g	RMS g	Freq Hz
8	0.5	0.0005	0.0002	80	0.0003	**	44	0.0086	0.0011	†
9	1	0.0005	0.0001	80	0.0003	**	44	0.0128	0.0015	†
10	2	0.0006	0.0001	80	0.0003	0.0001	55	0.0073	0.0011	†
11	3	0.0007	0.0002	40	0.0003	**	44	0.0114	0.0017	†
12	4	0.0005	0.0001	80	0.0003	**	44	0.0006	0.0001	80
13	5	0.0004	**	60	0.0002	**	60	0.0046	0.0005	†
14	6	0.0003	**	80	0.0002	**	25	0.0003	**	80
15	7	0.0004	0.0001	34	0.0003	**	40	0.0003	**	35
16	8	0.0006	0.0001	30	0.0005	0.0001	27	0.0004	**	26
17	9	0.0008	0.0001	23	0.0007	0.0001	24	0.0007	0.0001	24
18	10	0.0006	0.0001	72	0.0004	**	16	0.0006	**	41
		Gate								
		AGV			AGT			AGP		
		Pk-Pk* g	RMS g	Freq Hz	Pk-Pk* g	RMS g	Freq Hz	Pk-Pk* g	RMS g	Freq Hz
8	0.5	0.0180	0.0037	98	0.0085	0.0016	44	0.0800	0.0145	57
9	1	0.0226	0.0047	44	0.0103	0.0015	44	0.1074	0.0168	61
10	2	0.0457	0.0075	75	0.0146	0.0029	88	0.2600	0.0380	87
11	3	0.0209	0.0039	44	0.0150	0.0022	44	0.2057	0.0367	70
12	4	0.0197	0.0032	44	0.0135	0.0024	44	0.2194	0.0443	77
13	5	0.0207	0.0035	44	0.0130	0.0022	44	0.2057	0.0369	77
14	6	0.0366	0.0194	44	0.0110	0.0055	73	0.1828	0.0384	76
15	7	0.0446	0.0086	35	0.0196	0.0037	35	0.2585	0.0499	65
16	8	0.0823	0.0193	27	0.0308	0.0079	27	0.3200	0.0541	27
17	9	0.1600	0.0164	23	0.0800	0.0104	23	0.4800	0.0750	23
18	10	0.171	0.0243	65	0.0548	0.0110	73	0.2740	0.0542	73

\* Instantaneous maximum peak-to-peak (pk-pk) accelerations.  
 \*\* Less than 0.0001 g.  
 † Aperiodic.

Table 4  
Sluice Gate Pressures (psi)

Test No.	Gate Open ft	PGL						PGS					
		Max*	Avg	Min*	RMS	pk-pk	Freq Hz	Max*	Avg	Min*	RMS	pk-pk	Freq Hz
8	0.5	1.30	0.04	-0.46	0.20	1.57	3	0.48	0.19	-0.13	0.08	0.47	55
9	1	0.94	0.04	-0.50	0.15	1.14	2	0.46	0.06	-0.29	0.09	0.55	40
10	2	0.16	-0.31	-0.55	0.12	1.30	2	0.54	0.05	-0.45	0.13	0.65	53
11	3	0.80	-0.20	-0.60	0.12	1.00	9	0.70	0.13	-0.42	0.14	0.94	55
12	4	0.45	-0.24	-0.51	0.08	0.87	6	0.70	0.09	-0.56	0.16	0.90	43
13	5	0.67	-0.09	-0.44	0.09	0.94	4	2.73	0.26	-1.67	0.39	2.65	2
14	6	0.34	-0.17	-0.32	0.04	0.50	4	0.82	-0.05	-1.60	0.21	1.13	57
15	7	0.46	-0.11	-0.40	0.07	0.70	6	1.61	-0.44	-2.28	0.44	2.00	35
16	8	0.61	-0.09	-0.32	0.09	0.90	3	**	**	**	**	**	**
17	9	0.68	-0.03	-0.62	0.15	1.33	23	**	**	**	**	**	**
18	10	4.22	-0.21	-8.28	1.11	9.83	4	**	**	**	**	**	**

\* Isolated peaks.  
\*\* Transducer out.

Table 5  
Differential Pressures, Velocities, Air Discharge

Test No.	Gate Open ft	Differential Pressure (psf)			Frequencies (Hz)			AVI Avg			AVI Max*			SLI V <sub>P</sub> avg fps			
		Avg	Max*	Freq	Avg	Max*	Freq	V <sub>P</sub> fps	V̄ fps	Q cfs	V <sub>P</sub> fps	V̄ fps	Q cfs				
8	0.5	6.6	8.2	1	6.4	8.6	1	7.7	10.6	1	62.8	52.9	260	71.9	60.5	297	50.0
9	1	4.7	6.8	3	4.4	6.7	3	4.7	8.3	3	50.4	42.4	208	66.3	55.8	274	54.2
10	2	3.7	5.8	3	3.3	5.6	3	3.7	5.5	3	45.3	38.1	187	58.7	49.4	243	14.0
11	3	4.1	9.6	1	3.8	10.1	1	3.9	11.1	1	50.8	42.8	210	66.6	56.0	275	31.3
12	4	1.8	3.2	1	1.4	2.8	1	1.2	3.0	4	36.6	30.8	150	44.9	37.8	185	28.0
13	5	1.7	3.4	4	1.3	3.9	4	1.0	3.9	4	35.4	29.8	146	46.5	39.1	192	39.6
14	6	2.4	4.7	9	1.9	4.1	2	1.7	4.3	2	38.6	32.5	160	52.2	43.9	216	37.0
15	7	2.2	4.0	1	1.6	2.6	3	2.6	5.7	1	38.2	32.2	158	45.6	38.4	188	46.4
16	8	3.5	9.3	26	3.1	10.5	27	4.4	9.6	28	49.1	41.3	203	63.9	53.8	264	**
17	9	10.9	19.5	23	11.1	18.8	23	19.0	24.8	23	77.2	65.0	320	94.3	79.4	390	**
18	10	24.3	29.4	1	24.4		2	35.8	55.9	1	116.4	98.0	480	136.0	114.0	562	**

\* Instantaneous peaks.  
 \*\* Transducer out.

WYNOOCHEE DAM

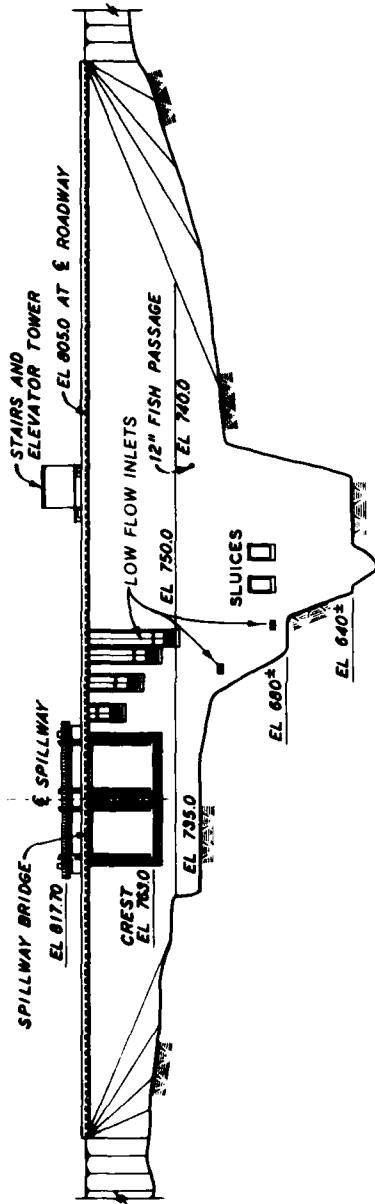

UPSTREAM ELEVATION

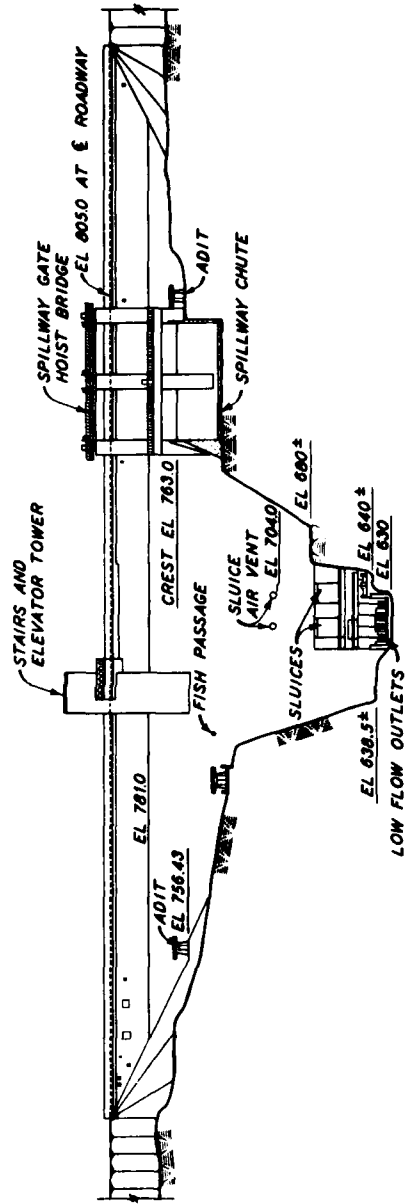

DOWNSTREAM ELEVATION

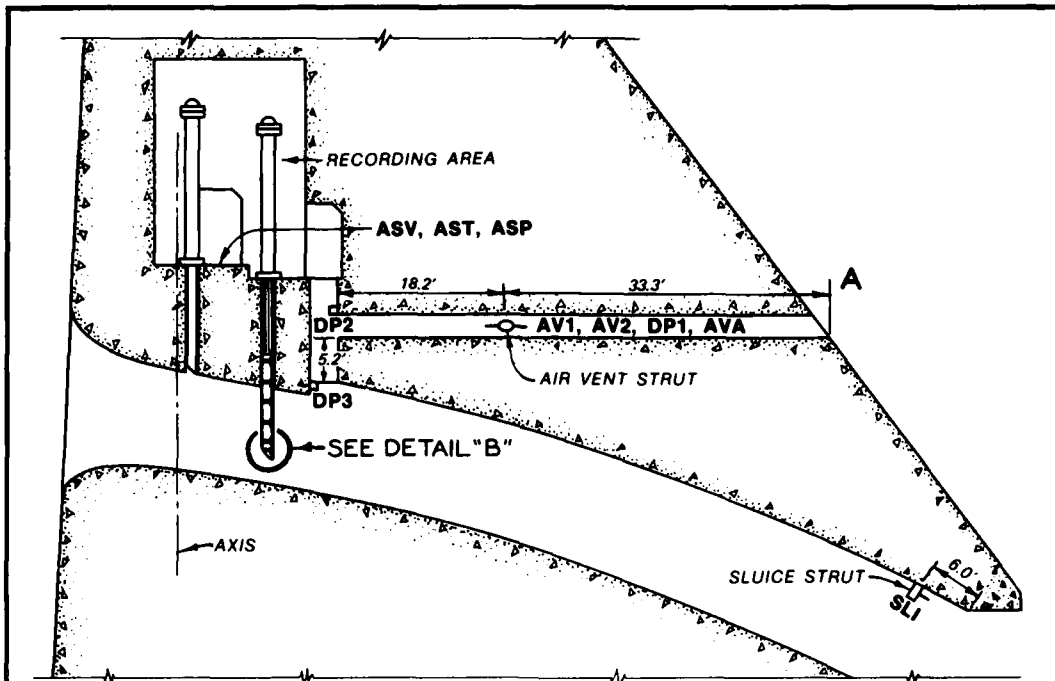

**DETAIL A**

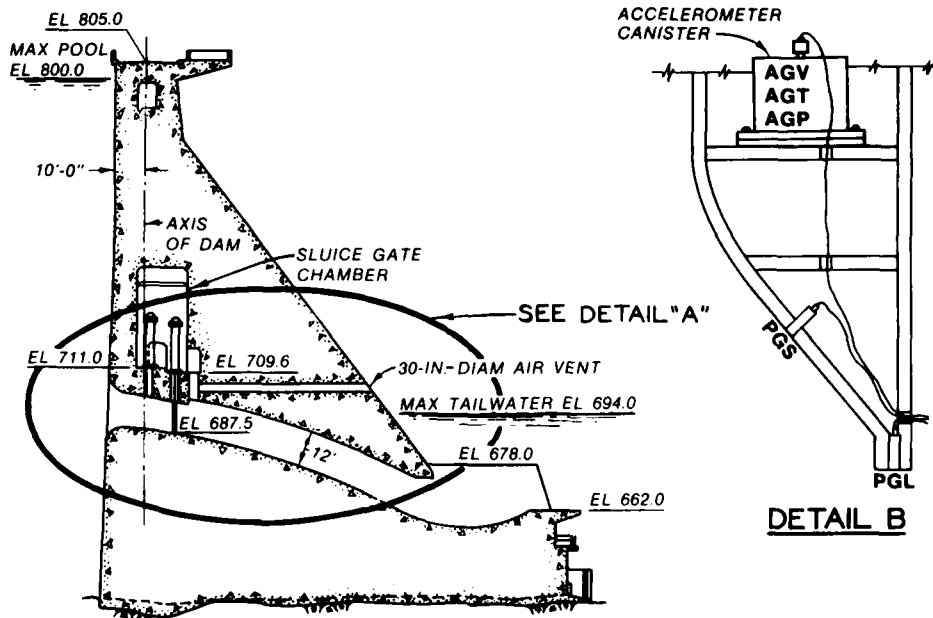

**DETAIL B**

**WYNOOCHEE DAM  
LOCATION OF INSTRUMENTATION  
IN STRUCTURE**

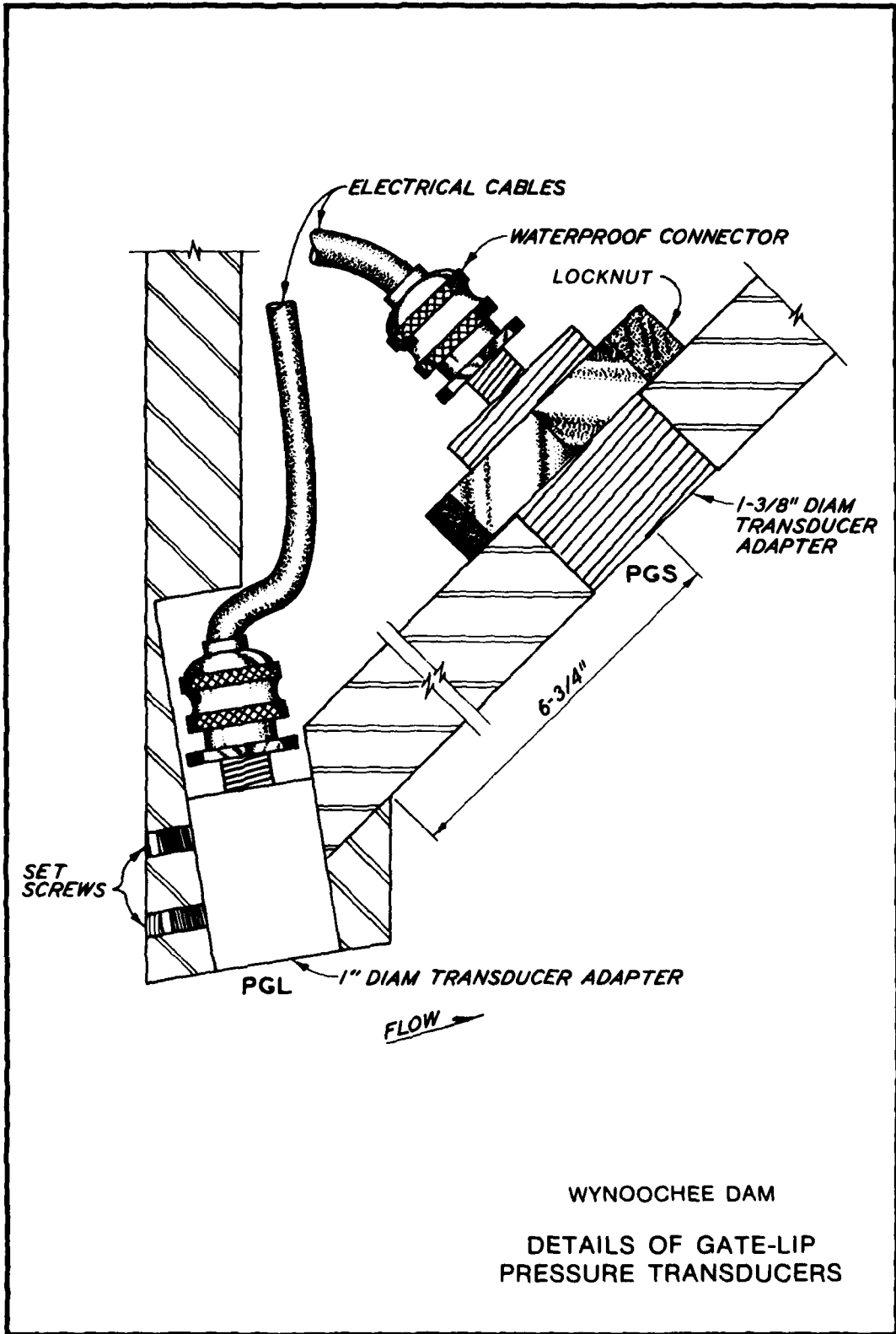

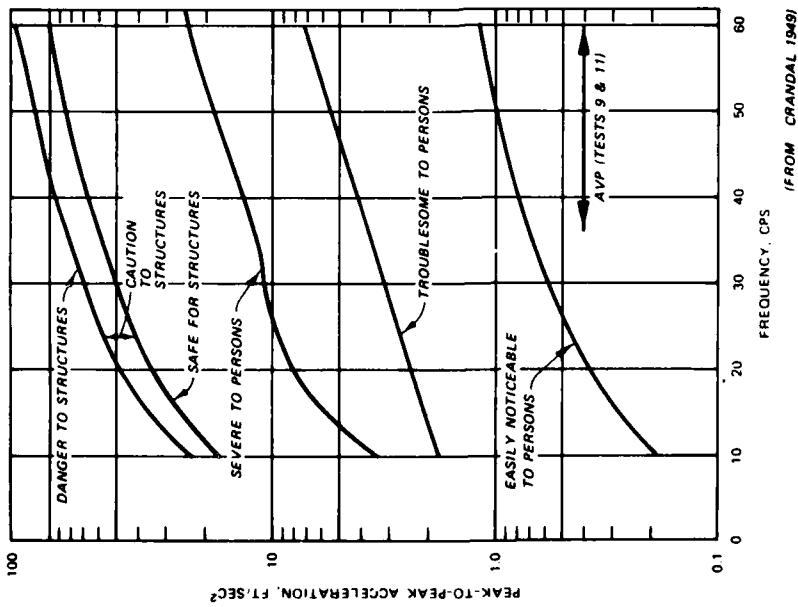

(FROM CRANDALL 1949)

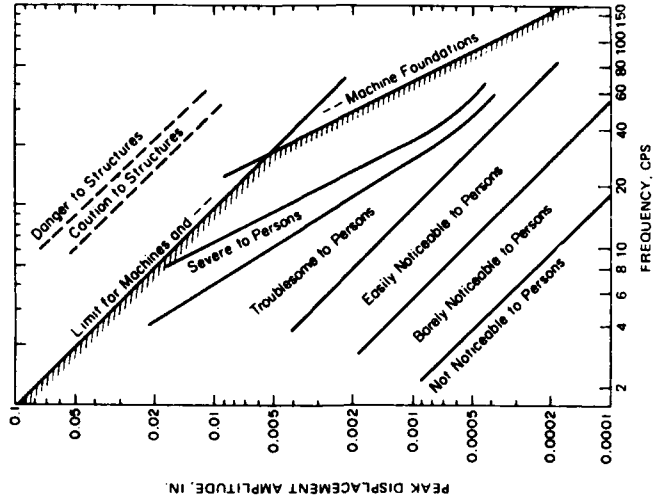

(FROM RICHART, HALL, AND WOODS, 1970)

# WYNOOCHEE DAM DAM AND VISTA HOUSE ACCELERATION AND DISPLACEMENT

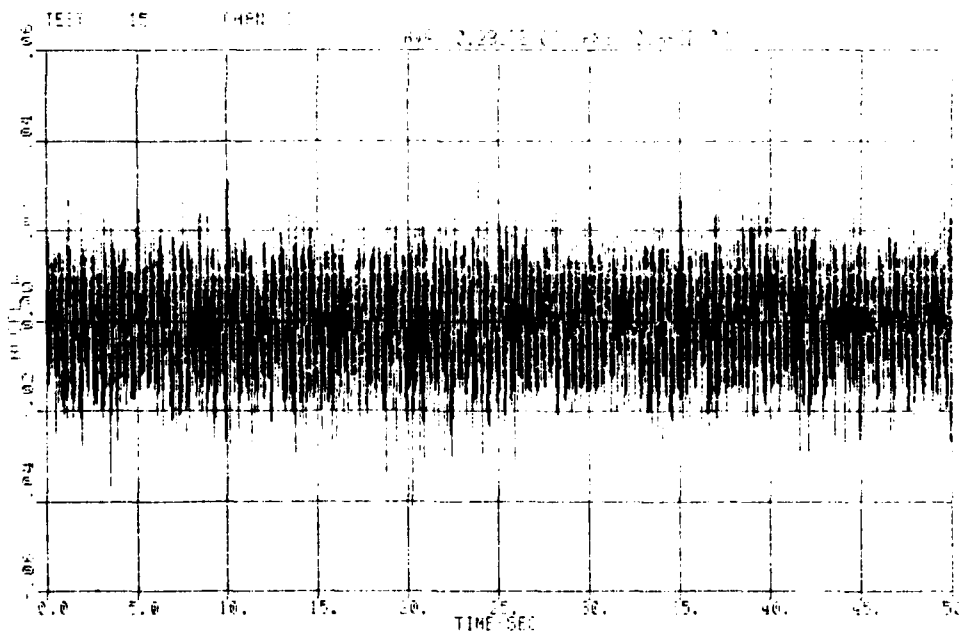
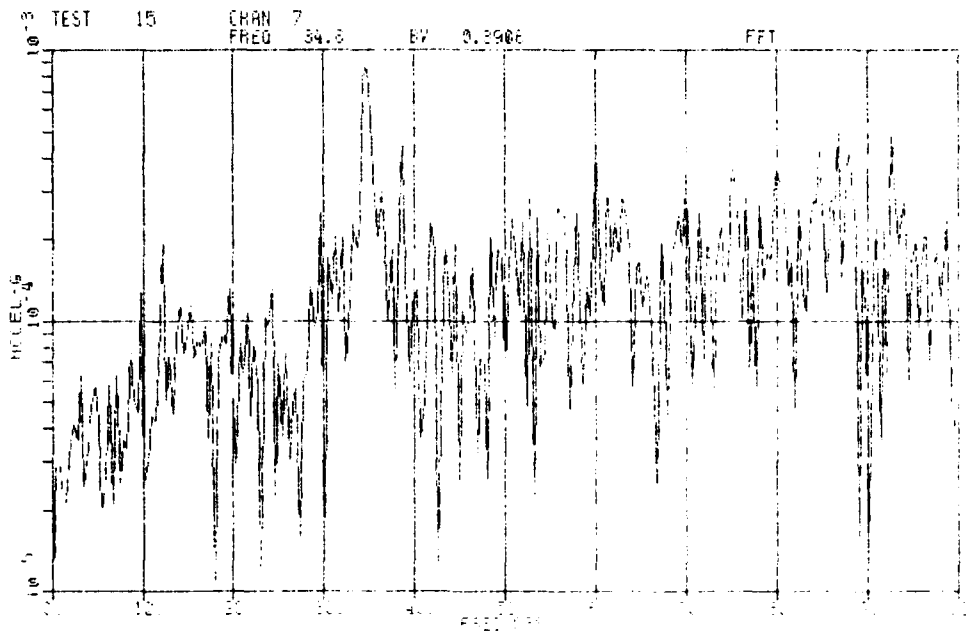

WYNOOCHEE DAM  
 VERTICAL GATE  
 ACCELERATION (AGV)  
 TEST 15, GATE OPEN 7 FT



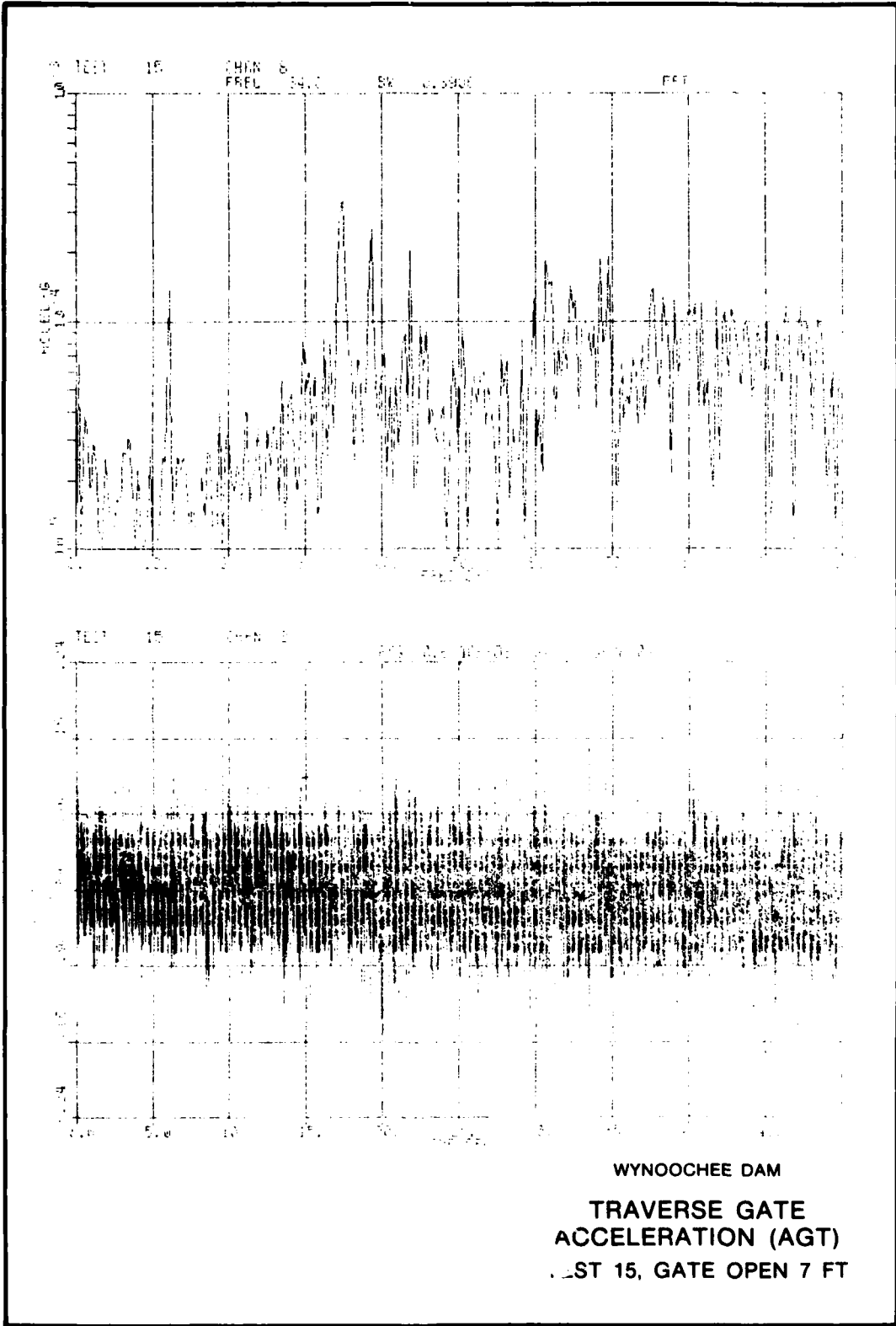
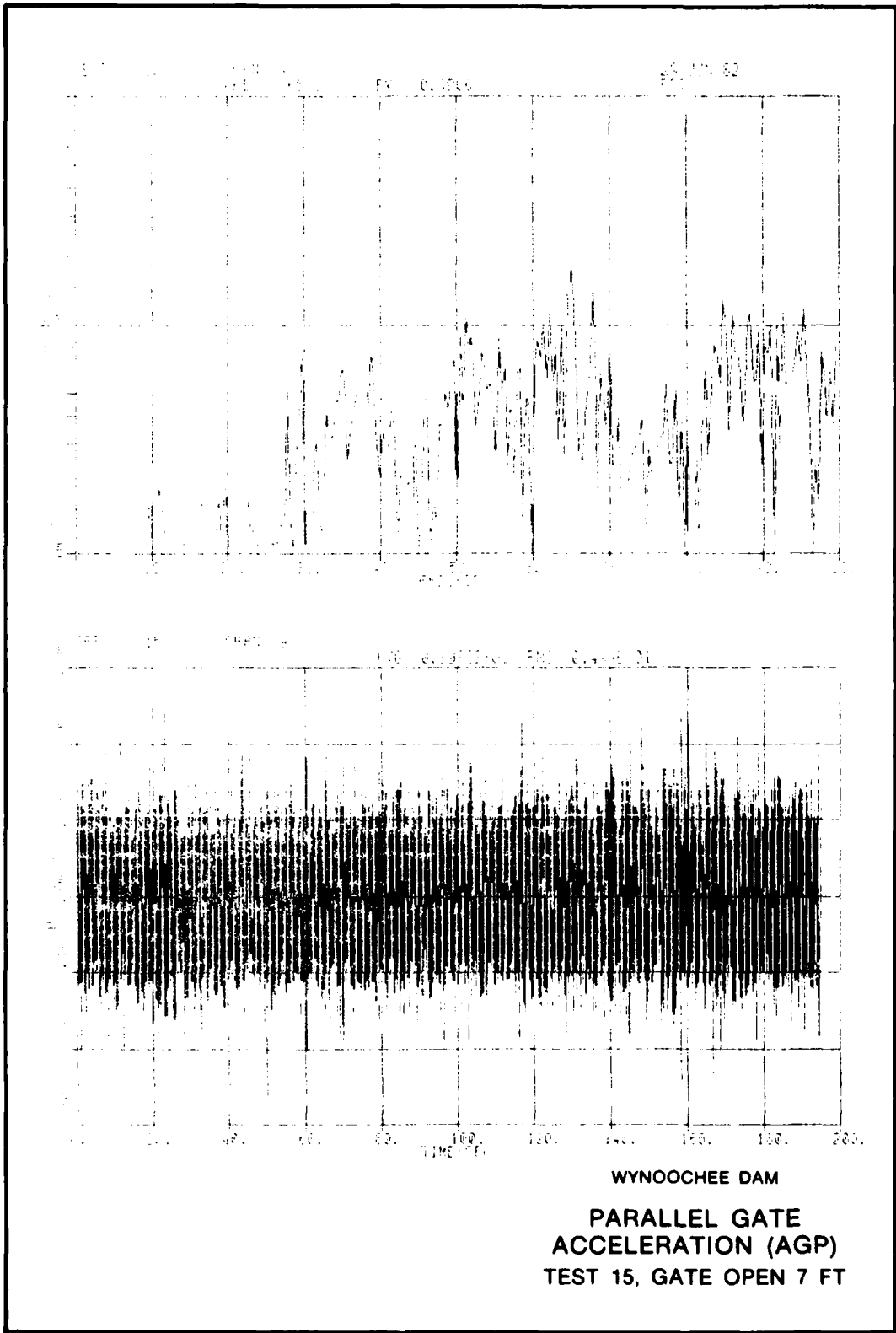

PLATE 6



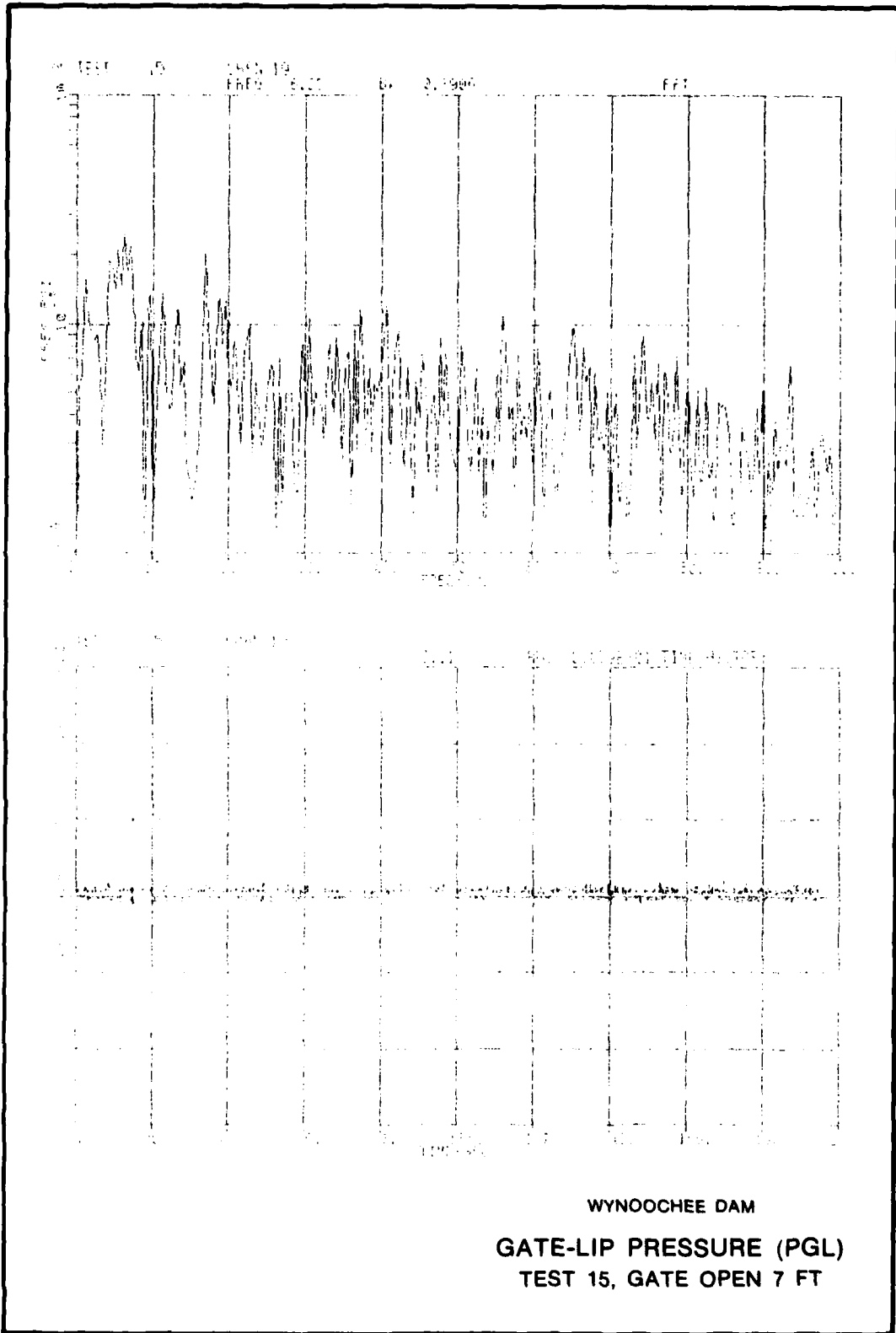
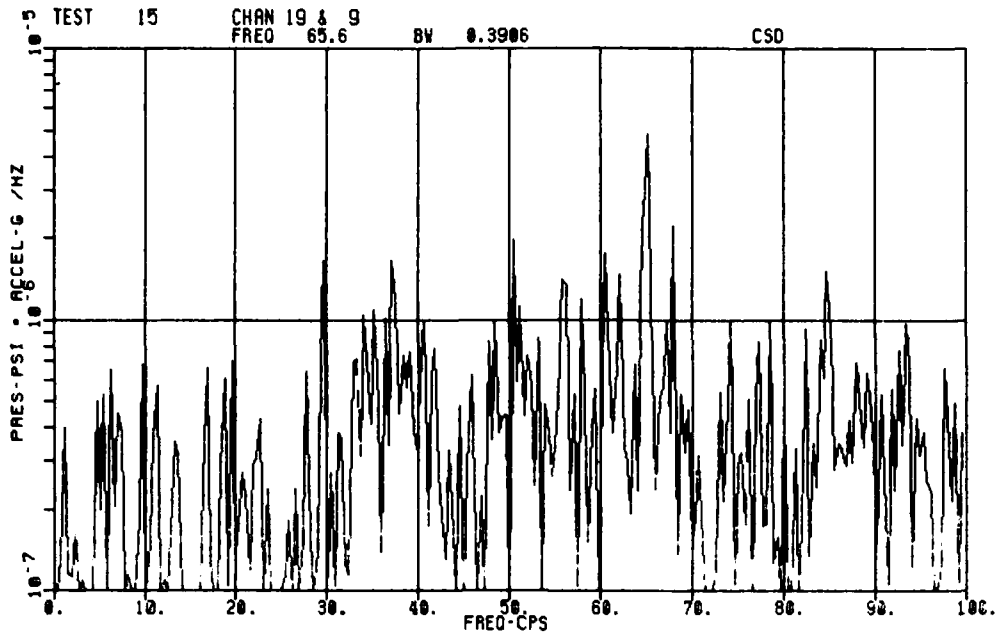
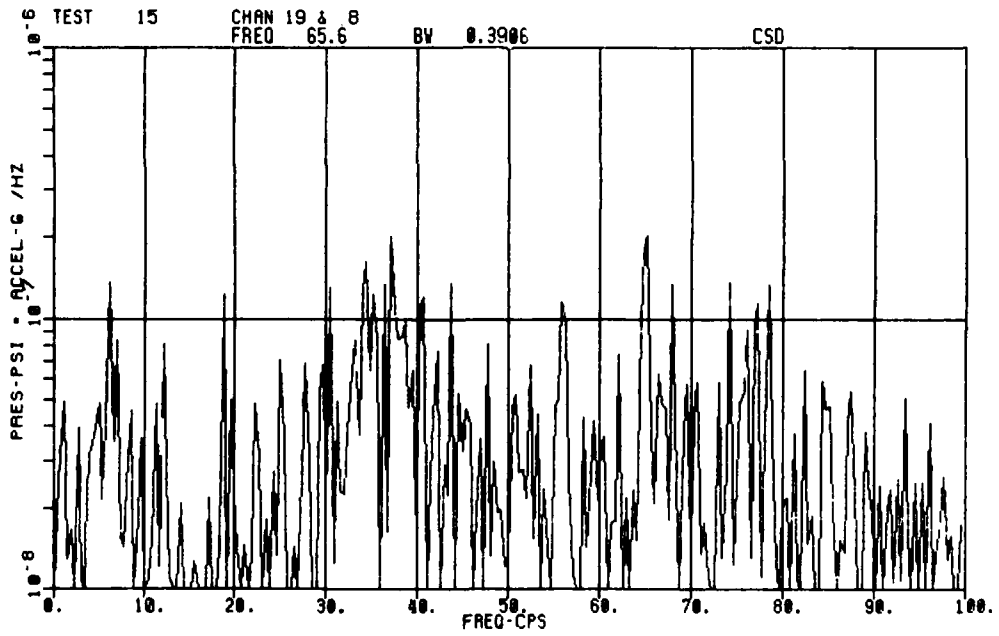

PLATE 8



a. GATE-LIP PRESSURE (PGL) × PARALLEL GATE ACCELERATION (AGP)



b. GATE-LIP PRESSURE (PGL) × TRANSVERSE GATE ACCELERATION (AGT)

WYNOOCHEE DAM  
 CROSS-SPECTRAL  
 DENSITY PLOT  
 TEST 15, GATE OPEN 7 FT

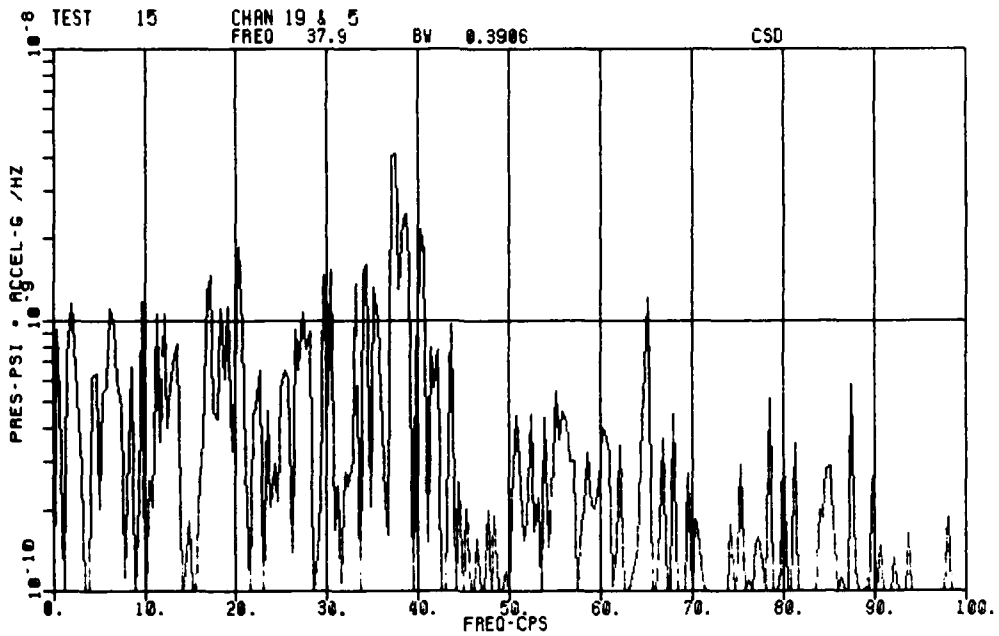

a. GATE-LIP PRESSURE (PGL) × TRANSVERSE VISTA HOUSE ACCELERATION (AVT)

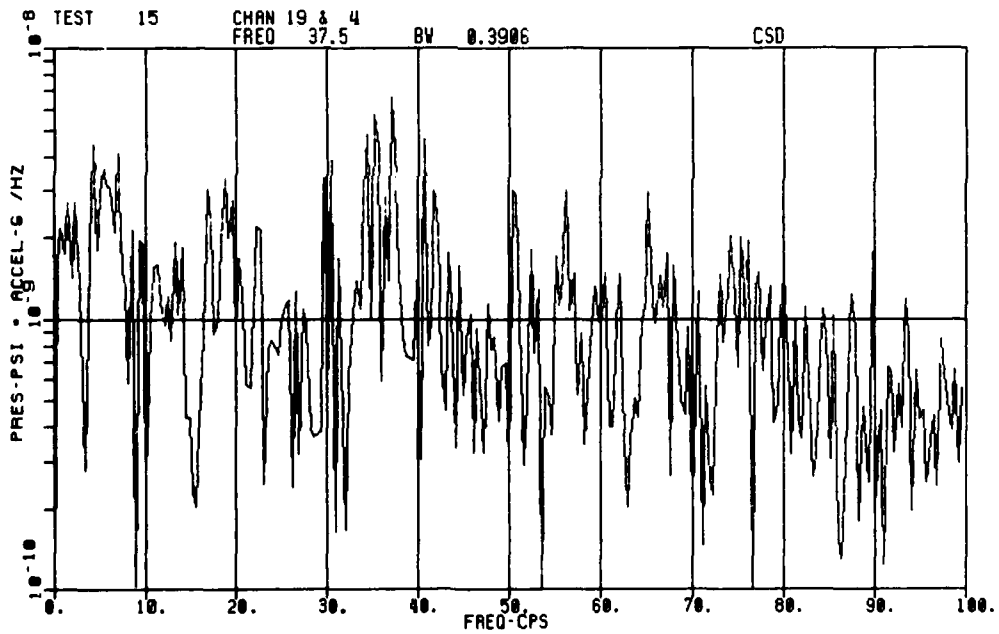

b. GATE-LIP PRESSURE (PGL) × VERTICAL VISTA HOUSE ACCELERATION (AVV)

WYNOOCHEE DAM

CROSS-SPECTRAL  
 DENSITY PLOT

TEST 15, GATE OPEN 7 FT

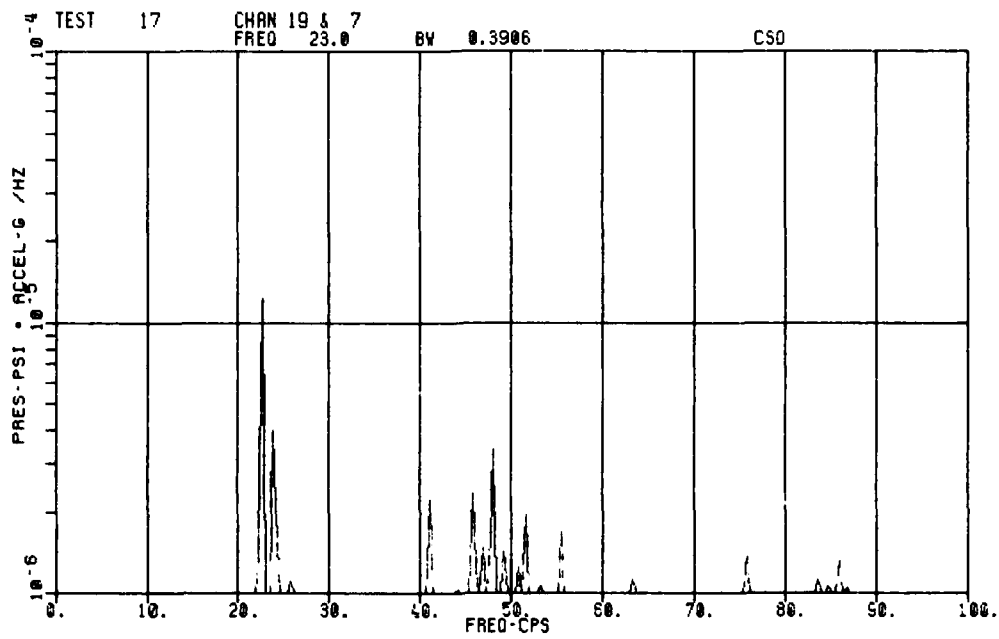

a. GATE-LIP PRESSURE (PGL) \* VERTICAL GATE ACCELERATION (AGV)

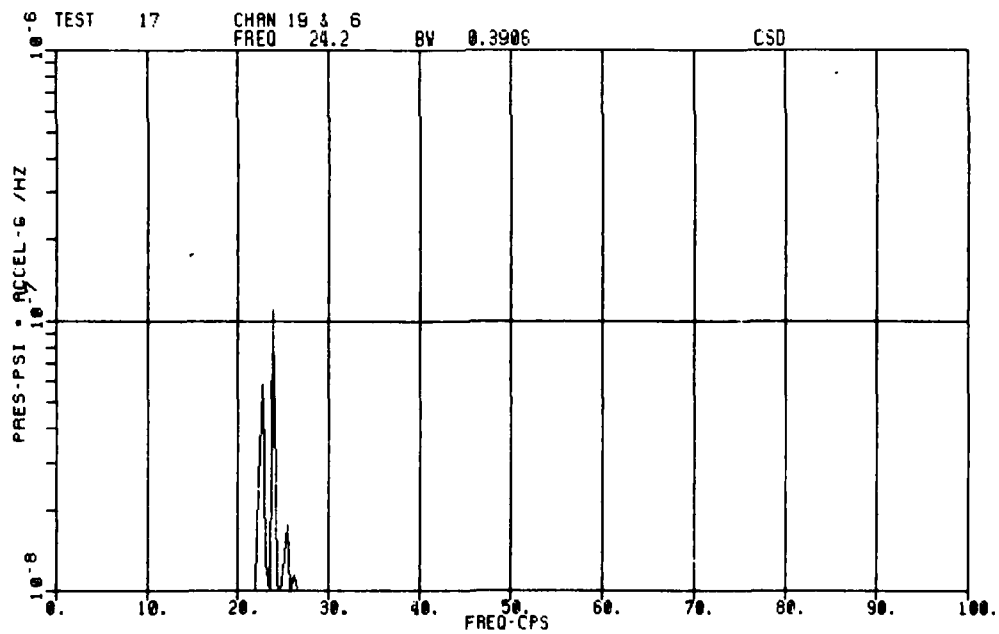

b. GATE-LIP PRESSURE (PGL) \* VERTICAL VISTA HOUSE ACCELERATION (AVV)

WYNOOCHEE DAM  
 CROSS-SPECTRAL  
 DENSITY PLOT  
 TEST 17, GATE OPEN 9 FT

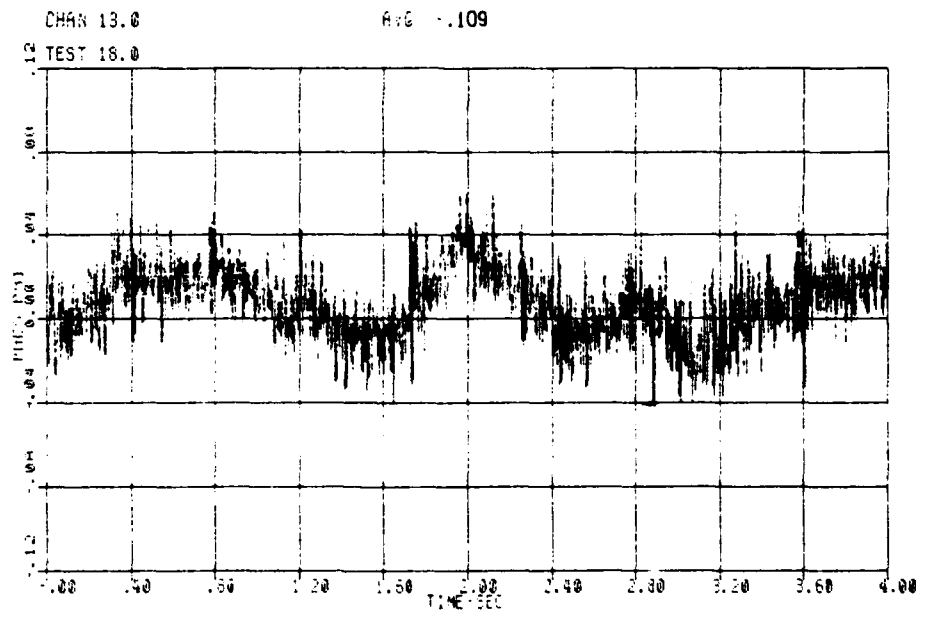
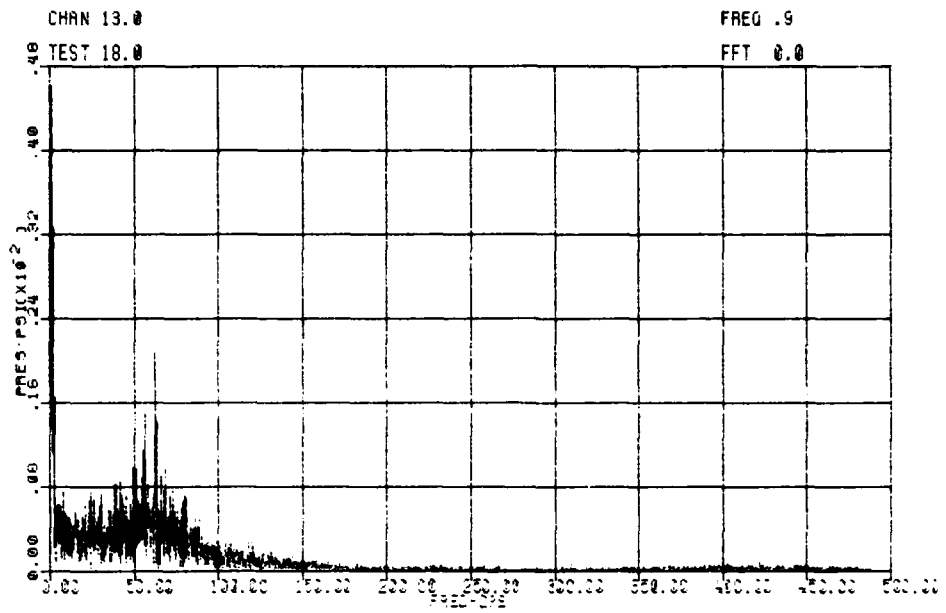

WYNOOCHEE DAM  
AIR-VENT DIFFERENTIAL  
PRESSURE (AVI)  
TEST 18. GATE OPEN 10 FT

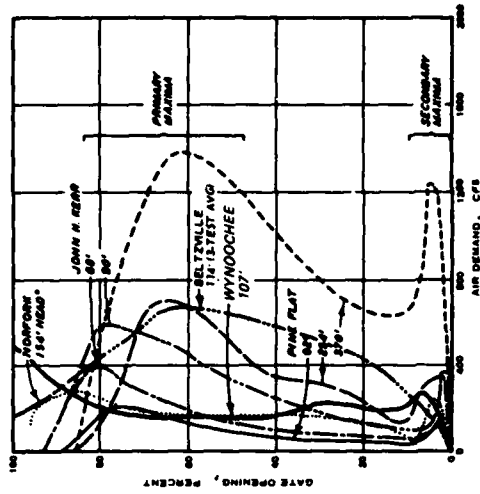

	CONDUIT		AIR VENT	
	LENGTH, FT	SIZE, FT TO	LENGTH, FT	DIAMETER, FT
JOHN H. KERR	117	5.67 x 10	90	2.50
NORFOLK	185	4 x 6	188	1.87
PINE FLAT	334	5 x 9	320	2.50
BELTZVILLE	631	2.83 x 7.33†	180	2.50
WYNOOCHEE	70	6 x 12	54	2.50

NOTE: \* HEADS ARE MEASURED FROM POOL TO CENTER LINE OF CONDUIT.  
 † USING ONE OF TWO GATE PASSAGES  
 (FROM: EM 1110-2-1602, 15 OCT 1960)

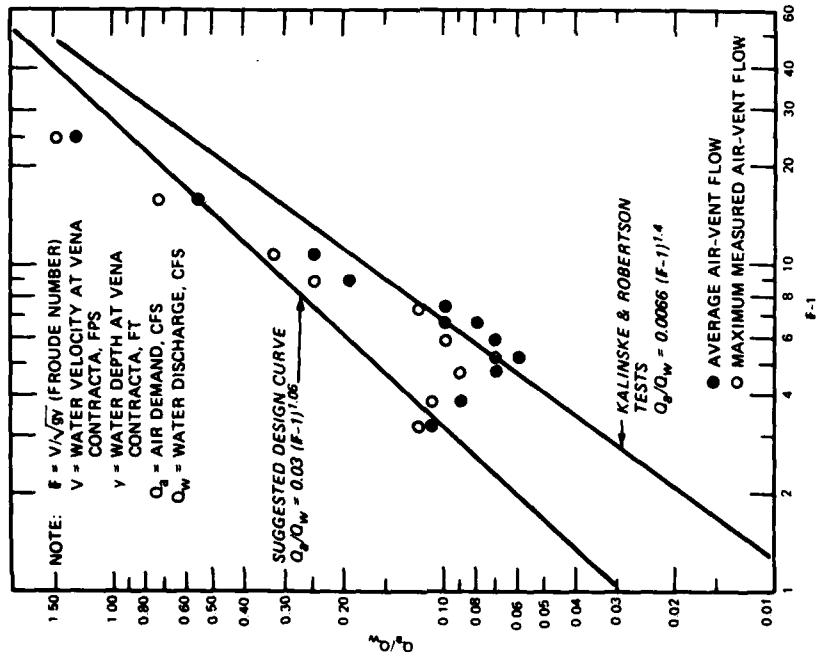

NOTE:  $F = V/\sqrt{gy}$  (FROUDE NUMBER)  
 $V$  = WATER VELOCITY AT VENA CONTRACTA, FPS  
 $y$  = WATER DEPTH AT VENA CONTRACTA, FT  
 $Q_a$  = AIR DEMAND, CFS  
 $Q_w$  = WATER DISCHARGE, CFS

SUGGESTED DESIGN CURVE  
 $Q_a/Q_w = 0.03 (F-1)^{1.06}$

KALINSKE & ROBERTSON TESTS  
 $Q_a/Q_w = 0.0066 (F-1)^{1.4}$

● AVERAGE AIR-VENT FLOW  
 ○ MAXIMUM MEASURED AIR-VENT FLOW

(FROM: HDC-060-1)

# VENT-AIR DEMAND TRANSDUCER AVI



CHAN 17.0

FREQ 1.4

TEST 18.0

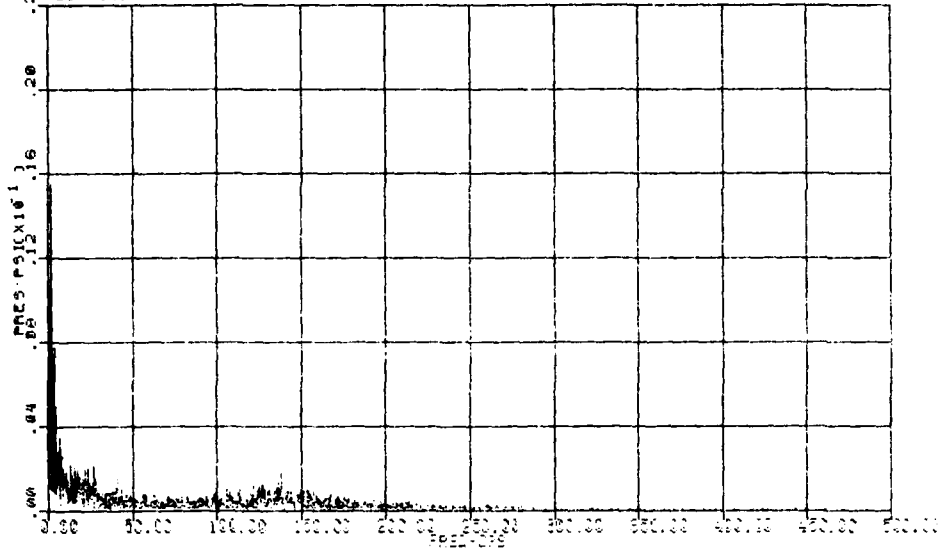

CHAN 17.0

AVE .249

TEST 18.0

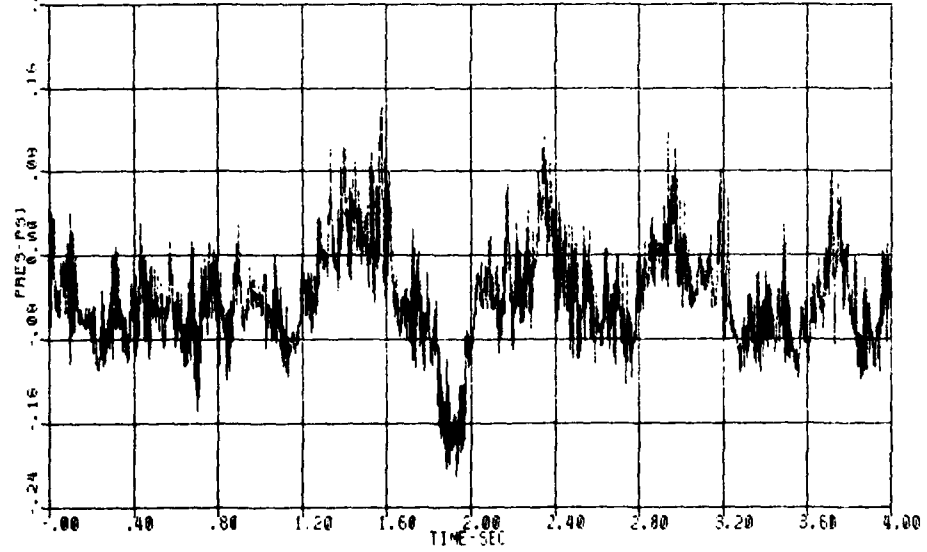

WYNOOCHEE DAM  
DIFFERENTIAL PRESSURE (DP3)  
TEST 18, GATE OPEN 10 FT

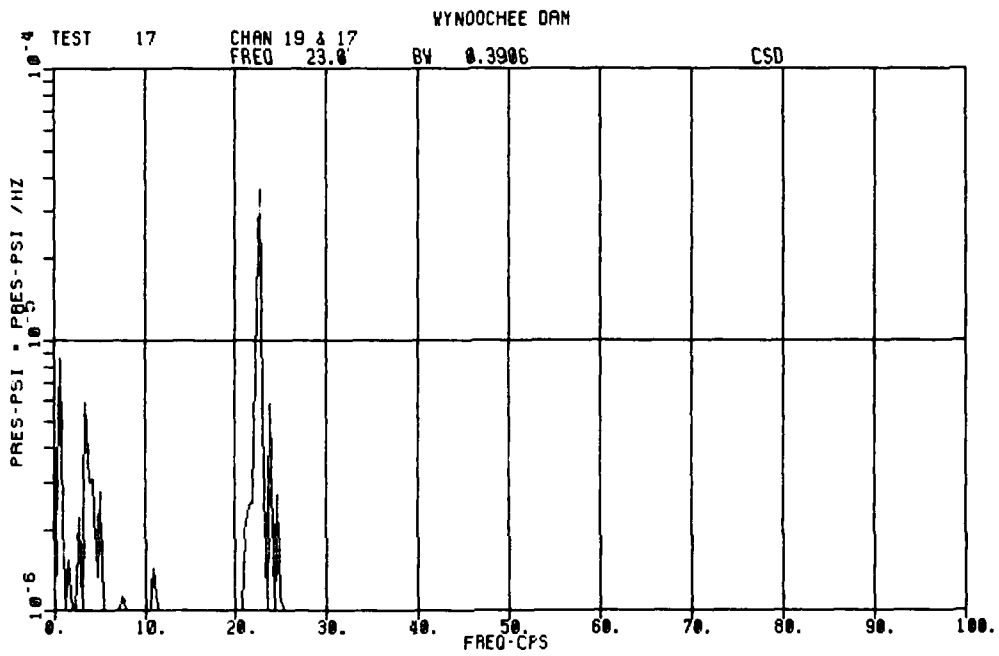

WYNOOCHEE DAM  
 CROSS-SPECTRAL  
 DENSITY FUNCTION  
 GATE-LIP PRESSURE (PGL)  
 × AIR-VENT PRESSURE (DP3)  
 TEST 17, GATE OPEN 9 FT

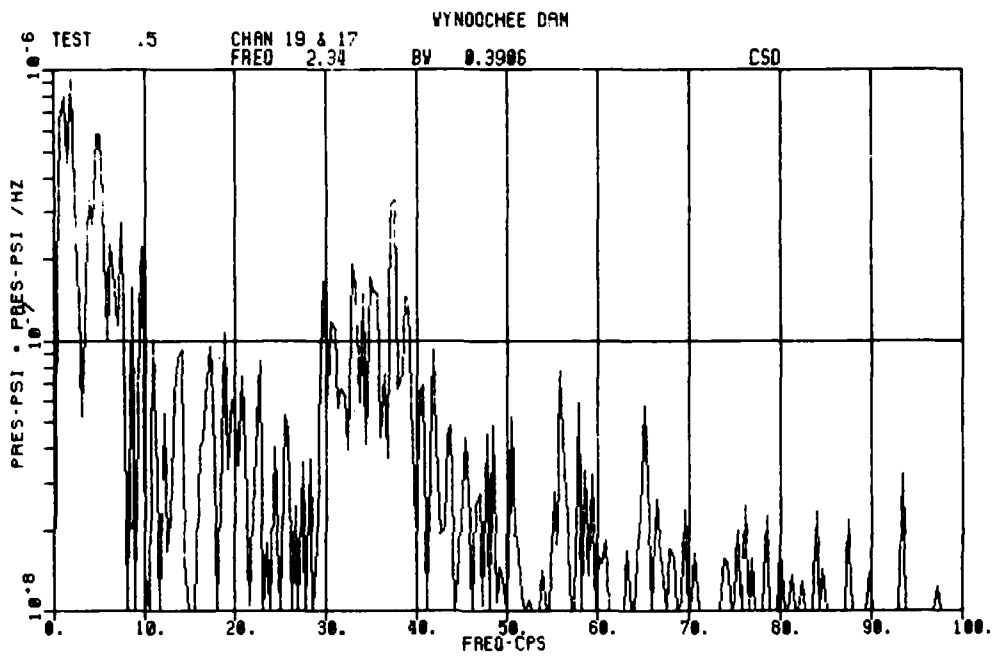

WYNOOCHEE DAM  
 CROSS-SPECTRAL  
 DENSITY PLOT  
 GATE-LIP PRESSURE (PGL)  
 × AIR-VENT PRESSURE (DP3)  
 TEST 15, GATE OPEN 7 FT

In accordance with letter from DAEN-RDC, DAEN-ASI dated 22 July 1977, Subject: Facsimile Catalog Cards for Laboratory Technical Publications, a facsimile catalog card in Library of Congress MARC format is reproduced below.

Hart, E. Dale

Air demand and vibration measurements, Wynoochee Dam, Wynoochee River, Washington / by E. Dale Hart (Hydraulics Laboratory, U.S. Army Engineer Waterways Experiment Station). -- Vicksburg, Miss. : The Station ; Springfield, Va. ; available from NTIS, 1982.

24, [5] p., 16 p. of plates : ill. ; 27 cm. --  
(Miscellaneous paper ; HL-82-2)

Cover title.

"December 1982."

Final report.

"Prepared for U.S. Army Engineer District, Seattle."

Bibliography: p. 24.

1. Hydraulic gates. 2. Hydraulic structures--Vibration.  
3. Wynoochee Dam (Wash.) I. United States. Army.  
Corps of Engineers. Seattle District. II. U.S. Army

Hart, E. Dale

Air demand and vibration measurements, Wynoochee : ... 1982.  
(Card 2)

Engineer Waterways Experiment Station. Hydraulics  
Laboratory. III. Title IV. Series: Miscellaneous  
paper (U.S. Army Engineer Waterways Experiment Station) ;  
HL-82-2.

TA7.W34m no.HL-82-2

**LMED**

**-8**