

AD-A119 993

CONSTRUCTION ENGINEERING RESEARCH LAB (ARMY) CHAMPAIGN IL F/6 13/1
OVERVIEW OF PASSIVE SOLAR DESIGN TECHNIQUES.(U)
SEP 82 D M JONCICH

UNCLASSIFIED

NL

AL
DYNAMIC

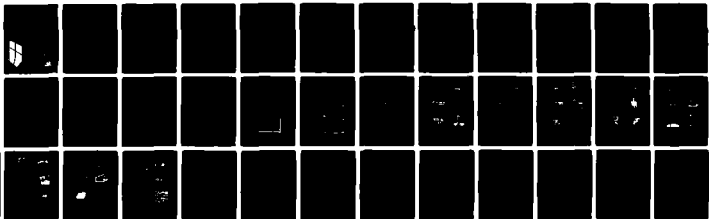

END
DATE
FILMED
11-82
DTIC

construction
engineering
research
laboratory



United States Army
Corps of Engineers
... Serving the Army
... Serving the Nation

15
SPECIAL REPORT E-179
September 1982

OVERVIEW OF PASSIVE SOLAR DESIGN TECHNIQUES

AD A119993

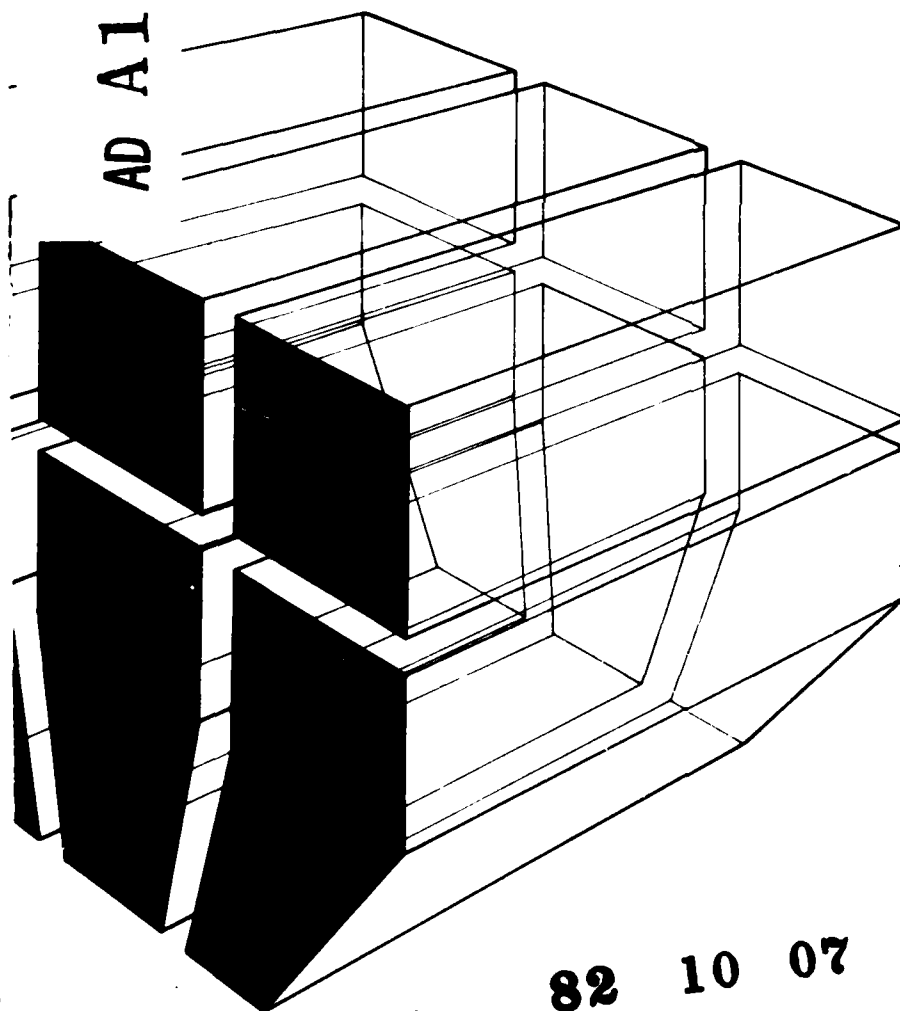

by
D. M. Joncich

DTIC
ELECTRONIC
S OCT 7 1982 D

A



82 10 07 008

DTIC FILE COPY

The contents of this report are not to be used for advertising, publication, or promotional purposes. Citation of trade names does not constitute an official indorsement or approval of the use of such commercial products. The findings of this report are not to be construed as an official Department of the Army position, unless so designated by other authorized documents.

**DESTROY THIS REPORT WHEN IT IS NO LONGER NEEDED
DO NOT RETURN IT TO THE ORIGINATOR**

UNCLASSIFIED

SECURITY CLASSIFICATION OF THIS PAGE (When Data Entered)

REPORT DOCUMENTATION PAGE		READ INSTRUCTIONS BEFORE COMPLETING FORM
1. REPORT NUMBER CERL-SR-E-179	2. GOVT ACCESSION NO. AD-A119 993	3. RECIPIENT'S CATALOG NUMBER
4. TITLE (and Subtitle) OVERVIEW OF PASSIVE SOLAR DESIGN TECHNIQUES		5. TYPE OF REPORT & PERIOD COVERED FINAL
		6. PERFORMING ORG. REPORT NUMBER
7. AUTHOR(s) D. M. Joncich		8. CONTRACT OR GRANT NUMBER(s)
9. PERFORMING ORGANIZATION NAME AND ADDRESS U.S. ARMY CONSTRUCTION ENGINEERING RESEARCH LABORATORY P.O. BOX 4005, Champaign, IL 61820		10. PROGRAM ELEMENT, PROJECT, TASK AREA & WORK UNIT NUMBERS IAO No. CWO-M81-18
11. CONTROLLING OFFICE NAME AND ADDRESS		12. REPORT DATE September 1982
		13. NUMBER OF PAGES 40
14. MONITORING AGENCY NAME & ADDRESS (if different from Controlling Office)		15. SECURITY CLASS. (of this report) Unclassified
		15a. DECLASSIFICATION/DOWNGRADING SCHEDULE
16. DISTRIBUTION STATEMENT (of this Report) Approved for public release; distribution unlimited.		
17. DISTRIBUTION STATEMENT (of the abstract entered in Block 20, if different from Report)		
18. SUPPLEMENTARY NOTES Copies are obtainable from the National Technical Information Service Springfield, VA 22151		
19. KEY WORDS (Continue on reverse side if necessary and identify by block number) passive systems solar energy buildings		
20. ABSTRACT (Continue on reverse side if necessary and identify by block number) This report presents an overview of the fundamental terminology, concepts, and techniques related to passive solar technology, and provides examples of passive strategies which can be incorporated into the inventory of Army buildings.		

DD FORM 1473 EDITION OF 1 NOV 65 IS OBSOLETE

UNCLASSIFIED

SECURITY CLASSIFICATION OF THIS PAGE (When Data Entered)

UNCLASSIFIED

SECURITY CLASSIFICATION OF THIS PAGE(When Data Entered)

BLOCK 20. (Cont'd)

The information in this report was developed from a search of the literature on passive solar systems. Three basic sources were used: The Passive Solar Design Handbook (Vols 1 and 2) and Regional Guidelines for Building Passive Energy Conserving Homes. These and other documents listed in the references provide detailed descriptions of the techniques discussed in this report.

UNCLASSIFIED

SECURITY CLASSIFICATION OF THIS PAGE(When Data Entered)

FOREWORD

This study was done on a reimbursable basis for the Directorate of Civil Works, Office of the Chief of Engineers (OCE) under IAO No. CWO-M81-18, dated 1 April 1981. The OCE Technical Monitor was Mr. J. Bickley, DAEN-CWO-M.

Appreciation is expressed to Mr. Lee Edgar and Ms. Annette Stumpf of CERL-ES for assistance they provided in the analysis of the AIA Climate Regions and in the development of the report figures.

This study was performed by the Energy Systems Division (ES), U.S. Army Construction Engineering Research Laboratory (CERL). Mr. R. G. Donaghy is Chief of ES.

COL Louis J. Circeo is Commander and Director of CERL, and Dr. L. R. Shaffer is Technical Director.

Accession For	
NTIS GRA&I	<input checked="" type="checkbox"/>
DTIC TAB	<input type="checkbox"/>
Unannounced	<input type="checkbox"/>
Justification	
Distribution/	
Availability Codes	
A	



CONTENTS

	<u>Page</u>
DD FORM 1473	1
FOREWORD	3
LIST OF TABLES AND FIGURES	5
1 INTRODUCTION.....	7
Background	
Objective	
Approach	
2 PASSIVE DESIGN CONSIDERATIONS.....	9
Human Comfort	
Energy Conservation	
Solar Access	
Analysis of System Performance	
3 PASSIVE SOLAR SYSTEM TYPES.....	13
Heating	
Cooling	
4 EXAMPLES BY CLIMATE REGION.....	16
5 CONCLUSION.....	17
FIGURES AND TABLES	18
REFERENCES	31
GLOSSARY	33
DISTRIBUTION	

TABLE

<u>Number</u>		<u>Page</u>
1	Design Considerations by Climate Region	18

FIGURES

1	Direct Gain	18
2	Thermal Storage Wall	19
3	Thermal Storage Wall With Thermocirculation Vents	19
4	Attached Sunspace	20
5	Climate Regions for the United States	20
6	Minimize Summer Heat Gain	21
7	Avoid Creating Additional Humidity	22
8	Protect From the Summer Sun	23
9	Use Mass to Moderate Temperature Swings	24
10	Use Wind for Natural Ventilation	25
11	Consider Evaporative Cooling	26
12	Minimize Winter Heat Loss	27
13	Reduce Infiltration Losses	28
14	Admit the Winter Sun	29
15	Capitalize on a Nearly Ideal Climate	30

OVERVIEW OF PASSIVE SOLAR DESIGN TECHNIQUES

1 INTRODUCTION

Background

The Army Energy Plan requires a substantial reduction in the amount of energy used to heat and cool Army buildings.¹ Recently, passive solar design has become recognized as an effective way to achieve this reduction. Generally, with a passive solar energy system, the thermal energy flows in buildings occur naturally. Passive systems are characterized by a minimum of mechanical equipment, and if properly designed, offer many advantages over complex heating and cooling systems.

Most of the advantages result from the simplicity of passive designs. Since these systems have few (or no) moving parts, their performance is reliable. Because most passive techniques incorporate conventional building materials, the systems tend to be long-lasting.

There are, however, some disadvantages. First, passive solar systems must be properly designed. This implies that the building community as a whole must become familiar with the fundamental concepts of passive design. Second, passive systems can cost more than conventional ones. However, this increased first cost will be offset by the future energy savings these systems afford. Finally, there is some problem with the "market acceptance" of the passive solar designs. In most cases, a passive system is integrated into the architecture of a building, which affects the structure's appearance. It may take some time before the public accepts these designs.

Objective

This report presents an overview of the fundamental terminology, concepts, and techniques related to passive solar technology, and provides examples of passive strategies which can be incorporated into the inventory of Army buildings.

Approach

The information in this report was developed from a search of the literature on passive solar systems. Three basic sources have been used: The Passive Solar Design Handbook (Vols 1 and 2) and Regional Guidelines for Building

¹ Army Energy Plan, ADA057987 (Headquarters, Department of the Army, 1978).

Passive Energy Conserving Homes.² These and other documents listed in the references provide detailed descriptions of the techniques discussed in this report.

² Passive Solar Design Handbook, Volume One of Two Volumes: Passive Solar Design Concepts, DOE/CS-0127/1 US-59 (Department of Energy, March 1980); Passive Solar Design Handbook, Volume Two of Two Volumes: Passive Solar Design Analysis, DOE/CS-0127/2 UC-59 (Department of Energy, January 1980); Regional Guidelines for Building Passive Energy Conserving Homes, HUD-PDR-355 (Prepared by the AIA Research Corporation for the Department of Housing and Urban Development, November 1978).

2 PASSIVE DESIGN CONSIDERATIONS

This chapter discusses several factors that must be considered in the design of a passive solar system: human comfort, energy conservation, solar access, and system performance.

Human Comfort

Three processes keep the human body comfortable: convection, evaporation/respiration, and radiation.* However, the extent to which these processes occur depends on air temperature, air speed, mean radiant temperature, and relative humidity of the space being occupied. Because many passive systems, unlike conventional approaches, take advantage of these variables, designers must understand how the occupants' comfort may be affected.

1. Air temperature -- determines the temperature difference between the body and the ambient, and this affects the rate of heat loss or gain through convection.

2. Air speed -- affects heat gain or loss due to convection. The chill factor measures the effect of air speed on heat loss in the winter. In the summer, the air speed is also very important when the body is trying to lose heat through evaporation to maintain comfort.

3. Mean radiant temperature (MRT) -- refers to the average surface temperature of all the surroundings (including walls, ceilings, windows, and floors) with which the body can exchange heat by radiant transfer. Different combinations of mean radiant temperature and air temperature can produce the same "comfort sensation." An understanding of this fact is essential to a good passive design. For example, one can be comfortable in a cool room if the MRT is high. Conversely, one may be uncomfortable in a room where the air temperature is high and the MRT is low -- possibly as a result of poorly insulated walls.

4. Humidity -- affects the rate at which the body loses heat by evaporation. During hot weather, for example, high humidity increases discomfort by decreasing the rate of moisture evaporation from the skin.

The Bioclimatic Chart developed by V. Olgyay provides a convenient way of estimating the impacts of these variables on comfort.³ After the designer understands the relationships among these variables, he/she can appreciate the impact of the passive considerations discussed below.

Energy Conservation

It is advantageous, from both an economic and an engineering standpoint, to make energy conservation the first consideration in the thermal design of buildings. Buildings lose energy primarily through conduction and

* See the glossary for definitions of terms related to passive solar design.
³ Victor Olgyay, Design with Climate (Princeton University Press, 1963).

infiltration. Because energy conservation measures have a significant impact on the performance of a passive solar system, the designer should be well aware of techniques for reducing these losses.⁴

Conduction losses are usually controlled by increasing the levels of thermal insulation in the structure. Most techniques for reducing heat loss from a residence during the winter are also effective in minimizing unwanted heat gain in the summer. In general, buildings in colder climates should be more heavily insulated than similar structures in warmer climates. Guidelines on minimum acceptable R-values for walls, ceilings, and floors have been developed by climate region for the United States.⁵

Other methods for reducing conduction losses include earth berming, particularly on northern exposures, and underground construction. Airing storm windows or using movable insulation over glazed surfaces can control heat loss through windows.

Infiltration losses from buildings can be minimized in several ways. Weatherstripping, caulking, windbreaks, and protected or air-locked entryways can be used. The integrity of vapor barriers can be checked closely when a building is constructed. When the infiltration rate is reduced to fewer than 0.5 air changes per hour, air-to-air heat exchangers can be used to preheat ventilation air before admitting it to the space.

Solar Access

Once the thermal requirements of the candidate building have been reduced to the lowest practical level, strategies for taking advantage of solar inputs to the structure may be considered. Of course, this concept of "solar access" is the central issue for all passive solar energy systems. Given a proper design, sunlight can be used effectively to light and heat a building.

The performance of any passive solar design depends on two major site-specific factors: the position of the sun and the amount of available insolation. Both of these vary during the day and throughout the year.

Solar Position

The sun's position is designated by two angles, the solar azimuth and the solar altitude. This angle information is used to determine the shading of solar collection surfaces at any time during the year.⁶ Several of the references provide excellent treatments of this subject (pp 31).

⁴ Donald Watson, Energy Conservation Through Building Design (McGraw-Hill, 1979).

⁵ Energy Conservation in New Building Design, Standard 90-75 (American Society of Heating, Refrigerating, and Air-Conditioning Engineers [ASHRAE]).

⁶ Edward Mazria, The Passive Solar Energy Book (Rodale Press, 1979).

Amount of Solar Radiation

While the intensity of solar radiation is relatively fixed, the availability of this resource at a particular site is strongly influenced by the local climate. As would be expected, the average radiation available in a cloudy climate could be significantly less than in a sunny one.

Solar insolation generally consists of two components: direct and diffuse radiation. Whereas the direct component may be more useful for solar heating applications, some passive strategies use the diffuse for daylighting.⁷ There are tables which list the amount of solar radiation at several sites in the United States.⁸

After the site-specific solar resource has been determined, other factors having a critical impact on the performance of a passive system must be assessed. These include siting, building orientation, and length/width/height ratios.

Siting. Site planning to assure solar access has been the subject of many studies.⁹ Factors to be considered include site layout, lot lines, lot orientation, solar rights, street width, and landscaping.

Building Orientation. South-facing houses generally assure lower energy consumption during both winter and summer. Knowing the relative amounts of solar radiation striking the various facades can help the designer decide on the building orientation. Proper location and orientation of windows is most important in reducing solar heat during the summer; there should be more glass on the south than on the east or west.

Length/Width/Height Ratios. In addition to proper orientation, a building benefits from appropriate ratios between its dimensions. The ideal shape maximizes heat gains from the outside in the winter and minimizes them in the summer.

When solar energy is used in space heating, the amount of sunlight entering the space must be controlled. Once solar radiation has been admitted to a structure, thermal mass is extremely important in limiting internal temperature swings. Heavy materials in buildings absorb excess daytime heat and tend to smooth the effects of fluctuating inputs of energy. Generally speaking, the more thermal mass, the better.

Carefully designed overhangs, parts of the building itself, solar films and screens, insulating drapes, or well-placed vegetation can serve to reduce cooling loads. However, a building may be designed to admit some sun in the summer for natural lighting. Common building elements for admitting sunlight include light shelves, south windows, skylights, and clerestories. Solar glazing often saves more energy and money by reducing the need for artificial lighting than it does by lowering fuel bills.

⁷ Martin Evans, Housing, Climate, and Comfort (John Wiley and Sons, 1980).

⁸ Passive Solar Design Handbook, Volume Two of Two Volumes: Passive Solar Design Analysis, DOE/CS-0127/2 UC-59 (Department of Energy, January 1980).

⁹ For example, see Duncan Erley, et al., Site Planning for Solar Access, HUD-PDR-481(2) (Department of Housing and Urban Development, May 1980).

Analysis of System Performance

It is very important to design passive solar systems carefully. In general, the principles of passive solar heating are straightforward, but their application to a specific project requires detailed analysis. For example, it is easy to put a large expanse of glass on the southern exposure of a building, thereby achieving a significant amount of solar heating in the winter. However, this approach also will cause excessive heat losses at night and problems with overheating during the summer.

Before any passive solar project is started, appropriate designs must be considered. To help the designer make a quantitative estimate of the thermal performance of a proposed passive design, the Solar Energy Research Institute has supported the development of a number of passive solar analysis tools.¹⁰ These tools range from detailed hourly simulations to the simplest rules of thumb.

¹⁰Greg Franta, et al., Solar Design Workbook, SERI/SP-62-308 (Solar Energy Research Institute, January 1981).

3 PASSIVE SOLAR SYSTEM TYPES

Thus far, a number of concepts common to all passive solar designs have been considered. This chapter describes more specifically some of the techniques now used for passive solar heating and cooling.

Heating

Direct Gain

The direct gain approach to passive solar heating is used most often. In this system (Figure 1), solar radiation entering through south-facing glazing is absorbed by and stored in the mass within the space. To reduce heat loss at night, movable insulation may be applied to the surface of the glazing. During the winter, the south glass takes full advantage of the sun, which is low in the sky. In the summer, the glass is shaded by overhangs or trees. The most common thermal storage materials are masonry and water.

The advantages of this strategy are its simplicity, its ease of construction, and its use of south glass to admit heat in the winter and light in the summer.

The system also has disadvantages. Interior temperature swings of 15 to 20°F (8.3 to 11.1°C) are common with direct gain. The system may produce both glare and ultraviolet degradation of interior surfaces. Large expanses of glass may cause a loss of privacy. Commercially available movable insulation can be expensive.

Thermal Storage Walls

In this application (Figures 2 and 3), the massive wall is directly behind the south glazing. If the wall has no vents (Figure 2), the outside surface of the wall heats as the sun strikes it; the interior surface of the wall releases this heat to the space by radiation and convection after the sun has set. If vents are added to the wall (Figure 3), heat can be distributed by natural convection (thermocirculation) from the exterior face of the wall, but only during daytime and early evening hours. Even when vents are used, however, most of the heat transferred to the living area is absorbed by and conducted through the wall itself. Common wall materials are masonry or water in containers. Vented thermal storage walls made of masonry are called Trombe walls.

The advantages of using thermal storage walls include the following: (1) temperature swings in the living space are less than those with a direct gain system, (2) problems with glare and ultraviolet degradation of interior surfaces are eliminated, and (3) the time delay between the absorption of radiant energy by the surface and the delivery of heat to the space provides warmth in the evening.

The main disadvantage is that a massive wall tends to be costly. In addition, the wall occupies valuable space in the living area and blocks the occupants' view to the south.

Attached Sunspaces

The attached sunspace (Figure 4) is really a combination of the direct gain and thermal storage wall systems. In this configuration, the building consists of two zones: a greenhouse, which is directly heated by the sun, and an indirectly warmed wall, which is attached to the rest of the living space. The heat stored in this wall is shared by the sunspace and the building. In some applications, windows and doors distribute to adjacent rooms the warm daytime air in the sunspace. Temperature fluctuations in the glazed area and the living space are moderated by the wall.

There are many advantages to the attached sunspace: (1) it can be used in remodeling since greenhouses are readily adaptable to existing buildings; (2) it offers additional, useful living space for the occupants of the building; (3) it can provide a substantial amount of energy to the building, while simultaneously acting as a buffer zone to reduce heat loss to the ambient; and (4) temperature swings in adjacent living areas are small.

The main disadvantage of this approach is its cost. In addition, there are many sunspace designs; this makes it hard to estimate the thermal performance of each specific application.

Cooling

The state of the art for passive cooling is much less developed than for passive space heating. There are few analysis methods for estimating the thermal performance of passive cooling strategies, and little hardware is available. For most cooling applications, the best approach is to shade the structure. Other strategies include cooling through convection, evaporation, radiation, and ground transfer.

Convection

At temperatures below 100°F (37.7°C), the movement of air across the skin cools by convection and evaporation. Windows most often provide this form of cooling. The designer must consider the speed and direction of the prevailing local winds, and the siting and orientation of the building. For climates where the temperature at night drops below 65°F (18.1°C), nighttime ventilation combined with thermal mass should be seriously considered.

Evaporation

The evaporation of water also can keep building occupants comfortable. For locations with low relative humidities, this mechanism can contribute significantly to the cooling of a building: the evaporation of 11.4 lb (5.2 kg) of water per hour at 75°F (23.9°C) produces the equivalent of 1 ton of refrigeration. Fountains, sprays, and roof ponds take advantage of this characteristic.

Radiation

Cooling occurs when a body at a higher temperature radiates energy to one at a lower temperature. The amount of cooling by radiation depends on several factors, including the temperature, emittance, and orientation of the surface being cooled; the "sky temperature"; and the presence of obstacles between the sky and the surface. While systems using this approach have been developed, cooling through radiation has not yet been widely adopted.

Ground Heat Transfer

Since the ground nearly always has a lower temperature than the air during the cooling season, ground heat transfer has been considered as a way to keep heat from a building. Putting a structure underground is one approach; another is drawing ventilation air through pipes imbedded in the earth. Techniques for ground heat transfer are still in the developmental stages. These systems have had problems with condensation.

4 EXAMPLES BY CLIMATE REGION

The AIA Research Corporation has developed regional guidelines for the building of passive, energy-conserving homes.¹¹ To do this, AIA: (1) divided the United States into a number of distinguishable climate regions; (2) assessed the yearly temperature, humidity, wind, and solar conditions for each region; (3) determined how each condition affected the energy consumption of a residence; and (4) made specific recommendations about passive strategies for each region. The following information is developed from this AIA study.

Figure 5 shows 16 climate regions for the United States. For each, the local weather conditions determine which design considerations are of the highest priority in developing an energy-conservative building. For example, in the northeast United States, adequate thermal insulation might be most important because of the severity of the winters there.

After analyzing the AIA study, the U.S. Army Construction Engineering Research Laboratory identified 10 design considerations (Table 1). Then each consideration's priority was established for the various climate regions. Clearly, each consideration does not apply to every region. In areas of high humidity, for example, one would not use evaporative cooling to reduce a building's cooling load.

Figures 6 through 15 recommend strategies which can be used for each design consideration. For example, climate region 6 consists of a large area in the Pacific Northwest; Table 1 indicates that the highest priority in this climate is minimizing the winter heat loss. Strategies for accomplishing this are given in Figure 12. The second priority for this region is admitting the winter sun; Figure 14 shows several ways to do this. Finally, examples of techniques for reducing the infiltration losses, the third priority, are found in Figure 13.

The procedure is the same for each region: Table 1 is used to determine the relative ranking of the design priorities; techniques for achieving each goal are found in the appropriate figures.

¹¹Regional Guidelines for Building Passive Energy Conserving Homes, HUD-PDR-355 (Prepared by the AIA Research Corporation for the Department of Housing and Urban Development, November 1978).

5 CONCLUSION

This report has presented an overview of the fundamental terminology, concepts, and techniques related to passive solar technology, and has provided examples of passive strategies which can be incorporated into Army buildings.

Passive solar energy is best applied to new construction, where the analyst can weigh a number of interrelated factors early in the building design. Most of the Army's housing inventory, however, is made up of existing structures. Fortunately, many of the concepts described in this report can be applied on a retrofit basis. For example, thermal insulation and storm windows, caulking, and weatherstripping can be added, and attached sunspaces constructed. While the adoption of a passive design ultimately will depend on the system's performance relative to its cost, there is clearly potential for fossil fuel savings.

Table 1

Design Considerations by Climate Region

DESIGN CONSIDERATION	Refer to Figure	CLIMATE REGION															
		1	2	3	4	5	6	7	8	9	10	11	12	13	14	15	16
Minimize summer heat gain	6			4					1	2		1	5			1	6
Avoid creating additional humidity	7								6	7	7			6	4	4	4
Protect from the summer sun	8	4	5	5				4	4	6	5	2	3	3	2	3	2
Use mass to moderate temperature swings	9		4		3	4		3			2	4	7	5	3		
Use wind for natural ventilation	10	5	6	6	5			5		4	3	7		1	1	2	3
Consider evaporative cooling	11				4			6				3	1				
Minimize winter heat loss	12	1	1	1		1	1	2	2	1	1	5	4			7	7
Reduce infiltration losses	13	2	2	2	2	3	3	7	5	5	6	6	6	4	6	5	
Admit the winter sun	14	3	3	3	1	2	2	1	3	3	4		2	2	5	6	5
Capitalize on a nearly ideal climate	15																1

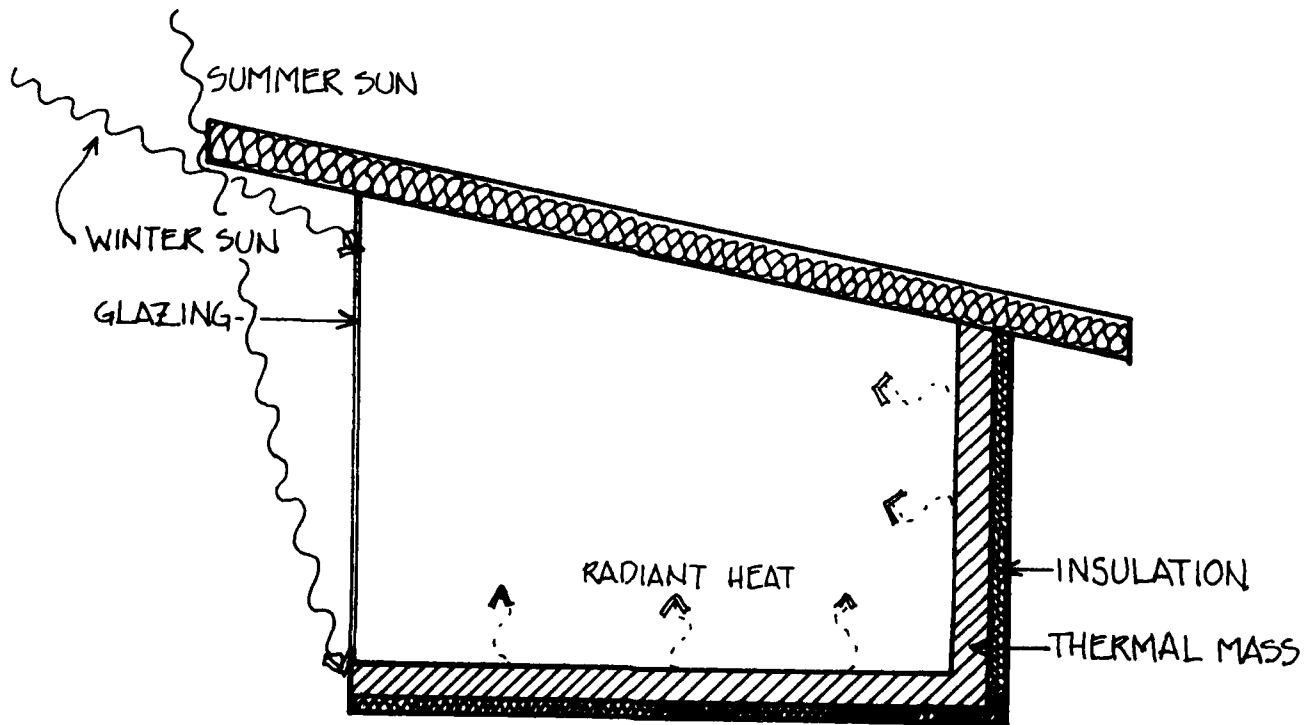

Figure 1. Direct gain.

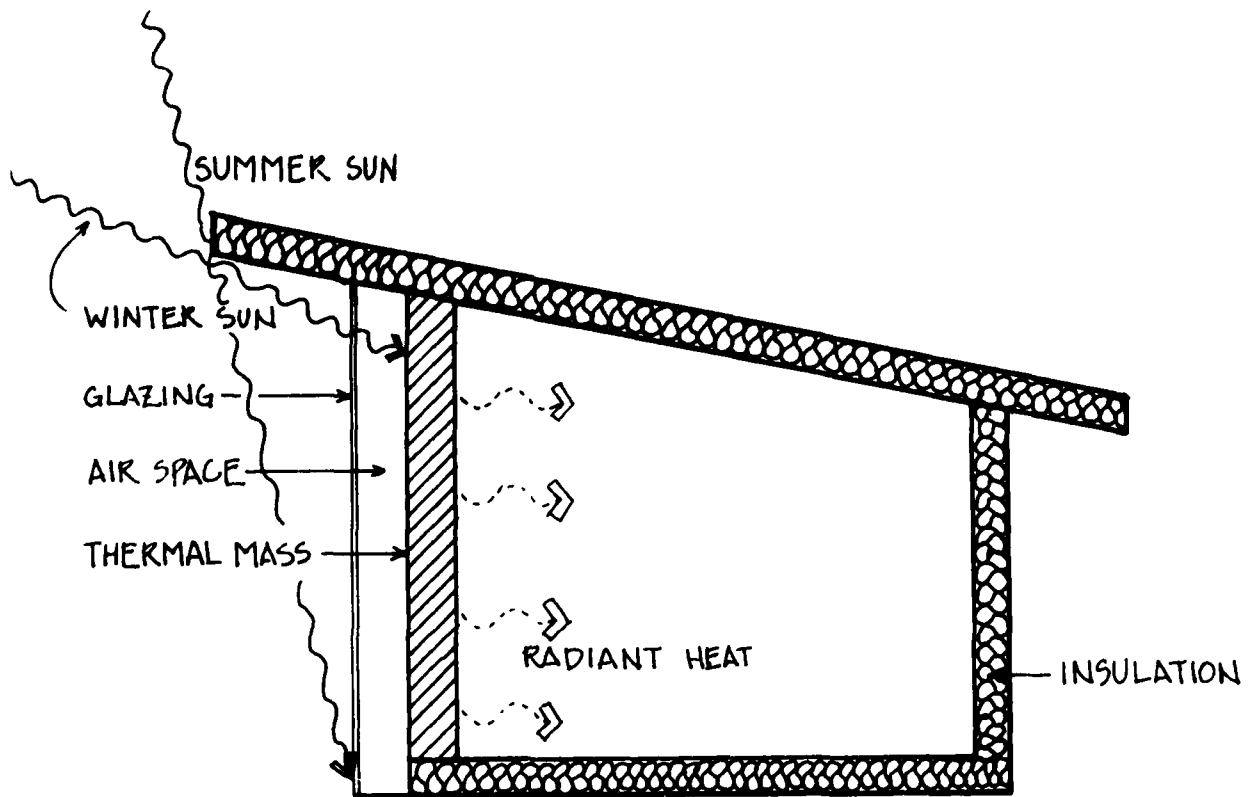

Figure 2. Thermal storage wall.

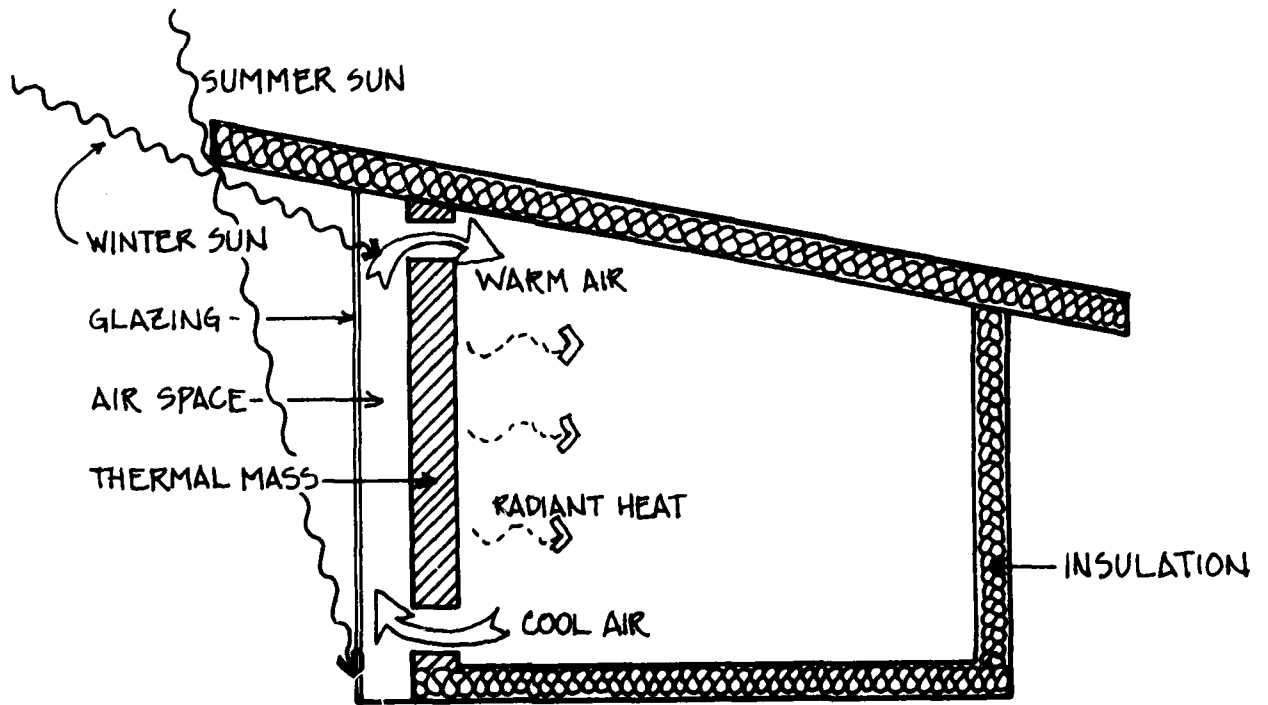

Figure 3. Thermal storage wall with thermocirculation vents.

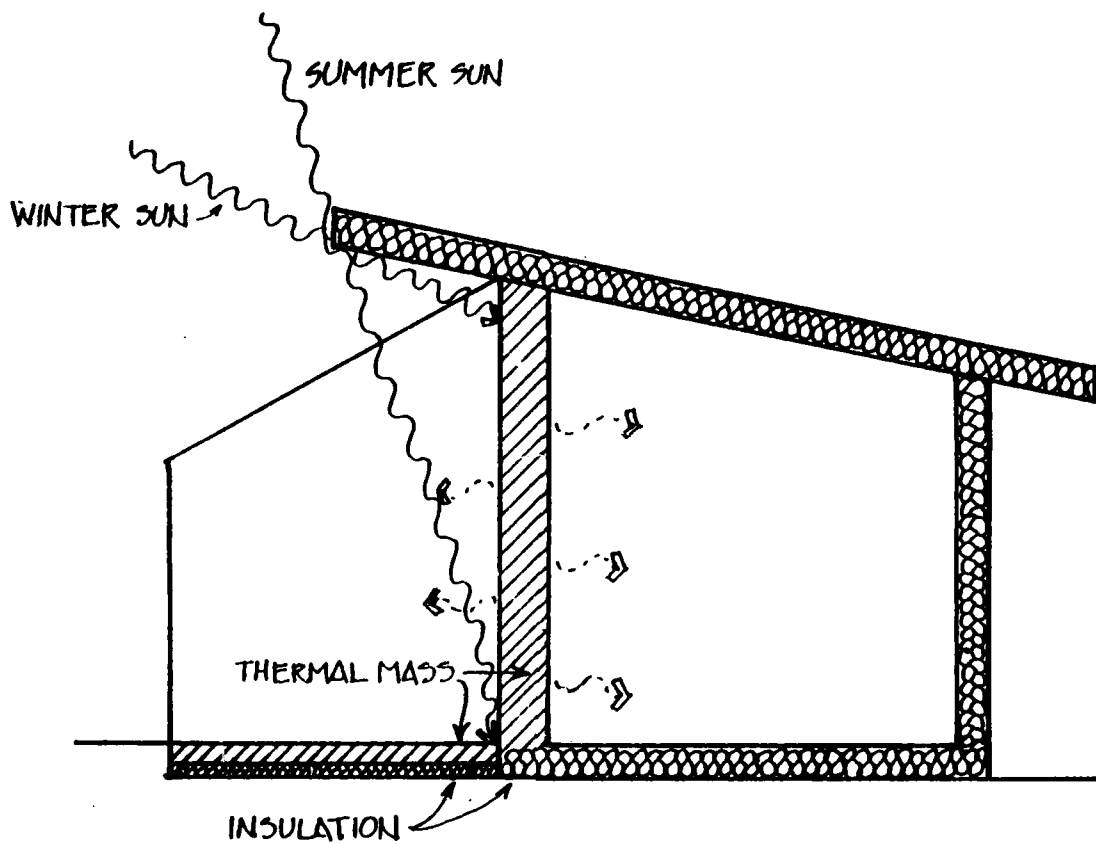

Figure 4. Attached sunspace.

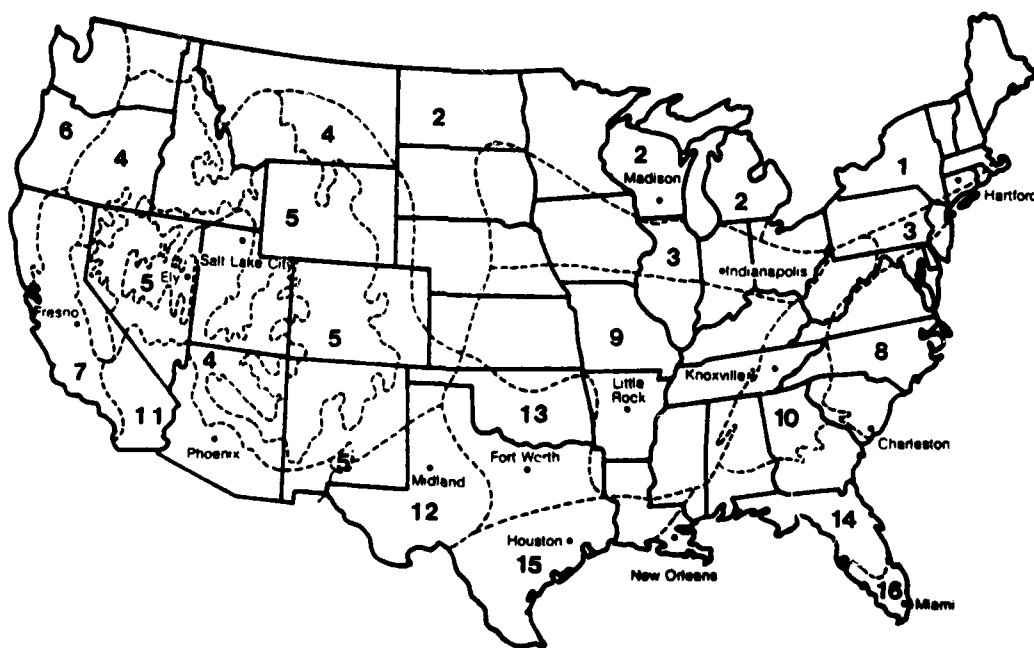
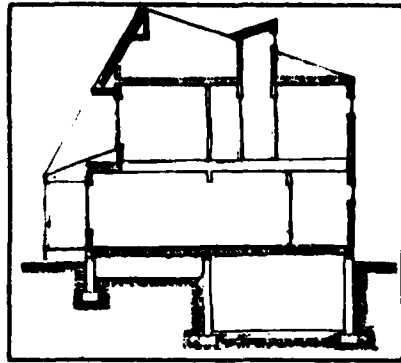
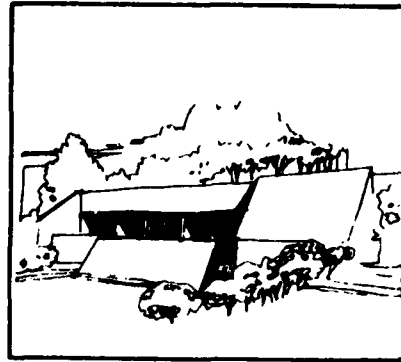

Figure 5. Climate regions for the United States.



Maximize thermal efficiency with insulation, caulking, and weatherstripping. Make insulation continuous around corners.



Use earth berms as insulative material. Ground temperatures remain at approximately 56°F year-round.

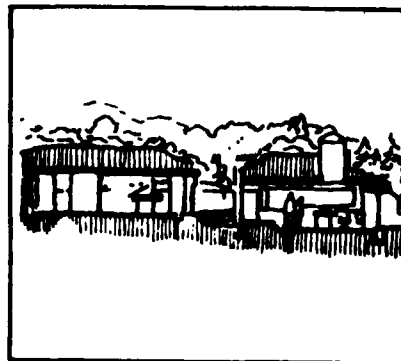

UNDERGROUND
Build homes partially underground to reduce exposure to high temperatures outside for underground passive cooling.

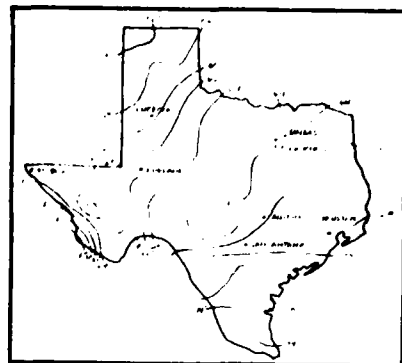

Underground temperatures for the state of Texas. Berm or site buildings into the ground to benefit from cooler ground temperatures. Beware of moisture conditions

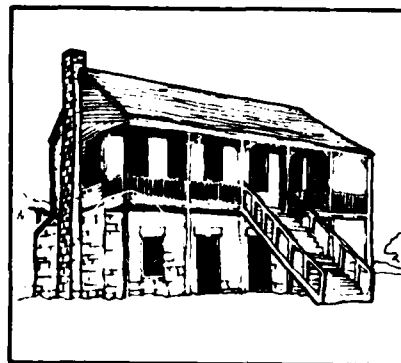

Zone the house. Insulated, heavy construction provides isolation from the liabilities of high summer temperatures, while light construction in other areas provides living spaces which catch the prevailing winds

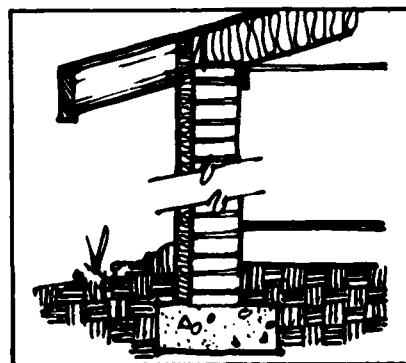

Insulate whether you are using wood or masonry construction. Insulation belongs on the exterior surface of the wall. Masonry exposed on the inside, with foam insulation covered by stucco, makes a cost effective wall

Figure 6. Minimize summer heat gain. (From Regional Guidelines for Building Passive Energy Conserving Homes, HUD-PDR-355 [prepared by the AIA Research Corporation for the Department of Housing and Urban Development, November 1978]).

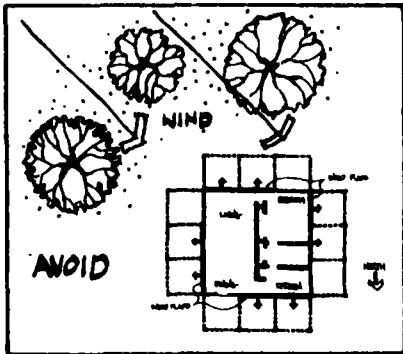

Don't place moisture-producing plants where the wind can carry their moisture inside.

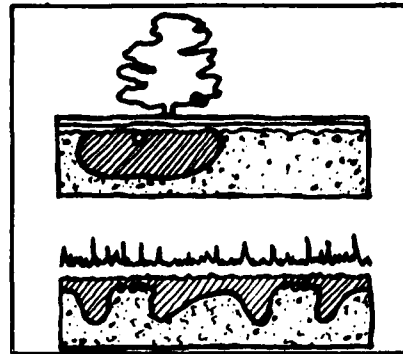

Use underground or drip irrigation systems to avoid creating humidity.

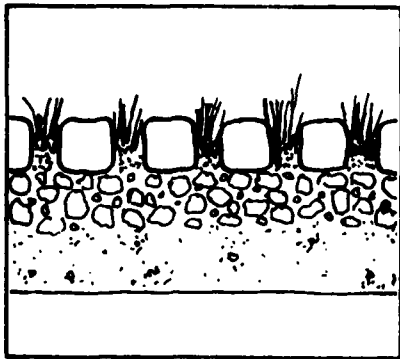

Use permeable paving materials to prevent puddles.



Remove plants from direct sunlight to reduce evaporation.

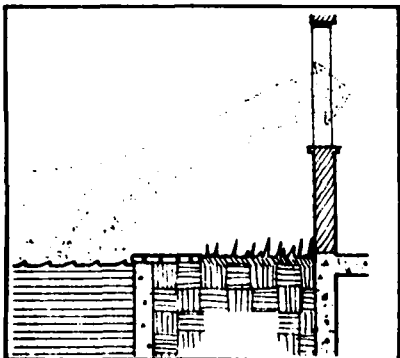

Do not place plants or pools in the sunshine or in the direction of prevailing winds, since this will add humidity.

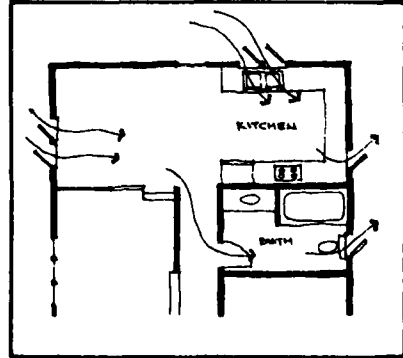

Ventilate kitchens, baths and laundry rooms in order to exhaust humid air.

Figure 7. Avoid creating additional humidity. (From Regional Guidelines for Building Passive Energy Conserving Homes, HUD-PDR-355 [prepared by the AIA Research Corporation for the Department of Housing and Urban Development, November 1978]).



Plant deciduous trees to keep out the hot summer sun

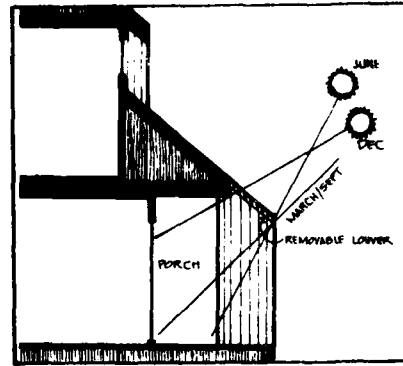

Design overhangs to let in winter sun while excluding higher summer sun

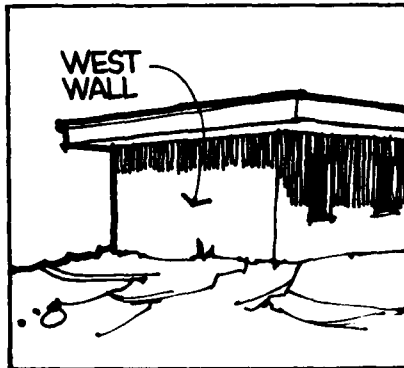

Avoid large glass exposures on the east and west where it's difficult to shade



Provide man-made shade for the building by using a double roof with an open space between.

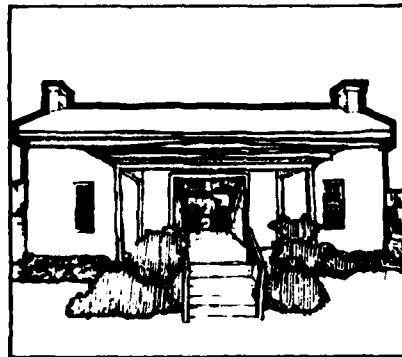

Light colored roofs and light colored walls help reflect sunshine

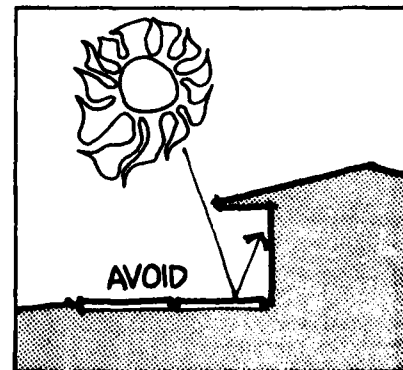

Beware of nearby structures and light-paved surfaces that can reflect solar heat into a home. Plants are good neighbors since they can shade and humidity for effective summer cooling.

Figure 8. Protect from the summer sun. (From Regional Guidelines for Building Passive Energy Conserving Homes, HUD-PDR-355 [prepared by the AIA Research Corporation for the Department of Housing and Urban Development, November 1978]).

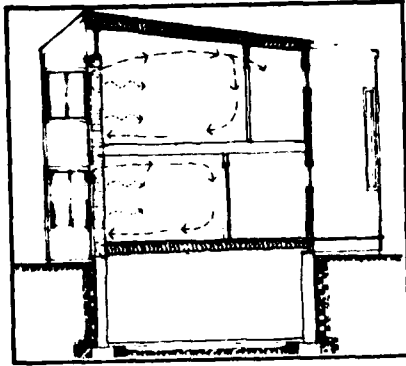

Use a mass Trombe wall for solar gain and storage of heat

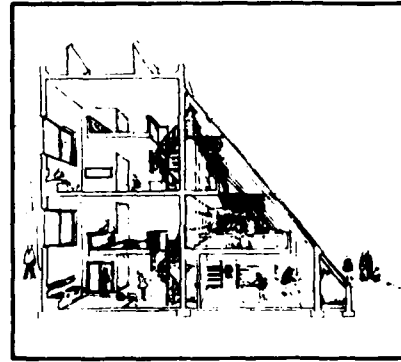

Use greenhouse spaces with some heat storage mass (barrels of water) as solar heating systems of the house

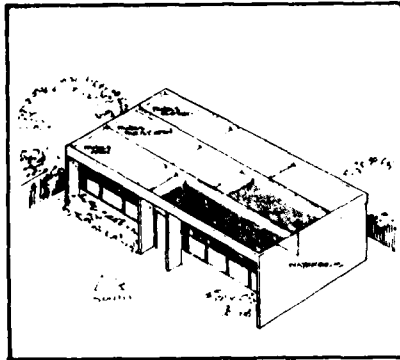

RADIANT COOLING

Massive materials should be shaded during the day and cooled at night. A passive house using water as the mass can achieve 100% natural cooling

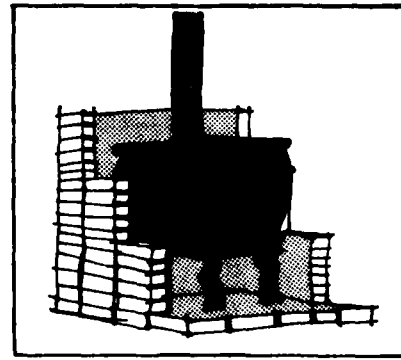

Select heating devices for their efficiency. Add thermal mass around an efficient stove. Bring combustion air directly into stoves and furnaces from outside.

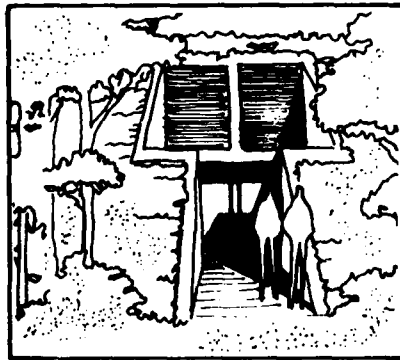

Use underground construction to reduce the effects of outdoor temperature fluctuations. This will provide more constant indoor temperatures, making the house cooler in the summer and warmer in the winter

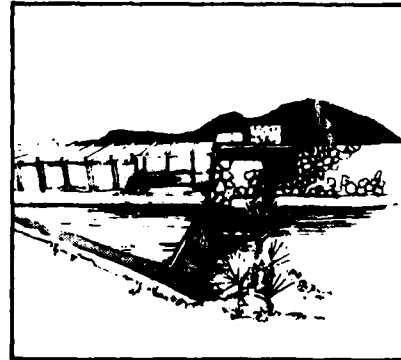

Use massive construction materials in the interior of the building to dampen the effects of high daytime temperatures. Adobe has both time-lag and heat storage capacity

Figure 9. Use mass to moderate temperature swings. (From Regional Guidelines for Building Passive Energy Conserving Homes, HUD-PDR-355 [prepared by the AIA Research Corporation for the Department of Housing and Urban Development, November 1978]).

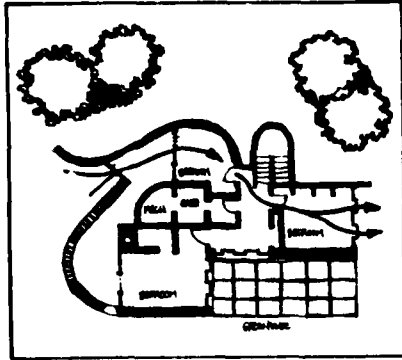

Use siting, fences, trees and wing walls to help channel winds

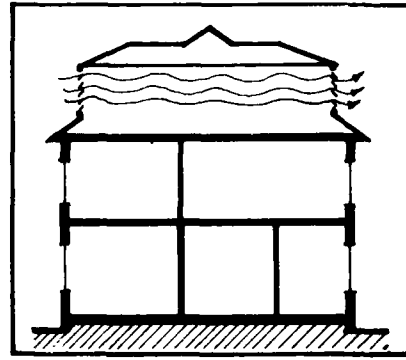

Vent the attic or the roof space

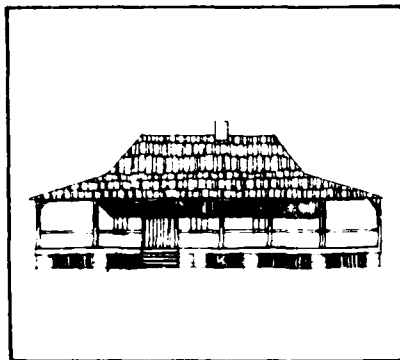

Raise the house to create a cool crawl space below the living areas

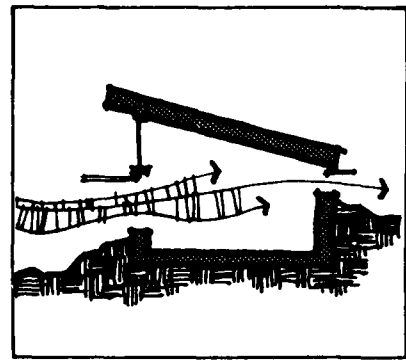

Provide cross ventilation for summer comfort by locating inlets and outlets in each room

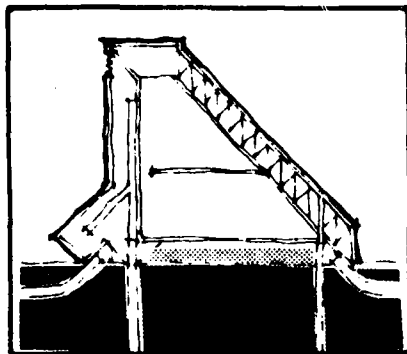

INDUCED VENTILATION

Use thermal chimneys when there are no breezes to induce air movement through the stack effect

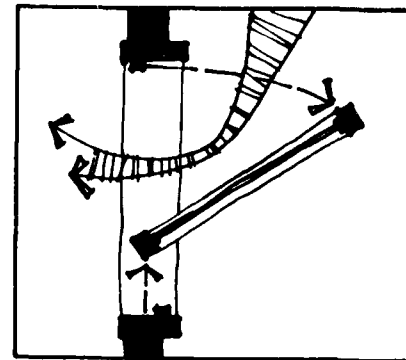

Use both high and low windows or vents in the house to improve air movement at night. Windows must be operable, preferably they should be of a vertical casement type to minimize unventilated air pockets

Figure 10. Use wind for natural ventilation. (From Regional Guidelines for Building Passive Energy Conserving Homes, HUD-PDR-355 [prepared by the AIA Research Corporation for the Department of Housing and Urban Development, November 1978]).

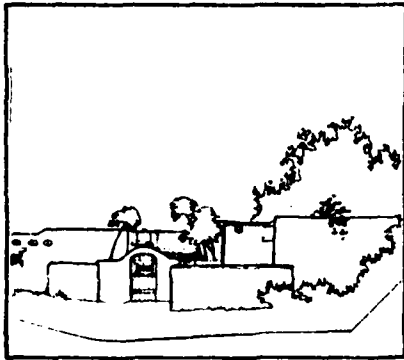

Use planting, both inside and out, to provide more comfortable humidities. Patios and courtyards can hold the tempering effects of a garden close to the house.

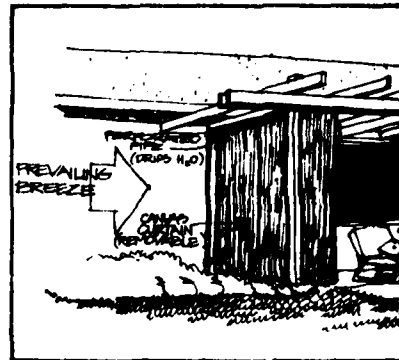

Evaporative cooling curtains can be used to cool the house. For energy conservation, mechanical evaporative coolers should be used instead of air conditioners.

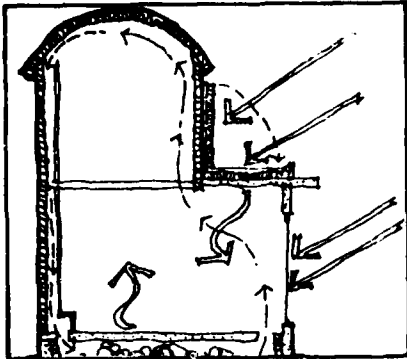

RADIANT COOLING
Provide roof ponds which use both evaporative cooling and radiation to the night sky to achieve 100% cooling.

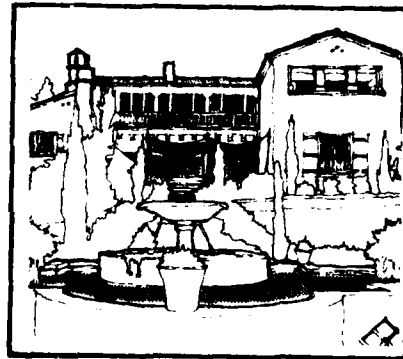

Locate fountains where afternoon breezes can blow over them and enter the house, providing cool humidified air.

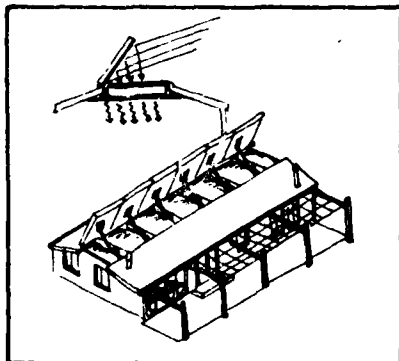

EVAPORATIVE COOLING
Spray roofs, walls and patios for evaporative cooling, or use evaporative coolers for reduced energy consumption.

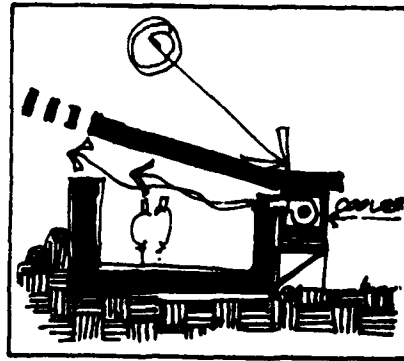

Use evaporative coolers instead of air conditioning to provide comfort during much of the over-heated period. Don't forget to shade the evaporative cooler.

Figure 11. Consider evaporative cooling. (From Regional Guidelines for Building Passive Energy Conserving Homes, HUD-PDR-355 [prepared by the AIA Research Corporation for the Department of Housing and Urban Development, November 1978]).

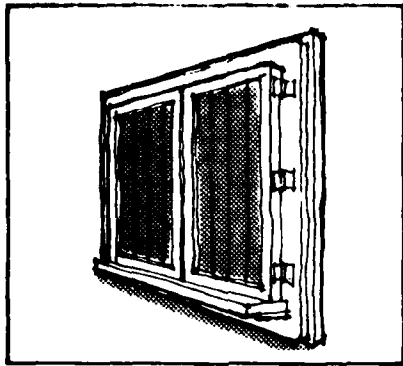

Prevent excessive heat loss through windows with shutters.



Build adjoining homes, shared heat can be the most energy efficient way to live.

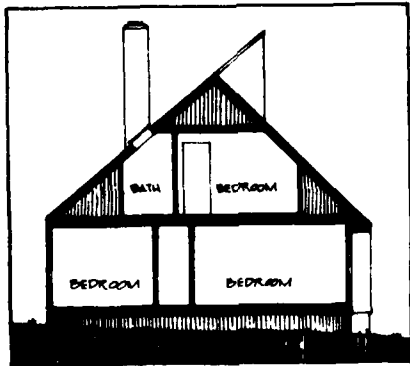

Minimize exterior surface area with compact floor plans and maximum utilization of space.

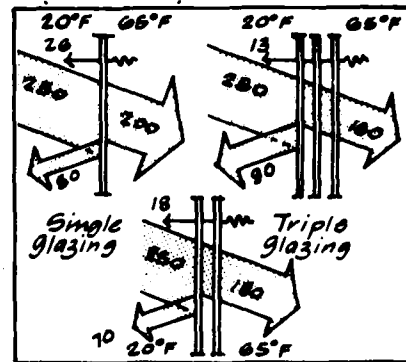

For maximum protection, use double glazing, and, in some instances, triple glaze window openings.

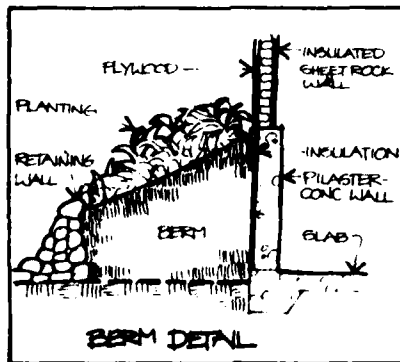

Reduce the heat loss of the building by insulating the exterior walls. Berms and partial undergrounding are effective methods of insulating.

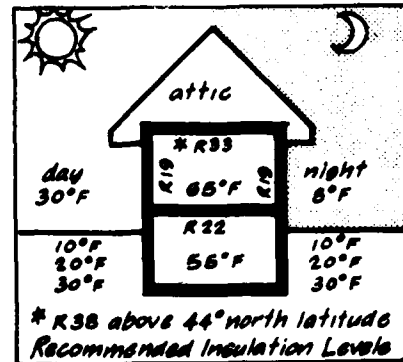

Proper site planning and building organization comes first. Then think of the thermal envelope, insulate to keep the heat in and cold out.

Figure 12. Minimize winter heat loss. (From Regional Guidelines for Building Passive Energy Conserving Homes, HUD-PDR-355 [prepared by the AIA Research Corporation for the Department of Housing and Urban Development, November 1978]).

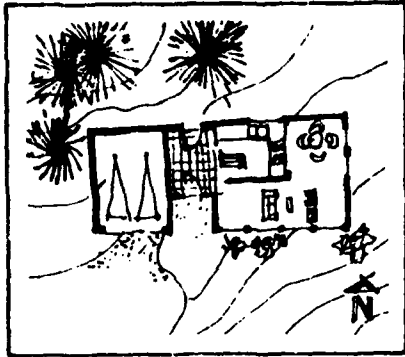

Use garages, storage and other spaces as buffers from the wind.

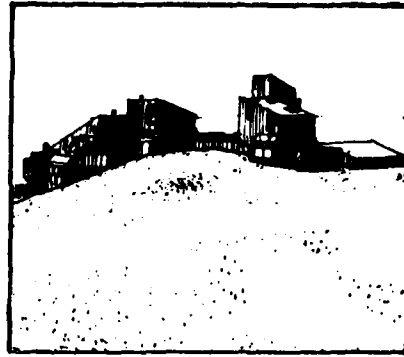

Cluster buildings to provide common shelter from the wind.

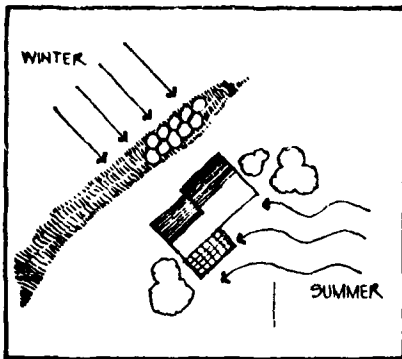

Divert winter winds around and over the house with landscaping and tight construction on the north and northwest.

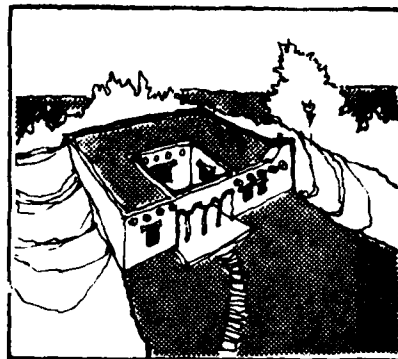

On the windiest sites, pack earth around buildings and add generous-courtyards to minimize wind and optimize sun exposures.

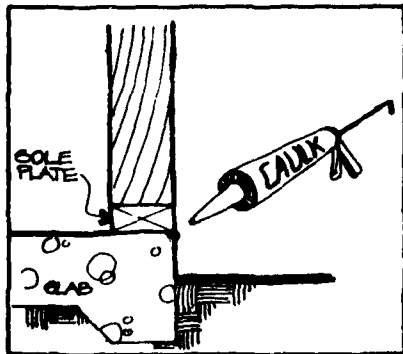

Seal the building against infiltration by caulking under the sole plate and around other openings in the building shell. Weatherstripping on doors and windows is also essential.

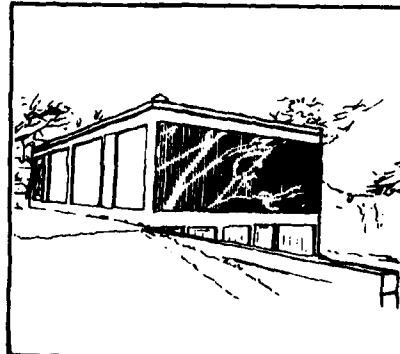

Use airlock or vestibule entries to prevent the house from emptying its heat everytime the door opens. In this example, the sunken entry keeps cold air in the doorway since cold air does not rise.

Figure 13. Reduce infiltration losses. (From Regional Guidelines for Building Passive Energy Conserving Homes, HUD-PDR-355 [prepared by the AIA Research Corporation for the Department of Housing and Urban Development, November 1978]).

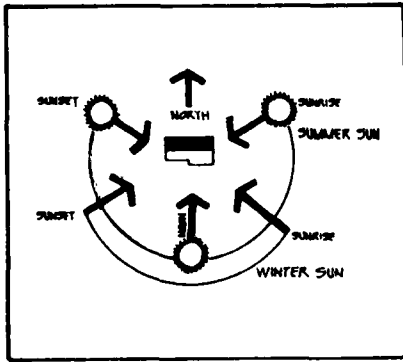

Orient and site glass to maximize exposure to the south and the low winter sun.

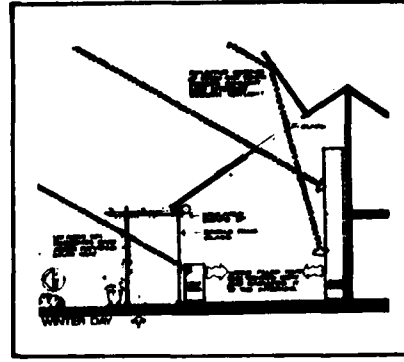

DIRECT GAIN
Collect and store solar radiation in floors, walls or ceilings for direct gain solar heating.

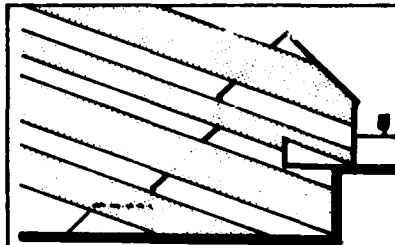

Sunshine is a controllable natural heating resource - throughout the region - if understood and properly used.

Determine how much sun is received inside by looking at building depth and opening placement. Winter sunshine reduces heating loads.

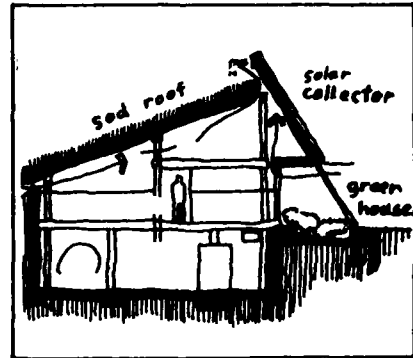

This bermed home uses large south windows and a dark colored concrete slab floor to achieve 95% solar heating

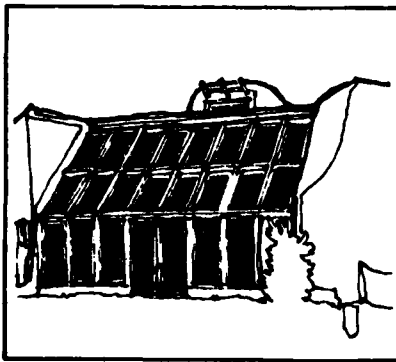

Attach spaces that are glazed and facing south. These are natural heating systems in winter. But be careful to vent them in the summer

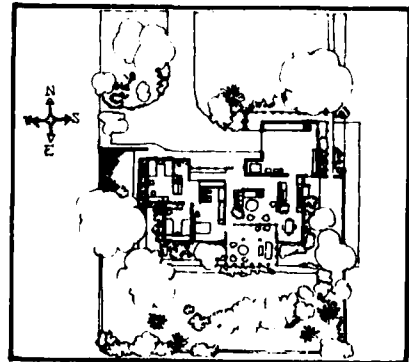

Stretch the building east-west to organize living spaces so they face the sun. Put less used spaces (corridors, garages, and baths) in the less advantageous positions

Figure 14. Admit the winter sun. (From Regional Guidelines for Building Passive Energy Conserving Homes, HUD-PDR-355 [prepared by the AIA Research Corporation for the Department of Housing and Urban Development, November 1978]).

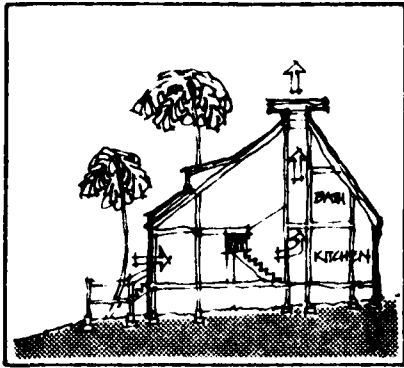

Isolate heat generating areas such as kitchens and laundries from living spaces

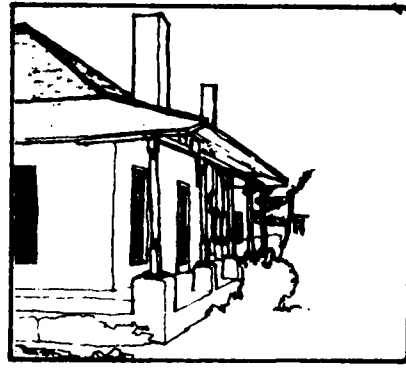

Design porches on the sunny sides of the building to provide shade plus outdoor living spaces

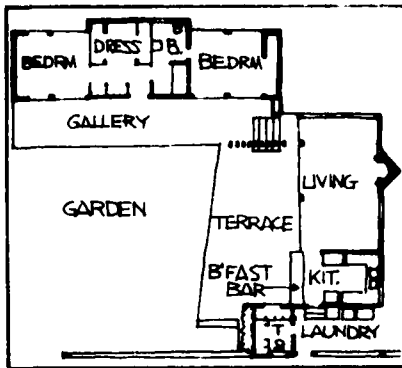

Build outdoor living spaces, such as galleries and terraces

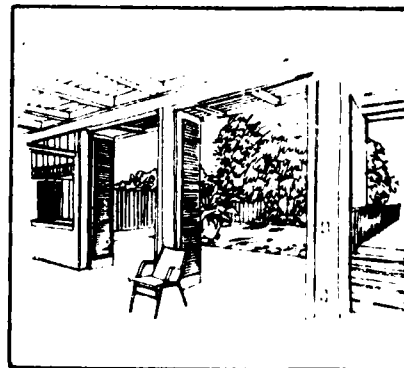

Build pavilion-like homes with open walls to bring indoor living spaces outdoors

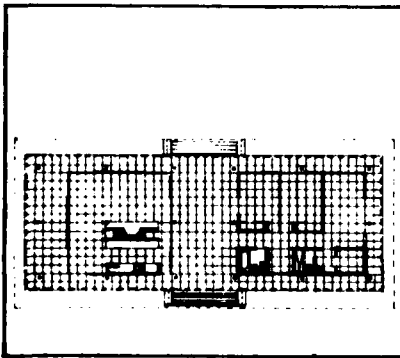

Use elongated floor plans to minimize internal heat gain and maximize exposure

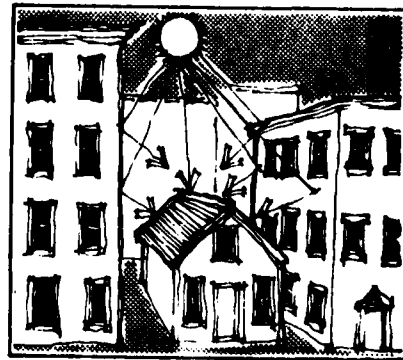

Avoid sites with overheated micro climate conditions

Figure 15. Capitalize on a nearly ideal climate. (From Regional Guidelines for Building Passive Energy Conserving Homes, HUD-PDR-355 [prepared by the AIA Research Corporation for the Department of Housing and Urban Development, November 1978]).

CITED REFERENCES

- Army Energy Plan, ADA057987 (Headquarters, Department of the Army, 1978).
- Energy Conservation in New Building Design, Standard 90-75 (American Society of Heating, Refrigerating, and Air-Conditioning Engineers [ASHRAE]).
- Erley, Duncan, et al., Site Planning for Solar Access, HUD-PDR-481(2) (Department of Housing and Urban Development, May 1980).
- Evans, Martin, Housing, Climate, and Comfort (John Wiley and Sons, 1980).
- Franta, Greg, et al., Solar Design Workbook, SERI/SP-62-308 (Solar Energy Research Institute, January 1981).
- Mazria, Edward, The Passive Solar Energy Book (Rodale Press, 1979).
- Olgay, Victor, Design with Climate (Princeton University Press, 1963).
- Passive Solar Construction Handbook, SSEC/SP-41187 (Southern Solar Energy Center, February 1981).
- Passive Solar Design Handbook, Volume One of Two Volumes: Passive Solar Design Concepts, DOE/CS-0127/1 US-59 (Department of Energy, March 1980).
- Passive Solar Design Handbook, Volume Two of Two Volumes: Passive Solar Design Analysis, DOE/CS-0127/2 UC-59 (Department of Energy, January 1980).
- Regional Guidelines for Building Passive Energy Conserving Homes, HUD-PDR-355 (Prepared by the AIA Research Corporation for the Department of Housing and Urban Development, November 1978).
- Watson, Donald, Energy Conservation Through Building Design (McGraw Hill, 1979).

UNCITED REFERENCES

- ASHRAE Handbook, 1981 Fundamentals (American Society of Heating, Refrigerating, and Air-Conditioning Engineers, Inc., 1981).
- Bainbridge, David, The First Passive Solar Catalog (Passive Solar Institute, 1978).
- Bainbridge, David, The Second Passive Solar Catalog (Passive Solar Institute, 1980).
- Building with Passive Solar, SSEC/SP-41191 (Southern Solar Energy Center, March 1981).
- Olgay, Victor, Solar Control and Shading Devices (Princeton University Press, 1957).

Shurcliff, William, Thermal Shutters and Shades (Brick House Publishing Company, 1980).

The First Passive Solar Home Awards, HUD-PDR-376 (Franklin Research Center, February 1979).

GLOSSARY*

absorber: A solid surface, usually dark colored, which is exposed to, and struck by, sunlight and which transforms radiant solar energy to heat energy.

absorptance: The ratio of the radiation absorbed by a surface to the total energy falling on that surface measured as a percentage.

air change: The replacement of a quantity of air in a volume within a given period of time. This is expressed in number of changes per hour. If a house has one air change per hour, all the air in the house will be replaced in a 1-hour period.

airlock entry: A vestibule enclosed with two air-tight doors for permitting entrance while limiting air or heat exchange.

ambient temperature: The prevailing temperature outside a building.

angle of incidence: The angle that the sun's rays make with a line perpendicular to a surface.

aperture: That part of the south-facing glazing that contributes to solar heating; literally, an opening.

auxiliary energy system: Equipment using energy other than solar both to supplement the output provided by the solar energy system, as required by the design conditions, and to provide full energy backup requirements when the solar heating or domestic hot water systems are not working.

auxiliary heating fraction (AHF): That part of the total building heating requirements supplied by the auxiliary heating system.

azimuth: The angular distance between true south and the point on the horizon directly below the sun.

berm: A man-made mound or hill of earth.

black body: A theoretically perfect absorber.

Btu (British Thermal Unit): Basic heat measurement, equivalent to the amount of heat needed to raise 1 lb of water 1°F.

Btu/DD/sq ft (heated area): A unit commonly used to express the inherent ability of the building shell to resist heat loss.

*This information is taken from Passive Solar Construction Handbook, SSEC/SP-41187 (February 1981).

building envelope: The elements of a building which enclose conditioned spaces, and through which thermal energy may be transferred to or from the exterior.

building load coefficient (BLC): BLC is a rough measure of the insulating quality of the home, exclusive of the south facade, used in estimating the solar savings fraction (SSF).

building skin conductance: Weighted average conductance of all the components of the building skin.

clerestory: Vertical window placed high in a wall near the eaves or between a lower roof and a higher roof; used for light, heat gain, and ventilation.

collector: An area of transparent or translucent glazing, usually on the south side of the home.

collector efficiency: The amount of energy gathered by a collector compared to the amount striking it.

comfort range: The range of climatic conditions within which people feel comfortable.

conduction: The transmission of heat through materials.

conductivity (k): The quantity of heat (Btus) that will flow through 1 sq ft of a material, 1 in. thick, in 1 hour, when there is a temperature difference of 1°F between both surfaces.

convection: The transfer of heat by movement of a fluid (liquid or gas).

convection, forced: Heat transfer through a medium such as air or water by currents caused by a device powered by an external energy source.

convection, natural: Heat transfer of a fluid such as air or water that results from the natural rising of the lighter, warm fluid and the sinking of the heavier, cool fluid.

declination: The angular distance of the sun north or south of the celestial equator. The declination varies between +23-1/2 degrees (summer) to -23-1/2 degrees (winter).

degree day (DD), cooling: See degree day for heating, except that the base temperature is established at 65°F, and cooling degree days are measured above the base.

degree day (DD), heating: A unit of heat measurement equal to 1 degree variation from a standard temperature (usually 65°F) in the average temperature of one day. If the standard is 65°F and the average outside temperature for one day is 50°F, then the number of degree days recorded for that day would be 15.

Delta T (ΔT): A difference in temperature.

density (p): The mass of a substance; expressed in pounds per cubic foot.

design life: The period of time during which a heating, cooling, or domestic hot water system is expected to perform its intended function without requiring major maintenance or replacement.

design temperature: A designated temperature close to the most severe winter or summer temperature extremes of an area, used in estimating heating or cooling demand.

diffuse radiation: Sunlight that is scattered by air molecules, dust, water vapor, and translucent materials.

direct gain (DG): A passive system in which solar radiation is admitted directly into the conditioned (or living) space, where it is converted to heat and stored.

direct radiation: Light that has traveled a straight path from the sun, as opposed to diffuse radiation.

dry bulb temperature: A measure of the temperature of the air.

efficiency: In solar applications, the amount of useful solar energy collected divided by the amount of solar energy available to the collector.

emittance: The ratio of the amount of heat radiated by a surface to the amount which would be radiated by a black body at the same temperature. Emittance values range from 0.05 for brightly polished metals to 0.96 for flat black paint.

equinox: Either of the two times during the year when the sun crosses the celestial equator and when the length of day and night are approximately equal. The autumnal equinox occurs on or about September 22, and the vernal equinox on or about March 22.

glazing: A covering of transparent or translucent material (glass or plastic) used for admitting light. Glazing reduces heat losses from re-radiation and convection. Examples: windows, skylights, greenhouses, and clerestories.

greenhouse effect: Ability of a glazing material to both transmit short wave solar radiation into a space and trap long wave heat generated by the conversion of the short wave radiation into heat.

gross floor area: The sum of the areas of all floors of a building, including basements, cellars, mezzanine and intermediate floored tiers, and penthouses of headroom height; measured from the exterior faces of exterior walls or from the centerline of the walls separating buildings.

gross wall area: The gross area of exterior walls consists of all opaque wall areas (including foundation walls; areas between floor spandrels; peripheral edges of floors; window areas, including sash; and door areas) where such surfaces are exposed to outdoor air and enclose a heated or mechanically cooled space, including interstitial areas between two such spaces.

heat: The form of energy that is transferred by virtue of a temperature difference.

heat capacity: The property of a material defined as the quantity of heat needed to raise 1 cu ft of the material 1°F. Numerically, the density multiplied by the specific heat.

heat gain: An increase in the amount of heat contained in a space, resulting from solar radiation and the flow of heat through the building envelope plus internal heat gain.

heat loss: A decrease in the amount of heat contained in a space, resulting from heat flow through walls, windows, roof, and other building envelope components.

heat loss coefficient (UA): The rate of energy transfer through the walls, roof, and floor of a house, calculated in Btu/hr/°F.

heat sink: A substance which can accept and store heat; a heat reservoir.

heat transfer medium: A medium -- liquid, air, or solid -- which is used to transport thermal energy.

heated space: Space within a building which is provided with a positive heat supply to maintain the air temperature at 50°F or higher.

HVAC system: A system that provides either collectively or individually the processes of comfort control including heating, ventilating, and/or air conditioning -- for a building.

incident angle: The angle between the incident ray from the sun and a line drawn perpendicular to the solar collector surface.

indirect gain passive system: A solar heating system in which sunlight first strikes a thermal mass located between the sun and a space. The sunlight absorbed by the mass is converted to heat and then transferred into the living space.

infiltration: The uncontrolled inward air leakage through cracks and interstices in any building element and around windows and doors of a building, caused by the pressure effects of wind or the effect of differences in the indoor and outdoor air density.

insolation: Total amount of solar radiation incident upon an exposed surface measured in Btu/hr/sq ft or in Langleys.

insulation: A material having a relatively high resistance to heat flow and used principally to reduce heat flow.

internal heat gain: Heat generated by equipment, appliances, lights, and people.

load collector ratio (LCR): The building load coefficient (BLC) divided by the total passive solar collector area. The LCR is used to determine the solar savings fraction.

microclimate: The climate of a defined local area, such as a house or building site, formed by a unique combination of factors, such as wind, topography, solar exposure, soil, and vegetation.

MMBTU: Million (10^6) Btus.

movable insulation: Insulation placed over windows when needed to prevent heat loss or gain, and removed for light, view, venting, or heat.

nocturnal cooling: Cooling by nighttime radiation, convection, and evaporation.

Nondepletable energy sources: Sources of energy (excluding minerals) derived from incoming solar radiation, including photosynthetic processes; from resulting phenomena, including wind, waves, and tides, lake or pond thermal differences; and from the earth, or gravity.

opaque: Impenetrable by light.

outside air: Air taken from the outdoors and, therefore, not previously circulated through the system.

passive solar system: An assembly of natural and architectural components -- including collectors, thermal storage devices, and transfer fluid -- which converts solar energy into thermal energy in a controlled manner. No fans or pumps are used to transfer thermal energy. The prime elements in a passive solar system are usually some form of thermal capacitance and solar energy control.

payback: A traditional measure of the economic viability of investment projects. A payback period is defined in several ways, one of which is the number of years required to accumulate fuel savings which exactly equal the initial capital cost of the system. Payback often does not accurately reflect the total life-cycle value of the investment.

peak load: The design heating and cooling load used in mechanical system sizing.

percent solar: A crude measure of the amount of heating or cooling a solar system provides, compared with the total demand.

power: The rate at which energy of all types is transmitted. In customary units, it is measured in watts (W) or Btu/hr.

radiation: The direct transport of energy through a space by means of electromagnetic waves.

reflectance: The ratio of the light reflected by a surface to the light falling upon it.

reflected radiation: Solar radiation reflected by light colored or polished surfaces. Can be used to increase solar gain.

refraction: The change in direction of light rays as they enter a transparent medium such as water, air, or glass.

resistance (R): The tendency of a material to reduce the flow of heat (see R-value).

R-value: A unit of thermal resistance used for comparing insulating values of different materials. The reciprocal of the conductivity. The higher the R-value of a material, the greater its insulating capabilities.

selective surface: A coating with high solar radiation absorbance and low thermal emittance, used on the surface of an absorber to increase system efficiency.

sensible heat: Heat that results in a temperature change.

shading coefficient (SC): The ratio of the solar heat gain through a specific glazing system under a given set of conditions, to the total solar heat gain through a single layer of clear, double-strength glass under the same conditions.

solar altitude: The angle of the sun above the horizon, measured in a vertical plane.

solar constant: The amount of solar radiation that reaches the outside of the earth's atmosphere.

solar heating fraction (SHF): The percentage of heating needs supplied by the passive solar system.

solar radiation: Electromagnetic radiation emitted by the sun.

solar retrofit: The application of a solar heating or cooling system to an existing building.

solar saving fraction (SSF): The difference in auxiliary heat required with and without a solar wall. The reference building is simply the same building without a solar wall.

$$SSF = \frac{\text{solar savings}}{\text{reference net thermal load}}$$

solar time: The hours of the day reckoned by the apparent position of the sun. Solar noon is that instant on any day at which time the sun reaches its maximum altitude. Solar time is very rarely the same as local standard time.

solar window: An opening that is designed or placed primarily to admit solar energy into a space.

specific heat: The number of Btus required to raise the temperature of 1 lb of a material 1°F.

specular: An imaging reflection. A mirror is a specular reflector.

storage: The assembly used for storing thermal energy so that it can be used when needed.

stratification: In the context of solar heating, the formation of layers in a substance where the top layer is warmer than the bottom.

suntempered: A structure which is designed or oriented to take into account climatic conditions, but which does not have features that are strictly passive, such as thermal mass.

thermal break: An element of low thermal conductivity placed so it reduces the flow of heat.

thermal capacity: See "heat capacity."

thermal conductance: See "conductance."

thermal energy: A material's heat, produced by the motion of molecules.

thermal mass: A thermally absorptive component used to store heat energy. In a passive solar system, the mass absorbs the sun's heat during the day and radiates it at night as temperatures drop. Thermal mass can also refer to the overall amount of heat storage capacity available in a given system or assembly.

thermal storage capacity: The ability of a material, per square foot of exposed surface area, to absorb and store heat. Numerically, the density times the specific heat times the thickness.

thermal storage roof: A passive system in which the storage mass is on the roof. The mass can be water or masonry; movable insulation is often used.

thermal storage wall: A passive system in which the storage mass is a wall between the collector and the living spaces to be heated. Several materials, including water or masonry, can be used for the mass.

thermal transmittance (U): Overall coefficient of heat transmission (air-to-air) expressed in units of Btu/hr/sq ft/°F. The U-value applies to combinations of different materials used in a series along the heat flow path (single materials that compose a building section, cavity air spaces, and surface air films on both sides of a building element).

thermocirculation: The convective circulation of fluid which occurs when warm fluid rises and is displaced by denser, cooler fluid in the same system.

thermosiphon: See "thermocirculation."

tilt angle: The angle of a collector relative to the ground. A general rule to calculate collector angle for winter heating is the latitude plus 10 degrees.

time lag: The period of time between the absorption of solar radiation by a material and its release into a space. Time lag is an important consideration in sizing a thermal storage wall.

translucent: Transmitting light but causing enough diffusion to eliminate perception of distinct images.

transmittance: The ratio of radiant energy transmitted through a transparent or translucent substance to the total radiant energy incident on its surface.

transparent: Transmitting light so that objects or images can be seen as if there were no intervening material.

Trombe wall: Another name for a "thermal storage wall," named after its inventor, Dr. Felix Trombe.

U-value: The number of Btus that flow through 1 sq ft of roof, wall, or floor in 1 hour, when there is a 1°F difference in temperature between the inside and outside air, under steady-state conditions. The U-value is the reciprocal of the resistance or R-value (see "thermal transmittance").

vapor barrier: A layer of material, resistant to the flow of water in the gaseous state, used to prevent condensation of water within insulation or dead air spaces.

ventilation, forced: Mechanically assisted movement of fresh air through a building; a fan or blower is used.

ventilation, induced: The thermally assisted movement of fresh air through a building, such as by thermocirculation.

ventilation, natural: The unassisted movement of fresh air through a building.

water wall: A passive technique for collecting solar energy. Water walls are usually black, water-filled containers exposed to the sun. These collect and store heat, which is used to warm a living space.

wet bulb temperature: The lowest temperature attainable by evaporating water into the air.

zone: In a building, a space or group of spaces with heating or cooling requirements similar enough that comfort conditions can be maintained throughout by a single controlling device.

GENL DISTRIBUTION

Chief of Engineers
 ATTN: Tech Monitor
 ATTN: DAEN-AS1-L (2)
 ATTN: DAEN-CCP
 ATTN: DAEN-CU
 ATTN: DAEN-CHE
 ATTN: DAEN-CMN-R
 ATTN: DAEN-CWO
 ATTN: DAEN-CVP
 ATTN: DAEN-NP
 ATTN: DAEN-NPC
 ATTN: DAEN-NPE
 ATTN: DAEN-NPO
 ATTN: DAEN-NPR-A
 ATTN: DAEN-RD
 ATTN: DAEN-RDC
 ATTN: DAEN-RDM
 ATTN: DAEN-RM
 ATTN: DAEN-ZC
 ATTN: DAEN-ZCE
 ATTN: DAEN-ZCI
 ATTN: DAEN-ZCM

FESA, ATTN: Library 22060

FESA, ATTN: DET III 79906

US Army Engineer Districts

ATTN: Library
 Alaska 99501
 Al Batín 09616
 Albuquerque 87103
 Baltimore 21203
 Buffalo 14207
 Charleston 29402
 Chicago 60604
 Detroit 48231
 Far East 96301
 Fort Worth 76102
 Galveston 77550
 Huntington 25721
 Jacksonville 32232
 Japan 96343
 Kansas City 64106
 Little Rock 72203
 Los Angeles 90053
 Louisville 40201
 Memphis 38103
 Mobile 36628
 Nashville 37202
 New Orleans 70160
 New York 10007
 Norfolk 23510
 Omaha 68102
 Philadelphia 19106
 Pittsburgh 15222
 Portland 97208
 Riyadh 09138
 Rock Island 61201
 Sacramento 95814
 San Francisco 94105
 Savannah 31402
 Seattle 98124
 St. Louis 63101
 St. Paul 55101
 Tulsa 74102
 Vicksburg 39180
 Wallis Wallis 69362
 Wilmington 28401

US Army Engineer Divisions

ATTN: Library
 Europe 09157
 Huntsville 35807
 Lower Mississippi Valley 39180
 Middle East 09038
 Middle East (Rear) 22601
 Missouri River 68101
 New England 02154
 North Atlantic 10007
 North Central 60605
 North Pacific 97208
 Ohio River 45201
 Pacific Ocean 96858
 South Atlantic 30303
 South Pacific 94111
 Southwestern 75202

US Army Europe

HQ, 7th Army Training Command 09114
 ATTN: AETU-DEH (5)
 HQ, 7th Army ODCS/Engr. 09403
 ATTN: AEAZM-EN (4)
 V. Corps 09079
 ATTN: AETVDEH (5)
 VII. Corps 09154
 ATTN: APTSDEM (5)
 21st Support Command 09325
 ATTN: AEREM (5)
 Berlin 09742
 ATTN: AEBA-EN (2)
 Southern European Task Force 09168
 ATTN: AESF-EN (3)
 Installation Support Activity 09403
 ATTN: AEURS-EP

8th USA, Korea

ATTN: EAFE (8) 96301
 ATTN: EAFE-Y 96358
 ATTN: EAFE-ID 96224
 ATTN: EAFE-AM 96208

8th USA, Korea

ATTN: EAFE-N 96271
 ATTN: EAFE-P 96259
 ATTN: EAFE-T 96212

ROK/US Combined Forces Command 96301
 ATTN: EUSA-MHC-CPC/Engr

USA Japan (USARJ)

Ch, FE Div, AJEN-FE 96343
 Fac Engr (Honshu) 96343
 Fac Engr (Okinawa) 96331

Rocky Mt. Arsenal, SARRM-IS 80022

Area Engineer, AEDC-Area Office
 Arnold Air Force Station, TN 37389

Western Area Office, CE
 Vandenberg AFB, CA 93437

416th Engineer Command 60623
 ATTN: Facilities Engineer

US Military Academy 10996
 ATTN: Facilities Engineer
 ATTN: Dept of Geography &
 Computer Science
 ATTN: DSCPER/MAEN-A

Engr. Studies Center 20315
 ATTN: Library

AMNRC, ATTN: DRMR-WE 02172

USA ARRCOM 61299

ATTN: DRCIS-RI-1
 ATTN: DRSAR-IS

DARCOM - Dir., Inst., & Svcs.

ATTN: Facilities Engineer
 ARADCOM 07801
 Aberdeen Proving Ground 21005
 Army Metals and Mechanics Res. Ctr. WESTCOM
 Corpus Christi Army Depot 78419
 Harry Diamond Laboratories 20783
 Dugway Proving Ground 84022
 Jefferson Proving Ground 47250
 Fort Monmouth 07703
 Letterkenny Army Depot 17201
 Natick R&D Ctr. 01760
 New Cumberland Army Depot 17070
 Pueblo Army Depot 81001
 Red River Army Depot 75501
 Redstone Arsenal 35809
 Rock Island Arsenal 61299
 Savanna Army Depot 61074
 Sharpe Army Depot 95331
 Seneca Army Depot 14541
 Tobyhanna Army Depot 18466
 Tooele Army Depot 84074
 Watervliet Arsenal 12189
 Yuma Proving Ground 85364
 White Sands Missile Range 88002

DLA ATTN: DLA-WI 22314

FORSOCOM

FORSOCOM Engineer, ATTN: AFEN-FE
 ATTN: Facilities Engineer
 Fort Buchanan 00934
 Fort Bragg 28307
 Fort Campbell 42223
 Fort Carson 80913
 Fort Devens 01433
 Fort Drum 13601
 Fort Hood 76544
 Fort Indiantown Gap 17003
 Fort Irwin 92311
 Fort Sam Houston 78234
 Fort Lewis 98433
 Fort McCoy 54646
 Fort McPherson 30330
 Fort George G. Meade 20755
 Fort Ord 93941
 Fort Polk 71459
 Fort Richardson 99505
 Fort Riley 66442
 Presidio of San Francisco 94129
 Fort Sheridan 60037
 Fort Stewart 31313
 Fort Wainwright 99703
 Vancouver Bks. 98660

HSC

ATTN: HSLO-P 78234
 ATTN: Facilities Engineer
 Fitzsimons AMC 80240
 Walter Reed AMC 20012

INSCOM - Ch, Instl. Div.

ATTN: Facilities Engineer
 Arlington Hall Station (2) 22212
 Vint Hill Farms Station 22186

MDW

ATTN: Facilities Engineer
 Cameron Station 22314
 Fort Lesley J. McNair 20319
 Fort Myer 22211

MTMC

ATTN: MTMC-SA 20315
 ATTN: Facilities Engineer
 Oakland Army Base 94626
 Bayonne MOT 07002
 Sunny Point MOT 28461

MRADCOM, ATTN: DRDNA-F 071160

TARCOM, Fac. Div. 48090

TECOM, ATTN: DASTE-LG-F 21005

TRADOC

HQ, TRADOC, ATTN: ATEH-FE
 ATTN: Facilities Engineer
 Fort Belvoir 22060
 Fort Benning 31905
 Fort Bliss 79916
 Carlisle Barracks 17013
 Fort Chaffee 72902
 Fort Dix 08440
 Fort Eustis 23604
 Fort Gordon 30905
 Fort Hamilton 11252
 Fort Benjamin Harrison 46216
 Fort Jackson 29207
 Fort Knox 40121
 Fort Leavenworth 66027
 Fort Lee 23801
 Fort McClellan 36205
 Fort Monroe 23651
 Fort Rucker 36362
 Fort Sill 73503
 Fort Leonard Wood 65473

TSARCOM, ATTN: STSAS-F 63120

USACC

ATTN: Facilities Engineer
 Fort Huachuca 85613
 Fort Ritchie 21719

WESTCOM

ATTN: Facilities Engineer
 Fort Shafter 96858

SHAPE 09055

ATTN: Survivability Section, CCB-OPS
 Infrastructure Branch, LAMDA

HQ USEUCOM 09128

ATTN: ECJ 4/7-LOE

Fort Belvoir, VA 22060

ATTN: ATZA-DTE-EM
 ATTN: ATZA-DTE-SW
 ATTN: ATZA-FE
 ATTN: Engr. Library
 ATTN: Canadian Liaison Office (2)
 ATTN: IWR Library

Cold Regions Research Engineering Lab 03755

ATTN: Library

ETL, ATTN: Library 22060

Waterways Experiment Station 39180

ATTN: Library

HQ, XVIII Airborne Corps and 28307

Pt. Bragg

ATTN: AFZA-FE-EE

Chanute AFB, IL 61868

3345 CES/DE, Stop 27

Horton AFB 92409

ATTN: AFRCE-MX/DEE

Tyndall AFB, FL 32403

AFESC/Engineering & Service Lab

NAPEC

ATTN: RDT&E Liaison Office
 Atlantic Division 23511
 Chesapeake Division 20374
 Southern Division 29411
 Pacific Division 96860
 Northern Division 19112
 Western Division 64066
 ATTN: Sr. Tech. FAC-03T 22332
 ATTN: Asst. CDR R&D, FAC-03 22332

NCEL 93041

ATTN: Library (Code LOBA)

Defense Technical Info. Center 22314

ATTN: DDA (12)

Engineering Societies Library 10017

New York, NY

National Guard Bureau 20310

Installation Division

US Government Printing Office 22304

Receiving Section/Depository Copies (2)

Joncich, David M.

Overview of passive solar design techniques. -- Champaign, IL : Construction Engineering Research Laboratory ; available from NTIS, 1982.
40 p. (Special report / Construction Engineering Research Laboratory ; E-179)

1. Solar energy -- passive systems. I. Title. II. Series: Technical report (Construction Engineering Research Laboratory) ; E-179.

FILME
— 8