

AD-A119 572

SIMMONS PRECISION PRODUCTS INC VERGENNES VT INSTRUM--ETC F/G 20/4
COMMERCIAL AIRCRAFT AIRFRAME FUEL SYSTEMS SURVEY AND ANALYSIS. (U)
JUL 82 P 6 WEITZ

DTPA03-80-C-0080

NL

UNCLASSIFIED

DOT/FAA/CT-82/80

1 of 2

4
PAGE



418-118

12

DOT/FAA/CT-82/80

Commercial Aircraft Airframe Fuel Systems Survey and Analysis

AD A119572

Simmonds Precision Products
Instrument Systems Division
Panton Road
Vergennes, Vermont 05491

DTIC
SEP 27 1982
E

July 1982

Final Report

This document is available to the U.S. public
through the National Technical Information
Service, Springfield, Virginia 22161.

DTIC FILE COPY



US Department of Transportation
Federal Aviation Administration
Technical Center
Atlantic City Airport, N.J. 08405

82 09 27 012

TECHNICAL REPORT STANDARD TITLE PAGE

1. Report No. DOT/FAA/CT-82/80	2. Government Accession No. AD-A119572	3. Recipient's Catalog No.	
4. Title and Subtitle COMMERCIAL AIRCRAFT AIRFRAME FUEL SYSTEMS SURVEY		5. Report Date July 1982	6. Performing Organization Code
		8. Performing Organization Report No. 181-320-100	
7. Author(s) P. G. WEITZ		10. Work Unit No.	
9. Performing Organization Name and Address SIMMONDS PRECISION PRODUCTS INSTRUMENT SYSTEMS DIVISION PANTON ROAD VERGENNES, VERMONT 05491		11. Contract or Grant No. DTFA03-80-C-0080	
		13. Type of Report and Period Covered FINAL REPORT October, 1980 - June, 1982	
12. Sponsoring Agency Name and Address U.S. DEPARTMENT OF TRANSPORTATION FEDERAL AVIATION ADMINISTRATION FAA TECHNICAL CENTER ATLANTIC CITY AIRPORT, NEW JERSEY 08405		14. Sponsoring Agency Code ACT 320	
		15. Supplementary Notes	
16. Abstract <p>↙ A selection of commercial aircraft airframe fuel systems has been studied to determine areas where incompatibility with antimisting kerosene fuel (AMK) may exist. Incompatibility can be due to reduced fuel system component performance with AMK or shear degradation of the AMK by the fuel system components.</p> <p>Survey results, to date, indicate that potential component performance problems with AMK are more significant than loss of AMK flammability protection due to shear degradation. Components of interest include ejector pumps, fuel filters, and auxiliary power units. ←</p>			
17. Key Words JET FUEL, FIRE SAFETY, AIRCRAFT FUEL, FUEL ADDITIVES		18. Distribution Statement THIS DOCUMENT IS AVAILABLE TO THE U.S. PUBLIC THROUGH THE NATIONAL TECHNICAL INFORMATION SERVICE, SPRINGFIELD, VIRGINIA, 22181.	
19. Security Classif. (of this report) UNCLASSIFIED	20. Security Classif. (of this page) UNCLASSIFIED	21. No. of Pages	22. Price

ACKNOWLEDGEMENTS

The information required for this study was obtained with the helpful cooperation of the many companies and individuals listed below. Their willingness to gather information and spend their time discussing aircraft fuel systems and components is greatly appreciated. Errors and omissions that may appear in this work are the responsibility of the author.

Mr. A. T. Peacock
McDonnell-Douglas Aircraft Corporation
Mail Code 36-41
3855 Lakewood Blvd.
Long Beach, California 90846

Mr. John Schaplowsky
Lockheed Aircraft Company
Dept. 733
Burbank, California 91510

Mr. J. E. Talbot
Mr. J. A. Bradshaw
Chief Engineer Propulsion Technology
British Aerospace
Weybridge/Bristol Division
Filton House
Bristol, England B5997AR

Mr. Don Nordstrum
Chief Mechanical Systems Engineer
Mr. Howard Skavdahl
Chief, Propulsion Research &
Product Development
Mr. Paul Zanoni
Boeing Commercial Airplane Co.
P.O. Box 3707
Seattle, Washington 98124

Mr. Jack Brunning
Chief Powerplant Engineer
British Aerospace
Weybridge/Bristol Division
Brookland Road
Weybridge, Surrey England KT130SF

Mr. Kenneth Grina
Mr. George C. Hopkins
Boeing Vertol Company
P.O. Box 16858
Philadelphia, Pennsylvania

Mr. Roy Riseley
de Havilland Aircraft
Garratt Blvd.
Downsview, Ontario
Philadelphia, Pennsylvania 19142

Mr. William Miles
Cessna Aircraft Company
Wallace Division
Wichita, Kansas 67277Canada M3K1Y5

Mr. Robert Barlow
Spirit Program Manager
Mr. George Paulis
Mr. Joseph Decarlo
Sikorsky Aircraft
Stratford, Connecticut Airport Road

Mr. H. T. Hamilton
Product Support Manager
Mr. George Cather
Short Brothers Limited
P.O. Box 241
Belfast BT3 9DZ
Northern Ireland

Mr. Paul Welsh
Group Engineer- Powerplant Design
Mr. Kenneth Collins
Powerplant Engineer
Bell Helicopter Textron
P.O. Box 482
Fort Worth, Texas 76101

Mr. Irwin Johnson
Mr. Raymond Best
Beech Aircraft
9700 East Central
Wichita, Kansas

Mr. Guido F. Pesotti
Technical Director
Empresa Brasileira Aeronautica, S.A.
Caixa Postal 343/1220
Sao Jose Dos Campos
Sao Paulo, Brazil

Mr. Jerry Tribble
Mr. Elliot C. Nichols
Piper Aircraft Corporation
Lakeland, Florida 33802

Mr. Robert G. Parke
Propulsion Project Engineer
Fairchild Swearingen Corporation
P.O. Box 894
San Antonio, Texas 78284

Mr. Ralph Pyott
Mr. Dick Anderson
Uniroyal, Inc.
Mishawaka, Indiana 46455

Dr. R. J. Mannheimer
Southwest Research Institute
6220 Culebra Road
San Antonio, Texas 78284

Dr. V. Sarohia
Jet Propulsion Laboratory
Pasadena, California

Mr. Frank C. Davis
Engineering Specialist
Garrett Turbine Engine Company
111 So. 34th St.
P.O. Box 5217
Phoenix, Arizona 85010

Mr. W. F. Jones
Chief Project Engineer
Mr. Richard E. Valley
Detroit Diesel Allison
P.O. Box 894
Indianapolis, Indiana 46206

Mr. Alex Hall
Mr. G. W. Crook
Pratt & Whitney Aircraft of
Canada Ltd.
Box 10
Longueuil, Quebec J4K 4X9

Mr. C. J. Cathey
Mr. J. V. Hickey
Mr. William Hubbard
Aerospatiale Helicopter Corporation
2701 Forum Drive
Grand Prairie, Texas 75051

Mr. Matt Carson
Aviation Electric, Ltd.
Box 2140
St. Laurent, Quebec
Canada H4L 4X8

Mr. John Teets
Mr. Doug Martin
Turbomach Division
International Harvester
4400 Ruffin Road
San Diego, California 92123



Accession For	
NTIS CRA&I	<input checked="" type="checkbox"/>
DTIC TAB	<input type="checkbox"/>
Unannounced	<input type="checkbox"/>
Justification	
By _____	
Distribution/	
Availability Codes	
Dist	Avail and/or Special
A	

TABLE OF CONTENTS

<u>SECTION</u>	<u>TITLE</u>	<u>PAGE</u>
1	INTRODUCTION	1-1
2	OBJECTIVE	2-1
3	STUDY AIRCRAFT	3-1
4	BASIS OF INVESTIGATION	4-1
5	INDIVIDUAL AIRCRAFT	5-1
	McDonnell Douglas DC-10-40	5-1
	Concorde	5-5
	Boeing 737	5-9
	Boeing 747	5-12
	Airbus Industrie A-310	5-17
	BAC 111-500	5-20
	L-1011-500	5-24
	DC-8-71	5-29
	DeHavilland Twin Otter	5-33
	DeHavilland Dash 7	5-36
	Shorts SD3-30	5-39
	Cessna 441	5-41
	Swearingen Metro III	5-43
	Convair 580	5-46
	Piper PA-42 Cheyenne III	5-48
	Embraer 110-P2	5-51
	Beech 99	5-53
	Bell 212 Helicopter	5-56
	Boeing Vertol 234-LR Helicopter	5-58
	Sikorsky Spirit S-76 Helicopter	5-62
	Aerospatiale AS 350D	5-64
	Aerospatiale SA 365N	5-66

TABLE OF CONTENTS (CONT.)

<u>SECTION</u>	<u>TITLE</u>	<u>PAGE</u>
6	ADDITIONAL FUEL SYSTEM COMPONENTS	6-1
7	FUEL SYSTEM PARAMETER RANGES	7-1
8	CURRENT RESEARCH REVIEW	8-1
9	CONCLUSIONS	9-1
10	REFERENCES	10-1

LIST OF ILLUSTRATIONS

<u>FIGURE</u>	<u>TITLE</u>	<u>PAGE</u>
1	DC-10 Fuel System	5-2
2	Concorde Fuel System	5-3
3	Boeing 737 Fuel System Schematic	5-10
4	Boeing 747 Fuel System Schematic	5-14
5	Boeing 747 Fuel System Line Sizes	5-15
6	A-310 Fuel System Schematic	5-18
7	BAC-111 Fuel System Schematic	5-21
8	Lockheed L-1011 Fuel System Schematic	5-25
9	Lockheed L-1011 Fuel Scavenge Transfer System	5-26
10	DC-8 Fuel Feed and Transfer System	5-30
11	DC-8 Fuel Dump System	5-31
12	DC-8 Fill System	5-32
13	DC-8 Vent System	5-32
14	DeHavilland Twin Otter Fuel System Schematic	5-35
15	DeHavilland Dash-7 Fuel System Schematic	5-37
16	Shorts SD3-30 Fuel System Schematic	5-40
17	Cessna 441 Fuel Distribution Schematic	5-42
18	Swearingen Metro Fuel System Schematic	5-44
19	Convair 580 Fuel System Schematic	5-47
20	PA-42 Cheyenne III Fuel System	5-49
21	Embraer EMB 110-P2 Fuel System Schematic	5-52
22	Beech C-99 Fuel System Schematic	5-54
23	Bell 212 Fuel System Schematic	5-57
24	Boeing Vertol 234 Fuel System	5-59
25	Boeing Vertol 234 LR Fuel System Schematic	5-60
26	Sikorsky S-76 Fuel System Schematic	5-63
27	Aerospatiale AS-350D Fuel System Schematic	5-65
28	Aerospatiale SA-365N Fuel System Schematic	5-67

SECTION 1 INTRODUCTION

Over the past 15 years much interest has been shown in developing aircraft turbine fuels that do not generate an easily ignitable mist cloud in an aircraft crash situation. The latest development in a series of experimental fuels of this type utilizes an additive called FM-9, produced by Imperial Chemical Industries of America (ICI Americas). It is added to commercial jet fuel at a concentration of approximately 0.3 percent.

The resulting mixture has been shown to have great benefit in reducing fireball generation in post crash fire situations. However, other properties of this fuel mixture can present some difficulties in the normal handling of the fuel both on the ground and in flight.

A memorandum of understanding between the governments of the United Kingdom of Great Britain and Northern Ireland and the United States has been established to thoroughly study and investigate the feasibility of using this fuel additive in all commercial jet aircraft in order to significantly reduce the deaths caused in post crash fire situations.

SECTION 2 OBJECTIVE

This study was performed as part of the Federal Aviation Administration's (FAA) Antimisting Fuel Engineering and Development Plan, FAA-ED-18-4.

The objective was to study the fuel systems of a representative sample of commercial aircraft covered by the Code of Federal Regulations, Title 14, parts 23, 25, and 29 for turbine powered aircraft to determine the range of conditions to which the antimisting kerosene fuel (AMK) would be exposed.

This information is required in the effort to minimize the need for changes in established aircraft fuel systems when using the AMK fuel.

**SECTION 3
STUDY AIRCRAFT**

Based on discussions with various airframe manufacturers and consideration of factors such as aircraft quantity, expected usage, passenger capacity, aircraft age, and unusual features, the aircraft listed in Table 3-1 were chosen for the study.

TABLE 3-1. FUEL SYSTEMS SURVEY AIRCRAFT

Aircraft	Engine Type	No. of Engines	Passenger Capacity	Total Fuel Quantity Gallons
LARGE TRANSPORTS				
Boeing 737	Turbofan	2	115-130	5,974
Boeing 747	Turbofan	4	442	51,100
Concorde	Turbojet	4	108-128	31,516
DC-10	Turbofan	3	250-380	36,200
L1011	Turbofan	3	250-330	32,000
A-310	Turbofan	2	205-255	14,531
BAC 111	Turbofan	2	119	3,722
DC-8-71	Turbofan	4	259	24,259
COMMUTER TRANSPORTS				
Beech 99	Turboprop	2	15	368
Piper-PA-42	Turboprop	2	8	580
Embraer 110-P2	Turboprop	2	18	464
Swearingen Metro	Turboprop	2	20	648
Shorts SD3-30	Turboprop	2	30	573
de Havilland Twin Otter	Turboprop	2	20	378
de Havilland Dash 7	Turboprop	4	50	1,480
Cessna 441 Conquest	Turboprop	2	9	475
Convair 580	Turboprop	2	40	1,730
ROTARY WING AIRCRAFT				
Bell 212	Turboshaft	2	14	212
Aerospatiale AS350D	Turboshaft	1	6	140
Aerospatiale SA365N	Turboshaft	2	14	300
Boeing Vertol Comm. Chinook	Turboshaft	2	44	2,100
Sikorsky Spirit S-76	Turboshaft	2	12	286

SECTION 4

BASIS OF INVESTIGATION

In order to understand the development of AMK and its unusual properties, a literature survey was performed. This information was obtained through the FAA, National Technical Information Service, and other sources. In addition, personal communication with AMK researchers yielded valuable information on the properties and limitations of the most recent AMK fuel.

As a result, the basis of this investigation was centered around three major factors: Safety, AMK Degradation, and Fuel System Component Performance. The following established factors related to AMK properties are of interest:

- a. Jet pump performance is significantly reduced with undegraded AMK (reference 1).
- b. Undegraded AMK filtration can result in filter plugging under some conditions (references 1, 2).
- c. Dynamic response of Fuel System Components can be slowed with undegraded AMK (reference 1).
- d. Boost pump performance is reduced with AMK (reference 1).
- e. AMK degrades under shear, reducing its resistance to flame propagation (references 1, 2, 3, 4).
- f. Undegraded AMK heat transfer capability is less than Jet A fuel.
- g. The spray patterns obtained in standard jet engine burner nozzles with undegraded AMK are inadequate for proper fuel combustion (references 3, 5).
- h. Water Absorption of AMK is greater than Jet A fuel (references 2, 4).

SECTION 5 INDIVIDUAL AIRCRAFT

The following discussion briefly describes the basic low pressure airframe fuel system, as supplied by the airframe manufacturer, for each of the study aircraft. The aircraft engines were not included in this study except for the auxiliary power units applicable.

McDonnell Douglas DC-10-40

- a. Fuel System Discussion - The DC-10-30 and -40 are the long range versions of this aircraft, which have a fuel capacity of 36,200 gallons (gal). There are three main tanks, one for each engine, plus auxiliary tanks in the center wing box.

Aircraft refueling can be accomplished through either two or four standard 2 1/2-inch MIL-A-25896D adapters, two of which are installed on each wing. The maximum initial flow rate through each adapter at 50 pounds per square inch gauge (psig) supply pressure is approximately 600 gal/min. This system utilizes refueling valves and controllers to initiate and terminate the refueling flow. This system can also be used to defuel the aircraft.

The fuel transfer philosophy during flight is as follows:

Fuel is transferred from the auxiliary tanks to the main wing tanks for use. The main wing tank fuel is used in three segments consisting of the inboard, outboard, and wing root areas.

The inboard compartment fuel is used first, with the outboard compartment held full for wing structural considerations. Late in the flight the outboard fuel is transferred inboard for use, and then fuel in the wing root area is used last. Float switches and indicator lights are used to indicate the fuel usage scheduling and status to the flight engineer.

A water scavenging system employing jet pumps is used to remove water from the tank low points and mix it with the fuel near the boost pump inlets. The motive flow comes from the engine feed lines and the secondary flow of water and fuel is drawn up through tubing rakes whose inlets are located in the tank low points.

A schematic of the basic fuel system is shown in Figure 1.

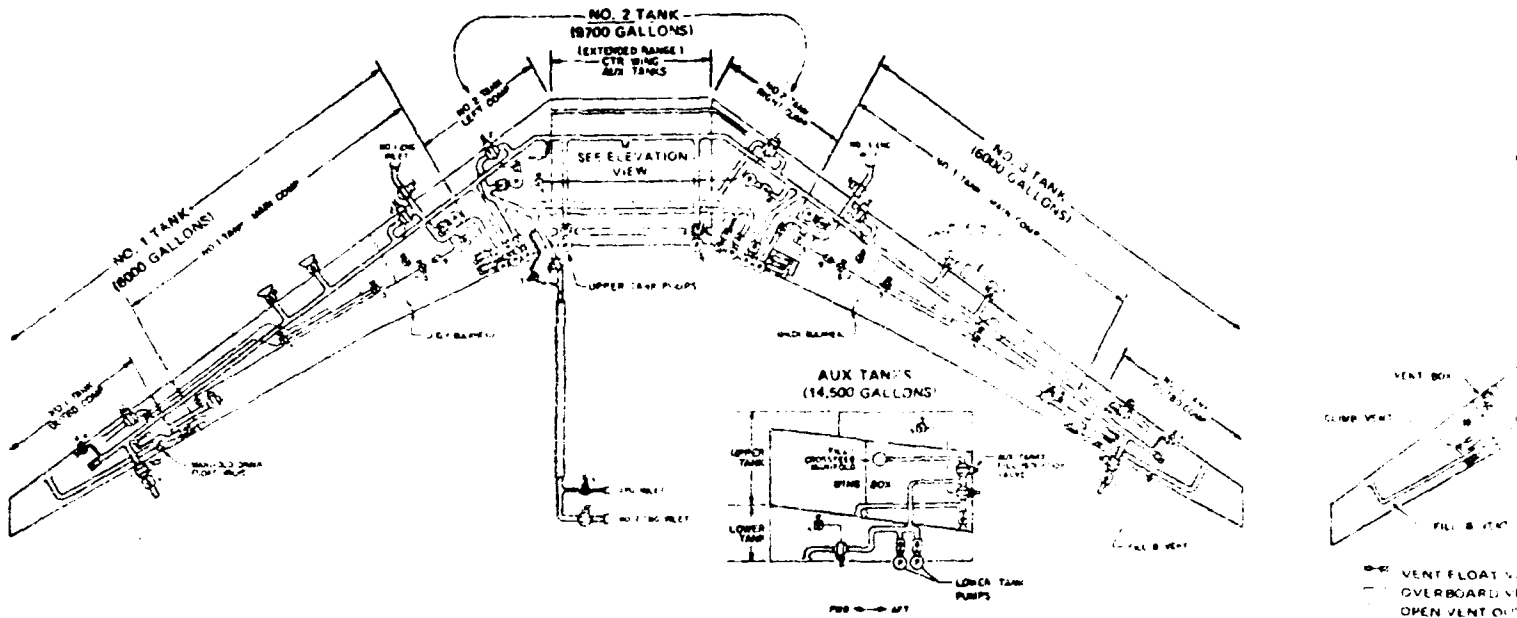

- ① APU START PUMP, D.C.
- ② FIRE SHUTOFF VALVE (MECHANICAL)
- ③ BOOST PUMP, A.C.
- ④ FILL SHUTOFF VALVE
- ⑤ TRANSFER VALVE
- ⑥ PRESSURE REFUEL/DEFUEL ADAPTER
- ⑦ CLIMB VENT FLOAT VALVE

- ⊠ CHECK VALVE, PRESSURE RELIEF
- ⊡ CHECK VALVE, OVERFLOW
- ⊢ SURGE RELIEF VALVE
- ⊣ DUMP SHUTOFF FLOAT SWITCH
- ⊤ MANIFOLD DRAIN FLOAT VALVE
- ⊥ SMALL TUBING
- ELECTRICAL WIRING

- 1 FUEL DUMP
- 2 CROSSFEED
- 3 APU FIRE SHUTOFF
- 4 MANIFOLD DRAIN/OUTBD FILL
- 5 FILL PILOT
- 6 TRANSFER FLOAT

- 7 FUEL DUMP
- 8 JET PUMP
- 9 JET PUMP
- 10 PUMP OUTLET
- 11 SUCTION FEED

- ⊠ VENT FLOAT VALVE
- ⊡ OVERBOARD VENT
- ⊢ OPEN VENT OUTLET
- ⊣ SUMP DRAIN VALVE
- ⊤ BULKHEAD W/OUT MANIFOLD DRAIN
- ⊥ OVERFILL RELIEF
- OVERFLOW CHECK

FUEL SYSTEM

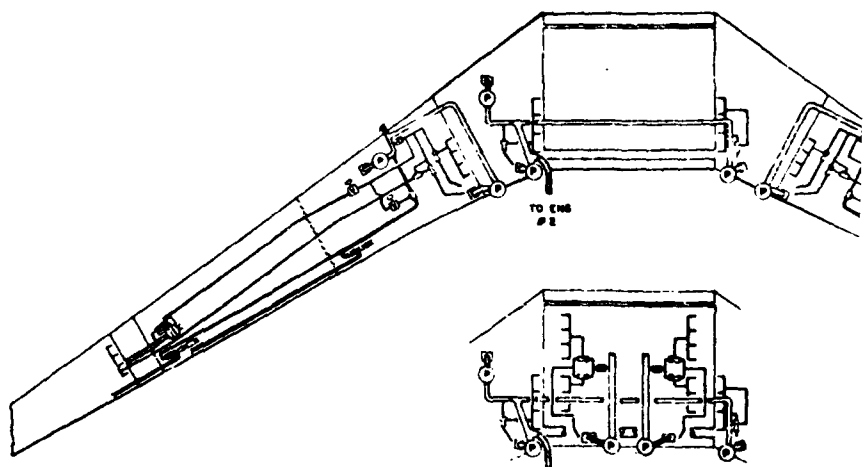

- ⊠ JET PUMP
- ⊡ PRESSURE ACTUATED VALVE
- ⊢ CHECK VALVE
- ⊣ TRANSFER FLOAT VALVE
- ⊤ BOOST PUMP, A.C.

CONTINUOUS SCAVENGE SYSTEM

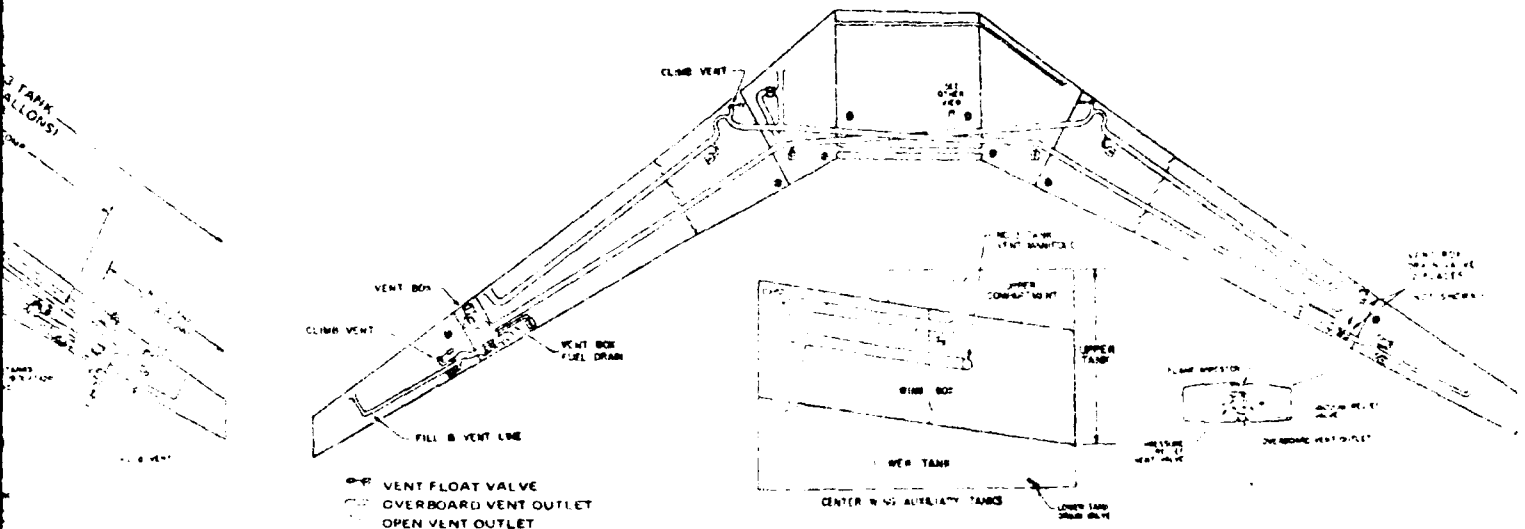

FUEL VENT SYSTEM

1 FUEL DUMP
 2 JET PUMP
 3 PUMP OUTLET
 4 SUCTION FEED

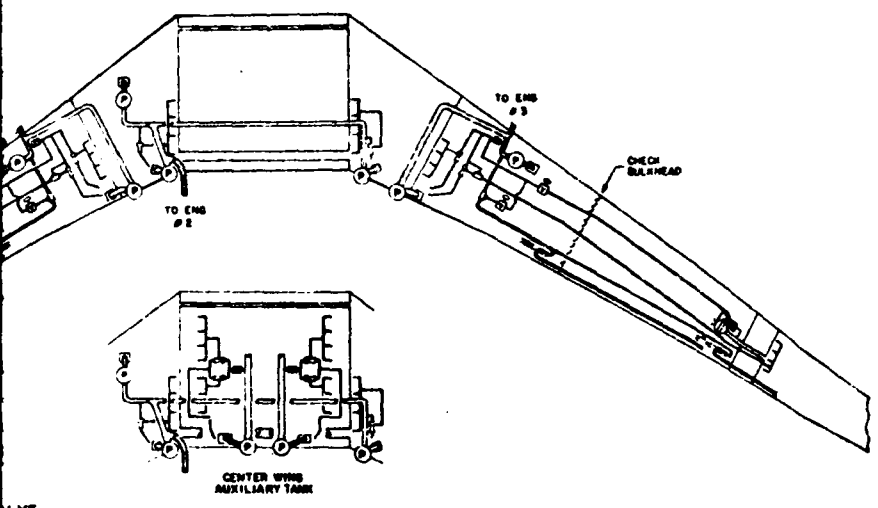

CONTINUOUS SCAVENGE SYSTEM

FIGURE 1. DC-10 FUEL SYSTEM

2

b. Fuel System Components And Features

1. **Line Sizes** - The main fuel system uses 2.0-inch to 3.0-inch outside diameter pipe. The scavenge and transfer system, uses 1/2-inch to 5/8-inch pipe.
2. **Boost Pumps** - Electrically driven 8000 revolutions per minute (rpm) centrifugal pumps rated at 46,000 lb/hr at 17 psig are used. Twelve are supplied for boost and transfer and at least 4 run continuously. Five are in each inboard wing tank and two are in the auxiliary tank. Fuel serves as a coolant for the electrical windings of these pumps. Nominal cruise flow is approximately 5000 lb/hr, and pump dead head pressure is 30 psi.
3. **Ejector Pumps** - Fourteen Ejector Pumps are supplied, 4 for transfer and 10 for scavenging. Five are located in each wing and 4 in the auxiliary center section tank. The scavenge pumps run continuously.
4. **Filters** - The boost pump inlets have 5 mesh screens, and no other filters are supplied.
5. **Suction Feed** - The suction feed condition during aircraft flight would occur only as a result of major pump and/or electrical failure. The fuel system design, however, provides for continuous operation under suction feed conditions.
6. **Vent System** - The vent system provides for equalization of tank pressure with ambient pressure. This system incorporates vent float valves and fine honeycomb mesh flame arrestors to prevent the possibility of lightning - ignited fuel vapor causing flames to travel into the tank space. Bypass valves are provided to avoid tank overpressure in the event of arrestor plugging.
7. **Jettison System** - A jettison system is provided which utilizes the centrifugal pumps to dump fuel overboard. The maximum rate obtainable is 6000 lbs/minute.
8. **Pressure Refueling** - Normal pressure refueling is performed with two hoses from one side of the aircraft; four hoses and both sides can be used. The 2 1/2-inch MIL-A-25896D adapter is used. This system utilizes a refueling valve which contains pilot float valves and small bleed lines of 0.125-inch maximum. The maximum initial fueling rate is 2170 gal/min. with four adapters used and 50 psig supply pressure, filling all tanks.
9. **Refuel Distribution Manifold** - A distribution line in each wing containing 1/4-inch holes is used to reduce static charge build-up and distribute fuel evenly.
10. **Heat Exchangers** - There are no airframe supplied heat exchangers using fuel as a heat sink on this aircraft.

11. Fuel Quantity Gauging System - A capacitance-type fuel quantity gauging system is used on this aircraft. No thermistor-type point level sensors are used.
 12. Auxiliary Power Unit (APU) - The APU is supplied by Garrett Airesearch; their part No. is TCSP-700-4. This unit has 10-micron and 40-micron paper filters, and a 6655 rpm gear pump which supplies 2000 pph at 750 psig. There are 18 nozzles, 9 with a diameter of 0.0125-inch and 9 with a diameter of 0.014-inch. The fuel control bypass metering system uses a flow passage which varies from 0.020-inch to 0.060-inch. This unit can be used either on the ground or in flight. The bypass system recirculates fuel back to the gear pump inlet, not to the bulk fuel.
- c. Potential AMK Degradation Sources - The primary source of AMK shear degradation is the continuous pumping and recirculation through the 8000 rpm boost pumps. Results given in reference 1 indicated that boost pump shear degradation was not severe, but the flammability test criteria presently being used have been revised. The high shear gear pump on the APU will probably result in some degradation, but since fuel bypassed in the APU is not returned to the tanks this will not affect the safety aspects of the bulk fuel. Some shearing action may occur in the refuel/defuel valve during the partially open condition but the effect will probably be small due to the short time spent at this condition.

Discussions with the Southwest Research Institute where AMK shear degradation studies are being done (reference 2) indicate that pregelling of the fuel may occur when it is passed through the pump so that subsequent passes may cause gelling to occur.

- d. Potential Component Performance Problems - Based on ejector pump performance studies reported in reference 1, the 14 ejector pumps used in this aircraft will have greatly reduced performance. According to reference 1, this can result in reduced scavenging efficiency. The tests reported on in this reference indicated that the ejector pumps were unable to keep the pump collector boxes full with AMK fuel. This caused the fuel level in these boxes to fall with the tank level, which could lead to uncovering of the boost pump inlets even though fuel still remained in the tanks. This did not occur with the standard Jet A.

In the DC-10, this can also affect the tip tank recirculation when the ejector pump loop is utilized under certain attitude conditions.

Boost pump performance will also be reduced but may not be a critical factor.

Small fluid passages present in the automatic shutoff valves and float transfer valves may result in increased response time with AMK.

Discussion with Southwest Research indicates that the 5 mesh pump inlet screens and the perforated distribution lines should function satisfactorily with AMK.

- e. Potential Safety Considerations - Possible pregelling of the AMK could result in some plugging of the pump inlet screens. Reduced jet pump performance may increase unusable fuel by allowing boost pump collector box fuel levels to fall below the boost pump inlet points under some conditions. Based on references 1, 2 and 3, the fine filters on the APU will probably experience plugging with AMK. Liquid water, if present, that is drawn up by the scavenge system and deposited in the bulk fuel near the boost pump inlet may cause sudden polymer precipitation.

CONCORDE

- a. Fuel System Discussion - The Concorde supersonic transport has a landing speed of 170-180 knots which is outside of the nominal speed range where AMK offers protection in a crash-fire situation. However, it is of interest to review this fuel system to determine what impact AMK would have on aircraft operation and AMK degradation.















The Concorde has 13 tanks, formed as sealed cells integral with the aircraft structure. They are located in the wings and the center and rear fuselage.

The aircraft is refueled through two refuel control units, one on each side of the aircraft in the wing lower fairings. This system utilizes automatic shutoff valves to control the fueling operation. Defueling is accomplished by pumping the fuel from the tanks through these refuel control units.

During flight, fuel is transferred from the main transfer tanks to the collector tanks, and the fuel is then pumped from the collector tanks to the engines. Fuel is also transferred as required to adjust the aircraft's center of gravity during transonic acceleration and deceleration. The fuel is also pumped through various heat exchangers and back to the tanks for cooling.







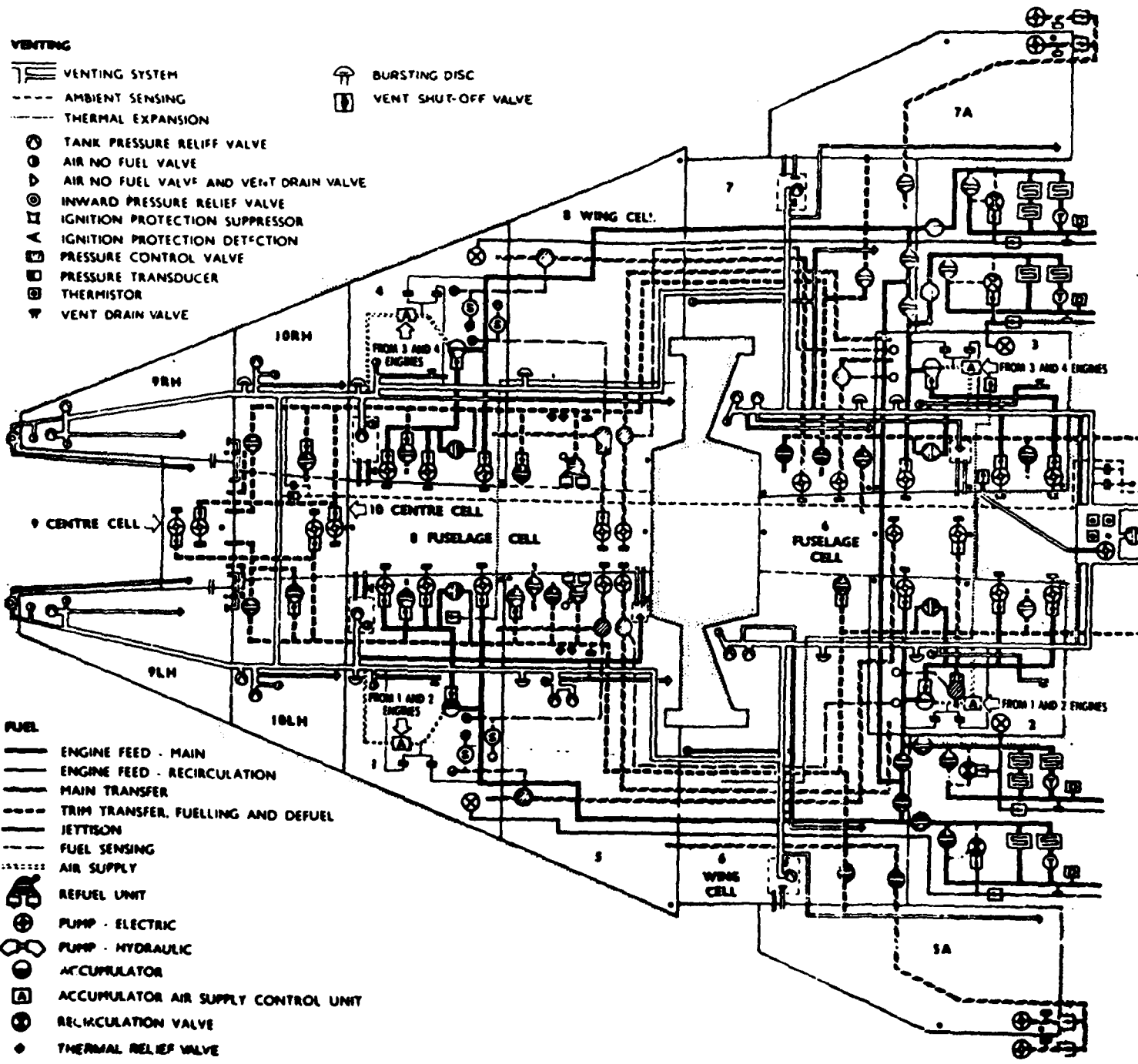







A schematic of the basic fuel system is shown in Figure 2.

VENTING

-  VENTING SYSTEM
-  AMBIENT SENSING
-  THERMAL EXPANSION
-  TANK PRESSURE RELIEF VALVE
-  AIR NO FUEL VALVE
-  AIR NO FUEL VALVE AND VENT DRAIN VALVE
-  INWARD PRESSURE RELIEF VALVE
-  IGNITION PROTECTION SUPPRESSOR
-  IGNITION PROTECTION DETECTION
-  PRESSURE CONTROL VALVE
-  PRESSURE TRANSDUCER
-  THERMISTOR
-  VENT DRAIN VALVE
-  BURSTING DISC
-  VENT SHUT-OFF VALVE



FUEL

-  ENGINE FEED - MAIN
-  ENGINE FEED - RECIRCULATION
-  MAIN TRANSFER
-  TRIM TRANSFER, FUELLING AND DEFUEL
-  JETTISON
-  FUEL SENSING
-  AIR SUPPLY
-  REFUEL UNIT
-  PUMP - ELECTRIC
-  PUMP - HYDRAULIC
-  ACCUMULATOR
-  ACCUMULATOR AIR SUPPLY CONTROL UNIT
-  RECIRCULATION VALVE
-  THERMAL RELIEF VALVE

FIGU

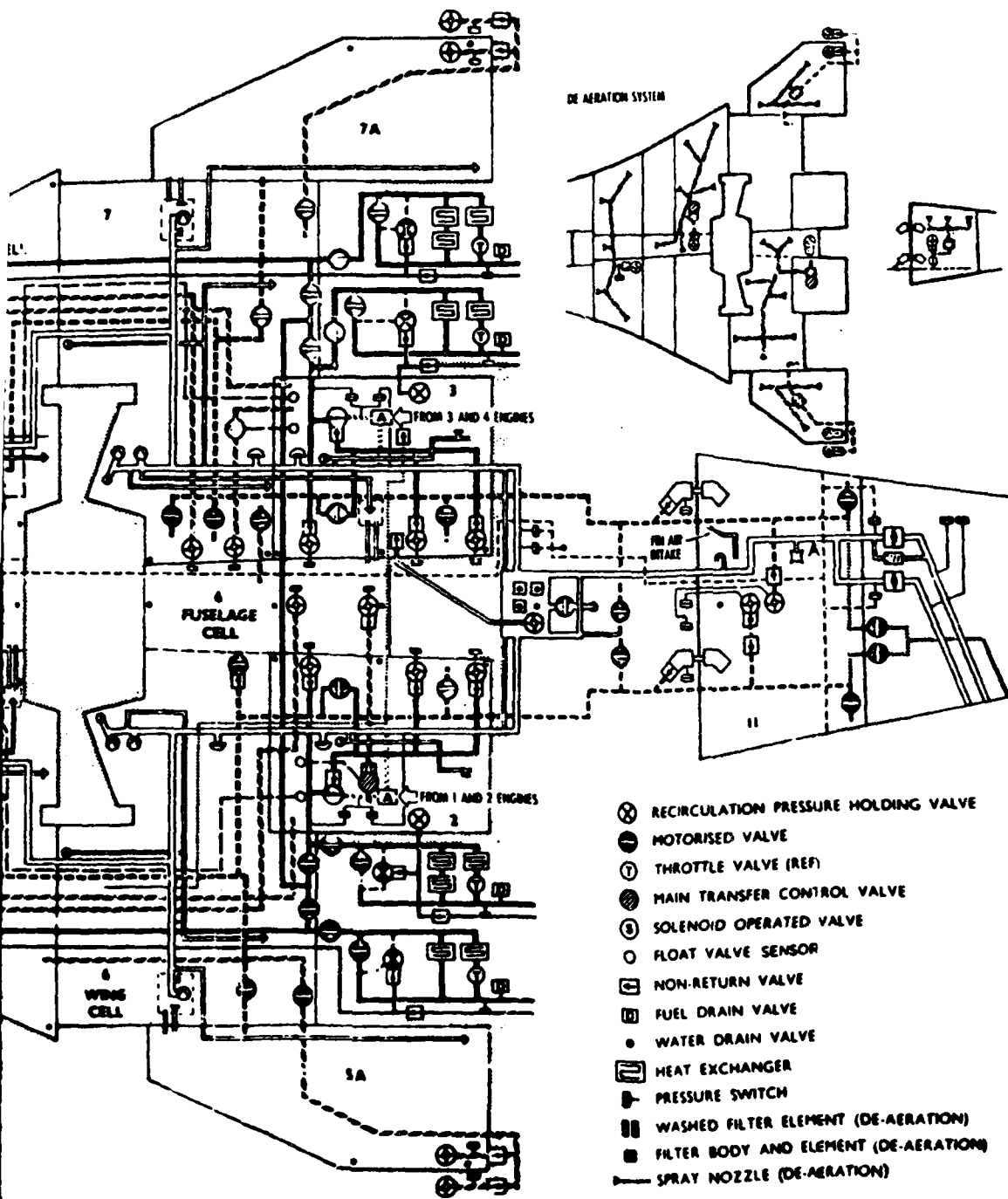

FIGURE 2. CONCORDE FUEL SYSTEM

b. Fuel System Components And Features

1. Line Sizes - The fuel system lines sizes are as follows:
 - Engine Feed - 2.0-inch
 - Main Transfer - 1 1/2-inch
 - Trim Transfer - 3-inch
 - Jettison - 4-inch and 2-inch
2. Thirty electrically driven centrifugal pumps and 2 hydraulically driven centrifugal pumps are supplied. Twelve of these run continuously and up to 18 are running during portions of the flight. The pumps have flow ratings of 2000 gal/hr to 12,000 gal/hr. No ejector pumps are used on this aircraft.
3. Filters - All of the pump inlets have metal screens with 0.2-inch to 0.1-inch openings. No other filters are supplied.
4. Suction Feed - Suction feed is not used on this aircraft.
5. Venting and Pressurization System - A vent pipe connects each tank to the atmosphere through rear fuselage vents. An ignition protection system automatically senses and extinguishes any fuel vapor combustion at the main vents.

At altitudes above 44,000 feet. the tanks are pressurized with air to maintain 2.2 pounds per square inch absolute (psia) pressure in the tanks to aid fuel pumping and prevent fuel boiling.
6. Jettison System - The tank pumps are used to jettison fuel overboard during flight. This operation is automatically stopped when collector tank levels fall to an underfull condition.
7. De-aeration System - Fuel de-aeration systems are provided in tanks where fuel remains static for long time periods. De-aeration prevents momentary increases in tank pressure and formation of air pockets around pump inlets due to air release from the fuel with decreasing tank pressure. These systems pump the fuel through spray nozzles with 0.060-inch diameter holes. Twenty-seven nozzles are used, each with 6 holes.
8. Pressure Refueling - Pressure refueling can be performed from both sides of the aircraft through four standard 2 1/2-inch MIL-A-25896D adapters.

The refueling system employs automatic shutoff valves and pilot valves which have 1/16-inch to 1/8-inch orifices.
9. Recirculation Control Valves - Recirculation control valves with tapered needles are used to control heat exchanger outlet flow.
10. Float Level Sensors - These sensors utilize pilot valves with 1/16-inch to 1/8-inch orifices.

11. Heat exchangers - Fuel is used in 10 heat exchangers, 6 for hydraulic fluid, 4 for air. Fuel is used in the shell side of the hydraulic fluid heat exchangers, and on the tube side of the air heat exchangers. Fuel flows through 0.040-inch by 0.060-inch passages in the fuel-air exchangers.
 12. Fuel Quantity Gauging System - A capacitance gauging system is used with thermistor point level sensors for high level shutoff and collector tank low level sensing.
 13. Flowmeter - Rotating vane volumetric flowmeters with capacitance-inferred density measurement are provided for each engine to measure the mass fuel flow rate. The afterburner flowmeter is located after the first stage engine fuel pump and the engine flowmeter is located after the second stage pump.
 14. Auxiliary Power Unit (APU) - There is no APU supplied with this aircraft.
- c. Potential AMK Degradation Sources - The primary source of AMK shear degradation is the continuous pumping and recirculation through the centrifugal pumps. Due to the extensive pumping through heat exchangers, control valves and de-aeration systems, more degradation will probably occur in this aircraft than in others studied.
- d. Potential Component Performance Problems - Based on reference 3, reduced heat exchanger performance will result with undegraded AMK. The de-aeration spray nozzles will not perform satisfactorily with undegraded AMK. The thermistor bead point level sensors may have increased response time with undegraded AMK due to its slower draining rate. The float level sensors, automatic shutoff valves and the recirculation control valves may have increased response time with AMK. Based on reference 3, the volumetric flowmeter may have reduced accuracy. The mesh screens in the pump inlets will probably perform satisfactorily with AMK.

- e. Safety - The high landing speed and fuel temperatures experienced with this aircraft will probably negate the full benefits of AMK in a landing crash fire situation.

Boeing 737

- a. Fuel System Discussion - The fuel in this aircraft is contained in two wing tanks, a center tank and an aft body tank, with a total capacity of 5974 gallons. The center tank fuel is held in 3 bladder type fuel cells.

Pressure refuel is performed using one standard 2 1/2-inch MIL-A-25896D adapter. Defueling using tank pumps is also achieved through this adapter.

The center tank and aft body tank are emptied first during the flight. The wing tank fuel then drains inboard and is used during the remainder of the flight.

Water scavenging and fuel transfer are achieved with boost pumps, boost pump bypass valves, check valves, fuel shutoff valves and pressure switches. The water scavenging philosophy is to have the boost pump inlets located at the tank low points so that any accumulated water will be drawn in with the fuel. No ejector pumps are supplied.

A schematic of the basic fuel system is shown in Figure 3.

- b. Fuel System Components And Features

1. Line Sizes - The main fuel system uses 1.0-inch to 2.0-inch pipe, and the scavenge system uses 3/4-inch pipe.
2. Boost Pumps - Electrically driven, 11,200 rpm, 20,000 lb/hr pumps are used for boost, transfer, and scavenging. Two run continuously, six are supplied. Cruise flow rate is approximately 6000 pph, zero flow pressure rise is 36 psi.
3. Ejector Pumps - No ejector pumps are supplied with this aircraft.
4. Filters - All of the pump inlets have 4 mesh screens. No other filters are supplied with the airframe.
5. Suction Feed - The suction feed condition during aircraft flight would occur only as a result of major pump and/or electrical failure.
6. Vent System - The vent system contains honeycomb flame arrestors with 0.05-inch triangular passages 1-inch long.
7. Pressure refueling - Pressure refueling is performed through the 2 1/2-inch MIL-A-25896D adapters. The system uses an automatic shutoff valve with a pilot valve mechanism containing approximately 0.125-inch diameter passages.

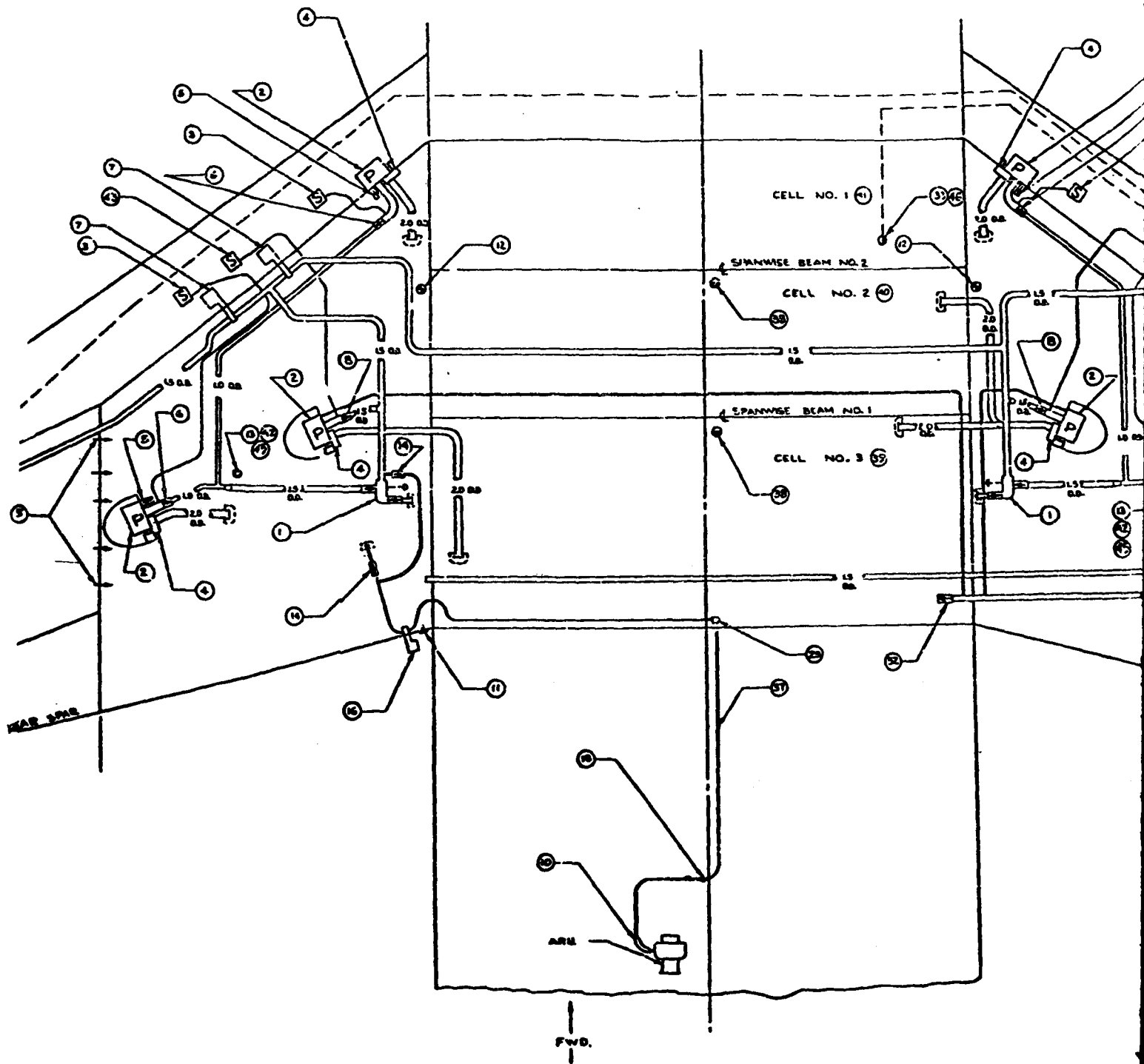

1

1

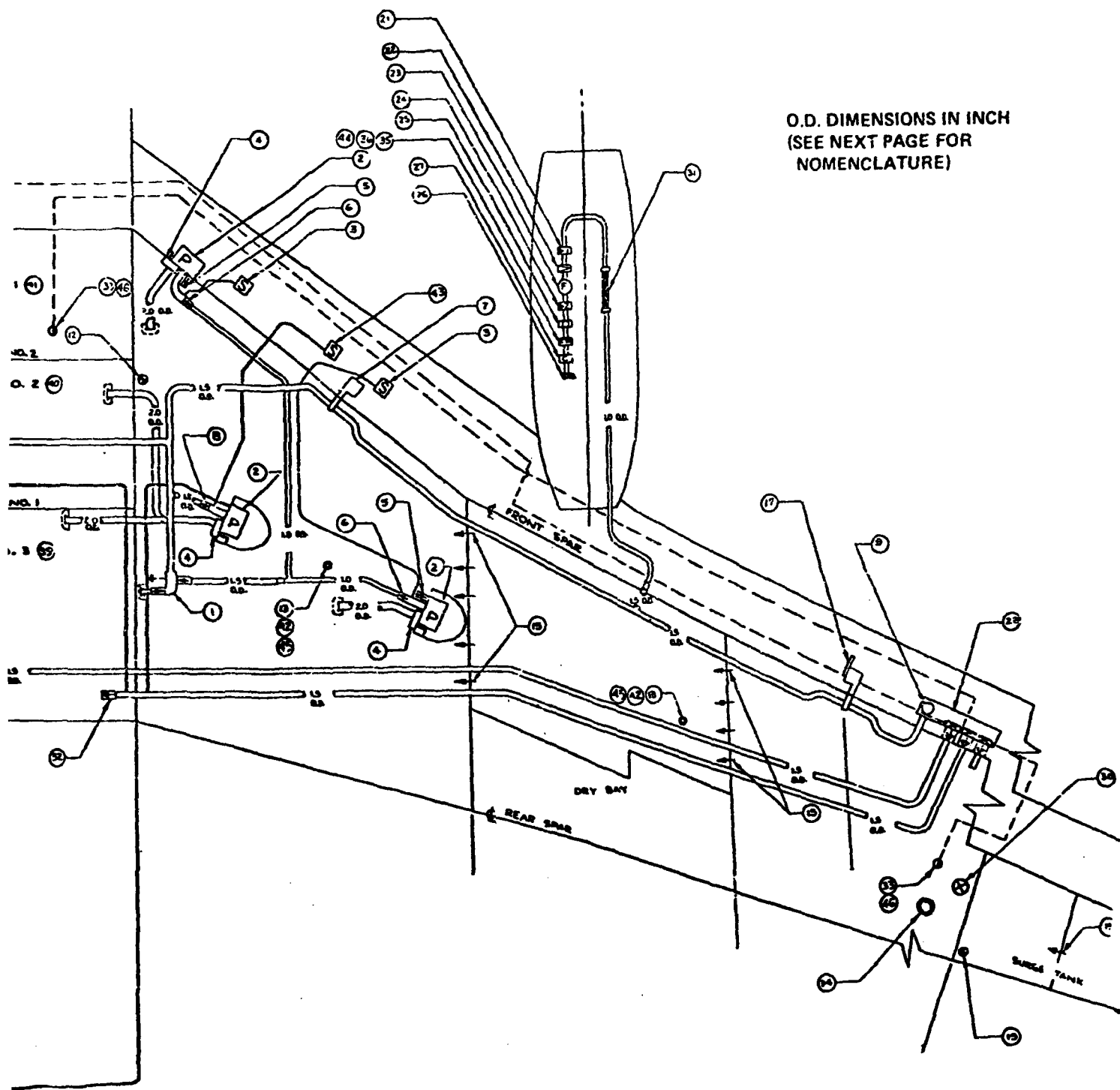

O.D. DIMENSIONS IN INCH
 (SEE NEXT PAGE FOR
 NOMENCLATURE)

FIGURE 3. BOEING 737 FUEL SYSTEM SCHEMATIC

2

ITEM

NOMENCLATURE

1.	Boost Pump By-Pass Valve
2.	Boost Pump
3.	Pressure Switch
4.	Pump Inlet Manual Valve
5.	Check Valve
6.	Check Valve Boost Pump
7.	Fuel Shutoff Valve
8.	Check Valve Boost Pump
9.	Cap Pressure Fueling
10.	Flexible Fuel Hose
11.	Temperature Bulb-Fuel
12.	Sump Drain Valve
13.	Stick and Core Assy. Dripstick (Calibration In Inches)
14.	APU Check Valve
15.	Baffle Rib Check Valve
16.	APU Fuel Shutoff Valve
17.	Defuel Valve Manual
18.	Seal Gasket
19.	Sump Drain Valve
20.	Hose Assy-Fire Proof
21.	Engine Pump 1st Stage
22.	Fuel Heater
23.	Fuel Filter
24.	Engine Pump 2nd Stage
25.	Fuel Control Unit
26.	Fuel Nozzle
27.	Fuel Oil Cooler
28.	Fueling Manifold
29.	Metallic Flex Hose
30.	Valve Vent Float
31.	Hose Assy-Fire Proof
32.	Check Valve
33.	Float Switch
34.	Filler Cap Ass'y
35.	Flowmeter Transmitter (KGS)
36.	Flowmeter Transmitter (LBS)
37.	Hose Assy
38.	Sump Drain Valve
39.	Fuel Bladder Cells (1 Cell Config.)
40.	Fuel Bladder Cells (2 Cell Config.)
41.	Fuel Bladder Cells (3 Cell Config.)
42.	Stick & Core Assy. (Dripstick) (Calibration in Lbs)
43.	Pressure Switch
44.	Flowmeter Transmitter Rate-Pointer
45.	Stick and Core Assy Dripstick (Calibration in Kilograms)
46.	Float Switch

NOMENCLATURE FOR FIGURE 3

8. Heat Exchangers - Hydraulic fluid exchangers are used on this aircraft. The hydraulic fluid is on the tube side, and fuel is on the shell side. The fuel is used as a static heat sink.
 9. Fuel Quantity Gauging System - A capacitance type fuel quantity gauging system is used on the aircraft. No thermistor type point level sensors are included.
 10. Auxiliary Power Unit (APU) - The APU is supplied by Garrett Airesearch; their Part Number is CTCP-85-129. This unit has a 40-micron paper filter, and a 4245 rpm gear pump which supplies 480 pph at 500 psig. The max bypass ratio is 4:1; and it has one nozzle with a primary opening of 0.0185-inch and a secondary opening of 0.021-inch. The fuel control bypass metering system uses a flow passage which varies from 0.020-inch to 0.125-inch.
- c. Potential AMK Degradation Sources - The primary source of AMK shear degradation is the pumping and recirculation through the 11,200 rpm centrifugal pumps. Since transfer and scavenging are also performed with these pumps, instead of low shear jet pumps, a greater number of passes through them will take place. Some shearing action may occur in the refuel/defuel valve during the partially open condition, but the effect will probably be small. Based on discussions with Southwest Research, the use of AMK as a static heat sink in the hydraulic fluid heat exchangers will be equivalent to Jet A.
 - d. Potential Component Performance Problems - The automatic shutoff pilot valve mechanism may have increased response time with AMK (reference 1). The APU will require the same type of degrader necessary for the main engines to insure proper combustor performance. The APU fuel control bypass metering system may not perform properly with undegraded AMK.
 - e. Potential Safety Considerations - Possible pregelling of the AMK in the pumps could result in some plugging of the pump inlet screens. Based on references 1, 3 and 2, the fine filters on the APU will probably experience plugging with undegraded AMK. Liquid water drawn up by the scavenge system and deposited in the bulk fuel may cause sudden polymer precipitation. Some boost pump performance loss will be obtained with AMK but may not be critical.

Boeing 747

- a. Fuel System Discussion - The fuel in this aircraft is contained in a center wing tank, tip reserve tanks and 4 main wing tanks. Auxiliary tanks are added between the reserve tank and the outboard main tank in some models. The maximum fuel capacity is 51,100 gallons.

Pressure refueling and defueling is performed with two 2 1/2-inch MIL-A-25896D fueling adapters.

Fuel is pumped from the center wing tank first until it is empty then from the main wing tanks. Fuel can be pumped and cross-fed between all tanks and engines.

A fuel scavenge pump in the center wing tank transfers fuel that is unavailable to the center wing tank boost pumps to the No. 2 main tank.

A water scavenge system scavenges water from low points in the main tanks and pumps it to a point near the boost pump inlet.

A schematic of the basic fuel system is shown in Figures 4 and 5.

b. Fuel System Components and Features

1. Line Sizes - The main fuel system uses 1.5-inch to 2.5-inch pipe, and the scavenge system uses 3/4-inch pipe.
2. Pumps Boost - Electrically driven, 7200 rpm centrifugal pumps with a 20,000 lb/hr rating at 13 psig are used. Four run continuously, 8 are supplied. Cruise flow is approximately 8000 pph, zero flow pressure is approximately 20 psig.

Transfer & Jettison - Four additional pumps identical to the boost pumps are supplied.

Fuel Scavenge and APU - These are vane pumps. The APU pump is battery powered and is used to supply fuel to the APU when 115/200 VAC power is not available.

Water Scavenge - Eight small jet pumps with 0.064-inch nozzles are used which run continuously.

3. Filters - The boost pumps, override pumps, APU pump and fuel scavenge pump have 4 mesh screens on the inlets. No other filters are supplied with the airframe fuel system.
4. Vent System - The vent system utilizes small honeycomb mesh flame arrestors.
5. Suction Feed - The suction feed condition during flight would occur only as a result of major pump and/or electrical failure. The aircraft can operate in the suction feed condition.
6. Pressure Refueling - Normal pressure refueling is performed with 2 hoses from the left side of the aircraft. The 2 1/2-inch MIL-25896D adapter is used. This system utilizes a refueling valve which contains pilot float valves and small bleed lines of approximately 0.125-inch diameter.
7. Refuel Distribution Lines - Several 4 foot to 5 foot lengths of 2-inch pipe with 1/8-inch holes are used to bleed off static charge and distribute the fuel.
8. Heat Exchangers - Hydraulic fluid/fuel heat exchangers are used in this aircraft. Hydraulic fluid is on the tube side and fuel is on the shell side. The fuel is used as a static heat sink.

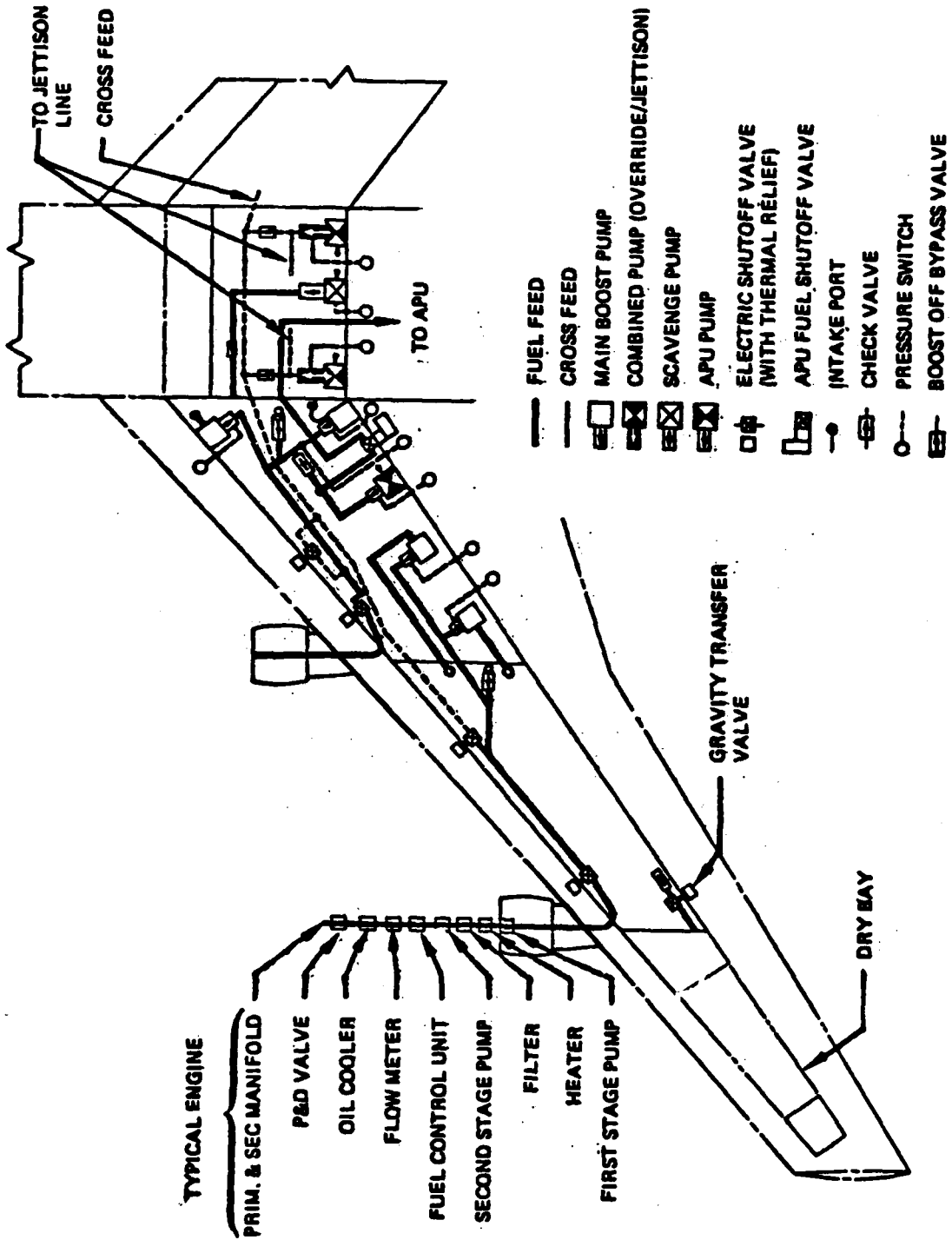

FIGURE 4. BOEING 747 FUEL SYSTEM SCHEMATIC

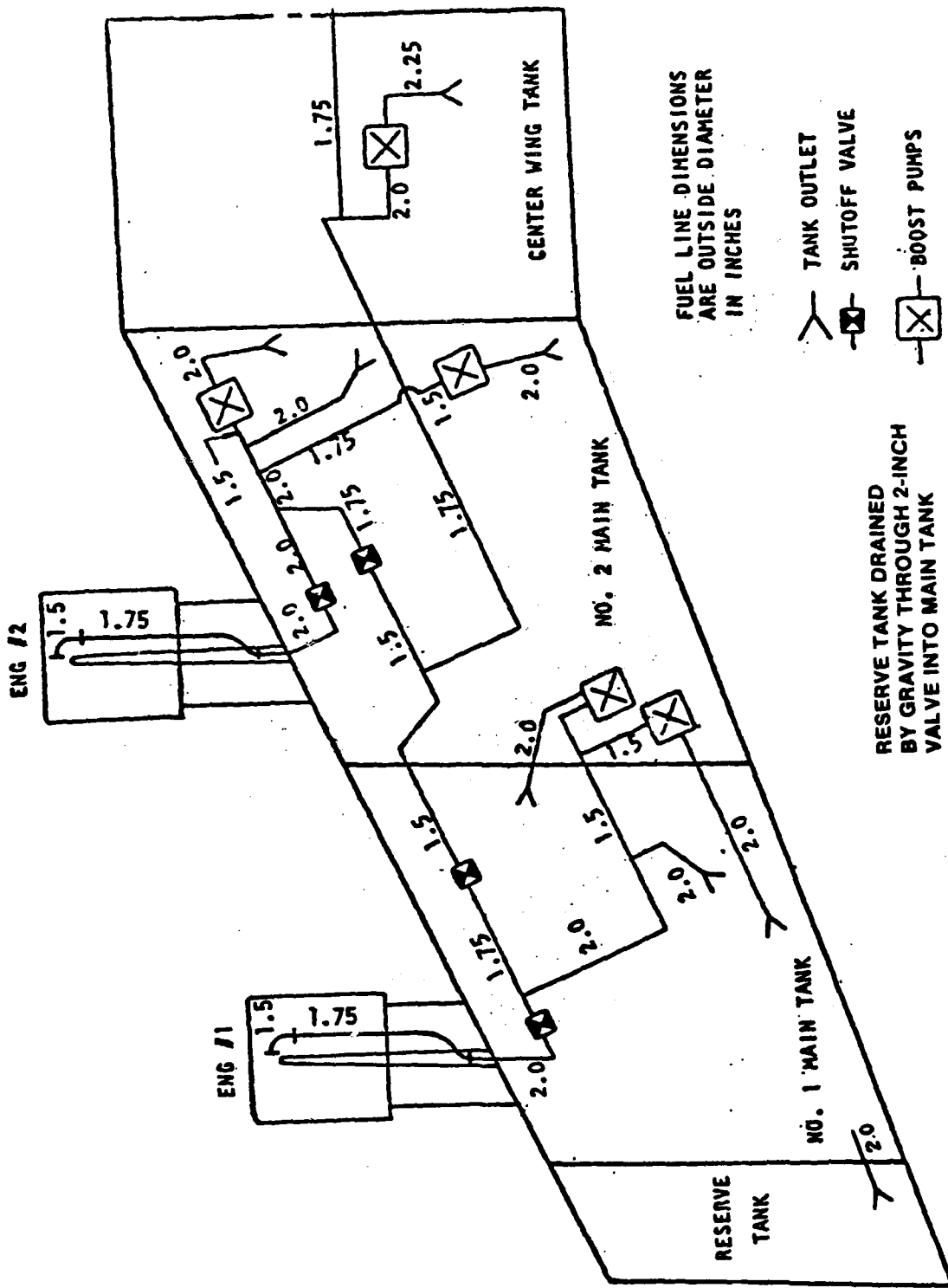

FIGURE 5. BOEING 747 FUEL SYSTEM LINE SIZES

9. Fuel Quantity Gauging System - A capacitance type fuel quantity gauging system is used on this aircraft. No thermistor type point level sensors are used.

10. The APU is supplied by Garrett Airesearch; their part no. is GTCP-660-4. This unit has 10-micron and 25-micron paper filters and a 4000 rpm gear pump that has 4000 pph flow at 600 psig. The max bypass ratio is 3.6:1. There are 8 primary nozzles with a diameter of 0.012-inch and 8 secondary nozzles with a diameter of 0.014-inch. The fuel control bypass flow metering system uses a 0.020-inch to 0.060-inch flow passage.

- c. Potential AMK Degradation Sources - The primary source of AMK shear degradation is the continuous pumping and recirculation through the 7200 rpm pumps.

Results given in reference 1 indicated that boost pump shear degradation of AMK was not severe, but the flammability test criteria have since been revised.

The high shear gear pump on the APU will cause some degradation, but since fuel bypassed in the APU is not returned to the tanks this will not effect the bulk fuel flammability properties.

Some shearing action may occur in the refuel/defuel valve during the partially open condition, but the effect will probably be small.

Discussions with the Southwest Research Institute, where AMK shear degradation studies are being done (reference 2), indicate that pregelling of the fuel may occur when it is passed through the pump so that subsequent passes may cause gelling to occur.

- d. Potential Component Performance Problems - Based on reference 1, the eight jet pumps used in this aircraft will have greatly reduced performance. This can result in increased unusable fuel and reduced scavenging efficiency.

Boost pump performance will also be reduced, but this may not be a critical factor.

Small fluid passages present in the automatic shutoff valves may have increased response time with AMK.

Discussion with Southwest Research indicates that the 4 mesh screens on the pump inlets should function properly with AMK.

The APU will require the same type of degrader necessary for the main engines to insure proper combustor performance. The APU fuel control bypass metering system may not function properly with AMK.

- e. Potential Safety Considerations - Possible pregelling of the AMK could result in some plugging of the pump inlet screens. Reduced jet pump performance may increase unusable fuel. Based on references 1, 2, and 3, the fine filters on the APU will probably experience plugging with

AMK. Liquid water, if present, that is drawn up by the scavenge system and deposited in the bulk fuel near the boost pump inlet may cause polymer precipitation.

Airbus Industrie A-310

- a. Fuel System Discussion - The fuel in this aircraft is contained in five tanks - center wing and right and left outboard and inboard. The total fuel quantity is 14,531 gallons.

Defueling is accomplished using two standard 2 1/2-inch fueling adapters on the right side of the aircraft.

Fuel is used in the order center, inboard and outboard except during takeoff when the center tank is not used. The tank sequence is automatic, but can be controlled manually at any time. A crossfeed system allows both engines to feed from one side, or all fuel to be used in one engine.

Two jet pumps are used for fuel scavenging and to keep the boost pump collector boxes full.

A basic schematic of the fuel system is shown in Figure 6.

- b. Fuel System Components and Features

1. Line Sizes - The engine feed lines are 2-inch, refuel and defuel are 1.5-inch to 3.0-inch, and the APU feed is 3/4-inch.
2. Boost Pumps - Electrically driven, 6000 rpm centrifugal pumps with a 40,000 lb/hr flow rating at 9 psig are used. Ten are supplied, six run continuously from the start of the flight, reducing to four as the tanks are emptied. The inner and center tank pumps have a zero flow pressure of 37 psig, the outer tank pump 18 psig. Cruise flow is approximately 4000 pph.
3. Ejector Pumps - Two jet pumps, one in each wing, are used to keep the outer tank pump collector box full. They run continuously.
4. Suction Feed - Suction feed during aircraft flight would occur only as a result of major pump and/or electrical failure.
5. Filters - The boost pump inlets have 8 mesh wire screens. No other filters are supplied with the airframe.
6. Pressure Refueling - Two standard 2 1/2-inch adapters are used for pressure refueling. An automatic shutoff valve utilizing a pilot valve with small orifices is used in this system. The system is also used for suction or pumped defueling.
7. Fuel Distribution - Several diffuser sections, consisting of 1 to 2 foot lengths of 2-inch pipe with 1/8-inch diameter holes, are used to distribute the fuel and reduce static charge build-up during the fueling operation.

LEGEND	
SYMBOL	DESCRIPTION
(Symbol)	WATER DRAIN
(Symbol)	MAGNETIC LEVEL INDICATOR
(Symbol)	FUEL QUANTITY INDICATOR PROBE
(Symbol)	HIGH LEVEL SENSOR
(Symbol)	LOW LEVEL SENSOR
(Symbol)	PRESSURE RELIEF OUTLET
(Symbol)	PRESSURE SWITCH
(Symbol)	NON RETURN VALVE (→) DIRECTION OF FLOW
(Symbol)	FUEL PUMP
(Symbol)	SEQUENCE VALVES

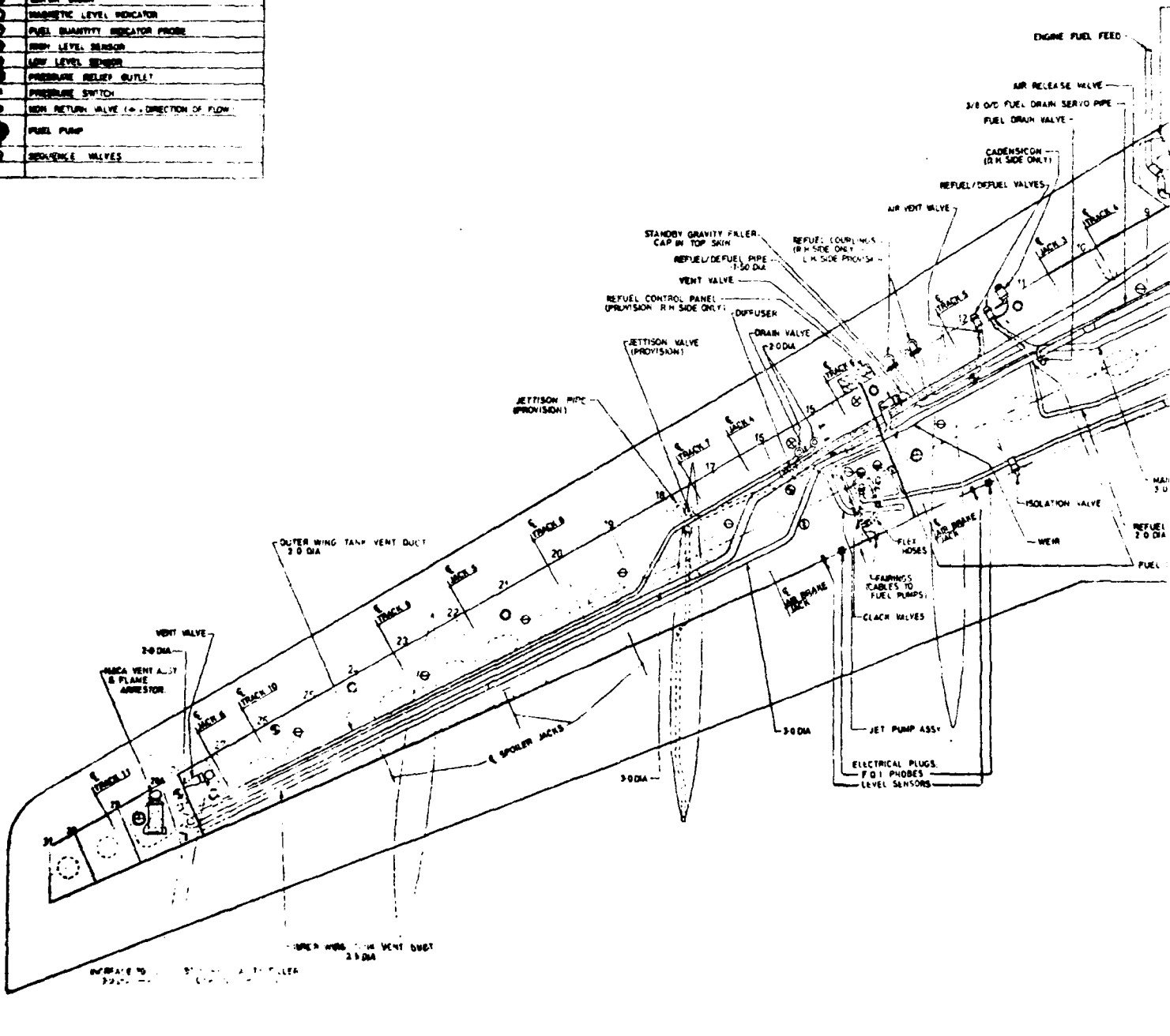

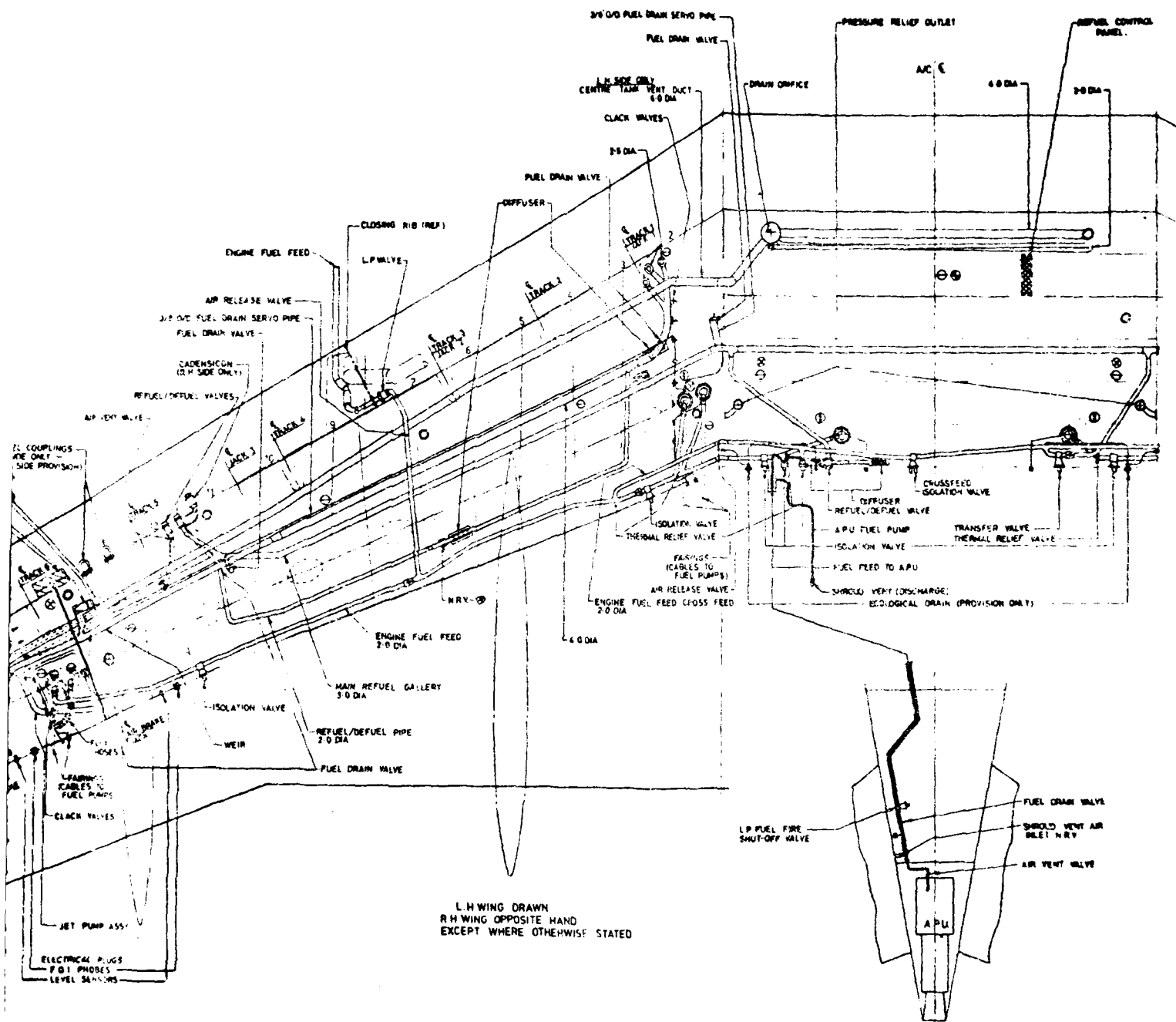

FIGURE 6. A-310 FUEL SYSTEM SCHEMATIC

2

8. Vent System - The vent system contains fine honeycomb mesh flame arrestors.
9. Heat Exchangers - No fuel heat exchangers are supplied with airframe.
10. Fuel Quantity Gauging System - A capacitance type fuel quantity gauging system is used on this aircraft. Thermistor type point level sensors are used for high and low level sensing and to shut-off the center tank pumps when the tank is empty.
11. Density Measurement - A fuel density measurement device called a Cadensicon is supplied with this aircraft.

It utilizes a mass balance method to measure fuel density and a sensor which measures fuel dielectric constant.

12. Auxiliary Power Unit (APU) - A Garrett GTCP-311-250 unit is supplied. This unit has a 10-micron synthetic fiber filter, and an 8300 rpm gear pump that supplies 2100 pph at 700 psig. Twelve fuel nozzles are used, 6 with an opening of 0.012-inch and 6 with an opening of 0.014-inch. The fuel control bypass metering line varies from 0 to 0.020-inch.

Potential AMK Degradation Sources - The primary source of AMK shear degradation is the continuous pumping and recirculation through the 6000 rpm boost pumps. The rpm of these pumps is significantly lower than some of the others encountered, and the degradation experienced will probably be less.

The high shear gear pump on the APU will probably result in some degradation, but since fuel bypassed in the APU is not returned to the bulk fuel this will not affect the bulk fuel flammability characteristics.

Discussions with Southwest Research, where degradation studies are being done, indicate that pregelling of the fuel may occur as it passes through the pump so that subsequent passes may cause gelling to occur.

- c. Potential Component Performance Problems - Based on reference 1, the two ejector pumps will have greatly reduced performance with undegraded AMK. This can result in inability to keep the boost pump collector box full.

Small fluid passages in the automatic shutoff valve and the level control valves may cause increased response time with undegraded AMK.

The 8 mesh screens on the pump inlets should function properly with undegraded AMK.

The mass balance density device may not function properly with undegraded AMK.

The thermistor type point level sensors will drain slowly with undegraded AMK and may not have the required response time, especially with the low level switching functions.

The APU will require the same type of degrader necessary for the main engines to insure proper combustor performance. The APU fuel control bypass metering system may not perform properly with undegraded AMK. The APU filter will probably experience plugging with undegraded AMK.

- d. Potential Safety Considerations - Possible pregelling of the AMK could result in some plugging of the pump inlet screens. Reduced jet pump performance may result in boost pump collector boxes not being kept full.

BAC 111-500

- a. Fuel System Discussion - The fuel in this aircraft is contained in three integral tanks, one in each wing and one in the center section in the unpressurized portion of the fuselage under the passenger cabin. The total fuel quantity is 3,722 gallons.

Aircraft refueling is performed through one standard 2 1/2-inch refuel/defuel adapter on the right side of the aircraft. The maximum refuel rate is 498 gal/min at 50 psi. The aircraft is defueled with this same adapter by either suction or boost pump flow.

The tanks are pressurized during flight from a flush ram-air intake located on the undersurface of the vent/surge tank.

Depending on flight conditions, this results in a fuel tank pressure approximately 1 psi above ambient. This prevents fuel boiling at high altitudes, especially if JP-4 is used.

Crossfeed is provided so either engine can feed from any tank.

Each engine is normally fed from its own tank, keeping fuel management to a minimum. The center tank fuel must be pumped to the wing tanks for transfer to the engine. Two jet pumps are used for this purpose.

Two APU fed lines are provided, one from the engine feed line and one directly from the left wing tank.

A basic schematic of the fuel system is shown in Figure 7.

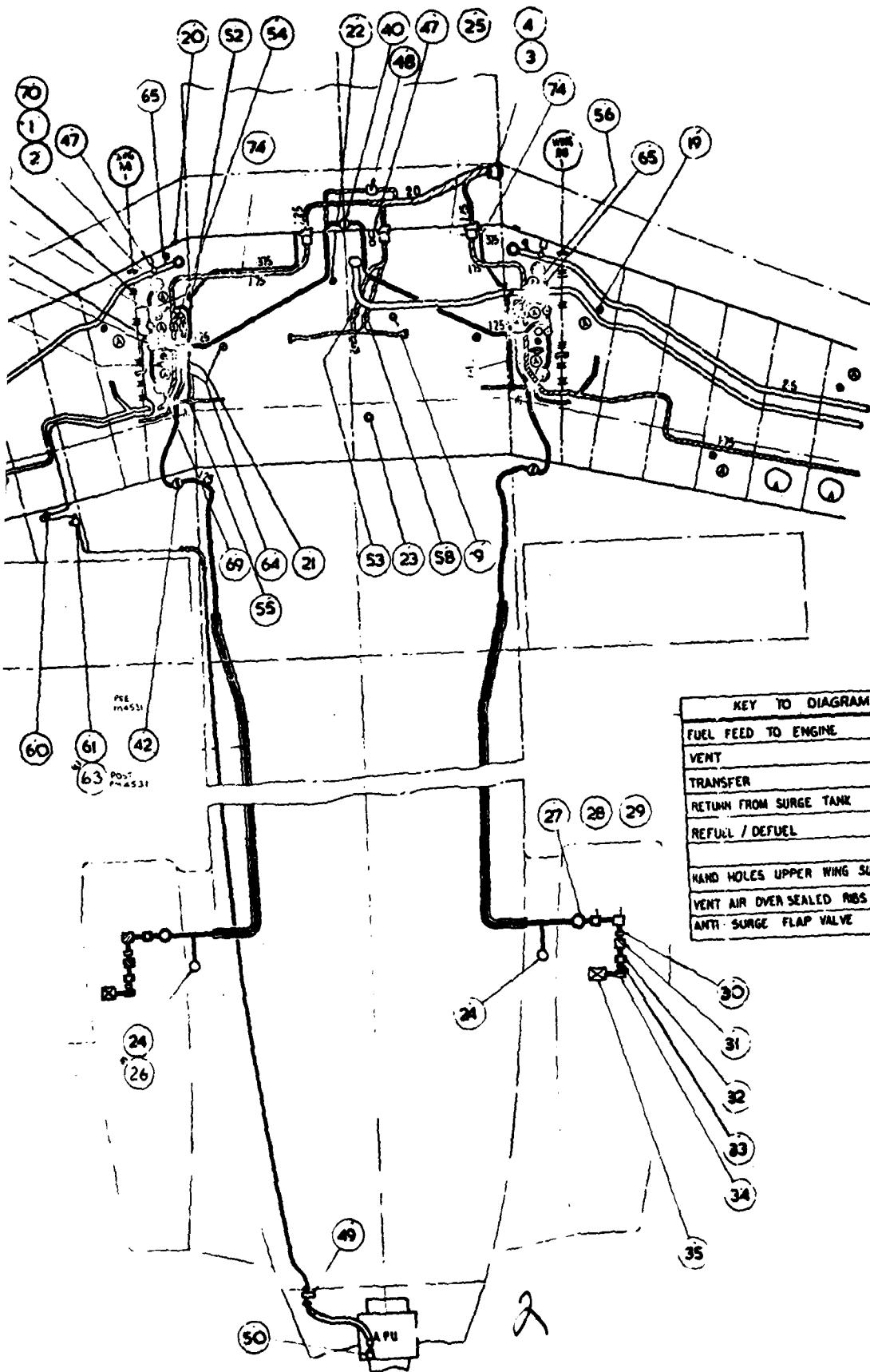

KEY TO DIAGRAM	
FUEL FEED TO ENGINE	
VENT	
TRANSFER	
RETURN FROM SURGE TANK	
REFUEL / DEFUEL	
HAND HOLES UPPER WING SURFACE	
VENT AIR OVER SEALED RBS	
ANTI SURGE FLAP VALVE	

ITEM NO.	DESCRIPTION
1	BOOSTER PUMP CANISTER
2	BOOSTER PUMP
3	FUELLING COUPLING
4	BLANKING CAP
5	LEVEL INDICATOR
6	LEVEL INDICATOR
7	LEVEL INDICATOR
8	LEVEL INDICATOR
9	LEVEL INDICATOR
12	SUCTION FEED VALVE
13	N.R.V. FLOAT OPERATED
17	FLOAT OPERATED VENT VALVE
18	INST. OF VENT SYSTEM INTAKE
19	TANK CONTINUED UNITS WING TANK
20	FUEL CONTINUE GAUGE TANK TERMINAL
21	COMBINED TANK & REFUEL UNIT WING TANK
22	TANK CONTINUED UNIT CENTRE TANK
23	COMBINED TANK & REFUEL CENTRE TANK
24	LOW PRESS WARNING SWITCH
25	REFUEL-DEFUEL VALVE
26	LOW PRESS, WARNING SWITCH
27	ENGINE BACKING PUMP
28	L.P. FUEL COOLED OIL COOLER
29	FUEL HEATER
30	TEMP. GAUGE
31	FILTER
32	FLOW METER
33	PRESS SWITCH
34	H.P. PUMP
35	METERING UNIT & H.P. VALVE
40	CROSS FEED VALVE
42	FUEL FEED VALVE
44	OVER WING FILLER CAP
45	OVER WING FILLER CAP WING TANK
47	FLOAT SWITCH MAX REFUEL CUT-OFF
48	POWER DEFUEL VALVE
49	A.P.U. LOW PRESS FILTER
50	A.P.U. FUEL CUT-OFF VALVE
51	N.R.V. A.P.U. FEED
52	N.R.V. DEFUEL WING
53	N.R.V. DEFUEL CENTRE TANK
54	N.R.V. REFUEL WING INBOARD
55	JET PUMP
56	N.R.V. JET PUMP FEED
57	N.R.V. FUEL FEED
58	N.R.V. REFUEL CENTRE TANK
60	A.P.U. FEED VALVE
61	A.P.U. BOOSTER VALVE
62	ANTI-SURGE VALVE
63	A.P.U. BOOSTER PUMP
64	TANK WATER DRAIN
65	VENT PIPE WATER DRAIN
66	SURGE TANK WATER DRAIN
69	PUMP ELEC. CON. & OUTTING WING TANK AFT
70	PUMP ELEC. CON. & OUTTING WING TANK FWD
73	FUEL FILLER CAP WATER DRAIN
74	REFUEL/DEFUEL VALVE & BLEED PIPES

b. Fuel System Components And Features

1. Line Sizes - The fuel system line sizes are as follows:
 - Engine Feed - 1 1/4-inch
 - Refuel/Defuel - 1 3/4-inch, 2.0-inch
 - Transfer - 1/2-inch, 1 1/4-inch
 - APU Supply - 3/8-inch
 2. Boost Pumps - Electrically driven, radial flow, 8000 rpm, 13,000 pph at 8 psig boost pumps located in the inboard section of each wing are used. Four are supplied, two run continuously. Cruise flow is approximately 3000 pph.
 3. Ejector Pumps - Two are supplied, both run continuously to transfer fuel from the center tank to the wing tanks.
 4. Filters - Screens with 1/8-inch openings are used at the boost pump inlets and the jet pump inlets. No other airframe fuel filters are supplied.
 5. Suction Feed - Suction feed during normal flight would occur only as a result of major pump and/or electrical failure. The aircraft can operate on suction feed if required.
 6. Pressure Refueling - Pressure refueling is performed through one standard 2 1/2-inch adapter on the right-hand side of the aircraft. An automatic shutoff mechanism using a pilot valve is used in this system. Provision for gravity fueling is also supplied.
 7. Fuel Quantity Gauging System - A capacitance-type fuel quantity gauging system is used. No thermistor type point level sensors are included.
 8. Auxiliary Power Unit (APU) - A Garrett GTCP-85-115CK unit is supplied. This unit has a 40-micron paper filter, 4245 rpm gear pump, max flow of 480 pph at 500 psig, and a max bypass ratio of 4:1. The fuel nozzles are 0.01185-inch and 0.021-inch, and the fuel control bypass metering system uses a 0.020-inch to 0.060-inch flow passage.
- c. Potential AMK Degradation Sources - The primary source of AMK shear degradation is the continuous pumping and recirculation through the two 8000 rpm boost pumps. Reference 1, again, indicates that boost pump shear degradation may not be severe. The high shear gear pump on the APU will cause some degradation but since the bypassed fuel is not circulated back to the tanks this will not affect the bulk fuel. As in the other aircraft, possible pregelling of the AMK in the boost pumps may occur.
- d. Potential Component Performance Problems - Based on reference 1, the two ejector pumps will have greatly reduced performance with undegraded

AMK. The boost pump performance will also be decreased, to a lesser degree.

Small fluid passages in the automatic shutoff pilot valve may cause increased response time in this system.

The 1/8-inch pump inlet screens should perform properly with undegraded AMK.

The APU will require the same type of degrader necessary for the main engines to insure proper combustor performance. The APU fuel control bypass metering system may not work properly with undegraded AMK. The APU filter will probably experience plugging with undegraded AMK.

- e. Potential Safety Considerations - Possible pregelling of the AMK in the boost pumps may cause some plugging of the inlet screens. Reduced jet pump performance may cause incomplete emptying of the center tank.

Based on references 1, 2, and 3, the APU filters will probably experience plugging with undegraded AMK.

L1011-500

- a. Fuel System Discussion - The fuel in the aircraft is contained in six tanks (two tanks in each wing and two center section tanks) with a total capacity of 32,000 gallons.

Pressure refueling and defueling is accomplished with the standard 2 1/2-inch MIL-A-25896 adapters, two of which are located on each wing. Automatic shutoff valves are used to control the fueling operation.

The crossfeed system permits any engine feed tank to supply fuel to any engine, but does not allow tank to tank transfer. This is accomplished with ejector pumps and fuel transfer valves in the fuel transfer system. During takeoff and climb each engine is fed from its own tank. When cruise altitude is reached, the left and right No. 2 wing tanks are shut off and the center tanks are used until empty. Each engine is then fed from its own wing tank until the end of the flight.

A water scavenging system using compound jet pumps with inlet rakes draws water and fuel from various low points in the various tanks and deposits it in the boost pump collector boxes.

A basic schematic of the fuel system is shown in Figures 8 and 9.

- b. Fuel System Components and Features
 1. Line Sizes - The main fuel system uses 1.5-inch to 2.5-inch pipe, and the scavenge system uses 5/8-inch lines.
 2. Boost Pumps - Electrically driven 10,000 rpm centrifugal pumps with a 45,000 lb/hr rating are used. Four dual element pumps are provided, one in each wing tank. Three elements run continuously,

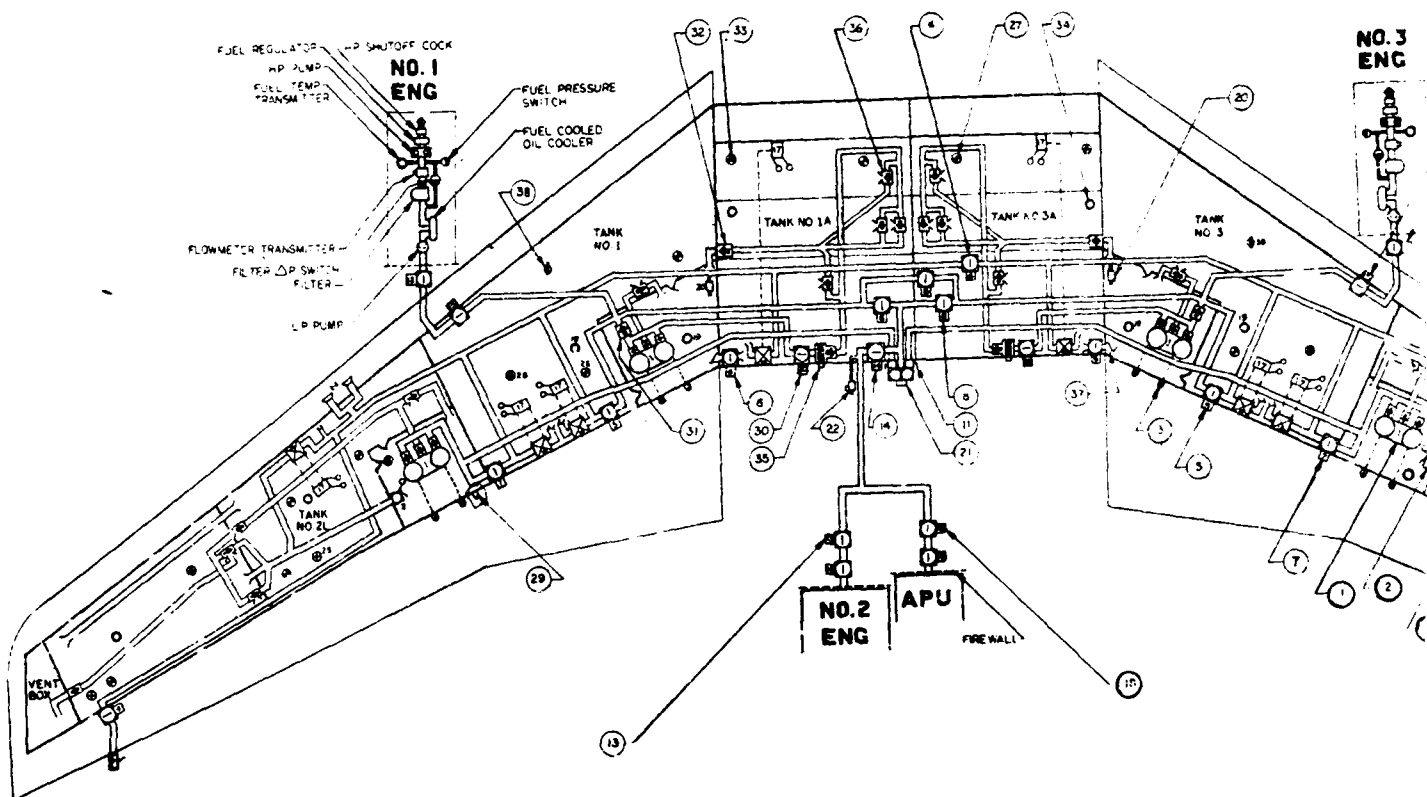
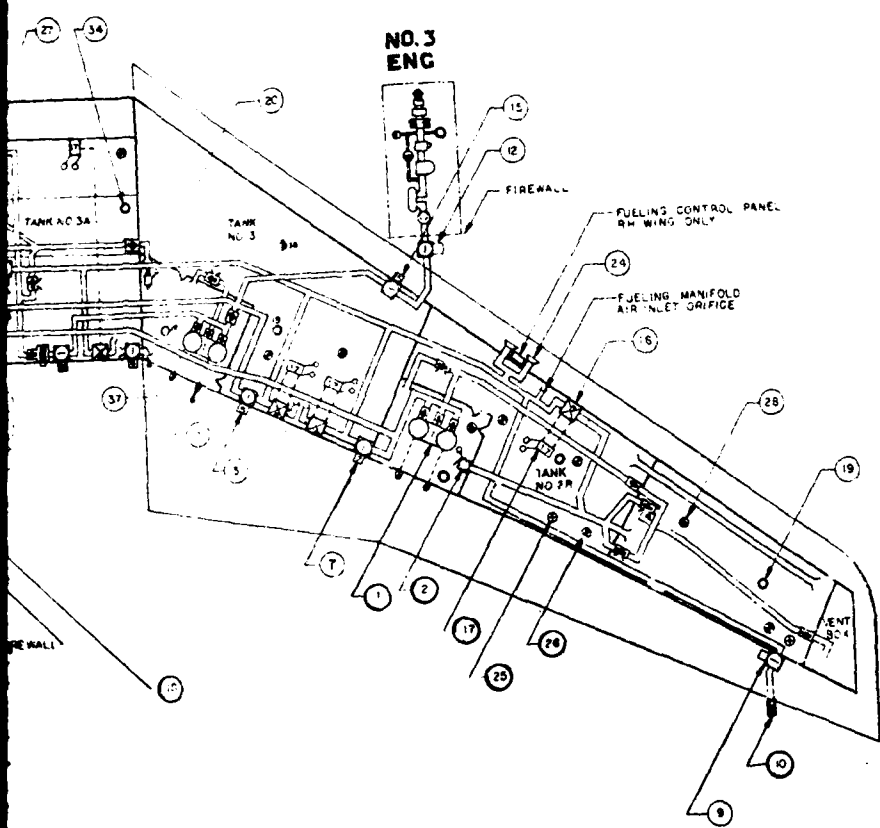
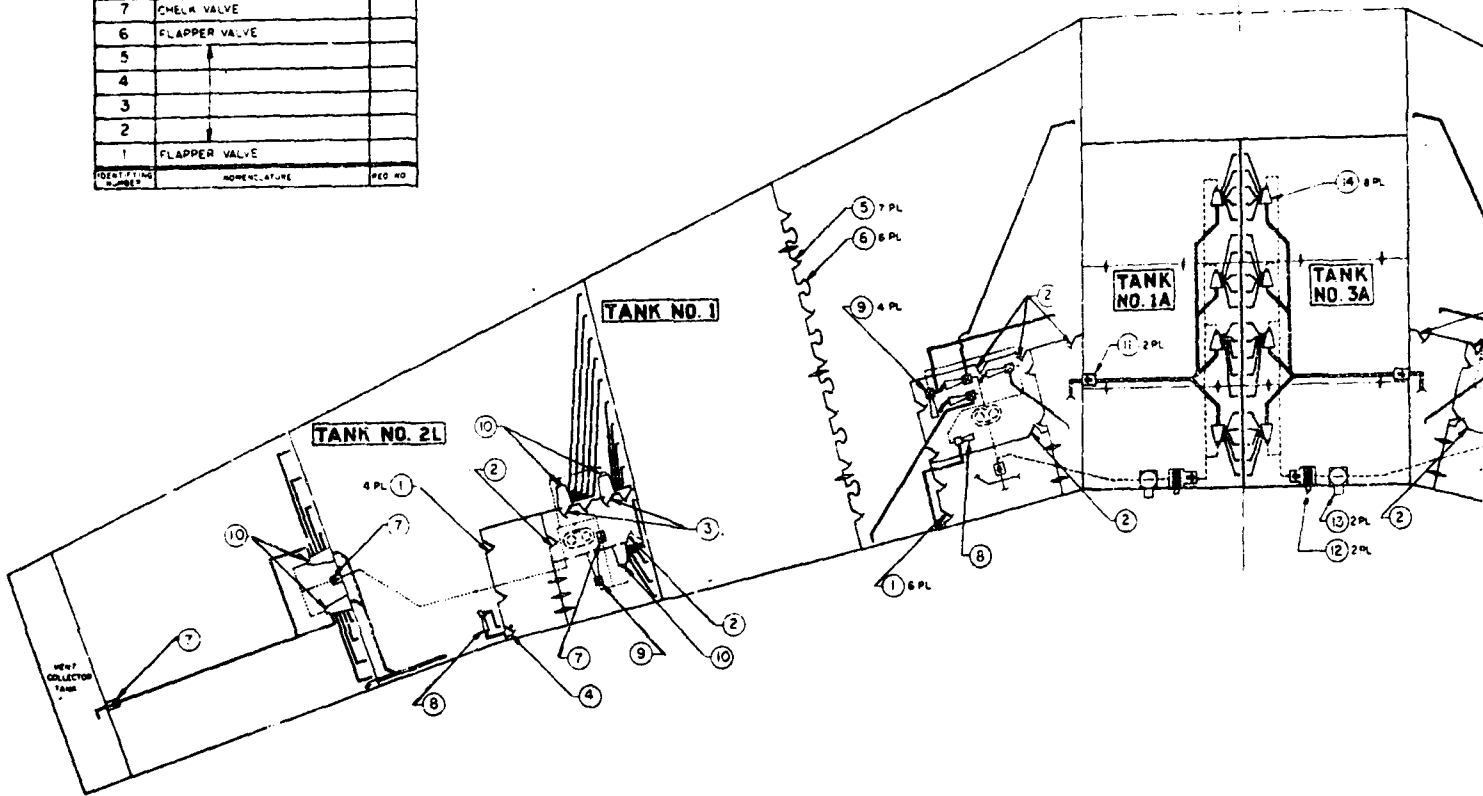

FIGURE 8. LOCKHEED L-1011 FUEL SYSTEM SCHEMATIC







38	LEVEL SENSING UNIT
37	FLAPPER CHECK VALVE
36	COMPOUND PUMP
35	STRAINER-CHECK VALVE
34	DRAIN VALVE
33	GAGING PROBE ARRAY
32	CHECK VALVE-TRANSFER LINE
31	CHECK VALVE-FEED LINE
30	TRANSFER & SCALES- MOTIVE FLOW VALVE
29	TEMPERATURE SENSOR
28	GAGING PROBE ARRAY
27	SIGHT GAGE-FUEL LEVEL
26	SIGHT GAGE-FUEL LEVEL
25	OVERWING GRAVITY FILLER
24	ADAPTOR PRESSURE FUELING
23	CHECK VALVE-TRANSFER LINE
22	SHUTOFF VALVE-MANUALLY OPERATED (DRAIN AND TEST PORT)
21	FLOW EQUALIZER
20	DRAIN VALVE-FUELING MANIFOLD
19	DRAIN VALVE
18	SHUTOFF VALVE-APU LINE (FIREWALL)
17	SWITCH-FUEL LEVEL CONTROL
16	SHUTOFF VALVE-FUELING
15	ENGINE NO. 1 & NO. 3 TANK VALVE
14	ENGINE NO. 2 TANK VALVE
13	SHUTOFF VALVE-MOTOR OPERATED (FIREWALL)
12	SHUTOFF VALVE-MOTOR OPERATED (FIREWALL)
11	SHUTOFF VALVE NO. 2, 2A, 2B, 2R TANK MANIFOLD (BEFORE NO.)
10	FLAME ARRESTOR-JETTISON
9	SHUTOFF VALVE-JETTISON
8	CROSSFEED VALVE-MOTOR OPERATED
7	SHUTOFF VALVE-DEF FUEL
6	GRAVITY INTERLOCKING TEST VALVE
5	SHUTOFF VALVE-DEF FUEL
4	SHUTOFF VALVE-DEF FUEL
3	PRESSURE CONTROL BOOST PUMP
2	VALVE-CROSS-TRANSFER-TRANSFER
1	SHUTOFF VALVE-DEF FUEL
REVISIONS	NOMENCLATURE

14	JET PUMP-COMPOUND	
13	XFR & SCAV MOTIVE FLOW VALVE	
12	STRAINER-CHECK VALVE	
11	CHECK VALVE	
10	JET PUMP-COMPOUND	
9	JET PUMP-LARGE	
8	JET PUMP-SMALL	
7	CHECK VALVE	
6	FLAPPER VALVE	
5		
4		
3		
2		
1	FLAPPER VALVE	
IDENTIFYING NUMBER	DESCRIPTION	REQ NO



LEGEND

- INDUCED FLOW LINE 
- MOTIVE FLOW LINE 
- TOTAL FLOW LINE 
- INDICATES FREE FLOW THRU BHD OPENINGS & BETWEEN STRINGERS 

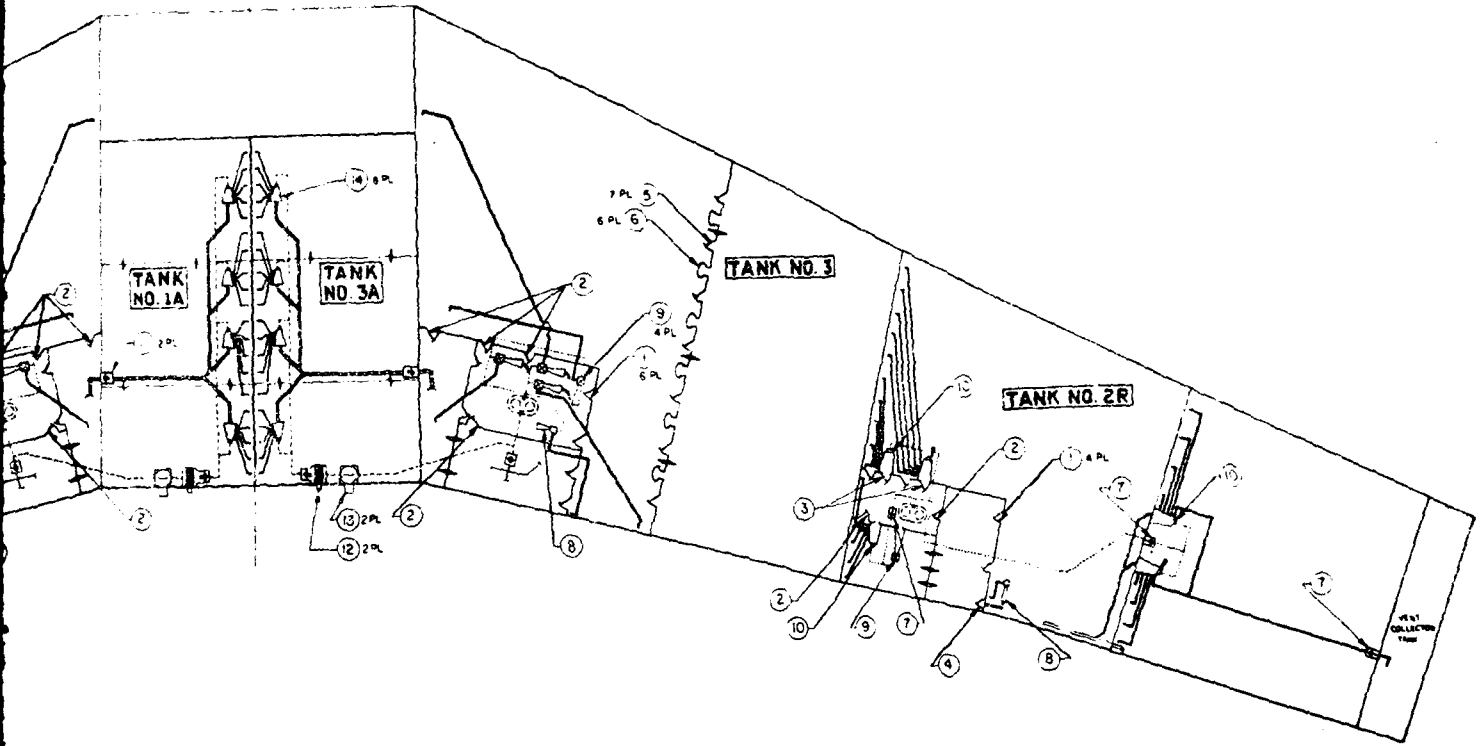

FIGURE 9. LOCKHEED L-1011 FUEL SCAVENGE/TRANSFER SYSTEM

2

six run during landing and takeoff. Cruise flow is approximately 5500 pph, dead head pressure is 40 psi.

3. Ejector Pumps - Thirty-four jet pumps are used in the scavenge and transfer system. Eighteen of these are compound pumps with a single motive flow stream and multiple secondary flow streams. They are used to scavenge water and transfer fuel. The wing scavenge system operates continuously, and the center tank system operates under manual control.
4. Filters - Fourteen mesh screens are used in the boost pump inlets and in the jet pump motive flow lines.
5. Suction Feed - The suction feed condition during aircraft flight would occur only as a result of major pump and/or electrical failure.
6. Vent System - The vent system contains honeycomb mesh flame arrestors with less than 0.01-inch openings.
7. Pressure Refueling - Pressure refueling is performed using the 2 1/2-inch MIL-A-25896D adapters, four are supplied, two on each wing. Automatic shutoff valves with pilot valves are used in this system which contain small lines 0.060-inch or greater.
8. Heat exchangers - No heat exchangers are used in the fuel system of this aircraft.
9. Fuel Quantity Gauging System - A capacitance type fuel quantity gauging system is used on this aircraft.

Thermistor bead point level sensors are used for low level jettison pump shutoff and low level transfer shutoff functions.
10. Auxiliary Power Unit (APU) - The APU is supplied by Hamilton Standard, part No. ST-6L-73. The engine portion of this unit consists of a Pratt & Whitney Canada ST6L-73 engine and a fuel control supplied by Aviation Electric.

The fuel control internal bypass metering valve utilizes a piston in a sleeve with 1/8-inch holes.

The engine utilizes a 6500 rpm, 1400 pph, 1000 psi gear pump with a bypass system that returns bypassed fuel to the pump inlet. The pump outlet has a 10-micron paper filter.

- c. Potential AMK Degradation Sources - The primary source of AMK shear degradation is the continuous pumping and recirculation through the 10,000 rpm boost pumps. Results given in reference 1 indicated that boost pump shear degradation was not severe, but the flammability test criteria presently being used have been revised. The high shear gear pump on the APU will probably result in some degradation, but since fuel bypassed in the APU is not returned to the tanks this will not affect the safety aspects of the bulk fuel.

Some shearing action may occur in the automatic shutoff valve during the partially open condition, but the effect will probably be small.

Discussions with the Southwest Research Institute, where AMK shear degradation studies are being done (reference 2), indicate that pregelling of the fuel may occur when it is passed through the pump so that subsequent passes may cause gelling to occur.

- d. Potential Component Performance Problems - Based on ejector pump performance studies reported in reference 1, the 34 jet pumps on this aircraft will have greatly reduced performance. This could result in increased unusable fuel, reduced scavenging efficiency, slower fuel transfer and possible underfilling of the boost pump collector boxes. The long lines leading to the compound jet pumps may cause additional pressure drop problems with undegraded AMK.

The slower draining time of the undegraded AMK may cause time response problems with the thermistor bead point level sensors.

The automatic shutoff valve pilot valve mechanism may have increased response time with undegraded AMK. The 14 mesh screens on the boost pump inlets and ejector pump motive flow lines should perform properly with undegraded AMK.

Boost pump performance will be reduced based on reference 1, but may not be critical. The APU fuel control bypass metering system may not perform properly with undegraded AMK. The APU filter may experience plugging with undegraded AMK.

- e. Potential Safety Considerations - Possible pregelling of the AMK could result in some plugging of the inlet filter screens. Reduced jet pump performance may increase unusable fuel and underfill the boost pump collector box. Based on references 1, 2, and 3, the fine filter on the APU may experience plugging with undegraded AMK. Liquid water drawn up by the scavenging system and deposited in the bulk fuel near the boost pump inlet may cause polymer precipitation. The 8 second response time required for the low level jettison shutoff thermistor sensor may be exceeded with AMK.

DC-8-71

- a. Fuel System Discussion - The fuel in this aircraft is contained in eleven tanks; leading edge, inboard main, outboard main, alternate and tip in each wing, plus a center wing tank. The total fuel quantity is 24,259 gallons.

Pressure refueling is performed using two standard 2 1/2-inch adapters.

Fuel is transferred by gravity from the forward auxiliary tanks to the center wing tanks and from the outboard wing tanks to the inboard wing tanks. Wing tip compartment fuel is held until late in the flight and transferred to inboard tanks by the flight crew. The aircraft uses suction feed on takeoff and landing, and one boost pump per engine during climb, cruise, and descent. Additional boost pumps are used for crossfeed and transfer at the option of the flight crew.

Fuel is jettisoned by a gravity flow system.

The tank venting system uses float vent valves and has no flame arrestors.

A basic schematic of the fuel system is shown in Figures 10 through 13.

- b. Fuel System Components And Features

1. Line Sizes - Engine feed and transfer lines are 1 1/2-inch and 2-inch.
2. Boost Pumps - Ten 8000 rpm, 35,000 pph, electrically driven centrifugal pumps are supplied for boost, crossfeed and transfer. Four run continuously for boost during climb, cruise, and descent. Cruise flow is approximately 3000 pph, pump zero flow pressure is 18 psig.
3. Ejector Pumps - Four ejector pumps are used one in each main tank. They run continuously, using motive flow from the centrifugal pumps, to scavenge fuel and water and to keep the boost pump collector boxes full.
4. Filters - The boost pump inlets utilize 5 mesh screens. No other filters are supplied with the airframe.
5. Suction Feed - Suction feed is used during aircraft landing and takeoff. The boost pumps are used during climb, cruise, and descent.
6. Vent System - The vent system utilizes vent float valves. No flame arrestors are used.
7. Jettison System - The DC-8 uses a gravity jettison system.

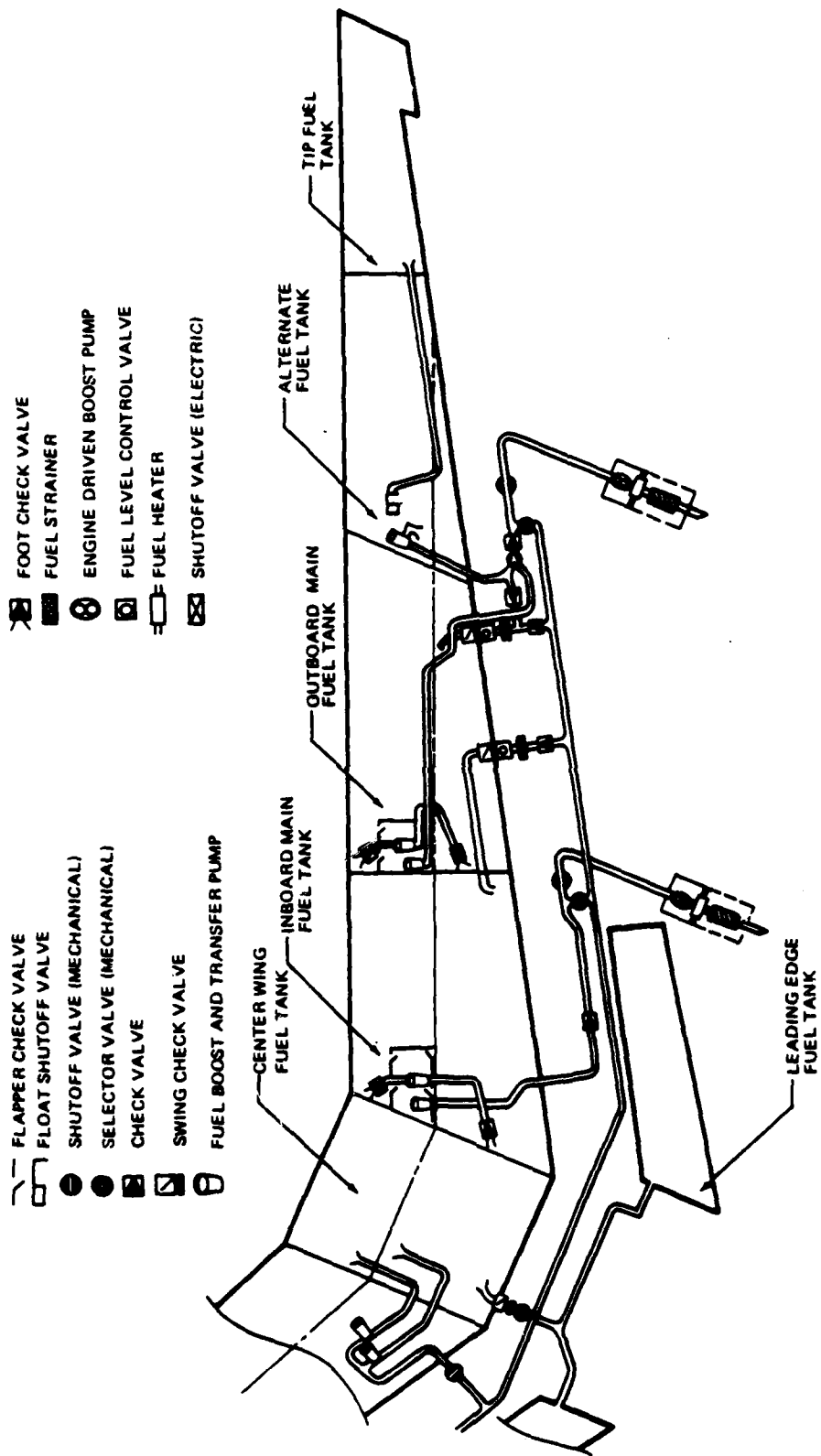

FIGURE 10. DC-8 FUEL FEED AND TRANSFER SYSTEM

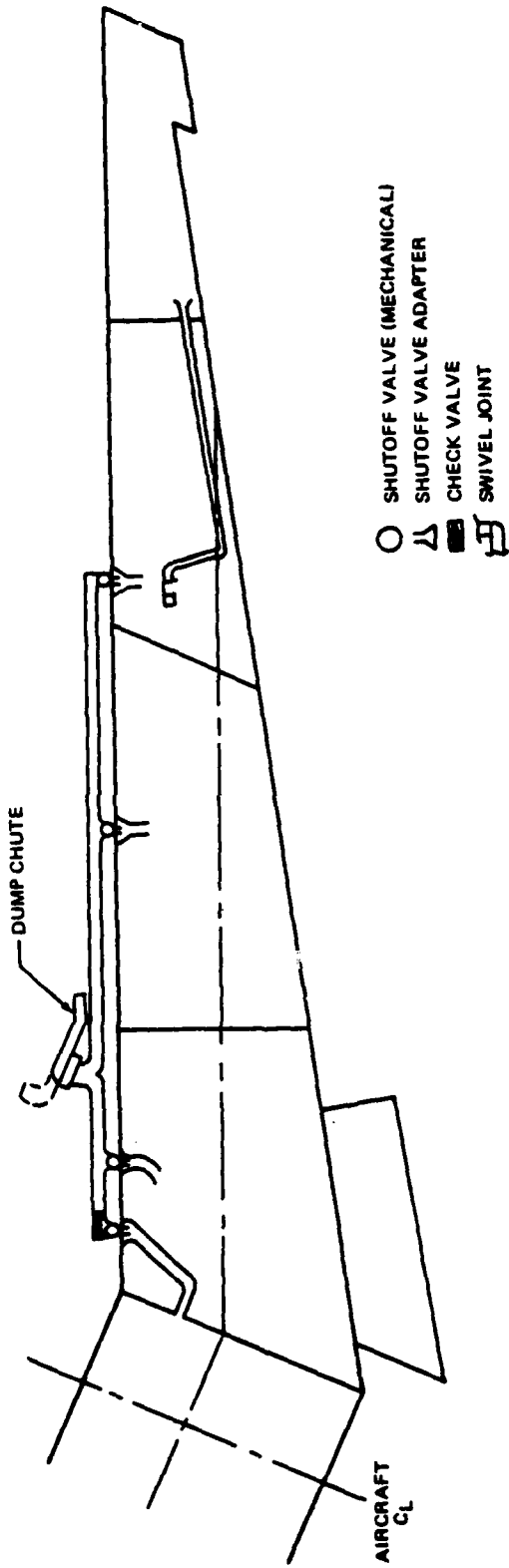

FIGURE 11. DC-8 FUEL DUMP SYSTEM

- ☐ CHECK VALVE
- ⊠ HYDRO-MECHANICAL SHUTOFF VALVE
- ELECTRIC SHUTOFF VALVE
- ▽ REFUELING ADAPTER
- ⊔ FLOAT SHUTOFF VALVE

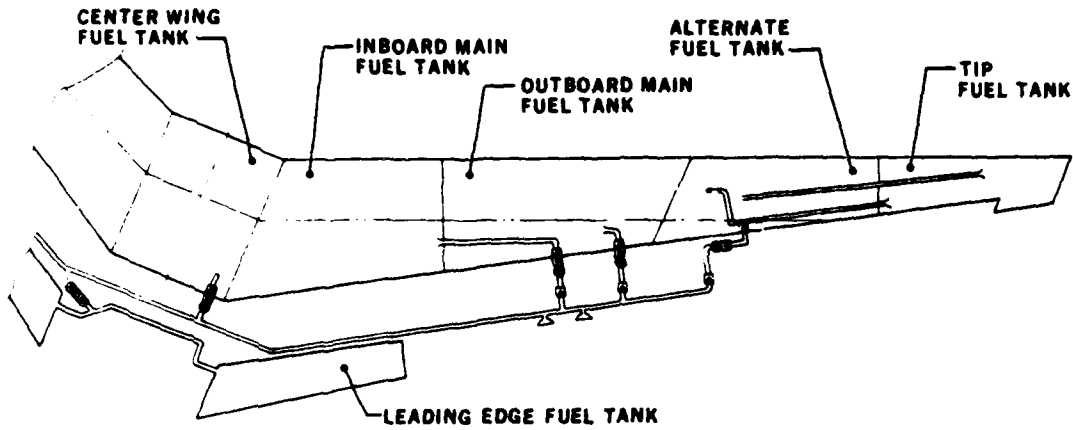

FIGURE 12. DC-8 FILL SYSTEM

- ⊔ FLOAT SHUTOFF VALVE
- ≡ BELLMOUTH INLET

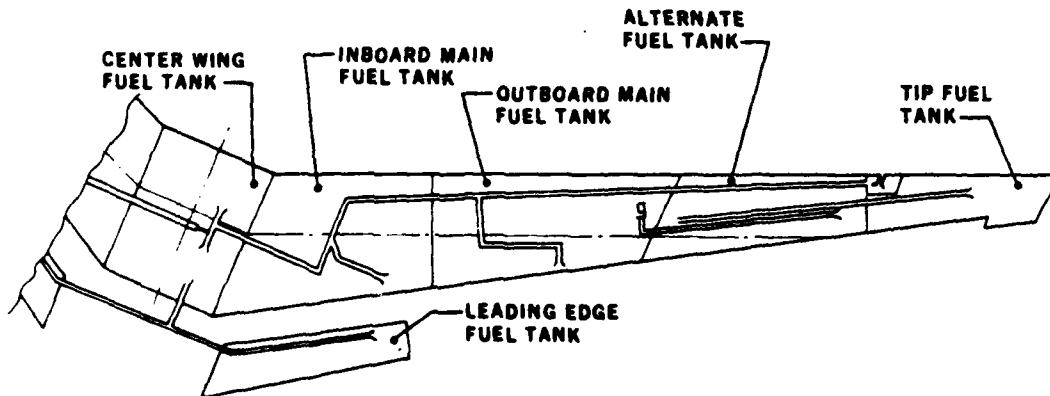

FIGURE 13. DC-8 VENT SYSTEM

8. Pressure Refueling - Pressure refueling is performed using two standard 2 1/2-inch adapters. Automatic shutoff valves incorporating pilot valves and small bleed lines are used.
9. Heat Exchangers - No fuel heat exchangers are supplied with the airframe.
10. Flowmeters - No fuel flowmeters are supplied with the airframe.
11. Fuel Quantity Gauging System - A capacitance fuel quantity gauging system is used. No thermistor type point level sensors are included.
12. Auxiliary Power Unit (APU) - The APU is supplied by Garrett Airesearch, part number GTCP85-98CK. This unit has a 40-micron paper filter, and a 4245 rpm gear pump which supplies 480 pph at 500 psig. The max bypass ratio is 4:1; and it has one nozzle with a primary opening of 0.0185-inch and a secondary opening of 0.021-inch. The fuel control bypass metering system uses a flow passage which varies from 0.020-inch to 0.125-inch.

- c. Potential AMK Degradation Sources - The primary source of AMK shear degradation is the pumping and recirculation through the 8000 rpm centrifugal boost pumps. Some shearing action may occur in the refuel/defuel adapter during the partially open condition, but the effect will probably be small.
- d. Potential Component Performance Problems - Based on ejector pump testing reported in reference 1, ejector pump performance will be greatly reduced with undegraded AMK.

Small fluid passages in the automatic shutoff valves may result in increased response time with undegraded AMK.

Due to slower flow with undegraded AMK, the gravity jettison rate may be reduced.

The 5 mesh screens on the boost pump inlets should perform satisfactorily with AMK.

- e. Potential Safety Considerations - Suction feed conditions during takeoff and landing could result in excessive pressure drops with undegraded AMK.

The fine filters on the APU may experience plugging with undegraded AMK.

DeHavilland Twin Otter

- a. Fuel System Discussion - The fuel in this aircraft is contained in two independent tanks located under the fuselage floor. Each tank has 4 cells holding a total of 382 gallons. The cells are bladder-type cells made from Uniroyal material US-566R.

Refueling is accomplished by gravity filling each tank separately.

The forward tank feeds the right engine, and the aft tank feeds the left engine.

Each tank has a collector cell which contains the boost pumps that feed the engine and three other cells. Fuel is transferred to the collector cell from the remaining cells with an ejector pump, and by gravity through an interconnecting manifold. Overfilling of the collector cell is controlled with a level control valve.

Crossfeed capability is provided with a manual control.

A basic fuel system schematic is shown in Figure 14.

b. Fuel System Components and Features

1. Line Sizes - The engine feed system use 5/8-inch lines, and the refuel/defuel lines are 1 1/2-inch and 1 1/4-inch.
2. Boost Pumps - Two electrically driven, 2000 rpm, 450 pph centrifugal pumps are located in each collector cell. Two run continuously, and two are for back-up. Cruise flow is approximately 360 lb/hr, dead head pressure is 40 psi.
3. Ejector Pumps - Two ejector pumps are run continuously to feed each collector cell full at all pitch attitudes.
4. Pressure Refueling - Pressure refueling is not performed on this aircraft.
5. Filters - The boost pump inlets have 8 mesh screens, and two 74-micron paper filters and two 10-micron paper filters are used in the engine feed lines.
6. Heat Exchangers - No heat exchangers are supplied with the airframe fuel system.
7. Auxiliary Power Unit (APU) - No APU is supplied with this aircraft.
8. Suction Feed - The suction feed condition during flight would occur only as a result of major pump and/or electrical failure.
9. Fuel Quantity Gauging System - A capacitance type fuel quantity gauging system is used on this aircraft. No thermistor type point level sensors are used.
10. Flow transmitter - A turbine type flow transmitter is used to measure fuel flow to each engine. It is located downstream of the pump and fuel filter.
11. Vent System - Fine mesh flame arrestors are utilized in the vent system.

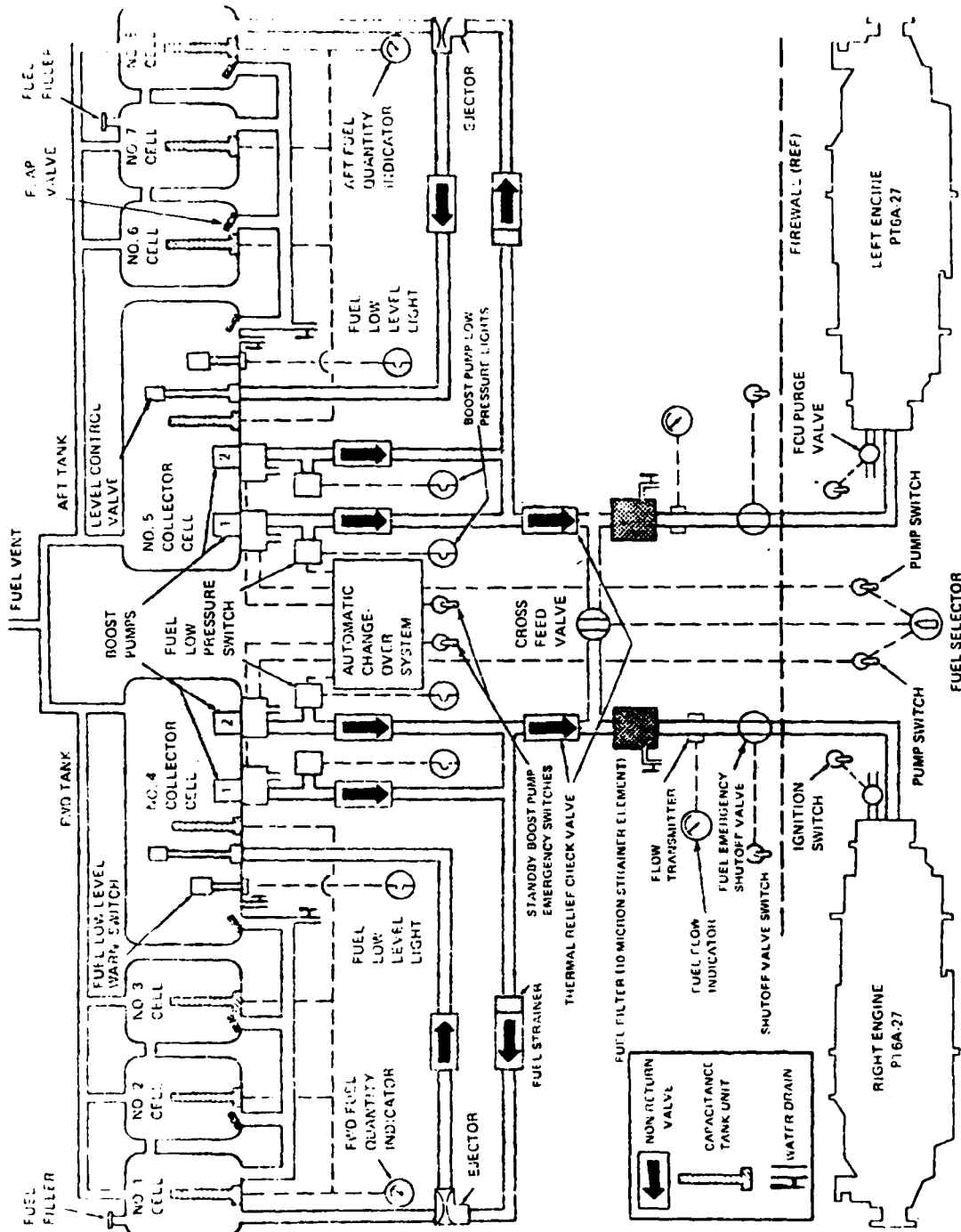

FIGURE 14. DEHAVILLAND TWIN OTTER FUEL SYSTEM SCHEMATIC

- c. Potential AMK Degradation Sources - The only source of AMK shear degradation is the continuous pumping and recirculation through the 2000 rpm boost pumps. Due to the relatively low speed of these pumps, degradation will be less than in other aircraft with high speed pumps.
- d. Potential Component Performance Problems - Based on ejector pump performance studies discussed in reference 1, the two ejector pumps used in this aircraft will have reduced performance. Since both gravity flow and the ejector pumps are used to keep the collector box full, reduced jet pump performance may not be a significant problem. Boost pump performance will also be reduced based on reference 1.

The level control valves may have increase time response with undegraded AMK.

The 8 mesh screens should perform properly with undegraded AMK.

Based on reference 3, the turbine flow meter will have accuracy and calibration problems with undegraded AMK.

- e. Potential Safety Considerations - Possible pregelling of the AMK in the boost pumps could result in some plugging of the inlet screen.

The 74-micron and 10-micron paper filters will probably experience plugging with undegraded AMK.

DeHavilland Dash 7

- a. Fuel System Discussion - The fuel in this aircraft is contained in four integral wing structure tanks, one for each engine. The total fuel capacity is 1480 gallons. Fuel can be transferred from one tank to another, but each engine can only draw fuel from its own tank.

Each fuel tank has two pumps, an ejector pump driven by motive flow from the engine-driven pump, and an auxiliary electric 12,000 rpm centrifugal pump used for transfer and standby. An additional ejector pump is used in each tank to keep the collector boxes full.

A pressure refuel/defuel system utilizing an MS24484-2 2 1/2-inch adapter is used for aircraft refueling. A master refuel/defuel valve with two pilot valves is used in this system.

A basic schematic of the fuel system is shown in Figure 15.

- b. Fuel System Components and Features

1. Line Sizes - The fuel system line sizes are as follows:

- Engine Feed - 5/8-inch
- Pump to Filter - 3/4-inch
- Refuel/Defuel - 1 1/2-inch and 1 1/4-inch

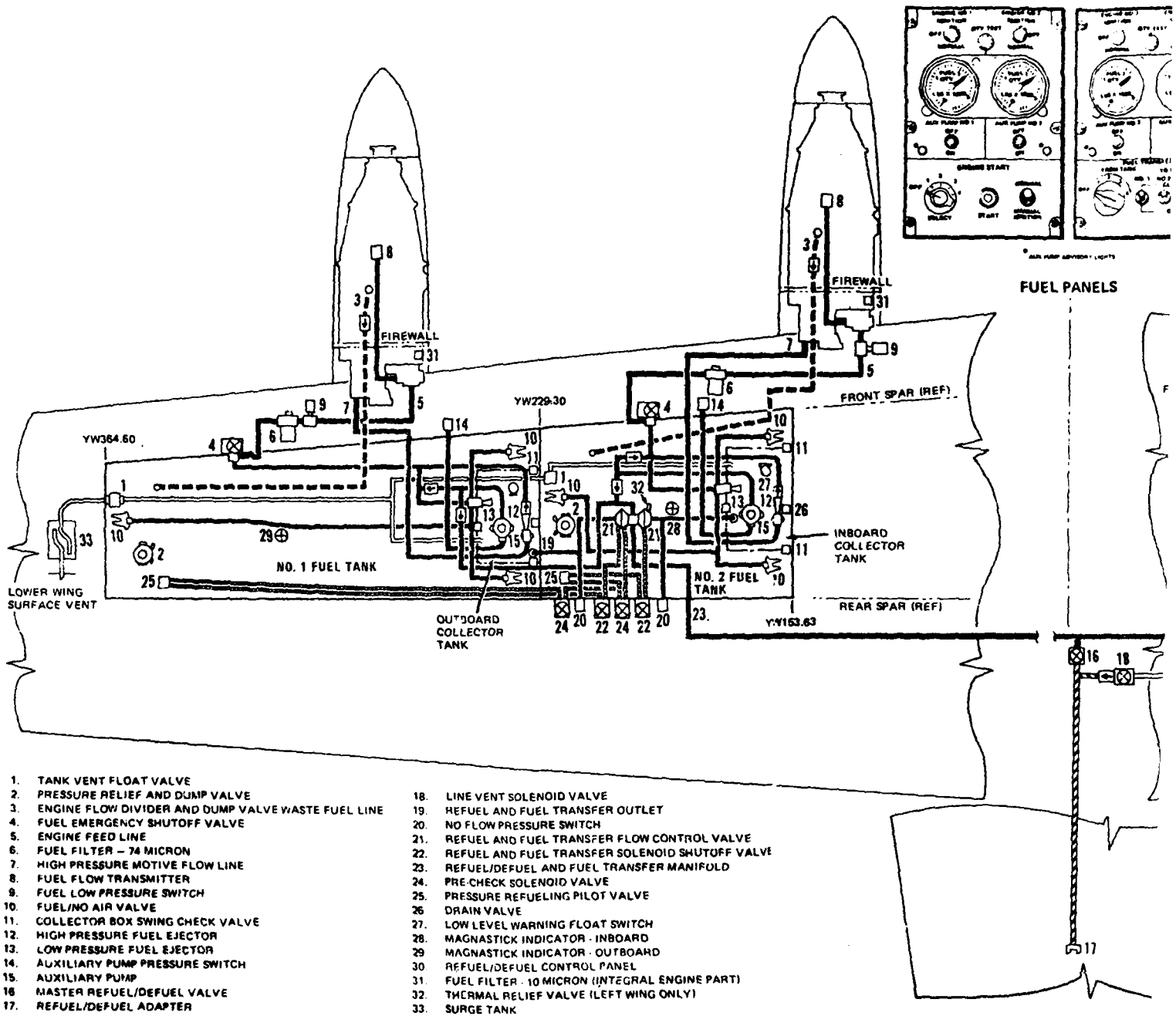
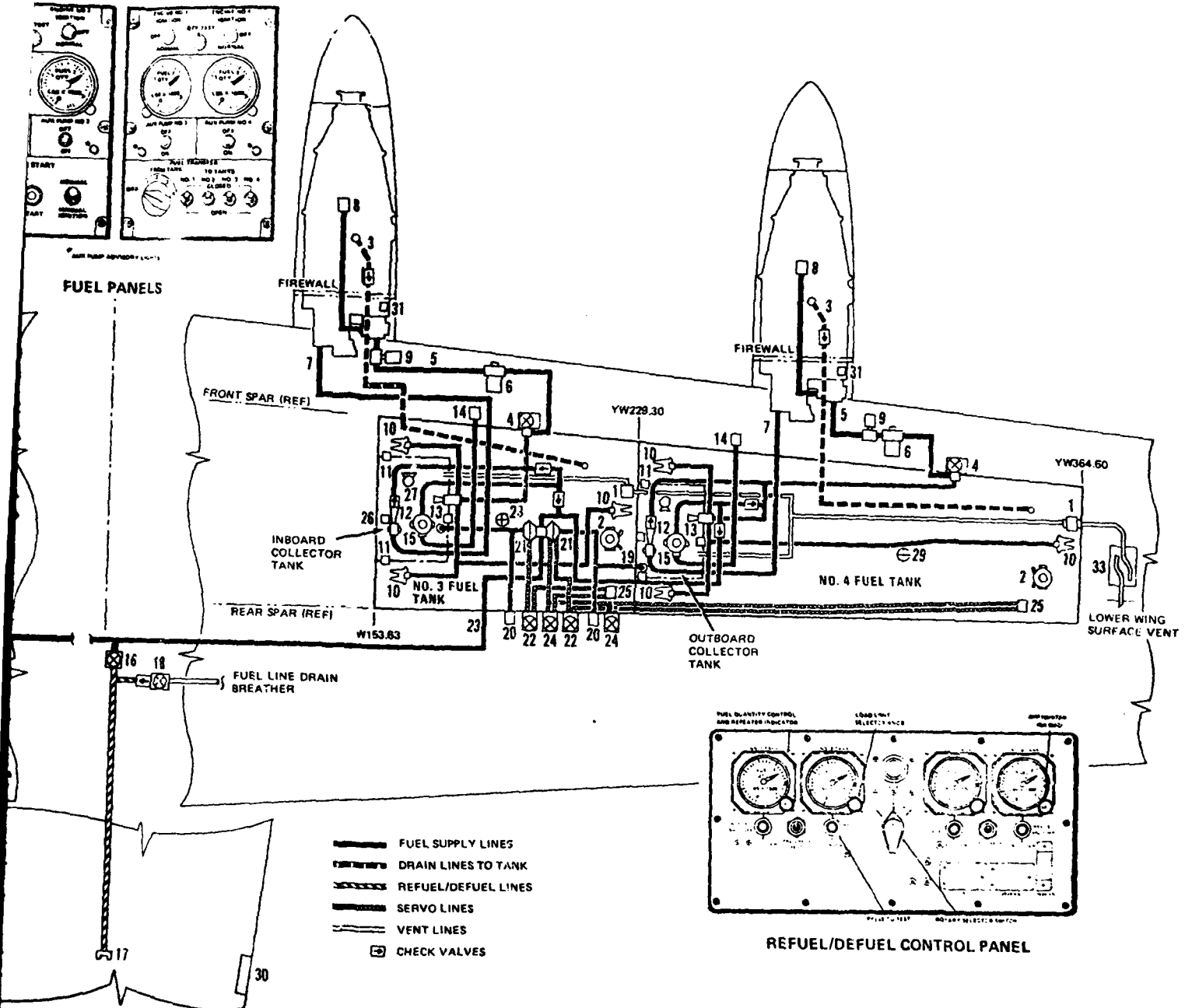
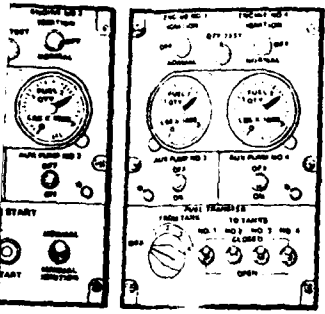
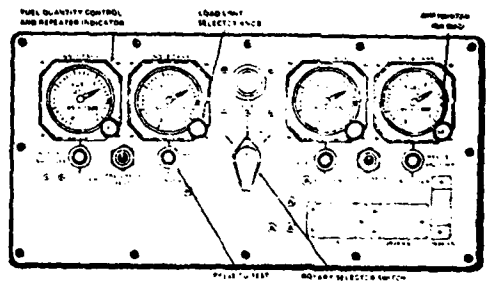

FIGURE 15. DEHAVILLAND DASH 7 FUEL SYSTEM SCHEMATIC



- FUEL SUPPLY LINES
- DRAIN LINES TO TANK
- REFUEL/DEFUEL LINES
- SERVO LINES
- VENT LINES
- ☒ CHECK VALVES



2

2. Boost Pumps - Four ejector pumps using motive flow from the engine driven fuel pump are used as boost pumps. They operate continuously.
 3. Ejector Pumps - Four low pressure ejector pumps are used to keep the boost pump collector boxes full. They operate continuously.
 4. Backup/Transfer - Four electrically driven 12,000 rpm centrifugal pumps are used for fuel transfer and boost pump backup. Unless there is a boost pump failure, they are seldom used.
 5. Filters - Four 74-micron paper filters are used in the engine feed lines.
 6. Pressure Refueling - Pressure refueling is done through a single 2 1/2-inch MS24484-2 adapter. A master refuel/defuel valve with two pilot valves are used in this system.
 7. Fuel Quantity Gauging System - A capacitance type fuel quantity gauging system is used on this aircraft. No thermistor type point level sensors are used.
 8. Flow meter - A turbine type flow transmitter is used to measure engine fuel flow rate on each engine. It is located downstream of the boost pump and filter.
 9. Auxiliary Power Unit (APU) - No APU is supplied with this aircraft.
 10. Heat Exchangers - No fuel heat exchangers are supplied with the airframe fuel system.
 11. Vent System - A vent system with vent float valves and two underwing vents is utilized.
- c. Potential AMK Degradation Sources - There are no significant sources of AMK degradation during normal fuel system operation. The 12,000 rpm centrifugal pump may cause some degradation when it is operating, but is normally not used.
- d. Potential Component Performance Problems - Based on reference 1, ejector pump performance will be greatly reduced. This may have a more significant impact on this aircraft than on others, since the main boost pump is of this type.

The automatic shutoff system may experience slower time response with undegraded AMK.

Based on reference 3, the turbine type flowmeters will have accuracy and calibration problems with AMK.

- e. Potential Safety Considerations - Based on references 1, 2, and 3, the 74-micron paper filters may experience plugging with undegraded AMK.

The reduced jet pump performance with undegraded AMK will significantly affect engine driven pump inlet conditions.

Shorts SD3-30

- a. Fuel System Discussion - The fuel in this aircraft is contained in two box-shaped containers mounted fore and aft within a faired compartment on top of the fuselage center section. The forward container is divided into 3 cells and the aft container is considered to be cell 4. Cells 1 and 2 are considered the forward tank, and cells 3 and 4 the aft tank.

Each tank gravity feeds a collector tank mounted in the fuselage right-hand sidewall.

A boost pump is mounted in each collector tank. Fuel passes from the boost pump through the filter to the engine. Crossfeed capability is provided with a manually operated valve.

Pressure refueling is done through a standard 2 1/2-inch adapter, utilizing automatic shutoff valves. Gravity refueling can also be utilized.

A basic fuel system schematic is shown in Figure 16.

b. Fuel System Components and Features

1. Line Sizes - The fuel system uses 3/4-inch and 5/8-inch lines, and 1-inch refuel/defuel lines.
2. Boost Pumps - Electrically driven, 10,800 RPM, 1400 pph centrifugal pumps are used. Two are supplied and both run continuously. If both failed, the engines can operate on suction feed up to an altitude of 20,000 feet. Cruise flow is 600 pph, dead head pressure is 27 psi.
3. Ejector Pumps - No ejector pumps are supplied with this aircraft.
4. Filters - Coarse screens are used on the boost pump inlets. Two 70-micron metal filters are used in the engine feed lines. Bypass lines around these filters are provided.
5. Fuel Quantity Gauging System - A capacitance type fuel quantity gauging system is used in this aircraft. No thermistor type point level sensors are used.
6. Pressure Refueling - Pressure refueling is performed utilizing a standard 2 1/2-inch adapter and automatic shutoff valves with small fluid passages.
7. Auxiliary Power Unit (APU) - No APU is supplied with this aircraft.

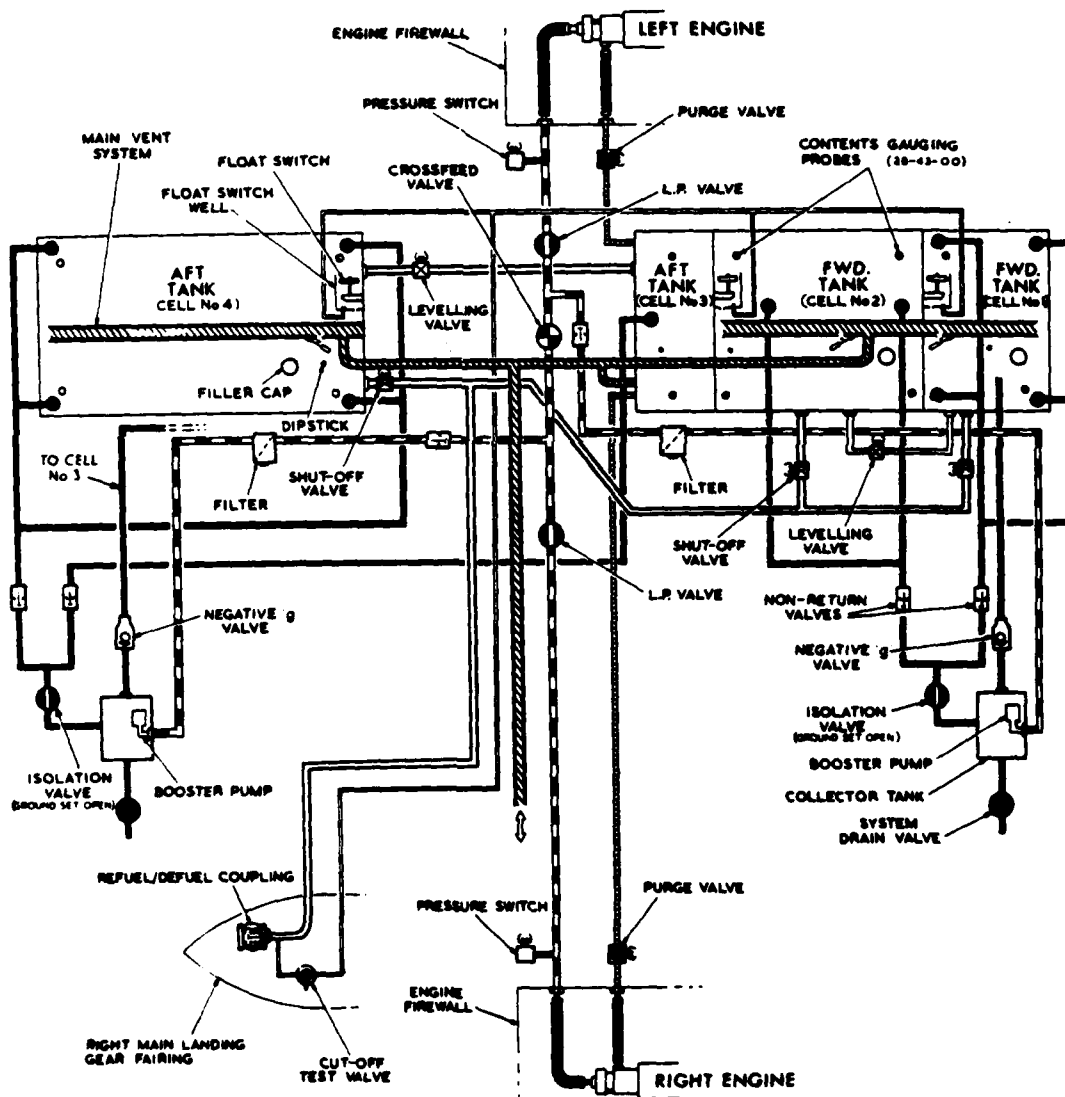
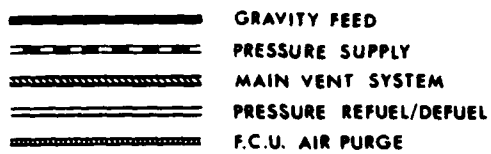

FIGURE 16. SHORTS SD3-30 FUEL SYSTEM SCHEMATIC

8. Heat Exchangers - No fuel heat exchangers are supplied with the airframe.
 9. Suction Feed - Suction feed during aircraft flight would occur only in the case of pump and/or electrical failure.
 10. Vent System - A vent system with no flame arrestors is utilized to equalize ambient and tank pressures and to protect against malfunction of the pressure refuel system.
- c. Potential AMK Degradation Sources - The only significant source of AMK shear degradation is pumping and recirculation through the boost pumps.
 - d. Potential Component Performance Problems - Based on reference 1, the boost pump performance will be reduced with AMK, but will not be critical.

Time response of the automatic shutoff valves in the refuel/defuel system will probably be slower with AMK.

- e. Potential Safety Considerations - Based on references 1, 2, and 3, the 70-micron metal filters may experience plugging with undegraded AMK.

Possible pregelling of the AMK in the boost pumps may cause some plugging of the pump inlet screens.

Cessna 441

- a. Fuel System Discussion - The fuel in this aircraft is contained in two integral wing tanks on each side of the aircraft. The total fuel quantity is 475 gallons.

Refueling is performed using gravity feed only. Each tank has a collector box which contains two (2) boost pumps, one that is used continuously and one for backup. Two (2) ejector pumps are provided in each wing for transfer and scavenging, and to keep the collector box full. Both of these operate continuously. Crossfeed capability is provided using a manually operated valve. Each engine is normally supplied with fuel from its own tank.

An open vent system is supplied with no flame arrestors.

A basic fuel system schematic is shown in Figure 17.

- b. Fuel System Components and Features
 1. Line Sizes - Engine feed and ejector pump total flow lines are 3/4-inch and ejector pump motive flow lines are 3/8-inch. Engine feed lines after the firewall shutoff valve are 1/2-inch.
 2. Boost Pumps - Electrically driven, 9000 rpm centrifugal pumps with a flow rating of 960 pph at 19.5 psi are used. Four are supplied, two run continuously. Total boost pump flow at cruise is approximately 250 pph, maximum pump dead head pressure is 40 psi.

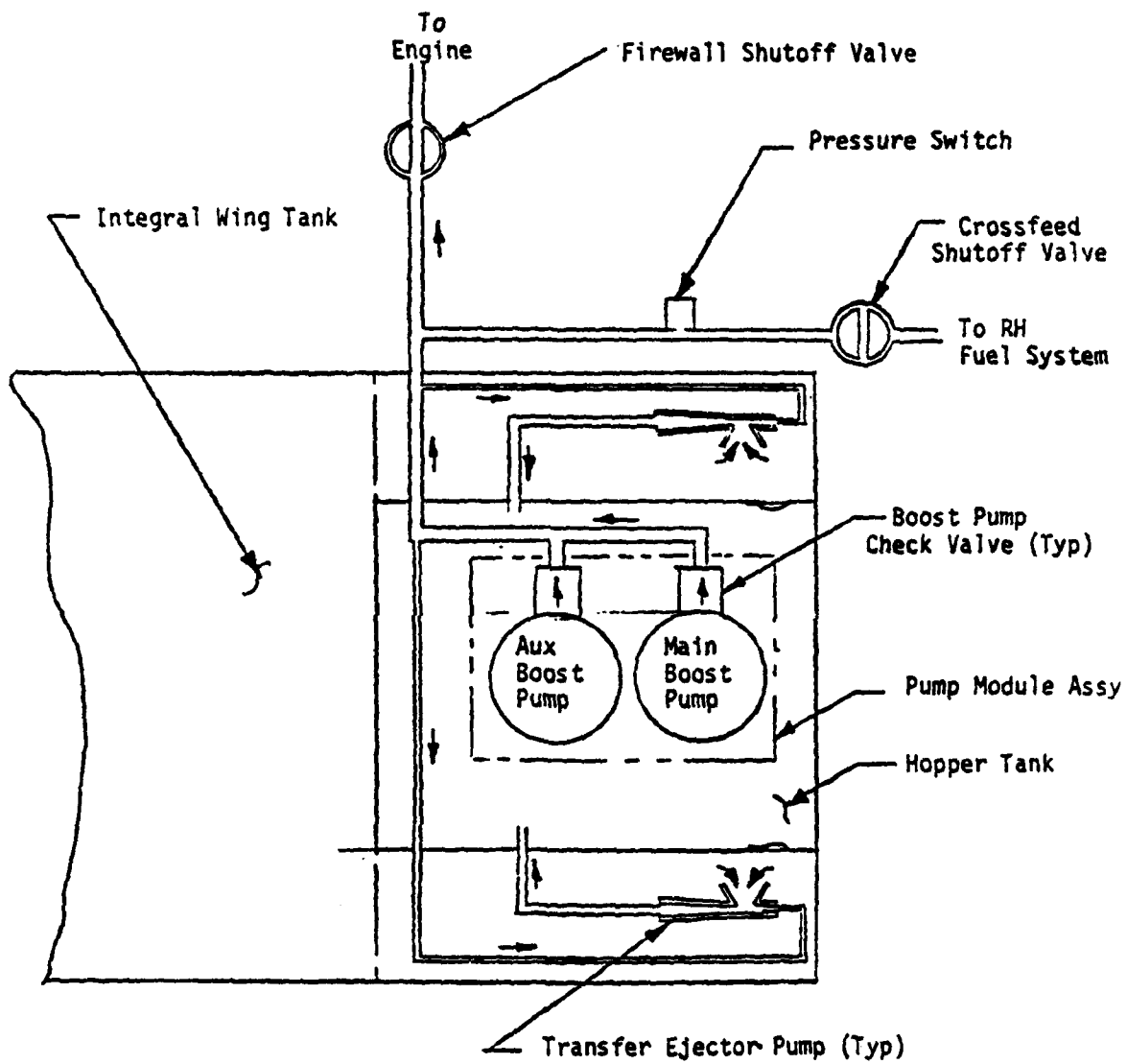

FIGURE 17. CESSNA 441 FUEL DISTRIBUTION SCHEMATIC

3. Ejector Pumps - Four ejector pumps are used for transfer, scavenging, and to keep the boost pump collector boxes full. All four run continuously.
 4. Filters - Sixteen mesh screens are used on the boost pump inlets. No other filters are supplied with the airframe.
 5. Suction Feed - Suction feed during flight would occur only as a result of a major pump and/or electrical failure.
 6. Fuel Quantity Gauging System - A capacitance type fuel quantity gauging system is supplied with this aircraft. No thermistor type point level sensors are used.
 7. Pressure Refueling - Pressure refueling is not used on this aircraft.
 8. Heat Exchangers - No fuel heat exchangers are supplied with the airframe fuel system.
 9. Auxiliary Power Unit (APU) - No APU is supplied with this aircraft.
- c. Potential AMK Degradation Sources - The only source of AMK shear degradation is the continuous pumping and recirculation through the 9000 rpm boost pumps.
- d. Potential Component Performance Problems - Based on reference 1, the four ejector pumps will have greatly reduced performance with undegraded AMK. Boost pump performance will also be somewhat reduced.
- The 16 mesh screens on the boost pump inlets should perform properly with undegraded AMK.
- e. Potential Safety Considerations - Possible pregelling of AMK in the boost pumps may cause some plugging of the inlet screens. Water drawn up by the scavenge system and deposited in the bulk fuel may cause polymer precipitation.

Swearingen Metro III

- a. Fuel System Discussion - The fuel in this aircraft is contained in two wing tanks, one for each engine. The total fuel capacity is 648 gallons. Crossfeed capability is available, controlled by a manually operated valve.

Refueling is performed with gravity flow only. Pressure refueling with automatic shutoff valves is not used.

Fuel drains by gravity from outboard to inboard, and the boost pumps are located in each inboard wing next to the fuselage. Jet pumps are used to scavenge water and keep the boost pump boxes full.

A basic fuel system schematic is shown in Figure 18.

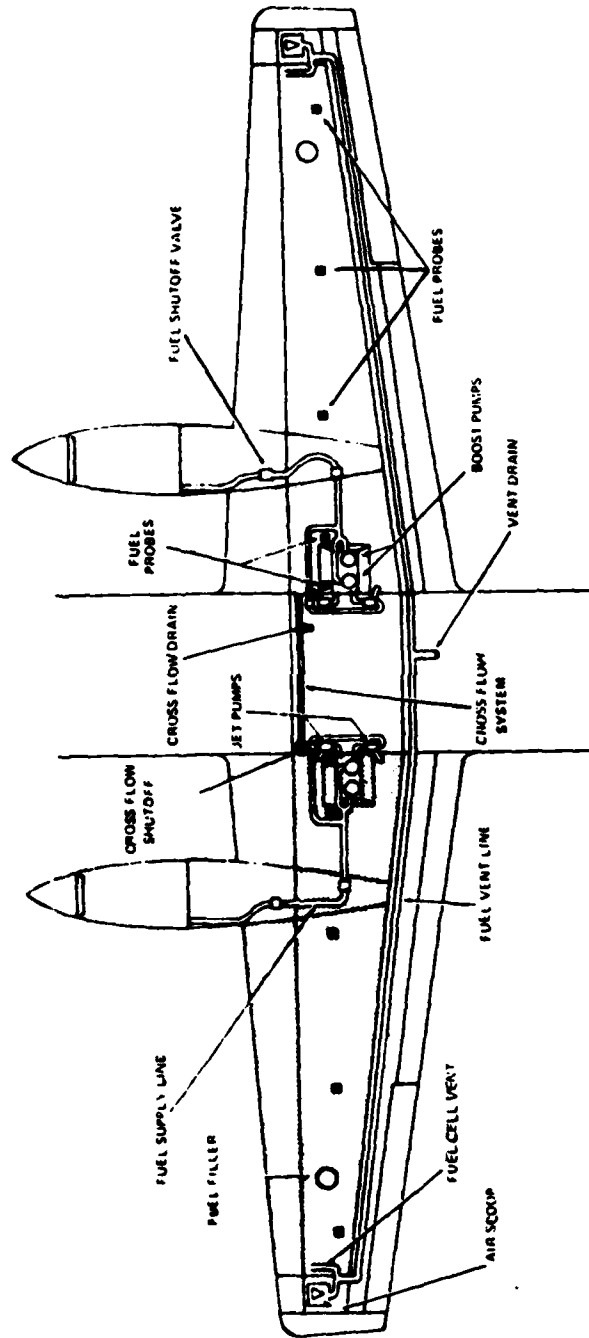

FIGURE 18. SWEARINGEN METRO FUEL SYSTEM SCHEMATIC

b. Fuel System Components and Features

1. Line Sizes - Fuel lines are 3/4-inch behind the firewall and 1/2-inch on the engine side of the firewall.
 2. Boost Pumps - Electrically driven, 6500 rpm, 3000 pph centrifugal pumps are used: four are supplied, two run continuously and two are used for backup. Nominal cruise flow is 1240 pph, dead head pressure is 30 psi.
 3. Ejector Pumps - Four ejector pumps run continuously to keep the boost pump boxes full and scavenge water.
 4. Filters - A preformed metal screen with 0.117-inch and 0.045-inch holes is used on the boost pumps. No other filters are supplied with the airframe.
 5. Pressure Refueling - Pressure refueling is not used on this aircraft.
 6. Suction Feed - Suction feed during flight would occur only in the event of a major pump or electrical failure.
 7. Heat Exchangers - No fuel heat exchangers are supplied with the airframe.
 8. Auxiliary Power Unit (APU) - No APU is supplied with this aircraft.
 9. Fuel Quantity Gauging System - A capacitance type fuel quantity gauging system is supplied. No thermistor type point level sensors are used.
- c. Potential AMK Degradation Sources - The only source of AMK shear degradation is pumping and recirculation through the 6500 rpm boost pumps.
- d. Potential Component Performance Problems - Based on reference 1, the ejector pump performance will be greatly reduced with undegraded AMK. Boost pump performance will also be reduced to a lesser degree.
- e. Potential Safety Considerations - Possible pregelling of AMK in the boost pumps could cause some plugging of the inlet screens. Liquid water drawn up by the ejector pumps and deposited in the bulk fuel could cause precipitation of polymer.

Convair 580

- a. Fuel System Discussion - The fuel in this aircraft is contained in two integral wing fuel tanks, one for each engine. Either tank can supply one or both engines using a crossfeed system. The total fuel quantity is 1730 gallons.

Refueling is performed with gravity only.

Fuel is fed by gravity to the boost pump inlets. The boost pumps are not submerged, and fuel bypassed in the pump is returned to the dump inlet, not to the bulk fuel. The boost pump inlets are not located in the tank low point, and sump drains are provided at the low points to keep water from entering the pump inlets. Fuel management other than crossfeeding is not performed.

A basic fuel system schematic is shown in Figure 19.

- b. Fuel System Components and Features

1. Line Sizes - The engine feed lines are 1-inch, and the tank to pump lines are 1 1/4-inch.
2. Boost Pumps - Electrically driven, 2250 rpm, 640 gal/hr vane type pumps are used. Two are supplied, both run continuously. Cruise flow rate is 1050 pph, dead head pressure is approximately 30 psi.
3. Ejector Pumps - No ejector pumps are supplied with this aircraft.
4. Filters - No. 2 mesh brass wire cloth is used on the tank fuel exit ports. No other filters are supplied with the airframe.
5. Suction Feed - Suction feed conditions during flight would occur only as a result of major pump or electrical failure.
6. Pressure Refueling - Pressure refueling is not used on this aircraft.
7. Fuel Quantity Gauging System - A capacitance type fuel quantity gauging system is supplied. No thermistor type point level sensors are used.
8. Auxiliary Power Unit (APU) - A Garrett GTCP 85-90 unit is installed. This unit has a 40-micron paper filter, and a 4245 rpm gear pump which supplies 480 pph at 500 psig. The maximum bypass ratio is 4:1; and it has one nozzle with a primary opening of 0.0185-inch and a secondary opening of 0.021-inch. The fuel control bypass metering system uses a flow passage which varies from 0.020-inch to 0.125-inch.
9. Heat Exchangers - A fuel/engine oil heat exchanger is supplied for each engine. The fuel is used on the tube side of this heat exchanger.

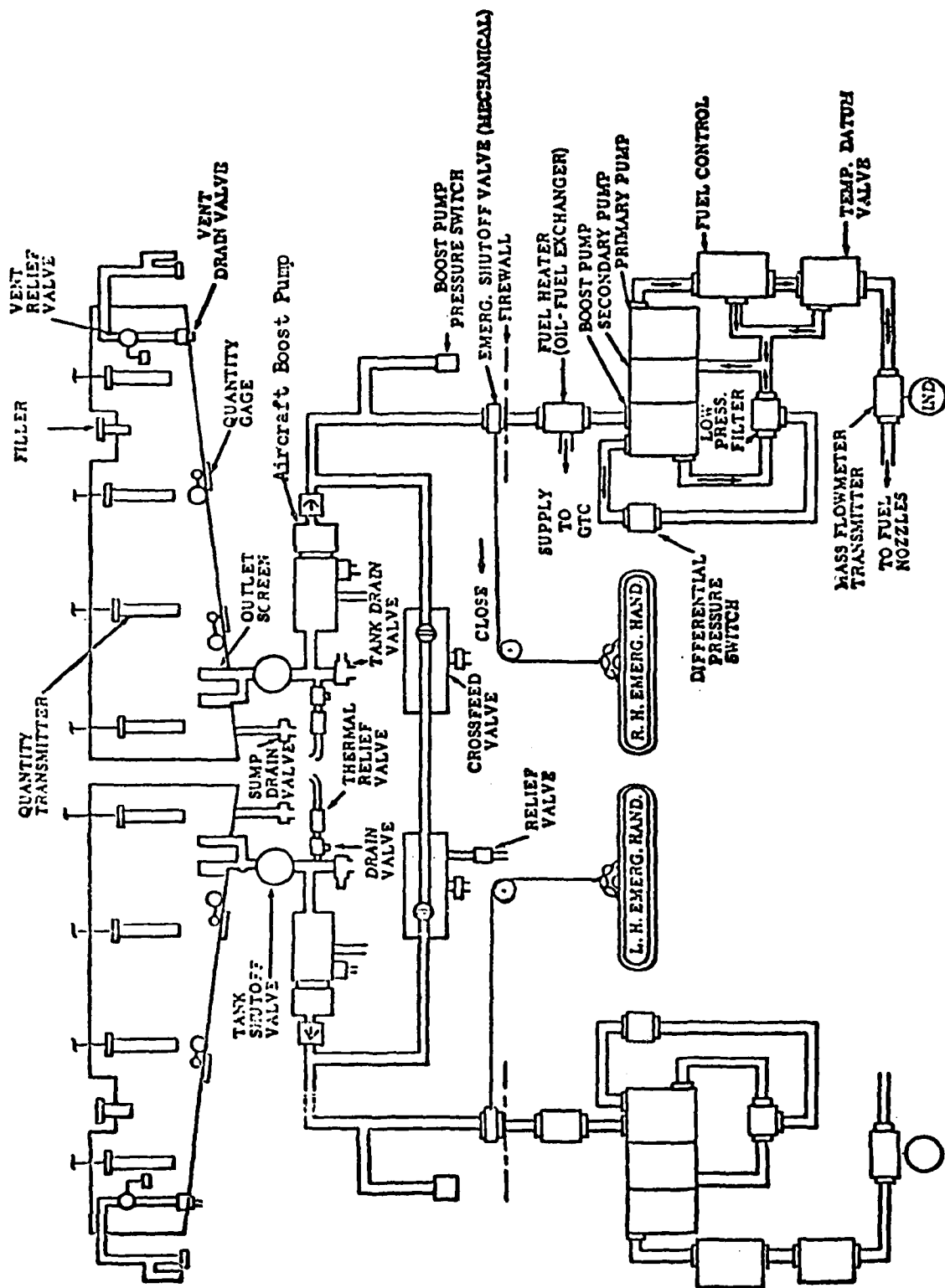

FIGURE 19. CONVAIRE 580 FUEL SYSTEM SCHEMATIC

10. Fuel Flowmeter - A General Electric 8TJ64GBN2 mass flowmeter transmitter measures fuel flow rate to each engine. It is located in the engine high pressure line downstream of the fuel control.
 11. Vent System - Each wing tank is vented, utilizing float type vent valves to prevent fuel from entering the vent system during ground maneuvers.
- c. Potential AMK Degradation Sources - There are no AMK shear degradation sources on this aircraft that will deposit degraded AMK into the bulk fuel. Both the boost pumps and the APU gear pump bypass fuel back to their inlets, not to the fuel tanks.
 - d. Potential Component Performance Problems - Based on reference 3, the low undegraded AMK heat transfer coefficient may result in performance problems with the fuel/oil heat exchangers. Based on reference 1, boost pump performance will be somewhat reduced. The tank exit screens should perform properly with AMK. Based on reference 3 the fuel flowmeter may have accuracy and calibration problems. The APU fuel control bypass metering system may not perform properly with AMK.
 - e. Potential Safety Considerations - The 40-micron paper filter on the APU may experience plugging with AMK.

Piper PA-42 Cheyenne III

- a. Fuel System Discussion

Fuel is contained in 10 tanks; five individual interconnected tanks in each wing, consisting of a wing tip fuel tank, a wet nacelle tank, and three bladder type fuel cells. The right and left wing fuel systems are independent of each other and are connected only when the crossfeed system is activated. Fuel to the engines is supplied from the inboard fuel cells. Only gravity refueling is used.

Fuel is supplied to the engines with engine driven vane pumps. A submerged centrifugal pump in each wing is used for start-up and whenever fuel supply pressure falls below 15 psi.

Four ejector pumps are supplied. Two transfer pumps, attached to the inboard aft fuel cell nipples, transfer fuel from the aft cell to the main fuel cell. These run continuously.

Two other ejector pumps are used only during starting and shutdown to pump fuel drained from the engine after shutdown back to the fuel cells.

A basic fuel system schematic is shown in Figure 20.

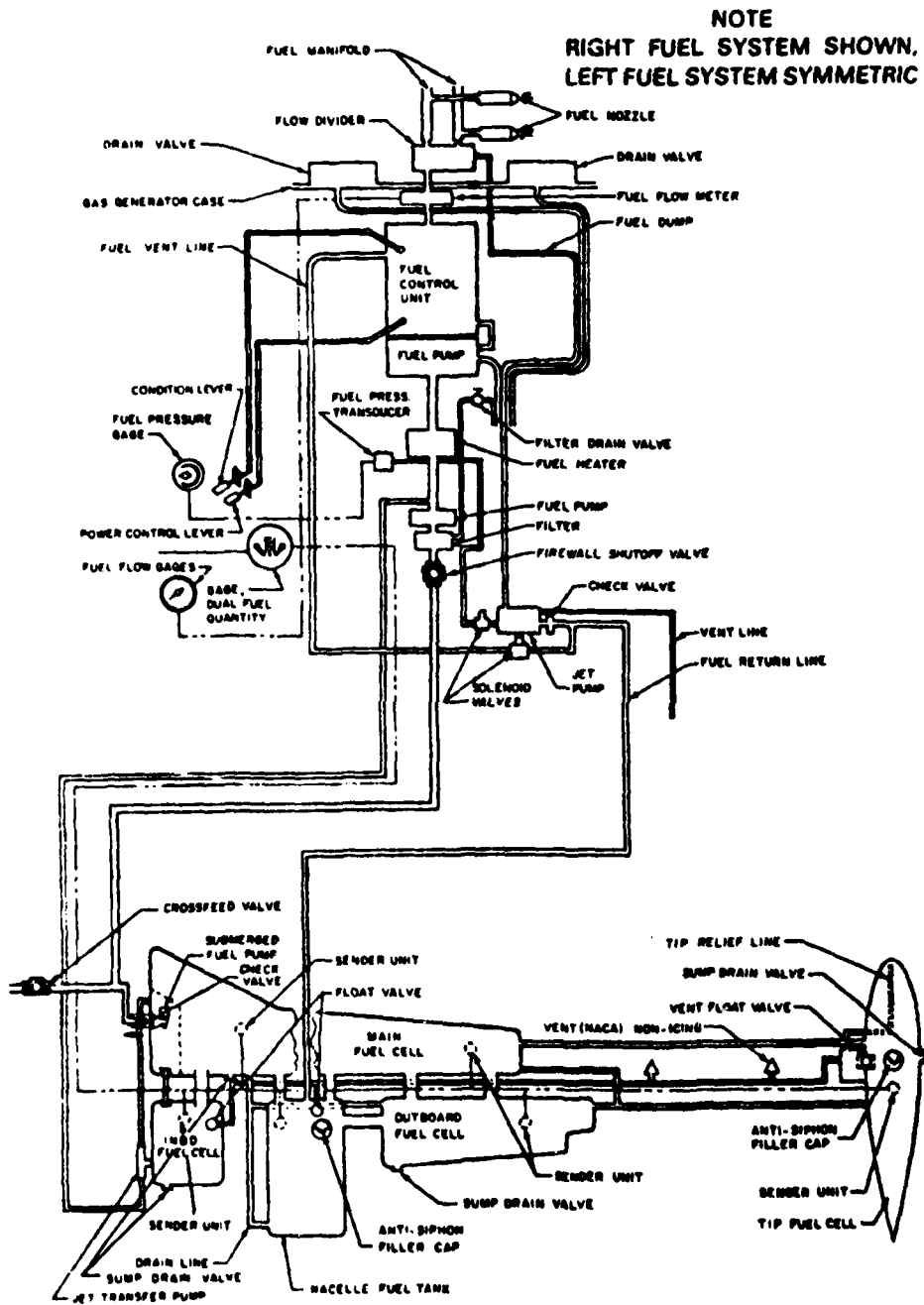

FIGURE 20. PA-42 CHEYENNE III FUEL SYSTEM

b. Fuel System Components and Features

1. Line Sizes - All lines are 1/2-inch or 3/8-inch.
 2. Boost Pumps - Engine driven, 3665 rpm, 1100 pph, vane pumps are used, one for each engine. They run continuously. An electrically driven, 9750 rpm, 600 pph submerged pump in each wing is used for engine starting and if fuel pressure falls below 15 psi.
 3. Ejector Pumps - Four ejector pumps are supplied. Two run continuously and two are used only during engine start and shutdown.
 4. Heat Exchangers - No fuel heat exchangers are supplied with the airframe.
 5. Suction Feed - Suction feed to the engine driven fuel pumps is continuous.
 6. Filters - Two metal element filters with a pore size of 0.0015-inch x 0.018-inch are used. Each is located upstream of the engine driven pump.
 7. Auxiliary Power Unit (APU) - No APU is supplied.
 8. Fuel Quantity Gauging System - A capacitance type fuel quantity gauging system is supplied. No thermistor type point level sensors are used.
 9. Vent System - The vent system uses honeycomb mesh flame arrestors.
 10. Flowmeters - A turbine type flowmeter is used to measure fuel flow to each engine. It is located in the engine high pressure line downstream of the fuel control.
- c. Potential AMK Degradation Sources - The only source of AMK shear degradation is pumping and recirculation through the engine driven vane pump.
- d. Potential Component Performance Problems - Pressure drop through suction feed to the engine driven fuel pumps may be high with undegraded AMK. Based on reference 1, jet pump performance will be greatly reduced with undegraded AMK. Based on reference 3, the fuel flowmeter may have accuracy and calibration problems.
- e. Potential Safety Considerations - Based on references 1, 2, and 3 the fine engine fuel filter may experience plugging with undegraded AMK.

Embraer 110-P2

- a. Fuel System Discussion - The fuel in this aircraft is contained in two integral fuel tanks, one in each wing. Each tank has two interconnected fuel cells, separated by the main landing gear wheelwell. The total fuel tank volume is 232 gallons per wing. Each wing tank feeds its own engine unless the crossfeed system is being used. This system allows both engines to be fed from either wing tank, but does not allow fuel to be transferred from one tank to another.

Refueling is performed by gravity only.

Fuel is supplied to the engine by submerged boost pumps in the inboard fuel cell. Fuel drains by gravity to this cell from the outboard cell.

A vent system incorporates flame arrestors, and a water collection and drain box to prevent rain water from entering the tanks.

A basic fuel system schematic is shown in Figure 21.

- b. Fuel System Components and Features

1. Line Sizes - Fuel system line sizes are as follows:
 - Fuel Supply and Crossfeed - 1/2-inch
 - Fuel Cell Interconnects - 3-inch rigid and 3/4-inch flexible
2. Boost Pumps - Electrically operated, 12,000 rpm, 180 gal/hr centrifugal pumps are used. Four pumps are supplied, two in each inboard fuel cell. Two run continuously, two are for backup.
3. Ejector Pumps - No ejector pumps are supplied.
4. Filters - Two stacked metal disk filters incorporating a bypass valve are used, one in each engine flow line. These filters have a 17-micron rating. Coarse screens on the boost pump inlets are also used.
5. Suction Feed - Suction feed during aircraft flight would occur only as a result of major pump and/or electrical failure.
6. Pressure Refueling - Pressure refueling is not performed on this aircraft.
7. Vent System - The vent system provides for equalization of tank internal and external pressures. Fine honeycomb mesh flame arrestors and a rain water collection and drain system are incorporated.
8. Fuel Quantity Gauging System - A capacitance type fuel quantity gauging system is supplied. No thermistor type point level sensors are used.

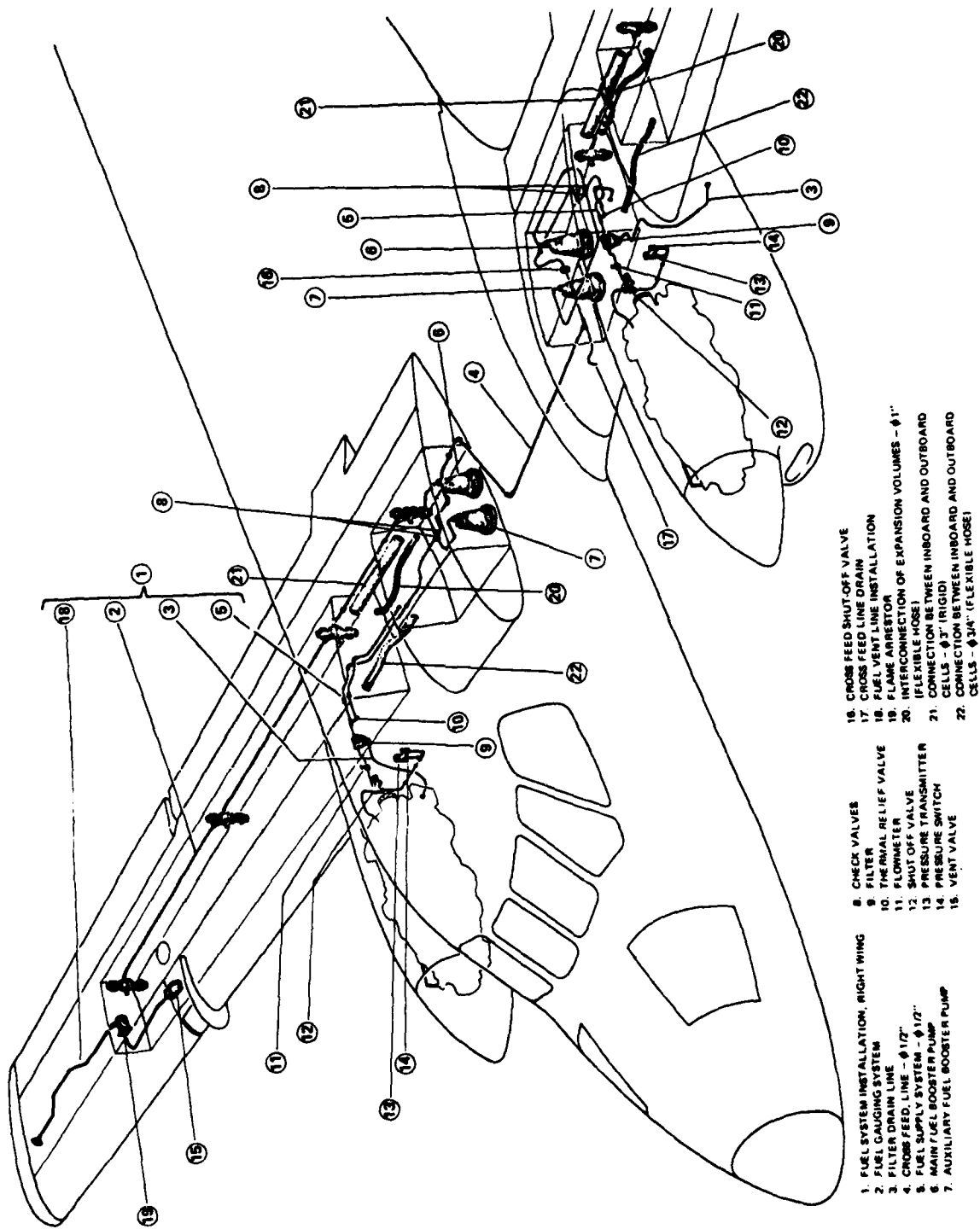

FIGURE 21. EMBRAER EMB 110-P2 FUEL SYSTEM SCHEMATIC

9. Heat Exchangers - No airframe supplied fuel heat exchangers are used.
 10. Flowmeter - A turbine type flow transmitter is used in each engine supply line. It is located downstream of the boost pump and fuel filter.
 11. Auxiliary Power Unit (APU) - No APU is supplied with this aircraft.
- c. Potential AMK Degradation Sources - The only source of AMK degradation is the pumping and recirculation through the centrifugal boost pumps.
 - d. Potential Component Performance Problems - Based on reference 1, boost pump performance will be somewhat reduced. The stacked metal disk filter may experience plugging with undegraded AMK. Based on reference 3, the fuel flowmeter may have accuracy and calibration problems.
 - e. Potential Safety Considerations - No potential safety considerations are apparent. Plugging of the engine fuel filter would result in the bypass valve opening, allowing the engine fuel supply to continue.

Beech 99

- a. Fuel System Discussion - The fuel in this aircraft is contained in 10 bladder cells, with a total capacity of 368 gallons. Each wing contains 3 interconnected cells, and there are two nacelle cells and two center cells.

The fuel drains by gravity from the wing cells to the center and nacelle cells. It is drawn from the center cells to the nacelle cells with jet pumps, where it is pumped to the engine with an engine driven vane pump. Crossfeed capability is provided.

Refueling is performed by gravity only.

The vent system utilizes fine mesh flame arrestors.

A basic fuel system schematic is shown in Figure 22.

- b. Fuel System Components And Features
 1. Line Sizes - Fuel lines are 0.50-inch x 0.035-inch wall and 5/8-inch x 0.035 wall.

Vent lines vary from 0.25 x 0.035-inch wall to 0.75-inch x 0.035-inch wall.
 2. Boost Pumps - The primary boost pump is an engine driven vane pump, 600 gph at 30 psia, 3665 rpm. Cruise flow is 350 gph, dead head pressure is 30 psi.

Two are supplied, both run continuously.

- ➔ CHECK VALVE
- ⊕ FUEL PROBE
- ⊖ SHUTOFF VALVE
- FILTER

ENGINE UNIT
ENGINE FUEL I
FUEL
FUEL F

PURGE VALVE
MOTIVE FLOW

STANDBY BOOST
PRESSURE SW

7

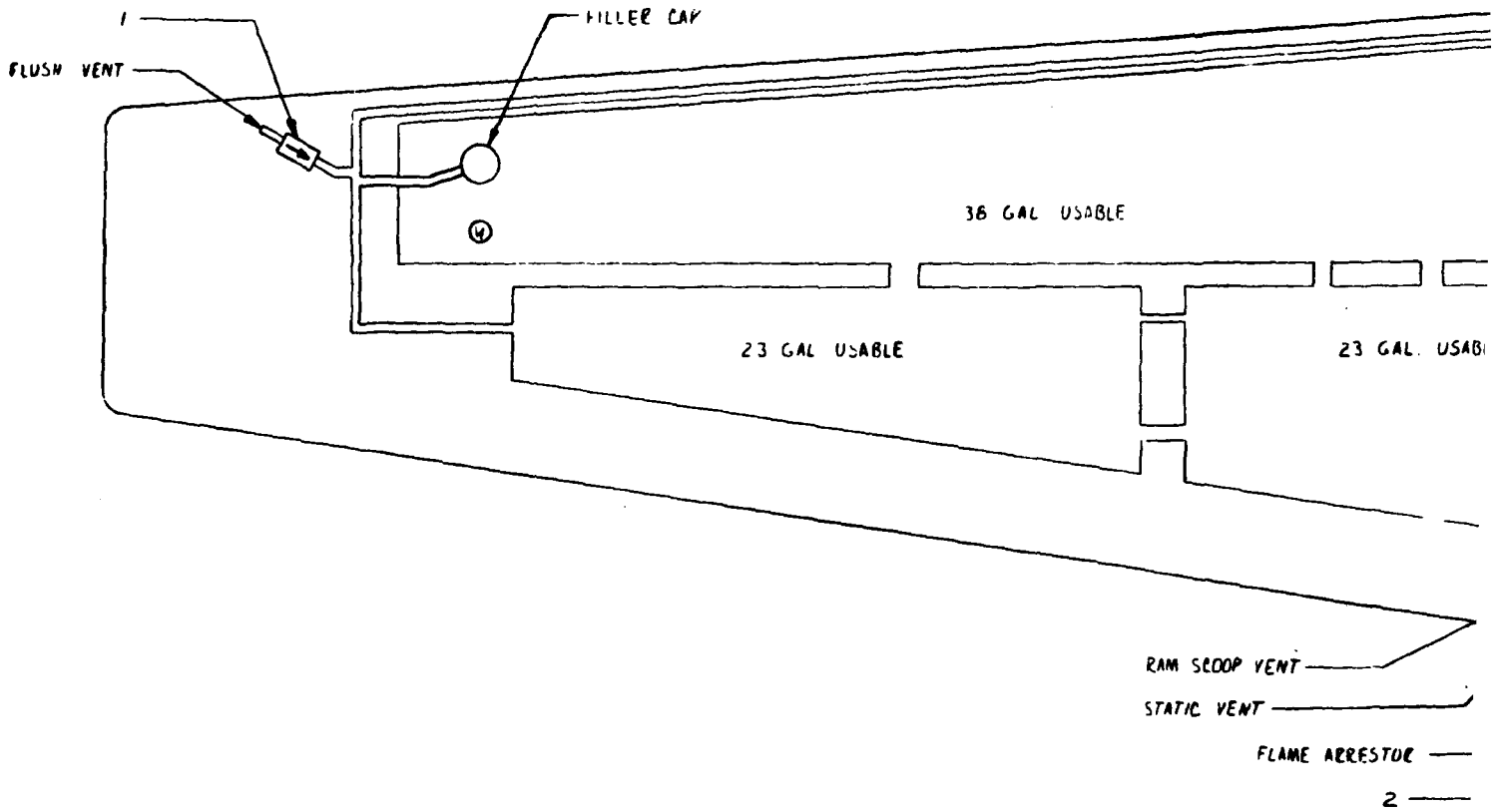

1

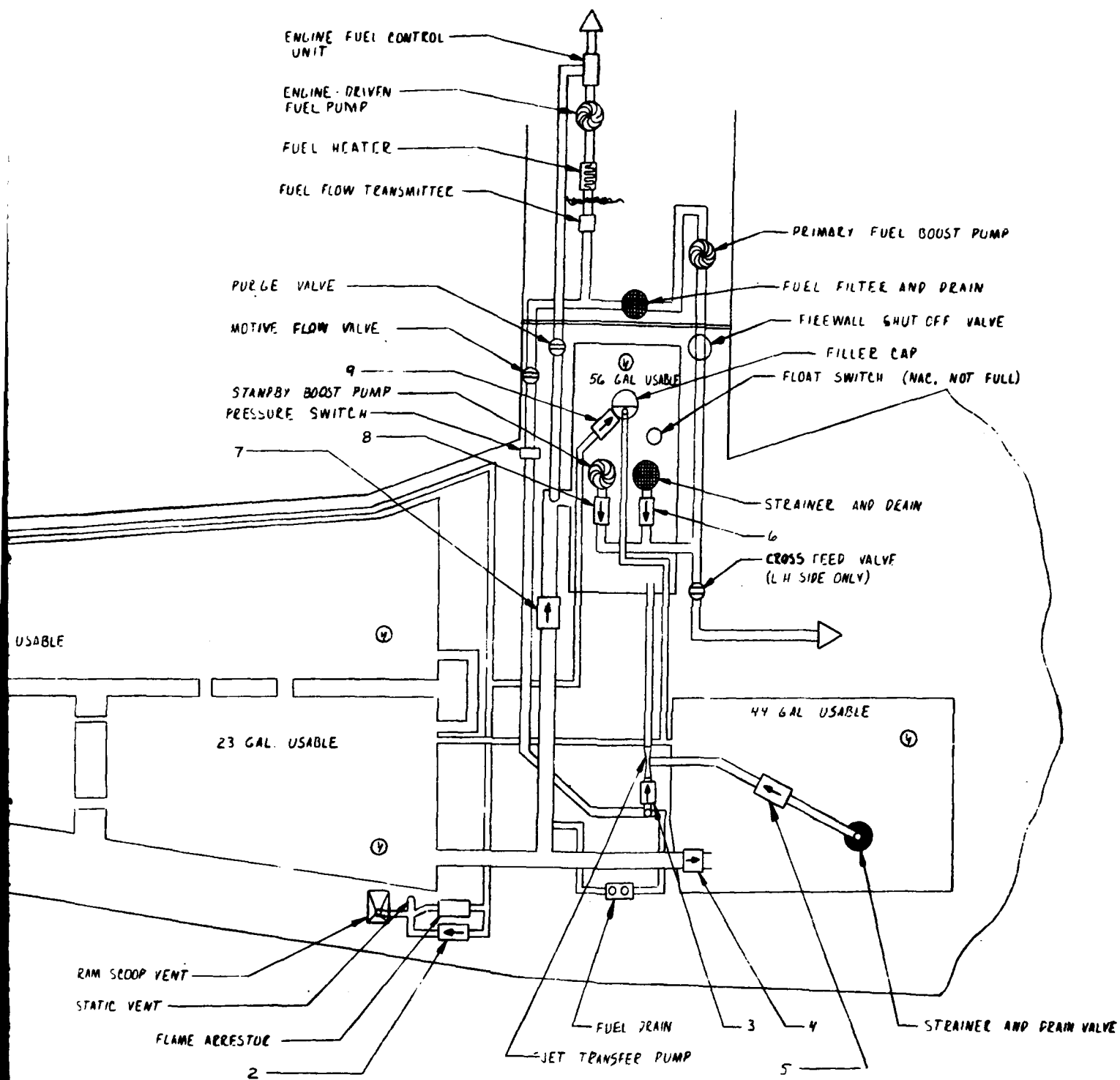

FIGURE 22. BEECH C-99 FUEL SYSTEM SCHEMATIC

2

The standby boost pump is an electrically driven 1200 pph centrifugal pump.

Two are supplied, but are only used in case of primary pump failure and for crossfeeding.

3. Ejector Pumps - Two ejector pumps are used to transfer fuel from the center tanks to the nacelle tanks. Both run continuously.
4. Filters - Two 20-micron metal filters with bypass valves are used one in each engine supply line.

The standby boost pumps have perforated metal inlet screens with 0.11-inch diameter holes.

Check valve strainers utilize 0.013-inch diameter holes.

5. Suction Feed - The engine driven vane pump operates on suction feed continuously.
 6. Pressure Refueling - Pressure refueling is not performed on this aircraft.
 7. Vent System - A vent system, utilizing fine mesh flame arrestors, provides for equalization or tank internal and external pressures.
 8. Fuel Quantity Gauging System - A capacitance type fuel quantity gauging system is supplied. No thermistor type point level sensors are used.
 9. Heat Exchangers - No airframe supplied fuel heat exchangers are used.
 10. Flowmeters - A turbine type fuel flow transmitter is used in each engine supply line. It is located downstream of the boost pump and fuel filter.
 11. Auxiliary Power Unit (APU) - No APU is supplied with this aircraft.
- c. Potential AMK Degradation Sources - The only source of AMK degradation is the pumping and recirculation through the engine driven vane pumps.
 - d. Potential Component Performance Problems - Based on reference 1, boost pump performance with undegraded AMK may be somewhat reduced. The two 20-micron metal filters may experience plugging with undegraded AMK. Based on reference 3, the fuel flowmeter may have accuracy and calibration problems.
 - e. Potential Safety Considerations - Higher pressure drop in the pump suction feed lines may be a problem with AMK. Plugging of the engine fuel filters would result in the opening of the filter bypass, allowing engine fuel flow to continue.

Bell 212 Helicopter

- a. Fuel System Discussion - The fuel in this aircraft is contained in two underfloor fuel cells and three aft upper fuel cells. All of these are the flexible bladder type, and the total fuel capacity is 212 gallons.

Refueling is performed by gravity only. Fuel drains by gravity from the aft upper cells to the right and left underfloor cells. Each of these cells provides fuel to its own engine from boost pumps located in the cells. Ejector pumps located in these cells are used to keep the box around the boost pumps fuel.

Complete crossfeed between tanks and engines is provided for by manual control.

A basic fuel system schematic is shown in Figure 23.

- b. Fuel System Components and Features

1. Line Sizes - The engine feed lines are 1/2-inch, all other lines are 5/8-inch and 3/4-inch.
2. Boost Pumps - Two 12,000 rpm, 635 pph centrifugal pumps are provided, one in each underfloor cell. Both pumps run continuously. Cruise flow is 365 pph.
3. Ejector Pumps - Two are supplied, one in each underfloor cell, to keep the boost pump boxes full. They run continuously.
4. Suction Feed - Suction feed during flight would occur only as a result of major pump and/or electrical failure.
5. Filters - No. 6 mesh screens are used on the boost pumps inlets, and 10-micron paper filters with a bypass loop are used in each engine feed line.
6. Heat Exchangers - No fuel heat exchangers are supplied with the airframe fuel system.
7. Pressure Refueling - Pressure refueling is not performed on this aircraft.
8. Fuel Quantity Gauging System - A capacitance type fuel quantity gauging system is supplied. No thermistor type point level sensors are used.
9. Auxiliary Power Unit (APU) - No APU is supplied.
10. A bleed line for each engine fuel control is used to return excess flow from the hydromechanical fuel control. This line utilizes a 0.050-inch orifice, sized by the engine manufacturer to maintain minimum required pressure in the fuel control under all conditions.

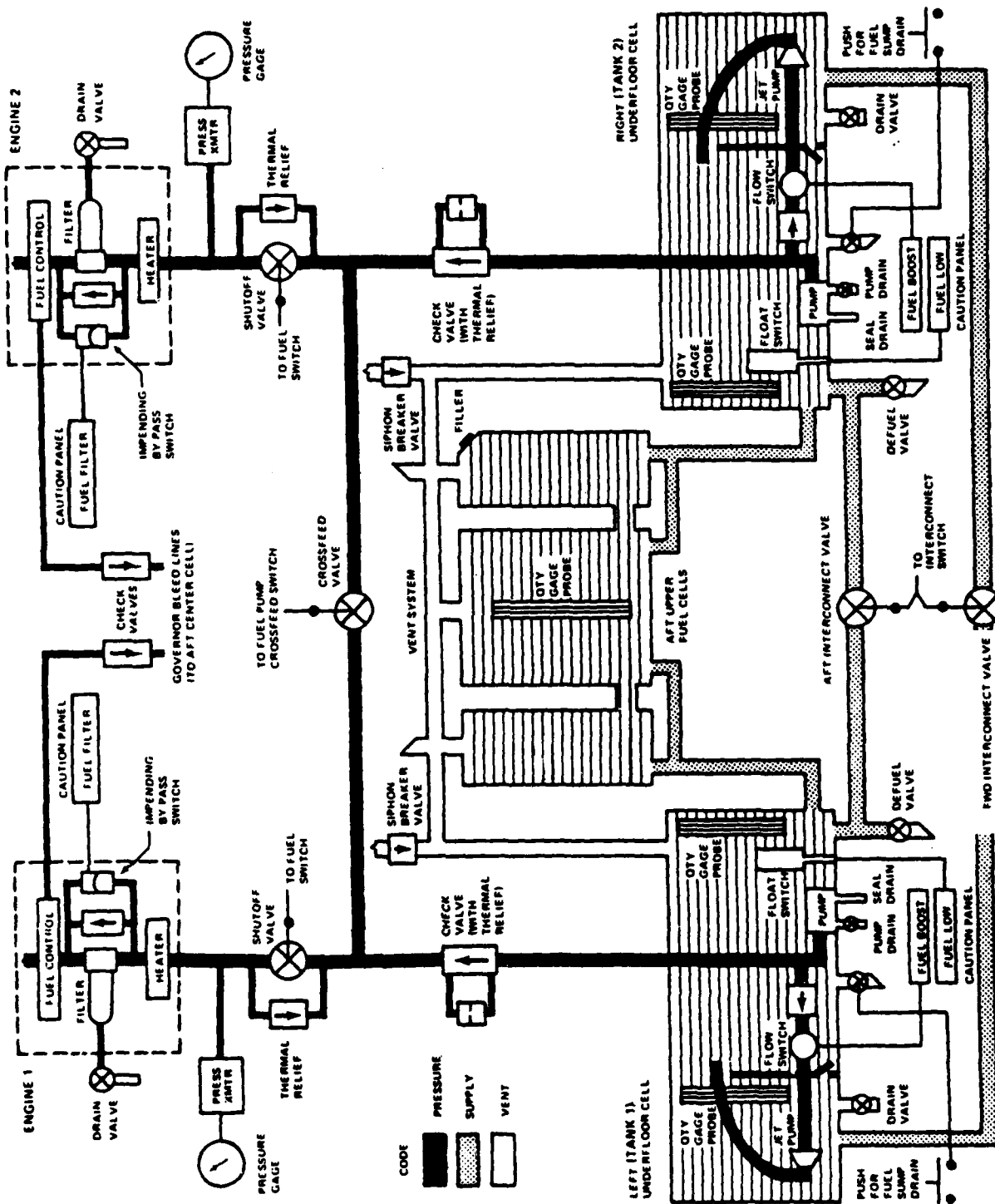

FIGURE 23. BELL 212 FUEL SYSTEM SCHEMATIC

11. Vent System - A vent system which interconnects all cells and utilizes two siphon breaker valves is supplied.
- c. Potential AMK Degradation Sources - The only source of AMK shear degradation is pumping and recirculation through the 12,000 rpm boost pumps.
- d. Potential Component Performance Problems - Based on reference 1, the two ejector pumps will have greatly reduced performance with undegraded AMK, and boost pump performance will also be somewhat reduced.
- The 10-micron paper filters will probably experience plugging with undegraded AMK, but the bypass loop should provide uninterrupted engine flow.
- Possible reduced flow in the fuel control bleed line with undegraded AMK should not cause significant problems.
- e. Potential Safety Considerations - Potential engine fuel control problems may exist due to bleed line orifice problems with undegraded AMK. The crash resistant bladder type fuel cells should enhance the fire safety of AMK in a crash situation.

Boeing Vertol 234-LR Helicopter

- a. Fuel System Discussion - The fuel in this aircraft is contained in two semi-cylindrical tanks, one on each side of the aircraft.
- Bladder fuel cells containing 5 baffles are used, holding a total quantity of 2100 gallons.
- Two submerged engine boost pumps are located in each tank. An APU pump is also provided. Each engine normally is fed from its own tank, but manually operated crossfeed is provided.
- Pressure refueling is performed using a standard 2 1/2-inch fueling adapter.
- A combustion type cabin heater which uses the aircraft fuel is used for cabin temperature control.
- A basic fuel system schematic is shown in Figures 24 and 25.
- b. Fuel System Components and Features
1. Line Sizes - The fuel system line sizes are as follows:
 - Main Fuel System - 3/4-inch to 2-inch
 - APU Feed System - 3/8-inch
 2. Boost Pumps - Four electrically driven, 10,300 rpm, 3500 pph centrifugal pumps are supplied. Two run continuously, two are for backup. Cruise flow is 2000 pph, dead head pressure is 35 psi.

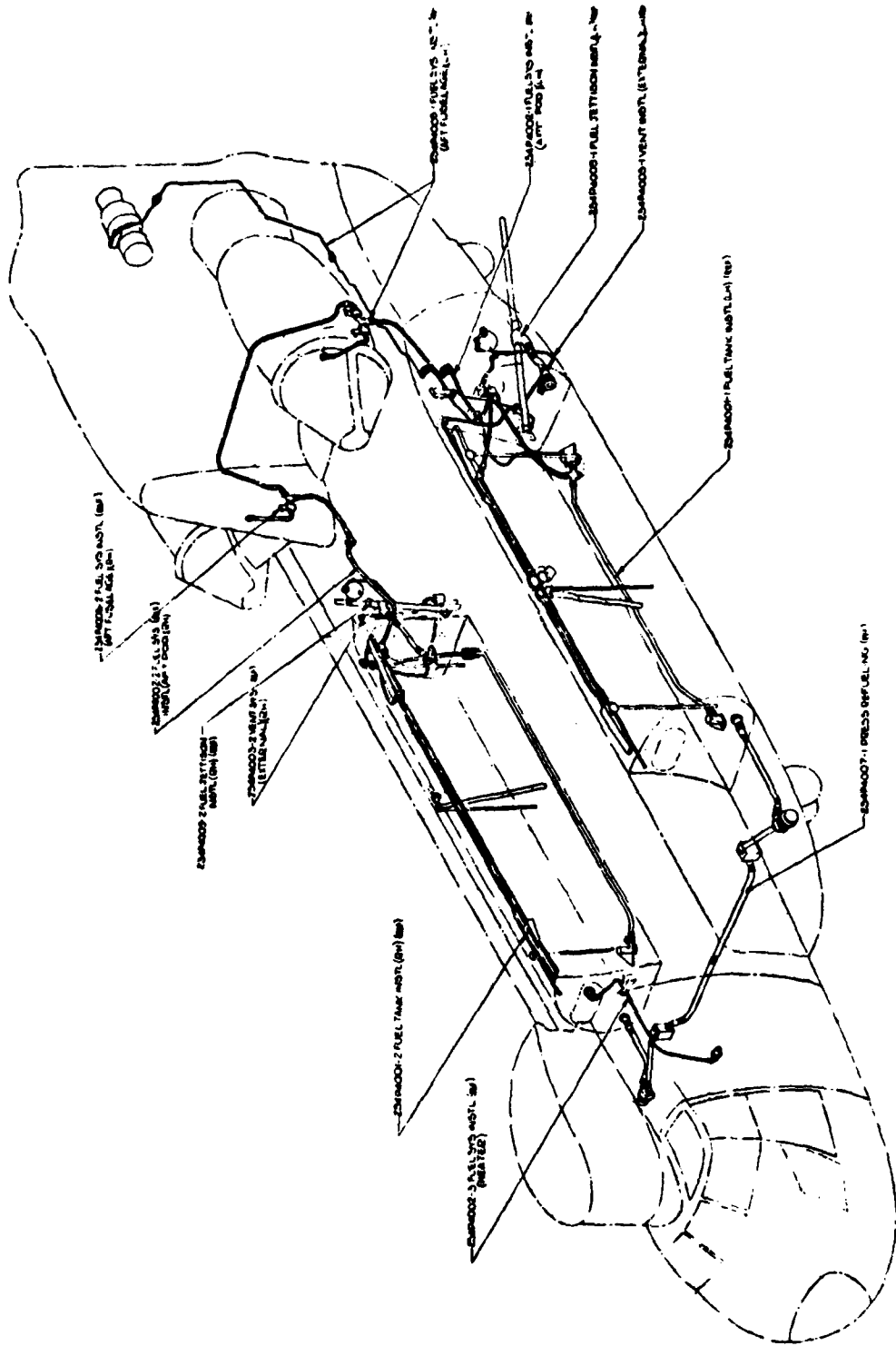

FIGURE 24. BOEING VERTOL 234 LR FUEL SYSTEM

3. Ejector Pumps - No ejector pumps are used.
 4. APU Pump - An electrically driven, 3000 rpm, 20 gal/hr rotary vane pump is used for the APU.
 5. Suction Feed - The suction feed condition during aircraft flight would occur only as a result of major pump and/or electrical failure.
 6. Filters - No. 4 mesh screens are used on the boost pump inlets and the suction feed pickup lines.
 7. Vent System - A valveless vent system with no flame arrestors is used.
 8. Pressure Refueling - Pressure refueling is performed through a single 2 1/2-inch MIL-A-25896D adapter. This system uses a level control valve and an automatic shutoff valve with 0.030-inch to 0.040-inch orifices, maximum flow is 300 gpm.
 9. Heat Exchangers - No fuel heat exchangers are supplied with the airframe fuel system.
 10. Flowmeter - A General Electric mass flow transmitter, which incorporates a turbine type element, is used to measure fuel flow to each engine. It is located downstream of the boost pump.
 11. Fuel Quantity Gauging System - A capacitance type fuel quantity gauging system is supplied. Thermistor type point level detectors are used for fuel low level sensing.
 12. Fuel Jettison - Fuel is jettisoned by gravity, at a rate of 35 gpm.
 13. Aircraft Cabin Heater - A jet fuel combustion type heater is used. This unit has its own gear pump and uses spark plug type ignition. A burner spray nozzle with an 0.050-inch spray nozzle is used.
 14. Auxiliary Power Unit (APU) - The APU for this aircraft is supplied by the Turbomach Division of International Harvester. It utilizes a 10-micron nominal, 25-micron absolute metal filter. The pump supplies 500 pph at 375 psig and 4,250 rpm. The fuel is sprayed through one 0.002-inch atomizing nozzle into a hot tube vaporizer before entering the burner. Fuel bypass ratio is 4 to 1.
- c. Potential AMK Degradation Sources - The only source of AMK shear degradation is pumping and recirculation through the 10,300 rpm centrifugal pump.
- d. Potential Component Performance Problems - Based on reference 1, the boost pump and APU pump performance will be somewhat reduced.

The APU and fuel fired cabin heater will probably require a degrader.

Based on reference 3, the flowmeters may have accuracy and calibration problems.

The level control valves, automatic fuel shutoff valves, and the low level thermistor sensors may have increased response time with undegraded AMK.

The No. 4 mesh screens on the boost pump inlets should perform properly with undegraded AMK. The 10-micron APU filter may experience plugging with undegraded AMK.

- e. Potential Safety Considerations - The crash resistant bladder fuel cells and breakaway fittings should supplement the AMK fire protection qualities.

Sikorsky Spirit S-76 Helicopter

- a. Fuel System Discussion - The fuel in this aircraft is contained in two metal tanks, one on each side of the aircraft. The total fuel quantity is 286 gallons.

Each engine is fed from its own tank using engine driven pump suction feed only. No in-tank pumps are used.

Refueling is performed by gravity only.

Crossfeed capability is provided so each engine can be fed from either tank.

A basic fuel system schematic is shown in Figure 26.

- b. Fuel System Components and Features

1. Line Sizes - The fuel system uses only one inch lines, except for the 1/4-inch engine priming line.
2. Pumps - No pumps are supplied with this aircraft.
3. Suction Feed - Suction feed to the engines is used continuously, using the engine driven fuel pumps.
4. Filters - Sixteen mesh screens are used on the check valve inlets. No other filters are supplied with the airframe.
5. Vent System - An open vent system with no flame arrestors is used.
6. Pressure Refueling - Pressure refueling is not used.
7. Heat Exchangers - No fuel heat exchangers are provided with the airframe.
8. Auxiliary Power Unit (APU) - No APU is supplied.

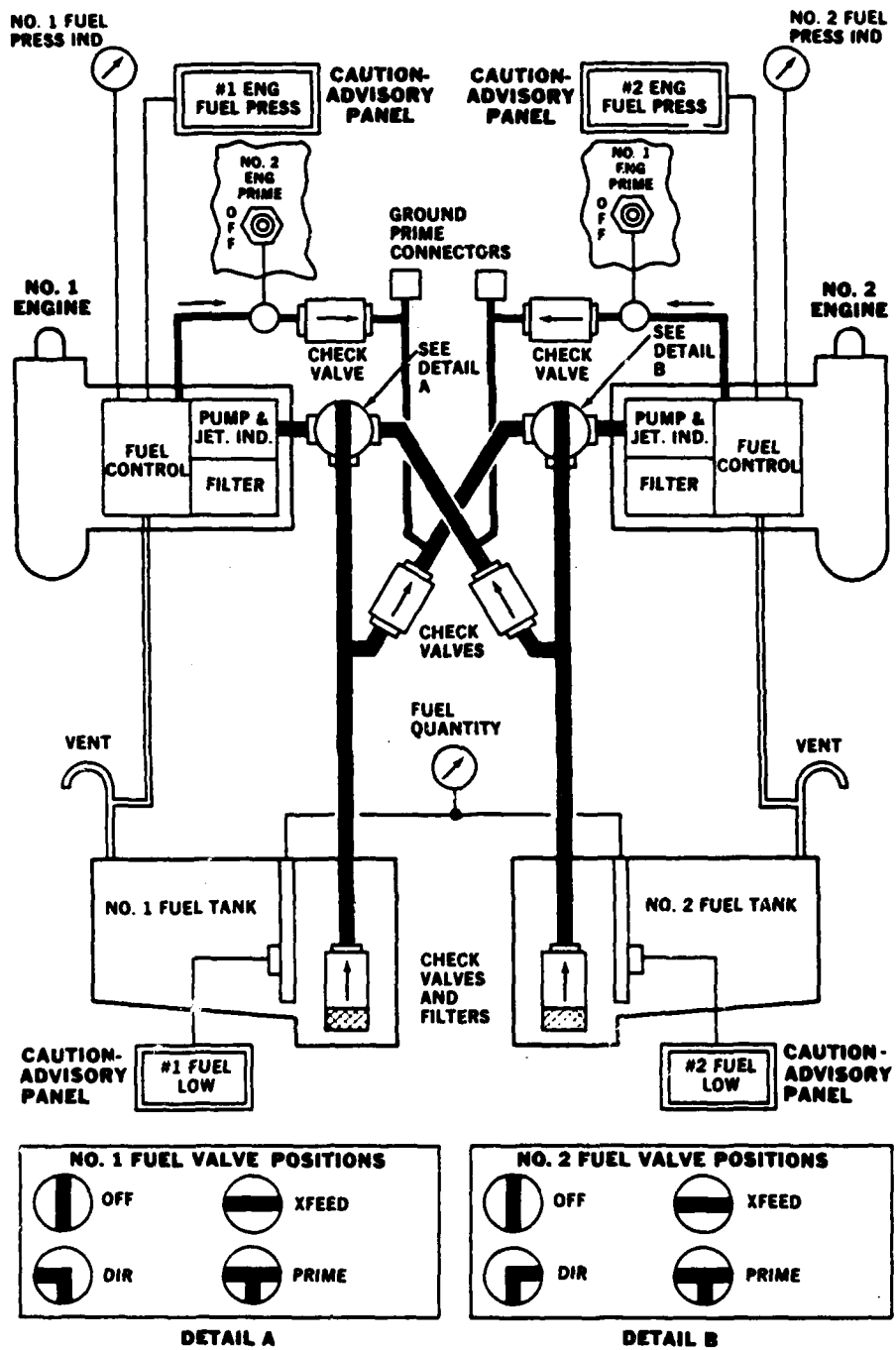

FIGURE 26. SIKORSKY S-76 FUEL SYSTEM SCHEMATIC

9. Fuel Quantity Gauging System - A capacitance type fuel quantity gauging system is supplied. No thermistor type point level sensors are used.
- c. Potential Sources of AMK Shear Degradation - There are no apparent sources of AMK shear degradation supplied with the airframe.
- d. Potential Component Performance Problems - Since suction feed is the only means of supplying fuel to the engine, possible increased pressure drop with AMK should be investigated at low flows. At high flows, drag reduction effects may reduce pressure drop. Poppet check valves are not used in the system because of their higher pressure drop. The 16 mesh screens should operate satisfactorily with undegraded AMK.
- e. Potential Safety Considerations - High pressure drop with undegraded AMK could possibly cause engine performance problems.

Aerospatiale AS350D Helicopter

- a. Fuel System Discussion - The fuel in this aircraft is contained in a single spin-molded polyamide (nylon) tank, holding 140 gallons. The tank is mounted behind the passenger compartment.

An electrically driven boost pump is mounted at the base of the tank, and fuel drains by gravity to the pump inlet. A drain plug and water bleed valve is located beneath the pump.

Gravity refueling is used, and the tank has an overboard vent line.

A basic fuel system schematic is shown in Figure 27.
- b. Fuel System Components And Features
 1. Line Size - The pump to engine line is 1/2-inch.
 2. Boost Pumps - One electrically driven 5500 rpm centrifugal pump with a rated flow of 250 liters/hr (66 gal/hr) is supplied. It runs continuously, varying flow with engine demand. Fuel is not bypassed back to the tank. Nominal flow is 44.9 gallons/hr., dead head pressure is 11.6 psi.
 3. Ejector Pumps - No ejector pumps are supplied with this aircraft.
 4. Pressure Refueling - Pressure refueling is not performed on this aircraft.
 5. Filters - One 10-micron metal filter equipped with a bypass valve and a mechanical bypass indicator is supplied. A coarse mesh screen is also used on the boost pump inlet.
 6. Suction Feed - Suction feed to the engine is used only in the event of pump failure.
 7. Heat Exchangers - No fuel heat exchangers are supplied.

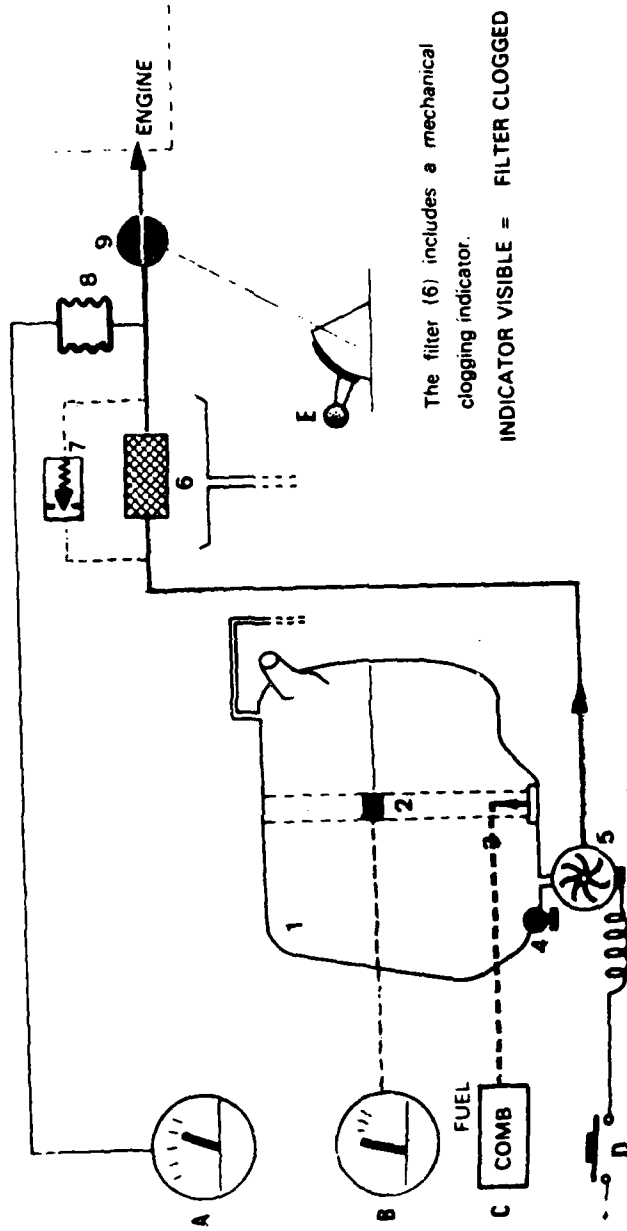

The filter (6) includes a mechanical clogging indicator.

INDICATOR VISIBLE = FILTER CLOGGED

1	Fuel tank : max. capacity, 532 liters (140 GAL)	9	Fuel shut-off valve : shuts off engine fuel supply (crash, engine fire)
2	Float type contents transmitter	A	Fuel pressure gauge
3	Low-level switch : illuminates the FUEL warning light when fuel level reaches 70 liters	B	Fuel contents gauge
4	Fuel drain and water bleed valve	C	Low-level warning light
5	Electric booster pump : delivers fuel at low pressure to the engine pump	D	Pushbutton : booster pump control
6	Fuel filter : 10 μ m capacity	E	Fuel shut off control lever
7	Bypass valve : opens to ensure continued engine fuel supply if filter is clogged		
8	Fuel pressure transmitter		

FIGURE 27. AEROSPATIALE AS-350D FUEL SYSTEM SCHEMATIC

8. Auxiliary Power Unit (APU) - No APU is supplied with this aircraft.
 9. Fuel Quantity Gauging System - A float/potentiometer fuel quantity gauging method is used. There are no thermistor type point level sensors.
- c. Potential AMK Degradation Sources - There are no significant sources of AMK shear degradation.
 - d. Potential Component Performance Problems - Based on reference 1, the boost pump performance with undegraded AMK will be somewhat reduced. The 10-micron filter will probably experience plugging with undegraded AMK. Some problems due to increased drag with undegraded AMK may occur in the float type gauging system.
 - e. Potential Safety Considerations - In the event of failure of the single boost pump, suction feed performance with undegraded AMK may not be satisfactory.

Aerospatiale SA365N Helicopter

- a. Fuel System Discussion - The fuel in the aircraft is contained in 5 bladder cells; Two forward, two center, and one aft. The cells are located in the bottom structure under the cabin and cargo compartment floor. The total fuel capacity is 300 gallons. The cells are divided into two groups with a capacity of 150 gallons each, one group for each engine. Each center cell contains a feeder tank which contains a boost pump. Jet pumps draw fuel from the cells and keep the feeder tank overflowing. A crossfeed system is provided which allows feeding of both engines from one tank group and transfer of fuel from one group to another.

Refueling is accomplished by gravity only.

A tank venting system which utilizes an expansion tank with an overboard vent is provided.

A basic fuel system schematic is shown in Figure 28.

- b. Fuel System Components And Features
 1. Line Sizes - Pump to engine line size is 20.4-mm.
 2. Boost Pumps - Two electrically driven boost pumps with a maximum flow of 1000 liter/hr (264 gal/hr) are provided, one in each center cell. Nominal flow is 500 liters/hr (132 gal/hr) at 8.7 psi. Dead head pressure is 15.3 psi. Both pumps run continuously, one for each engine.
 3. Ejector Pumps - Five ejector pumps are used to continuously pump fuel from the various cells to the boost pump feeder tanks.

(respectively for each system)

SUPPLY SYSTEM

- 1 - Jet pump
- 2 - Booster pump
- 3 - Feeder tank supply jet pump
- 4 - Accessory mounting plate
- 5 - Feeder tank
- 6 - Transfer pump

- 7 - Filler neck
- 8 - Filter unit
- 9 - Cross feed valve
- 10 - Main tanks
- 11 - Auxiliary tanks

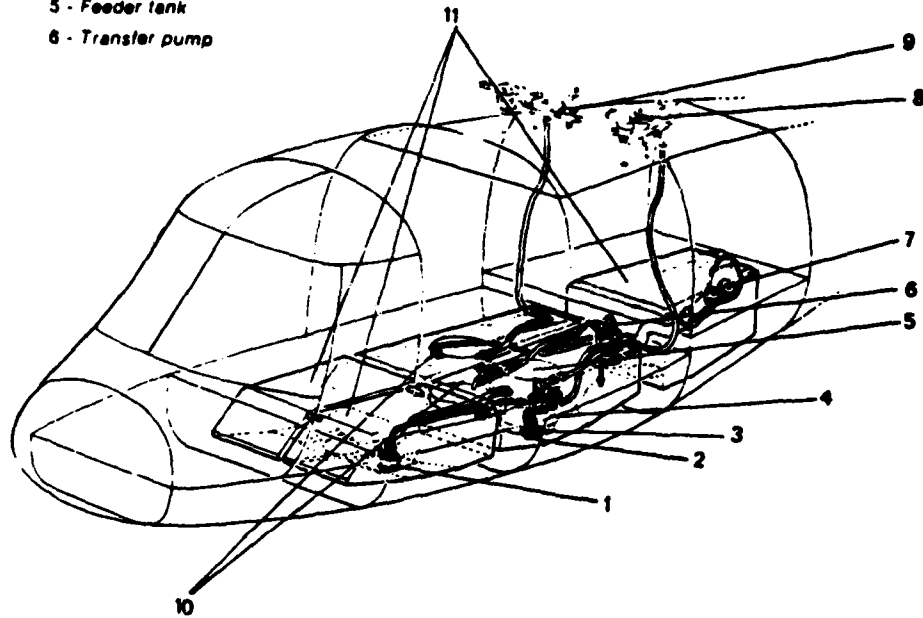

AIR VENT SYSTEM

- 12 - Cells
- 13 - Expansion tank
- 14 - Crossed air vent lines

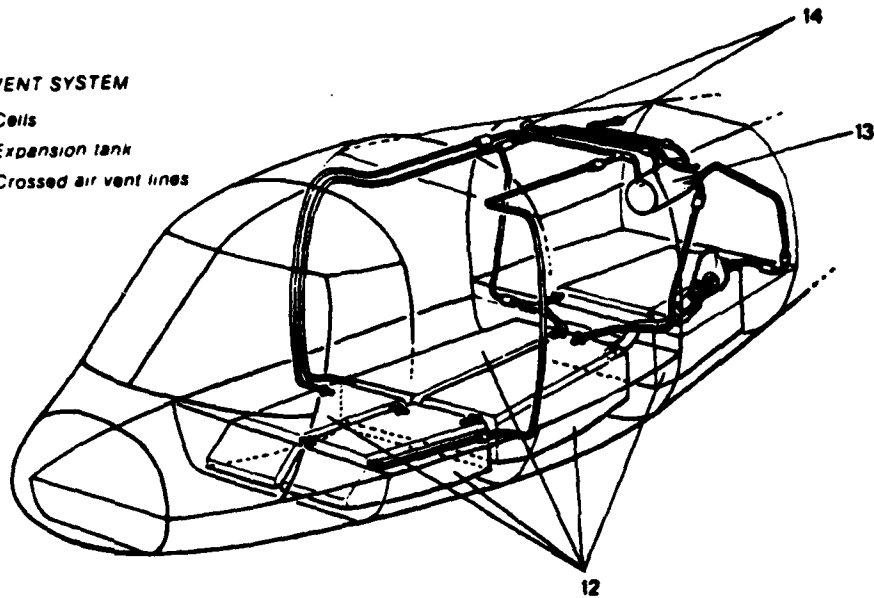

FIGURE 28. AEROSPATIALE SA-365N FUEL SYSTEM SCHEMATIC

4. Pressure Refueling - Pressure refueling is not performed on this aircraft.
 5. Filters - A 10-micron metal filter incorporating a bypass valve is used in each engine supply line.
 6. Heat Exchangers - No fuel heat exchangers are supplied with the airframe fuel system.
 7. Auxiliary Power Unit (APU) - No APU is supplied with this aircraft.
 8. Suction Feed - Suction feed during flight would occur only as a result of major pump and/or electrical failure.
 9. Fuel Quantity Gauging System - A capacitance type fuel quantity gauging system is supplied.
- c. Potential AMK Degradation Sources - The only source of AMK shear degradation is recirculation through the boost pumps.
- d. Potential Component Performance Problems - Based on information in reference 1, the five ejector pumps used in this aircraft will have reduced performance. This could result in underfilling of the collector tank. The 10-micron filter may experience plugging with AMK.

SECTION 6 ADDITIONAL FUEL SYSTEM COMPONENTS

In addition to the components and systems discussed in Section 5, various other components such as vent float valves, float level indicators, check valves, pressure switches, etc are used. A general discussion of some of these follows. Some applicable specifications are listed for these and the other major components discussed previously.

Some Component Specifications

Pressure Fuel Servicing Adapter	MIL-A-25896D, MS24484
Check Valves	MIL-V-7899C
Ejector Pumps	MIL-P-85315
Fuel Boost Pumps	MIL-P-5238C
Aircraft Fuel Pressure Switch	MIL-S-9395E
Aircraft Fuel Gauges	MIL-G-26988C
Level Control Valves	MIL-V-38003
General Specification For Fuel System Components	MIL-F-8615D
Vent Valves	MIL-V-81356A

Discussion

Check Valves - The check valves used in the aircraft fuel systems studied are either swing check or poppet type, most of which meeting MIL-V-7899 requirements. One of the requirements called out is the opening of the valve at a pressure differential of less than 8 inches of water. This could be a problem with AMK. Discussion with Sikorsky on their S-76 Helicopter has indicated that they only use swing type check valve because of the slightly higher pressure drop with the poppet type valves. Discussion with Boeing Vertol indicates that they have had contamination problems with poppet type valves on their aircraft.

Pressure Switches - Pressure switches meeting MIL-S-9395E should operate satisfactorily with AMK.

Vent Float Valves - Most of the aircraft use float vent valves in the vent system which are normally open when air or fuel vapor is in the vent line. If ground or flight attitude changes cause liquid to enter the vent line, the float rises and closes the vent to prevent liquid fuel from flowing out of the vent line. The valve also relieves positive or negative tank pressures. These valves should function properly with AMK.

Fuel Quantity Gauging System - All of the aircraft studied use capacitance type fuel quantity gauging systems. The primary specification covering this type of system is MIL-G-26988.

These gauges utilize the relationship between fuel dielectric constant and density to perform their function. Testing described in reference 1 indicated no significant difference in gauge operation on the C-141 aircraft fuel system simulator.

The properties of AMK may affect the operation of these gauging systems, however, in the following ways:

1. The newer gauging systems have higher accuracy requirements which may reveal differences between AMK and Jet A gauging.
2. The addition of FM-9 and the glycol-amine carrier fluid may cause a shift in the dielectric constant-density relationship.
3. The fact that water is more soluble in the AMK may cause an additional shift in the above relationship, as well as increasing the fuel electrical conductivity. This latter affect can cause significant errors in some capacitance systems.
4. Several of the aircraft studied utilize thermistor type point level sensors to give an independent indication of low or high fuel levels in certain tanks.

These sensors consist of a small thermistor bead with a current flowing through it, heating the bead to some temperature in air. When the bead is covered with liquid, the cooling effect changes the bead temperature and resistance. This results in a voltage change which indicates whether the bead is dry or wet, or when the liquid level has passed the bead location. For high level sensors, the performance with AMK should be satisfactory. Due to slower draining of the AMK relative to Jet A, time response required for low level sensors may not be met with AMK.

All of the component specifications listed above require testing in various fuels and test fluids which do not include AMK.

If AMK is added to the required list of test fluids, the components may not satisfy all the required performance demands with this fuel.

SECTION 7 FUEL SYSTEM PARAMETER RANGES

Dynamic Parameters

Based on this review of the selected aircraft fuel systems, the bulk antimisting kerosene fuel will be exposed to the following conditions induced by aircraft fuel system components:

Pressure : Pressure Refueling - 14.7 psia to 50 psig
Boost Pumps - 10 to 25 psig
Suction Defueling - 14.7 psia to -11 psig

Flow Rate : Pressure Refueling - 0 to 870,000 pph
Boost Pumps - 0 to 50,000 pph

Boost Pump rpm : 2000 to 12,000 rpm

Environmental Parameters

The bulk fuel will be exposed to the following environmental parameter ranges while being used in the aircraft studied:

Humidity - 0 to 100 percent relative humidity

Altitude & Pressure - Sea Level (14.7 psia) to 60,000 feet. (0.04 psia)

The 60,000 ft. pressure altitude would only be experienced in the Concorde fuel tanks if the pressurization system failed. Assuming this did not occur, the lowest pressure altitude experienced would be at 44,000 feet. (2.2 psia).

Temperature - Based on a review of references 6, 7, and 8 the lowest minimum bulk fuel temperature likely to be encountered is approximately -44° C (-47.2° F).

The studies described in references 6 and 8 involved the comparison of computer studies with actual flight fuel temperature measurements. The results were based on the expected one-day-a-year, 0.3 percent probability cold ambient temperature.

The calculation of the bulk fuel temperature with the models used involves various assumptions concerning fuel stratification and mixing. The comparison of the computer studies with actual data indicates that the stratification effect is small.

The highest bulk fuel temperature likely to be observed in the airframe fuel system will occur in the Concorde aircraft. Data indicates that fuel temperatures of approximately 80° C (176° F) will be experienced in some tanks near the end of the flight. Fuel that remains in tanks during landing can have a temperature of approximately 55° C (131° F).

The Concorde is the only aircraft studied that experienced constantly increasing fuel temperatures during flight; all the other aircraft experienced the opposite trend.

Emergency Conditions

Discussion with the various aircraft manufacturers indicates that unusual conditions such as emergency descents do not involve any significant changes in fuel system operation that would be of concern if AMK were being used.

Material Compatibility

Limited material compatibility testing of AMK with several aircraft engine seal elastomers was reported in reference 3. The materials that were tested were butadiene rubber, fluorosilicone rubber, and a fluorosilicone/fiberglass composite. These materials were judged to be compatible with AMK at 295° K and 340° K, but the tensile strength reduction of the butadiene and fluorosilicone was significant.

The fuel systems of the aircraft studied contain many polymeric and elastomeric materials used as coatings, sealants, gaskets, bladders and other parts. A partial list of these materials and some specifications covering them is given below.

<u>Material Description</u>	<u>Specification</u>
Fluorosilicone Rubber	MIL-R-25988
Fluorocarbon Elastomer	MIL-R-83248
Buna-N Rubber	MIL-R-6855
O-Ring Packing	MIL-P-5315
Polysulfide Sealant	.L-S-8802
Polysulfide Sealant	MIL-S-8748A
Polysulfide Sealant	MIL-S-7502C
Buna-N Coating	MIL-S-4383
Urethane Coating	MIL-C-27725A
Polysulfide Sealant	MIL-S-81323
Sealing Compound	MIL-S-8516
Fuel Cell Bladders	MIL-T-6396

Additional materials include epoxies, nylons, fluorocarbons, and other thermosetting and thermoplastic compounds.

The compatibility of the above materials with degraded and undegraded AMK will need to be known before wide scale introduction of AMK takes place.

Water Contamination

Water enters the aircraft fuel system from two sources: the fuel itself and the air drawn into the tanks through the vent system.

The solubility of water in jet fuel varies with temperature. At 20° C, approximately 0.008 percent by weight of water is present in saturated commercial jet fuel, assuming all free water has been removed. At -10° C, this value is reduced to 0.0025 percent. This indicates that if the approximately 340,000 lbs. of 20° C fuel on a 747 was chilled to -10° C and all of the water coming out of solution was removed, approximately 2.24 gallons of water would result.

Humid air drawn into the vent system during descent causes condensation on the cold tank structure and fuel surface. Since the fuel tanks usually have considerable empty volume after a long flight, significant amounts of water can be drawn in at this time. About 1/4 pint of water per 1000 gallons of fuel tank space can be condensed in this way (reference 8).

Additionally, introducing warm fuel into the cold tanks during refueling can result in water being separated from the fuel as it is chilled.

Free water is continually being generated in the aircraft fuel tanks through these mechanisms.

SECTION 8 CURRENT RESEARCH REVIEW

Research and testing is currently being performed by several investigators to more precisely define the properties and characteristics of antimisting kerosene and determine its suitability for commercial aircraft use.

Some of this work, reported in references 9 through 14, was reviewed to determine if results to date had any bearing on conclusions that were reached in the Commercial Aircraft Airframe Fuel Systems Survey and Analysis Interim Report. The following comments pertain to the results obtained by the referenced investigators.

Component Performance

Testing performed on the DC-10 fuel simulator (reference 14) indicates reduced jet pump performance, as was observed earlier in tests described in reference 1. If reduced performance with undegraded AMK is judged to be critical by aircraft fuel system engineers, this problem will be difficult to overcome.

Transfer valve tests on the same simulator indicated that gravity flow rates were reduced by 24 percent with undegraded AMK. Degraded AMK reduced the gravity flow rate by 9 percent. This reduced gravity flow characteristic may have an effect on gravity flow jettison systems as well.

Filling tests on the DC-10 simulator indicated lower flow rates and longer filling times with undegraded AMK. In addition, some gel formation was observed in the fill valves.

Float switch and float valve testing, as well as vent system flow testing in this simulator indicated no problems with AMK.

Fuel Filterability

The following points concerning the filterability of degraded AMK were stated in reference 13:

1. Small amounts of high molecular weight polymer may remain after AMK is degraded and may cause long term filter plugging.
2. Gel buildup occurs on metal filters even though the filter does not become plugged.
3. Extended tests indicated no actual filter plugging with degraded AMK.
4. The behavior of untested filters with degraded AMK may be predictable if the pressure-flow relationship with Jet A is known, based on Reference 13. Under some conditions initial filter clogging normalized velocity was found to be a function of AMK degradation level.
5. Reference 11 indicates that the FM-9 acts as a stabilizer for water suspension and may interfere with the operation of water-separator/filter units.

6. Reference 9 indicates that small quantities of poorly solubilized FM-9 can plug fine filters, but have little effect on other fuel properties. It was also found that Critical Filtration Velocity (CFV) was a more reliable parameter than the filtration ratio for determining AMK degradation status. The CFV is a function of filter properties and is lower in paper filters than in metal filters with the same particle size rating.
7. For most of the large aircraft airplane fuel systems surveyed, fine particle filters with micron ratings are not supplied with the airframe, so the above comments are not relevant.
8. Some of the smaller aircraft do have paper and metal fuel filters on the airframe which may have to be studied. The engines and APUs have filters of this type and their performance with AMK is of great importance.

Degradation/Fire Protection

Both references 9 and 10 concluded that large scale fire tests are necessary due to differences between the small and large scale conditions, such as air entrainment which occurs in the small scale model tests, but does not occur in actual crash conditions.

AMK degradation was found to occur in the DC-10 boost pumps (reference 14) and small centrifugal pumps (reference 11). This agrees with earlier tests performed on a C-141 simulator (reference 1).

Reference 9 also stated that an aircraft engine fuel pump and a needle valve can produce adequately degraded fuel at cruise flow conditions.

The penalty in thrust specific fuel consumption for a JT8D engine for the required degraded power was estimated to be 0.55 percent at 30 H.P. (reference 13).

AMK fire protection appears to be unchanged or improved if water contamination is present (reference 11).

Water Contamination

The impact of water contamination on both degraded and undegraded AMK appears to be significant.

According to reference 11, absorption of water by AMK is much higher than Jet A - up to 1300 ppm. Above 250-350 ppm water a second phase forms, depending on temperature, degradation level, and agitation. Above 150 ppm water, contact with cold surfaces causes a heavy precipitate to form in the AMK. When humid air is drawn through AMK, as occurs with some jet pump installations, large quantities of precipitate are formed.

Findings in reference 13 were of a similar nature. Operation of JT8D engine fuel systems with water contaminated, degraded AMK caused a white precipitate to form which plugged filters and left deposits in the plumbing and on the tank walls.

Heat Transfer Properties

Reference 13 finds that the heat transfer properties of undegraded AMK are the same as those of neat Jet A up to a certain critical wall shear rate in flowing AMK. Above this rate shear thickening occurs, and the heat transfer rate decreases.

For most of the airframe-supplied hydraulic fluid/fuel heat exchangers, the fuel is a static or very slowly moving heat sink, so heat transfer should not be impaired with AMK.

This reference also indicates that fuel degradation, as far as flammability is concerned, may not return the heat transfer properties to those of neat Jet A.

AD-A119 572

SIMMONS PRECISION PRODUCTS INC VERGENNES VT INSTRUM--ETC F/G 20/4
COMMERCIAL AIRCRAFT AIRFRAME FUEL SYSTEMS SURVEY AND ANALYSIS. (U)
JUL 82 P 6 WEITZ DTFA03-80-C-0080

UNCLASSIFIED

DOT/FAA/CT-82/80

NL

2 of 2

4 of 100



END
DATE
FILMED
11 82
DTIC

SECTION 9 CONCLUSIONS

Based on the aircraft fuel systems studied and a review of the references in Section 10, the following conclusions concerning the use of AMK have been reached:

- Based on the fuel systems surveyed, the loss of the flammability protection of AMK during flight due to shear degradation from system components does not appear to be a major problem. Boost pumping is the primary source of such degradation, and previous studies (reference 1) indicate that this is not severe.
- The proper performance of some fuel system components with AMK will be of more concern than the loss of AMK flammability protection.
- The extensive use of ejector pumps in the aircraft fuel systems studied, and their previously established poor performance with undegraded AMK warrants further study.
- The coarse screen filters used in most of the aircraft fuel systems should not be a problem when AMK is used.
- The various fine micron size filters used in auxiliary power units and some aircraft fuel systems will require further study of AMK filterability under actual operating conditions.
- Auxiliary power unit testing with degraders will be required to insure that proper APU performance with AMK can be maintained.
- The solubility of and integration of water with AMK under actual fuel system operating conditions is of major interest in determining fuel system performance with AMK. Reference 11 indicates some problems in this area.
- Heat exchangers which transfer heat to static, or near static, AMK should not experience performance losses.
- Aircraft pressure refueling times will be increased when AMK is used.

**SECTION 10
REFERENCES**

1. Pardue, R. E., Aircraft Fuel System Simulator Tests With Antimisting Kerosene (Jet A Fuel With FM-9 Additive), Report No. FAA-RD-79-52, May 1979).
2. Mannheimer, R. J., Degradation and Characterization of Antimisting Kerosene, September 1980 Interim Report to FAA.
3. Fiorentino, A., De Saro, R., and Franz, T., An Assessment of the Use Of Antimisting Fuel in Turbofan Engines, United Technologies Corporation, NASA CR-165258, December 1980.
4. Aircraft Research and Technology for Antimisting Kerosene Conference, February 18-19, 1981, Conference Proceedings, June 1981.
5. Sarohia, V., and Landel, R. F., Influence of Antimisting Polymer in Aviation Fuel Break-up, Jet Propulsion Laboratories, Pasadena, Ca., AIAA/SAE/ASME 10th Joint Propulsion Conference, June 30 - July 2, 1980, Paper No. AIAA-80-1287.
6. Pasion, A. J., In-Flight Fuel Tank Temperature Survey Data, NASA CR-159569; May 1979.
7. Pasion, A. J., Thomas, I., Preliminary Analysis of Aircraft Fuel Systems With Broadened Specification Jet Fuels, NASA CR-135198, May 1976.
8. Smith, Maxwell, Aviation Fuels, G.T. Foulis & Co., 1970.
9. Mannheimer, R. J., Degradation and Characterization of Antimisting Kerosene. To be published.
10. Fleeter, R., et al, Antimisting Kerosene Atomization and Flammability. To be published.
11. Yavrouian, A. H., et al, Influence of Liquid Water and Water Vapor on Antimisting Kerosenes. To be published.
12. Watt, J., and Sarohia, V., Frictional Characteristics and Heat Transfer of Antimisting Fuel in Tubes. To be published.
13. Fiorentino, A., An Assessment of the Use of Antimisting Fuel in Turbofan Engines, Progress Reports from May 1971 to October 1981, NASA Contract NAS3-22045.
14. Peacock, A. T., Testing of Antimisting Kerosene, Technical Progress Reports from May 1981 to November 1981, Contract Number F33700-81-C-0057.

END

DATE
FILMED

11-82

DTIC