

AD-A113 657

ROYAL SIGNALS AND RADAR ESTABLISHMENT MALVERN (ENGLAND)
AN ATMOSPHERIC REFRACTIVE INDEX FLUCTUATION METER, (U)
JAN 82 M J DORE, G J ANSTEY

F/G 4/1

UNCLASSIFIED

RSRE-MEMO-3433

DRIC-BR-82844

NL

1-1
5000



END
DATE
FORMED
5 1982
DTIC

AD A113657

ROYAL SIGNALS AND RADAR ESTABLISHMENT

Memorandum 3433

Title: AN ATMOSPHERIC REFRACTIVE INDEX FLUCTUATION METER

Authors: M J Dore and G J Anstey

Date: January 1982

SUMMARY

A modulated GaAs LED has been used as an incoherent source for a non saturating atmospheric refractive index fluctuation meter. Measurement of C_n^2 in the range 10^{-12} to 10^{-16} ($m^{-2/3}$) can be made using optical ranges of order 50 to 200 metres.

Further development may allow use of shorter ranges or measurement of lower values of C_n^2 .

$C(n)(2)$

$C(n)(2)$

(Via to the 12th power to 1/10 to the 16th power)

File 2/3 p. 10. 11

DTIC
COPY
INSPECTED
2

Accession For	
NTIS GRA&I	<input checked="" type="checkbox"/>
DTIC TAB	<input type="checkbox"/>
Unannounced	<input type="checkbox"/>
Justification	
By	
Distribution/	
Availability Codes	
Dist	Avail and/or Special
A	

This memorandum is for advance information. It is not necessarily to be regarded as a final or official statement by Procurement Executive, Ministry of Defence

Copyright
C
Controller HMSO London

AN ATMOSPHERIC REFRACTIVE INDEX FLUCTUATION METER

by

M J Dore and G J Anstey

SUMMARY

A modulated GaAs LED has been used as an incoherent source for a non saturating atmospheric refractive index fluctuation meter. Measurement of C_n^2 in the range 10^{-12} to 10^{-16} ($m^{-2/3}$) can be made using optical ranges of order 50 to 200 metres. Further development may allow use of shorter ranges or measurement of lower values of C_n^2 .

1 THE REQUIREMENT

A means for measuring the atmospheric refractive index turbulence structure constant at various sites was needed. The equipment needed to be portable and to be easily set up and operated by relatively unskilled operators. If possible a local, rather than long range average measurement was required.

2 POSSIBLE SOLUTIONS

It was believed that measurement of the intensity fluctuations on a light beam after transmission through a short horizontal path would provide the best basis for the instrument. Many workers have carried out measurements on these fluctuations and the small signal fluctuation theory is fairly well established, (1)(2). Initially it was felt that the use of a beam transmitted to a suitable reflector and returned to a receiver, located alongside the transmitter, would be convenient since power supplies would only be required at a single point. If a corner cube or cats eye type reflector was used the alignment of these is non critical.

Preliminary experiments showed that with a pulsed GaAs laser source of about 100mW mean power, the received power was adequate for turbulence measurements to be made over ranges of the order of 1 km. Apertures were of the order of 5 to 10 cms. However, some difficulties in interpreting the measured fluctuations became apparent. The corner cubes available were not accurate enough and more detailed measurement with a He:Ne laser showed that the reflected beam was being split into a number of separate although closely spaced beams. This gave rise to errors in the measured received signal and its fluctuations.

Use of cats eye type reflectors comprised of a lens with a mirror or diffuse reflector, at or near the focus, gave very clean reflected beams and easy alignment without any optical aid. Unfortunately however the cats eye reflectors were not

without problems. At close range the reflected beam, being close to diffraction limited angular width, was directed right back into the transmitter optics. Whilst this could be avoided by defocussing the cats eye, the resulting optical system did not lend itself to established analysis. At longer ranges, with the cats eye focussed for the narrowest return beam, it was clear that under conditions of heavy turbulence the returned beam was broken up to such an extent that the received fluctuations were as large as the mean signal. Under such conditions the usual approximations made in the theoretical treatment of signal fluctuation due to turbulence cannot be made.

A further non trivial problem with receiver and transmitter located close together is that of breakthrough of the high level transmitter signal into the sensitive detector circuitry. This can be especially difficult to avoid if pulsed GaAs laser sources are used.

On balance therefore it was considered that a one way optical path was much to be preferred. The lower energy loss over such a path suggested that it might be possible to dispense with laser sources and use GaAs LED's with a consequent simplification of source drive circuitry. Ochs et al (3) have described a single path optical device for measuring atmospheric turbulence which uses an incoherent source and large diameter optics. This was based on results published earlier (4) showing that such an arrangement should give a more accurate indication of high values of atmospheric refractive index fluctuations compared to meters based on coherent laser sources and small apertures. Their instrument used a continuously emitting tungsten lamp source. Two receivers were spaced apart in such a way that signal fluctuations due to daylight changes or vibration of the receivers' common mounting, were cancelled, but signal power fluctuations due to refractive index fluctuations were uncorrelated and could be summed. The use of an unmodulated source and daylight cancelling resulted in an instrument which

needed very careful initial setting up and frequent recalibration. These problems are greatly reduced by the use of a modulated source as described in this memorandum. A schematic diagram of the system is shown in Fig 1.

3 THEORY

According to Ochs et al (3)(4) the refractive index structure constant C_n^2 is given by

$$C_n^2 = 1.12 \left(\frac{V_f}{V_m} \right)^2 D^{7/3} L^{-3} \quad (1)$$

where V_f is the rms signal fluctuation due to refractive index fluctuations
 V_m is the mean signal
 D is the diameter of both transmitter and receiver lenses
 L is the optical path length

There are two conditions to be met for this equation to be valid (3).

Firstly to prevent saturation effects

$$D > \lambda^{-1/5} L^{8/5} (C_n^2)^{3/5} \quad (2)$$

Secondly to minimise the effect of small scale turbulence

$$D > 2\sqrt{\lambda L} \quad (3)$$

For $\lambda = 0.9$ microns, $L = 100$ m and $C_n^2 = 10^{-12}$ the first condition becomes $D > 1.6$ mm and the second becomes $D > 18$ mm. Both these are satisfied with the equipment to be described.

The range of C_n^2 usually lies between 10^{-12} and 10^{-16} ($m^{-2/3}$). Equation (1) shows that for $D = 0.1$ m and $L = 100$ m the expected range of V_f/V_m is 0.14 to 0.0014. The latter lower value of signal fluctuation, that is $0.0014V_m$, must be above

the receiver noise level. If the source has a radiance of W_s then the power received by the detector W_d is easily shown to be

$$W_d = \frac{W_s \pi^2 D^4 T}{16L^2} \quad (4)$$

where T is the overall lens transmission.

If as is convenient, a silicon photodiode detector is used with a responsivity of S amps/watt the mean signal from the photodiode will be

$$V_m = \frac{W_s \pi^2 D^4 S R T}{16L^2} \quad (5)$$

where R is the photodiode load resistor.

A typical high power GaAs lamp can have $W = 0.2$ watts/cm²/sr and a typical silicon photodiode may have $S = 0.5$ amps/watt. The transmission T of the overall optics (not optimum at 0.9 microns) was 0.5. For the purpose of indicating the order of magnitude of signal a representative value for R of 100 Kohms will be taken. Inserting the previously used values $D = 0.1$ m and $L = 100$ m we find

$$V_m = 0.3 \text{ volts}$$

It has been shown (5) that pulsed operation of the source improves the ratio of (signal) to (shot noise due to photodiode current arising from daylight) and the decision was made to pulse the lamp at a duty cycle of about 1:10 at a PRF of 10 kHz. This rate is more than adequate for fully sampling the turbulence signal fluctuations which extend from very low frequencies up to the order of 1 kHz, with decreasing energy at the higher frequencies (2)(6). Pulsing of the source also allows easy removal of signal fluctuations due to daylight variations by use of a high pass filter in the receiver. The use of a 1:10 duty cycle

allows a higher pulse current to be used to drive the GaAs source. In practice the received peak voltage was of order 1 V. For the lower level turbulence signal fluctuations, that is $V_f/V_m = 0.0014$ this means that other noise components in the receiver must be below 0.0014×1 , that is 1.4 mV rms when operating with lens apertures of 0.1 m at a range of 100 m.

4 DEMODULATION RIPPLE

The 10 μ s pulses at 10 kHz PRF are amplified and bandwidth limited for noise minimisation in the receiver electronics (Fig 3). The high pass filter is helpful in removing 1/f type noise from the silicon photodiode and from the operational amplifier used as a preamplifier. It also prevents the turbulence signal being regained by a simple smoothing of the pulses by an appropriate RC low pass filter. This is because the high pass filter restores the mean value of the signal to zero faster than the rate of change of turbulence fluctuations. However the turbulence signal is easily regained by use of a rectifier (as in conventional amplitude modulation detection) and running peak hold with a frequency response to about 300 Hz (7). A further low pass RC section (R30 and C12, 3 dB down at 300 Hz) reduces the rms ripple on the final turbulence signal to 0.0015 of the held peak value. This is marginally adequate for measurements down to $V_f/V_m = 0.0014$ and further filtering would be needed if such low values are to be investigated in detail.

5 OTHER NOISE SOURCES

5.1 Detector shot noise

Experiment showed that the current due to daylight produced by a 1 mm x 1 mm silicon photodiode could be as high as 5 μ A in midsummer. The shot noise associated with this current is ultimately limited to the 300 Hz bandwidth used for the turbulence fluctuations. Use of the usual shot noise current formula

$i_n = (2eIB)^{1/2}$ gives a noise output of 2.2 μV referred back to the 100 Kohm photodiode load.

5.2 Johnson noise from the detector load resistance

Calculation in the usual way gives a value of 0.7 μV rms in a bandwidth of 300 Hz.

5.3 Preamplifier noise

The input noise current of the LF351 preamplifier is given as 0.01 $\text{pA}/\text{Hz}^{1/2}$. This gives 0.02 μV noise in 300 Hz bandwidth referred to the preamplifier output. The input noise voltage is 16 $\text{nV}/\text{Hz}^{1/2}$ giving 0.3 μV noise referred to the preamplifier output.

It is clear that electronic noise sources do not limit the performance of the present equipment when used at full 0.1 m lens diameter at 100 m range. There is, in fact, a factor of order 600 in hand even for the lowest turbulence considered here that is $C_n^2 = 10^{-16} (\text{m}^{-2/3})$.

6 CIRCUIT DESCRIPTION

6.1 The source (Fig 2)

Pulses 10 $\mu\text{seconds}$ long repeated every 100 $\mu\text{seconds}$ are generated by a 555 Timer operating in an astable mode. These are amplified to produce 3 A current pulses which drive a high power light emitting diode (Plessey GAL 11 or 12) located at the focal point of a 203 mm focal length, f2 lens.

6.2 The receiver (Fig 3)

The pulses were detected by a high speed silicon photodiode positioned at the focal point of a lens identical to that used in the source equipment. IC(1) formed a virtual earth current preamplifier. High frequency noise was limited by a low pass filter with a rise time of approximately 2 $\mu\text{seconds}$.

The filtered pulses were then buffered and amplified by a factor of ten IC(2). Low frequency, including $1/f$, noise from the photodiode and preamplifier was restricted by a high pass filter. The turbulence induced fluctuations were detected by half wave rectifying and then running peak (envelope) holding. To reduce the pulse-pulse 20% droop across the holding capacitor C_V to 0.15% additional low pass filtering was used (R30, C12 - 3 dB at 300 Hz).

The average peak signal was obtained by using a 10 second time constant low pass filter (C14 R32). This was buffered and used as the denominator of the analogue divider type AD535 (Z input).

The turbulence signal was extracted by a high pass filter (-3 dB at 0.15 Hz) which blocked the dc component of the signal. This was also buffered (IC8) before being used as the numerator in the analogue divider.

The output from the divider was fed into the rms to dc converter AD536. The operations were done in this order to enable use of both the linear and the logarithmic outputs from the true rms to dc converter IC. The linear output is $10 \times V_f/V_m$ volts. The logarithmic output was amplified to give 50 μ V/dB. 0 dB can be set by R_{V4} .

A green LED and IC's 10 and 11 formed a signal window indicator. The LED will illuminate when the variable gain amplifier is set to give a mean signal of between 3 and 7 volts. This ensures that divider and rms to dc converter drifts and residual errors are negligible.

6.3 Calibration circuit (Fig 4)

To check the accuracy of the detector circuitry a calibration source was also built. 10 μ s pulses at a PRF of 10 kHz were generated by one half of a 556 Timer. The other half of the 556 also operated in an astable mode but at 80 Hz. This oscillator was used to modulate the 10 kHz carrier at known modulation depths, simulating the fluctuations due to atmospheric turbulence.

Modulation depths (rms modulation/mean peak carrier) of 0.5% and 5% were made available by switching between two appropriate resistors in the potential divider coupling the modulation to the carrier (R10 and R11). The modulated pulses drive a high brightness LED. This LED was held, when needed, at the centre of the receiver lens by a suitable concentric coupling arrangement.

The calibration circuit was used in the following way. The coupling plate is pushed onto the front of the detecting lens and the calibration circuit switched on. Having selected the required modulation depth and adjusted the detector gain, the meter, or chart recorder, can be calibrated.

7 FUTURE POSSIBILITIES

7.1 Use of very short path lengths

Inspection of Equations (1) and (5) shows that V_f the absolute value of the signal fluctuation due to refractive index turbulence is proportional to $D^{17/6} L^{-1/2}$. Shorter range operation therefore produces a larger absolute turbulence signal. This relation will only hold when the receiver is in the far field of the transmitter where the intensity obeys the usual $1/L^2$ law. The lower limit with the components used here is about 20 metres.

7.2 Smaller size and lower power consumption

The PRF used here can probably be reduced to perhaps 1 kHz which in principle allows a higher peak output from the GaAs lamp, or the same peak value could be maintained with consequent reduction in power supply requirements. It is likely that further study of the system will show that more compact optics for the transmitters and receivers can be used, especially as there is ample signal/noise ratio in hand (see section 5).

8 CONCLUSION

Pulsed GaAs lamp sources and silicon detectors can be used with modest optical systems to construct meters for measuring atmospheric refractive index fluctuations in the range $C_n^2 = 10^{-12}$ to 10^{-16} ($m^{-2/3}$). Time has not permitted a quantitative validation of the calibration equation (1) given by Ochs et al (3). However, initial trials show the expected strong dependence of turbulence on solar irradiation and give results of the expected order of magnitude and qualitative dependence on L and D.

ACKNOWLEDGEMENTS

The authors would like to express their thanks to Dr G Parry for valuable discussions on refractive index fluctuations and to Mr S Hopwood for his capable assistance with construction and trials.

REFERENCES

- (1) J W Strohbehn, Line of sight propagation through the turbulent atmosphere, a review. Proc IEEE Vol 56 No 8, Aug 1968 pp 1301-1318.
- (2) A S Clark, Atmospheric Scintillation Parts I, II and III. RARDE Technical Report 7/77, August 1977.
- (3) G R Ochs et al, An optical device for measuring refractive index fluctuations in the atmosphere. NOAA Tech Memo ERL WPL-30 Oct 77.
- (4) G R Ochs et al, A saturation resistant optical scintillometer to measure C_n^2 . JOSA March 1978 pp 334-338.
- (5) M J Dore, Short range optical communication using GaAs lamps: advantages of pulse modulation. SRDE (now RSRE) Tech Memo QP300, Sept 1964.
- (6) D H Hohn, Effects of atmospheric turbulence on the transmission of a laser beam at 0.6328 microns II - Frequency spectra. Applied Optics Sept 1966 pp 1433-1436.
- (7) H S Black, Modulation theory. Van Nostrand Reinhold 1953. Ch 16 on pulse amplitude modulation.

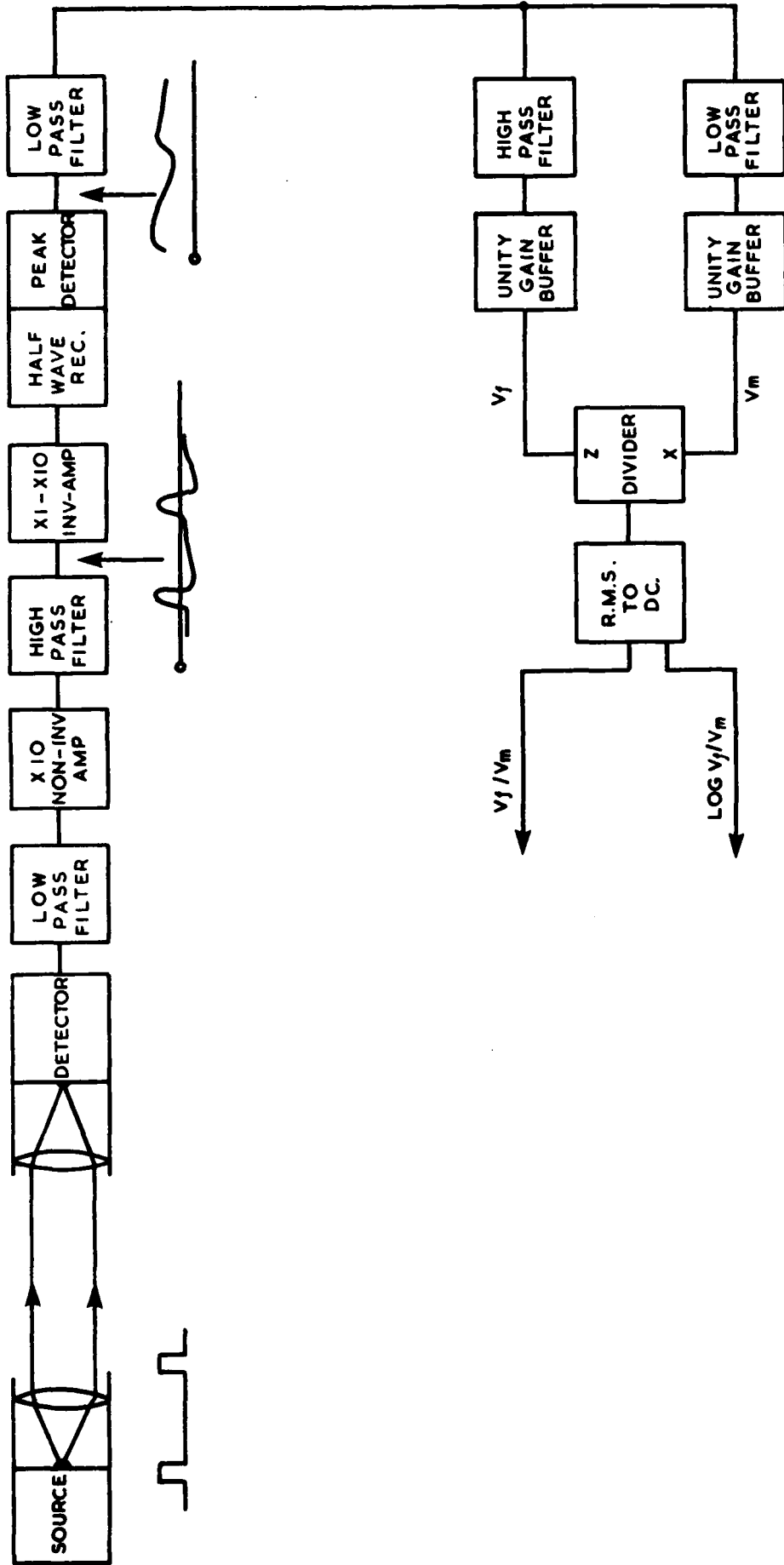

FIG. 1 SCHEMATIC DIAGRAM OF SYSTEM

R1	=	10KΩ		C1	=	50 μf
R2	=	1 KΩ		C2	=	0.1 μf
R3	=	1 KΩ		C3	=	68 μf
R4	=	47Ω		D1	=	2.7 V ZENER
R5	=	220Ω		D2	=	GAL IO
R6	=	39Ω		D3	=	1N4149
R7	=	1Ω				
R8	=	1Ω				
TR1	=	BCY70				
TR2	=	KS6220/17735				
IC1	=	555 TIMER				

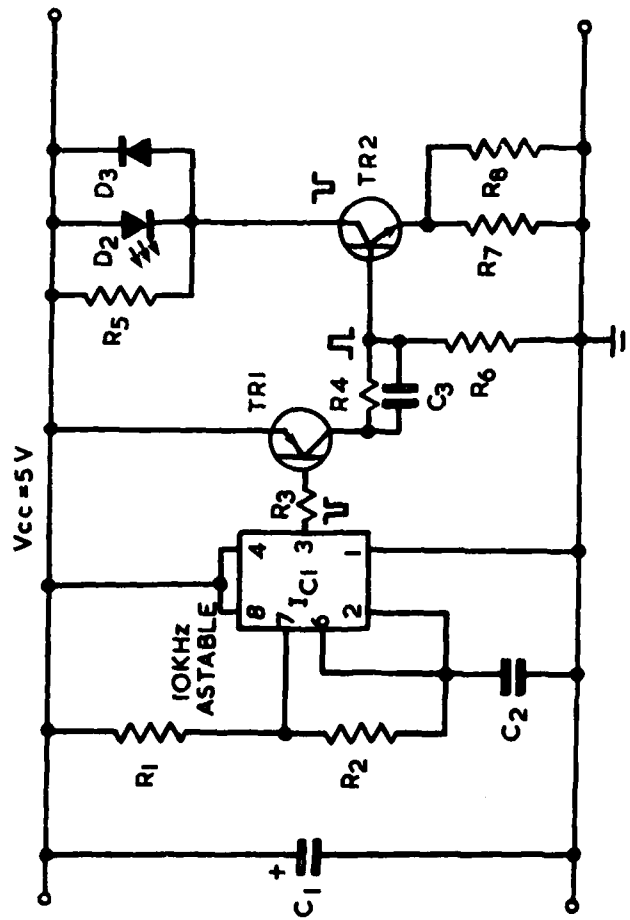
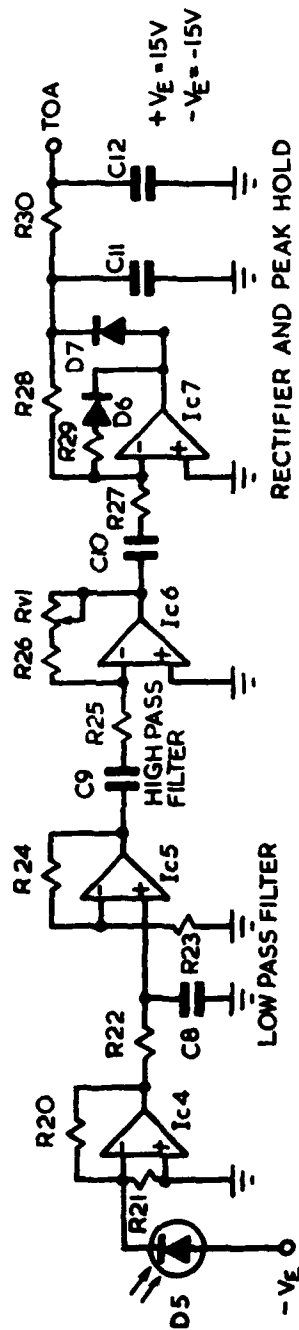
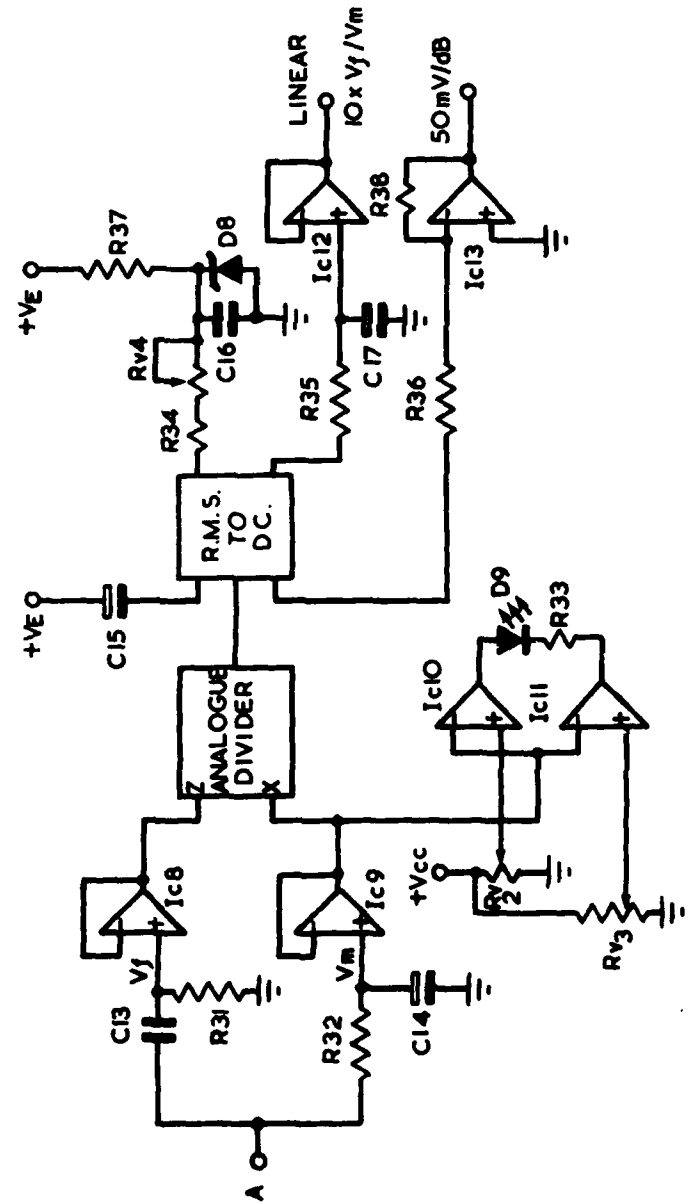

FIG. 2 CIRCUIT DIAGRAM OF SOURCE



- R20 = 100KΩ
- R21 = 100KΩ
- R22 = 5KΩ
- R23 = 1KΩ
- R24 = 9KΩ
- R25 = 1KΩ
- R26 = 1KΩ
- R27 = 47KΩ
- R28 = 47KΩ
- R29 = 47KΩ
- R30 = 100KΩ
- R31 = 1MΩ
- R32 = 1MΩ
- R33 = 2.4KΩ
- R34 = 2.5KΩ
- R35 = 1MΩ
- R36 = 6KΩ
- R37 = 5.8KΩ
- R38 = 100KΩ



- C8 = 100pf
- C9 = 22nf
- C10 = 220nf
- C11 = 10nf
- C12 = 4.7nf
- C13 = 1μf
- C14 = 10μf
- C15 = 10μf
- C16 = 100μf
- C17 = 100μf
- Rv1 = 10KΩ
- Rv2 = 10KΩ
- Rv3 = 10KΩ
- Rv4 = 500KΩ
- D5 = GAL12
- D6 = IN4149
- D7 = IN4149
- D8 = 1.22V LOW BANDGAP REF.
- D9 = MINIATURE LED
- Ic4 to Ic13 = J-FET OP-AMP 351

FIG. 3 CIRCUIT DIAGRAM OF RECEIVER

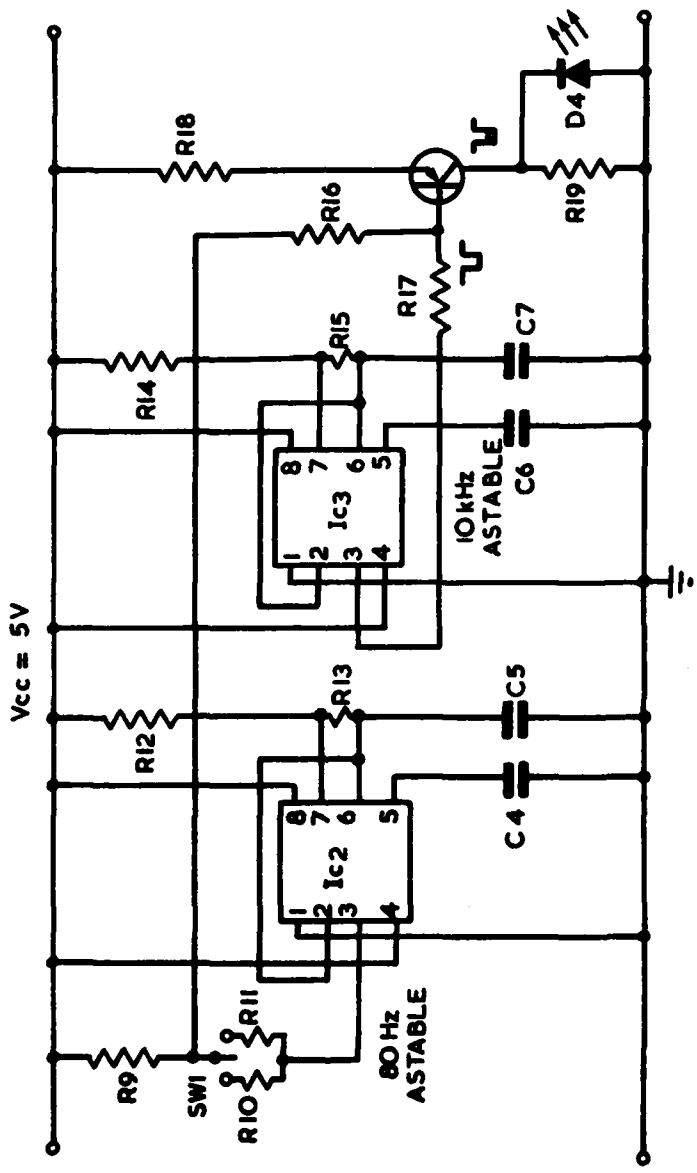

- | | |
|-------------------------------|------------|
| R9 = 100Ω | R14 = 10KΩ |
| R10 = 3K | R15 = 1KΩ |
| R11 = 33K | R16 = 2KΩ |
| R12 = 51KΩ | R17 = 3KΩ |
| R13 = 62KΩ | R18 = 100Ω |
| | R19 = 2KΩ |
| C4 = 10Nf | C6 = 10Nf |
| C5 = 150Nf | C7 = 0.1μf |
| D4 = GAL 3 | |
| SW1 = TURBULENCE RANGE SWITCH | |
| | O.5 to 5% |

FIG.4 DIAGRAM OF CALIBRATION CIRCUIT

LATE
LME
88