

AD-A110 945

FOREIGN TECHNOLOGY DIV WRIGHT-PATTERSON AFB OH
DEVICE FOR THE SELF-TUNING OF SERVO-SYSTEM CIRCUITS, (U)
JAN 82 B V NOVOSLOV, G A BALABOLOV
FTO-ID(RS)T-1519-81

F/6 9/5

UNCLASSIFIED

NL

1 of 1
20
200945



END
DATE
FILMED
3 82
DTIC

2
70

FTD-ID(RS)T-1519-81

AD A110945

FOREIGN TECHNOLOGY DIVISION

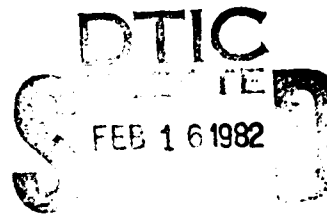

DEVICE FOR THE SELF-TUNING OF SERVO-SYSTEM CIRCUITS

by

B.V. Novoselov, G.A. Balabolov and A.A. Kobzev



Approved for public release;
distribution unlimited.

DTIC FILE COPY

70



82 02 16 053

EDITED TRANSLATION

FTD-ID(RS)T-1519-81

29 January 1982

MICROFICHE NR: FTD-82-C-000116

DEVICE FOR THE SELF-TUNING OF SERVO-SYSTEM CIRCUITS

By: B.V. Novoslov, G.A. Balabolov and A.A. Kobzev

English pages: 6

Source: USSR Patent Nr. 283352, 14 Nov 1970, pp. 1-4

Country of origin: USSR

Translated by: Roger T. Crozier

Requester: USAMICOM

Approved for public release; distribution unlimited.

Accession For	
NTIS CRA&I	<input checked="" type="checkbox"/>
DTIC TAB	<input type="checkbox"/>
Unannounced	<input type="checkbox"/>
Justification	
By _____	
Dist _____	
App _____ (date)	
Dist _____	
A	



<p>THIS TRANSLATION IS A RENDITION OF THE ORIGINAL FOREIGN TEXT WITHOUT ANY ANALYTICAL OR EDITORIAL COMMENT. STATEMENTS OR THEORIES ADVOCATED OR IMPLIED ARE THOSE OF THE SOURCE AND DO NOT NECESSARILY REFLECT THE POSITION OR OPINION OF THE FOREIGN TECHNOLOGY DIVISION.</p>	<p>PREPARED BY: TRANSLATION DIVISION FOREIGN TECHNOLOGY DIVISION WP.AFB, OHIO.</p>
---	--

U. S. BOARD ON GEOGRAPHIC NAMES TRANSLITERATION SYSTEM

Block	Italic	Transliteration	Block	Italic	Transliteration
А а	<i>А а</i>	A, a	Р р	<i>Р р</i>	R, r
Б б	<i>Б б</i>	B, b	С с	<i>С с</i>	S, s
В в	<i>В в</i>	V, v	Т т	<i>Т т</i>	T, t
Г г	<i>Г г</i>	G, g	У у	<i>У у</i>	U, u
Д д	<i>Д д</i>	D, d	Ф ф	<i>Ф ф</i>	F, f
Е е	<i>Е е</i>	Ye, ye; E, e*	Х х	<i>Х х</i>	Kh, kh
Ж ж	<i>Ж ж</i>	Zh, zh	Ц ц	<i>Ц ц</i>	Ts, ts
З з	<i>З з</i>	Z, z	Ч ч	<i>Ч ч</i>	Ch, ch
И и	<i>И и</i>	I, i	Ш ш	<i>Ш ш</i>	Sh, sh
Й й	<i>Й й</i>	I, y	Щ щ	<i>Щ щ</i>	Shch, shch
К к	<i>К к</i>	K, k	Ъ ъ	<i>Ъ ъ</i>	"
Л л	<i>Л л</i>	L, l	Ы ы	<i>Ы ы</i>	Y, y
М м	<i>М м</i>	M, m	Ь ь	<i>Ь ь</i>	"
Н н	<i>Н н</i>	N, n	Э э	<i>Э э</i>	E, e
О о	<i>О о</i>	O, o	Ю ю	<i>Ю ю</i>	Yu, yu
П п	<i>П п</i>	P, p	Я я	<i>Я я</i>	Ya, ya

*ye initially, after vowels, and after s, z, e elsewhere.
When written as ë in Russian, transliterate as yë or ë.

RUSSIAN AND ENGLISH TRIGONOMETRIC FUNCTIONS

Russian	English	Russian	English	Russian	English
sin	sin	sh	sinh	arc sh	sinh ⁻¹
cos	cos	ch	cosh	arc ch	cosh ⁻¹
tg	tan	th	tanh	arc th	tanh ⁻¹
ctg	cot	cth	coth	arc cth	coth ⁻¹
sec	sec	sch	sech	arc sch	sech ⁻¹
cosec	csc	csch	csch	arc csch	csch ⁻¹

Russian English

rot curl
lg log

DEVICE FOR THE SELF-TUNING OF SERVO-SYSTEM CIRCUITS

B. V. Novoselov, G. A. Balabolov and A. A. Kobzev, inventors

This invention relates to computer and automatic equipment components and may be employed in automated systems for regulation and control.

Existing devices for the self-tuning of servo-system circuits incorporate high- and low-frequency filters, scalars and comparators (adders).

But automated regulation and control systems [sistemy avtomaticheskogo regulirovaniya i upravleniya] frequently require changes in certain parameters depending upon the relationship between the amplitude of the effective output signal and the frequency of the interference superimposed upon it.

Existing circuits cannot provide these changes.

The servo-system circuit self-tuning device proposed here is distinguished by the fact that it additionally incorporates a series-connected power amplifier and stepping relay, one output of which is connected to the input of the regulated circuit, the other hard-wired to one of the adder (comparator) inputs. Additionally connected between the low-frequency filter and one of the scalars is an amplitude measurement and storage circuit and between the high-frequency filter and the other scalar a frequency-measuring circuit. It also has a timing oscillator, the output of which is connected with one of the power-amplifier inputs.

The purpose of the invention is to determine the algebraic difference between the amplitude of the effective low-frequency harmonic signal in a preceding half-period with both constant and variable amplitude and frequency and the frequency of the high-frequency harmonic interference superimposed upon it and modify in this function one parameter or another of the device correcting the system.

This purpose is accomplished by identification of the amplitude of the effective signal, determination of the frequency of the interference, comparison of these signals on the adder and then activation of the control device, which then varies its output value in proportion to the signal from the adder output.

The device proposed here helps correct a regulation and control system and, accordingly, substantially improves the quality of regulation with an input signal with interference.

Figure 1 is a block diagram of the device; Figures 2 and 3 are schematic diagrams of its circuitry.

The input of the low-frequency filter 1 and that of the high-frequency filter 2 are connected with both one another and the output of the device. The output of the low-frequency filter 1 is connected to the input of the amplitude measuring and storage circuit 3, the output of the high-frequency filter 2 with the frequency-measuring circuit 4. The output of the amplitude measuring and storage circuit 3 is connected to scaler 5, the output of frequency-measuring circuit 4 with scaler 6. Scalers 5 and 6 are connected with adder 7, the output of which is connected to relay amplifier 8. The output of amplifier 8 is connected to power amplifier 9, which is connected with the timing oscillator 10. The output of power amplifier 9 is connected to stepping relay 11. The sliding and nonsliding contacts of stepping relay 11 are connected to regulated circuit 12. Between stepping relay 11 and adder 7 there is follow-up direct feedback.

Low-frequency filter 1 is built around capacitor C1. Amplitude measuring and storage circuit 3 incorporates transistors T1 and T2; resistors R1, R2, R3, Rs, R9, R12, R14, R15, R17 and R21; capacitors C2-C5; diodes D1-D4 and relays P1-P5. High-frequency filter 2 is built around transformer Tr1; resistors R26 and R28 and capacitors C6 and C7.

Frequency-measuring circuit 4 incorporates transistors T3, T4 and T7; resistors R30-R32, R34-R37, R40 and R41, capacitors C10 and C11 and relay P7.

Adder 7 is built around tube L1, resistors R4-R6, R10, R11, R13, R16, R18-R20 and R22-R25 and relay amplifier 8, which consists of relay P6 and sliding contact 3Sh1 of stepping relay 11.

Timing oscillator 10 is built around transistors T5 and T6, resistors R27, R29 and R33; capacitors C8 and C9 and relay P8.

Power amplifier 9 consists of transistors T8 and T9, resistors R38, R39 and R42; diodes D5 and D6; stepping relay windings 1Sh1 and 2Sh1 and contacts 1P8 and 1P6.

Variable resistor R12 is scaler 5, variable resistor R36 scaler 6. The device functions as follows.

With the presence of an effective low-frequency input signal and high-frequency harmonic interference superimposed upon it, the low-frequency filter 1 will have an output voltage proportional to the amplitude and frequency of the signal, the high-frequency filter 2 an output voltage proportional to the amplitude and frequency of the interference. From the output of low-frequency filter 1 voltage is supplied to the circuit 3 measuring and storing the amplitude of the effective signal, at the output of which (grid of the left-hand half of tube L1) there occurs a signal proportional to the amplitude of the harmonic signal with both constant and variable parameters over the preceding half-period. The circuit 4 measuring interference frequency (capacitor C11) generates an output signal inversely proportional to interference frequency.

The output signals from the amplitude measuring and storage 3 and frequency-measuring 4 circuits are fed to adder 7 (grid of tube L1). A signal is generated at the adder 7 output proportional to the algebraic difference between the amplitude of the effective signal over the preceding half-period and the frequency of the interference. This actuates relay P6 and closes its neutral contact to the left or right depending upon whether the current is passing through winding 1Sh1 or 2Sh1 of stepping relay 11.

Sliding contact 3Sh1 of relay 11 moves to side or the other at the operating frequency of timing oscillator 10, which is introduced

to insure the precise functioning of stepping relay 11. As it moves, the sliding contact varies the parameters of the regulated circuit depending upon the relationship between signal amplitude and interference frequency. The angle of rotation of sliding contact 3Sh1 of stepping relay 11 is regulated by the setting of scalers 5 and 6 (resistors R12 and R36).

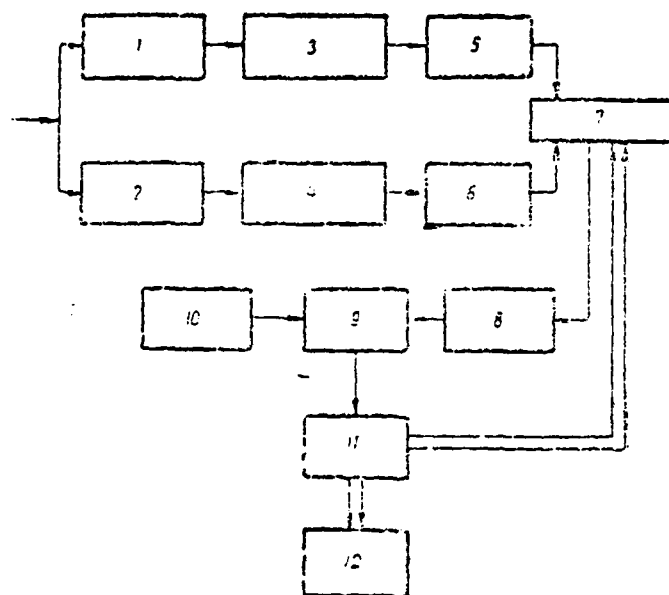

Figure 1

By rotating through a certain angle with a given ratio between effective signal and the interference, the sliding contact 3Sh1 varying the parameters of the regulated circuit varies the resistance in the anode circuit of the right half of tube L1 such that the currents in both halves of the tube are equal and, accordingly, that the current in the winding of relay P6 is

equal to zero. Relay P6 with contacts 1P6 switches off power amplifier 9. The working winding of stepping relay 11, through which up to this point current has been flowing, is now de-energized and sliding contact 3Sh1 stops moving. When the ratio between signal and interference parameters changes, the sliding contact again moves by a certain angle to one side or the other depending upon the signal/interference ratio as well as upon the setting of scalers 5 and 6.

If there is no interference in the signal, there will be no voltage at the output of the frequency-measuring circuit. A signal is generated at the output of the adder proportional to signal amplitude in the preceding half-period, and the sliding contact of the stepping relay rotates through an angle proportional to this value.

Patent claim: a device permitting the self-tuning of servo-system circuits incorporating high- and low-frequency filters, scalers and

comparator distinguished by the fact that with a view to expanding its functional capabilities it additionally incorporates a series-connected power amplifier and stepping relay, one of the outputs of which is connected to the input of the regulated circuit, the other hard-wired to one of the inputs of the comparator, the output of which is connected via an auxiliary relay amplifier with one of the inputs of the power amplifier, the second input of which is connected to the output of an additionally incorporated timing oscillator, between the low-frequency filter and one of the scalers there being added an amplitude measuring and storage circuit, between the high-frequency filter and the other scaler a frequency-measuring circuit.

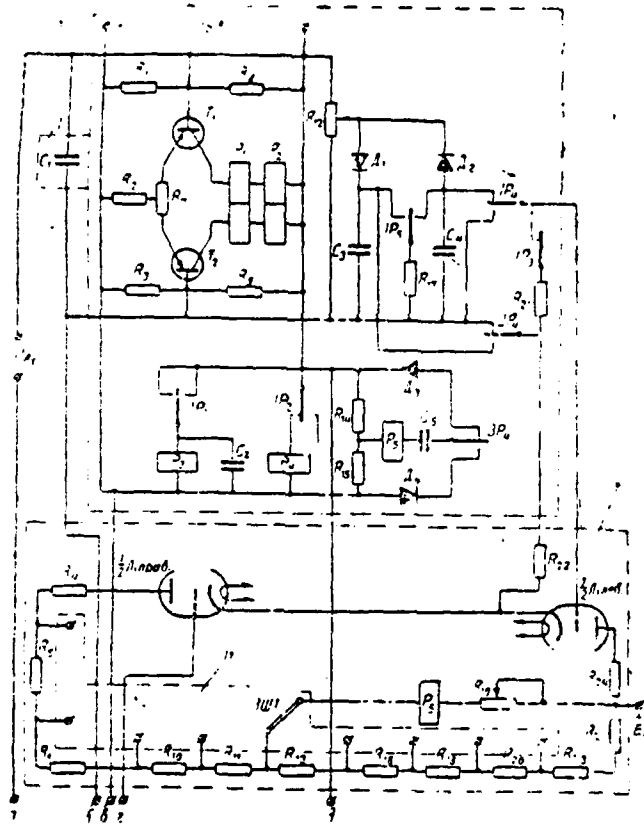

Figure 2

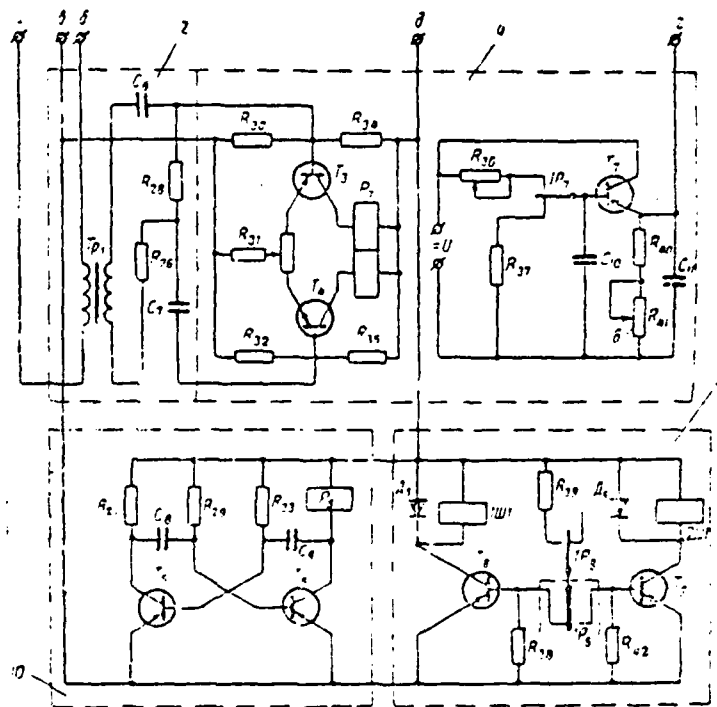

Figure 3

ED
88