

AD-~~X~~110 410

NAVAL FACILITIES ENGINEERING COMMAND ALEXANDRIA VA  
HEATING, VENTILATING, AIR CONDITIONING AND DEHUMIDIFYING SYSTEM—ETC(U)  
AUG 80

F/G 13/1

UNCLASSIFIED

NAVFAC-DM-3.3

NL

143  
AD 810

785

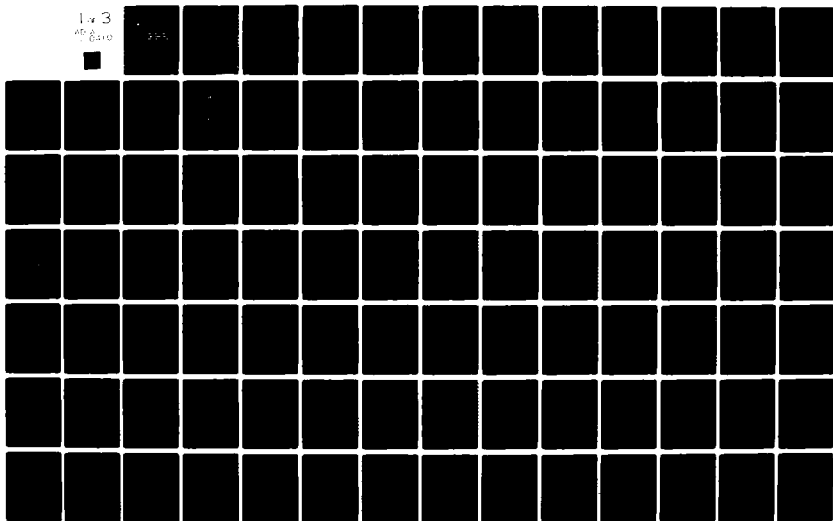

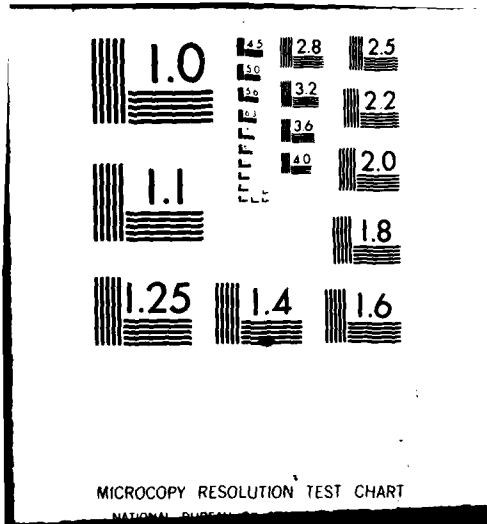

MICROCOPY RESOLUTION TEST CHART

NATIONAL BUREAU OF STANDARDS-1963-A

**LEVEL II**

*(Handwritten circle)*

**NAVFAC-DM-3.3  
AUGUST 1980**

**APPROVED FOR PUBLIC RELEASE**

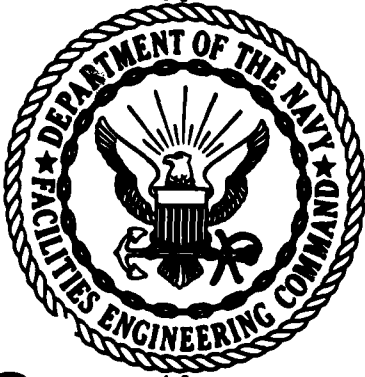

**AD A110410**

**DTIC  
SELECTED  
FEB 3 1982**  
*(Large handwritten 'D' and 'H')*

**HEATING, VENTILATING,  
AIR CONDITIONING AND  
DEHUMIDIFYING SYSTEMS**

**DESIGN MANUAL 3.3**

**DISTRIBUTION STATEMENT A**  
Approved for public release;  
Distribution Unlimited

**50MG PER COPY**

**DEPARTMENT OF THE NAVY  
NAVAL FACILITIES ENGINEERING COMMAND**

**200 STOVALL STREET  
ALEXANDRIA, VA. 22332**

*3571*  
**82 02 01 037**

DISTRIBUTION: (1 copy each unless otherwise specified)

SNDL		FF19	(Brooklyn, New Orleans, and Seattle only)	FR4	
23A1	(COMNAVFORAZORES only)	FF38		FT1	
24J1		FG2	(Balboa, Harold Holt, Nea Makri, Thurso, Stockton, and Ponce only)	FT2	
27C		FG3	(Cheltenham and East Machias only)	FT6	
39B		FG6	(Wahiawa and Norfolk only)	FT13	
39C1		FH3	(Beaufort only)	FT18	
39E		FH6	(Bethesda only)	FT19	(San Diego only)
42A3		FH8	(Cairo only)	FT22	
45B		FR25	(Philadelphia, Portsmouth VA, Camp Lajeune, Oakland, Newport, Great Lakes, and Long Beach only)	FT27	(Idaho Falls only)
49		FJ5		FT28	
51A		FKA6A1		FT31	
51B1		FKA6A2		FT37	
51B3		FKA6A3A		FT55	
B1	(SECDEF only)	FKA6A3B		FT64	
B2A	(JCS, NSA, DLA, and DNA only)	FKA6A9		FT73	
B5	(USCG only)	FKA6A12		FT74A	(MIT and Texas only)
C34	(Holy Loch, Souda Bay only)	FKA6A15	(Code 521)	FT74B	(California, Illinois, Rensselaer, Georgia Tech only)
C37D	(Port Hueneme only)	FKA6A16		FT78	
E3A		FKA9		V2	
FA6	(Bermuda, Brunswick, Cecil Field, Key West, Jacksonville, Virginia Beach only)	FKM8		V3	
FA7	(Guantanamo, Keflavik, Panama Canal, Mayport, Roosevelt Roads only)	FKM9		V5	
FA10		FKM12		V8	
FA18		FKM13		V12	
FA23	(Antigua, Brawdy, Buxton, Lewes only)	FKM15	(Philadelphia only)	V14	
FA25	(10 copies)	FKN1	(West and Lant only (85 copies each))	V15	
FA32		FKN1	(South and North only (50 copies each))	V16	(less Camp Smith)
FB6		FKN1	(Pac and Ches only (25 copies each))	V17	
FB7	(Alameda, Fallon, Lemore, Oak Harbor, Miramar, North Island, Moffet Field only)	FKN1	(Ches, FPO-1 only)	V23	
FB10		FKN2		V25	
FB21		FKN3	(6 copies each)	Copy to:	(one copy each unless otherwise indicated)
FB31	(Guam only)	FKN5		21A	
FB33		FKN8		A2A	(ONR only)
FB34	(Kadena only)	FKN10		A3	
FB36	(Big Sur, Coos Head, Ferndale, and Pacific Beach only)	FKP1B	(less Concord)	A4A	
FB41		FKP1B	(Concord only - 3 copies)	A5	
FB48		FKP1E		A6	(Code LFF)
FC3	(London only)	FKP1J		C7	(Brazil and Chile only)
FC4	(Sigonella only)	FKP1M		FD1	
FC5		FKP3A		FE1	
FC7		FKP7		FG1	
FC12		FKP8		FRA1A	
FD2		FKP11		FRA1B	(2 copies)
FE2		FRQ3		FRA1C	(Code 043 - 50 copies)
FE4	(Adak, Edsell, Hansa, Galeta Island, Homestead, Winter Harbor, Sabana Seca, and Sonoma only)	FKR1A		FRA1F	
FF1		FKR1B	(2 copies)	FRN2	(Port Hueneme (Code 156) only)
FF5	(Washington only)	FKR2A	(Dallas only)	FRI	
FF6		FKR3A		Additional copies are available from:	
		FKR3C		Commanding Officer	
		FKR3H		Naval Publications and	
		FKR4B		Forms Center	
		FKR5		5801 Tabor Avenue	
		FKR7E	(3 copies)	Philadelphia, PA 19120	
		FR3			

Unclassified

SECURITY CLASSIFICATION OF THIS PAGE (When Data Entered)

REPORT DOCUMENTATION PAGE		READ INSTRUCTIONS BEFORE COMPLETING FORM
1. REPORT NUMBER	2. GOVT ACCESSION NO.	3. RECIPIENT'S CATALOG NUMBER
	AD-A110 918	
4. TITLE (and Subtitle) NAVFAC Design Manual DM-3.3 Heating, Ventilating, Air Conditioning and Dehumidifying Systems		5. TYPE OF REPORT & PERIOD COVERED Design Criteria Final
		6. PERFORMING ORG. REPORT NUMBER DM-3.3
7. AUTHOR(s) Naval Facilities Engineering Command 200 Stovall Street Alexandria, VA 22332 (Code 0441)		8. CONTRACT OR GRANT NUMBER(s)
9. PERFORMING ORGANIZATION NAME AND ADDRESS Naval Facilities Engineering Command 200 Stovall Street Alexandria, VA 22332		10. PROGRAM ELEMENT, PROJECT, TASK AREA & WORK UNIT NUMBERS Engineering and Design
11. CONTROLLING OFFICE NAME AND ADDRESS Naval Facilities Engineering Command (Code: 0432) 200 Stovall Street Alexandria, VA 22332		12. REPORT DATE May 1980
		13. NUMBER OF PAGES 219
14. MONITORING AGENCY NAME & ADDRESS (if different from Controlling Office)		15. SECURITY CLASS. (of this report) Unclassified
		15a. DECLASSIFICATION/DOWNGRADING SCHEDULE
16. DISTRIBUTION STATEMENT (of this Report) Unclassified/Unlimited		
17. DISTRIBUTION STATEMENT (of the abstract entered in Block 20, if different from Report) Unclassified/Unlimited		
18. SUPPLEMENTARY NOTES		
19. KEY WORDS (Continue on reverse side if necessary and identify by block number) Air conditioning; calculation procedures; dehumidification; energy conservation considerations; heating; ventilating.		
20. ABSTRACT (Continue on reverse side if necessary and identify by block number) Basic guidelines for the design of heating, ventilating, air conditioning, and dehumidifying systems for Naval Shore Facilities are presented. The con- tents include administrative policy, engineering design criteria, calculation procedures, basic system descriptions, system and equipment selection criteria, control system criteria, and energy conservation considerations.		

## RECORD OF CHANGES

Change No.	Date of Change	Date entered	Signature of person entering Change

**ABSTRACT**

Basic guidelines for the design of heating, ventilating, air conditioning and dehumidifying systems for Naval Shore Facilities are presented. The contents include administrative policy, engineering design criteria, calculation procedures, basic system descriptions, system and equipment selection criteria, control system criteria, and energy conservation considerations.

DTIC  
COPY  
INSPECTED  
7

Accession For	
NTIS GRA&I	<input checked="" type="checkbox"/>
DTIC TAB	<input type="checkbox"/>
Unannounced	<input type="checkbox"/>
Justification	
By	
Distribution/	
Availability Codes	
Dist	Avail and/or Special
A	

## FOREWORD

This design manual is one of a series developed from an evaluation of facilities in the shore establishment, from surveys of the availability of new materials and construction methods, and from selection of the best design practices of the Naval Facilities Engineering Command, other Government agencies, and the private sector. This manual uses, to the maximum extent feasible, national professional society, association, and institute standards in accordance with NAVFACENGCOM policy. Deviations from these criteria should not be made without prior approval of NAVFACENGCOM Headquarters (Code 04).

Design cannot remain static any more than can the naval functions it serves or the technologies it uses. Accordingly, recommendations for improvement are encouraged from within the Navy and from the private sector and should be furnished to NAVFACENGCOM Headquarters (Code 04). As the design manuals are revised, they are being restructured. A chapter or a combination of chapters will be issued as a separate design manual for ready reference to specific criteria.

This publication is certified as an official publication of the Naval Facilities Engineering Command and has been reviewed and approved in accordance with SECNAVINST 5600.16.

D. G. ISELIN  
Rear Admiral, CEC, U. S. Navy  
Commander  
Naval Facilities Engineering Command



**MECHANICAL ENGINEERING DESIGN MANUALS**

<u>DM Number</u>	<u>Superseded Chapters in Basic DM-3</u>	<u>Title</u>
3.1	1	Plumbing Systems
3.2	2 & 2A	Industrial and Municipal Type Incinerators
3.3	3, 4 & 5	Heating, Ventilating, Air Conditioning and Dehumidifying Systems
3.4	6	Refrigeration Systems for Cold Storage
3.5	7 & 10	Compressed and Vacuum Air Systems
3.6	8	Central Heating Plants
3.7	9	Power Plants
3.8	11	Exterior Distribution of Utility Steam, HTW, CHW, Gas and Compressed Air
3.9	13 & 14	Elevators, Escalators and Dumbwaiters, Pneumatic Tube Systems
3.10	15	Noise and Vibration Control of Mechanical Equipment
3.11	-	Solid Waste Handling
3.12	-	Central Building Automation Systems
3.13	-	Solar Space and Domestic Water Heating
3.14	-	Power Plant Acoustics
3.15	-	Air Pollution Control
3.16	-	Thermal Storage
3.17	-	Cogeneration of Steam and Electricity
3.18	-	Domestic Water Requirements for Medical and Dental Facilities

## CONTENTS

	<u>Page</u>
<b>Section 1. ADMINISTRATIVE POLICY AND ENGINEERING DESIGN CRITERIA.....</b>	<b>3.3-1</b>
A. Scope.....	3.3-1
B. Cancellation.....	3.3-1
C. Administrative Policy.....	3.3-1
D. Engineering Design Criteria.....	3.3-2
<b>Section 2. HEATING SYSTEMS.....</b>	<b>3.3-28</b>
A. Heating Systems Description.....	3.3-28
B. System Selection Criteria.....	3.3-39
C. Equipment Selection Criteria.....	3.3-41
D. System Controls.....	3.3-56
<b>Section 3. VENTILATING SYSTEMS.....</b>	<b>3.3-64</b>
A. Ventilating Systems Description.....	3.3-64
B. System Selection Criteria.....	3.3-66
C. Equipment Selection Criteria.....	3.3-75
D. System Controls.....	3.3-76
<b>Section 4. AIR CONDITIONING SYSTEMS.....</b>	<b>3.3-78</b>
A. Air Conditioning Systems Description.....	3.3-78
B. System Selection Criteria.....	3.3-94
C. Equipment Selection Criteria.....	3.3-102
D. System Controls.....	3.3-146
<b>Section 5. DEHUMIDIFYING SYSTEMS.....</b>	<b>3.3-152</b>
A. Dehumidifying Systems Description.....	3.3-152
B. System Selection Criteria.....	3.3-159
C. Equipment Selection Criteria.....	3.3-162
D. System Controls.....	3.3-165
<b>Section 6. ENERGY CONSERVATION METHODOLOGY.....</b>	<b>3.3-167</b>
A. Policy.....	3.3-167
B. Energy Management Conservation Analysis....	3.3-167
C. Energy Performance Standards.....	3.3-167
D. Energy Conservation Methods.....	3.3-168
<b>References.....</b>	<b>3.3-Reference-1</b>
<b>Glossary.....</b>	<b>3.3-Glossary-1</b>
<b>Appendix A.....</b>	<b>3.3-A-1</b>
<b>Appendix B.....</b>	<b>3.3-B-1</b>
<b>Index.....</b>	<b>3.3-Index-1</b>

## FIGURES

<u>Figure</u>	<u>Title</u>	<u>Page</u>
1	Heating, Ventilating and Air Conditioning System Terminology .....	3.3-6
2	Sample Heat Balance Diagram .....	3.3-17
3	Electrical Connection Data Sheet .....	3.3-24
4	Piping Methods .....	3.3-31
5	Hot Water Reset Schedule .....	3.3-59
6	Constant Volume System.....	3.3-80
7	Dual Duct System .....	3.3-82
8	Multizone Unit System .....	3.3-83
9	Variable Air Volume System .....	3.3-85
10	Perimeter Zone Air System .....	3.3-86
11	Cost Comparison of Chilled Water Plants .....	3.3-123
12	Single-Bed Dehumidification System .....	3.3-154
13	Dual-Bed Dehumidification System .....	3.3-155
14	Rotary-Bed Dehumidification System .....	3.3-156
15	Liquid Absorption Dehumidification System .....	3.3-158
16	Dehumidifier Locations for a Multiple-Compartment Warehouse .....	3.3-164
17	Dehumidifier Locations for a Single-Compartment Warehouse .....	3.3-164
18	Outdoor Air Usage and the Psychrometric Chart .....	3.3-169
19	External Source Heat Pump System .....	3.3-171
20	Exhaust Air Heat Recovery with Rotary Air Wheel .....	3.3-173
21	Exhaust Air Heat Recovery with Counterflow Pattern Static Heat Exchanger .....	3.3-174
22	Exhaust Air Heat Recovery with Crossflow Pattern Static Heat Exchanger .....	3.3-175
23	Exhaust Air Heat Recovery Method with Heat Pipe ....	3.3-177
24	Exhaust Air Heat Recovery Method with Run-Around Closed-Loop System .....	3.3-178
25	Exhaust Air Heat Recovery Method with Run Around Open-Loop System .....	3.3-179
26	Heat-of-Light Heat Recovery Method with Light Troffer .....	3.3-180
27	Heat-of-Light Heat Recovery Method with Induced Air.	3.3-181
28	Refrigeration Method Heat Recovery with Conventional Refrigeration Machine Using Hot Water Coil.....	3.3-183
29	Refrigeration Method Heat Recovery with Conventional Refrigeration Machine Using Refrigerant Coil.....	3.3-184
30	Refrigeration Method Heat Recovery with Internal Source Heat Pump .....	3.3-185
31	Refrigeration Method Heat Recovery with Single-Bundle Condenser Water Circuit Method and Evaporative Cooling System .....	3.3-186
32	Refrigeration Method Heat Recovery with Single-Bundle Condenser Water Circuit Method and Open Cooling Tower .....	3.3-187

(FIGURES, continued)

33	Refrigeration Method Heat Recovery with Double-Bundle Condenser Water Circuit Method .....	3.3-188
34	Deadband Thermostat Diagram .....	3.3-190
35	Occupied/Unoccupied Condition Hot Water Reset Schedule .....	3.3-190

TABLES

<u>Table</u>	<u>Title</u>	<u>Page</u>
1	Location Considerations Required for Design Calculations .....	3.3-7
2	Building Detail Considerations Required for Design Calculations .....	3.3-8
3	Information on Heat Producing Devices Required for Design Calculations .....	3.3-9
4	Information on Building Operation Required for Design Calculations .....	3.3-9
5	Air Conditioning Load Estimating Factors .....	3.3-14
6	List of Typical Actuating Devices .....	3.3-25
7	Typical Local and Remote Control Devices for Fans .	3.3-26
8	Typical Local and Remote Control Devices for Pumps	3.3-27
9	Information Required on Project Drawings for Steam Unit Heaters, Hot Water Unit Heaters, Electric Unit Heaters, and Furnaces and Space Heaters .....	3.3-44
10	Information Required on Project Drawings for Condensate Return Pumping and Vacuum Return Pumping .....	3.3-48
11	Recommended Air Conditioning Systems for Various Buildings .....	3.3-97
12	Heat Rejection Factors - Open Compressor (Condensing Temp. F) .....	3.3-100
13	Heat Rejection Factors - Hermetic or Semi- Hermetic Compressors (Condensing Temp. F) .....	3.3-101
14	Refrigeration Equipment Selection Factors .....	3.3-124
15	Recommended Pipe and Fitting Materials for Various Services .....	3.3-135
16	Typical Load Breakdown of a Dehumidified Warehouse .	3.3-161

## Section 1. ADMINISTRATIVE POLICY AND ENGINEERING DESIGN CRITERIA

### A. SCOPE.

This manual includes the administrative policy of the Naval Facilities Engineering Command (NAVFAC) and the engineering design criteria for heating, ventilating, air conditioning and dehumidifying systems. Energy conservation considerations and methodology are presented in relation to system design criteria.

Both general and specific system design criteria are presented. System selection and equipment selection criteria are presented for each system. These design and selection criteria are to be used in conjunction with the naval administrative policy and the energy conservation methodology presented in this manual.

### B. CANCELLATION.

The material presented in this manual cancels and supersedes Chapters 3, 4 and 5 of DM-3, Mechanical Engineering, of September 1974 and changes 1, 2, 3 and 4.

### C. ADMINISTRATIVE POLICY.

#### 1. Objective.

The administrative policy of the Naval Facilities Engineering Command is to adhere to the current applicable design standards which fulfill the functional requirements of the proposed facility while maintaining a minimal over-all cost. The policy emphasizes simplicity of design with appropriate consideration given to energy conservation, operating costs, maintenance requirements and the potential for expansion.

#### 2. Heating Systems.

Heating systems shall be capable of maintaining the indoor design temperature at design conditions. Heating systems and air conditioning systems shall be combined in locations where air conditioning is authorized.

#### 3. Ventilating Systems.

Ventilating systems shall be capable of supplying sufficient quantities of outdoor air to meet and maintain indoor design ventilation requirements. Where required, ventilation systems shall be capable of removing noxious odors, fumes, heat and particulate matter from the conditioned space in conformance to design requirements.

4. Air Conditioning Systems.

Air conditioning systems shall be capable of maintaining the indoor design temperatures. Heating systems and air conditioning systems shall be combined in locations where air conditioning is authorized.

5. Dehumidifying Systems.

Dehumidifying systems shall be capable of maintaining the indoor design interior relative humidity level.

6. Energy Conservation.

Energy conservation shall be used in conjunction with heating, ventilating, air conditioning and dehumidifying systems' designs to create the most energy efficient system in full relation to life cycle costs. Energy conservation management shall include planning, organizing, implementing and controlling the expenditure of energy.

D. ENGINEERING DESIGN CRITERIA

1. Objective.

The engineering design criteria establish the basic guidelines for designing heating, ventilating, air conditioning and dehumidifying systems. Design requirements, design considerations, code requirements, system limitations and material limitations establish the basis for the design criteria. The basic terminology used throughout this manual is illustrated and defined in Figure 1.

To avoid duplication, design criteria common to heating, ventilating, air conditioning and dehumidifying systems are included in this chapter. Design criteria which are specific to one system are presented with its respective system.

2. Related Criteria.

Priority of indicated related criteria shall be (1) Construction Criteria Manual (DoD 4270.1-M), (2) NAVFAC Design Manuals and (3) other criteria.

Related criteria containing supplementary design criteria not specifically cited in this manual are as follows:

American Society of Mechanical Engineers (ASME):  
Boiler and Pressure Vessel Code  
Corrosion Protection (NAVFAC DM-3 Series)  
Economic Analysis (NAVFAC P-442)

Energy Conservation in New Building Design (American Society of Heating, Refrigerating and Air-Conditioning Engineers, ASHRAE Standard 90-75)  
National Board of Boiler and Pressure Vessels Inspection Code  
Natural and Mechanical Ventilation (ASHRAE Standard 62-73)  
Pollution Control Systems (NAVFAC DM-5.8)  
Standards of the Expansion Joint Manufacturers  
Thermal Environmental Conditions for Human Occupancy (ASHRAE Standard 55-74)

3. Outdoor Design Conditions.

Outdoor design conditions for comfort and process work spaces shall be calculated using the information listed in NAVFAC P-89. For locations not listed in NAVFAC P-89, the outside design conditions shall be obtained from the Naval Facilities Engineering Command, through the Engineering Field Division (EFD).

a. Design Criteria.

- (1) The following design criteria shall be followed to determine the outdoor design conditions if simultaneous heating, cooling, and dehumidifying processes are accomplished by one apparatus:
  - (a) For normal temperature/humidity control of a space, the 97-1/2 percent column for heating and the 2-1/2 percent column dry bulb temperature, with its corresponding mean coincident wet bulb temperature for cooling, shall be used.
  - (b) For spaces in which the effective temperature must be maintained within extremely close limits, the 99 percent column shall be used for heating and the 1 percent dry bulb and its corresponding mean coincident wet bulb temperature shall be used for cooling.
- (2) The following design criteria shall be followed to determine the outdoor design conditions for cooling and dehumidifying by separate apparatus:
  - (a) For normal temperature/humidity control of spaces, the 2-1/2 percent dry bulb column with its corresponding mean coincident wet bulb temperature shall be used.
  - (b) For dehumidification of spaces, the 2-1/2 percent dry bulb column with its corresponding mean coincident wet bulb temperature shall be used.

(3) The following design criteria shall be followed to determine the outdoor design conditions for separate heating systems:

(a) Heating systems shall be separate from ventilation and air conditioning systems in spaces where the effective temperature must be maintained within extremely close limits. NAVFAC approval shall be requested through the EFD.

(b) Where a separate heating system is used for comfort and process work, the 97-1/2 percent dry bulb column shall be used.

4. Indoor Design Conditions.

Consult DoD 4270.1-M for indoor design conditions.

5. Warm Humid Climate Design Criteria.

The high moisture content of air in warm humid climates requires special consideration when designing ventilating and air conditioning systems because of the potential for insulation around mechanical systems to become saturated.

a. Dehumidification Design Criteria.

(1) The system shall be capable of dehumidifying satisfactorily under conditions of relatively low sensible load.

(2) Humidistat controls shall be used.

(3) It may be beneficial to base supply air quantity on the latent heat load rather than the sensible heat load.

(4) The minimum sensible heat load may be a critical condition.

(5) Face velocity of air across the cooling coils may be considerably lower than that considered normal in other areas.

b. Air Conditioning Design Considerations.

(1) Central air conditioning systems shall be used when feasible.



- (2) Unitary air conditioning systems are acceptable for small spaces; however, fan coil units cannot be controlled well enough to achieve comfort at low sensible loads.
- (3) Chilled water systems must provide adequate cooling under all operating conditions without an appreciable rise in chilled water supply temperature.
- (4) Higher condenser water temperatures may be expected when using cooling towers. If higher condenser water temperature is realized, larger towers or increased compressor loads are required.

c. Ventilation.

- (1) An air balance shall be maintained to keep infiltration at a minimum in all areas of a building, including those areas which require exhaust systems.
- (2) Recirculated air shall be used in all areas of a building where it is not prohibited by specific design requirements.

d. Insulation and Vapor Barriers.

- (1) When cold fluids flow through pipes or ducts all year long, vapor pressure is always higher outside the insulation. Consequently, any moisture which infiltrates into insulation cannot escape. Eventual saturation and failure of the insulation are inevitable.
- (2) Pipes and ducts shall be installed in areas where dripping can be tolerated, and access shall be provided for replacement of insulation.

6. Terminology.

The mechanical ventilating system terminology used throughout this manual is illustrated and defined in Figure 1.

7. Calculation Information.

Calculations shall be recorded in a standard format to permit checking and to provide a reference for system modifications at a later date. They shall be identified as to station, building name and/or number and date. Indoor and outdoor design conditions and any assumptions used in the calculations shall be recorded. Design calculations should include, but not be limited to, indoor design temperature, outdoor design temperature, heat loss, heat gain, supply and exhaust ventilation requirements, humidification and/or dehumidification requirements and heat recovery quantities.

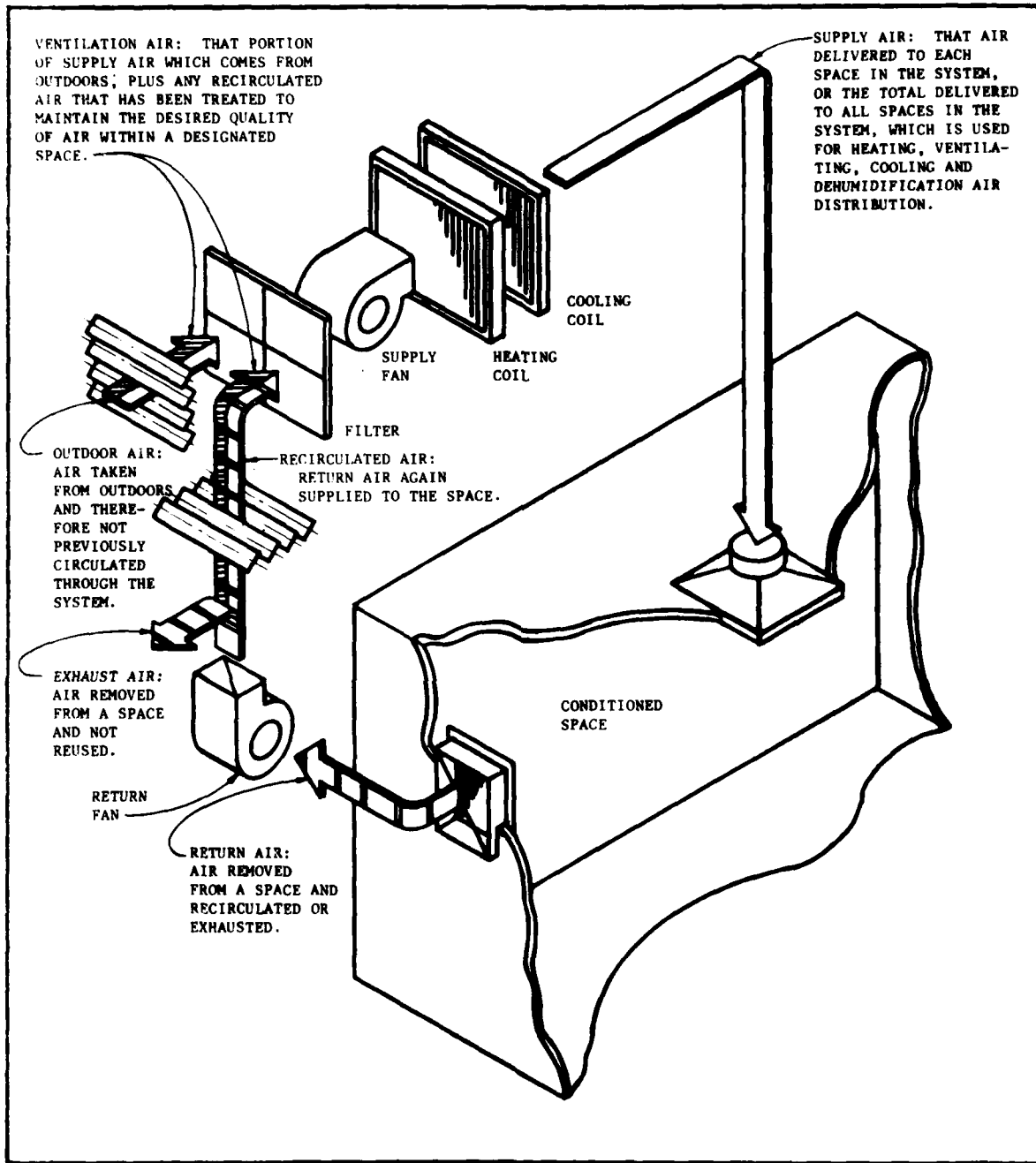

FIGURE 1  
 Heating, Ventilating and Air Conditioning System Terminology

a. Information Required for Calculations.

- (1) Calculations require basic background on building location, building details, heat producing devices to be used in the building and on building operation. Tables 1 through 4 respectively list the types of information required.

TABLE 1  
Location Considerations Required for  
Design Calculations

Considerations	Specific Factor	Detailed Information Required
Geographical . . . . .	Geographic location	Latitude, longitude and altitude.
	Facility orientation	Declination of the north/south axis of the facility from true north.
	Climatic conditions (From NAVFAC P-89. For locations not listed, contact NAVFAC through the Engineering Field Division)	Temperatures: dry bulb, wet bulb, mean coincident wet bulb and mean daily range; Prevailing wind direction, and mean wind speed.
Environmental . . . . .	Reflecting surface	Size, nature and location of reflective surfaces at or near the site.
	Soil	Load carrying capacity, corrosion properties where piping or equipment is to be buried in the ground.
	Water analysis	The corrosive and scaling properties of water. See DM-5 for details of water analysis.
	Atmosphere	Scaling or corrosion properties of atmospheric contaminants.
Locality . . . . .	Local labor and material	Availability and cost of civilian labor and materials.
	Accessibility	The available transport and access facilities.
	Standards, regulations and codes	The applicable naval and industrial standards, regulations and codes.

**TABLE 2**  
**Building Detail Considerations Required for**  
**Design Calculations**

Considerations	Specific Factor	Detailed Information Required
Life Span . . . . .	Operation and maintenance analyses	Type of construction and economic life (DOD 4270.1-M).
Architecture . . . . .	Project drawings	Plans, elevations, sections and details.
Structural . . . . .	Structural elements	Physical location and size of structural elements.
	Seismic considerations, building expansion and settlement	Location, expected movement and settlement of joints.
Construction Details . . . . .	Exterior walls and roof	Construction, details, color and insulation.
	Partition walls	Thickness and type of construction.
	Fire walls	Location and type of construction.
	Hung ceilings	Type of material (tile or plaster), insulation value and size of tile or panels.
	Floors	Thickness and type of construction.
	Windows	Type, size, type of sash material, type of glass, single or multiple glass, and fixed or openable.
	Doors	Type, size and usage.
	Shading devices	Internal: Type of device, color and reflectivity. External: Location and details of devices.
	Stairway and elevators	Construction details, size and usage.

**TABLE 3**  
**Information on Heat Producing Devices**  
**Required for Design Calculations**

Considerations	Specific Factor	Detailed Information Required
Lighting . . . . .	Type	Incandescent, fluorescent or high intensity discharge.
	Mounting	Exposed, recessed in hung ceiling, recessed in return plenum, spot lights, or other mountings.
	Load	Watts per unit area inclusive of auxiliary starting equipment in the case of fluorescent lighting.
Equipment . . . . .	Sensible heat sources	Quantity of equipment, heat output, and usage factor.
	Sensible and latent heat sources	Quantity of equipment, amount of sensible and latent heat loads, and usage factor.

**TABLE 4**  
**Information on Building Operation Required**  
**for Design Calculations**

Specific Factor	Detailed Information Required
Operation schedule . . . . .	Normal hours of operation and anticipated off-hour operation.
Occupancy . . . . .	Population, usage schedule, period of maximum occupancy load and type of activity.
Space requirements . . . . .	Space temperature and relative humidity.

b. Infiltration Considerations.

(1) Exterior Doors and Windows.

- (a) Infiltration through doors, windows, and cracks around windows and doors shall be accounted for in the design calculations. For specific design considerations, the ASHRAE Fundamentals Handbook shall be consulted.

(2) Exterior Walls.

- (a) Infiltration through the exterior walls shall be accounted for in the design calculations. For specific design considerations, the ASHRAE Fundamentals Handbook shall be consulted.

(3) Areas Under Negative Pressure.

- (a) For rooms maintained under negative pressure, infiltration shall be equivalent to the difference between amount of air exhausted and amount of air supplied.

8. Calculations.

a. Supply Air Quantity.

The equations for supply air quantity are designed for determining minimum supply air quantities based on space design requirements. Ventilation requirements and air change requirements may differ. The maximum of the three values shall be used for the supply air quantity.

(1) Heating.

- (a) Air quantity (Q) shall be calculated as follows:

$$\text{Equation: } Q = H_T / (1.08 \times dT) \quad (1)$$

where: Q = Supply air, cfm

$H_T$  = Heat loss, Btuh

dT = Difference in supply air and space design temperatures, F

(2) Air Conditioning.

- (a) Air quantity (Q) shall be calculated as follows:

$$\text{Equation: } Q = H_{GT} / (1.08 \times dT) \quad (2)$$

where: Q = Supply air, cfm

$H_{GT}$  = Total heat gain, Btuh

$dT$  = Difference in supply air and space design temperature, F

(b) Solar Load ( $H_S$ ).

- (1) The solar load for glass areas shall be calculated as follows:

Equation:  $H_S = A \times SC \times SHG$  (3)

where:  $H_S$  = Solar load, Btuh (per square foot)  
 $A$  = Area of glass  
 $SC$  = Shading coefficient from the ASHRAE Fundamentals Handbook  
 $SHG$  = Solar heat gain factor, Btuh, per square foot (from ASHRAE Fundamentals Handbook)

(c) Ventilation Load ( $H_{VS}$ )

- (1) The ventilation load shall be calculated as follows:

Equation:  $H_{VS} = 1.08 \times Q_V \times dT$  (4)

where:  $H_{VS}$  = Ventilation load, Btuh  
 $Q_V$  = Ventilation air supply, cfm  
 $dT$  = Difference in temperature between indoor and outdoor design temperatures, F

(d) Light Load ( $H_L$ ).

- (1) Light load shall be calculated as follows:

Equation:  $H_L = W \times 3.413$  (5)

where:  $H_L$  = light load  
 $W$  = watts based on space lighting level

(e) Power Load ( $H_P$ ).

- (1) The power load due to electrical machinery shall be calculated as follows:

Equation:  $H_P = W \times 3.413$  (6)

where:  $H_P$  = power load  
 $W$  = watts based on space usage

(f) Occupancy Load ( $H_O$ ).

- (1) The occupancy load for various activities shall be calculated as follows:

$$\text{Equation: } H_O = \text{Number of Persons} \times \text{HG0} \times \text{CLF} \quad (7)$$

where:  $H_O$  = Occupancy load  
 $\text{CLF}$  = Cooling Load Factor from the ASHRAE Fundamentals Handbook  
 $\text{HG0}$  = Heat gain from occupants, Btuh (from the ASHRAE Fundamentals Handbook)

- (g) Equipment Load ( $H_E$ ).

- (1) Equipment load shall be calculated as follows:

$$\text{Equation: } H_E = \frac{\text{bHP} \times \% \text{ Load} \times 2545}{\text{Eff.}} \quad (8)$$

where:  $H_E$  = Equipment load  
 $H_P$  = Equipment horsepower  
 $\text{Eff.}$  = Efficiency at corresponding load

b. Heat Loss.

- (1) Conduction ( $H_T$ ).

- (a) The heat loss for each surface due to conduction shall be calculated as follows:

$$\text{Equation: } H_T = \text{Summation of all surfaces: } (U \times A \times dT) \quad (9)$$

where:  $H_T$  = Heat loss  
 $U$  = Thermal transmittance value from the ASHRAE Fundamentals Handbook  
 $A$  = Surface area: glass, walls and floors  
 $dT$  = Difference in outdoor and indoor design temperatures, F

- (b) Peak winter conduction load ( $H_{TPW}$ ).

The peak winter conduction load shall be the conduction heat loss calculated at winter outdoor design temperatures.

- (2) Total.

- (a) The total heat loss ( $H_{TT}$ ) is due to the conduction and ventilation air heat load, total heat loss shall be calculated as follows:

$$\text{Equation: } H_{TT} = H_T + H_{VS} \quad (10)$$

where:  $H_{TT}$  = Total heat loss  
 $H_T$  = Heat loss due to conduction  
 $H_{VS}$  = Heat loss due to ventilation air



c. Heat Gain.

- (1) Heat gain ( $H_G$ ) shall be calculated as follows:

Equation: (11)

$$H_G = \text{Summation of all surfaces: } (U \times A \times \text{CLTD}) + (H_S + H_O + H_L + H_P + H_E)$$

where:  $H_G$  = Heat gain, Btuh

$U$  = Thermal transmittance value from the ASHRAE Fundamentals Handbook

$A$  = Surface area

$\text{CLTD}$  = Cooling load temperature difference,  $F$  (from the ASHRAE Fundamentals Handbook)

$H_S$  = Solar heat gain, Btuh (from the ASHRAE Fundamentals Handbook)

$H_O$  = Occupancy load, Btuh (from the ASHRAE Fundamentals Handbook)

$H_L$  = Light load, Btuh

$H_P$  = Power load, Btuh

$H_E$  = Equipment load, Btuh

- (2) Total heat gain ( $H_{TG}$ ) shall be calculated as follows:

Equation:  $H_{TG} = H_G + H_{VS}$  (12)

where:  $H_{TG}$  = Total heat gain

$H_G$  = Heat gain

$H_{VS}$  = Ventilation air heat gain

- (3) Air Conditioning Load Estimates.

(a) The appropriate value from Table 5 shall be used when estimating air conditioning loads. These factors should be used with discretion and engineering judgment since climate, internal load, ventilation, shade, building color and other factors influence the actual load.

(b) An estimate of air conditioning loads shall be considered when time or purpose does not warrant a detailed air conditioning load calculation or for preliminary cost estimates.

- (4) Total Maximum Air Conditioning Load.

(a) The maximum air conditioning load may not occur at the same period of "maximum internal sensible air conditioning loads." In such cases, separate air conditioning load calculations shall be made to determine "maximum internal sensible air conditioning load" and "maximum total air conditioning load."

**TABLE 5**  
**Air Conditioning Load Estimating Factors**

Application	Floor Area (ft <sup>2</sup> )/ton (except where noted) of Air Conditioning
Administration building . . . . .	450 - 600
Auditoriums . . . . .	0.04 - 0.06 tons/seat
Bachelor enlisted quarters . . . . .	725 - 900
Bachelor officer quarters . . . . .	725 - 900
Bowling alley . . . . .	0.8 - 1.4 tons/alley
Chapel . . . . .	0.02 - 0.03 tons/seat
Classrooms . . . . .	400 - 500
Computer rooms . . . . .	50 - 150
Dining halls . . . . .	175 - 450
Dispensaries . . . . .	450 - 550
Enlisted Men's and Officer's Clubs . . . . .	275 - 375
Hospital patient rooms . . . . .	450 - 550
Married personnel quarters . . . . .	900 - 1275
Recreation rooms . . . . .	375 - 450
Shops (precision equipment) . . . . .	450 - 550

(b) When determining the maximum air conditioning load transferred to refrigeration equipment, consider the lag factor for energy stored in the structure.

(c) The return air heat gain shall allow for heat gained across insulated or uninsulated return ducts and/or gain through ceiling return plenums which are outside the conditioned space.

d. Calculation Information Required for Equipment Selection.

(1) The heating system, pumps, fans, heat emission equipment and distribution system is sized on the total heat loss calculation.

- (2) The air conditioning system, pumps, and refrigeration equipment is sized on the total heat gain calculation. The fan, coil, and distribution system is sized on the air quantity calculation.

9. Heat Balance Analysis.

Heat balance analysis shall be performed during the initial stages of a design to identify a system's breakeven temperatures for various energy loads and the maximum heating and/or air conditioning requirements at outdoor design limits.

a. Calculations.

(1) Ventilation Load.

- (a) Since the sensible load component ( $H_{vs}$ ) of the ventilation load is predominant in winter, for simplicity, only the sensible load figures shall be used in calculating the heat balance.

(2) Light and Power Load.

- (a) Diversified Light and Power Load ( $H_{LP}$ ) is due to luminaires and electrical machinery and is calculated as follows:

$$\text{Equation: } H_{LP} = (0.90 \times H_L) + (0.50 \times H_P), \quad (13)$$

where:  $H_L$  and  $H_P = W \times 3.413$ .

- (b) For heat balance calculations, the light load ( $H_L$ ) may be taken as 90 percent of the installed capacity, assuming that not all lights are on at the same time.
- (c) For heat balance calculations, the power load ( $H_P$ ) may be taken as 50 percent or greater diversity on the installed capacity, assuming that all the equipment will not be operating at the same time.

(3) Occupancy Load.

- (a) For heat balance calculations, use 80 percent of the occupancy load, assuming all occupants will not be present at one time.

(4) Equipment Load.

- (a) Equipment load ( $H_E$ ) shall include loads from fans, pumps, computers and the heat producing equipment plus heat of compression from compressors.

(5) Breakeven Temperature.

Breakeven temperature ( $T_{BE}$ ) can be obtained, either graphically as illustrated in Figure 2, or it can be calculated if peak values of various energy components are known at winter design temperature.

Equation: (14)

$$T_{BE} = T_I - \frac{(H_{LP} + H_O + H_S + H_E)(T_I - T_W)}{(H_{TPW} + H_{VS})}$$

where:

$T_{BE}$  = Breakeven temperature considering solar load ( $T_{BE}$  without solar load is obtained by using  $H_S = 0$ )

$T_I$  = Indoor or room design dry bulb temperature, F

$H_{LP}$  = Diversified light and power load, Btuh

$H_O$  = Occupancy sensible load, Btuh

$H_S$  = Solar load, Btuh

$H_E$  = Equipment load, Btuh

$T_W$  = Ambient winter design dry bulb temperature, F

$H_{TPW}$  = Peak winter conduction load, Btuh

$H_{VS}$  = Ventilation load, Btuh

b. Heat Balance Diagram.

- (1) A heat balance diagram is used to visually show maximum heating and cooling loads required and the building breakeven point (Fig. 2). During winter months, there may be a surplus of heat in the interior spaces of buildings with high occupancy loads; however, heat may be required along the exterior envelope. It is possible to eliminate the need for external heat sources during occupied hours by transferring the surplus heat from the interior zones to where it is needed. For example, heat recovery techniques can eliminate undesirable waste which is inherent in the air conditioning systems where the boiler supplies the heat to the building while heat is simultaneously dissipated to the outside through cooling towers.

- (2) Because the heat balance diagram is based on occupied hours, supplementary heating may be required (1) during winter months when the outdoor temperature is so low that internal heat is not adequate to meet the project requirement, and (2) at night and on weekends and holidays when the building systems may be shut down.

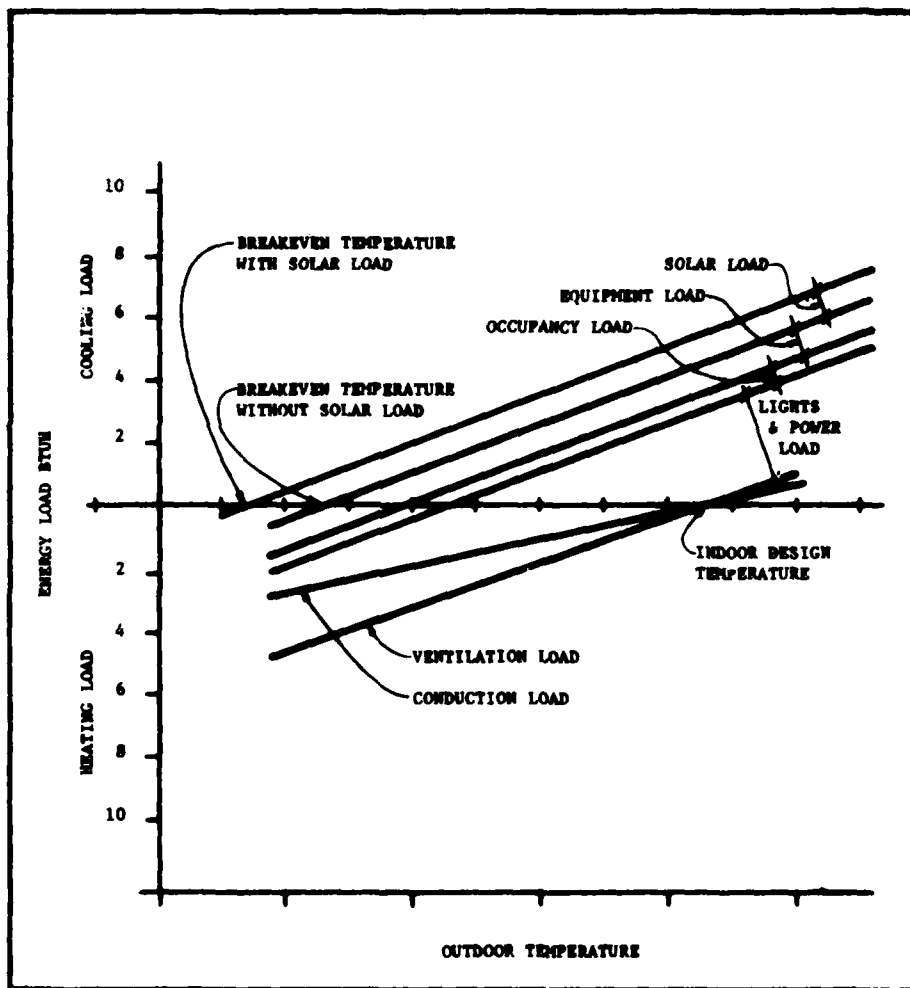

FIGURE 2  
Sample Heat Balance Diagram

## 10. Computer Energy Analysis.

A computer energy analysis shall be performed prior to the design of new buildings and major building retrofit projects where the gross floor area of a space which is heated and cooled is over 8,000 square feet or if where the gross floor area of a space which is only heated is over 32,000 square feet.

### a. Program Requirements.

- (1) The computer program shall use credible calculation methods.
- (2) The computer program shall be designed to vary the internal heating and cooling loads, the ventilation rates and the thermostat settings with the hours of the day and the days of the year in order to simulate normal building operations.
- (3) The computer energy analysis shall provide information necessary for the evaluation of a large number of system design alternatives in terms of energy conservation and long-range monetary savings. The computer energy analysis programs should be capable of analyzing relevant design alternatives. Projects which require a consideration of total energy systems as required by DoD 4270.1-M must be analyzed by a program which is capable of total energy system simulations. The following is a partial listing of design alternatives to be considered.

#### Architectural Alternatives

- (1) building orientation
- (2) building width and length
- (3) number of building stories
- (4) exterior wall construction
- (5) exterior wall insulation
- (6) roof construction
- (7) roof insulation
- (8) window area
- (9) window glass type, such as single glazed, double glazed or tinted
- (10) solar screening devices

#### Mechanical Alternatives

- (1) reciprocating, centrifugal, rotary screw and absorption chiller
- (2) natural gas, oil, coal or combination fired boiler

- (3) use of central heating plant
- (4) variable air volume system (low and high velocity)
- (5) dual duct system
- (6) multizone system
- (7) heat pump system
- (8) fan coil system
- (9) induction unit systems
- (10) double bundled condensers for heat recovery
- (11) rotary heat exchangers
- (12) run-around method
- (13) outdoor temperature reset control
- (14) night and weekend thermostat setback
- (15) economizer cycle
- (16) thermal storage

#### Lighting Alternatives

- (1) incandescent
- (2) fluorescent
- (3) high intensity discharge

#### b. Calculation Requirements.

- (1) Energy consumption shall be calculated by an hourly load and system simulation rather than the approximate degree day method.
- (2) Weather data shall be obtained from historical yearly weather data tapes which are available from the Department of Commerce, National Climatic Center, Federal Building, Ashville, North Carolina, 28801.
- (3) The heating and cooling load calculations and the heating and cooling system simulation should be performed by using data from NAVFAC P-89 on energy consumption estimates for sites within the United States. Yearly energy consumption should be calculated based on 365 days.
- (4) The heating and cooling loads shall take into account the thermal time lag of building materials based on the ASHRAE averaging method. See the ASHRAE Fundamentals Handbook.
- (5) The heating and cooling loads shall take into account the internal loads generated by people, lighting, machines and other sources.
- (6) The heating and cooling system simulations shall include the energy requirements of the mechanical

system components such as fans, pumps, chillers and boilers.

11. Safety Related Design Criteria.

All equipment shall comply with the OSHA safety requirements and DM-8. The design features presented below are intended to prevent injury to personnel and avoid equipment malfunction.

a. Moving Equipment.

Protective guards shall be provided for equipment in motion, such as belt drives, couplings and fans.

b. Equipment with High Operating Temperatures.

If the surface temperatures are high enough to cause burns, the equipment shall be insulated or shielded and warning signs shall be required.

c. Electric Motors.

A manual lock-out disconnect switch shall be provided for all electric motors which are not within sight of their controllers or do not have a disconnect switch near the motor.

d. Ventilation.

Refrigeration rooms shall be ventilated sufficiently to remove the refrigerant vapors from the room in case of an accidental leakage. See ANSI B9.1.

e. Emergency Switch.

Mechanical equipment rooms that house large refrigeration equipment shall have break-glass emergency switches located near the exits. These switches shall be wired to stop the power supply to all equipment except exhaust fans.

12. Architectural Criteria.

Architectural design considerations shall be coordinated with the architectural design criteria in DM-1. However, the following design factors require special considerations:

a. Mechanical Equipment Rooms.

- (1) The size of Mechanical Equipment Rooms shall be specified by room length, width, and height. Size shall not be specified by area or volume alone.



Room size shall provide adequate space for equipment installation and maintenance. If future expansion is planned, the size shall be based on future requirements. Equipment removal access shall be provided where required.

b. Shafts.

- (1) The size and location of shafts for ductwork and pipes shall be checked prior to ductwork and piping system design. The effects of the location of a shaft on the mechanical equipment and distribution systems shall be carefully determined.

c. Louvers.

- (1) The location and size of outdoor air intake, relief air discharge and exhaust air discharge louvers shall be investigated.
- (2) Outdoor air intakes shall be located in a manner to avoid intake of dust, smoke and exhaust air.

d. Cooling Tower Discharge.

- (1) Discharge at low levels or where it may come in contact with buildings shall be avoided.

e. Access Space.

- (1) The location and size of control panels and the type of service and maintenance a facility requires shall be checked when considering personnel access to an area or a piece of equipment.

f. Access Doors.

- (1) The location and size of access doors within the finished space shall be considered when arranging equipment in terms of use and maintenance requirements.

13. Structural Design Criteria.

Structural design considerations shall be coordinated with the structural design criteria in DM-2 Series. However, the following design factors require special consideration:

a. Foundations.

- (1) The following data shall be calculated:
  - (1) dead weight of equipment in operating conditions

- (2) dynamic weight of reciprocating or vibrating equipment
- (3) size and type of equipment bases
- (4) load distribution on the equipment bases

b. Wind Forces.

- (1) The design of outdoor equipment such as cooling towers, stacks, and their supports shall be based on the maximum wind velocities prevalent at the site. Exterior mechanical equipment shall be anchored, braced or guyed to withstand the wind velocity specified for design of structures in DM-2.

c. Seismic Considerations.

- (1) If the site is subject to earthquakes, the design of equipment (especially outdoor cooling towers and water tanks), piping systems, ductwork and foundations shall include suitable allowance for horizontal forces as specified in NAVFAC P-355 and P-355.1.

d. Location.

- (1) Equipment shall be located to transfer the weight directly to the main structural members, girders or columns; preferably columns.
- (2) The weight of the equipment to be used shall be determined in relation to platforms, stairs and elevators.

e. Pipe Supports.

- (1) The following shall be determined prior to the design of a system:
  - (1) weight of risers, including water column and unsupported pipe
  - (2) lateral thrust due to expansion joints
  - (3) dynamic forces at bends
  - (4) location and types of supports

f. Opening Through Structural Members.

- (1) Size and location of openings through structural members shall be based on the following factors:
  - (1) outside diameter of pipes or ducts, inclusive of any flange and insulation
  - (2) standard length of pipe or duct between joints

- (3) direction and extent of pitch for pipes

#### 14. Electrical Design Criteria.

Electrical considerations shall be coordinated with the electrical design criteria established in DM-4.1. However, the following design factors require special considerations.

##### a. Motor Starting Characteristics.

Selection of motor starting characteristics shall be based on in-rush current limitations of the electric installation.

##### b. Motor Controls.

(1) Motor controls shall include the following:

- (1) overload protection
- (2) momentary contact type, start-stop, push button controls for manual operation
- (3) Hand-Off-Automatic (H-O-A) selector for automatic operations with safety controls common to manual and automatic operation (semi-automatic and automatic systems only)
- (4) low voltage release
- (5) auxiliary contacts for interlocking and control circuits
- (6) control circuit transformer (when control voltage is different from the line voltage)
- (7) control circuit fusing in all controllers, NEMA Size 2 or larger
- (8) time-delay relays where several motors are interlocked to start automatically in a predetermined sequence (semi-automatic and automatic systems only)
- (9) pilot light on the cover of a motor when the motor is out of sight of the controller

##### c. Wiring.

- (1) If possible, all the controls and interlocks of equipment shall be prewired by the manufacturer so that the equipment will need power wiring only.
- (2) Emergency equipment shall be wired to the emergency supply panel.

##### d. Miscellaneous Electrical Requirements.

- (1) Electrical requirements shall be detailed on an Electrical Connection Data Sheet as part of the permanent project computations. Figure 3 is a sample Electrical Connection Data Sheet.

F I R M N A M E A N D A D D R E S S

ELECTRICAL CONNECTION  
DATA SHEET

JOB NAME	FIG. BY	CK'D BY	JOB NO.
SUBJECT	DATE	REV. DATE	PAGE OF

**BASIC DATA**

Current Characteristics: \_\_\_\_\_ V \_\_\_\_\_ Ph \_\_\_\_\_ Wire \_\_\_\_\_ Ga

Motor Data: \_\_\_\_\_ Hp or less to be \_\_\_\_\_ volts \_\_\_\_\_ phase  
 \_\_\_\_\_ Hp or over to be \_\_\_\_\_ volts \_\_\_\_\_ phase  
 \_\_\_\_\_ Hp or less, full voltage starting  
 \_\_\_\_\_ Hp or over, reduced voltage starting

Equipment Data: \_\_\_\_\_ Kw or less to be \_\_\_\_\_ volts \_\_\_\_\_ phase  
 \_\_\_\_\_ Kw or over to be \_\_\_\_\_ volts \_\_\_\_\_ phase

**ELECTRICAL CONNECTIONS**

System No.	Equipment and Location	Hp or Kw	Starter Type	Actuating Device and Location	Control Devices and Location

FIGURE 3  
Electrical Connection Data Sheet

(2) Table 6 includes a list of equipment and their typical actuating devices and Tables 7 and 8 include lists of the applications of local and remote control devices.

TABLE 6  
List of Typical Actuating Devices

Actuating Device	Equipment Served
Electric-Pneumatic (EP) Switch . . . . .	Fans: supply air, exhaust air and indoor cooling tower. Pumps: hot water, chilled water. Cooling tower water bypass valve. Time clocks.
Pneumatic-Electric (PE) Switch . . . . .	Fans: supply air, exhaust air, night setback thermostat, or time clock switch control of fans. Cooling tower fan for thermostat controlling of condenser water temperature. Reciprocating compressor control. Electric heating coil control.
Electric Thermostats . . . . .	Fans: low or high air temperature cutout. Pumps: low secondary water temperature cutout. Winterized cooling tower control. Room temperature control.
Air Flow Switch . . . . .	Electric heating coil safety control.
Damper Switch . . . . .	Supply air fan.
Pressure Switch . . . . .	Air compressor.
Humidistat . . . . .	Humidifier.

**TABLE 7**  
**Typical Local and Remote Control Devices for Fans**

Equipment and Application	Operational Mode		Local <sup>1</sup> Control Only	Both Local <sup>1</sup> and Remote Control	
	Manual	Automatic		Local	Remote
<b><u>SUPPLY FANS:</u></b>					
Normal Usage	X	---	(1)	(1), (3)	(1)
Night Room	Day	Night	(1), (3), (4)	(1), (3), (4)	(5)
Time Clock Switch Control	---	X	(2), (3)	(2), (3)	(5)
<b><u>RETURN FANS:</u></b>					
Normal Usage	X	---	(1)	(2)	(5)
Thermostat Control	Day	Night	(2)	(2)	(5)
Time Clock Switch Control	---	X	(2)	(2)	(5)
<b><u>EXHAUST FANS:</u></b>					
Normal Usage	X	---	(1)	(1)	(1)
Time Clock Switch Control	---	X	(2)	(2)	(2)
<b><u>COOLING TOWER FANS:</u></b>					
Normal Usage	X	---	(1)	(1)	(1)
Winterized	Winter	Summer	(2)	(6)	(6)
<b><u>REFRIGERATION ROOM FANS</u></b>	with emergency break glass switch	---	(1), (4)	(1), (4)	(1)
<sup>1</sup> Type of Control Device: (1) Momentary contact, start-stop, push button station. (2) Hand-Off-Automatic (H-O-A) selector switch. (3) Auxiliary contact in starter to interlock return fan. (4) Automatic actuating device wired in parallel with "Start" push button. (5) Pilot light only. (6) Local H-O-A selector switch & remote pilot light or remote H-O-A selector switch & local pilot.					

**TABLE 8**  
**Typical Local and Remote Control Devices for Pumps**

Equipment & Application	Operational Mode		Local <sup>1</sup> Control Only	Both Local <sup>1</sup> and Remote Control	
	Manual	Automatic		Local	Remote
<b>PUMPS:</b>					
Normal Chilled Water	X		(1)	(1)	(1)
Normal Condenser Water	X		(1)	(1)	(1)
Hot Water Heating with Outdoor Thermostat or Aquastat Control		X	(2)	(2)	(3)
Hot Water Heating Coil with Outdoor Thermostat Control	Day	Night	(1), (4)	(1), (4)	(1)
Condenser Water with Outdoor Thermostat Control	Day	Night	(1), (4)	(1), (4)	(1)
<sup>1</sup> Type of Control Device: (1) Momentary contact, start-stop, push button station (2) Hand-Off-Automatic (H-O-A) selector switch (3) Auxiliary contact in starter to interlock return fan (4) Automatic actuating device wired in parallel with "Start" push button					

## Section 2. HEATING SYSTEMS

### A. HEATING SYSTEMS DESCRIPTION.

Heating systems shall maintain the required design conditions in a space by supplying adequate heat to offset the heat loss. Heating sources may be steam, hot water, natural gas, oil, electricity or solar energy. The use of electricity requires prior approval from NAVFAC, requested through the EFD. Heating systems may be combined with ventilation systems when functionally and economically feasible.

Humidification systems shall maintain the required design conditions in a space by supplying moisture in the supply air.

Snow melting systems shall maintain access areas free of snow and ice as required. A fluid heating medium or electric high-resistance cables may be used as the heat source.

#### 1. Steam Heating Systems.

Steam heating systems are either one-pipe or two-pipe systems, upfeed or downfeed, and they are classified by steam pressure as follows:

<u>Classification</u>	<u>Operating Pressure</u>
Low Pressure	0- 15 psi
Medium Pressure	16- 50 psi
High Pressure	51-125 psi

The four acceptable methods for condensate return to the boiler within steam heating systems are listed below. In situations where the condensate is contaminated, it shall be piped directly to a drainage system or a rock-filled sub-surface drain in accordance with DM-5.3.

#### Condensate Return Methods

Hartford Return Method  
Flooded Return Main Method  
Dry and Wet Return Method  
Vacuum Return Method

#### a. Applications and Limitations.

Steam heating systems are suitable for the process loads and heating loads if temperature modulation is at a prime consideration. Condensate return systems shall be used with steam heating systems, except when the condensate is contaminated or design requirements specify otherwise. One-pipe steam heating systems shall not be used.



(1) Low Pressure Steam Systems.

(a) These systems are suitable for heating most buildings. They are compatible with unit heaters, central air handling units and steam to hot water heat exchangers.

(2) Medium Pressure Steam Systems.

(a) These systems are suitable for process work buildings. They are compatible with central air handling systems when the process load is large and in general with steam to hot water heat exchangers.

(3) High Pressure Steam Systems.

(a) These systems are suitable for process work buildings and site distribution systems. They shall not be used directly for heating but may be used in conjunction with steam to hot water heat exchangers.

(4) Hartford Return Method.

(a) The Hartford return method is suitable for direct flow of the condensate into the boiler providing the condensate can be returned by gravity action without flooding the return mains. The Hartford loop prevents the syphoning of boiler water back through gravity return lines if a vacuum is created in the return system. See the ASHRAE Systems Handbook for a technical diagram.

(5) Flooded Return Main Method.

(a) The flooded return main method requires a boiler return trap and an automatic air vent or a condensate return pumping unit. On multiple boiler installations, a condensate return pumping unit shall be used.

(6) Dry and Wet Return Method.

(a) The dry-return method is suitable for low pressure steam systems, avoid the wet-return method whenever possible. The gravity dry return method shall be used with two-pipe steam systems.

(7) Vacuum Return Method.

- (a) Vacuum return method is suitable for sub-atmospheric return systems which are used in high-efficiency, quick pickup steam heating systems.

b. Special Considerations.

(1) Low Pressure Steam Systems.

- (a) This system uses a condensate return system at or near atmospheric pressure.
- (b) The potential for pipe expansion shall be considered.
- (c) Piping runs shall have a uniform slope and shall be free from areas where condensate collection may occur.

(2) Medium Pressure Steam Systems.

- (a) The potential for pipe expansion shall be considered.
- (b) Piping runs shall have a uniform slope and shall be free from areas where condensate collection may occur.

(3) High Pressure Steam Systems.

- (a) The potential for pipe expansion shall be considered.
- (b) Piping runs shall have a uniform slope and shall be free from areas where condensate collection may occur.

2. Hot Water Heating Systems.

Hot water heating systems are classified by water temperature:

<u>Classification</u>	<u>Temperature F</u>
Low Temperature	less than 250°
Medium Temperature	250° to 350°
High Temperature	greater than 350°

The low temperature classification is further divided into a series-loop, one-pipe and two-pipe systems (Fig. 4).

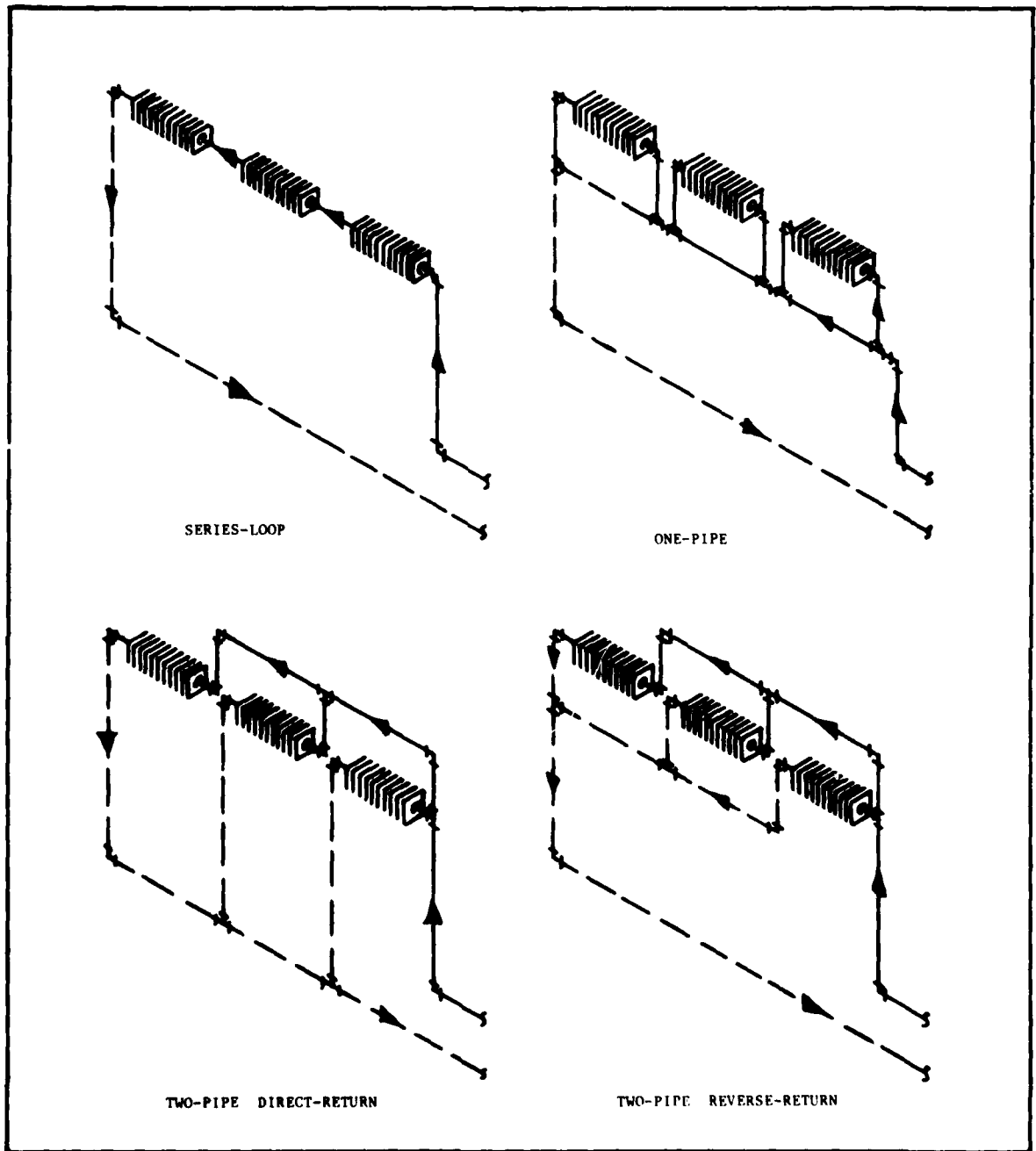

FIGURE 4  
Piping Methods

a. Applications and Limitations.

(1) Low Temperature Systems.

- (a) These systems should be limited to heating load of 10,000 MBh or less.
- (b) The series-loop system is suitable for use in small structures such as residences. In this system, the terminal units are mounted on the loop and considered as part of the loop.
- (c) The one-pipe system is suitable for use with single-zone systems and as the secondary component of a primary-secondary system. This system requires special diverting tees for the water flow from the main to the terminal unit.
- (d) The two-pipe system is suitable for use in systems which require connections to individual heat emission equipment and may use either a direct-return or reverse-return system. The two-pipe system is suitable for use in supply and return mains or in connecting series-loop and one-pipe systems from individual conditioned spaces.

(2) Medium Temperature Systems.

- (a) These systems are suitable for use in primary-secondary pumped systems when the heating load does not exceed 20,000 MBh.

(3) High Temperature Systems.

- (a) These systems are suitable for use (1) where the heating load exceeds 10,000 MBh, and (2) in central heating systems where heat is supplied from a central plant and (3) where water-to-water heat exchangers are used.
- (b) High temperature systems shall not be used for heating individual buildings or as the direct heating system, except where medium pressure steam might normally be used.

b. Special Considerations.

(1) Low Temperature Water Systems.

- (a) The series loop system requires flow control devices in all branches.

(2) Medium Temperature Water Systems.

- (a) For economical design and operation, temperature drop should range from 50° to 160° F.
- (b) The pipe expansion design used with this system is similar to the steam heating system's piping design.

(3) High Temperature Water Systems.

- (a) For economical design and operation, temperature drop should be 160° F or greater.
- (b) Dry nitrogen may be used for pressurizing the compression tank.
- (c) These systems shall be vented at all points with a small needle valve and an air-collecting chamber.

3. Hot Air Heating Systems.

Hot air heating systems supply air to a space at a higher temperature than the indoor design temperature. The air is normally heated by steam coils, hot water coils, electric resistance coils, or warm air furnaces. The design of these systems varies according to the facility's anticipated heat loss. See the NESCA Standards for specific design criteria.

a. Applications and Limitations.

- (1) In residential and small structures with heat losses less than 120,000 Btuh, single-zone perimeter hot air systems with ductwork below the floor may be used.
- (2) Structures with heat losses between 120,000 and 350,000 Btuh commonly have spaces with heating and ventilating loads which are not suitable for single-zone heating. In such cases, multiple, single-zone units; multizone units or combined hot air systems with hot water heat emission units may be used.
- (3) In structures with heat losses greater than 350,000 Btuh, a central fan system is suitable.

b. Special Considerations.

- (1) Spaces with stringent requirements for control of cleanliness, humidity and temperature usually

require additional design considerations with respect to air distribution.

4. Radiant Heating Systems.

Radiant heating systems employ large surfaces such as floors, ceilings, walls or a combination of surfaces heated to temperatures slightly higher than the inside temperature. The heating medium for radiant heating systems may be water, air or electricity.

a. Applications and Limitations.

- (1) Radiant heating systems are suitable for heating concrete floors on grade such as living quarters or vehicle repair shops. They are not suitable for industrial buildings having concrete floor on grade or for buildings with short or intermittent occupancy.

b. Special Considerations.

- (1) The cold or exterior sides of radiant heating surface shall be insulated to prevent heat loss.

5. Infrared Heating Systems.

Infrared heating systems are used primarily as spot heaters. The heating units may be electric, gas-fired or oil-fired.

a. Applications and Limitations.

- (1) Infrared heating systems are suitable for use only where heating of the entire ambient air is not required; for example, loading docks, fabrication shops or warehouses.

b. Special Considerations.

- (1) For most efficient use of an infrared system, line of sight and distance between the occupant and the heater must be considered.
- (2) Installation shall be in accordance with NFPA Standard, No. 31.

6. Electric Heating Systems.

Electric heating systems employ electricity to heat the air or water medium. A life cycle cost analysis, which includes added cost for demand charge, shall be conducted to determine the most economical method for heating prior to design of an

electric system. The use of electric heat requires approval of NAVFAC, requested through the EFD.

a. Applications and Limitations.

(1) Electric heating systems may be used:

- (1) in locations where 85 percent of the total power generated by the supplier is obtained from hydroelectric, nuclear, geothermal or coal generated power
- (2) in small, remote structures which cannot be heated economically by a central system or a self-contained system
- (3) in residential buildings when it is more economical in overall cost than a hot air system
- (4) in residential buildings as a supplemental heating system in spaces which require a higher space temperature
- (5) when an employee has a medical condition and a physician's statement saying the employee must work in a warm environment.

b. Special Considerations.

- (1) When possible, heating energy shall be generated during off-peak hours and stored in thermal storage tanks to alleviate the added expense of demand charges.
- (2) Facilities occupied less than 168 hours per week shall have a temperature setback to 50° F during unoccupied hours.
- (3) Safety disconnect switches shall be provided to disconnect the power supply in the event of failure of the air-circulation fan.

7. Heat Pump Heating Systems.

The main considerations in heat pump design shall be to provide the necessary winter heating requirements with as small a heating apparatus as possible. When considering the use of supplementary electricity for heat pumps, a thorough engineering analysis of all available energy sources and systems is required (See DoD 4270.1-M). The most efficient method of using electric power for heating is the water-to-air heat pump; the air-to-air heat pump is second in efficiency; and the third is the water-to-water heat pump. Therefore, when considering heat pumps, the water-to-air pump should be considered first.

a. Applications and Limitations.

(1) Water-to-Air Heat Pump System.

- (a) This system shall be used for facilities with heat loads up to about 50 tons.
- (b) A water supply at fairly constant temperatures and with minimum scaling or corrosive properties is required. During the winter, the water temperatures shall not fall below 50° F.
- (c) A suitable means for waste water disposal shall be determined prior to design of this system.
- (d) Wherever economically feasible, the internal heat of the building shall be used as a heat source.

(2) Air-to-Air Heat Pump System.

- (a) This system shall be used for facilities with loads up to 20 tons.
- (b) This system is suitable for use when the heating design temperature is 17° F (97-1/2 percent dry-bulb basis) or higher, and the yearly total heating degree-days is less than 4,000. This system shall not be used where 30 percent or more of the total annual hours below 65° F fall between 1 May and 1 November.
- (c) The temperature difference between the heating medium and the space to be heated shall be as small as possible. The temperature of the heating medium shall be scheduled with the outdoor air temperature. If a zone is subject to solar radiation, the temperature of the heating medium shall be scheduled with a compensating thermostat.
- (d) Mechanical systems shall not be unduly complicated and shall not be designed to require extensive maintenance and supervision.

(3) Water-to-Water Heat Pump System.

- (a) This system shall be used in facilities with heat loads above 50 tons.
- (b) In buildings where simultaneous interior cooling and perimeter heating are required, the water-to-water heat pump system may be energy



efficient if designed properly. Heat should be removed from the air conditioned space and transferred to the space requiring heating by a closed-loop water circuit. An auxiliary hot water boiler should be installed in series with the hot water supply to the perimeter heating units for additional heating when required.

b. Special Considerations.

- (1) The added cost of demand charges, as well as estimated power consumption and peak demands shall be considered in the cost analysis. Where power suppliers use natural gas to generate more than 10 percent of the total annual output, the probability of increased "fuel adjustment charges" caused by conversion to higher priced fuels shall also be a cost consideration.
- (2) For the air-to-air heat pump system, the possible requirement for additional power transmission and substation capacity shall be given full consideration.
- (3) To justify an electric heat pump system, annual owning and operating expenses during heating seasons shall be less than if heating by fossil fuel.

8. Solar Heating Systems.

Solar heating systems convert solar radiation into a usable heating source; they may be active or passive systems with water or air used as the heating medium. Solar heating systems may be used alone or in conjunction with mechanical systems depending upon the design requirements of the facility, the geographic location and the economic feasibility of the desired system.

a. Applications and Limitations.

- (1) Solar heating systems shall be selected and designed in accordance with MIL Handbook 1003/13.

b. Special Considerations.

- (1) A life cycle cost analysis shall be conducted and the results shall be approved by NAVFAC, requested through the EFD, prior to system design.

9. Humidification Systems.

The humidity of a space depends on the changes in moisture content of the hygroscopic material in the space and the

quantity and thermodynamic properties of air entering by infiltration or ventilation. The sensible heat added to the air when using pan or spray humidifiers shall be included in the heat consumption of the humidifier. The quantity of sensible heat loss depends on the design feature of the humidification equipment and is obtainable from the manufacturer's data.

a. Applications and Limitations.

- (1) According to the comfort charts in the ASHRAE Fundamentals Handbook, the wet-bulb temperature should be between 50° and 70° F in the winter. The outdoor winter design conditions for most regions show the moisture content of outdoor air to be relatively low even if the air is saturated. Therefore, to obtain winter humidities of 30 percent or above, it is necessary to add moisture to the air.

b. Special Considerations.

- (1) The following formula shall be used to determine the quantity of water required to increase the humidity of the ventilation air to room conditions:

$$\text{Equation: } W = Q (gr_2 - gr_1) \times \frac{60}{13.5 \times 7000} \quad (15)$$

Where:

- W = Water to be evaporated (pounds per hour)
- Q = Air entering the room (cubic feet per minute)
- gr<sub>2</sub> = Moisture in dry air corresponding to supply air conditions as obtained from psychrometric chart (grains per pound of dry air)
- gr<sub>1</sub> = Moisture in dry air corresponding to the design room condition as obtained from psychrometric chart (grains per pound of dry air)

- (2) Humidity shall not be raised more than absolutely necessary, due to high energy consumption for humidification.

10. Snow Melting Systems.

Snow melting systems may be pipe coils with forced mechanical circulation of heating fluid or electric high-resistance cables.

a. Applications and Limitations.

- (1) Snow melting systems are suitable for areas which require maintenance of traffic facilities, such as sidewalks, roadways, ramps and runways, despite adverse weather conditions.
- (2) The heating medium may be water mixed with antifreeze or it may be a heat transfer oil. Preference shall be given to heat transfer oil. Selection of the heating medium shall be based on both initial and operating costs of the system. Electric coils are not recommended based on high energy requirements.

b. Special Considerations.

- (1) Cathodic protection shall be provided when soil resistivity is less than 30,000 ohm-cm.
- (2) Consideration shall be given to waterproofing the system.

B. SYSTEM SELECTION CRITERIA.

The selection factors for heating systems for Naval Shore Facilities shall be based on the policy and design criteria as presented in Section 1. Specific factors requiring more detail are listed and explained in this section.

1. System Capacity Design Criteria.

The system capacity shall include the building heating load, the process heat load, domestic hot water heating load, and the ventilation load.

a. Design Considerations.

- (1) The building heating load and ventilation load shall be calculated as indicated in Section 1.
- (2) The total heating system capacity shall be based on normal demand rather than total connected load. Where a heating plant is utilized for loads which are not simultaneous (building heating loads, kitchen equipment loads, domestic hot water and process loads), the system shall be analyzed for the connected normal demand and off-peak conditions.
- (3) Individual terminal heating equipment shall be capable of supplying the maximum load for the required duration without adverse effects.

- (4) When the heat generating equipment is divided into two or more units, the division and size of each unit shall be determined from (1) the initial cost, (2) the standby capacity requirements, (3) the lowest required operating efficiency at off-peak conditions, and (4) the load requirements and total operating time at various loads.
- (5) Internal loads shall be neglected in heat loss calculations performed to size heating equipment.
- (6) Internal loads shall be considered when developing a heat balance to evaluate the application of heat recovery systems.
- (7) Building exposure shall be omitted in heat loss calculations.
- (8) Even when night temperatures in heated spaces are reduced to save energy, a heating plant sized to supply both heating and process loads does not require oversizing to permit quick pick-up.
- (9) If space heating is the only load connected to the heat generating equipment and night temperatures in heated spaces are reduced, the equipment shall be oversized by 10 percent to allow for quick pick-up. Terminal equipment shall not be oversized for quick pick-up.

b. Special Considerations.

- (1) None.

2. Individual/Central Heating Plants.

a. Individual Heating Plants.

- (1) Individual heating plants shall be selected when they are more economical than central heating plants as outlined in DM-3.6. Individual heating plants should be considered:
  - (1) when only a single building is under consideration
  - (2) when continuity of service is essential or when damage to a central heating plant cannot be tolerated
  - (3) for residences or quarters where the occupants pay for the utilities.

b. Central Heating Plants.

- (1) Central heating plants shall be selected when the total owning and operating cost of a central heating plant and its connecting distribution system is more economical than the owning and operating costs of an individual heating plant as outlined in DM-3.6.

c. EQUIPMENT SELECTION CRITERIA

Selection of heating equipment shall be based on Naval administrative policy, the size of the system, the anticipated useful life of the facility, the availability of a heat source for regeneration and the temperature control requirements.

1. Radiators, Radiant Convectors and Finned-Tube Radiation Units.

a. Design Considerations.

- (1) Baseboard radiation units are one of two types: finned tube and radiant convector units.
- (2) These units are suitable for use with steam or hot water heating systems.
- (3) Three types of covers are acceptable: solid, front-slotted; expanded-metal; and enclosed-cabinet.
- (4) Heat output ratings of cast-iron or baseboard unit elements shall be adjusted for the type of cover utilized.
- (5) Piping systems may be zoned, with each zone having an automatic control valve or pump controlled by a zone thermostat.

b. Special Considerations

- (1) Cast-iron and baseboard units shall be given equal consideration; however, baseboard units are preferred where appearance and compactness are of primary importance.
- (2) Wall-hung arrangements for radiation units shall be used to facilitate cleaning.
- (3) Flush-mounted units with solid, front-slotted covers should be used for senior officers quarters.
- (4) Baseboard radiation units are suitable for residences and offices.

- (5) Expanded-metal covers shall be considered adequate when used with baseboard units in industrial buildings.
- (6) Enclosed cabinet convactor covers shall be used with cast-iron or finned-tube units in buildings such as chapels, senior officers' residences, schools and hospitals.
- (7) Cast-iron radiators shall be covered only if appearance is of primary concern.

2. Electric Convectors or Strip Heaters.

a. Design Considerations.

- (1) Electric convectors or strip heaters shall be controlled by either an integral thermostat or a space thermostat.
- (2) Three types of covers are acceptable: solid, front-slotted, expanded-metal, and enclosed-cabinet.

b. Special Considerations.

- (1) None.

3. Radiant Heating Equipment.

a. Design Considerations.

- (1) Heating elements or ducts may be imbedded in metal panels, plaster or concrete. Metal panels or plaster are generally used in ceiling radiant heating systems. Plaster is used for wall systems. Concrete is used basically as a floor system.

b. Special Considerations.

- a. See ASHRAE Systems Handbook for additional information.

4. Unit Heaters.

a. Design Considerations.

- (1) Unit heaters are suitable for buildings such as shops, hangars, garages, gymnasiums.
- (2) Unit heaters use heat from steam, hot water, gas, oil or electric systems.

- (3) Unit heaters are usually suspended with the air flow either vertical or horizontal; air is circulated by propeller or centrifugal fans. Horizontal units are usually used with low to moderately high ceilings. Vertical units are used with high ceilings or where floor and wall space is limited.
- (4) Where heating requirements are intermittent, unit heaters with heat emission 25 percent greater than the calculated heat loss shall be used to provide for the building pick-up load.
- (5) Where the ductwork is connected to the unit heater, flexible connectors shall be used. The air velocity in the duct shall not exceed the air velocity developed across the face area of the heater.

The heaters shall be the vented type where the combustion products are directed outdoors with no cut-off dampers, except for back-draft hoods, unless located in an industrial area with sufficient ventilation to remove combustion products and avoid condensation. Installation shall comply with NFPA Standard, No. 31 and applicable codes.

- (6) Open flame, direct-fired heaters may be used only if they have suitable flame guards and are vented.
- (7) Direct-fired heaters shall be models approved by the American Gas Association or other approved testing agencies.
- (8) Gas connections to heaters shall be either rigid pipe or approved copper tubing. Flexible hose shall not be used unless it is American Gas Association approved flex metal hose.

b. Special Considerations.

- (1) The air temperature supplied by a unit should be 50° to 60° F higher than the temperature entering the unit.
- (2) To prevent stratification where unit heaters are located high, the discharge temperature of the air shall be lower than if the heater is located closer to the floor to insure that heat will reach the occupied space. Consideration should be given to unit heaters with centrifugal fans with vertical discharge nozzels where noise level is critical.

- (3) Where direct-fired unit heaters are installed within confined spaces, the minimum size of outdoor air intake vent for combustion air shall be 1 square-inch free area for each 1,000 Btuh of heating input capacity.
- (4) Where direct gas fired unit heaters are located in spaces where a negative pressure (with relation to outdoors) may occur, power ventors shall be used.
- (5) Wall or recessed type gas-fired space heaters used in personal living quarters shall be installed in accordance with DM-8 and NFPA.
- (6) Table 9 presents the information required on project drawings.

**TABLE 9**  
**Information Required on Project Drawings for**  
**Steam Unit Heaters, Hot Water Unit Heaters,**  
**Electric Unit Heaters, and Furnaces and Space Heaters**

Required Information	Type of Unit Heater			Furnaces & Space Heaters
	Steam	Hot Water	Electric	
Capacity:				
Btuh . . . . .	X	X	---	X
Kv . . . . .	---	---	X	---
Operating pressure:				
Steam, psig (actual) . .	X	---	---	---
Water, psig . . . . .	---	X	---	---
Operating temperature:				
Water, F . . . . .	---	X	---	---
Air temperature, F:				
Entering . . . . .	X	X	X	X
Final . . . . .	X	X	X	X
Air delivery, cfm @70 F .	X	X	X	X
Air discharge velocity, cfm . . . . .	X	X	X	---
Fan speed, rpm . . . . .	X	X	X	---
Condensate, lb/hr . . . . .	X	---	---	---
Air pressure drop through heater, in. of wter . . . . .	X <sup>1</sup>	X <sup>1</sup>	X <sup>1</sup>	X

<sup>1</sup> For centrifugal fan units only.



5. Duct Heaters.

a. Design Considerations.

- (1) Duct heaters shall be used to heat outdoor air which is ducted to specific spaces.
- (2) Duct heaters normally use heat from gas or electric systems.
- (3) Where the ductwork is connected to the duct heater, flexible connectors shall be used.
- (4) Direct-fired heaters shall be models approved by the American Gas Association or other approved testing agencies.
- (5) Gas connections to heaters shall be either rigid pipe or approved copper tubing. Flexible hose shall not be used unless it is American Gas Association approved flex metal hose.
- (6) In small structures, duct heaters shall have room thermostat to control the circulating fans.

b. Special Considerations.

- (1) Table 9 is a list of the information required on project drawings for duct heating systems.
- (2) Where duct furnaces are located in a space where a negative pressure with relation to the outdoors may occur, power ventors shall be used.

6. Heating Coils.

a. Design Considerations.

- (1) Steam and hot water coils are suitable for preheating or reheating purposes or for use as booster heaters. They may be used for warm air or ventilation air heating. Finned coils shall be used.
- (2) If hot water is the heat source for the coils, it shall enter on the air-exit side of the coils and exit on the air-entering side. Continuous high velocity water flow shall be maintained for coils handling outdoor air.
- (3) A vertical tube, top-fed coil shall be used for steam heating to insure good condensate drainage of steam coils. Traps should be sized 2 to 3 times the operating capacity of the coil to prevent back-up

and freezing in the coils. Vacuum breakers shall be installed in the condensate lines to prevent drawing the condensate back into the coil and freezing.

- (4) The condensate shall not be lifted if a modulating control valve is used because all available steam pressure can be expanded through the control valve, leaving no pressure for lifting the condensate.
- (5) A circulating pump shall be provided on preheat coils where a constant water flow is required to prevent freezing.
- (6) Use of antifreeze solution shall be considered for water coils subject to freezing temperature. Derate all capacities when using antifreeze solutions.

b. Special Considerations.

- (1) The heating capacity of a coil increases with an increase in the face velocity of the air passing through it or with an increase in average coil surface temperature. The most efficient range of air velocities is 500 to 650 feet per minute. An increase in air face velocity will raise the air pressure drop which reduces the efficiency required to move air through the coil.
- (2) Table 9 is a list of information required on project drawings for furnaces and space heaters.

7. Combined Heating and Ventilating Units.

a. Design Considerations.

- (1) Heating and ventilating units are designed to handle outdoor air and recirculated space air.
- (2) These units may be connected to duct systems to distribute warm air, if sufficient static pressure is available, or they may have a stub discharge or a directional nozzle if the unit is installed within the space to be heated. The fans shall be sized to develop the required static pressure for sufficient air delivery.
- (3) These units may be mounted on the floor, on the wall, or they may be suspended from the ceiling.

b. Special Considerations.

- (1) See the ASHRAE Equipment Handbook for additional information.

8. Condensate Cooler.

a. Design Considerations.

- (1) Condensate coolers may be used to preheat domestic hot water or preheat boiler make-up water.
- (2) The condensate cooler shall be sized for the discharge capacity of the condensate pump rather than the normal condensate rate of the system.
- (3) If the condensate cannot be returned to the boiler, sending it through a condensate cooler for heat recovery before dumping into a drainage system drain pit should be considered. Check local, state and federal codes and DM-5 Series.
- (4) The condensate cooler shall be located below the water heater if possible. An alternate arrangements for cooling water flow shall be provided since domestic hot water may not be continuous.
- (5) A water-seal loop shall be used in the condensate return inlet to the condensate cooler in order to keep the unit in flooded condition and improve heat transfer.

b. Special Considerations.

- (1) See the ASHRAE Systems Handbook for further information.

9. Condensate Return Pumping Unit.

a. Design Considerations.

- (1) Condensate return pumping units shall be the duplex type and equipped with an automatic sequence alternator.
- (2) Condensate pumps shall be used when the condensate cannot be returned by gravity.
- (3) The capacity of each pump of a duplex unit shall be three times the normal condensation rate.
- (4) Each pump on a receiver shall have an isolation valve for separate maintenance requirements.

b. Special Considerations.

- (1) Corrosion is less of a problem with vertical receivers because the amount of wet surface area exposed to air is less than that in horizontal receivers.
- (2) The information required on project drawings is presented in Table 10.

TABLE 10  
Information Required on Project Drawings for  
Condensate Return Pumping and Vacuum  
Return Pumping Units

Required Information	Condensate Return Pumping	Vacuum Return Pumping
Capacity: ft, EDR <sup>1</sup>	X	X
Operating discharge pressure, psig (actual)	X	X
<sup>1</sup> One square foot of EDR is defined as the emission of 240 British thermal units (Btu) per hour with steam at 215 F. in an ambient temperature of 70 F.		

10. Vacuum Return Pumping Unit.

a. Design Considerations.

- (1) Vacuum return pumping units shall be the duplex types with two vacuum pumps and two air pumps.
- (2) Vacuum pumps shall be used on vacuum and sub-atmospheric systems where piping and radiation equipment are under a vacuum.
- (3) Systems designed for a 10-inch mercury vacuum shall have air pumps with the capacity of at least 3.0 c.f.m./1000 MBh.
- (4) Systems designed for a 20-inch mercury vacuum shall have air pumps with a capacity of 4 to 8 c.f.m./1000 MBh.

b. Special Considerations.

- (1) The information required on project drawings is presented in Table 10.

11. Lift Traps and Fittings.

a. Design Considerations.

- (1) Lift traps and fittings shall not be used on low pressure heating systems.
- (2) Lift traps and fittings shall be used as little as possible in high pressure systems.

b. Special Considerations.

- (1) None.

12. Flash Tanks.

a. Design Considerations.

- (1) A flash tank shall be used to cool medium pressure and high pressure condensate below the flash-point before the condensate enters a low pressure condensate return system. When the quantity of high-temperature condensate is less than 100 pounds per hour, it is not necessary to use a flash tank. The condensate shall be run directly to condensate receiver or low pressure return main.
- (2) The flash steam may be piped to a low pressure main, vented to atmosphere outside building, or fed to unit heaters in a space which always requires heating.
- (3) When condensate is returned to a vacuum system, a float trap shall be provided.

b. Special Considerations.

- (1) See the ASHRAE Systems Handbook for a diagram and sizing information.

13. Humidification Equipment.

a. Design Considerations.

- (1) Humidification equipment shall be used only as directed by DoD 4270.1-M.
- (2) There are five basic types of humidifiers: (1) pan, (2) steam, (3) infrared, (4) atomizer and (5) wetted element.
- (3) The evaporation rate from humidification equipment is dependent on air temperature, humidity and air

velocity. See the ASHRAE Equipment Handbook for further information.

- (4) Humidifiers shall be located in the supply air stream to obtain the proper mixture of vapor before it is introduced into the space.
- (5) Humidifiers shall be located after the heating coil when the system has a heating coil to facilitate moisture pick-up.
- (6) Humidifiers shall be located after the heating coil and before the supply fan if central humidification is required.

b. Special Considerations.

- (1) Humidifiers generally should not be located inside the space to be conditioned.

14. Piping System Equipment.

a. General Design Considerations.

- (1) Piping layouts shall provide for flow control, sub-system isolation, pipe expansion, elimination of water hammer, air removal, and cathodic protection.
- (2) Pipes shall be pitched properly to avoid undrained pockets.
- (3) A large pipe size shall be used to prevent high steam velocity when condensate flows are opposite to the steam.
- (4) Expansion of steam and hot water piping shall be compensated for by offset legs, expansion loops or a combination of loops and legs. Expansion joints and ball joints shall be provided only when space restrictions make it difficult to use loops or legs.
- (5) The design of pipe expansion shall be in accordance with DM-3.8.
- (6) Isolation and drain valves are required in all piping systems.
- (7) Gate and butterfly valves shall be used only in open or closed position and shall provide positive shut off.
- (8) Angle, globe, plug and needle valves may be used for throttling service. For severe throttling service,

use valves with seats and discs of a minimum hardness of 300 Brinell.

- (9) Cathodic protection shall be provided as required because of dissimilar metals, stray currents or composition of soil (if direct burial pipe) as described in the DM-4 Series.
- (10) Piping should not be concealed unless absolutely required. When concealed, access openings shall be provided for servicing.
- (11) Additional piping information is given in Section 4.

b. Radiators, Convectors and Finned-Tube Unit Piping Connections.

- (1) Design Considerations.
  - (a) Multiple rows of finned-tube units should be arranged in a serpentine fashion.
  - (b) See the ASHRAE Systems Handbook for piping arrangements.
- (2) Special Considerations.
  - (a) Piping must be arranged to maintain the proper pitch under expansion and contraction pressures.
  - (b) Air vents shall be provided for system venting.

c. Unit Heater Piping Connections.

- (1) Design Considerations.
  - (a) See the ASHRAE Equipment Handbook for piping arrangements.
- (2) Special Considerations.
  - (a) None.

d. Condensate Traps.

- (1) Design Considerations.
  - (a) Condensate traps are used to drain steam mains, steam fed unit heaters, radiators, convectors, heating coils, water heaters and heat exchangers.

- (b) Condensate traps shall be provided at all low points in the steam piping system, providing relatively dry steam downstream of the trap location and reducing the possibility of water hammer in the piping.
- (c) The types of condensate traps used for heating are:
  - (1) float trap
  - (2) thermostatic trap
  - (3) float and thermostatic trap
  - (4) inverted bucket trap
  - (5) impulse trap
  - (6) thermodynamic trap
  - (7) upright bucket trap
  - (8) lift trap
  - (9) alternating return trap
- (d) The float trap action is controlled by the condensate level in a float chamber and can be used to lift condensate.
- (e) The thermostatic trap may be used to automatically vent air and non-condensibles from large coils. It may be used with unit heaters, radiators, and convectors where the condensate flow is gravity-controlled from the trap. The results of misuse of this trap are trap chatter or trap failure to remain closed. This type of trap shall not be used as a lift trap.
- (f) The float and thermostatic trap may be used in most heating applications where air must be vented and the condensate main is above the trap. Two trap functions are contained in one housing: a thermostatic vent trap and a high capacity float trap for condensate removal.
- (g) The inverted bucket trap operates by using the buoyancy of an inverted bucket to hold the discharge port closed. Steam and non-condensable gases fill the inverted bucket making it rise and close the discharge port at the same time forcing condensate out of the discharge port until it closes. The steam and non-condensable gases are vented out of the inverted bucket through a small hole in the top allowing the steam to condense and the bucket to sink and start refilling with steam; then the cycle is repeated. For proper operation, the trap must be flooded. Inverted bucket



traps are used on low pressure systems particularly with blast coils or unit heaters. The discharge from this type of trap is intermittent and requires a definite pressure differential.

- (h) The various impulse and thermodynamic traps depend upon the difference in specific volume of steam and water to limit flow through a fixed size orifice for flow control. These traps do not work well in a system where the condensate can back against the operating mechanism of the trap and open it when there is no condensate flow from the upstream side. These traps are particularly useful for steam tracing of pipe lines where there will be some flow at all times.
- (i) The upright bucket trap operates by using the buoyancy of an open bucket, floating in condensate, to hold the discharge port closed. When the trap fills with condensate, it overflows into the bucket. The bucket sinks and opens its discharge valve. The incoming steam and condensate provide the pressure source to maintain flow until the flow is all steam when the bucket regains buoyancy, floats and closes the discharge valve. This trap is suitable for a lift situation but requires a separate means of air removal such as a thermostatic trap.
- (j) Lift traps are a special form of upright bucket trap used to discharge condensate into an overhead condensate return main.
- (k) The alternating return trap is a specific form of lift trap used in lieu of a boiler feed pump. A float valve opens the vent valve to the atmosphere and the condensate flows into the piping system and the float chamber by gravity. The vent valve closes and boiler steam is admitted to the float chamber to equalize pressure and permit flow of condensate to the boiler by gravity. When the float chamber empties of condensate, the float sinks, the vent valve opens, and the cycle is repeated.

(2) Special Considerations.

- (a) For equipment with automatic controls, a check valve shall be provided to equalize the vacuum across the steam trap.

- (b) See the ASHRAE Systems Handbook for further limitations and applications of traps.

e. Heating Coil Valves.

(1) Design Considerations.

- (a) On steam and hot water coils, a control valve shall be used to control the heating medium to maintain space requirements.
- (b) Temperature regulating valves shall be used to regulate flow through steam coil.
- (c) A three-way valve or two-way valve shall be used to control flow of water through heating coils. A three-way valve will maintain constant flow through the mains, while a two-way valve will vary the water flow in the mains.
- (d) If a two-way valve method is used, a bypass valve shall be installed near the pump or a variable speed pump shall be used. In a large system with many coils, two-way valves may be more economical than three-way valves.

(2) Special Considerations.

- (a) None.

f. Pressure Reducing Valves.

(1) Design Considerations.

- (a) A single stage or multi-stage pressure reducing station shall be used, depending on the initial steam pressure and building requirements. See the ASHRAE Systems Handbook and the DM-3.8 for design.
- (b) Generally, separate pressure reducing valves and separate mains should be provided for processing and heating functions within the same building.

(2) Special Considerations.

- (a) When an absorption refrigeration system is a major portion of the steam demand of a building, a separate pressure reducing station shall be provided for the absorption machine, or a back-pressure regulator valve shall be

provided to limit steam demand on start-up of the absorption unit.

- (b) Steam traps shall be installed ahead of pressure reducing valve stations.

15. Instrumentation.

a. Thermometers.

(1) Design Considerations.

- (a) In piping systems, thermometers shall be located on the:

- (1) boiler-water leaving and entering pipes
- (2) heat exchanger water leaving and entering pipes
- (3) return pipe from each zone in a multi-zone system
- (4) hot water supply and return pipes from each set of coils
- (5) condensate cooler-condensate entering and leaving pipes.

- (b) In duct systems, thermometers shall be located:

- (1) in the outdoor air duct
- (2) in the return air duct
- (3) before and after each coil.

(2) Special Considerations.

- (a) Thermometer wells may be used in lieu of fixed permanent thermometers.

b. Pressure Gages.

(1) Design Considerations.

- (a) Pressure gages shall be located:

- (1) at the boiler discharge
- (2) before and after each pressure relief valve station
- (3) at suction and discharge flange of each circulating pump.

(2) Special Considerations.

- (a) Pressure gage tappings with gage cocks may be used in lieu of fixed permanent pressure gages.

c. Thermometer Wells and Pressure Gage Tappings.

(1) Design Considerations.

- (a) Thermometer wells shall be located in individual heating coil return piping and in the unit heater return piping.
- (b) Tappings complete with gage cocks shall be located in the steam inlet to each unit heater or heating coil and in the supply and return mains of each zone in multizone systems.

(2) Special Considerations.

- (a) Energy monitoring and control system monitoring points shall be installed as required by the EFD.

d. Flow Indicators.

(1) Design Considerations.

- (a) Flow indicators may be installed in pump returns for hot water systems.

(2) Special Considerations.

- (a) None.

e. Condensate Meters.

(1) Design Considerations.

- (a) Condensate meters are required for facilities served by central heat distribution system.

(2) Special Considerations.

- (a) Condensate meters shall be installed prior to building condensate connecting to central system return piping.

**D. SYSTEM CONTROLS**

1. Control Systems Description.

Control systems shall be as simple as possible but sufficient to meet the design conditions. They shall be designed for automatic compensation due to load changes in order to reduce operating expenses and conserve energy. Limit controls and safety controls shall be an integral part of the system and

designed to shut down the heating system if a control device fails or the electrical circuits overload.

Thermostats located in normally occupied spaces shall be factory-set as specified in DoD 4270.1-M. No space thermometers shall be provided. A thermostat shall be used to control radiators, convectors, finned-tube radiation or fan-coil units serving a single room. Preference shall be given to factory-installed internal thermostats which modulate water or steam flow or fan speed. Zone controls may be used for ducted warm air systems and hot water systems except where individual room fan-coil units are used. A time controller shall be integrated into the system to permit night and weekend temperature reduction. Heating systems shall be provided with an outdoor temperature sensing control which cuts off the heating system for all facilities when the outdoor temperature exceeds 65° F.

The power supply for control systems may be pneumatic, electric or hydraulic. Pneumatic control systems utilize compressed air at a pressure of 15 to 35 psig to control equipment. Electric/electronic systems use low voltage or line voltage to control equipment either directly or through pneumatic-electric relays. Hydraulic systems shall be used for control operation where pressures considerably higher than normally used by pneumatic systems are required for actuator operation.

a. Manual Control Systems.

Manual control systems provide only equipment on/off capabilities.

(1) Application and Limitations.

- (a) Manual controls are used (1) on equipment requiring strictly on-off modes, (2) where manual control of equipment speed or temperature variation is required and (3) when semi-automatic or automatic controls are not cost effective.
- (b) This method of control is generally limited to equipment that is to be left running or to spaces where the equipment is turned on when occupied and off when unoccupied. They may be used on individual space heating systems, such as radiators, convectors, and finned-tube radiation units.

(2) Special Considerations.

- (a) Manual control systems are quite often energy inefficient since equipment runs longer than necessary and spaces may become overheated.

b. Semi-Automatic Control.

Semi-automatic controls consist of two-position valves, modulating valves and damper controls that are actuated by room thermostats, master/submaster thermostats or pressure switches. The room thermostat shall be the master and the discharge thermostat shall be the submaster. The master thermostat shall reset the submaster according to room temperature requirements.

Air flow may be varied by using face and bypass dampers. Face and bypass damper control is to be used only when control of one variable is desired, usually dry bulb temperature. This type of control shall not be used for systems utilizing a high percentage of outdoor air, unless arrangements are made to humidify all the outdoor air and bypass the room air only. This control should be considered when diversity in heating load is desired.

A minimum fixed outdoor air supply control shall be used with semi-automatic control systems. Outdoor air dampers shall be interlocked with the supply fans, and the dampers shall open only when the supply fan is operating.

(1) Applications and Limitations.

- (a) Semi-automatic controls may be used on all heating systems where a manual on/off is provided for equipment start-up and shut-down, but automatic operation is required. The limitation for this type of control system is the need for personnel to start and stop each piece of equipment.

(2) Special Considerations.

- (a) Semi-automatic controls provide decreased energy consumption by supplying heat as necessary to meet heating demands.

c. Automatic Control Systems.

Automatic control systems are fully automated to include automatic on/off capabilities based on time clocks or temperature sensing devices. Fully automatic control systems may be used in conjunction with energy monitoring and control systems as discussed in Section 6 and DM-3.12.

(1) Applications and Limitations.

- (a) Automatic control systems shall be used for heating systems where the equipment is to operate over a 24 hour period.

(b) Automatic controls may be used on any heating system since they provide the most energy conscious method for operating a heating system.

(c) Night setbacks shall be used where possible to reduce energy consumption. Time clocks shall be used to turn off fans and pumps during unoccupied hours.

(2) Special Considerations.

(a) Automatic control systems provide the most energy efficient controls for a heating system.

2. System Controls Selection Criteria.

a. Radiators, Radiant Convectors and Finned-Tube Units

(1) Thermostatic control valve should be used when modulated hot water heating or low pressure steam is used. If thermostatic control valve is not used, a damper which will reduce the unit output at least 50 percent shall be used in the unit cover.

(2) Hot water heating radiation systems over 250 MBh shall have an outdoor temperature controlled reset schedule (Fig. 5) with positive shut off when outdoor air is 55° F or over.

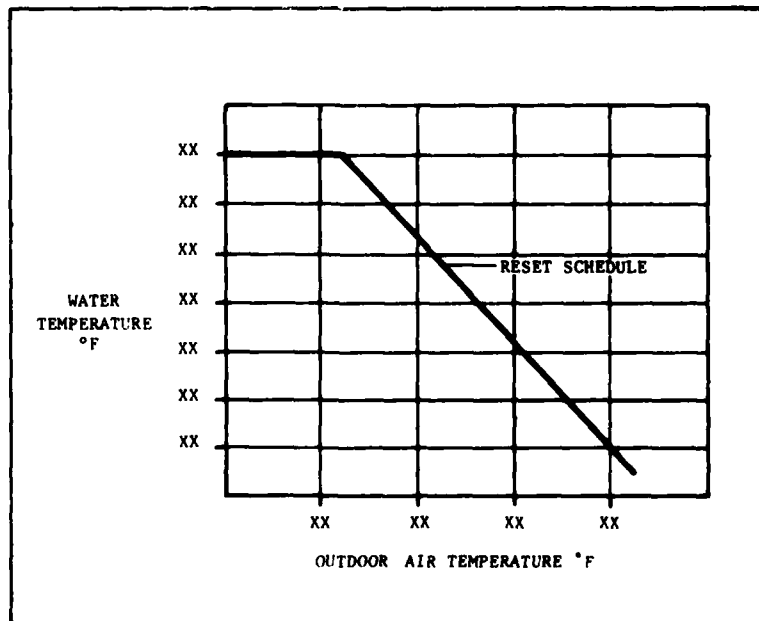

FIGURE 5  
Hot Water Reset Schedule

- (3) Room thermostatic control of pump shall be considered adequate for small systems installed in structures such as residences.

b. Electric Convectors or Strip Heaters.

- (1) Electric convectors or strip heaters shall be controlled by either an integral thermostat or a space thermostat.
- (2) Bathroom electric heaters shall be controlled by a maximum time setting of 30 minutes.
- (3) Thermostats shall be factory set for a maximum of 75° F and shall have a positive shut off when outdoor air is 65° F or over.

c. Radiant Heating Equipment.

- (1) Radiant heating equipment shall have a positive shut off when outdoor air is 65 F° or over.

d. Unit Heaters.

- (1) Gas and oil direct-fired unit heaters shall be equipped with an automatic pilot device and shall fire automatically according to the load.
- (2) A steam unit heater fan may be controlled by either a pressure switch in the steam supply main or an aquastat in the condensate line.
- (3) The hot water unit heater fan may be controlled by an aquastat in the return line.
- (4) Electric unit heaters shall be provided with an air flow interlock to shut off the heater on low air flow.
- (5) In small structures, unit heaters shall have thermostatic controls for each room for circulating fans.
- (6) Unit heater system shall have a positive shut off when outdoor air is 65° F or over.

e. Duct Heaters.

- (1) Gas fired duct heaters shall be equipped with an automatic pilot device and shall fire automatically according to the load.



- (2) Electric duct heaters shall be provided with an air flow interlock to shut off the heater on low air flow.
- (3) Duct heaters shall have a positive shut off when outdoor air is 65° F or over.

f. Heating Coils.

- (1) On steam and hot water coils, a control valve shall be used to control the heating medium to maintain space requirements.
- (2) Where a continuous supply of steam or hot water is not maintained, controls shall be provided to stop the fan when supply of heat is discontinued to prevent the circulation of cold air and freeze-up of heating coils. The steam system may be controlled by a pressure switch in the supply main and the hot water system may be controlled by an aquastat in the return line.
- (3) When face and bypass dampers are used on hot water coil handling outdoor air, the coils shall be piped with a two-way valve which operates in the full open position when the fan is energized.
- (4) When using hot water coils, a freeze-stat in the air discharge shall be provided to stop the fan and close the outdoor air damper in locations where the air temperature is expected to drop below 35° F.
- (5) Three-way valves or two-way valves may be used on hot water coils. A three-way valve will maintain constant flow through the mains, while two-way valves will vary the flow in the mains. If two-way valves are used, a bypass valve shall be installed near the pump or a variable speed pump shall be used. In a large system with many coils, two-way valves may be more economical than three-way valves.
- (6) Temperature regulating valves shall be used to regulate flow through a steam coil.
- (7) Heating coils shall have a positive shut off when outdoor air is 65° F or over.

g. Combined Heating and Ventilating Units.

- (1) The controls for combined heating and ventilating units shall be the same as for duct heaters when gas or electricity is used for heating and the same as heating coils when steam or hot water is used for heating.

h. Condensate Cooler.

- (1) No special control considerations for this system.

i. Condensate Return Pumping Units.

- (1) The pumps shall be controlled by float switches in the receiver. When duplex systems are used, they shall be provided with an automatic sequence alternator.
- (2) If condensate is returned directly to the boiler, the pumps shall be controlled by the water level regulator on the boilers.
- (3) For a multi-boiler installation, each boiler shall have a safety feeder and air automatic feed valve or similar device to insure a constant water supply to the boilers.

j. Vacuum Return Pumping Units.

- (1) The air pumps shall be controlled by a vacuum switch. Duplex air pumps shall be provided with an automatic sequence alternator.
- (2) The condensate return portion controls shall be the same as for condensate return units.

k. Lift Traps

- (1) No special control considerations for this system

l. Flash Tanks.

- (1) No special control considerations for this system

m. Humidifiers.

- (1) Humidity control shall be set to the minimum required by the space due to the high energy consumption required for humidification.

n. Piping Systems.

- (1) Pressure Reducing Valves.
  - (a) Pressure reducing valves shall be used to reduce the steam pressure as it enters a space to the maximum pressure required by individual units served.

3. Control Systems Equipment Selection Criteria.

a. Two-Position Controls.

Two-position controls operate heating systems by automatic on/off cycling in response to a space thermostat.

(1) Applications and Limitations.

- (a) Two-position controls are suitable for all heating systems where control of only one variable is desired.
- (b) With this control method, a cycling effect is caused by the operating differential of the thermostat which in turn allows the space temperature to vary up and down several degrees.

(2) Special Considerations.

- (a) This system is best suited for spaces where a slight temperature variation from thermostat setting is acceptable.

b. Modulating Controls.

Modulating controls shall be used with semi-automatic and automatic systems. They provide variable heating capabilities in response to space temperature fluctuations.

(1) Application and Limitations.

- (a) Modulating controls are suitable for all heating systems where simultaneous control of one or more variable is desired.
- (b) This control method is best suited for spaces where accurate, even space temperature is desired.

(2) Special Considerations.

- (a) Modulating controls provide a more even consistent environment than do two-positioned controls.
- (b) They are generally more expensive and more complex.

### Section 3. VENTILATING SYSTEMS

#### A. VENTILATING SYSTEMS DESCRIPTION.

Ventilating systems shall supply air to or remove air from a space to meet the design conditions. Ventilation may be accomplished by natural supply and natural return systems, natural supply and mechanical return systems, mechanical supply and natural return systems, or mechanical supply and mechanical return systems.

Ventilation systems require both a means of supply and return to obtain air flow, even if both are by natural forces. Therefore, all ventilation systems can be classed as either natural, from natural forces only, or mechanical, if either the supply or return is mechanically induced.

##### 1. Natural Ventilation Systems.

Natural ventilation employs non-mechanical forces to induce air circulation and removal. Air movement is created by the natural forces of the wind, the stack effect and the interior-exterior temperature difference which causes natural structure breathing. In this type of system, air typically enters a structure through openings at or near the floor level and escapes through openings high in the walls or in the roof.

##### a. Applications and Limitations.

- (1) Natural ventilating systems shall be used where the required air quantity can be induced by natural forces.
- (2) Natural ventilation is not adequate for spaces which require a continuous supply of outdoor air for human comfort or for the safe utilization of a process area. In general, natural ventilation systems are not adequate for occupied spaces with the following conditions:
  - (1) the open window area is less than 5 percent of the floor area
  - (2) the space is over 24 feet deep and without a means for distributing the air over the full area and depth of the space
  - (3) there is a means of distributing the air, but occupants are over 35 feet from a window or air inlet

- (4) dining room has a window area less than 6 percent of floor area.

b. Special Considerations.

- (1) Air inlets shall be located on the windward side of the building based on the prevailing wind conditions.
- (2) Air outlets shall be located on the leeward side of the building based on the prevailing wind condition. Air outlets may be located on the roof in the form of gravity ventilators, continuous monitors or ridge ventilators. Roof-mounted gravity ventilators shall be stationary, pivoting wind directional or rotating-turbine type.
- (3) When natural ventilation is provided for temperature control, a manual or automatic control system shall be provided to modulate the air flow.

2. Mechanical Ventilation Systems.

Mechanical ventilation systems employ fans to induce positive air circulation within spaces. Air movement is provided by fans or by fans combined with supply air and return air duct systems.

a. Applications and Limitations.

- (1) Mechanical ventilation shall be used:
  - (1) where the necessary quantity of outdoor and/or use schedule cannot be met by natural forces
  - (2) where required by DoD 4270.1-M
  - (3) where processes produce noxious or hazardous fumes
  - (4) where dust or vapor creates unsafe or unhygienic conditions
  - (5) for supply of outdoor air and removal of air from a high occupancy space, such as an auditorium or a dining facility
  - (6) for odor removal in toilet rooms
  - (7) for limited comfort of operating personnel typically in laundries, projection booths and kitchens
  - (8) where electronic or electric equipment is in confined spaces and close control of operating temperature is required.
- (2) Spaces where exhaust systems are used to remove contaminated or hot air shall be maintained at a

negative pressure to prevent exfiltration to other areas. Negative pressure shall be created by exhausting 5 to 10 percent more air than the supply air.

- (3) Where outdoor air is supplied for human comfort or a dust-free atmosphere is required, the space shall be maintained at a positive pressure to prevent infiltration of outdoor air. The volume of supply air shall be 5 to 10 percent more than the return air.
- (4) A return system shall be provided if the outdoor air supplied for ventilation exceeds the amount of air that can escape through a structure by normal exfiltration or as required to provide proper system function.
- (5) If anticipated fumes and vapors have a specific gravity greater than air, exhaust intakes shall be provided at the floor level.
- (6) Supply air shall be provided for areas with large exhaust systems. The supply air shall be conditioned and filtered.

b. Special Considerations.

- (1) Explosion-proof ventilation equipment shall be provided for areas where explosive vapors or dust are anticipated.
- (2) Filters shall be provided where particulate matter must be removed from the supply and/or exhaust air. See Section 4 for filter selection criteria.
- (3) Selection factors for fans are given in Section 4.

B. SYSTEM SELECTION CRITERIA.

1. Selection Basis.

Selection factors for ventilation systems for Naval Shore facilities shall be based on the policy and design criteria presented in Section 1. Specific factors requiring more detail are listed and explained in this section. Design calculations are listed first, then the specific criteria are categorized by occupancy areas for the following:

- (1) human occupancy areas
- (2) toilet and related areas
- (3) food handling areas

- (4) process hood areas
- (5) high heat areas.

Human occupancy areas consists of work areas, including private office, barracks, auditoriums, classrooms, conference rooms and chapels. Toilet and related areas consist of public toilet facilities, washrooms, shower rooms, janitor's closets and garbage rooms. Food handling areas include kitchens, dining rooms, dishwashing facilities, bakeries, and flour storage areas. Process hood areas include facilities with processes or systems that produce toxic, noxious or irritating gases or dust. High heat areas consist of areas which require ventilation to reduce temperature to a safe or comfortable range.

2. Design Calculations.

a. Sensible Heating and Cooling.

For heating and cooling air requirements of ventilation systems designed to control temperature in a space, see calculations in Section 1.

b. Chimney Effect.

When the indoor temperature is higher than the outdoor temperature, a chimney effect occurs, reducing pressure at the lower levels and increasing pressure at the higher levels. The following pressure difference equation permits calculating the available thermal force.

$$\text{Equation: } P_c = 0.52 P (h) \left( \frac{1}{T_o} - \frac{1}{T_i} \right) \quad (16)$$

- where:
- $P_c$  = Theoretical pressure difference across enclosure due to chimney effect, inches of water
  - $P$  = Absolute pressure, pounds per square inch
  - $h$  = Distance from neutral pressure level, or effective chimney height, feet. (The neutral pressure level in tall buildings varies between 0.3 and 0.7 of the building height.)
  - $T_o$  = Absolute temperature outside the building, degrees Rankin
  - $T_i$  = Absolute temperature inside the building, degrees Rankin

3. Human Occupancy Areas.

For computing supply air quantities, the Human Occupancy Category is divided into three areas: (a) primary areas, (b)

secondary areas and (c) high ceiling areas. Primary areas require an exchange rate that adequately removes body odor and distributes outdoor air within the space. Secondary areas are lightly occupied spaces but have the potential for human occupancy. High ceiling areas are spaces with a ceiling height of over 10 feet above the floor.

a. Design Considerations.

- (1) Primary Areas. The supply air quantity shall be six (6) air changes per hour or greater.
- (2) Secondary Areas. The supply air quantity shall be four (4) air changes per hour or greater.
- (3) High Ceiling Areas. The supply air quantity shall be computed using the volume of the occupied zone based on a 10 foot ceiling height.

b. Special Considerations.

- (1) Air conditioned spaces shall have a supply air circulation rate sufficient to meet the cooling load.
- (2) Minimum ventilation air quantities for mechanically supplied systems (including air for pressurization and infiltration) shall be the greater of the following:
  - (1) exhaust air quantities plus 10 percent
  - (2) 0.125 cubic feet per minute outdoor air per square foot of net floor area
  - (3) 5 cubic feet per minute of outdoor air per person exclusive of infiltration
  - (4) 10 cubic feet per minute of outdoor air per person in areas where smoking is permitted. Smoking is prohibited in auditoriums, elevators, shuttle vehicles, conference rooms and classrooms. Smoking areas will be set up in eating facilities and are allowed as follows in medical facilities, staff lounges, private offices, and other specially designated areas. Smoking is allowed in work areas and toilet facilities.
- (3) Mechanical supply and return systems shall be provided for classrooms. Corridors shall not be used as return or exhaust plenums.



4. Toilet and Related Areas.

a. Design Considerations.

- (1) Toilet areas shall be maintained under a negative pressure to prevent exfiltration of odors to other areas.
- (2) Toilet and related areas in interior spaces or without operable sash shall be equipped with mechanical ventilation. Toilets, which are seldom used, do not require mechanical ventilation when they have (1) at least one exterior wall with operable windows, or (2) a roof with an operable skylight. The glass area shall be a minimum of 10 percent of the floor area of the space served and shall be 50 percent operable.
- (3) For toilet areas, janitor's closets and garbage rooms, except in Bachelor Enlisted Quarters and Bachelor Officers Quarters, or individual quarters the exhaust air rate shall be 2 cfm per square foot of net floor area.
- (4) For shower rooms with gang showers, the exhaust air rate shall be 20 air changes per hour.
- (5) Where a mechanical exhaust system is designed, make-up air shall be drawn from an adjacent area, or it shall be provided by a mechanical system.
- (6) Exhaust systems for toilet areas, shower rooms, janitor's closets and garbage rooms shall not be connected to other ventilating systems. Duct runs shall be as short as possible to avoid leakage of moisture.

b. Special Considerations.

- (1) Where transfer grilles or ducts are used for make-up air, noise transmission to other spaces should be considered. Consider use of sight tight grilles.

5. Food Handling Areas.

a. Kitchen Areas - Design Considerations.

- (1) The outdoor air supplied to dining areas shall be used as the kitchen make-up air. If this is not

adequate to meet the requirements noted below, filtered and heated air shall be ducted to the kitchen and directed into the space horizontally to provide adequate mixing without directly contacting kitchen personnel.

- (2) Air changes for non-air conditioned kitchens shall be:
  - (1) in temperate zones: approximately 30 air changes per hour
  - (2) in tropical and semi-tropical zones: approximately 60 air changes per hour.
- (3) Ranges, ovens, broilers, deep-fat fryers and other appliances that present a fire hazard shall have exhaust hoods, ducts and fans.
- (4) The hoods shall:
  - (1) be capable of extracting grease using centrifugal force.
  - (2) have an Underwriter Laboratory approved 350° F fixed setting thermostat to shut down the exhaust fan, close the fire damper and actuate a fire extinguishing system on each hood. An easily accessible, independent, well identified manual switch for manually actuating each hood's fire extinguishing system shall be provided.
  - (3) have a fire damper in the outlet.
  - (4) have a separate duct system and exhaust fan.
  - (5) have an automatic cleaning system.
- (5) The exhaust fan motor shall be out of the air stream.
- (6) Neither volume dampers or splitters shall be between a hood and the fan.
- (7) The duct velocity shall range between 1500 to 1700 feet per minute to maintain vapor and particulate matter in suspension.
- (8) Ductwork shall be corrosion resistant steel, water tight welded construction.
- (9) The volume of air supplied during the heating season and to air conditioned kitchens shall be limited to the volume required by the various hoods. Outdoor air supplied to the dining area shall be exhausted through the kitchen ventilation system. If the kitchen exhaust air volume exceeds the outdoor air requirements of the dining area, the additional air required shall be supplied directly into the kitchen. Outdoor air supplied directly into the

kitchen shall be filtered, conditioned, and introduced horizontally at or near the ceiling, so that it will diffuse without causing drafts at the cooking level or on kitchen personnel.

b. Kitchen Areas - Special Considerations.

- (a) In air conditioned kitchens, the supply system shall be designed so the hoods exhaust primarily unconditioned air. In non-air conditioned kitchens, the supply system shall be designed for cross ventilation.

c. Dining Areas - Design Considerations.

- (1) Make-up air shall be filtered and, if required for comfort, heated.
- (2) The minimum outdoor air rate shall be 5 cfm per person in non-smoking areas and 10 cfm per person in smoking areas.

d. Dining Areas - Special Considerations.

- (1) The outdoor air supply to the dining room shall be used as kitchen make-up air to eliminate odors from entering the dining area.

e. Dishwashing Areas - Design Considerations.

- (1) The general supply air rate in all portions of dishwashing areas shall be 5 air changes per hour or greater.
- (2) The combined general supply air and make-up air to the exhaust hood shall be 30 air changes per hour or greater.
- (3) Make-up air should be drawn from other conditioned spaces in the building or filtered and heated outdoor air may be used.
- (4) Fan motors on the exhaust fans shall be out of the air stream.
- (5) Drains in the low points of the exhaust ducts shall be provided.
- (6) Ductwork shall be corrosion resistant steel, water tight welded construction.

f. Dishwashing Areas - Special Considerations.

- (1) If automatic conveyor dishwashers are used, an exhaust hood at each end shall be provided.
- (2) Design procedures for dishwashing hoods shall be in accordance with Industrial Ventilation Manual.

g. Bakeries - Design Considerations.

- (1) Make-up air shall be filtered.
- (2) A slight positive pressure shall be maintained.
- (3) Cooling rooms shall have a source of filtered air without odors or vapors. Make-up air may be taken from interior spaces or from the outdoors if filtered and heated.
- (4) Cooling rooms shall have an exhaust fan system which prevents warm air from entering other parts of the building.
- (5) Cooling rooms with exterior doors and windows shall be air-tight and interior doors shall be reasonably air-tight to prevent airborne contamination.

h. Bakeries - Special Considerations.

- (1) Controls for fans shall not be located in cooling rooms and should be provided with indicating pilot lights.

i. Flour Storage Areas - Design Considerations.

- (1) A gravity roof ventilator system shall be used to allow the room to breathe.
- (2) No inlet or air supply of outdoor air is required.

j. Flour Storage Areas - Special Considerations.

- (1) None.

6. Process Hood Areas.

a. Design Considerations.

- (1) Process hoods which may have areas with airborne contaminants which could collect inside the ductwork, shall be equipped with filters. Filters shall be sized, based on the contaminant as outlined in Section 4.

- (2) Hood ventilation rates shall meet or exceed those detailed in the OSHA Standards, Part 1910.
- (3) Spaces in which process hoods are installed shall be maintained at a slight negative pressure to prevent contamination of adjacent spaces.
- (4) Where the outdoor air temperature drops below 55° F for extended periods of time, the make-up air system shall be filtered and heated.
- (5) Outdoor air intakes and exhaust fan discharges shall be arranged to avoid short-circuiting.

b. Special Considerations.

- (1) Design procedures for process ventilation systems shall be in accordance with Industrial Ventilation Manual.
- (2) In spaces with processes involving explosives or inflammable substances, such as paint shops, all equipment shall be explosion proof and conform to NFPA Standard, No. 30 requirements for explosion proof equipment. For additional information see DM-4 Series.
- (3) Consider the use of heat recovery in conjunction with hood exhaust systems to provide heat to the make-up air as outlined in Section 6 of this manual.
- (4) Paint shop hoods shall be designed for operation on a year-round basis. Face velocity of paint spray booths shall be 125 fpm or greater across the face of the booth.

7. High Heat Areas.

a. Design Considerations.

- (1) In general, the outdoor air supply rate shall be based on the heat released and the difference between the maximum anticipated outdoor temperature and the maximum allowable indoor temperature.
- (2) Ventilation requirements of refrigeration compressor rooms shall be in accordance with ANSI B9.1, Safety Code for Mechanical Refrigeration.
- (3) The ventilation rate for foundries shall be 20-40 air changes per hour.

- (4) The ventilation rate for laundries shall be 30 or more air changes per hour.
- (5) The ventilation rate for projection booths shall be 30 or more air changes per hour if the air in the booth is not air conditioned. If it is air conditioned, ventilation shall be provided at the manufacturer's recommended rate through the lamp housing by means of direct connection. For booths where nitrocellulose base film is used, the NFPA Standard, No. 40 shall be used for equipment requirements.
- (6) The ventilation rate for mechanical and electrical equipment rooms shall be adequate to limit space temperature to 104° F. Natural ventilation shall be used when possible.
- (7) See DM-3.7, for ventilation requirements in Power Plants and Central Heating Plants.

b. Special Considerations.

- (1) Consider spot cooling for operators working near high heat sources, such as foundry furnaces.

8. Miscellaneous Applications.

a. Design Considerations.

- (1) Attic fans may be used on NAVFAC shore activity structures only when specified by project criteria. The ventilation rate for attics shall be 30 air changes per hour in locations above 37 degrees north latitude and 60 air changes per hour below 37 degrees north latitude. The air quantity shall be based on the volume of the building below the attic.
- (2) The ventilation rate for enclosed garages, driveways and loading platforms shall be adequate to maintain a carbon monoxide level of 50 parts per million, with peak levels, of less than one hour's duration, not to exceed 125 parts per million. A minimum ventilation rate of 1.5 cfm per square foot of floor space shall be provided throughout the facility.
- (3) The ventilation rate for garages shall be:
  - (1) 3.0 cfm per square foot or greater in the main entrance drive.
  - (2) 2.0 cfm per square foot or greater in the loading areas and in drives between parking areas.
  - (3) 0.5 cfm per square foot in parking areas.

- (4) Exhaust connectors shall be provided in automobile repair or test areas where prolonged automobile idling is anticipated.
- (5) In storehouse and hangers proper, natural ventilation is preferred.
- (6) The type and characteristics of toxic and explosive materials in special facilities, such as photographic and research laboratories and similar facilities shall be obtained from the sponsor. Ventilation shall be as recommended in NFPA Standard, No. 325-A, Industrial Ventilation and Flashpoint Index of Trade Name Liquids.

b. Special Considerations.

- (1) Where 4000 cfm or more air is exhausted and heated make-up air is introduced, heat recovery shall be considered as outlined in Section 6.

C. EQUIPMENT SELECTION CRITERIA.

1. Selection Basis.

Selection of ventilation equipment shall be based on Naval administrative policy, size of the system, anticipated useful life of the facility, and the air stream characteristics. Natural ventilation equipment shall be selected on the basis of a 4 mile per hour wind velocity.

2. Fans.

a. Design Considerations.

- (1) Fans shall be selected and installed as outlined in Section 4, "Air Conditioning Systems."
- (2) Fan wheel selection shall be based first on the abrasiveness of any airborne material and second on static pressure characteristics.

b. Special Considerations.

- (1) Special considerations are listed in Section 4, "Air Conditioning Systems."

3. Ductwork.

a. Design Considerations.

- (1) Ductwork shall be selected and installed as outlined in Section 4, "Air Conditioning Systems."

b. Special Considerations.

- (1) Industrial exhaust design shall be in accordance with Industrial Ventilation Manual.
- (2) Special considerations are also listed in Section 4.

D. SYSTEM CONTROLS.

1. Control Systems.

Control systems shall be as simple as possible but sufficient to meet the design conditions. Limit controls and safety controls shall be designed as integral parts of the system to shut down the ventilating system if a control device fails or the electrical circuits overload. High heat area exhaust fans shall have thermostatic controls set to limit maximum space temperature to 104° F.

a. Manual Controls.

Manual control systems provide only equipment on/off capabilities.

(1) Application and Limitations.

- (a) Manual controls are used (1) on equipment requiring strictly on-off modes, (2) where manual control of equipment speed or ventilation rate is required and (3) when semi-automatic or automatic controls are not cost effective.
- (b) This method of control is generally limited to equipment that is to be left running or to spaces where the equipment is turned "on" when the space is occupied and "off" when unoccupied.

(2) Special Considerations.

- (a) Manual control systems are energy inefficient since equipment runs longer than necessary and spaces may become overheated.

b. Automatic Control Systems.

Automatic control systems are fully automated to include automatic on/off capabilities based on time clocks or sensing devices. Fully automatic control systems may be used in conjunction with central monitoring systems as discussed in Section 6 of this manual and DM-3.12.



(1) Applications and Limitations.

- (a) Automatic control systems shall be used for ventilation systems where the equipment is to be operated on and off over a 24 hour period.
- (b) Time clocks shall be used to turn equipment on and off as required by the occupancy of a particular building.

(2) Special Considerations.

- (a) Automatic control systems provide the most energy efficient controls for a heating system.

2. Control Methods.

See Section 4.

3. Power Sources.

See Section 4.

## Section 4. AIR CONDITIONING SYSTEMS

### A. AIR CONDITIONING SYSTEMS DESCRIPTION.

Air conditioning systems shall maintain the space design requirements by simultaneously controlling the supply air temperature, humidity, and distribution to the space.

#### 1. Basic Air Conditioning Systems.

Air conditioning systems may be designed for low, medium, or high pressure air distribution. The following are the basic types of air conditioning systems which shall be considered:

- (1) self-contained system
- (2) built-up system
- (3) single duct system
- (4) constant volume system
- (5) dual air duct system
- (6) multizone unit system
- (7) variable air volume system
- (8) perimeter zone air system
- (9) fan coil system
- (10) induction unit system
- (11) heat pump system.

The equipment is generally located in a basement, penthouse, or service area rather than in the conditioned space. The equipment may or may not be located adjacent to the refrigeration equipment that supplies the cooling medium.

#### a. Self-Contained Systems.

These systems consist of a factory fabricated, packaged air conditioning unit.

##### (1) Applications and Limitations.

- (a) Self-contained systems may be used for any air conditioning system.

##### (2) Special Considerations.

- (a) These systems are generally less complicated to install and have a lower first cost than other systems.

- (b) These systems do not require central refrigeration equipment. Each unit has its own refrigeration equipment.

b. Built-Up Systems.

These systems consist of individual components that are assembled at the building site.

(1) Applications and Limitations.

- (a) These systems may be used as remote air handling systems which use a central cooling plant.

(2) Special Considerations.

- (a) These systems may reduce the required total capacity of the refrigeration plant due to load diversity.
- (b) A central station refrigeration plant is usually remotely located.
- (c) Built-up units are generally more efficient and better constructed than self-contained units.

c. Single Duct Systems.

These systems consist of an air handling system and a one zone duct system.

(1) Applications and Limitations.

- (a) These systems are suitable for use in large open spaces which have uniform and substantially constant loads.

(2) Special Considerations.

- (a) Modular equipment is permitted where the part load performance could be improved or where the duct sizes are excessive.

d. Constant Volume Systems.

In this system, the outdoor dampers and recirculating dampers are sequenced with the heating and cooling coils to satisfy the space requirements (Fig. 6). For a heating condition, the space thermostat controls the heating coil to achieve heating requirements; on a rise of outdoor temperature, the heating coil is closed off and the outdoor air and recirculating air dampers are

modulated to maintain set point. On a further rise of outdoor temperature, after the outdoor air damper is fully open, the cooling coil will be modulated. When the outdoor air requires more energy to cool than the recirculating air, the outdoor air is set at its minimum set point to provide ventilation.

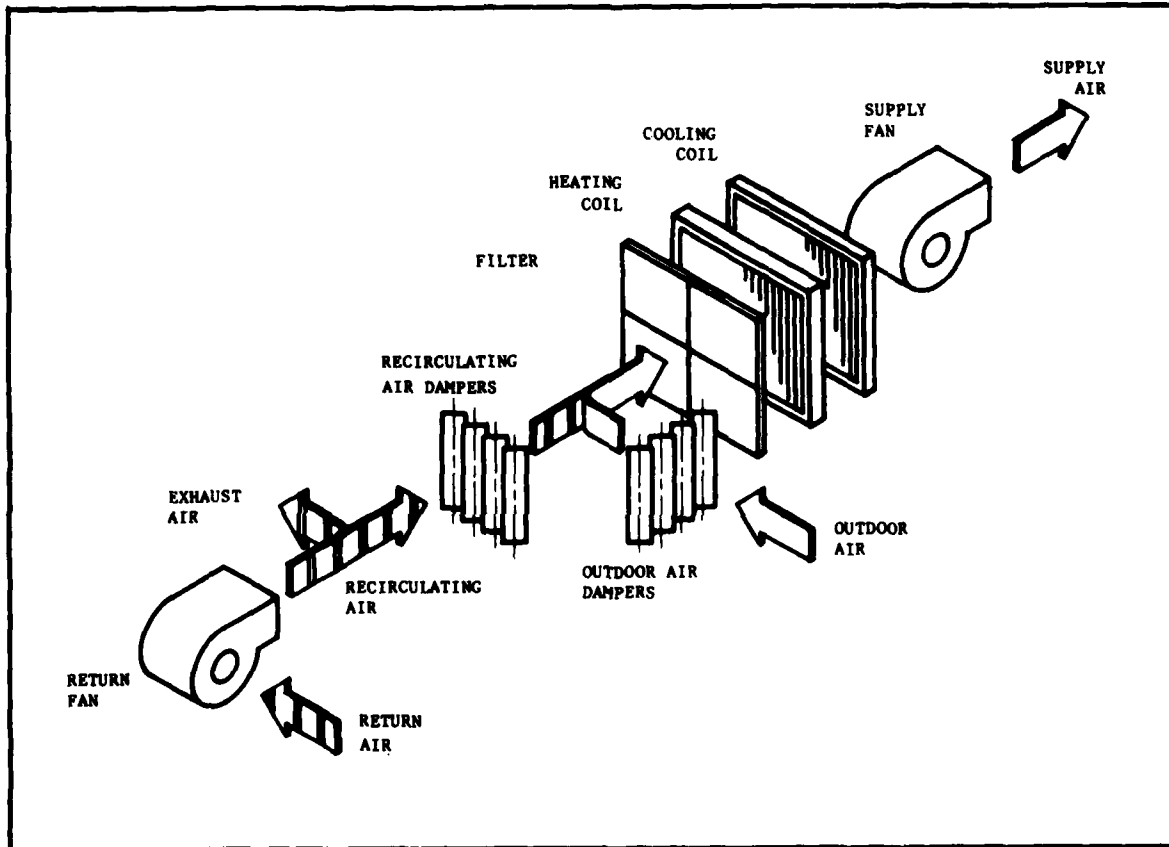

FIGURE 6  
Constant Volume System

(1) Applications and Limitations.

- (a) These systems are suitable for use where zone control is required as in auditoriums, meeting rooms, cafeterias, restaurants or small retail stores.

(2) Special Considerations.

- (a) This system utilizes the mixture of outdoor air and recirculated air to satisfy space heating/cooling requirements whenever possible, without requiring additional energy.

e. Dual Duct Systems.

These systems consist of a single fan, blow-through system with the discharge divided into two streams, one passing through a heating coil while the other passes through a cooling coil (Fig. 7).

(1) Applications and Limitations.

- (a) These systems are suitable for use in buildings with numerous zones. The zone requirements are met by using a mixing box that is controlled by a zone thermostat.
- (b) Design of this system requires special advance permission from NAVFAC requested through the EPD.

(2) Special Considerations.

- (a) These systems operate at a reduced demand when heating which results in some saving due to decreased fan horsepower.
- (b) On larger systems, additional system efficiency can be obtained by providing separate hot duct and cold duct fans. Individual mixing plenums shall be provided for each; thereby providing the capability to mix air to the temperature required for each duct, or as dictated by the outdoor/recirculating air conditions.

f. Multizone Unit Systems.

These systems may be classed operationally with single fan dual duct systems, but the mixing of warm and cold air is done at the unit with a single duct running to the controlled space (Fig. 8).

(1) Applications and Limitations.

- (a) These should be used in smaller areas where six to ten spaces need separate control. These systems are also suitable for use in fairly large buildings when multiple units are used and each unit serves several different zones.

(2) Special Considerations.

- (a) Condenser water, when available, should be used in the heating coil.

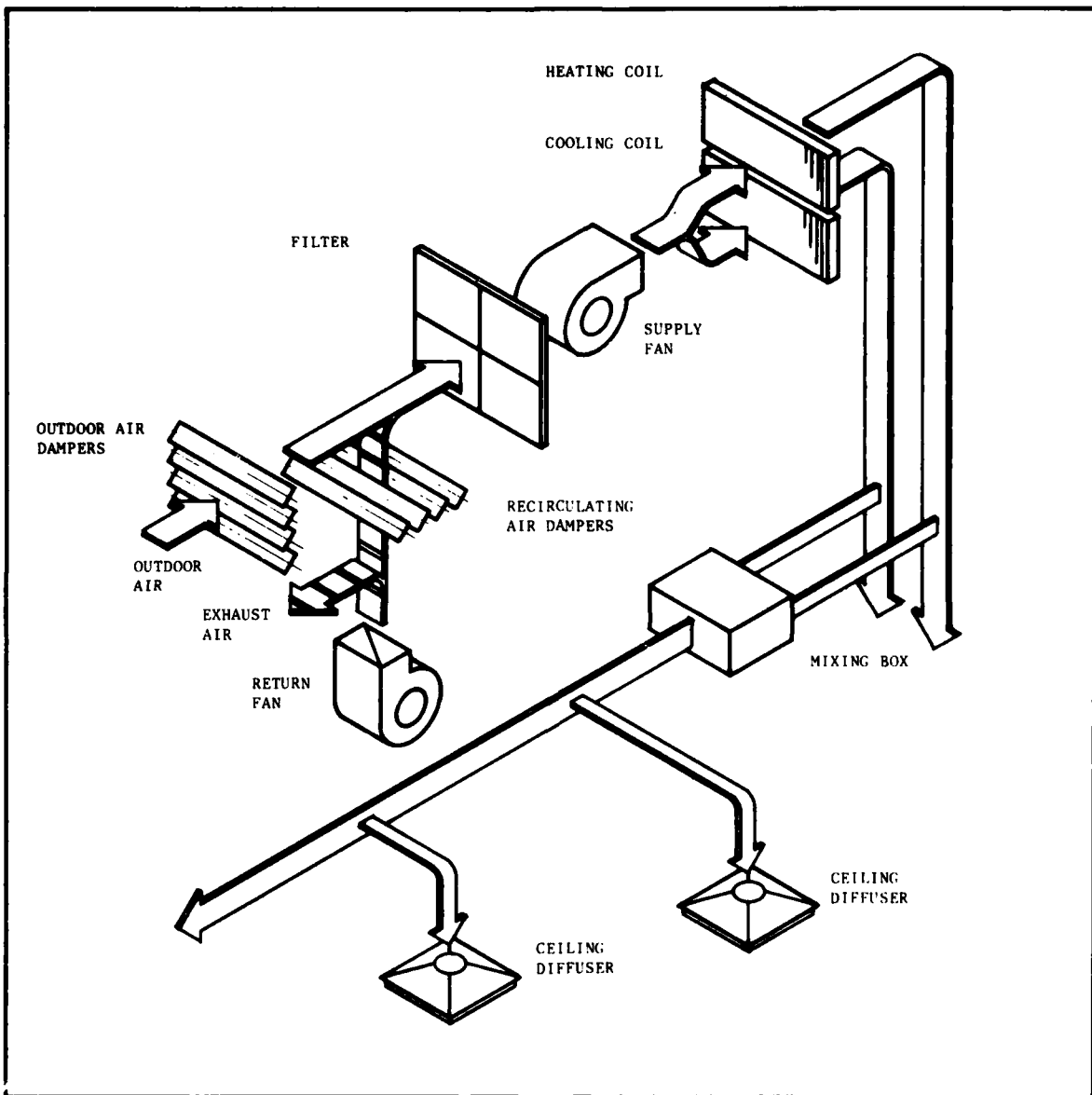
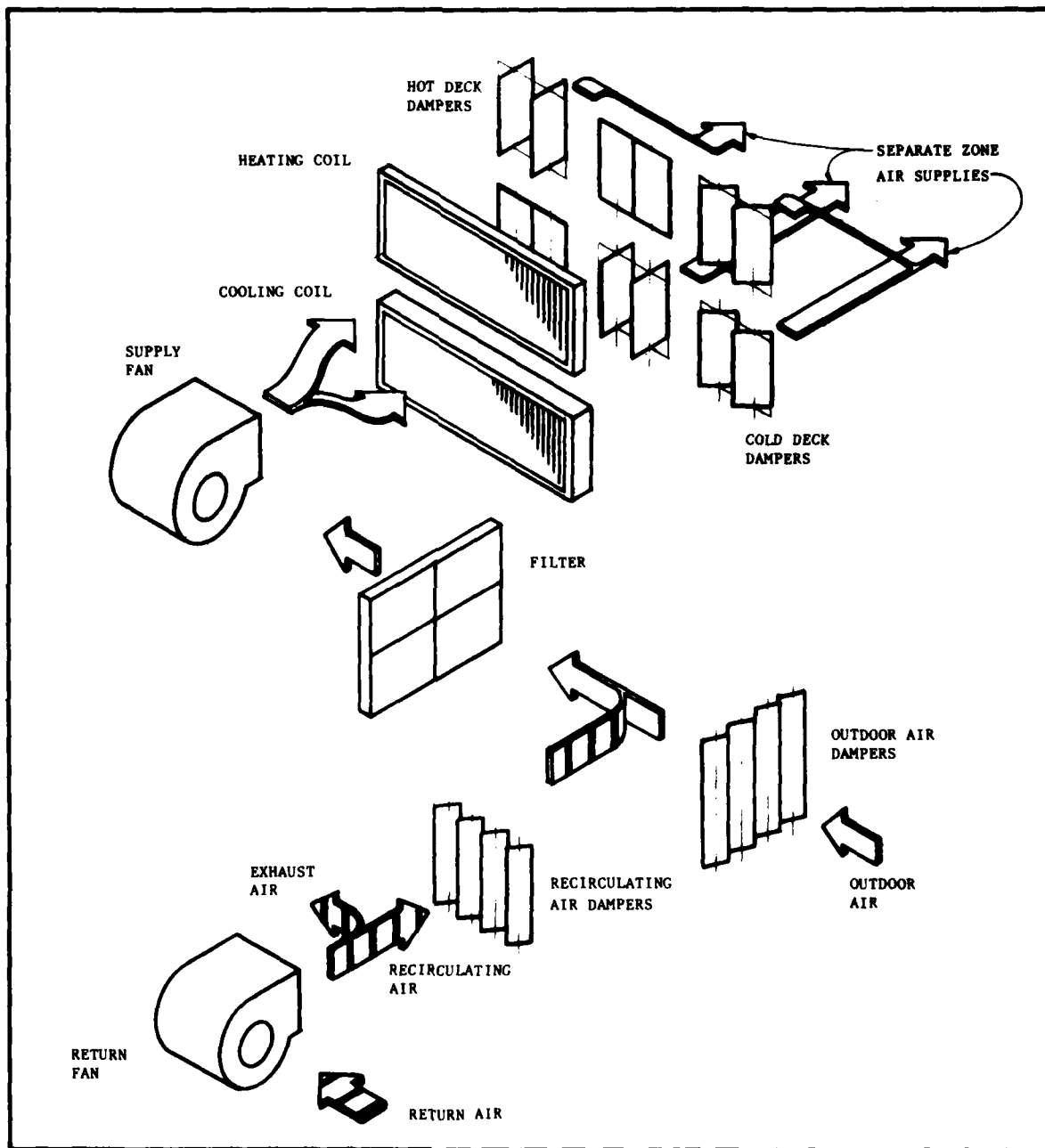

FIGURE 7  
Dual Duct System



**FIGURE 8**  
**Multizone Unit System**

g. Variable Air Volume Systems.

These systems are designed to provide the supply air at a constant temperature and to vary the quantity of supply air depending on space temperature requirements. The variable air volume system is one of the best air conditioning systems for energy conservation, since they minimize or eliminate the need for heating and require less fan horsepower due to the reduced air flow.

(1) Applications and Limitations.

- (a) These systems are best suited for use in spaces that always require cooling.
- (b) Perimeter zones will generally require some heating to offset the transmission loss through the exterior wall. This is achieved by varying the volume to offset solar load that may be present, establishing a preset minimum air volume. The heat is modulated only at minimum volume.
- (c) Either centrifugal fans with inlet vane controls (Fig. 9) or controllable pitch axial flow fans shall be used for supply and return. The controllable pitch axial fan generally is being the most efficient of the two types.

(2) Special Considerations.

- (a) During periods of light load, static pressure regulators reduce the total volume of air flowing through the system by gradually closing the inlet vanes or reducing the pitch angle on the axial fans. A proportional reduction in fan horsepower is realized and less energy is expended.
- (b) Return fans shall be controlled by monitoring supply and return air volumes and controlling the return fan volume to maintain the proper space pressure.

h. Perimeter Zone Air Systems.

Perimeter zone air systems have a separate duct system that offsets the transmission load at the wall and glass



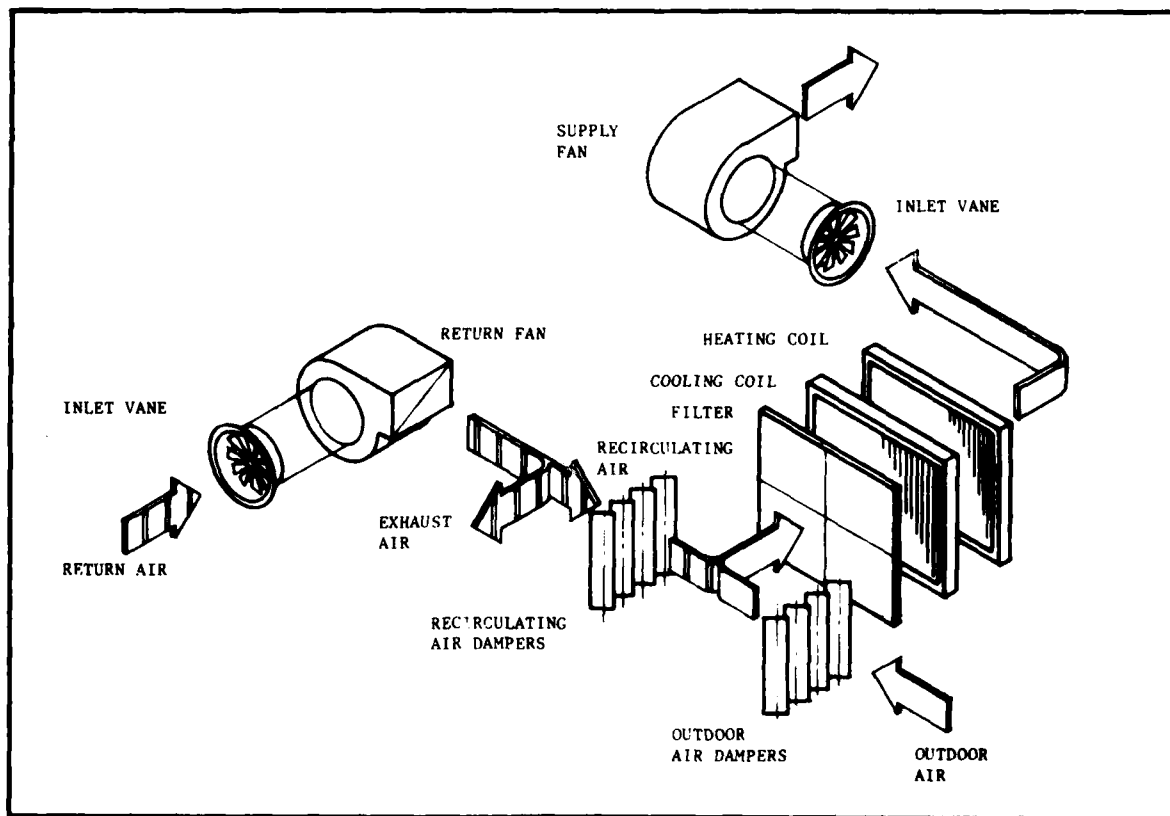

FIGURE 9  
Variable Air Volume System

(Fig. 10). The solar load is assigned to the main air system. The perimeter system consists of a fan, a cooling coil and a heating coil. In operation, the outdoor thermostat resets the supply fan discharge temperature on a preset schedule to exactly balance heat transmission gains or losses at the exterior wall of the building.

(1) Applications and Limitations.

- (a) These systems are suitable for seasonal cooling or heating in spaces where the load transmission is at the wall and glass.
- (b) These systems should be zoned, based on building exposure. If two units are used they are generally zoned for south and west exposure on one unit and north and east exposure on the other.

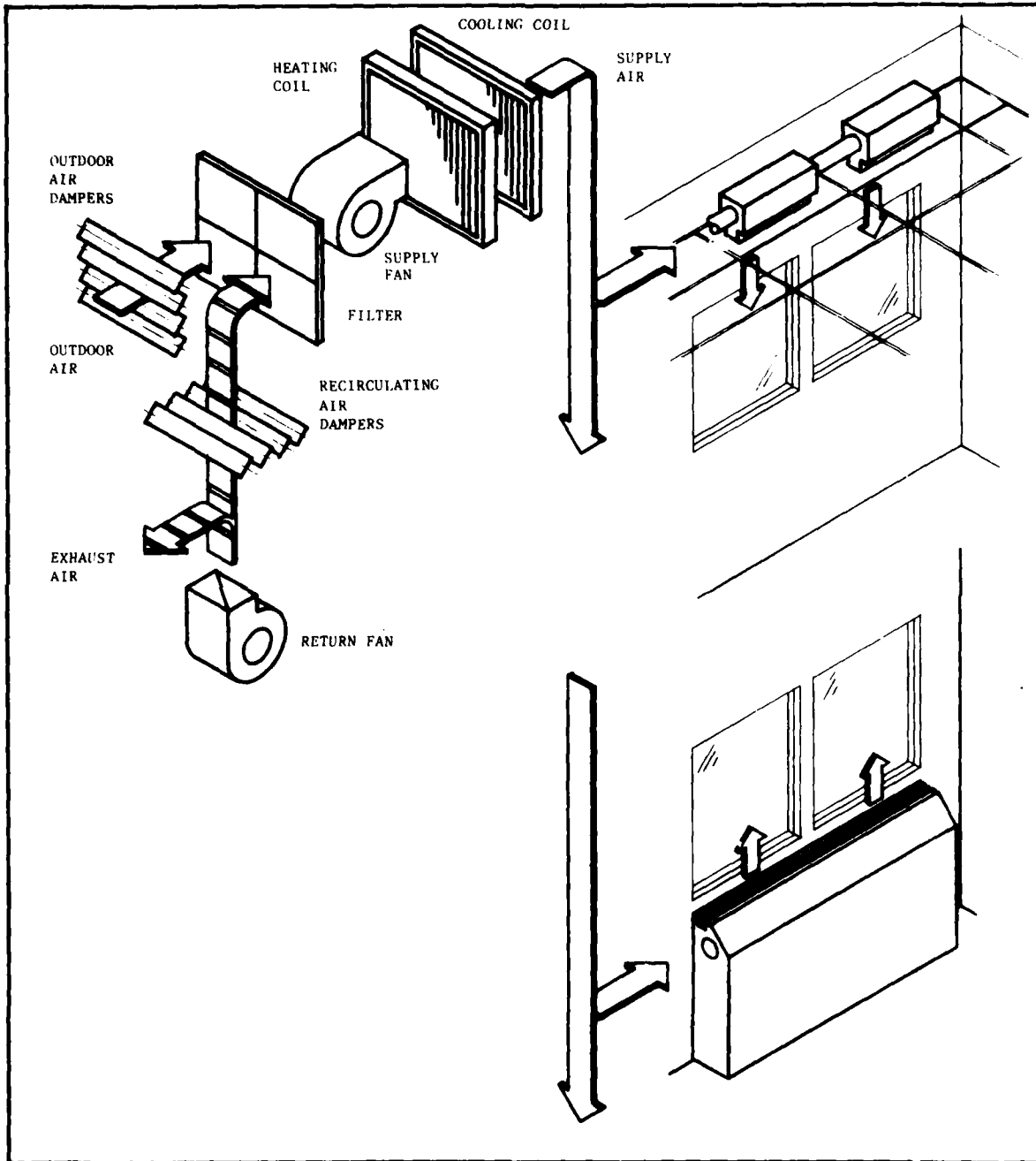
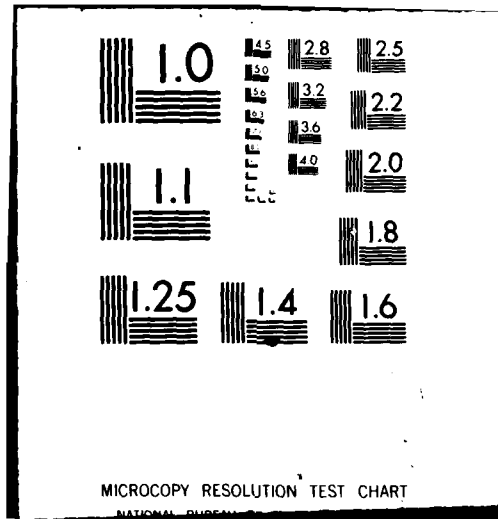

FIGURE 10  
Perimeter Zone Air System





(2) Special Considerations.

- (a) During unoccupied hours in the heating season, the fan operates on either a continuous or cycling basis.

i. Fan Coil Unit Systems.

The fan coil unit system combined with an interior air supply system is a combination air and hydronic system. These systems cool or heat to compensate for the transmission and solar variations and in many cases for part or all of the internal heat gain. The combined fan coil and interior air supply system is always a change-over system, where the water coil receives chilled water in the cooling season and heated water in the heating season.

(1) Applications and Limitations.

- (a) An analysis of winter solar loads and control zoning is necessary for fan coil systems.
- (b) These systems are suitable for use in areas where air from different rooms cannot be mixed and recirculated due to hygienic reasons.
- (c) These systems are suitable for use when large ducts cannot be installed for security reasons or physical space limitations.
- (d) These systems may be used for both sensible and latent cooling requirements.
- (e) Room unit systems shall not be considered where the units would not be easily accessible for service or where drains cannot be installed.
- (f) Outdoor air shall be taken directly from the outdoors by the individual units or from a central air handling unit.

(2) Special Considerations.

- (a) These systems may be more economical for central systems, especially for spaces requiring large ducts or spaces with high heat loads.

- (b) Units shall be zoned by exposure for change-over.
- (c) Individual unit temperature control is possible.
- (d) Provide condensation drains when the chilled water temperature is below the room dew point.

j. Induction Unit Systems.

A combination air and hydronic system is the high pressure induction unit system combined with an interior air supply system. These systems cool or heat to compensate for the transmission and solar variations and in many cases for part or all of the internal heat gain.

In this type of system, primary air is conditioned by a central air handling unit and is supplied to the conditioned space through the nozzles of the unit inducing a flow of room air over the secondary coil.

The combined high pressure induction system and interior air supply system can be either a non-change-over or a summer-to-winter change-over system. The coil always receives chilled water when designed for non-change-over, and the air stream is heated to compensate for the wall and window losses. The coil receives either hot water or chilled water when designed for a summer-to-winter change-over, and the air stream is either heated or cooled to the system requirements.

(1) Applications and Limitations.

- (a) An analysis of winter solar loads and control zoning is necessary for an induction unit system.
- (b) These systems are suitable for use in the perimeter of high rises or multistory buildings.
- (c) These systems are suitable for use in areas where air from different rooms cannot be mixed and recirculated due to hygienic reasons.
- (d) These systems are suitable for use when large ducts cannot be installed for security reasons or physical space limitations.
- (e) Room unit systems shall not be considered where the units would not be easily accessible for service or where drains cannot be installed.

- (f) These systems shall not be used in dusty areas where the nozzles and coils may need frequent cleaning nor for constant temperature maintenance in rooms with high internal loads.

(2) Special Considerations.

- (a) In systems operating without summer-to-winter change-over, the primary air supply temperature will be set on a predetermined schedule to offset transmission loss.
- (b) Provide condensation drains, when the chilled water temperature is below the room dew point.

k. Heat Pump Systems.

See Section 2, and DoD 4270.1-M for design considerations.

2. Refrigeration Systems.

Refrigeration systems consist of either a reciprocating compressor system, a centrifugal compressor system, or an absorption refrigeration system.

a. Reciprocating Compressor Systems.

Reciprocating compressor systems are refrigeration systems which should consist of factory assembled components. Field assembled units should be used only where flexibility cannot be obtained economically with a factory assembled unit.

(1) Applications and Limitations.

- (a) These systems are suitable for use in direct or indirect expansion systems.
- (b) Justification for using the multiple reciprocating compressors shall be based on an economic analysis or on an analysis of the combined summer-winter cooling load requirements.

(2) Special Considerations.

- (a) Parallel operation or cross connections of refrigerant piping shall be limited to open-type units.

b. Centrifugal Compressor Systems.

Centrifugal compressor systems utilize the angular momentum of a steadily flowing fluid to increase system pressure.

(1) Applications and Limitations.

- (a) These systems may be used in a wide variety of refrigeration and air conditioning systems.
- (b) These systems are suitable only for indirect expansion systems.

(2) Special Considerations.

- (a) Centrifugal compressors have greater volumetric capacities, size for size, than do positive displacement units.

c. Absorption Refrigeration Systems.

This system is a heat operated refrigeration system and requires medium or high temperature hot water or steam.

(1) Applications and Limitations.

- (a) These systems are suitable when first cost and operating expenses are lower than that of centrifugal and reciprocating compressor systems.

(2) Special Considerations.

- (a) Consider the extra owning and operating cost of condenser water systems.
- (b) Consider the savings in the cost of the foundation and the electrical wiring required for an absorption machine.
- (c) If the steam supply pressure is above that required by the absorption machine, the cost of pressure reducing valves shall be included.
- (d) These systems may have a higher steam consumption than steam turbine-driven centrifugal compressors, depending on the turbine efficiency.

3. Condenser Water Systems.

Condenser systems utilize water to extract heat from refrigerant systems.



a. Applications and Limitations.

- (1) Once-through systems use condenser water once and then reject it to a drainage system. These systems are suitable if a sufficient water supply is available with water temperature that is compatible for the cooling systems.
- (2) Multiple or recycled water cooling systems use the same condenser water over and over, and add make-up water as required to offset evaporation and loss due to spray. Cooling towers and spray ponds are examples of multiple or recycled water cooling systems used to cool condenser water to eliminate wasting domestic water.

b. Special Considerations.

- a. None.

4. Evaporative Cooling Systems.

Evaporative cooling is an adiabatic heat exchange system. The enthalpy of air remains constant, while the dew point rises and the dry bulb temperature falls, so the loss of sensible heat exactly equals the gain in latent heat. These systems provide sensible cooling without controlling room humidity.

a. Applications and Limitations.

- (1) These systems are suitable where the outdoor dry bulb temperature is 93° F or greater for more than 2000 hours during the six warmest months of the year or where the wet bulb temperature is 73° F or less for less than 100 hours during the six warmest months of the year.
- (2) See DoD 4270.1-M for further requirements and limitations.

b. Special Considerations.

- (1) Duct sizes are larger due to the large volume of air required for evaporative cooling.

5. Solar Cooling Systems.

Solar cooling systems may utilize cool night air to extract heat from the collector, which in turn extracts heat from the warm space, or it may use concentrating or evacuated tube solar collector to convert solar radiation and heat hot water to be used in the absorption cooling process. They may be liquid or air, passive or active systems.

a. Passive Air Systems.

Passive air systems make use of the cool night air. The warmer air enters the top of the collector, it cools and drops, forcing the cool air at the bottom into the space.

(1) Applications and Limitations.

(a) Passive air systems are suitable for air conditioning small single spaces.

(2) Special Considerations.

(a) These systems require a large collector surface.

(b) The controls are generally very simple and, to a large extent, manual type controls.

b. Passive Liquid Systems.

Passive liquid systems use the night air to cool the storage wall which absorbs warm air from the space during the day.

(1) Applications and Limitations.

(a) These systems are suitable for air conditioning small, single spaces.

(2) Special Considerations.

(a) These systems require a large collector surface, freeze protection and corrosion protection.

(b) The controls are generally very simple and, to a large extent, manual type controls.

(c) Care is required in the installation of a liquid system to prevent leakage.

c. Active Air Systems.

The active air system uses a fan and the night air to cool the space or storage system.

(1) Applications and Limitations.

(a) These systems are suitable for use in spaces served by central units with ductwork.

(2) Special Considerations.

- (a) These systems require a large collector surface and storage area.
- (b) The controls may be extremely involved depending upon the individual system design.
- (c) These systems require a fan, which is less efficient, more costly to operate, and noisier than the pump required for a liquid system.

d. Active Liquid Systems.

The active liquid system generally uses water at 180° F or above to drive an absorption chiller.

(1) Applications and Limitations.

- (a) These systems are suitable for use in spaces served by a central unit with ductwork.
- (b) These systems work well for retrofit work because they require less space for piping and equipment.
- (c) The controls may be extremely involved, depending on individual system design.

(2) Special Considerations.

- (a) These systems require the use of concentrating or evacuated tube collectors which are more efficient, but they require direct sunlight and sophisticated controls to keep the collectors facing the sun as it moves across the sky.
- (b) These systems require careful installation and maintenance to prevent system leaks. They require freeze and corrosion protection.

6. Humidification Systems.

Humidification systems maintain the proper relative humidity range for a particular space based on operating requirements.

a. Applications and Limitations.

- (1) These systems are suitable for maintaining the required relative humidity in special and process cooling applications, such as in laboratories, cleaning rooms, electronic equipment rooms and precision repair, calibration or processing areas.

b. Special Considerations.

- (1) Condensation can occur during winter cycle on or in structural components and results in excess maintenance and repair. Oxidation of parts can occur at relative humidities above 50 percent.

B. SYSTEM SELECTION CRITERIA

1. Explanation.

Selection factors for air conditioning systems for Naval Shore Facilities shall be based on the design criteria as presented in Section 1. Specific factors requiring more detail are listed and explained in this section.

2. Calculations.

Load calculations shall be made using one of the procedures in the ASHRAE Fundamentals Handbook, except where specified below. For an applicable computer program consult NAVFAC, requested through the EFD.

a. Load and Energy Calculations.

- (1) Calculations shall be made using the information in Section 1.
- (2) For small buildings such as family quarters with a gross floor area of 8,000 square feet or less, the simplified and manual method of calculating loads and energy requirements shall be used.
- (3) For large buildings with gross floor area over 8,000 square feet, an extensive computerized hourly dynamic analysis for load and energy calculations shall be made on a computer.

b. Hourly Weather Data.

- (1) Data from NAVFAC P-89 shall be used for the energy calculating procedure.

c. Annual Hourly Energy Analysis.

- (1) The annual hourly energy analysis using 8,760 hours shall incorporate the effectiveness of energy conservation features and systems as discussed in Section 6, "Energy Conservation Methodology."

d. Coefficient of Overall Heat Transfer.

- (1) See the ASHRAE Fundamentals Handbook to calculate the "U" factor for the type of construction involved. For maximum "U" values, see DoD 4270.1-M.

e. Outdoor to Indoor Temperature Difference.

- (1) The outdoor to indoor temperature difference shall be the difference between the indoor temperatures from DoD 4270.1-M and outdoor temperatures from NAVFAC P-89.

f. Transmission Load.

- (1) The transmission load shall be based on the actual temperature expected to prevail if adjacent spaces are not air conditioned.

g. Solar Load.

- (1) The solar load for glass areas shall be calculated to allow for shading.

h. Direct Solar Load.

- (1) The direct solar load shall be calculated only for the exposed area of the glass. Diffused radiation through the shaded areas of the glass shall be included in the calculations.

i. Exterior Shading Effect.

- (1) The exterior shading effect shall be calculated using the appropriate tables for solar attitude and azimuth angles.

j. Shade and Lag Factors.

- (1) Shade and lag factors shall be calculated for the following factors:

- (1) type of interior and exterior shading devices
- (2) type of glass
- (3) type of building construction
- (4) hours of operation
- (5) the allowable variation in space temperature.

k. Moisture Permeance.

- (1) The moisture permeance shall be calculated for design conditions with low dew points.

### 3. Systems.

#### a. Self-Contained Systems.

- (1) Self-contained systems may be installed anywhere where there is sufficient access space to move them in.
- (2) Multiple self-contained systems shall be used only in accordance with DoD 4270.1-M.

#### b. Built-Up Systems.

- (1) Remote air handling units may be installed only in accessible locations which can be provided with a condensate drain.
- (2) The number of air handling units shall be based on the economic division of the load considering (a) value of space occupied by equipment, (b) extent of ductwork and piping, (c) multiplicity of control, maintenance and operating points and (d) energy conservation factors.

#### c. Single Duct Systems.

- (1) This system may be equipped with a centrifugal fan, a centrifugal fan with vane inlets, a vane axial fan or a variable pitch fan, filter and cooling and heating coils.
- (2) Table 11 gives a listing of recommended air conditioning systems for various buildings.

#### d. Constant Volume Systems.

- (1) This system is generally equipped with a centrifugal fan, filter and cooling and heating coils.
- (2) This system is best suited to serving single zone application or a single space.

#### e. Dual Duct Systems.

- (1) This system should be equipped with a variable air volume fan.
- (2) If humidity control is critical, a pre-cooling coil may be required in the outdoor air intake.
- (3) The cost of sheet metal is high since two ducts are run with the hot duct carrying approximately 60 percent of the air capacity of the cold duct.

**TABLE 11**  
**Recommended Air Conditioning Systems**  
**For Various Buildings**

FACILITIES	Single Duct System	Constant Volume System	Dual Duct System	Multizone Unit System	Variable Air Volume System	Perimeter Zone Air System *	Fan Coil Unit System	Induction Unit System	Heat Pump System	Evaporative Cooling System **
Administration	X	X	X	X	X	X	X	X	X	X
Apartment Houses	-	-	-	X	-	-	X	X	X	-
Auditoriums	X	X	X	X	X	-	X	-	X	X
Barracks	X	X	X	X	X	X	X	X	X	X
Chapels	X	X	X	X	X	-	X	X	X	X
Garages	-	-	-	-	-	-	-	-	-	-
Gymnasiums	X	-	-	-	-	-	-	-	-	X
Hangars	-	-	-	-	-	-	-	-	-	-
Hangar Lean-Tos	-	-	-	-	-	-	-	-	-	-
Hospitals	X	X	X	X	X	X	X	X	X	X
Bachelor Officer Quarters	-	-	-	X	-	-	X	X	-	-
Personnel Housing	-	-	-	X	-	-	X	X	X	-
Pump Houses	-	-	-	-	-	-	-	-	-	-
Radio Receiving	X	X	X	X	X	-	X	X	X	X
Schools	X	X	X	X	X	-	X	X	X	X
Shops	X	X	X	X	X	-	X	-	-	X
Storehouses	X	X	-	X	-	-	-	-	-	X
Subsistence	-	-	-	-	-	-	-	-	-	-
Theaters	X	X	X	X	X	-	X	-	-	X
Transmitters	X	X	X	X	X	-	X	-	-	X
Gate or Guard House	-	-	-	-	-	-	-	-	-	-
Bakeries	X	X	X	X	X	-	-	-	X	X
Laundries	X	X	X	X	X	-	-	-	X	X

\* Dependent on building configuration.

\*\* Dependent on local weather conditions. Refer to DoD 4270.1-M.

(4) Individual controls may be installed in an unlimited number of spaces.

(5) Table 11 gives a listing of recommended air conditioning systems for various buildings.

f. Multizone Unit Systems.

(1) This system is suitable for use in buildings where separate control is required for 6-10 zones for each air handler.

- (2) Table 11 gives a listing of recommended air conditioning systems for various buildings.

g. Variable Air Volume Systems.

- (1) The size of the trunk ducts shall be based on diversity of load, since the maximum load demand follows the solar incidence for each exposure.
- (2) With present air diffusion techniques, it may become difficult to introduce air flow to the perimeter spaces without drafts in spaces which require more than 3 cfm of air flow per square foot for cooling.
- (3) The ductwork for this system shall be sized at medium to high pressure air distribution; this allows smaller, simpler duct layouts.
- (4) Table 11 gives a listing of recommended air conditioning systems for various buildings.

h. Perimeter Zone Air Systems.

- (1) When winter ambient temperatures are 25° F or below, the system shall be designed for upward air distribution at the sill height to avoid cold down drafts.
- (2) Table 11 gives a listing of recommended air conditioning systems for various buildings.

i. Fan Coil Unit Systems.

- (1) If the system is being used for both sensible and latent cooling, condensate drain pans and piping shall be provided.
- (2) The unit capacity can be regulated by controlling the water flow through a temperature actuated automatic water valve or by varying the fan speed. Varying the fan speed may be economical but requires constant water flow through all units, therefore, eliminating the diversity in sizing of pumps.
- (3) Fan coil units shall not be used in high humidity areas.
- (4) Table 11 gives a listing of recommended air conditioning systems for various buildings.

j. Induction Unit Systems.

- (1) Condensate drain piping is not required for the induction unit system except:



- (1) where the temperature of water circulating through the secondary coil is more than 3° F below the room design dew point temperature, and
  - (2) where there is a possibility of excessive outdoor air leakage from windows, or
  - (3) where the possibility of high percent loads exists.
- (2) Induction unit systems shall be designed to operate on the minimum quantity of air consistent with the following criteria:
- (1) Primary air dew point shall be as low as possible, but not lower than 46° F. For average conditions, design for a dew point of 48° F.
  - (2) The quantity of primary air supplied shall be sufficient to absorb the internal latent load with a safety margin of 10 percent.
  - (3) The total air supply from induction units shall provide a minimum of outdoor air.
  - (4) Where primary air is used as a source of heat, the temperature of primary air shall not exceed 140° F.
- (3) Table 11 gives a listing of recommended air conditioning systems for various buildings.

k. Heat Pump Systems.

- (1) See Section 2, and DoD 4270.1-M for design considerations.
- (2) Table 11 gives a listing of recommended air conditioning systems for various buildings.

l. Reciprocating Compressor Systems.

- (1) Factory-assembled components, either unitary self-contained or split type, shall be used in direct expansion systems.
- (2) Field-assembled direct expansion systems are suitable only where adequate flexibility cannot be obtained by packaged systems.
- (3) The maximum size of a single reciprocating compressor, a single packaged unit and the number of compressors per package unit shall be in accordance with DoD 4270.1-M.

(4) Separate refrigerant circuits shall be provided for parallel operation.

m. Centrifugal Compressor Systems.

(1) See DoD 4270.1-M for the appropriate size of centrifugal compressors.

n. Absorption Refrigeration Systems.

(1) When a heat source is available, the system may be used for cooling loads above 130 tons.

(2) The system may have higher steam consumption than steam turbine-driven centrifugal compressors, depending on the turbine efficiency.

o. Condenser Water Systems.

(1) For removal of condenser heat consider the heat input, heat rejection, and the quantity of condenser water.

(2) Heat input is the sum of the evaporator refrigerant effect and the driving force heat (compressor, steam, gas or hot water). Heat input will vary between 15,000 to 36,000 Btuh.

(3) The heat rejection factor (HRF) is the ratio between condenser heat input and heat absorbed by the evaporator. For compressor-driven refrigeration systems, select the HRF from Table 12 or 13.

TABLE 12  
Heat Rejection Factors - Open Compressor

Suction Temperature Degrees F	Condensing Temperature Degrees F							
	80	90	100	110	120	130	140	150
0	1.30	1.33	1.37	1.41	1.46	1.51	1.56	1.61
10	1.26	1.28	1.31	1.35	1.40	1.45	1.49	1.54
20	1.22	1.24	1.27	1.30	1.34	1.38	1.43	1.50
30	1.18	1.20	1.23	1.26	1.29	1.33	1.37	1.41
40	1.14	1.16	1.18	1.21	1.25	1.28	1.32	1.36
50	1.10	1.12	1.15	1.18	1.21	1.24	1.27	1.30

**TABLE 13**  
**Heat Rejection Factors - Hermetic or Semi-Hermetic Compressor**

Suction Temperature Degrees F	Condensing Temperature Degrees F							
	80	90	100	110	120	130	140	150
0	1.34	1.38	1.43	1.48	1.54	1.60	1.68	1.76
10	1.30	1.34	1.39	1.44	1.50	1.56	1.62	1.69
20	1.26	1.29	1.34	1.38	1.43	1.49	1.55	1.61
30	1.22	1.25	1.29	1.33	1.38	1.43	1.48	1.53
40	1.17	1.21	1.25	1.29	1.33	1.38	1.43	1.48
50	1.13	1.17	1.20	1.24	1.29	1.33	1.38	1.43

(4) Absorption machines have an HRF varying from 2.5 to 3.0. The HRF for this type of machine must be selected to assure non-proprietary equipment.

(5) The quantity of condenser water depends on:

- (1) the heat rejection of the refrigeration system
- (2) the entering condenser water temperature (generally 75° F for domestic water and 85° F for cooling tower water)
- (3) the leaving condenser water temperature (generally 95° F for compressor-driven systems and 103° F for absorption systems).

**p. Evaporative Cooling Systems.**

- (1) Actual evaporation rate and leaving air dry bulb temperature depends on equipment saturation efficiency, which varies 70-95 percent, depending on equipment design.
- (2) Water flow of sprays over the wetted surface shall be approximately 3 gallons per minute per cfm of air flowing through it. (See Equation 17).

$$\text{Equation : } W = Q \times (gr_2 - gr_1) \times \frac{60}{13.5 \times 7000} \quad (17)$$

where: W = water evaporated (pounds per hour)  
 Q = air handled by the equipment (cfm)  
 $gr_2$  = moisture in dry air corresponding to entering air wet bulb temperature and 100 percent saturated air as obtained from psychrometric chart (grams per pound)  
 $gr_1$  = moisture in dry air corresponding to entering air condition of dry bulb and wet bulb temperature as obtained from psychrometric chart (grams per pound)

- (3) Spray, rotary pad, or capillary type equipment shall be used.
- (4) The maximum possible temperature reduction equals the difference between entering dry bulb and wet bulb temperature.

q. Humidification Systems.

- (1) The relative humidity range for a particular facility shall be based on the operating requirements.
- (2) Electrical static charges on dielectric materials or parts occur at relative humidities below 30 percent and in explosive atmospheres.

C. EQUIPMENT SELECTION CRITERIA

1. Requirements.

Air conditioning equipment shall be selected based on the administrative policy stated in Section 1 plus the basic design requirements, the intended application of the system, its expected life cycle cost and its operating personnel requirements.

2. Design Considerations.

a. Cooling Load.

- (1) The load on air cooling equipment depends on three factors: quantity of air, condition of entering air and condition of leaving air. These factors should be considered as follows:
  - (1) determine the total supply air to be cooled,
  - (2) determine the condition of mixed outdoor air and recirculated air,
  - (3) select cooling equipment to provide the desired leaving supply air condition based on the quantity and condition of the entering air.

b. Air Velocity.

- (1) The total cooling capacity of cooling equipment increases with an increase in air velocity, causing a decrease in dehumidification capacity and an increased possibility of moisture carry-over. Therefore, the face velocity across cooling equipment should not exceed 550 feet per minute.

c. Depth of Cooling Media.

(1) Increasing the number of rows for finned type coils or length of water spray for air washers has the following effects:

- (1) the total cooling capacity is increased,
- (2) dehumidification is increased and the leaving air becomes more saturated,
- (3) the difference between leaving air wet bulb and the entering cooling medium temperature is reduced.

d. Flow Arrangement.

(1) The cooling capacity is increased with a counter flow type arrangement where the cooling medium is supplied on the air leaving side and returned on the air entering side.

e. Operating Temperatures.

(1) With given air entering and leaving conditions, the total cooling capacity increases with a drop in the average temperature of the cooling medium.

(2) The cooling capacity of a compressor at a given speed decreases as the evaporator temperature is reduced.

f. Duct System Pressure Loss.

(1) Calculations of the resistance of air handling systems shall include:

- (1) outdoor intake louvers
- (2) dampers
- (3) air filters
- (4) heating coils
- (5) cooling coils (wet, dry or sprayed condition)
- (6) moisture eliminators
- (7) fan entrance
- (8) fan suction vortex dampers
- (9) velocity pressure loss if fan outlet velocity is lower than duct velocity.

(2) Calculations of the resistance of duct systems shall include:

- (1) straight unlined or lined ductwork (see ASHRAE Fundamentals Handbook) Air Friction Charts
- (2) static press regain or loss due to transitions

- (3) fittings
- (4) branch take-offs
- (5) any obstructions
- (6) fire dampers
- (7) regulating dampers
- (8) take-off neck for air terminal device
- (9) air terminal device.

g. Compressor Drive (Refrigeration Systems Only).

(1) Electric Motor-Driven.

- (a) Electric motor-driven compressors are generally used for Naval Shore Facility installations and utilize squirrel-cage electric motors.
- (b) The rotor of squirrel-cage electric motors shall have high starting characteristics.

(2) Steam Turbine Driven.

- (a) Steam turbines shall be used for driving centrifugal compressors where an economic study proves steam power to be less expensive than electric driven.

(3) Gasoline and Diesel Engine Driven.

- (a) Gasoline and diesel engines shall be used for compressor drive where operation of cooling equipment is necessary in the event of electric power failure or if electric power is not available.

3. Air Cooling Equipment.

a. Direct Expansion Cooling Coils.

(1) Design Considerations.

- (a) For a given face area, a longer coil with fewer tubes across the face has least first cost.
- (b) Reducing tubes across the face will increase the pressure drop through the tubes and will thereby reduce the cooling capacity of the compressor. For best results, the maximum pressure drop of the refrigeration circuit across the coil shall be 1 psi or less.
- (c) Coils shall be a maximum of 10 feet in length for ease of handling.
- (d) The number of rows selected shall be based on the evaporating temperature required to give

the design cooling capacity and sensible heat ratio.

- (e) For a given coil performance, reducing the number of rows will necessitate a lower evaporating temperature.
  - (f) An even number of rows shall be provided so that inlet and outlet connections will be on the same end of the coil.
  - (g) Each coil section shall be provided with its own expansion valve and distribution header.
  - (h) Coils shall be selected so that a coil and compressor combination will have the required cooling capacity at their respective suction pressures. The system will then balance at the desired suction pressure.
  - (i) The suction pressure or the corresponding evaporator temperature will depend on the sensible heat ratio of space to be conditioned and should be determined from the manufacturer's data.
  - (j) In order to find balancing suction pressure curves, the capacity versus suction pressure shall be plotted for a compressor and coil. If the curves are not available from the manufacturers, they shall be developed from the manufacturer's equipment data.
  - (k) When compressors are provided with step capacity regulation, the coils shall be divided into sections equal to the number of capacity steps.
  - (l) Where an installation has more than one compressor, the minimum number of cooling coil sections and the cooling capacity of each shall be the same as that of the individual compressors. This arrangement will provide a positive method of dividing the load among the compressors and will also permit step capacity regulation.
- (2) Special Considerations.
- (a) In order to prevent frosting on a coil, the coils shall have sufficient rows to prevent the evaporator temperature from falling below 28° F.

b. Chilled Water Finned Cooling Coils.

(1) Design Considerations.

- (a) For the most economical cooling coils, the temperature of the chilled water should be 40-48° F and the water temperature rise should be 8-14° F.
- (b) For a given face area, a larger coil with fewer tubes across its face has least first cost.
- (c) Reducing the number of tubes across the face will increase the water velocity through the tubes and will thereby increase the pumping cost. For best results, the tubes across the face shall be selected for a water velocity of 3 to 5 feet per second.
- (d) Coils shall be a maximum of 10 feet in length for ease of handling.
- (e) The number of rows shall be selected to give the required cooling capacity and sensible heat ratio.
- (f) Coils should have an even number of rows so that the water-entering and water-leaving connections will be on the same end of the coil.
- (g) The number of sections in the coils will depend on the total cooling load of the system. For continuity of operation at partial load, consideration shall be given to a coil having two or more separately controlled sections.
- (h) Where more than two sections are required, select coils with the maximum tubes across the face to reduce the number of sections and piping cost.
- (i) The cooling coils shall have plugs and drainage valves for cleaning and draining.
- (j) Cooling coils using other than chilled water as the cooling medium (brine or well water), shall have cleanout plugs at both ends of every tube and on the headers, to permit cleaning at regular intervals.
- (k) A preheat coil may be required to maintain the temperature of the air entering the cooling coil above freezing conditions.



(2) **Special Considerations.**

- (a) An antifreeze solution may be required to prevent freezing.
- (b) Eliminators may be required to prevent condensate carry-over.

c. **Spray Type Finned Cooling Coils.**

(1) **Design Considerations.**

- (a) Spray type finned cooling coils may be used with either a chilled water or direct expansion system.
- (b) The allowable minimum water supply is 1 gallon per minute per square foot of coil face area.
- (c) Spray nozzles shall be designed to spray water uniformly on the entire coil face.
- (d) Fins and tubes shall be made from copper to prevent corrosion.
- (e) Provide proper bleed off of spray water to reduce contamination levels.

(2) **Special Considerations.**

- (a) Due to maintenance problems, sprayed coils are normally not recommended.

d. **Air Washers.**

(1) **Design Considerations.**

- (a) Air washers may be provided for:

- (1) systems where evaporative cooling is climatically feasible and may be used in lieu of cooling for part of the cooling season
- (2) coil systems requiring strict temperature control of near saturated supply air
- (3) for systems where special treatment is required for the air (bactericidal treatment)
- (4) the removal of foreign gases, vapors and odors
- (5) the removal of solids and liquids, except for carbonaceous and greasy particles.

- (b) The velocity of the air through an air washer shall be not more than 500 feet per minute.
- (c) The water supply shall be 2 or 3 gallons per minute per square foot of the face area.
- (d) Air washers that are designed for cleaning or purifying shall have a series of scrubber plates and nozzles on the leaving side. Water in the pan shall be arranged with a bleed-off to reduce contamination levels.
- (e) The air entering side shall have equalizing baffles and shall be arranged to obtain uniform distribution of air through the air washer.
- (f) The sound level of the air washer may be 50 to 60 decibels.

(2) Special Considerations.

- (a) Preheaters shall be provided to heat the entering air if the air temperature is likely to drop below 40° F.

e. Evaporators.

(1) Design Considerations.

- (a) Evaporators are used to absorb heat from air to liquid.
- (b) There are two basic types of evaporators, liquid cooling and air cooling.
- (c) Shell-and-coil or shell-and-tube type evaporators are used for chilling a liquid (usually water), while finned-surface type evaporators, are used for cooling air.
- (d) When a number of evaporators are connected in parallel, the load on each shall match the capacity unloading steps of the compressors.

(2) Special Considerations.

- (a) The pressure drop of the refrigeration circuit of the evaporator (not including the distributor) shall be 3 psi or less.

f. Solar Cooling.

(1) Design Considerations.

- (a) Glass used in collector cells, shall be protected from hailstones when appropriate. Such protection shall not hamper cleaning of glass surface.
- (b) If concentrating or evacuated tube collectors are used, a tracking system shall be provided to keep the collectors facing the sun.

(2) Special Considerations.

- (a) See the ASHRAE Applications Handbook for additional information.

g. Air Inlet Connections.

(1) Design Considerations.

- (a) Air duct connections to coils shall be arranged to produce uniform air velocity across the entire face of the coil.
- (b) Air flow on the entering side shall be normal to the coil for a distance 1-1/2 times the width of the coil or greater. If this is not feasible, baffles shall be provided to equalize the air flow.
- (c) Preheat coils should be as large as the cooling coils, if not, the slope of the ductwork from the preheat coil to the cooling coil shall not be more than 15 degrees with a line perpendicular to the coil face.

h. Air Outlet Connections.

(1) Design Considerations.

- (a) Where double inlet fans are used, the distance between the casing and fan inlet shall not be smaller than 1-1/2 times the diameter of the fan inlet.
- (b) On pull-through systems, the distance between the back of the fan and the cooling coil shall not be less than the fan casing width.
- (c) On blow-through systems, requiring a perforated plate for air distribution across the coil, a minimum distance 1/2 times the wheel diameter shall be provided between the fan discharge and perforated plates.

- (d) One side of the air handling unit shall have enough free space for withdrawal of the complete coil for service.
- (e) Field fabricated units shall have access doors and space of at least 2 feet 6 inches on both sides of the coil for inspection.
- (f) Air flow through the coil should be horizontal to facilitate condensate removal.
- (g) Cooling coils installed in tiers of two or more sections shall have drip troughs for each section to collect moisture so that it will not drip from the higher to lower section and then splash into the air stream.
- (h) Moisture eliminators shall be used when cooling coils are provided with water sprays.

(2) Special Considerations.

- (a) Moisture carry-over, on the air leaving side of the cooling coils, may be prevented by proper sizing of coils and ductwork configuration and/or by installing moisture eliminators.

4. Air Cleaning Systems.

a. System Design Considerations.

(1) Location.

- (a) Filters shall be located ahead of coils to avoid accumulation of dust on equipment.
- (b) Filters shall be located at a central point adjacent to the air handling equipment.
- (c) Filter banks shall be arranged to clean all air at the upstream side of bypass ducts, coils, eliminators, humidifiers and fans.
- (d) Filter frames shall be strong enough to support filters and allow for ease of service.
- (e) Joints in frames shall be air tight to avoid bypassing of unfiltered air.
- (f) Ducts or apparatus beyond filters shall be air tight to prevent dirt from entering the system.

(2) Installation.

- (a) Equipment shall be spaced with air connections arranged to give uniform air velocity across filter banks.
- (b) Electrostatic precipitators with washing arrangements shall allow enough headroom for a water basin and drain.
- (c) Pre-filters shall be provided for electrostatic units to prevent heavy collection of lint and insects which could result in shorting of high voltage plates.
- (d) A minimum clearance of two feet shall be provided for proper service and inspection.
- (e) An access door with minimum width of 18 inches and an electric light in a marine-type fixture shall be provided.
- (f) The slope of connecting ductwork shall not be more than 15 degrees.
- (g) For hospital filtration system requirements see DM-33 for filter requirements.

(3) Equipment Design Considerations.

- (a) Filters shall be selected with a minimum efficiency per ASHRAE Standard 52-76.
- (b) Select filters for the normal operating velocity recommended by the manufacturer to give an economic combination of static pressure loss and dust holding capacity.
- (c) For areas with heavy industrial dust (particle sizes above 60 microns) centrifugal separators shall be used.
- (d) For areas with temporary atmospheric impurities (particle sizes 1-100 microns), air filters or dust arrestors shall be used.
- (e) For areas with permanent atmospheric impurities (particle sizes 0.001-1 micron), electrostatic precipitators or dry media type absolute filters shall be used.
- (f) Viscous or dry throwaway filters shall be used in factory built air handling units up to 4,000 cfm capacity.

- (g) Dry, automatic, replaceable filters shall be used in factory built air handling units above 4,000 cfm capacity, and field fabricated air handling units.
  - (h) Electrostatic precipitators or absolute dry media filters shall be used for high efficiency filtration.
  - (i) For treatment of non-soluble gases, activated carbon filters shall be used.
  - (j) For areas where the gas or odor is not harmful to human beings, masking agents shall be used.
  - (k) Air washers shall be used for the removal of water soluble gases. Either a bleed-off for circulating water or chemical treatment to reduce the concentration of contaminant shall be used when treating water soluble gases.
  - (l) For dust free atmosphere, filters with 80-90 percent efficiency shall be provided.
  - (m) Where high filtration, above 90 percent efficiency is required, electrostatic precipitators or absolute dry media filters shall be provided as after filters.
- (4) Special Considerations.
- (a) Fire precautions may be required for localities where the lint content is high.
  - (b) Automatic sprinklers or other approved extinguishing systems are required for oil bath filters (see NFPA Standard 90A).
  - (c) Filters shall be made from non-combustible materials and shall meet the approval of fire control authorities.
  - (d) Outdoor air intakes shall be above ground or roof line and away from chimneys and exhaust systems.
  - (e) Outdoor air intake louvers shall have eliminator baffles to prevent water and snow from entering filters.
  - (f) Where odor-free interior is required, compare the cost of carbon filters with increasing the amount of outdoor air.

- (g) For normal comfort cooling, compare the cost of automatic dry or viscous filters, with dry throwaway or washable viscous filters.

5. Air Duct Systems.

a. Air Ducts.

(1) Design Considerations.

- (a) The equal friction method in the ASHRAE Fundamentals Handbook shall be used to determine the appropriate size ductwork.
- (b) Round ducts shall be used whenever possible. Under normal applications, a minimum duct size shall be 4 inches diameter.
- (c) For circular equivalent data, use the appropriate charts in the ASHRAE Fundamentals Handbook.
- (d) For rectangular duct design, see the SMACNA-Low Pressure Duct Construction Standards. Under normal applications, a minimum duct size of 6 by 6 inches shall be used.
- (e) Where ductwork is connected to any fittings of equipment such as heating coils, cooling coils or filters, the transitions should be as smooth as possible. The slope of transition shall be 15 degrees on the upstream side and less than 30 degrees on the downstream side. Transitions in elbows shall be avoided.
- (f) The reduction in area due to obstruction shall be 20 percent or less. Obstructions inside the ducts should be streamlined.
- (g) Access doors or panels shall be provided in ductwork for any apparatus requiring maintenance, inspection, and service and for:
  - (1) filters
  - (2) cooling coils
  - (3) heaters
  - (4) sound absorbers
  - (5) volume and splitter dampers
  - (6) fire dampers
  - (7) thermostats
  - (8) temperature controllers
- (h) For treatment of sound in high velocity ductwork see the ASHRAE Fundamentals Handbook.

(2) Special Considerations.

- (a) The aspect ratio shall be 6 to 1 or less except where space considerations are a governing factor.

b. Elbows.

(1) Design Considerations.

- (a) Smooth elbows with a center radius of 1-1/2 times the width of the duct shall be used for rectangular ducts. If this is not possible, a mitered elbow should be considered.
- (b) Mitered elbows shall not be used without turning vanes. Plate vanes shall be used in applications below 1600 feet per minute and formed vanes above 1600 feet per minute.
- (c) Smooth, curved elbows shall be used as far as possible on round ducts. If a smooth, curved elbow is not available, use a three-piece elbow for velocities below 1600 feet per minute and a 5-piece elbow for velocities above 1600 feet per minute. The throat radius shall not be less than 3/4 of the duct diameter.

(2) Special Considerations.

- (a) None.

c. Dampers.

(1) Design Considerations.

- (a) Volume dampers and/or splitter dampers shall be provided in ductwork wherever necessary to obtain proper control, balancing, and distribution. An automatic parallel blade damper shall be used if position control is required. An automatic opposed blade damper shall be used if modulating control is required. Self-closing gravity operated louvers shall be used when the backflow of air is to be stopped. Fire dampers should be located on the drawings and located in accordance with NFPA Standard 90B. However, refer to the local fire codes for use, location, and construction of fire dampers.

(2) Special Considerations.

- (a) None.



6. Room Air Distribution Devices.

The location of air distribution devices shall be coordinated with the architectural features of the space, such as columns, doors and windows.

The location of ceiling type outlets shall be coordinated with the lighting layout.

a. System Design Considerations.

(1) Air Flow.

(a) The direction of air flow into a room shall be toward the occupants.

(b) The air distribution shall be as uniform as possible.

(c) Temperature variation shall not exceed 2° F in the air conditioned space.

(d) Minimum room air movement shall be 20 feet per minute.

(e) Air outlets shall be located to provide a proper throw, drop and spread at or above the 20 feet per minute minimum and below the following maximum velocities:

- |  |                        |
|--|------------------------|
| (1) Sedentary Work: Offices,<br>residences, hospitals . . .                        | 50 feet<br>per minute  |
| (2) Slightly Active Work:<br>General offices, light<br>industrial applications . . | 75 feet<br>per minute  |
| (3) Industrial Work . . . . .  | 300 feet<br>per minute |

(f) Air should not blow against obstructions such as beams, columns, lights or sprinklers, nor on the backs of occupants.

(2) Location.

(a) Supply outlets shall be located uniformly within the range of their throw for uniformly distributed loads.

(b) Where loads are of the concentrated type, supply outlets shall be located near the load source.

- (c) Air around high heat load equipment shall be returned through grilles located near the equipment to avoid mixing with room air.
  - (d) Supply and return outlets shall be located for complete coverage of the entire space. There shall be no short circuiting between supply and return outlets.
  - (e) Where separate heat-distributing devices for heating are not provided below windows or for cold walls, the systems shall have a warm air supply at a low level below the glass to offset down drafts.
  - (f) Where both heating and cooling operations are performed by the same system, return intakes should be located at a low level. However, floor return grilles shall be avoided.
  - (g) Return air devices shall not be expected to correct faulty distribution produced by incorrect selection and location of supply devices.
  - (h) Direct connection of air outlets to the main ductwork shall be avoided, especially if the velocity of the air in a duct is higher than the neck velocity. The neck length of connection to ceiling diffusers shall be two-to-four times the diameter of the neck.
- (3) Smudge Prevention.
- (a) Smudges near supply outlets are produced by dust deposited from room air as it is induced near the outlet by the high velocity of the supply air.
  - (b) In order to prevent smudging, the outlet shall be installed below the ceiling surfaces so that the induced room air will not come in contact with the ceiling.
  - (c) Where minimum ceiling smudging is a prerequisite, mount the ceiling diffuser on antismudge rings which separate the outlet from the ceiling by a preset distance calculated to prevent smudging.
  - (d) Mount wall grilles at least 12 inches below the ceiling to reduce smudging.

(4) Individual Device Design Considerations.

- (a) Refer to the manufacturer's data for the throw characteristics.
- (b) Verify the effect of temperature range on distribution under the following conditions:
  - (1) when the temperature differential between room air and supply air exceeds 20° F. Check the suitability of induction type outlets for high temperature differential applications
  - (2) when the same outlet is used for heating and cooling.
- (c) See the ASHRAE Systems Handbook for recommended sound levels for various types of areas.
- (d) See the ASHRAE Fundamentals Handbook for a list of recommended maximum velocities.

(5) Wall-Mounted Supply Outlets Design Considerations.

- (a) Adjustable bar grille outlets allow adjustments to be made in horizontal and vertical planes.
- (b) Fixed pattern, wall-mounted outlets shall be avoided.
- (c) Wall-mounted outlets for spot cooling shall have directional adjustment.
- (d) Consider the use of ejector outlets for industrial work and spot cooling, which have a long throw requirement, when consideration of noise is not a design factor.

(6) Ceiling-Mounted Supply Outlets Design Considerations.

- (a) There are five basic types of ceiling-mounted supply outlets: (1) slot diffusers, (2) light troffers, (3) perforated panel diffusers, (4) ceiling diffusers and (5) perforated ceiling diffusers.
- (b) Ceiling outlets will deliver more air to a space than grilles and will generally permit use of a higher residual velocity.
- (c) Some of the advantages for using ceiling-mounted supply outlets are high induction rate, rapid temperature equalization and a higher supply air to room temperature differential.

- (d) Only standard commercial units with published performance ratings should be used.
  - (e) Slot diffusers and light troffers are generally rated for a maximum air supply rate of 2 cfm per square foot of treated space and a minimum of 0.8 to 1 cfm per square foot of treated space.
  - (f) Perforated panel diffusers, ceiling diffusers and perforated ceiling diffusers are generally rated for maximum air supplies of 3, 5 and 10 cfm per square foot respectively of treated space and a minimum of 0.8 to 1 cfm per square foot of treated space.
  - (g) Unit selection can be varied by changing the temperature differential used.
  - (h) Each supply outlet shall have deflection vanes so that the approach velocity will be uniform and normal to the outlet face.
- (7) Return Intakes.
- (a) Where supply outlets and return intakes are located at the same level, both should have a generally matching appearance.
  - (b) If supply outlets are used for return, it is not necessary to use deflection vanes.
- (8) Special Considerations.
- (a) Outlets for variable air volume systems must provide proper distribution at maximum and minimum air quantities.

## 7. Fans.

### a. Design Considerations.

- (1) Performance.
  - (a) Fans shall be selected to operate as close to the point of maximum efficiency as possible.
  - (b) Fans should absorb the least brake horsepower for the given conditions of airflow and static pressure.
  - (c) Fan outlet velocities shall not be less than the velocity of air in the duct for about four equivalent diameters downstream from the outlet.

- (d) See the ASHRAE Systems Handbook criteria for sound requirements.
- (2) Fan Arrangement.
- (a) Consider using single width fans below eight square feet of outlet area unless space restrictions warrant a double inlet fan.
  - (b) For general purpose duty, air conditioning and ventilation, Arrangement Numbers 2 and 4 for single-width single inlet (SWSI) fans, size 27 inches in diameter or smaller (See AMCA Standard 2404-66).
  - (c) For double-width, double inlet (DWDI) fans, Arrangement Numbers 3 or 7 shall be used (See AMCA Standard 2404-66).
  - (d) For general purpose duty, SWSI fans larger than 27 inches in diameter shall be of Arrangement Numbers 3 or 7 (See AMCA Standard 2404-66).
  - (e) Exhaust fans for kitchen range hoods, high temperature fumes and vapors, shall be single-width, single inlet, Arrangement Numbers 1, 8, or 9. (See AMCA Standard 2404-66).
  - (f) Where double-width, double inlet fans are used, inlet boxes with long shafts to keep bearings outside the main air stream shall be provided.
  - (g) Where the operating temperature exceeds 200° F, cooling arrangements for the bearings shall be provided.
- (3) Drive.
- (a) V-belt drive selection shall be based on a load factor of 1.4.
  - (b) V-belt drive pulleys shall have an adjustable pitch to allow a speed variation of  $\pm 5$  percent.
  - (c) The V-belt drive pulley shall be selected so that the pulley is at the midpoint of adjustment at design conditions.
  - (d) Fans with direct drive shall have flexible couplings.
  - (e) With direct drives, a motor large enough to deliver the desired air flow rate at 10 percent

above the calculated static pressure shall be used.

- (f) The overloading characteristic of fans shall be taken into account when selecting direct drive motors for forward curved fans.

(4) Operation.

- (a) Parallel operation of fans shall be avoided if possible.
- (b) If fans are selected for parallel operation, they should be backwardly inclined.
- (c) Each fan shall have self-closing or automatic discharge dampers to prevent backflow of air.
- (d) Fan motors shall be sized for individual operation of fans with increased air flow against reduced static pressure.
- (e) Field fabricated central air handling units shall have manually operated inlet vanes for balancing the system.
- (f) Fans of package units requiring precise balancing shall be provided with outlet volume dampers.

(5) Location and Installation.

- (a) Noise level, low resistance to air flow and accessibility of fans are factors that must be considered.
- (b) When the operating pressure of a fan is above 1.5 inches of water or when a room is designed for low noise level, the fan shall be located away from occupied rooms and acoustic treatment shall be provided.
- (c) Fans shall be located so that air flow to and from a fan shall have minimum disturbance.
- (d) Inlet sides shall have free space in the direction of flow equal to the inlet diameter.
- (e) Fans and bearings shall be accessible for normal service and repairs.
- (f) Fans and drive motors shall be mounted on sturdy frames effectively fixing the position of the drive motor and belt centers.

- (g) The entire assembly shall be mounted on a vibration isolation base of 90 percent minimum absorption efficiency at design speed.
  - (h) Connections between ductwork and fans shall be made by means of a fireproof fabric collar.
- (6) Accessories.
- (a) Cleanout door shall be provided for general purpose fans with a wheel diameter of 24 inches and larger.
  - (b) All fans handling kitchen hood exhaust or any other dirty atmosphere shall be provided with cleanout doors.
  - (c) Drain connections shall be provided for all fans handling saturated air, such as supply air fans for dehumidifying or humidifying equipment and evaporative condenser fans.
  - (d) Inlet and outlet screens shall be provided wherever inlets or outlets are accessible to fingers.
  - (e) For construction materials for Class I, II and III fans as defined by minimum outlet velocity versus static pressure limits, see AMCA Standard 1-66. Class standards are based on a "mean brake horsepower per square foot of outlet area" concept.

b. Applications.

- (1) Centrifugal Forward Curved Fans.
  - (a) This fan shall be used where a small fan size is required or when fans are part of packaged equipment.
- (2) Centrifugal Backward Curved Fans.
  - (a) This type of fan shall be used for general ventilation, air conditioning, and exhaust.
- (3) Airfoil Backward Inclined Fans.
  - (a) Airfoil fans shall be used in large heating, ventilating, and air conditioning systems where quiet operation and high efficiency are prerequisites.

(4) Propeller Fans.

- (a) Propeller fans shall be used for exhaust duty only where the system static pressure is not more than 1/2 inch of water.

(5) Axial Fans.

- (a) Axial flow fans may be used in place of centrifugal or in-line centrifugal fans if the resulting noise levels in the occupied space meets the design requirements.
- (b) Controllable pitch type shall be considered for variable air volume systems.

c. Special Considerations.

- (1) Materials for industrial exhaust fans shall be selected for corrosion resistance, abrasion resistance, and non-sparking characteristics required by the material being exhausted. Fan wheel characteristics shall be selected based upon the abrasiveness of the airborne material first and static pressure characteristics second.
- (2) Curved blade centrifugal fans are not suitable for handling exhaust from tool grinding shops or other metal grinding operations.
- (3) Fans for hot air, gas or vapor above 100° F shall have motor and drive mounted outside the airstream to insure motor cooling from the ambient air.
- (4) Fan motors and drives shall be protected from dust and/or dirt. Totally enclosed fan-cooled motors should be considered for such applications.
- (5) Fan motors and drives when exposed to flammable or explosive material shall be located out of the airstream. The fan wheel shall be of non-ferrous construction for spark-proof operation.
- (6) In-line centrifugal fans may be used in place of standard arrangement centrifugal fans where available space limits fan size.

8. Refrigeration Equipment.

a. Design Considerations.

- (1) System.



- (a) The selection of chilled water plants refrigeration equipment shall be based on an economic study comparing owning and operating expenses of various types of systems. See Figure 11 for an example of a cost comparison chart.

COST COMPARISON OF CHILLED WATER PLANTS <sup>1</sup>				
Cost Item	Electric Centrifugal	Steam Centrifugal <sup>2</sup>	Steam Absorption <sup>2</sup>	Piggy-Back Steam Cent. W/Absorption <sup>2</sup>
1. Capital costs				
a. Chiller unit				
b. Auxiliaries (cooling towers, condensers, etc)				
c. Controls & Instrumentation				
d. Wiring & Piping				
e. Any increase in bldg construction cost attributable to system				
f. Any decrease in bldg construction cost attributable to system				
g. Installation cost				
h. Miscellaneous				
2. Net Total Worth				
3. Annual Owning Cost (Annual fixed charge at 10% interest compounded annually)				
4. Annual Operating Cost				
a. Energy cost				
b. Maintenance cost				
c. Labor cost				
5. Total Operating Cost				
6. Total to Own & Operate (Sum of 3. & 4. above)				

1. This type analysis should be made for large individual bldg. plants or central plants.
2. This arrangement is predicated on having steam available from a central system or from a building steam heating boiler. If building is new and steam boiler capacity has to be increased for air conditioning, cost for additional capacity shall be charged to air conditioning system.

FIGURE 11  
Cost Comparison of Chilled Water Plants

- (b) Consideration shall be given to the added electrical demand charge if an electric chiller is being considered.
- (c) Operating expenses shall be based on a complete range of load conditions.

- (d) The type of system and number of machines shall depend on the required flexibility and reliability of service.
- (e) For a list of specific items on which selection shall be based, see Table 14.

TABLE 14  
Refrigeration Equipment Selection Factors

Systems	Considerations
General . . . . .	1. Load factor and characteristics of expected load variation. 2. Type of condensing medium, air or water. Availability and temperature of condensing medium. 3. Availability and characteristics of power supply.
Direct expansion system . . . . .	1. Maximum cooling load in Btuh. 2. Required evaporator temperature.
Indirect cooling system . . . . .	1. Type of cooling medium. 2. Quantity of cooling medium circulated in gallons per minute. 3. Design supply and return temperatures of cooling medium.

- (f) Additional requirements are given in DoD 4270.1-M.

**b. Refrigerants.**

**(1) Design Considerations.**

- (a) The choice of refrigerant is usually determined by considerations of safety, availability, ease of leak detection and cost.
- (b) For properties and performance of desirable refrigerants, see the ASHRAE Fundamentals Handbook.
- (c) ANSI Standard B 9.1 shall be used as a basis of selection for safety.
- (d) See the ASHRAE Fundamentals Handbook and ANSI Standard B 9.1 for further information.

(2) Special Considerations.

(a) None.

c. Reciprocating Compressors.

(1) Design Considerations.

(a) Compressor capacity can be controlled either by changing the speed of the drive or by the unloading of cylinders.

(b) Unloading the cylinders is usually considered when a compressor is driven by constant speed drive (squirrel-cage induction motors, diesel or gas engines).

(2) Special Considerations.

(a) The compressor lubrication system shall be such that it is not adversely affected while operating at low speeds if a variable speed drive is used.

d. Centrifugal Compressors.

(1) Design Considerations.

(a) Use inlet guide valve control when compressors are driven by constant speed motors and capacity reduction is not required below 10 percent.

(b) Use hot gas bypass control in addition to inlet guide valve control where capacity reduction below 10 percent is required.

(c) Use speed variation when compressors are driven by variable speed drive such as a turbine or wound rotor motor.

(2) Special Considerations.

(a) Surge problems should be considered if this type unit is run at partial load.

e. Absorption Chiller.

(1) Capacity reduction is achieved by:

(1) varying the volume of heating medium (steam or hot liquid) to the chiller

- (2) varying the temperature of the hot liquid to the chiller
- (3) varying the volume of the absorption solution to the generator.

(2) Special Considerations.

- (a) Some manufacturers also require the condenser water to be controlled at a constant temperature.

f. Evaporators.

(1) Design Considerations.

- (a) Evaporators are used to absorb heat from air to liquid.
- (b) There are two basic types of evaporators, liquid cooling and air cooling.
- (c) Shell-and-coil or shell-and-tube type evaporators are used for chilling a liquid (usually water), while finned-surface type evaporators, are used for cooling air.
- (d) When a number of evaporators are connected in parallel, the load on each shall match the capacity unloading steps of the compressors.
- (e) The pressure drop of the refrigeration circuit of the evaporator (not including the distributor) shall be 3 psi or less.

g. Water Coolers.

(1) Design Considerations.

- (a) Water coolers are used for large tonnage capacities and for central refrigeration plants serving a number of zones, each with its individual air cooling and air circulating unit.
- (b) The possibility of leakage causing consequent high replacement cost of refrigerant, when long refrigeration mains are necessary between condensing equipment and air conditioning units may make it desirable to provide water cooling equipment close to the condensing units and to circulate chilled water to the remote air-cooling coils.

- (c) Lowering the refrigerant temperature will reduce the size of the cooler but increase the size and power consumption of the compressor.
- (d) A cooler with a smaller diameter and longer length will be less expensive, but the frictional pressure drop of the water and refrigerant circuits will be higher.
- (e) The two basic types of water coolers are shell-and-coil and shell-and-tube.
- (f) The shell-and-coil cooler shall be used for small loads. The coils cannot be cleaned or replaced as conveniently as the tubes in shell-and-tube coolers.
- (g) The shell-and-tube cooler shall be used for large plants and shall be operated at a low mean temperature difference of between 6 and 20° F.
- (h) Selection of shell-and-tube coolers should be based on a mean temperature difference between 10 and 14° F. When selecting a unit, keep in mind: (1) the lower the refrigeration temperature the smaller the unit; however, this increases the size of the compressor, and (2) the smaller the diameter and longer the length the less expensive the system; however, the pressure drop is higher.
- (i) In flooded type coolers, a low pressure float control shall be used to maintain the proper refrigerant flow to the evaporator.
- (j) Dry expansion type coolers should be selected at the same mean temperature difference range as the flooded type.
- (k) The refrigerant temperature should be no lower than 28° F for dry expansion type coolers.
- (l) A thermostatic expansion valve shall be provided when using dry expansion type coolers.

(2) Special Considerations.

- (a) Flooded type shell-and-tube coolers are advantageous for a system where tubes need frequent cleaning due to the scaling properties of the water.
- (b) Flooded type shell-and-tube coolers require more refrigerant than the dry expansion type.

**h. Once-Through Condenser Water System.**

**(1) Design Considerations.**

- (a) The once-through system is designed for a flow rate of 1.5 to 2 gallons per minute per ton when the temperature of water entering the condenser is 75° F or higher.
- (b) The cooling water supply shall be from raw water sources only such as wells, lakes, ponds, rivers, or other bodies of water.
- (c) Materials used in construction shall be suitable for the quality of water available.
- (d) Condenser design shall be adaptable for mechanical cleaning as required by the quality of water available.
- (e) The systems shall be designed to use well water only when wells of sufficient capacity are available.
- (f) Wells shall not be drilled for air conditioning alone, unless it proves to be the most economical method.
- (g) Existing wells may be used if the water is of acceptable quality and temperature.
- (h) In well water systems, the waste water is usually returned to dispersion wells or leaching fields to make up for the water drawn from the cooling wells. In other systems, the waste water leaving the condenser is usually diverted to a drain.

**(2) Special Considerations.**

- (a) Economic considerations shall include the cost of pumping installation, filtration equipment and special construction materials required by the quality of water.

**i. Multiple or Recirculation Condenser Water System.**

**(1) System Design Considerations.**

- (a) Recirculation systems are usually designed for flow rates of 2.5 to 3.75 gallons per minute per ton which corresponds to a cooling range of 8 to 12° F.

- (b) Actual flow rates will depend on the evaporating temperature, condensing temperature, and design wet bulb temperature.
  - (c) A recirculation cooling device will cool the condenser water to approach a temperature of 6 to 12° F above the design wet bulb temperature.
  - (d) The smaller the approach temperature difference, the larger will be the size of the cooling device.
  - (e) Recirculation cooling devices shall be located to minimize problems of drift, fogging, air recirculation noise, and the entry of contaminants into the device such as foliage, fly ash, and earth.
- (2) Cooling Pond or Spray Pond - Design Considerations.
- (a) Condenser water shall be cooled by a cooling pond or spray pond only if the architectural scheme of the site permits.
  - (b) Water treatment shall be provided for the control of algae.
  - (c) If a spray pond is used, consideration shall be given to the effect of moisture carry-over due to wind.
  - (d) Water consumption will depend on the spray design and prevailing wind velocities at the site. For average conditions, total water consumption due to evaporation and other losses may be about 10 percent of the quantity circulated.
- (3) Mechanical Draft Cooling Tower - Design Considerations.
- (a) Cooling towers may be induced-draft or forced-draft. Induced-draft towers are preferred because they recirculate less moist air discharged from the unit and are more energy efficient.
  - (b) Towers shall be designed to avoid any recirculation of discharge air. If there is any chance of recirculation, towers shall be oversized by selecting them for a wet bulb temperature higher than the design wet bulb temperature.

- (c) Total water consumption shall be based on evaporation, drift, and other losses. As a minimum, 1.5 percent of the quantity of water circulated shall be used.
- (d) Cooling towers shall be constructed from materials that will not corrode or deteriorate under normal service.
- (e) Construction shall meet fire and safety codes. See NFPA Standard 214.
- (f) The following precautions shall be followed if condenser water systems are expected to work in freezing weather:
  - (1) Outdoor Piping: All outdoor piping exposed to freezing weather shall be arranged to drain into the cooling tower pan during off cycle. As an alternate, outdoor piping shall be traced either with steam lines or with electric heating cables to prevent freeze-ups.
  - (2) Water in Pan: During the off cycle, water in the pan shall be drained into a storage tank located in a heated area. Alternatively, water in the pan shall be kept from freezing by heating it with an immersion type heater (steam or electric). In large water pans, water may be kept warm by circulating it through a steam or electric water heater.
- (g) Water treatment shall be provided.

j. Air-Cooled Condensers.

- (1) Design Considerations.
  - (a) The most common available sizes of air cooled condensers range from 2 to 100 tons in capacity.
  - (b) They are usually used as an integral component of a factory-assembled condensing unit or in factory-matched components.
- (2) Special Considerations.
  - (a) Air cooled condensers larger than 100 tons may be applied where it is not economical to provide a water-cooled system due to high cost,



unavailability or unsuitability of water, where 12-month operation is required, or where an economic analysis favors air-cooled condensing.

- (b) Due to the large quantity of air handled, air cooled condensers are usually noisy. Therefore, consider noise transmission to the adjoining spaces.
- (c) The design of roof-mounted units shall compensate for higher roof ambients by increasing air flow and proper location of unit air intake.
- (d) The system selected shall minimize refrigerant charge or operating horsepower.
- (e) For economical selection, the condensing temperature shall be between 10° F and 30° F above the entering air temperature. In 100° F or higher ambient space temperatures, the condensing temperature should be limited to a maximum of 130° F.
- (f) Units shall be elevated above the ground to prevent dirt accumulation on the coil.
- (g) The air intake side shall be free from any obstructions that restrict air flow. They shall be located away from the air discharge side to avoid the bypassing of warm discharge air.
- (h) For acoustical control, see DM-1 and DM-3.10.
- (i) For a given compressor and entering air temperature, the condenser pressure will increase and cooling capacity will decrease as the condenser size is reduced.
- (j) For a given compressor and condenser size, the condensing pressure increases and the cooling capacity decreases as the entering air temperature increases.

k. Water-Cooled Condensers.

(1) Design Considerations.

- (a) In the double pipe condenser, the tube which carries the water is located within a larger tube, and the refrigerant gas is passed between the inner and outer tubes. It is usually used with small self-contained units.

- (b) The shell-and-coil water cooled condenser has a pipe coil inside a closed shell. The cooling water flows through the coil while the refrigerant gas to be condensed is discharged by the compressor into the shell. It is usually used on small and medium sized condensing units.
- (c) The shell-and-tube type cooled condenser has a number of tubes which are assembled in a large shell. The cooling water is circulated through the tubes and discharge gas from the compressor is condensed in the shell. This type of condenser can be cleaned and serviced very conveniently. Large sizes often are provided with marine-type boxes through which all the tubes can be reached without disconnecting the water pipes.

(2) Special Considerations.

- (a) The fouling factor, or scaling factor, depends on the quality of water. Generally, new condenser ratings are based on a fouling factor of 0.0005. Where water with higher scaling characteristics will be used, a higher fouling factor should be selected. See the ASHRAE Equipment Handbook for factor selection. Condensers selected for a higher fouling factor will be more expensive.
- (b) Increasing the size of the condenser will increase the compressor efficiency, but at the same time it will increase the initial cost of the condenser.
- (c) Increasing the cooling water flow will increase the condenser capacity, but it will also increase the pumping cost of the water consumption.
- (d) Reducing the shell diameter and increasing the tube length will reduce the initial cost, but it will increase the frictional pressure drop of the water circuit.

1. Evaporative Condensers.

(1) Design Considerations.

- (a) An evaporative condenser consists of an air induced-draft cooling tower with a bare pipe refrigerant coil wetted by the water spray in

the air stream. The water evaporating above the tubes extracts heat from the tubes and causes the hot discharge gas circulating through the tubes to condense. The water is recirculated by a pump and the water level is maintained by a float control.

- (b) Evaporative condensers for Refrigerant-12 are selected on the basis of a 25 to 30° F temperature difference between the entering wet bulb temperature and the condensing temperature.
- (c) Liquid subcooling coils may be used to reduce the temperature of the liquid below the temperature equivalent of the condensing pressure. While subcooling of the liquid increases the total refrigeration capacity, a more beneficial effect is the elimination of the expansion valve and liquid line troubles from flash gas.
- (e) The water consumption, inclusive of evaporation, drift and other losses, will be a minimum of 2 gallons per hour per ton of refrigeration.
- (f) Evaporative condensers should be used only when the water available for makeup does not have scaling properties. Otherwise, suitable water treatment should be provided for the water.

(2) Special Considerations.

- (a) Evaporative condensers are more prone to corrosion and scaling than any other type of condenser due to the high surface temperature of the tubes, the presence of air together with water, and the electrolytic action of dissimilar metals.

m. Receivers.

(1) Design Considerations.

- (a) Every refrigeration system shall have a receiver large enough to hold an entire refrigerant charge.
- (b) If the receiver of a factory-built system is not large enough, a supplementary receiver shall be provided.
- (c) In shell-and-coil and shell-and-tube condensers, the shell is also used as the receiver for the condensed refrigerant.

- (d) Separate receivers are provided for air-cooled, double-pipe, and evaporative condensers.
- (2) Special Considerations.
  - (a) For data concerning gas binding, see the ASHRAE Equipment Handbook.
- n. Safety Controls.
  - (1) Design Considerations.
    - (a) Safety controls shall be used to stop the refrigeration system until a fault has been located and corrected.
    - (b) Safety controls shall be wired, so that when the system stops under the action of any safety control it will not restart automatically until the fault has been corrected.
    - (c) The following is a list of minimum controls for safe operation of refrigeration systems:
      - (1) high discharge pressure cutout
      - (2) low evaporating pressure cutout
      - (3) low oil pressure cutout
      - (4) motor high temperature cutout
      - (5) flow switch for condenser water
      - (6) flow switch for chilled water and an interlock between chilled water pump and chiller
      - (7) low temperature cutout for water chiller
      - (8) receiver high pressure relief valve.
  - (2) Special Considerations.
    - (a) None.

9. Piping Systems.

a. System Design Considerations.

- (1) The selection of piping shall be based on economic and engineering judgment.
- (2) Copper piping is not corroded by fluorinated hydrocarbon refrigerants, even when mixed with moisture, and it is entirely free of the effects of scaling.
- (3) Steel pipe and fittings have lower material cost in larger sizes.

- (4) The choice between steel and copper shall be based on the estimated cost of each installation.
- (5) For safe pressure of piping and fittings corresponding to working pressures and temperatures, see ANSI B31.1 and B31.1a.
- (6) For appropriate information on piping material selection, see Table 15.

**TABLE 15**  
**Recommended Pipe and Fitting Materials for Various Services**

Service	Pipe	Fittings
Refrigerants 12, 22 and 500:		
Suction Line . . . . .	Hard copper tubing, Type L <sup>1</sup>  Steel pipe, standard wall. Lap welded or seamless for sizes larger than 2 in. IPS	Wrought copper, wrought brass or tinned cast brass. 150 lb welding or threaded malleable iron.
Liquid Line . . . . .	Hard copper tubing, Type L <sup>1</sup>  Steel pipe: Extra strong wall for sizes 1-1/2 in. IPS and smaller; standard wall for sizes larger than 1-1/2 in. IPS; Lap welded or seamless for sizes larger than 2 in. IPS.	Wrought copper, wrought brass or tinned cast brass. 300 lb welding or threaded malleable iron.
Hot Gas Line . . . . .	Hard copper tubing, Type L <sup>1</sup>  Steel pipe, standard wall. Lap welded or seamless for sizes larger than 2 in. IPS.	Wrought copper, wrought brass or tinned cast brass. 300 lb welding or threaded malleable iron.
Chilled Water . . . . .	Black . . Hard copper tubing. <sup>2</sup>	Welding, cast or iron. <sup>3</sup> Cast brass, wrought copper or wrought brass.
Condenser or Make-Up Water . .	Galvanized steel pipe. <sup>2</sup>  Hard copper tubing. <sup>2</sup>	Welding, galvanized, cast or malleable iron. <sup>3</sup> Cast brass, wrought copper or wrought brass.
Drain or Condensate Lines. . .	Galvanized steel pipe. <sup>2</sup>  Hard copper tubing. <sup>2</sup>	Galvanized drainage; cast or malleable iron. <sup>3</sup> Cast brass, wrought copper or wrought brass.
Steam or Condensate . . . . .	Black steel pipe. <sup>2,4</sup>	Welding or cast iron.
Hot Water . . . . .	Black steel pipe. Hard copper tubing. <sup>2</sup>	Welding or cast iron. <sup>3</sup> Cast brass, wrought copper or wrought brass.

<sup>1</sup> Soft copper Type L maying may be used for sizes 7/8" OD and smaller, except for sizes 1/4" and 3/8" OD Type K must be used for 1/4" and 3/8" OD sizes.

<sup>2</sup> Normally standard wall steel pipe is satisfactory for air conditioning applications. However, the piping material selected should be checked for the design temperature-pressure ratings.

<sup>3</sup> Normally, 125 lb cast iron and 150 lb malleable iron fittings are satisfactory for the usual air conditioning application. However, the fitting material selected should be checked for the design temperature-pressure ratings.

<sup>4</sup> For steam and condensate return lines, use schedule 80 wrought iron pipe.

b. Water Piping.

(1) System Layout.

- (a) Reverse return piping arrangements shall be used on closed systems, provided all the units or parallel circuits have nearly equal resistance.
- (b) Reverse return piping shall not be used on open systems or once-through systems.
- (c) Water flow, especially through heat transfer equipment, shall be in a direction to permit natural air venting.
- (d) A reverse return shall be provided in an upfeed system, and reverse supply shall be provided in a downfeed system.
- (e) Isolation and drain valves are required in all piping systems.

(2) System Design Considerations.

- (a) See the appropriate tables and charts in the ASHRAE Fundamentals Handbook for friction loss through the pipes.
- (b) See the following for recommended maximum water velocities in pipe:

Hot water . . . . .	6 feet per second
Cold or general (water service up to 4 inches)	8 feet per second
Cold or general (water service above 4 inches)	12 feet per second
Pump action without static head . . . . .	4 feet per second
Drain line . . . . .	4 feet per second

- (c) For noise considerations, a lower velocity for piping within occupied spaces shall be used.
- (d) The recommended minimum water velocity in pipe for hot and cold water, is 2 feet per second for pipe 2 inches or less. The pressure drop is 0.75 feet/100 feet for pipe over two inches.
- (e) Higher velocities shall be used in down-comer return mains feeding into air separation units located in the basement.

(f) The system pressure loss shall include (1) pipe friction based on 10 year old pipe, (2) valves, fittings and other associated equipment, (3) equipment pressure loss and (4) static lift in open systems.

(3) System Accessories.

- (a) All closed systems shall have expansion tanks to maintain the system pressure irrespective of the temperature variation.
- (b) Expansion tank systems shall be sized and located per the ASHRAE Systems Handbook.
- (c) Air vents shall be provided in the high points of systems, loops, heat transfer equipment or other locations where air may collect.
- (d) Air vents should be automatic and should be piped to the suitable drains.
- (e) Strainers of 40 mesh shall be provided in the suction piping of pumps.

c. Refrigerant Piping.

(1) System Design Considerations.

- (a) The main design objectives include:
  - (1) balanced refrigerant supply to evaporators
  - (2) economical pipe sizes without excessive pressure drop
  - (3) control of oil carry-over with assurance of proper return in case of carry-over
  - (4) Prevention of liquid refrigerant from entering into compression.
- (b) See the ASHRAE Fundamentals Handbook for friction pressure drop and velocity relationship of refrigerants.
- (c) The pressure drop in the lines should not exceed the pressure differential corresponding to a 2° F change at saturation pressure. The velocity of liquid shall not exceed 300 feet per minute.

In the case of lines with static lift or very long lines, the lines shall be sized for low

friction drop. Adequate means shall be provided for subcooling to prevent flashing. As an alternative, evaporators should be provided with flash tanks and float control. Refrigerant transfer pumps shall be provided where static lift is excessive.

(2) Suction Line Design Considerations.

- (a) The friction pressure drop of suction lines should not exceed a pressure differential corresponding to a 2° F change at suction pressures.
- (b) Vertical suction risers where compressors are installed above the evaporator should be sized for gas velocities in accordance with the ASHRAE Systems Handbook recommendations for minimum capacity. As an added precaution, a narrow oil loop or trap should be provided as near the evaporator as possible. The fittings of the trap should be closely coupled to minimize its oil holding capacity.
- (c) Where compressors are provided with capacity control, a double suction riser arrangement may be provided. Both risers should be sized for normal load at a velocity satisfactory for oil returning. The first riser should be so sized that oil is returning even at the minimum possible load. A trap is introduced between the two risers so that during partial load, when gas velocity is not sufficient to return oil through both the risers, the trap gradually fills with oil until the second riser is sealed off. Consequently the gas will travel up the first riser only and will have enough velocity to carry up the oil. With multiple compressor installations, the suction line connection to a compressor shall be taken off at the suction main or shall be provided with a trap near the compressor intake in such a manner that oil or refrigerant will not drain into the compressor intake during shut down.

d. Installation.

(1) Fittings.

- (a) Long radius elbows shall be used wherever possible.
- (b) For offsets, a 45 degree elbow shall be used instead of a 90 degree elbow.



- (c) "Bullheading" of tee connections shall be avoided.
- (d) Unions for screwed piping systems shall be provided where equipment and piping accessories have to be disconnected for service.
- (e) Flanges shall be provided for welded piping systems where equipment and piping accessories have to be disconnected for service.

(2) Supports.

- (a) Shields between insulation and supports of insulated piping shall be provided.
- (b) Roller type guided supports shall be provided where horizontal pipe is subject to expansion.
- (c) Vertical pipes and main risers shall be provided with base elbows designed to take the weight of the entire water column plus the weight of the pipe from the elbow up to the first anchor.

(3) Vibration.

- (a) Wherever piping is connected to moving components, such as water pumps or compressors, the following precautions shall be taken:
  - (1) hangers with vibration isolators shall be provided
  - (2) hangers should be massive enough to limit the amplitude of vibration
  - (3) pipe supports should be wide enough to avoid swivel action.
- (b) Piping should have inherent flexibility and should not touch the structure.
- (c) Flexible connections may be installed between moving components and piping. Dual use as a union point should also be considered. The pipe shall be anchored at the end away from the moving component.

(4) Expansion.

- (a) Piping system longer than 100 feet or having temperature variations of more than 50° F shall be analyzed for thermal expansion.

- (b) Piping shall be run with a change of direction in three planes so that it will have flexibility to absorb small expansion by torsion effect at the joints.
- (c) On straight pipes, expansion loops shall be provided if space conditions permit it.
- (d) Packing type expansion joints and ball joints shall be provided only if located in an accessible area. This type of expansion joint should not be used for refrigerant piping. Packing type expansion joints may be used for chilled water, hot water, or steam lines under limited conditions as indicated for expansion joints in Section 2.
- (e) Bellows type expansion joint shall be used where piping is not easily accessible. Bellows type joints can fail completely without warning while packing type joints fail slowly, giving warning by leakage.
- (f) Piping between expansion joints shall have rigid supports designed to carry the weight of pipe and fluid together with lateral thrust of the expansion joint.
- (g) Risers and mains shall be rigidly anchored to prevent undue strain on the branches.

e. Piping Connections.

- (1) Screw threads shall be used with pipes up to two inches in size.
- (2) Welding connections shall be used for steel pipe above two inches.
- (3) Brazing shall be used for brass valves and copper pipe fittings.
- (4) Soldering shall be used for copper pipe only for low pressure applications.
- (5) Flare type connections shall be used for copper tubing up to 7/8 inch outside diameter.
- (6) Fittings between dissimilar metals shall be insulated to prevent galvanic action.

## 10. Valves.

### a. Valve Design Considerations.

#### (1) Gate and Globe Valves.

- (a) Gate valves shall be the solid wedge type and shall not be used for throttling service.
- (b) Globe valves may be used for throttling service. Valves should have a regrinding seat ring and plug.
- (c) Where a low pressure drop is a prerequisite, either "Y" valves or angle valves shall be used.
- (d) Globe valves above the 8 inch size should be provided with a 3/4 inch bypass globe valve.

#### (2) Butterfly Valves.

- (a) Butterfly valves shall not be used for throttling service.
- (b) Ease of installation is an advantage with this type of valve, particularly where the working area is restricted.

#### (3) Check Valves.

- (a) Swing check valves for horizontal and vertical pipe lines shall be used where flow reversal is not desired.
- (b) Steam and condensate valves should have a regrinding seat and disc. Water valves should have a regrinding seat with renewable composition disc.
- (c) A silent spring loaded check valve shall be provided on the discharge side of each pump.
- (d) Plug cocks shall be provided for balancing a system not subject to frequent changes in flow. Automatic flow control valves shall be provided for balancing a system with frequent changes in flow.
- (e) Construction shall be:
  - (1) Valves two inches and less in size should be bronze
  - (2) Valves 2-1/2 inches and above should be iron.

b. Accessory - Design Considerations.

(1) Connections.

- (a) Threaded connections shall be used for low pressure systems only under conditions of light duty.
- (b) Union bonnets shall be used for general purpose duty for piping systems up to 2 inches.
- (c) All valves above two inches in size should have bolted bonnets. Valves for high pressure systems should have suitable pressure seals.

(2) Valve Stems.

- (a) Rising stem valves shall be used where the fluid is liable to damage threads or where indication of disc position is desired.
- (b) Condenser water systems shall have rising stem valves.
- (c) Non-rising stem valves should be used only where space restrictions require.
- (d) For inaccessible overhead valves, chain-operated handwheels complete with chain and chain guide shall be provided.

c. Refrigeration Valve Use - Design Considerations.

- (1) Valves shall be backseating globe valves.
- (2) Packed valves shall be used where frequent service is not expected and shall be provided with seal caps.
- (3) Valves for frequent operation shall be diaphragm packless valves with a seal cap.

11. Insulation.

a. System Design Considerations.

(1) Energy Conservation.

- (a) In distribution systems having extensive piping or ductwork, insulation shall be used to reduce heat gain or heat loss.
- (b) The thickness of insulation shall be selected by economic analysis to give the lowest sum of

annual cost of energy loss and insulation owning charges.

- (c) See the ASHRAE Fundamentals Handbook for charts and procedure for determining the most economical thickness of insulation.

(2) Condensation Prevention.

- (a) On some applications, heat gain or heat loss may be insignificant; however, insulation shall be used if surface condensation or icing is expected.
- (b) Insulation thickness shall be only the required thickness to prevent condensation or icing based on operating temperatures.
- (c) See the ASHRAE Fundamentals Handbook for charts and tables on the thickness of insulation required to prevent condensation at various operating temperatures and ambient dew point temperatures.
- (d) Wherever insulation is used to prevent condensation, a suitable vapor barrier shall also be used on the warm side to prevent absorption of moisture by insulation and corrosion of equipment.

(3) Properties.

The following are desirable characteristics of an insulation material: (1) low conductivity, (2) resistant to moisture, (3) resistant to decay, (4) resistant to fire, and (5) good handling characteristics.

b. Ductwork Insulation Design Considerations.

- (1) All air conditioning supply air ducts except those provided with sound-absorptive linings shall be insulated.
- (2) All air conditioning return air ducts and plenums except those within air conditioned spaces or in hung ceilings of air conditioned spaces shall be insulated.
- (3) Insulation thickness commonly used ranges from 1/2 to 1 inch.
- (4) Cold air ducts which pass through areas warmer than the normal outdoor temperature or which are subject

to direct solar radiation may be insulated with a thickness of two inches or more.

**c. Piping Insulation Design Considerations.**

- (1) All chilled water supply and return piping shall be insulated.
- (2) Refrigeration suction piping shall be insulated.
- (3) The following piping shall not be insulated:
  - (1) vent, relief, overflow and drain piping, except drain piping installed where the temperature of surrounding spaces is higher than the medium being drained shall be insulated
  - (2) pneumatic control piping
  - (3) condensate cooler discharge piping to sewers
  - (4) condenser water piping except where insulation is required to protect outdoor piping from freezing or where cooling towers are used to provide winter cooling requirements
  - (5) refrigerant discharge piping
  - (6) refrigerant liquid piping except when the temperature of surrounding space is higher than the condensing temperature.

**d. Equipment Insulation Design Considerations.**

- (1) All equipment carrying cold medium shall be insulated with a thickness varying from 1 to 5 inches.
- (2) Connections to equipment coils and drain pans, valves, and unions shall be fully insulated and arranged so that all condensation flows to and through the drain pan.
- (3) The manufacturer's recommendations should be followed for installation procedures.
- (4) A vapor barrier on the warm side of insulation shall be used to prevent moisture condensation in the insulation. The vapor barrier may also serve as a finishing cover for the insulation.

**12. Instrumentation.**

**a. Design Considerations.**

- (1) Where instruments are required for initial

adjustments only and will not be essential for normal operation, arrangement should be provided to correct the instruments without stopping or draining the system. For example, thermometer wells should be provided for checking temperature and gage cocks for pressure.

- (2) Instrumentations which have indications of variation in operating conditions should be used.
- (3) Instruments shall be self-compensating and shall not be affected by external changes in temperature or pressure.
- (4) Range should be such that, under normal conditions of operation, the indicating pointer will remain vertical.
- (5) Variations in operating conditions shall occur within the middle 1/3 of the range.
- (6) Pressure gages should not be affected by any pulsation of pressure in the pipeline.
- (7) A measuring instrument should be provided near automatic control devices, such as thermostats, humidistats, and pressure switches to facilitate adjustments and testing of the control device.
- (8) Recording type instruments shall be provided only where permanent records are required to analyze operating costs or effects on process applications.
- (9) Recording and indicating instruments should be combined with the control device to measure conditions at the point of control.
- (10) Multipoint remote indicators shall be used to check temperature, pressure, humidity, and other operating conditions of equipment and areas remotely located from the central control spaces.
- (11) In the case of large installations, it may be advantageous and economical to provide multipoint remote indicators at a central supervisory location instead of having several indicating type instruments installed at various different spaces.
- (12) All instruments and controls in one space should be combined on a single control board and arranged for rapid read out.
- (13) Control boards shall be located for walk-up access.

- (14) All electronic equipment facilities, not having continuous occupancy during operation, shall be provided with an overtemperature alarm signal system. It shall consist of at least one cooling type thermostat in the electronic equipment room and an audio alarm in an occupied control center. The thermostat shall normally be set to activate the alarm when the facility temperature reaches 90° F. Alarm circuit activation at lower temperatures may be used if dictated by equipment requirements.

b. Special Considerations.

- (1) Instrumentation shall not be a duplication of the energy monitoring and control system.

D. SYSTEM CONTROLS.

1. Control Systems Description.

Control systems shall be as simple as possible but sufficient to meet the design conditions. They shall be designed for automatic compensation due to load changes in order to reduce operating expenses and to conserve energy. Limit controls and safety controls shall be designed as integral parts of the system to shut down the cooling system if a control device fails or the electrical circuits overload.

Thermostats located in normally occupied spaces shall be factory-set as specified in DoD 4270.1-M. No space thermometers shall be provided.

The power supply for control systems may be pneumatic, electric, or hydraulic. Pneumatic control systems utilize compressed air at a pressure of 15 to 35 psig to control equipment. Electric/electronic systems use low voltage or line voltage to control equipment either directly or through pneumatic-electric relays. Hydraulic systems shall be used for control operation where pressures considerably higher than normally used by pneumatic systems are required for actuator operation.

a. Manual Control Systems.

Manual control systems provide only equipment on/off capabilities.

(1) Applications and Limitations.

- (a) Manual controls are used (1) on equipment requiring strictly on/off modes, (2) where manual control of equipment speed or



temperature variation is required, and (3) when semi-automatic or automatic controls are not cost effective.

- (b) This method of control is generally limited to equipment that is to be left running or to spaces where the equipment is turned on when occupied and off when unoccupied.

(2) Special Considerations.

- (a) Manual control systems are energy inefficient since equipment runs longer than necessary and spaces are overcooled.

b. Semi-Automatic Control.

Semi-automatic controls consist of two-position valves, modulating valves, and damper controls that are actuated by room thermostats, master/submaster thermostats, or pressure switches. The room thermostat shall be the master and the discharge thermostat shall be the submaster. The master thermostat shall reset the submaster according to room temperature requirements. Air flow may be controlled by either air volume control or a face and bypass damper control.

Air volume control may be used in interior zones and in some exterior zones if care is exercised to insure sufficient outdoor air is being supplied to meet requirements. In variable air volume systems, only one variable is controlled, either dry bulb temperature or relative humidity. Air distribution and noise level change constantly with the variations in air volume and outdoor air is reduced as the supply air volume is reduced.

Face and bypass damper control is to be used only when one variable is desired, usually dry bulb temperature. This type of control shall not be used for systems having a high percentage of outdoor air, unless arrangements are made to dehumidify all the outdoor air and bypass the room air only. This control should be considered when diversity in cooling load is desired.

A minimum fixed outdoor air supply shall be used for small systems where only one fan is used for supply and return air. Wherever economically possible, a variable outdoor air system shall be used to provide air conditioning requirements during intermediate seasons. Outdoor air dampers shall be interlocked with supply fans. Dampers shall open only when the supply fan is operating.

(1) Applications and Limitations.

- (a) Semi-automatic controls may be used on all cooling systems where on/off is provided for equipment start-up and shut-down, but automatic operation is required. The limitation for this type of control system is the need for personnel to start or stop each piece of equipment.

(2) Special Considerations.

- (a) Semi-automatic controls provide a decreased energy consumption by supplying only the amount of conditioned air required to meet air conditioning demands.

c. Automatic Control Systems.

Automatic control systems are fully automated to include automatic on/off capabilities based on time clocks or temperature sensing devices. Fully automatic control systems may be used in conjunction with central monitoring systems as discussed in Section 6 of this manual and DM-3.12.

(1) Applications and Limitations.

- (a) Automatic control systems shall be used for air conditioning systems where the equipment is to operate over a 24-hour period.
- (b) Automatic controls may be used on any air conditioning system since they provide the most energy conscious method for operating an air conditioning system.
- (c) Night setbacks shall be used where possible to reduce energy consumption. Time clocks shall be used to turn off fans and pump during unoccupied hours.

(2) Special Considerations.

- (a) Automatic control systems provide the most energy efficient controls for an air conditioning system.

2. System Controls Selection Criteria.

a. Air-Cooling Equipment.

- (1) For freeze protection, a low-limit thermostat shall be provided to stop the fans and close the outdoor

air dampers when the temperature of the air entering the coils drops to 35° F.

b. Air Cleaning Systems.

(1) No special control considerations are required.

c. Air Duct Systems.

(1) No special control considerations are required.

d. Fans.

(1) Speed control, by using multi-speed or variable speed motors, shall be provided in place of variable pitch pulleys where frequent or seasonal variation in capacity is required.

e. Refrigeration Equipment.

(1) Compressors.

(a) Compressors shall be provided with controls to allow satisfactory operation at partial load.

(2) Water Coolers.

(a) To avoid freeze-up problems, the refrigerant temperature for flooded type water coolers should be 35° F or above.

(3) Cooling Towers.

(a) Capacity control should be provided on cooling towers designed to work year around with variable load, so that the water temperature will not fall below the minimum temperature recommended by the manufacturer.

(b) Modulating damper control shall be used on the air outlets of small indoor cooling towers. Multi-speed fan motors and modulating damper controls shall be used on air inlets of large outdoor cooling towers.

(c) Modulating type, temperature actuated automatic valves, shall be used on systems needing condenser water at constant temperatures. The condenser return water shall be bypassed into the cooling tower or into the condenser water supply line.

(4) Air-Cooled Condensers.

- (a) An automatic head pressure control system shall be provided for air-cooled condensers scheduled to operate at low ambient temperatures.

(5) Safety Controls.

- (a) Safety controls shall be used to stop the refrigeration system until a fault has been located and corrected.
- (b) Safety controls shall be wired, so that when the system stops under the action of any safety control it will not restart automatically until the fault has been corrected.
- (c) The following is a list of minimum controls for safe operations of refrigeration systems:
- (1) high discharge pressure cutout
  - (2) low evaporating pressure cutout
  - (3) low oil pressure cutout
  - (4) motor high temperature cutout
  - (5) flow switch for condenser water
  - (6) flow switch for chilled water and an interlock between chilled water pump and chiller
  - (7) low temperature cutout for water chiller
  - (8) receiver high pressure relief valve.

f. Piping Systems.

- (1) No special control considerations are required.

g. Valves.

- (1) No special control considerations are required.

h. Insulation.

- (1) No special control considerations are required.

i. Instrumentation.

- (1) No special control considerations are required.

3. Control Systems Equipment Selection Criteria.

a. Two-Position Controls.

Two-position controls operate cooling systems by automatic on/off cycling at the demand of a space thermostat.

(1) Applications and Limitations.

- (a) Two-position controls are suitable for all air conditioning systems where control of only one variable is desired.
- (b) With this control method a cycling is caused by the operating differential of the thermostat which in turn allows the space temperature to vary up and down several degrees.

(2) Special Considerations.

- (a) This control system is best suited for spaces where a slight variation in temperature from thermostat setting is acceptable.

b. Modulating Controls.

Modulating controls shall be used with semi-automatic and automatic systems. They provide variable air conditioning capabilities in response to space temperature fluctuations.

(1) Applications and Limitations.

- (a) Modulating controls are suitable for all air conditioning systems where simultaneous control of one or more variables is desired.

(2) Special Considerations.

- (a) This system is best suited for spaces where accurate and even space temperature is desired.
- (b) They are generally more expensive and more complex than two-position controls.

4. Control Drawings.

a. Requirements.

- (1) A single line control diagram shall be included on project drawings to indicate each piece of control equipment and its relationship to other control components.
- (2) The control sequence shall be described on the project drawings and in the type specifications for each control system. The description shall be sufficiently detailed so that either pneumatic, electric, or hydraulic control systems can be applied.

## Section 5. DEHUMIDIFYING SYSTEMS

### A. DEHUMIDIFYING SYSTEMS DESCRIPTION.

Dehumidifying systems shall maintain space humidity within a prescribed range by removing moisture from the air by either an adsorption or an absorption process. Sorbents are used in the dehumidification function by adsorbing the water on the surface of the sorbent (adsorption) or by chemically combining with water (absorption). The dehumidification process uses either a regenerative or a non-regenerative process, depending upon reuse of the sorbent.

In the regenerative process the sorbent material is regenerated as part of the process, whereas, in the non-regenerative process the sorbent is discarded after use.

#### 1. Basic Dehumidification Systems.

##### a. Regenerative Dehumidification Systems.

A regenerative system is one in which no sorbent material is expended. Solid sorption material or liquid sorption solutions are used in regenerative systems.

#### (1) Application and Limitations.

- (a) Regenerative systems are suitable for use in warehouses and process areas where relative humidity control is required.
- (b) The lithium chloride liquid adsorption system and the refrigerated adsorption system are capable of dry bulb temperature reduction if required.
- (c) Maintenance of the regenerative systems is not extensive and the sorbent is a long life material.

#### (2) Special Considerations.

- (a) The regenerative process requires the addition or rejection of heat.
- (b) The availability of cooling water, a heating medium and a power source must be considered in selecting the type of regenerative system.

b. Non-Regenerative Dehumidification Systems.

A non-regenerative system is one in which the sorbent material must be replaced when its maximum moisture holding capacity is approached. The basic non-regenerative system is a solid sorption dehumidification system. A salt is used as the sorbent and it chemically combines with water to form a brine solution. The system requires a large contact chamber for brine formation. Rejuvenation of the system requires the brine to be drained from the contact chamber and fresh sorbent added.

(1) Applications and Limitations.

- (a) Non-regenerative systems are suitable for use in temporary warehouses, short-life facilities and for the protection of material or equipment in-transit.
- (b) They are also suitable for most regenerative system applications where the useful life of the facility does not provide an adequate time interval for payback of a regenerative system.

(2) Special Considerations.

- (a) Hygroscopic salt dehumidifiers are suitable for short life systems in remote areas. Since neither heating nor cooling is required for sorbent regeneration, the salt sorbent is added to the contact chamber and brine is drained away.
- (b) Salt systems require corrosion inhibitors to reduce the effect of the salt brine on metal, particularly upon steel.
- (c) Silica gel is not a satisfactory sorbent material in oily spaces such as industrial areas or power plants.

c. Specific Regenerative Systems.

(1) Solid Adsorption Dehumidification Systems.

There are three common regenerative, solid sorption systems: single-bed, dual-bed, and rotary-bed. These systems use beds of solid desiccant that are regenerated with heat. The simplest regeneration process involves removing moisture from the spent bed by blowing warm air through the desiccant. Solid desiccants used include silica gel, molecular sieves, activated alumina, or hygroscopic salts.

The single-bed system has one bed of desiccant and one fan (Fig. 12). It does not provide a continuous dry air delivery operation. Delivery of dried air from a single-bed system is necessarily intermittent, since the desiccant bed must be alternately used for sorption and desorption.

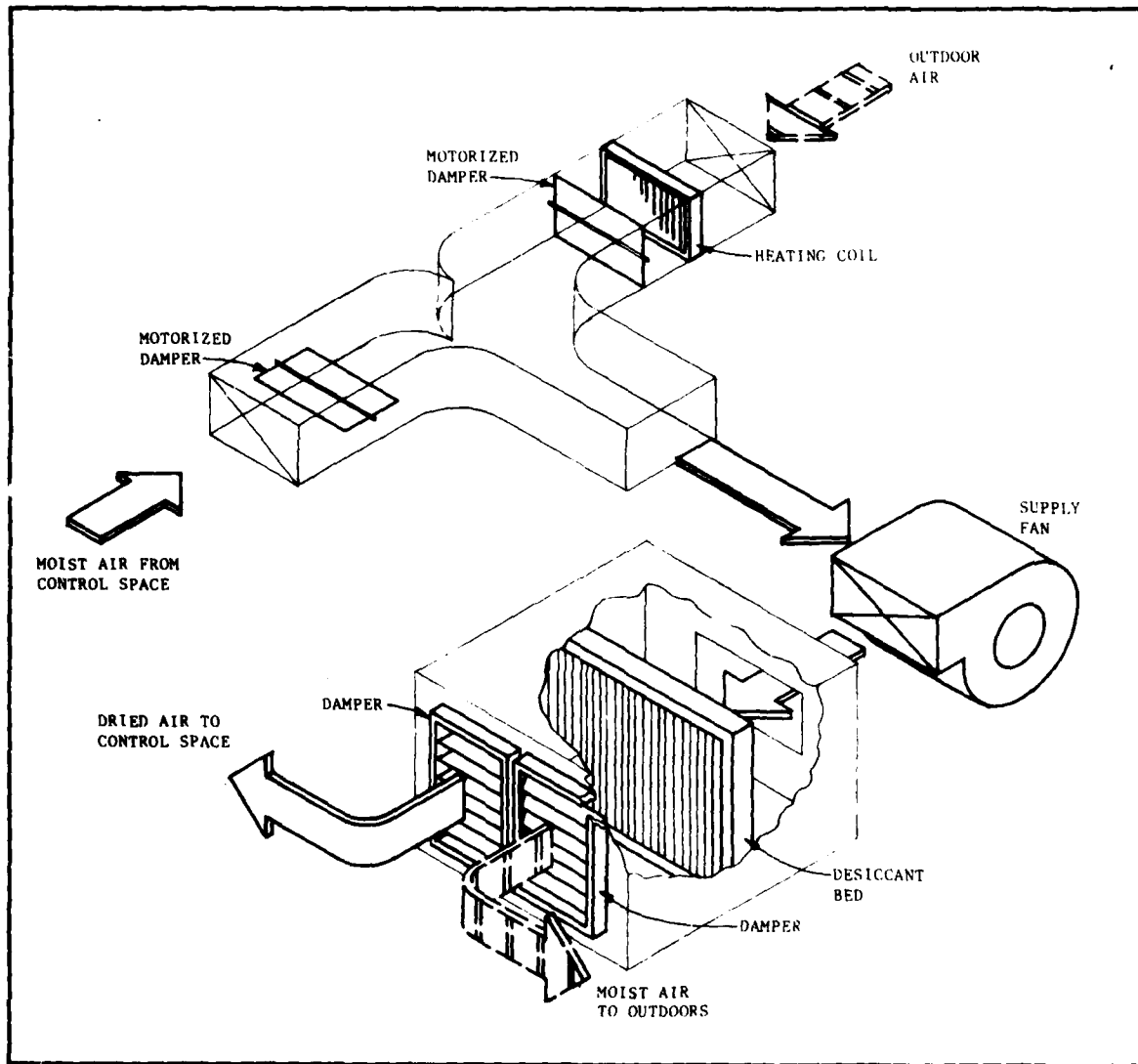

FIGURE 12  
Single-Bed Dehumidification System

The dual-bed system uses two beds of desiccant for moisture removal (Fig. 13). Moist air from the control space is circulated by the space supply fan through one bed, dehumidified, and dried air is returned to the space. The regeneration air supply



fan circulates outdoor air through a heating coil, across the spent desiccant bed to remove the moisture, and warm moist air is discharged to the outdoors. Motorized dampers reverse the functions between beds for regeneration purposes. The adsorption rate of this arrangement is not constant, but is acceptable for most warehousing functions.

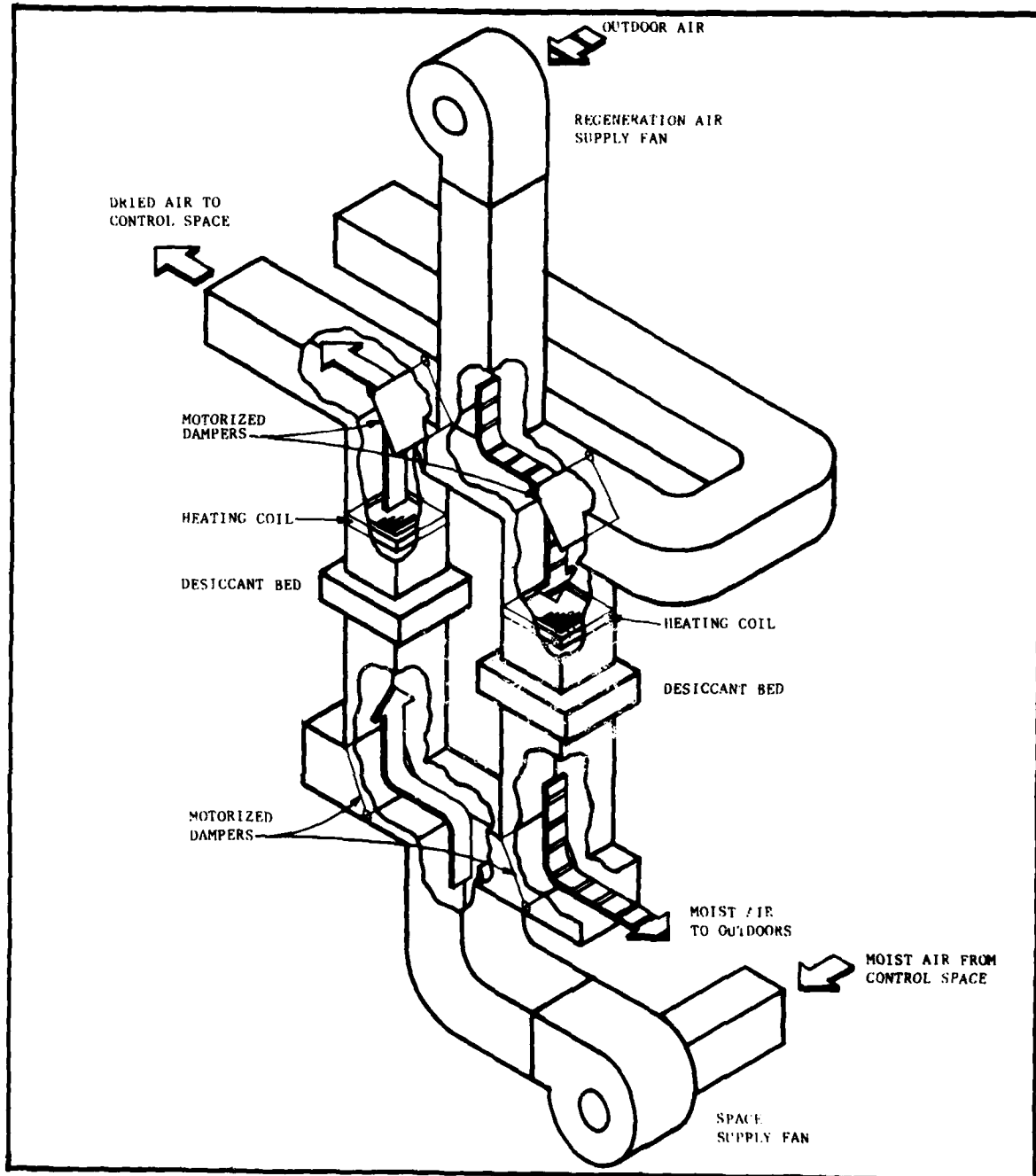
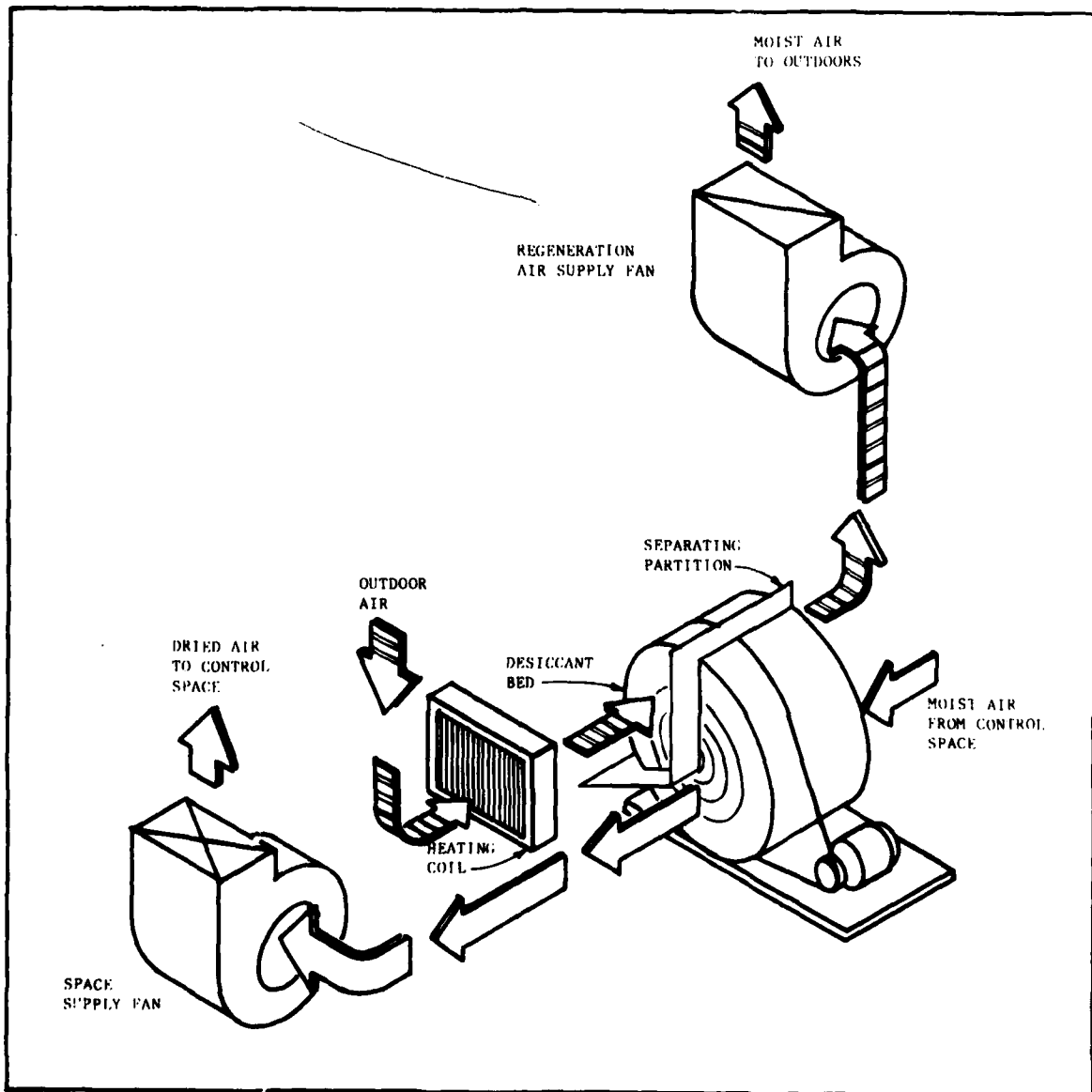

FIGURE 13  
Dual-Bed Dehumidification System

The rotary-bed system uses one bed of desiccant (Fig. 14). The bed is larger than in a single-bed unit but smaller than the beds in a dual-bed unit, therefore less desiccant is required. The two portions of the bed are separated by a partition to prevent leakage between the moist air from the control space and the regeneration air stream. The advantage of this unit is that uniform leaving-air conditions may be attained by controlling the regeneration air temperature.



**FIGURE 14**  
**Rotary-Bed Dehumidification System**

(a) Applications and Limitations.

The regenerative systems are suitable for most applications, either as a single unit, as two in series or in series with another type of dehumidifier. They are suitable for automatic control and are lower in maintenance cost than dehumidifiers using salts or liquids.

(b) Special Considerations.

When selecting a system, consider the expected life of the system and the control accuracy required.

(2) Liquid Absorption Dehumidification System.

This system uses a liquid absorbent. The vapor pressure of the sorbent is much higher than outdoor air, permitting regeneration with 2 psig steam pressure. The system consists of a space supply fan and contactor section with a cooling coil for conditioned air, regeneration air supply fan and regeneration section with a heating coil for regenerator air, and a sorbent solution circulating pump system (Fig. 15). Moist air is circulated through the contactor section where the sorbent solution is sprayed into the air stream. The sorbent solution absorbs water vapor from the air and forms droplets on the cooling coil. This sorbent/water mixture is diverted by the eliminators into a sump.

Simultaneously, outdoor air is circulated through the regenerator section where it is heated by the heating coil. The warm atmosphere in the regeneration section raises the vapor pressure which drives the water from the sorbent solution as it is sprayed into the air. The moisture laden air is diverted outdoors, and the regenerated sorbent solution flows to the sump for reuse.

(a) Applications and Limitations.

The liquid absorbent system is suitable for most dehumidification applications. Cooling can be incorporated by using cold or chilled water in the cooling coil of the contactor section.

(b) Special Considerations.

This is a continuous process capable of operating within close tolerance of moisture content and temperature. This dehumidification system may be used in hospitals if a bacteriostatic brine is used.

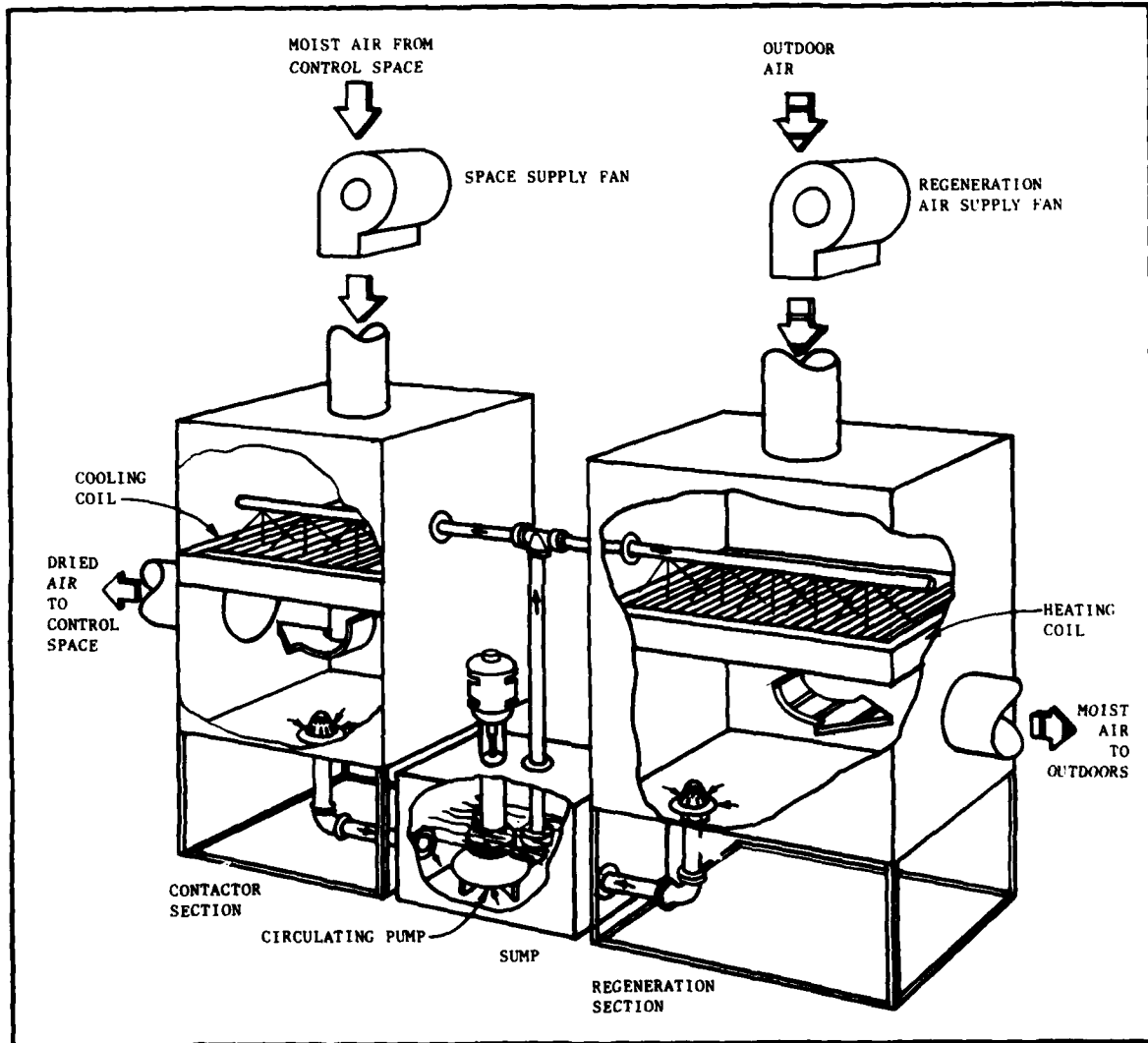

FIGURE 15  
Liquid Absorption Dehumidification System

## B. SYSTEM SELECTION CRITERIA.

### 1. Explanation.

Selection factors for dehumidification systems for Naval Shore Facilities shall be based on the administrative policy and design criteria as presented in Section 1. Specific factors requiring more detail are listed and explained in this section.

### 2. Design Calculations.

#### a. Dehumidification Load.

The dehumidification load is the rate at which water vapor is removed from a space to maintain the desired relative humidity.

##### (1) Design Considerations.

- (a) The dehumidification load shall be based on the greatest indoor to outdoor mean monthly dewpoint temperature difference based on design conditions.
- (b) Daily dehumidification loads vary with location, weather conditions, rate of storage turnover, construction materials, and tightness of construction. In the tropics and eastern United States, the maximum load is in the summer or rainy months. In the arid regions of the southwestern United States, the maximum load is in the winter months.

#### b. Load Factors.

##### (1) Transmission Load.

- (a) The transmission load through the roof, wall and floor (not on grade) is dependent on:
  - (1) the permeability of materials
  - (2) the indoor to outdoor vapor pressure difference
  - (3) the surface area.
- (b) The transmission load through a floor directly on grade is dependent on:
  - (1) the depth of water table below grade and the type of soil
  - (2) the degree of waterproofing of the floor
  - (3) the permeability of the floor

- (4) the vapor pressure gradient through the floor
- (5) the surface area.

(c) See the ASHRAE Fundamentals Handbook for permeability and vapor pressure tables.

(2) Infiltration Load.

(a) Infiltration of moisture due to space breathing is a function of:

- (1) the surface area
- (2) the daily temperature range inside the warehouse
- (3) the gross volume of the space
- (4) the average daily indoor to outdoor humidity difference.

(b) Infiltration of moisture through the walls is a function of:

- (1) the surface
- (2) the average wind velocity
- (3) the average daily indoor to outdoor humidity difference
- (4) tightness of constructed joints at eaves, doors, and windows.

(c) The design requirement for infiltration of moisture due to a change in the indoor to outdoor temperature shall be one percent of the building's volume for each 5° F change in the building temperature.

(3) Service Moisture Load.

(a) Moisture load due to air infiltration through open doors is a function of:

- (1) the door area
- (2) the open door time which may be estimated on a basis of the average amount of material in measured tons (40 cubic feet) passing through the open door
- (3) the average wind velocity
- (4) the average humidity of outdoor air during the design month.

(b) The amount of material transferred into and out of a normal operating warehouse (600 by 200 by 22 feet) varies from 35 to 75 measured tons per hour. Assuming store material is in equilibrium with the mean local relative humidity of

the outdoor air prior to being placed in the storage, the moisture load due to stored material turnover is a function of:

- (1) the average weight per cubic foot of hygroscopic crating and packing materials. (One cubic foot of material which is packed in wood boxes weighs approximately six pounds.)
- (2) the average turnover of the stores per day
- (3) the moisture above the space equilibrium to be removed by dehumidification.

(4) Dehumidification Load Breakdown.

(a) The data in Table 16 lists typical daily moisture load breakdown in pounds of water per day for a 600 by 200 by 22 foot dehumidified warehouse. The lower figures are for typical arid regions of the United States while higher figures are for humid areas of the United States and tropical climates.

TABLE 16  
Typical Load Breakdown of A  
Dehumidified Warehouse

Moisture Source	Moisture Load lb. water / day	Percent of Total Moisture Load (floor with membrane)
Floor (without a membrane)	180 to 420	---
Floor (with a membrane)	120 to 240	19
Wall transmission	50 to 100	8
Roof Transmission	20 to 60	3 to 5
Breathing	40 to 55	6 to 4
Wall Infiltration	150 to 300	24
Open door	200 to 400	32
Stores (5% annual turnover)	50 to 130	8 to 11

C. EQUIPMENT SELECTION CRITERIA.

1. General.

Selection of dehumidification equipment shall be based on Naval Administrative Policy, the size of the system, the anticipated useful life of the facility, the availability of a heat source for regeneration and the temperature/humidity control requirements.

2. Design Considerations.

a. Capacity.

- (1) The standard design conditions for moisture removal shall be calculated in pounds of water per day where the space air entering the dehumidifier is 70° F dry bulb and the relative humidity is 35 percent.
- (2) If the operating conditions are not the same as the standard design conditions, units shall be selected with manufacturer's rating at the particular design operating conditions.
- (3) The minimum unit capacity shall be 250 pounds of water per day at design conditions.
- (4) Where one machine is used, the total machine capacity shall be 2.0 times the calculated normal operating load.
- (5) Where two or more machines are used, the total machine capacity shall be 1.5 times the calculated normal operating load.

b. Number of Units.

If the normal operating load is greater than 250 pounds of water per day, two or more machines shall be provided.

c. Type of Process.

- (1) Regeneration systems are suitable for use in warehouses and process areas where relative humidity



control is required and payback can be achieved within the useful life of the facility.

- (2) Non-regeneration systems are suitable for use in temporary warehouses, short-life facilities, and for the protection of material or equipment in transit.

### 3. Special Considerations.

#### a. System Limitations.

- (1) The system limitations will depend particularly on the sorbent material used.

#### b. Types of Sorbent Material.

- (1) The following common sorbent materials may be used in dehumidifying systems:

- (1) lithium chloride
- (2) silica gel
- (3) activated alumina
- (4) molecular sieves
- (5) calcium chloride
- (6) urea
- (7) sodium chloride
- (8) glycols.

#### c. System Installation.

- (1) In warehouses, process plants and industrial facilities, the dehumidifying equipment may be located in the dehumidified space.
- (2) In finished areas, the equipment shall be located in equipment rooms which are adjacent to the dehumidified space.
- (3) Ductwork shall be kept to a minimum. Supply and return ducts shall be omitted, if possible. See Figure 16 for a typical multiple-compartment warehouse and Figure 17 for a single-compartment warehouse without main supply and return ducts.
- (4) Adequate access be allowed for maintenance purposes.

#### d. Regeneration Air.

- (1) Regenerative machines which use a sorbent material and are located in the dehumidified space shall have ductwork for regeneration air intake and discharge.

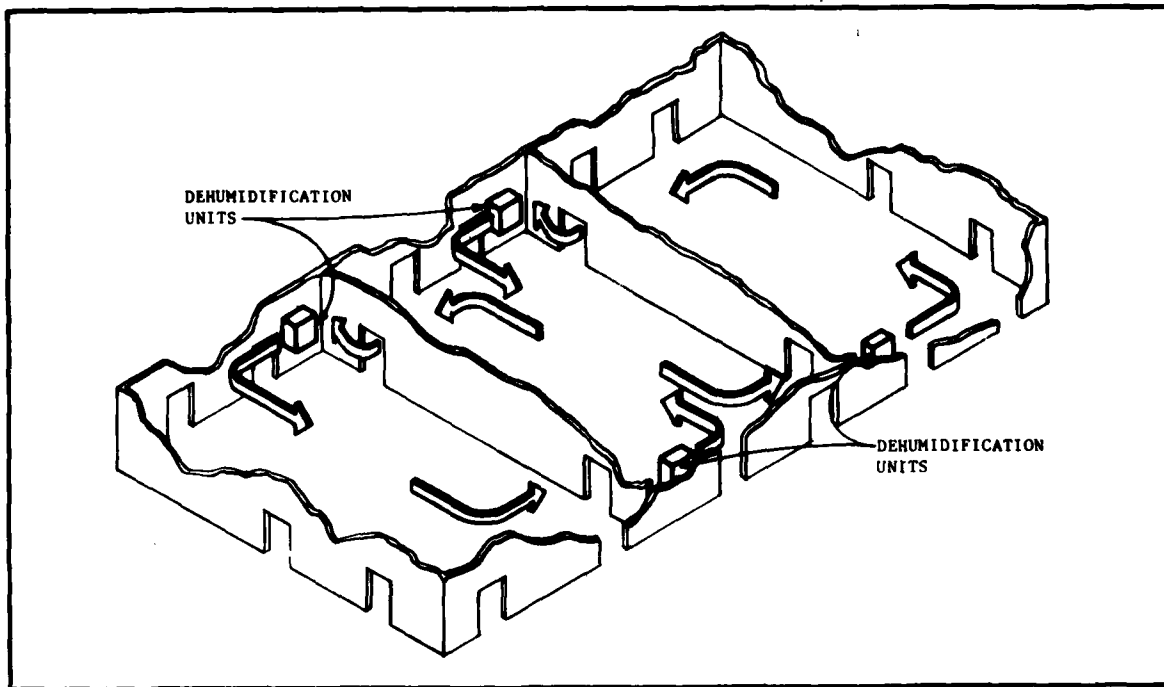

FIGURE 16  
Dehumidifier Locations for a Multiple-Compartment Warehouse

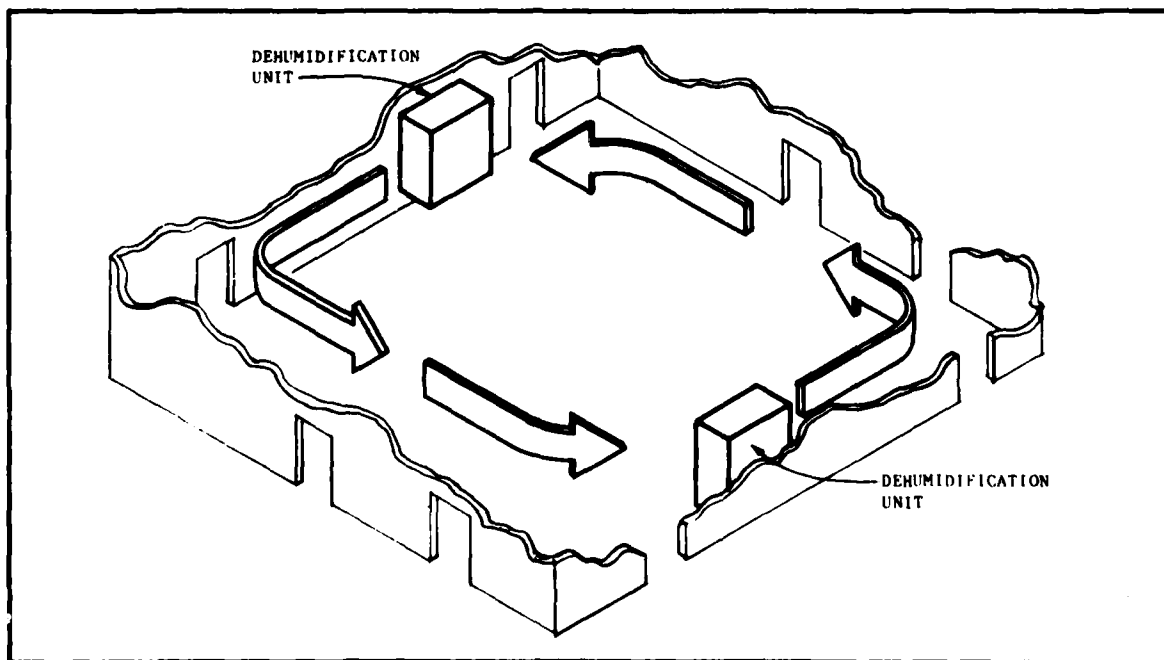

FIGURE 17  
Dehumidifier Locations for a Single-Compartment Warehouse  
3.3-164

- (2) Ductwork shall be designed to prevent leakage of the moisture-laden discharge air into the intake duct, and the intake and discharge outlets shall be located to prevent any recirculation of moisture-laden air from the discharge outlet.

e. Controls.

- (1) Electronic humidity controls shall be used.
- (2) The effective relative humidity control range for warehouse operation shall be 35 to 45 percent with a differential of  $\pm 1\frac{1}{2}$  percent at the control set points.
- (3) Fire interlocks shall be provided to interrupt the power supply to the machines when the fire alarm system or the fire sprinkler system is energized.

f. Instrumentation.

- (1) A combination temperature and humidity recorder shall be installed with each system.
- (2) A four-pen temperature recorder shall be used for recording the temperature of (a) the moist air to the dehumidifier, (b) the dried air leaving the dehumidifier, (c) the outdoor air used for regeneration, and (d) the regeneration air discharge to the outdoors.
- (3) One four-pen recorder with selector switch shall be provided for each 25 dehumidifiers or a fraction thereof.
- (4) Energy monitoring and control system monitoring points shall be as required by the EFD.

D. SYSTEM CONTROLS.

1. Control Systems.

- a. Factory installed, automatic controls shall be used in all dehumidification systems.
- b. Controls shall be adjustable for parallel or sequential operation of individual dehumidifiers.
- c. Step type controls reduce energy consumption since the minimum number of dehumidifiers are operating at any one time.

2. Control Methods.

- a. Two-position controls shall be used for individual dehumidifiers.
- b. Two-position controls require individual units, which are serving the same space, to have equal ratings.

3. Power Source.

- a. Electrical power shall be used for all dehumidifying systems.

## Section 6. ENERGY CONSERVATION METHODOLOGY

### A. POLICY.

Energy conservation methodology shall be applied to the design of all heating, ventilating, air conditioning, and dehumidifying systems. However, the criteria and considerations of the preceding sections shall be considered when incorporating specific energy conservation techniques.

### B. ENERGY MANAGEMENT CONSERVATION ANALYSIS.

An energy management conservation analysis shall be performed at the initial stages of the design efforts. The analysis should include a heat gain/heat loss analysis, an energy use analysis, and life cycle cost analysis. The analysis shall be based on the application of low energy requirement systems and possible heat recovery systems under consideration.

### C. ENERGY PERFORMANCE STANDARDS.

The most current energy performance standards shall be used as the design standard for energy usage. An energy budget shall be developed within guidelines established by the United States Department of Energy. The results shall be compared to the current energy standards for the facility under consideration.

Building Design Energy Budgets shall include only the energy required for space heating, space cooling, domestic hot water, and lighting. The budget shall relate to the buildings' gross square footage where the gross area is the sum of all floor areas of a building including basements, cellars, mezzanines, other intermediate floor tiers, and penthouses. All measurements shall be from the exterior wall of the building or from the center line of party walls. Conversion factors for calculating Energy Budgets are listed in Appendix B.

At specific installations where the energy source Btu content varies significantly from the value presented in Appendix B, the local value may be used when:

- (1) there is adequate data on permanent file covering a period of at least two years to support the different value
- (2) there is a fully documented basis to expect that the different value will remain in effect for the foreseeable future with the documentation to remain in a permanent file.

The energy budget shall apply only to the energy consumed within the building and out to the five-foot line around the building with the following exceptions. Where heating, ventilating, air conditioning or dehumidifying equipment, transformers or substations, or where heating plants are located outside the five-foot line, but serve only one building, the energy required to operate these facilities shall be chargeable to the building. Where heating plants serve two to four buildings, the energy requirements shall be prorated among the buildings. Where such facilities serve five or more buildings, these facilities shall be considered in the category of central plants. The system losses shall not be charged to the building in this case.

Energy in the form of steam, high temperature water, medium temperature water, or chilled water which is supplied from a central plant should be measured at the building boundary with proper credit given to the energy in the condensate return or water return.

Solar, geothermal, wind, or other renewable energy sources should be identified for any building, and data should be provided on a Btu per hour per square foot per year which can be expected from each source and should be included in the energy budget. If a building has two or more such sources, the Btu per hour per square foot per year for each source should be noted.

#### D. ENERGY CONSERVATION METHODS.

With the building envelope designed to minimize heating, cooling and lighting requirements, the following energy conservation methods may be used to their best advantage:

- (1) energy efficient systems
- (2) heat recovery systems
- (3) energy efficient control systems.

##### 1. Energy Efficient Systems.

###### a. Economizer Cycle System.

Buildings not equipped with internal/external zone heat recovery equipment, with air conditioning capacity greater than 120,000 Btuh, shall be designed to use maximum outdoor air in the region indicated in Figure 18 for cooling whenever cooling is needed at an outdoor condition such that:

- (1) The enthalpy of the outdoor air is lower than that of the return, and/or
- (2) The outdoor dry bulb temperature is lower than that of the return air, and

- (3) At low outdoor air temperatures, the humidification requirement does not exceed 2.5 times that required when sized for minimum outdoor air.

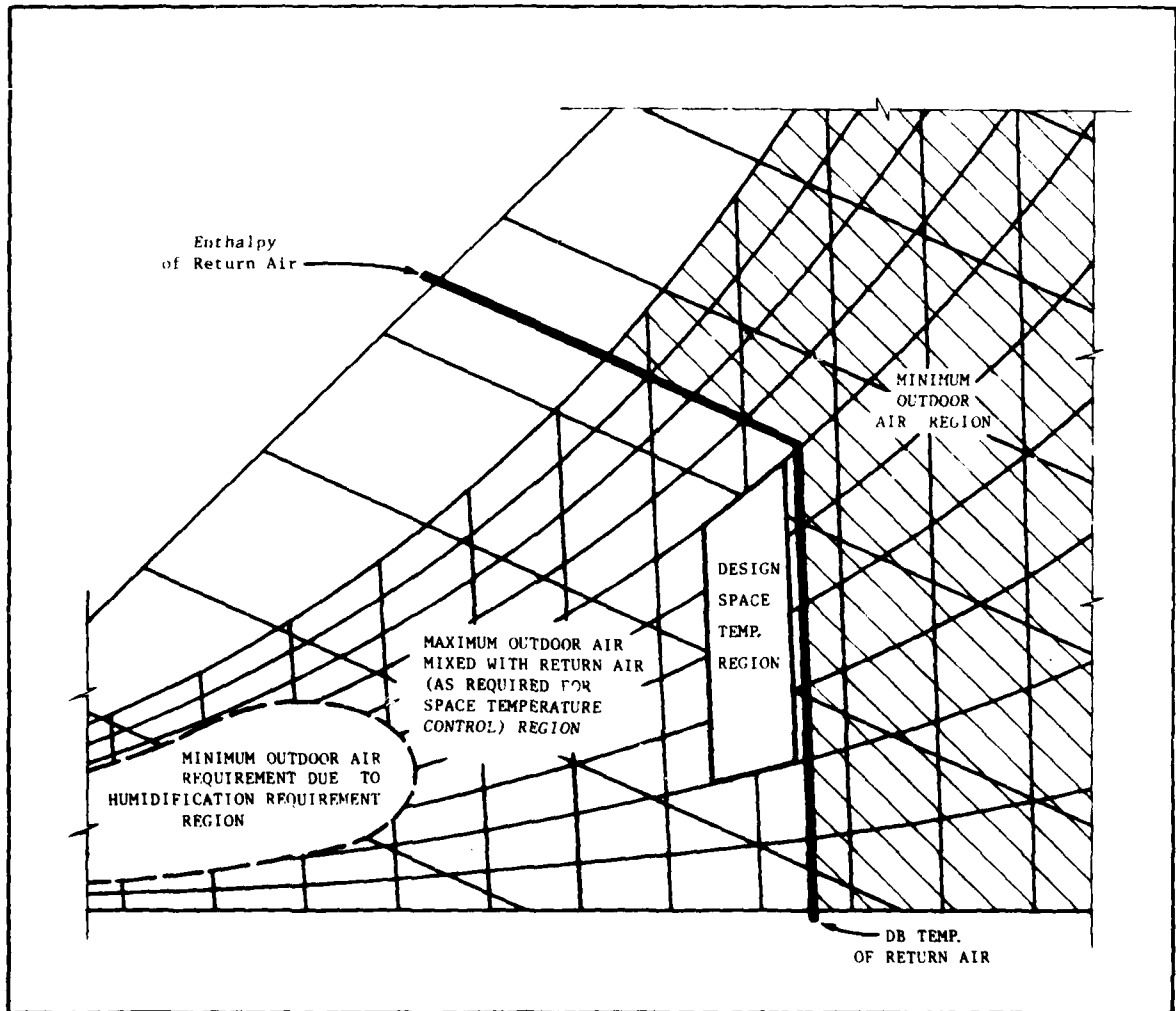

FIGURE 18  
Outdoor Air Usage and the Psychrometric Chart

b. Multiple Equipment System.

Single, central equipment usually is not operated at design load conditions; therefore, the equipment is not operating at its maximum efficiency. The multiple parallel equipment arrangement provides superior operating efficiency, added reliability along with the operating capacity required at design conditions. When equipment partial load operation is anticipated for a majority of its operating life, strong consideration should be given to this type of system. A life cycle cost analysis shall be run to determine the feasibility of a multiple equipment system. This system shall be used when energy savings will offset the higher first cost or where required by DoD 4270.1-M.

c. Direct Exhaust System.

The direct exhaust system removes the return air through the lighting fixtures or return grilles and exhausts the air directly to the outdoors. This reduces the cooling load in spaces which require high ventilation rates, as in spaces where the equipment dissipates large amounts of heat.

d. Variable Air Volume System.

This system is suitable for use in facilities which require year around air conditioning, when occupied, due to high internal heat gains. The system saves energy by supplying a nearly constant temperature of air and automatically varies the air flow, to satisfy the thermostat from the maximum volume required for conditioning to a predetermined minimum volume as required for proper ventilation. Individual zone temperature control is achieved by varying the volume of air to the space in lieu of expending energy to heat air for zone control. This also allows the system to run at reduced horsepower rather than at the horsepower required in a constant air volume system. If heating is required, it is supplied by heating coils located at the variable air volume duct system and/or by a perimeter air or hot water heating system.

e. External Source Heat Pump System.

This system provides heating and cooling from the same basic refrigeration cycle components. In the heating mode, the heat gain across the outdoor coil plus the heat of compression from the compressor is rejected across the indoor coil. The heating and cooling action may be reversed by reversing the pattern of refrigerant flow through the coils. In the cooling mode, the heat gain



across the indoor coil plus the heat of compression from the compressor is rejected across the outdoor coil. The external source heat pump extracts heat from or rejects heat to either outdoor air (Fig. 19), water or earth.

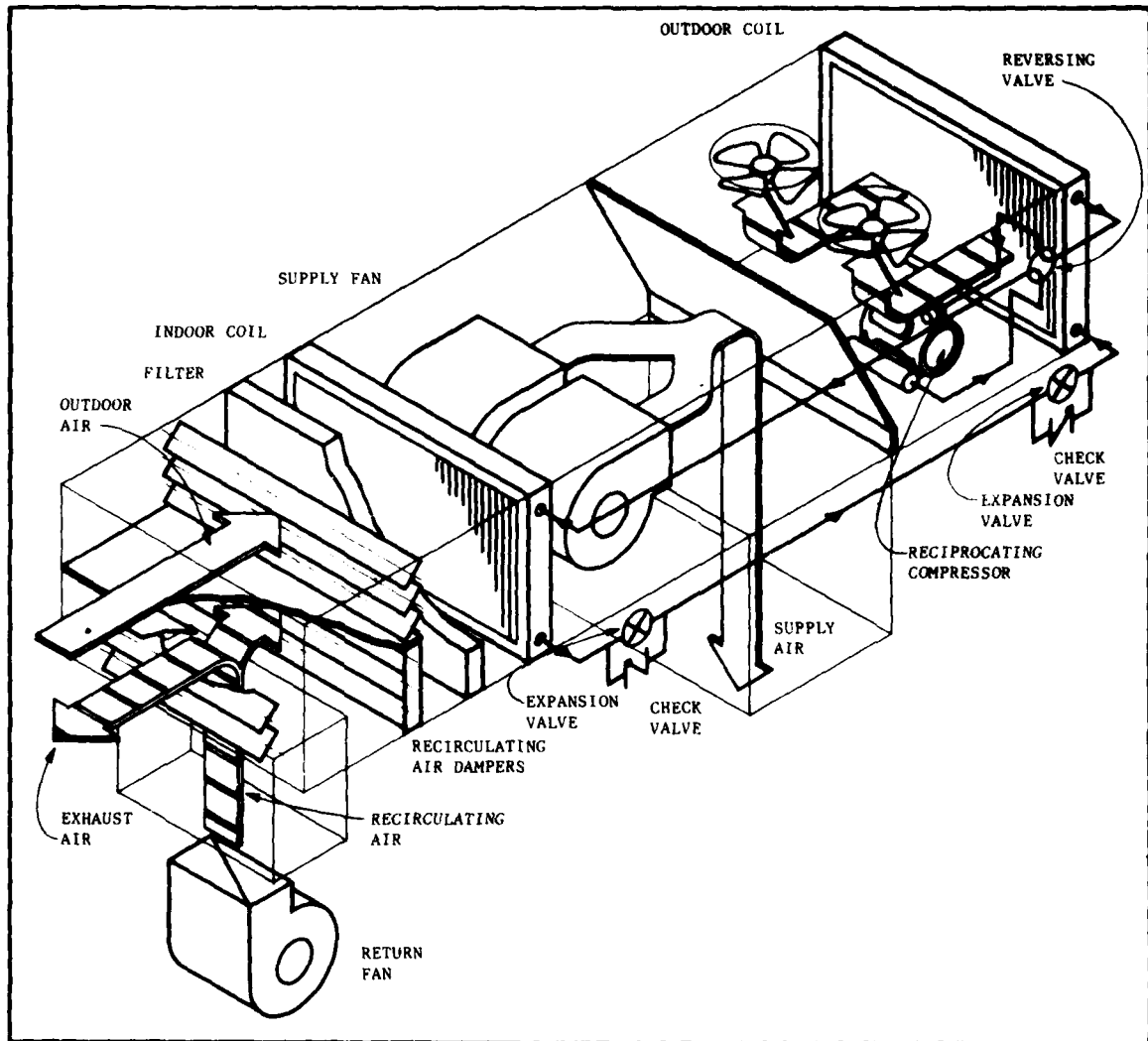

FIGURE 19  
External Source Heat Pump System

f. Solar System.

This system may be used for either heating or cooling. Heating systems generally use flat plate collectors. Flat plate collectors are simpler in construction and absorb both direct and diffuse radiation, but deliver low temperature air or water.

Where higher temperatures are required, concentrating or evacuated tube collectors shall be used. Cooling systems generally use concentrating or evacuated tube collectors to obtain hot water temperatures high enough to drive an absorption chiller. Concentrating and evacuated tube collectors are more complex in construction, require tracking devices, and absorb only direct radiation but deliver higher temperature water.

## 2. Heat Recovery Systems.

Economic factors to be considered when evaluating heat recovery systems include (1) increased system static pressure, (2) higher first cost, (3) higher maintenance cost, and (4) additional building space requirements.

### a. Exhaust Air Heat Recovery Method.

In the heating mode, heat from the exhaust air is recovered and used to preheat:

- (1) the outdoor air supply
- (2) domestic hot water
- (3) the boiler combustion air
- (4) boiler make-up water.

In the cooling mode, exhaust air is used to precool outdoor air.

Five methods are available for exhaust-air heat recovery. They are (1) the rotary air wheel method, (2) the static heat exchanger method, (3) the heat pipe method, (4) the run-around system/closed-loop method, and (5) the run-around system/open-loop method. See DoD 4270.1-M for additional information. The rotary air wheel, the static heat exchanger, and the heat pipe methods require the supply and exhaust ducts to be adjacent to each other. The run-around loop methods do not require adjacent ducts.

#### (1) Rotary Air Wheel Method.

Heat transfer takes place as a finned wheel rotates between the exhaust duct and the supply duct (Fig. 20). There are two types of rotary air wheels; one transfers only sensible heat, while the other transfers both sensible and latent heat. The wheels are 70 percent effective for equal supply and exhaust mass flow rates. This system shall be given full consideration in all air conditioning and ventilation systems where exhaust air is 4,000 cubic feet per minute or greater. To reduce cross

contamination between supply and exhaust air, a purge section must be provided. See the ASHRAE Equipment Handbook for additional information.

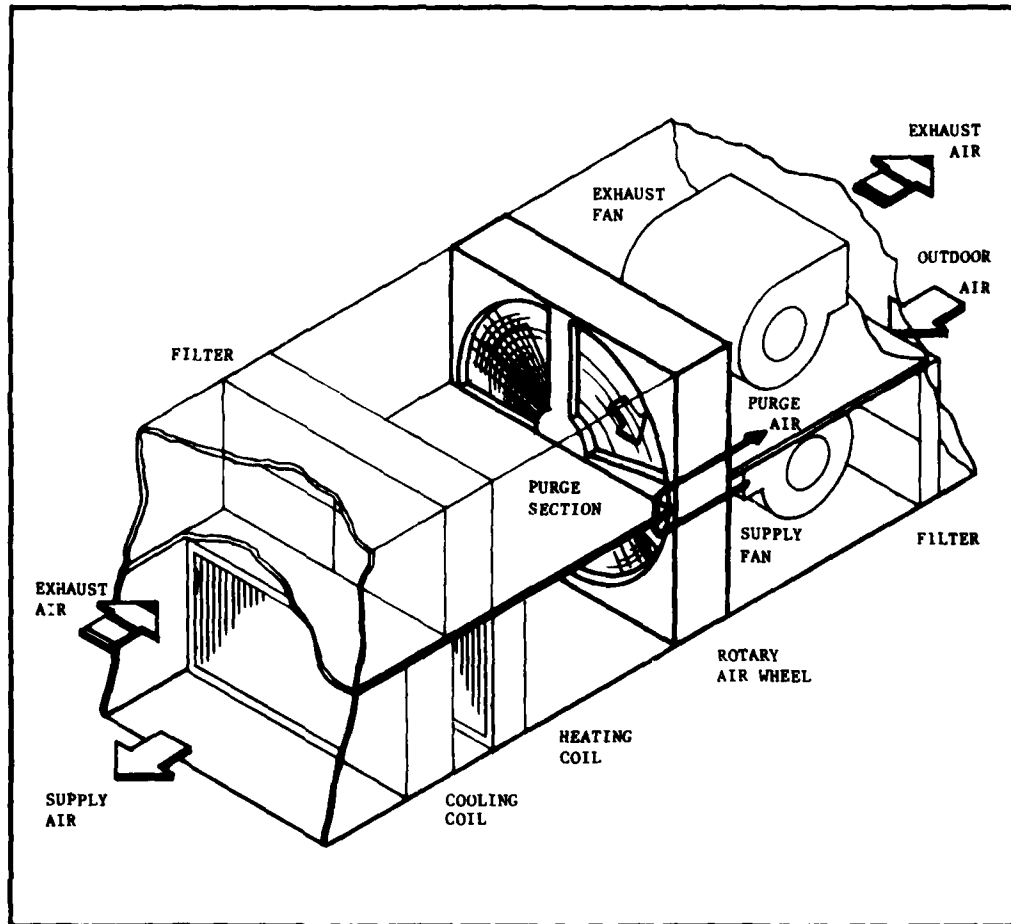
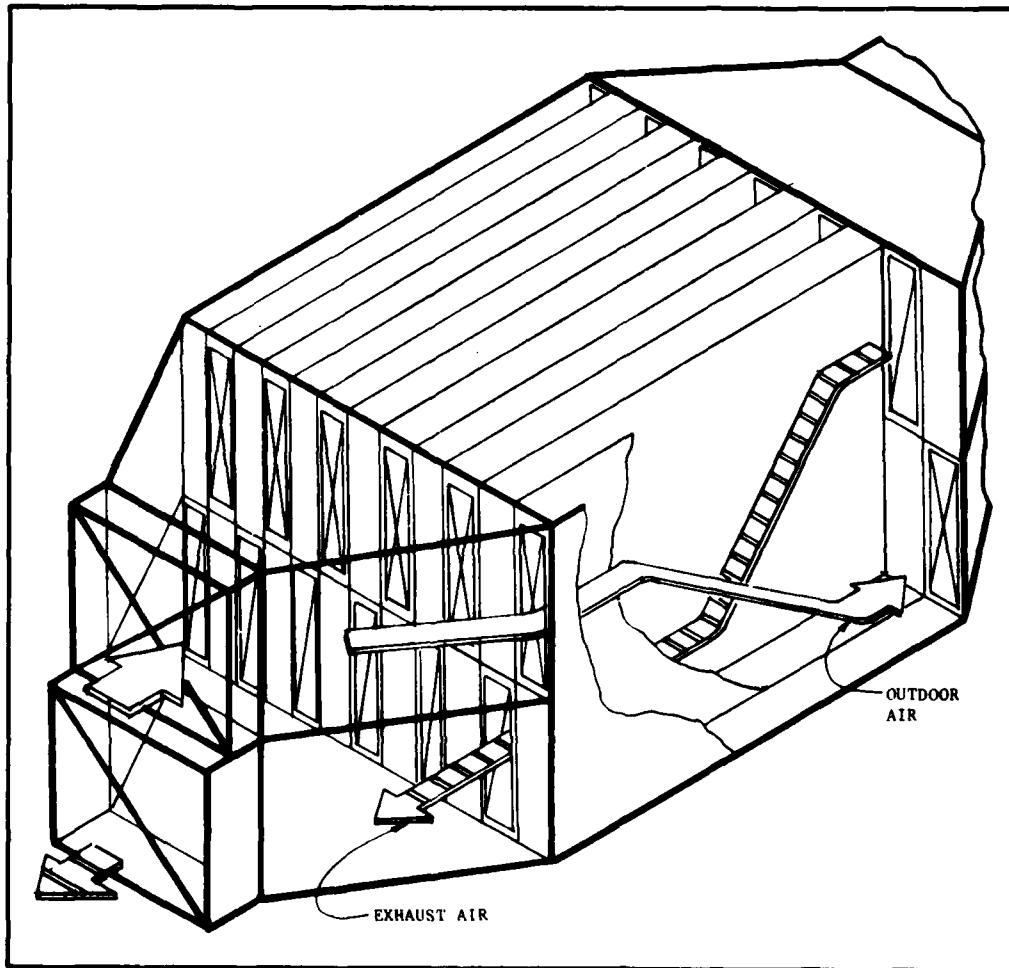

FIGURE 20  
Exhaust Air Heat Recovery with Rotary Air Wheel

(2) Static Heat Exchanger Method.

The heat transfer takes place in alternate passages that carry the exhaust and the supply air in a counterflow (Fig. 21) or crossflow pattern (Fig. 22). Static heat exchangers are 40-80 percent efficient in recovering heat depending on the specific system design, the temperature differences, and the flow rates. Crossflow is usually more

convenient, but counterflow is more efficient. Only sensible heat is transferred in this method. There are no moving parts and minimal chance for cross contamination.



**FIGURE 21**  
**Exhaust Air Heat Recovery with**  
**Counterflow Pattern Static Heat Exchanger**

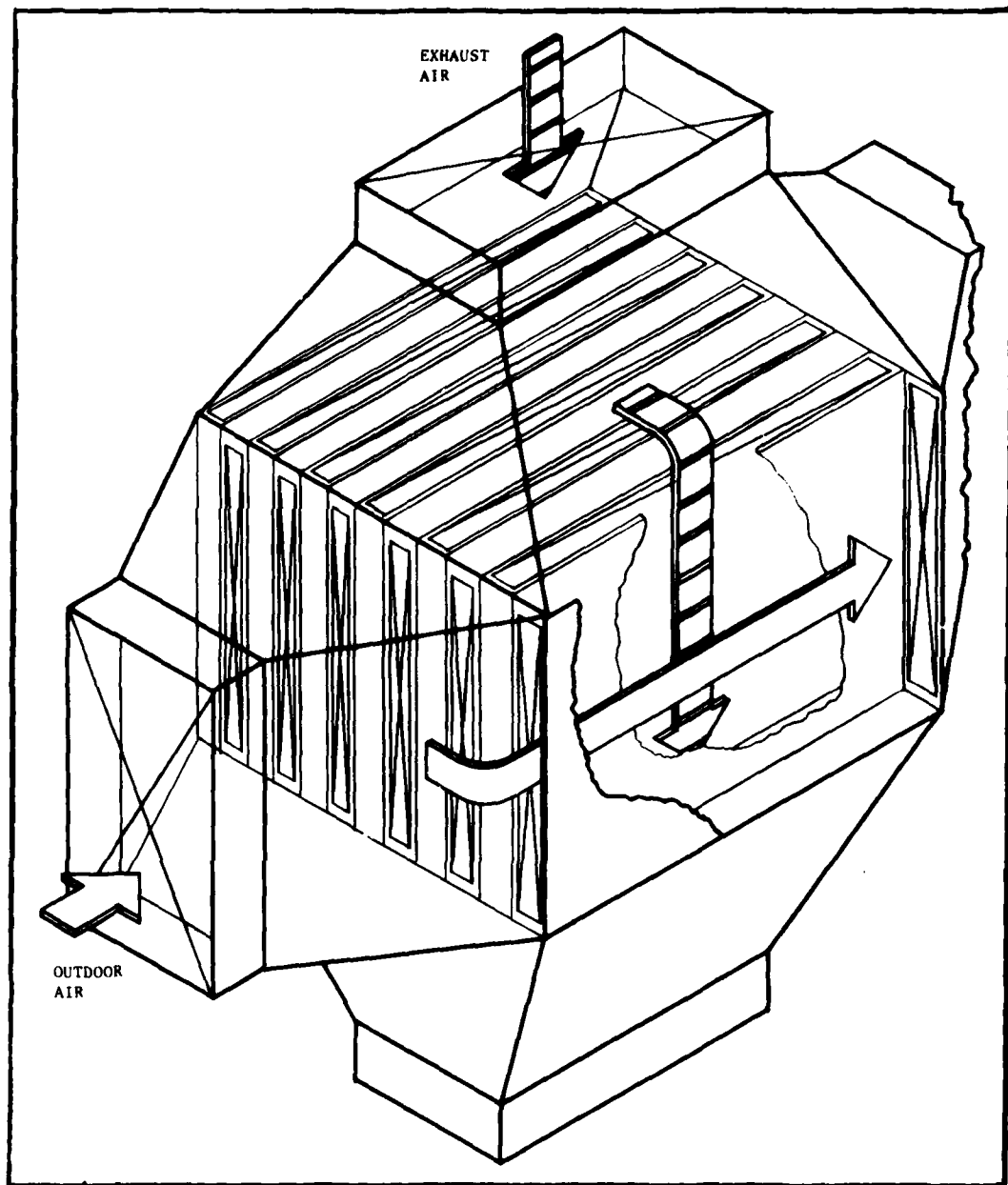

FIGURE 22  
Exhaust Air Heat Recovery with  
Crossflow Pattern Static Heat Exchanger

(3) Heat Pipe Method.

The heat pipe method is a self-contained, closed system which transfers sensible heat only (Fig. 23). It consists of a bundle of finned copper tubes, similar to cooling coils, sealed at each end, and filled with wick and working fluid. The working fluid may be water, refrigerant, methanol, or liquid metal for high temperatures. For the most efficient system, the exhaust and supply air should be counterflow. Performance is also improved by sloping the heat pipe with the warm side lower than the cool side.

(4) Run-Around System (Closed-Loop) Method.

The closed-loop method is a hydronic system that transfers sensible heat from the exhaust air to the outdoor air using water, glycol or some other sensible heat fluid (Fig. 24). It consists of two coils (one in the supply system and one in the exhaust system), a pump and a closed pipe loop. This method can be expected to increase the outdoor air temperature by 60-65 percent of the outdoor air and exhaust air temperature difference. The system requires an antifreeze solution if the winter design temperature is 32° F or below.

(5) Run-Around System (Open-Loop) Method.

The open-loop method transfers both sensible and latent heat. It is an air-to-liquid, liquid-to-air enthalpy recovery system (Fig. 25) where the working fluid flows into each cell with the aid of a pump in a manner similar to cooling tower flow. The sorbent liquid may be bacteriostatic if necessary. This system should not be used for high temperature applications.

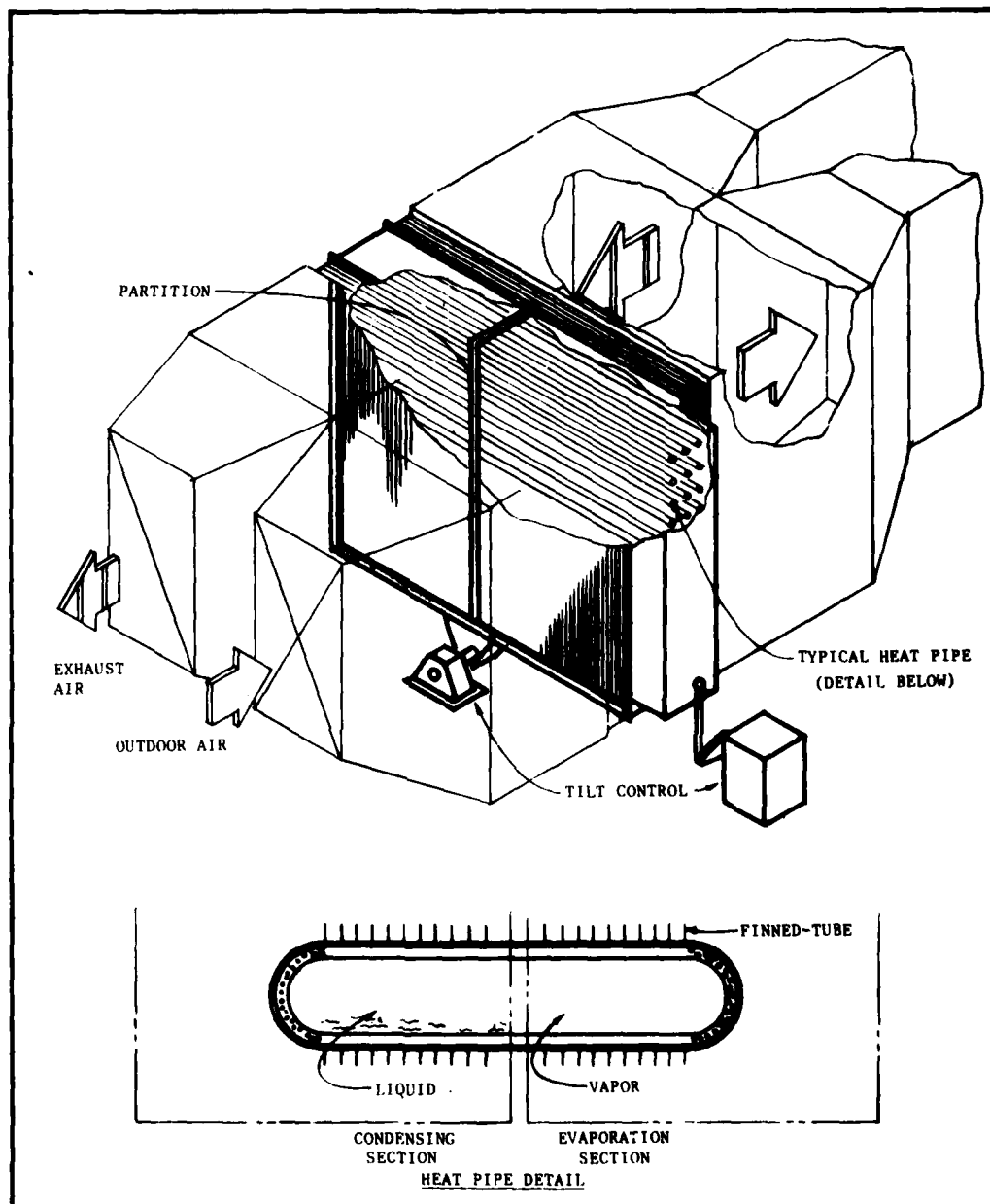

**FIGURE 23**  
**Exhaust Air Heat Recovery Method**  
**With Heat Pipe**

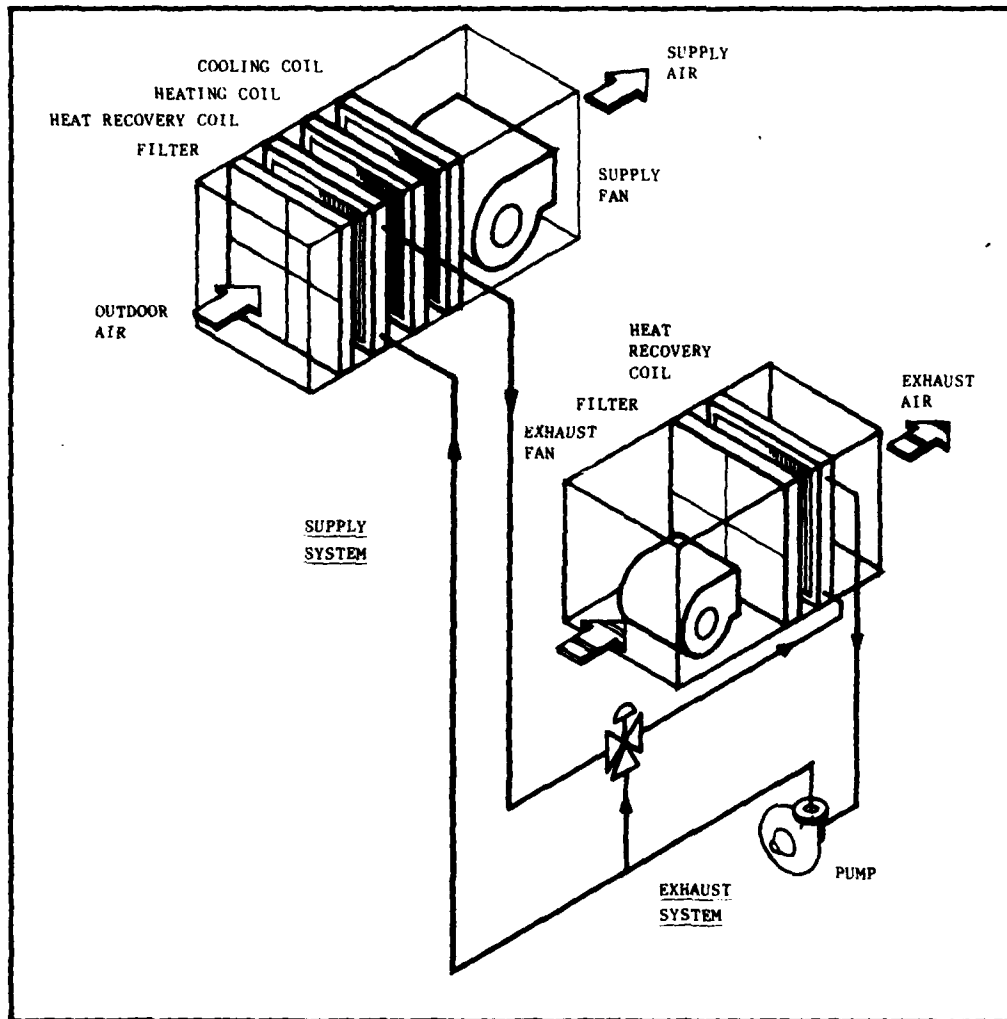

FIGURE 24  
Exhaust Air Heat Recovery Method with  
Run-Around Closed-Loop System



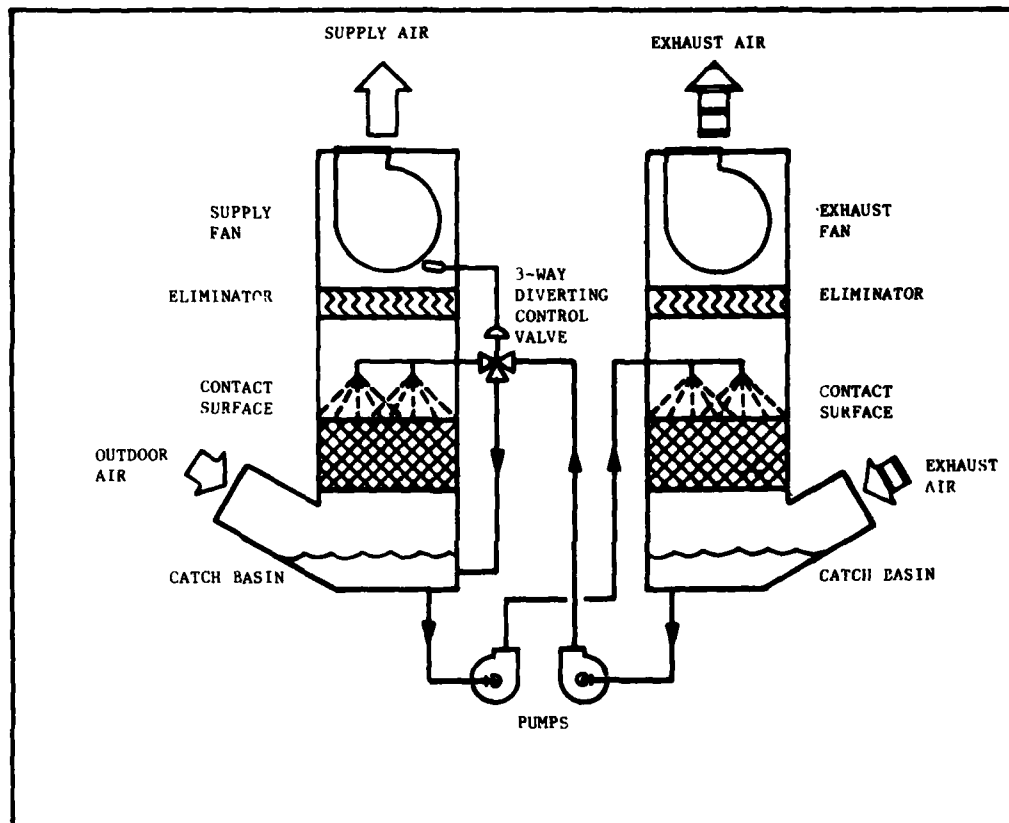

FIGURE 25  
Exhaust Air Heat Recovery Method  
With Run-Around Open-Loop System

b. Condensate Cooler/Hot Water Heat Recovery Method.

The condensate cooler method uses a heat exchanger which removes heat from condensate that is not returned to the boiler. This recovered heat may be used to preheat domestic hot water or boiler make-up water. See Section 3 for further information.

c. Heat-of-Light Heat Recovery Method.

The heat given off by lighting fixtures makes up a large portion of the total cooling load. Recovery of this heat reduces the energy requirements both by reducing the room cooling load and by recovering the usable heat. The recommended methods of heat-of-light recovery are the light troffer method and the induced air method. The

heat-of-light recovery method shall be used in air conditioned spaces, except for clean rooms, animal laboratories and laboratories with toxic, explosive, or bacteriological exhaust requirements.

(1) Light Troffer Method.

The light troffer method removes space air by pulling it through a light troffer and/or through a light fixture and transferring it into the ceiling plenum where it is routed into the return air system (Fig. 26). The room cooling load is reduced; therefore less air is required to cool the room, thereby making it possible to use smaller ducts and fan systems. The total cooling load is substantially reduced for an all outdoor supply system but not significantly for systems not capable of providing 100 percent outdoor air. This technique reduces the luminaire surface temperature and, therefore, increases ballast and lamp life.

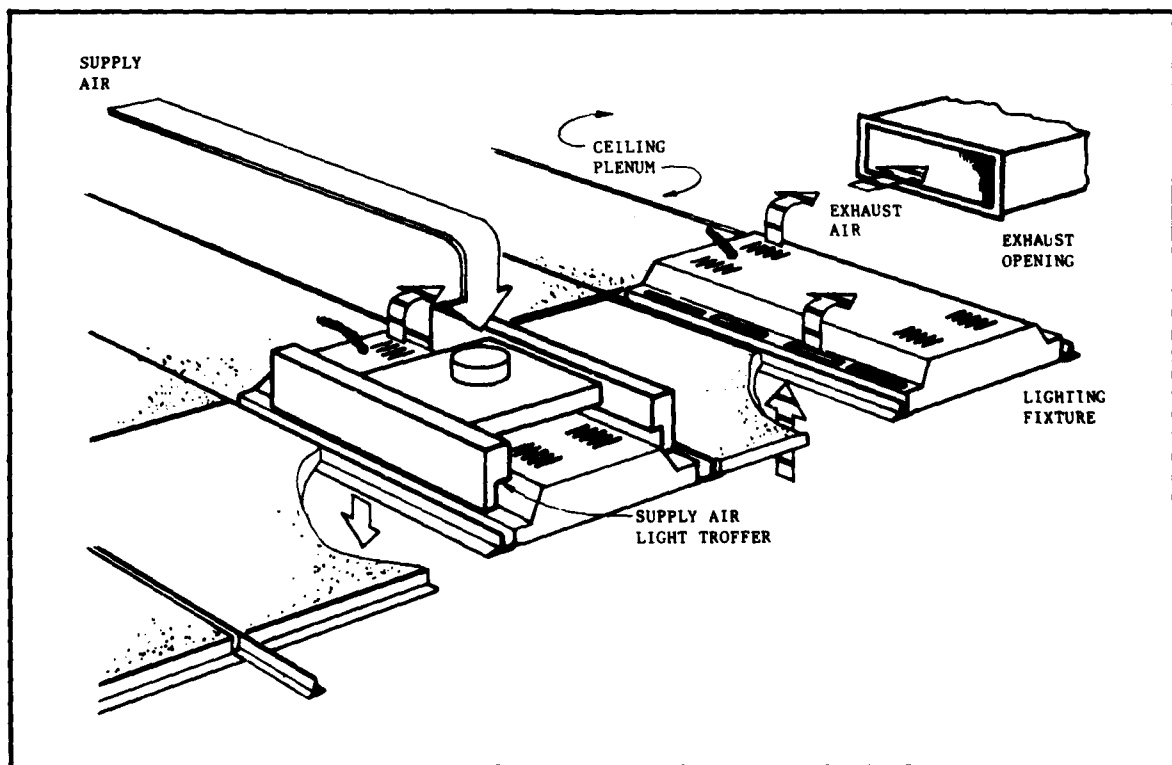

FIGURE 26  
Heat-of-Light Heat Recovery  
Method with Light Troffer

(2) Induced Air Method.

The induced air method removes space air by pulling it through the light troffer and/or through the lighting fixture and transferring it into the ceiling plenum where it is then either useful for heating (Fig. 27) or discharged to the outdoors.

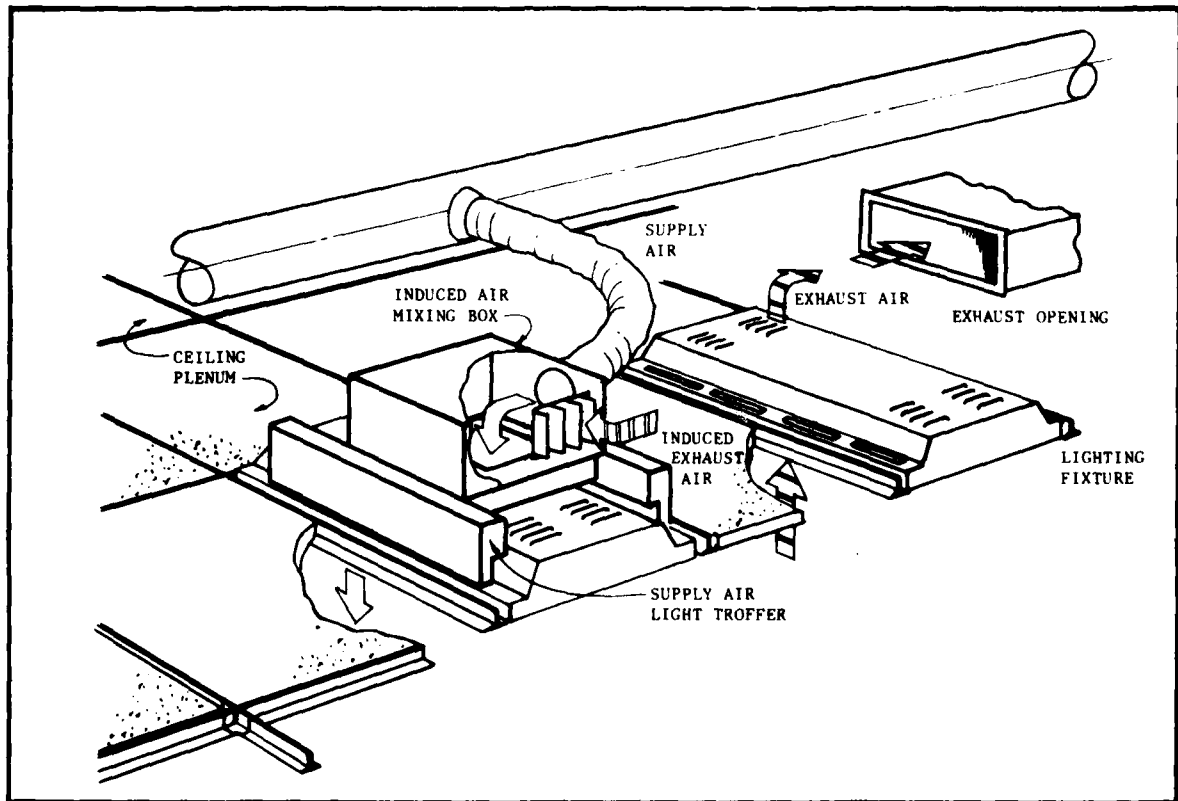

FIGURE 27  
Heat-of-Light Heat Recovery  
Method with Induced Air

d. Refrigeration Method Heat Recovery.

The refrigeration method of heat recovery utilizes the rejected heat from the refrigeration machine by four different techniques. They are: (1) the conventional refrigeration machine method, (2) the heat pump method, (3) the single condenser water circuit method, and (4) the double condenser water circuit method. Refrigeration method heat recovery is suitable when a refrigeration type compressor is being used and when simultaneous heating and cooling of one or more spaces is required.

(1) Conventional Refrigeration Machine Method.

The conventional refrigeration machine method uses a direct expansion cooling coil in conjunction with either a hot water coil (Fig. 28) or a refrigerant coil (Fig. 29) for heat recovery. The hot water heating system extracts heat from the refrigerant through a heat exchanger and is then pumped through a heating coil. For direct air heating, a condensing refrigerant coil is used instead of the heat exchanger and water pump. This method is used for lower tonnage systems with reciprocating compressors. An air-cooled condenser is used to reject heat when space heating is not required.

(2) Internal Source Heat Pump Method.

Heating and cooling is accomplished by self-contained units which either extract or reject heat to a common water loop (Fig. 30). Heat from the high heat gain area is rejected to the loop and heat required for the high heat loss area is extracted from the loop. When water temperature in the loop rises above a given point, generally 90° F, heat from the water loop is rejected to a cooling tower. If the water temperature falls below a given point, generally 60° F, heat is added to the water loop by a supplementary boiler.

(3) Single-Bundle Condenser Water Circuit Method.

The single-bundle condenser water circuit method utilizes a cooling coil in conjunction with a hot water system for heat recovery. When space heating is not required, heat is rejected through an evaporative cooler (Fig. 31) or through a heat exchanger and an open cooling tower (Fig. 32). Application of this system is limited to a maximum water temperature of 110° F. This system may be used with any type of compressor.

(4) Double-Bundle Condenser Water Circuit Method.

The double-bundle condenser water circuit method incorporates two separate condenser water circuits--one for the heating system and one for the cooling tower system (Fig. 33). Water temperatures of up to 125° F may be obtained by using higher compressor speeds, larger impellers, or two or more stages. Selection of the heat recovery machine is very critical due to the relatively high condensing temperatures required. To prevent cavitation of the compressor, operating load, and required condenser water heating temperatures shall be verified for all outdoor conditions.

AD-~~A~~110 410

NAVAL FACILITIES ENGINEERING COMMAND ALEXANDRIA VA F/6 13/1  
HEATING, VENTILATING, AIR CONDITIONING AND DEHUMIDIFYING SYSTEM--ETC(U)  
AUG 80

UNCLASSIFIED

NAVFAC-DH-3.3

NL

3,3  
000

■

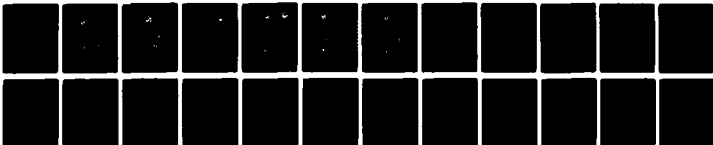

END  
GATE  
FRMCO  
-82  
DTIC

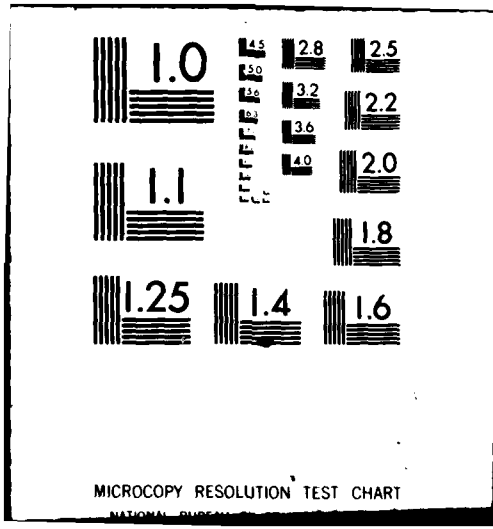

MICROCOPY RESOLUTION TEST CHART

NATIONAL BUREAU OF STANDARDS-1963-A

Consideration should be given to provide lower condensing temperatures under partial load conditions. The unit should be selected to operate at all times above 50 percent of full load.

Storage tanks may be incorporated into the system (See DM-3.16).

Economic evaluation shall be made for use of heat recovery machines in all large systems. If economically justified, such a large system may be designed for multiple machine installations (using conventional machines in conjunction with heat recovery machines).

### 3. Energy Efficient Control Systems.

#### a. Deadband Thermostats.

Deadband thermostats provide a temperature range in which no heating or air conditioning takes place (Fig. 34). This type thermostat shall be set to provide the deadband effect between heating and air conditioning temperatures as defined in DoD 4270.1-M.

#### b. Night Setback.

The night setback technique allows the heating system to start automatically when the minimum allowable space temperature is reached. This system is generally used in conjunction with time clocks.

#### c. Occupied/Unoccupied Hot Water Reset Schedule.

The reset schedule is a dual setting system (Fig. 35) which allows for use of internal heat due to equipment, light, and people to be used as part of the heat supply during occupied hours. During occupied hours, the setting is lower than during unoccupied hours since there is not as much internal heat gain during unoccupied hours.

#### d. Central Monitoring Control Systems.

The use of central monitoring control systems allows complete automatic operation of equipment. It provides more efficient control of heating, ventilating, air conditioning, and dehumidifying systems by duty cycling--not only heating and cooling as required--but also by duty cycling fan and motor operation as required by space temperatures.

Central monitoring control systems may be used with an energy management control system to monitor and record how much, and where energy in a building is being used.

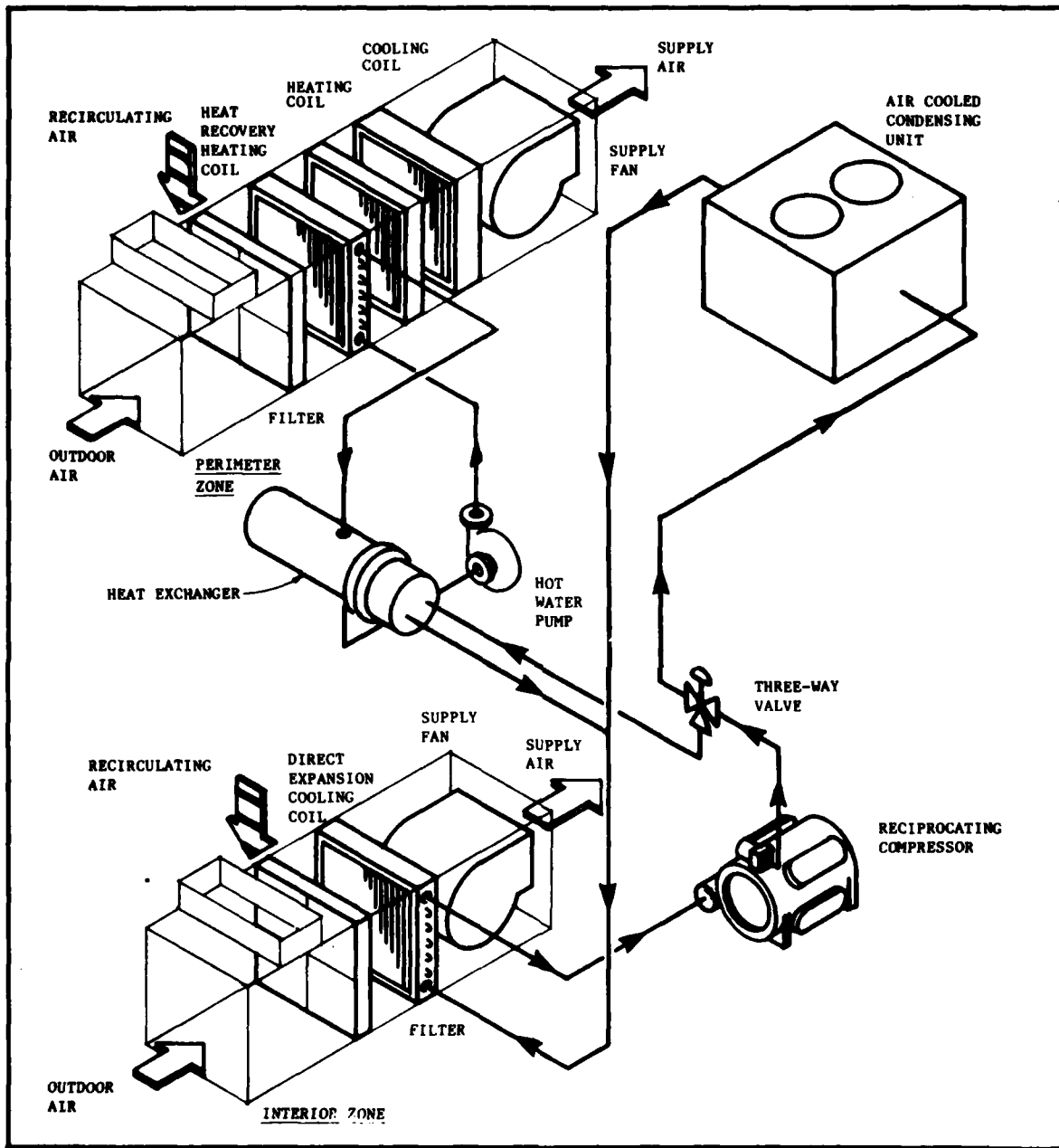
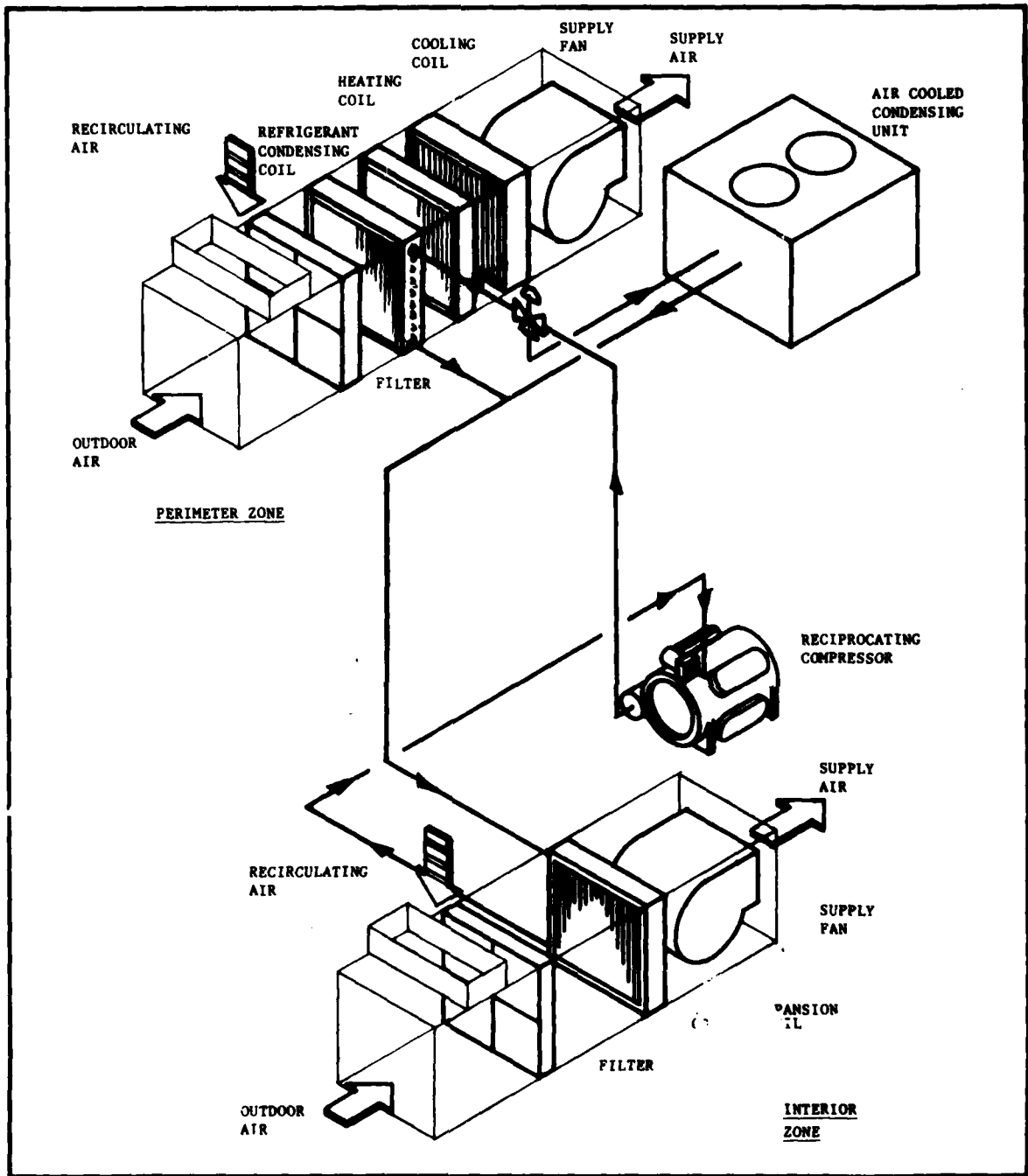
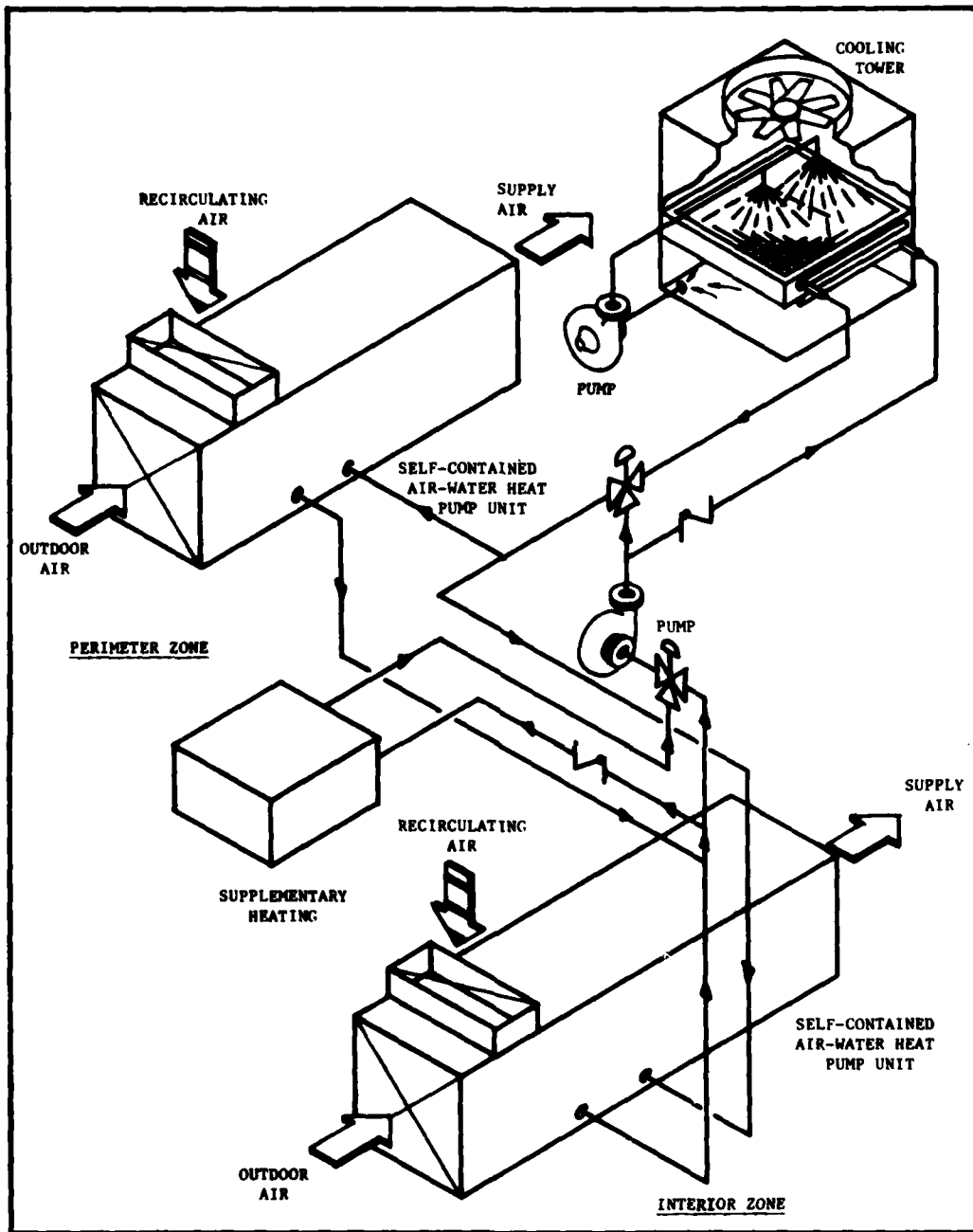

FIGURE 28  
 Refrigeration Method Heat Recovery  
 With Conventional Refrigeration Machine  
 Using Hot Water Coil





**FIGURE 29**  
**Refrigeration Method Heat Recovery**  
**With Conventional Refrigeration**  
**Machine Using Refrigerant Coil**



**FIGURE 30**  
**Refrigeration Method Heat Recovery**  
**With Internal Source Heat Pump**

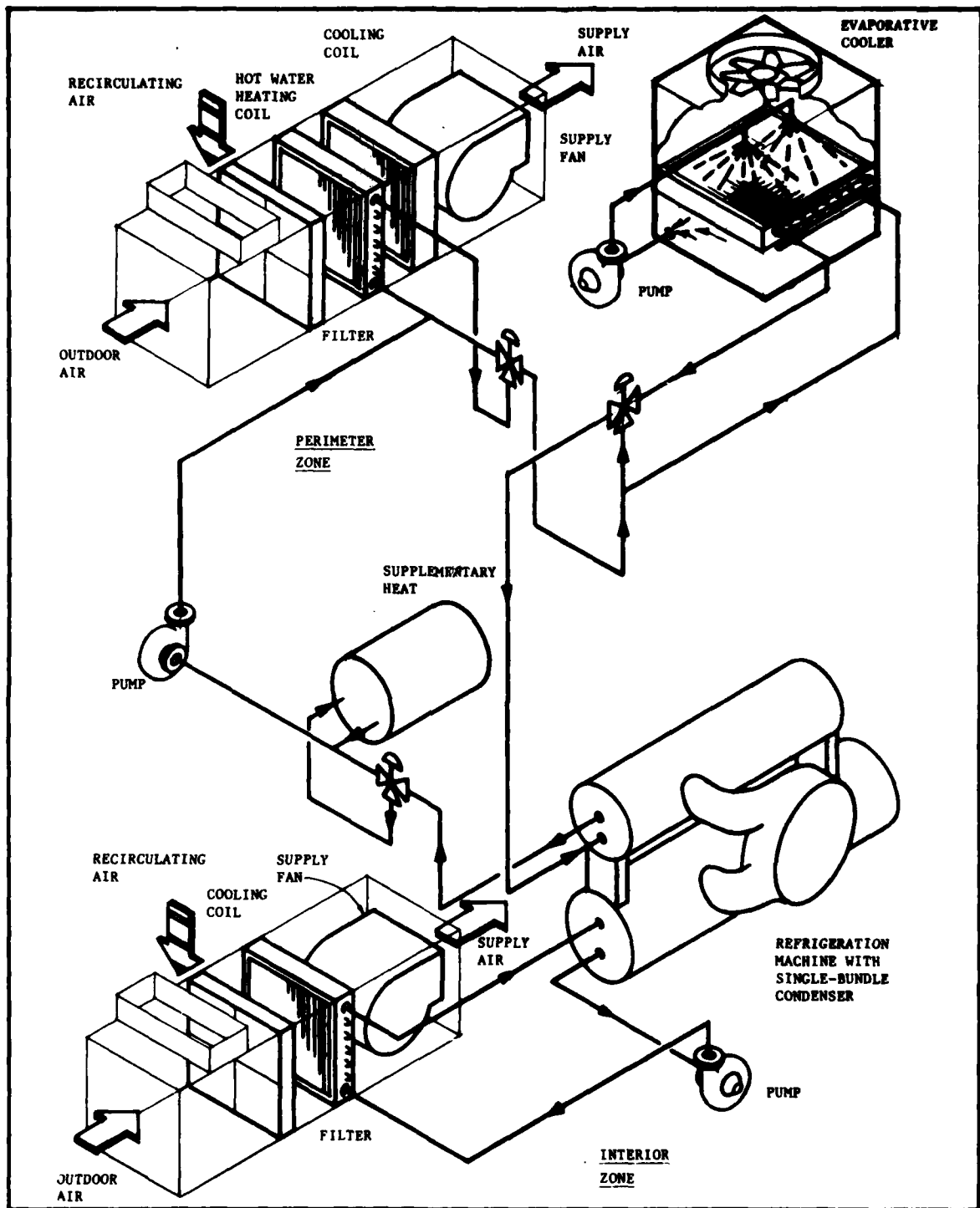
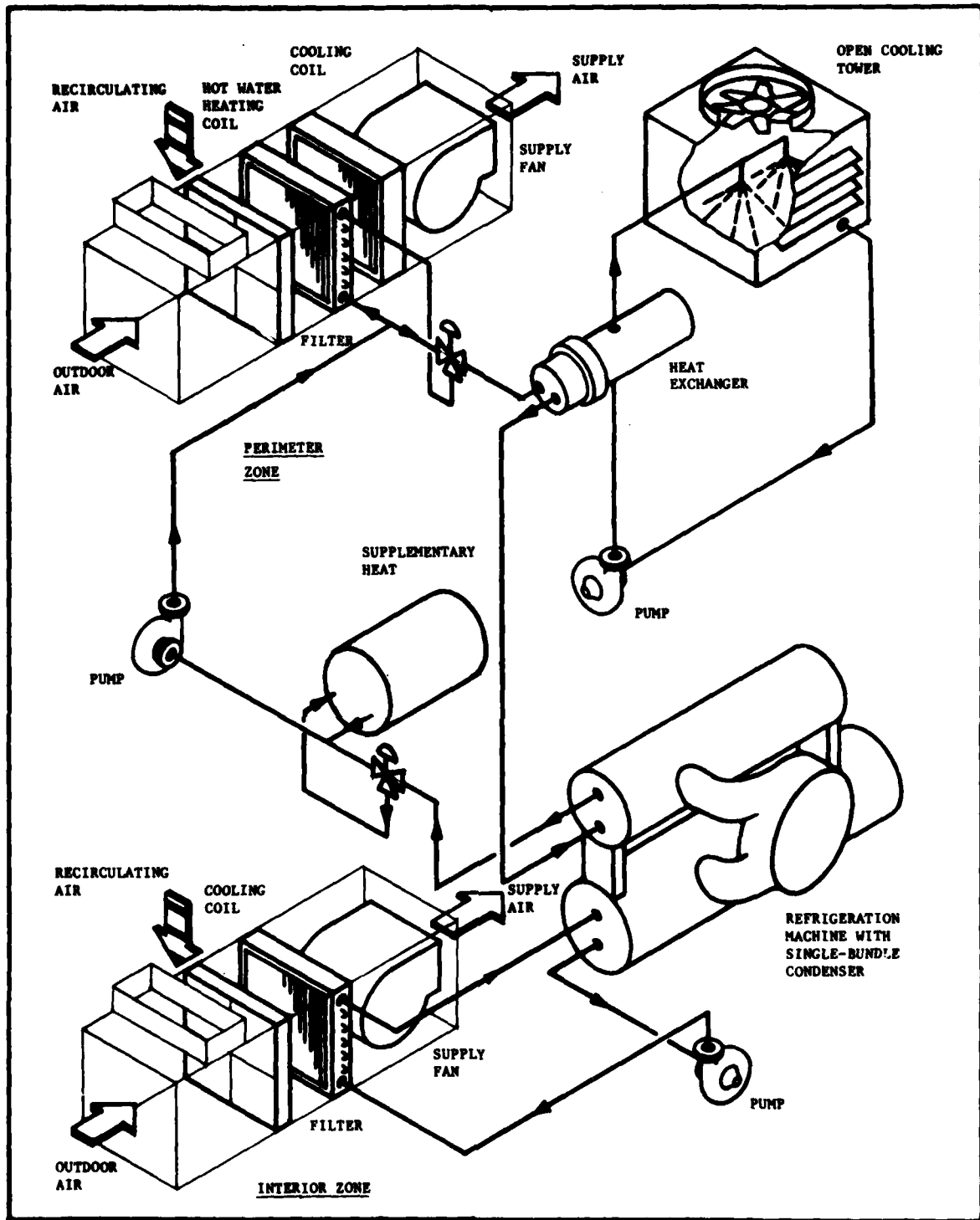
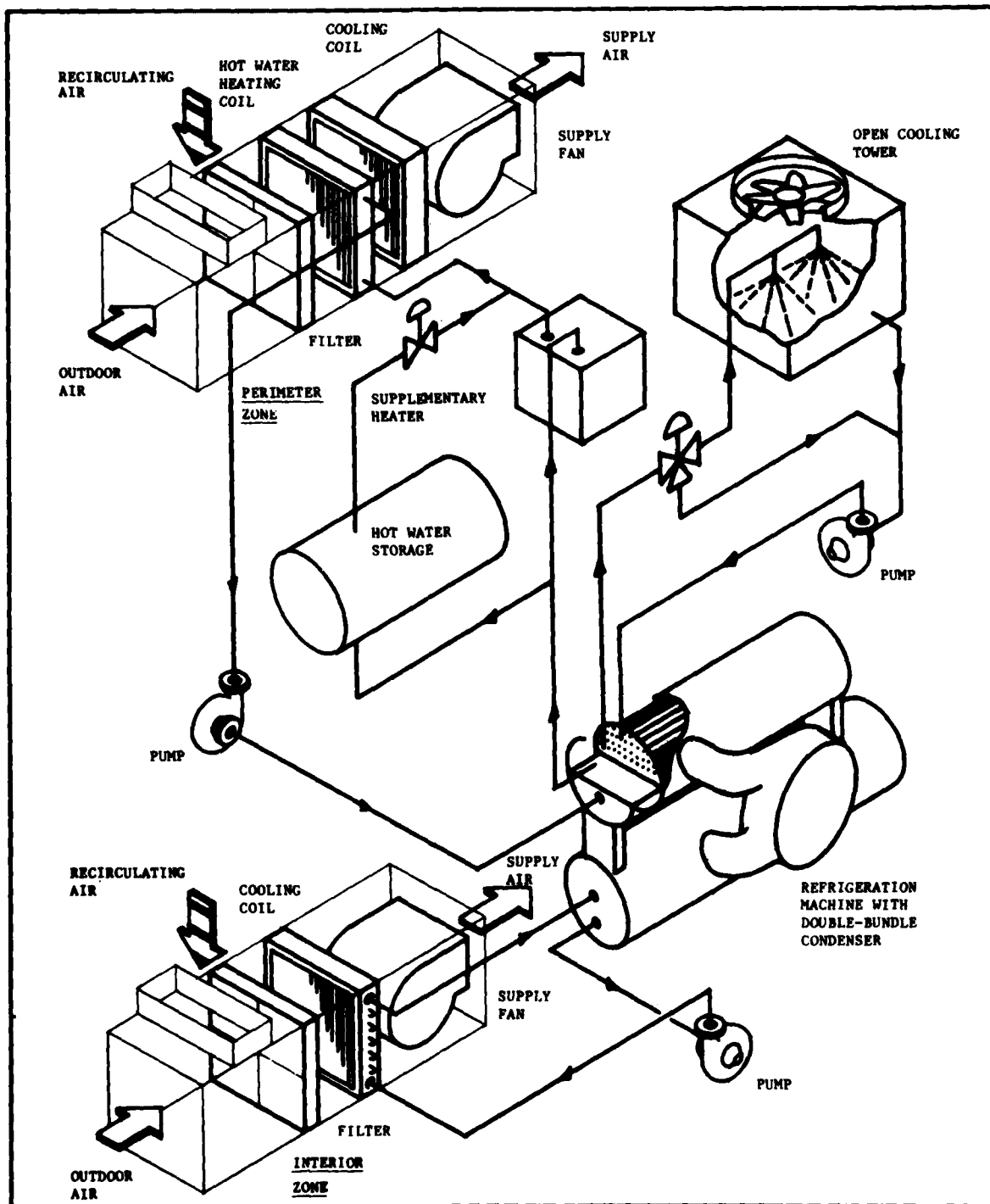

FIGURE 31  
 Refrigeration Method Heat Recovery with Single-Bundle Condenser  
 Water Circuit Method And Evaporative Cooling System



**FIGURE 32**  
**Refrigeration Method Heat Recovery with Single-Bundle Condenser**  
**Water Circuit Method and Open Cooling Tower**



**FIGURE 33**  
**Refrigeration Method Heat Recovery with**  
**Double-Bundle Condenser Water Circuit Method**

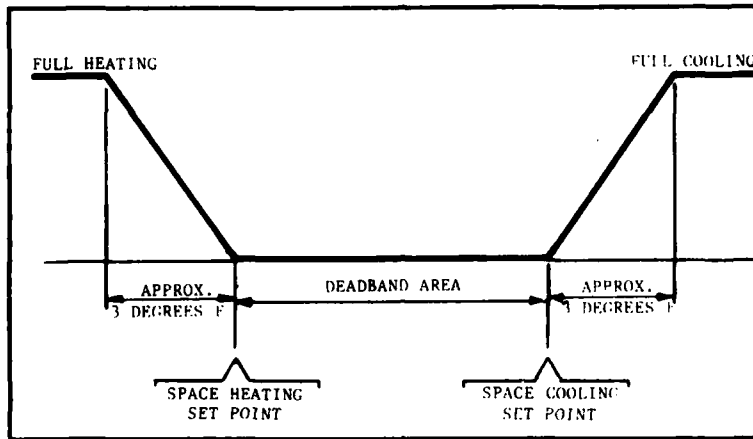

**FIGURE 34**  
Deadband Thermostat Diagram

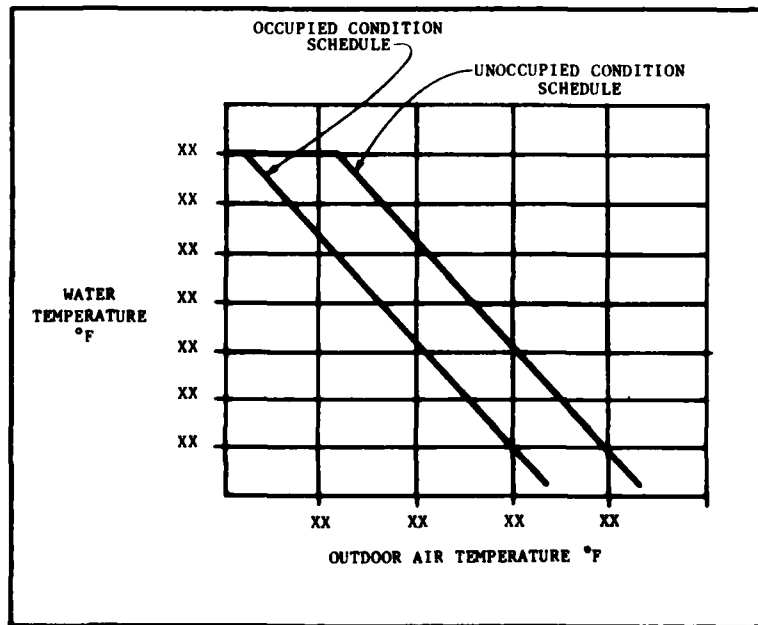

**FIGURE 35**  
Occupied/Unoccupied Condition  
Hot Water Reset Schedule

## References

Air Moving and Conditioning Association, AMCA, 30 West University Drive, Arlington Heights, IL 60004.

1-66 Product Definitions

2404-66 Drive Arrangements for Centrifugal Fans

American Gas Association, 1515 Wilson Boulevard, Arlington, VA 22209

American National Standards Institute, Inc., ANSI Standards, 1430 Broadway, New York, NY 10018.

B 9.1-71 Safety Code for Mechanical Refrigeration

American Society of Heating, Refrigerating, and Air-Conditioning Engineers, Inc., ASHRAE, 345 East 47th Street, New York, NY 10017.

ASHRAE Applications Handbook

ASHRAE Equipment Handbook

ASHRAE Fundamentals Handbook

ASHRAE Standards

52-76 Method of Testing Air Cleaning Devices used in General Ventilation for Removing Particulate Matter

55-74 Thermal Environmental Conditions for Human Occupancy

62-73 Standards for Natural and Mechanical Ventilation

90-75 Energy Conservation in New Building Design

ASHRAE Systems Handbook

Department of Defense Construction Criteria Manual, DoD 4270.1-M, Department of Defense, The Pentagon, Washington, D. C. 20301.

Industrial Ventilation: A Manual of Recommended Practice, 15th Ed., Edwards Brothers Incorporated, 2500 South State Street, Ann Arbor, MI 48104.

National Environmental Systems Contractors Association, NESCA, 1501 Wilson Blvd., Arlington, VA 22209.

National Fire Protection Association, NFPA, 470 Atlantic Avenue,  
Boston, MA 02210.

30	Flammable and Combustible Liquids, Code
31	Oil Burning Equipment Installation
40	Cellulose Nitrate Motion Picture Film
90-B	Warm Air Heating/Air Conditioning, Ventilation System
214	Water Cooling Towers
325-A	Flash Point Index for Trade Name Liquids

NAVFACENGCOM Documents available at U.S. Naval Publications and Forms Center, Philadelphia, PA 19120. TWX: 710-670-1685, TELEX: 834295, AUTOVON telephone number 422-3321. The stock number is necessary for ordering these documents and should be requested from the NAVFACENGCOM Division in your area.

DM-1	Architecture
DM-2	Structural Engineering
DM-3.6	Central Heating Plants
DM-3.8	Exterior Distribution of Utility Steam, HTW, CHW, Gas and Compressed Air
DM-3.10	Noise and Vibration Control of Mechanical Equipment
DM-3.12	Central Building Automation Systems
DM-3.13	Solar Space and Domestic Water Heating
DM-3.16	Thermal Storage
DM-4	Electrical Engineering
DM-5	Drainage Systems
DM-8	Fire Protection Engineering
P-89	Engineering Weather Data
P-355	Seismic Design For Buildings
P-355.1	Seismic Evaluation of Support for existing Electrical Mechanical Equipment and Utilities



Occupational Safety and Health Administration, OSHA, Clearing House,  
Chicago, IL 60646.

Part 1910 Occupational Safety and Health Standards

Sheet Metal Air Conditioning Contractors National Association, SMACNA,  
1611 North Kent Street, Arlington, VA 22209.

High Pressure Duct Construction Standard

Low Pressure Duct Construction Standard

## Glossary

Air conditioning	The process of treating air to meet the design requirements of a conditioned space by simultaneously controlling temperature, relative humidity, and air distribution.
Air:	
exhaust	Air which is removed from a space and not reused.
outdoor	Air which is taken from outdoors and has not been previously circulated through the system.
recirculated	Return air which is again supplied to a space.
return	Air which is removed from a space and recirculated or exhausted.
supply	Air which is delivered to a space which is used for heating, ventilating, air conditioning, dehumidifying, humidifying, and air distribution.
ventilation	The portion of supply air which comes from outdoors plus any recirculated air that has been treated to maintain the desired quality of air within a space.
Bacteriostatic brine	A liquid solution that will not support bacterial life.
Breakeven temperature	The outside air temperature at which a building's internal heat gain equals its heat loss.
Centrifugal compressor	A non-positive displacement compressor which depends on centrifugal effect to create a rise in pressure.
Coefficient of performance	The ratio of energy output to the energy input.
Damper	A valve or plate regulating the flow of air or other fluids.

<b>Exfiltration</b>	Air flow outward through cracks around windows and doors, and through floors and walls of a space or building.
<b>Grains of moisture</b>	Unit of measure for the amount of moisture in air equal to 1/7000th of a pound.
<b>Horsepower (brake)</b>	A unit of power equal to 33,000 foot pounds per minute; one electrical horsepower equals 746 watts.
<b>Infiltration</b>	The inward air leakage through cracks around windows and doors, and through floors and walls of a space or building.
<b>Latent heat</b>	The heat added or removed from a substance to effect a change of state without a change in temperature.
<b>Pressure</b>	<ul style="list-style-type: none"> <li>a. Absolute Pressure. The sum of the gage pressure and atmospheric pressure.</li> <li>b. Static Pressure. Pressure that is exerted in an outward direction, i.e., the pressure that extends the walls of a balloon after it has been inflated; the pressure of a fluid at rest.</li> <li>c. Velocity Pressure. Pressure that is exerted in a directional flow, i.e. the pressure of air moving in a duct.</li> <li>d. Total Pressure. The sum of static and velocity pressure as measured with a pitot tube in ductwork.</li> </ul>
<b>Reciprocating compressor</b>	A positive displacement compressor which changes the internal volume of the compression chamber(s) by reciprocating motion of one or more pistons.
<b>Sensible heat</b>	Heat which causes a change in the temperature of a substance.
<b>Sorbent</b>	A substance that absorbs moisture.
<b>Specific gravity</b>	The ratio of the weight of a given volume of substance to the weight of an equal volume of distilled water.

**Thermosyphon principle**

The transfer of heat in a medium, whereby the heat energy causes the warmer medium to become less dense and rise above the colder, more dense medium creating syphoning motion.

**Vacuum pump**

A device which uses mechanical force and motion to evacuate a gas from an area to create a sub-atmospheric pressure.

**APPENDIX A**  
**METRIC CONVERSION TABLES**

APPENDIX A

Metric Conversion Factors

SECTION 1

Conversions are approximate

450 - 600 ft <sup>2</sup> /ton	120 - 160 cm <sup>2</sup> /W
0.04 - 0.06 tons/seat	140 - 210 W/seat
725 - 900 ft <sup>2</sup> /ton	190 - 240 cm <sup>2</sup> /W
0.8 - 1.4 tons/alley	2815 - 4925 W/alley
0.02 - 0.03 tons/seat	70 - 105 W/seat
400 - 500 ft <sup>2</sup> /ton	105 - 130 cm <sup>2</sup> /W
50 - 150 ft <sup>2</sup> /ton	15 - 40 cm <sup>2</sup> /W
175 - 450 ft <sup>2</sup> /ton	45 - 120 cm <sup>2</sup> /W
450 - 550 ft <sup>2</sup> /ton	120 - 145 cm <sup>2</sup> /W
275 - 375 ft <sup>2</sup> /ton	75 - 100 cm <sup>2</sup> /W
900 - 1275 ft <sup>2</sup> /ton	240 - 340 cm <sup>2</sup> /W
375 - 450 ft <sup>2</sup> /ton	100 - 120 cm <sup>2</sup> /W
8000 FT <sup>2</sup>	745 m <sup>2</sup>
32000 FT <sup>2</sup>	2975 m <sup>2</sup>

SECTION 2

Conversions are approximate

0 - 15 psi	0 - 105 kPa
16 - 50 psi	106 - 345 kPa
51 - 125 psi	346 - 860 kPa
250° F	121° C
350° F	177° C
10,000 MBH	3 000 kW

20,000 MBH	6 000 kW
50° F	10° C
160° F	70° C
120,000 BTUH	35 000 W
350,000 BTUH	103 000 W
50 tons	175 000 W
20 tons	70 000 W
17° F	-8° C
4000 degree days heating	2200 metric degree days
65° F	18° C
70° F	21° C
60° F	16° C
1 in <sup>2</sup> free area per 1000 BTUH	2 mm <sup>2</sup> /W
500 - 650 FPM	2.5 - 3.3 m/s
10" hg	34 kPa
3 CFM/1000 MBH	5 L/s per 1000 kW
20" hg	68 kPa
4 to 8 CFM/1000 MBH	7 to 14 L/s per 1000 kW
100 lbs/hr	45 kg/hr
15 to 35 psig	105 - 240 kPa
250 MBH	73 kW
75° F	24° C
35° F	2° C

### SECTION 3

Conversions are approximate

24 ft	7 m
35 ft	10 m

10 ft	3 m
0.125 cfm/ft <sup>2</sup>	0.625 L/s per m <sup>2</sup>
5 cfm/person	2.5 L/s per person
10 cfm/person	5 L/s per person
2 cfm ft <sup>2</sup>	10 L/s per m <sup>2</sup>
350° F	177° C
1500 - 1700 ft/min	8 - 9 m/s
55° F	13° C
125 fpm	0.65 m/s
104° F	40° C
1.5 cfm/ft <sup>2</sup>	7.5 L/s per m <sup>2</sup>
3 cfm/FT <sup>2</sup>	15 L/s per m <sup>2</sup>
0.5 cfm.ft <sup>2</sup>	2.5 L/s per m <sup>2</sup>
4 mile/hour	1.8 m/s

#### SECTION 4

Conversions are approximate

93° F	34° C
73° F	23° C
180° F	82° C
8000 FT <sup>2</sup>	745 m <sup>2</sup>
3 CFM/FT <sup>2</sup>	15 L/s per m <sup>2</sup>
25° F	-4° C
3° F	-16° C
46° F	8° C
48° F	9° C
140° F	60° C
130 tons	457 000 W



15000 to 36000 BTUH	4400 to 10500 W
0° F	-18° C
10° F	-12° C
20° F	-7° C
30° F	-1° C
40° F	4° C
50° F	10° C
80° F	27° C
90° F	32° C
100° F	38° C
110° F	43° C
120° F	49° C
130° F	54° C
150° F	66° C
75° F	24° C
85° F	30° C
95° F	35° C
103° F	40° C
3 GPM of water per CFM of air	0.4 L/s of water per L/s of air
550 FPM	2.8 m/s
1 psi	7 kPa
10 ft	3 m
28° F	-2° C
40 - 48° F	4.5 - 9° C
8 - 14° F	(-13.5) - (-10)° C
3 to 5 ft/s	1 to 1.5 m/s
1 gpm/ft <sup>2</sup>	0.7 L/s per m <sup>2</sup>

500 FPM	2.5 m/s
2 or 3 gpm/ft <sup>2</sup>	1.5 or 2 L/s per m <sup>2</sup>
3 psi	21 kPa
2 ft 6 in	0.8 m
2 ft	0.6 m
18 in	0.5 m
4000 CFM	1900 L/s
4 in	100 mm
6 in	150 mm
1600 FPM	8 m/s
2° F	-16.5° C
20 FPM	0.1 m/s
50 FPM	0.25 m/s
75 FPM	0.4 m/s
300 fpm	1.5 m/s
12 in	305 mm
2 cfm/ft <sup>2</sup>	10 L/s per m <sup>2</sup>
0.8 to 1 cfm/ft <sup>2</sup>	4 to 5 L/s per m <sup>2</sup>
5 cfm/ft <sup>2</sup>	25 L/s per m <sup>2</sup>
10 cfm/ft <sup>2</sup>	50 L/s per m <sup>2</sup>
27 in	685 mm
200° F	93° C
1.5 in water pressure	4.5 kPa
24 in	610 mm
½" water pressure	1.5 kPa
6° F	-14° C
14° F	-10° C

28° F	-2° C
1.5 to 2 GPM/ton	30 to 40 mL/s per kW
2.5 to 3.75 GPM/ton	50 to 70 mL/s per kW
8 to 12° F	-13.5 to -11° C
6 to 12° F	-14.5 to -11° C
2 to 100 t	7000 to 350 000 W
2 gal/h/ton	8.2 L/h per kW
2" IPS	50 mm
150 lb pressure	1035 kPa
1½" IPS	38 mm
300 lb pressure	2070 kPa
7/8" OD	22 mm
1/4" OD	6.5 mm
3/8" OD	9.5 mm
125 lb pressure	860 kPa
6 fps	2 m/s
8 fps	2.5 m/s
12 fps	3.5 m/s
4 fps	1.2 m/s
2 fps	0.6 m/s
0.75 ft/100 ft pressure drop	0.75 m/100 m
100 ft	30 m
8 in	200 mm
3/4 in	19 mm
2½ in	64 mm
½ in	15 mm
1 in	25 mm

5 in	125 mm
15 psig	105 kPa
35 psig	245 kPa
35° F	2° C

#### SECTION 5

Conversions are approximate

2 psig	14 kPa
5° F	-15° C
40 ft <sup>3</sup>	1.1 m <sup>3</sup>
600 ft	185 m
200 ft	61 m
22 ft	6.5 m
35 - 75 measured tons/hr	40 - 85 m <sup>3</sup> /h
1 ft <sup>3</sup>	0.028 m <sup>3</sup>
6 lbs	2.7 kg
180 to 420 lbs water/day	80 to 190 kg/day
120 to 240 lbs water/day	55 to 110 kg/day
50 to 100 lbs water/day	25 to 50 kg/day
20 to 60 lbs water/day	10 to 30 kg/day
40 to 55 lbs water/day	20 to 25 kg/day
150 to 300 lbs water/day	70 to 140 kg/day
200 to 400 lbs water/day	90 to 180 kg/day
50 to 130 lbs water/day	25 to 60 kg/day
70° F	21° C
250 lbs water/day	115 kg/day

SECTION 6

Conversions are approximate

5 ft	1.5 m
120,000 BTUH	35000 W
4000 cfm	1900 L/s
32° F	0° C
90° F	32° C
60° F	15° C
110° F	43° C
125° F	52° C

**APPENDIX B**  
**ENERGY BUDGET CONVERSIONS**

APPENDIX B  
Energy Budget Conversions

<u>Energy Source</u>	<u>To Convert From</u>	<u>To</u>	<u>Multiply By</u>
Electricity	Kwh	Btu	3,413
Fuel Oil	gal	Btu	138,700
Natural Gas	ft <sup>3</sup>	Btu	1,030
Liquified Petroleum Gas (including propane and butane)	gal	Btu	95,500
Anthracite Coal	short ton	Btu	28,300,000
Bituminous Coal	short ton	Btu	24,580,000
Steam	pounds	Btu	1,000
High Temperature or Medium Temperature Water	gal	Btu	8.3 x (Supply temp. - Return temp.)

INDEX

A	Page	B	Page
ABSORPTION REFRIGERATION SYSTEMS.....	3.3-90, 3.3-100	BASIC AIR CONDITIONING SYSTEMS.....	3.3-78
ACTIVE AIR SYSTEMS.....	3.3-92	Built-Up Systems.....	3.3-79
ACTIVE LIQUID SYSTEMS.....	3.3-93	Constant Volume Systems.....	3.3-79
ADMINISTRATIVE POLICY.....	3.3-1	Dual Air Duct Systems.....	3.3-81
Air Conditioning Systems.....	3.3-2	Fan Coil Systems.....	3.3-87
Dehumidifying Systems.....	3.3-2	Heat Pump Systems.....	3.3-89
Energy Conservation.....	3.3-2, 3.3-167	Induction Unit Systems.....	3.3-88
Heating Systems.....	3.3-1	Multizone Unit Systems.....	3.3-81
Ventilating Systems.....	3.3-1	Perimeter Zone Air Systems..	3.3-84
AIR CLEANING SYSTEM.....	3.3-110, 3.3-149	Self-Contained Systems.....	3.3-78
AIR CONDITIONING EQUIPMENT...3.3-102		Single Duct Systems.....	3.3-79
Air Cleaning Systems.....	3.3-149	Variable Air Volume Systems.....	3.3-84
Air Cooling Equipment.....	3.3-104	BUILT-UP SYSTEMS.....	3.3-79, 3.3-96
Air Duct Systems.....	3.3-149		
Air Inlet and Outlet Connections.....	3.3-109	C	
Fans.....	3.3-118, 3.3-149	CALCULATIONS.....	3.3-10, 3.3-94
Instrumentation.....	3.3-150	Air Conditioning Calculations.....	3.3-10
Insulation.....	3.3-150	Air Conditioning Systems.....	3.3-94
Piping Systems.....	3.3-150	Air Quantities Calculations.....	3.3-10
Refrigeration Equipment...3.3-122,	3.3-149	Dehumidifying Systems.....	3.3-159
Valves.....	3.3-150	Equipment Selection Information.....	3.3-14
AIR CONDITIONING SYSTEMS.....	3.3-2, 3.3-78	Heat Balance Analysis.....	3.3-15
Basic Air Conditioning Systems.....	3.3-78	Heat Balance Diagram.....	3.3-16
Condenser Water Systems.....	3.3-90, 3.3-100	Heat Gain Calculation.....	3.3-13
Equipment Selection Criteria.....	3.3-102	Heat Loss Calculation.....	3.3-12
Evaporative Cooling Systems.....	3.3-91, 3.3-101	Heating systems.....	3.3-10
Humidification Systems.....	3.3-5, 3.3-102	Information Required.....	3.3-7
Refrigeration Systems.....	3.3-89	Ventilating Systems.....	3.3-67
Solar Cooling Systems.....	3.3-91, 3.3-108	CENTRIFUGAL COMPRESSOR SYSTEMS.....	3.3-90, 3.3-100
System Controls.....	3.3-146	COMBINED HEATING AND VENTILATING UNITS.....	3.3-46, 3.3-61
System Selection Criteria...3.3-94		COMPUTER ENERGY ANALYSIS.....	3.3-18
AIR COOLING EQUIPMENT.....	3.3-104	CONDENSATE COOLER.....	3.3-47, 3.3-62
AIR DUCT SYSTEMS.....	3.3-113, 3.3-149	CONDENSATE RETURN PUMPING UNIT.....	3.3-47, 3.3-62
AIR INLET AND OUTLET SYSTEMS.....	3.3-109	CONDENSER WATER SYSTEMS.....	3.3-90, 3.3-100, 3.3-128
AIR-TO-AIR HEAT PUMP SYSTEM...3.3-36		CONSTANT VOLUME SYSTEM.....	3.3-79, 3.3-96
ARCHITECTURAL CRITERIA.....	3.3-20		



D	Page
DEHUMIDIFYING SYSTEMS.....	3.3-2, 3.3-152
Equipment Selection	
Criteria.....	3.3-162
Non-Regenerative Dehumidification System.....	3.3-153
Regenerative Dehumidification System.....	3.3-152
Specific Regenerative Systems.....	3.3-153
System Controls.....	3.3-165
System Selection Criteria..	3.3-159
DUAL AIR DUCT SYSTEM..	3.3-81, 3.3-96
DUCT HEATERS.....	3.3-45, 3.3-60
DUCTWORK.....	3.3-75

E

ELECTRIC CONVECTORS OR STRIP HEATERS.....	3.3-42, 3.3-60
ELECTRICAL DESIGN CRITERIA....	3.3-23
ELECTRICAL HEATING SYSTEMS....	3.3-34
ENERGY CONSERVATION...3.3-2, 3.3-167	
ENERGY CONSERVATION METHOD- OLOGY.....	3.3-167
Energy Conservation	
Methods.....	3.3-168
Energy Management Conser- vation Analysis.....	3.3-167
Energy Performance	
Standards.....	3.3-167
ENERGY CONSERVATION METHODS..	3.3-168
ENGINEERING DESIGN CRITERIA....	3.3-2
Architectural Criteria.....	3.3-20
Calculations.....	3.3-10
Computer Energy Analysis....	3.3-18
Electrical Design Criteria..	3.3-23
Indoor Design Conditions....	3.3-4
Outdoor Design Conditions....	3.3-3
Related Criteria.....	3.3-2
Safety Related Design	
Criteria.....	3.3-20
Structural Design Criteria..	3.3-21
Warm Humid Climate Design	
Criteria.....	3.3-4
ENERGY MANAGEMENT CONSERVA- TION ANALYSIS.....	3.3-167
ENERGY PERFORMANCE STAND- ARDS.....	3.3-167
EQUIPMENT SELECTION CRI- TERIA.....	3.3-41, 3.3-75, 3.3-102

	Page
EQUIPMENT SELECTION CRI- TERIA, Continued	
Air Conditioning Equip- ment.....	3.3-102
Dehumidifying Equipment....	3.3-162
Heating Equipment.....	3.3-41
Ventilating Equipment.....	3.3-75
EVAPORATIVE COOLING SYSTEM...	3.3-91, 3.3-101

F

FANS.....	3.3-75, 3.3-118, 3.3-149
FAN COIL UNIT SYSTEM..	3.3-87, 3.3-98
FLASH TANKS.....	3.3-49, 3.3-62

H

HEAT BALANCE ANALYSIS.....	3.3-15
HEAT PUMP HEATING SYSTEMS....	3.3-35
HEAT PUMP SYSTEM.....	3.3-99
HEATING COILS.....	3.3-45, 3.3-61
HEATING EQUIPMENT.....	3.3-41
Combined Heating and Ven- tilating Units....	3.3-46, 3.3-61
Condensate Cooler...3.3-47, 3.3-62	
Condensate Return Pumping	
Unit.....	3.3-47, 3.3-62
Duct Heaters.....	3.3-45, 3.3-60
Electric Convectors or	
Strip Heaters.....	3.3-42, 3.3-60
Flash Tanks.....	3.3-49, 3.3-62
Heating Coils.....	3.3-45, 3.3-61
Humidification Equipment....	3.3-62
Instrumentation.....	3.3-55
Lift Traps and Fittings....	3.3-62
Piping System Equipment....	3.3-50
Radiant Heating Equipment...3.3-42	
Radiators, Convectors, and	
Finned-Tube Radiator	
Units.....	3.3-59, 3.3-41
Unit Heaters.....	3.3-42
Vacuum Return Pump..3.3-48, 3.3-62	
HEATING SYSTEMS.....	3.3-1, 3.3-28
Electric Heating Systems....	3.3-34
Equipment Selection Cri- teria.....	3.3-41
Heat Pump Heating Systems..	3.3-35, 3.3-89
Hot Air Heating Systems....	3.3-33

	Page
<b>HEATING SYSTEMS, Continued</b>	
Hot Water Heating Systems...	3.3-30
Humidification Systems.....	3.3-37
Infrared Heating Systems....	3.3-34
Radiant Heating Systems.....	3.3-34
Snow Melting Systems.....	3.3-38
Solar Heating Systems.....	3.3-37
Steam Heating Systems.....	3.3-28
System Controls.....	3.3-56
System Selection Criteria...	3.3-39
<b>HIGH-TEMPERATURE HEATING SYSTEMS.....3.3-30</b>	
<b>HOT AIR HEATING SYSTEMS.....3.3-33</b>	
<b>HOT WATER HEATING SYSTEMS.....3.3-30</b>	
High-Temperature Systems....	3.3-30
Low-Temperature Systems....	3.3-30
Medium-Temperature Systems..	3.3-30
<b>HUMIDIFICATION EQUIPMENT.....3.3-49,</b>	
	3.3-62
<b>HUMIDIFICATION SYSTEMS.....3.3-37,</b>	
	3.3-93, 3.3-102
<b>I</b>	
<b>INDOOR DESIGN CONDITIONS.....3.3-4</b>	
<b>INDUCTION UNIT SYSTEM.....3.3-88,</b>	
	3.3-98
<b>INFRARED HEATING SYSTEMS.....3.3-34</b>	
<b>INSTRUMENTATION.....3.3-55, 3.3-144,</b>	
	3.3-150, 3.3-165
<b>INSULATION.....3.3-142, 3.3-150</b>	
<b>L</b>	
<b>LIFT TRAPS AND FITTINGS.....3.3-49,</b>	
	3.3-62
<b>LIQUID ABSORPTION DEHUMIDI-</b>	
<b>FICATION SYSTEM.....3.3-157</b>	
<b>LOW-TEMPERATURE HEATING</b>	
<b>SYSTEMS.....3.3-30</b>	
<b>M</b>	
<b>MECHANICAL VENTILATING</b>	
<b>SYSTEMS.....3.3-65</b>	
<b>MEDIUM-TEMPERATURE HEATING</b>	
<b>SYSTEMS.....3.3-30</b>	
<b>MULTIZONE UNIT SYSTEM.....3.3-81,</b>	
	3.3-97

	Page
<b>NATURAL VENTILATING SYSTEMS...3.3-64</b>	
<b>NON-REGENERATIVE DEHUMIDI-</b>	
<b>FICATION SYSTEMS.....3.3-153</b>	
<b>O</b>	
<b>OUTDOOR DESIGN CONDITIONS.....3.3-3</b>	
<b>P</b>	
<b>PASSIVE AIR SYSTEMS.....3.3-92</b>	
<b>PASSIVE LIQUID SYSTEMS.....3.3-92</b>	
<b>PERIMETER ZONE AIR SYSTEMS...3.3-84,</b>	
	3.3-98
<b>PIPING SYSTEM EQUIPMENT.....3.3-50</b>	
<b>PIPING SYSTEMS.....3.3-62, 3.3-134,</b>	
	3.3-150
<b>R</b>	
<b>RADIANT HEATING EQUIPMENT...3.3-42,</b>	
	3.3-60
<b>RADIANT HEATING SYSTEMS.....3.3-34</b>	
<b>RADIATORS, CONVECTORS, AND</b>	
<b>FINNED-TUBE RADIATOR UNITS</b>	
	3.3-41, 3.3-51, 3.3-59
<b>RECIPROCATING COMPRESSOR</b>	
<b>SYSTEMS.....3.3-89, 3.3-99</b>	
<b>REFRIGERATION SYSTEMS.....3.3-89</b>	
Absorption Refrigeration	
Systems.....	3.3-90
Centrifugal Compressor	
Systems.....	3.3-90
Reciprocating Compressor	
Systems.....	3.3-89
<b>REFRIGERATION EQUIPMENT...3.3-122,</b>	
	3.3-149
<b>SPECIFIC REGENERATIVE SYS-</b>	
<b>TEMS.....3.3-153</b>	
Liquid Absorption Dehumidi-	
fication System.....	3.3-157
Solid Adsorption Dehumidi-	
fication Systems.....	3.3-153
<b>RELATED CRITERIA.....3.3-2</b>	
<b>S</b>	
<b>SAFETY DESIGN CRITERIA.....3.3-20</b>	

	Page
SELF-CONTAINED SYSTEMS.....	3.3-78, 3.3-96
SINGLE DUCT SYSTEMS.....	3.3-79, 3.3-96
SNOW MELTING SYSTEMS.....	3.3-38
SOLAR COOLING SYSTEMS.....	3.3-91, 3.3-108, 3.3-171
Active Air Systems.....	3.3-92
Active Liquid Systems.....	3.3-93
Passive Air Systems.....	3.3-92
Passive Liquid Systems.....	3.3-92
SOLAR HEATING SYSTEMS.....	3.3-37, 3.3-171
SOLID ADSORPTION DEHUMIDI- FICATION SYSTEMS.....	3.3-153
SPECIFIC REGENERATIVE SYSTEMS.....	3.3-153
STEAM HEATING SYSTEMS.....	3.3-28
STRUCTURAL DESIGN CRITERIA...	3.3-21
SYSTEM CONTROLS.....	3.3-56, 3.3-76, 3.3-146
Air Conditioning Systems....	3.3-78
Dehumidifying Systems.....	3.3-152
Heating Systems.....	3.3-28
Ventilating Systems.....	3.3-64
SYSTEM SELECTION CRITERIA...	3.3-39, 3.3-66, 3.3-94
Air Conditioning Systems....	3.3-94
Dehumidifying Systems.....	3.3-159
Heating Systems.....	3.3-39
Ventilating Systems.....	3.3-66

U

UNIT HEATERS.....	3.3-42, 3.3-60
-------------------	----------------

V

VACUUM RETURN PUMPING UNITS..	3.3-48, 3.3-62
VALVES.....	3.3-141, 3.3-150
VARIABLE AIR VOLUME...	3.3-84, 3.3-98
VENTILATING EQUIPMENT.....	3.3-75
Ductwork.....	3.3-75
Fans.....	3.3-75
VENTILATING SYSTEMS....	3.3-1, 3.3-64
Equipment Selection Cri- teria.....	3.3-75
Mechanical Ventilating Systems.....	3.3-65

VENTILATING SYSTEMS, Continued

Natural Ventilation Systems.....	3.3-64
System Controls.....	3.3-76
System Selection Criteria...	3.3-66

W

WARM HUMID CLIMATE DESIGN

CRITERIA.....	3.3-4
WATER-TO-AIR HEAT PUMP SYSTEM.....	3.3-36
WATER-TO-WATER HEAT PUMP SYSTEM.....	3.3-36