

AD-A106 997

AVCO EVERETT RESEARCH LAB INC EVERETT MA

F/G 22/4

MAUI OPTICAL TRACKING AND IDENTIFICATION FACILITY TRANSITION PR--ETC(U)

AUG 81 J CHAPMAN, T REED

F30602-77-C-0184

NL

UNCLASSIFIED

RADC-TR-81-243

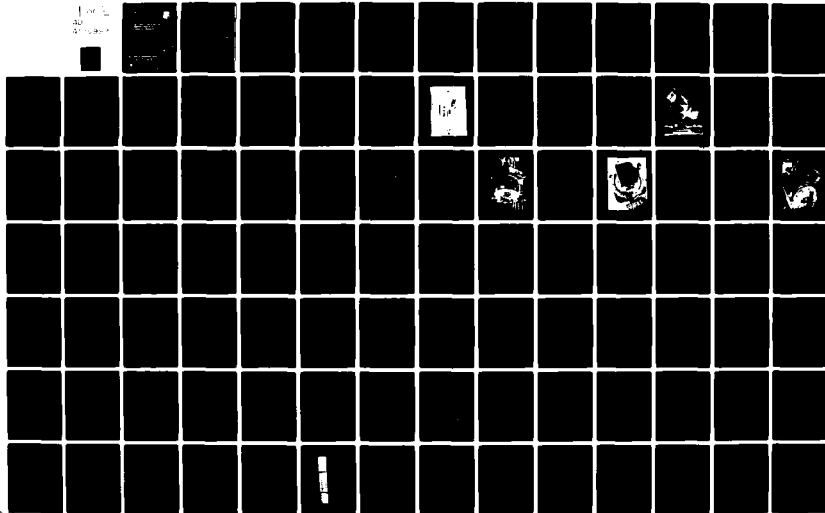

LEVEL II

(12)

24

WADC-TR-81-243
Final Technical Report
August 1981

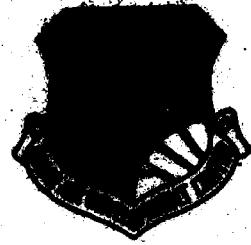

AD A106997

MAUI OPTICAL TRACKING AND IDENTIFICATION FACILITY TRANSITION PROGRAM

AVCO Everett Research Laboratory, Inc.

Dr. J. Chapman
Mr. T. Reed
AMOS Staff

APPROVED FOR PUBLIC RELEASE; DISTRIBUTION UNLIMITED

STIC
ELECT
NOV 4 1981
A

ENC FILE COPY

ROME AIR DEVELOPMENT CENTER
Air Force Systems Command
Griffiss Air Force Base, New York 13441

81 11 02 207

This report has been reviewed by the RADC Public Affairs Office, and is releasable to the National Technical Information Service (NTIS). It will be releasable to the general public, including foreign nations.

RADC-TR-61-243 has been reviewed and is approved for publication.

APPROVED:

James W. Cusack
JAMES W. CUSACK
Project Engineer

APPROVED:

Mylan A. Haugen
MYLAN A. HAUGEN, Col, USAF
Chief, Surveillance Division

FOR THE COMMANDER:

John P. Huss
JOHN P. HUSS
Acting Chief, Plans Office

If your address has changed or if you wish to be removed from the RADC mailing list, or if the addressee is no longer employed by your organization, please notify RADC (OCSR) Griffiss AFB, NY 13441. This will assist us in maintaining a current mailing list.

Do not return copies of this report unless contractual obligations or those on a specific document requires that it be returned.

UNCLASSIFIED

SECURITY CLASSIFICATION OF THIS PAGE (When Data Entered)

17 REPORT DOCUMENTATION PAGE		READ INSTRUCTIONS BEFORE COMPLETING FORM
18 6 10	1. REPORT NUMBER RADC-TR-81-243	2. GOVT ACCESSION NO. AD-A106997
	3. RECIPIENT'S CATALOG NUMBER	
	4. TITLE (and Subtitle) MAUI OPTICAL TRACKING AND IDENTIFICATION FACILITY TRANSITION PROGRAM	5. TYPE OF REPORT & PERIOD COVERED Final Technical Report 1 Aug 77 - 31 Jan 80
	6. AUTHOR(s) Dr. Jamie Chapman Mr. Thomas Reed AMOS Staff	7. PERFORMING ORG. REPORT NUMBER N/A
	8. PERFORMING ORGANIZATION NAME AND ADDRESS AVCO Everett Research Laboratory, Inc. 2385 Revere Beach Parkway Everett MA 02149	9. CONTRACT OR GRANT NUMBER(s) F30602-77-C-0184
	10. CONTROLLING OFFICE NAME AND ADDRESS Rome Air Development Center (OCSE) Griffiss AFB NY 13441	11. PROGRAM ELEMENT, PROJECT, TASK AREA & WORK UNIT NUMBERS 12424F 2290101
	11. MONITORING AGENCY NAME & ADDRESS (if different from Controlling Office) Same	12. REPORT DATE August 1981
		13. NUMBER OF PAGES 164
		14. SECURITY CLASS. (of this report) UNCLASSIFIED
		15. DECLASSIFICATION/DOWNGRADING SCHEDULE N/A
16. DISTRIBUTION STATEMENT (of this Report) Approved for public release; distribution unlimited.		
17. DISTRIBUTION STATEMENT (of the abstract entered in Block 20, if different from Report) Same		
18. SUPPLEMENTARY NOTES RADC Project Engineer: James W. Cusack (OCSE)		
19. KEY WORDS (Continue on reverse side if necessary and identify by block number) Laser Ranging IR Radiometry Satellite Observations Midcourse Measurements		
20. ABSTRACT (Continue on reverse side if necessary and identify by block number) This Final Report presents a summary of the Maui Optical Tracking and Identification Facility (MOTIF) Transition Program results. A description of the system hardware and software as well as the modifications and system upgrades that were accomplished during the program are presented.		

DD FORM 1473, JAN 73 EDITION OF 1 NOV 65 IS OBSOLETE

UNCLASSIFIED
SECURITY CLASSIFICATION OF THIS PAGE (When Data Entered)

042430

17

TABLE OF CONTENTS

<u>Section</u>	<u>Page</u>
2.3 <u>MOTIF Common Systems</u>	59
2.3.1 <u>Recording System</u>	59
2.3.2 <u>Video System</u>	60
2.3.3 <u>Common Support Equipment</u>	64
2.3.4 <u>Computer System</u>	66
2.3.5 <u>Timing System</u>	68
2.3.6 <u>Common Communications System</u>	71
2.3.7 <u>Facilities</u>	75
2.3.8 <u>Software (Common)</u>	78
2.4 <u>MOTIF Operation</u>	87
3.0 <u>MOTIF TRANSITION PROGRAM TASKS</u>	92
3.1 <u>Hardware Systems Development (WBS-200)</u>	94
3.1.1 <u>Communications System (WBS-210)</u>	94
3.1.2 <u>Data Transmission System (WBS-220)</u>	96
3.1.3 <u>Data Storage (WBS-230)</u>	97
3.2 <u>Software Systems Development</u>	99
3.2.1 <u>Mission Planning Subtask</u> <u>(WBS -031 and -310)</u>	99
3.2.2 <u>Object Verification Subtask (WBS-310)</u>	102
3.2.3 <u>Search and Surveillance Subtask (WBS-310)</u>	104
3.2.4 <u>Multiple Objects Subtask (WBS-310)</u>	109
3.2.5 <u>History Modification Subtask (WBS-310)</u>	110
3.2.6 <u>Direct Access of Satellite Catalog Subtask</u> <u>WBS-310)</u>	110

TABLE OF CONTENTS

<u>Section</u>	<u>Page</u>
3.2.7 <u>On-Line Diagnostics Subtask (WBS-310)</u>	111
3.2.8 <u>Satellite Library Subtask (WBS-310)</u>	113
3.2.9 <u>Paged Display Subtask (WBS-310)</u>	116
3.2.10 <u>Deep Space Ephemeris (HUJSAK or DP4) Program Subtask (WBS-031 and -310)</u>	119
3.2.11 <u>Reports and Messages (WBS-320)</u>	120
3.3 <u>System Test and Evaluation</u>	120
3.3.1 <u>Data Quality Control (WBS-410)</u>	121
3.3.2 <u>Validation and Verification (WBS-420)</u>	122
3.3.3 <u>Test Program (WBS-430)</u>	123
3.3.4 <u>EMI Testing (WBS-440)</u>	123
3.4 <u>Training (WBS-500)</u>	124
3.5 <u>Maintenance and Engineering</u>	125
3.5.1 <u>Routine Maintenance (WBS-610)</u>	125
3.5.2 <u>1.2 Meter Telescope Refurbishment (WBS-620)</u>	126
3.5.3 <u>Depot Maintenance (WBS-630)</u>	126
3.6 <u>DATA</u>	126
3.6.1 <u>Hardware Documentation (WBS-710)</u>	126
3.6.2 <u>Software Documentation (WBS-730)</u>	134
3.6.3 <u>Integrated Logistics Support (ILS) Program (WBS-740)</u>	136
3.7 <u>Operations (WBS 810, -820 and -830)</u>	136

LIST OF FIGURES

<u>Figure</u>	<u>Page</u>
2-1. AMOS/MOTIF aerial view.	11
2-2. Facility floor plan	12
2-3. MOTIF system block diagram.	13
2-4. Dual 1.2 Meter mount.	14
2-5. MOTIF equipment tree.	15
2-6. B29/B37 telescopes optical schematic.	20
2-7. Acquisition Telescope	22
2-8. AMTA/CMP package.	24
2-9. AMTA/CMP sensor package optical diagram	25
2-10. LLLTV package	26
2-11. LLLTV package optical diagram	28
2-12. Acquisition Telescope TV.	29
2-13. AMTA sensor head section view	30
2-14. Sky radiance/AMTA spectral bands.	31
2-15. AMTA FOV.	33
2-16. AMTA signal processing and recording block diagram	34
2-17. Contrast Mode Photometer performance estimate	37
2-18. Contrast Mode Photometer optical diagram.	38
2-19. Contrast Mode Photometer functional block diagram	42
2-20. MODCOMP IV computer configuration	47

LIST OF FIGURES

<u>Figure</u>	<u>Page</u>
2-21. MODCOMP II computer configuration	50
2-22. MODCOMP CLASSIC spare computer configuration. . . .	52
2-23. Data Transmission System (DTS) software block diagram	54
2-24. Communications System (CMS) software block diagram	57
2-25. Video System block diagram.	61
2-26. Sidereal display format	63
2-27. Mount control system.	67
2-28. Computer System block diagram	69
2-29. Timing System block diagram	70
2-30. Master intercom station	73
3-1. Work breakdown structure.	93
3-2. Mission planning program.	100
3-3. Example of mission plan	103
3-4. Search and surveillance capabilities.	107
3-5. Real-time satellite preparation (RATSAP).	112
3-6. Satellite library overview.	114
3-7. Ballistic display format.	118
3-8. Summary of operations - September 1977 - September 1979	141
3-9. MOTIF operations - September 1977 - September 1979	142

LIST OF TABLES

<u>Table</u>		<u>Page</u>
2-1	Principle Contrast Mode Photometer features and performance characteristics.	36
2-2	Television camera systems characteristics.	44
2-3	CDC vendor software.	86
3-1	MOTIF technical manuals.	128

1.0 INTRODUCTION

This final report presents a summary of AVCO Everett Research Laboratory, Inc. (AERL) efforts under the Maui Optical Tracking and Identification Facility (MOTIF) Transition Program, contract F30602-77-C-0184. It contains system performance data which demonstrates that program goals have been achieved.

This report is organized into three major sections. The first section, Introduction, includes subsections covering historical background, mission, program objectives and summary information. It tells why MOTIF was implemented and summarizes the Transition Program. The second section, System Description, describes the MOTIF hardware and software. System performance capabilities are presented. This section is intended to be a stand-alone MOTIF description. The third section, MOTIF Transition Program Tasks, presents details pertaining to each task included in the contract Statement of Work (SOW). It tells what was done to satisfy contract requirements.

Much detailed documentation concerning MOTIF has been developed. It includes hardware and systems manuals, software descriptions, test reports, plans and procedures, and operator position descriptions. This final report gives a synopsis of available information and guides the reader interested in more detail to the appropriate references.

1.1 Background/History

The DARPA Maui Observation Station (AMOS) was conceived by DARPA in the early sixties and was intended to be a ballistic missile mid-course optical measurement site. The design and construction (Phase I) contractor was the University of Michigan who functioned under the direct technical review of DARPA.

In mid-1969 the site achieved operational capability. At that time DARPA asked the Air Force Space and Missile Systems Organization (SAMSO) Deputy for Reentry Systems to assume responsibility for AMOS as executive agent for DARPA. Phase II contracts were let to the Lockheed Missile and Space Company (LMSC) for site operation and maintenance and to the AVCO Everett Research Laboratory, Inc. (AERL) for scientific direction. This phase was designated as research and development operations.

Beginning in January 1975, AERL became the sole contractor for AMOS, under Phase III of the program, with responsibility for efforts oriented more toward routine operations with an R&D overlay.

In late 1974 the Air Force Systems Command and the Aerospace Defense Command (ADCOM) had evaluated AMOS capabilities and determined that a portion of the site, the 1.2 m Telescope system, would be a valuable adjunct to the SPACETRACK network. Thus, plans were made by DARPA to develop this system into a routine operational capability for transition to the Air Force.

The Air Force Systems Command's, Rome Air Development Center (RADC) had experience with transitioning system capabilities to operational Air Force use. Therefore, in early 1976, AMOS program responsibilities were transferred from SAMSO to RADC.

In June of 1976 an Air Force sponsored definition phase effort, which lasted 13 months, was amended to the AMOS Phase III program.

In August of 1977 definition was completed and the MOTIF Transition Program was initiated. On 28 August 1979, ADCOM accepted the MOTIF from RADC to commence full-time operations under a separate Air Force contract.

1.2 Mission

MOTIF is operated as a primary sensor in support of the USAF SPACETRACK system. Its primary function is to provide positional and Space Object Identification (SOI) data requested by the NORAD Space Computational Center (SCC). The satellites of primary interest are deep space objects that are difficult for other NORAD Space Detection and Tracking System (SPADATS) sensors to observe due to their extreme range, and objects requiring special data to provide a better understanding of their mission. Deep space objects are defined as those in earth orbit with perigees greater than 5,555 kilometers and/or with eccentricities greater than 0.5.

The operational functions (in terms of general priority) of MOTIF are as follows:

- 1) Obtain metric and signature data on objects specified by the SCC;
- 2) When not otherwise tracking specific, tasked satellites, provide surveillance of deep space and geosynchronous orbits to detect unknown objects.

1.3 Program Objectives

The prime objective of the MOTIF Transition Program was to prepare the 1.2 m Telescope system and support equipment for turnover to ADCOM as an operational SPACETRACK sensor. Meeting this objective required developing new hardware, upgrading existing system capabilities, providing computer software additions or modifications, preparing technical documentation and implementing a test and evaluation program. A second objective of the MOTIF Transition Program was to conduct routine operations and maintenance during the transition period.

New hardware and existing equipment upgrades, along with new or modified software, were tasks aimed at improving the ability to acquire, track and collect data on large numbers of space objects; to process data rapidly and efficiently; and to transmit data to ADCOM in a timely manner. Existing equipment was severely limited in these areas. Mission Planning was a

manual process and preparation for tracking required lengthy pre-mission computer batch processing of element set data. These factors, along with lack of automatic search, limited the number of objects that could be tracked. The existing communications system was a 75 baud teletype (TTY) which utilized punched paper tape. It could not accommodate the larger volume of data to be transmitted to ADCOM. In addition to these shortcomings, no data processing capability, other than manual, existed.

Upgrades to both hardware and software documentation along with expanding the spare parts inventory, were necessary to permit MOTIF to achieve an operational availability goal of 95%. Existing documentation was adequate for operation as an R&D facility, but was not sufficient for routine operation and maintenance as an ADCOM SPACETRACK sensor.

1.4 Summary

The Communications System (CMS) and the Data Transmission System (DTS) tasks represented the major hardware procurements of the MOTIF Transition Program. The CMS has a MODCOMP (MC) II computer system with peripherals and an Analytics TLC-100 Telecommunications Line Controller. A MC IV computer system with peripherals and a Tektronix 4014-1 Graphics Display Terminal comprise the DTS. A MC V system with peripherals constitutes a spare system for both CMS and DTS. The CMS and DTS hardware systems provide the automatic data processing →

capability and improved communications response time required. They also provide added computer capability for other software enhancements.

Several new software capabilities were added during the MOTIF Transition Program to enhance the ability to track large numbers of satellites per night. The Real-Time Satellite Preparation (RATSAP) program was developed to replace the time consuming batch process previously used. This program provides the capability to track any object on the satellite library without the necessity of stopping the real-time operating system to run a batch process to generate tracking initial conditions. RATSAP makes use of the more sophisticated deep space, or DP4, tracking algorithm for all satellites of ephemeris type 3, 4, and 5. The Simplified General Perturbations, or SGP, is used for ephemeris types 0 and 1 while SGP4 is used for ephemeris type 2.

A new satellite library has also been developed. It provides subset structuring and operates in real-time with a link to the CMS computer. It makes use of 2-card element sets and includes tasks on all three MOTIF computers: MC II, MC IV and CDC 3500. Library capacity is dependent upon element type (deep space satellite elements require more data storage than near earth satellite elements) but is at least 5000 element sets.

Nightly mission plans are generated by new software which runs on the MC IV. This software produces a time ordered sequence of tracking operations (mission plan) for each night based upon ADCOM tasking. A file of satellites which will be above the MOTIF horizon for a particular night is generated. Tracking instructions, including priorities, contained in the ADCOM tasking messages are applied to the file, along with constraints imposed by earth shadow conditions, to generate the plan.

Software to aid the operator with acquisition and tracking operations has been developed. Automatic search and surveillance software provides both time and area search capability. Stare period duration and area size are operator controlled. An object verification algorithm assures the operator that the proper object has been acquired, and a multiple object capability was added to allow data acquisition on more than one object simultaneously in the field-of-view. The operator graphics display has also been improved for more efficient operation.

Two ancillary software programs were incorporated into the MOTIF system. A history modification program generates a printed report of data recorded on DTS history tape, and an on-line diagnostics task corrected a deficiency in the CDC system concerning its ability to isolate faults.

The hardware documentation task produced 46 equipment manuals in 25 volumes and seven operator position handbooks. Manuals covering facilities, dome, mount, telescope, computer, sensors, communications, timing, recording, and support equipment subsystems have been prepared and included in the MOTIF documentation library. Position handbooks for main console, dome console, video, radiometer, CMS, DTS and mission director were prepared. These are used for operator training.

Software documentation was also produced. CPCI Part I and Part II specifications were prepared for the Extended Real-Time Operating System (EROS), which operates on the CDC 3500/SC 1700 the DTS, which operates on the MCIV; the CMS, which operates on the MC II; and the Mission Support Software (MSS), which operates on all three computers.

Other miscellaneous tasks included in the MOTIF Transition Program were completed as planned. A data Quality Control Plan was prepared and submitted. The standard lamp source task has also been completed. A task to develop necessary reports and messages is complete and a Data Storage library has been implemented. A recommended Spare Parts List, Integrated Support Plan and a MOTIF Operational Hazard Analysis were prepared. Spare parts were procured as specified in the Recommended Spare Parts List to aid the MOTIF in attaining an operational availability goal of 95%.

1 3 6)
→ MOTIF was operated five nights per week, single shift to collect metric, photometric, and LWIR data, as tasked by ADCOM during the Transition Program. Special computer software was developed to process metric and photometric data in support of those operations. On the average and weather permitting, 15 to 30 objects were tracked for metric data with one tasked photometric track per night. ✓

Maintenance to support operations was provided on a daily basis during the Transition Program.

2.0 SYSTEM DESCRIPTION

2.1 General Description

MOTIF is located at an altitude of 3,049 meters (10,000 feet) on the island of Maui, Hawaii. It is collocated with the DARPA Maui Observation Station (AMOS). Much of the equipment and systems are shared by the two. Figure 2-1 shows the MOTIF/AMOS facility.

The Observatory incorporates four telescope systems: the MOTIF 1.2 m Telescope System, the DARPA 1.6 m Telescope System, the Laser Beam Director (LBD) and the Atmospheric Stellar Scintillometer. Control rooms, computer facilities, shops and other support facilities are also included. Figure 2-2 presents a floor plan that shows how the facility is utilized.

Figure 2-3 is a block diagram of the MOTIF system. This figure shows the flow of information among the MOTIF operating systems; those dedicated to MOTIF and those shared with DARPA. The heart of MOTIF is the twin 1.2 m Telescope system shown in Figure 2-4. Figure 2-5 shows the MOTIF System Equipment Tree. This defines the components of the 1.2 m Telescope System and those of the Common System shared with DARPA. These systems will be described in more detail in Sections 2.2 and 2.3, respectively. Section 2.4 will give a synopsis of how MOTIF operates.

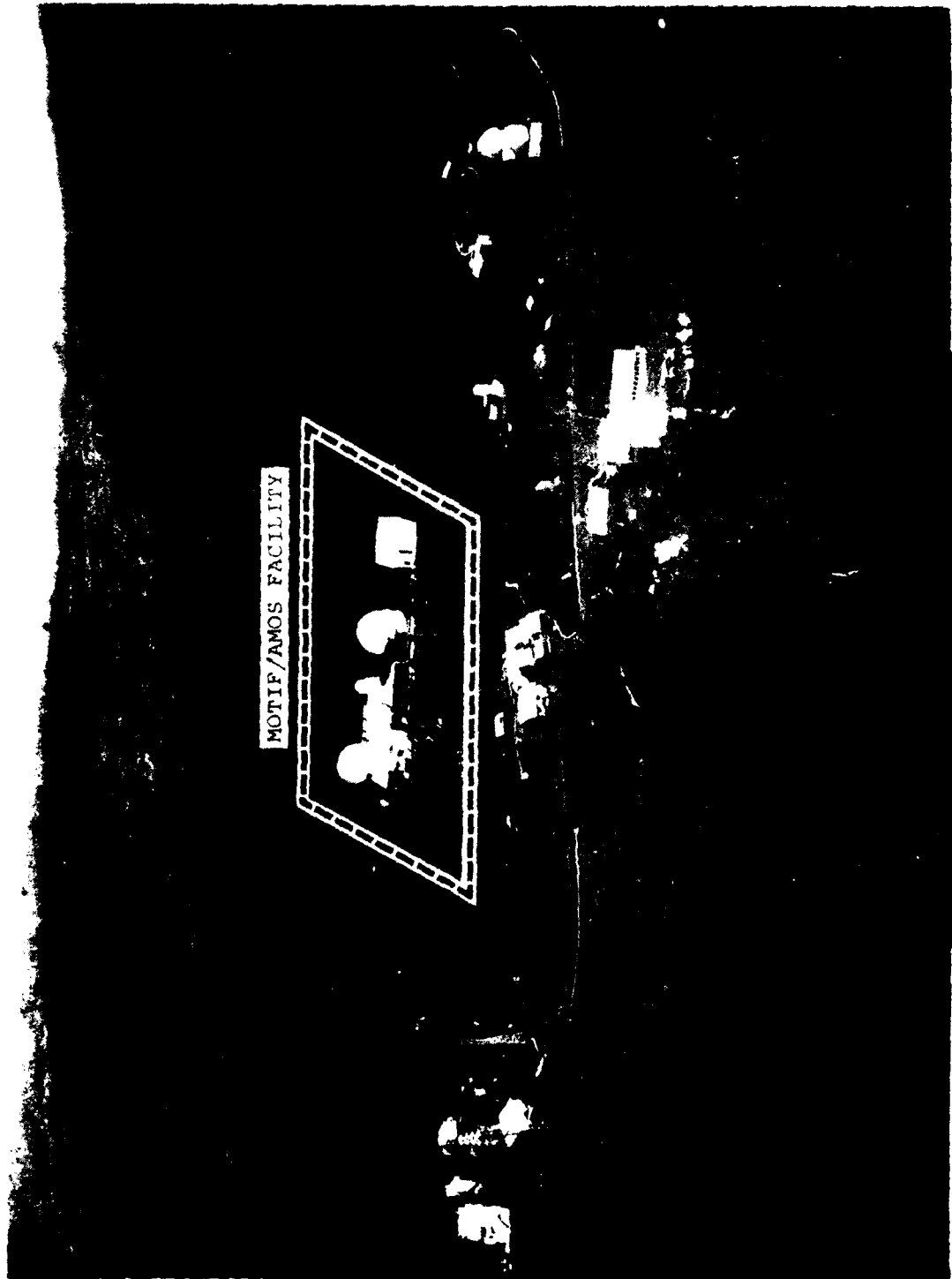

MOTIF/AMOS FACILITY

Figure 2-1. AMOS/MOTIF aerial view.

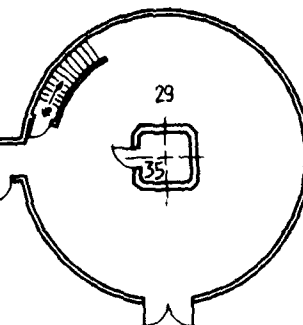
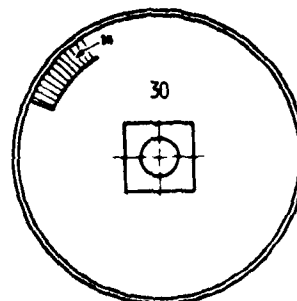
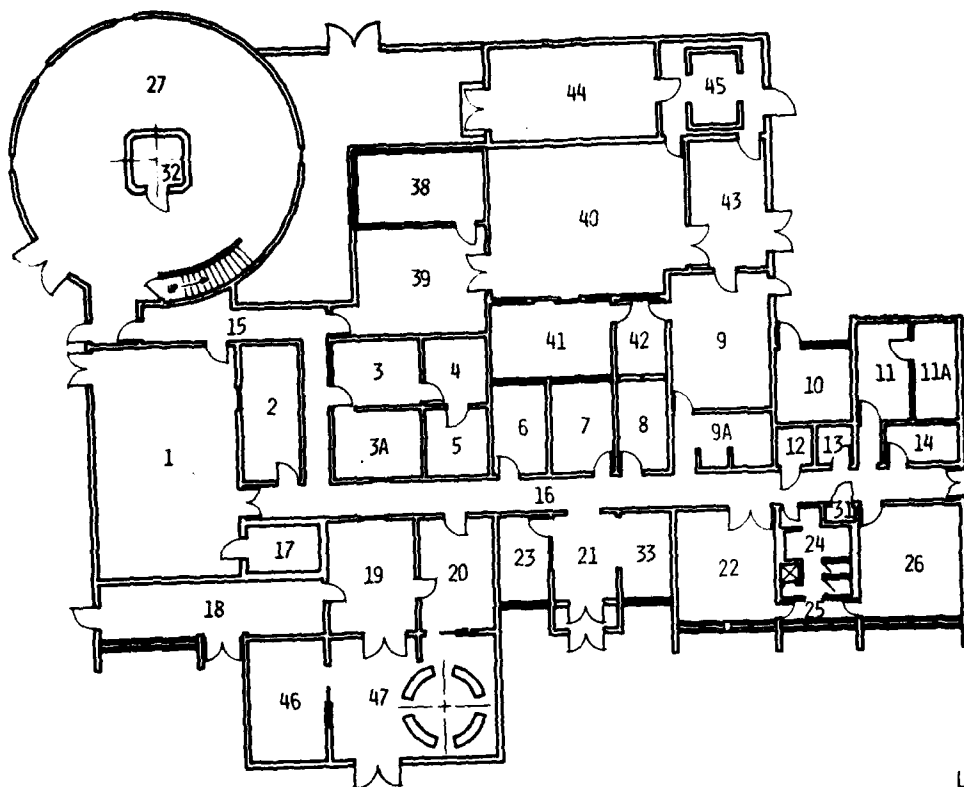
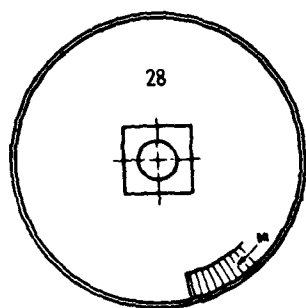

LEGEND

- 1 MAIN CONTROL ROOM
- 2 ATMOSPHERICS EQUIPMENT ROOM
- 3 TECH LIBRARY
- 3A CLEAN ROOM
- 4 OFFICE
- 5 AMTA LAB
- 6 OFFICE
- 7 OFFICE
- 8 OFFICE
- 9 CONFERENCE/DINING ROOM
- 9A KITCHEN
- 10 WATER PUMP ROOM
- 11 PHOTO WORK ROOM
- 11A VIDEO TEST EQUIPMENT ROOM
- 12 JANITOR'S ROOM
- 13 WOMEN'S TOILET

- 14 PHOTO LAB
- 15 HALL
- 16 HALL
- 17 VAULT
- 18 MECHANICAL-ELECTRICAL EQUIPMENT ROOM
- 19 LASER SUPPORT ROOM
- 20 LASER LAB
- 21 LOBBY
- 22 OPTICS LAB
- 23 OFFICE
- 24 MEN'S TOILET
- 25 PASSAGE
- 26 COMPENSATED IMAGING EQUIPMENT ROOM
- 27 LOWER LEVEL, 1.2m TELESCOPE DOME
- 28 UPPER LEVEL, 1.2m TELESCOPE DOME
- 29 LOWER LEVEL, 1.6m TELESCOPE DOME

- 30 UPPER LEVEL, 1.6m TELESCOPE DOME
- 31 STORAGE
- 32 SERVICE CELL
- 33 OFFICE
- 34 (NOT USED)
- 35 SERVICE CELL
- 36 UNDERGROUND WATER RESERVOIR
- 37 PUMP VAULT
- 38 CLASS "A" VAULT
- 39 COMMUNICATION CENTER
- 40 COMPUTER ROOM
- 41 DATA TRANS. SYSTEM ROOM
- 42 KEY PUNCH ROOM
- 43 OFFICE/STORAGE
- 44 COMPUTER-A.C. & POWER ROOM
- 45 STAR SENSOR DOME

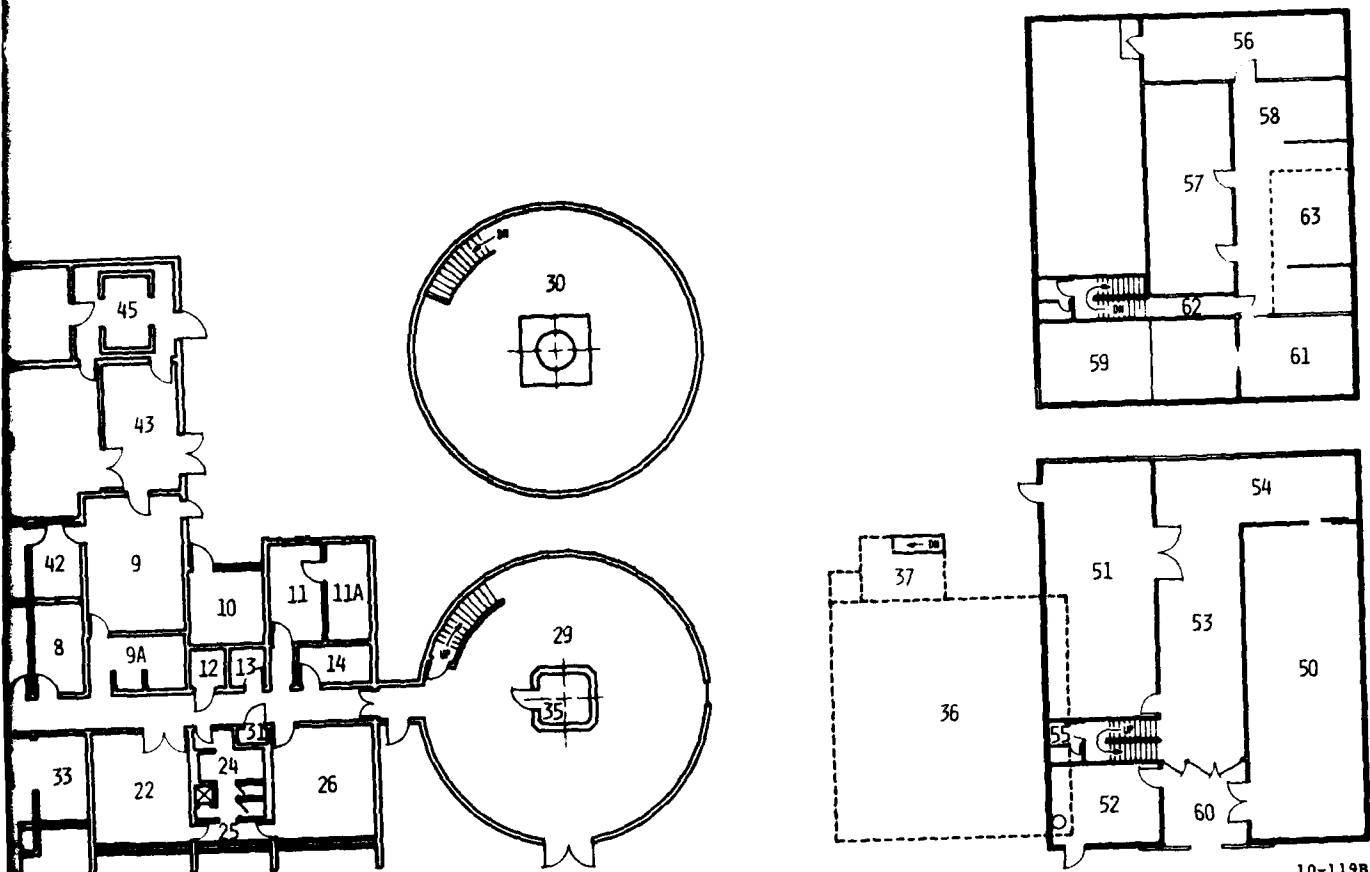

LEGEND

ELECTRICAL EQUIPMENT ROOM
PORT ROOM

IMAGING EQUIPMENT ROOM
TEL. 1.2m TELESCOPE DOME
TEL. 1.2m TELESCOPE DOME
TEL. 1.6m TELESCOPE DOME

- | | | | |
|----|----------------------------------|----|----------------------------------|
| 30 | UPPER LEVEL, 1.6m TELESCOPE DOME | 46 | LASER BEAM DIRECTOR CONTROL ROOM |
| 31 | STORAGE | 47 | LASER BEAM DIRECTOR |
| 32 | SERVICE CELL | 48 | (NOT USED) |
| 33 | OFFICE | 49 | (NOT USED) |
| 34 | (NOT USED) | 50 | MACHINE SHOP |
| 35 | SERVICE CELL | 51 | MIRROR PLATING ROOM |
| 36 | UNDERGROUND WATER RESERVOIR | 52 | CARPENTER SHOP |
| 37 | PUMP VAULT | 53 | MECHANICAL SHOP |
| 38 | CLASS "A" VAULT | 54 | WELDING BAY |
| 39 | COMMUNICATION CENTER | 55 | TOILET |
| 40 | COMPUTER ROOM | 56 | CALIBRATION LAB |
| 41 | DATA TRANS. SYSTEM ROOM | 57 | ENGINEERING SUPPORT OFFICE |
| 42 | KEY PUNCH ROOM | 58 | ELECTRONIC LAB |
| 43 | OFFICE/STORAGE | 59 | STORAGE AREA |
| 44 | COMPUTER-A.C. & POWER ROOM | 60 | OPEN WELL |
| 45 | STAR SENSOR DOME | 61 | SPARE PARTS STORAGE |
| | | 62 | HALL |
| | | 63 | SUPPLY CAGE |

10-119B

Figure 2-2. Facility floor plan.

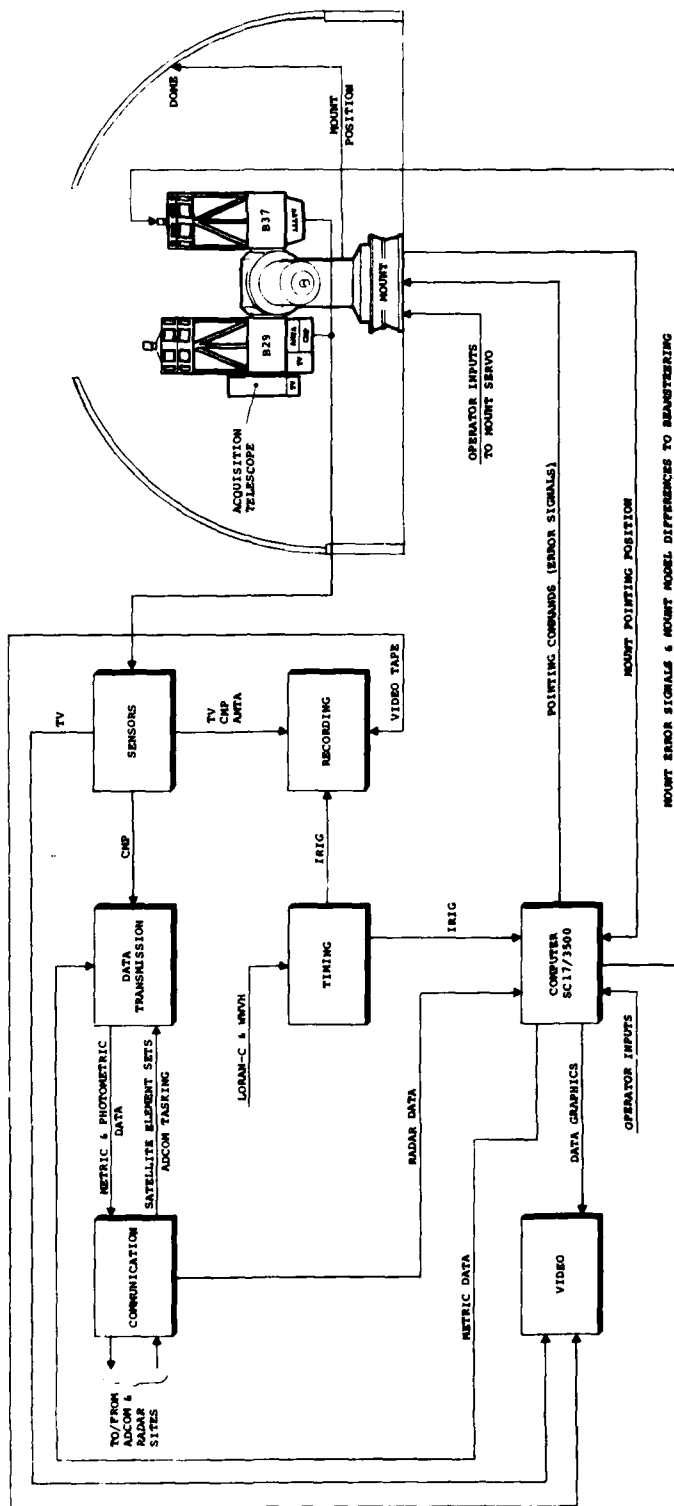

10-177

Figure 2-3. MORIF system block diagram.

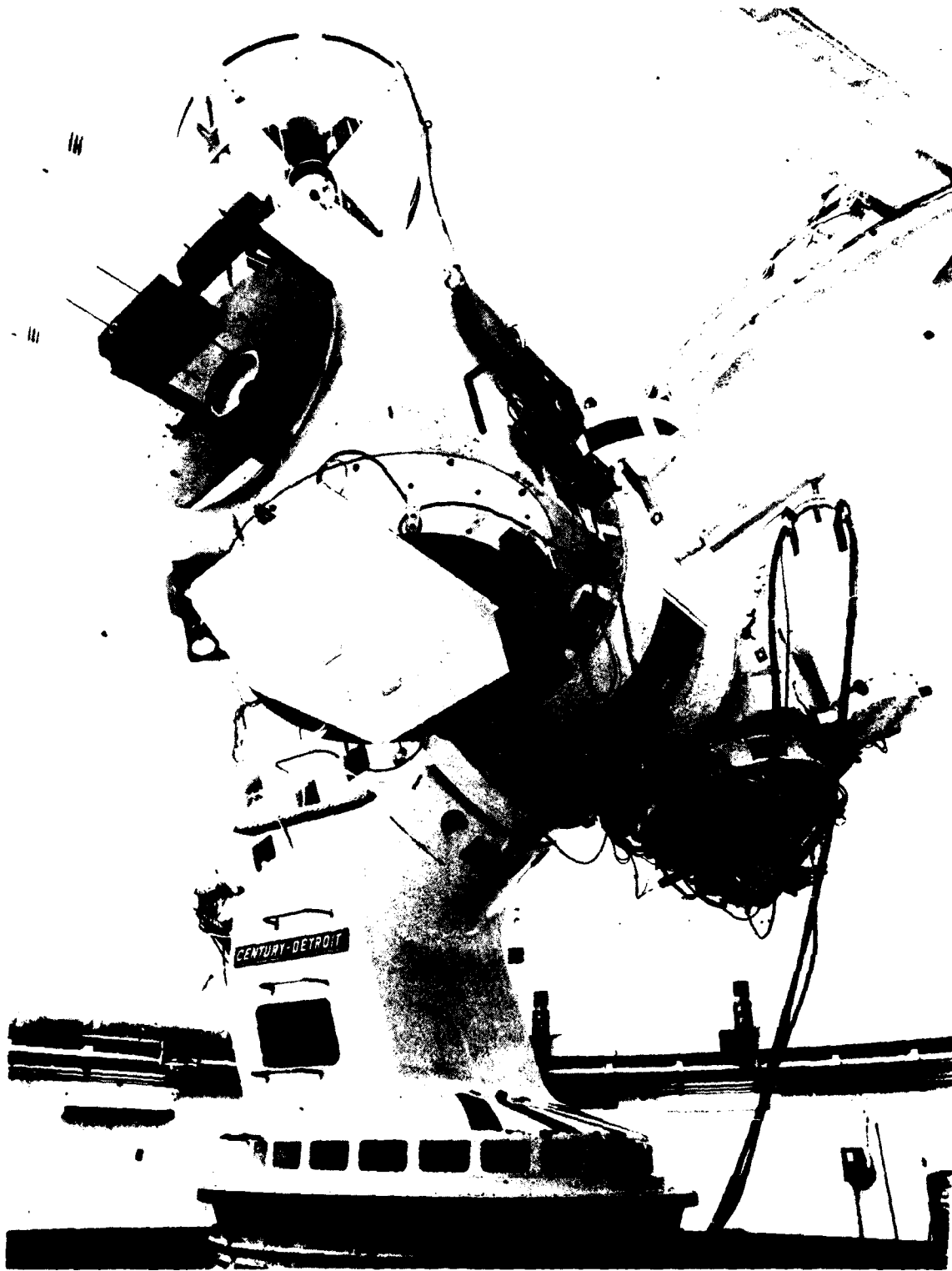

Figure 2-4. Dual 1.2 Meter mount.

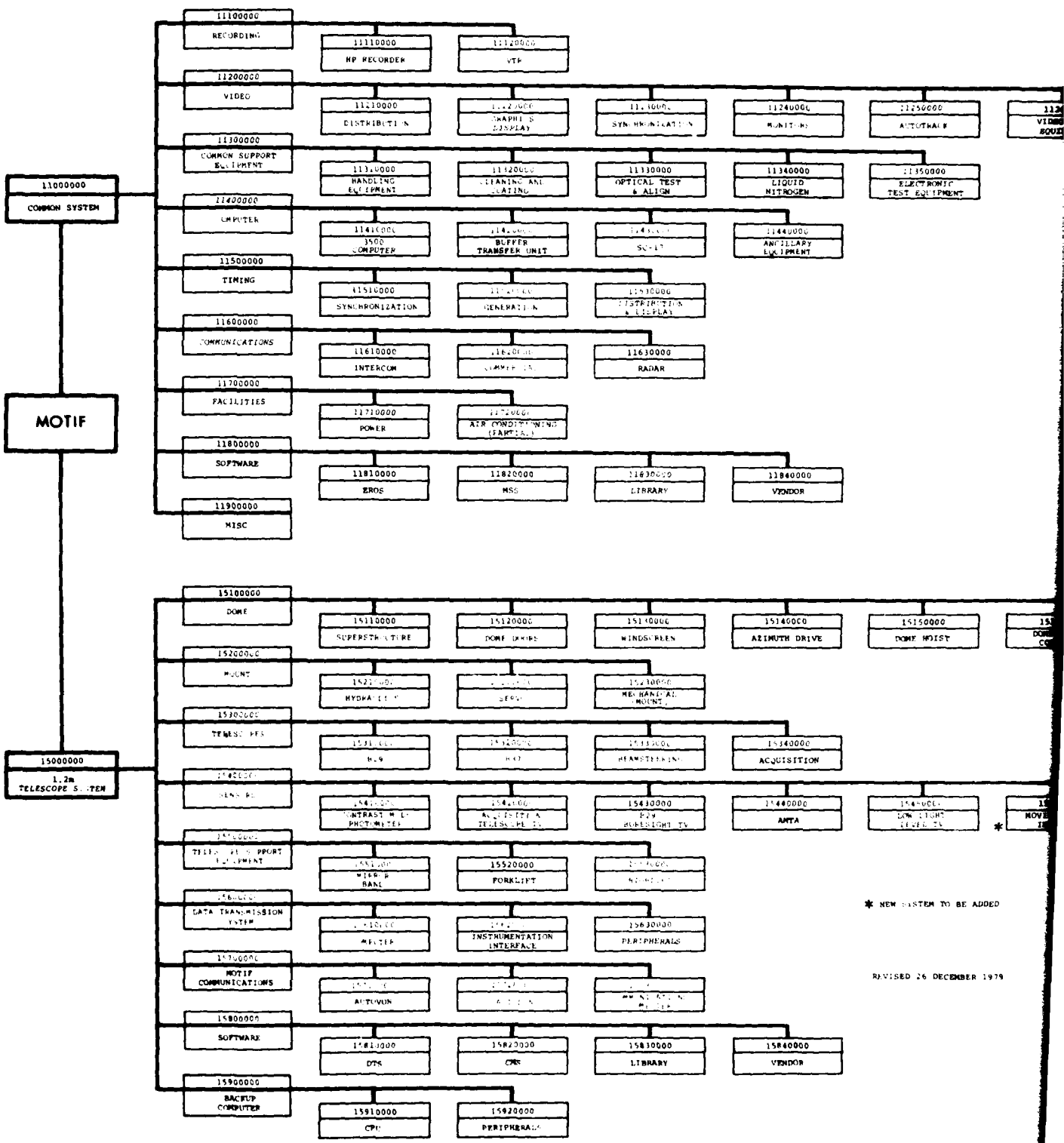
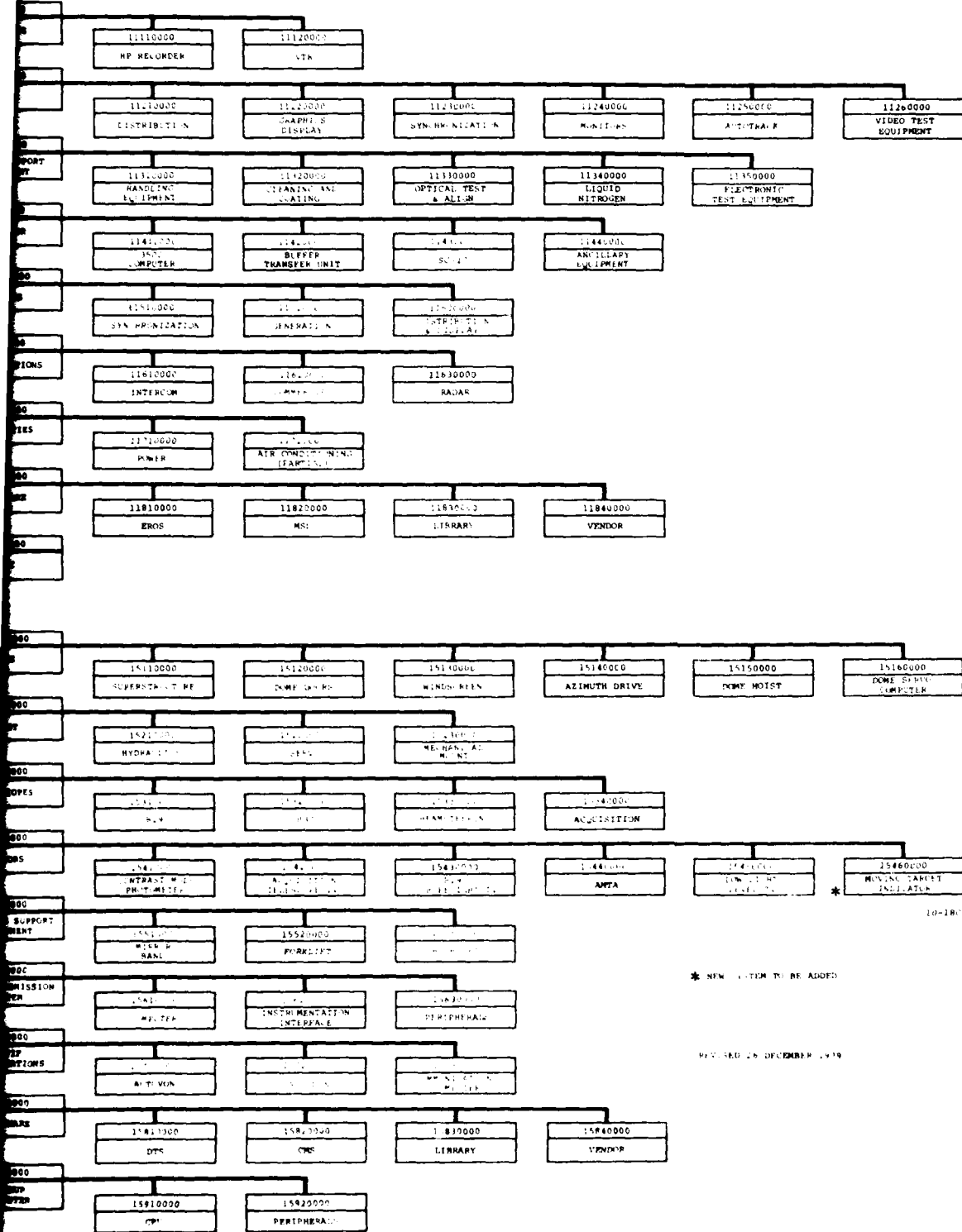

Figure 2-5



* NEW ITEM TO BE ADDED

REVISED IN DECEMBER 1979

Figure 2-5. MOTIF equipment tree.

2

2.2 1.2 Meter Telescope System

This section provides a physical and functional description of the eight MOTIF dedicated systems that make up the 1.2 m Telescope System:

- 1) Dome;
- 2) Mount;
- 3) Telescopes;
- 4) Sensors;
- 5) Telescope Support Equipment;
- 6) Data Transmission System;
- 7) MOTIF Communications;
- 8) Back-up Computer System.

A description of computer software dedicated to MOTIF is also given.

2.2.1 Dome System

The Dome System consists of five subsystems: Superstructure, Dome Doors, Dome Azimuth and Windscreen, Dome Hoist, and Dome Servo Computer. Details pertaining to the Dome System can be found in MOTIF manual LF-0079--.

The dome is a hemisphere of structural steel (Fig. 2-1) weighing nearly 40 tons. It has two 60-degree door segments which are opened during operations to provide a viewing port 20-feet wide by 120 degrees in arc. A moveable vinyl windscreen protects the telescope from wind buffeting when the doors are open. Viewing port azimuth position and windscreen elevation

position are both electronically controlled either manually or by an analog servo mechanism to maintain an unobstructed view from the telescope. The respective drive mechanisms are capable of rotating the dome at a rate of 20°/second and the windscreen at a rate of 10°/second.

A two-ton capacity hoist is affixed to an I-beam in the dome. The hoist can be positioned to any point within the dome area and can reach to the lower level of the dome. An 8-foot by 6-foot access hole cut into the dome floor allows equipment and materials to be raised to the operating level by the hoist.

2.2.2 Mount System

The Mount System consists of three subsystems: Hydraulics, Servo and Mechanical. Details are contained in the Mount System manual (LF-0072-).

The Mount structure (Fig. 2-4) is a three-axis device weighing nearly 90 tons. The axes are azimuth, polar, and declination configured to provide an equatorial mount on an azimuth turntable. All three axes have hydrostatic bearings which allow the axis to rotate on films of hydraulic oil 0.005" to 0.010" thick. The oil is temperature controlled and is provided to each bearing at a nominal pressure of 400 psi. This type of bearing and the use of direct drive dc torque motors combine to provide an extremely smooth, nearly friction-free motion. Tracking rates of 0.1 earth rate with no noticeable cogging are easily achievable.

Instrumentation affixed to each axis consists of a tachometer for velocity feedback, a synchro for coarse position feedback and a 23-bit shaft angle encoder (Inductosyn) for fine position feedback. These devices provide information to a hybrid servo system comprised of the CDC 3500 computer system (Section 2.3.4) and an analog servo computer. Command position or velocity signals, depending upon operating mode, are delivered via the analog servo computer to motor-generator (M-G) units. The M-G units provide the power amplification necessary to drive the dc torque motors.

The azimuth axis is equipped with a 3000 ft-lb motor, the polar axis is equipped with a 900 ft-lb motor and the declination axis is equipped with two 300 ft-lb motors, one on either side of the coupling between the two telescopes. These motors are capable of accelerating their respective axes at $2^\circ/\text{sec}^2$ to a maximum rate of $10^\circ/\text{sec}$. During operations, the azimuth axis is preset to a desired position and fixed. Tracking is accomplished with the polar and declination axes.

The combination of instrumentation available, computer software used, and procedures followed, results in excellent pointing and tracking capabilities. Absolute pointing accuracy, defined as the ability to point to a given angle in space (such as a known star position), is one to three seconds of arc.

Tracking accuracy, defined as the ability to maintain a target on the system boresight, is on the order of one second of arc, even while tracking near earth satellites.

2.2.3 Telescope System

The MOTIF Telescope System consists of three telescopes on a single mount. Two 1.2 meter aperture telescopes are mounted on the declination axis and are designated as the B29 and B37 telescopes. The designations B29 and B37 refer to the back working distance of each telescope, i.e., the distance in inches from the vertex of the primary mirror to the telescope focal point. The third telescope has an aperture of 22 inches and is used for target acquisition. More detailed information of these instruments are contained in the Telescope System manual (LF-0075-).

The B29 Telescope is an f/20 classical Cassegrain design with a focal length of 967 inches. Its optical schematic is shown in Figure 2-6. Invar rods minimize changes in the intermirror spacing between the primary and secondary mirrors due to temperature changes. The primary mirror, a solid f/3 paraboloid made of fused silica, is supported radially in its cell by a mercury belt and axially by an air bag. This support system maintains mirror position and figure at all altitudes and slewing rates. The secondary mirror, a hyperboloid made of cervit, is supported on a hub which has an electronic drive

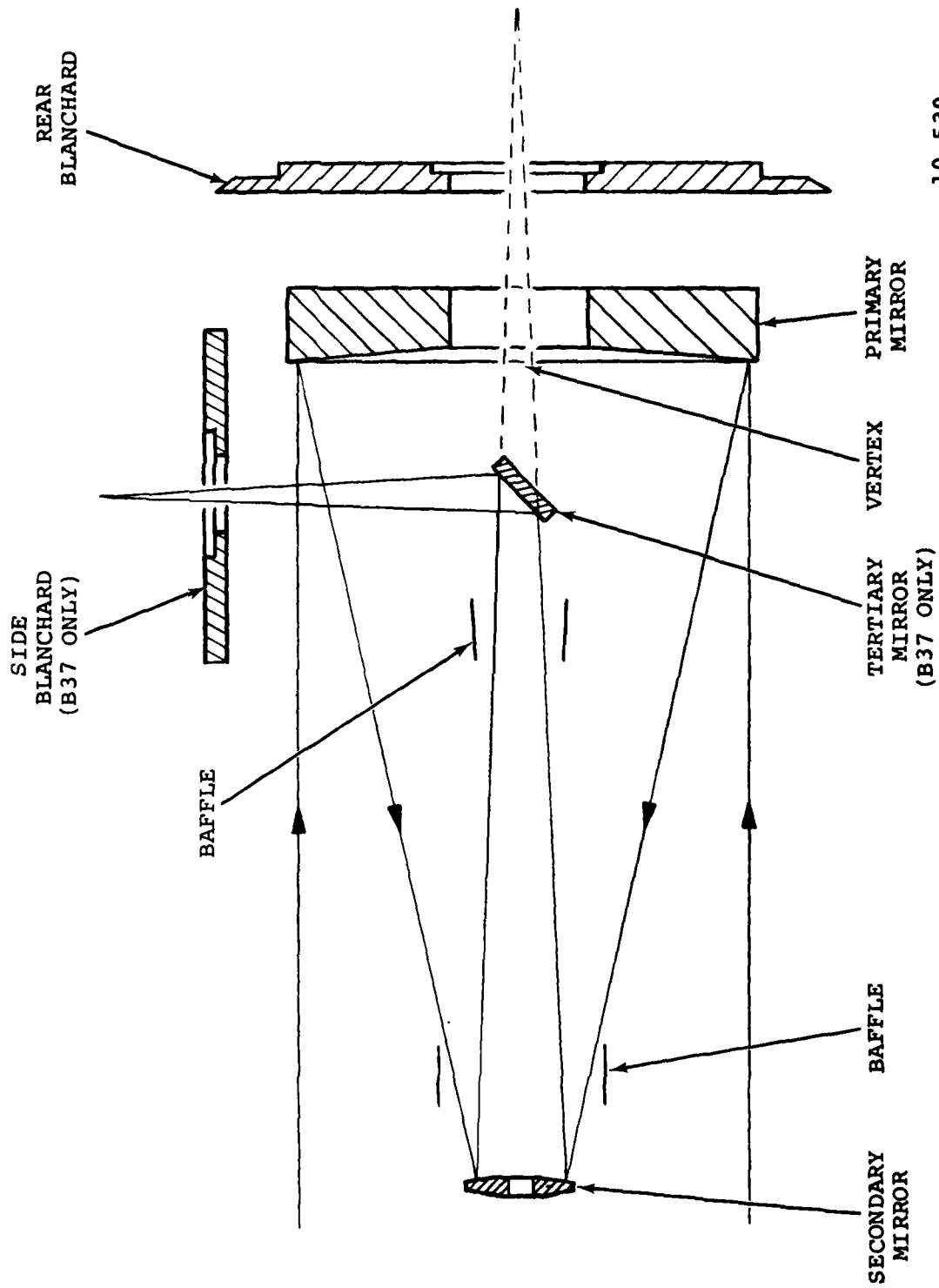

10-539

Figure 2-6. B29/B37 telescopes optical schematic.

system coupled to it. The drive is designed to oscillate the secondary mirror back and forth through an angle which is controlled by the operator and can be as large as ± 4 arcminutes. The back and forth motion, referred to as toggling or nodding, is done at a rate of 50 Hz to provide the required AC input to the radiometers attached to the telescope. The secondary mirror also has a remote electrical focussing drive.

The B37 Telescope is a Cassegrainian f/16 with a focal length of 768 inches. It has an option whereby the converging beam from the secondary mirror can be intercepted by a tertiary mirror and directed to a side Blanchard surface. The primary mirror is an f/3 paraboloid made of solid fused silica. It is supported in the same fashion as the B29 primary. The secondary mirror is also a hyperboloid made of cervit. It is equipped with a drive mechanism which changes the secondary mirror orientation under computer control to remove any non-parallelism between the optical axis of the two telescopes and to correct for mount motion caused by wind buffeting. The secondary mirror has a remote electrical focussing drive.

The 22-inch aperture Acquisition Telescope (Fig. 2-7) provides two focal lengths resulting in fields-of-view of 0.5 and 0.1 degrees. (NOTE: Figure 2-7 shows an 8-inch aperture telescope in front of the I-SIT camera. This telescope, which provides a 3-degree FOV, is not installed in the MOTIF acquisition telescope. A larger field capability will be added in the future.)

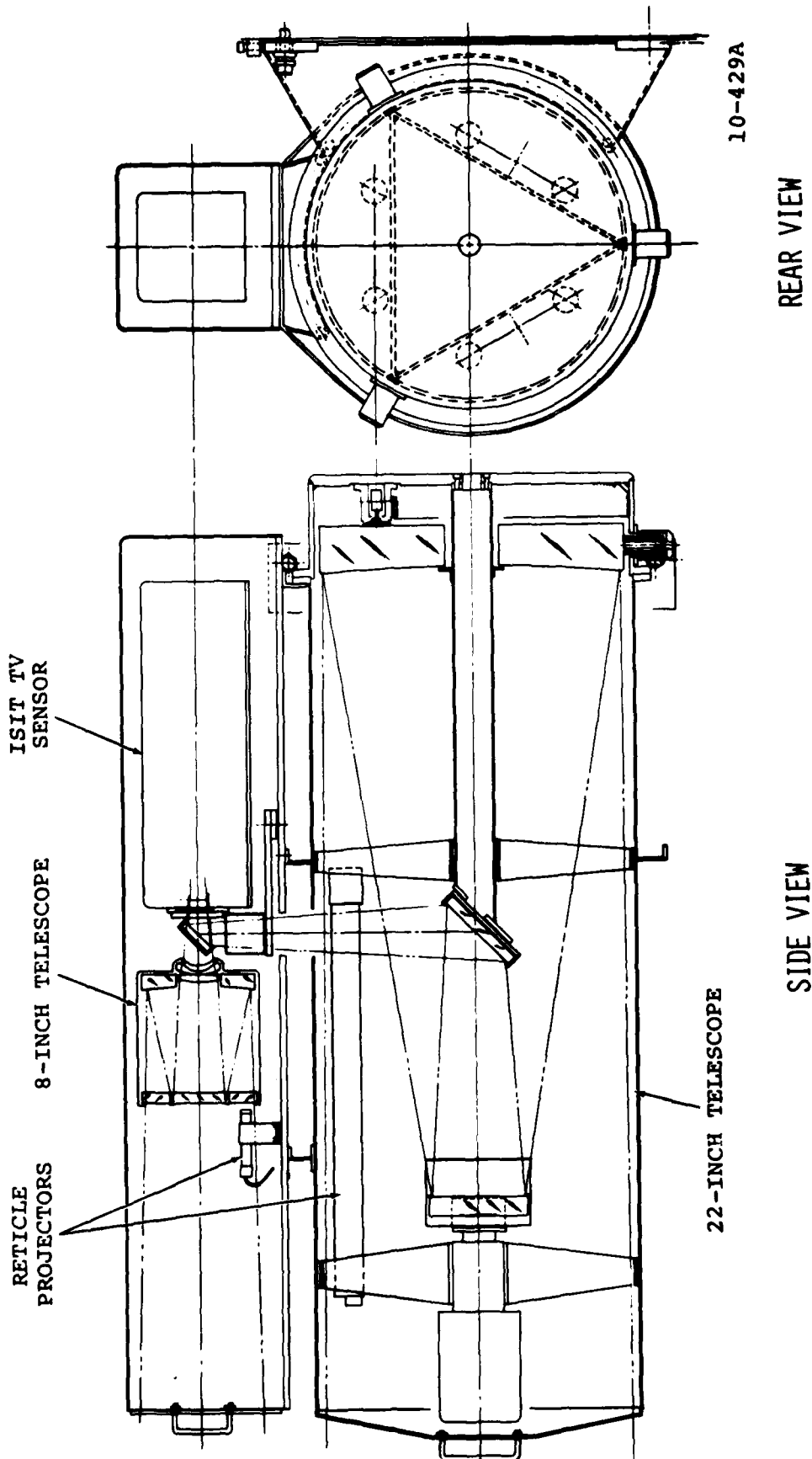

Figure 2-7. Acquisition Telescope.

The purpose of the B29 Telescope, which is approximately three times diffraction limit at visible light wavelengths, is to collect and focus target radiation so it can be sensed by the Contrast Mode Photometer (CMP), Advanced Multi-color Tracker for AMOS (AMTA), and the B29 Boresight Television. The B37 Telescope, which is better than two times diffraction limited, performs a similar function for the Low Light Level TV (LLLTV) package which is mounted on its rear Blanchard surface. The side Blanchard surface does not have a permanently mounted instrument package. The function of the Acquisition Telescope is to provide a larger FOV than is available from the B29 or B37 telescopes. Light collected by this telescope is imaged on to the photocathode of an ISIT TV camera. These sensor systems, when coupled to their respective telescopes, provide system performance capabilities which are described along with the sensors themselves, in the next section.

2.2.4 Sensor System

The MOTIF Sensor System consists of the Advanced Multi-color Tracker for AMOS (AMTA), Contrast Mode Photometer (CMP), Acquisition Telescope TV, B29 Boresight TV, and the Low Light level TV (LLLTV) package. The CMP, AMTA and B29 Boresight TV are all incorporated into an instrument package attached to the rear Blanchard surface of the B29 Telescope as shown in Figure 2-8. Figure 2-9 shows an optical schematic of the package. Figure 2-10 is a photograph of the LLLTV package

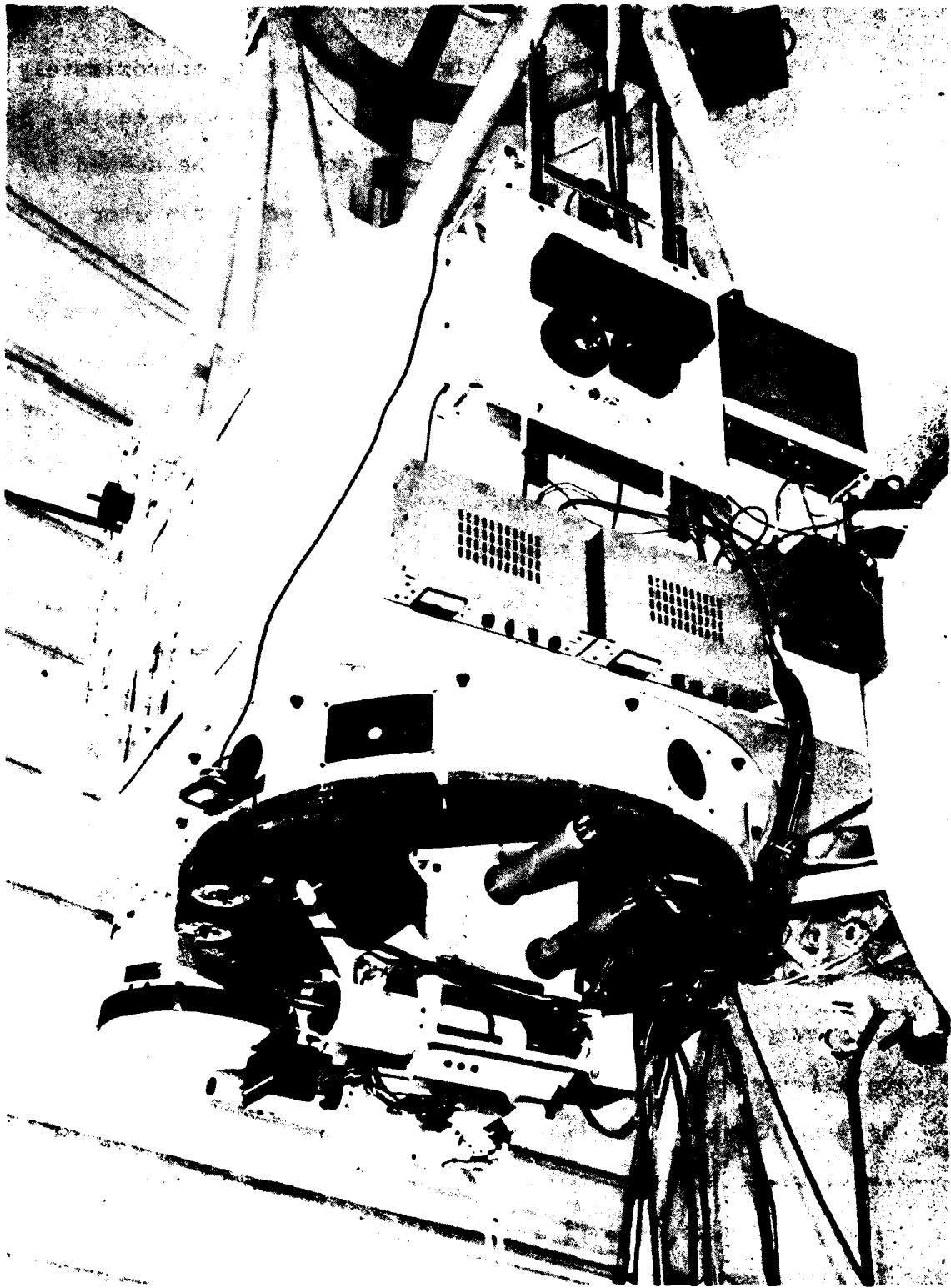
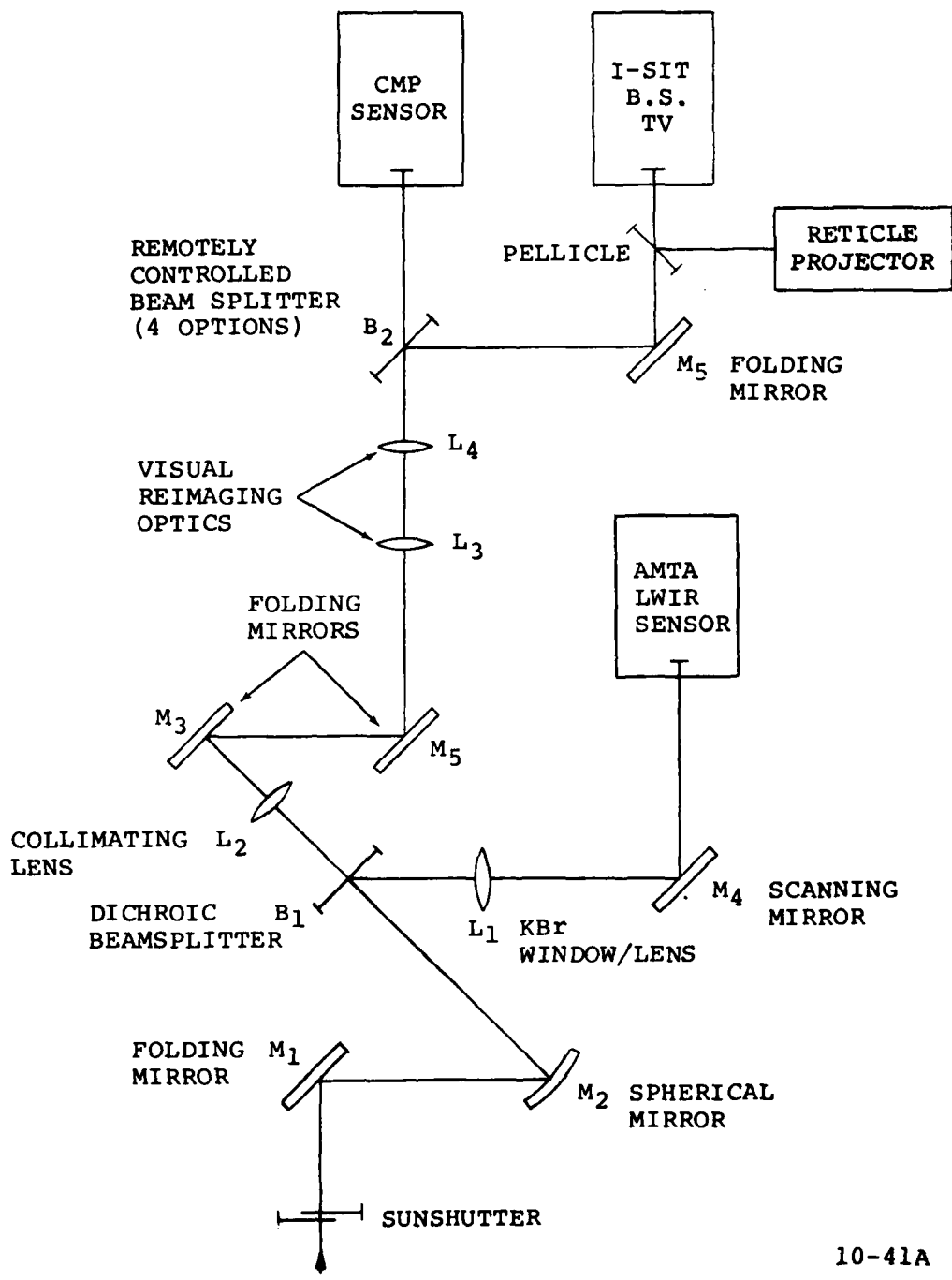

Figure 2-8. AMTA/CMP package.



10-41A

Figure 2-9. AMTA/CMP sensor package optical diagram.

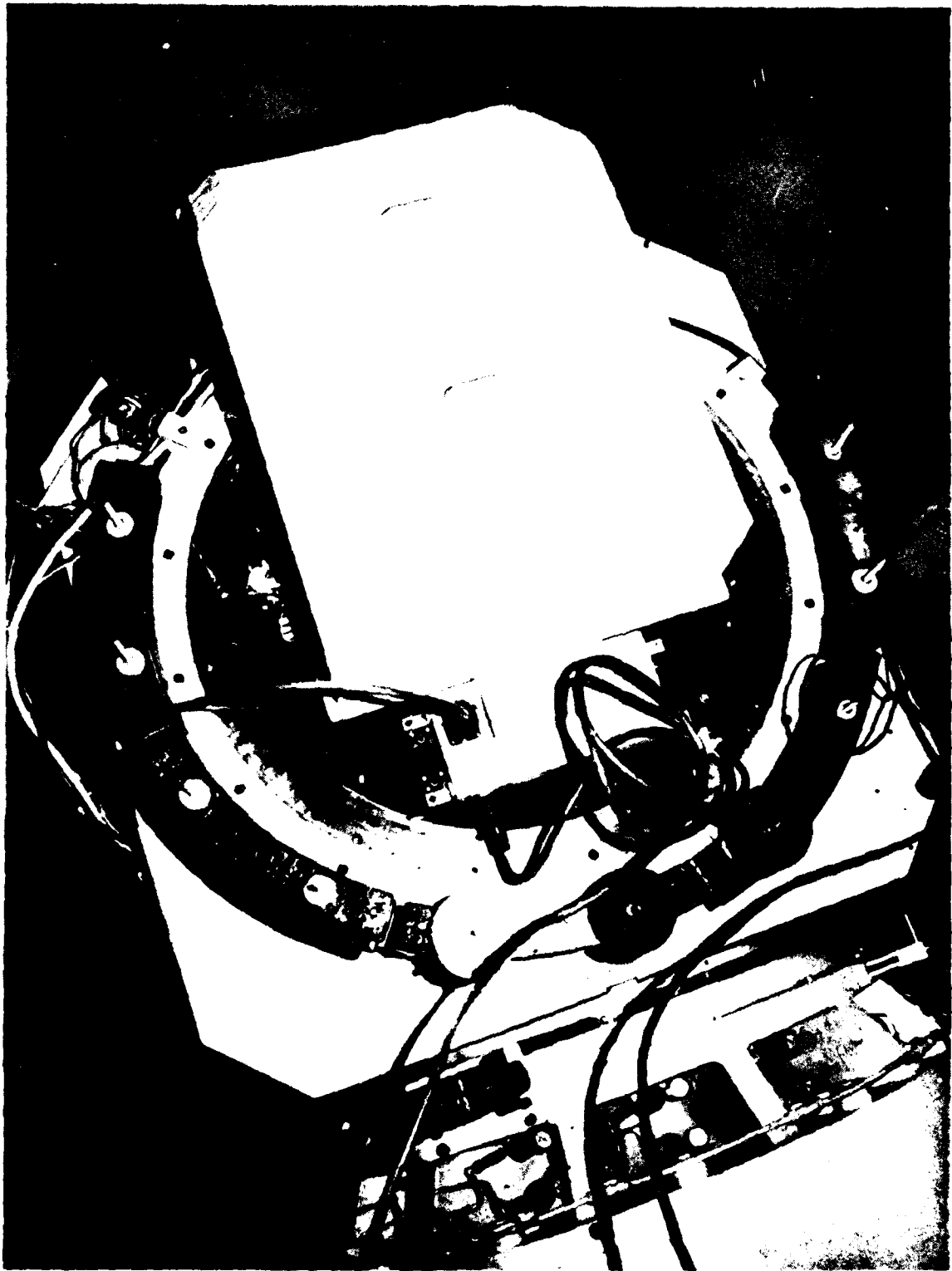

Figure 2-10. LLTV package.

mounted to the B37 telescope; an optical diagram is given in Figure 2-11. Figure 2-12 shows the mounting of the Acquisition Telescope TV. Details are presented in the Sensor System manual (LF-0076-).

AMTA

The AMTA (Fig. 2-13) is a contrast mode radiometric instrument, i.e., it measures the differential radiant flux density at the collecting aperture of the prime optics received from two adjacent locations in the field-of-view. The AMTA employs a square array of 25 cadmium-doped germanium (Ge: Cd) photoconductive detectors which, when cooled to the normal operating temperature of 12°K, provide background limited performance over the 3 to 22 micrometer spectral region. The AMOS Final Report (U), 1 January 1972 to 30 June 1975. (classified SECRET) lists NEFD specifications¹.

The sensor is fitted with seven remotely programmable spectral filters which are specially designed to optimize the output signal-to-noise ratio (SNR) within the atmospheric windows encompassed by the detector spectral response. Figure 2-14 shows the spectral characteristics of the AMTA filters along with theoretical and measured atmospheric spectral radiance profiles. An internal scan mirror or the secondary mirror of the prime optics (B29 telescope) is used

1. AMOS Final Report (U), 1 January 1972 to 30 June 1975, contract F04701-72-C-0081, AERL Doc. #M-1219.

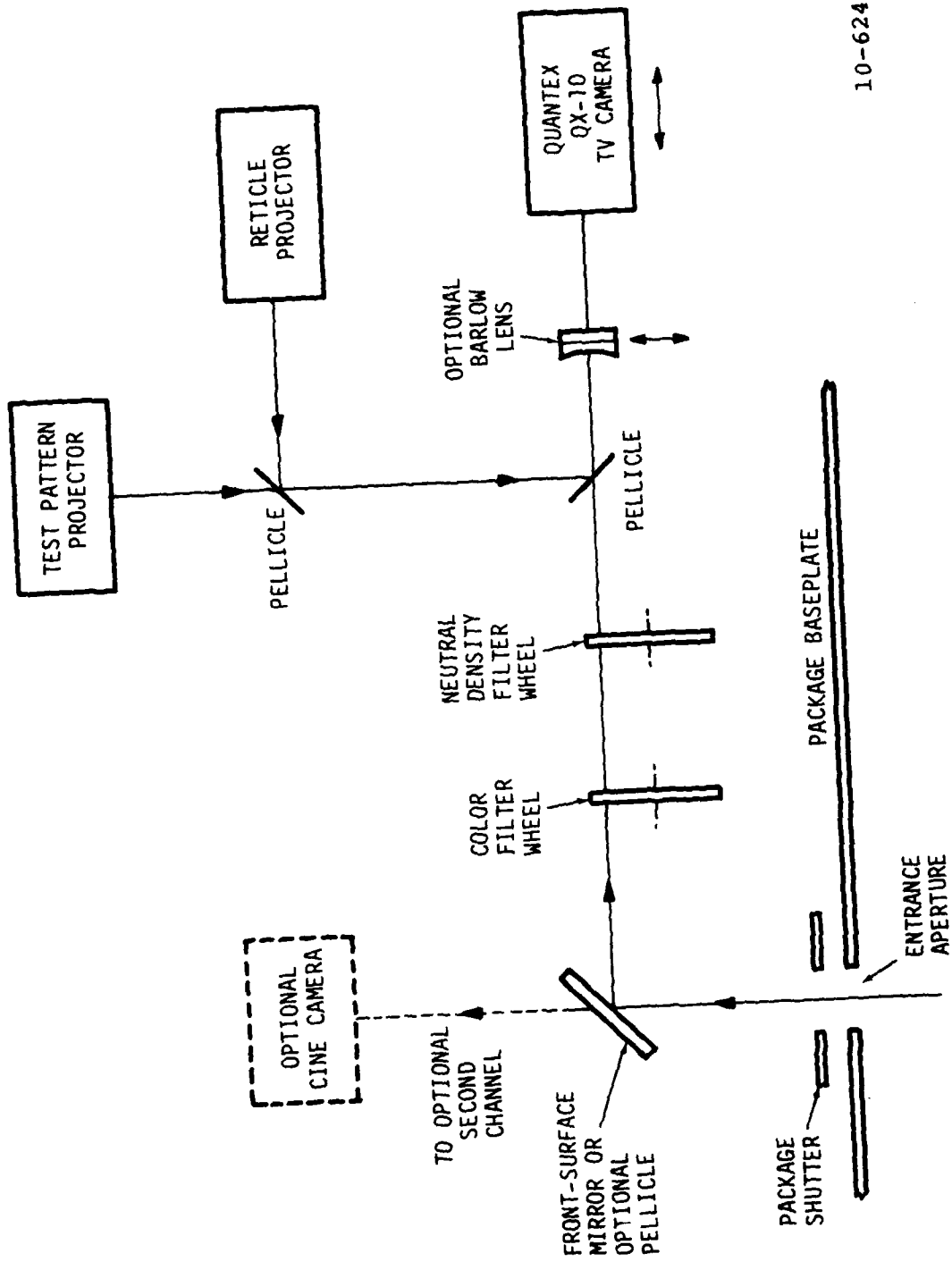

10-624

Figure 2-11. LLLTV package optical diagram.

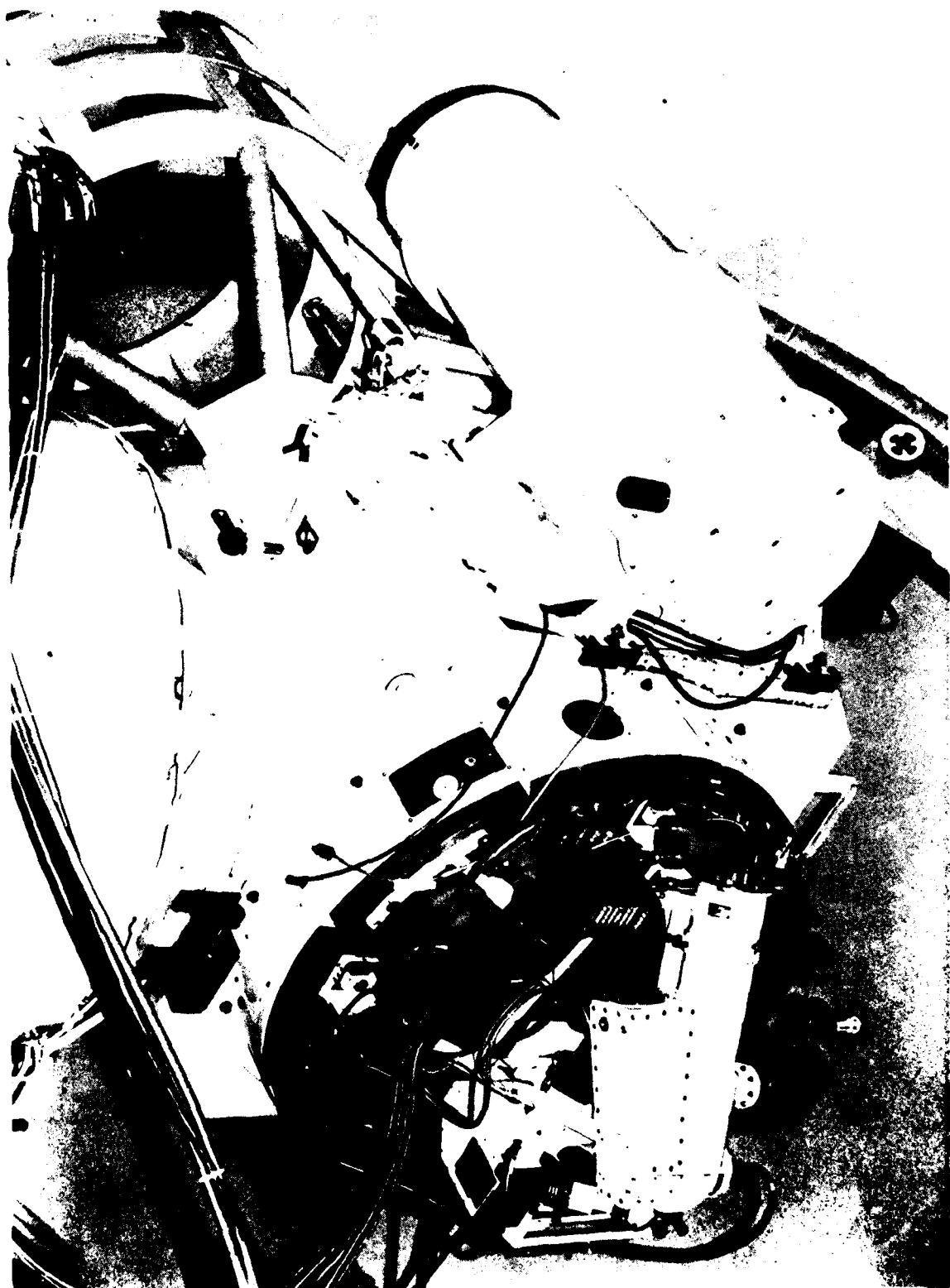

Figure 2-12. Acquisition Telescope TV.

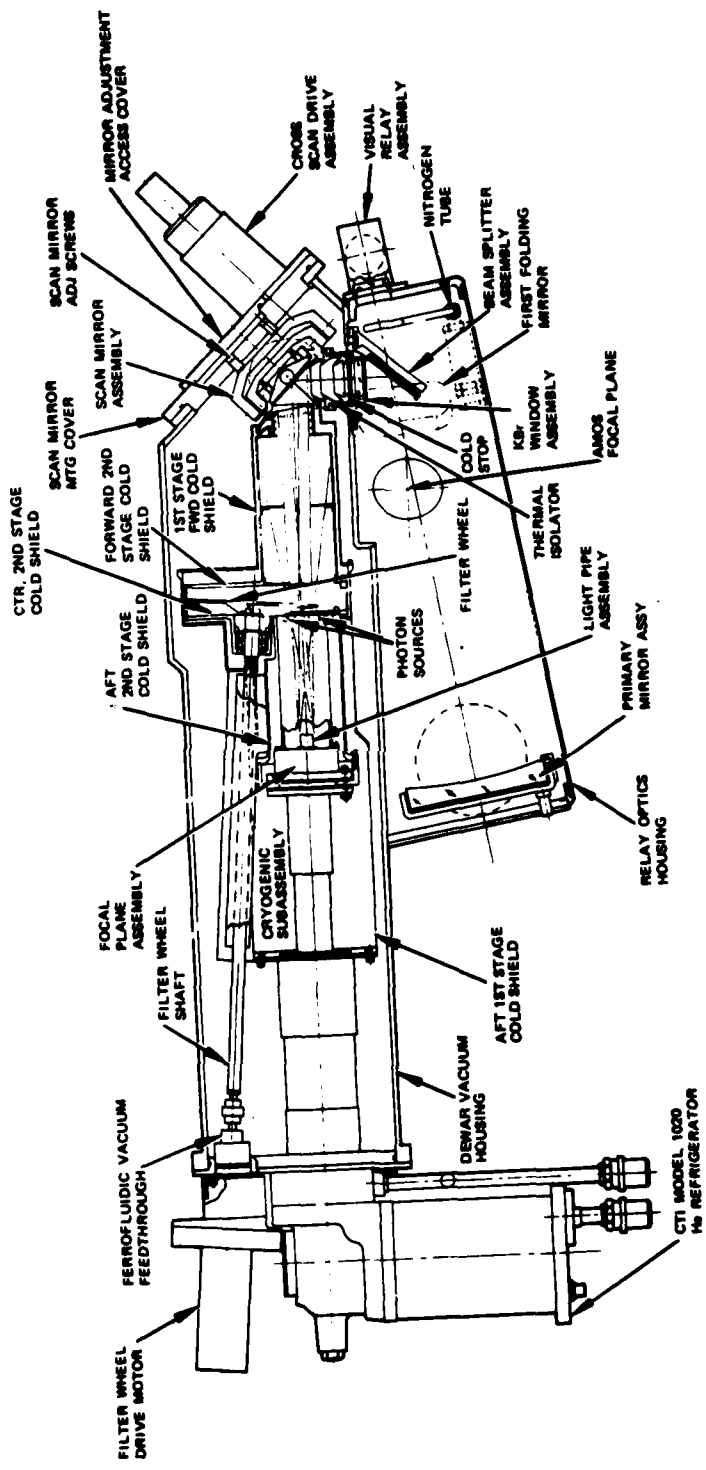
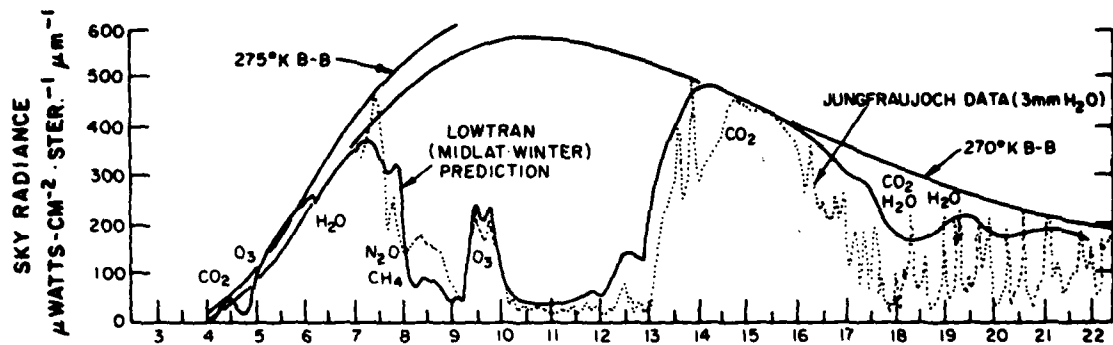
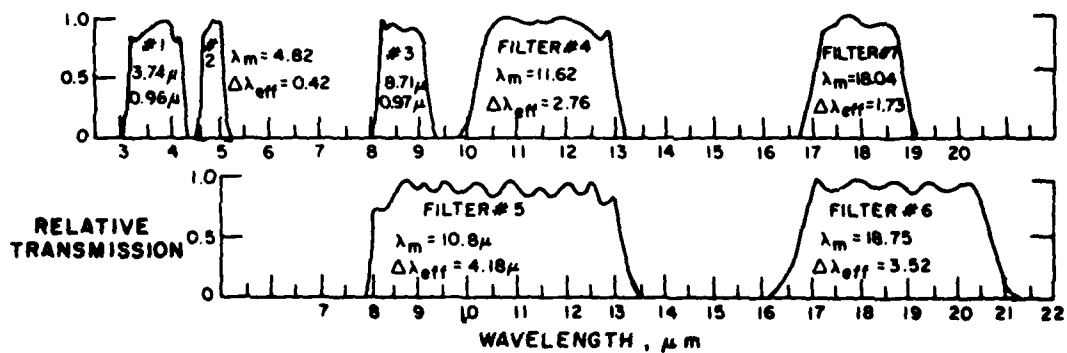

Figure 2-13. AMTA sensor head section view.



(A)



(B)

10-652

Figure 2-14. Sky radiance/AMTA spectral bands.

to move the instrument line-of-sight with square wave motion at a frequency of 50 Hz and an object space amplitude of 23 arc-seconds (one detector diagonal). With either scan option the FOV coverage is as shown in Figure 2-15.

Figure 2-16 is a functional block diagram of the AMTA ac and dc channel signal processing and recording systems. All sensor signals, ac and dc, are equipped with balanced line drivers and receivers which provide high rejection to local EMI and provide suitable drive impedance for the approximately 180' of twisted pair, shielded transmission line from the telescope to the control room. Each of the 25 ac channels is recorded on analog magnetic tape along with time and housekeeping information and is available for on-site post-mission processing and analysis. Four selected ac channels are processed in real-time and provide information to the system operator required for acquisition and tracking. The outputs of the four processed ac data channels are also recorded with 15-bit precision at a rate of 50 samples per second on the system digital recorder along with time, housekeeping and ten selected dc channels which are recorded with 12-bit precision at a rate of 90 samples per second (45 per mirror state). The digitally recorded ac and dc data can be retrieved post-mission and are used to assess object signature characteristics and atmospheric background radiance during the measurement interval.

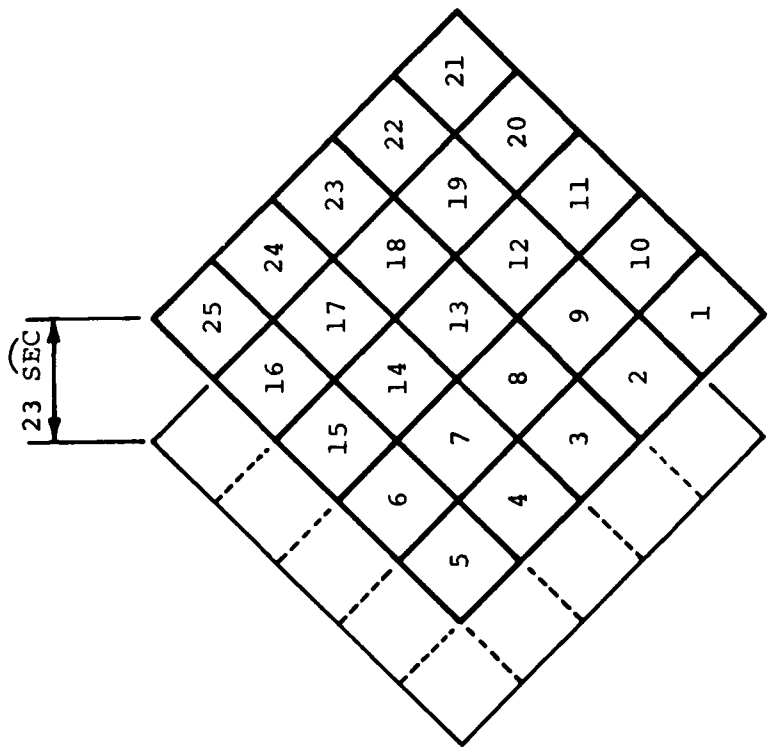

10-579

Figure 2-15. AMTA FOV.

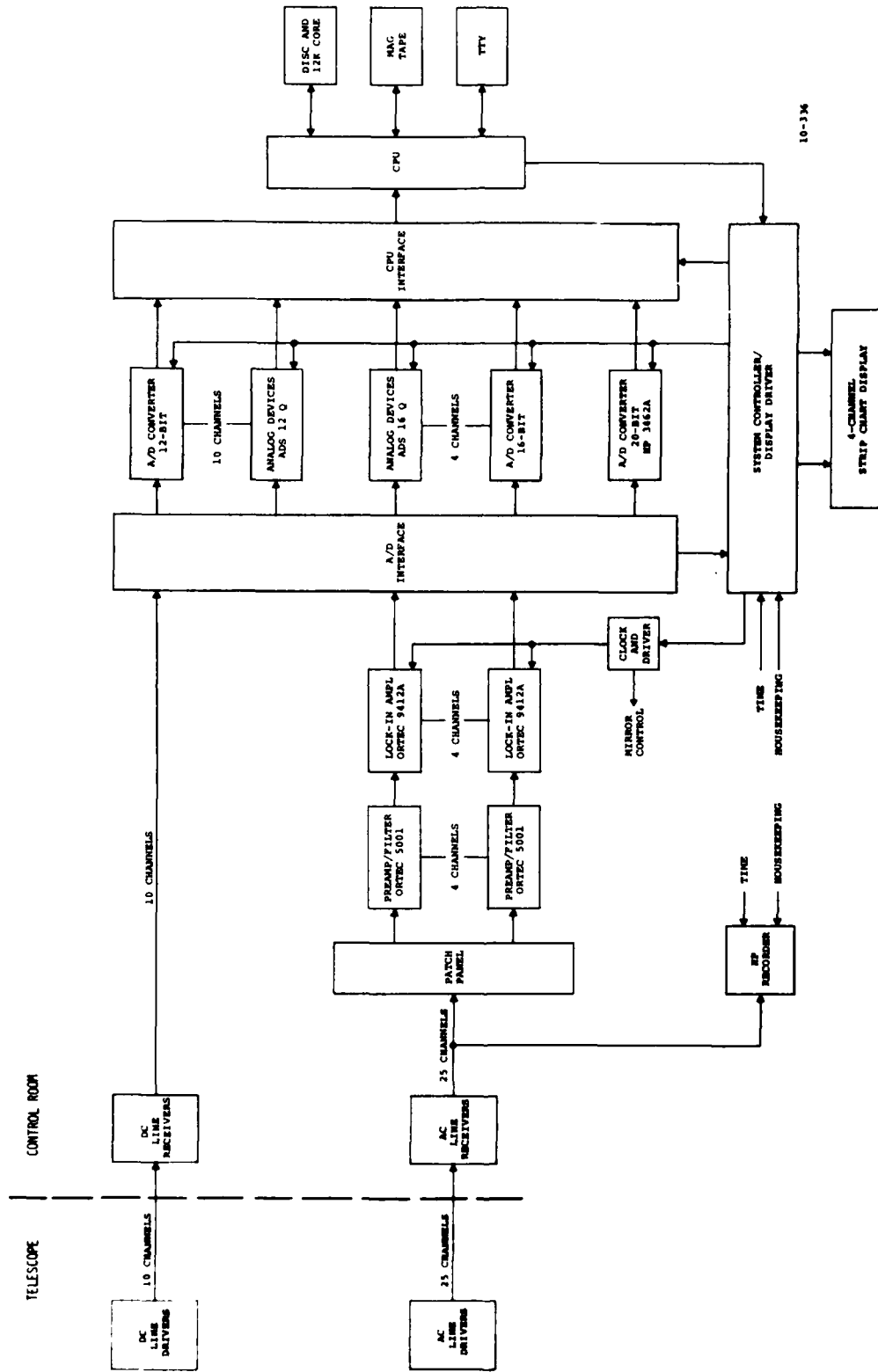

Figure 2-16. AMTA signal processing and recording block diagram.

Contrast Mode Photometer

The Contrast Mode Photometer (CMP) is a dual channel contrast mode radiometric instrument, i.e., it measures the differential radiant flux density at the collecting aperture of the prime optics received from two adjacent locations in the field-of-view. The principle features of the CMP are listed in Table 2-1. Since the limiting sensitivity of the system is a function of the various system performance settings (e.g., FOV, spectral filter, ND filter, CMP/TV beamsplitter setting, single-channel, dual-channel, etc.), it is difficult to characterize the system sensitivity by a single number. In addition, overall performance is a function of the background conditions at the precise time of a measurement. The estimated performance of the system in its most sensitive mode, i.e., dual-channel, full S-20R spectral response is shown in Figure 2-17 for two background situations representing dark sky and full moon conditions.

The system is designed to operate simultaneously with the AMTA LWIR sensor on the 1.2m B29 Telescope (Fig. 2-9). A schematic diagram illustrating the essential components of the telescope mounted portion of the CMP is shown in Figure 2-18. The first element which the beam encounters after passing through the AMTA optics is a beamsplitter which provides

Table 2-1. Principle Contrast Mode Photometer features and performance characteristics

1. Contrast mode operation.
2. Dual, uncooled, magnetically-focused, EMI 9658A (S-20R) photomultipliers.
3. Simultaneous two-color capability.
4. Polarization analyzer.
5. Variable field-of-view.
6. Dynamic range of approximately 10^8 (20 stellar magnitudes) utilizing pulse mode operation, augmented by neutral density filters.
7. Variable data range (1 KHz maximum).

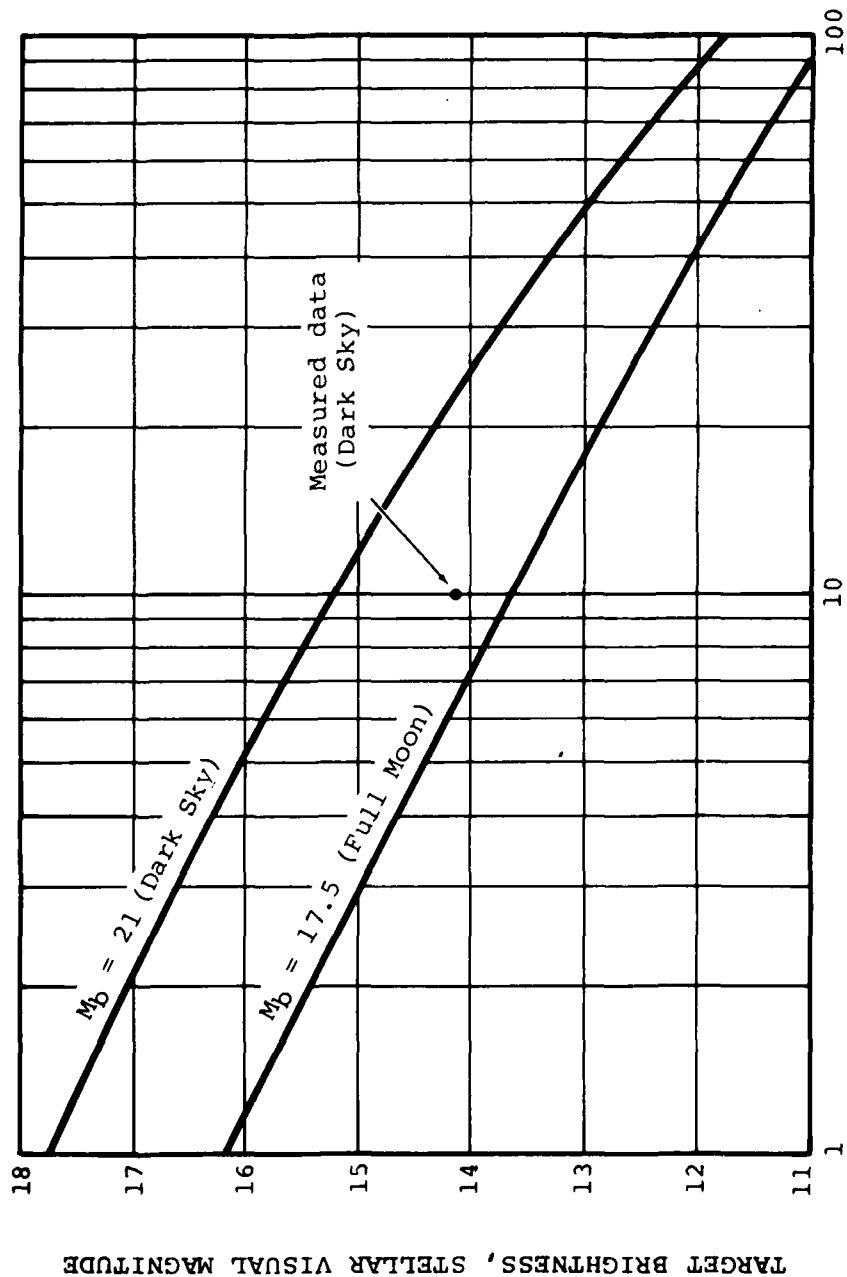

10-37A

SIGNAL TO NOISE RATIO (T=1 sec)

- M_b = Sky background per arcsec²
- Optical transmission = 0.15
- Atmospheric transmission = 0.80
- Background Rejection ratio = 300:1
- Dark count = 300 per second
- Field-of-view = 20 arcsec (177 arcsec²)

Figure 2-17. Contrast Mode Photometer performance estimate.

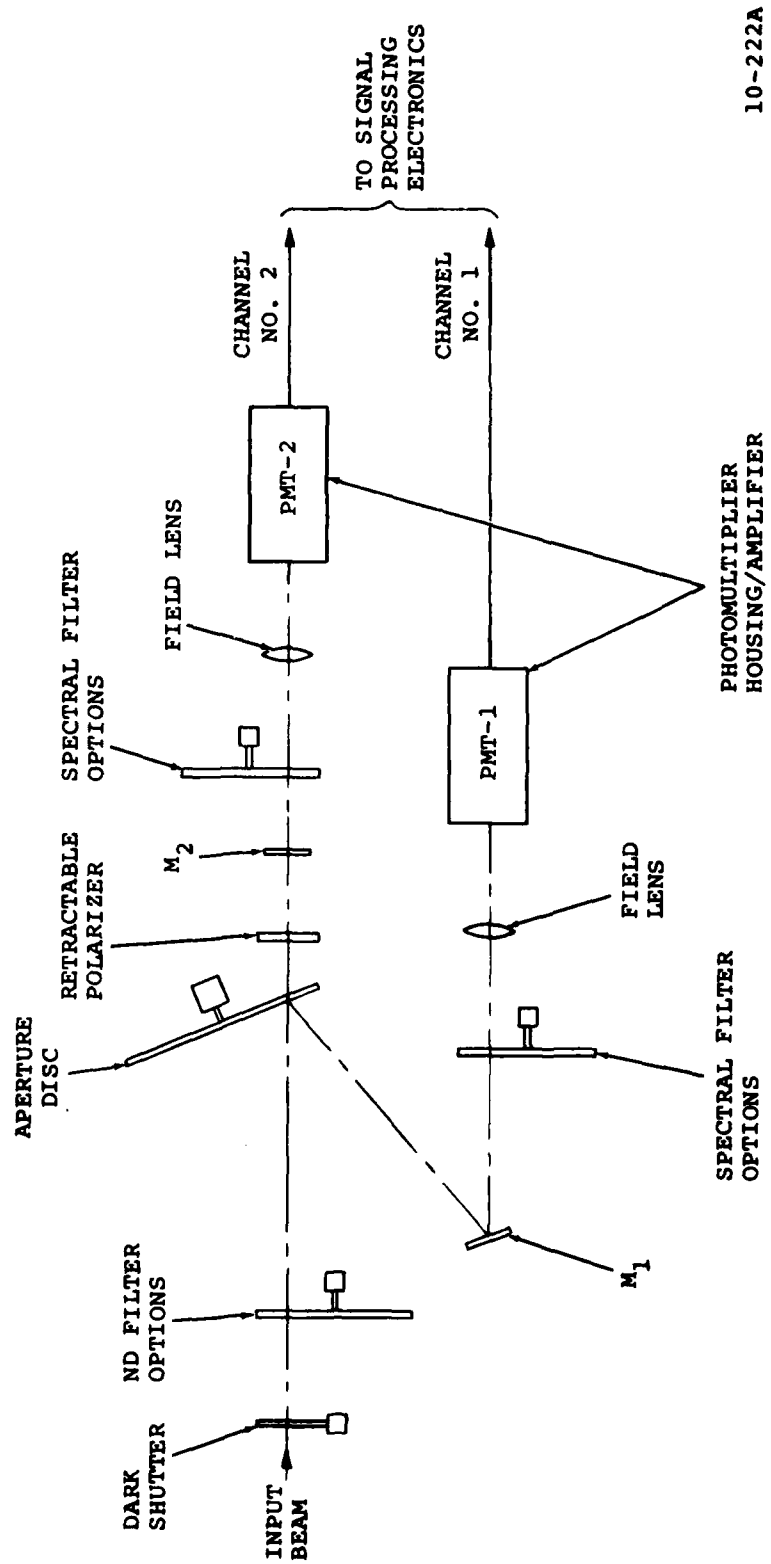

10-222A

Figure 2-18. Contrast Mode Photometer optical diagram.

four options for splitting the beam between the I-SIT boresight TV and the CMP. The available options are:

- 1) all of the beam transmitted to the CMP;
- 2) all of the beam reflected to the TV;
- 3) half of the beam to each sensor;
- 4) 80% of the beam to the CMP and 20% to the TV.

An 8-position neutral density filter wheel provides six neutral density options of 0.3, 0.6, 1.0, 2.0, 3.0, 4.0 as well as a clear and opaque option. The beam is then focussed on the aperture disc. This disc, in conjunction with the nodding secondary mirror of the 1.2m B29 telescope, provides the mechanism for simultaneously splitting the beam between the two photomultiplier tubes. (The system can also operate as a single channel conventional staring photometer with the nodding secondary disabled.)

The system utilizes two EMI 9658R, S-20, extended red photomultiplier tubes with magnetic focussing to reduce the effective cathode diameter which results in a reduction of dark count. At the nominal ambient dome temperature of 10-12°C, the reduction in dark count realized by magnetic focussing is equivalent to cooling the photomultiplier tubes to -20°C. Lenses are used to reimage the entrance pupil of the system onto the active photocathode area.

The two channels each have an 8-position spectral filter wheel with six identical spectral filter options as well as a

clear and opaque option. Three of the spectral filters are a combination of standard Corning color filters and a heat absorbing glass which, when coupled with the S-20R response of the photomultiplier, closely approximate the standard U-B-V photometry spectral bands. The remaining three spectral filters are red cut-on filters which provide contrast enhancement for measurements during twilight conditions.

The two channels have identical electronic processing which allows them to operate as two separate photometers capable of collecting simultaneous two-color information. In addition, one of the channels is equipped with a retractable polarizer which can be inserted into the beam. The polarizer rotates at one revolution per second and a reference pulse is generated twice per revolution which defines one of the polarization axes. By comparing the outputs of the two channels, the polarization characteristics of a target can be determined. The outputs of the two channels can be electronically combined which provides an enhanced sensitivity compared to a single channel system. The choice between single or combined channel operation is selectable from the system control console and is strictly based on the mission requirements.

The CMP utilizes pulse mode signal processing. Neutral density filters are inserted into the beam under bright background conditions or when measuring bright targets which might exceed the linear dynamic range of the pulse mode system.

A functional block diagram of the system electronics is shown in Figure 2-19. Each photomultiplier tube has its own high voltage supply which is adjusted to equalize channel gain. The photomultiplier tubes are housed in Pacific Photometric Instruments Model 3262 ambient temperature, RFI-shielded housings with built-in wide band amplifiers. The overall gain of each channel is approximately 10^7 . The output impedance of the wide band amplifier is 50 ohms which is suitable for driving the 200 feet of coaxial line from the telescope to the control room. In the control room the wide band amplifier outputs are applied to variable threshold pulse amplitude discriminators which are adjusted for maximum signal-to-noise ratio. Discriminator pulses (TTL compatible) are applied to the digital electronics.

The output of the digital processor consists of two 16-bit data words (one per channel) and two 16-bit status words which are applied to the Data Transmission System (DTS) where the data is edited, processed and formatted for transmission to ADCOM. The digital data is also converted to analog voltages which are recorded (along with status information) on a 14-track magnetic tape recorder. The analog recorded data can be processed and formatted for transmission to ADCOM using the CDC 3500 and SC-1700 computers.

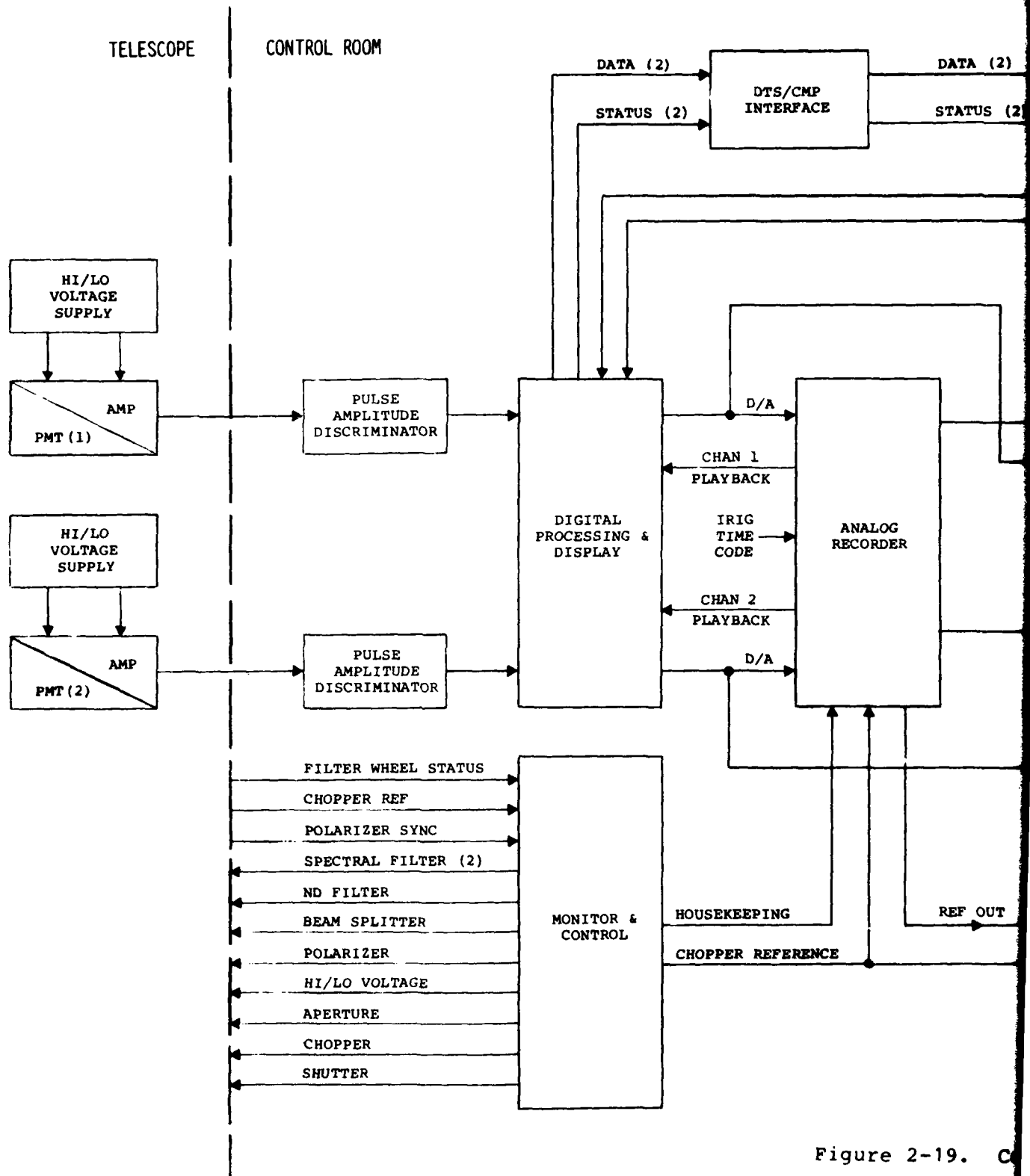
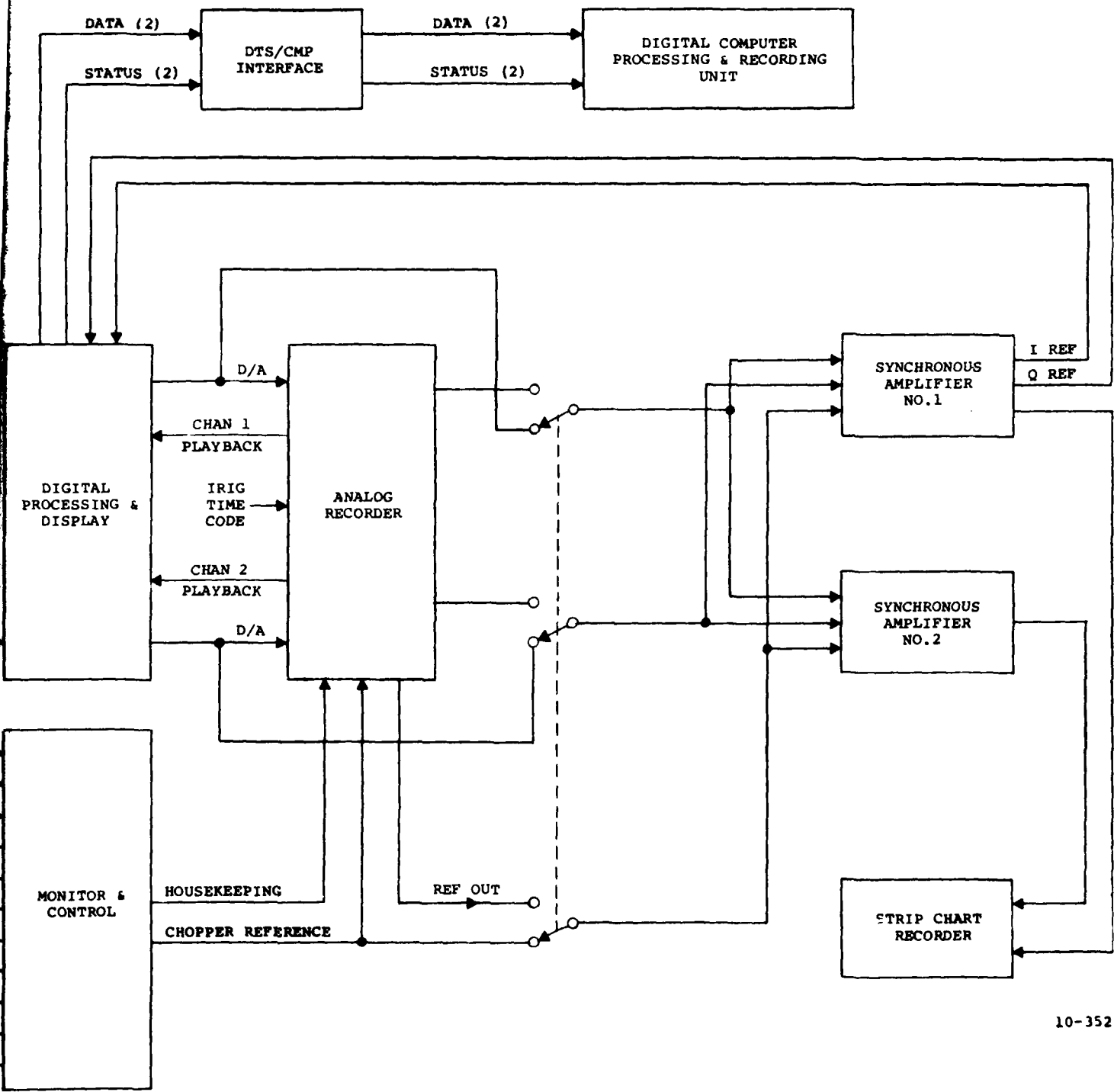

Figure 2-19. C



10-352

Figure 2-19. Contrast Mode Photometer functional block diagram.

2

Television Camera Systems

Three closed-circuit television (CCTV) systems are incorporated into the MOTIF:

- 1) AATS TV;
- 2) LLLTV;
- 3) B29 Boresight TV.

The AATS TV is the sensor for the acquisition telescope and is used to provide an operator with a remote display of his search field-of-view. The camera is a Quantex Corp. QX-11 (high gain I-SIT) which is connected to a Quantex Corp. DS-20 Digital Integrating and Storage Unit. Demonstrated sensitivity of this sensor is +17th visual magnitude on a dark (moonless) night.

The LLLTV is incorporated into an instrument package mounted to the rear Blanchard surface of the B37 telescope. It is a Quantex Corp. QX-10 (high gain I-SIT) camera connected to a Quantex Corp. DS-10 Digital Integrating and Storage Unit. Demonstrated sensitivity of this sensor is +18.5th visual magnitude on a dark (moonless) night.

A Cohu I-SIT camera is used as the B29 boresight camera. Demonstrated sensitivity of this sensor is +14.5 visual magnitude on a dark (moonless) night.

Details of each system are given in manuals LF-0075 (AATS), LF-0076, (LLLTV) and LFS0007S (B29 Boresight TV). Table 2-2 lists the pertinent features of each system when used in its operational configuration.

Table 2-2. Television camera systems characteristics

	AATS TV	LLTV	B29 TV
Type	I-SIT	I-SIT	I-SIT
Nomenclature	QX-11	QX-10	2856
Manufacturer	Quantex	Quantex	Cohu
Digital Processor	Yes, DS-20	Yes, DS-10	No
Sensitivity (includes optical system)	+17	+18.5	+14.5
FOV	0.1° and 0.5°	2' and 4'	4'
Filter Options	ND	ND and Spectral	ND
Reticle	Yes	Yes	Yes
Beamsplitter Options	No	Yes	Yes

2.2.5 Telescope Support Equipment

The Telescope Support Equipment consists of items that are used only by the 1.2 m Telescope System. Support items shared with other major systems, such as the Laser Beam Director, are included under Common Support Equipment. The Telescope Support Equipment consists of the Mirror Band, Forklift, and Highlift. Details are presented in the Telescope Support Equipment manual (LF-0078-).

The Mirror Band is a stainless steel band with an interior lined with rubber. It is used to grasp the 1.2 meter mirrors during recoating activities.

The forklift is a Yale and Towne Warehouser. It is used as a work platform in the Upper Level, 1.2 m Telescope Dome to gain access to telescope-mounted equipment.

The highlift provides a mobile telescoping work platform capable of reaching a height of 30 feet. It is used for the removal and servicing of items such as the upper dome door motors.

2.2.6 Data Transmission System

The Data Transmission System (DTS) consists of the following hardware:

- 1) A MODCOMP IV computer with 128k of 16-bit word memory and floating pointing capability;
- 2) One CRT/Alphanumeric keyboard terminal (MODCOMP Model 4620);

- 3) One graphics console (Tektronix Model 4014-1 with Enhanced Graphics and PLOT-10 software options);
- 4) Three Peripheral Controller Interfaces (MODCOMP Models 4905, 4903, and 5215);
- 5) Two 9-Track, 800 bpi, 75 ips tape drives (MODCOMP Models 4164 and 4165);
- 6) One 600 LPM line printer (MODCOMP Model 4211);
- 7) One 300 CPM card reader (MODCOMP Model 4411);
- 8) Two 25M byte, moving head disk drives (MODCOMP Models E4132 and E4133).

This equipment and the equipment that it interfaces to is shown in the block diagram of Figure 2-20. Hardware connected to the 5215 PCI switch may be switched manually or under program control between the DTS and (CMS) System.

The DTS interfaces directly to the CMP and to the CDC 3500 computer using MODCOMP Models 4801 General Purpose Data Interface and 1941 Satellite Coupler, respectively. Its purpose is to receive and store (both disc and tape) metric or positional tracking data from the CDC 3500 and photometric data from the CMP. Once the data is collected and stored it can be recalled and displayed to an operator. The DTS provides data editing and processing capabilities for both mission and calibration data. Processing photometric data consists of computing exo-atmospheric visual magnitude, normalized to 1000 kilometers,

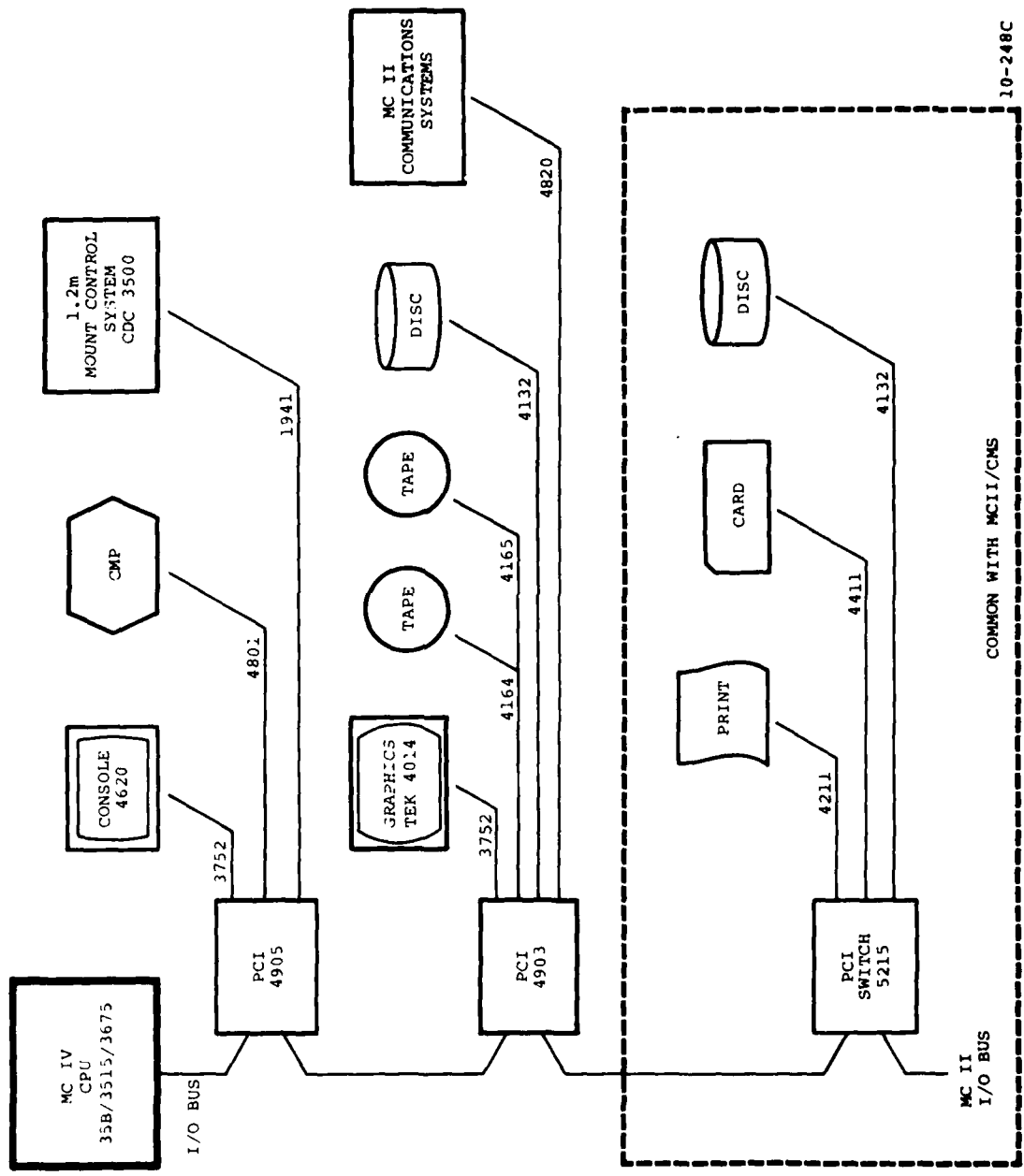

NOTE: NUMBERS ON PERIPHERAL DATA PATHS INDICATE CONTROLLER I.D.
 Figure 2-20. MODCOMP IV computer configuration.

10-248C

as a function of time and for operator selected integration times and sampling periods. Metric data processing consists of calculating target right ascension and declination angles as a function of time. Once processed, the data are formatted and made available to the CMS for transmission to the SCC via the MODCOMP Model 5215 switchable PCI. Data are available for transmission within 30 minutes of the termination of tracking for high priority targets.

The DTS software operating system is described in Section 2.2.9.

2.2.7 Communications System

The Communications System (CMS) interfaces to a full-duplex, synchronous 2400 baud AUTODIN circuit and consists of the following hardware:

- 1) A MODCOMP II computer with 64k words of 16-bit memory;
- 2) One CRT/Alphanumeric keyboard terminal (MODCOMP Model 4620);
- 3) One 75 lpm silent printer (MODCOMP Model 5212);
- 4) Two PCIs (MODCOMP Models 4903 and 5215);
- 5) One 9-track, 800 bpi, 75 ips tape drive (MODCOMP Model 4164);
- 6) One 10M byte cartridge disc (MODCOMP Model 4136);
- 7) One Telecommunications Line Controller (Analytics Model TLC-100);
- 8) Two KG-13 cryptographic devices with Western Union modems.

The MODCOMP II Computer also has access to a line printer, card reader, and 25 megabyte disk via the switchable 5215 PCI. Figure 2-21 shows a block diagram of the CMS.

The primary purpose of the CMS is to provide AUTODIN communications between MOTIF and ADCOM or other AUTODIN subscribers. The CMS hardware is designed to interface an AUTODIN Mode I line with the proper protocol; it has been certified by the Defense Communications Agency (DCA).

All incoming messages are routed to the cartridge disc unit which acts as a spooler to account for different operating speeds of other equipment. Messages are then identified and distributed. Text messages are routed to the printer, element set messages are routed to the DTS and to magnetic tape, and tasking messages are routed to the DTS; element set and tasking message headers are also routed to the printer.

All outgoing messages are spooled on the cartridge disc. Outgoing messages consist of text messages generated by an operator using the CRT/Alphanumeric Keyboard and data messages. The metric and photometric data messages come from the 25 megabyte disc unit connected to the switchable PCI.

CMS software CMS is described in Section 2.2.9.

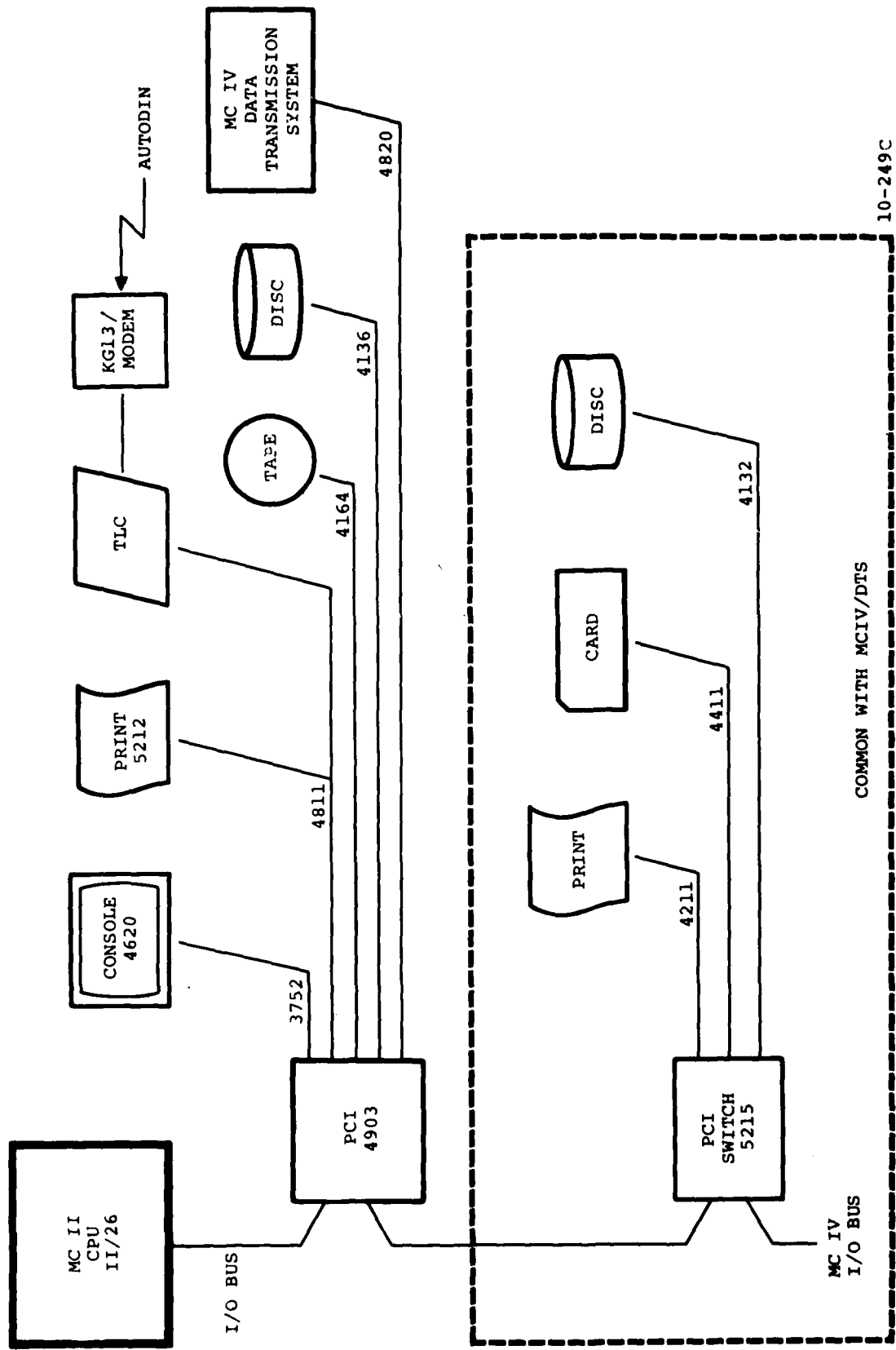

10-249C

NOTE: NUMBERS ON PERIPHERAL DATA PATHS INDICATE CONTROLLER I.D.

Figure 2-21. MODCOMP II computer configuration.

2.2.8 Back-Up Computer

The Back-up Computer consists of a MODCOMP CLASSIC (MCV) Computer with floating point and 128 K words of memory, which serves as a spare for either the MODCOMP IV in the DTS system or the MODCOMP II in the CMS system. The spare computer and the spare peripherals are shown in Figure 2-22. Physical substitution of the back-up MODCOMP CLASSIC consists of recabling the CPU I/O buss to the first PCI of the resident MODCOMP IV or MODCOMP II. In the event a peripheral or controller should fail, the defective unit would be replaced with one of the spares shown in Figure 2-22. The MODCOMP II operating system (MAX III) can be operated on the MODCOMP IV or V by running in the "ABSOLUTE" mode instead of the "VIRTUAL" mode. This bypasses use of the MODCOMP IV or V memory management hardware, thus, emulating the MODCOMP II.

A significant feature of the spare computer system is the fact that it is a completely operational system which can be utilized in an off-line mode for software development or other computer work.

2.2.9 Software (1.2 Meter Telescope System)

The 1.2 m Telescope System Software is divided into four categories:

- 1) Data Transmission System (DTS);
- 2) Communications System (CMS);

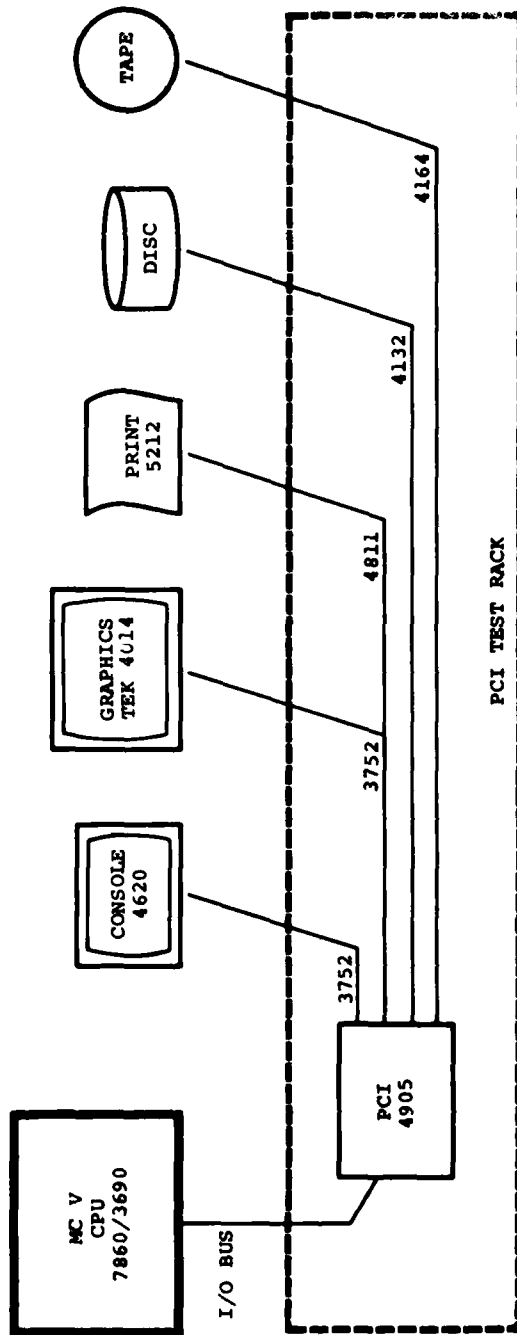

Figure 2-22. MODCOMP CLASSIC spare computer configuration.

3) Library;

4) Vendor.

MOTIF Requires additional software to operate; however, the additional software is considered common to MOTIF and DARPA and is described in Section 2.3.8.

Software descriptions are set forth in Computer Product Configuration Identification (CPCI) documents for major software systems. These are identified where applicable.

DTS CPCI

The MOTIF Data Transmission System CPCI (RTDTS) operates on the MCIV computer. It provides a capability for collecting, recording, editing, and processing large volumes of photometric and positional data, and dispatching data to be transmitted to the Communications System CPCI (CMS) in near-real-time.

The functions of the RTDTS are divided among four tasks (Fig. 2-23): Data Acquisition Task (DODAT), DTS Principal Task (DPTDO), Display Task (DODIS), and Observed Data Algorithms and Equations Task (DOODLE).

The Data Acquisition Task collects data from the Contrast Mode Photometer and the CDC 3500 computer (EROS CPCI) and creates disc files for near-real-time processing and magnetic tape files for data replay. Data replay is a capability that can be used in non-real-time to simulate real-time data acquisition functions by retrieving data from magnetic tape files to create disc files for processing.

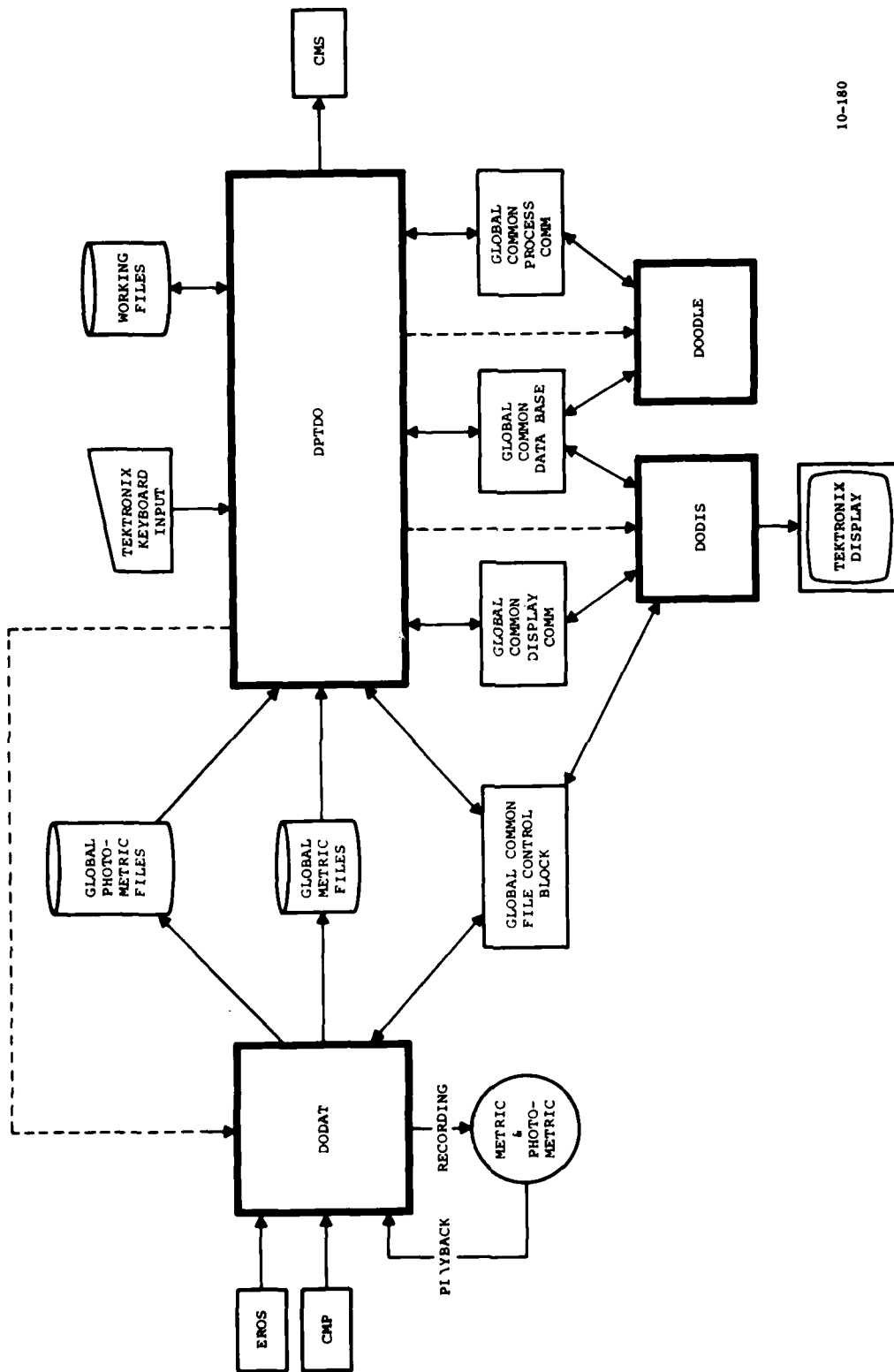

10-180

Figure 2-23. Data Transmission System (DTS) software block diagram.

The DTS Principal Task retrieves data from disc files, performs integration and creates data file summaries that are graphically displayed on a Tektronix 4014 terminal by the Display Task. It also interacts with the DTS operator to enable the operator to select integration, calibration, and display parameters, request graphic displays; and perform editing, processing and dispatching of data to the Communications System.

The Display Task generates three categories of displays:

- 1) A status page which includes all photometric and metric missions that have data stored on disc files;
- 2) Photometric data displays which include time histories of count rates or apparent, exo-atmospheric, or normalized visual magnitudes;
- 3) A metric data display which consists of a time history of right ascension and declination angles.

The Observed Data Algorithms and Equations Task performs the following:

- 1) calculates apparent, exo-atmospheric and normalized visual magnitudes from integrated photometric count rates;
- 2) processes sensor calibration data to compile system responsivity and the atmospheric extinction coefficient;
- 3) converts observed positional data to right ascension and declination coordinates.

A detailed description of the DTS software is given in manual number LF-0095-.

CMS CPCI

The Communications System CPCI (CMS) operates on the MCII computer system. It is used to accomplish the software interface between MOTIF operations and the AUTODIN link to ADCOM. CMS provides the following capabilities:

- 1) Recognizing and directing incoming messages based on content;
- 2) Recording both incoming and outgoing general service messages and message traffic identifications;
- 3) Generating and transmitting MOTIF administrative reports and documentation;
- 4) High-speed storage and retrieval of received data messages; e.g., satellite element sets and tasking messages;
- 5) Formatting and transmitting MOTIF positional and SOI data.

To actually provide the above capability, five primary software tasks are required, as follows (Fig. 2-24):

- 1) The Input Spooler task interfaces with the AUTODIN for input messages which are buffered to mass storage;
- 2) The Input Dispatcher task retrieves and discriminates the input messages;
- 3) The Output Spooler task interfaces with the AUTODIN for output messages which are buffered from mass storage;

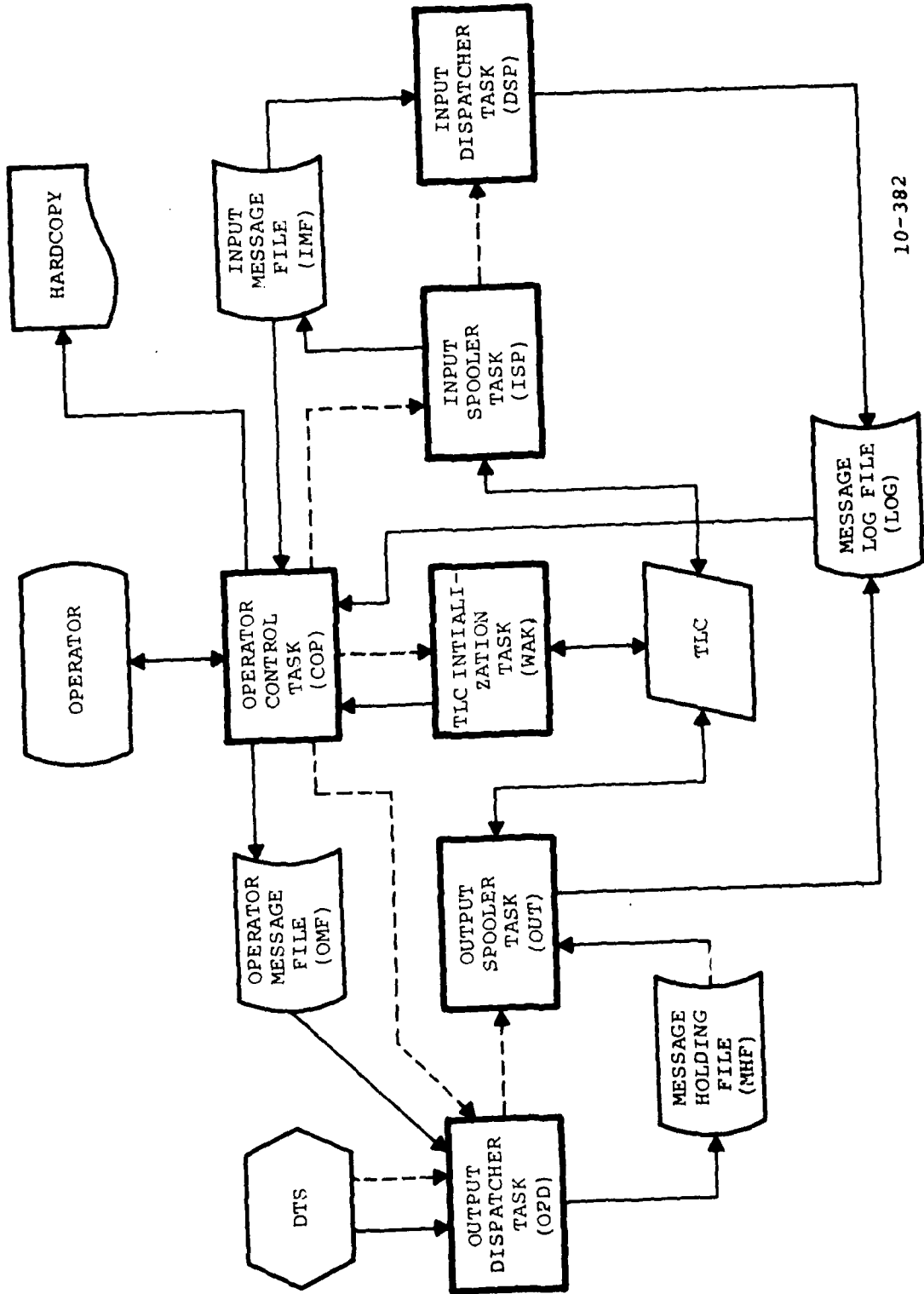

10-382

Figure 2-24. Communications System (CMS) software block diagram.

- 4) The Output Dispatcher task retrieves the MOTIF operational data, edits it into B-3 format for positional data and icosahexal SIGTRANS format for SOI data, and composes the edited data into JANAP 128 messages;
- 5) The Operator Control task is the operator's means of composing narrative messages and interrogating and controlling the CMS system.

A detailed description of the CMS software is given in manual number LF-0096-.

Library

Library routines consist of proven routines and subroutines that are used by more than one program. The library routines used by the DTS and CMS software are identified in LF-0095- and LF-0096-, respectively. This category of software does not include vendor library routines.

Vendor

Vendor software consists of operating systems, library routines, and system processors that are supplied by the computer manufacturer. The vendor software used by the DTS and CMS is supplied by MODCOMP. The DTS uses MAX IV and the CMS uses MAX III. A more detailed definition of these operating systems are contained in the DTS system manual (LF-0115-) and the CMS system manual (LF-0116-).

2.3 MOTIF Common Systems

This section provides a physical and functional description of the seven MOTIF Common Systems:

- 1) Recording;
- 2) Video;
- 3) Common Support Equipment;
- 4) Computer;
- 5) Timing;
- 6) Communications;
- 7) Facilities.

A description of computer software common to DARPA and MOTIF is also given.

2.3.1 Recording System

The Common Recording System is comprised of two separate and distinct recording subsystems that are shared between MOTIF and DARPA. These are the IVC-711P Video Tape Recorder and the Hewlett-Packard, Model 3955A, 14-track Magnetic Tape Recorder. Detailed information on the Recording System is given in manuals LC-0404-, LC-0335-, and LC-0029-.

The IVC-711P records up to one hour of video data. Its function is to record video data from one of the MOTIF telescope-mounted TV cameras, i.e., the Acquisition Telescope TV, B29 Boresight TV or the Low Light Level Television (LLLTV) mounted on the B37 telescope. An IRIG-B time code is recorded on the IVC-711P audio channel.

The Hewlett-Packard 3955A is a 14-track analog recorder equipped with an FM multiplexing unit that provides for the recording of 32 channels of data plus voice.

This instrument is used to record the raw data from the 25 AMTA detectors, AMTA housekeeping information, raw data from the CMP, CMP housekeeping information, IRIG-B time code, and voice. CMP data is not normally recorded on the HP 3955A; it is sent directly to the Data Transmission System (DTS) for storage and processing. Should the DTS be down for repair, CMP data can be stored by this recorder for processing at a later date.

2.3.2 Video System

The Common Video System consists of the Video Distribution, Graphics Display, Autotrack, Synchronization, Monitor, and Video Test Equipment subsystems. A block diagram of the Video System is shown in Figure 2-25. The Video System operates at Consultative Committee International Radio (CCIR) European monochrome television line and field rates of 625 lines/frame and 50 fields/second. The frames are interlaced at 2 fields per frame. Detailed information on the Video System is given in manual number LC-0407-.

The Video Distribution Subsystem consists of the video switch modules, isolation amplifiers, power supplies, a patch panel, and the video source select switches located at the

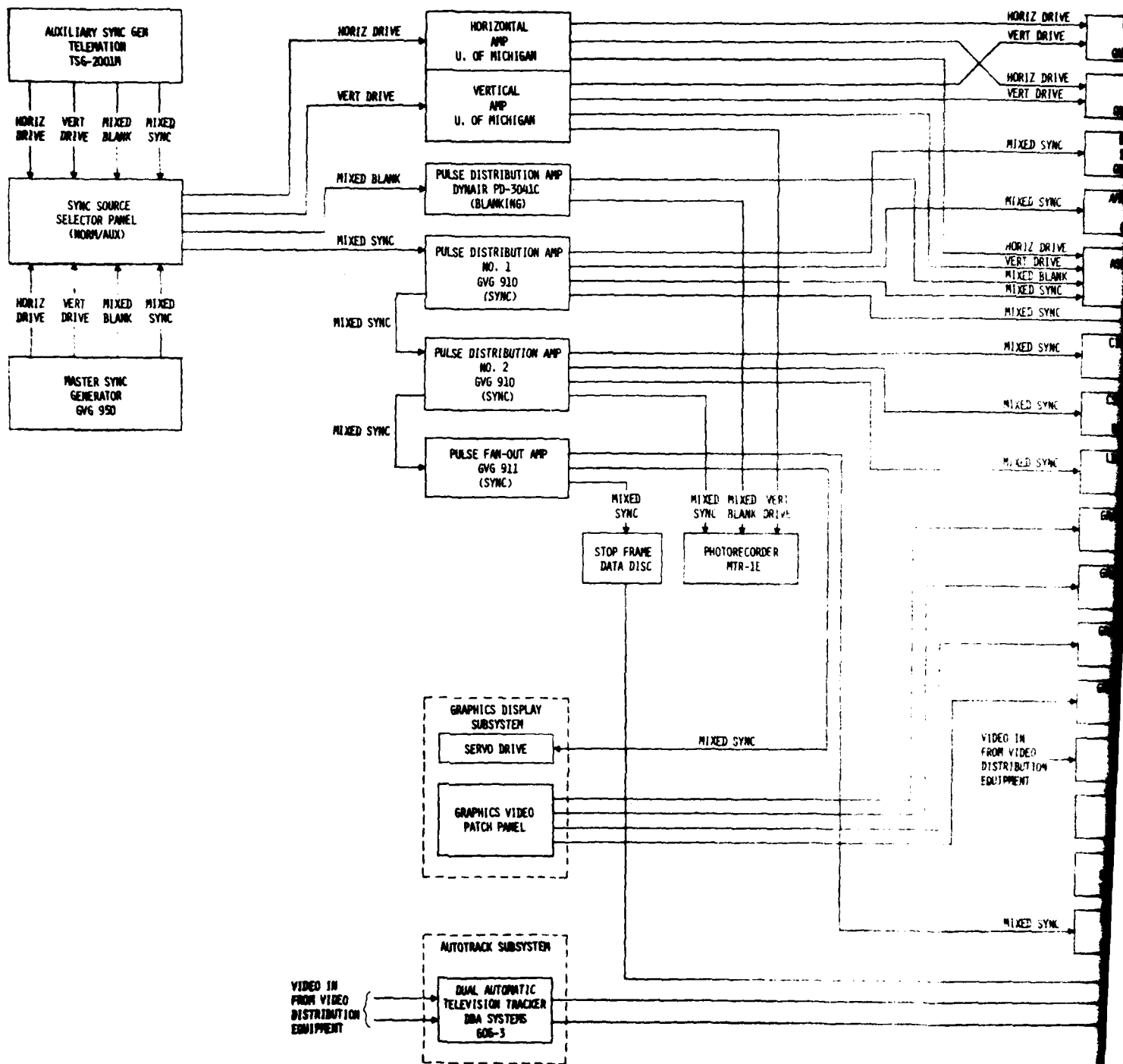

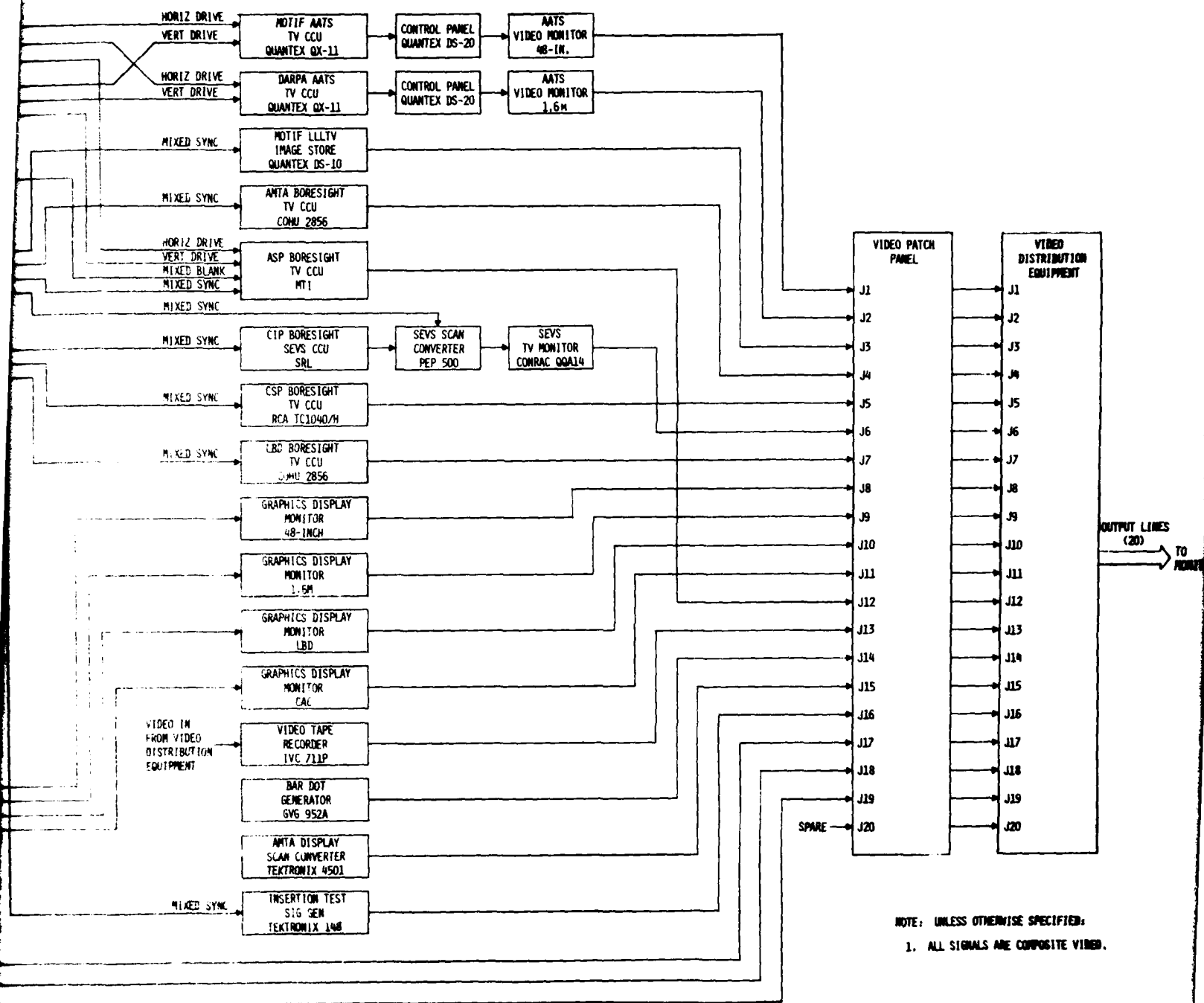

10-308

Figure 2-25. Video System block diagram.

20 switchable video monitors located throughout the Observatory.

The Distribution Subsystem accepts composite video inputs from the closed-circuit television cameras mounted on the telescope, the Graphics Display Subsystem the Video Tape Recorder (playback mode), the video bar-dot generator, and the insertion test signal generator. The Distribution Subsystem is capable of accepting up to 20 inputs and providing 20 outputs. Any one of the inputs can be displayed on any of the video monitors connected to the system.

The Graphics Display Subsystem is made by Data Disc. It consists of a Model 2222 servo drive, Model 5450 disc memory, Model 6601, video display generator, and a Model 6602 power supply. A video patch panel is also included.

The data that is displayed to the operator originates in the CDC SC1700 computer. Information is updated once per second and sent to the graphics display subsystem where the displays are generated. Data is then sent from the video patch panel to a dedicated video monitor in the Main Control Console (MCC) and also to the Video Distribution Subsystem so that it can be displayed on any one of the monitors equipped with a video source select switch. A typical operator display is shown in Figure 2-26.

For further information on the Graphics Display Subsystem, see the Computer System manual (LC-0409-) and the Video System manual (LC-0407).

1.2M SIDERAL ASN +1137

WIKIKAL PARAMETERS
WIKIPAU

48 MT AZ SET 01 0112.17

UT 18 42 48 ST 019 13 18

	COMMAND	MOUNT	OFFSETS
AZ	002 26 08	000 06 12	000 00 00
POL	332 15 31	002 03 41	000 00 00
DEC	332 15 30	332 15 30	000 00 00

AZ	102 31 28	102 25 19	
EL	030 36 12	041 30 32	

RC	019 04 04		
DEC	030 30 26		

EPOL EDEC
000 22 28 000 00 00

ER00X.XX P03/X.XX

Figure 2-26. Sidereal display format.

The Autotrack Subsystem consists of a DBA Systems, Inc. Model 606-3 Dual Automatic TV Tracker, DBA tracker Interface, AERL Autotrack Computer Interface, and Autotrack Fixed Function Keyboard.

The Autotrack Subsystem receives its input from the Video Distribution System in the form of a point source satellite image. The TV Tracker has two separate channels that allow it to track a satellite image produced by two different closed-circuit telescope-mounted TV cameras. The DBA Tracker Interface and the AERL Autotrack Computer Interface function to provide the CDC 3500 and SC-17 computers with tracker status and satellite Delta X and Delta Y information in the proper format.

Delta X and Delta Y are used by the Computer System to generate the error signals that are used to drive the satellite image, i.e., the telescope mount into coincidence with the TV camera boresight reticle.

The video system also includes the necessary equipment to synchronize the horizontal and vertical scanning rates of all video sensors; TV monitors to display signals from the closed-circuit cameras or graphics display subsystem; and video test equipment used to evaluate, calibrate, and align the closed-circuit television cameras.

2.3.3 Common Support Equipment

The Common Support Equipment consists of equipment, systems, and hardware that are used to support MOTIF and DARPA

maintenance activities. The Common Support Equipment is divided into five equipment categories:

- 1) Handling equipment;
- 2) Cleaning and coating;
- 3) Optical test and alignment;
- 4) Liquid nitrogen;
- 5) Electronic test equipment.

A description of this equipment is contained in manual number LC-0403-.

A Stokes 96-inch vacuum coating chamber is installed at the DARPA/MOTIF facility. This equipment is capable of coating large mirrors up to 80 inches in diameter. Coating equipment also includes a Kinney 18-inch bell jar chamber. This is used to deposit coatings of various types on the secondary mirrors or other optical components. Ancillary equipment includes the power supplies, vacuum pumps and gauges necessary to operate the coating chambers and a film thickness monitor for measuring depositions. The equipment is designed to permit overcoating with materials such as SiO. Mirror handling devices designed especially for the DARPA/MOTIF telescope systems are also included as common support equipment.

Liquid nitrogen is used in the cool-down process for the AMTA sensor. Equipment for producing up to 6.5 liters per hour is installed at the DARPA/MOTIF facility.

The complex electronic and optical equipment at DARPA/MOTIF requires sophisticated test equipment. Oscilloscopes, meters, wave analyzers, counters, function generators etc., and a well-equipped calibration laboratory, including secondary electronic standards, comprises the electronic test equipment. Optical benches, alignment tools, calibrated optical filters, laser sources and a Weiser-Robidyne standard light source are provided as optical test and alignment equipment.

2.3.4 Computer System

The computer system consists of a Control Data Corporation (CDC) 3500, and CDC SC 1700 computer (nomenclature SC-17) and a host of peripherals, interfaces and ancillary equipment. The primary purpose of the computer system is to provide real-time control of the mounts. A secondary purpose is to provide computational power in batch mode. The computer system is also referred to as the Mount Control System or MCS. A simplified diagram of the MCS is shown in Figure 2-27.

Major hardware components are the following:

- 1) CDC 3500 computer with 64k words core memory and floating point capability;
- 2) CDC SC 1700 computer with 16k words core memory and floating point capability;
- 3) A CDC buffer transfer unit (BTU) designed especially for AMOS/MOTIF to interface the SC 1700 and CDC 3500;

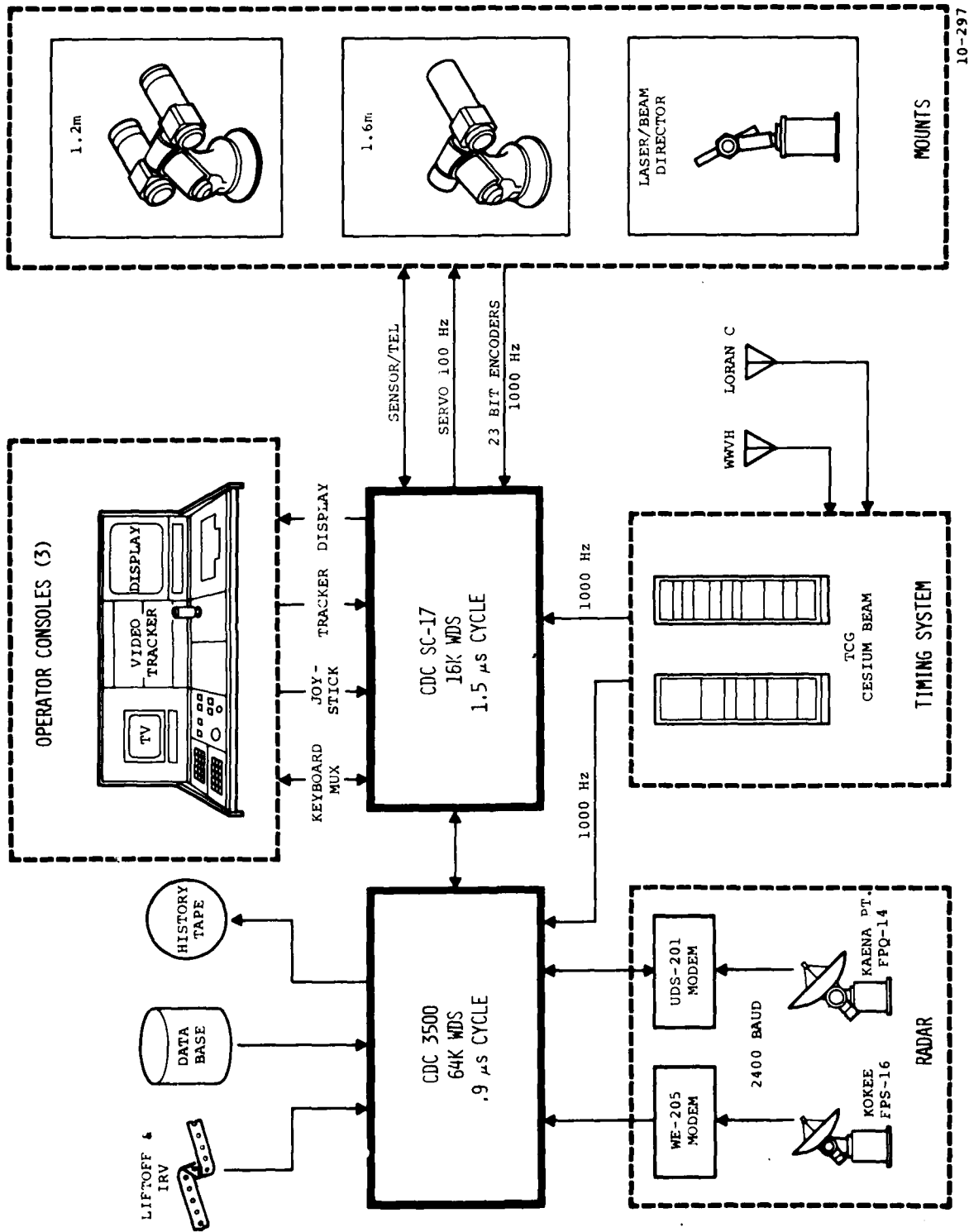

10-297

Figure 2-27. Mount control system.

- 4) Three CDC Model 659, 9-track tape units;
- 5) Three CDC Model 854, 6 megabyte disc units;
- 6) A CDC Model 405, 1000 CPM card reader;
- 7) A CDC Model 3691 paper tape reader/punch;
- 8) A CDC Model 512 1200 LPM line printer;
- 9) A Calcomp Model 565 Plotter;
- 10) A CDC Model 415 Card Punch;
- 11) An IT&T Model ASR 35 Teletype;
- 12) A CDC Model 304 Multiplexer which interfaces to WE 205A and UDS 201/150 radar data modems;
- 13) A CDC Model 3316 communications interface;
- 14) CDC Model 1500 I/O interfaces.

A block diagram of the computer hardware showing all interfaces is given in Figure 2-28. The software used with the computer system is described in Section 2.3.8. For more details, refer to the Computer manual (LC-0409-).

2.3.5 Timing System

The Timing System consists of the equipment illustrated in the block diagram of Figure 2-29. This system provides timing signals to both MOTIF and DARPA equipment.

The Timing System includes a cesium beam frequency standard. This provides long term stability of in $\pm 1 \times 10^{-11}$. The 1 MHz output from the cesium beam standard is used as the input to a time code generator. The generator produces the required timing

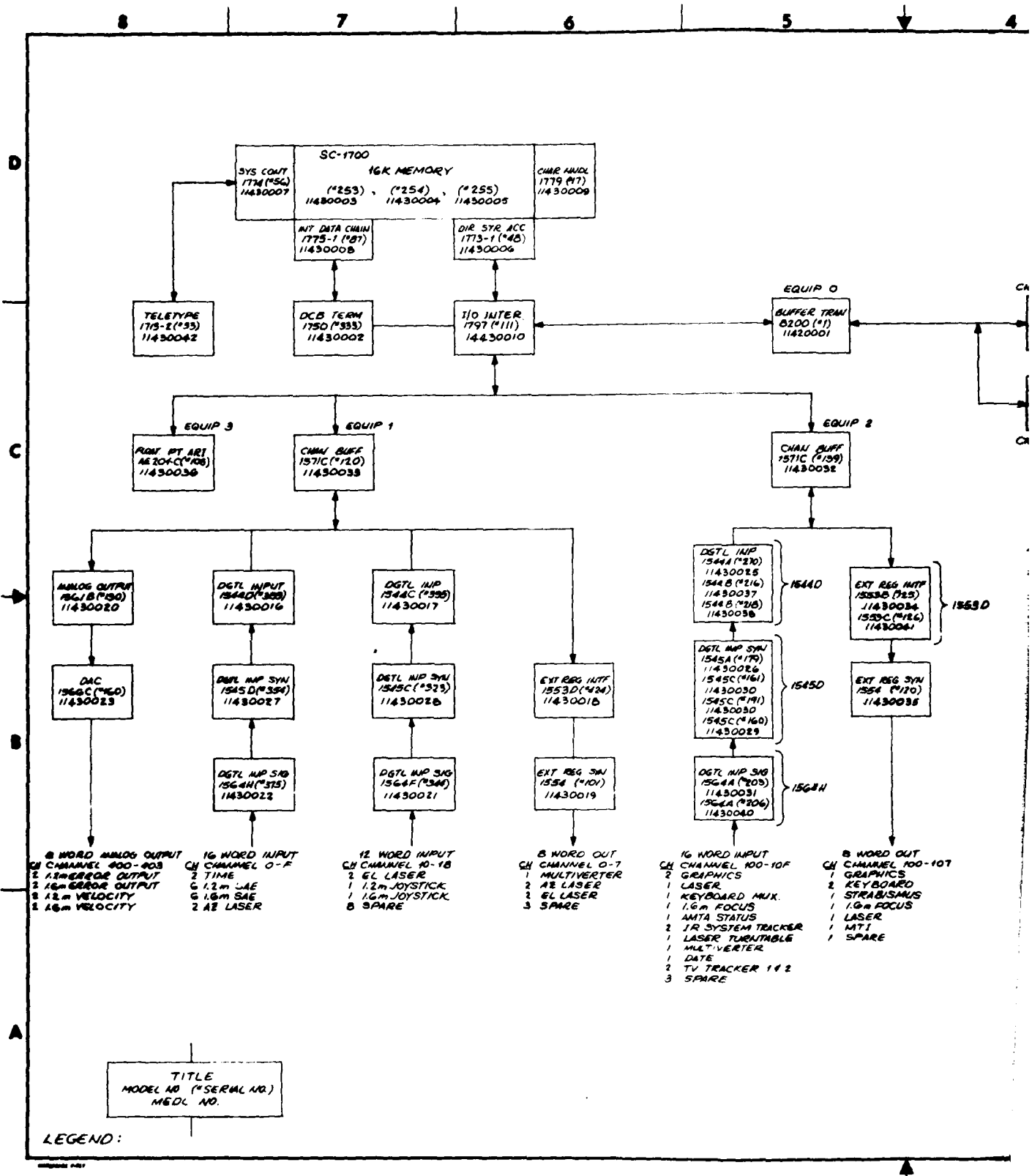

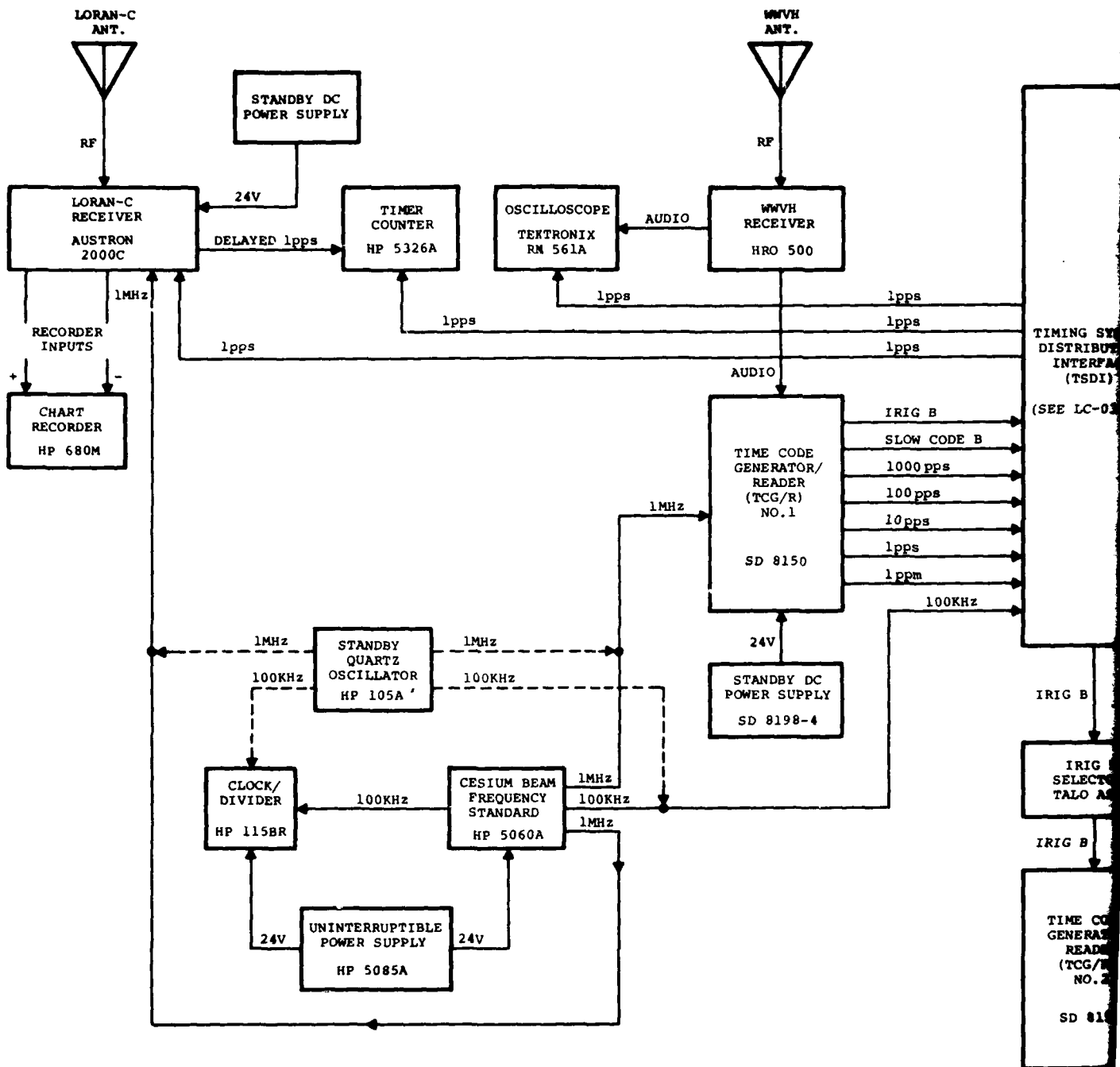

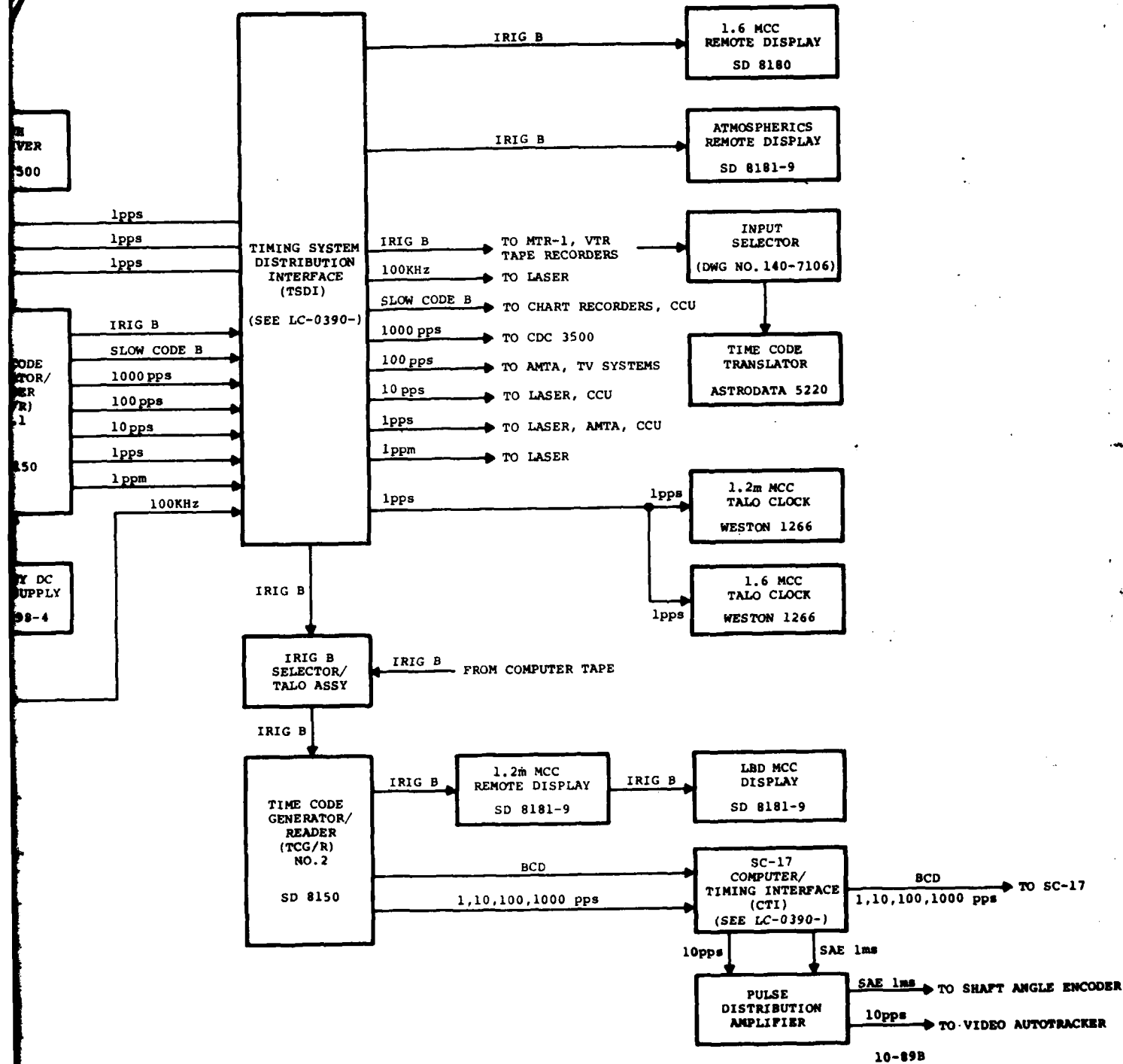

Figure 2-29. Timing System block diagram.

10-89B

required timing signals used by other major systems including IRIG-B, slow code B, BCD, and pulse rates of 1, 10, 100 k, 100k, and 1 M per second. Synchronization of the system is accomplished using a combination of WWVH and LORAN-C. This allows MOTIF time to be adjusted to within approximately 0.1 microseconds of universal time. Assuming an error budget for all system components, MOTIF data can be time tagged by the computer to within ± 5 microseconds of universal time.

2.3.6 Common Communications System

The Common Communications System consists of five subsystems:

- 1) Data Communications Circuits;
- 2) Observatory Intercom System;
- 3) Mobile Radiotelephone Communications;
- 4) Observatory Telephone System;
- 5) Public Address System.

For more detailed information on these subsystems, refer to MOTIF technical manual number LC-0408-.

The MOTIF/AMOS observatory is equipped with five data communications circuits. One of the circuits is a 75 baud teletype (TTY) line that can be switched between red and black equipment. Normally, this line enters the communications vault (Room 38) through appropriate filters and connects to KW-26 cryptographic equipment and to Model 28 TTY equipment. During any Western Test Range launch operation, the circuit is

switched to equipment consisting of one ASR 35 Teletype and one Model 28 Printer located outside the vault in Room 39. This equipment is used to transmit and receive hardcopy data (printed text and punched paper tape) from Vandenburg AFB.

The other four circuits are 2400 baud circuits used to transmit radar and telescope pointing information between AMOS/MOTIF and radar sites located on the islands of Kauai and Oahu, Hawaii; as well as for voice communications. These circuits terminate in a switching bay which allows the communicator to switch the proper equipment on-line. A line used to transmit radar data from the FPQ-14 site at Kaena Point, Oahu, to AMOS/MOTIF would be switched to the UDS 201B/150 modem; a line used to transmit radar data from the FPS-16 site at a Kohee Park, Kauai, to AMOS/MOTIF would be switched to the WECO 205A modem. Voice lines are switched to the intercom system. All lines can be connected individually to appropriate circuit test equipment.

The Observatory Intercom System consists of master and slave intercom stations and the main intercom electronics. Master or slave stations are located at various operator positions throughout the facility. A master intercom station is shown in Figure 2-30.

The intercom system provides seven networks, six voice direct circuits, three dial lines and access to the Observatory

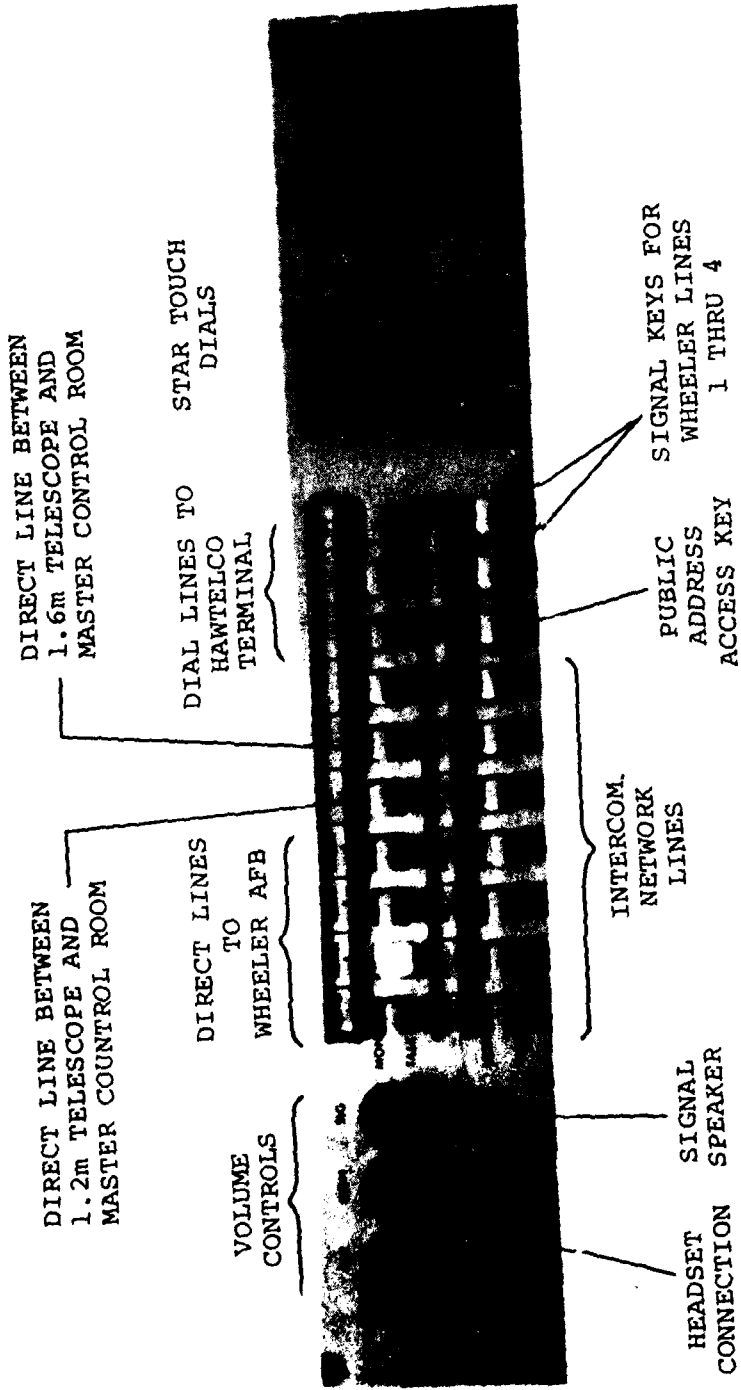

NOTES:

1. CIRCUIT ACCESS KEYS 1 THRU 17 ARE THREE-POSITION LOCKING KEYS; DOWN (TALK) TO THE TALK/RECEIVE MODE AND UP (MON) TO THE MONITOR MODE.
2. CIRCUIT KEY 18 IS NON-LOCKING; PUSH DOWN TO ACCESS THE OBSERVATORY PUBLIC ADDRESS SYSTEM.
3. CIRCUIT KEYS 19 AND 20 ARE THREE POSITION NON-LOCKING KEYS; DOWN TO SIGNAL DIRECT WHEELER LINES 2 AND 4 AND UP TO SIGNAL DIRECT LINES 1 AND 3.

10-130A

Figure 2-30. Master intercom station.

public address system. All circuits are completely isolated and can be switched to either a talk/listen position or a monitor only position. Four of the voice direct lines are connected to the switching equipment which allows the intercom panels to be connected to the voice/data lines between MOTIF and Wheeler AFB, Oahu, Hawaii.

The Mobile Radiotelephone Communications Equipment consists of VHF/FM radiotelephones located in all GSA vehicles, at the MOTIF contractor's office, and at the AMOS/MOTIF facility on Mount Haleakala.

The prime purpose of the radiotelephones is to provide a means of communication should emergency help be required while vehicles are traveling on the road to the Observatory. It is also used to transmit routine messages to personnel enroute and as a back-up to the commercial telephone system.

Observatory telephone service is provided by the Hawaiian Telephone Company. The system has seven voice lines, four are connected to the Observatory PABX, one to the Automatic Voice Network (AUTOVON), and two to the PABX located in the contractor's office in Puunene, Maui, Hawaii. A public address system is accessible through the telephone system.

2.3.7 Facilities

The MOTIF/AMOS facilities are divided into eight categories:

- 1) Buildings and Grounds;
- 2) Power;
- 3) Air Conditioning;
- 4) Water/Waste;
- 5) Shops;
- 6) Vehicles;
- 7) Emergency and Safety Equipment;
- 8) Compressed Air.

Information on facilities is contained in technical manual number LC-0382-.

MOTIF and AMOS are housed in two buildings, the Main Observatory Building and the Technical Support Building. The buildings reside on approximately 2.5 acres of land leased from the University of Hawaii. A 750 KVA transformer, underground pump room and 70,000 gallon water storage tank (both below grade), air conditioner condensing units, and diesel fuel storage tank and heat exchanger are located exterior to the buildings.

The AMOS/MOTIF facility uses electricity supplied by the Maui Electric Co., Ltd., as its prime source of power. Power from an electric company substation located just east of the Observatory is fed into the facility 750 KVA main transformer.

The transformer reduces the voltage from 23,000 volts to 480 volts. Power from the transformer is fed into the Main Observatory Building, through underground cables, and then distributed to various lighting and power panels.

The facility also has a 100 KVA standby diesel generator. This supplies power for the operation of heaters, lights, communications, and equipment needed to place the operating systems in a safe (stowed) condition. It does not supply sufficient power to operate MOTIF.

There are two air conditioning systems that are used by MOTIF. One is used to condition the air in the Main Control Room (Room 1) and the second is used to condition the air in rooms 38, 39, 40, and 41 where the Communications, Data Transmission, and Computer Systems are located. Two other systems are used exclusively by DARPA, one for the Laser Beam Director and one for room 26 where the Compensated Imaging System is located.

Potable water is collected from the building roof and stored in a 70,000 gallon underground tank. During dry weather, it is often necessary to supplement the supply of rain water by trucking water up the mountain from the valley where a commercial supply of water is available. The facility is equipped with a water treatment plant that filters and removes bacteria from the drinking water.

Waste water is routed to a septic tank located 45 feet north of the Main Observatory Building.

Three shops are located in the Technical Support Building: machine, welding/mechanical and carpentry. The machine shop is equipped with a Bridgeport mill, Sheldon metal working lathe, and a variety of miscellaneous tools such as a band saw, drill press, grinder, cut-off saw, brake, shear, press as well as many hand tools. A good supply of raw material is also maintained at the site. Most of the precision instrument packages have been fabricated on-site.

The welding/mechanical shop is equipped with both heliarc and acetylene welding equipment and with standard and specialized hand tools. Plumbing tools and equipment are also included in the mechanical shop.

The carpentry shop is used to make wooden packing crates and occasionally to make a model of some instrument to check clearances. It includes a table saw, jointer, sander and assorted hand tools.

Support vehicles consist of two forklifts located at the Observatory, two trucks located at the contractor's office in Puunene, Maui, Hawaii and several passenger vehicles.

The forklifts are used to unload equipment and supplies delivered to the Observatory and to move equipment between buildings. The trucks are used to transfer material from receiving terminals to the contractor's office and to the

Observatory. The passenger vehicles are used to transport personnel from the site contractor's office to the Observatory.

Emergency and safety equipment consists of first aid kits, a fire detection system, fixed and portable fire extinguishers, Halon fire extinguishing systems, a water/foam fire extinguishing system, emergency/supplemental oxygen, stretchers, and an emergency-equipped station wagon located at the Observatory.

2.3.8 Software (Common)

The Common Software consists of programs contained in the following four categories:

- 1) Extended Real-Time Operating System (EROS);
- 2) Mission Support System (MSS);
- 3) Library;
- 4) Vendor.

More detailed information is contained in the Computer Program Configuration Items (CPCIs). These are identified where applicable.

EROS CPCI

The Extended Real-Time Operating System CPCI (EROS) is a stand alone operating system customized to support real-time mount control functions. EROS operates on the CDC 3500 and SC-1700 computers and has the following distinguishing characteristics:

- 1) Tasks, which are the units that perform all functions of EROS, are scheduled and activated according to priority level.

- 2) There are three priority levels of interrupts. Servo updates are assigned highest priority to ensure minimum response time to maintain smooth servo control. Interrupt service time is minimized by scheduling tasks which are, in turn, activated by the scheduler according to assigned priorities.
- 3) Interrupt driven I/O drivers are designed for specific real-time requirements. These include drivers for standard devices such as magnetic tape, disc, CRT display, paper tape, typewriter, and special devices such as the 3316 communications multiplexer.
- 4) The capability to maintain two reference state vectors with up to six differential target state vectors per reference, each with Kalman filter input for tracking improvement.
- 5) The capability to update a reference state vector is used for multi-target missions where the relative target trajectories are better known than the trajectory of any one target.
- 6) Interface to a radar data link enables data from either the FPQ-14 or FPS-16 to be input to the Kalman Filter.
- 7) There are provisions to support the operation of two DBA Video Trackers.

- 8) Telescope control is provided to enable optical alignment of the two telescopes on the 1.2 meter mount and autofocusing on the 1.6 meter mount.
- 9) An automated search sequence is available as a target acquisition aid.
- 10) An algorithm that provides for target verification is used for satellite missions.
- 11) A capability to periodically step off and on a target trajectory permits second order background compensation for photometry and LWIR radiometry.
- 12) An automated sky scanner sequence provides for systematic telescope positioning in elevation for a constant azimuth.
- 13) Operator interface enables input of commands from the operator and output of display information.
- 14) Disc files provide constants and parameters and libraries for stars, satellites, and ballistic initial conditions. The star library contains positional information for over 10,000 stars, which may be retrieved by name, catalog number or by a proximity criterion. Ballistic initial conditions for missiles and satellites may be retrieved from disc files or calculated in real-time from information extracted from the satellite library.
- 15) A history recording is generated for post-mission data reduction and analysis.

During normal tracking operations, EROS controls the motion of the 1.2 m Telescope Mount, the 1.6 meter Telescope Mount, and the Laser Beam Director all simultaneously and independently. It computes object position and velocity as a function of time for any object tracked and provides outputs to the mount servo control systems. An analytical mount model is incorporated into EROS to improve pointing accuracy and a real-time Kalman filter improves tracking. Each telescope system has demonstrated 1 to 3 arcseconds absolute pointing accuracy and better than 5 arcseconds tracking accuracy, while under control of EROS.

Detailed information on EROS is contained in manual number LC-0436-.

MSS CPCI

The Mission Support Software (MSS) CPCI consists of three tasks: the Data Base Maintenance Task (DBM), the Mission Preparation Task (MPT) and the Data Reduction Task (DRT). The DBM allows inspection and alteration of the data base, which includes mathematical constants, site coordinates, mount parameters, sensor parameters libraries and EROS load modules. The MPT prepares data files and printouts for objects tasked for an upcoming operation, such as missiles and satellites. The DRT reduces data collected during the operation into either an on-site inspectable form or a form acceptable to ADCOM.

AD-A106 997

AVCO EVERETT RESEARCH LAB INC EVERETT MA
MAUI OPTICAL TRACKING AND IDENTIFICATION FACILITY TRANSITION PR--ETC(U)
AUG 81 J CHAPMAN; T REED F30602-77-C-0184

F/G 22/4

UNCLASSIFIED

RADC-TR-81-243

NL

2
11

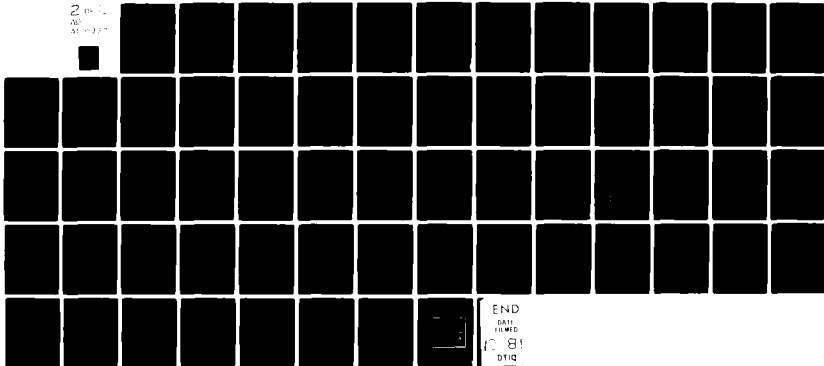

The DBM is made up of eight separate functions as follows:

- 1) Data File Maintenance (DFMAINT2);
- 2) Set Data Base File (SETDBF);
- 3) Automatic Mount Constants (AUTOCON4);
- 4) Star Library Maintenance (STARLIB);
- 5) Satellite Random Access Program (SATRAP, SATRAP4);
- 6) Linking Loaders (SPELL2, EZLOADR);
- 7) EROS Disk Loader (DISKLD);
- 8) EROS Disk Backup (BACKUP).

DFMAINT2 allows inspection and correction of mathematical constants and site-related constants on the EROS disk. SETDBF maintains constants on the MODCOMP disk shared by DTS and CMS. AUTOCON4 calculates new mount and sensor constants from position error data generated by EROS. STARLIB updates the MOTIF Star Library as needed. SATRAP maintains the Satellite Library on the EROS disk, while SATRAP4 does the same for the MODCOMP shared disk. SPELL2 is a linking loader used to generate the CDC 3500 portion of EROS, while EZLOADR is its SC-1700 counterpart. DISKLD loads, dumps or erases programs on the EROS disk. BACKUP is a disk protection facility that saves and restores the EROS disk to and from magnetic tape.

The MPT is comprised of five functions as follows:

- 1) AMOS Ephemeris Satellite Orbital Prediction
(AESOP, AESOP4);
- 2) Mission Planning (MISHAP);

- 3) Missile Preparation (MISPREP);
- 4) Satellite Preparation (SATPREP2);
- 5) Time of Sunrise (TSUNRISE).

AESOP determines the rise times of all objects tasked for an operation using the EROS Satellite Library. AESOP4 does the same for the MODCOMP shared disk Satellite Library. MISHAP uses the output from AESOP4 to schedule the objects for an operation. MISPREP prepares AMOS Track Number (ATN) data for a missile launch and updates the ATN File. SATPREP2 prepares ATN data for a satellite and updates the ATN File. TSUNRISE will generate an ephemeris of sunset, sunrise and twilights at MOTIF for any specified year.

The DRT consists of ten functions as follows:

- 1) History Tape Survey (SURVEY);
- 2) EROS Report Generator (ERG);
- 3) Analog to Digital Conversion (ALHPA, OMEGA, ALHPAC, OMEGAC);
- 4) Photometric Manual Calibration (PHOTOMAN);
- 5) Photometric Data Reduction (CMPTOGLE);
- 6) SOI Data Generation (SOYGEN);
- 7) AMTA Manual Jones Calibration (MANJONES);
- 8) AMTA Jones Calibration (JONES, RAD);
- 9) AMTA Data Reduction (TOGLPLOT);
- 10) Sensor Data Summary (DUMPTAPE, DIGITAPE).

SURVEY generates a brief description of any given section of an EROS history tape. ERG generates all history reports in cases where a hard-copy is desirable. ALPHA is the SC 1700 program used to convert AMTA analog data to digital data and OMEGA is the CDC 3500 program that generates the AMTA digital data tapes. ALPHAC and OMEGAC are the photometric counter-parts of ALPHA and OMEGA. PHOTOMAN allows entry of hand calculated calibration data into the photometric calibration file. CMPTOGLE reduces photometric data from the OMEGAC-generated data tape and the PHOTOMAN-generated calibration file and stores the reduced data on magnetic tape. SOYGEN produces a transmittable paper tape copy of the reduced photometric data with appropriate headers and trailers. MANJONES is the AMTA equivalent of PHOTOMAN. JONES and RAD allow automatic rather than manual calibration. TOGLPLOT is the AMTA data reduction program. DUMPTAPE prints the data from the TOGLPLOT-generated digital tape in a tabular form and DIGITAPE does the same for CMPTOGLE-generated tapes.

All MSS tasks are considered to be in support of, rather than a part of, MOTIF mission requirements. Detailed information on MSS is contained in manual number LC-0435-.

Library

Library routines consist of proven routines and subroutines that are used by more than one program. The Common System Software library routines are those that are used by EROS and MSS and run on the CDC 3500 computer. The MSS library routines are identified in manual number LC-0436-.

Vendor

The vendor software for the Common System consists of the software obtained from Control Data Corporation listed in Table 2-3. All of these programs run on the CDC 3500 computer.

Table 2-3. CDC Vendor Software

MSOS 5	CDC 3500 Mass Storage Operating System
COMPASS	Assembly Language
ANSI FORTRAN	American National Standards Institute Fortran Spec. X3.9
MS FORTRAN	CDC Version of Fortran
APC	Spooler
L-MSIO	Logical Mass Storage Input/Output
MSUTIL	Mass Storage Utility
UTILITY	Magnetic Tape Utility
MS COBOL	Mass Storage COBOL
COSY	Compressed Symbolic Processor
SIM 17	SC-17 Cross Assembler (Operates on CDC 3500)
ALGOL	Compiler
PERT/TIME	
SORT/MERGE	

2.4 MOTIF Operation

The MOTIF mission is to function as a primary SPACETRACK sensor in support of ADCOM. Two tasks are accomplished:

- 1) Track space objects as specified by ADCOM for the purpose of collecting metric and SOI data in accordance with tasking instructions; and,
- 2) Provide surveillance of the geosynchronous belt when not otherwise tasked for specific satellites.

MOTIF operates, as described below, to accomplish this mission. Operations are conducted seven nights per week from evening nautical twilight to morning nautical twilight. Maintenance is normally performed during daylight hours five days per week, and the communications center is operated 24 hours per day, seven days per week.

Satellite Mean Orbital Elements and Sensor Tasking instructions are received by the MOTIF Communication System (CMS) from ADCOM in AUTODIN message format. The CMS also receives and displays all other information sent to MOTIF via AUTODIN. The data is processed and used to update the appropriate files in the MOTIF Data Transmission System (DTS). The information is then used by the DTS to prepare the MOTIF mission plan for each evening's operations.

Upon arrival of the operations crew, system start-up is accomplished and initial calibrations are performed. Satellite tracking then commences in accordance with the mission plan.

The operator selects a satellite to be tracked using a keyboard on the Main Control Console. The keyboard interfaces to the CDC 3500 computer which calculates the position of the satellite as a function of time by integrating the ballistic equations of motion, using the orbital elements as the initial conditions. These calculations require accurate time which is obtained from the MOTIF Timing System. The pointing instructions incorporate a mount model computation to remove imperfections in the mount and telescope system.

When the calculations are completed (performed 1000 times per second), the pointing information is transferred to the SC 1700 computer. The position of the telescope mount is input to the SC 1700 computer from the Mount Servo System's shaft angle encoders (SAE). The SC 1700 computer generates error signals at a rate of 100 times per second that represent the difference between the computed position of the satellite and the mount pointing position. The servo system drives the mount until the error signals are reduced to zero.

Errors in the orbital element sets appear as look angle offsets while tracking the satellite. The operator observes these errors on the Video System displays and corrects for them, positioning the satellite image in the center of the boresight television reticle pattern. These offsets and the calculated satellite position and velocity are then used in a

Kalman filter algorithm to calculate improved pointing commands. This process is repeated until the Kalman filter converges and a smooth track is established.

Two types of data are collected at MOTIF: metric or position data and SOI data. Metric data is collected on every satellite tracked, SOI data is collected on certain specified satellites as requested by ADCOM. SOI data consists of either photometric signature data obtained with the CMP or LWIR data obtained with the AMTA. The CMP is restricted to nighttime use on visible targets; the AMTA can be operated at any time, 24 hours per day. During any typical night, tasking will require five photometric tracks, two LWIR tracks and up to 100 metric tracks.

During metric tracking operations, the operator interrupts the SC 1700 computer when the object is on the boresight. This signals the computer transfer one data point (right ascension and declination angles with a time tag) to the DTS. Once the required number of data points are collected, the DTS file is closed and available for review and processing. The data points are displayed, evaluated, edited if necessary, and sent to the CMS for transmission to ADCOM via AUTODIN. Real-time tracking operations continue simultaneously with data processing.

Photometric data can be collected on any satellite being tracked as long as its apparent visual magnitude is above the instrument threshold. When this data is required, the CMP operator activates the link between the CMP and the DTS. Data are collected at a rate of 50 Hz, digitized, and sent to the DTS. Once tracking is complete, the data can be displayed, evaluated, edited if necessary, processed, and sent to the CMS where it is formatted for transmission to ADCOM via AUTODIN. Processing in this case includes application of calibration parameters, normalizing and computing exo-atmospheric visual magnitude versus time.

LWIR data can also be collected on objects tracked that have sufficient LWIR signals in the various atmospheric transmission windows. When this data is required, the AMTA operator records data on magnetic tape and strip chart. Following the tracking mission, the data is manually processed to calculate a single point LWIR value in terms of radiant intensity. This value, along with the appropriate identification tags, is then sent to ADCOM via AUTODIN in message format.

Whenever either photometric or LWIR data are collected, appropriate calibrations are performed. Both standard source and stellar calibrations are included.

All other activities at MOTIF support the tracking operations function. Routine communications and maintenance tasks support operations on a daily basis. Performance assessment and quality control tasks maintain the integrity of MOTIF data. Hardware and software evaluation and improvement tasks are aimed at improving the MOTIF data products.

3.0 MOTIF TRANSITION PROGRAM TASKS

The MOTIF Transition Program (MTP) was structured into nine major categories, as follows:

- 1) Program Management;
- 2) Hardware and Systems Development;
- 3) Software Development;
- 4) Systems Test and Evaluation;
- 5) Training;
- 6) Maintenance;
- 7) Data;
- 8) Operations;
- 9) Materials.

Some of these tasks were level-of-effort tasks; that is, the task requirement was to supply the number of manhours or amount of material necessary to perform a specific function. Management, training, maintenance, operations, and materials were level-of-effort tasks. All other tasks had specific tangible outputs.

Most of the MTP tasks were divided into subtasks. These were identified in the Work Breakdown Structure (WBS) for the program (Fig. 3-1). Each of these subtasks will be described further in this report except for the management tasks (WBS-100) and the materials task (WBS-900). These were performed as required to complete the program.

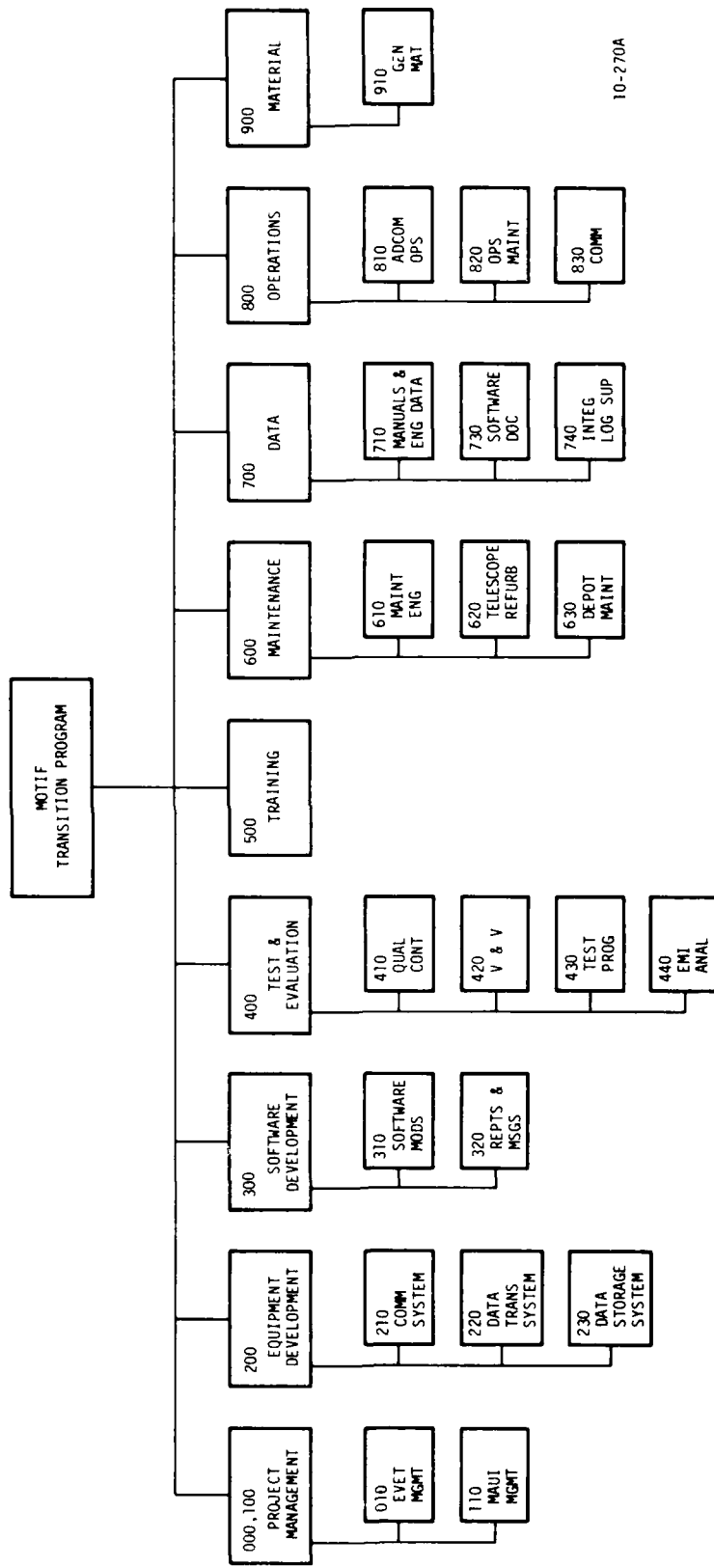

10-270A

Figure 3-1. Work breakdown structure.

3.1 Hardware Systems Development (WBS-200)

Two major hardware systems were developed for MOTIF: the Communications System (CMS) and the Data Transmission System (DTS). A minor hardware task, to supply a data storage system, was also included.

3.1.1 Communications System (WBS-210)

A communications system capable of transmitting and receiving classified data (up to and including SECRET) at a rate of 2400 baud was required to interface to the communications link provided to MOTIF as GFE. The GFE communications link includes two high-speed cryptographic units (KG-13), along with the associated data modem and J-box, all of which are integrated into the AUTODIN (JANAP-128 protocol) via one conditioned, full-duplex, synchronous, 2400 baud circuit.

The existing communications system at MOTIF consisted of one 75 baud circuit which interfaced Model 28 Teletype equipment through KW-26 cryptographic units. This system utilized punched paper tape for data input/output and was considered far too slow to meet MOTIF needs.

Requirements placed on the CMS were to transmit and receive information via the AUTODIN and to perform necessary code conversions including ASCII/binary/icosahexal, as required. It must include provisions for recognizing, sorting, and routing messages based on content; for generating a hard copy of both

incoming and outgoing text messages; and for high-speed storage/retrieval of received data messages such as satellite element sets and tasking messages. Finally, the system must provide an interface to the Data Transmission System (DTS) which allows rapid transmission of MOTIF data to ADCOM.

The basic design of the CMS was originally set forth in the government approved Data Transmission System Design Report, dated March 1977, with changes dated July 1977, submitted under data item A00J to contract F04701-75-C-0047. When the MTP started in August 1977, the MODCOMP II computer system (including peripherals) and an Analytics TLC-100 were ordered and a detailed system design was initiated.

Several problems were encountered during the design phase of the program. Most related to establishing firm requirements for software design. The method of identifying message content was not established for several months; the handshake between the MC II and the TLC-100 required several design iterations; and the firmware in the TLC-100, as originally delivered, was not compatible with required AUTODIN protocol. Problems were solved and the system completed. Final AUTODIN Category III tests were performed by DCA and the CMS was put on-line on 2 August 1979.

The CMS provided under this MTP task is described in Section 2.2.7; software incorporated into the CMS is described in Section 2.2.8.

3.1.2 Data Transmission System (WBS-220)

A data transmission system capable of recording, displaying, editing, processing, and transmitting (to the CMS) photometric and positional data generated by the MOTIF was required. The DTS had to provide processed data in digital format for transmission to ADCOM within 30 minutes after a tracking mission was terminated.

Data processing was performed manually with computer assistance prior to the development of the DTS. For positional data, it was necessary to terminate the real-time tracking program, load the batch operating system on the CDC 3500, replay the history tape under control of a program which punched a paper tape with the data, and take the paper tape to the Communications Center for transmission to ADCOM. For photometric data, it was necessary to terminate the real-time tracking program, load the batch operating system on the CDC 3500, replay the analog CMP data tape through an analog-to-digital converter to produce a digital data tape, replay the digital data tape under control of a program which punched a paper tape with the data, and take the paper tape to the Communications Center for transmission to ADCOM. In both cases, the process was very time consuming and did not allow tracking to continue simultaneously with data processing.

The design of the DTS was originally set forth in the government approved Data Transmission System Design Report, dated March 1977, with changes dated July 1977, submitted as data item A00J to contract F04701-75-C-0047. When the MTP started in August 1977, the MODCOMP IV computer system (including peripherals) and a Tektronix 4014-1 display device were ordered and the detailed system design was initiated.

The DTS, provided under this MTP task, is described in Section 2.2.6; software incorporated into the DTS is described in Section 2.2.8.

3.1.3 Data Storage (WBS-230)

A data storage system was required to accommodate the high volume of data expected during full-time operations. Once established, the storage system must be maintained and must incorporate an accounting or logging system which provides for rapid retrieval of data. The system must provide storage for both hard copy and magnetic tape data and accommodate both CLASSIFIED (up to and including SECRET) and UNCLASSIFIED information. It must provide proper (environmentally controlled) storage areas for magnetic tapes and be of sufficient size to store these tapes for up to 30 days for the case of photometric data and up to 10 days for the case of metric data. This is necessary to facilitate a retransmission of data if required by

the SCC for additional data reduction or for verification of a particular event. In addition, a satisfactory means of degaussing and verifying magnetic tape must also be implemented.

No previous data storage library existed at MOTIF. Considering the anticipated volume of data to be generated, this was felt to be a shortcoming. In addition, MOTIF previously had no provision for degaussing tapes and the only way to verify a tape was to use the CDC 3500, an unsatisfactory operational procedure.

Two storage areas were established at the observatory. One is in the communications vault (Room 38), for storage of hard copy data and magnetic tapes; the other is in the control room vault (Room 17), used for storage of magnetic tape recordings. Both of these areas meet the requirements for storage of SECRET material, both are temperature and humidity controlled, and the combination is of sufficient size to accommodate the quantity of data generated by MOTIF.

Sufficient tape storage racks and file cabinets were procured to implement the library. A Bell & Howell TD-2903-4B automatic tape degausser and a Data Devices International Century 22 (Mod V) Magnetic Tape Cleaner/Evaluator were also acquired to satisfy requirements.

3.2 Software Systems Development

MOTIF goals required a substantial increase in the number of observations of space objects during each operational period. Achieving this goal required additional software capabilities. Both the CDC 3500/SC-17 system and the MODCOMP IV system were utilized to generate the additional software capability required.

The task was comprised of a number of subtask modules. These include Mission Planning, Object Verification, Search and Surveillance, Multiple Objects, History Modifications, Direct Access to the Satellite Library, On-Line Diagnostics, Satellite Library Upgrade, Paged Display, Deep Space Ephemeris (HUJSAK or DP4) Program, and Reports and Messages Development.

3.2.1 Mission Planning Subtask (WBS-031 and -310)

An automatic mission planning capability was required to replace the existing manual one to allow MOTIF to plan and track an increased number of satellites per night. The software developed to satisfy this requirement accounts for satellite tasking as well as satellite availability. It is designed to run on the MCIV. An overview of the mission planning software is given in Figure 3-2.

The design specification for the Mission Planning Subtask divides the program into three basic elements:

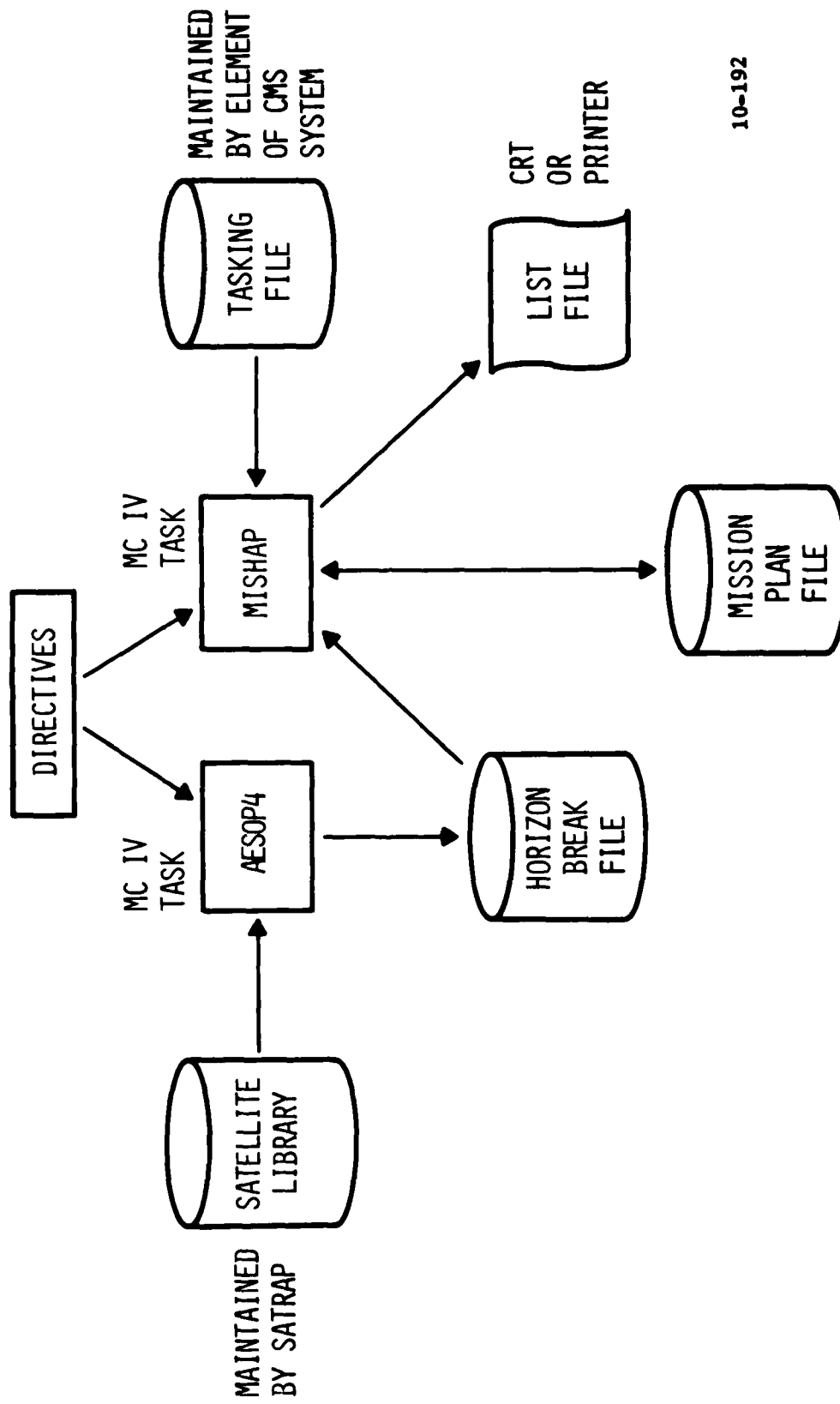

10-192

Figure 3-2. Mission planning program.

1) Horizon Break File Generator/Processor

The Horizon Break File is created from satellite elements which are stored on the satellite library. This is accomplished using a modified version of the previously existing AMOS satellite orbital prediction program, AESOP. The modified version of the AESOP program is called AESOP4. It includes a routine called WATSUP, which determines satellite rise and set times based on a method of Escobal, "Methods of Orbit Determination". AESOP4 provides information such as satellite lighting conditions, look angles, range and rise time. The records in this file are ordered by rise time and contain a pointer to an ephemeris file.

2) Tasking File Processor

The Tasking File contains the codes sent daily from the SCC in tasking messages. A subprogram transfers the codes into object order on the tasking file. The codes indicate tracking priority, type of tracking required, data transmission priority and, if needed, the SOI requirements.

3) Mission Plan Generator

A Mission Plan File is created by a program called MISHAP, which utilizes data in the Horizon Break File

and the Tasking File. The Mission Plan File contains time sequenced records at which specific events are to occur as well as the object's tasking parameters. Associated with each scheduled event (e.g., acquisition) is the object's positional parameters, moon position and sun illumination.

The SCC may send new tasking data at any time, even after the operations for an evening have already been scheduled and begun. An operator request capability is therefore provided to enter the updated tasking into the Tasking File and to reactivate the mission plan generator. The Mission Plan File may be reordered as a result.

Contents of the Mission Plan File may be listed (printout) at any time. This listing will be used by the operator to direct tracking activities. An example of a mission plan page is shown in Figure 3-3. More detailed information on MOTIF's mission planning capability is included in the MCC CPCI (LC-0435-).

3.2.2 Object Verification Subtask (WBS-310)

MOTIF must have the capability to ascertain, once detection is achieved, that the detected object is the desired object.

This task is accomplished using satellite positional uncertainty criteria. The form of satellite element uncertainty was determined and target verification criteria were defined by

DATE 09/20/79

>>> M O T I F W O R M S H E E T <<<

ACQUISITION RECORD / HISTORY

SCHEDULED PASSES

TIME	OBJECT/ TASKING	RISE/ SET	SHADOW IN/OUT	CULM/ ELV	MT AZ	EL SET	EL AGE	DEL POL	DEL DEC	MV	TIME	DATE
04:55	3929 35	03:00- 16:59		03:00 25	0.0	162	2					09/20/79

TIME	OBJECT/ TASKING	RISE/ SET	SHADOW IN/OUT	CULM/ ELV	MT AZ	EL SET	EL AGE	DEL POL	DEL DEC	MV	TIME	DATE
05:10	5888 35	03:00- 16:59		03:00 36	0.0	107	3					09/20/79

TIME	OBJECT/ TASKING	RISE/ SET	SHADOW IN/OUT	CULM/ ELV	MT AZ	EL SET	EL AGE	DEL POL	DEL DEC	MV	TIME	DATE
05:25	9941 35	03:00- 06:11			0.0	137	2					09/20/79

TIME	OBJECT/ TASKING	RISE/ SET	SHADOW IN/OUT	CULM/ FLV	MT AZ	EL SET	EL AGE	DEL POL	DEL DEC	MV	TIME	DATE
05:40	03194 3E	03:00- 06:41			0.0	218	2					09/20/79

Figure 3-3. Example of mission plan.

ADCOM. Numerical algorithms for relating element uncertainty to target state vector uncertainty and for comparing the target acquisition vector to the state vector uncertainty were developed. This task operates on the CDC 3500 computer as a routine in the EROS software (LC-0436-).

If the numerical algorithm used determines that the detection is outside the bounds of the uncertainty criteria, the routine will class the detection as an uncorrelated target (i.e., it is not the desired target) and report it as such to the DTS tagged with a 90,000 series object number.

3.2.3 Search and Surveillance Subtask (WBS-310)

Systematic search and surveillance patterns are required to facilitate rapid acquisition of tasked objects and to permit a deep space survey for uncataloged objects. Search is defined as the process of looking for a known, tasked object when given a nominal element set or other positional data on that object. That is, if the tasked object does not appear in the system field-of-view when using nominal pointing data, a search would be initiated. Surveillance is defined as the process of looking for unknown objects which are resident in deep space but are not contained in the current deep space catalog. These patterns must be computer controlled to insure consistency and accuracy. Previously available search capability was limited to manually adding offsets to the tracking commands.

Search and surveillance criteria include search patterns to provide horizon break and early-late (along orbit plane) capability and a selectable range of step sizes and stare times. Surveillance patterns are designed to provide coverage of 60 square degrees in a two hour period.

The design of the search and surveillance program is subdivided into three separate parts, as follows:

1) Search Pattern Generator

For each step in the search sequence for any selected pattern, the polar and declination offsets are calculated. Provision is included to prevent steps if search is "OFF" or in a "HOLD" condition and to retrieve previous steps if the operator requests "LAST FOV".

2) Operator Interfaces

The operator interface processes fixed function keyboard (FFK) inputs (i.e., initialization and set switches) and alphanumeric keyboard (ANK) inputs (i.e., decoding and redefining values).

3) EROS Modifications

The search and surveillance program operates on the CDC 3500 as a modification to the EROS program. Implementing this required the following:

- 1) modification of the existing FFK/ANK inputs enqueue/dequeue task to accept new tasks;
- 2) extension of the existing task table with new FFK/ANK processing tasks and a search pattern generating task;
- 3) modification of the existing task schedule to schedule added tasks:
- 4) modification of the existing coefficient update task to calculate sidereal coefficients for sidereal search, and to provide synchronization with search stare time;
- 5) inclusion of search offsets when calculating command angles within the servo update task; and,
- 6) modification of the existing Kalman update task to account for the accumulation of search steps.

Search and surveillance capabilities provided with the above design are shown in graphic representation in Figure 3-4.

Surveillance is accomplished using standard search functions as follows: the program is initiated with the input of a 9XXXX satellite number (an uncorrelated target) and activation of an appropriate search pattern. If an acquisition occurs, the metric data is reported with the satellite number selected.

Search pattern capabilities utilize both the FFK and ANK computer inputs. FFK inputs are as follows:

SURVEILLANCE

- TO GENERATE PSEUDO STATE VECTOR: S_{0H} OBJ 9NNNN E_{0T}
- UTILIZE SEARCH FUNCTION OPTIONS

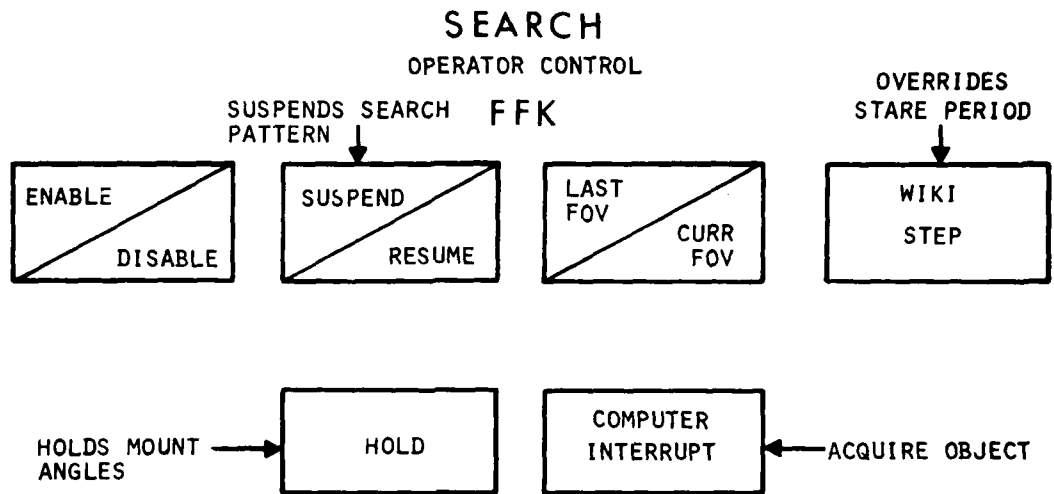

ANK

- GENERAL FORM: S_{0H} SRC X, P1, P2, P3, P4 E_{0T}

	X	P1	P2	P3	P4
RESET ALL PARAMETERS TO DEFAULT VALUES	Z				
STARE PERIOD	T	STARE PERIOD			
STARE MODE	M	S: SIDEREAL T: TRACK			
STEP SIZE	I	POL STEP	DEC STEP		
SEARCH PATTERN AND PARAMETERS	P	TIME	T-LATE	T-EARLY	OUT OF PLANE
		AREA	POL EXTENT	DEC EXTENT	
		FENC	EXTENT OF FENCE		
		SPIR			

10-193

Figure 3-4. Search and surveillance capabilities.

- 1) ENABLE/DISABLE - used to start and stop the search pattern;
- 2) SUSPEND/RESUME - allows the operator to delay the step to the next field if necessary;
- 3) LAST FOV/CURR FOV - allows the operator to return to the last search field;
- 4) WIKI STEP - allows the operator to override the stare period and move immediately to the next search field;
- 5) HOLD - used to stop the track at the current position;
- 6) COMPUTER INTERRUPT - used to interrupt the computer (to cause an input to the Kalman filter) when a target is acquired.

ANK inputs provide the following capabilities:

- 1) Selection of a stare period in seconds;
- 2) Selection of a stare mode of either sidereal (the telescope moves at the sidereal rate such that stars appear stationary and a target would move through the field) or track (the telescope moves at the target rate such that the target would be stationary and the stars would move through the field);
- 3) Selection of a step size in arcseconds independently for each axis;

- 4) Selection of a search pattern of time, area, fence or spiral. If time is selected, the program generates a pattern of steps along the trajectory which will cover an area defined by the early-late times selected and the out-of-plane position selected. Area search steps the telescope to the limits of the polar and declination positions selected. Fence search generates a triangular pattern to the limits selected. Spiral search generates a set of polar and declination steps which define a spiral pattern.

All of the above parameters defined by ANK input have nominal values which prevail unless changed by keyboard input. Additional information pertaining to the search and surveillance program is included in the EROS CPCI, LC-0436-.

3.2.4 Multiple Objects Subtask (WBS-310)

MOTIF requires the ability to collect metric data on multiple objects which appear simultaneously in the field-of-view. The capability designed is a real-time function with all additional objects tracked assigned a 90,000 sequence number.

This subtask was accomplished by designing and developing modifications to the real-time system, EROS, to allow dynamic assignment of target state vectors and identification of the different target states as unique objects. EROS allows up to five target states to be defined in addition to the primary state. Data obtained on an object while EROS is switched to

one of the five states is formatted, assigned a 90,000 sequence number and transferred to the DTS in the same fashion as routine tracking data. Additional information pertaining to the multiple objects program is included in the EROS CPCI, LC-0436-.

3.2.5 History Modification Subtask (WBS-310)

Additional computer hardware status information must be recorded in order to adequately analyze system performance. Prior to the completion of this task, information pertaining to a hardware anomaly which occurred during a mission was lost. The capability to generate metric and photometric reports from data collected by the DTS was also required.

This subtask was accomplished by modifying the EROS Report Generator, ERG, to generate a subsystem status report consisting of the diagnostic data acquired and recorded on the history tape as a result of the On-Line Diagnostics subtask. In addition to the status report, the necessary modifications and additions were included in ERG to generate a metric report and a photometric report, by object number, from the DTS digital tape. Details of this program are contained in the MSS CPCI, LC-0435-.

3.2.6 Direct Access of Satellite Catalog Subtask (WBS-310)

The MOTIF requirement to track large numbers of space objects each night necessitated implementing a real-time access to the satellite library to replace the previously existing

non-real-time program, SATPREP. SATPREP is still used as a back-up or for special satellite tracks; however, it is time consuming and it limits the number of objects which can be tracked to 40 before the real-time system has to be shut down to rerun SATPREP.

Figure 3-5 shows the new process called RATSAP. RATSAP utilizes the more advanced SGP4/DP4 algorithms for deep space satellite applications. The SGP algorithm is used for near earth applications. Operator input of object number using the ANK will cause RATSAP to retrieve, in real-time, the proper satellite elements and process them to provide the necessary acquisition vector. Modifications to both the CDC 3500 and SC 1700 subsystems of EROS were required to implement this capability. Additional details are included in the EROS CPCI, LC-0436-.

3.2.7 On-Line Disgnostics Subtask (WBS-310)

The SC 1700 computer system contains certain direct memory access (DMA) devices including:

- 1) Buffer Transfer Unit (BTU);
- 2) Parallel Floating Pont Arithmetic Unit (FPA);
- 3) Chaining Buffers (Model 1571).

CDC did not have adequate diagnostic software to support these devices. To solve this problem, a program module was designed which includes a buffer exchange of data from the SC 1700 to the

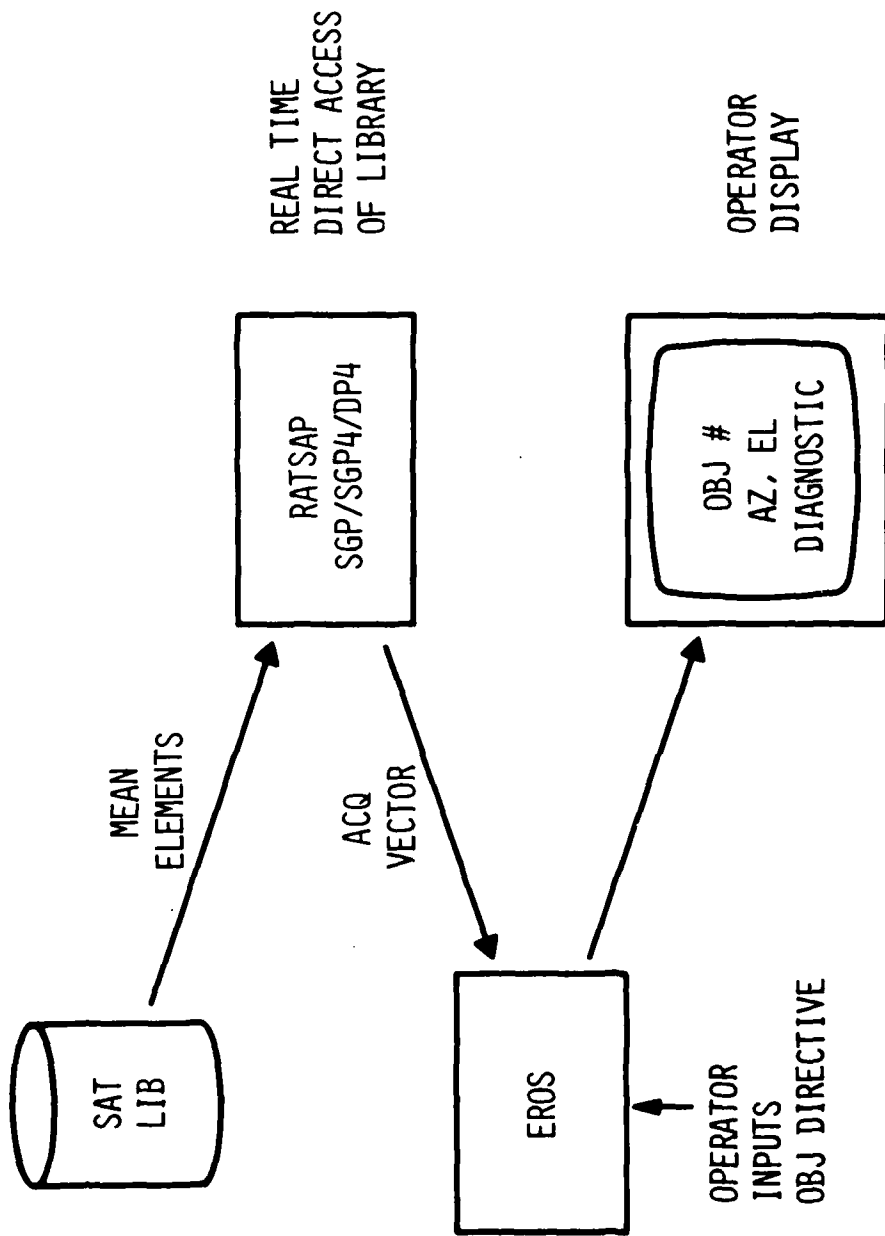

10-195

Figure 3-5. Real-time satellite preparation (RATSAP).

CDC 3500 via exchange jump transfers. A control program for restructure of the CDC 3500 subsystem to record this data on magnetic tape as well as displaying it on graphics was also developed. Details are included in the EROS CPCI, LC-0436-.

3.2.8 Satellite Library Subtask (WBS-310)

MOTIF is required to maintain a satellite element library (2-card element sets), which interfaces to the communications system to permit real-time updates. The library is required to retain previous element sets (for back-up and checking logical content of new elements), and must have a capacity for storing at least 500 element sets. As a minimum, all deep space satellites contained on the Consolidated Tasking list must be maintained in the library.

A new program was developed to satisfy requirements. This is the Satellite Library Random Access Program (SATRAP). It has both real-time and batch process components. It provides for a library on the MC IV system for access by the mission planning program and for a library on the CDC 3500 system for access by EROS. Figure 3-6 shows, in block diagram form, an overview of the satellite library. Details are included in the MSS CPCI, LC-0435-.

The satellite library is divided into subsets. Each subset has its own directory structure. This allows cross reference of an element set from different subsets. The directory structure is chained allowing dynamic expansion of the library.

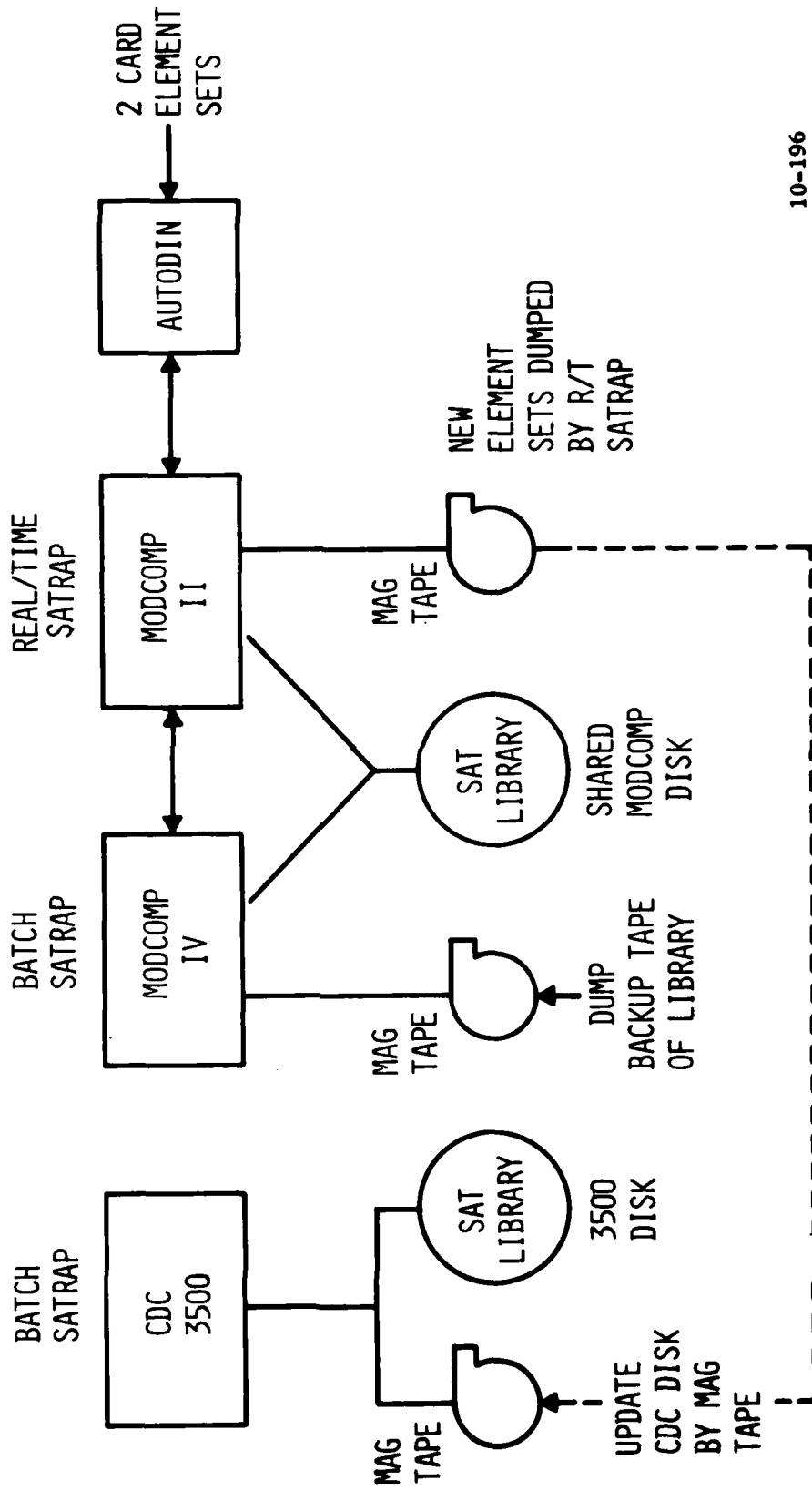

10-196

Figure 3-6. Satellite library overview.

Five subsets are provided as follows:

- 1) Near space orbits;
- 2) Elliptical orbits;
- 3) Synchronous orbits;
- 4) Beyond synchronous orbits;
- 5) Back-up element sets.

The deep space elements also store luni-solar perturbation and orbital resonance coefficients. Total capacity of the library is dependent on the mix of near earth and deep space satellites and is limited only by the available disc space.

Satellite element sets are received by the communications system from the SCC via AUTODIN. The element sets are in 2-card format. Software in the MC II system determines that an input message is an element set. This determination activates the real-time update program, RATSATRAP. This program sends the data to the 25 megabyte disc unit by activating the MC Model 5215 switchable controller. In addition, all element sets received by the MC II are recorded on magnetic tape as back up.

Real-time SATRAP, operating on the MC IV, performs several internal functions automatically. It checks (validates) new data before updating the library. When it updates an element set, the old set is routed to a separate subset to provide a last element retrieval capability. SATRAP determines which

subset the elements belong in and, for the case of deep space objects, calculates luni-solar perturbation and orbital resonance coefficients.

Two batch versions of SATRAP were developed. One to run on the MC IV and a second to run on the CDC 3500. These versions allow for input from AUTODIN, magnetic tape and cards for the MC IV and magnetic tape, cards and punched tapes for the CDC 3500. Output to disc, magnetic tape and cards is provided. Command directives to the MC IV can be input by CRT or punched cards; punched card input to the CDC 3500 is provided.

The following capabilities are programmed for the batch version of SATRAP:

- 1) Add and delete elements sets;
- 2) Copy elements to peripheral devices;
- 3) List directory content;
- 4) Print element sets;
- 5) Produce back-up tapes;
- 6) User access, random or sequential.

3.2.9 Paged Display Subtask (WBS-310)

The graphics display available to the Main Console Operator originally had one format. The same type of information was displayed whether tracking stars or satellites, and it always contained more data than the operator needed at any one time and was difficult to read. This shortfall was corrected by

providing multiple pages on the display, each tailored to the specific mode of operation.

Three pages are provided for telescope mount control use, one each to satisfy the functions of mount testing, calibration, and tracking. One additional page for diagnostics display is also provided. Figure 3-7 shows an example of the completed ballistic page. Following completion of the page format designs, the page formatting subroutines were developed. One routine is required for each of the pages. This task included developing necessary conversion routines to convert the pertinent data to the display format.

Page scheduling and queuing control routines were then developed to control the data interfaces between the SC-17 and the CDC 3500, and between the operator and the data disc device. These routines provide for automatic selection of the proper page display when the operator selects a computer operating mode: TEST, SIDEREAL, or BALLISTIC. The diagnostics page is normally displayed at the ancillary console in the computer room. The control routines also provide for operator selection of any page at any time (provided EROS is operating) by ANK input.

1.2M BALLISTIC ATN +5386
 WIKIKAL PARAMETERS
 BELLS AT 101371 0.00
 ATN 5386 LOADED

UT 16 32 03

	HISTORY OFF	FP0-14 OFF	COMMAND	MOUNT	FP0-16 OFF	OFFSETS
MZL	000	00	00	00	06	12
DEC	273	03	58	002	03	41
REL	047	10	23	332	15	30
	040	08	05	102	25	19
	016	20	03	041	30	32

EPOL EDEC
 270 59 81 074 58 05

ER00X.XX P03X.XX

Figure 3-7. Ballistic display format.

3.2.10 Deep Space Ephemeris (HUJSAK or DP4) Program Subtask
(WBS-031 and -310)

The AMOS SATPREP program, which generates initial conditions for real-time satellite tracking, makes use of the simplified general perturbations program (SGP) for converting mean orbital elements to osculating elements. SGP does not take full advantage of the new NORAD deep space ephemeris package which includes luni-solar perturbations for Molniya type orbits, extensions for drag, and one day and half day resonance terms for synchronous satellites. A new program, referred to as DP4 or HUJSAK, was provided to MOTIF as a replacement for SGP for all ephemeris types 3 through 5, and a program, referred to as SGP4, was provided for ephemeris type 2. These new programs were incorporated into the MOTIF tracking and mission planning software.

This subtask was initiated by performing an evaluation of the HUJSAK program to determine its operating requirements and characteristics. The program had to be modified slightly to operate on the MOTIF system and was installed as a replacement for the SGP program in RATSAP and in the modified AESOP program for mission planning. The program was verified by reproducing the test cases provided by NORAD.

Performance data (i.e., comparing acquisition statistics using the new program with those of the old) are not yet available since the SCC has not yet included the necessary perturbation terms in the element sets.

3.2.11 Reports and Messages (WBS-320)

Periodic reports from MOTIF are required to allow the SCC to stay abreast of the sites' status and performance. Information required includes maintenance down-time forecasts, influence of weather on operations, and details of objects tracked. This data is required for the SCC to determine satellite tasking for MOTIF and other SPACETRACK sensors.

The procedures for preparing the routine reports and messages specified by the "Program Introduction and Concept of Operation for MOTIF", dated July 1977, were generated under this task. The required messages were identified and the message formats developed. Following the identification of required messages, Record/Log books were established in which the necessary information is recorded. Information from this log book is used to formulate the Sensor Tasking Response Report which is submitted daily. The Maintenance Schedule is submitted monthly.

3.3 System Test and Evaluation

System test and evaluation of MOTIF included four tasks:

- 1) Data Quality Control;
- 2) Validation and Verification;
- 3) Test Program;
- 4) EMI Testing.

3.3.1 Data Quality Control (WBS-410)

The operational MOTIF is used to collect a high volume of metric and photometric data on space objects. ADCOM required consistently high data quality from MOTIF to allow the data to be rapidly and accurately understood. Techniques and procedures had to be developed and implemented to assure this consistent quality.

A Data Quality Control (QC) Plan was prepared which applies to both metric and photometric (SOI) data. This plan (AERL Document #1040) was delivered as CDRL-011. It defines data accuracy requirements, factors influencing accuracy, and procedures to establish baseline accuracies and to ensure they are maintained.

The Data QC task also included subtasks to purchase and incorporate a standard lamp source into the CMP and to update the Star Library. A carbon 14 I-Lite device was selected as the standard lamp source. Incorporation of the unit is described in the CMP manual (LF-0076-).

The new Star Library was formulated using the Yale Bright Star (BS) Catalog tape, which was obtained from the USNO, as a base. Up to the limit of the BS Catalog (9110 stars), AMOS star numbers (ASNs) are identical to BS numbers. The coordinates of the stars in the new library were updated to improve accuracy using data from the SAO. In addition, certain data and objects

contained in the original star library, but not available in the BS catalog, were added to ensure that the library meets the needs of both MOTIF and DARPA. Specifically, photometric parameters necessary for photometric data reduction were added. This was accomplished by including data from the combined astrometric-photometric catalog tape obtained from L.G. Taff of Lincoln Laboratory.

3.3.2 Validation and Verification (WBS-420)

Validation and Verification (V&V) were required to ensure that each item of documentation adequately described the hardware or software to which it pertains.

To accomplish validation, existing drawings were checked to ensure they were up to date and that obsolete drawings were purged from the documentation system. Each drawing was also inspected to ensure that it complies with applicable requirements for the form or level of drawing specified. Technical content of manuals were checked against pertinent specifications, drawings, and associated lists and standards to ensure that the manuals are technically accurate and meet MOTIF requirements. All new drawings and manuals were checked and approved for release by the cognizant System Responsible Engineer as they were developed.

Verification of one manual, AMTA, was performed by Government representatives. Remaining manuals will be verified during the

follow-on Operations, Maintenance and Support Program.

3.3.3 Test Program (WBS-430)

The "Program Introduction and Concept of Operations for MOTIF" set forth the basic operational capabilities and system performance requirements for the 1.2 m Telescope system. A test program was required to demonstrate that the MOTIF complied with the stated performance specifications.

A test plan (CDRL 003) was prepared and approved. Tests were then conducted in accordance with the plan. The test report, which is an attachment to this final report, provides complete details of the tests and their results.

3.3.4 EMI Testing (WBS-440)

The three major television stations in Hawaii and the telephone company have repeaters located on Mt. Haleakala which tend to create a strong electro-magnetic interference (EMI) environment. Effects of EMI have been observed at MOTIF primarily in the form of television interference.

To determine the magnitude of this problem, the Electro-magnetic Interference (EMI) environment at the observatory was measured by the 1843RD Electronics Engineering Squadron, AFCS, Hickam Air Force Base, Hawaii, 96853.

Measurements revealed that the facility's electronic equipment produced field intensity levels below 1 volt/meter. However, field intensities produced by commercial television relay stations are entering the MOTIF facility and are producing RFI to the electronics portion of the Optical Telescope Systems. The report recommended specific steps to eliminate the RFI. For complete details see report #PCA-EMC-79-05, dated 30 March 1979.

3.4 Training (WBS-500)

A training task was added to the MOTIF program as part of the Two Month Operation and Maintenance addition (ref: AERLP 139C, negotiated 21 March 1979). The purpose of the task was to hire additional operators and communicators in preparation for full-time MOTIF operations beginning 1 October 1979.

This task was accomplished as required. A five-person communications crew was available to begin 1 October 1979, as required. However, lack of cryptographic clearances for new hires was a problem and the communications center had to be staffed with qualified personnel originally planned for other tasks.

Two five-person operations crews were also available 1 October 1979. A crew level of six was planned. One crew member was assigned to the communications crew temporarily and another was hired to start mid-November 1979. These two will bring crew strength to the required six.

3.5 Maintenance and Engineering

Maintenance and engineering of the 1.2 m Telescope System, along with its support equipment, were required during the MOTIF Transition Program to ensure that all systems were operational and ready to support the ADCOM mission. Three tasks were included:

- 1) Routine Maintenance;
- 2) 1.2 m Telescope Refurbishment;
- 3) Depot Maintenance.

3.5.1 Routine Maintenance (WBS-610)

Maintenance and engineering were accomplished in accordance with the Maintenance Plan for MOTIF, dated 31 July 1977. This included preventive maintenance consisting of periodic lubrication of motors, pumps, etc; hydraulic system filter checks, inspection for rust or other corrosion, electronic systems tests and adjustments, sensor systems checks and adjustments, and periodic mount checks to ensure all components of the system were functioning properly.

Corrective maintenance was also performed as required to ensure that the MOTIF returned to an operational status as quickly as possible following a component failure. This maintenance activity applied to both dedicated MOTIF equipment and to common (shared) equipment.

3.5.2 1.2 Meter Telescope Refurbishment (WBS-620)

The most significant maintenance activity accomplished during the MTP was the refurbishment of the B29 and B37 telescopes in the spring of 1979. Both primary mirrors were cleaned and recoated with bare aluminum, mirror support mechanisms were checked and refurbished where necessary, and both telescopes were completely realigned. Prior to initiation of the work, a program plan was developed and procedures written. As the work progressed, procedures were updated where required. Completed documentation of this activity, in the form of step-by-step procedures, is included in the Telescope System Manual, LF-0075-.

3.5.3 Depot Maintenance (WBS-630)

This subtask was added to the MOTIF program as part of the Two Month Operation and Maintenance addition. The purpose of the task was to provide senior engineering support to maintenance activity as required.

3.6 Data

The data portion of the MOTIF program included three tasks:

- 1) Hardware Documentation;
- 2) Software Documentation;
- 3) Integrated Support Plan.

3.6.1 Hardware Documentation (WBS-710)

Existing technical documentation for the 1.2 m Telescope and its support systems was adequate for operation and maintenance

of the observatory as a research and development facility. For routine operation as an ADCOM SPACETRACK sensor, however, the technical documentation was not adequate. An operational availability goal of 95% for MOTIF demands a level of documentation which allows for rapid troubleshooting and repair. More detail was required in the areas of system definition, theory of operation and operating procedures. Operator positional handbooks were also required.

The Hardware Documentation Task generated new documentation and supplemented existing documentation. Four major divisions of documentation were prepared:

- 1) Systems manuals;
- 2) Equipment manuals;
- 3) Positional handbooks;
- 4) Engineering data.

The manuals were prepared in accordance with CDRL A001, positional handbooks were prepared in accordance with CDRL A004 and the engineering data (drawings) were supplied in accordance with CDRL A005. Table 3-1 gives a listing of new documentation prepared as part of this task. The AMOS Controls Software (ACONS) includes a complete listing of all documentation available for MOTIF; it is included here by reference only.

Table 3-1. MOTIF technical manuals
(Sheet 1 of 6)

1. BEAMSTEERING:

LF-0075-, 1 May 1979, 48-inch Telescope System,
Part B, Equipment Manuals, Section 1.0

2. MOUNT:

LF-0072-, 1 May 1979, Part A, Mount System Manual.

3. TELESCOPE:

LF-0075-, 1 May 1979, Part A, System Manual.

4. COMMON COMMUNICATIONS SYSTEM:

LC-0408-, 1 May 1979, System Manual for Common
Communications System.

5. TIMING:

LC-0390-, 1 May 1979,

a. Part A, Timing System Manual.

b. Part B, Equipment Manuals:

1. Section 1.0, SC-17, Computer/
Timing Interface.

2. Section 2.0, Timing System
Distribution Interface.

c. Part C, Vendor Manual Supplements:

1. Section 1.0, LCS0037S, Supplement 1,
1 May 1979, LORAN-C Receiver (Austron
2000C) and Standby Power Supply
(AMOS/MOTIF).

2. Section 2.0, LCS0040S, Supplement 1,
1 May 1979, Timer-Counter (HP 5326A).

Table 3-1. MOTIF technical manuals
(Sheet 2 of 6)

3. Section 3.0, LCS0394S, Supplement 1, 1 May 1979, Standby Power Supply, (SD 8198-4).
 4. Section 4.0, LCS0043S, Supplement 1, 1 May 1979, Frequency Divider and Digital Clock (HP 115BR).
 5. Section 5.0, LCS0047S, Supplement 1, 1 May 1979, Cesium Beam Frequency Standard (HP 5060A).
 6. Section 6.0, LCS0209S, Supplement 1, 1 May 1979, Instruction Manual WWV Receiver (HRO-500).
6. CMP:
- LF-0076-, 1 May 1979, Sensors System, Part B, Equipment Manuals, Section 1.0, Contrast Mode Photometer.
7. DOME:
- LF-0079-, 1 May 1979,
- a. Part A, System Manual.
 - b. Part B, Equipment Manuals:
 1. Section 1.0, Dome Superstructure.
 2. Section 2.0, Dome Doors.
 3. Section 3.0, Dome Azimuth Drive and Windscreen System.
 4. Section 4.0, Dome Hoist.
8. RECORDING SYSTEM:
- LC-0404-, 1 May 1979.

Table 3-1. MOTIF technical manuals
(Sheet 3 of 6)

9. DOME SERVO COMPUTER:

LF-0079-, 1 May 1979, Dome, Part B, Equipment
Manuals, Section 5.0.

10. COMMON SUPPORT EQUIPMENT:

LC-0404-, 1 May 1979.

- a. Part A, System Manual.
- b. Part B, Vendor Manual Supplements,
MEFCO Hydraset Model C - LCS0355S,
1 May 1979.

11. TELESCOPE SUPPORT EQUIPMENT:

LF-0078-, 1 May 1979.

- a. Part A, System Manual.
- b. Part B, Equipment Manual, Mirror Handling
Band, Section 1.0.
- c. Part C, Vendor Manual Supplements:
 1. Section 1.0, LFS0015S, Supplement 1,
1 May 1979, Yale RCF Series Warehouse
Straddle "Order Porter" RCF40M4T071.
 2. Section 2.0, LFS0024S, Supplement 1,
1 May 1979, Hi-Reach Telescoping Work
Platform (Model LB, Style C), Economy
Engineering Company.

12. MOUNT/MECHANICAL:

LF-0072-, 1 May 1979, Mount, Part B, Equipment
Manuals, Section 3.0, Mount Mechanical Equipment.

Table 3-1. MOTIF technical manuals
(Sheet 4 of 6)

13. MOUNT/HYDRAULICS:

LF-0072-, 1 May 1979, Mount, Part B, Equipment
Manuals, Section 1.0, Mount Hydraulics Equipment.

14. VIDEO:

LC-0407-, 1 May 1979.

- a. Part A, Video System Manual.
- b. Part B, Equipment Manual for Autotrack
Computer Interface.

15. FACILITIES:

LC-0382-, 1 May 1979.

- a. Part A, Facilities System Manual.
- b. Part B, Equipment Manuals:
 1. Section 1.0, Computer Air Conditioning
System.
 2. Section 2.0, Control Room Air
Conditioning System.
 3. Section 3.0, Power Distribution
System.

16. B29/B37 TELESCOPES:

LF-0075-, 1 May 1979, 48-inch Telescope System,
Part B, Equipment Manuals, Section 2.0, B29/B37
Telescopes.

17. AMTA:

LF-0076-, 1 May 1979, Part B, Equipment Manuals,
Section 2.0, AMTA Radiometer.

Table 3-1. MOTIF technical manuals
(Sheet 5 of 6)

18. LLLTV:
LF-0076-, 1 May 1979, Part B, Equipment Manuals,
Section 4.0, LLLTV.
19. B29 BORESIGHT TV:
LFS0006S, Supplement 1, 1 May 1979.
20. B29 BORESIGHT TV:
LFS0007S, Supplement 1, 1 May 1979.
21. SENSORS:
LF-0076-, 1 May 1979, Part A, Sensor System Manual.
22. COMPUTER SYSTEM MANUAL:
LF-0409-, 1 May 1979.
 - a. Part A, Computer System Manual.
 - b. Part B, Equipment Manual for Computer
Interface Equipment.
23. ACQUISITION TELESCOPE:
LF-0075-, 1 May 1979, Part B, Equipment Manual,
Section 3.0, Acquisition Telescope.
24. MOUNT SERVO:
LF-0072-, 1 May 1979, Part B, Section 2.0,
Mount Servo System.
25. MOTIF SYSTEM:
LC-0410-, 1 May 1979, MOTIF System Manual.

Table 3-1. MOTIF technical manuals
(Sheet 6 of 6)

MOTIF POSITIONAL HANDBOOKS

1. MOTIF MISSION DIRECTOR (MMD):
LF-0093-, 31 July 1979.
2. DOME AND MOUNT SYSTEMS OPERATOR (MSO):
LF-0088-, 31 July 1979.
3. VIDEO SYSTEM OPERATOR (VSO):
LF-0092-, 31 July 1979.
4. DTS/COMPUTER SYSTEMS OPERATOR (DSO)
LF-0094-, 31 July 1979.
5. MAIN CONSOLE OPERATOR (MCO):
LF-0089-, 31 July 1979.
6. RADIOMETER SYSTEMS OPERATOR (RSO):
LF-0091-, 31 July 1979.
7. COMMUNICATIONS SYSTEM OPERATOR (CSO):
LF-0090-, 31 July 1979.

3.6.2 Software Documentation (WBS-730)

Documentation of the MOTIF computer software was required for the same basic reasons the hardware documentation was required. It was also necessary to develop a system of software configuration management for implementation at the onset of the MOTIF follow-on program.

To satisfy requirements, MOTIF software was documented by preparing the Computer Program Configuration Item (CPCI) Part I Specification, "Performance and Design Requirements", (CDRL A002), and the CPCI Part II Specification, "Product Configuration and Detailed Technical Description", (CDRL A003) for each of four separate program areas as described below:

- 1) The Extended Real-Time Operating System (EROS), which runs on the CDC 3500 and SC 1700 computers, (manual #LC-0436-);
- 2) The Data Transmission System (DTS) which runs on the MODCOMP IV computer (manual #LC-0095-);
- 3) The Communications System (CMS), which runs on the MODCOMP II computer (manual #LC-0096-);
- 4) The Mission Support Software (MSS), which has programs running on all three computer systems (manual #LC-0435-).

These four CPCIs include all software required for MOTIF except for purchased software, such as a computer manufacturer's

operating system. Existing manufacturer's documentation was provided without modification.

A software configuration management system was also established which is compatible with ADCOMR 55-111. This system is a logical extension of the one employed by AERL at AMOS for the past several years. It includes two levels of control, depending on the magnitude of the change. The first level (Class II change) is under cognizance of the head of the computer group. With the aid of his staff, he is responsible for all elements of change control except for approval or disapproval of substantial modifications, such as would result in a new version. (A substantial modification is a Class I change as referred to in AFR 800-14 or MIL-STD 483.)

The second level (Class I change) is under cognizance of the MOTIF Program Manager who approves or disapproves substantial modification requests. This action will involve coordination with the Air Force.

Thus, the procedures already in effect contained the basic elements of the configuration management system required by ADCOMR 55-111. The major differences were in the degree of record keeping and documentation. The system will be formalized during the MOTIF follow-on program by establishing a Site Configuration Review Board, adopting the use of the standard ADCOM forms, and incorporating the procedures to keep current the documentation produced under the MOTIF Transition Program.

3.6.3 Integrated Logistics Support (ILS) Program (WBS-740)

An Integrated Support Plan (ISP), which sets forth procedures for achieving the Integrated Logistics Support Plan (ILSP) objectives provided by RADC was required. It was prepared in accordance with CDRL 010 and it addresses maintainability, reliability, maintenance, supply support, technical data, facilities, and transportation/handling. A recommended spare parts list (CDRL 007) was also prepared. Spare parts for mission critical equipment that were not in the existing inventory, and are contained in this list, were procured.

3.7 Operations (WBS-810, -820 and -830)

During the MOTIF transition period, operations in support of ADCOM tasking were required for metric, photometric, and LWIR data on specified space objects. The task was divided into two subtasks: Routine Operations (WBS-810) and Operations Maintenance (WBS-820), with the latter subtask used to account for the time when operations could not be supported due to adverse weather conditions. A third task, Communications (WBS-830), was added as part of the Two Month Operations, Maintenance and Support program to account for routine operation of the communications center.

At the onset of the operations task, computer processing software for metric and photometric data did not exist. The capability was being implemented in the DTS/CMS tasks, however,

an interim capability was required until the DTS/CMS became operational.

An interim metric data processing capability was developed by modifying the EROS Report Generator (ERG). During tracking operations, an acquired satellite was centered on the boresight TV by the operator and computer interrupts were made. The interrupts update the Kalman filter and flagged valid data points which were stored on history tape. Following the tracking missions, the history tapes were processed by ERG. ERG selected the proper (evenly spaced) data points and generated a printed report and a punched paper tape. The latter was used as input to the TTY in the existing communications system. Data were reported in azimuth and elevation coordinates initially, ADCOM later requested right ascension and declination coordinates be reported. This mode of operation was used until the DTS/CMS was completed; it continues to be a back-up mode if the DTS or the CMS should fail.

An interim photometric data processing capability was developed by modifying existing programs originally used for processing AMTA LWIR data. During SOI missions, photometric data were collected by the Contrast Mode Photometer and stored on analog tape. Following the tracking missions, the tapes were processed by the CDC 3500/SC 1700 system in three steps:

1) Step 1:

The analog data were digitized and formatted to create a digital data tape.

2) Step 2:

The digital tape was input to a special program along with state vector information and control options, to generate a tape of normalized, exo-atmospheric visual magnitude data.

3) Step 3:

The processed data tape was then input to a program which formatted the data and generated a punched paper tape for input to the TTY in the existing communications system.

This mode of operation was used until the DTS/CMS was completed; it continues to be a back-up mode if the DTS or the CMS should fail.

The first month of support (August 1977) was dedicated to establishing an operations crew, coordinating tasking and reporting between ADCOM and MOTIF, and defining procedures. Routine measurement operations began in September 1977 with tasking primarily for metric data. Photometric and LWIR observations were also initiated on a reduced scale basis. The number of SOI observations increased in the December-January time frame due to high priority support to project "Morning Light".

Operations support was provided by a crew consisting of a main control console operator, dome operator, sensor operator, video operator, and a crew chief. Support consisted of a single, seven hour operations shift, five nights per week, using the existing 1.2 m Telescope system. Metric data was obtained by acquiring and tracking tasked objects using the LLLTV on the B37 telescope or the B29 telescope boresight TV, computer processing the resultant tracking information, and sending it to ADCOM via the existing TTY communications system. Photometric data was obtained by the Contrast Mode Photometer on the B29 telescope, computer processing the information and delivering it via TTY to ADCOM. LWIR data was taken with the AMTA mounted on the B29 telescope. This data was manually processed to compute a single, representative data point.

Although the transition program was conducted simultaneously with operations, there were no significant schedule problems caused by hardware/software development. The 1.2 m Telescope refurbishment task required approximately two months of system downtime. The 1.2 m Telescope System was occasionally used, with prior concurrence, to support other programs. Support to the SAMSO Evaluation Program (SEP) in November 1977 and March 1978 and periodic support to the Strategic Aerospace Command (SAC) operational training missile tests from Vandenberg AFB are examples.

A summary, by month, of the number of objects tracked during the MOTIF Transition Program is given in Figure 3-8. This shows total objects and the number of SOI tracks.

Figure 3-9 gives a monthly summary of available operations time. This indicates amount of downtime due to weather and equipment.

The relatively low number of objects tracked in the July through September period reflects the increased time spent in tracing additional operation personnel, testing the new MOTIF hardware and software, and conducting the MOTIF Test Program.

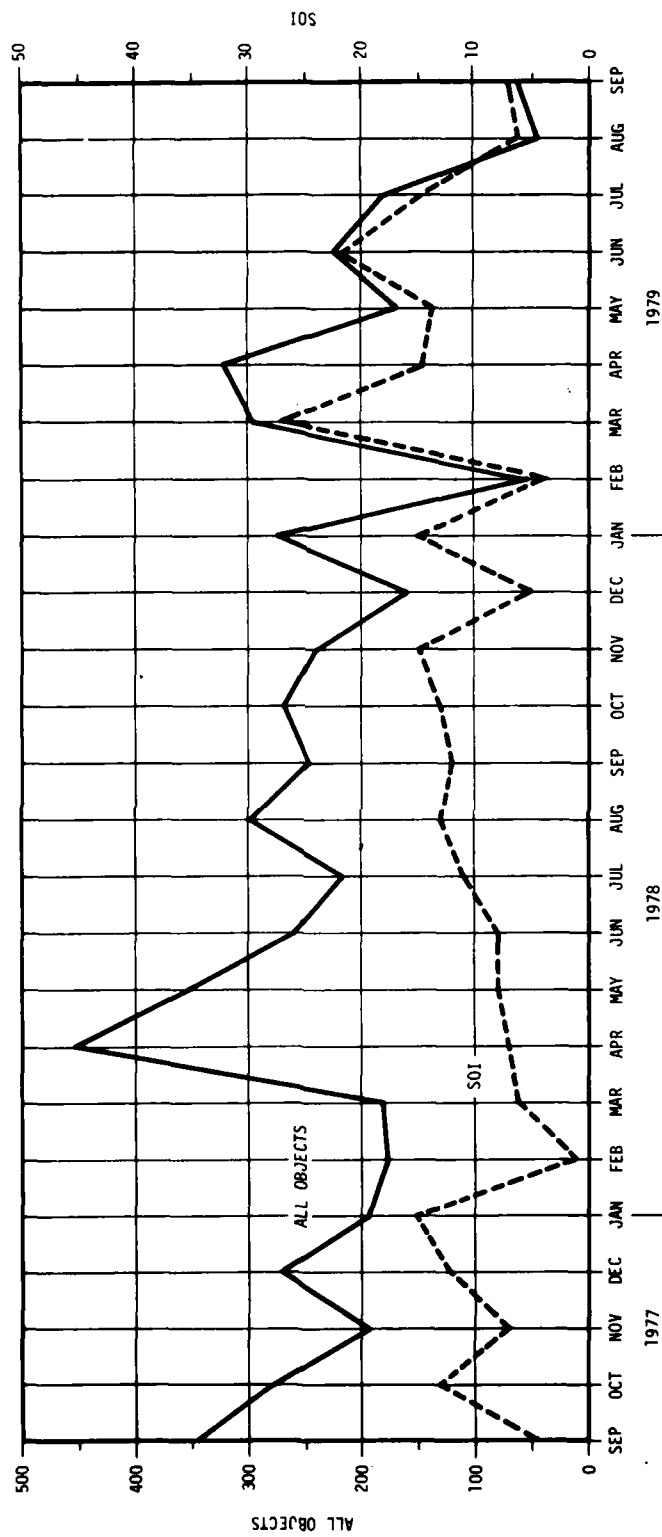

10-633

Figure 3-8 Summary of operations - September 1977 - September 1979

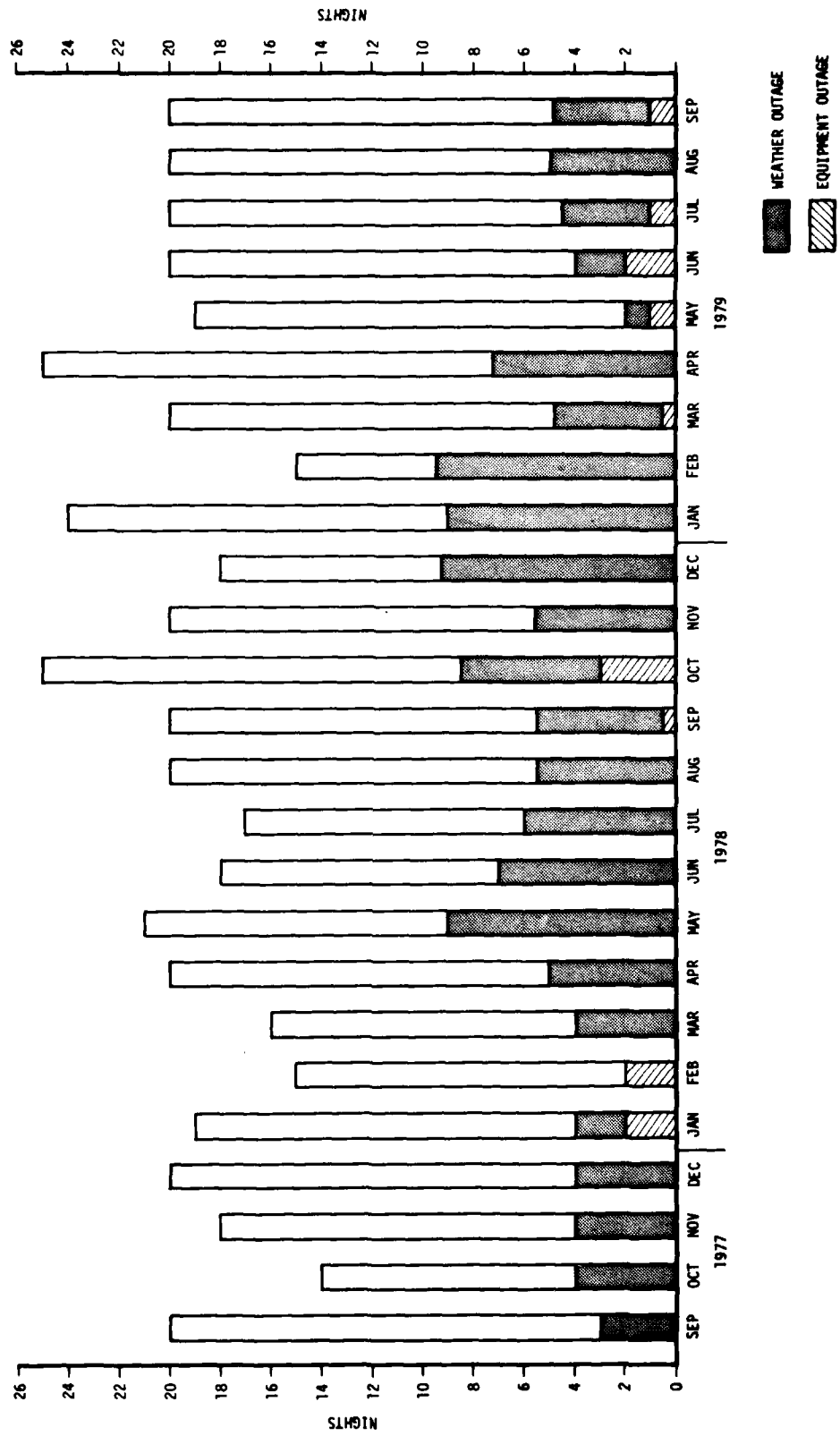

10-638

Figure 3-9 MOTIF operations - September 1977 - September 1979

MISSION
of
Rome Air Development Center

RADC plans and executes research, development, test and selected acquisition programs in support of Command, Control, Communications and Intelligence (C³I) activities. Technical and engineering support within areas of technical competence is provided to ESP Program Offices (POs) and other ESP elements. The principal technical mission areas are communications, electromagnetic guidance and control, surveillance of ground and aerospace objects, intelligence data collection and handling, information system technology, ionospheric propagation, solid state sciences, microwave physics and electronic reliability, maintainability and compatibility.

DATE
FILMED
— 8