

AD-A106 741 AIR FORCE INST OF TECH WRIGHT-PATTERSON AFB OH F/G 8/13
AN ALTERNATE APPROACH TO THE MEASUREMENT OF SOIL SURFACE HEAT F--ETC(U)
1981 B R MERRILL
UNCLASSIFIED AFIT-CI-81-337

1 of 1
4
20073

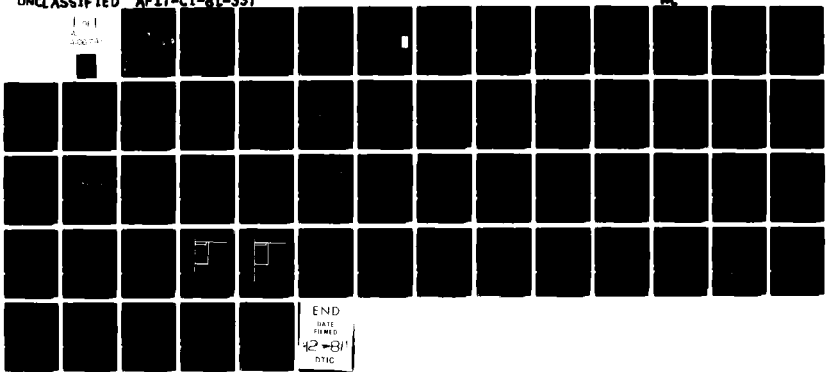

END
DATE
FILMED
42-81
DTIC

A F I T

UNCLASS
SECURITY CLASSIFICATION OF THIS PAGE (When Data Entered)

REPORT DOCUMENTATION PAGE		READ INSTRUCTIONS BEFORE COMPLETING FORM	
1. REPORT NUMBER 81-33T	2. GOVT ACCESSION NO. AD-A106714	3. RECIPIENT'S CATALOG NUMBER	
4. TITLE (and Subtitle) An Alternate Approach to the Measurement of Soil Surface Heat Flux.		5. TYPE OF REPORT & PERIOD COVERED THESIS/DISSERTATION	
6. AUTHOR(s) Bruce Rex/Merrill		6. PERFORMING ORG. REPORT NUMBER	
9. PERFORMING ORGANIZATION NAME AND ADDRESS AFIT STUDENT AT: Univ of Arizona		8. CONTRACT OR GRANT NUMBER(s)	
11. CONTROLLING OFFICE NAME AND ADDRESS AFIT/NR WPAFB OH 45433		10. PROGRAM ELEMENT, PROJECT, TASK AREA & WORK UNIT NUMBERS	
14. MONITORING AGENCY NAME (ADDRESS if different from Controlling Office) LEVEL II		12. REPORT DATE 1981	
		13. NUMBER OF PAGES 48	
		15. SECURITY CLASS. (of this report) UNCLASS	
16. DISTRIBUTION STATEMENT (of this Report) APPROVED FOR PUBLIC RELEASE; DISTRIBUTION UNLIMITED		15a. DECLASSIFICATION/DOWNGRADING SCHEDULE	
17. DISTRIBUTION STATEMENT (of the abstract entered in block 20, if different from Report) <i>91 masters thesis</i>		S DTIC ELECTE NOV 6 1981 D	
18. SUPPLEMENTARY NOTES APPROVED FOR PUBLIC RELEASE: IAW AFR 190-17		H 16 OCT 1981 Air Force Institute of Technology (ATC) Wright-Patterson AFB, OH 45433 Fredric C. Lynch FREDRIC C. LYNCH, Major, USAF Director of Public Affairs	
19. KEY WORDS (Continue on reverse side if necessary and identify by block number)			
20. ABSTRACT (Continue on reverse side if necessary and identify by block number) ATTACHED			

AD A106741

DTIC FILE COPY

012200 YW

TITLE: An Alternate Approach to the Measurement of Soil Surface Heat Flux

AUTHOR: Bruce Rex Merrill

RANK: Captain

BRANCH: USAF

DATE: 1981

PAGES: 48

DEGREE: M.S.

SCHOOL: University of Arizona

ABSTRACT: A new approach to the measurement of the conductive heat flux at the soil surface is presented. This approach provides the means to make measurements of the soil conduction heat flux. By sensing the temperature of the soil surface and using a temperature control circuit one forces an artificially created portion of the soil surface to mimic the temperature of the natural surface. By monitoring the power to maintain this control one makes a direct measurement of the conduction heat flux at the soil surface. Although the present instrument works only when the conduction heat flux is directed out of the ground there is nothing in principle to prevent the instrument from working when the flux is in the other direction. The error analysis shows that the two main sources of error are due to the electronics design and the errors associated with measuring the true temperature of a surface. Laboratory testing shows that unexplained error amounts to only a few percent at most. Laboratory testing also shows that the instrument is capable of measuring fluxes down to tenths of milliwatts per square centimeter.

Accession For	
NTIS GRA&I	<input checked="" type="checkbox"/>
DTIC TAB	<input type="checkbox"/>
Unannounced	<input type="checkbox"/>
Justification	
By	
Distribution/	
Availability Codes	
Dist	Avail and/or Special
A	

REFERENCES

- Bogoroditskii, N.P., and V. V. Pasyukov, 1967: Properties of Electronic Materials. Boston Technical Publishers, Inc., 350 pp.
- Fleagle, R. G., and J. A. Businger, 1963: An Introduction to Atmospheric Physics. Academic Press, 346 pp.
- Fritschen, L. J., and L. W. Gay, 1979: Environmental Instrumentation. Springer-Verlag, 216 pp.
- Fuchs, M., and A. Hadas, 1973: Analysis of the performance of an improved soil heat flux transducer. Soil Sci. Soc. Am. Proc., 37: 173-175.
- _____, and C. B. Tanner, 1968: Calibration and field test of soil heat flux plates. Soil Sci. Soc. Am. Proc., 32: 326-328.
- Guild, W. R., 1950: Note on heat transfer at the soil surface. Journal of Meteorology, 7: 140-144.
- Kern, C. D., 1965: Evaluation of infrared emission of clouds and ground as measured by weather satellites, AFCRL-65-840, Environment Research Paper No. 155, Air Force Cambridge Research Laboratories, Hanscom Field, Bedford, Mass.
- Kimball, B.A., and R. D. Jackson, 1975: Soil heat flux determination: A null-alignment method. Agric. Meteorology, 15: 1-9.
- _____, R. D. Jackson, F. S. Nakayama, S. B. Idso, and R. S. Reginato, 1976: Soil heat flux determination: Temperature gradient method with computed thermal conductivity. Soil Sci. Soc. Amer. J., 40: 25-28.
- Sellers, W. D., P. Dryden, J. C. Baum, P. C. Sinclair, P. J. Kinyicky, and P. J. Green, 1965: Final Report - An investigation of heat transfer from bare soil, Grant No. DA-AMC-28-043-65-G-11, Institute of Atmospheric Physics, The University of Arizona, Tucson, 88 pp.
- _____, 1965: Physical Climatology. The University of Chicago Press, 272 pp.
- Shaw, R., 1981: Comments on "A short-range objective nocturnal temperature forecasting model." J. Appl. Meteor., 20: 95-96.
- Sutherland, R.A., 1980: A short-range objective nocturnal temperature forecasting model. J. Appl. Meteor., 19: 247-255.
- _____, 1981 Reply. J. Appl. Meteor., 20: 96-97.
- Touloukian, Y.S., R. W. Powell, C. Y. Ho, and P. G. Klemens, 1970: Thermophysical Properties of Matter, Volume 2: Thermal Conductivity Nonmetallic Solids. IFI/Plenum, 1172 pp.

AFIT RESEARCH ASSESSMENT

The purpose of this questionnaire is to ascertain the value and/or contribution of research accomplished by students or faculty of the Air Force Institute of Technology (AFIT). It would be greatly appreciated if you would complete the following questionnaire and return it to:

AFIT/NR
Wright-Patterson AFB OH 45433

RESEARCH TITLE: An Alternate Approach to the Measurement of Soil Surface Heat Flux

AUTHOR: Bruce Rex Merrill

RESEARCH ASSESSMENT QUESTIONS:

1. Did this research contribute to a current Air Force project?
 a. YES b. NO
2. Do you believe this research topic is significant enough that it would have been researched (or contracted) by your organization or another agency if AFIT had not?
 a. YES b. NO
3. The benefits of AFIT research can often be expressed by the equivalent value that your agency achieved/received by virtue of AFIT performing the research. Can you estimate what this research would have cost if it had been accomplished under contract or if it had been done in-house in terms of manpower and/or dollars?
 a. MAN-YEARS _____ b. \$ _____
4. Often it is not possible to attach equivalent dollar values to research, although the results of the research may, in fact, be important. Whether or not you were able to establish an equivalent value for this research (3. above), what is your estimate of its significance?
 a. HIGHLY SIGNIFICANT b. SIGNIFICANT c. SLIGHTLY SIGNIFICANT d. OF NO SIGNIFICANCE
5. AFIT welcomes any further comments you may have on the above questions, or any additional details concerning the current application, future potential, or other value of this research. Please use the bottom part of this questionnaire for your statement(s).

NAME _____ GRADE _____ POSITION _____

ORGANIZATION _____ LOCATION _____

STATEMENT(s):

FOLD DOWN ON OUTSIDE - SEAL WITH TAPE

AFIT/NR
WRIGHT-PATTERSON AFB OH 45433
OFFICIAL BUSINESS
PENALTY FOR PRIVATE USE, \$300



NO POSTAGE
NECESSARY
IF MAILED
IN THE
UNITED STATES

BUSINESS REPLY MAIL
FIRST CLASS PERMIT NO. 73236 WASHINGTON D.C.

POSTAGE WILL BE PAID BY ADDRESSEE

AFTT/ DAA
Wright-Patterson AFB OH 45433



FOLD IN

81-331

AN ALTERNATE APPROACH TO THE MEASUREMENT OF
SOIL SURFACE HEAT FLUX

by

Bruce Rex Merrill

A Thesis Submitted to the Faculty of the
DEPARTMENT OF ATMOSPHERIC SCIENCE
In Partial Fulfillment of the Requirements
For the Degree of
MASTER OF SCIENCE
In the Graduate College
THE UNIVERSITY OF ARIZONA

1 9 8 1

STATEMENT BY AUTHOR

This thesis has been submitted in partial fulfillment of requirements for an advanced degree at The University of Arizona and is deposited in the University Library to be made available to borrowers under rules of the Library.

Brief quotations from this thesis are allowable without special permission, provided that accurate acknowledgment of source is made. Requests for permission for extended quotation from or reproduction of this manuscript in whole or in part may be granted by the head of the major department or the Dean of the Graduate College when in his judgment the proposed use of the material is in the interests of scholarship. In all other instances, however, permission must be obtained from the author.

SIGNED: Bruce R. Merrill

APPROVAL BY THESIS DIRECTOR

This thesis has been approved on the date shown below:

B. M. Herman
B. M. Herman
Professor of Atmospheric Science

7/15/81
Date

ACKNOWLEDGMENTS

The author would like to take this opportunity to acknowledge the support and encouragement provided by the faculty and staff of The University of Arizona. Special thanks must go to the author's advisors, Dr. Benjamin Herman, Dr. Robert Gall, and Dr. Richard Schotland as well as to Dr. Sean Twomey for their many informative discussions and helpful suggestions. Thanks also go to Mr. Richard Milliron for his expert machine shop assistance as well as to the many people in Dr. Schotland's electronics lab and in the Physics Electronics Shop for their guidance in electronic circuit design. Although many people have aided the author in this work, any errors are the sole responsibility of the author.

The author is extremely grateful to the United States Air Force for the opportunity to attend the University of Arizona as a sponsored student in the Civilian Institutions Division of the Air Force Institute of Technology.

TABLE OF CONTENTS

	Page
LIST OF ILLUSTRATIONS.	v
ABSTRACT	vi
1. INTRODUCTION	1
2. THEORY	6
3. INSTRUMENT DESIGN CONSIDERATIONS	13
4. CIRCUIT DESIGN AND OPERATION	20
5. ERROR ANALYSIS	24
6. LABORATORY TESTING AND RESULTS	39
7. RECOMMENDATIONS AND CONCLUSIONS.	44
REFERENCES	47

LIST OF ILLUSTRATIONS

Figure		Page
1.	Flux divergence in a differential volume.	7
2.	Energy budget of natural surface and insulated surface. . .	11
3.	Methods for insulating disks.	15
4.	Location and mounting temperature sensing beads	17
5.	Electronic circuit.	21
6.	Radiative exchange error for a temperature error of 0.1°C .	26
7.	Radiative exchange error vs. emissivity error	28
8.	Measurement error vs. disk temperature error	30
9.	Temperature field	33
10.	Laboratory sand box	40
11.	Measured flux vs. known flux.	42
12.	Circuit modification.	45

ABSTRACT

A new approach to the measurement of the conductive heat flux at the soil surface is presented. This approach provides the means to make measurements of the soil conduction heat flux. By sensing the temperature of the soil surface and using a temperature control circuit one forces an artificially created portion of the soil surface to mimic the temperature of the natural surface. By monitoring the power to maintain this control one makes a direct measurement of the conduction heat flux at the soil surface. Although the present instrument works only when the conduction heat flux is directed out of the ground, there is nothing in principle to prevent the instrument from working when the flux is in the other direction. The error analysis shows that the two main sources of error are due to the electronics design and the errors associated with measuring the true temperature of a surface. Laboratory testing shows that unexplained error amounts to only a few percent at most. Laboratory testing also shows that the instrument is capable of measuring fluxes down to tenths of milliwatts per square centimeter.

CHAPTER 1

INTRODUCTION

The ability to measure the terms in the surface energy budget is essential if one is to assess their importance. The major terms which enter into the energy budget are the soil conduction heat flux, S , the convective heat flux, H , the latent heat flux, L , and the radiative heat flux, R . While any of the terms can play a dominate role in the energy budget, this thesis will be limited to the study of the determination of the soil conduction heat flux. Although the study was limited to times when the soil conduction heat flux was directed out of the ground, the method proposed can in principle be used for the reverse case.

There are several methods for determining the soil conduction heat flux, S . The method chosen will depend on the researcher's need for accuracy as well as his economic and technological limitations. However, none of the currently used methods will provide a direct measurement of this heat flux. Since a direct flux measurement is generally preferred to an indirect measurement, it will be a major goal of this thesis to seek an alternate method by which direct measurement of the soil conduction heat flux can be made.

The proposed method is one of substitution. If part of the soil surface is thermally insulated from the soil conduction heat flux and heat is supplied by some measurable means such that equal

temperatures are maintained on both the insulated surface and the natural soil surface, then the rate at which heat is supplied divided by the area of the insulated surface equals the soil conduction heat flux. Since this thesis proposes a new method it seems appropriate that current techniques should be examined for their strengths and weaknesses before proceeding further.

Perhaps the most common technique makes use of the relationship between heat flux S (measured in mw/cm^2), and the temperature gradient, dT/dz , i.e.

$$S = K(dT/dz) \quad (1)$$

where K is the thermal conductivity in units of $\text{mw}/^\circ\text{C}\text{-cm}$. Although the equation is simple in form, it can pose many problems should one design an experiment based upon this relationship. For instance, Equation 1 establishes the need to determine K . Determination of K is difficult since soil is a mixture of solid, liquid and gas. Since this mixture is variable, K will have both spatial and temporal variations. One study (Kimball et al. 1976) has shown differences of 15% to 60% between experimental and theoretical techniques used to determine K . These differences show that determining K with an accuracy of 10% to 20% is not an easy task.

Other objections to this method include the mathematical and experimental methods used in replacing the differential dT/dz with the finite difference $\Delta T/\Delta z$. Mathematically, finite differencing attempts to linearize the relationship between T and z while in fact it may be

nonlinear. This may be corrected by making more than two measurements and fitting some appropriate curve. However, all the temperature measurements are at or below the surface and it is the surface value of dT/dz that is required. Experimentally this method requires the placement of temperature probes which must disturb the soil and hence change K . Thus, unless one waits for the soil to regain representative compaction and moisture distribution, values of K and dT/dz may not be representative of the surrounding soil.

Another method which is widely used is based on the relationship

$$V \cdot S = C(dT/dt) \quad (2)$$

where C is the volumetric heat capacity in units of $\text{mw-sec}/^\circ\text{C-cm}^3$, and dT/dt is the time rate of change of temperature. If horizontal homogeneity is assumed, then Equation 2 can be rewritten as

$$\int_{S_1}^{S_2} dS = \int_{z_1}^{z_2} C(dT/dt) dz \quad (3)$$

where z_1 equals the height of level one, z_2 equals the height of level two, S_1 equals the flux at z_1 , and S_2 equals the flux at level z_2 . There are difficulties using this approach. First, C is variable for the same reasons that K is variable. Secondly, the differential dT/dt must again be approximated by finite differencing which tends to produce large errors as the time scale shrinks and the temperature changes become smaller. Finally, even if $C(dT/dt)$ were known to an acceptable accuracy one must determine the lower boundary condition S_1 in order

to evaluate S_2 . In practice S_1 is often chosen at a sufficiently deep depth (Guild 1950) such that diurnal variations of temperature are not felt and the flux S_1 can be assumed to be negligible. An alternate method is to determine S_1 by the use of heat flux plates which will be described later. A somewhat more recent technique is the null-alignment procedure described by Kimball and Jackson (1975) which employs both Equations 1 and 3. In this procedure one makes an estimate of thermal conductivity, K , at a reference depth of 20 cm. Using a measurement of temperature gradient at this level of value for S can be determined for use in Equation 3. Generally right after sunrise and sunset the direction of the soil conduction heat flux will change and, hence, somewhere above 20 cm depth the temperature gradient will equal zero. Unless one was lucky in estimating K , the value of the heat flux computed by Equation 3 will not be zero where the temperature gradient is zero. Therefore, one must adjust the value of K so as to align the null points determined by measurement of dT/dz and computation via Equation 3.

The last general technique involves the use of heat flux plates. A description of their construction and calibration can be found in Fuchs and Tanner (1968), Fuchs and Hadas (1973), and Fritschen and Gay (1980). The basic idea is that a thin plate of known thermal conductivity is buried in the soil perpendicular to the heat flux. Measurements of temperature on the faces of the two faces perpendicular to the flux can then be related to the heat flux in the soil. The problems of this technique are many including selecting material for the plate of the proper thermal conductivity and heat capacity, performing

calibrations, blockage of moisture transport in the soil, and thermal contact errors. In an arid environment the most serious problem relates to the thermal properties of the material. If these properties differ significantly from the soil then the temperature field in the surrounding soil will be distorted both spatially and temporally. Furthermore, burying the plates requires that one disturb the soil, the problems of which have already been discussed.

CHAPTER 2

THEORY

In developing any new technique it is important to consider the physics governing the situation. Since this study deals with energy transfer at an interface, it seems appropriate to invoke the principle of energy conservation. The application of this principle is discussed by Fleagle and Businger (1963); however, it is apparent from the literature that the proper application is a subtle point (Sutherland 1980, Shaw 1981, Sutherland 1981). Therefore, it is worthwhile to review this basic principle.

If one considers a differential volume element as shown in Figure 1, then conservation of energy yields

$$\nabla \cdot F = C(dT/dt) \quad (4)$$

where F is any energy flux and C and dT/dt are as described in the Introduction. By assuming horizontal homogeneity, Equation 4 can be rewritten as

$$\int_{F_1}^{F_2} dF = \int_{z_1}^{z_2} C(dT/dt) dz. \quad (5)$$

If z_1 approaches z_2 then the right hand side of Equation 5 tends to zero, or

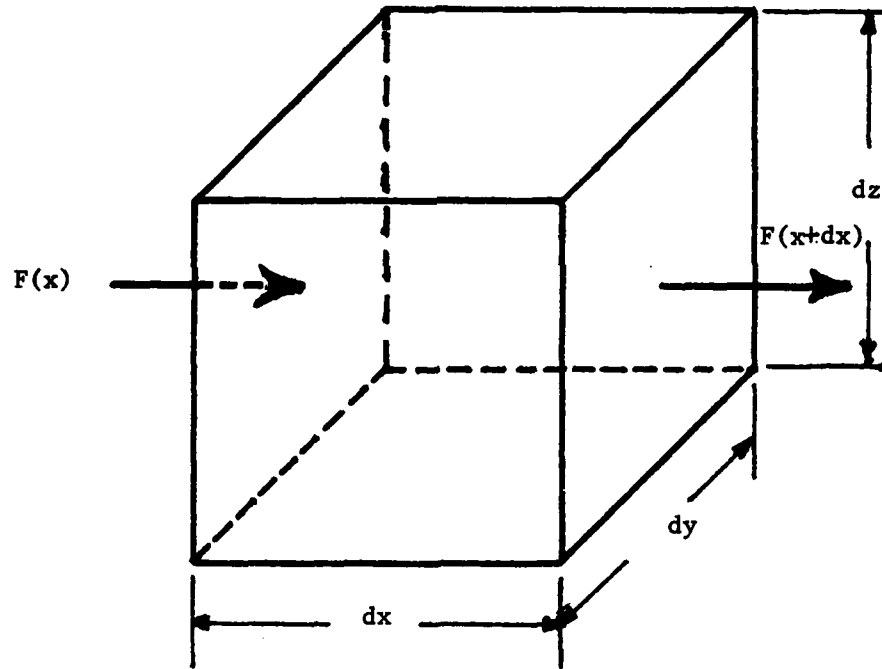

Figure 1. Flux divergence in a differential volume.

$$F_2 - F_1 = 0 \quad (6)$$

In writing Equation 6 it was assumed that positive quantities were directed upwards. However, by assuming that positive quantities are directed into the differential volume, one obtains the more common expression

$$\sum F = 0. \quad (7)$$

In applying Equation 7 one point which is often overlooked and leads to misunderstanding should be stressed. Specifically, although the following equation is true

$$\lim_{z_1 \rightarrow z_2} \int_{z_1}^{z_2} C(dT/dt) dz = 0 \quad (8)$$

this does not imply that dT/dt is zero, for indeed the temperature does change with time. However the question is raised, "If the summation of the fluxes equals zero how can the temperature change?" The answer is that temperature change is the result of flux divergence. Therefore the flux which enters a cross section of zero thickness must equal the flux which exits the same cross section. If this were not so, then the divergence at that point would be infinite leading to an infinite rate of temperature change.

If the principle components of F are those already mentioned, (i.e., soil conduction heat flux, convective heat flux, latent heat flux, and radiative heat flux) and the other forms of energy fluxes, (i.e.,

electrical, biological, etc.) are ignored, then Equation 7 may be re-written as

$$\sum F = S + H + L + R = 0 \quad (9)$$

where S,H,L,R are the principle components of F as referred to above. By considering the individual terms of Equation 9, one can reach a better understanding of how Equation 9 may be used to measure S.

The net radiative flux as written in Equation 10 has two components, R_s being the downward directed radiation due to atmospheric

$$R = R_s + R_G \quad (10)$$

emission and other sources, and R_G being the upward directed emission from the surface. Over an open field R_s is independent of location provided that there are no natural (trees, fog banks, etc.) or manmade (buildings, awnings, etc.) structures to interfere with R_s . The upward emission, R_G may be written as

$$R_G = \epsilon \sigma T^4 \quad (11)$$

where ϵ is emissivity and is a function only of material and temperature, σ is the Steffan-Boltzmann constant, and T is the surface temperature. Implicit in Equations 10 and 11 is the assumption that the radiation field does not penetrate the soil layers below the surface. Therefore, any two sections of soil surface will have the same value of R if their temperatures are the same.

Since the instrument presently has no way to separate the latent heat flux from the conduction heat flux, the instrument will be restricted to times when there is no latent heat flux. Thus the latent heat term in Equation 9 becomes zero.

Due to the no-slip boundary conditions imposed by the aerodynamics there can be no convective transfer right at the surface. Therefore, the heat transferred within approximately the first millimeter of air must be by molecular conduction. The exact depth of this boundary layer will depend upon several factors including temperature profile within the layer, surface roughness and some characteristic velocity measured in the free air outside the boundary layer. Often the physical complexities of the transfer process are lumped together in an empirical quantity called the bulk transfer coefficient B , such that

$$H = B(T - T_A) \quad (12)$$

where T is the surface temperature and T_A is the free air temperature at some preselected height above the surface. It should be stressed that the empirical quantity B is a function of many variables including atmospheric stability, turbulence, etc. Therefore the bulk transfer coefficient will have spatial and temporal variations. However, if the spatial variations are small and all other factors are the same, then at any given time the convective heat flux H , is only a function of surface temperature.

Under the conditions outlined in the preceding paragraphs, the energy budget for surface A in Figure 2 may be written as

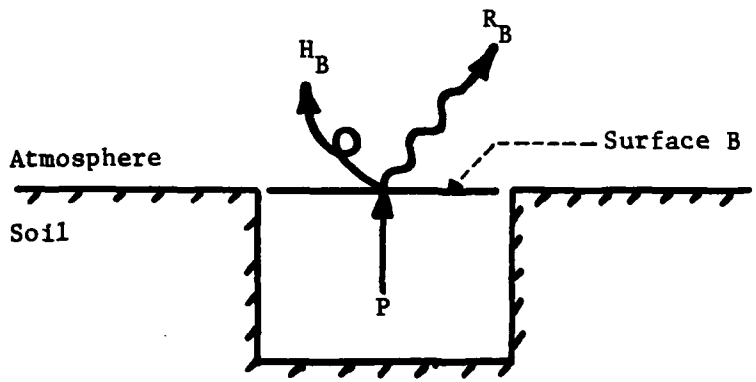
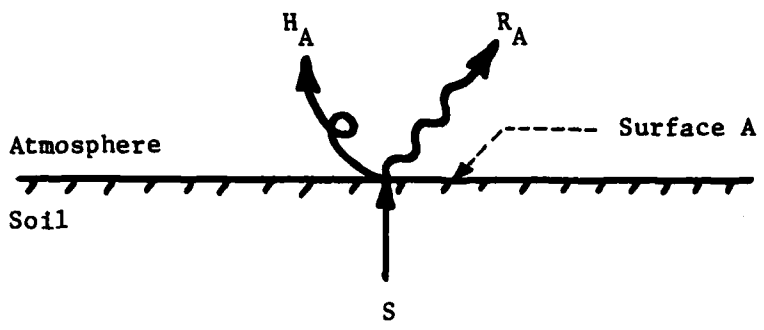

Figure 2. Energy budget of natural surface and insulated surface.

$$\sum F = S + H_A + R_A = 0. \quad (13)$$

Similarly the energy budget for surface B maybe written as

$$\sum F = P + H_B + R_B = 0 \quad (14)$$

where P is an energy flux supplied to surface B by some measurable means, e.g., ohmic heating. Implicit in Equation 14 and Figure 2 is that the underside of surface B is thermally and radiationally insulated from the surrounding environment. If surface B is of the same material, roughness, and temperature as surface A then for the reasons previously discussed

$$H_A = H_B \text{ and } R_A = R_B \quad (15)$$

and hence

$$P = S. \quad (16)$$

Therefore, since P is a measured quantity, S is known. The next chapter shall be devoted to a closer look at the instrument's requirements.

CHAPTER 3

INSTRUMENT DESIGN CONSIDERATIONS

Equation 9 which forms the basis of the instrument is written for a surface of infinitesimal thickness. Therefore, it is important that the insulated surface be kept as thin as possible. The surface must serve three functions. It must be of the proper roughness so that the convection is not altered. It must be of the proper emissivity so that the radiation is likewise not altered. Finally, it must afford a means by which a measurable amount of energy can be supplied to it.

To match the roughness and emissivity, a thin layer of the soil itself was chosen. There were several options available for heating the surface. The first possibility was to use ohmic heating via nichrome wire. This idea was rejected since the nichrome wire will produce hot spots in a thin surface. A second possibility was to use infrared radiation to heat the surface. While this would allow a more even heating of the thin surface the technical problems of accounting for all the radiation (i.e., scattering, absorption, reflection) are very large. Finally it was decided that a disk thermistor to which a coating of soil could be applied provided the best compromise. To insure a good thermal contact between the soil and the thermistor, a thin coating of ordinary white glue was used.

The thermistor chosen was produced by the Fenwal Company (Part No. ZB11J1) of Framingham, MA. Dimensionally it was 2.5 cm (1 in.) in diameter and 0.17 cm (0.069 in.) thick. It provided a nominal resistance of 10 ohms at 25°C. Both faces of the disk were coated with silver for the purpose of attaching wire leads and providing a uniform voltage across the disk. A thinner disk could have been obtained, however, the diameter would have been smaller. The larger diameter was preferred since small variations in surface roughness and emissivity will tend to average out over a larger surface. However, the smaller disk produced by Fenwal (Part No. NB11J1, diameter 2.0 cm, thickness 0.10 cm) offered a reduced aspect ratio between circumferential area ($2\pi r \cdot \text{thickness}$) and circular area (πr^2). This ratio is important when considering insulating methods.

Two means of insulating the disks were considered and are illustrated in Figure 3. Although both methods were tried, the difficulties in maintaining a vacuum and machining very thin walls in the pvc tubing (necessary to reduce the amount of heat conduction) made the simpler styrofoam insulator preferred. The styrofoam used had a density of 0.014 gm/cc and measurements of such low density styrofoam (Touloukian et al. 1970) indicate thermal conductivities near 0.2 mw/°C-cm. Since this conductivity is approximately 10% that of the soil, the insulator may not be considered perfect and will be a source of error. Another problem with the insulator is that it will distort the temperature field in the soil surrounding the disk. These temperature changes have the potential to alter the convective transfer in the vicinity of

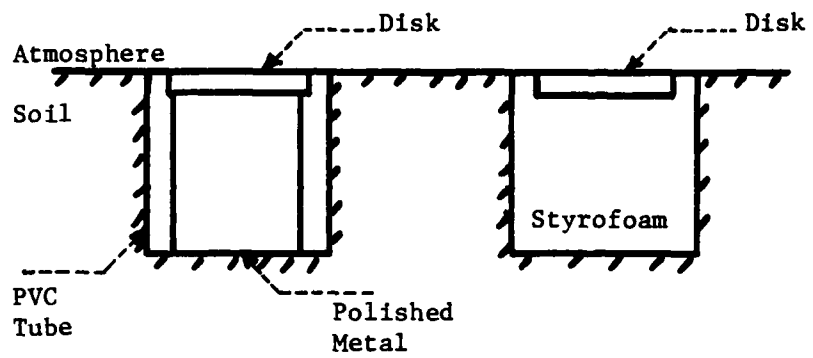

Figure 3. Methods for insulating disks.

the disk. Further, heat will be transferred through the sides of the disk if there are temperature differences between the disk and the surrounding soil. The relative magnitude of the heat which flows through the sides of the disk compared to that flowing perpendicular to the disk face can be reduced by reducing the aspect ratio as already mentioned. The styrofoam cylinders were cut 3.0 cm in diameter and 2.5 cm thick. A recessed area was machined in the styrofoam to allow the disk surface and insulator to be flush with the soil surface as indicated in (b) of Figure 4. To keep the disk firmly in the styrofoam it was attached with double stick tape.

The wire leads attached to the disk present another problem in thermally insulating the disk. The wires should be large enough to withstand the handling that will accompany field use while being as small as possible to restrict heat flow through the wires. This heat flow can be minimized by using well insulated wire and placing the wires such that the temperature of their environment is close to that of the disk (i.e., along the soil surface).

A number of methods for determining the disk and soil temperature were possible. One method was to remotely sense the temperature via infrared radiation. This represented the most desirable method since it did not require direct contact. Drawbacks to the remote sensing technique including higher cost in terms of developmental time and money as well as higher technology.

Another technique was to use small thermocouples attached to the disk and soil surface. Advantages to using very small thermocouples is

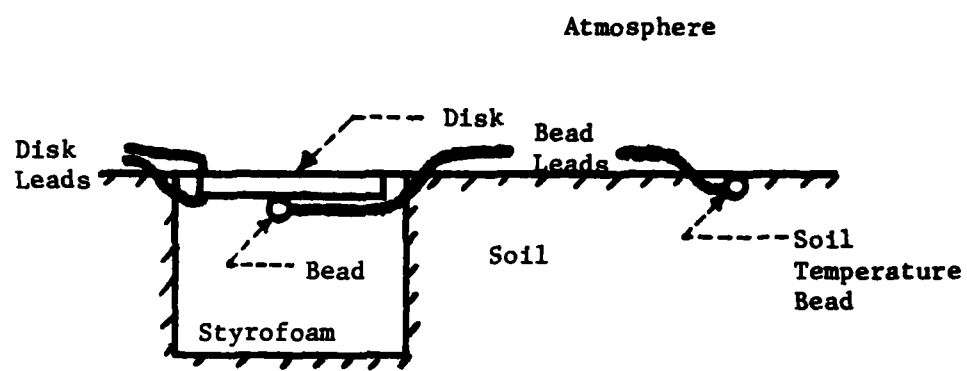

Figure 4. Location and mounting temperature sensing beads.

that their size will minimize distortions in the temperature field of the soil as well as providing a rapid response time. Furthermore, thermocouples present no problem in obtaining matched pairs since the voltage depends only on the metals used and the temperature difference. The problem with thermocouples is their small signal output. For example, to maintain the disk temperature within 0.1°C of the soil temperature, the signal generated by the thermocouples will be about four microvolts. To supply sufficient power to the disk from this signal requires amplifier gains of from 10^5 to 10^6 .

Designing amplifiers that operate on microvolt signals with gains of 10^5 to 10^6 pose major problems, therefore small precision bead thermistors were selected in lieu of thermocouples. In any design with thermistors the self-heating effect due to the measuring current must be considered. However, even with this taken into account amplifier gains can be reduced to 10^2 to 10^3 . The bead thermistors used were produced by Fenwal (Part No. UUB31J1). They had a nominal resistance of 1000 ohms at 25°C and a nominal diameter of 0.24 cm (0.095 in.). The small size minimizes distortion of the temperature field as well as offering a short time constant. The thermistors come from the company matched to within 0.2°C of a calibration curve. By using a temperature bath to selectively match them as well as using trimmer resistors in the electronics, the beads can easily be matched to each other to within 0.1°C over a limited temperature range.

To insure good thermal contact between the bead and the disk, the bead was attached with white glue. To eliminate edge effects, the

bead was located near the center of the disk. To eliminate any interference with convective or radiative transfer as well as to shield the bead from high frequency air temperature fluctuations, the bead was mounted on the underside of the disk as shown in Figure 4. With the bead mounted on the underside of the disk one might well question if the bead senses the surface temperature of the disk. Although the semiconductor material used to manufacture the disk was not known, Bogoroditskii and Pasyukov (1967) report that typical materials include ZnO, MgO, etc. Touloukian et al. (1970) reported thermal conductivities of these compounds to be near $300 \text{ mw}/^\circ\text{C-cm}$. This is approximately 100 times the conductivity of the soil. Therefore, it was assumed that the disk maintained a uniform temperature.

Figure 4 also shows the placement of the thermistor bead used to measure the soil temperature. It was just covered by the soil surface and senses the soil temperature via conductive and radiative exchange with the surrounding soil.

CHAPTER 4

CIRCUIT DESIGN AND OPERATION

The electronic circuit used to sense and maintain temperature is shown in Figure 5. The two bead thermistors used to measure temperature form two legs of a Wheatstone bridge. The differential voltage is then amplified in two stages. Each stage is composed of an LF356 operational amplifier. The first stage is balanced such that for zero input there is zero output. The second stage is balanced such that for zero input the output is sufficient to just turn on output transistor TIP29C. The purpose of the output transistor is two fold. The primary purpose is to drive the low impedance load, i.e., the 10 ohm disk thermistor. The secondary purpose, as will be described, is to act as a gate. If the temperature of the disk drops below the soil surface temperature, a voltage will develop across the bridge which will be amplified and power will be supplied to the disk to raise its temperature. If the disk has a temperature greater than the soil surface, a voltage of opposite sign will develop which will reverse bias the transistor preventing any power from flowing to the disk. If the transistor did not prevent this power from flowing, the disk's temperature would continue to increase and thermal runaway of the disk would result.

To measure the power, two RUSTRAK Model A recorders were used. Current was measured by sensing the voltage across the 0.5 ohm precision resistor in the output section. The other recorder measured the voltage

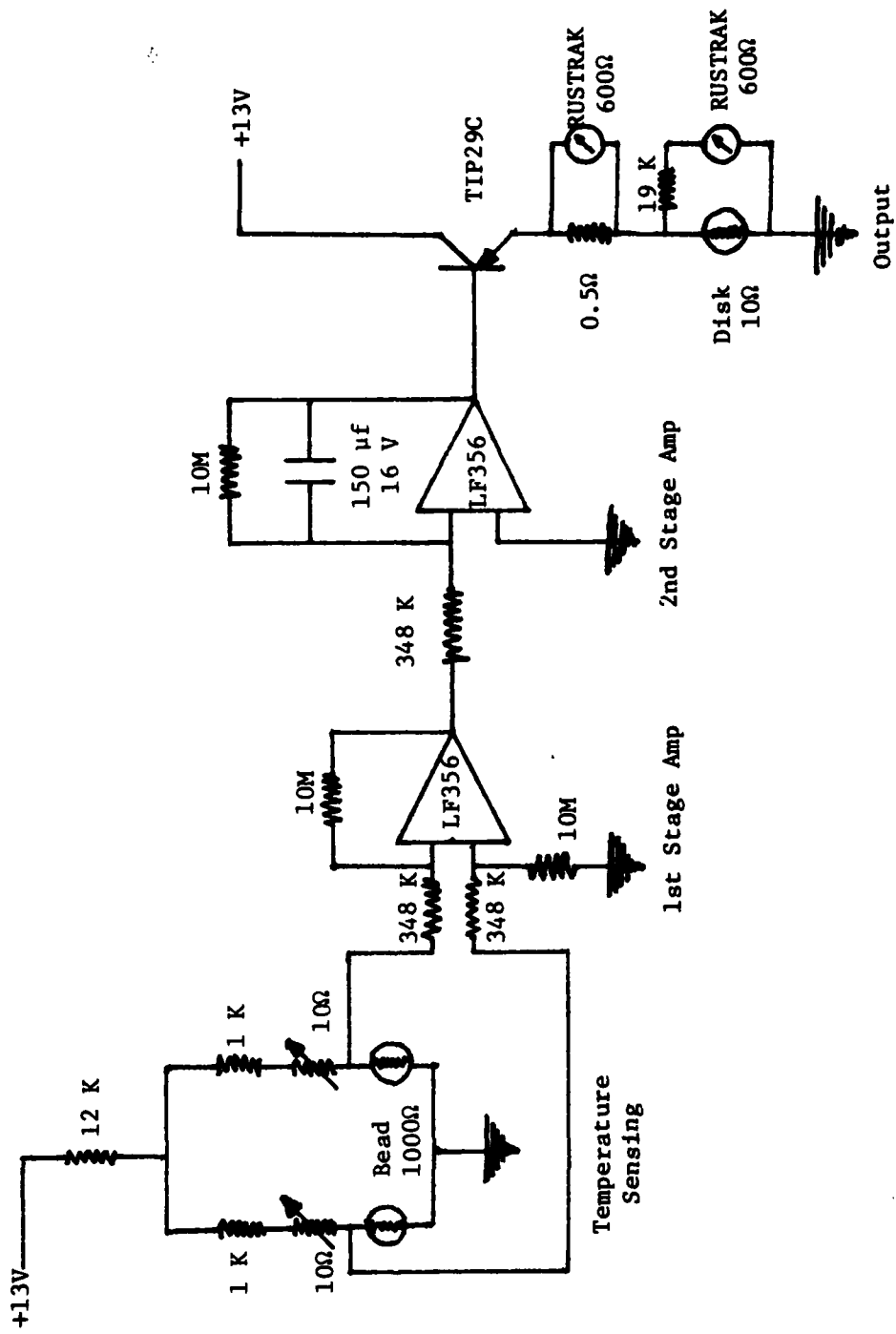

Figure 5. Electronic circuit.

across both the disk and its leads. Since the resistance of the disk is quite low the voltage across the leads can be significant. The resistance of the leads was 1.1 ohms. Being low frequency instruments the frequency response of the RUSTRAK meters was limited. In fact, amplitude response was down by 40% and 0.5 Hz. Since the sampling rate of the RUSTRAK meters is 0.5 Hz, the highest frequency resolvable would be 0.25 Hz and the amplitude of the frequency component of this signal would be severely reduced. Due to the short (1 sec) time constant of the bead thermistor's turbulence near the soil surface will cause the temperature of the bead to fluctuate. These high frequency temperature fluctuations will cause voltage and current fluctuations that will go undetected by the RUSTRAK meters. As will be shown, these fluctuations must be taken into account in the measurement process.

Since the load is resistive one need only multiply voltage by current to determine the power supplied to the disk. If the voltage and current fluctuate about a mean, then the instantaneous voltage V , and current I , may be written as

$$V = \bar{V} + V' \quad (17a)$$

$$I = \bar{I} + I' \quad (17b)$$

The bar indicates mean values while the prime is the fluctuation. The instantaneous power W , is given as

$$W = VI. \quad (18)$$

The average power is then

$$\bar{W} = \overline{VI} = \overline{(V + V')(I + I')} \quad (19)$$

or

$$\bar{W} = \overline{VI} + \overline{V'I} + \overline{VI'} + \overline{V'I'} . \quad (20)$$

If $\bar{V}' = \bar{I}' = 0$, then

$$\bar{W} = \overline{VI} + \overline{V'I'}. \quad (21)$$

The nature of the relationship between V and I requires that V' and I' be highly correlated, therefore one cannot disregard $\overline{V'I'}$. Since the frequency response of the meters was so poor a 150 μ f capacitor was placed across the second stage amplifier. The effect of the capacitor is to smooth the fluctuations before the power is delivered and the measurements are made. Thus the RUSTRAK readings will better indicate the actual power supplied to the disk. One point which should be stressed is that the combination of a 10M ohm resistor and a 150 μ f capacitor gives the second stage amplifier a time constant of 25 minutes. This is too long for actual field use and further thought should be given to the selection of any capacitor used to filter the signal. However since this thesis only tested the instrument under steady-state laboratory conditions the 150 μ f capacitor did not affect the results.

CHAPTER 5

ERROR ANALYSIS

Data from Sellers' et al. (1965) study of heat transfer from a bare soil surface, typical of conditions in an arid environment was used in the error analysis. The analysis will assume that the instrument is in thermal equilibrium with the atmosphere via radiative and convective processes.

Basically, the instrument delivers the heat flux necessary to maintain the temperature of a disk equal to the temperature of the surrounding soil surface. In order to specify instrument accuracy, it is necessary to assess how errors in maintaining the disk-soil temperature equality affect instrument performance. Using simple models the analysis will first study the effects of temperature errors on the physical processes fo radiative and convective exchange. Next, the analysis will look at how well the electronics can minimize the temperature error. Since any measurement must alter that which is being measured, this analysis will study how the instrument affects the measurement.

If Equation 14 is rewritten as

$$P = - (H + R) \quad (22)$$

then it is clear that if H remains constant any change in R will cause an equal change in P. From Sellers' data the average net nocturnal

radiative exchange between the soil surface and the sky is 8.11 mw/cm^2 . If the average soil surface temperature is 294.20°K and the soil emissivity is 0.91, then the effective blackbody temperature of the sky must be 270.92°K . If the disk and the soil surface have the same emissivity and they see the same sky temperature, then, since the temperature of the disk will generally not be equal to the temperature of the soil surface (i.e., some temperature difference is required to initiate a controlling action) the net radiative exchange between the disk and the sky will not equal the net radiative exchange between the soil surface and the sky. The relationship between temperature difference and the net radiative exchange is a function of sky temperature, surface temperature, and emissivity. If the sky temperature and emissivity remain constant then the difference, ΔR , in the net radiative exchange between the soil and sky and the disk and sky can be approximated as

$$\Delta R = 4\sigma\epsilon T^3 \Delta T \quad (23)$$

where σ is the Steffan-Boltzmann constant, ϵ is the emissivity, T is the soil surface temperature, and ΔT is the temperature difference between the disk and soil surface. Figure 6 shows the difference in net radiative transfer, R , for a range of soil surface temperature assuming ΔT equals 0.1°C . If the average soil flux is 5.26 mw/cm^2 , then Figure 6 indicates that the fractional error ($\Delta R/P = \Delta P/P$) will generally be less than 1% for a temperature difference of 0.1°C between the disk and the soil surface.

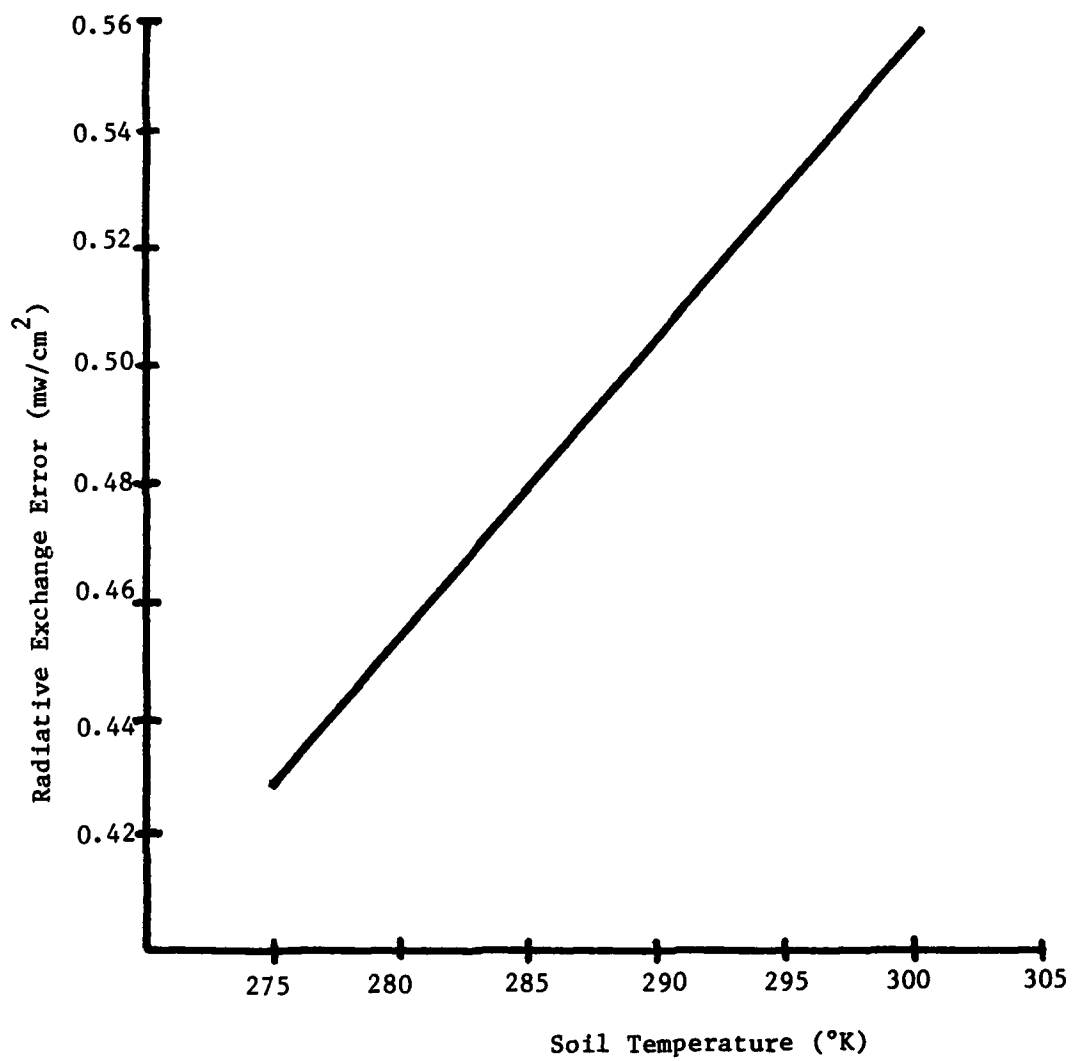

Figure 6. Radiative exchange error for a temperature error of 0.1°C .

Another potential source of error in the radiational balance is caused by variations of emissivity between the disk and the soil surface. Although typical values for soil emissivity may be 0.91 (Sellers 1965), variations of 0.05 can be expected (Kern 1965) depending upon soil composition. If the emissivity of the disk differs from that of the soil surface, the net radiative exchange between the disk and the sky will not equal the radiative exchange between the soil and the sky even if the disk and the soil surface are the same temperature and they see the same sky temperature. Figure 7 shows the percent difference in radiative transfer between the disk and the sky and the soil and the sky as a function of the emissivity difference between the disk and the soil. As Figure 7 shows, a 0.01 difference in emissivities can cause a 5% variation in the radiative transfer. Since the emissivity of any object is rarely known to better than ± 0.03 any attempt to cover the disk with anything other than soil could lead to errors in excess of 30% in estimating S.

The relationship between convective heat flux and surface temperature is more difficult to determine since it is a function of wind speed and surface roughness as well as temperature. However, by using average values from Sellers' et al. (1965) study one can make a first order approximation at the relationship. Due to the no-slip aerodynamic conditions at the soil surface all convective transfer must first occur as molecular conduction through a thin layer at the surface. The average temperature difference, ΔT , across the conduction layer is 0.59°C . If the convective heat flux is proportional to this temperature

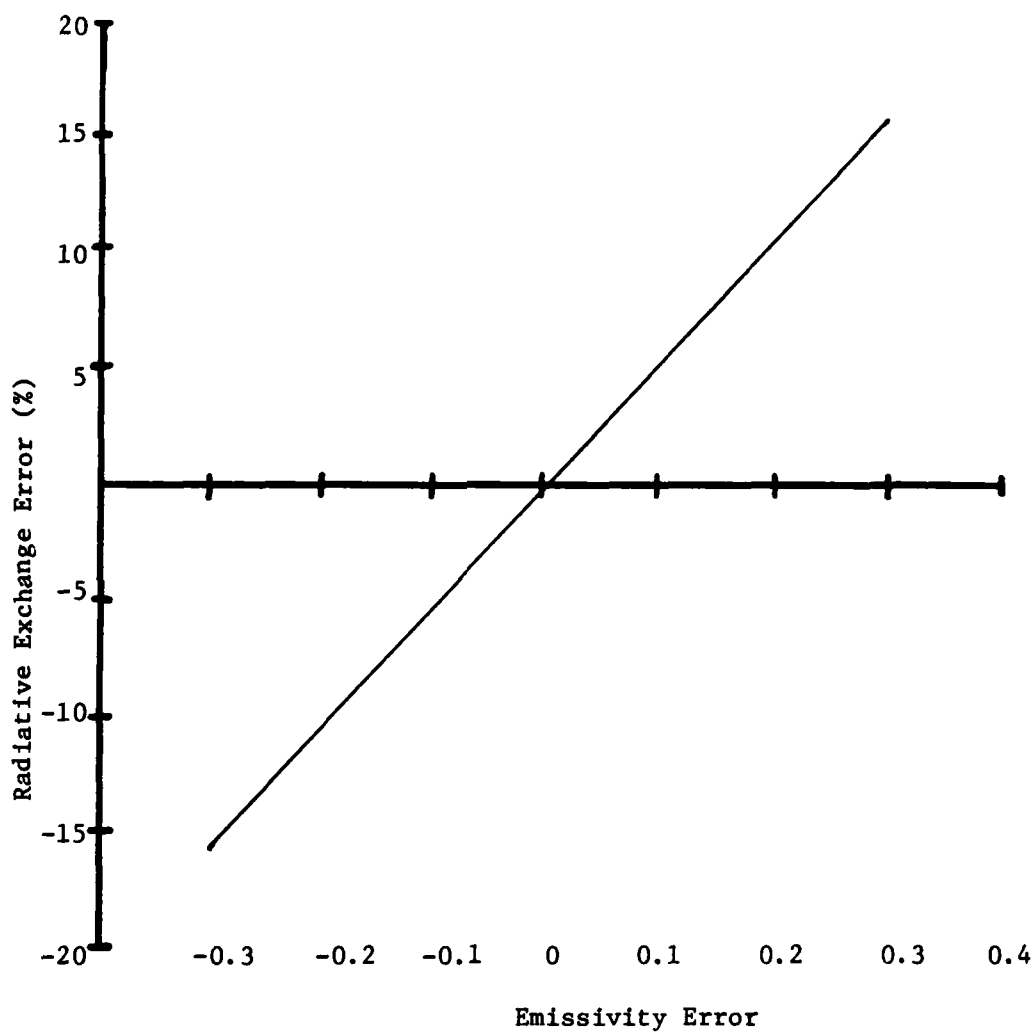

Figure 7. Radiative exchange error vs. emissivity error.

difference and the average convective flux is 3.39 mw/cm^2 , then a 0.1°C change in T will change the convective heat flux by 17% or 0.57 mw/cm^2 . A 0.1°C change will affect the net radiative exchange by 1% or 0.08 mw/cm^2 . Therefore, if the disk is 0.1°C warmer than the soil surface, P in Equation 14 will be increased by 0.65 mw/cm^2 above the average value of 5.26 mw/cm^2 resulting in a 12% error.

Using the sand box described in the next chapter, an experiment was performed to independently assess the relationship between changes in P and changes in the temperature difference between the disk and the soil. The instrument was placed in the box and the resistance of the soil thermistor bead was measured using a digital meter. A precision decade resistance box (calibrated in 0.01 ohm increments) was set to an equal resistance when measured with the same meter. The soil thermistor bead was then removed from the circuit and the resistance box was substituted in its place. The resistance of the box was then varied causing changes in the disk's temperature. If the disk's temperature was equal to the soil surface temperature before the resistance box was varied, then a 0.1°C change in the disk's temperature represents a 0.1°C temperature difference between the disk and the soil. Figure 8 shows the percent change in P as a function of changes in disk temperature. Based on the results of the foregoing theoretical and experimental analysis, it appears that a 0.1°C temperature error between the disk and the soil will result in a 10% error in the measurement P .

If an error level of 10% is acceptable then the electronics must be such that the temperature difference between the disk and the

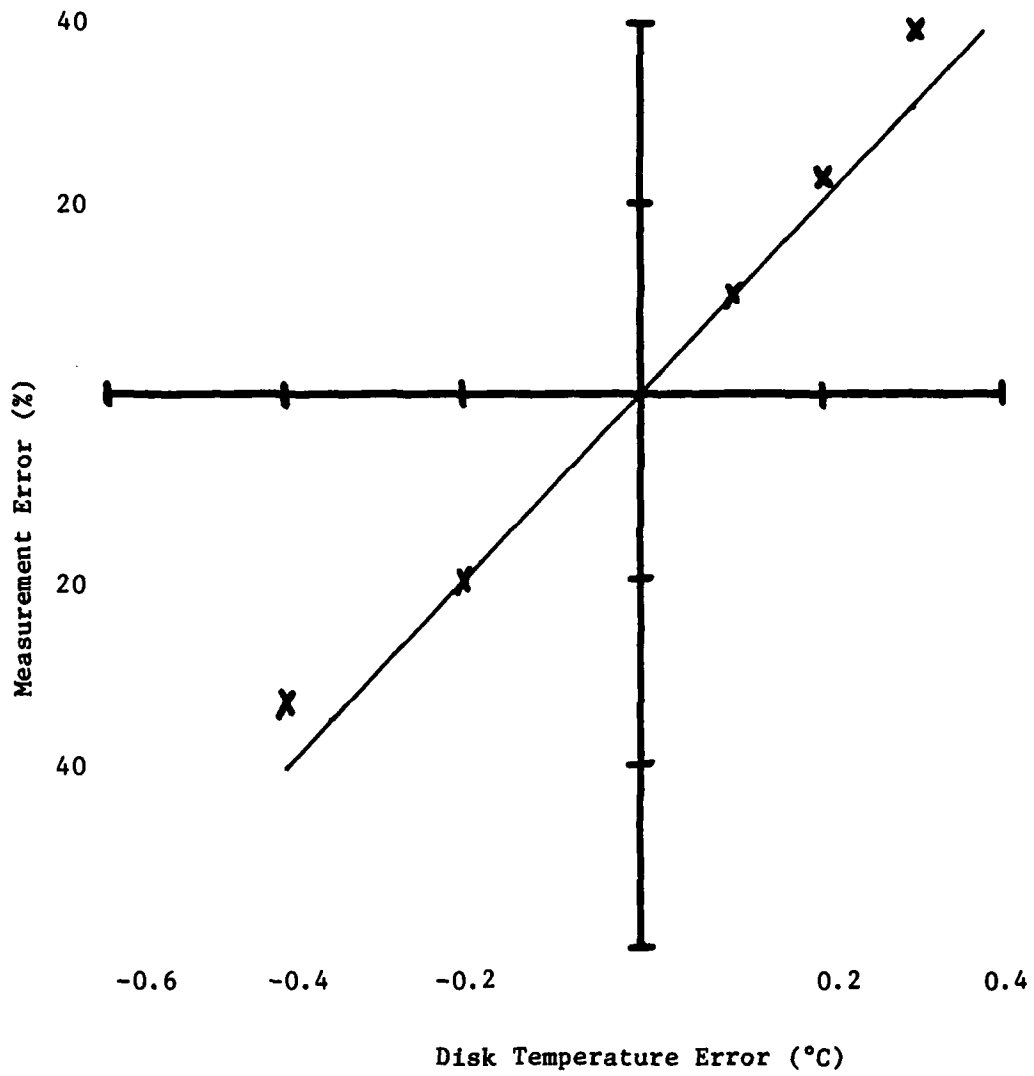
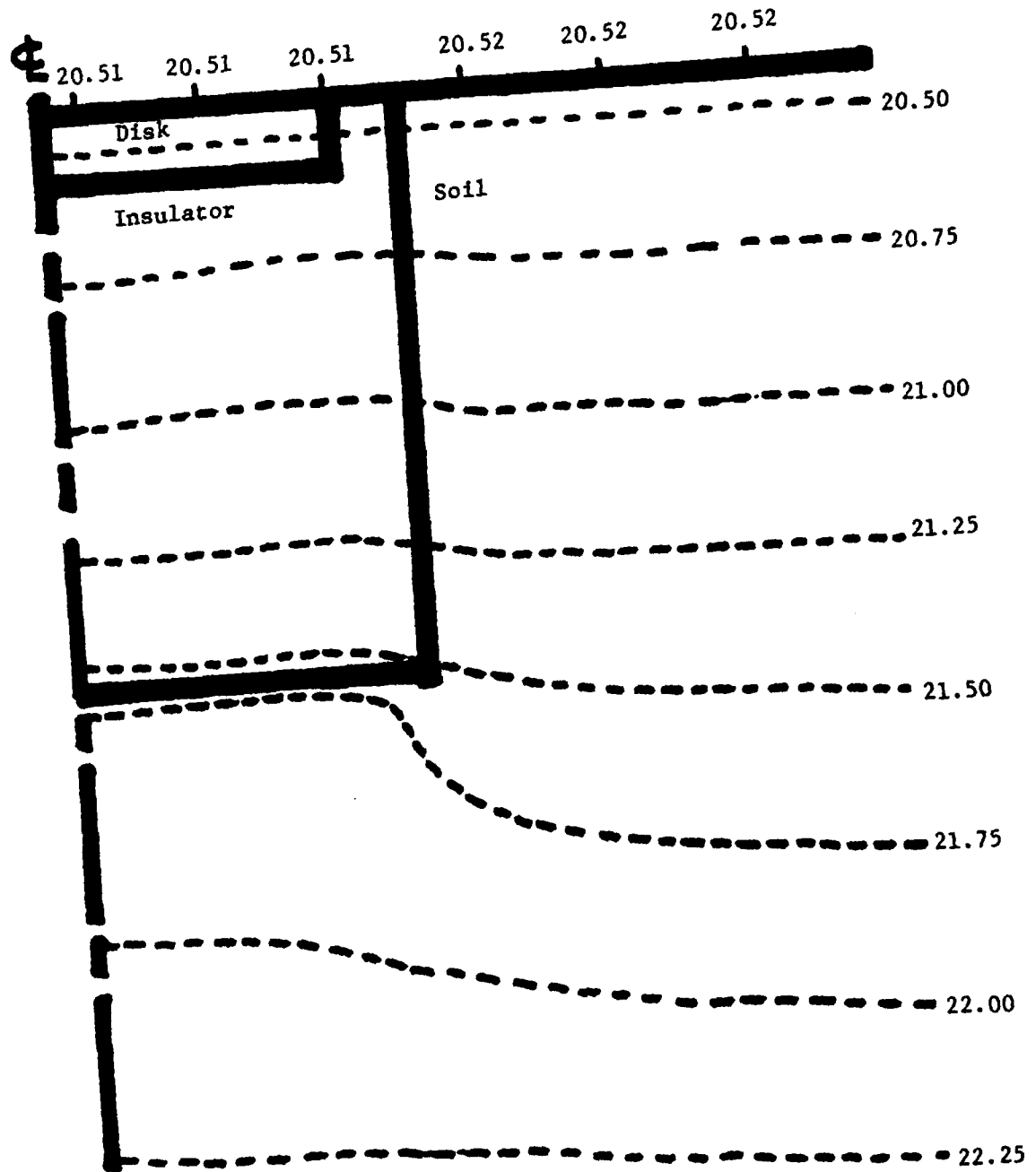

Figure 8. Measurement error vs. disk temperature error.

soil surface be no more than 0.1°C. The bead thermistors selected as temperature sensors have a tolerance of 0.2°C from a calibration curve over a range of 0°C to 70°C. Therefore, two thermistors could differ from each other by 0.4°C. However, as this represents the extreme difference, several thermistors were tested in a variable temperature mineral oil bath. The results showed that of the four tested, three were matched to each other to within 0.09°C and two were matched to within 0.03°C. However, even with perfectly matched thermistors, the disk must be at a lower temperature than the soil to generate a signal to provide power to heat the disk. From Sellers' data the maximum nocturnal soil conduction flux was 7.93 mw/cm². Using the circuit of Figure 6 and assuming the soil temperature to be 25°C, the disk temperature required to provide 10 mw/cm² is 24.907°C. The temperature difference of 0.093°C between the disk and soil is only correct if the disk has a resistance of 10 ohms. Since the disk is a thermistor its resistance will change as its temperature changes. The exact temperature difference required to generate sufficient power to counter the radiative and convective losses on a disk of different resistance is easily calculated if a record of the voltage and current supplied to the disk is made and the amplifier gain is known. To summarize the errors associated with the electronics portion of the system, if the thermistors are matched to 0.1°C and a temperature difference of 0.1°C is required, then the temperature difference between the disk and the soil surface could be as large as 0.2°C resulting in a 20% error. However, this error can be reduced to less than 10% by using thermistors matched to 0.03°C.

Until now a perfect thermal insulator was assumed; however, the thermal conductivity of the styrofoam can be 10% of the soil. The styrofoam insulator has two effects. First, since it is not a perfect insulator heat will be conducted through it. Secondly, since its conductivity is different from the soil, it will distort the temperature field in the surrounding soil. A computer model was used to study these two effects. The model (using standard cylindrical coordinates with angular displacement ϕ , radial displacement r , and vertical displacement z) assumed homogeneity with respect to the ϕ coordinate. Thus, the study was simplified to a two-dimensional function of z and r . The model assumed that the soil temperature field was undisturbed at a radial distance of five times the styrofoam cylinder radius and a depth of five times the styrofoam cylinder depth. The model used a numerical relaxation scheme to adjust the temperature field such that the net heat flux into each volume element was zero. Typical results from the computer study are shown in Figure 9 (a and b). The numbers at the top of figures 9a and 9b are the surface temperatures generated by the computer model. These figures show large distortions in the temperature field near the bottom of the insulator as heat is forced to flow around the insulator. This flow of heat causes the soil temperature to increase near the insulator. At the soil surface this increase in temperature ranged from 0.01°C at a soil conduction flux of 1 mw/cm^2 to 0.20°C at 12 mw/cm^2 . The errors associated with the temperature field distortion can be significant as will be shown.



Soil Heat Flux = 1 mw/cm^2 , Temperatures in $^{\circ}\text{C}$

(a)

Figure 9. Temperature field.

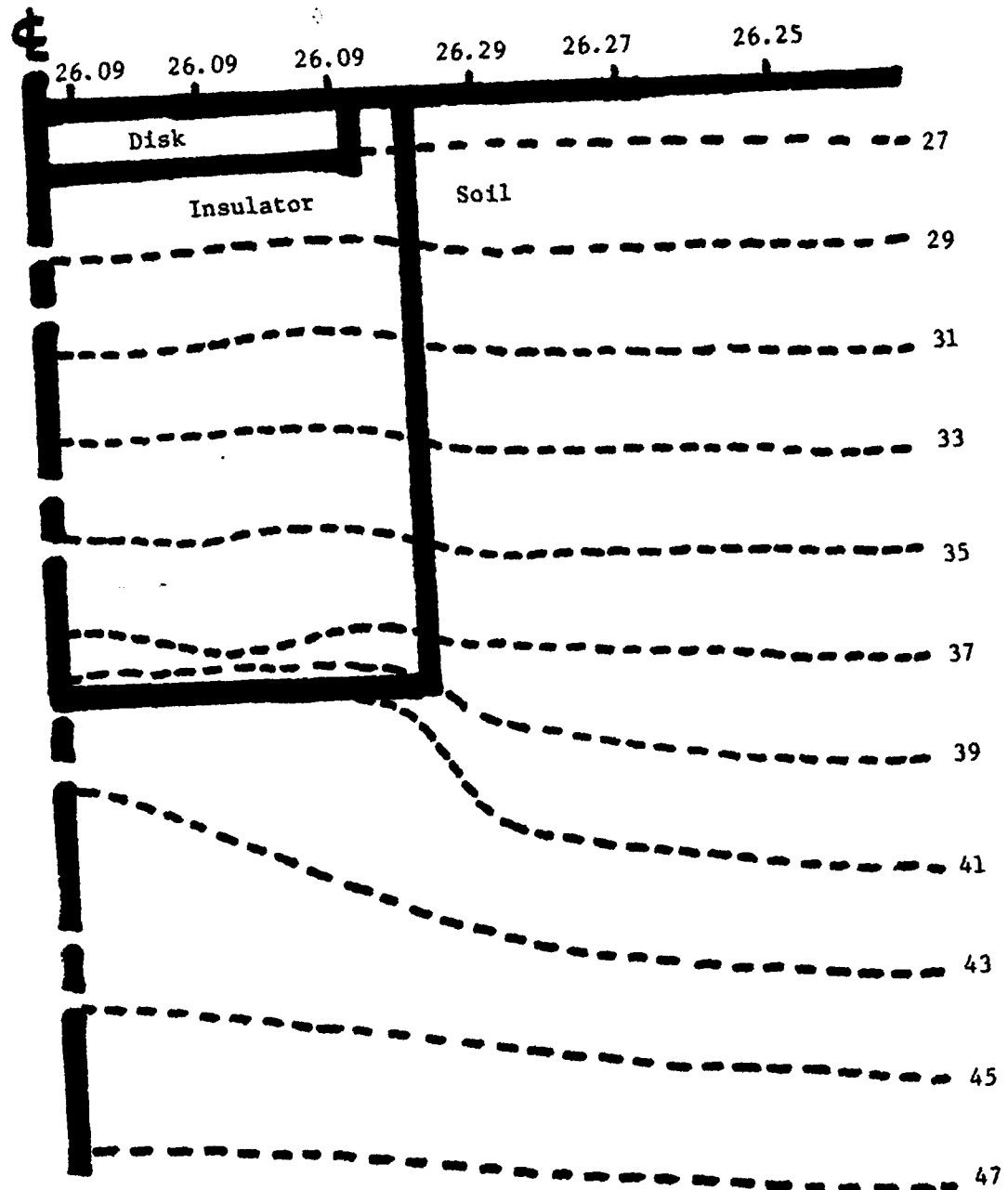

Soil Heat Flux = 12 mw/cm^2 , Temperatures in $^{\circ}\text{C}$

(b)

Figure 9. Continued

Since the disk does not see the surrounding soil, the increased temperature has no effect on the radiative exchange occurring at the disk. However, the increased temperature will affect the molecular boundary layer causing heat to leak to the disk. To calculate the heat leakage several assumptions were made. First, it was assumed that the air above the molecular boundary layer was sufficiently well mixed so that its temperature was unaffected by the changes in surface temperature near the insulator. Next it was assumed that the boundary layer was 0.05 cm thick and that the conductivity of the air was 0.26 mw/°C-cm. Finally, the average horizontal temperature gradient in the boundary layer at the edge of the disk was assumed equal to the radial surface temperature gradient generated by the computer model at the edge of the disk. Using a similar approach the leakage through the styrofoam was calculated assuming a styrofoam conductivity of 0.2 mw/°C-cm. The combined calculations of the heat leakage through the boundary layer and the styrofoam indicate that 11% of the required heat flux is provided through leakage. Therefore the measurement P, should be increased by 11% to account for this effect.

The measurement of the soil surface temperature provides another source of error. A vertical temperature gradient must exist in the soil if there is to be a flow of heat up to the soil surface. For typical soils with conductivities near 2.5 mw/°C-cm, the temperature gradient, dT/dz , at the surface is given by

$$dT/dz = S/2.5 \quad (24)$$

where S is the soil conduction heat flux. Since the bead used to measure the soil temperature was 0.16 cm in diameter, it was assumed that the bead actually sensed the soil temperature 0.08 cm below the soil surface. Thus the bead temperature was warmer than the surface temperature by an amount, ΔT , given by

$$\Delta T = 0.03 S. \quad (25)$$

Therefore for S equal 6 mw/cm^2 , ΔT will be 0.2 C causing the measurement P to be 20% too high. Since S was the quantity being determined and not known at the time Equation 25 was used, an iterative scheme was required. As a first guess for S the measurement P with all the other corrections included (call the P') was used in Equation 25 to calculate ΔT . The second guess for S was then given by

$$S = P' (1 - (\Delta T/1^\circ\text{C})) . \quad (26)$$

Equation 26 assumes the conclusion drawn earlier that a 0.1°C error in temperature control causes a 10% error in the measurement P . The value of S calculated from Equation 26 was then used in Equation 25 to calculate a new ΔT which was then used to calculate a new S from Equation 26. This process was repeated until S converged. The value to which S converged was the soil conduction heat flux.

Although this thesis only tested the instrument in the steady-state mode a few words can be said about the time dependent case. Equation 14, upon which the instrument is based, is correct only for a

surface of infinitesimal thickness and mass. Since the disk is of finite thickness and mass, the correct equation is

$$(C/A) \cdot (dT/dt) = R + H + P \quad (27)$$

where C is the heat capacity of the disk, A is the cross-sectional area of the disk (5 cm^2), and dT/dt is the time rate of change of the disk's temperature. To evaluate the magnitude of the term on the left hand side of Equation 27, it was assumed that dT/dt was equal to 1.52°C/hr , which was calculated from Sellers' data. The measured value of C was $0.45 \text{ cal}/^\circ\text{C}$. Thus the term on the left hand side of Equation 27 equals 0.15 mw/cm^2 . If the soil heat flux is 5.26 mw/cm^2 , the error incurred by ignoring the heat capacity of the disk is about 3%.

Finally, though not included in this analysis, another source of error is the natural variability of soil surface temperature. These variations can be caused by soil inhomogeneities which affect the local soil conductivity as well as changes in surface roughness which can affect the convective and radiative transfer.

In summary, it appears that there are several sources of error which may or may not work together. The largest single source of error would appear to be due to poorly matched bead thermistors. In the worst case the mismatching can result in a 40% error. However, this error can be reduced to a few percent by carefully selecting matched thermistors. The error in measuring the actual soil surface temperature provides the next largest source of error. At low fluxes (2 mw/cm^2) this error may

result in measurements 10% too high while at higher flux values (8 mw/cm^2) this error may approach 25%. Heat leakage through the styrofoam insulator and boundary layer results in measurements being 11% too low. Finally temperature differences between the disk and the soil (required for signal generation) can result in measurements 5% (at low flux) to 10% (at high flux) too low.

CHAPTER 6

LABORATORY TESTING AND RESULTS

In testing the instrument's performance a comparison of instrument response to known heat fluxes was done. To provide heat fluxes similar to those found in the real world a box was constructed as shown in Figure 10. Five layers of styrofoam 2.5 cm thick were used to make the box. Each layer was 1.21 meters on a side. The two top layers had a 99.5 cm diameter hole cut in them. The layers were put together with white glue. To provide heat to the box the bottom was strung with nichrome wire at 1 cm intervals. The magnitude of the heat flux supplied to the box was determined by dividing the electrical power dissipated by the nichrome wire by the area of the box (7775 cm^2). Sand was carefully poured into the box so as not to disturb the nichrome wire. The sand, typical of what might be found in an Arizona wash, had particle sizes ranging from fine dust to grains several millimeters in diameter. The sand had been washed and baked to remove any fungus. A fan was placed in the laboratory to insure that the air over the sand box was well mixed.

Although measurements of the vertical temperature gradient indicated that the sand box reached steady-state after five hours, testing was not done until the box had been operating for at least seven hours. Measurements of the horizontal temperature gradient in the soil near the sides of the box indicated that about 2% of the heat flowed

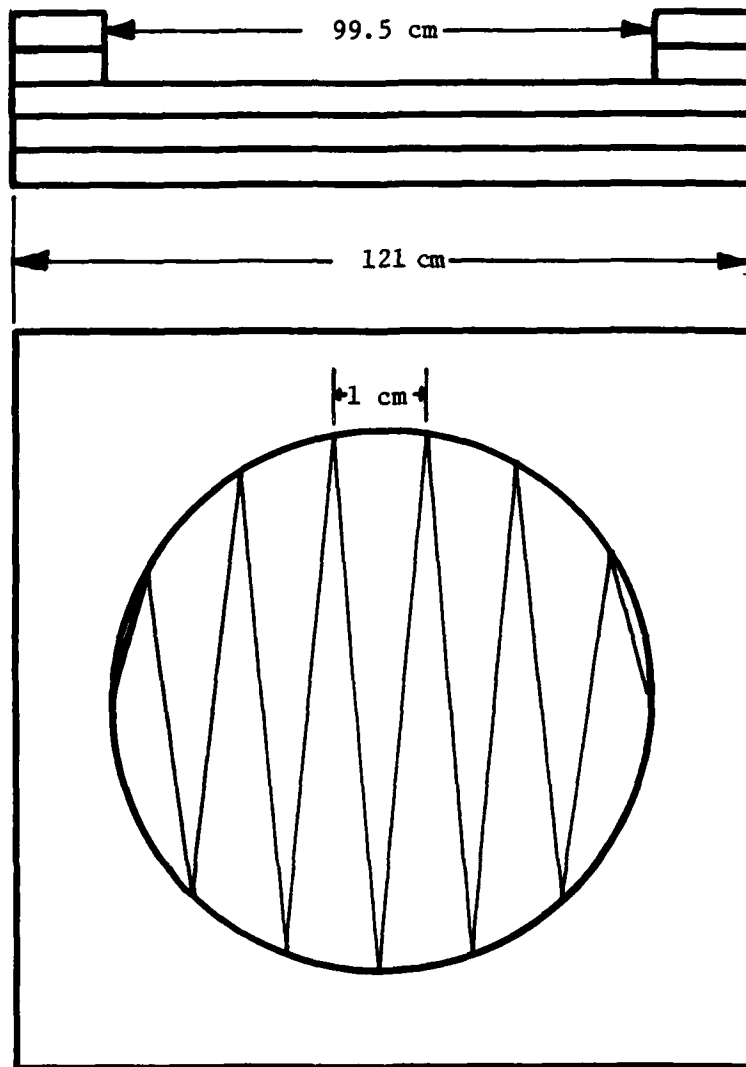

Figure 10. Laboratory sand box.

horizontally out the sides of the box. However, the horizontal gradients near the center of the box were small, therefore as long as the disk and sensor were kept within 10 cm of the center it was assumed that all the heat flow was vertical. Using a styrofoam conductivity of 0.2 mw/°C-cm and a soil conductivity of 2.7 mw/°C-cm it was estimated that 5% of the heat input flowed out the bottom of the box.

The disk and styrofoam insulator were placed so that the assembly was flush with the surface of the sand. The bead thermistor was placed so that it was just covered by the sand.

Figure 11 shows the results of the tests. The data is shown as flux measured by the instruments versus the known flux input from the nichrome wire. The measured flux has been corrected for the lead resistance to the disk. Corrections for the temperature difference between the disk and the soil, the flux leakage through the boundary layer and styrofoam insulator and the error in sensing the soil surface temperature as described in the previous chapter have all been applied. The known flux input has been corrected for the 5% flux leakage through the bottom of the box. The error bars represent the RUSTRAK meter error as well as the 0.03°C mismatch in bead thermistors.

The solid line in Figure 11 represents perfect agreement between measured and known flux values. The dashed line is the best fit line assuming a functional relationship

$$Y = m X + b \quad (28)$$

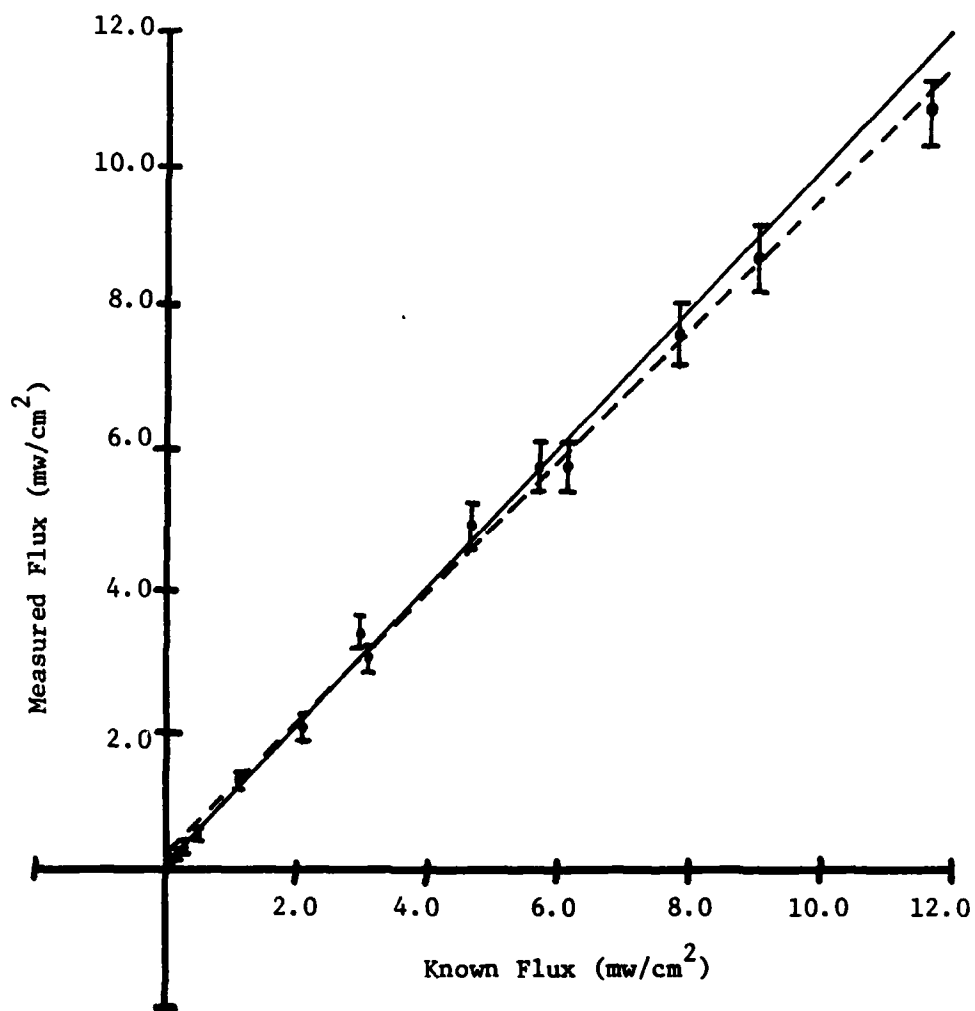

Figure 11. Measured flux vs. known flux.

where Y is the measured flux, X is the known flux, m is the slope, and b is the intercept. Regression analysis shows the slope is equal to 0.93 and the intercept equals 0.18. It appears there is good agreement between the known flux values and the measured flux values. The intercept may indicate an instrument bias possibly caused by mismatched thermistors or errors in balancing the LF356 op amps. The causes for the unexplained data spread may result from the assumptions in the error analysis (i.e., 5% heat leakage from the box, assumptions in sand and styrofoam conductivity, etc.) as well as the random variations in surface temperature mentioned in the error analysis.

CHAPTER 7

RECOMMENDATIONS AND CONCLUSIONS

After testing the device it became apparent that some parts of the electronics could be better designed. For instance, the temperature sensing section of Figure 5 should be fed with a precise voltage source since the present voltage divider allows voltage variations of a few percent to occur as the thermistors change resistance. Another possibility for redesign involves combining the output and temperature sensing sections. By using the disk thermistor to sense its own temperature, it may be possible to combine the two sections as indicated in Figure 12. The bridge would be fed with alternating current while the heating would be accomplished with direct current.

As mentioned in the introduction, this device substitutes one form of energy for another. This was done by blocking the soil conduction flux S and substituting a measurable power P . Similarly one might choose to block the radiative or convective flux. For instance, the radiative flux may be blocked by putting a reflective coating on the disk. The convective flux could be blocked by using polyethylene covers transparent to radiation as used on some radiometers. Thus, by using temperature control and selective blocking, other terms in the surface energy budget can be studied. It may be possible to develop a similar instrument for times when the soil conduction flux is directed

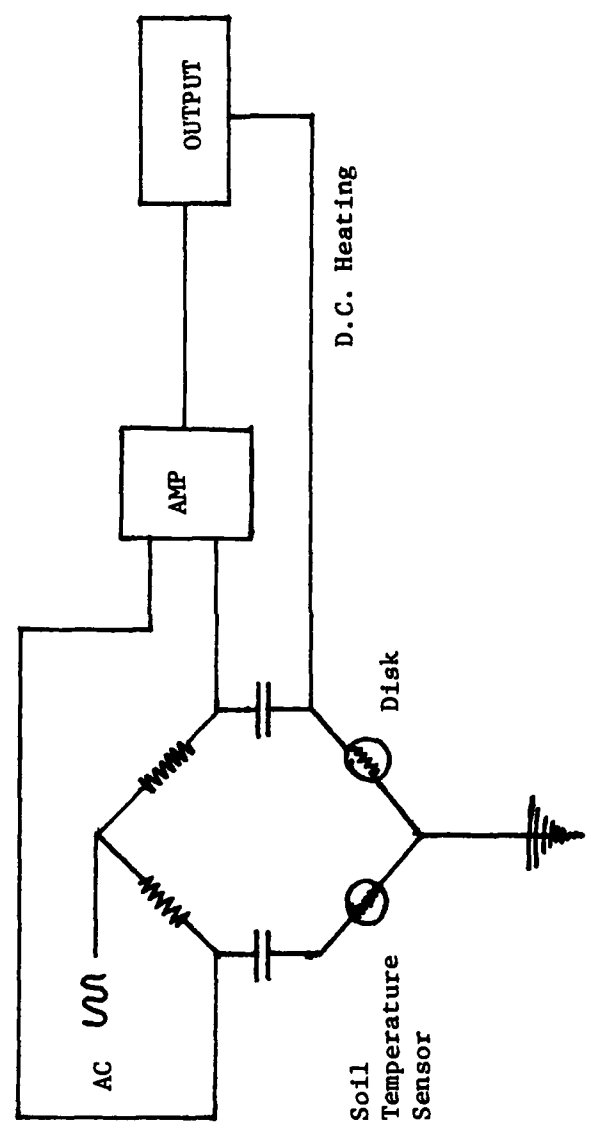

Figure 12. Circuit modification.

into the ground. This might be accomplished by the use of thermoelectric coolers in the same manner that the disk was used to supply heat.

While the instrument has neither been field tested nor compared to the techniques currently used, the results of the laboratory testing indicate that the instrument truly presents an alternate approach to the measurement of the soil conduction heat flux. Since the instrument presently only works in an arid environment and since it only works when the flux is directed out of the ground it is not likely that the device will replace the current techniques but rather should be used to supplement them.

REFERENCES

- Bogoroditskii, N. P., and V. V. Pasynkov, 1967. Properties of Electronic Materials. Boston Technical Publishers, Inc., 350 pp.
- Fleagle, R. G., and J. A. Businger, 1963. An Introduction to Atmospheric Physics. Academic Press, 346 pp.
- Fritschen, L. J., and L. W. Gay, 1979. Environmental Instrumentation. Springer-Verlag, 216 pp.
- Fuchs, M., and A. Hadas, 1973. Analysis of the performance of an improved soil heat flux transducer. Soil Sci. Soc. Am. Proc., 37:173-175.
- Fuchs, M., and C. B. Tanner, 1968. Calibration and field test of soil heat flux plates. Soil Sci. Soc. Am. Proc., 32:326-328.
- Guild, W. R., 1950. Note on heat transfer at the soil surface. J. of Meteorology, 7:140-144.
- Kern, C. D., 1965. Evaluation of infrared emission of clouds and ground as measured by weather satellites, AFCRL-65-840, Environment Research Paper No. 155, Air Force Cambridge Research Laboratories, Hanscom Field, Bedford, MA.
- Kimball, B. A., and R. D. Jackson, 1975. Soil heat flux determination: A null-alignment method. Agric. Meteorology, 15:1-9.
- Kimball, B. A., R. D. Jackson, F. S. Nakayama, S. D. Idso, and R. S. Reginato, 1976. Soil heat flux determination: Temperature gradient method with computed thermal conductivity. Soil Sci. Soc. Amer. J., 40:25-48.
- Sellers, W. D., 1965. Physical Climatology. The University of Chicago Press, 272 pp.
- Sellers, W. D., P. Dryden, J. C. Baum, P. C. Sinclair, P. J. Kinyicky, and P. J. Green, 1965. Final Report - An investigation of heat transfer from bare soil, Grant No. DA-AMC-28-043-65-G-11, Institute of Atmospheric Physics, The University of Arizona, Tucson, 88 pp.
- Shaw, R., 1981. Comments on "A short-range objective nocturnal temperature forecasting model." J. Appl. Meteor., 20:95-96.

Sutherland, R. A., 1980. A short-range objective nocturnal temperature forecasting model. J. Appl. Meteor., 19:247-255.

Sutherland, R. A., 1981. Reply. J. Appl. Meteor., 20:96-97.

Touloukian, Y.S., R. W. Powell, C. Y. Ho, and P. G. Klemens, 1970. Thermophysical Properties of Matter, Vol. 2: Thermal Conductivity Nonmetallic Solids. IFI/Plenum, 1172 pp.