

MISSOURI-KANSAS CITY DAM

AL A106640

LEVEL II

RAINTREE LAKE DAM
CASS COUNTY, MISSOURI
NO 20380

DTIC
ELECTE
NOV 04 1981
S D E

PHASE 1 INSPECTION REPORT
NATIONAL DAM SAFETY INSPECTION

1000 700 000



St. Louis District

PREPARED BY: U.S. ARMY ENGINEER DISTRICT, ST. LOUIS

FOR USE OF INSPECTOR



MAY 1970

81 10 29 000

UNCLASSIFIED

SECURITY CLASSIFICATION OF THIS PAGE (When Data Entered)

REPORT DOCUMENTATION PAGE		READ INSTRUCTIONS BEFORE COMPLETING FORM	
1. REPORT NUMBER	2. GOVT ACCESSION NO.	3. RECIPIENT'S CATALOG NUMBER	
	AD-A106640		
4. TITLE (and Subtitle) Phase I Dam Inspection Report National Dam Safety Program Raintree Lake Dam (MO 20388) Cass County, Missouri		5. TYPE OF REPORT & PERIOD COVERED Final Report	
7. AUTHOR(s) Black & Veatch, Consulting Engineers		6. PERFORMING ORG. REPORT NUMBER	
		8. CONTRACT OR GRANT NUMBER(s) DACW43-79-C-0040	
9. PERFORMING ORGANIZATION NAME AND ADDRESS U.S. Army Engineer District, St. Louis Dam Inventory and Inspection Section, LMSED-PD 210 Tucker Blvd., North, St. Louis, Mo. 63101		10. PROGRAM ELEMENT, PROJECT, TASK AREA & WORK UNIT NUMBERS	
11. CONTROLLING OFFICE NAME AND ADDRESS U.S. Army Engineer District, St. Louis Dam Inventory and Inspection Section, LMSED-PD 210 Tucker Blvd., North, St. Louis, Mo. 63101		12. REPORT DATE May 1979	
14. MONITORING AGENCY NAME & ADDRESS (if different from Controlling Office)		13. NUMBER OF PAGES Approximately 50	
		15. SECURITY CLASS. (of this report) UNCLASSIFIED	
16. DISTRIBUTION STATEMENT (of this Report) Approved for release; distribution unlimited		15a. DECLASSIFICATION/DOWNGRADING SCHEDULE	
17. DISTRIBUTION STATEMENT (of the abstract entered in Block 20, if different from Report) National Dam Safety Program, Raintree Lake Dam (MO 20388), Missouri - Kansas City Basin, Cass County, Missouri. Phase I Inspection Report.			
18. SUPPLEMENTARY NOTES			
19. KEY WORDS (Continue on reverse side if necessary and identify by block number) Dam Safety, Lake, Dam Inspection, Private Dams			
20. ABSTRACT (Continue on reverse side if necessary and identify by block number) This report was prepared under the National Program of Inspection of Non-Federal Dams. This report assesses the general condition of the dam with respect to safety, based on available data and on visual inspection, to determine if the dam poses hazards to human life or property.			

DD FORM 1 JAN 73 1473

EDITION OF 1 NOV 65 IS OBSOLETE

UNCLASSIFIED

SECURITY CLASSIFICATION OF THIS PAGE (When Data Entered)

58554

42

INSTRUCTIONS FOR PREPARATION OF REPORT DOCUMENTATION PAGE

RESPONSIBILITY. The controlling DoD office will be responsible for completion of the Report Documentation Page, DD Form 1473, in all technical reports prepared by or for DoD organizations.

CLASSIFICATION. Since this Report Documentation Page, DD Form 1473, is used in preparing announcements, bibliographies, and data banks, it should be unclassified if possible. If a classification is required, identify the classified items on the page by the appropriate symbol.

COMPLETION GUIDE

Block 2. General. Make Blocks 1, 4, 5, 6, 7, 11, 13, 15, and 16 agree with the corresponding information on the report cover. Leave Block 3 and 3 blank.

Block 1. Report Number. Enter the unique alphanumeric report number shown on the cover.

Block 2. Government Accession No. Leave Blank. This space is for use by the Defense Documentation Center.

Block 3. Recipient's Catalog Number. Leave blank. This space is for the use of the report recipient to assist in future retrieval of the document.

Block 4. Title and Subtitle. Enter the title in all capital letters exactly as it appears on the publication. Titles should be unclassified whenever possible. Write out the English equivalent for Greek letters and mathematical symbols in the title (see "Abstracting Scientific and Technical Reports of Defense-sponsored RDT/E," AD-667 000). If the report has a subtitle, this subtitle should follow the main title, be separated by a comma or semicolon if appropriate, and be initially capitalized. If a publication has a title in a foreign language, translate the title into English and follow the English translation with the title in the original language. Make every effort to simplify the title before publication.

Block 5. Type of Report and Period Covered. Indicate here whether report is interim, final, etc., and, if applicable, inclusive dates of period covered, such as the life of a contract covered in a final contractor report.

Block 6. Performing Organization Report Number. Only numbers other than the official report number shown in Block 1, such as series numbers for in-house reports or a contractor/grantee number assigned by him, will be placed in this space. If no such numbers are used, leave this space blank.

Block 7. Author(s). Include corresponding information from the report cover. Give the name(s) of the author(s) in conventional order (for example, John R. Doe or, if author prefers, J. Robert Doe). In addition, list the affiliation of an author if it differs from that of the performing organization.

Block 8. Contract or Grant Number(s). For a contractor or grantee report, enter the complete contract or grant number(s) under which the work reported was accomplished. Leave blank in in-house reports.

Block 9. Performing Organization Name and Address. For in-house reports enter the name and address, including office symbol, of the performing activity. For contractor or grantee reports enter the name and address of the contractor or grantee who prepared the report and identify the appropriate corporate division, school, laboratory, etc., of the author. List city, state, and ZIP Code.

Block 10. Program Element, Project, Task Area, and Work Unit Numbers. Enter here the number code from the applicable Department of Defense form, such as the DD Form 1498, "Research and Technology Work Unit Summary" or the DD Form 1634, "Research and Development Planning Summary," which identifies the program element, project, task area, and work unit or equivalent under which the work was authorized.

Block 11. Controlling Office Name and Address. Enter the full, official name and address, including office symbol, of the controlling office. (Equates to funding/sponsoring agency. For definition see DoD Directive 5200.20, "Distribution Statements on Technical Documents.")

Block 12. Report Date. Enter here the day, month, and year or month and year as shown on the cover.

Block 13. Number of Pages. Enter the total number of pages.

Block 14. Monitoring Agency Name and Address (if different from Controlling Office). For use when the controlling or funding office does not directly administer a project, contract, or grant, but delegates the administrative responsibility to another organization.

Blocks 15 & 15a. Security Classification of the Report: Declassification/Downgrading Schedule of the Report. Enter in 15 the highest classification of the report. If appropriate, enter in 15a the declassification/downgrading schedule of the report, using the abbreviations for declassification/downgrading schedules listed in paragraph 4-207 of DoD 5200.1-R.

Block 16. Distribution Statement of the Report. Insert here the applicable distribution statement of the report from DoD Directive 5200.20, "Distribution Statements on Technical Documents."

Block 17. Distribution Statement (of the abstract entered in Block 20, if different from the distribution statement of the report). Insert here the applicable distribution statement of the abstract from DoD Directive 5200.20, "Distribution Statements on Technical Documents."

Block 18. Supplementary Notes. Enter information not included elsewhere but useful, such as: Prepared in cooperation with . . . Translation of (or by) . . . Presented at conference of . . . To be published in . . .

Block 19. Key Words. Select terms or short phrases that identify the principal subjects covered in the report, and are sufficiently specific and precise to be used as index entries for cataloging, conforming to standard terminology. The DoD "Thesaurus of Engineering and Scientific Terms" (TEST), AD-672 000, can be helpful.

Block 20. Abstract. The abstract should be a brief (not to exceed 200 words) factual summary of the most significant information contained in the report. If possible, the abstract of a classified report should be unclassified and the abstract to an unclassified report should consist of publicly-releasable information. If the report contains a significant bibliography or literature survey, mention it here. For information on preparing abstracts see "Abstracting Scientific and Technical Reports of Defense-Sponsored RDT&E," AD-667 000.

MISSOURI-KANSAS CITY BASIN

RAINTREE LAKE DAM
CASS COUNTY, MISSOURI
MO 20388

Accession For	
NTIS GRA&I	<input checked="" type="checkbox"/>
DTIC TAB	<input type="checkbox"/>
Unannounced	<input type="checkbox"/>
Justification	
By _____	
Distribution/ _____	
Availability Codes	
Dist	Avail and/or Special
A	

PHASE 1 INSPECTION REPORT NATIONAL DAM SAFETY INSPECTION



**United States Army
Corps of Engineers**

*...Serving the Army
...Serving the Nation*

St. Louis District

PREPARED BY: U.S. ARMY ENGINEER DISTRICT, ST. LOUIS

FOR: STATE OF MISSOURI

MAY 1979



DEPARTMENT OF THE ARMY
ST. LOUIS DISTRICT, CORPS OF ENGINEERS
210 NORTH 12TH STREET
ST. LOUIS, MISSOURI 63101

IN REPLY REFER TO

SUBJECT: Raintree Lake Dam Mo. ID No. 20388
Phase I Inspection Report

This report presents the results of field inspection and evaluation of the Raintree Lake Dam. It was prepared under the National Program of Inspection of Non-Federal Dams.

SUBMITTED BY: SIGNED
Chief, Engineering Division

20 SEP 1979
Date

APPROVED BY: SIGNED
Colonel, CE, District Engineer

20 SEP 1979
Date

RAINTREE LAKE DAM
CASS COUNTY, MISSOURI

MISSOURI INVENTORY NO. 20388

PHASE I INSPECTION REPORT
NATIONAL DAM SAFETY PROGRAM

PREPARED BY:

BLACK & VEATCH
CONSULTING ENGINEERS
KANSAS CITY, MISSOURI

UNDER DIRECTION OF
ST. LOUIS DISTRICT CORPS OF ENGINEERS

FOR
GOVERNOR OF MISSOURI

MAY 1979

PHASE I REPORT
NATIONAL DAM SAFETY PROGRAM

Name of Dam	Raintree Lake Dam
State Located	Missouri
County Located	Cass County
Stream	Middle Big Creek
Date of Inspection	10 May 1979

Raintree Lake Dam was inspected by a team of engineers from Black & Veatch, Consulting Engineers for the St. Louis District, Corps of Engineers. The purpose of the inspection was to make an assessment of the general condition of the dam with respect to safety, based upon available data and visual inspection, in order to determine if the dam poses hazards to human life or property.

The guidelines used in the assessment were furnished by the Department of the Army, Office of the Chief of Engineers and developed with the help of several Federal and state agencies, professional engineering organizations, and private engineers. Based on these guidelines, this dam is classified as an intermediate size dam with a high downstream hazard potential. According to the St. Louis District Corps of Engineers, the estimated damage zone extends approximately ten miles downstream of the dam. Within the damage zone are one dwelling, one building, State Highway 291, and Lake Winnebago Dam with five homes and the city of Pleasant Hill.

Our inspection and evaluation indicates the spillway does not meet the criteria set forth in the guidelines for a dam having the above size and hazard potential. The spillway will not pass the probable maximum flood without overtopping but will pass 75 percent of the probable maximum flood, which is greater than the estimated 100-year flood. The spillway design flood recommended by the guidelines is 100 percent of the probable maximum flood. The probable maximum flood is defined as the flood discharge that may be expected from the most severe combination of critical meteorologic and hydrologic conditions that are reasonably possible in the region.

Deficiencies visually observed by the inspection team were erosion and the presence of excessive cracking of the concrete in the left spillway abutment wall. Seepage and stability analyses required by the guidelines were not available.

There were no observed deficiencies or conditions existing at the time of the inspection which indicated an immediate safety hazard. Future corrective action and regular maintenance will be required to correct or control the described deficiencies. In addition, detailed seepage and stability analyses of the existing dam, as required by the guidelines, should be performed. A detailed report discussing each of these deficiencies is attached.



Paul R. Gaman, PE
Illinois 62-29261



Paul B. MacRoberts, PE
Missouri E-15374



Harry L. Callahan, Partner
Black & Veatch

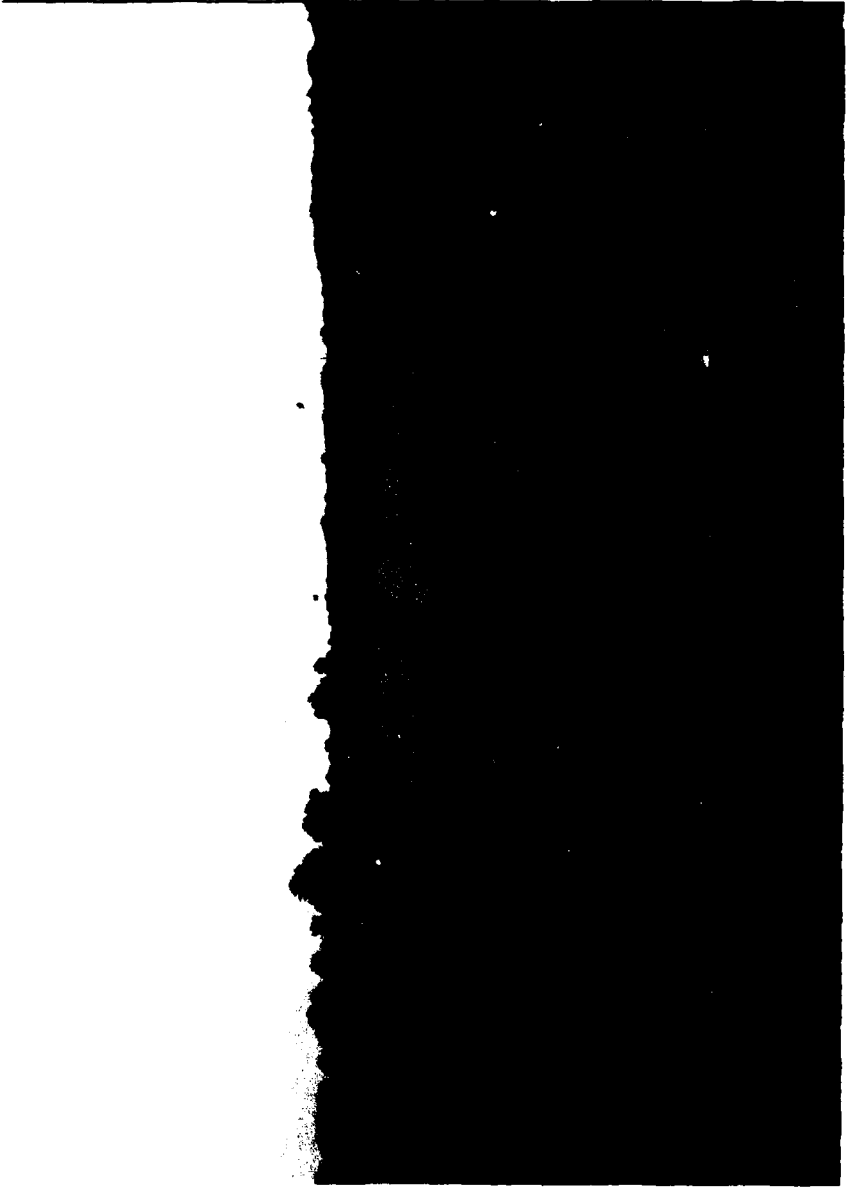

OVERVIEW OF LAKE AND DAM

PHASE I INSPECTION REPORT
NATIONAL DAM SAFETY PROGRAM
RAINTREE LAKE DAM

TABLE OF CONTENTS

<u>Paragraph No.</u>	<u>Title</u>	<u>Page No.</u>
SECTION 1 - PROJECT INFORMATION		
1.1	General	1
1.2	Description of Project	1
1.3	Pertinent Data	3
SECTION 2 - ENGINEERING DATA		
2.1	Design	5
2.2	Construction	5
2.3	Operation	5
2.4	Geology	5
2.5	Evaluation	5
SECTION 3 - VISUAL INSPECTION		
3.1	Findings	7
3.2	Evaluation	8
SECTION 4 - OPERATIONAL PROCEDURES		
4.1	Procedures	9
4.2	Maintenance of Dam	9
4.3	Maintenance of Operating Facilities	9
4.4	Description of Any Warning System in Effect	9
4.5	Evaluation	9
SECTION 5 - HYDRAULIC/HYDROLOGIC		
5.1	Evaluation of Features	10
SECTION 6 - STRUCTURAL STABILITY		
6.1	Evaluation of Structural Stability	12
SECTION 7 - ASSESSMENT/REMEDIAL MEASURES		
7.1	Dam Assessment	13
7.2	Remedial Measures	13

TABLE OF CONTENTS (Cont'd)

LIST OF PLATES

<u>Plate No.</u>	<u>Title</u>
1	Location Map
2	Vicinity Topography
3	Plan
4	Longitudinal Section
5	Cross Section
6	Spillway Cross Sections
7	Spillway Profile
8	Details
9	Photo Index

LIST OF PHOTOGRAPHS

<u>Photo No.</u>	<u>Title</u>
1	Upstream Face of Dam (Looking South)
2	Crest of Dam (Looking South)
3	Downstream Slope of Dam (Looking North)
4	Bench on Downstream Slope of Dam
5	Looking Downstream in Spillway Approach Channel
6	Cracking of Concrete in Box Culvert Abutment
7	Looking Upstream at Spillway Discharge Channel
8	Rock Cuts in Discharge Channel
9	Downstream Tailwater From Lake Winnebago

List of Photographs (Continued)

- 10 Access Tower to Gate Valve Vault
- 11 Discharge Channel for Low Level Outlet
- 12 Erosion Gully Formed on Approach Channel Bank
- 13 Erosion on Downstream Slope Near Waterline
- 14 Looking West from Highway 291 at Discharge Channel and Raintree Dam

APPENDIX

Appendix A - Hydrologic Computations

SECTION 1 - PROJECT INFORMATION

1.1 GENERAL

a. Authority. The National Dam Inspection Act, Public Law 92-367, authorized the Secretary of the Army, through the Corps of Engineers, to initiate a program of safety inspection of dams throughout the United States. Pursuant to the above, the District Engineer of the St. Louis District, Corps of Engineers, directed that a safety inspection of the Raintree Lake Dam be made.

b. Purpose of Inspection. The purpose of the inspection was to make an assessment of the general condition of the dam with respect to safety, based upon available data and visual inspection, in order to determine if the dam poses hazards to human life or property.

c. Evaluation Criteria. Criteria used to evaluate the dam were furnished by the Department of the Army, Office of the Chief of Engineers, in "Recommended Guidelines for Safety Inspection of Dams." These guidelines were developed with the help of several Federal agencies and many State agencies, professional engineering organizations, and private engineers.

1.2 DESCRIPTION OF PROJECT

a. Description of Dam and Appurtenances.

(1) The dam is an earth structure located in the valley of Middle Big Creek in northern Cass County, Missouri (Plate 1). The dam embankment is approximately 2,000 feet long and 50 feet high. The axis of the dam runs from slightly east of north to slightly west of south. The embankment has a riprap cover on the upstream face and a well-established cover of grass on the downstream face. A paved, 24-foot wide road follows the crest of the dam embankment. The reinforced concrete gate valve vault access tower for the outlet works is on the upstream face of the embankment approximately 300 feet from the right abutment.

(2) A spillway was constructed by excavating a channel around the right abutment of the dam (Plate 3). The channel is excavated through natural earth, limestone and shale and passes underneath the asphalt-paved road which crosses the dam embankment. The flow area beneath the road is comprised of 15 concrete box culverts, each 7.5 feet high and 12 feet wide. The boxes are separated by concrete walls 12 inches thick, having rounded ends. Downstream of the bridge, the channel is composed of a series of steps until it is 40 feet lower than the floor of the concrete boxes 450 feet downstream of the bridge. At this point, the spillway channel was filled with backwater from downstream Lake Winnebago.

(3) The design drawings show two 24-inch reinforced concrete pipes running through the embankment of the dam at Station 16 + 50. The pipe on the left is a sanitary sewer line, and the other is a low level outlet used as a diversion during construction. Both pipes have gate valves located at the bottom of the access tower.

(4) Pertinent physical data are given in paragraph 1.3.

b. Location. The dam is located in northern Cass County, Missouri, as indicated on Plate 1. The lake formed by the dam is shown on the United States Geological Survey 7.5 minute series quadrangle map for Raymore, Missouri in Section 6 of T46N, R31W.

c. Size Classification. Criteria for determining the size classification of dams and impoundments are presented in the guidelines referenced in paragraph 1.1c above. Based on these criteria, the dam and impoundment are in the intermediate size category.

d. Hazard Classification. The hazard classification assigned by the Corps of Engineers for this dam is as follows: The Raintree Lake Dam has a high hazard potential, meaning that the dam is located where failure may cause loss of life, and serious damage to homes, agricultural, industrial and commercial facilities, and to important public utilities, main highways, or railroads. For the Raintree Lake Dam the estimated flood damage zone extends downstream for approximately ten miles downstream of the dam. Within the damage zone are one dwelling, one building, State Highway 291 and Lake Winnebago Dam with five homes and the city of Pleasant Hill.

e. Ownership. The dam is owned by the Raintree Lake Development Corporation, 4280 Cole Younger, Lee's Summit, Missouri 64063, phone number (816)537-6656.

f. Purpose of Dam. The dam forms a 262-acre recreational lake.

g. Design and Construction History. Design data and as-built drawings were available from Andes and Roberts Construction Company, 17000 East Kentucky, Independence, Missouri 64050, phone number (816)257-1200. The design engineer was the late R.J. Spiegel; the design data was unable to be located. Construction began in 1973 and was completed in 1974.

h. Normal Operating Procedure. Normal rainfall, runoff, transpiration, evaporation, and flow through the spillway, all combine to maintain a relatively stable water surface elevation.

1.3 PERTINENT DATA

a. Drainage Area - 4,770 acres

b. Discharge at Damsite.

(1) Normal discharge at the damsite is through an uncontrolled spillway.

(2) Estimated experienced maximum flood at damsite - Unknown.

(3) Estimated ungated spillway capacity at maximum pool elevation 15,800 cfs (top of Dam El.964.9+).

c. Elevation (Feet above m.s.l.).

(1) Top of dam - 964.9 + (see Plate 3)

(2) Spillway crest - 955.0

(3) Streambed at toe of dam - 914.0 +

(4) Maximum tailwater - Unknown.

d. Reservoir.

(1) Length of maximum pool - 11,200 feet +

(2) Length of normal pool - 9,600 feet +

e. Storage (Acre-feet).

(1) Top of dam - 7,220

(2) Spillway crest - 3,570

(3) Design surcharge - Not available.

f. Reservoir Surface (Acres).

(1) Top of dam - 475

(2) Spillway crest - 262

g. Dam.

- (1) Type - Earth embankment
- (2) Length - 1,900 feet
- (3) Height - 50 feet \pm
- (4) Top width - 44 feet
- (5) Side slopes - upstream face 1.0V on 3.1H, downstream face 1.0V on 3.2H (see Plate 5)
- (6) Zoning - See Plate 5.
- (7) Impervious core - See Plate 5.
- (8) Cutoff - 25 foot wide trench with 1.0 V on 1.0 H side slopes (Plates 4 and 5).
- (9) Grout curtain - Unknown.

h. Diversion and Regulating Tunnel - A gated 24-inch reinforced concrete pipe with an inlet elevation of 922.5 feet m.s.l. was used as the diversion at the time of construction.

i. Spillway.

- (1) Type - 15 box culverts, each 7.5 feet by 12 feet (Plate 6).
- (2) Width of channel - 194 feet.
- (3) Crest elevation - 955.0 feet m.s.l.
- (4) Gates - None.
- (5) Upstream channel - Open approach channel in earth.
- (6) Downstream channel - Open channel comprised of limestone and shale, dropping approximately 40 feet in a distance of 450 feet in steps of 5 to 10 feet (Plate 7) at which point Lake Winnebago obscured the channel.

j. Regulating Outlets - A gated 24-inch reinforced concrete pipe located at Station 16 + 50 with a inlet elevation of 922.5 feet m.s.l. could be used as a low level outlet. At normal pool, the pipe could discharge approximately 65 cfs or 130 acre-feet per day.

SECTION 2 - ENGINEERING DATA

2.1 DESIGN

Design data were made available by Andes and Roberts Construction Company. The data included design and as-built drawings. Hydraulic and hydrologic calculations were made available by Mr. Earl C. Meserve, Hydraulic & Hydrology Consultant, 13002 E. 40th Street, Independence, Missouri 64055, phone number (816)833-3154.

2.2 CONSTRUCTION

Construction records were unavailable, however, the dam was completed in 1974.

2.3 OPERATION

Procedural criteria for operation of this dam were not available. Documentation of past experiences of a serious nature was also not available.

2.4 GEOLOGY

The dam is located across a broad, shallow valley formed in shale and limestone of the Kansas City Group of the Pennsylvanian System. The design drawings indicate that the abutments of the dam are in the Fontana Shale and Winterset Limestone and the deepest portion of the cutoff trench penetrates the Stark-Galesburg shale.

The soils of the watershed area consist of residual soils of the Sharpsburg-Higginsville, Polo-Sogn and Dennis-Roseland associations. The design drawings indicate that the soils in the vicinity of the dam consist of clay and are classified as CL. The soils are thicker on the ridges and valleys and are thinner on the slopes.

2.5 EVALUATION

a. Availability. Engineering data in the form of design and as-built drawings were made available by Andes and Roberts. Hydraulic and hydrologic calculations were made available by Earl C. Meserve.

b. Adequacy. The engineering data available were not sufficient to make a detailed assessment of design, construction, and operation. Seepage and stability analyses comparable to the requirements of the "Recommended Guidelines for Safety Inspection of Dams" were not available, which is considered a deficiency. These seepage and stability analyses should be performed for appropriate loading conditions (including earthquake loads) and made a matter of record.

c. Validity. The engineering data available were not sufficient to determine the validity of the design, construction, and operation.

SECTION 3 - VISUAL INSPECTION

3.1 FINDINGS

a. General. A visual inspection of Raintree Lake Dam was made on 10 May 1979. The inspection team included professional engineers with experience in dam design and construction, hydrology - hydraulic engineering, and geotechnical engineering. No representative of the Raintree Lake Development Corporation was present on the day of inspection. Specific observations are discussed below. No observations were made of the condition of the upstream face of the dam below the pool elevation at the time of the inspection.

b. Dam. The inspection team observed the following items at the dam. The upstream slope of the embankment above the water level was at a uniform slope with a well graded riprap covering extending to the edge of the asphalt paved road. The downstream slope is covered with a good thick stand of grass and also has a uniform slope with a 40 foot wide bench at the toe. There was evidence of pipeline installation across the downstream slope 10 feet below the crest of the dam and across the toe section and up each downstream abutment. Near the left abutment where the pipeline runs up the embankment, minor erosion was observed. (See Photo 13). The general condition of the dam was very good. Maintenance at the dam seems to be adequate; mowing of the grass on the downstream slope is periodically performed. Trees, animal burrows, sliding, cracking, and settlement were not observed on the embankments. No sloughing or seepage was observed on the downstream embankment.

c. Appurtenant Structures. The inspection team observed the following items pertaining to appurtenant structures. A trapezoidal channel was formed in the right abutment which acts as the approach channel for the multiple box culvert spillway. The multiple box culverts are under the road which follows the crest of the dam. The fifteen 7.5 feet by 12 feet box culverts, which are the natural control for the elevation of the lake, appeared to be in good condition. Some severe cracking was observed at the upstream edge and corner of the left abutment of the box culverts. The loss of concrete was noticed along with exposed rebar on the outside edge of the deck (see Photo 6). Some minor erosion was seen in the areas of the contact between the embankment slopes and the abutments of the spillway. An erosion gully has also formed in the approach channel (see Photo 12). The trapezoidal discharge channel, which was excavated in limestone and shale, has minor erosion taking place.

The gate valve vault access tower was locked on the day of inspection, although the exposed area of the tower seemed to be in good condition.

d. Reservoir Area. No slides or excessive erosion due to wave action were observed along the shore of the reservoir. The topography of the contributing watershed is characterized by gently rolling hills of low relief. The vegetation in the watershed is primarily comprised of grassland and woods.

e. Downstream Channel. Open channel comprised of limestone and shale, dropping approximately 40 feet in a distance of 450 feet in steps of 5 to 10 feet (Plate 7). Due to the tailwater elevation of Lake Winnebago beyond this point no observations were made.

f. Geology. A visual inspection of the geology and soils in the immediate vicinity of the discharge channel and spillway confirmed the data shown on the design drawings that could be checked without a sub-surface investigation. The spillway is cut into the Fontana shale and the discharge channel is cut into the Winterset Limestone, which is made up of closely jointed interbedded shale and limestone members. It can be extrapolated from the exposures in the discharge channel, that the dam abutments are in the Fontana Shale and Winterset Limestone. The observable embankment materials consist of silty clay (CL) materials. The soils exposed in the discharge and approach channel consist of silty clay residual soils.

3.2 EVALUATION

The various minor deficiencies observed at the time of the inspection are not believed to represent any immediate safety hazard. They do, however, warrant repair and future monitoring and control.

(1) Erosion observed on the embankment over the buried pipeline appears to be the result of surface runoff. It is suggested that possible improper compaction and/or the lack of a thick ground cover was a contributing factor to the erosion.

The erosion gullies were not extensive at the time of inspection, but if not controlled might lead to severe loss of embankment material.

(2) The condition of the concrete in the upstream edge of the left abutment should be corrected so that further deterioration does not take place.

SECTION 4 - OPERATIONAL PROCEDURES

4.1 PROCEDURES

The pool is primarily controlled by rainfall, runoff, evaporation, transpiration, and capacity of the uncontrolled spillway.

4.2 MAINTENANCE OF DAM

Maintenance apparently performed as required.

4.3 MAINTENANCE OF OPERATING FACILITIES

Maintenance apparently performed as required.

4.4 DESCRIPTION OF ANY WARNING SYSTEM IN EFFECT

There is no existing warning system for this dam.

4.5 EVALUATION

Discharge releases were reportedly made through the 24-inch pipe during construction. There has been no other time when water has been discharged through the low level outlet. The sanitary sewer line which also runs through the dam is in operation.

Maintenance at the dam apparently has been performed as evidenced by the mowing of the grass on the downstream embankment. Additional work should be accomplished on the erosion areas and on the cracking concrete of the spillway.

SECTION 5 - HYDRAULIC/HYDROLOGIC

5.1 EVALUATION OF FEATURES

a. Design Data. Design data pertaining to hydrology and hydraulics were made available by Earl C. Meserve. His design storm and flood were based on one-half of the probable maximum flood which equalled 13 inches of rainfall in six hours. The time of concentration for the basin was based on the Meserve Equation ($T_c = 10L / \sqrt{S}$; where L = length of longest watercourse in miles, S = slope of main channel in feet per mile.) The derivation of the unit hydrograph was by the Clark Method. His calculations provided for five feet of freeboard during the project design storm and the probable maximum flood would not overtop the dam.

b. Experience Data. The drainage area and lake surface area are developed from USGS Raymore Quadrangle Map. The spillway and dam layouts are from design drawings and field survey made during the inspection.

c. Visual Observations.

(1) The spillway is in good condition. The approach and discharge channels of the spillway are also in good condition.

(2) Drawdown facilities are available to lower the pool to Elevation 922.5 m.s.l. The access tower was locked during the time of the inspection, therefore the low level outlet could not be operated.

(3) A spillway and exit channel are located near the right abutment. Spillway discharges should not endanger the integrity of the dam due to the fact that outflow from the spillway will be contained in the discharge channel.

(4) No evidence exists that the dam has ever been overtopped.

d. Overtopping Potential. The spillway will not pass the probable maximum flood. The probable maximum flood is defined as the flood discharge that may be expected from the most severe combination of critical meteorologic and hydrologic conditions that are reasonably possible in the region. The spillway will pass 75 percent of the probable maximum flood without overtopping the dam. This flood is greater than the 100-year flood estimated to be 2,270 cfs developed from a 24-hour, 100-year rainfall. According to the recommended guidelines from the Department of the Army, Office of the Chief of Engineers, a high hazard dam of intermediate size should pass 100 percent of the probable maximum flood. The portion of the estimated peak discharge of the probable maximum flood overtopping the dam would be 6,220 cfs of the total discharge from the reservoir of 26,000 cfs. The estimated duration of overtopping is 2.7 hours with a maximum height of 1.6 feet. Failure

of upstream water impoundments shown on the 1975 revised USGS map would not have a significant impact on the hydrologic or hydraulic analysis. Although evidence of overtopping of the embankment was not visible, soils typical of the embankment surfaces are susceptible to erosion. Should the embankment be subjected to prolonged overtopping it is believed that the subsequent erosion could lead to failure.

According to the St. Louis District, Corps of Engineers, the effect from rupture of the dam could extend approximately ten miles downstream of the dam. There is one dwelling, one building, State Highway 291, and Lake Winnebago with five homes and the city of Pleasant Hill downstream of the dam which could be severely damaged and lives could be lost should failure of the dam occur.

SECTION 6 - STRUCTURAL STABILITY

6.1 EVALUATION OF STRUCTURAL STABILITY

a. Visual Observations. Visual observations of conditions which affect the structural stability of this dam are discussed in Section 3, paragraph 3.1b.

b. Design and Construction Data. No design data relating to the structural stability of the dam were found. Detailed seepage and stability analysis should be performed as required by the guidelines.

c. Operating Records. No operational records were available.

d. Post Construction Changes. No known post construction changes.

e. Seismic Stability. The dam is located in Seismic Zone 1 which is a zone of minor seismic risk. A properly designed and constructed earth dam using sound engineering principles and conservatism should pose no serious stability problems during earthquakes in this zone.

The seismic stability of an earth dam is dependent upon a number of factors: The important factors being embankment and foundation material classification and shear strengths; abutment materials, conditions, and strength; embankment zoning; and embankment geometry. Adequate descriptions of embankment design parameters, foundation and abutment conditions, or static stability analyses to assess the seismic stability of this embankment were not available and therefore no inferences will be made regarding the seismic stability. An assessment of the seismic stability should be included as part of the stability analysis required by the guidelines. It is anticipated that no serious stability problems would be experienced at this dam during an earthquake characteristic of Seismic Zone 1.

SECTION 7 - ASSESSMENT/REMEDIAL MEASURES

7.1 DAM ASSESSMENT

a. Safety. Several items noted during the visual inspection by the inspection team which should be monitored or controlled are erosion in several places on the embankment slope and the cracking of the concrete in the spillway abutment.

b. Adequacy of Information. Due to the lack of engineering design data, the conclusions in this report were based only on performance history and visual conditions. The inspection team considers that these data are sufficient to support the conclusions herein. Seepage and stability analyses comparable to the requirements of the "Recommended Guidelines for Safety Inspection of Dams" were not available, which is considered a deficiency.

c. Urgency. It is the opinion of the inspection team that a program should be developed in the near future to implement remedial measures recommended in paragraph 7.2b. If the safety deficiencies listed in paragraph 7.1a are not corrected, they will continue to deteriorate and lead to a potential of failure. The item recommended in 7.2.a should be analyzed on a priority basis by the owners of the dam.

d. Necessity for Phase II. The Phase I investigation does not raise any serious questions relating to the safety of the dam or identify any serious dangers that would require a Phase II investigation.

e. Seismic Stability. This dam is located in Seismic Zone 1. Adequate description of embankment design parameters, foundation and abutment conditions, or static stability analyses to assess the seismic stability of this embankment was not available and therefore no inferences will be made regarding the seismic stability. An assessment of the seismic stability should be included as part of the recommended stability analysis.

7.2 REMEDIAL MEASURES

a. Alternatives. The present spillway has the capacity to pass 75 percent of the probable maximum flood without overtopping the dam. In order to pass 100 percent of the probable maximum flood as required by the Recommended Guidelines, the spillway size and/or height of dam would need to be increased.

b. Operation and Maintenance Procedures. The following operation and maintenance should be implemented to correct the deficiencies observed at the time of inspection. Although these are considered to be of minor magnitude at this time, if left unattended or unrepaired each could ultimately become a potential source of failure.

(1) Fill and compact erosion gullies to original specifications. Provide slope protection through the use of vegetal ground cover where missing.

(2) The condition of the concrete in the upstream edge of the left box culvert abutment wall should be further investigated by an engineer experienced in the design of concrete structures to recommend future corrective action.

(3) Check the downstream face of the dam periodically for seepage and stability problems. If seepage flows are observed or sloughing on the downstream embankment slope is noted, the dam should immediately be inspected and the condition evaluated by an engineer experienced in design and construction of earthen dams.

(4) Seepage and stability analysis should be performed by a professional engineer experienced in the design and construction of dams.

(5) A detailed inspection of the dam should be made periodically by an engineer experienced in design and construction of dams. More frequent inspections may be required if additional deficiencies are observed or the severity of the reported deficiencies increases.

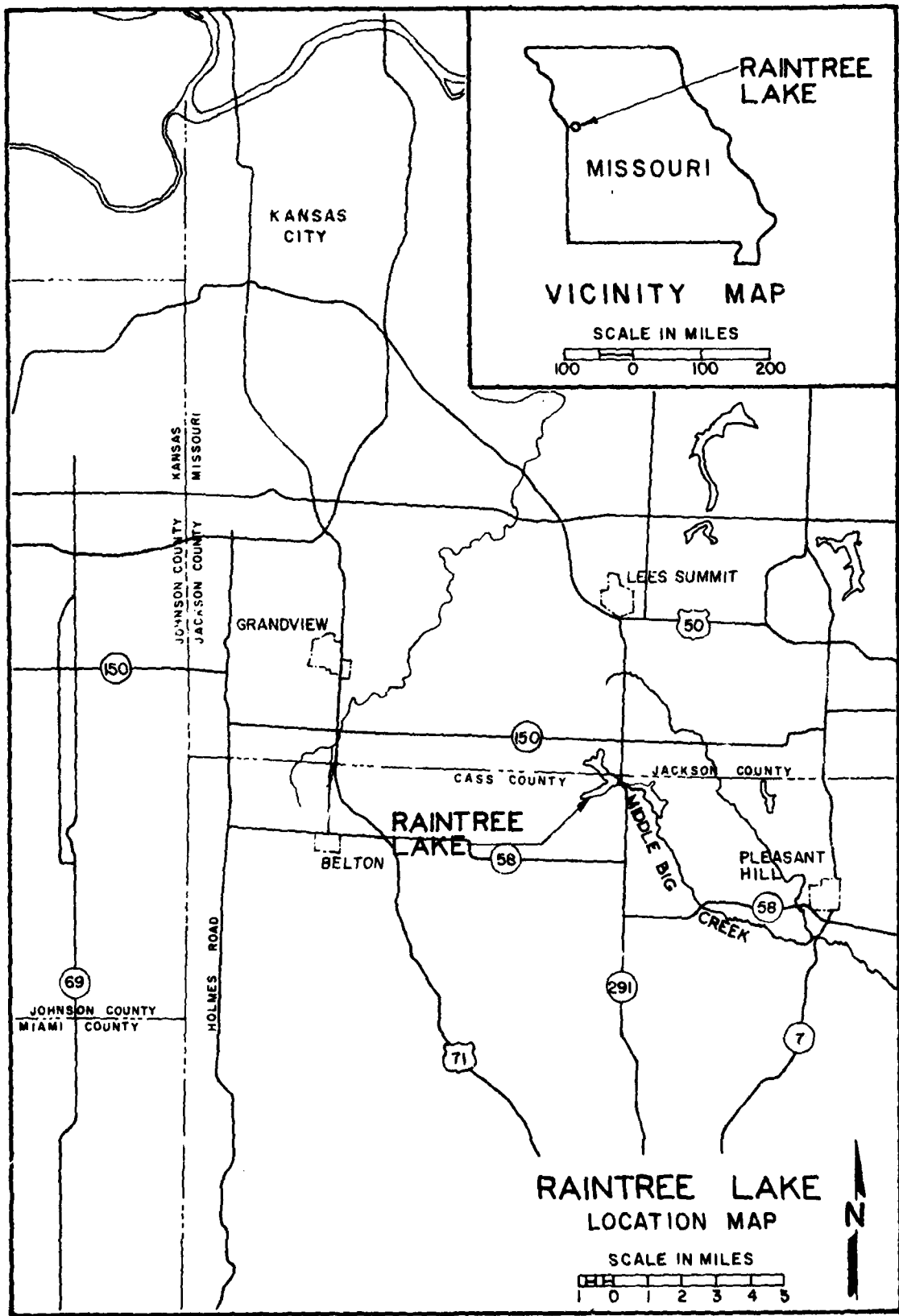

**RAINTREE LAKE
LOCATION MAP**

SCALE IN MILES
0 1 2 3 4 5

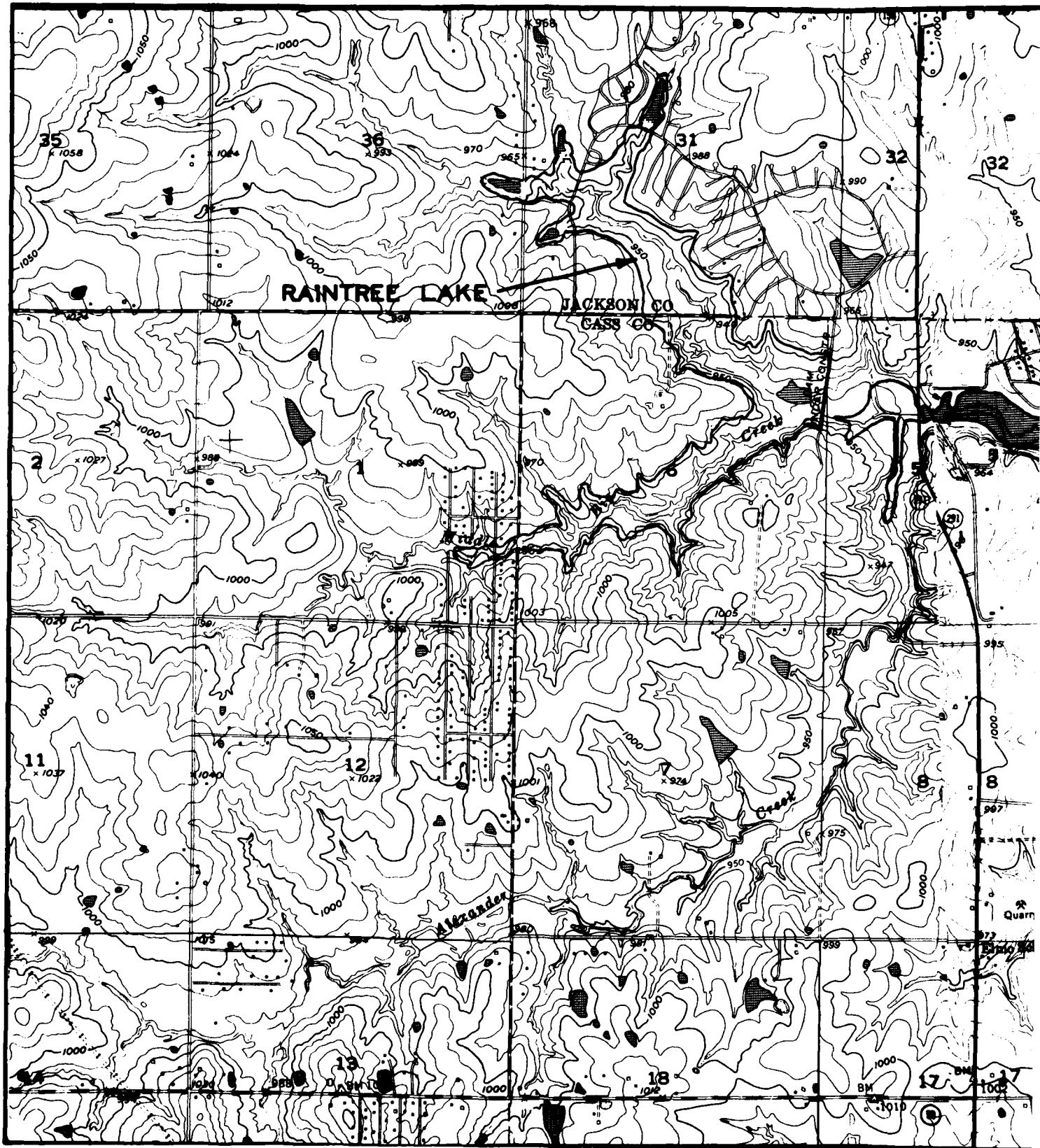

**RAINTREE LAKE
VICINITY TOPOGRAPHY**

SCALE IN FEET

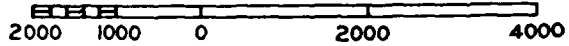

N

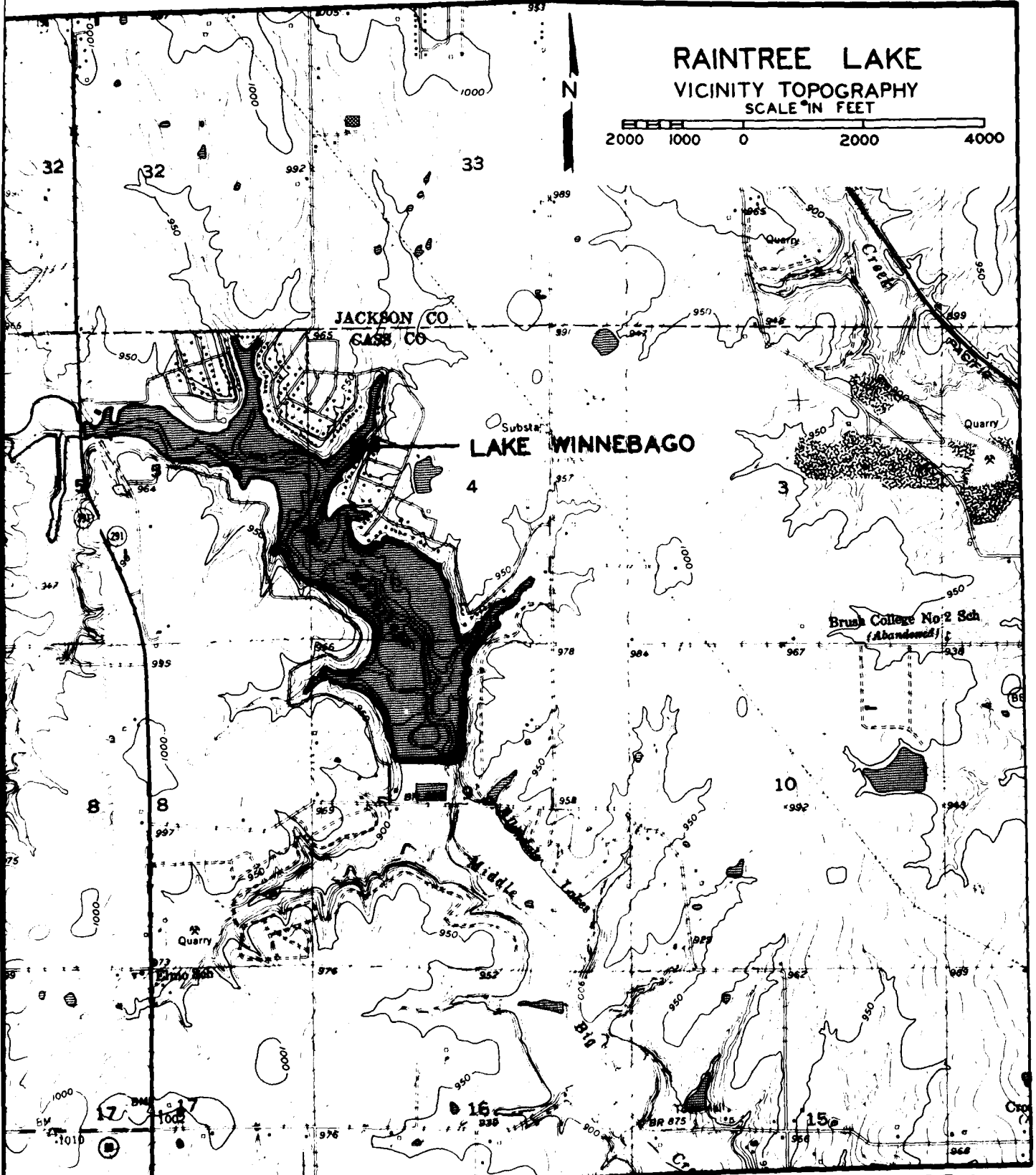
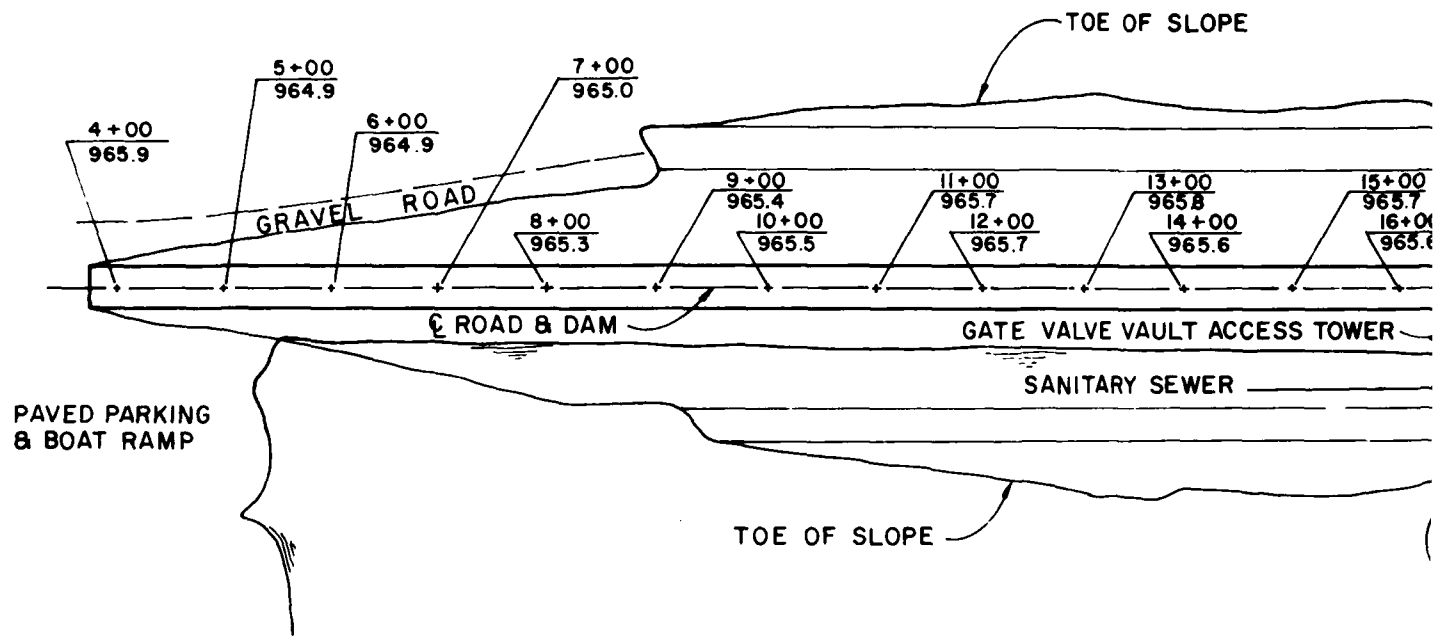

PLATE 2

2

LAKE 1



PAVED PARKING & BOAT RAMP

RAINTREE LAKE

(NORMAL POOL EL. 955.0)

NOTE: PLAN DATA OBTAINED FROM DESIGN DRAWINGS AND FIELD SURVEY.

LAKE WINNEBAGO

LAKE LEVEL AT TIME OF INSPECTION EL. 918.0

EL. 922.2

EL. 953.9

24+00
963.9

25+00
964.8

26+00
967.3

23+00
963.9

19+00
965.0

20+00
965.2

21+00
965.0

22+00
964.8

17+00
965.4

18+00
965.1

15+00
965.7

16+00
965.6

13+00
965.8

14+00
965.6

SPILLWAY
15- 7.5' x 12.0'
BOX CULVERTS
INLETS AT
EL. 955.0

APPROACH CHANNEL

CUTOFF COLLARS

INLET STRUCTURE
INV. EL. 922.5

OUTLET
DRAIN
PIPE

LIMITS OF
EXCAVATION

OUTLET INV. EL. 912.0

OPEN CHANNEL

OF SLOPE

VAULT ACCESS TOWER

RY SEWER

E LAKE

L EL. 955.0)



RAINTREE LAKE
PLAN

2

PLATE 3

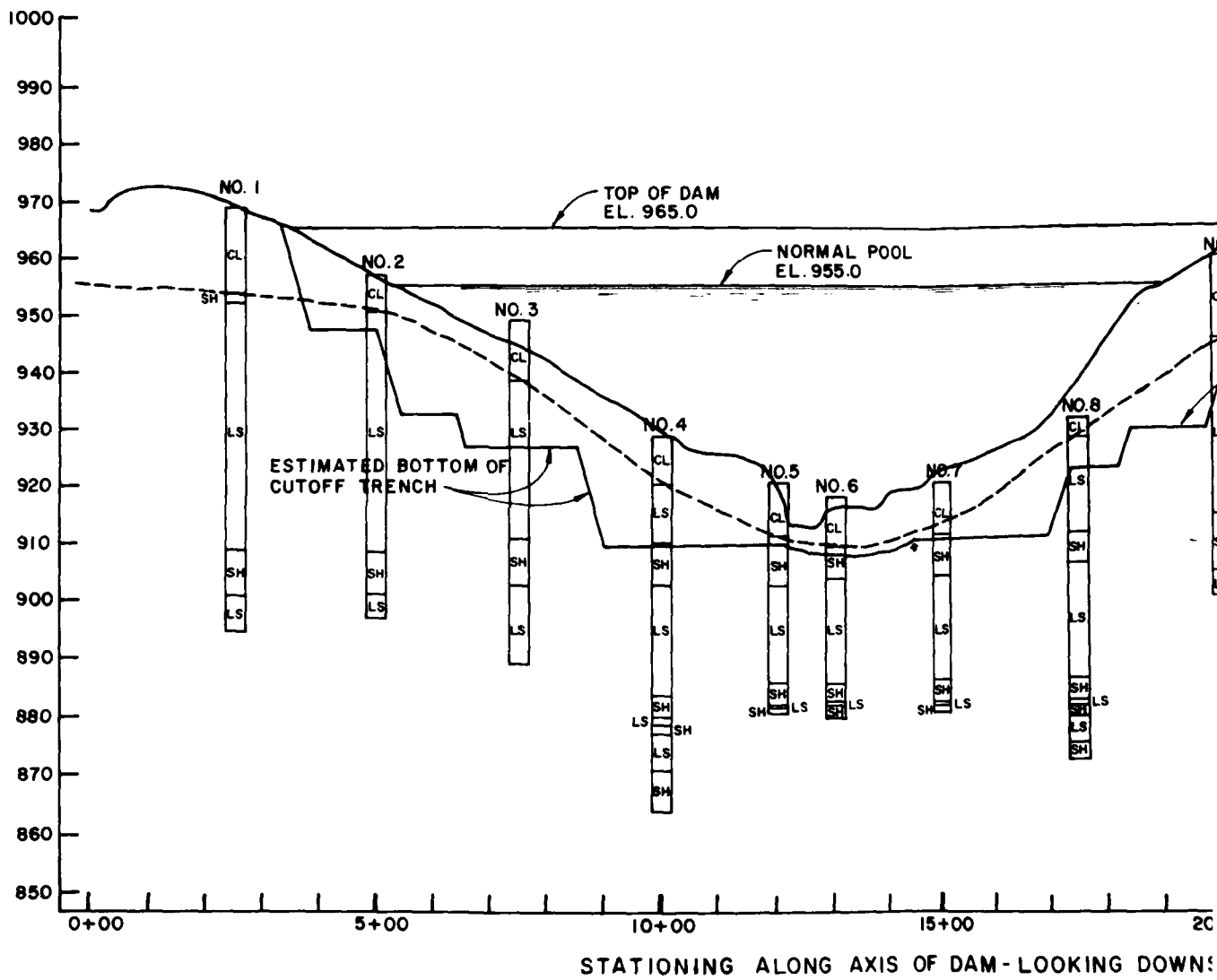

NOTE : DATA OBTAINED FROM
DESIGN DRAWINGS.

LEGEND

- CL - CLAY
- SH - SHALE
- LS - LIMESTONE

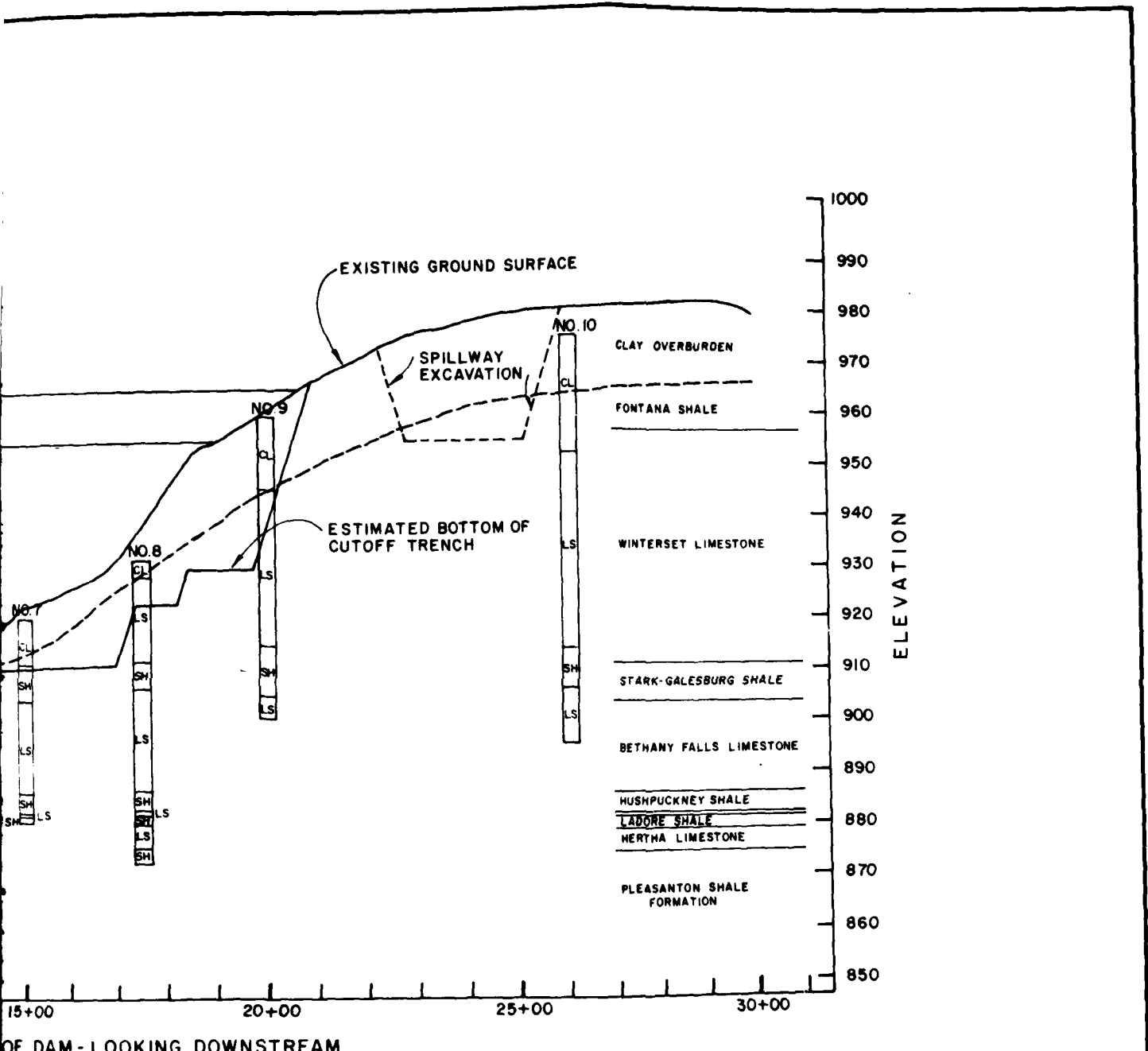

2

RAINTREE LAKE
LONGITUDINAL SECTION

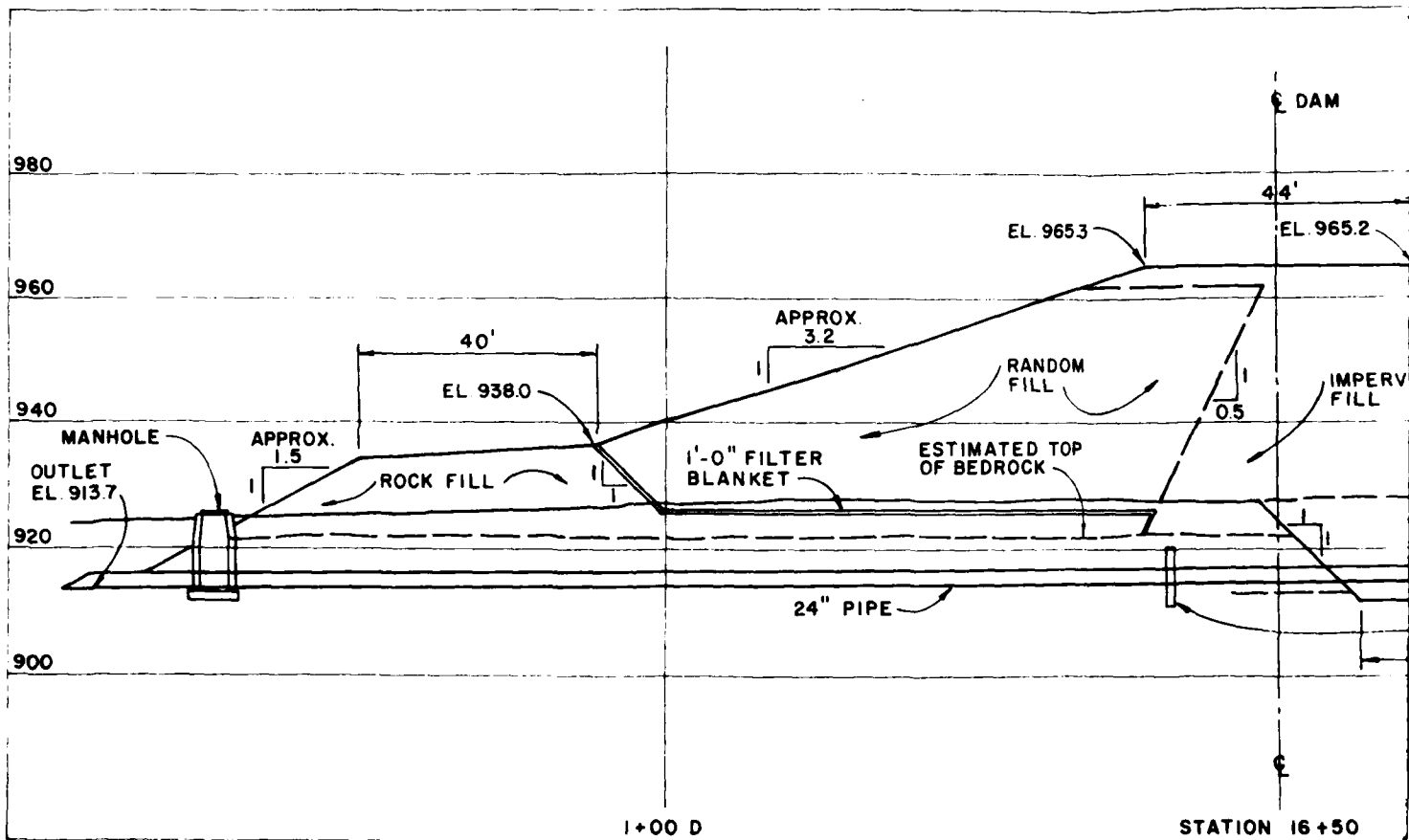

NOTE: CROSS SECTION AND SPILLWAY DATA
 OBTAINED FROM DESIGN DRAWINGS,
 EXCEPT EMBANKMENT ELEVATIONS
 WHICH ARE FROM FIELD SURVEY
 TAKEN AT STATION 14+00.

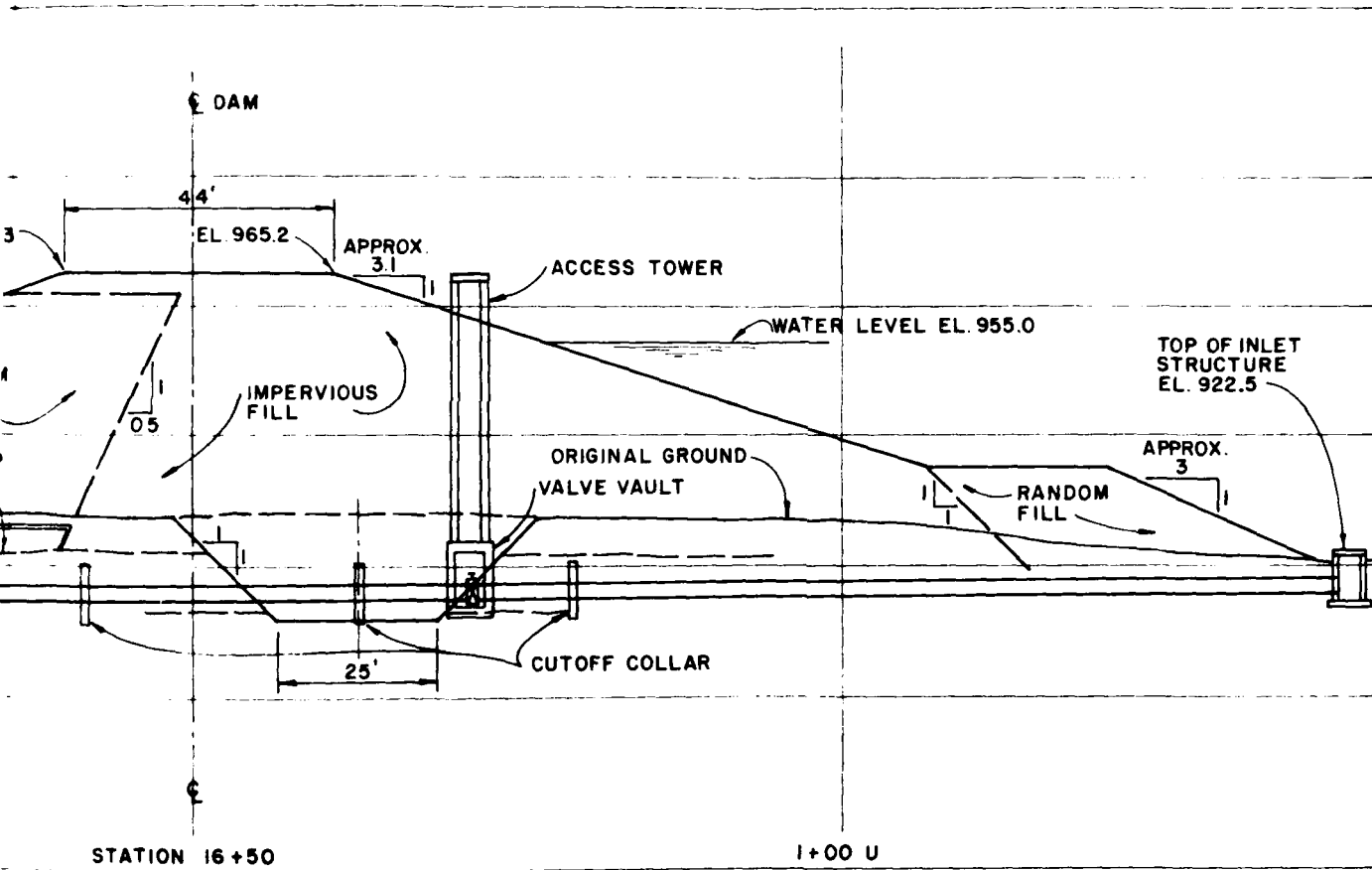

2

**RAINTREE LAKE
CROSS SECTION**

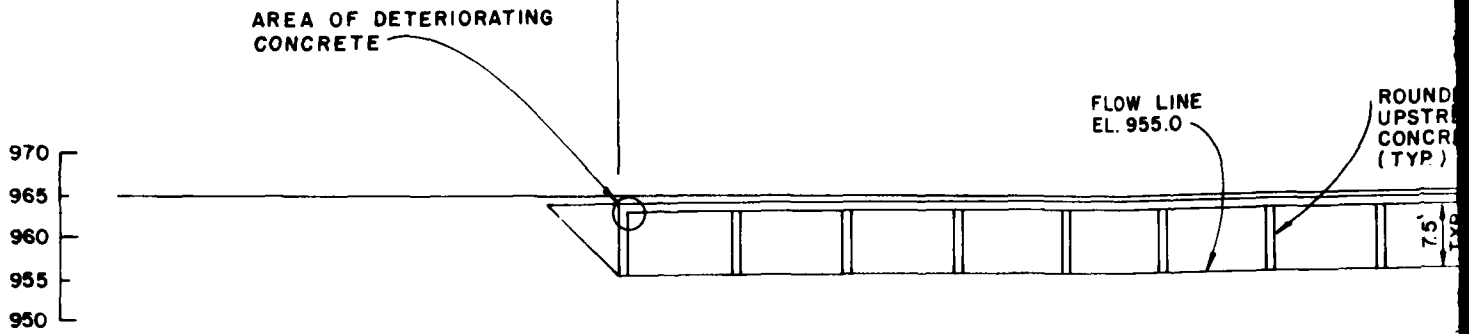

AT BRIDGE - LOOKING DOWNST

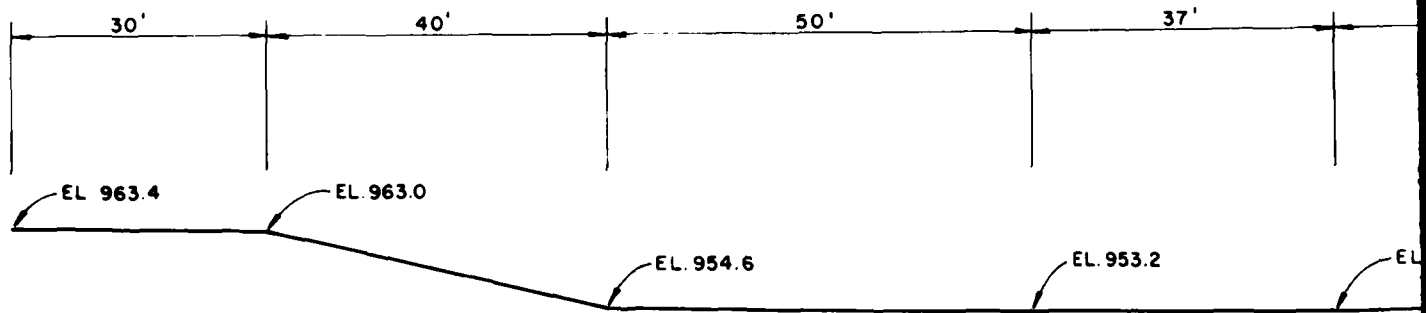

50' DOWNSTREAM OF BRIDGE - LOOKING D

1

196'

LINE
35.0

ROUNDED FACE ON
UPSTREAM SIDE OF
CONCRETE PIERS
(TYP)

ROAD

7.5'
TYP

12'
TYP

1'

970
965
960
955
950

IDGE - LOOKING DOWNSTREAM

37'

50'

40'

20'

15'

953.2

EL. 953.1

EL. 953.4

EL. 954.8

EL. 960.6

EL. 966.0

M OF BRIDGE - LOOKING DOWNSTREAM

2

RAINTREE LAKE SPILLWAY CROSS SECTIONS

PLATE 6

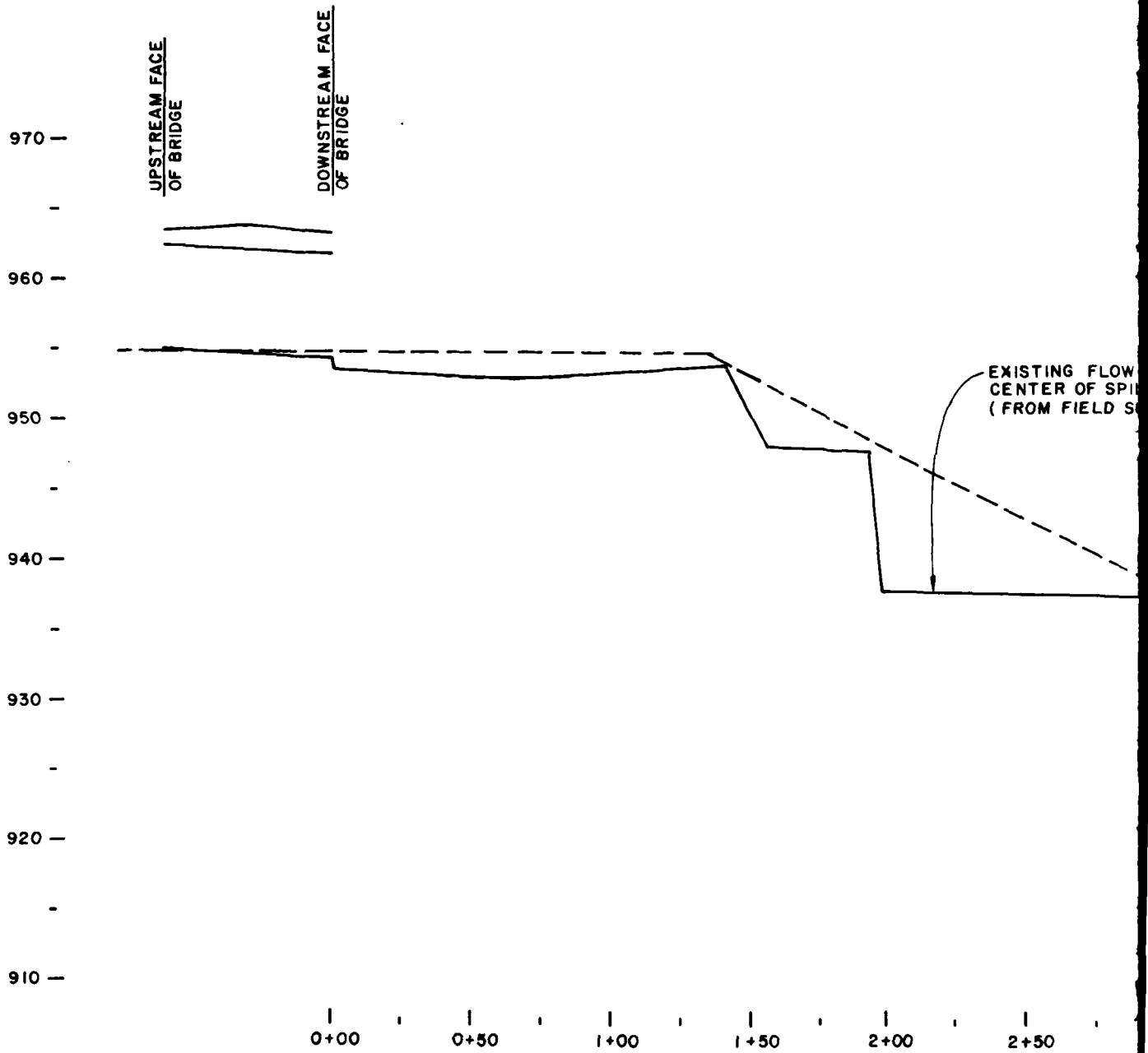

1

EXISTING FLOW LINE AT
CENTER OF SPILLWAY
(FROM FIELD SURVEY DATA)

PROPOSED FLOW LINE AT
CENTER OF SPILLWAY
(FROM DESIGN DRAWINGS)

10 % GRADE

LAKE WINNEBAGO
LEVEL AT TIME OF
INSPECTION EL. 918.0

2+00 2+50 3+00 3+50 4+00 4+50

2

RAINTREE LAKE SPILLWAY PROFILE

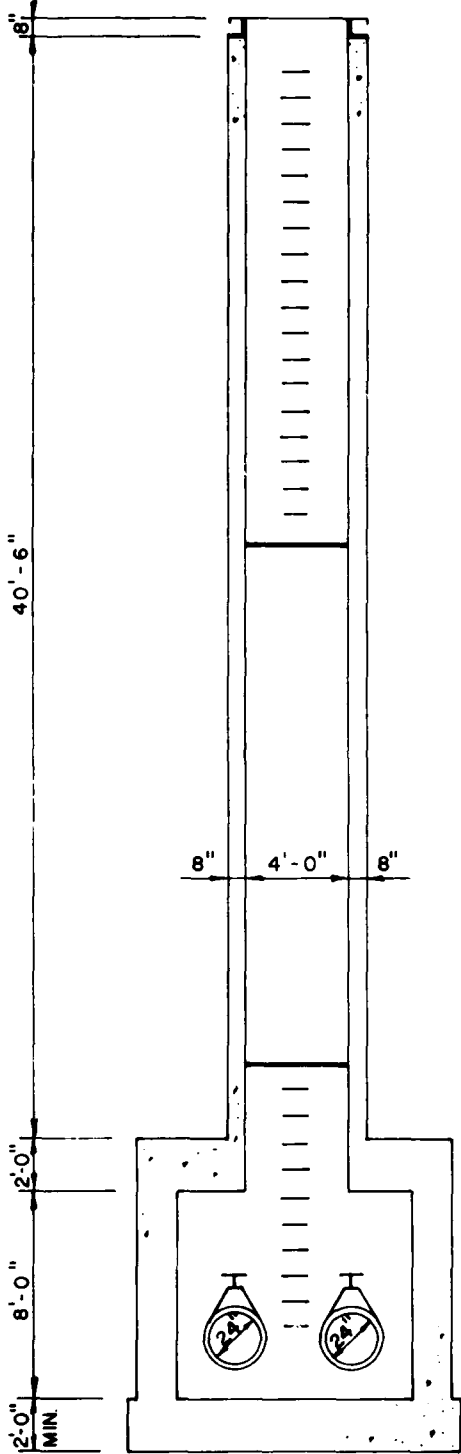

SECTION - ACCESS TOWER

CLAY & BAILEY EXTRA HEAVY DUTY
FRAME AND GRATE NO. 2163 OR
EQUIVALENT

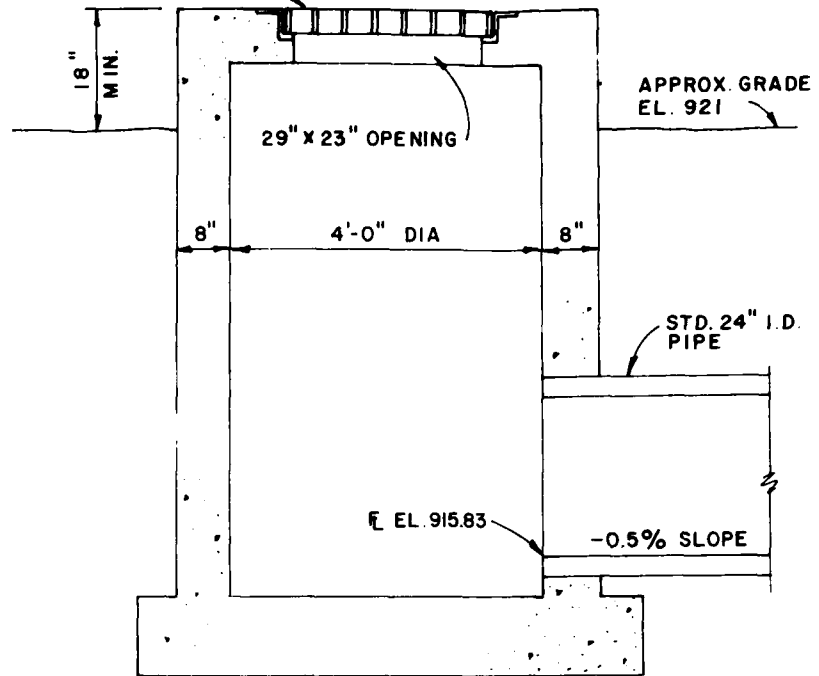

SECTION - INLET STRUCTURE

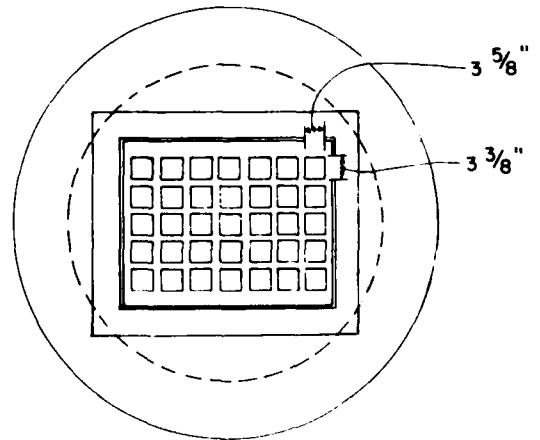

PLAN - INLET STRUCTURE

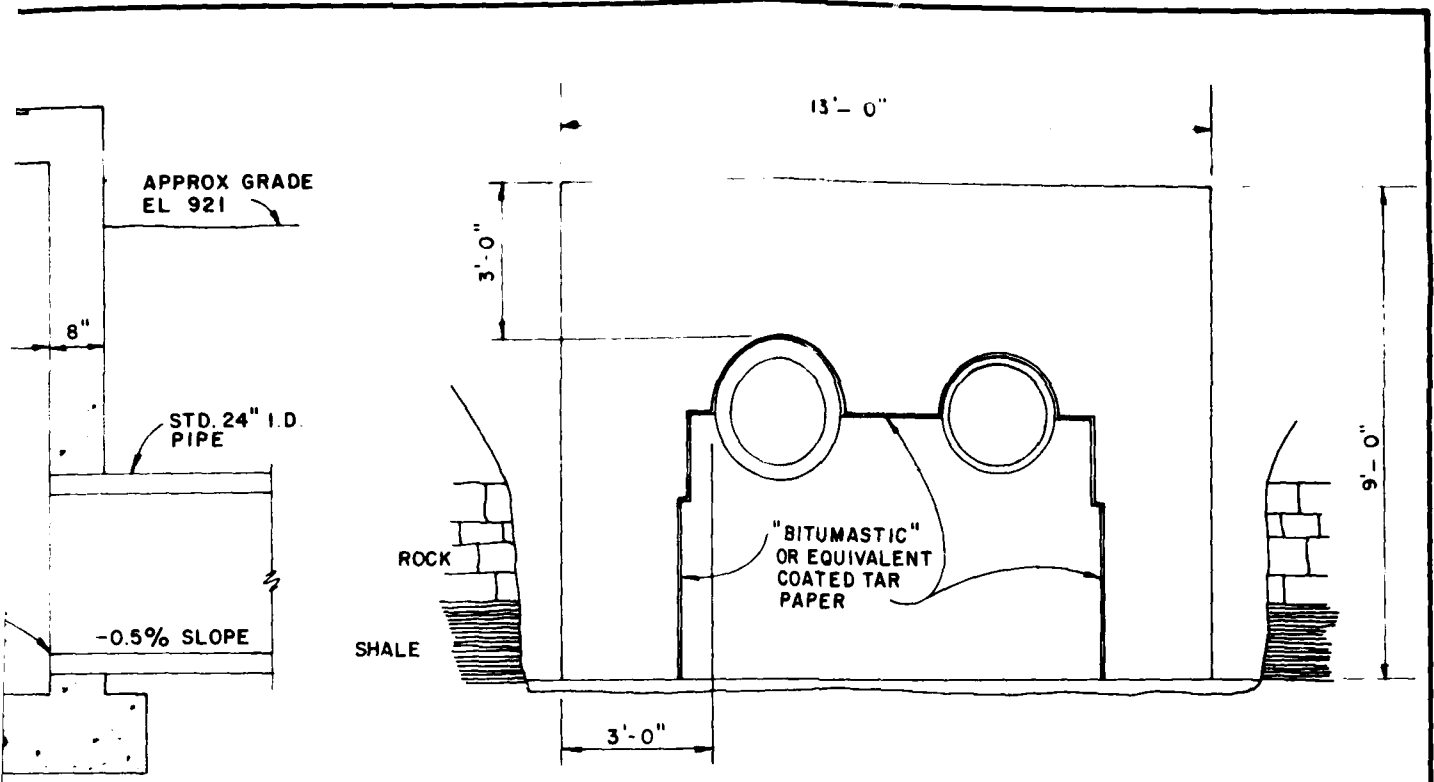

STRUCTURE

TYPICAL SECTION - CUTOFF COLLAR

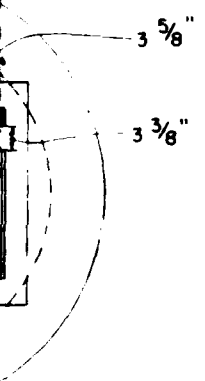

STRUCTURE

NOTE: DATA OBTAINED FROM
DESIGN DRAWINGS.

2

RAINTREE LAKE
DETAILS

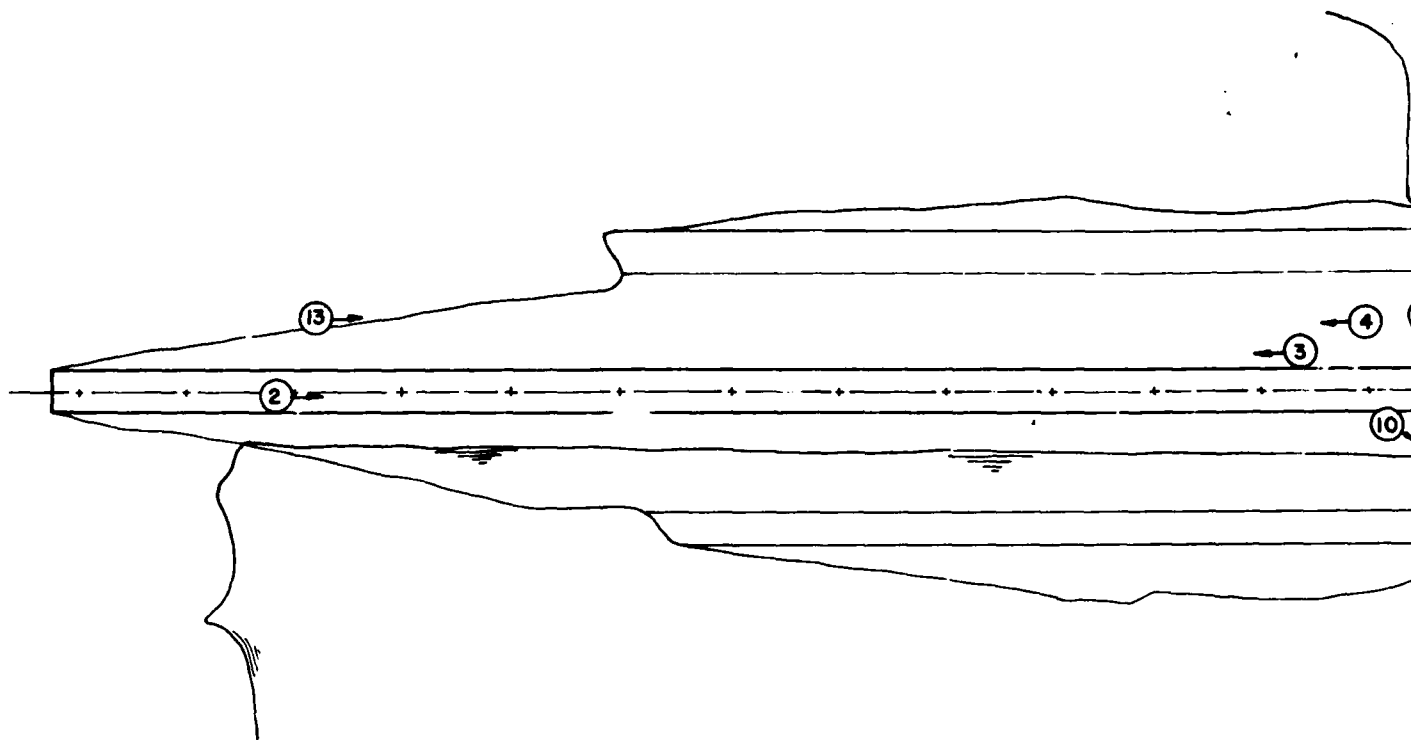

RAINTREE LAKE

LEGEND

① PHOTO LOCATION AND DIRECTION

1

14

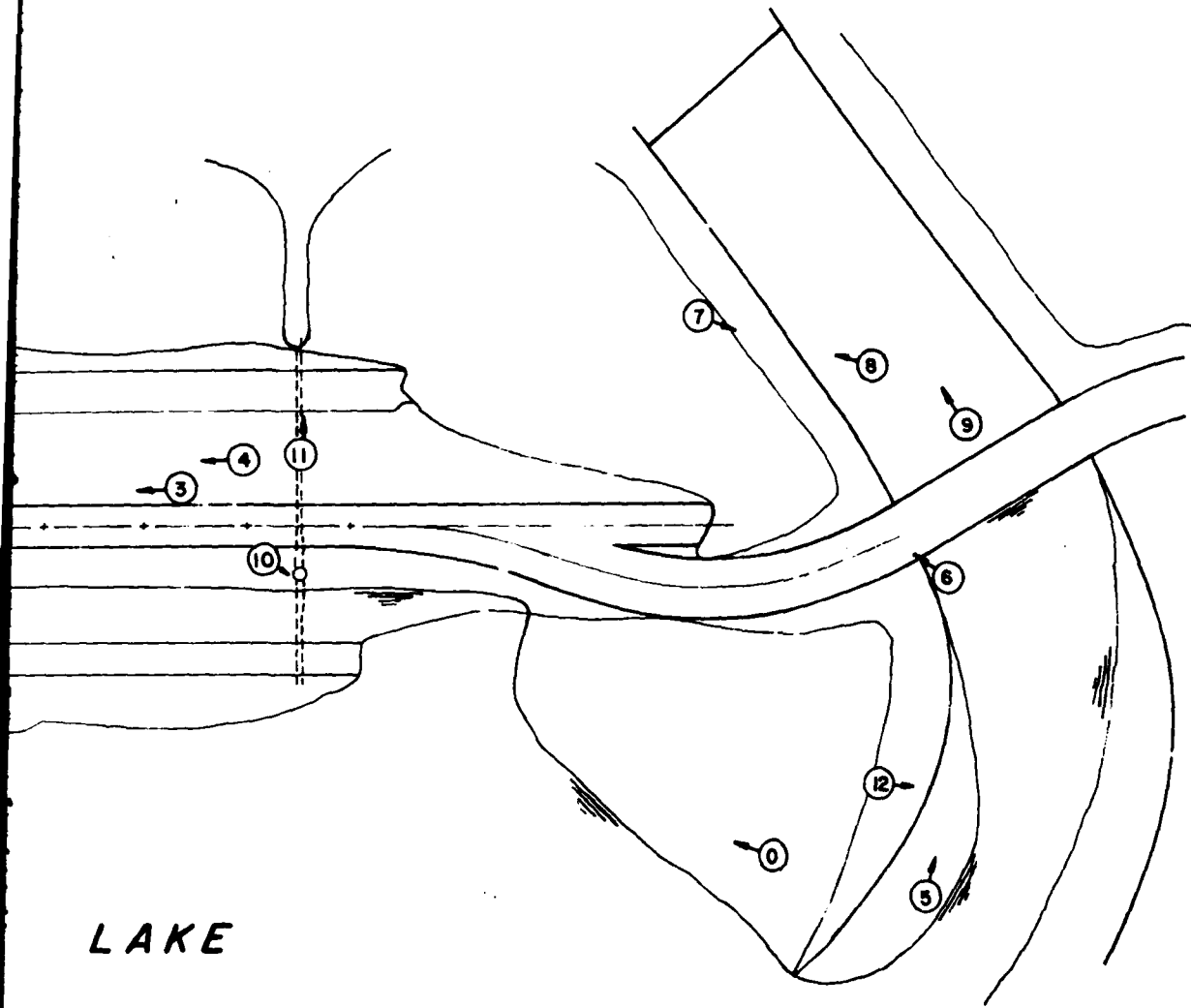

LAKE

2

RAINTREE LAKE
PHOTO INDEX

PLATE 9



PHOTO 1: UPSTREAM FACE OF DAM LOOKING SOUTH

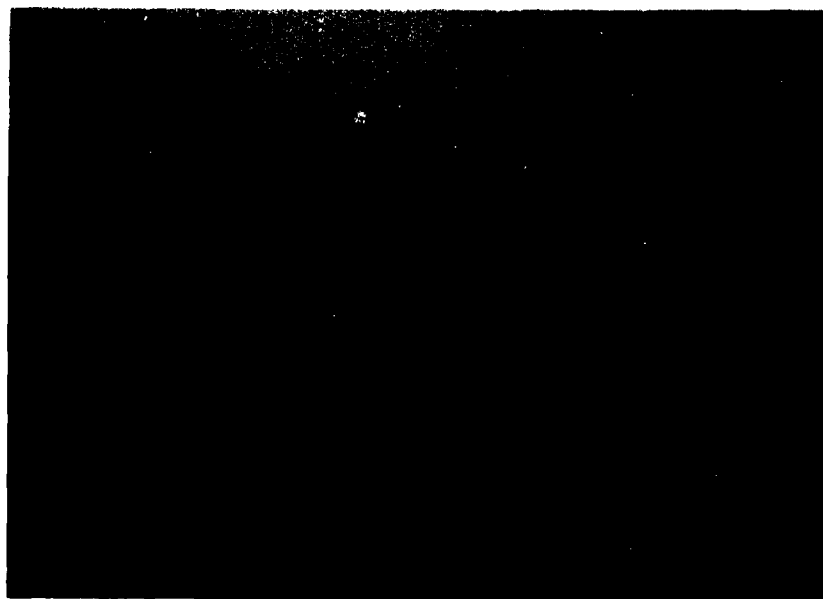

PHOTO 2: CREST OF DAM LOOKING SOUTH



PHOTO 3: DOWNSTREAM SLOPE OF DAM LOOKING NORTH



PHOTO 4: BENCH ON DOWNSTREAM SLOPE OF DAM



PHOTO 5: LOOKING DOWNSTREAM IN SPILLWAY APPROACH CHANNEL



PHOTO 6: CRACKING OF CONCRETE IN BOX CULVERT ABUTMENT



PHOTO 7: LOOKING UPSTREAM AT SPILLWAY DISCHARGE CHANNEL



PHOTO 8: ROCK CUTS IN DISCHARGE CHANNEL



PHOTO 9: DOWNSTREAM TAILWATER FROM LAKE WINNEBAGO



PHOTO 10: ACCESS TOWER TO GATE VALVE VAULT



PHOTO 11: DISCHARGE CHANNEL FOR LOW LEVEL OUTLET



PHOTO 12: EROSION GULLY FORMED ON APPROACH CHANNEL BANK



PHOTO 13: EROSION ON DOWNSTREAM SLOPE NEAR WATERLINE



PHOTO 14: LOOKING WEST FROM HIGHWAY 291 AT DISCHARGE CHANNEL
AND RAIN TREE DAM

APPENDIX A
HYDROLOGIC COMPUTATIONS

HYDROLOGIC COMPUTATIONS

1. The Soil Conservation Service (SCS) dimensionless unit hydrograph (1) and HEC-1 (2) were used to develop the inflow hydrographs and hydrologic inputs are as follows:

a. Forty-eight hour, probable maximum precipitation determined from U.S. Weather Bureau Hydrometeorological Report No. 33.

200 square mile, 24 hour rainfall inches	- 25.0
10 square mile, 6 hour percent of 24 hour 200 square mile rainfall	- 101%
10 square mile, 12 hour percent of 24 hour 200 square mile rainfall	- 120%
10 square mile, 24 hour percent of 24 hour 200 square mile rainfall	- 130%
10 square mile, 48 hour percent of 24 hour 200 square mile rainfall	- 140%

b. Drainage area = 4,770 acres.

c. Time of concentration: $T_c = (11.9 \times L^3/H)^{0.385} = 1.2 \text{ hours} = 72 \text{ minutes}$ (L = length of longest watercourse in miles, H = elevation difference in feet) (3).

d. The soil associations in this watershed are mainly Sharpsburg-Higginsville, Polo-Sogn, and Dennis-Roseland (4).

e. Losses were determined in accordance with SCS methods for determining runoff using a curve number of 82 and antecedent moisture condition III. The hydrologic soil groups in the basin were B, C, and D.

f. The 100-year frequency inflow hydrograph was developed using a curve number of 66 and antecedent moisture condition II. Data of the 100-year, 24-hour rainfall totaling 7.5 inches was provided by the Corps of Engineers, St. Louis District.

2. Spillway release rates are based on backwater analysis through the box culverts using HEC-2 (5).

Discharge rates over the top of the dam are based on the broad-crested weir equation:

$$Q = CLH^{1.5} \quad (C = 2.6, L = 100 \text{ to } 1,800 \text{ feet,} \\ H \text{ is the head on the weir) (3).$$

3. The elevation-storage relationship for the lake was constructed by planimetering the area enclosed within each contour shown on the USGS quadrangle map. The storage between two elevations was computed by multiplying the average of the areas at the two elevations by the elevation difference. The summation of these increments below a given elevation is the storage below that level.

4. Floods are routed through the spillway using HEC-1, modified Puls to determine the capability of the spillway.

- (1) U.S. Department of Agriculture, Soil Conservation Service, National Engineering Handbook, Section 4, Hydrology, August 1972.
- (2) U.S. Army Corps of Engineers, Hydrologic Engineering Center, Flood Hydrograph Package (HEC-1), Dam Safety Version, July 1978, Davis, California.
- (3) U.S. Department of the Interior, Bureau of Reclamation, Design of Small Dams, 1974, Washington, D.C.
- (4) Mid-America Regional Council, Regional Soil Guide, Kansas City, Missouri, March 1976.
- (5) U.S. Army Corps of Engineers, Hydrologic Engineering Center, Water Surface Profiles (HEC-2), November 1976, Davis, California.

PEAK FLOW AND STORAGE (END OF PERIOD) SUMMARY FOR MULTIPLE PLAN-RATIO ECONOMIC COMPUTATIONS
 FLOWS IN CUBIC FEET PER SECOND (CUDIC METERS PER SECOND)
 AREA IN SQUARE MILES (SQUARE KILOMETERS)

OPERATION	STATION	AREA	PLAN	RATIOS APPLIED TO FLOWS								
				RATIO 1	RATIO 2	RATIO 3	RATIO 4	RATIO 5	RATIO 6	RATIO 7	RATIO 8	RATIO 9
HYDROGRAPH AT	1	7.65 (19.30)	1	25504. (722.19)	27629. (782.38)	29755. (862.56)	31880. (902.74)	34005. (962.92)	36131. (1023.11)	38256. (1083.29)	40381. (1163.67)	42507. (1203.65)
	2	7.65 (19.30)	1	12186. (365.08)	13246. (375.08)	14338. (406.00)	15381. (435.53)	16875. (477.86)	18700. (529.52)	20967. (593.73)	23507. (665.66)	26022. (736.87)

SUMMARY OF DAM SAFETY ANALYSIS

PLAN 1	ELEVATION STORAGE	INITIAL VALUE	SPILLWAY CREST	TOP OF DAM			
	964.90	955.00	964.90	964.90			
	3566.	3566.	7217.	7217.			
	0.	0.	15764.	15764.			
RATIO OF PMF	MAXIMUM RESERVOIR W.S.ELEV	MAXIMUM DEPTH OVER DAM	MAXIMUM STORAGE AC-FT	MAXIMUM OUTFLOW CFS	DURATION OVER TOP HOURS	TIME OF MAX OUTFLOW HOURS	TIME OF FAILURE HOURS
.60	963.31	0.00	6458.	12166.	0.00	41.50	0.00
.65	963.60	0.00	6691.	13246.	0.00	41.50	0.00
.70	964.27	0.00	6915.	14338.	0.00	41.50	0.00
.75	964.75	0.00	7145.	15381.	0.00	41.50	0.00
.80	965.20	.30	7360.	16875.	1.17	41.33	0.00
.85	965.59	.69	7548.	18700.	2.00	41.33	0.00
.90	965.94	1.04	7715.	20967.	2.33	41.17	0.00
.95	966.23	1.33	7853.	23507.	2.50	41.17	0.00
1.00	966.52	1.62	7988.	26022.	2.67	41.00	0.00

DATE
ILME