

12

NPRDC TR 81-24

SEPTEMBER 1981

AD A106 370

# THE DEVELOPMENT OF FOUR JOB-ORIENTED BASIC SKILLS (JOBS) PROGRAMS

APPROVED FOR PUBLIC RELEASE;  
DISTRIBUTION UNLIMITED



DTIC  
ELECTE  
OCT 29 1981  
S B D

COPY

NAVY PERSONNEL RESEARCH  
AND  
DEVELOPMENT CENTER  
San Diego, California 92152

Best Available Copy

14) NPRDG-TR-81-24

11) September 1981

6) THE DEVELOPMENT OF FOUR JOB-ORIENTED BASIC SKILLS (JOBS) PROGRAMS.

10) Susan R. Harding  
Beth Mogford  
William H. Melching  
Morris Showel

12) 65

Northrop Services, Inc.  
San Diego, California 92110

DE 373AN

16) Z 1176 PN

17) Z 1176 PN

Reviewed by  
Edwin G. Aiken

9) Final Rept.  
Oct 78 - Oct 80

DTIC  
ELECTE  
OCT 29 1981  
S D  
B

Approved by  
James F. Kelly, Jr.  
Commanding Officer

Navy Personnel Research and Development Center  
San Diego, California 92152

i/ii

390772 x07

UNCLASSIFIED

SECURITY CLASSIFICATION OF THIS PAGE (When Data Entered)

REPORT DOCUMENTATION PAGE		READ INSTRUCTIONS BEFORE COMPLETING FORM
1. REPORT NUMBER NPRDC TR 81-24	2. GOVT ACCESSION NO. AD-A206370	3. RECIPIENT'S CATALOG NUMBER
4. TITLE (and Subtitle) THE DEVELOPMENT OF FOUR JOB-ORIENTED BASIC SKILLS (JOBS) PROGRAMS	5. TYPE OF REPORT & PERIOD COVERED Final Report October 78 - October 80	
	6. PERFORMING ORG. REPORT NUMBER	
7. AUTHOR(s) S. Harding, E. Mogford, W. Melching, and M. Showel	8. CONTRACT OR GRANT NUMBER(s)	
9. PERFORMING ORGANIZATION NAME AND ADDRESS Northrop Services, Inc. San Diego, California 92110	10. PROGRAM ELEMENT, PROJECT, TASK AREA & WORK UNIT NUMBERS Z1176-PN.03	
11. CONTROLLING OFFICE NAME AND ADDRESS Navy Personnel Research and Development Center San Diego, California 92152	12. REPORT DATE September 1981	
	13. NUMBER OF PAGES 65	
14. MONITORING AGENCY NAME & ADDRESS (if different from Controlling Office)	15. SECURITY CLASS. (of this report) UNCLASSIFIED	
	15a. DECLASSIFICATION/DOWNGRADING SCHEDULE	
16. DISTRIBUTION STATEMENT (of this Report)  Approved for public release; distribution unlimited.		
17. DISTRIBUTION STATEMENT (of the abstract entered in Block 20, if different from Report)		
18. SUPPLEMENTARY NOTES		
19. KEY WORDS (Continue on reverse side if necessary and identify by block number)  Job-oriented Basic skills Class "A" school		
20. ABSTRACT (Continue on reverse side if necessary and identify by block number)  This report describes the development of four training courses for Navy personnel whose ASVAB scores were below the minimums required for entry into Navy class "A" technical schools. The training courses were designed to increase their mastery of the skills and knowledge deemed to be prerequisites for success in selected Class "A" schools. This effort was directed towards preparing these low-scoring personnel to enter Class "A" schools in the following areas: Propulsion Engineering, Operations, Administrative/Clerical, and Electricity/Electronics.		

FORM 1 JAN 73 1473

EDITION OF 1 NOV 68 IS OBSOLETE

UNCLASSIFIED

SECURITY CLASSIFICATION OF THIS PAGE (When Data Entered)

III/IV

## FOREWORD

This research and development was conducted in support of Advanced Development Task Area Z1176-PN.03 (Improved Performance through Instruction in "A" School Related Basic Skills) under the sponsorship of the Chief of Naval Operations (Manpower, Personnel and Training) OP-01. The contracting officer's technical representative for this effort was Dr. Meryl Baker.

Appreciation is expressed to Antoinette Curione and Elaine Tostevin for their assistance in this effort.

JAMES F. KELLY, JR.  
Commanding Officer

JAMES J. REGAN  
Technical Director

Accession For	
NTIS GRA&I	<input checked="" type="checkbox"/>
DTIC TAB	<input type="checkbox"/>
Unannounced	<input type="checkbox"/>
Justification	
By _____	
Distribution/	
Availability Codes	
Dist	Avail and/or Special
<b>A</b>	

v/vi

## SUMMARY

### Problem

The Navy is finding it increasingly difficult to attract personnel with aptitude scores high enough to make them eligible for entry into Class "A" technical schools. Unless this situation is remedied, the Navy will not have enough technically trained personnel to accomplish its mission.

### Objective

The objective of this effort was to develop training courses for low aptitude students that would increase their mastery of the prerequisite skills and knowledge (S/Ks) they would need for success in selected Class "A" schools. The schools were to cover four training areas (strands)--Propulsion Engineering (PE), Operations (OPS), Administrative/Clerical (A/C), and Electricity/Electronics (E/E).

### Approach

This effort was conducted in two separate but overlapping phases. The first phase was designed to determine which S/Ks should be taught. This was carried out by identifying S/Ks that were prerequisites for success in the selected Class "A" schools and by testing a sample of "A" school-eligible and "A" school-ineligible recruits to find out how many of these S/Ks they possessed. The test results were then analyzed to determine which S/Ks should be taught in each course.

The second phase involved the development and administration of four JOBS courses. Materials developed for each course included a student guide, an instructor guide, supporting training and testing materials, and a set of evaluation tests to measure the effectiveness of each course. The courses were administered to Navy enlisted personnel who were ineligible for entry into Class "A" schools. Evaluation tests were administered before and after their JOBS training.

### Findings

1. Analysis of the evaluation test scores showed that the students had increased their mastery of selected basic S/Ks as a result of JOBS training. Precourse/postcourse differences in mean percentages of students attaining criterion were: PE, 47 percent; OPS, 43 percent; and A/C, 56 percent. (Postcourse scores for E/E are not available yet.)

2. Evaluation test results indicated that students made relatively greater gains in comprehension of technical terms than in mathematics. On literacy items, pre-course/postcourse differences in mean percentages correct were: PE, 36 percent; OPS, 54 percent; and A/C, 66 percent. On mathematics items, these differences were 28, 44, and 11 percent, respectively.

### Conclusions

1. Programs of instruction can be developed that will increase selected basic S/Ks of lower aptitude Navy personnel.

2. Test scores indicated that students gained more in the comprehension of technical terms than in mathematics.

## Recommendations

1. Close contact should be established between the course developers and the "A" schools so that JOBS courses can be more finely tuned to the needs of the students.
2. Provisions should be made to enable course developers to observe the conduct of instruction in JOBS classrooms.
3. JOBS courses should not be developed for complex, highly technical subjects unless instructors with demonstrated knowledge and experience in the subject matter are available.
4. The format of the instructor guide should be modified to eliminate the student activity column and to present all material vertically.
5. Overhead transparencies should not be used except in those instances where drawing or writing on the board would require too much artistic skill or time.

## CONTENTS

	Page
INTRODUCTION . . . . .	1
Problem . . . . .	1
Objective . . . . .	1
Background . . . . .	1
APPROACH . . . . .	2
DETERMINING COURSE CONTENT . . . . .	2
Content Selection Sequence . . . . .	2
Identifying Prerequisites for Success in Class "A" Schools. . . . .	3
Identifying Skills and Knowledge Possessed by JOBS-Qualified Personnel . . . . .	4
Content of Preassessment Batteries . . . . .	4
Organization of Preassessment Batteries . . . . .	5
Administration of Preassessment Batteries . . . . .	5
Analysis of Preassessment Battery Results . . . . .	5
Selecting the Skills and Knowledge to be Taught. . . . .	5
Length of Courses. . . . .	7
Typing. . . . .	7
Independent Study. . . . .	7
Placing Selected Skills and Knowledge into Modules . . . . .	7
Developing Learning Hierarchies Within Modules . . . . .	7
Preparing Objective Sheets for Each Lesson . . . . .	9
Training Requirements Analysis and Objectives Reports (TRAORs). . . . .	9
Segment Specification Document (SSD) . . . . .	9
COURSE DEVELOPMENT . . . . .	11
Course Development Sequence . . . . .	11
Deliverables . . . . .	11
Other Training Aids . . . . .	12
Evaluation Tests . . . . .	12
A Report on Procedure and Rationale . . . . .	13
Manuals . . . . .	13
Strategy for Teaching Technical Terms . . . . .	13
Implementation of the JOBS Program of Instruction (Courses). . . . .	14
RESULTS . . . . .	14
PROBLEMS ENCOUNTERED AND LESSONS LEARNED . . . . .	16
Timing of Revisions . . . . .	16
Adherence to Segment Specification Document (SSD) Requirements . . . . .	16
Instructor Qualifications and the Complexity of Instructional Materials . . . . .	16
Interaction Between the Development Staff, Instructors, and Observers . . . . .	16

	Page
Use of Overhead Transparencies . . . . .	17
Format of Instructor Guide (IG) . . . . .	17
Role of Student Guide (SG) . . . . .	17
Instructor's Adherence to Specifications in Instructor Guide. . . . .	18
CONCLUSIONS . . . . .	18
RECOMMENDATIONS . . . . .	18
REFERENCES . . . . .	19
APPENDIX--SUPPLEMENTARY INFORMATION IN ALPHABETICAL ORDER . . . . .	A-0



## INTRODUCTION

### Problem

Many Navy recruits cannot enter Class "A" technical schools because their scores on the Armed Services Vocational Aptitude Battery (ASVAB) are below the minimum standards established for entrance into these schools. Because of the Navy's continuing requirement for capable technical personnel, there is an urgent need to find ways of training low aptitude personnel for technical jobs. One solution would be to develop special training courses to increase their mastery of the prerequisite skills and knowledge (S/Ks) needed for success in Class "A" schools. If these courses were successful, they would enable some lower aptitude recruits to successfully complete Navy technical schools, thereby alleviating part of the Navy's current personnel shortage.

### Objective

The objective of this effort was to develop courses of instruction that would enable lower aptitude personnel to increase their mastery of selected basic S/Ks enough to permit them to enter and complete Class "A" schools in four training areas (strands): Propulsion Engineering (PE), Operations (OPS), Administrative/Clerical (A/C), and Electricity/Electronics (E/E). The courses were to teach S/Ks that were prerequisites to the follow-on Class "A" schools, not to improve the general aptitude of the students.

### Background

Current projections indicate that the manpower pool from which the Navy draws its recruits will shrink in the 1980s and 1990s. Coupled with the predictions of declining numbers are recent reports of declines in the academic skills of this pool. Regardless of current debates about which skills have declined and what actions are needed to remedy the situation, the net result is that the Navy will be increasingly forced to use lower aptitude personnel in more complex and demanding jobs.

One solution would be to correct these skill deficiencies through instructional programs that would teach lower aptitude recruits the "A" school prerequisites they appeared to lack. If there were a subsequent increase in the S/Ks of personnel completing these programs, such personnel would then be able to enter and, presumably, complete selected technical training courses. The Navy could in this way partially satisfy its requirements for technically trained individuals.

The idea that training in basic skills should be job-oriented is not new (Duffy, Carter, Fletcher, & Aiken, 1975; Sticht, 1975). However, most earlier efforts have focused on reading (Aiken, Duffy, & Nugent, 1977; Duffy, 1976; Sticht, 1970; Sticht, Caylor, Kern, & Fox, 1971). Previous research has emphasized the heavy literacy requirements of military schools and jobs, and the relatively poor reading ability of typical students and jobholders. As a result, job-oriented programs to improve the reading ability of military personnel were developed and have subsequently been described by Duffy et al. (1975) and developed by Sticht (1975) and by Huff, Sticht, Joyner, Groff, and Burkett (1977). Since each of these programs was to some degree successful, the job-oriented concept was adopted for the Navy's prerequisite skills program.

JOBS training refers to job-oriented basic skills instruction designed to develop the prerequisite skills that are required to complete initial job training. Although the instruction may superficially resemble simplified job training, it is more correctly an

attempt to increase S/Ks that will be generalizable to a variety of learning and performance situations.

## APPROACH

This effort was conducted in two separate but overlapping phases. The first phase was designed to determine which S/Ks should be taught in each course. This was carried out by identifying the S/Ks that were prerequisites for success in the selected "A" schools and by testing a sample of recruits to find out how many of these skills they possessed. The test results were then analyzed to determine which S/Ks to teach in each course.

The second phase involved the development and administration of the four courses. At NAVPERSRANDCEN's direction, the PE course was developed first, followed in order by courses for OPS, A/C, and E/E. Work was often in progress, however, on more than one strand. The courses were developed in accordance with established instructional systems development (ISD) procedures,<sup>1</sup> and each course included student guides (SGs), instructor guides (IGs), supporting training and testing materials, and a set of evaluation tests to measure the effectiveness of each course.

The courses were administered to students who were ineligible for entry into the selected "A" schools. Evaluation tests were administered to students before and after their JOBS training.

Throughout this report, the S/Ks needed to perform a task, the lessons needed to learn the S/Ks, and the task itself, are given the same name. Thus, lesson number 4.0 in the A/C course, the S/Ks taught in lesson 4.0, and the "A" school task that lesson 4.0 prepares the student to perform, are all entitled "solve a word problem involving arcs."

## DETERMINING COURSE CONTENT

This section outlines the procedures used to determine the content of the four JOBS courses. More detailed descriptions, and copies of many of the items described here, are provided in The Training Requirements Analysis and Objectives Report (TRAOR) prepared for each strand.

### Content Selection Sequence

The procedures used to produce the TRAOR were similar for each course:

- The prerequisites for success in Class "A" schools were identified.
- The entry level S/Ks possessed by JOBS-qualified (JQ) and school-qualified (SQ) personnel were identified.
- The S/Ks to be taught were selected.

---

<sup>1</sup>Procedures for Instructional Systems Development, NAVEDTRA 110.

- The selected S/Ks were organized into lessons and the lessons were placed in modules.
- Learning hierarchies were developed for the lessons.
- Objective sheets with sample test items were prepared for each lesson.
- Data collected to this point were incorporated into a TRAOR, and the TRAOR was reviewed by NAVPERSRANDCEN.

### Identifying Prerequisites for Success in Class "A" Schools

The S/Ks that students should have before entering a Class "A" school were identified by examining each school's training materials and by interviewing both faculty and students. Each school provided a set of training materials, including training objectives, lesson materials, study materials, references, and tests.

The focus of both the interviews and the examination of course materials was on identifying S/Ks that were needed but not taught in Class "A" schools, or that were taught but were difficult to learn. Interviews were conducted with students who were having difficulty with the training as well as with those who were not having difficulty. Faculty members who were interviewed included instructors, course administrators, and school administrators. The interviews were conducted at Class "A" schools in Great Lakes, Illinois (PE and OPS strands); Orlando, Florida (OPS strand); Meridian, Mississippi (A/C strand); and San Diego, California (E/E strand).

For the PE strand, two methods of analyzing the training material and interview data were tried. The first method, focusing primarily on an analysis of the training materials, sought to identify the total set of tasks performed by the student while in Class "A" school. This effort resulted in the generation of hundreds of task statements, such as:

- IDENTIFY resources for learning in the PE "A" school, given a description of the resource and how to assess each resource.
- DEFINE "hexagonal," given a passage that contains a word that is explained by the other statements that precede or follow it.
- CONTRAST the two types of high pressure valves to determine which parts have the same purpose, given a verbal explanation.

Attempts were made to organize these statements into a taxonomy but these efforts proved unproductive, and the approach was set aside. A taxonomy might have been possible, but the need to move forward in the development of the four courses prompted a shift to a second approach.

The second approach used the same data sources as before. After examining the training materials, the course developers hypothesized tentative sets of prerequisite S/Ks directly from analyses of training materials and interviews, with plans to verify or refute these prerequisites later, based on preassessment data. Examples of tentative task statements and skills include:

- Find information in a table.
- Add numbers.
- Read a setting on a micrometer.

- Comprehend a written passage.
- Solve word problems.

### Identifying Skills and Knowledge Possessed by JOBS-Qualified Personnel

The previous step identified the types of S/Ks that appeared to be essential for success in Class "A" school. It also identified which of these essential S/Ks were either not taught, or were taught with great difficulty, in Class "A" schools. The next step was to determine the extent to which JQs possessed these S/Ks. Determination of entry level characteristics of JQs was accomplished by administering a preassessment battery to samples of men in the apprenticeship program at the Naval Training Center, San Diego, California.

### Content of Preassessment Batteries

On the basis of information gained from examining training materials and conducting interviews, test items were constructed for inclusion in preassessment batteries for each strand (each TRAOR contains a copy of the corresponding preassessment battery). All test items were multiple choice. The test items fell into four categories: technical terms, reading, mathematics, and miscellaneous.

Technical Terms and Their Associated Concepts. Each strand has its own terminology and students must have, or acquire, some familiarity with these terms before they can understand the material taught in the corresponding Class "A" school. Terms that appeared frequently in the training materials and that were judged likely to be unfamiliar to JQs, or which were judged to be inadequately defined in the training materials were included in the preassessment batteries. The PE, OPS, A/C, and E/E preassessment tests included, respectively, 90, 170, 180, and 180 terms.

Reading. Reading demands are particularly heavy in the A/C strand, where students are required to use standard publications. Reading requirements are also heavy in strands that make extensive use of programmed instruction materials.

A somewhat specialized requirement is the ability to read or interpret information found in tables, charts, diagrams, schematics, or graphs. This includes using conversion tables and reading diagrams and schematics (PE); using indexes and tables of contents (AC); reading time zone charts and high low water charts (OPS); and interpreting graphs of waveforms (E/E). Each preassessment battery contained test items tailored to the reading requirements of the strand.

Mathematics. All schools reported that students had difficulty performing mathematical operations. The types and the difficulty of mathematics items prepared for preassessment batteries varied markedly. Items for the A/C strand were word problems requiring only addition, subtraction, multiplication, and division. At the other extreme, the preassessment test for the E/E strand included items covering signed numbers, squares and square roots, formulas, scientific notation, and trigonometric functions. Mathematics items for PE and OPS fell between these two extremes.

Miscellaneous. Miscellaneous items included reading measuring instruments (PE), filling out forms (OPS and A/C), and working with metric prefixes (E/E).

### Organization of Preassessment Batteries

Because of the large number of items covered, it was necessary to divide the preassessment batteries into parts, each part requiring 1 to 2 hours to complete. (Preassessment battery tests are listed in Table A-3 of the Appendix.)

### Administration of Preassessment Batteries

The preassessment batteries were administered to 539 men in the apprenticeship program at Naval Training Center, San Diego, during 1979 and 1980. Subjects were divided into two comparison groups for each test battery. The "A" school qualified group (SQs; N = 291) had ASVAB scores high enough to make them eligible for entrance into one of the Class "A" schools covered by the battery; the JOBS-qualified group (JQs; N = 248) had ASVAB scores too low for entrance into a Class "A" school.

The selection of the ASVAB cut-off scores used to separate the subjects into the SQ and JQ groups was influenced by the availability of personnel. To secure reasonable samples, these cut-off scores were slightly different, by  $\pm 1$  or 2 points, from the cut-off scores set by the "A" schools (the ASVAB cut-off scores used in this work are listed in Table A-1).

### Analysis of Preassessment Battery Results

The results of the preassessment batteries were described in detail in the TRAORs. Briefly stated, four patterns emerged:

- As was expected, the prevalent pattern was for SQs to perform better than JQs. For example, in the A/C strand, 75 percent of the SQs, but only 37 percent of the JQs, knew the definition of "requisition." In the E/E strand, 82 percent of the SQs, but only 50 percent of the JQs, could identify the square root of the number 1296.
- Both groups did very well on some items. Approximately 90 percent of both the JQs and the SQs in the OPS strand, for example, were able to add and subtract whole numbers.
- Both groups did very poorly on other items. Only 18 percent of both JQs and SQs in the E/E strand, for example, were able to identify the adjacent side of a given angle in a right triangle.
- There were a few instances where JQs performed better than SQs. This was probably due to random error.

### Selecting the Skills and Knowledge to be Taught

The results of the preassessment battery provided the basis for the selection of most of the S/Ks included in JOBS. The selection algorithm provided by NAVPERSRANDCEN is shown on Figure 1. An S/K was included if it met either of the following criteria:

- It was not taught in Class "A" school and 50 percent or less of the JQs could answer the corresponding test item correctly.
- It was taught in Class "A" school, but 50 percent or less of the SQs could answer the test item correctly. The difference between the percentage of SQs and JQs answering the test item correctly had to be at least 15 percent.

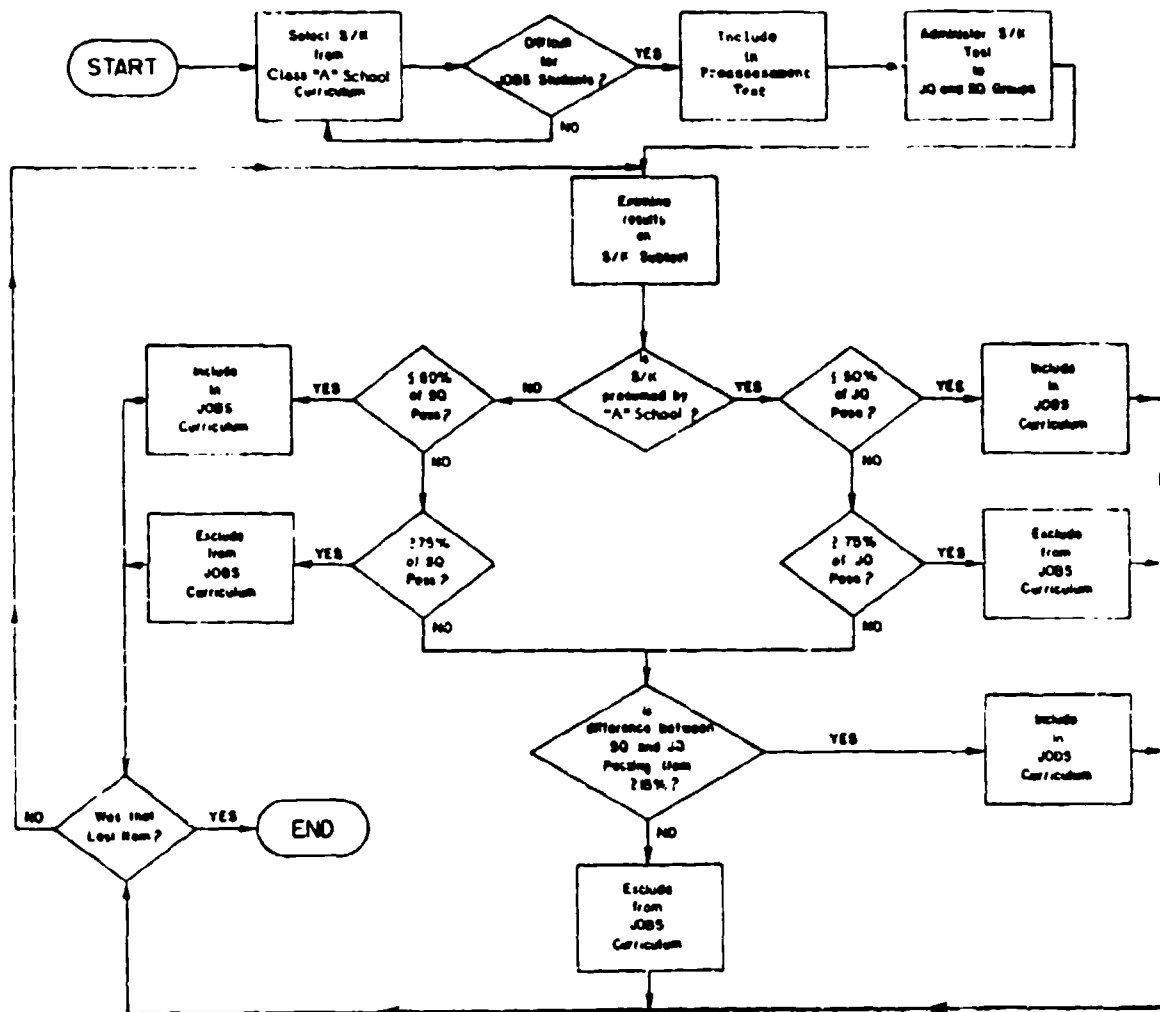

**Legend:**

- JQ = JOBS qualified
- SQ = Class "A" school qualified
- S/K = Skill/Knowledge

Figure 1. Algorithm for selection of training content for a JOBS course (typical).

It should be noted that the selection criteria provided for the inclusion of S/Ks taught in the Class "A" schools only when these were shown to be particularly difficult even for the SQs.

When more than one test item was needed to measure proficiency on a particular S/K, the selection criteria were applied to the item cluster rather than to a single question. Detailed descriptions of the selection procedure and of the S/Ks selected can be found in the TRAORs.

There were three important qualifications to the S/K selection procedure: the length of each course, the need for typing skills, and the inclusion of independent study.

#### Length of Courses

NAVPERSRANDCEN indicated that 4 weeks should be utilized for the PE, OPS, and A/C courses, and 8 weeks for the E/E course. These time constraints influenced decisions to include or exclude those marginal S/Ks that were slightly above or below the selection criteria.

#### Typing

It was not feasible to include typing in the A/C preassessment battery, even though the examination of training materials had revealed that typing was a major component of A/C training. Moreover, both students and faculty had recommended that the A/C course include typing. For these reasons, typing instruction was included in the JOBS program for the A/C strand even though it was not an item on the A/C preassessment battery. Students received one week of a commercially prepared typing program after they had completed the academic portion of the JOBS program.

#### Independent Study

The independent study approach requires the student to spend a considerable amount of class time working on his own, with relatively little assistance from instructors. Interviews revealed that most students in Class "A" schools were dissatisfied with this unfamiliar teaching method, especially those who were having difficulty. While independent study items were not included on the preassessment battery, it was decided to include some training in independent study in each JOBS course.

#### Placing Selected Skills and Knowledge into Modules

The S/Ks selected for inclusion in JOBS courses were grouped into modules and the modules were arranged in tentative learning sequences. (Table A-6 provides a complete list of the selected S/Ks, by module.) Some S/Ks were relevant to more than one strand. For example, the Decimal Numbers/Whole Numbers module subsumed eight S/Ks, six of which were taught in more than one course (see Table A-6).

#### Developing Learning Hierarchies Within Modules

Within each module, the S/Ks were arranged in a hierarchy map to indicate the teaching sequence (Figure 2). The module's terminal task, or objective, was placed at the top of the map, and the supporting or enabling S/Ks were arranged below it in a proposed learning sequence. Horizontal broken lines were drawn above and below the module hierarchy map. S/Ks that the student was assumed to possess prior to entering JOBS training, and S/Ks taught in earlier modules, were shown below the bottom line.

The Class "A" school tasks for which the JOBS-taught S/Ks were prerequisites were shown above the top line.

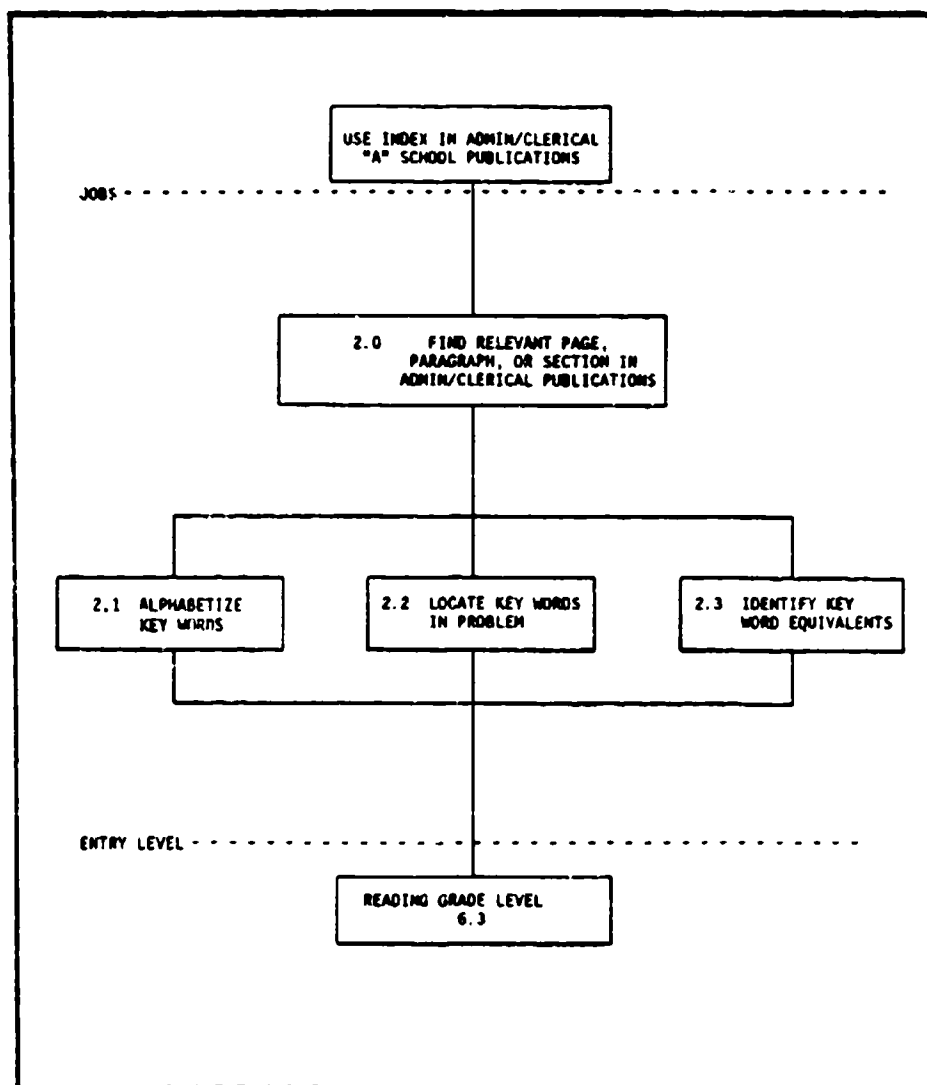

Figure 2. Module hierarchy map for A/C strand (typical).



Certain S/Ks could not be taught without first teaching other prerequisite S/Ks. These prerequisite S/Ks were added to module hierarchy maps, when necessary, even though they had not been covered in a preassessment test.

### Preparing Objective Sheets for Each Lesson

An objective sheet was prepared for each lesson on the module map. This sheet contained a formally stated objective for the lesson, one or more sample test items, the Instructional Quality Inventory (IQI) (Ellis & Wulfek, 1978) classification of the objective, and the estimated amount of instructional time that would be required to attain the objective. Figure 3 shows two examples of objective sheets prepared for the A/C strand; copies of all objective sheets can be found in the TRAORs.

### Training Requirements Analysis and Objectives Reports (TRAORs)

As consequences of reviews the following changes were made to draft TRAORs:

- Modules were dropped, added, and resequenced.
- Lessons within modules were dropped, added, and resequenced.
- Statements of objectives were reworded.
- Requests for further analysis of Class "A" school materials were made.
- Anticipated instructional time was reassigned.
- The format of testing was modified.

### Segment Specification Document (SSD)

The second deliverable prepared for each strand was the SSD. The Module Specifications and Lesson Specifications contained in the SSDs provided a transition between the somewhat general specifications contained in the TRAOR and the very detailed course materials developed in the second phase of the JOBS effort. As consequences of reviews, various elements of the SSDs were added, deleted, changed, or resequenced. Since changes were incorporated into the course materials directly, rather than into the SSDs themselves, no final versions of the SSDs were produced. Figures A-1 and A-2 are sample lesson and module specification sheets from the OPS SSD.

OBJECTIVE: 2.0 Given an Administrative/Clerical problem situation and index from an Administrative/Clerical publication, locate the page, paragraph, or section in the publication which contains information that will solve the problem. The standard is 802.

SAMPLE TEST ITEM:

2.0 You have been told by your superior that he wishes to send a letter to a person and wants to enclose a document in the letter. Unfortunately, the document is too big to fit in the envelope and will be sent in a separate envelope.

On what page and paragraph in the Correspondence Manual will you find guidance on how to say this when you prepare the letter?

Answer: Page VI-2, Paragraph 14

IQI CLASSIFICATION: Use rule - unaided

ANTICIPATED INSTRUCTIONAL TIME: 5 hours

OBJECTIVE: 2.1 Given five Administrative/Clerical terms arranged in random order, arrange the terms in alphabetical order. The standard is 802.

SAMPLE TEST ITEM:

2.1 Below are five words. Put them in alphabetical order by putting a 1, 2, 3, 4, or 5 in front of each word.

- (4) envelope
- (1) enclosure
- (3) endorsement
- (5) exhibit
- (2) enclosure line

IQI CLASSIFICATION: Use rule - unaided

ANTICIPATED INSTRUCTIONAL TIME: 3 hours

Figure 3. Lesson sheets for A/C strand (typical).

## COURSE DEVELOPMENT

The major areas of interest in the course development phase were:

- The course development sequence.
- The course components (deliverables).
- The strategy for teaching technical terms.
- The implementation of the four JOBS programs of instruction (courses).

### Course Development Sequence

The course development sequence was as follows:

- Draft versions of all course components were prepared.
- The drafts were revised and resubmitted as the preliminary final versions.
- The courses were implemented.
- Comments were received from JOBS instructors and classroom observers.
- The results of the postcourse and progress tests were analyzed.
- A revisions report was submitted describing the revisions to be made and the rationale for these changes.
- Revisions were made to the courses, resulting in the revised courseware draft version.
- Revised courseware drafts were submitted to NAVPERSRANDCEN for review.
- Revised courseware finals were prepared.
- Final courses were implemented.

A shortage of eligible students delayed revision of the initial draft course material for the E/E strand. NAVPERSRANDCEN undertook this task, however, and a final version of the E/E curriculum is now available.

### Deliverables

Nearly 10,000 pages of textual material and over 2400 other items were prepared for JOBS, exclusive of reports, drafts, and preliminary versions. The major deliverables produced were as follows:

- Curriculum outlines prepared for each course stated the number of hours allocated to each lesson and presented a suggested schedule.

- Instructor guides (IGs, Figure A-7) prepared for each module gave instructors step-by-step instructions for conducting all lessons.
- A demonstration guide was prepared to assist the E/E instructors in making the complex demonstrations required in the E/E course.
- Student guides (SGs, Figure A-6) prepared for each module gave step-by-step instructions for performing the skills presented in each lesson.
- Practice exercises (Figures A-8, A-9, A-17, and A-18) gave the students practice performing the S/Ks presented in each lesson.
- Supplementary exercises (Figure A-10) were provided in the PE, OPS, and A/C courses to enrich training on terms.
- Progress tests (Figure A-16) were designed to measure the student's mastery of the material presented in each lesson.
- Remediation exercises were given in the evening, to students who failed progress tests.
- Remediation tests were administered to students at the end of remediation training.
- Overhead transparencies (Figures A-3 and A-4) were the main type of training aid used in the JOBS courses.
- Lesson summaries containing the step-by-step procedures from the SGs were given to the students for use as references in their Class "A" school.

#### Other Training Aids

In the PE, OPS, and E/E courses, instructors were required to conduct a number of demonstrations. The equipment needed for these demonstrations was part of each course. Students in the A/C course were required to use three publications, the Bureau of Naval Personnel Manual, the Afloat Supply Procedures Manual, and the Correspondence Manual. The A/C course included a copy of each of these manuals for each student. A set of specially prepared cards were provided for practice in alphabetizing.

#### Evaluation Tests

Three forms of an evaluation test were prepared for each JOBS course, one form to be administered prior to the start of training, another to be administered at the completion of training, and a third to be administered several months later. (Thus far, only the first and second forms have been used.) These tests were designed to measure changes in proficiency resulting from JOBS training and to measure the extent to which these changes were maintained over time.

A concerted effort was made to ensure that the forms were equivalent. A pool of test items for each objective was developed. The course developers, with assistance from subject matter experts, reviewed all items critically and made any adjustments they felt necessary. Test items were then assigned to the three forms at random. The course developers had intended to assess the equivalence and reliability of the three tests, but

changes in project requirements and priorities mandated that these two aspects of test development be delayed.

#### A Report on Procedure and Rationale

A report entitled "Procedure and Rationale for the Design of Evaluation Test" was prepared for each course. These reports provide the rationale for the construction of the evaluation tests and the design of test items.

#### Manuals

Two manuals were developed. The first, entitled Manual of Instructions for Administering and Scoring the JOBS Evaluation Test, was prepared to provide guidance to test administrators. Included were the answers to each test item and forms for recording test results. The second, entitled An Orientation Manual for the Job-oriented Basic Skills (JOBS) Program Instructor, was designed to prepare personnel to be JOBS instructors. It included topics such as:

- Nature of mastery learning.
- Role of the instructor in the evaluation process.
- Responding to student performance.
- Special problems in teaching lower aptitude students.
- Format of material in JOBS programs.

All instructors were required to read the orientation manual and take the self-tests contained therein before starting their instructional duties.

#### Strategy for Teaching Technical Terms

Training on terminology was a major component of each course; the time devoted to them in the PE, OPS, A/C, and E/E strands was, respectively, 60, 38, 33, and 35 percent of the instructional time available.

As was noted earlier, previous research indicated that a major factor affecting performance in a technical school is the student's familiarity with the technical terms used in the school. Based upon these findings, test items concerned with terms were included on the preassessment battery; those that met the selection criteria were included in the four JOBS courses.

The selected technical terms were divided into clusters on the basis of their meanings. The clusters were divided into convenient groupings (segments) of 9 or 10 terms and two lessons were developed for each cluster. The first lesson taught definitions and gave examples of all of the words in the cluster. The second lesson taught comprehension of materials containing the newly-learned terms. In the first lesson, the students:

- Studied definitions and examples of each term in the first segment.
- Took practice and supplementary exercises.
- Read a "relationship" passage and answered questions about it.
- Generated sentences using the newly learned terms.

- Studied a diagram/summary of terms.
- Repeated the above sequence with the terms in the next segment.
- When all segments in the cluster had been completed, took the progress test for first lesson.

The number of class sessions required to complete the first lesson would vary with the number of segments in the cluster. In the second lesson the student:

- Studied "comprehension passages."
- Completed practice exercises.
- Took progress test for second lesson.

Because of the somewhat innovative approach to teaching technical terms, a more detailed discussion of the strategy for teaching them is presented in the appendix.

#### Implementation of the JOBS Program of Instruction (Courses)

Beginning in 1979, the four JOBS courses were implemented at the Naval Training Center, San Diego. The instructors were civilians employed by the San Diego Community College District, under contract with NAVPERSRANDCEN. To gain detailed information about the implementation, NAVPERSRANDCEN employed a number of university students as classroom observers. Using course materials as guides, they observed classroom activities and recommended improvements. Table 1 lists the numbers of students enrolled in each strand from the dates training began through June 1980.

Table 1  
JOBS Training Conducted as of June 1980

JOBS Program	Date JOBS Training Began	Number of Classes	Approximate Number of Students
PE	July 1979	19	234
OPS	Nov 1979	12	115
A/C	Jan 1980	11	113
E/E	Apr 1980	2	24

### RESULTS

Analyses of pre- and postcourse scores on the evaluation tests for the PE, OPS, and A/C courses showed that students increased their mastery of basic S/Ks as a result of JOBS training. Differences in mean percentages of students attaining criterion were: PE, 47 percent; OPS, 43 percent; and A/C, 65 percent. These scores are based on implementation of the "preliminary final" version of each course and test,

not upon the "revised courseware final" versions. Pre- and postcourse differences on the revised versions should be even greater since the revised versions are presumed to be superior to the earlier ones. The numbers of students attaining criterion on the pre- and postcourse tests are summarized in Table 2.

Table 2  
Evaluation Test Results for PE, OPS, and A/C Strands

Strand	Percentages of Students Attaining Criterion <sup>a</sup>		Increase (%)	N
	Precourse (%)	Postcourse (%)		
PE	37	84	47	57
OPS	28	71	43	9-40 <sup>b</sup>
A/C	18	74	56	28

<sup>a</sup>Criterion was specified in the formal statements of objectives for the four courses.

<sup>b</sup>Circumstances prevented some OPS students from completing both pre- and postcourse tests.

Two important areas in each JOBS program were technical terms and mathematics. All test items that assessed comprehension of terms were combined and the mean pre- and postcourse scores were then compared. The same procedure was followed for mathematics. Somewhat greater gains were found in the comprehension of terms and written passages than in mathematics. (The improvements in these two areas are shown in Table 3.)

Table 3  
Comparison of Improvements in Comprehension of Terms and Mathematics

Strand and Area	Mean Percentages Correct		Difference (%)
	Precourse (%)	Postcourse (%)	
PE Terms and Concepts	56	92	36
PE Mathematics	59	87	28
OPS Terms and Concepts	26	80	54
OPS Mathematics	36	80	44
A/C Terms and Concepts	16	82	66
A/C Mathematics	50	61	11

A complete evaluation of the JOBS program, including performance and attrition/loss rates of JOBS students in JOBS courses, in "A" schools, and in the fleet, has been conducted by NAVPERSRANDCEN (Baker & Huff, in press).

## **PROBLEMS ENCOUNTERED AND LESSONS LEARNED**

### Timing of Revisions

Rigid adherence to the instructional systems development (ISD) cycle was not always feasible. While the ISD cycle acknowledges the need to make revisions after initial program implementation, the JOBS experience indicated a frequent need for revisions during the development process. Specifically, it was not possible to generate objectives that would not subsequently need to be modified. In practice it was found that writers frequently identified omissions and/or contradictions in the objectives that they were attempting to follow. To provide complete instruction, it was often necessary to introduce student activities that required the specification of new objectives. The attempt to develop course tests simultaneously with, or prior to, program development was often frustrating and counterproductive; too often it was necessary to eliminate test items because of changes in objectives. Lastly, the objective writer cannot anticipate the problems a lesson writer may have to solve to account for variations in student backgrounds or instructor abilities.

### Adherence to Segment Specification Document (SSD) Requirements

The development staff frequently encountered problems that could best be resolved by deviating from the specifications found in the SSD. These deviations included making changes in the clustering of tasks into modules, the sequencing of modules, the arrangement of tasks within a module (the learning hierarchy), the training objectives, the generality, and the format of test items.

### Instructor Qualifications and the Complexity of Instructional Materials

A requirement to prepare instructional materials that could be used by relatively inexperienced instructors necessitated the preparation of extremely detailed IGs, especially in the E/E course. It was necessary, for example, to prepare a special demonstration guide for the E/E instructor to follow, step by step, when demonstrating certain basic phenomena to students. While this guide was useful, neither it nor the IG can possibly anticipate all of the questions that students may ask. Even experienced personnel often have difficulty explaining E/E concepts such as capacitive reactance.

In short, when the subject matter to be taught is extremely complex and technical, as it is in E/E, the use of an inexperienced instructor may be counterproductive.

### Interaction Between the Course Developers, Instructors, and Observers

The absence of regular contact between the JOBS instructors and the course developers was probably detrimental to the effort. If time had been available for writers to observe the conduct of instruction, insights into student and instructor interactions might have improved the quality of the materials prepared. As it was, writers obtained



information about their output some weeks or months after producing it. Even then, the feedback was second- and third-hand.

### Use of Overhead Transparencies

It is wasteful to use transparencies to display relatively simple concepts like circularity, parallelism, perpendicularity, etc. It would be better for the instructor to illustrate such concepts on the board, or to find examples of them in the classroom. It is often worthwhile to display long passages or core information such as statements of rules or definitions of new concepts. In these cases, use of overhead transparencies relieves the instructor from writing on the board, and it saves student time. Also, while the "generalities" are available in the SGs, it is preferred that the student's attention be on the instructor rather than partly on the instructor and partly on the SG. Nonetheless, in light of the cost of transparencies, the writer should consider carefully whether a given transparency is essential.

### Format of Instructor Guide (IG)

Navy specifications call for a three-column format for the major portion of the IG. The three columns are entitled Outline of Instruction, Instructor Activity, and Student Activity. (A sample page from an IG is shown in Figure A-7). The Student Activity column contains little significant information and much of the information it does contain can be inferred from the Instructor Activity column, since student activities are usually prompted by instructor activity. The three column format, printed horizontally on the page, with most of the information massed in the narrow center column, made use of the IG unnecessarily difficult. This format also required the instructor to periodically turn the IG, which was quite bulky, from horizontal to vertical and then back again.

### Role of Student Guide (SG)

The SG was designed to be used for self-paced instruction, should the Navy decide to convert the JOBS programs to the self-study approach. NAVEDTRA 110 provides general guidelines for using SGs, but it does not specify how they should be used in an instructor-led, group-paced program such as JOBS.

When technical terms were being taught, the students made full use of their SG. In these lessons, the students were directed to follow along in their SG as the instructor conducted the class, and the SG was fully integrated into the instruction.

In all other lessons, with a few minor exceptions, the SGs were used primarily for reviewing material presented by the instructor. The students read module and lesson overviews at the start of the lesson, attended to the material presented by the instructor, then returned to the SG, reading and working through the examples. Practice exercises were taken after the student had been given time to review, in the SG, the material just presented.

In practice, there was considerable deviation from the model just described. In addition to reading the overviews at the start of the lesson, students kept their SGs open during the entire lesson, and, to varying degrees, shifted their attention between their SG and the instructor. Since the SGs and the IGs did not "track" on a one-to-one basis, and since the examples cited in the SG were always different from those used by the

instructor, some confusion was inevitable. This state of affairs resulted from two factors: first, lack of instructor insistence that the SGs be used as specified in the IG; second, the fact that lessons on terms and concepts always preceded other lessons, thus setting a precedent for having students use their SG throughout the entire lesson.

#### Instructor's Adherence to Specifications in Instructor Guide

The IGs contained detailed specifications for conducting JOBS classes, and classroom observers alerted instructors who failed to adhere to these specifications. Despite these precautions, there is reason to believe that, to varying degrees, instructors deviated from IG specifications, either modifying or entirely omitting certain activities, or inserting activities not specified in the IG.

### CONCLUSIONS

The following conclusions are based on the implementation and evaluation of JOBS courses for the PE, OPS, and A/C strands. No evaluation results were available for E/E.

- Courses of instruction can be developed that will improve selected basic S/Ks of lower aptitude Navy personnel.
- JOBS training can enable many students with low ASVAB scores to complete Class "A" school training. It is assumed that these students could not have completed an "A" school without their JOBS training.
- Students gained more in the comprehension of technical terms and passages than in mathematics.

### RECOMMENDATIONS

The following recommendations are based on the results of the development and implementation of the four JOBS courses:

- Close contact should be established and maintained between the course developers and "A" schools so that JOBS courses can be more finely tuned to the needs of the students.
- Provisions should be made to enable course developers to observe the conduct of instruction in JOBS classrooms.
- JOBS courses should not be developed for complex, highly technical subjects unless instructors with experience in the subject matter are available.
- The student activity column of the IG should be removed, and all material on the IG should be presented vertically on the page. Student activities that warrant special attention, or that cannot be inferred from the information in the instructor activity column, can be presented in a box on the page.
- Overhead transparencies should not be used except in those instances where drawing or writing on the board would require too much artistic skill or time.

## REFERENCES

- Aiken, E. G., Duffy, T. M., & Nugent, W. A. Reading skill and performance in a sample of Navy Class "A" schools (NPRDC Tech. Rep. 77-28). San Diego: Navy Personnel Research and Development Center, 1977. (AD-A038 535)
- Baker, M. S., & Huff, K. H. An evaluation of the job-oriented basic skills program (NPRDC Tech. Rep.). San Diego: Navy Personnel Research and Development Center (in press).
- Duffy, T. M. Literacy research in the Navy. In Sticht, T. G., & Zapf, D. W. (Eds.). Reading and readability research in the armed services (HumRRO FR-WD-76-4). Alexandria, VA: Human Resources Research Organization, September 1976, pp. 115-151.
- Duffy, T. M., Carter, J. C., Fletcher, J. D., & Aiken, E. G. Language skills: A research and development plan for the naval service (NPRDC Spec. Rep. 76-3). San Diego: Navy Personnel Research and Development Center, October 1975.
- Ellis, J. A., & Wulfeck, W. H., II. The instructional quality inventory IV: Job performance aid (NPRDC Spec. Rep. 79-5). San Diego: Navy Personnel Research and Development Center, November 1978. (AD-A083 928)
- Huff, K. H., Sticht, T. G., Joyner, J. N., Groff, S. D., & Burkett, J. R. A job-oriented reading program for the Air Force: Development and field evaluation (HumRRO FR-WD-CA-77-3). Alexandria, VA: Human Resources Research Organization, May 1977. (Published as Air Force Human Resources Laboratory Technical Report AFHRL-TR-77-34, May 1977).
- Procedures for instructional systems development (NAVEDTRA 110). Pensacola: Chief of Naval Education and Training, Author, 1978.
- Sticht, T. G. Literacy demands of publications in selected military occupational specialties (HumRRO Professional Paper 25-70). Alexandria, VA: Human Resources Research Organization, October 1970.
- Sticht, T. G. A program of Army functional job reading training: Development, implementation, and delivery system (HumRRO-FR-WD-CA-75-7). Alexandria, VA: Human Resources Research Organization, June 1975.
- Sticht, T. G., Caylor, J. S., Kern, R. P., & Fox, L. C. Determination of literacy skill requirements in four military occupational specialties (HumRRO TR 71-23). Alexandria, VA: Human Resources Research Organization, November 1971.

**APPENDIX**  
**SUPPLEMENTARY INFORMATION IN ALPHABETICAL ORDER**

## APPENDIX CONTENTS

	Page
ASVAB Cutoff Scores . . . . .	A-1
Lessons Prepared . . . . .	A-1
Lesson Specification . . . . .	A-9
Module Specification . . . . .	A-9
Overhead Transparencies . . . . .	A-9
Practice Exercises . . . . .	A-9
Preassessment Batteries . . . . .	A-9
Programmed Instruction . . . . .	A-14
Progress Tests . . . . .	A-14
Remediation Exercises and Tests . . . . .	A-15
Revision Reports . . . . .	A-15
Student Guide (SG) . . . . .	A-17
Supplementary Exercises . . . . .	A-17
Terms Taught in the PE Course . . . . .	A-17
Strategy for Teaching Technical Terms: First Lesson . . . . .	A-17
Strategy for Teaching Technical Terms: Second Lesson . . . . .	A-29

### LIST OF TABLES

1. ASVAB Cutoff Scores for Admission to JOBS or an "A" School . . . . .	A-1
2. Lessons Prepared for each Program of Instruction . . . . .	A-2
3. Preassessment Battery Tests . . . . .	A-14
4. Numbers of Subjects Given Preassessment Batteries . . . . .	A-15
5. Terms Taught in the PE Course . . . . .	A-18

## LIST OF FIGURES

A-1. Lesson specification for OPS strand (typical) . . . . .	A-10
A-2. Module specification for OPS strand (typical) . . . . .	A-11
A-3. Overhead projection designed to compare different but related concepts (typical) . . . . .	A-12
A-4. Overhead projection designed to illustrate PE concepts (typical). . . . .	A-13
A-5. Page from a Revisions Report (typical). . . . .	A-16
A-6. Page from student guide (typical) . . . . .	A-19
A-7. Pages from instructor guide (typical) . . . . .	A-20
A-8. Practice exercise, definitions, from student guide (typical) . . . . .	A-21
A-9. Practice exercise, unencountered examples, from student guide (typical) . . . . .	A-22
A-10. Supplementary exercise, crossword puzzle, from student guide (typical) . . . . .	A-23
A-11. Supplementary exercise, syllable scramble, from student guide (typical) . . . . .	A-24
A-12. Relationship passage found in the student and instructor guides (typical) . . . . .	A-25
A-13. Instructions for relationship passage from instructor guide (typical) . . . . .	A-26
A-14. Diagram summary found in instructor guides and student guides (typical) . . . . .	A-28
A-15. Progress test, definitions (typical). . . . .	A-30
A-16. Progress test examples (typical). . . . .	A-31
A-17. Comprehension passage (typical) . . . . .	A-32
A-18. Practice exercise . . . . .	A-34

## SUPPLEMENTARY INFORMATION IN ALPHABETICAL ORDER

### ASVAB Cutoff Scores

The cutoff scores used to select candidates for admission to either a Class "A" school or a JOBS course are listed in Table A-1

Table A-1

ASVAB Cutoff Scores for Admission to JOBS or an "A" School

Strand	ASVAB Subtests	ASVAB Cutoff Scores	
		JOBS Qualification	"A" School Qualification
Propulsion Engineering	MK + AI	Under 94	94 or higher
Operations	WK + AR	Under 97	94 or higher
Administrative/Clerical	WK + AR	Under 99	99 or higher
Electricity/Electronics	MK + EI + GE + AR	190-224 <sup>a</sup>	225 or higher

<sup>a</sup>A minimum score (190) was set for selection as a JOBS-qualified subject for the E/E strand. No minimum scores were set for JOBS-qualified subjects for the other strands.

#### Legend:

MK = Mathematical Knowledge  
AI = Automotive Information  
WK = Work Knowledge

EI = Electronics Information  
GS = General Science  
AR = Arithmetic Reasoning

### Lessons Prepared

The lessons prepared for JOBS are listed in Table A-2. Lessons that are otherwise identical may have different lesson numbers, depending upon the course in which they are taught. For example, the lesson entitled "Add Numbers" is taught in PE Lesson 4.4, OPS Lesson 3.1, and A/C Lesson 3.1.

Table A-2

Lessons Prepared for each Program of Instruction

Module Title Lesson/Skill or Knowledge/Task	Lesson Number			
	PE	OPS	A/C	E/E
<b>Decimal Numbers/Whole Numbers</b>				
Add numbers	4.4	3.1	3.1	--
Subtract numbers	4.5	3.1	3.2	--
Multiply numbers	--	3.1	3.3	--
Divide numbers	--	3.1	3.4	--
Compute a percent by division	--	--	3.4	--
Compute a percent by multiplication	--	--	3.3	--
Solve word problems involving decimals and whole numbers	4.6	--	3.0	--
Compute an average	--	3.2	3.0	--
<b>Decimal/Percentages</b>				
Definition/examples of decimal numbers	4.1.1.1.1	3.1.1.1.1	--	3.1.1
Definition/examples of percentages	--	--	--	3.1.1
Label place values in decimal numbers	4.1.1.1	3.1.1.1	--	--
Write word equivalents of decimal numbers	4.1.1	3.1.1	--	--
Write digit equivalents of orally stated decimal numbers	4.1.2	3.1.2	--	--
Convert fractions to decimal numbers mathematically	4.2	--	--	3.4
Convert fractions to decimal numbers using a table	4.3	--	--	--
Convert decimal numbers to percentages	--	--	3.4	3.1
Convert percentages to decimal numbers	--	--	3.3	3.2
Convert decimal numbers to fractions	--	--	--	3.3
Round off decimal numbers	--	3.1.3	3.4	3.4.1
<b>Fractions</b>				
Definition/examples of key terms	--	--	--	2.1.1.1
Reduce fractions to lowest terms	4.1	--	--	2.1.1
Add fractions	--	--	--	2.1
Subtract fractions	--	--	--	2.2
Multiply fractions	--	--	--	2.3
Divide fractions	--	--	--	2.4
Solve math word problems involving fractions	--	--	--	2.0



Table A-2 (Continued)

Module Title Lesson/Skill or Knowledge/Task	Lesson Number			
	PE	OPS	A/C	E/E
<u>Transferring Key Information from Table to Form</u>				
Locate key information in a table	1.0	5.1	--	--
Locate key information on a form	--	5.2	--	--
Transfer key information from table to form	--	5.0	--	--
<u>Responding to Programmed Instruction</u>				
Match component names with descriptive statements	7.1	6.1	4.1	12.1
Select an appropriate study strategy	7.2	6.2	4.2	12.2
Respond to programmed instruction	7.0	6.0	4.0	12.0
<u>Comprehension of Propulsion Engineering Materials</u>				
Definitions and examples of key terms related to energy	6.1.1	--	--	--
Comprehension of propulsion engineering material related to energy	6.1	--	--	--
Definitions and examples of key terms related to measurement	6.2.1	--	--	--
Comprehension of propulsion engineering material related to measurement	6.2	--	--	--
Definitions and examples of key terms related to components	6.3.1	--	--	--
Comprehension of propulsion engineering material related to components	6.3	--	--	--
Definitions and examples of key terms related to maintenance	6.4.1	--	--	--
Comprehension of propulsion engineering material related to maintenance	6.4	--	--	--
<u>Comprehension of QM/OS Material</u>				
Definitions and examples of key terms related to measurement	--	2.1.1	--	--
Comprehension of QM/OS material related to measurement	--	2.1	--	--
Definitions and examples of key terms related to geometry	--	2.2.1	--	--
Comprehension of QM/OS material related to geometry	--	2.2	--	--

Table A-2 (Continued)

Module Title Lesson/Skill or Knowledge/Task	Lesson Number			
	PE	OPS	A/C	E/E
<u>Comprehension of QM/OS Material</u> (Continued)				
Definitions and examples of key terms related to navigation	--	2.3.1	--	--
Comprehension of QM/OS material related to navigation	--	2.3	--	--
Definitions and examples of key terms related to relative motion	--	2.4.1	--	--
Comprehension of QM/OS material related to relative motion	--	2.4	--	--
<u>Comprehension of A/C Material</u>				
Definitions and examples of key terms related to directives	--	--	1.1.1	--
Comprehension of A/C material related to directives	--	--	1.1	--
Definitions and examples of key terms related to correspondence	--	--	1.2.1	--
Comprehension of A/C material related to correspondence	--	--	1.2	--
Definitions and examples of key terms related to codes, ships, and supplies	--	--	1.3.1	--
Comprehension of A/C material related to codes, ships, and supplies	--	--	1.3	--
<u>Signed Numbers</u>				
Definitions/examples of key terms	--	--	--	1.1.1
Add signed numbers	--	--	--	1.1
Subtract signed numbers	--	--	--	1.2
Multiply signed numbers	--	--	--	1.3
Divide signed numbers	--	--	--	1.4
Multiple operations with signed numbers	--	--	--	1.0
<u>Locate Key Information in a Diagram</u>				
Identify components in a diagram	2.1	--	--	--
Find path of flow in a diagram	2.2	--	--	--
<u>Locate Key Information in a Schematic</u>				
Identify components in a schematic	3.1	--	--	--
Find path of flow in a schematic	3.2	--	--	--

Table A-2 (Continued)

Module Title Lesson/Skill or Knowledge/Task	Lesson Number			
	PE	OFS	A/C	E/E
<b><u>Squares/Square Roots</u></b>				
Definition/examples of key terms	--	--	--	4.1.1
Calculate squares of numbers	--	--	--	4.1
Calculate square roots of numbers	--	--	--	4.2
Solve math problems involving squares and square roots	--	--	--	4.0
<b><u>Scientific Notation</u></b>				
Definitions/examples of key terms	--	--	--	5.1.1.1
Conversion of standard notation to scientific notation	--	--	--	5.1.1
Conversion of scientific notation to standard notation	--	--	--	5.1.2
Addition in scientific notation	--	--	--	5.1
Subtraction in scientific notation	--	--	--	5.2
Multiplication in scientific notation	--	--	--	5.3
Division in scientific notation	--	--	--	5.4
Square roots in scientific notation	--	--	--	5.5
Multiple operation problems in scientific notation	--	--	--	5.0
<b><u>Solving Word Problems Using Formulas</u></b>				
Definition/examples of variables	--	3.3.1	--	--
Solve formulas for a specified variable	--	3.3	--	--
Select units of measurement for speed, distance, and time	--	3.4.1	--	--
Substitute data in a formula	--	3.4	--	--
Solve word problems using formulas	--	3.0	--	--
<b><u>Metric Prefixes</u></b>				
Match metric prefixes and powers of ten	--	--	--	6.1.1
Convert units of measure within the metric system	--	--	--	6.1.2
Add using metric prefixes	--	--	--	6.1
Subtract using metric prefixes	--	--	--	6.2
Multiply using metric prefixes	--	--	--	6.3
Divide using metric prefixes	--	--	--	6.4
Perform multiple operations using metric prefixes	--	--	--	6.0
<b><u>Formulas and Variational Analysis</u></b>				
Addition and subtraction in formulas	--	--	--	7.1.1.1.1
Multiplication and division	--	--	--	7.1.1.2

Table A-2 (Continued)

Module Title Lesson/Skill or Knowledge/Task	Lesson Number			
	PE	OPS	A/C	E/E
<u>Formulas and Variational Analysis</u> (Continued)				
Squares in formulas	--	--	--	7.1.1
Square roots in formulas	--	--	--	7.1.2
Reciprocal formulas	--	--	--	7.1.3
Product over sum formulas	--	--	--	7.1.4
Formulas requiring a combination of operations	--	--	--	7.1
Current flow in a schematic	--	--	--	7.2
Formulas and variational analysis	--	--	--	7.0
<u>Solving Word Problems Involving Arcs</u>				
Select units of measurement for arcs	--	4.1.1.1	--	--
Convert among degrees, minutes, and seconds	--	4.1.1	--	--
Convert degrees and minutes to decimal form	--	4.1.2	--	--
Convert decimal form to degrees and minutes	--	4.1.3	--	--
Add arcs	--	4.1	--	--
Subtract arcs	--	4.2	--	--
Solve a word problem involving arcs	--	4.0	--	--
<u>Graphs</u>				
Find the value of a point on a plotted line	--	--	--	8.1
Determine a trend represented by a plotted line	--	--	--	8.2
Determine a relationship represented by a plotted line	--	--	--	8.3
<u>Covarying Relationships</u>				
Table representations of covarying relationships	--	--	--	9.1
Graph representations of covarying relationships	--	--	--	9.2
Formula representations of covarying relationships	--	--	--	9.3
<u>Trigonometry</u>				
Definitions and examples of key terms	--	--	--	10.1.1.1
Solve for unknown sides of right triangles	--	--	--	10.1
Solve for unknown angles of right triangles	--	--	--	10.2

Table A-2 (Continued)

Module Title Lesson/Skill or Knowledge/Task	Lesson Number			
	PE	OPS	A/C	E/E
<u>Take Notes from an Oral Presentation or Written Passage</u>				
Identify the definition of a main idea and supporting ideas	--	1.1.1.1	--	--
Write the main idea of a paragraph	--	1.1.1	--	--
Identify the definition of a supporting idea	--	1.1.2.1	--	--
List the supporting ideas of a paragraph	--	1.1.2	--	--
List the main ideas and supporting ideas in the correct form for note taking	--	1.1	--	--
Write the main ideas and supporting ideas in a brief, concise manner	--	1.2	--	--
<u>Find Information in Administrative/ Clerical Publications</u>				
Find information in extract from A/C publications	--	--	2.1	--
Alphabetize key words	--	--	2.2.1	--
Find relevant page, paragraph, or article number in A/C publication index	--	--	2.2	--
Find information in publications	--	--	2.0	--
<u>Read Micrometers</u>				
Convert sleeve tick marks to numbers and words	5.1.1	--	--	--
Convert thimble tick marks to numbers and words	5.1.2	--	--	--
Add sleeve and thimble values	5.1	--	--	--
<u>Follow Independent Study Procedures</u>				
Identify components of lesson assignment	--	--	4.1	--
Select an appropriate study strategy	--	--	4.2	--
Follow independent study procedures and complete "A" school lesson assignments	--	--	4.0	--

Table A-2 (Continued)

Module Title Lesson/Skill or Knowledge/Task	Lesson Number			
	PE	OPS	A/C	E/E
<u>Comprehension of Materials Related to Electricity and Electronics</u>				
Definitions and examples of non-technical terms	--	--	--	11.1.1
Comprehension of E/E materials containing non-technical terms	--	--	--	11.1
Definitions and examples of key terms related to electricity	--	--	--	11.2.1
Comprehension of E/E materials containing electricity terms	--	--	--	11.2
Definitions and examples of key terms related to electronics	--	--	--	11.3.1
Comprehension of E/E materials containing electronics terms	--	--	--	11.3

### Lesson Specification

A Lesson Specification sheet was prepared for each lesson (Figure A-1). The Lesson Title, Lesson Number, Instructional Time, and Lesson Objective were identical to those stated in TRAOR. The "generality" passage was the first of two new elements introduced in the research and development process. The "generality" was a clear statement of the steps that must be performed by the student in order to accomplish the lesson's objective. When the objective of the lesson was to recognize or write the definition of a term, the "generality" was the definition rather than a set of procedural steps.

The "Special Teaching Points" passage was the second new element introduced in the research and development process. It consisted of special points of information that the researchers felt were important but could not conveniently be included within the generality. Not all Lesson Specification sheets contained "Special Teaching Points."

Sample test items, with answers, were included in the Lesson Specification sheets. They were similar to, but not identical with, the sample test items in the TRAOR.

### Module Specification

A Module Specification sheet was prepared for every module (Figure A-2). The Module Title and Module Number were identical to those stated in the TRAOR. The Introduction provided the rationale for including the material in the course.

### Overhead Transparencies

Figures A-3 and A-4 are examples of overhead transparencies developed for JOBS.

### Practice Exercises

Each lesson in the SG contained practice exercises of various types: fill-in, multiple choice, matching, constructed response, and true/false. Students made all entries on separate sheets of paper distributed by the instructor, rather than writing in the SGs themselves. Students were allowed to refer to their SGs, and to receive help from their instructor, when completing the practice exercises. The IG contained the same exercises, with the answers shown. Examples of practice exercises are shown on pages A-21, A-22, and A-34.

### Preassessment Batteries

Tests in each Preassessment Battery, and the numbers of items on each test, are shown in Figure A-3.

Examples of terms included on the preassessment batteries are listed below.

<u>Propulsion Engineering</u>	<u>Operations</u>	<u>Administrative/ Clerical</u>	<u>Electricity/ Electronics</u>
flange calibrate inertia	simultaneous vector meridians	concur in lieu of requisition	diligence dielectric watt

LESSON SPECIFICATION

LESSON TITLE: Solving word Problems Involving Arcs

LESSON NUMBER: 4.0

INSTRUCTIONAL TIME: 3.5 hours

DATE PREPARED: 17 August 1979

LESSON OBJECTIVE:

Given a word problem involving arcs, solve the problem using the appropriate mathematical operation, converting where required. Four out of five items must be correct.

GENERALITY:

To solve problems involving arcs, use the following steps:

1. Determine the mathematical operation required.
2. Decide if the arcs are expressed in the same units and convert arcs to same units if necessary.
3. Line up the numbers correctly.
4. Perform the operation.
5. Put answer in form asked for.

SAMPLE TEST ITEMS:

1. What is the sum of one arc of  $16^{\circ} 33' 17''$  and another arc of  $15^{\circ} 12' 13''$ ?  
\_\_\_\_\_
2. What is the final arc length if an arc of  $50^{\circ} 15' 30''$  is reduced by  $10^{\circ} 10' 15''$ ?  
\_\_\_\_\_

Figure A-1. Lesson specification for OPS strand (typical).



#### MODULE SPECIFICATION

MODULE TITLE: Solve a Word Problem Involving Arcs

MODULE NUMBER: 4.0

INSTRUCTIONAL TIME: 16 hours (includes 3.5 hours practice)

DATE PREPARED: 17 August 1979

#### INTRODUCTION:

This module contains seven objectives, including the terminal objective. The purpose of this module is to instruct JOBS students in fundamental math skills related to working with arcs. Adding and subtracting degrees is used regularly in OM "A" School for setting up navigational charts and is used in OS "A" School for setting up a circular screen. Adding and subtracting degrees is also necessary in charting direction and distance traveled to determine where your ship is located in relation to where it is ordered. Converting arc measures to decimals and vice versa is used in "A" School whenever degrees are broken down into minutes and seconds or in converting seconds to degrees or minutes. As indicated by the pre-assessment test, JOBS-qualified students performed poorly on converting arc measures ( $\bar{x} = 19\%$ ) and poorly on adding and subtracting degrees ( $\bar{x} = 50\%$ ).

Figure A-2. Module specification for OPS strand (typical).

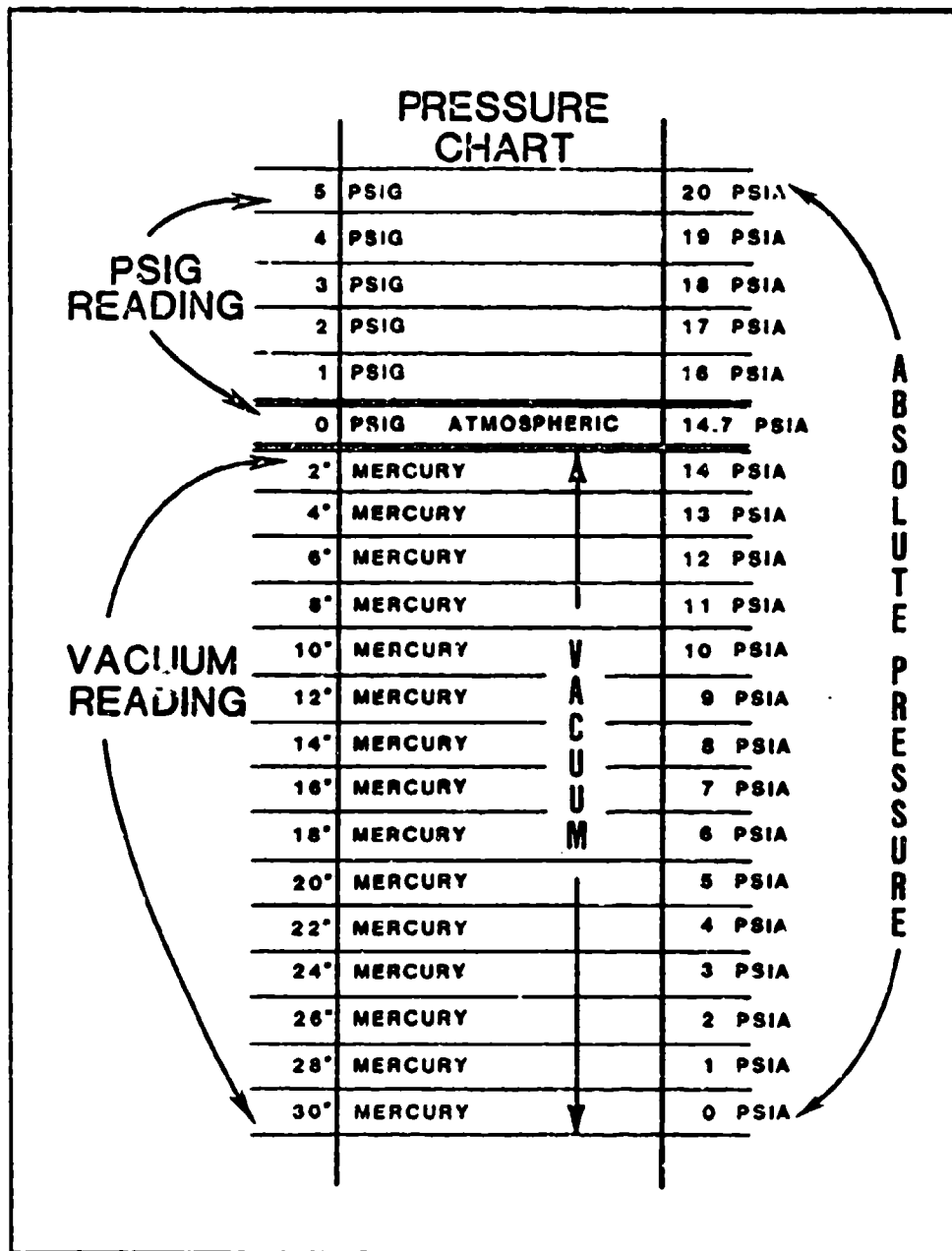

Figure A-3. Overhead projection designed to compare different but related concepts (typical).

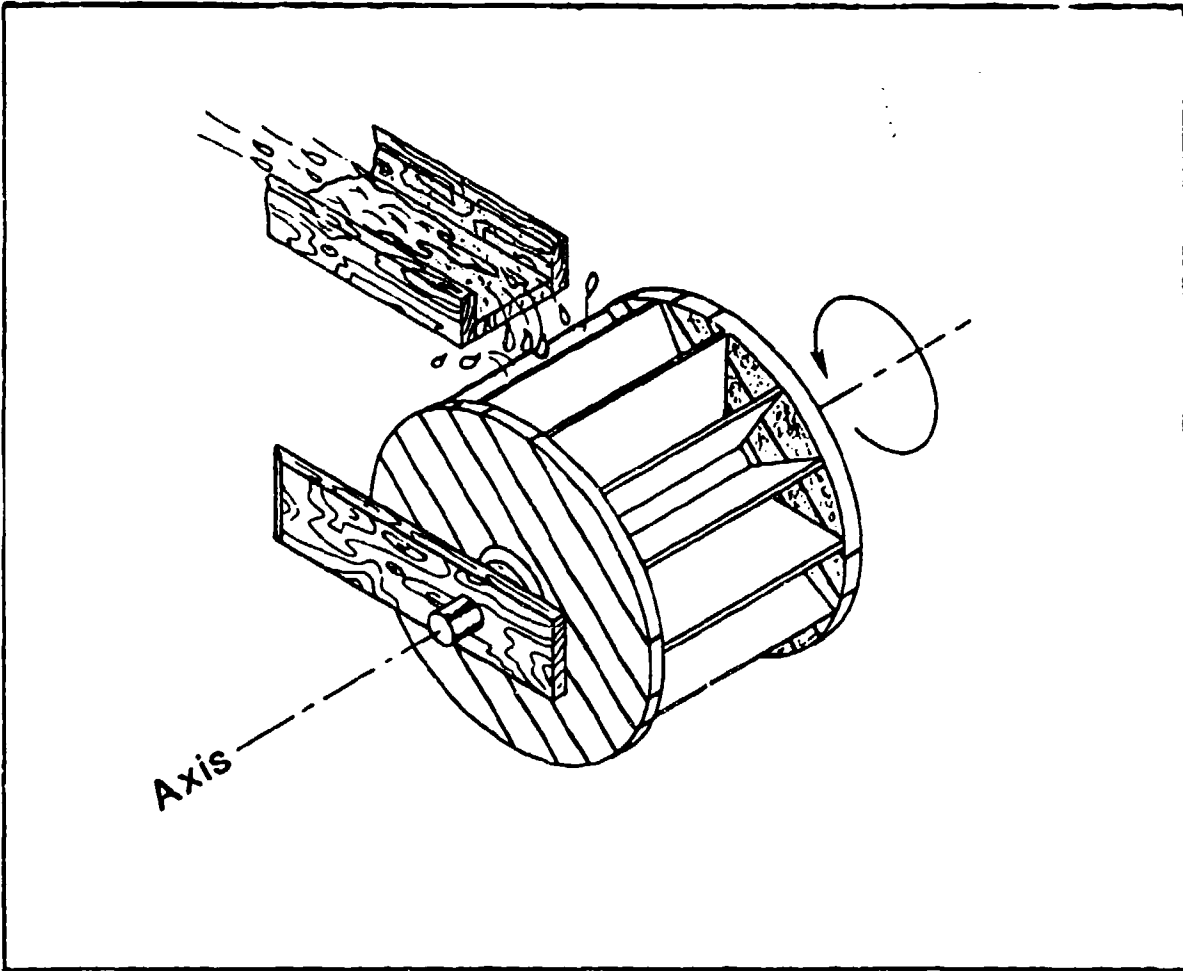

Figure A-4. Overhead projection designed to illustrate PE concepts (typical).

**Table A-3**  
**Preassessment Battery Tests**

Battery	Test Title	Number of Items in Test
PE	Scales/Math/Visuals/Literacy	56
PE	Vocabulary and Tables	96
OPS	Functional Literacy	46
OPS	Basic Science Concepts: A	95
OPS	Basic Science Concepts: B	95
OPS	Basic Mathematics	70
A/C	Basic Concepts: A	90
A/C	Basic Concepts: B	90
A/C	Using Publication	47
A/C	Filling out Forms/Computations	20
E/E	Mathematics: Phase I	63
E/E	Concepts and Relationships: Phase I	87
E/E	Mathematics: Phase II	132
E/E	Concepts and Relationships: Phase II	224

The numbers of subjects given the preassessment batteries are listed in Table A-4.

#### Programmed Instruction

Programmed instruction for the PE, OPS, and E/E strands followed the conventional format: the student was given bits of information, responded to a question, and then received immediate feedback by comparing his answer with that given in the text. There was an important difference, however, in the way programmed instructions were presented in the A/C strand. The A/C students were not given feedback until they had answered a series of questions. When the feedback occurred, it was given by the instructor, and the students learned only that their answers had been correct or incorrect.

#### Progress Tests

Each lesson contained a progress test designed to measure the student's mastery of the material presented in the lesson. The progress test was distributed by the instructor, and the students could not refer to their SGs when taking the test. The IG contained copies of all progress tests, with answers. The format of the progress tests was similar to that of the practice exercises. Pages A-30 and A-31 show pages from a typical progress test.

Table A-4

Numbers of Subjects Given Preassessment Batteries

Preassessment Battery/Strand	Number of Subjects <sup>a</sup>	
	JOBS Qualified	"A" School Qualified
Propulsion Engineering	57	124
Operations	44	52
Administrative/Clerical	98	60
Electricity/Electronics	49	55
Totals	248	291

<sup>a</sup>Since not all subjects took all parts of the preassessment battery for their particular strand, the N for any particular part of a preassessment battery was usually less than that shown in the table.

Remediation Exercises and Tests

The formats of the remediation exercises and tests were similar to those used for practice exercises and progress tests. Copies of the remediation exercises, with answers, were included in the IGs.

Revisions Reports

After the preliminary courses had been implemented, revisions reports were prepared for the PE, OPS, and A/C courses. Each revisions report explained the revision philosophy, the general revisions across the course, and the specific revisions by lesson. The philosophy stated that changes would be made on the basis of (1) previously agreed-upon modifications, (2) analysis of student performance on all progress tests and postcourse tests, and (3) comments from instructors and classroom observers.

The general revisions section listed broad categories such as "provide greater variety in testing format," "provide more than five test items for progress tests," or "use proper terminology when referring to a naval vessel." By far the largest section of each report, however, dealt with specific revisions. These changes were reported by lesson title and included identification of the problem, data source, extent of revision, and the rationale for making or not making the suggested revision. Figure A-5 is a sample page from a revisions report.

Lesson 4.1 Converting Fractions to Decimals Using a Chart

1. "Perhaps 4.1.2 should be made prerequisite to 4.1 or at the very least, reducing of multiples of 2 should be covered in 4.1 since fractions at lowest terms are required to use the chart."
  - a. Data Source: NPRDC review comments to Revision Report, 22 January 80.
  - b. Extent of Revision: The material in lesson 4.2 will be taught prior to 4.1, in other words the lessons will be reversed.
  - c. Rationale: After discussion with NPRDC (5 February 80), it was decided that the solution to this problem could best be found by revising the teaching order of Lessons 4.1 and 4.2. Further, the above comment was made in response to a typographical error (4.1.2 instead of 4.2) in the Draft Revisions Report.
2. "Need expanded section on reducing fractions. More practice items."
  - a. Data Source: NPRDC letter 1 November 79
  - b. Extent of Revision: An expanded section on reducing fractions will be included under Step 2 of the Generality.
  - c. Rationale: Teacher input, via NPRDC, indicates that the revision is necessary.
3. "Need section on recognizing improper fractions."
  - a. Data Source: NPRDC letter of 1 November 79
  - b. Extent of Revision: None
  - c. Rationale: JOBS instruction reflects "A" School instruction in that it provides prerequisites. Working with fractions is a part of JOBS because students will be using machinists scales in "A" School. A machinists scale will never give a reading that is an improper fraction because it measures parts of a whole number. Therefore, improper fractions should not be dealt with in JOBS since they will not be encountered in "A" School.
4. "Need section on how students can check the accuracy of their work."
  - a. Data Source: NPRDC letter 1 November 79
  - b. Extant of Revision: A section will be included after all steps of the generality have been presented. This section will teach students to check their work through mathematical conversion of a fraction to a decimal.
  - c. Rationale: Teacher input, via NPRDC, indicates that the revision is necessary.

Figure A-5. Page from a revisions report (typical).

## Student Guide (SG)

The SG included examples showing the student how to perform tasks covered in each lesson. The SG's examples were always different from those in the IG. The SGs used in the PE, OPS, and A/C courses contained glossaries of the technical terms found in the corresponding Class "A" school materials. These glossaries, which the students took with them to Class "A" schools, included far more terms than were taught in the JOBS program.

Students were directed to read and work through the examples in their SG after the instructors had completed their instruction. The SG could be used by students to preview or review a class or to make up an instructor-conducted class that they missed. Only practice exercises were included in the SG. Supplementary exercises, progress tests, remediation exercises, and remediation tests were distributed by the instructor.

## Supplementary Exercises

The supplementary exercises prepared for PE, OPS, and A/C focused on teaching terms and took the form of crossword puzzles, syllable scrambles, and word trees. (Supplementary exercises were not prepared for the E/E course because of time limitations.) The exercises were administered after the students had completed the practice exercises but before they had taken the progress test for the lesson. Sample pages from a supplementary exercise are shown on pages A-23 and A-24.

## Terms Taught in the PE Course

Table A-5 lists the technical terms taught in the PE course. Similar lists were prepared for the other strands.

## Strategy for Teaching Technical Terms: First Lesson

Two lessons were prepared for each cluster of terms. In the first lesson, students were given definitions, examples, non-examples, and alternate forms of terms in the segment being taught. The significance of each term was explained and the students were required to generate examples of the term's usage (Figures A-6 and A-7).

After receiving instruction, the student performed practice exercises. The first part of each practice exercise required the student to match a list of terms with a list of definitions (Figure A-8). The second part required the student to match the list of terms with a list of unencountered examples (Figure A-9).

After receiving a critique on the Practice Exercise, the student completed the supplementary exercises (Figures A-10 and A-11). After receiving a critique on the supplementary exercises, the student read a simple passage, the "relationship" passage, that integrated all of the terms in the segment (Figure A-12).

After they had read the "relationship" passage, the instructor questioned the students and then directed them to generate sentences using terms found in the passage. The IGs included sample questions to be asked and sample sentences to be generated (Figure A-13).

The final phase in teaching each segment was the diagram/summary (Figure A-14). This was a visual representation showing the relationship between the terms found in the

Table A-5  
Terms Taught in the PE Course

Cluster	Segment 1	Segment 2
I      Energy	molecule energy heat dissipate discharge convection radiation thermal energy volatile	gravity centrifugal force suction inertia potential energy leverage kinetic energy torque hydraulic pressure
II     Measurement	atmospheric pressure vacuum PSIG absolute pressure fluctuation BTU revolution RPM viscosity	diameter equivalent graduation increment linear calibrate tolerance parameter volume
III    Components	cylinder reciprocate linkage throttle propulsion casing auxiliary rotary shim ballast	fitting right angle flange offset junction seal gasket bypass alloy bimetallic chemically stable
IV    Maintenance	deteriorate corrosion alignment vibration friction abrasion erosion bind deaerate	solution impurities contaminated filter sediment residue brackish bilge rupture seepage



All substances in the world are made up of molecules - from the tiniest nut on a diesel engine to the largest aircraft carrier. Molecules are so small that they cannot even be seen through most microscopes.

MOLECULE

Smallest particle of matter (containing more than one atom) that still has the same physical characteristics of that matter

Examples of MOLECULE:

1. The smallest particle of water consists of 2 atoms of hydrogen and 1 atom of oxygen.
2. The smallest bit of carbon dioxide consists of 1 atom of carbon and 2 atoms of oxygen.

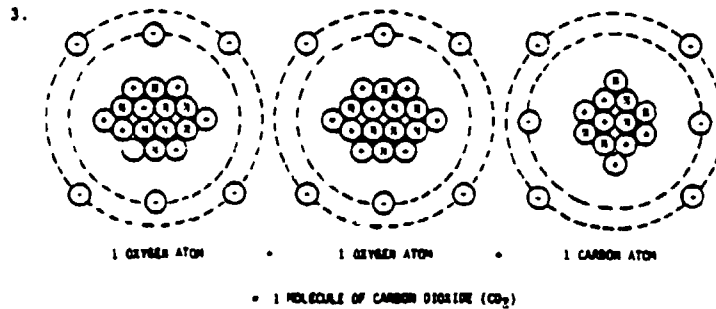

MORE EXAMPLES:

Figure A-6. Page from student guide (typical).

OUTLINE OF INSTRUCTION	INSTRUCTOR ACTIVITY	STUDENT ACTIVITY
<p>III. Explanation/Demonstration</p> <p>A. Instruction - Segment 1</p> <p>1. Molecule</p> <p>a. Introduction</p> <p>b. Definition</p> <p>c. Example</p>	<p style="text-align: center;"><b>MOLECULE</b></p> <p>Explain that everything, from the smallest grain of sand to an aircraft carrier, is made up of molecules.</p> <p>Have students read definition in S.G.</p> <p><b>SMALLEST PARTICLE OF MATTER (CONTAINING MORE THAN ONE ATOM) THAT STILL HAS THE SAME PHYSICAL CHARACTERISTICS OF THAT MATTER</b></p> <p>Show OH 6.1.1 A (leave on screen).</p> <p>Explain that <math>CCl_4</math>, the formula for carbon tetrachloride, means 4 atoms of chlorine, and 1 atom of carbon. This makes up one molecule of carbon tetrachloride.</p> <p>Explain that <math>H_2O</math>, the formula for water, means 2 atoms hydrogen, and 1 atom of oxygen. This makes up one molecule of water.</p>	<p>Watch board/listen/pronounce word.</p> <p>Read S.G.</p> <p>Watch board and listen.</p>

OUTLINE OF INSTRUCTION	INSTRUCTOR ACTIVITY	STUDENT ACTIVITY
<p>d. Non-example</p> <p>e. Student generated example/synonym/sentence</p>	<p>Refer to OH 6.1.1 A.</p> <p>Remind student that molecules are made up of <b>ATOMS</b> and that the <b>ATOMS</b> combine with each other to make molecules.</p> <p>Explain that a drop of water, a grain of salt, and a particle of gas each contain millions of molecules.</p> <p>Explain that molecules and atoms cannot be seen with the naked eye but can be seen with special microscopes.</p> <p>Explain that there are 92 different kinds of <u>natural</u> atoms in the universe, and that there are some man-made atoms.</p> <p>Encourage students to come up with their own examples. Discuss the appropriateness and direct them to write in their S.G.</p>	<p>Watch board and listen.</p> <p>Offer examples, discuss and write examples in S.G.</p>

Figure A-7. Pages from instructor guide (typical).

PRACTICE EXERCISE 6.1.1

Segment 1: Definitions

Directions: Match the terms and definitions by placing the letter of each term next to the correct definition. Note that there are two more terms than there are definitions. Two of the terms will not be used.

<u>Definitions</u>	<u>Terms</u>
___ 1. the transfer of heat by waves or rays in a straight line from a source	a. conduction
___ 2. smallest particle of matter (containing more than one atom) that still has the same physical characteristics of that matter	b. convection
___ 3. the capacity for doing work or producing an effect	c. discharge
___ 4. energy associated with the motion of molecules	d. dissipate
___ 5. to scatter; to disperse; to make disappear	e. energy
___ 6. the ease with which a liquid evaporates	f. heat
___ 7. to throw off; to send out under pressure or by force	g. molecule
___ 8. energy found in heat, because of the rapid movement of molecules	h. pressure
___ 9. the transfer of heat by the vertical circulation of molecules in a liquid or gas	i. radiation
	j. thermal energy
	k. volatile

Figure A-8. Practice exercise, definitions, from student guide (typical).

PRACTICE EXERCISE 6.1.1

Segment 1: Examples

Directions: Match the terms and examples by placing the letter of each term next to the correct example. Note that there are two more terms than there are examples. Two of the terms will not be used.

PART 1

Examples

- \_\_\_ 1. the capacity of a turbine to drive a ship
- \_\_\_ 2. the temperature inside the oven in the main galley
- \_\_\_ 3. forcing exhaust gases out of an engine
- \_\_\_ 4. waves of heat leaving a sun lamp
- \_\_\_ 5. the heating of water on a stove

Terms

- a. conduction
- b. convection
- c. discharge
- d. energy
- e. flammable
- f. heat
- g. radiation

PART 2

Examples

- \_\_\_ 1. sodium chloride: NaCl, consisting of 1 atom of sodium and 1 atom of chloride
- \_\_\_ 2. kerosene evaporating on the deck
- \_\_\_ 3. when cold water is mixed with hot water, the cold water becomes hotter.
- \_\_\_ 4. a geyser in Yellowstone Park
- \_\_\_ 5. heat rising from a kitchen stove

Terms

- a. centrifugal force
- b. convection
- c. dissipate
- d. molecule
- e. suction
- f. thermal energy
- g. volatile

Figure A-9. Practice exercise, unencountered examples, from student guide (typical).

SUPPLEMENTARY EXERCISE 6.1.1

Segment I

Crossword Puzzle

Directions: Fill in the crossword puzzle below.

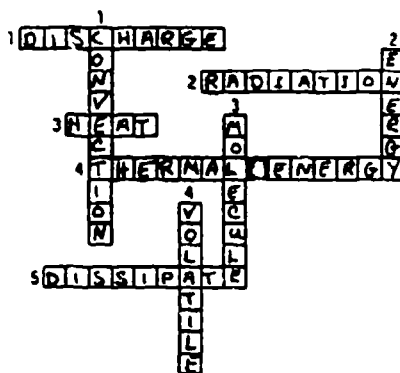

ACROSS

1. to throw off; to send out under pressure or by force
2. the transfer of heat by waves in a straight line from a source
3. energy associated with the motion of molecules
4. energy found in heat because of the rapid movement of molecules
5. to scatter; to disperse; to make disappear

DOWN

1. the transfer of heat by the vertical circulation of molecules in a liquid or gas
2. the capacity for doing work or producing an effect
3. smallest particle of matter (containing more than one atom) that still has the same physical characteristics of that matter
4. the ease with which liquid evaporates

Figure A-10. Supplementary exercise, crossword puzzle, from student guide (typical).

SUPPLEMENTARY EXERCISE 6.1.1

Segment I

Syllable Scramble

Directions: Unscramble the syllables of the words and write the word on the line next to the definition.

- |    |                   |   |                       |
|----|-------------------|---|-----------------------|
| 1. | tion-vec-con      | the transfer of heat by the vertical circulation of molecules in a liquid or gas  | <u>convection</u>     |
| 2. | htae              | energy associated with the movement of molecules  | <u>heat</u>           |
| 3. | mal-ther ner-e-gy | energy found in heat because of the rapid movement of molecules   | <u>thermal energy</u> |
| 4. | pate-si-dis       | to scatter; to disperse; to make disappear  | <u>dissipate</u>      |
| 5. | er-en-gy          | the capacity for doing work or producing an effect  | <u>energy</u>         |
| 6. | a-tile-vol        | the ease with which liquid evaporates   | <u>volatile</u>       |
| 7. | a-di-ra-tion      | the transfer of heat by waves or rays in a straight line from the source  | <u>radiation</u>      |
| 8. | charge-dis        | to throw off; to send out under pressure or by force  | <u>discharge</u>      |
| 9. | le-no-cule        | smallest particle of matter (containing more than one atom) that still has the same physical characteristics of that matter | <u>molecule</u>       |

Figure A-11. Supplementary exercise, syllable scramble, from student guide (typical).

### Heat and Its Uses

The terms related to heat and its uses, which you just learned in this lesson, will help you in PE "A" School when studying about the main engine, the boilers, and many of the other parts of the ship that give it power.

All substances are made up of molecules. When these molecules move around, two things occur: heat is produced, and this heat, in turn, creates energy. It is energy that powers ships.

In order for heat energy (thermal energy) to be used effectively, it must be transferred from one source to another. There are three ways in which this occurs: by convection, radiation, and conduction. These three types of heat transfer can be explained by using the same example. For instance, if you were to touch a boiler discharging steam, you would feel heat by means of conduction. If you were to hold your hand one foot away from the boiler, your hand would become warm because of radiation. If you were to feel heat while standing twenty feet away from the boiler, that would be an example of convection.

When heat is transferred, some dissipation always occurs. In other words, an object being heated is never as hot as the object which is heating it.

Heat has some very interesting effects on certain substances. Water normally does not evaporate very quickly. If you were to put two pans of water side by side, it would take quite a while for them to evaporate. Therefore, you can say that water is not very volatile. However, if you were to heat one of the pans of water to the boiling point, the water in that pan would evaporate much more quickly than the water in the other pan. Therefore, you can say that heat increases the volatility of a substance.

Figure A-12. Relationship passage found in the student and instructor guides (typical).

OUTLINE OF INSTRUCTION	INSTRUCTOR ACTIVITY	STUDENT ACTIVITY
<p data-bbox="327 223 558 265">E. Relationship Passage Segment 1</p> <p data-bbox="365 526 469 547">1. Content</p> <p data-bbox="403 658 525 679">a. Key words</p>	<p data-bbox="640 223 971 285">Explain that now the students will study the Relationship Passage for Segment 1.</p> <p data-bbox="640 298 977 381">Explain that the relationship passage uses the terms which they have just learned and show how these terms fit together.</p> <p data-bbox="640 393 971 513">Explain that studying this passage will help them remember how to use these terms and prepare them for the more difficult passages which come in the next lesson in this cluster.</p> <p data-bbox="640 526 938 567">Direct students to turn to S.G. page 6-21.</p> <p data-bbox="640 580 971 642">Direct students to follow along as you or selected students read the passage aloud.</p> <p data-bbox="640 654 987 737">Direct students to identify, circle, and state aloud, key words found in passage. Write words on board when stated.</p> <p data-bbox="680 750 812 928"> energy  heat  molecule  dissipate  volatile  discharge  convection  radiation  thermal energy </p>	<p data-bbox="1009 223 1070 244">Listen.</p> <p data-bbox="1009 526 1252 547">Turn to cited page in S.G.</p> <p data-bbox="1009 580 1301 600">Read aloud/listen/follow along.</p> <p data-bbox="1009 654 1169 675">Circle key words.</p> <p data-bbox="1009 687 1219 708">State key words aloud.</p> <p data-bbox="1009 741 1301 783">Watch as instructor writes key word on board.</p>

OUTLINE OF INSTRUCTION	INSTRUCTOR ACTIVITY	STUDENT ACTIVITY
<p data-bbox="409 1085 574 1127">b. Understanding Check</p>	<p data-bbox="644 1085 958 1147">Check on student's understanding of the content of the passage by asking the following questions.</p> <p data-bbox="644 1160 938 1201">Clarify or have other students clarify any misunderstanding.</p> <p data-bbox="644 1214 948 1255">1. What are the three ways in which heat moves?</p> <p data-bbox="683 1268 948 1309">(convection, radiation, and conduction)</p> <p data-bbox="644 1330 948 1371">2. What happens when molecules move around?</p> <p data-bbox="683 1384 974 1425">(heat and energy are produced)</p> <p data-bbox="644 1433 931 1475">3. What happens when heat is transferred?</p> <p data-bbox="683 1487 931 1529">(dissipation takes place)</p> <p data-bbox="644 1537 931 1578">4. How can you make a liquid evaporate more quickly?</p> <p data-bbox="683 1591 806 1632">(apply heat)</p> <p data-bbox="644 1641 971 1682">5. What is more volatile, a cold liquid or a hot liquid?</p> <p data-bbox="683 1694 822 1736">(a hot liquid)</p>	<p data-bbox="1012 1085 1176 1106">Answer questions.</p>

Figure A-13. Instructions for relationship passage, from instructor guide (typical).



c. Meaningful Sentences	State two or three key terms and ask students to use the words in a meaningful sentence.	Use key terms in sentences.
-------------------------	--	-----------------------------

OUTLINE OF INSTRUCTION	INSTRUCTOR ACTIVITY	STUDENT ACTIVITY
2. Diagram/Summary	<p>Correct or have other students correct any misuse of the terms.</p> <p>Possible sentences follow.</p> <ol style="list-style-type: none"> <li>1. When you <u>heat</u> a liquid, the <u>molecules</u> in the liquid move around.</li> <li>2. One way that <u>heat</u> is transferred is by <u>convection</u>.</li> <li>3. When you apply <u>heat</u> to a liquid the liquid becomes more <u>volatile</u>.</li> <li>4. <u>Radiation</u> and <u>conduction</u> are two of the three ways in which <u>heat</u> moves.</li> <li>5. <u>Heat</u> produces <u>energy</u> that, in turn is used to move ships.</li> </ol> <p>Show and discuss O.H. 6.1.1 NH.</p> <p>Explain how the diagram shows the relationship of the key terms as they were used in the Relationship Passage.</p>	<p>Ask questions.</p> <p>Study O.H.</p> <p>Listen.</p>

Figure A-13 (Continued).

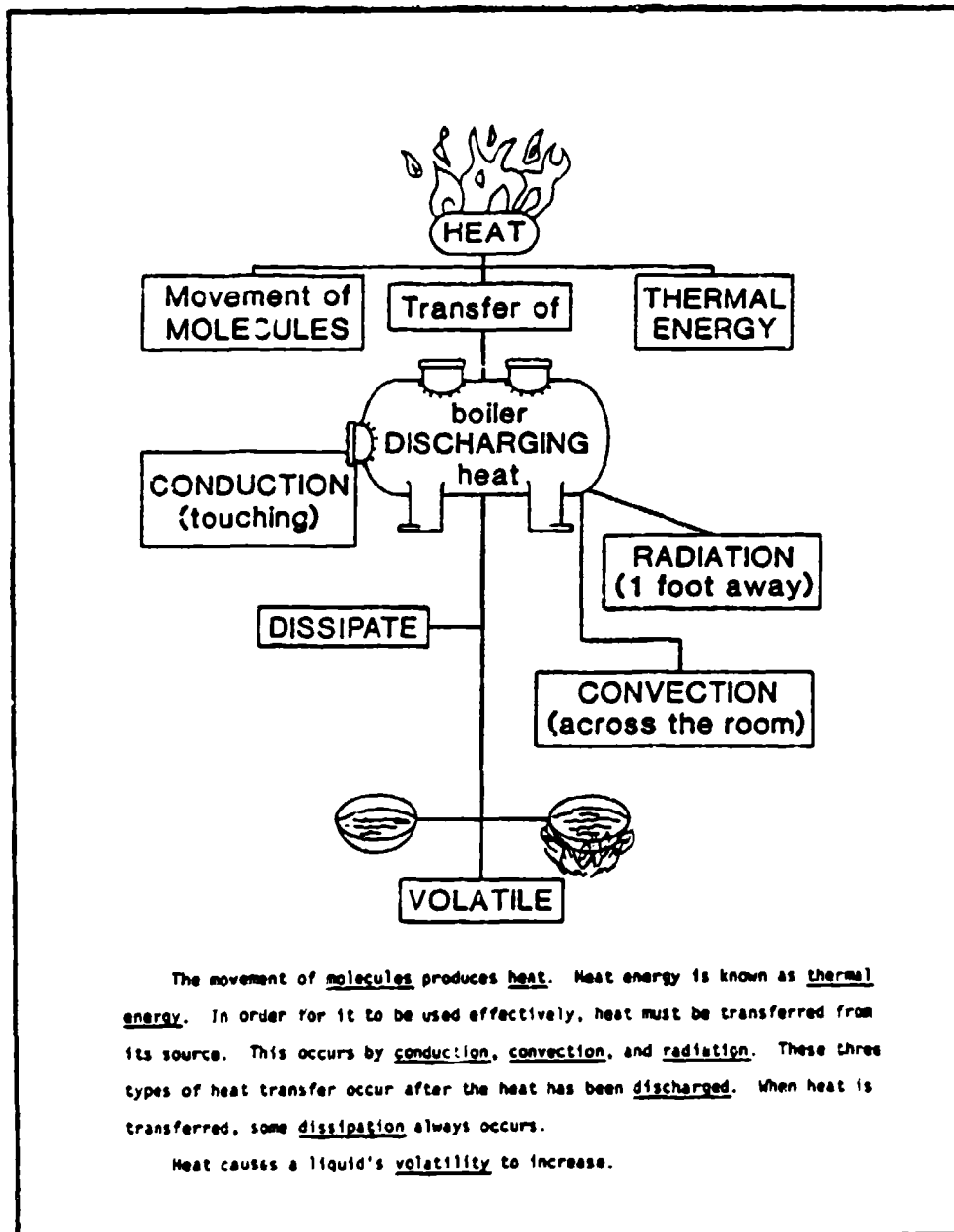

Figure A-14. Diagram/summary found in instructor guides and student guides (typical).

passage. Students studied the diagram and read a textual explanation of the relationships shown in the diagram. Working with the diagram constituted the summary for the segment.

When instruction on all segments in a cluster was completed, the student took a Progress Test which covered all of the terms in the cluster (Figures A-15 and A-16). The grouping of terms was different from that of the Practice Exercise and the examples listed were always unencountered ones.

#### Strategy for Teaching Technical Terms: Second Lesson

The second lesson for each cluster of terms gave the students practice in reading the kinds of technical material found in same-strand "A" schools. The students read a "comprehension" passage (Figure A-17) and then answered a set of questions (Figure A-18) about the content of the passage. The passage used terms found throughout the cluster. Instructors critiqued the students' performance after they had finished answering the questions. After repeating this procedure for a number of passages, the students took a progress test using a different passage and set of questions.

PROGRESS TEST 6.1.1

Definitions

**Directions:** Match the terms and definitions by placing the letter of each term next to the correct definition. Note that there are two more terms than there are definitions. Two of the terms will not be used.

<u>Definitions</u>	<u>Terms</u>
<u>e</u> 1. the capacity for doing work or producing an effect	a. centrifugal force
<u>g</u> 2. the force that causes an object to turn or rotate	b. convection
<u>l</u> 3. smallest particle of matter (containing more than one atom) that still has the same physical characteristics of that matter	c. discharge
<u>c</u> 4. to throw off; to send out under pressure or by force	d. dissipate
<u>d</u> 5. to scatter; to disperse; to make disappear	e. energy
<u>h</u> 6. pressure that is created by the movement and force of liquid	f. gravity
<u>r</u> 7. force that tends to draw all bodies toward the center of the earth	g. heat
<u>p</u> 8. energy found in heat because of the rapid movement of molecules	h. hydraulic pressure
<u>i</u> 9. the tendency for moving objects to continue moving and for objects at rest to remain at rest	i. inertia
<u>o</u> 10. the force that moves a solid, liquid, or gas into a space that has low air pressure	j. kinetic energy
<u>k</u> 11. the action of a lever; the mechanical power gained from using a lever	k. leverage
<u>m</u> 12. energy at rest; stored energy	l. molecule
<u>s</u> 13. the ease with which a liquid evaporates	m. potential energy
<u>j</u> 14. energy of motion	n. radiation
<u>p</u> <u>s</u> <u>g</u> 15. energy associated with the motion of molecules	o. suction
<u>n</u> 16. the transfer of heat by waves or rays in a straight line from a source	p. thermal energy
<u>a</u> 17. the tendency for a turning object to move away from the center	q. torque
<u>b</u> 18. the transfer of heat by the vertical circulation of molecules in a liquid or gas	r. vacuum
	s. volatile
	t. volume

Figure A-15. Progress test, definitions (typical).

PROGRESS TEST 6.1.1

Segment I: Examples

Directions: Match the terms and examples by placing the letter of each term next to the correct example. Note that there are two more terms than there are examples. Two of the terms will not be used.

PART 1

Examples

Terms

- |               |   |                      |
|---------------|---|----------------------|
| <u>e</u>      | 1. the temperature inside a boiler room                   | a. centrifugal force |
| <u>c</u>      | 2. an explosion in the boiler room                        | b. discharge         |
| <u>c or b</u> | 3. forcing paint out of a spray gun to paint the barracks | c. energy            |
| <u>f</u>      | 4. sunshine streaming in the window                       | d. gravity           |
|               |   | e. heat              |
|               |   | f. radiation         |

PART 2

Examples

Terms

- |          |  |                   |
|----------|--|-------------------|
| <u>g</u> | 1. gasoline evaporating  | a. convection     |
| <u>b</u> | 2. When a hot fluid is mixed with a cold fluid, the hot fluid becomes colder | b. dissipate      |
| <u>d</u> | 3. carbon dioxide (CO <sub>2</sub> ): 1 atom of carbon, 2 atoms of oxygen    | c. dissolve       |
| <u>a</u> | 4. the movement of heat in an electric coffee pot brewing coffee             | d. molecule       |
| <u>f</u> | 5. steam moving a locomotive   | e. suction        |
|          |  | f. thermal energy |
|          |  | g. volatile       |

Figure A-16. Progress test examples (typical).

PRACTICE EXERCISE 6.1

Part 1: Passage

**Directions:** Read the passage below and answer the questions that follow by circling the letter of the correct response.

HEAT ENERGY

Heat can be explained as the energy associated with the motion of molecules. The greater the heat, the faster the molecules move, and the more space the molecules occupy.

The molecules in ice, water, and steam are the same except for their motion. The molecules in solids (such as ice) move more slowly than the molecules in liquids (such as water) and these in turn move more slowly than the molecules in gases (such as steam).

When the molecules in ice move faster (by increasing the thermal energy), the thermal energy is at first used to raise the temperature of the ice. But when the temperature reaches a certain point (32° F), the thermal energy is no longer used to raise the temperature. Now it is used to change the fluid from its solid state, ice, to its liquid state, water.

If the thermal energy is further increased, the temperature of the water will rise. If the water temperature reaches 212° F (boiling point of water), the thermal energy will now be used to change the fluid from its liquid state to its gaseous state, steam. When all the water has changed to steam, the thermal energy will again be used to raise the temperature of the steam.

What happens is that the heat causes the molecules to move faster and faster, thus creating more and more kinetic energy. Heat applied to the water causes the molecules to move faster until finally a physical change takes place-- the water is changed to steam. The steam, in turn, can transfer its molecular kinetic energy into mechanical energy which can turn a turbine engine.

Figure A-17. Comprehension passage (typical).

Figure 1, on the opposite page, shows the boiling curve for water. Note that in Section A the temperature rises as thermal energy is increased. Section B starts at 212° F (the boiling point for water). In Section B, you should notice that the graph shows a flat line. This means that the thermal energy is not being used to increase the temperature of the water. Now it is being used to change the water from its liquid state to its gas state, or steam. Only when all the water has changed to steam will the thermal energy be used to increase the temperature of the steam. Section C in Figure 1 shows the temperature of the steam increasing.

It is interesting to note from this graph that water is not a very volatile substance. The boiling curve for a volatile substance such as alcohol would show a much shorter line in Section B.

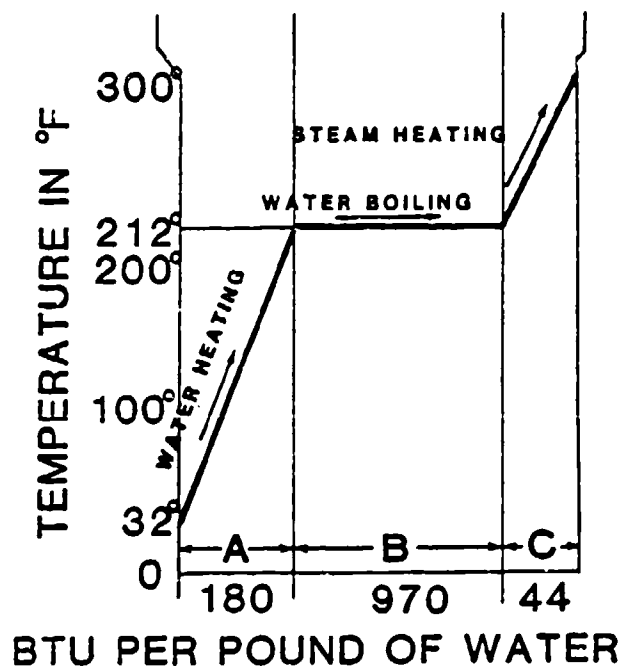

Figure 1. Boiling Curve for Water

Figure A-17 (Continued).

PRACTICE EXERCISE 6.1

Part 1: Questions

Directions: Answer the following questions about the passage by circling the letter in front of the correct response. You may go back and read the passage again if you wish.

1. Water begins to boil when its:
  - a. temperature reaches 32° F.
  - b. thermal energy reaches 180 BTU.
  - c. temperature reaches 212° F.
  - d. temperature reaches 300° F.
2. What happens when the temperature of water reaches 212° F?
  - a. All the water changes to steam.
  - b. The water stops boiling.
  - c. Its temperature remains 212° F until all the water has turned to steam.
  - d. Its temperature continues to rise.
3. Once the temperature of water reaches its boiling point, the thermal energy is used to:
  - a. raise the water temperature further.
  - b. make the water less volatile.
  - c. change the fluid from its solid state to its liquid state.
  - d. change the water into steam.

4. Looking at Figure 1, how many BTUs need to be added per pound of water to raise the temperature of the steam from 212° F to 300° F?
  - a. 970 BTU
  - b. 1 BTU
  - c. 44 BTU
  - d. 180 BTU
5. Water changes its physical state at:
  - a. 32° F.
  - b. 212° F.
  - c. at both 32° F and 212° F.
  - d. at neither 32° F or 212° F.

Figure A-18. Practice exercise (typical).



## DISTRIBUTION LIST

Assistant Secretary of the Navy (Director, of Manpower Analysis) (ODASN(M))  
Chief of Naval Operations (OP-01), (OP-11), (OP-12) (2), (OP-13), (OP-115) (2), (OP-140F2),  
(OP-987H)  
Chief of Naval Material (NMAT 00), (NMAT 08), (NMAT 08L)  
Chief of Naval Research (Code 200), (Code 440) (3), (Code 442), (Code 448)  
Chief of Information (OI-213)  
Chief of Naval Education and Training (02), (003), (N-2), (N-5)  
Chief of Naval Technical Training (016)  
Commandant of the Marine Corps (MPI-20)  
Commander Naval Military Personnel Command (NMPC-013C)  
Commander Navy Recruiting Command  
Commander Training Command, U.S. Atlantic Fleet  
Commander Training Command, U.S. Pacific Fleet  
Commanding Officer, Naval Education and Training Program Development Center (Technical Library) (2)  
Commanding Officer, Naval Education and Training Support Center, Pacific  
Commanding Officer, Naval Training Equipment Center (Technical Library)  
Commanding Officer, Recruit Training Command (Academic Training Division)  
Director, Career Information and Counseling School (Code 3W34)  
Director, Defense Activity for Non-Traditional Education Support  
Director, Management Information and Instructional Activity Branch Office, Memphis  
Director, Naval Civilian Personnel Command  
Director, Naval Education and Training Program Development Center Detachment, Great Lakes  
Director, Naval Education and Training Program Development Center Detachment, Memphis  
Director, Training Analysis and Evaluation Group (TAEG)  
Commander, Army Research Institute for the Behavioral and Social Sciences, Alexandria (PERI-ASL)  
Chief, Army Research Institute Field Unit, Fort Harrison  
Commander, Air Force Human Resources Laboratory (Scientific and Technical Information Office) Brooks Air Force Base  
Commander, Air Force Human Resources Laboratory (AFHRL/OT) Williams Air Force Base  
Commander, Air Force Human Resources Laboratory (AFHRL/LR) Wright-Patterson Air Force Base  
Commanding Officer, U.S. Coast Guard Research and Development Center, Avery Point  
Commanding Officer, U.S. Coast Guard Training Center, Alameda  
Superintendent, U.S. Coast Guard Academy  
Defense Technical Information Center (DDA) (12)