

AD-A102 543

NAVAL OCEANOGRAPHIC OFFICE NSTL STATION MS  
RESPONSE CHARACTERISTICS OF THE NEIL BROWN INSTRUMENT SYSTEMS, --ETC(U)  
OCT 80 M A PAIGB

F/G 8/10

UNCLASSIFIED

NOO-TR-259

NL

1 of 1  
400  
10/26/83

END  
DATE  
FILMED  
9-81  
DTIC

LEVEL II

12 TR-259

Technical Report

AD A102543 Response Characteristics of the Neil Brown Instrument Systems, Inc. Mark III CTD to Step Changes in Temperature and Conductivity

Marshall A. Paige

October 1980

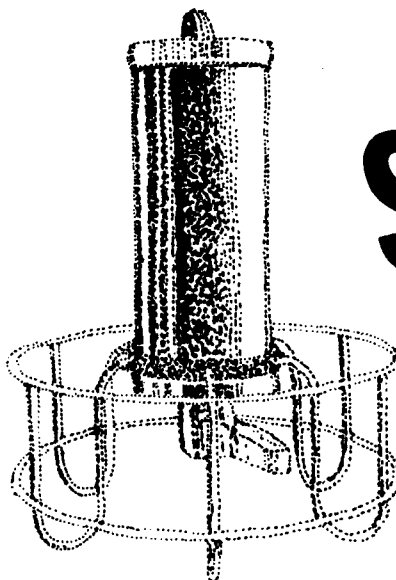

DTIC ELECTE  
AUG 7 1981  
S C D

Approved for public release; distribution unlimited

PREPARED BY  
COMMANDING OFFICER,  
NAVAL OCEANOGRAPHIC OFFICE  
NSTL STATION, BAY ST. LOUIS, MS 39522

PREPARED FOR  
COMMANDER  
NAVAL OCEANOGRAPHY COMMAND  
NSTL STATION, BAY ST. LOUIS, MS 39529

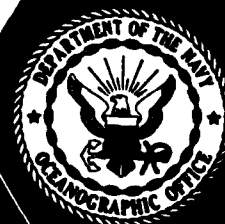

81 8 06 050

DTIC FILE COPY

x

FOREWORD

The U. S. Naval Oceanographic Office requirements for high accuracy and high resolution conductivity, temperature, and depth profiling instrumentation requires accurate knowledge of the dynamic response characteristics of the instrument. It is to this end that extensive research has been undertaken and upon which this report focuses.

A handwritten signature in black ink, appearing to read 'W. C. Palmer', with a large, stylized flourish above the name.

W. C. Palmer  
Captain, USN  
Commanding Officer



CONTENTS

	<u>PAGE</u>
1. Introduction	1
2. Requirements	1
3. Creation of a Temperature Step Change in Water	1
4. The Water to Water Drop Test Fixture	2
5. Drop Test Facility	3
6. Test Results - Temperature Time Constant	4
7. Test Results - Conductivity Time Constant	5
8. Summary	6

FIGURES

Figure 1 - Water to Water Drop Test Fixture	7
Figure 2 - Drop Test Facility	8
Figure 3 - NBIS CTD Thermistor Output as a Function of Step Input Method	9
Figure 4 - NBIS CTD Sensor Arm--End View	10
Figure 5 - NBIS CTD Thermistor Output - Water to Water Step Input	11
Figure 6 - NBIS CTD Thermistor Response to Temperature Step Change as a Function of Position	12

Accession For	
NTIS GSA&I	<input checked="" type="checkbox"/>
DTIC TAB	<input type="checkbox"/>
Unannounced	<input type="checkbox"/>
Justification	
By _____	
Distribution/	
Availability Codes	
Dist	Avail and/or
	Special
A	

**ACKNOWLEDGEMENTS:**

Thanks to Peter M. Harris for the outstanding art work... etc.

Thanks to Frank Bedwell for fabrication of the prototype--still going strong after two years!

Thanks to Stan Raffa and Carlos Mayoral for the computer software.

Special thanks to Mac McGraw for numerous typings of the manuscript.

## 1. Introduction

The Naval Oceanographic Office requirements for high accuracy and high resolution conductivity, temperature, and depth (CTD) measuring survey instrumentation has to date resulted in the purchase of fourteen Neil Brown Instrument Systems (NBIS) Inc., Mark III CTD Systems. In order to maximize resolution and minimize salinity spiking, which appears as noise resulting from the difference in the dynamic response characteristics of the conductivity and temperature sensors, a Weiner filter has been designed by Dr. T. M. Davis of NAVOCEANO wherein such phase shifts can be minimized. The degree to which such filtering is effective, however, depends largely on how accurately the linear system's (assumed) transfer functions are determined. Determination of the transfer characteristics of the instrument requires accurate measurement of the input/output response characteristics of the temperature and conductivity sensors and their associated electronics. It is to this end that extensive research has been undertaken and upon which this report focuses.

## 2. Requirements

As alluded to in the introduction, the requirement existed to impose a temperature step change to the temperature measuring system of the NBIS CTD and measure the output as a function of time. Initial attempts to do so consisted of air to water drop tests in which the CTD was allowed to free fall from air at ambient temperature into a temperature-controlled water bath at some lower temperature. Entry velocity was fixed at 1 m/sec (normal CTD drop rate) by releasing the CTD from a free fall height of 5.7 cm. The major operational problem associated with the air to water test method was achieving stable ambient conditions prior to a drop which often resulted in the inability to limit the change in temperature to less than 1 degree C. (Required to prevent amplifier saturation within the CTD electronics.) Response characteristics of the temperature measuring system were quantified by measuring the time constant of the resulting temperature/time plots. The time constant (T.C.), is defined as the time required for the sensor output to reach 63.2% of the magnitude of the imposed step change. Time constant data resulting from the air to water tests showed considerable scatter, often greater than 200 percent. Variability in the air to water test results was attributed to two possible causes: one, the inability to control and therefore reproduce the input step change conditions; and two, attempting to simulate the heat transfer characteristics of a temperature sensor moving through a water to water interface by moving the sensor through an air to water interface. Thus, the necessity to develop a test facility which could repeatedly create an actual water to water step change in temperature became apparent.

## 3. Creation of a Temperature Step Change in Water

The primary design objective was to create a sufficiently sharp water temperature step change such that the transit time of the sensor through the interface was short compared to one sensor time constant. Maximum resolution was obtained by wiring the CTD digitizer to sample temperature continuously, that is, once every 10 msec. It was therefore decided that a reasonable design goal for the thickness of the temperature gradient would be one centimeter or

the distance traveled by the temperature sensor in 10 msec when moving at one meter per second. Initial tests were conducted using an elastomeric rupture diaphragm to separate the two bodies of water at different temperatures. A dye was mixed with one body of water to permit visual observation of the degree to which the two fluids mixed at the interface upon rupture of the diaphragm. An instantaneous mixing over a distance of approximately three centimeters was observed. Because the mixed layer was three times the design goal, another approach was pursued.

In order to eliminate turbulent mixing at the interface, a fixture incorporating a rigid shutter to separate the two different temperature fluids was designed. Shutter retraction speed was made constant and relatively slow (approximately 8 mm/sec) to prevent turbulent mixing in the wake of the shutter. Dye tracers, emitted at the trailing edge of the shutter, verified a minimum of turbulent mixing (approximately 2 mm thick) caused by the shutter motion.

#### 4. The Water to Water Drop Test Fixture

The fixture, designed to create a water to water temperature step change, is shown in figure 1 as attached to the CTD in the drop test configuration. The fixture consists of a three-inch inside diameter sensor tube (a) which has an O-ring sealed port (b), the center line of which is 5.7 cm above the lower end of the sensor tube. The CTD sensor arm (c) is inserted into the port such that the thermistor and conductivity cell (d) are positioned on the center line of the sensor tube.

The water to water interface is maintained at the lower end of the sensor tube by means of a glass shutter (e) which rides in a set of guides (f) affixed to the sensor tube. The shutter seals against an O-ring located on the lower end of the sensor tube. Glass was chosen as the shutter material because of its high rigidity and low thermal conductance. Shutter retraction is accomplished by means of a pneumatic cylinder (g) attached to the shutter. Prior to a drop test, the shutter is manually moved from its fully retracted position to close off the sensor tube end, and in doing so, water is drawn into the non-pressurized end of the shutter actuation cylinder through a small orifice (h) located at the end of the shutter actuation cylinder. Constant shutter velocity during retraction is thus maintained as water is forced out of the orifice. Shutter retraction velocity is controlled by adjusting the air pressure at the shutter actuation cylinder inlet (i).

Mounted in the upper end of the sensor tube is an O-ring sealed piston (j) which is positioned to provide a four-inch stroke before clearing the upper end of the tube. The piston is suspended from an overhead monorail by means of a cable and turnbuckle.

A constant temperature water mass is created within the sensor tube by pumping water from an adjacent temperature-controlled bath through the sensor tube via supply (k) and return (l) ports in the tube wall. Shut-off valves on the supply and return ports are provided to seal the sensor tube prior to a drop test. Quick disconnects on the supply and return hoses at the sensor tube end permit rapid removal of the hoses prior to a drop test.



A pressure equalization line (m) is attached to the return port quick disconnect after removal of the return line and just prior to shutter retraction; the free end protrudes below the bath water surface. With the return valve open, the piston position is adjusted to eliminate the pressure differential across the shutter, thus preventing water inflow to or outflow from the sensor tube at the time of shutter retraction and consequent contamination of the interface.

A baffle tube (n), approximately eight inches in diameter and twelve inches in length, is positioned concentrically about the lower end of the sensor tube such that surface waves in the bath will not disturb the interface. In addition, the lower end of the baffle tube is sealed off to prevent similar disturbances caused by bath circulation currents. This is accomplished by covering the lower end of the baffle with a 1/8 inch thick foam sheet (o); the sheet is held in position by its positive buoyancy. Cross cuts in the sheet permit flow through the sheet as the CTD drops into the bath.

Because the piston remains fixed in space when the CTD/fixture free falls into the bath, the water in the sensor tube also remains fixed as long as the piston effects a seal within the sensor tube. Thus, the CTD sensors will literally drop through the interface created at the shutter end of the sensor tube.

Interface velocity past the sensors was measured to be 0.7 m/sec.

Crude measurements of the temperature gradient were made by passing a thermistor through the interface. Such measurements indicate a mixed layer of approximately 1.3 to 1.9 cm thickness. This represents the worst case as the thermistor motion causes mixing of the interface.

## 5. Drop Test Facility

The overall configuration of the drop test facility is shown in figure 2. Primary and auxiliary baths are each 1 m diameter by 2.5 m deep and will control to stabilities of  $\pm .002$  degree C/day over the range of -2 degrees C to 40 degrees C.

The CTD/drop test fixture is suspended from an electronic release mechanism which can be activated manually or by computer control. When a drop test is conducted under computer control, the computer begins data logging one second before firing the release.

A mechanical guide is attached to the temperature bath to provide pre-drop stability to the CTD/fixture assembly and also to prevent rotation of the assembly about a horizontal axis due to friction caused by the piston while the assembly is free falling into the bath.

Water is pumped from the auxiliary bath, through the sensor tube and returned to the auxiliary bath. The auxiliary bath is normally controlled at a temperature such that the temperature in the sensor tube will be 0.5 degree C. higher than the temperature in the primary bath.

Drop tests were conducted when the primary bath short term stability was  $\pm .001$  degree C., and the sensor tube stability was  $\pm .005$  degree C.

## 6. Test Results - Temperature Time Constant

Initially in the program, tests were conducted using both the air to water and water to water methods for the purpose of intercomparison. Over one hundred drops were made using three CTD's. Of the three instruments tested, two showed time constants for the air to water method to be consistently lower than that of the water to water method. One instrument, however, produced the reverse results. A representative sampling of the test results for the three instruments follows:

Instrument #1 - Air to Water	- T.C. = 50 msec
Water to Water	- T.C. = 150 msec
Instrument #2 - Air to Water	- T.C. = 47 msec
Water to Water	- T.C. = 95 msec
Instrument #3 - Air to Water	- T.C. = 60 msec
Water to Water	- T.C. = 45 msec

In an effort to determine the cause of the inconsistency in the data, a series of tests were conducted whereby various contributors to the temperature output data were considered separately. Three consecutive drop tests were conducted to determine the water to water test method repeatability. In each case, the temperature gradient across the shutter was adjusted to be nearly equal--that is 0.2 degree C.  $\pm$  .004 degree C. Total variation in the time constants as determined graphically from the plotted data was 13 msec (10 msec digitization rate). Non-repeatability can be attributed to the following causes: (a) Inability to precisely determine from the plot the point in time at which the temperature sensor enters the interface; and (b) Variability in the turbulent wake behind the shutter.

Sensor processing electronics (platinum and thermistor circuits) were subjected to simulated step changes (switched in resistors) which subsequently eliminated delay in the electronics as a possible source of the problem.

Three drops were made to look at the platinum sensor/circuit alone, and the consistency of the test data between methods was good. (Air to water = 246 msec, 256 msec; water to water = 254 msec.) Tests were then conducted with the platinum replaced by a fixed resistor.

The output of the thermistor/servo balanced bridge varied considerably as a function of the test method. To further eliminate the electronics as the cause of the difference, the output of the thermistor (in an external bridge) was recorded directly on an oscillograph recorder. The inconsistency between test methods persisted. Figure 3 presents a representative thermistor output for Instrument #1 for each test method. The initial assumption resulting from the above data was that the thermistor was malfunctioning because the water to water data taken with the other instruments had not shown the characteristic double plateau seen in figure 3. Inspection of the CTD sensor head prior to replacement of the thermistor resulted in the discovery that the thermistor paddle to which the thermistor is attached was not exactly horizontal but rotated counterclockwise with the thermistor bead slightly up (approximately 10 degrees) as viewed looking toward the CTD body. See figure 4. To eliminate the possibility that this small rotation had caused the variability in the data, the paddle was rotated clockwise to a position 10 degrees past the horizontal with the thermistor bead slightly down. The result was a decrease in the time constant from 150 msec, figure 3, to 54 msec. Figure 5.

Obviously, the turbulent wake in the vicinity of the thermistor bead caused by the wide flat paddle was the cause of the variability in the time constant data as determined by the two test methods. This phenomenon was not observed in the air to water method as mixing of a water to water interface was not involved.

Subsequent tests were conducted to determine the "cosine response" of the thermistor sensor. Data from those tests are presented on figure 6. Because NAVOCEANO deploys a side-by-side CTD/Niskin Rosette Sampler assembly, which is subject to considerable rocking due to ship motion, it is imperative that the thermistor be positioned in such a way as to minimize time constant variability as a function of sensor attitude. A 45-degree thermistor bead down position provides a plus or minus fifteen degree band width throughout which the thermistor time constant shows minimum variation (13 msec). In addition, the output curves in the minus 30 to minus 60 degree region show no non-exponential perturbations as seen on figure 5 where the thermistor position was minus 15 degrees. Four drop tests were conducted with the thermistor assembly adjusted to the minus 45 degree position. These tests were conducted over a one-week period with intermediate data being taken at various other angular settings during that time period. Results were extremely encouraging from the repeatability standpoint. Time constants determined were:

Test #1	T.C. = 48 msec
Test #2	T.C. = 49 msec
Test #3	T.C. = 48 msec
Test #4	T.C. = 49 msec

Previous data from the water to water test method, which indicated a repeatability of approximately 13 msec, were taken with Instrument #1 which at the time had its thermistor mounted in the critical positive 15 degree position. It is obvious from inspection of figure 6 that the positive 15 degree position resulted in a high degree of non-repeatability due to the subsequently determined turbulent wake effect.

#### 7. Test Results - Conductivity Time Constant

Time constant determination for the NBIS CTD conductivity sensor was made employing the same techniques previously described. Sea water at 34.5 ppt was circulated through the sensor tube, and the CTD/fixture was dropped into a bath at 35 ppt. Because conductivity is a function of temperature as well as salinity, it is desirable to reduce the degradation of the conductivity gradient due to heat conduction across the interface. An attempt to adjust the temperature differential across the shutter to near zero was abandoned due to a faulty auxiliary bath temperature controller. A temperature gradient of about 0.3 degree C. existed at the time of the drops.

Results of the tests conducted with one CTD resulted in the following values for conductivity sensor time constant:

Test #1	T.C. = 19 msec
Test #2	T.C. = 24 msec
Test #3	T.C. = 26 msec
Test #4	T.C. = 28 msec

Increased resolution was achieved by wiring the digitizer to sample conductivity every 10 msec.

It should be noted that the 30 mm cell with which this data was taken was a replacement for an original 8 mm micro-structure cell. Because of spatial limitations, the replacement cell had to be mounted at an angle of about 30 degrees to the vertical. Time constant dependence on the flushing length of the cell could result in time constant variations as a function of the angle of attack.

#### 8. Summary

Response characteristics of the NBIS CTD temperature and conductivity sensors have been determined by imposing actual step changes in the water environment and recording the resultant output.

Extreme variability in the temperature response characteristics was determined to be a result of the turbulent mixing of the two water masses in the wake of the thermistor mounting assembly. A 45-degree rotation of the thermistor assembly such that the thermistor bead was positioned well in front of the turbulent wake, provided maximum dynamic response and minimum variation in response as a result of instrument rotation about its horizontal axis.

Temperature response data indicate the time constant of the temperature measuring system to be approximately 50 msec.

Conductivity response data, although sparse, indicate the time constant of the conductivity measuring system to be approximately 20 msec. The above data were taken at an interface velocity past the sensors of 0.7 m/sec.

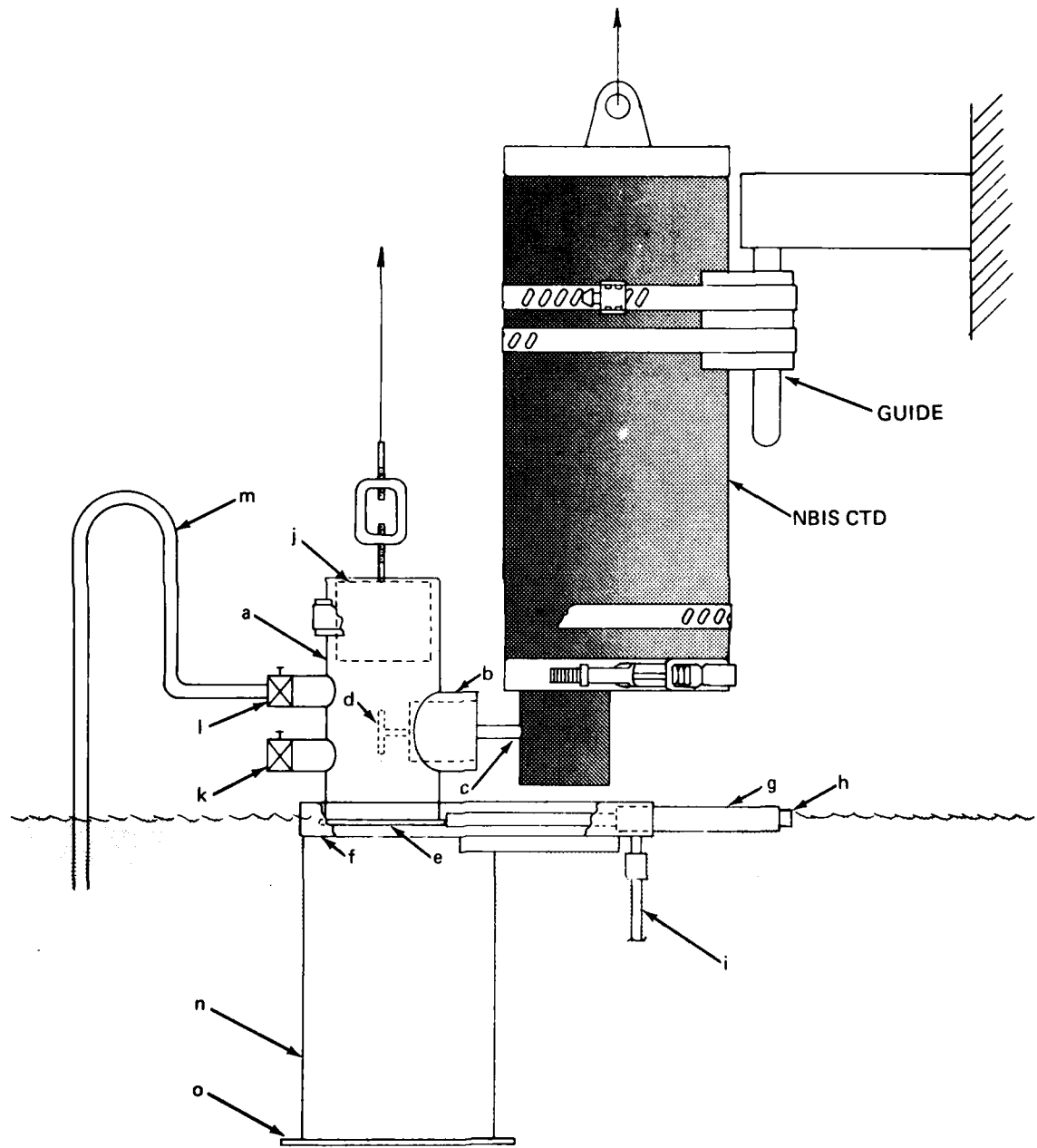

FIGURE 1. WATER TO WATER DROP TEST FIXTURE

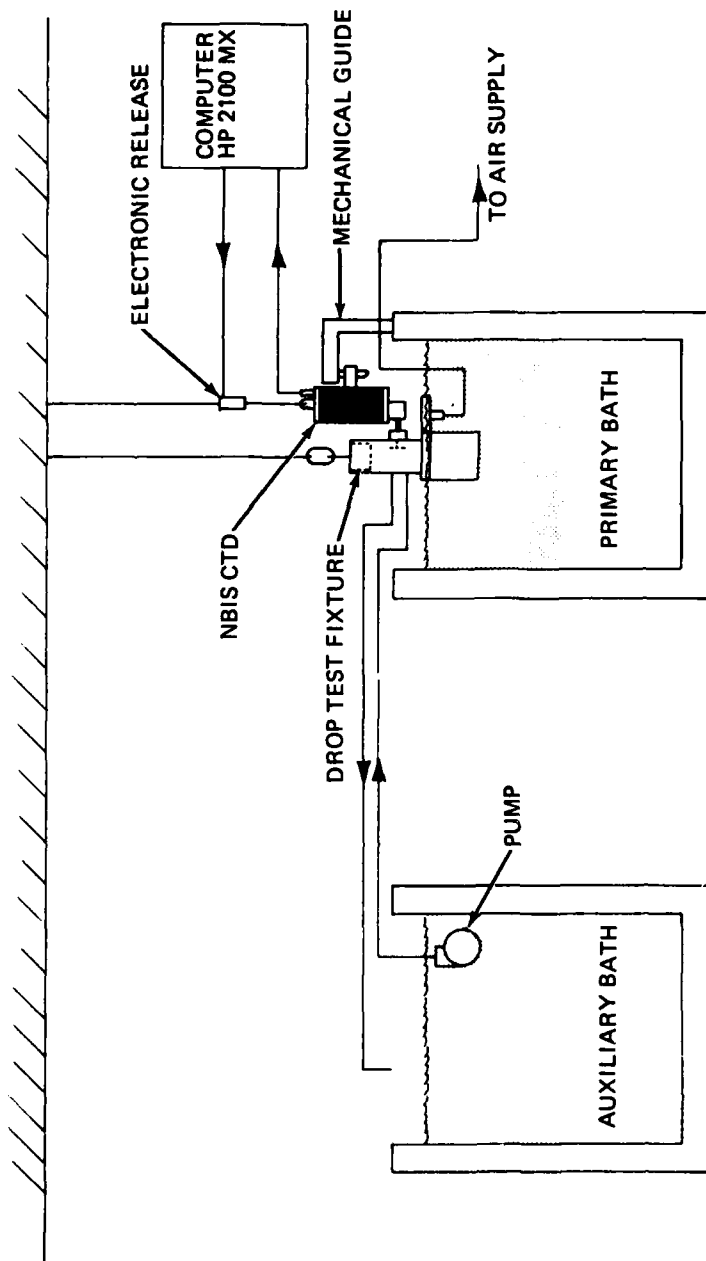

FIGURE 2. DROP TEST FACILITY

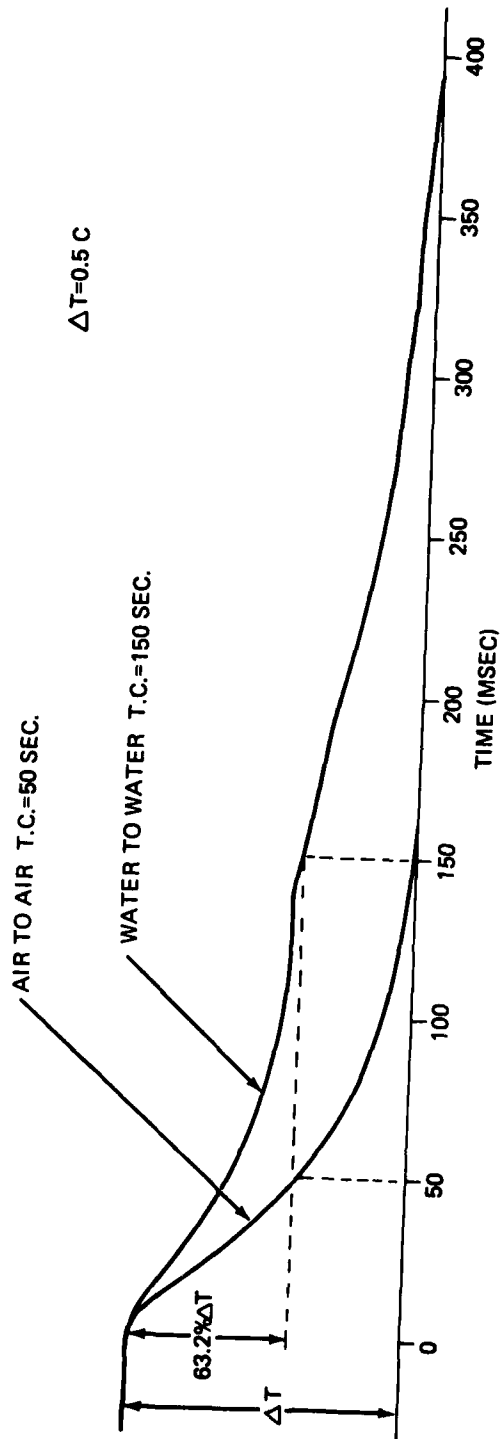

FIGURE 3. NBIS CTD THERMISTOR OUTPUT AS A FUNCTION OF STEP INPUT METHOD

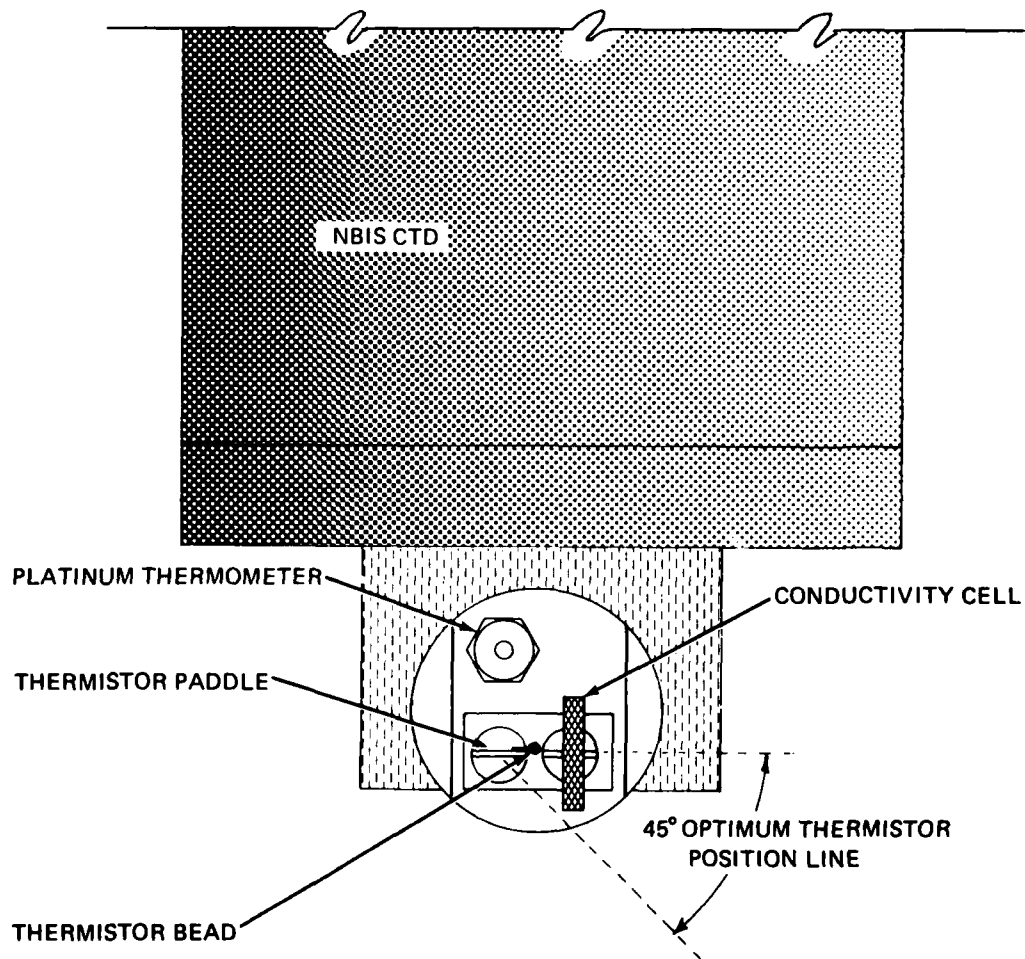

FIGURE 4. NBIS CTD SENSOR ARM – END VIEW



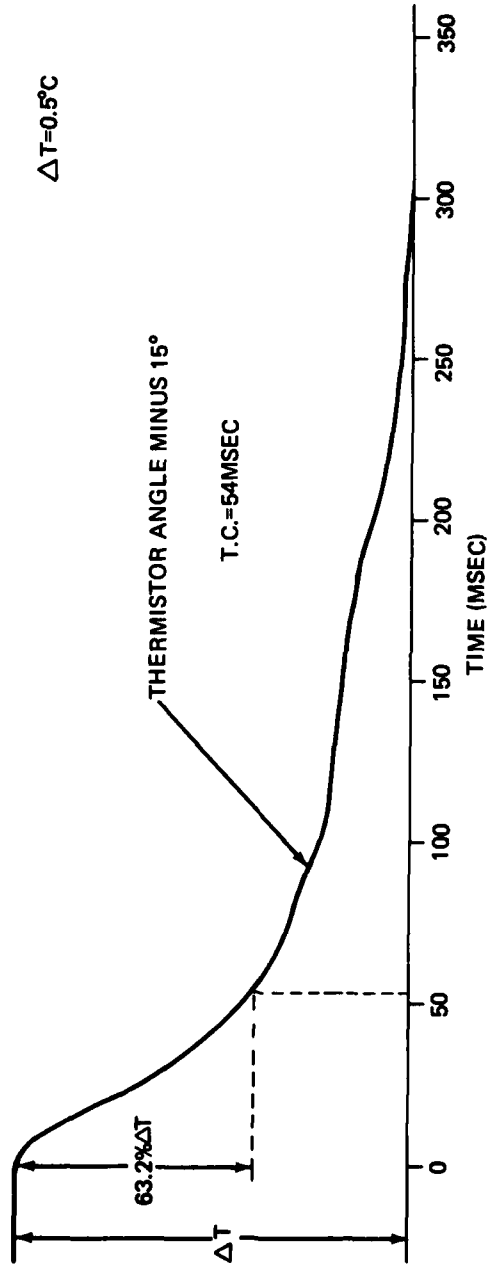

FIGURE 5. NBIS CTD THERMISTOR OUTPUT WATER TO WATER STEP INPUT

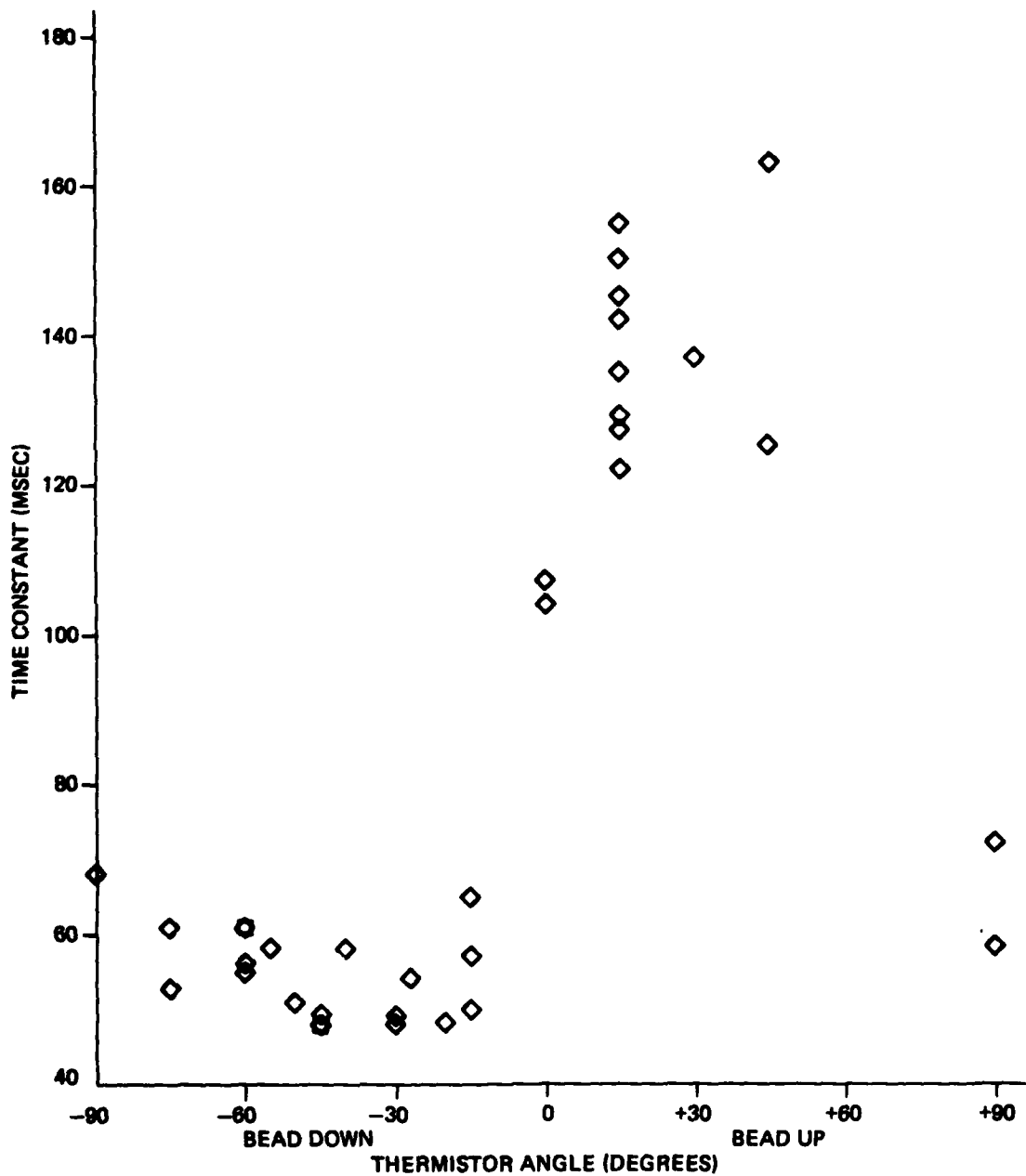

FIGURE 6. NBIS CTD THERMISTOR RESPONSE TO TEMPERATURE STEP CHANGE AS A FUNCTION OF POSITION

DISTRIBUTION LIST

NORDA  
NRL  
NUSC-Newport  
NUWES  
NCSC  
NPGS  
NCSC  
NATO  
NOAA/SAIL  
NOAA/T&EL  
NOAA/PMEL  
COMSCLANT  
NOAA/NMFS  
USGS, Woods Hole  
USGS, Reedwood City  
MSC, Williamsburg  
DTIC  
WHOI  
JHU/APL  
SIO  
Raytheon S.C.  
VIMS  
UM/RSMAS  
OSU  
LGO  
Energy Resources  
Raytheon O&ES  
Woodward Clyde Consultants  
EG&G International  
Univ Alaska/IMS  
Univ Del  
Univ Wash/SO  
Univ RI/NML  
Western Electric  
S Univ NY Stonybrook  
IMR-Norway  
IOLR-Israel  
CNR-Italy  
Navy/DSE New Zealand  
ANC/DNA Argentina  
OFD Korea  
AMTE England  
IIP Spain  
AUWE England  
OHMS/DS Australia  
JMSTC Japan  
JRFRL Japan  
CPFES Japan  
TPFES Japan  
JMRI Japan  
Inst Hidro Portugal  
UB/GI-Norway  
IOS-England  
SU/Faroe Is  
UT-Norway  
UL-England  
OGS-Italy  
CSIRO/DFO Australia  
ORI Japan  
IUN Italy  
Dannebro Vaerft, A/S Denmark  
GU/OI Sweden  
IEO Spain  
A/S Balticgade Denmark  
Prakla Seismos GMBH West Germany  
CNEXO-COB France  
MUNF Newfoundland  
HSRFRL Japan  
Hokkaido U Japan  
Hakuto Co., Ltd Japan  
Kagoshima U Japan