

AD-A102 217 BOEING AEROSPACE CO SEATTLE WA ENGINEERING TECHNOLOG--ETC F/G 11/4
GRAPHITE REINFORCED THERMOPLASTIC COMPOSITES.(U)
UNCLASSIFIED AUG 80 J JAGUISH, C H SHEPPARD, S G HILL N00019-79-C-0203
D180-26067-1 NL

1 of 1
AD-A
102217

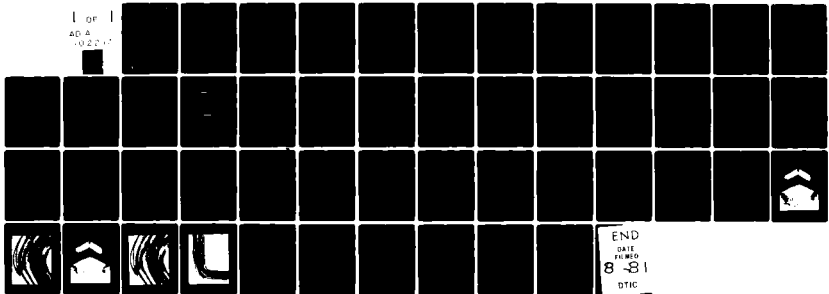

AD A102217

II

8

D180-26067-1

FINAL REPORT

GRAPHITE REINFORCED THERMOPLASTIC COMPOSITES

CONTRACT N00019-79-C-0203

By

J. Jaquish
C. H. Sheppard
S. G. Hill
E. E. House
W. A. Symonds

Prepared for

NAVAL AIR SYSTEMS COMMAND
U.S. DEPARTMENT OF THE NAVY
Washington, D.C. 20360

August 1980

Approved for Public Release; Distribution Unlimited

Engineering Technology Organization
Boeing Aerospace Company
Seattle, Washington 98124

DTIC
ELECTE
JUL 30 1981

ID

81 7 30 025

DTIC FILE COPY

14

15 21

D180-26067-1

FINAL REPORT

GRAPHITE REINFORCED THERMOPLASTIC COMPOSITES

CONTRACT N00019-79-C-0203

15

By

10

J. Jaquish
C. H. Sheppard
S. G. Hill
E. E. House
W. A. Symonds

Prepared for

(9, Final rpt.)
12 Feb 79-1
1000 84

NAVAL AIR SYSTEMS COMMAND
U.S. DEPARTMENT OF THE NAVY
Washington, D.C. 20360

11

August 1980

Accession For	
NTIS GRA&I	<input checked="" type="checkbox"/>
DTIC TAB	<input type="checkbox"/>
Unannounced	<input type="checkbox"/>
Justification	
By	
Distribution/	
Availability Codes	
Avail and/or	
Dist: Special	
A	

Approved for Public Release; Distribution Unlimited

Engineering Technology Organization
Boeing Aerospace Company
Seattle, Washington 98124

DTIC
ELECTE
S JUL 30 1981 D

4124.1

D

FOREWORD

This report summarizes the work performed by the Boeing Aerospace Company during the period from February 13, 1979 to May 13, 1980 for the Naval Air Systems Command, United States Department of the Navy, under Contract N00019-79-C-0203, entitled "Graphite Reinforced Thermoplastic Composites." Mr. Maxwell Stander (AIR 5163D3) was the program monitor.

The program was conducted by the Engineering Technology organization of the Boeing Aerospace Company, Seattle, Washington. Mr. W. A. Symonds was program manager; Mr. E. E. House was the technical leader. Principal investigators were Mr. C. H. Sheppard and Mr. S. G. Hill.

Key personnel contributing to the program were Mr. A. B. Hunter, Mr. R. Hodges, Ms. V. Monroe, Ms. J. Jaquish, and Mr. O. Davis. Technical efforts accomplished on a subcontract to TRW were performed by Mr. H. Lubowitz. For NASC, Dr. J. Augl was the technical consultant on proposed polymer formulations and synthesis procedures.

TABLE OF CONTENTS

	Page
1.0 INTRODUCTION AND SUMMARY	1
2.0 TECHNICAL DISCUSSION	3
2.1 Evaluation of Commercially Available Resins (Task I)	3
2.1.1 Prepreg Preparation	3
2.1.2 Laminate Consolidation (Molding)	8
2.1.3 Environmental Exposure	15
2.2 New Resin Synthesis and Characterization (Task I)	18
2.2.1 Synthesis of the Norbornene End Groups	19
2.2.2 Synthesis of Norbornene Oligomers	25
2.2.3 Preparation of Graphite/NTS Composite	31
2.2.4 Evaluation of NTS 20-1 Composite	33
2.2.4.1 Solubility in Methylene Chloride	33
2.2.4.2 Mechanical Properties	33
2.2.4.3 Reforming Evaluation	34
2.2.5 Summary of Polymer Work	34
2.3 Repair (Task II)	34
3.0 CONCLUSIONS AND RECOMMENDATIONS	39
3.1 Conclusions	39
3.2 Recommendations	40
REFERENCES	41

LIST OF ILLUSTRATIONS

Figure	Title	Page
1	KM-1 Melting Behavior	9
2	PKXA Melting Behavior	10
3a	Kapton Bag for KM-1 Press Cure	11
3b	Kapton Bag for PKXA, XU-218 Press Cures	11
4	FTIR, Reaction Product Equation 1 (PNI)	20
5	FTIR, Reaction Product Equation 2 (PNI)	21
6	DSC, Reaction Product Equation 1 (PNI)	22
7	DSC, Reaction Product Equation 2 (PNI)	23
8	DSC Second Run (PNI)	24
9	FTIR, Reaction Product Equation 3 (MNI)	26
10	DSC, Reaction Product Equation 3 (MNI)	27
11	FTIR, Reaction Product Number 1, PNI and DCDPS	29
12	FTIR, Reaction Product Number 2, PNI and DCDPS	30
13	Vacuum Bag for NTS 20-1 Cure	32
14	Postformed NTS 20-1 Laminate	35
15	Photomicrograph #1 of Postformed NTS 20-1 Laminate	36
16	Photomicrograph #2 of Postformed NTS 20-1 Laminate	37
Table	Title	Page
1	KM-1 Processing Studies	5
2	PKXA Processing Studies	7
3	XU-218 Processing Studies	13
4	Baseline Mechanical Properties: KM-1 and PKXA	16
5	Residual Strength After Environmental Exposure	17

1.0 INTRODUCTION AND SUMMARY

The capability of graphite reinforced composites to save weight and thus save fuel and increase performance in military and commercial aircraft has been adequately demonstrated. This current era of high fuel costs provides further incentive for greater utilization of these composite materials that, to date, have been predominantly graphite/epoxies. As is common with all thermosets, graphite/epoxy construction is expensive because of high material and fabrication costs compared to most metallic construction. The cost of graphite reinforced prepregs is volume-sensitive and has been declining for the past several years as usage of these prepregs has become more widespread. Also, fiber suppliers' investment in new facilities and fiber technology is expected to result in even further price reductions.

The current approach to reducing fabrication costs of graphite/epoxy structure is to automate the prepreg layup, trimming, and ply-stacking operations. This approach will undoubtedly lower production costs, but will surely require considerable capital outlay for specialized equipment.

An attractive alternative to the thermoset composites, with the potential of reducing fabrication costs of graphite composites to or below those of metals, is the use of thermoplastic matrix materials. The primary area of cost savings with thermoplastics compared to thermosets is the capability to perform manufacturing operations on existing high-production-rate equipment used for working metals. For example, it has been demonstrated (ref. 1 and 2) that graphite/thermoplastic composites can be sheared, punched, dimpled, and hot-formed using the production processes and equipment used for metallic construction.

At present, there are no graphite/thermoplastic structures on military or commercial aircraft, because currently available thermoplastic resins that are suitable for use as matrix materials are all degraded to some extent by exposure to certain fluids used in normal flight and maintenance operations.

The goal of this program was to overcome this fluid resistance deficiency. Two approaches were pursued: (1) evaluate new resins that show promise of improved fluid resistance over polysulfone, and (2) develop a new resin. A limited evaluation also was performed to demonstrate the suitability of thermoplastic resins to adhesively

bond graphite/epoxy composites using processes suitable for field (aboard ship) repair. The program was performed in two tasks: Task I, Resin Evaluation, and Task II, Repairs.

In Task I, the commercially available thermoplastic resins evaluated included polyethersulfone (KM-1) from ICI Industries, CM-1 fluorocarbon-based polymer from Allied Chemicals, a modified polysulfone (PKXA) from Union Carbide, XU-218 thermoplastic polyimide from Ciba-Geigy, and BR-31 polyphenylene sulfide from Phillips Petroleum. No one of these materials possessed the combination of low cost, processibility, and fluid resistance desired in graphite reinforced thermoplastic composites.

Also conducted in Task I was a resin formulation and synthesis effort aimed at making simple modifications to polysulfone to improve its solvent resistance. This task was successfully accomplished and the resin, NTS cross-linked polysulfone, was synthesized and its fluid resistance demonstrated.

In Task II, Repairs, the suitability of using thermoplastic resins as adhesives for repairing composites under shipboard conditions was investigated.

A detailed description of the work performed and results obtained in Tasks I and II are presented in Section 2.0. Conclusions reached based on these studies and recommendations for further studies are presented in Section 3.0.

2.0 TECHNICAL DISCUSSION

The objectives of this program were as follows:

1. Develop graphite reinforced thermoplastic composites that are resistant to aircraft fluids.
2. Evaluate repair techniques suitable for use on aircraft stationed with the fleet; i.e., aboard ship.

To accomplish these objectives, the program was performed in two separate tasks. In Task I, Resin Evaluation, commercially available resins were evaluated to determine their suitability for use as matrix resins in graphite/thermoplastic composites. Also in Task I, a new resin was formulated, synthesized, impregnated onto graphite fabric, and molded into a laminate.

In Task II, Repair, two easy-to-perform repair procedures were evaluated for using thermoplastics to join composite repair patches to composite aircraft structure. These repair procedures were: (1) use of a glue gun, and (2) resistance heating of a thermoplastic resin coated onto a metallized scrim cloth.

A description of Task I and II activities is presented in this section.

2.1 EVALUATION OF COMMERCIALY AVAILABLE RESINS (TASK I)

During this program, five candidate resins were selected for screening studies. The resins selected were: (1) KM-1 polyether sulfone from ICI, (2) CM-1 fluorocarbon from Allied Chemical, (3) PKXA modified polysulfone from Union Carbide, (4) XU-218 thermoplastic polyimide from Ciba-Geigy, and (5) BR-31 polyphenylene sulfide from Phillips Petroleum. The screening studies performed included process development, mechanical properties testing, and fluid resistance determinations.

2.1.1 PREPREG PREPARATION

All impregnation was performed in-house at Boeing on 24 x 24 style graphite fabric. The PKXA, XU-218, and KM-1 resins were solvent impregnated; the PKXA and XU-218 from methylene chloride, and the KM-1 from n,n-dimethylformamide (DMF), and also from a mixture of n-methyl pyrrolidinone (NMP), toluene, and methyl ethyl ketone

(MEK). The CM-1 was received from the supplier in film form and impregnation was accomplished by interleaving the CM-1 film with the graphite fabric and heating in a platen press. The BR-31 was insoluble in commonly used solvents and a suitable impregnation technique has not yet been developed. Particulars on each system follow:

KM-1

Graphite fabric/KM-1 prepreg was prepared by two different methods: (1) normal impregnation, and (2) vacuum-assisted impregnation. In the first method, the graphite fabric was laid flat under quartz lamps in a fume hood. A dilute solution of 10-15% KM-1 solids in hot (150°F) DMF was swept into one side of the fabric, allowed to dry until tack free, turned, and the process repeated on the reverse side. Remaining volatiles were removed by oven drying at temperatures to 450°F, as shown in Table 1. The second method, vacuum-assisted impregnation, was used to ensure thorough wetting of the graphite fibers during impregnation. In the latter method, hot dilute KM-1/DMF solution was poured onto the graphite fabric, which then was sealed in a vacuum bag. Full vacuum from a vacuum pump was applied and the KM-1 solution swept into the fabric until evenly distributed. While maintaining full vacuum, the bagged prepreg was placed under quartz lamps for 10 minutes to promote further solution flow and then cooled at 75°F for 30 minutes. The prepreg was removed from the vacuum bag, dried under quartz lamps, turned, and the procedure repeated for the reverse side. Remaining volatiles were removed by drying at temperatures to 450°F (Table 1).

The impregnation processes were repeated until the desired resin content of 35 to 40% was obtained.

As shown in Table I, several processing cycles were evaluated on KM-1. When it became apparent that too much variation was being obtained in laminate mechanical properties, the resin supplier, ICI, was contacted for help. ICI suggested that the DMF solvent, in some unexplained manner, might be forming a complex with KM-1 and thus causing the variation in mechanical properties. At the recommendation of ICI, the impregnating solvent was changed from DMF to a blend of NMP, toluene, and MEK.

Table 1. KM-1 Processing Studies

Panel No.	Drying Cycle	Molding Cycle	Flexural Strength, psi x 10 ³		Flexural Modulus, psi x 10 ⁶		ILS, psi x 10 ³		Remarks
			RT	300°F	RT	300°F	RT	300°F	
5	RT → 300°F, 2 hr	RT → 450°F, hold 30 min. Apply 200 psi 450°F → 650°F, hold 30 min. Cool under pressure							Complete delamination when cutting specimens 1/
9	RT → 300°F, 2 hr	RT → 450°F, hold 30 min. 450°F → 600°F, hold 30 min. Apply 200 psi, hold 15 min. Cool under pressure							30% RS failure during handling 1/
13	275°F, 3 hr	RT → 450°F, hold 30 min. 450°F → 600°F, hold 30 min. Apply 200 psi, hold 70 min. Cool under pressure	121.7	72.1	11.2	6.5	4.9		DMF Vacuum impregnated, 32.9% RS prepreg
K-1	300°F, 66 hr 450°F, 15 min.	600°F, apply 200 psi Hold 15 min. Cool under pressure	81.6	48.0	8.5	8.0	6.5	4.9	DMF Vacuum impregnated, 34% RS prepreg
K-5	RT → 360°F, 2 hr	200 psi, RT → 450°F Hold 30 min. 450 → 600°F, hold 75 min. 600 → 650°F, hold 30 min. Cool under pressure	54.0	27.3	7.9	8.2			NMP, Toluene, MEK 39.1% RS prepreg
K-6 2/	RT → 360°F, 1 hr	RT → 450°F, hold 30 min. 450°F → 600°F, hold 30 min. Apply 400 psi, hold 70 min. Cool under pressure	105.6	72.3	8.8	8.5			NMP, Toluene, MEK 37.2% RS prepreg
K-7	RT → 360°F, 1 hr	RT → 450°F, hold 30 min. 450°F → 650°F, hold 30 min. Apply 400 psi, hold 70 min. Cool under pressure	72.0	57.2	8.0	7.3			NMP, Toluene, MEK 37.2% RS prepreg
K-8	RT → 360°F, 1 hr	600°F, hold 45 min. Apply 400 psi, hold 90 min. Cool under pressure	106.7	72.4	10.5	9.1			NMP, Toluene, MEK 37.2% RS prepreg

1. All values are an average of 5 specimens.

1/ Specimens not double-wrapped in release-coated Kapton film to retain resin.

2/ Selected as optimum cycle.

The succeeding batches of graphite fabric/KM-1 prepreg were prepared by normal solvent impregnation from a room-temperature solution. The prepreg was dried at 275°F between resin applications, and final drying was accomplished at 360°F.

PKXA

Graphite fabric/PKXA prepreg was prepared by normal impregnation methods. The fabric was laid flat, and a dilute PKXA solution of approximately 10% PKXA solids in methylene chloride was swept into one side of the fabric. The prepreg was covered with FEP film for 10 to 20 minutes to aid in wetting of the fibers. Then, the FEP film was removed and the prepreg allowed to air dry until tack free. The process was repeated on the reverse side of the fabric. Remaining volatiles were removed by oven drying at temperatures to 275°F (Table 2). This process was repeated until the desired resin content of 35 to 40% was obtained.

CM-1

The CM-1 resin was supplied as a dry film in thicknesses ranging from 2 to 7 mils. The CM-1 film was interplied with graphite fabric at a weight ratio of 35% CM-1 to 65% graphite fabric. Impregnation was accomplished in a platen press as the first step in the laminate consolidation (molding) process (see Section 2.1.2).

BR-31

The BR-31 resin was supplied as pellets that were extremely tough and could not be ground into finer particles. Attempts to dissolve the BR-31 pellets in solvents customarily used for impregnation were unsuccessful. The solvents tried were DMF, NMP, ketones, alcohols, and methylene chloride. Because of this insolubility, attempts were made at hot melt impregnation. The first attempt consisted of dispersing BR-31 pellets on both sides of style 181 fiberglass and heating in a platen press at 500°F for 60 minutes. This experiment showed that the BR-31 resin will flow sufficiently to wet the reinforcement. The resin distribution was not uniform and this procedure is not considered a viable process. A process then was evaluated wherein the BR-31 pellets were first made into film form and then interplied with the graphite fabric, as was done with the CM-1 film. Several 4 x 4-inch pieces of BR-31 film were prepared in a platen press at 500°F and 100-125 psi. The film thickness obtained was

Table 2. PKXA Processing Studies

Panel No.	Drying Cycle	Molding Cycle	Flexural Strength, psi x 10 ³		Flexural Modulus, psi x 10 ⁶		ILS, psi x 10 ³		Remarks
			RT	300°F	RT	300°F	RT	300°F	
11		650°F, apply 200 psi Hold 50 min. Cool under pressure	79.8 76.3	46.4	7.4	6.6	4.8	3.4	39% RS prepreg
15	250°F	RT, apply 200 psi Heat to 575°F, hold 45 min. Cool under pressure	65.4	35.4	7.56 1/	5.8	5.8	2.2	
19		RT, apply 200 psi Heat to 575°F, hold 45 min. Cool under pressure	91.3	39.3	6.4		6.3	(400°F) 0.9 (300°F) 1.1	
P-5	RT → 275°F Hold 2 hr 275°F	Apply 150 psi, RT → 350°F Apply 400 psi, 350 → 600°F Hold 45 min. Cool under pressure							34.7% RS no-bleed cure; panel of bad quality
P-6	RT → 275°F Hold 2 hr 275°F	Apply 150 psi, RT → 350°F Apply 400 psi, 350 → 600°F Hold 45 min. Cool under pressure							34.7% RS no-bleed cure; panel of bad quality
P-8 2/	RT → 275°F Hold 2 hr 275°F	Apply 400 psi, RT → 600°F Hold 45 min. Cool under pressure	74.0 78.7	64.1 54.8	7.2 6.9	7.4 6.2			4-ply: 34.7% RS 3-ply: 32.4% RS Bleeder used

1. All values are an average of 5 specimens.

1/ One sample.

2/ Selected as optimum cycle.

0.020 to 0.035 inch, which is greater than the 0.010-inch thickness desired. The film-making process was refined and a BR-31 film of 0.01-inch thickness was prepared. The BR-31 film contained small bubbles and a number of small, elongated crystals dispersed throughout the film.

XU-218

Graphite fabric/XU-218 prepreg was prepared by normal solvent impregnation methods. The fabric was laid flat, and a dilute solution of approximately 5% XU-218 solids in methylene chloride was swept into one side of the fabric. The prepreg was covered with FEP film for 10 to 20 minutes to aid in wetting of the fibers. Then, the FEP film was removed and the prepreg allowed to air dry until tack free. The process was repeated on alternating sides of the fabric until the desired resin content of 35 to 40% was obtained. Remaining volatiles were removed by oven drying for 2 hours at 275°F.

2.1.2 LAMINATE CONSOLIDATION (MOLDING)

All laminate consolidation was accomplished in a 30-ton, 800°F, 12 x 12-inch-capacity platen press.

Before selecting a press molding cycle, the melt behavior and observed viscosity changes of dry resin with increasing temperature were examined using a Fischer-Johns melting point apparatus. At temperatures above 300°C (572°F), the thermometer in the Fischer-Johns device was replaced by a thermocouple attached to a chart recorder. KM-1 resin softened slightly at 250°C (482°F) and exhibited noticeable, gradually increased flow at temperatures above 270°C (518°F) (Fig. 1). At the highest observed temperature, 357°C (675°F), the consistency was somewhat thicker than honey. PKXA resin flowed at 180°C (356°F) and was thoroughly liquified with a few bubbles at temperatures above 260°C (500°F), as shown in Figure 2. BR-31 began to soften at 285°C (545°F).

After preimpregnation as described in Section 2.1.1, each sheet of prepreg was cut and stacked to the desired panel size and number of plies and then sealed in a Kapton vacuum bag (Fig. 3a and 3b) for press cure. To prevent excessive resin bleed-out, the

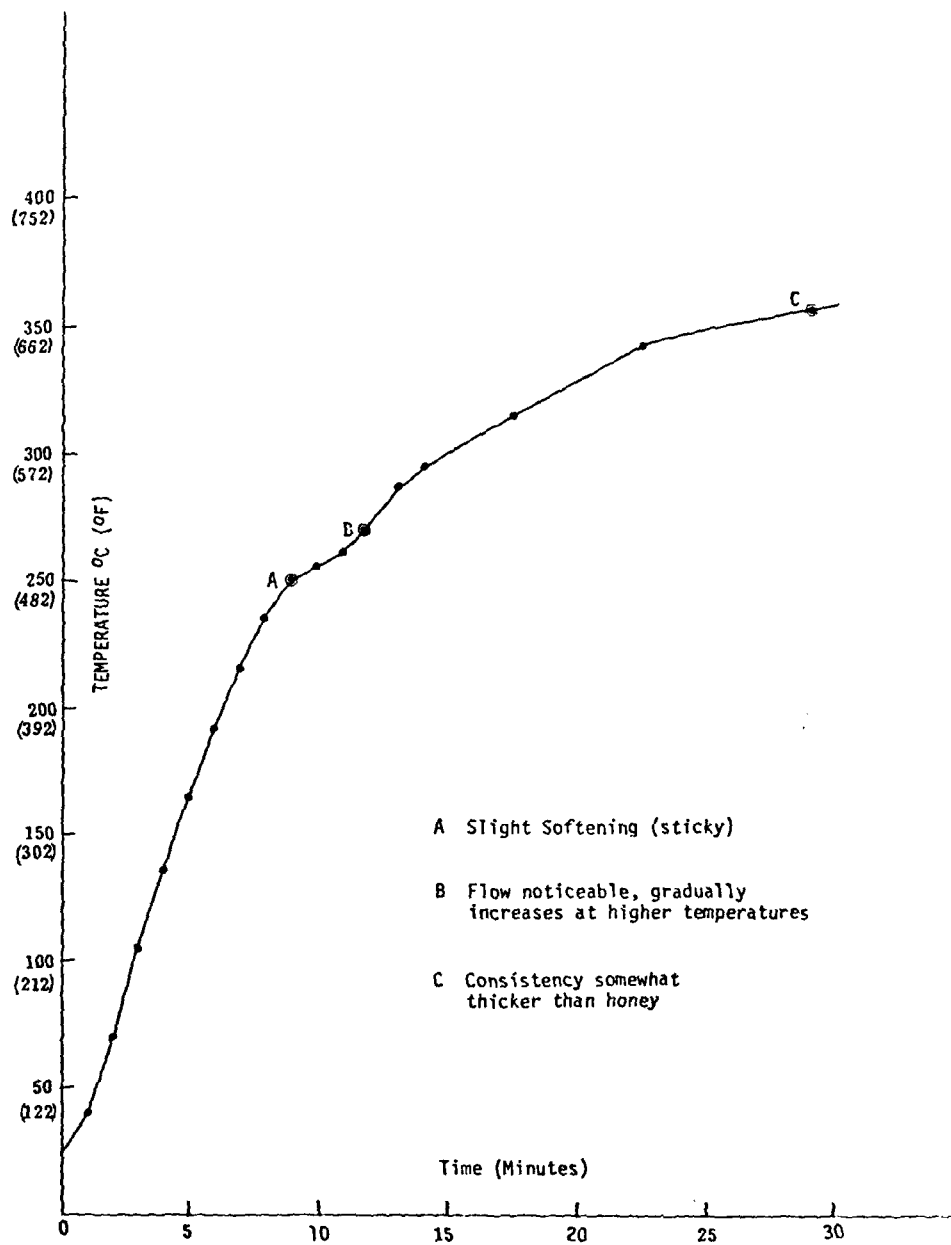

Figure 1. KM-1 Melting Behavior

PKXA MELTING BEHAVIOR

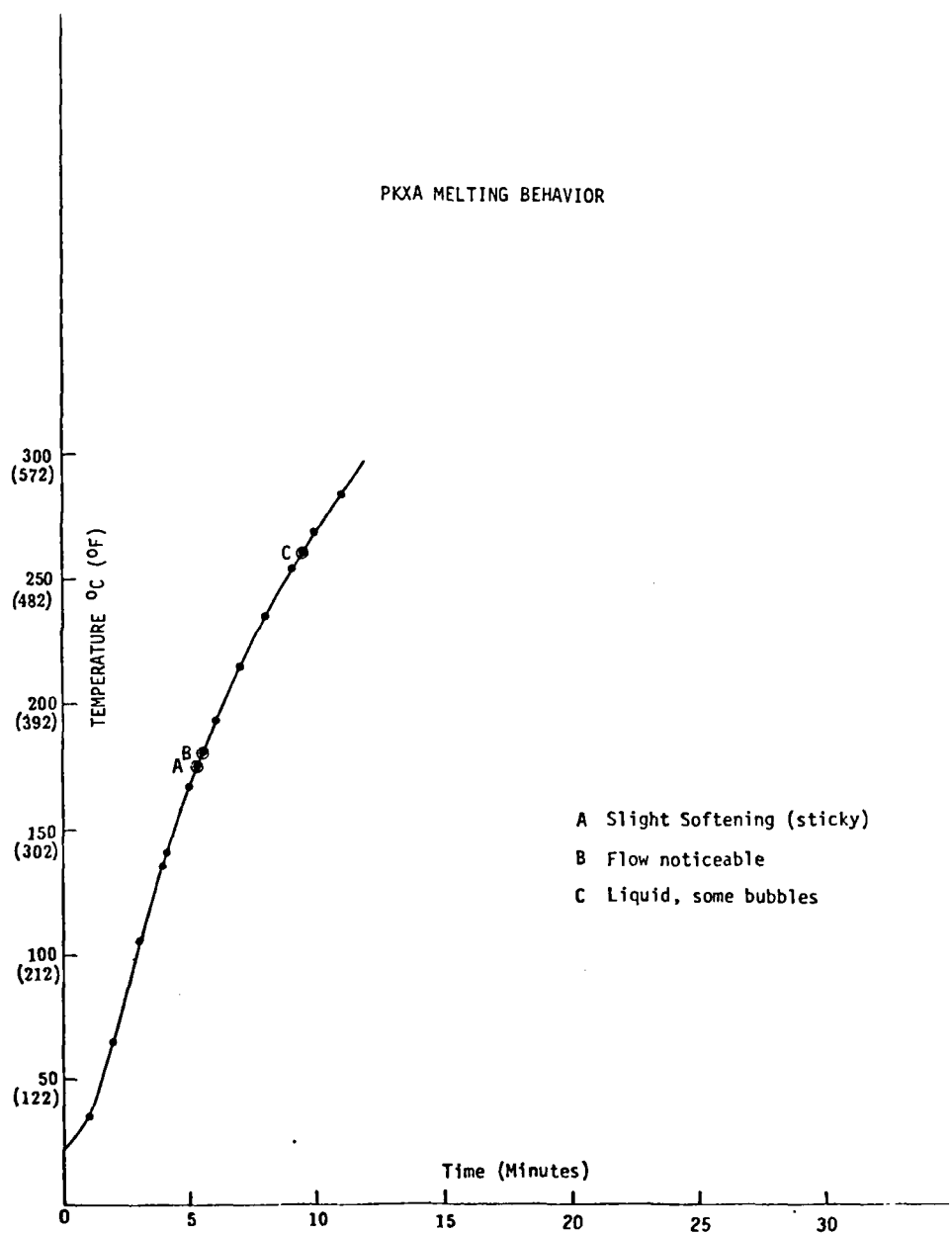

Figure 2. PKXA Melting Behavior

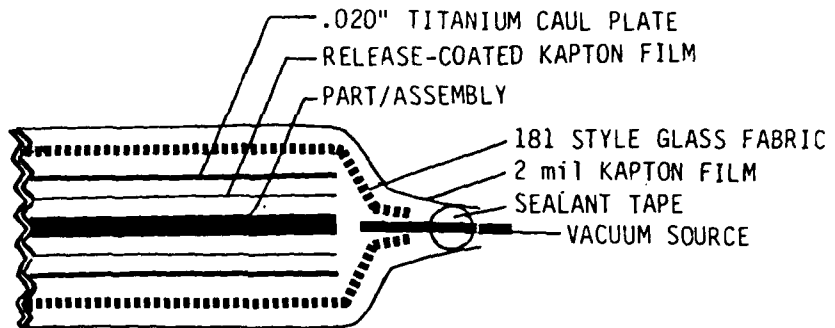

FIGURE 3a. KAPTON BAG FOR KM-1 PRESS CURE

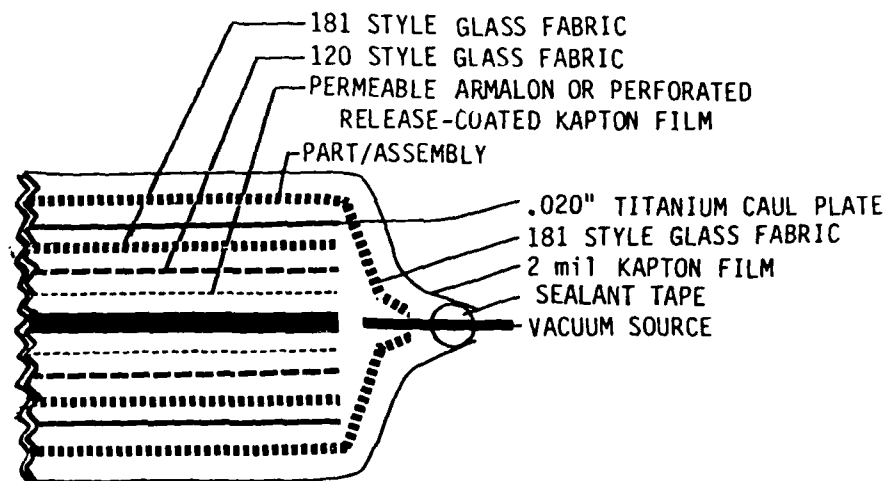

FIGURE 3b. KAPTON BAG FOR PKXA, XU-218 PRESS CURES

KM-1 panels were double-wrapped in 5-mil Kapton film that had been coated with Frekote 33 release agent.

Several molding cycles were evaluated for the KM-1 system (Table 1). The optimum cycle selected consisted of placing the bagged assembly into the press with contact pressure only, raising the temperature from room temperature to 450°F and holding for 30 minutes at 450°F, raising the temperature from 450°F to 600°F and holding 30 minutes at 600°F, then applying 400 psi pressure and holding for 70 minutes more at 600°F before cooling the laminate to room temperature under pressure in the press.

For CM-1 laminates, a combined preimpregnation and molding cycle was used. The desired weight of CM-1 dry film was interplied with cut and weighed graphite fabric and placed in a release-coated mold. This was either sealed in a Kapton vacuum bag or encased in aluminum foil under a dry argon purge. CM-1 panels were prepared by placing the bagged assembly into the press, raising the temperature to 620°F and holding for 30 minutes at 620°F, with contact pressure only to effect preimpregnation of the graphite fabric. After the 30-minute hold, 200 psi pressure was applied and held for another 30 minutes at 620°F. The laminate then was cooled to room temperature under pressure in the press. The following mechanical properties were obtained from the molded laminates when tested at 75°F:

- o Flexure strength: 54 to 85 x 10³ psi
- o Flexure modulus: 5.6 to 8.54 x 10⁶ psi
- o ILS: 4.9 to 7.0 psi

The optimum molding cycle for PKXA laminates selected from those evaluated (Table 2) consisted of placing the bagged laminate into the press, applying 400 psi pressure, , raising the temperature from room temperature to 600°F, and then holding at 600°F for 45 minutes before cooling to room temperature under pressure in the press. A porous Teflon release fabric coupled with glass bleeder was needed to remove volatiles (Fig. 3b).

Two molding cycles for XU-218 were evaluated. The laminates were vacuum bagged as shown in Figure 3b, inserted into a preheated (750°F or 725°F) press, held for 45 minutes prior to applying either 1000 or 1500 psi pressure, held for another 30 minutes, and then cooled to 75°F under pressure. Both cures resulted in laminates with poor mechanical properties, as shown in Table 3. Based on these low mechanical

Table 3. XU-218 Processing Studies

Drying Cycle	Molding Cycle	Flexural Strength, psi x 10 ³		Flexural Modulus, psi x 10 ⁶	
		RT	300°F	RT	300°F
RT → 275°F 275°F, 2 hr	725°F, hold 45 min. Apply 1000 psi Hold 30 min. Cool under pressure	33.4	25.1	4.2	3.4
RT → 275°F 275°F, 2 hr	750°F, hold 45 min. Apply 1500 psi Hold 30 min. Cool under pressure	44.8	31.1	5.4	4.6

NOTE

1. All values are an average of 5 specimens.

properties and fluid exposure results (Sec. 2.1.3), no further evaluation of this resin was performed.

To determine whether the BR-31 material would flow sufficiently to wet out fiber reinforcements, a small (2 x 2-inch) laminate was prepared. Four plies of BR-31 film were interleaved with seven plies of 181-style "S"-glass fabric for a calculated laminate resin content of 44.3%. The panel was cured in a platen press for 30 minutes at 650°F and contact pressure, then 60 minutes at 650°F and 200 psi. The laminate produced was well-consolidated and showed good flow. However, like the film, it showed numerous voids and crystals. In the laminate, the elongated crystals appeared to be both more numerous and larger than in the BR-31 film. Specimens cut from this laminate gave short beam shear strengths of 2030 psi at room temperature and 2410 psi at 300°F.

A 6 x 6-inch, seven-ply BR-31/T300 graphite fabric laminate was prepared using the same cure cycle, but with the addition of a Teflon-coated glass release fabric and glass bleeder plies to remove volatiles. Resin loss was extensive, yielding a composite that was poorly consolidated and not suitable for testing. No further effort was conducted during this program on the BR-31 system because of time and funding limitations.

A review of the data in Tables 1 and 2 shows that KM-1 and PKXA systems possess acceptable interlaminar shear and flexural shear properties. The CM-1 system also appears to possess acceptable mechanical properties, but an optimum cure cycle was not developed because sufficient CM-1 film was not available. While the CM-1 possesses good solvent resistance, as discussed in Section 2.1.3, it will not be evaluated further at this time because the supplier, Allied Chemicals Co., has withdrawn it from the market. Also, Allied projects a 50 to 70\$/lb cost for CM-1, which is too costly for thermoplastic matrix materials to be competitive with graphite/epoxy composites. One other deterrent to further evaluation of CM-1 is that, being a fluorocarbon-based polymer, it is possible that painting of the finished structure will turn out to be an expensive process.

Baseline properties determinations were then performed on KM-1 and PKXA laminates. These properties included tension, compression, flexure and interlaminar shear

at RT and 300°F. Results are presented in Table 4. These preliminary results indicate that graphite/KM-1 and graphite/PKXA are suitable for aircraft structural applications.

2.1.3 ENVIRONMENTAL EXPOSURE

As a screening test for determining the fluid resistance of the various graphite/thermoplastic systems, small pieces (1/8 x 1/4 inch) of the molded laminates were immersed in various fluids and their change in appearance noted after various lengths of exposure. The fluids used were MIL-L-7808 synthetic lubricant, MIL-H-5606 hydraulic fluid (standard petroleum base), MIL-H-83306 phosphate ester hydraulic fluid (SKYDROL 2300-W), and JP-4 fuel. The systems evaluated were KM-1, PKXA, CM-1, and Radel 5010, which had been evaluated under a previous NASC contract (N00019-77-C-0561). The specimens appeared unaffected after 30 days exposure. Specimens of these same systems, plus one additional system, XU-218, also were immersed in methylene chloride, an ingredient used extensively in paint strippers. The following results were observed:

- o CM-1: Unaffected after 30 days exposure
- o PKXA: Swelling and softening within 1 hour
- o XU-218: Considerable swelling within 5 minutes
- o KM-1: Swelling within 30 minutes, but no delamination after 5 days exposure. Previously tested flexure specimens also were exposed and delamination occurred within 10 minutes.
- o Radel 5010: Same as for KM-1

Two systems were then selected for residual strength determination after stressed and unstressed flexural specimens had been exposed in the aforementioned fluids for twenty-eight days. The two systems evaluated were graphite fabric/KM-1 and graphite fabric/PKXA. The data from these exposures are presented in Table 5. These test results show that the PKXA laminates were not severely degraded by the fluid immersion and the KM-1 laminates were. These findings are consistent with data obtained on tension specimens ($\pm 45^\circ$) that were prestressed to 20% of ultimate and immersed in these and other fluids for 30 days (ref. 1). Also, a polyether sulfone of lower molecular weight than KM-1 had previously been shown to be degraded by fluid immersion (ref. 2).

Table 4. Baseline Mechanical Properties: KM-1 and PKXA

Laminate	Temperature (°F)	Tension			Compression			Flexural			Shear Strength (ksi)
		Strength (ksi)	Modulus (msi)	Strength (ksi)	Modulus (msi)	Strength (ksi)	Modulus (msi)	Strength (ksi)	Modulus (msi)		
Graphite fabric/KM-1	RT	66.3	9.2	60.6	9.2	114.6	7.8	9.4	7.8	9.4	
	300	62.2	9.4	50.3	8.2	72.3	8.5	6.4	8.5	6.4	
Graphite fabric/PKXA	RT	55.0	8.8	50.1	8.1	76.4	7.0	4.9	7.0	4.9	
	300	43.4	8.5	38.2	7.1	54.8	6.2	4.8	6.2	4.8	

NOTE: All values are an average of 5 specimens.

Table 5. Residual Strength after Environmental Exposure

Exposure	Stress Level (% of Ultimate)	PKXA			KM-1		
		Flexural Strength x 10 ³ psi	Flexural Modulus x10 ⁶ psi	Flexural Strength x 10 ³ psi	Flexural Modulus x 10 ⁶ psi	Flexural Strength x 10 ³ psi	Flexural Modulus x 10 ⁶ psi
Control	0	76.4	7.04	114.6	7.8		
JP-4 Fuel 28 days	60	77.2 (+1.0)	7.0 (-0.6)	98.1 (-10.0)	7.0 (-20.0)		
	0	77.3 (+1.2)	7.2 (+2.3)	116.4 (+1.6)	7.7 (-1.3)		
MIL-H-5606 Hydraulic Fluid 28 days	60	73.7 (-3.5)	7.3 (+3.7)	90.7 (-18.3)	7.2 (-18.4)		
	0	73.6 (-3.7)	7.2 (+2.3)	93.5 (-18.4)	6.9 (-11.5)		
MIL-L-7808 Synthetic Lubricant 28 days	60	70.4 (-7.9)	6.6 (-6.3)	73.7 (-32.4)	6 (-27.7)		
	0	76.9 (+1.0)	7.3 (+4.1)	110.4 (-3.7)	7.7 (-1.3)		
MIL-H-83306 Hydraulic Fluid 28 days	60	61.5 (-19.5)	5.7 (-18.6)	1/	1/		
	0	72.5 (-5.1)	6.8 (-3.4)	--	--		
Salt Water Environment 28 days	60	78.8 (+3.1)	7.2 (+2.0)	100.1 (-8.2)	7.1 (-19.5)		
	0	73.7 (-3.5)	7.4 (+5.1)	116.2 (+1.4)	8.1 (+3.8)		

NOTE: 1. Values in () are percent change from control values.

2. All values are an average of 5 specimens.

1/ MIL-H-83306 hydraulic fluid is not used in naval aircraft systems. Specimens delaminated.

2.2 NEW RESIN SYNTHESIS AND CHARACTERIZATION (TASK I)

The objective of this study was to make simple modifications to polysulfone resin to improve its resistance to chlorinated solvents. With the concurrence of the NASC program monitor, an Engineering Services Subcontract was awarded to TRW to assist in the resin formulation and synthesis studies, with Hyman Lubowitz as the key TRW person assisting this program. A patent disclosure was prepared, co-authored by C. H. Sheppard and H. Lubowitz, covering the resin modifications discussed in this section. A disclosure on a new thermosetting polymer also was prepared.

Two separate concepts were pursued: (1) introduction of crosslinking sites through the use of norbornene end caps, and (2) introduction of crystallinity into the polymer. The first major effort was directed at the synthesis of the norbornene caps and their subsequent chemical characterization and reaction into polysulfone oligomers. Detailed discussion of the experimental effort is presented in this section.

2.2.1 SYNTHESIS OF THE NORBORNENE END GROUPS

The major thrust of the synthesis work during this program was the synthesis and identification of the norbornene caps and their subsequent reaction into polysulfone oligomers. Following are the chemical equations that were first used to make the norbornene end groups:

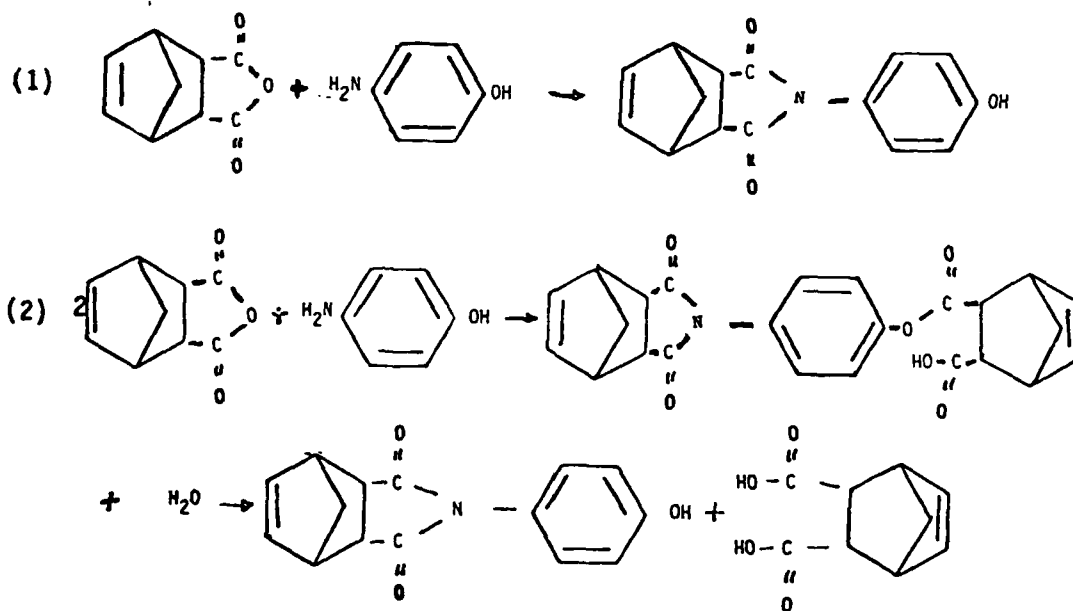

Both reactions were carried out in refluxing toluene/DMAC (67/33) and the imide end group obtained by preparation in water. After purification, melting points of the imide products obtained in the reactions were determined to be the same (i.e., 250-253°C). Samples of the two materials were characterized by use of the Fourier Infrared Spectrophotometer (FTIR) and the Differential Scanning Calorimeter (DSC) (Fig. 4 through 7). Results of these tests demonstrated that the two reactions products were the same. X-ray diffraction patterns also were obtained on the two products, yielding the same results. A second DSC scan was obtained on the imide product of reaction number 1 to demonstrate that the norbornene group was active (i.e., underwent a Reverse Diehls Alder reaction) (Fig. 8). As expected, the third time the material was heated, no melt endotherm occurred. To ensure that the imide products from the reactions were the postulated compound, additional chemical property information was obtained. The additional information consisted of the hydroxyl (-OH) content, acid (-COOH) content, and nitrogen (N) content. Results of

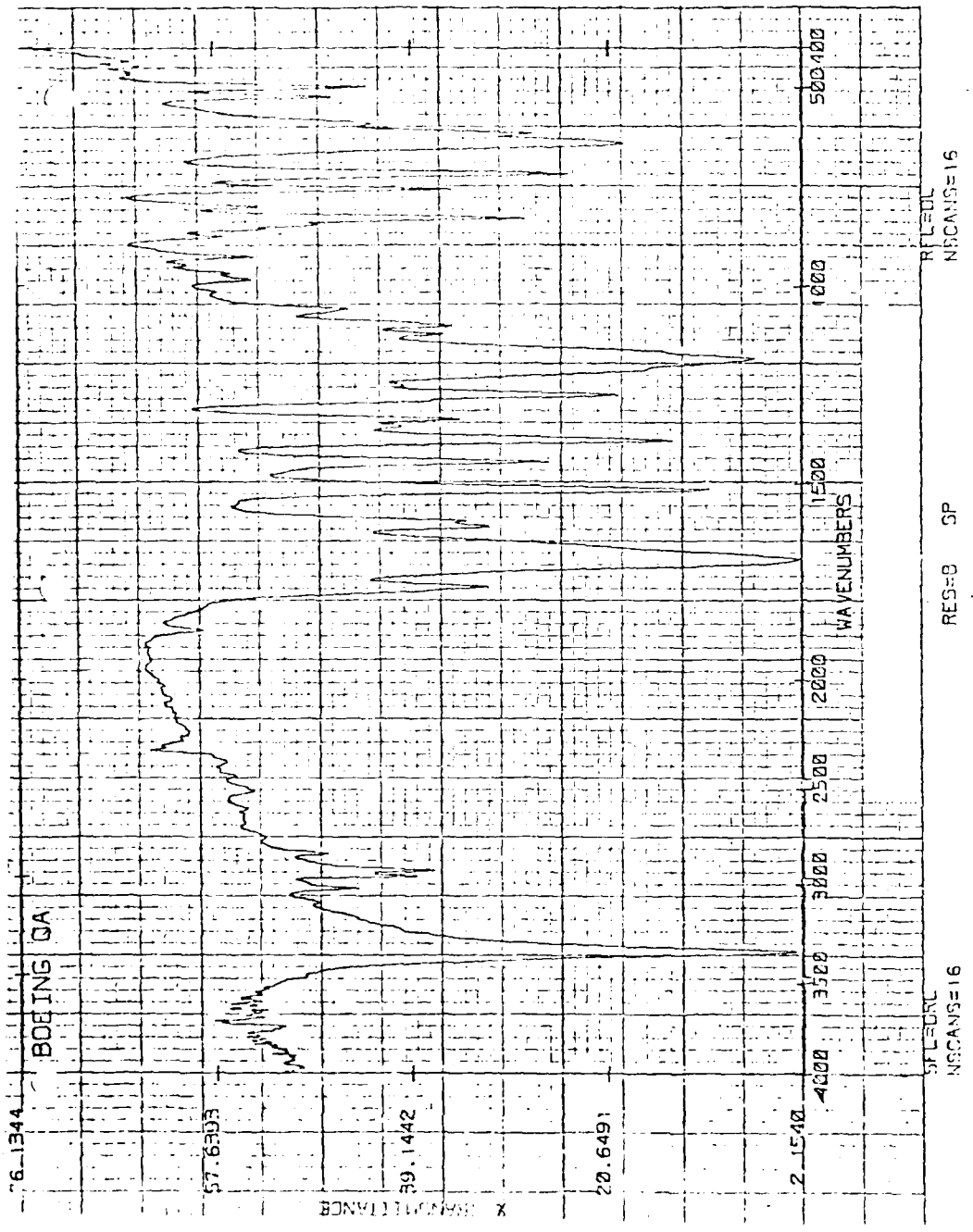

Figure 4. FTIR, Reaction Product Equation 1 (PNI)

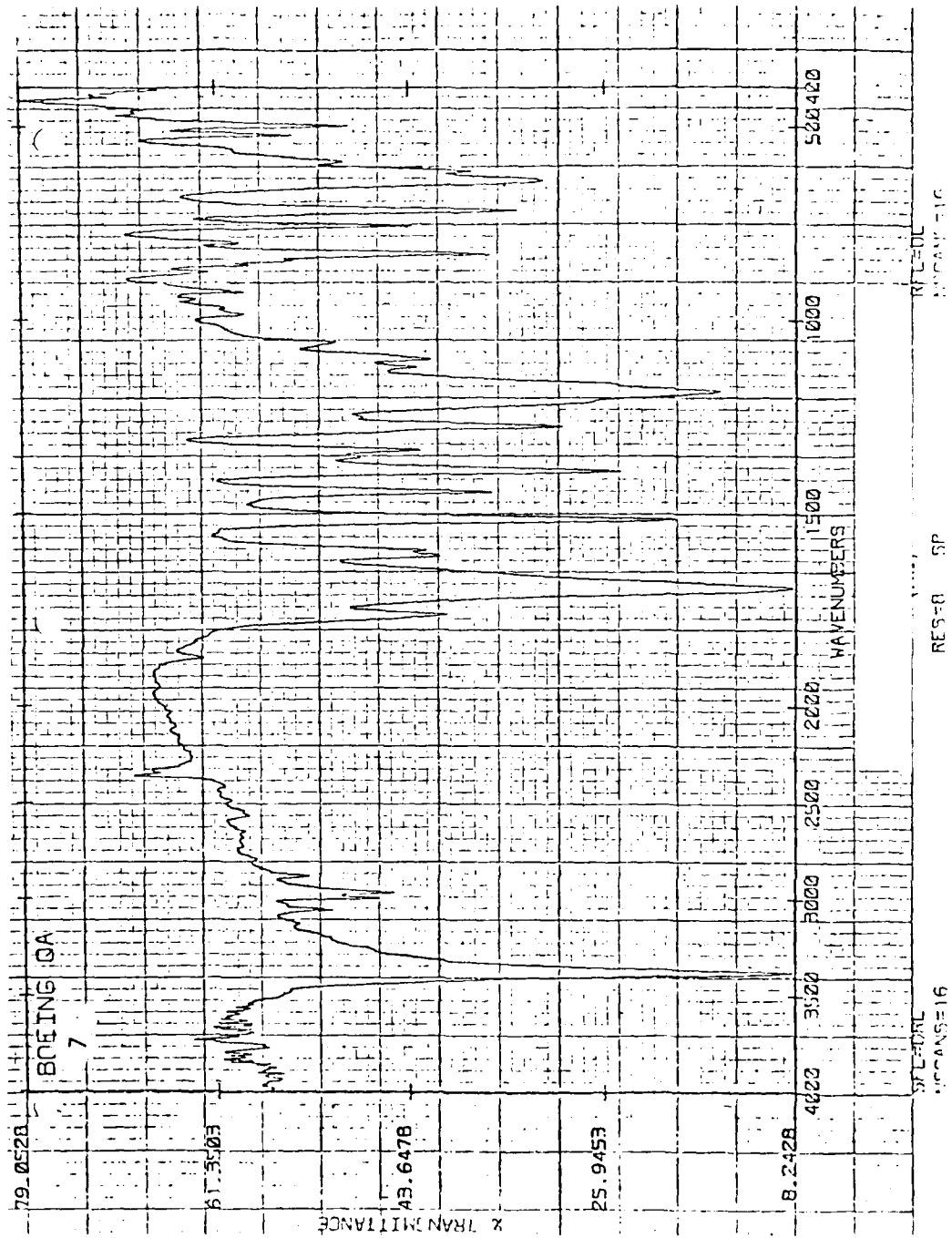

Figure 5. FTIR, Reaction Product Equation 2 (PNI)

UNIT NO. 900304

DUPLICATE INSTRUMENTS

SAMPLE: _____ RUN NO.: _____

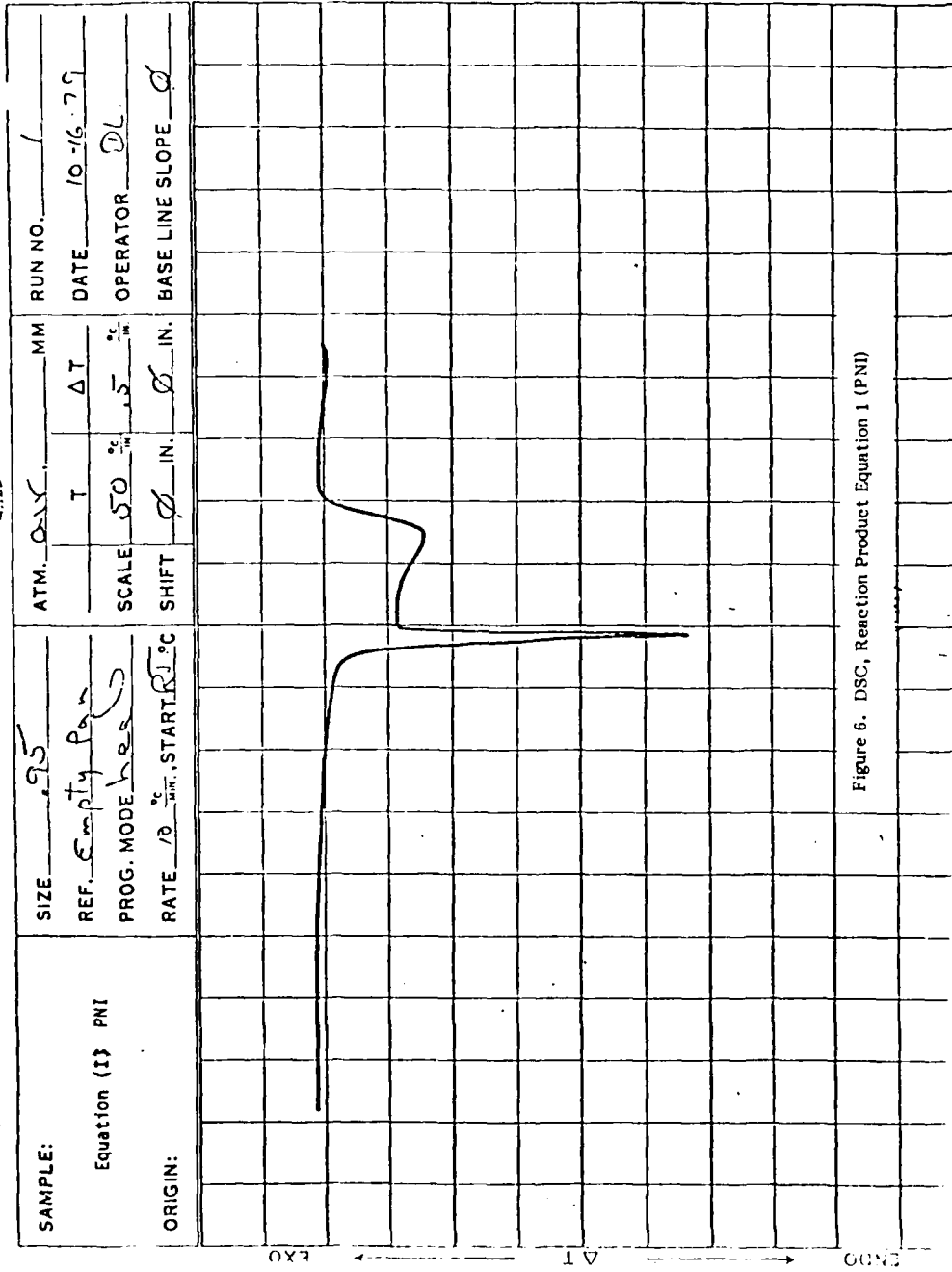
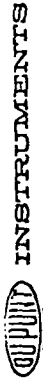

Figure 6. DSC, Reaction Product Equation 1 (PNI)

Figure 6. DSC, Reaction Product Equation 1 (PNI)

PART NO. 940304



SAMPLE: Equation (2) PNI	SIZE	.85 mg.	ATM. DIV.	MM	RUN NO.	1
	REF.	Empty pan	T	ΔT	DATE	10-16-79
ORIGIN:	PROG. MODE	heat	SCALE	50 $\frac{^{\circ}\text{C}}{\text{IN}}$	OPERATOR	DL
	RATE	10 $\frac{^{\circ}\text{C}}{\text{MIN.}}$	SHIFT	IN.	BASE LINE SLOPE	0

SAMPLE: _____ RUN NO.: _____

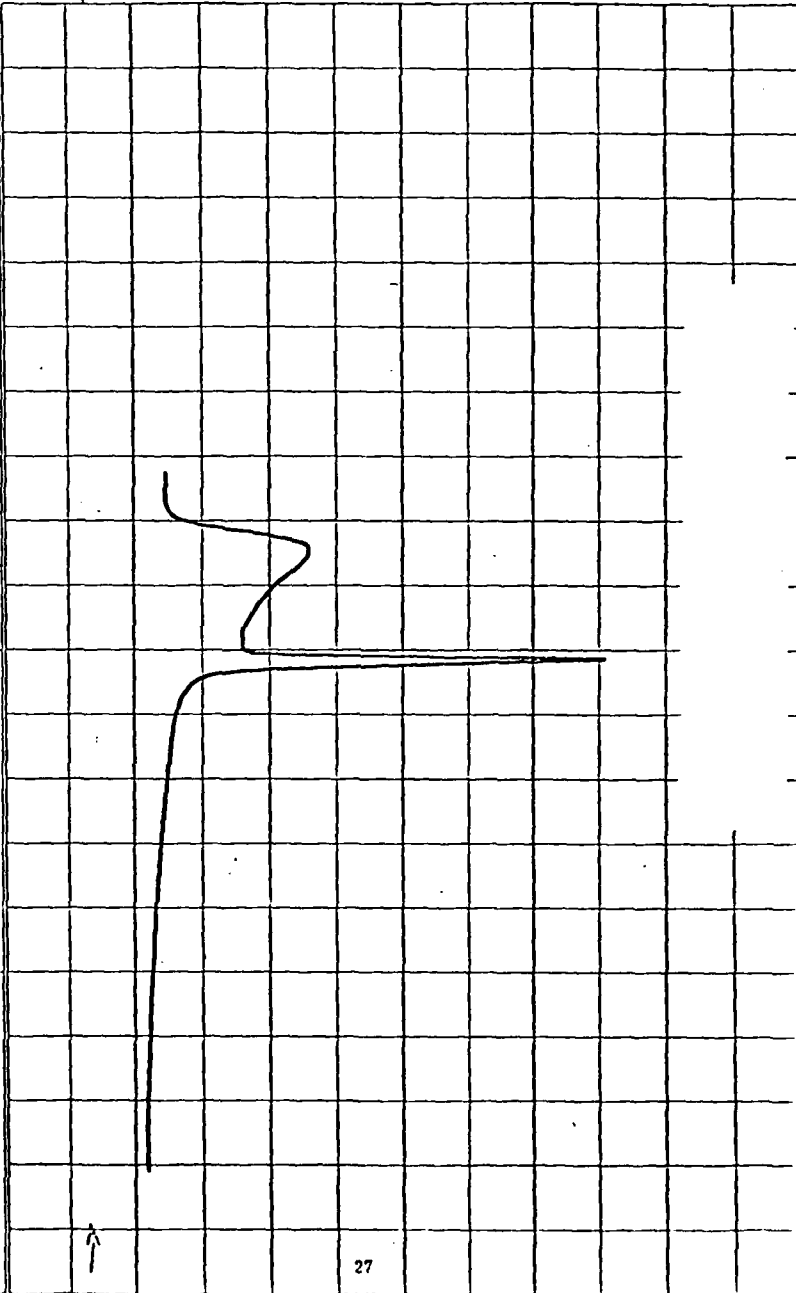

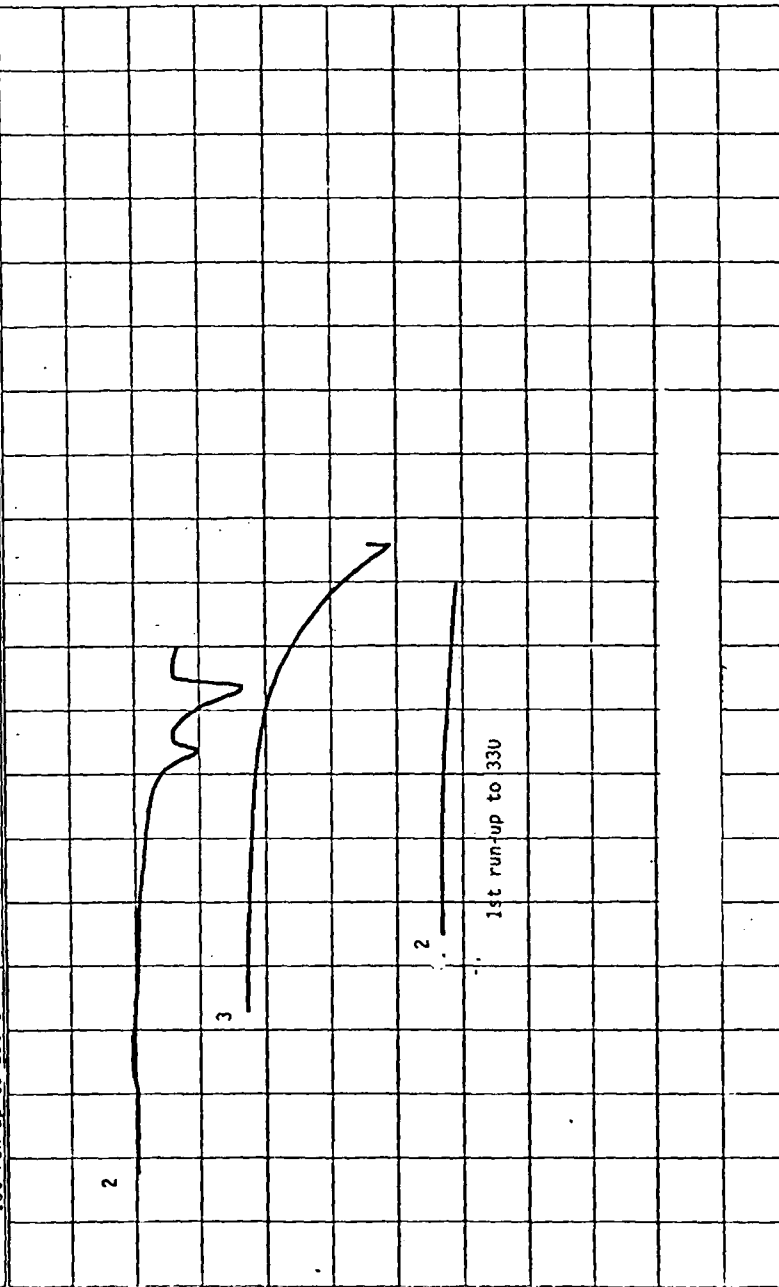

Figure 7. DSC, Reaction Product Equation 2 (PNI)

UNIT NO. 200204

 INSTRUMENTS

SAMPLE: 2nd Run-up		SIZE 2.90	ATM. GAY	MM	RUN NO. 1
ORIGIN: 1st run-up to 250°C		REF. Empty Pan	T	ΔT	DATE 10-17-77
		PROG. MODE heat	SCALE 50 $\frac{^{\circ}\text{C}}{\text{mm}}$	$\frac{^{\circ}\text{C}}{\text{mm}}$	OPERATOR DL
		RATE 10 $\frac{^{\circ}\text{C}}{\text{min}}$, START 17°C	SHIFT	IN. ϕ	BASE LINE SLOPE 0



SAMPLE: _____ RUN NO.: _____

Figure 8. DSC Second Run (PNI)

these tests, in conjunction with the infrared spectra, confirmed that the products obtained were indeed the desired norbornene compound (i.e., -OH value near theoretical and -COOH negligible). To demonstrate the synthesis procedure, a second compound was made using the same techniques and is represented by the following equation:

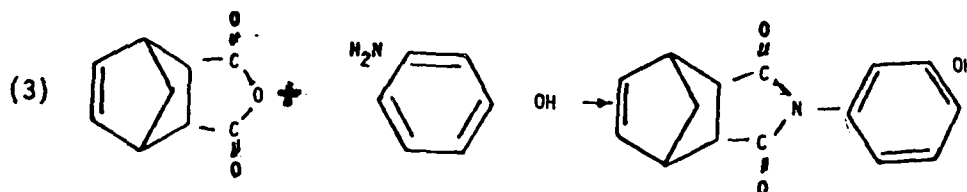

As was the case with the norbornene-imide compound obtained in equation (1), the norbornene-imide obtained in equation (3) was characterized by FTIR and DSC. In addition, the nitrogen content of the equation (3) imide compound (imide nature of compound identified by its infrared spectra) was close to the theoretical value (i.e., 5.79% versus 5.49%). For the infrared spectra and DSC data, see Figures 9 and 10. The only difference in the chemical structure of the two compounds was the location of the phenolic hydroxyl (-OH) with relation to the imide group. In the norbornene compound of equations (1) and (2), the phenolic (-OH) is para to the imide group (PNI), whereas in the compound of equation (3), the phenolic (-OH) is meta to the imide group (MNI).

2.2.2 SYNTHESIS OF NORBORNENE OLIGOMERS

The PNI compound (i.e., product obtained from equation (1)) was first reacted with the dichlorodiphenol sulfone (DCDPS), as shown in the following equation):

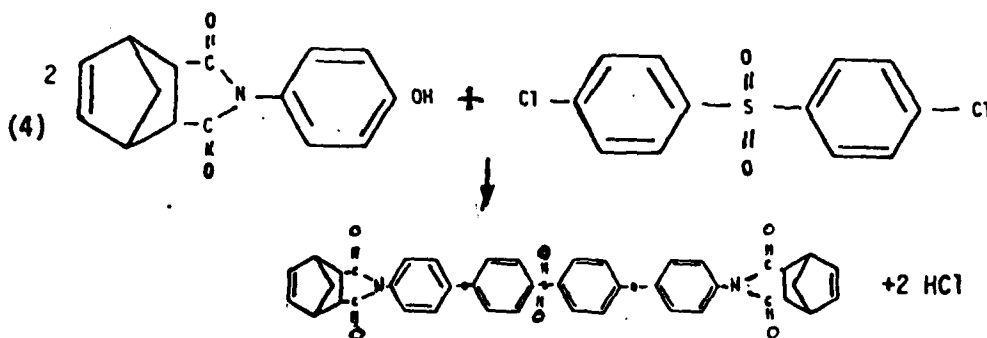

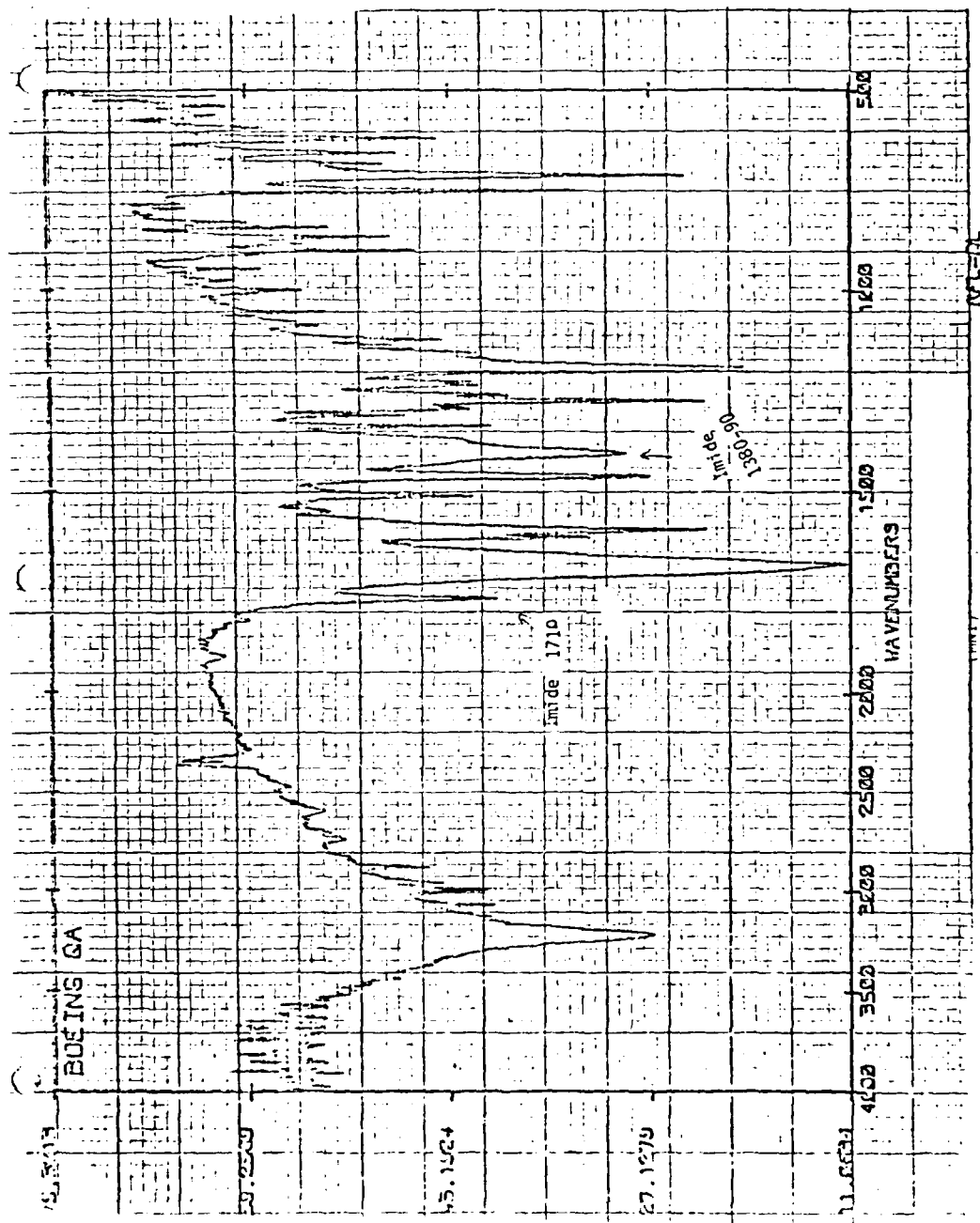

Figure 9. FTIR, Reaction Product Equation 3 (MNI)

PART NO. 900304

DUPLICATE INSTRUMENTS

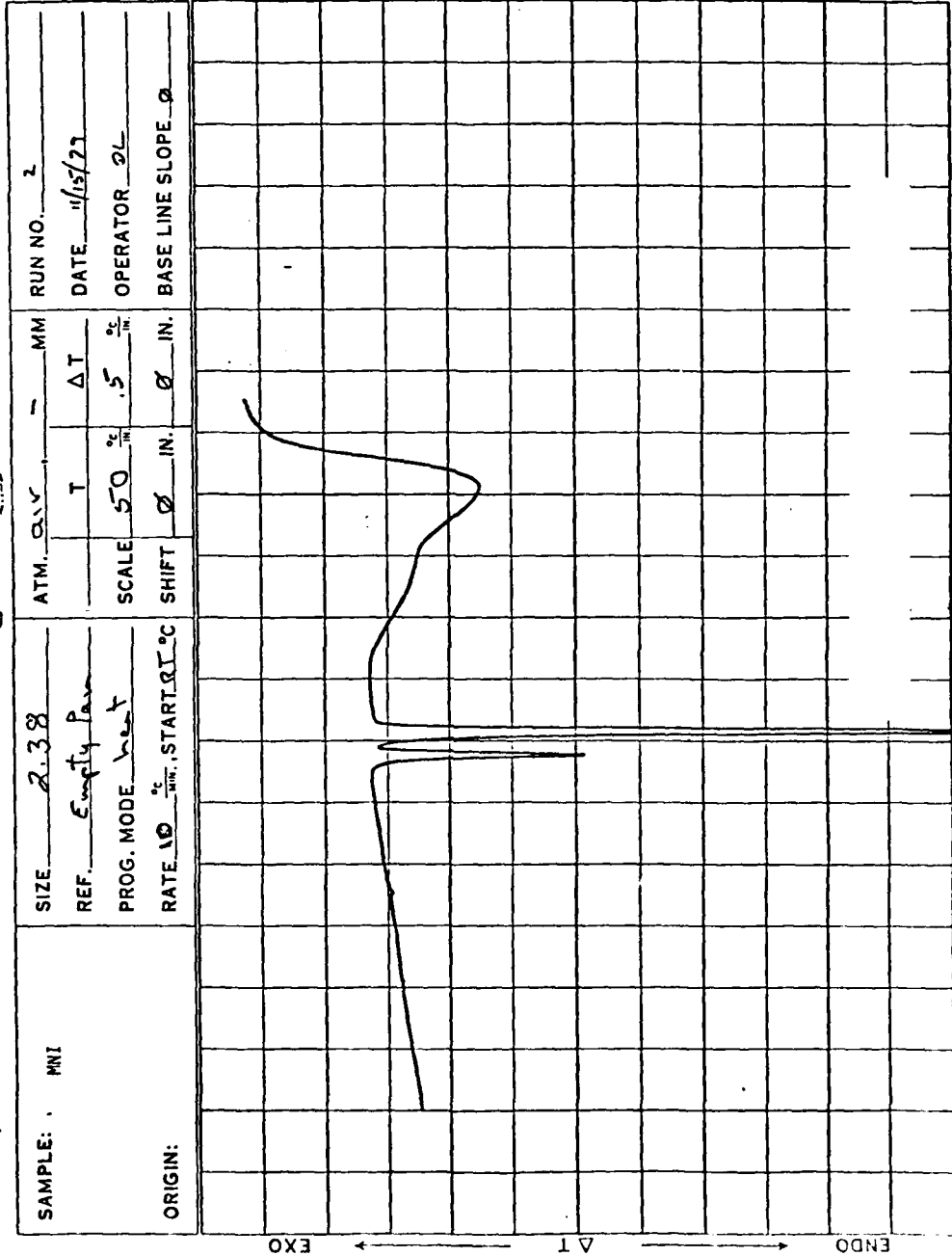
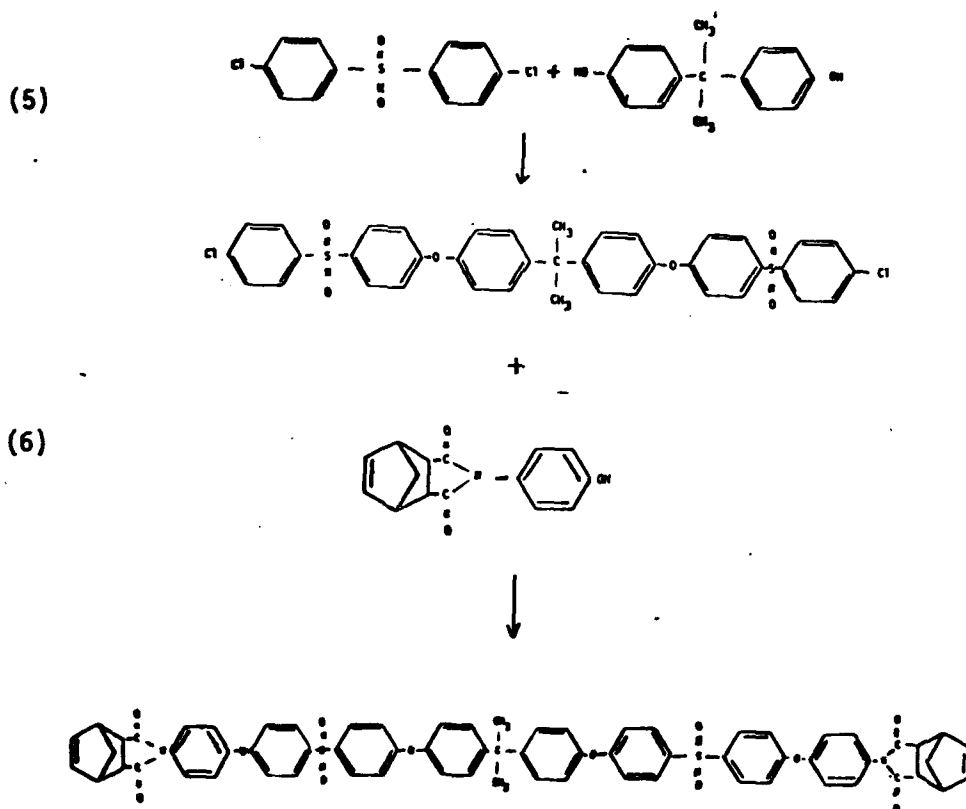

Figure 10. DSC, Reaction Product Equation 3 (MNI)

After the reaction, two separate compounds and their FTIR spectra were obtained. Analysis of the spectra (Fig. 11 and 12) indicates that the two compounds obtained were most probably the mono and di substituted phenol-ether of DCDPS and PNI. This observation was indicated by the presence of organic chloro groups in Figure 11 and their absence in Figure 12. In addition, the melting points of the two compounds were different (i.e., 170-190°C versus 210-225°C).

The second norbornene capped oligomer made consisted of the products of a two-state reaction (see equations (5) and (6)). The formula molecular weight of the oligomer was calculated as 1313.



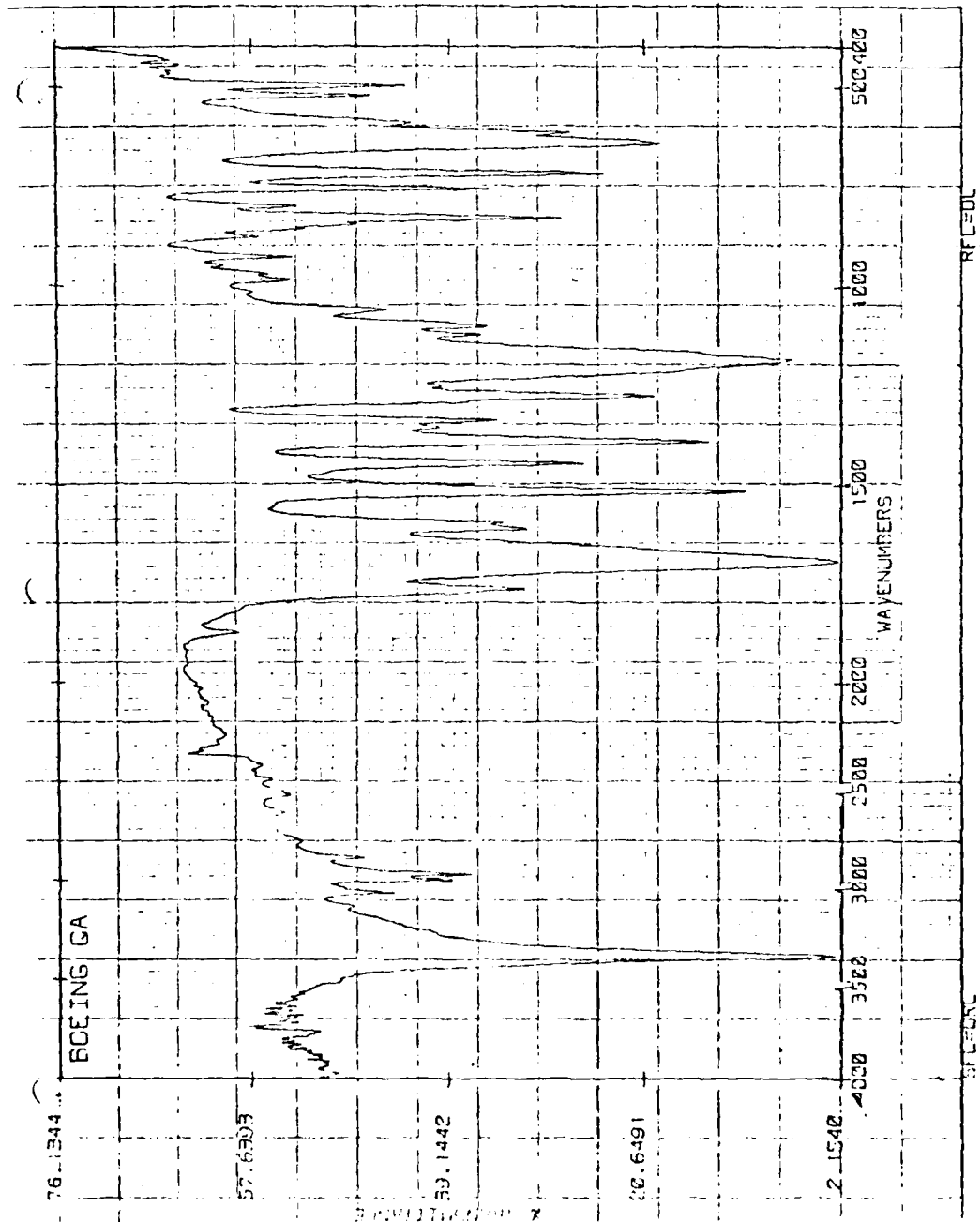

Figure 11. FTIR, Reaction Products Number 1, PNI and DCDPS

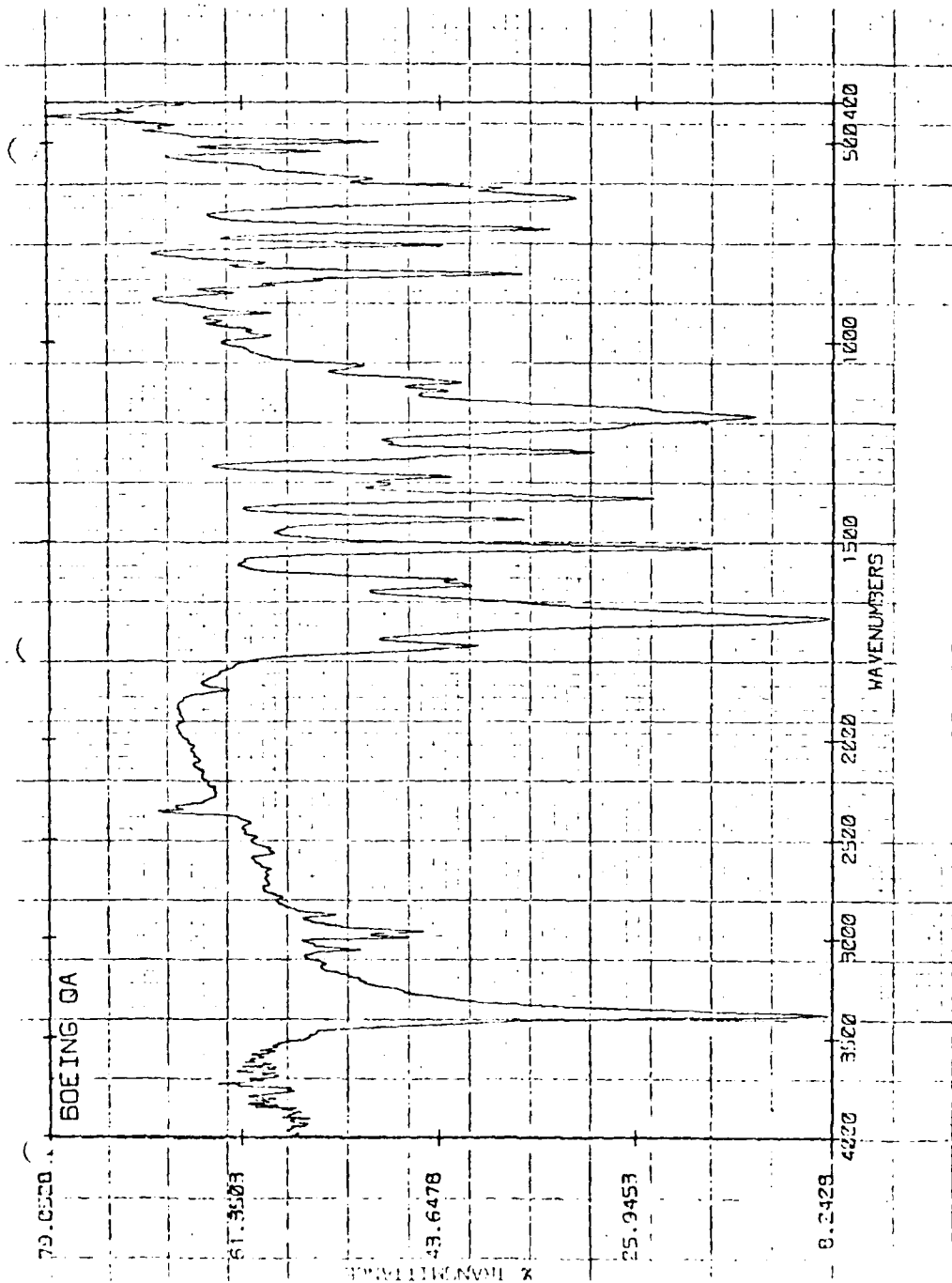
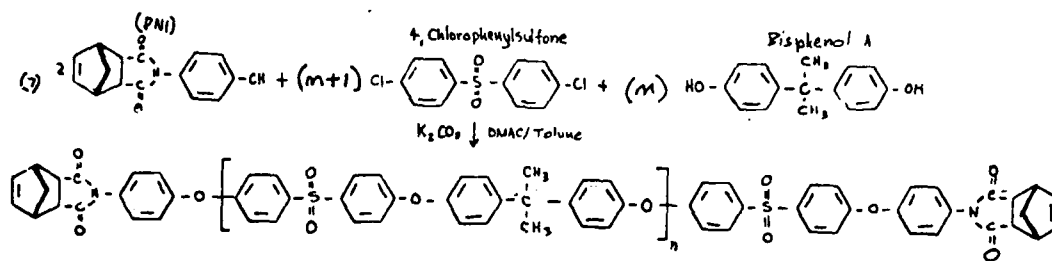

Figure 12. FTIR, Reaction Products Number 2, PNI and DCOPS

A resinous product was obtained from this reaction, and the Fisher-Johns melting point test indicates that the resinous product completely liquifies at 180-260°C. Since this temperature is lower than the 275°C required by the norbornene cap to undergo the reverse diehls alder reaction, a second norbornene capped polysulfone oligomer was made. The only difference was to raise the FMW of the oligomer to 20,000 (see Equation 7). This molecular weight was selected because it was lower than the postulated molecular weight of the PKXA polysulfone polymer and would provide improved processing characteristics (i.e., vacuum bag processing capability, whereas the P1700 polymer required 200 psi).



2.2.3 PREPARATION OF GRAPHITE/NTS COMPOSITE

The preparation procedure for NTS 20-1 resin and graphite/NTS composite follows.

Resin Preparation (NTS 20-1) (See Equation 7)

Place 4.39 g (0.017 mole) PNI, 110.07 g (0.383 mole) DCDPS, and 85.53 g (0.375 mole) BPA into a 3l resin kettle with a 5 percent molar excess (55.6 g) of K_2CO_3 . Add 511.2 g n,n-dimethylacetamide (DMAC) and 255.6 g toluene to produce a mixture which is 25 percent solids in a 2:1 solution, by weight, of DMAC and toluene. Equip the resin kettle with a mechanical stirrer, thermometer, condenser, Dean Stark trap, and inert gas purge.

Heat the mixture in an oil bath at 140°C for 96 hours. Then raise the temperature to 165°C and remove the toluene by extraction. Slowly add the DMAC solution to cold tap water in a Waring blender. Blend to a fine slurry and filter. Rinse with deionized water until rinse water is free of Cl, as indicated by the addition of AgNO₃. Dry 24 hours at 100°C, lightly covered, in an air-circulating oven.

Prepreg Preparation

NTS 20-1/graphite fabric prepreg, at 36 percent resin solids, was prepared by solvent impregnation from dilute methylene chloride solution. The graphite fabric was spread flat on a release film (FEP) in a fume hood. The approximately 10-15 percent prepregging solution was evenly swept into the fabric and allowed to air dry. This procedure was repeated, on alternating sides of the fabric, until the desired weight of resin had been applied. The prepreg then was dried 2 hours at 275°F in an air-circulating oven.

Cure

Seven plies of NTS 20-1 prepreg were stacked, double-wrapped in release-coated 2-mil Kapton film, and sealed in a vacuum bag for high-temperature cure, as in Figure 13.

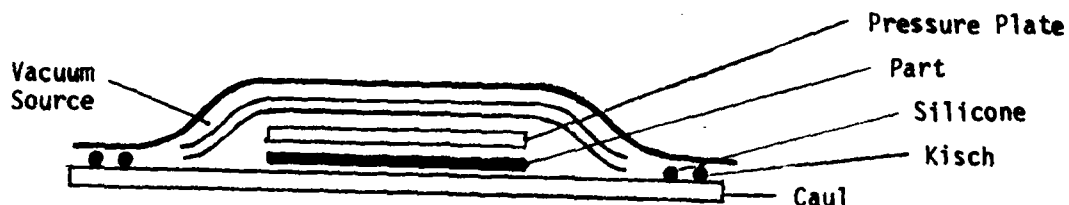

Figure 13. Vacuum Bag for NTS 20-1 Cure

The part was cured under vacuum pressure by heating to 600°F and maintaining the temperature for 30 minutes. It was then post-cured, under restraint, 6 hours at 625°F.

2.2.4 EVALUATION OF NTS 20-1 COMPOSITE

A short series of tests was conducted on the cured NTS composite. The tests included solubility in methylene chloride, mechanical properties, and cursory reforming. To ensure that something unique had occurred with the NTS resin, a control panel was fabricated and underwent identical testing. The control panel consisted of the same graphite fabric impregnated with P1700 polysulfone. The only difference in the processing cycle was that 200 psi was required to consolidate the graphite/P1700 composite, whereas only vacuum pressure was required using the NTS 20-1 composite. Details of the experiments are described in this section.

2.2.4.1 Solubility in Methylene Chloride

Samples of the two composites were machined into 1 x 0.5-inch coupons and placed in a bottle containing methylene chloride. The samples were observed until ply separation occurred. The results of the testing revealed conclusively that the P1700 graphite composite had ply separation in 3 hours, whereas the NTS 20-1 graphite composite remained intact, with only slight swelling after immersion times to 2 months. This test amply demonstrated that the NTS resin had changed the character of the polysulfone system.

2.2.4.2 Mechanical Properties

The composites under consideration (P1700 and NTS 20-1) were machined into short beam shear specimens and tested at ambient conditions and 300°F using the following procedure. The testing was accomplished on a flexure testing fixture using three-point loading with the span being equal to four times the specimen thickness. Results of testing are reported below:

	<u>Short Beam Shear, ksi</u>	
	RT	300°F
P1700 Composite	7.07	5.14
NTS 20-1 Composite	7.61	5.41

2.2.4.3 Reforming Evaluation

To determine if the NTS 20-1 composite could be reprocessed similarly to the P1700 polysulfone, a test was conducted where a small coupon was reformed over a 90-degree angle. The flat coupon was placed on an aluminum angle and vacuum bagged. The assembly was placed into an autoclave and formed using the conventional P1700 cure schedule (i.e., 200 psi at 600°F for 30 minutes). After removing the assembly from the vacuum bag, the previously flat specimen had reformed to the shape of the aluminum tool (see Figure 14). The specimen was then mounted and photomicrographs were taken (Figures 15 and 16). As can readily be seen, there was little or no deformation of the graphite fabric plies during the reforming operation. As evidenced by the end of the specimen, the individual plies had moved sufficiently to permit the flat coupon to readily form over the 90-degree angle.

2.2.5 SUMMARY OF POLYMER WORK

Significant progress was made during this program in obtaining a polysulfone composition that is insoluble in methylene chloride. The NTS polymer obtained demonstrated, when made into a graphite composite, that it possessed all of the desired properties hoped for at the start of the program. A summary of the major accomplishments follows:

1. Two imide-containing norbornene compounds were synthesized.
2. Two norbornene compounds were synthesized.
3. Two norbornene-capped polysulfone oligomers were synthesized.
4. 20,000 FMW NTS polymer was chemically analyzed.
5. 20,000 FMW NTS polymer was used to fabricate a graphite composite.
6. The NTS graphite composites demonstrated the same mechanical properties and reformability as P1700 composites, but with the added feature of insolubility in methylene chloride.

2.3 REPAIR (TASK II)

Two repair methods of joining graphite/epoxy repair patches to damaged graphite/epoxy structure evaluated were: (1) resistance heating, and (2) use of glue guns.



Figure 14. - Postformed NTS20-1 Laminate



Figure 15.—Photomicrograph #1 of Postformed NTS20-1 Laminate



Figure 14.—Postformed NTS20-1 Laminate



Figure 15.—Photomicrograph #1 of Postformed NTS20-1 Laminate

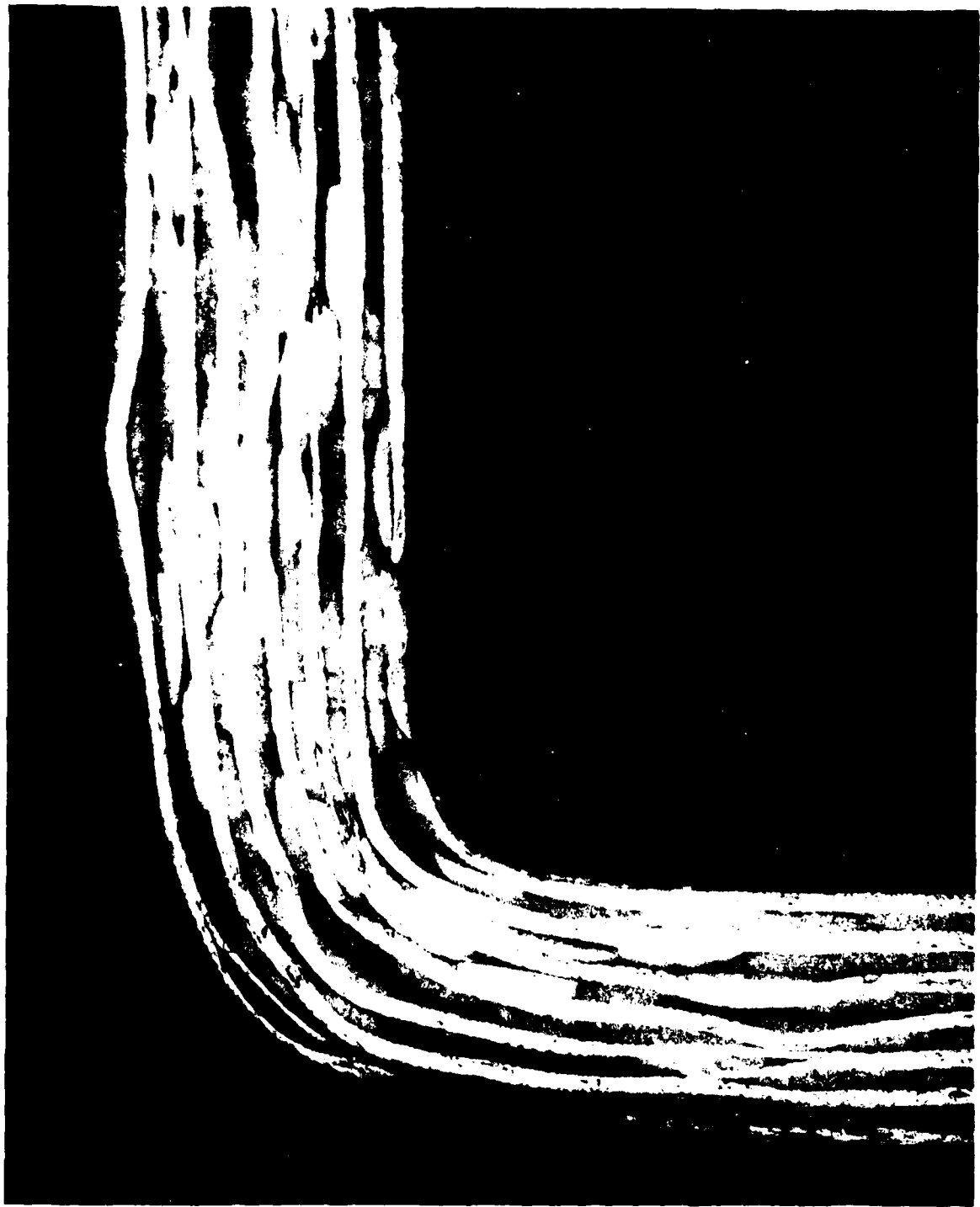

Figure 16.—Photomicrograph #2 of Postformed NTS20-1 Laminate

The resistance heating approach used to simulate joining repair doublers to structure being repaired consisted of impregnating thermoplastic polymers onto electrically conductive scrim cloth, which was then positioned between the details to be joined, pressure applied, and the heat required to soften the thermoplastic resin obtained by applying electrical current to the conductive scrim. Arrangements were made for Mobay Chemical Corporation to metallize a style 112 glass scrim cloth and a 0.007-inch graphite fabric supplied by Boeing. The metallizing process, which is proprietary to Mobay, is based upon precipitation coating from a metal salt solution. Nickel, copper, and gold have been applied to fabrics, with other metals a possibility. After the glass scrim and graphite fabric had been nickel coated by Mobay, they were made into adhesive film at Boeing by impregnating them with: (1) NTS 20-1 or (2) Radel 5010. These adhesive films were used to bond graphite/epoxy, single lap joint specimens. A variable, dc power supply provided the current for heating the metallized scrim which in turn melted the thermoplastic resin. Joint strengths in excess of 1000 psi were achieved with the graphite scrim. The 112 glass scrim was too flimsy and broke during the bonding process.

A new polymer developed by TRW, based upon thermoplastic bismaleimide technology, was evaluated. Simple lap joints were prepared of the following adherend combinations: aluminum to aluminum, graphite/epoxy to graphite/epoxy, graphite/KM-1 to graphite/KM-1, and aluminum to KM-1. A glue gun developed by TRW was used to prepare the specimens. While the glue gun performed well, the resin did not wet out sufficiently to produce high-quality bond joints. TRW can modify the resin to resolve this problem. Attempts to form composite-to-composite joints using Radel 5010 as the adhesive and a Norton high-temperature glue gun also were unsuccessful because the glue gun did not possess sufficient heat capacity to melt the resin.

3.0 CONCLUSIONS AND RECOMMENDATIONS

The primary objective of this program was to develop graphite reinforced thermoplastic composites that are resistant to fluids likely to be encountered in aircraft flight and maintenance operations. A secondary objective was to demonstrate simple repair procedures suitable for use on Naval aircraft stationed aboard ship. The studies conducted successfully achieved the objectives of the program. The conclusions reached from this program are presented in Section 3.1 and recommendation for further study/applications are presented in Section 3.2.

3.1 CONCLUSIONS

1. The KM-1 polyethersulfone, also designated 600P, possessed acceptable mechanical properties. KM-1 was more resistant to aircraft fluids than polysulfone, but not to the level desired for aircraft structural applications. KM-1 is not recommended for use in Naval aircraft structure.
2. Graphite/PKXA composites had lower mechanical properties than graphite/polysulfone, but acceptable fluid resistance as determined by the evaluations performed herein. PKXA is acceptable for use in selected Naval aircraft structure.
3. XU-218 polyimide composites had low mechanical properties and were rapidly degraded by methylene chloride. XU-218 is not acceptable for use in Naval aircraft structure.
4. BR-31 polyphenylene sulfide resin appears to be unaffected by fluid exposure. Further evaluation is needed before its suitability for use in Naval aircraft structure can be determined.
5. CM-1 showed promise of possessing acceptable fluid resistance and mechanical properties for use in Naval aircraft structure.
6. The new thermoplastic resin developed on this program exhibited excellent potential of being suitable for use in Naval aircraft structure.
7. Acceptable adhesive lap joints were prepared using resistance heating to melt thermoplastic resins that had been impregnated onto metallized scrim.
8. Attempts to prepare adhesive lap joints using a glue gun and Radel 5010 were unsuccessful.

3.2 RECOMMENDATIONS

Based on results of evaluations performed during this program, the following recommendations are offered:

1. Optimize the synthesis and processing procedures on the new thermoplastic resin (NTS 20-1) developed on this program.
2. Continue processing studies of the BR-31 resin.
3. Further investigate the suitability of large area repairs using the glue gun and resistance heating techniques demonstrated on this program, except use a lower temperature melting resin such as a modification to NTS 20-1.

REFERENCES

1. Unpublished data, Boeing Aerospace Company, Seattle, Washington.
2. Hill, S. G., House, E. E., and Hoggatt, J. T., "Advanced Thermoplastic Composite Development," Final Report on Contract N00019-77-C-0561, Boeing Aerospace Company, Seattle, Washington, May 1979.

SECURITY CLASSIFICATION OF THIS PAGE (When Data Entered)

REPORT DOCUMENTATION PAGE		READ INSTRUCTIONS BEFORE COMPLETING FORM
1. REPORT NUMBER D180-26067-1	2. GOVT ACCESSION NO. AD-A102217	3. RECIPIENT'S CATALOG NUMBER
4. TITLE (and Subtitle) Graphite Reinforced Thermoplastic Composites	5. TYPE OF REPORT & PERIOD COVERED Final Report	
6. AUTHOR(s) - S.G. Hill, E.E. House, C.H. Sheppard, W.A. Symonds, J. Jaquish	7. PERFORMING ORG. REPORT NUMBER	
8. PERFORMING ORGANIZATION NAME AND ADDRESS Boeing Aerospace Company P.O. Box 3999 Seattle, Washington 98124	9. CONTRACT OR GRANT NUMBER (s) N00019-79-C-0203	
10. CONTROLLING OFFICE NAME AND ADDRESS Naval Air Systems Command (AIR 5163D3) U.S. Department of the Navy Washington, D.C. 20361	11. PROGRAM ELEMENT, PROJECT, TASK AREA & WORK UNIT NUMBERS	
12. MONITORING AGENCY NAME & ADDRESS (if different from Controlling Office)	12. REPORT DATE August 1980	13. NUMBER OF PAGES 45
	14. SECURITY CLASS. (of this report) Unclassified	15a. DECLASSIFICATION/DOWNGRADING SCHEDULE
16. DISTRIBUTION STATEMENT (of this Report) Approved for public release: Distribution Unlimited		
17. DISTRIBUTION STATEMENT (of the abstract entered in Block 20, if different from Report)		
18. SUPPLEMENTARY NOTES		
19. KEY WORDS (Continue on reverse side if necessary and identify by block number) Polysulfone PKXA NTS 20-1 Polyphenylene sulfide BR-31 XU-218 Polyethersulfone KM-1 Thermoplastic polymers CM-1 Thermoplastic polyimide Graphite/Thermoplastic Composites		
20. ABSTRACT (Continue on reverse side if necessary and identify by block number) The objectives of this program were to: (1) Develop graphite reinforced thermoplastic composites that are resistant to aircraft fluids and, (2) Evaluate repair techniques suitable for use on aircraft stationed with the fleet.		

The thermoplastic resins obtained from material suppliers and evaluated were PKXA polysulfone, KM-1 polyether sulfone, XU-218 thermoplastic polyimide, CM-1 fluorocarbon based polymer and BR-31 polyphenylene sulfide. Also, a modified polysulfone (NTS 20-1) was invented, synthesized and evaluated.

Resin characterization studies were performed. Impregnation and laminating procedures were optimized. Mechanical properties were determined on graphite reinforced composites. A study was conducted to determine resistance of graphite fabric/thermoplastic composites to fluids likely to be encountered in aircraft flight and maintenance operations.

Two procedures for repairing graphite composites using thermoplastic materials were investigated. They were: use of a glue gun and, resistance heating of a metallized scrim that had been impregnated with a thermoplastic resin.

