

AD-A102 107

BATTELLE COLUMBUS LABS OH
SYMPOSIUM ON TOXIC SUBSTANCE CONTROL: DECONTAMINATION, APRIL 22--ETC(U)
JUN 81

F/6 15/2

DAA629-76-0-0100

UNCLASSIFIED

ARC SL-SP-81012

NL

1 of 2
AD A
102 107

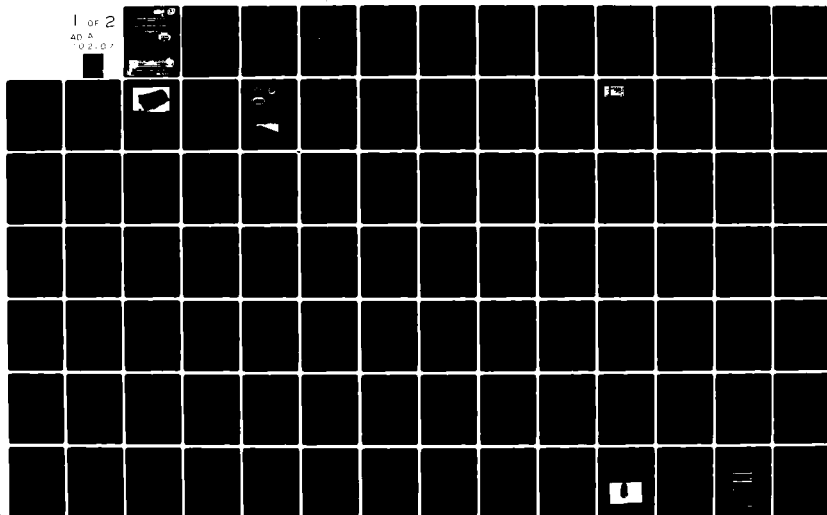

AD A102107

Disclaimer

The findings in this report are not to be construed as an official Department of the Army position unless so designated by other authorized documents.

Disposition

Destroy this report when it is no longer needed. Do not return it to the originator.

UNCLASSIFIED

SECURITY CLASSIFICATION OF THIS PAGE(When Data Entered)

20. ABSTRACT (Contd)

biological decontamination, liquid blasting, water-jets as methods for physical decontamination, and surface active displacement solutions. Summaries of one day workshop sessions on the subjects of chemical methods of toxic substance decontamination, physical methods of toxic substance removal, contamination monitoring, personnel decontamination, and contamination avoidance for the future were also presented.

Accession For	
NTIS GRA&I	<input checked="" type="checkbox"/>
DTIC TAB	<input type="checkbox"/>
Unannounced	<input type="checkbox"/>
Justification	
By _____	
Distribution/	
Availability Codes	
Dist	Avail and/or Special
A	

UNCLASSIFIED

SECURITY CLASSIFICATION OF THIS PAGE(When Data Entered)

PREFACE

Chemical and biological (CB) defense must be an integrated system of the components described in Figure 1. The components form a wheel that has four spokes: detection, contamination control, protection, and the medical aspects.

Detection: The first spoke is detection of the presence of a toxic environment – an extremely lethal environment. It requires automatic alarms to warn of the presence of a hazard in time to initiate protective action to continue the mission, monitoring equipment to measure the presence and location of toxics, and kits to identify the nature of the contaminant.

Contamination Control: The second spoke is a two part program – the use of methods to minimize the effects of contamination, and ease the burden of Decontamination, that is, **Contamination Avoidance**; then, **Decontamination** to clean up equipment and critical areas that have become contaminated, with logistically superior methods and less manpower intensive procedures. The current doctrine emphasizes scrubbing. There must be a better way as we cannot afford the time, men, or equipment.

Physical Protection: The third spoke is Physical Protection of people and equipment – for the **individual** so that he/she can operate safely continuing the mission in the highly toxic contaminated area; and **collective** so that areas can be kept clean for individuals to work without the burden and encumbrance of individual protection, and can get rest and relief from the individual protective burden.

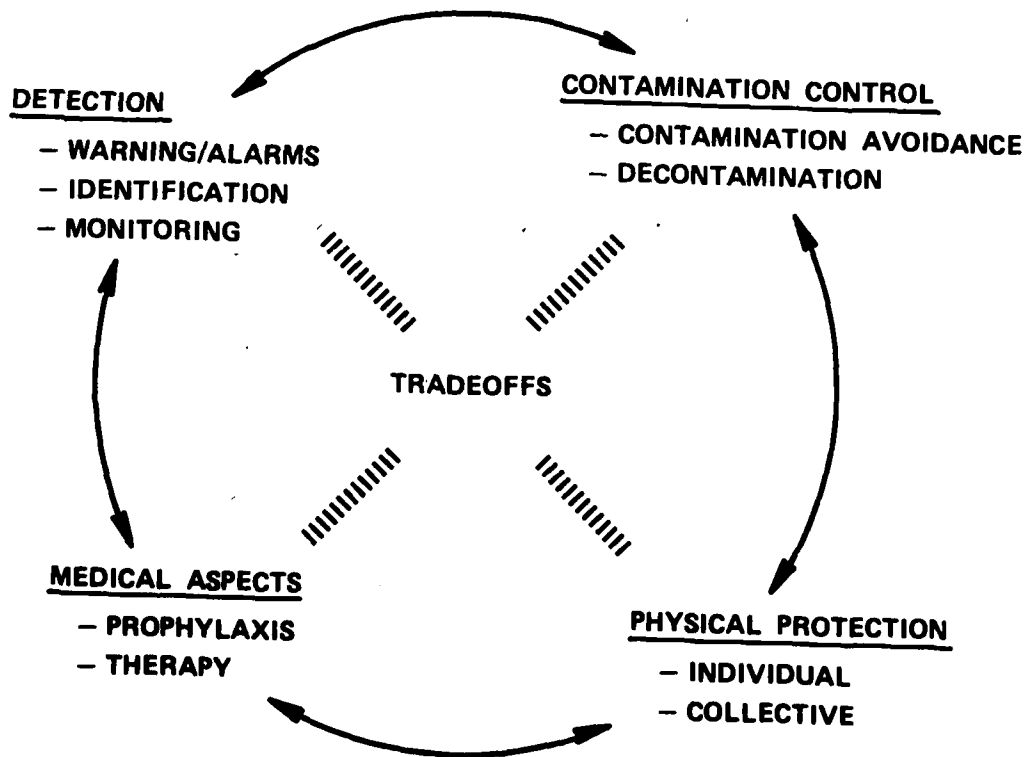

FIGURE 1. Integrated CB defensive system.

Medical: The fourth spoke is medical – prophylaxis for the individual to help his body sustain exposure to toxics; and, **therapy** – treatment to sustain life after exposure and return the individual to full functionality at the earliest time. We also need to improve doctrine on handling casualties on a chemical battlefield.

The challenge that we and everyone else faces is where does one make the trade-offs to resolve the total toxic environment problem. How will detection facilitate protection? How will detection assist in contamination control? How do the medical aspects interact with the others? A system approach to the total problem is essential to balance the tradeoffs.

There are rarely enough resources to do the whole job, but right now there are at least two priority programs in the chemical area. They are, develop and field a new mask, and develop and field an improved decontamination system. Detection is important to both of these. We have some approaches in this area and we need more. Monitoring for contamination is a difficult problem, especially as part of the decontamination problem.

The U.S. Army Training and Doctrine Command (TRADOC) is also using Figure 1 except that, from their point of view, they replace the tradeoffs with training. TRADOC is talking in terms of training soldiers to live in a CB environment on the defensive basis. The Chemical Systems Laboratory is talking in terms of tradeoffs so that one can apply limited research and development dollars in a balanced program to achieve greatest payoff.

Summarizing the problem, we are dealing with the most toxic chemicals around. We are dealing with small quantities of these materials that are widely dispersed – in densities of grams per square meter. We are dealing with potentially thickened and tacky materials which make decontamination more difficult. There is needed technology for detection on surfaces, logistically improved decontamination techniques, improved test techniques, and systems studies. The challenge is to see how fast we can move out and obtain solutions.

Acknowledgments

We would like to thank Ms. Susan R. Armstrong and Mr. Phillip N. Wells whose efforts were invaluable in arranging for the symposium publicity and facilities, Mr. Carl R. Spilker and the Report and Library Services for assistance in preparing the Proceedings and most of all, Dr. James A. Baker of the Chemical Systems Laboratory, ARRADCOM, for sponsoring the symposium.

FOREWORD

George G. Outterson
Battelle's Columbus Laboratories

Toxic substances may be decontaminated using chemical and physical methods. Some methods used by the Army to decontaminate primarily chemical agents are outlined.

Several decontamination methods, such as fire or strong bleaches, are designed for use on equipment or terrain and would be far too severe for personnel. Thus, a section addresses personnel decontamination. Associated with decontamination is the need for monitoring to determine when decontamination is complete. Monitors presently available for use are described. Finally, measures can often be taken to minimize contamination before an agent attack are addressed.

Chemical Methods of Toxic Substance Decontamination

There are two general categories of chemical decontaminants presently used by personnel to detoxify chemical agents: standard and field expedient decontaminants. Standard decontaminants are those developed specifically for use by military personnel. Field expedient decontaminants are those materials that are readily available in a military environment.

The standard decontaminants are DS-2, supertropical bleach (STB), and the components of the M258 decontamination kit. Table 1 lists the agents for which each of these standard decontaminants is used.

TABLE 1. Standard Chemical Decontaminants

Decontaminant	Agents Used On
STB	Blister and nerve agents
DS-2	All chemical agents
M258 Kit	
Sodium Hydroxide, Ethanol, Phenol, Water	G-Series nerve agents
Chloramine B, ZnCl ₂ , Ethanol, Water	Blister and V-Series nerve agents

A large number of field expedient decontaminants have also been identified for the detoxification of chemical agents. Among these are ammonia (NH₃), caustic soda (NaOH), sodium carbonate (Na₂CO₃), lime (CaO), laundry bleach (5 percent NaOCl), and TSP or trisodium phosphate (Na₃PO₄). Oxidation by fire and steam hydrolysis are other field expedient techniques. These decontaminants and techniques however, are not effective against all agents in general.

Chemical decontaminants may be applied using either standard or field expedient equipment. The standard equipment for applying chemical decontaminants is the M12A1 Skid-Mounted Power-Driven Decontaminating Apparatus. Table 2 describes the performance and capacity characteristics of the M12A1. DS-2 may be applied using the M-11 1-1/2-quart DS-2 portable decontaminating apparatus. Table 3 describes the performance and capacity characteristics for this equipment item. DS-2 can also be applied from bulk containers using brooms, mops, or brushes.

Physical Methods of Toxic Substance Removal

Physical methods do not necessarily detoxify chemical agents, but remove the agents from personnel, equipment, and/or terrain. Probably the most important physical removal method is aeration. The agents evaporate and are dispersed in the air. Aeration is important for all of the volatile agents.

Active physical removal methods include the use of flat sticks (such as are in the M258 kit), pads containing Fuller's earth, heat in the form of fire or steam, and high pressure water rinses. Another method is simple washing with hot soapy water.

Contamination Monitoring

There are two primary devices that are presently used to monitor for chemical agents: The M-8 series alarm and the M256 chemical agent detector kit. The M-8 series alarm is a point source alarm that actively samples ambient air and reacts to low concentrations of nerve agents. The M-8 alarm detector also detects several other agents including HCN, CNCl, COCl₂, Cl₂CNOH, and BrC₆H₄CH₂CN. The M256 chemical agent detector kit is a passive detector that shows a color change when a nerve, blister, or blood agent is present. The M256 kit also contains ABC M-8 detector paper that is used to blot the surfaces suspected of agent contamination. The M-8 paper changes color when an agent is present.

A liquid agent detector (LAD) and an advanced liquid agent detector (ALAD) have been developed to replace M-8 paper.

A number of monitoring instruments have been developed or purchased for use during depot storage and demilitarization operations. Typically, these instruments are used to detect extremely low concentrations of specific agents. The instruments are often suitable primarily for fixed installation rather than portable deployment in a rapidly moving battlefield.

Personnel Decontamination

The M258 Skin Decontamination Kit is used by individual soldiers to decontaminate themselves. The kit contains two vials and several plastic sticks. The plastic sticks are used to remove visible droplets of agents from the skin and clothing. Vial I contains an aqueous solution of sodium hydroxide, ethanol, and phenol, and is used to decontaminate the G-series of nerve agents. Vial II contains chloramine B and ZnCl₂ in a water-ethanol solution and is used to decontaminate the other agents, i.e., mustard and VX. Portable showers may be erected for personnel decontamination.

TABLE 2. Characteristics of the M12A1 Power-Driven Decontamination Apparatus

Working pressure	60-130 psi
Coverage per filling (Average for smooth surface)	1300 m ²
Discharge rate	
One spray gun	25 gpm
Two spray guns	50 gpm
Tank capacity for STB slurry	310 gal

TABLE 3. Characteristics of M-11 Portable Decontaminating Apparatus

Capacity	1-1/3 quart
Working solution	DS-2
Weight of filled apparatus	6 lb
Effective spray range	6-8 ft
Coverage per filling	15 m ²
Pressurization	N ₂ cylinder

Contamination Avoidance

Contamination avoidance refers to measures taken in advance of a chemical attack to minimize chemical contamination. The measures can include both specific actions on the part of military personnel during operations and considerations in the design and specification of military equipment.

An example of the former is the use of overhead shelters to minimize surface contamination from liquid droplets of agents. An example of the latter is the use of polyurethane paints. Chemical decontamination is easier and more complete when the surfaces being decontaminated have been coated with polyurethane paints, which do not absorb agents.

TABLE OF CONTENTS

	Page
PREFACE	3
FOREWORD	5
KEYNOTE ADDRESS	11

PAPERS

SOME LASER TECHNIQUES FOR CHEMICAL DETECTION	19
LASER-INDUCED DECOMPOSITION OF ORGANOPHOSPHATES	27
NEW TECHNOLOGY FOR THE DESTRUCTION OF TOXIC WASTES	39
EVALUATION OF DECONTAMINATION FORMULATIONS	45
COMPATIBILITY OF MATERIALS WITH CHEMICAL AGENTS AND DECONTAMINANTS	59
BIOLOGICAL DECONTAMINATION FROM THE ARMY'S POINT OF VIEW	71
INVESTIGATION OF TECHNIQUES FOR THE DECONTAMINATION OF MILITARY VEHICLES AND PERSONNEL PROTECTION ITEMS.	79
DECONTAMINATION BY LIQUID BLASTING	89
ASPECTS OF WATER-JET USAGE FOR PHYSICAL DECONTAMINATION	103
SURFACE-ACTIVE DISPLACEMENT SOLUTIONS	109

WORKSHOP SUMMARIES

CHEMICAL METHODS OF TOXIC SUBSTANCE DECONTAMINATION	115
PHYSICAL METHODS OF TOXIC SUBSTANCE REMOVAL	119
CONTAMINATION MONITORING	123
PERSONNEL DECONTAMINATION	129
CONTAMINATION AVOIDANCE FOR THE FUTURE	133
DISTRIBUTION LIST	139

KEYNOTE ADDRESS

BG Gerald G. Watson
Fort McClellan, Alabama

Dr. Edward W. Ungar, Director, Battelle's Columbus Laboratories introduced General Watson: "It's a real honor to have as our keynote speaker, Brigadier General Gerald G. Watson. General Watson is Deputy Commander for Training at the U.S. Army Military Police and Chemical School Training Center in Fort McClellan, Alabama. General Watson."

Thank you very much. Dr. Ungar, ladies and gentlemen, it's a pleasure to be here. Wherever there's a group of people gathered together to talk about the chemical warfare program, I am always delighted to participate. It's something I've held very dear, something I've spent a lifetime working on, and finally I can see activity and things happening that should have been going on a long time ago. It's a nice feeling. Why do I feel this way? Simply because I think that for too long our Army has been at risk when compared with the Soviet Union. I hope that we are now in a position to start to reduce this risk through our growth and our industrial and government involvement in the solutions to this problem.

Before I get into our subject for today, I want to report to you where we are in several key areas of the chemical warfare program. As most of you know, the Army decided about a year and a half ago to reestablish its chemical school at Fort McClellan, Alabama. Two-thirds of the school is already at Fort McClellan. We started our first class at Fort McClellan on the 25th of April 1980. By the first of August, the entire school will be operational at Fort McClellan. We'll have a staff of about 400 people. We will have an average student load of about 700. So the combined effort will be somewhere around 1,000 to 1,100 in the initial phase.

With regard to force structure, many of you have read reports that 2 or 3 years ago we had about 2,200 chemical trained personnel through our entire Army. That has changed. We now have in each division an NBC Company. This company plus other chemical trained personnel, totals about 250 people in each of our combat divisions. That isn't much; probably isn't enough, but it's certainly a long way from the 20 that we had there less than 18 months ago. The force structure is probably one of the best successes we have had simply because we have had to swim hard upstream during a period when the entire force structure was being reduced.

The other key area is the chemical systems program review. On the 28th of May, we are going to have a general officer conference that will look at the entire chemical program. It will examine the program in terms of doctrine, retaliatory capability, force structure, our obscuration, and sustainability. I would expect that when the conference opens, it will be attended by most of the leadership of the Army. And we are going to look at this program and from this you will see some action plans that will create new starts within the entire chemical warfare program.

I think it would be foolish of me to stand here and talk to you about a scientific matter since your credentials are rather impressive. I would like to compliment Battelle and, of course, the United States Army Laboratory for this occasion today. Two years ago this would not have been possible. I think both of you are to be complimented on putting together this kind of symposium so that we can come and talk about one of the great problems in our Army today.

I want to talk to you today in terms of tactical situations. I would like to talk to you in terms of what the soldier is going to experience on the battlefield. Because I think, in some cases, we've

gotten away from this important concept. I think you as scientists and engineers, need to have an appreciation of just how big the problem is. I have a few simple charts that I hope that I can convey to you the message that the chemical warfare problem on the battlefield is a rather huge one.

In Figure 1, I have taken a simple corps sector consisting of three divisions deployed side by side. To your right, you'll see what we would call our combat battalions and where they are going to be located in the defense, initially. Behind them are the reserve units, our key supply systems, supply routes, and command and control systems.

Now, as we move to the rear we find the corps area and this is where a lot of our general support organizations/functions are located. And then beyond that are the echelons above corps where many of our nuclear weapons systems, our airfields, and those other kinds of combat support activities that we need in order to be able to prosecute the war are located.

Figure 2 is to scale. And it shows you in depth what the Soviet Union is capable of delivering on our forces. Beginning up front with their first echelon divisions, they can simultaneously hit us with nonpersistent agent in our battalion defensive areas. And in our division rear areas with persistent agent: thickened GD, mustard. They can rely on their own second echelon divisions to extend the range all the way into our rear and hit our key support systems, our command and control systems and our key logistics nodes. In Figure 3, the entire battlefield, you can see the downwind distances of the vapor hazards that would exist for short periods of time where the nonpersistent agent has been employed. As we move on into the rear you can see the problem created by the persistent agent. It will be around for several days.

Now, I believe you can begin to see the magnitude of the Soviet effort. They have available within their force structure, the weapons systems that will allow them to strike deep within our forces.

You can see from this chart why the Soviet Union has collective protection and positive pressure systems in their combat vehicles. This allows them to keep the momentum of the battle going.

Figure 4 indicates their capability in terms of its impact on our forces, you can see that as much as 50 percent of the battle could be covered with some kind of toxic cloud for short periods of time and as much as 10 percent with persistent agent.

Here is what we're talking about in terms of casualties and the amount of equipment that we think is going to become contaminated. This should provide you a good appreciation for the kind of job that we have to do, the work that must be accomplished. This is the requirement. We hope that you can develop a system for us to use on the contaminated battlefield in order to minimize the level of effort required to operate.

Figure 5 indicates that when we start to plan and program our chemical defensive efforts we plan and program in four areas.

In looking at decontamination we have traditionally talked of decontamination in terms of emergency decontamination, partial decontamination, and total decontamination. Our decontamination doctrine requires us to talk of it in these terms. We have configured our development program to satisfy these needs. I think the question that really should be raised at this point is "Is this satisfactory?"

When we look at the individual, we're basically talking here in terms of matters of minutes that the individual must react to get the major pieces of contamination off of him if he is going to avoid becoming a casualty. What do we have to do that with? Not a whole lot. We have a kit that will

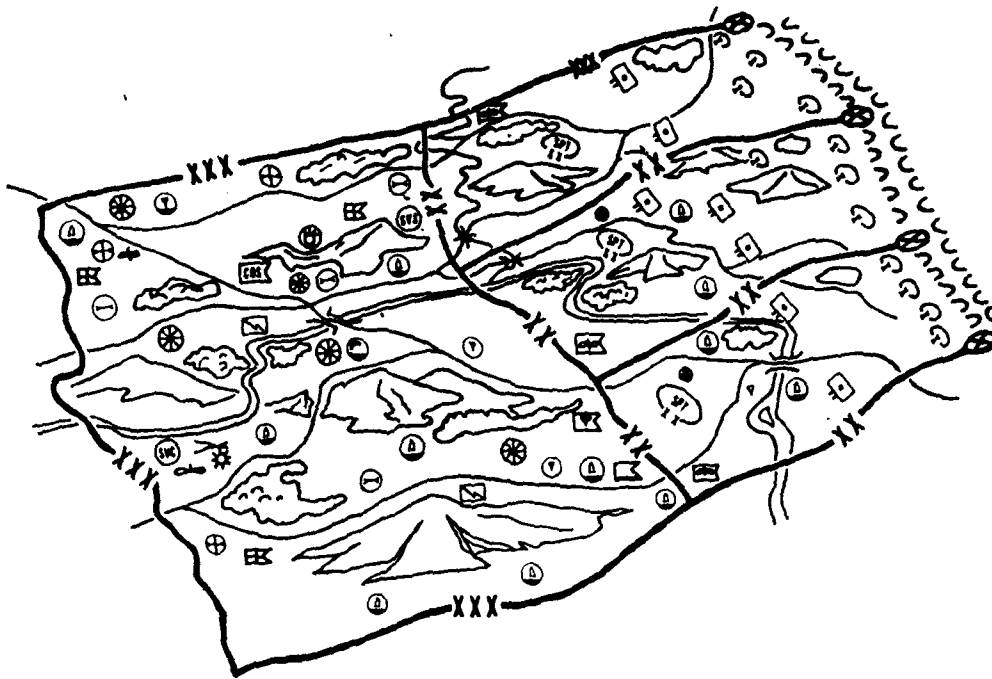

FIGURE 1. The Corps sector.

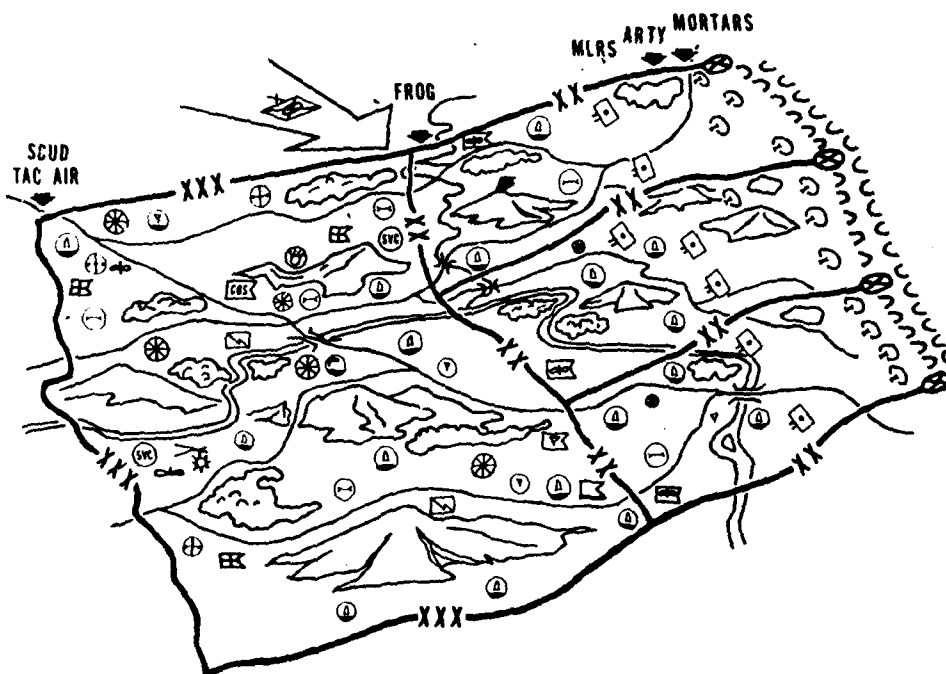

FIGURE 2. The battlefield.

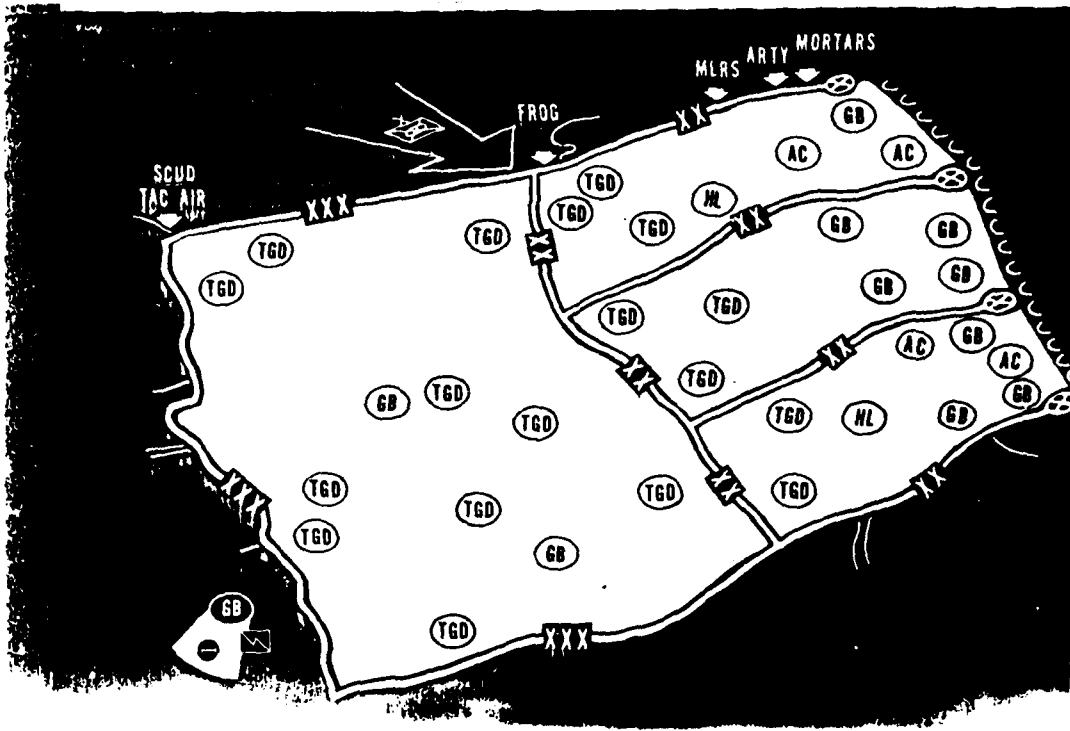
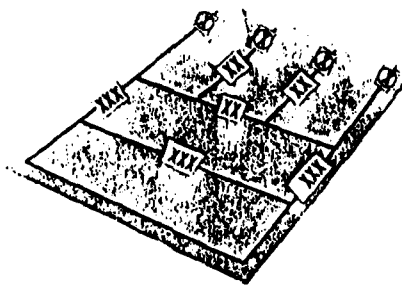

FIGURE 3. The contaminated battlefield.

10%
OF BATTLEFIELD
WILL BE
CONTAMINATED
WITH
PERSISTENT
AGENT (DAYS)



50%
OF BATTLEFIELD
WILL BE
COVERED
WITH
NONPERSISTENT
VAPORS (HOURS)

20% OF SOLDIERS WILL HAVE PERSISTENT AGENT ON THEM

20% VEHICLES CONTAMINATED

29% PERSONNEL EXPOSED

15% CASUALTIES

5% CASUALTIES PARTIAL EFFECTS

5% TAB-TOTAL FORCE (INDIRECT)

5% CASUALTIES-RESIDUAL (INDIRECT)

FIGURE 4. Effects of the contaminated battlefield.

allow a soldier to blot and remove some of the large pieces. Whether or not the soldier can find it and get into that kit and do the things that he needs to do in order to survive is rather doubtful in my mind. We need a better way for the individual soldier to decontaminate himself in order to survive.

The other two types of decontamination are partial and total decontamination. Until now, the United States Army has pursued a basic philosophy of total decontamination. I think that that's probably the wrong way to go.

I don't believe that we have the manpower, the time and the equipment required to do total decontamination of the forces and continue to fight. We must find a better and shorter way. Partial decontamination appears to be the direction that we need to travel at least until we better understand the phenomenon of partial decontamination.

Figure 6 is an example of the kind of things that we are talking about. If I look at the individual soldier and I start to measure his combat effectiveness as a function of the gas mask he wears, somewhere around the 12-hour mark his combat efficiency is going to start to drop. He's going to be at about 75 percent of his total combat efficiency at the end of 12 hours. Look what happens to him if you leave the mask on him for 24 hours. He's somewhere less than 50 percent combat effective. The decision that we need to make is one that in some way allows us to get the individual out of his mask at a point in time where he can retain a high level of combat effectiveness. Partial decontamination in this case would allow us to do that.

Well this is kind of the problem, as I see it, that the Soviet Union is going to create for us. Contamination creates for us an unacceptable level of resources required to decontaminate. In manpower, we have a manpower-intensive doctrine. In terms of time, we have a time-intensive doctrine. And we are just beginning to understand the logistics burden that we have created for ourselves by having large quantities of decontaminating solution and water that we need to cart around the battlefield to decontaminate ourselves and our equipment. Our chemical company that we put in the division can decontaminate only about 80 percent of the personnel workload. If we look at the numbers of pieces of large equipment, tanks, vehicles, and weapons systems, we can totally decontaminate only a small percentage of the entire quantity.

If we look at our equipment only, we are talking about less than 50 percent of that equipment which could be decontaminated with our current ongoing capability. I guess I'd like to leave you with the thought that we simply cannot afford the manpower that is required to decontaminate all the equipment that could become contaminated. It's too expensive not in terms of dollars, but in terms of manpower. We must find a better way.

The time required for an NBC Company that has three platoons to do one tank battalion is about 4-1/2 to 5 hours just to decontaminate one tank battalion. That's too long. We don't have 5 to 6 hours. So we must find a better way to do it. I think the challenge to you is to help us find that way. We can't afford to cart large volumes of material. We have to be able to do the job with a lot less material and still do an effective and efficient job.

Thank you for the opportunity to come here. I hope I've given you some thoughts. I really wanted you to see the battlefield as we see it so that you understand the magnitude of the problem.

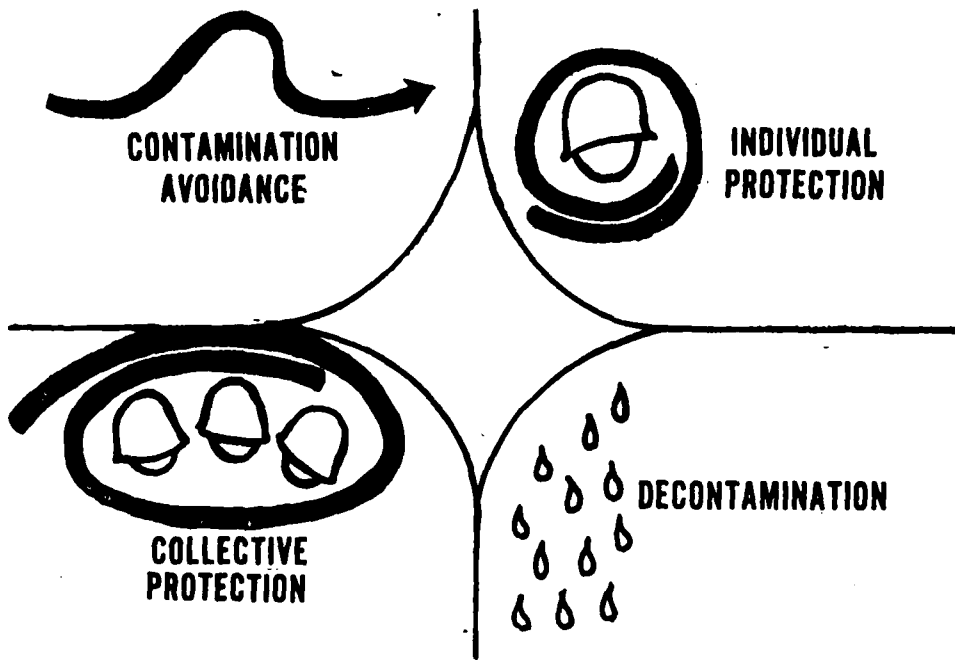

FIGURE 5. Concept of chemical defense.

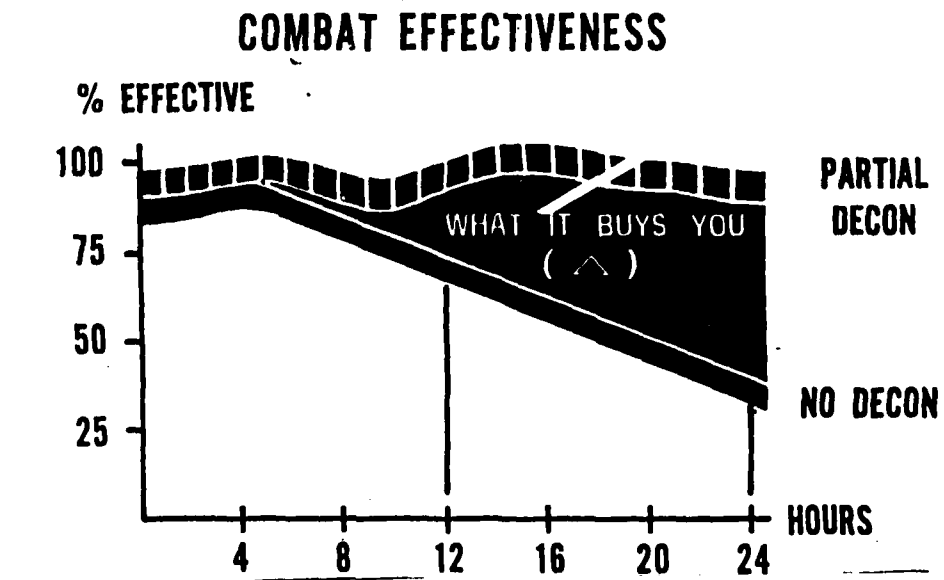

FIGURE 6. Decontamination.

BRIGADIER GENERAL GERALD G. WATSON

Brigadier General Gerald G. Watson was commissioned Second Lieutenant in 1957 when he received his Chemical Engineering degree from Trinity University in San Antonio.

For the next 13 years he has had various commands in Germany, Vietnam, and in the United States, as well as attending the Chemical Officer's Advanced Course at Fort McClellan; the Command and General Staff College, Fort Leavenworth; and the Air Force Institute of Technology, Dayton, where he received his M.S. in Logistics Systems Management.

In September 1970, General Watson was appointed Chief of the newly activated Chemical Munitions System Division, Headquarters, U.S. Army Munitions Command, in which he served as the Commodity Manager for all chemical weapons systems and equipment across all commodity life cycles and was the U.S. Army Munitions Command Project Officer for all chemical and biological disposal programs.

General Watson assumed command of Rocky Mountain Arsenal on 7 July 1972. While serving as the Commander, General Watson was directly responsible for the facilities design, construction and the initiation of the largest chemical munitions demilitarization operation ever undertaken by the United States Army.

He graduated from the U.S. Army War College in 1976 and was assigned as Chief, Chemical and NBC Defense Division, Office of the Deputy Chief of Staff for Operations and Plans, Headquarters, Department of the Army, Washington, D.C., in charge of the re-establishment of the Army's entire Chemical Warfare Program.

In August 1979, General Watson assumed duties as the Deputy Commander for Training at Fort McClellan, Alabama.

Among General Watson's decorations are the Legion of Merit, the Army Commendation Medal, the Air Medal, the Meritorious Service Medal and Bronze Star.

SOME LASER TECHNIQUES FOR CHEMICAL DETECTION

Robert K. Sander and M. I. Buchwald
University of California
Los Alamos Scientific Laboratory

ABSTRACT

Spectroscopy provides a fast sensitive method for chemical analysis. Lasers are high intensity narrow bandwidth, collimated light sources in the infrared, visible, and ultraviolet spectral regions. Wavelength tunable lasers can be used for spectroscopic chemical identification by means of techniques such as optoacoustic spectroscopy, thermal lensing, and fluorescence excitation. These methods all share the useful characteristic that their detection sensitivity to small quantities of chemicals improves with higher laser intensity. We have developed apparatuses to use these techniques for trace chemical identification and detection. In addition, a useful improvement to thermal lensing, which we designate thermal deflection spectroscopy, has been developed.

INTRODUCTION

Light absorption methods for chemical detection have been used for many years since they offer some real advantages over other methods. Optical absorption can be used as a probe for chemicals at a distance from the detector, thus preventing exposure of the operator to toxic or hazardous materials. The advent of laser light sources enhances the utility of traditional absorption techniques. Thus, the beam-like nature of laser light provides remote detection at much larger distances; the high intensity provides greater sensitivity for real time detection; and the narrow linewidths and tunability provide selectivity and specificity in identifying the toxic chemical in a complex environmental sample.

In traditional absorption spectroscopy, light is passed through a sample and the ratio of light intensity transmitted to light intensity incident on the sample, I/I_0 , is measured. Beer's law is used to relate this measurement to the quantity of absorbing material present in the sample. Increasing the intensity of the incident light does not affect this ratio nor does it appreciably affect the accuracy of the measurement if the amount of light absorbed is small. The reason is that one is measuring the effect of a small number of molecules on a large amount of light and trying to observe small changes in a large quantity.

Fortunately, a group of techniques which are collectively termed excitation spectroscopy have been developed over the past century or so and have been much less used until the advent of lasers. These methods include fluorescence spectroscopy^(1,2) and the optoacoustic effect⁽³⁾. Their common characteristic is that they follow the effects of the light absorbed rather than light transmitted. Fluorescence spectroscopy, for instance, measures the light emitted from the sample at a different wavelength following absorption. For a small sample there may be very little fluorescent light emitted, but the amount of fluorescence is proportional to the incident light intensity. Thus, the sensitivity of this method for trace chemical detection is greatly enhanced by the use of powerful lasers. The emitted light may be distinguished from the incident light by its different wavelength and by the difference in propagation direction. Laser-induced fluorescence has been used to detect compounds in the part-per-trillion range⁽¹⁾.

OPTOACOUSTIC EFFECTS

In the optoacoustic effect, a microphone is used to detect a pressure pulse following deposition of the absorbed light energy in the sample. This method shares with fluorescence the same characteristic of having a detection sensitivity that improves with increasing laser light intensity. The optoacoustic effect has been used to detect compounds in the sub-part-per-billion range⁽⁴⁾.

In a complex environmental sample there may be many different chemicals present; to prevent false alarms a toxic chemical detection method must also be an identification method. One needs to have a "fingerprint" pattern of peaks and valleys in the optical absorption spectrum of the compound of interest so that as the laser is scanned in wavelength, the excitation of fluorescence (or acoustic energy) mirrors that pattern of peaks and valleys, i.e., where there is no absorption there can be no fluorescence. This pattern can then be used to specifically identify the compound. In fluorescence spectroscopy it is also possible to measure the set of wavelengths emitted from the sample for a fixed excitation wavelength and thus obtain a two dimensional pattern for even better identification.

The requirement for a wavelength tunable laser light source is important, Figure 1 shows the range of various laser tuning techniques. Most methods begin with powerful, efficient driver lasers shown on the bottom of the figure. The driver lasers often are limited in tuning range, but these driver outputs can be shifted to new wavelengths by means of the techniques shown in the upper part of the figure. Sometimes the shift is fixed as in Raman shifting⁽⁵⁾; sometimes the shift is continuously tunable as in dye lasers⁽⁶⁾ or optical parametric oscillators⁽⁷⁾. These methods cover the ultraviolet, visible, and infrared regions of the spectrum.

In Figure 2 are shown the chemical agents of interest on the left side of the figure and the simulants with which we have worked on the right side. They are similar in that all of them are phosphonate esters. In Figure 3 is shown an infrared absorption spectrum of pure liquid OSP along with assignments of the absorption peaks to specific bond stretching frequencies⁽⁸⁾. These bonds are present in both the chemical agents as well as our simulants. Superimposed on the graph in dashed lines are the wavelengths of some CO₂ laser lines. A CO₂ laser could be rapidly tuned from one line to another to provide the kind of spectral signature previously discussed.

Figure 4 shows a concept of how optoacoustic detection could be used for point monitoring. An amplitude modulated laser beam, if it is absorbed in the duct, deposits energy in the air and produces a pattern of pressure waves which are detected by the microphone. The sound intensity is greatly increased if the modulation frequency corresponds to a resonant mode of the duct. Slots allow a fresh air sample to flow through the device for a quick response to contamination. While similar devices exist, it would be useful if optoacoustic detection could be used for remote monitoring, and more specifically, as single-ended remote monitoring devices were both the detector and the laser are in the same place. Such a concept is depicted in Figure 5. Using a 300-watt CO₂ laser and a cloud of Freon 12, we have generated sound intensities of over 100 decibels.

THERMAL DEFLECTION

When the modulated CO₂ laser is absorbed in a gas sample, both acoustic pressure waves and transient temperature increases are produced. We have discussed the detection of the pressure pulses; the temperature increase produces a decrease in the refractive index of the air. This effect has been used as a chemical detection technique and is called thermal lensing spectroscopy. In our modification, the gradient in refractive index at the CO₂ laser beam can be used to deflect a second probe laser beam such as a helium neon laser, and the deflection can be measured with a dual photodiode⁽¹⁰⁾. A device to accomplish this is shown in Figure 6. A CO₂ laser is modulated by a slotted wheel, 1. A helium neon laser beam travels parallel and adjacent to the CO₂ following the germanium beam combiner, 2. A 15-cm cell filled with air and varying partial pressures of absorber causes deflection of the helium neon beam with a lever arm, L, of 2 meters. A beam stop, 3, of pyrex prevents the CO₂ laser from damaging the photodiode. The dual photodiode has two silicon photodiodes with a narrow gap between them and so balanced that a small motion of the HeNe spot off of center will produce a signal in the differential amplifier. A spot motion of 10⁻³ spot diameters can be detected.

In Figure 7 is seen the deflection signal observed for a CO₂ laser input to the cell as shown. The average CO₂ power at a repetition rate of 20 Hz is 0.1 watt. The absorber is DMMP at its room temperature vapor pressure of approximately 1 torr, mixed with 680 torr of air.

Varying the partial pressure of absorber by successive dilutions is difficult because of absorption on the cell walls, however, Figure 8 can be obtained using Freon 12 as the absorber gas mixed with N₂ gas at 760 torr. Signal is determined from the peak of plots such as Figure 7. Focusing the lasers into the cell gives a larger signal than the collimated beams. The latter measurements have been multiplied by a factor of 23 to place them on the same scale.

Figure 9 was plotted to test the effect of higher power CO₂ lasers on the signal. The good straight-line behavior suggests that the sensitivity of the technique will improve with higher power lasers.

This experiment can be extended to a single-ended remote detection method if one realizes that the deflected image of the HeNe spot can be at a target and monitored by means of a telescope with a dual photodiode at the focus. Such a device is shown in Figure 10. The modulation of the CO₂ laser appears as a modulated motion of the HeNe laser spot on the rock. This experiment has been performed in a lab and proves to be remarkably insensitive to the surface roughness of the rock. Fortunately, CO₂ lasers operate in a window in the atmospheric transmission spectrum where there are few interfering absorbers naturally present^(11,12) and they are line tunable over a wide range and are also efficient.

LASER-INDUCED FLOURESCENCE

As part of a contract, we have also developed an apparatus for measuring laser-induced fluorescence. The machine is a research instrument build for maximum flexibility (Figure 11.). It consists of a pulsed nitrogen laser at 3371 Å which pumps a tunable dye laser in the green to orange region of the spectrum. The dye laser is frequency doubled in a nonlinear crystal to provide a source of tunable ultraviolet light, which excited the sample. The fluorescence is picked off from the side and focused into a monochrometer. A photomultiplier tube detects the pulses of light, and a boxcar amplifier averages the resulting electrical pulses for a stripchart recorder to display. Data are displayed as a function of either the excitation wavelength (determined by the dye laser) or the emission wavelength (determined by the monochrometer setting). Because of the extreme sensitivity of this apparatus, even part-per-million impurities in the liquid samples have been shown to give erroneous results.

SUMMARY

In summary, both the optoacoustic and thermal deflection techniques show high potential for use as point or remote detection methods at the part-per-million level. The next steps in the program will be to extend the work to the chemical agents and to develop an optimal set of wavelengths for agent identification in a real world environment. The laser-induced fluorescence technique requires further testing on purified samples.

REFERENCES

- (1) D. D. Davis, W. S. Heaps, D. Philen, M. Rogers, T. McGee, A. Nelson, and A. J. Moriarity, *Rev. Sci. Instru.* **50**, 1505 (1979).
- (2) I. B. Berlman, *Handbook of Fluorescence Spectra of Aromatic Molecules*, 2nd ed. (Academic Press, NY 1971).
- (3) L. B. Kreuzer, *J. Appl. Phys.* **42**, 2934 (1971).
- (4) C. K. N. Patel and R. J. Kerl, *Appl. Phys. Lett.* **30**, 578 (1977).
- (5) T. R. Loree, R. C. Sze, D. L. Barker, and P. B. Scott, *I.E.E.E.J. Quantum Electron.* **15**, 337 (1979).
- (6) F. P. Schäfer ed., *Dye Lasers* (Springer-Verlag, New York, 1973).
- (7) R. L. Byer and R. L. Herbst in *Nonlinear Infrared Generation*, Y. R. Shen ed., (Springer-Verlag, New York, 1977).
- (8) L. Fagerlind, I. Lidgren, J. Santesson, K. E. Stensiö, G. Wallerberg, B. Östman, FOA 1 Report A 1541-C2(C4), Defense Research Institute, Stockholm, Sweden (1971).
- (9) J. R. Whinnery, *Accounts Chem. Res.* **7**, 225 (1979).
- (10) M. I. Buchwald and R. K. Sander, Los Alamos Scientific Lab report LA-UR-79-3443 (1979).
- (11) C. Young and R. E. Chapman, *J. Quant. Spect. Radiat. Transfer* **14**, 679 (1974).
- (12) M. S. Shumate, R. T. Menzies, J. S. Margolis, and L. G. Rosengren, *Appl. Opt.* **15**, 2480 (1976).

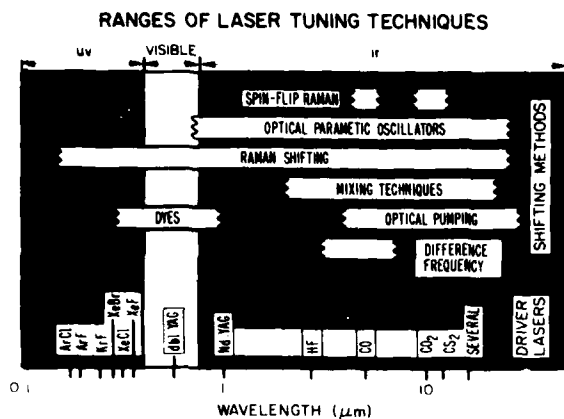
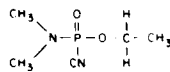
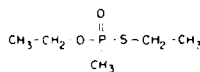

FIGURE 1. A survey of various techniques for producing tunable lasers.

MOLECULAR STRUCTURE OF CHEMICAL AGENTS AND SIMULANTS



GA



OSP

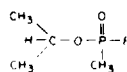

GB

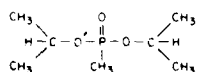

DIMP

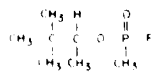

GD

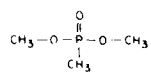

DMMP

USA

FIGURE 2. Structures of chemical agents and simulants.

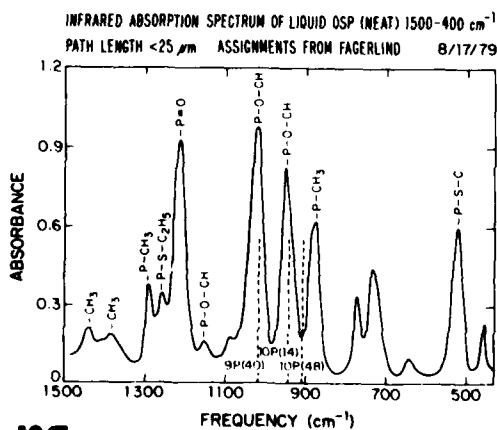

FIGURE 3. The infrared absorption spectrum of neat liquid OSP, and CO_2 laser emission lines which could be used to fingerprint the presence of OSP.

ACOUSTIC DETECTION FOR POINT
OR PERIMETER MONITORING

USA

THE LASER BEAM IS MODULATED AT AN ACOUSTIC
FREQUENCY CORRESPONDING TO A RESONANT MODE
OF THE BEAM DUCT (ORGAN PIPE)

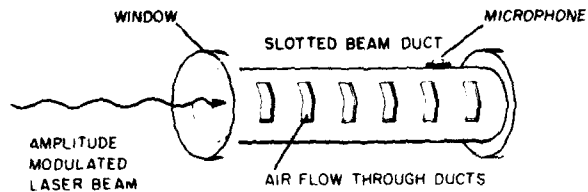

FIGURE 4. A conceptual design of an
optoacoustic cell for chemical
detection.

REMOTE FIELD DETECTION

USA

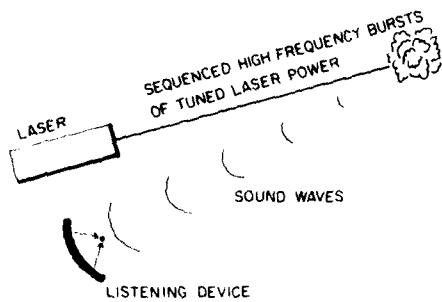
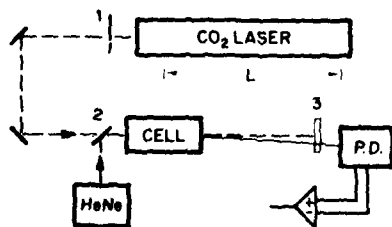

FIGURE 5. A conceptual design of a system
for remote chemical detection using
the optoacoustic effect.

THERMAL DEFLECTION APPARATUS



USA

FIGURE 6. The apparatus used for thermal
deflection experiments on trace
chemicals.

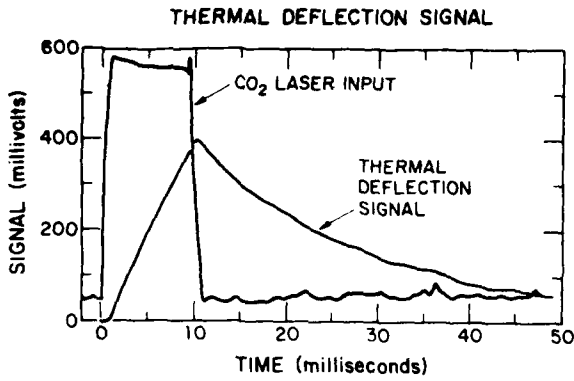

FIGURE 7. The time-resolved thermal deflection signal as observed on an oscilloscope.

USA

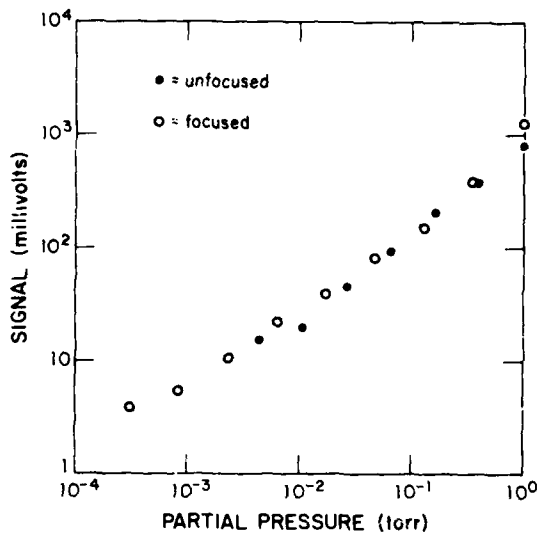

FIGURE 8. A plot of signal versus concentration obtained by successive dilution of a gas sample. The experiment was performed both for focused laser beams and for collimated laser beams.

USA

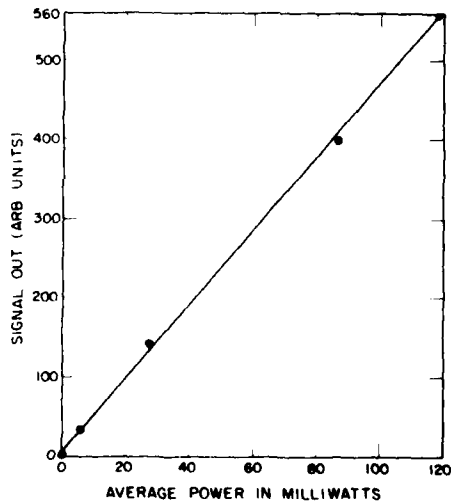

FIGURE 9. A plot of thermal deflection signal strength versus CO₂ laser power incident on the cell.

REMOTE DETECTION BY THERMAL LENSING

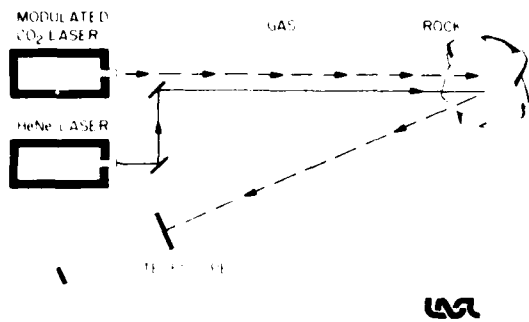

FIGURE 10. The apparatus used for quasi-single ended remote detection by thermal deflection. At the focus of the telescope is the dual photodiode which monitors deflection of the Helium Neon spot on the rock. In lab tests the sensitivity is similar to the apparatus of Figure 6.

LASER INDUCED FLUORESCENCE

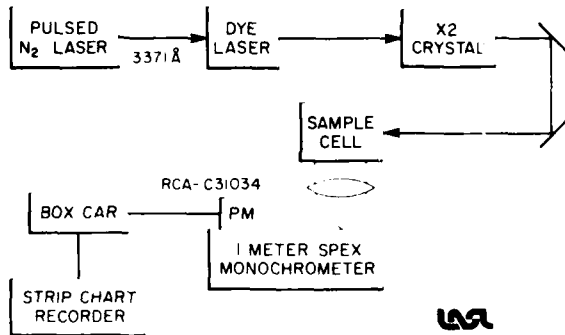

FIGURE 11. The laser apparatus for producing and detecting fluorescence. Spectra may be taken as a function of excitation wavelength or as a function of emission wavelength.

LASER-INDUCED DECOMPOSITION OF ORGANOPHOSPHATES*

L. J. Radziemski, R. K. Sander, R. S. McDowell,
F. B. Wampler, and W. B. Lewis
University of California, Los Alamos Scientific Laboratory
Los Alamos, New Mexico

ABSTRACT

The organophosphorus compounds diisopropyl methylphosphonate (DIMP), dimethyl methylphosphonate (DMMP), and O-ethyl-S-ethyl methylphosphonothiolate (OSP), have been irradiated in the ultraviolet with a quadrupled Nd:YAG laser at 266 nm. All of these compounds absorb strongly below 300 nm due to electronic transitions involving the P=O bonds. The laser output was 20-30 mJ per shot, and irradiations varied from hundreds to tens-of-thousands of shots. The pure liquid samples were contained in a cell designed to trap the gases evolved during the irradiation. This cell was fitted with infrared windows so that the gaseous decomposition products could be collected in the head space over the liquid samples and analyzed by infrared absorption spectroscopy. The gases evolved from each compound and the corresponding quantum yields are presented. All three samples exhibit a shift in the UV absorption edge into the visible after irradiation. The pH of the liquid samples of DIMP and OSP decrease during the course of the irradiation.

The decomposition of DIMP at other UV laser wavelengths, as well as by Hg lamp irradiation and pyrolysis, is discussed. The decomposition product gases for laser irradiation and Hg lamp illumination were essentially identical, and the relative amounts similar. These products differed, however, from the products of pyrolysis. The results of decomposition of DIMP by the various methods are summarized. The ratio of product gas pressure to propylene (a product gas in all methods) pressure is also given.

INTRODUCTION

The potential of photochemistry for destroying or catalyzing destruction of hazardous chemical compounds cannot be overlooked. Sunlight itself does this, but at a rate too slow to be useful for decontamination. Photons have desirable properties for this purpose. They leave no residue and are not contaminated themselves. Lasers offer a better means to deliver photons than do conventional light sources. The electrical input to a laser is converted to a light beam and the radiation can be delivered in short time intervals (nanoseconds) at high repetition rates over long distances. Photochemical reactions are sensitive to these properties. Lasers can be tuned or chosen to radiate in wavelength regions where molecules have absorption bands, which makes for more efficient use of energy.

*Work performed under the auspices of the U. S. Department of Energy for the U. S. Army Chemical Systems Laboratory.

OBJECTIVES

The objectives in this study were primarily to identify laser wavelengths that would interact with agent simulants and to demonstrate that photochemical reactions do occur. A secondary objective was to determine whether these reactions differed from pyrolytic reactions (heating) and from mercury irradiation (standard photochemical technique). It was found that photochemical reactions did occur subsequent to laser irradiation, that these differed from pyrolytic reactions but not from mercury irradiation, and that the efficiency of the reaction was a function of wavelength.

RESEARCH EFFORTS AND RESULTS

The procedure, apparatus, diagnostics, results, and directions suggested by this work are discussed below.

Choosing the Wavelength—the First Experiments

Agent simulants are known to have UV absorption bands in the 150 to 300-nm region in the UV and at $10\ \mu\text{m}$ in the IR. We decided to concentrate on UV irradiation first because the Los Alamos Scientific Laboratory has been active in developing excimer lasers in this region. Table 1 shows currently available excimer laser wavelengths and typical energy outputs and powers. Figure 1 illustrates how three of these and 4x Nd:YAG fall within the absorption spectrum of DIMP.

Our first irradiation experiments were extremely simple, as illustrated in Figure 2. The KrF or 4x Nd:YAG laser was used to irradiate a cuvette of the liquid simulant (neat). A detector monitored the energy absorbed by the sample. Many diagnostics were used to detect changes in the liquid. We first observed that the neat samples changed color upon irradiation, going from clear to yellow to amber. This change showed up in the UV absorption spectrum, where the absorption edge shifted towards the visible. Infrared absorption spectra of the liquid showed no changes. Apparently the absorption spectrum of the parent molecule obscured any changes caused by a product molecule. Changes in pH were observed, the liquid going always from basic to acidic upon irradiation. The NMR technique showed changes in structure at the few percent level, an indication of a product molecule. Bubbles were observed forming in the liquid and escaping from the top surface.

In this preliminary phase of the work, DMMP, DIMP, OSP, and 2-CEES were irradiated. The formulas for these compounds and the agents that they simulate are given in Tables 2 through 5. Figure 3 summarizes the results of the observations for these compounds. An X indicates a positive effect, and a circle the absence of an effect. A blank indicates that the test was not made.

Diagnostic: Infrared Absorption of Gaseous Decomposition Products

The first experiments proved that the laser radiation interacts with the liquid. To quantify this effect and get an idea of the details of the decomposition, an IR absorption diagnostic was developed to monitor the decomposition gases. Figure 4 illustrates the cell design. The liquid was

TABLE 1. Primary Lasers in the Ultraviolet

Laser Type	Output Wavelength (nm)	Energy Output (mJ)	Peak Power (MW)
ArF	193	350	12
KrCl	222	45	4.5
KrF	248	720	18
XeBr	282	60	2
XeCl	308	180	5
XeF	354	500	12

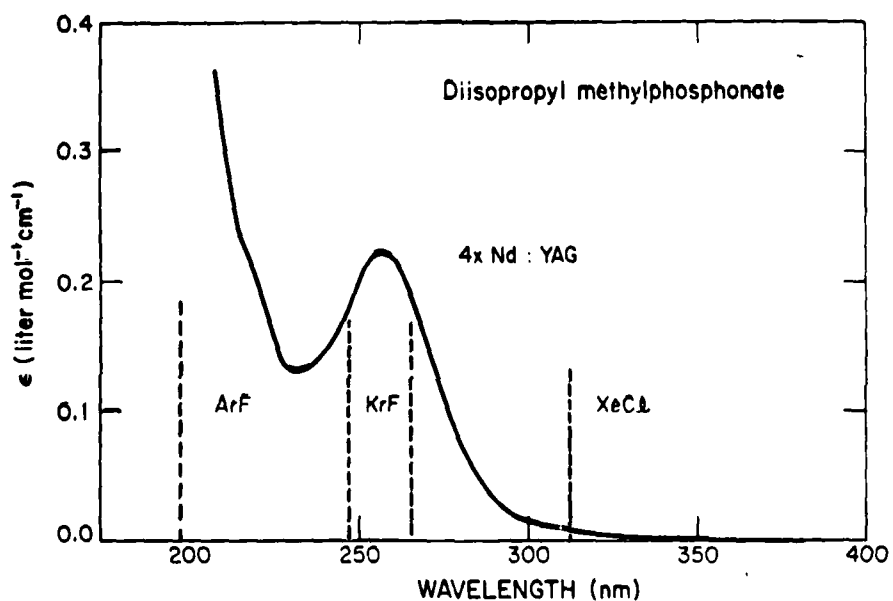

FIGURE 1. The UV absorption spectrum of DIMP.

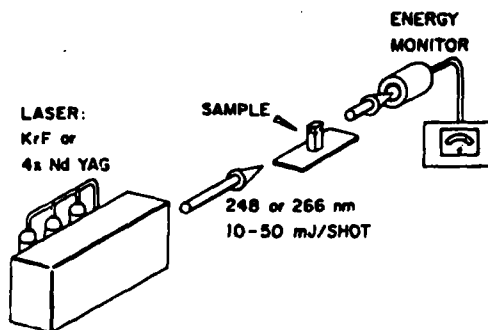
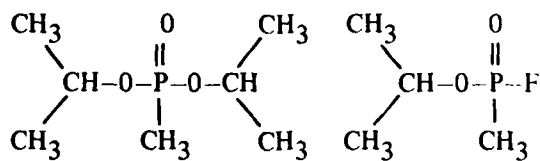

FIGURE 2. Apparatus for laser irradiation of simulants.

TABLE 2. DIMP/GB

Formula:



Gaseous Products and Quantum Efficiency

Product	Pressure (torr)	QE(a)(%)
CH ₄	75 ± 30	1.5
CO	60 ± 15	1.3
CH ₃ CH=CH ₂	50 ± 10	1.0

(a) $QE = \frac{\text{No. of molecules of a species produced}}{\text{No. of photons absorbed}}$

TABLE 3. OSP/VX

Formula:

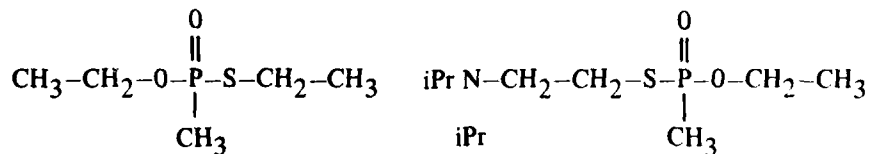

Gaseous Products and Quantum Efficiencies

Product	Pressure (torr)	QE(%)
C ₂ H ₆	~20	1.5
C ₂ H ₄	23 ± 5	1.8
COS	Small amount	

TABLE 4. 2-CEES/mustard

Formula:

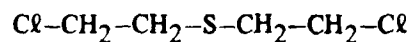
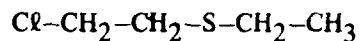

Gaseous Products and Quantum Efficiencies

Product	Pressure (torr)	QE(%)
C_2H_4	50 ± 25	1.2
C_2H_2	Small amount	
$\text{CH}_2 = \text{CHCl}$	~ 3	0.07
$\text{CH}_3\text{CH}_2\text{SH}$	Small amount	

TABLE 5. DMMP

Formula:

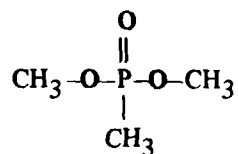

Gaseous Product and Quantum Efficiency

Product	Pressure (torr)	QE(%)
CH_4	12 ± 2	0.5

	UV	IR	NMR	pH	GAS	COLOR
DMMP	X	O	O	O	X	X
DIMP	X	O	O	X	X	X
OSP	X	O	X	X	X	X
2-CEES	X				X	X

FIGURE 3. Observed effects of laser irradiation.

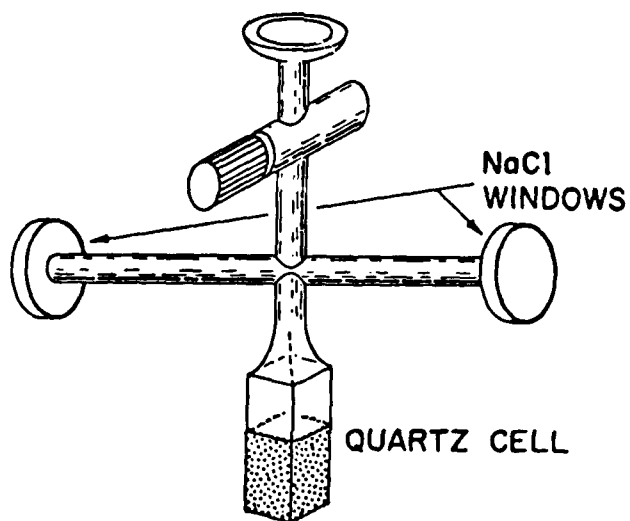

FIGURE 4. Cell for UV irradiation and IR diagnostic.

irradiated through the quartz portion and the evolved gas was trapped in the space between the top of the liquid and the stopcock, a space that had been previously evacuated. The absorption spectra of the evolved gases were recorded by putting the cross tube, which has IR windows, in the sample beam of a Perkin-Elmer 180.

One of the first irradiations of DIMP yielded the gaseous-product spectrum shown in Figure 5. The gases C_3H_6 (propylene), CH_4 (methane), and CO were identified. A suggested mechanism for the production of the propylene is illustrated in Figure 6. From the energy absorbed, the number of laser shots, and the pressures of the gaseous products produced, the quantum efficiency can be calculated. Table 2 summarizes these results for the spectrum illustrated in Figure 5. Tables 3, 4, and 5 do the same for representative irradiations of OSP, 2-CEES, and DMMP, respectively. In all cases the quantum efficiencies for a given product molecule range from 0.1 to 2 percent.

At this point all the evidence indicated a photochemical reaction in each simulant which was caused by laser irradiation. A number of significant questions presented themselves:

- Is the decomposition different from that caused by pyrolytic processes?
- Is the decomposition different from that caused by mercury irradiation?
- Do the effects depend on wavelength?

Other Decomposition Experiments

First, some simple experiments were conducted with each of the four simulants to determine whether the samples were simply being pyrolyzed. One or 2 ml of the liquid was placed in an ampule. The remaining air was evacuated and the ampule was sealed off and placed in an oven at 180 to 200 C for 30 to 120 min. The results are summarized in Table 6. In most cases the pyrolysis yielded a different set of decomposition products than did the laser experiments. For OSP, the ratios of the pressures of the C_2H_6 and C_2H_4 were different for the two experiments. It was concluded that the mechanism of laser decomposition differs from that of the pyrolytic decomposition.

Next, DIMP irradiation with the mercury 254-nm line was attempted. After 3 to 6 days of irradiation, enough product gas was obtained to record spectra. These results are summarized in Table 7. The products resulting from mercury-lamp irradiation do not differ drastically from those resulting from laser irradiation at nearby wavelengths (4 x Nd:YAG at 266 nm). The DIMP was also irradiated with a number of laser wavelengths to compare the types of gaseous products evolved. More types of gases are formed as the wavelength decreases (energy of the irradiating photon increases). The quantum yield for mercury irradiation was also similar to KrF or 4 x Nd:YAG, as shown in Table 8. It was concluded that laser and mercury-lamp irradiation give essentially the same results for the laser energy and power levels being used. Of course, the difference is that the laser experiments were done in a few hours and the mercury experiments in a few days.

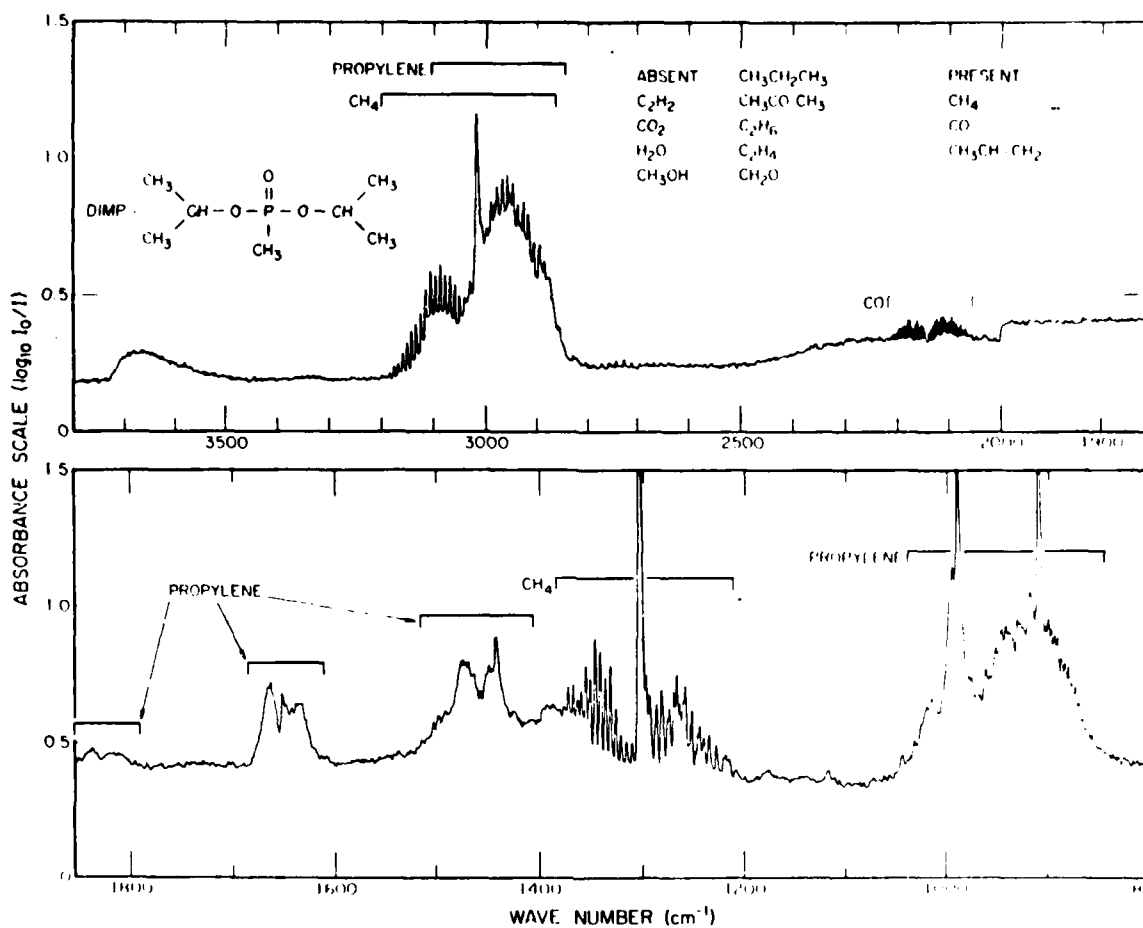

FIGURE 5. Gaseous-product decomposition spectrum for DIMP, irradiated by KrF.

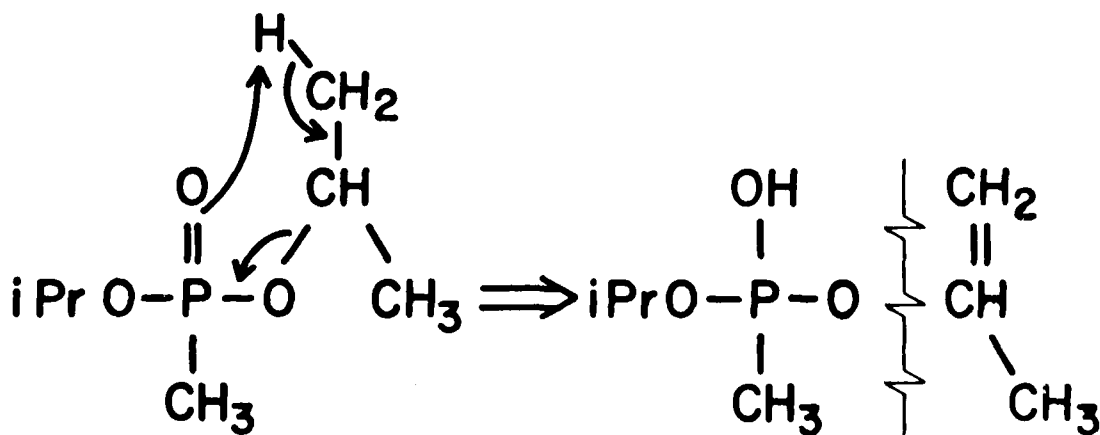

FIGURE 6. Possible DIMP decomposition mechanism.

TABLE 6. Comparison of Gaseous Decomposition Products Produced by Laser Irradiation and Pyrolyses

	Laser Products	Pyrolysis Products
DIMP	CH ₄ CO CH ₃ CH = CH ₂ C ₂ H ₂ C ₂ H ₄	CH ₃ CH = CH ₂
OSP	C ₂ H ₆ C ₂ H ₄ OCS	C ₂ H ₆ C ₂ H ₄
DMMP	CH ₄	CH ₃ OCH ₃
2-CEES	C ₂ H ₄ C ₂ H ₂ CH ₂ = CHCl CH ₃ CH ₂ SH	C ₂ H ₄ HCl CH ₃ CH ₂ SH

TABLE 7. Gaseous Decomposition Products of DIMP—Wavelength Dependence

Product: Wavelength	Product:					
	C ₃ H ₆	C ₂ H ₄	C ₂ H ₂	CH ₄	CO	CH ₃ OH
ARF (193 nm)	×	×	×	×	○	×
KrF (248 nm)	×	×	×	×	×	×
4 x Nd:YAG (266 nm)	×	×	○	×	○	×
XeCl ₂ (308 nm)	×	○	○	×	○	○
Hg Lamp (264 nm)	×	×	○	×	○	×

TABLE 8. Quantum Yield as a Function of Wavelength (Percent)

Product: Wavelength	Product:				
	C ₃ H ₆	C ₂ H ₄	C ₂ H ₂	CH ₄	CO
ARF (193 nm)	0.8	0.8	1.0	1.7	0
KrF (248 nm)	0.7	0.5	0.4	1.0	0.2
4 x Nd:YAG (266 nm)	0.3	0.3	0	0.7	0
XeCl ₂ (308 nm)	0.5	0	0	0.6	0
Hg Lamp (254 nm)	0.7	0.7	(a)	1.1	0

(a) Not available.

Quantum Yield as a Function of Wavelength

The quantum yields for various gases and laser wavelengths, all with neat DIMP as the starting material, are summarized in Table 8. There is a slight trend to increasing quantum yield as the photon energy increases, i.e., the wavelength decreases. This indicates that ArF would be the most efficient laser to use. One possible explanation of this wavelength dependence is the cage effect.

SUMMARY AND CONCLUSIONS

The significant results of these studies so far are:

1. Laser irradiation of the simulants DIMP, DMMP, OSP, and 2-CEES produces a unique set of decomposition products for each irradiated compound.
2. The decomposition products produced by laser irradiation differ from those produced by pyrolysis.
3. For DIMP, the quantum efficiency and decomposition products are the same for both laser and mercury-lamp irradiation.
4. The quantum yield goes up with increasing wavelength.
5. The quantum yield is low, about 1 percent of the photons being used.

Table 9 summarizes the gases evolved from each compound and corresponding quantum yields. Table 10 summarizes the results of DIMP decomposition by the various methods.

In future work, different analytical techniques will be tried, concentrating on the analysis of the liquid product through GC. Gas-phase photodecomposition will be used to study the mechanisms of photodissociation directly. The products and quantum yields resulting from CO₂ irradiation will be studied. An agent test is planned for the near future.

TABLE 9. Gaseous Decomposition Products and Quantum Yields

DIMP ^a		DMMP		OSP	
product	ϕ^b	product	ϕ	product	ϕ
CH ₄	0.015	CH ₄	0.005	C ₂ H ₆	0.015
CO	0.013			C ₂ H ₄	0.018
CH ₃ CH=CH ₂	0.010			COS	trace
C ₂ H ₄	0.013				

(a) irradiation at 248 nm, KrF.

(b) $\phi = (\text{number of product molecules produced per unit time}) /$
 (number of photons absorbed per unit time).

TABLE 10. DIMP: Ratio of product gas pressure to propylene pressure. An "X" in a column denotes that the product gas was absent.

Irradiation	C ₃ H ₆	CH ₄	C ₂ H ₄	CH ₃ OH	CO
	propylene	methane	ethylene	methanol	carbon monoxide
ArF 193 nm	1.0	2.2	0.9	1.0	X
KrF 248 nm	1.0	3.0-0.75(?)	1.0-0(?)	X	1.0
Nd:YAG 4x 266 nm	1.0	2.2	1.2	0.3	X
Hg lamp (254 nm)	1.0	1.4	1.0	0.5	X
pyrolysis	1.0	X	X	X	X

NEW TECHNOLOGY FOR THE DESTRUCTION OF TOXIC WASTES

S. A. Hoenig, G. T. Sill, L. M. Kelley, and K. J. Garvey
University of Arizona
Tucson, Arizona

ABSTRACT

New technology for toxic waste disposal might well include

- (1) corona discharge systems to break up germs and chemical compounds by exposure to ozone, ultraviolet, and strong electrical fields
- (2) a combination of combustion with the corona system to enhance the destruction process
- (3) bubbling ozone through liquid wastes to induce oxidation
- (4) application of electrical currents to "draw out" heavy metal ions by electrophoresis so that the remaining liquid can be burned
- (5) injection of electrons and/or positive ions to induce chemical reactions.

Experimental results on Process 1 are presented.

INTRODUCTION

The disposal of industrial waste has been a problem from the very invention of the railroad, when the clinkers were simply "dumped along the track". As the chemical industry expanded to its present size, the waste-disposal problem became far more serious because of the quantity of material involved, the increased toxicity, and the tendency of the materials to leach into water supplies after burial in a landfill.

Other waste-disposal problems of increasing severity include military materials that may involve bacteria or viruses (with special coatings that resist attack by sunlight or oxidizing agents), poison gases, and/or toxic chemicals. Medical wastes include modified DNA carriers and/or hazardous chemicals. In every case these "extra-hazardous" materials must be destroyed 100 percent before the residues can be released to the environment.

An ideal disposal system for toxic wastes should not be energy intensive, must not require constant control by highly trained technicians, should be insensitive to changes in feedstock, and must convert the wastes to some nontoxic form by a process with an easily measured end point.

In the following section the existing technology for disposal of industrial and military wastes is reviewed with a view to suggesting some new systems that might make disposal somewhat simpler.

TOXIC WASTE DISPOSAL TECHNOLOGY

Industrial Wastes

Current disposal systems involve either direct or fuel-aided combustion processes, with the use of catalytic combustion where practical. A review by Strauss⁽¹⁾ indicates that the existing systems are generally effective in large-scale operations where a steady flow of relatively constant composition is present. If smoky flames are observed, steam can be added to induce a "water-gas" reaction that produces H_2 and CO , which tend to burn with less smoke. This in turn requires more equipment and complex control systems for best operation. In general, there seems to be no question that the combustion process requires careful monitoring and relatively expensive equipment if it is to function properly.

If especially toxic materials or heavy metals are involved (as is often the case with waste dumps), simple combustion is not fully effective and the resultant emissions must be filtered. Then the filters themselves present a disposal problem. It seems that more effective systems are needed, particularly for highly toxic wastes. The products of the disposal equipment should be in the form of water and carbon dioxide or nontoxic solids that can be landfilled without environmental hazard.

Toxic Military Wastes

Disposal of military wastes presents a special set of problems because of the high toxicity involved and the need for a "field usable" disposal system that can be moved to a munitions storage area when a need exists. In some cases, it may be necessary to destroy contaminated clothing or weapons that have been rendered unfit for use by exposure to NBC vectors. Here again a simple system that can be used by relatively untrained personnel is needed.

Present techniques for the disposal of toxic military wastes involve oxidation by one or more specialized formulations (e.g., DS-2, CS-1). The action involves a complex series of processes that may result in other chemicals that are less toxic but still irritating.⁽²⁾ Other systems that have been investigated include the use of ultraviolet light combined with an absorbing dye as a sensitizer. The process is thought to involve the production of singlet molecular oxygen by absorbed ultraviolet. The singlet molecule can oxidize either amine or sulfur compounds that are resistant to other decomposition agents.⁽³⁾ The demonstrated success of this approach, on certain toxic materials, suggests that ultraviolet and excited oxygen should be seriously considered as part of any decontamination process.⁽³⁾

One problem with these chemical techniques is their complexity, in that the actual mechanisms are poorly understood and the "end point" of the reaction is not easy to determine. Another difficulty with the chemical approach is the specificity of the reactions, such that an enemy might introduce some "new compound" that could not be destroyed by the chemical technique. It seems reasonable to suggest one or more "direct" approaches that could be expected to "work" on any organic material and have an easy-to-detect end point.

NEW TECHNOLOGY FOR DISPOSAL OF TOXIC WASTES

A number of new and/or modified waste-disposal technologies are below. The discussion is divided into liquid, gaseous, and solid wastes. Where overlaps in technology are practical, this is indicated.

Liquid Wastes

Liquid materials may well be the most serious problem in terms of quantity and the nature of the material, in that the liquid may contain appreciable amounts of heavy metals that preclude simple combustion for disposal. The problem is even more complex if the liquid waste is in a landfill where various solid materials (e.g., soil) and water may be present. In this case it is suggested that the first task is to prevent or stop seepage into near-by streams which can spread the contamination over a wide area.

The most practical technique for liquid waste disposal may be the application of electrophoresis to remove water and densify the remaining semi-solid mass. Electrodensification of mine wastes has been studied by the U.S. Bureau of Mines.⁽⁴⁾ It has been demonstrated that most of the residual water can be removed by this means, leaving behind an essentially solid material. This technique might be applied to landfills to draw out the water and isolate the waste from nearby lakes and streams. The resulting contraction of the waste dump might well make it feasible to introduce sheet piles or concrete walls to permanently separate the waste from the local water table.

Assuming that the wastes are isolated and suitable for in situ treatment, the following techniques might be used to render the material harmless:

- (1) Bubbling a strong oxidizer (e.g., ozone or chlorine) through the liquid to induce oxidation and chemical change. The results of experimental studies indicating that ozone can be used to oxidize acrolein, allyl alcohol, glycerol, and acetaldehyde has been presented by Weirzbicki.⁽⁵⁾ This technique may be of particular advantage to the military wherein it appears that relatively low-cost and lightweight apparatus for generating ozone may soon be available for purification of water supplies. The potential application of ozone for destruction of toxic materials would make the ozone system that much more useful. In this connection there is another reason for making use of ozone as an oxidizer, i.e., Netzer⁽⁶⁾ has shown that certain heavy metals can be oxidized and precipitated out of liquid solutions by exposure to ozone. Further study of the process in various chemical systems is needed, but this technique offers the possibility of removing heavy metals from liquid waste by ozonization and filtration.
- (2) Injection of positive ions or electrons into the liquid with the objective of inducing chemical reaction, precipitation, etc.⁽⁷⁾ One example might be the injection of sodium ions to cleave chlorine from chlorinated hydrocarbons and to deposit sodium chloride. Experience in the electric power industry indicates that even the most stable hydrocarbons are fragmented if sparking and ion injection occur. The mechanism involved is not well understood, but the process is known to yield gaseous hydrogen, and H_2 detectors are often installed on large transformers where an oil failure could be disastrous.
- (3) Removal of heavy metals by electrophoresis. This technique was suggested earlier for removal of water from landfills, but it can also be adapted (with very similar equipment) to the removal of heavy-metal ions from liquid waste. Removal of heavy metals has two advantages. First, this may make the waste suitable for disposal by conventional (e.g., combustion techniques) means and, second, the metals thus removed may themselves be valuable

enough to justify the process. Here the interest would be in elements like mercury and silver, but it might be quite possible to remove other heavy metals (e.g., cadmium or arsenic) at the same time without excessive expenditure.

- (4) Burning of the remaining materials after the heavy metals have been removed, provided that destruction is complete. In this connection, it may be practical to make use of a corona discharge system following treatment in the combustion apparatus. The corona discharge provides a highly oxidizing environment that might be expected to complete the oxidation of any wastes that pass through the combustion system. Corona discharges have also been shown to be effective for the destruction of bacterial spores and toxic materials.⁽⁸⁾ Other experiments have demonstrated the application of corona discharges to the induction of chemical reactions.⁽⁹⁾

Gaseous Wastes

The most logical technique for this procedure would be combustion, provided that the energy required is not excessive. If the material is not flammable it may be more practical to make use of the corona discharge to reduce the compounds to a simpler and less toxic form. Reactions of this type have been reported.⁽⁹⁾ In some cases there might be a solid residue which could be suitable for landfill disposal.

Solid Wastes

For complete destruction, the solid materials would probably have to be shredded and then disposed of by combustion or by combustion plus the corona discharge. For field decontamination, where material (uniforms or equipment) might be needed for reuse, it may be possible to expose such material to a combination of heat and ultraviolet light or heat, ultraviolet light, and ozone to first desorb the chemicals and then destroy them by oxidation.

Some of the above technologies have been tested for microbiological systems or toxic chemical control, while others are merely speculative.

STUDIES AT THE UNIVERSITY OF ARIZONA

The initial work at the University of Arizona was associated with a program designed to provide contaminant-free breathing air to the crew of a military vehicle. It was anticipated that dust would be removed by an electrostatic precipitator (ESP) and that any ozone produced by the associated corona discharge would be removed by passing the effluent gases through an iron oxide catalyst.⁽¹⁰⁾

If the ESP unit was available for dust control, the question arose as to its ability to destroy bacterial spores and toxic chemicals. To examine this question, the system shown in Figure 1 was constructed and tested with *B. stearothermophilus* spores and fumes of methyl parathion. The results appeared in the March issue of the *Journal of the Air Pollution Control Association*.⁽⁸⁾ Here, it need only be noted, that with a residence time of 0.66 seconds, there was 100 percent destruction of the *B. stearothermophilus* spores. The parathion studies were performed at a lower flow velocity because of apparatus limitations, but again, the destruction efficiency was some 99.7 percent. These data are evidence of the ability of the corona discharge to destroy a variety of

NEW TECHNOLOGY FOR DISPOSAL OF TOXIC WASTES

A number of new and/or modified waste-disposal technologies are below. The discussion is divided into liquid, gaseous, and solid wastes. Where overlaps in technology are practical, this is indicated.

Liquid Wastes

Liquid materials may well be the most serious problem in terms of quantity and the nature of the material, in that the liquid may contain appreciable amounts of heavy metals that preclude simple combustion for disposal. The problem is even more complex if the liquid waste is in a landfill where various solid materials (e.g., soil) and water may be present. In this case it is suggested that the first task is to prevent or stop seepage into near-by streams which can spread the contamination over a wide area.

The most practical technique for liquid waste disposal may be the application of electrophoresis to remove water and densify the remaining semi-solid mass. Electrodensification of mine wastes has been studied by the U.S. Bureau of Mines.⁽⁴⁾ It has been demonstrated that most of the residual water can be removed by this means, leaving behind an essentially solid material. This technique might be applied to landfills to draw out the water and isolate the waste from nearby lakes and streams. The resulting contraction of the waste dump might well make it feasible to introduce sheet piles or concrete walls to permanently separate the waste from the local water table.

Assuming that the wastes are isolated and suitable for in situ treatment, the following techniques might be used to render the material harmless:

- (1) Bubbling a strong oxidizer (e.g., ozone or chlorine) through the liquid to induce oxidation and chemical change. The results of experimental studies indicating that ozone can be used to oxidize acrolein, allyl alcohol, glycerol, and acetaldehyde has been presented by Weirzbicki.⁽⁵⁾ This technique may be of particular advantage to the military wherein it appears that relatively low-cost and lightweight apparatus for generating ozone may soon be available for purification of water supplies. The potential application of ozone for destruction of toxic materials would make the ozone system that much more useful. In this connection there is another reason for making use of ozone as an oxidizer, i.e., Netzer⁽⁶⁾ has shown that certain heavy metals can be oxidized and precipitated out of liquid solutions by exposure to ozone. Further study of the process in various chemical systems is needed, but this technique offers the possibility of removing heavy metals from liquid waste by ozonation and filtration.
- (2) Injection of positive ions or electrons into the liquid with the objective of inducing chemical reaction, precipitation, etc.⁽⁷⁾ One example might be the injection of sodium ions to cleave chlorine from chlorinated hydrocarbons and to deposit sodium chloride. Experience in the electric power industry indicates that even the most stable hydrocarbons are fragmented if sparking and ion injection occur. The mechanism involved is not well understood, but the process is known to yield gaseous hydrogen, and H₂ detectors are often installed on large transformers where an oil failure could be disastrous.
- (3) Removal of heavy metals by electrophoresis. This technique was suggested earlier for removal of water from landfills, but it can also be adapted (with very similar equipment) to the removal of heavy-metal ions from liquid waste. Removal of heavy metals has two advantages. First, this may make the waste suitable for disposal by conventional (e.g., combustion techniques) means and, second, the metals thus removed may themselves be valuable

toxic substances. At this point it should be noted that the use of a corona discharge to initiate chemical reactions has been reported by many investigators. The data up to 1976 have been reviewed in Reference (9) where it was noted that many chemical compounds were oxidized to CO₂ and H₂O while the remaining material was condensed into a solid form that could be collected and disposed of rather easily.

The University of Arizona studies are continuing. We hope to demonstrate that ozone can be used to sterilize medical apparatus that would otherwise have to be exposed to steam or ethylene oxide.

CONCLUSIONS

Some very preliminary studies have indicated that corona discharge techniques either alone or combined with heating and combustion may be worth investigating. Other systems involving injection of electrons, positive ions, or ozone might well be useful and are worth looking at.

If the wastes have been landfilled, first priority should be given to isolation of the wastes from the nearby water table. Here the best technique would seem to be electrophoresis to draw out water in the waste dump, followed by the installation of sheet piles or concrete dams to prevent any migration of toxic materials toward the water table

SUMMARY

In this paper, the technology available for destruction of toxic wastes is reviewed, and some improved systems for confining liquid materials that have been deposited in a landfill are suggested. More effective destruction of toxic wastes might be achieved by using electrophoresis and/or ozone injections to precipitate or draw out heavy metals that might otherwise preclude combustion. The combination of combustion with a corona discharge or the use of heat and a corona discharge might well be used for disposal of toxic substances that have been deposited on a solid surface.

Experimental studies on the application of the corona discharge to the destruction of bacteria and toxic wastes are reviewed and suggestions are offered for future studies.

REFERENCES

- (1) Strauss, W., *Industrial Gas Cleaning*, Pergamon Press, New York (1966).
- (2) Davis, G. T., Block, F., Sommer, H.Z., and Epstein, J., "Studies on the Destruction of Toxic Agents VX and HD by the All-Purpose Decontaminants DS-2 and CD-1", Edgewood Arsenal Technical Report EC-TR-75024, Department of the Army, Aberdeen Proving Ground, Maryland (May, 1975).
- (3) Kenley, R., Kirshen, N., and Mill, T., "Catalytic Oxidation Processes for Amines and Sulfur Compounds", Final Report, ARCSL-CR-79029, SRI International for U.S. Army Armanent Research & Development Command, Chemical Systems Laboratory, Aberdeen Proving Ground, Maryland (February, 1979).
- (4) Sprute, R. H., and Kelsh, D. J., "Laboratory Experiments in Electrokinetic Densification of Mill Tailings", U.S. Department of the Interior, Bureau of Mines Report 7892,7900 (1974).
- (5) Weirzbicki, T., "Oxidation of Acrolein, Allyl Alcohol, Glycerol and Acetaldehyde with Ozone", *Zesz. Nauk. Politech. Slask. Inz. and Sanit.*, 13, 95-112 (1969).
- (6) Netzer, A., Bowers, A., and Norman, J. D., "Removal of Trace Metals from Wastewater by Lime and Ozonation," IN: *Pollution, Engineering and Scientific Solutions*, E. S. Barrekette, (Ed.), Plenum Press, New York (1969) p 380.
- (7) Felici, N., and Lacroix, J. C., "Electroconvection in Insulating Liquids with Special Reference to Uni- and Bi-Polar Injection", *J. Electrostatics*, 5, 135 (1978).
- (8) Hoenig, S. A., Sill, G. T., Kelley, L. M., and Garvey, K. J., "Destruction of Bacteria and Toxic Organic Chemicals by a Corona Discharge", *J. Air Pollution Control Assoc.*, 30 (3), 277 (March, 1980).
- (9) McTaggart, F. K., *Plasma Chemistry in Electrical Discharges*, Elsevier, New York (1967).
- (10) Neely, W. C., West, A. D., and Hall, T. D., "Ozone Removal from Arc Lamp Cooling Air", *J. Physics, E: Scientific Instruments*, 8, 543 (1975).

EVALUATION OF DECONTAMINATION FORMULATIONS

G. D. Sides, E. B. Dismukes, R. B. Spafford, and J. T. Brown
Southern Research Institute
Birmingham, Alabama

J. Epstein* and G. T. Davis
Chemical Systems Laboratory
Aberdeen Proving Ground (EA), Maryland

ABSTRACT

The objective of the research program described is to develop a water-based chemical decontamination system that will be effective against blister agents, G-agents, and V-agents. The primary advantage of a water-based system is the absence of a need to transport large quantities of solvents to the field to decontaminate equipment. In addition to the water base, the decontamination system should be noncorrosive and should consist of components that can be readily mixed and solubilized in the field. The specific agents against which decontamination formulations have been evaluated are mustard [bis-(2-chloroethyl) sulfide], VX (O-ethyl S-2-diisopropylaminoethyl methylphosphonothiolate), and GD (pinacolyl methylphosphonofluoridate). GD has been investigated in both the neat and thickened forms.

BEHAVIOR OF AGENTS IN WATER

Prior to discussing water-based decontamination formulations, it is instructive to review briefly the behavior of the agents of interest in water:

Mustard

Mustard undergoes hydrolysis to hydrochloric acid and thiodiglycol via the mechanism:

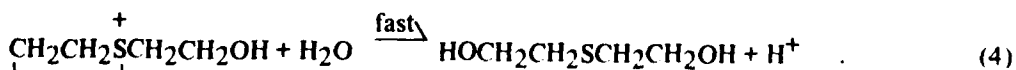
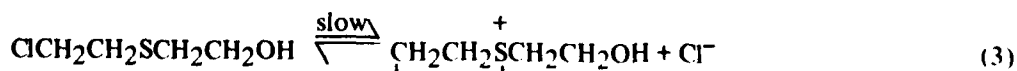
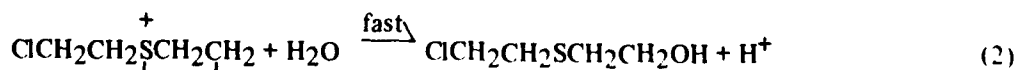
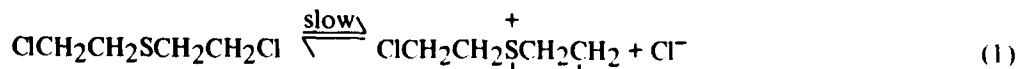

*Presently a consultant at 4020 Essex Road, Baltimore, Maryland 21207.

Bartlett and Swain⁽¹⁾ have shown that mustard hydrolysis proceeds with a rate constant* equal to 0.155 min^{-1} (for the disappearance of mustard). They also found that the rate of hydrolysis is controlled by the slow dissociation step [Reaction (1)] and is independent of pH.

The half-life for mustard in water is 4.5 min (computed from the rate constant given above). About 20 half-lives are required to reduce the concentration of an agent in solution by a factor of 10^6 . Thus, about 90 min is needed to reduce the amount of mustard in a given volume of water from 1 g to $1 \mu\text{g}$. As a general rule⁽²⁾, a decontamination formulation should reduce the agent concentration by a factor of 10^6 within 1 to 3 min. Obviously, water alone is not a suitable decontaminant for mustard.

In addition to destroying agents rapidly, a water-based decontamination formulation should enhance the solubilities and rates of solution for the agents against which it will be used. This requirement is extremely important for mustard. The solubility of mustard in water⁽³⁾ is about 0.09 percent by weight (0.90 mg/ml), and its rate of solution⁽⁴⁾ is only $1.2 \times 10^{-5} \text{ g cm}^{-2} \text{ min}^{-1}$. The low rate of solution would obviously be the limiting factor in the decontamination of mustard by water alone. For example, approximately 830 min would be required to dissolve 1 g of mustard spread over a 100 cm^2 area, whereas only about 90 min would be required to destroy 99.9999 percent of the mustard once it is in solution. Thus, for this example, the decontamination rate for mustard would be limited by the rate of solution and not by the hydrolysis rate.

Agent VX

The hydrolysis of agent VX has been studied by several authors^(5,6). In the pH range 7 to 10, hydrolysis proceeds via the cleavage of the P-S, O-C, and S-C bonds to produce methylphosphonic acids, mercaptans, sulfides, and other compounds.⁽⁶⁾ The rate of hydrolysis of agent VX is strongly dependent on pH. For example, the rate constant for hydrolysis is $1.2 \times 10^{-5} \text{ min}^{-1}$ at pH 7 (where the major reaction is P-S cleavage to produce ethyl methylphosphonic acid and 2-diisopropylaminoethylmercaptan) and $2.3 \times 10^{-4} \text{ min}^{-1}$ at pH 9.5 (where P-S, O-C, and S-C cleavage reactions are important).

Most of the data generated during the research effort described below were obtained for aqueous solutions with a pH of about 9.5. At this pH, VX has a half-life of about 2900 min. (Even at a pH of 12, the half-life for the destruction of VX in water is 140 min.) Thus, water alone is certainly not suitable for the decontamination of agent VX.

Whereas the half-life obtained in our laboratory (4.9 min) for agent mustard is in good agreement with published data⁽¹⁾, the half-life obtained for VX at pH 9.5 (about 1100 min**) is almost a factor of three shorter than the half-life obtained by Epstein et al.⁽⁶⁾ This difference is probably due to the effect of the anions HCO_3^{-1} and CO_3^{-2} from the 0.19 M NaHCO_3 /0.057 M Na_2CO_3 buffer used in our experiments. However, even the half-life obtained with the help of the buffer solution is not short enough for water alone to be of any value in the destruction of VX.

The solubility of agent VX in water⁽⁷⁾ at 25 C is 3 percent by weight (30 mg/ml), and the agent is completely miscible with water in all proportions below 9.4 C. The rate of solution of VX in

*All data reported here were obtained at 25 C unless otherwise noted.

**Extrapolated from a micellar catalysis study.

distilled water⁽⁸⁾ at 25 C is $4 \times 10^{-5} \text{ g cm}^{-2} \text{ min}^{-1}$. Thus, the rate of solution of VX is also expected to be an important factor in the decontamination of equipment exposed to VX by water-based formulations.

Agent GD

Agent GD hydrolyzes in water to produce HF and pinacolyl methylphosphonic acid:

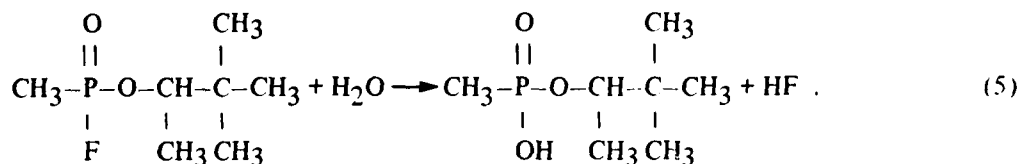

As for VX, the rate of hydrolysis for GD is strongly dependent on pH. The following equation⁽⁹⁾ may be used to calculate the rate of hydrolysis of GD:

$$k = 7.45 \times 10^{-5} + 0.55[\text{H}^+] + 833[\text{OH}^-] \quad (6)$$

where k is in units of min^{-1} . Thus, at pH 7, $k = 0.00016 \text{ min}^{-1}$, and the half-life for GD is about 4400 min. At pH 9.5, $k = 0.026 \text{ min}^{-1}$ (for a half-life of about 26 min).

The half-life for GD in water at pH 9.5 obtained in our laboratory (5 min) was shorter than the half-life (26 min) computed from Equation (6). This difference is probably due to the anion effect of the carbonate/bicarbonate buffer discussed above. Even with the help of the anion effect, a 10^6 reduction in the GD concentration in a given volume of water at pH 9.5 requires about 100 min (20 half-lives). Obviously water alone would not be suitable for the rapid decontamination of equipment exposed to agent GD.

The solubility of agent GD in water⁽⁷⁾ at 20 C is 2.1 percent by weight (21 mg/ml). Although no rate of solution data exist for GD, laboratory experience indicates that the rate of solution is much greater than that of mustard. Thus, the rate of solution of GD is not expected to be the limiting factor in the decontamination of equipment with water-based formulations.

Summary of the Behavior of Mustard, GD, and VX in Water

Table 1 shows the half-lives obtained in the course of our studies for mustard, GD, and VX in water at pH 9.5. Quite obviously, a chemical reagent must be added to the buffer solution to increase the rate of destruction of the agents. In addition, some component such as a detergent must be a part of the formulation in order to increase the rate of solution of agent mustard.

TABLE 1. Agent Behavior in Water at pH 9.5

Agent	$t_{1/2}$, min	$20t_{1/2}$, min
Mustard	4.9	98.
GD	5.	100.
VX	1100.	22000.

EVALUATION OF 3-PAD SALT SOLUTIONS

As mentioned above, any water-based formulation must contain reactive components that will enhance the rates of agent destruction and must also contain detergent components capable of increasing the rates of solution for the agents — particularly, mustard. Data reported by Higuchi et al⁽¹⁰⁾ and Epstein et al⁽¹¹⁾ have shown acceleration of the reaction between organophosphorous esters and an oximate functional group covalently bound to the backbone of a micelle. The oxime function was selected primarily on the basis of the well documented⁽¹²⁾ high reactivity of oximate ions with organophosphorous esters. Most of Higuchi's work has involved studies of the reaction between Paraoxon (diethyl *p*-nitrophenyl phosphate) and 1-*n*-dodecyl-3-pyridiniumaldoxime iodide (3-PAD-I)*. An acceleration of this reaction by a factor of more than 50 has been observed at pH 9.3.

In addition to the data for Paraoxon described above, Epstein et al⁽¹¹⁾ reported a rate constant of $9.8 \times 10^{-3} \text{ min}^{-1}$ for the decomposition of VX in an aqueous solution 0.0031 M in 3-PAD-I and buffered at pH 9.3. The VX half-life (71 min) under these conditions is more than an order of magnitude shorter than the half-life measured for VX in our laboratory at pH 9.3 in the absence of 3-PAD-I. Thus, further investigation of the 3-PAD salts as the basis of decontamination formulations seemed in order. The results of this investigation are summarized below for each agent.

Agent VX

Experiments were conducted to determine the effectiveness of 3-PAD·CH₃SO₃ solutions at pH 9.3 against agent VX. The methane-sulfonate salt was chosen due to its greater solubility than the iodide salt. The data shown in Figure 1 illustrate the variation of the rate constant for VX destruction as a function of the 3-PAD·CH₃SO₃ concentration. The solid line in the figure is the result of a fit of the data for which [3-PAD·CH₃SO₃] > 0.001 M to the functional equation for the rate constant predicted by micellar acceleration theory.⁽¹³⁾ The data shown in Figure 1 yield a value of $6.1 \times 10^{-4} \text{ min}^{-1}$ for the rate constant ($t_{1/2} = 1100 \text{ min}$) in the absence of 3-PAD·CH₃SO₃ and a value of 0.14 min^{-1} for the rate constant for the reaction of VX and the oximate ion in the micelle. A value of $6.6 \times 10^{-3} \text{ min}^{-1}$ was obtained for the rate constant in a solution $2.93 \times 10^{-3} \text{ M}$ in 3-PAD·CH₃SO₃. This compares quite well with the value of $9.8 \times 10^{-3} \text{ min}^{-1}$ obtained for a solution $3.1 \times 10^{-3} \text{ M}$ in 3-PAD-I by Epstein et al.⁽¹¹⁾

The most concentrated solution tested against VX was 0.05 M in 3-PAD·CH₃SO₃. This concentration represents approximately the solubility of the salt at 25 C. The rate constant for the destruction of VX at this concentration is 0.078 min^{-1} . This corresponds to a half-life of about 8.9 min. Thus, the reduction of the concentration of VX in solution by a factor of 10^6 would require about 180 min.

Although the rate of the destruction of VX in 3-PAD salt solutions is still much less than desired for a decontamination formulation, there is enough acceleration of its destruction to warrant the investigation of the effectiveness of 3-PAD salt solutions against GD and mustard. In addition, data obtained by Epstein et al⁽¹¹⁾ showed that it may be possible to obtain further acceleration of VX destruction by adding a cosurfactant such as CTAB (cetyltrimethylammonium bromide) or by increasing the pH of the formulation.

*Approximately 66 percent of the 3-PAD-I ($\text{pK}_a \sim 9.2$) exists as the oximate ion at pH 9.5.

Agent GD

Experiments were conducted to determine the effectiveness of 3-PAD salt solutions against agent GD. Figure 2 illustrates the behavior of agent GD in various test solutions (unbuffered water, buffered water, buffered CTAB, and buffered 3-PAD·Cl). The rate of hydrolysis of GD as a function of pH has been discussed briefly above. The rate of disappearance of GD (0.006 M) in a solution 0.01 M in CTAB at pH 9.6 is the same as its rate of disappearance in buffered water at pH 9.6. However, as is shown by the horizontal line in Figure 2, GD is destroyed so rapidly in a solution 0.01 M in 3-PAD·Cl that no agent could be detected in the first sample aliquot taken in the experiment. A half-life less than 0.1 min for GD was estimated from the sensitivity of the technique used to detect the agent. Thus, a 10^6 reduction in the GD concentration by a 3-PAD salt solution at pH 9.6 would require less than 2 min.

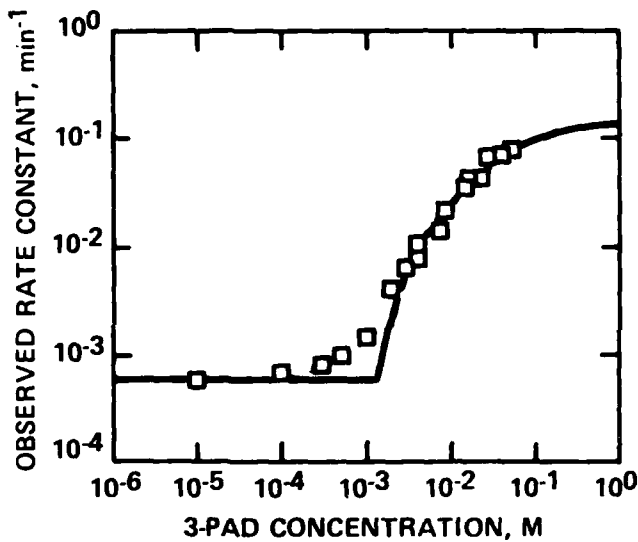

FIGURE 1. Rate constant for the disappearance of agent VX (6×10^{-4} M) in 3-PAD·CH₃SO₃ solutions buffered at pH 9.3.

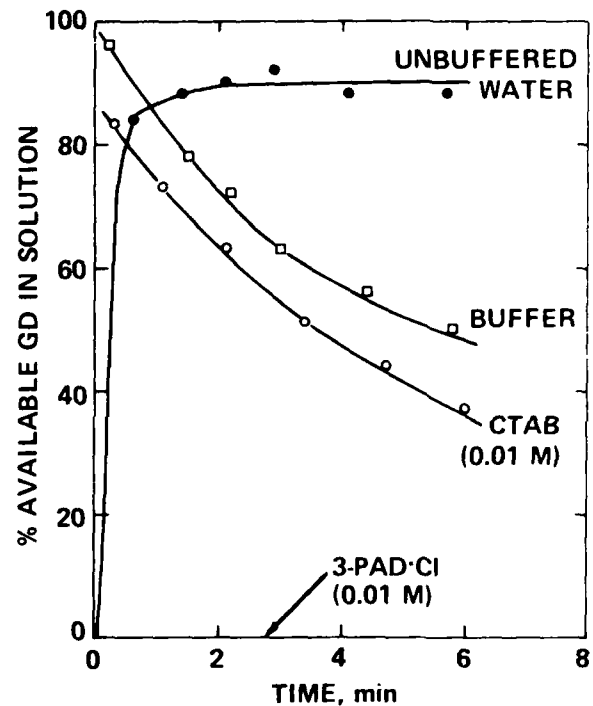

FIGURE 2. Behavior of GD (0.006 M) from the neat agent in aqueous solutions buffered at pH 9.6 (except for unbuffered water).

Some experiments were also conducted to determine the effectiveness of 3-PAD salt solutions against thickened agent GD. Figure 3 illustrates the behavior of GD from the thickened agent in various solutions. There is little difference in the rates of solution or rates of destruction of the agent in buffer, CTAB, or CTAC (chloride analog of CTAB) at pH 9.6. However, GD (0.006 M) is destroyed rapidly in a solution 0.005 M in 3-PAD·Cl - agent could be detected in only one of the samples taken as a function of reaction time. The GD is destroyed so effectively at a 3-PAD·Cl concentration of 0.01 M that no GD could be detected in any sample aliquot.

Mustard

No experiments were performed in our laboratory to test the effectiveness of 3-PAD salt solutions against mustard since Bodor et al⁽¹⁴⁾ had already shown that 3-PAD micelles have no significant effect on the rate of destruction of the compound "half-mustard" (chloroethyl ethyl sulfide).

Summary of the Effectiveness of 3-PAD Salt Solutions Against VX, GD, and Mustard

The data described above are summarized in Table 2. Although 3-PAD salt solutions accelerate (with respect to buffer solution alone) the destruction of VX by a factor of about 100 and GD by a factor estimated greater than 50, there is no acceleration of the destruction of mustard. In addition, even though the destruction of VX is accelerated, the half-life in 3-PAD salt solutions is still such that approximately 180 min is required to produce a 10^6 reduction in its concentration. However, as mentioned above, Epstein et al⁽¹¹⁾ have demonstrated that the addition of a cosurfactant to 3-PAD salt solutions may result in greater acceleration of the hydrolysis of VX than the 3-PAD salt alone. Thus, it is possible that 3-PAD salt solutions with a cosurfactant may be effective against GD and VX. However, 3-PAD salt solutions show no promise for mustard.

TABLE 2. Summary of Agent Destruction in 3-PAD Salt Solutions at pH 9.5

Agent	3-PAD Salt, M	$t_{1/2}$, min	$20t_{1/2}$, min
VX	0.05	8.9	180
GD (or TGD)	0.01	<0.1	<2
Mustard	0.05	4.5	90

EVALUATION OF POTENTIAL NUCLEOPHILES AGAINST MUSTARD

The data presented in Table 2 show that the 3-PAD salt solutions are quite effective against agent GD. In addition, it was thought that these solutions may be suitable for use against VX with the addition of a cosurfactant. However, experimental evidence showed that 3-PAD salt solutions do not accelerate the rate of destruction of mustard in aqueous solution. At this point in the research program the decision was made to attempt to find a nucleophilic reagent that would cleave Cl^- from mustard at a rate faster than the slow dissociative ionization that occurs in the normal hydrolysis of the agent. If the reaction of the nucleophile and mustard could be accelerated by micelles, then perhaps a decontamination formulation consisting of 3-PAD micelles, a cosurfactant, and a nucleophilic reagent would provide the all-purpose formulation we were seeking.

Bodor et al^(14,15) have studied the effect of a number of nucleophilic surfactants including 3-PAD salts, cetyldimethylaminoethanol bromide, cetyldimethylaminothioethanol bromide, and N-methyl octanohydroxamic acid on the hydrolysis of half-mustard. They found no change in the rate of hydrolysis of the model compound in aqueous solutions of these surfactants.

Chaimovich et al⁽¹⁶⁾ showed that the displacement of fluorine in dinitrofluorobenzene by the thiophenoxide ion can be accelerated by CTAB micelles. Figure 4 illustrates the data obtained in an investigation of the thiophenoxide ion-CTAB system as a potential decontaminant for mustard. In a buffer solution at pH 9.8, mustard hydrolyzes with a half-life of about 4.9 min. When the buffer solution is made 0.03 M in CTAB, the mustard hydrolysis half-life is lengthened to about 11 min. The longer half-life observed is apparently due to the dissolution of mustard in the CTAB micelles. When thiophenol was added to the buffered CTAB solution, no acceleration of the destruction of mustard was observed. The rate of hydrolysis of mustard in buffer in the absence of CTAB micelles was also found to be unaffected by the presence of thiophenol. At this point in the research program, the search for nucleophilic reagents for the destruction of mustard was abandoned in favor of the more promising approach described below.

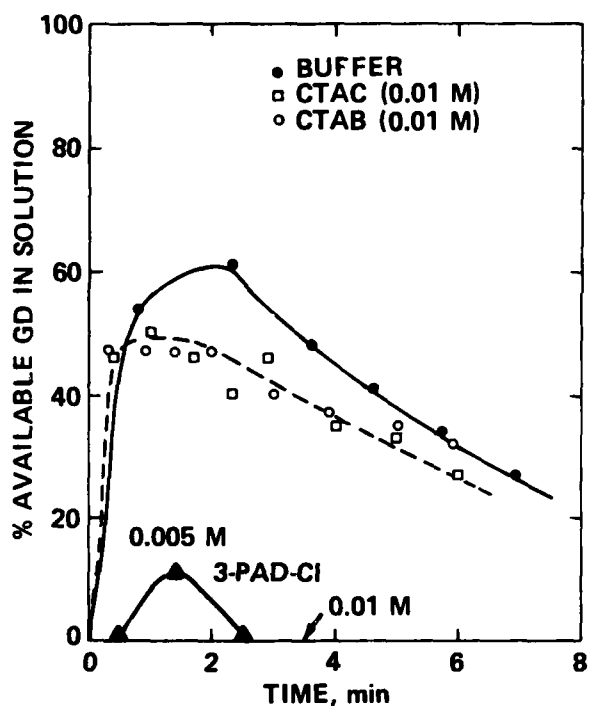

FIGURE 3. Behavior of GD (0.006 M) from the thickened agent in aqueous solutions buffered at pH 9.6.

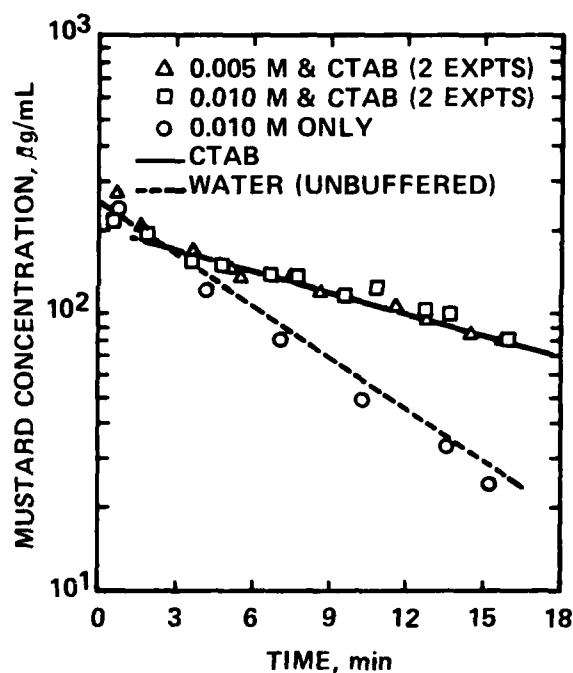

FIGURE 4. Disappearance of mustard in solutions of thiophenol, 0.030 M in CTAB and buffered at pH 9.8.

EVALUATION OF 3-CHLORO-4,4-DIMETHYL-2-OXAZOLIDINONE SOLUTIONS

It is well known that sodium hypochlorite or bleaching powder solutions are potent mustard decontamination formulations. However, hypochlorite solutions are highly corrosive and incompatible with nucleophilic reagents such as the 3-PAD salts. Kaminski et al⁽¹⁷⁾ have synthesized various soft chloroamines and investigated^(14,15) their potential against half-mustard. They found that for a 3- to 5-fold excess of the chloroamine 3-chloro-4,4-dimethyl-2-oxazolidinone (NCO), the rate of disappearance of half-mustard in water at pH 9.3 is faster than the hydrolytic rate. The half-mustard is presumably destroyed by oxidation to the sulfoxide.

Figure 5 illustrates data obtained in our laboratory in an investigation of the effectiveness of NCO in CTAB solutions at pH 9.8. Except for a sharp initial drop in the mustard concentration, the solutions 0.0010 M, 0.0039 M, and 0.0048 M in NCO and 0.03 M in CTAB all exhibit the same rate of decay for mustard as a solution containing only CTAB (0.03 M). For the solution 0.0072 M in NCO and 0.03 M in CTAB, the sharp initial drop results in the complete destruction of all of the mustard. It is interesting to compare the rate of destruction of mustard in a fresh (about 1-hour old) 0.0039 M NCO solution (0.03 M in CTAB) with that observed for the same solution after it is aged approximately 24 hours. Whereas about 30 percent of the mustard remains in the fresh solution after 12 min, all of the mustard is destroyed before the first sample (at $t \sim 30$ sec) can be taken in the aged solution.

A mass spectral investigation of the aging effect described above revealed that the chloroamine NCO is converted to the analogous bromoamine 3-bromo-4,4-dimethyl-2-oxazolidinone (NBO) in the CTAB solution. Thus, it is likely that the NBO is responsible for the rapid destruction of mustard in the aged NCO/CTAB solution. Gas chromatographic and UV spectrophotometric data show that the conversion of NCO to NBO proceeds through an intermediate - the identity of which is not known. It is likely that this intermediate is responsible for the sharp initial drop in the mustard concentration shown in Figure 5 for the fresh solutions.

EVALUATION OF 3-BROMO-4,4-DIMETHYL-2-OXAZOLIDINONE SOLUTIONS

Mustard

Data obtained in the investigation of solutions containing 3-bromo-4,4-dimethyl-2-oxazolidinone (NBO) and CTAB are summarized in Table 3. Whether the solutions were fresh or aged, no mustard could be detected in the first sample taken from the test solutions. The half-life for mustard in NBO/CTAB solutions at pH 9.6 was estimated to be less than 0.1 min.

In the course of determining the effectiveness of the NBO/CTAB formulation, GC and UV spectrophotometric techniques showed that there was a reaction between the bromide ion and NBO that occurred quickly upon mixing solutions containing NBO and CTAB. Higuchi⁽¹⁸⁾ determined the product of this reaction to be the tribromide ion Br_3^- . Since there was some concern that this species was responsible for the rapid destruction of mustard, the chloride analog (CTAC) of CTAB was substituted as the surfactant of choice. The last entry in Table 3 shows that the NBO/CTAC formulation also destroys mustard with a half-life estimated less than 0.1 min. Thus, an NBO/CTAC formulation is capable of a 10^6 reduction of a given concentration of mustard in less than 2 min.

TABLE 3. Destruction of Mustard in 3-Bromo-4,4-Dimethyl-2-Oxazolidinone (NBO) Solutions at pH 9.6

Agent Concn, M	Detergent	Concn, M	NBO Concn, M	pH ^(a)	t _{1/2} , min
0.0016	—	—	—	Unbuffered	4.9
0.0016	CTAB	0.003→ 0.03	—	9.8	4.9→ 11.6
0.0034	CTAB	0.030	0.010	9.7	<0.1 ^(b)
0.0034	CTAB	0.030	0.010	9.7	<0.1 ^(c)
0.0034	CTAB	0.030	0.010	9.7	<0.1 ^(d)
0.0034	CTAC	0.029	0.0050	9.6	<0.1 ^(b)

(a) Buffer used: HCO₃⁻/CO₃²⁻.

(b) Fresh solution.

(c) One-day-old solution.

(d) Two-day-old solution.

Agent GD

The NBO/CTAC formulation was also tested against agent GD. These data are shown in Figure 6. It may be seen that GD (0.006 M) is destroyed with a half-life of about 0.4 min in solutions buffered at pH 9.6, 0.03 M in NBO, and 0.034 M in CTAC. Though not as effective as 3-PAD solutions, the NBO/CTAC formulation will produce a 10⁶ reduction in the concentration of GD within about 8 min.

Agent VX

The NBO/CTAC formulation was also tested against agent VX. It was found that approximately a 10 to 15-fold excess of NBO was required for the complete destruction of VX (no VX detected in any of the sample aliquots). The half-life for VX under these conditions was estimated to be less than 0.3 min. Thus, a 10⁶ reduction in the concentration of VX would require less than 6 min.

Summary of the Effectiveness of the NBO/CTAC Formulation

Table 4 summarizes the half-life data measured or estimated for the agents tested against the experimental NBO/CTAC formulation. As may be seen, the times required for a 10⁶ reduction in the concentration of VX, GD, or mustard are less than 6 min, about 8 min, and less than 3 min, respectively. Although only the time for mustard falls within the desired 1 to 3 min range, the NBO/CTAC formulation shows much better general purpose capability than the 3-PAD-based formulation.

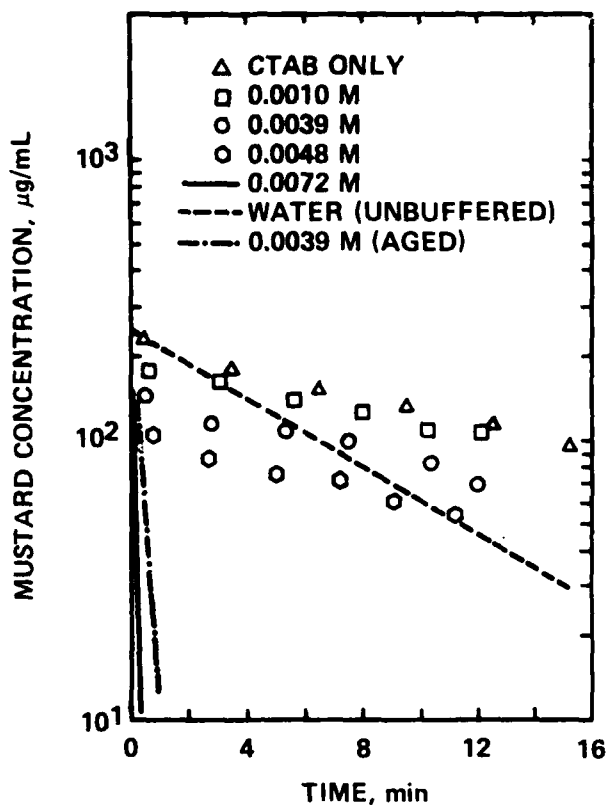

FIGURE 5. Disappearance of mustard in solutions of 3-chloro-4,4-dimethyl-2-oxazolidinone, 0.030 M in CTAB and buffered at pH 9.8.

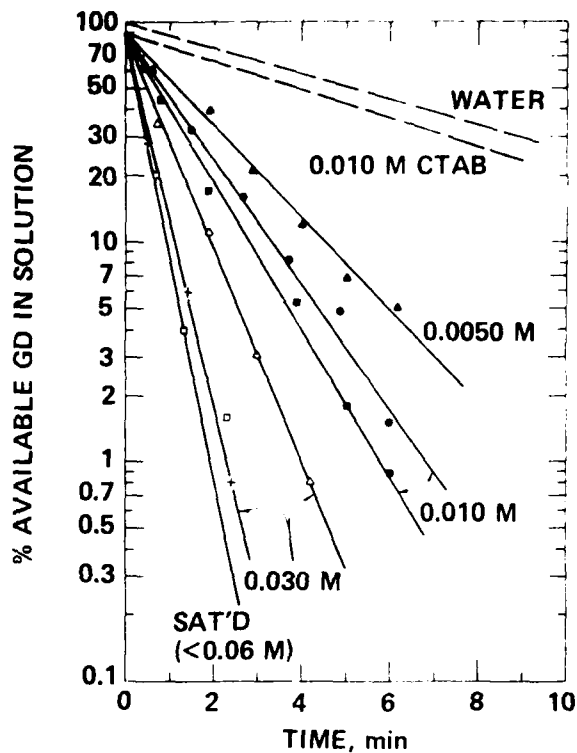

FIGURE 6. Destruction of GD from the neat agent in aqueous solutions 0.034 M in CTAC, buffered at pH 9.6, and with the NBO concentrations shown.

TABLE 4. Summary of NBO/CTAC Formulation Test Data

Agent	$t_{1/2}$, min	$20t_{1/2}$, min
VX	<0.3	<6
GD	~0.4	~8
Mustard	<0.15	<3

COMPATIBILITY OF 3-PAD SALTS AND NBO IN AQUEOUS SOLUTIONS

Even though the NBO/CTAC formulation shows promise, one of the goals of this phase of the investigation was to find an effective reagent for the destruction of mustard that could be added to 3-PAD salt solutions. However, immediately upon the addition of NBO to a 3-PAD salt solution, a change in the color of the solution occurs. This color change is indicative of a rapid reaction between NBO and 3-PAD. As expected, 3-PAD/NBO mixtures have proven ineffective against mustard. This finding is the same as that experienced by Bodor et al.(14,15)

OTHER PROPERTIES OF NBO/CTAC SOLUTIONS

Many practical problems and gaps in our knowledge must be investigated prior to declaring formulations based on NBO and CTAC to be ready for field use. Preliminary data obtained in some of these areas are discussed below.

Stoichiometry of the Destruction of Agents

Gas chromatographic and indirect iodometric techniques were used to determine the stoichiometries of the reactions between NBO and the agents. These data are summarized in Table 5. It may be seen that mustard reacts with NBO on a 1:1 basis, the hydrolysis of GD is catalyzed by NBO, and approximately 10 to 15 moles of NBO are required to destroy each mole of agent VX.

TABLE 5. Stoichiometry of NBO-Agent Reactions at pH 9.5

Agent	d[NBO]/d[Agent]
Mustard	1
GD	0
VX	10-15 ^(a)

(a) For complete destruction of the agent.

Solubility of NBO in CTAC Solutions

Figure 7 illustrates the solubility of NBO in solution (at pH 9.6) obtained as a function of the CTAC concentration. The data may be represented quite well by the equation

$$[\text{NBO}] = 0.34 [\text{CTAC}] + 0.02 \quad (7)$$

Thus, the solubility of NBO in 1 M CTAC buffered at pH 9.6 is about 18 times the solubility of NBO in buffer alone.

Stability of NBO/CTAC Formulations Buffered at pH 9.6

Figure 8 illustrates the stability of the active bromine content of various NBO/CTAC solutions over a period of about 160 hours. The data show the loss of about 20 percent of the NBO within a week for the worst case (0.0085 M CTAC solution).

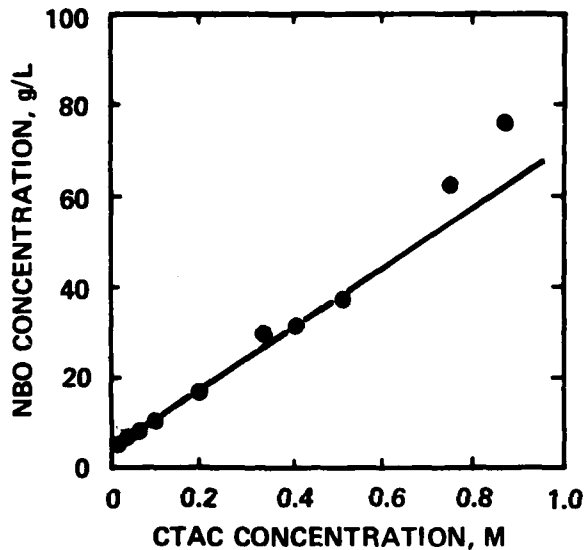

FIGURE 7. Solubility of NBO in CTAC solutions buffered at pH 9.6.

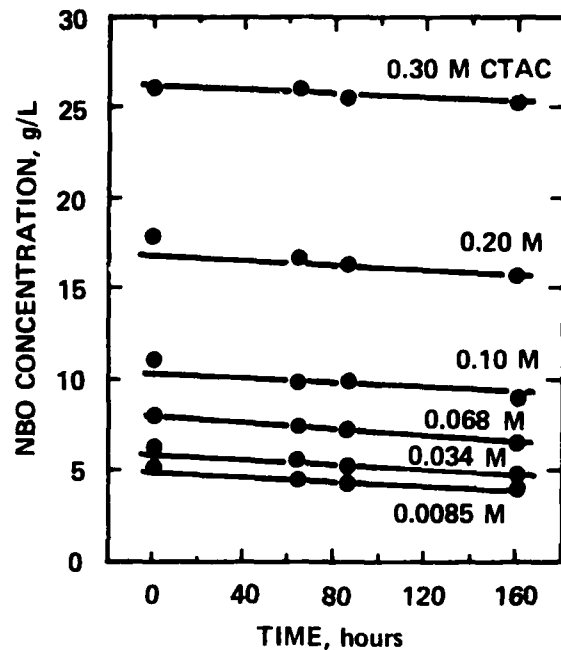

FIGURE 8. Stability of NBO in CTAC solutions buffered at pH 9.6.

QUESTIONS TO BE RESOLVED

The current research efforts have uncovered gaps in our knowledge concerning water-based decontamination formulations and particularly for the NBO/CTAC system. Questions yet to be answered include:

- Are there other surfactants that would be more suitable with respect to
 - NBO solubility and rate of solution,
 - agent solubility and rate of solution,
 - stability of the formulation, and
 - the rates of reaction of the agents with NBO?
- How effective is an NBO-based formulation on various surfaces?

- How corrosive are NBO-based formulations?
- What are the capacities of the NBO/CTAC formulation with respect to the destruction of the agents?
- What are the economics of an NBO-based decontamination formulation?
- Are other buffer systems more suitable with respect to buffering capacity?
- What is the toxicity of the proposed formulation?

Research efforts are now under way to answer these questions.

ACKNOWLEDGMENTS

The authors would like to acknowledge the helpful discussions with T. Higuchi, J. J. Kaminski, and L. Caldwell of INTER_x Research Corporation (Lawrence, Kansas) and N. Bodor of the University of Florida (Gainesville, Florida). Most of the chemicals used in this research effort were supplied by INTER_x. This work was supported by the Chemical Systems Laboratory under Contract No. DAAK11-77-C-0081.

REFERENCES

- (1) P. D. Bartlett and C. G. Swain, *J. Am. Chem. Soc.*, **71**, 1406 (1949).
- (2) J. Epstein, Private Communication, March, 1980.
- (3) R. M. Herriott, *J. Gen. Physiol.*, **30**, 449 (1947).
- (4) M. M. Demek, G. T. Davis, W. H. Dennis, Jr., A. L. Hill, R. L. Farrand, N. P. Musselman, R. J. Mazza, W. D. Levine, D. H. Rosenblatt, and J. Epstein, Edgewood Arsenal Technical Report 4417 (1970).
- (5) T. R. Fukuda and E. M. Stafford, *J. Am. Chem. Soc.*, **79**, 6083 (1957).
- (6) J. Epstein, J. J. Callahan, and V. E. Bauer, *Phosphorus*, **4**, 157 (1974).
- (7) J. Epstein, Private Communication, April, 1980.
- (8) J. W. Jovanec, G. T. Davis, F. Block, L. W. Daasch, and J. B. Bouck, Quarterly Progress Report, Applied Chemistry Section, Chemical Branch, Research Division, Chemical Systems Laboratory, September, 1978.
- (9) T. V. Healy, Porten Technical Paper No. 79 (November, 1948).

- (10) T. Higuchi, N. Bodor, J. J. Kaminski, J. P. Wylie, and K. W. Knutson, Final Report for Chemical Systems Laboratory Contract DAAA15-74-C-0147, January, 1978.
- (11) J. Epstein, J. J. Kaminski, N. Bodor, R. Enever, J. Sowa, and T. Higuchi, *J. Org. Chem.*, **43**, 2816 (1978).
- (12) A. L. Green, G. S. Sainsbury, B. Saville, and M. Stanfield, *J. Chem. Soc.*, **1958**, 1583.
- (13) J. H. Fendler and E. J. Fendler, *Catalysis in Micellar and Macromolecular Systems*, Academia Press, New York (1975).
- (14) N. Bodor and other INTER_x Research Corporation personnel, Private Communication, September, 1978.
- (15) N. Bodor, L. Caldwell, T. Higuchi, and J. J. Kaminski, Quarterly Reports for Chemical Systems Laboratory Contract No. DAAK11-77-C-0098.
- (16) H. Chaimovich, A. Blanco, L. Chayet, L. M. Costa, P. M. Monteiro, C. A. Bunton, and C. Paik, *Tetrahedron*, **31**, 1139 (1975).
- (17) J. J. Kaminski, N. Bodor, and T. Higuchi, *J. Pharm. Sci.*, **65**, 1733 (1976).
- (18) T. Higuchi, Private Communication, June, 1979.

COMPATIBILITY OF MATERIALS WITH CHEMICAL AGENTS AND DECONTAMINANTS

**R. E. Sharpe and R. J. Dick
Battelle
Columbus Laboratories
Columbus, Ohio**

ABSTRACT

A prototype handbook covering the compatibility of chemical agents with 134 materials in seven categories was prepared. In preparing this prototype handbook, a matrix of chemical agents – exposure conditions – materials and standard test procedures were developed. A search of the current literature did not supply quantitative data for the standardized conditions of exposure, materials, and test procedures specified by the matrix. The prototype provides the framework for coordination of further research efforts on compatibility of materials with chemical agents and decontaminants.

* * * * *

An urgent need has been identified by Chemical Systems Laboratory personnel for a handbook that they could use as a reference data book on the compatibility of materials with chemical agents and decontaminating materials. This handbook is seen as a design advisory for future materials use and as a guide for maintenance and protection of presently used materials and equipment. It would be a systematic, materials-oriented source of information on the effect of selected chemical compounds on the properties of materials. Data in the handbook should result from standardized testing procedures so that direct correlations and comparisons will be possible. The handbook would be open-ended, in that data could be added when required and when available through an established collection procedure.

Such a handbook does not exist at this time. However, the possibility for the handbook does exist. Under the sponsorship of the Chemical Systems Laboratory, the first steps in this direction have been taken. That is, work has been initiated toward preparing a prototype handbook covering the compatibility of chemical agents and decontaminants with various materials. This prototype is intended to serve as a core document for a working handbook which will be completed at some future time. Concurrent with this objective is the development of a matrix of agents, materials, and standard test procedures which could be used to supply specific data for the handbook.

Matrix preparation, the basis for the prototype handbook, was approached through the following phases:

Components Selection:

- Agents**
- Decontaminants**
- Exposure Densities**
- Exposure Times**
- Temperatures**

Literature Search

Materials Selection

Material Properties Selection

Test Procedure Selection

Agents, decontaminants, and exposure conditions were selected in conjunction with Chemical Systems Laboratory personnel. Exposure conditions include density, temperature, and exposure time. Densities for chemical agents include 1 gram per square meter, 5 grams per square meter, and total immersion. Density of decontaminants would be limited to total immersion. Exposure times of 1, 6, and 24 hours at each density were set. Exposure temperatures of 23C (73F) and 71C (160F) were selected with the possibility that some exposures may be made at lower (arctic) temperature. The extreme temperatures would be used when practical, depending on the physical and chemical properties of the compounds involved.

The literature survey was initiated to supplement, if possible, a literature review of pertinent data in the CSL library. As expected, the survey showed that a rather large volume of work has been done in this area. The work has been of a problem-solving nature and has not been under the restrictions that have been set for this prototype. Therefore, they are of limited value to the matrix and prototype handbook efforts.

Materials selection for the prototype handbook matrix considered input from many sources. Material lists submitted to CSL from various military agencies and technical reports of studies by military components were a prime consideration in materials selection. These documents originated in Army, Navy, and Air Force units and from manufacturers of military equipment, vehicles, weapons, clothing, etc.

The materials lists usually consisted of materials used in constructing specific military equipment. For the prototype handbook, these lists were carefully considered since these are materials of immediate interest for use-evaluation purposes. Many of these materials are covered by Military and Federal Specifications. These materials are standardized and most are available. If a complex or manufactured product was referenced, applicable Military or Federal Specifications were consulted to determine the component materials.

From these considerations, the materials were divided into seven categories:

- Adhesives and Sealants
- Metals, Ferrous
- Metals, Nonferrous
- Organic Coatings
- Plastics
- Rubber and Elastomers
- Textiles

A list of about 130 materials has been selected as representative of the seven categories (listed Tables 1-7 below).

Since thousands of materials could be considered, the final selection was aimed at simply developing a materials matrix representative of current use and of a materials spectrum in each category so that some data could be extrapolated until all of the handbook data have been obtained. It is anticipated that categories such as ceramics, inorganic compounds, lubricants, composite materials, etc., can be added as the prototype develops into the complete handbook.

Materials in the above categories differ in their chemical and physical properties and in their end use applications, but the components of each category generally have common properties. From materials-oriented sources such as Guidebooks, Buyers Guides, Encyclopedias, handbooks, and specialized reference books, properties were selected for each category of materials. The property lists were narrowed to a workable number. Military and Federal Specifications were also sources of use-oriented properties.

The purpose of the tests are to measure the degree of interaction of the chemical agents with the selected materials. Test procedures selected vary with the categories of materials, since the tests must be appropriate to the materials use. Ultimately, the tests were chosen to evaluate the effect of the agent on material properties.

ASTM standard tests were selected to describe properties of materials before and after exposure to chemical agents and decontaminating compounds. These test procedures were used since they find wide acceptance in Military and Federal Specifications. Further, ASTM test methods are reviewed on a regular basis and modified when deemed necessary. All of the ASTM methods concerned with the types of materials covered in the prototype handbook were reviewed and tests were finally chosen to measure the effect of exposure to chemicals on the properties of materials.

Tables 1 through 7 present tentative matrix components for the seven categories previously described.

Test methods were selected to measure properties of the materials that define the end-use patterns of that category. For example, the tests for the first category (Table 1) measure the performance of the materials as adhesives or sealants. For the metals groups (Tables 2 and 3), the emphasis is on determining the corrosive effects of chemical compounds on these materials. Because of the short time periods involved, changes in mechanical properties probably would be of interest only if corrosion were severe. With organic coatings (Table 4), again the properties tested were performance-oriented, measuring film hardness, gloss, blistering, adhesion, impact resistance, etc. Plastics (Table 5) are evaluated for changes in properties such as tensile strength, elongation, hardness, gloss, and mar resistance. For transparent plastics, change in light transmittance is important. The physical properties of rubber (Table 6) such as tensile properties, hardness, compression set, and surface cracking dictate the test methods. Tear resistance, breaking strength, and effect of chemicals textile materials (Table 7).

Figure 1 summarizes the system that has been outlined for Developing the Prototype Handbook. Table 8 indicates a possible format for handbook page.

TABLE 1. Adhesives and Sealants

Materials

MIL-A-8576 Acrylic-base adhesive
MMA-A-1617, Rubber-base adhesive
MIL-A-5092, Rubber-base adhesive
MMM-A-132, Epoxy adhesive
MIL-A-46106, Silicone adhesive sealant
MIL-S-8516, Polysulfide sealant
MIL-S-8784, Polysulfide sealant
MIL-S-8802, Polysulfide sealant
MIL-S-81733, Polysulfide sealing and coating compound
MIL-S-11030, Polysulfide sealing compound
MIL-S-11031, Polysulfide sealing compound non-curing
MIL-A-8623, Epoxy, metal-to-metal

Properties-Tests

Resistance of adhesive bonds to chemical reagents	ASTM A-262
Peel resistance of adhesives	D-1876
Strength properties of adhesive bonds in shear by compression	D-905
Strength properties of adhesive bonds in shear by tension	D-1002
Rheological (flow) properties of elastomer sealants	C-639

TABLE 2. Metals, Ferrous

Materials

Grade 30 Gray Iron
 Type 50007, Malleable
 A-286, Iron-base Superalloy
 Class 90,000, Alloy Steel
 A-106, Carbon Steel
 C 1020, Carbon Steel
 HY-80, Low-alloy Steel
 300M, Ultra-high Strength Steel
 4130, Ultra-high Strength Steel
 17-7PH, Age-hardenable Stainless Steel
 PH-13-8Mo, Age-hardenable Stainless Steel
 301, Austenitic Stainless Steel
 304L, Austenitic Stainless Steel
 316, Austenitic Stainless Steel
 347, Austenitic Stainless Steel

Properties-Tests

Laboratory Immersion Corrosion Testing of Metals	ASTM G-31
Susceptibility to Intergranular Attack in Stainless Steels	ASTM A-262
Pitting Corrosion, Recommended Practice for Examination and Evaluation	ASTM G-46
Preparing, Cleaning, and Evaluating Corrosion Test Specimens	*ASTM G-1
Corrosion and Corrosion Testing, Definitions and Terms	*ASTM G-15
Applying Statistics to Analysis of Corrosion Data	*ASTM G-16
U-bend Stress Corrosion Test Specimens	*ASTM G-30
Impact Testing of Cast Irons	ASTM A-327
Mechanical Testing of Steel Products	ASTM A-370
Tension Testing of Metallic Materials	ASTM E-8
Brinell Hardness of Metallic Materials	ASTM E-10
Methods of Mechanical Testing, Definitions of Terms	*ASTM E-6
Hardness Conversion Tables for Metals	*ASTM E-104

* Secondary or supporting procedures.

TABLE 3. Metals, Nonferrous

Materials

1100, Aluminum Alloy
 2024, Aluminum Alloy
 2219, Aluminum Alloy
 5052, Aluminum Alloy
 6061, Aluminum Alloy
 7075, Aluminum Alloy
 7178, Aluminum Alloy
 Haynes 188, Cobalt Alloy
 102 Oxygen-free Copper
 260 Cartridge Brass (70%)
 521 Phosphor Bronze C
 444 Admiralty
 614 Aluminum Bronze D
 Common Lead
 HM21A-T8 Magnesium Alloy
 270 Nickel
 Monel 404 Nickel Alloy
 Monel K500 Nickel Alloy
 Inconel 718 Nickel Alloy
 Grade 2 Babbit (Tin)
 Ti-6Al-4V, Titanium Alloy
 Ti-4Al-3Mo-1V, Titanium Alloy
 Ti-140A, Titanium Alloy
 A6 40A, Zinc Alloy

Properties-Tests

Corrosion Resistance

Laboratory Immersion Corrosion Testing of Metals	ASTM G-31
Preparing, Cleaning, and Evaluating Corrosion Test Specimens	*ASTM G-1
Exfoliation Corrosion Susceptibility in 7XXX Series Aluminum Alloys	ASTM G-34
Corrosion and Corrosion Testing, Definition of Terms	*ASTM G-15
Applying Statistics to Analysis of Corrosion Data	*ASTM G-16
U-Bend Stress Corrosion Test Specimens	*ASTM G-30

Mechanical Testing

Tension Testing of Metallic Materials	ASTM E-8
Tension Testing Wrought- and Cast-Aluminum and Magnesium-Alloy Products	ASTM B-557
Brinell Hardness of Metallic Materials	ASTM E-10
Rockwell Hardness	ASTM E-18
Methods of Mechanical Testing, Definition of Terms	*ASTM E-6
Hardness Conversion Tables for Metals	*ASTM E-104

* Secondary or supporting procedures.

TABLE 4. Organic Coatings

Materials

MIL-E-5557, Alkyd
MIL-E-7729, Alkyd
MIL-P-17973, Alkyd-chlorinated rubber
MIL-L-81352, Acrylic, Naval weapons
MIL-L-19537, Acrylic-nitrocellulose
MIL-L-52909, Acrylic, Camouflage
MIL-L-46159, Acrylic, Low-reflective aircraft
MIL-D-5550, Cellulose Acetate Butyrate
MIL-D-23003, Type II; Epoxy nonskid
MIL-C-22750, Epoxy-polyamide
MIL-P-47115, Epoxy clear and pigmented
MIL-C-7439, Elastomeric
TT-V-119, Spar Varnish, phenolic
TT-E-522, Phenolic Enamel
MIL-C-83231, Polyurethane, rain erosion resistant
MIL-C-83286, Polyurethane, aerospace
MIL-C-27227, Polyurethane, aircraft
MIL-C-83466, Polyurethane, thermal flux resistant
MIL-C-47247, Silicone
MIL-L-14486, Vinyl lacquer

Properties-Tests

Blistering of Paints	ASTM D-714
Indentation Hardness of Organic Coatings	D-1474
Elongation of Attached Organic Coatings	D-522
Film Hardness by Pencil Test	D-3363
Specular Gloss	D-523
Abrasion Resistance	D-968
Visual Evaluation of Color Differences of Opaque Materials	D-1729
Adhesion of Organic Coatings	D-2197
Impact Resistance	D-2794
Adhesion by Tape Test	D-3359

TABLE 5. Plastics

Materials

ABS
Acetal
MIL-P-8184, XT Acrylic
MIL-P-25690, Acrylic
Cellulose Acetate
Cellulose Acetate Butyrate, L-P-349
Diallyl phthalate, (Glass-fiber filled)
MIL-R-21931, Epoxy resin
MIL-P-18177, Epoxy, Glass-fiber filled
MIL-P-25393, Glass-fiber filled
FEP, Fluorocarbon
PTFE, Fluorocarbon
MIL-M-20693, Polyamide
L-P-410
Phenol Formaldehyde
Polyphenyl sulfone
L-P-383, Polyester
MIL-P-7575, Polyester
MIL-E-20693, Type I, Class 1
L-P-390, Low-density Polyethylene
L-P-390, Medium-density Polyethylene
L-P-390, High-density Polyethylene
L-P-394, Polypropylene
L-P-394, Polypropylene
MIL-M-24041, Polyurethane molding resin
MIL-P-26514, Polyurethane Foam
L-P-393, Polycarbonate
MIL-P-46144, Polycarbonate
MIL-P-83310, Polycarbonate
MIL-I-23053/2, Polyvinyl chloride

Properties-Tests

Resistance of Plastics to Chemical Reagents	ASTM D-543
Tensile Properties of Plastics	D-638, D-1708, D-882
Indentation Hardness of Rigid Plastics (Barcol)	D-2583
Mar Resistance of Plastics	D-673
Specular Gloss of Plastic Films	D-2457
Resistance of Plastic Materials to Abrasion	D-1242
Index of Refraction of Transparent Plastics	D-542
Deviation of Line-of-Sight through Transparent Plastics	D-881
Haze and Luminous Transmittance of Transparent Plastics	D-1003

TABLE 6. Rubber and Elastomers

Materials

NR	Natural Rubber
IR	Synthetic Isoprene, MIL-R-6855, Class 2
IIR	Isobutene-Isoprene
BR	Polybutadiene
SBR	Styrene-butadiene
NBR	Nitrile, MIL-R-6855, Class 1
CR	Chloroprene, MIL-I-23053/1
PTR	Polysulfide
EPDM	Ethylene propylene
ACM	Polyacrylate
ANM	Polyacrylate-acrylonitrile
VMQ	Silicone
	AMS-3347
	ZZ-R-765
	MIL-R-46089 (Sponge)
	MIL-R-25988
EU	Polyether urethane
AU	Polyester urethane
CSM	Chloro-sulfonyl-polyethylene

Properties-Tests

Rubber Properties in Tension	ASTM D-412
Rubber Property, Effect of Liquids	D-471
Rubber Property, Compression Set	D-395
Rubber Property, Durometer Hardness	D-2240
Rubber Deterioration- Surface Cracking	D-518
Rheological (Flow) Properties of Elastomers	C-639

TABLE 7. Textiles

Materials

Acrylics
Aramids
 MIL-C-43842
Cellulosics
 Viscose
 Acetate
Nylon
 MIL-W-4088
 MIL-W-27265
 V-T-295
Polyester
 V-T-285
Polyolefin
Vinyl
 CCC-A-680
Cotton
 CCC-C-428
 CCC-C-443
 CCC-C-419
 T-C-571
 V-T-276
Wool
Linen
Silk

Properties-Tests

Elastic Properties of Textile Fibers	ASTM D-1774
Breaking Load and Elongation of Textile Fibers	ASTM D-1682
Tear Resistance of Woven Fabrics by Falling Pendulum (Elmendorf) Apparatus	ASTM D-1424
Tearing Strength of Woven Fabrics by the Tongue (Single Rip) Method (Constant-Rate-of-Traverse Tensile Testing Machine)	ASTM D-2262
Nonwoven Fabrics, Testing	ASTM D-1117
Sewing Threads, Testing	ASTM D-204

TABLE 8. Representative Handbook Data Sheet

Organic Coatings

Polyurethane

MIL-C-46168 Coating, Aliphatic Polyurethane, Chemical Agent Resistant

Agent	Agent Density	Agent Exposure, hours at 23C(71F)	Blister Rating ASTM D-714 FED. 141-6461	Indentation Hardness ASTM-D-1474 FED. 141-6212	Gloss, 60° ASTM D-523 FED. 141-6101
Agent A	0	0	X-xx	xxx	xx
Agent A	1 g/m ²	1	Z-zz	zzz	zz
Agent A	1 g/m ²	6	Z-zz	zzz	zz
Agent A	1 g/m ²	24	Z-zz	zzz	zz
Agent A	5 g/m ²	1	Z-zz	zzz	zz
Agent A	5 g/m ²	6	Z-zz	zzz	zz
Agent A	5 g/m ²	24	Z-zz	zzz	zz
Agent A	Total	1	Z-zz	zzz	zz
Agent A	Total	6	Z-zz	zzz	zz
Agent A	Total	24	Z-zz	zzz	zz
Agent B	0	0	X-xx	xxx	xx
Agent B	1 g/m ²	0	Y-yy	yyy	yy
Agent B	1 g/m ²	6	Y-yy	yyy	yy
Agent B	1 g/m ²	24	Y-yy	yyy	yy
Agent B	5 g/m ²	1	Y-yy	yyy	yy
Agent B	5 g/m ²	6	Y-yy	yyy	yy
Agent B	5 g/m ²	24	Y-yy	yyy	yy
Agent B	Total	1	Y-yy	yyy	yy
Agent B	Total	6	Y-yy	yyy	yy
Agent B	Total	24	Y-yy	yyy	yy

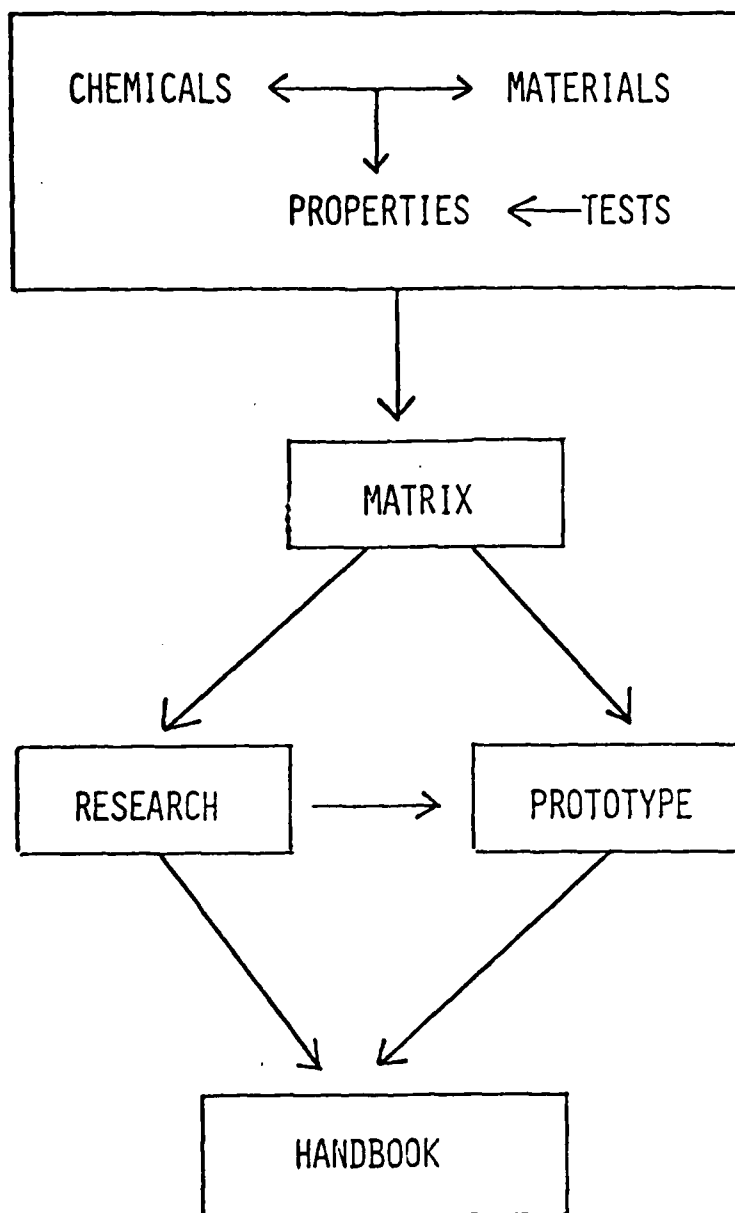

FIGURE 1. Handbook development scheme.

BIOLOGICAL DECONTAMINATION FROM THE ARMY'S POINT OF VIEW

J. B. Harstad
Chemical Systems Laboratory, USAARRADCOM
CB Detection and Alarms Division
Aberdeen Proving Ground, Maryland

ABSTRACT

The status of biological decontamination from the Army's standpoint is overviewed. The military objective is to maximize a field army's effectiveness after biological attack by reducing contamination to a safe level. The Army's prime needs are to develop a means of monitoring biological contamination, to develop and field a multipurpose NBC decontamination system, and to develop a rapid means of determining when contamination has been reduced to a safe level. This ideal biological decontaminant is characterized and past studies are delineated. Current approaches using (1) ASH – activated solution hypochlorite or SLASH – self-limiting ASH, (2) steam/hot water, or (3) jet engine exhaust are described and their pros and cons are discussed.

BACKGROUND

Biological warfare is considered to be a weapon of mass destruction. Unprotected and unwarned troops and other personnel in the target area will suffer enormous casualties in the event of a biological attack. Even after the attack, the presence of the agent in the area will continue to cause casualties among newly exposed personnel as a result of secondary aerosols.

From the standpoint of military and civil defense, biological contamination is defined as the presence of disease-producing microorganisms on personnel, equipment, supplies, and terrain caused by the intentional use of biological-threat agents as a weapon. Biological agents comprise pathogenic species of bacteria, rickettsia, viruses, or fungi; the most likely means of their employment is by dispersal as aerosols for infection by inhalation. The airborne particles are carried by air currents and are deposited on surfaces to varying degrees as the cloud moves through the target area. Biological contamination constitutes a hazard to personnel since secondary aerosols are readily produced by human activity and vehicle traffic in the contaminated area. To avoid casualties and to permit the use of contaminated equipment, it is necessary that troops in the area wear a protective mask and clothing until decontamination can be accomplished.

It is difficult to know whether biological contamination has occurred because the attack aerosol will be invisible and thus not observable on surfaces contaminated by it.

Warning of a biological attack by a detection and alarm system will indicate the presence of biological contamination in the vicinity of the alarm. A network of alarms will further indicate the likely areas of contamination. Biological-agent test kits being developed by the Army will be used to monitor for the presence and diminution of biological contamination; however, application of

the kits for that purpose may be constrained by the sensitivity of the method and the probable presence of interfering amounts of biological background. The dosage for the highly infectious agents may actually be less than the sensitivity threshold of the detection kit. In response to the need for a contamination monitor, attention is being given, in the Army's biological research and development defense programs, to the development of a reconnaissance detection capability for field use.

OBJECTIVE

The primary objective of biological decontamination from the Army's point of view is to maximize the effectiveness of the field army after a biological attack by reducing to a safe level the contamination on personnel, equipment, materiel, buildings, and areas.

Depending on the stability of the attack agent, biological contamination may last from only a few hours (vegetative bacterial pathogens) to months or years (bacterial spores). Consequently, effective decontamination is a high priority requirement to obviate the need for prolonged wearing of masks and protective clothing. An ideal biological decontaminant from the Army's point of view

- (1) Is effective against both biological and chemical agents
- (2) Is effective against the most resistant potential agent (bacterial spores)
- (3) Acts rapidly even at relatively low concentrations
- (4) Acts reasonably independent of temperature and RH
- (5) Is nontoxic and noncarcinogenic
- (6) Is nonflammable and noncorrosive
- (7) Is inexpensive and readily available
- (8) Stores well under ambient conditions
- (9) Requires only simple application, field situation
- (10) Has no secondary hazards (contaminated effluents).

These objectives are receiving attention in the current Army Research and Development Programs for CB decontamination and contamination avoidance.

Table 1 summarizes the findings from previous studies, many of which were conducted in the Army's physical defense program at Ft. Detrick, Frederick, Md., from 1946 to 1971. The highly effective vapor-phase decontaminants betapropiolactone (BPL), formaldehyde, and ethylene oxide (ETO) are not effective against chemical agents. Peracetic acid (PAA) is also ineffective against chemical agents.

TABLE 1. Summary of Past Biological Decontamination Studies

Target	Decontaminant
Personnel (skin)	Soap and water, ASH (activated hypochlorite solution) spray, SLASH (self-limiting activated hypochlorite solution) spray
Personnel, clothed and masked	PAA (peracetic acid) spray, ASH or SLASH spray
Clothing	Ethylene oxide (ETO) vapor, autoclave, laundry, ASH, SLASH
Gas mask	Bleach, ETO, PAA wipe
Surfaces	Bleach, ASH, SLASH
Vehicles	ETO, BPL, formaldehyde vapors, bleach, washing, steam
Building interior	BPL, formaldehyde, ASH vapor
Gastight space	ETO
Terrain	Dust suppressant, bleach, lye, fire
Aerosol	ASH vapor

CURRENT APPROACHES

Over the past several years, an intensive effort has been conducted at CSL to develop new ways of decontaminating biological agents that would destroy the agents without deteriorating the equipment and endangering the personnel. Many potential decontaminants were investigated. The program recently has been combined with the chemical decontamination effort in order to develop decontamination methods and systems that are effective against both biological and chemical agents. Dual-purpose decontamination methods currently under investigation and/or development are:

- (1) ASH (activated solution of hypochlorite) and SLASH (self-limiting ASH) systems
- (2) Steam/hot water decontamination system
- (3) Jet engine exhaust decontamination system.

These systems are discussed below.

ASH and SLASH Systems. Activation of the ASH and SLASH decontaminants consists of converting the germicidally inactive hypochlorite ion to the germicidally active hypochlorous acid by the addition of an acid which is stronger than hypochlorous acid, such as acetic or citric acid. Hypochlorous acid is volatile; when the water content of ASH has evaporated, the total hypochlorite content will also have evaporated as hypochlorous acid. No hypochlorite will remain to cause corrosion of metals or deterioration of materials. SLASH is a self-limiting activated solution of hypochlorite in which the elimination of hypochlorous acid is controlled by the addition of citric acid. Even if the decontamination solution penetrates into inaccessible locations, the hypochlorous acid will, nevertheless, be destroyed (reduced) in situ after a short time. Both ASH and SLASH are Naval Research Laboratory (NRL) developments.

ASH and SLASH have application for decontamination in both the liquid and vapor phases. ASH vapor has been used to decontaminate biological aerosols both in a chamber and in the field. Open-air tests with field-generated biological simulant aerosols showed that a countercloud of ASH drastically reduced the downwind hazard. Results of these tests are shown in Figure 1. Figure 2 shows the results of the chamber tests. This technique provides a method for contamination avoidance after the onset of a biological attack. ASH and SLASH solutions have application in decontaminating surfaces, and they are more rapid than vapors for this purpose.

Steam/Hot-Water Decontamination System. The steam/hot-water decontamination system is a truck-mounted apparatus intended to remove contaminants from U.S. Army fighting vehicles such as tanks, troop carriers, supply vehicles, gun and rocket carriers, etc. A combination of high-pressure hot water, steam, and detergent (or decontaminant) is used to accomplish this purpose. The apparatus can also provide showers for personnel or it can be used to apply firefighting foam. High-pressure hot-water spray removed more than 99.99 percent of the contamination from metal and rubber surfaces (Table 2) while decontamination of porous surfaces such as cloth and wood was less effective. With this system, however, the effluents (wash water) were contaminated. The next step will be to add a decontaminant to reduce the effluent contamination.

Jet-Exhaust Decontamination System. The jet-exhaust decontamination system is a vehicle-mounted jet engine intended to rapidly decontaminate tactical combat vehicles by means of a high-velocity stream of hot exhaust gases. Recent studies indicate that the current jet engine exhaust requires approximately 5 to 10 minutes, depending on the vehicle type, to reduce surface contamination by 99 percent when using only hot exhaust gases. However, the studies indicated a possible secondary aerosol hazard from particles being blown off the jet blast (Table 3). A continuous low-level secondary aerosol would be generated by a field station decontaminating a fleet of tanks. For example, a contamination of 10^8 cells per vehicle would convert to 10^5 cells blown off, and this would constitute a hazard in the immediate area.

ARMY'S PRIME NEEDS

Prime considerations in the Army's continuing decontamination program are the development and fielding of multipurpose NBC decontamination systems as well as a rapid means of determining when the contamination has been reduced to a safe or acceptable level. The systems must be logistically usable under field conditions. Decontamination should be rapid and reasonably independent of climatic conditions and it should not create undue secondary hazards. Emphasis is placed on

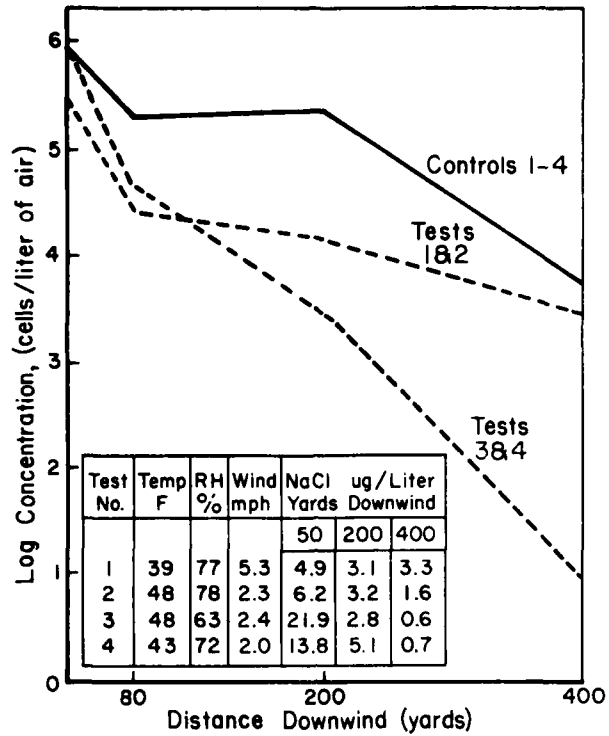

FIGURE 1. BG-Cloud Neutralization Trials-DPG

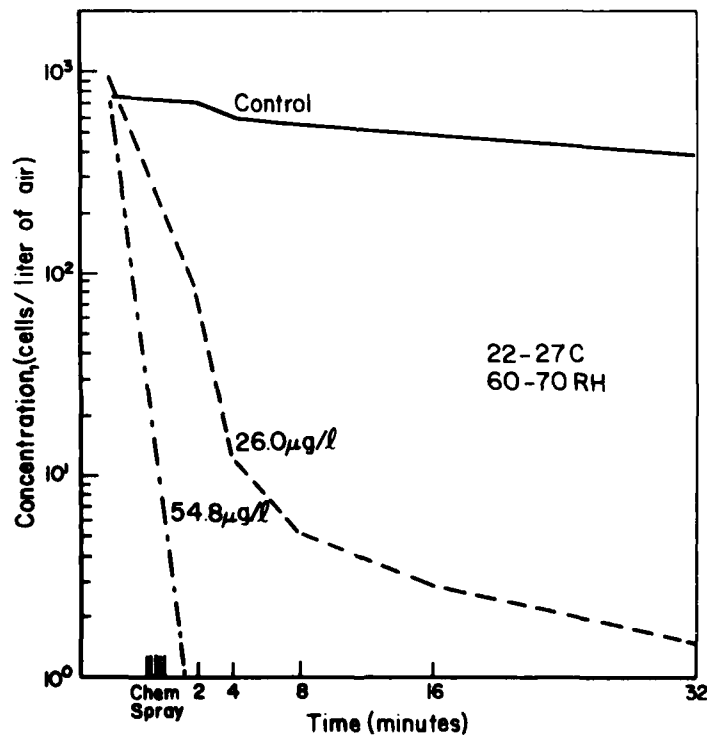

FIGURE 2. Exposure of *Bacillus subtilis* var. *niger* Spores in Aerosol to Acidified-Sodium Hypochlorite Aerosol.

TABLE 2. Comparison of Hot Water and Wash-on-Wheels Removal of Biological Contamination from Test Surfaces

Surface	Reduction (percent)		
	Hot Water	WOW Water	WOW Water + HOCl (pH 6)
Urethane paint ^(a)	99.9999	99.998	99.999
Alkyd paint ^(a)	99.998	99.997	99.996
Rubber ^(b)	99.98	99.99	99.998

(a) Painted sheet metal; 32 cm² area.

(b) Tire sidewall; 32 cm² area.

TABLE 3. Secondary Aerosol Produced by Decontamination of Biologically Contaminated Surfaces by Jet Engine Exhaust

Contaminated Test Surface	Number of Tests	Secondary Aerosol Particle Fraction	
		Mean	Range
Painted steel	24	0.0007	0 to 0.01
Other materials ^(a)	20	0.0001	0 to 0.002
Combat vehicles	6	0.0009	0 to 0.002

(a) Rubber, ceramic, and plastic.

new concepts and innovative methods for CB decontamination in ongoing R&D programs at the Chemical Systems Laboratory (CSL). Candidate decontaminant methods will be evaluated alone and in combination with radiation or mechanical action. Microwaves, laser photolyses, laser-induced catalyses, and high-intensity infrared radiation are examples.

A means of monitoring for biological contamination is another prime need of our military services. As mentioned earlier, this will be very difficult to accomplish in the case of highly infectious agents which are a hazard at concentrations below the microbial background likely to be present on personnel, equipment, and terrain. Techniques are needed for effective recovery of viable biological agents from personnel and from materiel surfaces, recovery from which may be curtailed because of porosity, weathering, texture, etc. A highly sensitive and rapid assay method is required to selectively detect the viable pathogens in the recovered samples.

An automatic monitor is needed to determine when decontamination of personnel and materiel has successfully been accomplished. This monitor may use techniques similar to those used by the contamination monitor, but will require higher sensitivity to detect the decrease of viable biological agents to all clear or tolerable levels.

Development of a rapid biological automatic monitor represents a formidable problem because of the need for a system with high sensitivity. Rapid means involving the use of kits for this purpose are being developed at CSL. Present methods center on rapid tests for the detection of bacterial protein levels, as well as for the detection of viral nucleic acid. A fractionating filter system is under development for separation of the particles of interest from interfering background materials. Most of the work on this system is still in the research stage, but the system appears to show promise. When successfully developed, the system will be used to monitor contamination levels in a postattack environment as well as to indicate the cloud passage condition.

INVESTIGATION OF TECHNIQUES FOR THE DECONTAMINATION OF MILITARY VEHICLES AND PERSONNEL PROTECTION ITEMS

J. J. Reidy, G. R. Riley, and C. V. Robinson
Battelle
Columbus Laboratories
Columbus, Ohio

ABSTRACT

A series of research projects has been undertaken by Battelle's Columbus Laboratories on behalf of the U.S. Army Chemical Systems Laboratory to identify and to develop improved methods for decontaminating military vehicles and personnel protection items. On the basis of these studies (1) the feasibility of using infrared heat as a decontamination technique for vehicle exteriors was established, and a system concept was developed; (2) the feasibilities of using a vehicle's exhaust system, compressed-air system, and electrical system as power sources for decontamination spraying equipment were established, and proof-of-principle models were devised that represent concepts that can be developed into practical spraying equipment; (3) an interior surface decontamination system utilizing flowing hot air was developed for use in a large-scale decontamination process and is presently undergoing more extensive testing; (4) a prototype capture-scavenging system was developed for use in the testing of a decontamination system that utilizes the exhaust gases of a jet engine; (5) design guidelines handbooks for both the interiors and exteriors of military vehicles were developed to aid in the design of vehicles that are both less susceptible to contamination and easier to decontaminate; and (6) a hand-held contaminant monitoring system was investigated. In addition, the physical effects of several decontaminating methods for personnel protection and clothing items are being determined in a current study; the results should indicate which methods hold the most promise for more extensive testing.

INTRODUCTION

As part of a major effort by the Chemical Systems Laboratory of the U.S. Army Armament Research and Development Command to improve the defensive posture of U.S. and other NATO forces with regard to chemical warfare, Battelle's Columbus Laboratories has been involved in a series of research projects intended to identify and to develop more effective techniques for the decontamination of military vehicles and personnel protection items. This paper presents an overview of four major areas of this research -- vehicle decontamination techniques, vehicle design to facilitate decontamination, decontamination techniques for personnel protection items, and contamination monitoring system development.

VEHICLE DECONTAMINATION TECHNIQUES

Current methods of decontaminating military vehicles exposed to chemical-warfare agents usually involve manual scrubbing with brushes and decontaminant. These procedures are costly in terms of both time and manpower, and also require a great deal of personnel-contaminant interface. Battelle's research effort in combat vehicle decontamination has emphasized investigations of alternative techniques that utilize energy from a variety of sources and minimize the exposure of military personnel to the hazardous contaminant.

Feasibility of Using a Portable Infrared Heat Source to Decontaminate Military Vehicles

One attractive means for supplying heat to vaporize agent contaminants from the exteriors of military vehicles, particularly for in-field operations, would be a portable infrared heat source.⁽¹⁾ Because neither the efficiency of heat as a decontaminating medium nor the availability of a suitable portable infrared heat source had been established, a study was undertaken to determine the feasibility of using infrared heat to vaporize contaminating chemical agents from the exterior surfaces of military vehicles. Depending upon the feasibility of using infrared radiation as a means of decontamination, supporting objectives were to identify infrared sources that could be applied to decontaminating operations and to prepare a conceptual layout of a portable infrared decontamination system that would be feasible for in-field use.

Preliminary calculations indicated that a source temperature of 1450 C (2640 F) is required for raising a contaminated surface to 300 C (572 F), the boiling point of the nerve agent VX, in 30 seconds. It was initially believed that the temperature of the contaminated surface would have to at least approach 300 C if the agents were to be quickly vaporized from the surface, although subsequent experiments indicated that these temperatures need not be that high. Because the decontamination procedure envisioned as the goal of this study was to be an in-field operation, the main interest was in units applicable to open-space heating rather than those applicable to closed-spaced heating. On the basis of a literature survey, it appeared that commercially available units adaptable to vehicle decontamination would most likely be either gas fired or electric powered, rather than oil fired.

A search was undertaken for suitable commercial radiant heaters or burners having surface temperatures of at least 1100 C (2000 F). Four units were selected for initial testing: one gas burner; one oil burner; a quartz T-3 lamp; and a ceramic-type heater. These heaters were evaluated in tests involving the vaporization from test panels of materials that simulated the boiling point and vapor pressure characteristics of chemical agents VX, GD, and HD. These tests revealed that a panel surface temperature of 90 to 100 C (190 to 210 F) was sufficient to vaporize the GD and HD simulants in 45 to 60 seconds. The VX simulant required substantially higher temperatures and a longer time for evaporation. The tests also revealed that both the gas and oil burners had fairly low radiant efficiencies, and that the electrical heaters consumed electricity at an approximate rate of 43 kW/m² of heater surface, which would therefore necessitate a large auxiliary generator. In addition, it was seen that none of the four heaters was designed to withstand the probable high mechanical shock loads that would be encountered in a portable field-heater system. Therefore, although these tests demonstrated the feasibility of using infrared heat as a decontamination technique, it became apparent that none of the tested units was appropriate for application in a large, portable heater bank for in-field use.

An additional commercial radiant heater – an Inconel-screen radiant gas burner – was then selected for testing. This heater has the following advantages: it is highly resistant to mechanical and thermal shock loads; it is an atmospheric-type burner, which eliminates any need for premix blowers or pressurized atomizing air, as was required for the previous oil and gas burners; and it has a burner surface temperature of approximately 820 C (1500 F), which, on the basis of the previous tests, is sufficient to vaporize the simulants.

In evaporation tests similar to the previous ones, three of these heaters manifolded together demonstrated superior performances relative to the heaters previously evaluated. Residue tests designed to determine whether the simulants were being removed successfully by evaporation indicated that the residue level for both polyurethane (MIL-C-46168)-painted test panels and alkyd (MIL-E-52798)-painted steel test panels was less than 1 percent. In addition, no damage was observed following heat-damage tests in which the polyurethane- and alkyd-painted panels were heated to 200 C (390 F), although some discoloration did occur when the panels were heated above 250 C (480 F).

On the basis of test results, the Inconel-screen radiant heater was incorporated into system concept drawings. The resulting system concept centers around a 2.7 x 4.6-m (9 x 15-ft) foldable heater bank assembly of 3 rows with 20 heaters per row. Each heater had a capacity of 17.6-kW (60,000 Btu/hr). The radiant efficiency of the heaters is approximately 50 percent, which would provide an approximate radiant heat output of 8.8 kW (30,000 Btu/hr) per heater. The heater bank, along with a propane tank, a propane vaporizer, and a heater-bank handling system, would be mounted on a 5-ton truck. Calculations indicate that the heater bank would have a heat intensity sufficient to raise the temperature of a painted 1.6-mm (0.062-in.)-thick panel from 22 C (72 F) to 90 C (194 F) in 15 to 30 seconds. Approximately 6 minutes would be required for a 5-cm (2-in.)-thick load panel to reach 90 C.

The basic system concept would decontaminate the side of a vehicle drawn up parallel with the heater bank. However, the concept can be modified to provide for the decontamination of the front and rear vehicle surfaces by the addition of 1.9 x 1.9-m (6 x 6-ft) heater panels designed to swing out at the forward and rear ends of the center and lower rows of the main heater bank.

Brief consideration was given to the possibility of developing means to suppress the infrared signature from the conceptualized decontamination unit. However, because of the expected hot-exhaust-gas volume and the heater surface temperature, elimination or concealment of the heater-bank infrared signal does not appear to be practical. In addition, the decontaminated vehicles themselves will be hot and thus will emit their own infrared signal.

The use of microwave, ultraviolet, and X-ray radiation as a means of decontamination was briefly considered, but all three methods were rejected. The wavelength of a microwave is too short for effective absorption by paint and agent layers, and thus would produce no significant heating. In addition, a high-intensity microwave source could be harmful to personnel. Ultraviolet radiation would be likely to have little effect on chemical agents, and also could be harmful to personnel. X-radiation was rejected because of a clear potential danger to personnel.

Feasibility of Utilizing a Military Vehicle as Power Source for Decontamination Spray Equipment

The use of hand-pumped, high-pressure spray units has been considered as a means for decreasing the time and effort required for current military vehicle decontamination procedures, but the physical effort necessary to pressurize the spray units has been found to be excessive for personnel wearing protective clothing. As an alternative to manual operation, a large powered unit could be used to drive the spray equipment, but this would involve an additional system that would have to be carried on board the contaminated vehicle or by a decontamination crew. However, a standard military vehicle itself (either a contaminated vehicle or one operated by a decontamination crew) embodies several sources of energy that possibly could be applied to the spraying operation. Consequently, an investigation of the feasibility of using these energy sources to power pressure-driven spray equipment during vehicle decontamination procedures was undertaken.(2)

Because general feasibility was of primary interest, and because of the multitude of vehicle types included in the Army's inventory, efforts were concentrated on the applicability of one vehicle, the M35A1 2.5-ton truck. The vehicle energy sources most likely for practical application were identified as the engine exhaust system, the air-compressor system, and the electrical system. The amount of available usable power was determined to be 8.2 hp for the exhaust system, 0.6 hp for the compressed-air system, and 0.72 hp for the electrical system. Furthermore, the form of energy was different for each system: high-temperature [96 to 204 C (200 to 400 F)], low-pressure (15 psi), dirty gas from the exhaust system; high-pressure (100 psi), relatively clean air at near-ambient temperatures from the compressed air system; and low-voltage, direct-current (24 vdc) energy from the electrical system. These different power capabilities and different energy forms require the use of basically different types of equipment to convert the available energy to the force necessary to produce and deliver a spray stream.

With the exception of compressed-air-driven spray guns, off-the-shelf equipment appropriate for direct use from the vehicle energy sources was generally unavailable. Therefore, concept generation, design, and laboratory fabrication were necessary to produce devices capable of demonstrating the feasibility of tapping a vehicle's energy sources for spraying. Proof-of-principle models constructed by Battelle researchers were used to spray a decontaminant (DS2), a decontaminant simulant (95 percent glycerine in water), or plain water, using the three vehicle systems as power sources.

The most feasible means for using the engine exhaust was found to be an ejector-based spray unit in which an orifice was incorporated to increase the pressure of the exhaust-gas stream for atomizing and delivering the decontaminant. Two proof-of-principle models were constructed. The larger of the two had a throughput of 2.8 gpm; the smaller had a throughput of 1 gpm. As had been postulated, tests of the ejectors operating from an M35A1 truck exhaust demonstrated that the activity of the DS2 decontaminant was affected adversely by the high temperature of the exhaust stream. Otherwise, the ejector sprayers performed well and would be best implemented for large-scale decontamination involving more than one contaminated vehicle and using water-based detergent or bleach decontaminants.

The feasibility of using a vehicle's compressed-air system for spraying was demonstrated by connecting a commercial paint-spray gun to the tire inflation hose carried on an M35A1 truck. The throughput of the gun operated from this source was 0.0025 gpm. Although the gun performed well, its practical application would be restricted to vehicles having a self-contained tire-inflating capability. Furthermore, its throughput would be too low for decontaminating more than one vehicle within a reasonable time.

Two feasible means for utilizing a vehicle's direct-current electrical power were identified. One entailed the use of a 28-vdc to 110-vac inverter to directly power a commercial airless spray gun. This unit worked well, but its in-field practicality was questionable because of the need for the extra equipment represented by the inverter and the probable short life of the inverter, which had not been designed to power inductive loads such as the spray gun. The other electrically powered device was a commercial spray gun, rebuilt with a circuit interrupter to operate directly from 24-vdc power. This unit performed well in spraying tests, with a throughput of 0.005 gpm. It also was the most universally applicable of the proof-of-principle models because all vehicles in the Army inventory (except the 1-1/4-ton commercial pickup truck) have 24-vdc power systems. *This unit would be best implemented as on-board equipment for vehicle self-decontamination.*

As an additional task effort, a concept was generated for a one-step device to puncture a sealed 1-quart decontaminant can while securing and sealing the can to the air-driven and electrically powered spray guns. This concept would allow the quick replenishment of decontaminant and permit it to be carried safely and efficiently on board the vehicles. A special nozzle/brush extension assembly also was devised as an attachment for these spray guns to improve the mixing of the decontaminant with the contaminating agent and to assist in the vehicle cleaning operation.

On the basis of the results obtained in this investigation, it was concluded that a vehicle's exhaust system, compressed-air system, and electrical system are all usable as power sources for decontamination spraying equipment, and that the proof-of-principle models represent concepts that can be developed into practical spraying systems.

Exploratory Development of a System for the Decontamination of Combat-Vehicle Interiors

Present methods of decontaminating combat-vehicle interiors involve the application of a corrosive chemical decontaminant followed by a difficult vacuuming process. In hopes of determining a more effective interior-decontamination technique, a study was undertaken to identify and evaluate alternative methods of decontaminating combat-vehicle interiors, and to recommend a practical and effective interior-surface decontamination system (ISDS) that could be adopted for use in a large-scale decontamination process.⁽³⁾ Included in these objectives were the testing of alternative techniques in the removal of a chemical-agent simulant from the interiors of an M35A1 truck, an M113 armored personnel carrier (APC), and an M48A5 tank, and the modification of commercial hardware into a working experimental prototype. The factors considered in evaluating the alternative techniques included time and effectiveness in removing a chemical-agent simulant, manpower requirements, personnel-agent interface, and applicability to a large-scale decontamination process.

Four alternative techniques – hot airflow, steam application, washing with detergent and water, and absorption/vacuuming with diatomaceous earth and with Dutch powder – were evaluated in preliminary tests involving the removal of the chemical-agent simulant diethyl phthalate from a metal plate (diethyl phthalate simulates the nerve agent VX). The results of these tests indicated that hot airflow and steam application were the most promising of the four methods in terms of further investigation, and thus these techniques were chosen for continued testing.

Engine exhaust and space heaters were considered as sources of hot air for use in further tests. Tests involving the removal of diethyl phthalate from the interior of an M35A1 2.5-ton truck revealed that the heat-distribution characteristics of engine exhaust (supplied through connecting flex hoses by the LDS-465-1C turbocharged engine of a second M35A1 truck) are more effective than those of a space heater in the decontamination of a vehicle interior, and thus engine exhaust was chosen as the hot-airflow source for use in subsequent tests.

Hot airflow and steam application were then compared in tests involving the removal of diethyl phthalate from the interiors of an M113 APC and an M48A5 tank. Steam generated by a steam cleaner was quick and effective in removing simulant from the relatively smooth interior surface of the M113; however, this method was unsuccessful when tested on the M48A5 because the numerous recesses and protrusions of the M48A5 interior prevented proper positioning of the steam-cleaner nozzle. Because hot airflow in the form of engine exhaust was effective in removing the simulant from both vehicles, the hot-airflow technique was determined to be applicable to a wider range of combat vehicles than the steam-application technique.

A cleaner, more powerful, and more practical hot-air source than engine exhaust was desired, and thus several commercial heaters were evaluated. One of these heaters was chosen for testing because of its heat range [maximum output of 400,000 Btu/hr, based on an initial temperature of -54 C (-65 F)], temperature ceiling [140 to 150 C (284 to 302 F)], flexibility (various hose attachments and configurations), and versatility (already a military inventory item). In a test involving the removal of diethyl phthalate from the interior of an M113 APC, the 12-in.-diameter hoses of two of these heaters were positioned in the interior of the M113 so as to generate a swirling airflow. Under these conditions, and with an ambient temperature of 1 C (34 F), the diethyl phthalate was removed in 60 minutes. In addition, because the swirling airflow had generated an even heat buildup in the M113 interior (the average interior temperature rise was 55 C (131 F), no heat damage to interior components was evident.

To facilitate the generation of a swirling interior airflow, special hose manifolds were designed and built for application of the heater in the interior decontamination of the M48 and M60 tanks, M113 APC, and 2.5-ton and 5-ton trucks. Then, as part of a current project, the modified ISDS was applied to the interiors of an M60 tank, M113 APC, and 5-ton truck. The data from these test runs, which include interior air and surface temperatures and surface air velocities during the application of the interior-surface decontamination system, are being used in the design and operation of a small-scale test chamber. The test chamber is being used in analytical tests designed to quantify the effectiveness of the ISDS in the removal of simulated agents from samples of materials used in vehicle interiors. Gas chromatography is being used for residue analysis, and test procedures and equipment are being modified for eventual use with live agents in simulated vehicle interiors.

Development of a Jet-Engine Total Scavenging Collection System

A novel decontamination method currently under investigation at the Chemical Systems Laboratory involves the utilization of a hot stream of exhaust gas from a jet engine to decontaminate vehicle exteriors. As part of an effort to prepare tests that will be conducted in a toxic test chamber at the Chemical Systems Laboratory, an experimental apparatus for trapping and retaining the generated gases is needed to allow an assessment of the relative roles of evaporation and thermal and oxidative degradation involved in the method. Consequently, a prototype capture-scavenging system has been designed at Battelle for use in the toxic test chamber. The capture-scavenging system will be used to collect, store, and analyze the exhaust gases, and the chemical analysis of all effluents.

The capture-scavenging system, which is 64 in. wide by 82 in. high by 30 in. deep, consists of a jet engine mounted in a stainless steel engine guide, which positions the jet engine in the center of the chamber. The engine is mounted in the guide by maintaining a tight seal around the engine to prevent leakage of exhaust gases. The exhaust gases are collected in a stainless steel chamber which is connected to the jet

The second section is a specimen chamber. This chamber is conically shaped with a spherical bottom, and is divided at the interface of the sphere and cone by the specimen holder. The holder can rotate in the chamber, thereby providing various angles for impinging the jet exhaust blast on the specimen. The holder will also turn 180 degrees to protect the specimen from the exhaust before and after a test run.

The third section is an exhaust and analysis section. A centrifugal blower provides continuous suction on the specimen chamber so that the jet engine is not required to start and stop for each test. An intake nozzle is provided to remove the gas sample from the exhaust stream for analysis.

Other features of the system include an evacuated glove box around the jet engine guide and the specimen chamber. In addition, a syringe microburet is provided for applying agent to the specimens.

DESIGN GUIDELINES TO FACILITATE VEHICLE DECONTAMINATION

Military vehicles and equipment generally have been designed without a great deal of consideration for the problems created by contamination by chemical warfare agents. As a result, many of the current military vehicles have design characteristics that make them susceptible to contamination and that hamper decontamination efforts. For example, chemical contaminants may adhere to areas of poor access, creating a potential contact or vapor hazard as well as a difficult decontamination problem. In addition, some vehicle materials may absorb contaminants or may be incompatible with decontaminants. In an effort to help overcome these design shortfalls in the future, two concurrent projects were undertaken to develop handbooks of design guidelines for both vehicle exteriors and vehicle interiors.

The handbooks provide guidelines for designing military equipment and vehicles so as to minimize contamination by chemical, biological, and radiological agents and to increase the effectiveness of decontamination processes. The guidelines do not presume to dictate requirements for the layout, configuration, or construction of military hardware or for the selection of materials to be used therein, nor do they prescribe presently used design techniques. Rather, they are intended to bring the problems of contamination and decontamination to the attention of designers and to suggest approaches that eliminate or reduce the size of these problems.

The guidelines are based upon reviews of several current military vehicles and missile systems, including the M60 tank, M109 howitzer, M35 2.5-ton truck, M113 APC, M88 tank recovery vehicle, AVLB bridging vehicle, and TOW and Chaparral missile systems. The handbooks provide photographs and discussions of contamination/decontamination-related design problems found in the military vehicles and missile systems, and provide alternative design suggestions and drawings. The handbooks also provide information on contaminants and decontaminants in order to help the designer place the problems of contamination and decontamination in their proper perspectives within the overall equipment design.

INVESTIGATION OF TECHNIQUES TO DECONTAMINATE PERSONNEL PROTECTION ITEMS

To be practical for field use, a decontamination method for personnel protection items must not only reduce chemical and biological warfare agents to acceptable levels, but must also avoid damaging the contaminated items themselves to an extent that they may no longer be used. With

this latter objective in mind, a current study was undertaken to identify feasible methods for the in-field decontamination of personnel protection items, and to evaluate the physical effects of these methods on items that would have to be decontaminated in the field, thereby determining which of the methods holds the most promise for more extensive testing. Within the context of this study, personnel protection items refer to clothing and other items worn by personnel in chemical warfare environments.

On the basis of a literature survey and interviews and concept sessions, the following concepts, with their various means of application, were selected for testing:

- Dry heat – conventional oven, infrared, vehicle exhaust, vacuum furnace
- Moist heat – steam wand, steam cabinet, autoclave
- Ultrasonics – ultrasonic vibration of water
- Boiling – boiling water
- Laundry – hot water and detergent.

Samples of 13 personnel protection items, including cotton fatigues, Nomex uniforms, charcoal overgarments, rubberized cloth, and canvas carriers, were subjected to each of the selected methods under varying laboratory conditions designed to determine the physical effects of each method on the test items. Following each test, the samples were checked for obvious signs of damage, such as fading, charring, and noticeable loss of strength. In addition, those samples that appeared to suffer little or no damage were tested for breaking strength as well as for shrinkage.

Each of the methods resulted in at least some adverse effects on the test samples, ranging from severe for the conventional oven and for infrared radiation to relatively minor for the steam wand. On the basis of a comparison of the physical effects of each method on the test items, four methods – autoclave, ultrasonics, vacuum furnace, and steam wand – were selected for more extensive testing. In addition, a new technique – microwave radiation – was recommended for testing to determine its physical effects on the test items.

CONTAMINATION MONITORING SYSTEM DEVELOPMENT

The Chemical Systems Laboratory is currently involved in a Contamination Monitoring System (COMS) development program.⁽⁴⁾ As part of this research effort, a potential need has been established for a hand-held monitoring system for use by individual soldiers to determine whether agent contamination is present on personnel, equipment, and terrain. For feasible use by individual soldiers, the COMS must not only rapidly and reliably detect threat agents but must also discriminate chemical agents from such environmental interferences as decontaminating solutions and products of agent decontamination.

As part of this effort to develop a hand-held, automatic contamination monitor for use by individual soldiers, Battelle undertook a study to provide associated technical support, including conceptual system development. The scope of the Battelle research effort included a review of the current enemy threat and U.S. response doctrine and policy; a review and evaluation of potential techniques for sensing and identifying chemical agents, measuring the levels of concentration, and relating these measurements to battlefield hazards; an identification of system requirement and

operational parameters, which involves such factors as sensitivity, response time, selectivity, reliability, and maintainability; and an identification and outlining of potential use concepts, which involves sampling procedures, standardization, calibration procedures, and use limitations.

REFERENCES

- (1) Mank, J. F., and Riley, G. R., "Investigation of the Feasibility of Using a Portable, Infrared Heat Source to Decontaminate Military Vehicles", Final Report under Contract No. DAAK40-78-C-0004 to U.S. Army Armament Research and Development Command, Chemical Systems Laboratory (December 8, 1978).
- (2) Christenson, B. C., Riley, G. R., Roop, D. E., and Tierney, J. M., "The Feasibility of Utilizing a Military Vehicle as the Power Source for Decontamination Spray Equipment", Final Report under Contract No. DAAK40-78-C-0004 to U.S. Army Armament Research and Development Command, Chemical Systems Laboratory (December 1978).
- (3) Brunel, R. L., Doerschuk, D. C., Riley, G. R., and Robinson, C. V., "Exploratory Development of a System for the Decontamination of Combat Vehicle Interiors", Final Report under Contract No. DAAK40-78-C-0004 to U.S. Army Armament Research and Development Command, Chemical Systems Laboratory (January 1980).
- (4) Baum, J. V., Outterson, G. G., Prociw, T. M., Reidy, J. J., Riley, G. R., and Williams, L. W., "COMS III: A Contamination Monitoring System", Final Report under Contract No. DAAK40-78-C-0004 to U.S. Army Armament Research and Development Command, Chemical Systems Laboratory (February 1980).

DECONTAMINATION BY LIQUID BLASTING

S. J. Bless
University of Dayton Research Institute
Dayton, Ohio 45469

C. A. Akers
Calspan
Buffalo, New York

D. A. Summers
University of Missouri
Rolla, Missouri

J. L. Zakin
The Ohio State University
Columbus, Ohio

R. A. Mackay
Drexel University
Philadelphia, Pennsylvania

ABSTRACT

Experiential and theoretical considerations have led us to conclude that highly efficient decontamination systems based on high-pressure water are feasible. The principal removal mechanism will be physical action of the water stream on contaminant drops. Substrate damage can be avoided. Consideration of a tradeoff matrix has shown that an optimum system would probably feature pressures of at least several thousand psi and rapidly oscillating continuous jets. Considerable payoff will also probably result from use of long-chain polymers to stabilize the jets and decontamination chemicals to prevent redeposition.

* * * * *

I am reporting on the activities of an Impact Cleaning Study Group organized by CSL last fall (1) to identify the most promising approaches for using impact cleaning for vehicle decontamination; (2) to assess the state of the art in the technologies pertinent to the recommended approaches; (3) to compile a tradeoff matrix that will assist CSL in selecting a research plan that is most supportive of army requirements; and (4) to specify a research plan that will generate an adequate technology base for design of impact cleaning decontamination systems. The approach that we took towards achieving these objectives was to first look at the phenomenology relevant to impact cleaning processes. Accordingly, we included in our study: surface chemistry effects, impact cleaning phenomena, and physical chemistry considerations relevant to impact cleaning. The results of those investigations were compiled into a tradeoff matrix in which we could balance system parameters with operational considerations that would apply to a vehicle decontamination system. From the tradeoff matrix, we identified the most promising parameters for an impact cleaning system, and used them to recommend a research program in surface chemistry and in water cleaning technology that we hoped would allow the army to proceed to designing a prototype system optimized from the point of view of speed, of cost, and of efficiency.

The study began with a critical look at surface chemistry, since we felt that before rationally designing an impact cleaning process, one had to understand the physical nature of what had to be cleaned. It would be necessary to develop simulants that mimic the important properties of the agents to be cleaned. This would not be possible until one knew what the properties were and knew which were the important ones.

Several parameters characterize a system consisting of a drop of contaminant sitting on a solid surface. The most important are the surface tensions of the solid, the liquid, and solid-liquid interface. These can be combined to define the work of adhesion which is the work that you must do to get that drop off the surface, i.e., the work you have to do to create the new surface area that replaces the surface area which you eliminated (see Figure 1). That work of adhesion, which has to be done by a mechanical system, is a function of the surface tensions. But, if the surface is not

smooth, if it's rough, then the work of adhesion increases and one must also include the surface roughness as a parameter to consider. If the surface is porous, and the pores are filled with air, then the work of adhesion is reduced. But, if the pores are filled with liquid, then the work of adhesion is increased again as in a rough surface. For rough surfaces, viscosity of the agent and the nature of the porosity must be described.

These physical parameters for surface chemistry cleaning need to be specified for all materials of interest. The chemical threats considered in this symposium and the surfaces relevant to vehicle decontamination include not only virgin surfaces (metal, paint, cloth, rubber, glass, and plastic) but also the presence of dirt or fouling which has a first order effect on the impact cleaning process. By dirt, we mean mud, salt spray, oil and grease, propellant residues, water, fuel, and other things.

As an approach to considering physical cleaning, we considered the cleaning process in terms of several parameters: pressure, flow rate, nozzle configuration, pulsations, temperature, standoff, polymer, and decontamination chemicals. I'm going to talk about each of these parameters as they affect a vehicle decontamination system. This presentation will be followed by that of David Summers who will describe *existing* impact cleaning processes using these parameters.

A water blasting system is defined by the pressure, flow rate, nozzle diameter, and velocity. Pressure and velocity are of course related by the stagnation pressure (see Figure 2). Now it's going to turn out that the kinds of pressures that interest us are pressures like 2 to 5 ksi so that we are going to be concerned with fluid velocities in the range of up to little over 200 m/s. In general it's good to use as large a nozzle diameter as possible to increase standoff distance. Nozzle diameters of a few millimeters are probably going to be relevant for the kinds of pressures that we are considering, about 20 pascals, and flow rates will be tens of gallons per minute (see Figure 3).

In considering the best pressure to use for a system, there are a number of problems. The pressure must be high enough that the contaminant can be efficiently removed from the surface. But, the pressure must not be high enough to damage the surface or to introduce mechanical problems into a practical system.

There have been many studies of effective pressures to accomplish different kinds of jobs. Table 1 was taken from data supplied by one manufacturer, but is typical of many sets of data. No one has ever tried to clean the kinds of thickened agents that are of concern here. Thus, we must make some predictions based on experience. In general, to clean sticky viscoelastic materials, one needs as high a pressure as possible. Pressures as high as 10,000 psi are not too high. Pressures of at least several thousand psi seem necessary to effectively remove viscous materials. On the other hand, pressures much higher than a few thousand psi also start to remove paint. From these kinds of data, the Study Group concluded that the optimum pressure for physically cleaning vehicles will probably be around 3,000 psi. There is still a problem with damage of the substrate, but there are some ways that damage to the substrate can be reduced. The Air Force, for example, has done quite a lot of research into damaged substrates with a view to preventing rain erosion. Typical data are shown in Figure 4, extracted from a recent Air Force review report by Schmitt. It shows that when considering impact damage on a surface, there is usually a dwell time when no damage occurs, which turns out to be typically a few tenths of a second. One way to prevent excessive damage to a surface is to keep the jet moving rapidly over the surface so that damage does not accumulate. Another technique for ductile surfaces may be to keep the angle of obliquity high (see Figure 5); the erosion loss due to a high velocity jet impact is substantially reduced once the attack angle is higher than 60 degrees. In summary, it looks to us like one should consider pressures of several thousand psi, a jet that doesn't dwell too long in any one place, and fairly high obliquity angles.

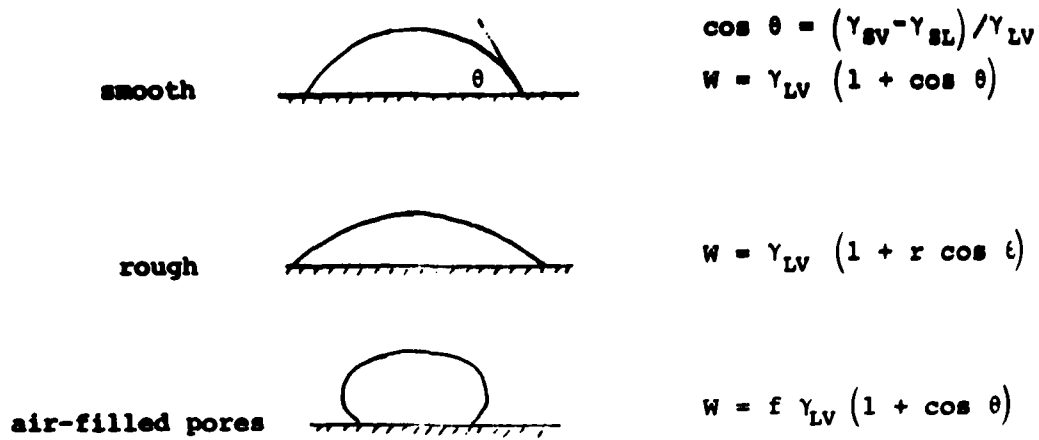

FIGURE 1. Adhesion effects.

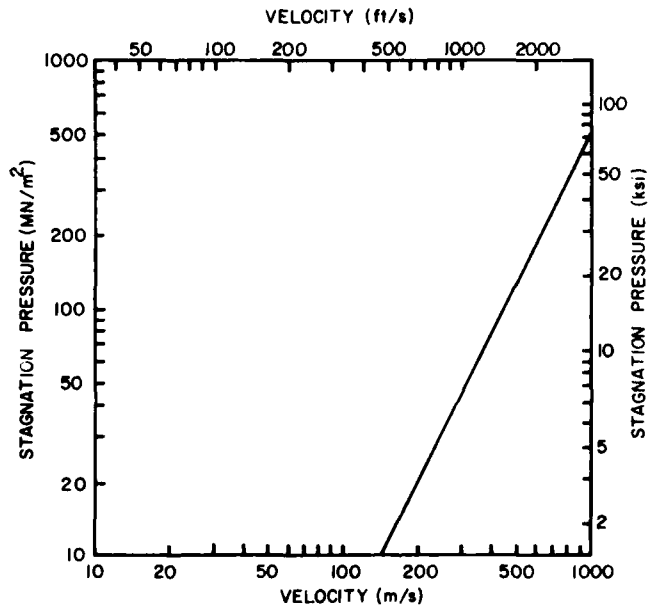

FIGURE 2. Stagnation/velocity relationship.

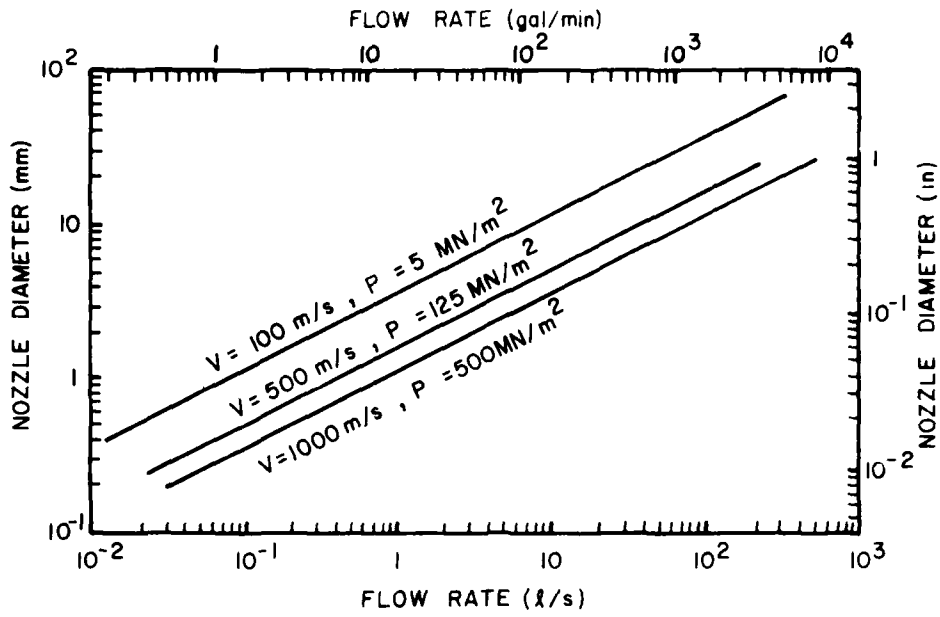

FIGURE 3. Flow rate at various nozzle diameters.

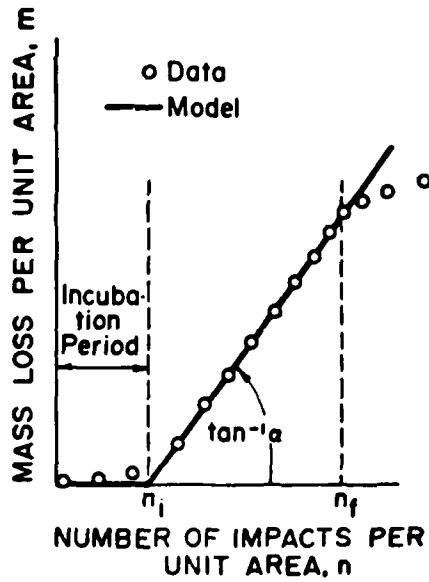

FIGURE 4. Effect of dwell time on surface damage.

TABLE 1. Typical Pressure Range for Water Cleaning

Cleaning Applications	Recommended Pressures, ksi
Latex, resins, calcium carbonate, drilling mud, metal burrs, silicates	10
Mastics, cement, loose paint, rust, tar and PVC	7
Loose paint, rust, asphalt, mastic	6
Concrete curing films, potash, PVA, iron oxide and loose paint	5
Paraffin wax, grease, aluminum burrs, hard clay, crude residues	3
Dirt, mud, grease, algae, scum, and related soft deposits	1 to 2
Bonded paint, tight rust, mastics, asphalt	5 to 10

Source: Aqua-Dyne Literature

It turns out that there is another advantage to jets which have short dwell times. Figure 6 is a graph taken from a recent German report by the Woma Company which shows the efficiency in terms of energy needed to remove certain amounts of material. Column B, which is by far the most efficient system considered, is for a jet oscillated at right angles to the direction of traverse with a frequency of a couple of Hertz. Thus, when the jet is dithered, not only is substrate damage reduced, but there results vastly increased cleaning efficiency.

When considering the parameters included in "nozzle design" the most important question is whether to use a fan-shaped nozzle that produces a spray or round nozzle that produces a jet. Figure 6 is also relevant to this point. Bar (A) is for a jet and Bar (C) is for a fan nozzle. In general, jet nozzles are more efficient than fan nozzles even for small standoffs, but the really significant advantage of jets over spray nozzles is at relatively large standoff distances, for which spray nozzles become ineffective.

To understand why, consider the flow at the orifice of a jet, which probably looks something like Figure 7. Water comes out of a nozzle as a continuous stream and it breaks up due to a variety of different instabilities at some distance away from the nozzle. In particular, the Helmholtz instability will lead to fluid breakup into a spray around the jet. There is a region near a nozzle in which a jet is continuous, and then beyond that a jet consists of a spray. The spray is very fine; it's really an aerosol with drops as small as 10 microns at the kinds of velocities considered here. Unfortunately, there is very little good documentation for what the flow issuing from a jet looks like. However, we do have some examples of fluid breakup in a flow which is probably similar to a water jet. Figure 8 is a picture from some experiments recently done at the University of Dayton which involved splashes. In this case, the splash is made by a projectile leaving a liquid surface, so the surface is being launched upwards into the air. The container measured about 6 inches across. Figure 8 shows the splash fully developed. The camera system used to take these pictures had a

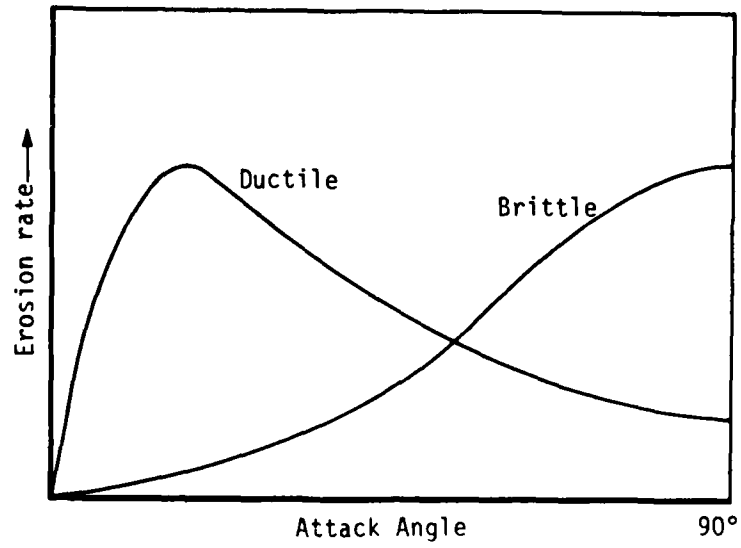

FIGURE 5. Erosion rate changes with varying attack angle.

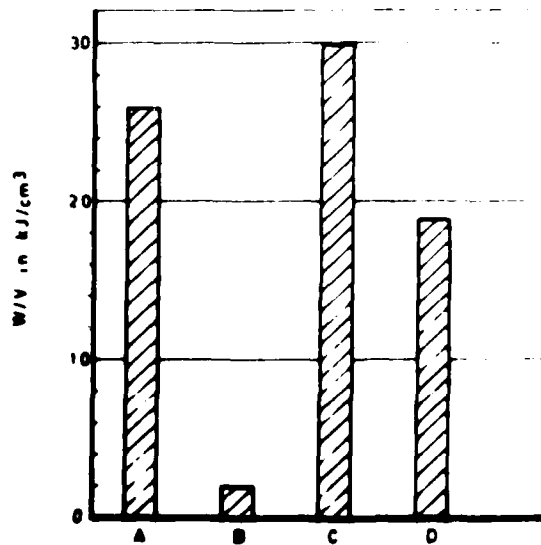

FIGURE 6. Energy needed to remove specified amounts of material.

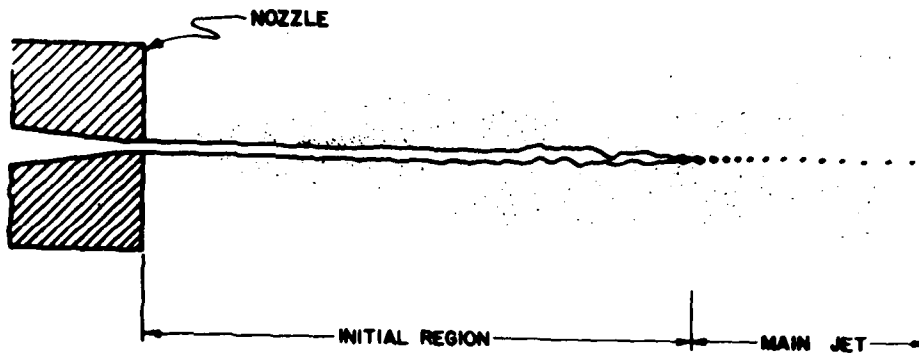

FIGURE 7. Flow at orifice of a jet.

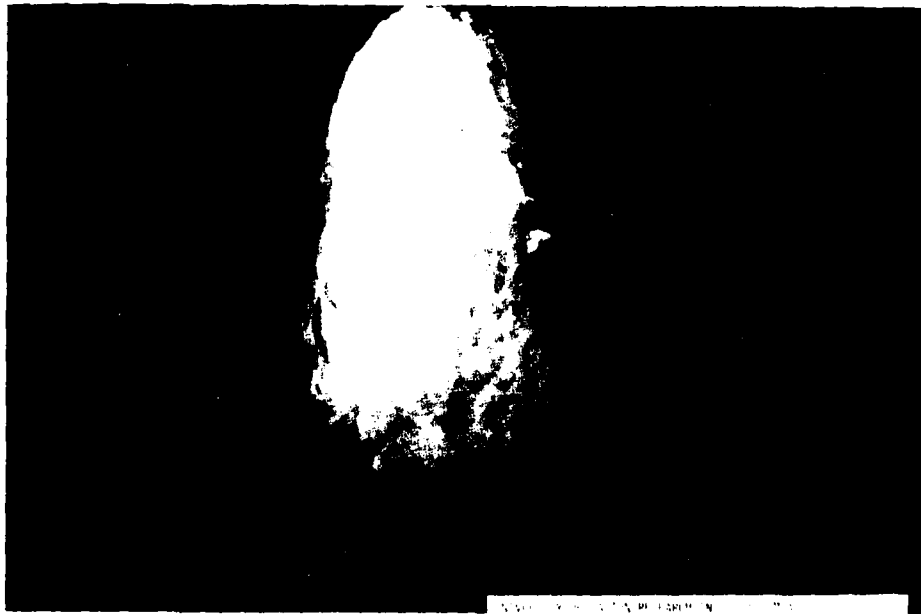

FIGURE 8. Splash from projectile leaving surface.

resolution of 5 microns, and the thing that really astonished us about this flow is that there are no drops visible. Apparently when a high velocity stream of water is projected into the air, the stream is either continuous, as in the lower portion of this photograph, or is an aerosol, as in the upper portion in which the drop size is less than 5 microns. This same kind of phenomenon probably takes place in a water jet or in a spray. It is very hard to project a mist like that any distance at all. For this reason, most sprays systems operate only at a standoff distance of about a foot. Most of them are best operated at just a few inches. On the other hand, a well-designed jet will operate at distances of several hundred nozzle diameters. Since we think that standoff will be a critical parameter in a vehicle decontamination system, we favor jet nozzles.

The geometric design of nozzles is fortunately an area which does not need very much additional work. Figure 9 for example, was taken from a classic paper by Leech and Walker, who found that the best shape for a nozzle from the point of view of jet coherence, is a 13 degree acceptance cone followed by a 3 to 1 straight section. Many investigators since this have carried out similar experiments and come to the same conclusion. Another critical aspect of nozzle design for a jet system is the condition of the flow as it reaches the nozzle. The flow should not have any vorticity in it; the velocity profile should be flat. Again those are things that are well within the present state of the art.

In efforts to improve jet coherence length to maximize standoff, there is another important consideration besides nozzle design – the addition of fluids to stabilize the jet. Figure 10, for example, shows pioneering work that was done by Hoyt et al with firehose type jets (50 psi). In the top one (pure water), you can see that as soon as the jet begins to leave the nozzle it begins to break up into instabilities, these grow and consume the entire jet. The growth of these instabilities can be greatly reduced by including very small concentrations of long chain polymers to the water. The Study Group felt that this is a technology which should certainly be considered in the development of any vehicle decontamination system.

Other parameters involved in jet design are temperature and pulsations. We concluded that neither was likely to have a very dramatic effect on the cleaning rate. However, another factor of importance is the addition of some kind of decontamination chemicals to the jet itself. There are a number of reasons why one would like to add decontamination chemicals to the jet. However, there is a problem in that as water issues from a nozzle it breaks up into drops, strikes the surface, and further breaks up into smaller drops, new surface is being continually formed. It takes time for any kind of surface-active agent to reach the surface and lower the surface tension. Figure 11 shows some sample data for an alcohol indicating the time it takes for newly formed alcohol solutions to reach equilibrium surface tension. We have done calculations which indicate that if surfactants were added to water used in a jet, the water would probably take several tenths of seconds to reach equilibrium surface tension, and that this time scale is so long that it is unlikely that the cleaning efficiency of a jet will be improved by adding any kind of decontamination chemicals to the jet itself. However, there are three other important applications for decontamination chemicals in a cleaning jet. First, there will always be some residual areas in which a jet has difficulty penetrating, and it would be worthwhile considering putting something in the solution so that those areas are decontaminated also. Second, it would be critical to prevent readhesion to material mechanically removed from a surface; chemicals are also needed for that. Third, it would be desirable to prevent recontamination by leaving a low-surface-tension film on a surface after liquid cleaning.

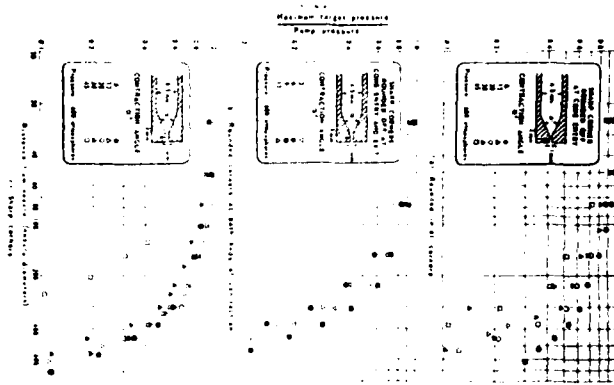

FIGURE 9. Effects of nozzle design.

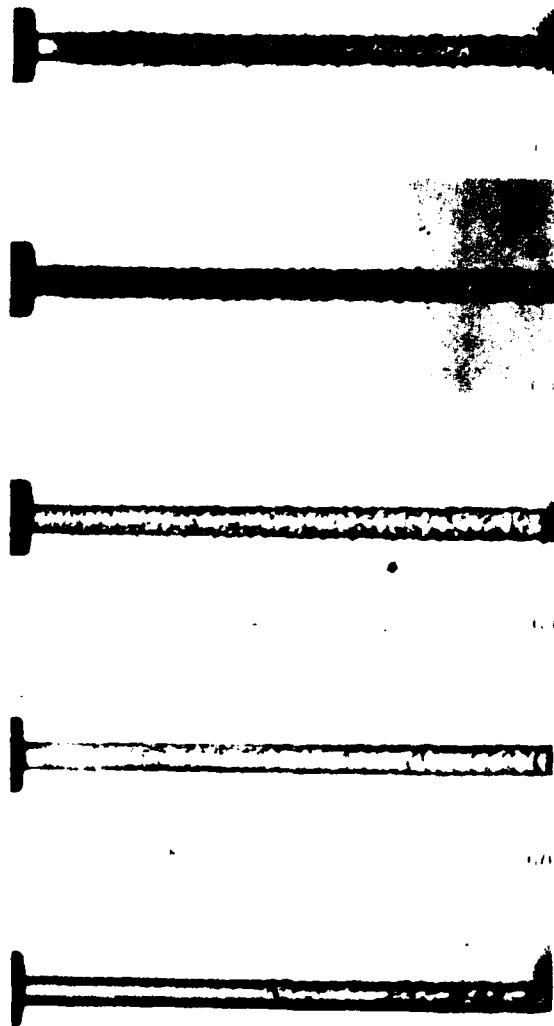

FIGURE 10. Instabilities in firehose type jets.

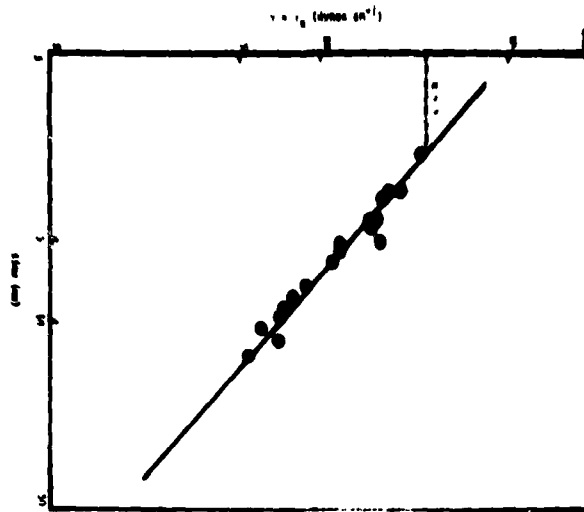

FIGURE 11. Time for alcohol solution to reach equilibrium surface tension.

We used the insight gained in this review of physical properties to construct a tradeoff matrix in which we could balance system parameters with operational considerations (shown in Figure 12). These were broken down into several categories; those considerations which affect the initial R&D phase of a system, cost and the time, those which affect the logistics, and those which affect the effectiveness of the decontamination process.

From this matrix, a number of important conclusions emerged. It became apparent that some techniques were not really worth considering, such as the use of abrasives in the jet and the use of extremely high pressures, whereas the use of medium pressures in the 3000 psi range, the use of polymer solutions, the use of oscillating jets, and the use of multiple nozzles looked very good. In fact, we concluded that it was probable that with an array of nozzles otherwise optimized, it would be possible to clean a military vehicle in a matter of minutes.

We thought through what would be needed to develop an optimum decontamination system based on these findings, and we recommend a research plan. It is shown in Table 2. The first part of the research plan is concerned with the physical chemistry which we feel should be antecedent to a detailed cleaning study. It is necessary to understand the physical chemistry characteristics of agents, the rheology of the agent, the surface bulk chemistry of the agent, and how the agent changes with time. This includes characterization of the surface of the solid, metal or cloth, and characterization of fouling, grease, dirt, and paint. For surfaces of interest, porosity, roughness, hardness, and bulk density should be described and considered. Regarding surface-agent interactions, research goals include measurement of adhesion, of wettability, of thickness of the drops on the surface, of penetration into a surface, and of solubility. As a result of these studies, it will be possible to develop realistic simulants for thickened agents which mimic those physical properties which most affect physical cleaning. We feel it is also very important that DOD establish some sort of cleanliness specifications so that the research community can decide what their goals are in terms of agent removal.

Under the heading mechanical cleaning, we recommend a multiyear program that would systematically research those physical cleaning parameters which appear to be most pertinent to

Operational Considerations	System Parameters												
	Hi Pressure (≈3000 psi)	Medium Pressure	Continuous Jet	Spray	Flow Straighteners	Nozzle Oscillation	Multiple Nozzles	High Flow Rate	Polymer Additives	Decon Additives	High Temperature	Abrasive Particles	
Development effort													
risk	-	+	+	+	+	+	+	0	+	0	0	-	
cost	-	0	0	+	0	0	0	-	0	0	-	0	
time	0	0	+	+	0	0	?	0	0	0	0	0	
Life Cycle Cost													
initial equipment	-	0	0	+	0	0	-	0	0	0	-	0	
maintenance	-	0	0	?	+	-	0	?	0	-	-	-	
support equipment	0	0	0	0	0	0	0	0	-	-	-	0	
crew size	0	0	0	-	0	0	+	+	0	0	0	-	
training	-	0	?	-	0	0	0	0	-	-	0	-	
energy efficiency	+	+	+	-	+	+	?	0	+	0	0	-	
fluid efficiency	+	+	+	-	+	+	?	0	+	+	+	0	
Effectiveness													
time	+	+	+	-	+	+	+	+	?	?	?	0	
versatility	+	+	+	0	0	?	0	0	+	+	0	-	
goodness of decon	+	+	+	+	0	0	+	0	?	+	0	?	
secondary decon problems	?	?	0	+	0	0	0	0	0	+	0	-	
TOTALS	0±1	6±1	7±1	1±1	5	3±1	3±3	1±1	2±2	1±1	-3±1	-7±1	

- + probably significant benefit
- probably adversely affected
- 0 probably relatively small effect
- ? unknown effect, possibly large

FIGURE 12. Matrix balancing system parameters and operational considerations.

TABLE 2. Research Plan

-
- I. Target Characterization**
- A. Physical Chemical Characterization of Agents**
 - Rheology of Agent
 - Surface and Bulk Chemistry
 - Effects of time
 - B. Characterization of Surface**
 - Metals, cloth, etc.
 - Grease and dirt
 - Paint and other coatings
 - Parameters
 - Porosity
 - Roughness
 - Hardness
 - Bulk Chemistry
 - C. Surface – Agent Interaction**
 - Adhesion
 - Wettability
 - Thickness (MMD)
 - Penetration
 - Solubility
 - D. Simulant Development**
 - Detection technique also necessary
 - E. Cleanliness Specifications**
 - Residual Concentration tolerated
 - (Not part of impact cleaning study, but results required)
- II. Mechanical Cleaning Mechanisms**
- A. Mechanical Cleaning Mechanisms**
 - Pressure
 - Temperature
 - Angle of attack
 - Traverse velocity
 - Incremental distance
 - Standoff
 - Flow volume
 - Fluid additives
 - Multistream interactions
 - Effect of sprays
 - B. Application Technology**
 - Additives
 - Nozzle mechanical design principles
 - Jet and spray production and projection
 - C. Data Required**
 - Removal rates
 - Removal efficiencies
 - Evidence of physical processes
- III. Physical Chemistry Aspects of Cleaning**
- A. Chemical Interactions During Impact**
 - Synergisms with best mechanical systems
 - B. Stabilization to Prevent Redeposition**
 - C. Chemical Removal of Residues**
- IV. Surface Contact Inhibition**
- A. Lower Surface Tension to Prevent Readhesion**
 - B. Develop Permanent Paint Component**
-

vehicle decontamination: pressures in the range of several thousand psi, temperatures mostly ambient, rather high angles of attack, effects of traverse velocity, effect of distance between adjacent jets, effect of standoff, as well as the effects of adjacent streams and, to some extent, sprays. Considering application technology, it is important to investigate the effects of additives to increase standoff distances, finalize the nozzle design, and look at how to project the spray. Data required in the study should be removal rates, removal efficiencies, and very importantly, some kind of physical evidence of what the physical process is. Along with these physical studies, physical chemistry aspects of cleaning should be investigated. These should feature the best physical cleaning systems to see if improvements are possible by adding chemicals. Especially critical here is to determine how agents that have been lofted can be stabilized to prevent redeposition. Lastly, decontamination chemicals will probably be necessary to remove residues left by the jet. Apart from cleaning, we think that it's very important to look at techniques to lower the surface tension after the decontamination has been completed to prevent recontamination, and this might be done by adding something to the cleaning solution or even the paint component.

ASPECTS OF WATER-JET USAGE FOR PHYSICAL DECONTAMINATION

D. A. Summers*
University of Missouri
Rolla, Missouri

ABSTRACT

This paper follows the review of the recent activity of the Impact Cleaning Group in assessing jet cleaning technology. The paper discusses the current equipment availability as it relates to high pressure jet cleaning. The practical use of the equipment in the field is reviewed. Potential changes to the system, such as the addition of abrasives, fluid cavitation, and rust inhibitors in the fluid are mentioned.

The physical events of liquid drop and jet impact on dry and wet surfaces are discussed briefly. The areas in which research is required are outlined.

INTRODUCTION

In many instances within the past 10 years, the use of water as a means of cleaning surfaces has changed from the simple use as a lubricant and solvent. In what has become a large and growing industry – surface cleaning – water is applied to the contaminated surface at a sufficiently high velocity to mechanically remove the unwanted material. This additional effect has made water jets much more efficient and reduced both the time required to clean a surface and also the amount of water applied. Two examples can illustrate this point. The first of these is on a larger scale.

For most of the airport runways in the United States, there is a problem with buildup of rubber on the concrete surfaces, arising from the initial impact of the tires at the point where aircraft land. Over the past 5 or 6 years, this rubber has been increasingly removed by the use of high-pressure water jets.⁽¹⁾ Most typically, the cleaning equipment is mounted on a large trailer which is driven up and down at a speed of approximately 10 mph, cleaning a swath of runway as it goes. Where the airport is in intermittent use, this can frequently be done between aircraft take-off and landing.

On a smaller scale, water jets have very strongly penetrated the market within the past 8 years. There is a major problem in chemical plants resulting from the deposition of material, most frequently in the bundles of heat-exchanger tubes. Historically, these tubes were cleaned mechanically by driving steel drills down through the tubes; this required a great deal of care lest the tube wall be destroyed. This problem has been overcome, and, in the process, cleaning time has been reduced by a factor of at least 10, through the use of high-pressure water jets. Individual tubes are cleaned in ~1 minute, as opposed to the 10 minutes to 1 hour that it used to take; also, because the water jets are incapable of penetrating through the metal, and yet effectively remove all the scale buildup, the process is much improved in regard to risks of the operation.

*Professor of Mining Engineering and Director of the Rock Mechanics & Explosives Research Center.

It might be mentioned in passing that the surface condition, after high-pressure water-jet cleaning, is generally much less amenable to the buildup of further deposits of material than is normally the case. The surface in this case is cleaned to a much higher level than would be achieved with conventional mechanical cleaning aids.

EQUIPMENT AVAILABILITY

The size of the equipment available ranges from a very small intensifier unit to the 200 to 300-hp units which are now used in the North Sea to clean the barnacles and other growth from the oil rigs. These have been used very effectively both on the surface and under water.

Water-jet cleaning systems, however, are not nearly as simple to optimally design as it might at first appear. It has unfortunately been my experience during some 15 years in the water-jet industry that many people think that it is simply a matter of pointing the nozzle, fed by a hose from the pump, at your target and you will get effective cleaning. Would that it were that simple. At almost all stages in the process, there are many things that can go wrong if the operator is not aware of the particular problems and parameters of the situation.

One can examine some of the factors by a superficial review of a system, starting at the pump. While systems of widely different pressure are available, realistically it is unlikely in these particular circumstances that one would want to use cleaning pressures as high as 10,000 psi. And for the particular applications in question, as has been mentioned in Dr. Bless' paper, we would not recommend going above 3,000 psi because of the chance of paint removal. However, even in this pressure range, it is of critical importance that the pump be capable of dealing with relatively dirty fluid. Some pumps are and some pumps are not capable of this. Having broken a pump because of unanticipated problems with the water used, I can assure you that you do need to be very careful in purchasing pumps to ensure that you have something that will deal with the sort of water conditions that might be encountered.

The transmission line from the pump to the nozzle is generally a high-pressure hose. One must remember that a relatively high volume of fluid is being pushed down through a relatively narrow tube. If you make the hose diameter too small, then a great deal of the energy originally put into the water from the pump can be lost as friction in the line. In our opinion, at least 1/2-in.-ID tubing hose is required for this particular part of the system.

The next thing that the fluid encounters is the lance section or the rigid section of pipe through which it passes just before entering the nozzle. This is most frequently a rigid steel tube, generally fitted with a control valve to determine whether or not the nozzle will be operated at pressure. For safety reasons, a dump valve is generally placed in this lance so that, if the operator should trip or in some way lose control of the lance, merely releasing the trigger will dump the flow out to a large orifice, thereby reducing the pressure of the jet and minimizing any risk to the operator or any other adjacent personnel.

It has only recently been widely appreciated that in the section of the pipe leading into the nozzle flow stabilization is of critical importance (most recently this has been illustrated by some work which has been reported out of Australia). If the turbulence of the flow behind the nozzle is not minimized, which normally is done by having a straight section of at least 100 tube diameters behind the nozzle, then high lateral accelerations will still exist in the jet as it exits through the nozzle. This causes a more rapid jet disintegration and a dramatic reduction in the effective length of the jet. To give a

simple example, from our own research, identical nozzles were used in two different applications for rock cutting. One system had a long straight section behind the nozzle, and the second had a path flow into the nozzle which went through two sharp bends. The first jet was capable of cutting sandstone some 6 ft from the nozzle; with the second jet, the rock was barely cut at 9 in.

The problem of ensuring good flow is compounded by an inadequate distance behind the nozzle to ensure the required straight section. Many industries have solved this problem by using flow straighteners. These are generally devices of a honeycomb or latticelike structure, placed two or three diameters behind the nozzle in the tubing; which stabilize the flow and thus make a dramatic improvement in the flow of the jet from the nozzle.

The next component is the nozzle body. Two different types of jets are normally considered effective in cleaning. The one that has been most widely studied is the solid jet. These jets are discussed in more detail in the next section.

There have been many studies of nozzle geometry effects. Unfortunately, it has been our experience in examining the literature on the subject that, in many instances, the very rigid controls necessary to ensure optimum jet generation from a nozzle body have not been followed through. Nozzles have been attached to tubing which bends just prior to the nozzle, the internal surface finish of the nozzle has been poor, or there has been a mismatch between the entrance section to the nozzle and the exit section of the tubing.

Minor factors such as these have a major effect on jet performance and can overpower the changes in jet performance attributable to the changes in nozzle geometry. With that caveat in mind, there have been a number of excellent studies done on nozzle design, and the prevalent opinion at present is that the design commonly referred to as a Leach and Walker design (after the study done by Dr. Stan Leach and Gordon Walker at the Safety in Mines Research Establishment in Sheffield, England) presently remains the optimum design for solid jet generation.

JET STRUCTURE

At present, there is some discussion on whether solid jets or spray jets are most efficient means of cleaning large surfaces. The need for large areal removal rates is stressed because the problem to be faced is not that posed by a simple car wash facility which might be used by one car owner every half hour. Instead, it is much more likely that a decontamination station will need to process a large number of vehicles as rapidly as possible. This directs one's thinking toward the use of an automated facility and leans more toward a solid jet system, with its attendant advantages than toward a spray jet system.

As mentioned previously, looking at the variety of jet patterns that can be used, the only two strong candidates that are viable are the fan-jet system and the solid jet. Where the fan-jet nozzle is held relatively close to the surface (normally within 1 ft), it can be the most effective system of the two, giving high areal coverage and, at the same time, being relatively simple to operate. Where the standoff distance increases beyond 1 ft, or where a solid-jet nozzle is oscillated at relatively high frequency, then the solid jet becomes the much more efficient of the two systems. Research in this area has been identified in Germany.

For automated facilities, solid jets have a particular advantage in that the control of the distance from the cleaning to the target surface becomes much less critical. As mentioned previously, we have, for example, been able to cut sandstone at a distance of up to 6 ft from a normal water-jet nozzle, and the forces required to clean sandstone are likely to be considerably higher than those necessary to decontaminate surfaces. With this in mind, the optimum system is likely to be some form of oscillating solid jet. The jet will maintain its ability over a greater distance, in part because there is so much more fluid contained in a solid piece traveling through the air, and it generates a different kind of turbulence and resistance in the air than does the droplet that is generated by the fan jet. There the water is broken into small droplets as it emerges from the nozzle, and thereafter it acts as an individual drop passing through the air. (The behavior of such drops has been relatively well characterized by the Air Force in looking at the effect of rain on aircraft structures, and the droplets undergo a certain characterizable breakup into smaller drop sizes which ultimately reach a point where the droplet is no longer damaging. The speed of the droplets is also more rapidly decelerated.)

SOLID JET SYSTEMS

When one examines use of an oscillating solid water jet system, there really has not been a great deal of work done with this in the United States for large areal surface cleaning. Where the jet is oscillated, definition of the breakup of the jet, after it leaves the nozzle, is not well understood.

Most typically, the method of investigation historically has been to make a series of traverses of a high-pressure transducer or a similar instrument across the jet at different distances from the nozzle. The pressure profile generated is recorded on a graph and, in this way, characterizes the jet structure. The major improvement in jet throw is most frequently through an increase in the diameter of the jet orifice. An increase in the jet pressure, however, often reduces effective jet length.

IMPROVEMENT TECHNIQUES

For applications where difficulties with conventional cleaning are found, the water jet system can be improved on in practice by one of four different methods. The first is to introduce abrasive particles into the fluid system. This is extremely effective in cutting through relatively thick material; for example, it has been used at 10,000 psi to slice pieces from an oil derrick leg of 9-in.-thick steel. On the other hand, even at relatively low pressures, the abrasive in the jet fluid will remove paint, which gives a very nice surface for refinishing, but is not likely to be particularly effective in terms of maintaining the integrity of the substrate.

The second method, which is being used with a considerable degree of success in such applications as pipe cleaning, cleaning military casings of explosives, and those where the distance from the nozzle to the target material is relatively short, is to deliberately introduce cavitation into the jet flow. This is normally achieved either by putting a blunt body in the nozzle, or by generating a swirling vortex within the nozzle conic section. Where such a cavitation is generated, the result is a series of very small, very high-pressure pulses generated on the target surface where the cavitation bubbles collapse. These small pinprick events will very often crack the contaminant on the surface or penetrate the surface itself, allowing the main pressure of the jet stream to exploit these fractures and extend them to remove larger volumes of material.

In the current circumstances it is unlikely that cavitating flows will be advantageous, for two reasons. The first is that the distance from the nozzle to the surface is much more critical with cavitation systems than with the droplets from a fan-jet nozzle. The second is that the intensity of damage created goes beyond that required.

The third method of improvement is to impart additives to the water. This requires some additional consideration. Relatively small amounts of polymer will dramatically improve the jet structure. Depending upon which polymer is used, concentrations will range from 200 to 3000 ppm. This will improve the throw of the jet and also its cleaning ability. In higher concentrations, the polymer will reduce the penetration of the jet into any substrate. The jet thus becomes a much more mechanical scrubbing system over the surface than a penetration mechanism, which is normally the case with jet fluid effect. In industrial trials in chemical plants, the use of additives over conventional water jets has proved to be advantageous, both economically and temporally. The disadvantage to the system is, of course, the cost and the need to titrate the correct concentration of the polymer into the water flow. This problem has, however, been solved by the vendors of the chemicals and nowadays suitcase size systems can be purchased to meter the small concentrations required of fluid into the flow, once it passes through the pump.

However, the economic aspect and implications of polymer use in combat conditions and the gain in effectiveness for this type of cleaning operation still need to be established.

The fourth method of enhancing cleaning is to heat the water. Whether this would be particularly advantageous in situations where one is attacking an agent that might be susceptible to heat or that might react to heat is questionable. However, under certain instances, particularly where one is dealing with a greasy contaminant, the use of higher temperature fluid, up to steam heat, has proven effective in reducing the amount of time required for cleaning and improved its effectiveness.

TARGET IMPACT

It is perhaps pertinent to discourse very briefly on the way in which water jets impact a surface and the stresses that are generated. When a water droplet hits a clean surface, the water under the interface collapses faster than the water can get away from the center of the droplet. This generates very high stresses on the target surface and, hypothetically, causes the fluid in the center of the droplet to behave more as a solid body. At a sufficiently high impact velocity, this generates the typical Hertzian ring fractures that one normally associates with the impact of a solid indenter on a rigid surface.

Once the initial flow condition has passed, the material in the center of the impact zone is compressed downward; the surfaces around the edge of the ring crack are therefore displaced relatively upward so that, as the jet then flows laterally outward, erosion occurs on the fracture wall away from the impact zone. This is one of the mechanisms by which surface damage is initiated. Surface damage is also initiated where the surface is broken by relatively large fracture surfaces, such as is the case, for example, with rock, where each grain boundary can be identified as such a surface. In this instance, the water will penetrate into the crack and generate a fluid wedge which is pressurized by the impact of the succeeding fluid so that the crack grows and a grain or crystal may be removed.

These events, to a large extent, are predicated on the surface being relatively dry and solid. The surface may be made resistant to attack by using a thin elastomeric coating. This is done, for example, by the Air Force personnel who are concerned with maintaining the integrity of items from the space shuttle to supersonic fighters. They have developed paints such as Astrocoat which are resistant to droplet erosion.

PROBLEM AREAS

Very little is understood about what occurs when the jet impact is on a fluid or quasiplastic material coating the target surface. It is known that rubbery or viscous materials, the common example cited being wet paint, are one of the more difficult kinds of materials for high-pressure water jets to remove, and NASA has had some problems in cleaning the space shuttle. The heat shield tiles must be cleaned off after each flight. NASA has recently changed the glue which holds these tiles on, and therefore has obtained a different response to water-jet cleaning. Cleaning of the shuttle is now much more difficult than it was with the earlier glue.

CLEANING OF CONTAMINATED SURFACES

Because of a lack of knowledge of the parameters of rapidly oscillating jets and the behavior of jets impacting wet surfaces, the problem should be approached from two aspects. First, the amount of energy required of a jet if it is to penetrate and remove contaminant at different stages in the contaminant life on the surface must be determined. Second, one must be able to understand how much energy will be transmitted to the surface by different jet systems as a function of system parameters and standoff distance in order to determine which would be the most effective.

SURFACE-ACTIVE DISPLACEMENT SOLUTIONS

A. E. Meyer, C. K. Akers, and R. E. Baier
Calspan Corporation
Buffalo, New York

ABSTRACT

The objectives of the Calspan research reported here are to find a surface active-displacement solution that will (1) displace liquid contaminant from a surface, (2) leave a residue that will inhibit future contamination, and (3) help prevent corrosion of the surface. The water/butanol/surfactant solutions do not require ultrasonics or scrubbing.

One hundred surfactants were screened via drop-spread tests, surface tension analysis, internal reflection IR spectroscopy, scanning electron microscopy, pH, gas chromatography, and paint hardness on four test surfaces—steel, aluminum, alkyd paint and polyurethane paint. In addition DS2 and the German Emulsion were evaluated. Seventy-five surfactants were originally chosen, results are given for six, and 24 others currently are being studied. To date 1.0% in butanol/water (0.8/9.2) of Zonyl FSN (DuPont) and of Chemadene NA30 (Richardson) seem most effective in decontaminating the four test surfaces.

INTRODUCTION

The experiments and results discussed here were obtained at Calspan Corporation under contract with the Chemical Systems Laboratory in the latter part of 1978 and early 1979.⁽¹⁾ Also outlined is the current research that began earlier this year.

The role of surface tension of liquids in emulsification and everyday cleaning applications is not new. At Calspan, however, we are applying the concepts of surface energy primarily to displacement of liquid surface contaminants. This work is after the fashion of the past research conducted at the Naval Research Laboratories, except that we do not propose to use ultrasonics in the cleaning method.⁽²⁾

There are three primary objectives:

- Displace the liquid contaminant from the surface
- Leave a residue behind that will inhibit future contamination
- Help to prevent future corrosion of the surface.

Past and Current Research Efforts

In our research we are seeking SADS that will push the toxic agent away from the surface without the aid of ultrasonics or scrubbing. Currently, SADS are simple mixtures of water, butanol, and a surfactant.

Many systems that have been developed for cleaning and renovating surfaces utilize mechanical action (scrubbing, for instance) or ultrasonics. The current practice for dealing with toxic chemical agents is treatment with a highly alkaline solution such as DS2 or the German Emulsion system, in tandem with scrubbing or spray action. The purpose of these solutions is to detoxify the agents in place—all in all, a good idea. Unfortunately, DS2 and the German Emulsion also act as paint removers. The SADS system that we are working on will remove the agent from the contaminated surfaces, rather than detoxify it. Detoxification of the agents can then be handled in a second step, away from and harmless to the clean surfaces. Of course, we would like to have the best of both worlds—remove and detoxify at the same time. Research to modify surfactants to do just that is ongoing at CSL. But, in the interest of expediency, it seems best to take one thing at a time just now.

At Calspan, we have screened over 100 surfactants, primarily using the following techniques: droplet spreading tests, surface tension analyses, internal reflection infrared spectroscopy, scanning electron microscopy, and pH. We also make use of gas chromatography and paint hardness tests.

As mentioned earlier, the SADS are made up of water, butanol, and a surfactant. The butanol in the SADS not only contributes to the low surface tension of the SADS, but also enables the droplet to reach the solid surface due to a degree of solubility in the liquid contaminant. Upon reaching the solid surface, the surfactant goes to work. Assuming that the surface tension of the SADS is lower than that for both the contaminant and the solid, the SADS will push the contaminant away and, in effect, stake its own territory.

Our droplet spreading tests evaluate how much "clean area" will result by a 10 μ l droplet of SADS falling from a height of 1 cm onto a layer of simulant. The simulant is 0.04 mm thick and is spread on an aluminum plate.

We also determine the liquid/vapor surface tension of the surfactants and the SADS. Accurate measurements are made with a surface tensiometer, which measures the work required to separate the liquid from itself. Again, the lower the surface tension of the surfactant and the SADS, the more likely it is to be effective in displacing the liquid contaminants from a surface.

The measurement of contact angles of liquids on solid surfaces serves an important purpose. The cosines of the average contact angles of droplets of a series of highly purified liquids on a given surface are plotted against the liquid/vapor surface tensions of the liquids. The intercept of the plotted line with the surface tension axis is called the "critical surface tension" of the solid. Any liquid having a surface tension below this critical surface tension will spread on the solid. Chemical warfare agents generally have surface tensions in the range 30 to 33 (dynes/cm) and, will therefore spread on steel ($\gamma_c \sim 40$ dynes/cm), aluminum (~ 40 dynes/cm), polyurethane paint (~ 40 dynes/cm), and alkyd paint (~ 35 dynes/cm).

These four materials are being used as test surfaces in our studies with the SADS system. Contact-angle data plots are also utilized to evaluate the effect of a SADS residue on the surface tensions of the test surfaces.

Also in our research we are seeking SADS systems that will leave a coating on the solid which will inhibit recontamination by the toxic agents. It should be clear that one means of inhibiting recontamination is by lowering the critical surface tensions of the target surfaces to a point below the surface tensions of the chemical agents. The agents then will tend to "bead up" on the surface and will be easier to remove. As a future consideration, we suggest that reformulation of the paints used on equipment would be beneficial.

The DS2 and German Emulsion solutions were evaluated by the same methods as the SADS and some of the results are shown in Table 1. The dismal results of the droplet spreading tests can be explained easily by the surface tensions of the solutions. The candidate SADS, on the other hand, create a "clean area" of greater than 10 cm², and have pH's between 6 and 8.

Data on the six candidate SADS chosen from over 75 solutions evaluated during our previous effort are shown in Table 2. Currently, we are evaluating an additional 24 surfactants. Nonionic surfactants are preferred because they tend to give a more consistent performance when water of varying hardness is used. The γ l/v in the center column is the liquid/vapor surface tension of the surfactant product alone. This ranges from 20 to 35 dynes/cm. The γ l/v for the concentrates is for the surfactant/butanol mixture. The effect of the butanol is seen here; all values are between 21 and 25 dynes/cm. The farthest column to the right gives the surface tension of the surfactant/butanol/water mixture. This last column, then, is the SADS. The water, which has a surface tension of about 70 dynes/cm, has little effect on the surface tension of the SADS. All of the values are below the surface tensions of the test surfaces and are below the surface tensions of most chemical agents.

Internal reflection infrared spectroscopy is used to identify the nature of the SADS residue and to determine the effectiveness of the SADS in removing the liquid contaminant from a test surface.

Some of the data obtained on the removal of the simulant from the polyurethane and alkyd paint surfaces are given in Table 3. Various levels of treatment were tested in each case. For the contaminated polyurethane paint, increasing the number of sprays generally increased the amount of TBEP removed from the surface.

There is no trend in the data for the alkyd tests. We found, through hardness tests and the like, that the alkyd paint acts like a sponge in the presence of the simulant and that the contaminated alkyd paint would have to be removed for any treatment to be totally effective. If the use of alkyd paint is necessary, consideration should again be given to reformulation in order to lower its critical surface tension and, therefore, render it more impervious to chemical agent attack.

The effectiveness data for all four test surfaces are presented in Table 4. The two more promising SADS are the one using the fluorosurfactant and the one using a betaine. Various levels of treatment are given, and it can be seen that there is a treatment level beyond which very little additional effect occurs. We want to stress that these data are only the beginning. The SADS used to produce these results were of the simplest composition: water, butanol, and a surfactant. Presently, we are looking into the use of other organic solvents (such as the fluorinated solvents) and the use of combinations of surfactants to achieve maximum effectiveness.

Other parameters also have to be taken into consideration, including solvent flash point, solution cost, and the effect that ordinary dirt and grease will have on the efficiency of the SADS system.

REFERENCES

1. Meyer, A. E., Akers, C. K., and Baier, R. E., "Surface-Active Displacement Solutions for Removing Chemical Warfare Agents from Contaminated Surfaces", Calspan Final Report prepared for ARRADCOM, Chemical Systems Laboratory (February 1979).
2. Publications by H. R. Baker, M. K. Bennett, R. N. Bolster, and W. A. Zisman, Naval Research Laboratories.

TABLE 1. DS2 and German Emulsion

	<u>DS2</u>	<u>German Emulsion</u>
pH	10.3	11.8
γ_{lv} (dynes/cm)	45.1	31.2
Droplet Spreading Against TBFP (at 15 Seconds) (cm ²)	No spread	4.8

TABLE 2. Characteristics of Candidate Surfactants

Manufacturer	Product	Chemical Type	Ionic Type	$\gamma_{lv}(a)$	HLB	Effective SADS Concentration (%)	pH	Concentrate $\gamma_{lv}(a)$	SADS $\gamma_{lv}(a)$
Union Carbide	L 7500	Organo-Modified Silicone	Non	28	4-5	0.1	7.30	25	26
Union Carbide	Tergitol NP-27	Nonylphenol- polyethylene (7) glycol ether	Non	34	11.7(b)	1.0	7.00	25	26
Diamond Shamrock	Hyonic PF-100	Ethoxylated (10) nonylphenol	Non	35	14-16	1.0	7.15	25	26
DuPont	Zonyl FSN	Fluorosurfactant	Non	20	4-5	1.0	7.10	21	21
Alcolac	Siponate 330	Alkyl sulfonate	An	30	11.7(b)	0.1	7.30	25	26
Richardson	Chemadene NA 30	Betaine	Ampho- teric	32	4-5	1.0	6.00	25	25

(a) dynes/cm.

(b) Supplied by manufacturer.

TABLE 3. Removal of TBEP From Polyurethane, Alkyd Surfaces^(a)

SADS	Surface					
	Polyurethane			Alkyd		
	No. of Sprays			No. of Sprays		
	10X	5X	3X	10X	5X	3X
Control A	59	63	43	<2.5	<2.5	<2.5
Tergitol	33	25	18	23	<2.5	8
Hyonic	60	58	45	20	<2.5	<2.5
Siponate	38	33	2.5	<2.5	<2.5	10
Chemadene	84	58	43	13	10	5
L-7500	48	18	40	2.5	<2.5	<2.5
Zonyl	74	44	64	<2.5	<2.5	23

(a) Percentage of removal of simulant.

TABLE 4. Removal of TBEP From Test Surfaces^(a)

No. of Sprays	Surface							
	Polyurethane		Alkyd		Steel		Aluminum	
	SADS		SADS		SADS		SADS	
	Zonyl(b)	Chemadene(c)	Zonyl	Chemadene	Zonyl	Chemadene	Zonyl	Chemadene
3X	64	43	23,23	5,34	68	55	93	78
5X	44	58	<25, 28	10, 8	88	48	>98	89
10X	74	84	<2.5, 23	13, 28	83	53	>98	86
15X	88		23	50				
20X	98	95	39	43				
25X	>98	88	41	43				

(a) Percentage of removal of simulant

(b) 1.0% Zonyl FSN (DuPont) in butanol/water (0.8/9.2)

(c) 1.0% Chemadene NA30 (Richardson) in butanol/water (0.8/9.2).

WORKSHOP SUMMARY: CHEMICAL METHODS OF TOXIC SUBSTANCE DECONTAMINATION

Chairperson: P. M. Harvey
Chemical Technology Branch
Dugway Proving Ground, Utah

A practical decontamination system must be effective against all threat agents. It need not, however, contain only a single active component. We have some concern that potentially useful chemically reactive decontaminants studied in the past may have been rejected or forgotten because they were ineffective or only partially effective against one agent. The surfactant + N-halo compound mixtures described by Dr. Gary Sides at this meeting show that broad applicability can be achieved by combining chemically and physically active decontaminants. We see no reason that compatible combinations of two or more chemically reactive species could not be employed where this would be advantageous.

We do not, however, see the possibility of devising a decontaminant that is universal in the sense of being usable in all field situations. For example, physical removal may be adequate and more economical for exterior surfaces of vehicles, weapons, shelters, and ships, but for vehicle interiors, a low-liquid-volume, chemically reactive decontaminant is needed. Electronic and other sensitive equipment usually cannot tolerate aqueous decontaminants. Possible alternatives include reactive gases, powdered solids, and dilute nonconducting emulsions of aqueous decontaminants in volatile fluorocarbon solvents.

Decontaminant solutions must be designed to dissolve or swell the polymers used in thickened agents. We see no acceptable way of chemically degrading the thickeners without making the decontaminant extremely aggressive to paints and polymers on equipment.

Nucleophilic Reagents

Organophosphorus nerve agents are relatively easily hydrolyzed, particularly with perhydroxide, hypochlorite, or metal ion catalysis; consequently, the destruction of mustard remains the greater challenge for nucleophilic chemistry. Attempts to hydrolyze mustard in aqueous systems have been thwarted by the low solubility of the agent and by the slow rate-limiting intramolecular ionization. One approach that might accelerate this step would be to add an electrophilic species (A) that would associate with or complex the incipient chloride ion:

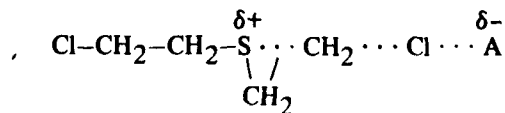

Several candidates were discussed, but all were rejected because of hydrolytic instability, toxicity, or cost.

The standard decontaminant DS2 suffers from problems of flammability and paint softening. It is doubtful that these problems can be cured by making only small changes. DS2's success as a decontaminant for mustard is related to its ability to dissolve the agent and to destroy it by an

elimination reaction that is considerably faster than intramolecular ionization. It is likely that the active species in DS2 is the 2-methoxyethoxide ion, which is more basic than the hydroxide ion and would be protonated if water were added. The formation of products from nucleophilic reaction of butoxide ion in microemulsions containing butanol and hydroxide suggests the use of a surfactant-alcohol-base concentrate which could be field-mixed with water to produce a decontaminant with DS2-like activity. The use of quaternary alkylammonium alkoxides in the corresponding alcohols as decontaminants was mentioned. Lower alcohols would be unacceptable because of their flammability.

Oxidative Reagents

The major problem with calcium hypochlorite is its corrosivity. Water-soluble encapsulation or the use of epoxy-lined containers would minimize problems in storage. A double emulsion of oil-coated drops of aqueous hypochlorite suspended in plain water might be effective as a non-corrosive decontaminant. Problems with preparing and handling calcium hypochlorite slurries might be alleviated by (a) using an air stream or an effervescent system to keep the solid suspended; (b) complexing the calcium ion with a sequestering agent to increase solubility; or (c) switching to the more soluble chloride-free sodium hypochlorite-sodium hydroxide complex. It may be attractive to generate hypochlorite solution on shipboard by electrolysis of seawater. The use of a suitable redox couple may permit the use of a less corrosive oxidant; for example, cerium ion catalyzes the oxidation of sulfides by sodium bromate.

The N-halo compounds 3-bromo-4,4-dimethylloxazolidinone and sodium dichloroisocyanurate seem to be satisfactory alternative sources for hypochlorous acid or hypochlorite, and we see little justification for looking for more exotic halogenating agents at this point.

Hydrogen peroxide was shown a long time ago to be effective against GB and mustard; it was rejected as a field decontaminant because of storage-stability problems. We feel that hydrogen peroxide should be reconsidered in the light of more recent industrial developments in packaging, including chemical stabilization and encapsulation. Phase transfer and micellar catalysis have been used synthetically with hydrogen peroxide and may have application in decontamination. The possibility of generating monoperoxy sulfate in the field from sodium sulfite and atmospheric oxygen is of potential interest.

Other Reactive Systems

Several reductive systems were considered. Nickel borohydride, generated *in situ* from sodium borohydride and a catalytic amount of a nickel (II) salt, has been used to dechlorinate insecticides like chlordane and might convert mustard to diethyl sulfide. The use of cetyltrimethylammonium borohydride or cyanoborohydride may be worth examining. The reactivity of G and V agents is uncertain. Costs are likely to be higher than oxidative systems.

The possibility of destroying mustard with an electrophilic reagent was considered. Metal ions such as mercuric ion might form insoluble or nontoxic complexes. Most alkylating agents are toxic or cannot be used in aqueous systems, but a cationic micellar methylating agent has recently been described which can be used in water and which might convert mustard to 2-chloroethanol and methyl 2-chloroethyl sulfide or dimethyl sulfide.

Carbenes such as methylene or dichlorocarbene might react with mustard to give unstable sulfur ylids which would undergo rearrangement or elimination. The compatibility of carbene-generating reagents with polymers is a potential problem.

Miscellaneous Approaches

It may be attractive to incorporate decontamination reaction catalysts into surfaces and surface coatings of equipment and vehicles. Alternatively, regenerable reactive polymers, such as N-chloronylon, may have application.

The use of additional energy input to accelerate chemical decontamination has uncertain value and practicality. Photochemical reactions and ultrasonic catalysis of hydrolytic reactions were briefly considered.

There was substantial interest in the possibility of using bacteria (or enzymes derived from bacteria) to hydrolyze agents. Potential problems are storage stability and excessive specificity. The use of oxalate oxidase or glucose oxidase to generate hydrogen peroxide in the field was mentioned.

The use of surfactants as additives to reactive decontamination systems was discussed. It is not clear whether nonionic and zwitterionic surfactants would show the same retardation of mustard hydrolysis exhibited by some cationic and anionic surfactants which are able to increase the water solubility of that agent. The potential utility of reactive microemulsions needs to be investigated; one possibility related to DS2 has already been mentioned. A particularly interesting approach to a multiple-use decontaminant would be a surfactant-cosurfactant mixture, possibly containing an agent-reactive chemical, which could be diluted with a small amount of water to give a microemulsion or with a large amount of water to give a micellar solution. The relatively high cost of the surfactant may be a problem.

There was interest in encapsulation to improve storage stability and reduce corrosive effects of reactive decontaminants and in the use of foams to apply highly concentrated decontaminants efficiently, particularly where limited availability of water may be a problem. As a modification of the Navy's self-destructing hypochlorite decontaminant (SLASH), it might be possible to use controlled or timed-release packaging of the chemical that deactivates the unreacted hypochlorite.

* * *

The limited progress we were able to make toward suggesting quick fixes for existing decontaminants points to the need for balancing our limited research resources between immediate needs and future decontamination technology.

WORKSHOP SUMMARY: PHYSICAL METHODS OF TOXIC SUBSTANCE REMOVAL

Chairperson: W. Waskom
Naval Surface Weapons Center
Dahlgren, Virginia

Our tasks in this field are very difficult, one of the reasons being that historically we have used scenarios that give us 100 percent protection. It was really gratifying to me on Tuesday to hear General Watson say that somewhere between an emergency decontamination system and the total decontamination later there is a thing called partial decontamination that we can live with. Now, this is the first time in my memory that someone in the position of authority, such as General Watson, has admitted this and I think this is going to make our tasks much easier.

I want to thank all the individuals who participated in the physical removal portion. The discussions were straightforward and honest, and provided a good exchange of information between the R&D community and the operators, industry, and the military. Specifically, we want to thank Steve Bless, David Summers, and Anne Meyer for their excellent presentations on Tuesday. These really and truly laid the groundwork for our discussion as we saw it yesterday.

Additionally, we would like to thank Dewey Parks from Brunswick who gave an impromptu presentation on the truck-mounted jet-engine decontamination system that they are working on for CSL. Also, Kent Adams from Port Hueneme had a display on the Marine Corps shower module system, which I think leads us into the total discussion of physical decontamination. This display was initially set up in the personnel-decontamination-system group. Since it is also a method of physical removal, we asked Mr. Adams to come over and share with us that which had already been shown in another section. This of course led into one of the major discussions that we had, namely, what the boundaries are between physical removal and chemical removal. We included in chemical removal such things as the thermal, infrared, etc. The boundaries between physical removal and avoidance, or between physical removal and the other decontamination systems is what we want to discuss. We concluded that no one method of decontamination can stand alone. Different methods require greater or lesser application, depending upon the aspects of the situation. Some of those are: What are the objectives of the decontamination? What types of decontamination are being considered? What decontaminations are available? Hopefully, the summation of these workshop reports will draw attention to these many problems and draw them all together in one paper.

Another major question considered to be important in our workshop was: Why are we re-inventing the wheel with all our R&D? There are a tremendous number of items, objects, and materials on the shelf in other countries and in industry that could be used today to get something in the field to serve as a stop-gap solution to the decontamination problem. Concerning this intermediate thing that General Watson was talking about, while we go back to our R&D, either update, modify, improve, or invent something new. The need is to get something in the field right now. The general conclusion appeared to be that perhaps the not-invented-here syndrome precludes us from going out and buying and using things that are available today. For example, Mr. Summers did a little homework with the Columbus Yellow Pages and found that right here in Columbus at least four companies have pressure cleaning equipment, and one of them had equipment that could work up in the 10,000 psi range. Now if the individuals here in Columbus can do it, with some modification, there is no reason why the armed forces can't do the same thing.

Another area of concern was gathering of the data. Where do we, especially the R&D community, get the information? The R&D community needs to know what the requirement is and what has gone on in the past before they can proceed with their R&D efforts, and I place this requirement strictly on the operators to establish the parameters of the needs of the R&D community. I think most of us have seen that sometimes the operators don't really know what they need or want. Hopefully this is not universal, but it does happen far too often. On the other side of this coin, the facts are that the poor operator is as hard pressed for information and requirements as the R&D community. Thus there is an urgent need to establish the threat for both of these communities, and provide them with background information. We need to know what levels of contamination we can live with, for what type of operations, for what type of people, under what type of attack, and for each service type scenario.

As the lead service and the executive agent under the joint services agreement, I would suggest that the Department of the Army take this section in hand posthaste. Because, until these questions are answered, the objectives for research and development and procurement are unknown quantities. And in this time when a ban on open air testing is imposed, simulants are required. In this case I will turn the tables on the R&D community and tell them that they are the ones who need to make their needs and requirements known to the operators and to the Services. The scientists are the ones that can tell the operator what simulants are available. They have to tell the military. Before I summarize, I would like to discuss one other subject that is very dear to me—water washdown systems for shipboard. Other countries have shown that with the operation of an improved water washdown system up to 99 percent of all contamination can be removed. I consider the synergistic effect of this system to be a major breakthrough. It really improves the operational capability, for it will: (1) reduce the hazard to those individuals performing tasks exterior to the hull of the ship, (2) reduce the amount of collected agent that could be transported into the interior of the hull, and (3) reduce the vapor hazard associated with any residual contamination.

Just a quick word about the current system which is aboard our ships. The system consists of many pipes and nozzles, and it sprays huge plumes of water all over the ship, relying on the wind to carry the water from the bow on toward the stern. It has been estimated that only about 10 to 20 percent of this water is actually effective; the rest of it goes into the atmosphere and overboard. At the same time, it precludes the use of many of the optic systems aboard ship, the infrared systems, and other systems such as fire control, and obviously the saltwater spray cannot be used around any type of aircraft, to name but a few of the problems. Within NATO, the naval subpanel for NBC defense has taken on the task of recommending the size, shape, function, etc., for the nozzles of a water washdown system that will solve some of these problems. The due date for the solution is in October, 1982. Another of the associated problems that we must contend with in this solution is not to degrade any other existing shipboard capability, for example, the fire-fighting capability.

To summarize, we have listed our problems. We want to determine what is contaminated. We need a surface measurement method. We have to know what the safety level is.

The next questions are: What is required to decontaminate? What is the amount and/or the time per item? As we look at the mechanical, chemical, and thermal systems, and combinations of thereof, discussed above, we also ask: What are the operationally tolerable levels of contamination for vapor emission and for contact hazards? We recognize that there are some constraints the source of material and water, and whether there would be freshwater or seawater. Since we need power to run the equipment, where do we get the chemicals, the electronics, the heat? There's a logistic load on the user, not only as to where you get the materials to do the decontamination, but how do you transport and store the materials. What is the cost and the shelf

life? Then, under constraints, for the lack of a better word, we call it vulnerability, will the total decontamination system, if we strip everything down, cause rust, will it cause corrosion, will it create a signature for energy-guided weapon systems coming in? In the area of basic research, we ask: What are the basic mechanisms of decontamination? What is the standoff distance for mechanical cleaning under the various conditions? What are the surface active problems for the wide variety of materials to be decontaminated; for example, the skin of a tank is very sturdy and very hard and we can get right up there and pound at it; at the same time, for electronics equipment or tender helicopter skins, we need totally different methodology. We need a methodology for areal locations such as the hard-to-get places. Interior dissemination of some decontaminants will result in a hazard sometimes equal to that presented by the agent itself.

We looked at new technology applications – laser, microwave, etc. We thought about some alternative methods. We asked the question: Is the jet engine that we heard about the best source of heat and/or for mechanical decontamination process? For example, can the exhaust of each individual vehicle be used as its own decontamination capability? We need to decontaminate selectively. Going back to the problems mentioned, we need a surface measurement capability, decontamination of the area, and then resumption of the operation.

Finally, we discussed a few practicalities. We must think along some of the following lines. What is currently available that can be used, or what can we slightly modify. First, use existing hardware when possible; modify it if it can be used. Second, if we invent or design something new, what applications, other than our pure decontamination, can it fulfill in the inventory of the armed forces? Lastly, let us not forget the life-cycle costs. In most cases, procurement is only the tip of the iceberg.

As can be seen, we did not solve many problems, if any. We did bring these situations to the front and they have so been reported. I want to make one last point. Meetings in workshops such as this are only as effective as the efforts put into them after we get home. A simple trip report does nothing. So I would suggest that all of us go home, get off the dime, put the fire under the Department of the Army, and get on with the program.

WORKSHOP SUMMARY: CONTAMINATION MONITORING

Chairperson: M. Massen
U.S. Air Force Systems Command
Wright-Patterson Air Force Base, Ohio

Since we were a little hardpressed as to how to attack the contamination monitoring aspects, the Workshop was opened by a discussion of the Air Force analogy of our mission and requirements in both philosophical and real world, operational terms. I guess a one-line statement would be that the Air Force has to be able to fly and fight at any time in support of the Army ground forces anywhere in the world in all environments. That is a very all-encompassing statement but that is the reason we wear the (Blue) uniform. In other words, regardless of what limitation or bad stuff that the bad guys may throw at us, we still have to get the airplanes airborne and get the bombs on the target. So the problem is exceedingly compound and complex. All environments mean both day and night in any location; no longer do we have the luxury of considering the chemical threat to be purely in central Europe. It can now occur anywhere - Southeast Asia, Southwest Asia, Africa, South America, the Northern Tier Areas. The goal of the Air Force has always been to be able to fly into and out of those locations, but for the first time the CB equipment now is having to be designed and operated in those types of environments, temperature, humidity, climate, etc. We still have to get the airplanes airborne and be able to get the ordnance off the aircraft to support the Army Commander, for when he's facing a line of enemy tanks, he cannot call time out to the war just because the Air Force can't get the airplanes airborne.

The Air Force mission is broken out into several main areas. The traditional one everyone thinks about is the fighter role. But it is only a small portion of the Air Force mission. Another very important one (certainly as far as the Army's concerned) is the transport role into and out of an area with cargo, both people and equipment. The evacuation of medical casualties from either chemicals, biological agents, or bullets is very important. Those people have to be flown out to the different medical facilities. Some of those facilities will be overseas, some will be back in the United States. The problem becomes critical if an airplane is contaminated by the personnel or equipment boarding the aircraft. When the equipment or the persons which get in the airplane are contaminated, the airplane becomes contaminated. Now if it flies back into the United States, where is it going to land? The EPA is certainly going to have a lot of heartburn over that; so this is a problem that certainly has to be addressed, yet we still have to be able to evacuate. Just because the EPA says that you can't land at podunk airpatch or the civilian airbase, if peoples' lives are at stake that airplane is going to have to land somewhere. Our task is to reduce risks, yet still accomplish the mission.

During a full-fledged combat operation, which is what we would have to assume if bad guys are using chemical and biological agents, a lot of the civilian airliners would be called up to military service. Now the interiors of Delta Airlines, Eastern Airlines, and United Airlines airplanes, etc., are far different from the C-141 aircraft. The civilians have nice plush seats, nice carpeting, good facilities; the C-141's don't have that. The nice plush carpeting may become contaminated. What do we do with that? Those planes may also have to be decontaminated, assuming people get on board with contaminated bodies or the equipment cargo is contaminated. Thus, contamination monitoring of the aircraft is indeed important. This does not mean that if a person does have some agent on him, he cannot board the aircraft. He is still going to board the plane. The Air Force, therefore, tasked to accomplish the effective combat mission, whether in a contaminated environment or not, must make trade-offs between the protective equipment versus accomplishment of the mission, and whether or not to decontaminate. The ultimate bottom line is that the mission

has to be accomplished, with or without decontamination. Thus, finding out the level of contamination of both people or equipment will certainly give the unit commander the knowledge as to what he has to do to still be able to accomplish his mission.

The size of an aircraft is certainly a factor. Large aircraft present different problems from those encountered with the small fighter aircraft. This is not to say one is either more critical or less critical than the other, but they are different concerns. The outside of an aircraft is less critical than the interior, as far as the Air Force is concerned.

Inside the buildings where the support personnel would be working, administration people, the cooks, chefs, bottle washers, the behind-the-lines folks that keep the war effort going, and also need to be protected, or decontaminated if they cannot be adequately protected.

On the outside, there are about 20 maintenance personnel required to launch each and every airplane. So that 20 to 1 ratio is fairly significant when the number of people has to be considered as being potentially contaminated. Currently, we're assuming that when one or more bombs, rockets, etc., are released over a given airbase, the whole base is arbitrarily a worse case contamination. We're now in the process of fielding equipment to actually give us the quantitative data to let us know which portions of the base are less contaminated than others. But those items are not fielded yet, although they are relatively just around the corner.

Another aspect of an Air Force mission is the type of base itself. The European bases are relatively fixed and stable locations. However, the majority of the state side forces that would deploy overseas would probably not go into fixed locations. They would go into an area that has a runway or a landing strip and a source of water for drinking; and that's it. From there, the units, as they deploy in, will carry with them all equipment and all the supplies that they need to conduct flight operations: spare parts, avionics equipment, test equipment, fuel, the whole gamut; and from those locations the combat sorties will be launched. Be they in the heart of a jungle, middle of a desert, on an atoll, or wherever the closest location to the battle arena may be, that is where a lot of units are going to fly into. These people may be living in tents, or living and sleeping under the wings of larger aircraft because no tents can be set up; we don't know. The facilities will not be hardened nor protected from bombs so that if the area is cratered by bombs, the fragments may destroy buildings. Thus, just any type of internal building collective protection may or may not be reliable. So what we have to do is to assume that the ultimate protection has to be at the body level. What the Air Force did in the early to mid-70's, was to finally decide to get our heads out of the sand and realize that we do have to be able to operate in a toxic environment, either chemical or biological. Thus, a fairly intensive study was conducted in order to determine the best approach to solve the problem; and that approach proved to be relatively simple. It was a two-phased attack. Phase I was called the near-term-equipage levels. We were tasked to immediately field existing off-the-shelf equipment to allow the conduct of combat sorties. If the equipment had limitations, we would accept them as long as the mission could be safely accomplished. That has now been accomplished; the majority of the equipment is in the field at the present time. Very little research and development on the equipment was accomplished because of the time limitations. Normal procuring and contracting cycles and procedures were temporarily shelved. The 9 months to 1 year contracting process normally required now was not done at that time in all instances.

The near term bought us the capability to operate in a toxic environment while we were able to do more exotic and scientifically, esthetically pleasing research and development for the second generation of equipment. The second-generation equipment has been designed to cure the problems and deficiency limitations of the first-generation equipment, always keeping in

mind that the mission has to be accomplished within certain time frames. I will not go into the actual dates and time frames, but suffice it to say that world events within the past 6 to 7 months have actually increased that time frame. So development of the second-generation equipment that was going to be accomplished at a very nice leisurely pace and would be essentially 100 percent perfect has now been extended to beyond the second generation. Equipment that we are working on now will still have to allow us to accomplish the mission, but reduce as much as possible the limitations of the near-term equipment. Again, it will act as a bridge until the scientifically acceptable knowledge can be developed that will permit third-generation equipment to be developed properly. Thus, we're back as we were in '73 or '74, not having the luxury of time to be able to do things in the traditional R&D manner.

During the workshop we discussed some of the requirements that the government saw (we being the primary users) for contamination monitoring. Why is it needed? When will it have to be accomplished, who would do it, and for whom? It may not be necessary to decontaminate 100 percent of the population. It is necessary to find out where the critical paths are and the choke points in the operational environment, be it Army, Air Force, or Navy. Since each of the Services has slightly different requirements from an operational standpoint, some of the equipment may have to be different; some of the equipment may be applicable to one Service and not to another Service. So where those differences are, that one particular agency, be it Air Force or Navy, by the Joint Service Agreement, can move out essentially on its own to develop equipment unique to that particular agency.

One of the real big questions for decontamination and contamination monitoring is how will the equipment be used? Will it be handheld, body worn, mounted in vehicles (vehicles meaning tanks), or carried on board aircraft or ships. The mission accomplishment has to be the main driver in the design of the equipment because the mission has to be accomplished; so the design criteria have to be worked around those parameters.

In the Air Force we do not have the traditional R&D community and the user community separated by clear black and white lines. During the early conceptual phases of development of equipment, the users are very integral portions of and participants in the discussions and they continue to be that throughout the design and evaluation of equipment. Thus, as the items are being developed, if the users have some problems with something being designed, these are voiced early on so that they can be worked around. The problem that we have found quite often is that the users really do not know at times how they want to employ a certain item. They know that they still have to get the airplanes launched and get the ordnance over the target area; but beyond that they are really not too sure how a particular item is to be employed. Thus, the R&D community has scattered throughout, several of the operator-type individuals who are able to use some of their past experience, yet still be removed from the trenches of the operational environment, to perhaps offer some suggestions and ideas on how to work around certain limitations.

One of the questions of some concern was the actual activation levels of the detection device itself. If it is made supersensitive, false readings may occur. If it is not sensitive enough, there may be some agents present that are not detected which may lead to some casualties from individuals who were exposed to chemical or biological agents and didn't know it. Therefore, from the operational viewpoint, in the Air Force we're asking the questions: what are the minimums we actually need, and what are the minimums that are actually acceptable? Specificity, i.e., trying to determine exact agents, may or may not be a requirement. The problem is that if a general agent detector, let's just say for all nerve agents or all blood agents, were fielded, a lot of agents might go undetected. Yet, if a device is designed to identify every one of the several hundred different varieties and variations of agents, they also may pick up things like dirt.

grease, solvents, hydraulic fluid, and vapors from JP4 or JP5 that are prevalent on airfields, thus giving false indications. So the monitoring of contamination is fairly dependent upon those concerns. Types of agents are important from the standpoint of the effects that they may produce on individuals. Some agents are purely liquid and have no vapor offgas, and if the man walks around a puddle and doesn't walk through it, that puddle is no threat to him. So the types of agents that we need to monitor against and decontaminate for are also fairly critical. We are getting a lot of data and information from various sources — the universities, the Army research laboratories, and foreign sources; and we are using them in the development of the contamination monitoring and decontamination equipages. Physical size is important because the Air Force, while essentially a mobile unit, is mobile from the standpoint of flying into the combat arena, not moving away from it. We have to take into the environment all the equipment needed for combat operations, so weight becomes a very important factor. The C-5's and C-141 airlift aircraft can hold only so much tonnage and have so much volume. So the smaller something is, logically the better it should be, but the prime concern becomes the man that's going to use that contamination monitoring device. He still has a mission to accomplish out-on the flight line while still holding the device or using the equipage regardless of what it may be. So if it's too heavy, where more than one individual may be required to operate it, that unit commander has just reduced his work force availability by the number of people that are used to require to operate the equipment. Size, weight, power supply are all critical. There may not always be a power outlet in the middle of the flight line somewhere, something that can be plugged into. Batteries sometimes are reliable and sometimes are not, depending on the weather conditions. A temperature of -40 is certainly different than 120, yet the Air Force at any time can be in either or both of those type of environments.

The physical environment, temperature, humidity, and weather all have very important aspects and considerations in the design in the fielding of equipment. So the logistic burden that follows has to be considered, not only of the life cycle costing but the delivery of decontaminants. We won't always have a source of saltwater or dirt if we're out in the middle of a desert out in Southwest Asia. Those items may not be available, and if an airplane gets hit with saltwater, I don't really know yet if a real big problem exists.

If the bad guys are using drugs and bugs and we are fighting for the ranch, maybe we're just going to have to write off some resources as being essentially lost in combat. After it's over with, one licks his wounds and picks up from there. Thus, if it turns out that some sort of corrosive agent is useful, as long as it does not hinder the mission, it may be acceptable. Now airplanes are rather peculiar beasts because the canopies are, of course, the medium that the crew members look out and see through. If they become visually restrictive and the crew members cannot fly the airplane, that airplane is a grounded — a lost resource. This means that the canopies cannot become corroded, pitted, or significantly degraded since this would prevent the airplane from getting over the target area. If wings, and similar aircraft parts get a little pitted, that might be an acceptable risk.

The last area considered in the discussion, which is probably more significant than any of the other five points, is how to solve the problems. This seems to come between the government and the industry interactions. We in the government must be able to communicate to industry better than we have heretofore. Quite often we think of the mission as being the ultimate objective, forgetting about industry's P&L statements, balance sheets, and other business considerations. Right now, of course, chemical warfare and chemical defense are fairly high priority items in the Department of Defense and some of the other government agencies. Five years from now they may not be. We have to realize that it may be unfair to ask American industry to fully gear up for a very intensive R&D and production-type situation that 4 or 5 years from now may have gone away. Then what does industry do with all their plant, equipment, and tooling that they have

invested in very heavily, and the personnel that they hired to actually work the lines. Those are things that we have to consider, we meaning the government developers, as we task industry through our RFP's and our requirements. Also, we must consider whether it is within the American capability, and if it is not, how much beyond the capability it is to determine whether it is important enough to ask industry to take the risk. We also need to be able to provide industry with a means for determining what our testing requirements and procedures really are. It is relatively difficult to develop, from in-house self-generated purposes, an unsolicited proposal if a particular company does not know what that item would be eventually tested against. Those in industry know that it is expensive and risky to go through the corporate hierarchy to get management commitments to develop and invest R&D dollars in both a paper proposal and possibly prototype if it is not going to work; yet if it does work, you may have a salable product.

The majority of the military testing procedures and requirements are listed in the various military standards and specifications. Finding out which ones are applicable at any one time is a difficult task, as differentiated from impossible. A lot of the engineers that work with me on the development of some of the personal air-crew protection equipment will pick out a specification that is, for example, 30 years old, and they do not question the numbers that are in those specifications. They are hard pressed if anyone questions why we build a helmet with a specified type of impact penetration or why we have a glove that has this particular type of liquid penetration when such liquid concentration may not be applicable inside an airplane. If we are actually over-specifying our requirements, industry must let us know.

The procurement process has been designed over the past 20 years to prevent mistakes from being repeated, but those mistakes are generally geared to the large aircraft. The multimillion fighter aircraft, or transport aircraft, costs overruns, etc., have spawned a fairly complex procurement process. Unfortunately those regulations are still used as the guidelines for the smaller dollar programs. A \$20,000 design study or study of existing computer models has to go through essentially the same wickets and follow the same regulations as a \$200-million major aircraft procurement. How to get around that, at least from my prospective, defies resolution at the level of those of us in this room.

A final suggestion presented in the working group which I fully support is that a forum needs to be established on a continual basis for the government and industry to communicate with one another -- either formally or informally. We in the government at times may ask for something that, by a particular number (such as a weight limitation), is physically impractical to produce, but which, given a small deviant from that level, may be within engineering and manufacturing capability. Yet that number is embedded somewhere in the specification that was plucked out of the air 30 years ago. We need to know whether our requirements are too stringent or not stringent enough. Some of the protective levels that we are gearing to right now are engineering "best guesses". Some of them are probably too stringent, and some of them are probably not stringent enough. This is where the academia, industry, and government interplay come into the scheme of things.

Our office at Wright-Patterson is the end of the R&D cycle to fielding equipment for the operational squadrons and wings. What we have to do, is to take the research data and mix it up with engineering capability and produce an item. We certainly do not have all of the knowledge or know where to get the knowledge, but we are certainly available to answer questions, if we can, as to the sources of the data, or possibly to help in the resolution of some of the differences or difficulties in various military standards or specifications.

In closing, I would like to thank the participants of the contamination monitoring panel. We had some excellent discussions. Some were lively and some were fairly germane and to the point. The consensus when we left, at least from what I was able to gather, was that the panel discussion was fairly worthwhile. Those people in industry left with a little more knowledge of how those in government can help them, and I left with a little more knowledge on how I as a government representative can help industry so that we can work together to solve this seemingly insurmountable problem.

WORKSHOP SUMMARY: PERSONNEL DECONTAMINATION

Chairperson: T. M. Prociv
Battelle, Columbus Division, Columbus, Ohio

This panel considered the protection of the combat infantryman who has to operate under probably the most adverse circumstances any of us could think of. The protection of this individual is key to the operability of the fighting forces. A lot of discussion centers on where responsibilities for protecting the soldier lie, and whether the protection should be physically active or responsive. The workshop panel came up with a number of categories of concern and basic equipment and/or commodities necessary for a defensive posture. It was looking for the science that would lead to the development of these kinds of protection systems. Basically it followed three criteria

- Identify the problems
- Discuss any potential solutions
- Recommend future research possibilities.

In some of these cases it was successful and in some of the others there weren't any existing data to support our future research recommendations. In the following text, each area is discussed separately, addressing the workshop recommendations.

Skin Decontamination

The issue of **skin decontamination** has been plagued with confusion. The conventional decontaminants available in the Army system presently have a number of undesirable properties. Generally, they are very corrosive, not only to the equipment that the soldier might be wearing but also to his skin. In some instances it might cause forms of secondary dermatitis and depending on the duration of contact, some of the current decontaminants might even be considered vesicants. Most of them are very damaging to the eyes and, thus, have to be applied with extreme care. The research community indicated a basic problem area in understanding the transport and behavior of decontaminants and agents on the skin since there aren't any existing models that can be validated for chemical agents and decontaminants. Thus it is generally necessary to develop the safety and efficacy data to understand the mechanism of action before corrective steps can be taken.

The panel members agreed that some of the needs that should be considered for the individual soldier are: (1) to develop a single kit that the soldier can use for both skin decontamination and decontamination of his equipment — a very compact kit, one that will not be thrown away, and (2) to look more into water-based decontaminants, or any combination of chemicals and compounds, such as those mentioned in other presentations at this symposium, which might give us a useful, non-corrosive, nonirritating reactant with a number of the chemical agents. Saltwater, like in the other groups, was again brought up. This is an important factor, since for a decontaminant that works in saltwater, there is an almost inexhaustible supply of solvent.

Decontamination for mustard is almost nonexistent. The old barrier salves are not available in the system anymore. The M258 kit, however, may in the future provide some removal and decontamination protection. For hydrogen cyanide, there is a well defined threat. The only treatment available is amyl nitrite capsules which are very difficult to use. You have to keep an individual breathing to use it, and hydrogen cyanide enters the blood system and causes breathing to stop.

Our foreign allies have a number of skin decontamination systems and personnel equipment decontamination systems that we have not quite looked at yet. These systems were brought up in the meetings, and an effort in the future to look at what everyone outside our borders has implemented was recommended.

Antidotes

The second topic of concern is the antidote system. This topic can be considered an internal decontamination method. The Army Medical R&D Command indicated that antidotes are their highest priority research item right now. They have established a task force to develop a new nerve agent antidote replacement. It was suggested that TAB, the prime antidote in today's Army, may be replaced in the near future. Some of the problems with TAB and other existing antidotes are their undesirable side effects. It is also very difficult to prevent abuse of the antidotes by the troops. The current antidotes systems are somewhat incapacitating and can severely affect performance. As heard during the keynote address, the antidote itself may be responsible for potentially 5 percent of the casualties in the field.

Data Base

The information data system is probably one of the biggest shortfalls in developing physical protection technology. The data base that exists on antidotes can, at best, be described as "ad hoc". It needs to be defined and documented in a better manner. In the immediate future, a concerted research effort has to be made, including efforts by the pharmaceutical industry and the pesticide industry. These industries have a considerable amount of information that has not changed hands with the government. And, again we need to look at the foreign technology. In short, a lot of information is available, but as yet we haven't quite got our hands on it.

Barrier Salves

Barrier salves were also considered by this workshop. These salves can be best described as interim protection at any time when the protective clothing might be removed, and possibly can provide some heat relief to soldiers that have to work in the protective clothing. The Army could benefit from a thorough risk/benefit analysis study, to determine the trade-offs in barrier salves versus protective clothing. The barrier salves might be effectively used to at least cover those parts that might be exposed when the protective overgarment or any of the clothing is opened to provide ventilation. In the chemical environment, the soldier is generally a walking capsule. If salves can be incorporated that allow a reasonable transpiration rate the soldiers' capability will be improved. In the future, what the medical R&D people should be looking to is an unlikely bedfellow like the cosmetic industry. This industry has done a tremendous amount of research on the types of chemicals that provide adequate protective cover and adequate color, yet do not inhibit transpiration rates. Again skin-model research in this area was noted.

Protective Clothing

In the protective clothing category, the general opinion of the workshop is that protective clothing would be fine if a war was fought in Northern Europe, or further north. Soldiers in European climates actually liked the clothing, as it provides adequate protection. Anywhere else in the world though, a heat load problem occurs. During the keynote address, General Watson did

address some of the heat load problems as related to the incapacitation of the soldier. Another identified problem of the overgarment is its surface integrity. If at anytime the characteristics of the surface of that overgarment are changed, the actual absorbing capability and protection capability are degraded. There is some evidence that overprinting camouflage or adding a fireproofing agent will change the protection capabilities significantly. There is also evidence that just wetting the surface might change the absorptive characteristics. This implies that there needs to be some kind of an improvement in the type of materials used in the protective garment. Another operational problem is that there are no residual life indicators to the liners. There is no way that the individual soldier can tell when his liner is saturated and that he is, in fact, not receiving protection. There are no data on the effects on the useful life of these garments when exposed to zinc smokes, phosphorus smokes, infrared screening smokes, or conventional solvents. The soldier is going to be required to operate in a smoke environment and a study of the useful life of protective garments in such environments would develop important operational data for military planners.

The future requires more materials and advanced development for materials of varying permeability and absorptivity. Much materials compatibility work needs to be done with both chemical agents and decontaminants.

Gloves

As for protective gloves, the current technology requires a soldier to wear a butyl rubber glove with roughly 6 to 7 hours of protection. The biggest problem with this glove material is that even after a short period of time the soldier will experience maceration of the skin, and will lose any ductility or tactility for the conventional motor operations of his hands. The Navy expressed a concern in that sailors would lose their ability to operate sophisticated equipment if they are forced to wear these bulky, cumbersome types of gloves. In most cases, even normal routine maintenance of equipment would be hampered. Some of the solutions to these problems already may be out there; there was news of a new polyurethane-Saran, sandwich glove that will be available soon. This formulation will still result in an impermeable glove. However, it may improve some of the sensory uses of the hands. The new materials technology really has to be advanced in this area, again looking for materials of variable permeability.

Protective Mask

The XM30 concept was determined by the workshop participants to be highly engineered and has good future potential. Future research should be conducted in the evaluation of additional materials. The success of the design could be attributed to the fact that this is a second mask program and many of the problems were experienced in the first mask program.

Casualty Decontamination

Casualty decontamination in a chemical environment was of much concern to the medical R&D people. The operation of a medical facility in a front line battlefield NBC environment is not well defined. Note that only the medical research community was represented, and this type of doctrinal matter is the responsibility of the Health Services Command.

Some other problem areas in a battlefield hospital were also discussed. In regard to detection, the medical community really does not know how to assess the degree of a patient's decontamination. There is a real concern that contaminated patients would be brought into a hospital facility who in the field were determined to be decontaminated. If the detection method was not adequate and contamination was present on these patients, the entire hospital staff and personnel will have been exposed to a potential hazard.

Medical Equipment

One of the issues the medical R&D researchers need to address in the future is *remote monitoring of vital signs*, i.e., being able to check the blood pressure, heart beat, temperature, etc., without removing the overgarment. That requirement should stimulate a lot of engineering thought. Additionally, no attempt has been made to harden medical equipment against chemical attack, and it is expected that this too will be a future requirement.

Concerning solutions, the only thing we can say is that the therapy and treatment in a chemical environment really do need to be reassessed and to be well defined in the doctrine. The coordination of the R&D Command and industry is going to play a very vital role in this.

Institutional Concerns

In closing, some general comments should be addressed that were brought up during the course of the workshop. The fighting forces are right now faced with a potential mass casualty situation in the chemical warfare arena. Many soldiers' lives are on the line today and a crisis situation exists. The industrial community needs to contribute their skills and expertise to the solutions of the problems. Mentioned earlier were some of the procurement stumbling blocks, unusual money allocations, general disregard for original or unsolicited ideas, too small a funding level and a general lack of information provided to industry. It is well known that industry has the ability to respond and to mobilize, provided that the industry is encouraged to do so.

Summary

There are some basic decisions that need to be made. Many of today's problems can be solved by *quick-fix or commercial commodities*. *The institutional-type systems that are preventing industry from getting involved quickly need to be waived or changed*. The only other alternative is to accept some lower quality products or copies of products which will only be a sink for monies desperately needed for research, development and production of superior NBC defense items.

WORKSHOP SUMMARY: CONTAMINATION AVOIDANCE FOR THE FUTURE

Chairperson: F. Kolbrener
Bendix Environmental and Process Instruments Division

Our aim was to identify any possible concepts that could be used to aid Armed Forces in avoiding contamination. The charters of the other workshop groups were clear cut – they were seeking better methods to decontaminate equipment whether washing, burning, heating, or removing. They also examined personnel decontamination – largely limited to washing and removal methods. The avoidance group, on the other hand, was not fettered by that type of situation. We let our imaginations roll and we assembled about 90 different ideas some of which may be close to each other. We did not attempt to evaluate the ideas; we just assembled them. We had an opportunity to create. If you didn't participate in this group, you missed an opportunity because you could have defined some ideas that you maybe wanted to work on. You'll have to await the next symposium for this kind of opportunity again.

Most of the credit for the output of this group goes to Leonard Michael and Art Barry. They acted as subchairpersons of two smaller work groups. I could not have done it without their help. They did much of the stenographic work, spawned conversations and kept their groups on track.

Table 1 shows the manner in which we operated. First we explained the chemical battlefield as we had been introduced to it before. It was immediately apparent that some of our group had never before seen the battlefield diagram and were unfamiliar with its organization – let alone which way was the front or back. Second, we reviewed all available chemical defense equipment and the doctrine covering its use. Third, we set down some definitions to guide our discussions. We defined "contamination" as being a residual hazard. As I sat here today, it became apparent to me that the air in this room could also become contaminated, and a method of decontamination would be to change the air in the room. We could very easily have aerosol droplets suspended in the air and not yet deposited on any surface. Thus, my point is that the term contamination can be defined in different ways. The second part of the definition of contamination was that contamination had the capability to cause casualties. Therefore, "contamination avoidance", we decided more or less, prevented contamination of people, terrain, and equipment. Basically, any procedure can go here, if, for instance, you decide to decontaminate to a lower level of contamination, you are in effect preventing a person from becoming a casualty. Even decontaminating equipment or terrain is a form of contamination avoidance. So, you can readily see that we had an extremely broad area to explore.

TABLE 1. How the Workshop Operated

-
- Battlefield
 - Current Equipment
 - Doctrines
 - Defined: Contamination and Avoidance
 - Formed Two Groups to Brainstorm
 - Classified Ideas
-

Next, we formed two groups of brainstormers and they brainstormed almost until lunchtime. Ideas were proposed and built upon. Our ideas were categorized and classified in terms of different areas. As you see in Table 2, classification categories, we developed about ninety ideas which we classified into three areas. They are multiple classifications reflected here. In other words, an idea could have fallen under more than one category. Our main problem after gathering the ideas, was to determine in what form to report them. First we attempted to categorize them as near term or far term. That was basically unsuccessful since we could not adequately define what constituted near term or far term. We finally decided that we would list ideas that might possibly be done with existing technology and are available now with a small amount of engineering. Then we defined the ideas that might need research and some things that might need applied research (development) and then some ideas that were policy. Our group didn't even limit itself just to equipment, but we even went to policy. And that's how the break-out went. And some of these are multiples. In fact, one of them, I remember, fell into three categories because it was applicable in some systems now and some systems in the future and these could be looked at in different ways. Table 3 indicates the breakdown of ideas.

We didn't make any evaluation, we didn't make any arguments for or against. We didn't try to say this idea is good and that one is bad. We didn't have the time for that because we ran out of time. We didn't have enough time to pull the ideas apart. So we put together Table 2. Of the about 90 ideas, some I know that the Army has considered. I recognized some that Dr. LeBirge had mentioned a couple of years ago and asked to be evaluated. We didn't debate ideas because any attempt to do that in the brainstorming sessions might have stifled somebody else coming up with an idea.

You may have seen some of the ideas developed before since they're not all novel and some may need reevaluation. Some of them are concepts I hadn't ever considered before -- for instance, foam. I never thought of covering equipment with foam that might be washed off easily to keep another piece of equipment or someone from getting contaminated. This would be just a barrier of a sort that may be easily handled.

Some of the ideas demonstrate that many people are approaching the problem the same way. It doesn't matter whether the chief scientist in the Army or the DOD suggests something, or somebody from a private company, or one of the labs suggests something.

Many people have the same basic types of ideas and collectively have a lot of them. We even had somebody suggest that we go back to a World War II plastic cover for soldier use. Some of you may remember that. It came in a little green plastic container and you can buy them now in the surplus stores for fifty cents for protection at football games. They had a little slit in the front to put a rifle out of and someone said well why don't we go right back to that? So maybe there are some older concepts that we can dust off and reuse.

I'm not going to go over all the ideas we assembled, but that's basically how we did it. We assembled a large list which eventually will come out in the symposium report -- a lot of different concepts that could be looked at. Much, much greater detail can be added by somebody else who's qualified to really go in depth and tear them apart and determine what can be done and who should develop them. We didn't really feel we had that within our charter. We sent out to brainstorm ideas and that's what we did. Hopefully, they will be the jumping off point for CSL and Battelle in their investigations.

Maybe some ideas will find their way into the STOG eventually (Science and Technology Objectives Guide) to guide the 6.1 and 6.2 efforts for the future. Some other issues came up. We collected some suggestions from the people in our group from industry -- actually they were

TABLE 2. Contamination Avoidance Workshop

-
- P Battle doctrine—what do you do to avoid contamination.
 - D Need improved detectors, such as laser systems (IR range)
 - A Provide protective covers—suits, tarps, etc.
 - A Provide permanent NBC (CPS) shelters.
 - D Provide positive pressure system vehicle compartments.
 - AD Provide electrostatic protection means—fabrics, hoods with eye pieces. (Material-A; Equipment—D)
 - ARDP Provide coatings on skin—creams, oils. (2nd generation—R; 3rd generation—P)
 - A Provide “peel off” coatings on vehicles.
 - AD Personnel wear contact lens (clear or corrective) to immediately protect eyes.
 - AD Provide foam protective coatings for vehicles, equipment. (2nd generation—D)
 - AD Use “wet” type suits.
 - A Temporary covers on vehicles.
 - AD Introduce electrostatic charged fog as initial protective cover.
 - P Move unit if threatened.
 - P Use detector-alarms to evaluate terrains, channeling operations into lesser contaminated areas.
 - AD Button up vehicle—activate CPS.
 - AD Design structures for smoother surfaces. (Technology—A)
 - AD Provide heat deflectors on vehicle exhaust to direct heat for decontamination.
 - RD Introduce catalyst in external structural materials to neutralize agent effects.
 - D Use vehicle exhaust to provide a heat decontaminating umbrella.
 - Introduce decontaminating agent into exhaust.
 - Blow pathway with exhaust for sweeping procedures.
 - D Use support vehicle to clean pathway by laying down decontaminants.
 - P Bring in Corps of Engineers to lay down cover over contaminated terrain corridors.
 - P Limit entry of contaminated personnel into mission operational areas.
 - DP Use helicopters to detect clean areas for relocation.
 - AP Use decon facilities as protective shelters during alerts.
 - ADP Separate driver and mission operation crew compartments. (Roland—A)
 - R Produce “dust cloud” cover modes—made by vehicles.
 - R Launch counter decontaminating agents as neutralizers.
 - A Provide field blowers to move agents (dissipate).
 - A Use flame weapons to produce heat, circulate contaminant, clean ground.
 - A Use natural water systems/streams for wash off.
 - A Use helicopter’s downwash to minimize contamination and for decontamination.
 - AD Use NBC filters in CPS.
 - AD Use NBC preferred paint systems.
 - P Utilize intelligence, countermeasures and sabotage means as interference.
 - R Engage enemy binary CB system with counter weapons.
 - R Provide breakdown mechanisms for reducing thickened agent viscosity (visco-electric properties).
-

- A - Technology available.
- R - Technology requires research.
- D - Technology requires development.
- P - Policy or conceptual item.

TABLE 2. (Continued)

R	Provide mechanism for fluorescing, coloring contaminated clouds as a means of physical visibility.
A	Carry water, provide reverse osmotic means for decontaminating (doubtful) sources.
ARD	Immunize personnel medically. (British-A; R, D-Unknown)
P	Retreat from battlefield-regroup.
P	Use better diplomacy.
AD	Use bangalore torpedoes to clean pathways. (Mod.-D)
D	Utilize automatic systems upon detection, prevent contamination or limit it.
A	Use foam in hardened condition to protect equipment (preuse).
A	Provide means for immediate overpressure with breathable air. Also use as emergency back up in CPS.
R	Use ozone, UV systems that may be feasible protection.
P	Introduce more mechanization for remote control of detection, methodology of clean up, decontamination.
R	Improve on camouflage.
A	Use hand-held laser diode-detectors.
AD	Provide personnel ventilated face protection in helmets. (British-A)
AD	Provide plastic (vinyl) bubbles, inflatable as a pre/alter temporary shelter.
AD	Provide CPS citadels for mobile (vary) and stationary weapons.
D	Provide agent coloring detectors on vehicle coatings (pre-impregnated).
P	Stay upwind.
R	Reduce surface porosity-hard finish surfaces.
R	Provide better seals on hatches, apertures.
AD	Provide quick encapsulation systems (body bags) for entry into shelters, operation areas without contaminating the environment. (British-A)
P	Avoid war.
P	Lay down fire lane on advancing contaminant clouds.
A	Seed clouds to hasten dispersement of contaminants.
A	Deterrent policy of massive retaliation.
D	Oral prophylactic against nerve agent.
A	Charcoal cloth as equipment/material wrap.
D	Automatic self-inflating vehicular envelope.
R	Vehicular electrostatic charge to prevent contamination.
R	New CW decontaminant.
D	Add miniature sprayer (atomizer) to M258 kit.
D	Employ remotely placed (i.e., tube launched) chemical agent detectors for reconnaissance. Launch a warning flare.
A	Antichemical missile defense which would destroy incoming missile with a fire ball.
R	Frequent training with simple decontamination methods.
A	Liquid, noncorrosive, film coating for vehicles.
A	Throwaway poncho for individual.
D	Hasty cover (i.e., carport design) for ground crews to service aircraft in mask only.
R	Air curtain as a kinetic protective device on vehicles.
R	Low-pressure sand blasting for decontamination in locales like the Middle East.
R	Perimeter emplaced warning device which would automatically fire rockets.
P	Smoke cloud detection done by color change of cloud.
P	Smoke cloud which would dye the chemical agent as it penetrates the smoke.

TABLE 2. (Continued)

A	One piece suit for individual protection.
R	Polyethelene covers for logistical material, such as palletized material. Covers would be biodegradable.
D	Suction device which would remove contaminants by negative pressure.
R	Protection to water source (i.e., pond) by surface alcohol cover or emplace electrostatic charge with wires.
A	Paint-containing reagent to neutralize chemical agent on contact.
A	Reduce leakage on vehicles.
A	Increase usage of organic vehicular covers.
A	Impermeable poncho to cover fohole.
A	Survival blanket (mylar contained in cigarette pack size container) for individual with capability of sticking several together for vehicle cover. Give individual several for frequent use.
A	Casualty bag.
ARD	Chemical reconnaissance.

problems – that basically have already been covered by two other groups so I'm not going to go into great depth. One of our members said, "You know, we in industry who develop and build equipment should get in on the decisions to implement certain policies before they're actually implemented", polyurethane paint happened to be the specific example that he chose and he felt that sometimes some of the people in government aren't necessarily aware of all of industry's problems with OSHA and EPA. When you add problems with the suppliers and the state of the art in manufacturing, industry may be in a bind. I'm not sure how to do it, but somehow the companies need to be in very early in decisions to get their thoughts in as to how something might be implemented. This point was echoed by some of the other people in the group. We're not sure how it's to be done. We're going to leave that to people that have some better ideas of industry and government interaction.

TABLE 3. Idea Categories and Research Needs

Currently Available Technology – Some Engineering	Some Research	Applied Research and Development	Policy
44	19	33	16

We also came up with the need to educate that U.S. public and Congress on the threat and get them mobilized to support the services and industry in developing solutions. It really goes beyond chemical biological defense. It's the whole defense problem in general. As we discussed it, I suggested "Write to your congressman." That doesn't always work, but maybe that's a start. People can write to their congressmen, but something else needs to be done—there isn't a whole lot of support. General Watson said it very clearly when he said, "We don't know if the Congress is going to support our efforts to get an offensive capability."

Well, that just points up the fact that we've got to get people aware of the fact that there's a threat and that it needs to be addressed.

Another point that I've become aware of lately and the last thing that I'm going to talk about is a suggestion. There needs to be a general awareness among development people as to the lead time to build equipment. I recently had experience with this. Certain types of materials from vendors, especially anything linked to oil, have tremendously long lead times. If you were to place a contract to buy something you could definitively define right now, with a company, I don't care who they are: and could say, I need this widget built, I dare say it will take most companies at least a year depending on what's in the construction. Especially for plastics of any kind. Then after receipt of the parts, it still takes time to assemble them and test the item.

Additionally, the whole community must be aware of the time lags from the time you decide you want something to the time it can be delivered to a use in the field.

If I wanted a table right now, and it had certain materials in it, I dare say it might take us 6 months to build no matter who I gave the job to. Unless they happen to have the materials on hand. All companies seem to be very much reliant on their suppliers to supply parts for things. A company that makes electronic equipment has to go to companies which make connectors. The connector industry is very big and they've got more than enough business. They're not going to drop what they have to make one connector needed for 500 units or something that one Armed Service wants. There are problems and I think that fact needs to be brought out so that people are aware of them.

DISTRIBUTION LIST 4

Names	Copies	Names	Copies
CHEMICAL SYSTEMS LABORATORY			
ATTN: DRDAR-CLF	1	Commander	
ATTN: DRDAR-CLC-B	1	SED, HQ, INSCOM	
ATTN: DRDAR-CLC-C	1	ATTN: IRFM-SED (Mr. Joubert)	1
ATTN: DRDAR-CLC-E	1	Fort Meade, MD 20755	
ATTN: DRDAR-CLJ-R	3	DEPARTMENT OF THE ARMY	
ATTN: DRDAR-CLJ-L	3		
ATTN: DRDAR-CLJ-M	1	HQDA (DAMO-NCC)	1
ATTN: DRDAR-CLT	1	WASH DC 20310	
ATTN: DRDAR-CLN	2		
ATTN: DRDAR-CLW	1	Federal Emergency Management Agency	
ATTN: DRDAR-CLW-C	1	Office of Mitigation and Research	
ATTN: DRDAR-CLW-P	1	ATTN: David W. Bensen	1
ATTN: DRDAR-CLW-E	1	Washington, DC 20472	
ATTN: DRDAR-CLB-C	1		
ATTN: DRDAR-CLB-P	1	Deputy Chief of Staff for Research,	
ATTN: DRDAR-CLB-PO	1	Development & Acquisition	
ATTN: DRDAR-CLB-R	1	ATTN: DAMA-CSS-C	1
ATTN: DRDAR-CLB-T	1	ATTN: DAMA-ARZ-D	1
ATTN: DRDAR-CLB-TE	1	Washington, DC 20310	
ATTN: DRDAR-CLY-A	1		
ATTN: DRDAR-CLY-R	6	US Army Research and Standardization	
		Group (Europe)	
COPIES FOR AUTHOR(S):		ATTN: DRXSN-E-SC	1
Physical Protection Division	1	Box 65, FPO New York 09510	
RECORD SET: ATTN: DRDAR-CLW-A	1		
		HQDA (DAMI-FIT)	1
DEPARTMENT OF DEFENSE		WASH, DC 20310	
		Commander	
Defense Technical Information Center		HQ 7th Medical Command	
ATTN: DTIC-DDA-2	12	ATTN: AEMPM	1
Cameron Station, Building 5		APO New York 09403	
Alexandria, VA 22314			
Director		Commander	
Defense Intelligence Agency		DARCOM, STITEUR	
ATTN: DB-4G1	1	ATTN: DRXST-ST1	1
Washington, DC 20301		Box 48, APO New York 09710	
		Commander	
Special Agent in Charge		US Army Science & Technology Center-	
ARO, 902d Military Intelligence GP		Far East Office	
ATTN: IAGPA-A-AN	1	ATTN: MAJ Borges	1
Aberdeen Proving Ground, MD 21005		APO San Francisco 96328	

Commander 2d Infantry Division ATTN: EAIDCOM APO San Francisco 96224	1	Commander US Army Foreign Science & Technology Center ATTN: DRXST-MT3 220 Seventh St., NE Charlottesville, VA 22901	1
Commander 5th Infantry Division (Mech) ATTN: Division Chemical Officer Fort Polk, LA 71459	1	Director US Army Materiel Systems Analysis Activity ATTN: DRXSY-MP ATTN: DRXSY-TN (Mr. Metz) Aberdeen Proving Ground, MD 21005	1 2
OFFICE OF THE SURGEON GENERAL			
Commander US Army Medical Bioengineering Research & Development Laboratory ATTN: SGRD-UBD-AL Fort Detrick, Bldg 568 Frederick, MD 21701	1	Commander US Army Missile Command Redstone Scientific Information Center ATTN: DRSMI-RPR (Documents) Redstone Arsenal, AL 35809	1
Headquarters US Army Medical Research and Development Command ATTN: SGRD-PL Fort Detrick, MD 21701	1	Director DARCOM Field Safety Activity ATTN: DRXOS-C Charlestown, IN 47111	1
Commander USA Biomedical Laboratory ATTN: SGRD-UV-L Aberdeen Proving Ground, MD 21010	1	Commander US Army Natick Research and Development Command ATTN: DRDNA-O ATTN: DRDNA-VC ATTN: DRDNA-VCC ATTN: DRDNA-VM ATTN: DRDNA-VR ATTN: DRDNA-VT Natick, MA 01760	1 1 1 1 1 1
US ARMY HEALTH SERVICE COMMAND		US ARMY ARMAMENT RESEARCH AND DEVELOPMENT COMMAND	
Superintendent Academy of Health Sciences US Army ATTN: HSA-CDH ATTN: HSA-IPM Fort Sam Houston, TX 78234	1 1		
US ARMY MATERIEL DEVELOPMENT AND READINESS COMMAND		Commander US Army Armament Research and Development Command ATTN: DRDAR-LCU-CE ATTN: DRDAR-PMA (G.R. Sacco) ATTN: DRDAR-SCA-W ATTN: DRDAR-TSS ATTN: DRCPM-CAWS-AM Dover, NJ 07801	1 1 1 2 1
Commander US Army Materiel Development and Readiness Command ATTN: DRCLDC ATTN: DRCSF-P 5001 Eisenhower Ave Alexandria, VA 22333	1 1		

US ARMY ARMAMENT MATERIEL READINESS
COMMAND

Commander
US Army Armament Materiel
Readiness Command

ATTN: DRSAR-ASN 1
ATTN: DRSAR-SF 1
ATTN: DRSAR-SR 1
Rock Island, IL 61299

Commander
USA ARRCOM
ATTN: SARTE 1
Aberdeen Proving Ground, MD 21010

Commander
US Army Dugway Proving Ground
ATTN: Technical Library
Docu Sect 1
Dugway, UT 84022

US ARMY TRAINING & DOCTRINE COMMAND

Commandant
US Army Infantry School
ATTN: NBC Division 1
Fort Benning, GA 31905

Commandant
US Army Missile & Munitions Center
and School
ATTN: ATSK-CD-MD 1
ATTN: ATSK-DT-MU-EOD 1
Redstone Arsenal, AL 35809

Commandant
USAMP&CS/TC&FM
ATTN: ATZN-CM-CDM 1
Fort McClellan, AL 36205

Commander
US Army Infantry Center
ATTN: ATSH-CD-MS-C 1
Fort Benning, GA 31905

Commander
US Army Infantry Center
Directorate of Plans & Training
ATTN: ATZB-DPT-PO-NBC 1
Fort Benning, GA 31905

Commander
USA Training and Doctrine Command
ATTN: ATCD-Z 1
Fort Monroe, VA 23651

Commander
USA Combined Arms Center and
Fort Leavenworth
ATTN: ATZL-CA-COG 1
ATTN: ATZL-CAM-IM 1
Fort Leavenworth, KS 66027

Commander
US Army TRADOC System Analysis
Activity
ATTN: ATAA-SL 1
White Sands Missile Range, NM 88002

US ARMY TEST & EVALUATION COMMAND

Commander
US Army Test & Evaluation Command
ATTN: DRSTE-CM-F 1
ATTN: DRSTE-CT-T 1
Aberdeen Proving Ground, MD 21005

DEPARTMENT OF THE NAVY
Chief of Naval Research
ATTN: Code 443 1
800 N. Quincy Street
Arlington, VA 22217

Commander
Naval Explosive Ordnance Disposal
Facility
ATTN: Army Chemical Officer
Code AC-3 1
Indian Head, MD 20640

Commander
Naval Surface Weapons Center
Code G51 1
Dahlgren, VA 22448

Chief, Bureau of Medicine & Surgery
Department of the Navy
ATTN: MED 3C33 1
Washington, DC 20372

Commander
Naval Weapons Center
ATTN: Technical Library (Code 343) 1
China Lake, CA 93555

US MARINE CORPS

Director, Development Center
 Marine Corps Development and
 Education Command
 ATTN: Fire Power Division 1
 Quantico, VA 22134

DEPARTMENT OF THE AIR FORCE

HQ Foreign Technology Division (AFSC)
 ATTN: TQTR 1
 Wright-Patterson AFB, OH 45433

Commander
 Aeronautical Systems Division
 ATTN: ASD/AESD 1
 Wright-Patterson AFB, OH 45433

HQ AFLC/LOWMM 1
 Wright-Patterson AFB, OH 45433

HQ, AFSC/SDNE 1
 Andrews AFB, MD 20334

HQ AMD/RD
 ATTN: Chemical Defense OPR 1
 Brooks AFB, TX 78235

HQ AFISC/SEV 1
 Norton AFB, CA 92409

NORAD Combat Operations Center
 ATTN: DOUN 1
 Cheyenne Mtn Complex, CO 80914

Air Force Aerospace Medical Research
 Laboratory
 ATTN: AFAMRL/HE 1
 Dr. C.R. Replogle
 Wright-Patterson AFB, OH 45433

USAF SAM/RZW 1
 Brooks AFB, TX 78235

HQ AFTEC/SGB 1
 Kirtland AFB, NM 87117

OUTSIDE AGENCIES

Battelle, Columbus Laboratories
 ATTN: TACTEC 1
 505 King Avenue
 Columbus, OH 43201

Toxicology Information Center,
 WG 1008
 National Research Council 1
 2101 Constitution Ave., NW
 Washington, DC 20418

US Public Health Service
 Center for Disease Control
 ATTN: Lewis Webb, Jr. 1
 Building 4, Room 232
 Atlanta, GA 30333

ADDITIONAL ADDRESSEES

Commander
 US Army Environmental Hygiene Agency
 ATTN: Librarian, Bldg 2100 1
 Aberdeen Proving Ground, MD 21010

Stimson Library (Documents) 1
 Academy of Health Sciences
 Bldg. 2840
 Fort Sam Houston, TX 78234

DATE
ILMED
-8