

AD-A101 654

CONSTRUCTION ENGINEERING RESEARCH LAB (ARMY) CHAMPAIGN IL F/8 10/1
DEVELOPMENT OF AN ACCEPTANCE TEST FOR SOLAR ENERGY SYSTEMS. (U)
JUN 81 D M JONCICH, D L JOHNSON

UNCLASSIFIED

NL

1 of 1
ADA
T00654

END
DATE
FILMED
8-81
DTIC

TECHNICAL REPORT E-173

LEVEL II

12
135

construction
engineering
research
laboratory



United States Army
Corps of Engineers
... Serving the Army
... Serving the Nation

TECHNICAL REPORT E-173
June 1981

DEVELOPMENT OF AN ACCEPTANCE TEST
FOR SOLAR ENERGY SYSTEMS

DEVELOPMENT OF AN AC

AD A101654

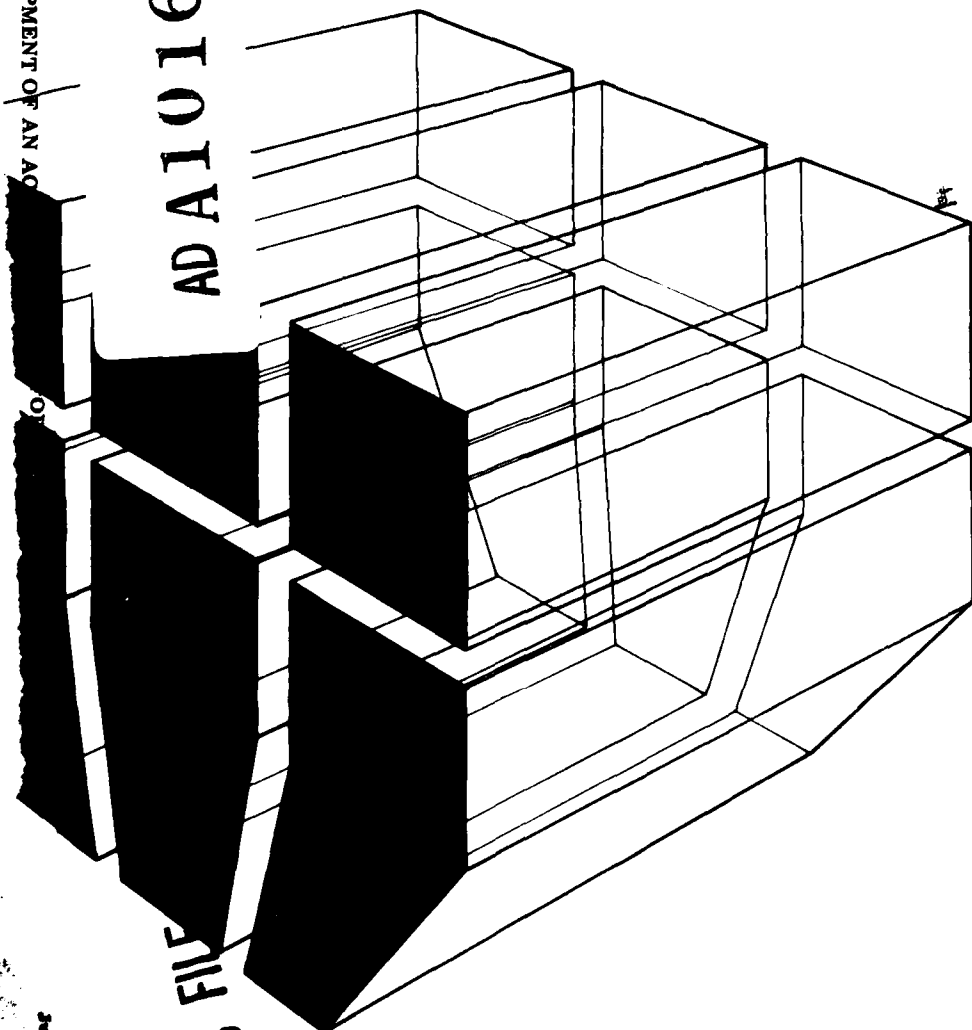

by
D. M. Joncich
D. L. Johnson

DTIC
ELECTE
JUL 21 1981
S D D



Approved for public release; distribution unlimited.

81 7 20 064

June 1981

35

DTIC FILE

The contents of this report are not to be used for advertising, publication, or promotional purposes. Citation of trade names does not constitute an official indorsement or approval of the use of such commercial products. The findings of this report are not to be construed as an official Department of the Army position, unless so designated by other authorized documents.

***DESTROY THIS REPORT WHEN IT IS NO LONGER NEEDED
DO NOT RETURN IT TO THE ORIGINATOR***

UNCLASSIFIED

SECURITY CLASSIFICATION OF THIS PAGE (When Data Entered)

REPORT DOCUMENTATION PAGE		READ INSTRUCTIONS BEFORE COMPLETING FORM
1. REPORT NUMBER 14 CERL-TR-E-173	2. GOVT ACCESSION NO. AD-A202654	3. RECIPIENT'S CATALOG NUMBER
4. TITLE (and Subtitle) 6 DEVELOPMENT OF AN ACCEPTANCE TEST FOR SOLAR ENERGY SYSTEMS	5. TYPE OF REPORT & PERIOD COVERED 9 FINAL Repts	6. PERFORMING ORG. REPORT NUMBER
7. AUTHOR(s) 10 D. M. Joncich D. L. Johnson	8. CONTRACT OR GRANT NUMBER(s) AOA 08-9644, 2 January 1979	
9. PERFORMING ORGANIZATION NAME AND ADDRESS U. S. ARMY CONSTRUCTION ENGINEERING RESEARCH LABORATORY P.O. BOX 4005, Champaign, IL 61820	10. PROGRAM ELEMENT, PROJECT, TASK AREA & WORK UNIT NUMBERS 12 92	
11. CONTROLLING OFFICE NAME AND ADDRESS	12. REPORT DATE June 1981	13. NUMBER OF PAGES 80
14. MONITORING AGENCY NAME & ADDRESS (if different from Controlling Office)	15. SECURITY CLASS. (of this report) UNCLASSIFIED	15a. DECLASSIFICATION/DOWNGRADING SCHEDULE
16. DISTRIBUTION STATEMENT (of this Report) Approved for public release; distribution unlimited.		
17. DISTRIBUTION STATEMENT (of the abstract entered in Block 20, if different from Report)		
18. SUPPLEMENTARY NOTES Copies are obtainable from the National Technical Information Service Springfield, VA 22151		
19. KEY WORDS (Continue on reverse side if necessary and identify by block number) solar heating solar air conditioning acceptance tests		
20. ABSTRACT (Continue on reverse side if necessary and identify by block number) This report describes the development and field evaluation of a short-duration procedure and an instrumentation package for testing whether a newly installed solar energy system is performing to design specifications.		

UNCLASSIFIED

SECURITY CLASSIFICATION OF THIS PAGE(When Data Entered)

BLOCK 20 CONTINUED

The U.S. Army Construction Engineering Research Laboratory: (1) defined a general solar system schematic and identified its major components; (2) developed test procedures for determining the thermal performance of these components; (3) bought and programmed equipment to perform the prescribed component test and to produce the test data; (4) subjected the acceptance test concept and instrumentation package to a field evaluation at a newly installed Army solar energy system; (5) incorporated the results of the field evaluation as modifications to the solar acceptance test.

This report concludes that a simple, quantitative test of short duration can determine whether a newly installed solar system is operating as specified. The results of the research have revealed the potential for performing such a test with low-cost metering installed at the time of building construction.

UNCLASSIFIED

SECURITY CLASSIFICATION OF THIS PAGE(When Data Entered)

FOREWORD

This work was performed under a reimbursable order for the Directorate of Military Programs, Office of the Chief of Engineers (OCE), under Advice of Allotment dated 2 January 79, subject: "Solar Energy Systems Acceptance Test." Mr. Ed Zulkofske, DAEN-MPE-E, served as the OCE Technical Monitor.

This study was performed by the Energy Systems Division (ES), U.S. Army Construction Engineering Research Laboratory (CERL). Mr. R. G. Donaghy is Chief of ES.

Appreciation is expressed to Dr. Chang Sohn, mechanical engineer, for his contribution to the development of the computer programs for acquiring and analyzing data.

COL L. J. Circeo is Commander and Director of CERL, and Dr. L. R. Shaffer is Technical Director.

Accession For	
NTIS GRA&I	<input checked="" type="checkbox"/>
DTIC TAB	<input type="checkbox"/>
Unannounced	<input type="checkbox"/>
Justification	
By _____	
Distribution/	
Availability Codes	
Dist	Avail and/or Special
A	

DTIC
ELECTE
S JUL 21 1981 D
D

CONTENTS

	<u>Page</u>
DD FORM 1473	1
FOREWORD	3
LIST OF TABLES AND FIGURES	6
1 INTRODUCTION.....	9
Background	
Objective	
Approach	
Scope	
Mode of Technology Transfer	
Outline of Report	
2 DESCRIPTION OF THE SOLAR SYSTEM COMPONENTS.....	12
Component Overview	
Solar Collector Array	
Heat Exchanger	
Storage Tank	
Miscellaneous	
3 SELECTION OF EQUIPMENT FOR ACCEPTANCE TESTING.....	34
Basis of Selection	
Pipe-Mounted Sensor Descriptions	
Other Sensors	
Data Acquisition System	
Other Test Equipment	
4 DEVELOPMENT OF AN INTEGRATED ACCEPTANCE TEST PROCEDURE.....	43
Combining the Component Tests	
Preliminary Test Phase	
Dynamic Test Phase	
Static Test Phase	
Programming of the Data Acquisition System	
5 SOLAR ACCEPTANCE TEST FIELD EVALUATION.....	51
Site Description	
Results of the Preliminary Test	
Dynamic Test Results	
Static Test Results	
6 INCORPORATION OF THE RESULTS OF THE FIELD EVALUATION.....	63
Summary of the Test Results	
Review of Equipment-Related Problems	
7 CONCLUSIONS.....	68
REFERENCES	69

CONTENTS (Cont'd)

	<u>Page</u>
APPENDIX A: Test Procedures for Electrical Controls of Solar Energy Systems	71
APPENDIX B: Calculation of the Ground Temperature for System With Below-Ground Tanks	77
DISTRIBUTION	

TABLES

<u>Number</u>		<u>Page</u>
1	Qualifications for Test Conditions of Collector Efficiency Measurement According to ASHRAE 93-77	17
2	Evaluation of the Dynamic Characteristics of the Storage Tank Using a Comparison of the Average Tank Temperature (T_T) and the Tank Outlet Temperature (T_{T0})	24
3	Sensor Symbols and Description	45
4	Specified Design Conditions for the Heat Exchanger	54
5	Illustration of the Preliminary Printout of Test Data Obtained During 1 Day of Measurements at the Field Test (15-Minute Average Values) -- 12/07/79	60
6	Component Test Results	63
A1	Representative Values of the Test Temperatures at Which the Controls Should Be Checked	73
B1	Values of the Thermal Diffusivity for Various Types of Soil	80

FIGURES

1	Schematic Illustration of a Solar Energy System Operating in the Storage Mode	13
2	Placement of Sensors for Collector Efficiency Measurement	16
3	Simple Interpretation of Collector Efficiency Measurements	17
4	Locations of Sensors for the Measurement of the Heat Exchanger Performance	21
5	Sensor Placement for the Measurement of the Dynamic and Static Characteristics of the Storage Tank	23
6	Illustration of a Short Circuit in the Tank Flow	24
7	Predicted Decay of Tank Temperature Under Static Test Conditions (pumps off)	26
8	Graphic Presentation of Data To Be Used in the Analysis of Static Tank Test Measurements	26

FIGURES (Cont'd)

<u>Number</u>		<u>Page</u>
9	The Use of High (H) and Low (L) Control Points by the Controls of a Solar Energy System	30
10	Regions To Consider When Locating a Control Sensor in the Storage Tank	31
11	Illustration of the First and Second Parts of the Measurement Cycle of the Clamp-on Flowmeter	37
12	Mounting Arrangement for Clamp-on Pipe-Mounted Sensors	37
13	Mounting Arrangement for the Solar Pyranometer	39
14	Mounting Arrangement for the Wind Sensors and the Outside Air Temperature Sensor	39
15	Mounting Arrangement for the Tank Temperature Sensor	40
16	General Solar System Schematic	44
17	Schematic Diagram of the Solar Energy System at the Site of the Field Evaluation	52
18	Plot of Collector Array Data for 1 Day, Showing Both "Qualified" and "Unqualified" Points	58
19	"Qualified" Collector Array Data	58
20	Decay in the Storage Tank Temperature With Time	61
A1	Arrangement for Testing the Controller and Sensors Before Their Installation	72
A2	Arrangement for the Simulation Test of the Controller	75
B1	Calculation of the Average Depth of the Tank	78
B2	Mean Annual Ground Temperature (Units of Degrees Fahrenheit)	79
B3	Annual Temperature Amplitude at the Surface (Units of Degrees Fahrenheit)	79

DEVELOPMENT OF AN ACCEPTANCE TEST FOR SOLAR ENERGY SYSTEMS

1 INTRODUCTION

Background

The incorporation of solar energy systems in Army buildings is part of the national effort to reduce the consumption of energy from conventional sources. Although the technical feasibility of solar heating and cooling has been established in theory,¹ errors in system installation have been reported which can potentially offset the energy savings expected from these new systems. Because of this, Corps District personnel normally perform simple checks at the time of the solar system's construction to verify that the system has been installed according to building specifications.

Under current practice, these checks are generally qualitative, consisting primarily of visual inspections of the solar equipment. In most cases, representative system temperatures are also recorded and examined for their reasonableness. While these checks confirm that the proper solar equipment has been correctly installed, they are deficient in two important respects. First, they do not provide enough information to allow a quantitative measurement of the system's thermal performance. Second, they do not directly compare the system's actual performance with that implied by the building specifications. Such a comparison is complicated by the fact that on any given day, the solar system's behavior is strongly dependent on the prevailing weather conditions (e.g., sunshine) and on the history of the system itself (as reflected by the storage tank temperature). Because in many cases solar system costs can be substantial, a more quantitative estimate of system performance would be in the Army's best interest.

Therefore, the Office of the Chief of Engineers (OCE), asked the U.S. Army Construction Engineering Research Laboratory (CERL) to establish guidance that, ideally, would ensure that expected energy savings are realized when solar energy systems are installed in Army buildings.

¹ D. M. Joncich, D. J. Leverenz, D. C. Hittle, and G. N. Walton, Design of Solar Heating and Cooling Systems, Technical Report E-139/ADA062719 (U.S. Army Construction Engineering Research Laboratory [CERL], 1978); E. R. Durlak, Solar Heating of Buildings and Domestic Hot Water, Technical Report 877 (Naval Civil Engineering Laboratory [NCEL], 1980); W. A. Beckman, S. A. Klein, and J. A. Duffie, Solar Heating Design by the F-Chart Method (John Wiley and Sons, Inc., 1977); F. Krieth and J. Kreider, Principles of Solar Engineering (Hemisphere Publishing Corp., 1978).

Objective

The overall objective of this study is to develop systematic procedures for checking the acceptability of a solar contractor's work. The purpose of this report is to describe the development and field evaluation of a short duration procedure and an instrumentation package for testing whether a newly installed solar energy system is performing to design specifications.

Approach

To meet this objective of this phase of the study, CERL:

1. Defined a general solar system schematic and identified its major components.
2. Developed test procedures for determining the thermal performance of these components.
3. Bought and programmed equipment to perform the prescribed component tests and to produce the test data.
4. Subjected the acceptance test concept and instrumentation package to a field evaluation at a newly installed Army solar energy system.
5. Incorporated the results of the field evaluation as modifications to the solar acceptance test.

Scope

The solar acceptance test described in this report consists primarily of measurements of the performance of the collector array, the system's heat exchanger, and the thermal storage tank. Auxiliary and distribution components (e.g., heat pumps, chillers, boilers) are not treated by the test; since these units are off-the-shelf items, they are covered by conventional acceptance procedures. In addition, the test is limited to systems containing liquid, flat-plate collectors and employing sensible heat storage. The test is applicable to systems of any size, although for the smaller ones (< 100 sq ft [9.29 m²] of collector area), instrumentation costs may become a significant fraction of the total system cost.

The test described in this report seeks to determine the acceptability of the contractor's work at the time of building construction. While the overall solar system performance is inherently affected by the component sizes and methods of interconnection, it is assumed that these considerations are related to the system's design and not to its acceptance.

Mode of Technology Transfer

The field test procedures for testing solar energy systems generated from this study will be incorporated as revisions to the Corps of Engineers Guide Specification 13985 on solar equipment.

Outline of Report

Chapter 2 describes specific procedures for testing the performance of the major components of a general solar energy system. Chapter 3 discusses the equipment necessary for performing these tests. Chapter 4 describes how the individual test procedures are combined in an overall acceptance test for a solar energy system. The results of a field evaluation of the acceptance test are presented in Chapter 5; Chapter 6 explains how these results were incorporated into the test. Finally, Chapter 7 contains conclusions which are based on the work performed.

2 DESCRIPTION OF THE SOLAR SYSTEM COMPONENTS

Component Overview

The acceptance test presented here is applicable to a class of solar energy systems which contain liquid, flat plate collectors and employ sensible heat storage; such systems are widely applicable for space heating, cooling, and domestic water heating. Although there are many possible variations in the configuration of such systems, common features emerge when the system is viewed in terms of its components. Consequently, it is possible to prescribe an acceptance test which is applicable to this broad class of systems.

For the purpose of the test, a solar system in this general class is considered to consist of the following major components: solar collector array, a heat exchanger, and a thermal storage tank. These components will be discussed separately in the next three sections of this chapter. Three minor components -- the system controls, collector fluid, and pumps -- will be discussed last.

A sketch of the general solar energy system to be treated here is given in Figure 1. The arrows in this sketch indicate the direction of fluid flow when the system is operating in the so-called storage mode. This mode, in which the energy collected is stored in a tank, is common to most solar systems. Provisions for other modes depends upon the details of a particular design.

In the storage mode, the system operates as follows: (1) part of the solar energy incident upon the collectors is absorbed by them, thereby raising their temperature. (2) When the collector temperature is sufficiently higher than the tank temperature, the controls turn on the two pumps. (3) The collector pump circulates the collector fluid through the array of solar collectors and through one side of the heat exchanger. The tank pump simultaneously circulates fluid from the storage tank through the other side of the heat exchanger. The combined action of these two pumps results in a transfer of the collected energy to the storage tank.

With the solar system operating in this mode, the dynamic characteristics of the solar components can be investigated; this will be referred to as the dynamic phase of the acceptance test. A second phase, called the static phase, involves measurements while all pumps are turned off and is primarily concerned with undesirable energy losses during quiescent periods.

Although solar systems can have many other modes besides these, the additional modes are associated with the use of solar energy by other components, such as heat pumps, absorption chillers, or fan coil units. Provisions for such modes would vary from one design to another. The checking of auxiliary components (e.g., heat pumps, absorption chillers, boilers) is covered by conventional testing procedures. Consequently, measurements in the other modes are not included in the acceptance test.

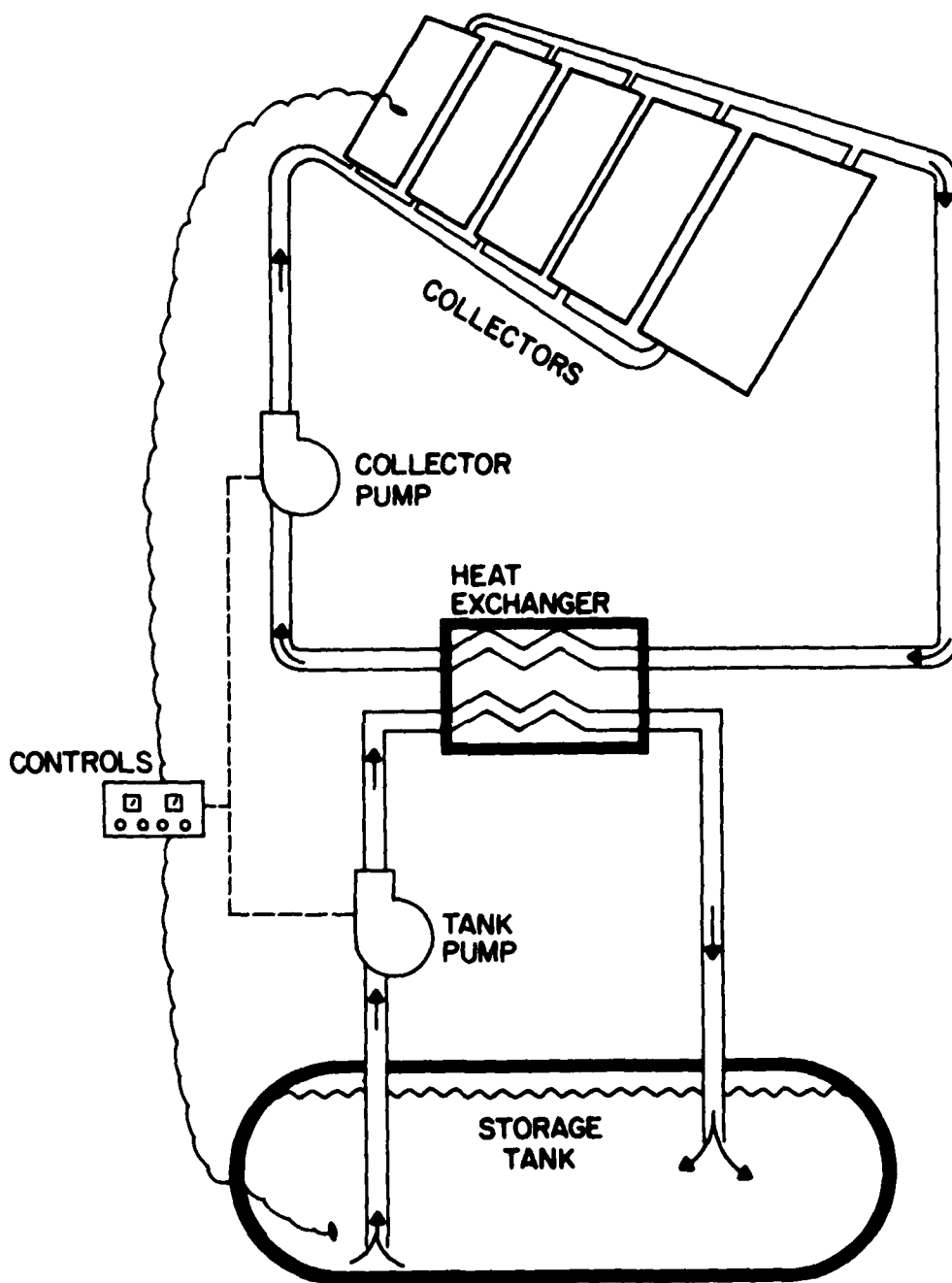

Figure 1. Schematic illustration of a solar energy system operating in the storage mode.

During the latter stages of the development of this acceptance test, compilations of various problems found in newly installed solar systems were published.² Since these reports contain information based on practical experience, the acceptance test was reviewed after the receipt of the reports, and attempts were made, when possible, to incorporate methods of detecting the most commonly reported problems. Throughout this document, the information in these reports will be cited, and the applicability of the acceptance test in dealing with the most common problems will be noted.

Solar Collector Array

A previous report on the performance of a solar system revealed that the solar collector array is by far the most inefficient component in the solar system.³ The evaluation of the performance of this component was also found to be considerably more complex than that of the other components. In addition, the cost of the solar collector array is expected to constitute a major fraction of the total cost of systems suitable for installation in Army buildings. Despite the complexity and high-cost factor of the array, the building specifications should contain a performance specification for this component so that competitive bidding can be obtained. When these considerations are added to the concerns about possible installation errors, testing the performance of this component before acceptance is crucial.

A method for testing and rating the performance of an individual solar collector was developed by the National Bureau of Standards and later adopted, with minor changes, by the American Society of Heating, Refrigerating, and Air Conditioning Engineers (ASHRAE) as a standard (ASHRAE 93-77).⁴ Although this standard test procedure was developed for use on a single collector, it is readily extended to an array of solar collectors. The application of this testing procedure in the field is more difficult than in standards laboratories where one has (1) the ability to control the collector inlet temperature directly, and (2) the ability to control the collector orientation by mounting the unit on a platform that can be rotated. The effect of this lack of control in a field application is twofold: (1) it lengthens the time needed for the test, and (2) the user must employ indirect means to control

² Mitchell Cash, "Learning from Experience," Solar Age, Vol 3, No. 11 (November 1978), pp 14-19, 32; "Solar System Heat Losses," Solar Engineering, Vol 4, No. 7 (July 1979), pp 17-20; The Final Proceedings of the Second Solar Heating and Cooling Commercial Demonstration Program Contractors' Review, DOE/CS/4131-1, Vol 1, Report to the U.S. Department of Energy (U.S. Department of Energy, 1979).

³ D. M. Joncich, D. J. Leverenz, and D. L. Johnson, The Performance of an Experimental Solar Heating System, Interim Report E-144/ADA066699 (CERL, 1979).

⁴ J. S. Hill and T. Kusuda, Methods of Testing for Rating Solar Collectors Based on Thermal Performance, NBSIR 74-635 (National Bureau of Standards, 1974); ASHRAE Standard 93-77, Methods of Testing to Determine the Thermal Performance of Solar Collectors (American Society of Heating, Refrigerating, and Air-Conditioning Engineers [ASHRAE], 1978).

the collector inlet temperature. The ASHRAE standard procedure also includes a measurement of the thermal time constant of the single collector; since the degradation of such a parameter is not subject to a construction error, this measurement is not included in the acceptance test.

The standard test for rating the performance of solar collectors involves measuring the collector efficiency as a function of the so-called fluid parameter. The collector efficiency, η , and fluid parameter, F , are defined by Eqs. 1 and 2.

$$\eta = \frac{Q_{out}}{I} \quad [Eq 1]$$

$$F = \frac{T_F - T_A}{i} \quad [Eq 2]$$

where:

- Q_{out} = the energy output of the collector array
- I = the solar energy incident upon the array
- i = the solar flux intensity in the plane of the collectors
- T_F = the fluid temperature
- T_A = the site ambient temperature.

With the sensor placement shown in Figure 2, these quantities can be measured using the relations given in Eqs. 3, 4, 5, and 6.

$$Q_{out} = \rho C C_{PC} W_C (T_{CO} - T_{CI}) dt \quad [Eq 3]$$

$$I = A_C i dt \quad [Eq 4]$$

$$T_f = T_{CI} \quad (\text{for ASHRAE}) \quad [Eq 5]$$

$$T_F = 1/2(T_{CI} + T_{CO}) \quad (\text{for NBS}) \quad [Eq 6]$$

where:

- A_C = the collector area (gross area for ASHRAE test, net for NBS).
- T_{CI} = inlet temperature to collector array (from heat exchanger)
- T_{CO} = outlet temperature of collector array (to heat exchanger)

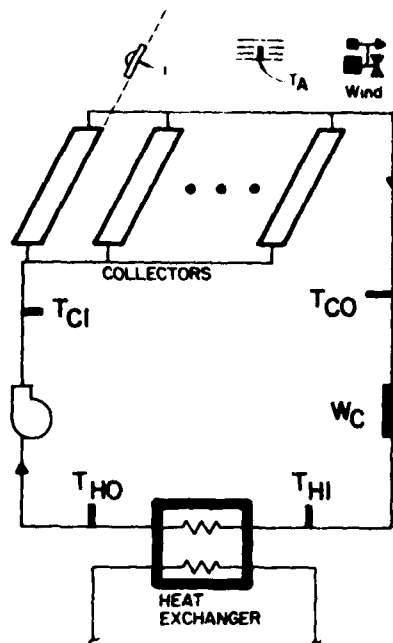

Figure 2. Placement of sensors for collector efficiency measurement.

- W_C = flow rate through the collector array
- i = solar flux intensity
- C_{PC} = specific heat of the collector fluid
- ρ_C = density of the collector fluid.

Before any measurements, the standard procedure requires that the collector be allowed to stagnate for 3 days, each of which must have a total irradiation intensity greater than 1500 Btu/sq ft-day (4.722 kWh/m²-day). Each efficiency value is to be computed for a 15-minute interval in which the solar system is operating under quasi-steady-state conditions. The corresponding fluid parameter value is computed from an average of the temperature(s) and irradiation intensity for the same 15-minute interval. These measured values can be separated into two groups -- "qualified" and "unqualified" -- in accordance with the qualifications of the measurement conditions listed in Table 1. Only the "qualified" values are useful as a standard measure of the thermal performance of the collector.

For evaluation purposes, a plot of efficiency versus fluid parameter is made with these qualified data points and the data is usually fit to a straight line with negative slope as illustrated in Figure 3. This plot provides a convenient method of evaluating the behavior of the collector under the test conditions. In the simplest possible model, the collector performance can be discussed in terms of two energy loss mechanisms, as illustrated in Figure 3. These losses can be described as follows:

Table 1

Qualifications for Test Conditions of Collector Efficiency Measurement According to ASHRAE 93-77

<u>Quantity</u>	<u>Qualification of Test Condition</u>
Irradiation:	Magnitude \geq 200 Btu/sq ft/h. (0.63 kW/m ²)
Steadiness	Irradiation must be steady throughout the 15-minute interval
Incident Angle	< 30 degrees
Transfer fluid (specific heat and density)	Variation < 0.5 percent during each 15-minute test interval
Outside air temperature	Variation < 54°F (30°C) for all data points measured in test
Wind (to be reported with test data)	Measured values of speed and direction

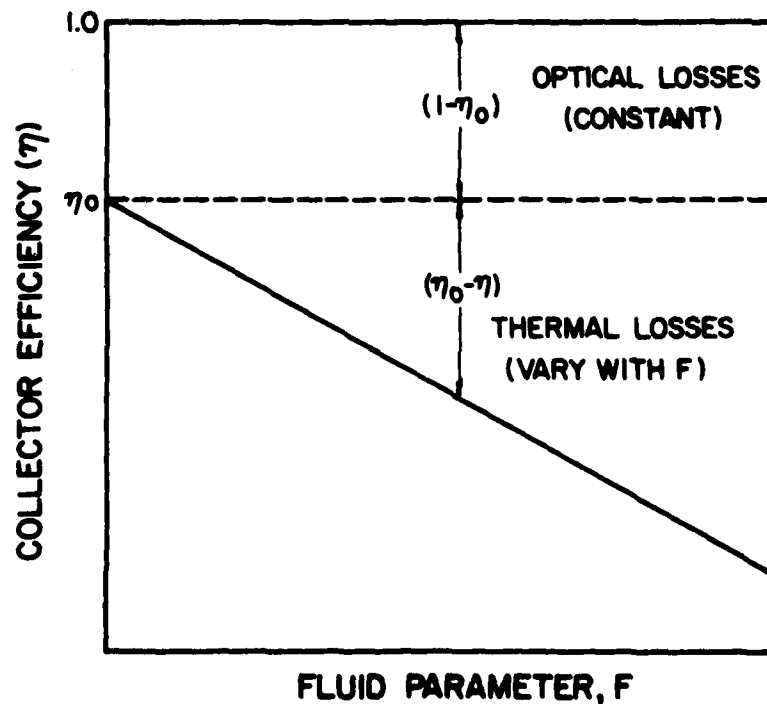

Figure 3. Sample interpretation of collected efficiency measurements.

1. Optical losses -- these are given by $[1 - \eta_0]$ and are constant (i.e., independent of F) since they exhibit no significant dependence upon the temperature of the collector or the air. These optical losses are due predominantly to absorption in the glass cover and the reflection from the absorber plate.

2. Thermal losses -- these are given by $[\eta_0 - \eta]$ and are due predominantly to conduction and convection losses from the collector to the air. Since these thermal losses are roughly proportional to the difference in temperature between the collector and the air, they increase linearly with the fluid parameter, F .

By including in the acceptance test the efficiency measurements which adhere to the standard procedure described above, it is possible to make meaningful comparisons of the acceptance test data with manufacturer's data or the performance stipulated in the specifications. For example, the acceptance test data for the array can be compared to the single-collector data measured by standards laboratories; since additional loss mechanisms (for example, collector flow imbalance, piping losses) are associated with an array of collectors, a certain tolerance of collector efficiency loss should be allowed for the array in such a comparison.

In theory, the acceptance test data can be compared with measured data in two ways. First, the graph of efficiency versus fluid parameter can be constructed with the measured array data plotted as discrete points and the expected behavior as a straight line. This graphic presentation allows the user to examine the data's quality and to interpret conveniently the results, as described previously with reference to Figure 3 (p 17). Second, the measured array data can be analyzed with a least-squares routine in which the data is fit to a straight line; the slope and intercept values from this analysis can then be displayed and used to generate a table of values for a direct quantitative comparison either with manufacturer's data or the performance stipulated in the specifications.

The above comparisons can be used to detect many of the construction flaws that have been reported in the references cited earlier. To demonstrate how the measured data can be used to detect such installation errors, the discrepancies can be divided into three types:

1. Measured value of intercept is low (but slope is normal) -- this is a symptom of high optical but normal thermal losses. Reported defects producing this symptom include: (a) a dirty or clouded glass cover plate, which can be caused by outgassing from the glue on an insulation material and outgassing of flux residue left by the bonding process. Instances of dirty cover plates due to a failure to maintain a clean environment when handling the collectors has also been reported. A failure to maintain a clear glass cover plate means that abnormally high absorption can be expected. (b) A streaked or shiny absorber plate -- the black coating that was applied to the surface of the absorber plate can peel away or decompose when exposed to the combination of high-intensity sunlight and stagnation temperature encountered in collectors. The optical defects cited above can be found with a visual inspection of the collectors.

2. Measured value of slope is high (but intercept is normal) -- this symptom indicates that the thermal losses are higher than normal but the optical properties are acceptable. Suitable candidates to be considered for this problem include: (a) a thermal short between the collector absorber plate and the glass cover, such as would be produced by a pronounced bowing of the absorber plate; (b) defective or wet insulation behind the absorber plate; (c) a failure to maintain a vacuum in an evacuated tube collector. Problems (a) and (b) can be investigated by a visual inspection; checking (c) requires that the collector be opened.

3. Both measured values unacceptable -- this symptom indicates that the problem is neither entirely optical nor entirely a thermal problem in the collector. Causes of this type of problem include: (a) severe flow imbalance in the collectors. This can result from an air blockage, particularly if collector headers are bowed. An air blockage effectively reduces the active area of the collector area and hence lowers the entire line representing the efficiency on the graph. (b) Piping losses -- this is a likely cause if the piping run between the collector array and the heat exchanger is relatively long (as compared to the length of pipe along the collector header), particularly if that piping is underground. Instances of large piping losses for underpiping in which the insulation had become soaked with groundwater have been reported.

Problems of type (a), severe flow imbalances, can be investigated by searching for array temperature nonuniformities. This can be done with infrared photography⁵ or a pistol thermometer if the system contains uniform flat plate collectors with a single cover. For other types of collectors, a search for non-uniformities in the outlet temperatures of individual collectors could be used to investigate severe flow imbalances if provisions for such temperature measurements were specified in the system design.

Problems of type (b), large piping losses, can be investigated by examining the differences in the temperatures measured at the collector array and those measured at the collector side of the heat exchanger.

Finally, one common collector array problem is a thermosiphoning of the collector fluid when the pumps are turned off (e.g., at night). When accompanied by flow in the tank loop (which could be produced either by thermosiphoning in that loop or by normal operation of the pump in the tank loop), the result is a large loss of energy from the storage tank. When the thermosiphoning in the collectors is not accompanied by flow from the tank, there is a potential danger of freezing and subsequent rupturing of the heat exchanger if the outside air temperature is below the freezing point of the tank fluid. Evidence of thermosiphoning in the collector loop can be obtained by performing measurements at night with the sensors shown in Figure 2, and then examining the measured values for an indication that flow is occurring when the collection pump is not operating.

⁵ A. Eden and J. Tinsley, Third Interim Technical Report on USAFA Solar Test House -- Design Parameters, CEEDO-TR-78-32 (Civil and Environmental Engineering Development Office, September 1978), pp 4.1-4.4.

Heat Exchanger

In climates with freezing temperatures, the collector fluid can be frozen at night. To prevent a rupture of metal piping in the collector array, an antifreeze solution is commonly used for the collector fluid. The heat exchanger serves to isolate this antifreeze from the water in the storage tank. Since the collected energy must be transferred to the storage via the heat exchanger, the performance of this component is vital to the successful operation of the solar energy system.

The performance of a heat exchanger can be measured with the sensors placed as shown in Figure 4. These sensors permit a determination of the efficiency, Γ , and effectiveness, ϵ , as defined by Eqs. 7, 8, and 9.

$$\Gamma = \frac{Q_{\text{tank}}}{Q_{\text{out}}} \quad [\text{Eq 7}]$$

$$= \frac{C_C P_C W_C (T_{HI} - T_{HO})}{\{\min\} (T_{HI} - T_{SI})} = \frac{\rho_S C_P S W_S (T_{SO} - T_{SI})}{\{\min\} (T_{HI} - T_{SI})} \quad [\text{Eq 8}]$$

$$\{\min\} = \text{minimum of } \rho_C C_P C W_C \text{ \& } \rho_S C_P S W_S \quad [\text{Eq 9}]$$

where:

Q_{tank} = energy transferred to the tank

Q_{out} = energy into the heat exchanger from the collectors

T_{HI} = temperature of heat exchanger from collectors

T_{HO} = temperature of heat exchanger outlet to collectors

T_{SO} = temperature of the heat exchanger outlet to storage

T_{SI} = temperature of the heat exchanger inlet from storage

W_S = flow rate of the tank fluid through the heat exchanger

ρ_S = density of the tank fluid

$C_P S$ = specific heat of the tank fluid.

The energy output of the collectors has already been given in Eq 3 while the energy from the heat exchanger to the tank is given in Eq 10.

$$Q_{\text{tank}} = \int \rho_S C_P S W_S (T_{SO} - T_{SI}) dt \quad [\text{Eq 10}]$$

The above quantities should be measured during a test in which the fluid through both sides of the heat exchanger is at the normal operating values.

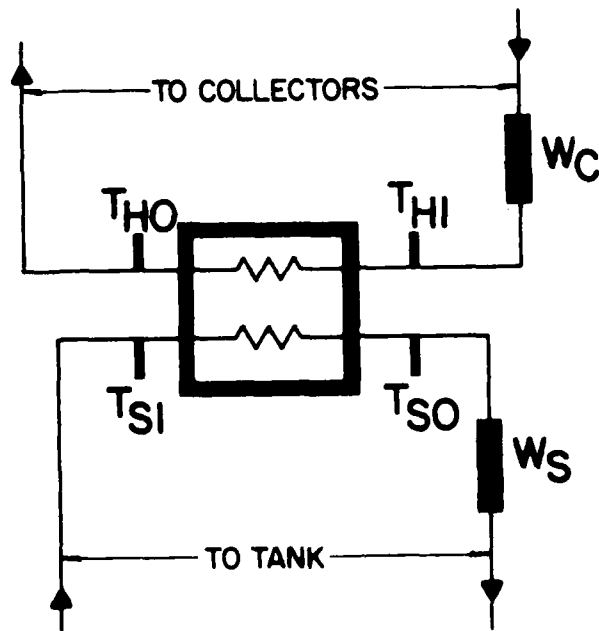

Figure 4. Locations of sensors for the measurement of the heat exchanger performance.

To eliminate effects of the finite heat capacity of the metal comprising the pipes and the heat exchanger, the temperature and flow values should be allowed to reach their steady-state values before data are taken. These requirements will be met if the test conditions stated for the "qualified" data points in the collector efficiency measurement (Table 1) are also imposed for the heat exchanger measurement. In addition, the time interval of 15 minutes used in Table 1 is satisfactory for measurements of the heat exchanger performance.

The average efficiency calculated from "qualified" data points can then be compared with the performance expected from a consideration of the information available in the specifications or from the manufacturer. An efficiency of greater than 95 percent should be obtained for a heat exchanger operating satisfactorily; acceptable values of the effectiveness would lie in the range of 0.3 to 0.8.

Storage Tank

Problems which have been encountered with the performance of thermal storage tanks in solar energy systems can be grouped into two types:

1. Dynamic problems -- these are characterized by poor energy transfer to the tank when the collector and tank pumps are operating. Two common sources of this type of problem are inappropriate sensor placement in the tank and a short-circuiting of the flow from the tank inlet to the tank outlet.

2. Static problems -- these are distinguished by unacceptably high energy loss rates which occur when all pumps are turned off. One possible cause of this problem is a failure to insulate the tank properly; for example, the insulation may become soaked with groundwater, or tank supports may not be adequately insulated. Another possible cause is thermosiphoning in the tank loop with simultaneous thermosiphoning in the collector loop as discussed in the last section.

The dynamic and static characteristics of the storage tank can be investigated with the sensor placement as shown in Figure 5. These sensors allow measurements of the following quantities:

- T_T -- Average tank temperature
- T_{TO} -- Tank outlet temperature
- T_A -- Air temperature (used if tank is above ground)
- T_G -- Ground temperature (used if tank is below ground)

An illustration of a dynamic problem -- a short circuit in the tank flow -- is provided by Figure 6. The nearness of the inlet and outlet piping shown in this figure allows part of the fluid from the inlet pipe to proceed directly to the outlet pipe. Note that a complete short-circuit of the tank flow would be indicated if the tank outlet temperature were equal to the tank inlet temperature; this extreme case would indicate a complete absence of any energy transfer to the tank. A partial short-circuiting of the tank flow would be indicated when the tank outlet temperature is greater than the average tank temperature but less than the tank inlet temperature. A measurable short-circuiting of the tank flow is considered unacceptable since it leads to a degradation in the system performance.

In a well-mixed tank, the tank outlet temperature would be found to be equal to the average tank temperature; this absence of any short-circuit (and of any stratification) is acceptable. The most desirable operating characteristic is revealed when the tank outlet temperature is less than the average tank temperature; this indicates that stratification is occurring which will lead to a more efficient operation of the solar collection. Table 2 presents a summary of the results of this discussion; the table reveals that measurements of the tank outlet and average tank temperatures under dynamic test conditions can be used to detect any degree of short-circuiting of the tank flow.

A static test of the tank can gauge the ability of the tank to retain thermal energy. To assist in understanding the tank's behavior under these conditions, the simplest model for the system will be considered. In this model, the tank contains a fluid of uniform temperature and is immersed in a medium of uniform temperature which does not vary with time. In addition, the thermal resistance of the tank's insulation would be uniform across the outside of the tank. In this model, the tank temperature would decay according to Eqs. 11 and 12.

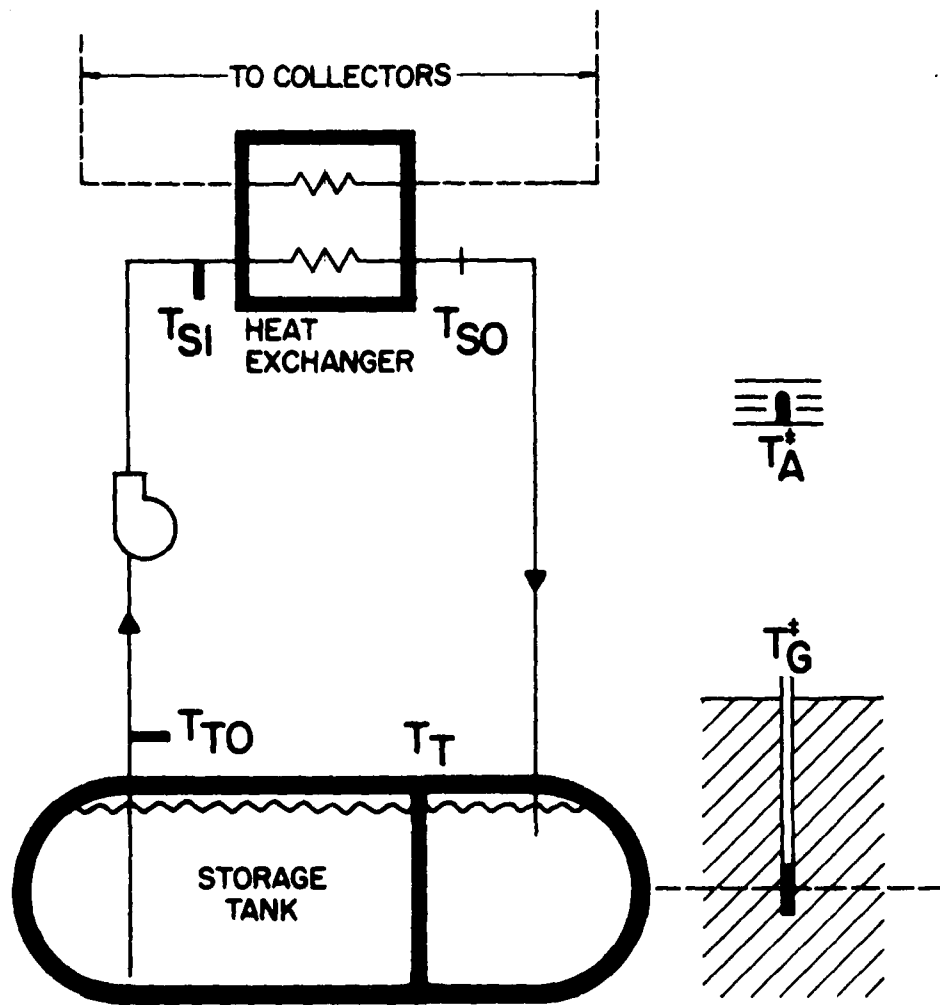

Figure 5. Sensor placement for the measurement of the dynamic and static characteristics of the storage tank (\dagger indicates use depends on the tank sites).

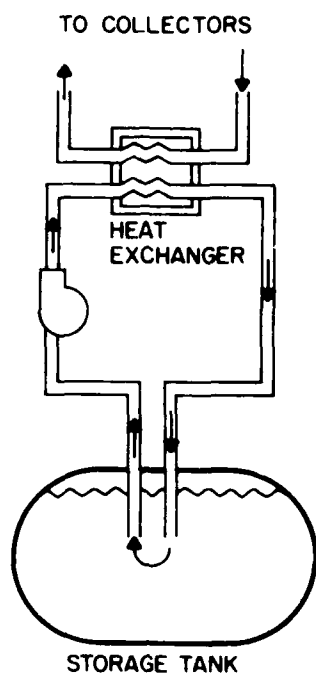

Figure 6. Illustration of a short-circuit in the tank flow.

Table 2

Evaluation of the Dynamic Characteristics of the Storage Tank Using a Comparison of the Average Tank Temperature (T_T) and the Tank Outlet Temperature (T_{T0})

Results of Comparison

Conclusion

$T_{T0} > T_T$

A measurable amount of short-circuiting exists; performance is not acceptable.

$T_{T0} = T_T$

Tank is well-mixed (no short-circuiting and no stratification); performance is acceptable.

$T_{T0} < T_T$

Stratification in the tank is occurring; this is most desirable.

$$T_T = T_M + (T_T^0 - T_M) e^{-t/\tau} \quad [\text{Eq 11}]$$

$$\tau = [\rho_S C_{PS} \frac{V}{A}] R \quad [\text{Eq 12}]$$

where:

T_T = the (average) tank temperature

T_T^0 = T_T at time $t = 0$

T_M = the temperature of the surrounding medium

τ = tank time constant

R = "R-value" of the tank's insulation

A = surface area of the tank

V = volume of the tank

ρ_S = density of the tank fluid

C_{PS} = specific heat of tank fluid.

The behavior predicted by Eq 11 is demonstrated in Figure 7; this figure indicates that the tank temperature decays exponentially toward the temperature of the surrounding medium. To prevent a rapid decay of the tank temperature (which indicates a high loss rate of the stored energy), a tank with a large time constant is needed. Eq 12 indicates that this can be achieved by providing the tank with insulation which has a high R-value. To obtain a perspective on the magnitude of the tank time constant that can be achieved, consider a 20,000-gal (75.708-m³) tank of water in the shape of a right circular cylinder whose length is 28 ft (8.53 m) and whose diameter is 11 ft (3.35 m). If the tank is insulated with a material having an R-value equal to 16, Eq 12 predicts a tank time constant of 2314 hrs or 96 days.

This calculation indicates that a test period of a few days is short compared to the large time constants expected for well-insulated tanks. Consequently, very little of the curvature depicted in Figure 7 will be seen in the data acquired during a short-duration test. Throughout this test period, the condition $t \ll \tau$ is satisfied and Eq 11 can be approximated by Eq 13.

$$T_T = T_T^0 - (T_T^0 - T_M) \frac{t}{\tau} \quad [\text{Eq 13}]$$

The linear decay of the tank temperature with time predicted by this equation is sketched in Figure 8. Although this model is quite simple, it can be used as a guide in developing a procedure for testing the static tank performance and as an aid in interpreting the resulting measurements. The model requires that measurements of the tank temperature as a function of time be performed

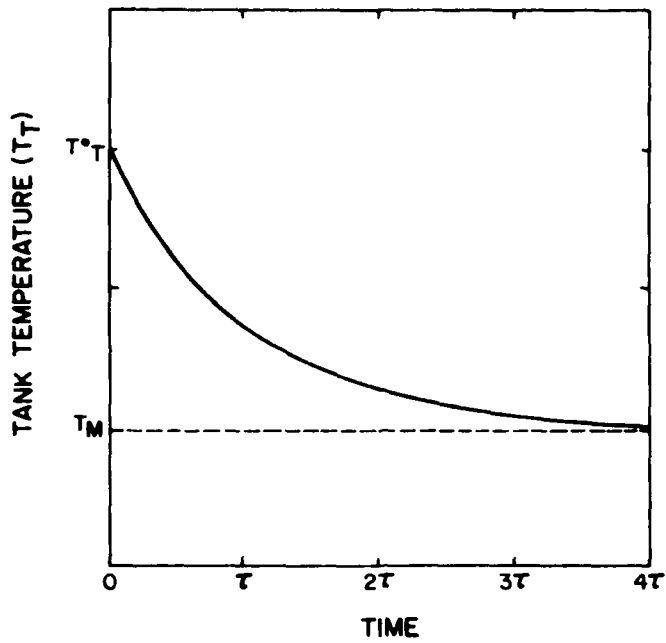

Figure 7. Predicted decay of tank temperature under static test conditions (pumps off).

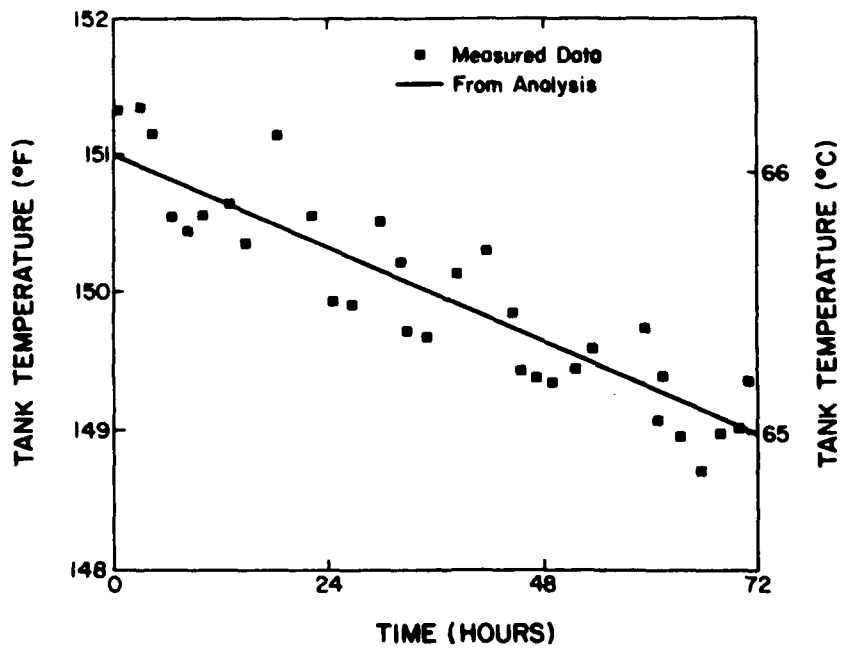

Figure 8. Graphic presentation of data to be used in the analysis of static tank test measurements.

while the system pumps are turned off. To overcome the difficulties presented by vertical temperature gradients in the tank that result from stratification, a temperature probe which averages over the vertical direction must be used.

The data from the measurements of the tank temperature as a function of time can then be plotted as indicated on Figure 8. These data may exhibit considerable scatter because of the small temperature decrease expected for a well-insulated tank during a short test. However, this effect can be mitigated by analyzing the data with a least-squares procedure to obtain the slope and intercept of a straight line; the intercept represents the value of the initial tank temperature while the slope represents the tank decay rate. A straight line can be drawn on the same graph with the data using these measured values; the graph can then be inspected for a pronounced nonlinearity of the data. Such nonlinearity would indicate invalid test conditions had occurred during the measurements.

As a first step in evaluating the tank's static performance, the tank decay rate can be examined for any preliminary indication of an unusually high energy loss rate. This can be done roughly by comparing the temperature decrease for an interval of 1 day with the temperature increase observed during the daylight hours on a sunny day with the system operating in the storage mode (as in the collector test discussed in the previous section). Unless the system is approaching the high temperature cut-off limit (which would indeed be unusual for a newly installed solar system), a system is unacceptable if it loses at night a substantial fraction of the energy collected during the day. A typical value for a tank temperature increase during a sunny day is 20°F (11°C); the causes of a tank decay rate of more than 2°F (1.1°C) per day for such a system should be investigated in more detail.

A more quantitative indication of the tank's performance can be obtained by calculating the tank's time constant. An inspection of Eq 13 reveals that the time constant can be obtained from the values of the slope, intercept, and surrounding medium temperatures as given by Eq 14.

$$\tau = \frac{(\text{intercept} - T_M)}{\text{slope}} \quad [\text{Eq 14}]$$

The model used to derive Eq 14 assumed the medium surrounding the tank was characterized by a constant and uniform temperature. For above-ground tanks, the air temperature can be expected to vary rapidly with time but not with distance. For below-ground tanks, the ground temperature normally varies with depth but does not vary rapidly with time.

However, the effect of either of these variations is insignificant provided that the variation is small compared to the temperature difference given in the numerator of Eq 14. This condition is easily met if the tank temperature is allowed to reach 150°F (65.5°C) or higher before the static test is conducted. Moreover, the effect of these variations can be partially compensated by employing an appropriate average value of the quantities in Eq 14. This compensation occurs because of the linear dependence of the loss rate upon the two temperatures. Although simultaneous measurements to obtain the air temperature should present no difficulty, the measurement of the ground temperature at an average depth of the below-ground tank may be difficult for some installations, particularly since some tanks may be buried below paved

parking lots. This quantity does not vary rapidly with time, however, and a procedure for calculating it has been published.⁶ The effect of using a calculated value instead of a measured value would be negligible for tank tests in which a tank temperature of 150°F (65.5°C) or higher was employed.

After a value of the tank time constant is obtained, as described above, this value should be examined to see whether it is reasonable. The basis for this examination should be the definition of the time constant given in Eq 12 and illustrated in Figure 7; specifically, the tank time constant is the time required for the temperature difference (tank minus surroundings) to decay to 63 percent of its initial value. Alternatively, the meaning of the tank time constant can be viewed in terms of the energy loss rate from the tank; it is the time required for roughly 63 percent of the stored thermal energy to be lost to the surroundings. A tank time constant of several months is high enough to ensure that only a small fraction of the stored energy will be lost to the surroundings for a normal solar energy system. Therefore, a measurement which indicates a tank time constant of less than 1 month should be critically examined.

As a final step in evaluating the tank test data, an R-value of the tank's insulation is implied by the data. As indicated by Eq 8, the R-value can be calculated with the value of the tank constant and the values of the tank fluid parameters and geometry using the relation given in Eq 15.

$$R = \left[\frac{A}{SCPSV} \right] \tau \quad [\text{Eq 15}]$$

This value, inferred from the measurements, can then be compared to either the value contained in the specifications for the system or to a value calculated from the thickness and type of insulation contained in the specifications.

Caution should be exercised when this comparison is made. It should be noted that only one energy loss mechanism -- thermal loss through the tank's insulation -- was considered in the simple model used to evaluate the tank test data. Consequently, the use of this model to evaluate the data implies that the effect of other energy loss mechanisms is incorporated into an effective R-value. The R-value specified for the tank's insulation represents an upper limit for this quantity. A value lower than this could be due to either deficient insulation or the presence of other energy loss mechanisms, such as a thermosiphoning of the tank fluid. These other sources of energy loss should be considered before it is assumed that a low measured R-value is caused by deficient tank insulation.

The effective R-value found for the tank should be within a factor of two of the insulation value specified for the tank. The need to allow this much tolerance in such a comparison is due to two factors. The first involves the lack of precision in determining the R-value of the tank insulation at the time of the test. For instance, it is common practice to quote R-value for insulating materials that were measured at 50°F (10°C), a value appropriate for materials used to insulate an outside wall or roof of a building. However, the tank test is to be conducted at a temperature in the range of 150°F

⁶ Kenneth Labs, "Underground Building Climate," Solar Age, Vol 4, No. 10 (October 1979), pp 44-50.

(65.6°C). Since standard references indicate that the thermal insulating properties of common materials vary with temperature by as much as 30 percent per 100°F (37.7°C), a difference between the calculated and measured values should be expected because of the various temperatures involved in this comparison.⁷ An even larger difference can result when a urethane foam is used for the tank insulation. The density of this insulation can be conveniently varied to provide a wide range of strengths. Although this variation allows the material to accommodate a wide range of tank weights, it has been reported that the insulation properties of this material vary by a factor of three over the range of compositions that can be obtained.⁸ Thus, the lack of precise information on the composition of this material leads to an imprecise knowledge of the actual R-value that should be compared with the measured value.

The second factor making it necessary to allow a large tolerance in this comparison is the difficulty of measuring the small energy losses through the insulation of a well-insulated tank. There are two problems with such measurements:

1. Other energy losses, though small, can be significant when compared to the insulation losses for a well-insulated tank.

2. The small magnitude of the energy losses means that the tank temperature will decrease only a little during the test interval; small errors in the measurement of the average tank temperature are significant when measuring such a small temperature decrease.

On the other hand, measurements performed on a tank with a high loss rate can be expected to yield more precise results. Measurements which produce an effective R-value that is lower than the specified insulation by a factor of three or more should be considered more serious; such a result would indicate an unacceptably high energy loss rate for the system. Problems with such high energy loss rates due to seepage of ground water into the tank's insulation have been reported.

Miscellaneous

Controls

Differential thermostats are used in solar energy systems to control the operation of the pumps which transfer the collected energy to the storage tank. These controls should turn on the pumps only when the conditions indicate that enough energy transfer will occur. If the electrical controls allow the pumps to operate during other periods (e.g., at night), the results will be as follows: (1) the circulation of the hot tank fluid through the collectors will lead to a high loss rate of the stored energy since the collectors are poorly insulated in comparison to the tank, (2) there will be an excessive consumption of electrical energy, which can greatly increase the operating costs of the system. On the other hand, valuable collected energy will be

⁷ "Heat Transfer and Fluid Flow," General Electric Data Book, Section 515.24 (April 1978), p 5.

⁸ Encyclopedia of Engineering Materials & Processes, H. R. Clauser, ed. (Reinhold, 1963), pp 697-699.

A number of problems involving the electrical controls have been reported.⁹ One type of problem involves the placement of the temperature sensors used by the solar system controller. The sensor used to detect collector temperature should be mounted inside a collector which can be considered typical for the array; in particular, a collector which will be shaded for part of the day should be avoided. The sensor should be mounted securely to the absorber plate, preferably on the back to shield the unit from direct solar radiation. The practice of mounting this sensor in the air between the absorber plate and the glass cover will not produce satisfactory control of the system; this mounting arrangement should not be accepted.

Similar care should be exercised in placing the control sensor inside the storage tank. The considerations here have been discussed elsewhere and will be summarized briefly here with the aid of Figure 10.¹⁰ This figure shows four choices, labeled A, B, C, and D, for the location of the tank sensor. Placing this sensor in the region marked "A," near the orifice of the return pipe, would expose the sensor to the rapidly fluctuating temperatures associated

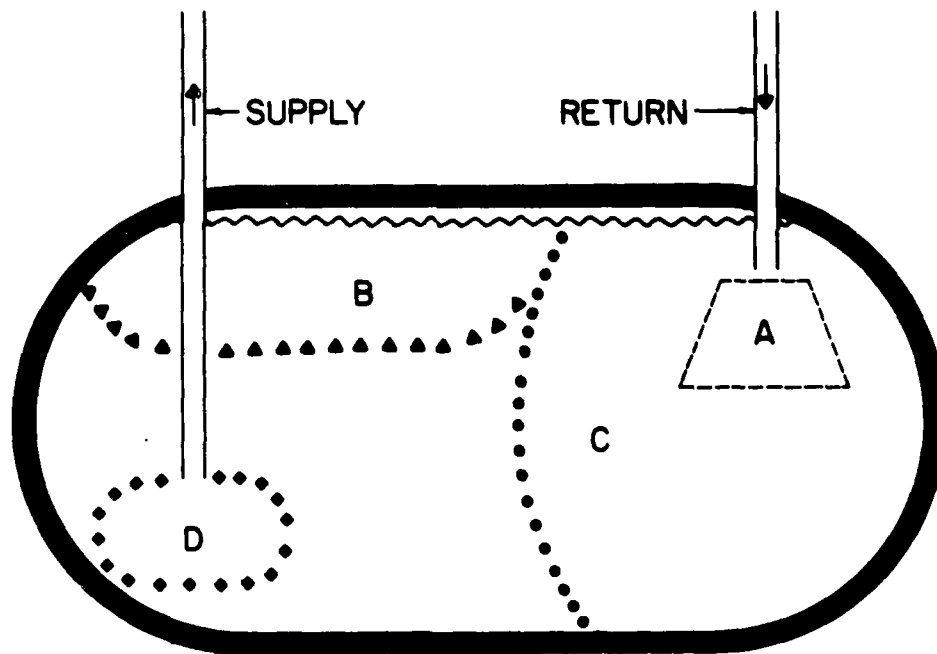

Figure 10. Regions to consider when locating a control sensor in the storage tank. (Region A is entirely unacceptable; region D is most desirable.)

⁹ The Final Proceedings of the Second Solar Heating and Cooling Commercial Demonstration Program Contractors' Review, DOE/CS/4131-I, Vol I, Report to the U.S. Department of Energy (U.S. Department of Energy, 1979).

¹⁰ James Easterly, "Engineering Concerns in Solar System Design and Operation," Solar Age, Vol 4, No. 10 (October 1979), pp 56-61.

with the fluid when the system is first turned on. This could cause excessive cycling of the pumps. In addition, this location would have a temperature considerably higher than other parts of the tank during steady-state operation. Consequently, this location would also effectively boost the control points to higher values, and the resultant higher-temperature operation would lead to a degradation of the system efficiency. In tanks where stratification can occur, the sensor should not be placed in the high temperature regions of the tank since that would also result in an erroneously high indication of the temperature. Region "B," near the top of the tank, is excluded for vertically stratified tanks and region "C," near the return end of the tank, is excluded for horizontally stratified tanks. Region "D," near the orifice of the supply pipe, is the most desirable for virtually all cases since the sensor detects the actual temperature of the fluid which is being supplied to the collector. The placement of both of the control sensors should be visually inspected during their installation to prevent the potential controls problems discussed above.

It has also been emphasized that installation of the cables between the sensors and the controller demands careful attention.¹¹ Four factors should be considered when searching for defects in the installation of such cables.

1. Breakage at bends -- since installation of the cable will typically involve many sharp bends, the wire can break if it is inflexible, such as a solid conductor. Stranded conductor cables which provide more flexibility than solid types are recommended for such installations.

2. Damage by moisture and weather -- a seepage of moisture through the insulation jacket of the cable can partially short-circuit the leads and cause the system to perform unsatisfactorily. Cables left immersed in standing water should be suspected of causing problems, even if such cables were indicated suitable for outdoor installation. If a cable was not designed for outdoor use, degradation of the cable insulation can also be produced by exposure to sunlight or air pollutants. Unsupported lengths of outdoor cable can also cause problems; the wires can break in strong winds.

3. Damage by heat and construction materials -- since the cables may contact hot surfaces (such as the collector, tank, and piping), the insulation on the cable can melt if not designed to withstand temperatures of at least 200°F (93.3°C). The cable insulation can also be damaged when roof penetrations are made or when cables are installed beneath pavement if molten asphalt or pitch is allowed to contact the cable.

4. Electrical interference -- electrical interference with the relatively small signal levels of the sensors can occur if the cables were installed near high-voltage (117 V ac) lines. This interference can cause spurious operation of the system's pumps. The use of twisted pair or shielded cable lessens the amount of electrical interference from such sources; however, interference can still occur if sensor leads are run within the same conduit as high-voltage wiring. Such an installation practice should not be accepted.

¹¹"Sensor Hookup Cables Demand Attention," *Solar Age*, Vol 14, No. 5 (May 1979), pp 50-51 (prepared from Field Service Bulletins issued by the Solar Division of Hawthorne Industries).

In addition to the problems caused by the installation defects cited above, failures can also be produced by defects in the components purchased from a manufacturer. Because of the wide range of operating temperatures for both control sensors in solar energy systems, the performance requirements for these electrical controls are more rigorous than those imposed by many conventional systems. Since it is extremely difficult to distinguish between a problem caused by a defective component and that caused by a defective installation technique, it has been strongly recommended that such components be tested by the contractor before installation.¹²

Collector Fluid

One type of collector fluid commonly used in solar energy systems is an inhibited ethylene-glycol water solution. The concentration of this solution can be adjusted to provide the level of freeze protection deemed necessary by standard engineering practice. Since this concentration is normally adjusted by the contractor during the installation, the value should be checked before final acceptance of the building. In addition, the values of the specific heat and density of the collector fluid vary with the concentration. Since a knowledge of these fluid parameters is required for the data analysis discussed in this chapter, a measurement of the parameters will provide an accurate value for evaluating the performances of other components.

Pumps

Finally, the improper sizing of the pumps in a solar energy system can lead to an excessive consumption of electrical energy. Following the confirmation of satisfactory performance of the electrical controls, the electrical energy consumption of the pumps can be monitored when the collector efficiency measurements are taken. An electrical energy consumption no greater than about 5 percent of the collected energy for the same period of time is considered acceptable.

¹²Rick Schwolsky, "Solar Aid -- Rx for Installers," Solar Age, Vol 3, No. 5 (May 1978), pp 8, 42.

3 SELECTION OF EQUIPMENT FOR ACCEPTANCE TESTING

Basis of Selection

The instrumentation hardware required for the component test procedures described in Chapter 2 can be discussed in terms of two types of equipment. First, sensors are needed for measuring the physical quantities solar radiation, wind speed and direction, site ambient temperature, and system fluid temperatures and mass flow rates. Second, a data acquisition system is required for collecting, converting, storing, and analyzing the information from these sensors. Two features were considered of primary importance in selecting the equipment for the solar acceptance test:

1. The overall instrumentation package must be accurate enough to allow a reliable and quantitative estimate of a component's thermal performance. Although the accuracy of some measurements depends to some extent on the specific operating parameters of a particular solar energy system, general guidelines are delineated in a study of the monitoring requirements for the National Solar Heating and Cooling Demonstration Program.¹³ This study concludes that an accuracy of 5 percent is needed to measure the performance of solar energy systems, and that this level can be achieved for most systems with commercially available equipment.

To obtain a perspective on the stringency of these accuracy requirements, consider Eq 3, in which the rate of energy transfer is given as the product of the flow through, and the temperature difference across, the collector array. To achieve an overall accuracy of 5 percent, the accuracy of the flow measurement, expressed as a percent of the nominal reading, must be better than 5 percent while the accuracy of the temperature measurement must be better than 0.50°F (0.28°C) for a typical temperature difference of 10°F (5.55°C). Although sensors with this accuracy are available commercially, it should be noted that some are not intended for measurements requiring this level of accuracy. Consequently, considerable care must be taken to ensure that the selected sensors are intended for precision measurement purposes and not just a rough indication of the fluid temperature or flow.

2. CERL wanted to base the acceptance test on an instrumentation package which disrupted the normal operation of the candidate solar system as little as possible. In reviewing the procedures for testing system components, it was found that the sensor requirements for performing these tests could be subdivided into two distinct categories, according to whether they are mounted on the system piping.

The pipe-mounted sensors are used to determine the temperatures and mass flow rates of fluids within lines. Because these quantities are required input for all the component tests, CERL felt that it would be quite beneficial to make these measurements inherently nondisruptive. Therefore, transducers

¹³E. Streed, M. McCabe, D. Waksman, J. Hebrank, and T. Richtmyer, Thermal Data Requirements and Performance Evaluation Procedures for the National Solar Heating and Cooling Demonstration Program, NBSIR 76-1137 (National Bureau of Standards, August 1976), pp 64, 76.

which attached to the pipe exterior were obtained. It should be pointed out that these measurements are strongly system-dependent in that the diameter and composition of piping vary considerably from system to system.

The second category of sensors is composed of all probes which are not pipe-mounted. Included here are sensors for taking climatological data (such as the site solar radiation, wind speed and direction, and ambient air and ground temperatures) and for measuring the tank temperature. While all the climatological data can be taken without affecting the operation of the solar system, it was decided that the tank's average temperature could be measured accurately only by inserting a probe into the storage vessel.

The remainder of this chapter describes the sensor package and data acquisition system bought for the field evaluation of the solar acceptance test concept. In addition, other test equipment for determining the collector fluid specific heat, the collector cover plate temperature, and the parasitic power consumption of the system pumps is described.

Pipe-Mounted Sensor Descriptions

Pipe-mounted sensors are required for checking the inlet temperatures at the collector array and heat exchanger, the outlet temperatures at the collector array, heat exchanger, and storage tank, and the flow rate in the system collector and storage loops. In keeping with the philosophy of nonintrusive measurement, contact temperature sensors and a clamp-on ultrasonic flowmeter were obtained for testing.

Clamp-On Temperature Sensor

As indicated in reference texts, precision electric resistance thermometers are used in serious engineering measurements of temperature.¹⁴ As the temperature of the environment surrounding the sensor changes, the resistance of the sensing element varies in a predictable and reproducible manner. Platinum is almost universally used in precision resistance probes when a wide range of temperatures is to be measured, while copper and nickel are considered acceptable materials for temperatures up to 250°F (121°C).

Four-wire contact nickel sensors were used in the acceptance test. (A four-wire determination of the sensor resistance was elected so that the effects of lead wire resistance would be minimized.) Having a nominal resistance of 100 Ω and a temperature coefficient of .32 Ω /°C (0.18 Ω /°F) at room temperature, these sensors are sold in lots of five, matched to 0.1 Ω . A self-contained silicone adhesive allows for attachment to electrically conductive piping, and the element time constant is negligible.

A comparison of the temperature indicated by the sensors and calibrated platinum elements was made before the field evaluation of the acceptance test. Under equilibrium conditions, the agreement between the two was excellent.

¹⁴H. Baker, E. Ryder, and N. Baker, Temperature Measurement in Engineering, Vol 2 (John Wiley & Sons, 1961), pp 4, 20.

Clamp-On Flowmeter

A commercial flowmeter which employs nonintrusive sensors was also purchased and tested. The manufacturer's description of this equipment claimed an ability on the part of the flow measurement system to operate with copper, steel, brass, or polyvinyl chloride (PVC) pipe in diameters ranging from 1 to 60 in. (25.4 to 1524 mm). The accuracy of the flow determination was indicated to no worse than 1.5 percent of actual flow for fluid velocities in the range from 1 to 30 ft/sec (0.31 to 9.1 m/sec). Furthermore, a linearity of 1 percent of reading and a zero stability of 0.015 ft/sec (0.0046 m/sec) were claimed. The output of this device is a dc voltage in the range 0 to 10 V, directly proportional to the fluid flow rate.

Although this unit provides highly automated measurements of flow, it is advisable to understand the basis of the measurement technique employed. As shown in Figure 11, two ultrasonic transducers are attached to the outside of a pipe in which fluid is flowing. In the first part of the measurement cycle, an electrical signal is sent to the downstream transducer, which converts this signal into ultrasonic pulse and injects it into the fluid stream. After traveling to the upstream transducer, the ultrasonic signal is received and converted into an electrical signal. The electronics inside the mainframe process the electrical signals to obtain the transmit time for the pulse transmitted upstream.

In the second part of the measurement cycle, the roles of the two transducers are reversed (the upstream transducer transmits and the downstream transducer receives), and the mainframe processes the electrical signals to obtain a transit time for the ultrasonic pulse traveling downstream. The flow rate of the fluid in the pipe is proportional to the difference in upstream and downstream transit times.

The performance of this unit was also investigated before the field evaluation of the acceptance test. The output of the ultrasonic meter was compared to flow rates calculated at a weigh tank in a laboratory at the University of Illinois. After some practice with transducer mounting, the agreement between the computed and measured flowrate was generally found to be better than 5 percent for 2-in. (50.8-mm) Type L copper pipe. Agreement of this order was considered satisfactory for the purpose of the acceptance test.

Typical Temperature-Flow Mounting Detail

Figure 12 illustrates the use of the clamp-on sensors. As indicated in the figure, temperature sensors are placed at the inlet and outlet of the component being tested. After all electrical connections are made, insulation is placed around the sensing elements so that the temperature measured on the pipe exterior accurately reflects the temperature inside. The flowmeter can be placed either at the component outlet or inlet as shown.

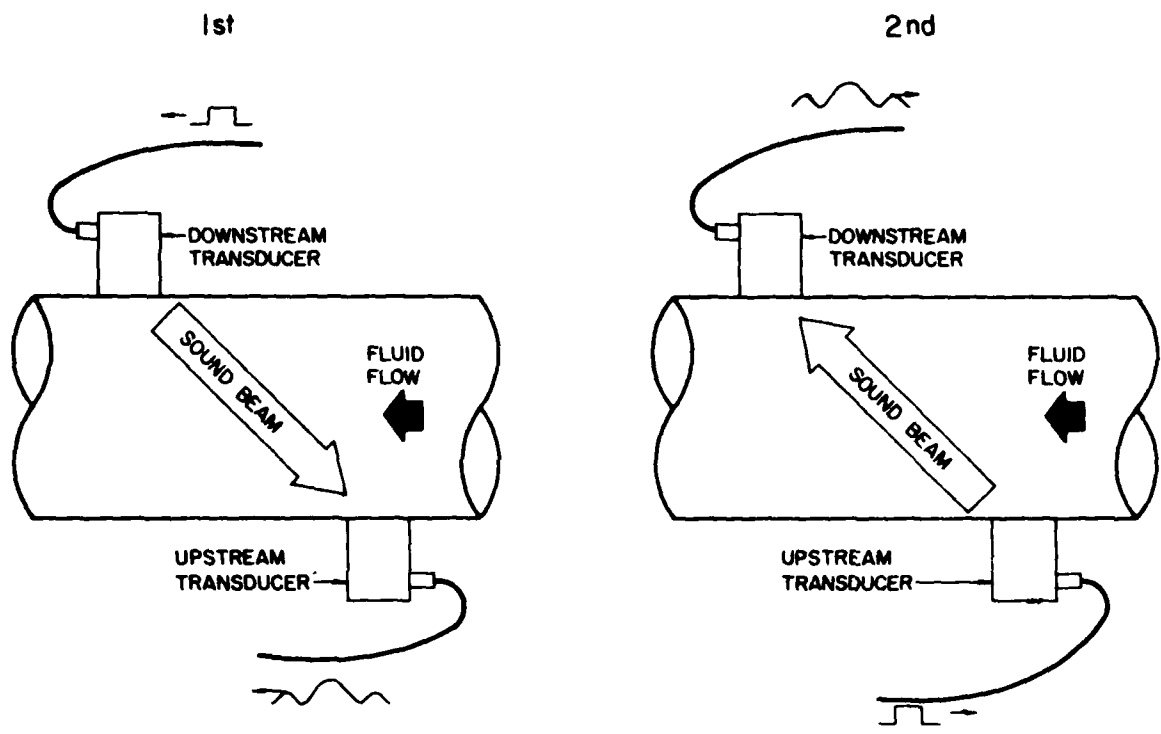

Figure 11. Illustration of the first and second parts of the measurement cycle of the clamp-on flowmeter.

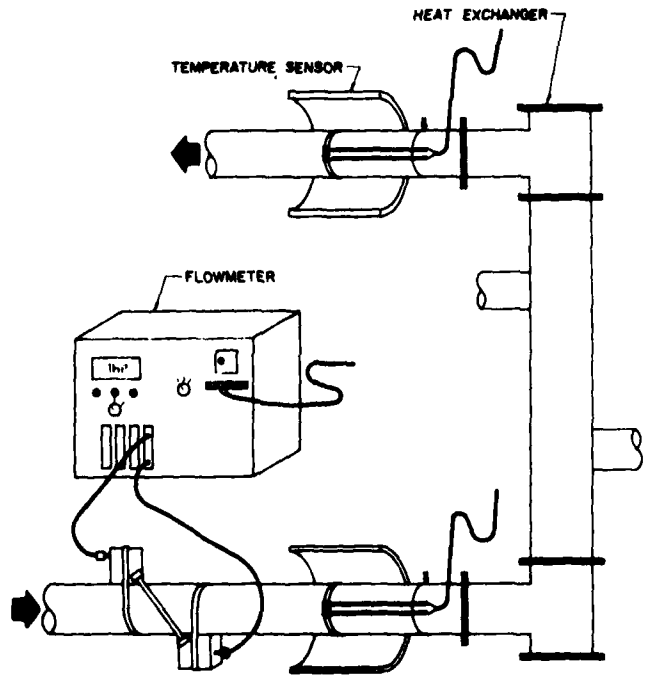

Figure 12. Mounting arrangement for clamp-on pipe-mounted sensors.

Other Sensors

The other sensors for the acceptance test provided measurements of the solar radiation, wind speed and direction, outside air temperature, average tank temperature, and (in some instances) the ground temperature. The mounting arrangement selected for the instrument which measured solar radiation, a pyranometer, is shown in Figure 13. The pyranometer is mounted on a tripod with adjustable screws which allow the unit to be oriented in the plane of the solar collectors. This unit can be quickly assembled and located near the solar collector array. Care should be taken to ensure that the orientation of the pyranometer is the same as that of the solar collectors and that there is no surface nearby which is reflecting a significant amount of light upon the pyranometer.

Specifications for the pyranometer include an ability to measure spectral radiation over the range of 0.3 to 3 microns. The device's linear response is +1 percent from 0 to 443 Btu/hr-sq ft (0 to 1400 W/m²) with a time constant of less than 5 seconds and temperature compensation of ±1.5 percent from -4 to 104°F (-20 to 40°C). The pyranometer's nominal sensitivity is 25.23 mV/Btu-hr sq ft (8 mV/W-m²).

A similar technique was used for the wind sensors and the outside air temperature sensor, as shown in Figure 14. These sensors were mounted on a second tripod to be located near the solar collector array. If a measurement of the ground temperature had been desired, a four-wire platinum resistance thermometer included in the test package could have been buried in the vicinity of the tank at the average tank depth.

A measurement of the average tank temperature was needed for both the static and the dynamic tests of the tank. In the static test, a capability to detect a relatively small temperature increment was necessary because well-insulated tanks are expected to decrease slowly in temperature during a reasonable test period. Since vertical thermal gradients in the tank can produce large changes in the temperature at a particular point in a tank, an ordinary probe (which provides a measurement at one point) cannot provide a reliable indication of the average tank temperature. The normal solution to this problem, obtaining an average temperature with several ordinary probes distributed vertically, is well suited when the probes are to be installed by a contractor. However, when portability is required, this solution is not particularly convenient. A distributed temperature sensor provides an even more accurate average of the tank temperature and is well suited to a portable test unit. The sensor selected for the acceptance test equipment contains a precision platinum resistance element distributed throughout the length of the sensor; this provides a continuous average of tank temperature with the precision afforded by the platinum resistance element. To allow different tank heights to be accommodated, a flexible unit was chosen so that it could be bent as illustrated in Figure 15.

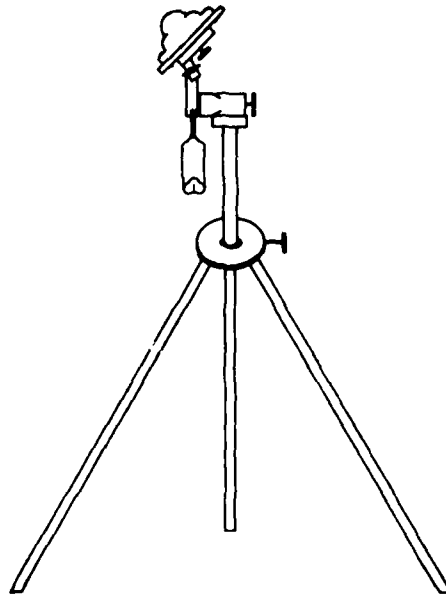

Figure 13. Mounting arrangement for the solar pyranometer.

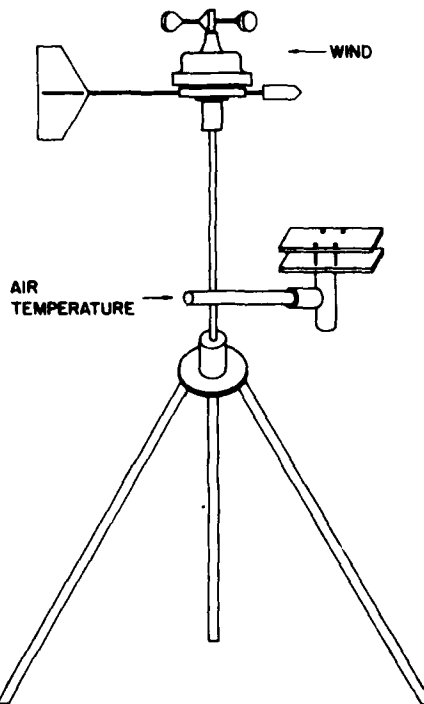

Figure 14. Mounting arrangement for the wind sensors and the outside air temperature sensor.

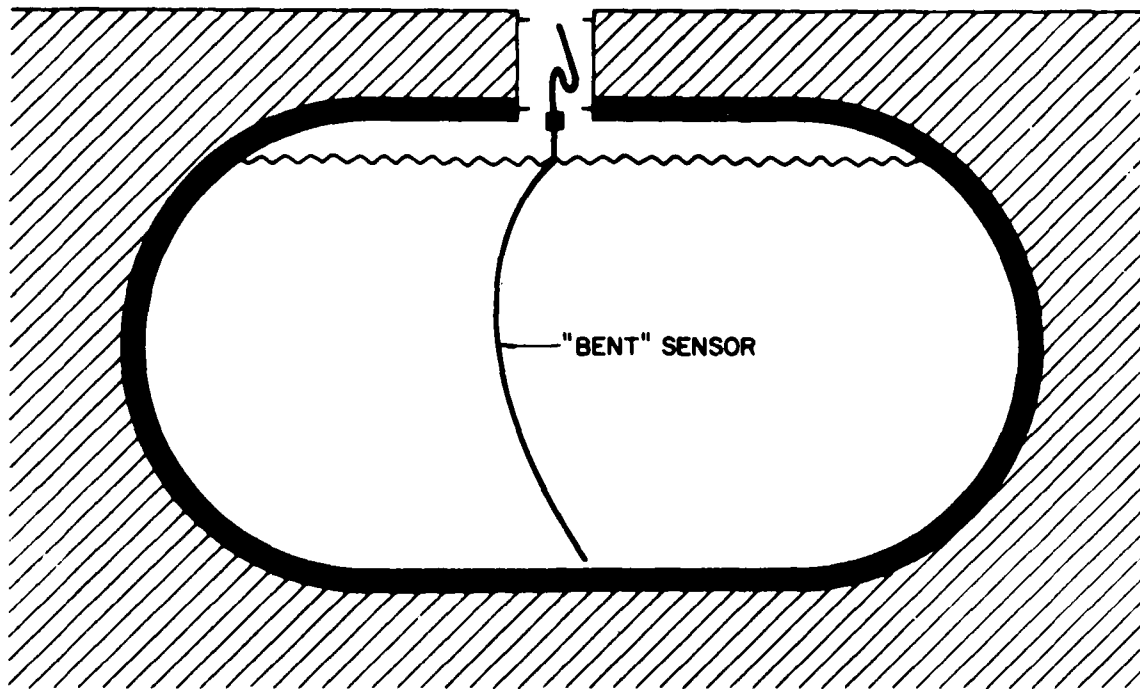

Figure 15. Mounting arrangement for the tank temperature sensor.

Data Acquisition System

Wires from all the sensors were routed to the multiplexer of the acceptance test's data acquisition system. This microprocessor-based unit first converts the sensor outputs into useful engineering information. The resistance of the four-wire temperature probes, for example, is translated into the temperature in the vicinity of the probe. Similarly, the voltage outputs of the clamp-on flowmeter and solar pyranometer are converted into the fluid flow rate and the solar radiation, respectively.

In addition to manipulations such as these, the data system is capable of executing programs for storing and analyzing the test results. Finally, these results may be printed on a hard copy device for user examination.

The data acquisition system used in the acceptance test consists of the following major components:

1. Calculator -- the features of this unit include a keyboard, a magnetic tape cartridge unit for storage of data and programs, a display, and a small (cash-register size) printer.
2. Voltmeter -- this unit measures the output (voltage, current, or resistance) of a sensor and displays the result. The operation of this unit can be controlled either by the push-buttons on the front panel or remotely by the calculator.

3. Multiplexer -- this unit contains a set of relays which function as switches under the control of the calculator. When wired to the voltmeter and a group of sensors, the scanner is used to connect each sensor one at a time to the voltmeter. Thus, a large number of sensors can be measured with a single voltmeter by scanning through the sensors sequentially.

4. Printer -- this unit prints and plots the data under program control of the calculator.

One important feature of this data system is the high level of accuracy it provides in acquiring and analyzing data. When used with the sensors employed in the acceptance test, the accuracy of the voltmeter is specified as 0.005 percent for dc voltage and 0.003 percent for four-wire resistance. The calculator processes numbers with 12-digit accuracy. Since the data system's accuracy is much higher than the sensor's, the error contribution from the data system is insignificant, and the overall accuracy of the measurement is limited only by the sensors.

Other Test Equipment

Several minor items were selected for use in the acceptance test. One of these is the pistol thermometer. This hand-held unit is battery-operated and is conveniently carried in the leather holster provided. When the unit is aimed at a surface and the trigger squeezed, the direct reading meter behind the handle indicates the temperature of the surface at which the unit was aimed. The model selected has a measuring range of 60 to 250°F (16 to 121°C), an accuracy of 2 percent of full scale, and a resolution of about 2°F (1°C).

The unit was selected for use in detecting severe flow imbalances (which result, for example, from air blockages) among the collectors in an array. The basis of this measurement is the higher temperature operation of a collector on a sunny day when there is little or no flow through it. For an array of singly-glazed, flat-plate collectors, such a higher temperature operation would result in a higher temperature of the cover glass. Consequently, severe flow imbalances in collector arrays of this type can be detected by comparing the temperatures measured at the same point (preferably near the center) of the cover glass on each collector. The portability and noncontact temperature measurement afforded by the pistol thermometer allow the user to rapidly shoot the temperature profile of a collector array and detect collectors which have an adequate rate of flow. In addition, operation of this thermometer is much simpler than infrared photography, which has been used to detect air blockages in the past. However, because the unit measures the collector's cover glass temperature rather than its plate temperature, the pistol thermometer's use is limited to singly glazed collectors.

Another item selected for the acceptance test was a solar technician's kit, including:

1. Refractometer -- this allows the user to measure the index of refraction of an antifreeze solution based on either ethylene glycol or propylene glycol. This measurement is used in the acceptance test to compute the concentration, freezing point, specific heat, and density of the solution.

2. Hand-held Multimeter -- this unit can perform a variety of electrical tests associated with the installation of the electronics. For example, the unit can be used for checking the continuity of lead wiring for sensors, checking the voltage outputs of flowmeters during installation, and measuring the electrical signals associated with the controls.

The final item selected for the acceptance test unit was a recording ammeter for determining the electrical power consumed by the pumps in the solar energy system.

4 DEVELOPMENT OF AN INTEGRATED ACCEPTANCE TEST PROCEDURE

Combining the Component Tests

Once the solar system components were defined, the variables determining their thermal performance described, and an instrumentation package for measuring these variables identified, an integrated procedure for performing the solar energy system acceptance test had to be developed. Figure 16 depicts the system's three major components as they are normally expected to be interconnected. In addition, the figure shows the location of all sensors required by the various component tests of Chapter 2. The sensor labels are defined by Table 3. It may be seen from the table that, to monitor the performance of all components, a measurement must be made of the solar radiation, the wind speed and direction, 10 system temperatures, and two flow rates. The value of other system parameters must also be determined before this monitoring can be completed. These parameters include the collector array area (A_C) and the collector and storage fluid specific heat (C_{PC} and C_{PS}) and densities (ρ_C and ρ_S).

With measurements taken under sunny conditions and the system in normal operation, the major component tests provide information on the performance of the collector array, heat exchanger, and thermal service tank.

Collector Array

The collector array efficiency (Eq 1) is plotted as a function of the fluid parameter (Eq 2), using appropriately qualified data points (Table 1). It is understood that each efficiency value is to be computed for a 15-minute interval during which the solar system is operating under quasi-steady-state conditions. The corresponding value of fluid parameter is computed from an average of the collector inlet and site ambient temperatures and irradiation intensity for the same 15-minute interval. To make such a plot, measurements must be made of the collector fluid's specific heat (C_{PC}), density (ρ_C), and flow rate (W_C); the collector array inlet (T_{CI}) and outlet (T_{CO}) temperatures; the solar radiation (I); and the ambient air temperature (T_A).

Heat Exchanger

The heat exchanger's performance is described in terms of its efficiency (Eq 7) and effectiveness (Eq 8) under quasi-steady-state conditions. The time interval of 15 minutes employed for the collector test is equally satisfactory for use here. To tabulate the performance of this unit, measurements must be made of the collector and storage loop specific heats (C_{PC} and C_{PS}), densities (ρ_C and ρ_S), fluid flow rates (W_C and W_S), inlet temperatures (T_{HI} and T_{SI}), and outlet temperatures (T_{HO} and T_{SO}).

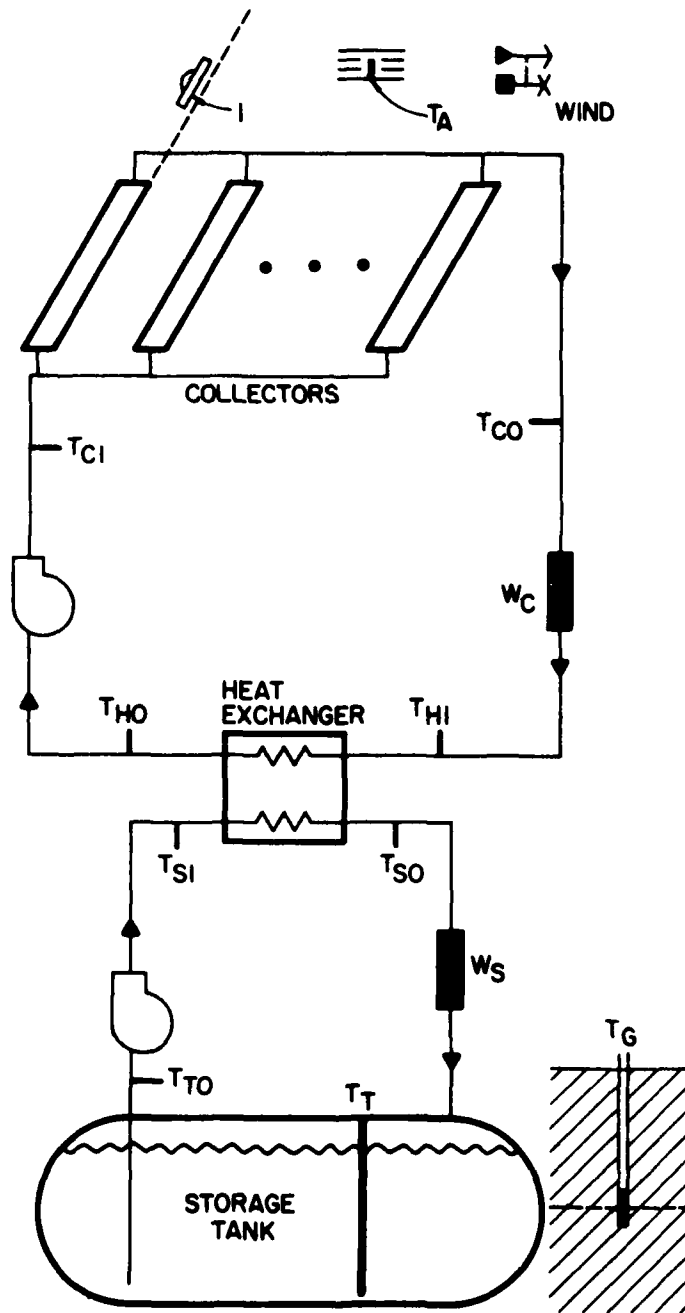

Figure 16. General solar system schematic.

Table 3
Sensor Symbols and Description

<u>Sensor Symbol</u>	<u>Sensor Description</u>
T _{CI}	Collector Inlet Temperature
T _{CO}	Collector Outlet Temperature
T _{HI}	Heat Exchanger Input Temperature (from Collector Array)
T _{HO}	Heat Exchanger Output Temperature (to Collector Array)
T _{SO}	Heat Exchanger Output Temperature (to Storage)
T _{SI}	Heat Exchanger Input Temperature (from Storage)
T _{TO}	Storage Tank Outlet Temperature
T _A	Outside Air Temperature
T _T	Average Tank Temperature
T _G	Ground Temperature
D _W	Wind Direction
S _W	Wind Speed
I	Solar Radiation
W _C	Flow in Collector Loop
W _S	Flow in Storage Loop

Thermal Storage Tank

The two aspects of the tank's performance may be described according to whether or not the system's pumps are activated. The dynamic behavior is measured by the degree of stratification achieved (Table 2) when the pumps are on. To assess this behavior, a knowledge of the tank outlet (T_{TO}) and average (T_T) temperature is required. The purpose of the static tank is to allow a comparison of the measured (Eq 15) and specified "R-value" of the tank insulation. Measurements must be made of the average tank temperature (T_T) and the temperature of the surrounding medium (T_G for underground and T_A for above-ground tank) as a function of time. These measurements must be made when energy is neither added to nor withdrawn from the thermal storage vessel.

The solar energy system acceptance test can be performed in three distinct phases taking about 1 week of sunny weather to complete.

1. Preliminary Test Phase -- an evaluation of the system constants and of the minor components -- control and pumps -- is made during this phase. The sensors are also installed and checked.
2. Dynamic Test Phase -- this phase involves measuring of the dynamic properties of the system components, and is performed during normal operation when the system pumps are on.
3. Static Test Phase -- the primary task during this phase is determining the storage tank's ability to retain thermal energy.

These three test phases are discussed more fully in the following sections.

Preliminary Test Phase

The preliminary test phase may be subdivided into four major tasks.

Review of the Solar System Drawings and Specifications

Before the measured and specified component performance can be compared, values must be established for the parameters which determine the expected performance of these components. Specifically, the building drawings and specifications should be reviewed for specified collector area, the slope and intercept of the collector performance curve (according to ASHRAE 93-77), the heat exchanger effectiveness, the "R-value" of the tank insulation, and the collector fluid concentration. The design values of the collector and storage loop flow rates should also be recorded for future reference.

In most cases, the heat exchanger's effectiveness will not be given directly, but must be computed from a knowledge of the temperature differentials and flow rates specified at the heat exchanger in the system design. Furthermore, the efficiency of this unit, as described in Eq 7, is normally assumed to be equal to one; that is, there is no provision for heat loss at this component for the purpose of the system design.

The "R-value" of the tank insulation may be stated implicitly in terms of a specified thickness of a particular type of insulation. Sufficient information is normally provided to allow an estimate of this quantity.

Measurement of Solar System Constant Parameters

The first quantities to be measured are the collector and storage fluid specific heats and densities. While the hand-held refractometer described in Chapter 3 actually measures the fluid index of refraction, it is a straightforward matter to compute, from a knowledge of this quantity, the solution's concentration, freezing point, specific heat, and density.

If only one clamp-on flowmeter is available, a measurement of the flowrate in the storage loop should also be made at this time. It is assumed that, for future energy balance calculations, the value of this quantity is constant whenever the storage pump is on.

A minor aspect of the solar acceptance test involves comparing the solar energy collected during any given period and the power expended by the pumps for its collection. The recording ammeter described in Chapter 3 may be used to determine this consumption whenever the collector and storage pumps are activated. (It is assumed that the consumption of the pumps is constant.) While the ammeter measures current rather than true power, the latter may be estimated if a default pump power factor is used. Because an accurate determination of parasitic power consumption was not considered to be a factor crucial to the solar system acceptance, no effort to obtain a true power meter was made.

Finally, the collector array area, as installed, should be determined. It is recommended that the collectors be measured and counted to do this.

At this point, a comparison can be made between the specified and measured values of the collector loop fluid concentration and storage loop flow rate. The actual collector array area can also be compared to the specified value of this quantity.

Evaluation of the System Controls

As described in Chapter 2, problems with solar system controls can generally be grouped into two categories. The first of these -- sensor or electronic malfunctions -- is most easily determined before the system is constructed. Therefore, a rigorous on-site diagnosis of these components is not considered part of the acceptance test. Instead, it is recommended that their performance be checked before system installation. A set of test procedures for solar system electrical controls is given in Appendix A.

The second category of problems reflects errors in controller installation. For the solar acceptance test, CERL feels that a visual inspection of the control sensor and cable installation is sufficient, if the tests of Appendix A were performed before the controls were put in place. The placement of the collector and tank sensors used by the controller should be examined visually. In addition, the routing of the control cables should be

inspected for breakage at bends, damage by moisture and weather, damage by heat and construction materials, and a susceptibility to electrical interference.

Equipment Set-Up and Testing

The final task in the preliminary phase of the acceptance test involves equipment set-up and testing.

Tripods are used to support the sensors which measure solar radiation, outside air temperature, and wind speed and direction. These units can be quickly assembled and placed near the solar collectors. The adjusting screws on the tripod which holds the pyranometer, the unit which is to measure solar radiation, should be used to orient the pyranometer in the plane of the collectors. The user should check the mounting arrangement for this unit to ensure that no nearby surface is reflecting a significant amount of light upon the pyranometer. The assembly of the wind sensors and outside air temperature sensor on the other tripod is straightforward.

The contact temperature sensors and flow transducer are also attached to the pipes at the appropriate locations as described in Chapter 3. Wires from all sensors are routed to the data acquisition system, and a verification is made that all sensors are reporting reasonable values. This is particularly important for the clamp-on flowmeter and the contact temperature sensors.

Dynamic Test Phase

This test phase involves measuring the dynamic properties of the system components with the electronic instrumentation and sensors. Because of the severe constraints imposed by the collector efficiency measurements described in Chapter 2, the overriding concern during this phase is with testing under conditions which will allow the performance of the collectors to be evaluated. A thorough check of the collector array's performance requires that measurements in this phase be conducted on three or more days. The following considerations apply to the scheduling of these days for the dynamic measurements.

The Need for Qualified Points

Since only qualified data points can be used to evaluate the collector performance, each of these days must produce some qualified data points if a thorough check is to be made. Essentially, this requires that each test day be sunny, with relatively low winds.

The Need for a Wide Range of F-Values

To determine the intercept and slope of the collector efficiency curve, measurements should be performed so that data can be obtained over a wide range of tank temperatures. This can be done by scheduling the first day of measurements to coincide with the initial operation of the system; that is, before the tank fluid has been heated appreciably by the system. By removing all loads on the system, the tank temperature will increase on each successive sunny day, thus permitting a wide range of tank temperatures to be tested.

If the tank temperature is already fairly high when personnel arrive at the site to perform the test, it may be possible to manually force the system to use the stored energy, thereby lowering the tank temperature. For example, a solar system that provides heating for domestic hot water could be manipulated in this way by (1) turning off any backup for domestic hot water heating and (2) turning on hot water faucets overnight.

Although the timing of this test phase is crucial to its success, the unpredictability of the weather and of the system's completion date mean that a precise scheduling of the test in advance is difficult.

Measurements of the heat exchanger's effectiveness, and of the tank's dynamic performance are taken while the collector array is monitored. Once the dynamic test phase is complete, the measured performance of these components can be compared to the specifications.

The graph of collector array efficiency versus fluid parameter can be constructed with the measured array data plotted as discrete points and the expected behavior as a straight line. If a significant deviation is found, the pistol thermometer may be used on singly glazed arrays to check for severe flow imbalance from collector to collector.

The thermal losses of the heat exchanger, reflected by its efficiency, should be no greater than 5 percent of the energy transferred. The operating effectiveness of the component can be compared to the effectiveness calculated from the system's design data.

The degree of tank stratification is indicated by a comparison of the tank outlet and average temperatures when the pumps are on. Under no condition should the outlet temperature be substantially greater than the average.

While the collectors, heat exchanger, and tank are the major components of a solar energy system, line losses can contribute to a degradation of the overall thermal performance of the system. With the sensors located as shown in Figure 16, these losses may be estimated throughout the system by comparing the temperature at the outlet of one component to the temperature at the inlet of the next. For any given run of pipe, this loss should never exceed 1 percent of the energy being transferred.

Static Test Phase

This test phase is concerned primarily with the measurement of the tank's ability to retain thermal energy. It is most desirable for this test to be performed at a reasonably high tank temperature, preferably above 150°F (65.5°C). This condition should prevail after completion of the dynamic test phase since the system was controlled to allow the tank temperature to increase to a high value. During this static measurement, all energy transfers to or from the tank via pumps must be stopped. Since the loads on the tank should have been removed during the dynamic test phase, this condition need merely be extended into the static tank test period to prevent the energy transfer from the tank at any load. In addition, steps must be taken to ensure that the collector array does not transfer any energy into the tank during this interval. Although a test period of 3 days is desirable, an

overnight test can be used if the demands of the construction process do not permit the collector operation to be stopped during the day. An overnight test can detect severe energy losses from the tanks but cannot be expected to yield effective R-values of high precision.

The presence of thermosiphoning in the system can also be checked during this phase. Although the static tank test should reveal the presence of a significant amount of simultaneous thermosiphoning in both loops, it is essential to detect thermosiphoning in the collector loop even when it is not accompanied by thermosiphoning in the tank loop. Since the equipment and procedure used in the dynamic test phase provide measurements of the temperatures and flows useful in detecting thermosiphoning in either loop, a search for such thermosiphoning can be made by merely repeating that measurement overnight with the pumps turned off. The measured values of the temperatures and flows in each loop can then be examined for any evidence of thermosiphoning.

Programming of the Data Acquisition System

The data acquisition system described in Chapter 3 was programmed to perform the component test procedures which had been developed. Briefly stated, this programming effort resulted in five subprograms which covered all aspects of data entry, acquisition, conversion, storage, and analysis. An INITIALIZATION subprogram was written to store values of the system constants on the magnetic tape cassette. DYNAMIC and STATIC ACQUISITION subprograms were developed to perform these tests on the solar system selected for a fluid evaluation of the acceptance test concept. Finally, both DYNAMIC and STATIC ANALYSIS subprograms were written to analyze the respective test results and to output these results on the data system printer.

5 SOLAR ACCEPTANCE TEST FIELD EVALUATION

Site Description

A field evaluation of the solar acceptance test was performed by personnel from CERL during the week of 2 December 1979 at a 40,000 sq ft (3716 m²) U.S. Armed Forces Reserve Center in Albuquerque, NM. The purpose of this evaluation was three-fold. First, CERL wanted to establish whether the acceptance test procedures described in Chapter 4 were workable in the environment of an installed and operating solar energy system. Second, such an evaluation would provide valuable information about the accuracy and reliability of the portable instrumentation package developed for the tests. Third, CERL wanted to see whether the test was user-oriented.

The solar system at the Reserve Center was designed to assist in domestic water heating and space heating and cooling. Although the system is quite complex (having collectors, heat exchangers, hot and cold storage tanks, a heat pump, an absorption chiller, and numerous valves and modes of operation), its collection and storage aspects are well described for test purposes by the schematic of Figure 17. It should be noted that in spite of its complexity, the system is equivalent to the general solar system schematic assumed for the test.

The Reserve Center was chosen for the field evaluation because the building's heating, ventilating, and air-conditioning (HVAC) system had been previously instrumented in conjunction with a separate research effort. As a result, sensors, whose level of accuracy was consistent with the requirements of the acceptance test, had already been installed at all major system components. Thus, it was possible to compare the outputs of the in-place and portable sensors. In addition, the CERL personnel performing the test had already gained some familiarity with the facility itself and with the system's operation.

Results of the Preliminary Test

The four tasks of the preliminary test phase were performed as described in Chapter 4.

Review of System Drawings and Specifications

The building specifications were first consulted to determine the design's collector array area; the following information was found:

1. GENERAL: The Contractor shall furnish and install flat plate solar collector panels with a gross collector area of 10,115 sq. ft. (8,600 sq. ft. net effective area) minimum, on steel support structures, as detailed on the drawings.

COLLECTOR ARRAY
10,125 SQ FT (940.64m²),
SINGLY-GLAZED,
FLAT-PLATE (SUNWORKS)

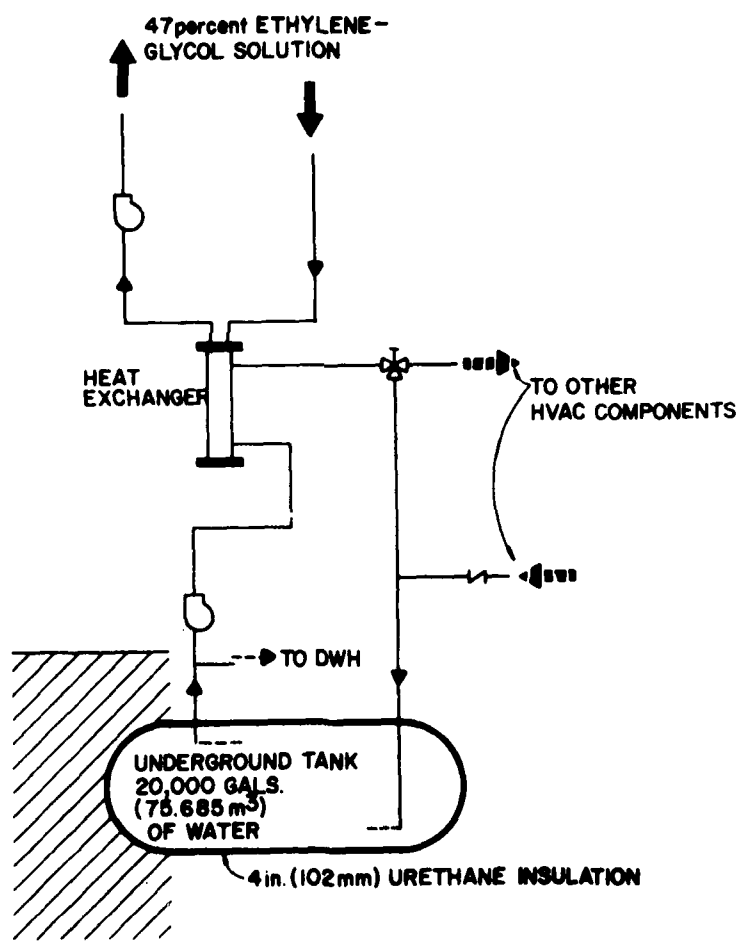
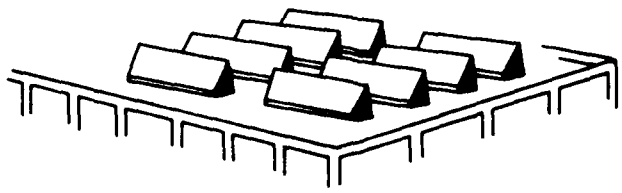

Figure 17. Schematic diagram of the solar energy system at the site of the field evaluation.

The building drawings expressed these area requirements somewhat differently, and called for the installation of 10,642 sq ft (987 m²) of collectors. When questioned about the discrepancy in the stated array areas, a representative of the Fort Worth District indicated that the smaller value was, in fact, correct.

The slope and intercept of the minimum acceptable single collector performance curve were to meet this specification:

Minimum required performance shall be based on efficiency of 57% when $f = 0.15$ and 47% when $f = 0.30$ where f is inlet water temperature in collector minus ambient air temperature all divided by total isolation [sic].

In addition, the contractor was required to submit certified collector test data to substantiate his claim of the performance of the selected panel.

When many such collectors are piped into an array, some degradation in thermal performance is allowed to account for flow imbalances and piping losses. For this design, this allowance was expressed by the following specification:

The Contractor guarantees that this installation is free from mechanical defects. He agrees to replace or repair, to the satisfaction of the Contracting Officer, any part of his installation which may fail or which results in a loss of performance efficiency greater than 5% of the data basis for acceptance within a period of one year after final acceptance, provided that such failure is due to defects in the materials or workmanship or to failure to follow the specifications and drawings.

This was interpreted to mean that the array performance could be, at most, 5 percent worse than that of a single collector.

Finally, the collector fluid concentration was specified by the following statement:

The circulating medium shall be 40% by volume solution of ethylene glycol and water.

The system drawings (Table 4) also contained enough information to allow a calculation of the expected heat exchanger effectiveness. With an assumed glycol concentration of 40 percent, Eqs. 8 and 9 may be used to compute an effectiveness of 0.42 for the component in this system. The values of tube and shell flow rate noted in the table were also recorded for a future comparison to the measured values of the parameters collector and storage loop flow rate (W_c and W_s), respectively.

Guidance for the thermal resistance of the tank insulation was contradictory. A section of the specifications reads as follows:

INSULATION FOR HOT EQUIPMENT ABOVE 60°F (15.6°C) AND COLD EQUIPMENT BELOW 60°F (15.6°C):

Table 4
Specified Design Conditions for the Heat Exchanger*

Symbol	Service	Surface Sq Ft (Min.)	Tube			Shell		
			GPM	Temperature In Out	P.D.	GPM	Temperature In Out	P.D.
86	Solar	275	180	115 105	15	163	90 100.6	30
87	Solar	275	180	115 105	15	163	90 100.6	30

*These heat exchangers handle 40 percent glycol solution.

General: Insulation shall be of the rigid block or semirigid board type suitable for the temperature service encountered. Insulation thickness shall be 1-in. thick material. Hot equipment handling media to 250°F, such as heat exchangers, hot water (solar) storage tanks, expansion tanks, unjacketed boilers or parts of boilers shall be covered.

The drawings, however, stated:

STORAGE TANKS: Furnish and install two (2) below grade design water storage tanks. Tanks to be designed for 50 psig internal pressure. Interior surface to have enamel finish suitable for continuous duty completely submerged in 220°F water. Tanks shall have all necessary connections for filling, gauging, venting, supply and return fittings access manhole - located as shown. Each tank shall have 20,000 gallon capacity, approximately 11 ft. diameter by 28 ft. length. Exterior surface to have minimum thickness of 4" urethane lagged on insulation, insulation to be secured to tank exterior with Dow #11 mastic, mitered spaces between insulation to be closed with mastic and entire exterior to be covered with finish coat of mastic or asphalt coating. Tanks shall be ASME stamped construction.

It was assumed that the 4-in. (102-mm) requirement was intended. The ASHRAE Handbook and Product Directory: 1977 Fundamentals cites an R-value of roughly 25 for this thickness of urethane insulation.¹⁵

Measurement of the Solar System Constant Parameters

The hand-held refractometer was used to measure the collector fluid index of refraction after the pump in the collector loop had been active for about 45 minutes. For an ethylene-glycol and water mixture, a value of 1.376 for this quantity implies a specific heat of 0.85 Btu/lb-°F specific gravity of

¹⁵Handbook and Product Directory: 1977 Fundamentals (ASHRAE, 1977).

1.05. A knowledge of these quantities is required for future energy balance calculations. It should be noted that this measured index of refraction implies a 47 percent mixture of glycol in water; this is to be compared to the value of 40 percent contained within the system specifications.

Since water is used in the storage loop, the specific heat and specific gravity of the fluid were taken to be unity.

Next, an attempt was made to measure the storage loop flow rate using the clamp-on flow meter. Because this unit did not function properly, no value could be assigned to W_s at this time; the failure of the ultrasonic flowmeter will be discussed more fully later in this chapter.

Sunworks Inc. had been awarded the collector array contract with its bid of the singly glazed, selective surface, internally manifolded Selector. The array area was then estimated on site by measuring the dimensions of a single collector and multiplying by the total number of collectors. The gross area of a single unit was 20.71 sq ft (1.92 m^2), and 489 collectors had been installed by the contractor. Hence, the gross array area was computed to be 10,125 sq ft (940.65 m^2).

This is to be contrasted with the 10,115 sq ft (939.71 m^2) called for by the solar system specifications. To within the area of a single collector, the contractor at this site had met the requirement for installed array area.

Finally, the power consumption of the collector and storage pumps was determined; for these units, values of 7.9 kW and 9.1 kW, respectively, were recorded for future reference.

Evaluation of the System Controls

The routing of the control sensor cables and placement of the collector sensor were visually inspected. (The tank sensor was inaccessible, so its placement could not be checked.) The actual performance of the controls was inferred from this solar system's operation. Under the sunny conditions which prevailed during the field evaluation, collection of solar energy was initiated by the controller when the collector temperature (as measured at T_{CO}) was about 12°F (6.7°C) greater than the average tank temperature. Collection stopped when the difference between these temperatures was only 4°F (2.2°C). Furthermore, no excessive pump cycling was noted. Considering these factors, CLRRL concluded that the solar system controls were functioning acceptably. It is still recommended, however, that the controls be tested by the procedure given in Appendix A before their installation.

Equipment Set-Up and Testing

The most disturbing finding to emerge from the field evaluation of the acceptance test concept and hardware was the ultrasonic flowmeter's failure to perform at all during the week of the test. The transducer for the flowmeter was repeatedly attached to the 6-in. (152.4-mm) Schedule 40 carbon steel pipe of the collector main in accordance with the manufacturer's instructions. Although due precautions were taken in performing this task, the light used to signal empty pipe conditions (on the unit's mainframe) remained on at all times. This malfunction was particularly disconcerting in view of the fact

that the normal operation of the flow measurement system had been verified in the laboratory before the field evaluation.

While this unit's unreliability makes impractical the concept of a completely nonintrusive test instrumentation package, the flowmeter's failure did not prevent an evaluation of the acceptance test procedures. Fortunately, as a result of the separate monitoring effort mentioned previously (p 51), both the collector and storage loops at the site contained venturi flowmeters and differential pressure signal conditioners. The voltage output of these pressure transducers was used during the test to calculate the fluid flowrate in both these loops.

The accuracy of a contact temperature sensor was also checked at this time. A single sensor was attached to the collector main at the array outlet. Insulation was applied behind the assembly, as described previously, and the unit allowed to come to thermal equilibrium. A measured probe resistance of 128.6 Ω implied a temperature within the pipe of 153°F (67.22°C). An independent measurement of this temperature was then made using a calibrated, mercury-in-glass thermometer, which was inserted in a thermo-well at the same location. It read 156°F (68.9°C). Because the contact sensor calibration had been checked before the week of the field evaluation, it could only be assumed that the massive collector piping was having a significant impact on the time constant of the contact temperature sensor response.

Based on these results, it became clear that determining the collector array's efficiency would require a more accurate measurement of temperature than was provided by the contact sensor assembly. Therefore, for the field evaluation, the temperature within pipes was measured by four-wire platinum sensors which had already been installed in thermo-wells at appropriate locations in the facility during construction.

CERL also encountered difficulties in installing the probes for the static tank test. The underground tank at the site of the field evaluation not only was pressurized, but was also under a paved parking lot. These findings affected the field evaluation in two ways. First, there was no access to the tank which would allow insertion of the tank average temperature probe. Second, CERL would have had to locate the sensor for measuring the ground temperature far from the tank itself. For the test results which follow, the average tank temperature was determined by platinum, four-wire sensors which were installed at different levels in the tank at the time of building construction. The ground temperature was calculated from average local weather data rather than being measured at the site.

In spite of these instrumentation problems, the field evaluation of the acceptance test concept proceeded as scheduled. But the solar system's thermal performance was based on sensors already installed at the site rather than on portable ones included as part of the test package.

Wires from the existing sensors were routed to the data acquisition system so that simple sensor checks could be performed. The accuracy of the temperature sensors was established whenever possible by comparing the measured values to those of simple indicating mercury thermometers in adjacent piping locations. In all cases, these were found to agree within 1°F (0.55°C) -- the

accuracy of the simple thermometer. An initial measurement of the two venturi outputs indicated flow rates of 401 gpm ($1.52 \text{ m}^3/\text{min}$) and 331 gpm ($1.25 \text{ m}^3/\text{min}$) in the collector and storage loops, respectively. While no independent means was available for calibrating these devices, the consistency of simple energy balances at the system heat exchanger, using both integrated and average values, suggested that the readings were accurate. In fact, with the use of the existing venturi flowmeters and platinum temperature sensors, all preliminary results confirmed the high level of accuracy expected from measurements taken with the test equipment.

Dynamic Test Results

This test was performed so that the dynamic properties of the collector array, the heat exchanger, and the storage tank could be established. A preliminary printout of the data obtained during the execution of the DYNAMIC ACQUISITION subprogram for 7 December 1978 is shown in Table 5. This table, containing the average values of all measured quantities for each 15-minute interval of the test period for that day, summarizes virtually all the information required to compute the performance of the system major components.

For example, the collector efficiency for the time labeled 11:00 is given by the array thermal output divided by the solar radiation incident on the array for that 15-minute interval. Using Eq 3 with the values for T_{CI} , T_{CO} , W_C , ρ_C , and C_{pC} listed in the table, the energy output of the array for that time is computed to be 2.7×10^5 Btu (2.85×10^5 kJ). A calculation of the total solar energy incident upon the collectors for the same interval, given by Eq 4 with the values for I and A_C shown, yields 6.3×10^5 Btu (6.65×10^5 kJ). The array efficiency, therefore, was 43 percent. The average value of the fluid parameter for the same time, given by Eq 2 using the tabulated values for the appropriate parameters, is found to be 0.35. This efficiency fluid parameter pair constitutes one point on a graph of the collector array performance.

Figure 18 shows a number of such points which were plotted automatically by the data system as it executed the dynamic analysis subprogram. The figure displays both the unqualified and qualified data points for inspection by the operator. The solid line represents the minimum single collector performance permitted by the solar system specifications, while the dashed line defines the limits of acceptable performance allowed the entire array. Although the qualified data points meet or exceed the values required by the specifications, there is a noticeable drop in the array efficiency at higher values of the fluid parameter where the test qualifications are not met. This example illustrates the need to delete these unqualified points before comparing the measured and specified array performance.

The qualified data from 4 days' worth of dynamic collector tests are summarized in Figure 19. The range in fluid parameters shown resulted from the fact that the static tank test was performed during the night between two of the dynamic collector tests. In this way, the tank temperature on the second day of collector tests was significantly warmer (30°F [16.6°C]) than on the first. This plot clearly reveals that the collector array performance at this site meets or exceeds that stipulated by the system specifications.

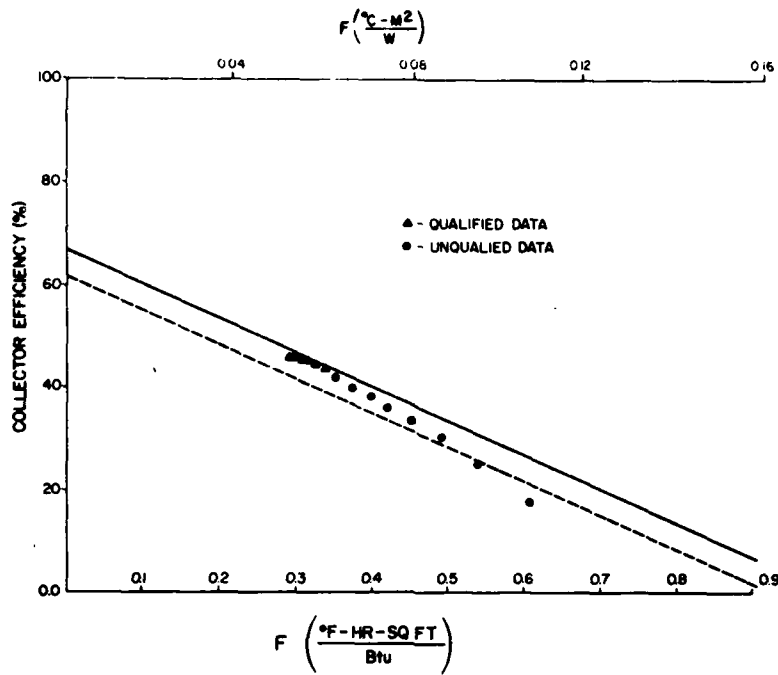

Figure 18. Plot of collector array data for 1 day, showing both "qualified" and "unqualified" points.

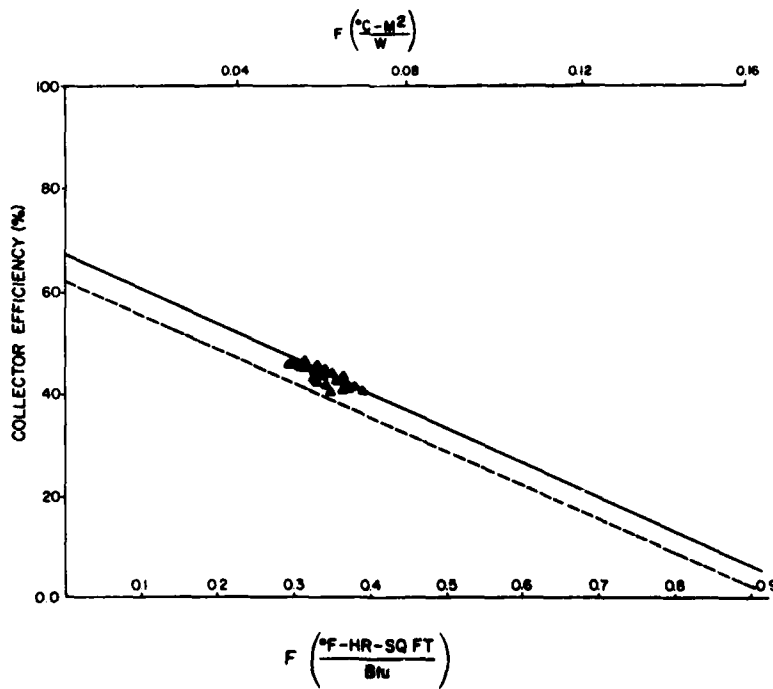

Figure 19. "Qualified" collector array data.

Although there was no indication of a flow imbalance among the individual collectors, measurements with the pistol thermometer were conducted to test the usefulness of this unit. Measurements indicated that the thermometer could easily detect "hot spots" which were produced by a bowing of the collector absorber plate and the resulting contact with the cover glass. It was concluded that the resolution of the thermometer was roughly 2°F (1.1°C), and that the unit would be useful for detecting stagnation in collectors.

The dynamic performance of the heat exchanger was then analyzed. First, the measured and design flowrates were compared on both the tube and shell side of the component. The specified values for these quantities (Table 4) were stated to be 360 gpm ($1.36 \text{ m}^3/\text{min}$) and 326 gpm ($1.23 \text{ m}^3/\text{min}$), respectively. The agreement between these values and the measured ones (401 gpm [$1.52 \text{ m}^3/\text{min}$] and 331 gpm [$1.25 \text{ m}^3/\text{min}$]) is roughly 10 percent.

The heat exchanger effectiveness may also be computed from the data listed in Table 5. For example, if the values of T_{HI} , T_{HO} , T_{SI} , and T_{SO} for the 15-minute interval labeled 11:00 are inserted into Eq 8 and Eq 9 with the appropriate fluid specific heats and densities, an effectiveness of 0.39 is computed for this period. (Many calculations indicated that this result was representative.) This is to be compared with the design value of 0.42 for the component; such agreement is considered acceptable.

The thermal losses at the heat exchanger may be computed from the same data. Once again, for the 15-minute interval of the 11:00 point, the energy delivered to the tube (collector) side of the unit is computed to be 2.77×10^5 Btu (2.92×10^5 kJ). The energy transferred to the tank for the same period is 2.72×10^5 Btu (2.87×10^5 kJ). A heat loss in this amount (roughly 2 percent) was considered entirely acceptable.

The dynamic characteristics of the thermal storage tank may be determined by comparing the average reading of the tank outlet temperature probe to that of the tank average temperature sensor for any 15-minute interval. At the time of the acceptance test's field evaluation, this tank outlet probe did not exist; the heat exchanger's inlet sensor was used in its place. In examining the data of Table 5, it can be seen that the tank outlet temperature, as reflected by T_{SI} , never significantly exceeded (by more than 1°F [0.56°C]) the average tank temperature, T_T . This analysis indicated that the tank conditions are those of a well-mixed tank; that is, no evidence of short-circuit flow was found. Thus, the dynamic performance of the thermal storage was considered acceptable.

To compare the solar energy collected for a given 15-minute interval to the power consumption of the system pumps for the same period, the consumption of these pumps recorded previously was first converted to Btus. The total pumping power, given by the sum of 7.9 kW and 9.1 kW, is equivalent to 5.8×10^4 Btu for a 1-hour collection. For a 15-minute interval, then, the total power consumption of both pumps constitutes approximately 5 percent of the 2.7×10^5 Btu (2.85×10^5 kJ) of collected energy noted previously. In terms of the guidelines generally given for solar design, a parasitic consumption on this order is reasonable.

Table 5

Illustration of the Preliminary Printout of Test Data Obtained During One Day of Measurements at the Field Test (15-Minute Average Values) -- 12/07/79

Building: Albuquerque Reserve Center
 Location: Albuquerque, New Mexico

System Constants: $A_C = 10.127 \text{ ft}^2$; $\rho_C = 8.75 \text{ lb/gal}$; $C_{PC} = .85 \text{ Btu/lb} - \text{OF}$; $\rho_S = 8.33 \text{ lb/gal}$; $C_{PS} = 1.0 \text{ Btu/lb} - \text{OF}$; $W_S = 331 \text{ gpm}$

No. Clock	Fluid Temp - Collector		Fluid Temp - Coll Side		Fluid Temp - Tank Side		Avg Tank Temp T_T (OF)	Air Temp T_A (OF)	Sun I (Btu/Ft ² -Hr)	Wind Dir (deg)	Wind Spd (mph)	Coll. Flow W_C (gpm)	Pump On Time (min)
	TCI (OF)	TCO (OF)	THI (OF)	THO (OF)	In	Out							
1 09:30	129.2	132.7	133.2	129.6	122.8	126.4	121.9	41.4	217.3	0	0	402	15.0
2 09:45	131.2	135.5	136.0	131.6	123.3	128.0	122.3	42.2	230.2	0	0	401	15.0
3 10:00	132.9	137.9	138.4	133.3	124.1	129.4	123.0	43.4	241.1	0	0	402	15.0
4 10:15	134.7	140.2	140.7	135.1	125.0	131.0	123.9	45.4	252.9	0	0	401	15.0
5 10:30	136.6	142.6	143.1	137.0	126.1	132.7	125.0	47.6	264.0	0	0	401	15.0
6 10:45	138.3	144.8	145.3	138.7	127.3	134.3	126.2	47.5	264.7	0	0	401	15.0
7 11:00	139.0	145.0	145.5	139.3	128.5	135.1	127.5	50.4	250.3	0	0	402	15.0
8 11:15	140.6	147.0	147.5	141.0	129.7	136.7	128.7	51.4	270.2	0	0	402	15.0
9 11:30	142.5	149.4	149.9	142.9	131.0	138.5	130.0	52.5	284.0	0	0	401	15.0
10 11:45	144.5	151.6	152.1	144.9	132.2	140.6	131.4	54.2	286.8	0	0	400	15.0
11 12:00	145.6	152.4	152.9	146.0	133.5	141.9	132.7	54.4	269.8	0	0	402	15.0
12 12:15	146.6	153.1	153.7	147.0	134.8	142.9	134.0	52.8	266.2	0	0	401	15.0
13 12:30	147.0	153.1	153.6	147.4	135.9	143.5	135.3	52.6	261.5	0	0	400	15.0
14 12:45	148.3	154.4	155.0	148.7	137.1	144.8	136.4	53.2	267.5	0	0	400	15.0
15 13:00	149.3	155.4	156.0	149.7	138.2	145.9	137.6	53.3	263.1	0	0	401	15.0
16 13:15	150.0	155.9	156.5	150.4	139.4	146.8	138.8	53.1	256.2	0	0	400	15.0
17 13:30	150.5	156.0	156.6	150.9	140.4	147.4	139.8	53.6	247.5	0	0	402	15.0
18 13:45	150.8	165.0	156.5	151.2	141.4	147.9	140.9	54.1	239.8	0	0	401	15.0
19 14:00	151.2	155.9	156.5	151.6	142.4	148.4	141.9	54.5	231.1	0	0	401	15.0
20 14:15	150.8	154.9	155.4	151.2	143.1	148.3	142.6	54.9	199.2	0	0	401	15.0
21 14:30	149.8	152.8	153.3	150.2	143.8	147.6	143.2	55.2	188.3	0	0	401	15.0
22 14:45	150.2	153.3	153.8	150.6	144.2	148.1	143.7	56.0	191.4	0	0	401	15.0
23 15:00	149.4	151.5	152.0	149.7	144.7	147.5	144.1	56.0	146.2	0	0	401	15.0
24 15:15	147.6	148.6	149.2	148.0	144.9	145.6	144.3	55.2	126.4	0	0	244	9.1

The final task in the dynamic phase of the acceptance test field evaluation involved an attempt to estimate the system's line losses. Referring to the data of Table 5 it is seen that, for the time labeled 11:00, the measured collector outlet temperature of 145°F (62.8°C) was less than the measured inlet temperature, 145.5°F (63°C), at the collector side of the system heat exchanger. This behavior is reflected in other places in Table 5. While this result is attributed to a slight probe mismatch between the two sensors reporting these temperatures, the conclusion was that, to within the accuracy of the determination, the system's line losses were negligible.

Static Test Results

A static test of the tank was performed overnight between the fourth and fifth days of the field evaluation. After manually disabling all pumps which could deliver energy to -- or withdraw it from -- the storage vessel, CERL executed the subprogram for acquiring the static test data.

The results are depicted in Figure 20, which shows a linear decay of tank temperature for the 13 hours of the test. The straight line represents a linear least squares fit to the measured data points. With an initial average tank temperature of 132.2°F (55.7°C), the rate of temperature decay was calculated to be -0.97°F/day (-0.54°C).

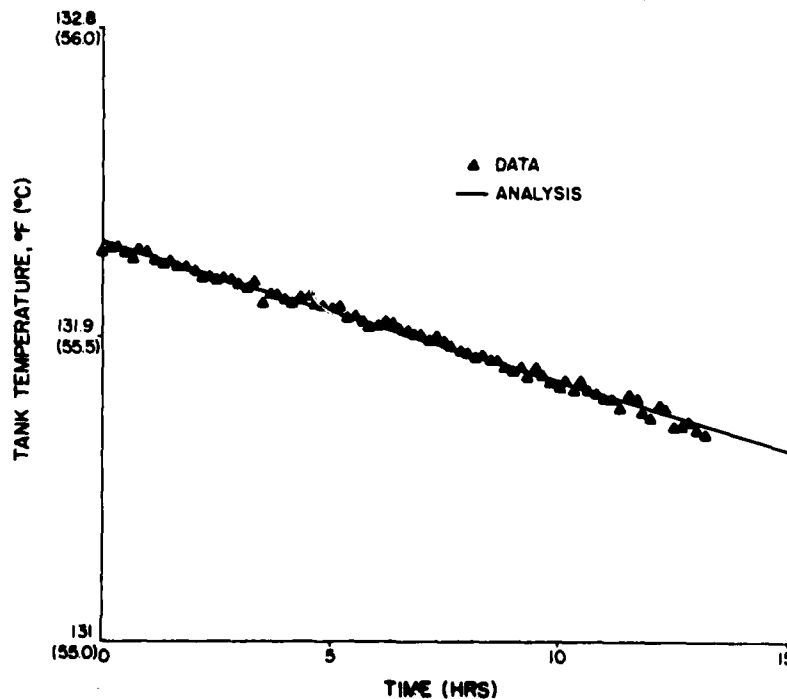

Figure 20. Decay in the storage tank temperature with time.

Before the time constant of the storage vessel can be calculated (Eq 14), a value must be assigned to the temperature of the surrounding medium. In the case of the underground tank at the site of the field evaluation, this quantity could not be measured directly because the storage vessel was under a paved parking lot. Consequently, a ground temperature of 54°F (12.2°C), calculated using the procedure given in Appendix B, was assumed for the results which follow. A value of roughly 1900 hours was then computed for the tank time constant.

With appropriate values inserted for the parameter of Eq 15, a calculation of the measured "R-value" of the tank insulation was then performed. The R-13 which resulted is to be compared to the R-25 calculated from the system specifications. Potential sources for this discrepancy have already been discussed in Chapter 2. First, the "specified" value of R-25 was taken from an ASHRAE table for urethane measured at 50°F (10°C). The tank test, however, was conducted at 132°F (55.5°C). Since the thermal insulating properties of common materials vary with temperature, a discrepancy between the calculated and measured values should be expected because of the different temperatures involved in the comparison. Second, urethane foam is available in many densities, each with different insulating properties. The lack of precise information on the composition of the tank insulation at the site led to an uncertainty about the R-value to be expected.

After considering these factors, CERL re-examined the tank's static performance to determine the reasonableness of the thermal losses that were measured. The Sheet Metal and Air Conditioning Contractor's National Association (SMACNA) has developed a stringent standard which defines the maximum loss to be tolerated from an insulated storage vessel.¹⁶ According to this standard, any loss in excess of 2 percent of the tank's thermal capacity over 12 hours is considered unacceptable. The thermal capacity of the tank at the site of the field evaluation is given by the amount of energy required to heat 20,000 gal (75.685 m³) of water from 50°F (10°C) (groundwater temperature) to 220°F (160°C) (the maximum allowable design temperature). The measured rate of tank temperature decay, roughly 1°F/day (0.6°C), corresponds to a loss of only 3 percent of this value in a 12-hour period. Therefore, it was concluded that this tank was performing acceptably.

A final task performed during the static test involved verifying that no thermosiphoning of fluid was occurring while the collector and storage pumps were off. The two system flow rates were sampled on several occasions while the tank temperature was decaying. No evidence of thermosiphoning was found.

With the completion of this final task of the static test phase, the field evaluation of the solar acceptance test concept and hardware was concluded. The results of the field evaluation are summarized in the following chapter. Modifications to the test procedures and instrumentation package are also suggested.

¹⁶Heating and Air Conditioning Systems Installation Standards for One and Two Family Dwellings and Multifamily Housing Including Solar (Sheet Metal and Air Conditioning Contractor's National Association [SMACNA], 1977).

6 INCORPORATION OF THE RESULTS OF THE FIELD EVALUATION

While the solar system at the site of the acceptance test's field evaluation performed to design specifications, a number of important findings were recorded during the test. These findings are described in the two sections which follow. The first of these summarizes the results of the solar system component tests. In addition, possible simplifications of the acceptance test procedure are described. The second section reviews the problems which were experienced with the test hardware; an alternate approach to the solar system instrumentation is suggested.

Summary of the Test Results

A number of the component test results are summarized in Table 6. The table indicates that the agreement between measured and specified values of the parameter is generally excellent. The discrepancy which appears between the columns corresponding to the R-value of the tank insulation has already been discussed (p 62); it was attributed to an incomplete knowledge of the properties of the insulation rather than to poor behavior on the part of the tank itself. In addition to the agreement documented by Table 6, the collector array's performance at the site of the field evaluation clearly met or exceeded that stipulated by the system specifications. Furthermore, the system's controls operated properly, and the tank dynamic behavior was found entirely satisfactory.

Two major observations can be made from these results. Assuming that the acceptance test is performed with functioning electronics, a completion of this field evaluation has demonstrated that:

Table 6
Component Test Results

<u>Parameter</u>	<u>Symbol</u>	<u>Specification</u>	<u>Measured Value</u>
Collector Fluid Concentration	--	40 percent	47 percent
Collector Fluid Specific Heat	C_{PC}	--	0.85 Btu/lb m °F (4.2 kJ/kg°C)
Collector Fluid Density	C	--	8.76 lb m/gal (1050 kJ/m ³)
Collector Array Area	A_C	10,115 sq ft (939.7 m ²)	10,127 sq ft (940.8 m ²)
Heat Exchanger Effectiveness		0.42	0.39
Heat Exchanger Efficiency		1.0	0.98
Tank R-value	R	"25"	13
Parasitic Pump Power (%)	--	--	0.05

1. A short-duration test can determine whether a newly installed solar energy system is performing to design specifications.

2. The specific test procedures which had been defined for determining the thermal performance of the components in a representative solar system are workable in the field. In particular, the collector, heat exchanger, and tank tests yielded quantitative and reproducible results.

In addition to these observations, three issues regarding the evaluation of a solar system's thermal performance arose:

Determining the Collector Array's Efficiency

The thermal losses of the solar heat exchanger and the system piping were found to be only a small fraction of the energy transferred from the collector array to the storage tank. This suggests that, with little sacrifice in accuracy, the collector array's efficiency can be determined on the tank side rather than the collector side of the heat exchanger.

The benefits to be realized from such a modification are three-fold. First, the number of sensors required for evaluating the system's performance is reduced. Specifically, the temperature probes at the outlet of the collector array (T_{CO}) and at the outlet of the collector side of the heat exchanger (T_{HO}) could be eliminated. The array inlet temperature (T_{CI}) must still be measured since it is used in calculating the collector fluid parameter. Also, the remaining heat exchanger temperatures must be known to allow computation of the exchanger's effectiveness and of the solar energy collected.

Second, if this change were adopted, the stringent accuracy requirements on the determination of the collector loop flow rate (W_C) may be relaxed considerably. Since the solar energy collected is now measured on the other side of the system's heat exchanger, a ± 20 percent determination of the collector flow would be enough to compare with the design value of this quantity. Such a determination could be made easily by measuring the pressure drop at the collector pump and computing the flow rate from the pump curve.

Third, this new approach is advantageous because calculation of the collector array's energy harvest would be based on the temperature rise of water rather than a water-glycol mixture. Given that this calculation requires a knowledge of the specific heat and density of the circulating fluid, and that these quantities are well known for water, the accuracy of the computed energy collection would be increased.

There appear to be no disadvantages in incorporating this modified procedure for checking the collector array's efficiency. Enough information is still available for computing the collector's energy harvest and fluid parameter, and for estimating the heat exchange effectiveness. If a significant discrepancy is found between the measured and expected array performance, possible sources of collector flow imbalance or system thermal losses can be investigated as before.

Measuring Average Tank Temperature

The dynamic aspect of the tank behavior was conveniently and accurately determined by comparing the tank outlet and average temperatures when the storage pump was in operation. Furthermore, an analysis of the tank's static behavior was meaningful -- provided that average tank temperature was measured. However, at the site of the field evaluation, the storage vessel was pressurized; this made it difficult to insert a temperature averaging probe at the time of the test. The process of solar system acceptance would be simplified if the specifications of all future Army solar projects required an average tank temperature sensor to be installed at the time of building construction. (This requirement is realistic for tanks with volumes greater than 500 gal [1892 L]).

Calculating Ground Temperature

One problem in determining the tank static performance was that the vessel was beneath a paved parking lot. This made it difficult to measure the ground temperature near the tank. It is therefore advised that, for future solar acceptance tests, this quantity be calculated by the procedure explained in Appendix B. Given that the static test is performed to identify serious problems with tank heat loss, CERL believes that a test based on a computed ground temperature would be accurate enough for test purposes, particularly when applied to tanks with temperatures above 150°F (65.5°C).

Determining the tank's expected static behavior was also complicated because the design R-value of the tank's insulation was inferred from the building specifications. For future solar designs, therefore, this R-value should be explicitly stated in the system's specifications. Such a statement would make the solar acceptance test easier to perform.

These factors notwithstanding, very little scatter was seen in the data which reflected the decay in the tank temperature with time. This fact suggests that a sophisticated, microprocessor-based data acquisition system is not required for the tank static test. Rather, the output of the tank's average temperature sensor could be displayed on a direct reading dial, and the rate of the tank temperature decay determined by a manual plot of the storage temperature with time. When combined with the knowledge of a calculated ground temperature (or measured air temperature for above-ground tanks), the static performance of this component could easily be estimated by hand.

Review of Equipment-Related Problems

Chapter 3 explained that the instrumentation package for performing the solar acceptance test had to be accurate and portable. Problems were encountered during the field evaluation with the accurate, nondisruptive measurement of both fluid temperature and fluid mass flow rate. The problem with the clamp-on flowmeter has already been described (p 55). While it is clear that this unit could be made to function properly, anything short of total reliability would be unacceptable for this short duration test. The performance of the contact temperature sensors has also been discussed, and is considered unsatisfactory as well (p 56). The question now becomes: what means for measuring system temperatures and flow rate are most realistic?

During the field evaluation, it became clear that the agreement between the four-wire platinum probes and simple mercury-in-glass thermometer was always better than 1°F (0.6°C). In view of this, the component test procedures were examined to see which temperature measurements could be performed with the mercury thermometers. The conclusion was that, with the exception of the average tank temperature and the inlet and outlet temperatures on the tank side of the heat exchanger, all readings could be taken manually. Since this type of thermometer is available with 0.5°F (0.28°C) resolution, there would be no sacrifice in the accuracy of the temperature measurement. While these sensors are not nonintrusive, installing them during building construction would not have a significant impact on the solar system costs.

A mercury thermometer is not suitable for measuring the average tank temperature. However, either a pneumatic or electronic sensor directly readable to 1°F (0.6°C) could be required by the system specifications. (As noted previously, this probe is to be installed at the time of building construction.) Many of these sensors are commercially available, and their cost is not excessive.

While readings of the inlet and outlet temperatures on the tank side of the heat exchanger could, in theory, be taken visually, the method is not advised for practical reasons. These quantities must be known for calculating the solar energy collected. To compute this energy according to the prescribed procedure, the difference between these outlet and inlet temperatures must be multiplied by the storage loop capacity rate ($\rho_s C_p s W_s$), and this product integrated over a 15-minute interval. This integral would be difficult to perform by hand. In fact, it was for this computation that the capabilities of the microprocessor-based data acquisition system were fully used in the original concept of the acceptance test instrumentation package.

This concept must now be re-examined:

A device for integrating a flow-temperature difference product is commercially available. Known as a Btu-meter, this instrument could be used for computing, totaling, and displaying the solar energy collected for any number of 15-minute intervals. Such a meter would be used as follows: the collection of solar energy at the candidate system would be initiated by the system controls, and the components allowed to equilibrate thermally. Readings of the Btu-meter would be logged at the beginning and end of the same 15-minute interval for which the solar radiation was integrated. This would allow a computation of the collector array's efficiency for that interval. The collector fluid parameter could be estimated by noting the collector's inlet and site ambient temperatures during the same period. Once it had been confirmed that this efficiency-fluid parameter point was qualified, a number of these points could be plotted as representative of the array's thermal performance. While the accuracy and reliability of these units have not yet been verified in a laboratory environment, the specifications of several of these indicate that they would be accurate enough for monitoring the collector array's performance. Furthermore, incorporating a Btu-meter into the acceptance test's instrumentation package would eliminate the need for a sophisticated data system to perform this function.

As mentioned earlier (p56), the agreement between mercury thermometers and calibrated four-wire platinum probes was excellent. This finding would

suggest that many of the component tests which were performed automatically by the data acquisition system during the field evaluation could readily be done by hand. In particular, the heat exchanger's effectiveness could be estimated by computing the appropriate ratios of temperatures measured with simple indicating thermometers. The dynamic aspect of the tank's behavior could be assessed by a manual comparison of the tank outd average tank temperatures when the storage pump is operating. The static performance of this component could be evaluated from a manual plot of the decay in average tank temperature with time while the storage pump is off. All of these measurements would be accurate enough for the purpose of a solar system acceptance test. Furthermore, if these tests were performed manually, the need for a separate data system would be further reduced.

Given these points, three advantages of a manual solar acceptance test based on mercury thermometers, a tank average temperature probe, and a Btu-meter are readily apparent:

1. Such a manual test could be more easily performed by a contractor or his representative since it would not require an understanding of the operation and programming of a complex data system. Furthermore, if this test were performed by the solar contractor, a team of Army personnel would not have to be maintained to perform solar energy system acceptance tests.

2. The cost of equipment required by the test is reduced substantially. About \$50,000 was spent for the entire instrumentation package described in Chapter 3. The price of a Btu-meter and several accurate thermometers is significantly less than this amount. It is estimated that a Btu-meter, if installed during building construction, could be put in place for \$1500. The installed cost of a mercury thermometer is roughly \$200.

The savings in labor costs are more difficult to assess. It cannot be denied that the manual approach to the system acceptance would require more hand calculations than does the automated one. In either case, however, the test would take about 1 week to perform, so it is not clear what the exact differences in labor costs between the two methods would be.

3. An added benefit from the new approach to the test is that the Btu-meter would be left in the system after the acceptance test had been completed. It would therefore continue to report on the solar energy collected for years to come. This information would be invaluable for system maintenance.

While the instrumentation described above is neither portable nor non-intrusive, CERL believes that incorporating a Btu-meter would facilitate monitoring of solar system performance. A number of commercially available Btu-meters could be evaluated in the laboratory and their suitability for this purpose established. Once developed, such a short-duration test would allow a quantitative determination of whether a newly installed solar system is performing as designed.

7 CONCLUSIONS

This report has described the development and field evaluation of an instrumentation package and short-duration procedure for testing whether newly installed solar energy systems are performing to design specifications.

The results of the field evaluation showed that the acceptance test concept can be usefully applied to solar energy systems. The results indicate that quantitative measurements of solar system components can be used to detect construction deficiencies and thus prevent many of the problems commonly reported for solar energy systems.

In addition, the field evaluation revealed the potential for performing an acceptance test with simple, low-cost meters installed at the time of building construction. In comparison with the sophisticated hardware used for the field evaluation, the metering approach has the advantages of (a) lower hardware cost, (b) lowered skill requirements for the test operator, (c) ease of inclusion in building specifications by the designer, and (d) provisions for continued use during the subsequent operation and maintenance of the solar energy system. To realize these savings, a meter which can accurately measure energy transfer -- a Btu-meter -- is required. The viability of using Btu-meters for measurements in solar energy systems is currently under investigation.

REFERENCES

- ASHRAE Standard 93-77, Methods of Testing to Determine the Thermal Performance of Solar Collectors (American Society of Heating, Refrigerating, and Air-Conditioning Engineers [ASHRAE], 1978).
- Baker, H., E. Ryder, and N. Baker, Temperature Measurement in Engineering, Vol 2 (John Wiley & Sons, 1961), pp 4, 20.
- Beckman, W. A., S. A. Klein, and J. A. Duffie, Solar Heating Design by the F-Chart Method (John Wiley and Sons, Inc., 1977).
- Cash, Mitchell, "Learning from Experience," Solar Age, Vol 3, No. 11 (November 1978), pp 14-19, 32.
- Durlak, E. R., Solar Heating of Buildings and Domestic Hot Water, Technical Report 877 (Naval Civil Engineering Laboratory [NCEL], 1980).
- Easterly, James, "Engineering Concerns in Solar System Design and Operation," Solar Age, Vol 4, No. 10 (October 1979), pp 56-61.
- Eden, A., and J. Tinsley, Third Interim Technical Report on USAFA Solar Test House -- Design Parameters, CEEDO-TR-78-32 (Civil and Environmental Engineering Development Office, September 1978), pp 4.1-4.4.
- Encyclopedia of Engineering Materials & Processes, H. R. Clauser, ed. (Reinhold, 1963), pp 697-699.
- The Final Proceedings of the Second Solar Heating and Cooling Commercial Demonstration Program Contractors' Review, DOE/CS/4131-1, Vol 1, Report to the U.S. Department of Energy (U.S. Department of Energy, 1979).
- Handbook and Product Directory: 1977 Fundamentals (ASHRAE, 1977).
- Heating and Air Conditioning Systems Installation Standards for One and Two Family Dwellings and Multifamily Housing Including Solar (Sheet Metal and Air Conditioning Contractor's National Association [SMACNA], 1977).
- "Heat Transfer and Fluid Flow," General Electric Data Book, Section 515.24 (April 1978), p 5.
- Hill, J. S., and T. Kusuda, Methods of Testing for Rating Solar Collectors Based on Thermal Performance, NBSIR 74-635 (National Bureau of Standards, 1974).
- Joncich, D. M., D. J. Leverenz, D. C. Hittle, and G. N. Walton, Design of Solar Heating and Cooling Systems, Technical Report E-139/ADA062719 (U.S. Army Construction Engineering Research Laboratory [CERL], 1978).
- Joncich, D. M., D. J. Leverenz, and D. L. Johnson, The Performance of an Experimental Solar Heating System, Interim Report E-144/ADA066699 (CERL, 1979).

Krieth, F., and J. Kreider, Principles of Solar Engineering (Hemisphere Publishing Corp., 1978).

Labs, Kenneth, "Underground Building Climate," Solar Age, Vol 4, No. 10 (October 1979), pp 44-50.

Schwolsky, Rick, "Solar Aid -- Rx for Installers," Solar Age, Vol 3, No. 5 (May 1978), pp 8, 42.

"Sensor Hookup Cables Demand Attention," Solar Age, Vol 14, No. 5 (May 1979), pp 50-51 (prepared from Field Service Bulletins issued by the Solar Division of Hawthorne Industries).

"Solar System Heat Losses," Solar Engineer, Vol 4, No. 7 (July 1979), pp 17-20.

Streed, E., M. McCabe, D. Waksman, J. Hebrank, and T. Richtmyer, Thermal Data Requirements and Performance Evaluation Procedures for the National Solar Heating and Cooling Demonstration Program, NBSIR 76-1137 (National Bureau of Standards, August 1976), pp 64, 76.

APPENDIX A:

TEST PROCEDURES FOR ELECTRICAL CONTROLS OF SOLAR ENERGY SYSTEMS

A satisfactory performance of the electrical controls is vital to the successful operation of a solar energy system. Some components of the electrical controls can perform acceptably for conventional systems but can fail when used in a solar energy system because of the more rigorous requirements imposed by these systems. Because of the wide temperature range used for both sensors, it is quite possible that a solar energy system will fail to operate properly at temperatures within a certain range, even though it operates satisfactorily at temperatures in a different range. Consequently, it is essential to check the operation of the electrical controls over the entire operating range specified for the system. Although it is not reasonable to expect the solar system to experience the entire temperature range during a test of short duration, a procedure for the electrical controls can simulate operation over this temperature range. This principle is used in the two testing techniques discussed below. The first technique tests both the controller and the sensors; it is most readily performed before installation of these components. The second technique tests only a controller which was designed for resistive sensors and can be performed at any time.

Simulation Test for Both the Controller and Sensors

A procedure for testing the electrical controls has been published by Rick Schwolsky, and it was recommended that contractors perform this test before installation of the components.¹⁷ As discussed in Chapter 2, it is extremely difficult to distinguish between problems caused by an installation defect and those caused by a defective component. Consequently, these components should be tested before installation so that any problems that occur will not be erroneously attributed to a defect in a component purchased from a manufacturer. Although the test was devised to be performed by a contractor, this test can be done by other personnel at the site, provided that the control components can be obtained before installation. Accordingly, a test procedure which follows Schwolsky's is given below. If the contractor has not performed this test (or its equivalent) on the electrical controls, it should be done by available personnel.

The test is to be performed at a workbench with the arrangement shown in Figure A1. The test equipment consists of two containers of water, two indicating thermometers, a lamp, and an immersion heater. One of these containers should be labeled "TANK," and the other one "COLLECTOR." The sensor which will be used in the tank should be placed in the container labeled "TANK," and the sensor to be used in the collector should be placed in the container labeled "COLLECTOR." The lamp is to be used as if it were the pump and is to be wired to the controller following the instructions of the manufacturer. The controller can then be connected to an electrical outlet and turned on.

¹⁷Rick Schwolsky, "Solar Aid -- Rx for Installers," Solar Age, Vol 3, No. 5 (May 1978), pp 8, 42.

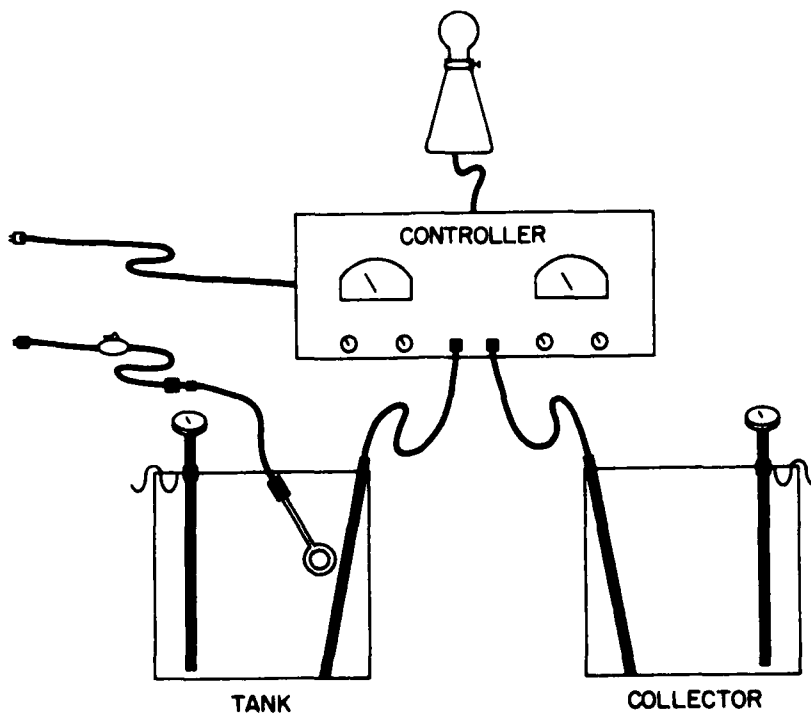

Figure A1. Arrangement for testing the controller and sensors before their installation.

The temperatures of the two containers are to be varied in a manner which simulates the temperature range specified for the performance of those components in the solar energy system. Three or more temperatures in this operating range should be chosen to test the controls. These points should include the lowest, middle, and highest temperatures of that operating range. Table A1 lists some representative values for test temperatures and can be used as a guide in selecting these temperatures. The immersion heater, connected to an extension cord equipped with an on/off switch, is to be used to heat the two liquids to the desired test temperatures.

The following steps can then be performed to measure the control points at each of the selected test temperatures. (It is most convenient to start at the lowest temperature and then repeat the steps for successively higher test temperatures.)

1. Heat the TANK liquid: the immersion heater should be placed in the container marked "TANK" and used to heat the TANK liquid to within 5°F (2.8°C) of the desired test temperature. The immersion heater should then be turned off and the temperature reading noted. This liquid must be stirred before reliable temperature measurements can be obtained.

After reaching the test temperature, the lamp should be "off" since this condition corresponds to a hot tank and a cold collector. If it is not, the wiring in the arrangement should be checked for a defect.

Table A1

Representative Values of the Test Temperatures at Which the Controls Should Be Checked

Type of Solar System	Test Temperatures		
	Low	Middle	High
Domestic Hot Water (DHW) only	70 ^o F (21 ^o C)	110 ^o F (43 ^o C)	150 ^o F (65 ^o C)
Space Heating and DHW	80 ^o F (27 ^o C)	130 ^o F (54 ^o C)	180 ^o F (82 ^o C)
Space Cooling, Space Heating, and DHW	100 ^o F (38 ^o C)	150 ^o F (65 ^o C)	200 ^o F (93 ^o C)

2. Heat the COLLECTOR liquid: place the immersion heater in the container marked "COLLECTOR" and heat this liquid to a temperature just below the temperature noted for the TANK liquid (say, 5^oF [2.8^oC]). This liquid should be stirred to ensure that the temperature reading of the indicating thermometer corresponds to that experienced by the controller sensor.

The TANK liquid should be stirred again and a final value of its temperature recorded. The lamp should have remained off during this period if the unit is functioning properly.

3. Measure the high control point: by turning the immersion heater on for short intervals, slowly heat the COLLECTOR liquid above the temperature of the TANK. During this interval, the COLLECTOR liquid should be continuously stirred and the lamp should be observed. When the lamp is fully turned on, the COLLECTOR temperature should be recorded and the TANK temperature rechecked without delay (TANK liquid must be stirred first). This TANK temperature is then subtracted from the COLLECTOR temperature and the resulting difference recorded as the high control point for this test temperature.

Note that a variable-speed controller should begin supplying a fraction of full power to the lamp as soon as the COLLECTOR temperature is slightly greater than the TANK temperature; a dim glow from the lamp should be seen. As the temperature of the COLLECTOR liquid is raised to the high control point, the lamp should become brighter until the full power level is reached.

4. Measure the low control point: transfer the immersion heater to the TANK liquid and heat this liquid slowly by turning the heater on for short intervals. During this time, the TANK liquid should be continuously stirred

and the lamp observed. When the lamp goes out, the TANK temperature should be recorded and the COLLECTOR temperature rechecked without delay (TANK liquid must be stirred first). This TANK temperature can then be subtracted from the COLLECTOR temperature and the resulting difference recorded as the low control point for this test temperature.

The values for the low and high control points at each test temperature should then be compared to those contained in the specifications. Values within 20 percent of those specified would be considered acceptable. The designation of a fractional tolerance for this comparison leads to more stringent requirements for designs which call for low values of the control points; however, this is in accordance with the need for more stringent requirements for such small values.

Note that the above test was not concerned with any comparison of the absolute values of temperatures between the indicating thermometers and the controller sensors; a satisfactory performance in the above test is all that is needed to demonstrate that the electrical controls are working properly. In the event the test indicates an unsatisfactory performance, however, such a comparison can be useful in revealing a defective component or the need for an adjustment of the controller. Some controllers are equipped with displays which indicate the temperatures of the sensors. The manufacturer's literature should be consulted for an interpretation of these symptoms which should be in the form of a troubleshooting guide. In addition, variable resistors can be substituted for the sensors in the above arrangement and used to test for a defect in the controller, provided (1) that this controller uses resistive sensors and (2) that the resistance versus temperature of the sensors is given by the manufacturer. It is particularly advantageous to use these variable resistors if any adjustments of the controller are attempted. The above test will have to be repeated if such an adjustment is attempted.

Simulation Test for the Controller

During the installation of some solar energy systems, the contractor may not have done the test discussed in the preceding section, and it may not have been possible for other personnel to obtain the components before installation. In such cases, it is recommended that at least the controller's performance be checked over the entire range of operating temperatures. The test described in this section can be performed if (1) the controller is designed for resistive sensors, and (2) the resistance of the sensors versus temperature can be obtained from the manufacturer.

The arrangement of the components for this test is shown in Figure A2. The controller can be wired to the pumps or to a lamp in this test. The wiring from the tank sensor is to be disconnected at the controller, and wiring from those connections on the controller extended to the resistor marked "TANK." Similarly, the collector sensor should be disconnected and a variable resistor marked "COLLECTOR" substituted for it.

Three or more test points are to be selected as discussed in the preceding section. The following steps, similar to those in the preceding section, can then be performed to measure the low and high control points at each of the selected test temperatures.

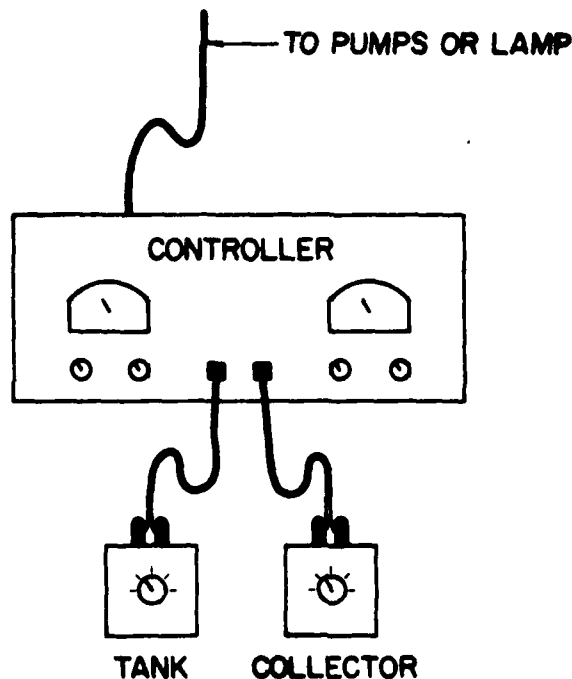

Figure A2. Arrangement for the simulation test of the controller.

1. Fix the TANK Temperature: the TANK resistor should be set to correspond to the selected test temperature. This can be done as follows: (a) consult the manufacturer's literature and obtain the value of the sensor resistance which corresponds to the desired temperature; (b) adjust the setting of the variable resistor to this value.

2. Vary COLLECTOR Resistor: the COLLECTOR resistor should then be set at a value corresponding to a temperature much colder than the tank (say, 20°F [11°C] lower). The pumps or lamp should not be on when this adjustment has been completed. The resistor should then be varied in the direction corresponding to an increasing temperature. When the pumps or lamp are turned on by the controller, the resistance value of the COLLECTOR resistor should be recorded and the manufacturer's table used to convert the value into the corresponding temperature.

The temperature corresponding to the TANK resistor can then be subtracted from the value of the temperature found for the COLLECTOR resistor and the resulting difference recorded as the high control point.

3. Fix COLLECTOR Temperature: the COLLECTOR resistor should be set at a value which corresponds to a temperature sufficiently higher than the TANK so that the pumps or lamp will remain on. This value can be the last value recorded in step 2, or one which corresponds to the closest "even" value of temperature as indicated by the manufacturer's table.

4. Vary TANK Temperature: the TANK resistor can now be varied in a manner corresponding to an increasing temperature. As this value approaches the value of the COLLECTOR resistor, the controller should turn off the pumps or lamp. The value at which this occurred should be recorded and converted into a temperature with the manufacturer's data.

The temperature corresponding to this TANK value should be subtracted from the temperature value used to set the COLLECTOR resistor, and the resulting difference recorded as the low control point.

The values measured for the low and high control points at each test temperature should then be compared to those contained in the specifications. Values within 20 percent of those specified would be considered acceptable.

APPENDIX B:

CALCULATION OF THE GROUND TEMPERATURE
FOR SYSTEMS WITH BELOW-GROUND TANKS

In the evaluation of the storage tank's ability to retain thermal energy, the temperature of the surrounding medium is required. For solar systems which have the tank located below ground level, a measurement to obtain this temperature value may be difficult. Consequently, provisions for calculating this value have been included in the acceptance test. The procedure follows that which was published by Kenneth Labs, who indicated that the temperature of the ground could be calculated with the following formulas.¹⁸

$$T(x,t) = T_M - A_S e^{-x} [\pi/365]^{1/2} \cos \quad [\text{Eq B-1}]$$

$$= \frac{2\pi}{365} (t-t_0 - \frac{x}{2} [\frac{365}{\pi}]^{1/2}) \quad [\text{Eq B-2}]$$

where

$T(x,t)$ = temperature, in degrees Fahrenheit, at depth x , on day t

x = depth below ground, in feet

t = day of the year

T_M = mean annual ground temperature, in degrees Fahrenheit

A_S = annual temperature amplitude at the surface, in degrees Fahrenheit

t_0 = day of minimum surface temperature

α = thermal diffusivity of the soil, in sq ft/day.

These values can be obtained as follows:

1. Calculate average depth: as illustrated in Figure B1, the average depth of the tank is obtained by adding the thickness of the layer of dirt on top of the tank, d , to one half the height of the tank, h . This calculation is indicated in Eq B3.

$$x = d + 1/2(h) \quad [\text{Eq B-3}]$$

The values of h and d can be obtained from the drawings of the tank installation contained in the specification.

¹⁸Kenneth Labs, "Underground Building Climate," Solar Age, Vol 4, No. 10 (October 1979), pp 44-50.

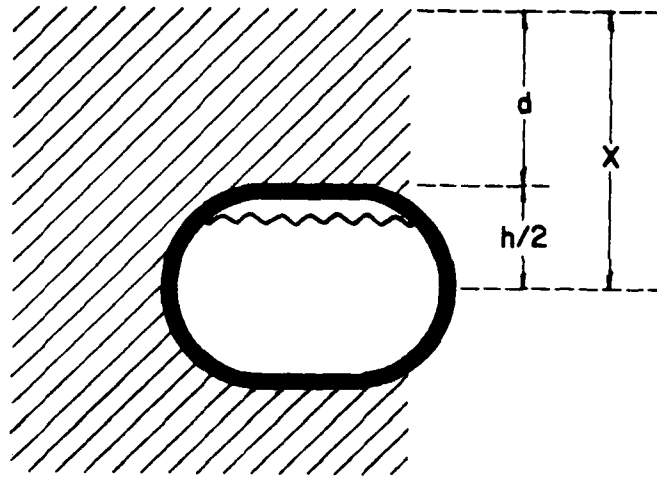

Figure B1. Calculation of the average depth of the tank.

2. Determine the mean annual ground temperature: this value can be obtained with the aid of Figure B2. This figure contains a map of the continental United States with numbered lines superimposed upon it. The number next to each line is the value of the mean annual ground temperature (T_M) for the area of the state through which that line passes.

As an example, consider the location of a solar energy system in the State of Florida. If the system were in the southern part of the state, the value of 77 would be used for T_M .

3. Select a value of the annual temperature amplitude: this value can be obtained with the aid of Figure B3. The procedure is identical to that used in Step 2.

4. Select a value for the thermal diffusivity of the soil: this value can be obtained with the aid of Table B1. The table contains values of the thermal diffusivity for various types of soil. The user should consult the Boring Logs in the specifications and select a value from Table B1 for the soil type which most closely matches the soil at the construction site.

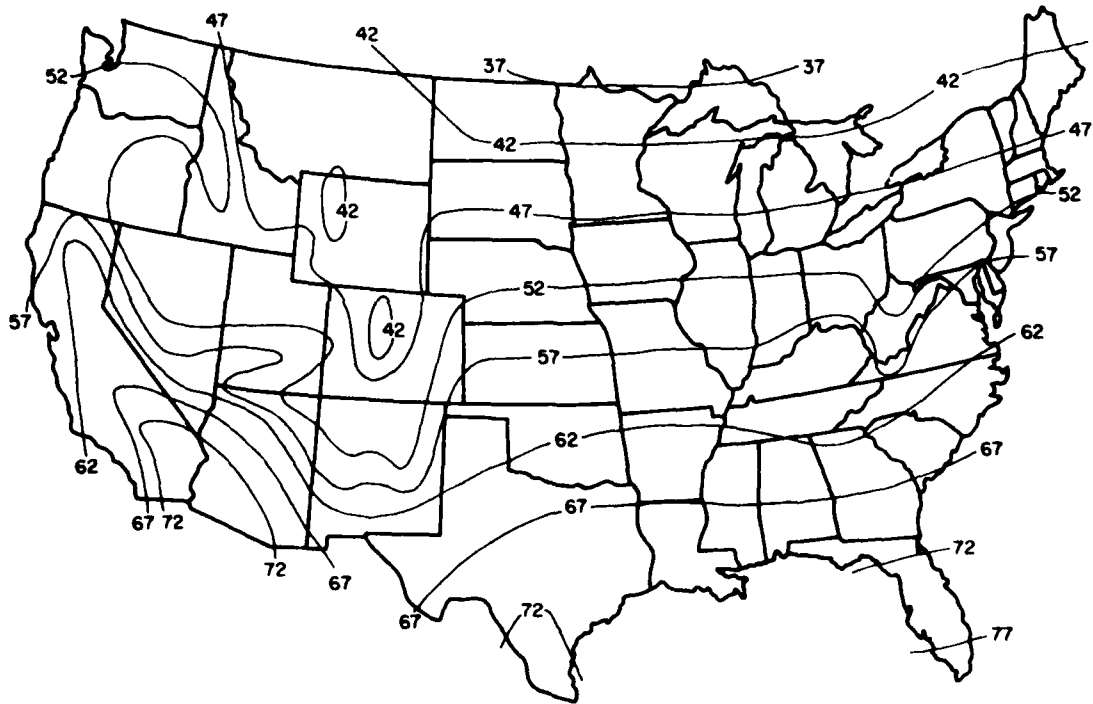

Figure B2. Mean annual ground temperature (units of degrees Fahrenheit).

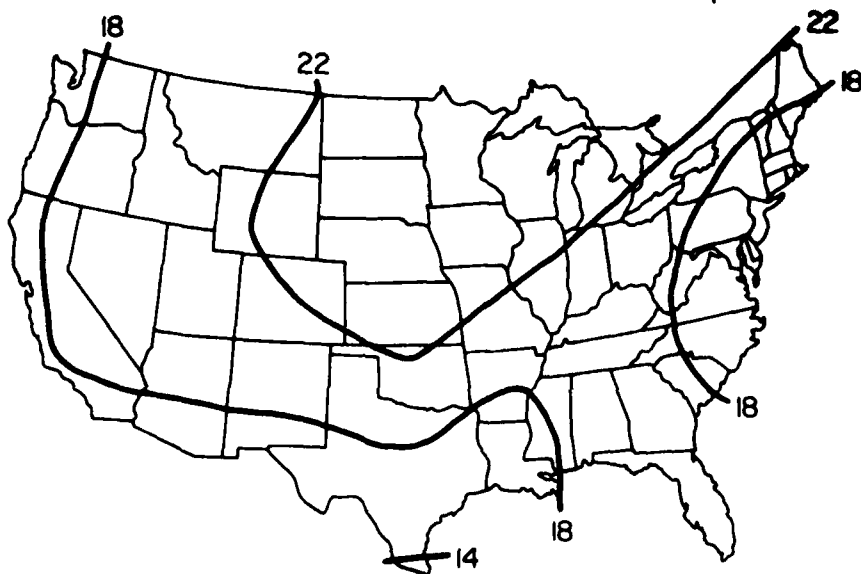

Figure B3. Annual temperature amplitude at the surface (units of degrees Fahrenheit).

Table B1

Values of the Thermal Diffusivity
for Various Types of Soil

Description of Soil	Thermal Diffusivity 10^{-2} sq ft/day (m^2/hr)
Wet Soil	96 (0.372)
Average Rock	96 (0.372)
Heavy Soil, Damp	60 (0.232)
Heavy Soil, Dry	48 (0.186)
Light Soil, Damp	48 (0.186)
Light Soil, Dry	26 (0.101)

CERL DISTRIBUTION

Chief of Engineers
 ATTN: Tech Monitor
 ATTN: DAEN-ASI-L (2)
 ATTN: DAEN-CCP
 ATTN: DAEN-CW
 ATTN: DAEN-CWE
 ATTN: DAEN-CWM-R
 ATTN: DAEN-CWO
 ATTN: DAEN-CWP
 ATTN: DAEN-MP
 ATTN: DAEN-MPC
 ATTN: DAEN-MPE
 ATTN: DAEN-MPO
 ATTN: DAEN-MPR-A
 ATTN: DAEN-RD
 ATTN: DAEN-RDC
 ATTN: DAEN-RDM
 ATTN: DAEN-RH
 ATTN: DAEN-ZC
 ATTN: DAEN-ZCE
 ATTN: DAEN-ZCI
 ATTN: DAEN-ZCM

US Army Engineer Districts
 ATTN: Library

Alaska
 Al Batin
 Albuquerque
 Baltimore
 Buffalo
 Charleston
 Chicago
 Detroit
 Far East
 Fort Worth
 Galveston
 Huntington
 Jacksonville
 Japan
 Kansas City
 Little Rock
 Los Angeles
 Louisville
 Memphis
 Mobile
 Nashville
 New Orleans
 New York
 Norfolk
 Omaha
 Philadelphia
 Pittsburgh
 Portland
 Riyadh
 Rock Island
 Sacramento
 San Francisco
 Savannah
 Seattle
 St. Louis
 St. Paul
 Tulsa
 Vicksburg
 Walla Walla
 Wilmington

US Army Engineer Divisions
 ATTN: Library

Europe
 Huntsville
 Lower Mississippi Valley
 Middle East
 Middle East (Rear)
 Missouri River
 New England
 North Atlantic
 North Central
 North Pacific
 Ohio River
 Pacific Ocean
 South Atlantic
 South Pacific
 Southwestern

Waterways Experiment Station
 ATTN: Library

Cold Regions Research Engineering Lab
 ATTN: Library

US Government Printing Office
 Receiving Section/Depository Copies (2)

Defense Technical Information Center
 ATTN: ODA (12)

Engineering Societies Library
 New York, NY

FESA, ATTN: Library

ETL, ATTN: Library

Engr. Studies Center, ATTN: Library

Inst. for Water Res., ATTN: Library

Army Instl. and Major Activities (CONUS)

DARCOM - Dir., Inst., & Svcs.
 ATTN: Facilities Engineer
 ARRADCOM
 Aberdeen Proving Ground
 Army Matls. and Mechanics Res. Ctr.
 Corpus Christi Army Depot
 Harry Diamond Laboratories
 Dugway Proving Ground
 Jefferson Proving Ground
 Fort Monmouth
 Letterkenny Army Depot
 Natick Research and Dev. Ctr.
 New Cumberland Army Depot
 Pueblo Army Depot
 Red River Army Depot
 Redstone Arsenal
 Rock Island Arsenal
 Savannah Army Depot
 Sharpe Army Depot
 Seneca Army Depot
 Tobyhanna Army Depot
 Tooele Army Depot
 Watervliet Arsenal
 Yuma Proving Ground
 White Sands Missile Range

FORSCOM

FORSCOM Engineer, ATTN: AFEN-FE
 ATTN: Facilities Engineers
 Fort Buchanan
 Fort Bragg
 Fort Campbell
 Fort Carson
 Fort Devens
 Fort Drum
 Fort Hood
 Fort Indiantown Gap
 Fort Irwin
 Fort Sam Houston
 Fort Lewis
 Fort McCoy
 Fort McPherson
 Fort George G. Meade
 Fort Ord
 Fort Polk
 Fort Richardson
 Fort Riley
 Presidio of San Francisco
 Fort Sheridan
 Fort Stewart
 Fort Wainwright
 Vancouver Bks.

TRADOC

HQ, TRADOC, ATTN: ATEN-FE
 ATTN: Facilities Engineer
 Fort Belvoir
 Fort Benning
 Fort Bliss
 Carlisle Barracks
 Fort Chaffee
 Fort Dix
 Fort Eustis
 Fort Gordon
 Fort Hamilton
 Fort Benjamin Harrison
 Fort Jackson
 Fort Knox
 Fort Leavenworth
 Fort Lee
 Fort McClellan
 Fort Monroe
 Fort Rucker
 Fort Sill
 Fort Leonard Wood

INSCOM - Ch. Instl. Div.
 ATTN: Facilities Engineer
 Vint Hill Farms Station
 Arlington Hall Station

WESTCOM

ATTN: Facilities Engineer
 Fort Shafter

MDW

ATTN: Facilities Engineer
 Cameron Station
 Fort Lesley J. McNair
 Fort Myer

HSC

HQ USAHSC, ATTN: HSLO-F
 ATTN: Facilities Engineer
 Fitzsimons Army Medical Center
 Walter Reed Army Medical Center

USACC

ATTN: Facilities Engineer
 Fort Huachuca
 Fort Ritchie

MTMC

HQ, ATTN: MTMC-SA
 ATTN: Facilities Engineer
 Oakland Army Base
 Bayonne MOT
 Sunny Point MOT

US Military Academy

ATTN: Facilities Engineer
 ATTN: Dept of Geography &
 Computer Science

USAES, Fort Belvoir, VA

ATTN: ATZA-DTE-EM
 ATTN: ATZA-DTE-SU
 ATTN: Engr. Library

Chief Inst. Div., IBSA, Rock Island,

USA ARRCOM, ATTN: Dir., Instl & Svc
 TARCOC, Fac. Div.
 TCCOM, ATTN: DRSTE-LG-F
 TSARCOM, ATTN: STSAS-F
 HARAD COM, ATTN: DRDNA-F
 AMPRC, ATTN: DRXMR-WE

HQ, XVIII Airborne Corps and
 Ft. Bragg
 ATTN: AFZA-FE-EE

HQ, 7th Army Training Command
 ATTN: AETTG-DEH (5)

HQ USAREUR and 7th Army
 ODCS/Engineer
 ATTN: AEAEN-EH (4)

V Corps
 ATTN: AETVDEH (5)

VII Corps
 ATTN: AETSDEH (5)

21st Support Command
 ATTN: AEREH (5)

US Army Berlin
 ATTN: AEBE-EN (2)

US Army Southern European Task Force
 ATTN: AESE-ENG (5)

US Army Installation Support Activity
 Europe
 ATTN: AEUES-RP

8th USA, Korea
 ATTN: EAPE
 Cdr, Fac Engr Act (8)
 AFE, Yongsan Area
 AFE, 2D Inf Div
 AFE, Area II Spt Det
 AFE, Cp Humphreys
 AFE, Pusan
 AFE, Taegu

DLA ATTN: DLA-WI

USA Japan (USARJ)
 Ch, FE Div, AJEN-FE
 Fac Engr (Honsu)
 Fac Engr (Okinawa)

ROK/US Combined Forces Command
 ATTN: EUSA-HMC-CPC/Engr

416th Engineer Command
 ATTN: Facilities Engineering

Norton AFB
 ATTN: AFRCE-MX/DEE

EHE Team Distribution

Fort Belvoir, VA 22060
ATTN: DRDME-G
ATTN: FESA-TSD
ATTN: Canadian Liaison Officer (2)

Fort Leavenworth, KS 66027
ATTN: ATZLCA-SA

USA ARRADCOM
ATTN: DRDAR-LCM-SP

US Army Engineer Districts
ATTN: Chief, Engineer Division

US Army Engineer Divisions
ATTN: Chief, Engineer Division

Naval Facilities Engineering Command
ATTN: Code 032E
ATTN: Code 1023
ATTN: Code 11130
ATTN: Code 044

Naval Civil Engineering Laboratory
ATTN: Code L03AE
ATTN: Code L08A
ATTN: Code L60

Alexandria, VA 22314
ATTN: DLA-W
ATTN: DRCIS

Army-Air Force Exchange Service
ATTN: Chief, Engineering Div

Andrews AFB, WASH DC 20331
ATTN: AFSC-DEE

McClellan AFB, CA 95652
2852 APG/DE

Patrick AFB, FL 32925
ATTN: XRQ

Tyndall AFB, FL 32403
ATTN: RD

Wright-Patterson AFB, OH 45433
ATTN: POE

Washington, DC
DCNO (Logistics)
ODAS (EE&S)
ODAS (I&H)
HQDA (DALO-TSE-F) (3)
Office of Planning & Dev, OFEPM
Director, Building Technology & Safety Div
Public Buildings Service
Assistant Sec for Conservation & Solar Energy
Assistant Sec for Resource Applications
National Institute of Building Sciences
Director, Center for Building Technology
Energy Research and Development Foundation

Department of Energy
Oak Ridge, TN 37830

Joncich, David M

Development of an acceptance test for solar energy systems / by D. M. Joncich, D. L. Johnson. -- Champaign, IL : Construction Engineering Research Laboratory ; Springfield, VA ; available from NTIS, 1981.
80 p. (Technical Report ; E-173)

1. Solar heating-quality control. 2. Solar air conditioning-quality control.
I. Johnson, David L. II. Title. III. Series: U. S. Army. Construction Engineering Research Laboratory. Technical Report ; E-173.