

AD-A101 588

HYDRA CORP VIENNA VA

F/6 16/4.2

SEA-BASED DEPLOYMENT OF FLOATING-LAUNCH MISSILES, APPENDICES. (U)

DEC 80 J E DRAIN

OTA-133-0830,0

UNCLASSIFIED

TR-102-80-APP

NL

for 1
Access



END
DATE
FILMED
8-8-11
DTIC

AD A101588

TR-102-80 (Appendices)

2

LEVEL III

A101587

SEA-BASED DEPLOYMENT OF
FLOATING-LAUNCH MISSILES

DTIC
ELECTE
JUL 20 1981
S D E

APPENDICES

December 15, 1980

Hydra Corp.

9310 TELFER CT.
VIENNA, VA. 22180
(703) 281-4489

DTIC FILE COPY

DISTRIBUTION STATEMENT A
Approved for public release;
Distribution Unlimited

81 7 20 014

4

9 Fiscal Note # 1101-24 1 11 18-

UNCLASSIFIED

SECURITY CLASSIFICATION OF THIS PAGE (When Data Entered)

REPORT DOCUMENTATION PAGE		READ INSTRUCTIONS BEFORE COMPLETING FORM
1. REPORT NUMBER HYDRA Corp. TR-102-80 (Append.)	2. GOVT ACCESSION NO. AD-A101	3. RECIPIENT'S CATALOG NUMBER 588
4. TITLE (and Subtitle) Sea-Based Deployment of Floating-Launch Missiles, (Appendices, Information Furnished by J.J. Henry Co., Inc., and Rohr Marine, Inc.)		5. TYPE OF REPORT & PERIOD COVERED Final Report 11-15-80 to 12-15-80
7. AUTHOR(s) John E. Drain	15	6. PERFORMING ORG. REPORT NUMBER TR-102-80 (Append.)
9. PERFORMING ORGANIZATION NAME AND ADDRESS HYDRA Corporation 9310 Telfer Court Vienna, VA, 22180		8. CONTRACT OR GRANT NUMBER(s) OTA 133-0830.0
11. CONTROLLING OFFICE NAME AND ADDRESS Office of Technology Assessment 600 Pennsylvania Ave., SE Washington, D.C. 20510	11	10. PROGRAM ELEMENT, PROJECT, TASK AREA & WORK UNIT NUMBERS
14. MONITORING AGENCY NAME & ADDRESS (if different from Controlling Office) 11 74-175-4-1111		12. REPORT DATE 15 December, 1980
		13. NUMBER OF PAGES 37
		15. SECURITY CLASS. (of this report) Unclassified
		15a. DECLASSIFICATION/DOWNGRADING SCHEDULE
16. DISTRIBUTION STATEMENT (of this Report) Approved for public release; distribution unlimited.		
17. DISTRIBUTION STATEMENT (of abstract entered in Block 20, if different from Report)		
18. SUPPLEMENTARY NOTES This study was undertaken in support of an Office of Technology Assessment review of various MX basing options.		
19. KEY WORDS (Continue on reverse side if necessary and identify by block number) MX Basing Containership MX Deployment Surface Effect Ship (SES) Sea-Based Missiles Floating-Launch Missiles HYDRA Missiles		
20. ABSTRACT (Continue on reverse side if necessary and identify by block number) The basic report presents systems concepts descriptions for sea-based MX missiles, using surface ships as transporters. Near-term (1985-1990) and far-term (1990-2000) systems are described. Floating launch methods are proposed, using either encapsulated missiles or the simpler (bare) HYDRA-type vertical floating launch. Parameters described include: force composition, missile jettison techniques, port facilities, deployment areas, personnel requirements, system costs, vulnerability, countermeasures, and C3 considerations. Appendices include containerships and surface effects ships (SES) data.		

DD FORM 1 JAN 73 1473

UNCLASSIFIED

SECURITY CLASSIFICATION OF THIS PAGE (When Data Entered)

413,444

APPENDIX A

Information Furnished by:

J.J. Henry Co., Inc.

J. J. HENRY CO. INC.

· NAVAL ARCHITECTS · MARINE ENGINEERS · MARINE CONSULTANTS ·



December 10, 1980

CENTURY BUILDING
2341 JEFFERSON DAVIS HIGHWAY
SUITE 838
ARLINGTON, VIRGINIA 22202
703-920-3435

Mr. John Drain
President, Hydra Corporation
9310 Telefer Ct.
Vienna, Virginia 22180

Dear Mr. Drain,

In accordance with your request regarding possible application of the SL-7 high speed containship in a MX role we are pleased to submit enclosure (1) as a quick look response to your specific questions.

If you have any additional questions, or we may be of any additional assistance, please contact me.

Very truly yours,

J. J. HENRY CO., INC.

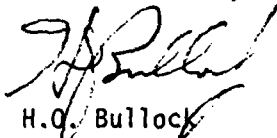
H.G. Bullock
Manager

Accession For	
NTIS GRA&I	<input checked="" type="checkbox"/>
DTIC TAB	<input type="checkbox"/>
Unannounced	<input type="checkbox"/>
Justification	
By _____	
Distribution/	
Availability Codes	
Avail and/or	
Dist	Special
A	

Enclosure

The information presented below is in response to your questions concerning the J.J. Henry Co., Inc. designed high speed container ship, the SL-7. The questions and the answers are listed below.

1. Question: What are the cost and possible construction schedules at a high priority for a production run of 24 SL-7's or for a production run of 32 SL-7's.

The cost of a repeat SL-7 commercial design in 1980 dollars is \$135 million. This includes the necessary berthing for a crew of approximately 200, it is emphasized this repeats the SL-7 commercial design.

To incorporate those features which traditionally always are included in military conversion of commercial ships this price would be expected to be in the area of \$200 million in 1980 dollars for each SL-7 conversion. Those features added include military communication systems, additional internal subdivision to enhance damaged stability, self defense weapons, redundant electrical power and distribution, extra fire fighting systems, and capability of at sea refueling.

According to the Maritime Administration, eight commercial United States shipyards have the necessary dock facilities and capability to construct the SL-7 which has a length of 946 feet and a beam of 105 feet and 6 inches.

Figure 1 shows a nominal schedule for construction at a high national priority. This schedule demonstrates that 32 ships could be constructed in about a five year period, provided that:

- (a) Pre-ordering of long lead material such as reduction gears, steam turbines, cranes and guns was ordered prior to start of the lead ship construction.
- (b) Work load of the affected five shipyards could be integrated to make their facilities and corporate commitment available to this program.
- (c) Modifications to the basic SL-7 design are minimized to ensure maximum applicability of the original design.
- (d) Development of the SL-7 contract design is complete and available for review well prior to award of the lead ship detail design and shipbuilding contract.
- (e) The SL-7 design used reflects consultation with all projected participating shipyards to produce a design which has a minimum of design bias. That is to say, the design is oriented to the less capable shipyards (less capable weight handling equipment, etc.).
- (f) A high degree of standardization is maintained in the ship at all the building yards. Major components must be identical with this standardization continuing down to the component level if possible. Otherwise, working plan problems will arise in modifying the lead ship design.

TIME IN MONTHS
 -12 -10 -8 -6 -4 -2 0 +2 +4 6 8 10 12 14 16 18 20 22 24 26 28 30 32 34 36 38 40 42 44 46 48 50 52 54 56 58 60

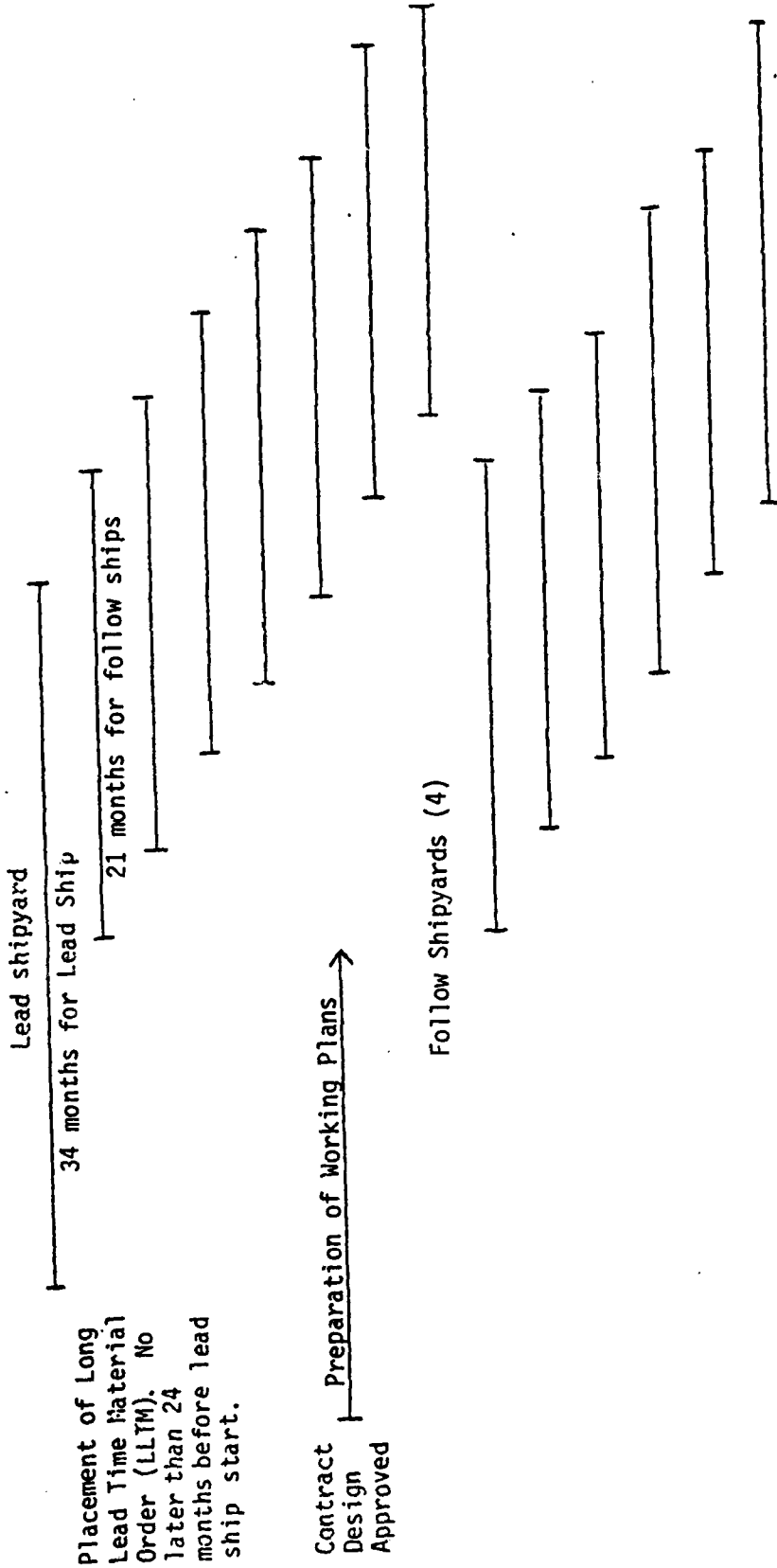

NOMINAL CONSTRUCTION SCHEDULE FOR SL-7 PRODUCTION OF 32 SHIPS

FIGURE 1

This will produce 32 ships in about five years. For a production run of 24 ships, no significant variation is anticipated since the eight existing SL-7's will require conversion in any case. The construction schedule as laid out provides more construction time per ship than was required during construction of the existing SL-7's.

2. Question: What is the crane capability for lifting 150 ton 8' x 8' x 80' containers from the main deck level (either permanent installation or portable Cranes on Deck (COD))?

The current SL-7 commercial design does not include this feature. Figure (2) shows the deck coverage available for five installed 150 ton capacity cranes which are commercially available. This feasible arrangement covers the deck and gives the maximum number of 8' x 8' x 80 containers to be off loaded. The cost of each crane is \$1.3 million in 1980 dollars. These cranes are fixed with structure extending into the basic structure. However, they can be removed. The use of cranes on deck is not considered a viable alternative in view of the lift requirement of 150 tons. Use of a crane configuration such as Figure (2) allows crane placement of the container over the side in a controlled manner. This allows sufficient time for a counter flooding system to control excessive roll during the container implantment.

3. Question: Could additional propulsion capacity be able to increase speed over current SL-7 capability?

The currently installed SL-7 geared turbine steam plant is capable of 33 knots at a draft of 34 feet, and probably higher at the design draft of 30 feet. As Figure 3 shows, the fuel cost is significantly increased as the propulsion capacity is increased.

Any significant increase in installed SHP would cause a redesign of structure and produce only marginal increases in speed.

4. Question: Would there be extra cost for provision for additional fuel and berthing for up to 220 persons.

Yes, and provisions for the 220 man crew are included in question number 1.

As for fuel, if an operating scenario of 60 days underway is assumed with 56 days at 12 knots loiter speed, and 4 days at high speed of 33 knots, the fuel cost for 60 days at 1980 fuel costs is approximately \$782,000. Note that the fuel consumed in 4 days at 33 knots exceeds that consumed in 56 days at 12 knots. Referring to Figure 3 will show this speed-fuel consumption relationship. To provide sufficient fuel for this scenario, 1600 tons of additional fuel capacity beyond the 4434 ton capacity of the original SL-7 must be provided. The operating speed profile will produce a range of about 19,000 nautical miles. Cost of providing the necessary 1600 tons of fuel to support this scenario would be in the conversion of existing ballast tanks to fuel and clean ballast, and is included in the conversion costs of question number 1.

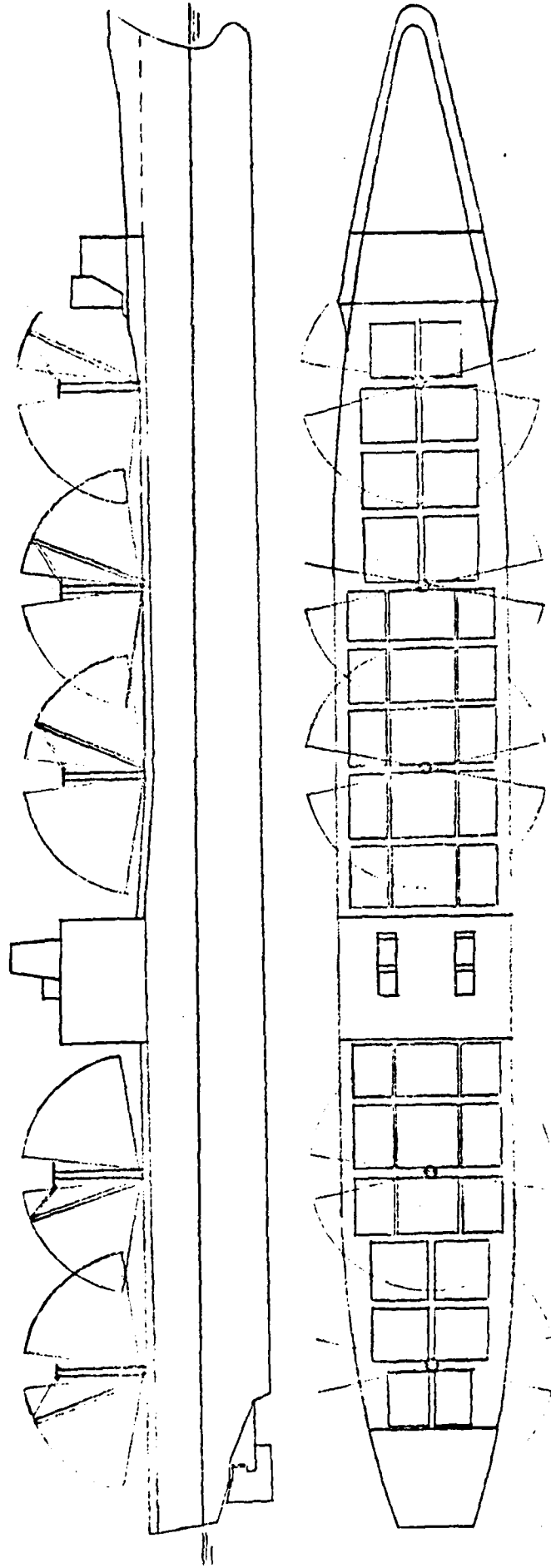

SL-7 CONTAINER SHIP WITH 5
150 LTON CAPACITY CRANES

Figure 2

SL-7 CONTAINER SHIP
SPEED vs. FUEL CONSUMPTION

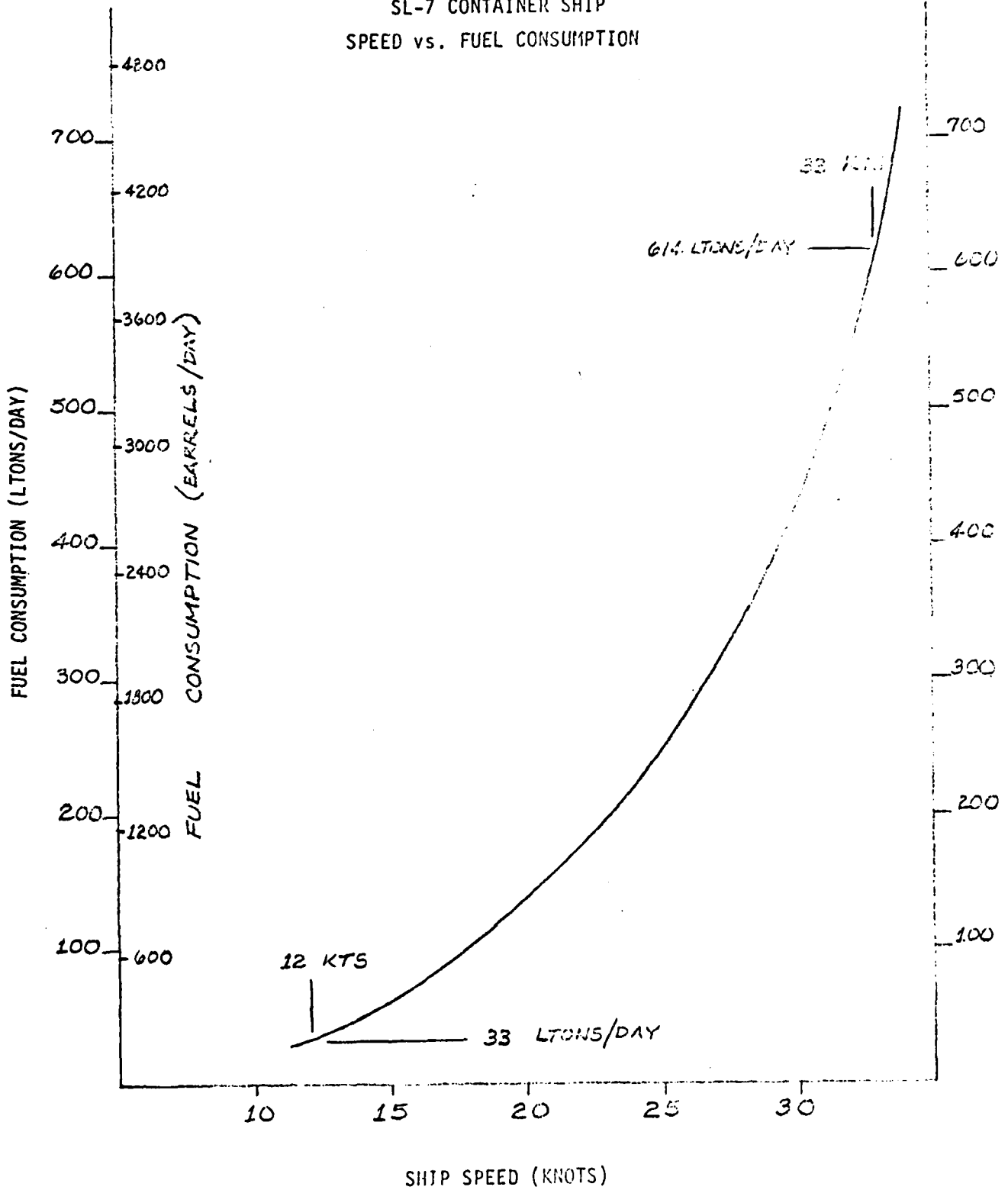

Figure 3

5. Question: What would be the cost for installation for two 76mm OTO MELARA automatic deck guns, 1 forward and 1 aft?

The MK 75, 76mm, OTO MELARA gun is presently manufactured in the United States under Italian License by the Northern Ordnance Division of FMC Corporation. They report that for a buy of 64 mounts, the lead time from contract award to delivery of the first unit is two years, with a delivery rate of 15 per year. Thus, with a contract award 1 year before start of the lead ship (at -12 months) the production run would support all 32 ships.

The cost of each mount in 1980 dollars is \$2.3 million per mount, or \$4.6 million per ship. Installation and initial support costs are estimated at an additional \$2 million per ship provided the design is modified to accept the mounts before completion of the contract design.

6. Question: What is the estimated yearly operation cost less personnel of the SL-7 ships?

Summarizing the information above, the annual fuel cost using the scenario described in the response to question number four, amounts to about \$4.7 million per ship. Added consumables, maintenance and refit costs would be approximately \$1.8 million per ship for a total yearly operating cost per ship estimated at \$6.5 million plus personnel costs.

7. Question: Estimate the frequency and duration of overhaul period and at sea time cycle.

American Bureau of Shipping (ABS) requirements are 2 to 6 weeks of overhaul every four years. Merchant practice is generally 350 days of continuous operation with the remaining two weeks for required maintenance and unexpected delays.

A typical operating cycle would be 60 days operating with 2 to 4 days turnover between crews, and a two week refit period each year. A thirty day refit period every four years would be reasonable. Removal of missiles and other unique mission support equipment would make the ship easily adaptable to merchant ship overhaul practices. Figure 4 shows this typical profile for one ship.

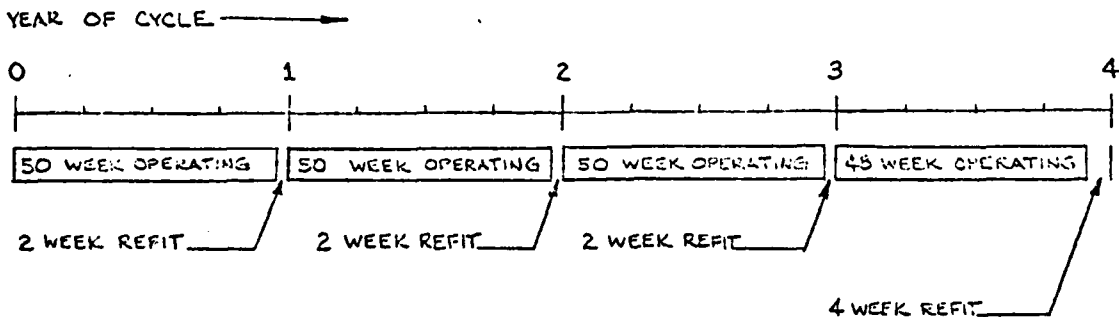

TYPICAL OPERATION/MAINTENANCE CYCLE

Figure 4

8. Question: What are the specifications of the SL-7 design?

SL-7 Specifications

Length Overall	946' 1½"
Beam	105' 6"
Draft - Design	30'
Operating	34'
Propulsion	Geared Steam Turbines
Shafts	2
Boilers	2
Shaft Horespower (total)	120,000
Depth at Main Deck (fwd of aft deck house)	64'
Depth at Main Deck (aft deck house to fantail)	68' 6"
Speed (light draft)	33 + KTS
Displacement - 30' draft	43,000 tons
34' draft	50,300 tons
Fuel Capacity	4,434 tons
Fuel Consumption - 33 KTS	614 tons/day
25 KTS	240 tons/day
19 KTS	159 tons/day
12 KTS	34 tons/day
Electrical Capacity	2 installed, 3000 KW Ships Service Turbo Generator
	1 installed, 1500 KW Ships Service Diesel Generator
	1 installed, 60 KW Emergency Diesel Generator
Crew Size	70

For comparison purposes, Figure (5) shows typical containerships. This figure clearly shows that from the standpoint of speed capability, the SL-7 is unique among other current containships.

DESIGN NAME	LENGTH OVERALL (FEET)	DRAFT AT SERVICE SPEED (FEET-INCHES)	SERVICE SPEED (KNOTS)
C7-S-68C "AMERICAN LANCER"	700	27 - 9	21.5
C5-S-78A "DEFIANCE"	601	31 - 0	24.0
C6-S-85B "PRESIDENT JEFFERSON"	669	29 - 0	23.0
C7-S-88A "SEA-LAND PRODUCER"	720	29 - 6	23.0
SL-7 "SEA-LAND GALLOWAY"	946	34 - 0	33.0
C6-S-69C "PRESIDENT VAN BUREN"	663	28 - 4	22.0



Figure 5

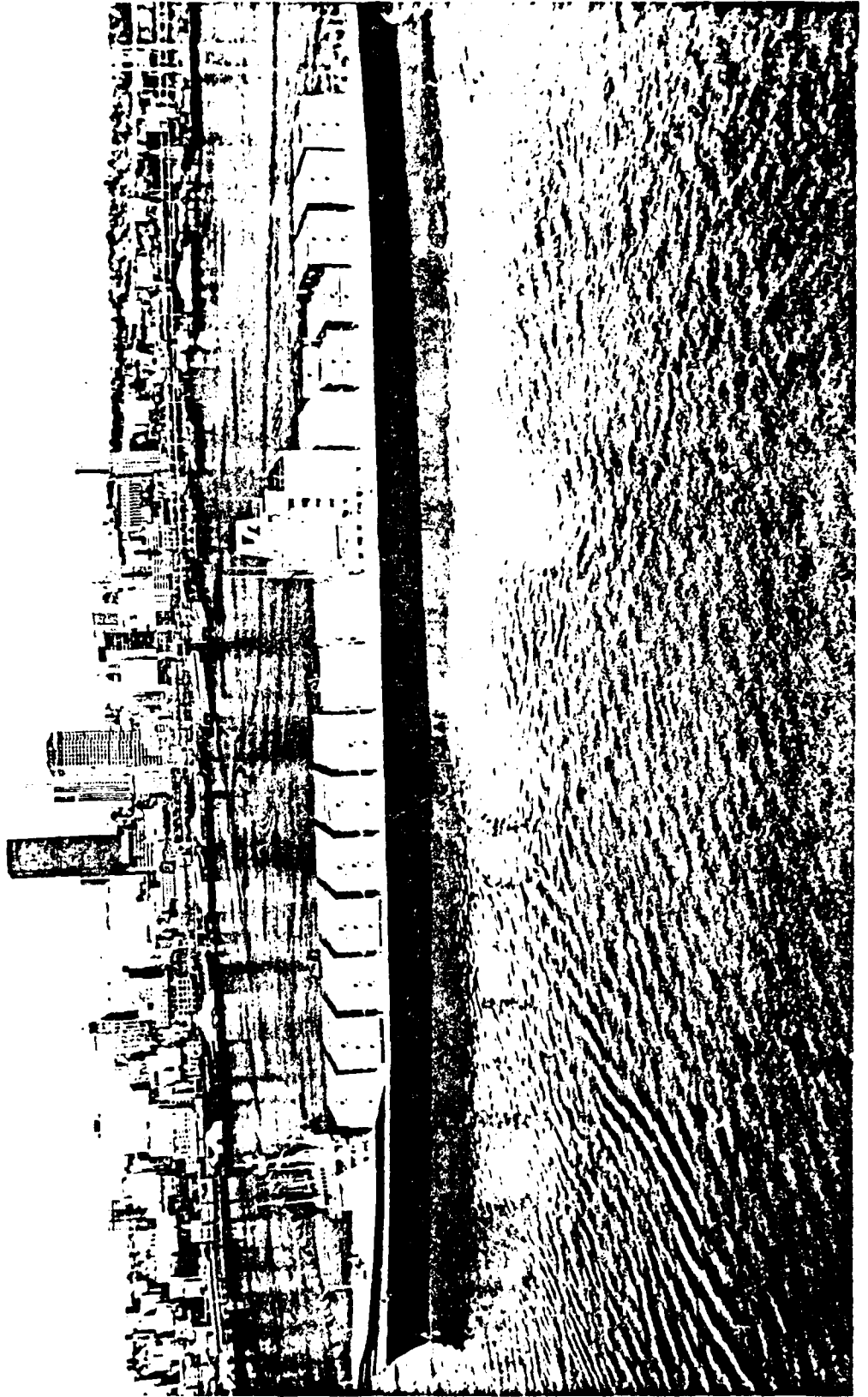

36-7 Containership

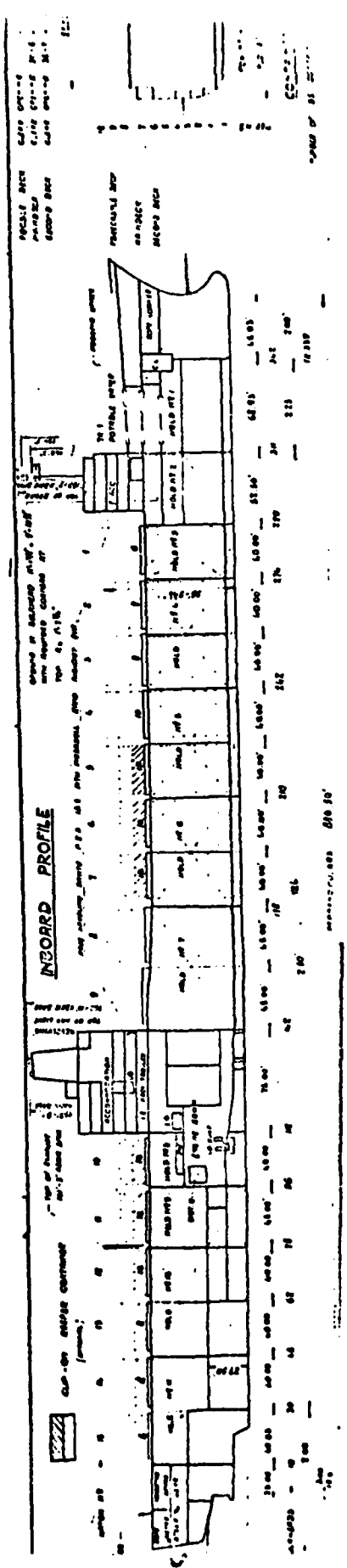

SL-7

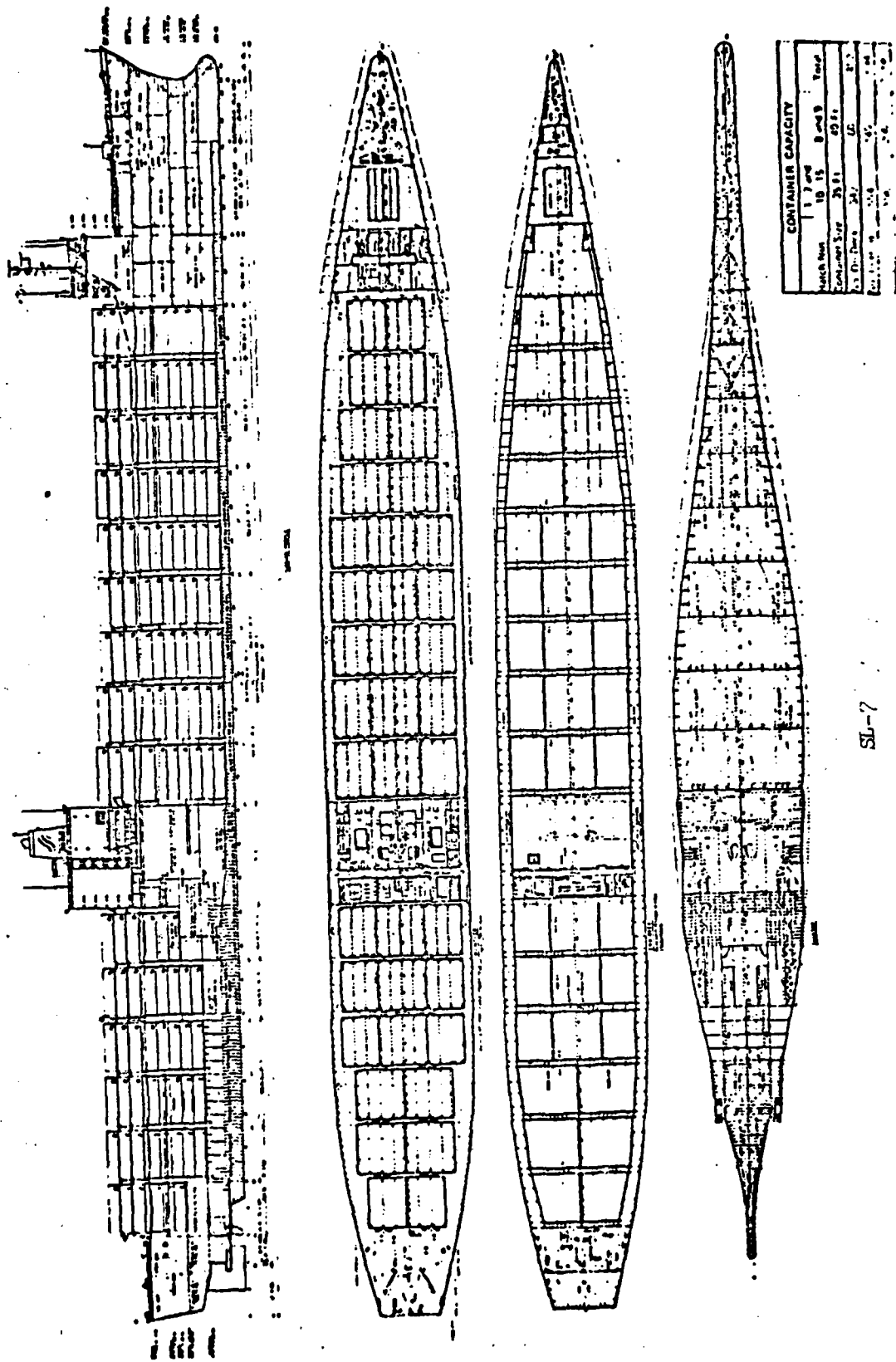

Fig. 11 General arrangement

SI-7

STUELCKENMAST® — Pendulum Types

Double Pendulum Type

This is the heavy-duty type and it covers the range from 150 t SWL up to the highest loads required. It is characterized by the cargo tackle split into two parts, one on each side of the derrick head. One part of the cargo tackle can be fastened to the derrick, which effects the hook speed to increase correspondingly to the reduction of the load. For the swinging-through manoeuvre the connecting traverse of the lower cargo blocks has to be disconnected and both parts of the cargo tackle swing through. The whole manoeuvre takes about 8 minutes or less depending on the SWL.

Split Purchase Type

The Split Purchase Type is intended for capacities between 60 and 150 t SWL. It also, allows increased hook speeds with one part of the cargo tackle fastened to the derrick.

The swinging-through manoeuvre is easier and faster, because it can be done without disconnecting the connecting traverse of the lower cargo blocks.

Both Pendulum Types are driven by two cargo winches and two span winches, all of equal pull on the drum. The second cargo winch effects high speeds on the hook. In cases where high hook speeds are not required, only one cargo winch may be installed without any change to the operation of the Stuelcken-Mast.

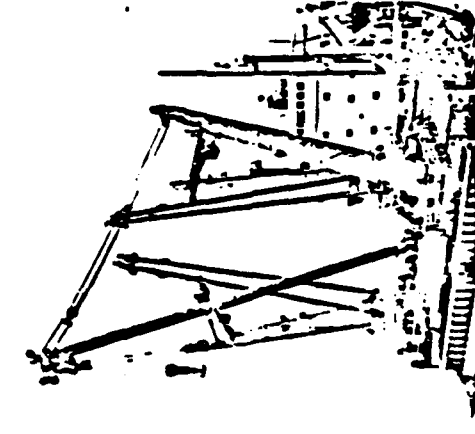
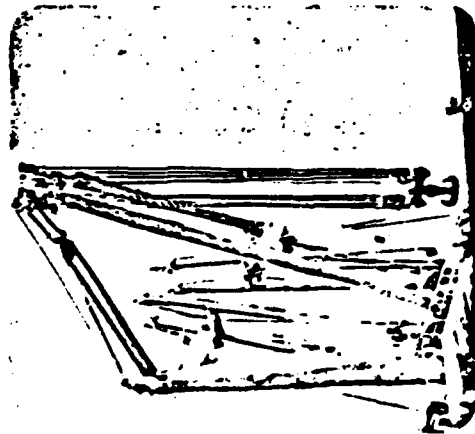
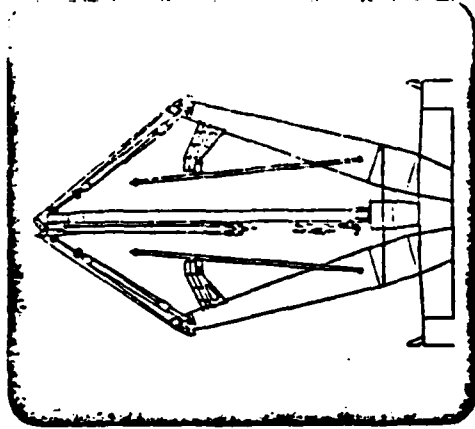
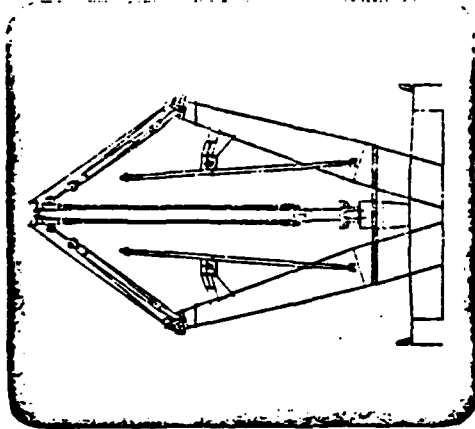

TABLE 2.1 PRINCIPAL CHARACTERISTICS OF U. S. FLAG LASH SHIPS

Item	Characteristic	Prudential Grace Lines	Pacific Far East Line	Delta Steamship Lines	Waterman Steamship Corp.	Central Gulf Steamship Corp.
1	MARAD Design	C8-5-81b	C8-S-81b	C9-S-81d	C9-S-81d	C9-S-81d
2	Hull Numbers (MARAD)	228 229 230 236 237	231 232 233 234 235 238	259 260 261	262 263 264	265 274 275
3	Ship Names	LASH ITALIA LASH TURKIYE LASH ESPANA LASH ATLANTICO LASH PACIFIC	THOMAS E. CUFFE GOLDEN BEAR PACIFIC BEAR JAPAN BEAR CHINA BEAR PHILLIPPINE BEAR	DELTA MAR DELTA NORTE DELTA SUD	ROBERT E. LEE STONEWALL JACKSON SAM HOUSTON	GREEN VALLEY GREEN HARBOR GREEN ISLAND
4	Length overall including overhang	820'-0"	820'-0"	893'-4"	893'-4"	893'-4"
5	Length overall excluding crane overhang	772'-0"	772'-0"	845'-4"	845'-4"	845'-4"
6	Length between perpendiculars	724'-0"	724'-0"	797'-4"	797'-4"	797'-4"
7	Molded Breadth (Beam)	100'-0"	100'-0"	100'-0"	100'-0"	100'-0"
8	Depth (Molded) at the side	60'-0"	60'-0"	60'-0"	60'-0"	60'-0"
9	Shaft Horsepower (ABS Max.)	32,000	32,000	32,000	32,000	32,000
10	Speed, Normal @ 28' W.L.	22.5 Knots	22.5 Knots	22 Knots	22 Knots	22 Knots
11	Draft, Design	28'-0"	28'-0"	28'-0"	28'-0"	28'-0"
12	Deadweight Tonnage @ 28' W.L.	17,990 L.T.	17,904 L.T.	21,552 L.T.	21,901 L.T.	21,901 L.T.
13	Full Load Draft	35'-1-1/4"	35'-1-3/16"	38'-1-1/2"	38'-1-1/2"	38'-1-1/2"
14	Deadweight Tonnage @ Full Load Draft	29,820 L.T.	29,749 L.T.	40,592 L.T.	40,679 L.T.	46,153 L.T.
15	U. S. Gross Tonnage	26,406	26,456	32,269	32,269	32,269
16	U. S. Net Tonnage	18,706	18,706	24,767	24,767	24,767
17	Displacement (Design)	32,761 L.T.	32,700 L.T.	38,062 L.T.	38,062 L.T.	38,062 L.T.
18	Displacement Maximum Draft	44,606 L.T.	44,606 L.T.	57,082 L.T.	57,082 L.T.	56,451 L.T.
19	Light Ship Displacement	14,786 L.T.	14,857 L.T.	16,510 L.T.	16,162 L.T.	16,161 L.T.

TABLE 2.1 PRINCIPAL CHARACTERISTICS OF U. S. FLAG LASH SHIPS (Continued)

Item	Characteristic	Prudential Grace Lines	Pacific Far East Line	Delta Steamship Lines	Waterman Steamship Corp.	Central Gulf Steamship Corp.
20	Length on 28'-0" Waterline	740'-0"	740'-0"	813'-4"	813'-4"	813'-4"
21	Length @ Scantling Draft			815'-2"	815'-2"	815'-2"
22	Scantling Length			790'-8-9/16"	790'-8-9/16"	790'-8-9/16"
23	Scantling Draft	35'-0"	35'-0"	38'-0"	38'-0"	38'-0"
24	Depth @ Main Deck Molded - Centerline	61'-0"	61'-0"	61'-0"	61'-0"	61'-0"
25	Light Ship Draft	15'-3-1/8"	15'-3-5/8"	14'-6-1/4"	14'-3-3/8"	14'-3-3/8"
26	Length Overall including crane overhang	820'-0"	820'-0"	893'-4"	893'-4"	893'-4"
27	Speed - Maximum Draft	19.1 Knots	19.1 Knots	19.1 Knots	19.1 Knots	19.1 Knots
28	Accommodations	40	45	45	38	35
29	Lifeboats - Diesel	(1) 50 Persons	(1) 50 Persons	(1) 48 Persons	(1) 45 Persons	(1) 35 Persons
30	Lifeboats - Hand Powered	(1) 50 Persons	(1) 50 Persons	(1) 48 Persons	(1) 45 Persons	(1) 35 Persons
31	Davits - Gravity Type	2	2	2	2	2
32	Fuel	5,344 L.T.	5,344 L.T.	5,740 L.T.	5,740 L.T.	5,740 L.T.
33	Liquid Cargo	1,164 L.T.	1,164 L.T.	None	None	None
34	Cargo and Ballast Tanks			389,093 cu.ft.	389,093 cu.ft.	389,093 cu.ft.
35	Diesel Oil	112.72 L.T.	112.72 L.T.	114.04 L.T.	112.7 L.T.	112.7 L.T.
36	Lube Oil	67.65 L.T.	76.86 L.T.	85.73 L.T.	76.5 L.T.	76.5 L.T.
37	Salt Water Ballast	16,063 L.T.	16,063 L.T.	10,174 L.T.	8,808 L.T.	8,808 L.T.
38	Passive Stabilizer Tanks	1,679.45 L.T.	1,679.45 L.T.	1,682.58 L.T.	1,682.6 L.T.	1,682.6 L.T.
39	Fresh Water Tanks	792.58 L.T.	792.58 L.T.	853.18 L.T.	853.18 L.T.	853.18 L.T.
40	Main Propulsion	Steam	Steam	Steam	Steam	Steam
41	Endurance (Nautical Miles)	15,000	15,000	15,000	15,000	15,000
42	Number of Propellers	One	One	One	One	One
43	Evaporator Capacity - Gallons/Day	25,000	25,000	25,000	25,000	25,000

TABLE 2.1 PRINCIPAL CHARACTERISTICS OF U. S. FLAG LASH SHIPS (Continued)

Item	Characteristic	Prudential Grace Lines	Pacific Far East Line	Dell. Steamship Lines	Waterman Steamship Corp.	Central Gulf Steamship Corp.
44	Steering Gear - Elect. Mtd. (2) 75 H.P. Motors	Sperry Rand	Sperry Rand	Avondale	Avondale	Avondale
45	Refrigeration - Containerized	3 Tons	3 Tons	3 Tons	3 Tons	3 Tons
46	Air Conditioning	(2) 40 Ton Units	(2) 40 Ton Units	(2) 45 Ton Units	(2) 45 Ton Units	(2) 45 Ton Units
47	Generator Capacity - Ships Service T.G.	2,500 KW	2,500 KW	2,000 KW	2,000 KW	2,000 KW
48	Generator Capacity - Aux. Diesel	2,000 KW	2,000 KW	2,000 KW	2,000 KW	2,000 KW
49	Generator Capacity - Emerg. Diesel	250 KW	250 KW	250 KW	250 KW	250 KW
50	Generator Load Analysis Maximum Sea Load Maximum Port Load Deck Machinery Included (Sea)	2,201 KW 1,600 KW 40 KW	2,201 KW 1,600 KW 40 KW	2,214 KW 3,020 KW 55 KW	1,850 KW 1,206 KW 40 KW	1,820 KW 2,326 KW 40 KW
51	Emergency Generator Load Analysis Maximum Sea Load Maximum Port Load	246 KW 134 KW	246 KW 134 KW	242 KW 138 KW	242 KW 138 KW	242 KW 138 KW
52	Number of Cargo Holds	6	6	7	7	7
53	Cargo Holds arranged to carry lighters only, access in wing walls, using wing tanks for grain or ballast.	Containers Fwd.	Containers Fwd.	Containers Fwd.	Lighters Only	Lighters Only
54	Barge Size - Length Barge Size - Width Barge Size - Height	61'-6" 31'-2" 13'-0"	61'-6" 31'-2" 13'-0"	61'-6" 31'-2" 13'-0"	61'-6" 31'-2" 13'-0"	61'-6" 31'-2" 13'-0"
55	Barge Weight	80 L.T.	80 L.T.	80 L.T.	80 L.T.	80 L.T.
56	Dry Cargo - No. of Lighters	49	49	55	89	89
	Grain Capacity Below Deck On Main Deck at Centerline On Hatch Covers	712,800 cu.ft. 39,600 cu.ft. 217,800 cu.ft.	712,800 cu.ft. 39,600 cu.ft. 217,800 cu.ft.	1,023,100 cu.ft. 80,400 cu.ft. 603,000 cu.ft.	,065,300 cu.ft. 80,400 cu.ft. 643,200 cu.ft.	1,065,300 cu.ft. 80,400 cu.ft. 643,200 cu.ft.
	Bale Capacity Below Deck On Main Deck at Centerline On Hatch Covers	702,000 cu.ft. 39,000 cu.ft. 214,500 cu.ft.	702,000 cu.ft. 39,000 cu.ft. 214,500 cu.ft.	999,600 cu.ft. 78,400 cu.ft. 588,000 cu.ft.	1,038,800 cu.ft. 78,400 cu.ft. 627,200 cu.ft.	1,038,800 cu.ft. 78,400 cu.ft. 627,200 cu.ft.

NOTE: Second tier of lighters restricted to a maximum of 380 L.T. due to stowage of container lift frame above hatch.

TABLE 2.1 PRINCIPAL CHARACTERISTICS OF U. S. FLAG LASH SHIPS (Continued)

Item	Characteristic	Prudential Grace Lines	Pacific Far East Line	Delta Steamship Lines	Waterman Steamship Corp.	Central Gulf Steamship Corp.
57	Alternate Lighters Grain Capacity Bale Capacity	12 237,600 cu.ft. 234,000 cu.ft.	12 237,600 cu.ft. 234,000 cu.ft.	None None None	None None None	None None None
58	Containers Bale Capacity	250 350,700 cu.ft.	334 350,700 cu.ft.	144 151,200 cu.ft.	None None	None None
59	Alternate Number of Containers Bale Capacity	720 757,000 cu.ft.	720 757,000 cu.ft.	None None	None None	None None
60	Lighter Gantry Crane (Capacity)	500 S.T.	500 S.T.	510 S.T.	500 S.T.	510 S.T.
61	Lighter Gantry Crane (Builder)	Alliance	Alliance	Morgan	Alliance	Morgan
62	Container Gantry Crane (Builder)	Paceco	Paceco	Skagit	None	None
63	Capacity of Container Crane	30 L.T.	30 L.T.	30 L.T.	None	None
64	Maximum Lift Position of Lighter Gantry Crane	96'-0" A.B.L.	96'-0" A.B.L.			
65	30 Ton Container Crane secured over Hatch #1 - Frames 52 - 58. Outside cargo cannot be carried forward of Frame 60	Yes	Yes	Yes	No Container Crane	No Container Crane
66	Lighter Handling - Portable LCM Guide Rails	No	No	Yes	Yes	Yes
67	Tiedown to suit 500 Ton Gantry	Suitable	Suitable	Suitable	Suitable	Suitable
68	Constant Tension Mooring Winches	(8) @ 150,000#		(4) @ 150,000# pull	(4) @ 150,000# pull	(4) @ 150,000# pull
69	Barge Handling Winches - Stern Well	2	2			
70	Retrieving Winches Aft - Stern Well	2	2			
71	Mooring Winches Aft - Stern Well	2	2			
72	LASH Gantry Crane - Manufacturer Gantry Motors Hoist Motors	Alliance (4) @ 150 H.P. (4) @ 150 H.P.	Alliance (4) @ 150 H.P. (4) @ 150 H.P.	Morgan (4) @ 150 H.P. (4) @ 150 H.P. (for Morgan Crane)	Alliance (4) @ 150 H.P. (4) @ 150 H.P.	Morgan (4) @ 150 H.P. (4) @ 150 H.P. (for Morgan Crane)
73	Lighter load frame tie down arrangement					
74	Light Weight Snug Stowing Anchors	(2) @ 22,470 lbs.	(2) @ 22,470 lbs.	(2) @ 22,470 lbs.	(2) @ 22,470 lbs.	(2) @ 22,470 lbs.
75	Spare Anchor	(1) @ 19,110 lbs.	(1) @ 19,110 lbs.	(1) @ 19,110 lbs.	(1) @ 19,110 lbs.	(1) @ 19,110 lbs.

TABLE 2.1 PRINCIPAL CHARACTERISTICS OF U. S. FLAG LASH SHIPS (Continued)

Item	Characteristics	Prudential Grace Lines	Pacific Far East Line	Delta Steamship Lines	Waterman Steamship Corp.	Central Gulf Steamship Corp.
86	General Arrangement Main Deck - Fitted with tension mooring winches, stowage lockers and gantry tie downs on wing walls - No Interference	Yes		Yes	Yes	Yes
87	Maximum S. W. Bending Moment	377,669 ft. tons	377,669 ft. tons	538,555 ft. tons	538,555 ft. tons	538,555 ft. tons
88	Deck Plating and Framing Aft - Adequate for outside cargo deck loading.	Yes	Yes	Yes	Yes	Yes
89	Firemain Stations on Main Deck Wing Walls Aft of Frame 52 - No Interference.	Yes	Yes	Yes	Yes	Yes
90	Miscellaneous Longitudinal Bulkheads Aft	Suitable	Suitable	Suitable	Suitable	Suitable
91	M. T. Longitudinal Bulkheads - 35' and 40' off Centerline Aft - Adequate for outside deck cargo.	Yes	Yes	Yes	Yes	Yes
92	I. B. Plating in way of holds is designed for the carriage of lighters.	Yes	Yes	Yes	Yes	Yes
93	Top plating in the way of Hold #1 stiffened for the carriage of containers.	Yes	Yes	Yes	No	No
94	Fire Stations on Wing Walls - No Interference.	Yes	Yes	Yes	Yes	Yes
95	Location of Exhaust Fans on Wing Walls - No Interference.	10	10	10	10	6
96	Plumbing and Deck Drains - No Interference	Suitable	Suitable	Suitable	Suitable	Suitable
97	Intake Fans on Wing Walls - No Interference	2	2	2	2	2
98	Craneway Extension Aft	48'-0"	48'-0"	48'-0"	48'-0"	48'-0"
99	Fire Control Plan - No Interference	Suitable	Suitable	Suitable	Suitable	Suitable

TABLE 2.1 PRINCIPAL CHARACTERISTICS OF U. S. FLAG LASH SHIPS (Continued)

Item	Characteristic	Prudential Grace Lines	Pacific Far East Line	Delta Steamship Lines	Waterman Steamship Corp.	Central Gulf Steamship Corp.
100	Access in Box Girders - No Interference	Suitable	Suitable	Suitable	Suitable	Suitable
101	Access and Stowages in Wing Walls - No Interference	Suitable	Suitable	Suitable	Suitable	Suitable
102	32' and 40' levels, Hatches #1 and #2 fitted with Container Guides	Yes	Yes			
103	When containers are carried seven high, the load imposed on the lowest container in the tier shall not exceed 100 L. T.					
104	When lighters or containers, or both, are carried on hatch covers, the hatch cover load shall not exceed 527 L. T. for lighters or 727 L. T. for containers.		Yes			
105	Alternate stowage of containers and lighters require major changes in guide structure.	Yes	Yes			
106	The container crane would have to be removed to stow lighters at Hold 1a.	Yes	Yes			
107	Maximum lift operating position of container gantry crane.	93'-0" A.B.L.	93'-0" A.B.L.			
108	When containers are required to be stowed seven high and weigh more than 15 tons, the 7th container tier must be carried empty. If the first (6) tiers weigh less than 15 tons each, the balance or part of the balance of the load to make up may be carried in the 7th tier of containers.	Yes				
109	A total of 62 lighters may be carried if stowed two high on the main deck and hold and hatch covers, but the upper lighter must be empty if the lower lighter is full. Lower Lighter - 410 S.T. Upper Lighter - Empty Lower Lighter - 273.33 S.T. Upper Lighter - 136.67 S.T.	Yes				

APPENDIX B

Information Furnished by:
ROHR MARINE, INC.

