

AD-A101 345

CORPS OF ENGINEERS BUFFALO N Y BUFFALO DISTRICT
ELLICOTT CREEK BASIN, NEW YORK. WATER RESOURCES DEVELOPMENT. PH--ETC(U)
AUG 73

F/8 13/2

UNCLASSIFIED

NL

1 of 6
AD-A101 345

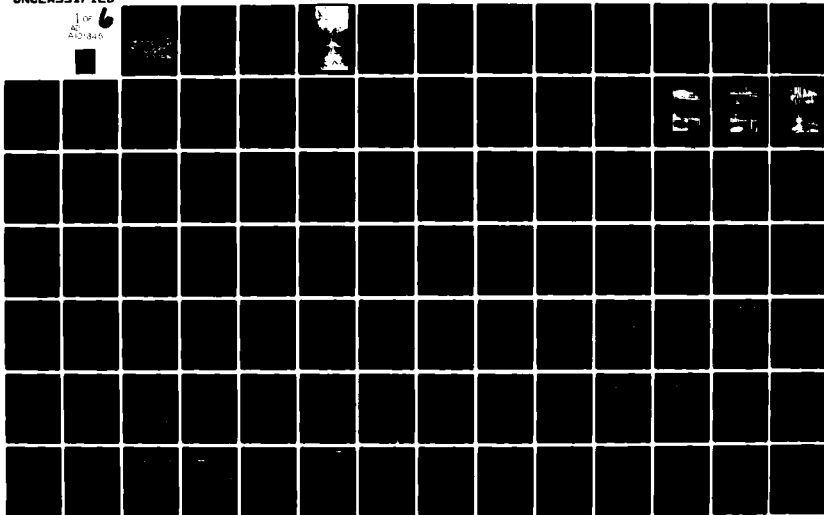

ELLICOTT CREEK BASIN LEVEL NEW YORK

AD A101345

PHASE 2
VOLUME 2
APPENDICES

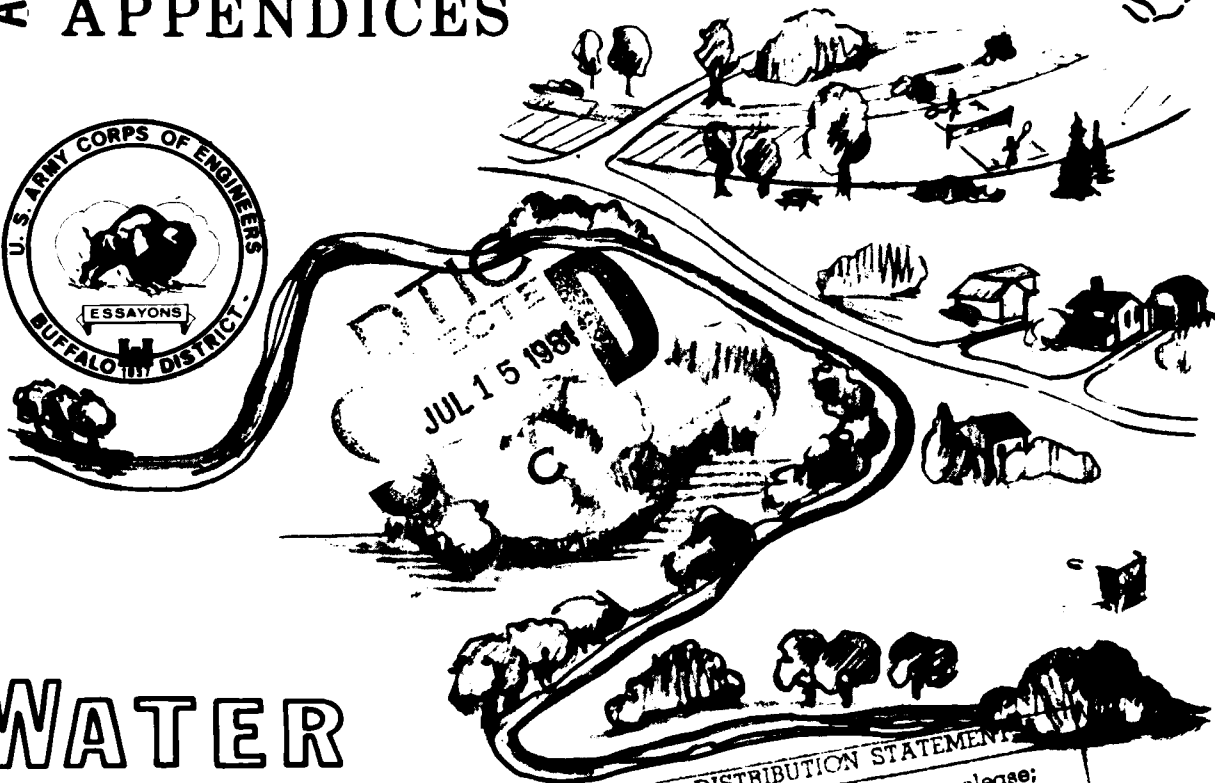
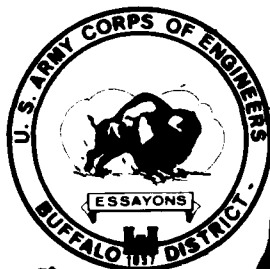
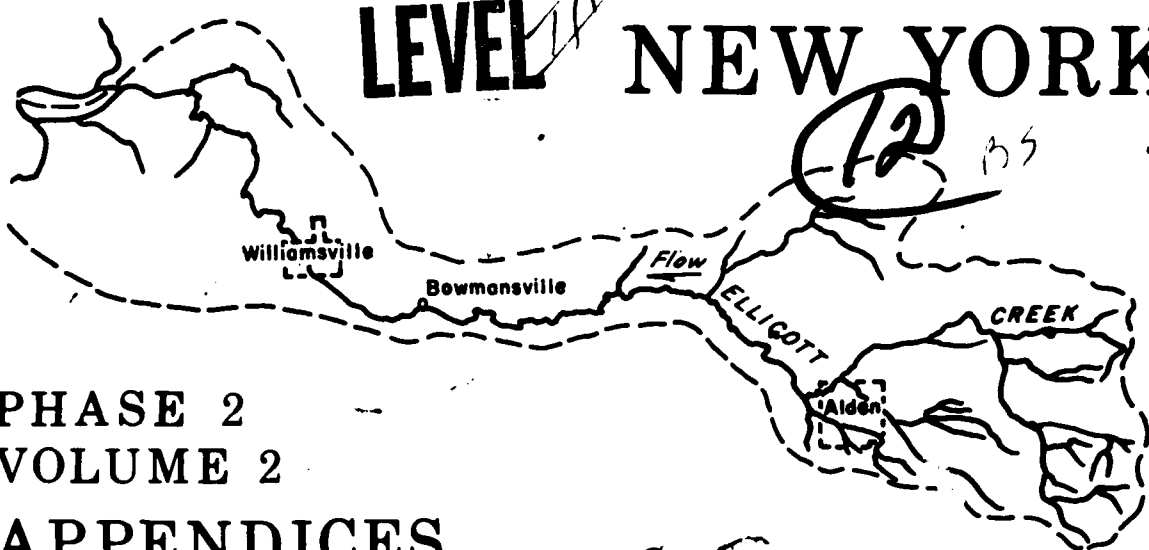

DTIC FILE COPY

WATER RESOURCES DEVELOPMENT

DISTRIBUTION STATEMENT
 Approved for public release;
 Distribution Unlimited

AUGUST
1973

81 7 13 211

REPORT DOCUMENTATION PAGE		READ INSTRUCTIONS BEFORE COMPLETING FORM
1. REPORT NUMBER	2. GOVT ACCESSION NO.	3. RECIPIENT'S CATALOG NUMBER
	AD-A207 345	
4. TITLE (and Subtitle)		5. TYPE OF REPORT & PERIOD COVERED
Ellicott Creek Basin, New York. Water Resources Development. Phase 2. Volume 2 Appendices		Final Rept.
7. AUTHOR(s)		6. PERFORMING ORG. REPORT NUMBER
9. PERFORMING ORGANIZATION NAME AND ADDRESS		8. CONTRACT OR GRANT NUMBER(s)
U.S. Army Engineer District, Buffalo 1776 Niagara Street Buffalo, New York 14207		WAB 4E
11. CONTROLLING OFFICE NAME AND ADDRESS		10. PROGRAM ELEMENT, PROJECT, TASK AREA & WORK UNIT NUMBERS
U.S. Army Engineer District, Buffalo 1776 Niagara Street Buffalo, New York 14207		(B) 4221
14. MONITORING AGENCY NAME & ADDRESS (if different from Controlling Office)		12. REPORT DATE
		1973
		13. NUMBER OF PAGES
		26
		15. SECURITY CLASS. (of this report)
		15a. DECLASSIFICATION/DOWNGRADING SCHEDULE
16. DISTRIBUTION STATEMENT (of this Report)		
Distribution Unlimited		
17. DISTRIBUTION STATEMENT (of the abstract entered in Block 20, if different from Report)		
18. SUPPLEMENTARY NOTES		
19. KEY WORDS (Continue on reverse side if necessary and identify by block number)		
Water Resources Development Ellicott Creek		
20. ABSTRACT (Continue on reverse side if necessary and identify by block number)		
Increasing population, urbanization and planned development with in the next few years by the State University of New York (SUNYAB), Urban Development Corporation (UDC), New York State Department of Transportation (DOT), and Planned Environment Systems incorporated require efficient use of water resources in the Ellicott Creek Basin. There is, therefore, an increasing demand for water supply, flood control, outdoor recreation, water quality, preservation of the natural environment, and fish and wildlife conservation. The report is a restudy of a survey report completed in 1970 that recommended construction of a dam →		

SECURITY CLASSIFICATION OF THIS PAGE(When Data Entered)

→ and multi-purpose reservoir at Sandridge with downstream channel improvement. The present study considers current and future problems, desires and needs of residents and other interests in the Ellicott Creek Basin, projects, future needs, and recommends the most viable solution to meet the significant short and long term water resources and related needs.

SECURITY CLASSIFICATION OF THIS PAGE(When Data Entered)



PHASE 2, VOLUME 2, APPENDICES
ELLICOTT CREEK BASIN, NEW YORK (AUGUST 1973)

PEN AND INK CHANGES

- | Page No. | Change |
|----------|---|
| E-17 | Following paragraph 6.3.1.1. (f) add "The requirement that the local interests assume all costs in connection with fulfillment of the local flood protection requirements is subject to limitation set forth in Section 3 of the 1936 Flood Control Act. In accordance therewith, should their costs for lands and relocations exceed Federal costs for construction, local interests are entitled to reimbursement of one-half of the excess." |
| E-18 | At the bottom of the page add "The total estimated first costs for the required local cooperation for the local flood protection measures, \$6,233,000, exceeds the estimated Federal cost for construction, \$3,925,000, by \$2,308,000. Pursuant to Section 3 of the 1936 Flood Control Act local interests would be entitled to reimbursement of one-half of, the excess, \$1,154,000. Accordingly, total project costs apportioned to local interests would amount to a net \$5,449,000. Federal first costs would amount to \$4,295,000 plus \$1,154,000, a total of \$5,449,000." |
| E-24 | Prior to "Effect floodplain management by:" add "The requirement that local interests assume all costs in connection with fulfillment of the local flood protection requirements is subject to limitation set forth in Section 3 of the 1936 Flood Control Act. In accordance therewith, should their costs for lands and relocations exceed Federal costs for construction, local, interests are entitled to reimbursement of one-half of the excess." |
| A-30 | Paragraph 22.7, third line from bottom, change Plate A2, to A-11.

Paragraph 23.1, last line, sentence should read-ETL 1110-2-120, May 1971 and ETL 1110-2-1601 dated July 1970. |

Accession No. _____
Date _____
By _____
Series _____
Volume _____
Page _____
A

INTRODUCTION

This volume, entitled Appendices, is the second of two volumes of the Phase 2 report for the Ellicott Creek Review Survey. It and its companion volumes, Phase 2 Volume I, Main Report, and the Environmental Impact Assessment, present the concluding stages of the Ellicott Creek Review Survey.

Presented herein are the technical details of the four alternatives examined in depth as part of the Phase 2 studies. These details permit a comparison of the proposals and an evaluation of each one's advantages and disadvantages.

A recommendation on a proposed Project is provided in Appendix E.

TABLE OF CONTENTS

APPENDIX A -> HYDROLOGY AND HYDRAULIC DESIGN .

APPENDIX B -> FLOOD DAMAGES AND BENEFITS

APPENDIX C -> CONSERVATION BENEFITS

APPENDIX D -> PLANS OF IMPROVEMENTS AND
ESTIMATES OF COST

APPENDIX E - PLAN FORMULATION AND COST
ALLOCATION

APPENDIX F - NON-FEDERAL ALTERNATIVES

APPENDIX G - GEOTECHNICAL ASPECTS

GENERAL PLATES

LIST OF GENERAL PLATES

<u>Number</u>	<u>Title</u>
1	Basin Map
2	Flooded Areas, Mile 0 to 10
3	Flooded Areas, Mile 10 to 22
4	Major Channel Improvements
5	Diversion Channel
6	Minor Channel Improvements
7	Considered Improvements
8	Sandridge Dam Plan and Section and Harlow Road Section
9	Damage Reaches and Flooded Area Map
10	Bowmansville Reservoir & Pavement Road Dam

APPENDIX A - HYDROLOGY AND HYRDAULIC DESIGN

LIST OF TABLES

LIST OF PHOTOGRAPHS

LIST OF PLATES

<u>HYDROLOGY</u>	<u>Page</u>
1 - GENERAL	A-1
2 - CLIMATOLOGY.	A-1
3 - PRECIPITATION.	A-1
4 - SNOWFALL	A-4
5 - TEMPERATURE.	A-4
6 - RUNOFF AND STREAMFLOW DATA	A-4
7 - MAXIMUM KNOWN FLOODS	A-7
8 - NOTABLE STORMS	A-9
9 - UNIT HYDROGRAPHS	A-10
10 - STANDARD PROJECT FLOOD	A-11
11 - PROBABLE MAXIMUM FLOOD AND SPILLWAY DESIGN FLOOD.	A-12
12 - RESERVOIR RULE CURVE OPERATIONS.	A-15
13 - RATING CURVES UNDER EXISTING CONDITIONS.	A-21
14 - RATING CURVES FOR CONDITIONS WITH LOCAL IMPROVEMENTS	A-22
15 - RATING CURVES FOR CONDITIONS WITH SANDRIDGE RESERVOIR	A-22
16 - RATING CURVES FOR CONDITIONS WITH BOWMANSVILLE AND PAVEMENT RESERVOIRS.	A-22
17 - DISCHARGE-FREQUENCY CURVES, EXISTING CONDITIONS	A-23
18 - DISCHARGE-FREQUENCY CURVES, IMPROVED CONDITIONS.	A-24
19 - EVAPORATION.	A-26
20 - SEDIMENTATION.	A-27
 <u>HYDRAULIC DESIGN CRITERIA FOR CHANNEL IMPROVEMENTS</u>	
21 - DESIGN DISCHARGES.	A-27
22 - CHANNEL DESIGN	A-28
23 - BANK PROTECTION.	A-30
24 - INTERNAL DRAINAGE.	A-30

HYDRAULIC DESIGN CRITERIA FOR THE
CONSIDERED SANDRIDGE DAM AND RESERVOIR

25 - DESCRIPTION	A-31
26 - AREA-VOLUME CURVE	A-33
27 - RESERVOIR POOL ELEVATIONS	A-33
28 - SPILLWAY DESIGN	A-34
29 - ALTERNATE SPILLWAYS	A-34
30 - LOW-LEVEL OUTLET WORKS.	A-35
31 - STILLING BASIN	A-36
32 - TAILRACE CHANNELS	A-36
33 - DIVERSION DURING CONSTRUCTION	A-37
34 - SPILLWAY APPROACH CHANNEL	A-38
35 - SPRING CREEK DIVERSION.	A-38
36 - OTHER STRUCTURES.	A-38

HYDRAULIC DESIGN FOR
THE DIVERSION CHANNEL

37 - DESIGN DISCHARGE.	A-39
38 - CHANNEL DESIGN	A-39
39 - INTERNAL DRAINAGE	A-40
40 - ELLICOTT CREEK CROSSING	A-40

HYDRAULIC DESIGN CRITERIA FOR
THE CONSIDERED BOWMANSVILLE-
PAVEMENT SCHEME

41 - DESCRIPTION	A-41
42 - AREA-VOLUME CURVES	A-41
43 - RESERVOIR POOL ELEVATIONS	A-42
44 - SPILLWAY DESIGN	A-42
45 - ALTERNATE SPILLWAYS	A-43
46 - LOW LEVEL OUTLET WORKS	A-44
47 - STILLING BASIN	A-44
48 - TAILRACE CHANNELS	A-45
49 - DIVERSION DURING CONSTRUCTION	A-46

LIST OF TABLES

<u>Number</u>	<u>Title</u>	<u>Page</u>
A1	Climatological Stations Adjacent to the Ellicott Creek Basin	A-2
A2	Average Monthly Precipitation in Inches	A-3
A3	Average Monthly Snowfall in Inches	A-5
A4	Average Monthly Temperature in Degrees Fahrenheit	A-6
A5	Peak Discharges of Major Floods on Ellicott Creek at the Williamsville Gaging Station	A-8
A6	Table of Correlation Coefficients	A-17
A7	Design Discharges for Considered Local Improvements, Reaches 0-4	A-19
A8	Closure Structures Required on Ellicott Creek	A-32

LIST OF PLATES

<u>Number</u>	<u>Title</u>
A1	Climatologic and Hydrologic Station Map
A2	3-Hour Unit Hydrograph
A3	Standard Project Flood Hydrograph at Williamsville Gage
A4	Sandridge Reservoir Synthetic 1-Hour Unit Hydrograph
A5	Sandridge Reservoir Spillway Design Flood Inflow and Outflow Hydrograph
A6	Mean Monthly Flow Frequency Curves - Ellicott Creek
A7	Mean Daily Flow Frequency Curves - Ellicott Creek
A8	Rule Curve Operation and Maximum Mean Daily 100-Year Flow
A9	Stage-Discharge Curves - Reaches 0 through 4
A10	Stage-Discharge Curves - Reaches 4A through 12
A11	Discharge-Frequency Curves - Reaches 0 and 1
A12	Discharge-Frequency Curves - Reach 2
A13	Discharge-Frequency Curves - Reaches 3 and 4
A14	Discharge-Frequency Curves - Reaches 4A through 7
A15	Discharge-Frequency Curves - Reach 8
A16	Discharge-Frequency Curves - Reach 9
A17	Discharge-Frequency Curves - Reach 10
A18	Discharge-Frequency Curves - Reach 11

List of Plates - 2

<u>Number</u>	<u>Title</u>
A19	Discharge-Frequency Curves - Reach 12
A20	Area-Volume Curve at the Proposed Sandridge Reservoir
A21	Bowmansville Reservoir Spillway Design Flood Inflow and Outflow Hydrograph
A22	Pavement Reservoir Spillway Design Flood Inflow and Outflow Hydrograph
A23	Area-Volume Curve at the Proposed Bowmansville Reservoir
A24	Area-Volume Curve at the Proposed Pavement Reservoir

LIST OF PHOTOGRAPHS

<u>Number</u>	<u>Subject</u>
Photo 1	Flooding in Ellicott Creek County Park, March 1936 Flood
Photo 2	Flooding in the Town of Amherst, March 1936 Flood
Photo 3	Flooding in the Town of Amherst, March 1956 High Water Occurrence
Photo 4	Flooding in the City of Tonawanda, January 1959 Flood
Photo 5	Flooding in Village of Williamsville, March 1960 Flood
Photo 6	Flooding in Town of Cheektowaga, March 1960 Flood

APPENDIX A - HYDROLOGY AND HYDRAULIC DESIGN

HYDROLOGY

1 - GENERAL

1.1 - Ellicott Creek is the largest tributary of Tonawanda Creek and drains an area of approximately 110 square miles in Erie, Genesee and Wyoming counties. Its source is about 22 miles easterly of Buffalo, at an elevation about 1,300 feet above mean sea level. It flows in a northwesterly direction, discharging into the canalized section of Tonawanda Creek at an elevation of approximately 564 feet. The topography of the watershed varies from flatlands near the mouth to steep hills around the headwaters. Near the headwaters, the stream flows through steep valleys and is fed by small streams and gullies from the hillsides. The stream pursues a meandering course and achieves a total length of approximately 47 miles in a basin roughly 27 miles long. The slope of the stream varies from about 2 feet per mile in the flatlands near its mouth to about 70 feet per mile near the headwaters. There is a precipitous drop of about 60 feet over a length of about 0.2 miles in the village of Williamsville. The Ellicott Creek basin is shown on Plate A1.

2 - CLIMATOLOGY

2.1 - There are no climatological stations located in the Ellicott Creek basin. The seven precipitation stations and one first-order weather station located adjacent to the basin are shown on Plate A1. The first-order weather station is located at Greater Buffalo International Airport. Type, location and period of record for each are shown in Table A1.

3 - PRECIPITATION

3.1 - The average annual precipitation for the eight stations is 35.36 inches. Table A2 shows monthly and yearly average precipitation for each of the stations and the combined averages for the eight stations. The monthly averages vary from a minimum of 2.5 inches in February

TABLE A1 - Climatological Stations Adjacent
to the Ellicott Creek Basin

Station-Name:	Index No.:	County:	Latitude:	Longitude:	Elevation:	Record (1):	Years:
ARCADE	: 0220	: Wyoming	: 42°32'	: 78°25'	: 1,490	: NR,S,T,P	: 46
BATAVIA	: 0443	: Genesee	: 43°00'	: 78°11'	: 900	: NR,S,T,P	: 38
BUFFALO WB AIRPORT	: 1012	: Erie	: 42°56'	: 78°44'	: 705	: R,S,T,P,J	: 112
LINDEN	: 4767	: Genesee	: 42°53'	: 78°10'	: 1,120	: NR,S,P	: 56(2)
LOCKPORT 2 NE:	4844	Niagara	43°11'	78°39'	520	NR,S,T,P	83
STAFFORD	: 8152	: Genesee	: 42°59'	: 78°05'	: 915	: NR,S,T,P	: 37(2)
WALLES	: 8910	: Erie	: 42°45'	: 78°31'	: 1,090	: R,P	: 21
WARSAW 5 SW	: 8962	: Wyoming	: 42°41'	: 78°12'	: 1,715	: NR,S,T,P	: 17

(1) Type of record code:

R-recording gage
NR-non-recording gage
S-snowfall and snow on ground

T-temperature
P-precipitation
J-supplemental data

(2) Station discontinued in 1968

TABLE A2 - Average Monthly Precipitation in Inches¹

Station	:Jan.:	Feb.:	Mar.:	Apr.:	May :	June:	July:	Aug.:	Sep.:	Oct.:	Nov.:	Dec.:	Annual
ARCADE	: 3.17:	2.61:	3.01:	3.19:	4.01:	4.17:	3.91:	3.64:	3.66:	3.36:	3.10:	3.10:	40.93
BATAVIA	: 2.19:	2.25:	2.60:	2.99:	3.10:	2.77:	2.89:	3.08:	2.72:	2.60:	2.58:	2.26:	32.03
BUFFALO WB AIRPORT	: 3.11:	2.83:	2.84:	2.62:	2.93:	2.78:	2.89:	2.94:	3.09:	3.18:	3.14:	3.20:	35.55
LINDEN	: 2.37:	2.30:	2.61:	3.01:	3.07:	3.46:	3.25:	3.28:	3.06:	3.19:	2.92:	2.31:	34.83
LOCKPORT 2 NE	: 2.39:	2.44:	2.49:	2.78:	3.11:	2.46:	2.65:	3.04:	2.87:	2.73:	2.68:	2.41:	32.05
STAFFORD	: 2.21:	2.24:	2.42:	2.89:	3.02:	2.69:	2.84:	2.94:	2.81:	2.65:	2.48:	2.08:	31.27
WALES	: 2.92:	2.51:	3.36:	3.39:	3.09:	2.64:	3.24:	2.94:	3.04:	3.11:	3.05:	3.19:	36.48
WARSAW 5 SW	: 2.92:	2.81:	3.43:	4.00:	3.20:	3.46:	3.19:	4.25:	3.05:	3.55:	2.99:	2.84:	36.69
AVERAGE	: 2.66:	2.50:	2.85:	3.11:	3.19:	3.05:	3.11:	3.26:	3.04:	3.05:	2.87:	2.67:	35.36

Years of record to 1967

to a maximum of 3.26 inches in August. The lowest average monthly precipitation, 2.19 inches, is found at Batavia in January, whereas the highest average monthly precipitation, 4.25 inches, is found at Warsaw in August. Average annual precipitation varies from 31.27 inches at Stafford to 40.93 inches at Arcade.

4 - SNOWFALL

4.1 - The average annual snowfall for the stations shown in Table A3 is 80.6 inches. The highest average monthly snowfall is 22.4 inches in January at Arcade.

5 - TEMPERATURE

5.1 - The average annual temperature, for the six stations recording temperature, is 46.6 degrees F. July is the warmest month and January the coldest, with average monthly temperatures of 69.2 and 23.3 degrees F, respectively. Table A4 shows the average monthly temperatures.

6 - RUNOFF AND STREAMFLOW DATA

6.1 - Two continuous recording stream gauging stations have been operated by the U.S. Geological Survey on Ellicott Creek in Erie County, New York. One is located on the downstream side of Wehrle Drive bridge in the village of Williamsville, and measures the discharge from an area of 75 square miles. The other was located on the downstream side of Walden Avenue bridge in Millgrove and measured the discharge from an area of 40.7 square miles. The Erie County Department of Public Works has maintained staff gages at the Niagara Falls Boulevard and Stoney Road bridge sites since 1961. A new gage was installed in 1972 on the upstream side of Sheridan Drive Bridge. It covers a drainage area of 77.6 square miles.

6.2 - The Millgrove gage was established in March 1963 but its record is too short and it has not been used in this study. This gage was discontinued on September 30, 1969 because of budgetary restrictions. The first record of stages and discharges at the Williamsville gage began on October 14, 1955 with the installation of a wire-weight gage located at Wehrle Drive bridge. On December 17, 1958,

TABLE A3 - Average Monthly Snowfall in Inches

Station	Jan.	Feb.	Mar.	Apr.	May	June	July	Aug.	Sep.	Oct.	Nov.	Dec.	Annual
ARCADE	22.4	17.5	15.2	4.1	0.3	T	0	0	T	1.3	11.8	19.6	92.2
BATAVIA	20.1	21.5	16.0	4.2	0.3	0	0	0	T	0.3	11.3	17.9	91.6
BUFFALO WB AIRPORT	19.6	17.6	11.5	3.2	0.2	0	0	0	T	0.4	7.9	18.0	78.4
LINDEN	19.7	19.2	13.1	2.9	0	0	0	0	0	T	10.4	14.8	80.0
LOCKPORT 2 NE	12.5	13.3	9.8	2.1	T	0	0	T	T	0.1	5.7	10.4	53.9
STAFFORD	16.1	18.1	15.1	3.0	T	0	0	0	0	2.0	8.9	13.6	75.0
WARSAW 5 SW	18.5	17.3	19.6	7.0	0.3	0	0	0	0	0.5	12.5	17.2	92.9
AVERAGE	18.4	17.7	14.3	3.7	0.2	T	0	T	T	0.7	9.7	15.9	80.6

T-Trace race.

TABLE A4 - Average Monthly Temperature in Degrees Fahrenheit

Station	:Jan.:	Feb.:	Mar.:	Apr.:	May	:June:	July:	Aug.:	Sep.:	Oct.:	Nov.:	Dec.:	Annual
ARCADE	:21.2:	24.6:	30.0:	44.5:	54.8:	63.4:	67.1:	66.1:	59.4:	49.2:	38.1:	25.6:	45.3
BATAVIA	:23.9:	25.2:	32.6:	44.9:	55.4:	65.5:	69.2:	68.1:	61.2:	51.4:	39.2:	27.3:	47.0
BUFFALO WB AIRPORT	:25.0:	24.7:	32.0:	43.0:	54.3:	64.8:	70.1:	68.5:	62.3:	51.1:	39.4:	29.2:	47.1
LOCKPORT 2 NE	:25.3:	25.3:	32.7:	44.8:	56.1:	66.2:	71.1:	69.6:	62.4:	52.0:	40.0:	28.8:	47.9
STAFFORD	:24.7:	24.7:	32.6:	45.4:	57.0:	66.9:	71.3:	69.4:	62.4:	52.0:	39.7:	28.3:	47.9
WARSAW 5 SW	:19.9:	22.9:	28.1:	44.3:	44.3:	63.0:	66.6:	65.7:	59.3:	49.6:	37.1:	24.6:	44.6
AVERAGE	:23.3:	24.6:	31.3:	44.5:	53.6:	65.0:	69.2:	67.9:	61.2:	50.9:	38.9:	27.3:	46.6

this gage was replaced with a recording gage and continuous records are available to date. The Williamsville and Millgrove gage sites are approximately 15 miles and 4 miles downstream, respectively, from the considered Sandridge damsite.

6.3 - The Williamsville gage gives fairly accurate representation of peak flows in the upper reaches of Ellicott Creek because flows are only moderately affected by valley storage. Downstream from Williamsville, however, conditions differ. Comparisons of discharge measurements made during flood stages at Niagara Falls Boulevard, with discharges recorded at the Williamsville gage during the same floods, show that the peak discharge for a given flood is often considerably less at Niagara Falls Boulevard than at the Williamsville gage even though the former has approximately 26 square miles more drainage area than the latter. This reduction in discharge is created by low banks and flat topography which provide abundant overbank storage in the reaches of Ellicott Creek below Williamsville.

7 - MAXIMUM KNOWN FLOODS

7.1 - Historical documents state that two floods of approximately equal magnitude occurred in March 1916 and January 1929. The greatest known flood in the study area occurred on March 17, 1936, although the 1916 and 1929 flood stages exceeded the 1936 flood at various locations. The maximum recorded flood at the Williamsville gage occurred in March 1960 as a result of 5 days of snowmelt which caused a large amount of runoff from the 8 inches of snow covering the area. Other floods probably occurred prior to 1916, but no definite dates or stages can be established because of the lack of development and records in the area at the time. Based on high watermarks obtained from newspaper articles and local residents, the peak discharge of the 1936 flood and other notable floods which occurred prior to the period of record have been estimated by the Buffalo District. The estimated discharges of these, and the recorded discharges of recent floods, are shown in Table A5.

TABLE A5 - Peak Discharges of Major Floods
on Ellicott Creek at the
Williamsville Gaging Station

Year	Date	Discharge (cfs)	cfs/sq mi
1916	March 28	5,000 (1)	67
1929	January 18	5,000 (1)	67
1936	March 25	6,500 (1)	87
1940	April 1	4,100 (1)	55
1955	December 5	1,910	25
1956	March 7	2,510	33
1957	January 23	2,410	32
1960	March 31	4,860 (2)	65
1963	March 18	4,040	54
1964	March 5	1,890	25
1966	February 12	2,110	28
1972		3,300 (1)	43

(1) Estimated by Buffalo District

(2) Maximum discharge of record

8 - NOTABLE STORMS

8.1 - The major damaging floods in the Ellicott Creek basin have often been caused by melting snow, coincident with moderate amounts of precipitation. Although damaging floods have occurred, and can occur, at all times of the year, almost all major floods have occurred in the late winter or early spring (January - April). Relatively few damaging floods have been produced by precipitation alone. This is due to the orientation of the basin with respect to the usual direction of travel of frontal systems in this area. Ellicott Creek flows generally in a west-northwesterly direction, whereas the frontal systems normally travel from west to east.

8.2 - Since no discharge records are available prior to 1955, the peak discharges of many of the major floods on Ellicott Creek have been estimated from high watermarks supplemented by information obtained from newspaper articles and interviews with local residents. The greatest discharge in the last 50 years reportedly occurred in March 1936. This flood was caused by heavy snowmelt. A rare summer flood occurred the following year, in June 1937, as a result of intense rainfall on the already saturated watershed. Although the peak discharge has not been determined due to lack of high-watermark data, the storm is well documented. Heavy rainfall was recorded on June 17 - 18 and again during June 20 - 21. A total of 4.26 inches was recorded for this period of which 1.5 inches fell in a 3-hour period on June 21. From a study of this storm, it appears that the storm center entered the basin from the southwest, then veered easterly so as to travel almost parallel to the Ellicott Creek basin.

8.3 - The January 1929 flood was produced by a sudden thaw accompanied by a 48-hour rain. Of the total 1.51 inches of precipitation that fell, 1.09 inches fell on January 18. At the same time the temperature rose to a maximum of 62 degrees F and remained above freezing until the evening of January 19. The Amherst Bee newspaper indicated this flood to be the most destructive flood on record at that time and stated that several foundations and homes were washed away.

8.4 - The March 1936 flood was produced by a sudden thaw following a record snowfall, as reported at the Buffalo Weather Bureau Airport Station. A record 38.5 inches of snow fell during the month of March, of which 19.5 inches fell on March 17 - 18. The maximum and minimum temperatures recorded for the period March 18 through 22 were 35 and 25 degrees F, respectively. On March 23 a warming trend



PHOTO 1- Photo showing the depth of flooding in Ellicott Creek County Park during the March 1936 flood. This park is located in the town of Tonawanda. Even with the depth of flooding indicated, only minor damages were sustained to the park and its facilities. Example of excellent flood plain usage.



PHOTO 2 - Photo showing flooding conditions on Sweet Home Road near the intersection of North Ellicott Creek Road near creek mile 4.8 in the town of Amherst during the March 1936 flood.



PHOTO 3- Photo showing flooding conditions on North Forest Road near the intersection of Maple Road in the town of Amherst, near creek mile 9.3 during the March 1956 high water occurrence. This intersection is the initial point where Ellicott Creek overflows its banks.



PHOTO 4- Photo showing flooding conditions on Frederick Road in the city of Tonawanda, near creek mile 1.5, during the January 1959 flood.



PHOTO 5- Photo showing flooding conditions in the vicinity of Lehn Springs Drive in the village of Williamsville during the March 1960 flood.



PHOTO 6- Photo shows flood water flowing over Rein Road near creek mile 16.1 in the town of Cheektowaga during the March 1960 flood.

began and extended through to March 27. During this period, the temperature reached a maximum of 55 degrees F on March 24 and remained above freezing for the 5-day period. Although the flooding conditions were not so severe as the January 1929 flood in the village of Williamsville, it was considered by local residents to be even more destructive than the 1929 flood. Experts agree that never in the records of the town has such a volume of water passed under the Main Street bridge in Williamsville. Three vehicular bridges were destroyed. Many farmers in the area south of the village limits were stranded and helpless to render aid to suffering livestock and damaged property because of being totally surrounded by high water. Many residents in the flood areas suffered first-floor damage in their homes. Rescue parties carried food and drinking water to the marooned residents by flat-bottom boats. Photographs 1 and 2 show flooding conditions during this flood.

8.5 - The March 1960 flood was also produced by a sudden thaw following the second coldest March on record. Temperatures for the period March 1 through March 26 averaged only 20 degrees F, with a high of 35 degrees F and a low of -2 degrees F. Temperatures began to rise on March 27 to 54 degrees F and continued above 50 degrees F for the 5-day period to March 31. The maximum temperature was recorded on March 30 at 69 degrees F and on March 29 it was 67 degrees F. This 5-day period of above-freezing temperatures caused a large amount of runoff from the 8 inches of snow covering the area. The creek crested at 5:00 a.m. on March 31, at 8.99 feet, which is the maximum stage of record at the Williamsville gage. Photographs 3 and 4 show flooding conditions in the study area.

9 - UNIT HYDROGRAPHS

9.1 - In 1968 the Army Corps of Engineers, Buffalo District, under the authorization of Section 214 of the Flood Control Act of 1965, developed generalized curves for determining the Clark unit graph parameters, T_c and R , for any ungaged location within the Erie-Niagara basin of New York State. These curves were developed after a considerable number of flood hydrographs has been reproduced at the various gage station within the basin. During this study, a 3-hour unit graph was developed at the Ellicott Creek gage location which gave good flood hydrograph reproductions for both the storms of April 24 - 26, 1961 and April 19 - 23,

1963. The values of peak discharge and lag time were found to be 1,800 cfs and 25.5 hours, respectively. This unit graph is shown on Plate A2 and was used to develop the standard project flood at Williamsville which is subsequently discussed.

9.2 - Synthetic unit graphs are required at various ungaged locations in the basin for the development of the probable maximum and spillway design floods. These unit graphs have been derived from the above generalized curves. The synthetic unit graphs have been slightly modified, however, following extensive routing studies, so that when routed and combined at Williamsville, the resulting "total" unit graph closely approximates the unit graph developed from the 1961 and 1963 storm studies.

10 - STANDARD PROJECT FLOOD

10.1 - The standard project storm (SPS) determination has been carried out in accordance with Civil Engineer Bulletin 52-8. SPS index rainfall is 10 inches for a duration of 96 hours. Since the Ellicott Creek basin meets the criteria for small drainage basins discussed in Paragraph 2-03b of the above reference, the simplified procedure has been used. This permits the rainfall values to be determined directly from the depth-area curves without preparing an isohyetal pattern for basin shape correction.

10.2 - The standard project flood (SPF) hydrograph has been computed using the Hydrologic Engineering Center program 23-J2-L228. The total rainfall for the SPS amounts to 13.5 inches and, deducting losses of 2.62 inches, the runoff amounts to 10.88 inches. Losses are based on an initial loss of 0.5 inches and an infiltration rate of 0.05 inches per hour. The standard project flood peak and lag time have been calculated to be 17,400 cfs and 28.5 hours, respectively, and are shown on Plate A3. The unit hydrograph and standard project flood flow determination were submitted to the Office, Chief of Engineers, through North Central Division, by letter dated January 12, 1970. North Central Division concurred by first endorsement dated January 26, 1970 and the Office, Chief of Engineers, approved the estimate by the second endorsement dated February 5, 1970.

11 - PROBABLE MAXIMUM FLOOD AND
SPILLWAY DESIGN FLOOD

11.1 - The probable maximum flood and spillway design flood estimates for use in the design of the Sandridge dam and reservoir have been prepared in accordance with EM 1120-2-101, Paragraphs 1-70 and 1-77c, "Survey Investigations and Reports" dated October 12, 1964. They were submitted to North Central Division by letter dated November 20, 1969. North Central Division concurred by first endorsement dated December 3, 1969 and the Office, Chief of Engineers, approved the estimate by second endorsement dated December 23, 1969.

11.2 - Synthetic 1-hour unit hydrographs under reservoir conditions have been determined using Clark's method of synthesis for each subarea. The total drainage area upstream of the damsite is separated into three land subareas and 2.5 square miles of reservoir pool area. Subarea 1 (local area) has a drainage area of 8.5 square miles; subarea 2 (Spring Creek area) has a drainage area of 6.4 square miles. Both of these areas drain directly into the reservoir pool. Subarea 3 (Eleven Mile Creek), having a drainage area of 15.7 square miles, covers the remainder of the total drainage area. This area does not drain directly into the reservoir pool.

11.3 - The unit hydrographs of these three land subareas have been combined to obtain one unit hydrograph for the entire land area that drains into the reservoir. To this unit hydrograph, the unit hydrograph for the reservoir surface area is added to obtain the unit hydrograph for the drainage area upstream of the dam. The peak ordinate of this 1-hour unit hydrograph is then increased by 25 percent for calculation of the spillway design flood under reservoir conditions. This has been done in accordance with instructions contained in EM 1110-2-1405 and an article contained in the May 1964, Journal of the Hydraulics Division of the American Society of Civil Engineers, written by Franklin F. Snyder. It states that consideration should be given to increasing the unit hydrograph peaks by 25 to 50 percent when unit hydrographs are based on floods of relatively small volume of runoff compared to the magnitude of the spillway design flood.

11.4 - The probable maximum flood hydrograph has been determined by applying the increments of expected rainfall excess to the ordinates of the synthetic 1-hour unit hydrograph for the 33.1 square miles of drainage area upstream of the damsite. The 24-hour probable maximum precipitation index from Hydrometeorological Report No. 33,

dated April 1956, of 22 inches has been reduced by 18 percent, in accordance with criteria defined by the "Hop Brook Letter", Office, Chief of Engineers, 1964.

11.5 - By applying the rainfall excess to the 1-hour unit hydrograph, the resulting inflow hydrograph for the spillway design flood indicates a peak discharge of 66,600 cfs. To develop the outflow hydrograph for the spillway design flood through the reservoir, it is assumed that the reservoir has been filled to the maximum flood control pool elevation at this inception of the flood. Routing of the spillway design flood through the reservoir results in a peak discharge of 40,500 cfs. The 1-hour unit hydrograph and spillway design flood inflow and outflow hydrographs for the Sandridge damsite are shown on Plates A4 and A5.

11.6 - For comparison purposes, a synthetic 1-hour unit hydrograph has also been developed for the drainage area upstream of the damsite of 33.1 square miles under natural conditions. The rainfall excess from the probable maximum storm is also applied to the 1-hour unit hydrograph at the damsite under natural conditions (with peak increased 25 percent). This produces a peak discharge of 40,200 cfs. In effect this shows that the peak outflow for such a catastrophic flood would be dampened by the considered reservoir.

11.7 - The probable maximum flood and spillway design inflow flood estimates for use in the design of the Bowmansville and Pavement dams and reservoirs have been prepared utilizing the standard project flood hydrographs computed for the Williamsville gaging station. The Standard Project Flood has been obtained by prorating the ordinates of the Standard Project Flood hydrograph at the Williamsville gaging station by the ratio of the respective drainage areas at the Bowmansville and Pavement sites to that and at the Williamsville gaging location. The Probable Maximum Flood hydrographs are obtained by increasing the ordinates of the SPF hydrographs by a further fraction of 2.5 to reflect flood flows under the PMF conditions. This fraction of 2.5 is based on a 100 percent increase of the SPF hydrograph to account for the increased precipitation over and above the SPF causing the PMF as outlined in Civil Engineering Bulletin 52-B, paragraph 2-04, "Standard Project Flood Determination," March 1952, while the remaining 50 percent increase is to account for the more efficient runoff condition with the presence of reservoirs in the described

locations.

11.8 - In the determination of the probable maximum inflow flood hydrograph for the Bowmansville location, it is assumed that no flood attenuation is provided by the upstream Pavement Reservoir, in view of the latter's very small storage capacity relative to the volume of the flood hydrograph.

11.9 - The resulting inflow hydrographs for the spillway design floods for the Bowmansville and Pavement locations have peak discharges of 40,020 cfs and 36,190 cfs. To develop the outflow hydrographs for the spillway design floods through these two reservoirs, the criteria adopted reflect the assumption that the reservoir water level's at the inception of the floods are slightly different from those for the case of the Sandridge Reservoir. In the Bowmansville-Pavement scheme, it is assumed that the reservoirs are at their normal operating water levels at the inception of the floods. Routing the spillway design floods through the respective reservoirs, with uncontrolled spillways, results in peak discharges of 39,220 cfs and 35,870 cfs respectively for the Bowmansville and Pavement reservoirs. Because of the very large volume in these flood hydrographs relative to small storage capacities, no appreciable flood attenuation is realized. The spillway design inflow and outflow flood hydrographs for these two locations are shown on Plates A-21 and A-22.

11.10 - Alternately, if control spillways were to be located at the outlets of the reservoirs, the routed peak discharges are computed to be 38,800 cfs and 36,000 cfs respectively for the Bowmansville and Pavement Reservoirs.

12 - RESERVOIR RULE CURVE OPERATIONS

12.1 - Past records show that most floods on Ellicott Creek occur in the late winter or early spring. The demand for reservoir storage for other purposes is greatest in the summer, a time when it appears there is only a limited need for flood protection. To make the best possible use of available water resources, it would be desirable to provide a large impoundment at the beginning of the summer recreation season each year, if this does not reduce the degree of flood protection. Studies have been made to analyze the need for flood control storage on a monthly basis. The studies conducted and the rule curve developed from them are discussed in the following paragraph.

12.2 - The objective of the rule curve operation is to draw down the reservoir during the winter below the summer conservation pool elevation. During the recreation season there would be evaporation losses and some drawdown for low-flow augmentation and municipal water supply.

12.3 - Mean monthly flow frequencies for the Williamsville gage, located downstream of the reservoir, have been prepared by applying the methods found in "Statistical Methods in Hydrology", Leo R. Beard, dated January 1962. The analysis used includes both the high and low mean monthly flow frequencies for the historic record. The results of these studies are plotted on a composite frequency curve for all months for frequencies ranging from the maximum 100-year to the minimum 100-year monthly flow in convenient, intermediate steps. This material is of limited value because the record at the Williamsville gage goes back only to 1956. Extension of the Ellicott Creek record through the use of correlation analyses is used as a means of extending the historic record over a period more appropriate for planning purposes. Two U.S. Geological Survey gaging stations have been used to extend the Ellicott Creek record, including the Cayuga Creek gage located at Lancaster, N.Y., just south of the Ellicott Creek basin. It has a continuous record from 1939 to the present. A second station used for correlation purposes is located at Linden on Little Tonawanda Creek. This station has the longest historic record in the area, extending back to 1913 and overlapping the Ellicott Creek record from 1956 to the present. The records of Cayuga Creek and Little Tonawanda Creek have been correlated with the Ellicott Creek records by months using the methods described in Beard's text.

12.4 - Correlation coefficients (R), which define the proportion of variance of the dependent variable that has been defined using regression equations, are tabulated by months for each of the two stations in Table A6. A two-station correlation analysis has also been attempted, but does not produce significantly better results than the individual station analysis and is not used.

12.5 - It will be noted from Table A6 that the coefficients obtained for the winter and spring flows, during which historic flood events have occurred, are quite high. Those coefficients for the summer events do not account for as much of the variance as may be desired. However, low-correlation coefficients in the summer are, in part, the result of flows being added to Ellicott Creek from a quarrying operation above the gauge. For this reason, it is felt that a good correlation during the low-flow summer months, when these additions will constitute a larger share of the flow, is not possible. As a check on the accuracy of the reconstituted flow information, a historic monthly mass curve analysis has been prepared and compared with mass curves of Ellicott Creek flows developed independently using the Cayuga Creek and Little Tonawanda Creek flows for the same period. The total variation in flow volume for the 10-year period from 1957 through 1966 is found to be less than 1 percent of the total runoff volume for each reconstituted record. This accuracy is considered acceptable, and the flow records for Ellicott Creek were extended as described below.

12.6 - Using the regression equations developed in the analysis described above, monthly flow records for Ellicott Creek have been generated for the period from 1939 to 1956, using Cayuga Creek flows as the generating mechanism. Ellicott Creek flows, from the period 1913 to 1939, have been generated using Little Tonawanda Creek flows as the generating data. The entire record, both generated and historic, from 1913 through 1967, has then been analyzed to develop flow frequency analysis by months for the entire period. The record prior to 1956 is computed using Cayuga Creek gage records because it has a better correlation with the Ellicott Creek gage than the Little Tonawanda gage. The generation of the record before 1939 is accomplished using Little Tonawanda gage record since this is the only long-term station available. A plot of the minimum and maximum mean monthly flow frequencies developed from the extended flow records is shown on Plate A6.

12.7 - Maximum mean daily flows by months are analyzed next. Flood peaks experienced historically on Ellicott Creek have been of relatively short duration, falling wholly within 1-day periods in each instance. Flood volume analyses of mean daily flows are, therefore, felt to be a significant guide in developing the reservoir storage required to contain a major Ellicott Creek flooding event. The historic mean daily flow records for the Williamsville gage have been analyzed as well as the reconstituted extended record using the methods described in Beard's text. The maximum mean daily flows have been

TABLE A6 - Table of Correlation Coefficients

Month	R for Ellicott and Cayuga	R for Ellicott and L. Tonawanda
January	.981	.921
February	.916	.966
March	.927	.923
April	.928	.842
May	.978	.932
June	.763	.792
July	.350	-
August	.960	.582
September	.953	.579
October	.846	.768
November	.775	.370
December	.741	.855

converted to runoff in inches per day for the basin, by months, to define the maximum amount of storage that would be required to contain specific return frequency floods. A composite curve of mean daily flow frequencies has been prepared by months in a manner similar to that used for the mean monthly flows described earlier. Plate A7 contains the frequencies for the extended record. From this analysis, the peak storage required to completely contain the 100-year maximum mean daily flow in the month of March is 2.1 inches, and that during summer months the storage required drops to about 1.6 inches. However, based on recorded flow statistics from the Williamsville gage, the 100-year maximum mean daily flow in the months of March and August were found to be 3.2 and 1.1 inches, respectively.

12.8 - The selection of a rule curve for flood control storage at the Sandridge reservoir is based on a survey of the preceding analyses of flow frequencies, both by monthly and by mean daily flows. As a part of this analysis, two major factors are considered: the amount of flood control storage required to contain the entire maximum mean daily 100-year runoff and the ability of the reservoir to fill flood control storage at the end of the maximum flood storage period. Reservation of storage for flood control during the months of January through March would be established at 4 inches, and this quantity would be reduced to 2 inches of storage during the summer months.

12.9 - However, there is always the possibility that a 100-year summer flood event could be as severe as the spring one, despite the findings of the frequency analysis which show otherwise. The adequacy of the proposed 2-inch flood storage volume has therefore been checked by routing the 100-year spring-balanced flood hydrograph through the reservoir under summer reservoir conditions. It was found that an additional rise of about 1/2 foot in the water level would result with the reduced summer flood storage allowance. Additionally, the flood discharge at the Williamsville gaging location, the flow index of the basin in the study, does not change appreciably from the one obtained with the 4-inch flood storage volume. Consequently, it is concluded that the 100-year summer flood event yields results similar to the spring flood, both in water level in the reservoir and discharges in the creek under summer reservoir conditions, despite the reduced flood storage allowance. The 2-inch flood storage allowance during the summer months is therefore adequate for this feasibility study stage. However, it is suggested that the 100-year summer flood hydrograph be synthesized and routed through the reservoir during detailed design study to confirm the above findings.

TABLE A7 - Design Discharges for Considered
Local Improvements, Reaches 0-4

Reach	Description of Reach	Major Channel Improvement (cfs)	Minor Channel Improvement (cfs)	Diversion Channel
0	Confluence with Tonawanda Creek: to Niagara Falls Boulevard	8,700	6,600	8,700
1	Niagara Falls Boulevard to Sweet Home Road	8,700	6,600	8,700
2	Sweet Home Road to Millersport Highway	7,800	5,700	-
3	Millersport Highway to Maple Road	7,600	5,300	-
4	Maple Road to Sheridan Drive	7,600	5,300	7,600

12.10 - A plot of the recommended flood control storage by months is contained in Plate A8. Included in the figure is the plot of the 100-year mean daily flow frequency by months computed from the historic records and from the extended records. In each case the storage required to contain the maximum 1-day event is well within the storage allocated for flood control. The rule curve shows that the reservoir volume would be increased by 2 inches of runoff during the period April 1 to May 15 each year. These dates are for general guidance only. Filling operations may start earlier or later in a given year after a careful study of upstream snow cover and other factors which might affect flooding. There appears to be sufficient runoff to make the filling operation feasible.

12.11 - Different criteria were used in the selection of operation rule curves for the Bowmansville and Pavement reservoirs, since the functioning of these reservoirs is very different from that of the Sandridge Reservoir. The Bowmansville Reservoir is primarily a flood retention reservoir with recreational facilities while the Pavement Reservoir is strictly a subimpoundment to allow for low flow augmentation without affecting the level of the Bowmansville Reservoir.

12.12 - The rule of operation for the Bowmansville Reservoir is as follows:

- to maintain a constant recreational pool level at elevation 720 feet.
- the controlled reservoir release is not to exceed 1,100 cfs during flood conditions
- maintain a minimum flow of 25 cfs downstream of the Bowmansville Reservoir in low flow augmentation.

This operation rule is to satisfy the multi-purpose nature of the reservoir.

12.13 - The normal rule of operation in maintaining a constant pool level at elevation 720 feet is to always make available an Intermediate Regional Flood (a 100-year flood) impoundment capacity at this location. During design flood conditions, the rule of operation is such that the discharge at the Williamsville gage would not exceed 1,800 cfs so that flood damages, if any, downstream from the Williamsville location would be kept at an economic minimum. It is estimated that for this flood condition, this design criterion can be met by limiting the release from the Bowmansville Reservoir to approximately 1,100 cfs.

12.14 - For the more infrequent floods, the above release criteria would result in additional release through the spillway while adequate flood storage volume is available to absorb the flow excess in the reservoir for more frequent flood events.

12.15 - For the case of the Pavement Reservoir, the rule of operation is to fill the reservoir pool by May 1st, and release water only to maintain elevation 720 feet in Bowmansville, and a minimum flow of 25 cfs downstream of Bowmansville. The Pavement Reservoir is not designed for flood control purposes, and the 100-year flood is assumed to pass through the reservoir without any attention.

13 - RATING CURVES UNDER EXISTING CONDITIONS

13.1 - Rating curves (stage-discharge curves) are needed to calculate average annual flood damages. The flood plain has been divided into damage reaches, as shown on Plate 9. Index points have been selected within each reach to show representative stages. Rating curves have been derived at the index point for each reach to show the stage-discharge relationship.

13.2 - A flood profile has been drawn using high-water-mark data from the 1960 flood. The discharge corresponding to the flood stage at a given index point has been determined from the discharge-frequency curve. The 1960 flood establishes one point on each of the rating curves. The elevation of zero flow has been determined from profiles of the existing thalweg. This establishes another point on each rating curve. Other points have been established by backwater calculations and the curves drawn through the array of points.

14 - RATING CURVES FOR
CONDITIONS WITH LOCAL IMPROVEMENTS

14.1 - Modified rating curves have been developed for those reaches where local improvements are considered. Backwater calculations establish an array of points at each index point to show the stage-discharge relationship under these conditions.

15 - RATING CURVES FOR
CONDITIONS WITH SANDRIDGE RESERVOIR

15.1 - Rating curves for improved conditions with Sandridge reservoir alone would be the same as for existing conditions. Modified rating curves have been developed from backwater calculations in reaches 0-4 for improved conditions with the reservoir in combination with minor channel improvement. All rating curves are shown on Plates A9 and A10 for comparison.

16 - RATING CURVES FOR
CONDITIONS WITH BOWMANVILLE
AND PAVEMENT RESERVOIRS

16.1 - As there is no economically justifiable channel improvement downstream of the Bowmansville Reservoir, rating curves for conditions with Bowmansville and Pavement Reservoirs would be the same as for existing conditions except for Reach 12, which is to be inundated by the Bowmansville Reservoir.

17.- DISCHARGE-FREQUENCY CURVES,
EXISTING CONDITIONS

17.1 - The Williamsville gage at Wehrle Drive provides discharge records from 1955 to the present. A Beard-type (statistical) discharge-frequency curve has been computed from the annual peak discharge during this period. The short period of record, which includes an unusually low-peak discharge in water year 1958 (496 cfs), produces a discharge-frequency curve with discharges for the infrequent floods considerably higher than appeared reasonable. Therefore, Beard-type generalized regional frequency curves have been developed using peak discharges from three western New York gaging stations with basin characteristics similar to the Ellicott Creek basin and the records from the Williamsville gage. The inflow to each reach has been computed on the basis of 55 years of record from the correlation study. A formula is obtained for determining the mean annual discharge for various reaches on Ellicott Creek,

$$Q_r = 1770 \left[\frac{D.A.r}{75.0} \right]^{0.691}$$

in which Q_r is the mean annual discharge for any reach and D.A.r is the drainage area in square miles for that reach. The standard deviation of 0.2730 is obtained in the correlation study for the Williamsville gage. Plates A11 to A19 show the discharge-frequency curves derived by this method for the reaches included in the study.

17.2 - Large volumes of flood waters are stored in the low, flat flood plain below Williamsville, particularly between Maple Road and Niagara Falls Boulevard, during the more damaging floods on Ellicott Creek. Initial overbank storage begins at the intersection of North Forest Road and Maple Road at a discharge of approximately 1,800 cfs at the Williamsville gage. At discharges above 1,800 cfs, discharge measurements taken by Buffalo District personnel show a lower discharge at Niagara Falls Boulevard than the coincident discharge at the Williamsville gauge, which has only about 75 percent of the Niagara Falls Boulevard drainage area. Lesser flows, with little or no overbank storage, register the expected higher discharges at Niagara Falls Boulevard. A discharge-frequency relationship at Niagara Falls Boulevard is developed by assigning to the peak flows the same frequency as the coincident peak discharge at the Williamsville gage. Discharge-frequency curves for reaches 0-4 have been developed by assuming the discharge for a given frequency of occurrence at any point between the Williamsville gage and Niagara Falls

Boulevard, varied directly with the change in drainage area. The upper portions of these curves are lower and the lower portions are higher than the Wehrle Drive frequency curves.

17.3 - Continued urbanization of the Ellicott Creek basin will change lag time and infiltration parameters so that peak discharges will undoubtedly increase in future periods. The net results of population trends in Erie County show a definite increase in the area adjacent to Ellicott Creek. During the 1960 to 1966 period, the population of communities in the basin increased 12.3 percent. In the town of Amherst, the population increased 26 percent for the same period. The impact of the proposed State University campus and the U.D.C. development in Amherst has not been fully evaluated, but preliminary estimates indicate that by the year 1980 full development of the basin in the town will take place. Based on these considerations, the discharge-frequency curves for reaches 0-4, without Sandridge Reservoir, have been modified by increasing the peak discharges by 5 percent. Upstream of reach 4, flood plain development without the reservoir is slower and discharges have been increased by 3 percent. With Sandridge Reservoir, some restrictions will be placed on development of the flood plain in areas that will not receive a high degree of protection. As a result, discharges with the reservoir for a given frequency are increased 4 percent in reaches 0-4 and 2 percent upstream of reach 4. These increases are considered to be conservative and will be refined during detailed design studies for the Ellicott Creek basin.

18 - DISCHARGE-FREQUENCY CURVES, IMPROVED CONDITIONS

18.1 - With major channel improvement in reaches 0-4, overbank ponding of large volumes of flood water will not occur. Flood waters will run off into the enlarged channel increasing the discharge downstream. An enlarged diversion channel downstream of Niagara Falls Boulevard will be required as part of this plan to protect downstream areas. The frequency curves for reaches 0-4 have been derived by the correlation formula discussed in a previous paragraph without the modifications for overbank ponding.

18.2 - Discharge-frequency curves for the Sandridge Reservoir proposal have been developed after a study of the various volumes of flood control storage; namely, 2 inches, 4 inches and 6 inches. Studies indicated that about 4 inches of storage in the reservoir would be the upper limit that could be used effectively. Additional flood storage at the Sandridge site would not reduce peak flows for even the most infrequent flood because the reservoir controls only about 30 percent of the Ellicott Creek basin.

18.3 - During the course of the analysis, it was found that any flood with a return period less than 50 years is totally absorbed within the flood control storage in the reservoir, whether it be either 2-inch or 4-inch storage. The discharge-frequency curves for reaches downstream from the Sandridge Dam are therefore functions of their respective drainage areas and are the same for both of these flood control storage volumes.

18.4 - The discharge-frequency curves with the Sandridge Reservoir for the various reaches shown on Plates A11 to A19 have been derived from those at the Williamsville gaging location.

18.5 - Discharge-frequency curves for the diversion channel scheme are derived primarily from those for the major channel improvement. For the reaches of Ellicott Creek upstream of the diversion takeoff point and downstream from the junction between the creek and the diversion channel, the discharge-frequency curves remain unchanged from that of the major channel improvement. For the intervening reaches, the discharge-frequency curves for the existing creek and the diversion channel, respectively, depend entirely on the hydraulics of the takeoff section and the hydraulic rating of the existing channel immediately downstream of the takeoff point. This junction is so designed that the diversion channel starts to receive water from Ellicott Creek when the flow in the latter exceeds 2,000 cfs. At 100-year flood design conditions, the diversion channel carries a flow in the existing creek. While the flow allocation in the respective channels is a function of the hydraulics of the junction at the diversion takeoff point, the discharge-frequency curves for the combined discharge remain identical with those for the major channel improvement in the reaches under consideration.

18.6 - Discharge frequency curves for the Bowmansville-Pavement scheme have been derived on the basis of the operations of the Bowmansville Reservoir as discussed in paragraph 12.12. The discharge frequency curves would be the same with and without the structure for discharges up to those with a return period of about 1.4 years.

18.7 - For more infrequent floods, the Bowmansville Reservoir would store excess flood water to hold the release from the reservoir at 1,100 cfs. Eventually, for a flood expected about once every hundred years, the flood volume exceeds the impoundment capacity provided at the Bowmansville location, resulting in a total reservoir release greater than 1,100 cfs. This is reflected by the discontinuity in the discharge frequency curves for the various reaches, which have been derived from the one at the Bowmansville reservoir location. (See Plates A11 to A19).

18.8 - However, no additional discharge values are available for floods more infrequent than the 200-year event. The shape of the frequency curve beyond the 100-year flood value has been estimated bearing in mind the fact that the shape of the frequency curve would tend to approach that for the existing condition for extreme floods.

19 - EVAPORATION

19.1 - Evaporation losses from Sandridge Reservoir have been estimated from information contained in an unpublished report by the Erie-Niagara Water Resources Board entitled "Investigations of Dams and Reservoirs Having Potential for Multiple-Purpose Use". It is estimated that losses will vary from a maximum of 4.4 inches in July to a minimum of 0.5 inches in winter months. Average losses annually from the maximum conservation pool area of 2,150 acres will amount to 23.5 inches. During the year, precipitation falling directly on the reservoir pool, based on long-term precipitation station records, 35.36 inches (see Table A2), will more than offset the free surface evaporation losses. However, during the summer months, the evaporation losses will exceed precipitation, and this net loss has been considered in evaluating possible draw-downs.

20 - SEDIMENTATION

20.1 - Sufficient storage is to be provided in the reservoirs for the accumulation of sediment during the 100-year project life. The amount of sediment expected over this period for the Sandridge Reservoir location is estimated to be 300 acre-feet. For the Bowmansville-Pavement scheme, because of less sediment availability, the value is estimated to be 400 acre-feet even though the drainage area at this site is considerably larger. This additional storage requirement is being provided in the Pavement location. These figures have been calculated from a sediment yield study undertaken by the U. S. Geological Survey for the Erie-Niagara Water Resources Board. Field measurements of stream sediment loads in the Erie-Niagara Basin during the high flow periods of 1963 and 1964 forms the basis of sedimentation allowance in this study. No allowance has been made for possible reservoir bank erosion due to drawdown of the reservoir. It is expected that the rate of drawdown of the reservoir will be regulated in such a manner that bank erosion will be negligible.

HYDRAULIC DESIGN CRITERIA FOR CHANNEL IMPROVEMENTS

21 - DESIGN DISCHARGES

21.1 - In selecting a design discharge for a local protection project, consideration is given to providing an acceptable degree of protection for the type and degree of development in the flood plain. This decision is made after maximizing net benefits. The general policy of the Corps of Engineers is to provide a high degree of protection in urban areas subject to heavy flood damages. For those plans of improvement that show little promise of being economically justified after obtaining preliminary estimates of benefits and costs, studies are often discontinued after consideration of a single design discharge selected through judgment.

21.2 - For major channel improvement alone, in reaches 0-4, the selected design discharges are shown in Table A7. The plan would protect against the 100-year flood. For minor channel improvement in this same area, which would only be considered in combination with Sandridge Reservoir, the flood protection would be slightly greater. Design discharges would be reduced as indicated in Table A7 because of the proposed reservoir.

21.3 - Where improvements are necessary in the existing creek as part of the diversion channel scheme, the improvements are identical with major channel improvements for the same reaches.

22 - CHANNEL DESIGN

22.1 - Channel dimensions and grades for the channel improvement have been established by backwater computations made in accordance with instructions contained in Appendix III of EM 1110-2-1409, "Backwater Curves in River Channels". The backwater computations have been made by "Method 1" in Appendix III of the above reference which utilized Manning's equation. Values of the roughness coefficient "n" used are: .030 for the existing channel, .025 for the improved channel, and .030 to .035 for improved, riprapped sections. The loss coefficients for adjusting the changes in velocity head vary from a minimum of 0.2 for a gradual convergence to a maximum of 0.7 for a sharp divergence. Bridge losses have been computed from the formula for restricted openings:

$$Q = KA(2gh+V^2)^{1/2}$$

Where K = Contraction coefficient (varies from .92 to .95 depending on the relative constriction)

A = Net area of the bridge opening based on the downstream water surface elevation

h = Differential head from upstream to downstream

V = Average velocity of approach.

Where the plan requires new bridges, waterway openings have been provided which give the same flow area as the upstream channel cross-section at design flow conditions.

22.2 - High-velocity sections are designed into the plans of improvement to raise both the design water surface and channel bottom elevation to the natural levels upstream of the project.

22.3 - The improved channel sections are designed with a trapezoidal cross-section having side slopes of 1 vertical on 2-1/2 horizontal. The existing slopes are steeper than this in some reaches. An investigation of the existing channel indicates that no serious erosion or maintenance problems are evident in the reaches presently considered for improvement.

22.4 - The channel improvement alignments have been selected using aerial photographs, topographical surveys and field inspections. Elevations of all surveys, flood damage data, high watermarks and proposed improvements are referenced to United States Coast and Geodetic Survey datum.

22.5 - In an effort to lessen the flood hazard in the lower reaches of Ellicott Creek, Erie County completed construction of a diversion channel from Ellicott Creek to Tonawanda Creek in the summer of 1965. It begins about 800 feet downstream of Niagara Falls Boulevard and extends due west from Ellicott Creek across Ellicott Creek Park to Tonawanda Creek. The channel is dry during periods of low flow in Ellicott Creek, except for a short reach at the westerly end which is affected by backwater from Tonawanda Creek. The diversion channel has been designed to receive flood waters from Ellicott Creek when the discharge at Niagara Falls Boulevard exceeds 1,700 cfs. The existing capacity of the diversion channel is 2,000 cfs at a prediversion discharge of 6,200 cfs, expected once in 100 years. Under improved conditions, with some form of channel improvement in reaches 0-4, the diversion channel would be widened to carry diverted flows from the 100-year flood.

22.6 - The elevation of Tonawanda Creek, which has been used for starting backwater computations at the downstream limit of the diversion channel, has been based on records of Niagara River stages from the United States Lake Survey gage located at Tonawanda Island, New York. In selecting a design river stage, consideration has been given to the annual maximum daily mean stage that might be expected once in 10 years. A tailwater rating curve has been developed at the confluence of the diversion channel with Tonawanda Creek by backwatering a constant discharge of 2,000 cfs in Tonawanda Creek and varying the discharge in the diversion channel.

22.7 - Three rating curves have been developed for Ellicott Creek at the point where the diversion channel begins: one for the diversion channel itself; one for Ellicott Creek just downstream of the diversion channel; and one for Ellicott Creek just prior to diversion. The rating curve for the diversion channel has been developed by backwater computations starting at the confluence of the diversion channel with Tonawanda Creek and proceeding up the diversion channel. The Ellicott Creek rating curve after diversion has been developed by backwater computations starting at the mouth of Ellicott Creek. The pre-diversion rating curve has been developed by summing the discharges, for a given stage, from the first two. This last curve, shown on Plate A2, reach 0, was used as the starting point for backwater computations for both existing and improved conditions in reaches 0-4.

23 - BANK PROTECTION

23.1 - In the selection of improved channels, an attempt has been made to design for a mean velocity of 6 fps with steady uniform flow. For this report, it is assumed that riprap bank protection would be needed at those locations where mean velocities would be greater than 6 fps, and at points where swift localized currents along the shore would be expected. Based on past practices and ~~experiences~~. it is assumed that bank protection will be provided by a 12-inch riprap layer on a 6-inch bedding layer, with an average stone weight of 30 to 50 pounds. In preconstruction planning, location of required riprap and exact determination of riprap gradation limits will be designed in accordance with ETL 1110-2-60, June 13, 1969.

24 - INTERNAL DRAINAGE

24.1 - The town of Amherst has separate storm and sanitary sewer systems. During high flows, the existing channel cannot adequately carry away storm drainage and the ponded water sometimes enters the sanitary sewer system through street manholes, flooding basements. In some locations, the storm receptacles in the streets are below the top of existing channel banks. Basements connected to the sanitary sewer lines in these areas could be inundated prior to overbank flow. In order to eliminate this form of basement flooding, the town of Amherst, in 1963, passed the following resolution:

"The main sanitary drain for any building may be installed hung below the first floor or installed under the cellar floor. Floor drains are not permitted. Laundry trays and washers installed in cellars shall have a gate valve in their waste lines. All plumbing fixtures installed in cellars and basements shall be on a branch line from the main sanitary drain and shall have a gate valve in this branch line to prevent flooding in the event the street sanitary sewer becomes clogged. Such gate valves shall be closed at all times except when the fixtures are in use."

Based on this resolution, direct flooding should only occur through basement windows or other openings in the structure.

24.2 - Since construction of levees is not part of the considered local protection plans in reaches 0-4, there would be no change in the storm drainage pattern. However, to prevent backup during high creek flows, flap gates and some new headwalls will be required. Of the fifty-one discharge lines that now empty into the channel, twenty-one of them, listed in Table A8, would require closure structures. No sluice gates would be required on the storm outlets because, if the flap gate is inoperative, ponding in the streets from channel backup would cause a minimum amount of damage to units in the area.

HYDRAULIC DESIGN CRITERIA FOR THE CONSIDERED SANDRIDGE DAM AND RESERVOIR

25 - DESCRIPTION

25.1 - The considered Sandridge dam consists of a concrete side channel spillway together with an earth-fill embankment. The spillway and embankment sections would have a total length of approximately 8,300 feet. The Sandridge Dam would impound the waters of Ellicott Creek and Spring Creek, and would form a normal conservation pool of about 2,150 acres. Maximum reservoir depth in the summer conservation pool would be 43 feet. Average depth west of

TABLE A8 - Closure Structures Required on Ellicott Creek

Approximate Station	Right or Left Bank	Description of Existing Outlet	Closure Structures Required
172+00	R.B.	60-inch R.C.P., no headwall	Headwall and flap gate
173+00	R.B.	60-inch R.C.P. attached to concrete headwall	Flap gate
179+00	R.B.	24-inch C.M.P., no headwall	Headwall and flap gate
181+00	R.B.	2 x 2-foot concrete box culvert	Flap gate
187+00	L.B.	60-inch R.C.P., no headwall	Headwall and flap gate
203+00	R.B.	30-inch C.M.P., no headwall	Headwall and flap gate
210+00	R.B.	2 x 2-foot concrete box culvert	Flap gate
220+00	L.B.	60-inch R.C.P. attached to concrete headwall	Flap gate
228+00	R.B.	2 x 2-foot concrete box culvert	Flap gate
241+00	L.B.	30-inch R.C.P. attached to concrete headwall	Flap gate
241+50	L.B.	30-inch C.M.P. attached to concrete headwall	Flap gate
241+50	R.B.	36-inch C.M.P., no headwall	Headwall and flap gate
273+00	R.B.	30-inch C.M.P., no headwall	Headwall and flap gate
319+00	L.B.	24-inch R.C.P., no headwall	Headwall and flap gate
428+50	R.B.	72-inch R.C.P. attached to concrete headwall	Flap gate
446+00	R.B.	36-inch R.C.P., no headwall	Headwall and flap gate
447+00	R.B.	60-inch R.C.P. attached to concrete headwall	Flap gate
497+50	R.B.	30-inch R.C.P. attached to concrete headwall	Flap gate
503+00	R.B.	42-inch R.C.P. attached to concrete headwall	Flap gate
504+00	R.B.	30-inch R.C.P. attached to concrete headwall	Flap gate
504+50	R.B.	36-inch R.C.P. attached to concrete headwall	Flap gate

Harlow Road would be about 17 feet. The reservoir east of Harlow Road would be maintained at a constant pool elevation during drawdown operations for fish and wildlife conservation uses. This region occupies 425 acres, or approximately 20 percent of the reservoir surface of the summer conservation pool. Average depth in the conservation area would be about 2 feet; maximum depth would be 5 feet. A low closure-dike would be required at the northeast corner of the proposed Sandridge Reservoir boundary to assure that Ellicott Creek flows would not cross the basin divide to Murder Creek, a tributary of Tonawanda Creek.

26 - AREA-VOLUME CURVE

26.1 - The area-volume curve shown on Plate A20 has been computed using U.S. Geological Survey 7-1/2-minute topographic maps with a 10-foot contour interval. Maps are available for the town of Alden with a 5-foot contour interval and 2-1/2-foot contour interpolations. However, the town of Alden maps cover only the western third of the reservoir. The fish and wildlife conservation portion of the reservoir located east of Harlow Road affects the reservoir area-volume curve, since it would be designed to maintain a constant water surface during drawdown operations. The proposed operation for fish and wildlife conservation would have no effect on the reservoir area-volume curve above elevation 855.

27 - RESERVOIR POOL ELEVATIONS

27.1 - The top of dam elevation 867.5 is considered the topographic limit of the site since only minimal diking is required to contain the reservoir at this level, and extensive diking would be required to prevent flow across the divide between the Ellicott Creek and the Tonawanda Creek basins at a higher elevation. Allowing for 3 feet of freeboard, the maximum reservoir elevation during the probable maximum flood (PMF) would be 864.5. The PMF storage would be on top of the full flood control pool, set at elevation 856.5. To provide 4 inches of flood control storage, which is equivalent to 7,060 acre-feet, the winter conservation pool would be set at 852.5. During the summer, the flood control storage would be reduced to 2 inches and the summer conservation pool would be at elevation 855.

28 - SPILLWAY DESIGN

28.1 - Because of the short time available for operation of the spillway gates during major flood events, an uncontrolled side-channel spillway north of Spring Creek is recommended. The spillway capacity is determined by providing a combination of sufficient overflow area and reservoir storage so that the dam will not be overtopped during the probable maximum flood. Different layouts of the side-channel spillway have been considered for cost optimization. An L-shaped, ungated spillway with first a 100-foot and then a 400-foot spill section, crested at elevation 856.5 feet, has been found to be most economical. The spillway passes the probable maximum flood with a flow depth of about 8 feet over the spillway, equivalent to an outflow peak discharge of 40,500 cfs.

29 - ALTERNATE SPILLWAYS

- (a) Gated - Initial studies have shown that it is more economical to provide a gated structure rather than a larger ungated spillway. The ogee geometry would be designed for a head of 16 feet or approximately $\frac{3}{4}$ of the maximum head on the spillway crest. Each tainter gate is dimensioned so that the width equaled 1.4 times the height. This ratio has proven to be the most economical for gate construction. Studies have been made to determine the most economical spillway considering three, four, five or six tainter gates. The four-gate structure proves to be the best. This design would result in an ogee discharge coefficient in excess of 4.0 at the maximum expected head. The spillway would pass the probable maximum flood with a surcharge of 3.5 feet over the top of the spillway gate elevation and with an outflow peak discharge of 38,500 cfs. The upstream ends of spillway piers and the wingwalls would be designed to reduce contraction losses. However, because of the time element in the operation of a gated structure during a major flood event, this alternative is abandoned in favor of an uncontrolled L-shaped side channel spillway.

- (b) Fuse Plug - Consideration has been given to a fuse plug-type spillway constructed of erodible granular material with an impervious upstream core which would be triggered when overtopped by large flood flows. It would be used in conjunction with an outlet works capable of passing flood inflows of nearly the 100-year frequency. Subsequent exploratory drill-hole information disclosed that shale bedrock was too deep for placing a concrete sill and abutment training walls. If the erodible plug is to be founded on overburden, extensive use of riprap and filter would be necessary to control the plug erosion once it was triggered. This scheme becomes too expensive for further consideration.
- (c) Low-Head Spillway on Soil - An alternative scheme has been investigated considering a low-head spillway structure founded on soil. The low-head ogee section has been sized for the most economical layout consistent with existing foundation conditions. At the selected location, the ogee section would use a minimum amount of mass concrete. Excavation would be required for stripping only. Separate low-level outlet works would not be necessary due to the low-elevation spillway design. Although costs for this alternative are favorable, it has been decided that the proposed ungated spillway founded on bedrock provides the most conservative design for this level of study.

30 - LOW-LEVEL OUTLET WORKS

30.1 - Low-level outlet works are to consist of three 5-foot 8-inch diameter conduits through the main dam section. The invert of the conduit entrances is to be set at elevation 809. Conduits are to be designed to allow reservoir drawdown operations from the spillway crest elevation of 856.5 to about elevation 811.5 in a period of 10 days, assuming a constant reservoir inflow of 50 cfs. The average release is to be less than 1,500 cfs over the 10-day period. This drawdown is to allow emergency dewatering for inspection and repair of the dam.

30.2 - Each conduit is to be provided with two gate valves: one for normal operation, a second for emergency use. The gate valves would be capable of operating at partial openings so that they can be used for making low-flow releases. An air vent is provided in the roof of each conduit, just downstream of the gate valves to reduce possible cavitation damage during discharges at partial gate openings.

31 - STILLING BASIN

31.1 - The proposed stilling basin for the side-channel spillway is to be designed in accordance with ASCE Proceedings, Paper 1402, of the Journal of the Hydraulics Division¹. At this stage, the effect of friction on the chute has been ignored. Due to the nature of the proposed spillway (see Plate 8 for spillway layout), the total energy head for the design of the stillway basin has been taken as elevation 852.5 feet minus the stillway basin floor elevation. The basin length is defined by the length of the hydraulic jump. The detailed design of the stillway basin is to be carried out in the final design stage.

32 - TAILRACE CHANNELS

32.1 - Two tailrace channels are to be provided for the Sandridge Reservoir, one for the spillway and the other for the low-level outlet.

32.2 - The spillway tailrace channel is to be located along Spring Creek. Because of the expected discharges through the spillway, rechannelization work includes providing a straight approach to the Alden-Crittenden Bridge and enlargement of the bridge opening to accommodate the design discharge.

32.3 - The low-level outlet tailrace channel utilizes the existing Ellicott Creek channel. The rechannelization work is similar to that for the spillway tailrace.

¹Hydraulic Design of Stilling Basins: High Dams, Earth Dams, and Large Canal Structures (Basin II) by J. N. Bradley and A. J. Peterka.

32.4 - The layouts of these tailrace channels are shown on Plate 8. It should be emphasized that these layouts are for feasibility study purposes only. In final design, a more detailed analysis will have to be carried out.

33 - DIVERSION DURING CONSTRUCTION

33.1 - The proposed Sandridge structure (see Plate 8) is to be constructed over both Ellicott Creek and Spring Creek. Diversion of Ellicott Creek during construction of the low level outlets is to be accomplished by providing a temporary dike around the low level outlet excavation. Some groundwater inflow can be expected and is to be removed by continuous pumping. Since the side-channel spillway is located away from the Spring Creek channel, no anticipated diversion work for the creek is required. Construction of the spillway structure, the low level outlets and the majority of the embankment is to be completed before the Ellicott Creek and Spring Creek channels are finally closed. These two channels are then to be closed by small temporary cofferdams and Spring Creek allowed to flow into the reservoir area. The local foundation for the embankment is then to be stripped and prepared to receive the embankment fill material. The cofferdam at the Ellicott Creek diversion needs only to be sized to hold back the expected inflows for the time required for foundation preparation and raising of the embankment to the cofferdam height. Beyond this elevation, the embankment material can be placed and raised ahead of the rising reservoir water surface. The size of the cofferdam is to be minimized by planning their construction for the summer low-flow period. With channel closure, the Ellicott and Spring Creek inflows are to be diverted through the low-flow outlet works. These are to handle inflows to the limit of their capacity. Once the embankment is raised above the spillway crest elevation of 856.5 feet, additional diversion capacity is obtained through the spillway bays.

34 - SPILLWAY APPROACH CHANNEL

34.1 - With a side-channel spillway located near Spring Creek, it is necessary that an approach channel be excavated parallel to the Sandridge embankment. The channel will be approximately 2,800 feet long and is shown on Plate 8. Special revetment is to be provided along the upstream face of the embankment to protect erosion during flood discharge period.

35 - SPRING CREEK DIVERSION

35.1 - Since the proposed dam axis is upstream of the natural junction of Spring Creek and Ellicott Creek, a channel between Spring Creek and the main reservoir requires to be excavated. The new Spring Creek channel is to be constructed as part of the spillway approach channel, as shown on Plate 8.

36 - OTHER STRUCTURES

36.1 - In order to maintain a constant pool elevation of 855 in the portion of the reservoir designated for fish and wildlife conservation, the existing Harlow Road embankment would be raised to an elevation of 858.7 for a length of 3,700 feet. The existing Harlow Road culvert on Ellicott Creek would be removed. Seventy 30-inch diameter corrugated metal pipe culverts, set at critical slope with invert elevation of 855, would be provided through the proposed Harlow Road embankment. These culverts would pass flood flows up to the 25-year recurrence interval. Greater floods would cause overtopping of the embankment, which would act as a broad-crested weir. The proposed Harlow Road embankment section would act as a critical depth control when passing the probable maximum flood.

HYDRAULIC DESIGN FOR THE DIVERSION CHANNEL

37 - DESIGN DISCHARGE

37.1 - The purpose of the diversion channel is to relieve the main channel of that portion of the flood water in excess of its capacity at the takeoff location, so as to prevent flooding downstream of this point. Based on the design criteria and design discharge for the major channel improvement scheme and the takeoff location of the diversion channel, the design discharge is established as 5,000 cfs.

38 - CHANNEL DESIGN

38.1 - Besides serving as a flood relief measure for Ellicott Creek, this diversion channel is also to be used as a recreational area during the nonflooding season. Thus, the channel dimensions are established on aesthetic and functional considerations, in addition to hydraulic ones.

38.2 - At the takeoff location from Ellicott Creek, the channel is to be designed to receive water from Ellicott Creek when flow in the creek exceeds approximately 2,000 cfs. For the 100-year flood design conditions, the existing Ellicott Creek will carry a flow of about 2,600 cfs, while the remaining flood discharge will take its course along the diversion channel. These values are to be refined during detailed design studies when more precise mapping of this location becomes available. Except for a short reach near the downstream junction of the diversion channel and Ellicott Creek, where there is a backwater from Ellicott Creek, the diversion channel is dry under normal low-flow periods.

38.3 - Since the channel is to be used as a recreational area during the low-flow season, the channel design is based on the assumption that it is to be grass lined, with a mean design velocity of 5 fps and a Manning's roughness coefficient "n" equal to 0.03.

38.4 - However, because of the natural topography along the route of the proposed diversion channel alignment, it is necessary to provide a 5-foot drop near the takeoff location in order that the above design criteria are met. For the short reach just downstream from the falls, the

channel is to be concrete to prevent erosion as well as to act as an energy dissipator. The selection of a vertical drop over a more gradual riprapped, high-velocity channel section is purely on aesthetic considerations, since a longer riprapped section is the equivalent of the concrete energy dissipator. This however, is a decision that can be reviewed during detailed engineering. Plate 5 shows a typical cross-section of the diversion channel.

39 - INTERNAL DRAINAGE

39.1 - In some locations along the route of the diversion channel, the proposed alignment interrupts the existing groundwater table, three existing storm water drains and one existing sanitary sewer. Provision has been made for these circumstances.

39.2 - In order to eliminate excessive wetting of the channel bottom due to groundwater seepage, a drainage system consisting of two 1-foot diameter drain pipes, interconnected by a filter blanket underlying the channel bottom, is proposed for the problem reaches. The groundwater collected by the system is then pumped from the diversion channel to the existing creek at two locations along the route.

39.3 - The storm and sanitary sewers interrupted by the diversion channel, are presently located very close to the invert elevation of the channel at crossing points. It is proposed that where they cross, the drains and sewers be relaid just below the diversion channel invert at that point, so as to not impair their utilization. A study of the capacities of the existing sewers indicates no especial difficulty need be anticipated.

40 - ELLICOTT CREEK CROSSING

40.1 - The alignment of the diversion channel is such that it crosses the existing Ellicott Creek just upstream from Millersport Highway. A study of the bottom elevations of the creek and the proposed diversion channel at this location indicates no anticipated difficulty. It is proposed that six 7-foot concrete culverts be installed to convey the 2,600 cfs design flood flow underneath the proposed channel bottom. The invert of the conduit entrance is to be set at elevation 567 feet. Riprap protection will also be provided upstream and downstream of the crossing as necessary.

HYDRAULIC DESIGN CRITERIA FOR
THE CONSIDERED BOWMANSVILLE -
PAVEMENT SCHEME

41 - DESCRIPTION

41.1 The Bowmansville Reservoir is designed to retain flows which would otherwise cause considerable damages in the reaches downstream of the Williamsville gaging location for the Intermediate Regional Flood i.e. that flood having a return period of 100 years. The Pavement Reservoir is designed primarily as a sub-impoundment to the Bowmansville Reservoir, to replace waters released from it for low flow augmentation purposes. Multi-purpose use is confined to the Bowmansville Reservoir. The Pavement Reservoir is single-purpose in intent.

41.2 The plan philosophy is that by utilizing the available storage at the Pavement Reservoir location as a sub-impoundment, Bowmansville Reservoir can be maintained as a year-round, constant-level facility, providing an attractive recreational centre.

41.3 After any flood occasion, and when flow conditions in the creek are normalized, the impounded water in the Bowmansville Reservoir is released into the creek, under control, through low level outlet structures. The maximum volume to be retained in the reservoir after any flood, and when downstream flows have normalized, is that volume necessary for recreational purposes. This volume has been set at elevation 720 feet, and gives a reservoir with a maximum depth of some 10 feet. This 10 feet deep is considered the minimum desirable for a recreational lake.

The safe release from the reservoir during flood periods is set at 1,100 cfs so as not to cause flooding downstream of the Williamsville gaging location.

42 - AREA-VOLUME CURVES

42.1 The area-volume curves shown on plates A23 and A24 are derived from 1949 U. S. Geological Survey

topographic maps with a 10 foot contour interval. For the Pavement Road Reservoir the storage in adjacent quarries has not been included in the area-volume curve of the latter.

43 - RESERVOIR POOL ELEVATIONS

43.1 The dam crest and reservoir pool elevations for both the Bowmansville and Pavement Reservoirs are based on functional considerations.

43.2 The top of dam elevation for the Bowmansville Reservoir is elevation 740. With a free board allowance of 3 feet, the maximum reservoir elevation during the probable maximum flood (PMF) would be 737. Because of the operation and location of the Bowmansville Reservoir, the PMF would be on top of the normal reservoir operating level of 720 feet with a full flood control pool set at elevation 730 feet. The spillway, in this case, is 600 feet wide, crested at the full flood pool elevation.

43.3 For the Pavement Reservoir, since it is a single purpose, low flow sub-impoundment only, the spillway crest elevation is set at elevation 753.5 feet to provide sufficient storage for this purpose plus an allowance for evaporation loss and sediment accumulation. This crest elevation and a crest width of 600 feet results in a maximum reservoir elevation during the probable maximum flood (PMF) at elevation 760 feet. With a 3 foot free-board allowance, the top of dam elevation for the Pavement Reservoir is set at 763 feet.

44 - SPILLWAY DESIGN

44.1 Uncontrolled spillways are proposed for both the Bowmansville and Pavement Reservoirs at the request of the Corps of Engineers and also so that associated cost estimates may be compared on a common basis with the estimate for the Sandridge scheme. The spillway capacity has been determined by providing a combination of sufficient overflow area and reservoir storage, so that the dam will not be overtopped during the probable maximum flood.

44.2 Different layouts of these spillway sections have been tried, and it is recommended that two 600 foot spillways, crested at elevation 730 and 753.5 feet, respectively, are constructed for the Bowmansville and Pavement Reservoirs. The spillway sections pass the design probable maximum flood with flow depths of 7.0 and 6.5 feet respectively, equivalent to peak discharges of 39,220 cfs for the Bowmansville spillway and 35,870 cfs for the Pavement spillway.

45 - ALTERNATE SPILLWAY

(a) Gated

45.1 Because of the functional constraints imposed on the reservoirs by the uncontrolled spillways, alternative schemes with gated spillways have been examined. The probable maximum flood hydrograph was routed through the Bowmansville and Pavement Reservoirs with gated spillways crested at elevation 720 feet and elevation 743 feet respectively, using the Hydrologic Engineering Center program 22-J2-210. It was found that for the Bowmansville Reservoir, a 250 foot gated spillway structure would accommodate the probable maximum flood. The maximum water level during the PMF was shown as elevation 732.5 feet, leading to a dam crest elevation of 735.5 feet. In the Pavement Reservoir, it was found that a 200 foot spill section would be sufficient for the condition and a dam crest at elevation 758.5 feet necessary, after a 3 foot freeboard allowance had been included.

45.2 A comparison of these design parameters with the ones for uncontrolled spillways shows that the gated structures would result in reduced dike elevations and structure size. It is to be recognized that the location of the Bowmansville-Pavement scheme makes more time available for the operations of the spillway gates during major flood events, relative to the proposed Sandridge site. The time element is therefore much less critical as a design consideration.

46 - LOW LEVEL OUTLET WORKS

46.1 The low level outlet works for the Bowmansville Reservoir are to consist of nine 4 foot diameter conduits through the spillway ogee section. The invert of the conduit entrances is to be set at elevation 704. The outlet flow capacity has been selected at 1,500 cfs for a reservoir elevation of 730 feet, which is sufficient to lower the reservoir from overflow crest to conservation level in four days with a 100 cfs inflow. The conduits can also be used for emergency dewatering of the reservoir for inspection and repair of the dam, as well as for low flow augmentation purposes.

46.2 For the Pavement Reservoir, the low level outlets are to consist of three 3 foot diameter conduits, with an entrance invert elevation of 724 feet. They are designed primarily to allow for reservoir drawdown operation from spillway crest elevation of 753.5 to about 724 in a period of 10 days, assuming a constant reservoir inflow of 100 cfs. The average release over this 10 day period is to be less than 400 cfs.

Each of the conduits in the two reservoirs is to be provided with two gate values, one for normal operation and the other for emergency use. They are to be capable of operating at partial gate opening, so that they can be used for water quality releases. An air vent is also to be provided at each conduit to reduce possible cavitation damage during discharge at partial gate opening.

47 - STILLING BASIN

The preliminary selection of stilling basin for both the Bowmansville and Pavement Reservoirs is based on procedures described in ASCE Proceedings Paper 1402, of the Journal

of the Hydraulic Division.¹ To be conservative, the effect of friction on the chute is assumed to be negligible. For the Bowmansville Reservoir, the total energy head is taken as the difference between maximum water level at elevation 737 feet and the stilling basin flood elevation, while same criterion is also applied in determining the design head in the case of the Pavement Reservoir. The basin length is defined by the length of the hydraulic pump. A detailed design of the stilling basin will be required if this project is selected.

Since the spillway of the Pavement Dam is partially submerged by the year-round conservation pool from the Bowmansville Reservoir, a roller bucket type of energy dissipator is recommended at the foot of the spillway, instead of providing a stilling basin. Rip-rap protection is to be used in the tailrace channel.

48 - TAILRACE CHANNEL

A tailrace channel is to be provided for each of the two reservoirs considered in this scheme. These tailrace channels are to be located along the existing creek. For the Bowmansville Reservoir, due to a relatively wide spill section compared with the existing channel, a transition section is to be provided. Because the existing channel downstream from the dam has a very low conveyance capability, channel improvement as well as minor rechannelization work are also to be provided as part of tailrace channel works.

For the Pavement Reservoir, the work required for the tailrace channel is limited to straightening and clearing, the existing stream.

The layouts of these tailrace channels are shown on Plate D14. It should be emphasized that these layouts are for feasibility study purposes only. A more detailed analysis will need to be carried out in the final design.

¹ Hydraulic Design of Stilling Basins: High Dams, Earth Dams, and Large Canal Structures (Basin II) by J. N. Bradley and A. J. Peterka.

49 - DIVERSION DURING CONSTRUCTION

Both of the proposed dams for the Bowmansville and Pavement Reservoirs are to be constructed over the Ellicott Creek. The diversion channel works during the construction of these structures are to be carried out in a general manner similar to that suggested for the proposed Sandridge Scheme.

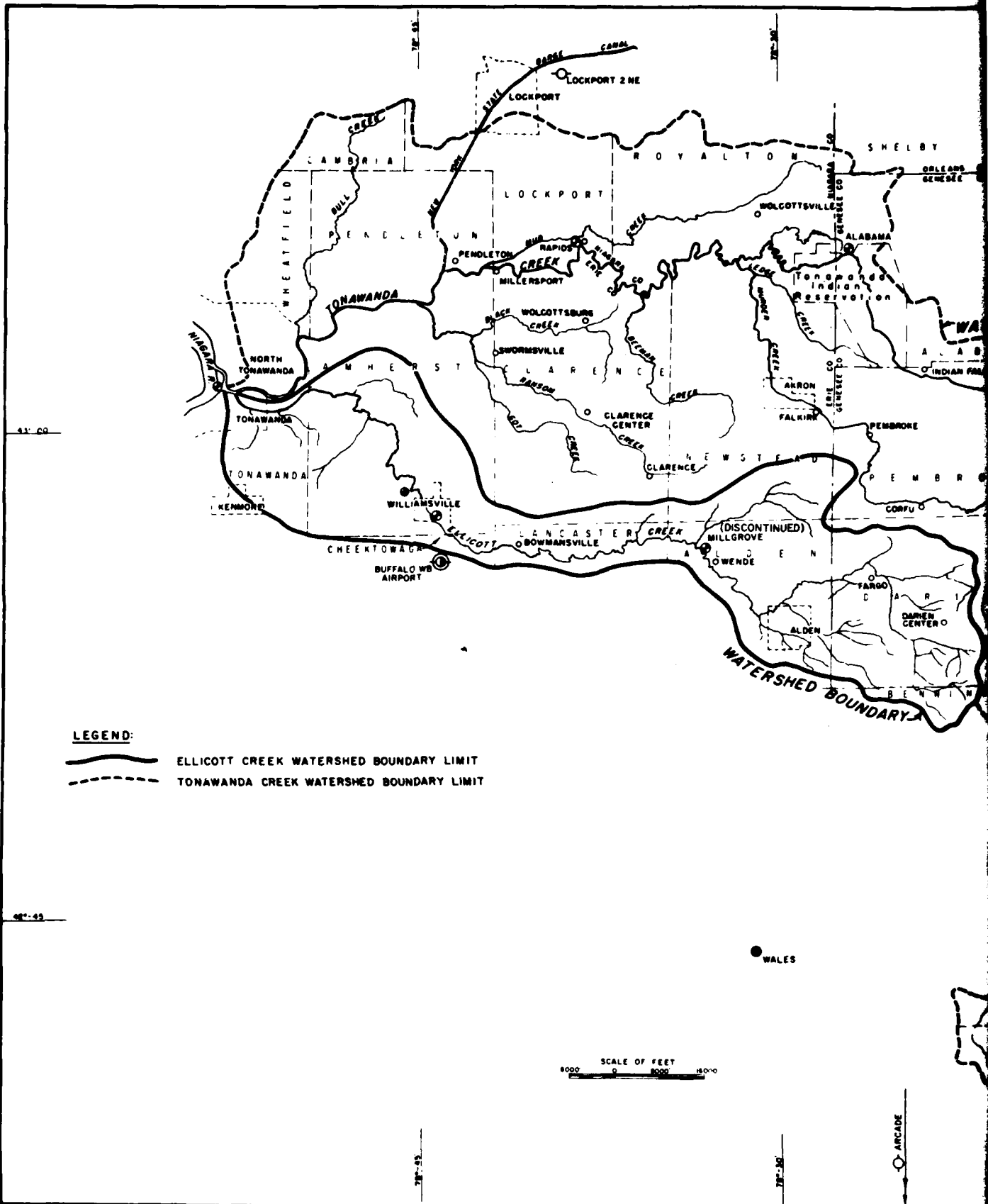

LEGEND:
 ————— ELLICOTT CREEK WATERSHED BOUNDARY LIMIT
 - - - - - TONAWANDA CREEK WATERSHED BOUNDARY LIMIT

SCALE OF FEET
 0 5000 10000

ARCADIE

WALE

48° 43'

78° 51'

78° 30'

78° 51'

78° 30'

41° 00'

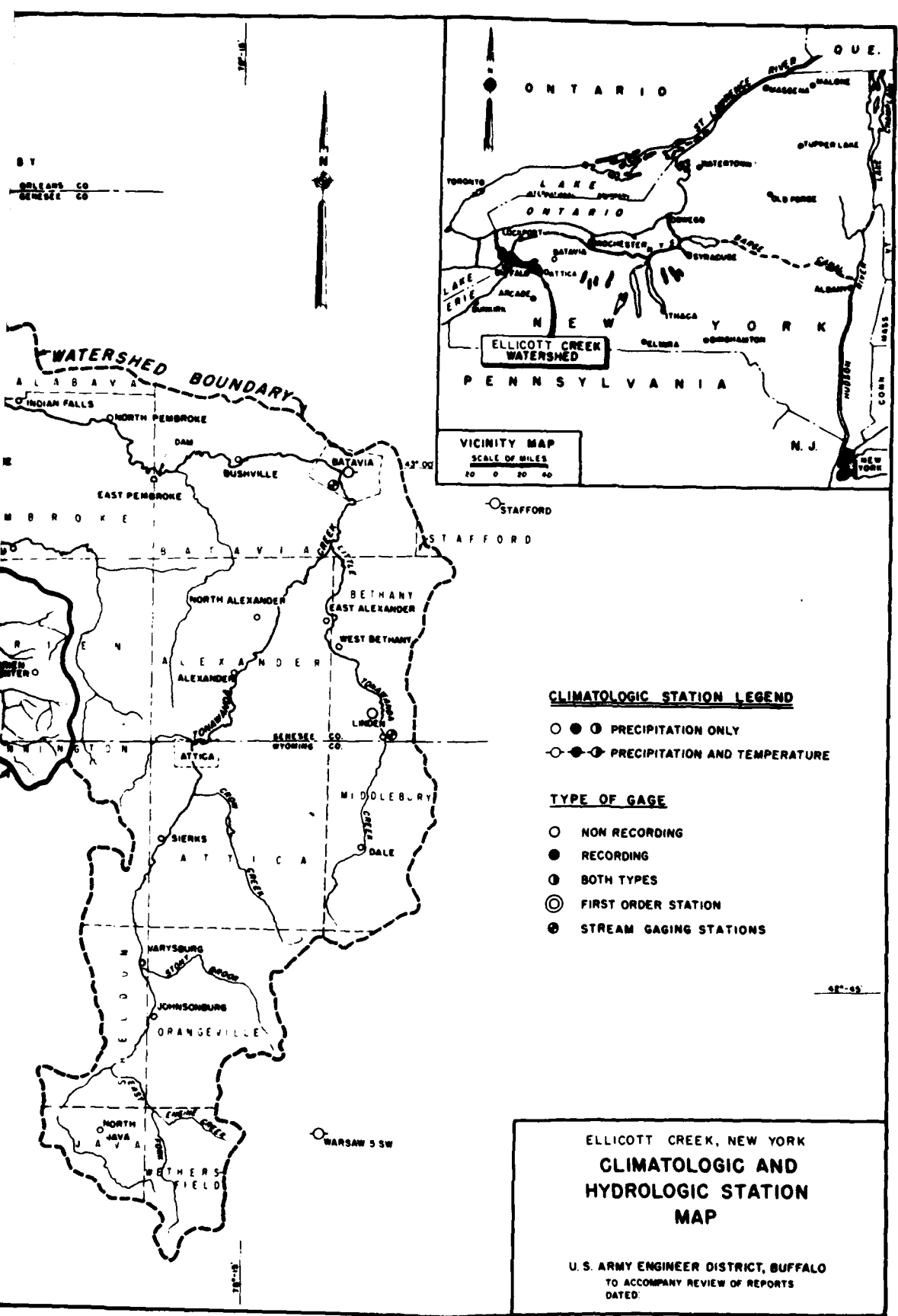

CLIMATOLOGIC STATION LEGEND

- ● ○ PRECIPITATION ONLY
- ● ○ ● ● PRECIPITATION AND TEMPERATURE

TYPE OF GAGE

- NON RECORDING
- RECORDING
- ① BOTH TYPES
- ⊙ FIRST ORDER STATION
- ⊕ STREAM GAGING STATIONS

ELLICOTT CREEK, NEW YORK
CLIMATOLOGIC AND
HYDROLOGIC STATION
MAP

U. S. ARMY ENGINEER DISTRICT, BUFFALO
 TO ACCOMPANY REVIEW OF REPORTS
 DATED:

DISCHARGE IN THOUSANDS OF C.F.S.

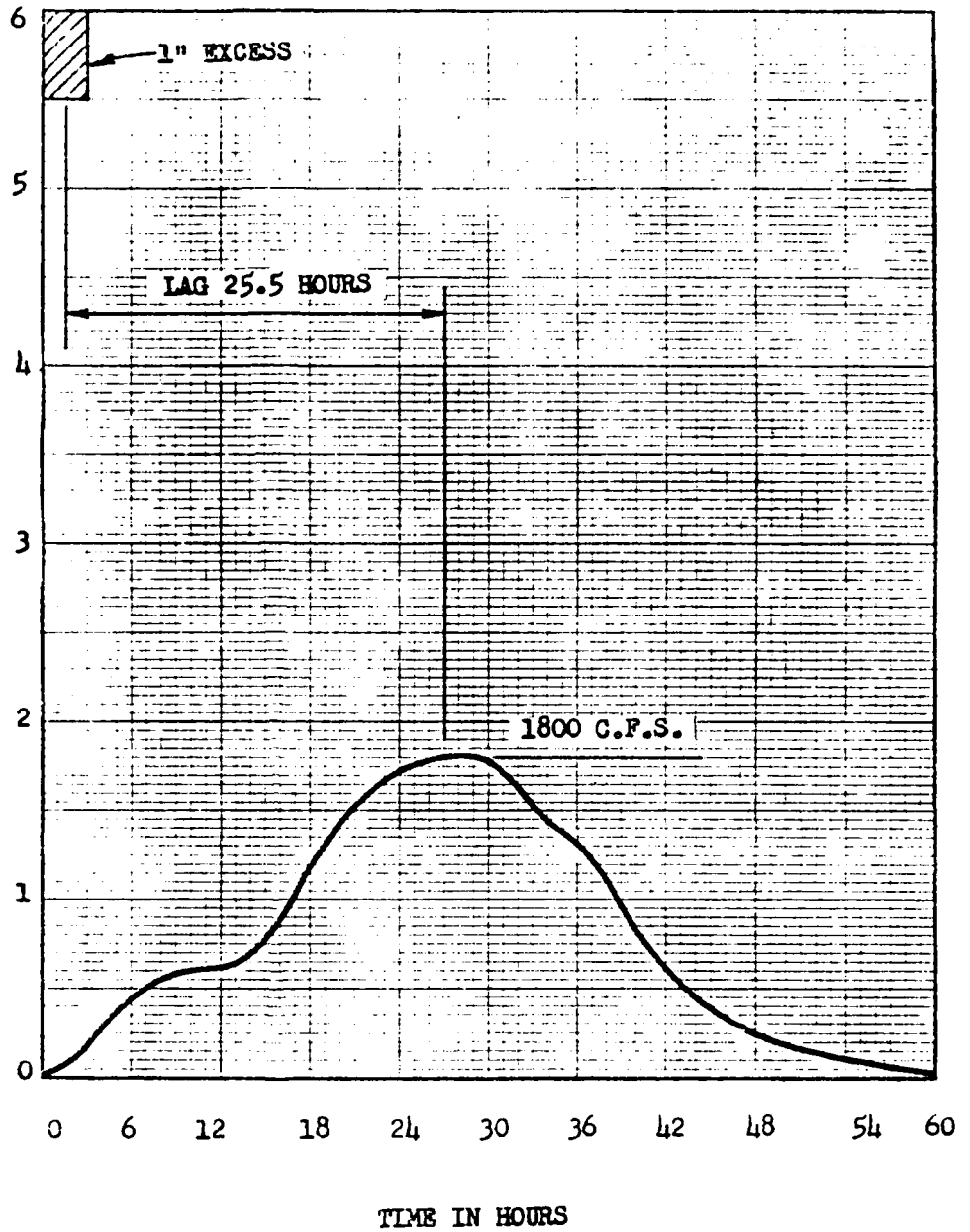

ELLICOTT CREEK, N.Y.

AT WILLIAMSVILLE

3-HOUR
UNIT HYDROGRAPH
1970

PLATE A2

DISCHARGE IN THOUSANDS OF C.F.S.

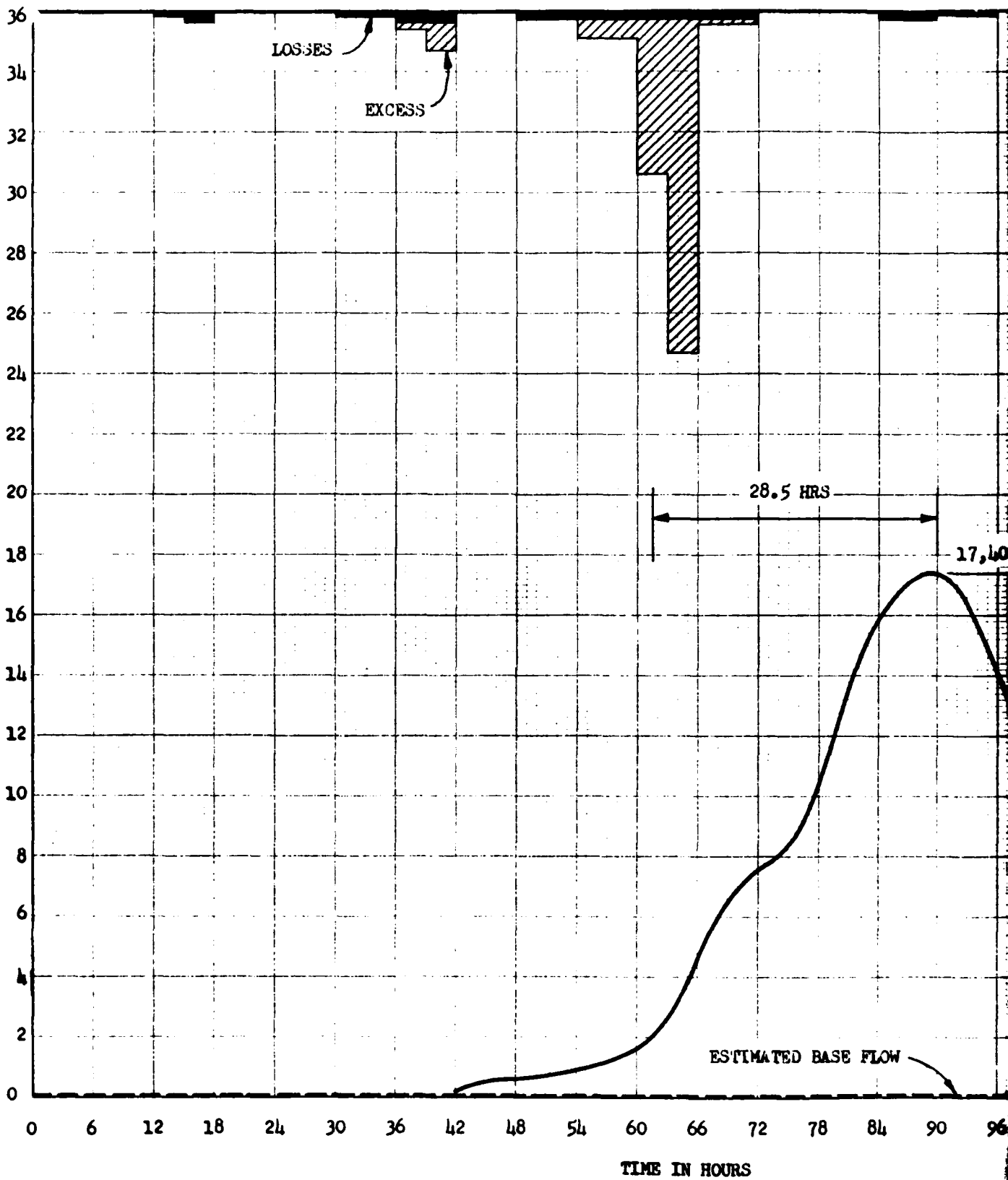

TIME IN HOURS

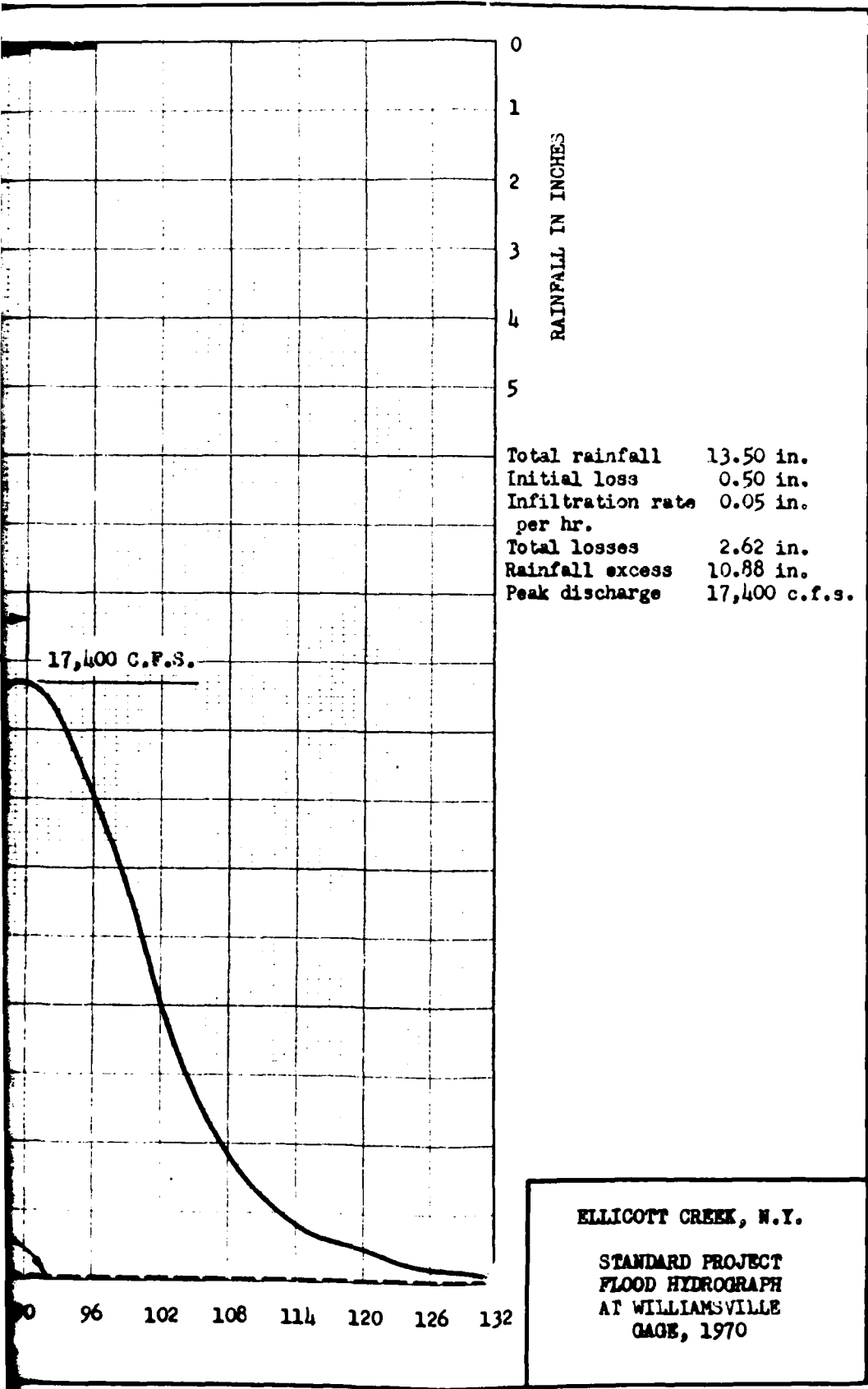

ELLICOTT CREEK, N.Y.

STANDARD PROJECT
 FLOOD HYDROGRAPH
 AT WILLIAMSVILLE
 GAGE, 1970

DISCHARGE IN THOUSANDS OF C.F.S.

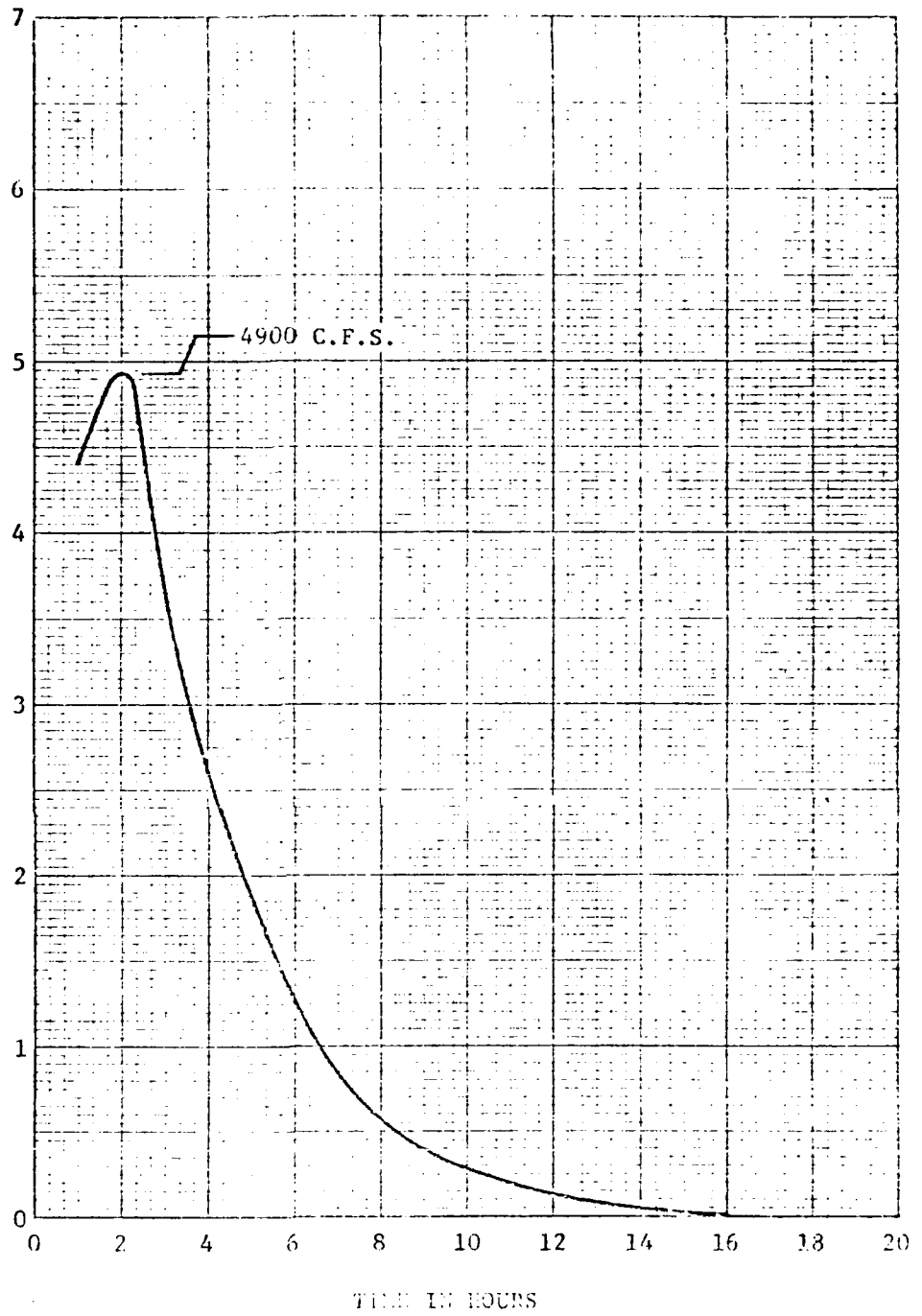

ELLICOTT CREEK, N.Y.

SANDRIDGE RESERVOIR
SYNTHETIC 1 - HOUR
UNIT HYDROGRAPH

1970

PLATE A4

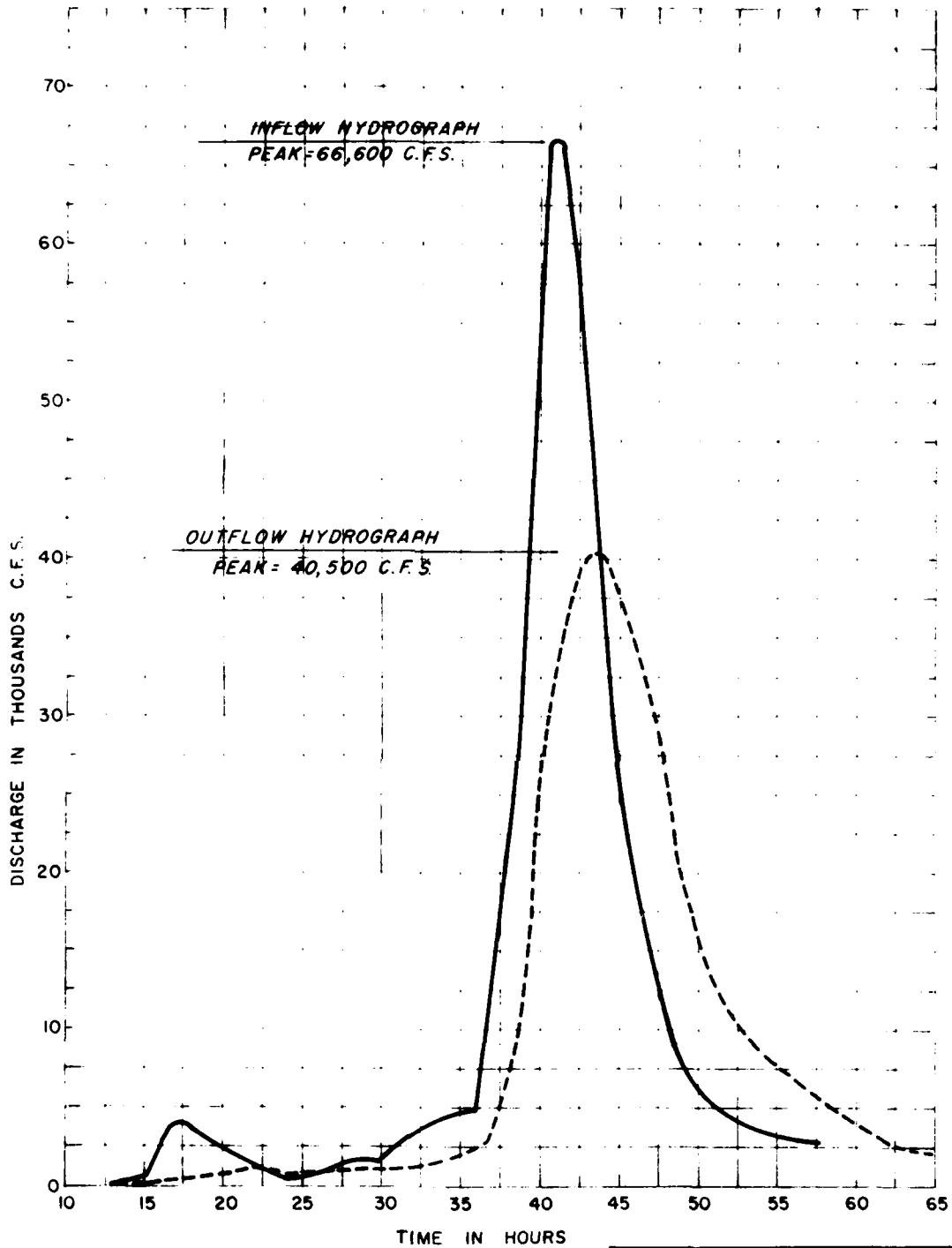

NOTE: CREST AT ELEV. 856.5 FT.

ELLICOTT CREEK, NEW YORK
**SANDRIDGE RESERVOIR
 SPILLWAY DESIGN FLOOD
 INFLOW AND OUTFLOW
 HYDROGRAPH**
 U.S. ARMY ENGINEER DISTRICT, BUFFALO

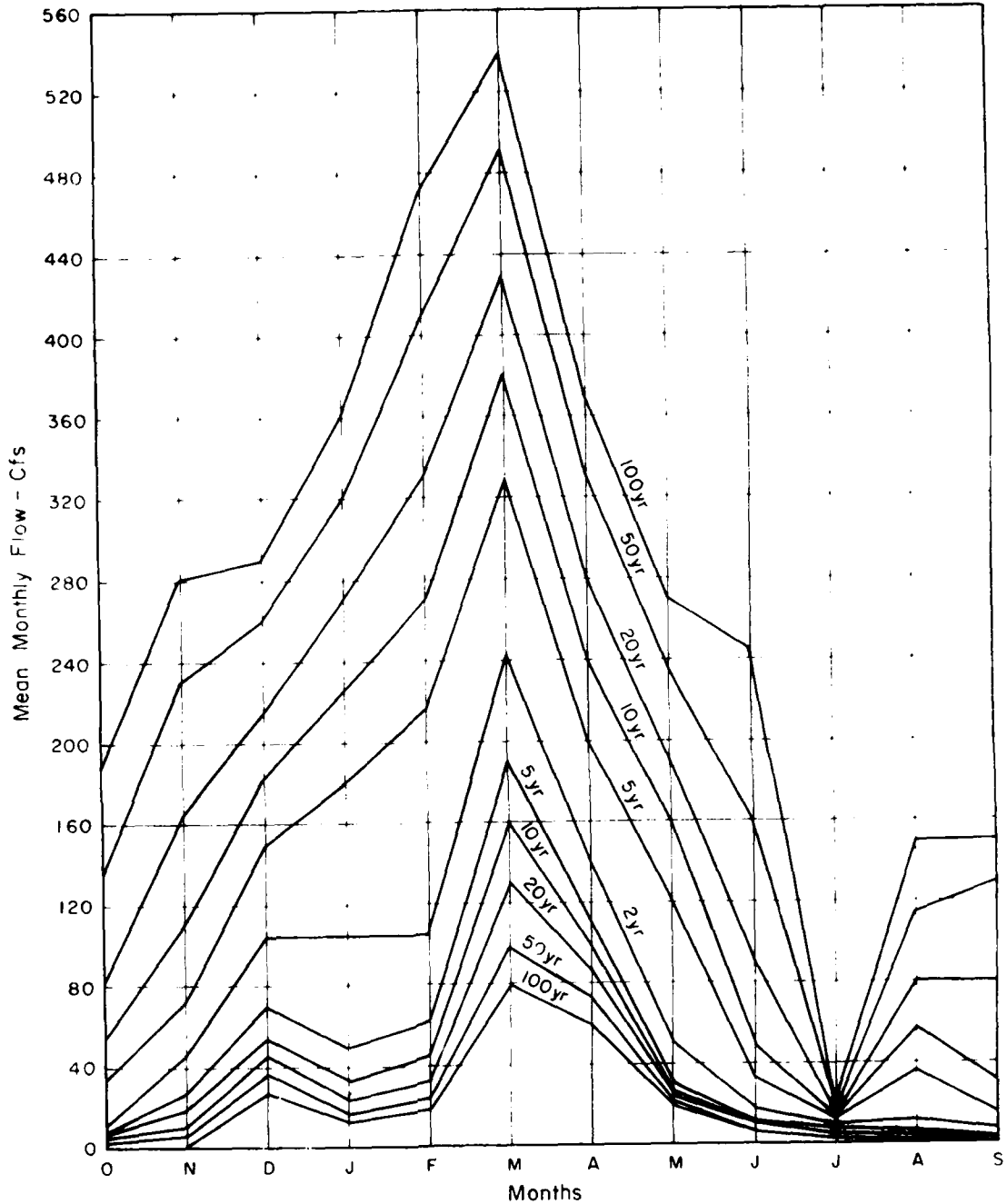

NOTE :

Data generated from 1912 - 1967 records
 1912 - 1938 Little Tonawanda Creek
 1939 - 1955 Cayuga Creek
 1956 - 1967 Ellicott Creek
 Ellicott Creek at Williamsville

ELLICOTT CREEK NEW YORK

**MEAN MONTHLY FLOW
 FREQUENCY CURVES
 ELLICOTT CREEK**

U.S. ARMY ENGINEER DISTRICT, BUFFALO
 TO ACCOMPANY SURVEY REPORT
 DATED: 1970

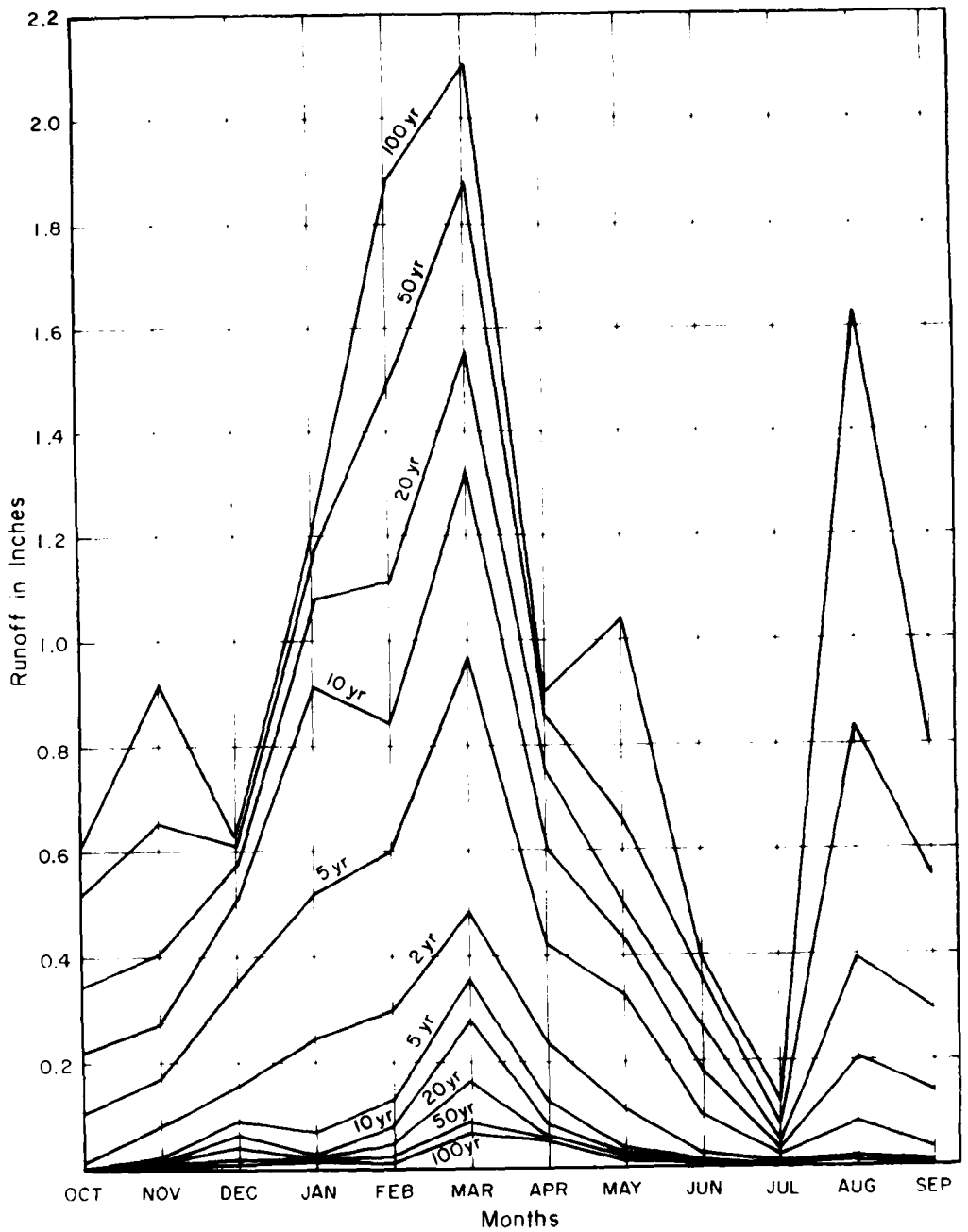

NOTE:
 Data generated from 1912-1967 records
 1912-1938 Little Tonawanda Creek
 1939-1955 Cayuga Creek
 1956-1967 Ellicott Creek
 Ellicott Creek at Williamsville

ELLICOTT CREEK NEW YORK

MEAN DAILY FLOW
 FREQUENCY CURVES
 ELLICOTT CREEK

U.S. ARMY ENGINEER DISTRICT, BUFFALO
 TO ACCOMPANY SURVEY REPORT
 DATED: 1970

PLATE A7

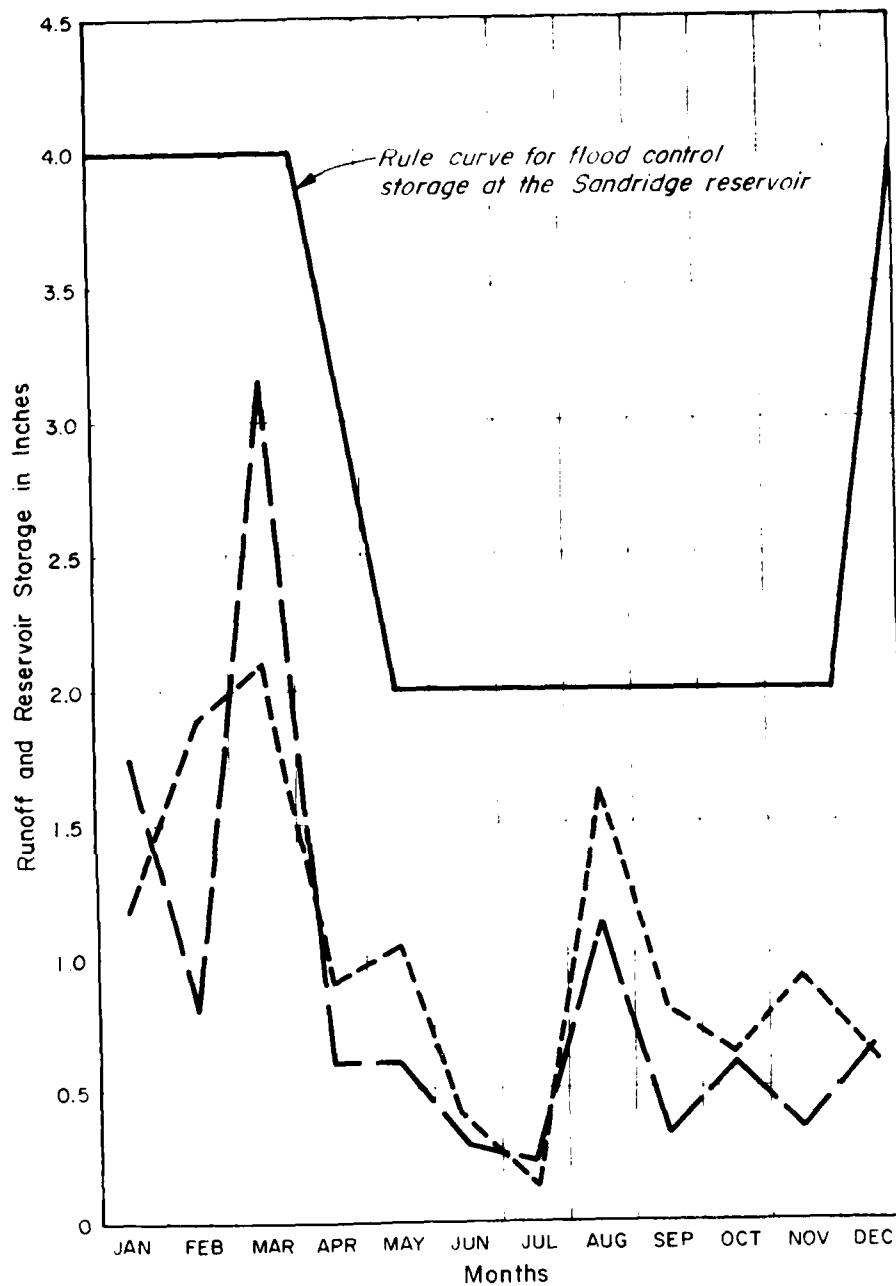

LEGEND

- — — Maximum mean daily 100 yr flow, 1956 - 67 record
- - - - Maximum mean daily 100 yr flow, 1913-67 developed record

ELLICOTT CREEK NEW YORK

RULE CURVE OPERATION AND
MAXIMUM MEAN DAILY
100 YR FLOW

U.S. ARMY ENGINEER DISTRICT, BUFFALO
TO ACCOMPANY SURVEY REPORT
DATED: 1970

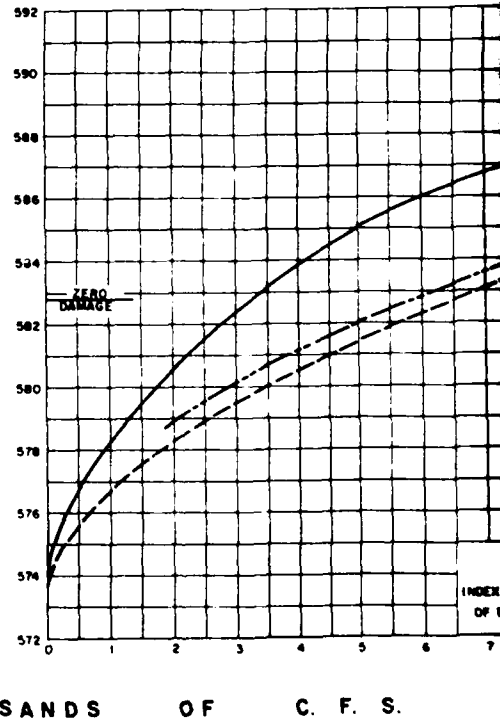
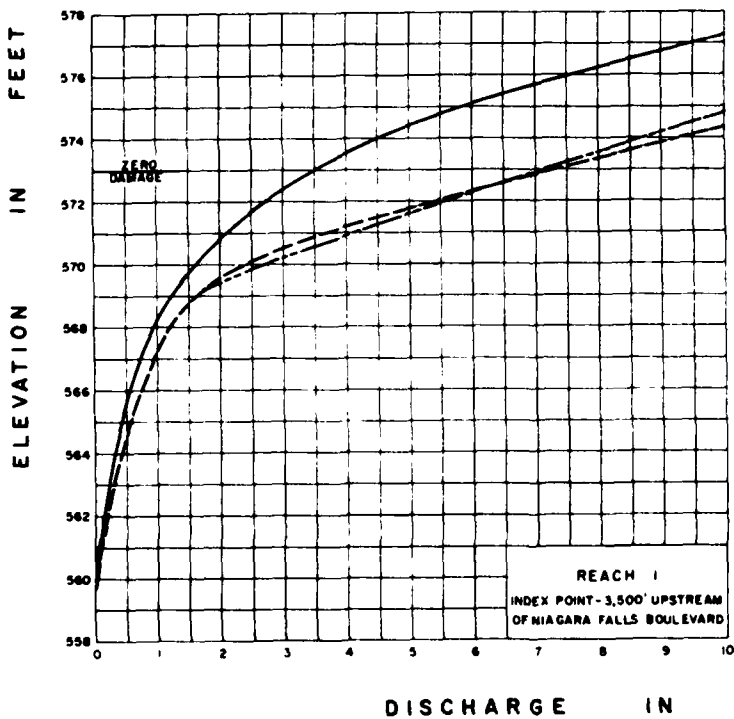
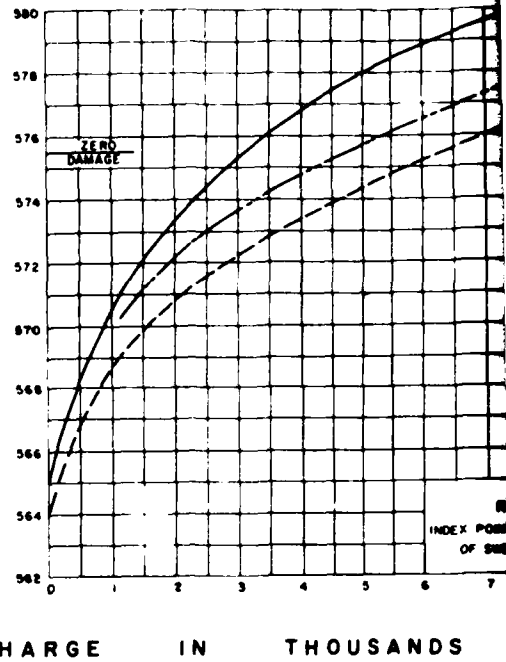
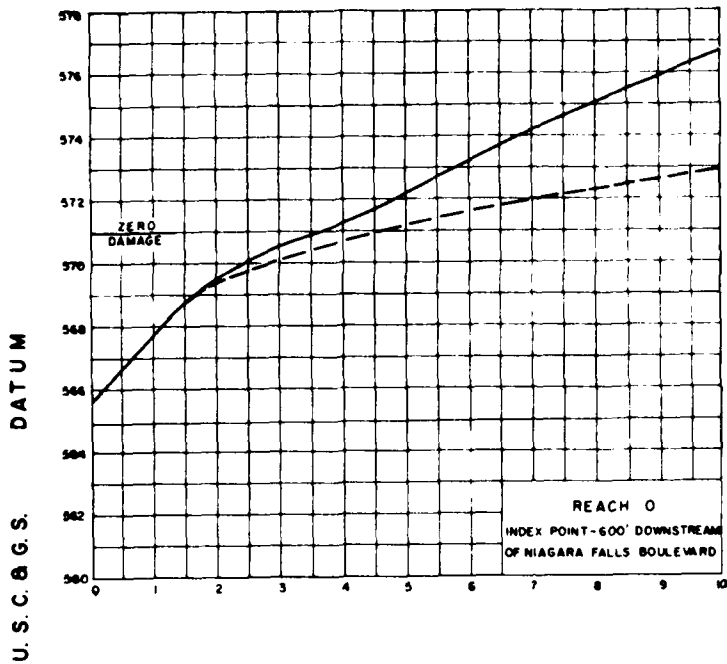

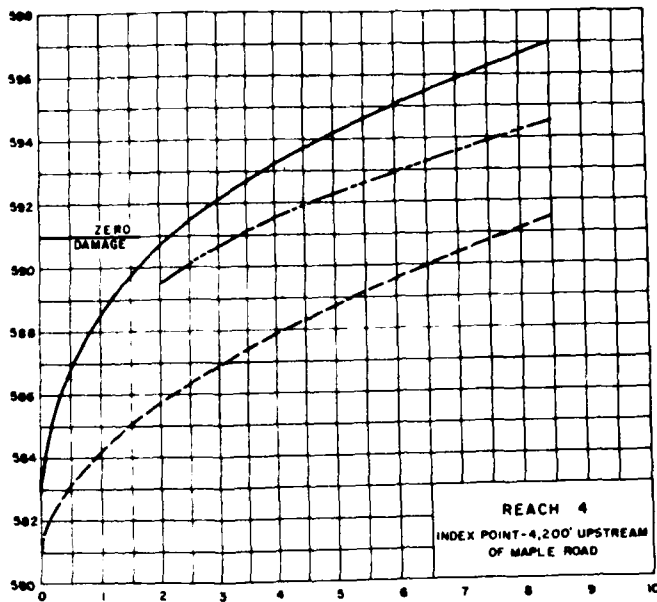
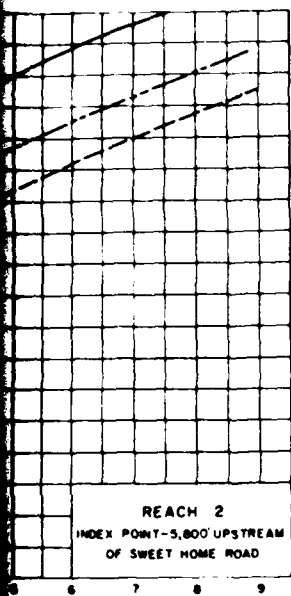

SANDS OF C. F. S.

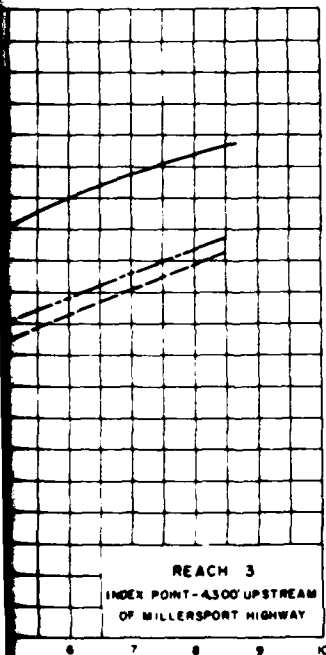

LEGEND

- INDICATES EXISTING CHANNEL CONDITIONS
- - - INDICATES MAJOR CHANNEL IMPROVEMENT ONLY
- · - · INDICATES MINOR CHANNEL IMPROVMENT WITH SANDRIDGE RESERVOIR

ELLICOTT CREEK, NEW YORK
STAGE-DISCHARGE CURVES
 REACHES 0 THRU 4
 U. S. ARMY ENGINEER DISTRICT, BUFFALO
 TO ACCOMPANY SURVEY REPORT
 DATED: 1970

1

2

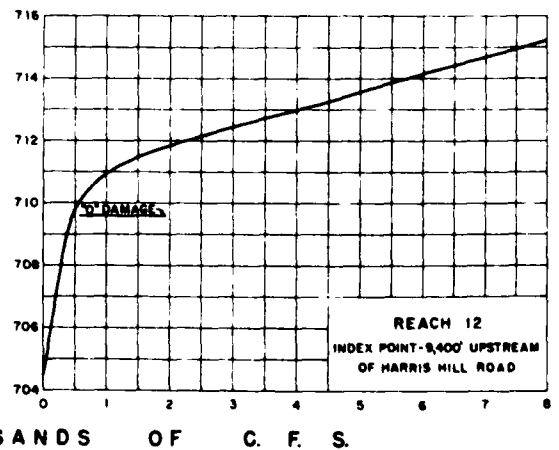
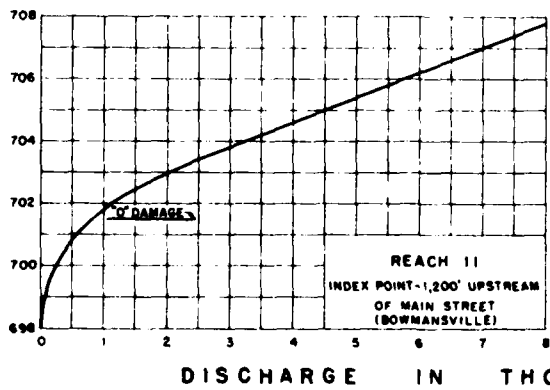
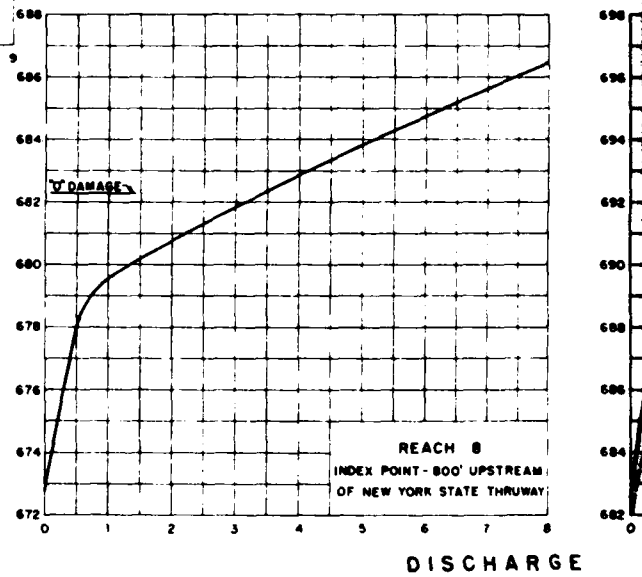
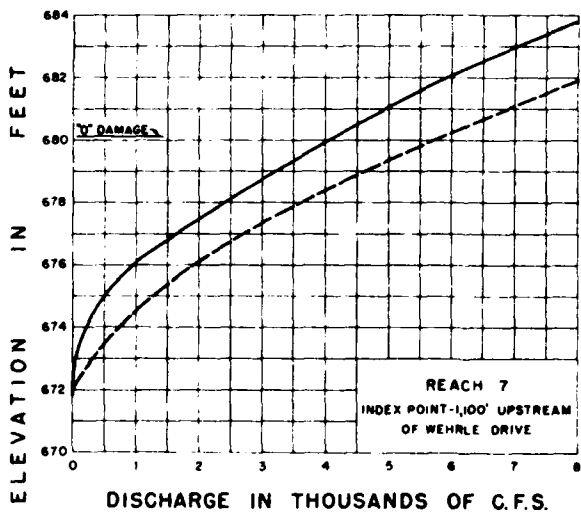
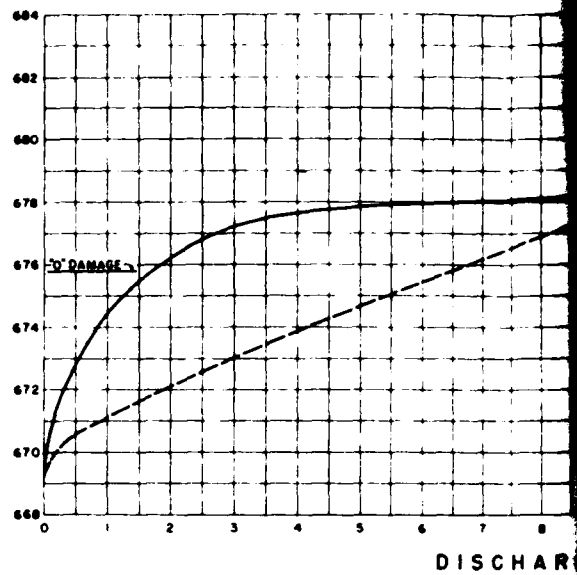
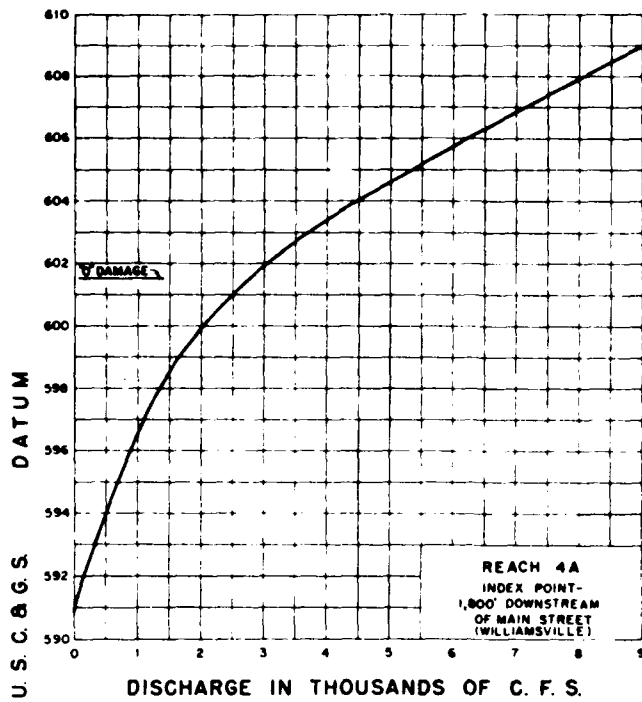

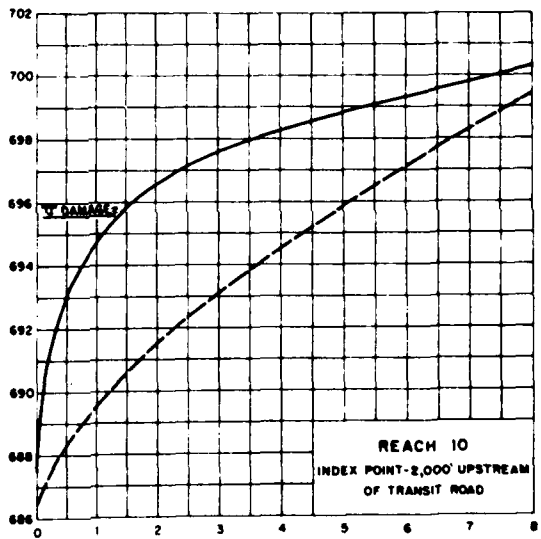
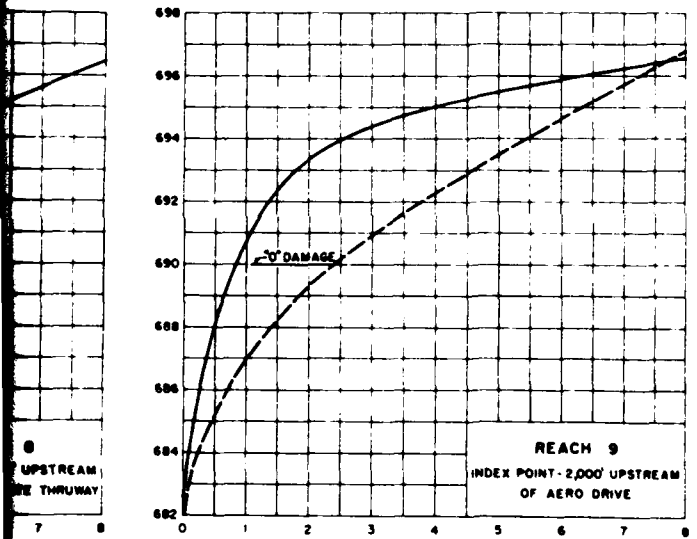
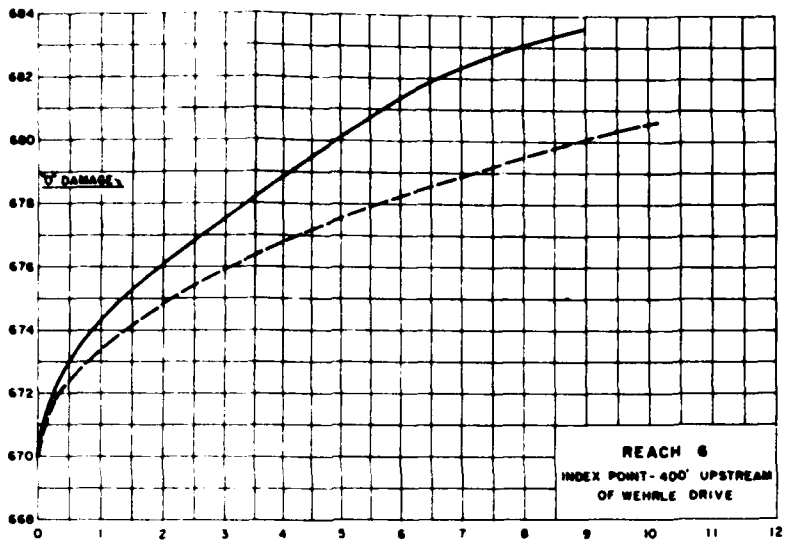
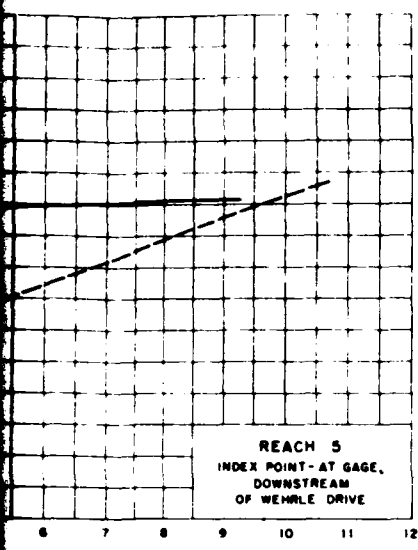

LEGEND
 ——— INDICATES EXISTING CHANNEL CONDITIONS
 - - - - - INDICATES IMPROVED CHANNEL CONDITIONS

ELLCOTT CREEK, NEW YORK
STAGE-DISCHARGE CURVES
REACHES 4A THRU 12
 U. S. ARMY ENGINEER DISTRICT, BUFFALO
 TO ACCOMPANY SURVEY REPORT
 DATED 1970

1

2

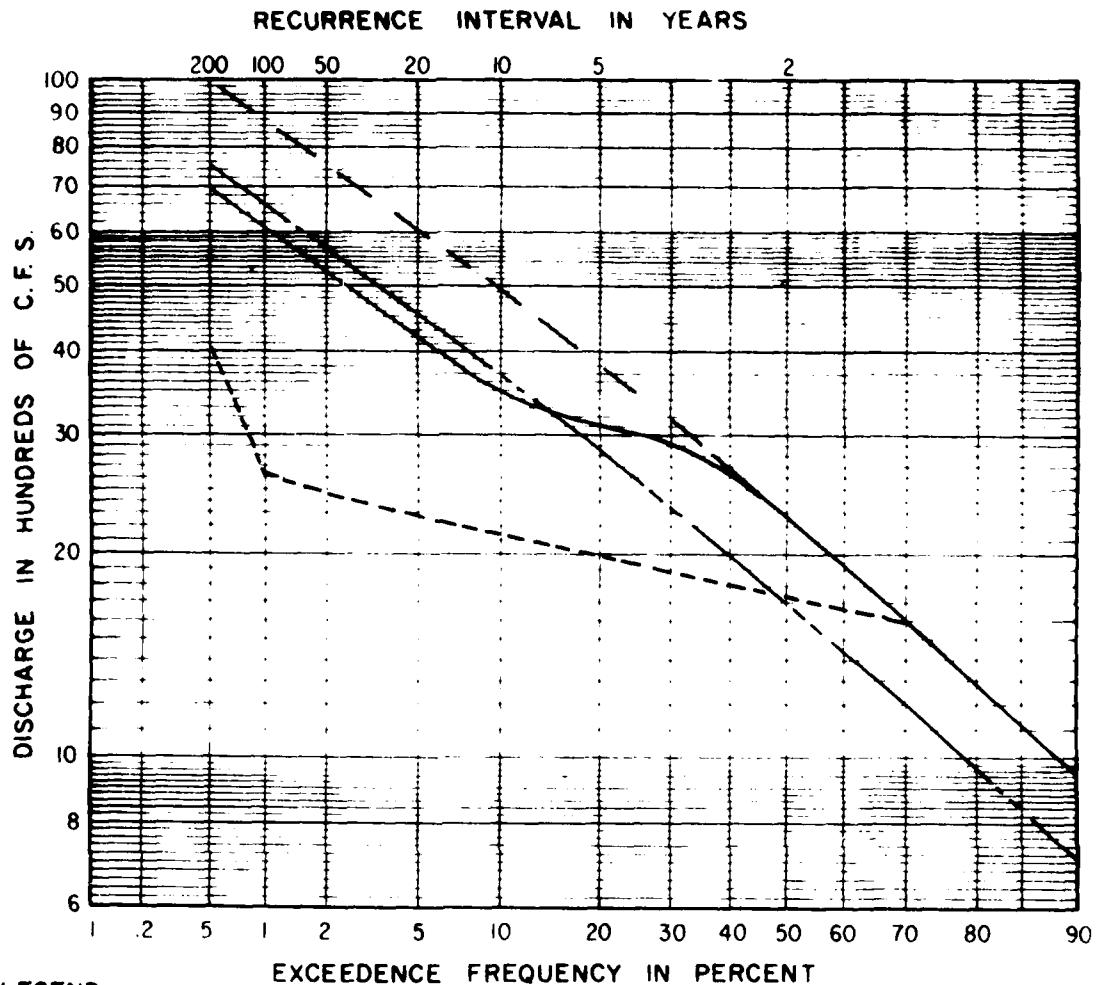

LEGEND:

- EXISTING CONDITIONS
- - - - - IMPROVED CONDITIONS - MAJOR CHANNEL IMPROVEMENTS ONLY
(DIVERSION CHANNEL SCHEME IS IDENTICAL)
- · - · - IMPROVED CONDITIONS - 4" STORAGE RESERVOIR WITH MINOR
CHANNEL IMPROVEMENTS
- · · · · IMPROVED CONDITIONS - BG INSVILLE PAVEMENT SCHEME

ELLICOTT CREEK, NEW YORK
 DISCHARGE-FREQUENCY
 CURVES
 REACHES 0 & 1 1972

U.S. ARMY ENGINEER DISTRICT, BUFFALO

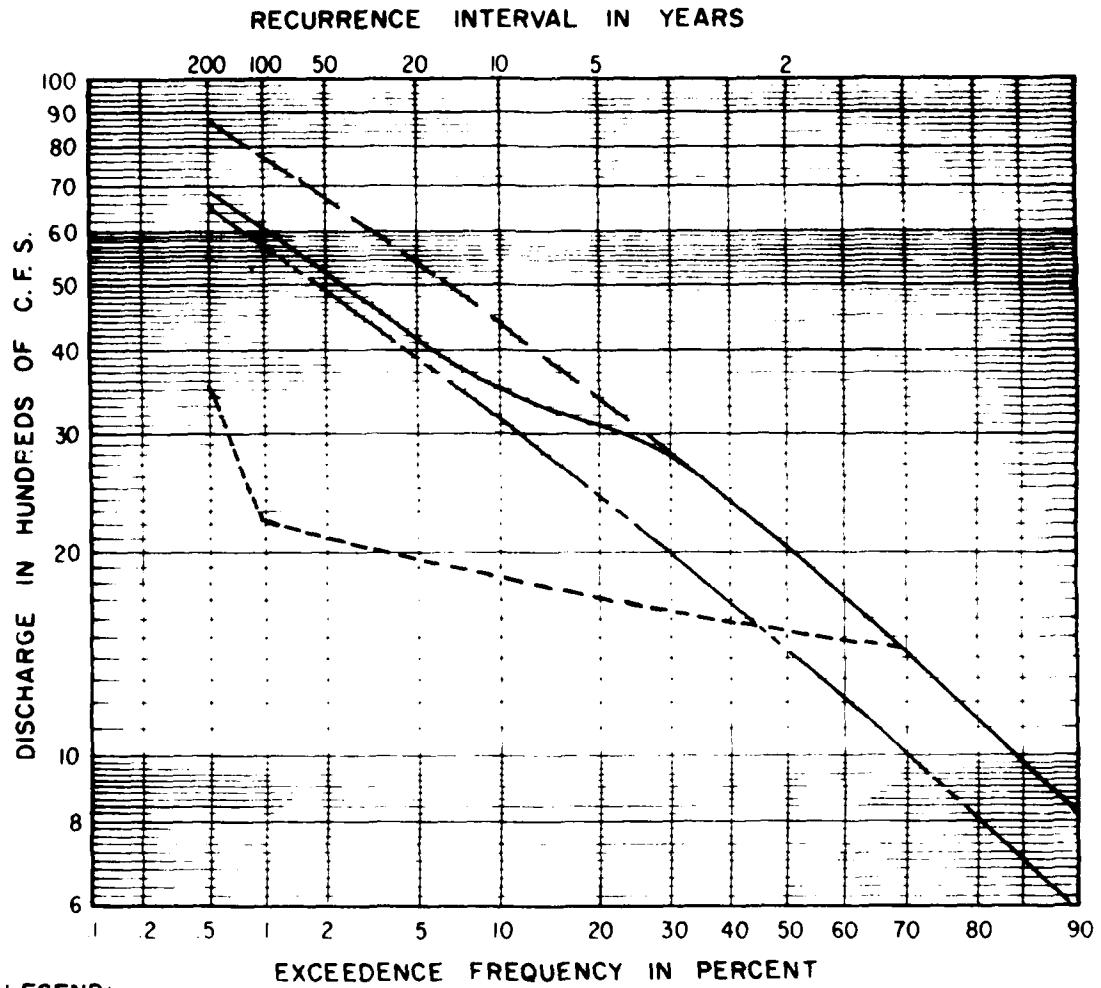

LEGEND:

- EXISTING CONDITIONS
- - - - - IMPROVED CONDITIONS - MAJOR CHANNEL IMPROVEMENTS ONLY
(DIVERSION CHANNEL SCHEME IS IDENTICAL)
- · - · - IMPROVED CONDITIONS - 4" STORAGE AT RESERVOIR WITH MINOR
CHANNEL IMPROVEMENTS
- · · · · IMPROVED CONDITIONS - BOWMANVILLE - PAVEMENT SCHEME

ELLICOTT CREEK, NEW YORK
 DISCHARGE - FREQUENCY
 CURVES
 REACH 2 1972
 U S ARMY ENGINEER DISTRICT, BUFFALO

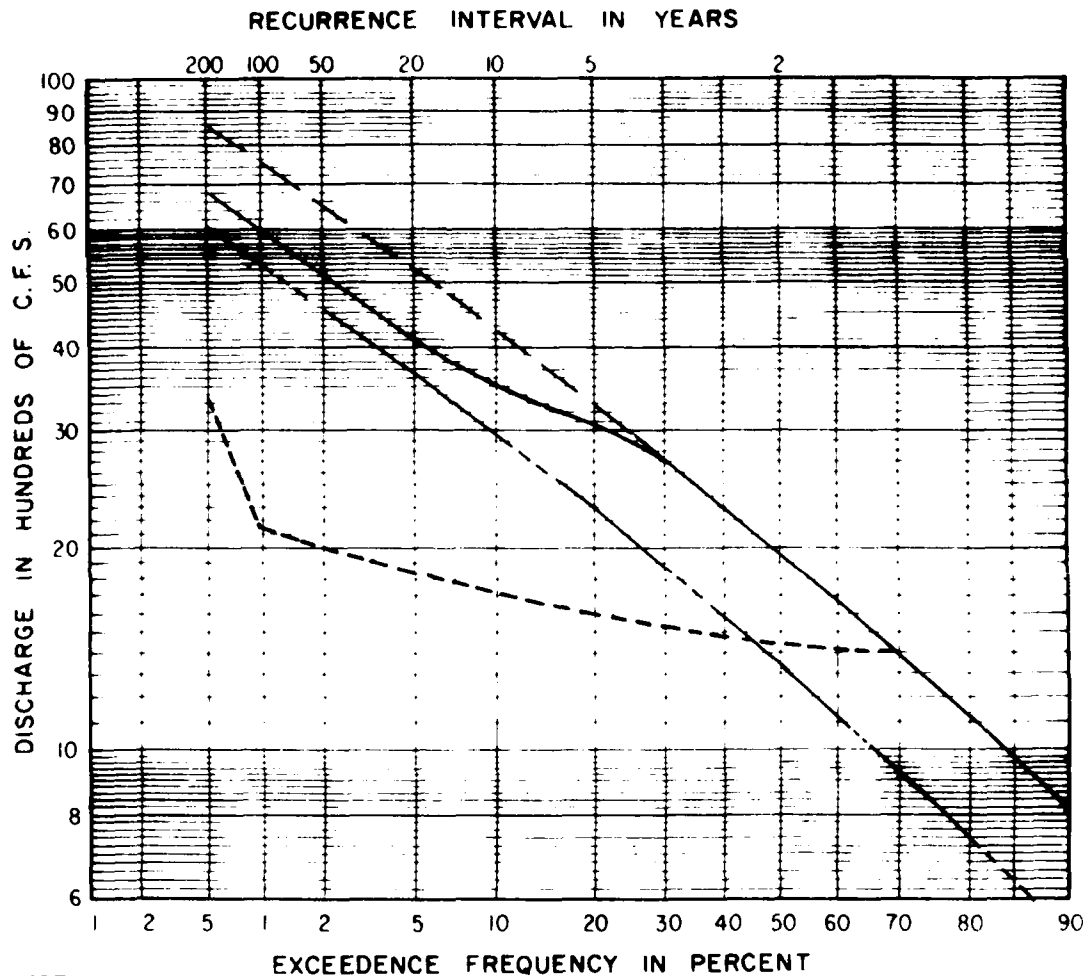

LEGEND:

- EXISTING CONDITIONS
- IMPROVED CONDITIONS - MAJOR CHANNEL IMPROVEMENTS ONLY
(DIVERSION CHANNEL SCHEME IS IDENTICAL)
- · - · - IMPROVED CONDITIONS - 4" STORAGE AT RESERVOIR WITH MINOR
CHANNEL IMPROVEMENTS
- IMPROVED CONDITIONS - BOWMANSVILLE - PAVEMENT SCHEME

ELLICOTT CREEK, NEW YORK
 DISCHARGE-FREQUENCY
 CURVES
 REACHES 3 & 4 1972
 U.S. ARMY ENGINEER DISTRICT, BUFFALO

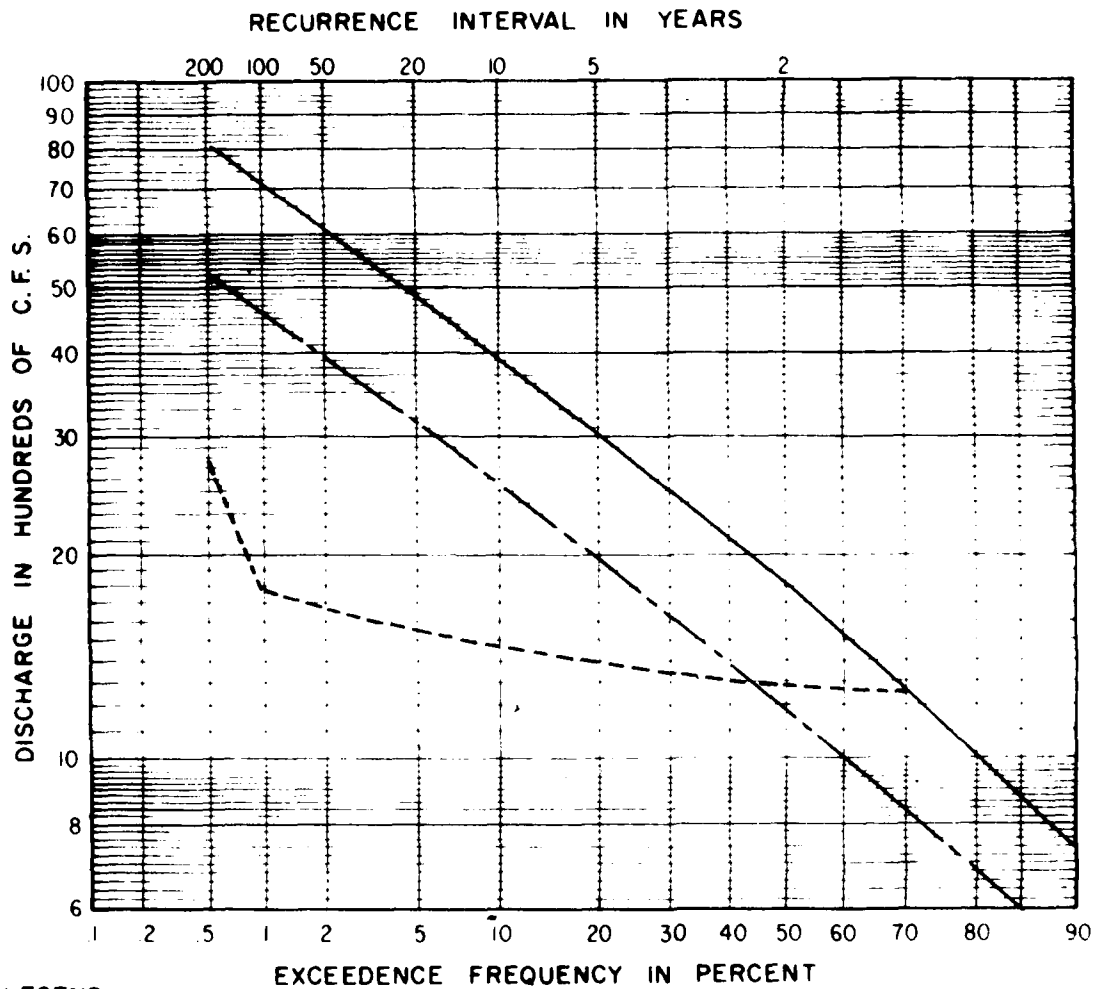

LEGEND:

- EXISTING CONDITIONS
- - - IMPROVED CONDITIONS - 4" STORAGE AT RESERVOIR
- · · IMPROVED CONDITIONS - BOWMANSVILLE - PAVEMENT SCHEME

ELLICOTT CREEK, NEW YORK
 DISCHARGE-FREQUENCY
 CURVES
 REACH 4A TO 7 1972
 U.S. ARMY ENGINEER DISTRICT, BUFFALO

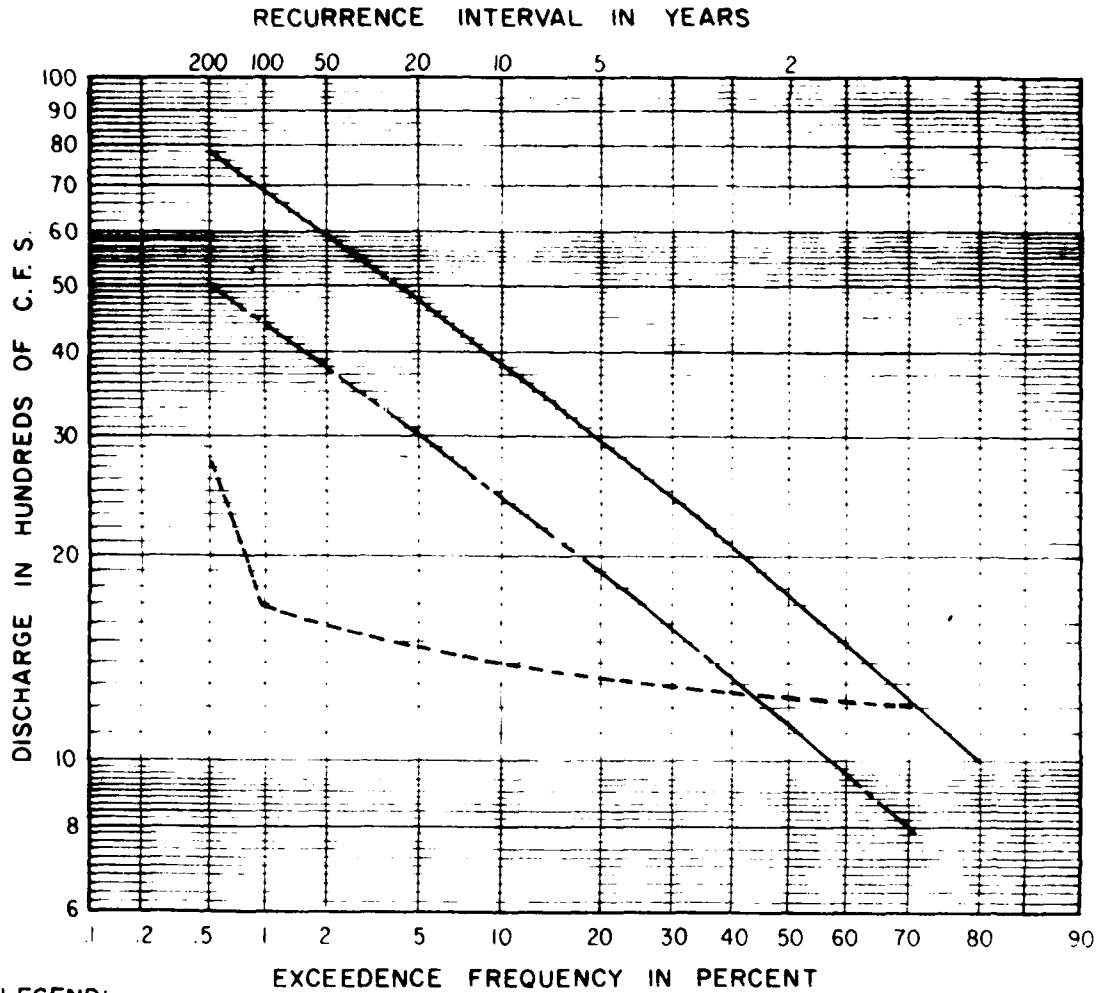

LEGEND:

- EXISTING CONDITIONS
- IMPROVED CONDITIONS - 4" STORAGE AT RESERVOIR
- IMPROVED CONDITIONS - BOWMANVILLE - PAVEMENT SCHEME

ELLICOTT CREEK, NEW YORK
 DISCHARGE-FREQUENCY
 CURVES
 REACH 8 1972
 U.S. ARMY ENGINEER DISTRICT, BUFFALO

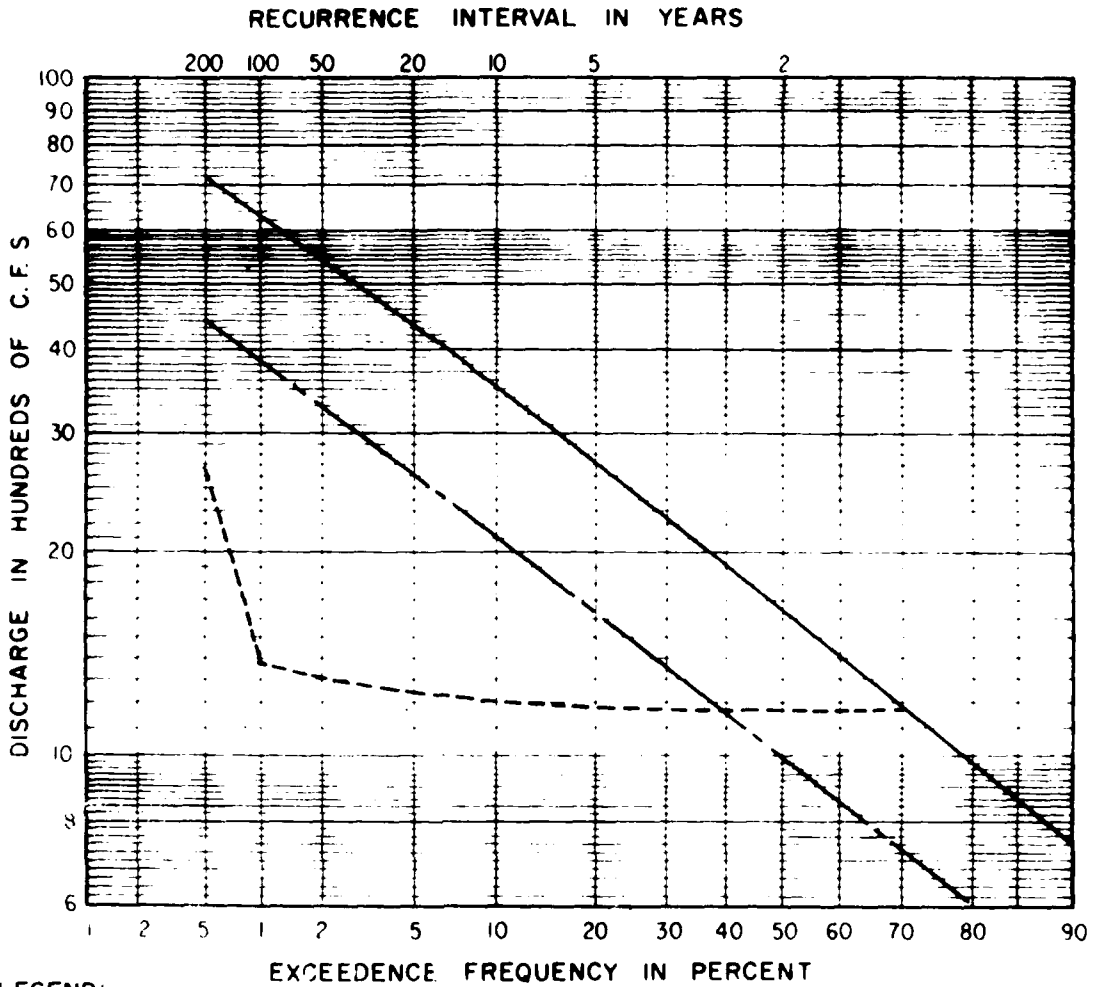

LEGEND:

- EXISTING CONDITIONS
- - - - - IMPROVED CONDITIONS - 4" STORAGE AT RESERVOIR
- IMPROVED CONDITIONS - BOWMANVILLE - PAVEMENT SCHEME

ELLICOTT CREEK, NEW YORK
 DISCHARGE-FREQUENCY
 CURVES
 REACH 9 1972
 U. S. ARMY ENGINEER DISTRICT, BUFFALO

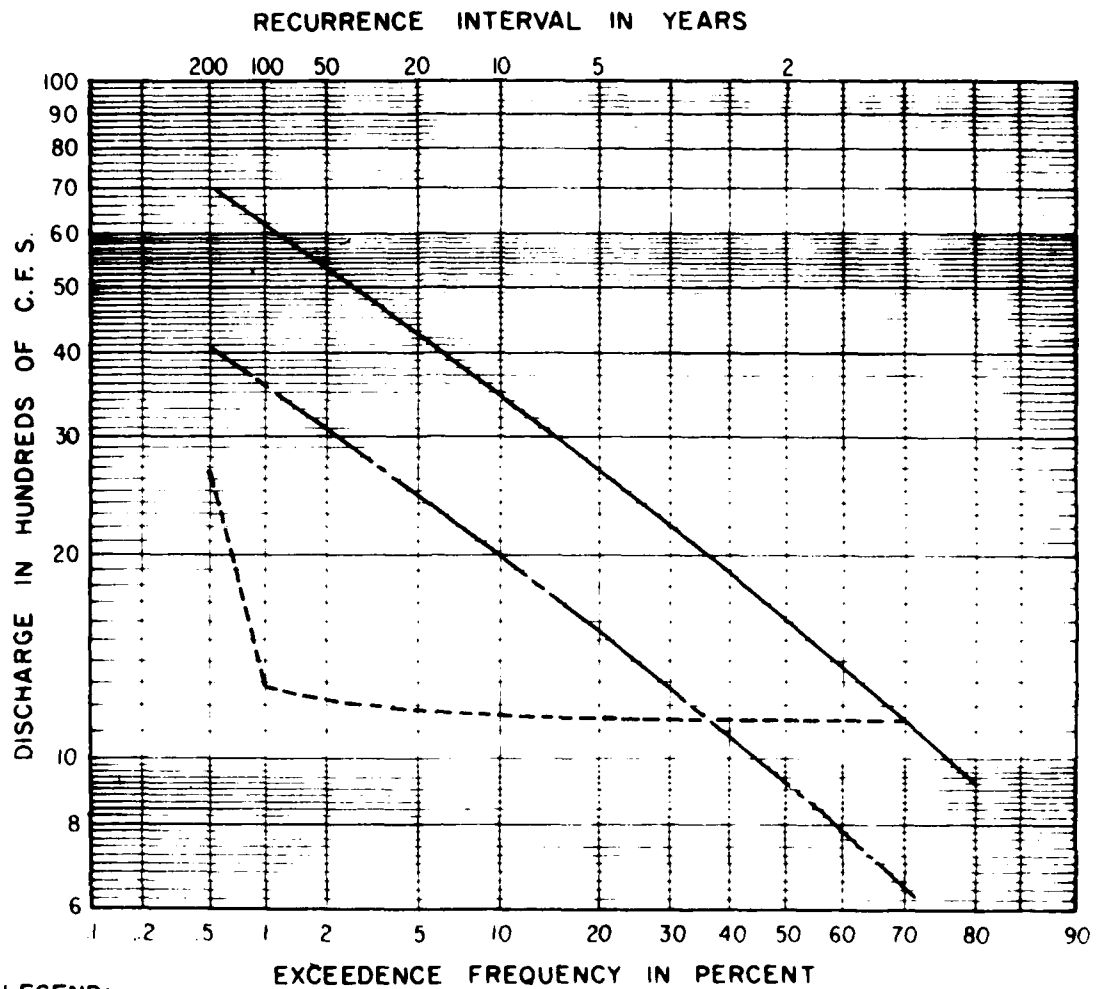

LEGEND:

- EXISTING CONDITIONS
- IMPROVED CONDITIONS - 4" STORAGE AT RESERVOIR
- IMPROVED CONDITIONS - BOWMANVILLE - PAVEMENT SCHEME

ELLICOTT CREEK, NEW YORK
 DISCHARGE-FREQUENCY
 CURVES
 REACH 10 1972
 U.S. ARMY ENGINEER DISTRICT, BUFFALO

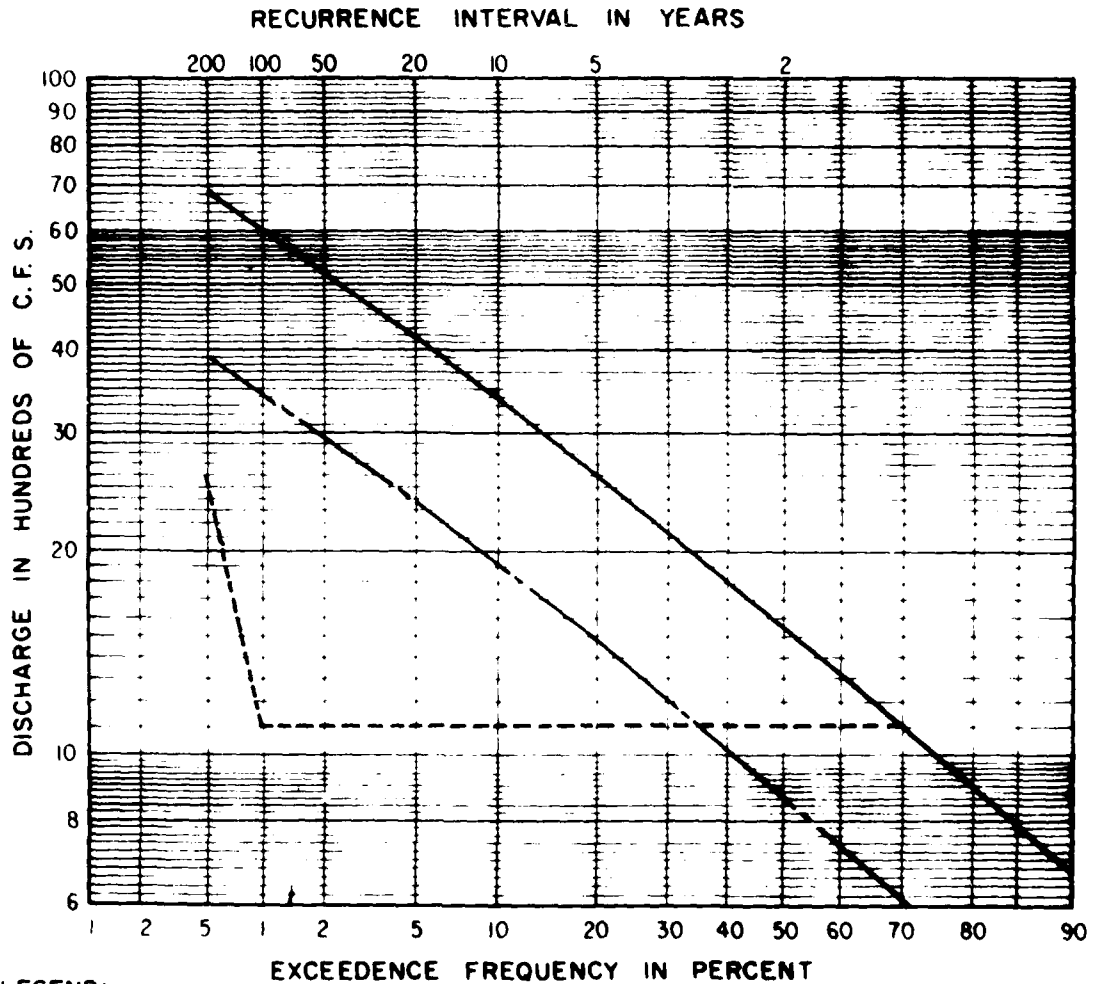

LEGEND:

- EXISTING CONDITIONS
- - - IMPROVED CONDITIONS - 4" STORAGE AT RESERVOIR
- · · IMPROVED CONDITIONS - BOWMANVILLE - PAVEMENT SCHEME

ELLICOTT CREEK, NEW YORK

DISCHARGE-FREQUENCY
CURVES

REACH II 1972

U.S. ARMY ENGINEER DISTRICT, BUFFALO

PLATE A18

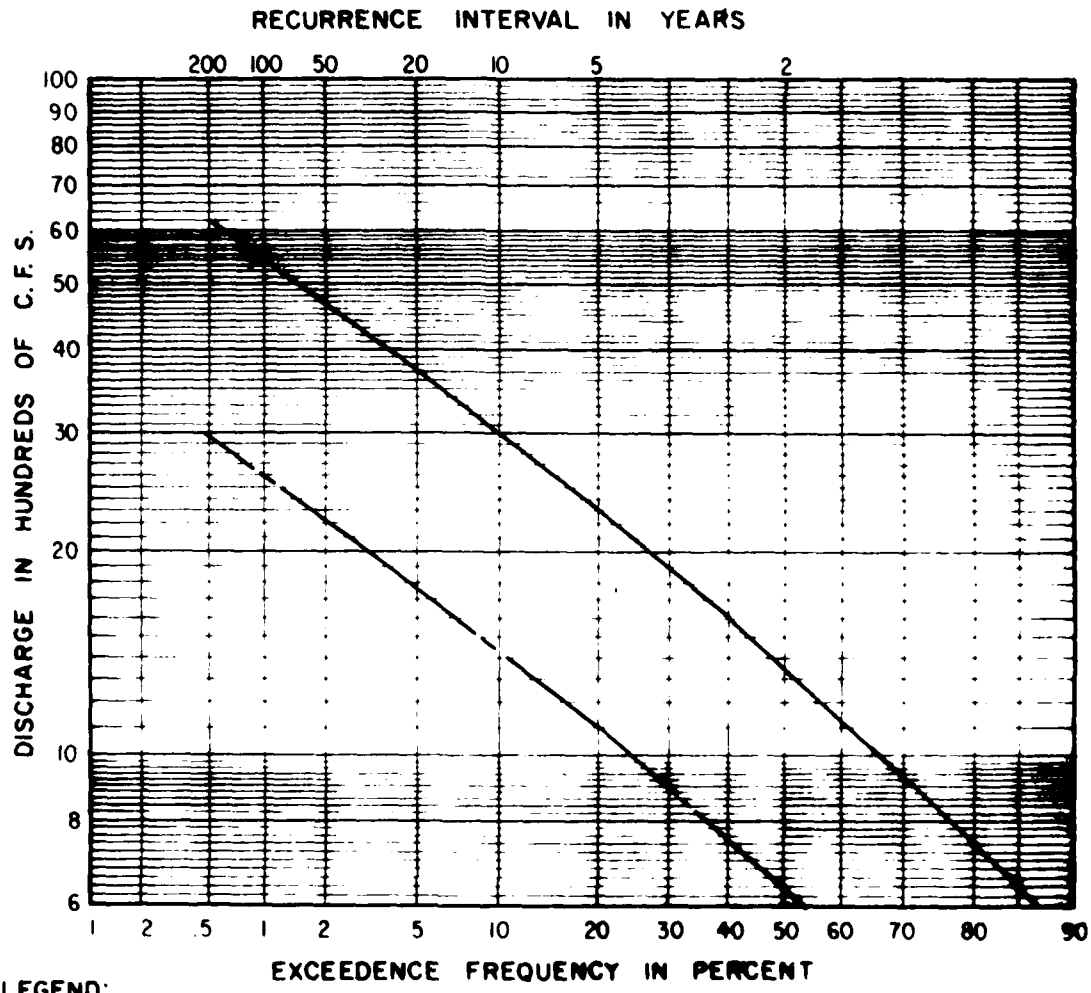

LEGEND:

————— EXISTING CONDITIONS

- - - - - IMPROVED CONDITIONS - 4" STORAGE AT RESERVOIR

ELLICOTT CREEK, NEW YORK
 DISCHARGE-FREQUENCY
 CURVES
 REACH 12 1972
 U.S. ARMY ENGINEER DISTRICT, BUFFALO

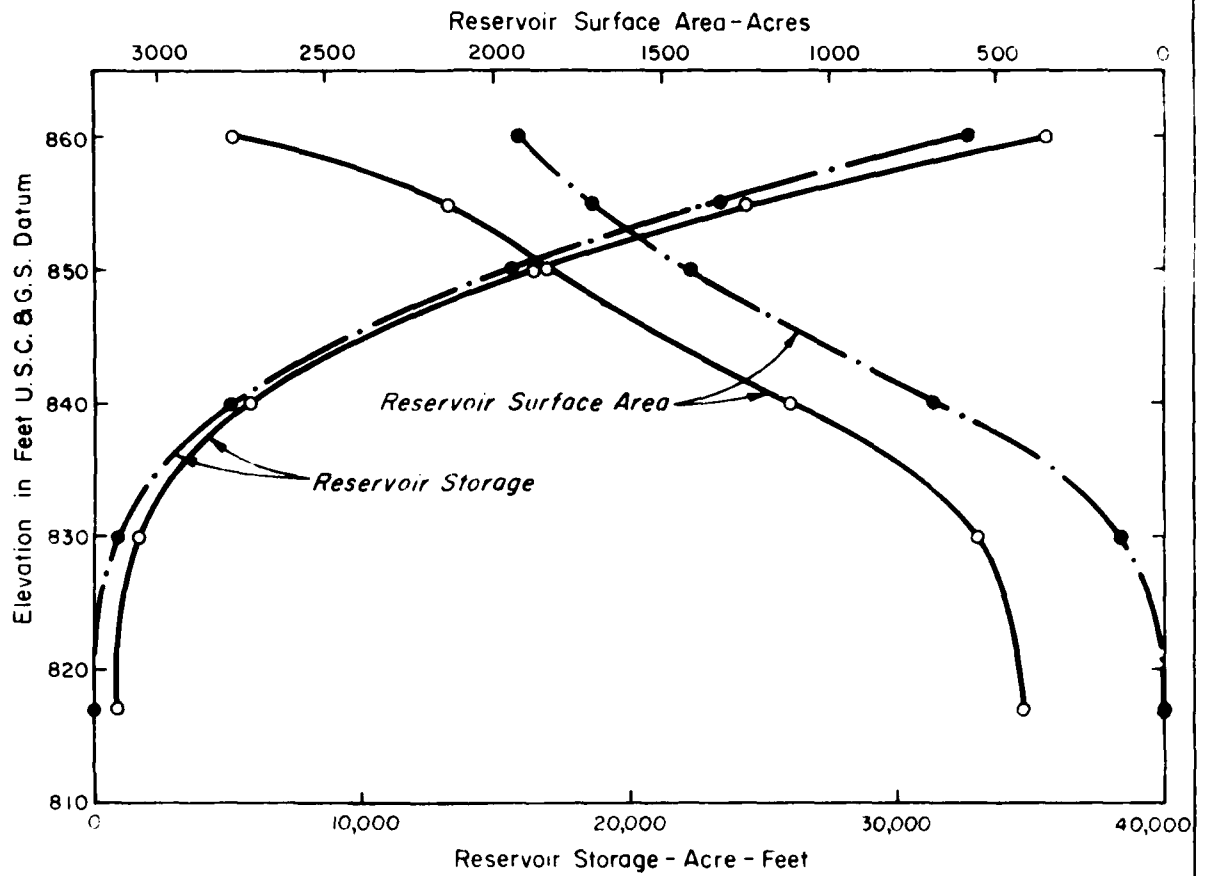

LEGEND :

- Total reservoir
- Reservoir west of Harlow Road

ELLICOTT CREEK NEW YORK
 AREA - VOLUME CURVE
 AT THE PROPOSED
 SANDRIDGE RESERVOIR

U.S. ARMY ENGINEER DISTRICT, BUFFALO
 TO ACCOMPANY SURVEY REPORT
 DATED: 1970

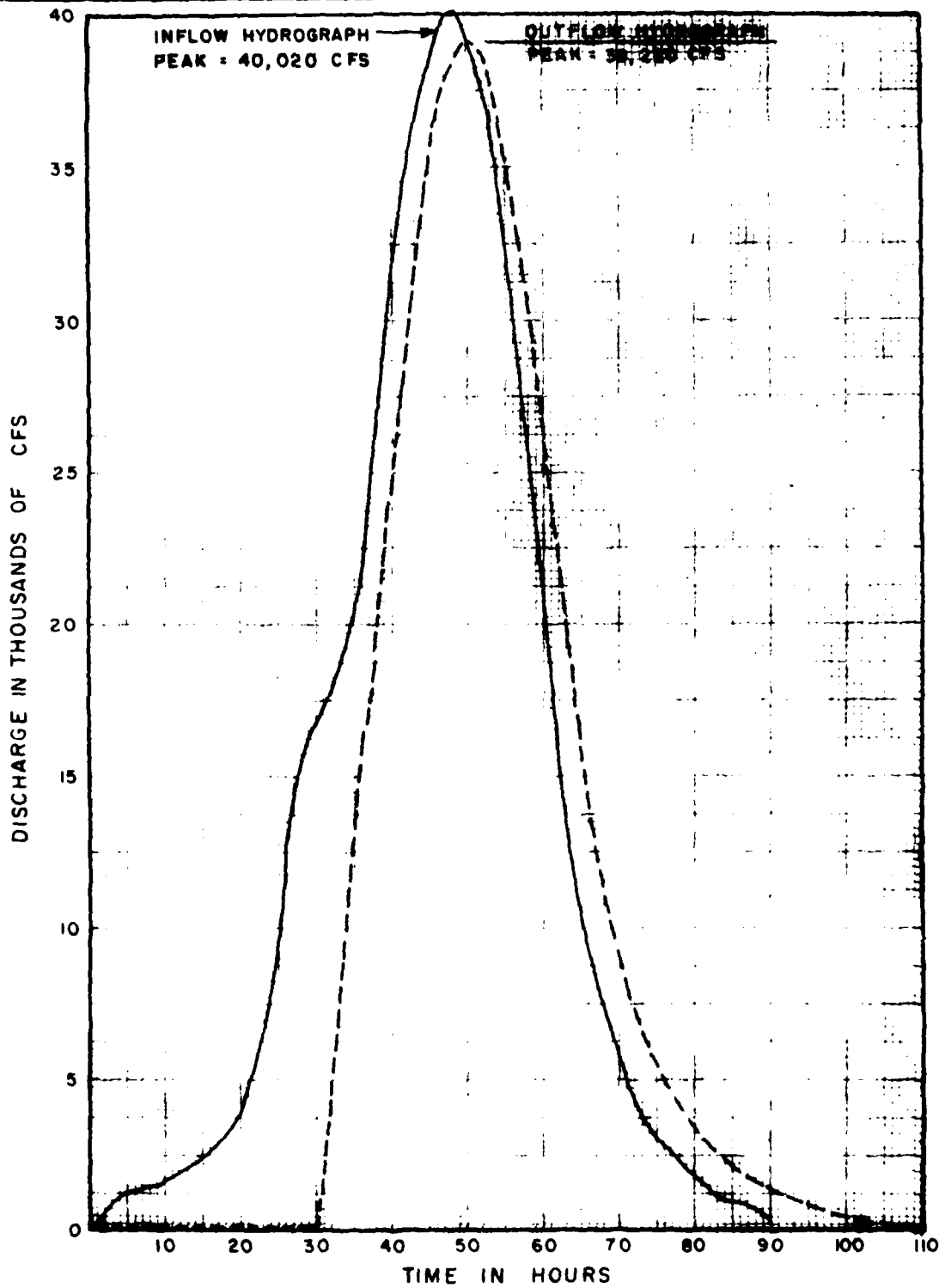

ELLICOTT CREEK NEW YORK
 BOWMANVILLE RESERVOIR
 SPILLWAY DESIGN FLOOD
 INFLOW AND OUTFLOW
 HYDROGRAPH

U.S. ARMY ENGINEER DISTRICT, BUFFALO
 TO ACCOMPANY SURVEY REPORT
 DATED 1973

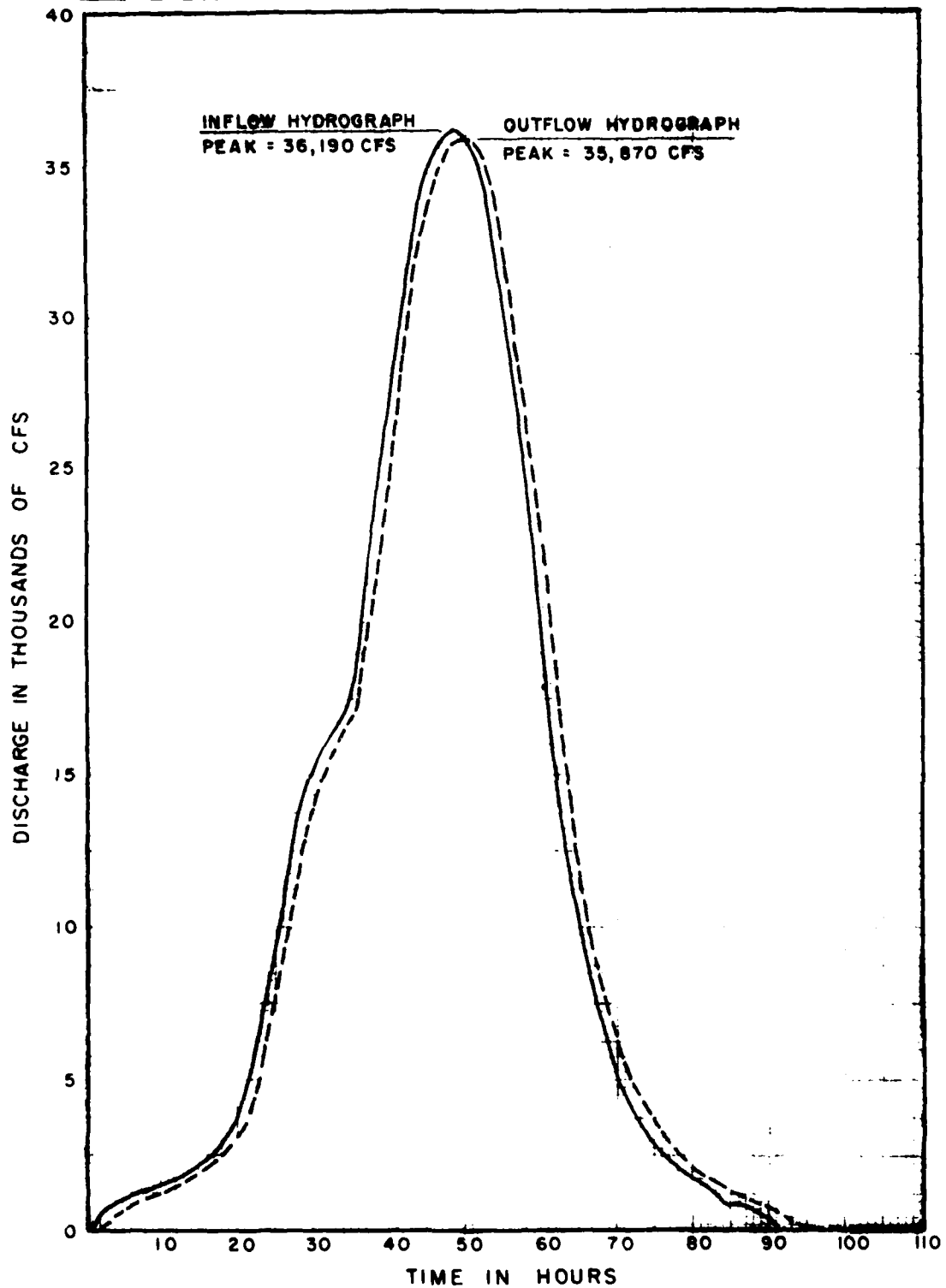

ELLICOTT CREEK NEW YORK
 PAVEMENT RESERVOIR
 SPILLWAY DESIGN FLOOD
 INFLOW AND OUTFLOW
 HYDROGRAPH

U.S. ARMY ENGINEER DISTRICT, BUFFALO
 TO ACCOMPANY SURVEY REPORT
 DATED 1973

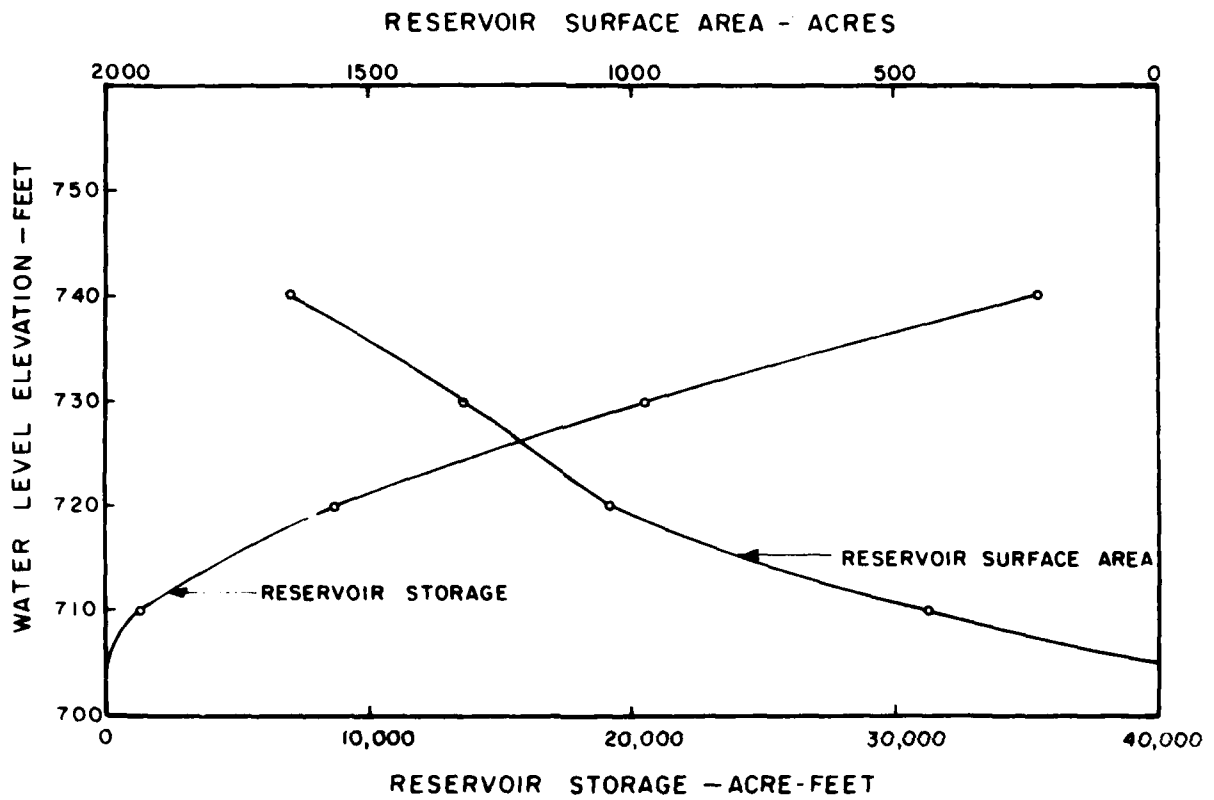

ELLICOTT CREEK NEW YORK
 AREA - VOLUME CURVE
 AT THE PROPOSED
 BOWMANVILLE RESERVOIR
 U.S. ARMY ENGINEER DISTRICT, BUFFALO
 TO ACCOMPANY SURVEY REPORT
 DATED 1973

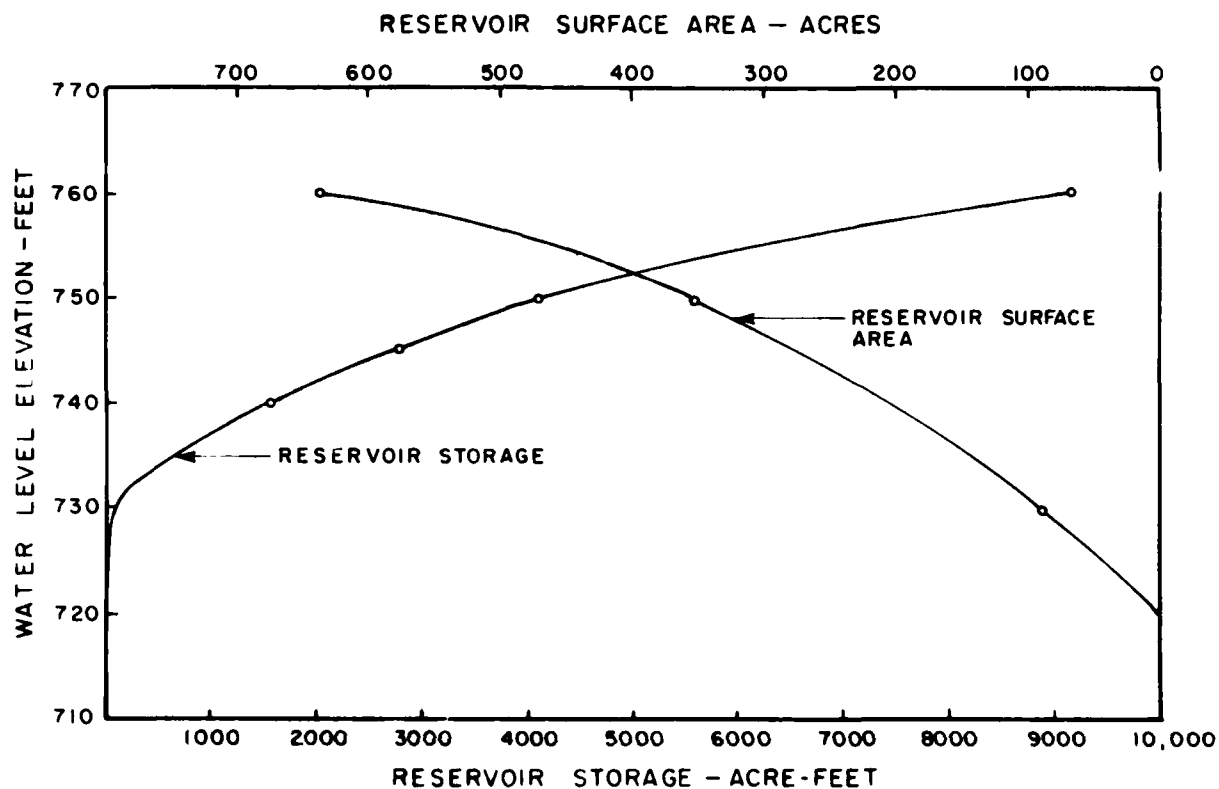

ELLICOTT CREEK NEW YORK
 AREA-VOLUME CURVE
 AT THE PROPOSED
 PAVEMENT RESERVOIR
 U.S. ARMY ENGINEER DISTRICT, BUFFALO
 TO ACCOMPANY SURVEY REPORT
 DATED 1973

FLOOD CONTROL AND ALLIED PURPOSES
ELLCOTT CREEK, NEW YORK

APPENDIX B
FLOOD DAMAGES AND BENEFITS

TABLE OF CONTENTS

		<u>Page</u>
1	EXTENT AND CHARACTER OF FLOODED AREA	B-1
	1.1 General	B-1
	1.2 Extent of Flooding	B-1
	1.3 Character of Flooded Area	B-2
	a. City and Town of Tonawanda	B-2
	b. Town of Amherst	B-2
	c. Town of Cheektowaga	B-3
	d. Town of Lancaster	B-3
	1.4 Description of Flood Damage Reaches	B-3
2	DAMAGES	B-7
	2.1 Damage Survey by Corps of Engineers	B-7
	2.2 Method of Estimating Flood Damage	B-7
	2.3 Stage-Damage Curves	B-11
	2.4 Average Annual Damages, Existing Conditions	B-11
	2.5 Average Annual Damages, Improved Conditions	B-12
3	BENEFITS	B-17
	3.1 General	B-17
	3.2 Average Annual Benefits, Existing Development	B-17
	3.3 Damages to Future Development, General	B-17
	3.4 Average Annual Benefits, Future Development, Reaches 4A thru 12	B-31
	3.5 Total Average Annual Benefits	B-38

TABLES

B1	Damage Reaches	B-5
B2	Approximate Number of Units Subject to Flooding by March 1960 Stages	B-9
B3	Estimated Damages for a Recurrence of March 1960 Stages	B-10
B4	Total Estimated Average Annual Damages, Existing Conditions	B-12

TABLE OF CONTENTS (cont'd)

TABLES

<u>Number</u>		<u>Page</u>
B5	Estimated average annual damages with considered major channel improvement.	B-13
B6	Estimated average annual damages with Diversion Channel.	B-14
B7	Average annual damages with Sandridge Reservoir, 4-inch storage at reservoir and minor channel improvements.	B-15
B8	Estimated average annual damages with minor channel improvements.	B-16
B9	Estimated average annual damages with Bowmansville-Pavement Scheme.	B-16
B10	Estimated average annual flood control benefits, existing conditions of development with considered major channel improvements.	B-18
B11	Estimated average annual flood control benefits, existing conditions of development with diversion channel.	B-19
B12	Estimated average annual flood control benefits, existing conditions of development, with 4-inch storage at reservoir and minor channel improvements.	B-20
B13	Estimated average annual flood control benefits, existing conditions of development with Bowmansville-Pavement Scheme.	B-21
B14	Estimated land available within the 100-year flood level, for future development in reaches 0 through 4.	B-23

TABLE OF CONTENTS (cont'd)

TABLES

<u>Number</u>		<u>Page</u>
B15	Land use categories of existing and future development within the 100-year flood plain.	B-25
B16	Estimated average annual flood control benefits, to future development, major channel improvements.	B-27
B17	Estimated average annual flood control benefits to future development with Diversion Channel.	B-28
B18	Estimated average annual flood control benefits to future development with minor channel improvements.	B-29
B19	Estimated average annual flood control benefits to future development with Bowmansville-Pavement Scheme.	B-30
B20	Estimated average annual flood control benefits to future development.	B-34
B21	Estimated average annual flood control benefits, future development.	B-35
B22	Total estimated average annual flood control benefits, existing and future development.	B-36
B23	Total estimated average annual benefits, 4-inch storage at reservoir and minor channel improvement.	B-38
B24	Total estimated average annual benefits, major channel improvements.	B-39
B25	Total estimated average annual benefits, Diversion Channel.	B-40

TABLE OF CONTENTS (cont'd)

TABLES

<u>Number</u>		<u>Page</u>
B26	Total estimated average annual benefits, Bowmansville-Pavement Scheme.	B-41
B27	Estimated total average annual benefits, November 1972 price levels.	B-42

PLATES

B1	Damage Reaches and Flooded Area Map
B2	Stage-Damage Curves Reach 0 thru 4
B3	Stage-Damage Curves for Ellicott Creek Reaches 4A thru 12
B4	Damage-Frequency Curves Reaches 0 thru 4
B5	Damage-Frequency Curves Reaches 4A thru 12

APPENDIX B

FLOOD DAMAGES AND BENEFITS

1 EXTENT AND CHARACTER OF FLOODED AREA

1.1 GENERAL

1.1.1 Floods in the lower Ellicott Creek basin usually occur during the late winter or early spring from melting snow augmented by precipitation. The March 1960 flood produced the largest discharge recorded at the Williamsville gage in its 15 years of record.

1.1.2 Because of its magnitude, widespread effect, and recent occurrence, the March 1960 flood was selected as the base flood. A preliminary damage survey, extending from Niagara Falls Boulevard upstream to Stony Road was made in the summers of 1962 and 1963. A detailed damage survey was also conducted in the spring of 1969 in the areas where improvements appeared economically feasible. The results of these two damage surveys were used as a basis for determining average annual losses from estimated future flood occurrences, and benefits that would be developed by the considered plans of improvement. Economic studies were also made during the 1969 survey to determine possible future development in the flooded areas which would affect the benefits expected to be derived over the life of the proposed improvements. In the final table the results are updated to reflect price levels of Nov. 1972. This procedure avoids the necessity of updating and redrawing each individual table and plate as presented in the 1970 Survey Report.

1.2 EXTENT OF FLOODING

1.2.1 Flooding along Ellicott Creek has inundated large areas of land in the city of Tonawanda and the towns of Tonawanda, Amherst, Cheektowaga and Lancaster. The area subject to flooding in the downstream reaches is shown on Plate B1. The 1960 flood inundated approximately 20 acres in the town of Tonawanda (includes the city of Tonawanda), 3,200 acres in the town of Amherst, 450 acres in the town of Cheektowaga and 890 acres in the town of Lancaster.

AD-A101 345

CORPS OF ENGINEERS BUFFALO N Y BUFFALO DISTRICT
ELLICOTT CREEK BASIN, NEW YORK. WATER RESOURCES DEVELOPMENT. PH--ETC(U)
AUG 73

F/0 13/2

UNCLASSIFIED

NL

2 of 6
AD-A101 345

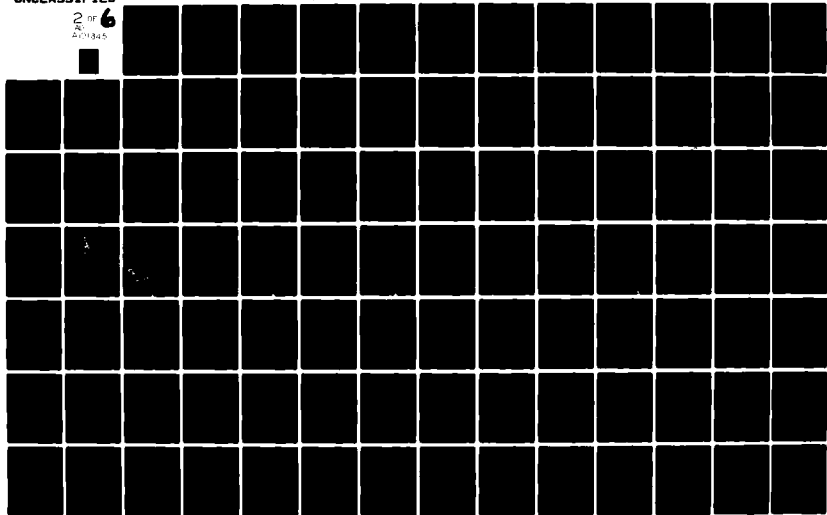

1.2.2 In the lower reaches of the town of Amherst, the flood plain between Niagara Falls Boulevard and Millersport Highway covers vast areas of low, flat terrain, mostly on the right bank of the creek. The maximum width of the flood plain is about two miles. Between Millersport Highway and Main Street the flood plain is somewhat smaller, having a maximum width of about 4,000 feet. Within the village of Williamsville the flood plain is restricted to the low areas adjacent to the creek, reaching a maximum width of about 1,500 feet. Upstream of the village, there are two large undeveloped areas where the flood plain reaches a maximum width of about one mile. One of the areas is between Youngs Road and Transit Road in town of Cheektowaga and the other is between Harris Hill Road and Stony Road in the town of Lancaster. The hamlet of Bowmansville is between these two areas, and flooding in Bowmansville is similar to the situation at Williamsville in that it is localized and restricted to low areas in close proximity to the creek, and is generally caused by channel restrictions.

1.3 CHARACTER OF FLOODED AREA

1.3.1 In general, units subject to damage along Ellicott Creek are residential. Description and type of development in the flood plain by towns is as follows:

- a. City and town of Tonawanda - This reach covers a distance of approximately 3.4 miles and extends from the confluence of Tonawanda Creek upstream to Niagara Falls Boulevard. In this reach development in the flood plain is confined to residential and commercial units. There is a large commercial boating facility along with many private boat docks. Also located in this reach is Ellicott Creek Park. In the park is the diversion channel, constructed by Erie County to divert water from Ellicott Creek to Tonawanda Creek.
- b. Town of Amherst - In the reach from Niagara Falls Boulevard upstream to the Main Street bridge in the village of Williamsville, development is primarily high value residential units with a scattering of commercial units

throughout this 9.7 mile length. In this reach there are also three golf courses, two private and one municipal. Part of the proposed campus for the State University of New York at Buffalo (SUNYAB) will be located within the area flooded by the 1960 highwater occurrence. Total cost of the university complex is expected to be \$650 million. The site for the Campus is on the left bank of Ellicott Creek and is enclosed by the creek, Sweet Home Road and Maple Road.

1.3.2 In the reach from Main Street to Youngs Road the flood plain is characterized by residential development with very little vacant land left for development. Commercial properties which comprise the business center for the village are located primarily on Main Street.

- c. Town of Cheektowaga - In the reach from Youngs Road to Transit Road there is a scattering of residential and commercial developments. The extended jet runway for the Greater Buffalo International Airport is located in this reach.
- d. Town of Lancaster - In the reach from Transit Road to Stony Road, the flood plain is characterized by a scattering of commercial and residential units. Private enterprise plans to build a \$50 million domed stadium on the fringe of the flood plain. Peripheral development by private interest will extend into the flood plain. Upstream from Stony Road the flood plain is not well defined because only limited flood damages have been reported. Available information indicates that most flooding would be restricted to a narrow strip along the existing channel.

1.4 DESCRIPTION OF FLOOD DAMAGE REACHES

1.4.1 The location of index points, limits of the damage reaches, and the March 1960 flood outline are shown on Plate B1. The damage reaches were selected so that the areas within each reach would be flooded from the same source and be affected similarly by flooding and by the considered plan of improvement. The index point for each reach was selected as a point at which changes in water surface elevations would be representative throughout the reach.

The location of the index points, a brief description of the damage reaches, initial damaging stage and discharge, and recurrence interval in years under natural conditions are given in Table B1, following:

TABLE Bl. - Damage Reaches

Reach No.	Index Point location	Initial discharge (cfs)	Initial stage (feet)	Approximate recurrence interval (years)	Description of reach
0	600 ft. downstream of Niagara Falls Blvd.	3600	571.1	15	Confluence with Tonawanda Creek to Niagara Falls Blvd.
1	3500 ft. upstream of Niagara Falls Blvd.	3500	573.0	10	Niagara Falls Blvd. to Sweet Home Road
2	5800 ft. upstream of Sweet Home Road	3100	575.5	6	Sweet Home Road to Millersport Highway
3	4300 ft. upstream of Millersport Highway	3200	582.8	7	Millersport Highway to Maple Road
4	4200 ft. upstream of Maple Road	2100	591.0	2	Maple Road to Sheridan Drive
4a	1800 ft. downstream of Main Street	2800	601.5	4	Sheridan Drive to Main St. in Williamsville
5	U.S.G.S. gage downstream of Wehrle Drive	1800	675.9	2	Main Street in Williamsville to Wehrle Drive
6	400 ft. upstream of Wehrle Drive	3700	678.5	8	Wehrle Drive to Williamsville village line

TABLE B1 (cont'd)

Reach No.	Index Point location	Initial discharge (cfs)	Initial damaging stage (feet)	Approximate recurrence interval (years)	Description of reach
7	1100 ft. upstream of Wehrle Drive	4200	680.1	12	Williamsville village line to New York State Thruway
8	800 ft. upstream of New York State Thruway	3500	682.3	8	New York State Thruway to Youngs Road
9	2000 ft. upstream of Aero Drive	850	690.0	1	Youngs Road to Transit Road
10	2000 ft. upstream of Transit Road	1400	695.6	2	Transit Road to Main St. in Bowmansville
11	1200 ft. upstream of Main Street in Bowmansville	800	701.5	1	Main Street in Bowmansville to Harris Hill Road
12	9400 ft. upstream of Harris Hill Road	450	709.6	1	Harris Hill Road to Stony Road

2. DAMAGES

2.1 DAMAGE SURVEY BY CORPS OF ENGINEERS

2.1.1 A preliminary damage survey was made of the total area affected by the March 1960 highwater occurrence. The areas flooded in reaches 0 to 7 were covered in a damage survey made in April through June 1962. The areas flooded in reaches 8 to 12 were covered in a damage survey made in May through June 1963. A re-survey in reaches 0 to 4 was conducted in the spring of 1969 because of widespread development in the flood plain since the 1962 survey. The March 1960 flood was used as a basis for the surveys because of its recent occurrence and relative magnitude. From interviews with property owners, businessmen and public officials, sufficient information was obtained so that losses could be estimated for flood levels above and below that caused by the base flood.

2.2 METHOD OF ESTIMATING FLOOD DAMAGE

2.2.1 Highwater elevations were established for the March 1960 flood in reaches 0 to 12 by inspection and through interviews with individuals. At the time of the preliminary damage survey, the 1960 flood elevations were projected by hand level so that depth of flooding could be estimated for every unit in the flood. Damages to the units were evaluated as costs of repairs or, if necessary, replacement, using both the owners experience and estimates obtained from dealers or servicemen. The monetary values of the damage to the residential buildings and furnishings were based on the depreciated value of the article or replacement in kind. During interviews with owners and managers of commercial units, the interviewers noted the overall condition of the building and equipment, and the type and relative quantity of product or merchandise. Public officials and utility companies furnished information, from bookkeeping and payroll records, for extra labor and clean-up costs. Almost all commercial, public and utility units that would be affected by a recurrence of the 1960 flood were covered by interviews during the damage surveys. Nonrecurring damage was not included and indications of change in conditions or operations were considered in the computation of average annual damage.

Also determined were time and money expended for flood fighting, clean-up, lost wages and evacuation. Table B2 shows the approximate number of units affected in the different reaches by the March 1960 flood. Sufficient information was obtained during the damage interviews so that losses could be estimated for flood levels one foot above and below the 1960 flood levels. The estimates of recurring damage for the units covered by the interviews were then applied to the other units in the flooded area having a similar value, construction and depth of flooding. The estimated damage for a recurrence of the 1960 flood, and for levels one foot higher and lower are listed by reaches in Table B3.

TABLE B2 - Approximate number of units subject to flooding by March 1960 stages, (March 1969 conditions of development)

Reach No.	Residential	Commercial	Other (1)	Total
0	405	1	1	407
1	67	1	1	69
2	245	2	1	248
3	360	1	2	363
4	227	4	5	236
4a	2	0	1	3
5	87	0	0	87
6	48	0	0	48
7	22	0	0	22
8	7	0	0	7
9	26	0	0	26
10	12	2	4	18
11	21	0	0	21
12	19	0	0	19
TOTAL	1,548	11	15	1,574

(1) Includes damages to public property, churches, institutions, utilities, highways, etc.

TABLE B3 - Estimated damages for a recurrence of March 1960 stages (March 1969 price levels and conditions of development)

Reach No.	Flood Stages		
	1960-1	1960	1960 + 1
0	\$ 30,000	\$ 320,000	\$1,100,000
1	20,000	110,000	330,000
2	350,000	630,000	1,150,000
3	260,000	610,000	1,260,000
4	130,000	205,000	295,000
4a	9,000	18,300	27,400
5	5,700	18,800	39,000
6	3,300	29,300	44,500
7	1,400	5,200	10,300
8	1,100	2,200	3,600
9	2,700	6,200	10,400
10	18,100	41,000	64,200
11	3,600	7,800	14,200
12	13,200	23,200	35,400
TOTAL	\$848,000	\$2,027,000	\$4,384,000

2.3 STAGE-DAMAGE CURVES

2.3.1 The estimated values listed in Table B3 were plotted against the corresponding stages at each index point as determined from the high water marks from the 1960 flood. The elevation of zero damage for each reach was estimated from the data obtained during the interviews. These four points were used to develop the stage-damage curves for each reach. The stage-damage curves for reaches 0 through 4 are shown on Plate B2 and are based on March 1969 price levels and conditions of development. The stage-damage curves for the remaining reaches are shown on Plate B3 and are based on July 1964 price levels and conditions of development at the time of the 1962 - 1963 damage survey.

2.4 AVERAGE ANNUAL DAMAGES, EXISTING CONDITIONS

2.4.1 The stage-damage curve for each reach was used in conjunction with the appropriate full development discharge-frequency and stage-frequency curves in order to determine the damage-frequency relationship for that reach. The average annual damage for existing conditions for each reach was obtained by determining the area under the appropriate damage-frequency curve. Damage values for reaches 4a through 12 were adjusted by price level so all reaches could be compared on a common basis. The estimated average annual damages on March 1969 price levels are shown in Table B4. The damage-frequency curves are shown on Plate B5. Due to the comparatively small amounts of damages in reaches 4a through 12, only total damage values are shown.

TABLE B4 - Total estimated average annual damages, existing conditions (March 1969 price levels and conditions of development)

Reach	Average annual damages			
	Residential	Commercial	Other	Total
0	\$ 9,730	\$120	\$1,310	\$ 11,160
1	7,910	30	410	8,350
2	51,610	90	1,600	53,300
3	47,920	60	2,240	50,220
4	35,700	390	2,610	38,700
Sub-total:	\$152,870	\$690	\$8,170	\$161,730
4a				2,650
5				4,710
6				2,150
7				460
8				170
9				1,460
10				4,350
11				3,150
12				3,260
TOTAL				\$184,090

2.5 AVERAGE ANNUAL DAMAGES, IMPROVED CONDITIONS

2.5.1 Each of the considered plans of improvement would reduce or eliminate flood damages in some reaches. Average annual damages to be expected under the considered plans were developed in the same manner as described in the preceding paragraph. Estimated average annual damages with major channel improvements, designed for 100-year protection (reaches 0 through 4) are shown in Table B5. Table B6

shows average annual damages with Diversion Channel. Table B7 shows average annual damages for 4-inches of reservoir storage and minor channel improvements in reaches 0 through 4. Table B8 shows average annual damages for minor channel improvement alone in reaches 0 to 4. Although this plan was not seriously considered by itself, the values are needed for cost allocation purposes. Table B9 shows average annual damages for the Bowmansville-Pavement Scheme for reaches 0 through 4. The damage-frequency relationships under improved conditions are also shown on Plates B4 and B5. The areas under the modified damage-frequency curves represent the total residual average annual damages with the considered improvements.

TABLE B5 - Estimated average annual damages with considered major channel improvement. (March 1969 price and conditions of development)

Reach	Average annual damages				Total
	Residential	Commercial	Other		
Q	:	:	:	:	:
0	\$ 1,600	\$0	\$260	\$ 1,860	
1	780	0	40	820	
2	5,530	0	110	5,640	
3	3,440	0	120	3,560	
4	240	0	0	240	
TOTAL	\$11,590	\$0	\$530	\$12,120	

TABLE B6 - Estimated average annual damages with Diversion Channel (March 1969 price levels and conditions of development)

Average annual damages - Diversion Channel					
Reach	Residential	Commercial	Other	Total	
0	\$ 1,600	\$0	\$260	\$ 1,860	
1	780	0	40	820	
2	5,530	0	110	5,640	
3	3,440	0	120	3,560	
4	240	0	0	240	
TOTAL	\$11,590	\$0	\$530	\$12,120	

TABLE B7 - Average annual damages with Sandridge Reservoir, 4-inch storage at reservoir and minor channel improvements. (March 1969 price levels and conditions of development)

Reach	Average annual damages			
	Residential	Commercial	Other	Total
0	\$ 230	\$0	\$ 40	\$ 270
1	70	0	0	70
2	3,890	0	70	3,960
3	20	0	0	20
4	3,200	0	120	3,320
Sub- Total	\$7,410	\$0	\$230	\$ 7,640
4a				470
5				1,840
6				210
7				50
8				10
9				540
10				830
11				1,360
12				1,210
TOTAL				\$14,160

TABLE B8 - Estimated average annual damages with minor channel improvements. (March 1969 price levels and conditions of development)

Reach	:	Average annual damages
0	:	\$ 1,860
1	:	1,640
2	:	21,660
3	:	7,030
4	:	13,700
TOTAL	:	\$45,890

TABLE B9 - Estimated average annual damages with Bowmansville-Pavement Scheme (March 1969 price levels and conditions of development)

Reach	Average annual damages			
	Residential	Commercial	Other	Total
0	\$ 1,600	\$0	\$260	\$ 1,860
1	780	0	40	820
2	5,530	0	110	5,640
3	3,440	0	120	3,560
4	240	0	0	240
Sub-Total	\$11,590	\$0	\$530	\$12,120
4a	:	:	:	470
5	:	:	:	1,840
6	:	:	:	210
7	:	:	:	50
8	:	:	:	10
9	:	:	:	540
10	:	:	:	830
11	:	:	:	1,360
TOTAL	:	:	:	\$17,430

3. BENEFITS

3.1 GENERAL

3.1.1 Flood control benefits were calculated for each considered plan of improvement. Benefits would result from a reduction in flood damages, to existing development and to future development that would be expected without flood protection.

3.2 AVERAGE ANNUAL BENEFITS, EXISTING DEVELOPMENT

3.2.1 Average annual benefits, from reduction of flood damages for existing conditions of development were determined for each considered plan of improvement. The benefits were calculated by subtracting average annual damages with and without the considered improvements. The estimated average annual flood control benefits based on March 1969 price levels for the considered improvements are shown in Tables B10 through B13.

3.3 DAMAGES TO FUTURE DEVELOPMENT, GENERAL

3.3.1 The areas subject to heaviest flood damage along the creek are in the lower reaches in the town of Amherst. The terrain is flat and there are no other large undeveloped areas as close to downtown Buffalo. Average commuting time would be about 30 minutes. The town of Amherst is noted for its excellent public schools, high quality community services and beautiful homes. The town is generally considered to be one of the most prestigious residential communities in Western New York. Many new homes, ranging in value from \$30,000 to \$50,000 have been constructed in the flood plain in recent years. The rate of development has been accelerated by a new 650-million dollar State University Campus being constructed on the fringe of the flood plain. The University proposes to furnish on-campus housing for 14,000 of the proposed 50,000 students. Undoubtedly a number of students and some university employees will be living in what is now the Ellicott Creek flood plain adjacent to the campus.

TABLE B10 - Estimated average annual flood control benefits, existing conditions of development, with considered major and minor channel improvements. (March 1969 price levels and conditions of development)

Reach: Existing No. : conditions	Average annual damages		Average annual benefits	
	: improvement (1)	: improvement (2)	: improvement (3)	: improvement (3)
0	\$ 11,160	\$ 1,860	\$ 9,300	\$ 9,300
1	8,350	820	7,530	6,710
2	53,300	5,640	47,660	31,640
3	50,220	3,560	46,660	43,190
4	38,700	240	38,460	25,000
TOTAL:	\$161,730	\$12,120	\$149,610	\$115,840

- (1) From Table B4
- (2) From Table B5
- (3) From Table B8

NOTE: Major channel improvement is based on a discharge having a recurrence interval of once in about 100 years. Minor channel improvement is based on a discharge having a recurrence interval of once in about 30 years.

TABLE B11 - Estimated average annual flood control benefits, existing conditions of development with diversion channel. (March 1969 price levels and conditions of development)

		Average annual damages		Average annual benefits	
Reach:	Existing	Diversion	Diversion	Diversion	Diversion
No. :	conditions (1)	channel (2)	channel	channel	channel
0	\$ 11,160	\$ 1,860	\$ 9,300		
1	8,350	820	7,530		
2	53,300	5,640	47,660		
3	50,220	3,560	46,660		
4	38,700	240	38,460		
TOTAL:	\$161,730	\$12,120	\$149,610		

(1) From Table B4
 (2) From Table B6

TABLE B12 - Estimated average annual flood control benefits, existing conditions of development, with 4-inch storage at reservoir and minor channel improvements. (March 1969 price levels and conditions of development.)

Reach No.	Average annual damages		Average		Percent reduction
	Existing Conditions (1)	improved conditions (2)	annual benefits	annual	
0	\$ 11,160	\$ 270	\$ 10,890		98
1	8,350	70	8,280		99
2	53,300	3,960	49,340		93
3	50,220	20	50,200		100
4	38,700	3,320	35,380		91
4a	2,650	470	2,180		82
5	4,710	1,840	2,870		61
6	2,150	210	1,940		90
7	460	50	410		89
8	170	10	160		94
9	1,460	540	920		63
10	4,350	830	3,520		81
11	3,150	1,360	1,790		57
12	3,260	1,210	2,050		63
TOTAL	\$184,090	\$14,160	\$169,930		92

(1) From Table B4.

(2) From Table B7

TABLE B13 - Estimated average annual flood control benefits, existing conditions of development with Bowmansville-Pavement Scheme. (March 1969 price levels and conditions of development).

REACH NO.	AVERAGE ANNUAL DAMAGES : EXISTING CONDITIONS (1)	AVERAGE ANNUAL DAMAGES : AGES WITH SCHEME (2)	AVERAGE ANNUAL BENEFITS
0	11,160	\$ 1,860	\$ 9,300
1	8,350	820	7,530
2	53,300	5,640	47,660
3	50,220	3,560	46,660
4	<u>38,700</u>	<u>240</u>	<u>38,460</u>
SUB-TOTAL	<u>161,730</u>	<u>\$12,120</u>	<u>\$149,610</u>
4a	2,650	470	2,180
5	4,710	1,840	2,870
6	2,150	210	1,940
7	460	50	410
8	170	10	160
9	1,460	540	920
10	4,350	830	3,520
11	<u>3,150</u>	<u>1,360</u>	<u>1,790</u>
TOTAL	180,830	\$17,430	\$163,400

(1) From Table B4
(2) From Table B9

3.3.2 A Flood Plain Information Report was prepared by the Corps of Engineers in 1968 showing the areas subject to flooding along lower Ellicott Creek. The rapid rate of residential development in these areas has not been noticeably affected by the report, but commercial developments have included flood proofing. The only real deterrent has been the high interest rates and limited availability of private financing which has slowed down construction throughout the country. The land appears to be well suited for residential development except for the flood threat. There has not been a flood of any significance in recent years and even a major event would probably not cause devastating damages to many property owners. Rather, it would inundate hundreds of acres to a comparatively shallow depth. In effect, this appears to be a flood plain where thousands of people are willing to risk limited flood damages because of the many favorable attributes of living there. Complete development of the flood plain has been forecast for 1975-1980 by local planning agencies. On the surface this appears to be an optimistic estimate since about two-thirds of the land was still undeveloped in 1969. However, in the summer of 1970, a public agency and a private corporation announced plans for early development of residential communities with estimated costs totaling \$628,000,000, all within the area flooded in 1960.

3.3.3 Increased development in reaches 0 through 4 was estimated by: (1) determining the extent of those areas which would develop within the 100 year flood level without flood protection; (2) finding what percent of the presently developed areas these new developments would be; and (3) assuming that future development would be very similar to the present development in the area. It is not expected that the development trends will change radically from what is already there. The total land available and the amount and type of developed land in each reach were determined from a 1968 master development plan, tax maps, aerial photographs and field inspections. The development plan was prepared for the town planning board. It outlines areas that would be developed for various purposes and includes recreation areas and other aesthetic considerations. The acreage that will be developed for various purposes will probably not change significantly and damages to future development can be evaluated from the 1968 plan without appreciable error. Table B14 show the estimated land available for future development as outlines in this paragraph.

TABLE B14 - Estimated land available within the 100-year flood level, for future development in reaches 0 through 4

Reach No.	Area in Acres			Miscellaneous land (1)
	Total available	Presently developed	Land available for future development	
0	472	390	0	82
1	1,562	292	1,210	60
2	2,738	549	2,010	179
3	1,558	614	839	105
4	155	98	19	38
TOTAL:	6,485	1,943	4,078	464

(1) Areas considered to be reserved for open spaces and recreation; also includes area of channel and rights-of-way.

3.3.4 Estimates of benefits to future development were based on estimated benefits to existing development in reaches 0 through 4. A ratio of area expected to be occupied to the area now occupied was used as a means to determine average annual benefits to future development. Although some flood proofing measures are expected to be provided by the builders, the new units will generally be of better quality and therefore, without flood protection, subject to higher unit damages than the existing ones. It was assumed that the stage-damage relationship per unit would remain the same. This assumption is considered valid because average annual damages and benefits calculated for existing conditions were based on a rather thorough damage survey completed in 1969. The majority of the structures surveyed were constructed in recent years. The ratio of average annual benefits per acre to existing development was used to determine the average annual benefits per acre to future development. This method was used for each land use category (residential, commercial, and other). Complete development is expected by the time recommended improvements would be constructed and benefits were not discounted. Table B15 shows the land use categories of existing and future development in acres and Tables B16 through B18 show the average annual flood control benefits to future development calculated by this method.

TABLE B15 - Land use categories of existing and future development within the 100-year flood plain.

Reach: No.:	Residential development		Commercial development	
	: Presently: developed:	: Future: development:	: Presently: developed:	: Future: development:
0	274	0	16	0
1	261	743	25	391 (2)
2	504	1,551	13	146 (2)
3	408	756	48	7
4	42	19	18	0
TOTAL:	1,489	3,069	120	544

- (1) Ratio of future development acres to present development.
- (2) In reaches 1 and 2, 43 acres and 146 acres, respectively, of commercial and industrial development is not indicative of existing development in those reaches. Future average annual benefits for these areas is explained in paragraph 3.3.6. The remaining area in reach 1, 348 acres, was treated in the normal manner.

TABLE B15 (cont'd)

Reach:	Other development, acres	Miscellaneous unavailable land, acres
No. : Presently developed:	Future development:	Factor (1):
0	100	0
1	6	12.67
2	32	9.78
3	158	0.48
4	38	0
TOTAL:	334	465
		464

(1) Ratio of future development acres to present development.

TABLE B16 - Estimated average annual flood control benefits to existing and future development, major channel improvements. (March 1969 price levels and conditions of development.)

Reach No.	Average annual benefits existing development (1)			
	Residential	Commercial	Other	Total
0	\$ 8,130	\$120	\$1,050	\$ 9,300
1	7,130	30	370	7,530
2	46,080	90	1,490	47,660
3	44,480	60	2,120	46,660
4	35,460	390	2,610	38,460
TOTAL	\$141,280	\$690	\$7,640	\$149,610

Reach No.	Factor	Average annual benefits Future development (3)			Total
		Residential	Commercial	Other	
0	(2)	\$ 0	\$ 0	\$ 0	\$ 0
1	(2)	20,320	420	4,690	25,430
2	(2)	141,930	0	14,570	156,500
3	(2)	82,290	10	1,020	83,320
4	(2)	16,310	0	0	16,310
TOTAL		\$260,850	\$430	\$20,280	\$281,560

(1) Table B4 less Table B5

(2) From Table B15. Example: Reach 1, future residential benefits = $\$7,130 \times 2.85 = \$20,320$.

(3) Does not include extraordinary benefits shown in Table B20 and discussed in paragraphs 3.3.5 and 3.3.6.

TABLE B17 - Estimated average annual flood control benefits to existing and future development with Diversion Channel. (March 1969 price levels and conditions of development.)

Reach No.	Average annual benefits existing development (1)			
	Residential	Commercial	Other	Total
0	\$ 8,130	\$120	\$1,050	\$ 9,300
1	7,130	30	370	7,530
2	46,080	90	1,490	47,660
3	44,480	60	2,120	46,660
4	35,460	390	2,610	38,460
TOTAL	\$141,280	\$690	\$7,640	\$149,610

Reach No.	Factor	Average annual benefits Future development (3)			Total
		Residential	Commercial	Other	
0	(2)	\$ 0	\$ 0	\$ 0	\$ 0
1	(2)	20,320	420	4,690	25,430
2	(2)	141,930	0	14,570	156,500
3	(2)	82,290	10	1,020	83,320
4	(2)	116,310	0	0	16,310
TOTAL		\$260,850	\$430	\$20,280	\$281,560

(1) Table B4 less Table B6.

(2) Same as Table B16.

(3) Same as Table B16.

TABLE B18 - Estimated average annual flood control benefits to existing and future development with considered 4-inch storage at reservoir and minor channel improvement. (March 1969 price levels and conditions of development.)

Reach No.	Average annual benefits existing development (1)			
	Residential	Commercial	Other	Total
0	\$ 9,500	\$120	\$1,270	\$ 10,890
1	7,840	30	410	8,280
2	47,720	90	1,530	49,340
3	47,900	60	2,240	50,200
4	32,500	390	2,490	35,380
TOTAL	\$145,460	\$690	\$7,940	\$154,090

Reach No.	Factor	Average annual benefits Future development (3)			Total
		Residential	Commercial	Other	
0	(2)	\$ 0	\$ 0	\$ 0	\$ 0
1	(2)	22,340	420	5,190	27,950
2	(2)	146,980	0	14,960	161,940
3	(2)	88,620	10	1,080	89,710
4	(2)	14,950	0	0	14,950
TOTAL		\$272,890	\$430	\$21,230	\$294,550

(1) Table B4 less Table B7.

(2) Same as Table B16.

(3) Same as Table B16.

TABLE B19 - Estimated average annual flood control benefits to existing and future development with Bowmansville-Pavement Scheme. (March 1969 price levels and conditions of development.)

REACH NO.	AVERAGE ANNUAL BENEFITS			
	EXISTING DEVELOPMENT (1)			
	RESIDENTIAL	COMMERCIAL	OTHER	TOTAL
0	\$ 8,130	\$120	\$1,050	\$ 9,300
1	7,130	30	370	7,530
2	46,080	90	1,490	47,660
3	44,480	60	2,120	46,660
4	<u>35,460</u>	<u>390</u>	<u>2,610</u>	<u>38,460</u>
TOTAL	\$141,280	\$690	\$7,640	\$149,610

REACH NO.	AVERAGE ANNUAL BENEFITS				
	FUTURE DEVELOPMENT (3)				
	FACTOR	RESIDENTIAL	COMMERCIAL	OTHER	TOTAL
0	(2)	\$ 0	\$ 0	\$ 0	\$ 0
1	(2)	20,320	420	4,690	25,430
2	(2)	141,930	0	14,570	156,500
3	(2)	82,290	10	1,020	83,320
4	(2)	<u>16,310</u>	<u>0</u>	<u>0</u>	<u>16,310</u>
TOTAL		\$260,850	\$430	\$20,280	\$281,560

(1) Table B4 less Table B9.

(2) From Table B15.

Example: Reach 1 future residential
benefits = \$7,130 x 2.85 = \$20,320.

(3) Same as Table B16.

3.3.5 Several tracts of vacant land in reaches 1 and 2 are about two feet lower than the 100-year flood level. Based on a recent development plan for the town of Amherst, 111 acres of this land would be occupied by commercial development and 78 acres would be occupied by industrial development. The existing stage-damage curve used to calculate annual damages and benefits to future commercial development is not considered applicable to this area because, in general, existing commercial development has been constructed on high ground. Generalized stage-damage curves developed from damage survey data in nearby areas were used to estimate future commercial damages and benefits in these two reaches. The average annual commercial damage using these generalized curves is \$206 per acre.

3.3.6 At the present time there is no industrial development in the town subject to damage from Ellicott Creek overflow. Generalized stage-damage curves for future industrial development were developed in the same manner as described above. These new stage-damage curves were used with their appropriate stage-frequency curves to determine average annual damages and benefits. The average annual industrial damage using these generalized curves is \$416.00 per acre. Shown in Table B20 are the average annual damages and benefits to future commercial and industrial development for the considered plans of improvement.

3.4 AVERAGE ANNUAL BENEFITS, FUTURE DEVELOPMENT, REACHES 4A THROUGH 12

3.4.1 Flood damages upstream of reach 4 are comparatively minor. Annual damages under existing conditions are estimated to be \$22,360 while damages downstream in reaches 0 to 4 are about 7 times larger. There is a potential in the flood plain, particularly in reaches 9 through 12 where large undeveloped areas are subject to frequent flooding. Even under improved conditions with Sandridge Reservoir the annual flood damages would only be reduced by about 70 percent. Therefore, some form of flood plain zoning or other building restrictions should probably be required in these areas as an item of local cooperation before construction of proposed improvements. Studies by the New York State Division of Water Resources indicate that these areas will be developed in the near future even without flood protection unless restricted by zoning or

other legal tools. An upstream reservoir could create a false sense of security. The intent here is not to retard growth but to ensure wise use of the flood plain to control future damages. Part of reach 12 is scheduled for intense development in connection with the new \$50-million domed stadium, to be constructed by ~~private~~ enterprise. The general location of the stadium site is shown on Plate 7. Private interests expect to develop residential communities and a convention center with hotels, stores and office areas near the stadium. It appears that they will build in their own flood protection. However, other developers will undoubtedly be attracted to this general area and they may not be aware of the flood threat.

3.4.2 For anyone not familiar with the Ellicott Creek flood plain and development trends in the Buffalo metropolitan area it might be difficult to understand why the upper reaches of the flood plain do not have the same development characteristics as the lower reaches. The large undeveloped areas in reaches 9 through 12 are further away from the city and there are other areas a comparable distance away which will probably average about 15 minutes longer compared to Amherst. Also, the problems of clearing the flood plain and providing utility services in the upper reaches are much more difficult than in the town of Amherst. These reasons are significant but probably the most important factor is the general public's attitude. A community such as Amherst seems to have the amenities that the suburbanite wants for his family. There is still a tendency to view the upper reaches as being "out in the woods." The new domed stadium could provide the impetus to accelerate development of these upstream reaches. However, it appears that there is still time to weigh the merits of alternative solutions before widespread development takes place. In the present state of development, restriction of further development is still practicable and would be more economical than providing high degree of protection. As a minimum, a right-of-way should be kept available for local protection works if they should be needed later.

3.4.3 It is expected that some increase in flood damages will occur in the near future in these upstream reaches because of the large areas still available for development. Since the magnitude of existing damages is small, it is not unreasonable to assume that these damages would at

least double by the time the proposed improvements are constructed. It is also expected that minor damages between reach 12 and the dam site, a distance of about 15 miles, would be greater. No damage survey has been made of this area but it is estimated that at least 1,000 acres were flooded in 1960. The land is mostly undeveloped or used for agricultural purposes. A handful of residential properties may have suffered minor damages. It was assumed that \$5,000 in average annual benefits in this reach, referred to as reach 13, would be a reasonable value to credit to the considered reservoir. Shown on Table B21 are the average annual benefits to existing and future development, upstream of reach 4.

TABLE B20 - Estimated average annual flood control benefits to future commercial and industrial development (March 1969 price levels and conditons of development)

Future		Residual average annual COMMERCIAL damage:		Average annual benefits	
Reach:	average	Major	Diversion:	Sandridge:	Bowmansville
annual	Channel:	with	Minor:	Pavement	Channel:
COMMERCIAL:	Imp.:	Channel:	Scheme	Imp.:	Channel:
damage	:	Imp.:	:	:	Imp.:
1	\$ 6,400	\$550	\$550	\$ 550	\$ 5,850
2	19,820	240	240	240	19,580
Sub-	:	:	:	:	:
Total:	\$26,220	\$790	\$790	\$790	\$25,430
Future		Residual average annual INDUSTRIAL damage:		Average annual benefits	
average	:	:	:	:	:
annual	:	:	:	:	:
INDUSTRIAL:	:	:	:	:	:
damage	:	:	:	:	:
1	\$ 9,800	\$120	\$120	\$120	\$ 9,680
2	22,650	0	0	0	22,650
Sub-	:	:	:	:	:
Total:	\$32,450	\$120	\$120	\$120	\$32,330
TOTAL:	\$58,670	\$910	\$910	\$910	\$57,760
:	:	:	:	:	:

17. A summary of average annual flood control benefits to future development for the considered plans of improvement are shown in Table B21. Table B22 shows total average annual flood control benefits to existing and future development.

TABLE B21 - Estimated average annual flood control benefits to future development. (March 1969 price levels and conditions of development).

Reach No.	Average annual benefits to future development			
	Major Channel Improvement	Sandridge 4-inch Storage with Channel Improvement	Diversion Channel	Bowmansville Pavement Scheme
0	\$ 0	\$ 0	\$ 0	\$ 0
1	40,960	44,150	40,960	40,960
2	198,730	204,410	198,730	198,730
3	83,320	89,710	83,320	83,320
4	16,310	14,950	16,310	16,310
4a		4,360		4,360
5		5,740		5,740
6		3,880		3,880
7		820		820
8		320		320
9		1,840		1,840
10		7,040		7,040
11		3,580		3,580
12		4,100		(1)
13		5,000		
TOTAL:	\$339,320	\$389,900	\$339,320	\$366,900

TABLE B22 - Total estimated average annual flood control benefits, existing and future development. (March 1969 price levels and conditions of development)

: Total average annual benefits, existing and future development	
Reach No.	: Major : Diversion : Sandridge storage:Bowmansville - Channel : and minor channel: Pavement improvement : Scheme
0	: \$ 9,300 : \$ 9,300 : \$ 10,890 : \$ 9,300
1	: 48,490 : 48,490 : 52,430 : 48,490
2	: 246,390 : 246,390 : 253,750 : 246,390
3	: 129,980 : 129,980 : 139,910 : 129,980
4	: 54,770 : 54,770 : 50,330 : 54,770
4a	: : : 6,540 : 6,540
5	: : : 8,610 : 8,610

TABLE B22 (cont'd)

Reach No.	: Total average annual benefits, existing and future development	
	: Major Channel : Improvements	: Diversion Channel : improvements
6	: \$ 5,820	: \$ 5,820
7	: 1,230	: 1,230
8	: 480	: 480
9	: 2,760	: 2,760
10	: 10,560	: 10,560
11	: 5,370	: 5,370
12	: 6,150	: 6,150
13	: 5,000	: 5,000
TOTAL	: \$488,930	: \$488,930
		: \$599,830
		: \$530,300

3.5 TOTAL AVERAGE ANNUAL BENEFITS

3.5.1 A summary of annual benefits attributable to the 4-inch storage at Sandridge Reservoir and minor channel improvement, the proposed plan of improvement, is shown in Table B20. Tables B21 and B22 show the estimated average annual benefits for the other considered plans of improvements.

TABLE B23 - Total estimated average annual benefits, 4-inch storage at reservoir and minor channel improvement (March 1969 price levels and conditions of development)

Reach:	REDUCTION IN FLOOD LOSSES		
No. :	Existing development (1):	Future development (2):	Total
0 :	\$ 10,890	\$ 0	\$ 10,890
1 :	8,280	44,150	52,430
2 :	49,340	204,410	253,750
3 :	50,200	89,710	139,910
4 :	35,380	14,950	50,330
4a :	2,180	4,360	6,540
5 :	2,870	5,740	8,610
6 :	1,940	3,880	5,820
7 :	410	820	1,230
8 :	160	320	480
9 :	920	1,840	2,760
10 :	3,520	7,040	10,560
11 :	1,790	3,580	5,370
12 :	2,050	4,100	6,150
13 :	-	5,000	5,000
TOTAL:	\$169,930	\$389,900	\$559,830

(1) From Table B13.

(2) From Table B21.

TABLE B24 - Total estimated average annual benefits, major channel improvements (March 1969 price levels and conditions of development)

		<u>REDUCTION IN FLOOD LOSSES</u>		
Reach:	Existing	Future		
No. :	development (1)	development (2)	Total	
0 :	\$ 9,300	\$ 0	\$ 9,300	
1 :	7,530	40,960	48,490	
2 :	47,660	198,730	246,390	
3 :	46,660	83,320	129,980	
4 :	38,460	16,310	54,770	
TOTAL:	\$149,610	\$339,320	\$488,930	

(1) From Table B10.
 (2) From Table B21.

Table B25 - Total estimated average annual benefits, Diversion Channel (March 1969 price levels and conditions of development)

		REDUCTION IN FLOOD LOSSES		
Reach:	Existing	Future		
No. :	development (1) :	development (2) :	Total	
0 :	\$ 9,300 :	\$ 0 :	\$ 9,300	
1 :	7,530 :	40,960 :	48,490	
2 :	47,660 :	198,730 :	246,390	
3 :	46,660 :	83,320 :	129,980	
4 :	38,460 :	16,310 :	54,770	
TOTAL:	\$149,610 :	\$339,320 :	\$488,930	

(1) From Table B11.

(2) From Table B21.

TABLE B26 - Total estimated average annual benefits,
Bowmansville - Pavement Scheme (March
1969 price levels and conditions of
development.)

REDUCTION IN FLOOD LOSSES				
	Existing		Future	
	development (1)	:	development (2)	Total
0	\$ 9,300	:	\$ 0	: \$ 9,300
1	7,530	:	40,960	: 48,490
2	47,660	:	198,730	: 246,390
3	46,660	:	83,320	: 129,980
4	38,460	:	16,310	: 54,770
4a	2,180	:	4,360	: 6,540
5	2,870	:	5,740	: 8,610
6	1,940	:	3,880	: 5,820
7	410	:	820	: 1,230
8	160	:	320	: 480
9	920	:	1,840	: 2,760
10	3,520	:	7,040	: 10,560
11	1,790	:	3,580	: 5,370
TOTAL	\$163,400	:	\$366,900	: \$530,300

(1) From Table B13.

(2) From Table B21.

3.5.2 In order that benefits be as nearly up to date as possible, and be comparable with estimates of annual costs, dollar values in Table B23 through B26 have been adjusted to March 1972 price levels in Table B27.

TABLE B27 - Estimated total average annual benefits, November 1972 price levels (1)

Description of considered improvements:	:Total average :annual benefits
1 :4-inch storage at Sandridge reservoir :and minor channel improvements :	\$761,930 : :
2 :Major channel improvements, reaches 0-4: :	665,430 :
3 :Diversion channel improvements, :reaches 0-4 :	665,430 (2) :: :
4 :Bowmansville-Pavement Scheme :	721,740 :

(1) Building cost index = $\frac{\text{Nov 1972}}{\text{March 1969}} = \frac{1060.7}{779.61} = 1.361$

(2) Further investigation of project effectiveness indicates there would be an additional reduction of \$25,000 in residual damages in reaches 1, 2 and 3. Since these reaches of existing Allicott Creek Channel will not carry flood flows after completion of the Diversion Channel.

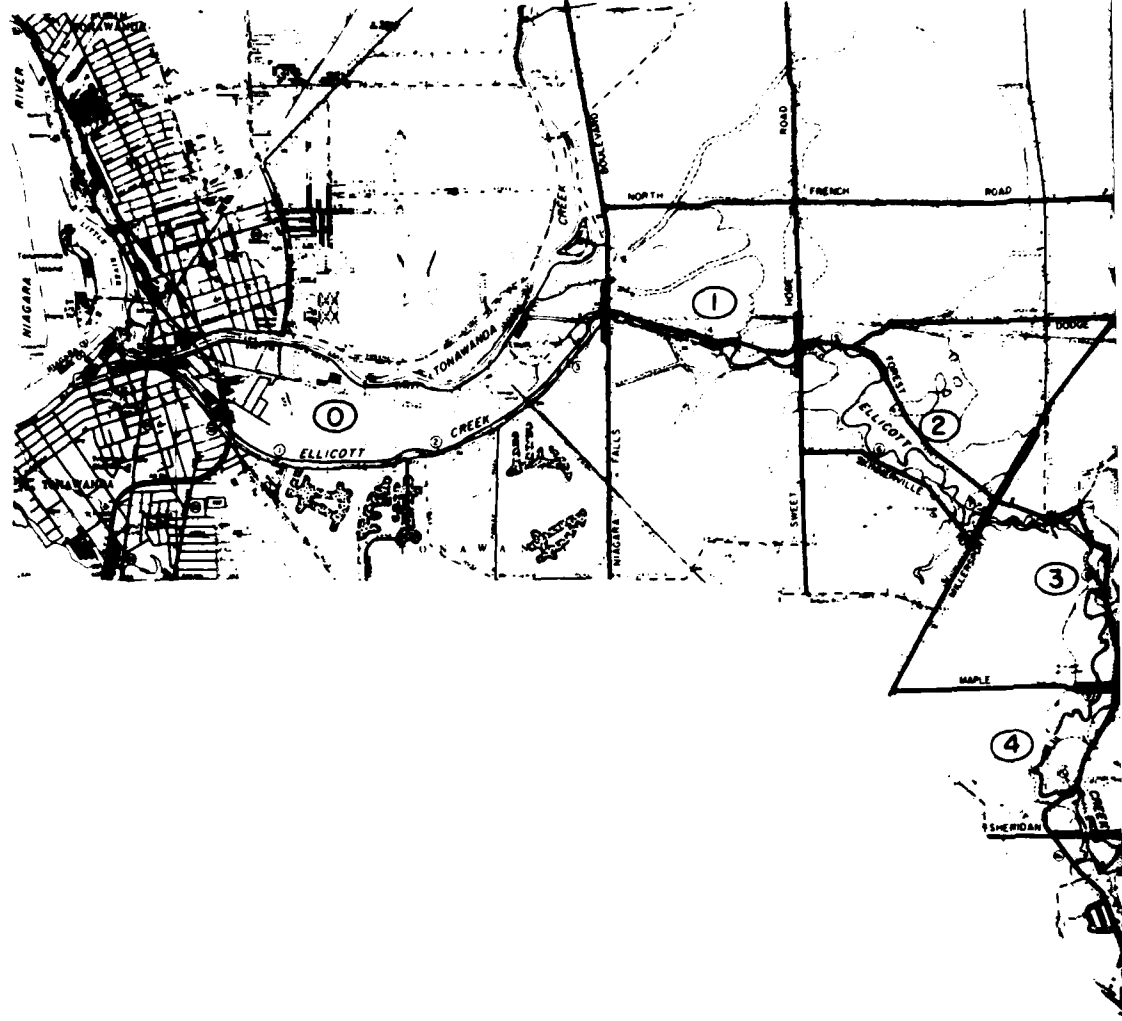

LEGEND

⑤ DISTANCE FROM MOUTH IN MILES

③ DAMAGE REACH

MARCH 1960 FLOOD LINE

— LIMITS OF DAMAGE REACHES

SCALE OF MILES



SCALE OF FEET



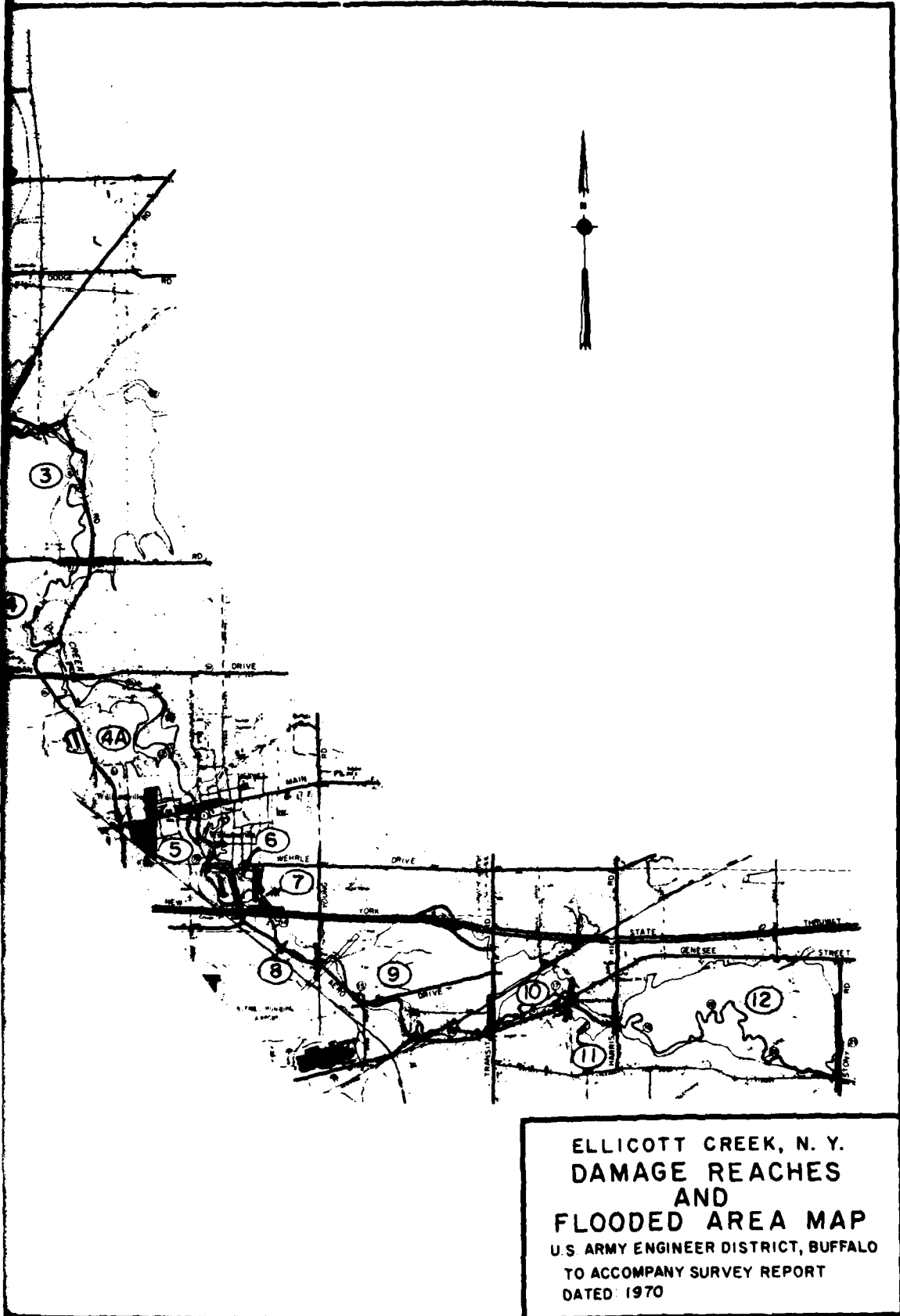

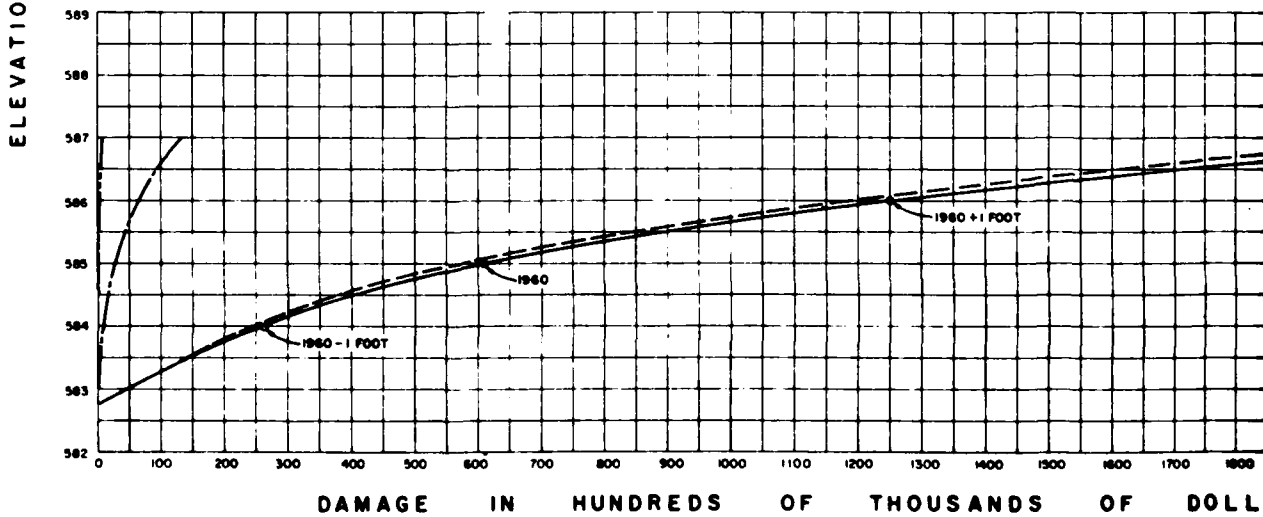
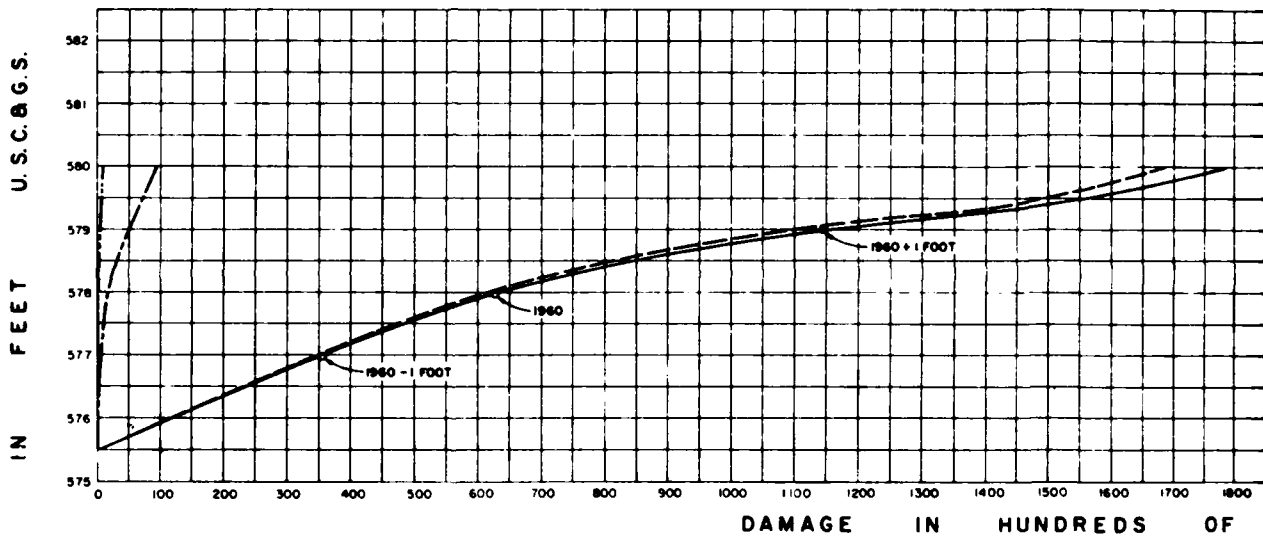
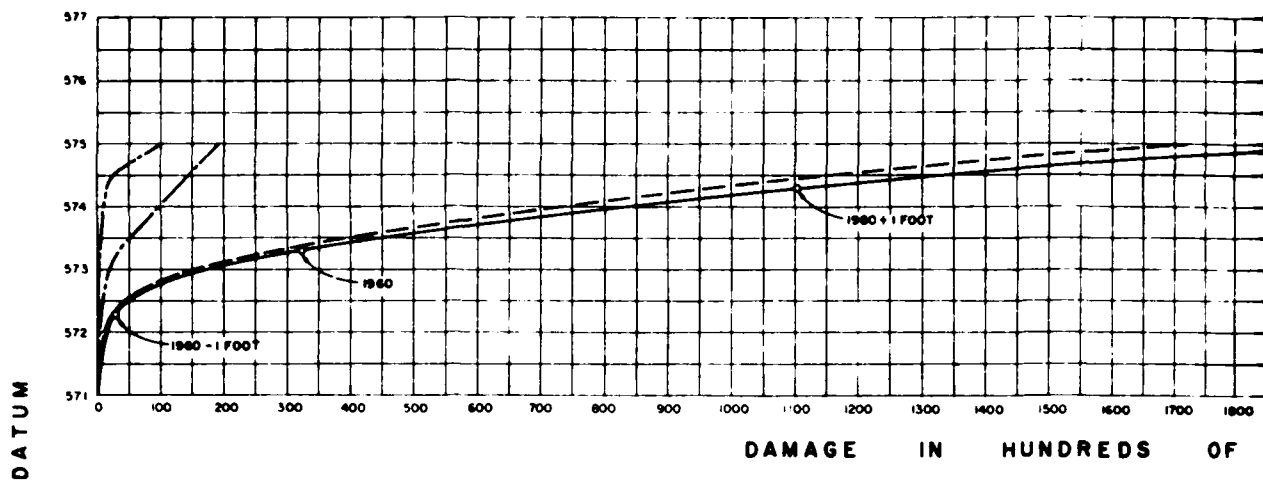

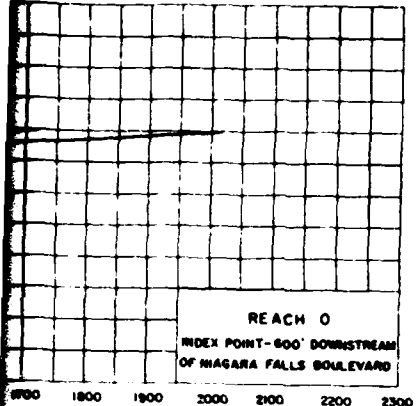

REACH 0
INDEX POINT-600' DOWNSTREAM
OF NIAGARA FALLS BOULEVARD

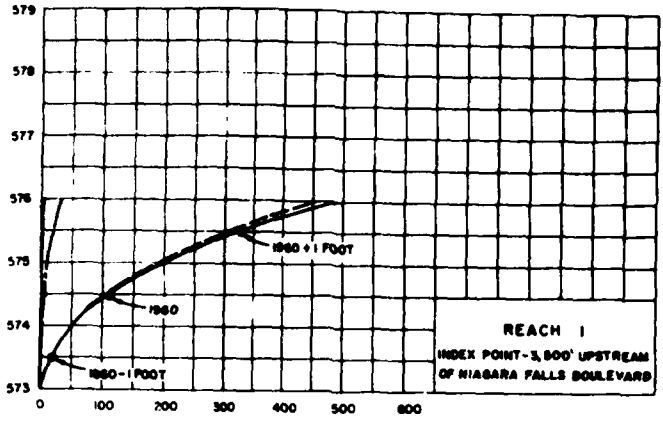

REACH 1
INDEX POINT-3,800' UPSTREAM
OF NIAGARA FALLS BOULEVARD

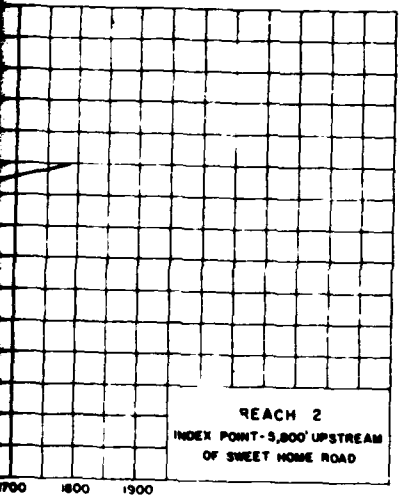

REACH 2
INDEX POINT-3,800' UPSTREAM
OF SWEET HOME ROAD

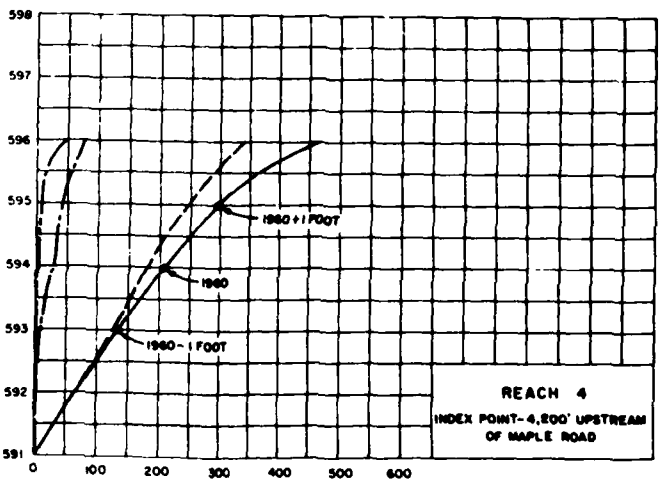

REACH 4
INDEX POINT-4,800' UPSTREAM
OF MAPLE ROAD

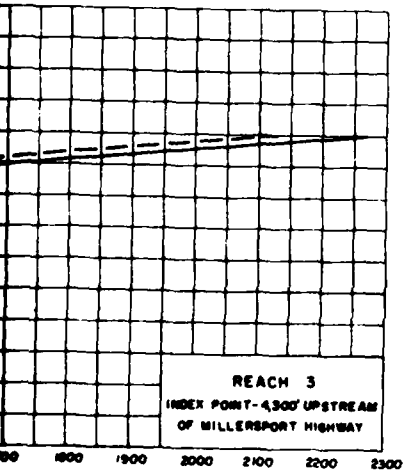

REACH 3
INDEX POINT-4,300' UPSTREAM
OF MILLERSPORT HIGHWAY

DOLLARS

LEGEND:

- — 1960+1 FOOT ESTIMATED DAMAGE FOR FLOOD 1 FOOT HIGHER THAN THE 1960 FLOOD
- — — — — INDICATES COMMERCIAL DAMAGE
- — — — — INDICATES PUBLIC AND OTHER DAMAGE
- — — — — INDICATES RESIDENTIAL DAMAGE
- — — — — INDICATES TOTAL DAMAGE

NOTE:

ALL VALUES SHOWN ARE ON THE MARCH 1969 PRICE LEVEL AND CONDITIONS OF DEVELOPMENT AT THE TIME OF THE 1969 DAMAGE SURVEY.

ELLICOTT CREEK, NEW YORK
STAGE-DAMAGE CURVES
REACHES 0 THRU 4
U. S. ARMY ENGINEER DISTRICT, BUFFALO
TO ACCOMPANY SURVEY REPORT
DATED: 1970

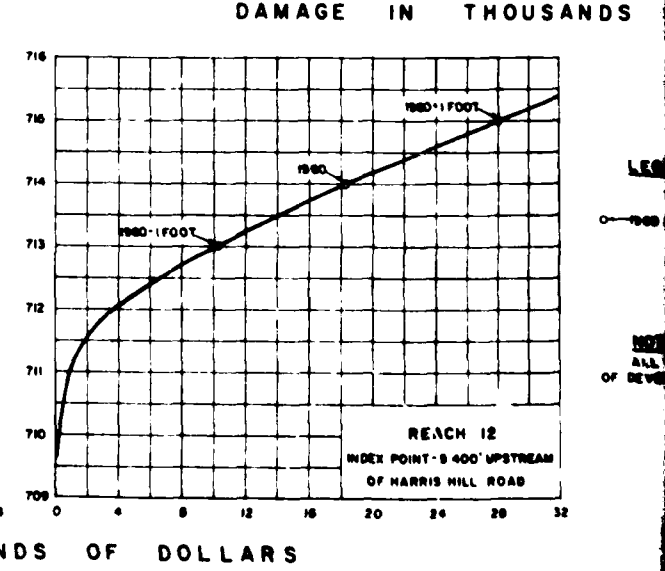
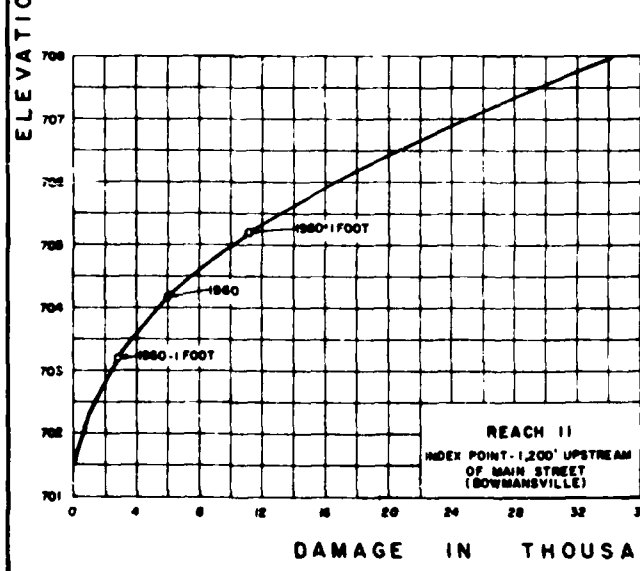
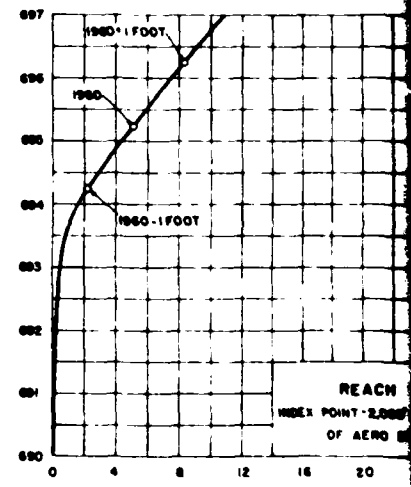
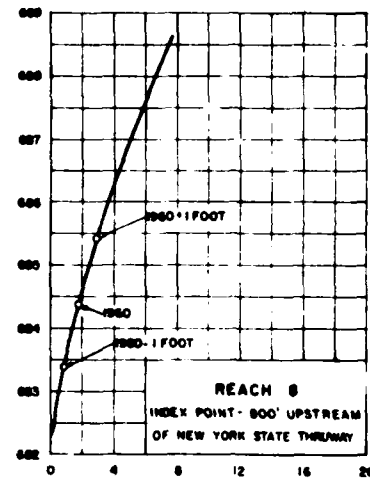
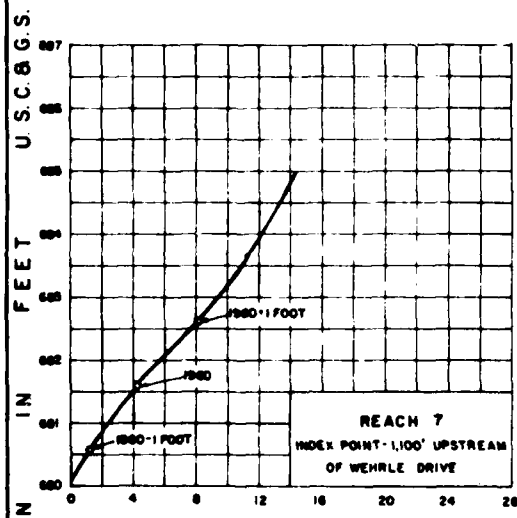
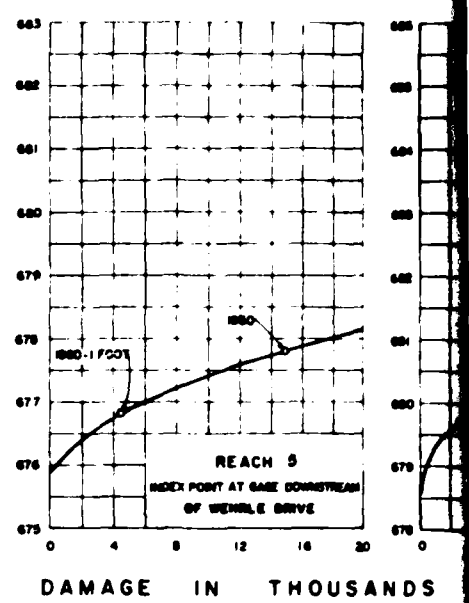
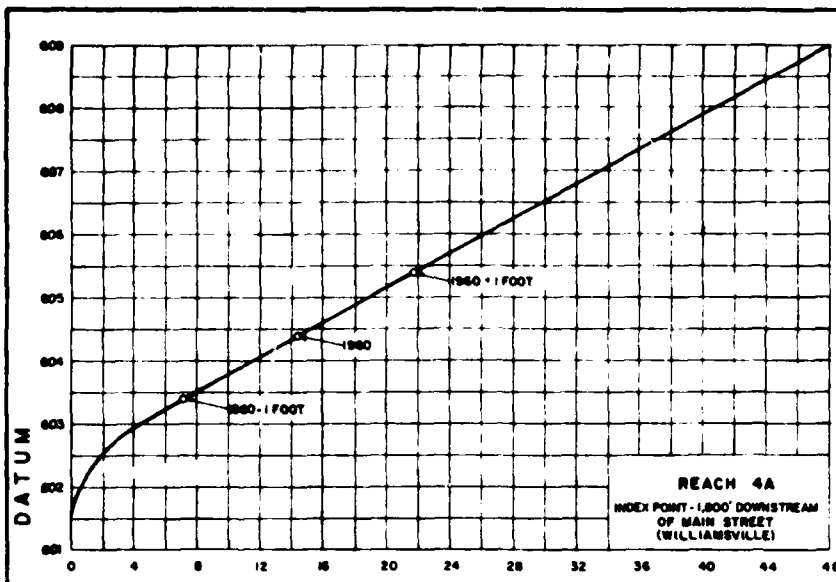

LEG
ALL
OF DEVE

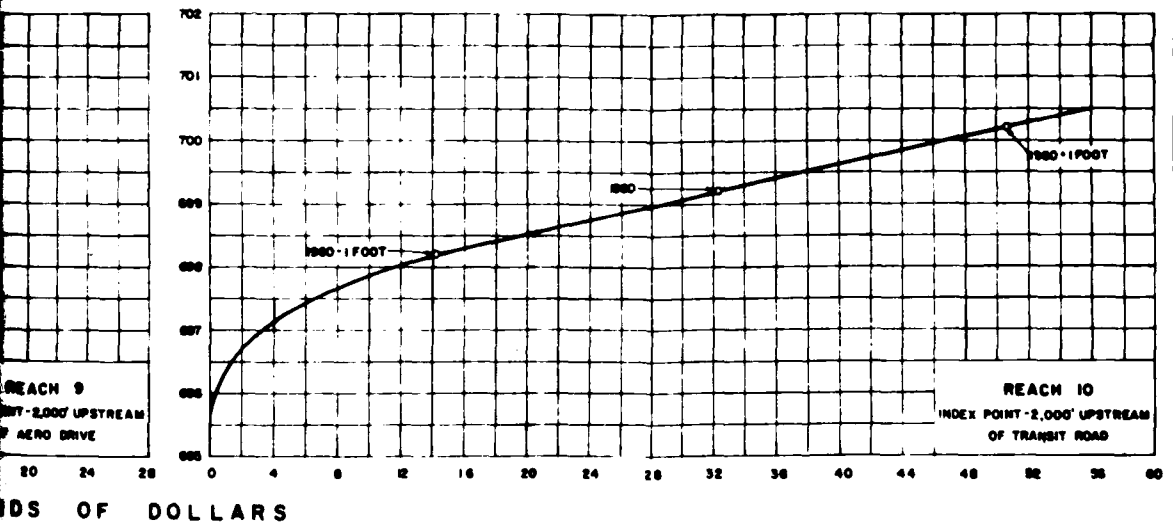
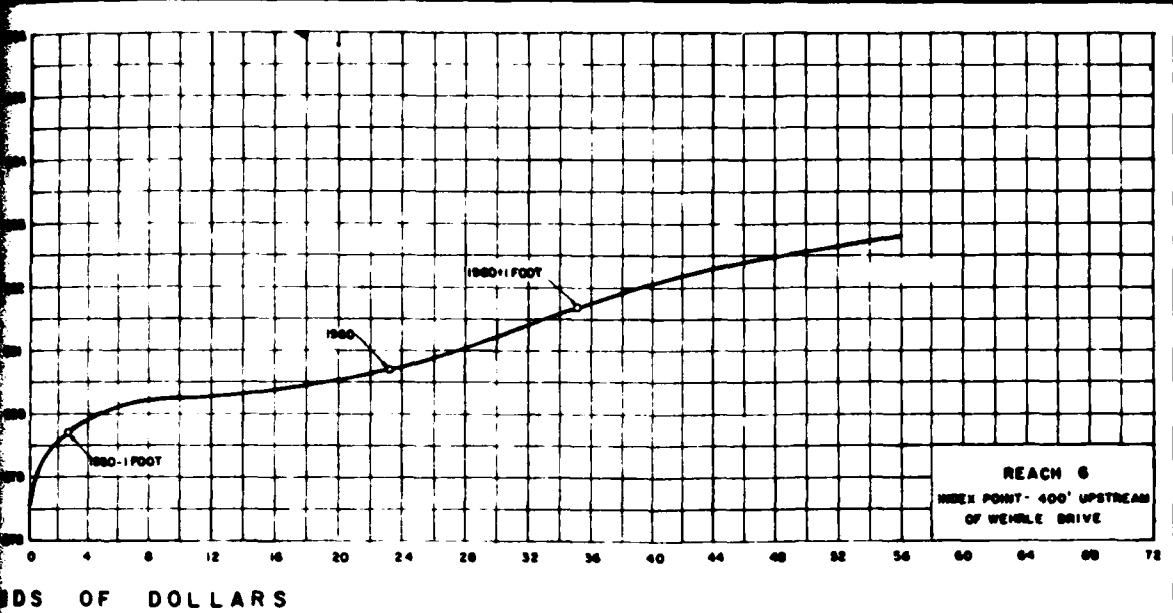

LEGEND:

— 1980 + 1 FOOT ESTIMATED DAMAGE FOR FLOOD 1 FOOT HIGHER THAN THE 1980 FLOOD

NOTE:
 ALL VALUES SHOWN ARE ON THE JULY 1964 PRICE LEVEL AND CONDITIONS OF DEVELOPMENT AT THE TIME OF THE 1962 DAMAGE SURVEY.

**STAGE - DAMAGE CURVES
 FOR ELLICOTT CREEK
 REACHES 4A THRU 12**

U. S. ARMY ENGINEER DISTRICT, BUFFALO
 TO ACCOMPANY
 DATED: 1970

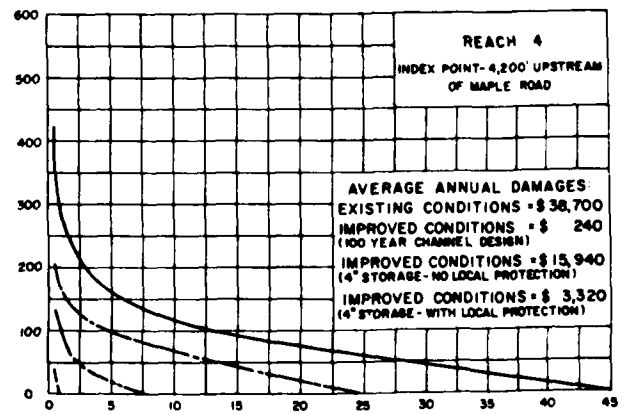
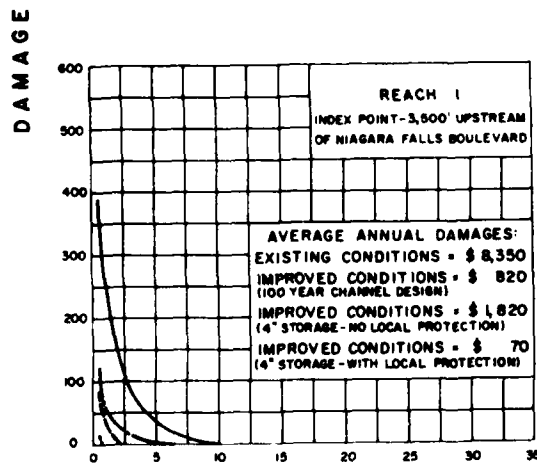
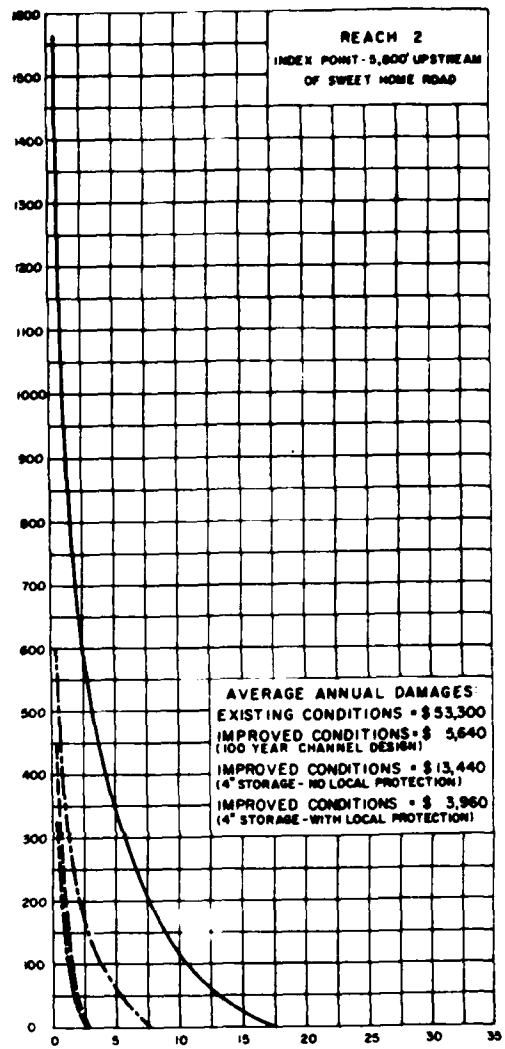
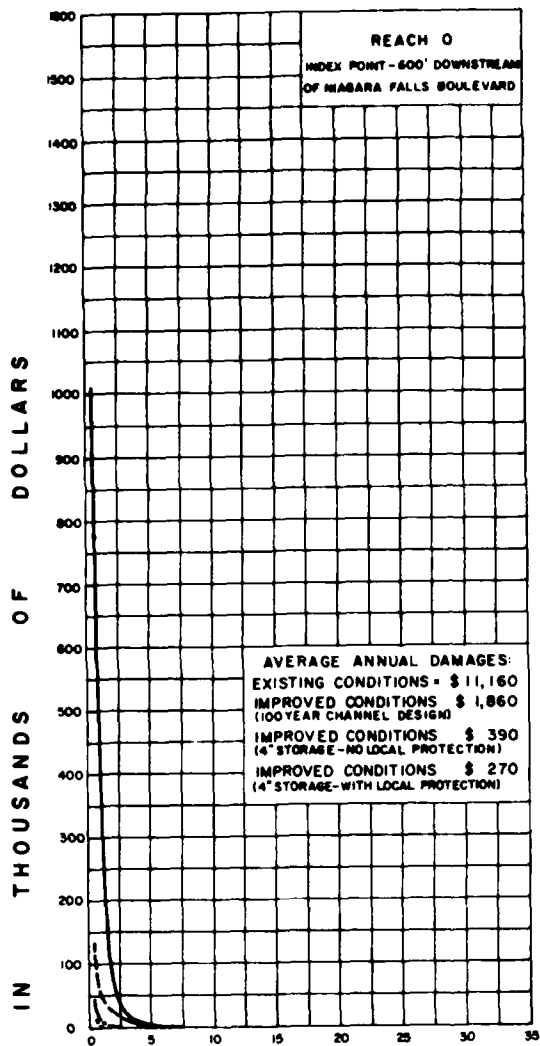

F R E Q U E N C Y I N P E R C E N T

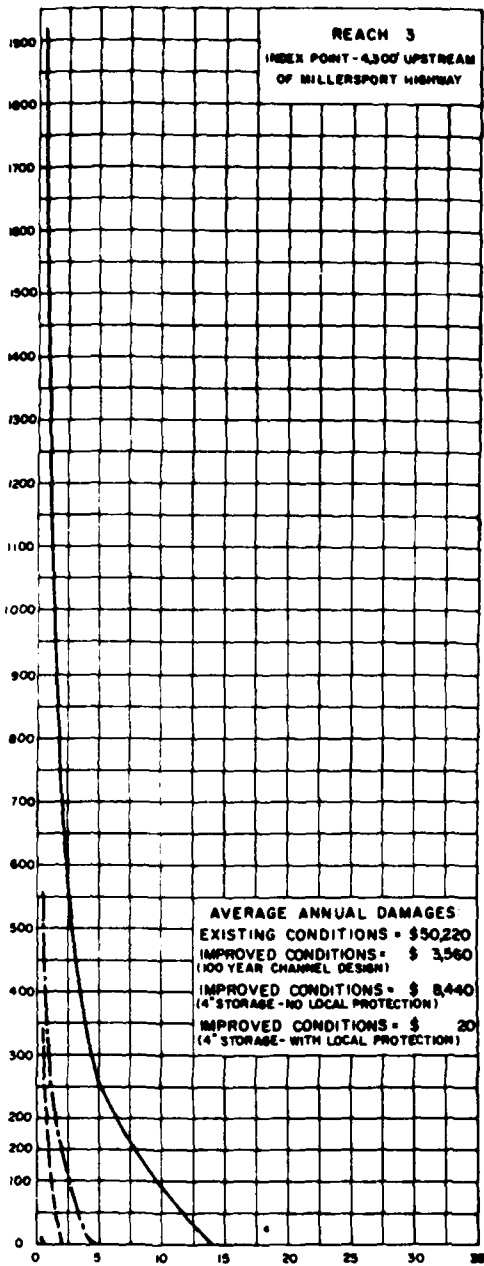

LEGEND:

- INDICATES EXISTING CONDITIONS
- - - - - INDICATES IMPROVED CONDITIONS (100 YEAR CHANNEL DESIGN)
- · - · - INDICATES IMPROVED CONDITIONS (4' STORAGE - NO LOCAL PROTECTION)
- - - - - INDICATES IMPROVED CONDITIONS (4' STORAGE WITH LOCAL PROTECTION)

NOTE:

DAMAGES ARE BASED ON MARCH 1969 PRICE LEVELS.

ELLICOTT CREEK, NEW YORK

DAMAGE - FREQUENCY CURVES

REACHES 0 THRU 4

U. S. ARMY ENGINEER DISTRICT, BUFFALO
TO ACCOMPANY SURVEY REPORT
DATED: 1970

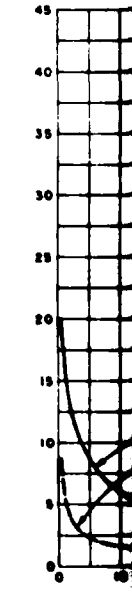
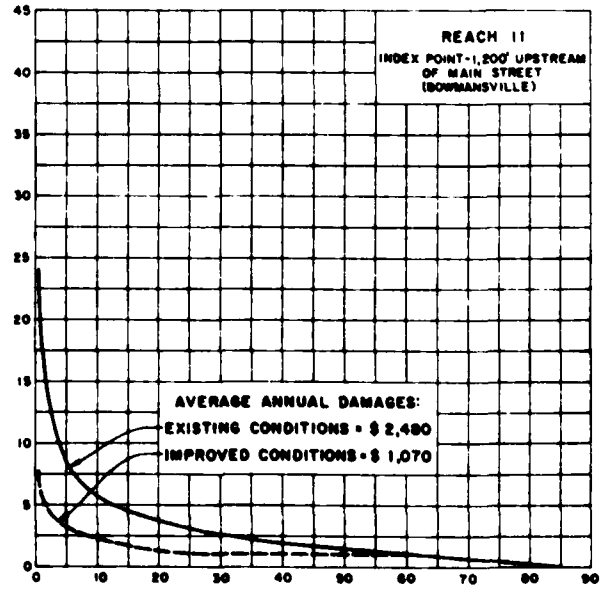
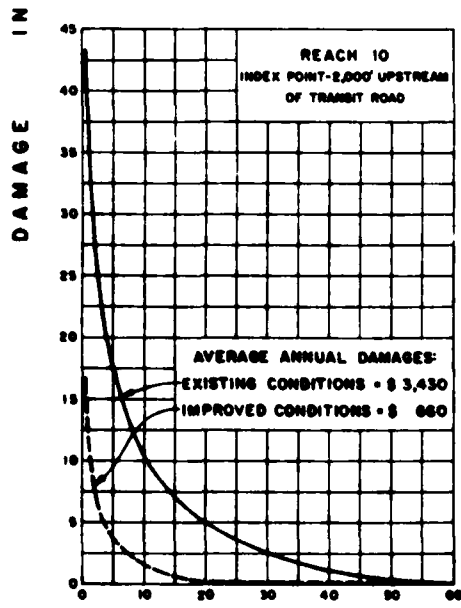
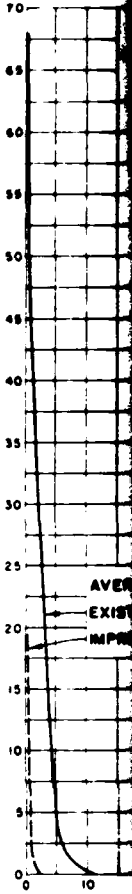
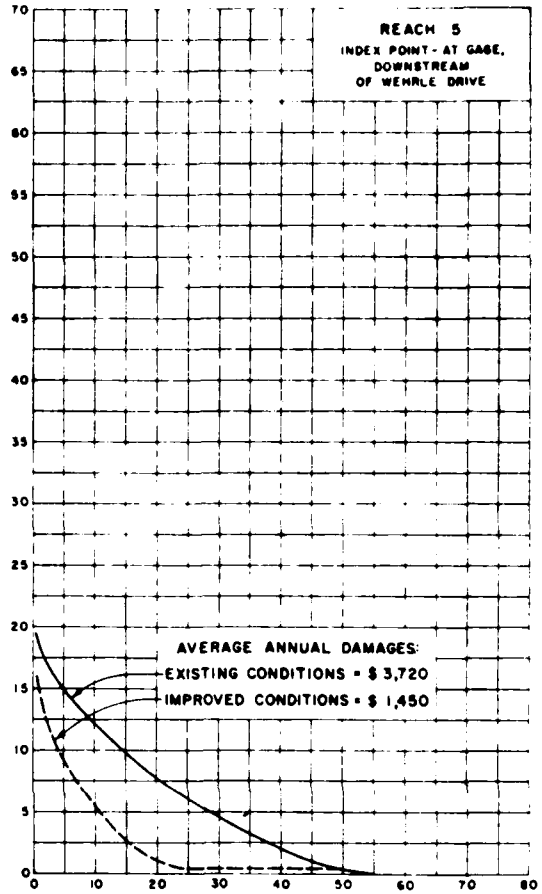
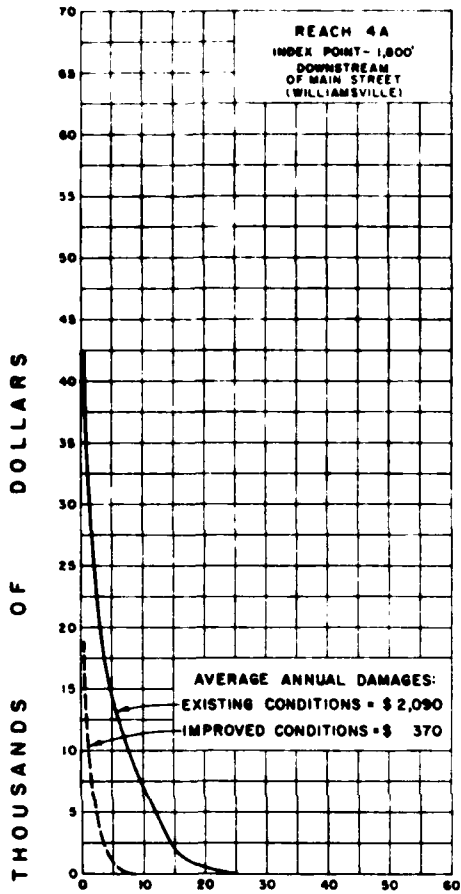

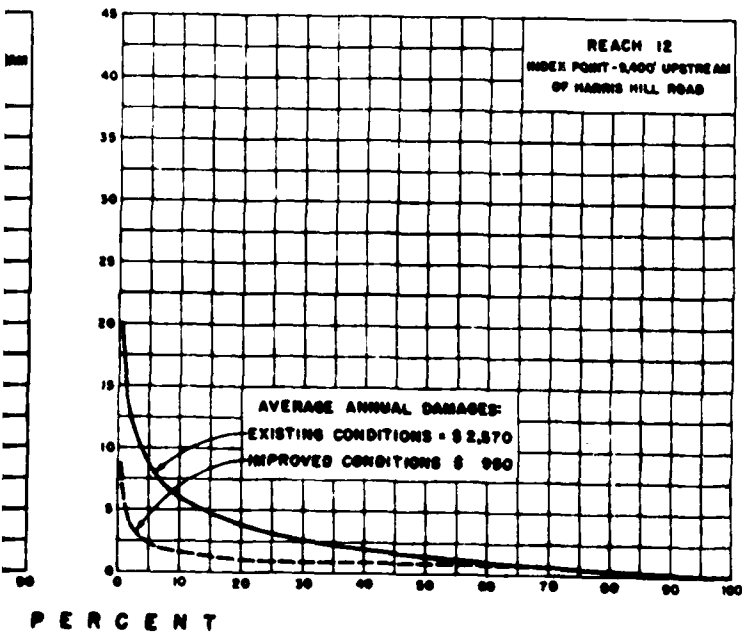
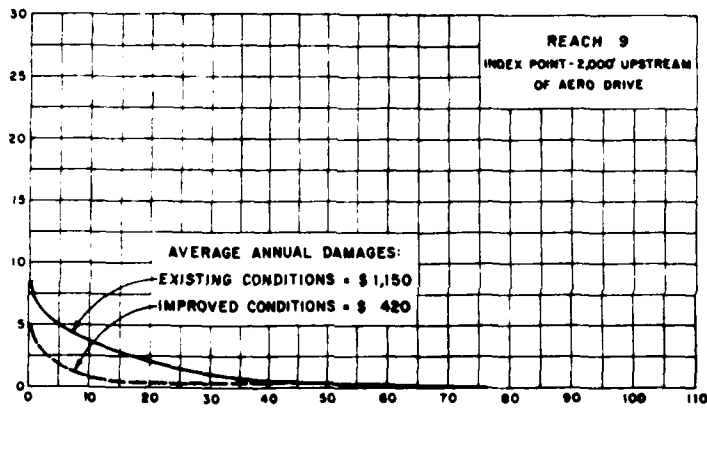
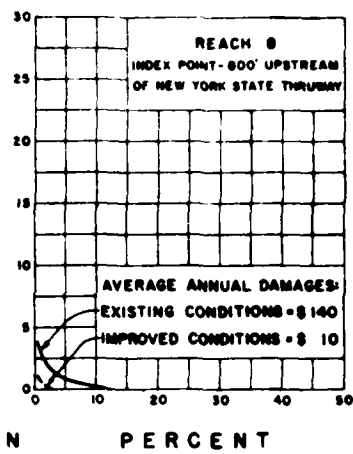
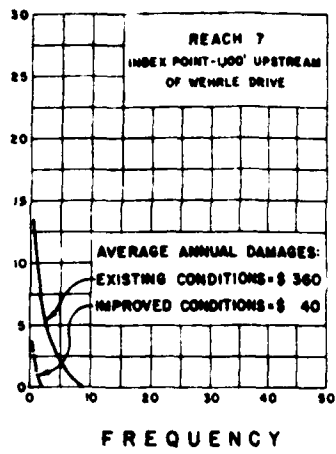
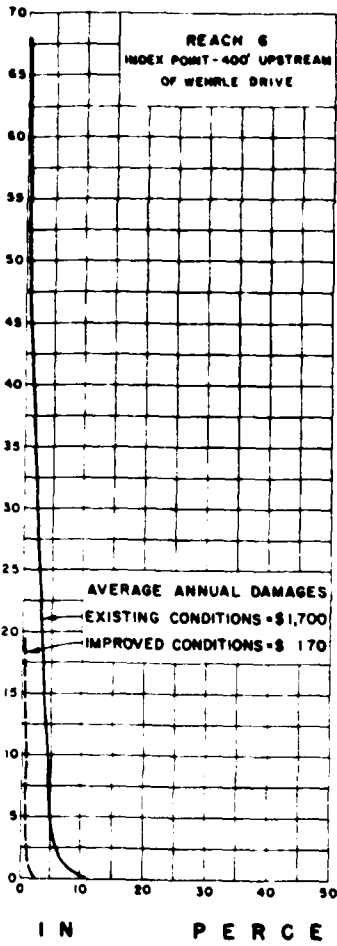

NOTE:
 THE IMPROVED CONDITIONS REFERS TO 4'
 RESERVOIR STORAGE.
 DAMAGES ARE BASED ON JULY 1964 PRICE LEVELS.

ELLCOTT CREEK, NEW YORK

DAMAGE-FREQUENCY CURVES
REACHES 4A THRU 12

U. S. ARMY ENGINEER DISTRICT, BUFFALO
 TO ACCOMPANY SURVEY REPORT
 DATED: 1970

FLOOD CONTROL AND ALLIED PURPOSES
ELLICOTT CREEK, NEW YORK

APPENDIX C
CONSERVATION BENEFITS

TABLE OF CONTENTS

	<u>Page</u>
1 - INTRODUCTION	C-1
1.1 General	C-1
2 - WATER ORIENTED RECREATION	C-1
2.1 Existing Facilities	C-1
2.2 Inventory	C-3
2.3 Participation	C-3
2.4 Needs	C-4
2.5 Design Criteria for Recreation Facilities	C-4
2.6 Evaluation of Recreation	C-6
2.6.14 Existing Site User-Origin Curves	C-13
2.6.15 Proposed Site User-Origin Curves	C-14
2.6.16 Total Annual Visitation	C-15
2.6.17 Day-Use and Camper Demand Curves	C-22
2.6.18 Sandridge Recreation Benefits	C-26
2.6.19 Bowmansville - Pavement Recreation Benefits	C-26
2.7 Sandridge Recreation Facilities	C-29
2.8 Bowmansville - Pavement Recreation Facilities	C-31
3 - WATER QUALITY BENEFITS	C-32
3.1 General	C-32
4 - MUNICIPAL WATER SUPPLY	C-35
4.1 General	C-35
4.2 Water Supply Area	C-35
4.3 Existing Water Sources	C-38
4.4 Potential Water Sources	C-38
4.5 Preliminary Economic Evaluations	C-39
4.6 Schemes for Water Supply Systems	C-40
4.7 Description of Water Supply Schemes	C-40
4.8 Economic Evaluation of Alternatives	C-42
4.9 Municipal Water Supply Benefits	C-48

Table of Contents - 2

	<u>Page</u>
5 - FISH AND WILDLIFE	C-48
6 - SUMMARY OF CONSERVATION BENEFITS	C-50
CORRESPONDENCE	

Table of Contents - 3

TABLES

<u>Number</u>		<u>Page</u>
C1	Instantaneous Summer Sunday Participation, Erie-Niagara Supply Area	C-5
C1A	Population	C-8
C2	Major Channelization - Recreation Benefits	C-9
C3	Diversion Channel - Recreation Benefits	C-10
C4	Minor Channelization - Recreation Benefits	C-11
C5	Recreation Reservoir Used in Demand Curve Analysis	C-14
C6	Annual Day-Use Visitation at the Proposed Sandridge Reservoir	C-16
C7	Day-Use Visitation at the Proposed Sandridge Reservoir	C-17
C8	Design Attendance for Day-Use Facilities at the Proposed Sandridge Reservoir	C-18
C9	Camper-Visitation at the Proposed Sandridge Reservoir	C-19
C10	Annual Day-Use Visitation at the Bowmansville-Pavement Scheme	C-21
C11	Day-Use Visitation at the Proposed Bowmansville - Pavement Scheme	C-21
C12	Design Attendance for Day-Use Facilities at the Proposed Bowmansville - Pavement Scheme	C-23

Table of Contents - 4

TABLES

<u>Number</u>		<u>Page</u>
C13	Economic Evaluation of Recreation Benefits at the Proposed Sandridge Reservoir	C-27
C14	Economic Evaluation of Recreation Benefits at the Proposed Bowmansville - Pavement Scheme	C-28
C15	Design Load for Boating at the Proposed Sandridge Reservoir	C-30
C16	Design Load for Boating at the Proposed Bowmansville - Pavement Scheme	C-32
C17	Recreation Benefits at the Proposed Bowmansville - Pavement Scheme - Red Run Drain and Lower Clinton River Method	C-33
C18	Population Equivalents and Water Supply Needs for Recreation Facilities Potentially Served by the Sandridge Reservoir	C-36
C19	Water Supply Needs for Potential Users of the Sandridge Reservoir	C-37
C20	Existing and Potential Water Supply Sources for the Local Area near the Sandridge Site	C-39
C21	Estimated First Cost and Annual Costs for Water Supply Scheme 1	C-43
C22	Estimated First Cost and Annual Costs for Water Supply Scheme 2	C-44
C23	Estimated First Cost and Annual Costs for Water Supply Scheme 3	C-45

Table of Contents - 5

TABLES

<u>Number</u>		<u>Page</u>
C24	Estimated First Cost and Annual Costs for Water Supply Scheme 4	C-46
C25	Estimated First Cost and Annual Costs for Water Supply Scheme 5	C-47
C26	Comparison of Annual Costs for the Five Water Supply Schemes	C-48
C27	Average Annual Fish and Wildlife Benefits for Sandridge Reservoir	C-49
C28	Summary of Conservation Benefits	C-50

LIST OF PLATES

<u>Number</u>	<u>Title</u>
C1	Existing Site Day-Use User-Origin Curves
C2	Day-Use User-Origin Curve for Sandridge Reservoir
C3	Existing Site Camper User-Origin Curves
C4	Camper User-Origin Curve for Sandridge Reservoir
C5	1975 and 2000 Day-Use Demand Curves at the Sandridge Reservoir
C6	2000 Camper Demand Curve at the Sandridge Reservoir
C7	General Location of Recreation Activities at the Sandridge Reservoir
C8	General Location Map for Water Supply and Water Quality Uses of the Sandridge Reservoir

APPENDIX C

CONSERVATION BENEFITS

1. INTRODUCTION

1.1 GENERAL

1.1.1 The conservation benefits which may be ascribed to the four alternatives under consideration can be subdivided into four categories:

1. Increased recreational opportunity benefits.
2. low-flow augmentation benefits.
3. Municipal water supply benefits.
4. Fish and wildlife benefits.

1.1.2 The major channelization scheme provided only local neighborhood parks between the old and new channel, where cut-offs are proposed, of the four type-benefits mentioned above.

1.1.3 The diversion channel scheme similarly provide only recreation benefits; it creates a long ribbon park suitable for bikeways and hiking trails.

1.1.4 The reservoir schemes provide more conventional recreation centers with facilities for camping, swimming, boating and fishing as well as picnicking, in addition to water quality and low flow augmentation benefits. Only the Sandridge scheme provides water supply and fish and wildlife benefits.

2. WATER ORIENTED RECREATION

2.1 EXISTING FACILITIES

2.1.1 Historically, most water recreation activity in the western New York area gravitated towards the Great Lakes shoreline. This pattern evolved because of the absence of nearby inland lakes, and the obvious recreation opportunities offered by these large bodies of water.

2.1.2 Lake Erie and the Niagara River support many different water recreation activities, including all forms of power boating, swimming, sailing, fishing, water skiing, and others as well. A number of state, county, and local public parks have been built along the United States shore. Several privately owned beaches serving public use are also available along the Canadian shore of Lake Erie near Buffalo. Numerous private recreational boating facilities have been developed along the sheltered Niagara River. Private homes and recreation cottages border much of the Lake Erie shoreline. While providing many public opportunities, problems such as lack of public access, steep shore bluffs, narrow cobble beaches, severe lake wind conditions, shore water quality, and intensive shore development have restricted both recreation development and use.

2.1.3 Lake Ontario provides recreation opportunities similar to Lake Erie. A number of public parks now exist or are under development along the shore. Most of these parks are within day-use range of the major population areas in western New York. However, many of the problems which limit recreation use on Lake Erie are also present on Lake Ontario. In addition, because of Lake Ontario's greater depth, low water temperatures often discourage swimming.

2.1.4 On the periphery of the study area there exist a number of inland lakes which support many water recreation activities. The Finger Lakes region lies to the east in central New York. To the south, Chautauqua Lake and the Allegheny Reservoir provide large surface areas for recreation use.

2.1.5 However, most of these lakes are too distant for convenient day use by western New York residents, and have private ownership patterns (with the exception of the Allegheny Reservoir) which reduce opportunities for public use.

2.1.6 The interior of the area offers recreation activities of primarily the non-water variety such as picnicking, camping, outdoor sports, nature study, hiking, sightseeing and others. A number of state, county, local and private recreation areas have been developed to provide public opportunities for these land based recreation activities. The inland streams of the region offer limited water flow during the summer. The few inland lakes are very small and are mostly unavailable for public use.

2.2 INVENTORY

2.2.1 An inventory of all public and private recreational resources in the study area was prepared as part of the Erie-Niagara Basin recreation investigations by the Division of Water Resources of the New York State Conservation Department. During the summer of 1966, a number of state and county parks were surveyed during peak usage periods to evaluate patterns of usage, origin of visitors, intensity of use, expenditures, and other salient facts. Besides providing useful numerical data to evaluate potential sites, these surveys enabled qualitative assessments of the capability of regional recreation facilities.

2.2.2 All public and private recreational boating facilities along the Great Lakes were inventoried and data on lake-front recreation patterns and opportunities was obtained. In addition, an inventory of private campgrounds in the study area was assembled.

2.2.3 For the purpose of comparing regional supply to regional demand, an eight-county region in western New York plus a part of Ontario, Canada was defined as the supply area. Since most outdoor recreation participation occurs within a two hour drive, this study area was judged to be appropriate for analysis. The counties studied were Allegany, Cattaraugus, Chautauqua, Erie, Genesee, Niagara, Orleans, and Wyoming.

2.2.4 The inventory included facilities planned for construction in 1970.

2.3 PARTICIPATION

2.3.1 Participation of the western New York population in water based recreation was determined for the four activities of swimming, boating, camping, and picnicking, using Bureau of Outdoor Recreation procedures of analysis. Although potential water recreation developments can satisfy other activities, analysis was limited to these four because they are most closely associated with water-oriented recreation and their needs serve as indices of total recreation needs. Also, there are more specific data available about these activities, which makes them more tractable for numerical analysis.

2.3.2 Participation estimates through the year 2020 were made based on population projections made for the Erie-Niagara Basin Plan and on the Bureau of Outdoor Recreation participation rate projections.

2.4 NEEDS

2.4.1 Estimated participation minus supply is defined as need. Table C1 summarizes the regional recreational needs for the years 1970, 1980, 2000 and 2020 in terms of instantaneous participation on a typical summer Sunday.* The indicated needs are based on the projected participation minus the 1970 supply. Normal expansion of park systems will satisfy a portion of this need; however, three of the four activities have a serious need in 1970 and participation projections are increasing at a faster rate than the historical long term growth in supply.

2.5 DESIGN CRITERIA FOR RECREATION FACILITIES

2.5.1 The reservoir-oriented recreation facilities are described in Appendix D, and estimates of annual visitation and instantaneous summer Sunday attendance are described later in this appendix. A comparison of the design load in Table C8 with the 1980 needs shown above indicates that Sandridge would satisfy less than ten percent of the region's projected recreation needs.

* Based on an inventory taken in 1966 of all public and private recreational resources in the study area, prepared as part of the Erie Niagara Basin recreation investigations by the Division of Water Resources of the New York State Conservation Department.

TABLE C1 - Instantaneous summer Sunday recreation participation,
Erie-Niagara supply area

Activity	Year			
	1970	1980	2000	2020
<u>Swimming (Beach)</u>	:	:	:	:
Participation	: 199,600	: 220,500	: 268,000	: 318,000
Supply	: 112,000	: 112,000	: 112,000	: 112,000
Surplus (Deficit)	: (87,600)	: (108,500)	: (156,000)	: (206,000)
<u>Boating</u>	:	:	:	:
Participation	: 76,700	: 84,600	: 103,200	: 121,500
Supply	: 47,000	: 47,000	: 47,000	: 47,000
Surplus (Deficit)	: (29,700)	: (37,600)	: (56,200)	: (74,500)
<u>Camping</u>	:	:	:	:
Participation	: 67,400	: 74,000	: 90,600	: 106,500
Supply	: 64,000	: 64,000	: 64,000	: 64,000
Surplus (Deficit)	: (3,400)	: (10,000)	: (26,600)	: (42,500)
<u>Picnicking</u>	:	:	:	:
Participation	: 127,500	: 141,000	: 171,000	: 201,000
Supply	: 133,000	: 133,000	: 133,000	: 133,000
Surplus (Deficit)	: 5,500	: (8,000)	: (38,000)	: (68,000)
<u>Total For 4 Key Activities</u>	:	:	:	:
Participation	: 471,200	: 520,600	: 632,800	: 747,000
Supply	: 356,000	: 356,000	: 356,000	: 356,000
Surplus (Deficit)	: (115,200)	: (164,600)	: (276,800)	: (391,000)

Supply for each recreational activity has been taken as a constant because of an inability to ascertain planned expansion. Some expansion of the park systems may be anticipated and so the deficits are likely to be less than stated.

2.6 EVALUATION OF RECREATION BENEFITS

2.6.1 The evaluation of the recreation benefits to be ascribed to the channel improvement schemes has been based on the method printed in the U.S. Army Corps of Engineers Report on the Red Run Drain and Lower Clinton River (April 1970).

2.6.2 Since the parks to be provided lie in or near metropolitan areas, the most common benefit will be picnics held on a summer weekend. The standards of the Red Run Drain Report have been adopted to evaluate this use. Fifteen picnic units per acre have been allowed for, with an average of 5 persons per unit. With due allowance for inclement weather a total of 28 summer and 20 late spring and early fall design days has been taken.

2.6.3 The rights of way necessary for each of these schemes make suitable bicycling and hiking trails. Standards of 80 hikers/mile and 20 cyclists/mile have been taken.

2.6.4 Canoeing has been allowed for at the rate of two canoeists/acre of water surface gained, and in the winter weekends it has been assumed that ice skating and tobogganing would be provided in at least some sections of the parks.

2.6.5 In each of these schemes provision has been made for a nature trail two miles long with a capacity of 50 persons per mile.

2.6.6 Since some of these facilities will be used by more than one group in each day a daily turnover factor has been used as a multiplier to indicate the total design load per day, but since some people will participate in more than one activity the total activity days have been divided by a factor to indicate the true number of recreation days.

2.6.7 The value of a recreation day has been selected as \$1.00 which is the same as that chosen for the Red Run Drain Study and is consistent with the values suggested by the Water Resources Council in "Standards of Planning Water and Land Resources" (July 1970). This value may

also be compared with the updated figure of \$1.18 (Table C-13) at Sandridge, and \$1.08 (Table C-14) for day-use at Bowmansville.

2.6.8 The recreation benefits for the two channel improvement schemes are given in Tables C2 and C3. Benefits ascribed to the minor channel improvement section of the Sandridge scheme are shown in Table C4. It may be noted that no provision has been made for sports facilities since they are adequately provided for by the UDC development in Amherst.

2.6.9 On the next page are to be found population statistics for the Ellicott Creek Basin, being Table 3.1 of the Phase 2, Volume 1, Main Report. To derive recreation benefits for the two channelization schemes, it has been assumed that only people living within a five mile band on each side of the stream would visit the parks (for they are essentially neighborhood parks.) The affected population is that living on Reaches 1 - 4, principally the residents of Amherst and Williamsville Village. The relationship between population and facility-utilization, for summer and winter recreation, is indicated in Tables C-2 through C-4. In discussions with representative local residents, the League of Women Voters, Councilmen in local government, etc., the need for these facilities has been stressed by these representatives.

TABLE CIA (Table 3.1 of Main Report)

POPULATION

Silicon Creek Basin ^{1/}	Historical				Projected ^{2/}	
	1940	1950	1960	1970	1980	1990
Alden town	4,613	4,899	7,615	9,787	12,931	16,173
Alden village	954	1,252	2,042	2,651	3,280	4,330
Amherst town	19,356	33,744	62,837	93,929	117,555	143,076
Williamsville village	3,614	4,649	6,316	6,835	6,320	6,320
Bennington town, Wyoming	1,481	1,558	1,983	2,544	3,203	4,028
Suffalo city	575,901	580,132	532,759	462,768	416,146	385,683
Cheektowaga town	25,006	45,354	84,056	113,844	129,311	140,587
Clarence town	4,426	6,331	13,267	18,168	22,335	26,126
Darien town, Genesee	1,667	1,899	2,357	2,745	3,277	4,002
Lancaster town	15,299	18,471	25,605	30,634	35,266	39,812
Newstead town	4,268	4,653	5,825	6,322	7,053	8,708
Pembroke town	2,391	2,866	3,451	3,959	4,589	5,458
Tonawanda city	13,008	14,617	21,561	21,898	22,335	22,394
Tonawanda town	32,155	55,270	105,032	107,282	108,151	111,972
Kenmore village	18,612	20,066	21,261	20,980	21,260	21,260
T o t a l	699,571	769,794	866,348	873,880	882,152	908,019
<u>Regional</u>						
Erie County	798,377	899,238	1,064,688	1,112,368	1,163,787	1,231,634

1/ Town populations also include village population

2/ Prepared by NYS Office of Planning Services

TABLE C2

MAJOR CHANNELIZATION - RECREATION BENEFITS

Facility	No of Units	Design Instant Load	Daily Turnover	Design Load	No of Design Days	Total Activity Factor	Recreation Days
Picnic tables	240*	5/table	2	2400	28 summer	67,200	2 : 33,600
Bike - Hike trails	7 miles						
(a) bicycling	-	20/mile	2	280	28 summer	7,840	2 : 3,920
(b) hiking	-	80/mile	1	560	20 spring & fall	11,200	1 : 11,200
Nature trail	2 mile	50/mile	8	800	28 summer	22,400	2 : 11,200
				800	20 spring & fall	16,000	1 : 16,000
Canoeing	135 ac	2/acre	8	2160	28 summer	60,480	2 : 30,240
Ice Skating	4 ac	400/acre	2	3200	27 winter	86,400	1 : 86,400
Total recreation days							192,560
Recreation benefit/year							\$192,560

*16 acres at 15 tables per acre

TABLE C3

DIVERSION CHANNEL - RECREATION BENEFITS

Facility	No of Units	Design Load	Instant Load	Daily Turnover	Design Load	No of Design Days	Total Activity	Recreation Days
Picnic tables	1012*	5/table	5060	2	10120	28 summer	283,360	2 : 141,680
Bike - Hike trails	3-1/2 miles							
(a) bicycling	-	20/mile	70	2	140	28 summer	3,920	2 : 1,960
					140	20 spring & fall	2,800	1 : 2,800
(b) hiking	-	80/mile	280	1	280	28 summer	7,840	2 : 3,920
					280	20 spring & fall	5,600	1 : 5,600
Nature trail	2 mile	50/mile	100	8	800	28 summer	22,400	2 : 11,200
					800	20 spring & fall	16,000	1 : 16,000
Canoeing	20 ac	2/acre	40	8	320	28 summer	8,960	2 : 4,480
Ice Skating	10 ac	400/ac	4000	2	8000	27 winter	216,000	2 : 108,000
Tobogganing	67 1/2 ac	50/acre	3375	2	6750	27 winter	182,250	2 : 91,125
Total recreation days								386,765
*67 1/2 useful acres at 15 tables per acre								Recreation benefit/year : \$386,765

TABLE C4

MINOR CHANNELIZATION - RECREATION BENEFITS

Facility	No of: Units	Design Load	Instant Load	Daily Turnover	Design Load	No of: Design Days	Total Activity	Recreation Days
Picnic tables	195*	5/table	975	2	1950	28 summer	54,600	2 : 27,300
Bike - Hike trails	2½ mi							
(a) bicycling	-	20/mile	50	2	100	28 summer	2,800	2 : 1,400
					100	20 spring & fall	2,000	1 : 2,000
(b) hiking	-	80/mile	200	1	200	28 summer	5,600	2 : 2,800
					200	20 spring & fall	4,000	1 : 4,000
Nature Trail	2 mi	50/mile	100	8	800	28 summer	22,400	2 : 11,200
					800	20 spring & fall	16,000	1 : 16,000
Canoeing	50 ac	2/acre	100	8	800	28 summer	22,400	2 : 11,200
Ice Skating	4 ac	400/acre	1600	2	3,200	27 winter	86,400	1 : 86,400
Total recreation days								\$162,300
Recreation benefit/year								\$162,300

*13 acres at 15 tables per acre

2.6.10 The evaluation of water-based outdoor recreation attendance and benefits at both the Sandridge Reservoir and the Bowmansville-Pavement Scheme are determined primarily by demand curve analysis. This method measures the consumer's willingness to pay for a given quantity of recreation, given the recreation supply conditions that exist in the area under study. The method is described in this report only insofar as it is necessary to evaluate the assumptions upon which the recreation benefit totals of this report are based. More detailed descriptions may be found in Economics of Outdoor Recreation by Marion Clawson and Jack L. Knetsch, and in the "Summary of Visitor Surveys" report by the New York State Division of Water Resources, March 1967.

2.6.11 The demand curve for recreation at a particular site expresses the quantity of recreation which consumers are willing to purchase at varying prices per unit of recreation service. As the price goes down, people are willing to purchase more services, and as the price goes up, people are willing to purchase less. This same kind of demand-price relation holds true for almost all kinds of services and commodities which people are willing to buy. The use of the demand curve in recreation determines the amount of investment resources which people are willing to put into the recreation sector of the economy. The investment amount is determined on the same supply and demand market basis as is the amount of resources devoted to food, clothing, automobiles, etc.

2.6.12 The demand curve for the potential site can be used to forecast the number of recreationists who would use the site. It also can be used to calculate the monetary value of user benefits which can be attributed to the site. This latter step requires the development of the relationship between travel distance to reach the site and the cost of travel. Using appropriate monetary values for vehicle operation and time value, and discomfort, it is possible to equate distance to the site with travel costs.

2.6.13 The demand curve method can be divided into five steps.

- a. Collect data in order to develop the user-origin curves for existing sites.

- b. Using the curves developed in Step a, choose a curve applicable to the site being studied, considering the relative size and quality of the site, accessibility, nearness to population centers and the existence of other nearby sites.
- c. Calculate the total annual visitation from the user-origin curves and the populations distribution.
- d. Using appropriate values for vehicle operation expenses and travel time with the user origin curve, estimate the site demand curves by calculating site visitation under various levels of simulated prices.
- e. Compute the monetary benefits by determining the area under the demand curve.

2.6.14 Existing Site User-Origin Curves

2.6.14 User-origin data were collected during the above mentioned western New York park survey of 1966 and were available from other sources for several reservoirs in the east and midwest. Of the six parks in western New York where this data was collected, three were on the Great Lakes, two were on the Finger Lakes, and only one (Allegheny State Park) was an inland reservoir. Allegheny State Park is resource oriented and farther from the urban population than Sandridge. The five reservoir based recreation facilities listed in Table C5 are similar to the Sandridge and Bowmansville-Pavement Schemes in terms of size and nearness to population. The user-origin curves for these sites are presented on Plate C1. The curves indicate the number of annual recreation visits per capita from zones at increasing distance from the site. For example, on an average, the people from a zone 25 to 35 miles from Enders made 0.34 visits per capita annually.

2.6.14.2 The curves for these five reservoirs fall within a fairly tight range with the exception of the Cagles Mill-Mansfield, Indiana curve at about 50 miles, and the lower part of the Whitney Point curve.

2.6.14.3 The two variations are reasonable, given the population distribution surrounding the Indiana site and the location of competing recreation areas surrounding Whitney Point.

Since urban participation is generally higher than rural participation, the rise in the Indiana curve is due to the heavy Indianapolis contribution at about 45 miles. The drop-off in the Whitney Point curve reflects the beginning of the Finger Lakes region at about 40 miles from Whitney Point.

TABLE C5
Recreation reservoirs used in demand curve analysis

Site	Location	Water Acreage
Whitney Point	Binghamton, N.Y.	1200
Hinckley Lake	15 miles South of Cleveland, O.	100
Strunk Reservoir	South - Central Nebraska	1600
Enders Reservoir	South - Central Nebraska	1550
Cagles Mill-Mansfield: Reservoirs (combined)	Central Indiana	2000 and 1400

2.6.15 Proposed Site User-Origin Curves

2.6.15.1 The user-origin curves of existing sites were used to forecast the user-origin curves for the proposed Sandridge site. The transfer of an existing site user-origin curve to a potential site involves a degree of judgment. Since the five curves are from facilities similar to the proposed Sandridge facilities and because they are grouped very closely, the user-origin curve shown on Plate C2 is an approximate average and was selected as appropriate for evaluation of the Sandridge site. The curve shown on Plate C2 was also used in the evaluation of the Bowmansville-Pavement Scheme.

2.6.15.2 Similar analyses were made for the camper user-origin curves and these are shown on Plates C3 and C4. The camper data from western New York parks were considered more appropriate than the day-use data because campers appear to be less sensitive to the nature of the water resource.

2.6.16 Total Annual Visitation

2.6.16.1 The annual day-use visitation at Sandridge is estimated at 996,900 in 1980 and at 1,244,000 in 2010. The latter estimate was derived by using the New York State Division of Water Resources population projections and assuming the user-origin curve would remain constant. After 2010, visitation is assumed to remain constant. Table C6 summarizes these results. It is estimated that 80 percent of the annual visitation will occur during the 13-week summer recreation season between Memorial Day and Labor Day. A summary of the estimated day-use visitation at the Sandridge site is presented in Table C7. The total day-use recreation visitation at the Sandridge Reservoir was converted into design loads to size specific recreation facilities. The design attendance (typical summer Sunday) was itemized to the number of people engaged in specific activities. This itemization is called the design mix. For each specific activity a turnover factor was established which defines the number of people using each facility during the typical summer Sunday. A turnover factor of 2.0 was established for all day-use activities at the proposed reservoir. The total recreations visitation on a typical summer Sunday was divided by this turnover factor to obtain the design loads for day-use facilities. These design loads are shown in Table C8.

2.6.16.2 Day-use recreation visitation and design loads were estimated in a similar manner for the Bowmansville-Pavement Scheme. The estimated annual day-use visitation of 1,342,000 in 1980 and 1,678,000 in 2010 is greater than that for the Sandridge site and reflects the site's location which is some 10 miles nearer Buffalo and associated urban centers of population. Cayuga Creek in Como Park could provide a counter attraction for people from Lancaster but the greater expanse of both land and water recreational areas at Bowmansville could well provide the greater attraction. Estimated annual day-use visitation and design loads are summarized in Table C8.

2.6.16.3 Annual camper visitation was derived by procedures similar to those used for day-use visitation. The camper user-origin curve is shown on Plate C4, and Table C9 summarizes the total annual camper visitation. Although Table C1 indicates a need for camper facilities in 1970 and a growth in that need through 2020, it was recognized that a large campground will be

TABLE C6. - Annual day-use visitation at the proposed Sandridge Reservoir

Concentric Zone		Transport costs ^{1/}		Annual per capita visitation ^{2/}	
Miles	Per party	Per person	Per person	1980	2010
	\$	\$	\$		
0-10	1.52	0.34	1.40		
10-20	3.55	0.79	0.58		
20-30	5.58	1.24	0.28		
30-40	7.61	1.69	0.16		
40-50	9.64	2.14	0.11		
Concentric Zone					
Miles	1980	Population	2010	Total annual visitation	
				1980	2010
0-10	86,600		108,000	121,200	151,200
10-20	1,092,000		1,362,000	633,400	790,500
20-30	483,100		603,000	135,300	168,800
30-40	108,650		136,000	17,400	21,700
40-50	815,000		1,016,000	89,600	111,800
TOTAL	2,585,350		3,225,000	996,900	1,244,000

^{1/} Assumes a travel time value of \$2.00/hr/party at an average speed of 40 mph with 4.5 people per party.

^{2/} From user-origin curve (Plate C2).

TABLE C7. - Day-use visitation at the proposed Sandridge Reservoir

	Day-use visitation	
	1980	2010
Annual	996,900	1,244,000
Recreation season ^{1/}	797,500	995,200
Typical summer Sunday ^{2/}	30,700	38,300
Peak day ^{3/}	41,700	52,100
Typical summer Saturday ^{2/}	15,300	19,100
Typical summer weekday ^{2/}	3,100	3,800

^{1/} 80% of annual attendance would occur during the 15 week period from Memorial Day to Labor Day.

^{2/} Average weekly attendance = $\frac{\text{Recreation Season Attendance}}{13 \text{ weeks (15-2 weeks of assumed inclement weather)}}$

^{3/} The recreation season includes three holidays. The attendance on the peak day of the recreation season is estimated at 1.36 times the typical summer Sunday attendance.

TABLE C8. - Design attendance for day-use facilities at the proposed Sandridge Reservoir

Activity	1980 Design mix %	Instantaneous design attendance for day-use facilities, typical summer Sunday	1980	2010
Boating <u>1/</u>	7.1	1,215	:	1,215
Swimming <u>2/</u>	55	7,770	:	9,860
Picnicking <u>2/</u>	40	5,650	:	7,170
Hiking <u>2/</u>	5	710	:	900
Playgrounds <u>2/</u>	10	1,410	:	1,790
			:	
	117	16,755	:	20,935
			:	

1/ Design mix percentage for boating is limited by the reservoir surface area. The design mix for boating would be reduced to 6% in 2010. (See Table C15).

2/ Instantaneous design attendance = (Typical summer Sunday attendance less boating design attendance) x design mix x $\frac{1}{\text{turnover factor}}$

TABLE C9. - Camper-visitation at the proposed Sandridge Reservoir

Concentric Zone		Transport costs ^{1/}	Per person	Annual per capita visitation ^{2/}
Miles	Per party	:	:	:
0-10	2.52	:	0.56	0.0070
10-20	4.55	:	1.01	0.0085
20-30	6.58	:	1.46	0.0100
30-40	8.61	:	1.91	0.0085
40-50	10.64	:	2.36	0.0060
Concentric Zone				
Miles	Population 2010	:	Total annual visitation ^{3/}	2010
0-10	108,000	:	800	
10-20	1,362,000	:	11,600	
20-30	603,000	:	6,000	
30-40	136,000	:	1,100	
40-50	1,016,000	:	6,100	
TOTAL	3,225,000	:	25,600	

^{1/} Assumes a travel time value of \$2.00/hr/party at an average speed of 40 mph with 4.5 people per party.

^{2/} From camper demand curve (Plate C5).

^{3/} Existing and planned camping facilities in the vicinity of the proposed Sandridge Reservoir are considered adequate to the year 2000.

TABLE C10. - Annual day-use visitation at the proposed Bowmansville Pavement Scheme

Concentric Zone Miles	Per party \$	Transport costs ^{1/} Per person \$	Annual per capita visitation ^{2/}
0-10	1.52	0.34	1.40
10-20	3.55	0.79	0.58
20-30	5.58	1.24	0.28
30-40	7.61	1.69	0.16
40-50	9.64	2.14	0.11
Concentric Zone Miles	1980	Population 2010	Total annual visitation 1980 2010
0-10	510,000	638,000	712,000: 890,000
10-20	668,600	832,000	386,000: 485,000
20-30	483,100	603,000	137,000: 169,000
30-40	108,650	136,000	17,000: 22,000
40-50	815,000	1,016,000	90,000: 112,000
TOTAL	2,585,350	3,225,000	1,342,000: 1,678,000

^{1/} Assumes a travel time of \$2.00/hr/party at an average speed of 40 mph with 4.5 people per party.

^{2/} From user-origin curve (Plate C2).

Table C11. - Day-use visitation at the proposed Bowmansville - Pavement Scheme

	Day-use visitation	
	1980	2010
Annual	1,342,000	1,678,000
Recreation Season ^{1/}	1,072,000	1,340,000
Typical Summer Sunday ^{2/}	41,300	51,500
Peak Day ^{3/}	56,200	70,000
Typical Summer Saturday ^{2/}	20,650	25,750
Typical Summer Weekday ^{2/}	4,130	5,150

1/ 80 percent of annual attendance would occur during the 15 week period from Memorial Day to Labor Day.

2/ Average weekly attendance = $\frac{\text{Recreation Season Attendance}}{13 \text{ weeks}}$ (15-2 week of assumed inclement weather.)

50 percent of average weekly attendance comes on Sunday.
 25 percent of average weekly attendance comes on Saturday.
 5 percent of average weekly attendance comes on each weekday.

3/ The recreation season includes 3 holidays. The attendance on the peak day of the recreation season is estimated at 1.36 times the typical summer Sunday attendance.

constructed at the adjoining Darien Lakes State Park in the near future and should satisfy the near term need for camping facilities in the immediate area. Therefore, it was assumed that no camping facilities would be constructed at Sandridge in 1975, but that facilities would be built in 2000 when the first major replacement and expansion occur. Annual camper visitation at Sandridge was estimated at 25,600 visitors in 2010. The average stay was estimated to be 2.5 days per visitor resulting in 64,000 annual camper days in 2010. However, this projected figure may need revision as the 1970 Census showed population growth rates had not matched previous predictions. Since camping facilities are not needed till 2,000 A.D., the next census will give figures from which more accurate estimates can be made.

2.6.16.4 Due to the nearness of the Bowmansville-Pavement Scheme to Buffalo, camping facilities have not been provided. Bowmansville has been developed as a recreation area convenient for day visitors rather than for campers who would probably favor a facility somewhat further away from their normal habitat.

2.6.17 Day-Use and Camper Demand Curves

2.6.17.1 Demand curve analysis relates the expected visitation at a potential site to the monetary costs involved in visiting the site. The user-origin curves relating park visitation and distance traveled to a site (Plates C2 and C4) were converted to demand curves for the total recreation experience by using travel costs as a proxy for price.

2.6.17.2 The miles traveled to visit a site were converted into monetary units by evaluating the two parts of travel:

- a. Variable costs of operating an automobile for the round trip mileage involved in visiting a site.
- b. Costs of time and of travel to the automobile passengers.

2.6.17.3 The vehicle operating cost used in this study is the same as that recommended by the American Association of State Highway Officials for road user benefit studies. This value is equal to \$0.0516 per vehicle-mile. The approximate cost for time of travel is more difficult to establish. The problem is one of determining what the typical party size of 4 to 5 people would be willing to pay,

TABLE C12. - Design attendance for day-use facilities at the proposed Bowmansville - Pavement Scheme

Activity	1980 Design		Instantaneous Design Attendance for Day Use Facilities, Typical	
	Mix Percent	1980	Summer Sunday	2010
Boating	7 ^{1/2}	600	600	600
Swimming	55	11,100	11,100	13,900
Picnicing	40	8,100	8,100	10,100
Hiking	5	1,000	1,000	1,250
Playgrounds	10	2,000	2,000	2,500
	117	22,800		28,350

1/ Design mix for boating is limited by the reservoir surface area.

2/ Instantaneous design attendance = (Typical summer Sunday Attendance less boating design attendance) x design mix x $\frac{1}{\text{Turnover factor}}$

in addition to the vehicle operating cost, to forego having to spend time, travel discomfort and driver strain in going to and from the site.

2.6.17.4 The American Association of State Highway Officials uses a cost of time of \$0.86 per person hour for road-user benefit studies. Assuming an average party size of 4.5 persons, the value of time per vehicle hour at this rate would be about \$3.90. However, the AASHO rate is based upon inter-city travel studies wherein recreation was not necessarily the trip purpose. Willingness to pay for reduced travel time may be considerably different when the trip purpose is related to a person's job rather than when it is related solely to recreation.

2.6.17.5 A consideration in evaluating the costs of travel time and discomfort is that many visitors put a positive value on the trip. A sizeable proportion of the park visitors questioned by the Division of Water Resources in the 1966 user survey considered the trip to be enjoyable. Apparently, sightseeing along the travel route is a valued activity for many people.

2.6.17.6 The value of the scenic drive may, however, be undergoing a change. According to the recreation development agency for the Detroit area, the Huron-Clinton Metropolitan Authority, current studies indicate that the day of the Sunday afternoon drive is over. Today few families plan a leisurely drive through the countryside to admire the beauties of nature, but instead prefer to travel along fast, double lane, freeway routes to a specific area. More and more people are traveling directly to a park so that nearly all of their leisure time can be spent at the recreation area.^{1/} This conclusion by the Authority, which implies a cost of travel time, is based upon extensive user surveys in the Detroit area.

2.6.17.7 In this study, a time and travel cost value of \$2.00 per vehicle-hour was used. The \$2.00 rate is the same as that used in the Meramec Basin Study conducted by Washington University of St. Louis.^{2/} In the Meramec study, \$1.50 was considered a reasonable time and travel cost value for the driver, \$0.50 was added for one passenger, and all other passengers were considered to have zero time and travel value.

^{1/} The Huron-Clinton Metropolitan Authority, Eleventh Biannual Report, December 31, 1963.

^{2/} The Meramec Basin, Water and Economic Development, Washington University, St. Louis, Missouri, 1961.

2.6.17.8 An assumed parking fee of \$0.50^{3/} per car, or in the case of camping, an assumed campsite fee of \$1.50^{3/} would be added to vehicle operation and time costs to obtain total party costs.

2.6.17.9 The party costs by zone are given as the bottom axis of the user-origin curves of Plates C2 and C4. The costs shown reflect a time and travel cost of \$2.00 per vehicle-hour.

2.6.17.10 A demand curve is developed from the user-origin curve by simulating increases in park entrance fee. This demand curve is used to compute the consumer's surplus, or monetary benefits, from recreation at the site. The consumer's surplus is the value of this commodity over and above its actual market price to the consumer. It is the difference between what a park visitor would pay to enjoy the recreation experience, and what he actually does pay. The total monetary benefits are equal to this consumer's surplus, plus the parking or camping fee upon which the original demand curve data are based.

2.6.17.11 The technique of developing this demand curve involves the hypothetical raising of park entrance fees and the use of the previous user-origin curve to determine visitation from each zone surrounding the site. For example, on the user-origin curve for day-use (plate C2) if the entrance fee at the potential park is increased from \$0.79 to \$1.24 per visitor, the annual per capita visitation rate of the 0-10 mile zone falls from 0.59 to 0.28.

2.6.17.12 Using this technique for the proposed Sandridge recreation facilities the demand curves, assuming a travel time cost of \$2.00 per hour per party, are shown on plates C5 and C6.

^{3/} In 1972 these were raised to \$1.00 and \$2.50 respectively in the Western New York area.

2.6.18 Sandridge Recreation Benefits. As noted above, the total monetary benefits are equal to the area under the demand curve (consumer surplus), plus the parking or camping fee upon which the original demand curve data are based. The annual benefits from recreation activities are summarized in Table C13, assuming a car parking fee of \$0.50¹/ per site per day. The updated-to-1972 value is \$1.18, based on the New York State Consumer Price Index corrections.

2.6.19 Bowmansville-Pavement Recreation Benefits. Recreation benefits for the proposed Bowmansville-Pavement Scheme have been extrapolated from the curves prepared above for the Sandridge facilities. The annual benefits from recreation activities are summarized on Table C14. A 1972 value of \$1.08 has been selected to reflect the inferiority of this site relative to the Sandridge site as a recreational area.

raised to \$1.00 and \$2.50 respectively
Area.

TABLE C13. - Economic evaluation of recreation benefits at the proposed Sandridge Reservoir

	1975	2000-2074
Day-Use Visitation	996,900	1,244,000
Annual Camper-Days	-0-	64,000
Day-Use Parking Fees	\$111,000	\$ 138,000
Camper Fees	-0-	\$ 21,400
Day-Use Consumer Surplus	\$670,000 ^{1/}	\$ 845,500 ^{2/}
Camper Consumer Surplus	-0-	\$ 56,400 ^{2/}
Total Annual Recreation Benefits	\$781,000	\$1,061,000
Recreation Benefits per Visitor-Day	\$ 0.784 ^{3/}	\$ 0.79
Recreation Benefits per Camper-Day	\$ -	\$ 1.21
Average Annual Recreation Benefits ^{4/}	\$	\$ 951,430
Updated value ^{5/} Nov 1972		\$1,436,659

^{1/} Area under the 1975 day-use demand curve shown on plate C5.

^{2/} Areas under the 2000 day-use and camper demand curves shown on plate C6.

^{3/} Bureau of Outdoor Recreation statistics - Nov. 1960

^{4/} Assuming straight growth in day-use visitation between 1975 and 2000, and all future benefits discounted at 5-1/2%. Camper benefits would first accrue in the year 2000.

^{5/} New York State Consumer Price Index = $\frac{\text{Nov 1972} = 133.3}{\text{Oct 1960} = 88.2} = 1.51$

TABLE C14. - Economic evaluation of recreation benefits at the proposed
Bowmansville - Pavement Scheme

	1975	2000 - 2074
Day use visitation	1,342,000	1,678,000
Day use parking fees	149,000	186,000
Day use consumer surplus	915,000 ^{1/}	1,139,000 ^{2/}
Total annual recreation benefits	\$1,064,000	\$1,325,000
Recreation benefits per visitor day	0.795	0.79
Average annual recreation benefits ^{3/}		\$1,268,000
Updated value ^{4/} , November 1972		\$1,723,212

- 1/ Extrapolated from the 1975 day-use demand curve shown on Plate C-5.
- 2/ Extrapolated from the 2,000 day-use demand curve shown on Plate C-6.
- 3/ Assuming straight line growth in day-use visitation between 1975 and 2,000 and all future benefits discounted at 5-1/2 percent.
- 4/ New York State Consumer price index $\frac{\text{Nov 1972}}{\text{Oct 1960}} = \frac{133.3}{88.2} = 1.51$. A reduction of 10% per visitor day relative to Sandridge has been effected to reflect the inferiority of this location to the Sandridge site as a recreation location.

2.7 SANDRIDGE RECREATION FACILITIES

2.7.1 A detailed description of the recreation facilities at the proposed Sandridge Reservoir is presented below. Initial construction of day-use facilities would take place in 1975. Additional day-use facilities would be constructed in 2000. Initial construction of the camping facilities would also take place in 2000. The expected life of recreation facilities is 25 years. Therefore, periodic replacement is necessary during the 100-year project life.

2.7.2 Beaches for swimming would be located so as to minimize effects of drawdown of the proposed reservoir pool. Slopes in the areas selected are about 5%. The soils in the proposed beach areas are fine sandy loams. Heavy use would cause turbidity unless the beach is prepared by blanketing with sand. The prepared sand beach would extend one foot below the summer pool elevation. The underwater portion of the beach would be covered with pit run sand extended to 10 feet below the normal pool level. This would allow for 5 feet of drawdown without a significant decrease in the quality of swimming. A 30-foot grass strip would be provided at the periphery of the dry beach.

2.7.3 Picnic facilities would be located in wooded areas somewhat removed from other activities except for about 450 tables placed to serve the swimming areas. Other locations would be set adjacent to areas which appear suitable for playgrounds or nature trails and hiking (see plate C7). Most of the picnic areas would have a view of the lake. The proposed picnicking intensity for the Sandridge site is 10 tables per acre in the picnicking areas. This intensity would maintain the spacious characteristics, distribute loading on sandy soils, and allow selection of the better drained sites on the wet soils.

2.7.4 Design load for boating is a combination of need, facilities provided, and usable reservoir surface. Standard criteria were used to estimate the distribution of boats and boating visitors at the proposed Sandridge Reservoir, as shown in table C15.

TABLE C15.- Design load for boating at the proposed Sandridge Reservoir

Use	: Instantaneous Boating Use--Public Facilities		: Water Surface Acres	
	: No. of Boats	: No. of Participants	: Total	: Total
Fishing	: 120	: 4 ^{1/}	: 480	: 240
Water-Skiing	: 110	: 3	: 330	: 1100
Boating (Power boats and Sailboats)	: 135	: 3	: 405	: 405
TOTAL	: 365	: -	: 1215 ^{2/}	: 1745 ^{3/}

^{1/} Assumes family fishing

^{2/} Boating design attendance is two times instantaneous use.

^{3/} Reservoir surface area used to establish design load for boating is minimum conservation pool (elevation 850) of 1800 acres adjusted downward to prevent conflicting water use near swimming beaches and launching ramps.

Launching facilities would be sized to provide 40 launchings per ramp. A total of 14 ramps would be required for boating activities. Six of the required launching ramps would be used for fishing. These six ramps are considered as part of the development costs for fish and wildlife conservation, and not for recreation development. Sixty feet of dock would be provided for each ramp. Three boats could be tied to each side providing about one-half hour of storage for launched boats.

2.7.5 Campgrounds would not be constructed until the year 2000. Sufficient land would be reserved for their development at that time. The campgrounds would be selected to be isolated from day use activities, and located east of

County Line Road. Careful selection of sites would be needed to utilize the existing trees. Some trees may need to be planted to furnish the proposed 240 campsites. The campgrounds are planned to be laid out in six loops of 40 sites each.

2.7.6 The peak daily use water supply needs at the proposed recreation facilities are estimated to be 0.9 mgd in 2000 and 1.1 mgd in 2020. Initial construction of the water supply facilities would be based on the 2000 needs. The water treatment plant at the Sandridge Reservoir would be built to serve nearby communities. Water supply needs of the recreation facilities would require additional plant capacity.

2.7.7 A collection system and sewage treatment plant would be necessary, and is provided in the cost estimates.

2.7.8 The recreation benefits for the proposed Sandridge Reservoir were determined by demand curve analysis. The average annual recreation benefits are estimated to be \$1,436,659.

2.8 Bowmansville - Pavement Recreation Facilities

2.8.1 Recreation facilities at the proposed Bowmansville - Pavement Scheme would be equal to those provided at Sandridge. Camping facilities would not however be provided due to the greater proximity of the proposed scheme to Buffalo and associated urban areas.

2.8.2 Of the 241 acres of land proposed for recreation purposes at Bowmansville, approximately 140 acres would be required to provide recreational facilities to the same scale as those proposed for Sandridge. If required, additional facilities could be provided on some of the remaining land at a later date.

2.8.3 Due to the smaller surface area of the proposed Bowmansville Reservoir at conservation level, boating facilities would be reduced to approximately half of the those proposed for Sandridge. Design loads for boating are summarized on Table C-16.

TABLE C16. - Design Load for boating at the proposed
Bowmansville - Pavement Scheme

Use	Instantaneous Boating Use - Public Facilities				
	No. of Participants			Water surface - Acres	
	No. of Boats	Per Boat	Total	Per Boat	Total
Fishing	60	4 ^{1/}	240	2	120
Water skiing	60	3	180	10	600
Boating (power boats and sailboats)	60	3	180	3	180
	180		600 ^{2/}		900 ^{3/}

1/ Assumes family fishing.

2/ Boating design attendance is two times instantaneous use.

3/ Reservoir surface area used to establish design load is minimum conservation pool area (elevation 720) of approximately 900 acres.

2.8.4 By way of comparison, the capability of the proposed recreation facilities to cope with the potential annual visitation was also determined using the methods proposed in the Corps of Engineers Survey Report on the Red Run Drain and Lower Clinton River. It was found that the facilities proposed would provide a potential capacity for 1,028,000 recreation days over the year. While this figure compares well with the potential visitation determined on the basis of population, it seems possible that the facilities, as proposed, could be regarded as a minimum.

2.8.5 The Red Run Drain method of determining recreation benefits is shown on Table C17. Using a value of \$1.08 per recreation day, recreation benefits would amount to \$1,110,000.

3 WATER QUALITY BENEFITS

3.1 GENERAL

3.1.1 In summer the flow in Ellicott Creek drops to very low levels and as a result has the potential to become objectionable from the point of view of odors and exposed mud flats. Augmentation of the low flows can be considered a benefit since it prevents this condition. Placing a value on this benefit is difficult since the benefits are purely aesthetic. Only the

TABLE C17. Recreation benefits at the proposed Bowmansville - Pavement Scheme - Red Run Drain and Lower Clinton River Method

	No. of Units	Design Load/Unit	Instant Load	Daily Turn-over	Design Load	No. of Design Days	Total Activity	Factor	Recreation Days
Picnic tables	1,120 ^{1/}	5	5,600	2	11,200	36 Summer 20 Winter Fall	403,200	2	201,600
Playground	5	20	100	3	300	36 Summer 20 Winter Fall	10,800	2	5,400
Trails: Hiking	12	80	960	2	1,920	36 Summer 20 Winter Fall	69,120	2	34,560
Cycle	12	20	240	1	240	36 Summer 20 Winter Fall	38,400	1	38,400
Nature	2	50	100	8	800	36 Summer 20 Winter Fall	4,800	1	4,800
Boating	-	-	600 ^{2/}	2	1,200	36 Summer 20 Winter Fall	28,800	2	14,400
Swimming	-	-	-	-	11,500 ^{3/}	36 Summer	414,000	1	414,000
Winter Sport	4	1,000	4,000	1	4,000	30 Winter	120,000	1	120,000
TOTAL RECREATION DAYS									1,027,680

C 33

^{1/} 112 acres at 10 tables/acre as at Sandridge. Red Run Drain Report proposes density of 15 tables/acre.

^{2/} See table C16.

^{3/} 80 percent of summer design load excluding boating.

reservoir schemes have any capability of supplying water in the dry season and provision was made in the Sandridge scheme to augment the summer flow with a minimum addition of 10 cfs. This figure was based on the requirement to dilute the sewage effluents entering the stream.

The length of the Creek most objectionable in the Summer is to be found from the Amherst No. 1 Sewage Treatment Plant downstream, to the confluence with Tonawanda Creek. The twin senses of sight and smell are offended.

Minimum water quality benefits have been evaluated on the basis of inducing 10 cfs in the downstream end of Ellicott Creek, at the present location of Amherst treatment plant No. 1, which is being phased out. The induced water is treated effluent from Tonawanda Plant No. 16, some five miles Northwest of the Amherst plant. The transmission cost from Tonawanda No. 16 is estimated to be \$1,200,000, yielding annual interest and amortization charges of \$67,000. Annual operation and maintenance costs are estimated to be \$6,000. Annual power costs for pumping are estimated to be \$15,000. The annual incremental treatment cost to treat the effluent from Tonawanda No. 16 for Ellicott Creek to a higher degree of quality than required for Tonawanda Creek is estimated to be \$102,000. This incremental treatment includes nitrification, mixed-media filtration, and some additional sludge removal. Total annual costs for this least cost alternative therefore become \$190,000 and is taken as the benefit for water quality storage in the Sandridge alternative.*

3.1.2 The Bowmansville - Pavement Scheme will also augment low flows in Ellicott Creek during the summer months. In this case the Pavement reservoir will be gradually depleted by allowing water to pass into the Bowmansville reservoir and hence into Ellicott Creek. Bowmansville will be maintained as near as possible to the conservation level of elevation 720. As in the case of Sandridge, the least cost alternative is treated effluent from Tonawanda No. 16, at an annual value of \$190,000 and this is taken as the benefit for water quality storage for this scheme.

*At a meeting between the Corps of Engineers and Federal E.P.A. officials in Rochester, New York on July 3, 1973, it was considered the effect of E.P.A. regulations on future water quality makes this benefit inadmissible, as the regulations are designed to cause water quality improvement.

4. MUNICIPAL WATER SUPPLY

4.1 GENERAL

4.1.1 The potential for using the proposed Sandridge Reservoir as a source of municipal water supply for the local area was considered as one function of the multiple purpose project. Water supply needs for the town and village of Alden, the town of Darien, and the village of Akron and town of Newstead are growing and present supply sources may not be sufficient to meet future requirements. In addition, the Sandridge recreation facilities and the Darien Lakes State Park will be in operation and will need a water supply. Evaluation of the water supply aspects of the Sandridge Reservoir showed that its most attractive use would be to supply the water needs of the recreation facilities, the town and village of Alden and the village of Akron and town of Newstead.

4.2 WATER SUPPLY AREA

4.2.1 Land use for the local area surrounding the proposed reservoir varies from rural agricultural to semi-rural population centres. Five population centres which could benefit from a Sandridge water supply system are the town of Alden, the village of Alden, the town of Darien, the village of Akron and the town of Newstead. In addition, the system could supply water to two recreation areas, Darien Lake State Park and the proposed Sandridge recreation facilities. The location of these potential users is shown on Plate C8.

4.2.2 The water needs for potential users are based on their population or population equivalents. Table C18 summarizes the population equivalents and water needs for the two recreation centres. The water supply needs for all potential users are shown in Table C19.

TABLE C18. - Population equivalents and water supply needs for recreation facilities potentially served by the Sandridge Reservoir

	Population Equivalent ^{1/}		Unit Water Supply Requirement		Water Supply Needs ^{1/}	
	1980	2010	gpcd	Requirement	1980	2010
Sandridge recreation facilities	:	:	:	:	:	:
Day-Users	41,700	52,100	20	:	850,000	1,050,000
Campers	0	1,080	50	:	0	50,000
Darien Lakes State Park ^{2/}	:	:	:	:	850,000	1,100,000
	:	:	:	:	:	:

^{1/} Peak day use.

^{2/} Exact facilities unknown, assume requirement equal to Sandridge.

TABLE C19. - Water supply needs for potential users of the Sandridge Reservoir

	Total Water Supply Needs	1/ 2/
	2000	2020
	mgd	mgd
Town and Village of Alden	6.2	9.5
Town of Darien	0.9	1.1
Sandridge Recreation Facilities	1.0 <u>3/</u>	1.2 <u>3/</u>
Darien Lakes State Park	1.0 <u>3/</u>	1.2 <u>3/</u>
Village of Akron and Town of Newstead	2.4	3.0

1/ Based on water treatment plant design for peak day use. Average daily use equals one-half peak day use.

2/ Includes 10% for treatment plant use.

3/ Only during recreation season (June through September).

4.3 EXISTING WATER SOURCES

4.3.1 The potential users of the Sandridge Reservoir presently obtain their water supplies from various sources. Ground water supplies the needs for the town and village of Alden. The village of Akron and town of Newstead are supplied from the Akron Reservoir in Wyoming County. This reservoir also supplies water to the Darien Water District.

4.3.2 Existing water supply systems are inadequate to meet the growing needs of the local area near the Sandridge site. Ground water resources may not provide an adequate water supply to meet the growing needs of the town and village of Alden. Expansion of the Akron Reservoir has been under investigation to provide an increased supply for the village of Akron and town of Newstead. The Darien Water District receives its water from the Akron Reservoir, and the supply available to the District is directly influenced by the growing needs of the village of Akron.

4.4 POTENTIAL WATER SOURCES

4.4.1 Water requirements for the town and village of Alden and the village of Akron and town of Newstead could be supplied by extending the Erie County Water Authority (ECWA) system. The ECWA is presently being expanded in the town of Lancaster. The present plans of the ECWA do not show expansion beyond Lancaster until after the year 2000. Alden and Akron could meet their water needs by constructing transmission mains to the nearest terminal location of the ECWA.

4.4.2 The water needs of the village of Akron and town of Newstead could also be met through the expansion of the existing Akron Reservoir system in Wyoming County. Future needs would require construction of a new reservoir in Wyoming County (French Brook Reservoir) and new or improved transmission facilities.

4.4.3 The water supply needs for all or any combination of the potential users in these communities could be met by the proposed Sandridge Reservoir. Existing and potential water sources for all users are summarized in table C20. The location of these facilities is shown on plate C8. Storage of 2,220 acre-feet would meet needs

through the summer. Inflow would be adequate at other times.

4.5 PRELIMINARY ECONOMIC EVALUATIONS

4.5.1 Preliminary economic evaluation of potential water supply sources indicated that the water supply needs for the proposed recreation facilities at the Sandridge site would be provided from the Sandridge Reservoir. Since this need is created by the reservoir, no benefits are claimed for this purpose. Water supply needs for the Darien Lakes State Park are presently being investigated by the Genesee State Park Commission. For the purpose of this survey report, it has been assumed that this recreation facility would be served from a source other than the Sandridge Reservoir. It was also assumed that the Darien Water District would continue to obtain water supply from the Akron Reservoir.

4.5.2 The remaining potential water supply users are the town and village of Alden and the village of Akron and town of Newstead. Alternative plans to meet the water supply needs of these remaining users are described below.

TABLE C20. - Existing and potential water supply sources for the local area near the Sandridge site

Location	: Existing : Supply Source	: Potential : Supply Sources
Alden (T & V)	: Ground water	: Extension of ECWA : Sandridge Reservoir
Akron (V) & Newstead (T)	: Akron Reservoir	: Extension of ECWA : Expansion of Akron : Reservoir : Sandridge Reservoir
Darien Water District	: Akron Reservoir	: Akron Reservoir
Darien Lakes State Park	: Ground water	: Akron Reservoir
Sandridge recreation facilities	: None	: Sandridge Reservoir

AD-A101 345

CORPS OF ENGINEERS BUFFALO N Y BUFFALO DISTRICT
ELLICOTT CREEK BASIN, NEW YORK. WATER RESOURCES DEVELOPMENT. PH--ETC(U)
AUG 73

F/G 13/2

UNCLASSIFIED

NL

3 of 6
AD1345

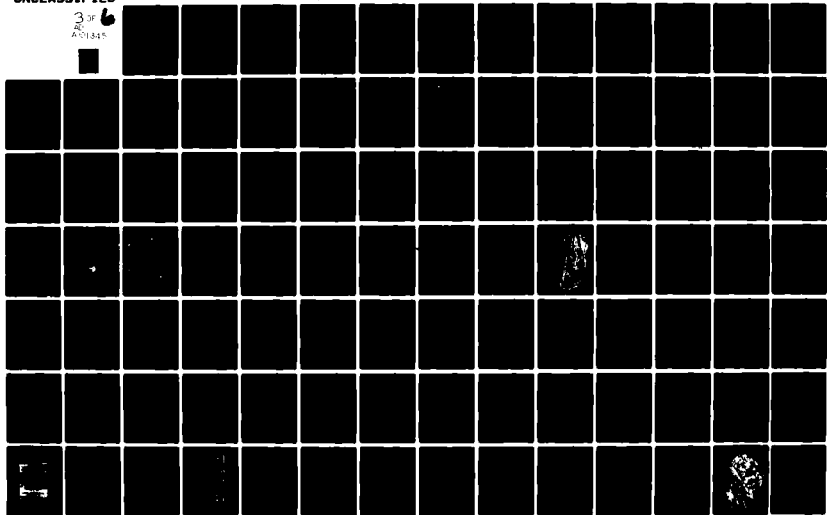

4.6 SCHEMES FOR WATER SUPPLY SYSTEMS

4.6.1 Consideration was given to five schemes to evaluate the feasibility of the Sandridge Reservoir as a potential municipal water supply source. The schemes are:

1. Supply the town and village of Alden from a central water treatment plant at the Sandridge Reservoir.
2. Supply the town and village of Alden from an extension of the Erie County Water Authority.
3. Supply the village of Akron and town of Newstead from a central water treatment plant at the Sandridge Reservoir.
4. Supply the village of Akron and town of Newstead from an extension of the Erie County Water Authority.
5. Supply the village of Akron and town of Newstead from the existing Akron Reservoir plus an additional reservoir in Wyoming County (French Brook Reservoir).

The water supplied after 2020 by the Sandridge project was assumed to remain constant at the 2020 level.

4.7 DESCRIPTION OF WATER SUPPLY SCHEMES

4.7.1 Scheme 1. A central water treatment plant would be constructed near the southern extremity of the proposed Sandridge dam to serve the town and village of Alden, as shown on plate C8. Initial treatment facilities would be constructed in 1975, and would be sized for the projected water needs for 2000. The treatment plant capacity would be expanded in 2000 to meet the projected 2020 needs. The economic life of the treatment facilities is assumed to be 50-years, and that for the distribution system to be 100-years. First costs were determined by evaluating engineering and economic studies prepared by private engineering consultants. Costs for the water

treatment plant facilities were determined from the report, "Erie County, New York, Comprehensive Public Water Supply Study", by Greeley and Hansen Engineers, 1969. Operation, maintenance and pumping costs were also obtained from this Greeley and Hansen report. The transmission system was sized for the peak daily water use needs. Unit costs for the transmission mains, excavation, placement and backfill were obtained from current contractor's bid prices. Operation and maintenance costs were assumed to be proportional to costs developed for the multiple purpose dam and reservoir.

4.7.2 Scheme 2. Water supply needs for the town and village of Alden could be met by extending the Erie County Water Authority system from the town of Lancaster. The town and village of Alden would be required to construct transmission mains to the nearest terminal location of the ECWA system.

4.7.3 Scheme 3. Water supply for the village of Akron and town of Newstead would be provided from the Sandridge Reservoir. Description of this scheme is similar to the above description for scheme 1.

4.7.4 Scheme 4. Water supply needs for the village of Akron and town of Newstead could be met by extending the Erie County Water Authority system from the town of Lancaster. As in scheme 2, the village of Akron would be required to construct transmission mains to the nearest terminal location of the ECWA system.

4.7.5 Scheme 5. Future water needs of the village of Akron and town of Newstead could be met by expanding the existing water supply facilities and replacing the existing transmission facilities. The capacity of the existing Akron Reservoir would be increased by constructing a new reservoir in Wyoming County (French Brook Reservoir). The new reservoir would supplement the storage in the existing Akron Reservoir. The existing water treatment plant at the Akron Reservoir would be modified and expanded to increase its present capacity. A new 14-inch diameter pipeline would be constructed between the existing Akron Reservoir and the village of Akron. The old 10-inch diameter pipeline would serve as a backup system but would normally not be in use. First costs for this water supply scheme were estimated from current unit prices and from

quantities determined in a consultant's report to the village of Akron. Annual costs for operation, maintenance and pumping were estimated from the Erie County report referenced in paragraph 4.7.1.

4.8 ECONOMIC EVALUATION OF ALTERNATIVES

4.8.1 The estimated capital costs and annual costs for the five water supply schemes are shown in table C21 and C23. Annual costs include interest on investment, amortization over a 100-year project life, operation and maintenance, and purchase of power for pumping. An interest rate of 5½% is considered appropriate by local interests. Annual costs are presented for comparison in table C26.

4.8.2 It must be noted that the cost of providing a reservoir to supply municipal water needs in Schemes 1 and 3 is for this single purpose use only. The allocated cost of a multiple purpose reservoir would be substantially less.

TABLE C21. - Estimated first cost and annual costs for water supply Scheme 1 (October 1969 price levels).

<u>Alden (T & V) from the Sandridge Reservoir :</u>		<u>Cost</u>
<u>Capital Cost</u>		:
1975	Water treatment plant	:\$1,312,000
1975	Transmission system	: 129,000
2000	Expansion (present worth at 5½%)	: <u>230,970</u>
	Subtotal Water Treatment and Transmission	: 1,671,970
1975	Single purpose water supply reservoir:	<u>5,600,000</u>
	Total First Cost	:\$7,271,970
<u>Annual Cost</u>		:
<u>Water Treatment and Transmission</u>		:
	Interest (5½%)	:\$ 92,390
	Amortization (100-years)	:
	Operation and maintenance	: 53,400
	Power cost for pumping	: 28,600
	Periodic Replacement	: <u>7,000</u>
	Subtotal	:\$ 181,390
<u>Single Purpose Reservoir</u>		:
	Interest (5½%)	:\$ 309,400
	Amortization (100-years)	:
	Operation and maintenance	: <u>64,000</u>
	Subtotal	:\$ 373,400
	Total Annual Cost	:\$ 554,790

TABLE C22. - Estimated first cost and annual costs for water supply Scheme 2 (October 1969 price levels)

<u>Alden (T & V) from Extension of the ECWA</u>		<u>Cost</u>
		:
<u>Capital Cost</u>		:
1975	Water treatment plant	:\$1,352,000
1975	Transmission system	: 1,115,000
2000	Expansion (present worth 5½%)	: <u>232,700</u>
		:
	Total First Cost	:\$2,699,700
		:
<u>Annual Cost</u>		:
	Interest (5½%)	:\$ 149,190
	Amortization (100-years)	:
	Operation and maintenance	: 27,400
	Power cost for pumping	: 77,800
	Periodic replacement	: <u>7,400</u>
		:
	Total Annual Cost	:\$ 261,790
		:

TABLE C23. - Estimate of capital and annual costs of water supply Scheme 3 (October 1969 price levels)

Akron (V) & Newstead (T) from the Sandridge Reservoir		Cost
<u>Capital Cost</u>		
1975	Water treatment plant	:\$ 568,000
1975	Transmission system	: 1,105,000
2000	Expansion (present worth at 5½%)	: <u>43,090</u>
	Subtotal Water Treatment and Transmission	: 1,716,090
1975	Single purpose water supply reservoir	: <u>5,300,000</u>
	Total First Cost	:\$7,016,090
<u>Annual Cost</u>		
<u>Water Treatment and Transmission</u>		
	Interest (5½%)	:\$ 94,830
	Amortization (100-years)	:
	Operation and maintenance	: 22,800
	Power Cost for pumping	: 16,400
	Periodic replacement	: <u>2,800</u>
	Subtotal	:\$ 136,830
<u>Single Purpose Reservoir</u>		
	Interest (5½%)	:\$ 292,880
	Amortization (100-years)	:
	Operation and maintenance	: <u>63,600</u>
	Subtotal	: 356,480
	Total Annual Cost	:\$ 493,310

TABLE C24. - Estimated first costs and annual costs for water supply Scheme 4 (October 1969 price levels)

Akron (V) & Newstead (T) from Extension of the		Cost
ECWA		
<u>Capital Cost</u>		
1975	Water treatment plant	:\$ 588,000
1975	Transmission system	: 1,400,000
2000	Expansion (present worth at 5½%)	: <u>36,200</u>
TOTAL FIRST COST		:\$2,024,200
<u>Annual Cost</u>		
	Interest (5½%)	:\$ 111,860
	Amortization (100-years)	:
	Operation and maintenance	: 22,800
	Power cost for pumping	: 30,000
	Periodic replacement	: <u>2,800</u>
TOTAL ANNUAL COST		:\$ 167,460

TABLE C25. - Estimated first cost and annual costs for water supply Scheme 5 (October 1969 price levels)

Akron (V) & Newstead (T) from Expansion of Akron		Cost
		Reservoir:
<u>Capital Cost</u>		:
1975	French Brook Reservoir	:\$ 484,000
1975	Water treatment plant	: 594,000
1975	Transmission system	: 1,780,000
2000	Expansion (present worth at 5½%)	: <u>43,090</u>
		:
TOTAL FIRST COST		:\$2,901,090
		:
<u>Annual Cost</u>		:
		:
	Interest (5½%)	:\$ 160,320
	Amortization (100-years)	:
	Operation and maintenance	: 22,800
	Power cost for pumping	: 20,000
	Periodic replacement	: <u>3,000</u>
		:
TOTAL ANNUAL COST		:\$ 206,120
		:

TABLE C26. - Comparison of annual costs for the five water supply schemes

Scheme	User	Source	Annual Cost
1	Alden (T & V)	Sandridge	554,790 ^{1/}
2	Alden (T & V)	ECWA	261,790
3	Akron (V) & Newstead (T)	Sandridge	493,310 ^{1/}
4	Akron (V) & Newstead (T)	ECWA	167,460
5	Akron (V) & Newstead (T)	Akron Reservoir	206,120

^{1/} Includes cost of a single purpose water supply reservoir.

4.9 MUNICIPAL WATER SUPPLY BENEFITS

4.9.1 Annual costs for the least costly municipal water supply schemes to serve the town and village of Alden and the village of Akron and town of Newstead are estimated at \$429,250. This cost is a combination of water supply benefits. However, the local communities would have to construct transmission facilities and a central treatment plant in order to use Sandridge Reservoir for water supply. These costs can be determined from the estimates for schemes 1 and 3 by deleting the reservoir costs. The net annual benefits would then be \$111,030 (i.e. 429,250 - 181,390 - 136,830). Updated to Nov 1972 this value becomes \$111,030 x 1.330 = \$147,670^{1/}

^{1/} Building Cost Index = $\frac{\text{Nov 1972}}{\text{Oct 1969}} = \frac{1060.70}{797.44} = 1.330$

5 FISH AND WILDLIFE

5.1 The U.S. Fish and Wildlife Service in cooperation with the New York State Division of Fish and Wildlife studied the Sandridge reservoir site to determine the estimated benefits

for including this purpose in the multiple purpose project. Their report is presented at the end of this appendix. A summary of the average annual benefits is shown in Table C27.

TABLE C27. - Average annual fish and wildlife benefits for Sandridge Reservoir

Fish	Fisherman-days	Unit Value	Annual Benefits
Muskellunge	19,700	\$5.00 ^{1/}	\$ 98,500
Bass	59,100	1.50	88,600
Total	78,800		\$187,100
Downstream fishing benefits:	1,850 fisherman-days @ \$1.50+=		\$ 2,800
Nature Visitors:	32,000 visitor-days @ \$0.50		= <u>16,000</u>
			\$205,900
TOTAL AVERAGE ANNUAL BENEFITS			
:updated value (x 1.15) Nov 1972:			\$236,700

^{1/} Muskellunge is a highly prized game fish.

5.2 Consideration was given to providing a roadway with parking nodes along the proposed Harlow Road dike to increase the number of nature-visitor days. The U.S. Fish and Wildlife Service estimates that an additional 9,800 nature-visitor days would be credited to the project for a net increase in benefits of \$4,900 annually. However, the added cost of including these improvements in the recommended plan would be considerably greater than the benefits. A roadway with parking nodes would not be economically justified. For this report, the benefits were excluded and Harlow Road would serve only as a dike and service road.

5.3 The fish and wildlife report, shown later, estimates that annual restocking costs would be \$3,100. Maintenance of other fish and wildlife facilities would also be required although these costs are expected to be minor. It was assumed that specific annual operation and maintenance costs for fish and wildlife would be about \$5,000 annually.

6 SUMMARY OF CONSERVATION BENEFITS

6.1 A summary of the average annual conservation benefits rounded to the nearest thousand dollars is shown below.

TABLE C28. - Summary of Conservation Benefits

Item	Average Annual Benefits			
	Major chan- nelization	Diversion Channel	Sandridge and minor channel	Bowmanville Pave- ment Scheme
Recreation	\$192,560	\$386,770	\$1,599,000 ^{1/}	\$1,723,210
Water quality	-	-	190,000 ^{2/}	190,000 ^{2/}
Water supply	-	-	147,670	-
Fish and Wildlife	-	-	236,790	-
TOTAL	\$192,560	\$386,770	\$2,173,460 ^{3/}	\$1,913,210 ^{4/}

^{1/} Sandridge + minor channel = \$1,436,659 + 162,300 = \$1,598,959

^{2/} Zero benefits

^{3/} Net = \$2,173,460 - \$190,000 = \$1,983,460

^{4/} Net = \$1,913,210 - \$190,000 = \$1,723,210



UNITED STATES
DEPARTMENT OF THE INTERIOR
FISH AND WILDLIFE SERVICE
BUREAU OF SPORT FISHERIES AND WILDLIFE

U. S. POST OFFICE AND COURTHOUSE
BOSTON, MASSACHUSETTS 02109

April 27, 1970

District Engineer
Buffalo District
U. S. Army Corps of Engineers
1776 Niagara Street
Buffalo, New York 14207

Dear Sir:

This is our conservation and development report on the fish and wildlife resources that may be affected by construction of a multi-purpose reservoir at the Sandridge site, Ellicott Creek, Township of Alden in Erie County, and Township of Darien in Genesee County, New York. The study is being conducted under authority of Section 214 of the Flood Control Act of October 27, 1965, and is part of a detailed comprehensive study of the Erie-Niagara Basins.

This report was prepared under authority of the Fish and Wildlife Coordination Act (48 Stat. 401, as amended; 16 U.S.C. 661-666 inc.), in cooperation with the New York State Conservation Department, Division of Fish and Wildlife and has its concurrence as indicated by letter dated March 25, 1970.

We understand that the reservoir site is being considered for multi-purpose use, including flood control, fish and wildlife, recreation, water quality, and water supply. The dam will be located on Ellicott Creek near the eastern boundary of the Village of Alden. The reservoir created will be about 4.5 miles long and about one mile wide. It will control a drainage area of about 33 square miles.

The topography of the area is characterized by low, gently-rolling hills. The principal land use is dairy and cash-crop farming. Small farm woodlots are interspersed with the agricultural land. The small timber tracts consist mainly of ash, maple and aspen.

PROJECT PLAN

The dam will consist of an earth-fill embankment and a concrete spillway with gates. The maximum flood pool will be 2,300 acres in area at elevation 855.5^{1/2}. A conservation pool of 2,150 acres at elevation 855 will be held in early summer. The conservation pool will provide for recreation, water supply, and low-flow augmentation during the recreation season. Minimum instantaneous low-flow augmentation releases will be 25 cfs during the period of June through September. Municipal water supply may be needed at a future date for the Town and Village of Alden, the Village of Akron, and the Town of Newstead. Until such time as municipal water supply is needed (probably about 2020) the maximum drawdown of the conservation pool for low-flow augmentation will be 5.0 feet by September 1 once in 20 years. We understand that drastic changes in discharge rates will be avoided insofar as possible.

That portion of Harlow Road within the maximum flood pool will be raised to form a dike one mile long and impound a 425-acre fish and wildlife pool; the pool will be held at elevation 855. Maximum depth will be five feet and average depth will be two feet. Seventy 30-inch galvanized, corrugated steel culvert pipes, slightly sloped, will be placed in the dike with inverts at elevation 855. A maintenance roadway will be built on top of the dike. This pool will not be affected by low-flow drawdown.

The preliminary project recreation plan recommends construction of 14 small-boat launching ramps. Six ramps would be especially for fishing purposes at the conservation and fish and wildlife pools. They would be utilized by hunters during the waterfowl season. Reservoir zoning recommendations include restriction of boating use within 300 feet of swimming beaches.

There will be some channel improvement in two reaches downstream from the dam in the Town of Amherst.

Pertinent reservoir data are shown in table 1.

^{1/2} All elevations are in feet above mean sea level.

Table 1. Reservoir Reservoir Data.

Pool	Elev.	Area (ac.)	Volume (ac.-ft.)	Aver. depth (ft.)	Max. depth (ft.)	Seasonal duration
Streambed elev.	812	--	--	--	--	--
Minimum pool (main pool)	850.0	1,600	--	--	--	--
Max. flood- control pool	856.5	2,300	31,000	--	47	As necessary for flood control
Conservation pool (includes f&w pool)	855	2,150	27,500	17	43	Drawdown to max. of 5.0 ft. by Sept. 1. Average once in 20 years.
Fish & wildlife pool impounded by dike	855	425	--	2	5	Year round

A total of 3,985 acres will be acquired for the reservoir, exclusive of recreation lands. An additional 1,100 acres are required to provide recreational facilities; these project lands are immediately west of Darien Lakes State Park and north of Broadway.

FISH AND WILDLIFE RESOURCES

The effects of project development on fish and wildlife resources are determined by comparing the estimated utilization of these resources under without-the-project conditions with those estimated with the project in operation. Utilization is expressed as the average annual fisherman- or hunter-days over the 100-year life of the project and is a reflection of the productive capability of affected habitat types. The dollar values of benefits given in this report are net recreational values. They are based on "Evaluation Standards for Primary Outdoor Recreation Benefits" adopted by the President's Ad Hoc Water Resources Council, June 4, 1964. Evaluations contained in this report are further based on initial operations, i.e. no water diversions for municipal supplies.

1/ See "Supplement No. 1 - Evaluation Standards for Outdoor Recreation Benefits", to Senate Document No. 97, 87th Congress, 2nd Session.

Fishery Resources: Without the Project

Fish populations in the drainage area consist primarily of rock bass, suckers and minnows. This combination does not provide a significant recreational stream fishery. Fishing pressure, therefore, is practically non-existent. Largemouth bass occur downstream, from the Williamsville area westward.

Fishery Resources: With the Project

Construction of the reservoir will inundate about 4.5 miles of the main stem Ellicott Creek and create a 1,725-acre reservoir west of Harlow Road and a 425-acre fish and wildlife impoundment east of the road. Inundation will convert an insignificant stream fishery to a significant lake-type fishery.

The principal game fish species being considered for management in the reservoir are muskellunge and largemouth bass. Annual stocking of muskellunge by the State will be necessary, but the bass population will sustain itself through natural propagation. Annual stocking costs are estimated at about \$3,100. Except for the Niagara River, fishing opportunities for muskellunge are non-existent in the Erie-Niagara Basin. Since the conservation pool will be no lower than elevation 850.0 once in 20 years (generally the minimum elevation will be higher), at least 1,600 acres of water will be available for fishing. Estimated average annual utilization of this reservoir fishery during the 100-year life of the project is 80,000 fisherman-days, which will have a net recreational value of \$190,000 annually. This is based on an assumption that 25 percent of the fishermen will fish for muskellunge and 75 percent for bass, having a unit value of \$5.00 and \$1.50, respectively.

The channel improvements are not expected to materially increase or decrease the stream fisheries; however the minimum instantaneous downstream releases of 25 cfs for low-flow augmentation during low flows will provide warmwater fishery benefits. An estimated 1,800 additional fisherman-days will be provided annually for a distance of about 16 miles. The value of these benefits will be about \$2,800 annually.

Table 2 shows the average annual fishery utilization and values with and without the project.

Table 2. Average Annual Fishery Utilization and Values.

Area evaluated	Without the project (Fisherman-days)	With the project (Fisherman-days)	Fishery benefits
Stream fishery	0	1,800	\$ 2,800
Reservoir fishery	0	<u>80,000</u>	<u>190,000</u>
		81,800	\$192,800

Wildlife Resources: Without the Project

Principal wildlife species are ring-necked pheasant, ruffed grouse, cottontail, white-tailed deer, squirrel, raccoon, woodcock, waterfowl and common furbearers. The bottom-land area, most of which lies within the full pool flow line, provides good-to-excellent habitat for wildlife. Without the project it is estimated that the project area will support 3,900 hunter-days for small game and 280 hunter-days for big game annually. Waterfowl use is minimal because of the relative scarcity of water-associated habitat.

Wildlife Resources: With the Project

Construction and operation of the reservoir will eliminate 2,150 acres of upland and forest wildlife habitat. The productive capability of lands lying within the flood pool will be reduced as a result of seasonal flooding. These losses plus expected intensive recreational use of the remaining land will eliminate virtually all of the hunter use on the project for small game and big game.

The conservation pool will create waterfowl habitat which will be used primarily by migrating birds. About 250 acres of water 18 to 24 inches deep will be available for waterfowl feeding. Shallow waters are especially valuable as feeding areas for the so-called "puddle ducks". Use of the pool and adjoining shoreline by breeding birds probably will be minimal, however, there will be an increase in waterfowl use by migrating birds in the spring and fall. Waterfowl utilization which is minimal at present, will increase even more with the establishment of aquatic plant life in the shallower reservoir waters. An estimated 1,000 waterfowl-hunter days annually will accrue to the reservoir. This increase in waterfowl hunting opportunities will partially compensate for the reduction in small game and big game hunting opportunities.

Table 3 shows the average annual wildlife utilization with and without the project.

Table 3. Average Annual Wildlife Utilization

<u>Wildlife Group</u>	<u>Without-the-project</u> <u>(Hunter-days)</u>	<u>With-the-project</u> <u>(Hunter-days)</u>	<u>Change</u>
White-tailed deer	280	0	- 280
Small game	3,900	0	- 3,900
Waterfowl	Trace	1,000	1,000 ^{1/}

^{1/} Not a benefit - merely compensates for reduction in big game and small game hunting opportunities.

In addition to attracting the fishermen and hunters, as well as general recreationists, this project will also attract those who are primarily interested in nature (the flora and fauna) for nature's sake. This group (nature visitors) will utilize the project over a longer period than most groups. Their principal season will extend from April through November.

The Bureau's Iroquois National Wildlife Refuge located about 15 miles north of the Sandridge Reservoir site is used as a basis for projecting nature visitor utilization at the Sandridge Reservoir project. Concentrations of waterfowl attract most of the nature visitors. While waterfowl numbers are not expected to be as great as those utilizing the Iroquois National Wildlife Refuge, nevertheless it is anticipated that waterfowl will draw many nature visitors to the Sandridge project. It is estimated that this visitor group will account for about 32,000 visitor-days annually, having a value of \$16,000.

DISCUSSION

In order to reduce siltation and to retain as high water quality as possible in the reservoir, project plans should include measures to prevent or materially reduce the silt load that might otherwise enter the impoundment from the surrounding project area.

The wildlife pool should be provided with drawdown facilities so that, as necessary for proper management and control of the fish and wildlife resources, the water-level can be manipulated.

The land-taking line around fish and wildlife pool should be "filled in" or "squared off" as much as possible so as to reduce the amount of irregular boundary line, thereby simplifying administration and management of the fish and wildlife resources by the New York Division of Fish and Wildlife.

The Division of Fish and Wildlife and this Bureau should be consulted during detailed project planning so that when the reservoir is constructed it will afford the best possible combination of fish and waterfowl habitats.

The project could provide additional nature-visitor days, if a hard surface road is constructed on top of the Harlow Road dike, and 2 vehicle-parking nodes are attached thereto. The road and nodes should be included in the project plans. Each node should be capable of accommodating five vehicles. These facilities will increase the nature-visitor use by an estimated 9,800 visitor-days annually having a value of \$4,900.

Hunting should be permitted on all Federally-acquired lands except in areas where the non-hunting visiting public might be endangered.

RECOMMENDATIONS

It is recommended:

1. That project plans include measures to prevent or materially reduce the possibility of silt entering Sandridge Reservoir from the surrounding project area.
2. That the wildlife pool be provided with drawdown facilities so that pool levels can be manipulated as required for proper fish and wildlife management.
3. That land-taking around the fish and wildlife pool be planned so as to result in a boundary having as few angles as possible.
4. That the New York Division of Fish and Wildlife and the Bureau of Sport Fisheries and Wildlife be consulted during detailed project planning concerning reservoir construction so that the completed impoundment will provide the best possible fish and waterfowl habitats.
5. That the Harlow Road dike be topped with a hard surface road, and two five-vehicle parking nodes be constructed adjacent to the road for accommodating additional nature visitors amounting to an estimated 9,800 visitor-days annually.
6. That hunting be permitted on all Federally-acquired lands except in areas where the non-hunting visiting public might be endangered.

Please advise us of any changes in project plans so that we can prepare a new report if necessary.

Sincerely yours,



Acting Regional Director



STATE OF NEW YORK
 CONSERVATION DEPARTMENT *Division of Fish and Game*

W. G. Bentley

STUART KILBORNE
 Commissioner
 JASON LAWRENCE
 Deputy Commissioner
 EIGHTON A. HOPE
 Deputy Commissioner
 ROBERT E. YOUNG
 Deputy Commissioner
 IRWIN H. KING
 Secretary

ALBANY, NEW YORK 12221
 Great Basin Studies
 Reg. Supt. _____
 Asst. Reg. Supt. _____
 Corps _____
 Special Studies (3) _____
 March 25, 1970 _____
 Admin. Asst. _____
 Clerk- Steno (1) _____
 Files _____

A. G. Hall
 Director
 (518) 457-5500
 D. H. Wallace
 Deputy Director
 of Fish and Game
 for Marine Region
 (518) 365-5400
 W. G. Bentley
 Assistant Director
 for Fish and Game
 (518) 457-5500
 W. J. Goodman
 Assistant Director
 for Law Enforcement
 and Field Services
 (518) 457-5500

Mr. Richard E. Griffith
 U.S. Department of the Interior
 Fish and Wildlife Service
 Bureau of Sport Fisheries and Wildlife
 U.S. Post Office and Courthouse
 Boston, Massachusetts 02109

Re: Review Draft of report on
 fish and wildlife resources
 in relation to planned con-
 struction at Sandridge Site,
 Ellicott Creek, Erie and
 Genesee Counties, New York

Sick
 Dear Mr. Griffith:

We have reviewed the draft of this
 report as requested in Mr. Schrader's letter of March 17,
 1970.

We concur with the report, in general,
 but would like to make the following comments or suggestions:

1. On page 1 the length of the reservoir
 is given as 3.5 miles; on page 4 it is
 shown as 4.5 miles.
2. On page 6, last sentence, we would like
 to suggest that the word "partially" be
 added before the word "compensate".

Sincerely,

RECEIVED
 MAR 31 1970
 R. B. S.

A. G. Hall
 A. G. Hall
 Director
 Division of Fish and Wildlife

STATE
UNIVERSITY
CONSTRUCTION FUND



January 5, 1970

District Engineer
United States Army
Corps of Engineers
Buffalo District
1776 Niagara Street
Buffalo, New York 14207

Dear Sir:

Representatives from your office and the Division of Water Resources, New York State Conservation Department, have discussed with us the improvements being considered for flood control and allied purposes on Ellicott Creek. Of the alternatives being considered, the plan which would provide an upstream multiple-purpose reservoir in combination with minor downstream channel improvement would be of greatest value to the State University Construction Fund.

With the improvements described above, significant savings are possible during and after construction of the proposed new State University campus in Amherst. Specific areas where these savings would be realized include: reduced quantities of earth fill required for flood protection; reduced operational costs for treatment of make-up water for our proposed 60-acre lake, reduced costs for relocating Bizer Creek (a tributary of Ellicott Creek that now flows through the campus site), and reduced construction costs by extension of the construction season through improved drainage.

With the considered reservoir and channel improvement plan, we anticipate that present value of these savings could be approximately \$2 million.

We look forward to the implementation of your project and to working with you in the future.

Very truly yours,

Handwritten signature of Anthony G. Adinolfi.
Anthony G. Adinolfi
General Manager

cc: F. W. Montanari, Div. of Water Resources
Regional Basin Board, West Seneca



IN REPLY REFER TO:

UNITED STATES
DEPARTMENT OF THE INTERIOR
BUREAU OF OUTDOOR RECREATION
FEDERAL BUILDING
1421 CHERRY STREET
PHILADELPHIA, PENNSYLVANIA 19102

JUL 17 1970

Colonel Ray L. Hansen
District Engineer
Corps of Engineers
Buffalo District
1776 Niagara Street
Buffalo, New York 14207

Dear Colonel Hansen:

In accordance with Mr. Ralph H. Gallinger's letter of February 9, 1970, we have reviewed your draft survey report for flood control and allied purposes on Ellicott Creek, New York. We appreciate this opportunity to comment and regret the delay in replying. A heavy workload, accompanied by severe manpower and budgetary restrictions, have forced us to establish and operate on a priority basis. This, unfortunately, has resulted in some lag in meeting many of our responsibilities. Furthermore, it has limited our report reviews to an in-house function and to one of a cursory nature.

Within general authority contained in the Bureau's Organic Act of 1963 (77 Stat. 49) and the Federal Water Project Recreation Act (79 Stat. 213) and in accord with provisions of the National Environmental Policy Act of 1969 (83 Stat. 852), we offer the following comments.

It is noted that you have recommended the construction of the multiple-purpose Sandridge reservoir together with channel improvement in downstream reaches. The adoption of such a plan is subject to certain conditions of local cooperation including the implementation of an effective flood plain management scheme for the upstream area.

The total first costs of the structural program is estimated to be \$19,141,000 with the Federal share fixed at \$13,970,000. Significant benefits are anticipated through the satisfaction of a portion of the flood control, water-oriented outdoor recreation, and fish and wildlife resource needs depicted for the basin. Water quality and water supply benefits also are expected to be accrued by the project.

Average annual equivalent recreation benefits are computed to be \$922,000 and are solely attributed to planned facility developed and subsequent utilization thereof at the proposed Sandridge reservoir. Initial

visitation, 1980, is expected to be 996,900 with an ultimate of 1,308,000 being realized in 2010. Recreational opportunities to be provided in 1980 will include boating, swimming and picnicking. Camping will be added to the list of activities to be enjoyed in 2010. Initial and future separable recreation costs of providing such services have been set at \$2,560,000 and \$340,000, respectively.

Ellicott Creek is the largest tributary of Tonawanda Creek and drains an area of approximately 110 square miles in Erie, Genesee and Wyoming Counties. Land utilization along the 47 miles traversed by this meandering stream varies considerably. The type of development ranges from primarily industrial and commercial in the lower one mile reach to residential through Williamsville to agricultural in the upper section. With excellent access to the latter area via the New York Thruway, two major highways, numerous secondary roads, and commercially operated transportation services and due to its proximity to Buffalo, only 22 miles to the west, the pressures of urban sprawl are currently being felt.

Existing water resource projects in the study area include flood control works and a reservoir utilized for water supply on Elevenmile Creek. The flood protection program primarily involved channel alternations and clearing and snagging operations over some eight to nine miles of the main channel. It also included installation of a small gate controlled dam in the Williamsville area.

It is understood information developed in a 1967 comprehensive water resources planning study of the Erie-Niagara Basin by Harza Engineers under contract to the New York State Water Resources Commission and the Erie-Niagara Basin Regional Water Resources Planning and Development Board constituted the major data source for the present effort. In regard to recreation, it is found that, for the most part, material presented in the Ellicott Creek Suvey Report is identical to that which appeared in Harza's draft report "Appraisal of Water-Oriented Recreation Development," which this office had the opportunity to review. The findings reveal a need for water-oriented recreation day use facilities, much of which is required to meet the demands of the people residing in and around the Buffalo area. These results compare quite favorably with conclusions reached in the Genesee, Lake Erie and Lake Ontario Basin studies and are in basic accord with the current New York State Comprehensive Outdoor Recreation Plan.

The proposed multiple-purpose Sandridge project presents an opportunity to meet a portion of the region's water-oriented recreation needs. The earthen dam will be located on Ellicott Creek immediately east of the Village of Alden. Total project lands amount to some 3965 acres in area which include 1100 to be acquired for recreation purposes. At the beginning of summer, the conservation pool, elevation 855, will cover

2150 surface acres. This water area includes a 425 acre sub-impoundment to be managed as a fish and wildlife resource. Maximum drawdown over the recreation season in the main water body will be 5.0 feet once in 20 years. In most years, drawdown is not anticipated to exceed 2.5 feet. And from a recreation standpoint, it is crucial that the water levels of this shallow impoundment be maintained at or above the aforementioned limits.

Darien Lakes State Park, currently undeveloped, is located adjacent to the project lands and presents an opportunity to combine areas into one management unit. This represents a very definite asset and it is our understanding that this is the intent of the State of New York. In addition, this provides the latitude to increase the level of needs satisfaction, both quantitatively and qualitatively, through the development of a more varied recreation program. However, we do have some reservations regarding the design methodology, spacial standards and facility placement utilized and/or planned for the Sandridge portion. We consider this a minor issue which can be resolved at the design memorandum stage at which time involvement on the part of the State's parks and recreation personnel is recommended. Furthermore, amelioration of our concerns should not have a depreciating affect on the favorable benefit cost ratio.

It is also felt that an editorial change is in order regarding the recreation evaluation analysis. On page 19, paragraph 47 and on page C5, paragraph C16 it is cited that Bureau of Outdoor Recreation procedures were followed. Since no standard methodology is utilized or advocated by this Bureau, the reference should be made more specific.

The recommended minor channel improvements basically involves the enlargement of two $1\frac{1}{2}$ mile sections downstream of Sandridge reservoir. In addition to streambed widening, the proposed alternations include channel relocation and straightening, placement of additional culverts under Tonawanda Creek road, and modifications to four highway bridges and numerous storm drainage outlets. In toto, such works are bound to have a detrimental impact, both ecologically and aesthetically. Most of these losses will be incurred through the advocated changes of the main channel.

It should be noted that this Bureau is not opposed uncategorically to all local flood protection devices. However, it is our belief that any flood protection programs which allow for the planned or unplanned needless exploitation of flood plains can no longer be condoned and justifiably supported. This seems to be the case here as evidenced in your benefit/cost analysis. The continued, but accelerated, encroachment of development upon the flood plain similar in nature to that which has already occurred has been taken into account in the determination of the need for and much of the justification for the recommended protective devices. Under

existing conditions you have reported that residential property damages make up 94 percent of the total. Ample opportunities for such future development certainly must exist outside the flood plain.

Admittedly, several alternatives were explored and the need for structural improvements were based quite heavily on the apparent unwillingness of local town officials to accept your earlier flood plain information report as an answer to their flood problems. However, one possible alternative which seemingly has not been investigated is the provision of dry bed diversion channels which would only be inundated under flood conditions. Conceivably, the implementation of such a device could be incorporated into the development of a recreation and/or open space program. In this case, strong flood plain land use controls would be a necessity.

In summary, this Bureau is in basic agreement with your recommendation for the construction of the multiple purpose reservoir provided that the recreation area be combined with Darien Lakes State Park and managed by the State of New York as one unit. In addition, State parks and recreation personnel must be made an active party to the development of the recreation master plan at the design memorandum stage. This Bureau finds it cannot support the advocated minor channel improvements. It is suggested that that portion involving channel relocation, straightening and widening be deleted and/or other alternatives be more thoroughly explored. One such alternative which should be investigated, as aforementioned, would involve providing dry bed diversion channels inundated only under flood conditions in conjunction with appropriate land use controls.

Sincerely yours,

Rolland B. Handley
Regional Director

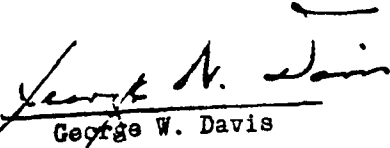
By: 
George W. Davis



UNITED STATES
DEPARTMENT OF THE INTERIOR
FISH AND WILDLIFE SERVICE
BUREAU OF SPORT, FISHERIES AND WILDLIFE
35 TEMPLE STREET
CONCORD, NEW HAMPSHIRE 03301

February 12, 1973

District Engineer
Buffalo District
U. S. Army Corps of Engineers
1776 Niagara Street
Buffalo, New York 14207

Dear Sir:

This letter is intended to aid in your planning for flood control and allied purposes on Ellicott Creek, Erie, Genesee and Wyoming Counties, New York. It is based on previous information in our files and the information contained in your Phase I and Phase II Review Survey Reports for Flood Control and Allied Purposes on Ellicott Creek.

We understand that at this time you are considering four structural alternative proposals for flood control, with a fifth alternative, that of no action, still a possibility. These four proposals were chosen from a list of 30 alternatives examined originally, which fell into broad classifications of channel modification, diversion, reservoirs, levees, floodplain management, public acquisition or combinations of these classifications.

The four structural alternatives under consideration are:

(1) Major channel modification, consisting of about seven miles of channel enlargement and realignment in the town of Amherst, extending from the confluence of Tonawanda Creek with the existing Ellicott Creek diversion channel to the Sheridan Drive bridge. Channel bottom widths would be enlarged to between 80 to 110 feet, with the exception of two 800-foot long high velocity sections, which would have 60 and 40-foot bottom widths. The existing diversion channel would be widened to a maximum of 230 feet, about double its present width. One highway bridge and two foot bridges would be replaced, and three other highway bridges modified. Seven creekside parks, ranging in size from half an acre to seven acres would be developed in pockets of open space.

(2) A diversion channel approximately 3-1/2 miles long, also in Amherst, extending from just below Maple Road to a point 2,000 feet downstream of Sweet Home Road. It will have a bottom width of 90 feet and a depth of 10 feet. This proposal also includes about 8,000 feet and 5,000 feet of channel modifications between Sheridan Drive and Maple Road, and from 2,000 feet below Sweet Home Road to Niagara Falls Boulevard, respectively. The changes necessary to the existing diversion channel would be the same as described in (1) above. One bridge will be replaced, two bridges modified, and seven new bridges will be required under this proposal. A bikeway, nature trails, rest areas, picnic tables and general landscaping will be provided as recreational features.

(3) A dam and reservoir in the townships of Alden and Darien, at the Sandridge site. The earthfill dam will be 8,200 feet long with a maximum height of 65 feet, and a top width of 20 feet. The dam will impound the runoff from about 33 square miles, and features a conservation pool of 2,150 acres at elevation 855 1/. This includes a fish and wildlife subimpoundment of 425 acres, also at elevation 855. The main pool will have a maximum depth of 45 feet, while the fish and wildlife pool will have an average depth of two feet. This plan also entails some three miles of channel modifications, in two separate reaches each 1-1/2 miles long. One reach would extend from the confluence with the existing diversion channel to Sweet Home Road, with a new channel width of 90 feet. The other reach extends from 3,000 feet upstream of the Millersport bridge to Maple Road. This stretch requires a 120-foot bottom width. The existing diversion channel would also be widened to 200 feet. Modifications to four bridges would be required. Seven roadside parks identical to those in (1) above would be provided.

(4) A combination of the Bowmansville Reservoir and Pavement Reservoir in Bowmansville. The Bowmansville Reservoir would be formed by 25,000 feet of dikes between Genesee Street, Harris Hill Road, and Pleasant Drive, have a conservation pool of about 1,000 acres at elevation 720, with a maximum depth of 10 feet. The Pavement Reservoir will be just upstream of the Bowmansville site, and would be formed by a dam located 1,500 feet east of Pavement Road. At elevation 752 the reservoir would impound about 4,800 acre-feet of water, or about 310 surface acres. During the months of July, August, and September, water would be released from the Bowmansville Reservoir to augment low flows in Ellicott Creek. This water would be made up by inflow from Pavement Reservoir, thus assuring a constant water level in Bowmansville Reservoir, while the Pavement Reservoir would be drawn down completely by September of each year.

1/ All elevations are in feet above mean sea level.

The environmental considerations associated with each proposal are as follows:

- (1) Major channelization: From our viewpoint this alternative is not acceptable in that it will destroy what little fishing habitat is present in Ellicott Creek without providing any mitigation or possibility of enhancement. Widening of the channel will eliminate trees and other vegetation that tend to afford some shade to the stream, thereby raising the water temperature. The flat bottom channel will also have the same effect, by spreading the water over a greater area and decreasing its depth. No fish and wildlife benefits would be provided. Although the plan does provide for creekside parks, the attractiveness of the creek as a whole will be reduced when the meandering stream is replaced by a hydraulically efficient channel. Although it can be argued that at the present time Ellicott Creek has negligible fish and wildlife value due to pollution and low flows, the potential is there for future improvement.
- (2) Diversion channel: Our feelings on this plan are mixed. While it would be much less destructive than alternative (1), it would provide no fish and wildlife benefits. The area taken by the diversion channel represents a loss of wildlife habitat, as the land consists of old fields and some wooded areas. The fact that the channel bottom would be grass instead of concrete is a plus. We understand that the lower reach of the channel will contain a stretch of backwater, which conceivably could provide a small amount of fishing opportunity. Recreational features incorporated into the plan would provide some opportunity for nature study and bird watching. On the negative side, 13,000 feet of channelization would be required, with the concomitant destructive effects mentioned above.
- (3) Sandridge Reservoir: In terms of fish and wildlife benefits provided, this plan is clearly superior to the rest. We provided you with a Conservation and Development Report on April 27, 1970, in which we presented the fish and wildlife benefits and losses associated with the project. To summarize those figures, the project would provide a total of 81,800 man-days of reservoir and stream fishing, plus 1,000 man-days of waterfowl hunting. The project would also provide benefits for nature study and bird watching. However, the project would eliminate 2,150 acres of wildlife habitat, for a loss of 4,180 man-days of small and big game hunting. Another undesirable feature is the three miles of channelization required, for the reasons delineated under alternatives 1 and 2 above.

- (4) **Bowmansville and Pavement Reservoirs:** This plan would also provide some fish and wildlife benefits, though much less than the Sandridge Reservoir. Based on incomplete information, we would predict an annual benefit of 10,000 man-days of fishing at the Bowmansville Reservoir, plus 1,000 man-days of stream fishing. These are for comparison with Sandridge, and are subject to revision. At this time we foresee no wildlife hunting benefits. However, some nature study and bird watching benefits would be provided. This proposal would result in the loss of some 1,500 acres of wildlife habitat. This reservoir scheme does have an advantage in that no channelization would be necessary.

Based on our evaluation of the four structural alternatives, we could support the selection of the Sandridge Reservoir project. This project would provide the most fishery benefit in an area in need of additional fishing opportunity. The loss of wildlife habitat is just that, but with the few benefits and the fact that there is ample wildlife habitat in the area, we feel the loss is justified. The required channelization is regrettable, and we would state a general recommendation that it be kept to a bare minimum, and a V-bottom pilot channel be designed instead of a flat bottom, to concentrate water during low flow periods.

We could also support the Bowmansville-Pavement Reservoir, and to a somewhat lesser extent, the diversion channel proposal. We could not support major channelization.

The above recommendations are based on the philosophy that if structural solutions are the only alternatives to flood control, they might as well provide some fish and wildlife benefits. We are disturbed at hearing that the state university, Urban Development Corporation, and the domed stadium are all planning to encroach on the floodplain, with the expectation that federal tax dollars will be spent to protect their investment. We cannot endorse strongly enough your proposal to require floodplain management as one requirement of local cooperation.

We will be pleased to assist you further in the selection of a proposal. When a plan has been selected, we will prepare a C&D report with detailed recommendations for fish and wildlife mitigation and enhancement. Please keep us advised of the progress of your study.

This letter and the information it contains is for assistance in project planning only. It is not a report of the Fish and

Wildlife Service. It is not to be used in lieu of an approved report for inclusion in or with any report transmitted by your agency to higher authority for review or approval.

Sincerely yours,

Melvin R. Evans
Melvin R. Evans
Supervisor
Concord Area Office

CC: Regional Office,
Boston, Mass.

UNITED STATES ENVIRONMENTAL PROTECTION AGENCY

REGION II
26 FEDERAL PLAZA
NEW YORK, NEW YORK 10007

JUL 23 1973

Colonel Robert L. Moore
Department of the Army
Buffalo District, Corps of Engineers
1776 Niagara Street
Buffalo, New York 14217

Dear Colonel Moore:

This is in response to a request by your office for an assessment of potential water quality benefits from the proposals set forth in the Ellicott Creek Restudy. The Federal Water Pollution Control Act Amendments of 1972 requires, in part, that in the planning of any reservoir by a Federal Agency, inclusion of storage for regulation of streamflow be considered, except that such storage shall not be provided as a substitute for adequate treatment or other methods of controlling waste at the source. Responsibility was assigned by the Act to the Environmental Protection Agency for determining the need, value and impact of storage for water quality control.

Portions of EPA's policy are significant to our determinations and have been stated for your convenience. As a basic element of the policy, EPA defines adequate treatment as "the best available pollution control technology economically achievable including advanced waste treatment techniques, land disposal, land management practices, process and procedure innovations, changes in operating methods and other alternatives." In addition EPA's policy is specific in that it states, "when EPA recommends provision of storage for water quality control, all the environmental consequences of such provision should be considered so that EPA will be in a position to comment favorably on the water quality aspect of the project when the environmental impact statement on the project is circulated for comment."

Considering our late involvement in the Ellicott Creek Restudy, this agency has within its manpower restraints made every effort to thoroughly investigate the four selected alternatives which will form a part of the Corps final recommended plan. By utilizing all available information from Federal and State agencies as well as the local regional planning board we feel confident that both the environmental impact and the water quality potential of these proposals have been thoroughly investigated.

In the Ellicott Creek project area, the four alternatives considered were:

- (1) Major Channel Improvement;
- (2) Diversion Channel;
- (3) Bowmansville Lake and Pavement Road Dam; and
- (4) Sandridge Lake and Minor Channel Improvement.

Particular attention was given to the Sandridge reservoir project since it was previously considered to be the only proposal which could satisfy the water quality needs of the basin.

For the purpose of discussing water quality needs, we have divided the basin into two parts:

a. Upstream Reach - Head waters to Amherst SD #1 treatment plant (free flowing portion).

b. Downstream Reach - Amherst SD #1 treatment plant to confluence of Ellicott Creek with Tonawanda Creek (primarily Niagara Backwater Area to just above Sweet Home Road).

In the upstream reach there are a dozen municipalities and industries discharging to the stream. While their discharge flows are small, their impact may be substantial due to Ellicott Creek's naturally intermittent conditions. However, in 1970, of 345 samples collected in the upstream reach during the critical period, only two of eleven stations had any values below 5.2 mg/l of dissolved oxygen. Present water quality standards require 4 mg/l of dissolved oxygen. At these two stations, all values were above 2.7 mg/l with the average values above 5.9 mg/l and the extreme minimum occurring when the stream flow was less than 4.0 cfs.

Based on our analysis we have concluded that application of adequate treatment as called for by EPA's policy, would bring the upstream reach into satisfactory compliance with stream standards.

Turning next to the downstream reach, frequent violations of the minimum dissolved oxygen criteria occur during the critical period. The oxygen sag curve for this reach demonstrates the extreme affect of the Amherst SD #1 sewage treatment plant. Quite often during the summer months, discharges from this plant comprise the largest portion of the flow in Ellicott Creek. Close examination of the 1970 data collected for this ten mile reach shows that the oxygen sag bottoms out about 5 miles upstream of the confluence with Tonawanda Creek. However, Ellicott Creek has already substantially recovered before reaching the confluence and has an average dissolved oxygen content of 6.6 mg/l at that point.

We recognize the complexity of the problem in this lower reach since there is an industrial discharge as well as stormwater discharges to the creek complicated by the backwater effect of the Niagara River. However, there is little doubt that the major cause of the stream's present condition is the discharge from the overloaded SD #1 sewage treatment plant. Therefore, provision of adequate treatment should remedy the major problems in this reach, negating the need for flow augmentation.

The environmental impact of each proposal was considered and is briefly summarized below:

(1) Bowmansville Lake and Pavement Road Dam - Substantial socio-economic impact caused by the two impoundments and the attendant effects of inundation.

(2) Sandridge Lake and Minor Channel Improvement - In order to provide adequate flood protection, the reservoir project also requires downstream channelization which in itself has a significant environmental impact. This alternative has two significant drawbacks:

(a) Regarding flood control, it proposes two separate projects to provide adequate downstream flood protection. This same protection is provided by the less costly Diversion Channel alternative.

(b) Concerning water quality, it would mean enlargement of the stream's cross-sectional area, further reducing the already low velocities in the backwater area.

The reservoir itself would have a substantial socio-economic impact accompanied by a lesser, but still noteworthy impact in the area of wildlife, geology, natural resources, and esthetics.

(3) Major Channel Improvement - Esthetically objectionable as well as ecologically damaging.

(4) Diversion Channel - Considered to have the least environmental impact of all the alternatives.

In summary, according to EPA Policy, there can be no water quality benefits given for any of the above proposals for any reach of Ellicott Creek after provision of adequate treatment has been provided for all discharges. It has therefore been decided that provision of water quality benefits should not be a factor in the project choice. Thus, to accomplish the purpose of flood control, I support the selection of the Diversion Channel alternative together with regulation of the land use and development of the flood plain as this approach appears to have the least adverse impact on the environment.

-4-

Your concern for the environment is sincerely appreciated.

Sincerely yours,

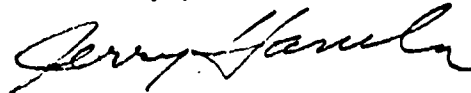

Gerald M. Hansler, P.E.
Regional Administrator

cc:

Mr. Russell Mt. Pleasant - New York State Department
of Environmental Conservation

Mr. John McMahon - New York State Department of
Environmental Conservation

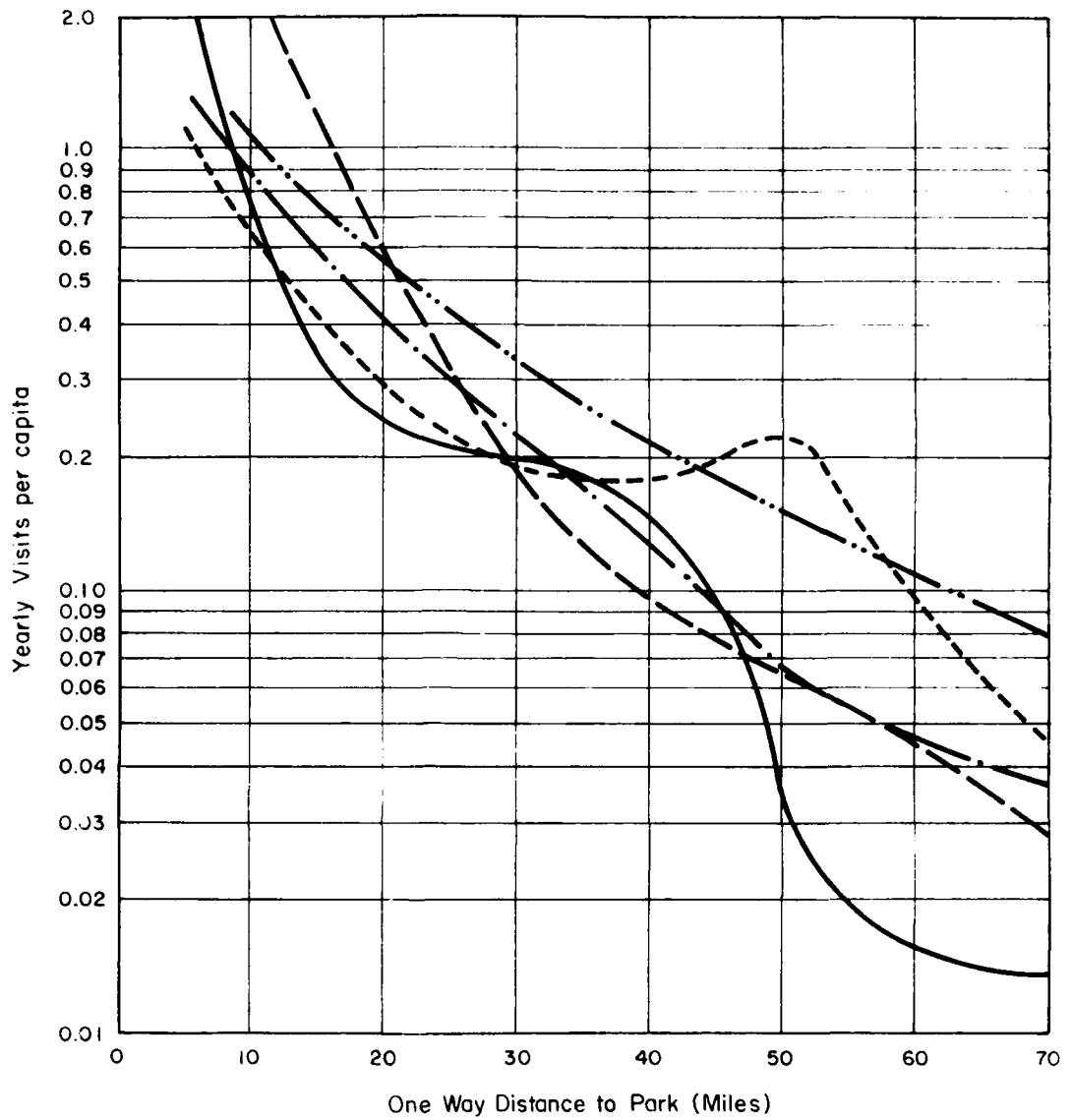

LEGEND :

- Cagles Mill and Mansfield Reservoirs
- Enders Reservoir
- Strunk Reservoir
- - - - - Hinckley Lake
- Whitney Point Reservoir

ELLICOTT CREEK NEW YORK
**WATER-ORIENTED RECREATION
 EXISTING SITE DAY-USE
 USER-ORIGIN CURVES**

U.S. ARMY ENGINEER DISTRICT, BUFFALO
 TO ACCOMPANY SURVEY REPORT
 DATED: 1970

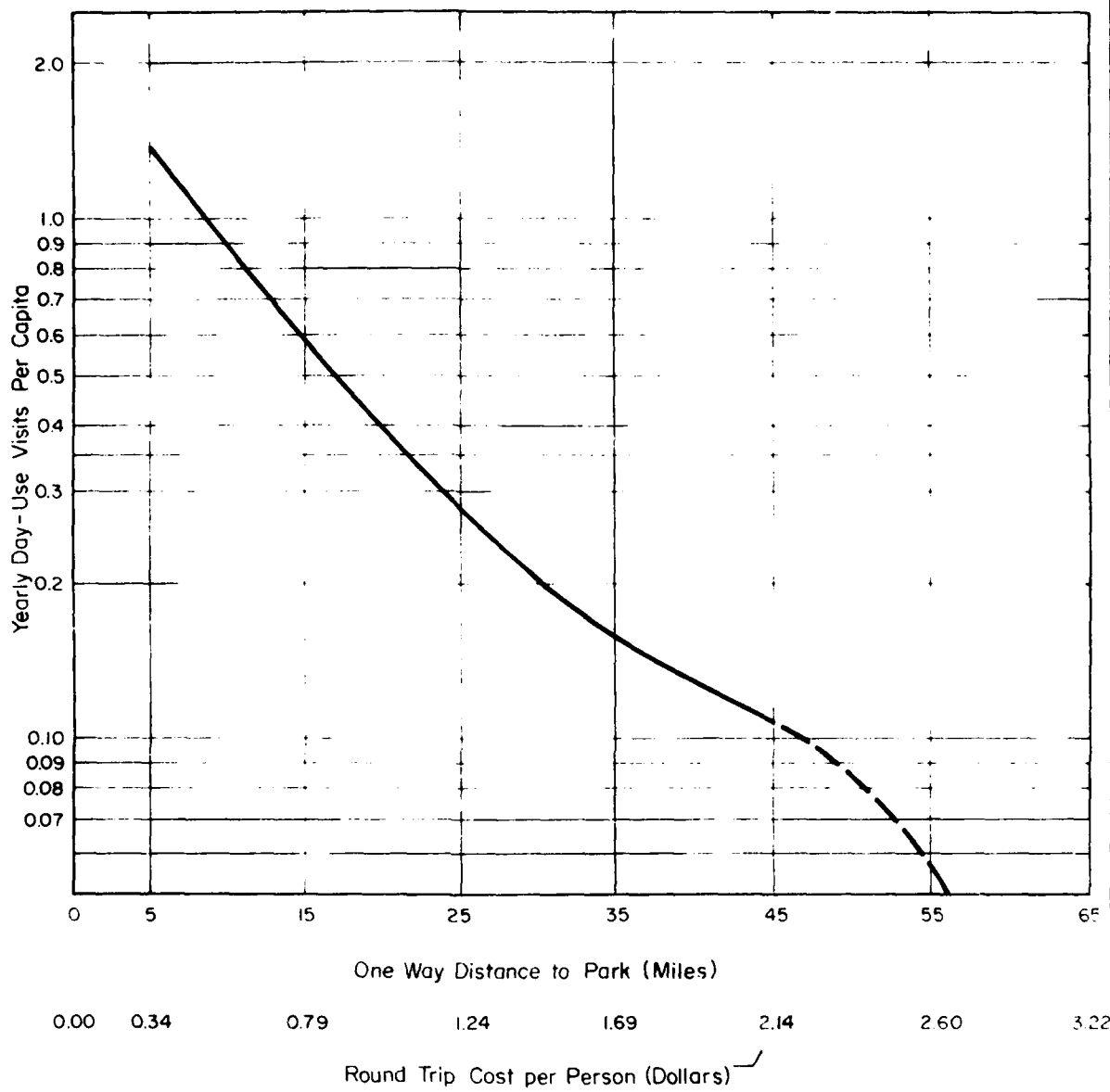

ELLICOTT CREEK NEW YORK
 DAY USE USER-ORIGIN CURVE
 FOR SANDRIDGE RESERVOIR

 U.S. ARMY ENGINEER DISTRICT, BUFFALO
 TO ACCOMPANY SURVEY REPORT
 DATED: 1970

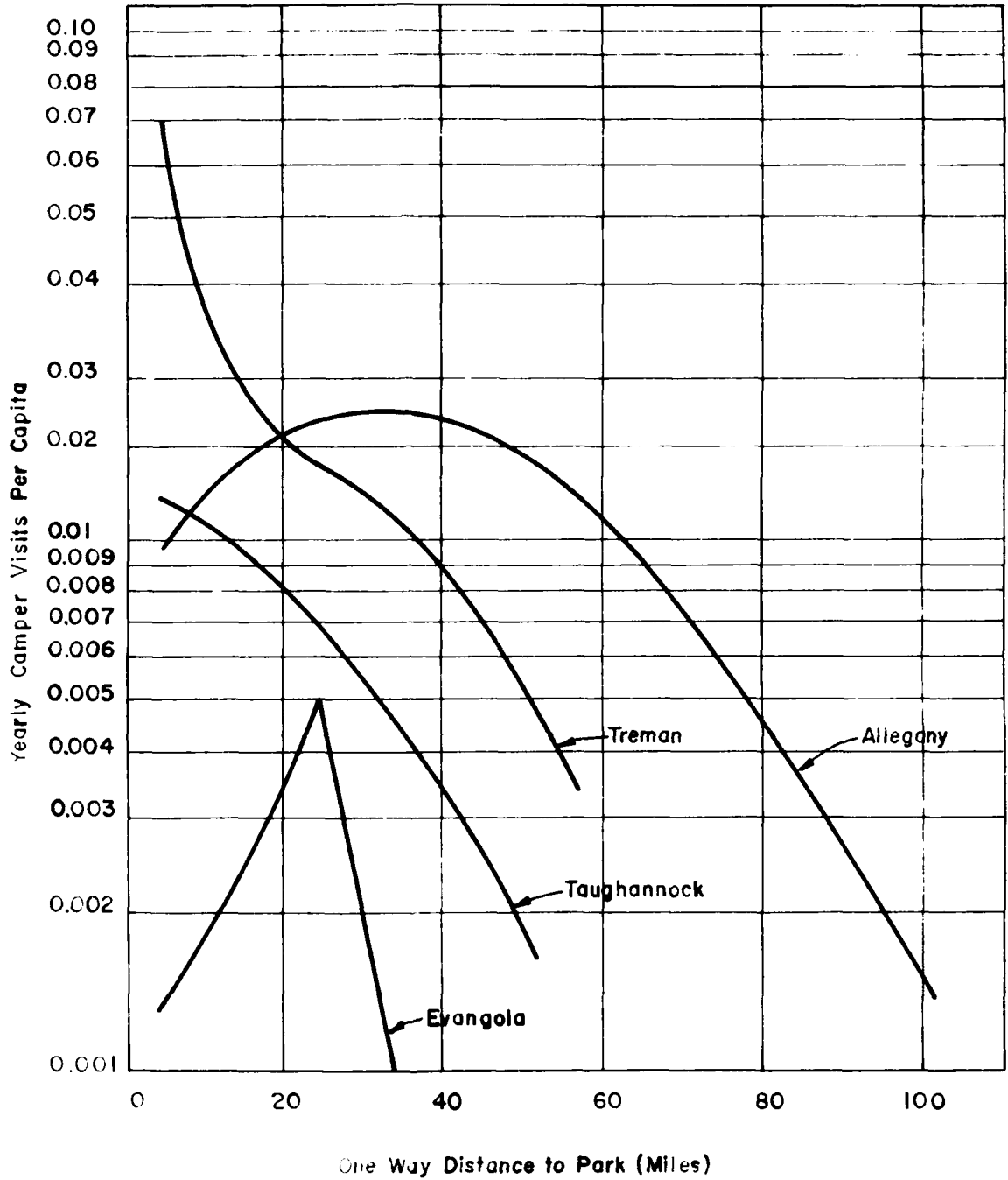

ELLICOTT CREEK NEW YORK
 WATER-ORIENTED RECREATION
EXISTING SITE CAMPER
USER-ORIGIN CURVES
 U.S. ARMY ENGINEER DISTRICT, BUFFALO
 TO ACCOMPANY SURVEY REPORT
 DATED: 1970

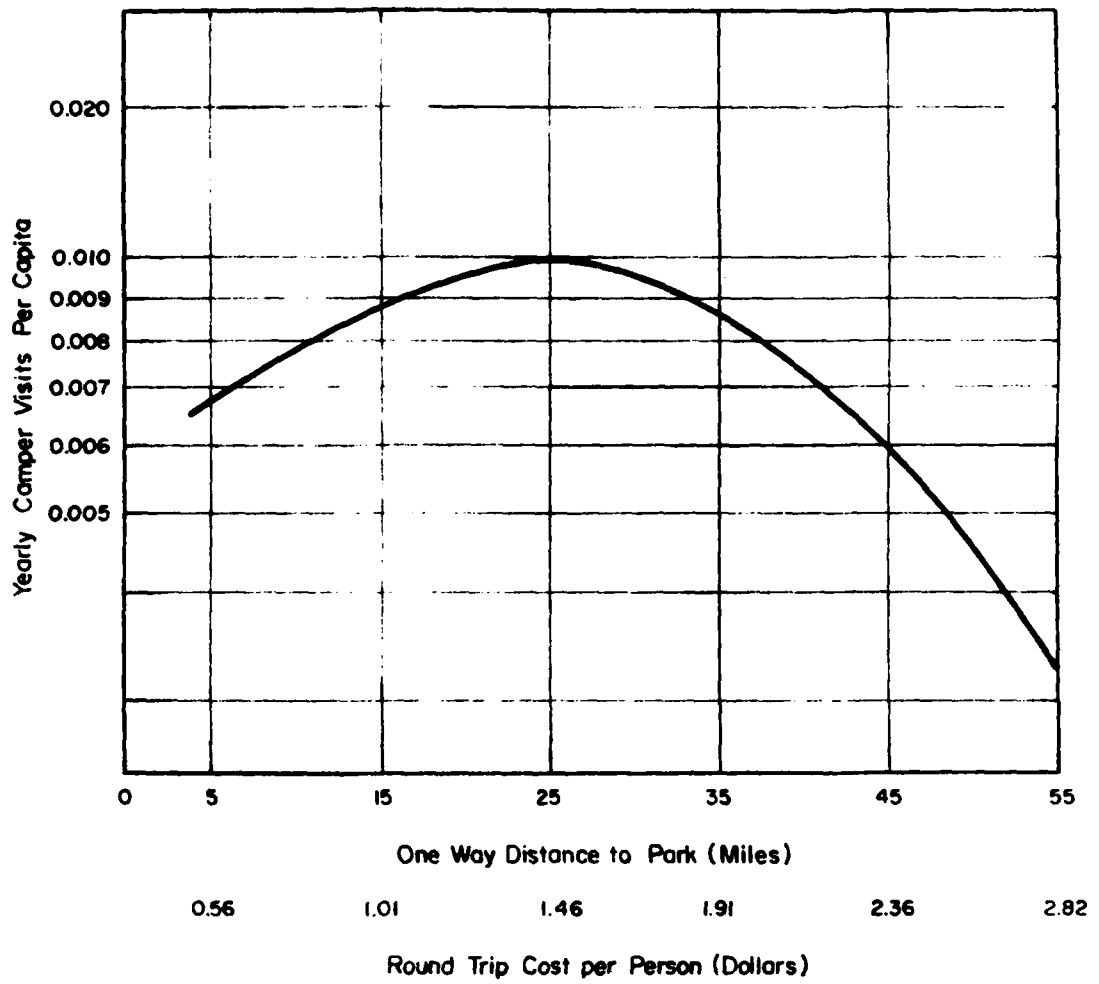

ELLICOTT CREEK NEW YORK
 CAMPER USER - ORIGIN CURVE
 FOR SANDRIDGE RESERVOIR
 U.S. ARMY ENGINEER DISTRICT, BUFFALO
 TO ACCOMPANY SURVEY REPORT
 DATED: 1970

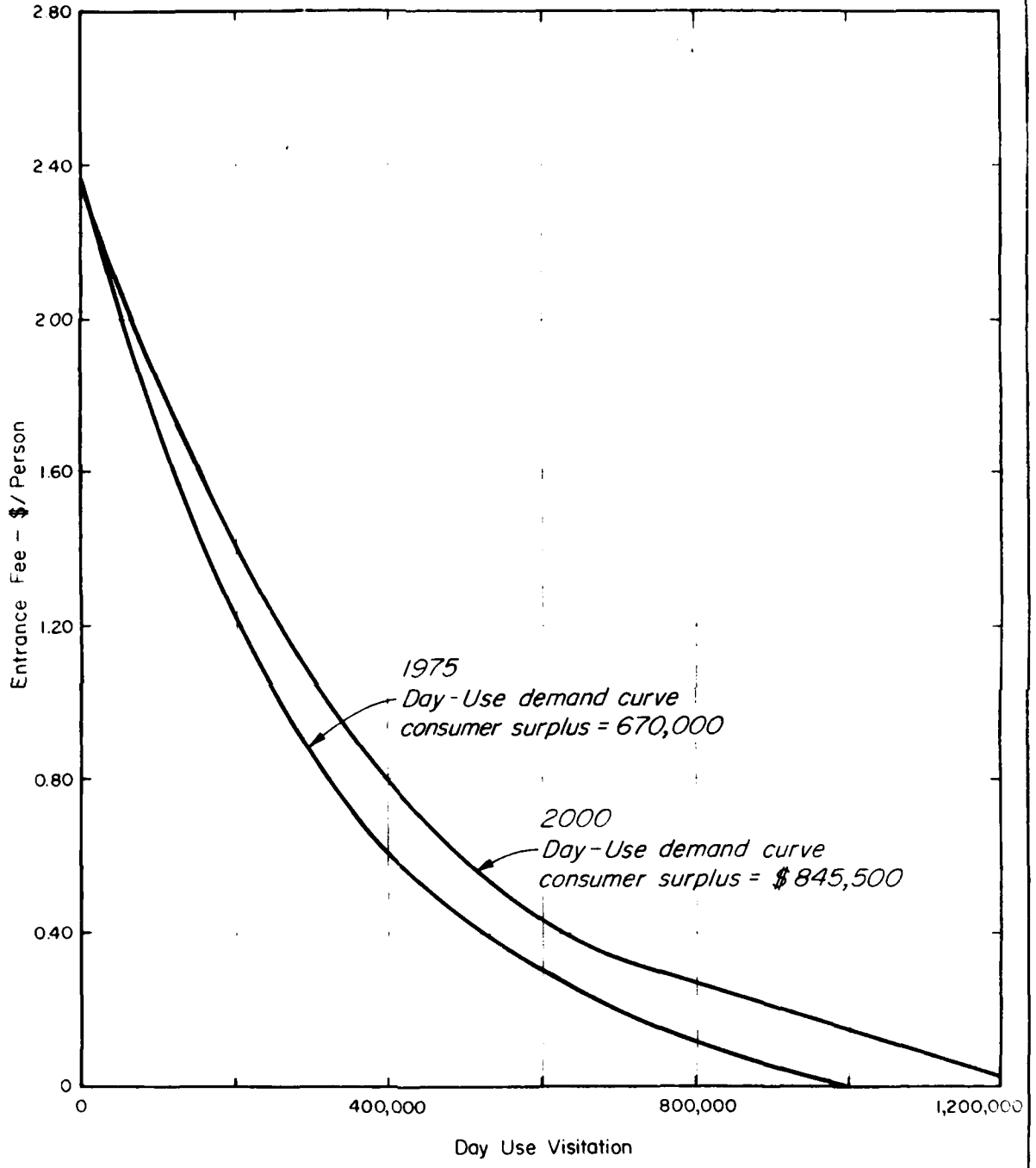

ELLCOTT CREEK NEW YORK
 1975 AND 2000 DAY - USE
 DEMAND CURVES
 AT THE SANDRIDGE RESERVOIR
 US ARMY ENGINEER DISTRICT, BUFFALO
 TO ACCOMPANY SURVEY REPORT
 DATED: 1970

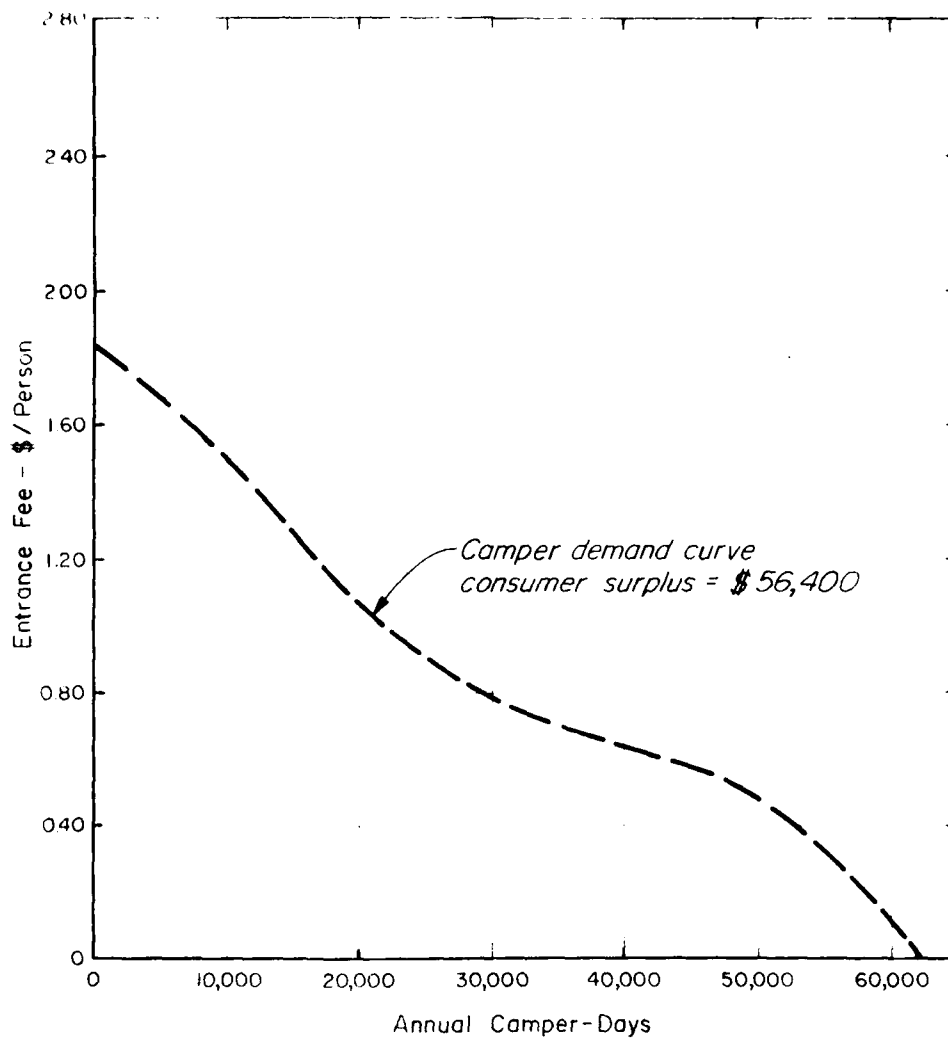

ELLICOTT CREEK NEW YORK
 2000 CAMPER
 DEMAND CURVE AT THE
 PROPOSED SANDRIDGE RESERVOIR
 U.S. ARMY ENGINEER DISTRICT, BUFFALO
 TO ACCOMPANY SURVEY REPORT
 DATED: 1970

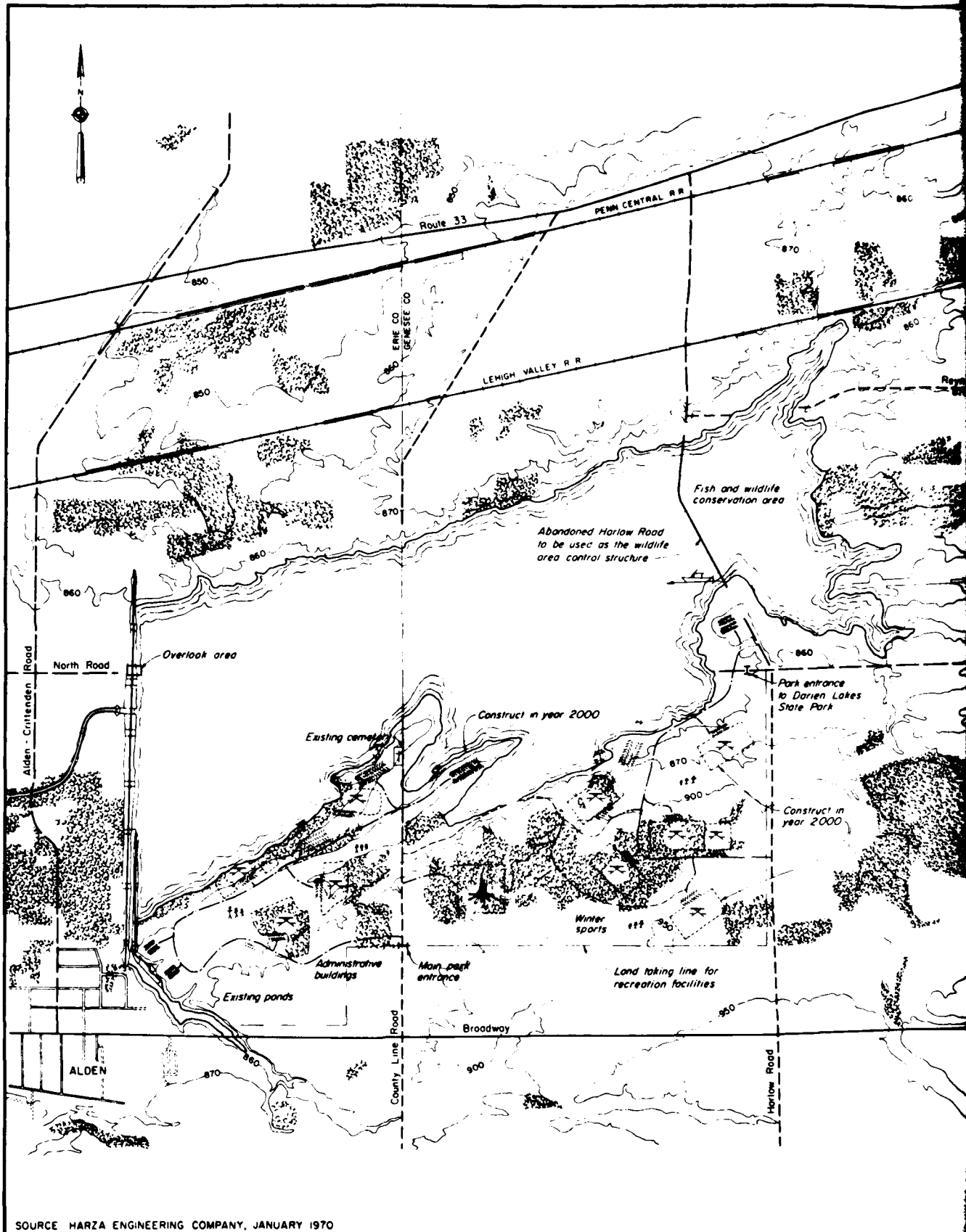

SOURCE HARZA ENGINEERING COMPANY, JANUARY 1970

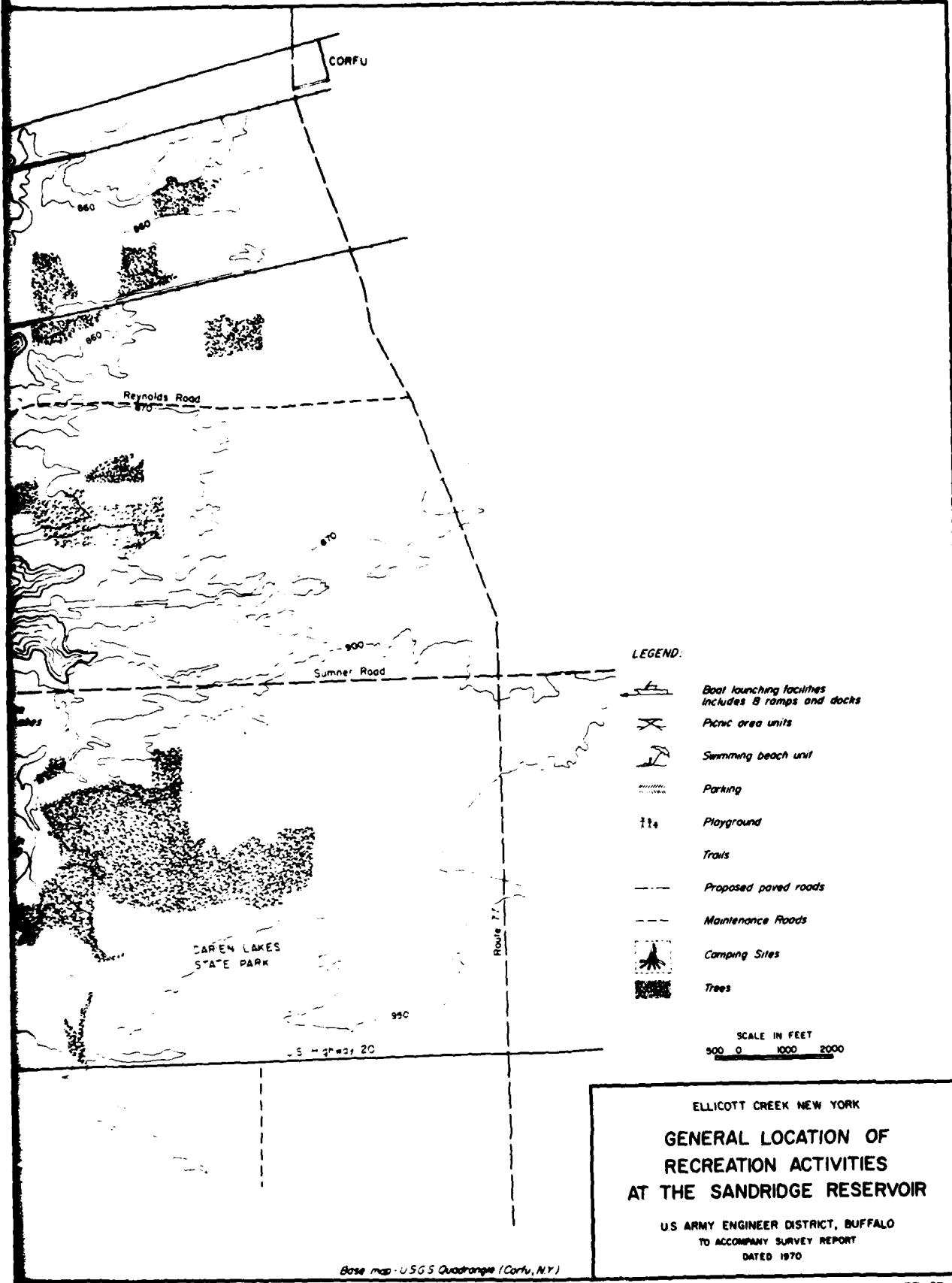

CORFU

860

870

880

Reynolds Road

870

870

900

Sumner Road

870











DAREN LAKES
STATE PARK

Route 7

930

U.S. Highway 20

LEGEND:

-  Boat launching facilities
Includes B ramps and docks
-  Picnic area units
-  Swimming beach unit
-  Parking
-  Playground
-  Trails
-  Proposed paved roads
-  Maintenance Roads
-  Camping Sites
-  Trees

SCALE IN FEET
500 0 1000 2000

ELLCOTT CREEK NEW YORK
**GENERAL LOCATION OF
 RECREATION ACTIVITIES
 AT THE SANDRIDGE RESERVOIR**
 U.S. ARMY ENGINEER DISTRICT, BUFFALO
 TO ACCOMPANY SURVEY REPORT
 DATED 1970

Base map: U.S.G.S. Quadrangle (Corfu, N.Y.)

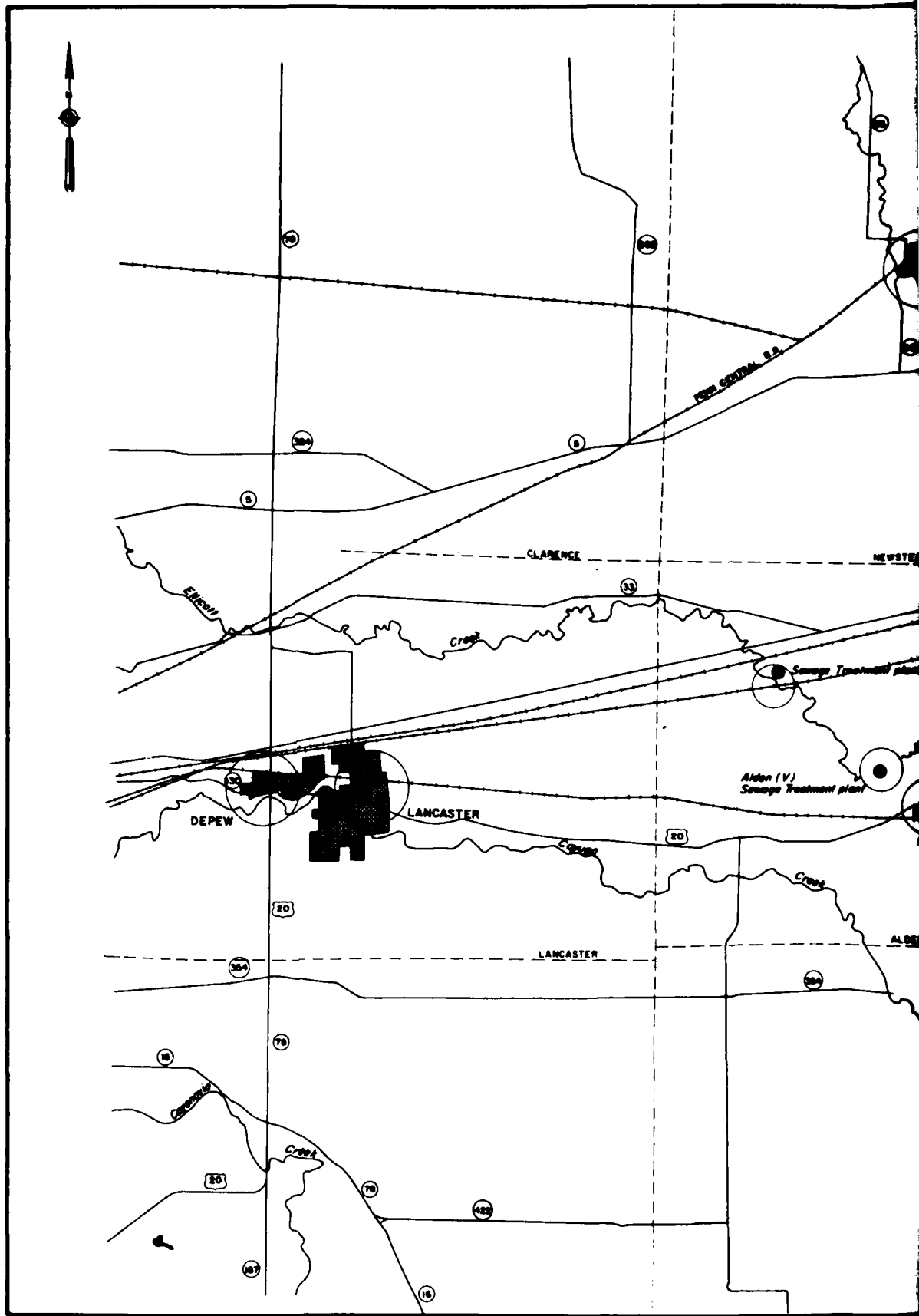

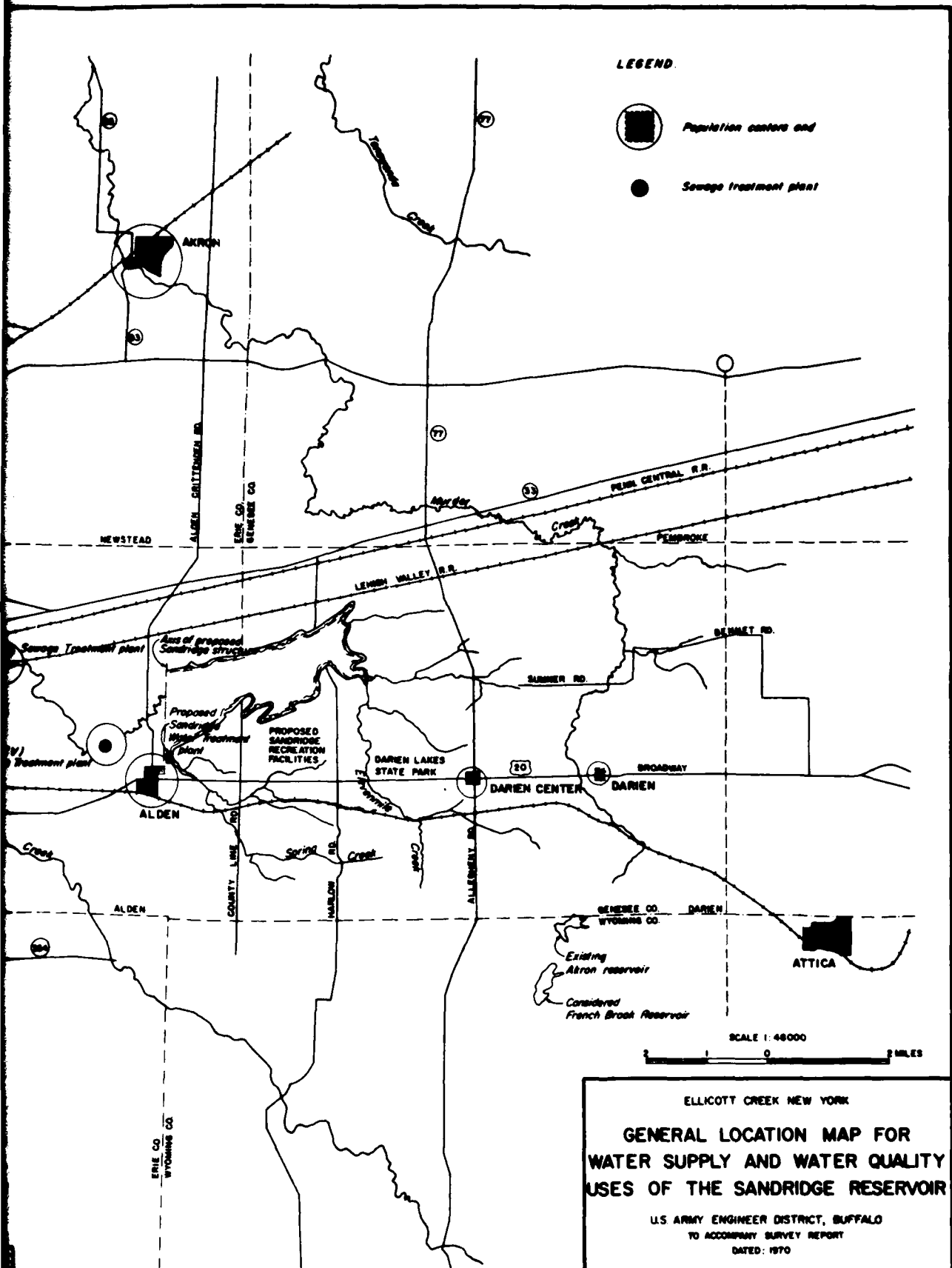

ELLICOTT CREEK NEW YORK

**GENERAL LOCATION MAP FOR
WATER SUPPLY AND WATER QUALITY
USES OF THE SANDRIDGE RESERVOIR**

U.S. ARMY ENGINEER DISTRICT, BUFFALO
TO ACCOMPANY SURVEY REPORT
DATED: 1970

Flood Control and Allied Purposes
Ellicott Creek, New York

Appendix D

Plans of Improvements And
Estimates of Cost

Table of Contents

	<u>Subject</u>	<u>Page</u>
1	General	D-1
2	Sandridge Reservoir and Minor Channel Improvements	D-1
	2.1 Sandridge Dam and Reservoir	D-1
	2.1.1 Location	D-1
	2.1.2 Description	D-1
	2.1.3 Selected Spillway and Stilling Basin	D-2
	2.1.4 Low Level Outlet Works	D-2
	2.1.5 Embankment	D-3
	2.1.6 Overlook Area	D-3
	2.1.7 Closure Dike	D-3
	2.1.8 Relocations	D-4
	2.1.9 Recreation Facilities	D-4
	2.1.10 Fish and Wildlife Facilities	D-5
	2.2 Minor Channel Improvement, Reaches 0-4	
	2.2.1 General	D-6
	2.2.2 Channel	D-6
	2.2.3 Diversion Channel	D-7
	2.2.4 Recreation Facilities	D-7
	2.3 Flood Reduction	D-7
	2.4 Estimate of Cost	D-7
	2.5 Annual Operation, Maintenance and Replacement	D-13
	2.6 Annual Costs	D-24
	2.7 Construction Schedule	D-24
	2.8 Compatibility of Multiple Purpose Use - Effects on Drawdown and Volume	D-24
	2.8.1 General	D-24
	2.8.2 Recreation	D-24
	2.8.3 Fish and Wildlife	D-27
	2.8.4 Low Flow Augmentation	D-27
	2.8.5 Water Supply	D-27
	2.8.6 Evaporation	D-29
	2.8.7 Sedimentation	D-30
	2.8.8 Reservoir Drawdown	D-30

Table of Contents (cont'd)

	<u>Subject</u>	<u>Page</u>
3	Diversion Channel	D-32
	3.1 General	D-32
	3.2 The Diversion Channel	D-32
	3.3 Channel Improvements	D-33
	3.4 Recreation Facilities	D-34
	3.5 Bridges	D-34
	3.6 Flood Reduction	D-34
	3.7 Estimate of Cost	D-35
	3.8 Annual Cost	D-35
	3.9 Construction Schedule	D-35
4	Major Channel Improvement, Reaches 0-4	D-42
	4.1 General	D-42
	4.2 Channel	D-42
	4.3 Diversion Channel	D-42
	4.4 Bridges	D-43
	4.5 Recreation Facilities	D-43
	4.6 Flood Reduction	D-43
	4.7 Estimate of Cost	D-44
	4.8 Annual Cost	D-44
	4.9 Construction Schedule	D-44
5	Bowmansville Lake - Pavement Road Dam	D-48 A
	5.1 General	D-48 A
	5.2 Bowmansville Lake	D-48 A
	5.2.1 Location	D-48 A
	5.2.2 Description	D-48 A
	5.2.3 Selected Spillway and Stilling Basin	D-48 A
	5.2.4 Low Level Outlet Works	D-50
	5.2.5 Embankment	D-50
	5.2.6 Recreation Facilities	D-50
	5.2.7 Miscellaneous	D-50
	5.2.8 Estimate of Cost	D-51
	5.3 Pavement Road Dam and Reservoir	D-51
	5.3.1 Location	D-51
	5.3.2 Description	D-51
	5.3.3 Selected Spillway	D-57
	5.3.4 Low-Level Outlet Works	D-58
	5.3.5 Miscellaneous	D-58
	5.3.6 Flood Reduction	D-58
	5.3.7 Estimate of Cost	D-59
	5.3.8 Annual Cost	D-59

TABLES

<u>Number</u>		<u>Page</u>
D1	Estimated first costs for the proposed Sandridge Reservoir	D-8
D2	Estimate of first costs for recreation facilities at the proposed Sandridge Reservoir	D-14
D3	Estimate of first cost for fish and wildlife conservation at the proposed Sandridge Reservoir	D-18
D4	Estimated first costs for minor channel improvements, lower Ellicott Creek	D-20
D5	Estimate of annual costs for the proposed Sandridge dam and reservoir, recreation facilities and fish and wildlife facilities	D-25
D5A	Minor Channel Improvements	D-25
D6	Summary of annual costs, Sandridge Reservoir and Minor Channel Improvements	D-26
D7	Projected water supply demand on Sandridge Reservoir	D-28
D8	Monthly water supply demands on Sandridge Reservoir in the year 2020	D-29
D9	Changes in reservoir draft, in month-second-feet, for conditions in the year 2020	D-31
D10	Estimated first cost for Diversion Channel Scheme	D-36
D11	Estimate of annual costs for the Diversion Channel Scheme	D-41

TABLES (cont'd)

<u>Number</u>		<u>Page</u>
D12	Estimated first costs for major channel improvement, lower Ellicott Creek	D-45
D12A	Summary of first cost; major channel improvement	D-48
D13	Major Channel Improvement	D-48
15.1	Bowmansville Lake (Ungated)	D-52
15.2	Pavement Road Reservoir	D-60
15.3	Bowmansville Lake - Pavement Road Reservoir	D-62
15.4	Annual Costs for Bowmansville - Pavement Scheme	D-63

PLATES

<u>Number</u>	
D1	General Location of Public Utilities at the Sandridge Reservoir
D2	General Location of Recreation Activities at the Sandridge Reservoir
D3	Major Channel Improvements
D4	Diversion Channel
D5	Minor Channel Improvements
D6	Flooding Reduction With Sandridge Scheme
D6A	Ellicott Creek Floodplain Intermediate Regional Flood
D7	Construction Schedule Sandridge Scheme
D8	Sandridge Reservoir Mass Curve
D9	Typical Bridge Over Diversion Channel
D10	Flooding Reduction With Diversion Scheme
D10A	Ellicott Creek Floodplain Intermediate Regional Flood
D11	Construction Schedule Diversion Channel
D12	Flooding Reduction With Channelization Scheme
D12A	Ellicott Creek Floodplain Intermediate Regional Flood

PLATES (cont'd)

Number

D13	Construction Schedule - Major Channel Improvements
D14	Bowmansville Spillway Plan and Section
D15	Pavement Road Spillway Plan and Section
D16	Bowmansville Reservoir Typical Dike Section
D17	Construction Schedule - Bowmansville Scheme
D18	Construction Schedule - Pavement Road Scheme
D19	Flooding Reduction with Bowmansville and Pavement Road Scheme
D19A	Ellicott Creek Floodplain Intermediate Regional Flood
D20	Proposed Bridges for Diversion Channel Plan

PHOTOS

Sandridge Lake

Terrain for Diversion Channel
South of Ellicott Creek

Terrain for Diversion Channel
North of Ellicott Creek

Ellicott Creek Diversion Channel

Channelization Park

Bowmansville Lake

APPENDIX D

PLANS OF IMPROVEMENT AND
ESTIMATES OF COST1. GENERAL

1.1 The Review Survey Report Phase I, the Public Workshop and the Public Meeting held to discuss the findings in the Phase I Report, clearly indicated four schemes to have the greatest potential for satisfying the criteria for resolving the Ellicott Creek problem. These schemes are given brief titles as follows:

- (i) Sandridge Reservoir & Minor Channel Improvements
- (ii) Diversion Channel
- (iii) Major Channel Improvements
- (iv) Bowmansville Lake - Pavement Road Dam

1.2 This section records a study of the details of each of these schemes and presents an estimate of cost for each one.

2. SANDRIDGE RESERVOIR AND MINOR CHANNEL IMPROVEMENTS2.1 Sandridge Dam & Reservoir2.1.1 Location

2.1.1.1 The proposed Sandridge dam is located on Ellicott Creek about 1500 feet east of the Alden-Crittenden Road in the town of Alden, Erie County. The village of Alden is adjacent the left abutment. The reservoir pool is 3.6 miles long and extends into Genesee County. The dam and reservoir area are shown on Plate 7.

2.1.2 Description

2.1.2.1 The proposed Sandridge Reservoir would be multi-purpose and is intended to provide flood control, recreation, fish and wildlife conservation, low flow augmentation and water supply. The summer conservation pool would have a surface area of 1725 acres; a further 425 acres upstream of Harlow Road are to be operated for fish and wildlife conser-



SANDRIDGE LAKE



vation. The drainage area of 33.1 square miles at the dam site includes the Spring Creek watershed. A channel connecting Spring Creek with the main reservoir would be excavated a short distance upstream of the dam.

2.1.2.2 Three existing roadways would be abandoned within the reservoir's boundary and Harlow Road would require raising and conversion into a control structure between the fish and wildlife pool and the main conservation pool. The normal summer conservation pool of the proposed reservoir would cause a backwater in Spring Creek south of the Broadway (US Route 20) crossing. The culvert under Route 20 would have to be reconstructed and the roadway raised to accommodate the higher water levels within the reservoir. The more important project features are discussed in the following paragraphs. Plate 8 provides details of many of these features.

2.1.2.3 The Alden Union cemetery on the south side and adjacent to the proposed reservoir will need to be relocated. Additionally there are unique fossil beds by the South abutment. At the detailed design stage it may be found necessary to realign this abutment.

2.1.3 Selected Spillway and Stilling Basin

2.1.3.1 The selected spillway would be an uncontrolled side-channel spillway, located at the south end of the dam. The length of spillway crest would be 400 feet, discharging into a chute 100 feet wide. Section C-C, Plate 8, illustrates the double spilling design feature of the spillway. The double-spill is used to dissipate the energy in decrements rather than in a single fall.

2.1.4 Low Level Outlet Works

2.1.4.1 The low level outlet works would consist of three 5'-8" diameter conduits through the earth dam. Each conduit would be provided with two pneumatic cylinder-operated gate valves, one for normal operation, the other for emergency use. An air vent would be provided to the roof of each conduit to reduce the possibility of cavitation damage during discharge at partial valve openings. Normal seepage would be handled by a submerged sump pump located in the central valve chamber. Dewatering of a flooded gallery could be handled by the same pump or pumps.

2.1.5 Embankment

2.1.5.1 The earth fill embankment with an impervious core would be approximately 8200 feet long. The upstream face would be partially riprapped with a side slope of 1 on 3; the downstream face would be grass covered with a side slope of 1 on 2.5. Seepage control would be provided by a slurry trench in the higher head sections of the embankment and by an impervious blanket in the lower head sections, or by some other, more efficient method which may be devised at the detailed design stage.

2.1.5.2 There are some unique fossil beds (Michelenoceras aldenense) adjacent the left abatement as the dam is presently aligned. At the detail design stage some realignment of the abatement may be found necessary.

2.1.6 Overlook Area

2.1.6.1 An overlook area would be constructed to provide a clear view of the proposed dam and reservoir. This overlook area would be located on top of the dam, near the termination of the existing North Road. A parking area, comfort stations, and permanent walkways would be provided in addition to the overlook facilities. The overlook area would be enclosed with a guard rail to protect the visitors as they view the project.

2.1.7 Closure Dike

2.1.7.1 A closure dike would be necessary at the northeast corner of the proposed Sandridge reservoir boundary. Field surveys have determined that a saddle exists at approximately 1600 feet south of the Penn Central Railroad tracks and 4200 feet west of Alleghany Road. The minimum saddle elevation is 854.4 feet. It would be necessary to construct the closure dike to the top of the dam elevation of 867.5. Assuming some stripping of the overburden is required, the closure dike would be approximately 18 feet high. This earthfill structure would be constructed from locally available material, and it would have grassed side slopes of 1 on 4. The length of the proposed closure dike would be approximately 700 feet, and its base would be about 130 feet wide.

2.1.8 Relocations

2.1.8.1 The proposed reservoir would inundate land areas which presently contain approximately three miles of a high pressure petroleum products pipeline, 11.4 miles of power and telephone lines, and six producing gas wells. The petroleum pipeline would be relocated around the left abutment of the proposed dam from County Line Road west to the Alden-Crittenden Road. Existing power and telephone lines would be abandoned, and the poles would be removed. The producing gas wells are of low yield and therefore would be purchased and capped. Most of the roadways within the proposed reservoir boundary would be abandoned. The local region near the proposed Sandridge site is considered to have sufficient alternate roadways so that only minimal inconvenience to local residents would occur. Relocation of about 67 houses and related buildings, presently located in the reservoir site, would be required. About 15 other residences would be relocated to provide the land for recreational development. Plate D1 shows gas and power lines in the area.

2.1.8.2 U. S. Route 20, at the Spring Creek crossing, would be raised, larger culverts installed, and the abutting road graded. Alden Union Cemetery is located on the south side of the reservoir. It would not be inundated by normal reservoir operations, but its relocation is considered desirable and provision has been made for this in the estimate of cost. Flowage easements would be purchased in the downstream reaches. Some frequently flooded undeveloped land would be flooded for longer durations during normal reservoir operations for flood control.

2.1.9 Recreation Facilities

2.1.9.1 The recreation facilities at the proposed Sandridge Reservoir would be located south of the reservoir, West of Harlow Road. As shown on Plate D2, these facilities would adjoin the Darien Lakes State Park, which is presently being developed. The rolling hills, open spaces, and lack of developments at the reservoir site create an impression of spaciousness which would be enhanced by the expanse of water created by the reservoir. The planned recreation facilities would be compatible with these natural characteristics and would consider the topography of the site. Initial construction would take place on completion of construction of the dam.

2.1.9.2 Reservoir lands range in slope from about 1/2 to 5 percent, being somewhat steeper above elevation 850 feet. North of the reservoir, the land rises gently to the divide. Slopes on the south side are steeper but do not exceed 10 percent except in isolated areas.

2.1.9.3 The soil characteristics related to trafficability and surface drainage were used to locate the specific recreation facilities shown on Plate D2. Also considered were the existing ground cover, topography and elevation of the ground water table. Careful attention to these soil properties and physical characteristics would be necessary during the design phase.

2.1.9.4 Outdoor recreation facilities would be provided for swimming, picnicking, boating, camping and hiking. Additional service facilities would be provided to assure high quality recreational use. These service facilities include beach change shelters, comfort stations, parking lots, water supply and sewage collection and treatment. Major considerations given to the design of recreation facilities were described in Appendix C and are summarized below.

2.1.9.5 Beaches for swimming would be located so as to minimize effects of reservoir pool drawdown. The beaches would be prepared to minimize water turbidity. Picnic facilities would be located in wooded areas somewhat removed from other activities except for those tables placed to serve the swimming areas. Launching ramps, docks and service facilities would be provided for boating activities. Campgrounds would not be constructed until the year 2000. Sufficient land would be reserved for their development at that time. Water supply and waste collection and treatment systems would be provided to meet the projected needs of the Sandridge recreation facilities.

2.1.10 Fish and Wildlife Facilities

2.1.10.1 The reservoir area east of Harlow Road is approximately 425 acres. The conservation area would be operated to maintain a minimum pool elevation at 855. This will provide a significant shallow area for wildlife propagation and fish spawning.

2.1.10.2 The present elevation of Harlow Road at Ellicott Creek is 849.3. The existing road would be raised to elevation 858.7 with side slopes of 3 horizontal to 1 vertical. Both sides and the 26-foot wide crest would be riprapped. A series of seventy 30-inch diameter corrugated metal pipe culverts with invert elevation 855 would pass through the embankment. This design will prevent overtopping the embankment during flood events up to the 25 year recurrence interval. The culverts would be set at critical slope to prevent embankment erosion.

2.1.10.3 Six boat launching ramps and corresponding docks and parking areas would be required for fishing. These facilities were described in Appendix C.

2.2 MINOR CHANNEL IMPROVEMENT, REACHES 0-4

2.2.1 GENERAL

2.2.1.1 This channel improvement plan was designed to augment flood protection that would be provided by the proposed Sandridge Reservoir. With the reservoir alone, annual flood damages would be reduced by about 75 percent in the lower reaches in the town of Amherst. This area is expected to be intensely developed in the near future. Projections show that annual residual flood damages with the reservoir alone would exceed \$100,000 annually. An alternative, if the reservoir were constructed, would be to provide minor channel improvement in the areas subject to high residual damages. This plan would not be an acceptable alternative alone but only in combination with Sandridge Reservoir. Over 90 percent of annual flood damages would be eliminated with the combined plan. The channel improvement element is discussed in the following paragraphs and shown on Plate 6.

2.2.1.2 Many of the features of the minor channel improvement plan would be similar to the major channel improvement plan discussed in paragraphs 4.1 through 4.9. The diversion channel leading to Tonawanda Creek would be enlarged. Two sections of Ellicott Creek channel, each about 1½ miles long, would be enlarged. Nearly 50 discharge lines from local storm drainage would be modified by adding flap gates and new headwalls where necessary. Three highway bridges would require foundation protection. Major items are discussed below.

2.2.2 CHANNEL

2.2.2.1 The downstream improved channel section would extend from the confluence with the diversion channel to Sweet Home Road bridge. The channel bottom width would be 90 feet. The upstream section would extend from a point 3,000 feet upstream of the existing Millersport Highway bridge to Maple Road. It would have a 120-foot bottom width. A high velocity section would be constructed just upstream of Maple Road to reduce stream velocities to non-erosive levels.

2.2.3 DIVERSION CHANNEL

2.2.3.1 The improved diversion channel in Ellicott Creek Park would be a modified version of the plan described in paragraph 4.3. The bottom width would be 200 feet and two 106" x 166" Lo-Hed concrete pipes would be required under Tonawanda Creek Road, in addition to the existing culvert, to pass the design flood.

2.2.4 RECREATION FACILITIES

2.2.4.1 The recreation facilities in this scheme are the same as those for the major channel improvements, described in paragraph 4.5. The exact locations of these areas are shown on Plate D5.

2.3 FLOOD REDUCTION

2.3.1 Plates D6 and D6A show the extent of the flooded area without this structural measure, and the reduction in flooded area caused by this plan.

2.3.2 A study of the design water surface on Plate 6 for this proposal indicates that a small degree of overbank flow occurs just upstream of Sweet Home Road bridge, and also just downstream of Millersport Highway bridge. In each case the degree of overtopping is of such minor significance that it can be rectified in the detail design stage. Rectification at the Sweet Home Road locality will diminish stage elevations at Millersport. In addition, the elevation of North Forest Road at the Millersport Road end of the creek is above zero-damage elevation, elevation 575.5, providing a barrier to floodwaters.

2.3.3 The structural measure, as designed at this stage, may therefore be considered to eliminate flooding from Maple Road bridge downstream, resulting from Intermediate Regional Flood conditions.

2.4 ESTIMATE OF COST

2.4.1 A detailed estimate of first costs for the proposed dam and reservoir is shown in Table D1. The estimate is based on current costs of similar construction projects.

TABLE D1 - Estimated first costs for the proposed Sandridge Reservoir

Item	Quantity	Unit	Unit Cost	Amount
LAND AND DAMAGES				
Lands, Fee Title (3965 acres)			LS	\$ 1,403,000
Farms & Residences (67)			LS	1,127,000
Flowage Easements			LS	345,000
Acquisition Costs			LS	333,500
Contingencies			LS	379,500
Total Land and Damages				\$ 3,588,000
RELOCATIONS				
Petroleum Pipeline	1,600	FT	196	\$ 313,600
Utility Lines	11.4	MI	1930	22,000
Route 20 at Spring Creek			LS	354,600
Gas Wells (6)			LS	350,000
Alden Union Cemetary			LS	670,000
Dam South Abutment (fossil beds)			LS	500,000
Miscellaneous Items			LS	\$ 52,000
Contingencies			LS	425,800
Total Relocations				\$ 2,688,000
RESERVOIR CLEARING				
	200	AC	500	\$ 100,000
Miscellaneous Items				
Contingencies			LS	\$ 5,000
Total Reservoir Clearing			LS	21,000
				\$ 126,000

TABLE D1(Continued)

Item	Quantity	Unit	Unit Cost	Amount
DAM				
Diversion & Care of Water			LS	\$ 68,000
Cleaning & Grubbing Under				
Embankment	33.5	AC	650	22,000
Stripping	110,000	CY	0.85	94,000
Excavation				
Channel between Spring &				
Ellicott Creek	102,500	CY	1.10	113,000
Core Trench	13,500	CY	1.25	17,000
Embankment				
Impervious Material				
Borrow (including Placement)	553,000	CY	1.85	1,023,000
Placement only of				
Excavated Material	152,000	CY	0.30	46,000
Pervious Fill	445,000	CY	1.65	734,000
Closure Dike				
Impervious Material (borrow)	7,000	CY	1.85	13,000
Pervious Fill	5,000	CY	1.65	8,000
Stripping	2,000	CY	0.85	2,000
Slurry Trench	13,800	SY	32.00	442,000
Grout Curtain	1,750	LF	20.00	35,000
Slope Protection				
Riprap	29,000	CY	14.00	406,000
Filter	14,500	CY	12.00	174,000
Seeding	11.7	AC	:1,000.00:	12,000

TABLE D1 (Continued)

Item	Quantity	Unit	Unit Cost	Amount
DAM (Continued)				
Embankment Roadway				
Overlook Area (Including Parking and Building)	8,150	FT	7.00	\$ 57,000
Sub-Total		IS		<u>66,000</u>
				\$ 3,332,000
Miscellaneous Items				150,000
Contingencies				633,000
Total Dam				<u>\$ 4,115,000</u>
SPILLWAY AND LOW FLOW CONDUIT				
Excavation (common)	138,000	CY	1.50	\$ 207,000
Excavation (rock)	14,200	CY	5.00	71,000
Dewatering for Spillway Basin			LS	33,000
Foundation Preparation	4,200	SY	3.00	12,500
Concrete (mass) (Including cement and reinf. and formworks)				
	23,690	CY	60.00	1,421,500
Concrete (struc) (Including cement and reinf. and formworks)				
	9,660	CY	115.00	\$ 1,111,000

TABLE D1 (Continued)

Item	Quantity	Unit	Unit Cost	Amount
SPILLWAY AND LOW FLOW CONDUIT				
(Continued)	:	:	:	:
Concrete Bridge (Including cement & reinf. & formworks)	75	CY	215.00	\$ 16,000
Grouted Rock Anchors	3,330	LF	8.00	26,500
Filter & Drain Material	360	CY	10.00	3,500
Spillway Gates	:	:	LS	120,000
Slide Gates	:	:	LS	60,000
Service Building	:	:	LS	6,000
Sub-Total	:	:	:	\$ 3,088,000
Allowance for New Lateral Spillway	:	:	:	\$ 2,035,000
Miscellaneous Items	:	:	LS	144,000
Contingencies	:	:	LS	780,000
Total Spillway and Conduit	:	:	:	\$ 6,047,000
SUB-TOTAL, DIRECT COSTS-RELOCATIONS, RESERVOIR, DAM & SPILLWAY				
ENGINEERING AND DESIGN	:	:	:	\$ 12,976,000
SUPERVISION AND ADMINISTRATION	:	:	:	\$ 2,206,000
	:	:	:	\$ 1,194,000

TABLE D1 (Continued)

Item	Quantity	Unit	Unit Cost	Amount
FIRST COSTS--RELOCATIONS, RESERVOIR, DAM & SPILLWAY	:	:	:	\$16,376,000
TOTAL FIRST COSTS, WITH LANDS	:	:	:	\$19,964,000

2.4.3 A detailed estimate of first costs for the proposed recreation facilities is shown in Table D2. The estimate was based on costs of similar facilities provided in the region by the Genesee State Park Commission.

2.4.4 The first cost of the Harlow Road control structure and other fish and wildlife conservation costs are shown in Table D3.

2.4.5 A detailed estimate of first costs for considered minor channel improvement in reaches 0-4 is shown in Table D4. The estimate is based on current costs of similar construction projects.

2.5 ANNUAL OPERATION, MAINTENANCE AND REPLACEMENT

2.5.1 The annual operation, maintenance and major replacement (O, M & R) costs for the proposed dam were estimated by considering similar data for five existing reservoirs operated by the Pittsburgh District, Corps of Engineers. The O, M & R costs include the services of a permanent staff and temporary seasonal employees and also the costs of land management, necessary equipment, normal repairs, periodic major replacements and engineering services.

2.5.2 Operation and maintenance of the recreation facilities at the proposed Sandridge Reservoir would probably be provided by the State Division of Parks. Unit annual O & M costs have been established at \$0.40/visitor day for both day-use and camping activities. Experience has shown that the major cost items have a life of approximately 25 years. It has been assumed that all facilities, except land, would be replaced every 25 years. Annual O & M costs for fish and wildlife include periodic restocking of the reservoir, estimated to be \$3,100 by the Bureau of Sport Fisheries in 1970. There will be some increase in this figure should this reservoir proposal be selected as the Ellicott Creek Project. Other minor maintenance items are included in the O, M & R cost.

TABLE D2 - Estimate of first costs for recreation facilities at the proposed Sandridge Reservoir

Item	Quantity	Unit	Unit Cost	Amount
LANDS AND DAMAGES				
Fee title (1100 acres)	:	:	:	\$ 388,000
Farms and Residence (15)	:	:	:	233,200
Acquisition	:	:	:	80,000
Contingencies	:	:	:	46,300
Sub-total (lands) =	:	:	:	\$ 747,500
PICNIC AREAS				
Comfort Stations	7	EA	30,000.00	\$ 210,000
Shelters	7	EA	27,000.00	189,000
Outdoor Fountains with water pipes	37	EA	850.00	31,500
Picnic Tables	1,120	EA	100.00	112,000
Garbage Cans	375	EA	25.00	9,500
Clearing (Selective)	112	AC	150.00	17,000
Parking Lots	381,000	SF	1.00	381,000
Sub-Total (Picnic Areas) =	:	:	:	\$ 950,000
BEACHES				
Comfort Stations	9	EA	32,000.00	288,000
Change Shelters	3	EA	70,000.00	210,000
Clearing and Grubbing	45	CY	1,000.00	\$ 45,000

TABLE D2 (Continued)

Item	Quantity	Unit	Unit Cost	Amount
Sand	23,300	CY	5.00	\$ 116,500
Gravel (Pit Run)	43,400	CY	1.50	65,000
Seeding	3	AC	200.00	500
Parking Lots	504,000	SF	1.00	504,000
Sub-total (Beaches) =				\$1,229,000
BOAT LAUNCHING FACILITIES				
Comfort Stations	2	EA	20,000.00	\$ 40,000
Boat Ramps	8	Lanes	2,500.00	20,000
Docks	8	EA	1,300.00	10,500
Parking Lots	124,000	SF	1.00	124,000
Sub-total (Boat Facilities) =				\$ 194,500
SANITATION FACILITIES				
Sewage Treatment Plant		LS		\$ 110,000
Collection System		LS		320,000
Sub-total (Sanitation Facilities) =				\$ 430,000
WATER SUPPLY				
Supply		LS		\$ 260,000
Distribution		LS		135,000
Sub-total (Water Supply) =				\$ 395,000

TABLE D2 (Continued)

Item	Quantity	Unit	Unit Cost	Amount
SIGNS		LS		\$ 7,000
ROADS				
2-way Asphalt	27,000	LF	25.00	\$ 675,000
1-way Asphalt	3,000	LF	13.00	39,000
2-way Gravel	6,000	LF	16.00	96,000
Sub-total (Roads) =				\$ 810,000
PLAYGROUNDS		EA	20,000.00	\$ 60,000
HIKING				
Trails	63,000	LF	0.20	\$ 12,500
Parking Lots	14,800	SF	1.00	15,000
Sub-total (Hiking)				\$ 27,500
ADMINISTRATION BUILDINGS				
Main	1	EA		\$ 70,000
Secondary	2	EA	14,000.00	28,000
Sub-total (Admin. Buildings) =				\$ 98,000
CONTINGENCIES		LS		\$1,050,500
SUB.-TOTAL, INITIAL DEVELOPMENT				\$5,251,500

TABLE D2 (Continued)

Item	Quantity	Unit	Unit Cost	Amount
ENGINEERING AND DESIGN	:	:	:	\$ 368,000
SUPERVISION AND ADMINISTRATION	:	:	:	\$ 368,000
FIRST COST-LESS LANDS	:	:	:	\$5,987,500
TOTAL FIRST COST, INITIAL DEVELOPMENT	:	:	:	\$6,735,000
EXPANSION IN YEAR 2000	:	:	:	
Day Use Facilities	:	LS	:	\$ 610,000
Camping Facilities	:	LS	:	<u>1,430,000</u>
TOTAL EXPANSION COST	:	:	:	\$2,040,000
PRESENT WORTH OF EXPANSION COST (x0.404)	:	:	:	\$ 825,000
TOTAL FIRST COSTS	:	:	:	\$7,560,000

TABLE D3. - Estimate of first cost for fish and wildlife conservation at the proposed Sandridge Reservoir

Item	Quantity	Unit	Unit Cost	Amount
HARLOW ROAD CONTROL STRUCTURE				
Clearing of Sides	2.5	AC	650.00	\$ 1,600
Fill	56,000	CY	1.30	72,800
Slope protection	15,100	CY	9.00	135,900
Filler	8,680	CY	10.00	86,800
Conduit (30 inch)	3,500	FT	20.00	70,000
Removal of original culvert and guard posts		LS		10,000
Miscellaneous Items		LS		19,400
Contingencies		LS		76,500
FIRST COST HARLOW ROAD				\$473,000
BOAT LAUNCHING FOR FISHING				
Ramps	6	EA	2500.00	\$ 15,000
Docks	6	EA	1300.00	7,800
Parking	93,000	SF	1.00	93,000
Miscellaneous Items		LS		5,400
Contingencies		LS		21,800
FIRST COST BOAT LAUNCHING				\$143,000
SUB-TOTAL FIRST COSTS				\$616,000

TABLE D3 (Continued)

Item	Quantity	Unit	Unit Cost	Amount
ENGINEERING AND DESIGN	:	:	:	\$100,000
SUPERVISION AND ADMINISTRATION	:	:	:	<u>56,000</u>
TOTAL	:	:	:	\$772,000

TABLE D4 . - Estimated first costs for minor channel improvements,
Lower Ellicott Creek

Item	Quantity	Unit	Cost	Non-Federal	
				Federal	Federal
LAND AND DAMAGES					
Lands, fee title	32	AC	7000.00	:	\$224,000
Easements	35	AC	LS	:	50,000
Boathouses	3	LS	LS	:	21,000
Residences	4	EA	35000.00	:	140,000
Golf Course			LS	:	30,000
Acquisition costs			LS	:	50,000
Contingencies				:	40,000
Sub-Total				:	\$555,000
RELOCATIONS					
Modify Niagara Falls Blvd. bridge			LS	\$ 69,000	:
Modify Maple Rd. bridge			LS	29,000	:
Modify North Forest Rd. bridge			LS	32,000	:
Modify drainage outlets			LS		\$153,000
Modify sewer siphon			LS		12,000
Contingencies			LS	32,000	50,000
Sub-Total			LS	\$ 162,000	\$215,000

TABLE D4 (Continued)

Item	Quantity	Unit	Cost	Federal	Non-Federal
CHANNELS					
Clearing			LS	\$ 57,000	
Excavation	330,000	CY	2.50	825,000	
Embankment	6,000	CY	1.55	9,000	
Riprap	12,200	CY	13.00	159,000	
Seeding	124	AC	500.00	62,000	
Diversion Channel		LS		240,000	
Contingencies		LS		<u>370,000</u>	
Sub-Total				<u>\$1,722,000</u>	
ENGINEERING AND DESIGN				\$ 189,000	\$ 73,000
SUPERVISION AND ADMINISTRATION				<u>\$ 110,000</u>	<u>\$ 55,000</u>
TOTAL FIRST COSTS				\$2,183,000	\$898,000

TABLE D4 - (cont'd)

Item	Quantity	Unit	Unit Cost	Amount	
				Federal	Non-Federal
RECREATION FACILITIES					
LANDS AND DAMAGES					
Lands, fee title	13	AC	7000.00	\$ 45,500	\$ 45,500
Acquisition Costs		LS		2,000	2,000
Contingencies		LS		6,500	6,500
Sub-Total (Lands)				<u>54,000</u>	<u>54,000</u>
PICNIC AREAS					
Landscaping	15	AC	2500.00	\$ 18,750	\$ 18,750
Comfort Stations	4	EA	30,000.00	60,000	60,000
Outdoor fountains with water pipes	6	EA	850.00	2,550	2,550
Picnic tables	20	EA	100.00	1,000	1,000
Clearing	15	AC	150.00	1,150	1,150
Parking Lots	20,000	SF	1.00	10,000	10,000
Playgrounds	3	EA	20000.00	30,000	30,000
Total Picnic Areas				<u>\$ 123,450</u>	<u>\$ 123,450</u>
CONTINGENCIES					
			LS	\$ 29,550	\$ 29,550
SUB-TOTAL, INITIAL DEVELOPMENT				\$ 153,000	\$ 153,000
ENGINEERING AND DESIGN				\$ 15,500	\$ 15,500

TABLE D4 (Continued)

Item	Quantity	Unit	Unit Cost	Amount	
				Federal	Non-Federal
SUPERVISION AND ADMINISTRATION	:	:	:	\$ 15,500	\$ 15,500
FIRST COST-LESS LANDS	:	:	:	184,000	184,000
TOTAL FIRST COST	:	:	:	238,000	238,000

TABLE D4A - Summary of first cost, Sandridge Dam and Reservoir and Minor Channel Improvements

ITEM	AMOUNT
DAM & RESERVOIR	\$19,964,000
RECREATION AT DAM	7,560,000
FISH & WILDLIFE	772,000
MINOR CHANNEL IMPROVEMENT	3,081,000
RECREATION FACILITIES ALONG IMPROVED CHANNEL	476,000
TOTAL	\$31,853,000

2.6 ANNUAL COSTS

2.6.1 Annual costs include 5-1/2 percent interest on investment, amortization of investment over a 100-year project life at 5-1/2 percent and operation, maintenance, and replacement costs. It is assumed that two years will be required to complete construction of the project and therefore the investment cost for each project element includes interest for one year on all first costs except lands and damages. Another annual cost included in the estimate is "Loss of Production." This is an economic cost that reflects loss of crop and other land productivity in the reservoir, for the recreation facilities and wildlife area are shown in Table D5.

2.6.2 Non-Federal maintenance of the channel includes repair and maintenance of structures in addition to the channel. Federal maintenance would be limited to periodic inspections. Table D5A shows the computations for annual costs for the Channel works.

2.6.3 Table D6 summarizes annual costs for this proposed plan.

2.7 CONSTRUCTION SCHEDULE

2.7.1 A tentative construction schedule for this scheme is shown on Plate D7.

2.8 COMPATIBILITY OF MULTIPLE PURPOSE USES - EFFECTS ON DRAWDOWN AND VOLUME

2.8.1 GENERAL

2.8.1.1 The potential for using the proposed Sandridge Reservoir for several purpose functions has been shown in Appendix C. The purpose of this section is to show the effects on drawdown and volume of the proposed Sandridge Reservoir when these functions are combined in a multiple purpose reservoir system.

2.8.1.2 Use of the Sandridge Reservoir to control downstream flood damages has been discussed in Appendix B. Hydrologic and hydraulic analyses indicate that 6,060 acre-feet of storage below elevation 856.5 would control runoff upstream of the dam for at least the 100-year flood event during the winter and spring (Appendix A). Studies show that only half of this volume would be needed during the summer months.

2.8.2 RECREATION

2.8.2.1 The summer conservation pool elevation was

TABLE D5 - Estimate of annual costs for the proposed Sandridge dam and reservoir, recreation facilities and fish and wildlife facilities.

ITEM	AMOUNT	
<u>Sandridge Dam and Reservoir</u>		
Interest (5½ percent)	\$	1,147,600
Amortization (100-years)		5,400
Operation, Maintenance & Replacement		121,800
Loss of Production		<u>5,000</u>
TOTAL ANNUAL COST	\$	1,279,800
<u>Sandridge Recreation Facilities</u>		
Interest (5½ percent)	\$	433,900
Amortization (100-years)		2,100
Operation, Maintenance & Replacement		484,400
Periodic Replacement		<u>145,600</u>
TOTAL ANNUAL COST	\$	1,066,000
<u>Fish and Wildlife Facilities</u>		
Interest (5½ percent)	\$	44,800
Amortization (100-years)		200
Operation, Maintenance & Replacement		<u>7,000</u>
TOTAL ANNUAL COST	\$	52,000

TABLE D5A - Minor Channel Improvements & Recreation Facilities - Annual Costs

ITEM	AMOUNT	
	FEDERAL	NON-FEDERAL
<u>CHANNEL IMPROVEMENTS</u>		
Interest (5½ percent)	\$126,700	\$ 52,100
Amortization	600	200
Maintenance	<u>700</u>	<u>13,300</u>
TOTAL	\$128,000	\$ 65,600
<u>RECREATION FACILITIES</u>		
Interest (5-1/2 percent)	\$ 13,800	\$ 13,800
Amortization	<u>100</u>	<u>100</u>
TOTAL	\$ 13,900	\$ 13,900

TABLE D6 - Summary of Annual Costs,
Sandridge Reservoir and
Minor Channel Improvements.

SANDRIDGE DAM & RESERVOIR	\$1,279,800
SANDRIDGE RECREATION FACILITIES	1,066,000
FISH AND WILDLIFE	52,000
MINOR CHANNEL IMPROVEMENTS	193,600
RECREATION FACILITIES ALONG IMPROVED CHANNEL	<u>27,800</u>
TOTAL	\$2,619,200
	SAY \$2,619,000

established at elevation 855 by considering the topographic limitations and recreation benefits of the proposed dam and reservoir. Recreation facilities would be designed to allow some drawdown for evaporation and other project purposes. The facilities also would allow for high summer flood control pool elevations by providing sufficient prepared beaches and a grass buffer zone. A winter conservation pool elevation of 852.5 was established to double the flood control storage during the winter and early spring months.

2.8.3 FISH AND WILDLIFE

2.8.3.1 Drawdown of the reservoir to serve other purposes of the multiple purpose system could affect the adequacy of the reservoir to support fish and wildlife. Since the Sandridge site has an excellent littoral zone, drawdown of the reservoir would not be detrimental to fish (west of Harlow Road). The conservation region east of Harlow Road was designed so that the water surface would be maintained at the normal conservation pool elevation of 855 during any drawdown operations. Thus, drawdown of the reservoir would not be deleterious to fish or wildlife. Operating the reservoir in this manner would minimize the possibility of unsightly mud flats which might appear with greater pool fluctuations.

2.8.4 LOW FLOW AUGMENTATION

2.8.4.1 During the summer months the mean discharge in Ellicott Creek near Alden is often less than two cfs. Projected reservoir releases were based on expected sewage treatment plant discharges in the year 2020. For low flows in Ellicott Creek expected once in 20 years, 25 cfs would be released during the period June through September, 15 cfs during May and October, 5 cfs during November and lesser flows during the winter months. Reservoir storage for water quality was based on these releases. In actual practice the reservoir releases would vary with the sewage treatment plant discharge and not remain constant over long periods as indicated above. The simplified approach that was used would produce conservative results.

2.8.5 WATER SUPPLY

2.8.5.1 Projected water supply needs that could be met from Sandridge Reservoir are summarized below in Table D7. Engineering studies show that average daily use is about

TABLE D7 - Projected water supply demand on Sandridge Reservoir

	1980		2020	
	Average Daily Use mgd	Peak Daily Use mgd	Average Daily Use mgd	Peak Daily Use mgd
Town and village of Alden	1.60	3.2	4.30	8.6
Village of Akron and town of Newstead	0.80	1.6	1.35	2.7
Sandridge recreation facilities	0.45 ^{1/}	0.9 ^{1/}	0.55 ^{1/}	1.1 ^{1/}
	2.85	5.7	6.20	12.4

^{1/} Only during summer recreation season.

one-half the peak daily use. Storage for water supply was based on average daily consumption in the year 2020, 6.2 million gallons per day, which is equivalent to an average discharge of 9.6 cfs. Monthly variations in consumption were determined on the basis of water production variations contained in the report "Erie County Comprehensive Public Works Study." The monthly requirements based on an average consumption of 9.6 cfs are shown in Table D8.

TABLE D8 - Monthly water supply demands on Sandridge Reservoir in the year 2020.

Month	Percentage of Annual Demand	Monthly Demand in cfs
January	94	9.0
February	95	9.1
March	94	9.0
April	92	8.8
May	96	9.2
June	111	10.7
July	119	11.4
August	112	10.8
September	105	10.1
October	97	9.3
November	94	9.0
December	93	8.9

2.8.6 EVAPORATION

2.8.6.1 Evaporation losses from Sandridge Reservoir were estimated from information contained in a report by the Erie Niagara Water Resources Board entitled "Investigations of Dams and Reservoirs Having Potential for Multiple-Purpose Use." It was estimated that losses would vary from a maximum of 4.4 inches in July to a minimum of 0.5 inches in winter months. Average losses annually from the maximum conservation pool area of 2150 acres would amount to 23.5 inches. Precipitation during the year falling directly on the reservoir pool, based on long term precipitation station records, at 35.36 inches would more than offset the free surface evaporation losses. However, during the summer months, the evaporation losses would exceed precipitation and this net loss was considered in evaluating possible drawdowns.

2.8.7 SEDIMENTATION

2.8.7.1 Sufficient storage would be provided in the reservoir for the accumulation of sediment during the 100 year project life. The amount of sediment expected over this period was estimated to be 300 acre-feet. This figure was calculated from a sediment yield study undertaken by the U.S. Geological Survey for the Erie-Niagara Water Resources Board. Field measurements of stream sediment loads in the Erie-Niagara Basin provided the basis for this study.

2.8.8 RESERVOIR DRAWDOWN

2.8.8.1 Expected drawdowns in Sandridge Reservoir were studied to determine the compatibility of using the reservoir for flood control, recreation, fish and wildlife, water quality and water supply. Table D9 shows the expected changes in reservoir draft, on a monthly basis, assuming withdrawals for water quality and water supply in the year 2020. This information was plotted as a mass curve with mean monthly low flows expected in the reservoir once in 20 years, to show the net effect of operating the multiple purpose reservoir under extreme conditions. The mass curve is shown on Plate D8. It was assumed that the reservoir would be at elevation 855 on 1 May. A review of streamflow records shows that this can normally be done if filling operations are started soon after the winter flood threat has passed. By 1 September, the end of the summer recreation season, the mass curve indicates a drawdown of 121 month-second-feet which is equivalent to 7300 acre-feet. This would reduce the conservation pool about five feet over the four-month period to elevation 850. This drawdown represents an extreme condition expected once in 20 years based on demand in the year 2020. It was concluded that the multiple purpose project could be operated to serve all the above purposes with reasonable compatibility. Greater drawdown under these extreme conditions can be expected in the late fall as shown in the mass curve. However, drawdowns in the non-recreation season will not cause any serious problems.

TABLE D9 - Changes in reservoir draft, in month-second-feet, for conditions in the year 2020.

Month	Water Quality Releases	Water Supply Withdrawals	Net effect evaporation and precipitation	Total net effect
January	0	-9.0	+6.3	-2.7
February	0	-9.1	+6.5	-2.6
March	0	-9.0	+6.0	-3.0
April	-2.0	-8.8	+4.8	-6.0
May	-15.0	-9.2	+1.2	-23.0
June	-25.0	-10.7	-2.6	-38.3
July	-25.0	-11.4	-3.8	-40.2
August	-25.0	-10.8	-1.0	-36.8
September	-25.0	-10.1	+1.3	-33.8
October	-15.0	-9.3	+4.2	-20.1
November	-5.0	-9.0	+6.2	-7.8
December	-1.0	-8.9	+6.3	-3.6
TOTAL	-138.0	-115.3	+35.4	-217.9

2.8.8.2 The 7300 acre-feet of storage was allocated to water supply, water quality and evaporation losses according to the relative magnitude of storage that each would use individually during the four month period if inflow were neglected. The storage was allocated as follows:

Water quality:	4750 acre-feet
Water supply:	2220 acre-feet
Evaporation losses:	<u>330</u> acre-feet
Total:	7300 acre-feet

3 - DIVERSION CHANNEL

3.1 GENERAL

3.1.1 Plate 7 illustrates the location of application of this plan. The alternative considers the construction of a channel, parallel to the existing creek, extending from a point in the creek some 800 feet downstream of Maple Road, to another point about 2,000 feet downstream of Sweet Home Road. The plan would eliminate most flood damages in the Amherst area expected with a flood having a recurrency interval of once in 100 years.

3.1.2 Three highway bridges would be modified, and eleven new bridges would be built, including those presently proposed (June 1973) in U.D.C.'s Audubon development in Amherst.* Three local storm drains would cross the diversion channel through pipes laid underneath it, to prevent local storm water problems. Three sanitary sewer pipes cross the channel, two of them at elevations lower than that of the bottom of the channel, the third one would have to be lowered to avoid interference with the waterflow in the diversion channel. The creek would be crossed once by the diversion channel, near Millersport Highway; at this point a culvert will be provided in the creek. Channel improvements would be considered in the existing creek from Sheridan Drive to the take-off point, upstream of the diversion channel, and from the confluence point of the diversion channel and Ellicott Creek up to Ellicott Creek Park. The existing diversion channel in Ellicott Creek Park would also be improved.

3.1.3 The following paragraphs discuss this alternative in a more detailed manner.

3.2 THE DIVERSION CHANNEL

3.2.1 Details of the Diversion Channel are to be found in Plate 5. The cross section of the diversion channel is approximately trapezoidal, with a depth of ten feet, and bed width which varies as recorded below: from Niagara Falls Boulevard to a point approximately 3,400 feet upstream, the bed width is 110 feet, from this point to 400 feet upstream of Millersport Highway the designed bed width is reduced to 100 feet, and from here to a section approximately 1,300 feet

* See Plate D-20

downstream of Maple Road the bed width is increased to 120 feet. The channel would be grass lined, with side slopes of 1v. to 3h. Three longitudinal drains would be provided to prevent the groundwater from getting into the channel; two pumping stations discharge collected groundwater to the existing creek. With these features, the major portion of the length of the channel is expected to be normally dry throughout the Summer and Fall of an average year. In the last mile of the diversion channel from the confluence point with Ellicott Creek, the backwater from Ellicott Creek creates an impoundment with an average depth of four feet. The reach is to be used as a canoeing area.

3.2.2 Preliminary optimization of design requires the provision of an energy dissipator just downstream of the take-off point. Any storm water drains crossing the diversion channel for this purpose. The same method would be used for Ellicott Creek at the crossing point.

3.2.3 The north bank elevations between Sweet Home Road and a point 2,500 feet upstream of Dodge Road, is very slightly lower than the design water surface. In order to prevent flooding the spoil excavated in the construction of the diversion channel would be used to fill this lower area approximately two feet above its existing level. Reconnaissance of the zone shows this to presently be an undeveloped area and hence no problems are anticipated for raising grade in this area. The limit of grade raising is the existing elevated railroad grade crossing east-west along the north side of this area.

Other spoil excavated in the construction of the diversion channel will be disposed of in the sculptured recreational areas to be provided alongside the channel, and also in Pfohl Park in areas which are currently liable to frequent flooding.

3.3 CHANNEL IMPROVEMENTS

3.3.1 The channel improvements upstream and downstream of the diversion channel would follow the course of the existing creek. The bottom width of the improved trapezoidal channel would vary from 80 feet to 110 feet, except near the upstream end of the project where two 800-foot-long sections of the channel sides and bottom would be riprapped. The total length



TERRAIN FOR DIVERSION CHANNEL SOUTH
OF ELLICOTT CREEK.



DIVERSION CHANNEL NORTH

of improved channel would be about 2.5 miles.

3.3.2 The existing diversion channel in Ellicott Creek Park would be enlarged to carry the greater flows that would occur with upstream channel enlargement. At the Tonawanda Creek end of the existing diversion channel, three 106" x 166" Lo-Hed concrete pipes would be added to an existing culvert under Tonawanda Creek Road to pass the design flow. The diversion channel itself would be widened to 230 feet, about double the existing width. This widening would require the cutting down of trees on both banks of the channel and the resiting of two transmission towers.

3.4 RECREATION FACILITIES

3.4.1 This alternative provides for the development of a strip park, about 140 feet wide, adjacent the diversion channel, from Millersport Highway to the confluence point with Ellicott Creek. This strip, together with the bed of the diversion channel, would be appropriately landscaped to offer an attractive area for picnicking and general leisure. Ordinarily the channel itself would be used as a recreation area. A bikeway would be incorporated in the diversion channel along its total length. Plate D4 shows the exact location of the channel and recreation areas. The plate on the following page illustrates the concept of the diversion channel, the bikeway and the recreational area adjacent.

3.5 BRIDGES

3.5.1 A total of eleven new bridges are required, and three existing bridges require modification. Plate D20 illustrates the locations of the new bridges required; they are primarily located in the U.D.C. "Audubon" development in Amherst. From the standpoint of cost responsibility, six bridges are a U.D.C. cost, three a N.Y. State cost and two an Erie County cost.

Bridges requiring modification to pass design flows are Niagara Falls Boulevard, Maple Road and North Forest Road. In most instances, sheet piling would be driven around the abutments for protection, after the existing opening is deepened.

3.6 FLOOD REDUCTION

3.6.1 Plates D10 and D10A show the extent of the flooded area without this structural measure, and the reduction in flooded area caused by this plan.

3.6.2 Plate 5 illustrates the design channel grade, the associated bank profiles and the design water surface. Elevations have been selected on the basis of hydraulic data and criteria provided in Appendix A. With the more accurate topographical information which will be available at the detail design stage refinement of design will remove the minor overbank flow at the upstream end of the proposed improvement-length, so that at this stage of study it may be said the proposal provides protection in Amherst from Intermediate Regional Flood conditions. Plates D10 and D10A reflect this.

3.7 ESTIMATE OF COST

3.7.1 A detailed estimate of first costs for the considered diversion channel is shown in Table D10. The estimate has been based on current costs of similar construction projects in the Buffalo area.

3.8 ANNUAL COST

3.8.1 Annual cost would include maintenance, 5½ percent interest on investment and amortization of investment over an assumed 100-year project life at this constant rate of interest. Federal costs are seen to be confined to periodic inspections; operation and maintenance costs are seen to be a non-Federal responsibility. Table D11 shows the computations for annual cost.

3.9 CONSTRUCTION SCHEDULE

3.9.1 A tentative construction schedule for this scheme is shown on Plate D11.



ELLKOTT CREEK DIVERSION CHANNEL

TABLE D10 - Estimated first cost for Diversion Channel Scheme

Description	Quantity	Unit	Cost/ Unit	Amount	
				Federal	Non-Federal
LANDS & DAMAGES					
Lands, channel	75	AC	7,000		\$ 525,000
Lands, parks	31	AC	7,000		217,000
Boathouses	3		LS		21,000
Residences	11	EA	30,000		330,000
Acquisition costs			LS		35,000
Easements	4	AC	1,250		5,000
Contingencies			LS		100,000
Sub-Total					\$1,233,000
RELOCATIONS					
Relocate Hydro Towers	2	EA	10,000	\$ 20,000	
Modify Niagara Falls Boulevard Bridge			LS		69,000
Modify Maple Road Bridge			LS		69,000
Modify North Forest Rd. Bridge			LS		69,000
New Bridges at:					
Campbell Boulevard (6 lane)	1	EA	750,000		750,000
Lockport Expressway (4 lane)	1	EA	610,000		610,000
UDC (4 lane)	1	EA	610,000		610,000
Millersport Highway (4 lane)	1	EA	440,000		440,000
Sweet Home Road (4 lane)	1	EA	440,000		440,000
North Forest Road (2 lane)	1	EA	220,000		220,000

TABLE D10 (cont'd)

Description	Quantity	Unit	Cost/ Unit	Amount	
				Federal	Non-Federal
UDC (2 lane)	2	EA	220,000		\$ 440,000
UDC (Ramp)	3	EA	29,000		87,000
Contingencies		LS			893,000
Sub-Total					\$ 4,490,000
CHANNELS					
Clearing	60	AC	650	39,000	
Excavation	758,300	CY	1.85	1,403,000	
Embankment	150,300	CY	0.80	120,000	
Riprap	20,000	CY	13	260,000	
Diversion Channel (Ellicott Creek Park)			L.S.	432,000	
Contingencies				184,000	
Sub-Total				\$2,438,000	
ENERGY DISSIPATOR					
Concrete Floor	437	CY	120	52,500	
Concrete side walls	175	CY	150	26,500	
Backfill	1,300	CY	5	6,500	
Relief walls & drains	1,200	LF	25	30,000	
Contingencies				28,500	
Sub-Total				\$ 144,000	
STORM DRAIN CROSSINGS					
			LS	\$ 105,000	
CREEK/CHANNEL CROSSING					
Dewatering during construction			LS	\$ 3,000	
Excavation	2,500	CY	5	12,500	

TABLE D10 (cont'd)

Description	Quantity	Unit	Cost/ Unit	Amount	
				Federal	Non-Federal
Backfill	1,300	CY	2	\$ 2,700:	:
7' concrete pipes supply laying	1,000 1,000 1,000	LF LF LF	14 2	14,000: 2,000:	:
Concrete					
Pipe surround					
Concrete 2,000 psi	865	CY	30	25,950:	:
Re-steel	45	TONS	300	13,500:	:
Formwork	3,000	sf	1.50	4,500:	:
Headwalls 3,000 psi	286	CY	100	28,600:	:
Wingwalls 3,000 psi	27	CY	120	3,240:	:
Floor 3,000 psi	26	CY	90	2,340:	:
Riprap	175	CY	13	2,275:	:
Contingencies				11,395:	:
Sub-Total				\$ 126,000:	:
FILTERS (CHANNEL DRAINAGE)					
Excavation	16,200	CY	1.50	\$ 24,500:	:
Pervious material	16,200	CY	6.50	105,500:	:
Perforated pipe 12" ø asphalt coated	43,500	LF	2.50	109,000:	:
Pumping Stations	2				

TABLE D10 (cont'd)

Description	Quantity	Unit	Cost/ Unit	AMOUNT	
				Federal	Non-Federal
Excavation	1,000	CY	10	\$ 10,000	
Concrete	50	CY	150	7,500	
Backfill	950	CY	3	3,000	
Superstructure			LS	6,000	
Miscellaneous Steel			LS	2,000	
Elect. Inst.				5,000	
Mech. Inst. included					
2 x 2 x 7.5 HP Pumps				15,000	
Discharge channels				2,000	
Contingencies				48,500	
Sub-Total				\$ 338,000	
RECREATIONAL FACILITIES					
Landscaping	100	AC	2,500	\$ 125,000	\$ 125,000
Picnic areas:					
Comfort Stations	3	EA	36,000	54,000	54,000
Outdoor fountains with					
water pipes	7	EA	850	3,000	3,000
Picnic tables	30	EA	100	1,500	1,500
Parking Lots	20,000	SF	1	10,000	10,000
Bike and Foot Paths	7,000	SY	6	21,000	21,000
Playgrounds	3	EA	20,000	30,000	30,000
Foot bridges	3	EA	35,000	52,500	52,500
Fencing	10,000	LF	1	5,000	5,000
Contingencies				45,000	45,000
Sub-Total				\$ 347,000	\$ 347,000
SUB-TOTAL, RELOCATIONS, CHANNELS, ENERGY DISSIPATOR, CREEK CROSSING, FILTERS AND RECREATION FACILITIES					
				\$3,770,000	

TABLE D10 (cont'd)

Description	Quantity	Unit	Cost/ Unit	AMOUNT	
				Federal	Non-Federal
ENGINEERING AND DESIGN	:	:	:	(\$ 320,000)	\$ 312,000
SUPERVISION AND ADMINISTRATION	:	:	:	205,000	221,000
TOTAL	:	:	:	\$4,295,000	\$6,603,000
First years interest on non-Federal Bridge Costs @ 5-1/2%	:	:	:		275,000
TOTAL FIRST COST	:	:	:	\$4,295,000	\$6,878,000
TOTAL	:	:	:		\$11,173,000

(1) Exclusive of \$175,000 expended on restudy of alternatives.

TABLE D11 - Estimate of annual costs for
the Diversion Channel Scheme

ITEM	AMOUNT	
	FEDERAL	NON-FEDERAL
ANNUAL COSTS		
Interest (5½%)	\$236,200	\$378,300
Amortization (100 years)	1,100	1,800
Operation & maintenance	<u>700</u>	<u>25,300</u>
	\$238,000	\$405,400
TOTAL	\$643,400	

4 MAJOR CHANNEL IMPROVEMENT, REACHES 0-4

4.1 GENERAL

4.1.1 The considered plan would provide about seven miles of channel enlargement and realignment mostly in the town of Amherst, extending from the confluence of Tonawanda Creek with the Ellicott Creek diversion channel to the Sheridan Drive bridge. The plan was designed to eliminate most damages expected with a flood having a recurrence interval of once in 100 years. One highway bridge and two foot bridges would be replaced. Three other highway bridges would be modified to conform with the improved channel. Local storm drainage systems discharge into the channel at about 50 points. New headwalls and flap gates would be required on some of these lines to prevent back-up during high creek flows. The more important features of the considered plan are discussed in the following paragraphs.

4.2 CHANNEL

4.2.1 The bottom width of the improved trapezoidal channel would vary from 80 feet to 110 feet except near the upstream end of the project where two 800-foot-long high velocity sections would be constructed. At one high velocity section the channel would taper to a 60-foot bottom width, and at the other it would taper to a 40-foot bottom width. Their purpose would be to raise both the water surface and channel bottom to the elevations in the unimproved reach upstream. At both these sections the channel sides and bottom would be riprapped. The main channel would also be riprapped where necessary to protect against erosive velocities.

4.3 DIVERSION CHANNEL

4.3.1 An existing diversion channel, connecting Ellicott Creek with Tonawanda Creek at the downstream end of the considered plan, would be enlarged to carry the greater flows that would occur with upstream channel enlargement. It was constructed in 1965 by the county to divert high flows on Ellicott Creek to Tonawanda Creek. Under normal conditions most of the diversion channel is dry. It is grass lined except for a paved section used for parking in Ellicott Creek Park. Under improved conditions the diversion channel would be widened to a maximum width of 230 feet, which is about double the present width. Initial diversion from

Ellicott Creek would occur at about the two-year flood frequency under both existing and improved conditions. At the Tonawanda Creek end of the diversion channel, three 106" x 166" Lo-Hed concrete pipes would be added to an existing culvert under Tonawanda Creek Road, to pass the design flow.

4.4 BRIDGES

4.4.1 The bridge at Sweet Home Road cannot be economically modified to pass design flows, and needs to be replaced. Erie County authorities are currently effecting this replacement as part of the University of Buffalo grand design. Bridges at Niagara Falls Boulevard, Maple Road and North Forest Road would be modified. In most instances, sheet piling would be driven around the abutments for protection after the existing opening is deepened. The Millersport Highway bridge will probably be removed and not replaced during construction of the proposed new SUNYAB campus on the edge of the flood plain. Possible changes to this bridge were excluded in the considered plan. The Audubon Golf Course has two foot bridges that cross Ellicott Creek. These bridges would be replaced or modified under improved conditions.

4.5 RECREATION FACILITIES

4.5.1 The recreation facilities in this scheme consist of seven parks located along the channel. The total area of parks would be fifteen acres and the area of the individual parks would vary from seven acres to one half acre. These recreation areas would be landscaped and provided with picnic tables, comfort stations, playgrounds, outdoor fountains and parking lots. Plate D3 shows the exact locations of the parks and the easy access from the neighboring roads. The plate of the following page illustrates the concept of type of recreational areas.

4.6 FLOOD REDUCTION

4.6.1 Plates D12 and D12A show the extent of the flooded area without this structural measure, and the reduction in flooded area caused by this plan.

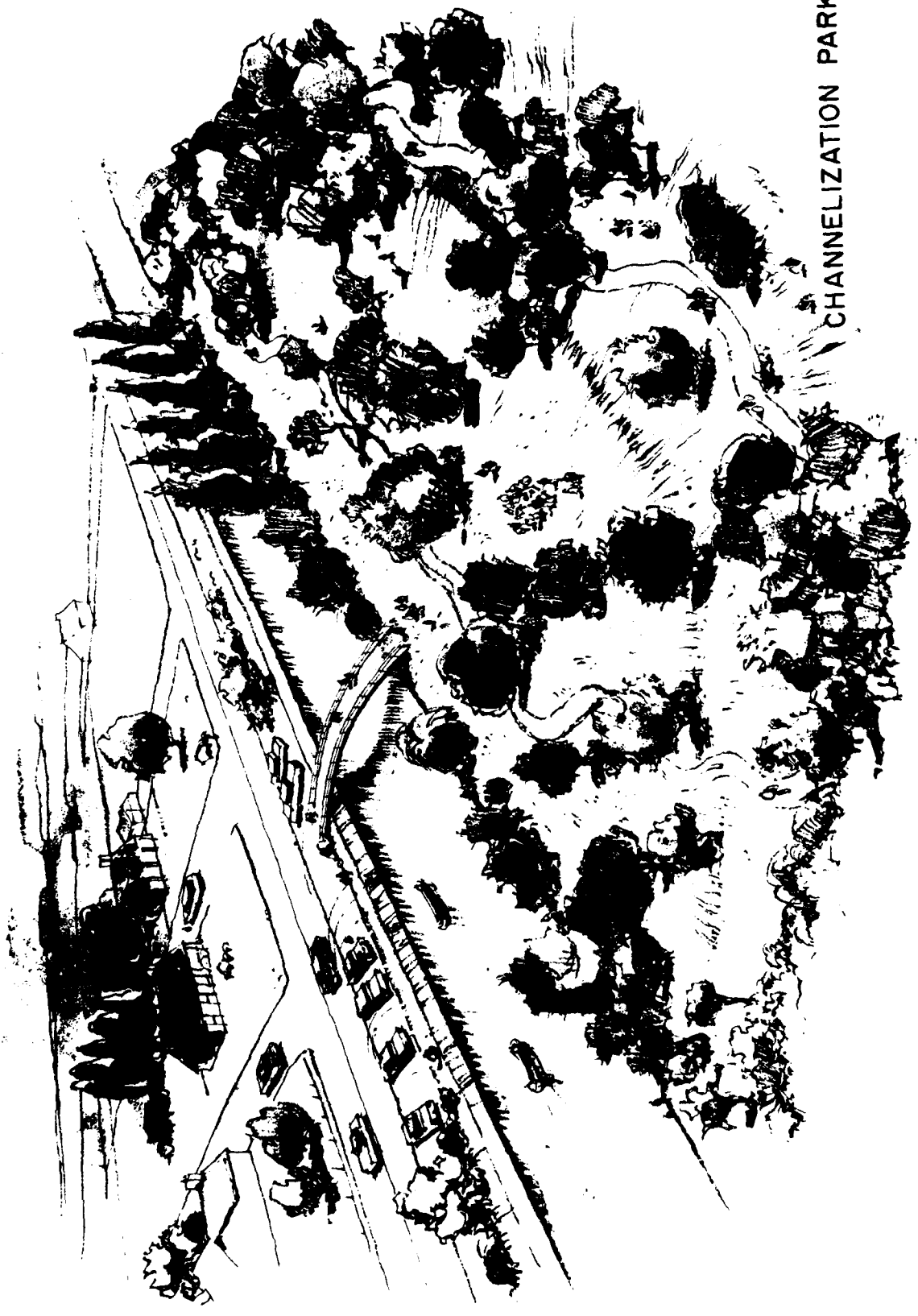

CHANNELIZATION PARK



4.6.2 A study of the design water surface on Plate 4 for this proposal indicates slight overbank flow occurs in a short length of creek just upstream of Sweet Home Road bridge, by Millersport Highway bridge and at two small areas on the left bank upstream of Millersport.

4.6.3 The degree of overbank flow indicated at this stage of the Study is considered very minor, and well capable of resolution at the detail design stage. At that stage the detailed topographic information obtained from field surveys of the land adjacent the creek will facilitate optimization of measures to produce a design water surface which eliminates overbank flow in these areas. The design water surface as presently indicated may therefore be considered to satisfy the design criterion of protection from the Intermediate Regional Flood condition.

4.7 ESTIMATE OF COST

4.7.1 A detailed estimate of first costs for considered major channel improvement in reaches 0-4 is shown in Table D12. The estimate is based on current costs of similar construction projects. It was assumed that two years would be required to complete construction. Total investment includes interest for one year during construction.

4.8 ANNUAL COST

4.8.1 Annual costs would include maintenance, 5½ percent interest on investment and amortization of investment over an assumed 100-year project life. Non-Federal maintenance would include repair and maintenance of structures and channels. Federal maintenance would be limited to periodic inspections. Table D13 shows the computations for annual costs.

4.9 CONSTRUCTION SCHEDULE

4.9.1 A tentative construction schedule for the scheme is shown on Plate D13.

AD-A101 345

CORPS OF ENGINEERS BUFFALO N Y BUFFALO DISTRICT
ELLICOTT CREEK BASIN, NEW YORK. WATER RESOURCES DEVELOPMENT, PH--ETC(U)
AUG 73

F/G 13/2

UNCLASSIFIED

ML

4 of 6
201320

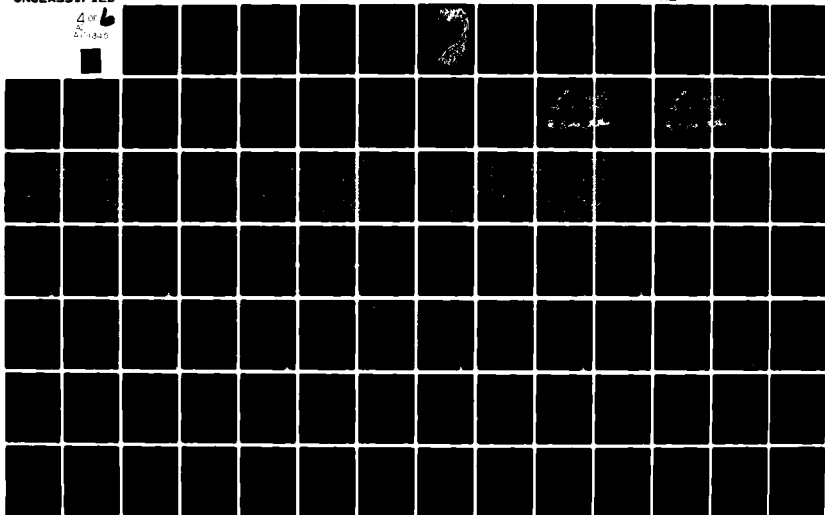

TABLE D12 - Estimated first costs for major channel improvement, lower Ellicott Creek

Item	Quantity	Unit	Unit Cost	Amount	
				Federal	Non-Federal
LANDS AND DAMAGES					
Lands, fee title					
Easements (72 acres)	65	AC	7,000		\$ 455,000
Boathouse (3)			LS		97,500
Residences	5	EA	35,000		21,000
Golf Course			LS		175,000
Acquisition costs			LS		30,000
Contingencies			LS		30,000
Sub-Total					52,500
					\$ 861,000
RELOCATIONS					
Relocate Hydro Towers				\$ 20,000	
Modify Niagara Falls Blvd. bridge			LS	69,000	
Modify Maple Road bridge			LS	69,000	
Modify North Forest Rd. bridge			LS	69,000	
Modify drainage outlets			LS		146,000
New foot bridges	2	EA			67,000
Modify sewer siphon					12,000
Contingencies				45,000	85,000
Sub-Total				\$ 272,000	\$ 310,000

TABLE D12 (cont'd)

Item	Quantity	Unit	Unit Cost	AMOUNT	
				Federal	Non-Federal
CHANNELS					
Clearing			LS	\$ 200,000	
Excavation	918,000	CY	2.00	1,836,000	
Embankment	5,000	CY	1.55	8,000	
Riprap	49,600	CY	13.00	645,000	
Seeding	210	AC	500	105,000	
Diversion Channel			LS	432,000	
Contingencies				920,000	
Sub-Total				\$4,146,000	
ENGINEERING AND DESIGN				\$ 353,000	\$ 62,000
SUPERVISION AND ADMINISTRATION				208,000	43,000
TOTAL FIRST COSTS				\$4,979,000	\$1,276,000

TABLE D12 (cont'd)
RECREATION FACILITIES

Items	Quantity	Unit	Unit Cost	Amount
RECREATION FACILITIES				
LANDS AND DAMAGES				
Lands, fee title	15	AC	7,000	\$ 105,000
Acquisition Costs		LS		4,000
Total Land				\$ 109,000
Picnic Areas				
Landscaping	15	AC	2,500	\$ 37,500
Comfort Station	5	EA	30,000	150,000
Outdoor fountains with water pipes	7	EA	850	5,950
Picnic tables	20	EA	100	2,000
Clearing	15	AC	150	2,250
Parking Lots	20,000	SF	1.00	20,000
Playgrounds	3	EA	20,000	60,000
Total Picnic Areas				\$ 277,700
CONTINGENCIES				
SUB-TOTAL INITIAL DEVELOPMENT			LS	69,300
ENGINEERING AND DESIGN				\$ 347,000
SUPERVISION AND ADMINISTRATION				35,000
FIRST COST-LESS LANDS				35,000
TOTAL FIRST COST, RECREATION FACILITIES:				\$ 417,000
TOTAL FIRST COST, RECREATION FACILITIES:				\$ 526,000*

*This cost is shared equally between Federal and non-Federal Authorities.

TABLE 12A - Summary of first cost; major channel improvement

ITEM	AMOUNT	
	FEDERAL	NON-FEDERAL
Channel Works	\$4,979,000	\$1,276,000
Recreation Facilities	<u>263,000</u>	<u>263,000</u>
TOTAL	\$5,242,000	\$1,539,000

TABLE D13 - Major Channel Improvement

ITEM	AMOUNT	
	FEDERAL	NON-FEDERAL
<u>ANNUAL COSTS</u>		
Interest (5½ percent)	\$ 304,200	\$ 89,300
Amortization (100-years)	1,400	400
Maintenance	<u>700</u>	<u>25,300</u>
TOTAL	\$ 306,300	\$115,000

5. BOWMANVILLE LAKE - PAVEMENT ROAD DAM

5.1 GENERAL

This proposed solution to the Ellicott Creek flooding problem seeks to satisfy the requirements of a reservoir draining a greater proportion of the Ellicott Creek basin than does the Sandridge Reservoir, the provision of a water-oriented recreational center convenient to population centers and a source of water that may be drawn upon when flows in Ellicott Creek reach such low values that water quality is impaired. To satisfy these criteria it has been necessary to use two reservoirs jointly, the more upstream of them (Pavement Road Reservoir) being a sub-impoundment of the main lake, Bowmansville Lake.

5.2 BOWMANVILLE LAKE

5.2.1 Location

The proposed Bowmansville Lake is located on Ellicott Creek, between Harris Hill and Pavement Roads in the east-west direction, and Genesee Street and Pleasant View Drive in the north-south direction. It is about 3 miles long and 1 mile wide. The location area is shown on Plate 11, and a concept of it is illustrated on the next page.

5.2.2 Description

Bowmansville Lake would be multi-purpose in concept and intended to provide flood control, recreation, and low flow augmentation in Ellicott Creek. Under normal conditions the pool would have a surface area of 1,040 acres. It would be contained within levees on the west, north and south sides, and feature open recreational areas on the east, where the terrain slopes gently upwards. The total length of dikes necessary to create the impoundment would be about 5.8 miles.

5.2.3 Selected Spillway and Stilling Basin

The selected spillway would be an uncontrolled concrete gravity ogee section founded on rock, located on the creek course, some 500 feet upstream of Harris Hill Road. The

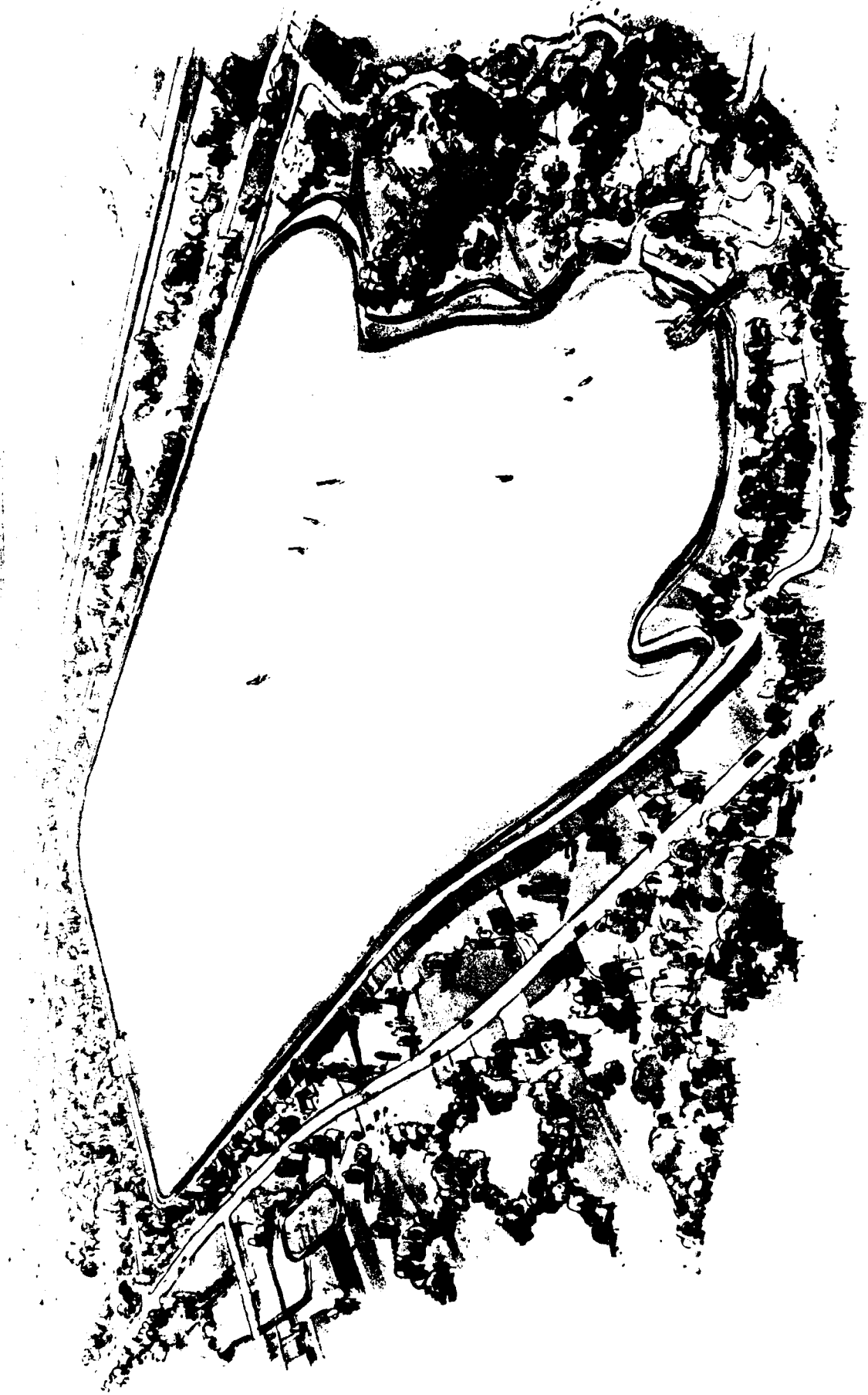

BOWMANSVILLE LAKE

spillway is designed to pass the maximum probable flood with a head-water of 7 feet, and the crest shaped to prevent cavitation under this extreme condition. The length of the spillway would be 645 feet and include nine piers, 5 feet wide, provided to support a 20 foot wide bridge that is part of the roadway system running on top of the levees. The spillway crest elevation would be 730 feet. Uplift pressure under the spillway would be reduced by a gallery parallel to the structure axis or by some other better method to be chosen when the final design is being made. The ogee section is dimensioned to be safe against overturning and sliding.

The proposed stilling basin would be a structure 645 feet wide and 40 feet long, designed according to United States Bureau of Reclamation recommendations (Type II). The hydraulic jump for the maximum discharge is expected to be well balanced (the Froude number is equal to 7) and the turbulence and waves created by the jump would be confined to the stilling basin area.

Uplift pressure under the stilling basin would be reduced by relief holes through the concrete slab and filter layers on top of the bedrock surface. The downstream end of the stilling basin slab would be connected to the underlying rock by a cutoff section extending eight feet into bedrock. Riprap would be provided at the downstream end of the stilling basin to protect the tailrace channel floor.

Reinforced concrete cantilever training walls would extend for the entire length of the stilling basin, and be designed to resist the pressures exerted by the earth embankment and the hydrostatic pressure of the water flowing through the spillway. Relief holes would be provided through the walls to reduce the pore pressures in the backfill.

There would be an earth transition downstream of the spillway to bring the water course width from 645 feet at the spillway to the approximately 200 feet wide creek course at this point. Plate D14 illustrates some details of the spillway and stilling basin.

5.2.4 Low Level Outlet Works

The low level outlet works consist of nine 4-foot diameter conduits through the spillway section. Each conduit would be provided with two valves, one for normal operation, the other for emergency use. Cavitation would be prevented by providing an air vent to the roof of each conduit.

5.2.5 Embankment

The earth fill embankment with an impervious core is approximately 5.8 miles long. The upstream face would be partially riprapped, with a side slope of 1 on 3; the downstream face would be grass covered with a side slope of 1 on 2.5. Seepage control would be provided by a cut-off trench extending to the bedrock surface. The bottom width of this trench is about 25 feet with side slopes of 1 on 1.5. An impervious blanket would be provided in the lower head sections.

A one-way road system would be provided on the ridge of the levees, to be used by visitors to the recreation areas. Plate D16 shows a typical cross section of the earth embankment.

5.2.6 Recreation Facilities

The overall project provides for the development of two recreation areas, located near Pavement Road and to the north-east and southeast of Bowmansville Lake. These areas would be appropriately landscaped and are intended to be used for picnicking and general leisure activities. The total area of recreation land is about 241 acres. Beaches, with shelters and sanitation facilities, would be provided along the water line in the two recreation areas.

Boat launching facilities would also be provided as part of this recreational development.

5.2.7 Miscellaneous

The existing bridge at Harris Hill Road would be modified and raised about 5 feet, and the one at Pavement Road would be modified but not raised, in order to accomodate the new

conditions created by the reservoir. Stony Road would be inundated by the reservoir and so would need to be abandoned. However, north-south traffic is not considered to be unreasonably affected because of the proximity of Harris Hill and Pavement Roads. An existing telephone line in the reservoir area would need to be relocated and four producing gas wells would need to be purchased and capped.

Some 53 residences in the lake and construction areas would need to be acquired.

5.2.8 Estimate of Cost

Table 15.1 shows an estimate of first costs for this impoundment. The estimate is based on current construction costs in the Buffalo area. Because no subsurface geotechnical exploration has been done, knowledge of subsurface conditions are imprecise and the estimates of cost are necessarily conservative, since they are based on imprecise foundation and geotechnical knowledge of the area.

5.3 PAVEMENT ROAD DAM AND RESERVOIR

5.3.1 Location

The proposed Pavement Dam and resulting reservoir are located on Ellicott Creek, just upstream of Pavement Road and the Bowmansville Lake. It is about 2.5 miles long and varies considerably in width along its length, as a result of the topography. Plate 11 shows the location of this reservoir.

5.3.2 Description

Pavement Road Reservoir is designed as a sub-impoundment to the Bowmansville Lake, to replace flows from the latter released for low flow augmentation in Ellicott Creek. It is formed in a natural terrain depression, and the only water-retaining structures are the spillway with abutments that close the gorge at the downstream end of the reservoir, and a small closure dike, some 500 feet long near Peppermint Road. Under normal conditions the reservoir area would be

TABLE 15.1 - BOWMANSVILLE LAKE (Ungated)

ITEM	QUANTITY	UNIT	UNIT COST	AMOUNT
<u>LAND AND DAMAGES</u>				
Lands and Fee Title	1,152	AC	2,000	2,304,000
Residences	53		35,000	1,855,000
Contingencies		LS		198,000
Acquisition Costs		LS		84,000
Total Land and Damages				4,441,000
<u>RELOCATIONS</u>				
Telephone Line		LS		30,000
Modify bridge at Harris Hill Road		LS		70,000
Gas Wells (4)		LS		400,000
Contingencies				60,000
Total Relocations				560,000
<u>RESERVOIR CLEARING</u>				
Contingencies	350	AC	544	190,400
Total Reservoir Clearing			LS	19,100
				209,500
<u>DAMS AND LEVEES</u>				
Drilling Program			LS	50,000
Diversions and care of cf water			LS	30,000
Cleaning and Grubbing	50	AC	608	30,400
Striping	153,000	CY	0.55	84,200

ITEM	QUANTITY	UNIT	UNIT COST	AMOUNT
Excavation Core Trench Embankment	210,000	CY	1.00	\$ 210,000
Impervious Material Borrow (incl. placement)	1,120,500	CY	1.00	1,120,500
Pervious fill	1,000,000	CY	1.25	1,250,000
Slope protection				
Riprap	120,000	CY	14.00	1,680,000
Seeding	39	AC	407.0	15,900
Toe-train	31,000	CY	10.0	310,000
Embankment Roadway	30,000	FT	12.0	360,000
Miscellaneous Items				100,000
Contingencies				350,000
Total dam and levees				\$5,591,000
<u>SPILLWAY AND LOW FLOW</u>				
<u>CONDUITS</u>				
Excavation (common)	40,000	CY	1.30	52,000
Excavation (rock)	12,000	CY	3.40	40,800
Dewatering for Spillway Basin			LS	100,000
Foundation preparation	6,000	SY	3.40	20,400
Concrete (mass;weir,piers)	19,400	CY	61.00	1,183,400
Concrete (structural)	5,700	CY	102.00	581,400
Concrete Bridge	680	CY	200.00	136,000
Grouted Rock Anchors			LS	30,000
Riprap	4,000	CY	14.00	56,000
Low level outlets valves			LS	60,000
Tailrace Transition to Creek			LS	70,000

ITEM	QUANTITY	UNIT	UNIT COST	AMOUNT	
				FEDERAL	NON-FEDERAL
Contingencies				\$ 336,500	
Total spillway and low flow conduits				\$2,366,500	
Sub-total relocations, reservoir clearing, dam and spillway				\$9,027,000	
ENGINEERING AND DESIGN				608,000	
SUPERVISION & ADMINISTRATION:				608,000	
FIRST COST-LESS LANDS				10,243,000	
TOTAL FIRST COSTS (LAKE WORKS)				14,684,000	

Bowmansville Lake, Recreation Facilities

ITEM	QUANTITY	UNIT	COST	UNIT	AMOUNT
<u>RECREATION FACILITIES</u>					
LANDS AND DAMAGES					
Lands	241	AC	2,000		482,000
Residences	5		35,000		175,000
Acquisition Costs			LS		17,600
Contingencies					41,400
Total Land					<u>716,000</u>
PICNIC AREAS					
Comfort Stations	3	EA	28,968		86,900
Shelters	3	EA	26,520		79,600
Outdoor Fountains with					
Water pipes	8	EA	870		7,000
Picnic Tables	235	EA	95		22,300
Garbage Cans	80	EA	28		2,200
Clearing	24	AC	136		3,300
Parking Lots	80,000	SF	0.96		76,800
Landscaping	150	AC	3,000		<u>450,000</u>
Sub-Total					<u>728,100</u>
BOAT LAUNCHING FACILITIES					
Comfort Stations	2	EA	19,856		39,700
Boat Ramps	6	Lanes	2,448		14,700
Parking Lots	26,040	SF	0.96		<u>25,000</u>
Sub-Total					<u>79,400</u>
SANITATION FACILITIES					
Collection System			LS		70,000
Connection to Existing					
Sanitation System			LS		<u>70,000</u>
Sub-Total					<u>140,000</u>
WATER SUPPLY					
Supply			LS		56,000
Distribution			LS		<u>30,000</u>
Sub-Total					<u>86,000</u>

ITEM	QUANTITY	UNIT	UNIT COST	AMOUNT
ROADS				
2-Way Asphalt	6,000	LF	25.20	151,200
1-Way Asphalt	1,000	LF	13.60	13,600
2-Way Gravel	2,000	LF	16.30	32,600
Sub-Total				<u>197,400</u>
PLAYGROUNDS	2	EA	20,400	40,800
ADMINISTRATION BUILDINGS				
Main	1	EA		50,000
Secondary	1	EA	10,000	10,000
Sub-Total				<u>60,000</u>
CONTINGENCIES			LS	160,300
SUB-TOTAL, INITIAL DEVELOPMENT:				1,492,000
ENGINEERING AND DESIGN				104,000
SUPERVISION AND ADMINISTRATION				<u>104,000</u>
TOTAL FIRST COST, INITIAL DEVELOPMENT, (RECREATION FACILITIES)				2,416,000

about 415 acres. The Pavement Road reservoir is formed each year from the spring thaw runoff of melted snow and ice and any precipitation. The water is retained till drawn off through the year to maintain a constant lake level in the downstream Bowmansville Lake. In late autumn when the sub-impoundment is no longer needed to supply replenishment water to the Bowmansville Lake, what little water is left in the reservoir is released so as to prepare it for the next year's impoundment.

5.3.3 Selected Spillway

The selected spillway would be an ungated concrete gravity ogee section founded on rock, located on the creek course, some 1300 feet upstream of Pavement Road. Geologic conditions dictate a low elevation to the spillway foundation; the downstream Bowmansville Lake produces high tail water elevations at the spillway; the spillway is therefore designed to work under submerged conditions. It is a slotted bucket type, designed in accordance with U. S. Bureau of Reclamation recommendations. The total length of spillway is 645 feet and includes 9 piers 5-feet wide that support a maintenance bridge crossing over the spillway. The gorge opening is closed by the previously described spillway and concrete gravity section on each side of the spillway. The length of this gravity section is about 100 feet at each side of the spillway. The crest elevation of the spillway is 753.5 feet.

Due to the presence of pervious material in the area of the spillway and abutments, impervious blankets will need to be provided in the upstream zone of the structure. In view of a lack of geologic, borehole information, the length, thickness and details of this blanket will need to be determined in the final design stage when this information will be available from a drilling program. In this instance assumptions of soil conditions and rock elevations have been made from map reviews, site observations and discussions with quarry operators in the area. Riprap would be provided in the downstream zone of the spillway to prevent erosion.

5.3.4 Low-Level Outlet Works

The low level outlet works consist of three 3-foot diameter conduits through the spillway section, with the same type of valves and aeration devices as were described for the Bowmansville spillway.

5.3.5 Miscellaneous

The function of supply of make-up water to the Bowmansville Lake is a vital one but makes the lake level in the Pavement Road reservoir fluctuate over the year. At the end of each year this reservoir is emptied, since its storage volume is needed in the overall scheme of operation of the plan. This water-level fluctuation is environmentally disadvantageous. Fish life cannot exist, wildlife will soon leave the area for more stable habitats, vegetation will wither from alternate submergence and emergence, and the resulting effect will be generally aesthetically unattractive.

Pavement Road reservoir is formed in one quarry as may cause water problems in an adjacent quarry. These two quarries form a major part of the tax base in Lancaster and the loss of this tax base, without compensating incoming revenue, is liable to put a heavy financial burden on the local community.

5.3.6 Flood Reduction

Plates D19 and D19A show the extent of the flooded area without this structural measure and the reduction in flooded area caused by this plan.

Prior studies by the Corps of Engineers (1970 Survey Report For Flood Control and Allied Purposes) have shown that flood protection in Amherst from the Intermediate Regional Flood is obtained by regulating the flow at the Williamsville gage to 1800 cfs. Floodwater routing studies for the Bowmansville site show that releases from the reservoir during an Intermediate Regional Flood condition must not exceed 1100 cfs if the regulation figure of 1800 cfs at the Williamsville gage is not to be exceeded. At this rate of flow some flooding occurs in reaches 9 and 10. Structural measures for flood protection in these two reaches cannot be economically justified.

5.3.7 Estimate of Cost

Table 15.2 is an estimate of first costs for the Pavement Road dam and reservoir. Compensation costs for the flooded gravel quarries and gas wells have been derived without contact with the owners or operators, as such contact was considered to be potentially a source of future difficulties. Rational approaches and assessments of value have been used to derive compensation figures. Construction costs are based on late 1972 prices for this type of work in the Buffalo area. Overall costs also reflect the paucity of sub-surface geotechnical information and are a little conservative.

5.3.8 Annual Cost

Table 15.3 presents the Summary Estimate. Annual costs of this proposal include operation and maintenance charges, 5-1/2 percent interest on investment and amortization of investment over an assumed 100-year project life. Table 15.4 shows the computations for annual costs.

TABLE 15.2 - Pavement Road Reservoir

ITEM	QUANTITY	UNIT	UNIT COST	AMOUNT
<u>LAND AND DAMAGES</u>				
Lands - fee	450	AC	350	\$157,500
Residences (2)		LS		60,000
Acquisition Costs				21,800
Contingencies				47,700
				<u>\$287,000</u>
<u>RELOCATIONS</u>				
Gas wells (5)		LS		500,000
Gravel plants (2)		LS		500,000
Contingencies				200,000
Total relocations				<u>\$ 1,200,000</u>
<u>RESERVOIR CLEARING</u>				
Reservoir area	400	AC	544	217,600
Contingencies				43,500
Total reservoir clearing				<u>\$ 261,100</u>
<u>SPILLWAY AND LOW FLOW CONDUITS</u>				
Excavation (common)	227,420	CY	1.30	\$ 295,600
Excavation (rock)	4,200	CY	3.40	14,300
Dealing with water		LS		100,000
Blankets and Impervious fill	87,830	CY	5.50	483,100
Foundation preparation	8,000	SY	3.40	27,200
Concrete (mass)	85,270	CY	61.00	5,201,500
Concrete (structural)	500	CY	102.00	51,000
Concrete bridge	680	CY	200.00	136,000
Grout curtain		LS		75,000
Riprap	11,000	CY	14.00	154,000

ITEM	QUANTITY	UNIT	UNIT COST	AMOUNT	
				FEDERAL	NON-FEDERAL
Low level outlet valves			LS	\$ 40,000:	:
Drilling program			LS	50,000:	:
Miscellaneous Items			LS	50,000:	:
Contingencies			LS	800,000:	:
TOTAL				\$ 7,477,700:	:
SUB-TOTAL RELOCATIONS, RESERVOIR					
CLEARING, AND SPILLWAY				\$ 8,938,800:	:
ENGINEERING AND DESIGN					
				623,600:	:
SUPERVISION AND ADMINISTRATION					
				623,600:	:
FIRST COST-LESS LANDS					
				10,186,000:	:
TOTAL FIRST COSTS					
				10,473,000:	:

TABLE 15.3 - Bowmansville Lake - Pavement
Road Reservoir

ITEM	AMOUNT
<u>BOWMANVILLE RESERVOIR</u>	
Lands and Damages	\$ 4,441,000
Relocations	560,000
Reservoir clearing	209,500
Dams and Levees	5,591,000
Spillway and low flow conduit	2,666,500
Engineering and Design	608,000
Supervision and administration	608,000
Total First Costs, less lands	10,243,000
Total First Cost	14,684,000
Interest During Construction	563,300
Investment Cost for Bowmansville:	\$15,247,300
Reservoir:	
<u>RECREATION FACILITIES</u>	
Land and Damages	\$ 716,000
Picnic Areas	728,100
Boat Launching facilities	79,400
Sanitation Facilities	140,000
Water supply	86,000
Roads	197,400
Playgrounds	40,800
Administration Buildings	60,000
Contingencies, engineering, supervision, administration, etc.	368,300
First Cost, less lands	1,700,000
Total First Cost	2,416,000
Interest During Construction	93,500
Investment Cost for Recreation:	
Facilities:	\$ 2,509,500
<u>PAVEMENT RESERVOIR</u>	
Lands and Damages	\$ 287,000
Relocations	1,200,000
Reservoir clearing	261,100
Spillway and low flow conduit	7,477,700
Engineering and Design	623,600
Supervision and Administration	623,600
Interest during construction	560,200
Investment for Pavement	
Reservoir:	\$11,033,200
GRAND TOTAL INVESTMENT COST	\$28,790,000

TABLE 15.4 - Annual Costs for Bowmansville - Pavement Scheme.

ITEM	AMOUNT
<u>ANNUAL COSTS</u>	
Interest (5½ percent)	\$1,583,500
Amortization (100 years)	7,500
Maintenance	240,000
TOTAL	\$1,831,000

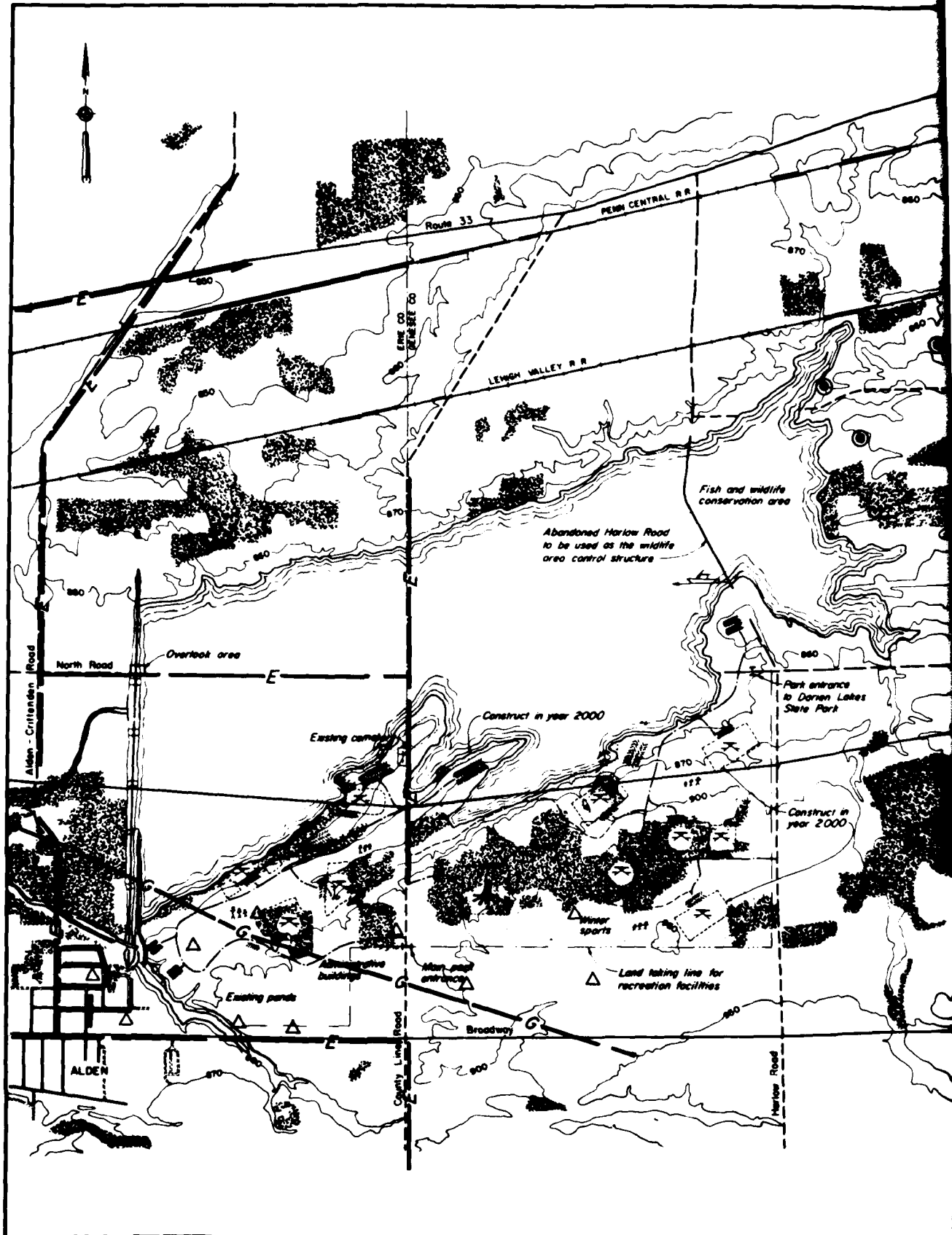

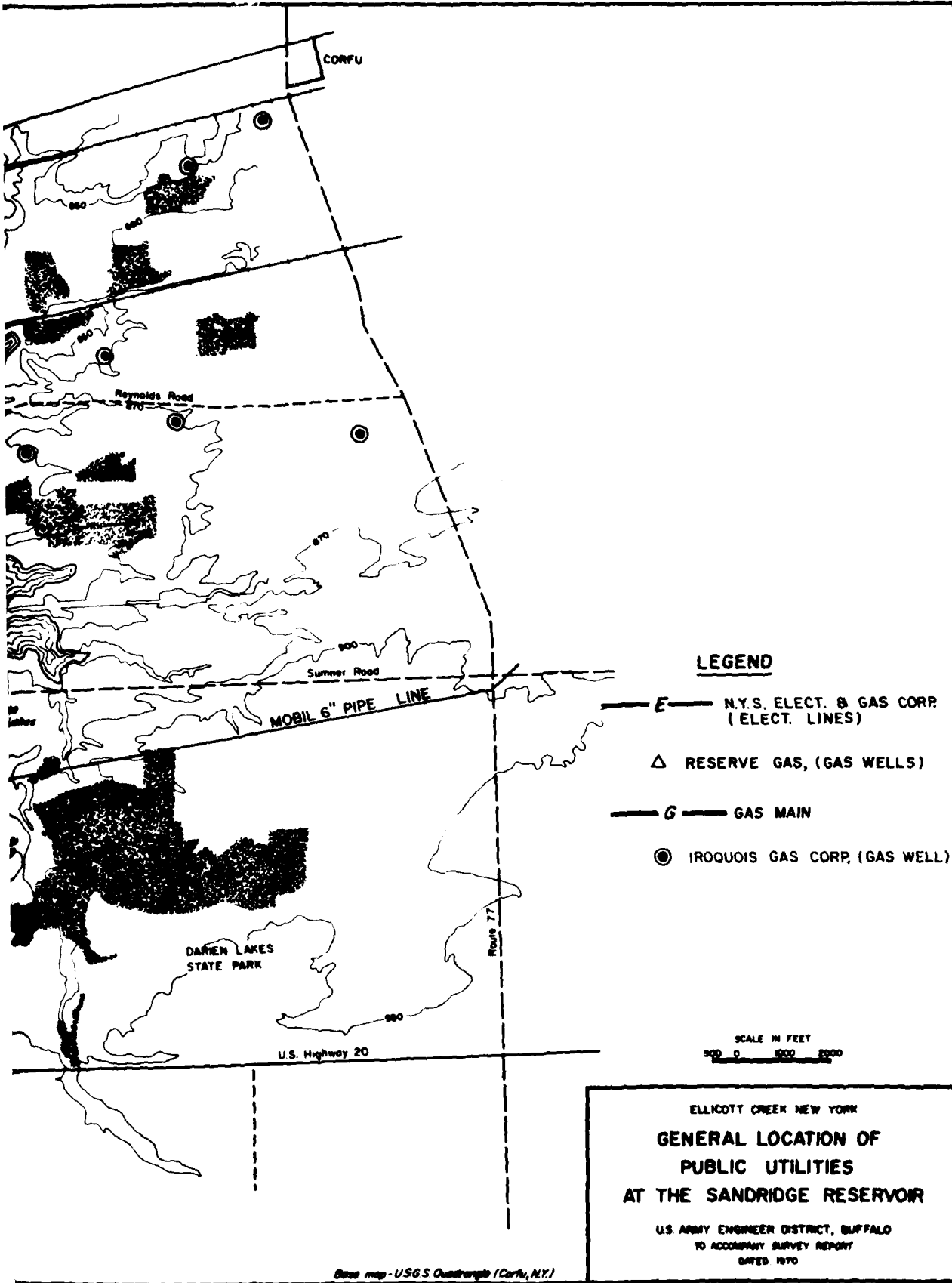

LEGEND

- E** N.Y.S. ELECT. & GAS CORP. (ELECT. LINES)
- △** RESERVE GAS, (GAS WELLS)
- G** GAS MAIN
- IROQUOIS GAS CORP. (GAS WELL)

SCALE IN FEET
 500 0 1000 2000

ELLICOTT CREEK NEW YORK
**GENERAL LOCATION OF
 PUBLIC UTILITIES
 AT THE SANDRIDGE RESERVOIR**
 U.S. ARMY ENGINEER DISTRICT, BUFFALO
 TO ACCOMPANY SURVEY REPORT
 DATED 1970

Base map - U.S.G.S. Quadrangle (Corfu, N.Y.)

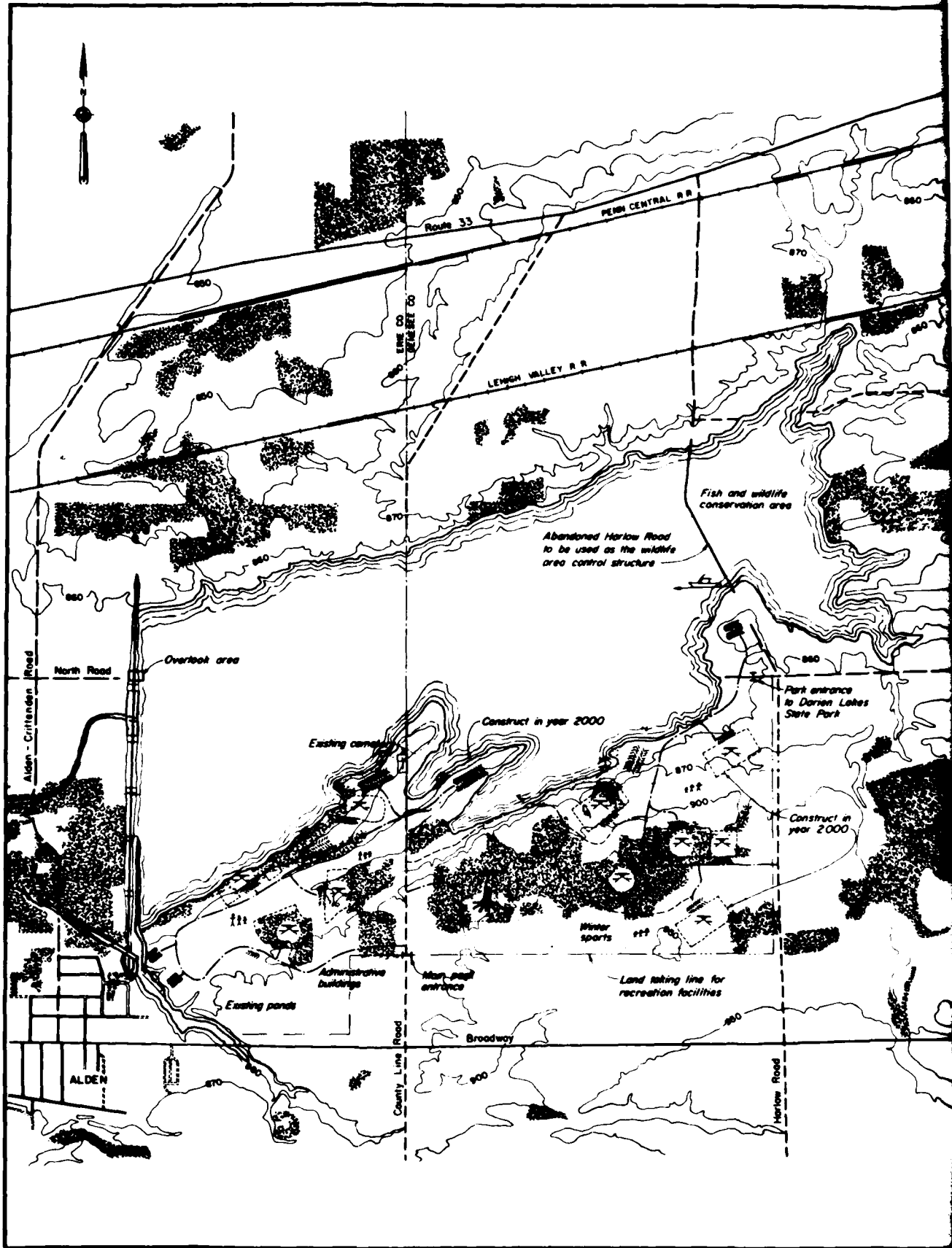

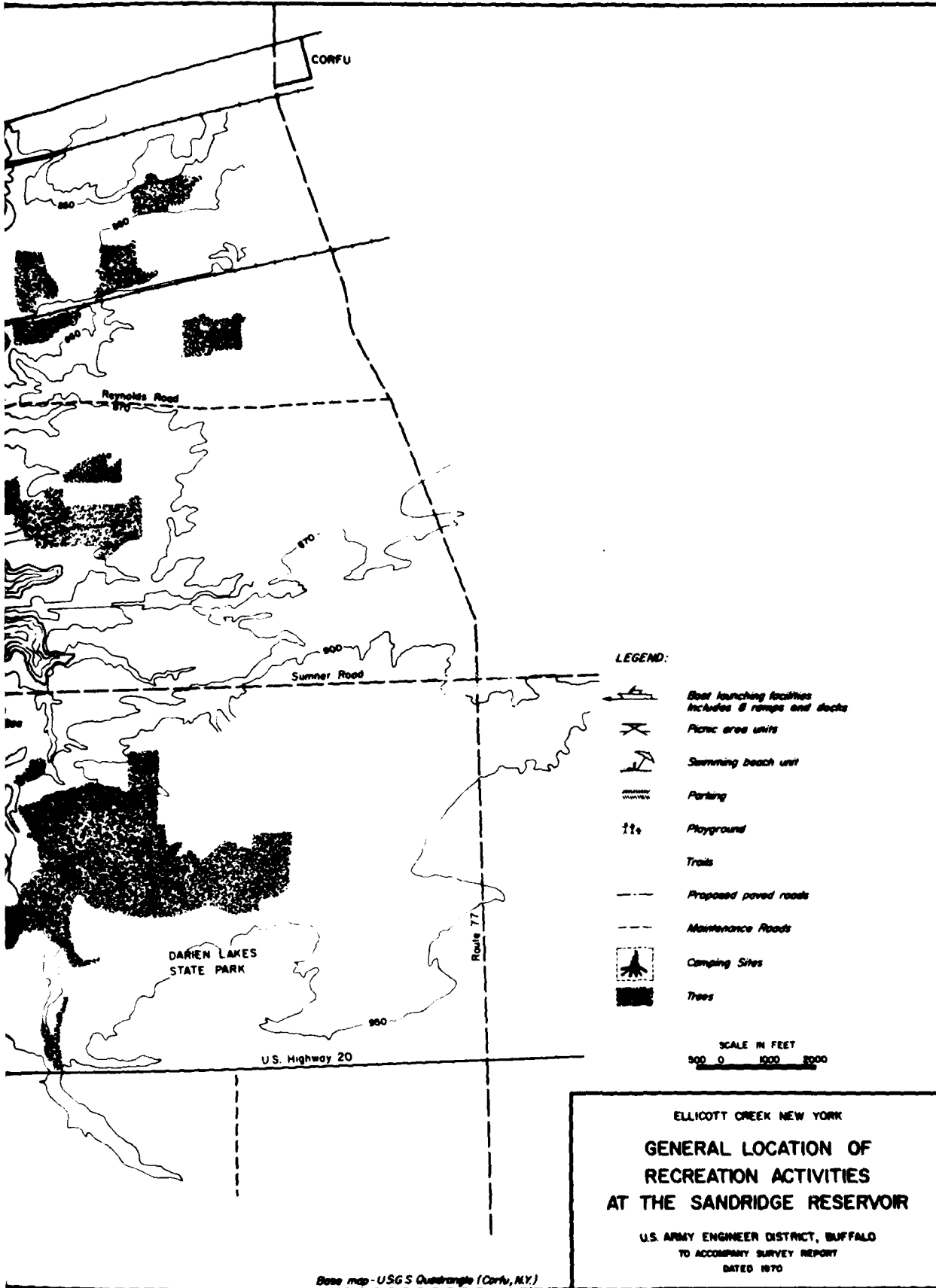

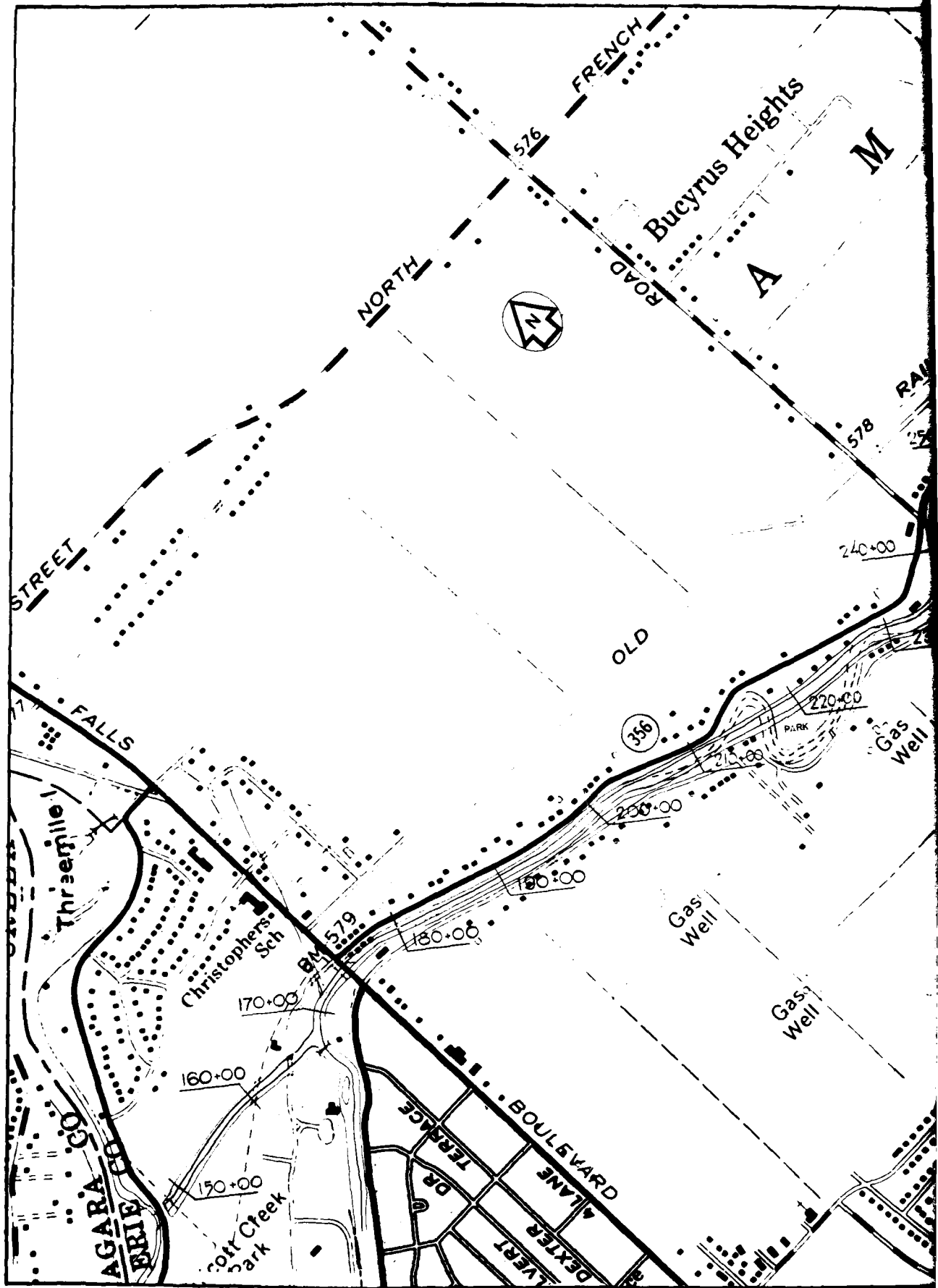

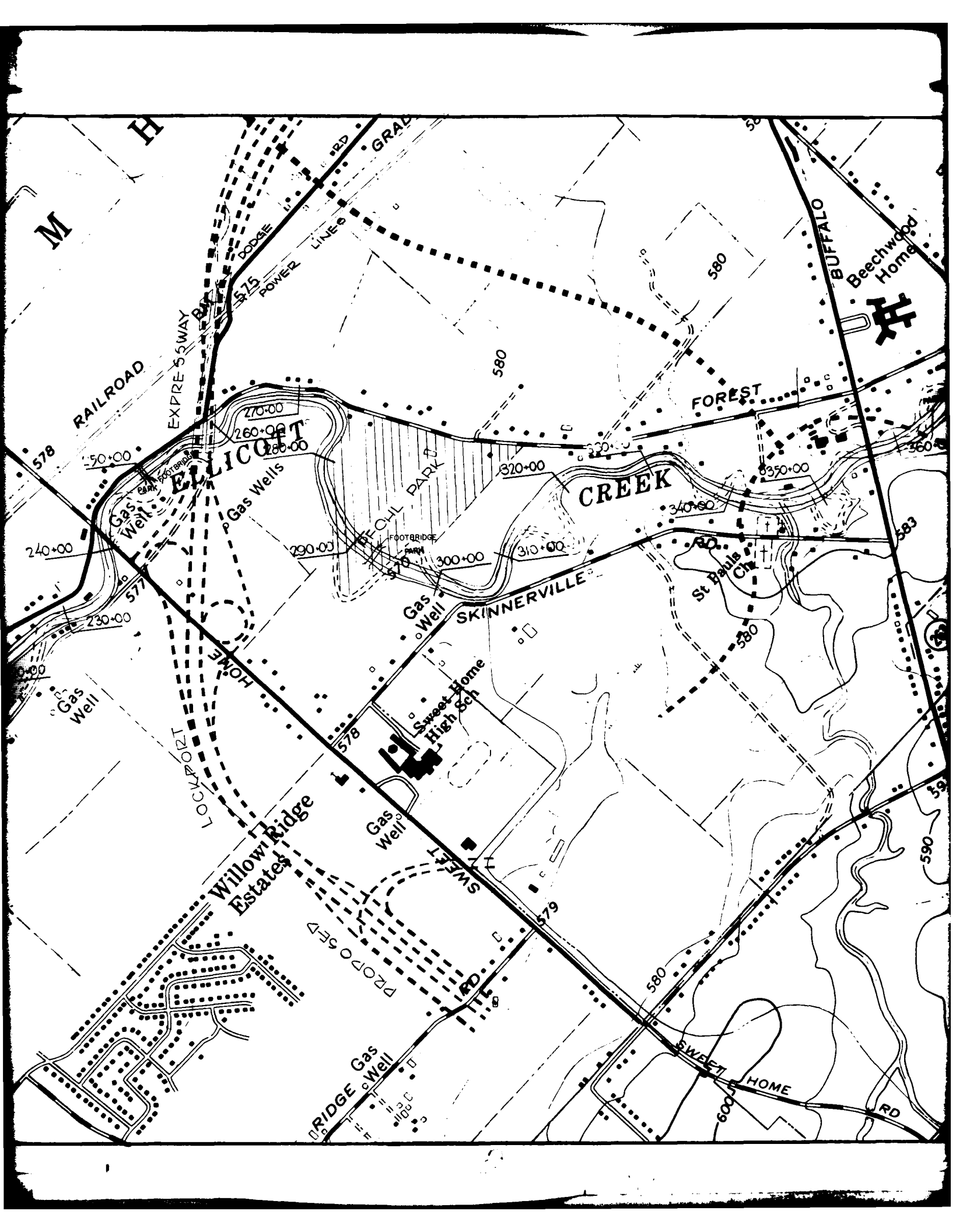

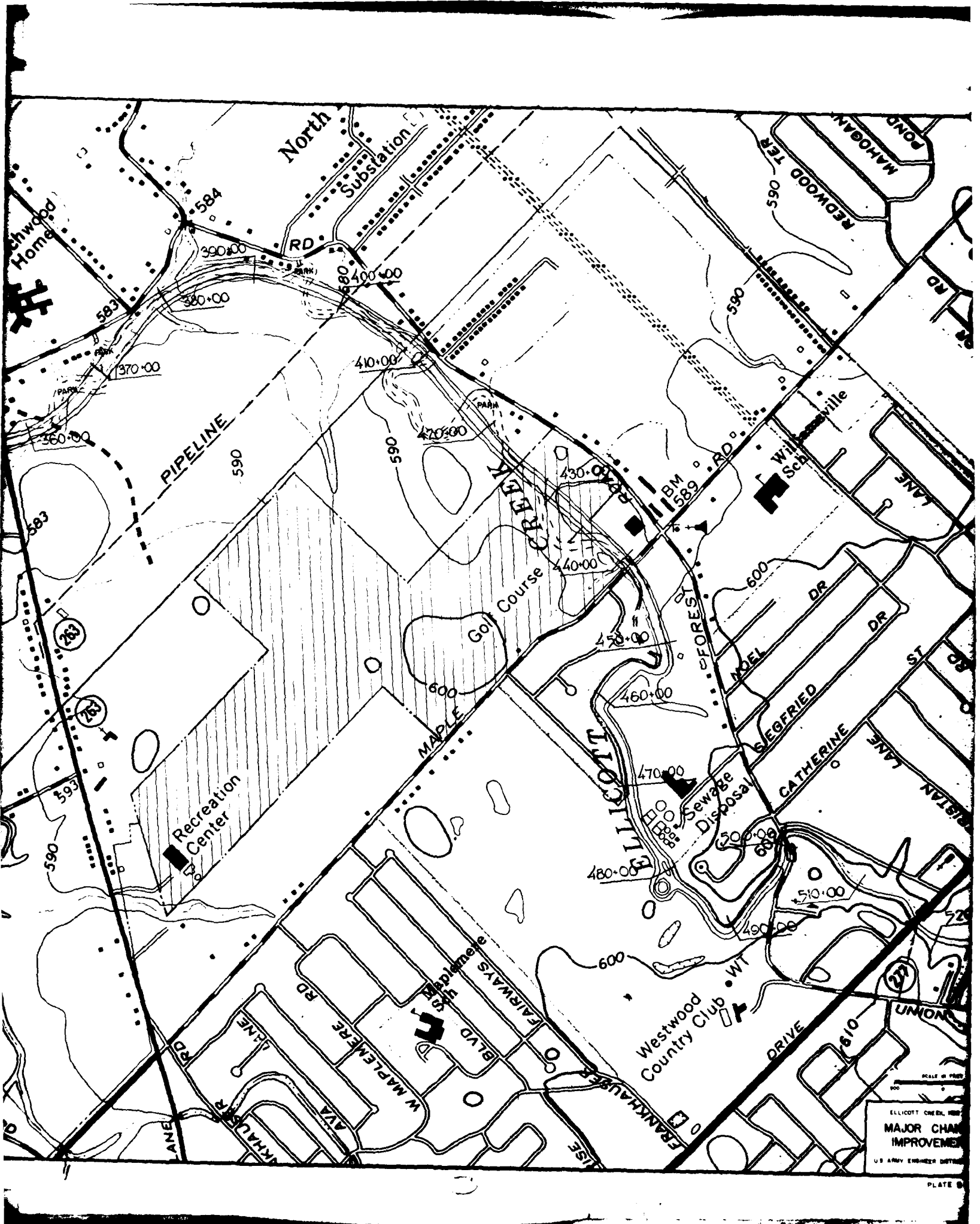

SCALE 1" = 100'
ELLICOTT CREED, INC.
MAJOR CHANNEL IMPROVEMENT
U.S. ARMY ENGINEER DISTRICT
PLATE 8

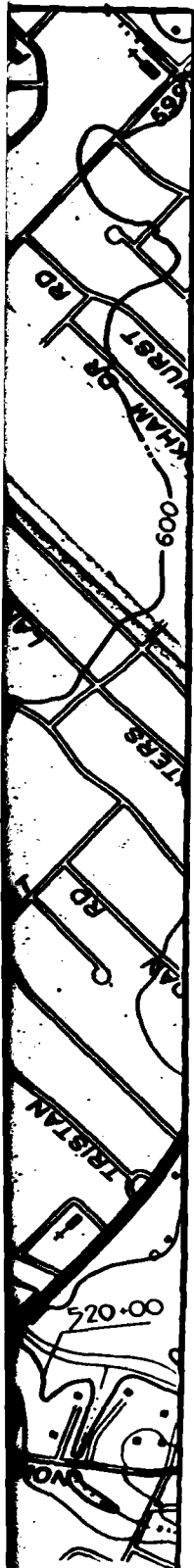

GREENE, NEW YORK
CHANNEL
MOVEMENTS
SHEEP CREEK DISTRICT, BUFFALO
PLATE D 3

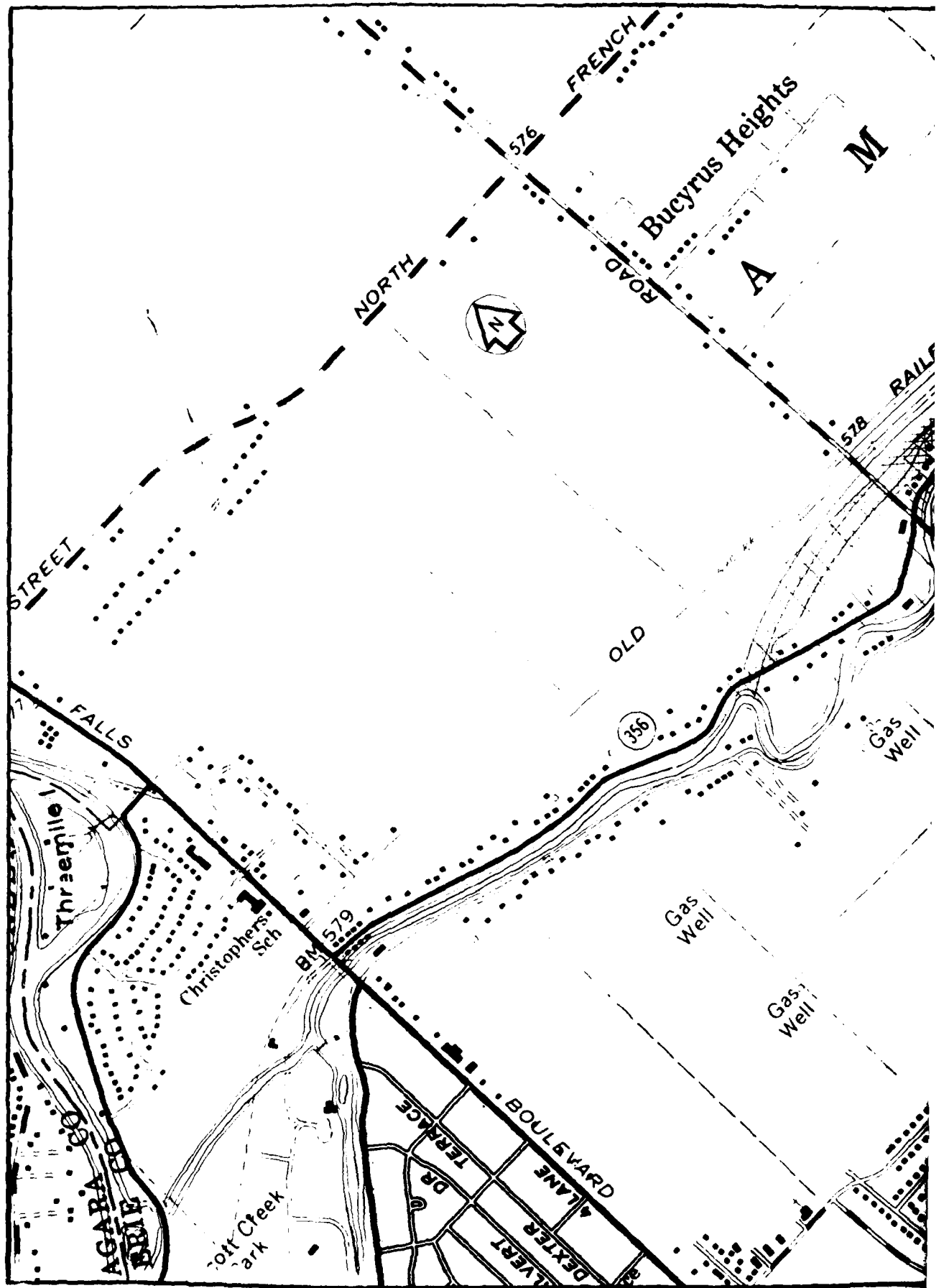

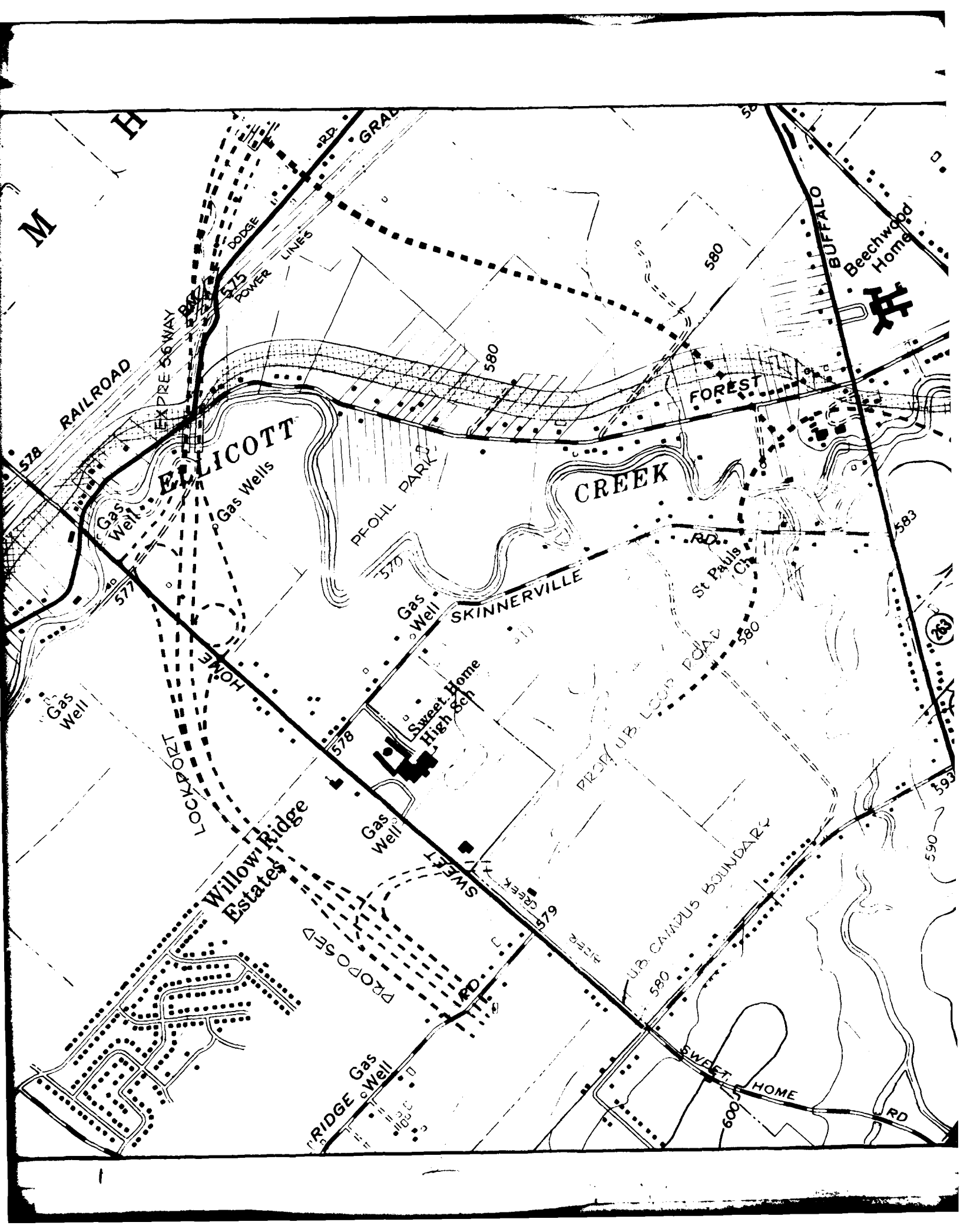

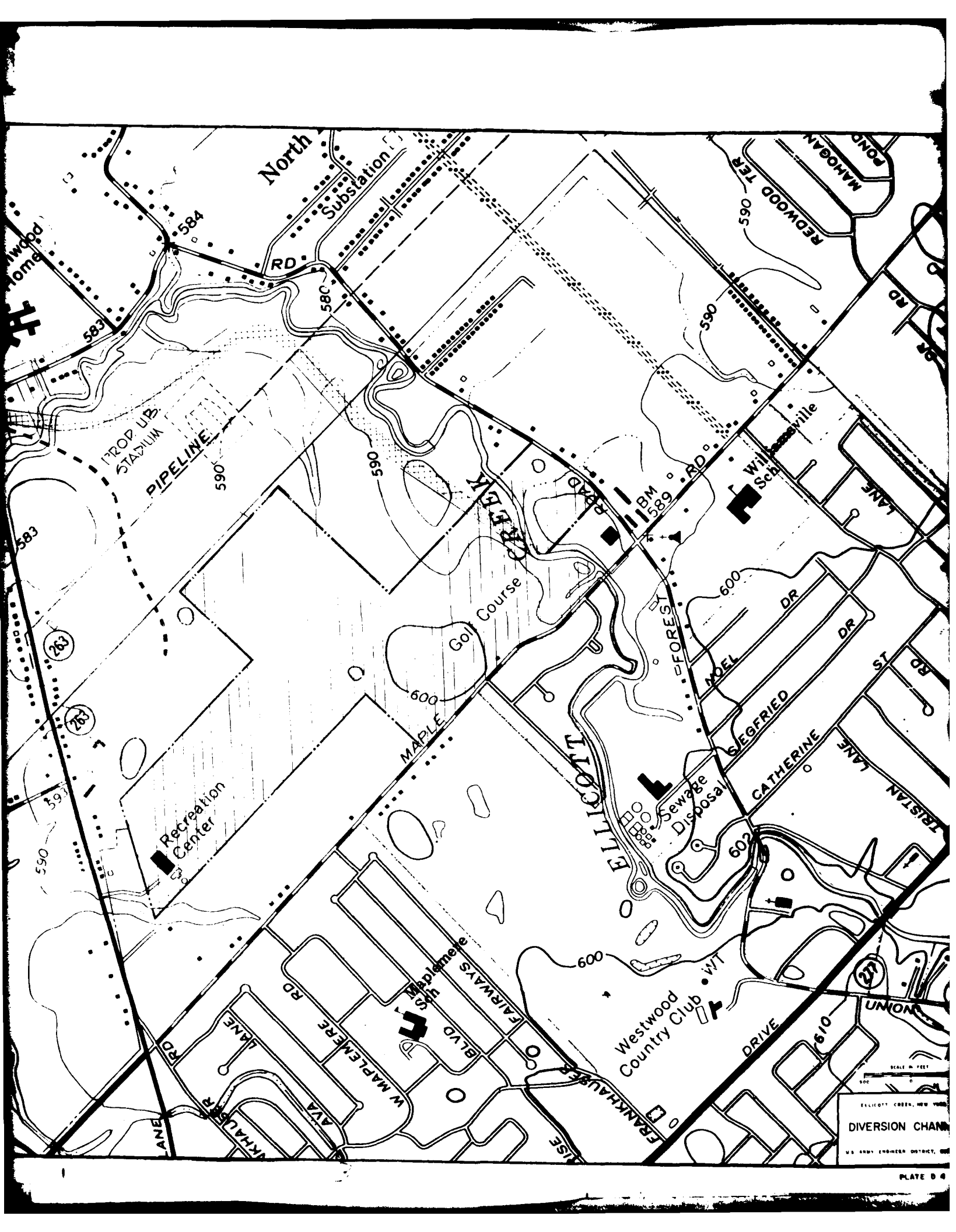

SCALE IN FEET
1" = 500'
ELLIPTIC CREEK, NEW YORK
DIVERSION CHANNEL
U.S. ARMY ENGINEER DISTRICT, NEW YORK

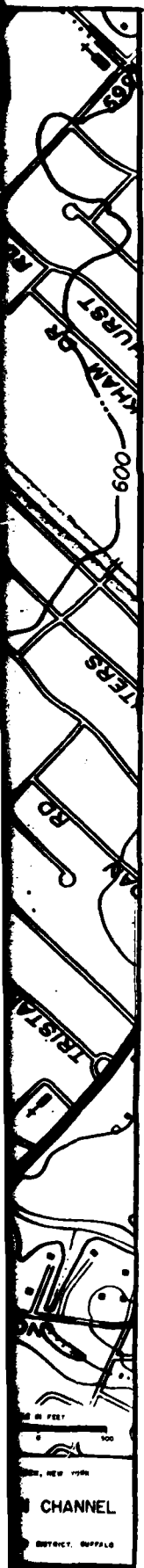

0 500
NEW YORK
DISTRICT, BUFFALO
CHANNEL
DATE 0 0 /

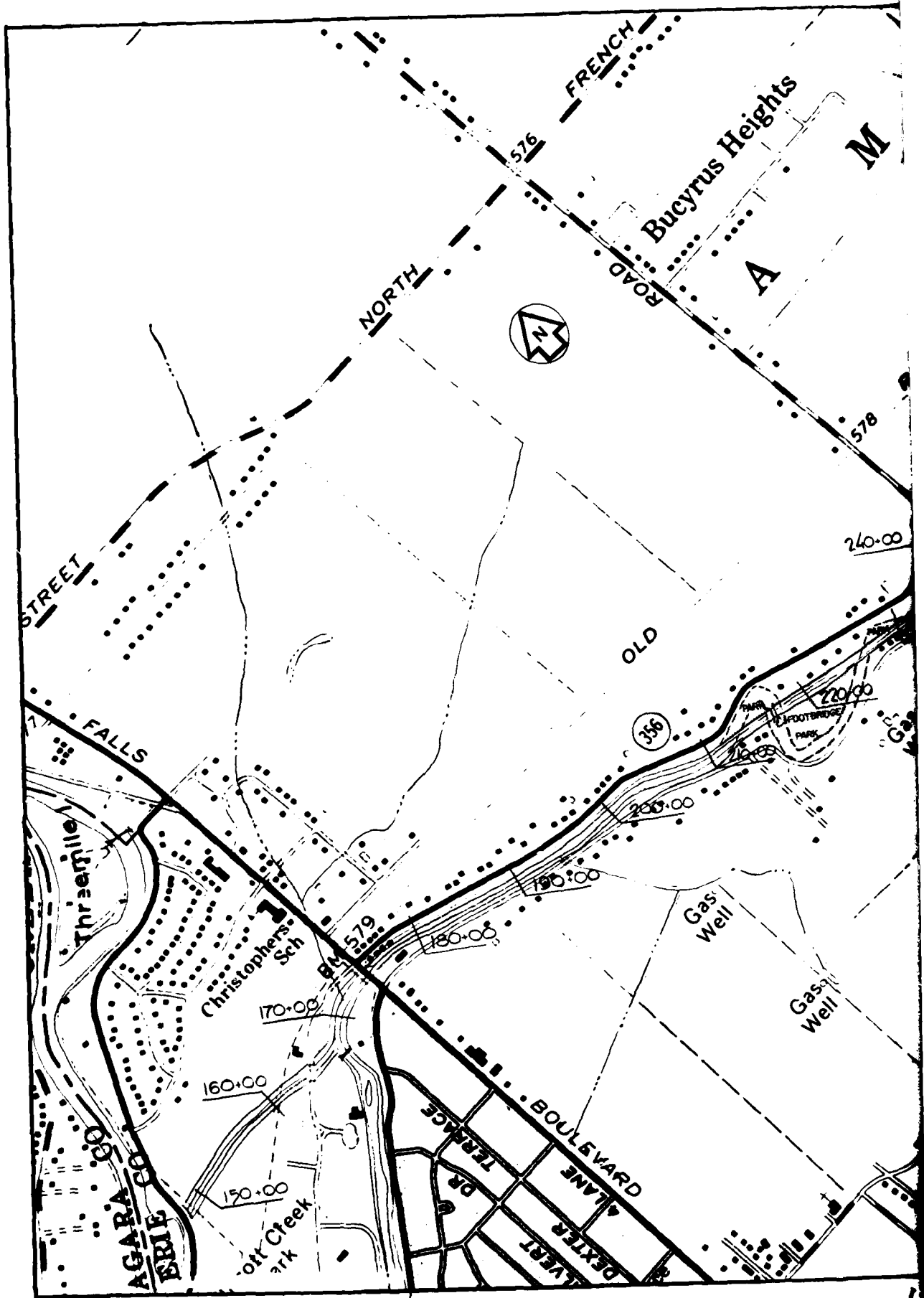

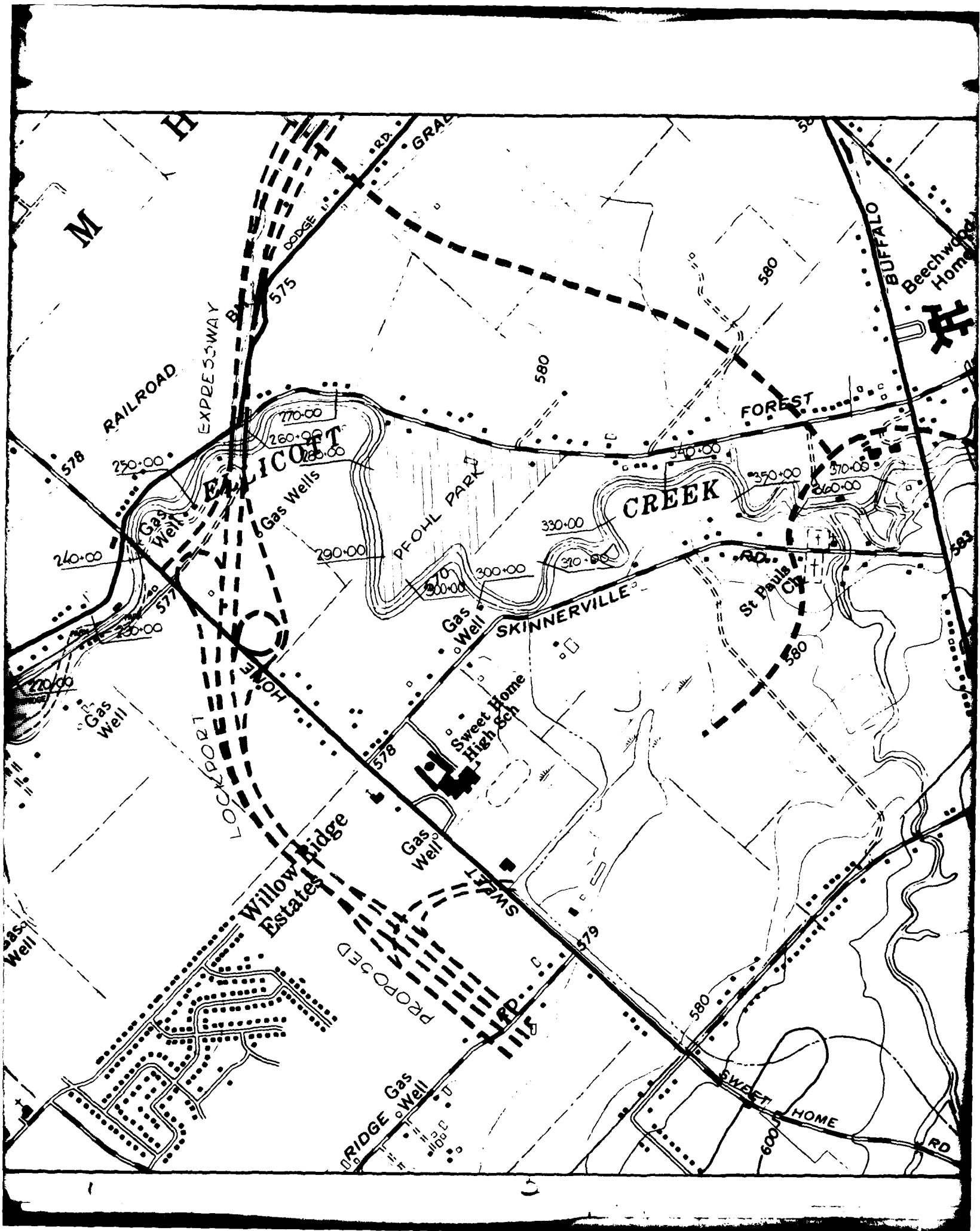

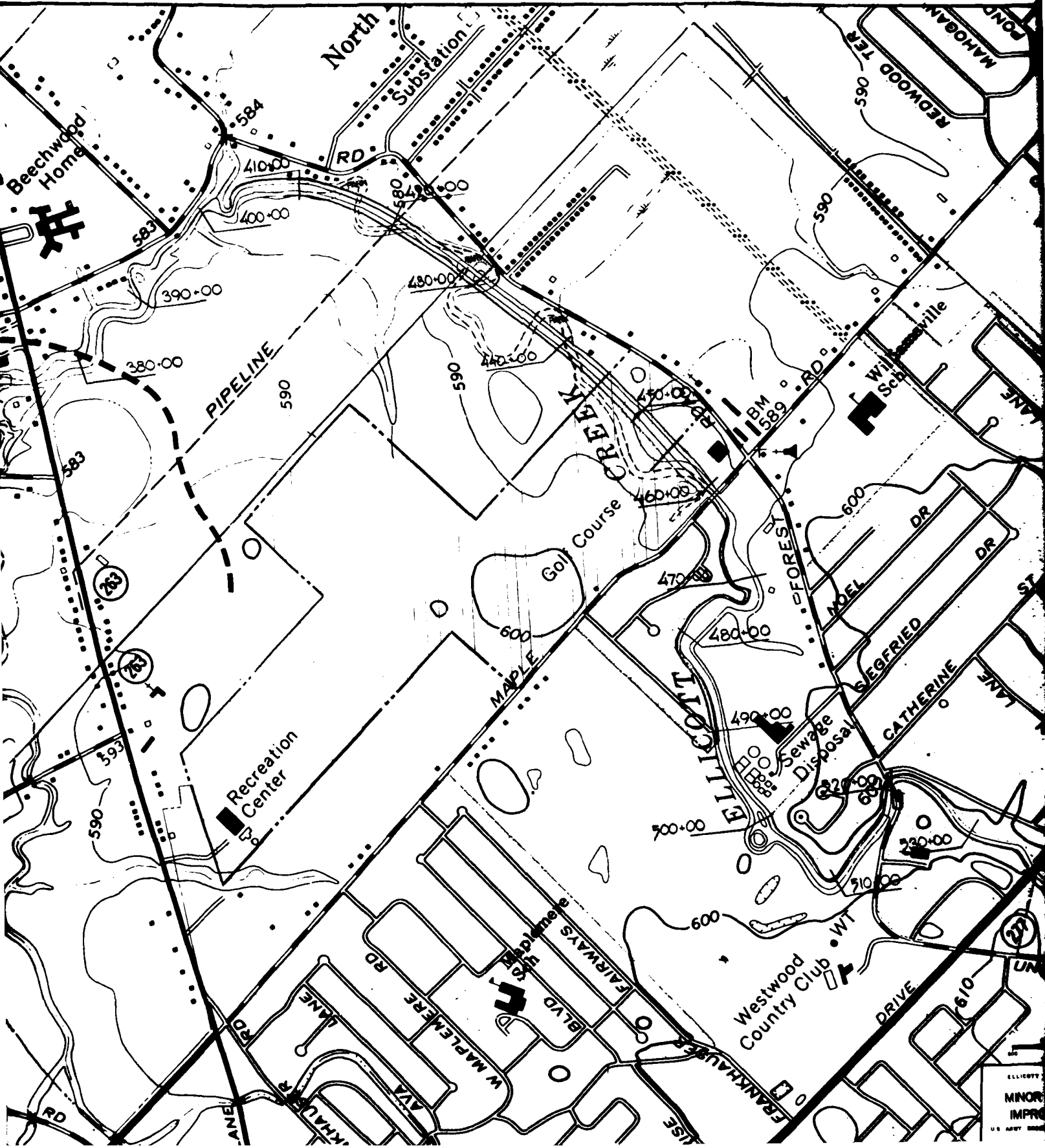

ILLINOIS
MINOR
IMPRO
U.S. ARMY ENGINEERS

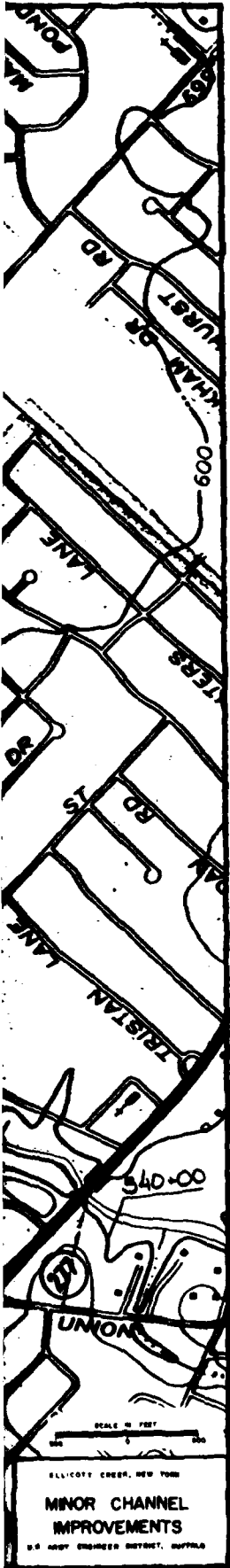
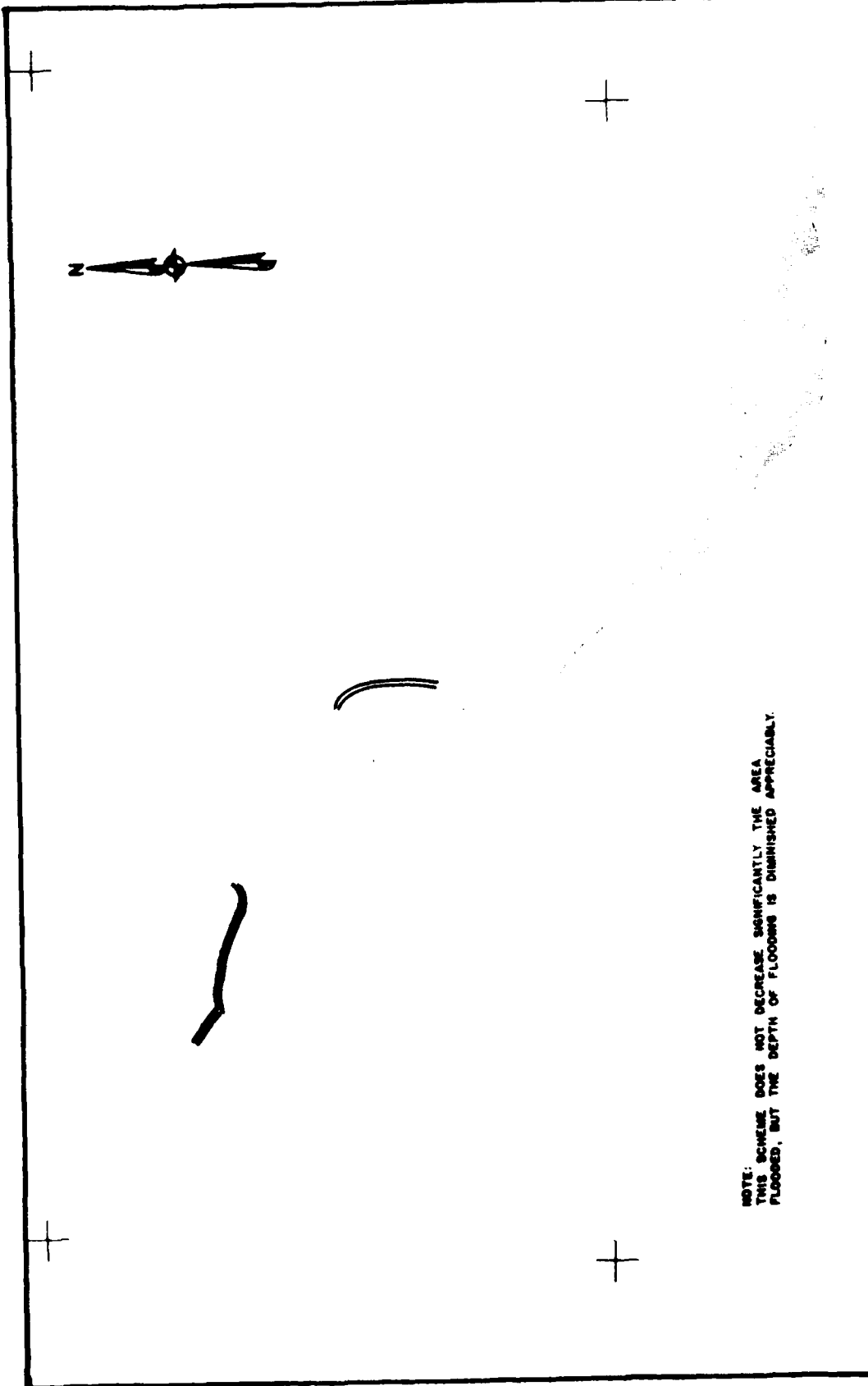

PLATE 05



NOTE: THIS SCHEME DOES NOT DECREASE SIGNIFICANTLY THE AREA FLOODED, BUT THE DEPTH OF FLOODING IS DIMINISHED APPRECIABLY.



ELLCOTT CREEK, NEW YORK
**FLOODING REDUCTION WITH
 SANDRIDGE SCHEME**
 U. S. ARMY ENGINEER DISTRICT, BUFFALO

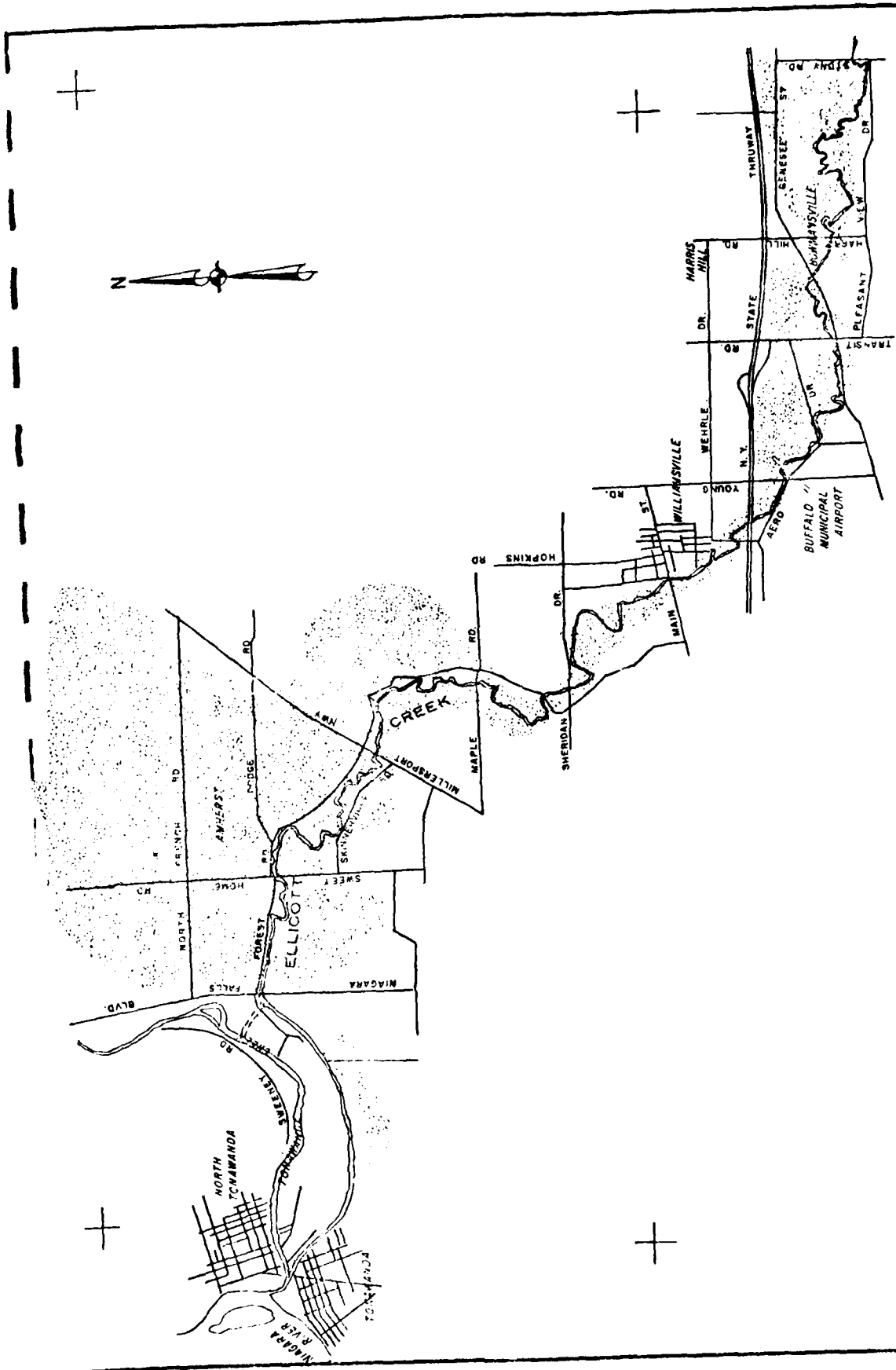

ELLICOTT CREEK, NEW YORK
**ELLICOTT CREEK FLOODPLAIN
 INTERMEDIATE REGIONAL
 FLOOD**
 U.S. ARMY ENGINEER DISTRICT, BUFFALO



YEAR II

S O N D J F M A M J J A S O N D

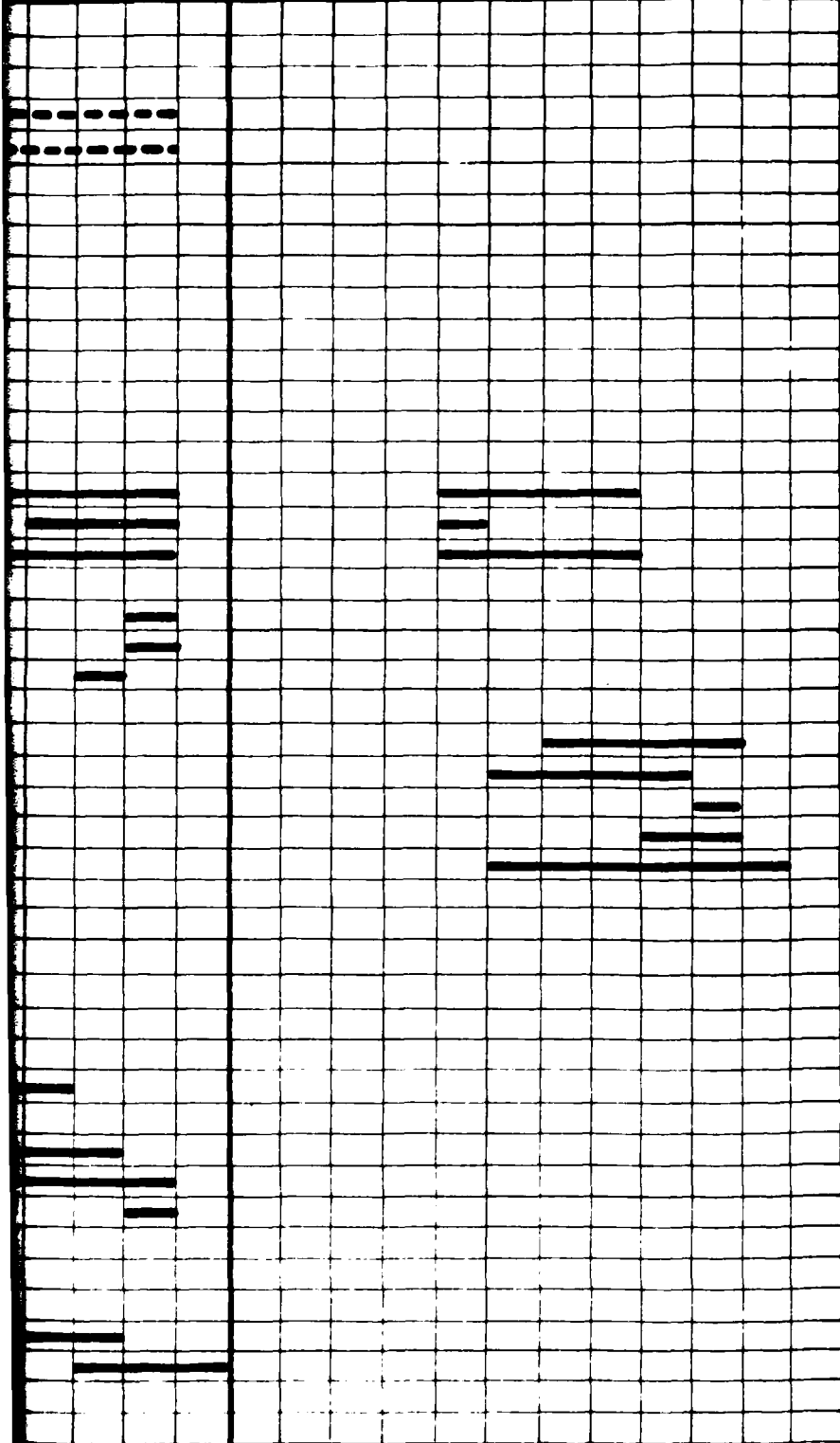

ELLICOTT CREEK, NEW YORK

CONSTRUCTION SCHEDULE
SANDRIDGE SCHEME

U. S. ARMY ENGINEER DISTRICT. BUFFALO

PLATE D-7

MINOR CHANNEL IMPROVEMENTS

YEAR I

J F M A M J J A S O

RELOCATIONS

- MODIFY NI. F. BLVD. BRIDGE
- MODIFY SWEET HOME ROAD BRIDGE
- MODIFY MAPLE ROAD BRIDGE
- MODIFY NORTH FOREST RD. BRIDGE
- MODIFY DRAINAGE OUTLETS
- MODIFY SEWER SIPHON

CHANNELS

- CLEARING
- EXCAVATION
- EMBANKMENT
- RIPRAP
- SEEDING
- DIVERSION CHANNEL

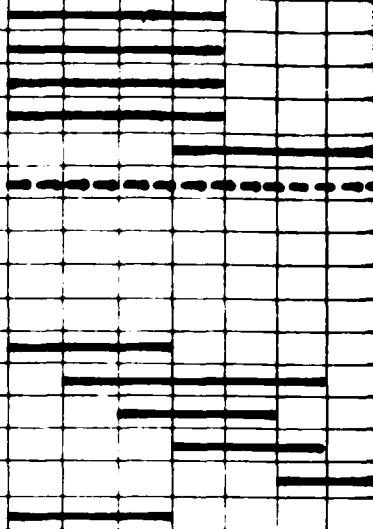

YEAR II

S O N D J F M A M J J A S O N D

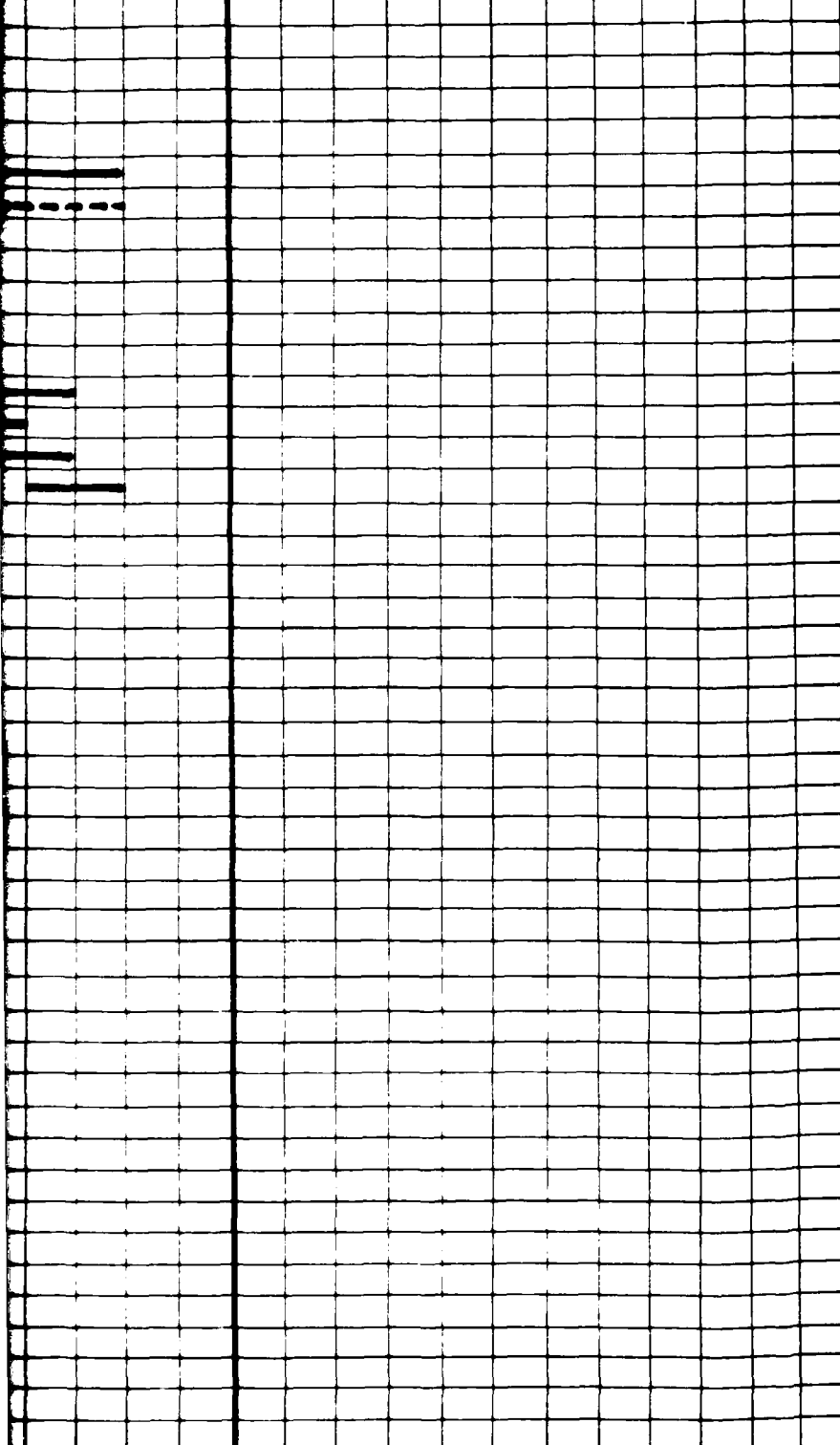

----- DISCONTINUOUS ACTIVITY

ELLICOTT CREEK, NEW YORK

CONSTRUCTION SCHEDULE
SANDRIDGE SCHEME

U. S. ARMY ENGINEER DISTRICT, BUFFALO
PLATE D-7 CONT'D.

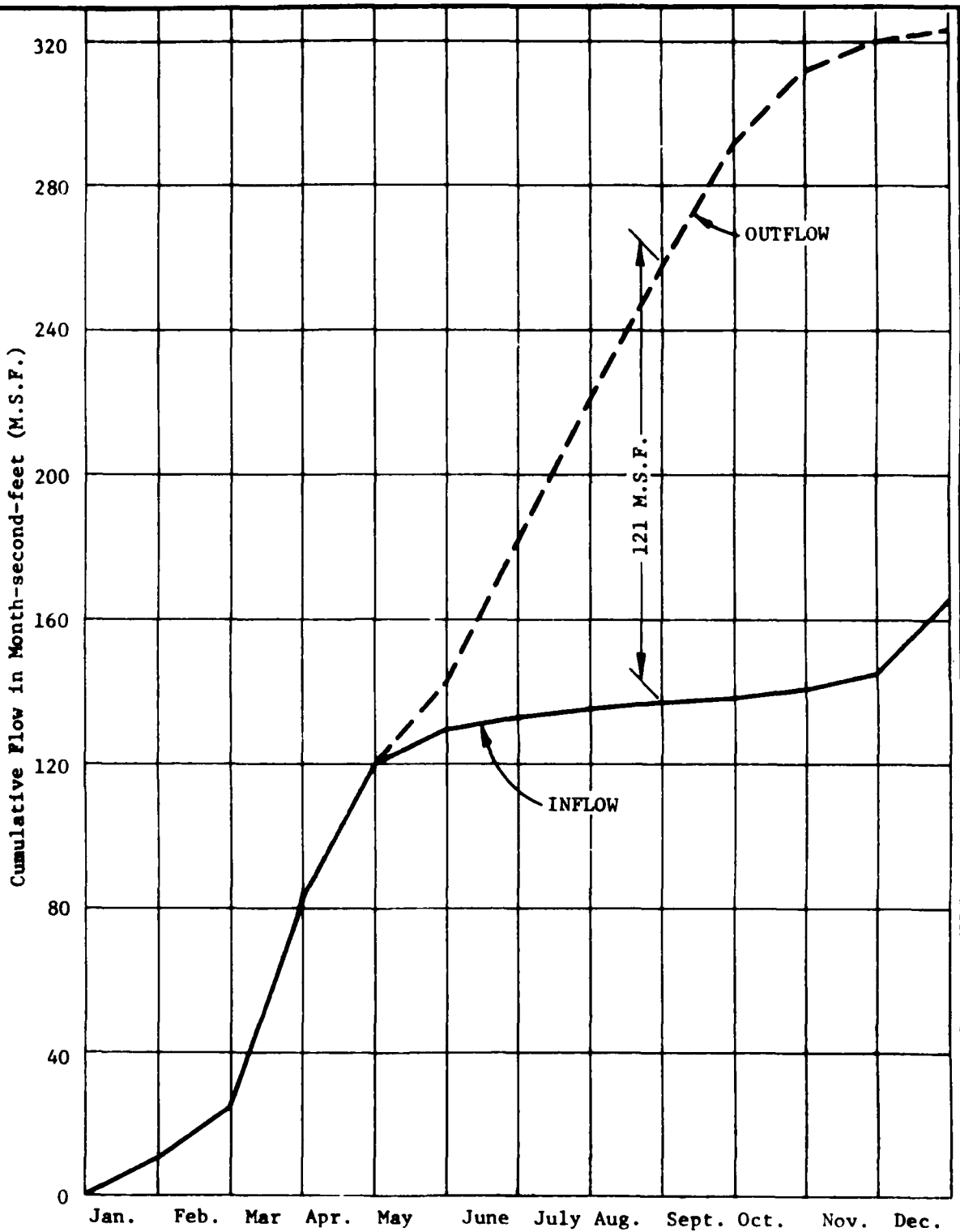

NOTE: Inflow curve shows the cumulative low flows expected once in 20 years. Outflow curve shows releases for water quality and water supply plus evaporation losses.

ELLICOTT CREEK, NEW YORK

**SANDRIDGE RESERVOIR
MASS CURVE**

U. S. ARMY ENGINEER DISTRICT, BUFFALO

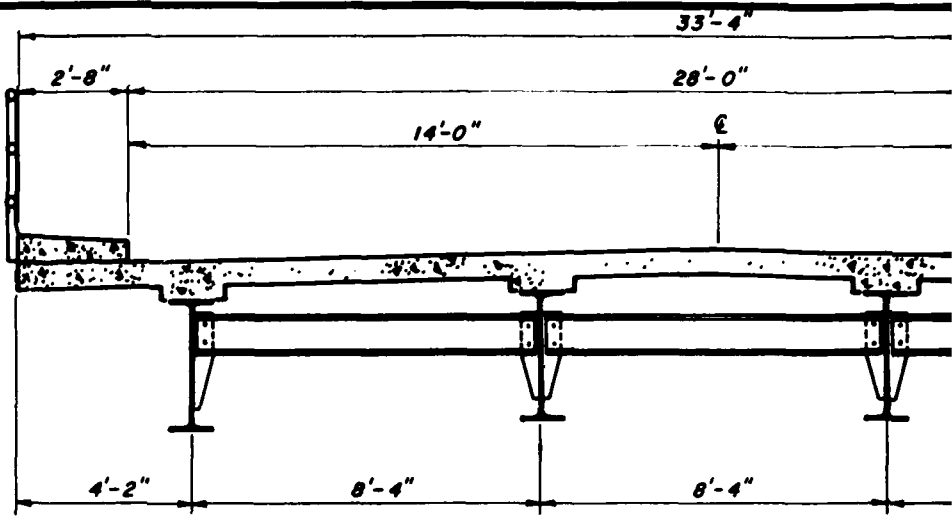

SECTION

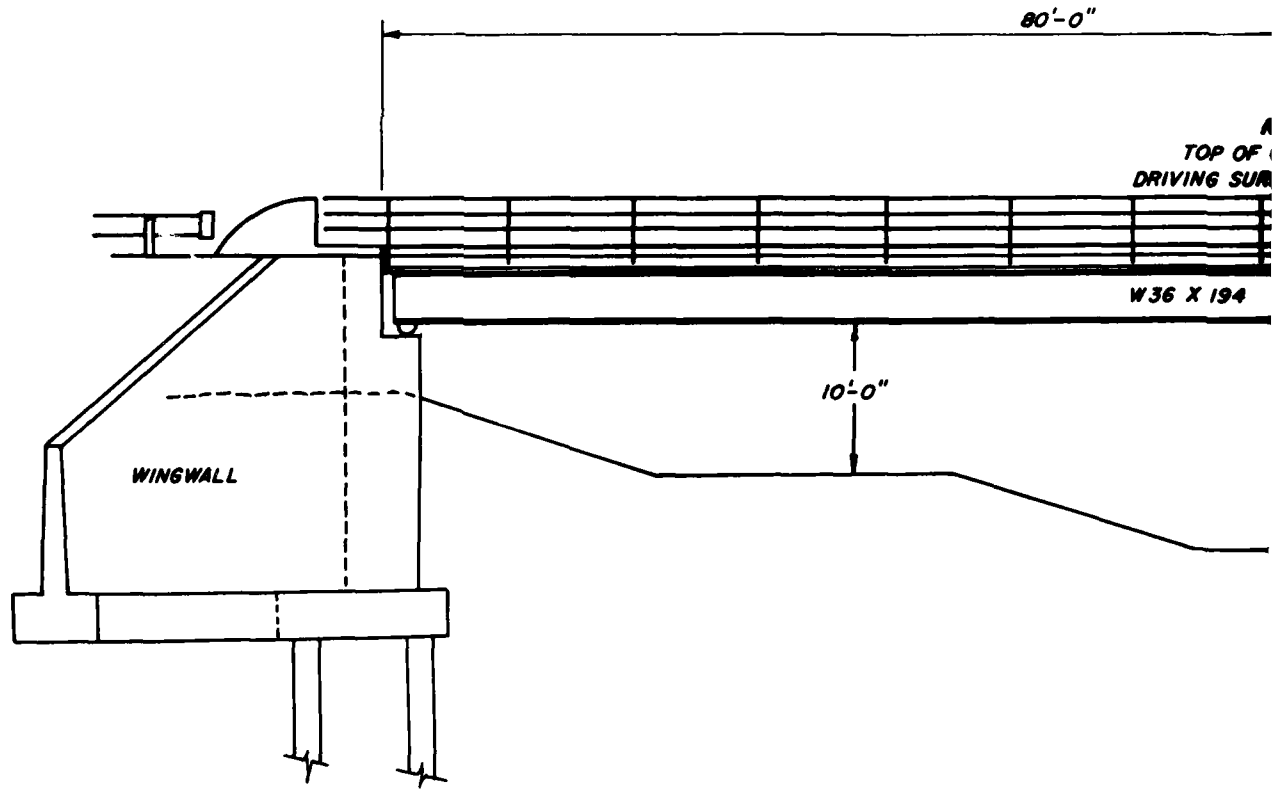

TOP OF
DRIVING SUR

W36 X 194

WINGWALL

10'-0"

80'-0"

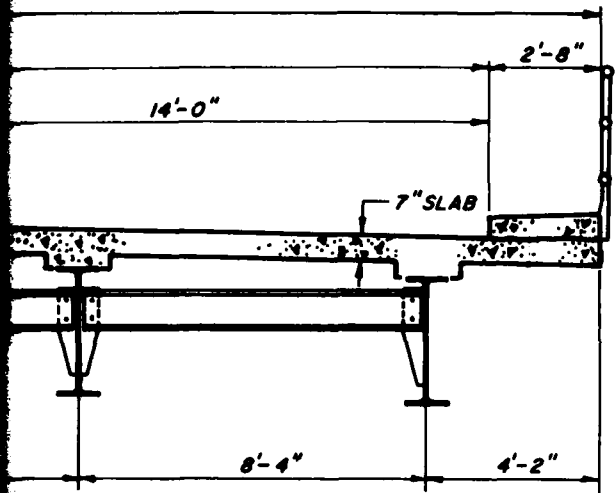

80'-0"

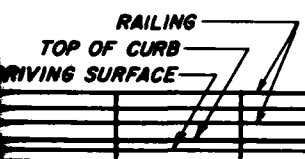

36 X 194

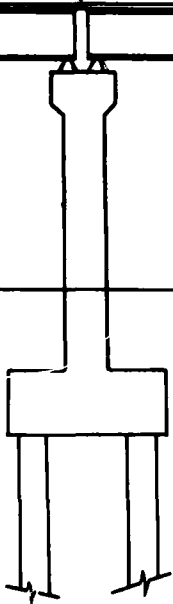

ELEVATION

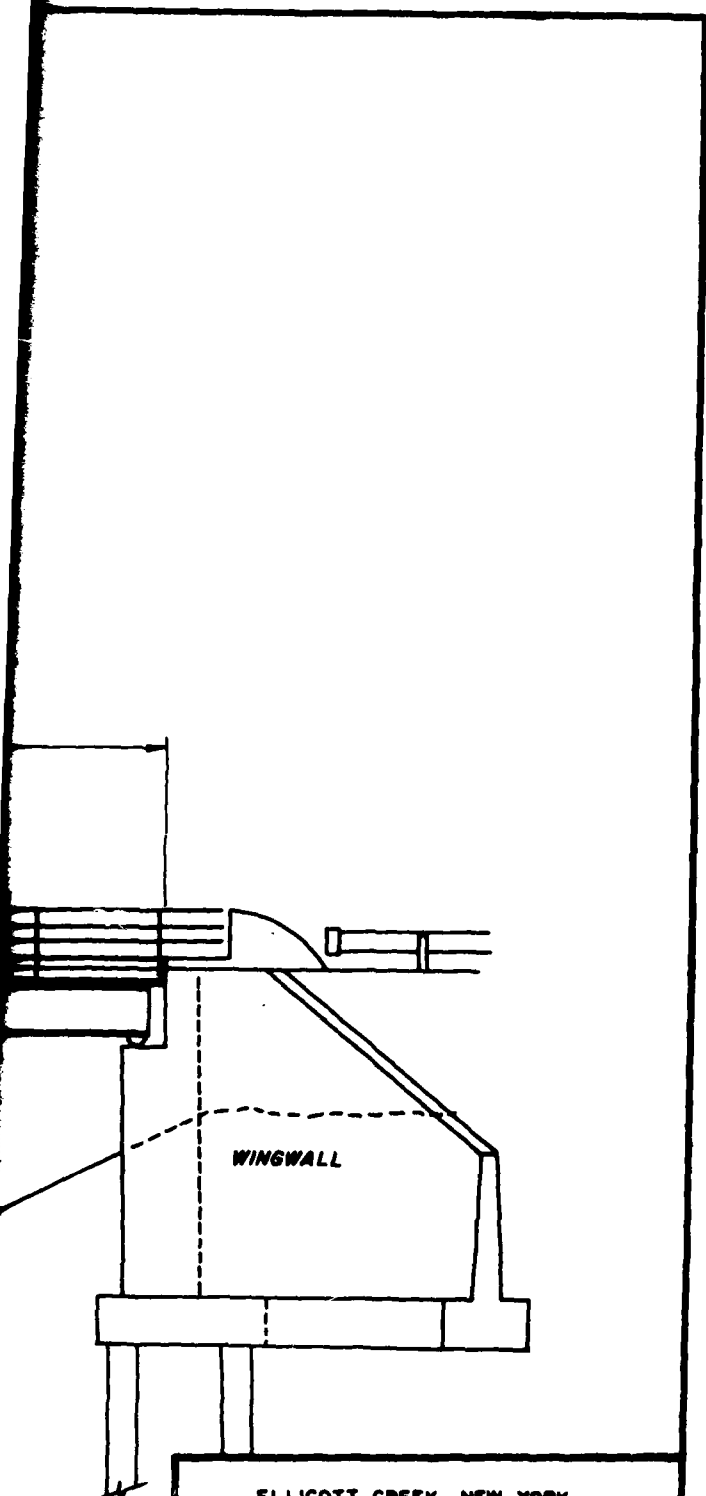

WINGWALL

ELLICOTT CREEK, NEW YORK
TYPICAL BRIDGE OVER
DIVERSION CHANNEL
U.S. ARMY ENGINEER DISTRICT, BUFFALO

PLATE D9

3

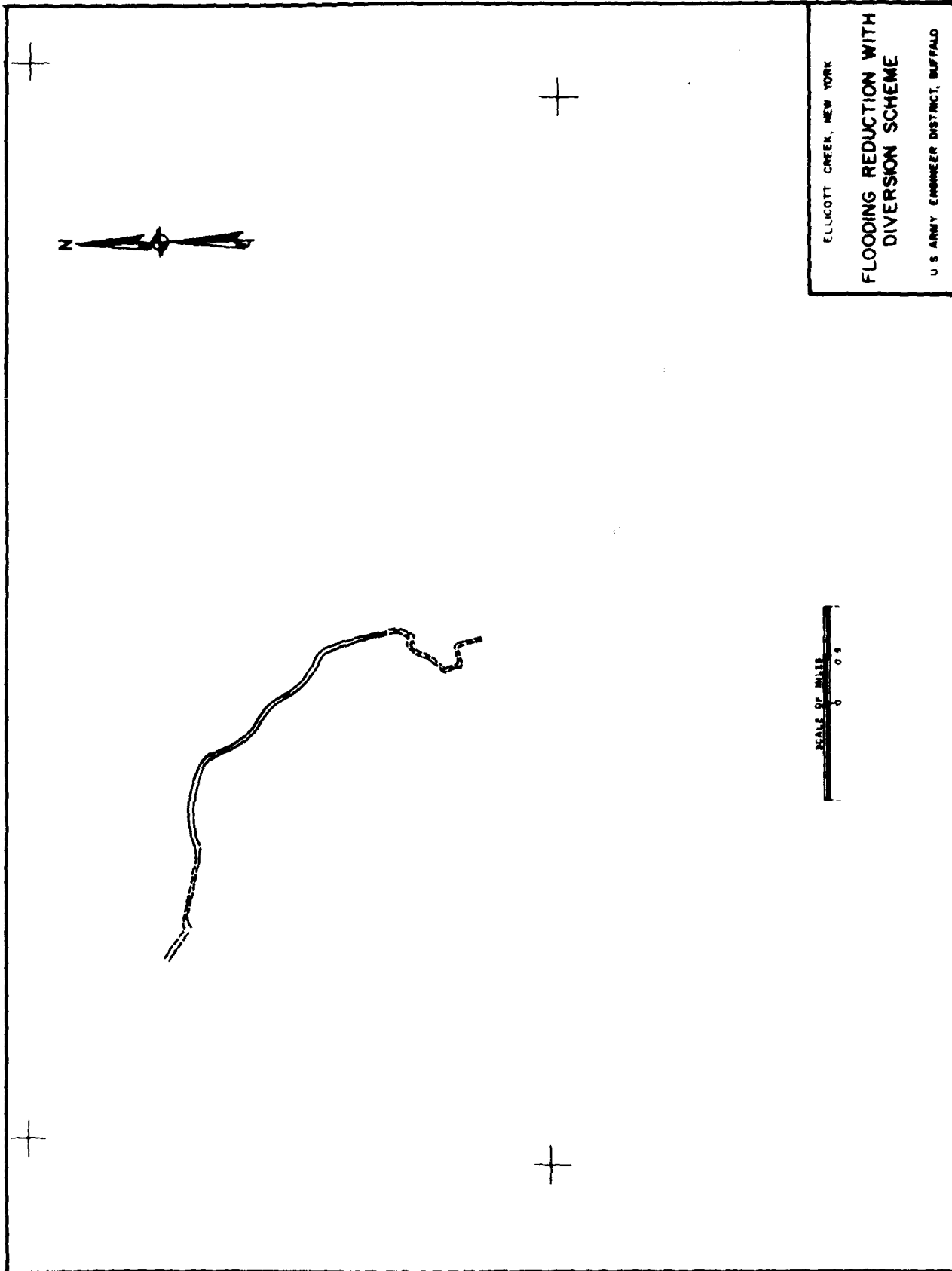

ELLICOTT CREEK, NEW YORK

FLOODING REDUCTION WITH
DIVERSION SCHEME

U S ARMY ENGINEER DISTRICT, BUFFALO



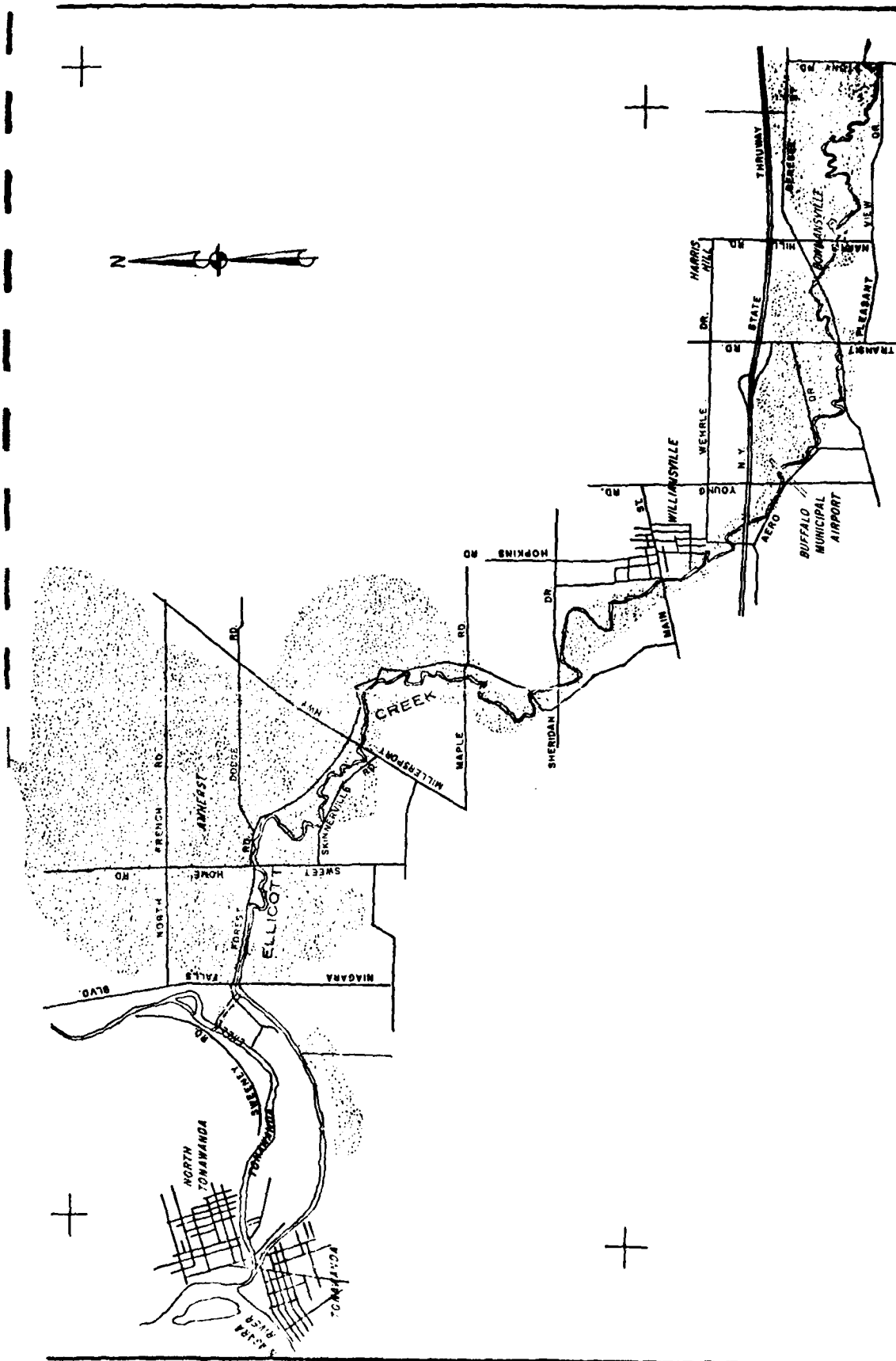

ELLICOTT CREEK, NEW YORK
**ELLICOTT CREEK FLOODPLAIN
 INTERMEDIATE REGIONAL
 FLOOD**
 U.S. ARMY ENGINEER DISTRICT, BUFFALO



YEAR II

S O N D J F M A M J J A S O N D

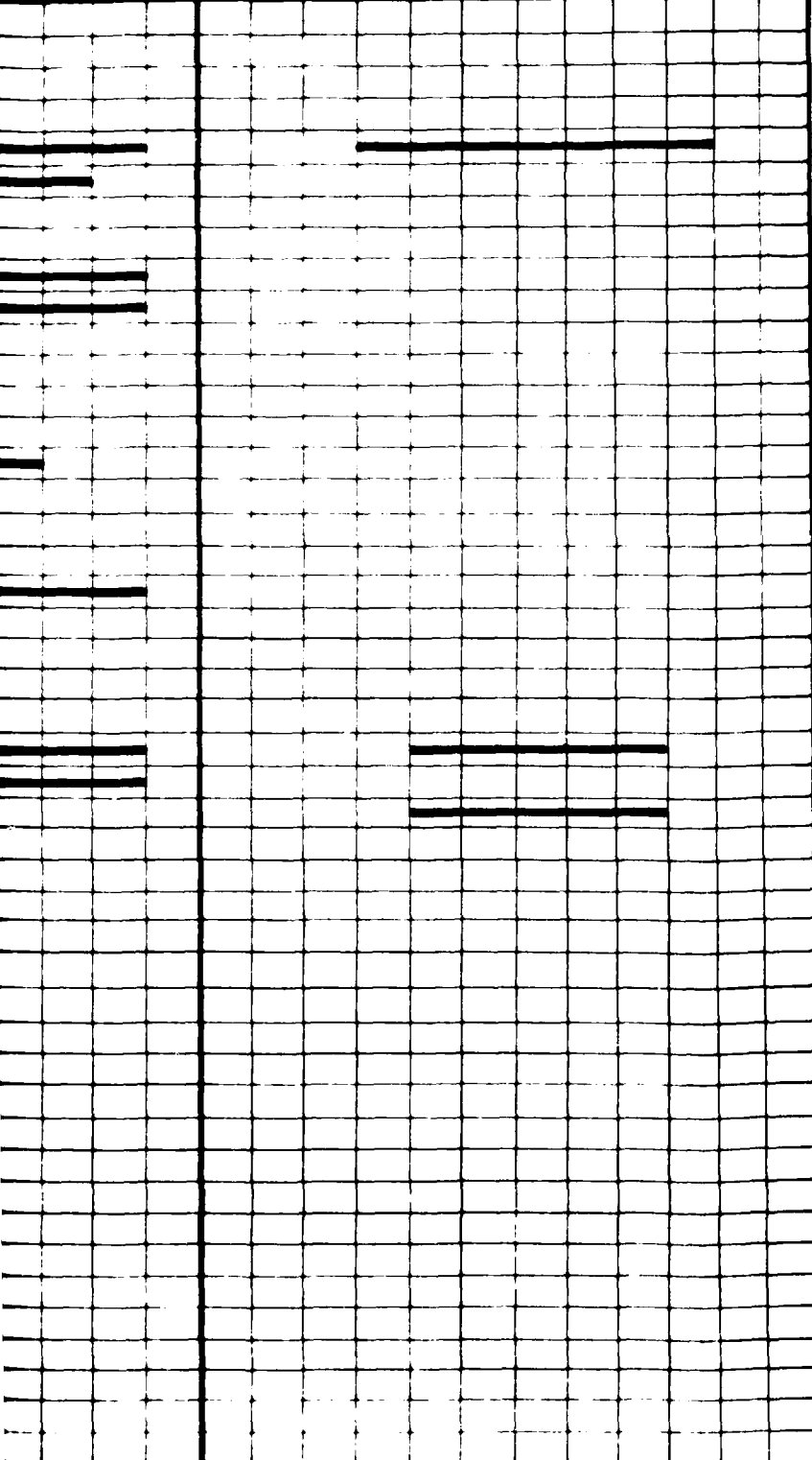

ELLCOTT CREEK, NEW YORK

CONSTRUCTION SCHEDULE
DIVERSION CHANNEL

U. S ARMY ENGINEER DISTRICT, BUFFALO
D 11

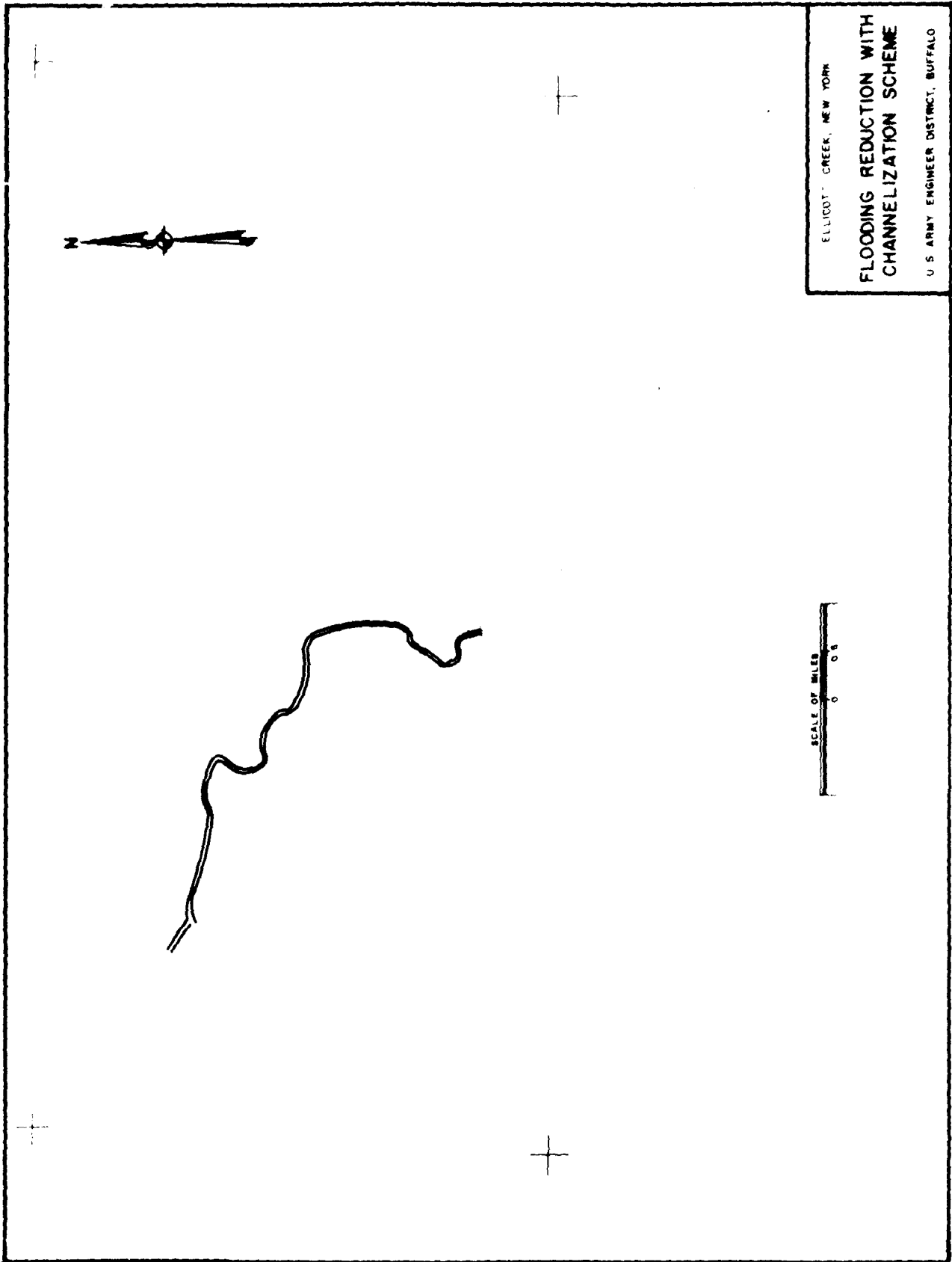

ELLICOTT CREEK, NEW YORK

FLOODING REDUCTION WITH
CHANNELIZATION SCHEME

U S ARMY ENGINEER DISTRICT, BUFFALO

SCALE OF MILES
0 0.8

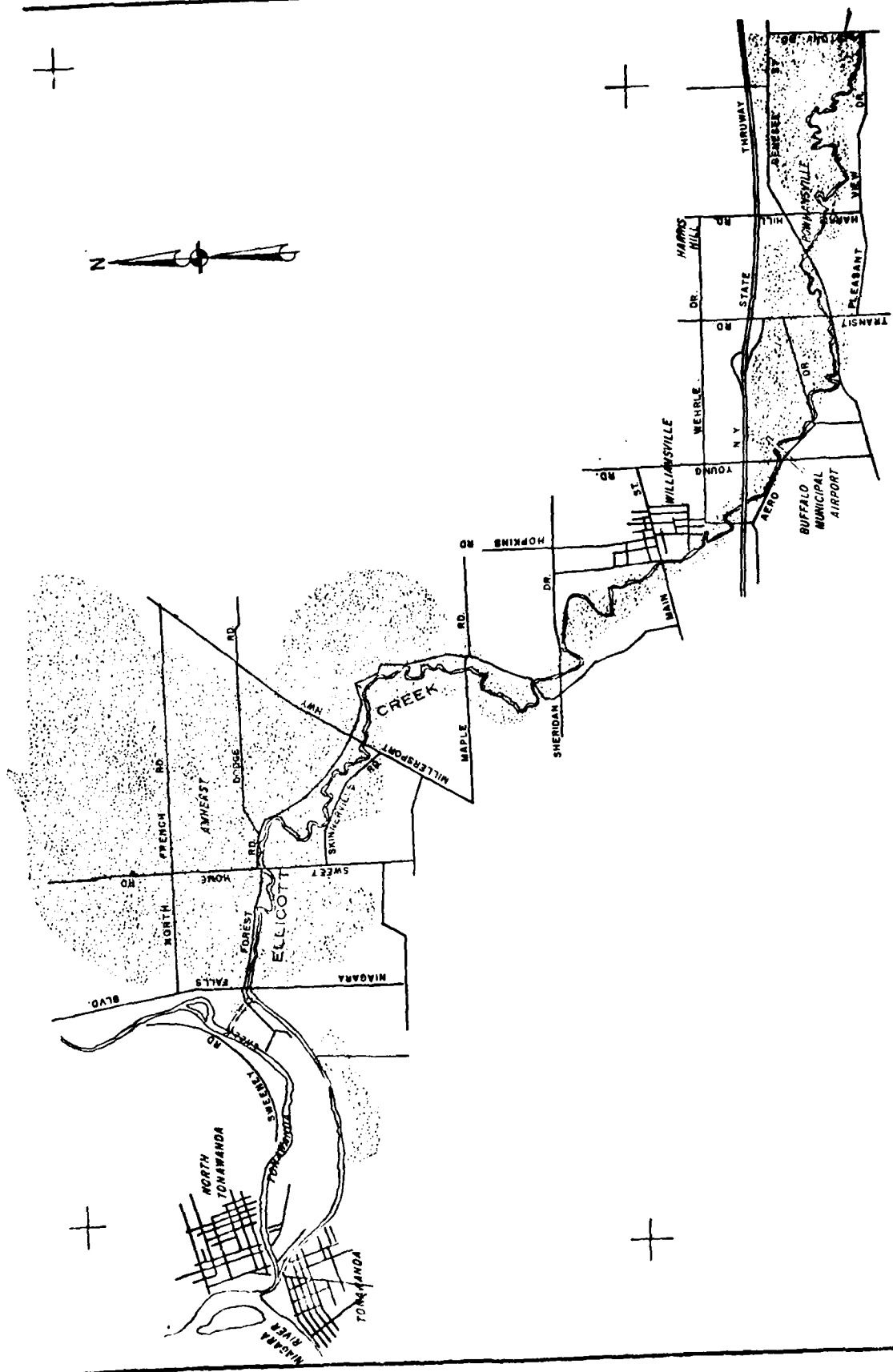

ELLICOTT CREEK, NEW YORK
**ELLICOTT CREEK FLOODPLAIN
 INTERMEDIATE REGIONAL
 FLOOD**
 U.S. ARMY ENGINEER DISTRICT, BUFFALO

YEAR II

S O N D J F M A M J J A S O N D

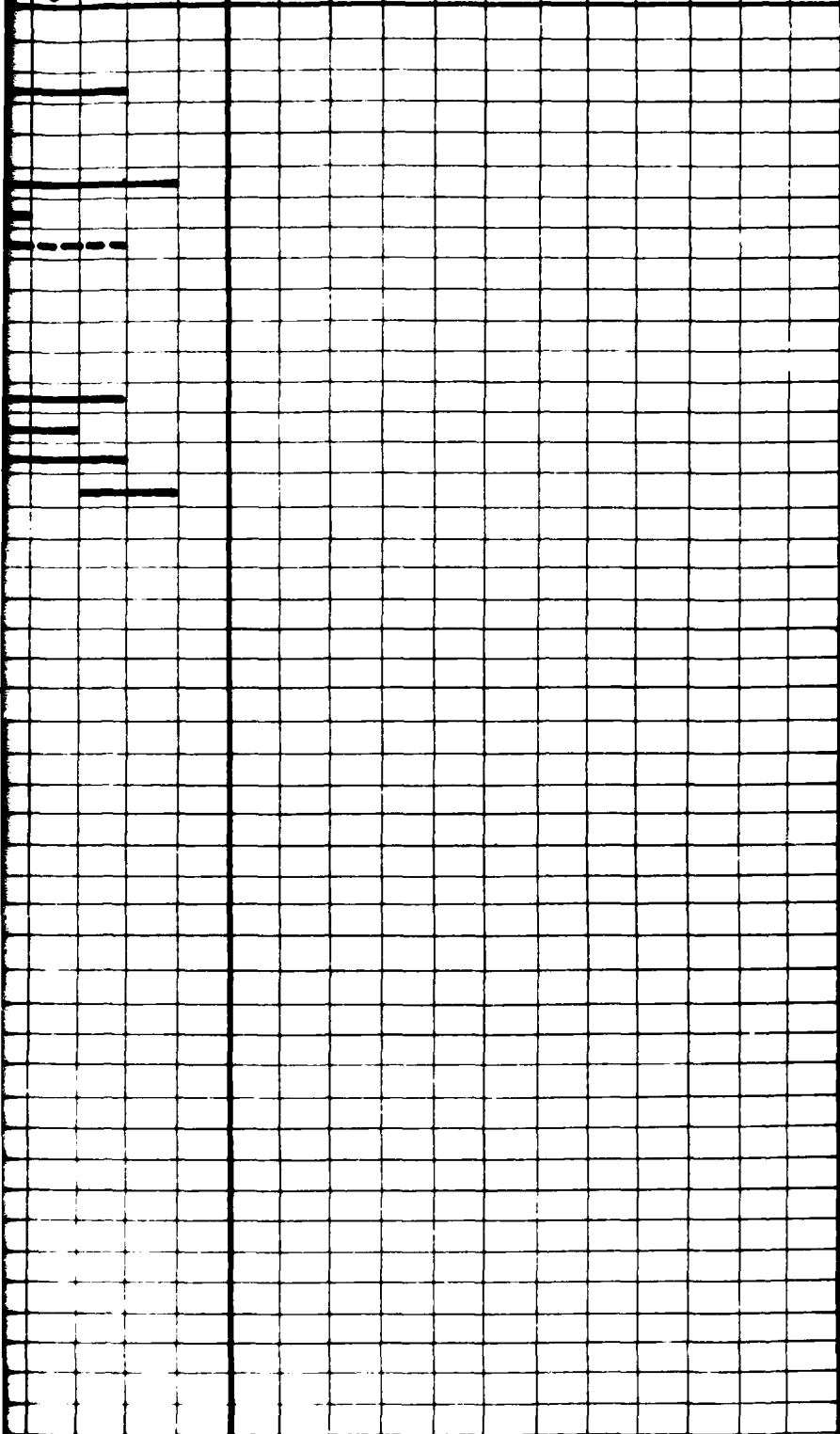

----- DISCONTINUOUS ACTIVITY

ELLICOTT CREEK, NEW YORK

CONSTRUCTION SCHEDULE
MAJOR CHANNEL IMPROVEMENTS

U. S. ARMY ENGINEER DISTRICT, BUFFALO

D 13

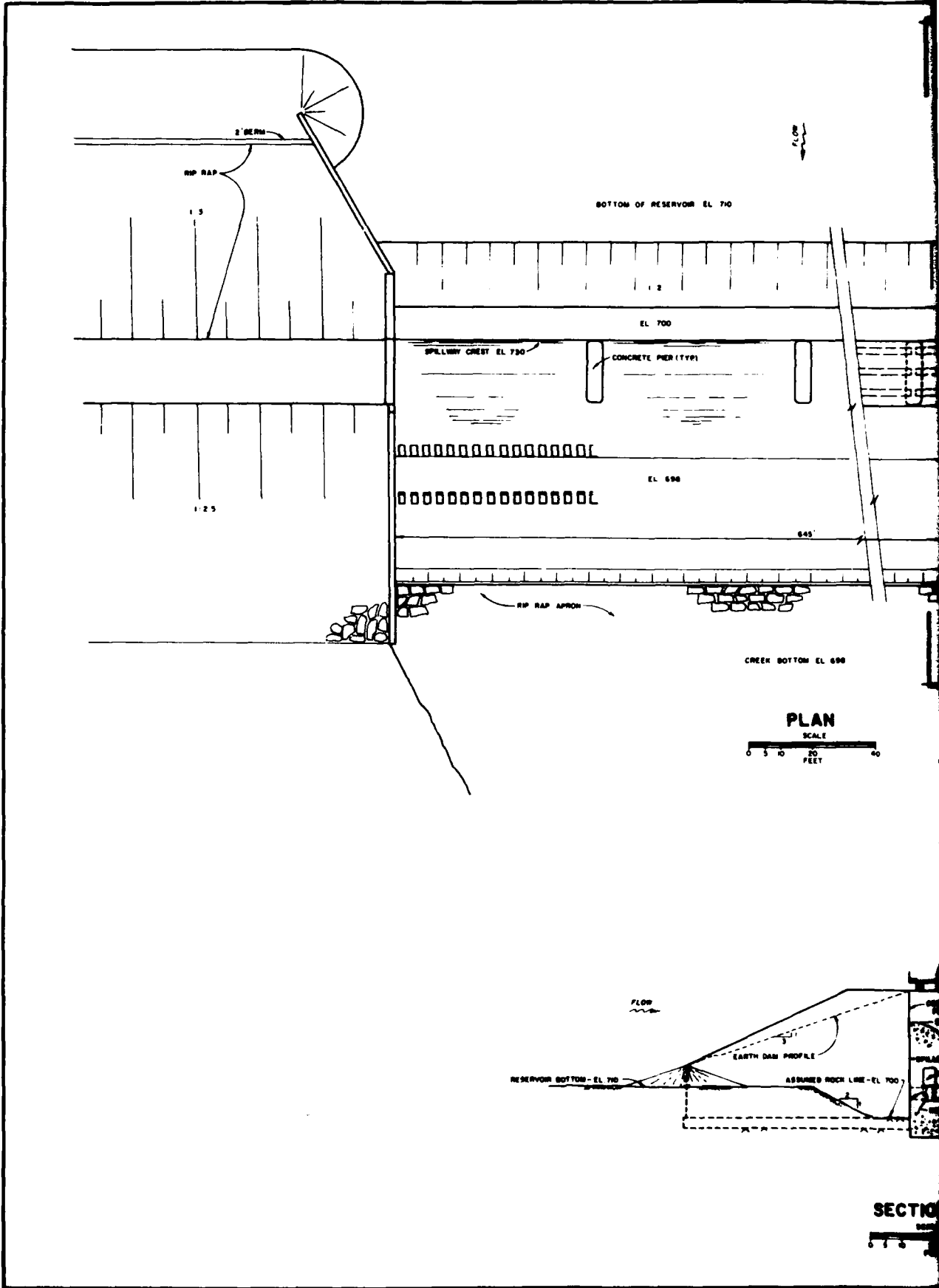

SECTION

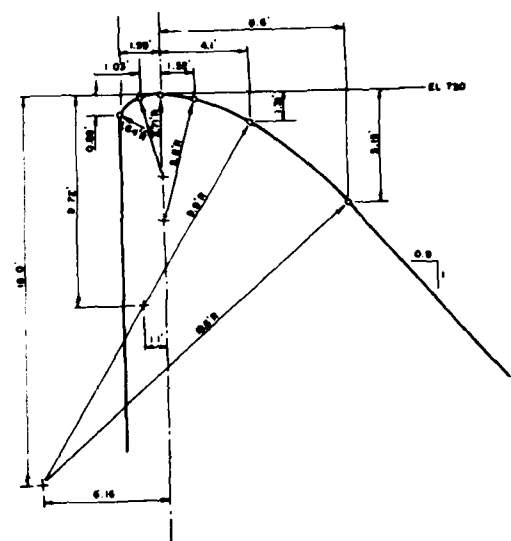
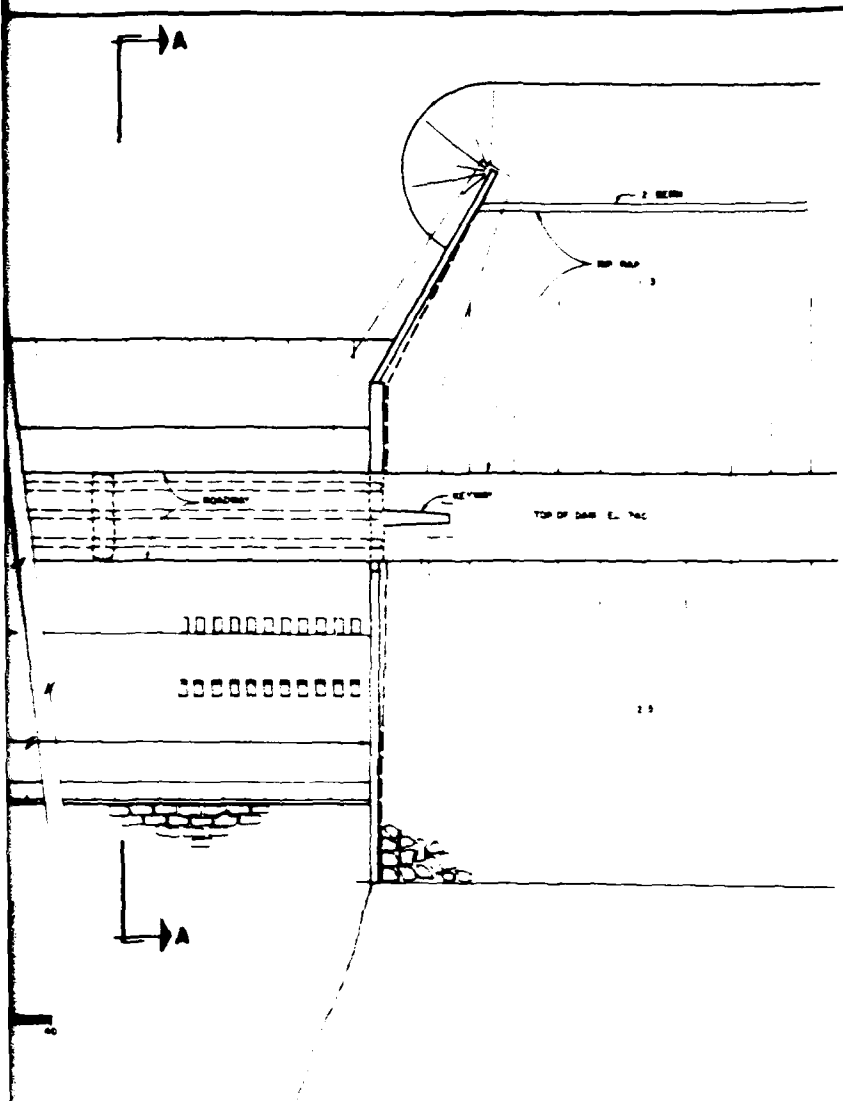

SPILLWAY CREST GEOMETRY
SCALE
0 1 2 3 4 5
FEET

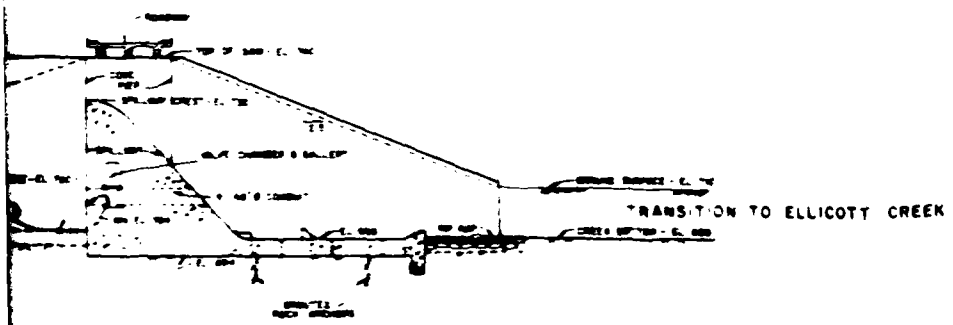

SECTION A-A
SCALE
0 1 2 3 4 5
FEET

ELLICOTT CREEK, NEW YORK
**BOWMANVILLE
SPILLWAY
PLAN & SECTION**
U. S. ARMY ENGINEER DISTRICT OFFICE
PLATE D 14

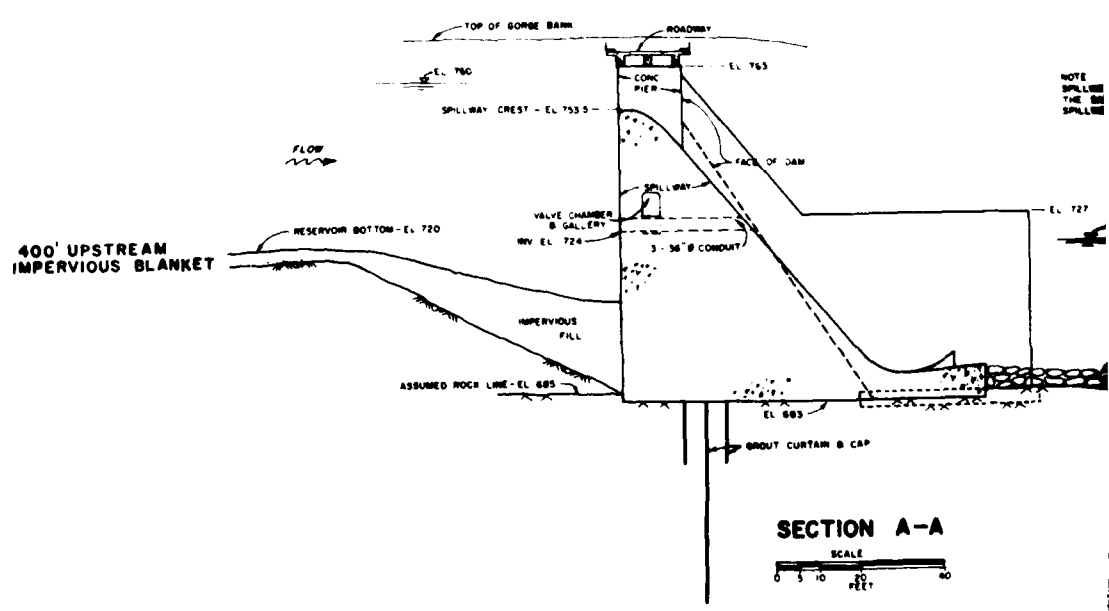
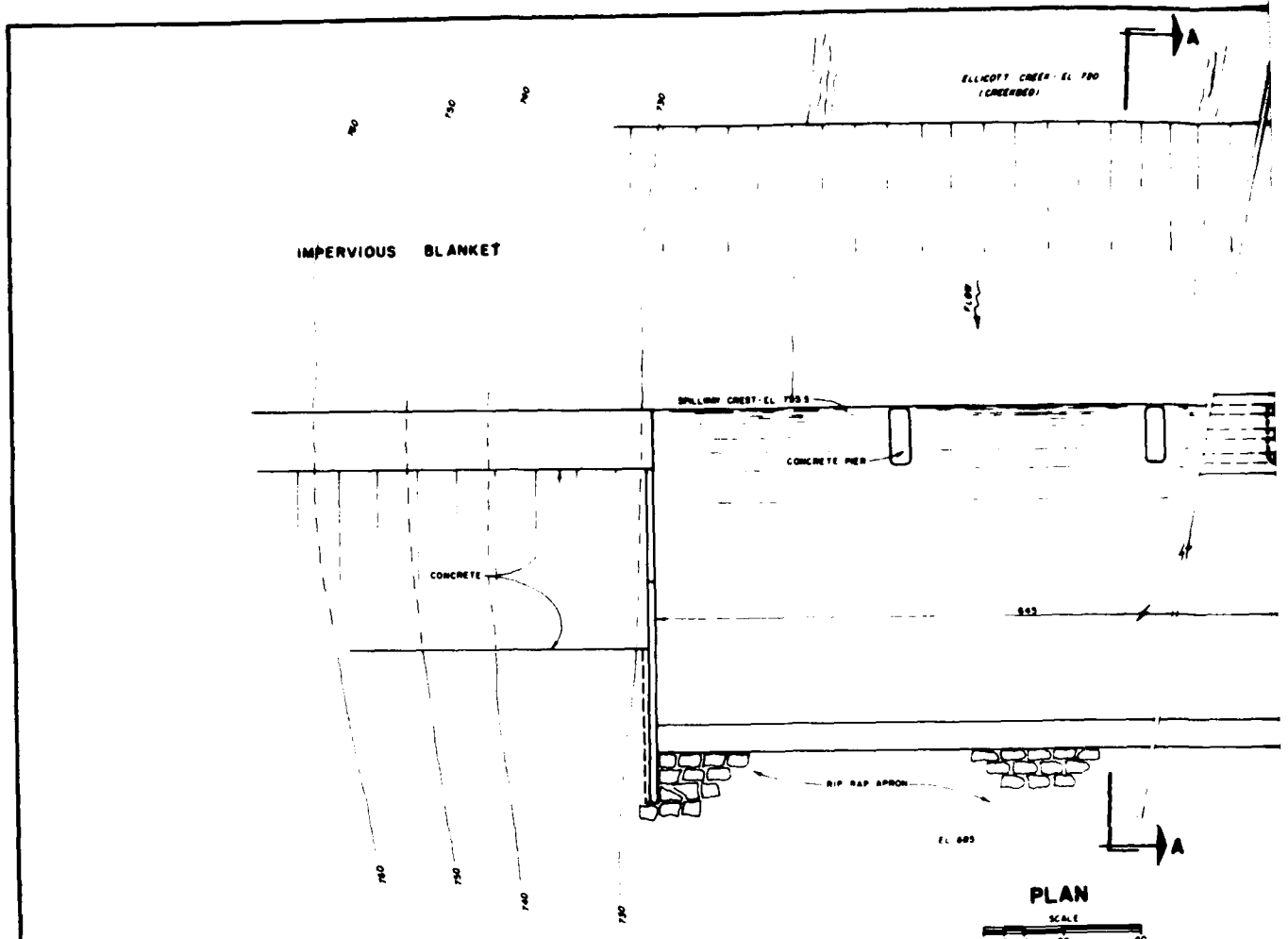

NOTE
SPILLWAY
THE
SPILLWAY

SECTION A-A

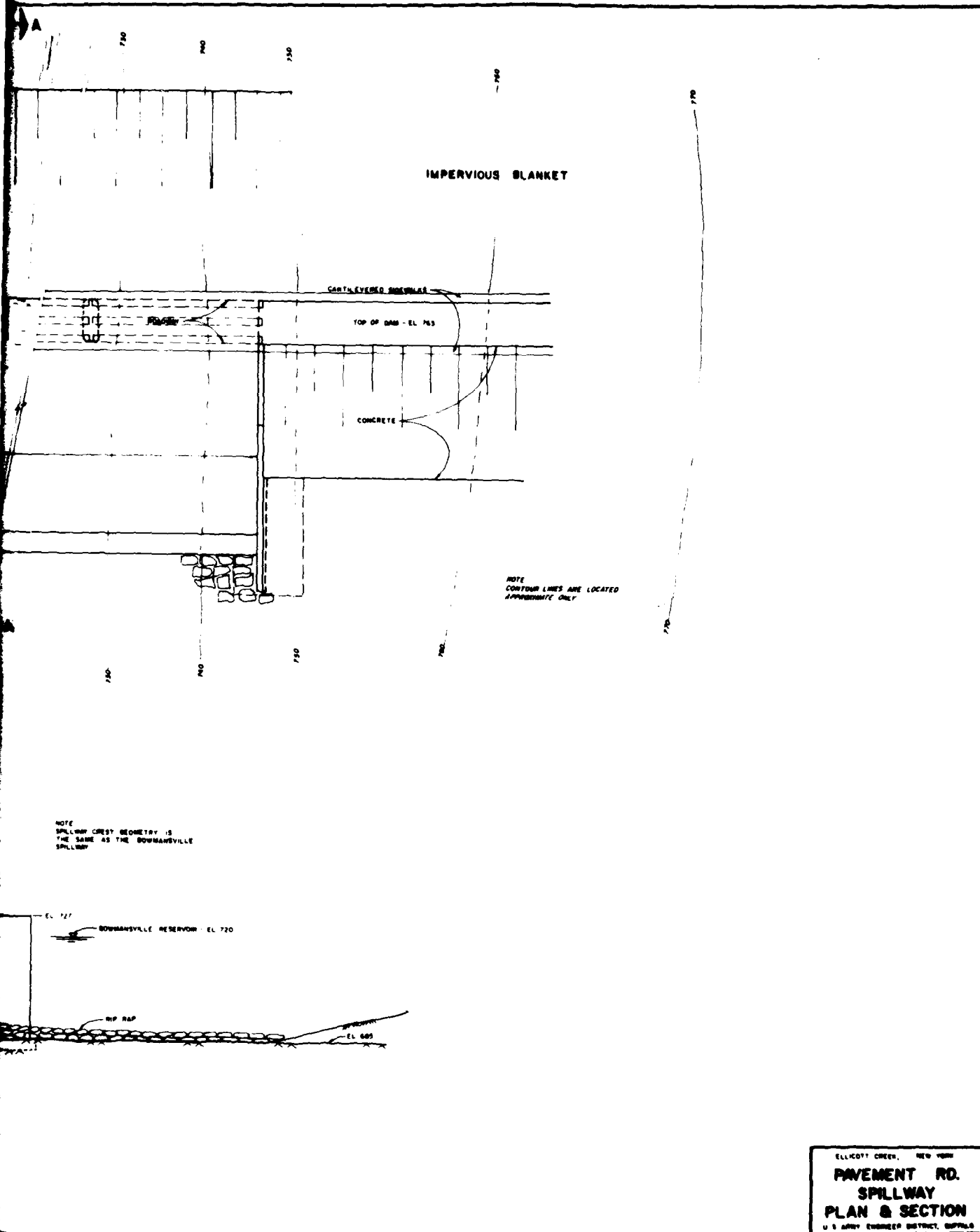

ELLICOTT CREEK, NEW YORK
**PAVEMENT RD.
 SPILLWAY
 PLAN & SECTION**
 U.S. ARMY ENGINEER DISTRICT, BUFFALO

PLATE D18

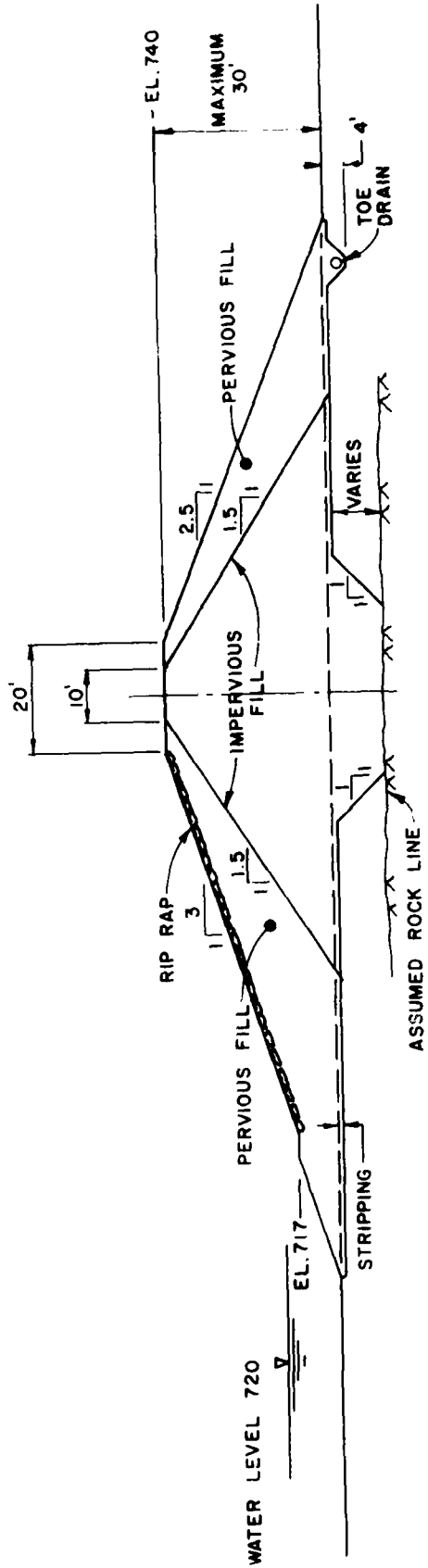

DIKE SECTION
 SCALE 1" = 30'

ELLICOTT CREEK, NEW YORK
BOWANSVILLE RESERVOIR
 TYPICAL DIKE SECTION
 U.S. ARMY ENGINEER DISTRICT, BUFFALO

YEAR II

S O N D J F M A M J J A S O N D

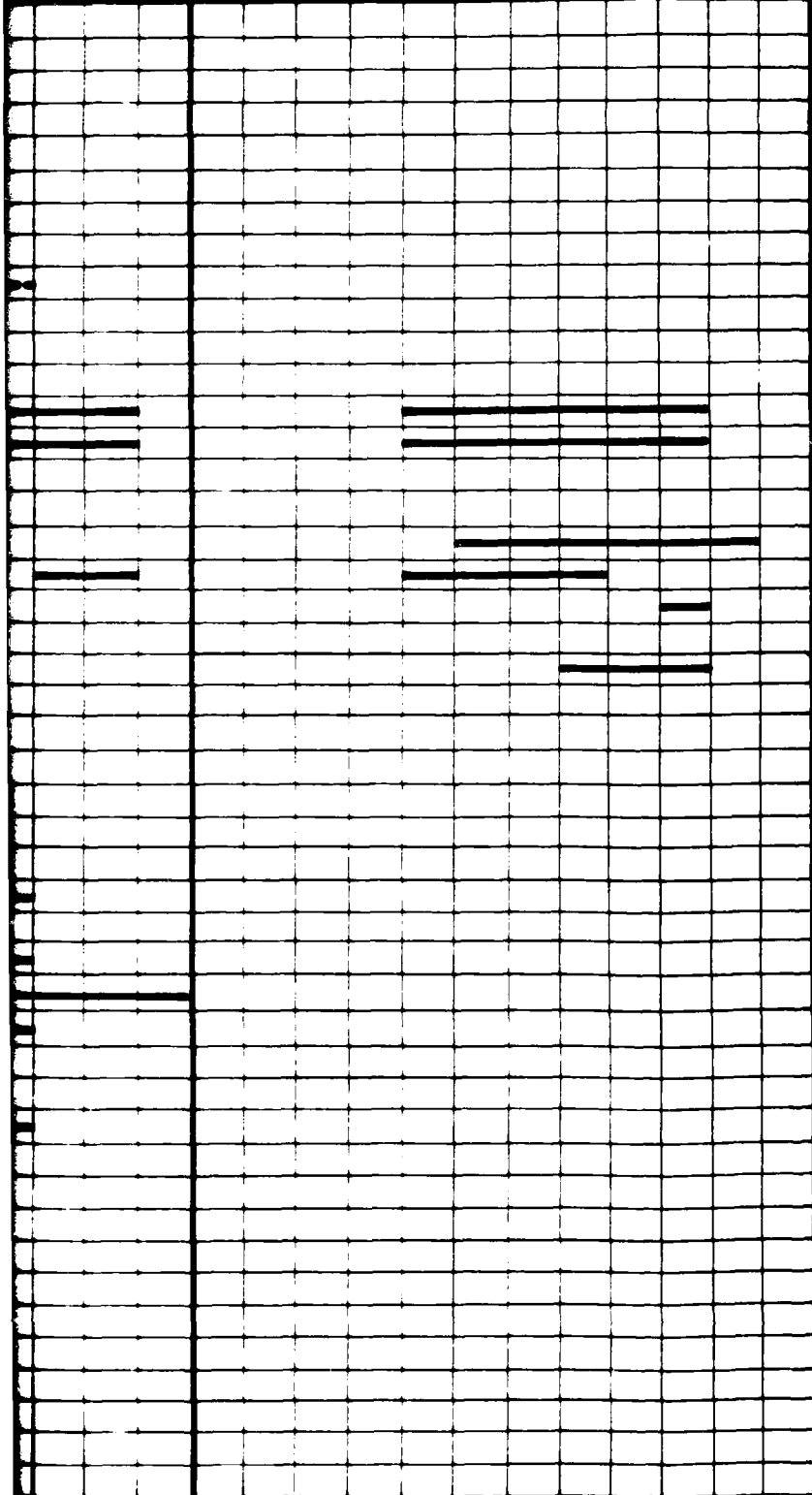

----- DISCONTINUOUS ACTIVITY

ELLICOTT CREEK, NEW YORK

CONSTRUCTION SCHEDULE
BOWMANVILLE SCHEME

U. S. ARMY ENGINEER DISTRICT, BUFFALO

D17

YEAR II

S O N D J F M A M J J A S O N D

----- DISCONTINUOUS ACTIVITY

ELLICOTT CREEK, NEW YORK

**CONSTRUCTION SCHEDULE
PAVEMENT ROAD SCHEME**

U. S. ARMY ENGINEER DISTRICT, BUFFALO
D 18

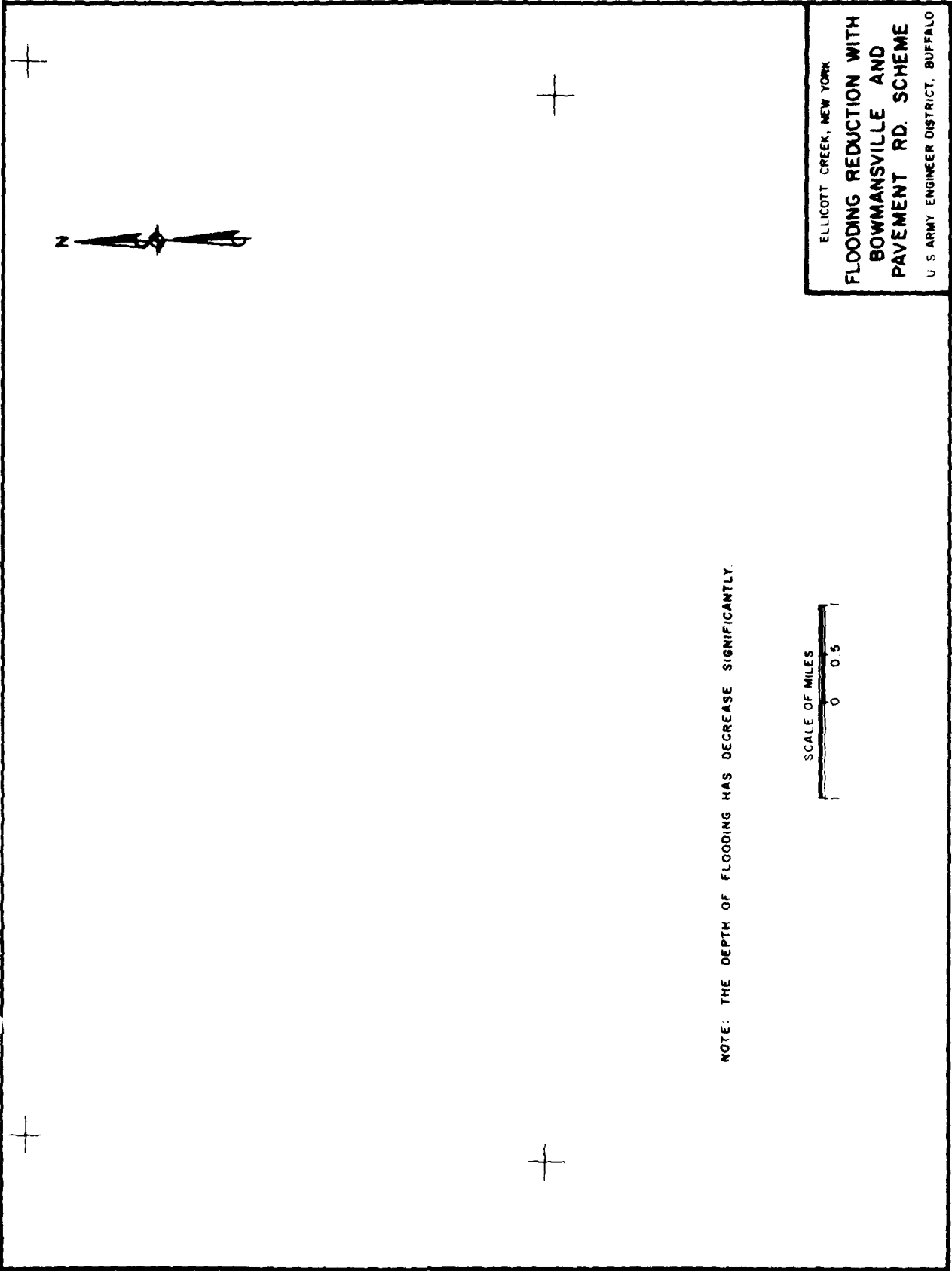

NOTE: THE DEPTH OF FLOODING HAS DECREASE SIGNIFICANTLY.



ELLICOTT CREEK, NEW YORK
FLOODING REDUCTION WITH
BOWMANVILLE AND
PAVEMENT RD. SCHEME
U S ARMY ENGINEER DISTRICT, BUFFALO

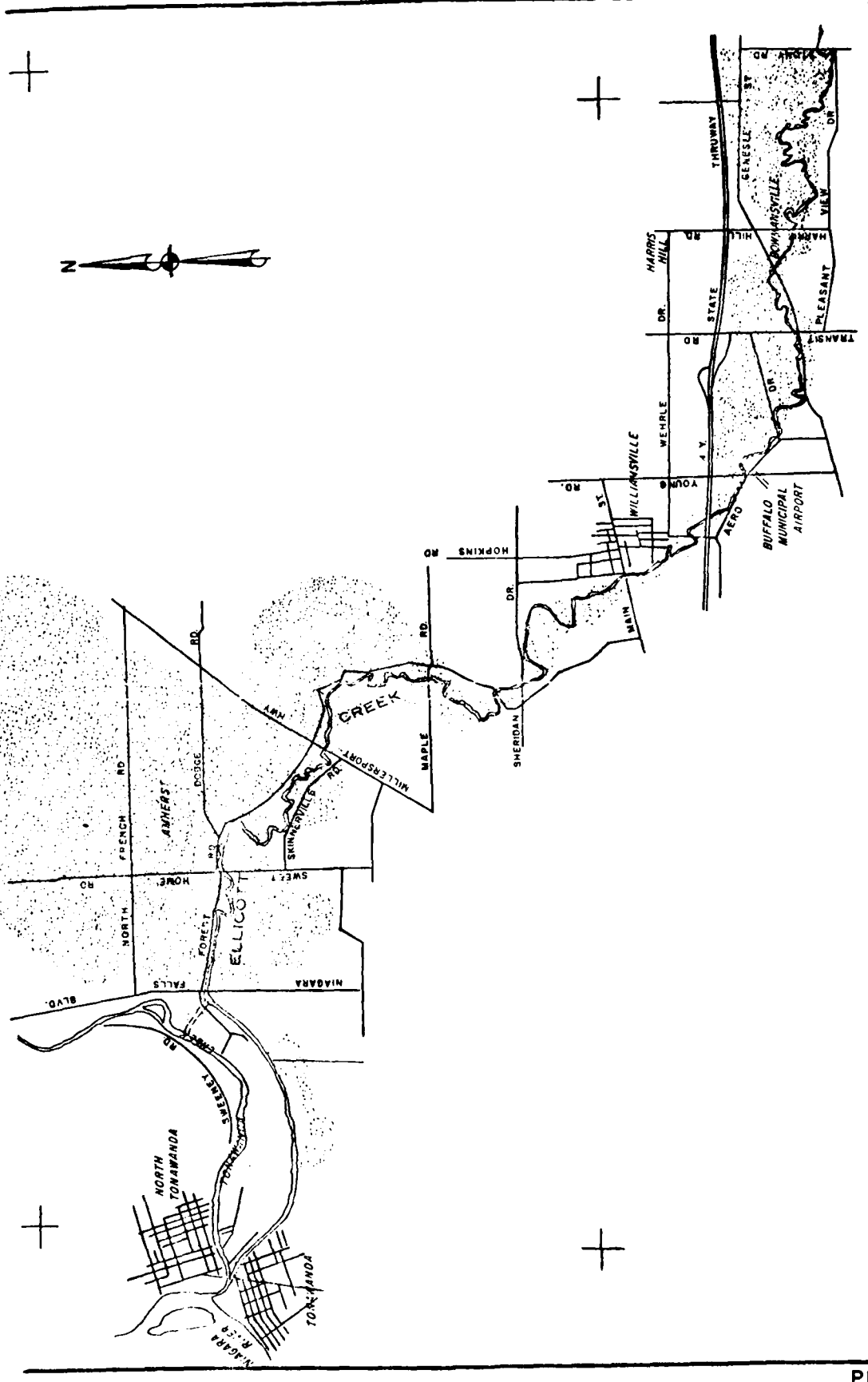

ELLICOTT CREEK, NEW YORK
**ELLICOTT CREEK FLOODPLAIN
 INTERMEDIATE REGIONAL
 FLOOD**
 U.S. ARMY ENGINEER DISTRICT, BUFFALO



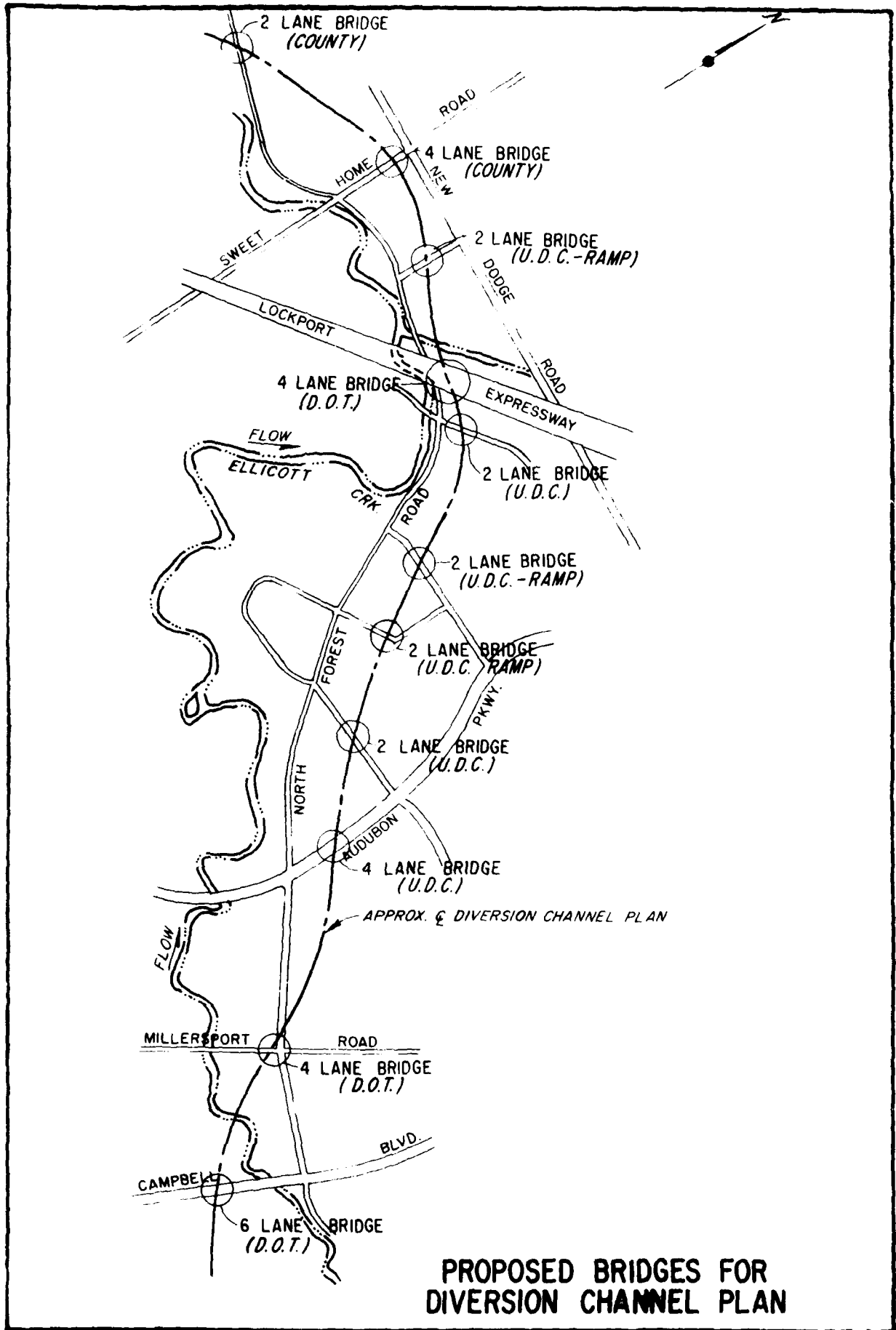

**PROPOSED BRIDGES FOR
DIVERSION CHANNEL PLAN**

TABLE OF CONTENTS

APPENDIX E - PLAN FORMULATION AND COST ALLOCATION

<u>Section</u>	<u>Title</u>	<u>Page</u>
1	General	E-1
2	Major Channel Improvement	1-3
3	The Diversion Channel	E-5
4	Sandridge Reservoir With Minor Channel Improvement	E-9
5	Bowmansville Lake - Pavement Road Dam	E-14
6	Project Formulation	E-16
6.1	General	E-16
6.2	Benefits; Tangible and Intangible	E-16
6.3	Project Selection	E-17
	6.3.1 Diversion Channel	E-17
	6.3.1.1 Division of Plan Responsibilities	E-17
	6.3.1.2 Cost Allocation	E-18
	6.3.1.3 Cost Apportionment	E-18
	6.3.1.4 Federal Responsibilities	E-19
	6.3.1.5 Non-Federal Responsibilities	E-19
	6.3.2 Sandridge Reservoir and Minor Channel Improvements	E-20
	6.3.2.1 Local Cooperation	E-20
	6.3.2.2 Policy For Water Supply	E-21
	6.3.2.3 Policy for Improvement of Water Quality	E-21
	6.3.2.4 Policy for Fish and Wildlife	E-21
	6.3.2.5 Policy for Recreation	E-21
	6.3.2.6 Assurances of Local Cooperation	E-22
	6.3.2.7 Allocation of Costs	E-23
6.4	Recommendation	E-24

TABLE OF CONTENTS

TABLES

<u>Table No.</u>	<u>Title</u>	<u>Page</u>
E-1	Study Objectives	E-2A
E-1A	Multi-Objective Matrix	E-2B
E-2	Major Channel Improvement	E-3
E-3	Diversion Channel	E-5
E-4	Specific Costs	E-7
E-5	Sandridge Lake with Minor Channel Improvement	E-9
E-5A	Sandridge Lake and Minor Channel Improvement (Without Water Quality)	E-11A
E-6	Cost Sharing Dam and Lake	E-11
E-6A	Cost Sharing Dam and Lake	E-11A
E-7	Bowmansville Lake	E-14
E-8	Comparison of Benefits and Costs	E-16
E-9	Cost Allocation	E-18
E-10	Cost Apportionment	E-18
E-11	Separable Costs and Remaining Benefits Method Scheme	E-22A,B
E-11A	Separable Costs and Remaining Benefits Method	E-22C,D

APPENDIX E - PLAN
FORMULATION AND
COST ALLOCATION

1 - GENERAL

1.1 The Phase II Review Survey Report has confined its detailed examinations of possible solutions to the problems of Flood Control and Other Possible Benefits on Ellicott Creek to four schemes. These four schemes have been selected from a preliminary examination of thirty-one possible solutions; the preliminary examination constituted the Phase I Study and is recorded in the Phase I Report, 1972.

1.2 The selection of the four most promising schemes has been based on the requirements of engineering feasibility, viability, provision of multi-benefits, and acceptance by a large proportion of the Creek basin population.

1.3 The schemes examined in the Phase II Study are:

- (i) Major Channel Improvement
- (ii) The Diversion Channel
- (iii) Sandridge Reservoir with Minor Channel Improvements
- (iv) Bowmansville Lake - Pavement Road Dam

1.4 None of these schemes simultaneously satisfies the design criteria and a major portion of the Creek Basin population. Two, namely the Diversion Channel and the Sandridge Reservoir

are more generally liked than the other two. Indeed, though engineeringly feasible, viable and providing benefits not much less than the other two schemes, the Major Channel Improvement and Bowmansville Lake alternatives received little or no support and much hostility from a preponderance of the basin population.

1.5 The Phase II study details have received wide review; at public meetings, workshops and by Government agencies and departments. The "Records" of the public meetings and workshops cover the comments at the public gatherings. Comment from the government agencies and departments has been in the form of written observations. Among the several agencies and departments to have reviewed the Phase II study are The North Central Division of the U. S. Corps of Engineers, The New York State Department of Environmental Conservation, The Fish and Wildlife Service of the Department of the Interior, the State University of New York at Buffalo, The Bureau of Outdoor Recreation, the Erie-Niagara Counties Regional Planning Board, and the Governor's Office the State of New York.

1.6 In order to facilitate comparison of the four alternative measures, recourse has been made to a matrix illustrating the effects of each plan on the four major objectives of National Economic Benefit, Environmental Quality, Social Factors and Regional Development. The matrix is presented as Table E-1 overleaf. The matrix of the four alternatives shown in the main report and reflecting no monetary value for water quality and elimination of Pavement Road dam is shown in Table E-1A.

TABLE E-1

STUDY OBJECTIVES	UNIT	Major Channel-ization	Diversioh Channel	Sand-ridge Minor Channeliza-tion	Bowmans-ville plus Pavement
NATIONAL ECONOMIC DEVELOPMENT					
URBAN FLOOD DAMAGE REDUCTION	\$	665,430	690,430	761,930	721,740
FISH & WILDLIFE BENEFIT	\$	--	--	236,790	--
INCREASED RECREATIONAL OPPORTUNITY	\$	192,560	386,770	1,599,000	1,723,210
TOTAL ANNUAL BENEFITS	\$	857,990	1,077,200	2,935,390*	2,634,950*
ANNUAL CHARGES	\$	421,300	643,400	2,619,000	1,831,000
BENEFIT / COST RATIO	\$	2.03	1.67	1.12	1.44
ENVIRONMENTAL QUALITY					
EFFECT ON NATURAL ENVIRONMENT	ACRES	- 3	-106	-183	-690
EFFECT ON MAN MADE ENVIRONMENT	ACRES	0	0	- 50	- 10
EFFECT ON OPEN SPACES (PARKS)	ACRES	+16	+67.5	+ 13	+112
EFFECT ON UNIQUE ECOLOGICAL AREAS	ACRES	0	0	0	0
EFFECT ON WATER QUALITY	-O+	0	0	+	+
PASTORAL RIVER	MI.	- 7	0	-2.5	-5.5
SOCIAL FACTORS					
AREA PROTECTED	ACRES	6013	6013	>6013	>6013
DRAINAGE AREA CONTAINED	SQ. MI.	0	0	33.1	69
INDUSTRIES PROTECTED	NO.	0	0	0	0
BUSINESSES PROTECTED	NO.	9	9	11	11
FARMS PROTECTED	NO.	0	0	0	0
ESSENTIAL SERVICES PROTECTED	NO.	10	10	15	15
LOW INCOME FAMILIES PROTECTED	NO.	0	0	0	0
TOTAL RESIDENCES PROTECTED (1969)	NO.	1304	1304	1548	1529
LOSS OR GAIN ON TAX BASE	-O+	0	0	0	0
REGIONAL DEVELOPMENT					
ECONOMIC STABILITY	-O+	+	+	+	+
JOBS CREATED	NO.	0	+	+	+
LOW FLOW AUGMENTATION BENEFIT	\$	0	0	190,000	190,000
MUNICIPAL WATER SUPPLY BENEFIT	\$	0	0	147,670	--

* INCLUSIVE REGIONAL BENEFITS

ELLICOTT CREEK, NEW YORK

MULTI-OBJECTIVE MATRIX

U. S. ARMY ENGINEER DISTRICT, BUFFALO

TABLE E-1A MULTI-OBJECTIVE MATRIX - ALTERNATIVE STUDIES, ELLICOTT CREEK, NY

STUDY OBJECTIVES	COST	RANGE CHARACTERIZATION	DIVERSION CHANNEL	BOELENVILLE LAKE	SAVED FLOOD PLAYS BELOW STREAM IN MOVEMENT
<u>NATIONAL ECONOMIC DEVELOPMENT</u>					
Urban flood damage reduction (annual)	\$	665,000	699,000 (1)	722,000 (1)	762,000
Fish and wildlife benefit (annual)	\$	-	-	-	237,000
Increased recreational opportunity (annual)	\$	193,000	387,000 (1)	1,723,000	1,598,000 (1)
Low flow augmentation benefit (annual)	\$	0	0	0	0
Municipal water supply benefit (annual)	\$	0	0	0	148,000
Total annual benefits	\$	358,000	1,077,000 (1)	2,445,000 (1)	2,745,000 (1)
Annual charges	\$	421,300	643,400 (1)	1,161,000	2,619,000
Benefit/cost ratio		2.04	1.67 (1)	2.11 (1)	1.05 (1)
Net annual benefits over annual charges	\$	436,700	433,600 (1)	1,284,000 (1)	126,000 (1)
Total investment cost	\$	7,153,900	11,173,000 (1)	17,757,000	33,322,000
<u>ENVIRONMENTAL QUALITY</u>					
Water surface created	Acres	0	0	1,040	2,150
Effect on natural environment (wooded)	Acres	-3	-106	-450	-183
Effect on man made environment	Acres	0	0	-7	-50
Effect on open spaces (parks)	Acres	+16	+67.5	+112	+1100
Effect on unique natural areas	Acres	0	0	0	-1
Effect on stream flow	- 0 +	0	0	0	+
Pastoral stream (neutral)	Mi.	-7	-2	-3.3	-5.5
<u>SOCIAL FACTORS</u>					
Area protected	Acres	6013	6013	8400	7300
Drainage area controlled	Sq. Mi.	0	0	67	33.1
Industries protected	No.	0	0	0	0
Businesses protected	No.	9	9	11	11
Essential services protected	No.	10	10	15	15
Total residences protected (1969)	No.	1304	1304	1529	1548
Total residences relocated	No.	5	11	53	82
Loss or gain on tax base (short term)	- 0 +	-	-	-	-
<u>REGIONAL DEVELOPMENT</u>					
Economic stability	- 0 +	+	+	+	+
Jobs created	- 0 +	0	0	+	+

(1) Revisions subsequent to late stage meeting on 2 May 1973.

2 - MAJOR CHANNEL IMPROVEMENT

2.1 - Preceding Appendices individually provide data on this proposed measure. Summarized in Table E-2 below the Federal and non-Federal portions of the proposed total cost.

TABLE E-2

Item	CONSTRUCTION COST			Annual Benefits
	Federal	Non-Federal	Total	
Flood Control	:\$4,979,000:	\$1,276,000:	\$6,255,000:	\$665,000
Recreation	: 263,000:	263,000:	526,000:	193,000
Total First Cost	:\$5,242,000:	\$1,539,000:	\$6,781,000:	
Int. During Construction:	288,300:	84,600:	372,900:	
Total Investment	:\$5,530,300:	\$1,623,600:	\$7,153,900:	
5-1/2% - 100 yr. int. and:	:	:	:	
amortization	: 305,600:	89,700:	395,300:	
OM & R	: 700:	25,300:	26,000:	
Total Annual Cost	: 306,300:	\$ 115,000:	\$ 421,300:	
Total Annual Benefits	:	:	:	:\$858,000
BCR	:	:	:	: 2.04

2.2 - A study of comparative effects, as shown on the matrix, of this proposal relative to the others show that except for the effect of the pastoral river, this proposal is no less attractive than the other three. However, from the representations at the workshops and the public meetings it is obvious the pastoral nature of Ellicott Creek is felt by the local population to be a very important and desirable feature. Damage to a seven-mile length of it by effecting major channel improvements is unacceptable to those who live in the area to be affected, and a significant proportion of those who live and work in the Basin. Another deficiency in this proposal lies in its ineffectiveness in improving water flow in its operative length of the creek.

2.3 - The scheme provides protection from flooding in Amherst only, seven small spot parks along portions of the realigned creek, destroys aquatic life in the realigned creek, does not in any way improve water quality and has no outstanding compensatory merit.

2.4 - As a means of eliminating flood damage in Amherst, this plan is the most economical of all those examined. However, the effect on the environment was felt to negate any of the positive benefits and it was, therefore, generally unacceptable. Among those who expressed opposition to the proposal were the Sierra Club, the Fish and Wildlife Service, the State Department of Environmental Conservation and the Office of the Governor, New York State.

2.5 - For the reasons stated above, and despite the scheme's attractive benefit to cost ratio, it is rejected as a possible solution to the Ellicott Creek problem.

3 - THE DIVERSION CHANNEL

3.1 - Preceding Appendices individually provide data on this proposed measure. Summarized in Table E-3 below are Federal and non-Federal portions of the proposal total cost.

TABLE E-3
DIVERSION CHANNEL

Item	CONSTRUCTION COST			Annual Benefits
	Federal	Non-Federal	Total	
Flood Control	:\$3,925,000:	\$6,233,000:	\$10,158,000:	\$ 690,000*
Recreation	: 370,000:	370,000:	740,000:	387,000
Total First Cost	:\$4,295,000:	\$6,603,000:	\$10,898,000:	
Int. on bridge Cons. 5-1/2%:	:	275,000:	275,000:	
Total Investment	:\$4,295,000:	\$6,878,000:	\$11,173,000:	
5-1/2% - 100 yr. int. and amortization	: 237,300:	380,100:	617,400:	
OM & R	: 700:	25,300:	26,000:	
Total Annual Cost	:\$ 238,000:	\$ 405,400:	\$ 643,400:	
Total Annual Benefits	:	:	:	:\$1,077,000
B/C Ratio	:	:	:	1.67

*Relative to Major Channel Improvements, there is a further reduction in flood damages in Reaches 2 and 3, valued at \$25,000.

3.2 - This proposed measure derives from an attempt to find a solution as effective as the Major Channel Improvement proposal, but without the associated enormous environmental damage. A study of the matrix shows that it provides the same degree of protection and some four times as much recreation space as the previous scheme. **Relative to augmenting low flows it has the same drawback as the channel improvement scheme in that it has no effect at all on water flows.** By choosing an alignment for the diversion itself that passes through an underdeveloped area proposed for urban development or University playing fields, there are no costs for demolition works to accommodate the diversion channel. Additionally, by removing floodwaters from a five-mile length of the creek in Amherst there is no necessity to effect any change to the existing creek and therefore, there is no environmental damage to the creek along this reach.

3.3 - Benefits from this scheme are to be found in two areas only, flood damage reduction downstream of Williamsville only, and recreation potential.

3.4 - The general reaction to this proposed measure is sharply divided into two main factions; those who feel it is the best available solution and those who feel it is second to the Sandridge Reservoir proposal. Support for the scheme is based on the many positive features it possesses, some of which are recorded below:

- It is implemented in the area most subject to flooding; thus the inconveniences are experienced by those who benefit the most.
- It provides flood protection at a minimum cost to the pastoral image of Ellicott Creek in the floodplain.
- It provides a linear park in an area which is recreation-space deficient.
- It provides the twin benefits of flood protection and recreation in the area of need, at a very small fraction of the cost of the Sandridge Reservoir proposal.
- It does not rely on its recreation potential to justify its overall viability.

The major disadvantages to the scheme lie in two main areas, as noted below:

- It does not assist in any way in increasing the flow of water in Ellicott Creek.
- Its flood prevention effect is limited to the Amherst area, and areas upstream are afforded no protection.

3.5 - Among those with whom this proposal finds great support are the Sierra Club, the League of Women Voters of Amherst, the Conservation Advisory Council to the Town Board of Amherst, and the Buffalo District Corps of Engineers. Indeed, it is the recommended project by the Buffalo District Corps of Engineers.

3.6 - Amongst those who are opposed to the scheme are the Urban Development Corporation, Amherst, the Facilities Planning Branch of the State University of New York at Buffalo, and the office of the Governor, New York State.

3.7 - Specific Costs. Table E-4 summarizes component costs for this proposal. Details of the costs are to be found in Appendix D.

TABLE E-4

Item	Federal	Non-Federal
Lands and Damages	\$	\$1,233,000
Relocations, Bridge Modifications and New Bridges	272,000	5,000,000
Diversion Channel and Associated Works	3,653,000	--
Recreation	370,000	370,000
TOTAL FIRST COST	\$4,295,000	\$6,603,000
Interest on Bridge Construction @5-1/2%	--	275,000
Total Investment	\$4,295,000	\$6,878,000
		= \$11,173,000

The main work of diversion channel construction, bridge modification and new bridge construction at Sweet Home Road and North Forest Road is seen to take only one year and so no interest is charged on this cost. The recreation facilities, similarly, will be provided in one year and so no interest is charged on this cost. The number and specific locations of new bridges in the U.D.C.'s Audubon development is not necessarily firm at the time of writing, nor is the schedule for construction. **Eight bridges and three ramps, at locations shown on Plate D-20, have currently been provided for.** It is assumed that new bridge construction will take a 2-year period, and interest is taken for one year on the capital cost of the bridges.

3.8 - Other Costs. The Diversion Channel scheme does not cause the loss of any revenue as is generally usual in proposals of this nature. There is no loss of existing tax base, as the channel is in University of Buffalo open space recreational area on the South side of the creek, and it passes through, an undeveloped tract, the property of the Urban Development Corporation, and currently to be developed as a

mixed value residential suburb for the Town of Amherst, on the North side of Ellicott Creek. The housing development can be built around this grass-lined feature and associated strip park.

4 - SANDRIDGE RESERVOIR WITH
MINOR CHANNEL IMPROVEMENT

4.1 - A previous study, recorded in a Report by the Buffalo District Corps of Engineers, and entitled "Survey Report for Flood Control and Allied Purposes, Ellicott Creek, New York, 1970" has determined that for flood control and other benefits, a reservoir at Sandridge, with channel improvements less extensive than those described in paragraph 2 as Major Channel Improvements, represents a viable and attractive solution.

4.2 - Preceding Appendices individually provide data on this proposed measure. Summarized in Table E-5 are Federal and non-Federal portions of the proposed total cost as presented at the late stage public meeting on 2 May 1973. On 3 July 1973, the Federal EPA stated that monetary water quality benefits are not ascribable to the Sandridge Reservoir and therefore a revised estimate and allocation of cost are presented in Tables E-5a and E-6a respectively.

TABLE E-5
 SANDRIDGE LAKE AND MINOR CHANNEL IMPROVEMENT

Item	Federal	Non-Federal	Total	Annual Benefits
Flood Control	\$ 8,484,000	\$ 898,000	\$ 9,382,000	\$ 762,000
Water Quality	2,735,000	--	2,735,000	190,000
Recreation	8,971,000	9,042,000	18,019,000	1,835,000
Water Supply	--	2,146,000	2,146,000	148,000
Total First Cost	\$20,190,000	\$12,092,000	\$32,282,000	
Int. During Const.	910,000	545,000	1,455,000	
Total Investment	\$21,100,000	\$12,637,000	\$33,737,000	
5-1/2% - 100 yr. Int. and Amortization	1,166,000	698,000	1,864,000	
OM & R	106,700	671,300	778,000	
Total Annual Cost	\$ 1,272,700	\$ 1,369,300	\$ 2,642,000	
Total Annual Benefits				2,935,000
BCR				1.12

4.3 - The Sandridge Reservoir site, shown on Plate 7, appears to be the best possible choice for multiple-purpose storage on Ellicott Creek. Other sites have been studied but all eliminated because of limited capacity or high development costs. Local residents have suggested the development of a series of small reservoirs as an alternative to the Sandridge site. This alternative would be much more expensive and would not provide as many multiple-purpose benefits. The cost of constructing three reservoirs having a capacity of 10,000 acre-feet each would be more than double the cost of constructing a single 30,000 acre-foot reservoir. The cumulative annual

costs for maintenance and operation of a series of reservoirs would also be considerably greater than the cost for a single large reservoir.

4.4 The Sandridge site has been studied to determine which purposes should be included in a multiple purpose plan, to arrive at the best possible use of available resources. To meet the water-oriented needs predicted for the next fifty years, the reservoir project is designed for maximum development. The terrain limits the top of dam to elevation 867.5 which is about 54 feet above the thalweg of the existing channel at the dam site. No attempt has been made to assess the increased water needs after the year 2020, because of the obvious inaccuracies. It has been found that predicted needs for flood control, municipal water supply, water quality management, outdoor recreation and fish and wildlife can all be accommodated in the reservoir. The recreation benefits are based on the realization that there will be fluctuations in the summer recreation pool because of the need to serve other purposes. The maximum demands for water supply and water quality management occur during the Summer and early fall months. The five purposes appear reasonably compatible and adverse effects from multiple-purpose operation may be insignificant during most years.

4.5 Benefits for each purpose have been calculated by conventional methods and are discussed in detail in Appendices B and C.

4.6 Specific and Joint-Use Costs. The costs of component parts of the multiple purpose project are either assigned to specific purposes or to joint use as indicated in Table E-6. The costs shown are an abbreviated form of the cost estimate shown in Appendix D where the reservoir project is discussed in detail. The total project first cost, plus interest during construction and the present worth of deferred construction for future recreation facilities, represents the total investment. The construction period is assumed to be two years. Interest at the current Federal rate, 5-1/2 percent, has been applied to appropriate first costs for one year. Annual costs include interest, and amortization at 5-1/2 percent, assuming a 100-year project life. Other annual costs include operating and maintenance costs, replacement costs and loss of production. Loss of production reflects the loss of crop and other land productivity to permit construction of the project. The

estimated average annual benefits and overall benefit cost ratio are shown to complete the economic picture.

TABLE E-6 (1)
COST SHARING DAM AND LAKE

	<u>Flood Control</u>	<u>Water Quality</u>	<u>Recreation</u>	<u>Water Supply</u>	<u>Total</u>
Federal	\$6,301,000	\$2,735,000	\$ 8,732,000	\$ ---	\$17,768,000
Non-Federal	---	---	8,810,000	2,146,000	10,956,000
TOTAL	\$6,301,000	\$2,735,000	\$17,542,000	\$2,146,000	\$28,724,000

COST SHARING MINOR CHANNEL IMPROVEMENT

Federal	\$2,183,000	\$ ---	\$ 239,000	\$ ---	\$2,422,000
Non-Federal	898,000	---	238,000	---	1,136,000
TOTAL	\$3,081,000	\$ ---	\$ 477,000	\$ ---	\$3,558,000

TOTAL COST SHARING SANDRIDGE LAKE AND MINOR CHANNEL IMPROVEMENT

Federal	\$8,484,000	\$2,735,000	\$ 8,971,000	\$ ---	\$20,190,000
Non-Federal	898,000	---	9,048,000	2,146,000	12,092,000
TOTAL	\$9,382,000	\$2,735,000	\$18,019,000	\$2,146,000	\$32,282,000

(1) Data presented at late stage public meeting on 2 May 1973.

TABLE E-5a
SANDRIDGE LAKE AND MINOR CHANNEL IMPROVEMENT
(WITHOUT WATER QUALITY)

Item	Federal	Non-Federal	Total	Annual Benefits
Flood Control	\$ 9,836,000	\$ 898,000	\$10,734,000	\$ 762,000
Recreation	9,205,000	9,282,000	18,487,000	1,835,000
Water Supply	--	2,632,000	2,632,000	148,000
Total First Cost	<u>\$19,041,000</u>	<u>\$12,812,000</u>	<u>\$31,853,000</u>	
Int. During Const.	878,000	591,000	1,469,000	
Total Investment	<u>\$19,919,000</u>	<u>\$13,403,000</u>	<u>\$33,322,000</u>	
5-1/2% - 100 yr. Int. and Amortization	1,100,000	741,000	1,841,000	
OM & R	<u>127,700</u>	<u>650,300</u>	<u>778,000</u>	
Total Annual Cost	\$ 1,227,700	\$ 1,391,300	\$ 2,619,000	
Total Annual Benefits				\$2,745,000
BCR				1.05

TABLE E-6a
COST SHARING DAM AND LAKE

	<u>Flood Control</u>	<u>Recreation</u>	<u>Water Supply</u>	<u>Total</u>
Federal	\$7,653,000	\$ 8,967,000	--	\$16,620,000
Non-Federal	<u>---</u>	<u>9,044,000</u>	<u>\$2,632,000</u>	<u>11,676,000</u>
TOTAL	\$7,653,000	\$18,011,000	\$2,632,000	\$28,296,000

T SHARING MINOR CHANNEL IMPROVEMENT

Federal	\$2,183,000	\$ 238,000	--	\$ 2,421,000
Non-Federal	<u>898,000</u>	<u>238,000</u>	<u>--</u>	<u>1,136,000</u>
TOTAL	\$3,081,000	\$ 476,000	\$ --	\$ 3,557,000

AND SANDRIDGE LAKE AND MINOR CHANNEL IMPROVEMENT

	9,205,000	\$ --	\$19,041,000
		<u>2,632,000</u>	<u>12,812,000</u>
		31,853,000	\$31,853,000

4.7 - Other Costs. At public meetings two items of dam siting caused expressions of concern. The first related to the proximity of the Alden Union Cemetery to the reservoir and the pleasure and picnic areas (See Plate D1). Desecration of graves was feared, and concern expressed at the appropriateness of having an area of solemnity and sorrow and quiet contemplation so close to areas dedicated to the pursuit of happiness. A change of cemetery location is considered desirable. After discussion with appropriate authorities on the subject, an estimate of \$1 million to remove and re-inter the cadavers was derived. This sum is included in the costs presented in this section.

4.8 - The other point of concern related to the fossils Michelenoceras Aldenense, the beds containing which abut the south abutment of the dam. A partial realignment of the dam axis can be accomplished at the detail design stage and the extra construction cost is assessed at \$750,000. This sum likewise is included in the estimate figures presented in this section.

4.9 - Other costs naturally included the loss of taxes from the 5000-acre appropriation for the project. There are, however, State and Federal regulations to minimize the immediate impact of tax losses in circumstances such as this.

4.10 - The Sandridge dam and reservoir proposal is perhaps the most controversial of the four proposals. Despite its enormous cost, it is the preferred project for the Office of the Governor of the State of New York, the State Department of Environmental Conservation, the Urban Development Corporation of Amherst, the Town Board of Amherst, the Fish and Wildlife Service of the Department of the Interior. Vehemently opposed to it, among others, are generally the people of Alden, Congressmen Conables and Kemp, and conservationists who decry the loss of 5,000 acres for a need not generally believed to exist.

A copy of the letter expressing the Governor's support for this proposal, is appended to this section.

One final point is worthy of mention. At a meeting between the Corps of Engineers and Federal EPA officials in Rochester, New York on July 3, 1973, the EPA stated the effect of EPA regulations on future water quality in the Creek makes the inclusion of water quality benefits in this proposal invalid.

Therefore, the average annual costs for the scheme are \$2,619,000 but average annual benefits become \$2,745,000 and the B/C ratio is barely unity.

5 - BOWMANVILLE LAKE -
PAVEMENT ROAD DAM

5.1 - Preceding Appendices individually provide data on this proposed measure. In this proposed scheme the function of the Pavement Road dam is to impound water to provide water quality and low flow augmentation benefits in downstream waters of Ellicott Creek. However, under the incremental cost and benefit method of assessing viability, the Pavement Road dam annual costs exceed annual benefits and so it is eliminated from the proposal. Bowmansville Lake is therefore examined in isolation.

Summarized in Table E-7 below are Federal and non-Federal portions of the proposed total cost of Bowmansville Lake only.

TABLE E-7
 BOWMANVILLE LAKE

Item	Federal	Non-Federal	Total	Annual Benefits
Flood Control	\$ 8,906,000	\$	\$ 8,906,000	\$ 722,000
Recreation	6,159,000	2,035,000	8,194,000	1,723,000
Total First Cost	\$15,065,000	\$2,035,000	\$17,100,000	
Int. During Const.	579,000	78,000	657,000	
Total Investment	\$15,644,000	\$2,113,000	\$17,757,000	
5-1/2% - 100 yr. int. and amortization	864,000	117,000	981,000	
OM & R	35,000	145,000	180,000	
Total Annual Cost	\$ 899,000	\$ 262,000	\$ 1,161,000	
Total Annual Benefits				\$2,445,000
BCR				2.11

5.2 - Of the four possible solutions which were subjected to Phase II Study examination, this was the proposal that found least all round support, and most hostility. At Public Meetings and Workshops it was reiterated that Lancaster did not need, nor did it desire, a public works program of this nature.

5.3 - On the one hand were the educationalists who objected to the siting of a totally artificial reservoir adjacent to a large school. The fear of loss of child human life in the

event of embankment failure could not be allayed. It is difficult to stress the sophisticated design methods in design use today to people who only too frequently read of dam failures in the national newspapers.

5.4 - The environmentalists and recreationalists objected to the scheme. Eleven hundred acres of land being inundated to create a recreation facility in an area that currently contains Como Park on Cayuga Creek, the abandoned Nike missile site on the outskirts of Lancaster and scheduled to soon be a park, with several other small recreation areas in the vicinity, was felt unnecessary in the context.

5.5 - At a public meeting on March 17, in Williamsville, the Department of Environmental Conservation representative stated that at a previous meeting in Albany the Recreation and Parks Department felt it could not support expenditures on recreational facilities at this site.

5.6 - While the Fish and Wildlife Service was prepared to support this scheme, the office of the Governor of the State of New York considered it did not meet the overall needs of the basin and preferred the Sandridge Lake proposal.

5.7 - A major objection to the proposal, from the Lancaster Town Board, lay in the siting of the reservoir. While no other location in this area was suitable for a reservoir, this particular site was the tentative location of a multi-million dollar domed recreation and business complex. To the Board the complex represented an expanding economy and a broad tax base for the community. The major benefits the industrial expansion would bring would be lost if the area were inundated to form an unwanted recreation center. The Board was therefore quite strongly against the proposal.

5.8 - Because the scheme has no positive support and because there is very considerable local antagonism to it, it is not considered suitable for recommendation as a project.

6 - PROJECT FORMULATION

6.1 - General. Of the four schemes examined in detail in Phase II of the Study, two, namely the Diversion Channel and the Sandridge reservoir, are seen to be the best proposals to satisfy the project criteria. A summary of benefits and costs for these two is presented below.

TABLE E-8
COMPARISON OF BENEFITS AND COSTS

Plan of Improvement	Average Annual Benefits	Average Annual Costs	Net Benefit	Benefit to Cost Ratio
Diversion Channel	1,077,000	643,400	433,600	1.67
Sandridge Dam and Minor Channel Improvement	2,936,000	2,642,000	294,000	1.11

In the case of the Sandridge Scheme, the EPA has determined that no water quality benefits would accrue, therefore the economics for this scheme are as follows:

Sandridge Reservoir and Minor Channel Improvements:

Average Annual Benefits	-	\$2,745,000
Average Annual Costs	-	2,619,000
Net Benefit	-	126,000
B/C Ratio	-	1.05

6.2 - Benefits; Tangible and Intangible. The tangible benefits have been recorded at some length in the Appendices; flood damage reduction, recreation, water supply, water quality. Intangible benefits represent real and important values even though their magnitude cannot be expressed quantitatively. Such benefits can, however, be identified and described and their relative importance weighed subjectively in the final project evaluation. Examples of intangible benefits common to both schemes are the decrease in the chance of disease or loss of life due to flood reduction, higher property values because the flood risk is diminished, easier property exchange, improved social and physical well being because of recreation facilities.

The major intangible benefit belonging to one and not the other lies in the low flow augmentation capability of the Sandridge reservoir. Each summer the aesthetic appeal of Ellicott Creek could possibly be maintained by suitable releases of flow from the reservoir.

6.3 - Project Selection

6.3.1 - Diversion Channel. The Diversion Channel scheme is considered to be a local flood protection project. As such, it is bound by certain Federal legal conditions. These conditions are enumerated below.

6.3.1.1 - Division of Plan Responsibilities.

Local interests are required to:

- (a) Provide without cost to the United States all lands, easements and rights-of-way necessary for the construction and maintenance of the project;
- (b) Hold and save the United States free from all claims for damages incident to construction and operation of the project;
- (c) Take over, maintain and operate the project, after completion in accordance with regulations prescribed by the Secretary of the Army;
- (d) Accomplish, without cost to the United States, all relocations of highways, highway bridges, buildings, utilities and special facilities;
- (e) Prescribe and enforce regulations to prevent encroachment on channels and on rights-of-way necessary to proper functioning of the project, and
- (f) Provide leadership in preventing unwise use of floodplains by use of appropriate floodplain management techniques to reduce flood losses.

For recreation in non-reservoir projects, the current policy is that local interests contribute 50 percent of the first cost of recreation facilities and bear all costs for maintenance, operation

and replacement. It is also required that a competent and properly constituted public body regulate the use, growth and development of the facilities with the understanding that the facilities be open to all on equal terms.

6.3.1.2 - Cost Allocation. Costs have been allocated to flood control and recreation in accordance with the general policy requirements outlined above. A summary of first costs and cost allocation is presented in the following table.

TABLE E-9
COST ALLOCATION; DIVERSION CHANNEL

Purpose	First Cost of Construction	Operation, Maintenance and Replacement Cost	Total
Flood Control	\$10,158,000	\$21,000	\$10,179,000
Recreation	740,000	5,000	745,000
Totals	\$10,898,000	\$26,000	\$10,924,000

6.3.1.3 - Cost Apportionment. The State of New York, Erie County, and the Town of Amherst are presently the only non-Federal public bodies required to share costs and/or responsibilities. The apportioned costs are indicated in the following table, and include initial construction investment cost, and operation and maintenance cost.

TABLE E-10
COST APPORTIONMENT

Item	Federal	State	County	Town	Total
<u>Construction Costs</u>	\$	\$	\$	\$	\$
Flood Control	3,925,000	5,318,000	915,000	--	10,158,000
Recreation	370,000	--	--	370,000	740,000
Total	4,295,000	5,318,000	915,000	370,000	10,898,000
<u>Annual Operation & Maintenance Costs</u>					
Flood Control	700	20,300	--	--	21,000
Recreation	--	--	--	5,000	5,000
Total	700	20,300	--	5,000	26,000

6.3.1.4 - Federal Responsibilities. The Federal Government would construct the diversion channel and channel work associated with it, protect the abutments of the Niagara Falls Boulevard, Maple Road and North Forest Road bridges, construct the energy dissipator, and relocate power transmission towers for the flood control portion of the project.

If the project is authorized and funded for construction, the Federal Government will finalize design, advertise for bids, award the contract, pay the Contractor (or Contractors), accept or refuse the final constructed flood control project and inspect the project along with non-Federal interests who bear the responsibility of maintenance to insure that the project is adequately maintained.

For recreation facilities, the Federal Government will provide one-half the cost of initial recreation facilities. The Federal Government will coordinate with non-Federal interests responsible for constructing recreation facilities to insure that they are adequate and do not interfere with the effectiveness of the flood control project. Further, the Federal Government will periodically inspect operation of recreation facilities to insure that they are made available and open to all on equal terms.

6.3.1.5 - Non-Federal Responsibilities. Non-Federal interests are required to furnish all lands, easements and rights-of-way for construction of the project, and construct new bridges required associated with construction of the flood control works. They are also responsible for annual maintenance of the flood control project.

For recreation, non-Federal interests will provide one-half the cost of initial recreation facilities, pay all cost for annual maintenance, operation and replacement and administer operation of recreation

facilities to permit use by all on equal terms, and prevent encroachment of facilities on channel capacity to pass flood flows.

Assurances of local cooperation described above will be required during advanced engineering studies.

6.3.2 - Sandridge Reservoir and Minor Channel Improvement. The Sandridge Reservoir scheme is not a local protection project but a conventional reservoir one and it too is governed by Federal legal conditions. These conditions are enumerated below:

6.3.2.1 - Local Cooperation. Local Interests are required to:

Provide without cost to the United States all lands, easements, and rights-of-way necessary for the construction and maintenance of the project;

Hold and save the United States free from all claims for damages incident to construction and operation of the project;

Take over, maintain and operate the project, after completion, in accordance with regulations prescribed by the Secretary of the Army;

Accomplish, without cost to the United States, all relocations of highways, highway bridges, buildings, utilities and special facilities;

Prescribe and enforce regulations to prevent encroachment on channels and on rights-of-way necessary to proper functioning of the project; and

Provide leadership in preventing unwise use of floodplains by use of appropriate floodplain management techniques to reduce flood losses.

6.3.2.2 - Policy For Water Supply. All costs allocated to water supply functions must be met by local interests. The Water Supply Act of 1958, provides for payment of these costs over the life of the project, with no interest to be charged until the water is first used, but the interest-free period shall not exceed 10 years.

6.3.2.3 - Policy for Improvement of Water Quality. If benefits are classed as widespread, no local contribution is required for improvement of water quality. Local interests are required to provide adequate (usually considered as equivalent to secondary) treatment before wastes are discharged into the stream. Although the waste discharges would occur in a short length of stream, beneficial effects of quality improvement would affect all the reaches downstream as well as parts of Niagara River, an international stream, and can thus be considered widespread. Local interests would be required, to the full extent of their legal capability, to control against removal of streamflow made available for water quality control.

6.3.2.4 - Policy for Fish and Wildlife. Local interests are required to pay one-half the separable costs of initial facilities, one-half the costs of lands for the fish and wildlife purposes only, one-half the costs of future additional facilities, all costs for facilities in excess of those considered basic, and separable costs for operation, maintenance and interim replacement. Local contribution is not required for joint costs of basic fish and wildlife facilities included in a reservoir project.

6.3.2.5 - Policy for Recreation. As in the case of fish and wildlife facilities, local interest are required to pay one-half the separable costs of initial basic recreation facilities, one-half the costs of lands for recreation only, one-half the costs of future additional facilities, all costs for facilities in excess of those considered basic, and separable costs for operation, maintenance and interim replacement.

6.3.2.6 - Assurances of Local Cooperation. In accordance with the policies described above, responsible local interests would be required to furnish assurances that they will:

(a) With regard to local flood protection features of the project:

Provide without cost to the United States all lands, easements and rights-of-way necessary for construction and maintenance;

Hold and save the United States free from all claims for damages incident to construction and operation;

Take over, maintain and operate, after completion, in accordance with regulations prescribed by the Secretary of the Army;

Accomplish, without cost to the United States all relocations of highways, highway bridges, buildings, utilities and special facilities; and

Prescribe and enforce regulations to prevent encroachment on channels and on rights-of-way necessary to proper functioning of the work.

(b) With regard to reservoir features of the project:

Provide leadership in preventing unwise use of floodplains by use of appropriate floodplain management techniques to reduce flood losses;

Prescribe and enforce regulations to prevent encroachment that would reduce the existing channel capacities downstream of the damsite;

Hold and save the United States free from damages due water-rights claims resulting from construction and operation of project;

	<u>Flood Control</u>	<u>Water Quality</u>	<u>Recreation</u>	<u>Water Supply</u>	<u>Total</u>
Benefits	\$ 430,000	\$ 190,000	\$ 1,673,000	\$ 148,000	\$ 2,441,000
Alternative Costs	670,000	620,000	1,709,000	627,000	3,626,000
Benefits Limited	430,000	190,000	1,673,000	148,000	2,441,000
Separable Costs	47,000	8,000	1,545,000	8,000	1,608,000
Remaining Benefits	383,000	182,000	128,000	140,000	833,000
Ratio	.460	.218	.154	.168	1.000
Allocated Joint Costs	375,000	178,000	125,000	137,000	815,000
Total Allocated Financial Cost	422,000	186,000	1,670,000	145,000	2,423,000
B/C Ratio	1.02	1.02	1.00	1.02	1.01
Separable OM & R Charges	---	---	637,000	---	637,000
Allocated OM & R Charges	58,000	28,000	20,000	21,000	127,000
Total Allocated OM & R	58,000	28,000	657,000	21,000	764,000
Annual Investment Cost	364,000	158,000	1,013,000	124,000	1,659,000
Capitalized Investment Cost	6,587,000	2,859,000	18,331,000	2,244,000	30,021,000
Adjustment For Dis. Future	---	---	---	---	---
Total Allocated Investment	6,587,000	2,859,000	18,331,000	2,244,000	30,021,000
Investment In Spec. Use Lands and Facilities	---	---	8,783,000	---	8,783,000
Investment in Joint Use Lands and Facilities	6,587,000	2,859,000	9,548,000	2,244,000	21,238,000
Interest On Joint Use Lands and Facilities	286,000	124,000	414,000	98,000	922,000
Alloc. Const. Cost-Joint Use Land and Facilities	6,301,000	2,735,000	9,134,000	2,146,000	20,316,000
Const. Cost Of Spec. Use Land and Facilities	---	---	8,408,000	---	8,408,000
Total Alloc. Const. Cost	6,301,000	2,735,000	17,542,000	2,146,000	28,724,000
Const. Cost of Future Rec.	---	---	825,000	---	825,000
Const. Cost of Dev. Plans	---	---	---	---	---
Const. Cost of Water Res. Proj.	6,301,000	2,735,000	16,717,000	2,146,000	27,899,000
Total Const. Cost of Water Res. Proj.	6,301,000	2,735,000	17,542,000	2,146,000	28,724,000

TABLE E-11 (con't)

	<u>MINOR CHANNEL IMPROVEMENT</u>			
	\$	---	\$	\$
TOTAL PROJECT FIRST COST	\$ 3,081,000	---	\$ 477,000	\$ 3,558,000
Interest During Construction Investment	423,000	123,000	812,000	1,455,000
Interest and Amortization	9,805,000	2,858,000	18,831,000	33,737,000
Operation and Maintenance	542,000	158,000	1,040,000	1,164,000
	72,000	28,000	657,000	778,000
TOTAL ANNUAL COST	614,000	186,000	1,697,000	2,642,000
Benefits-Minor Channel	332,000	---	178,000	510,000
TOTAL ANNUAL BENEFITS	762,000	190,000	1,851,000	2,951,000
B/C Ratio	1.24	1.02	1.09	1.12
			\$ 2,146,000	\$ 32,282,000

AD-A101 345

CORPS OF ENGINEERS BUFFALO N Y BUFFALO DISTRICT
ELLCOTT CREEK BASIN, NEW YORK. WATER RESOURCES DEVELOPMENT. PH--ETC(U)
AUG 73

F/6 13/2

UNCLASSIFIED

NL

5 of 6
AC 1345

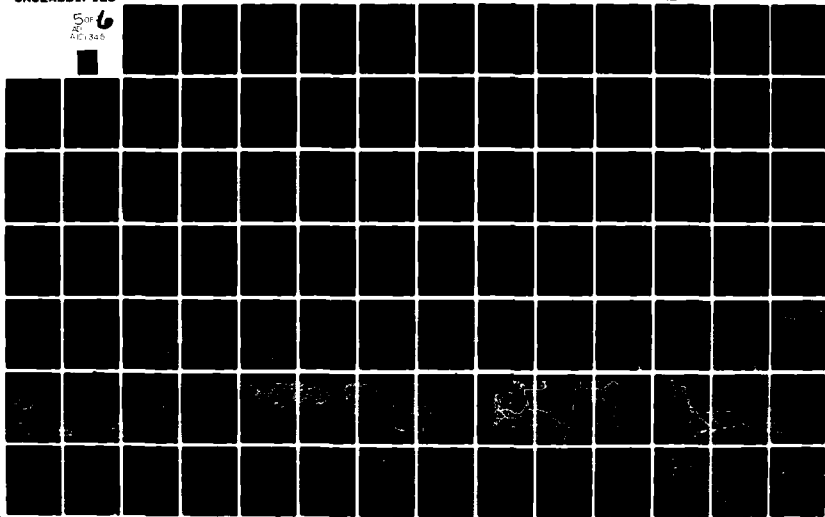

TABLE E-11A
SEPARABLE COSTS & REMAINING BENEFITS METHOD

	<u>Flood Control</u>	<u>Recreation</u>	<u>Water Supply</u>	<u>Total</u>
Benefits	\$ 430,000 (1)	\$ 1,673,000	\$ 148,000	\$ 2,251,000
Alternative Costs	670,000	1,709,000	627,000	3,006,000
Benefits Limited	430,000	1,673,000	148,000	2,251,000
Separable Costs	93,000	1,546,000	56,000	1,695,000
Remaining Benefits	337,000	127,000	92,000	556,000
Ratio	.606	.228	.166	1.000
Allocated Joint Costs	426,000	160,000	117,000	703,000
Total Allocated Financial Cost	519,000	1,706,000	173,000	2,398,000
B/C Ratio	0.83	0.93	0.86	0.94
Separable OM & R Charges	---	637,000	---	637,000
Allocated OM & R Charges	77,000	29,000	21,000	127,000
Total Allocated OM & R	77,000	666,000	21,000	764,000
Annual Investment Cost	442,000	1,040,000	152,000	1,634,000
Capitalized Investment Cost	7,998,000	18,820,000	2,751,000	29,569,000
Adjustment For Dis. Future	---	---	---	---
Total Allocated Investment	7,998,000	18,820,000	2,751,000	29,569,000
Investment In Spec. Use Lands & Fac.	---	8,704,000	---	8,704,000
Investment in Joint Use Lands & Fac.	7,998,000	10,116,000	2,751,000	20,865,000
Interest on Joint Use Land & Fac.	345,000	437,000	119,000	901,000
Alloc. Const. Cost-Joint Use Land and Facilities	7,653,000	9,679,000	2,632,000	19,964,000
Const. Cost of Spec. Use Land and Facilities	---	8,332,000	---	8,332,000
Total Alloc. Const. Cost	7,653,000	18,011,000	2,632,000	28,296,000
Const. Cost of Future Rec.	---	825,000	---	825,000
Const. Cost of Dev. Plans	---	---	---	---
Const. Cost of Water Res. Proj.	7,653,000	17,186,000	2,632,000	27,471,000
Total Const. Cost of Water Res. Proj.	7,653,000	18,011,000	2,632,000	28,296,000

TABLE E-11A (Con't)

	<u>MINOR CHANNEL IMPROVEMENT</u>			
Minor Channel First Cost	3,081,000	476,000	---	3,557,000
TOTAL PROJECT FIRST COST	10,734,000	18,487,000	2,632,000	31,853,000
Interest During Construction	495,000	853,000	121,000	1,469,000
Investment	11,229,000	19,340,000	2,753,000	33,322,000
Interest and Amortization	620,000	1,069,000	152,000	1,841,000
Operation and Maintenance	91,000	666,000	21,000	778,000
TOTAL ANNUAL COST	711,000	1,735,000	173,000	2,619,000
Benefits-Minor Channel	332,000	162,000	---	494,000
TOTAL ANNUAL BENEFITS	762,000	1,835,000	148,000	2,745,000
B/C Ratio	1.07	1.06	0.86	1.05

Exercise to the full extent to their legal capability, control against removal of stream-flow made available for water quality control; and

Enter into a contract or contracts, satisfactory to the Secretary of the Army, providing that they will:

- In accordance with the Water Supply Act of 1958, amended, reimburse the United States for those parts of the construction cost and annual operation, maintenance and major replacement costs allocated to municipal water supply; and
- In accordance with the Federal Water Project Recreation Act of 1965, reimburse the United States for one-half the separable construction costs for recreation and fish and wildlife facilities, including costs for facilities and initially deferred but scheduled to be installed over the life of the project, and bear all costs for operation and maintenance of the facilities and major replacements thereto.

6.3.2.7 - Allocation of Costs. The separable costs--remaining benefits method was used to allocate costs to the project purposes. The basic theory of this method is that each purpose will be allocated at least the separable cost of including it as a project purpose. The remaining joint costs are distributed according to the relative magnitude of remaining benefits. The cost of an alternative single purpose project for each purpose was calculated and substituted for benefits in the allocation of joint costs if it was less than the benefit estimate.

The separable cost for a given purpose is the difference between the cost of the multiple purpose project and the cost of the project with that purpose omitted. Specific costs of facilities needed to serve only one purpose would be included in the separable costs. Details of the cost allocation used to present the Sandridge dam and minor channel improvement alternative at the late stage public meeting on 2 May 1973 are shown in Table E-11, following Table E-11a reflects elimination of benefits for water quality.

6.4 - Recommendation. After a review of all the foregoing, and giving due weight to the intangible benefits associated with each of the two proposals, it is recommended that the Diversion Channel be authorized for construction, in lieu of a multiple-purpose reservoir at the Sandridge site near Alden, NY, and approximately three miles of channel improvement along Ellicott Creek, mostly in the Town of Amherst, by the Corps of Engineers in general accordance with the plan presented in this report at an estimated cost of \$11,173,000 for construction and \$26,000 annually for operation and maintenance, with such modifications as in the discretion of the Chief of Engineers might be advisable, provided that, prior to initiation of construction, local interests furnish assurances to the Secretary of the Army that they will:

Provide without cost to the United States all lands, easements and rights-of-way necessary for construction and maintenance;

Hold and save the United States free from all claims for damages incident to construction;

Take over, maintain and operate, after completion, in accordance with regulations prescribed by the Secretary of the Army;

Accomplish, without cost to the United States, all relocations of highways, highway bridges, buildings, utilities and special facilities;

Prescribe and enforce regulations to prevent encroachment on channels and on rights-of-way necessary to proper functioning of the work and;

Effect floodplain management by:

- Not permitting structural development within the 100 year floodway in those areas not protected by the Project as developed by the Corps of Engineers;
- Not permitting future development within a possible residual 100 year flood outline unless it can be proven there will be no increase in flood risk;
- Requiring future development outside the 100 year flood outline but within the Standard Project Flood (SPF) outline to be constructed so that the first floor elevation is at or above the SPF level;

- Requiring floodproofing of structures to the SPF elevation in lieu of raising them; or
- Combining the two methods, raising structures to the SPF elevation or floodplaining structures to the SPF elevation, i.e. raise some and floodproof the remainder.

With regard to recreation facilities:

Contribute 50 percent of the first cost of recreation facilities;

Bear all cost for maintenance, operation and replacement of the recreation facilities;

Establish rules to control the use, growth, and development of the recreation facilities, with the understanding that public facilities will be open to all on equal terms.

The net cost to the United States for the recommended improvements for flood control is estimated at \$4,135,000 for initial construction and \$700 annually for inspection, and the net cost to the United States for the recommended improvements for recreation is estimated at \$370,000.

It is further recommended that improvement for flood control be undertaken whenever the required local cooperation is furnished and funds become available. The required local cooperation for recreation facilities can be furnished separately at any time after completion of the flood control works and when funds, as necessary, become available.



STATE OF NEW YORK
EXECUTIVE CHAMBER
ALBANY 12224

NELSON A. ROCKEFELLER
GOVERNOR

June 5, 1973

Dear Colonel Moore:

After thorough consideration of the Corps' Ellicott Creek Restudy by all concerned agencies of the State of New York, the State remains convinced that the Sandridge Lake and Ellicott Creek minor channel improvements project, as authorized by the Omnibus Rivers and Harbors Act of 1970, will best meet the overall needs of the area, and that the other three alternatives being evaluated are unacceptable.

Investigation of the desirability and feasibility of this project formally began, under State auspices, more than a decade ago. The Erie-Niagara Basin Regional Water Resources Planning Board, which was the first such agency established under New York's statewide water resources planning program, undertook a comprehensive planning program in which the Corps and other federal agencies played a crucial cooperative role. The product of this seven-year planning program was the Erie-Niagara Basin Plan, issued in 1970.

The Plan proposed the Sandridge project as a critical element of the overall program to meet the water resource and associated needs of the Basin. Sandridge was included in the early action program under the Plan, and was assigned the highest priority for implementation.

On the basis of the report by the Corps of Engineers on the Ellicott Creek Basin, which confirmed the Basin Board's

June 5, 1973

recommendation and at the urging of the State of New York, authorization for the project was included in the Omnibus Rivers and Harbors Act of 1970. This authorization, however, included a requirement that all possible alternative methods be investigated by the Corps prior to commencement of the Sandridge project.

None of the three project alternatives to the Sandridge project under evaluation as part of the Ellicott Creek Restudy would meet the overall needs of the basin.

Both the Major Channel Improvement and Diversion Channel alternatives would be seriously disruptive of the natural environment of the most densely populated area of the Ellicott Creek Basin. Both fail to provide for low-flow augmentation.

The Bowmansville Reservoir alternative fails to provide low-flow augmentation, substantial regional recreational benefits, or water supply potential.

On the other hand, the Sandridge project, including the minor downstream channel improvements which are part of it, will meet the crucial needs of the basin and will provide substantial benefits in terms of fish and wildlife, recreation, water supply, and low-flow augmentation in the interests of a quality urban environment.

In terms of flood control, the Sandridge project would accomplish the greatest degree of flood damage reduction. In the case of each of the three alternatives as well as Sandridge, adequate flood plain management efforts will also be required to achieve optimum protection of the basin from flood losses.

The minor downstream channel improvements which are part of the Sandridge project will afford substantial flood control benefits by themselves. These improvements could be accomplished expeditiously as the first phase of the overall project; thus, significant immediate benefit will ensue from the Sandridge project which would not be available from the alternatives.

June 5, 1973

Accordingly, the State of New York, after review of the alternatives, the reports thereon, and the views presented at the May 2 public hearing, reaffirms its support for the Sandridge Lake and Ellicott Creek minor channel improvements project, as authorized by the Omnibus Rivers and Harbors Act of 1970.

Because it is the State's hope that this project will be initiated expeditiously, we urge quick completion of your Report. We also urge that appropriations be provided the Corps to enable the immediate construction of the minor channel improvements, as well as for detailed design of the remainder of the project. In addition, we urge the Corps to recommend special appropriations for the development of additional detailed flood plain mapping for the Basin so that meaningful flood plain management actions may be taken coordinate with the effectuation of the project.

Sincerely,

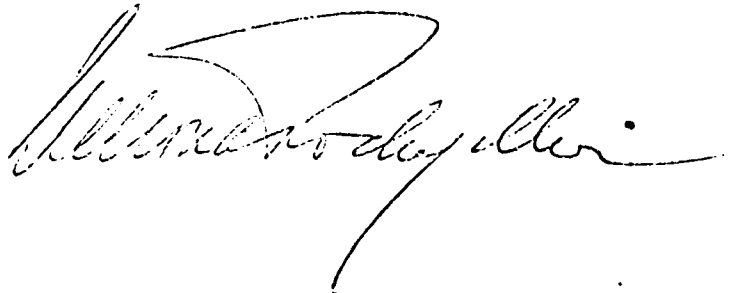
A handwritten signature in cursive script, appearing to read "William J. Doyle". The signature is written in dark ink and is positioned to the right of the typed name and address.

Colonel Robert L. Moore
Buffalo District
Corps of Engineers
1776 Niagara Street
Buffalo, New York 14207

FLOOD CONTROL AND ALLIED PURPOSES
ELLICOTT CREEK, NEW YORK

APPENDIX F
NON-FEDERAL ALTERNATIVES
TABLE OF CONTENTS

	<u>Subject</u>	<u>Page</u>
1	Purpose and Scope	F-1
2	Designated Floodways and Encroachment Lines	F-1
3	Zoning	F-2
4	Subdivision Regulations	F-2
5	Building Codes	F-3
6	Development Policies	F-3
7	Flood Proofing	F-4
8	Temporary Evacuation	F-5
9	Permanent Evacuation	F-5
10	Open Spaces	F-5
11	Warning Signs	F-6
12	Flood Insurance	F-6
13	Bridges	F-7
14	Land Uses Permitted	F-8
16	Technical Assistance Available	F-10
17	Potential Flood plain Management Areas	F-10
	17.1 General	F-10
	17.2 Reaches 8 & 9	F-10
	17.3 Bowmansville	F-11
	17.4 Harris Hill Road To Alden Crittenden Road	F-12

PLATES

Number

F1	Profiles Mile 0 to 6.5
F2	Profiles Mile 6.5 to 13.0
F3	Profiles Mile 13.0 to 22.0

APPENDIX FNON-FEDERAL ALTERNATIVES1 - PURPOSE AND SCOPE

1.1 The purpose of this Appendix is to present to local officials of the towns of Amherst, Cheektowaga, Lancaster and Alden, a discussion of flood plain management techniques that would reduce future flood losses. The appendix will familiarize officials with flood plain regulations and other measures available, and locates areas where floodplain management principles are recommended as a part of the selected Project.

2 - DESIGNATED FLOODWAYS AND ENCROACHMENT LINES

2.1 A floodway is a strip of land on either side of a stream, that is used only to carry floodwaters. The flood plain refers to all lands susceptible to flooding. Construction or land filling should not be permitted within the floodway unless it can be clearly established that other portions of the flood plain will not be subjected to greater damages or that the new buildings will not be subject to unreasonable risk.

2.2 For the study area along Ellicott Creek a floodway limit equal to the 100-year flood outline, with the reservoir in place, could be established by the communities involved. The 100-year flood outline and profile are shown on Plates 2, 3, F1, F2 and F3 for the reach between the Niagara River and Stony Road in the town of Lancaster. Only limited information is available for flood conditions between Stony Road and the Sandridge Dam site. This 15-mile reach has apparently been surveyed; the survey information should be presented in a similar manner. The information is expected to be available shortly from the Corps of Engineers, Buffalo District.

2.3 If the floodway concept is adopted by local communities, the floodway under existing conditions should not be used until the reservoir or other flood control improvements have been constructed. The floodway could then be reduced. Buildings already in the floodway could be flood-proofed to the 100-year elevation.

3 - ZONING

3.1 Zoning could be used to prevent unwise development in the flood plain. Each town could use zoning ordinances to control and direct the use and development of land and property within its jurisdiction. Zoning would insure the safekeeping of property for public health and welfare and the best use of available land. Division of communities into various zones should be the result of a comprehensive planning program for the entire area. The designated floodway could be zoned for the purpose of passing floodwaters and for other limited uses that do not conflict with that primary purpose. The ordinance could also establish regulations for the flood plain areas outside of the floodway. These include designating elevations below which certain types of development cannot be constructed. The Flood Plain Management Section of the Buffalo District Corps of Engineers is available to assist the towns in the preparation of such an ordinance.

4 - SUBDIVISION REGULATIONS

4.1 A subdivision is defined as a tract of land divided into lots for the purpose of either sale or building development. Subdivision regulations are used by local governments to specify the manner in which land may be divided. These requirements may state the required width of streets, requirements for curbs and gutters, size of lots, elevation of land, freedom from flooding, size of drainage ditches, and other items pertinent to the general welfare. Subdivision regulations within the project area should provide an efficient means of controlling construction in presently undeveloped flood plain areas. The following provisions should be included in regulations for flood damage prevention:

- Show extent of the flood plain on subdivision maps.
- Show floodway limits, or encroachment lines.
- Prohibit fill that would restrict flow in the channel and floodway.

Require that subdivision roads be above the elevation of a selected flood level.

Require that each lot contain a building site with an elevation above a selected flood level.

5. - BUILDING CODES

5.1 A building code is a set of regulations adopted by a local governing body, setting forth standards for the construction of buildings and other structures for the purpose of protecting the health, safety, and general welfare of the public. A well-written and properly enforced building code for each town involved would effectively reduce damages to buildings allowed to be constructed in the flood plain. Requirements which should be specified in the building code to reduce flood damage include:

Prevent floatation of buildings from their foundations by requiring proper anchorage.

Establish basement elevations and minimum first-floor elevations consistent with potential floods.

Require structural strength to withstand either water pressure or high-velocity flowing water.

Prohibit equipment that might be hazardous to life when submerged: That is chemical storage, boilers electrical equipment, etc.

6. - DEVELOPMENT POLICIES

6.1 Policy and action decisions, by the towns, to prevent construction of streets and utility systems in undesirable areas will deter development in flood plains. Street improvements, schools and other public facilities located elsewhere would exert positive leadership toward utilization of higher ground, and reduce the potential of flood plain exploitation.

7 - FLOOD PROOFING

7.1 Flood proofing of structures can significantly reduce damages to properties subject to flooding. Although flood proofing is more economically applied to new construction it is also applicable to existing facilities. Flood proofing is most applicable in one or more of the following situations.

Where moderate flooding with low stage, low velocity, and short duration is experienced.

Where the traditional type of flood protection is not feasible.

Where individuals desire to solve their flood problems without collective action, or where collective action is not possible.

Where activities dependent on stream locations need some degree of protection.

Where a resource manager desires a higher degree of protection than that which is provided by a flood control project.

7.2 Many different flood-proofing measures have been recognized and studied. The names given most of them are self-explanatory. Included in these measures, which can be used in the Ellicott Creek area, are the following items:

Seepage control	Watertight caps	Appliance protection
Sewer adjustment	Proper anchorage	Utility adjustments
Permanent closure	Underpinning	Roadbed protection
Openings protected	Timber treatment	Elevation or raising
Interiors protected	Structural design	Temporary removal
Protective coverings	Fire protection	

7.3 A useful guide, "Introduction to Flood Proofing", prepared by the Center for Urban Studies, University of Chicago, under the sponsorship of the Corps of Engineers, is available upon request. It presents many helpful suggestions and briefly outlines and illustrates the possibilities of this approach. A sketch showing some flood-proofing techniques is shown on Plate F-3.

8. - TEMPORARY EVACUATION

8.1 Temporary evacuation of persons and property from the path of floodwaters plays an important part in reducing flood losses. When a flood is expected, individuals and/or town agencies can cooperate by the following actions:

Buildings can be evacuated.

Materials can be either raised above floodwaters or removed to higher ground.

Emergency protective measures can be undertaken.

Flood fighting and relief agencies can be activated

9. - PERMANENT EVACUATION

9.1 Permanent evacuation of developed areas subject to frequent inundation involves the acquisition of lands, by purchase (through the power of eminent domain if necessary), removal of impediments, and the relocation of the population from such areas. Land acquired in this manner could be used for picnic areas, parks, or other purposes that would neither interfere with flood flows nor result in material damage from floods.

10. - OPEN SPACES

10.1 A greater emphasis is being placed on the growing need for vastly increased areas for recreational and other open-space uses. Areas adjacent to streams and other bodies of water have a natural attraction and are readily adaptable to recreation. Parks, playgrounds, and picnic areas can utilize lands which would not be suitable for facilities requiring permanent structures. The towns involved should use the Ellicott Creek flood plain for such purposes, thereby reaping secondary bene-

fits from flood damage prevention. Federal grants are available to assist communities in acquiring such open spaces, when linked with a program of comprehensive planning.

11. - WARNING SIGNS

11.1 A method which could also be used by the towns to discourage development is the erection of flood warning signs in the flood plain area, or the prominent posting of previous high-water levels. These signs carry no enforcement but simply serve to inform prospective buyers that a flood hazard exists.

12. - FLOOD INSURANCE

12.1 A recently enacted National Flood Insurance Bill established a program of Federal assistance for flood insurance, to be related to a unified national program for flood plain management. Further information is available from the Federal Insurance Administrator in Washington, D. C. The basic elements of this program are discussed below:

It provides for the formation of insurance company pools under the supervision of the Secretary of Housing and Urban Development.

It provides Federal premium subsidies and reinsurance coverage.

It provides that the property owner will bear part of the cost in the form of a premium.

It authorizes an alternative program under which private companies would act as fiscal agents for the United States Government, in the event a program of private industry participation cannot be carried out.

It sets initial insurance limits for residential properties, with provisions for gradual extension to most other forms of businesses, governmental operations, and other flood plain occupants.

It prohibits the writing of policies after June 30, 1970, unless permanent land-use regulations, with effective enforcement provisions, have been adopted, and at any time for property declared to be in violation of State or local land development ordinances.

It prohibits the granting of Federal disaster assistance with respect to property which is covered, or could, under certain circumstances, have been covered by flood insurance under the act.

It authorizes the Secretary of Housing and Urban Development to identify, within 5 years of the Bill's enactment, all flood plain areas, and within 15 years to establish flood-risk zones and make estimates of flood-caused losses in those zones. The most probable future role for flood insurance is that it will provide a useful means of accomplishing other programs which will reduce the risk to a point where insurance is economically feasible. Flood insurance is not a complete solution to flood problems but is a possible means of providing the difference between partial flood protection and complete coverage against loss, for structures already within the flood plain.

13. - BRIDGES

13.1 Community expansion will bring about the desire for more stream crossings. From a construction standpoint, the most economical method of providing crossings consists of roadways on earth embankments, with a small bridge or culvert to pass streamflows. However, this is least desirable from a flood damage point of view. If the structure is kept at a low elevation, it is frequently flooded and fails to serve its intended purpose. Bridges should be kept high, above the flood plain, so that they will not act as a dam and increase flood stages upstream. Therefore, all future stream crossings should be designed to provide:

Adequate waterway opening.

Adequate bridge clearance above flood flows.

13.2 The profiles furnished by the Corps of Engineers for Ellicott Creek will be very useful in the construction of adequate bridge openings (see Plates, F-1, F-2 & F-3).

14. - LAND USES PERMITTED

14.1 In the absence of a State flood plain management program in New York, the following uses should be considered by the towns for the floodway and the flood-plain.

a. Open-space uses not requiring a closed building, i.e. agricultural cropland, livestock feeding and grazing (in compliance with public health standards), controlled wildlife areas, or open type public and private recreation areas.

b. Storage yards for equipment and material either properly anchored to prevent their moving into bridges or other debris-catching areas, removable within limited time available after flood warning, or not subject to major damage by floods. The storage of explosive, buoyant or flammable-liquid materials in large quantities shall not be permitted.

c. Railroads, streets, bridges, and public utility wire and pipelines for transmission and local distribution.

d. Commercial excavation of materials from pits, strips, or pools, providing that no stockpiling of materials, products, or overburden shall create a restriction to the passage of flood flows.

e. Non-restrictive improvements in stream channel alignment, cross section, and capacity in the normal maintenance thereof.

f. Uses of a type not appreciably damaged by floodwaters, provided no structures for human habitation shall be permitted.

g. Structures that are designed to have a minimum effect upon the flow of water, and are firmly anchored to prevent the structure from floatation.

15. - In addition, in the fringe areas of the land subject to flooding by the 100-year flood, and outside the floodway required to convey the 100-year discharge, the following regulations should also be considered:

a. Buildings or structures may be located in these areas, provided first floors are placed above the elevation of the 100-year flood.

b. Foundations of all structures shall be designed and constructed to withstand flood conditions at the proposed construction site.

c. Basements, lower floors, or appurtenances located below the elevation of the 100-year flood shall be designed and constructed to prevent passage of water into the building or structure, to withstand flood conditions, including hydrostatic pressures of elevated water tables and the momentum of flood flows. Materials for construction shall be of the type not deteriorated appreciably by water. Windows, doorways, and other openings into the building or structure that are located below the elevation of the 100-year flood shall be designed and constructed incorporating adequate flood proofing.

d. All electrical equipment, circuits, and installed electric appliances shall be located so as to not be subject to flooding or shall be flood proofed to prevent damage resulting from inundation by the 100-year flood.

e. Sanitary and storm sewer drains shall be equipped with valves capable of being closed, manually or automatically, to prevent backup of sewage and storm waters into the building or structure. Gravity draining of basements may be eliminated by mechanical devices.

f. Chemical storage, explosive, buoyant and flammable-liquid storage, either shall be located above the 100-year flood level or shall be adequately flood proofed to prevent floatation of tanks, other appreciable damage, and escape into the floodwaters of toxic materials.

g. Land may be filled, provided such fill extends 15 feet beyond the limits of any building or structure erected.

h. Street surfaces shall lie above the elevation of the 100-year flood.

16 - TECHNICAL ASSISTANCE AVAILABLE

16.1 Effective flood plain development plans require careful evaluation of the flooding potential and the determination of the effects upon flood flows of future flood plain use. These engineering determinations require technical experience and information which most communities do not have. In response to this need, the U.S. Army Corps of Engineers and the U.S. Geological Survey have programs to assist communities in evaluating the flood potential and relating it to flood plain management practices. The Corps of Engineers Flood Plain Management Services are available, to the extent funds are provided, to provide technical assistance to local governments in interpreting and evaluating basic flood data and to assist them in making decisions for wise use of flood plain lands.

17 - POTENTIAL FLOOD PLAIN MANAGEMENT AREA

17.1 GENERAL

The Review Survey Phase I Report presents the results of an examination of the potential for the application of Floodplain Management principles along Ellicott Creek. With reference to Plate 9, it shows that suitable areas of application for these principles are:

Reaches 8 & 9

Bowmansville

Harris Hill Road to the Alden Crittenden Road (upstream of Stony Road)

17.2 REACHES 8 & 9

17.2.1 Plate 9 illustrates the location and extent of these reaches.

17.2.2 The upstream limit considered in this flood-protection measure is Transit Road, and the downstream limit is the New York State Thruway Bridge over the creek. From Plate 2 and 3 it can be seen that both the floodplain and the floodway are narrow in Reach 8, but that the floodplain has a maximum width of some 4,000 feet in Reach 9, and the floodway is only slightly narrower. The northern limit of the floodplain is the embankment that is the New York State Thruway; the southern limit is high land adjacent the creek.

17.2.3 Such development as there is in these two reaches is primarily residential with support commercial units. A study of the 1972 aerial photography of the area show it to be largely open, unused space, traversed by small creeks or streams. Though the floodplain is virtually undeveloped, urbanization has occurred to the very boundaries of the floodplain, partly, no doubt, as a result of the proximity of the Buffalo International Airport to these two reaches.

17.2.4 The photographs also indicate that urbanization is beginning to occur in the floodway, particularly on the land between Aero Drive and the New York Central Railway tracks.

17.2.5 If action were taken immediately, then the case for floodplain management techniques in these reaches is strong. Existing development could be floodproofed and further development confined to low-value flood-damage uses. However, the suggestion to employ floodplain management techniques has been made previously and often (the 1968 Floodplain Report, the 1970 Survey Report), and no action has yet been taken. Similar inaction at this time will make the future application of floodplain management laws futile.

17.3 BOWMANSVILLE

17.3.1 The length of Ellicott Creek considered covers Reaches 9 and 10.

17.3.2 In this length the existing development is scattered and generally in strips along the existing roads. Floodproofing measures will not only benefit existing development, but future development also. In assessing the economics

of the measure in these reaches, the same philosophy has been used for assessing damages as was used in the 1970 Corps of Engineers Report i.e. the total future damages will double the present. On this basis and allowing a sum of \$2,000 per house for floodproofing measures, the benefit-to-cost ratio is 1.35. The measure is, therefore, both economic and attractive.

17.4 HARRIS HILL ROAD TO ALDEN CRITTENDEN ROAD

17.4.1 This reach covers virtually the whole length of the creek from Harris Hill Road to the site of the Sandridge dam, a straight line length of 9.2 miles. There is not, regrettably, any record of the extent of flooding in this length of Ellicott Creek. Plate 3 illustrates the extent of the floodplain and the floodway between Harris Hill Road and Stony Road, a length of 1.4 miles from the westerly limit of the reach under consideration.

17.4.2 Because factual information on flooding exists only for that portion of the creek between Harris Hill Road and Stony Road, recommendations will be made only for this length. For the portion east of Stony Road, the comment will be in the nature of a general assessment.

17.4.3 The floodplain between Harris Hill Road and Stony Road is confined by the high land that is Harris Hill Road, the New York State Thruway, Stony Road, and Pleasant View Drive. A study of the 1972 aerial photography shows the land use in this area is strip residential development along the four roads with support commercial units. The whole of the center section is apparently undeveloped and contains the beds of numerous creeks or small streams. There is information private interests may build a \$50 million domed stadium on the fringe of the floodplain adjacent Pleasant View Drive. Inevitably, this will cause further development and peripheral development of some \$300 million is anticipated.

17.4.4 The terrain from north to south is dished with periphery elevations of about 720 feet and valley elevations just in excess of 700 feet. The 1960 flood had a water elevation of 718.6 feet. The depth of floodwater in this floodway on this occasion can, therefore, be described as severe.

17.4.5 This stretch of the creek and its floodplain may be stated to be a suitable location for the application of floodplain management techniques. Almost the entire area is undeveloped, and a major portion of the floodplain is the floodway. The passing of legal instruments now to enforce floodplain management will undoubtedly save large sums of money on flood damages in the future. This is particularly important in the light of the domed stadium and associated development intentions.

17.4.6 It is important to note, however, that the construction of an impoundment (i.e. Sandridge Reservoir) upstream of this location will considerably reduce the extent of the floodplain here, opening the possibility of profitable land development.

17.4.7 The aerial photography shows that from Stony Road to the Alden-Crittenden Road the creek flows through open land with few major buildings or industry in it. There are quarry workings adjacent Peppermint Road and Genesee Street at Pavement Road. The County Home and Infirmary is located between the creek and Walden Avenue near Millgrove. The County Penitentiary (Industrial Farm) is near the Home. There is strip housing development adjacent all good roads.

17.4.8 The main land use in this length is shown from the photographs to be farming. There are frequent occurrences of woodland areas. The area could be described in general as farmland. Field reconnaissances have shown that while some farm houses have been disused, many are still operative and are in good condition.

17.4.9 Vocal response from this general area to the 1970 Sandridge proposal has been mainly a request that the farms and farmland be left undisturbed. There is no evidence of any desire to urbanize, but perhaps it would be prudent to zone the area for farming only.

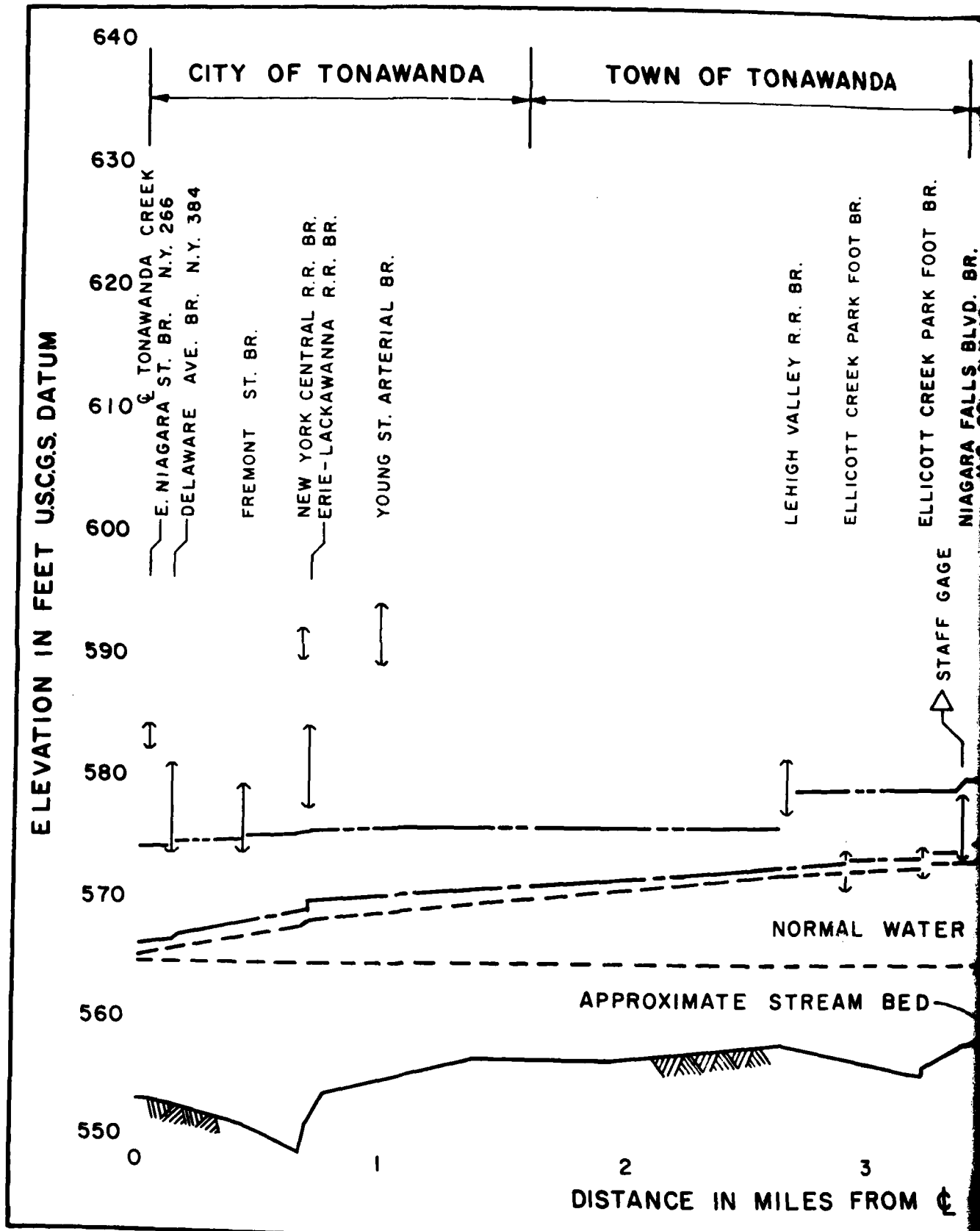

IDA

TOWN OF AMHERST

LEGEND:



STAFF GAGE LOCATED AT ABUTMENT DOWNSTREAM OF NIAGARA FALLS BRIDGE. ZERO OF STAFF EQUALS 564.98 U.S. DATUM.

--- STANDARD PROJECT FLOOD

--- INTERMEDIATE REGIONAL FLOOD

--- MARCH 1960 FLOOD

--- APPROXIMATE STREAM



APPROXIMATE FLOOR ELEVATION

APPROXIMATE LOW STEADY FLOOD

ELLICOTT CREEK PARK FOOT BR.

NIAGARA FALLS BLVD. BR.
U.S. 62 - N.Y. 18

SWEET HOME RD. BR.

STAFF GAGE



NOTES:

CREST PROFILES ARE BASED ON THE FOLLOWING:
1. EXISTING CHANNEL CONDITIONS
2. EXISTING STRUCTURES
3. EXISTING CONDITIONS OF BANKS
LARGE SCALE FILLING WILL BE REQUIRED AT THESE PROFILES UNLESS SUFFICIENT FILLING IS PROVIDED.

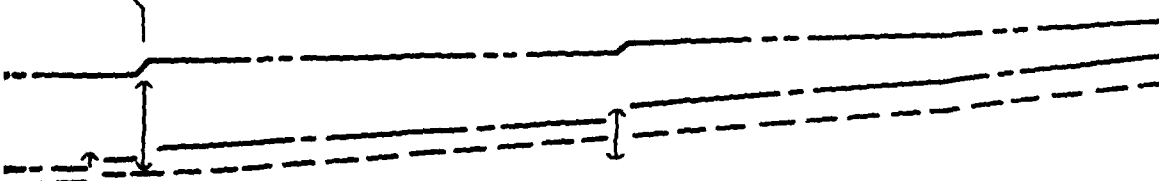

WATER SURFACE

BED

3 4 5 6
FROM CENTER OF TONAWANDA CREEK

ELLICOTT CREEK
ERIE COUNTY, NEW YORK
FLOOD PLAIN INFORMATION
PROFILES
MILE 0 TO 0.5
U.S. ARMY ENGINEER DISTRICT NO. 1
JANUARY 1968

LOCATED ON R...
DOWNSTREAM SIDE
A FALLS BOULEVARD
ERC OF STAFF BASE
PL 58 1 5 1 3 3

PROJECT FLOOD
LATE RES IDUAL FLOOD
NO FLOOD
VE STREAM BED
TE FLOOR ELEVATION
TE LOW STEEL ELEVATION

ARE BASED ON THE
WEL CONDITIONS
CTURES
TIONS OF DEVELOPMENT
ING WILL RAISE THE
FICIENT FLOODWAY IS

OTT CREEK
ITY, NEW YORK
NFORMATION REPORT
OFILES
O TO 6.5
ER DISTRICT, BUFFALO
MAY 1968

PLATE FI

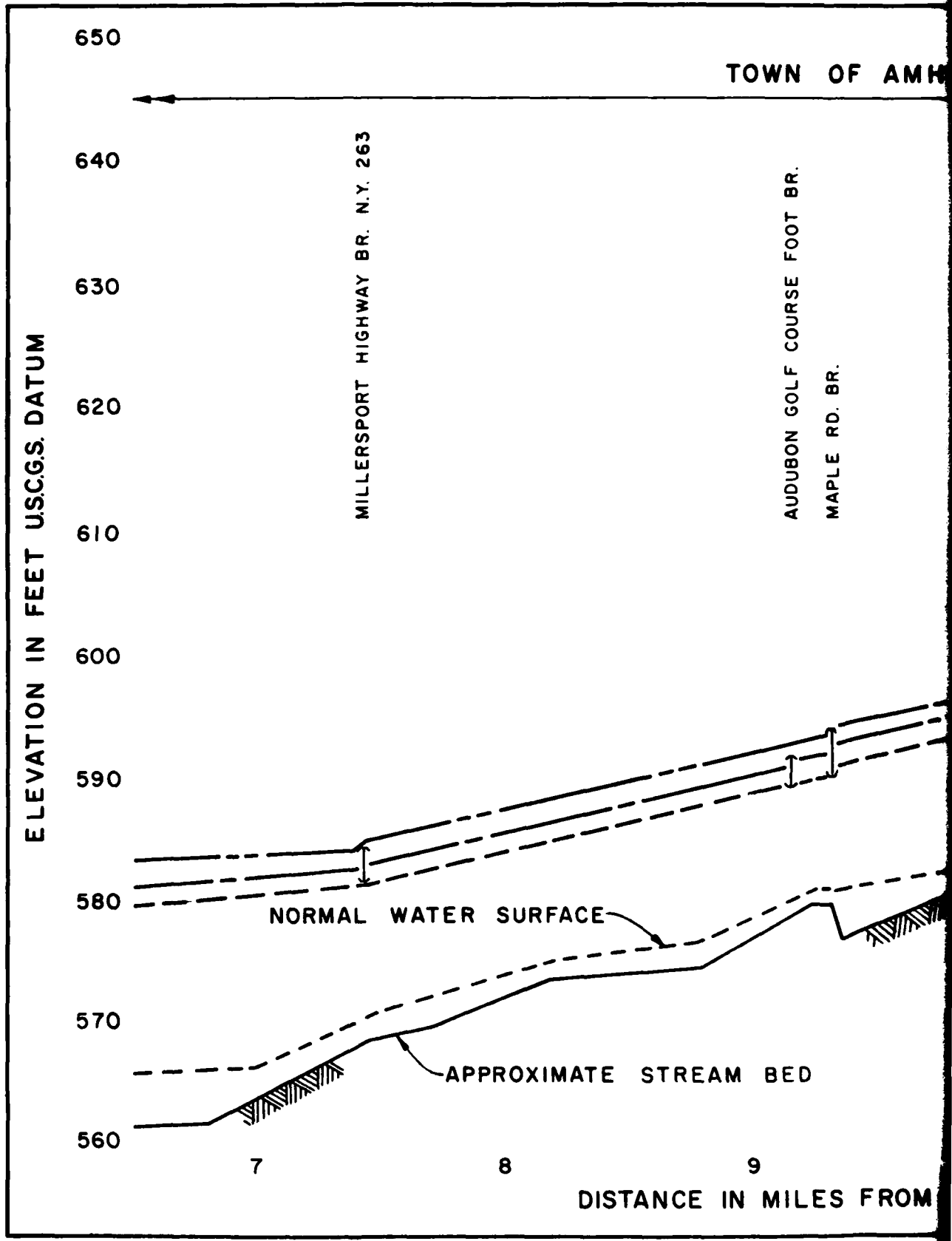

N OF AMHERST

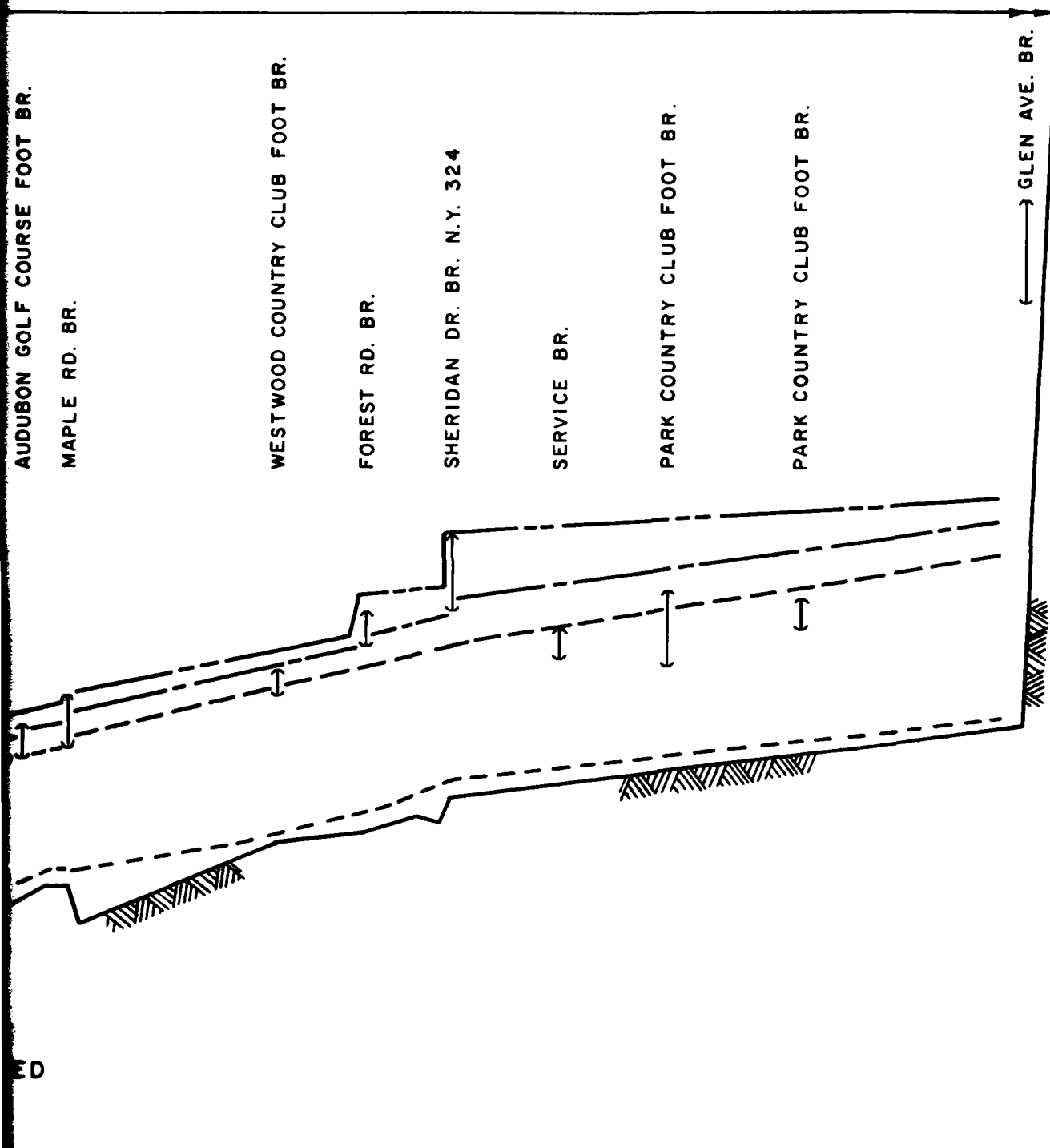

LEGEND:

- STANDARD
- INTERMED
- MARCH 1960
- APPROXIMA
- APPROXIMA
- APPROXIMA

NOTES:

- CREST PROFILES ARE AS FOLLOWS:
1. EXISTING CHANNEL
 2. EXISTING STRUCTURE
 3. EXISTING CONDITIONS
- LARGE SCALE FILLING IS SHOWN BY HATCHING. PROFILES UNLESS SUFFICIENTLY PROVIDED.

ED

10 11 12 13

MILES FROM \downarrow OF TONAWANDA CREEK

ELLICOTT
 ERIE COUNTY
 FLOOD PLAIN IN
 PRO
 MILE 6
 U.S. ARMY ENGINE
 JAN

STANDARD PROJECT FLOOD
INTERMEDIATE REGIONAL FLOOD
MARCH 1960 FLOOD
APPROXIMATE STREAM BED
APPROXIMATE FLOOR ELEVATION
APPROXIMATE LOW STEEL ELEVATION

PROFILES ARE BASED ON THE
EXISTING CHANNEL CONDITIONS.
EXISTING STRUCTURES
EXISTING CONDITIONS OF DEVELOPMENT
SCALE FILLING WILL RAISE THE
UNLESS SUFFICIENT FLOODWAY IS

ELLICOTT CREEK
SARATOGA COUNTY, NEW YORK
FIELD PLAIN INFORMATION REPORT
PROFILES
MILE 6.5 TO 13.0
ARMY ENGINEER DISTRICT, BUFFALO
JANUARY 1968

PLATE F2

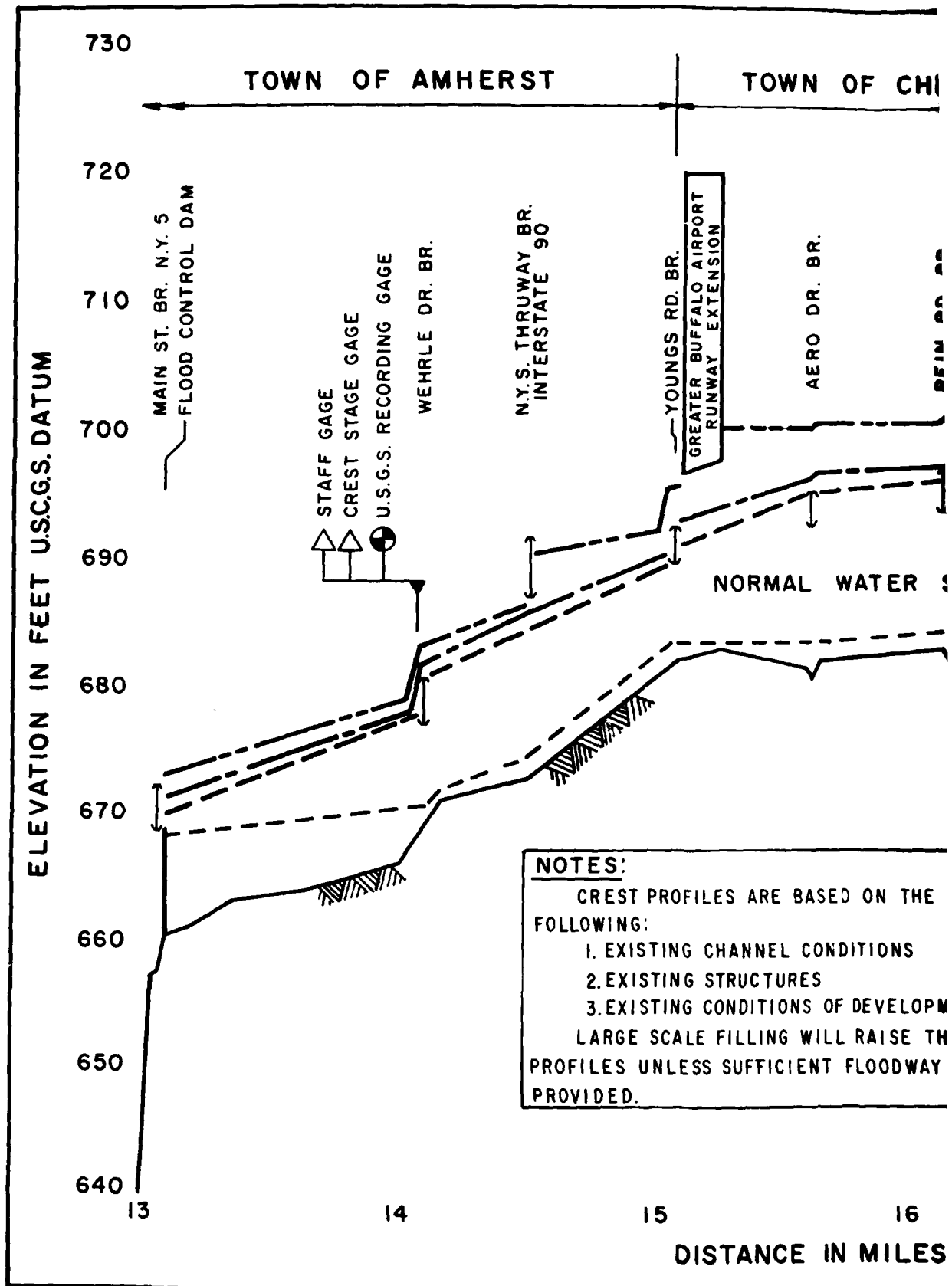

OF CHEEKTOWAGA

TOWN OF LANCASTER

REIN RD. BR.

LEGEND:

- STANDAR
- INTERM
- MARCH
- APPROX
- ↑ APPROX
- ↑ APPROX

APPROXIMATE STREAM BED

WATER SURFACE

LEGEND:

- △ STA
- ON
- WE
- GA
- ⊕ U.
- RH
- CR
- △ ST
- UP
- ZE
- U.

NEW YORK CENTRAL R.R. BR.

TRANSIT RD. BR. N.Y. 78

MAIN ST. BR.
GENESEE ST. BR. N.Y. 33

HARRIS HILL RD. BR.

ON THE
ITIONS
DEVELOPMENT
RAISE THE
FLOODWAY IS

16

17

18

19

20

MILES FROM $\frac{1}{2}$ OF TONAWANDA CREEK

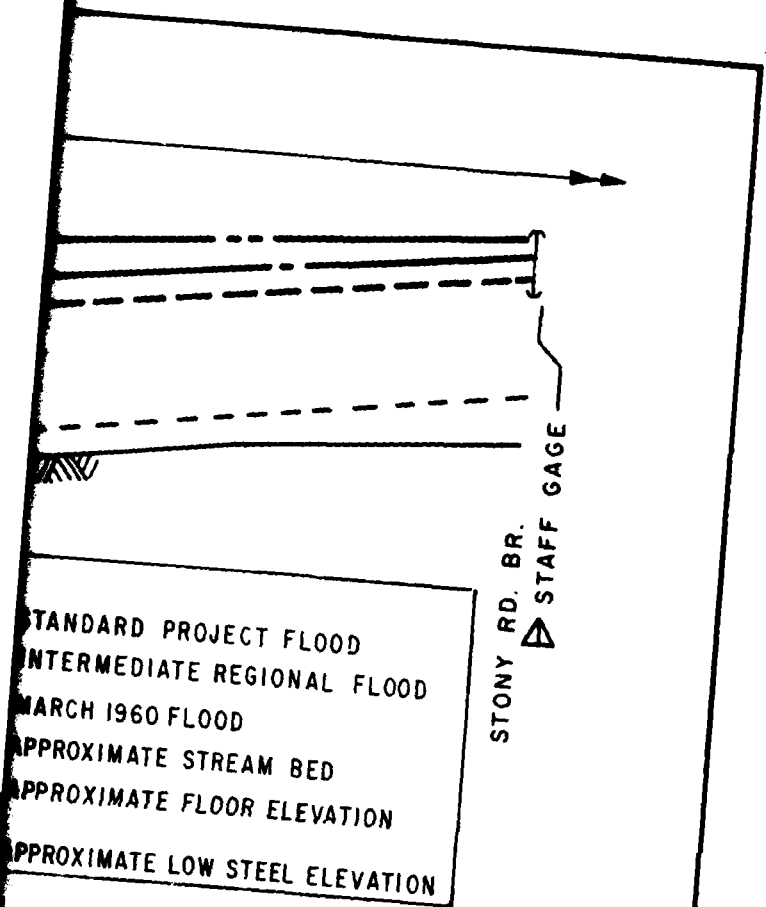

STANDARD PROJECT FLOOD
 INTERMEDIATE REGIONAL FLOOD
 MARCH 1960 FLOOD
 APPROXIMATE STREAM BED
 APPROXIMATE FLOOR ELEVATION
 APPROXIMATE LOW STEEL ELEVATION

21

22

ND:

STAFF AND CREST STAGE GAGE LOCATED ON RIGHT BANK DOWNSTREAM SIDE OF WEHRLE DRIVE BRIDGE. ZERO OF STAFF GAGE EQUALS 668.92 U.S.C.G.S. DATUM.

U.S.G.S. RECORDING GAGE LOCATED ON RIGHT BANK DOWNSTREAM SIDE OF WEHRLE DRIVE BRIDGE.

STAFF GAGE LOCATED ON RIGHT ABUTMENT UPSTREAM SIDE OF STONY ROAD BRIDGE. ZERO OF STAFF GAGE EQUALS 710.54 U.S.C.G.S. DATUM.

ELLICOTT CREEK
 ERIE COUNTY, NEW YORK
 FLOOD PLAIN INFORMATION REPORT
 PROFILES
 MILE 13.0 TO 22.0
 U.S. ARMY ENGINEER DISTRICT, BUFFALO
 JANUARY 1968

PLATE F3

TABLE OF CONTENTS

APPENDIX G

GEOTECHNICAL ASPECTS

	<u>Subject</u>	<u>Page</u>
1	Location and Topography	G-1
2	Scope of Field Investigations	G-2
	2.1 Previous Investigations	G-2
	2.1.1 Investigation by Corps of Engineers	G-2
	2.1.2 Subsurface Investigations by Corps of Engineers	G-3
	2.2 Present Investigation	G-4
3	Geology	G-4
	3.1 Bedrock Geology	G-4
	3.2 Overburden	G-5
	3.3 Groundwater	G-6
4	Significant Geotechnical Aspects of Selected Alternative Schemes..	G-6
	4.1 Alternative A - Diversion Channel Improvement	G-7
	4.2 Alternative B - Major Channel Improvement	G-7
	4.3 Alternative C - Sandridge Reservoir with Minor Downstream Channel Improvement...	G-8
	4.3.1 General	G-8
	4.3.2 Dam Foundation	G-9
	4.3.3 Embankment	G-11
	4.3.4 Reservoir	G-11
	4.3.5 Ground Water Conditions	G-12
	4.4 Alternative D - Bowmansville and Pavement Reservoirs	G-13
	4.4.1 General	G-14
	4.4.2 Dam Foundations	G-14
	4.4.3 Reservoirs	G-17
5	Seismic Considerations	G-18

PLATES

Number

G1	Plan of Investigation Area
G2	Bedrock Geology of Ellicott Creek Basin
G3	Surficial Geology of Ellicott Creek Basin
G4	Geological Profile Section
G5	Geological Profile - Bowmansville Reservoir
G6	Seismic Risk Zones
G7	Epicentral Locations

TABLE

Page

GI	General Geologic Column of the Area
----	-------------------------------------

G-4 A

1 - LOCATION AND TOPOGRAPHY

The Ellicott Creek basin area lies within the western portion of the Erie-Ontario Lowland which is bounded on the north by Lake Ontario and on the south by the Allegheny Plateau. The generally flat to rolling lowland surface is interrupted by the three east-west trending escarpments known as the Niagara, Onondaga and Portage Escarpments, the latter forming the northern edge of the Allegheny Plateau. The east-west trending belts delineated by the escarpments are known as the Ontario Plain, the Huron Plain and the Erie Plain, named from north to south.

Elevations increase southward from 244 feet at Lake Ontario to over 1,700 feet along the Portage escarpment in southern Erie County. The present topographic relief is primarily due to preglacial erosion, and has been further modified by glacial action. The general rise in land surface elevation toward the south is considered to reflect the relatively more intensive erosion in the northern part of the basin.

The project area lies within the Erie Plain which presents a gently rolling surface, generally between 600 feet and 900 feet in elevation with a westward decrease in elevation of about 10 feet per mile. The plain slopes upward toward the Allegheny Plateau to the south.

Drainage follows a rough trellis pattern which reflects the structure and relative erosion resistance of the underlying bedrock units, with the courses of the main streams tending to follow alternate northerly and westerly directions. The headwaters of Ellicott Creek are on the Portage Escarpment, from which it flows over the Erie Plain for about two thirds of its length, then cuts northward across the Onondaga Escarpment onto the Huron Plain and joins the Niagara River near the town of Tonawanda.

2 - SCOPE OF FIELD INVESTIGATIONS

2.1 - Previous Investigations

Previous investigations have dealt primarily with the proposed Sandridge damsite and have consisted of geologic and engineering reconnaissance, and included a number of borings made during the appraisal study undertaken by Harza Engineering Company in 1967. The locations of the 1967 auger borings are shown on Plate G-1.

2.1.1 - Investigation by Corps of Engineers

This investigation was initiated with reconnaissance geologic mapping of the proposed Sandridge damsite and reservoir areas and a review of selected geologic literature covering the western New York region. The reconnaissance level geologic map, plotted on a 1:24,000-scale base map prepared from the USGS Corfu and Clarence quadrangles is shown on Plate G.2. The surface investigation also included reconnaissance for earth borrow areas, location of concrete aggregate sources and riprap sources. The following publications were used as reference for the Corps study:

Buehler, E. J. and Tesmer, I. H. Geology of Erie County, New York, Buffalo Society of Natural Sciences Bulletin Vol. 21, No. 3, 1963.

Buehler, E. J. Editor, Geology of Western New York Guidebook, State University of New York at Buffalo, 1966.

La Sala, A. M., Jr., Ground Water Resources of the Erie-Niagara Basin, New York, U.S. Geological Survey, New York State Conservation Department - Division of Water Resources. Basin Planning Report ENB - 3, 1968.

New York State Geologic Map, 1961, Scale 1:250,000.

2.1.2 - Subsurface Investigations by Corps of Engineers

The 1967 subsurface investigations consisted of borings put down along the Sandridge dam axis at proposed locations of spillway and road relocations, and in earth borrow areas. Eight borings were put down on widespread centers along the dam alignment; seven borings were put down at the locations of two alternative spillways; twenty-four borings were put down within potential borrow areas, and four borings were put down along Harlow Road in the upstream portion of the reservoir. Locations of all boreholes are shown on Plate G-1.

Along the dam axis and at spillway locations, borings were put down in cased holes which permitted continuous drive sampling of overburden to the top of bedrock, followed by core drilling of bedrock in each hole. Standard 2-inch od split-spoon samplers were used to make continuous Standard penetration tests in overburden. Shelby tube samplers (3-inch od) were used to obtain undisturbed samples of cohesive overburden materials. However, out of six attempts to obtain Shelby tube samples, only two were successful. Soil samples were logged at the drill site and preserved for laboratory testing.

Rock core drilling was accomplished with either Acker TH or C.M.E. 45 rotary drilling rigs using NX, "M" Series, double-tube core barrels. The holes were generally cored to a depth of 50 feet into bedrock, with one hole extended 150 feet into bedrock. Core recovery was generally found to be excellent. All core was logged at the drill site and photographed. Representative cores were preserved in wax coatings for future testing.

Permeability tests were undertaken in selected portions of the holes within overburden, and water pressure tests were run covering all portions of the borings in bedrock.

A C.M.E. 75 rotary drill rig with 6-inch and 8-inch continuous flight augers was used for exploration of the proposed downstream channel improvement works, and for assessment of potential borrow areas.

Log data from the damsite exploratory boreholes and the results of seismic survey are given on the geologic section on Plate G-4. Additional pertinent exploration data are given in the text following.

2.2 - Present Investigation

The present investigation was limited to a review of all available geotechnical data and to field reconnaissance of the project area. Available geotechnical data included air photos, information contained and referenced in the 1970 Corps of Engineers report, and other more recent data. In particular, useful information was obtained from the paper entitled "Geophysical Methods Applied to Community Planning" (Hodge, D. S. et al).

3 - GEOLOGY

3.1 - Bedrock Geology

The bedrock surface underlying the Erie-Ontario Lowland is formed by sedimentary formations of Upper Ordovician, Silurian, Middle Devonian and Upper Devonian ages. The geologic column and description of rock units underlying the project area is given in Table G-1 and the bedrock geology is shown on Plate G-2. The strata comprising these formations are principally shale, siltstone, limestone and sandstone which form a homoclinal structure dipping southward at approximately 40 feet per mile. Due to local modifications, the regional dip is reported to range from 17 feet per mile to as much as 60 feet per mile. Devonian shale and siltstone beds exhibit minor folds with a few feet of closure which are a result of gravity creep or local glacial forces.

The Niagara and Onondaga Escarpments are formed by relatively erosion-resistant limestone formations within the stratigraphic sequence. The Erie Plain, within which the proposed Sandridge project is located, is underlain by shales with thin limestone interbeds of Middle Devonian and Upper Devonian age, which occur stratigraphically between the Onondaga Escarpment and the shale-sandstone formations forming the Portage Escarpment.

TABLE G-1

GENERAL GEOLOGIC COLUMN OF THE AREA

G-4A

SYSTEM	GROUP	FORMATION	L I T H O L O G Y
M I D D L E D E V O N I A N		M O S C O W	i) <u>WINDOM SHALE MEMBER:</u> MEDIUM GREY TO OLIVE-GREY CALCAREOUS. NUMEROUS CONCRETIONS ii) <u>KASHONG SHALE MEMBER:</u> SOFT GREY. THIN UNIT AT BASE OF THE FORMATION
		L U D L O W V I L L E	i) <u>TICHENOR LIMESTONE MEMBER:</u> MASSIVE, THIN UNIT, FOSSILIFEROUS. RESISTANT TO EROSION ii) <u>WANAKAH SHALE MEMBER:</u> MEDIUM GREY FOSSILIFEROUS. CALCAREOUS. NUMEROUS CONCRETIONS iii) <u>LEDYARD SHALE MEMBER:</u> DARK GREY, CALCAREOUS. NUMEROUS PARTINGS iv) <u>CENTERFIELD LIMESTONE MEMBER:</u> MASSIVE THIN UNIT
		S K A N E A T E L E S	i) <u>LEVANNA SHALE MEMBER:</u> DARK GREY, CALCAREOUS ii) <u>STAFFORD LIMESTONE MEMBER:</u> MASSIVE FOSSILIFEROUS UNIT
		M A R C E L L U S	i) <u>OATKA CREEK SHALE MEMBER:</u> BLACK CALCAREOUS SHALE. CALCAREOUS CONCRETIONS
		O N O N D A G A	i) <u>MOOREHOUSE LIMESTONE MEMBER:</u> LIGHT GREY LIMESTONE. NUMEROUS CORALS. CHERTY ii) <u>NEDROW LIMESTONE MEMBER:</u> INTERMIXED LIGHT-GREY LIMESTONE AND DARK GREY CHERT iii) <u>EDGECLIFF LIMESTONE MEMBER:</u> LIGHT-GREY LIMESTONE WITH CHERT NODULES. CORALLINE LOCALLY
		- - - U N C O N F O R M I T Y - - -	
U P P E R S I L U R I A N		A K R O N	i) <u>AKRON DOLOSTONE:</u> LIGHT-GREY, WEATHERED LOCALLY. SHALY OCCASIONALLY. NUMEROUS PARTINGS
		B E R T I E	i) <u>BERTIE LIMESTONE:</u> LIGHT TO DARK GREY ARGILLACEOUS LIMESTONE. SHALY LOCALLY. DOLOMITIC OCCASIONALLY
		C A M I L L U S	i) <u>CAMILLUS SHALE:</u> GREY. NUMEROUS GYPSUM NODULES

NOTE: ALL INFORMATION BASED ON PREVIOUS STUDIES

3.2 - Overburden

The surficial deposits shown on Plate G-3 found generally blanketing the bedrock surface in the region, are the result of Pleistocene glaciation. A succession of ice advances and retreats with intervening flooding by glacial lakes has left a variety of depositional features which include till sheets, moraines, lake bottom deposits, beaches and outwash deposits. The variable nature of these surficial deposits is a parameter of prime significance to the engineering geology of the region.

The overburden in the vicinity of Ellicott Creek generally varies in thickness from approximately 20 feet to 60 feet, (Plate G-4), although bedrock is exposed locally. Overburden deposits vary in composition across the project area and include:

- (a) Glacial till: an unsorted, impervious mixture of very stiff to hard clay, silt, sand, some gravel, and stones (generally less than 25 percent), deposited at the base of the overriding Wisconsin glacier. Standard penetration test blow counts in this material vary from 50 to 250.
- (b) Ice-contact deposits: generally overlying the till and consisting of relatively permeable fine to medium sand with some permeable coarse sand and gravel.
- (c) Glacial lake deposits: consisting of firm to stiff silty sandy clays and sandy silts that have settled out from lakes fed by the melting ice. Silt and clay content of these deposits generally exceeds 75 percent. Although the unit is not water yielding, local water-bearing sandy layers from 2 to 8 feet thick have been reported. The average thickness of glacial lake deposits is about 20 feet.
- (d) Outwash deposits: consisting of relatively permeable sand and gravel.
- (e) Organic deposits: consisting of swamp deposits formed due to the accumulation of decayed plant matter. Deposits of up to 10 feet in thickness have been recorded in the low-lying Ellicott Creek flood plain.
- (f) Alluvial deposits: found locally in the vicinity of Ellicott Creek.

The areas within which the above-mentioned soil types occur at surface are shown on Plate G-3. As the organic deposits are small and localized, they have not been shown on the soil map.

The surficial geology over the major part of the project area consists of glacial till deposits of Pleistocene Age. The tills include both overconsolidated deposits formed during the overriding of the ice sheet, and normally consolidated moraines formed during ablation of the ice. Ice contact, glacial lake deposits and outwash deposits were subsequently formed.

3.3 - Groundwater

Static water levels in the project area were found to be generally quite high, and were commonly recorded by the Corps of Engineers at 10 to 20 feet below the ground surface. The three escarpments, namely the Niagara, Onondaga and Portage, act as groundwater divides with the flow moving generally to the north or west.

Although the information available on groundwater is relatively limited, the previous studies indicated that groundwater aquifers are known to occur locally at various levels within the bedrock strata. Although minor lacustrine sand deposits have been found to be water bearing, these are generally too thin to act as important sources of groundwater.

4 - SIGNIFICANT GEOTECHNICAL ASPECTS OF SELECTED ALTERNATIVE SCHEMES

Four basic alternative schemes, designated A, B, C and D, have been selected in this study as most appropriate for the control of Ellicott Creek. Significant geotechnical aspects of these schemes which will require detailed consideration during final design are indicated in the following sections.

4.1 - Alternative A - Diversion Channel Improvement

The proposed Diversion Channel scheme involves the construction of a diversion channel from near Maple Road to a return to the Creek point about 2,000 feet downstream of Sweet Home Road. Improvements to the existing channel are required between Sheridan Drive and Maple Road, and again downstream of the diversion channel return point.

The upper Silurian Camillus shale bedrock of the area is generally overlain by 20 to 25 feet of glacial till, within which the proposed diversion channel would be located. Maximum slope heights would be in the order of 10 feet, with slopes of 2.5H:1.0V.

Due to the limited height of the bank slopes, and the generally competent glacial till surficial geology, no major geotechnical problems would be anticipated for the proposed diversion channel. However, a number of geotechnical factors must be adequately considered during final design, including the requirement for scour protection, the potential for problems of siltation, and the possibility of changes in the local water table elevations in the vicinity of the proposed diversion channel.

4.2 - Alternative B - Major Channel Improvement

The proposed major channel improvement includes the Ellicott Creek basin area from Sheridan Drive downstream to and including the existing diversion channel which connects to Tonawanda Creek. The improvements would include widening of the channel bottom to widths varying from 80 to 110 feet, two riprapped high-velocity sections near the upper end, replacement of one highway bridge and two footbridges, and necessary modifications to three highway bridges, a culvert and about fifty storm sewer outfalls.

The surficial geology along Ellicott Creek from the existing diversion channel at Tonawanda Creek to the Millersport highway comprises lacustrine silt and clay deposits. Beyond the Millersport highway, upstream to Sheridan Drive, the surficial material is expected to be glacial till.

The results of the exploratory program conducted by Harza Engineering Company in 1967 indicated that the lacustrine deposits were soft and interbedded with sand and gravel lenses. The driller's logs often reported "running" silts and clays.

The major geotechnical consideration within the lacustrine deposits would be that of slope stability, especially in areas near existing highways and bridges. The possibility of scour erosion of the soft banks during flooding is a related concern. The current design includes a number of fill sections on top of the bank cuts for the purpose of increasing the height of the channel bank. Further study during final design would be required to define the areas of maximum excavation and fill, and to sample and test the lacustrine deposits in these areas with respect to slope stability and scour. If the height of slope significantly exceeds the floodwater cut limit of 8 feet, it is probable that the 2.5H:1.0V slopes would not be stable and would require flattening, particularly in the area of permanent structures such as bridge crossings.

Scour protection in high-velocity sections and possible silting problems in low-velocity reaches of the channel must also be taken into account.

4.3 - Alternative C - Sandridge Reservoir with Minor Downstream Channel Improvements

4.3.1 - General

The Ellicott Creek valley is approximately 2.5 miles wide and trends in a westerly direction at the location of the proposed Sandridge dam axis. Ellicott Creek occupies a narrow channel, bordered by adjacent low narrow flood plains within an area of generally low relief. The low point of the valley at the damsite is in the Ellicott Creek channel at approximately elevation 812. From this point the land surface rises gently northward to approximately elevation 875 on the rounded crest of the narrow ridge which would form the right abutment of the proposed dam. Southward from the Ellicott Creek valley, the surface rises gradually beyond the left abutment to about elevation 950 on the divide between the Ellicott Creek drainage area and the valley of Cayuga Creek.

The dam proposed for the multipurpose reservoir would be located on Ellicott Creek near the eastern boundary of the village of Alden. The dam would be an earth structure some 8,200 feet long with a maximum height of 55.5 feet, and would also intercept Spring Creek, a tributary of Ellicott Creek.

Geological explorations which were done to outline the general foundation conditions and to establish preliminary design concepts are outlined in Section 2.

4.3.2 - Dam Foundation

The geologic deposits in the valley consist of glacial till overlain in part by ice contact deposits consisting of sands and gravels, and in part by lacustrine silts and clays. The ice contact deposit is exposed at the surface over about 25 percent of the crest length, and is up to 30 feet thick. Lacustrine deposits are exposed over the remaining portion of the foundation, and comprise layered clays, silts and sands, with some gravel and organic material. Standard penetration tests conducted by Harza Engineering Company within this material gave blow count values varying from less than 5 to greater than 50, indicating foundation material varying from soft and weak clays and silts to relatively dense sand and gravel. The ice contact deposits which extend over 25 percent of the dam foundation are considered to be permeable.

The underlying glacial till is described as dense and impervious, varying in thickness from 35 feet to almost 0 feet directly beneath the present Ellicott Creek.

The shale bedrock in the area was considered to be dense and relatively impervious on the basis of the exploratory drilling and water pressure testing conducted in 1967. However, as noted in the 1970 Corps report, the drill holes were vertical and were thus subparallel to the major vertical joint system in the area, and the results of the water pressure tests may therefore not be truly representative of the rock permeability.

The proposed design and treatment of the dam foundation outlined in the 1970 report reflects the geological conditions in several ways. Construction of an upstream impervious blanket in the abutment areas was proposed, being 3 to 5 feet thick by 250 feet wide where the reservoir depth would be up to 10 feet, and 5 to 10 feet thick by 370 feet wide where the reservoir depth would be 10 to 20 feet. For reservoir depths in excess of

20 feet, a positive cutoff to bedrock was proposed through construction of a slurry trench. In order to provide seepage control in the bedrock, a shallow grout curtain was proposed.

It was recognized in the 1970 report that for areas within which the glacial till and lacustrine deposits occur at surface, it may be possible to reduce the foundation treatment substantially. Further exploration of these materials during final design, including sampling, laboratory testing, and field pumping, would be necessary to determine if local deepening of the core trench would provide adequate seepage control in these areas.

For the proposed slurry trench cutoff, it may be possible to obtain satisfactory results by sealing the trench against the glacial till rather than continuing to bedrock, and this alternative will require detailed consideration during final design.

Further testing of the relatively weak lacustrine deposits must be undertaken during final design in order to ensure their suitability as stable foundation materials for the dam.

Additional water pressure testing from inclined holes within the bedrock, intersecting the major vertical joint set, will be necessary to obtain representative data upon which to base the design of the proposed grout curtain. It is considered probable that the grouting work could be kept to a minimum. In association with further testing of the bedrock permeability, the probability of developing significant downstream uplift pressures could then be assessed, to enable optimum design of any necessary pressure relief system.

It has been recommended that the necessary concrete structures, primarily the spillway, be founded directly upon the shale bedrock. However, as noted in the 1970 report, final design must recognize the potential existence of interbed shale layers of relatively low shear strength.

4.3.3 - Embankment

The design of the proposed dam includes a central impervious core with supporting upstream and downstream shells. The dam slopes and material types for the various dam zones are shown on Plate 8. During the previous studies, it was determined that materials for the dam embankment are available locally in sufficient quantity and quality, while materials for riprap and aggregates are available commercially in the Buffalo area. Tests of the material outlined in the 1970 report are considered as confirmation of the suitability of quality and quantity, although some more detailed tests would be useful prior to final design. The materials tested included those for potential use as pervious and impervious fill, riprap, and concrete aggregate.

4.3.4 - Reservoir

Reconnaissance mapping of the proposed reservoir indicated that soils of glacial origin underlie the surface practically throughout the area. The distribution of the several soil types found on the surface is shown on the geologic map, Plate G-3. The surface of the high ground which will form the reservoir rim is comprised of impervious clayey to silty till containing gravel and larger sized particles (locally of boulder size) of varied rock types. Bordering the till on the south side of the valley is a gently sloping terrace which has been interpreted as a glacial lake beach. It has been suggested that the beach material, which consists of gravelly sand with minor silt content, represents an ice-contact deposit which has been reworked under glacial lake conditions. The interior portion of the shallow reservoir basin is blanketed with glacial lake bottom sediments. These materials are generally impervious, consisting of sandy silt or sandy clay containing lenses of clay, fine sand and isolated pockets of fine gravel.

The outwash deposits are represented as elongated wooded ridges on the aerial photographs. In the vicinity of the damsite these occur on the north side of the right abutment reservoir rim.

Some further study is warranted in final design to determine whether any sandy deposits cross the reservoir rim, forming potential seepage paths. Such deposits may not necessarily be limited to the main channel fills but could cross till ridges, having been formed by meltwater channels away from the ice sheets in glacial times. Slides in the reservoir rim are not considered to be a major problem as the ground is gently sloping everywhere. However, as the project would be used for recreation, some study should be directed toward the possibility of local slides occurring in the weakest lacustrine deposits, during reservoir operation.

4.3.5 - Ground Water Conditions

The water supply for the town of Alden is pumped from a sand and gravel aquifer on the left bank of Ellicott Creek. Three drilled wells and a hand dug well field north of the town supply approximately 290,000 gallons per day. The aquifer consists of pervious ice contact deposits and runs in a general northeast-southwest direction. The eastern part of this zone will pass under the proposed Sandridge damsite hence some information on the regional ground water flow system was required to see if the dam could influence the yields of these wells.

Original ground water levels of the drilled wells were obtained from municipal records in Alden and piezometric levels in three exploratory drill holes were made available by the Department of Environmental Conservation.

An analysis of these data indicate a piezometric gradient normal to the river or to the northwest from Alden. Therefore ground water recharge apparently occurs from the high ground south of Alden and directly into the gravels in the immediate areas of the wells. The report of the Erie-Niagara Basin - Ground Water Resources, states that average annual

recharge to the sand and gravel deposits in the Alden area is between 200,000 and 400,000 gallons per day per square mile.

No data are available on the influence of pumping on the original piezometric surface, however, based upon the average consumption of the town of Alden and the possible recharge mentioned above, the water table has probably not been altered significantly. The dug wells made between 1,890 and 1,900 at the junction of Spring Creek and Crittenden Street are still in use and apparently have not been affected by the newer wells west of Colonial woods Drive.

It is believed therefore, that a dam with a cut-off to rock or an impervious upstream blanket over the aquifer would not reduce the output of these wells but in fact could increase their potential capacity. The capacity of the dug well field however, could be reduced somewhat as its area of recharge is smaller lying close to the limit of the aquifer and the shale outcrops in Spring Creek.

The reservoir will increase the existing piezometric levels in the dam area and could drive the flow system into the shale below the sand and gravel. Depending upon the permeability and mineralogy of the rock, this flow might lead to some contamination of the aquifer. However, significant contamination is not believed likely as any zone of higher permeability in the upper portion of the shale is probably diluted by previous flows. An assessment of the water quality in the upper horizons of the shale should be made to test this hypothesis.

4.4 - Alternative D Bowmansville and Pavement Reservoirs

Alternative D involves the construction of two reservoirs:

- (a) Bowmansville Reservoir
- (b) Pavement Reservoir

4.4.1 - General

The proposed Bowmansville reservoir would require a main dam constructed just upstream of Harris Hill Road, and continuous levees on the north, and south sides. The prime functions of this alternative would be the availability of a storage capacity sufficient for the 100-year flood event, together with the impoundment of 4,750 acre-feet for low flow augmentation of the creek, and the provision of some water-oriented recreation. The proposed Pavement damsite and reservoir seeks to maximize the recreational potential for the Bowmansville reservoir without detriment to the need for low flow augmentation and to provide storage for sedimentation and evaporation, generally in the months of July, August and September of each year. Because it impounds water from the spring thaw floods, the reservoir would exist from March through September.

These criteria are satisfied by designing the Bowmansville reservoir to hold a constant elevation recreation lake at elevation 720, with an additional impoundment capability that can accept the 100-year flood event flows. With the crest of the dam and levees at elevation 740, this total impoundment capability is provided. The low flow augmentation volume requirement of 4,750 acre-feet is met by construction of an upstream reservoir at Pavement Road, having a capacity of 4,800 acre-feet.

4.4.2 - Dam Foundations

- (a) Bowmansville Damsite - The overburden deposits at the proposed Bowmansville damsite primarily consist of a thin cover of glacial till comprised of light brown, moist silt with gravel and cobbles up to 3-inch maximum size. Locally, the top 1-inch to 6 inches of overburden consists of organic material.

The bedrock exposed just downstream of the proposed damsite is Onondaga Limestone of Devonian age. The dip of the bedrock is approximately 40 to 45 feet per mile and is uniform towards the south.

The Onondaga Limestone is approximately 110 feet thick and consists of three members. The lowest member is gray coarse-grained limestone, generally only a few feet thick. At places this member grades laterally into reef deposits that increases its thickness (Buehler & Tesmer 1963, pp 35 and 36). The middle member of the Onondaga Limestone comprises approximately 40 to 45 feet of cherty limestone, with the upper member being 50 to 60 feet thick and consisting of dark gray to tan limestone of varying texture.

Due to its relatively high solubility in water, the Onondaga formation contains joints that have been enlarged due to solution of the limestone. Locally, solutioning along bedding joints has been great enough to cause the rock overlying the solution openings to settle. A collapsed solution zone in the Onondaga Limestone discharges a large volume of water into a quarry and most of the water is reported to come from the solution zones. Similar features have been reported in other locations.

The surficial cover upstream of the proposed Bowmansville damsite generally varies from 5 to 15 feet, however, bedrock is exposed at river level immediately downstream of Harris Hill Road. Although the glacial till deposits may be considered as generally impervious, geotechnical investigation, i.e. exploratory drilling, piezometric surveys, and perhaps seismic surveys of the foundation should be carried out in both the surficial deposits and to bedrock in order to ensure that no problem exists with respect to reservoir tightness.

For the purposes of the current report, an impervious core section founded on bedrock with supporting shells has been selected for the dam on the basis of the available glacial till materials for the core and sand gravel deposits for the shell. Depending upon the results of field explorations a homogeneous section, with appropriate internal drainage, could be considered.

Final design must account for foundation grouting, a suitable pressure relief system, and excavated slopes. Depending on local variations of the thickness of the till, an upstream impervious blanket may be required in some areas to limit underseepage. It is also possible that some remedial work of the rock foundation, in addition to curtain grouting, could be required. This would depend upon the extent of solution activity and existence of zones of soft collapsed rock.

- (b) Pavement Damsite - The surficial materials at the proposed Pavement damsite and reservoir area are mainly outwash deposits consisting of sandy gravel with some silt in the right abutment and glacial till overlying the outwash deposits in the left abutment.

Outwash deposits in the left and right abutment reservoir rims are greater than 40 feet thick based on observations of quarries in the vicinity. A literature study revealed that two gas wells were drilled in the vicinity of the proposed damsite by Iroquois Gas Company through a surficial cover of 62 feet and 82 feet respectively. From these limited data, it has been assumed that the elevation of bedrock beneath the spillway structure would be approximately 685 feet. The bedrock exposed about 1,500 feet downstream of the proposed damsite is light gray calcareous shale underlain by Onondaga Limestone.

The outwash deposits are considered to be pervious. The construction of the dam will flood the gravel pits on the right abutment which have been excavated below the proposed dam crest elevation. Depending upon the continuity of the outwash deposits, possible flooding by seepage could occur in other quarries located to the south of Ellicott Creek. It may further result in general seepage problems into other low lying areas surrounding the reservoir. Furthermore, the Onondaga limestone lies beneath the outwash deposits and outcrops are found in the river bed at Ransom and Town Line Roads. As mentioned in the Bowmansville area, similar problems might exist because of the solution enlarged joint systems.

Detailed design of the spillway structure will require extensive exploration on the pervious outwash deposits in order to determine an optimum design with respect to the thickness and properties of the deposits. Final design must consider the interrelated problems associated with deep excavation in pervious silts, sands, and gravels and scour and settlement problems of concrete structures founded on these variable deposits. If the foundation is excavated to rock, remedial treatment such as curtain grouting and upstream impervious blanket will likely be necessary. Reference to the collapse structures and open jointing observed in this limestone was made above. If the foundation soils are of a quality such that it is necessary to excavate to rock, a suitable cut-off and impervious upstream blanket will be required.

In order to define these problems more accurately, detailed geotechnical studies including sampling, laboratory testing, water pressure testing, piezometer installations and field pumping would be required. Drilling must be carried out in the dam and reservoir area to define the depth, continuity and quality of the overburden, and the condition of the underlying bedrock. Regional ground water studies carried out by La Sala, 1968, suggests the sulphate concentration in the project area is between 100 and 500 ppm. Further study of the ground water chemistry is suggested in order to determine if there is a need to utilize sulphate resisting cement for the concrete structures.

4.4.3 - Reservoirs

- (a) Bowmansville Reservoir - A reconnaissance field trip to the proposed reservoir area and a study of the available geologic literature indicated that a thin cover of glacial till generally overlies the Onondaga Limestone. Plate G-5 shows a generalized section just downstream of Stoney Road. As mentioned above, reservoir tightness will be a function of the grout curtain and thickness of the till blanket overlying the open jointed limestone.

- (b) Pavement Reservoir - The northern part of the reservoir rim consists of outwash deposits which generally comprise sandy gravel with some silt. The southern edge of the reservoir rim consists of glacial till underlain by outwash deposits which may be continuous southward to East Lancaster. The uniform water levels in the flooded gravel pits suggests this continuity and also indicate that leakage through these gravels away from the Pavement Reservoir is a possibility. The problem of the water tightness of the reservoir governs the feasibility of this site; however, insufficient geologic data exist at this time to completely define the extent of the problem.

5 - SEISMIC CONSIDERATIONS

The seismic risk map published by ESSA/Coast and Geodetic Survey for the continental U.S.A. is shown in Plate G-6, and indicates that the Ellicott Creek basin lies within an area designated as seismic risk Zone 3. This zone indicates an area within which major destructive earthquakes may occur, and is considered to primarily reflect the effects of the major St. Lawrence Valley fault known as Logan's Line. It may be noted from Plate G-6 that the general seismic risk within the Buffalo area is considered to be equal to that within the well-known California earthquake zone.

The USCGS seismic risk map is intended to serve as an initial guide to the level of considerations which must be given to the design of structures within a particular area of the U.S.A. Thus it may be stated that the proposed dam and reservoir works must receive detailed design consideration with respect to their stability under earthquake conditions. Detailed assessment of the magnitude of the maximum design earthquake which should be considered will require review of the historical earthquake record of the area. Plate G-7 indicates the epicentral location of recorded earthquakes in the area between the years 1534

and 1959 (after Smith, 1966. Dominion Observatory of Canada). The largest recorded earthquake in the vicinity of the project area occurred near Attica, N.Y. on August 12, 1929. The shock was felt over an extensive area, and was of Richter Magnitude 5.8. It has been reported that, in the eastern part of Attica, 251 house chimneys collapsed and a number of brick buildings were damaged (Seismological Society of America Bulletin, Volume 21).

In conjunction with analysis of the maximum design earthquake anticipated, further testing of the dam foundation materials will be required with regard to their potential for liquefaction under seismic loading. In this respect, particular attention must be paid to the ice-contact deposits and the glacial lake beach deposits, in terms of adequately defining the grain size distribution and relative densities of these materials.

The design of the dam section itself must be checked to verify its stability under dynamic conditions, and consideration must be given to the effects of potential seiche action in the reservoir. However, it is considered that these factors will be of secondary concern compared to the testing and analysis of the foundation materials.

In undertaking the detailed exploration, testing, and design of the proposed dam and reservoir structures with regard to seismic conditions, due consideration must also be given to any faults which are delineated within the project area, both in terms of a possible epicentral location of the design earthquake, and in terms of the potential for differential displacements across a fault line.

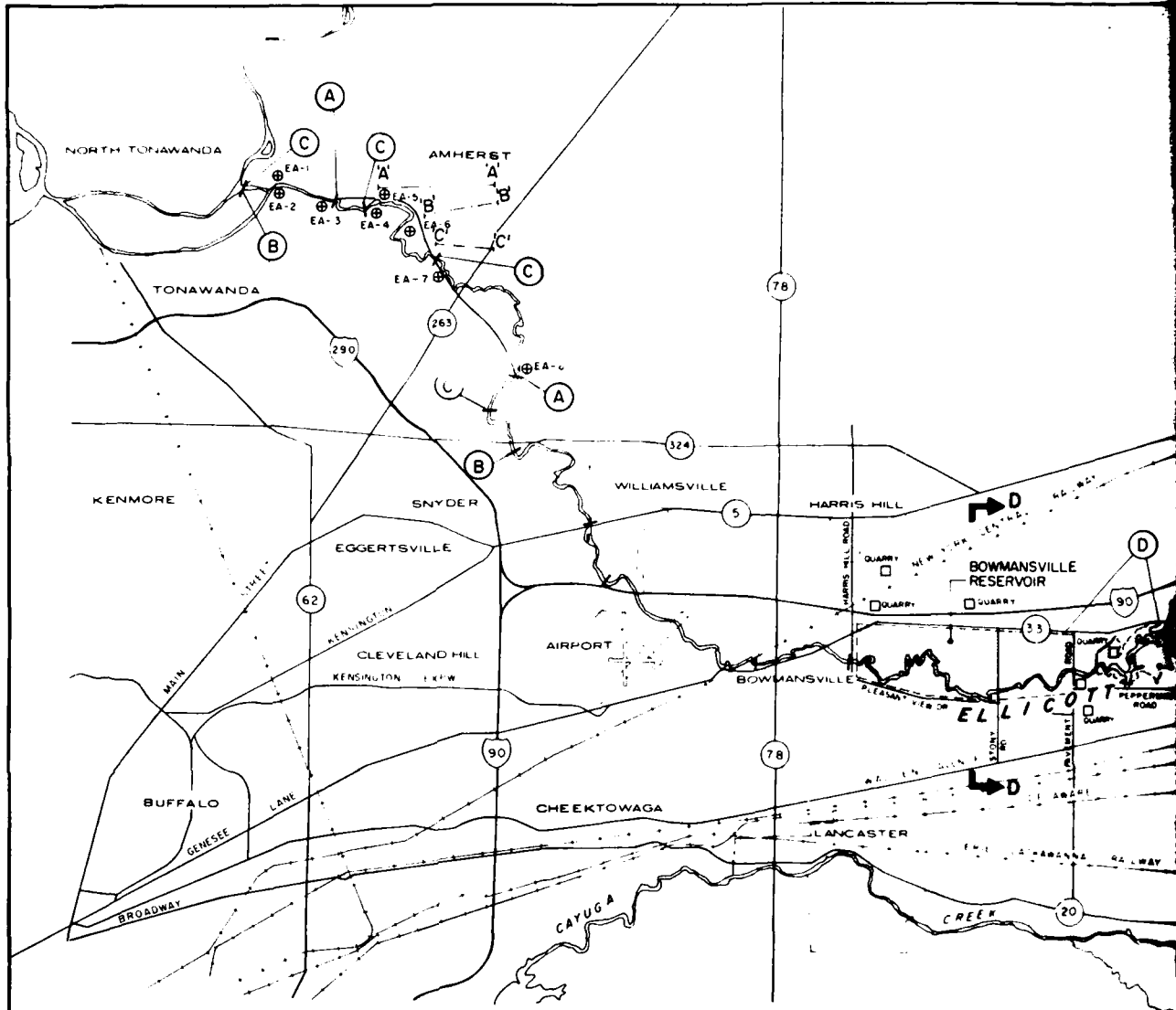

LEGEND

- DRILL HOLE WITH ROCK CORE DRILLING, 1969 PROGRAM
- AUGER HOLE IN SANDRIDGE DAMSITE, 1969 PROGRAM
- ⊙ AUGER HOLE WITH INTERMITTENT SAMPLING, 1967 PROGRAM
- ⊕ AUGER HOLE IN DIVERSION CHANNEL, MAJOR CHANNEL AND MINOR CHANNEL IMPROVEMENT, 1969 PROGRAM
- (A) DIVERSION CHANNEL IMPROVEMENT
- (B) MAJOR CHANNEL IMPROVEMENT
- (C) SANDRIDGE DAM AND MINOR CHANNEL IMPROVEMENT
- (D) BOWMANVILLE AND PAVEMENT DAMS

NOTE

THE GEOLOGICAL PROFILE SECTIONS ALONG 'A'-A', 'B'-B' AND 'C'-C' SHOWN ON PLATE G-4
 'D'-D' SHOWN ON PLATE G-5

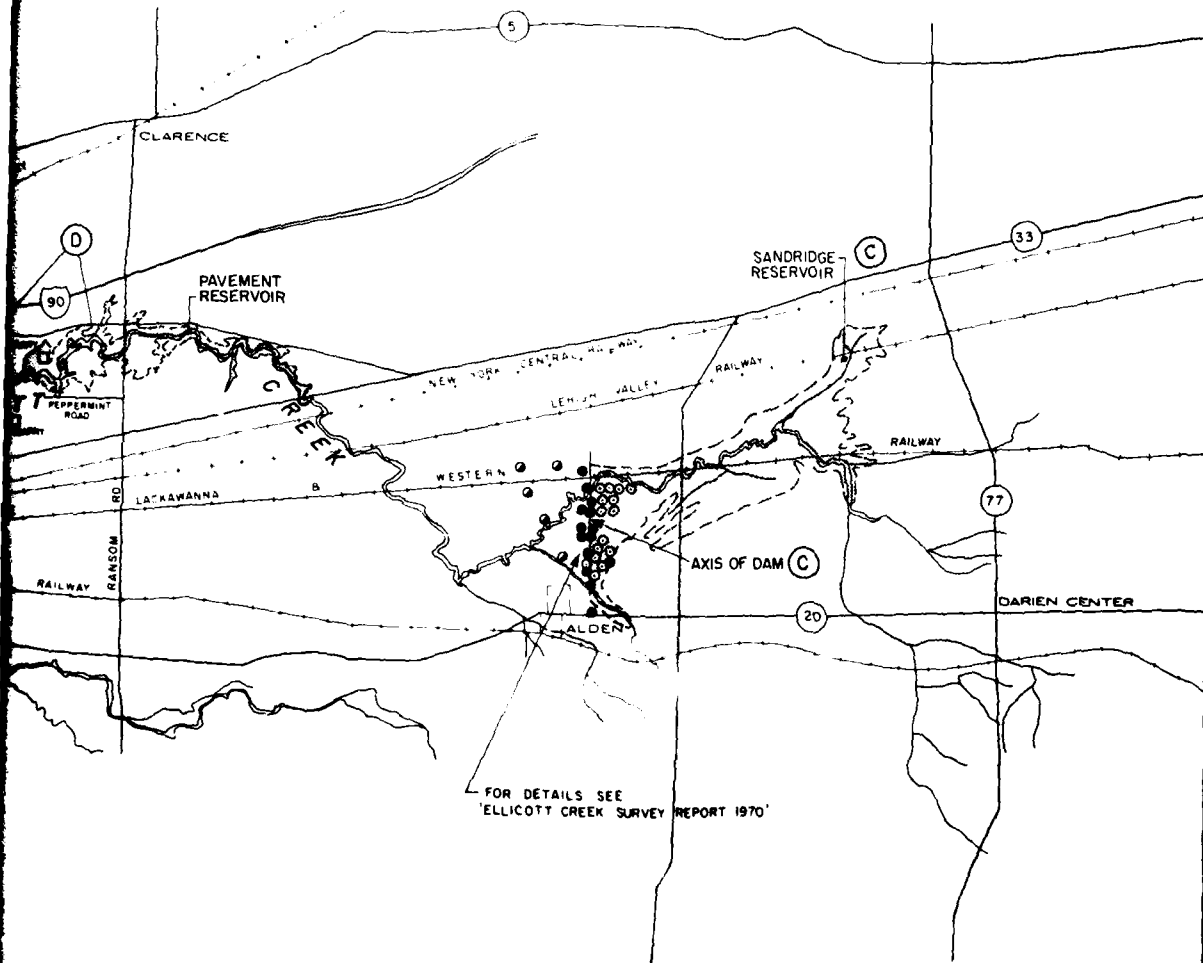

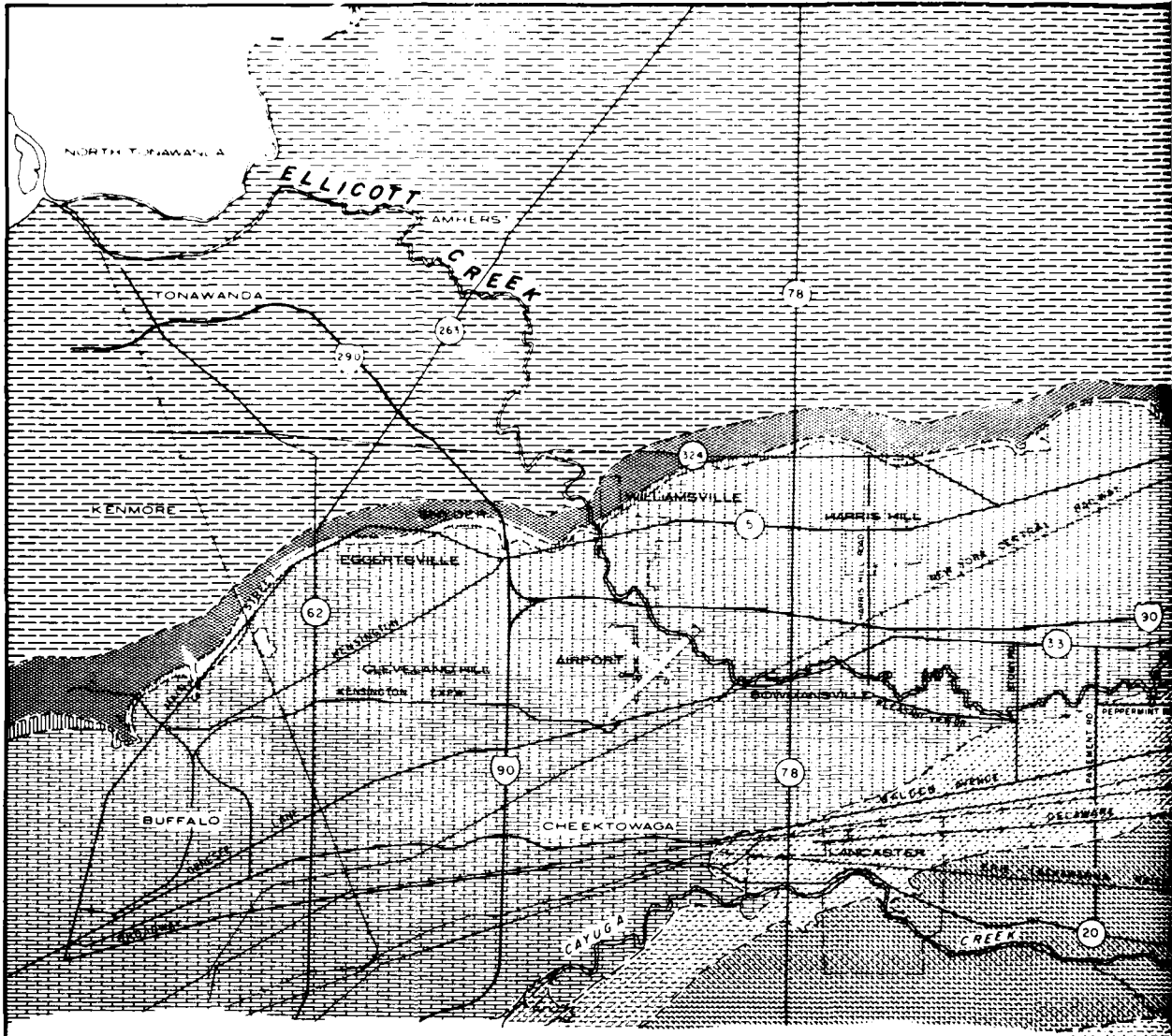

0 5000 10000
SCALE IN FEET

ELLICOTT CREEK NEW YORK
PLAN OF INVESTIGATION AREA
U.S. ARMY ENGINEER DISTRICT BUFFALO
A SURVEY REPORT
DATE 1970







UPPER DEVONIAN

SENECA GROUP



-  WEST FALLS FORMATION
-  SONYEA FORMATION
-  GENESEE FORMATION

MIDDLE DEVONIAN

HAMILTON GROUP

-  MOSCOW SHALE
-  LUDLOWVILLE SHALE
-  SKANEATELES SHALE
-  MARCELLUS SHALE
-  ONONDAGA LIMESTONE

UPPER SILURIAN

-  AKRON DOLOSTONE
-  BERTIE LIMESTONE
-  CAMILLUS SHALE

--- APPROXIMATE GEOLOGICAL CONTACT

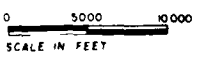
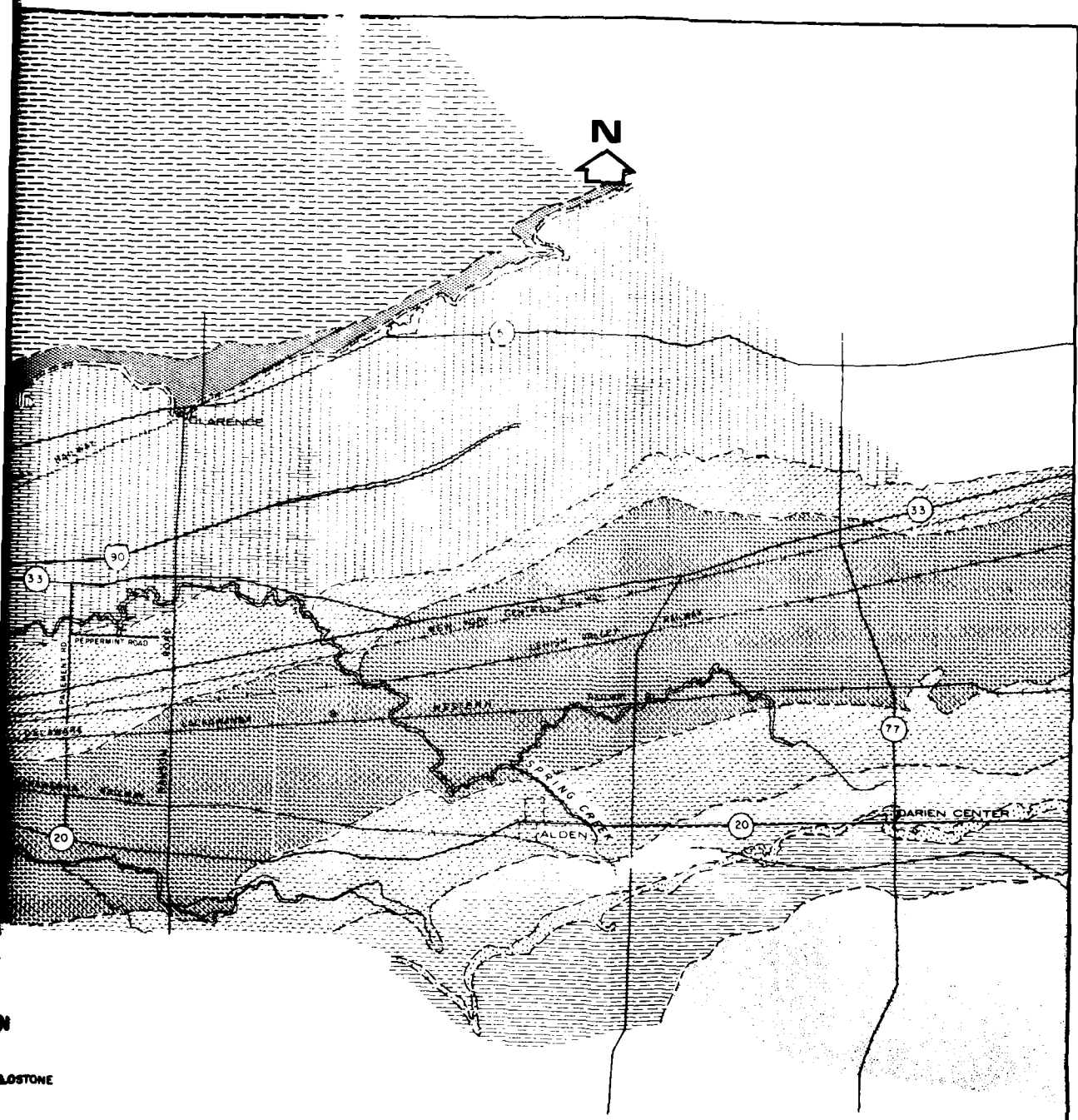

NOTE
 GEOLOGICAL INFORMATION IS BASED ON THE
 FOLLOWING PUBLICATIONS:

- NEW YORK STATE GEOLOGIC MAP
 1961, SCALE 1:250,000
- BUEHLER, E. J. AND TESMER, I. H.
 GEOLOGY OF ERIE COUNTY, NEW YORK
 BUFFALO SOCIETY OF NATURAL SCIENCES
 BULLETIN VOL. 21, No. 3, 1963
- LA SALA, A. M., JR.
 GROUND WATER RESOURCES OF THE
 ERIE - NIAGARA BASIN, NEW YORK
 U.S. GEOLOGICAL SURVEY, NEW YORK STATE CONSERVATION
 DEPARTMENT - DIVISION OF WATER RESOURCES
 BASIN PLANNING REPORT ENB-3, 1968





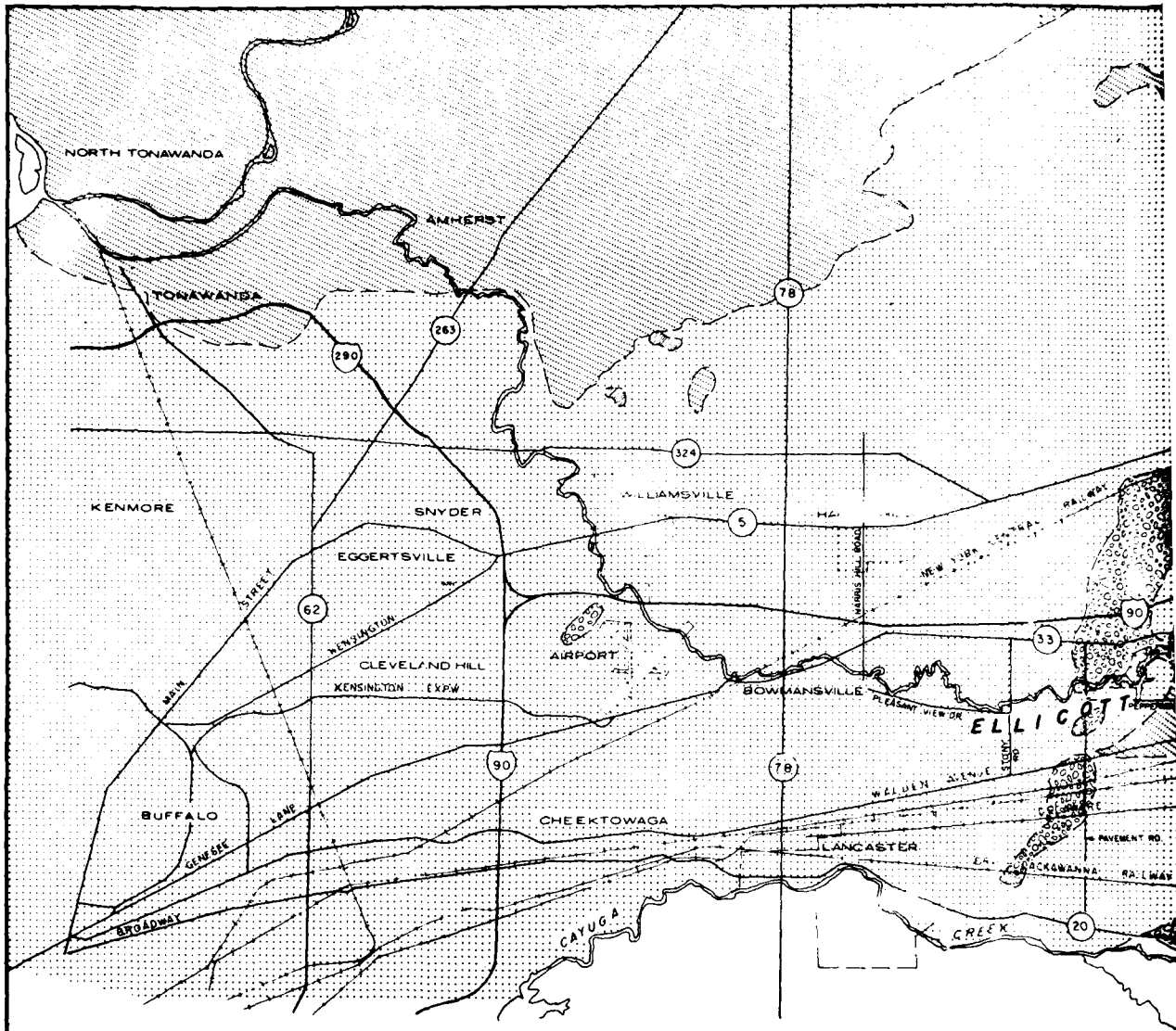

ELLICOTT CREEK NEW YORK

**BEDROCK GEOLOGY
 OF ELLICOTT CREEK BASIN**

U. S. ARMY ENGINEER DISTRICT, BUFFALO
 TO ACCOMPANY SURVEY REPORT
 DATED 1972



LEGEND

-  ALLUVIUM
-  OUTWASH DEPOSITS
-  LAKE DEPOSITS
-  ICE-CONTACT DEPOSITS
-  TILL
-  APPROXIMATE GEOLOGICAL CONTACT

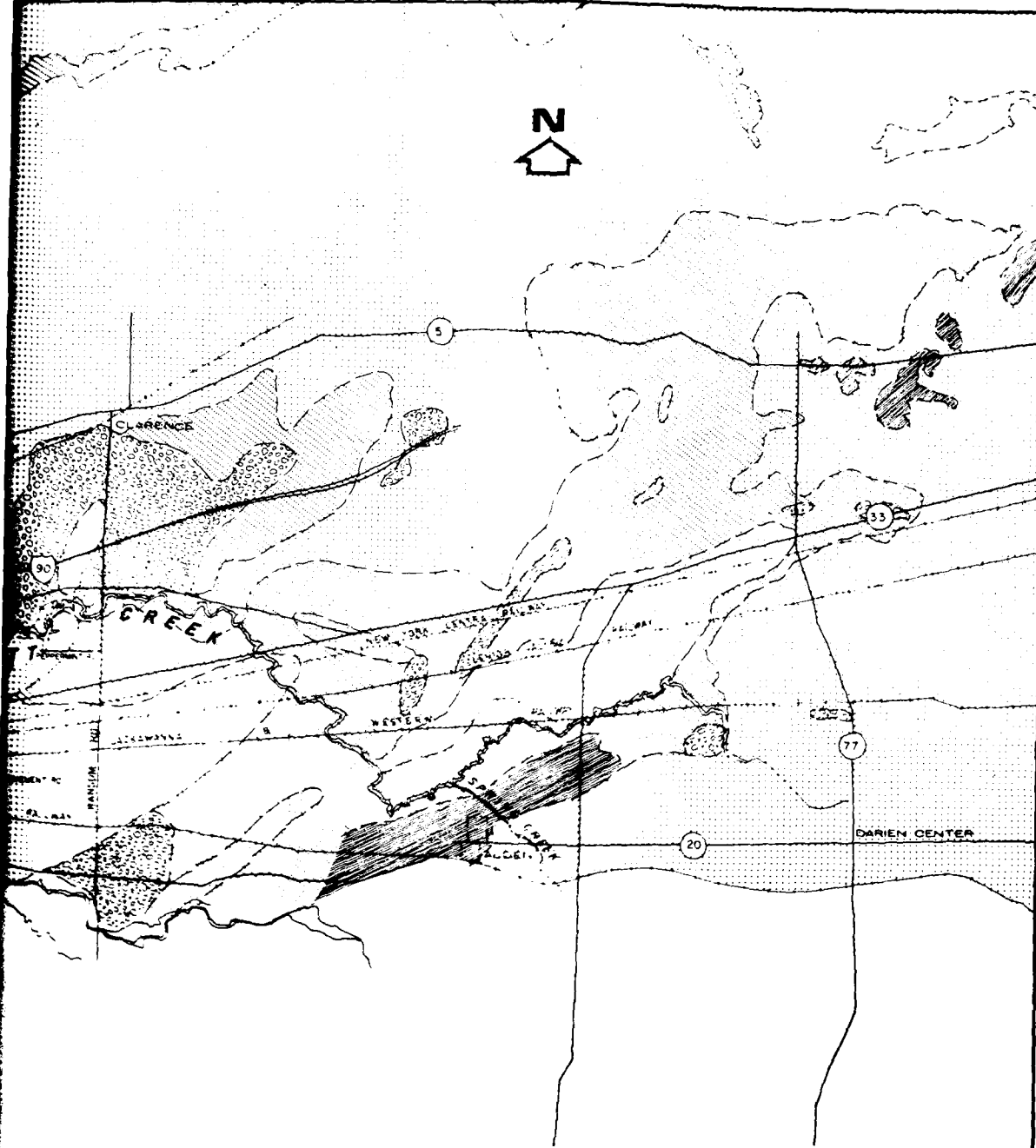

NOTE

GEOLOGICAL INFORMATION IS BASED ON THE FOLLOWING PUBLICATIONS

NEW YORK STATE GEOLOGIC MAP
961 SCALE 1:250,000

BUEHLER, J. AND TESMER, H.
GEOLOGY OF ERIE COUNTY, NEW YORK
BUFFALO SOCIETY OF NATURAL SCIENCES
BULLETIN VOL. 2, NO. 3, 1963

LA SALLA, A. M., JR.
GROUND WATER RESOURCES OF THE
ERIE-WAGARA BASIN, NEW YORK

U.S. GEOLOGICAL SURVEY, NEW YORK STATE
CONSERVATION DEPARTMENT - DIVISION OF
WATER RESOURCES
BASIN PLANNING REPORT END - 3, 1960

0 5000 10000
SCALE IN FEET

ELLICOTT CREEK NEW YORK
**SURFICIAL GEOLOGY
OF ELLICOTT CREEK BASIN**

U.S. ARMY ENGINEER DISTRICT, BUFFALO

TO ACCOMPANY SURVEY REPORT
DATED 1972

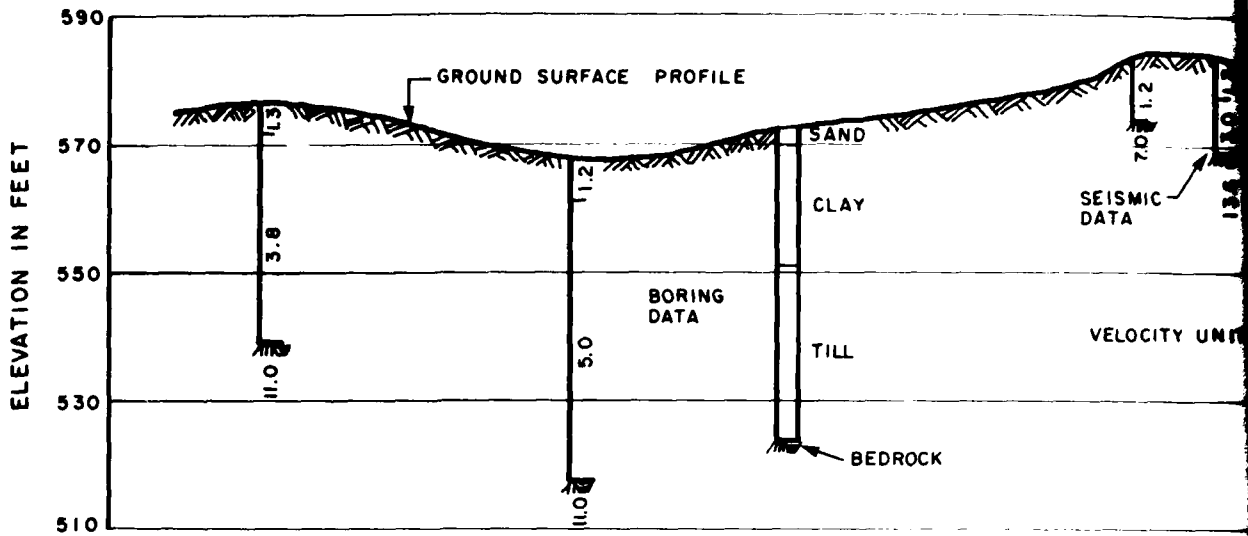

SECTION A - A

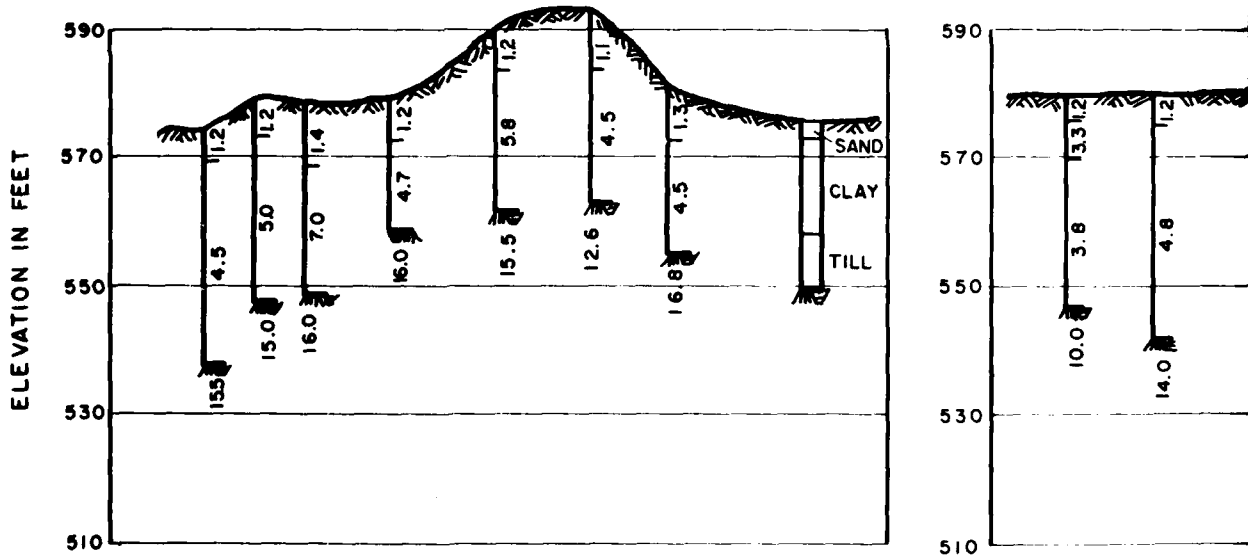

SECTION B - B



BASED ON RESULTS OF SEISMIC SURVEY BY D.S. HODGE ET AL.
FOR SECTION LOCATIONS SEE PLATE G-1

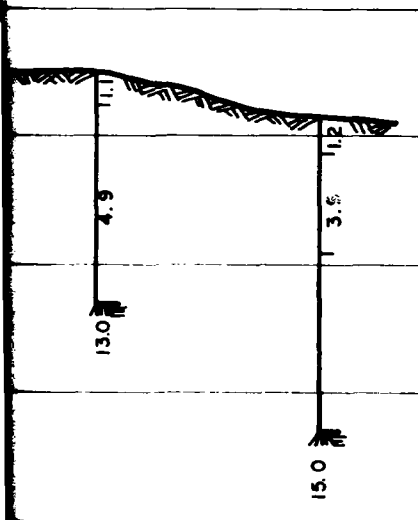
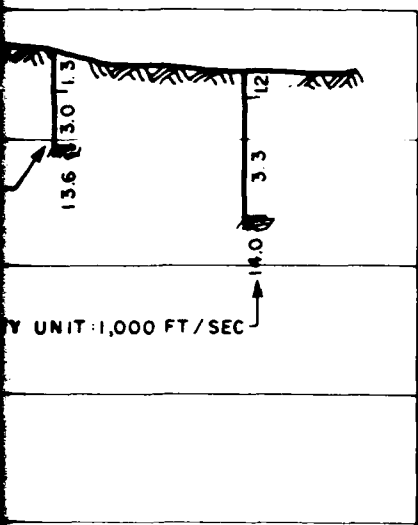

SECTION C-C

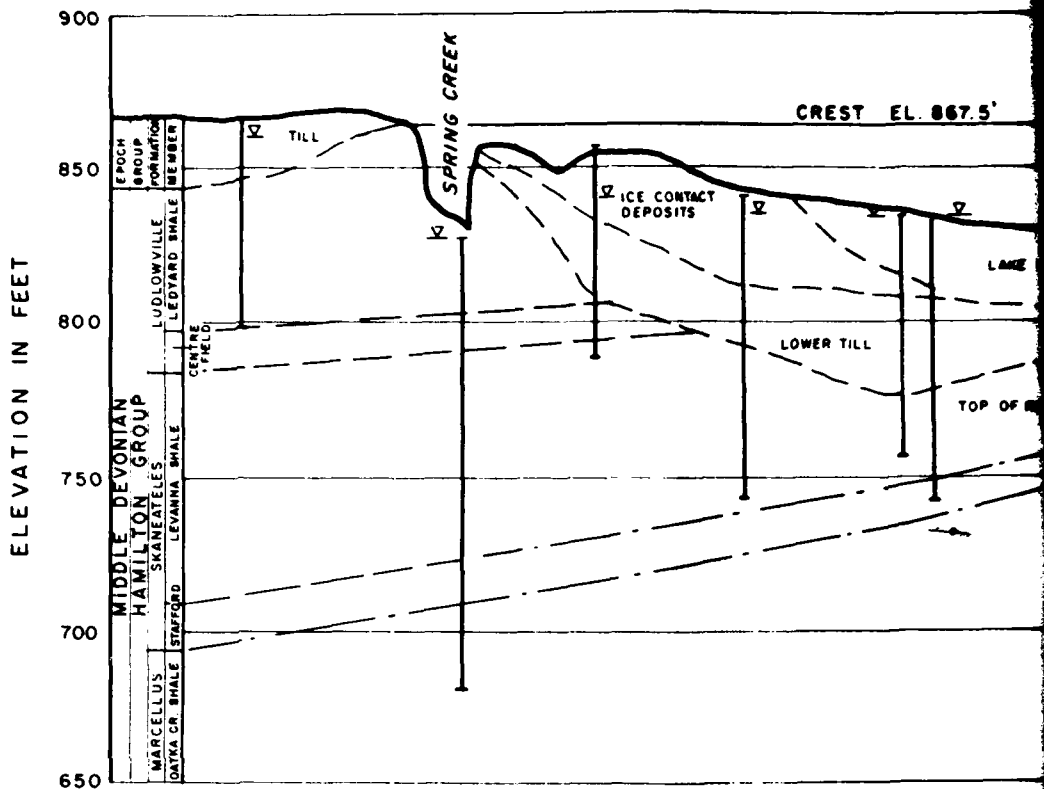

PROFILE ALONG AXIS

0 1000 2
SCALE IN FEET

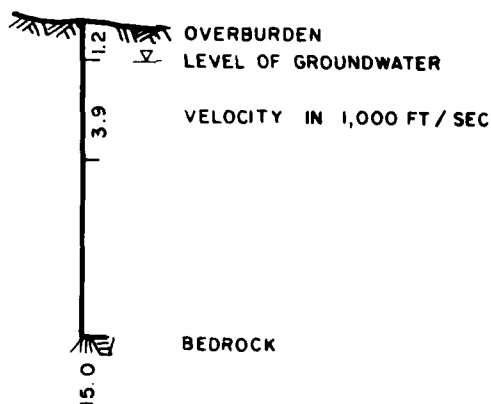

NOTE

PROFILE ALONG AXIS OF DAM
SURVEY REPORT FOR FLOOD
AND ALLIED PURPOSES:
U.S. ARMY CORPS OF ENGINEERS
NOTES OF PERCENTAGES OF
RECOVERY AND BLOW COUNTS
BEEN OMITTED HERE FOR CLARITY
REFER TO ABOVE REPORT FOR

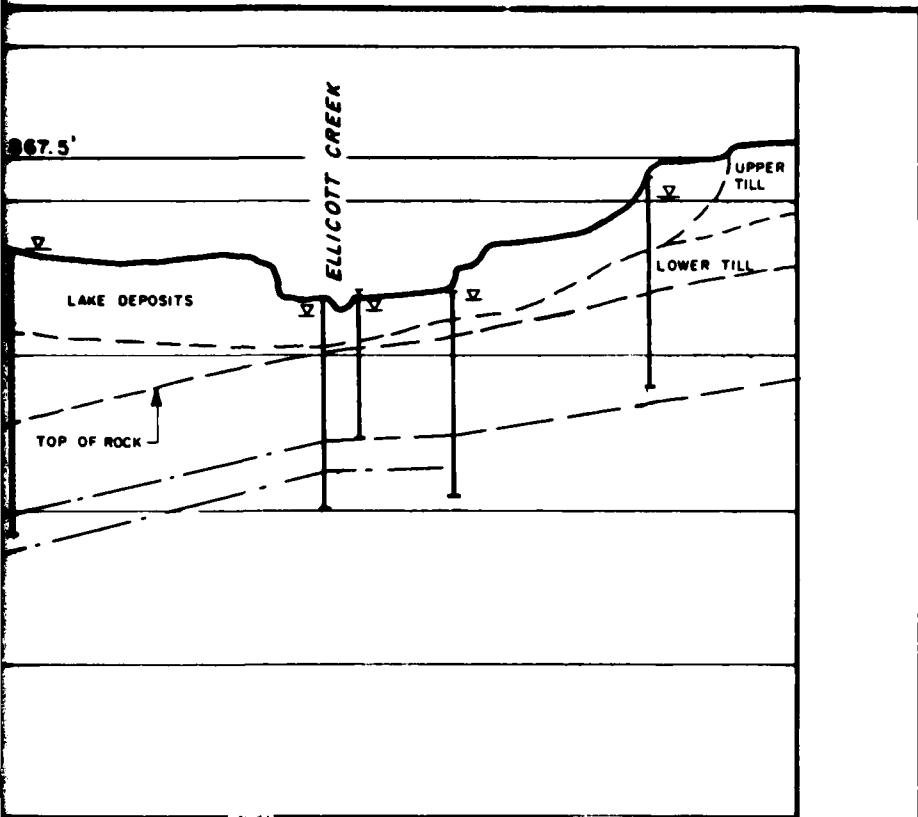

AXIS OF DAM

2000

OF DAM TAKEN FROM
 FLOOD CONTROL
 IS :
 ENGINEERS, 1970
 ES OF CORE
 COUNTS HAVE
 FOR CLARITY.
 RT FOR DETAILS.

ELLICOTT CREEK NEW YORK
GEOLOGICAL PROFILE SECTIONS
 U.S. ARMY ENGINEER DISTRICT, BUFFALO
 TO ACCOMPANY SURVEY REPORT
 DATED 1972

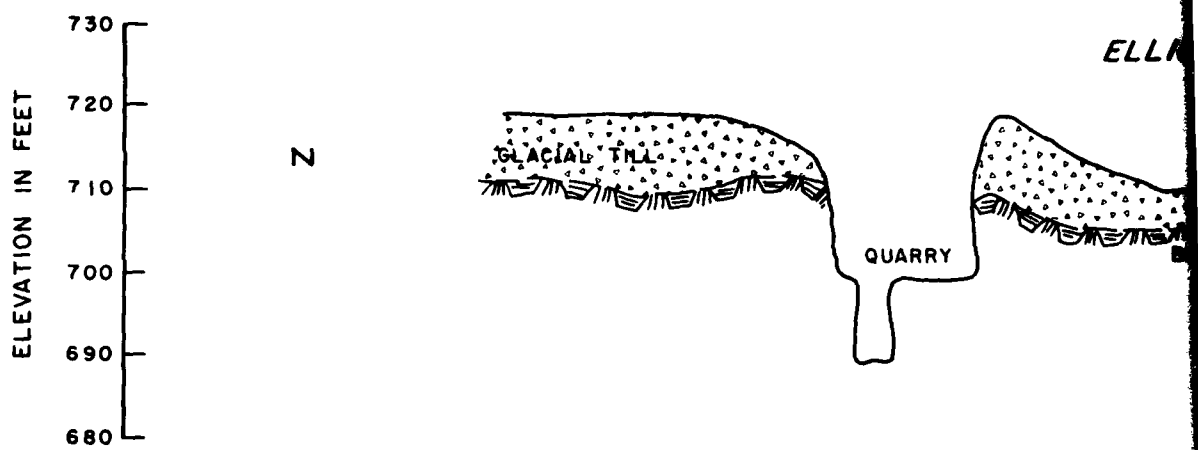

SECTION THROUGH QU
 (DOWNSTREAM OF STON

NOTE
 ELEVATION OF BEDROCK SURFACE
 SHOWN IS APPROXIMATE

ELLICOTT CREEK

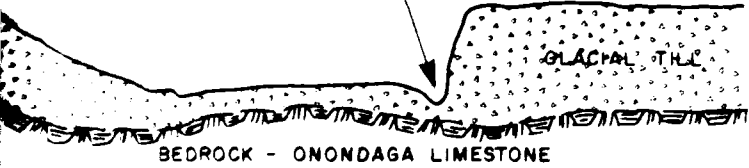

S

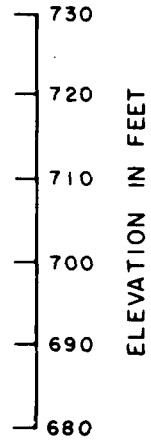

ROUGH QUARRY SITE
(NAM OF STONY ROAD)



ELLICOTT CREEK NEW YORK
GEOLOGICAL PROFILE SECTION
BOWMANVILLE RESERVOIR

U.S. ARMY ENGINEER DISTRICT, BUFFALO
TO ACCOMPANY SURVEY REPORT
DATED 1972

PLATE G-5

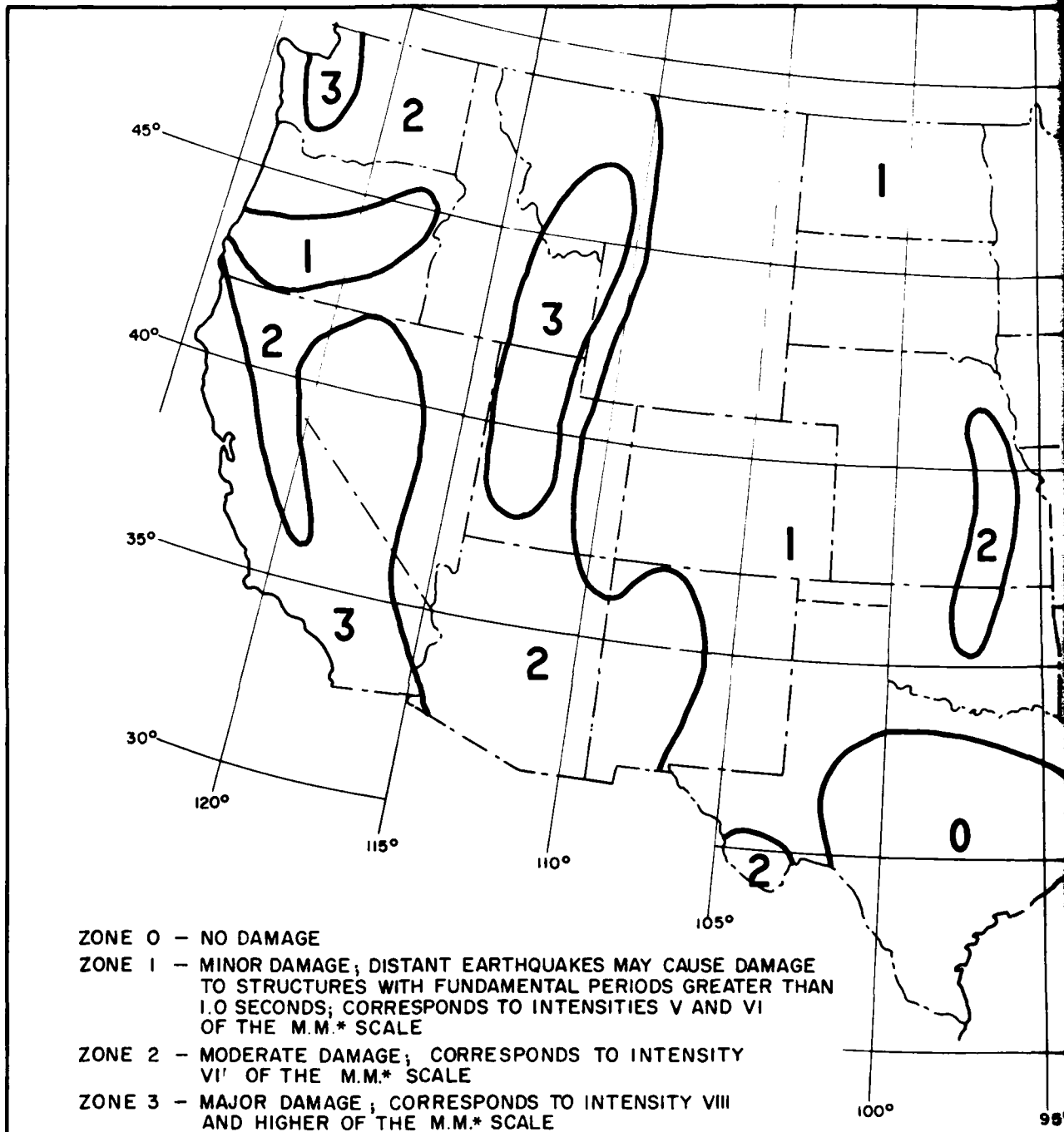

THIS MAP IS BASED ON THE KNOWN DISTRIBUTION OF DAMAGING EARTHQUAKES AND THE M.M.* INTENSITIES ASSOCIATED WITH THESE EARTHQUAKES; EVIDENCE OF STRAIN RELEASE; AND CONSIDERATION OF MAJOR GEOLOGIC STRUCTURES AND PROVINCES BELIEVED TO BE ASSOCIATED WITH EARTHQUAKE ACTIVITY.
 THE PROBABLE FREQUENCY OF OCCURRENCE OF DAMAGING EARTHQUAKES IN EACH ZONE WAS NOT CONSIDERED IN ASSIGNING RATINGS TO THE VARIOUS ZONES.

* MODIFIED MERCALLI INTENSITY SCALE OF 1931

(AFTER ALGERMISSEN, 1969)

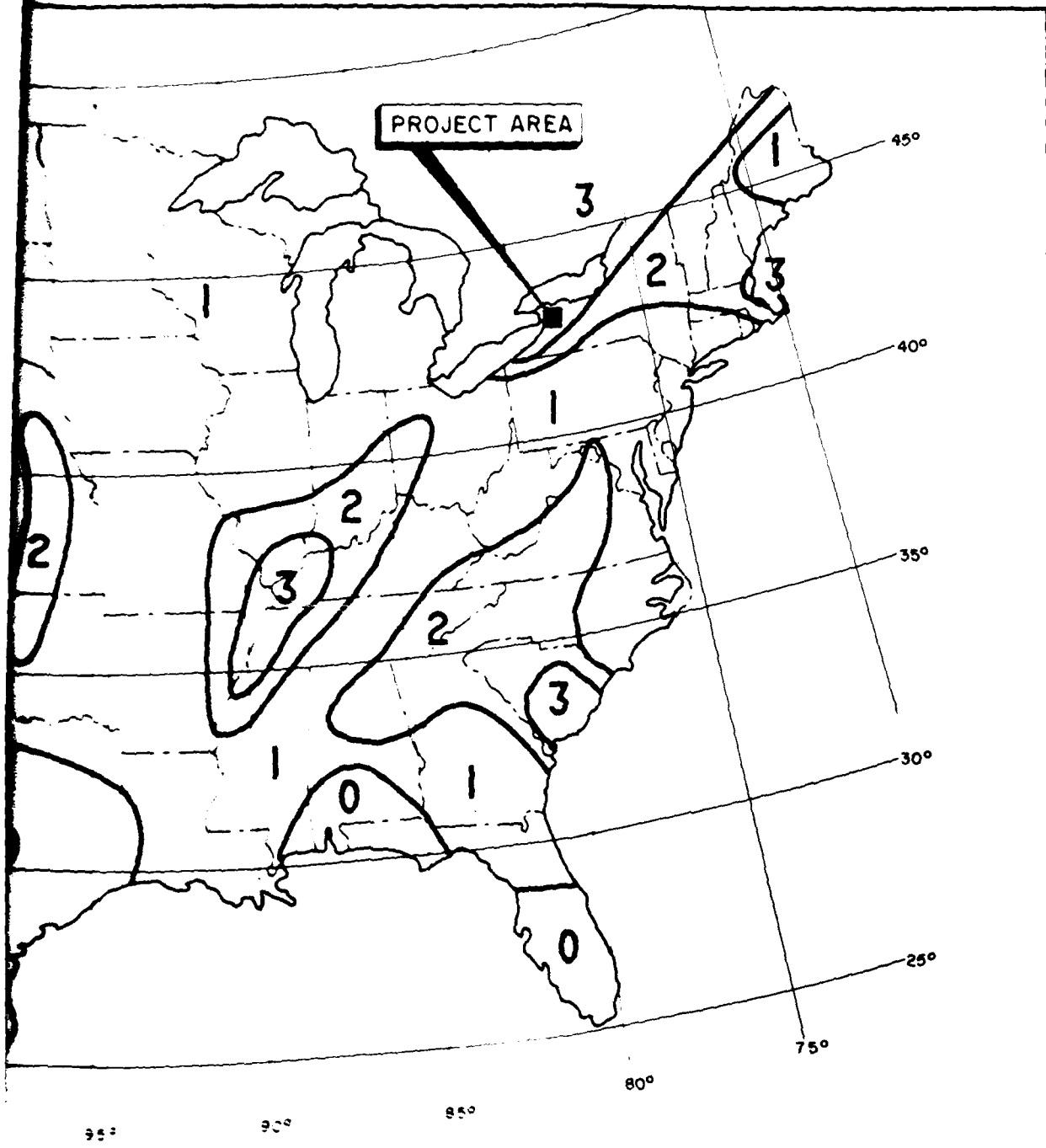

PROJECT AREA

THE
RELEASE
TO BE
ZONE

ELLCOTT CREEK NEW YORK
SEISMIC RISK ZONES
U.S. ARMY ENGINEER DISTRICT, BUFFALO
TO ACCOMPANY SURVEY REPORT
DATED 1972

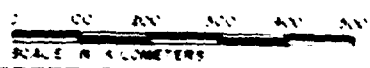

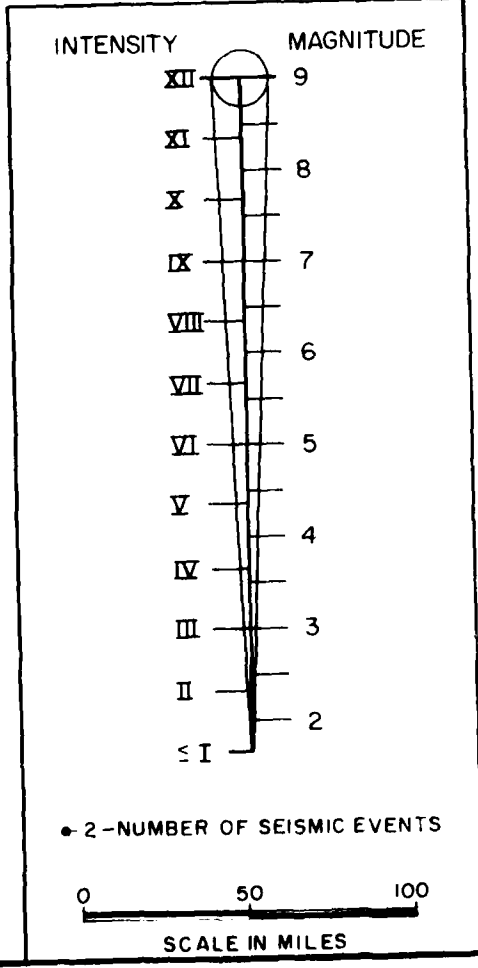
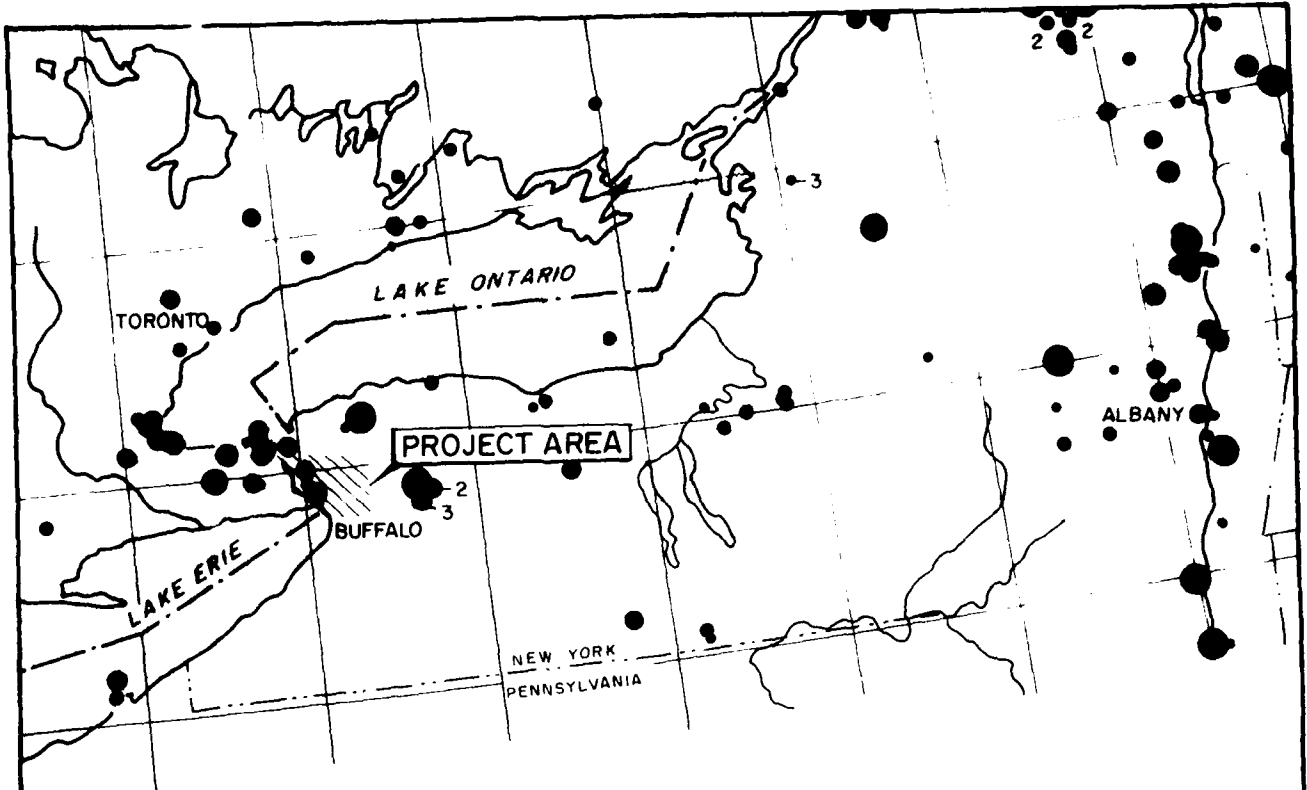

(AFTER SMITH, 1966)

ELLICOTT CREEK NEW YORK
EPICENTRAL LOCATIONS
 U.S. ARMY ENGINEER DISTRICT, BUFFALO
 TO ACCOMPANY SURVEY REPORT
 DATED 1972

1

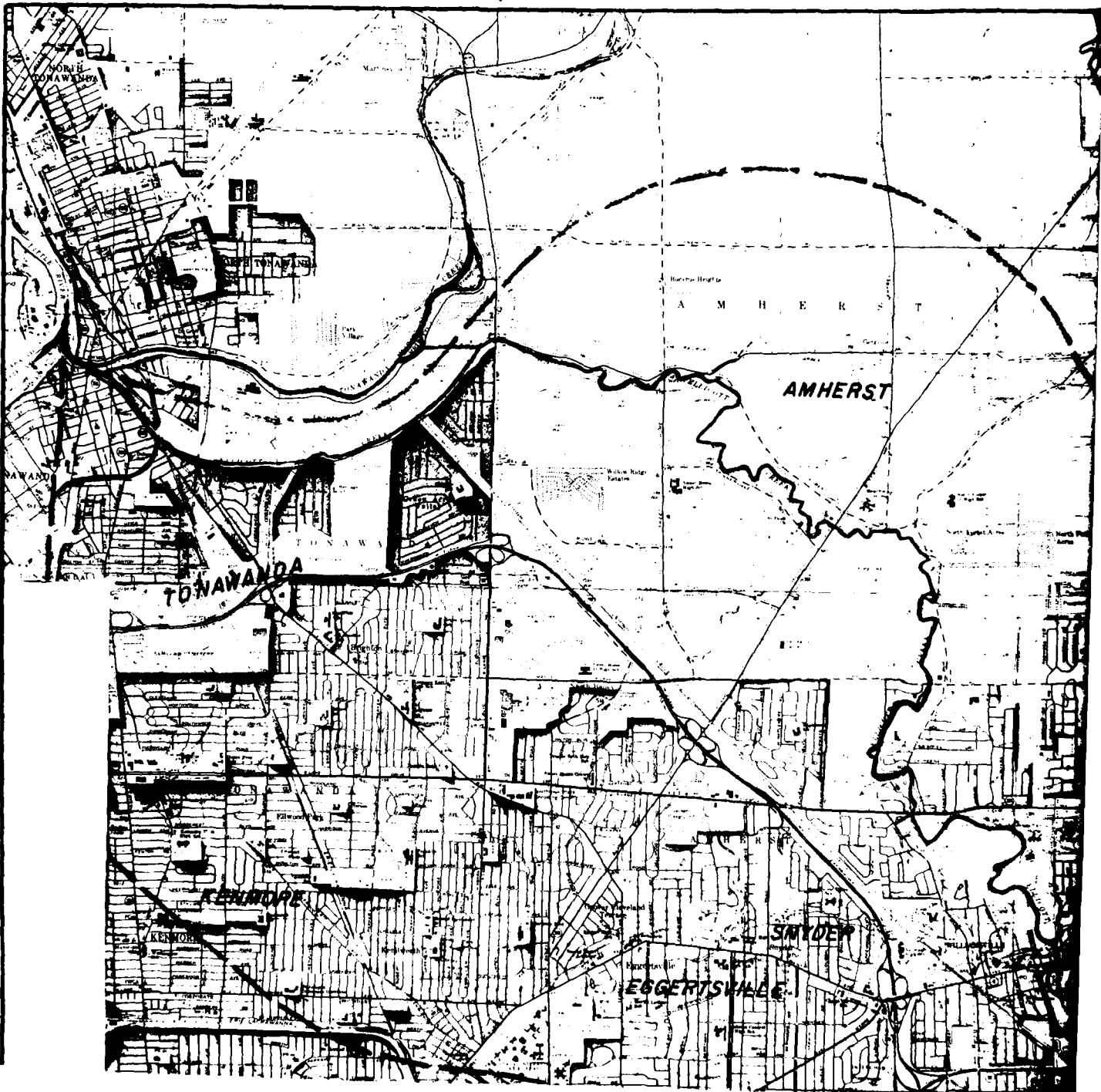

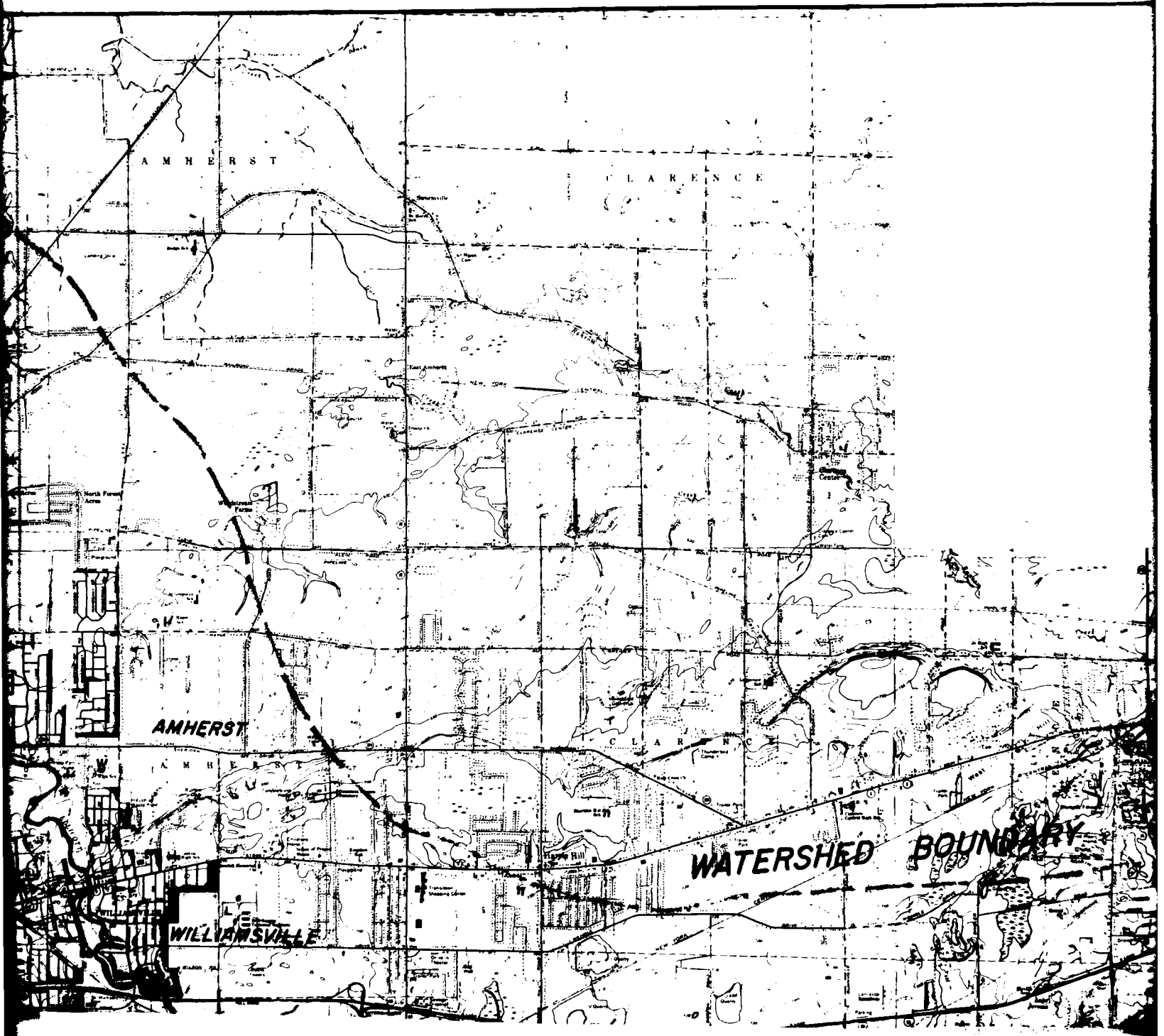

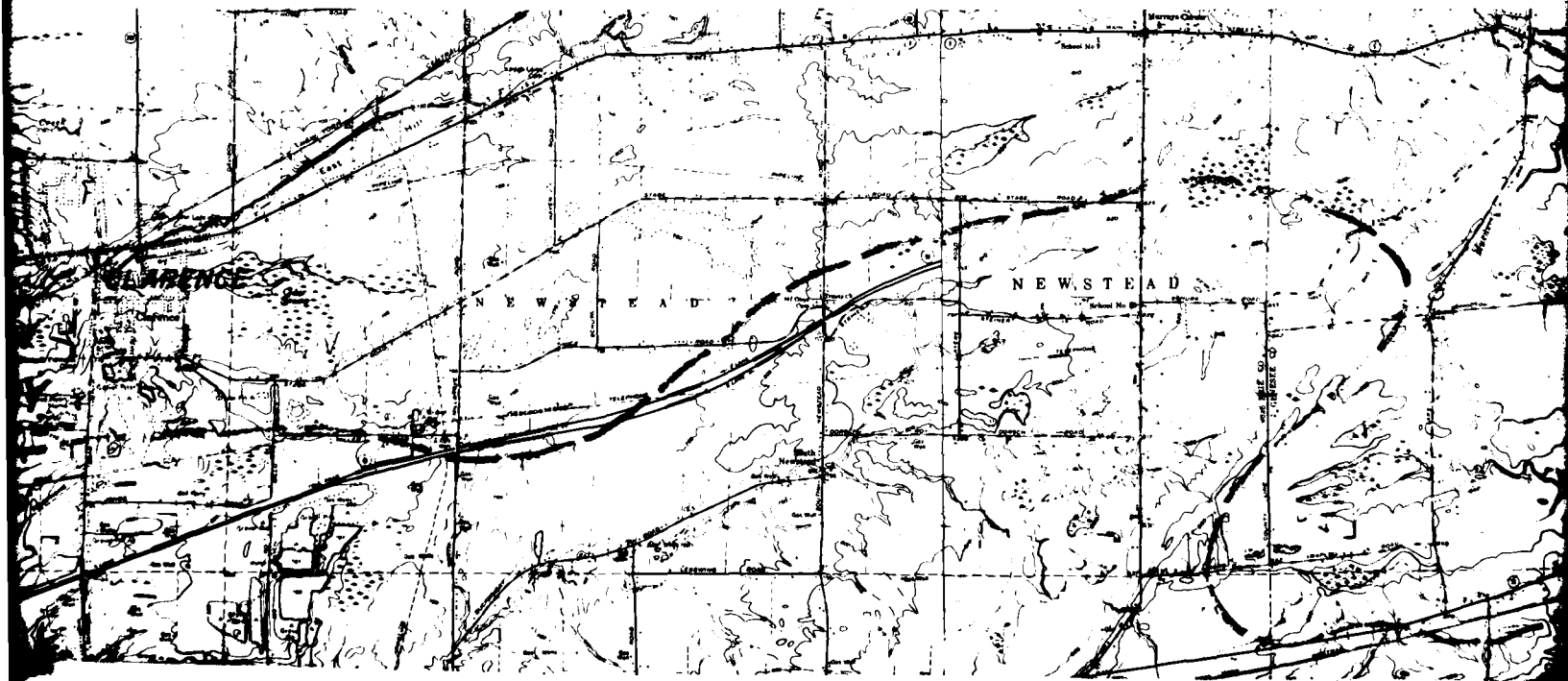

1

4

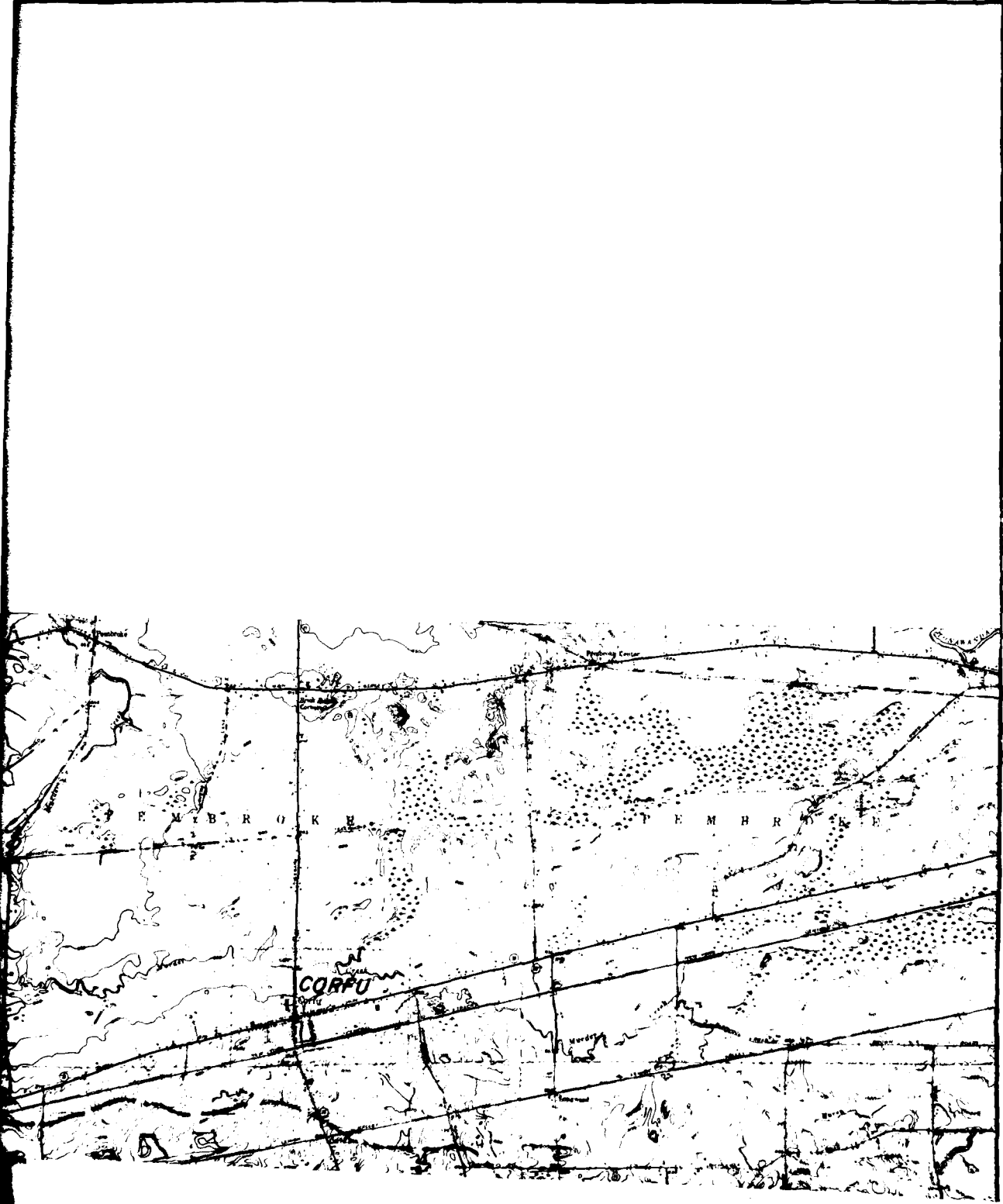



PHOTOGRAPHED FROM UNITED STATES DEPA

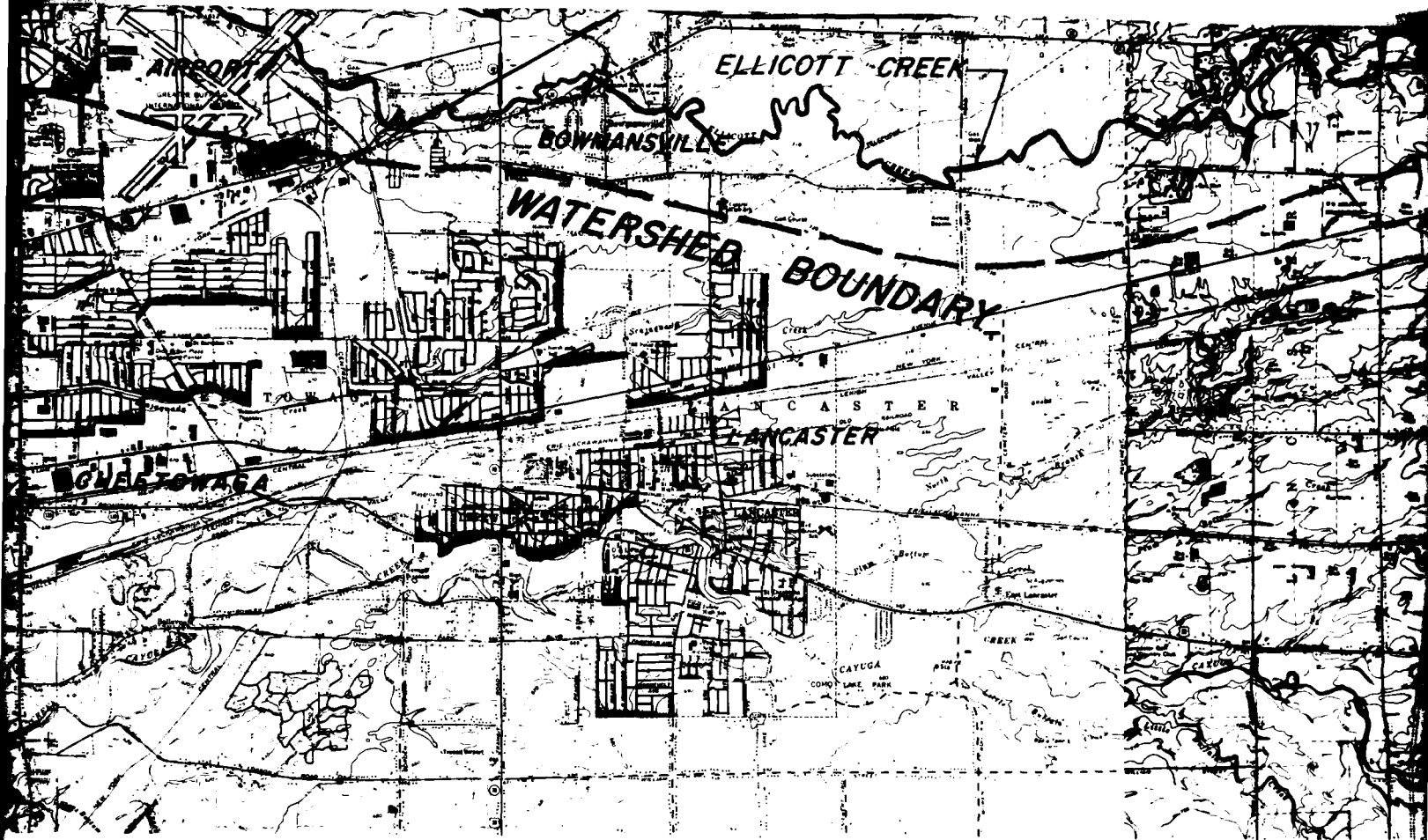

STATES DEPARTMENT OF THE INTERIOR GEOLOGICAL SURVEY MAPS

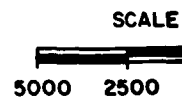

4

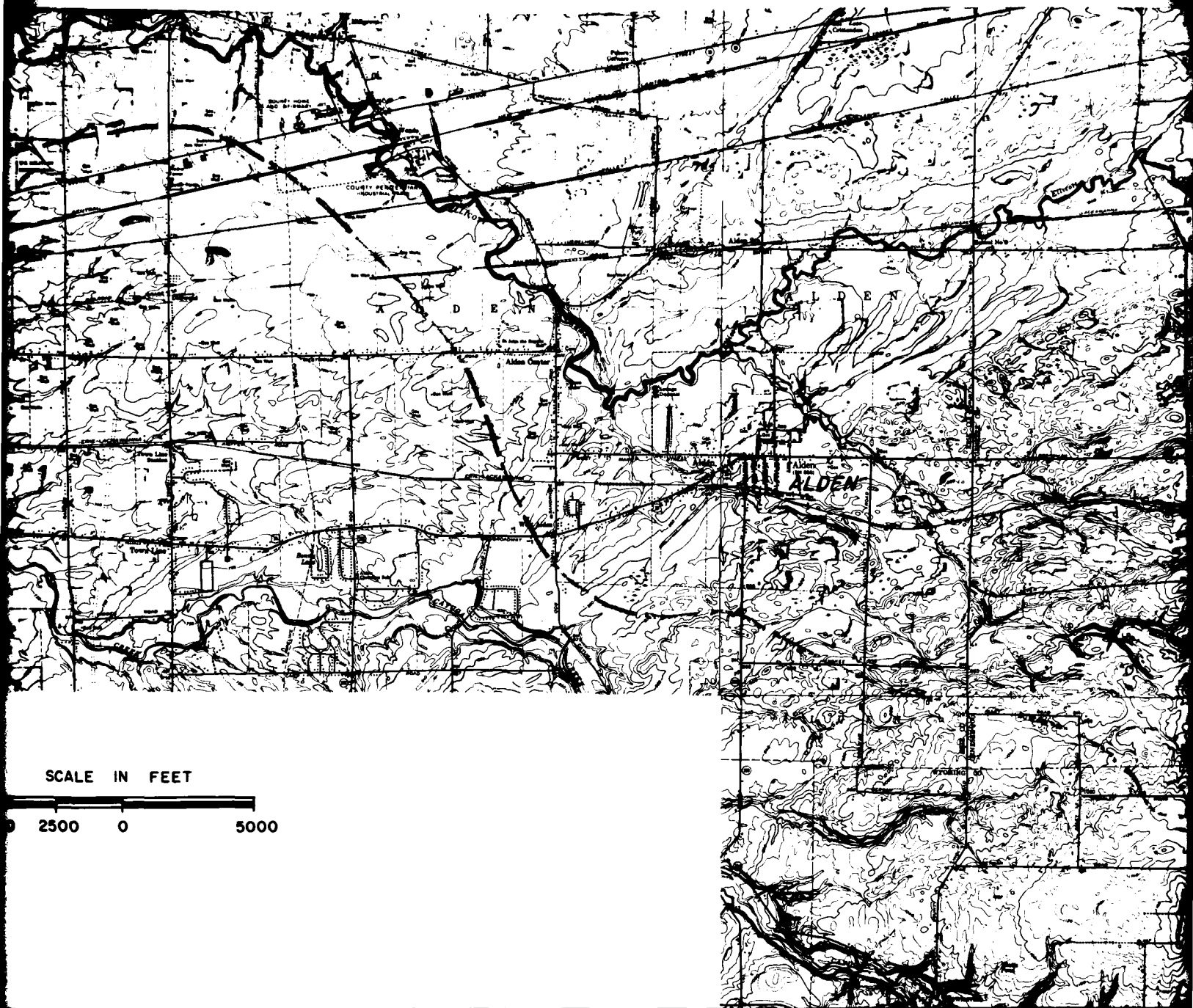

7

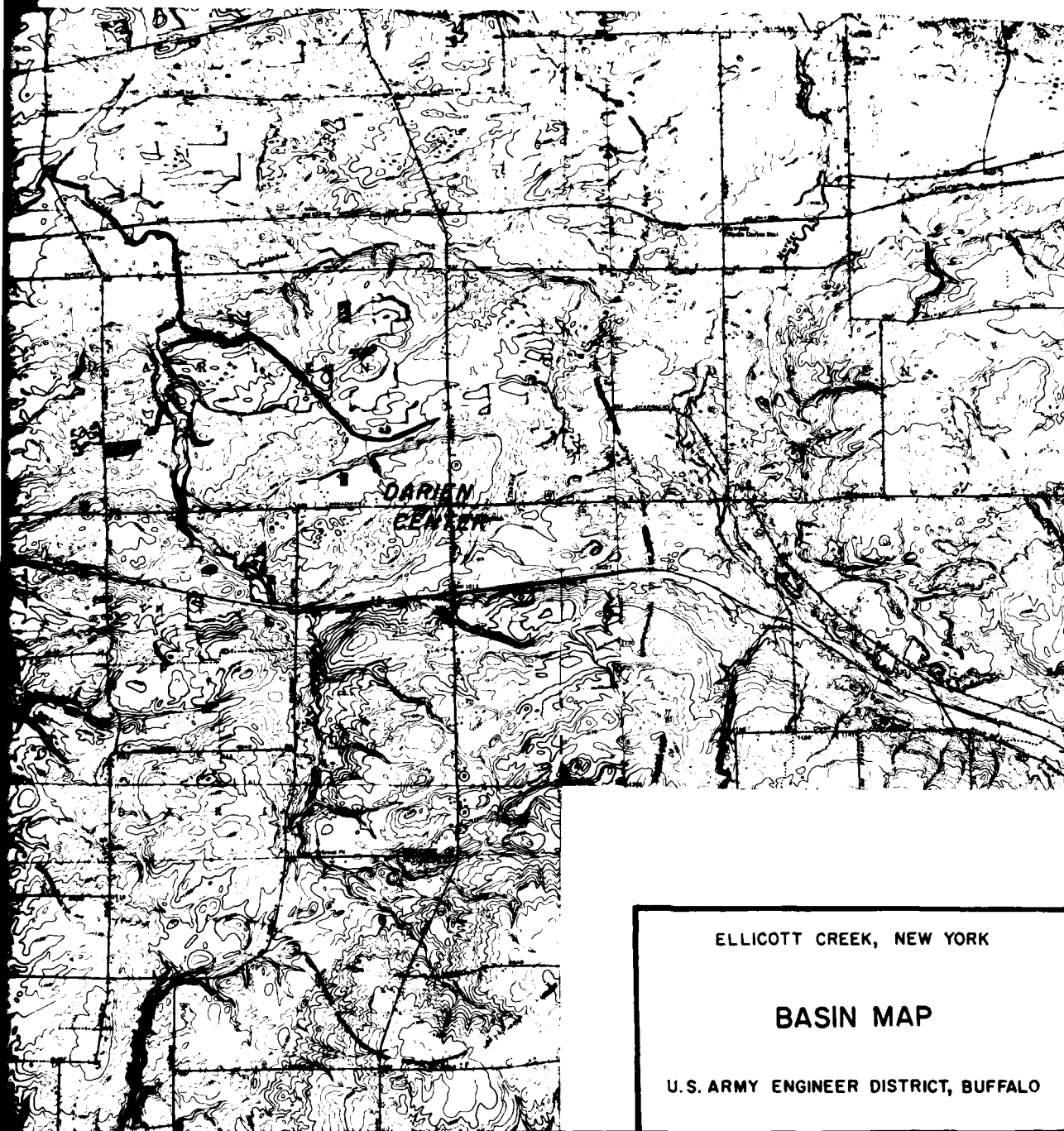

ELLICOTT CREEK, NEW YORK

BASIN MAP

U.S. ARMY ENGINEER DISTRICT, BUFFALO

PLATE I

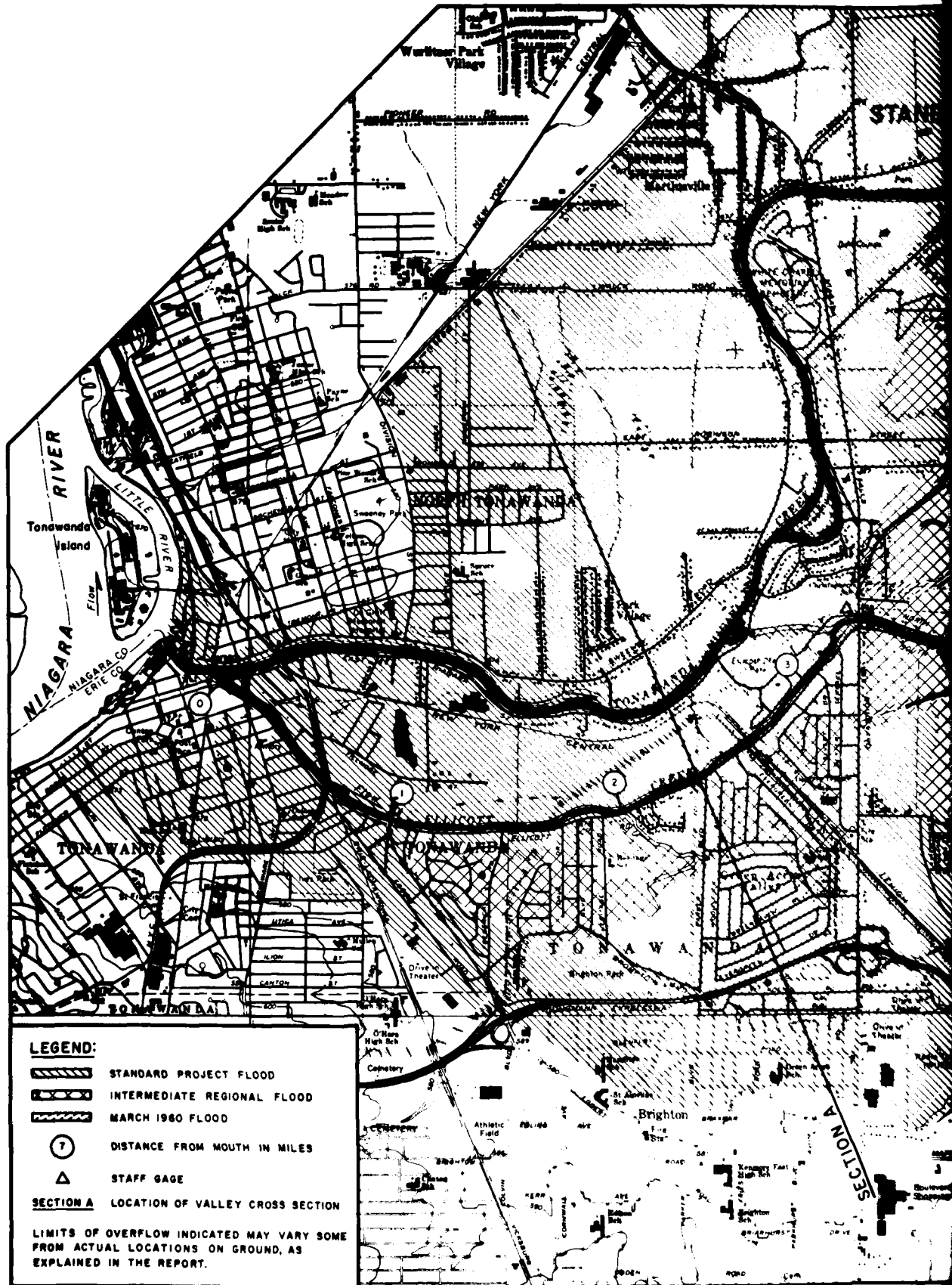

STANDARD PROJECT FLOOD

INTERMEDIATE

REGIONAL

FLOOD

20 YEAR FLOOD

CONSIDERED AMHERST
MARSH PARKWAY

A M H E R S T

PROPOSED STATE UNIVERSITY
STATE UNIVERSITY NEW YORK

SECTION C

SECTION B

SECTION D

AUDUBON GOLF COURSE

North Bailey

SCALE IN THOUSANDS OF FEET

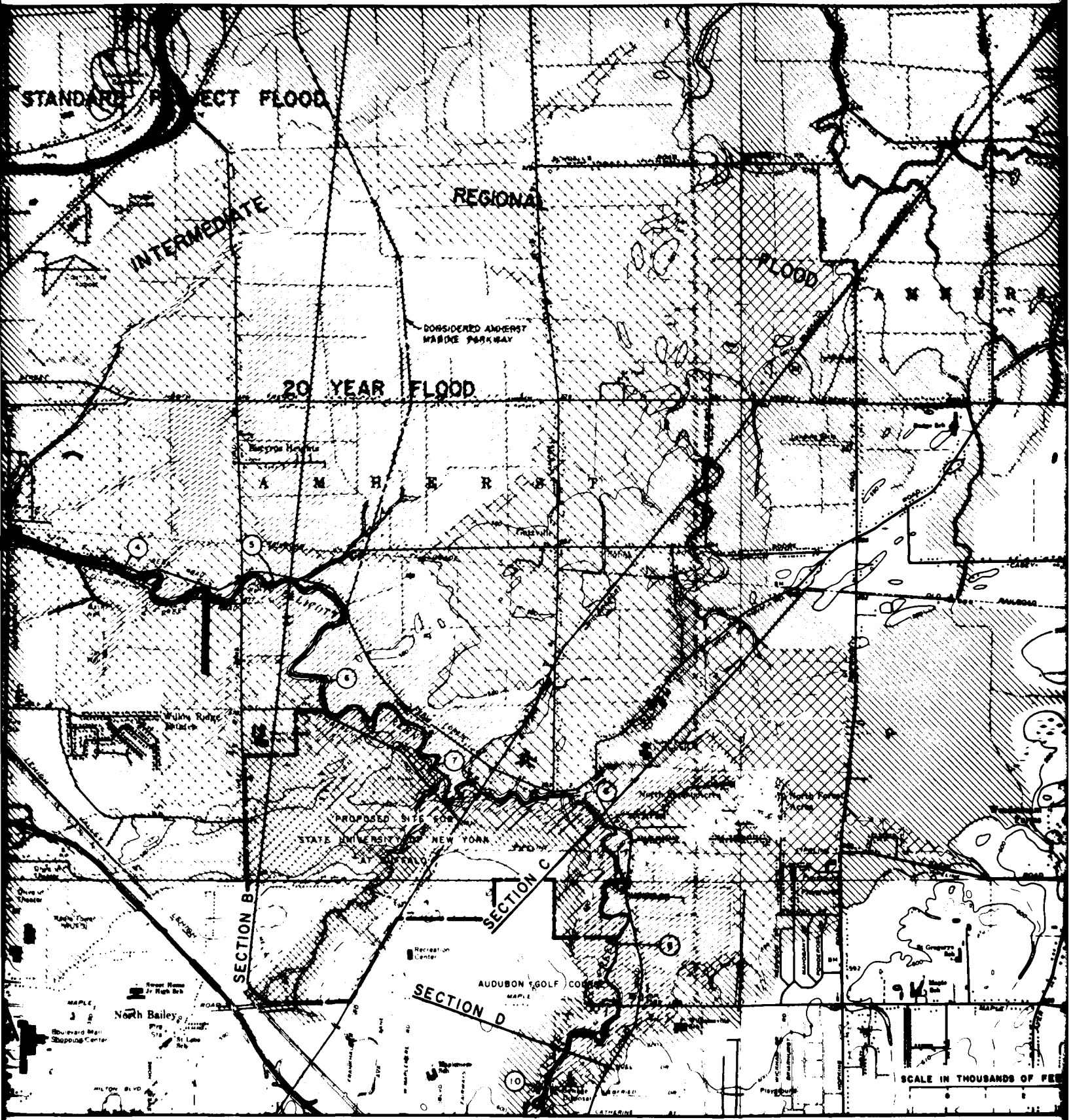

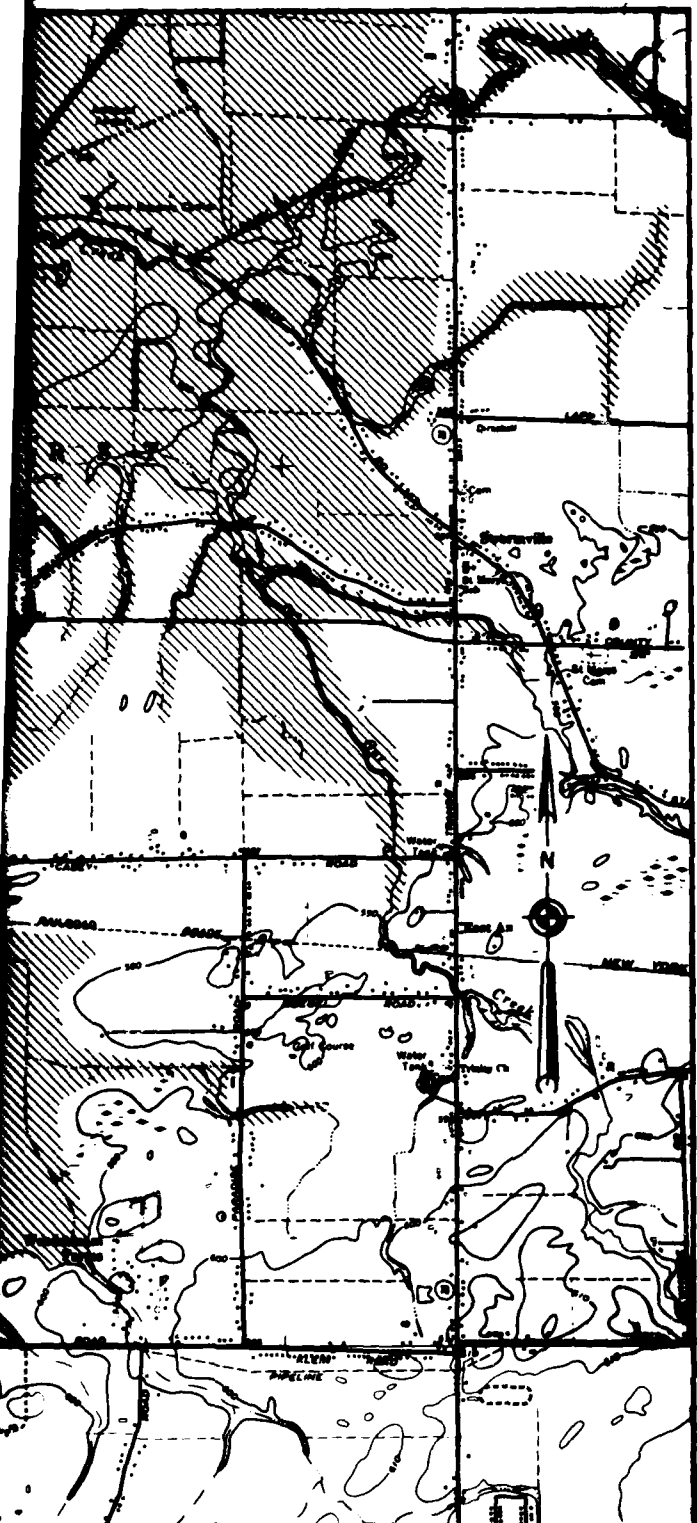

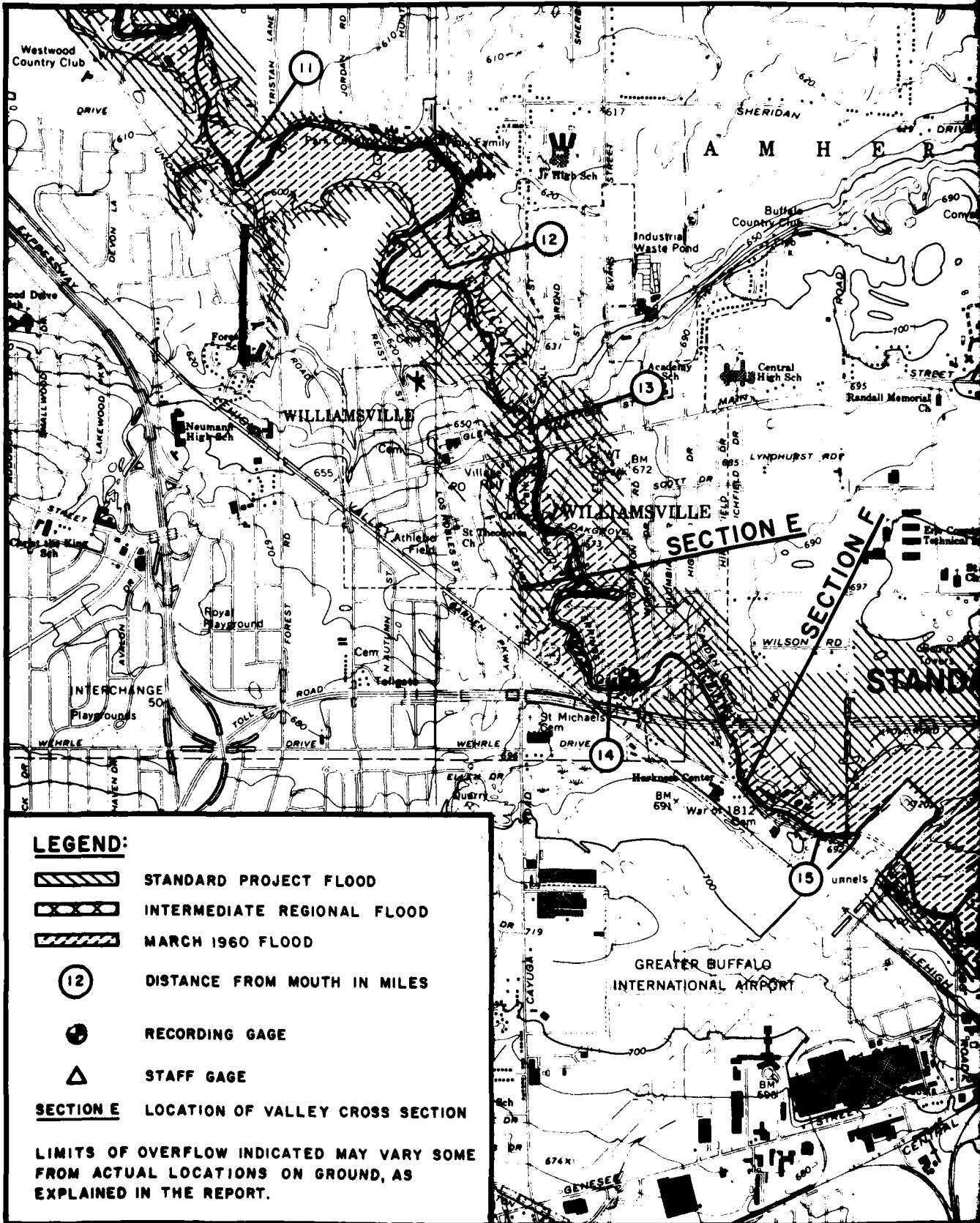

ELLICOTT CREEK
ERIE COUNTY, NEW YORK
FLOOD PLAIN INFORMATION REPORT.
FLOODED AREAS
MILE 0 TO 10
U.S. ARMY ENGINEER DISTRICT, BUFFALO
JANUARY 1968

THOUSANDS OF FEET



LEGEND:

-  STANDARD PROJECT FLOOD
-  INTERMEDIATE REGIONAL FLOOD
-  MARCH 1960 FLOOD

 DISTANCE FROM MOUTH IN MILES

 RECORDING GAGE

 STAFF GAGE

SECTION E LOCATION OF VALLEY CROSS SECTION

LIMITS OF OVERFLOW INDICATED MAY VARY SOME FROM ACTUAL LOCATIONS ON GROUND, AS EXPLAINED IN THE REPORT.

ELLICOTT
ERIE COUNTY,
FLOOD PLAIN INFO
FLOODED
MILE 10
U.S. ARMY ENGINEER
JANUARY

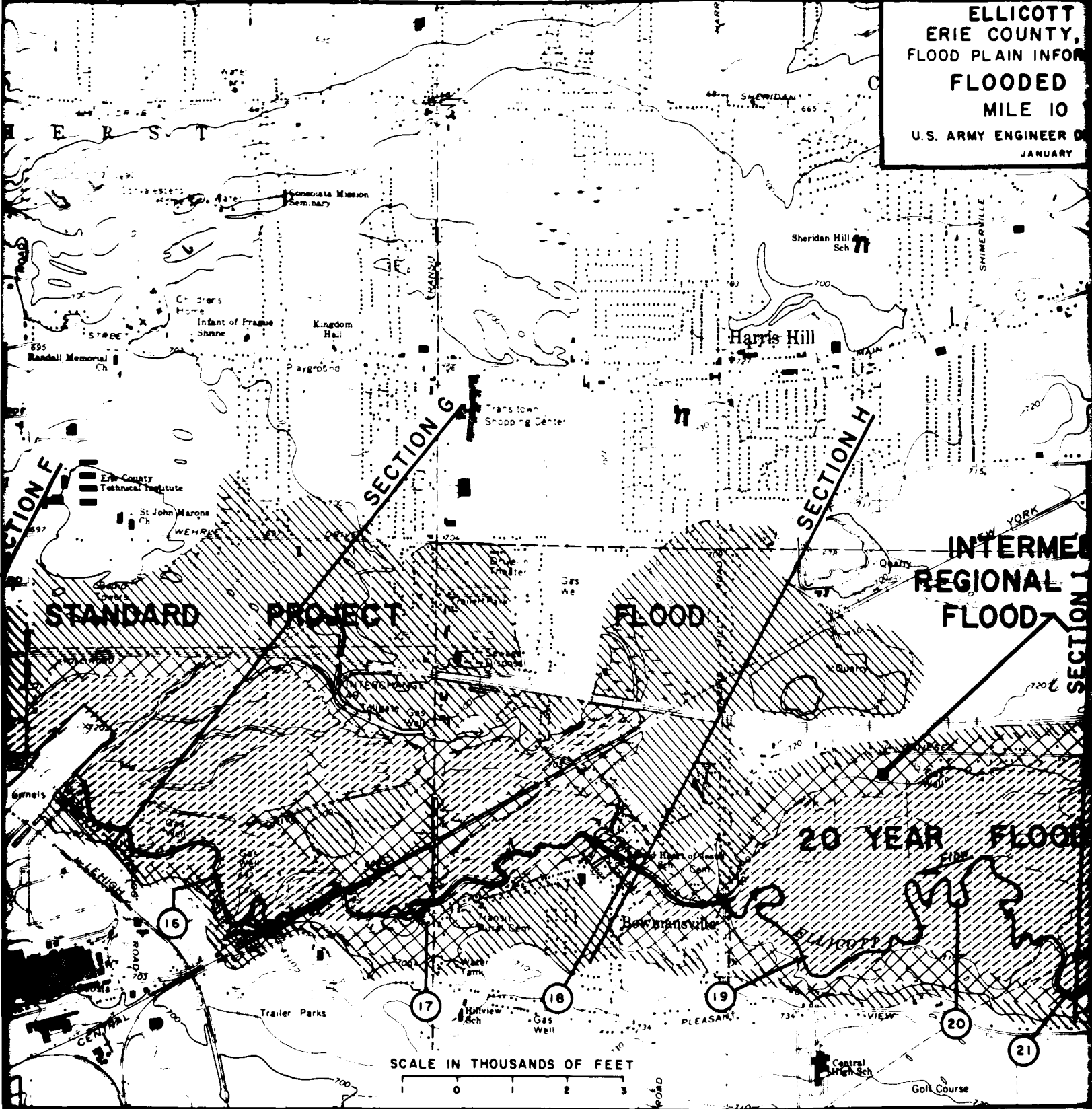

**COTT CREEK
COUNTY, NEW YORK
AN INFORMATION REPORT
FLOODED AREAS
SECTION 10 TO 22
SINGER DISTRICT, BUFFALO
JANUARY 1968**

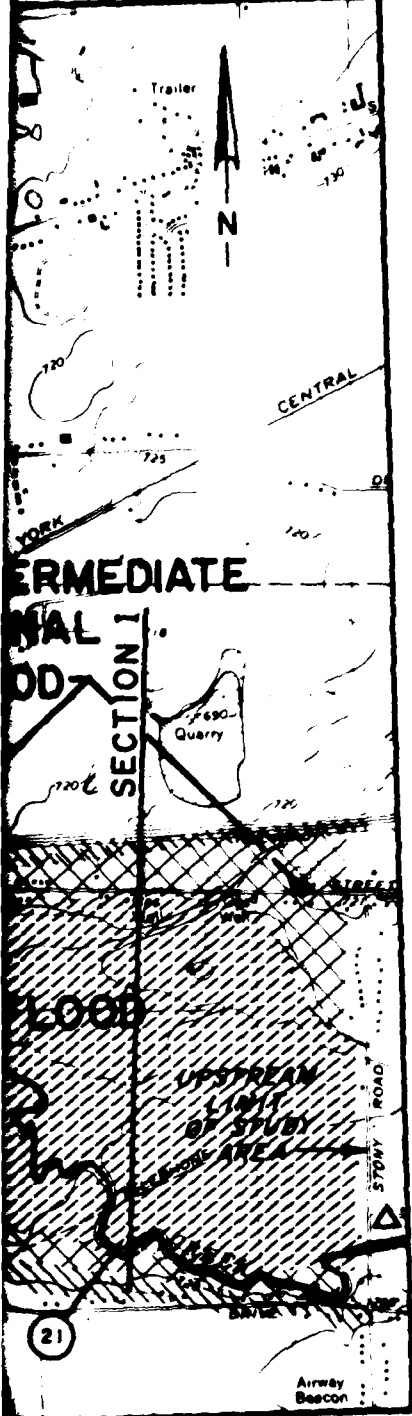
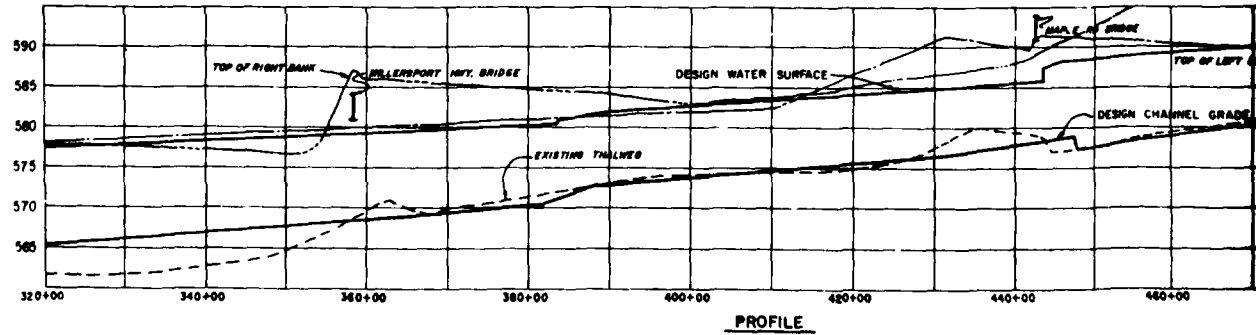
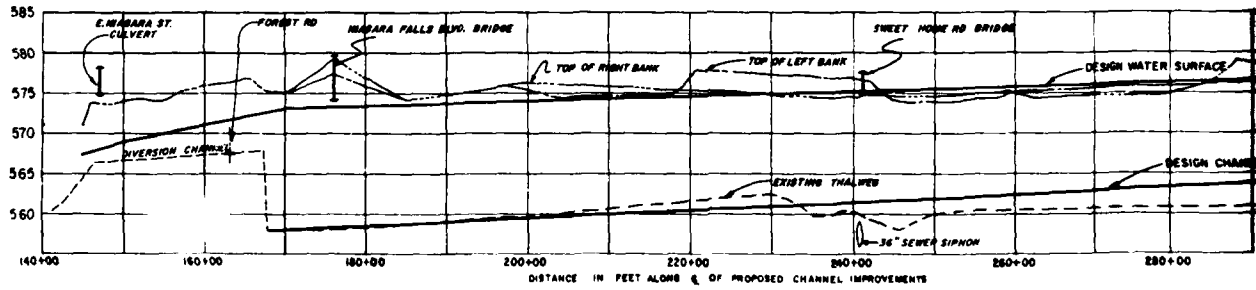
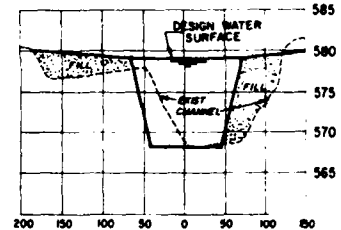
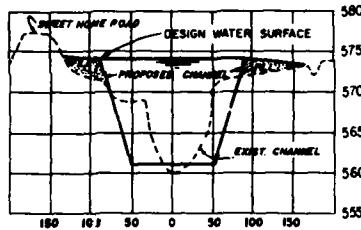
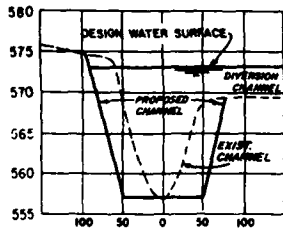
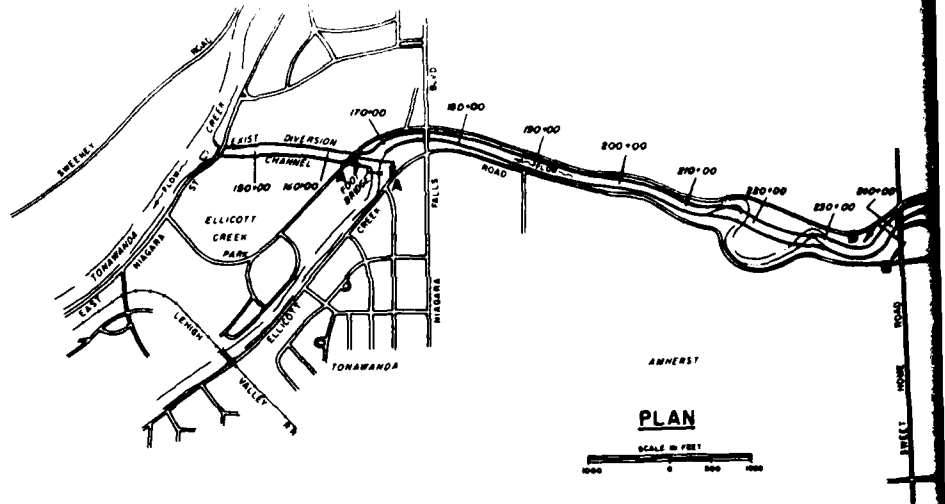
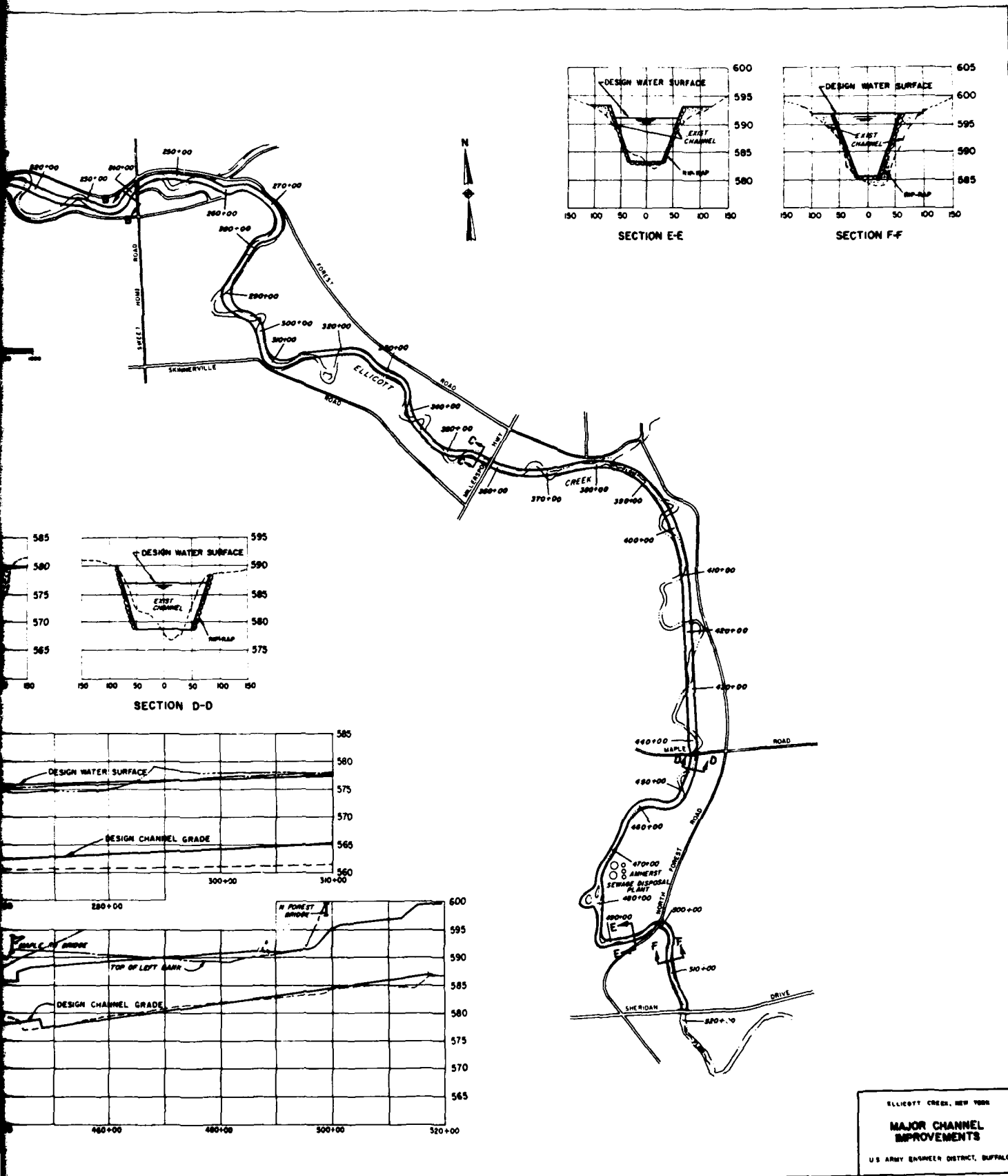
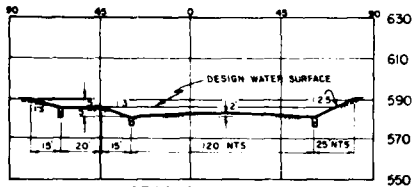
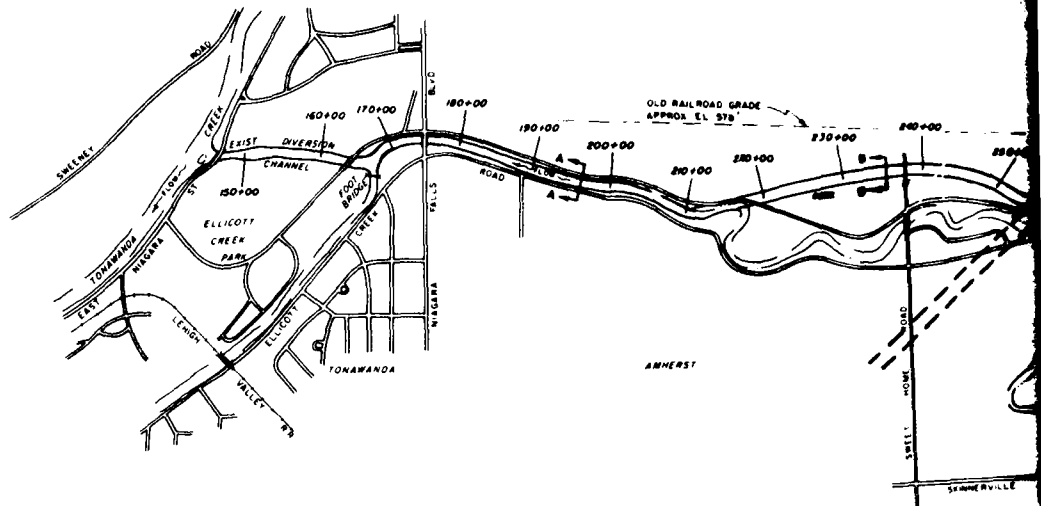

PLATE 3





ELLICOTT CREEK, NEW YORK
MAJOR CHANNEL IMPROVEMENTS
 U.S. ARMY ENGINEER DISTRICT, BUFFALO



SECTION C-C

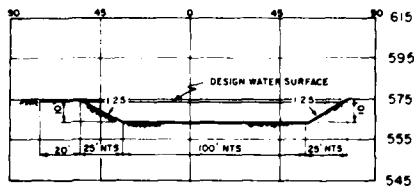

SECTION B-B

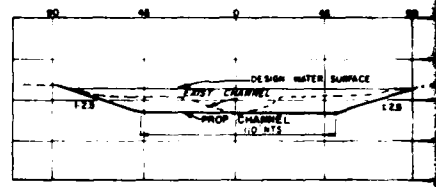

SECTION A-A

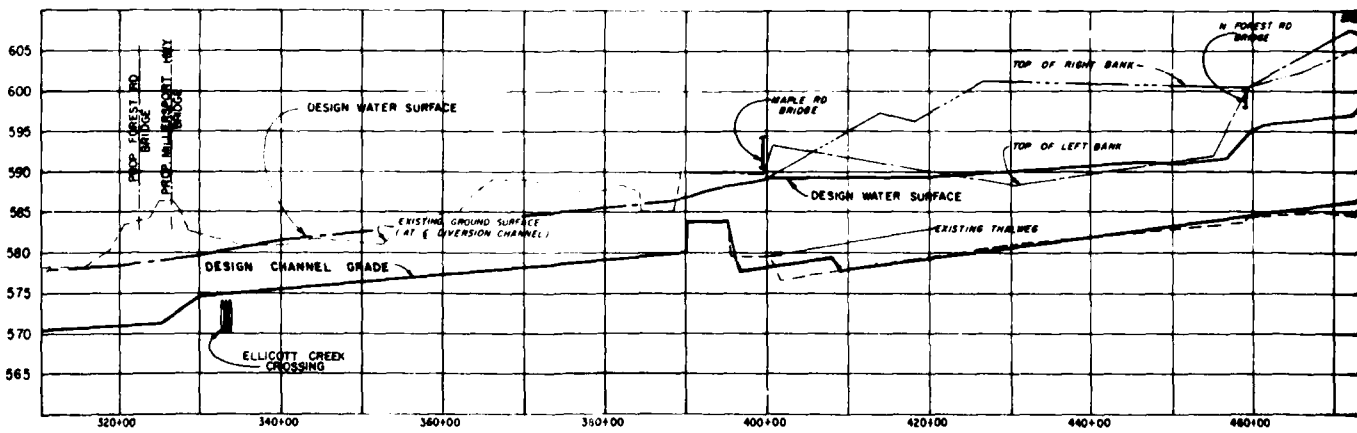
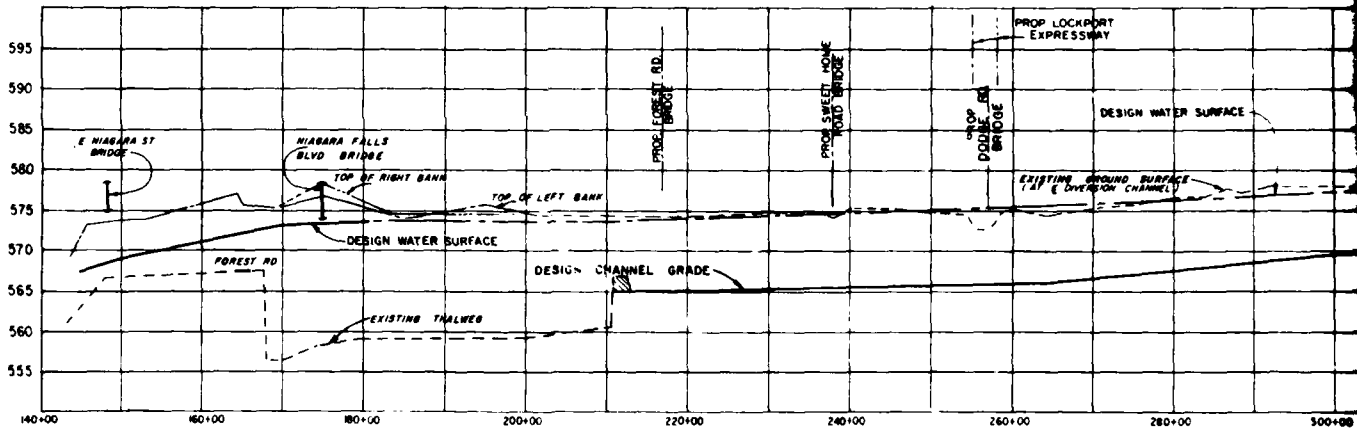

PROFILE

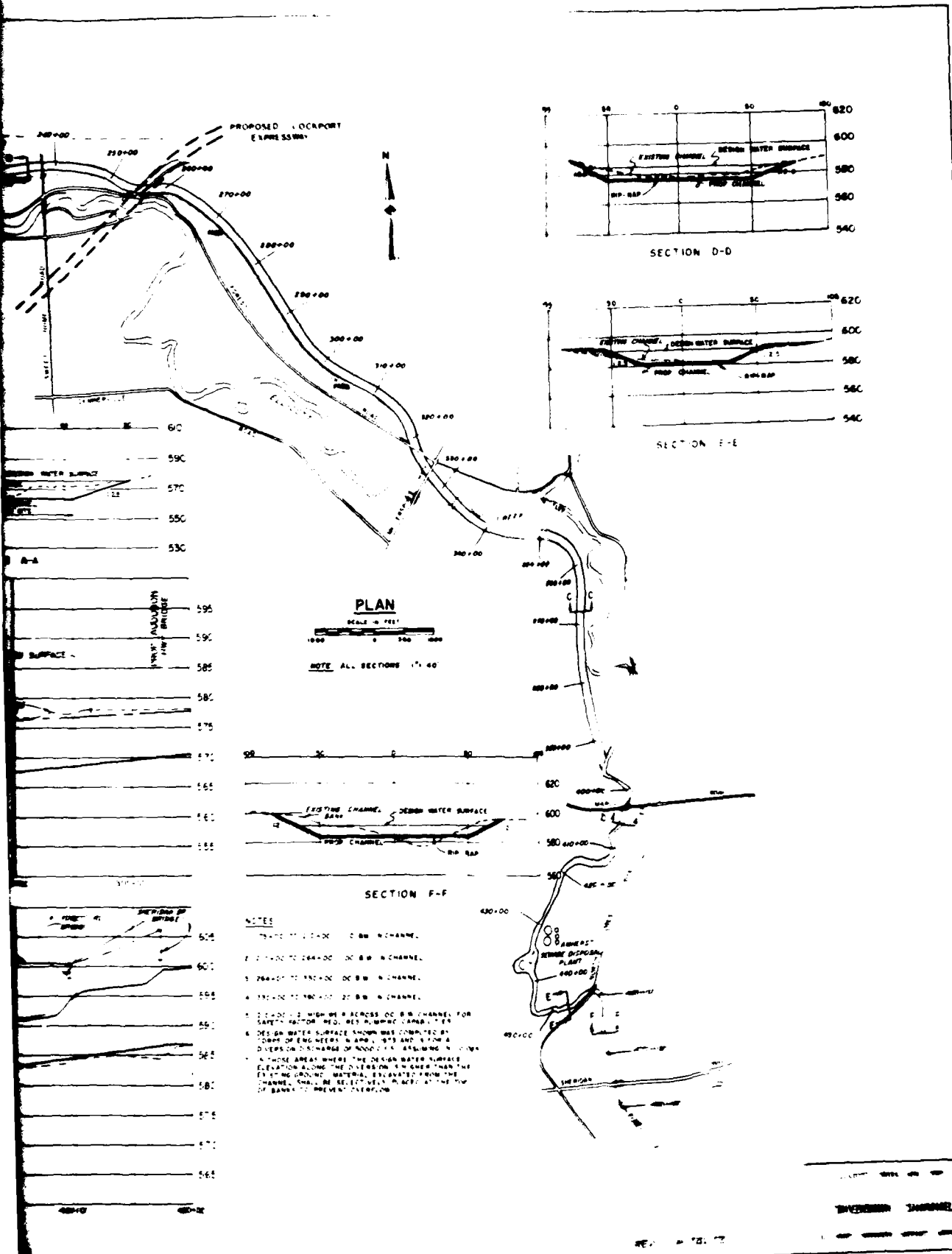

DATE: 10/1/75

DESIGNED BY: [Name]

CHECKED BY: [Name]

SCALE: 1" = 40'

PROJECT: [Name]

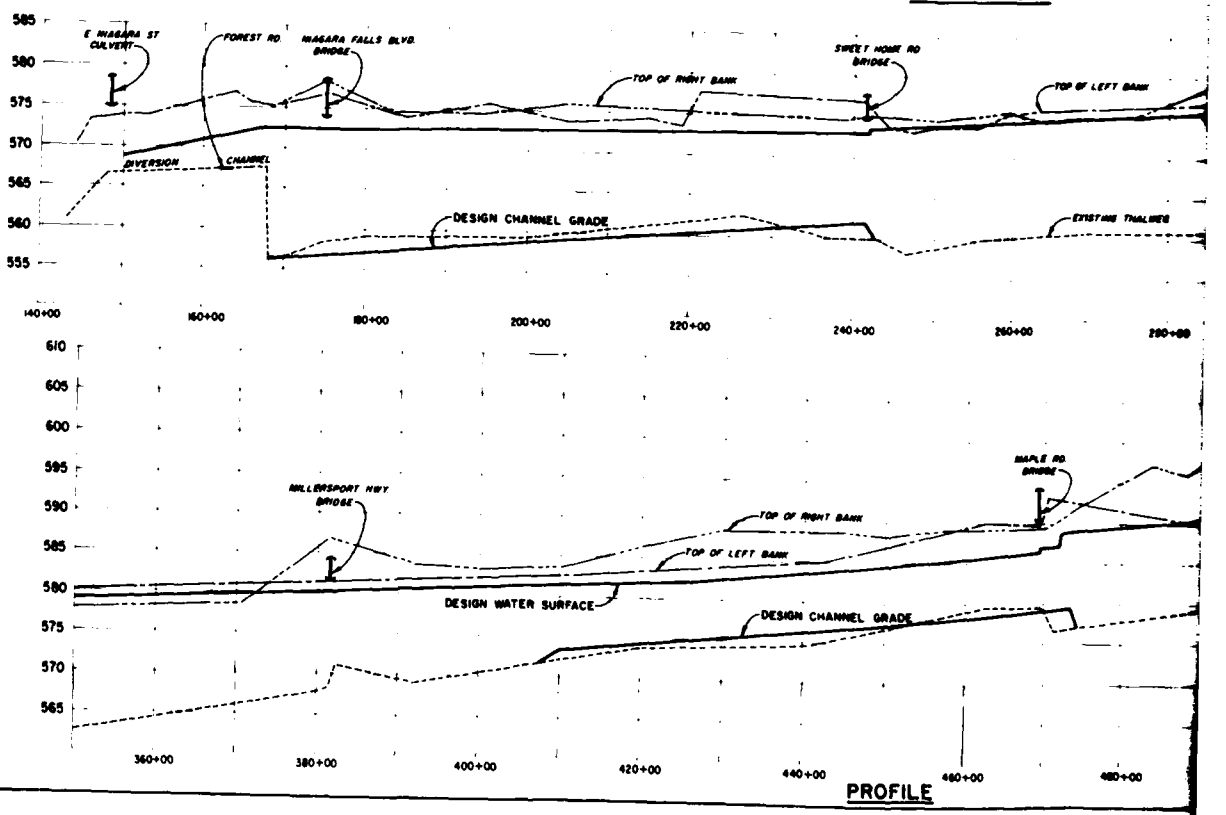
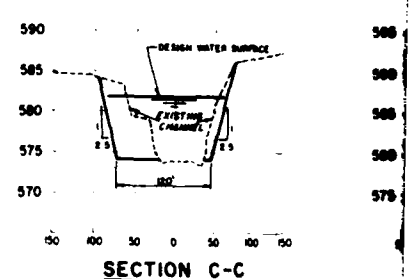
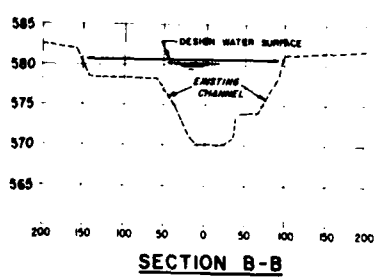
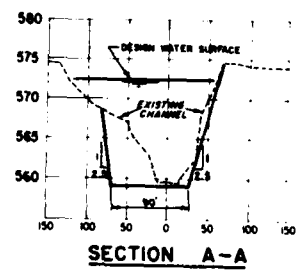
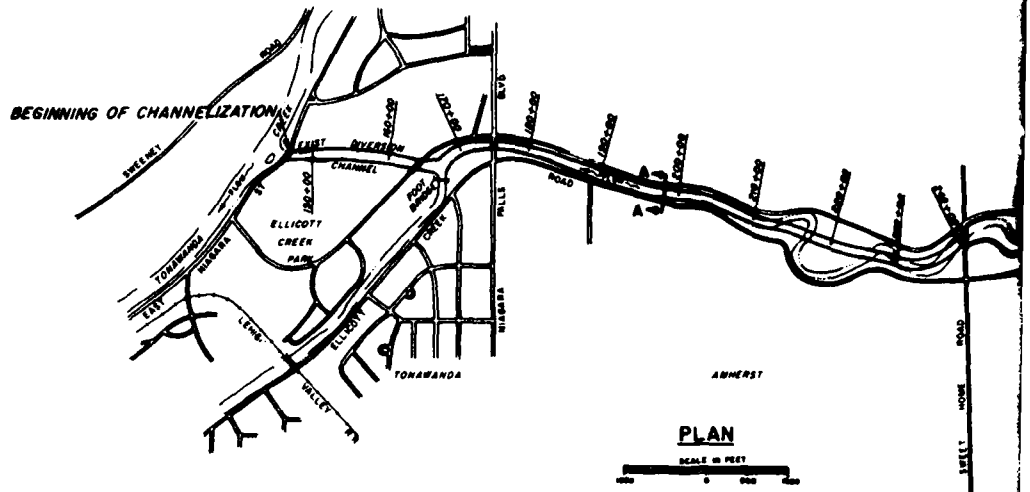

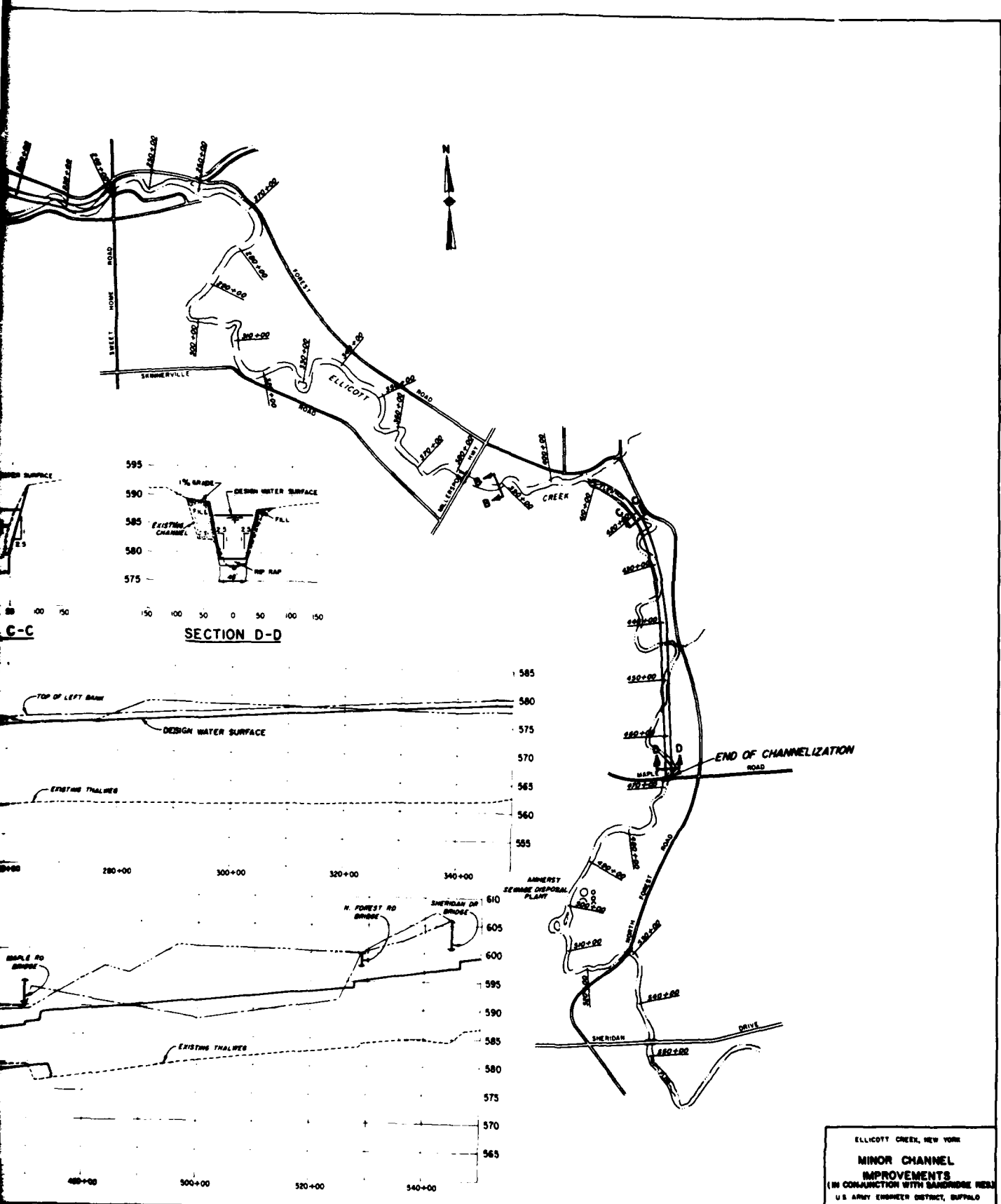

ELICOTT CREEK, NEW YORK
MINOR CHANNEL IMPROVEMENTS
 (IN CONJUNCTION WITH SANDRIDGE RESERVOIR)
 U.S. ARMY ENGINEER DISTRICT, BUFFALO

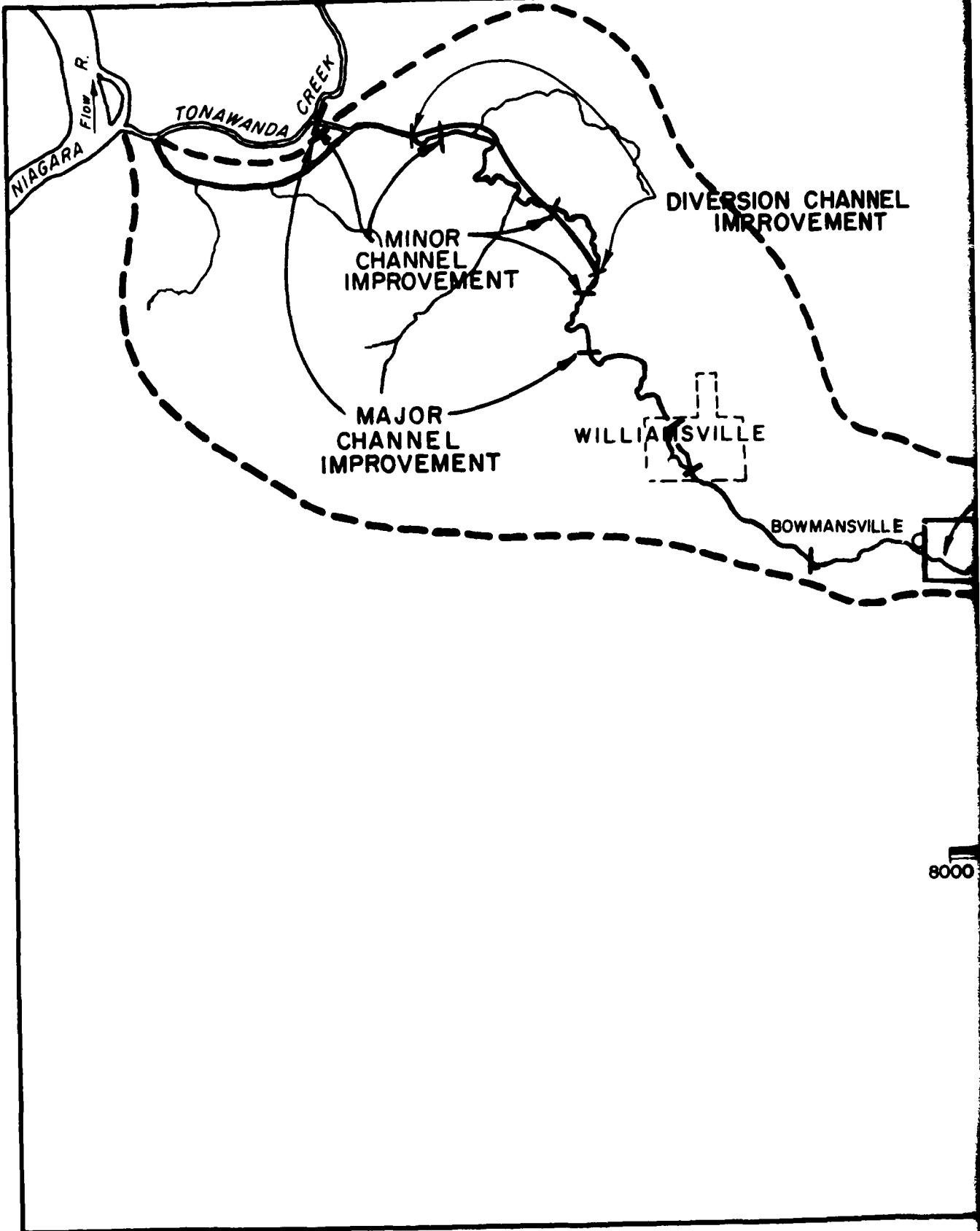

MANUEL
MENT

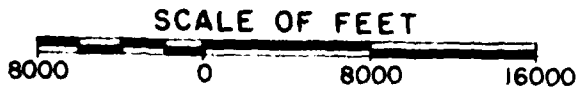
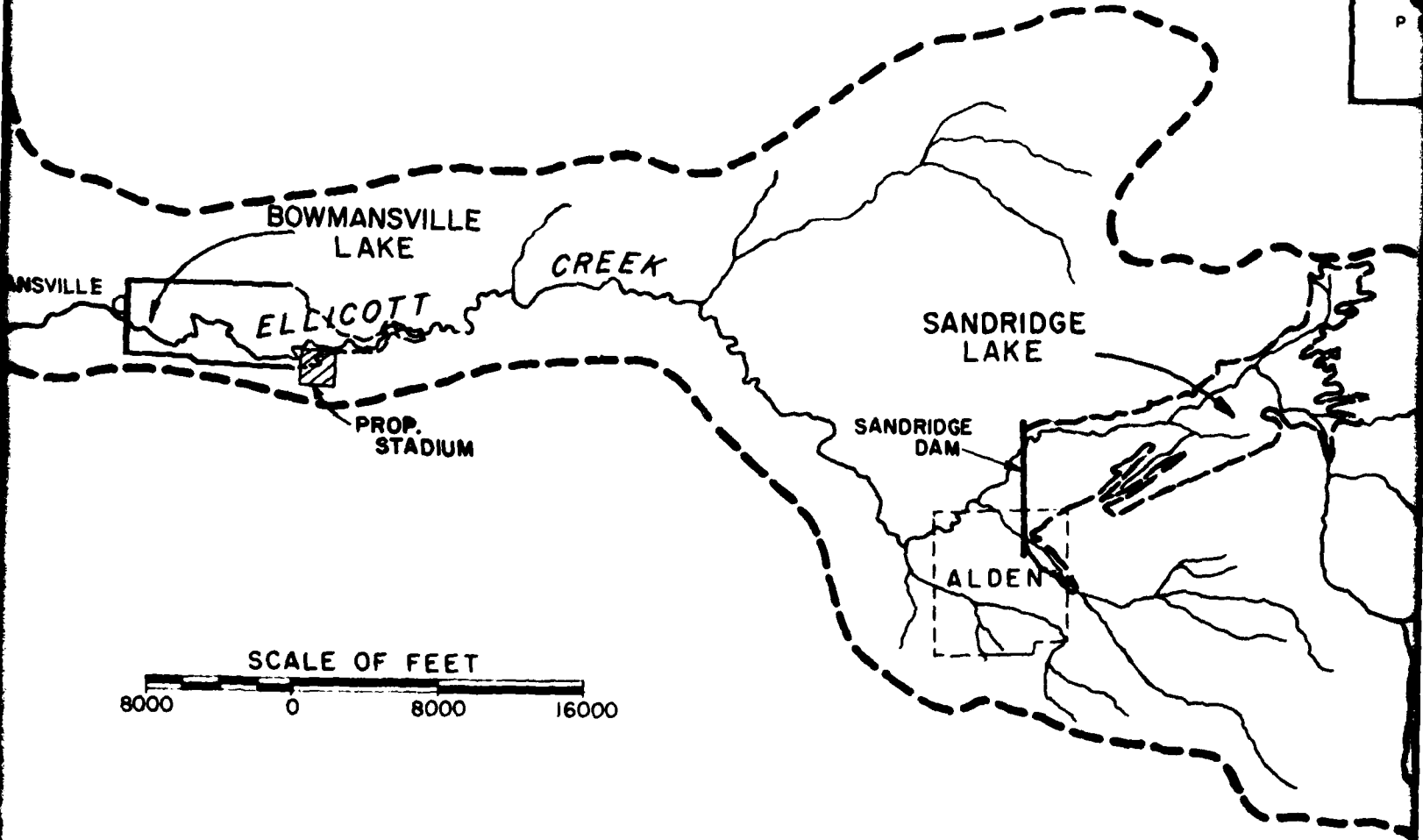

ELLICOTT
CONSIDER
U. S. ARMY

1

2

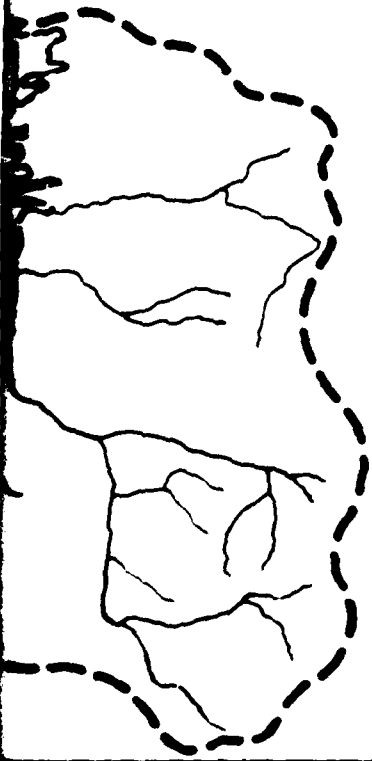
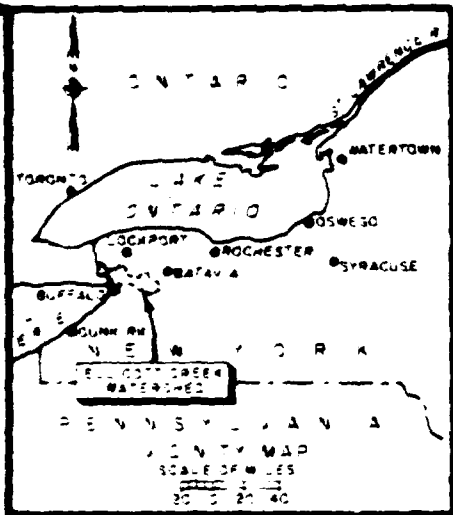

ELLCOTT CREEK, NEW YORK

CONSIDERED IMPROVEMENTS

U.S. ARMY ENGINEER DISTRICT, BUFFALO

PLATE 7

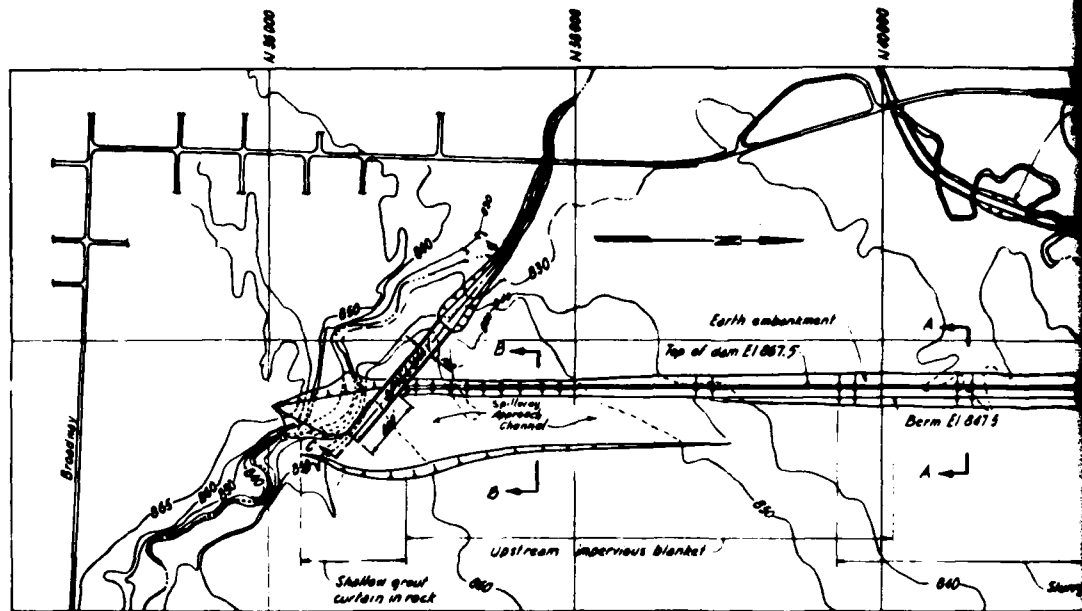

PLAN
Scale 0 400 800 feet

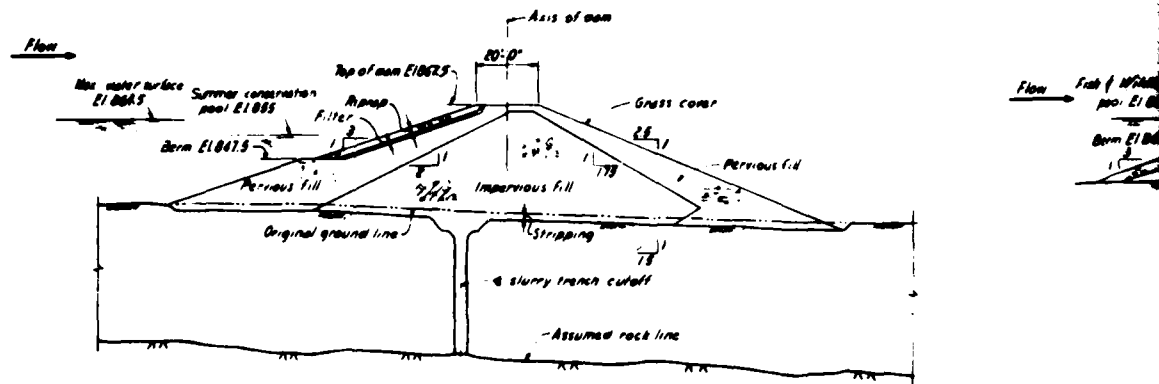

SECTION A-A

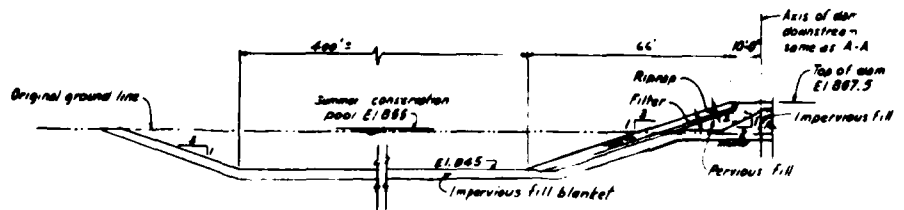

SECTION B-B

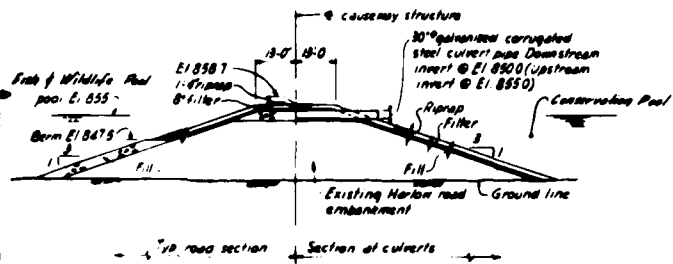
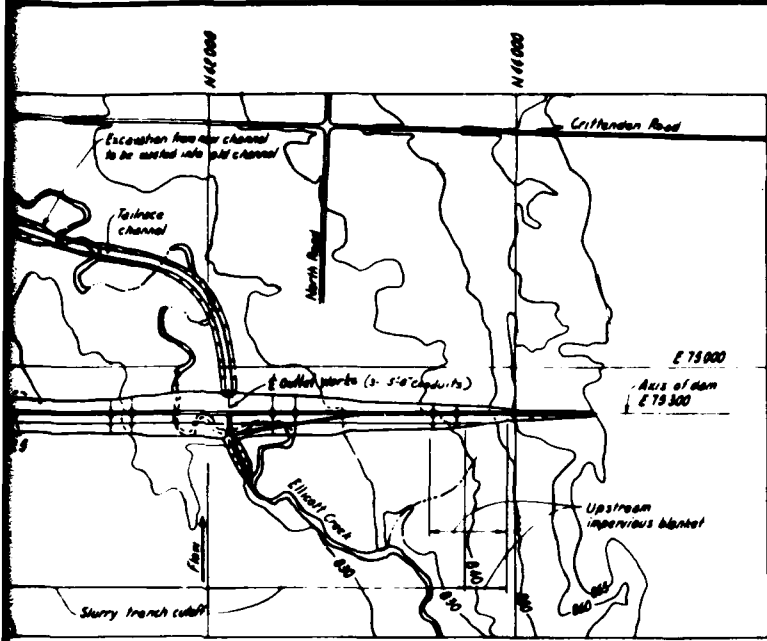

HARLOW ROAD
(Overflow Section)

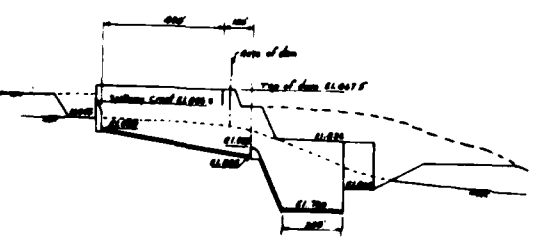

SECTION C-C
1" = 200' HORIZ.
1" = 40' VERT.

Scale 0 20 40 Feet
Except as shown

ELLCOTT CREEK, NEW YORK
**SANDRIDGE DAM PLAN AND SECTION
AND HARLOW ROAD SECTION**
U.S. ARMY ENGINEER DISTRICT, BUFFALO



LEGEND

⑥ DISTANCE FROM MOUTH IN MILES

③ DAMAGE REACH

--- MARCH 1960 FLOOD LINE

— LIMITS OF DAMAGE REACHES

SCALE OF MILES



SCALE OF FEET



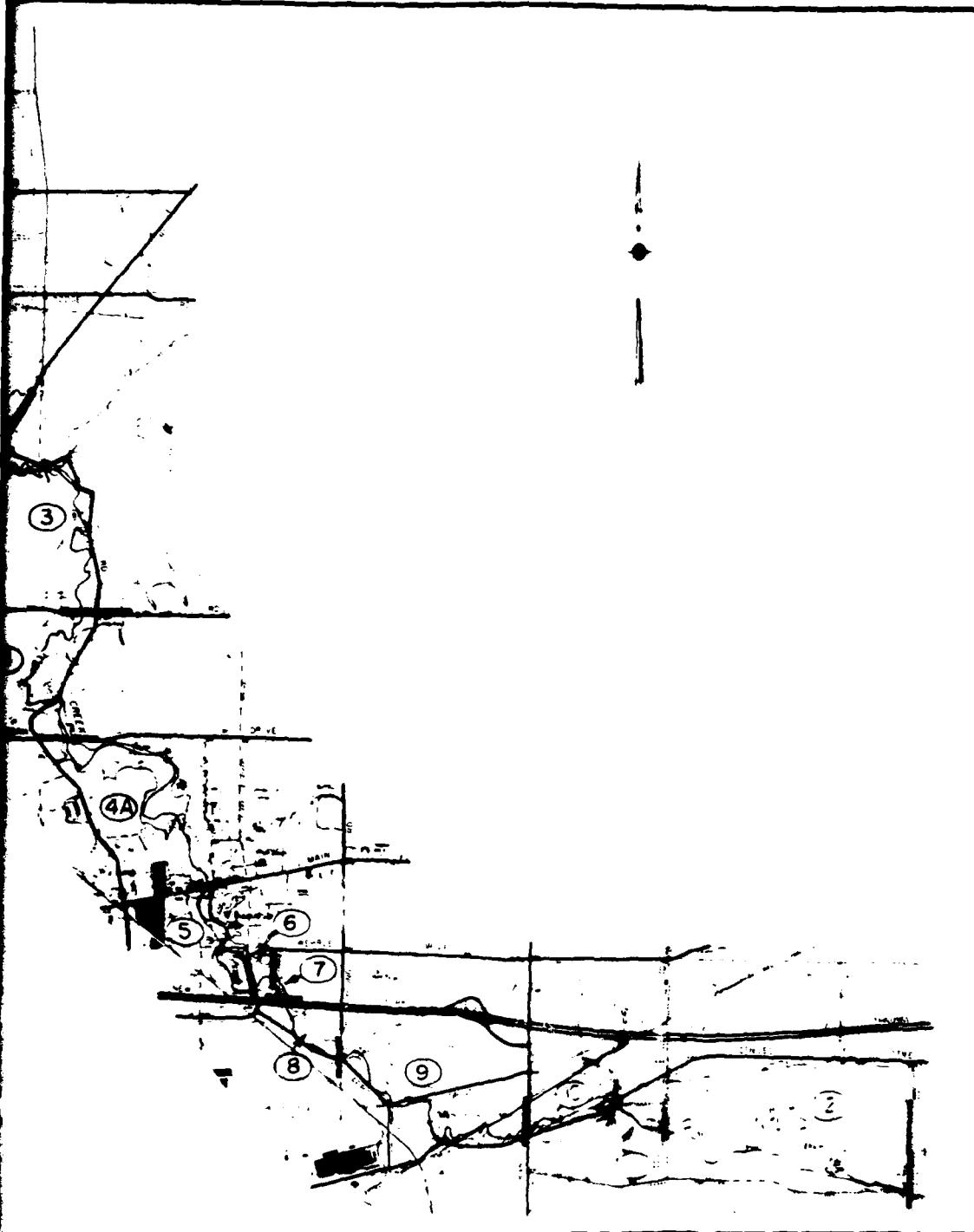

FLOOD DAMAGE AND
DAMAGE REPAIRS
AND
FLOODED AREA MAP
U.S. ARMY ENGINEER DISTRICT BUFFALO
TO ACCOMPANY SURVEY REPORT
DATED 1970

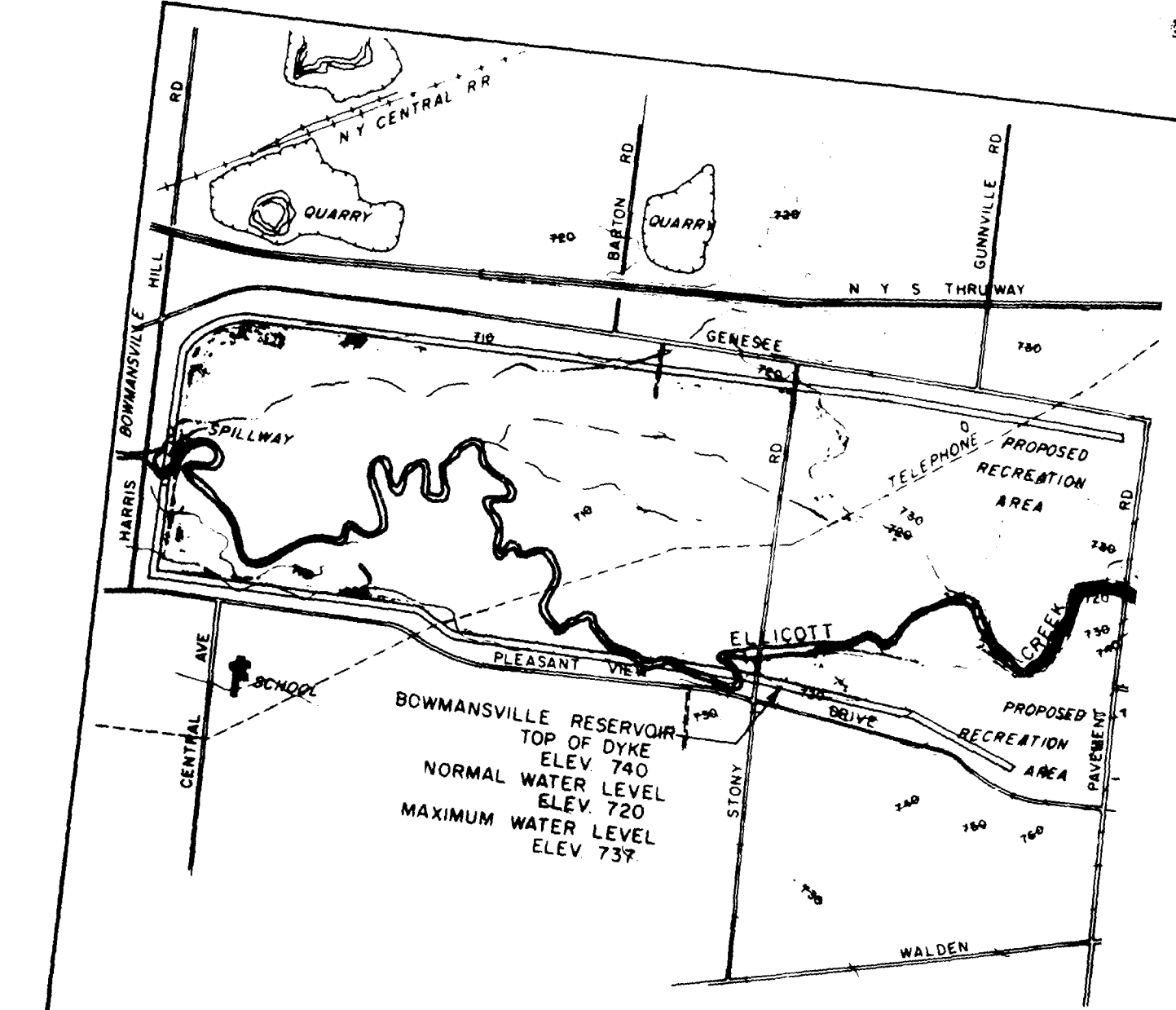

AD-A101 345

CORPS OF ENGINEERS BUFFALO N Y BUFFALO DISTRICT
ELLCOTT CREEK BASIN, NEW YORK. WATER RESOURCES DEVELOPMENT, PH--ETC(U)
AUG 73

F/G 13/2

UNCLASSIFIED

NL

678
124



END

DATE

FILED

8-8-73

DTIC

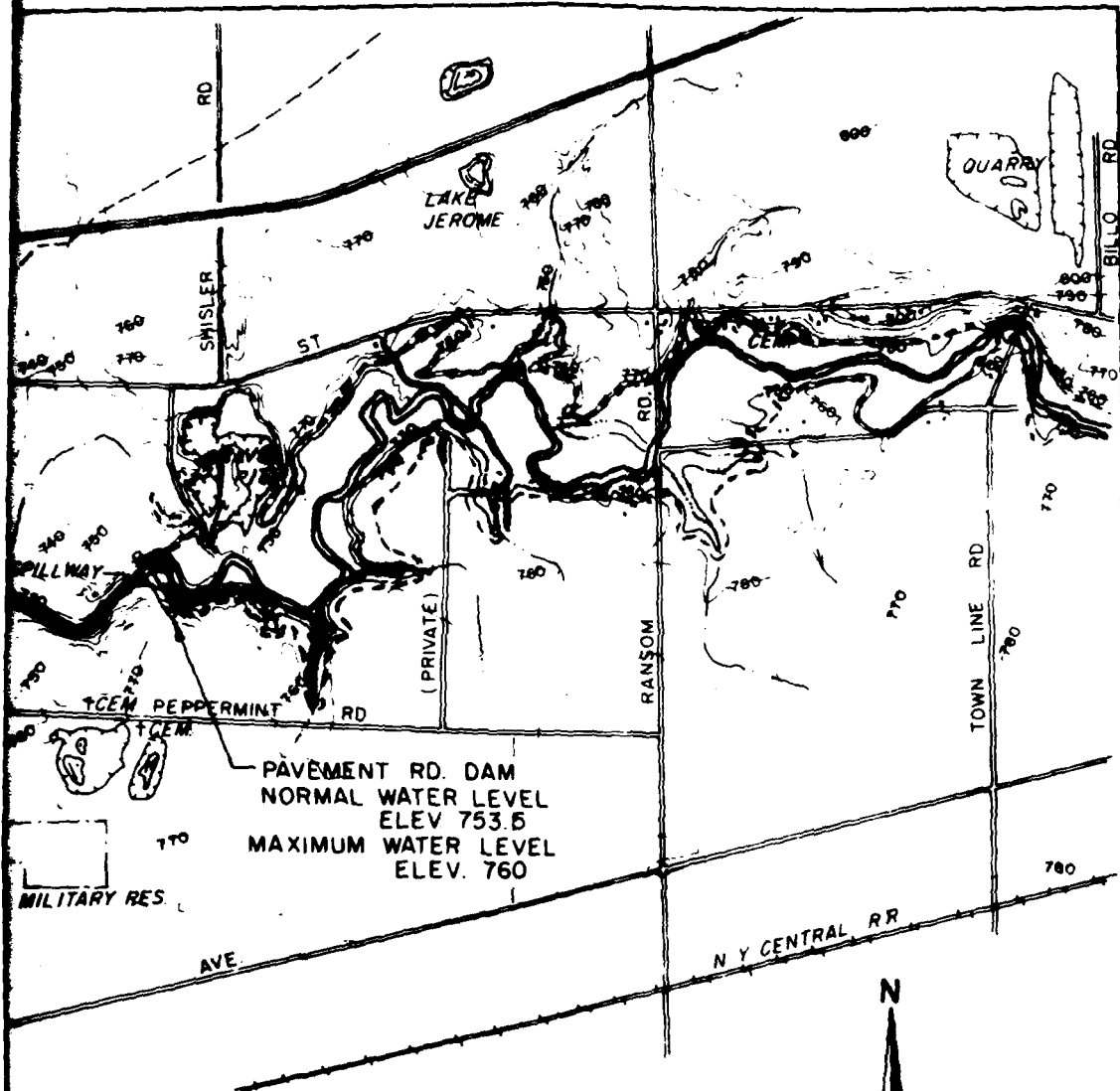

ELLICOTT CREEK, NEW YORK
**BOWMANSVILLE RESERVOIR
 & PAVEMENT ROAD DAM**
 U.S. ARMY ENGINEER DISTRICT, BUFFALO

PLATE 10

1

2

80 F