

AD-A101 252

GANNETT FLEMING CORDRY AND CARPENTER INC HARRISBURG PA F/G 13/13
NATIONAL DAM INSPECTION PROGRAM, DUCK HARBOR POND DAM (NDI ID N--ETC(U)
MAY 81 F FUTCHKO DACW31-81-C-0018

UNCLASSIFIED

NL

for /
AD-A101-252



END
DATE
FILMED
8-81
DTIC

AL 11 11 11 11 11 11

National Dam Inspection Program.
Duck Harbor Pond Dam (NDI ID Number
PA-00144, DER ID Number 64-54), Dela-
ware River Basin, Little Equinunk Creek,
Wayne County, Pennsylvania. Phase I
Inspection Report.

DELAWARE RIVER BASIN
LITTLE EQUINUNK CREEK, WAYNE COUNTY
PENNSYLVANIA

DUCK HARBOR POND DAM

NDI ID No. PA-00144

DER ID No. 64-54

DUCK HARBOR LUMBER AND CHEMICAL CO., INC.

PHASE I INSPECTION REPORT
NATIONAL DAM INSPECTION PROGRAM

Accession For	
NTIS CPA&I	<input checked="" type="checkbox"/>
DTIC TAB	<input type="checkbox"/>
Unannounced	<input type="checkbox"/>
Justification	<i>from 58</i>
By	
Distribution/	
Availability Codes	
Dist	Avail and/or Special
A	

Prepared by
GANNETT FLEMING CORDDRY AND CARPENTER, INC.
Consulting Engineers
P.O. Box 1963
Harrisburg, Pennsylvania 17105

For

DEPARTMENT OF THE ARMY
Baltimore District, Corps of Engineers
Baltimore, Maryland 21203

MAY 1981

PREFACE

This report is prepared under guidance contained in Recommended Guidelines for Safety Inspection of Dams, for Phase I Investigations. Copies of these guidelines may be obtained from the Office of Chief of Engineers, Washington, D.C. 20314. The purpose of a Phase I Investigation is to identify expeditiously those dams which may pose hazards to human life or property. The assessment of the general condition of the dam is based upon available data and visual inspections. Detailed investigations, and analyses involving topographic mapping, subsurface investigations, testing, and detailed computational evaluations are beyond the scope of a Phase I Investigation; however, the investigation is intended to identify any need for such studies.

In reviewing this report, it should be realized that the reported condition of the dam is based on observations of field conditions at the time of inspection along with data available to the inspection team. In cases where the reservoir was lowered or drained prior to inspection, such action, while improving the stability and safety of the dam, removes the normal load on the structure and may obscure certain conditions which might otherwise be detectable if inspected under the normal operating environment of the structure.

It is important to note that the condition of a dam depends on numerous and constantly changing internal and external conditions, and is evolutionary in nature. It would be incorrect to assume that the present condition of the dam will continue to represent the condition of the dam at some point in the future. Only through continued care and inspection can there be any chance that unsafe conditions be detected.

Phase I inspections are not intended to provide detailed hydrologic and hydraulic analyses. In accordance with the established Guidelines, the spillway design flood is based on the estimated "Probable Maximum Flood" for the region (greatest reasonably possible storm runoff), or fractions thereof. The spillway design flood provides a measure of relative spillway capacity and serves as an aid in determining the need for more detailed hydrologic and hydraulic studies, considering the size of the dam, its general condition and the downstream damage potential.

DUCK HARBOR POND DAM
 NDI ID No. PA-00144; DER ID No. 64-54
 PHASE I INSPECTION REPORT
 NATIONAL DAM INSPECTION PROGRAM

CONTENTS

	<u>Description</u>	<u>Page</u>
	Brief Assessment of General Condition and Recommended Action	111
SECTION 1	- Project Information	1
SECTION 2	- Engineering Data	6
SECTION 3	- Visual Inspection	7
SECTION 4	- Operational Procedures	9
SECTION 5	- Hydrology and Hydraulics	10
SECTION 6	- Structural Stability	12
SECTION 7	- Assessment, Recommendations, and Proposed Remedial Measures	14

APPENDICES

<u>Appendix</u>	<u>Title</u>
A	Checklist - Engineering Data.
B	Checklist - Visual Inspection.
C	Photographs.
D	Hydrology and Hydraulics.
E	Plates.
F	Geology.

PHASE I INSPECTION REPORT
NATIONAL DAM INSPECTION PROGRAM

BRIEF ASSESSMENT OF GENERAL CONDITION

AND

RECOMMENDED ACTION

Name of Dam: Duck Harbor Pond Dam
NDI ID No. PA-00144
DER ID No. 54-54

Size: Intermediate (12.5 feet high;
1,103 acre-feet)

Hazard Classification: Significant

Owner: Duck Harbor Lumber and Chemical Co., Inc.
Mr. Melvin Hill, President
RD 1
Equinunk, PA 18417
Attention: Mr. Joel Hill, Secretary

State Located: Pennsylvania

County Located: Wayne

Stream: Little Equinunk Creek

Date of Inspection: 14 April 1981

Based on the criteria established for these studies, Duck Harbor Pond Dam is judged to be in good condition. The recommended Spillway Design Flood (SDF) for the size and hazard classification of the dam varies between 1/2 of the Probable Maximum Flood (PMF) and the PMF. The selected SDF is the 1/2 PMF. The existing spillway will pass only about 13 percent of the PMF before overtopping of the dam occurs. The spillway capacity is rated as inadequate.

A few deficiencies were observed, all of which are considered to be minor. Maintenance of the dam is good.

The following remedial measures, listed in approximate order of priority, are recommended to be undertaken by the Owner without delay:

(1) As part of the regular maintenance program, remove trees growing along the toe of the dam and replace the missing stones at the top of the dam.

(2) Expand the regular inspection program to include monitoring of seepage and concrete spalling. Take appropriate action if conditions worsen.

In addition, the Owner should institute the following operational and maintenance procedures:

(1) Develop a detailed emergency operation and warning system for Duck Harbor Pond Dam. When warnings of a major storm are given by the National Weather Service, the Owner should activate the emergency operation and warning system.

(2) During periods of unusually heavy rains, provide round-the-clock surveillance of the dam.

(3) As presently required by the Commonwealth, initiate a program of formal annual inspections by a professional engineer experienced in the design and construction of dams. Utilize the inspection results to determine if remedial measures are necessary.

DUCK HARBOR POND DAM

Submitted by:

GANNETT FLEMING CORDDRY
AND CARPENTER, INC.

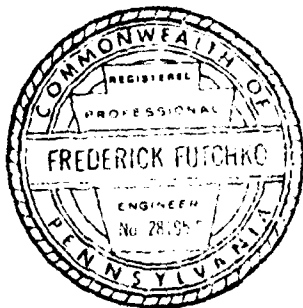

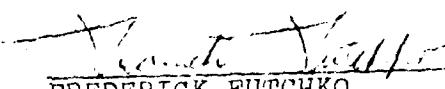

FREDERICK FUTCHKO
Project Manager, Dam Section

Date: 18 June 1981

Approved by:

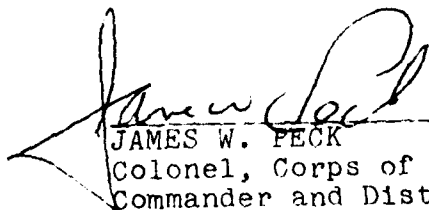
DEPARTMENT OF THE ARMY
BALTIMORE DISTRICT, CORPS OF
ENGINEERS

JAMES W. PECK
Colonel, Corps of Engineers
Commander and District Engineer

Date: 24 JUNE 1981

DUCK HARBOR POND DAM



Overview

DUCK HARBOR POND DAM
NDI ID No. PA-00144; DER ID No. 64-54
PHASE I INSPECTION REPORT
NATIONAL DAM INSPECTION PROGRAM

SECTION 1
PROJECT INFORMATION

1.1 General.

a. Authority. The Dam Inspection Act, Public Law 92-367, authorized the Secretary of the Army, through the Corps of Engineers, to initiate a program of inspection of dams throughout the United States.

b. Purpose. The purpose of the inspection is to determine if the dam constitutes a hazard to human life or property.

1.2 Description of Project.

a. Dam and Appurtenances. Duck Harbor Pond Dam is a dry masonry dam with a concrete cutoff wall along the upstream face. The dam is 155 feet long and 12.5 feet high.

The main spillway is a concrete paved section located near the center of the dam. The weir crest is 11.4 feet long and 1.8 feet below the top of the dam. A dry masonry ramp that is paved with concrete extends downstream from the dam at the main spillway. This structure acts as a spillway chute. The remainder of the top of the dam is dry stone masonry about 15 feet wide and acts as an auxiliary spillway. The elevation along the auxiliary spillway is variable. The outlet works consists of a 4-foot wide by 6.2-foot high rectangular opening just to the right of the main spillway. At the upstream end of the opening, concrete anchors two vertical timber posts to the upstream concrete facing. The posts are set with a 2.0-foot clear opening. Stoplogs are placed across this opening. The top elevation of the stoplogs, which can be varied, controls pool elevation.

The various features of the dam are shown on the photographs in Appendix C and on the plates in Appendix E. A description of the geology is included in Appendix F.

b. Location. Duck Harbor Pond Dam is located on Little Equinunk Creek in Damascus Township, Wayne County, Pennsylvania. The dam is shown on USGS Quadrangle, Long Eddy, Pennsylvania-New York, at latitude N 41° 45.2' and longitude W 75° 12.0'. The upstream end of the reservoir is shown on USGS Quadrangle, Galilee, Pennsylvania. The dam is 2.0 miles southwest of Lookout, Pennsylvania. A location map is shown on Plate E-1.

c. Size Classification. Intermediate (12.5 feet high, 1,103 acre-feet).

d. Hazard Classification. Downstream conditions indicate that a significant hazard classification is warranted for Duck Harbor Pond Dam (Paragraphs 3.1e and 5.1c(5)).

e. Ownership. Duck Harbor Lumber and Chemical Co., Inc., Mr. Melvin Hill, President, RD 1, Equinunk, PA 18417, Attention: Mr. Joel Hill, Secretary.

f. Purpose of Dam. Recreation and water supply for sawmill.

g. Design and Construction History. Duck Harbor Pond Dam was originally constructed circa 1905 to 1907 to replace a dam that had been breached. The remains of the breached dam are about 200 feet downstream from the existing structure. The Owner, whose family has always owned the dam, recounted stories of the dam being built by hand-labor, using oxen to move the massive dry stone masonry. The Commonwealth first made note of the dam in 1917, when they prepared a brief report on it. No recommendations were forthcoming from that report. Subsequently, the dam was inspected periodically by the Commonwealth. The structure had deteriorated quite severely by 1948, when the Commonwealth ordered repairs to be made. The Owner complied. Another inspection by the Commonwealth in 1965 indicated that further maintenance was required. The Owner again complied with the orders of the Commonwealth.

The Owner stated that, within the last 5 years, the upstream concrete face had been replaced. He described the face as having been placed in a trench that was at least 5 feet deep. He also stated that the outlet works was completely rebuilt in October 1979. Judging by the photographs in the PennDER files, the ramp downstream from the main spillway was built sometime between 1965 and the present.

h. Normal Operational Procedure. The reservoir pool is maintained at the main spillway crest level with excess inflows discharging over the spillway. Although the downstream mill has not been used for a number of years, the outlet works is capable of being operated to supply water to the downstream mill dam. During the fall and winter months, the pool is maintained about 3 feet below main spillway crest.

1.3 Pertinent Data.

a.	<u>Drainage Area.</u> (square miles)	3.5
b.	<u>Discharge at Damsite.</u> (cfs)	
	Maximum known flood	Unknown
	Outlet works at maximum pool elevation	160
	Spillway capacity at maximum pool elevation	
	Main	85
	Auxiliary	102
	Total	187
c.	<u>Elevation.</u> (feet above msl.)	
	Top of dam	1393.8
	Maximum pool	1393.8
	Normal pool (main spillway crest)	1392.0
	Auxiliary spillway crest	Varies
	Upstream invert outlet works	Unknown
	Downstream invert outlet works	1381.3
	Streambed at toe of dam	1381.3
d.	<u>Reservoir Length.</u> (miles)	
	Normal pool	1.21
	Maximum pool	1.22
e.	<u>Storage.</u> (acre-feet)	
	Normal pool	728
	Maximum pool	1,103
f.	<u>Reservoir Surface.</u>	
	Normal pool	204
	Maximum pool	214

g.	<u>Dam.</u>	
	<u>Type</u>	Dry stone masonry.
	<u>Length (feet)</u>	155, including spillways.
	<u>Height (feet)</u>	12.5
	<u>Top Width (feet)</u>	Approx. 15
	<u>Side Slopes</u>	
	Upstream	3V on 1H
	Downstream	Vertical
	<u>Zoning</u>	None
	<u>Cutoff</u>	Concrete wall on upstream face of dam.
	<u>Grout Curtain</u>	None
h.	<u>Diversion and Regulating Tunnel</u>	None
i.	<u>Spillway.</u>	
	<u>Main</u>	
	<u>Type</u>	Concrete weir
	<u>Length of Weir (feet)</u>	11.4
	<u>Crest Elevation (feet above msl.)</u>	1392.0
	<u>Upstream Channel</u>	Reservoir
	<u>Downstream Channel</u>	Concrete paving across top of dam and down ramp to toe.

1. Spillway. (Cont'd.)

Auxiliary

Type

Broad-crested
stone masonry
weir

Length of Weir (feet)

144

Crest Elevation

Varies, El.
1392.1 to
El. 1394.7

Upstream Channel

Reservoir

Downstream Channel

Natural
Stream

j. Regulating Outlets

Two-foot
wide sluice-
way with
stoplogs
used to
control flow.

SECTION 2
ENGINEERING DATA

2.1 Design.

a. Data Available. There is no design information for Duck Harbor Pond Dam. Verbal descriptions provided by the Owner are in Paragraph 1.2g. No design calculations are available.

b. Design Features. The project is described in Paragraph 1.2a. The various features of the dam are shown on the photographs in Appendix C and on Plate E-2 in Appendix E.

c. Design Considerations. There is insufficient information to assess the design of the dam.

2.2 Construction.

a. Data Available. There is very little information concerning the original construction of the dam and subsequent modifications to it. Verbal descriptions given by the Owner are in Paragraph 1.2g.

b. Construction Considerations. There are insufficient data to assess the construction of the dam.

2.3 Operation. There are no formal records of operation. Records of inspections performed by the Commonwealth are available for the period from 1924 to 1965. A summary of the inspection reports is included in Appendix A. The Owner reported two instances when the dam has been overtopped to a significant depth. These are further discussed in Section 5.

2.4 Evaluation.

a. Availability. Available data were provided by the Bureau of Dams and Waterway Management, Department of Environmental Resources, Commonwealth of Pennsylvania (PennDER). The Owner was available for information during the visual inspection.

b. Adequacy. The type and amount of available design and other engineering data are very limited. The assessment of the dam is based on the combination of available data, visual inspection, performance history, hydrologic and hydraulic assumptions, and calculations developed for this report.

c. Validity. There is no reason to question the validity of the available data.

SECTION 3

VISUAL INSPECTION

3.1 Findings.

a. General. The overall appearance of the dam and appurtenant structures is good. Noteworthy observations are described in the following paragraphs. The complete visual inspection checklist and sketch of the dam are presented in Appendix B. A profile of the top of the dam is included in Appendix B. Datum for the survey performed for this inspection was at the main spillway crest, Elevation 1392.0, as shown on USGS mapping. On the day of the inspection, the reservoir pool was 0.6 foot below the level of the main spillway crest.

b. Dry Stone Masonry Structure. This structure is in good condition. To the right of the spillway along the downstream edge, a few stones have been displaced. The top of the dam is covered with a thin layer of soil. At one area, this soil has washed through the dry masonry, leaving a depression on the top (Photograph F). Mature trees are growing along the downstream toe of the dry masonry. Clear seepage, estimated at 60 gpm, was flowing from beneath the stones to the left of the spillway ramp (Photograph B).

The concrete facing on the upstream side of the dry masonry is in good condition. A few shrinkage cracks were observed.

c. Appurtenant Structures. The main spillway, which is essentially a concrete paved section across the top of the dam, is in good condition. The concrete is slightly spalled at a few locations (Photograph D).

For the purposes of this report, the auxiliary spillway is considered to be the top of the dry masonry dam exclusive of the main spillway. This is discussed further in Section 5.

The outlet works is in excellent condition (Photograph E). It was noted that some of the outlet works discharge passing over the top outlet works stoplog was flowing into the dry masonry.

d. Reservoir Area. The watershed is mostly wooded with only minor rural development. Less than 10 percent is farm fields. There is one small dam in the watershed. It is less than 3 feet high and impounds negligible storage. The Pennsylvania Fish Commission maintains a public boat launching ramp along the shore of Duck Harbor Pond.

e. Downstream Conditions. As noted in Section 1, there is a breached dam immediately downstream from Duck Harbor Pond Dam. The stream extends from the breached dam for about 300 feet to a public road. Just downstream from the road, on the left bank of the stream, are two small mobile homes (trailers) about 5 feet above streambed. The mobile homes were of such size that they did not appear to be permanent residences. About 0.4 mile downstream of these mobile homes is a mill dam. The reservoir is completely silted in. The mill is the property of the Duck Harbor Lumber and Chemical Co. The Owner stated that it is a historic landmark because it contains the first Francis Turbine used in Pennsylvania. Although the mill is functionally operational, it is not used at present.

About 0.4 mile downstream of the mill, the stream flows under PA Route 191 and then generally parallels the road for 2.3 miles. The only building along this reach that is close to the stream is an abandoned schoolhouse. Along this reach, the stream also passes under a few rural roads. It was judged that, if the dam were to fail, probably only a few, if any, lives would be lost. Accordingly, a significant hazard classification has been assigned to Duck Harbor Pond Dam.

SECTION 4

OPERATIONAL PROCEDURES

4.1 Procedure. The reservoir is normally maintained at the level of the spillway crest with excess inflows discharging over the spillway and into the downstream channel. The pool is maintained about 3 feet below spillway crest during the fall and winter months.

4.2 Maintenance of Dam. There are no established procedures for maintenance of the dam. Maintenance work has generally been performed on an unscheduled basis. Although the dam is checked daily by the Owner, no formal reports are maintained.

4.3 Maintenance of Operating Facilities. There is no established procedure for maintenance of the outlet works facilities.

4.4 Warning Systems in Effect. There is no emergency operation and warning system for the dam.

4.5 Evaluation of Operational Adequacy. Although the maintenance procedures are informal, the maintenance of the dam is generally good. The minor maintenance deficiencies noted in Section 3 are believed to be caused by unfamiliarity with dam maintenance requirements rather than with poor maintenance scheduling. The daily inspection program is good, but formal annual inspections by an experienced engineer are necessary to detect hazardous conditions before they might threaten the dam. An emergency operation and warning system is necessary to reduce the risk of dam failure should adverse conditions develop and to prevent loss of life should the dam fail.

SECTION 5

HYDROLOGY AND HYDRAULICS

5.1 Evaluation of Features.

a. Design Data. There are no hydrologic or hydraulic design calculations available for Duck Harbor Pond Dam. According to a report prepared by the Commonwealth in 1917, the main spillway capacity was estimated at 50 cubic feet per second (cfs).

b. Experience Data. The Owner reported that the dam was overtopped by about 5 feet during the flood of May 1942 and during Tropical Storm Diane in 1955. The Owner stated that these depths of overtopping were his visual estimates and that high water elevations for these storms were not obtained. No damage was reported from these overtoppings.

c. Visual Observations.

(1) General. The visual inspection of Duck Harbor Pond Dam, which is described in Section 3, resulted in a number of observations relevant to hydrology and hydraulics.

(2) Dry Stone Masonry Structures. The entire top of dam appears capable of acting as an auxiliary spillway. The top of dam elevation was selected, based on the profile shown in Appendix B, as the elevation where the left abutment started to overtop (Elevation 1393.8). The top of the dam at the right abutment is Elevation 1394.7.

(3) Appurtenant Structures. No deficiencies relevant to hydrology or hydraulics were observed at the main spillway or outlet works.

(4) Reservoir Area. The one small dam in the watershed would have no effect on the hydrology at Duck Harbor Pond Dam. No conditions were observed in the reservoir area or watershed that might present a hazard to Duck Harbor Pond Dam.

(5) Downstream Conditions. If the dam were to fail, two small mobile homes and a sawmill that is presently not in use would be flooded. The mill dam is almost completely silted, and its possible failure during a failure of Duck Harbor Pond Dam would not increase the hazards downstream. Moreover, PA Route 191 would be flooded for a significantly long time. Downstream conditions indicate that a significant hazard classification is warranted for Duck Harbor Pond Dam. The two mobile homes are sufficiently close to the stream that they would be flooded before the full spillway capacity of Duck Harbor Pond Dam was being discharged.

d. Overtopping Potential.

(1) Spillway Design Flood. According to the criteria established by the Office of the Chief of Engineers (OCE), the Spillway Design Flood (SDF) for the size (intermediate) and hazard potential (significant) of Duck Harbor Pond Dam is between one-half of the Probable Maximum Flood (PMF) and the PMF. Since the dam and reservoir are on the low end of the intermediate size category, the 1/2 PMF was selected as the SDF for Duck Harbor Pond Dam. The watershed and reservoir were modeled with the U.S. Army Corps of Engineers' HEC-1DB computer program. A description of this computer program is included in Appendix D. The assessment of the hydrology and hydraulics is based on existing conditions, and the effects of future development are not considered.

(2) Summary of Results. Pertinent results are tabulated at the end of Appendix D. The analysis reveals that Duck Harbor Pond Dam can pass about 13 percent of the PMF before overtopping of the dam occurs.

(3) Spillway Adequacy. The criteria used to evaluate the spillway adequacy of a dam are described in Appendix D. Since the dam cannot pass the 1/2 PMF, which is the SDF, the spillway capacity is rated as inadequate.

SECTION 6
STRUCTURAL STABILITY

6.1 Evaluation of Structural Stability.

a. Visual Observations.

(1) General. The visual inspection of Duck Harbor Pond Dam, which is described in Section 3, resulted in a number of observations relevant to structural stability. These observations are evaluated herein for the various features.

(2) Dry Stone Masonry Structure. The displaced stones may have been moved by vandals. Their replacement would improve the structural integrity of the dam. The soil that has washed through the top of the dam, thereby causing a depression, is of no concern. The Owner stated that the soil had been placed across the top solely to provide a roadbed for vehicular access. The few shrinkage cracks in the upstream facing are to be expected, since there are no joints in the concrete facing. These cracks are of no concern at present.

The root systems of large trees can grow through a dam and provide seepage paths. Because the upstream concrete facing is relatively new and because dry stone masonry is pervious, the trees at the top of the dam are presently not a hazard. If they are not removed in the near future, the roots could start to affect the upstream concrete wall.

Although the quantity of seepage to the left of the spillway ramp is significant, it is not concentrated. It appeared that much, if not all, of this seepage could have been the outlet works discharge flowing through the dry stone masonry walls of the outlet works tunnel. If this was the source of all the seepage, then the seepage would not be of any concern.

(3) Appurtenant Structures. The minor spalling along the main spillway walls is of no concern at present. No other deficiencies were observed at the outlet works or main spillway.

b. Design and Construction Data. No stability calculations for the dam are available. For this study the stability of the structure was analyzed with the pool at 1/2 PMF level. Full uplift was considered. For this condition, the resultant was determined to be within the middle third. The factor of safety against sliding was

determined to be adequate. The toe pressure was computed to be relatively small. Since foundation conditions are unknown, it is not possible to assess if the toe pressure is adequate. However, based on the age and history of the dam, toe pressures do not appear to be of concern. For this analysis, it was assumed that no scour from water flowing over the dam occurred at the toe of the dry masonry.

c. Operating Records. There are no operating records maintained for Duck Harbor Pond Dam and Reservoir. The operating procedures followed by the Owner do not indicate cause for concern relative to the structural integrity of the dam. There is no record of any stability problems at the dam.

d. Post-construction Changes. The modifications listed previously are maintenance repairs and do not adversely affect the structural stability of the dam.

e. Seismic Stability. Duck Harbor Pond Dam is located in Seismic Zone 1 where earthquake loadings are not considered to be significant for low dams with no readily apparent stability problems. Since no readily apparent stability problems were observed, the seismic stability of the dam is considered to be adequate.

SECTION 7
ASSESSMENT, RECOMMENDATIONS, AND
PROPOSED REMEDIAL MEASURES

7.1 Dam Assessment.

a. Safety.

(1) Based on criteria established for these studies, Duck Harbor Pond Dam is judged to be in good condition. The recommended Spillway Design Flood (SDF) for the size and hazard classification of the dam varies between the 1/2 PMF and the PMF. The selected SDF is the 1/2 PMF. The existing spillway will pass about 13 percent of the PMF before overtopping of the dam occurs. The spillway capacity is rated as inadequate.

(2) Several deficiencies were observed, all of which are considered to be minor.

(3) A summary of the features and observed deficiencies is as follows:

<u>Feature</u>	<u>Observed Deficiency</u>
Dry Stone Masonry Structure	A few stones missing from top; trees at toe, seepage.
Spillway	Minor spalling.

b. Adequacy of Information. The information available is such that an assessment of the condition of the dam can be inferred from the combination of available data, visual inspection, past performance, and computations performed as part of this study.

c. Urgency. The recommendations in Paragraph 7.2 should be implemented without delay.

d. Necessity for Further Investigations. Further investigations by the Owner will not be required to accomplish the remedial measures outlined in Paragraph 7.2.

7.2 Recommendations and Remedial Measures.

a. The following remedial measures, listed in approximate order of priority, are recommended to be undertaken by the Owner without delay:

(1) As part of the regular maintenance program, remove trees growing along the toe of the dam and replace the missing stones at the top of the dam.

(2) Expand the regular inspection program to include monitoring of concrete spalling and seepage. Take appropriate action if conditions worsen.

b. In addition, the Owner should institute the following operational and maintenance procedures:

(1) Develop a detailed emergency operation and warning system for Duck Harbor Pond Dam. When warnings of a major storm are given by the National Weather Service, the Owner should activate the emergency operation and warning system.

(2) During periods of unusually heavy rains, provide round-the-clock surveillance of the dam.

(3) As presently required by the Commonwealth, initiate a program of formal annual inspections by a professional engineer experienced in the design and construction of dams. Utilize the inspection results to determine if remedial measures are necessary.

APPENDIX A

CHECKLIST - ENGINEERING DATA

CHECKLIST

NAME OF DAM: Duck Harbor Dam

ENGINEERING DATA

NDI ID NO.: PA-00144 DER ID NO.: 64-54

DESIGN, CONSTRUCTION, AND OPERATION
PHASE I

Sheet 1 of 4

ITEM	REMARKS
AS-BUILT DRAWINGS	None in Records See Plans F-2.
REGIONAL VICINITY MAP	See Plan F-1
CONSTRUCTION HISTORY	Built circa 1950 to 1951
TYPICAL SECTIONS OF DAM	See Plans A & B None in Records.
OUTLETS: Plan Details Constraints Discharge Ratings	None

ENGINEERING DATA

ITEM	REMARKS
RAINFALL/RESERVOIR RECORDS	None
DESIGN REPORTS	None
GEOLOGY REPORTS	None
DESIGN COMPUTATIONS: Hydrology and Hydraulics Dam Stability Seepage Studies	None
MATERIALS INVESTIGATIONS: Boring Records Laboratory Field	None
POSTCONSTRUCTION SURVEYS OF DAM	None

ENGINEERING DATA

ITEM	REMARKS
BORROW SOURCES	UNKNOWN
MONITORING SYSTEMS	NONE
MODIFICATIONS	None other than Repairs
HIGH POOL RECORDS	Flooding in 1942 & 1965, Cause repaired 5' overtopping (see notes depth)
POSTCONSTRUCTION ENGINEERING STUDIES AND REPORTS	1917 Report by Commonwealth - No Recommendations for Modifications.
PRIOR ACCIDENTS OR FAILURE OF DAM: Description Reports	None

ITEM	REMARKS
<p>MAINTENANCE AND OPERATION RECORDS</p>	<p>No. Inoperative Records</p>
<p>SPELLWAY: Plan Sections Details</p>	<p>None in Records See PLATE E-2</p>
<p>OPERATING EQUIPMENT: Plans Details</p>	<p>None</p>
<p>PREVIOUS INSPECTIONS Dates Deficiencies</p>	<p>1921 (by Owsen) - Annual inspection of concrete. 1924 - Finishings in spillway. Top of dam could have been top of spillway. This is a large size of concrete - may be from spillway. Operating concrete about 1000 ft. long. 1930 - Top of dam is low adjacent to spillway. Dam could have been overtopped. Considerable length to left of spillway. 1933 - Considerable length to left of spillway dam could have overtopped. This is low adjacent to spillway.</p>

ENGINEERING DATA

ITEM	REMARKS
<p>PREVIOUS INSPECTIONS (CONTINUED)</p>	<p>1937 - Logs and debris along crest leakage - "Downstream side where sluiceway submerged. All water flowing through sluiceway." 1941 - Top of dam was settled. "Leakage through sluiceway". Debris along toe. stoplogs at weir</p>
	<p>1948 - Pool very low "right side has just been faced with concrete". New gate control timbers recently placed. Top of dam low. (Repairs ordered).</p>
	<p>1952 - Good condition. 1965 - Top of dam high. Sluiceway crest poor, weathered, and eroded</p>
	<p>"Weathering causing poor water passage through remaining sluiceway in which possible leakage at toe. (Repairs ordered)</p>

APPENDIX B

CHECKLIST - VISUAL INSPECTION

CHECKLIST

VISUAL INSPECTION

PHASE I

Name of Dam: Duck Harbor Pond County: WAYNE State: PENNSYLVANIA
NDI ID No.: PA-00144 DER ID No.: 64-54
Type of Dam: Day Retention Hazard Category: SIGNIFICANT
Date(s) Inspection: 14 April 1981 Weather: Overcast/Light Rain Temperature: _____
Soil - Moist to wet

Pool Elevation at Time of Inspection: 1391.4 msl/Tailwater at Time of Inspection: 1381.3 msl

Inspection Personnel:

J. Hill (Duck Harbor Dam & Chemical)
D. Wolf (GFECC)
D. Everette (GFECC)

A. Whitman (GFECC) Recorder

CONCRETE/MASONRY DAMS

Sheet 1 of 2

VISUAL EXAMINATION OF	OBSERVATIONS	REMARKS OR RECOMMENDATIONS
ANY NOTICEABLE SEEPAGE	60 GPM FLOW BENEATH STONES TO LEFT OF SPILLWAY RAMP	SOURCE MAY BE WATER IN OUTLET WORKS OPENING.
JUNCTION OF STRUCTURE WITH: Abutment Embankment Other Features	No deficiencies	
DRAINS	None	
WATER PASSAGES	4' x 6.2' openings THROUGH DAM CONCRETE JOINTS ON BOTTOM.	No deficiencies
FOUNDATION	(Approved)	

CONCRETE/MASONRY DAMS

Sheet 2 of 2

VISUAL EXAMINATION OF	OBSERVATIONS	REMARKS OR RECOMMENDATIONS
Dry <i>initially</i> CONCRETE SURFACES: Surface Cracks Spalling	None	Top or show could function as an auxiliary spillway.
STRUCTURAL CRACKING	Minor SURFACE CRACKING ON UPSTREAM CONCRETE FACE	
ALIGNMENT: Vertical Horizontal	Horizontal - UPSTREAM SIDE IS INFERIOR DUE TO POOR FORMING ALIGNMENT. VERTICAL - SEE PROFILE	No deficiencies
MONOLITH JOINTS	No VERTICAL JOINTS IN UPSTREAM CONCRETE FACE	
CONSTRUCTION JOINTS	No deficiencies on UPSTREAM CONCRETE FACE.	
STAFF GAGE OR RECORDER	None	

OUTLET WORKS

Sheet 1 of 1

VISUAL EXAMINATION OF	OBSERVATIONS	REMARKS OR RECOMMENDATIONS
CRACKING AND SPALLING OF CONCRETE SURFACES IN OUTLET CONDUIT	Dry Mixture Opening THROUGH dam. Filling is to be filled with concrete.	Good Condition
INTAKE STRUCTURE	Sluiceway Good Condition	
OUTLET STRUCTURE	None	
OUTLET CHANNEL	Natural Stream	
EMERGENCY GATE	Wooden Structure	

UNGATED SPILLWAY

Sheet 1 of 1

VISUAL EXAMINATION OF	OBSERVATIONS	REMARKS OR RECOMMENDATIONS
CONCRETE WEIR	Good Condition	
APPROACH CHANNEL	Reservoir	
DISCHARGE CHANNEL	Concrete Paved Across top of dam AND down ramp	Minor Spalling Along concrete at top
BRIDGE AND PIERS	None at site	

INSTRUMENTATION

Sheet 1 of 1

VISUAL EXAMINATION OF	OBSERVATIONS	REMARKS OR RECOMMENDATIONS
MONUMENTATION/SURVEYS	NONE	
OBSERVATION WELLS		
WEIRS		
PIEZOMETERS		
OTHER	None	

DOWNSTREAM CHANNEL

Sheet 1 of 1

VISUAL EXAMINATION OF	OBSERVATIONS	REMARKS OR RECOMMENDATIONS
CONDITION: Obstructions Debris Other	Paved About 200' down stream, other creek	
SLOPES	Rain water erosion	
APPROXIMATE NUMBER OF HOMES AND POPULATION	2 small probably some houses	

RESERVOIR AND WATERSHED

Sheet 1 of 1

VISUAL EXAMINATION OF	OBSERVATIONS	REMARKS OR RECOMMENDATIONS
SLOPES	Slopes are	
SEDIMENTATION	No signs of observed problems.	Mud and is still in
WATERSHED DESCRIPTION	90% wooded 10% farmland Minor signs of erosion	

BY DRE DATE 9-21-81
 CHKD BY _____ DATE _____

SUBJECT DUCK HARBOR POND DAM
PROFILE

SHEET NO _____ OF _____
 JOB NO 8596.5A

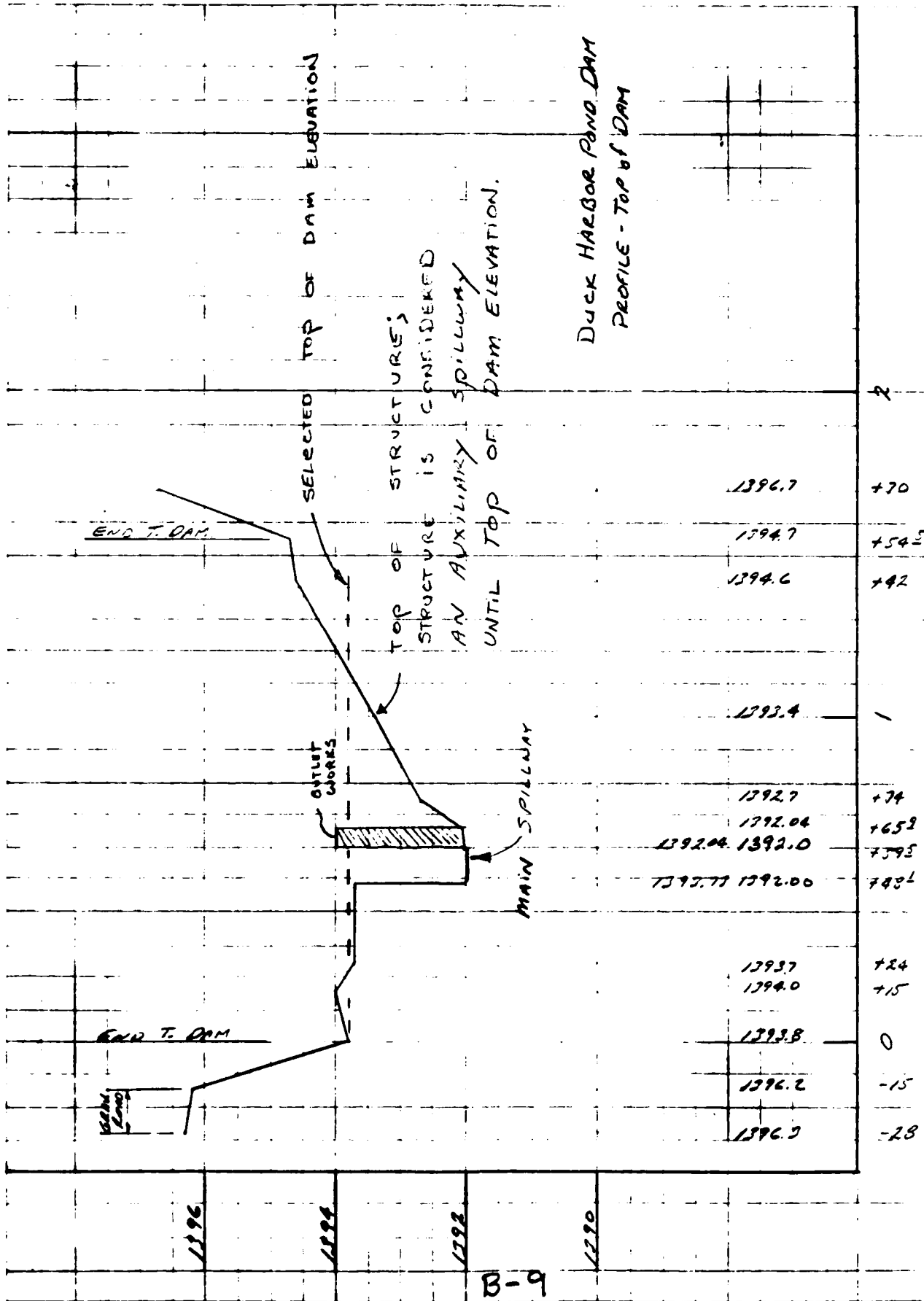

B-9

DATE OF INSPECTION: 14 APRIL 81
POOL ELEVATION: 1391.4

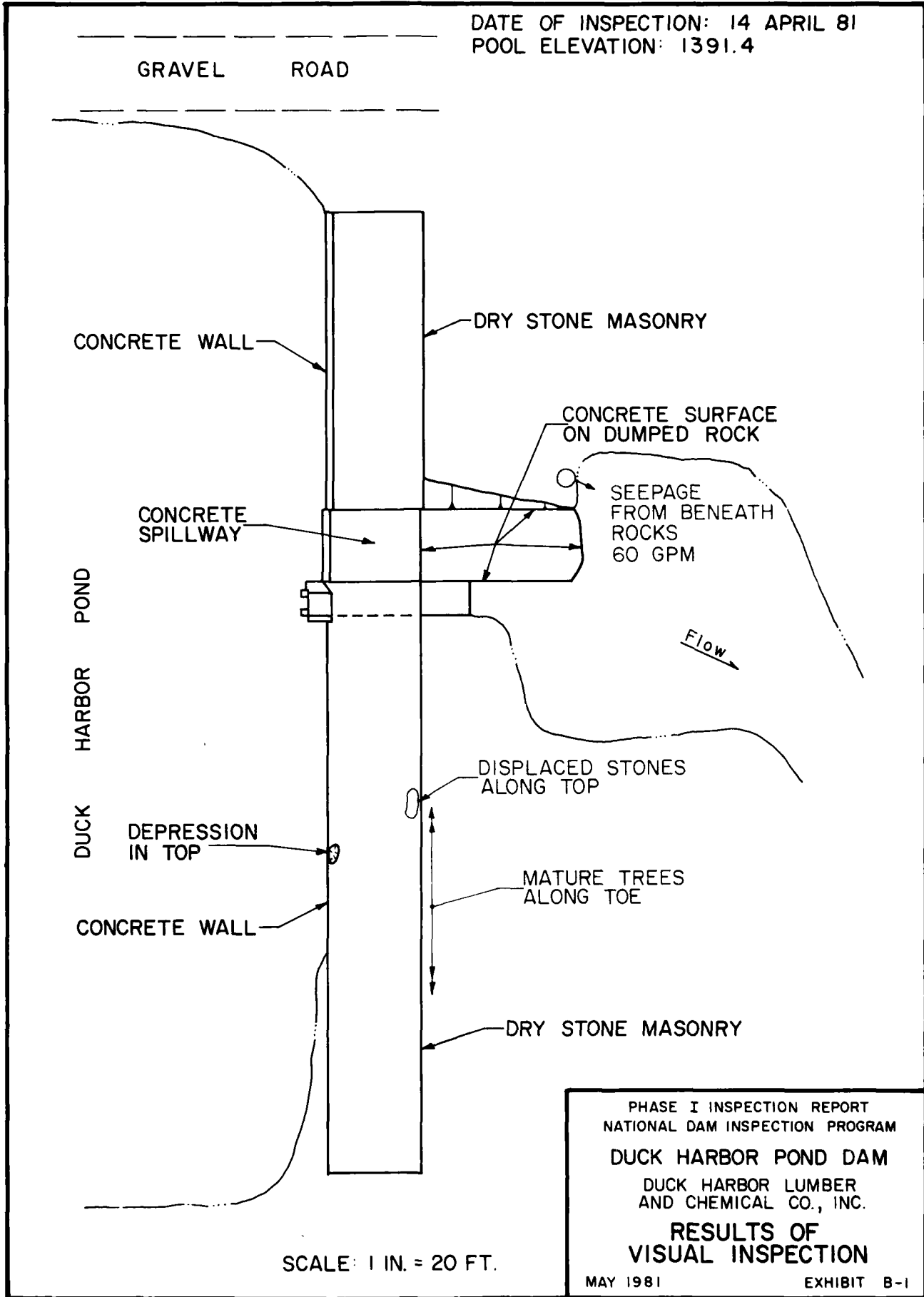

PHASE I INSPECTION REPORT
NATIONAL DAM INSPECTION PROGRAM

DUCK HARBOR POND DAM

DUCK HARBOR LUMBER
AND CHEMICAL CO., INC.

RESULTS OF
VISUAL INSPECTION

MAY 1981

EXHIBIT B-1

APPENDIX C
PHOTOGRAPHS

DUCK HARBOR POND DAM



A. Downstream Face and Outlet Works



B. Downstream Face

DUCK HARBOR POND DAM



C. Top of Dam



D. Spillway

DUCK HARBOR POND DAM

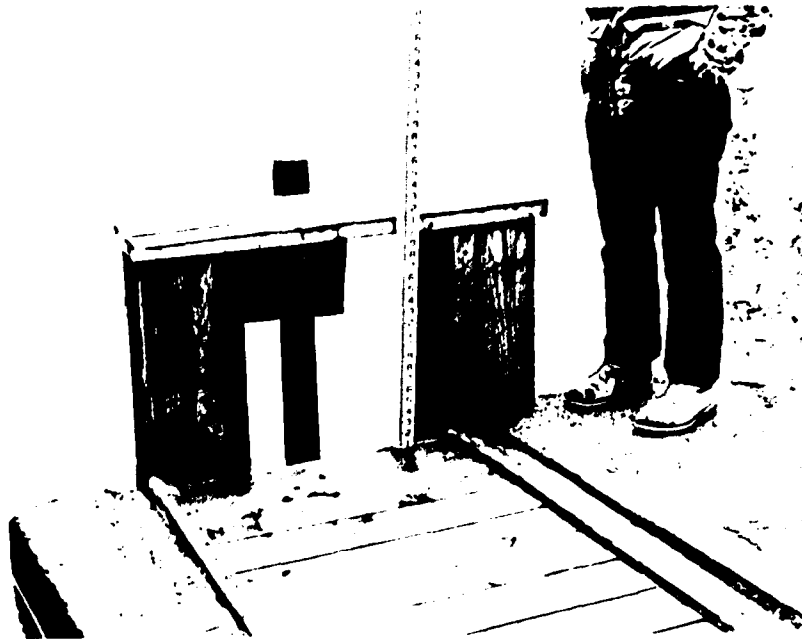

E. Outlet Works



F. Depression in Top

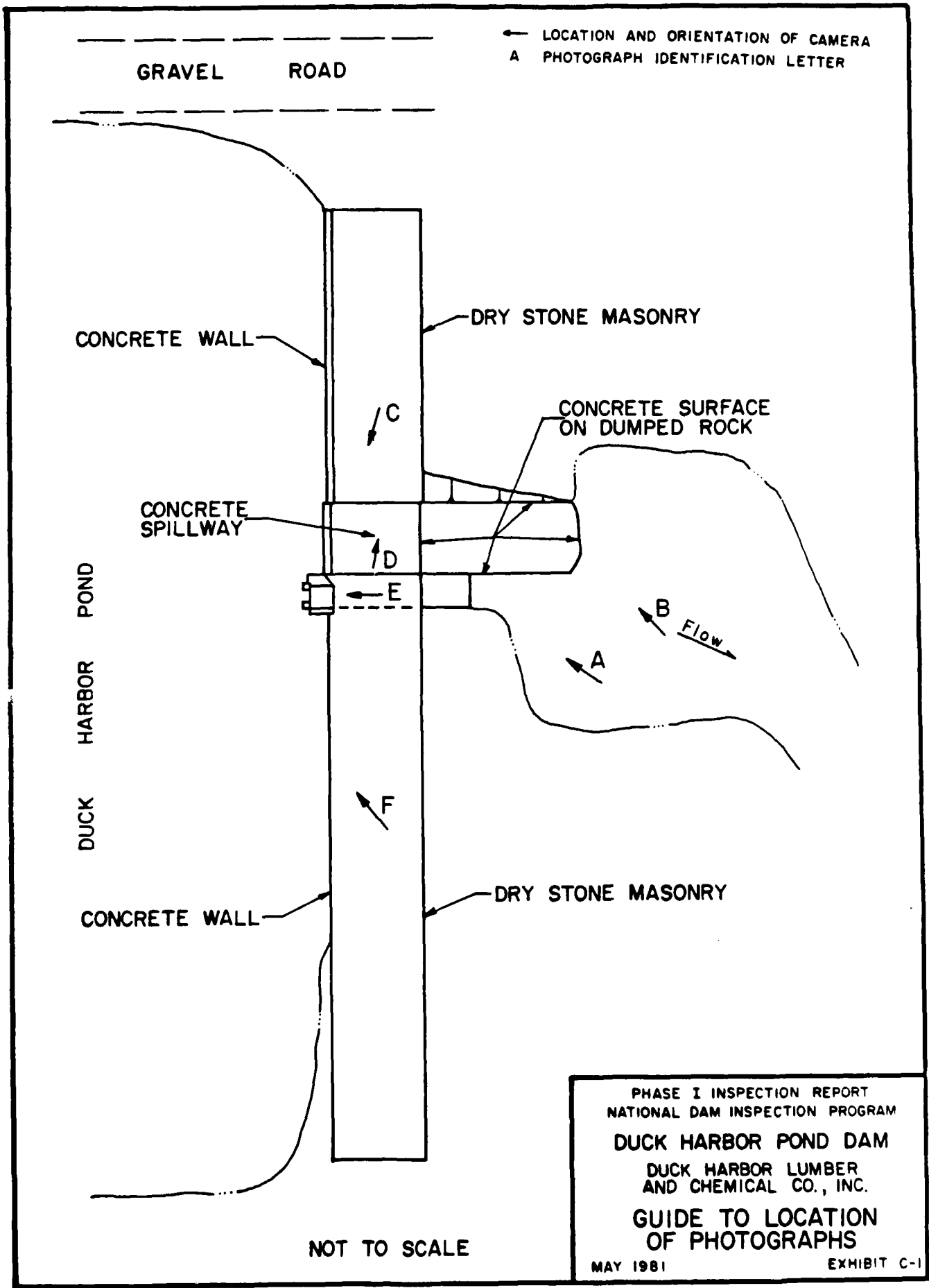

GRAVEL ROAD

← LOCATION AND ORIENTATION OF CAMERA
 A PHOTOGRAPH IDENTIFICATION LETTER

CONCRETE WALL

DRY STONE MASONRY

CONCRETE SURFACE ON DUMPED ROCK

CONCRETE SPILLWAY

DUCK HARBOR POND

CONCRETE WALL

DRY STONE MASONRY

NOT TO SCALE

PHASE I INSPECTION REPORT
 NATIONAL DAM INSPECTION PROGRAM
 DUCK HARBOR POND DAM
 DUCK HARBOR LUMBER
 AND CHEMICAL CO., INC.
 GUIDE TO LOCATION
 OF PHOTOGRAPHS
 MAY 1981 EXHIBIT C-1

APPENDIX D
HYDROLOGY AND HYDRAULICS

APPENDIX D

HYDROLOGY AND HYDRAULICS

Spillway Capacity Rating:

In the recommended Guidelines for Safety Inspection of Dams, the Department of the Army, Office of the Chief of Engineers (OCE), established criteria for rating the capacity of spillways. The recommended Spillway Design Flood (SDF) for the size (small, intermediate, or large) and hazard potential (low, significant, or high) classification of a dam is selected in accordance with the criteria. The SDF for those dams in the high hazard category varies between one-half of the Probable Maximum Flood (PMF) and the PMF. If the dam and spillway are not capable of passing the SDF without overtopping failure, the spillway capacity is rated as inadequate. If the dam and spillway are capable of passing one-half of the PMF without overtopping failure, or if the dam is not in the high hazard category, the spillway capacity is not rated as seriously inadequate. A spillway capacity is rated as seriously inadequate if all of the following conditions exist:

(a) There is a high hazard to loss of life from large flows downstream of the dam.

(b) Dam failure resulting from overtopping would significantly increase the hazard to loss of life downstream from the dam from that which would exist just before overtopping failure.

(c) The dam and spillway are not capable of passing one-half of the PMF without overtopping failure.

Description of Model:

If the Owner has not developed a PMF for the dam, the watershed is modeled with the HEC-1DB computer program, which was developed by the U.S. Army Corps of Engineers. The HEC-1DB computer program calculates a PMF runoff hydrograph (and percentages thereof) and routes the flows through both reservoirs and stream sections. In addition, it has the capability to simulate an overtopping dam failure. By modifying the rainfall criteria, it is also possible to model the 100-year flood with the program.

APPENDIX D

DELAWARE River Basin

Name of Stream: LITTLE EGGINVINK CREEK
 Name of Dam: DUCK HOLLOW FORD
 NDI ID No.: PA-00144
 DER ID No.: 64-54

Latitude: N 41°45.2' Longitude: W 75° 12.0'
 Top of Dam Elevation: 1293.5
 Streambed Elevation: 1381.3 Height of Dam: 12.5 ft
 Reservoir Storage at Top of Dam Elevation: 1,104 acre-ft
 Size Category: INTERMEDIATE
 Hazard Category: SIGNIFICANT (see Section 5)
 Spillway Design Flood: VARIES 1/2 PMF TO 10 PMF

UPSTREAM DAMS

Name	Distance from Dam (miles)	Height (ft)	Storage at top of Dam Elevation (acre-ft)	Remarks
<u>CREEK STRUCTURE</u>	<u>AS NOTED ON</u>			
<u>PLATE E-1</u>	<u>ONLY 2-3' HIGH</u>	<u>NOT</u>	<u>NOT</u>	<u>NOT SIGNIFICANT TO ANALYSIS.</u>

DOWNSTREAM DAMS

<u>BURNED DAM</u>	<u>300 FT.</u>	<u>N/A</u>	<u>N/A</u>	<u>NOT SIGNIFICANT TO ANALYSIS.</u>
<u>MILL DAM</u>	<u>0.4</u>	<u>N/A</u>	<u>SILTED TO TOP OF LEAK</u>	

DELAWARE River Basin
 Name of Stream: LITTLE EQUUSMUNK CREEK
 Name of Dam: LOCK HARBOR DAM
 DETERMINATION OF PMF RAINFALL & UNIT HYDROGRAPH
 UNIT HYDROGRAPH DATA:

Sub-area	Drainage Area (square miles)	Cp (1)	Ct (2)	L miles (3)	L _{ca} miles (4)	L' miles (5)	Tp hours (6)	Map Area (7)	Plate (8)
A	3.45	0.45	1.23	N/A	N/A	1.9	1.81	1	1
Total	3.45								

(1) & (2): Snyder Unit Hydrograph coefficients supplied by Baltimore District, Corps of Engineers on maps and plates referenced in (7) & (8)

The following are measured from the outlet of the subarea:

(3): Length of main watercourse extended to divide

(4): Length of main watercourse to the centroid

The following is measured from the upstream end of the reservoir at normal pool:

(5): Length of main watercourse extended to divide

(6): $Tp = C_t \times (L \times L_{ca})^{0.3}$, except where the centroid of the subarea is located in the reservoir. Then

$Tp = C_t \times (L')^{0.6}$

Initial flow is assumed at 1.5 cfs/sq. mile

Computer Data: QRCSN = -0.05 (5% of peak flow)

RTIOR = 2.0

RAINFALL DATA:

PMF Rainfall Index = 21.0 in., 24 hr., 200 sq. mile
 Hydromet. 40 Hydromet. 33
 (Susquehanna Basin) (Other Basins)

Zone: N/A 1

Geographic Adjustment Factor: N/A 1.0

Revised Index Rainfall: N/A 21.0

RAINFALL DISTRIBUTION (percent)

Time	Percent
6 hours	<u>11</u>
12 hours	<u>123</u>
24 hours	<u>123</u>
48 hours	<u>142</u>
72 hours	<u>-</u>
96 hours	<u>-</u>

Data for Dam at Outlet of Subarea A

Name of Dam: Duck Harbor Dam

<u>SPILLWAY DATA:</u>	<u>Existing Conditions</u>	<u>Design Conditions</u>
Top of Dam Elevation	<u>1393.8</u>	
Spillway Crest Elevation	<u>1392.0</u>	
Spillway Head Available (ft)	<u>1.8</u>	
Type Spillway	<u>Spillway - Crested</u>	
"C" Value - Spillway	<u>3.1</u>	
Crest Length - Spillway (ft)	<u>11.4</u>	
Spillway Peak Discharge (cfs)	<u>85</u>	
Auxiliary Spillway Crest Elev.	<u>Provisional</u>	
Auxiliary Spill. Head Avail. (ft)	<u>As per design</u>	
Type Auxiliary Spillway	<u>As per design</u>	
"C" Value - Auxiliary Spill. (ft)	<u>HEC-1 DE</u>	
Crest Length - Auxil. Spill. (ft)	<u>PROGRAM</u>	
Auxiliary Spillway Peak Discharge (cfs)		
Combined Spillway Discharge (cfs)		

Spillway Rating Curve:

<u>Elevation</u>	<u>Q Spillway (cfs)</u>	<u>Q Auxiliary Spillway (cfs)</u>	<u>Combined (cfs)</u>
_____	_____	_____	_____
_____	_____	_____	_____
_____	_____	_____	_____
_____	_____	_____	_____
_____	_____	_____	_____
_____	_____	_____	_____
_____	_____	_____	_____
_____	_____	_____	_____
_____	_____	_____	_____
_____	_____	_____	_____

<u>OUTLET WORKS RATING:</u>	<u>Outlet 1</u>	<u>Outlet 2</u>	<u>Outlet 3</u>
Invert of Outlet	_____	_____	_____
Invert of Inlet	_____	_____	_____
Type	_____	_____	_____
Diameter (ft) = D	_____	_____	_____
Length (ft) = L	_____	_____	_____
Area (sq. ft) = A	_____	_____	_____
N	_____	_____	_____
K Entrance	_____	_____	_____
K Exit	_____	_____	_____
K Friction = $29.1N^2L/R^{4/3}$	_____	_____	_____
Sum of K	_____	_____	_____
(1/K) $0.5 = C$	_____	_____	_____
Maximum Head (ft) = HM	_____	_____	_____
Q = $CA\sqrt{2g(HM)}$ (cfs)	_____	_____	_____
Q Combined (cfs)	<u>160</u>	_____	_____

BY _____ DATE _____

SUBJECT _____

SHEET NO _____ OF _____

CHKD BY _____ DATE _____

JOB NO _____

DUCK HARBOR POND OUTLET WORKS

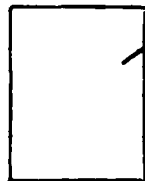

4' x 6.2' opening THROUGH DAM

- 1381.3 AT DOWNSTREAM END

ENTRANCE - LOOKING DOWNSTREAM:

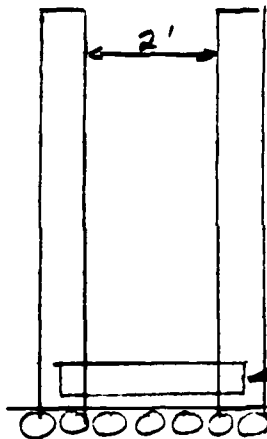

- 1392.0 NORMAL POOL

STOP LOGS USED TO CONTROL ELEVATION

- 1383 ESTIMATE

$$Q = C L H^{3/2} \quad C = 3.1 \quad H = 9' \quad L = 2'$$

$$Q = \underline{167 \text{ CFS}} \approx \underline{160 \text{ CFS}}$$

(Approach effects significant)

Data for Dam at Outlet of Subarea A

Name of Dam: Duck Hill Pool

STORAGE DATA:

Elevation	Area (acres)	Storage		Remarks
		million gals	acre-ft	
<u>1381.3</u> =ELEVO*	<u>0</u>	<u>0</u>	<u>0</u>	
<u>1392.0</u> =ELEV1	<u>204</u> =A1		<u>726</u> =S1	<u>USGS</u>
<u>1398.7</u>	<u>208</u>		<u>872</u>	
<u>1398.4</u>	<u>211</u>		<u>1,019</u>	
<u>1398.7</u>	<u>213</u>		<u>1,083</u>	
<u>1398.8</u>	<u>214</u>		<u>1,157</u>	<u>Top of Dam</u>
<u>1394.0</u>	<u>215</u>		<u>1,187</u>	
<u>1394.7</u>	<u>218</u>		<u>1,208</u>	
<u>1400.0</u> **	<u>228</u>			<u>USGS</u>

* ELEVO = ELEV1 - (3S1/A1)

** Planimetered contour at least 10 feet above top of dam

Reservoir Area at Normal Pool is 9 percent of subarea watershed.

BREACH DATA: NOT Used

See Appendix B for sections and existing profile of the dam.

Soil Type from Visual Inspection: _____

Maximum Permissible Velocity (Plate 28, EM 1110-2-1601) _____ fps
(from $Q = CLH^{3/2} = V \cdot A$ and depth = $(2/3) \times H$) & $A = L \cdot \text{depth}$

HMAX = $(4/9 V^2/C^2)$ = _____ ft., C = _____ Top of Dam El. = _____

HMAX + Top of Dam El. = _____ = FAILURE

(Above is elevation at which failure would start)

Dam Breach Data:

BRWID = _____ ft (width of bottom of breach)

Z = _____ (side slopes of breach)

ELBM = _____ (bottom of breach elevation, minimum of zero storage elevation)

WSEL = _____ (normal pool elevation)

T FAIL = _____ mins = _____ hrs (time for breach to develop)

BY _____ DATE _____

SUBJECT _____

SHEET NO _____ OF _____

CHKD BY _____ DATE _____

JOB NO _____

SELECTED COMPUTER OUTPUT

HEC-1 DB MODEL

	<u>PAGE</u>
1. INPUT	D-8
2. SUMMARY OF PEAK FLOWS	D-9
3. DUCK HARBOR POND DAM	D-10

 FLOOD HYDROGRAPH PACKAGE (HEC-1)
 DAM SAFETY VERSION JULY 1978
 LAST MODIFICATION 03 APR 80

1	A1								
2	A2								
3	A3								
4	B	300	0	0	0	0	0	-4	0
5	B1	5	0						
6	J	1	6						
7	J1	1	.5	.4	.2	.1			
8	K	0	1						
9	K1								
10	M	1	3.65					1	
11	P	21	111	123	133	142			
12	T						1	.05	.09
13	W	1.81	.65						
14	X	-1.55	-0.06	2.0					
15	X1	1							
16	K1								
17	Y								
18	Y1	1							
19	ZA	0	204						
20	SE1781.3	1392	1400						
21	SE	1392	11.6						
22	SD1393.8								
23	SL	0	35	46	70	75	120	155	170
24	SV1192.1	1392.7	1393.4	1393.7	1393.73	1393.8	1394	1395	1396
25	K	00							

-1392

SEE NOTE

DI 00

NOTE. \$L + \$V CARDS ARE USED TO MODEL THE AUXILIARY SPILLWAY. THE FLOW COMPUTED USING THE \$L + \$V CARDS IS ADDED TO THE FLOW COMPUTED FROM THE \$\$ CARD. THE DEPTH OF OVERTOPPING IS THE DIFFERENCE BETWEEN THE POND ELEVATION AND THE ELEVATION SHOWN ON THE \$D CARD. THE DEPTH OF FLOW OVER THE TOP OF THE DAM, AS MEASURED FROM THE LOW ELEVATION ON THE \$V CARD, IS GREATER THAN THE COMPUTED DEPTH OF OVERTOPPING.

PEAK FLOW AND STORAGE (END OF PERIOD) SUMMARY FOR MULTIPLE PLAN-RATIO ECONOMIC COMPUTATIONS
 FLOWS IN CUBIC FEET PER SECOND (CUBIC METERS PER SECOND)
 AREA IN SQUARE MILES (SQUARE KILOMETERS)

OPERATION	STATION	AREA	PLAN	RATIOS APPLIED TO FLOWS					
				RATIO 1	RATIO 2	RATIO 3	RATIO 4	RATIO 5	RATIO 6
				1.00	.50	.40	.30	.20	.10
HYDROGRAPH AT	1	345 (0.94)	1	6920 (106.20)	3464 (88.10)	2771 (78.48)	2070 (58.86)	1386 (39.26)	693 (19.62)
ROUTED TO	1	345 (0.94)	1	5372 (152.12)	2275 (64.62)	1661 (47.03)	1063 (30.09)	535 (14.57)	121 (3.42)

SUMMARY OF DAM SAFETY ANALYSIS
DUCK HARBOR POND DAM

PLAN 1

ELEVATION
 STORAGE
 OUTFLOW

INITIAL VALUE
 1302.00
 729.
 0.

SPILLWAY CREST
 1392.00
 729.
 0.

TOP OF DAM
 1393.80
 1101.
 187.

RATIO OF PPF	MAXIMUM RESERVOIR V.S.FLEV	MAXIMUM DEPTH OVER DAM	MAXIMUM STORAGE AC-FT	MAXIMUM OUTFLOW CFS	DURATION OVER TOP HOURS	TIME OF MAX OUTFLOW HOURS	TIME OF FAILURE HOURS
1.00	1398.26	4.66	2110.	5372.	26.50	43.25	0.00
.50	1396.26	2.66	1644.	2275.	20.25	44.00	0.00
.40	1395.75	1.95	1531.	1661.	18.75	44.25	0.00
.30	1395.18	1.38	1403.	1063.	16.75	44.75	0.00
.20	1394.48	.68	1251.	535.	13.50	45.75	0.00
.10	1393.51	0.00	1042.	127.	0.00	48.25	0.00

BY _____ DATE _____
CHKD BY _____ DATE _____

SUBJECT _____

SHEET NO _____ OF _____
JOB NO _____

I
SUMMARY OF PERTINENT RESULTS

	<u>PMF</u>	<u>1/2 PMF = SDF</u>
RAINFALL (inches)	23.86	N/A
RUNOFF (inches)	21.69	10.85
PEAK INFLOW (CFS)	6,929	3,464
DUCK HARBOR POND DAM		
PEAK OUTFLOW (CFS)	5,372	2,275
DEPTH OF OVERTOPPING* (FT.)	4.46	2.46
DURATION OF OVERTOPPING (HRS.)	24.50	20.25

* Above EL. 1393.8

NOTES:

1. LIMITS OF DOWNSTREAM FLOODING ARE ESTIMATES BASED ON VISUAL OBSERVATIONS.
2. CIRCLED NUMBERS INDICATE STATIONS USED IN COMPUTER ANALYSIS.
3. THIS MAP SHOULD NOT BE USED IN CONNECTION WITH THE EMERGENCY OPERATION AND WARNING PLAN.

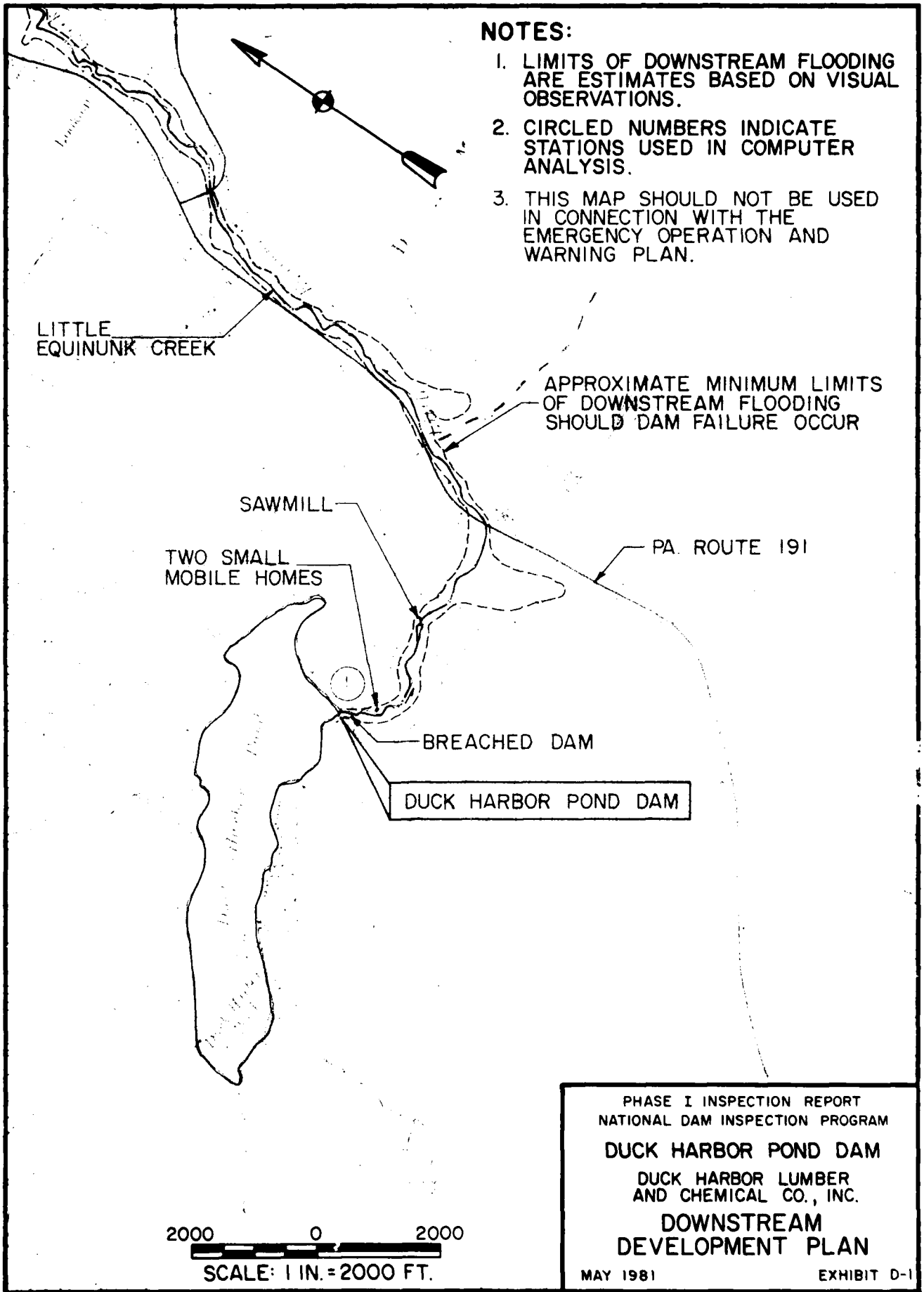

PHASE I INSPECTION REPORT
NATIONAL DAM INSPECTION PROGRAM

DUCK HARBOR POND DAM

DUCK HARBOR LUMBER
AND CHEMICAL CO., INC.

**DOWNSTREAM
DEVELOPMENT PLAN**

MAY 1981

EXHIBIT D-1

APPENDIX E

PLATES

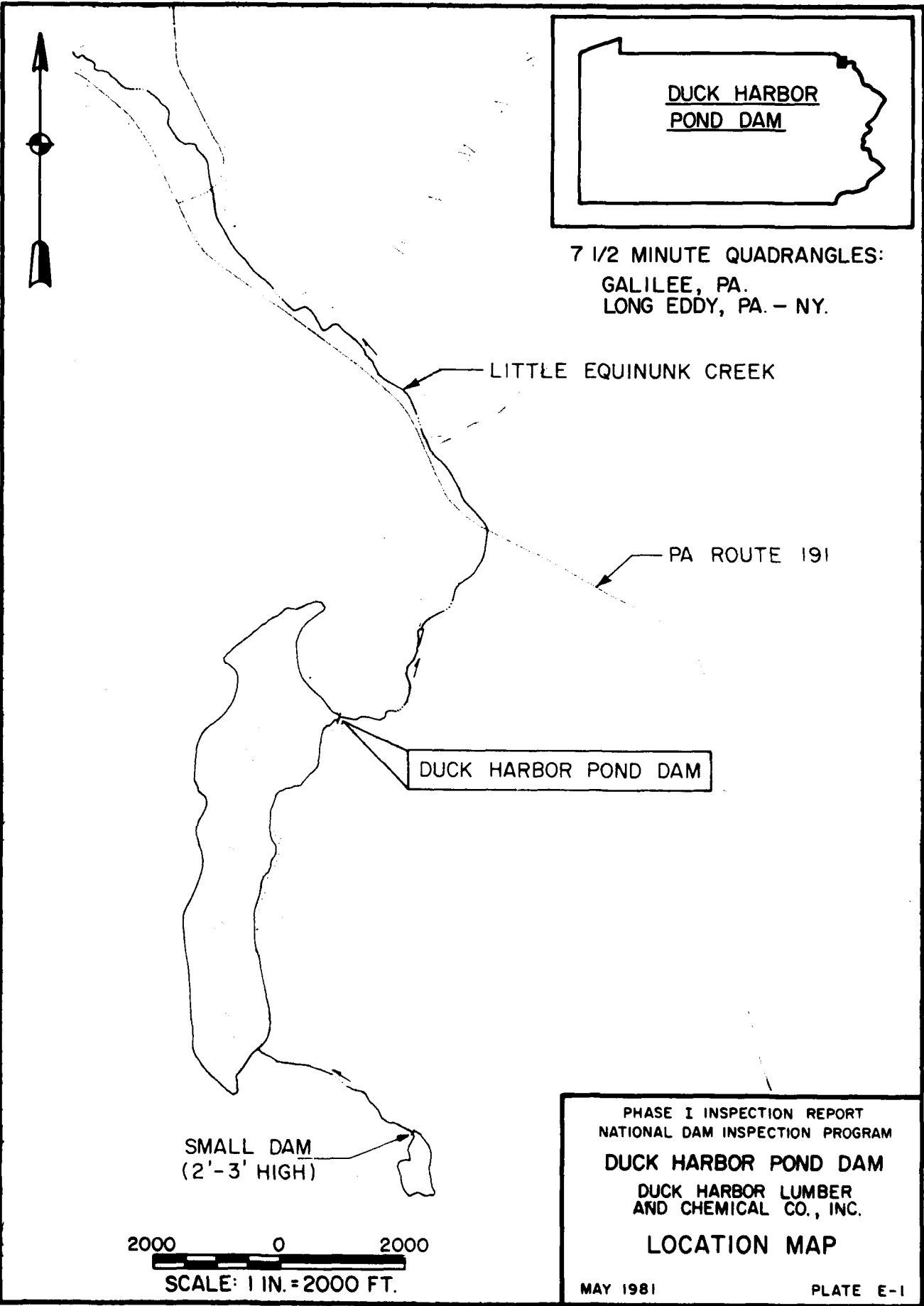

DUCK HARBOR
POND DAM

7 1/2 MINUTE QUADRANGLES:
GALILEE, PA.
LONG EDDY, PA. - NY.

LITTLE EQUINUNK CREEK

PA ROUTE 191

DUCK HARBOR POND DAM

SMALL DAM
(2'-3' HIGH)

PHASE I INSPECTION REPORT
NATIONAL DAM INSPECTION PROGRAM

DUCK HARBOR POND DAM

DUCK HARBOR LUMBER
AND CHEMICAL CO., INC.

LOCATION MAP

MAY 1981

PLATE E-1

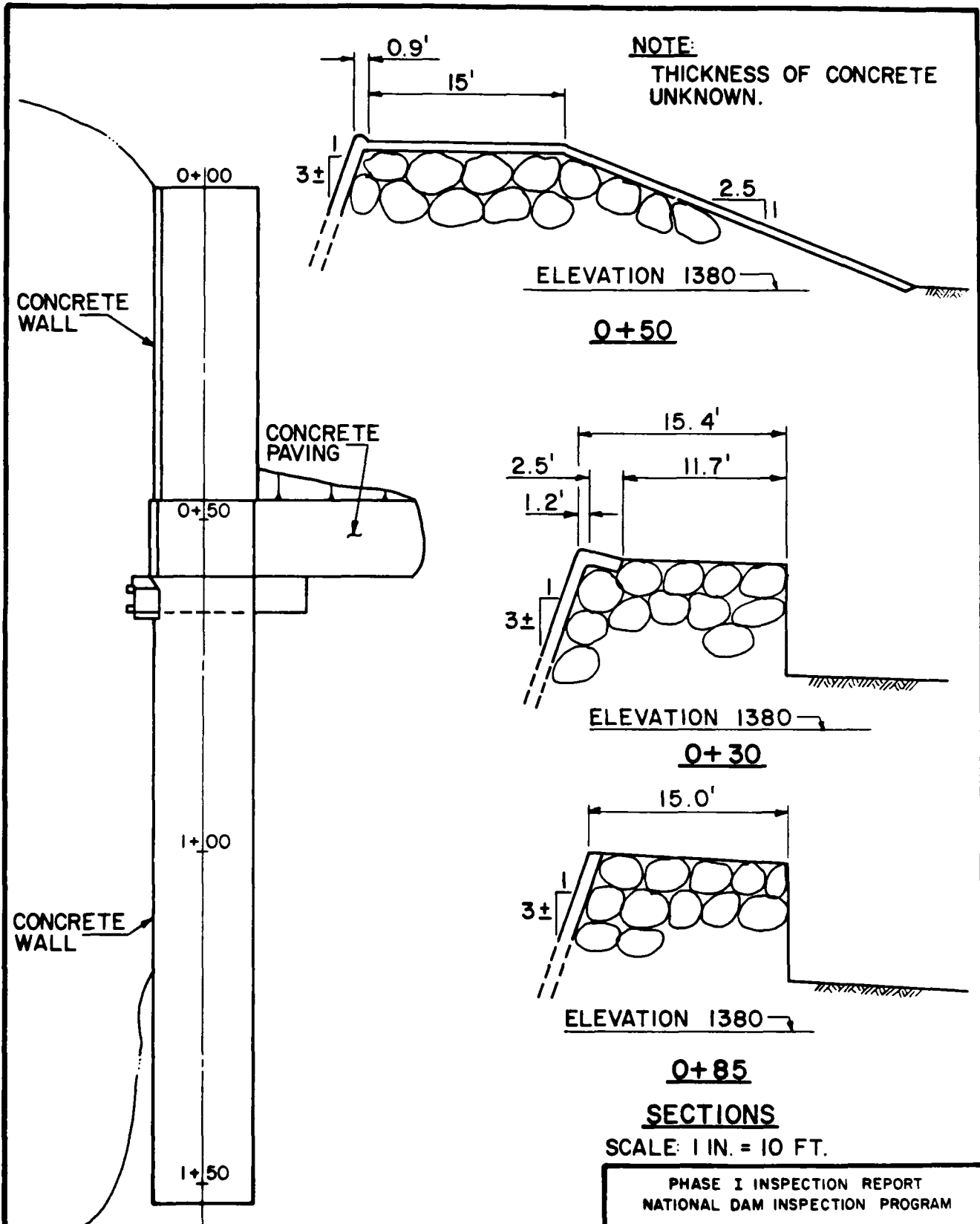

PLAN
SCALE: 1 IN. = 20 FT.

SECTIONS
SCALE: 1 IN. = 10 FT.

PHASE I INSPECTION REPORT
 NATIONAL DAM INSPECTION PROGRAM
 DUCK HARBOR POND DAM
 DUCK HARBOR LUMBER
 AND CHEMICAL CO., INC
PLAN AND SECTIONS
 MAY 1981 PLATE E-2

APPENDIX F

GEOLOGY

DUCK HARBOR POND DAM

APPENDIX F

GEOLOGY

Duck Harbor Pond Dam is located in Wayne County within the Appalachian Plateau Physiographic Province. The most pronounced topographic feature in the area is Camelback Mountain, which is part of the Pocono Plateau Escarpment. The escarpment has a well-defined, southwestward trend from Camelback Mountain, but it is irregular between Camelback Mountain and Mt. Pocono, which lies to the north. Streams east of the escarpment drain directly to the Delaware River, while those to the west drain to the Lehigh River.

The Pocono Plateau Section lies to the west of the escarpment. This area is relatively flat, with local relief seldom exceeding 100 feet. The topography has been greatly influenced by continental glaciation. Many features were created by deposition of glacial materials. The entire plateau lacks well-developed drainage.

East of the escarpment is the Glaciated Low Plateaus Section of the province. This area is characterized by preglacial erosional topography with locally-thick glacial deposits. Local relief is generally 100 to 300 feet.

Bedrock units of the sections described above are the lithified sediments of offshore marine, marginal marine, deltaic environments, and fluvial environments associated with the Devonian Period. These units include siltstones of the Mahantango Formation, siltstones and shales of the Trimmers Rock Formation, and seven mapped members of the Catskill Formation. These members include sandstones, siltstones, and shales of the Towamensing Member; sandstone, siltstone and shale of the Walcksville Member; sandstones, siltstones and shale of the Beaverdam Run Member; sandstone and shale in the Long Run Member; sandstones and conglomerates in the Packerton Member; sandstones and some conglomerates in the Poplar Gap Member; and sandstones and conglomerates in the Duncannon Member.

Duck Harbor Pond Dam is underlain by the Catskill Formation. The Catskill Formation is predominantly red to brownish gray shales and sandstone with interbedded siltstones and conglomerates. Sandstones present are thickbedded, fine-to coarse-grained and exhibit very low primary porosity due to a clay and silica matrix. Effective porosity results from fractures and parting planes.

The rocks are well-indurated and generally are not susceptible to slope failure; however, the presence of well-developed bedding and joint planes will result in some rockfall from vertical and high-angle cut slopes.

Bedrock is entirely overlain by glacial till of Late Wisconsin Age. This till is an unsorted mixture of clay, silt, sand, and gravel. It is moderately cohesive and is generally derived locally from the sandstones of the Catskill Formation. Thickness of the till varies from 5 to 75 feet.

Foundation conditions at the dam are unknown.

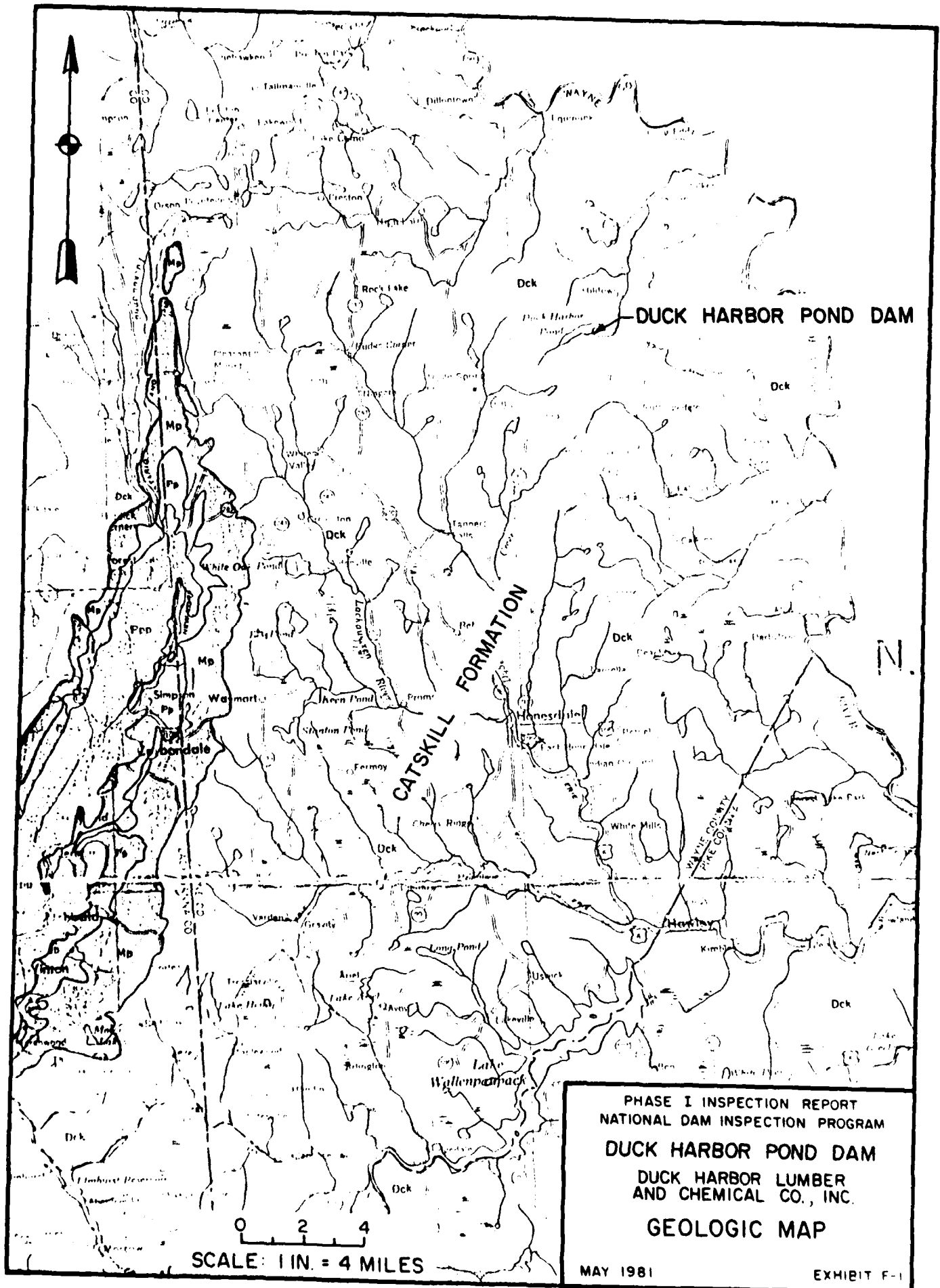

0 2 4

SCALE: 1 IN. = 4 MILES

PHASE I INSPECTION REPORT
 NATIONAL DAM INSPECTION PROGRAM
 DUCK HARBOR POND DAM
 DUCK HARBOR LUMBER
 AND CHEMICAL CO., INC.
 GEOLOGIC MAP
 MAY 1981 EXHIBIT F-1

