

AD-A099 784

ROYAL SIGNALS AND RADAR ESTABLISHMENT MALVERN (ENGLAND)
AUTOMATIC MEASUREMENT OF CATHODE RAY TUBE MTF'S.(U)
AUG 80 6 ANSTEY, M J DORE

F/G 9/1

UNCLASSIFIED

RSRE-MEMO-3301

DRIC-BR-76188

NL

1
2
3
4
5
6
7
8
9
10



END
DATE
FILMED
6-81
DTIC

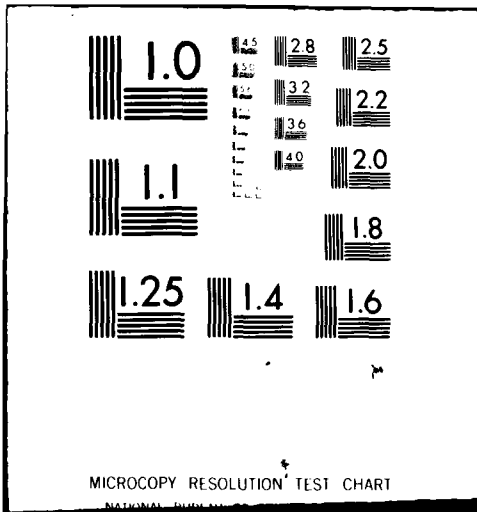

UNLIMITED

BR76188 ✓

① 43

LEVEL II

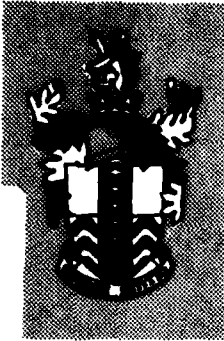

RSRE
MEMORANDUM No. 3301 ✓

ROYAL SIGNALS & RADAR ESTABLISHMENT

AD A 099784

AUTOMATIC MEASUREMENT OF CATHODE RAY TUBE MTF'S

Authors: G Anstey and
M J Dore

DTIC
ELECTE
JUN 05 1981
S E D

SRE MEMORANDUM No. 3301

DTIC FILE COPY

PROCUREMENT EXECUTIVE,
MINISTRY OF DEFENCE,
RSRE MALVERN,
WORCS.

~~This document is the property of Procurement Executive, Ministry of Defence.
Its contents should not be made public either directly or indirectly without
approval from the Secretary of State for Defence (Director RSRE).~~

81 6 03 023

23

✓ @1@ADA098784
@6@Automatic Measurement of Cathode Ray Tube MTF'S

- @8@U
- @11@Aug 80
- @14@RSRE-MEMO-3301
- @18@DRIC
- @19@BR-76188
- @20@U
- @end@

(18) DRIZ / (19) BR-76188

(12) 19

ROYAL SIGNALS AND RADAR ESTABLISHMENT

Memorandum 3301

TITLE:- (6) AUTOMATIC MEASUREMENT OF CATHODE RAY TUBE MTF'S

AUTHOR:- (10) G. ANSTEY ~~---~~ M. J. DORE

DATE:- (11) AUG 1980

(14) RSRE-MEMO-3301

SUMMARY

This memorandum describes a semi-automatic facility which directly plots the dynamic modulation transfer function of cathode ray tubes. A sine-wave pattern is generated which moves at a chosen rate across the screen. The intensity of the spatial pattern is measured by a stationary optical detector. Some discussion is given of the potential of pulse output signal processing to determine the ultimate performance capability. The high signal to noise ratio obtained is illustrated by some preliminary results.

Accession For	
NTIS GRA&I	<input checked="" type="checkbox"/>
DTIC TAB	<input type="checkbox"/>
Unannounced	<input type="checkbox"/>
Justification	
By	
Distribution/	
Availability Codes	
Dist	Avail and/or Special
A	

This memorandum is for advance information. It is not necessarily to be regarded as a final or official statement by Procurement Executive, Ministry of Defence

RSRE MEMORANDUM 3301

AUTOMATIC MEASUREMENT OF CATHODE RAY TUBE MTF'S

G Anstey & M J Dore

LIST OF CONTENTS

- 1 Introduction
 - 2 Direct MTF measurement
 - 3 Choice of Output Signal Processing
 - 4 Semi-Automatic MTF System
 - 4.1 Video Generation
 - 4.2 Measureing Equipment
 - 5 Measurement Procedure
 - 6 Results
 - 7 Conclusions
 - 8 MTF's of Image Intensifier Tubes
 - 9 Future Work
 - 10 Acknowledgements
- References
Appendix 1

1. INTRODUCTION

Electro-optical imaging techniques are increasingly being used in Surveillance and Weapon systems. The CRT still remains the best display device for information in pictorial form. Several methods are used to measure the resolution of cathode ray tubes (CRT).

Shrinking Raster and Line Width are two subjective methods. In the shrinking raster method the raster line spacing is reduced until the lines are just on the verge of merging together. The height of the raster is then measured and divided by the number of lines. The number obtained is a measure of the resolution. The line width method uses a single line scan. The focused line is viewed with a microscope and its width measured against a calibrated graticule. Both of these methods rely on the observer judging, in the first case, the point of mergence, and in the second case, the extremity of the line width.

Another subjective method is called the TV Limiting Response. A wedge pattern is used to determine the spatial frequency at which the lines of a well illuminated, high contrast wedge are just resolved. The wedge pattern is equivalent to a square wave modulation function, and the highest spatial frequency which can be resolved is sometimes also referred to as the 'limiting square wave response'.

Yet another measurement - this time objective - is the Half Power Width. A single line is viewed by a microscope lens which produces a magnified image in the plane of a variable width slit, aligned parallel to the line. The slit is opened sufficiently to allow all the light from the imaged line to pass through and fall upon a photomultiplier. The output from the photomultiplier is displayed by an oscilloscope. The slit width is then gradually reduced until the displayed pulse height is halved. The slit width can be read off the micrometer. Dividing this width by the magnification of the microscope lens, gives the Half Power Width of the CRT spot.

Great care must be taken not to confuse the Half Power Width with the often quoted width between the half peak intensity points. This latter is 1.75 times larger than the Half Power Width for a Gaussian spot or line.

Objective spatial frequency resolution measurements have been achieved by focusing a raster line or lines onto a perpendicular grating consisting of groups of opaque and transparent bars. The spatial frequency of each group is different. The depth of modulation of the light transmitted through the grating is measured by a photomultiplier. The modulation amplitudes for each spatial frequency are expressed as a percentage of the zero spatial frequency amplitude. The spatial frequencies are found from the physical dimensions of the bars and the magnification of the optical system. The spatial frequency response curve can then be plotted as a percentage of the zero frequency amplitude versus the spatial frequency. This plot is referred to as the Contrast Transfer Function. This function is not the same as the sine-wave response.

The overall performance of any system is dependent upon the individual elements making up such a system. The overall imaging performance is best obtained by multiplying together the sine-wave responses or Modulation Transfer Functions (MTF's) of the individual components. However, none of the common CRT resolution measuring techniques mentioned above give information sufficient to calculate the MTF over wide spatial frequency ranges. This memorandum describes an equipment which has semi-automated the direct measurement of the MTF's of CRT's.

2. DIRECT MTF MEASUREMENT

One technique is to electronically generate stationary sine-waves. The depth of modulation for various spatial frequencies can be measured by traversing an optical sensor across the pattern and noting the maximum and minimum luminances. Two problems are encountered with this method. The first is that the granular nature of phosphors results in local variations in luminous efficiencies across the screen. The second is that, due to the very small screen area which must be viewed, a poor electrical signal to noise ratio (S/N) is obtained even when a photomultiplier is employed.

Both of these problems may be overcome by moving the generated sine-wave pattern across the screen at a constant rate and leaving the optical detector system stationary. The first problem is overcome because the optical detector is now looking at one area of the screen. The second problem of poor S/N can be overcome by averaging over as many successive fields as are required to obtain a good S/N ratio.

This moving pattern method has been developed and is in use at the Royal Aircraft Establishment and at the BBC for assessing CRT's (1) (2). Both at present use discrete spatial frequencies and display the sinusoidal component of the output from the photomultiplier on an XY plotter.

The method described here is taken a stage further to semi-automate the process of plotting the MTF curves. This will allow the study of the effects of changes in CRT operating conditions. Also because of the longer signal integration periods made possible, measurements can be extended to higher spatial frequencies where the modulation depth is very small. Very low spatial frequencies of order 2 or 3 cycles/picture width can also be measured. It is hoped this will allow more precise normalisation of the MTF curve.

3. CHOICE OF OUTPUT SIGNAL PROCESSING

The output pulses from the photomultiplier may be processed in two ways. They may be passed directly to a low pass filter which passes only the modulation components below say 10 Hz (depending on the rate at which the pattern is moved across the screen) and therefore produces a sinusoidal output for subsequent display or measurement. Alternatively the peak pulse output may be held to the end of a field and then sampled and held until the next similar sequence occurs during the next field. The output from the sample and hold is then a reconstructed sine-wave like that shown in Fig 1.

There seems to be little to choose between these two methods. Each has been used. The choice of peak sample and hold made here was therefore made on the grounds that it would be useful to be able to measure the large signal spatial transfer characteristics of displays. Such a measurement would show whether video amplifier slew rate limitations were affecting high spatial frequency response. Because of the well known high degree of non-linearity of the light output versus grid drive voltage characteristic of CRT's such spatial frequency curves are of course not true MTF's in the mathematical sense. The direct low pass filter method would tend to output the fundamental of the distorted sine-wave intensity pattern and would be difficult to normalise. Another possible advantage is that with short phosphor decay times the amplitude of the sine-wave output from the peak sample and hold arrangement is very largely independent of the rate at which the sine-wave pattern is traversed across the screen. In fact even at a rate of traverse so fast that fewer than two samples of the sine-wave per cycle are obtained, the peak to peak voltage excursion at the output of the sample and hold remains equal to that for the case where many samples per cycle are obtained. This is because the +ve peak and -ve peak are those occurring during a lengthy sampling time, and the pattern traverse rate and spatial periodicity are not related to the CRT field rate.

The reconstituted sine-wave is next passed to +ve and -ve running peak hold circuits with a decay time constant of 10 seconds. The +ve and -ve peak magnitudes are then added and the final output smoothed by a simple RC low pass filter. This can have as long a time constant as necessary provided the spatial frequency is changed sufficiently slowly to avoid lag in response. The +ve and -ve peak hold time constant of 10 seconds appears to be suitable for a wide range of conditions.

A detailed consideration of the effects of shot noise from the photo-multiplier on this type of processing has not been made. For low modulation depths such as are normally employed for MTF measurements the effect will be small as the shot noise will be very similar on both peaks and troughs. For large modulation depths the shot noise will be significantly greater on the peaks and virtually zero on a trough of zero light output. The direct filter approach may be less vulnerable to noise from this point of view.

The peak hold holds the pulse due to the highest luminance line from amongst those lines seen by the slit-photomultiplier combination, and therefore the system measures the MTF of a single line. This is the best MTF the display can achieve. Thus the effects of line to line or field to field jitter are minimised. These effects could be assessed by remeasuring the degraded MTF with a direct low pass filter arrangement which will average the effects from all the lines seen by the slit-photomultiplier combination.

4. SEMI-AUTOMATIC MTF SYSTEM

Fig 2 shows the block diagram of the semi-automatic MTF measuring system and consists of two main sections. The first section generates the video signal which is fed to the CRT. The second consists of the optical sensing and signal processing equipment.

4.1 VIDEO GENERATION

The variable frequency oscillator (VFO) generates the sine-waves which are readily varied between 100 KHz and 10 MHz by an input control voltage. A VFO using the principle of charging and discharging a capacitor from constant current sources is particularly suitable. A Hewlett Packard Type 3312A Function Generator was used here but others are available. It is necessary to gate out the VFO during line and field blanking periods to prevent the VFO output from upsetting the triggering of the CRT scan circuits. The Amplitude Modulation section of the VFO can conveniently be used to suppress the VFO output during these periods. This was achieved by directly feeding the 2V negative going mixed blanking from the Sync Pulse Generator into the Mod INT/EXT socket of the VFO and adjusting the Amplitude Modulation depth.

The 'moving' pattern was achieved by using a Scan Delay Generator such as is used in Boxcar detection. A Brookdeal type 425A was used here. This instrument can progressively delay a pulse with respect to a reference pulse. The progression rate can be set as desired by the controls provided on the instrument. The reference used to trigger the Scan Delay Generator was Line Drive, from the Sync Pulse Generator. The Time Base range (maximum delay) was set to 50 μ sec, this being the nearest to the 52 μ s active line time. The pulse width at the output of the Scan Delay Generator was set to 1 μ sec. The Scan Delay Pulse amplitude is then changed from its fixed 1V to TTL logic level by the pulse Generator to make it compatible with the VFO external trigger input.

The output from the VFO was fed into a resistive adding network. This combined the VFO output with Mixed Blanking and Mixed Syncs, from the Sync Pulse Generator. A variable resistor is provided to allow the amplitude of mixed blanking to be set to provide the required mean picture luminance (see Fig 3). This control allows the effect of the CRT gamma curve on the MTF to be investigated. This composite video signal can be fed to any monitor. The

sine-wave modulation voltage was flat within 3 dB over the frequency range 0.1 to 10 MHz. Absolute MTF measurements must be obtained by appropriate correction at present. Unfortunately the inputs of different monitors appear to present different resistances and reactances and need differing correction. Figs 4 and 5 are uncorrected so as to show typical S/N ratios achieved. For small CRT's an additional correction for the finite slit width used will be required - in some cases this correction may be minimised by the use of an even smaller slit width, combined with longer integration times to restore the S/N ratio.

4.2 MEASURING EQUIPMENT

The CRT display is viewed by a Ferranti Microspot Analyser. This comprises a low power microscope with a slit in the focal plane of the magnified image. The amount of light passing through the slit is detected by a photomultiplier. The slit width referred back to the display is 6 μm . The signal produced by the photomultiplier consists of groups of negative going pulses (see Fig 1) at field frequency, the number of pulses depends on how many lines are imaged on the slit. The pulse amplitudes are proportional to the luminance of the phosphor area defined by the slit. The pulse amplitudes vary as the spatial pattern moves. The difference between the maximum and minimum pulse heights is proportional to the depth of intensity modulation displayed by the CRT.

The peak pulse, in each field, is held by the peak detector circuit to the end of the field. At the end of the field the peak value is first held by a sample and hold circuit and then the peak hold is reset. The output of the sample and hold is a reconstitution of the sine-wave modulation. The positive and negative peak excursions of the sample and hold circuit are extracted by the +ve and -ve peak follower circuits. The difference between the peaks and troughs is obtained from a summing amplifier and fed, via a low pass filter, into the Y amplifier of the chart recorder.

To provide automatic operation, the ramp output from the chart recorder (which is proportional to the X deflection) is fed via an interface circuit (see Appendix 1) into the voltage controlled oscillator input of the VFO. Hence, the spatial frequency displayed by the CRT is linearly related to the X deflection of the chart recorder.

5. MEASUREMENT PROCEDURE

A detailed standard setting up procedure for displays to be measured has yet to be established. Ideally the mean luminance should be set as known points below the onset of saturation. The RAE has suggested that 20%, 50% and 80% of the video voltage drive for saturation should be used (5). The 50% level was approximated in these preliminary measurements and set as follows: The black level luminance of the monitor was set using a standard PLUGE Test pattern. The contrast was set, using the grey scale section of the PLUGE pattern, to the maximum for which there was no observable saturation.

The mean dc level of the composite video signal was then set to 350 mV (half the standard full white value of 700 mV) above back porch level. The modulation depth was nominally only 10% (+ 35 mV) about the mean dc level. Adequate final MTF S/N ratio was achieved with this depth of modulation at mean luminances as low as 50 cd/m^2 . The slit was perpendicular to the lines by maximising the output as a relatively high spatial frequency.

6. RESULTS

Fig 4 shows two MTF curves for a typical commercial 8½" diagonal monitor. The upper curve is the on axis MTF and the lower is the MTF at a position about 2 inches in from the side of the display. The MTF's are 3 dB down as approximately 220 cycles/picture width and 170 cycles/picture width respectively.

Fig 5 shows the MTF of a special high resolution (X239) 2 inch diameter tube. This tube has a phosphor with a decay time constant to 10% which was longer than the field period. Hence, the MTF is a dynamic one for a particular rate of pattern motion. This tube is 3 dB down at 230 cycles/picture width but the response is well maintained at higher spatial frequencies. The MTF structure at low spatial frequencies seen here has also been commented on by workers at RAE, but was found at lower spatial frequencies. This special tube exhibited a number of anomalous results thought to be due to the possible use of a phosphor with two components with differing decay times. These effects remain to be explored.

7. CONCLUSIONS

The MTF measuring system described provides a basis for automatic accurate MTF measurements. Repeatability is good so that relative changes in MTF due to changes in operating conditions are readily assessed. A typical run takes about 15 minutes.

The signal generating part of the system uses relatively cheap commercially available instruments, with a minimum of additional interfacing. A single composite video voltage is used. No other connections or circuit modification to the monitor being measured are necessary.

The output circuitry used here is unnecessarily complicated for routine measurements, being designed to explore large signal performance. A very simple system would result if the photomultiplier output were simply fed to a low pass filter and the filter output detected by an ac voltmeter with a suitably long output time constant.

Dynamic MTF's are obtained if the rate of pattern motion is chosen for this purpose.

8. MTF's OF IMAGE INTENSIFIER TUBES

The displayed pattern has also been tried as a test pattern for the measurement of the MTF of an image intensifier tube. Despite the high ratio of peak to mean luminance occurring in a scanned raster display a promising result was obtained. The high peak to mean ratio could easily be reduced by using a higher field frequency and reduced field scan amplitude.

9. FUTURE WORK

With this MTF equipment it is hoped to investigate:

- (a) The variations between the MTF's of eight similar small commercial monitors which are available.
- (b) The MTF's of various small electromagnetic and electrostatic deflection tubes.

- (c) The combined MTF's of displays and suitable magnifiers
- (d) The effect of MTF's of jitter, both line to line and field to field
- (e) The effect of spot wobble
- (f) Large Signal "MTF"s
- (g) Normalisation of MTF's to very low spatial frequency response

10. ACKNOWLEDGEMENTS

The authors would like to thank Mr J E Noakes and Mr I H Teear of the Technical Investigations Section BBC Television Centre for valuable discussions on their pulse technique. The authors would also like to thank Mr R J Corps, Dr J Banbury and Mr B Whitfield of the RAE Farnborough and Mr D Leyland of Thorn Brimar Manchester for detailed discussions and guidance on MTF measurements.

REFERENCES

- (1) W V THOMAS Television Pattern Generator for Display Assessment.
RAE Farnborough Technical Memorandum FS144 November 1977
- (2) J E NOAKES A Method of Assessing the Sharpness of Picture Monitors
and some Comparative Measurements. Report No 73 BBC Television
Services October 1978
- (3) Lucien M Biberman Perception of Displayed Information Plenum Press 1973
- (4) THORN BRIMAR MICROSPOT MANUAL
- (5) Private Communications with Dr J Banbury RAE Farnborough

APPENDIX 1 DETAILED CIRCUIT OPERATION

PEAK DETECTOR/SAMPLE AND HOLD (FIG 6)

The most negative peak of the output pulses from the photomultiplier, during active field time is held by C_1 . During active field time, the CMOS analogue gate SW(b) is open circuit, SW(a) is short circuit and the monostable output from Q_2 is high. SW(d), is open circuit during this period, therefore, the voltage across C_1 appears at the output of the unity gain follower.

The largest negative peak voltage occurring during each field is transferred to C_2 before the start of the next field. Field sync is used from the Sync Pulse Generator to drive a dual monostable to provide suitably timed switch inputs. C_1 is shorted to ground to prepare it for the next frame.

TR_3 and TR_4 provide the necessary interface between the field sync pulse of -2V amplitude to the +5V to -5V needed to drive the negative trigger input of monostable 1.

A unity gain buffer is used to transfer the signal on C_2 to the low pass filter (R_3, C_3). This filter is required to remove switching transients.

THE POSITIVE AND NEGATIVE PEAK FOLLOWERS AND PEAK TO PEAK SUMMING CIRCUIT (FIG 7)

The 1 μ f and 10 M ohm network on the non-inverting input of the times 10 amplifier ensures adequate low frequency ac coupling. The output from the times 10 amplifier goes into a positive and negative peak follower simultaneously. The output from each peak follower is fed into a difference amplifier. The output from this is the peak to peak amplitude of the reconstituted sine-wave. This output signal is passed via a low pass RC filter into the XY chart recorder.

INTERFACE CIRCUIT (FIG 8)

An operational amplifier with current feedback is used to provide a current source for the frequency control input to the VCO. A current mirror TR_6 and TR_7 provides the correct polarity. A current drive was very effective in removing stubborn 'hum' problems encountered when using a voltage drive.

CIRCUIT LIMITATIONS

One of the present circuit limitations is the linearity of the peak detector. The emitter of TR_2 is not clamped to 0 volts. Hence when the base of TR_1 is biased to 0 volts if V_{be2} then the emitter of TR_2 will assume a voltage other than 0 volts. Because the base voltage, emitter current transfer characteristic is non-linear at the low current end of the curve, the response is not linear for pulse heights less than 0.4 V. Mean luminances and modulation depths must be arranged to provide this minimum at all times. At present this, therefore, does not allow measurements at 100% modulation depth.

The VFO uses the principle whereby a constant current source charges and discharges a capacitor. With this type of generator the output can only be stopped at the same voltage level at which it started. Hence, to ensure clean phase locking of the main oscillator, a trigger pulse of duration equal to or greater than the period of the main oscillator is used. Thus the length of the output pulse from the pulse generator can be shortened at higher VFO

frequencies. This reduces the VFO stop to start interval and prevents excessive loss of signal from the peak holds during this interval. At present the output pulse length has to be changed once during a run. The change (from 10 μ s to 1 μ s) is conveniently done when the VFO reaches 1 MHz. Usually the rate of progression of the pulse from the Scan Delay Generator was changed from 5 μ s/s to 50 μ s/s so that the frequency of the reconstituted sine-wave output remained in the flat pass band of the times 10 amplifier and the positive and negative peak hold circuits. The measured frequency response of the latter combination was flat within 4% between 0.5 Hz and 50 Hz. This measurement was made under typical operating conditions using a fixed spatial frequency and varying the rate of pattern movement.

FIG.1

OUTPUT PULSES FROM PHOTOMULTIPLIER

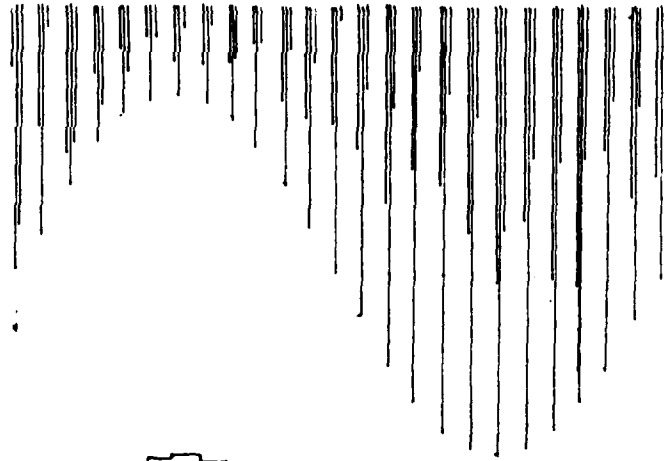

OUTPUT FROM SAMPLE and HOLD

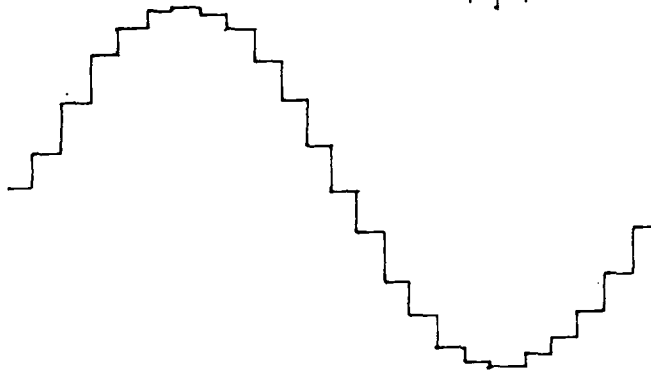

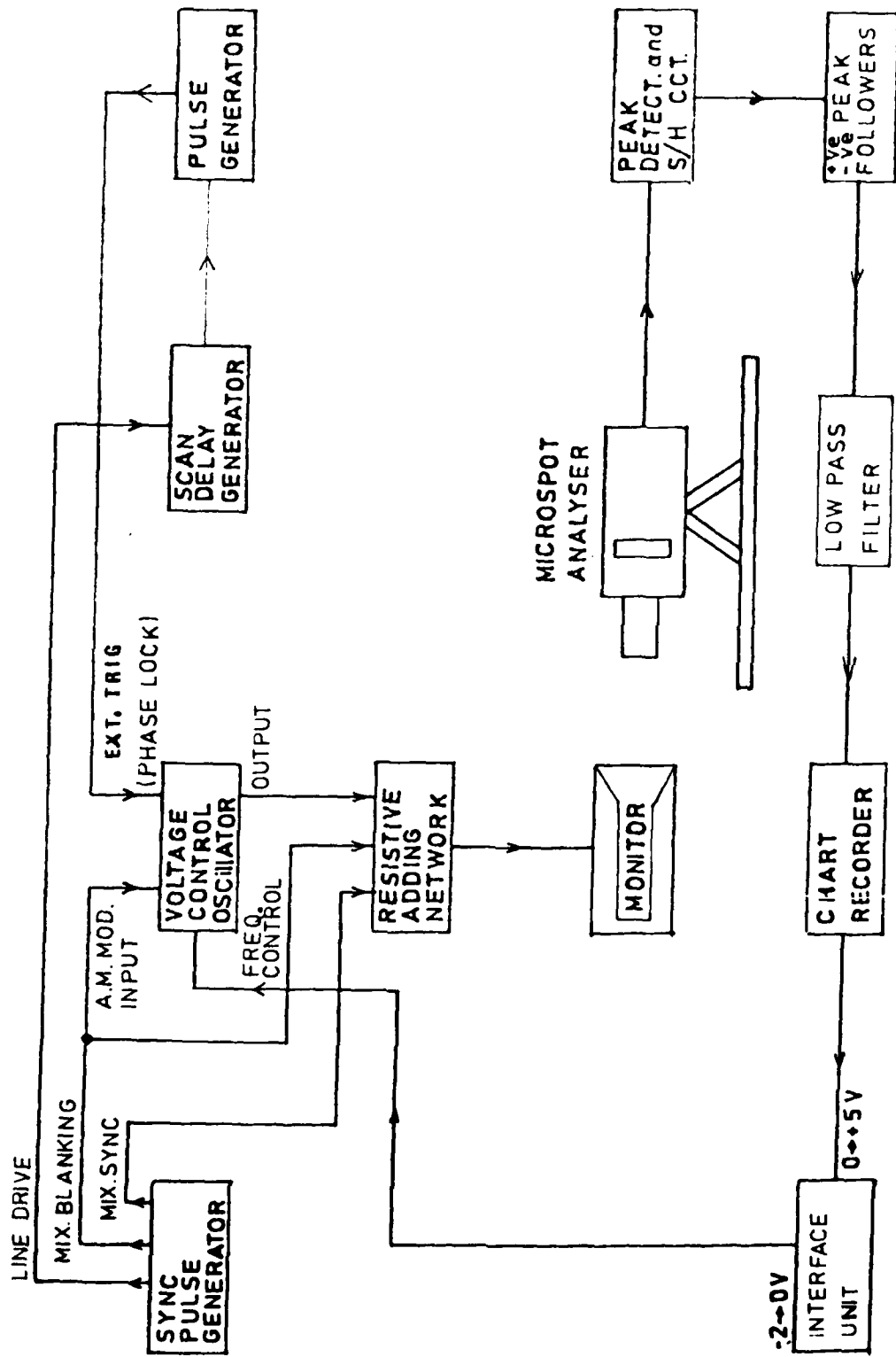

FIG. 2

MODULATION TRANSFER FUNCTION
MEASURING EQUIPMENT

FIG. 3

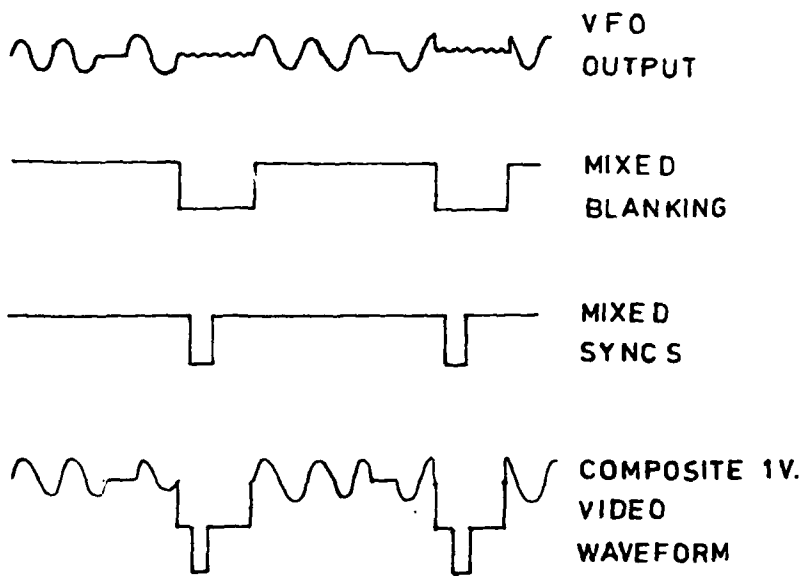

FIG. 4
8 INCH MONITOR

UPPER TRACE - CENTRE

LOWER TRACE - EDGE

SCREEN LUMINANCE = 50 cd/m²

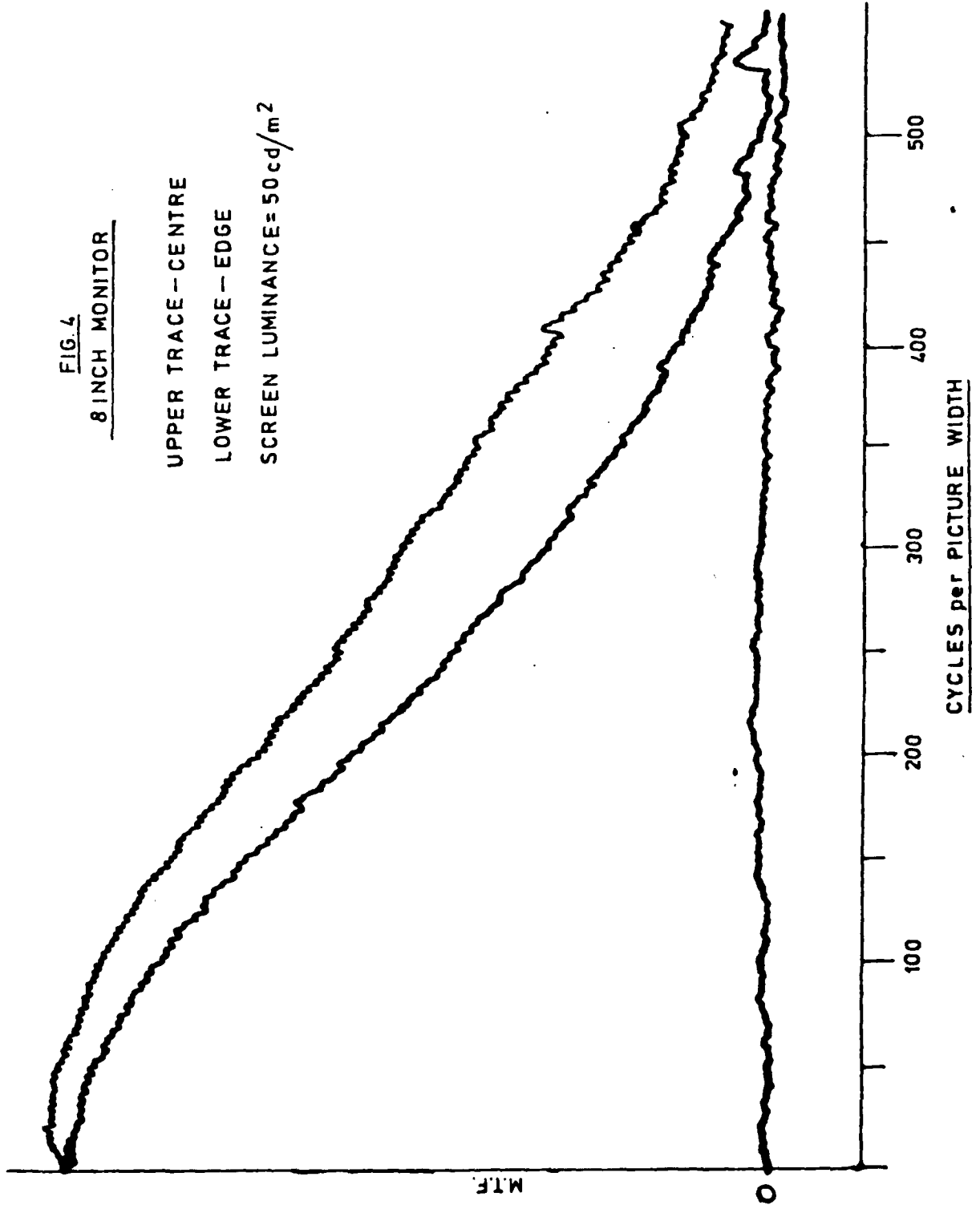

FIG. 5

X 239 2 INCH

UPPER TRACE—CENTRE

LOWER TRACE—EDGE

SCREEN LUMINANCE = 78 cd/m^2

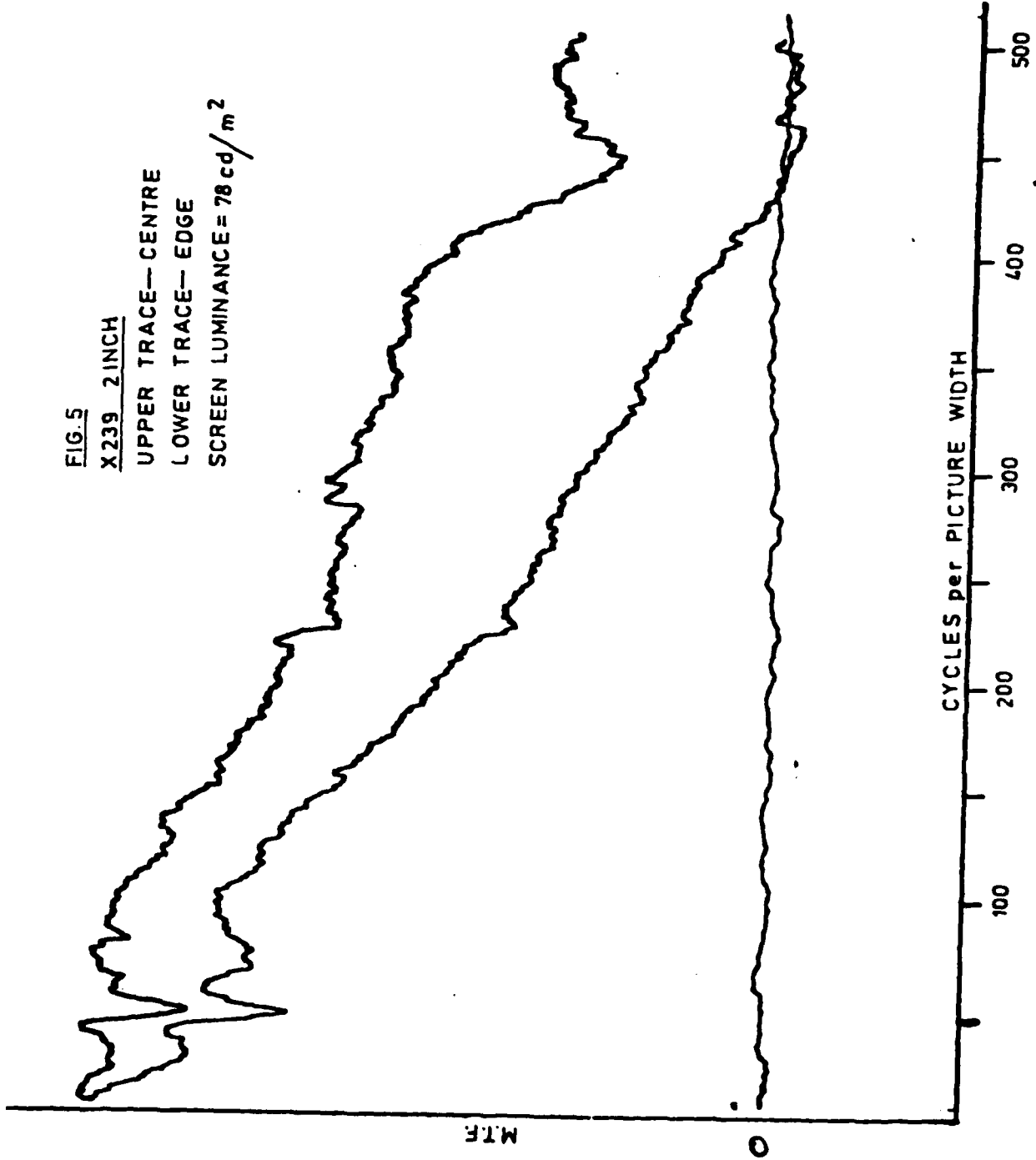

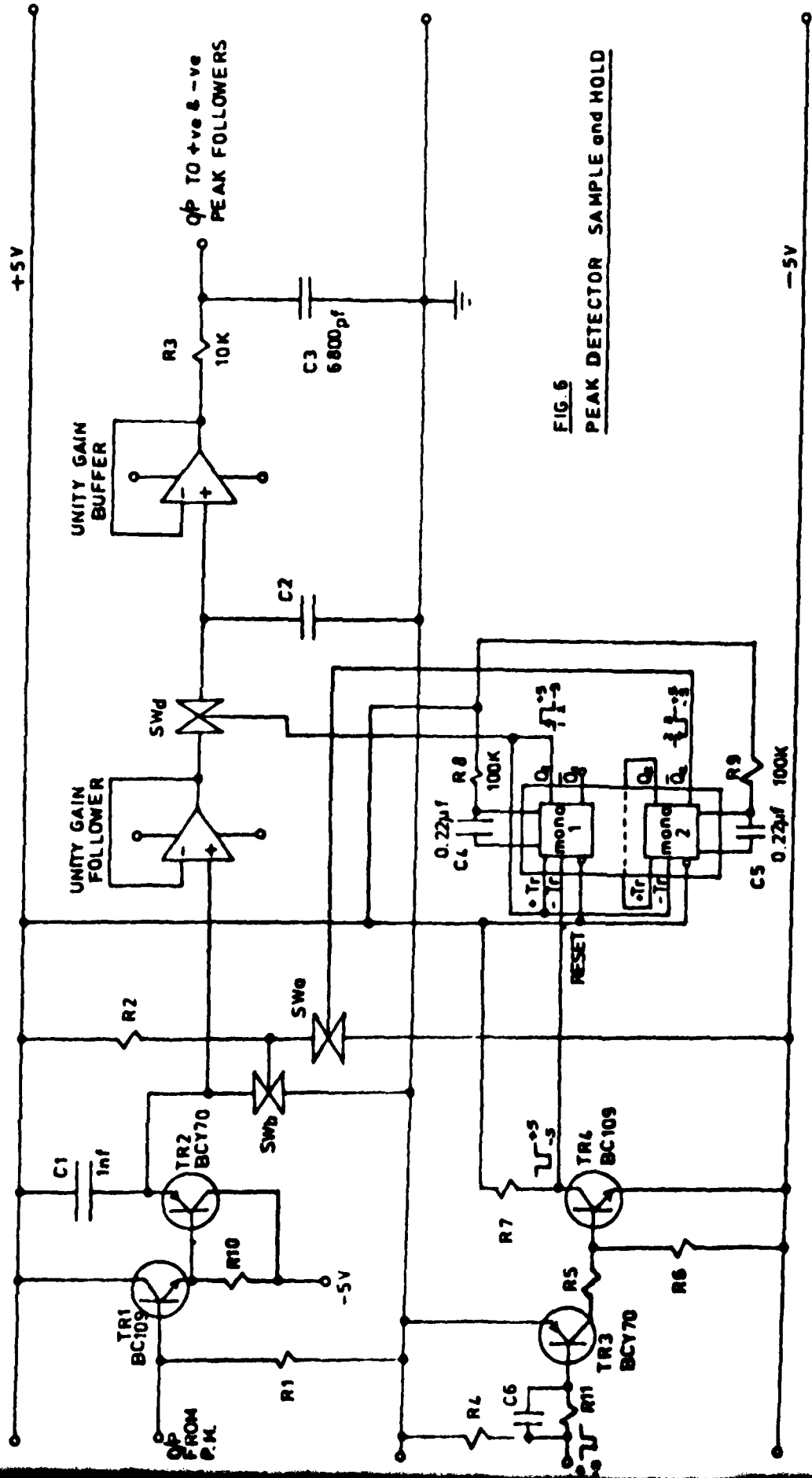

FIG. 5
PEAK DETECTOR SAMPLE and HOLD

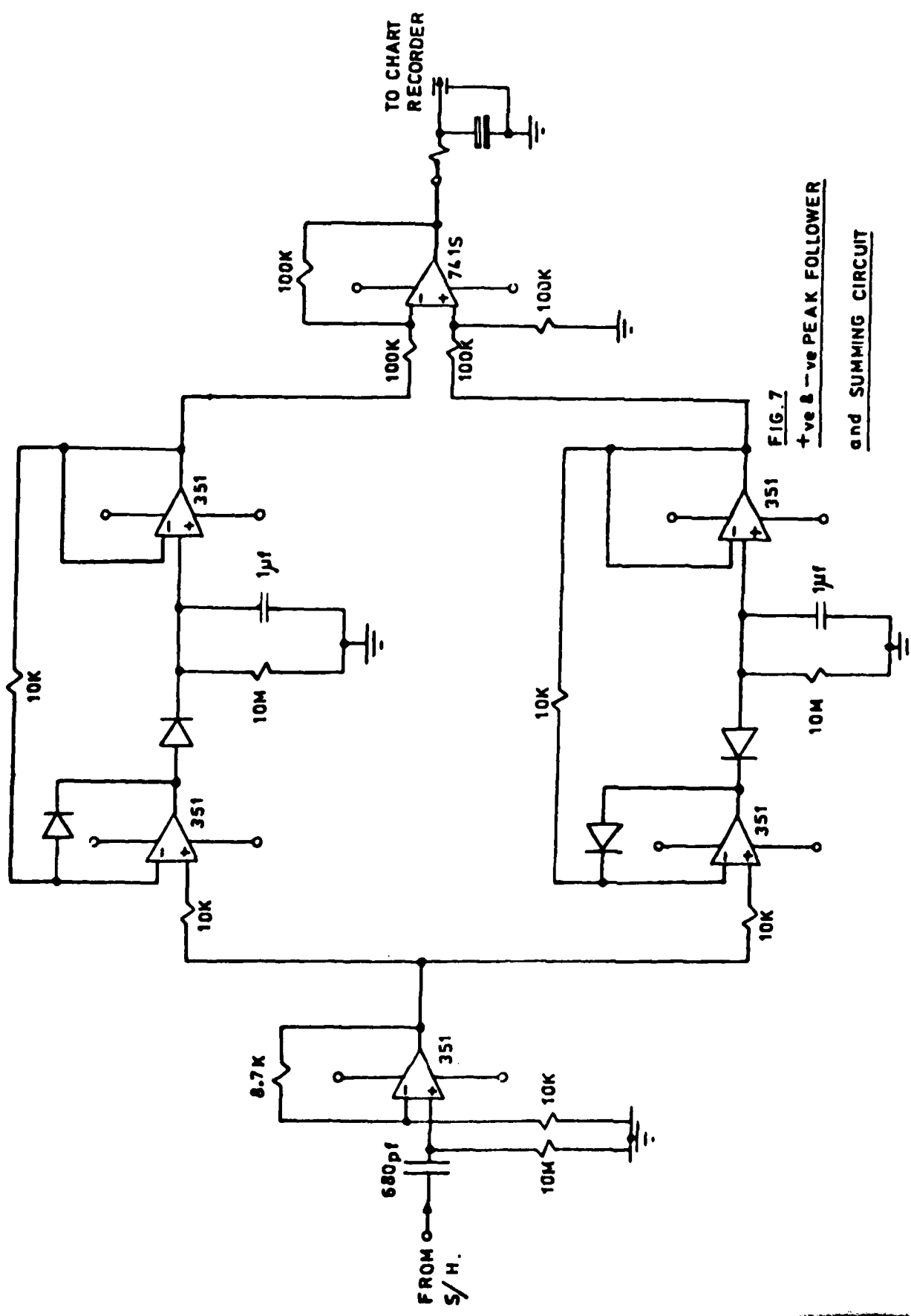

FIG. 7
+ve & -ve PEAK FOLLOWER
and SUMMING CIRCUIT

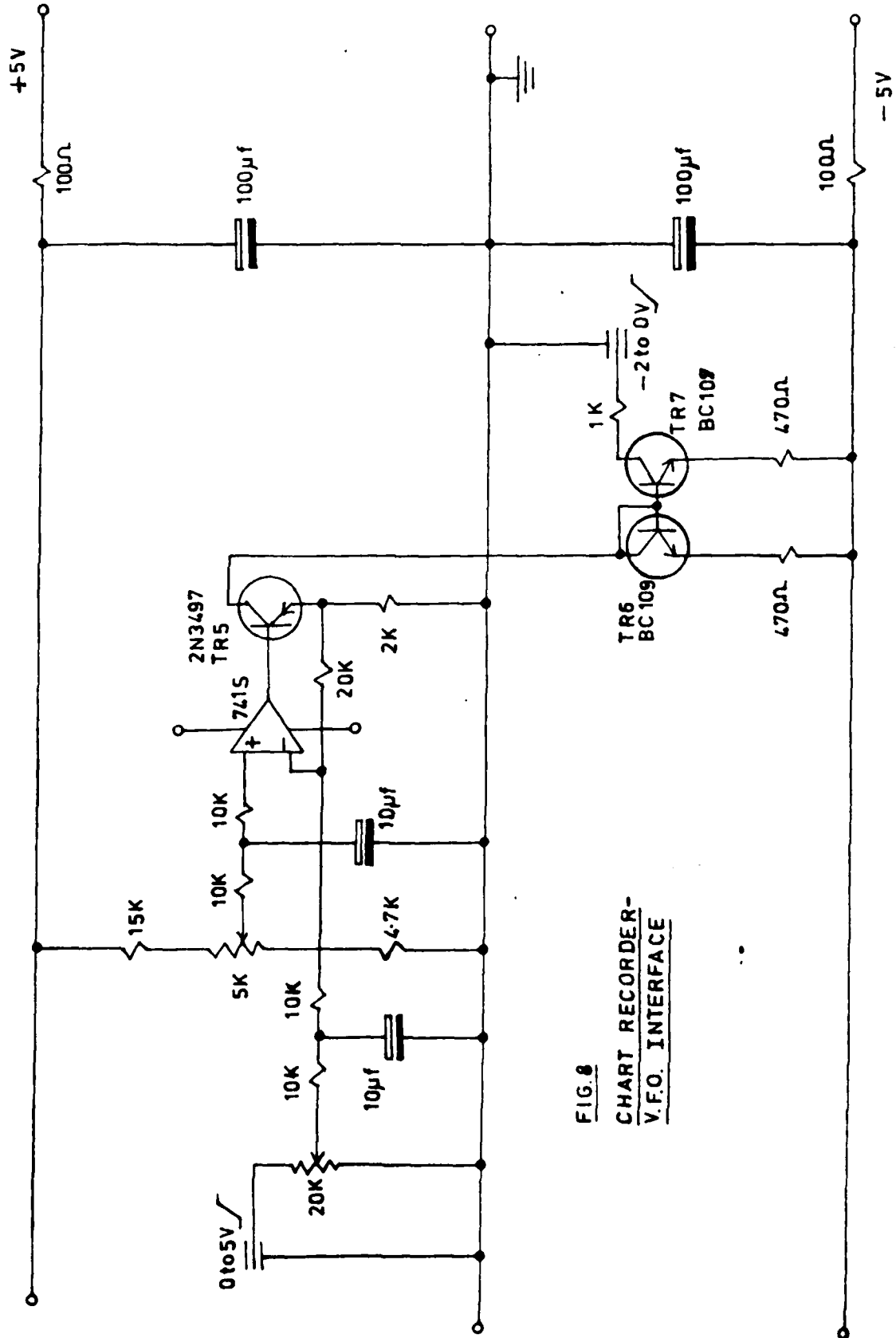

FIG. 6
CHART RECORDER-
V.F.O. INTERFACE