

LEVEL III

AD-E430564

K2 12

AD

AD A 095342

TECHNICAL REPORT ARBRL-TR-02277

CHARGE DESIGN CONSIDERATIONS AND THEIR EFFECT ON PRESSURE WAVES IN GUNS.

Ingo W. May  
Albert W. Horst

December 1980

DTIC ELECTE  
S FEB 23 1981 D  
D



US ARMY ARMAMENT RESEARCH AND DEVELOPMENT COMMAND  
BALLISTIC RESEARCH LABORATORY  
ABERDEEN PROVING GROUND, MARYLAND

Approved for public release; distribution unlimited.

DDC FILE COPY

81 2 05 009

Destroy this report when it is no longer needed.  
Do not return it to the originator.

Secondary distribution of this report by originating  
or sponsoring activity is prohibited.

Additional copies of this report may be obtained  
from the National Technical Information Service,  
U.S. Department of Commerce, Springfield, Virginia  
22151.

The findings in this report are not to be construed as  
an official Department of the Army position, unless  
so designated by other authorized documents.

*The use of trade names or manufacturers' names in this report  
does not constitute indorsement of any commercial product.*

UNCLASSIFIED

SECURITY CLASSIFICATION OF THIS PAGE (When Data Entered)

REPORT DOCUMENTATION PAGE		READ INSTRUCTIONS BEFORE COMPLETING FORM
1 REPORT NUMBER TECHNICAL REPORT ARBRL-TR-02277	2. GOVT ACCESSION NO. AD-A095 342	3 RECIPIENT'S CATALOG NUMBER
4 TITLE (and Subtitle) CHARGE DESIGN CONSIDERATIONS AND THEIR EFFECT ON PRESSURE WAVES IN GUNS	5 TYPE OF REPORT & PERIOD COVERED BRL TECHNICAL REPORT	6 PERFORMING ORG. REPORT NUMBER
7. AUTHOR(s) Ingo W. May and Albert W. Horst	8. CONTRACT OR GRANT NUMBER(s)	
9. PERFORMING ORGANIZATION NAME AND ADDRESS U. S. Army Ballistic Research Laboratory ATTN: DRDAR-BLP Aberdeen Proving Ground, MD 21005	10 PROGRAM ELEMENT, PROJECT, TASK AREA & WORK UNIT NUMBERS 11162218AH80	
11. CONTROLLING OFFICE NAME AND ADDRESS U.S. Army Armament Research & Development Command U.S. Army Ballistic Research Laboratory ATTN: DRDAR-BL Aberdeen Proving Ground, MD 21005	12. REPORT DATE December 1980	13 NUMBER OF PAGES 64
14 MONITORING AGENCY NAME & ADDRESS (if different from Controlling Office)	15 SECURITY CLASS. (of this report) UNCLASSIFIED	15a. DECLASSIFICATION/DOWNGRADING SCHEDULE
16 DISTRIBUTION STATEMENT (of this Report) Approved for public release; distribution unlimited.		
17 DISTRIBUTION STATEMENT (of the abstract entered in Block 20, if different from Report)		
18 SUPPLEMENTARY NOTES		
19 KEY WORDS (Continue on reverse side if necessary and identify by block number) Interior Ballistics Charge Design Guns Pressure Waves		
20 ABSTRACT (Continue on reverse side if necessary and identify by block number) jmk Combustion instability, usually manifested as longitudinal pressure waves, has long been a serious problem in the design of high-performance, conventional guns. The source of this phenomenon was identified correctly to lie in the ignition phase of the interior ballistic cycle. Only recently, however, has it been understood that the ignition phase not only involves functioning of the igniter train components themselves but also depends on such factors as distribution of ullage, flow restrictions, and propellant bed mobility. The		

DD FORM 1473 1 JAN 73 EDITION OF 1 NOV 65 IS OBSOLETE

UNCLASSIFIED

SECURITY CLASSIFICATION OF THIS PAGE (When Data Entered)

UNCLASSIFIED

SECURITY CLASSIFICATION OF THIS PAGE(When Data Entered)

concepts of local as well as macroscopic gas permeability have been shown to be important factors governing the formation, growth, and dissipation of pressure waves. High gas generation rates during the ignition and flamespreading phase, as defined by both burning surface and linear burning rates, also lead to increased levels of traveling pressure waves. The integration of these concepts into two-phase-flow interior ballistic codes now is beginning to allow a more precise unraveling of the interaction among these complex processes.

Accession For	
NTIS GRA&I	<input checked="" type="checkbox"/>
DTIC TAB	<input type="checkbox"/>
Unannounced	<input type="checkbox"/>
Justification	
By _____	
Distribution/	
Availability Codes	
Dist	Avail and/or Special
A	

DTIC  
SELECTED  
FEB 23 1981  
S D D

UNCLASSIFIED

SECURITY CLASSIFICATION OF THIS PAGE(When Data Entered)

TABLE OF CONTENTS

	Page
LIST OF ILLUSTRATIONS . . . . .	5
LIST OF TABLES . . . . .	7
I. INTRODUCTION . . . . .	9
II. PRESSURE-WAVE PHENOMENOLOGY . . . . .	11
III. EXPERIMENTAL CONSIDERATIONS . . . . .	17
IV. CHARGE-DESIGN FACTORS INFLUENCING PRESSURE WAVES . . . . .	20
A. Ignition Stimulus . . . . .	20
B. Mass Burning Rate . . . . .	29
C. Permeability . . . . .	34
D. Chamber and Charge Geometry . . . . .	40
V. RELIABLE GUN IGNITION . . . . .	47
VI. CONCLUSIONS . . . . .	51
REFERENCES . . . . .	55
DISTRIBUTION LIST . . . . .	61

LIST OF ILLUSTRATIONS

Figure	Page
1. Pressure vs Time Data from an Ignition Study in a 155-mm Gun <sup>22</sup> . . . . .	14
2. Pressure-Time Records for a Navy 5-In./38-Caliber Blowout Gun <sup>25</sup> . . . . .	15
3. Pressure-Space-Time Profiles <sup>25</sup> . . . . .	16
4. Typical Location of Pressure Transducers in Chamber. . . . .	18
5. Typical Centercore-Ignited Artillery Propelling Charge . . . . .	18
6. Pressure-Time and Pressure Difference Profiles for a Properly Ignited, High-performance Charge. . . . .	19
7. Pressure-Time and Pressure Difference Profiles for a Properly Ignited, Localized Base Ignition. . . . .	19
8. Catastrophic Pressure-Wave Behavior Observed in a 175-mm Gun Firing. . . . .	21
9. Comparison of Pressure-Time Curves for NACO Propellant Firings with Primers MK 48 Mod 2 and MK 48 Mod 4 <sup>35</sup> . . . . .	23
10. Ignition Study Test Results <sup>40</sup> . . . . .	25
11. Velocity vs Maximum Pressure for Test Configuration <sup>40</sup> . . . . .	26
12. Predicted Effect of Ignition in the 8-In., M110E2 Howitzer (M188E1, Zone 9 Propelling Charge) <sup>8</sup> . . . . .	27
13. Pressure Difference Simulation for 5-In./54-Caliber Gun <sup>14</sup> . . . . .	28
14. Burning Rate Descriptions Selected to Achieve Equivalent Rates at 25 kpsi <sup>44</sup> . . . . .	30
15. Influence of Burning Rate Description on Predicted Initial Reverse Pressure Difference (Coefficients Selected to Achieve Equivalent Burning Rate at 25 kpsi) <sup>44</sup> . . . . .	31
16. Effect of Charge Configuration on Chamber Pressure <sup>49</sup> . . . . .	34
17. Pressure-Time and Differential Pressure-Time Traces for 7- and 19-Perforated Grains <sup>46</sup> . . . . .	35
18a. Pressure-Time Trace for 5-In./38-Caliber Gun with Pyro Propellant and Primer MK 48 Mod 2 <sup>35</sup> . . . . .	36

LIST OF ILLUSTRATIONS (continued)

Figure	Page
18b. Pressure-Time Trace for 5-In./38-Caliber Gun with NACO Propellant and Primer MK 48 Mod 2 <sup>35</sup> . . . . .	36
19a. Pressure-Time Curves for Oto Melara 76-mm Gun with Potassium Sulfate Confined in a Polyethylene Bag <sup>51</sup> . . . . .	37
19b. Pressure-Time Curves for Oto Melara 76-mm Gun with Granular Potassium Sulfate Dispersed in Propellant Bed <sup>51</sup> . . . . .	38
20. Propelling Charge Assembly for 76-mm Oto Melara Gun. . . . .	40
21. Comparison of Theoretical Predictions of Pressure Difference with Experimental Results <sup>57</sup> . . . . .	41
22. Special Experimental Propelling Charges for 5-In./54-Caliber Gun <sup>57</sup> . . . . .	42
23. Pressure-Time Profiles for the 8-In., M110E2 Howitzer Breechblow (M188E1, Zone 9 Propelling Charge) <sup>8</sup> . . . . .	44
24. Air Gun Impact Test Results for M6 Propellant <sup>51</sup> . . . . .	45
25. Igniter Simulator Apparatus <sup>63</sup> . . . . .	48
26. Effect of Standoff on the Amplitude of $-\Delta P_i$ <sup>65</sup> . . . . .	49
27. Pressure Wave Sensitivity for the 175-mm, M107 Gun (M86A2, Zone 3 Propelling Charge) <sup>8</sup> . . . . .	52
28. Distribution of Pressure Wave Amplitudes for the 175-mm, M107 Gun (M86A2, Zone 3 Propelling Charge) <sup>8</sup> . . . . .	52
29. Probability of High-Amplitude Pressure Waves for the 175-mm, M107 Gun (M86A2, Zone 3 Propelling Charge) <sup>8</sup> . . . . .	53

LIST OF TABLES

Table	Page
1. Effect of Loading Density on Pressure Waves. . . . .	33
2. Summary of Predictions and Results for Rum Point Firings of June 19, 1975 <sup>56</sup> . . . . .	43
3. Concepts for Pressure-Wave Reduction . . . . .	54



## I. INTRODUCTION

Combustion instability in conventional guns as manifested by longitudinal pressure waves has been a phenomenon largely ignored by propelling charge designers unless accompanied by catastrophic failures. A similar situation existed for many years within the rocket motor design community. Today, however, the principle that combustion instability design considerations must be integrated into the overall propulsion design approach is well accepted<sup>1</sup>. The problem in both communities, however, has been the intrinsic difficulty of specifying acceptable levels of instability and integrating into the overall propulsion package development process the techniques and approaches known to minimize combustion instability.

From a pragmatic viewpoint, combustion instability in guns as exhibited by pressure waves is of concern only because of its causal connection with high chamber pressures, which, in turn, may lead to breechblows, ballistic variability, projectile prematures, and fuze malfunctions. The relationship, however, is not necessarily a simple one. Low-performance propelling charge and gun combinations seem to be able to tolerate a fairly substantial level of pressure waves without any apparent effect on maximum chamber pressures. Maximizing some performance parameter, such as muzzle velocity, usually leads to increased pressure wave problems. This problem has been discussed recently in the context of current development efforts<sup>2</sup>. Typically, the charge designer is asked to launch a specified projectile at a muzzle velocity necessary to achieve a given range, target penetration, or time of flight. This projectile launch velocity must be achieved out of a gun with an interior ballistic envelope usually designed to meet different performance requirements. It is indeed rare for a gun charge designer to dictate those gun envelope parameters important to him (e.g., loading density, maximum operating pressures, projectile travel, propellant type, etc.). Normally one rather quickly determines if a specified launch velocity is attainable using the simpler interior ballistic models<sup>3</sup>. When additional, stringent design requirements for velocity precision, ballistic temperature coefficient, useful wear life, muzzle flash and blast, propellant availability, chamber residue, packaging geometry, and compatibility with other, similar weapon systems and projectiles are added, the design easily can become a challenge. These more or less

<sup>1</sup>"Combustion Instability in Solid Rocket Motors", Chemical Propulsion Information Agency, Laurel, MD. Publ. 290, Nov. 1977.

<sup>2</sup>I. W. May, "The Role of Ignition and Combustion in Gun Propulsion: A Survey of Developmental Efforts", Thirteenth JANNAF Combustion Meeting, Chemical Propulsion Information Agency, Laurel, MD, Publ. 281, Sept. 1976.

<sup>3</sup>P. G. Baer, "Practical Interior Ballistic Analysis of Guns", *Interior Ballistics of Guns*, Ed. M. Summerfield and H. Krier, *Progress in Astronautics and Aeronautics*, Vol. 66, 1979.

firm and clear requirements need to be validated during the development cycle of the charge. Hence potentially serious but less well-defined pressure-wave problems often are ignored. Only when pressure waves have, or are suspected to have, impacted directly on a well-defined performance requirement has the available, though meager, technology been applied in the past. Indeed it only recently has become accepted practice to determine if nominal pressure wave characteristics of a propelling charge, as measured during limited test programs, are likely to reach high amplitudes. If this is possible, then interior ballistic system sensitivity to pressure waves is determined.

This recent emphasis on pressure waves is the result of many diverse problems encountered in both Army and Navy gun development programs. In the past five years these have resulted in experimental<sup>4-8</sup> and theoretic-

---

<sup>4</sup>J. H. Wiegand, J. H. Smith and A. W. Horst, "Ignition Studies at Indian Head", *Proceeding of the Tri-Service Gun Propellant Symposium, Picatinny Arsenal, Dover, NJ, Oct. 1972.*

<sup>5</sup>A. W. Horst, T. C. Smith, and S. E. Mitchell, "Experimental Evaluation of Three Concepts for Reducing Pressure Wave Phenomena in Navy 5-inch, 54-Caliber Guns: Summary of Firing Data", *Naval Ordnance Station, Indian Head, MD. MR 76-258, Aug 1976.*

<sup>6</sup>W. G. Soper, "Ignition Waves in PYRO Propellant", *Combustion and Flame, Vol. 22(2), April 1974, pp. 273-276.*

<sup>7</sup>J. J. Rocchio, K. J. White, C. R. Ruth, and I. W. May, "Propellant Grain Tailoring to Reduce Pressure Wave Generation in Guns", *12th JANNAF Combustion Meeting, Chemical Propulsion Information Agency, Laurel, MD, Publ. 273, December 1975.*

<sup>8</sup>A. W. Horst, I. W. May, and E. V. Clarke, Jr., "The Missing Link Between Pressure Waves and Breechblows", *Ballistic Research Lab., Aberdeen Proving Ground, MD., ARBRL-MR-02849, July 1978. (AD #A058354)*

cal<sup>9-14</sup> efforts to understand and model the phenomenology of pressure waves in guns.

It is the aim of this paper to illustrate some of the historical aspects of gun pressure-wave phenomena, to present some current diagnostic information on pressure-wave measurements, and to discuss, in the context of current experimental and theoretical understanding, the basic charge design factors influencing the creation and growth of pressure waves. Finally, a new procedure for assessing safety aspects due to pressure waves will be outlined.

## II. PRESURE-WAVE PHENOMENOLOGY

A brief historical background on gun pressure-wave phenomenology has been presented previously<sup>15</sup>. More recently, a survey on pressure-wave generation in gun systems has been reported by Budka and Knapton<sup>16</sup>.

<sup>9</sup>K. K. Kuo, R. Vichrevetsky, and M. Summerfield, "Generation of an Accelerated Flame Front in a Porous Propellant", AIAA Paper 71-210, New York, Jan. 1971.

<sup>10</sup>P. S. Gough, "Numerical Analysis of a Two-Phase Flow with Explicit Internal Boundaries", Naval Ordnance Station, Indian Head, MD., CR 77-5, April 1977.

<sup>11</sup>E. B. Fisher and K. W. Graves, "Propellant Ignition and Combustion in the 155-mm Howitzer", Calspan Corp., Buffalo, N.Y., VQ-5524-D-2, Jan. 1975.

<sup>12</sup>K. K. Kuo, J. H. Koo, T. R. Davis, and G. R. Coates, "Transient Combustion in Mobile Gas Permeable Propellants", Acta Astronautica, Vol. 3, 1976, pp. 573-591.

<sup>13</sup>H. Krier, "Predictions of Flamespreading and Pressure Wave Propagation in Propellant Beds", Ballistic Research Lab., Aberdeen Proving Ground, MD., CR 275, Nov. 1975. (AD #B009170L)

<sup>14</sup>A. W. Horst, C. W. Nelson and I. W. May, "Flame Spreading in Granular Propellant Beds: A Diagnostic Comparison of Theory to Experiment", AIAA Paper 77-586, Orlando, Fla., July 1977.

<sup>15</sup>I. W. May and E. V. Clarke, Jr., "A Case History: Gun Ignition Related Problems and Solutions for the XM-198 Howitzer", Ballistic Research Lab., Aberdeen Proving Ground, MD., IMR 150, Oct. 1973.

<sup>16</sup>A. J. Budka and J. D. Knapton, "Pressure Wave Generation in Gun Systems: A Survey", Ballistic Research Lab., Aberdeen Proving Ground, MD., MR 2567, Dec. 1975. (AD #B008893L)

Goode and Weald<sup>17</sup> attempted to classify different categories of pressure-wave irregularities. The classic interior ballistics textbooks by Corner<sup>18</sup> and Hunt and Hinds<sup>19</sup> also briefly mention the existence and the perverse nature of pressure waves.

The first observation of pressure waves in a gun chamber was made by Vielle<sup>20</sup> (circa 1880) with his invention, the recording crusher gage. The significance of pressure waves, their origin and connection with high pressure and catastrophic failure was, however, not appreciated fully until the 1930's, with the advent of reliable piezoelectric gages capable of withstanding the rigors of a gun environment. Kent, in early work with piezoelectric gages<sup>21,22</sup>, correctly identified the cause of pressure waves in the 155-mm Gun, Model 1918, M1, as being due to vigorous base ignition of the charge. He also reasoned<sup>23,24</sup> that some

---

<sup>17</sup>J. B. Goode and D. E. Weald, "Survey-Fluid Dynamic Aspects of the Internal Ballistics of Guns", Advisory Group for Aerospace Research and Development (NATO), AGARD Conference Proceedings No. 40, Sept. 1966, pp. 1-12.

<sup>18</sup>J. Corner, *Theory of the Interior Ballistics of Guns*, Wiley, New York, 1950.

<sup>19</sup>F. R. W. Hunt and G. H. Hinds, *Internal Ballistics*, Philosophical Library, New York, 1951, p. 80.

<sup>20</sup>P. Vielle, quoted by C. Cranz in *Lehrbuch der Ballistik*, Vol. II, Springer-Verlag, Berlin, 1926, p. 151.

<sup>21</sup>R. H. Kent, "Study of Ignition of 155-mm Gun in Connection with Project KW 250-Study of the Factors Involved in the Design of Propelling Charges", Ballistic Research Lab., Aberdeen Proving Ground, MD., MR 4, Feb. 1935. (AD #493405)

<sup>22</sup>R. H. Kent, "Study of Ignition of 155-mm Gun", Ballistic Research Lab., Aberdeen Proving Ground, MD., R22, Oct. 1935. (AD #494703)

<sup>23</sup>R. H. Kent, "Velocity Dispersion Obtained with Charles of Slender Base Section in the 155-mm Gun G.P.F.," Ballistic Research Lab., Aberdeen Proving Ground, MD., R45, March 1936.

<sup>24</sup>R. H. Kent, "Study of the Ignition and Velocity Dispersion of FNH Powder in the 155-mm Gun G.P.F.," Ballistic Research Lab., Aberdeen Proving Ground, MD., R91, Dec. 1937. (AD #491768)

of the velocity dispersion accompanying this particular charge/gun combination resulted from pressure oscillations traversing the chamber, leading to slightly higher pressures and velocities. In his attempt to reduce the velocity dispersion, he employed various ignition train configurations to achieve smooth pressure-time curves. Some of his results are shown in Figure 1. His basic concepts of annular space around the charge to allow flamespreading and pressure equilibration throughout the chamber are still useful, as are the results of his experiments with central and centercore ignition. He recognized the benefits of the natural convective channels found in strip and stacked charges. He also commented on the additional safety factor required in the gun design when large-amplitude pressure-waves are present.

The work by Hedden and Nance<sup>25</sup> represents one of the most comprehensive experimental studies of pressure-waves resulting from variations in the location of the ignition source in a propellant bed and the effects of free space or ullage on wave generation and propagation. Hedden and Nance used a blowout gun made by cutting off a Navy 5-In./38-Caliber Gun approximately 9.5 in. (24.1 cm) forward of the origin-of-rifling and modified by installing an orifice at a point representing the location of the projectile base. Three pressure gages were installed: at mid-chamber, 3 in. (7.6 cm) forward of the breech, and 3 in. (7.6 cm) rearward from the orifice. In properly controlled experiments, the pressure-time histories could be made to duplicate actual gun performance. By adjusting the free space behind and in front of the charge and by adjusting the location of a point-type, localized ignition source, these experiments were able to determine how pressure-waves could be induced and avoided.

They concluded that placing the ullage completely toward either end of the chamber and igniting the charge adjacent to the ullage produced the largest-amplitude waves. Moving the point of ignition away from the ullage reduced wave amplitude. Distributing the free space at both ends of the charge and igniting the charge in the center gave smooth pressure-time records. Some representative results showing the space/ignition relationship and resulting pressure-time histories from the different gage locations are illustrated in Figures 2 and 3.

Other studies, by Bauman and Bird<sup>26</sup> and Gowen and Elzufon<sup>27</sup>, confirmed the importance of geometric effects such as location of the ignition source and the distribution of free space in the chamber.

<sup>25</sup> S. E. Heddon and G. A. Nance, "An Experimental Study of Pressure-Waves in Gun Chambers," Naval Proving Ground, Dahlgren, VA., R 1534, April 1957.

<sup>26</sup> N. Bauman and E. Bird, "Ignition Problems in Separate-Loading Ammunition," Joint Army-Navy-Air Force Second Symposium on Propellant Ignition, Vol. II, Solid Propellant Information Agency, Silver Spring, MD., October 1956.

<sup>27</sup> L. Gowen and E. Elzufon, "A Review of Igniter Studies and Their Application to Igniter Design," Joint Army-Navy-Air Force Second Symposium on Solid Propellants, Vol. II, Solid Propellant Information Agency, Silver Spring, MD., Oct. 1956.

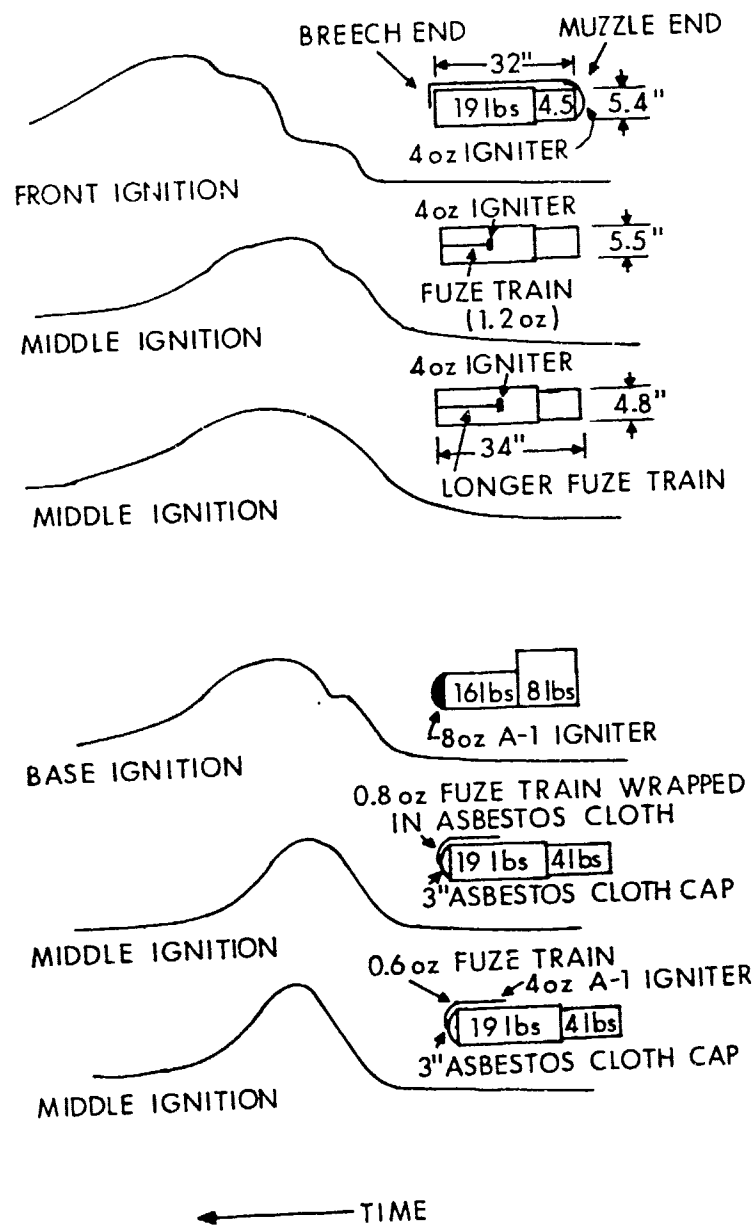

Figure 1. Pressure vs. Time Data From an Ignition Study in a 155-mm Gun<sup>22</sup>

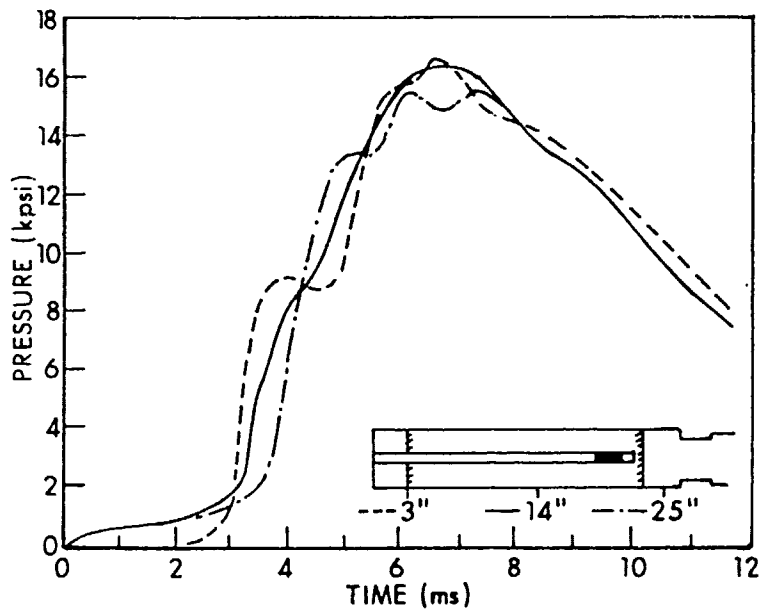
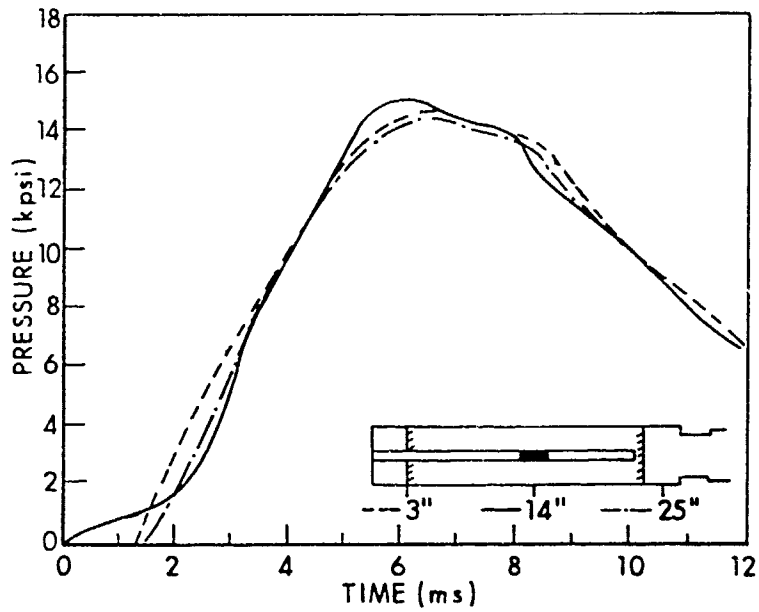

Figure 2. Pressure-Time Records for a Navy 5-In./38 Caliber Blowout Gun<sup>25</sup>

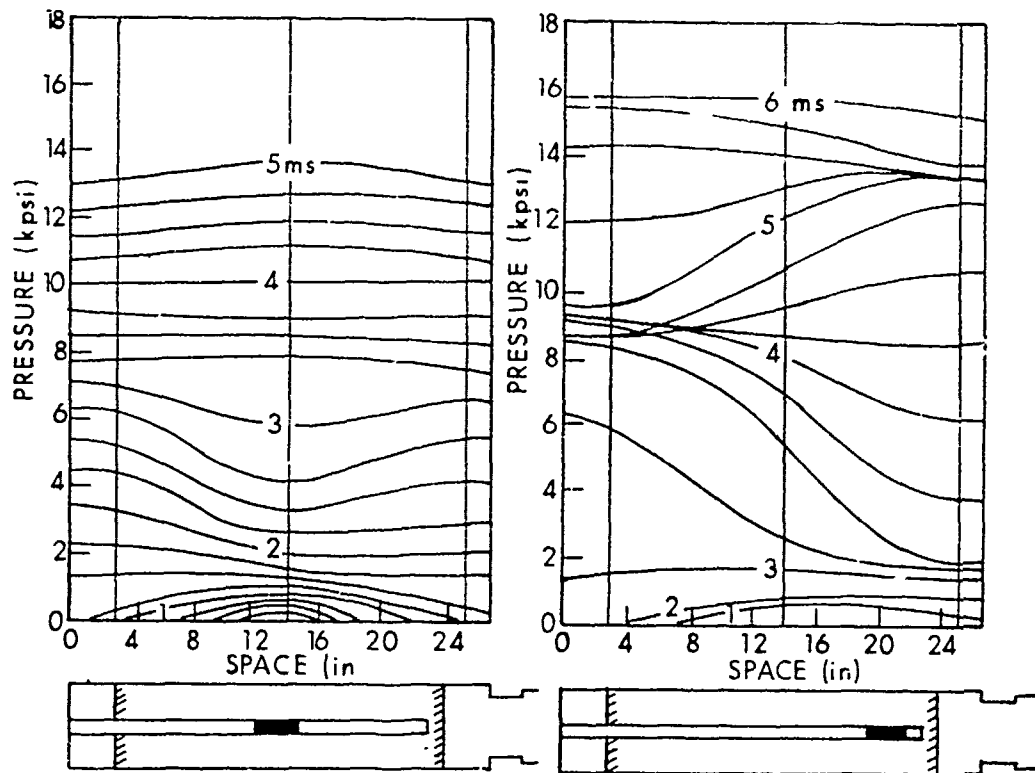

Figure 3. Pressure-Space-Time Profiles<sup>25</sup>

Lockett<sup>28</sup>, in a brief review of some British work on propellant ignition, explicitly states that failure to achieve simultaneous ignition in granular propellant charges can lead to axial pressure waves of sufficient magnitude to reach gun-damaging pressures. He further states,

"It may be pertinent to point out at this juncture that there is always some uncertainty in the interpretation of what might be dismissed as minor irregularities in the pressure-time curve. We have, by bitter experience, learned to regard such irregularities with a degree of suspicion which has delayed in some cases the finalization of a suitable ignition system for a particular weapon, because of the apparent ease with which such minor flaws can turn over to major irregularities by some mechanism not yet understood".

<sup>28</sup>N. Lockett, "British Work on Solid Propellant Ignition", *Bulletin of the First Symposium on Solid Propellant Ignition*, Solid Propellant Information Agency, Silver Spring, MD., September 1953.



An interesting difficulty is referred to by Gowen and Elzufon<sup>27</sup>. In an attempt to reduce hangfires, they increased the amount of igniter material. When that problem was solved for a particular cool-burning, single-base propellant at the low temperatures, pressure waves developed at the high temperatures. Apparently they could not solve both the hang-fire and pressure-wave problem simultaneously. Another conclusion from this work, since confirmed by many other investigators, is that pressure waves are less likely to develop or are of lower amplitude at lower temperatures. For the case of brittle propellant grains, however, mechanical failure of the grain at the lower temperatures can lead to a different phenomenon, as evidenced by our catastrophic experience with M17 triple-base propellant in the 76-mm tank guns in Korea<sup>29</sup>. This propellant exhibited breakup even in closed-bomb burning rate experiments<sup>30</sup>. In an earlier report, Lane<sup>31</sup> had speculated that low-temperature propellant brittleness contributed to excess velocity dispersion. He also conjectured that peak pressure increases were the result of higher-amplitude pressure-waves. A more recent, further development of the impact of propellant mechanical properties on pressure waves will be discussed in a following section.

### III. EXPERIMENTAL CONSIDERATIONS

Pressure waves often have been confused with what euphemistically has been called "erratic" propellant burning. In fact, for multigranulated, zoned propelling charges, the characteristic "steps" seen in pressure vs time curves obtained in one location sometimes have been ascribed erroneously to the burning of different increments of a charge. Only the more recent practice of multiple-location pressure measurements has allowed unambiguous tracking of pressure waves. Of particular usefulness is the technique of differential chamber pressure measurements<sup>17,32</sup>. Pressure gages are installed in separated, longitudinal positions along the gun chamber, typically as shown in Figure 4. The signals from these gages then are subtracted from one another, resulting in a sensitive indicator of pressure waves. An example of a rather typical high-performance bag charge design is shown in Figure 5. When

<sup>29</sup>*"Ignition Study of Gun, 76-mm, T91", Aberdeen Proving Ground, Firing Record P-52014, Project TA11302, Feb. 1952.*

<sup>30</sup>*K. H. Russell and H. M. Goldstein, "Investigation and Screening of M17 Propellant Production for Lots Subject to Poor Low Temperature Performance", Picatinny Arsenal, Dover, NJ., DB-TR-7-61, June 1961.*

<sup>31</sup>*J. R. Lane, "Sub-Zero Firings in the 76-mm Gun", Ballistic Research Lab., Aberdeen Proving Ground, MD., MR 215, Sept. 1943. (AD #493524)*

<sup>32</sup>*T. G. Hughes, "Product Improvement Test of Charge, Propelling M86A1, for 175-mm Gun, M113", Ballistic Research Lab., Aberdeen Proving Ground, MD., DPS-2551, April 1967.*

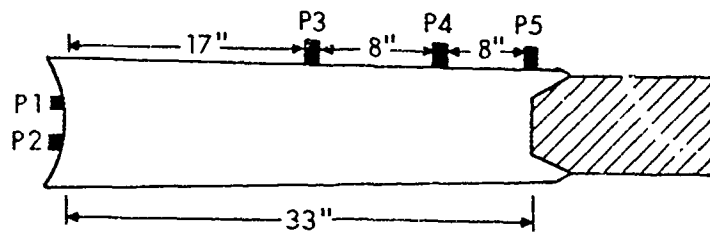

Figure 4. Typical Location of Pressure Transducers in Chamber

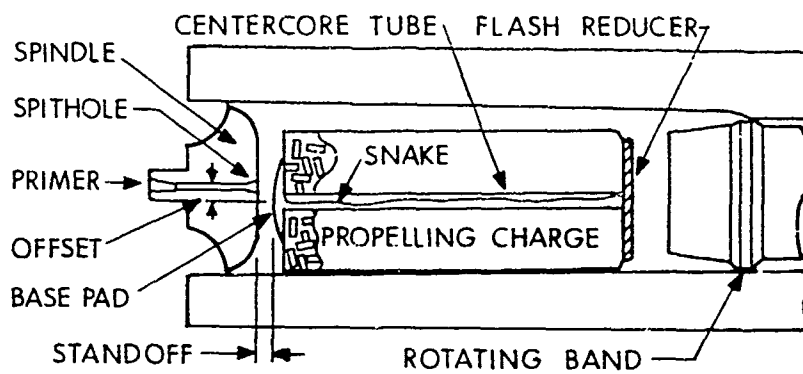

Figure 5. Typical Centercore-Ignited Artillery Propelling Charge

the centercore ignition train functions rapidly and uniformly throughout the entire propelling charge, near ideal ignition is achieved. This type of ignition results in a pressure-time trace, as shown in Figure 6. There is no evidence of any pressure waves in the basic pressure-time traces. More importantly, the difference of breech pressure minus chamber-mouth pressure shows only the expected "Lagrangian" pressure gradient resulting from the gas velocity gradient between breech and projectile base. A severe case of pressure waves due to a malfunctioning centercore is shown in Figure 7. In this case, the pressure-difference curve shows clearly the initial gas pressurization occurring near the breech region. Then rapid pressurization is seen by the forward gage. After the stagnation or flow reversal point, the wave returns to the breech and again is reflected. One notes many flow reversals before complete damping occurs late in the interior ballistic cycle. The first negative minimum on the pressure-difference curve,  $-\Delta P_i$ , currently is used as an index of how well an ignition train has performed. It also is being used in a failure analysis procedure to be discussed later. The pressure-difference curve also is used as a powerful tool in comparing theoretical and experimental pressure-time curves<sup>14</sup>.

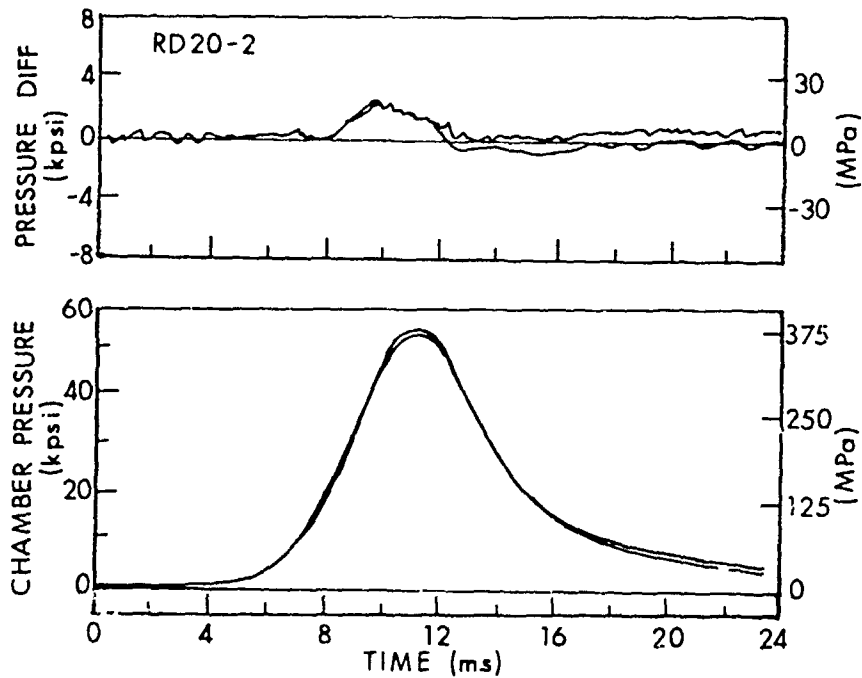

Figure 6. Pressure-Time and Pressure-Difference Profiles for a Properly Ignited, High-Performance Charge

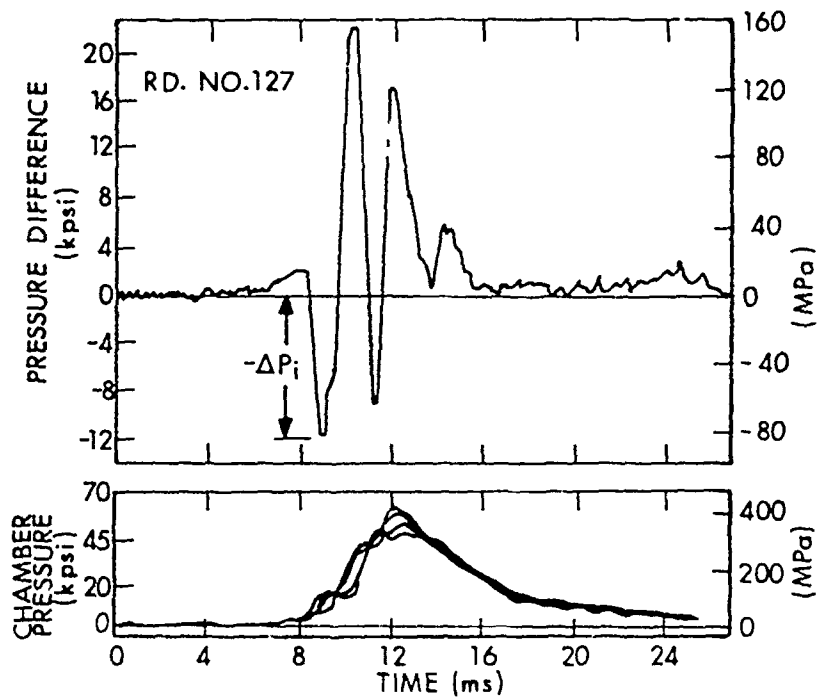

Figure 7. Pressure-Time and Pressure-Difference Profiles, Localized Base Ignition

#### IV. CHARGE DESIGN FACTORS INFLUENCING PRESSURE WAVES

The quantitative description of the generation, growth, and development of pressure-waves is reviewed by Gough<sup>33</sup> and Krier<sup>34</sup>. The essential qualitative physics is summarized<sup>8</sup> in the following manner. The propellant bed is ignited in a localized region of the chamber. This occurs typically in the breech region, although cases of accidental and deliberate forward ignition have been observed, with a mirror-image development of the wave phenomenon. The propellant and igniter gases penetrate into the bed, convectively heating grains to ignition and resulting in flamespread. The pressure gradient and drag move the granular propellant forward, compacting in against the projectile base. The combustion-driven pressure wave reaches the projectile, stagnates, and is reflected toward the breech. Wave growth or dissipation is determined by the local gas generation rate, available free volume, bed permeability, and projectile motion. The pressure waves continue to reflect between the breech and projectile until dissipated. In extreme cases, when the pressure generated exceeds the yield stress of the gun, a catastrophic breechblow is the result. An example is shown in Figure 8. This breechblow was the result of removing the normal centercore ignition train from a 175-mm gun propelling charge. It is a classic example of severe, breech-localized ignition, with chamber pressures in excess of twice what is seen with a normally functioning centercore ignition train.

The aforementioned qualitative description has buried in it the dominant factors that affect the dynamic behavior of pressure waves. They are ignition stimulus, gas generation rate, initial bed permeability to gas flow, and initial ullage distribution. The influence of these factors now will be discussed in the light of some of the more recent experimental and analytical results.

##### A. Ignition Stimulus

This factor was the first to be recognized as having a dominant influence on pressure-wave generation. The basic work by Kent<sup>21</sup>, Heddon and Nance<sup>25</sup>, and others clearly illustrates the importance of the location of ignition stimulus in the gun chamber. The realization of axially distributed ignition as the ideal has led to the routine application, at least for high-performance systems, of bayonet metal primers in cased rounds and combustible centercore ignition systems in bag charge systems.

<sup>33</sup>P. Gough, "Modeling of Two-Phase Flow in Guns, *Interior Ballistics of Guns*, Ed. M. Summerfield and H. Krier, *Progress in Astronautics and Aeronautics*, Vol. 66, 1979.

<sup>34</sup>H. Krier and M. J. Adams, "An Introduction to Gun Interior Ballistics and a Simplified Ballistic Code," *Progress in Astronautics and Aeronautics*, Vol. 66, 1979.

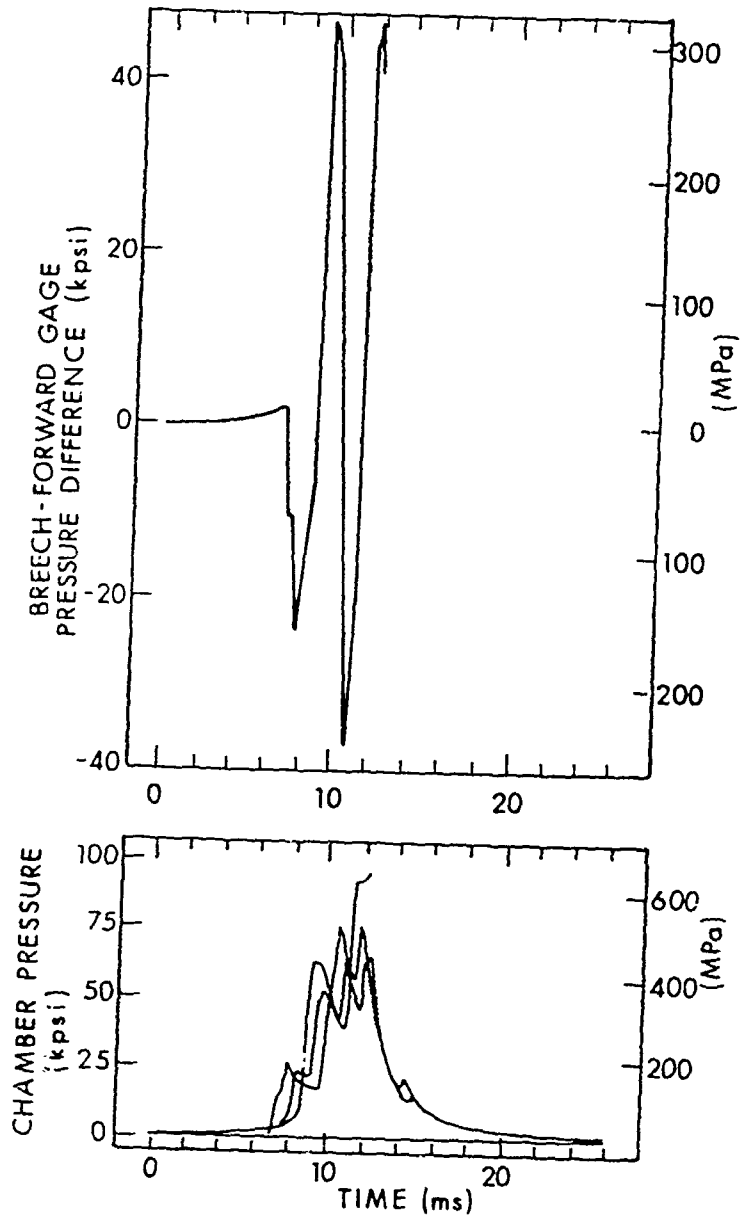

Figure 8. Catastrophic Pressure-Wave Dynamic Behavior Observed in a 175-mm Gun Firing

Other parameters, however, play an equally important role, especially for "nonideal" ignition systems. These are the rate at which both energy and gas pressure are delivered by the ignition train, as well as the total energy delivered to the propellant bed and the total "ignition" pressure. In practice, even centercore igniters for both cased and bag charge systems rarely function in the ideal manner. A typical example of the nonideal behavior of a bayonet primer has been described<sup>35</sup>. Figure 9 shows the firing results obtained using two versions of the MK 48 Primer tested in the Navy 5-In./38-Caliber Gun. The MK 48 Mod 2 Primer, venting largely in the first half of the chamber, results in strong pressure-wave symptoms. The longer MK 48 Mod 4 Primer, with venting more centrally located, leads to much improved pressure-time curves. It should be noted that the mere act of placing vent holes distributed over a full chamber length bayonet primer does not insure uniform venting. The studies by Vest<sup>36</sup>, and more recently by Smith<sup>37</sup> and East and McClure<sup>38</sup>, quite clearly indicate that pressure-wave phenomena inside bayonet primers can readily produce spatially and temporally uneven ignition gas venting. With our current knowledge and diagnostic capabilities, the design of new bayonet primers with near-ideal functioning is relatively straightforward. The recent work by Smith<sup>39</sup> supports this view. The unique problems of low-pressure combustible ignition systems for bag charges will be discussed separately.

Another recent, extensive study on the effects of igniter location<sup>40</sup> shows clearly the benefits of rapid, distributed ignition in reducing pressure waves. For this study, charges with nine different ignition system configurations with the same amount of black powder were fired out of a 5-In./54-Caliber Gun. The results are shown schematically in

<sup>35</sup>A. W. Horst and A. C. Haukland, "Gun Interior Ballistics: 1972 Annual Report," Naval Ordnance Station, Indian Head, MD., TR 386, April 1973.

<sup>36</sup>D. C. Vest, "On the Performance of Primers for Artillery Weapons", Ballistic Research Lab., Aberdeen Proving Ground, MD., R852, March 1953. (AD #13294)

<sup>37</sup>T. C. Smith, "Development of Electric Primer Mark 48 Mods 3 and 4 for the 5-inch, 38-Caliber Gun", Naval Ordnance Station, Indian Head, MD., TR 396, Feb. 1974.

<sup>38</sup>J. L. East and D. R. McClure, "Experimental Studies of Ignition and Combustion in Naval Guns", Twelfth JANNAF Combustion Meeting, Chemical Propulsion Information Agency, Laurel, MD., Publ. 273, Aug. 1975.

<sup>39</sup>T. C. Smith, "Rapid Ignition of Granular Propellant Beds with a 'Hotline' Igniter", 1978 JANNAF Propulsion Meeting, Chemical Propulsion Information Agency, Laurel, MD., Publ. 293, Feb. 1978.

<sup>40</sup>A. W. Horst, "Navy Gun Interior Ballistics Modeling Efforts: An Overview", 1973 JANNAF Propulsion Meeting, Chemical Propulsion Information Agency, Laurel, MD., Publ. 242, Sept. 1973.

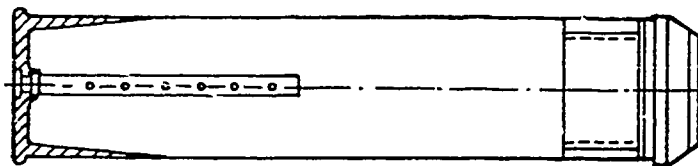
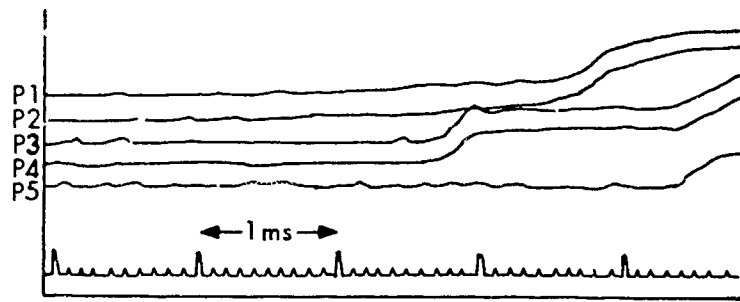

MOD 2 CONFIGURATION

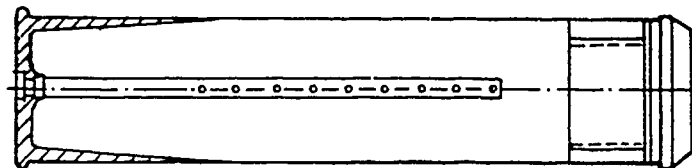
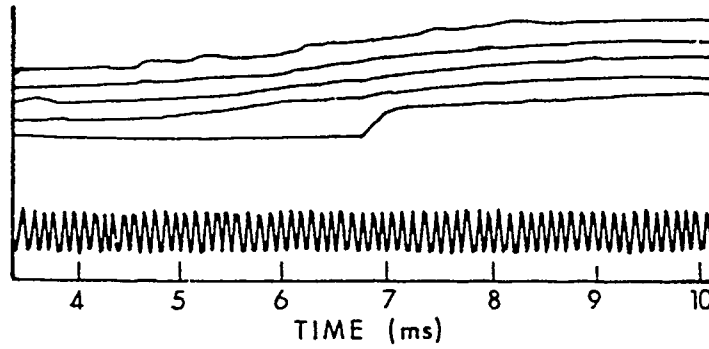

MOD 4 CONFIGURATION

Figure 9. Comparison of Pressure-Time Curves for NACO Propellant Firings with Primers MK 48 Mod 2 and MK 48 Mod 4<sup>35</sup>

Figure 10. The black powder in configuration I was ignited with a low-velocity detonation cord. Figures 10 and 11 clearly show the strong influence that pressure waves have on chamber pressure and muzzle velocity. One conclusion that can be drawn from these data is that, unless an ignition system functions with good reproducibility, ballistic variability can be increased. Another example of the effect of ignition variability on ballistic uniformity has been reported by Clarke and May<sup>41</sup> for a 155-mm howitzer bag charge. For base-ignited propelling charges, as the average pressure-wave level increased for a particular ignition system, the variability in the pressure-wave content increased, with accompanying increased muzzle velocity dispersion. During the development of this base-ignited charge, it also was noted that the faster base-pad igniter tested resulted in a higher level of pressure-waves, as might be expected.

Although several parametric, two-phase-flow, interior ballistic calculations concentrating on the ignition stimulus have been performed<sup>11,42</sup>, of particular note are the results by Horst et al.<sup>8</sup> using the NOVA code<sup>10</sup> to simulate an 8-in. howitzer breechblow induced by a deliberate blockage of the centercore ignition train. The effect of distributed ignition vs severe, localized ignition on pressure-wave generation is seen clearly in the computed pressure-time traces of Figure 12. It appears that current one-dimensional two-phase-flow interior ballistic codes that incorporate ignition and flamespread predict the appropriate trends as igniter location and delivery rate are varied. More impressive, perhaps, is the good agreement obtained between theory and experiment<sup>14</sup> in the simulation of the 76-mm Oto Melara and the 5-In./54-Caliber Gun. The latter is shown in Figure 13. For this cased gun simulation, experimentally measured primer output data were used as input to the NOVA calculation. Simulations for bag charge pressure-wave dynamics are, at present, not quite so successful.

---

<sup>41</sup>E.V. Clarke and I. W. May, "Subtle Effects of Low Amplitude Pressure Wave Dynamics on the Ballistic Performance of Guns", Eleventh JANNAF Combustion Meeting, Chemical Propulsion Information Agency, Laurel, MD., Publ. 261, September 1974.

<sup>42</sup>E. Fisher, K. Graves and A. Trippe, "Application of a Flamespread Model to Design Problems on the 155-mm Propelling Charge", Twelfth JANNAF Combustion Meeting, Chemical Propulsion Information Agency, Laurel, MD., Publ. 273, December 1975.



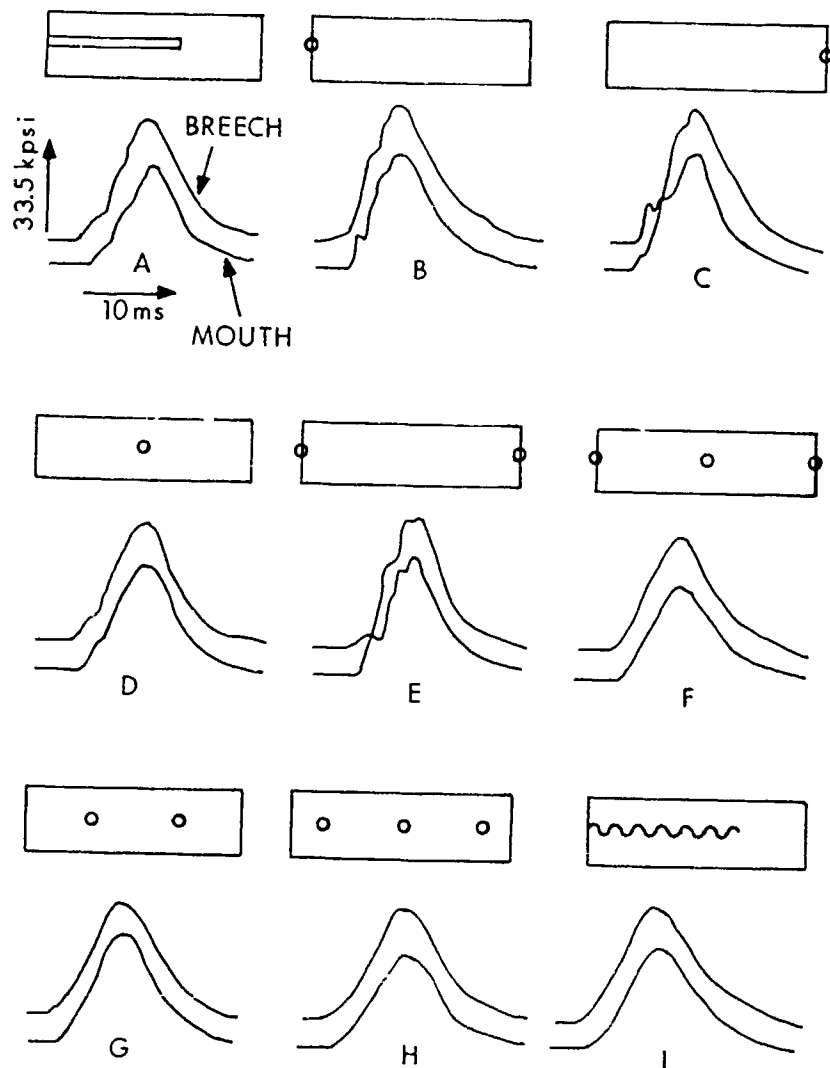

Figure 10. Ignition Study Test Results<sup>40</sup>

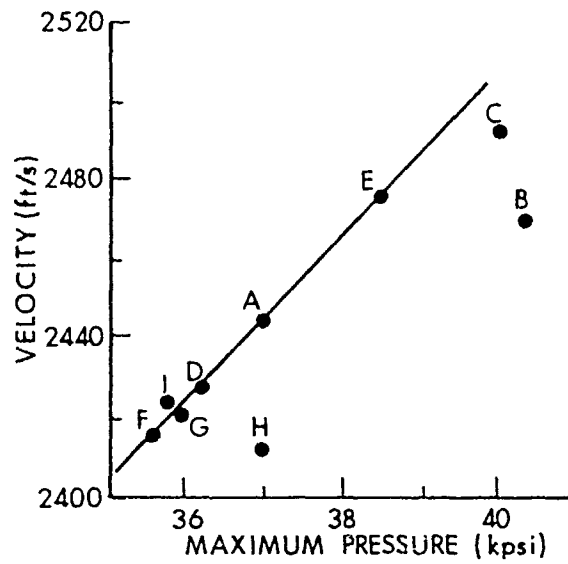

Figure 11. Velocity vs. Maximum Pressure for Test Configuration<sup>40</sup>

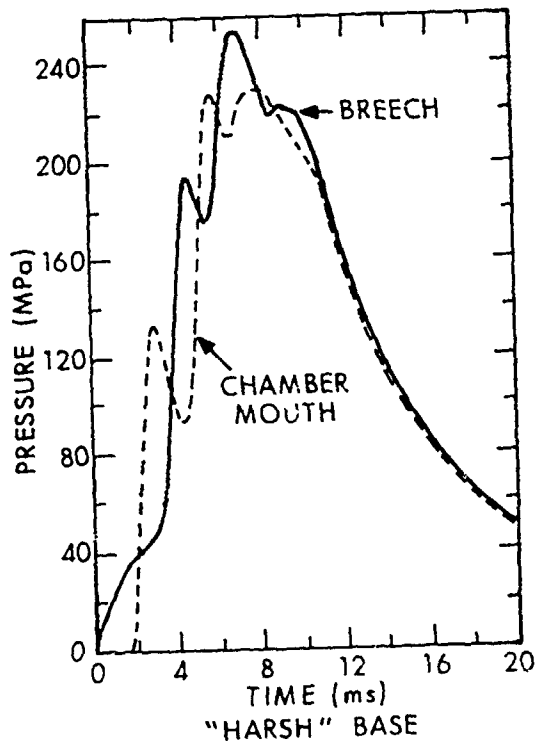
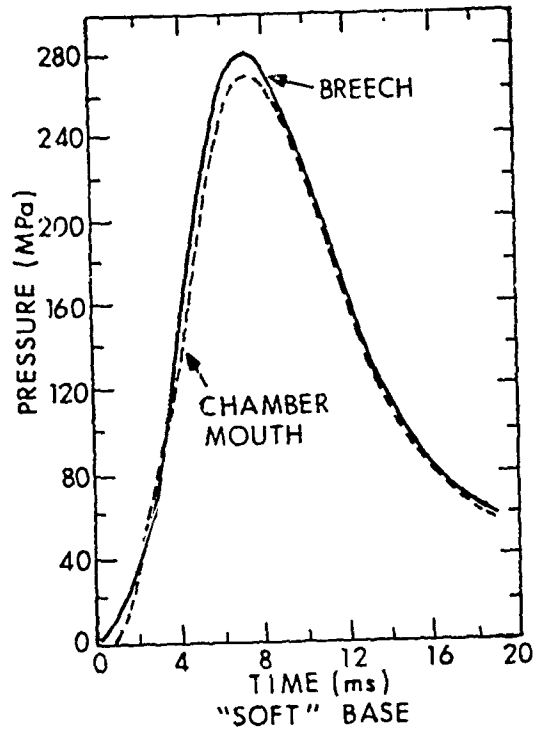

Figure 12. Predicted Effect of Ignition in the 8-In., M110E2 Howitzer (M188E1, Zone 9 Propelling Charge)<sup>8</sup>

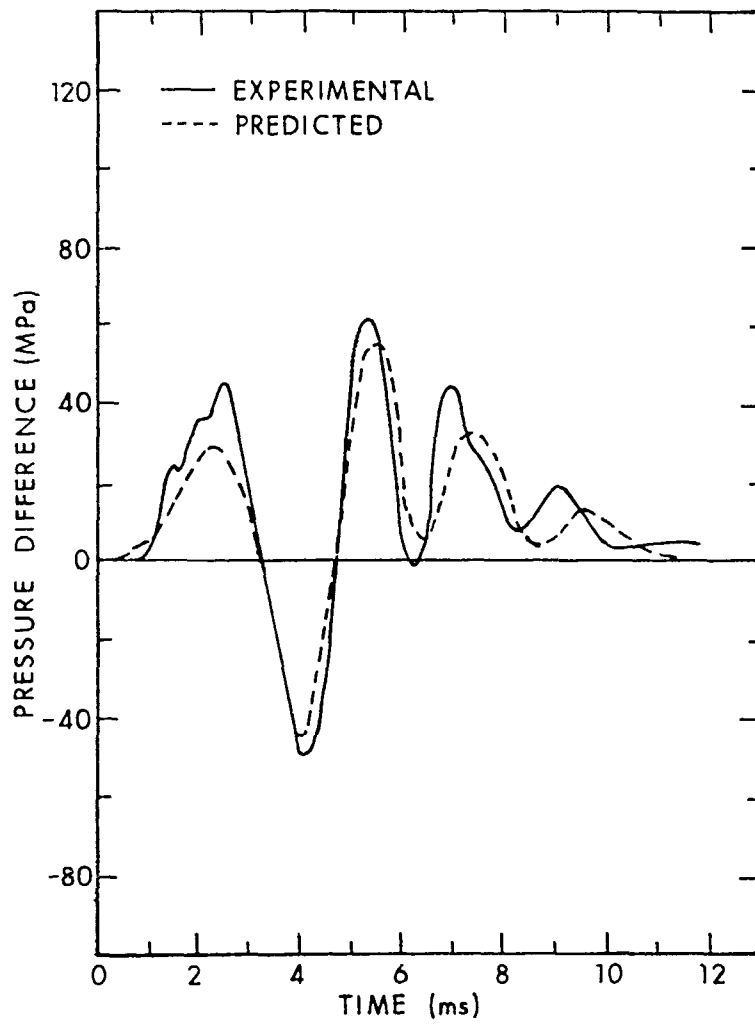

Figure 13. Pressure Difference Simulation for 5-In./54-Caliber Gun<sup>14</sup>

From the arguments presented by Hicks<sup>43</sup> and based on the analysis of some of the experimental results, the following conclusion can be drawn. The more localized the ignition stimulus is in the chamber and the higher its energy delivery rate to the propellant, the more severe a case of local propellant ignition, burning, and gas pressure buildup can be expected. In addition, the ignition stimulus is, of course, coupled strongly to the initial gas generation rate, propellant bed permeability, and charge/chamber geometry factors important in determining charge motion.

#### B. Mass Burning Rate

The contribution of the initial gas generation rate to the growth of pressure waves is well illustrated in a parametric study<sup>44</sup> on the influence of the burning rate description on the predicted initial reverse pressure difference. This NOVA study considers a propelling charge for the 5-In./54-Caliber Gun with combinations of propellant burning rate coefficients and exponents chosen such that the maximum chamber pressures and muzzle velocities remained roughly constant. The burning rate exponents varied significantly, as shown in Figure 14. The important point to note is that, in the low-pressure region, the extreme burning rate descriptions varied by a factor of two. In other words, the high exponent burning rate is substantially lower in the ignition regime. This results in a lower propellant gas production rate. Hence any localized pressures generated will have more time to be dissipated throughout the chamber and thus should lead to a reduction of pressure-waves. Indeed the computed results in Figure 15 show nearly a factor of two reduction in the reverse pressure difference. There are several important deductions that can be drawn from this analysis. Since burning rates increase with initial temperatures, one would expect, in general, a lower level of pressure waves at low temperatures than at high temperatures. In fact, such a trend has been observed routinely in recent charge development efforts for a 155-mm howitzer<sup>45</sup>. Although, in the realm of speculation<sup>45</sup>, we should expect that deterred or inhibited propellants will also be less likely to support the growth of pressure waves. An analysis of the initial surface area of multiperforated grain geometries indicates that ballistically equivalent 19- and 37-perforated

<sup>43</sup>B. L. Hicks, "Some Characteristics of the Practical Ignition of Propellants", Ballistic Research Lab., Aberdeen Proving Ground, MD., MR 640, Dec. 1952. (AD #3342)

<sup>44</sup>A. W. Horst, "Influence of Propellant Burning Rate Representation of Gun Environment Flamespread and Pressure-Wave Predictions", Naval Ordnance Station, Indian Head, MD., MR 76-255, March 1976.

<sup>45</sup>J. W. May, C. W. Nelson, J. J. Rocchio and K. J. White, "The Role of Ignition in Artillery Propulsion", Proceedings of the Third International Symposium on Ballistics, Deutsche Gesellschaft fur Wehrtechnik, Karlsruhe, Germany, March 1977.

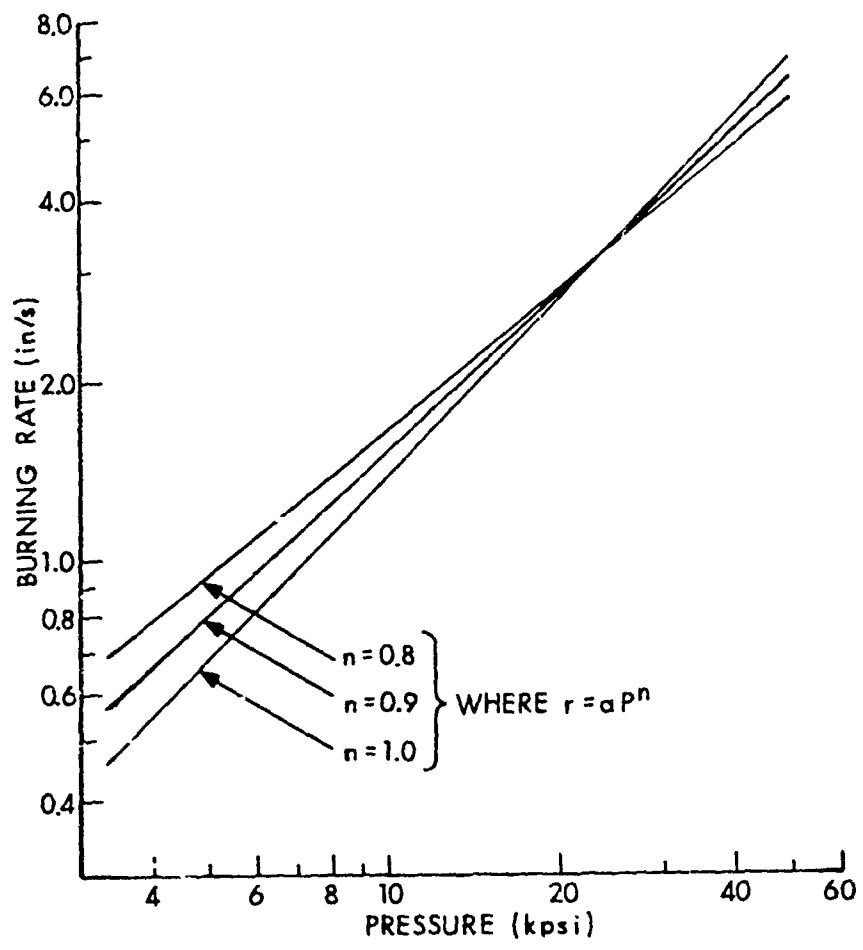

Figure 14. Burning Rate Descriptions Selected to Achieve Equivalent Rates at 25 kpsi<sup>44</sup>

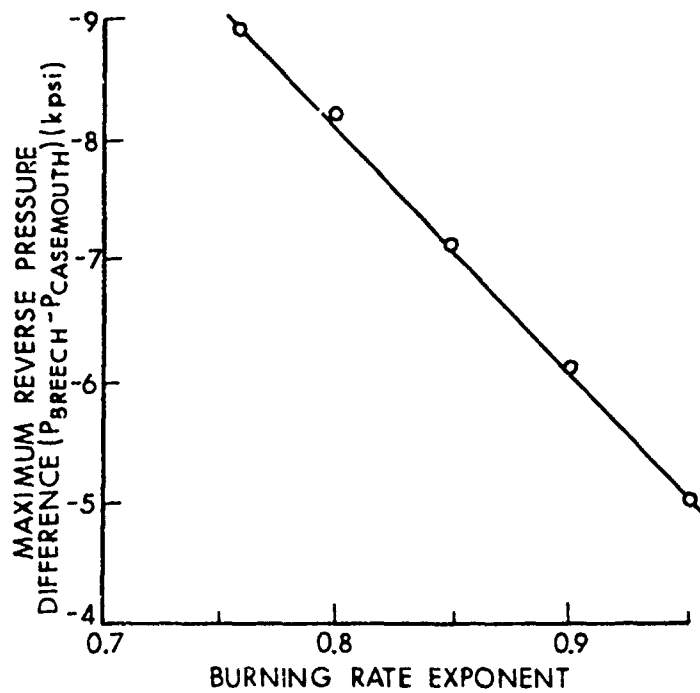

Figure 15. Influence of Burning Rate Description on Predicted Initial Reverse Pressure-Difference (Coefficients Selected to Achieve Equivalent Burning Rate at 25 kpsi)<sup>44</sup>

grains have reduced initial surface areas over 7-perforated grains and hence should offer a reduction in pressure-wave tendencies<sup>46</sup>. A more subtle effect also might be of importance. It has long been postulated<sup>19</sup> that ignition of the inner perforations is delayed until some critical pressure or flow condition is reached. This factor, admittedly not well documented, also would enhance the pressure-wave reduction of multi-perforated propellants. Since the more unusual 19- and 37- perforated grain geometries also improve gas flow permeability, discussion of experimental results will be deferred to the next section.

Because the low-pressure mass burning rate now is known to be an important factor in pressure-wave phenomenology, it is somewhat disappointing to discover that good, low-pressure burning rate data for gun propellants are almost nonexistent. Another study by Horst et al.<sup>14</sup> points out this dilemma. In attempting to achieve a reasonable simulation of experimental results for base-ignited charges, the low-pressure burning rate had to be increased artificially by the addition of a small constant value to the closed-bomb  $ap^n$  fit. On a relative basis, this has a substantial effect on the low-pressure burning rate and improves substantially the agreement between simulation and experiment. It is tempting to conjecture that a transient burning rate contribution is the likely explanation. The observation that this effect appears to be associated more with base ignition is puzzling. Kooker and Nelson<sup>47</sup> have examined the responses of three different transient burning models under typical gun pressurization envelopes. Their main conclusions are that the effect is usually important only in the low-pressure region, and burning rate enhancement factors on the order of 10 are plausible. Experimental verification is lacking, however. Of a more practical nature is the inference that a charge operating at a higher pressure is more likely to have pressure-wave problems than a lower pressure charge. This is the result of the enhanced, low-pressure mass burning rate required to obtain the higher pressures. Because of the effect of available volume on the generated pressure and its feedback on the burning rate, one also should expect increased pressure-wave generation as the loading density and the maximum chamber pressure increase. An example of this effect is shown in Table 1<sup>48</sup>. It should be noted, however, that this effect also is complicated by both charge geometry and bed-permeability effects.

---

<sup>46</sup>J. J. Rocchio, C. R. Ruth and I. W. May, "Grain Geometry Effects on Wave Dynamics in Large Caliber Guns", Thirteenth JANNAF Combustion Meeting, Chemical Propulsion Information Agency, Laurel, MD., Publ. 281, Dec. 1976.

<sup>47</sup>D. E. Kooker and C. W. Nelson, "Numerical Solution of Three Solid Propellant Combustion Models During a Gun Pressure Transient", Ballistic Research Lab., Aberdeen Proving Ground, MD., R 1953, January 1977. (AD #A035250)

<sup>48</sup>Aberdeen Proving Ground, Firing Record P-82415, March 1974.



A rather more unusual effect, demonstrating the importance of high local mass burning rates in the generation of pressure waves, is reported by Minor and DiLorenzo<sup>49</sup>. Their work is concerned largely with the design and evaluation of a low-zone, 155-mm charge that minimizes the occurrence of stuck projectiles. For this particular howitzer, the task is a nontrivial problem. The thrust produced by a nominal low-zone charge can, under some marginal conditions, be less than projectile friction. However, by increasing the jerk ( $da/dt$ ) imparted to the projectile through very high pressurization rates, the frictional force appears to be reduced, whereas the thrust is increased. With very high pressurization rates, some early charge configurations resulted in severe pressure waves with very low loading densities, on the order of  $0.1 \text{ g/cm}^3$ . Only when the propellant charge was stretched over the length of the chamber, as shown in Figure 16, were the pressure waves eliminated. Apparently, even for low loading density charges, it is possible to reach a point where the local mass burning rate is so large that pressure dissipation through the nearly empty chamber is limited effectively by choked flow conditions. The full-length charge distributes the gas pressurization over the whole chamber; hence, pressure gradients are effectively minimized.

TABLE 1. EFFECT OF LOADING DENSITY ON PRESSURE WAVES

Rd. number	Density $\text{g/cm}^3$	Observed peak pressure, MPa	$-\Delta P_i$ MPa	Ideal peak pressure (no waves), MPa
121	0.54	225	27	226
126	0.60	307	51	286
127	0.64	439	84	341

There is another, perhaps more insidious, factor to be considered under the topic of mass burning rates. Propellant grain breakup, especially at low temperatures, results in increased surface area, hence increased mass burning. This effect will be discussed in the section on charge and chamber geometry factors likely to contribute to grain fracture. It should be obvious so far that the impact of high mass generation rates on pressure waves may be mitigated or aggravated by chamber and charge permeability considerations that influence pressure dissipation characteristics.

<sup>49</sup>T. C. Minor and J. DeLorenzo, "Charge Design Approaches to the Reduction of Low Zone Stickers", 1976 JANNAF Propulsion Meeting, Chemical Propulsion Information Agency, Laurel, MD., Publ. 280, Dec. 1976.

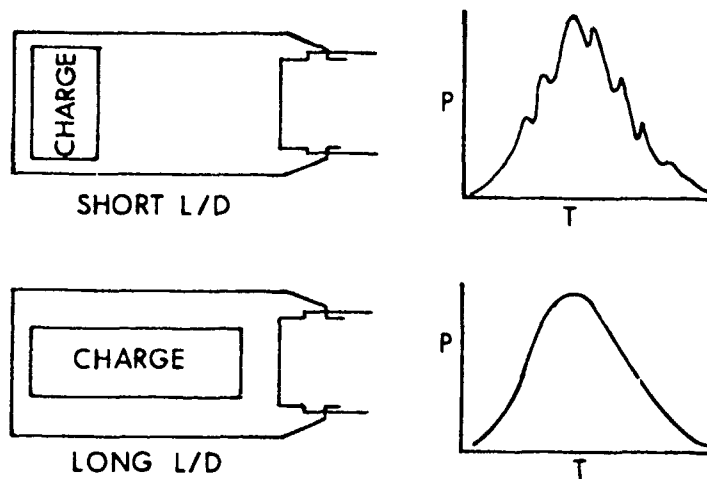

Figure 16. Effect of Charge Configuration on Chamber Pressure<sup>49</sup>

### C. Permeability

The importance of gas flow permeability as a factor in pressure-wave formation was recognized by Kent<sup>20</sup> in his studies of charge-design approaches for pressure-wave reduction. From rather limited data, he concluded that the natural flow channels of strip and stick or stacked granular propellant dissipated any local pressure buildup. His studies on tapered charges also led him to the conclusion that free space over a subchamber diameter charge helped mitigate any initial pressure-wave buildup.

The charge-design practice of the United Kingdom has been to use, almost exclusively, stick propellant for bag charge guns. This practice is the result of great difficulties encountered in eliminating pressure-wave problems with granular propellants and traditional ignition-train designs. For cased guns, because of the relative ease of obtaining good centercore ignition through the use of high-pressure bayonet primers, granular propellants generally are used. A recent attempt by Fisher<sup>42</sup> to model ignition and flamespread of stick propellant indeed has confirmed the great effect of the increased permeability on pressure-wave reduction.

A more formal analysis by Hicks<sup>43</sup> developed approximate characteristic times for pressure-dissipation throughout a chamber based on the critical chamber dimensions, ullage distribution, and grain size. The analysis, although limited in scope, was based on the premise that, if the characteristic pressure-dissipation time were short compared to a characteristic convective heating-to-ignition time, then wave formation is unlikely. This intuitively pleasing and useful analysis later led Rocchio

et al.<sup>46</sup> to propose the use of the 19-perforated grain geometry as a means of reducing pressure-waves. Simple flow-through-packed-bed analysis had shown that the gas permeability of packed beds increases with grain dimension. In order to maintain interior ballistic equivalency, however, the total initial surface area cannot change drastically. With the 19-perforated geometry, one can obtain a significant increase in grain size over a 7-perforated grain and maintain ballistic equivalency, i.e., operate at the same maximum chamber pressure, muzzle velocity, and almost the same charge weight. Other geometries, such as 37-perforation grains, also are being explored currently for pressure-wave reduction potential. Since the equivalent web for a 19-perforated grain also reduces the initial surface area, as previously mentioned, a sympathetic effort is obtained. Early experimental results<sup>46</sup> are illustrated in Figure 17. Later, Horst et al.<sup>50</sup> confirmed that a major reduction in pressure-wave amplitude is observed. Theoretical calculations using the NOVA code<sup>50</sup> confirmed that indeed a two-fold reduction in measured  $-\Delta P_i$ , can be expected. This is in excellent agreement with experiment. Another analysis by Fisher<sup>42</sup> resulted in similar results. Of further interest is the speculation<sup>46</sup> that the ignition of the available surface area in the perforation is delayed until some critical pressure is obtained. This would, of course, further enhance the pressure-wave reduction possibilities via the low-pressure mass burning rate effect.

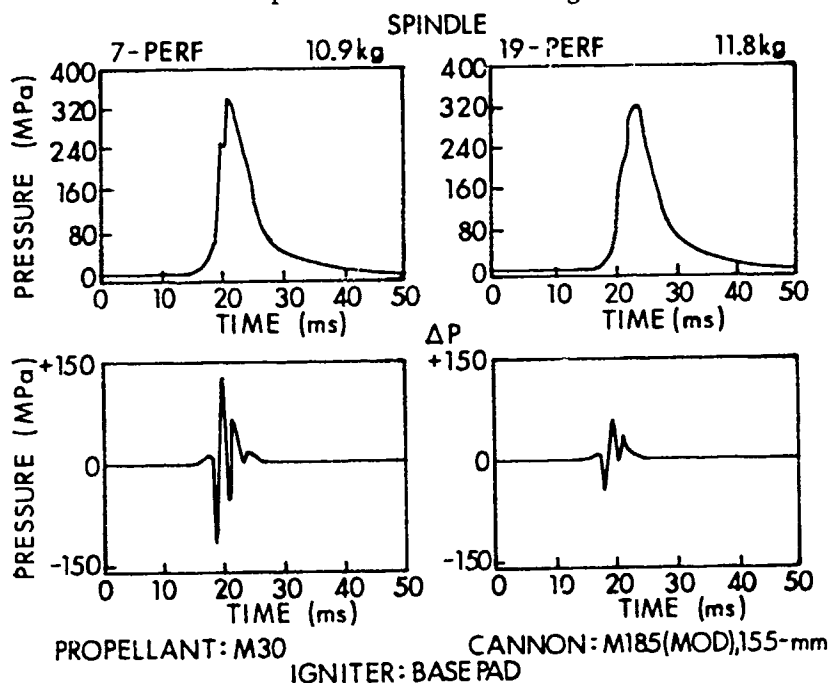

Figure 17. Pressure-Time and Differential Pressure-Time Traces for 7- and 19-Perforated Grains<sup>46</sup>

<sup>50</sup> A. W. Horst, T. C. Smith and S. E. Mitchell, "Key Design Parameters in Controlling Gun Environment Pressure Wave Phenomena-Theory Versus Experiment", Thirteenth JANNAF Combustion Meeting, Chemical Propulsion Information Agency, Laurel, MD., Publ. 281, December 1976.

Another, not so pleasant, example of the impact of permeability on pressure-wave formation is the Navy experience<sup>35</sup> that accompanied the switch from Pyro to NACO propellant for the 5-In./38-Caliber Gun. In this instance, a very low flame temperature propellant, NACO, replaced a more typical single-base propellant, Pyro, to increase the wear life of naval guns. Since the burning rate of NACO propellant is much lower than for Pyro, a smaller web size propellant has to be used to maintain ballistic equivalency. These smaller grains resulted in a substantial decrease in permeability and a significant increase in pressure-wave formation, as illustrated in Figures 18. A marginal situation suddenly had become catastrophic. The impact of the combustion-driven gas and solid waves compressed the closure plug and accelerated it into the projectile base. This resulted in an unacceptably high projectile explosive premature initiation rate.

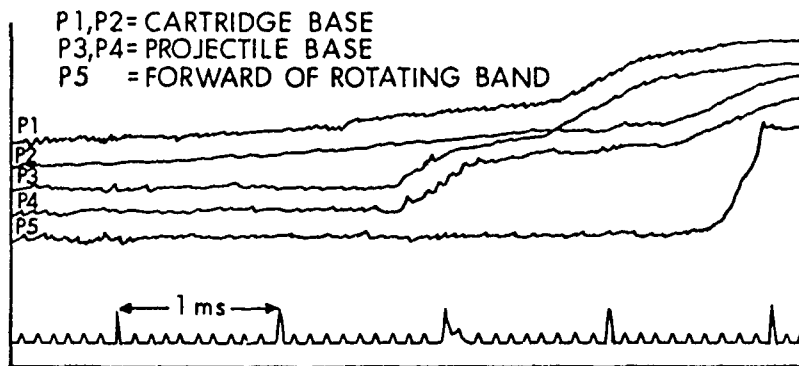

Figure 18a. Pressure-Time Trace for 5-In./38-Caliber Gun with Pyro Propellant and Primer MK 48 Mod 235

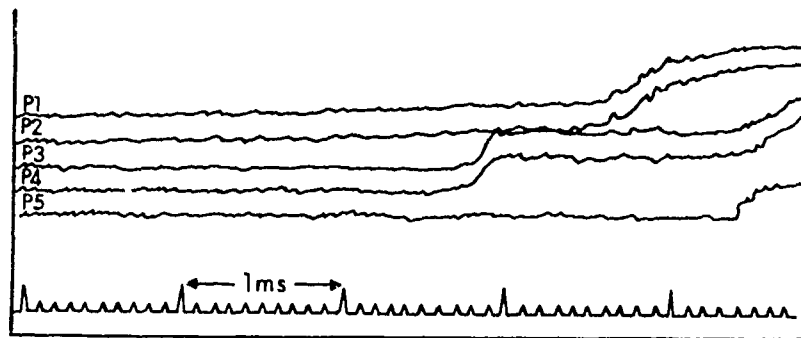

Figure 18b. Pressure-Time Trace for 5-In./38-Caliber Gun with NACO Propellant and Primer MK 48 Mod 235

Another example involving the effects of propellant bed resistance to gas flow on the formation of catastrophic pressure-waves has been reported by Olenick<sup>51</sup> in his summary of the 76-mm Oto Melara malfunction investigation. An exhaustive study clearly identified the source of a breechblow to be accidentally loose, granular, flash reducer salt filling the normal propellant grain interstices. This led to a significant reduction in permeability and allowed the formation of steep pressure gradients, as shown in Figures 19. Although some chemical flamespread inhibition effect cannot be ruled out, the current permeability interpretation is considered the more likely one.

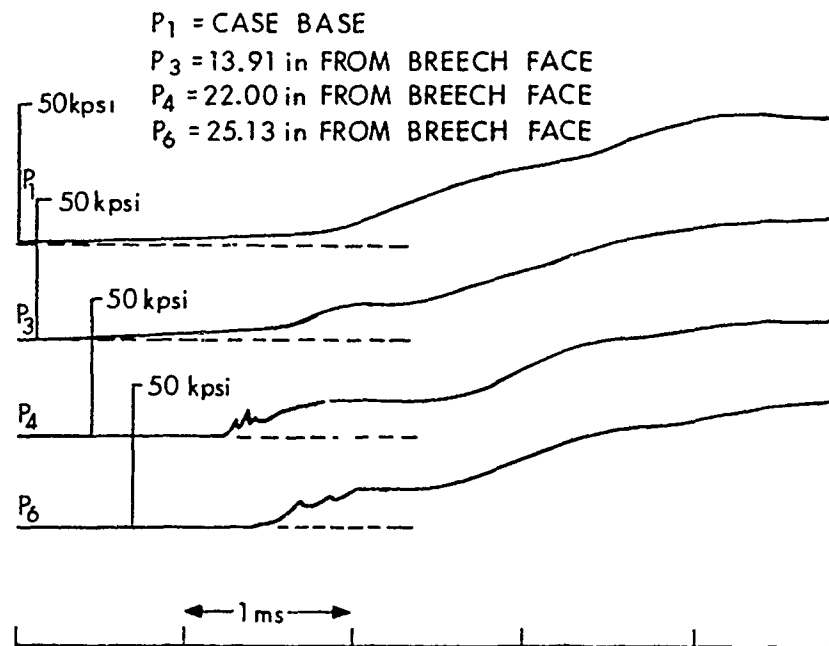

Figure 19a. Pressure-Time Curves for Oto Melara 76-mm Gun with Potassium Sulfate Confined in a Polyethylene Bag<sup>51</sup>

<sup>51</sup>P. J. Olenick, "Investigation of the 76-mm/62 Caliber Mark 75 Gun Mount Malfunction", Naval Surface Weapons Center, Dahlgren, VA., TR 3144, October 1975.

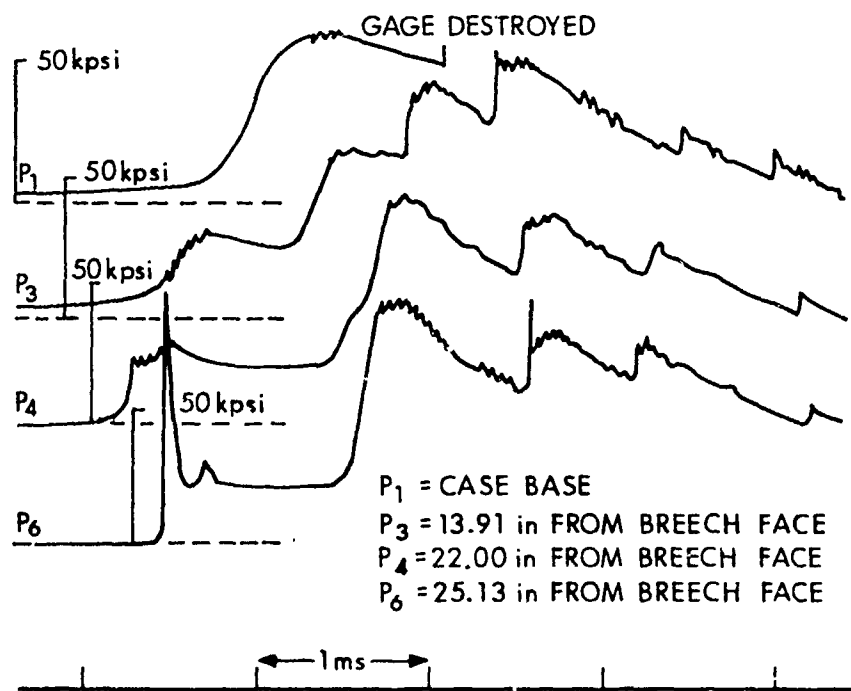

Figure 19b. Pressure-Time Curves for Oto Melara 76-mm Gun with Granular Potassium Sulfate Dispersed in Propellant Bed<sup>51</sup>

The concept of flow channels around a charge, as opposed to through the propellant bed, has been exploited recently in the development of a base-ignited, intermediate-zone propelling charge for a 155-mm Army howitzer<sup>52</sup>. For a variety of reasons, general practice has been to design virtually full chamber diameter charges. For less than full performance charges, this may allow a substantial amount of free, forward ullage. In the loading density region of approximately 0.45 g/cm<sup>3</sup>, stretching the charge to full chamber length has been found to allow the use of a simple, low-cost, base ignition system. The full-bore diameter charge, however, virtually demands a reasonably well-functioning center-core ignition train. The reduced-diameter, chamber-length charge with some breech standoff reduces the normally expected, localized, ignition-induced, pressure-wave potential by allowing rapid pressure equilibration throughout the chamber. As long as rigidity is maintained during the early ignition phase, charge fluidization and grain pileup will not result in loss of this powerful design approach for increasing permeability. A preliminary, pseudo-two-dimensional analysis by Gough<sup>53</sup> has confirmed that a flow channel over a charge offers a significant pressure-wave reduction potential.

A special topic to be considered is the importance of permeability in the design of conventional bayonet primers. The observed deficiencies of standard primers led Vest et al.<sup>54,55</sup> to consider the use of special primer formulations extruded as strands. The natural flow channel typical with stick propellants also resulted in improved uniform gas venting over the entire primer length. Extension of this work resulted in the use of Benite (Black Powder Extruded Nitrocellulose) strands<sup>56</sup> instead of granular black powder in Army bayonet primers.

<sup>52</sup>I. W. May and E. V. Clarke Jr., "The Reverse Chamber Pressure Gradient: A Tool for Assessing the Effects of Wave Dynamics on the Ballistic Performance of Guns", *Proceedings of the 2nd International Symposium on Ballistics, American Defense Preparedness Assoc., Daytona Beach, Fla., March 1976.*

<sup>53</sup>P. S. Gough, "The Influence of Annular Ullage and Bag Rupture on the Ballistic Predictions of the NOVA Code", *Paul Gough Associates, Inc., Portsmouth, N.J., TR 77-4, September 1977.*

<sup>54</sup>D. C. Vest, E. V. Clarke, Jr., W. W. Shoemaker and W. F. Baker, "On the Performance of Primers for Artillery Weapons", *Ballistic Research Lab., Aberdeen Proving Ground, MD., R852, March 1953. (AD #13294)*

<sup>55</sup>D. C. Vest, "A General Discussion of Extruded Igniter Compositions", *Ballistic Research Lab., Aberdeen Proving Ground, MD., MR 894, June 1955. (AD #74459)*

<sup>56</sup>H. H. Hassmann, "Evaluation of Benite, An Extruded Form of Black Powder in Separate Loaded Ammunition", *Picatinny Arsenal, Dover, N.J., R 1, in Separate Loaded Ammunition", Picatinny Arsenal, Dover, N.J., R 1, August 1958.*

#### D. Chamber and Charge Geometry

The importance of charge configuration on pressure-wave formation has been discussed previously in terms of its effect on permeability and ignition stimulus. As pointed out by Horst and Gough<sup>57</sup>, an additional factor must be kept in mind. That factor is the tendency of a charge to allow motion of the propellant bed and subsequent pileup and compaction at an internal boundary such as the projectile base, the breech, or a closure plug is encountered. Compaction of a granular bed reduces porosity, decreases gas permeability, and increases the steepness of a combustion-driven pressure front. The reduced free volume caused by bed compaction leads to enhanced reverse pressure gradients. Moreover, the impact of the moving propellant and other solids such as closure plugs may add significant additional stress to the projectile, besides the normal gas pressure. A further undesirable consequence of propellant motion and compaction is the possibility of grain fracture, leading to enhanced mass burning rate via the increased exposed surface area.

The early work by Hedden and Nance<sup>25</sup> clearly had shown the undesirable pressure-wave effects of ullage in the front or rear of a charge. An unambiguous interpretation in terms of enhanced charge motion was, however, not made. The experimental results and theoretical analysis of Horst and Gough<sup>57</sup> are quite convincing on the importance of the boundary conditions. Their conclusion is that "increasing wave amplitudes are predicted when the propelling charge is weakly confined and when ullage is present between the bed and the base of the projectile". Their theoretical analysis of the 76-mm Oto Melara propelling charge assembly depicted in Figure 20 concentrated on the effects of using three different representations of the wad and spacer boundary adjacent to the projectile. Eliminating the filler and stretching the bed to the projectile base virtually eliminated pressure waves, as shown in Figure 21. In the second representation, the inertia of the boundary was taken

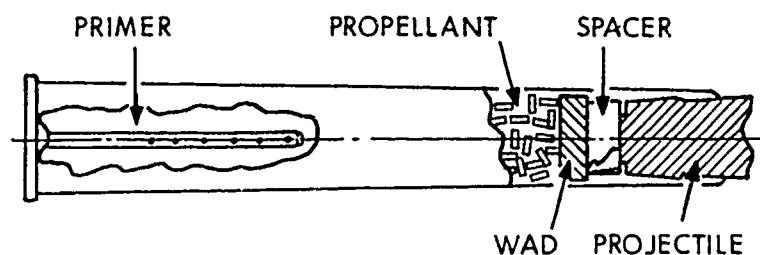

Figure 20. Propelling Charge Assembly for 76-mm Oto Melara Gun

<sup>57</sup> A. W. Horst and P. S. Gough, "Influence of Propellant Packaging and Performance of Navy Case Gun Ammunition", *Journal of Ballistics*, Vol. 1, pp. 229-257, March 1977,.



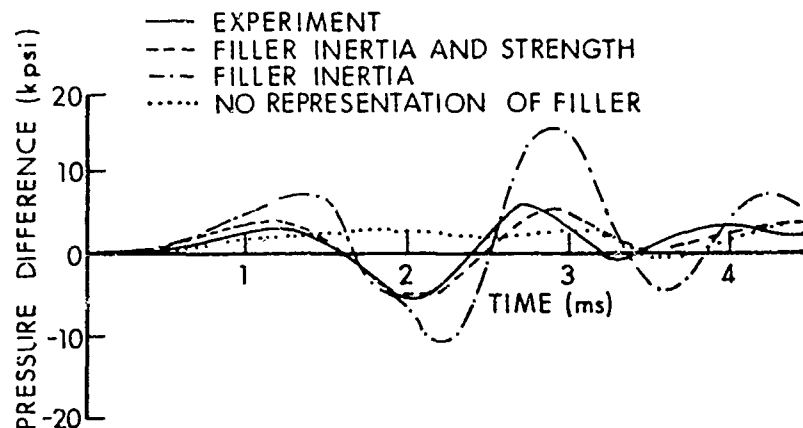

Figure 21. Comparison of Theoretical Predictions of Pressure Difference with Experimental Results<sup>57</sup>

to be that of the inert compactibles until the base of the projectile was reached. Compactibility of the wad and spacer was neglected. With this representation, the magnitude of the reverse pressure gradient was substantially overpredicted, presumably because the neglect of the strength of the inert elements overestimates the rate of deceleration of the boundary. In the third calculation, an explicit representation of the compactibility of the wad and space was included using experimental compressive stress vs strain data for these filler components. This more realistic treatment of the boundary resulted in good agreement with experiment, as shown in Figure 21.

In a related exercise, the effect of reducing the nominal, allowed propellant motion due to incomplete packing of 5-In./54-Caliber propelling charges was examined. Two experimental configurations, shown in Figure 22, were tested. In the first one, a wraparound foam spacer was used to eliminate any residual ullage and thus reduce initial bed motion. In the second configuration, foam nodules were dispersed in the bed to expand it fully to the closure plug. The experimental results shown in Table 2 dramatically illustrate the effect of reduced charge motion. NOVA simulations predict similar levels of pressure-wave reduction.

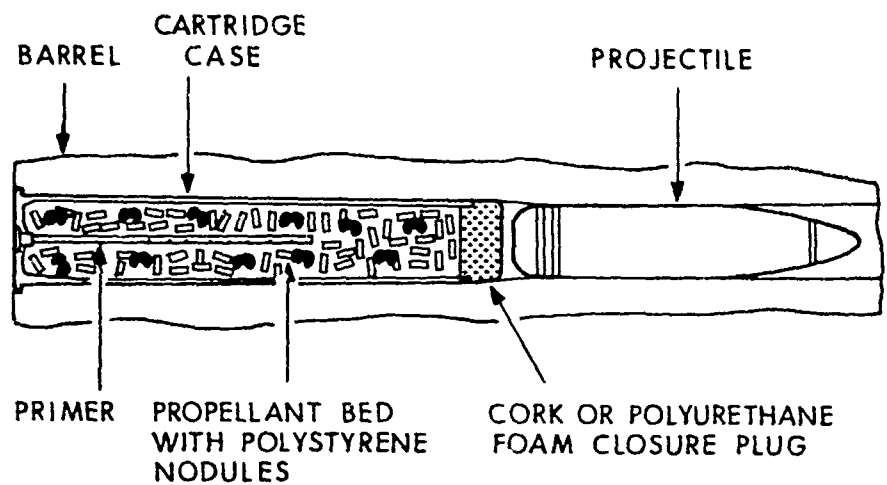
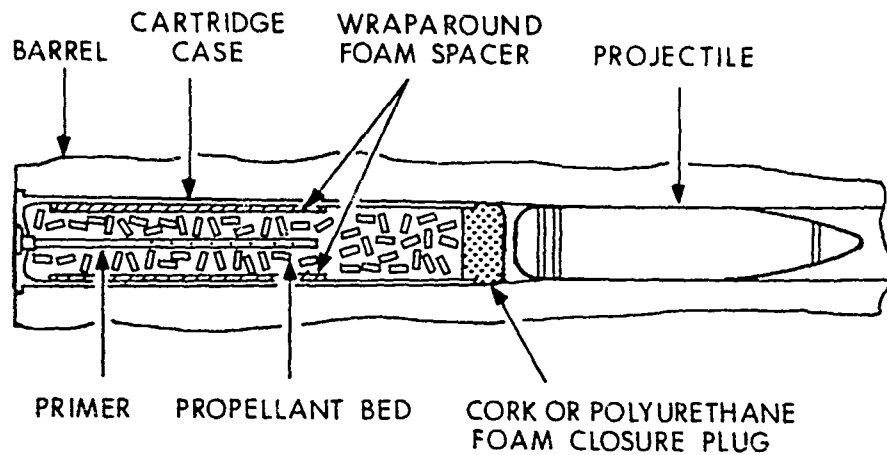

Figure 22. Special Experimental Propelling Charges for 5-In./54-Caliber Gun<sup>57</sup>

An analysis of data<sup>58</sup> for two different-length, base-ignited, intermediate-zone charges for a new 155-mm howitzer shows the combined effect of reduced charge motion and increased permeability. Major reductions in pressure-wave amplitudes are achieved. An important consideration in obtaining the reduced motion inherent in a full chamber length charge is the requirement that charge integrity be maintained during the early portion of the ignition phase. Hence, packaging strength must be considered. This agrees with the general observation that lacing jackets improve the pressure-wave characteristics of a charge. Premature rupture of a bag charge will, of course, result in a complete rearrangement of the assumed initial charge configuration.

TABLE 2. SUMMARY OF PREDICTIONS AND RESULTS FOR RUM PCINT FIRINGS OF JUNE 19, 1975<sup>56</sup>

Parameters	Muzzle Velocity, ft/s	Maximum pressure, psi	Initial reverse pressure difference, psi
NOVA Code predictions			
Nominal configuration	2,820 <sup>a</sup>	49,497	-11,162
Expanded bed	2,783 <sup>a</sup>	47,587	-4,455
Average difference <sup>b</sup>	-37	-1,910	6,707
Experimental results <sup>b</sup>			
Nominal configuration	2,670	47,250	-5,110
Wraparound spacer configuration	2,632	47,208	.29
Polystyrene nodule configuration	2,634	45,958	-847
Average difference	-37	-2,667	4,857

<sup>a</sup>Prediction included no downbore resistance or heat loss to the barrel.

<sup>b</sup>Mean values for six-round samples.

Grain fracture has been mentioned previously as a concern in any charge configuration likely to lead to substantial propellant bed motion. Some early NOVA simulations<sup>45</sup> had resulted in the observation that maximum chamber pressure increases did not accompany an increase in ignition-induced pressure-waves. A later, more systematic study<sup>8</sup> quite conclusively showed that an additional increased mass burning rate process such as transient burning or grain fracture had to be included. An example of the effect of mild and strong base ignition without an enhanced mass burning rate contribution is shown in Figure 12. No increase in chamber pressure is seen for this simulation of an 8-In. Howitzer propelling charge despite widely different levels of pressure waves. Experimentally, this level of increase in pressure-waves is accompanied by a major increase

<sup>58</sup>*Aberdeen Proving Ground, Firing Record P-82446, September 20, 1974.*

in maximum chamber pressure for a low-temperature-conditioned charge; a lesser increase can be expected for an ambient temperature-conditioned charge. In the attempt to simulate a breechblow induced by a deliberate ignition train malfunction<sup>8</sup>, the effects of a pseudo-transient burning rate contribution as well as grain fracture were evaluated. Figure 23 shows the actual pressure vs time traces for this breechblow, obtained with a low-temperature-conditioned charge. The results of the analysis, admittedly somewhat lacking in rigor because of simplifying assumptions, indicated that grain fracture may be the more likely phenomenon to explain the large increases in peak pressure observed. The apparent strong temperature dependence of the chamber pressure sensitivity to pressure-waves is consistent with brittleness characteristics of gun propellants. Triple-base propellants commonly used for the higher performance propelling charges have a history of low-temperature anomalous behavior. The newer triple-base formulations, however, do not exhibit the dramatic grain fracture evidence seen in the closed-bomb burning results by Russel and Goldstein<sup>50</sup> for the older formulations. Nevertheless, Schubert and Schmidt<sup>59</sup> have shown that even modern triple-base propellants become more brittle at lower temperatures and at higher strain rates than do single- and double-base propellants.

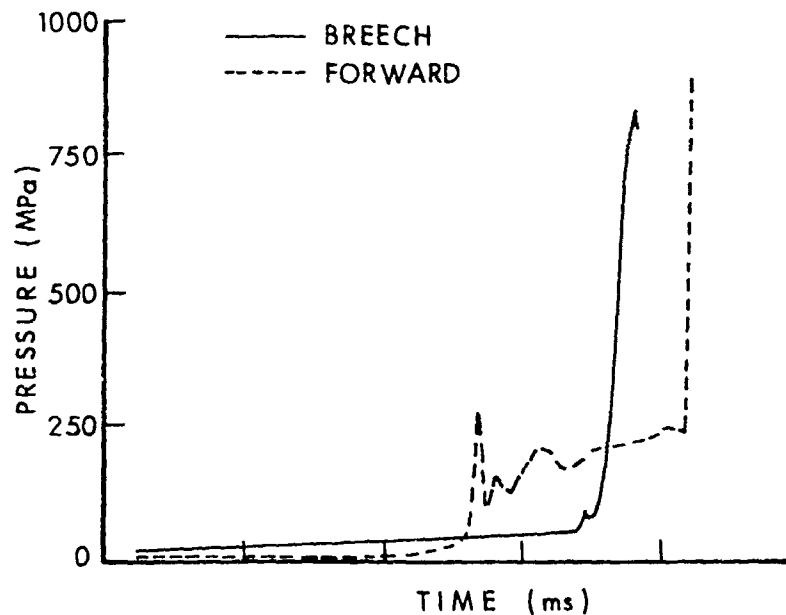

Figure 23. Pressure-Time Profiles for the 8-In., M110E2 Howitzer Breechblow (M188E1, Zone 9 Propelling Charge)<sup>8</sup>

<sup>59</sup>H. Schubert and D. Schmidt, "Embrittlement of Gun Powder", *Proceedings of the International Symposium on Gun Propellants*, Picatinny Arsenal, Dover, N.J., October 1973.

The possible involvement of grain fracture in the 76-mm Oto Melara breechblow<sup>51</sup> incident was investigated experimentally at the Naval Weapons Laboratory in 1972. Air gun tests were performed in which single grains of M6 propellant were impacted on a steel plate to determine breakup characteristics at different temperatures. Predictably, typical results shown in Figure 24 indicated that the velocity threshold decreases with temperature.

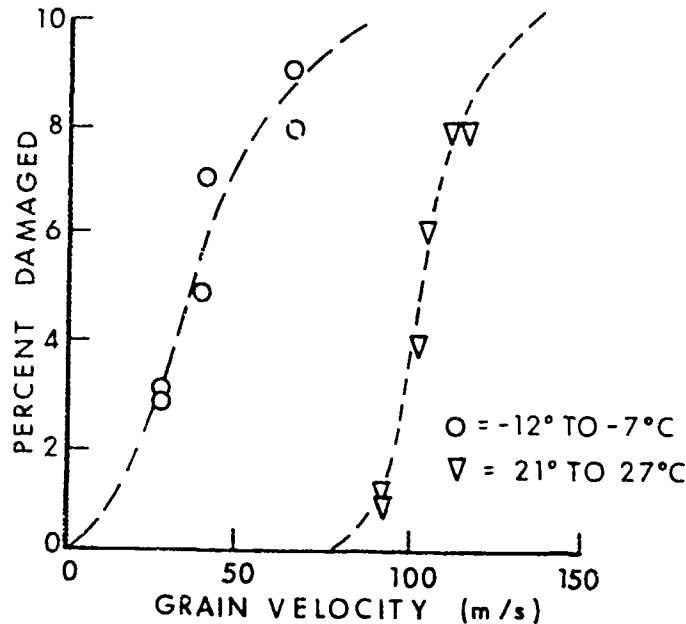

Figure 24. Air Gun Impact Test Results for M6 Propellant<sup>51</sup>

The NOVA simulation for the 8-In. Howitzer breechblow predicted velocities of at least 60 m/s for grains striking the projectile base under base ignition conditions. This should be substantially above the threshold velocities for triple-base propellants at  $-45^{\circ}\text{C}$ , considering the M5 data of Figure 24, and given that the triple-base propellant is inherently more brittle and at an even lower temperature.

From a pragmatic standpoint this suggests several approaches toward minimizing peak chamber pressure enhancement due to grain fracture. The most obvious one is, of course, to minimize the creation of pressure-waves by increasing the availability of centercore ignition trains, a topic to be discussed next. Another approach is to minimize the contribution from charge configurational aspects such as ullage. Eliminating ullage near the projectile base may reduce the velocity of grains impacting the projectile, perhaps below the critical threshold velocity for grain fracture. Finally, raising this threshold velocity by improved processing or formulation changes ought not to be neglected.

In addition to contributing to propellant grain fracture, charge motion and compaction introduce a related safety concern for the survival of the projectile. The response of a projectile and its components to the impact of a closure plug or the propellant bed itself is a complex subject of great concern during the past few years. A classic example of the importance of the charge/projectile interface is found in the 5-In./38-Caliber Gun premature study by Culbertson et al.<sup>60</sup> and the 8-In./55-Caliber Gun close-aboard malfunction investigation by Shamblen and O'Brasky<sup>61</sup>. In both instances, the causes of projectile malfunctions were shown to be related directly to shock excitation of the projectile resulting from charge component impact induced by high-amplitude pressure waves.

The origin of the pressure-wave problem causing the 5-In./38-Caliber Gun malfunctions has been discussed in the previous section on permeability. Data reported by Soper<sup>62</sup> from flash radiograph-instrumented experiments performed with fiberglass chambers indicated that the forward boundary of the NACO propellant bed accelerated to a velocity of about 250 m/s at closure plug impact onto the projectile base. The shock excitation produced by this impact was sufficient to initiate the high-explosive fill. The analysis by Soper also indicates that the peak stress level on the projectile base due to impact was about 35 kpsi, whereas the measured gas pressure in a sidewall gage was only about 1/5 of this value. Although quantitative measurements in such an environment may be open to question, the point to be made is that normal gas pressure measurements in a high-amplitude pressure-wave environment do not allow an adequate assessment of the interior ballistic forcing function acting on a projectile. Instrumented projectile measurements are necessary.

Shamblen and O'Brasky<sup>61</sup> attributed fuze malfunctions observed with the 8-In./55-Caliber reduced charge to shock excitation of the projectile by propelling charge component impact. Interestingly, the reduced charge with much increased forward ullage provided a more severe shock acceleration environment than did the higher-performance full service charge. The change to a larger granulation propellant with increased permeability and reduced initial mass burning rate eventually provided a more acceptable shock loading environment similar to that of the full service charge.

---

<sup>60</sup>D. W. Culbertson, M. C. Shamblen and J. S. O'Brasky, "Investigation of 5"/38 Gun In-Bore Ammunition Malfunctions", Naval Weapons Lab., Dahlgren, VA., TR-2624, December 1971.

<sup>61</sup>M. C. Shamblen and J. S. O'Brasky, "Investigation of 8"/55 Close Aboard Malfunctions", Naval Weapons Lab., Dahlgren VA., TR-2753, April 1973.

<sup>62</sup>W. G. Soper, "Ignition Waves in Gun Chambers", *Combustion and Flame*, Vol. 20(2), April 1973, pp. 157-162.

A recent concern has been the influence of certain chamber-geometry factors on the development of pressure waves. These include the effects of area reduction due to chambrage, forcing cones, normal projectile boattails, breech details, and, perhaps most importantly, area reduction associated with long, fin-stabilized projectiles with tapered bodies penetrating deeply into the propellant bed. Given some initial pressure-wave formation from an ignition stimulus, pressure-wave focusing and growth are to be expected with, perhaps, enhanced bed compaction and grain fracture. An unusually high sensitivity of peak chamber pressure to rather modest levels of pressure waves recently has been observed for such a fin-stabilized projectile. This observation has been rationalized on the basis of pressure-wave focusing. A theoretical analysis is in progress.

#### V. RELIABLE GUN IGNITION

The primary concern over pressure waves during the past half dozen years has been with safety hazards such as breechblows and prematures. Failure rates for such catastrophic events normally are required to be lower than one per million. This safety reliability requirement places a difficult burden on the propulsion system designer, as well as on the test and evaluation agency that has to safety-certify a munitions item on the basis of minimal testing.

This problem is particularly acute for high-performance bag charge designs using granular propellant. Typically such charges require complex, low-pressure, centercore ignition trains as shown in Figure 5. The high-pressure, bayonet primers commonly used in cased ammunition generally are designed more easily to function with great reliability as far as timing and spatial distribution of output are concerned. The experimental techniques and approaches used by Smith<sup>39</sup> and earlier by Vest et al.<sup>54</sup> have shown the proper methodology to be used in the design and testing of reliable, high-pressure bayonet primers. The fact that far from ideal, high-pressure primers are found in many fielded gun systems is not due to a lack of basic understanding.

For low-pressure, combustible, centercore ignition trains, the current understanding and practice do not appear to be nearly as well in hand. The reasons for this situation include the following: the intrinsic geometry variability of bag charge systems; the sensitivity of the several ignition transfer events occurring at low pressures to variability of cloth barriers; the intrinsic flamespread variability of black powder, the most commonly used material; and, finally, the lack of a well-developed, simple diagnostic technique that allows an unambiguous functional evaluation of centercore ignition trains. The recent work by

White et al.<sup>63</sup> and Shulman et al.<sup>64</sup> only confirms that currently used ignition train simulators such as that shown in Figure 25, although capable of telling much about the timing sequence of the primer, basepad and centercore functioning events, do not, however, reveal the critical parameters of how much energy is released to the propellant bed as a function of position and time. Experimental efforts are currently underway to obtain precisely this information. The complexity of the undertaking casts some doubt, however, as to whether the technique can be used as a routine method for evaluating the functional reliability of such an ignition train.

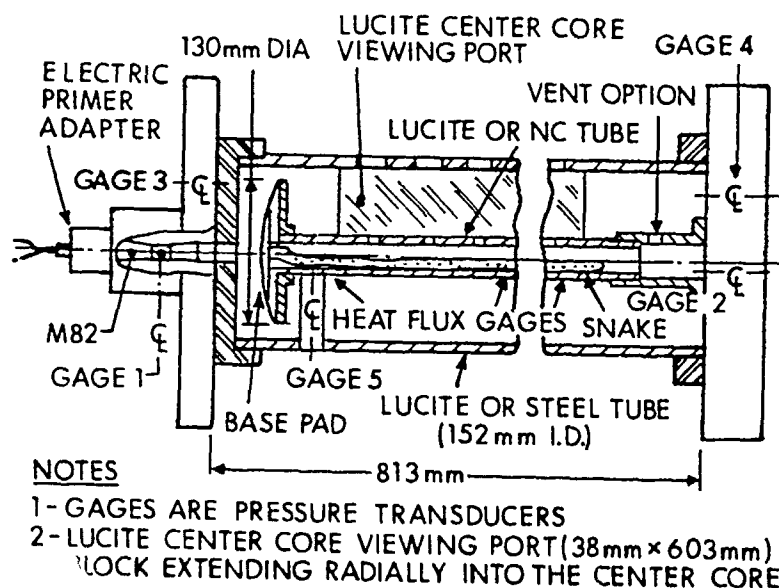

Figure 25. Igniter Simulator Apparatus<sup>63</sup>

<sup>63</sup>K. J. White, C. F. Price, H. E. Homes and I. W. May, "Black Powder and Clean Burning Igniter Train Studies", Thirteenth JANNAF Combustion Meeting, Chemical Propulsion Information Agency, Laurel, MD., Publ. 281, December 1976.

<sup>64</sup>L. Shulman, C. Lenchitz and L. Bottei, "Laboratory Studies to Develop Reduced Ignition Delays in the 155-mm Howitzer", 1974 JANNAF Propulsion Meeting, Chemical Propulsion Information Agency, Laurel, MD., Publ. 260, December 1974.



Basically, a typical centercore ignition train should function in the following manner. A primer jet of hot gases and particles impinges on the base pad and ignites it. With perfect alignment between the primer vent and the centercore, the jet may puncture through the base pad into the centercore and ignite the cloth-covered, black-powder-filled snake. With some offset in the alignment, the basepad's function is to burn through the cloth layers and ignite the snake, which then ignites the propellant bed.

White et al.<sup>63</sup> have discussed the effects of primer total energy output and rate of delivery, the effect of primer vent exit configuration, charge standoff, the effect of cloth barriers, alignment, and black powder distribution in the snake. Shulman et al.<sup>64</sup> have discussed the effects of black powder quickness on centercore functioning. Recent data suggest that manufacturing tolerances for the same class of black powder are so wide that a factor of two difference in quickness is possible. Such differences could have disastrous results in shifting the delicate balance of centercore flamespread times toward earlier propellant bed ignition. It also has been shown that the cloth characteristics of the basepad and snake can have a significant effect on the ignition transfer from the base pad to the snake. In fact, a cloth change made to improve sturdiness at one point in the development of a charge for a new 155-mm howitzer resulted in a low-temperature hangfire in which the propellant finally was ignited before the centercore. A breechblow resulted!

An example of the effect of charge standoff on centercore functioning is shown in Figure 26 for an intermediate-performance, 155-mm propelling charge<sup>65</sup>. The highest level of pressure waves was obtained

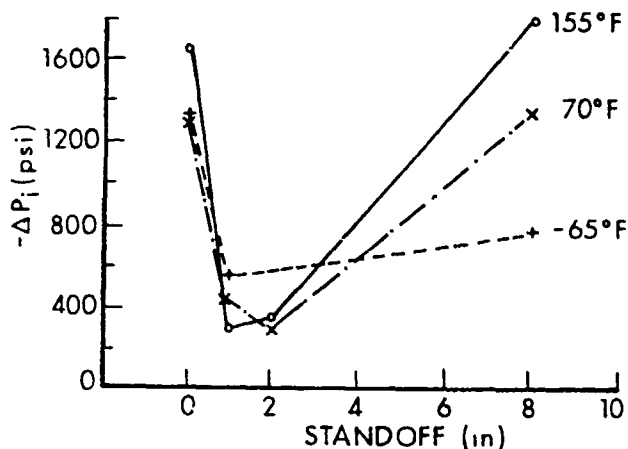

Figure 26. Effect of Standoff on the Amplitude of  $-\Delta P_i$ <sup>65</sup>

<sup>65</sup>E. V. Clarke, I. W. May and J. R. Kelso, "Effects of Pressure-Wave Dynamics on the Ballistic Performance of Guns", Ballistic Research Lab., Aberdeen Proving Ground, MD., IMR 311, November 1974.

with the charge contacting the breech face (zero standoff) and when contacting the projectile base (20-cm standoff). At 2- to 5-cm standoff, a minimum appears to exist. In addition, the pressure-wave level tends to decrease with temperature. The most plausible explanation for these observations is that, at zero standoff, the effects of primer-jet center-core misalignment should be most pronounced, the local breech pressurization is greatest, and the impact of charge motion should be more severe. At the intermediate standoffs, the primer jet plume has a chance to expand, thus reducing the effects of primer-centercore offset. The additional free volume in the breech region also will reduce the pressurization effects, as well as initial charge motion. At maximum standoff, the primer jet is thought to be too weak to penetrate through the centercore efficiently. Because of the large free volume, the pressurization rate is low, ignition delays are long, and heating of ignition materials (such as Benite or black powder) and propellant generally favors propellant ignition. During a 155-mm howitzer malfunction investigation, the effect of primer-centercore misalignment was examined. Results reported by Hassmann and Yermal<sup>66</sup>, at least in this instance, clearly showed that reduced and more reproducible ignition delays accompanied those charges fired with the improved alignment.

The difficulties encountered in the design of an extremely low-pressure reliable centercore ignition system lead to the following conclusion: a breakthrough in design is clearly desirable. The cloth barriers must be eliminated. The geometry variabilities of bag charge diameter, length, and relative chamber location must be reduced. A more reproducible, predictable igniter material with superior ignition and flamespread characteristics is clearly desirable. At the same time, all of the design approaches previously discussed should be implemented to minimize the effects of a malfunctioning centercore ignition train. A more detailed discussion of implementing these conclusions has been presented recently by Rocchio et al.<sup>67</sup> in the context of combustible case artillery charges.

As indicated before, a real problem exists in evaluating the safety reliability of a propelling charge. Largely on the basis of an observed sensitivity of peak chamber pressure to initial reverse pressure difference sensitivity curve developed by Clarke et al.<sup>65</sup> for a 155-mm howitzer, a new failure rate estimation technique currently is being tested in the U.S. Army. Essentially, it can be summarized as follows<sup>8</sup>:

---

<sup>66</sup>H. Hassmann and A. Yermal, "Controlled Ballistic Firing at Aberdeen Proving Ground Relating to Malfunction Investigation of 155-mm Propelling Charge, XM123E1, in 155-mm Towed Howitzer, XM198", Picatinny Arsenal, Dover, N.J., July 1973.

<sup>67</sup>J. Rocchio, C. R. Ruth, I. W. May and K. J. White, "A Consumable Case for Artillery Systems", 1978 JANNAF Propulsion Meeting, Chemical Propulsion Information Agency, Laurel, MD., Publ. 293, February 1978.

1) Charge design sensitivity firings are conducted to determine the relationship between  $-\Delta P_i$  and maximum chamber pressure for that charge/temperature/weapon combination. Intentionally defeated centercore charges may be included in this series to assure that data from a localized-ignition/high-pressure-wave firing can be obtained with a reasonable number of tests.

2) A failure criterion is identified, usually in terms of some maximum permissible chamber pressure, dictated most often by breech or payload failure levels.

3) This failure level is reinterpreted in terms of a  $-\Delta P_i$  level, determined from the sensitivity curve developed in step 1.

4) A firing data base then is obtained which is believed to be representative of "real world" propelling charges, typical of those to be fielded for use.

5) The probability of failure (as defined in step 3) then can be determined statistically with respect to the distribution of  $-\Delta P_i$  values from step 4.

Thus, a  $-\Delta P_i$  failure level tailored to the sensitivity of the particular system of interest is employed. Application of this procedure can be described briefly with respect to the 175-mm, M107 Gun. The relationship between  $-\Delta P_i$  and maximum chamber pressure for M86A2 (Zone 3) Charges fired in the M107 Gun, based on charge design sensitivity firings, is presented in Figure 27. A  $-\Delta P_i$  failure criterion also can be identified on this curve, corresponding to known breech failure pressure levels. Figure 28 then presents the cumulative distribution of  $-\Delta P_i$  levels for a data base considered to represent a typical sample of real-world changes. The probability of achieving the  $-\Delta P_i$  failure level, as determined using Kolmogorov-Smirnov statistics for two different population distribution functions, is presented in Figure 29. Although confidence levels associated with this statistical procedure are quite low, the prediction of one failure in about half a million firings compares quite favorably with historical data of half a dozen breechblows in some two and one-half million firings to date. This agreement, although satisfying, must be considered somewhat fortuitous.

## VI. CONCLUSION

The preceding sections have attempted to summarize the salient features of pressure-wave phenomenology in guns. The progress in our experimental and theoretical understanding of the physics of pressure waves has indeed been satisfying. The two old, opposing attitudes of "all pressure-waves are unacceptable" and "we haven't blown a gun yet with this charge, so why should we worry" are being replaced slowly with a more thorough understanding of the complex interactions of the critical parameters, allowing a more reasoned analysis for each system

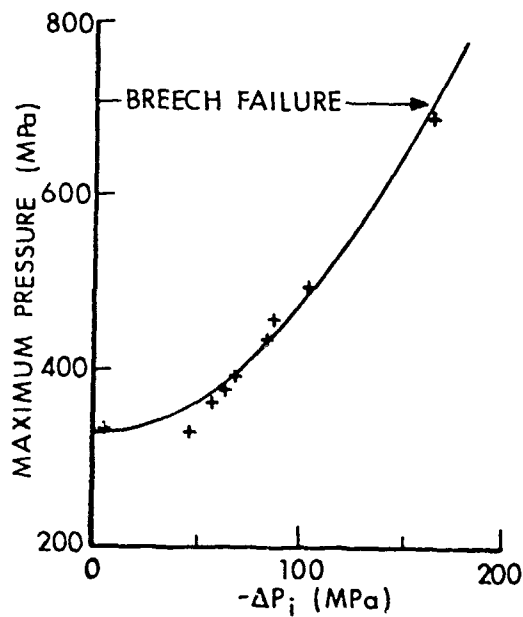

Figure 27. Pressure-Wave Sensitivity for the 175-mm, M107 Gun (M86A2, Zone 3 Propelling Charge)<sup>8</sup>

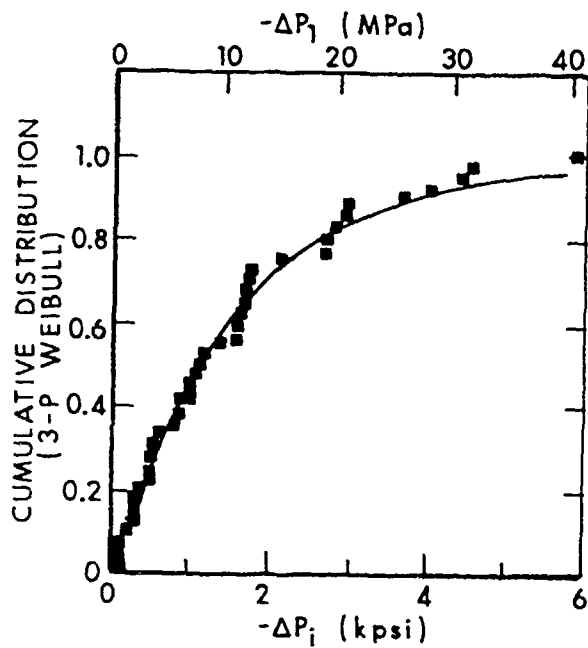

Figure 28. Distribution of Pressure-Wave Amplitudes for the 175-mm, M107 Gun (M86A2, Zone 3 Propelling Charge)<sup>8</sup>

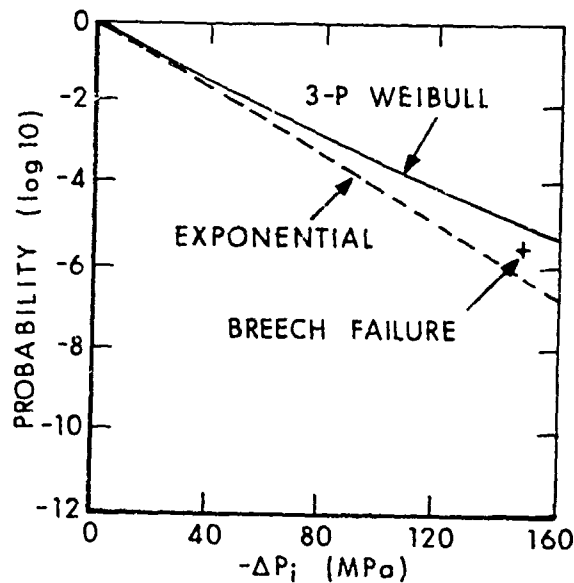

Figure 29. Probability of High-Amplitude Pressure-Waves for the 175-mm, M107 Gun (M86A2, Zone 3 Propelling Charge)<sup>8</sup>

under consideration. For new propelling charges, it is clearly desirable to design for minimum pressure-wave tendencies. The design approaches in Table 3 can be powerful tools for achieving that goal. When combined with the knowledge of a given system peak pressure sensitivity to pressure waves, a much clearer picture is obtained of how much care must be exercised in the quest for minimum pressure waves. The problem of shock excitation of projectiles accompanying charge motion induced by pressure waves still requires hard experimental data to assess the "impact" on projectile safety. Designing for minimum pressure waves will, of course, eliminate or at least reduce this factor and, hence, should be the preferred course of action. With the advent of ever more complex and sophisticated projectiles, this design philosophy should be adopted as the norm.

TABLE 3. CONCEPTS FOR PRESSURE-WAVE REDUCTION

- 
- 1) Improved igniter design
    - Speed
    - Venting uniformity
  - 2) Reduced initial gas generation rate
    - 19- or 37-perforated grain geometry
    - Delayed ignition of grain perforations
    - High exponent burning rate
    - Deterred propellants
  - 3) Increased bed permeability
    - Stick propellant
    - 19- or 37-perforated grain geometry
  - 4) Reduced initial charge motion
    - Spacers
    - Full-length charges
    - Stick propellant
-

## REFERENCES

1. "Combustion Instability in Solid Rocket Motors", Chemical Propulsion Information Agency, Laurel, MD., Publ. 290, Nov. 1977.
2. I. W. May, "The Role of Ignition and Combustion in Gun Propulsion: A Survey of Developmental Efforts", Thirteenth JANNAF Combustion Meeting, Chemical Propulsion Information Agency, Laurel, MD., Publ. 281, September 1976.
3. P. G. Baer, "Practical Interior Ballistic Analysis of Guns", Interior Ballistics of Guns, Ed. M. Summerfield and H. Krier, Progress in Astronautics and Aeronautics, Vol. 66, 1979.
4. J. H. Wiegand, J. H. Smith and A. W. Horst, "Ignition Studies at Indian Head", Proceeding of the Tri-Service Gun Propellant Symposium, Picatinny Arsenal, Dover, NJ, October 1972.
5. A. W. Horst, T. C. Smith, and S. E. Mitchell, "Experimental Evaluation of Three Concepts for Reducing Pressure Wave Phenomena in Navy 5-inch, 54-Caliber Guns: Summary of Firing Data:", Naval Ordnance Station, Indian Head, MD. MR 76-258, August 1976.
6. W. G. Soper, "Ignition Waves in PYRO Propellant", Combustion and Flame, Vol. 22(2), April 1974, pp. 273-276.
7. J. J. Rocchio, K. J. White, C. R. Ruth, and I. W. May, "Propellant Grain Tailoring to Reduce Pressure Wave Generation in Guns", 12th JANNAF Combustion Meeting, Chemical Propulsion Information Agency, Laurel, MD, Publ. 273, December 1975.
8. A. W. Horst, I. W. May, and E. V. Clarke, Jr., "The Missing Link Between Pressure Waves and Breechblows", Ballistic Research Lab., Aberdeen Proving Ground, MD., ARBRL-MR-02849, July 1978. (AD #A058354)
9. K. K. Kuo, R. Vichnevetsky, and M. Summerfield, "Generation of an Accelerated Flame Front in a Porous Propellant", AIAA Paper 71-210, New York, Jan. 1971.
10. P. S. Gough, "Numerical Analysis of a Two-Phase Flow with Explicit Internal Boundaries", Naval Ordnance Station, Indian Head, MD., CR 77-5, April 1977.
11. E. B. Fisher and K. W. Graves, "Propellant Ignition and Combustion in the 155-mm Howitzer", Calspan Corp., Buffalo, N.Y., VQ-5524-P-2, Jan. 1975.
12. K. K. Kuo, J. H. Koo, T. R. Davis, and G. R. Coates, "Transient Combustion in Mobile Gas Permeable Propellants", Acta Astronautica, Vol. 3, 1976, pp. 573-591.

REFERENCES (continued)

13. H. Krier, "Predictions of Flamespreading and Pressure Wave Propagation in Propellant Beds", Ballistic Research Lab., Aberdeen Proving Ground, MD., CR 275, November 1975. (AD #B009170L)
14. A. W. Horst, C. W. Nelson and I. W. May, "Flame Spreading in Granular Propellant Beds: A Diagnostic Comparison of Theory to Experiment", AIAA Paper 77-586, Orlando, Fla., July 1977.
15. I. W. May and E. V. Clarke, Jr., "A Case History: Gun Ignition Related Problems and Solutions for the XM-198 Howitzer", Ballistic Research Lab., Aberdeen Proving Ground, MD., IMR 150, October 1973.
16. A. J. Budka and J. D. Knapton, "Pressure Wave Generation in Gun Systems: A Survey", Ballistic Research Lab., Aberdeen Proving Ground, MD., MR 2567, December 1975. (AD #B008893L)
17. J. B. Goode and D. E. Weald, "Survey-Fluid Dynamic Aspects of the Internal Ballistics of Guns", Advisory Group for Aerospace Research and Development (NATO), AGARD Conference Proceedings No. 40, September 1966, pp. 1-12.
18. J. Corner, Theory of the Interior Ballistics of Guns, Wiley, New York, 1950.
19. F. R. W. Hunt and G. H. Hinds, Internal Ballistics, Philosophical Library, New York, 1951, p. 80.
20. P. Vielle, quoted by C. Cranz in Lehrbuch der Ballistik, Vol. II, Springer-Verlag, Berlin, 1926, p. 151.
21. R. H. Kent, "Study of Ignition of 155-mm Gun in Connection with Project KW 250-Study of the Factors Involved in the Design of Propelling Charges", Ballistic Research Lab., Aberdeen Proving Ground, MD., MR 4, February 1935. (AD #493405)
22. R. H. Kent, "Study of Ignition of 155-mm Gun", Ballistic Research Lab., Aberdeen Proving Ground, MD., R22, October 1935. (AD #494703)
23. R. H. Kent, "Velocity Dispersion Obtained with Charges of Slender Base Section in the 155-mm Gun G.P.F.," Ballistic Research Lab., Aberdeen Proving Ground, MD., R45, March 1936.
24. R. H. Kent, "Study of the Ignition and Velocity Dispersion of FNH Powder in the 155-mm Gun G.P.F.," Ballistic Research Lab., Aberdeen Proving Ground, MD., R91, December 1937. (AD #491768)
25. S. E. Heddon and G. A. Nance, "An Experimental Study of Pressure Waves in Gun Chambers", Naval Proving Ground, Dahlgren, VA., R 1534, April 1957.



REFERENCES (continued)

26. N. Bauman and E. Bird, "Ignition Problems in Separate-Loading Ammunition", Joint Army-Navy-Air Force Second Symposium on Propellant Ignition, Vol. II, Solid Propellant Information Agency, Silver Spring, MD., October 1956.
27. L. Gowen and E. Elzufon, "A Reveiw of Igniter Studies and Their Application to Igniter Design", Joint Army-Navy-Air Force Second Symposium on Solid Propellants, Vol. II, Solid Propellant Information Agency, Silver Spring, MD., October 1956.
28. N. Lockett, "British Work on Solid Propellant Ignition", Bulletin of the First Symposium on Solid Propellant Ignition, Solid Propellant Information Agency, Silver Spring, MD., September 1953.
29. "Ignition Study of Gun, 76-mm, T91", Aberdeen Proving Ground, Firing Record P-52014, Project TAl1302, February 1952.
30. K. H. Russel and H. M. Goldstein, "Investigation and Screening of M17 Propellant Production for Lots Subject to Poor Low Temperature Performance", Picatinny Arsenal, Dover, NJ., DB-TR-7-61, June 1961.
31. J. R. Lane, "Sub-Zero Firings in the 76-mm Gun", Ballistic Research Lab., Aberdeen Proving Ground, MD., MR 215, September 1943. (AD #493524)
32. T. G. Hughes, "Product Improvement Test of Charge, Propelling M86A1, for 175-mm Gun, M113", Ballistic Research Lab., Aberdeen Proving Ground, MD., DPS-2351, April 1967.
33. P. Gough, "Modeling of Two-Phase Flow in Guns", "Interior Ballistics of Guns", Ed. M. Summerfield and H. Krier, Progress in Astronautics and Aeronautics, Vol. 66, 1979.
34. H. Krier and M. J. Adams, "An Introduction to Gun Interior Ballistics and a Simplified Ballistic Code", Progress in Astronautics and Aeronautics, Vol. 66, 1979.
35. A. W. Horst and A. C. Haukland, "Gun Interior Ballistics: 1972 Annual Report", Naval Ordnance Station, Indian Head, MD., TR 386, April 1973.
36. D. C. Vest, "On the Performance of Primers for Artillery Weapons", Ballistic Research Lab., Aberdeen Proving Ground, MD., R 852, March 1953. (AD #13294)
37. T. C. Smith, "Development of Electric Primer Mark 48 Mods 3 and 4 for the 5-inch, 38-Caliber Gun", Naval Ordnance Station, Indian Head, MD., TR 396, February 1974.

REFERENCES (continued)

38. J. L. East and D. R. McClure, "Experimental Studies of Ignition and Combustion in Naval Guns", Twelfth JANNAF Combustion Meeting, Chemical Propulsion Information Agency, Laurel, MD., Publ. 275, August 1975.
39. T. C. Smith, "Rapid Ignition of Granular Propellant Beds with a 'Hotline' Igniter", 1978 JANNAF Propulsion Meeting, Chemical Propulsion Information Agency, Laurel, MD., Publ. 293, February 1978.
40. A. W. Horst, "Navy Gun Interior Ballistics Modeling Efforts: An Overview", 1973 JANNAF Propulsion Meeting, Chemical Propulsion Information Agency, Laurel, MD., Publ. 242, September 1973.
41. E. V. Clarke and I. W. May, "Subtle Effects of Low Amplitude Pressure Wave Dynamics on the Ballistic Performance of Guns", Eleventh JANNAF Combustion Meeting, Chemical Propulsion Information Agency, Laurel, MD., Publ. 261, September 1974.
42. E. Fisher, K. Graves and A. Trippe, "Application of a Flamespread Model to Design Problems on the 155-mm Propelling Charge", Twelfth JANNAF Combustion Meeting, Chemical Propulsion Information Agency, Laurel, MD., Publ. 273, December 1975.
43. B. L. Hicks, "Some Characteristics of the Practical Ignition of Propellants", Ballistic Research Lab., Aberdeen Proving Ground, MD., MR 640, December 1952. (AD #3342)
44. A. W. Horst, "Influence of Propellant Burning Rate Representation of Gun Environment Flamespread and Pressure Wave Predictions", Naval Ordnance Station, Indian Head, MD., MR 76-255, March 1976.
45. I. W. May, C. W. Nelson, J. J. Rocchio and K. J. White, "The Role of Ignition in Artillery Propulsion", Proceedings of the Third International Symposium on Ballistics, Deutsche Gesellschaft fur Wehrtechnik, Karlsruhe, Germany, March 1977.
46. J. J. Rocchio, C. R. Ruth and I. W. May, "Grain Geometry Effects on Wave Dynamics in Large Caliber Guns", Thirteenth JANNAF Combustion Meeting, Chemical Propulsion Information Agency, Laurel, MD., Publ. 281, December 1976.
47. D. E. Kooker and C. W. Nelson, "Numerical Solution of Three Solid Propellant Combustion Models During a Gun Pressure Transient", Ballistic Research Lab., Aberdeen Proving Ground, MD., R 1953, January 1977. (AD #A035250)
48. Aberdeen Proving Ground, Firing Record P-82415, March 1974.

REFERENCES (continued)

49. T. C. Minor and J. DeLorenzo, "Charge Design Approaches to the Reduction of Low Zone Stickers", 1976 JANNAF Propulsion Meeting, Chemical Propulsion Information Agency, Laurel, MD., Publ. 280, December 1976.
50. A. W. Horst, T. C. Smith and S. E. Mitchell, "Key Design Parameters in Controlling Gun Environment Pressure Wave Phenomena-Theory Versus Experiment", Thirteenth JANNAF Combustion Meeting, Chemical Propulsion Information Agency, Laurel, MD., Publ. 281, December 1976.
51. P. J. Olenick, "Investigation of the 76-mm/62 Caliber Mark 75 Gun Mount Malfunction", Naval Surface Weapons Center, Dahlgren, VA., TR 3144, October 1975.
52. I. W. May and E. V. Clarke Jr., "The Reverse Chamber Pressure Gradient: A Tool for Assessing the Effects of Wave Dynamics on the Ballistic Performance of Guns", Proceedings of the 2nd International Symposium on Ballistics, American Defense Preparedness Assoc., Daytona Beach, Fla., March 1976.
53. P. S. Gough, "The Influence of Annular Ullage and Bag Rupture on the Ballistic Predictions of the NOVA Code", Paul Gough Associates, Inc., Portsmouth, N.J., TR 774-4, September 1977.
54. D. C. Vest, E. V. Clarke, Jr., W. W. Shoemaker and W. F. Baker, "On the Performance of Primers for Artillery Weapons", Ballistic Research Lab., Aberdeen Proving Ground, MD., R852, March 1953. (AD #13294)
55. D. C. Vest, "A General Discussion of Extruded Igniter Compositions", Ballistic Research Lab., Aberdeen Proving Ground, MD., MR 894, June 1955. (AD #74459)
56. H. H. Hassmann, "Evaluation of Benite, An Extruded Form of Black Powder in Separate Loaded Ammunition", Picatinny Arsenal, Dover, N.J. R 1, August 1958.
57. A. W. Horst and P. S. Gough, "Influence of Propellant Packaging and Performance of Navy Case Gun Ammunition", Journal of Ballistics, Vol. 1, March 1977, pp. 229-257.
58. Aberdeen Proving Ground, Firing Record P-82446, September 20, 1974.
59. H. Schubert and D. Schmidt, "Embrittlement of Gun Powder", Proceedings of the International Symposium on Gun Propellants, Picatinny Arsenal, Dover, N.J., October 1973.

REFERENCES (continued)

60. D. W. Culbertson, M. C. Shamblen and J. S. O'Brasky, "Investigation of 5"/38 Gun In-Bore Ammunition Malfunctions", Naval Weapons Lab., Dahlgren, VA., TR-2624, December 1971.
61. M. C. Shamblen and J. S. O'Brasky, "Investigation of 8"/55 Close Aboard Malfunctions", Naval Weapons Lab., Dahlgren, VA., TR-2753, April 1973.
62. W. G. Soper, "Ignition Waves in Gun Chambers", Combustion and Flame, Vol. 20(2), April 1973, pp. 157-162.
63. K. J. White, C. F. Price, H. E. Homes and I. W. May, "Black Powder and Clean Burning Igniter Train Studies", Thirteenth JANNAF Combustion Meeting, Chemical Propulsion Information Agency, Laurel, MD., Publ. 281, December 1976.
64. L. Shulman, C. Lenchitz and L. Botlei, "Laboratory Studies to Develop Reduced Ignition Delays in the 155-mm Howitzer", 1974 JANNAF Propulsion Meeting, Chemical Propulsion Information Agency, Laurel, MD., Publ. 260, December 1974.
65. E. V. Clarke, I. W. May and J. R. Kelso, "Effects of Pressure Wave Dynamics on the Ballistic Performance of Guns", Ballistic Research Lab., Aberdeen Proving Ground, MD., IMR 311, November 1974.
66. H. Hassmann and A. Yermal, "Controlled Ballistic Firing at Aberdeen Proving Ground Relating to Malfunction Investigation of 155-mm Propelling Charge, XM123E1, in 155-mm Towed Howitzer, XM198", Picatinny Arsenal, Dover, N.J., July 1973.
67. J. Rocchio, C. R. Ruth, I. W. May and K. J. White, "A Consumable Case for Artillery Systems", 1978 JANNAF Propulsion Meeting, Chemical Propulsion Information Agency, Laurel, MD., Publ. 293, February 1978.

DISTRIBUTION LIST

<u>No. of Copies</u>	<u>Organization</u>	<u>No. of Copies</u>	<u>Organization</u>
12	Commander Defense Technical Info Center ATTN: DDC-DDA Cameron Station Alexandria, VA 22314	1	Commander US Army Armament Research and Development Command ATTN: DRDAR-SCA-T, L. Stiefel Dover, NJ 07801
1	Director Defense Advanced Research Projects Agency ATTN: E. F. Blase 1400 Wilson Boulevard Arlington, VA 22209	1	Commander US Army Armament Materiel Readiness Command ATTN: DRSAR-LEP-L, Tech Lib Rock Island, IL 61299
1	Director Institute for Defense Analyses ATTN: R. C. Oliver 400 Army-Navy Drive Arlington, VA 22202	1	Director US Army ARRADCOM Benet Weapons Laboratory ATTN: DRDAR-LCB-TL Watervliet, NY 12189
1	Commander US Army Materiel Development and Readiness Command ATTN: DRCDND-ST 5001 Eisenhower Avenue Alexandria, VA 22333	1	Commander US Army Watervliet Arsenal ATTN: SARWV-RD, R. Thierry Watervliet, NY 12189
1	Commander US Army Materiel Development and Readiness Command ATTN: DRCDE-DW, S.R. Matos 5001 Eisenhower Avenue Alexandria, VA 22333	1	Commander US Army Aviation Research and Development Command ATTN: DRSAV-E P. O. Box 209 St. Louis, MO 63166
2	Commander US Army Armament Research and Development Command ATTN: DRDAR-TSS Dover, NJ 07801	1	Director US Army Air Mobility Research and Development Laboratory Ames Research Center Moffett Field, CA 94035
1	Commander US Army Armament Research and Development Command ATTN: DRDAR-LCE Dover, NJ 07801	1	Commander US Army Communications Rsch and Development Command ATTN: DRDCO-PPA-SA Fort Monmouth, NJ 07703

DISTRIBUTION LIST

<u>No. of Copies</u>	<u>Organization</u>	<u>No. of Copies</u>	<u>Organization</u>
1	Commander US Army Electronics Research and Development Command Technical Support Activity ATTN: DELSD-L Fort Monmouth, NJ 07703	1	Commander Naval Surface Weapons Center ATTN: Code 633, J.L. East Dahlgren, VA 22448
2	Commander US Army Missile Command ATTN: DRSMI-R DRSMI-TK, R.G. Rhoades Redstone Arsenal, AL 35809	1	Commander Naval Surface Weapons Center ATTN: G. B. Wilmot Silver Spring, MD 20910
1	Commander US Army Missile Command ATTN: DRSMI-YDL Redstone Arsenal, AL 35809	1	Commander Naval Underwater Systems Ctr Energy Conversion Dept. ATTN: Code 5B331, R.S. Lazar Newport, RI 02840
1	Commander US Army Tank Automotive Research & Development Cmd ATTN: DRDTA-UL Warren, MI 48090	1	Commander Naval Weapons Center ATTN: Code 388, R.L. Derr China Lake, CA 93555
1	Director US Army TRADOC Systems Analysis Activity ATTN: ATAA-SL, Tech Lib White Sands Missile Range NM 88002	1	Superintendent Naval Postgraduate School Dept of Mechanical Engineering ATTN: A.E. Fuhs Monterey, CA 93940
1	Chief of Naval Research ATTN: Code 473, R.S. Miller 800 N. Quincy Street Arlington, VA 22217	1	Commander Naval Ordnance Station ATTN: P. L. Stang Indian Head, MD 20640
1	Commander Naval Sea Systems Command ATTN: 62R2, J.W. Murrin National Ctr, Bldg. 2, Rm 6E08 Washington, DC 20362	1	Program Manager, AFOSR Directorate of Aerospace Sciences ATTN: Dr. L. H. Caveny Bolling AFB, DC 20332
		1	AFATL/DLDD (O.K. Heiney) Eglin AFB, FL 32542

DISTRIBUTION LIST

<u>No. of Copies</u>	<u>Organization</u>	<u>No. of Copies</u>	<u>Organization</u>
1	Atlantic Research Corporation ATTN: M. K. King 5590 Cherokee Avenue Alexandria, VA 22314	1	Hercules, Inc. Eglin Operations AFATL/DL DL ATTN: R.L. Simmons Eglin AFB, FL 32542
1	AVCO Corporation AVCO Everett Rsch Lab Div ATTN: D Stickler 2585 Revere Beach Parkway Everett, MA 02149	1	IITRI ATTN: M.J. Klein 10 W. 35th Street Chicago, IL 60615
1	Calspan Corporation ATTN: E. B. Fisher P. O. Box 400 Buffalo, NY 14221	1	Olin Corporation Badger Army Ammunition Plant ATTN: R.J. Thiede Bababoo, WI 53913
1	Foster Miller Associates, Inc. ATTN: A.J. Erickson 135 Second Avenue Waltham, MA 02154	1	Olin Corporation Smokeless Powder Operations ATTN: R.L. Cook P.O. Box 222 St. Marks, FL 32355
1	General Applied Sciences Labs ATTN: J. Erdos Merrick & Stewart Avenues Westbury Long Island, NY 11590	1	Pulsepower Systems, Inc. ATTN: L.C. Elmore 815 American Street San Carlos, CA 94070
1	General Electric Company Armament Systems Dept. ATTN: M.J. Bulman, Rm. 1311 Lakeside Avenue Burlington, VT 05402	1	Rockwell International Corp. Rocketdyne Division ATTN: BA08, J.E. Flanagan 6633 Canoga Avenue Canoga Park, CA 91304
1	Hercules, Inc. Allegany Ballistics Laboratory ATTN: R.B. Miller P.O. Box 210 Cumberland, MD 21502	1	Science Applications, Inc. ATTN: R.B. Edelman, Suite 423 23146 Cumorah Crest Woodland Hills, CA 91364
1	Hercules, Inc. Bacchus Works ATTN: K.P. McCarty P.O. Box 98 Magna, UT 84044	1	Thiokol Corporation Wasatch Division ATTN: J.A. Peterson P.O. Box 524 Brigham City, UT 84302

DISTRIBUTION LIST

<u>No. of Copies</u>	<u>Organization</u>	<u>No. of Copies</u>	<u>Organization</u>
1	Universal Propulsion Company ATTN: H.J. McSpadden 1800 W. Deer Valley Rd. Phoenix, AZ 85027	1	University of Southern California Mechanical Engineering Dept. ATTN: OHE200, M. Gerstein Los Angeles, CA 90007
1	Brigham Young University ATTN: M.W. Beckstead Provo, UT 84601	1	University of California, San Diego AMES Dept. ATTN: F.A. Williams P.O. Box 109 LaJolla, CA 92037
1	California Institute of Technology Jet Propulsion Laboratory ATTN: L.D. Strand 4800 Oak Grove Drive Pasadena, CA 91103	1	University of Illinois AAE Dept. ATTN: H. Krier Transportation Bldg. Rm. 105 Urbana, IL 61801
1	Johns Hopkins University/APL Chemical Propulsion Infor- mation Agency ATTN: T.W. Christian Johns Hopkins Road Laurel, MD 20810	1	University of Massachusetts Dept. of Mechanical Engineering ATTN: K. Jakus Amherst, MA 01002
1	Pennsylvania State University ATTN: G.M. Faeth 214 M.E. Building University Park, PA 16802	1	University of Waterloo, Dept. of Mechanical Engineering ATTN: C.E. Hermance Waterloo, Ontario, Canada
1	Purdue University School of Mechanical Engineering ATTN: J.R. Osborn TSPC Chaffee Hall West Lafayette, IN 47906		<u>Aberdeen Proving Ground</u>  Dir, USAMSAA ATTN: DRXS1-D DRXS1-MP, H. Cohen  Cdr, USATECOM ATTN: DRSTE-TO-F Dir, USACSL, Bldg. E3516 ATTN: DRDAR-CLB-PA
1	Southwest Research Institute Institute Scientists ATTN: W.H. McLain P.O. Drawer 28510 San Antonio, TX 78228		
1	University of California Los Alamos Scientific Lab. ATTN: T3, D. Butler Los Alamos, NM 87554		