

AD-A094 972

PRINCETON UNIV NJ JOSEPH HENRY LABS OF PHYSICS
SYMMETRY BREAKING FAR FROM EQUILIBRIUM.(U)
JAN 81 L SNEEDON

F/6 20/13

N00014-77-C-0711

NL

UNCLASSIFIED

| of |
AD-
ACRAB#



END
DATE
FILMED
3-81
DTIC

LEVEL

12

AD A094972

6

Symmetry Breaking Far From Equilibrium

10 L. Sneddon

Joseph Henry Laboratories of Physics
Princeton University
Princeton, N.J.
08544

DTIC
SELECTE
FEB 12 1981

12 / 17

ABSTRACT

Mechanical rept.

An examination of the Rayleigh-Bénard convection experiment shows that the defining features of long range order and spontaneous symmetry breaking, as they occur in equilibrium transitions, are also observed far from equilibrium. The broken symmetry is not, as has been suggested, translational invariance, but rather a discrete symmetry under velocity reversal. Some experimental consequences of these observations are outlined.

11 21 Jan 81

15

*Research supported in part by ONR N00014-77-C-0711

DDC FILE COPY

DISTRIBUTION STATEMENT A
Approved for public release;
Distribution Unlimited

41330 81 2 11 047

1. Introduction

Instabilities occurring far from equilibrium exhibit features reminiscent of equilibrium phase transitions. Divergent correlation lengths¹, order parameters with a singular dependence on external conditions^{1,2,3,4} and critical slowing down^{1,3,4} have been observed, and associated critical exponents measured, in a variety of systems far from equilibrium. Theoretically, non-equilibrium transitions have been described⁵ using a Ginzburg-Landau theory analogous to that of equilibrium transitions. Other parallels between equilibrium and non-equilibrium phenomena have also been drawn.^{6,7,8}

In particular it has been claimed^{7,8} that a transition from a homogeneous to an inhomogeneous state, for example the onset of a roll pattern at the first convective instability⁹, constitutes the spontaneous breaking of translational symmetry. Since spontaneous symmetry breaking occurs in equilibrium systems, it is claimed that this breaking of translational symmetry is another important similarity between equilibrium and non-equilibrium phenomena.

It has been pointed out¹⁰, however, that, as opposed to say crystallization, the structures which occur far from equilibrium are always determined by boundary conditions: in a convection cell, for instance, there is always an integral number of rolls. Further it is noted that no consequences of broken symmetry such as rigidity^{10,11} and Goldstone modes have been observed in these structures far from equilibrium. The conclusion is reached that^{10,11,12} the observations of broken symmetry far from equilibrium are superficial and "there exists neither a theoretical nor an experimental basis for deciding

Dist	Special
A	

whether or not dissipative systems¹³ have structural properties analogous to equilibrium ones".

The purpose of this paper is twofold. Firstly it is pointed out, through a consideration of the Rayleigh-Bénard convection experiment, that the central, defining features of long range order and spontaneous symmetry breaking, as they occur in equilibrium systems, are also observed far from equilibrium. The symmetry which is observed to be broken is not translational symmetry but rather a discrete symmetry under velocity reversal. Secondly, some experimental consequences of this observation are outlined.

In Section 2 the meanings of the terms long range order and spontaneous symmetry breaking, as applied not only to equilibrium systems but also to systems far from equilibrium, are carefully specified. The Rayleigh-Bénard convection experiment is then examined in Section 3 to show that at both the first and the second instability, long range order and spontaneous symmetry breaking occur. In the final section, a comparison with equilibrium systems is given, the question of translational symmetry is addressed and some experimental consequences of symmetry breaking far from equilibrium are outlined.

2. Long Range Order and Spontaneous Symmetry Breaking

Given the disagreements in the literature mentioned above over whether or not spontaneous symmetry breaking has been observed far from equilibrium, it is important to be clear about what one means by this term.

In equilibrium physics, the term is used to describe, roughly speaking, the onset of a state which breaks, in an organized way over a macroscopic scale, a symmetry of the microscopic dynamics, in a way which is not pre-determined by the experimental arrangement.

Many symmetry breaking transitions in equilibrium physics can be described in terms of a local dynamical variable which can vary in space and time. Examples are the magnetization density in magnetic transitions and the phase of the wavefunction in superconducting and superfluid transitions. Many non-equilibrium systems also exhibit transitions describable in terms of a local dynamical variable, for example fluid velocity in hydrodynamic systems and concentration in chemical systems.

Spontaneous symmetry breaking can therefore be defined a little more precisely as follows.

If the microscopic dynamics are invariant under some transformations of the dynamical variable, these transformations will be referred to as symmetry transformations. A dynamical field $v(x,t)$ will be defined as the deviation of a dynamical variable from the value which is invariant under all the symmetry transformations.

Long range order can then be defined as the existence of a macroscopic space-time domain D and a dynamical field $v(x,t)$, such that $v(x,t)$ is non-zero somewhere in D and is periodic over D in at least one space or time dimension. "Periodic" will be taken to include "constant" as the simplest case.¹⁴ This definition of long range order implies, through the definition of $v(x,t)$, the breaking of a symmetry.

Two configurations of a dynamical field $v(x,t)$ in D , describing long range order, will be said to be symmetric if they can be mapped onto each other by symmetry transformations.

Symmetric external conditions, with respect to a given long range order are those at which the system can have different but symmetric configurations of the long range order, depending on the way the external conditions were achieved.

A system will be said to exhibit spontaneous symmetry breaking if it exhibits long range order under symmetric external conditions.

Equilibrium phenomena represent special cases in the above definitions since the time dependence of $v(x,t)$ is the most trivial: $v(x,t)$ is independent of t in equilibrium systems. In an equilibrium ferromagnetic, for instance, the symmetry is under rotations of magnetization vectors; the invariant value is zero; the dynamical field is the magnetization; it acquires a non-zero value which is constant in space and time over macroscopic scales; two different directions of magnetization are related by the symmetry transformation; the symmetric external conditions are those with zero applied uniform field; and different directions of magnetization can be obtained by reducing fields pointing in different directions to zero.

These definitions of long range order and spontaneous symmetry breaking can now be applied to a non-equilibrium experiment: The Rayleigh-Bénard convection cell.

3. Rayleigh-Bénard Convection

Rayleigh-Bénard convection⁹ is the flow of a fluid contained between horizontal thermally conducting plates, and heated from below. The Rayleigh number R_a is proportional to the temperature difference between the plates. For small R_a the fluid is at rest and heat is transferred solely by conduction. At a critical value R_c of R_a a transition or instability occurs to a flow pattern consisting of convection rolls. This flow pattern is constant in time. For low values of the Prandtl number (ratio of kinematic viscosity to thermal diffusivity), a second transition occurs at a higher value of R_a , to a flow consisting of transverse oscillations of the rolls.

3.1 The First Instability

The microscopic dynamics are invariant under the reversal of the components of all velocities azimuthal to the convection rolls. There is nothing in the equations of motion which prefers one direction of roll flow over the other. The symmetric value of this velocity component is zero and so the actual value is a dynamical field.

Once the transition has occurred the value of this dynamical field is constant in D , along a roll and in time. The system thus exhibits long range order.

By directly inducing a roll pattern with either sense of azimuthal flow and then letting the external conditions revert to those described above, with long range order present, the rolls can be formed with either sense, at the same external conditions. These

two configurations are symmetric and the system thus exhibits spontaneous symmetry breaking.

3.2 The Second Instability

The microscopic dynamics are invariant under reversing the component of all velocities transverse to the rolls. That flow component is therefore a dynamical field.

Its value, once the second instability has occurred, oscillates periodically in D , in space along a roll, and in time. The system thus exhibits a new long range order.

By changing the way the system is prepared, the sense of the transverse velocities as observed over any finite interval of time, can be reversed, and these two configurations are symmetric. The standard external conditions are thus symmetric and the system exhibits a second spontaneous symmetry breaking.

Thus the defining features of long range order and spontaneous symmetry breaking, as they occur in equilibrium, are also observed far from equilibrium, at a transition to a stationary state, and also at a transition to a time-dependent state.

4. Comments and Experimental Consequences

4.1 Comparison with Equilibrium Models

In the transitions just discussed, the fundamental symmetry breaking, which defined the dynamical field, was the breaking of a discrete symmetry between two configurations. Thus, in this respect, the transitions are similar to phase transitions in Ising models.

Further, the first instability led to a $v(x,t)$ which was constant

in time and in one spatial direction. Thus the system at the first instability is like Ising models with ferromagnetic interactions in two of their dimensions. If one considers moving in space from one roll or vortex to the next, however, one encounters oscillations in space. Thus, the first transition is like those of Ising models with competing ferromagnetic and antiferromagnetic bonds along one spatial direction. An example of such a model is the ANNNI model which has an oscillatory magnetic ordering in one direction, and ferromagnetic ordering in the other directions.

The state which arises after the second instability has oscillations in time and in two space dimensions. It is thus analogous to the equilibrium ordered phase of an Ising model with oscillatory order in three dimensions.

4.2 The Transition to Inhomogeneity

As remarked in the Introduction, the onset of inhomogeneity, such as occurs at the first instability of both the convection experiment and the Couette Taylor flow system, has been described^{2,9} as a spontaneous symmetry breaking transition. The translational symmetry of the near equilibrium state is said to be broken by the onset for example of convection rolls and Taylor vortices respectively.

The finite size of these experiments means that there is in fact no translational symmetry there to be broken. In a freezing transition, one speaks of breaking translational symmetry even though all experiments have a finite size. The difference is that freezing will occur in volumes with an arbitrarily large number, for instance Avagadro's number, of unit cells. The effect of the

boundaries can thus be made negligibly small compared to bulk effects. This is not the case in the Rayleigh-Bénard and Couette Taylor experiments. These experiments are typically done at a small number (roughly 4 to 400) of unit cells (convection rolls or Taylor vortices). Further, there is evidence^{15,9} that, as the number of unit cells reaches around 100, the whole pattern becomes unstable. It has been claimed¹² that in such systems fluctuations are expected to destroy the long range order in the infinite system.

Thus there is no translational symmetry to be broken. Connected with this is the fact that different states, related to each other by translations (see §2), are not observed. Thus these transitions far from equilibrium do not constitute spontaneously broken translational symmetry.

It was shown in §3 however that, underlying this inhomogeneity in the Rayleigh-Bénard experiment is a spontaneously broken discrete symmetry.

4.3 Experimental Consequences: The Effect of Symmetry Breaking Boundary Conditions

When an external field breaks the symmetry associated with an equilibrium symmetry-breaking transition, this transition becomes rounded instead of sharp.

Now certain boundary effects in the Rayleigh-Bénard and the Couette Taylor¹⁶ experiments are known to produce a smoothing¹⁷ or rounding of the respective instabilities. This rounding can be understood¹⁷ in terms of extra terms introduced by the boundaries into the corresponding amplitude equations.

Symmetry considerations, and the comparison with equilibrium

transitions, give a simple qualitative explanation, however. These end effects are known to induce convection rolls (vortices in the Couette Taylor system) even quite close to equilibrium. In inducing these rolls (vortices), which simply grow smoothly in amplitude as the driving is increased, the ends are selecting a sense of roll (vortex) flow velocity, and hence breaking the symmetry of the transition: symmetry under reversal of this velocity. From experience with equilibrium transitions with a symmetry breaking field applied, one therefore expects that the transitions are rounded, as observed.

A stronger test of these symmetry arguments, however, would be to use them predictively, rather than descriptively.

A prediction can be obtained as follows. The symmetry arguments depend not on the magnitude of the boundary effects, but on whether or not their sense is such as to break the symmetry associated with the transition. Consider then two rectangular convection cells, A and B, with aspect ratio equal to a small odd integer, say 3. Let cell A have a small amount of heat flowing in one face and an equal flow out of the opposite face, where these two faces are parallel to the length of the convection rolls (Figure 1a). Let cell B be identical except that the sense of one of the side wall heat flows is reversed, its magnitude remaining constant, so that on both sides, heat is flowing in, say, at equal rates (Figure 1b).

The effect of heat flowing in (out) at a side wall is to induce, even for $R_a < R_c$, a roll with fluid flow upward (downward) at the wall. If at larger R_a a roll pattern fills the cell, one can consider how the two possible senses of azimuthal flow compare with that of the boundary rolls. This can most simply be seen in a diagram. In Figure 2 the senses of the boundary roll flow are indicated by arrows outside the boundary. For an odd number of rolls, cells A and B have the possibilities shown in Figures 2a and 2b respectively. (The sense of flow is always observed to alternate from one roll to the next.)

In cell A, Flow 1 coincides with the boundary induced flow at both boundaries, while Flow 2 is opposite to the induced flow at both boundaries. Thus in cell A the boundary effects break the symmetry between Flows 1 and 2. In cell B¹⁸, Flow 1 coincides with the induced flow on the left hand boundary and is opposite to that on the right hand boundary. Flow 2 is opposite to the induced flow at the left boundary and coincides with that at the right boundary. In a rectangular cell, there is nothing to distinguish left from right and the symmetry between Flow 1 and Flow 2 is therefore not broken in cell B.

The comparison with equilibrium symmetry breaking then predicts

the following. In cell A the boundary effects will round the transition, while in cell B they will not and, although the magnitudes of heat flow are the same as for cell A, the transition will remain sharp.

Perhaps the simplest parallel equilibrium case is that of an Ising antiferromagnet. A staggered field breaks the symmetry and smooths out the transition. A uniform field does not break the symmetry and, although T_c is reduced, a sharp transition remains.

4.4 Conclusion

An examination of the Rayleigh-Bénard convection experiment has shown that the first two instabilities exhibit, far from equilibrium, the onset of long range order and the spontaneous breaking of a discrete symmetry. An experimental prediction based on this observation has been outlined.

Acknowledgements

The author is grateful for conversations with P. Anderson, M. Cross, R. Fisch, J. Gollub, H. Greenside, P. Hohenberg, D. Stein, H. Swinney, R. Walden, and A. Wightman.

References

1. J. Wesfried, Y. Pomeau, M. Dubois, C. Normand, and P. Bergé, J. de Physique 39, 725 (1978).
2. P. Bergé, Phys. Rev. Lett. 32, 1041 (1974).
3. R.J. Donnelly, K.W. Schwartz, P.H. Roberts, Proc. R. Soc. London A283, 531 (1965); J.P. Gollub, M.H. Freilich, Fluctuations, Instabilities and Phase Transitions, Natl. Advanced Study Inst. (Plenum Press) B11, 195 (1975); J.P. Gollub, M.H. Freilich, The Physics of Fluids, 19, 618 (1976).
4. M. Giglio and A. Vendramini, Phys. Rev. Lett. 39, 1014 (1977).
5. J. Swift and P.C. Hohenberg, Phys. Rev. A15, 319 (1977).
6. D. Nelson and Toner Preprint (1980).
7. G. Nicolis and I. Prigogine, "Self-Organization in Non-Equilibrium Systems", Wiley (N.Y.) 1977.
8. H. Haken, "Synergetics", Springer Verlag (Berlin-N.Y.) 1977.
9. G. Ahlers and R.P. Behringer, Progress in Theor. Phys. Supp. No. 04, p.186 (1978).
10. P.W. Anderson, Can Broken Symmetry Occur in Driven Systems? Remarks at Solvay Conference, Brussels 1978, preprint.
11. P.W. Anderson, Some General Thoughts About Broken Symmetry, 1980 preprint.
12. D.L. Stein, J. Chem. Phys. 72, 2869 (1980).
13. "Dissipative systems" means here systems driven to steady, non-equilibrium states.
14. This definition includes the low temperature phase of a spin glass (spatial incoherence and temporal coherence: "freezing")

and initial hydrodynamic chaos or turbulence (spatial coherence and temporal incoherence). It excludes fully-developed turbulence.

15. G. Ahlers and R.P. Behringer, Phys. Rev. Lett. 40, 712 (1978).
16. H. Swinney, Prog. Theor. Phys. Supp. 64, 164 (1978).
17. T.B. Benjamin, Proc. R. Soc. London A359, 1-26 (1978); T.B. Benjamin, Proc. R. Soc. London A359, 27-43 (1978); P. Hall, K. Walton, Proc. R. Soc. London A358, 199-221 (1977); P.G. Daniels, Proc. R. Soc. London A358, 173-197 (1977).
18. The heat flow at the walls is assumed sufficiently small not to destroy the transition to an odd number of rolls.

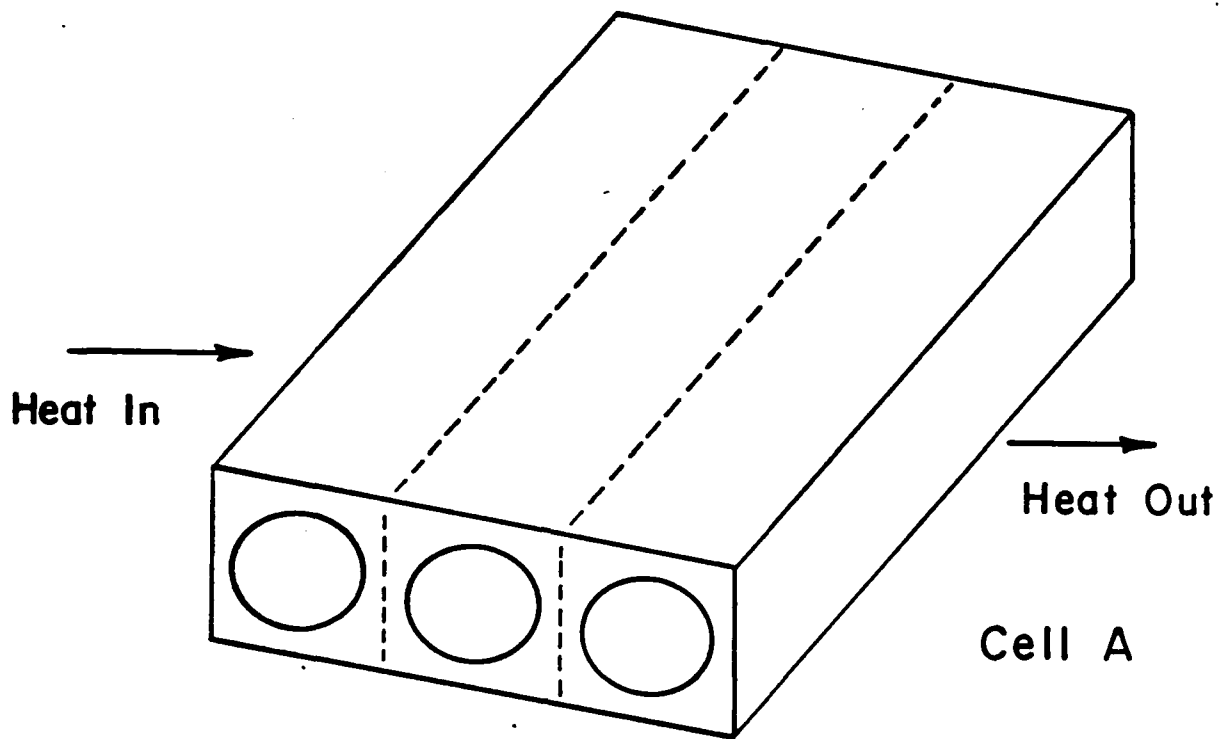

(a)

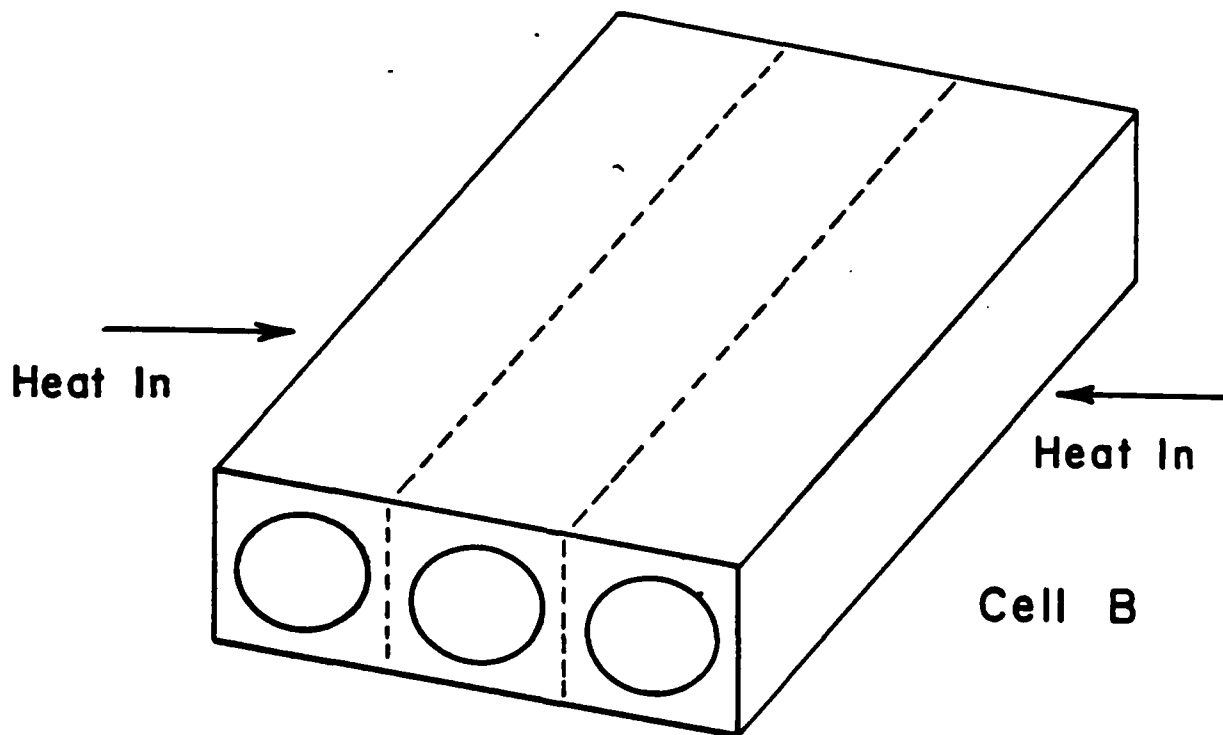

(b)

FIG 1.

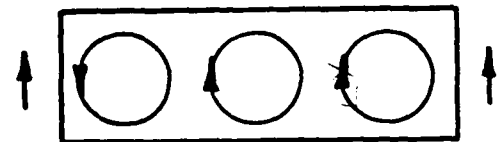
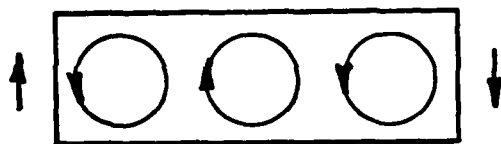
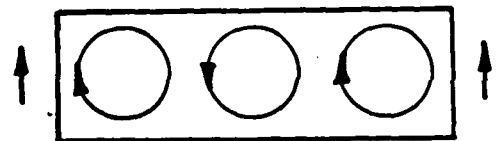
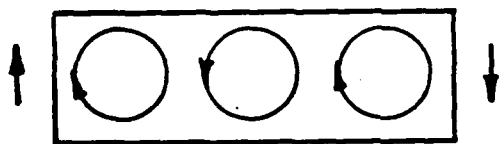

Cell A

(a)

Cell B

(b)

FIG. 2

UNCLASSIFIED

SECURITY CLASSIFICATION OF THIS PAGE (When Data Entered)

REPORT DOCUMENTATION PAGE		READ INSTRUCTIONS BEFORE COMPLETING FORM
1. REPORT NUMBER	2. GOVT ACCESSION NO.	3. RECIPIENT'S CATALOG NUMBER
	AD-A094972	
4. TITLE (and Subtitle)	5. TYPE OF REPORT & PERIOD COVERED	
Symmetry Breaking Far from Equilibrium	Technical Report, 1980 Preprint	
	6. PERFORMING ORG. REPORT NUMBER	
7. AUTHOR(s)	8. CONTRACT OR GRANT NUMBER(s)	
L. Sneddon	N00014-77-C-0711	
9. PERFORMING ORGANIZATION NAME AND ADDRESS		10. PROGRAM ELEMENT, PROJECT, TASK AREA & WORK UNIT NUMBERS
Department of Physics, Princeton University Princeton, N.J. 08544		NR 318-058
11. CONTROLLING OFFICE NAME AND ADDRESS		12. REPORT DATE
Office of Naval Research (Code 427) Arlington, Va. 22217		January 21, 1981
		13. NUMBER OF PAGES
		13 + 2 Figures
14. MONITORING AGENCY NAME & ADDRESS (if different from Controlling Office)		15. SECURITY CLASS. (of this report)
		Unclassified
		15a. DECLASSIFICATION/DOWNGRADING SCHEDULE
16. DISTRIBUTION STATEMENT (of this Report)		
Approved for public release; distribution unlimited.		
17. DISTRIBUTION STATEMENT (of the abstract entered in Block 20, if different from Report)		
18. SUPPLEMENTARY NOTES		
submitted to Phys. Rev. A.		
19. KEY WORDS (Continue on reverse side if necessary and identify by block number)		
symmetry breaking, non-equilibrium, long range order, instability.		
20. ABSTRACT (Continue on reverse side if necessary and identify by block number)		
An examination of the Rayleigh-Bénard convection experiment shows that the defining features of long-range order and spontaneous symmetry breaking as they occur in equilibrium transitions, are also observed far from equilibrium. The broken symmetry is not, as has been suggested, translational invariance, but rather a discrete symmetry under velocity reversal. Some experimental consequences of these observations are outlined.		

DD FORM 1473
1 JAN 73

EDITION OF 1 NOV 68 IS OBSOLETE
S/N 0102-LF-014-6601

UNCLASSIFIED

SECURITY CLASSIFICATION OF THIS PAGE (When Data Entered)

DATE
FILMED
— 8