

AD-A094 346

ROSENSTIEL SCHOOL OF MARINE AND ATMOSPHERIC SCIENCE --ETC F/G 0/3
INVESTIGATION OF HYDRODYNAMIC EFFECTS OF THE PROPOSED MARINA F0--ETC(U)
DEC 73 J F MICHEL

UNCLASSIFIED

UM-RSMAS-73076

NL

1 of 1
00 6/24/81

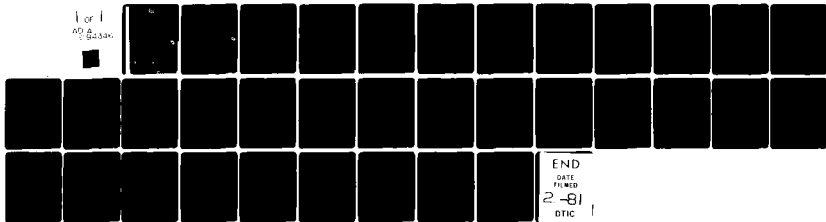

END
DATE
FILMED
2-81
DTIC

*Ordered
2/25/80*

LEVEL ~~1~~

Q
b.s. *FY-74*
OSP REP

UNIVERSITY OF MIAMI

ROSENSTIEL SCHOOL OF MARINE AND ATMOSPHERIC SCIENCE

AD A 094346

REPORT

December 1973

INVESTIGATION OF HYDRODYNAMIC EFFECTS OF THE PROPOSED
MARINA FOR MIAMI BEACH, FLORIDA

by

John F. Michel, Associate Professor
Division of Ocean Engineering

SDTC
ELECTED
FEB 2 1981
D
C

X **DOC FILE COPY**

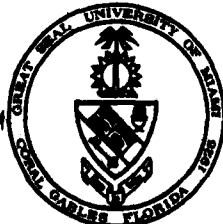

DISTRIBUTION STATEMENT A
Approved for public release;
Distribution Unlimited

MIAMI, FLORIDA 80 9 3 059

①

ROSENSTIEL SCHOOL OF MARINE AND ATMOSPHERIC SCIENCE ✓
UNIVERSITY OF MIAMI

REPORT

December 1973

② INVESTIGATION OF HYDRODYNAMIC EFFECTS OF THE PROPOSED
MARINA FOR MIAMI BEACH, FLORIDA,

by

③ [John F. Michel] Associate Professor
Division of Ocean Engineering

DTIC
SELECTED
FEB 2 1981
C

for

THE CITY OF MIAMI BEACH
FLORIDA

Rickenbacker Causeway
Miami, Florida 33149

Warren S. Wooster
Dean

14 UM-RSMAS-73076

DISTRIBUTION STATEMENT A
Approved for public release;
Distribution Unlimited

465-25

TABLE OF CONTENTS

	Page
List of Figures	
List of Tables	
Introduction and Background	1
Purpose of the Study	1
Description of the Area	2
The Numerical Model	4
The Field Work	5
Processing the Data	8
Calibration of the Model	12
Operation of the Model	12
Discussion	17
Summary	22
References	30

Accession For		
NTIS GRA&I	<input checked="" type="checkbox"/>	
DTIC TAB	<input type="checkbox"/>	
Unannounced	<input type="checkbox"/>	
Justification	<i>see file</i>	
By	<i>Jan 81</i>	
Distribution/		
Availability Codes		
Dist	Avail and/or	Special
<i>A</i>		

LIST OF FIGURES

		Page
Figure 1	Area Map Showing Reach Designations	3
Figure 2	Results of Calibration - Ebb Tide	6
Figure 3	Results of Calibration - Flood Tide	13
Figure 4	Areas Eliminated From Reach 1 as a Result of Marina Construction	16
Figure 5	Exchange with North Biscayne Bay Effect of Ship Channel Dredging - Spring Tide	18
Figure 6	Exchange with North Biscayne Bay Effect of Ship Channel Dredging - Neap Tide	19
Figure 7	Exchange with North Biscayne Bay - Case 1 Spring Tide	20
Figure 8	Exchange with North Biscayne Bay - Case 1 Neap Tide	21
Figure 9	Exchange with North Biscayne Bay - Case 2 Spring Tide	23
Figure 10	Exchange with North Biscayne Bay - Case 2 Neap Tide	24
Figure 11	Exchange with North Biscayne Bay - Case 3 Spring Tide	25
Figure 12	Exchange with North Biscayne Bay - Case 3 Neap Tide	26

LIST OF TABLES

Table 1	Summary of Tidal Data	7
Table 2	Summary of Discharge Measurements	9
Table 3	Results of Tidal Component Analysis	11
Table 4	Comparison of Alternate Marina Plans with Existing Conditions - Case 1	27
Table 5	Comparison of Alternate Marina Plans with Existing Conditions - Case 2	28
Table 6	Comparison of Alternate Marina Plans with Existing Conditions - Case 3	29

Investigation of Hydrodynamic Effects of the Proposed
Marina for Miami Beach, Florida

Introduction and Background

Under Professional Services Agreement dated 16 August 1972, the City of Miami Beach employed the firm of Greenleaf/Telesca, Planners, Engineers, Architects Inc. to prepare a feasibility study and master plan for a marina complex to be located on the east shore of Meloy Channel south of the MacArthur Causeway. Personnel of the Rosenstiel School of Marine and Atmospheric Sciences of the University of Miami under the direction of this author participated in the study and prepared a portion of the report(1). As a result of the preliminary work it became evident that the configuration of the marina as proposed might change the hydraulic characteristics of Meloy Channel sufficiently to cause major changes in the exchange between north Biscayne Bay and the Atlantic Ocean via Government Cut.

During subsequent negotiation with Grennleaf/Telesca. the Department of Natural Resources of the State of Florida determined that a hydrographic study would be required before a permit for the construction could be issued. Accordingly, a contract for the study was negotiated between the City of Miami Beach and this organization.

Purpose of the Study

This study is designed to determine by means of a numerical model the total effect of the proposed marina construction on the circulation of Biscayne Bay with particular regard to that portion of

P-1

the Bay lying north of the MacArthur Causeway. Alternate plans for constructing the marina are considered as is the effect of deepening the main ship channel which is presently under contract by the U.S. Army corps of Engineers. The area studied is shown on Figure 1.

Description of the Area

The area studied lies between mainland Miami and Miami Beach which is situated on a barrier island. It is bordered on the north by the Julia Tuttle Causeway and on the south by the main ship channel which is included. There are no natural terrain features remaining in the area as all of the islands and channels are man-made. This causes a uniformity in horizontal and vertical configuration that does not occur naturally, but greatly facilitates the development of a model.

Flow through the area is broken by two major barriers, the MacArthur Causeway which has relatively large openings at each end and the Venetian Causeway which has 7 openings at relatively uniform spacing.

Tides in the area as reported by the National Ocean Survey(2) are semidiurnal and have a mean range of 2.0 feet and a spring range of 2.4 feet. The effect of wind on the water surface elevations would be small between the MacArthur and Venetian Causeways as the area is relatively deep and fetches are short. In the area between the Julia Tuttle Causeway and the Venetian Causeway significant set-up would be likely during periods of strong winds from the east or west, however, no data are available.

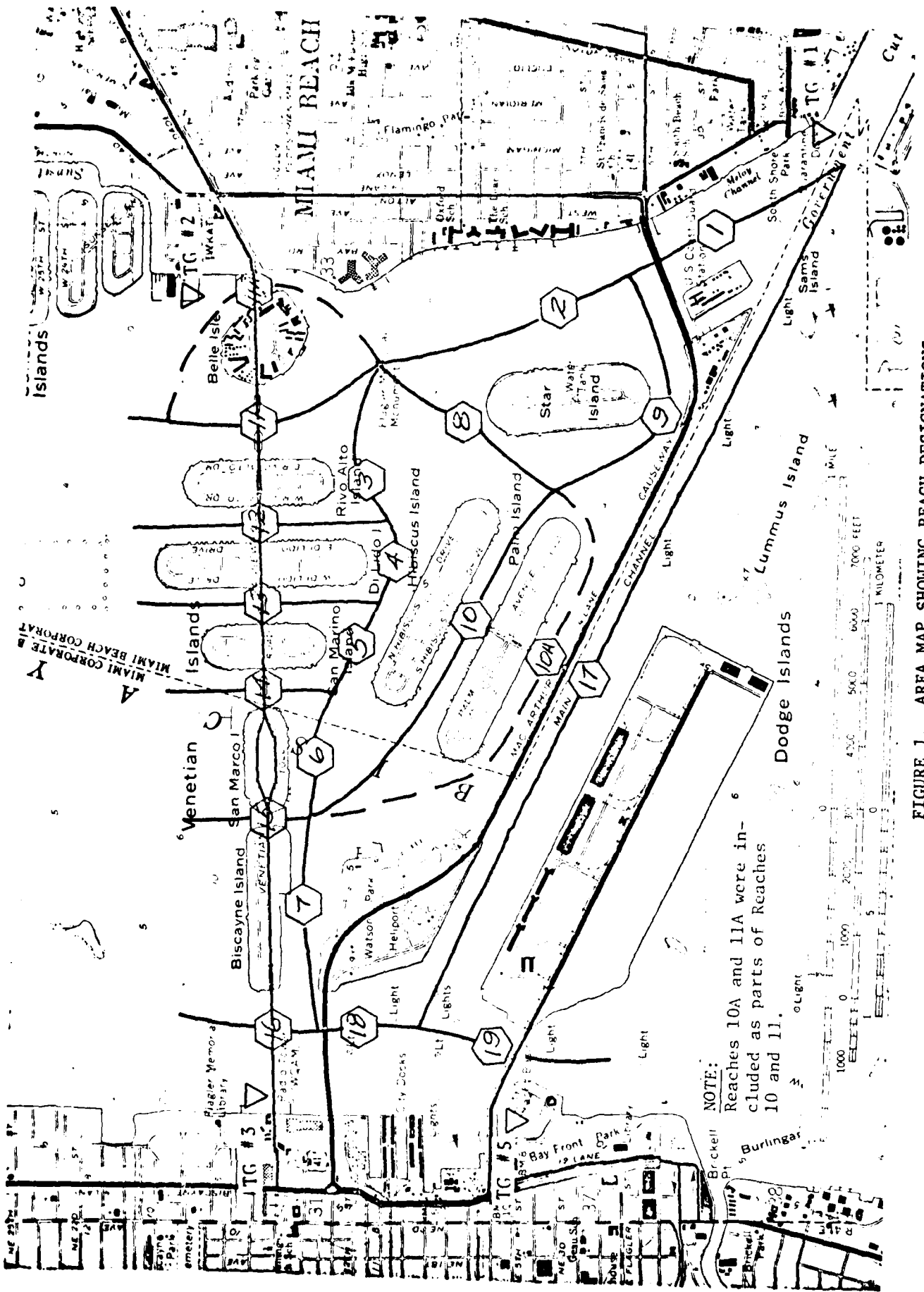

NOTE:
 Reaches 10A and 11A were included as parts of Reaches 10 and 11.

FIGURE 1. AREA MAP SHOWING REACH DESIGNATIONS

The Numerical Model

The numerical model applied here is based on the theory that an area such as this one where flow is well canalized can be broken in to a series of reaches where flow is essentially one dimensional. Manning's formula is used to determine the head loss in the reach as a function of the discharge and the channel geometry

In doing this, a friction factor k is computed so that for each reach:

$$\Delta\eta_n = k_n Q_n^2 \quad (1)$$

where: $\Delta\eta_n$ is the head loss in the reach(ft)

Q_n is the discharge through the reach(ft³/s)

and k_n is the resistance coefficient(ft⁵/s²)

The value of k is computed from Manning's relationship

$$Q_n = \frac{1.486}{n} R_n^{2/3} A_n S_n^{1/2} \quad (2)$$

where: 1.486 = a conversion factor from metric to English units
(3.281 ft/m)^{1/3}

n = Manning's roughness coefficient(ft)^{1/6}

R_n = the hydraulic radius(ft) which is the cross sectional area of the channel, A_n (ft²) divided by the wetted perimeter, P_n (ft)

S_n = the hydraulic gradient(ft/ft)

which for uniform flow

$$= \Delta\eta \div L \text{ where } L_n = \text{the length of the reach(ft)}$$

Substituting in Equation (2) and squaring we have

$$Q_n^2 = \left(\frac{1.486}{n}\right)^2 \frac{A_n^{10/3}}{P_n^{4/3}} \frac{\Delta\eta}{L_n} \quad (3)$$

which gives:

$$k_n = \frac{P_n^{4/3} L_n}{2,208 A_n^{10/3}} \quad (4)$$

Obviously in an area affected by tide k_n will vary with time as P_n and A_n vary with the water surface elevation. In the present model, this variation was found to be small on the conservative side due to the large depth of the channels so it was ignored.

Figure 2 shows a schematic diagram of the waterways systems as modelled. Characteristics of the waterways are shown on the figure.

The boundary conditions are prescribed by the water surface elevations at the mouth and the geometry.

The Field Work

The program of field work was designed to determine boundary conditions for the numerical model such as tidal data and to obtain discharge data for calibration of the model.

The program of tidal recording was begun on 26 June 1973 and continued until 19 October. Two Fischer Porter digital recording gauges were employed by utilizing a permanent station at the south end of Miami Beach marked "TG #1" on Figure 1 and moving the other gauge to other stations as shown on Figure 1. Tide gauge No. 4 is not shown on the figure. It was located at the intersection of the Julia Tuttle Causeway and the Miami shoreline just off of the Figure. Table 1 summarizes the tidal data obtained. It will be seen later that not all of these data were required to operate the numerical model.

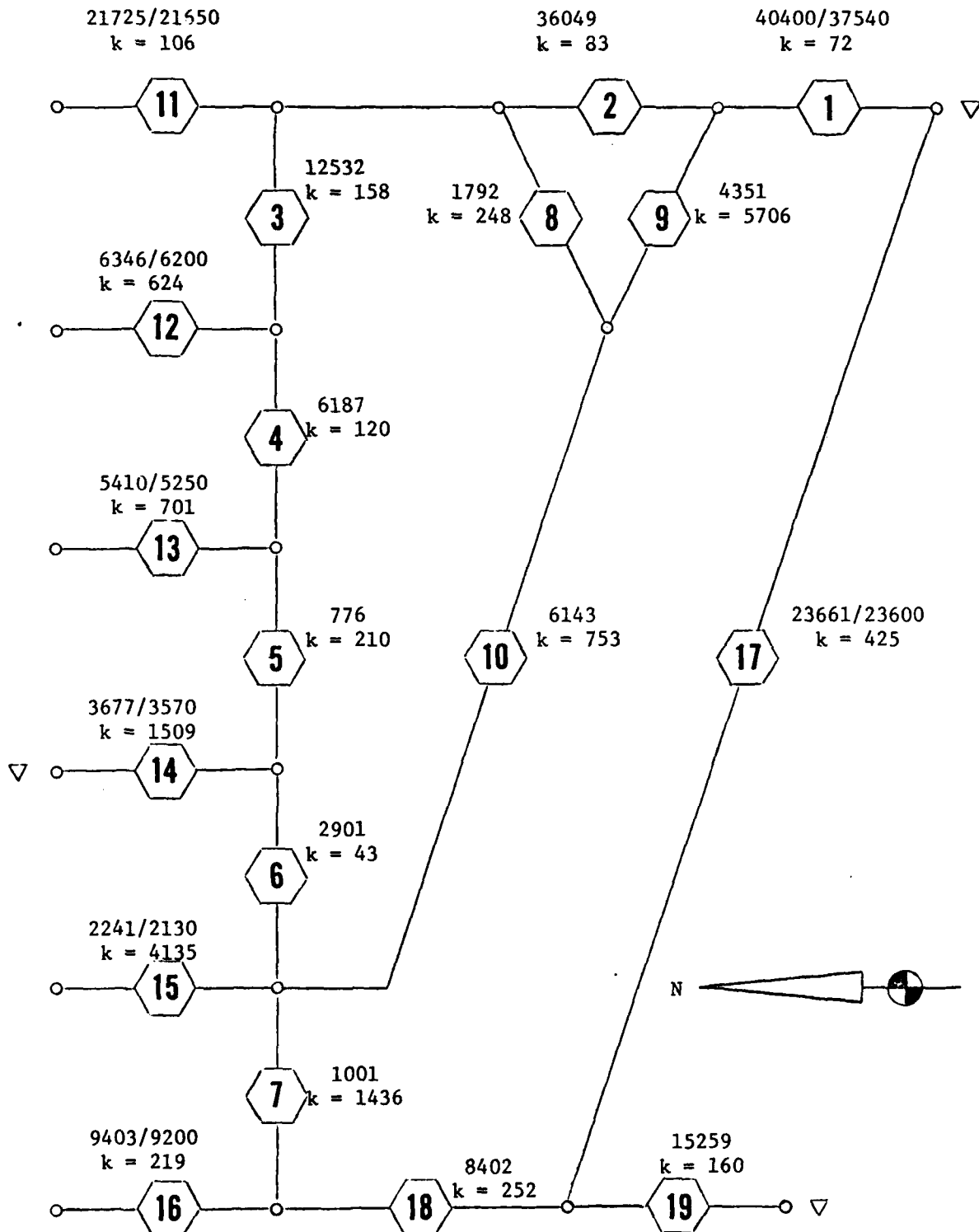

NOTES:
 1. Flows in ft^3/s : computed/measured
 2. k in $10^{-12} \text{ft}^5/\text{s}^2$

FIGURE 2
 RESULTS OF CALIBRATION
 EBB TIDE

TABLE 1
Summary of Tidal Data

	<u>Start</u>			<u>Stop</u>		
	<u>Hr</u>	<u>Day</u>	<u>Mo</u>	<u>Hr</u>	<u>Day</u>	<u>Mo</u>
TG #1	1500	26	6	1000	24	7
	1500	25	7	1200	2	10
	1400	8	16	1200	19	10
TG #2	1100	3	7	1200	16	7
TG #3	1100	18	7	0900	10	8
TG #4	1400	21	8	1000	7	9
TG #5	1300	7	9	1200	19	10

Notes: All dates 1973

The discharge measurements for model calibration were designed to obtain maximum flows for ebb and flood tide so that instrumental errors and threshold problems would be at a minimum. This sampling consisted of a bathymetric profile to determine the cross-sectional area of the channel along with a series of current meter readings which were integrated over the channel cross-section to determine the total discharge. Table 2 shows the location and dates of the discharge measurements. Stations indicated refer to the reaches of the model as designated on Figure 1.

During the above series of measurements float studies were made to determine the primary direction of flow on the flood and ebb tides.

Processing the Data

Upon completion of the data collection program, the tidal data were analyzed harmonically for components at five frequencies. The analysis was based on the formula:

$$\eta = \eta_0 + \sum_{i=1}^n a_i \sin(\sigma_i t + \delta_i) \quad (5)$$

where η is the water surface elevation (ft)
 η_0 is the mean elevation (ft)
 i is the number of the component
 n is the total number of components
 a_i is the amplitude of the i th component (ft)
 σ_i is the frequency of the i th component or $2\pi/T =$ the period(hrs)
 t the time (hrs)
 δ_i is the lag of the i th component

TABLE 2

Summary of Discharge Measurements

<u>Reach</u>	<u>Date of Measurement</u>	
	<u>Ebb</u>	<u>Flood</u>
1	31 Jul 73	7 Aug 73
9	9 Aug 73	9 Aug 73
11	30 Jul 73	8 Aug 73
11A	30 Jul 73	24 Jul 73
12	1 Aug 73	2 Aug 73
13	1 Aug 73	3 Aug 73
14	6 Aug 73	6 Aug 73
15	6 Aug 73	6 Aug 73
16	---	3 Sep 73
17	24 Aug 73	18 Oct 73
18	18 Oct 73	---
Julia Tuttle		
Miami Span	24 Sep 73	---
Julia Tuttle		
Miami Beach Span	28 Sep 73	---
Government Cut	24 Aug 73	22 Aug 73

For the purpose of analysis, this equation is simplified by expansion to:

$$\eta = n_0 + \sum_{i=1}^n s_i \sin \sigma_i t + c_i \cos \sigma_i t \quad (6)$$

where:

$$s_i = a_i \cos \delta_i$$

$$c_i = a_i \sin \delta_i$$

and
$$s_i^2 + c_i^2 = a_i^2$$

all of which are constants for any component.

As a result of this analysis it was determined that the system could be described within the accuracy of the measurements by Tide Gauges No. 1 and 2 as the difference between Gauges No. 2 and 3 were very small. Analyses of the concurrent records of Gauges No. 1 and 2 gave the results as shown in Table 3.

Tidal differences to be used in the model were obtained by reconstructing tides on the basis of the components of the difference as shown in Table 3. In doing this, equation 6 above was used. Periods for maximum differences corresponding to spring tides and minimum differences corresponding to neap tides were selected and values computed for 15 minute intervals during two tidal cycles. The periods selected corresponded to 50 to 75 hours after 0000 hrs on 1 June 1973 for spring tide and 268 to 293 hours for neap tide.

The discharge measurements were integrated for each reach and plotted for comparison to the tidal data.

TABLE 3
Results of Tidal Component Analysis

MWL		<u>TG #1</u> 1.22	<u>TG #2</u> 1.25	<u>Diff</u> .03
M ₂	s	-.66	-.43	.21
(T=12.42)	c	-.80	-.94	-.13
S ₂	s	.04	.08	.02
(T=12.00)	c	-.11	-.08	.02
N ₂	s	-.17	-.15	.02
(T=12.66)	c	-.01	-.06	-.05
K ₁	s	.11	.10	-.01
(T=23.93)	c	.06	.08	.02
O ₁	s	.11	.11	-.01
(T=25.82)	c	.00	.01	.01

Note: Values are in feet. Datum is City of Miami Beach datum
Period, T, is in Hours

Bathymetric data were supplemented by soundings from the National Ocean Survey hydrographic survey of the area and the resistance coefficient k was computed for each reach in the model. For this calculation a value of n from Manning's formula of .030 was used as an estimate. At this stage the model was ready for calibration.

Calibration of the Model

Calibration of the model was based on conditions of maximum measured discharge. After the initial run of the program with uncalibrated values of k , adjustments of the values were made until the ratios of measured flows to computed flows were reproduced with a reasonable degree of accuracy. Separate calibrations were made for ebb and flood tide to account for asymmetries in the system. After the flows were balanced, all values of k were modified to reflect the measured tidal differences. This had the effect of changing the value of n from its originally estimated value of .030 to .025 for the ebb calibration and .022 for the flood calibration. In view of the fact that the entire system was dredged, bulkheaded and only slightly vegetated, these values are considered to be reasonable. Results of the calibration are shown on Figures 2 and 3.

Operation of the Model

In operating the model it was desired to study the total ebb and flood flows during the tidal cycles rather than instantaneous or average discharge values, as the total flows give a better indication of changes in the circulation.

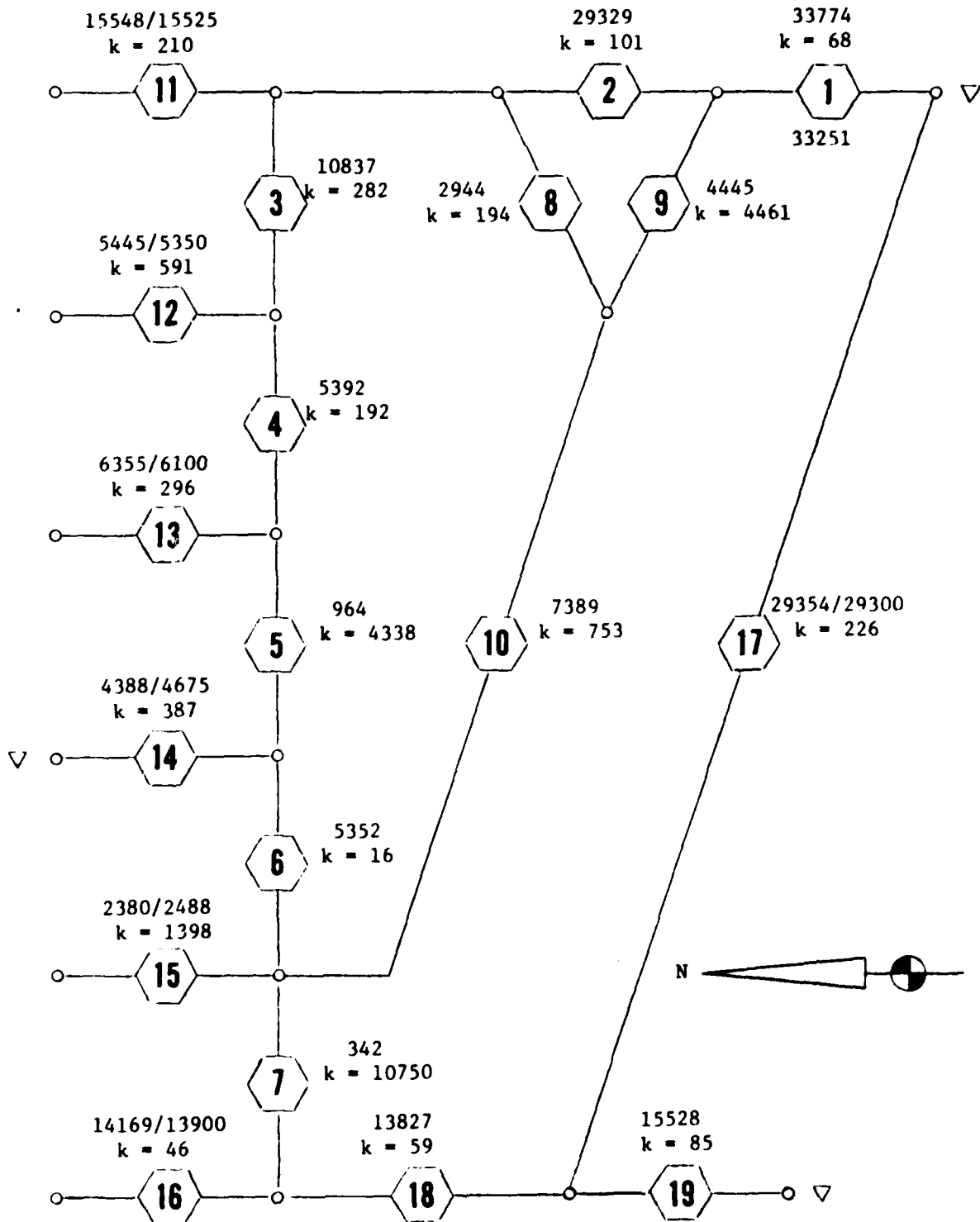

- NOTES:
1. Flows in ft^3/s : computed/measured
 2. k in $10^{-12} \frac{\text{ft}^5}{\text{s}^2}$

FIGURE 3
RESULTS OF CALIBRATION
FLOOD TIDE

This parameter is represented by:

$$\Omega = \int_{t=0}^{t=\frac{T}{2}} Q \Delta t \quad (6)$$

where:

Ω is the total flow on a tide (ft^3/tide)

t is a unit of time (s)

and T is the tidal period, in this case 12.82 hours
= 46,152 s

From equation 1 it can be seen that:

$$Q = \left(\frac{\Delta \eta}{k} \right)^{1/2} \quad (7)$$

where k is a constant. Considerable computer time was saved by calculating values of Q for each reach corresponding to a head differential of .25 feet across the system. These values were labelled $Q_{.25}$. From these the value of Q for any value of $\Delta \eta$ is given as

$$Q = Q_{.25} \left(\frac{\Delta \eta}{.25} \right)^{1/2} \quad (8)$$

which reduces equation 6 to:

$$\Omega = Q_{.25} \int_{t=0}^{t=\frac{T}{2}} \left(\frac{\Delta \eta}{.25} \right)^{1/2} \Delta t \quad (9)$$

this permits the solution for total flow without loss of accuracy by integration of the tide curve rather than the discharge curve.

As stated earlier, the value of Δt was selected as 15 minutes = 900 seconds.

In operating the model it was necessary to consider several sets of circumstances as compared to the existing conditions represented by the calibrated model. These were:

1. The decrease in resistance caused by the dredging of the main ship channel.
2. The construction of the proposed marina by alternate methods as shown on Figure 4: either with a breakwater only allowing free flow through the marina or a totally enclosed marina.

Model runs were made for spring and neap tides under ebb and flood conditions for all possible combinations of these effects, ie:

1. The ship channel dredging only. This has the effect of reducing k in Reach 17 for 425×10^{-12} to 230×10^{-12} for the ebb tide and from 226×10^{-12} to 132×10^{-12} for the flood tide.
 2. The marina with breakwater only. This increased k in Reach 1 from 72×10^{-12} to 92×10^{-12} for the ebb tide and from 69×10^{-12} to 87×10^{-12} for the flood.
 3. The marina in its completely enclosed configuration. This increases k in Reach 1 to 270×10^{-12} for the ebb and 255×10^{-12} for the flood.
 4. A combination of 1 and 2. This is referred to as Case 1.
 5. A combination of 1 and 3. This is referred to as Case 2.
- Since the deepening of the ship channel is nearly certain to occur well before the construction of the marina it is necessary to consider only cases 1 and 2 in assessing its effects.

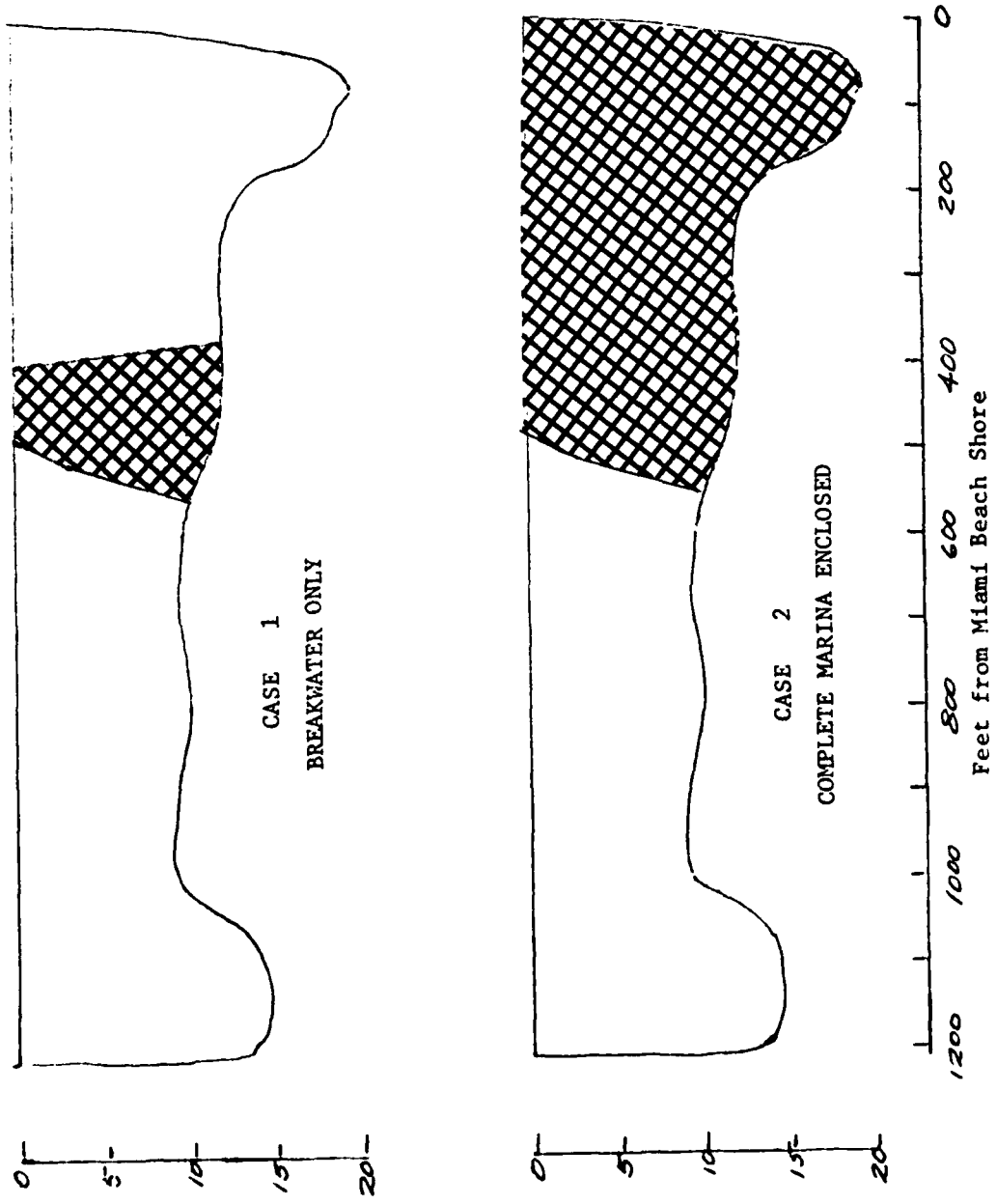

FIGURE 4
AREAS ELIMINATED FROM REACH 1
AS A RESULT OF MARINA CONSTRUCTION

Discussion

The tidal data obtained appear to be very good particularly for Gauges 1 and 2. The slight increase in mean level from Gauge 1 to 2 and the slight decrease in amplitude as shown on Table 3 is absolutely typical of their situation.

The measured discharges as well as the calibrated model runs would indicate a nodal point in north Biscayne Bay slightly north of the 79th Street Causeway. This agrees with actual observations made on the other projects over the last few years. It can be seen that during the ebb tide flow on the east side of the bay predominates while on the flood tide flow on the west side predominates. Also the ebb volume is larger than the flood volume which indicates a slight but positive circulation in the north Bay between Baker's Haulover and Government Cut.

Figures 5 and 6 show the results of the ship channel dredging only. It can be seen that this has a relatively slight influence on the North Bay, but it does improve the circulation with the maximum effect along the west side of the bay. It is interesting to note that the flood tide flows in the east part of the bay remain the same, but flood flows are increased slightly. As will be seen later, the improvement in circulation as a result of the dredging tends to offset the effect of the marina construction.

Figures 7 and 8 show Case 1 with the breakwater only in the marina. As would be expected, the flow is reduced as compared to existing conditions in Reach 1 and generally in the east part of the system. Nevertheless, the reduction in these reaches is only on the order of 5 percent which will have little effect. It should be noted, however, that

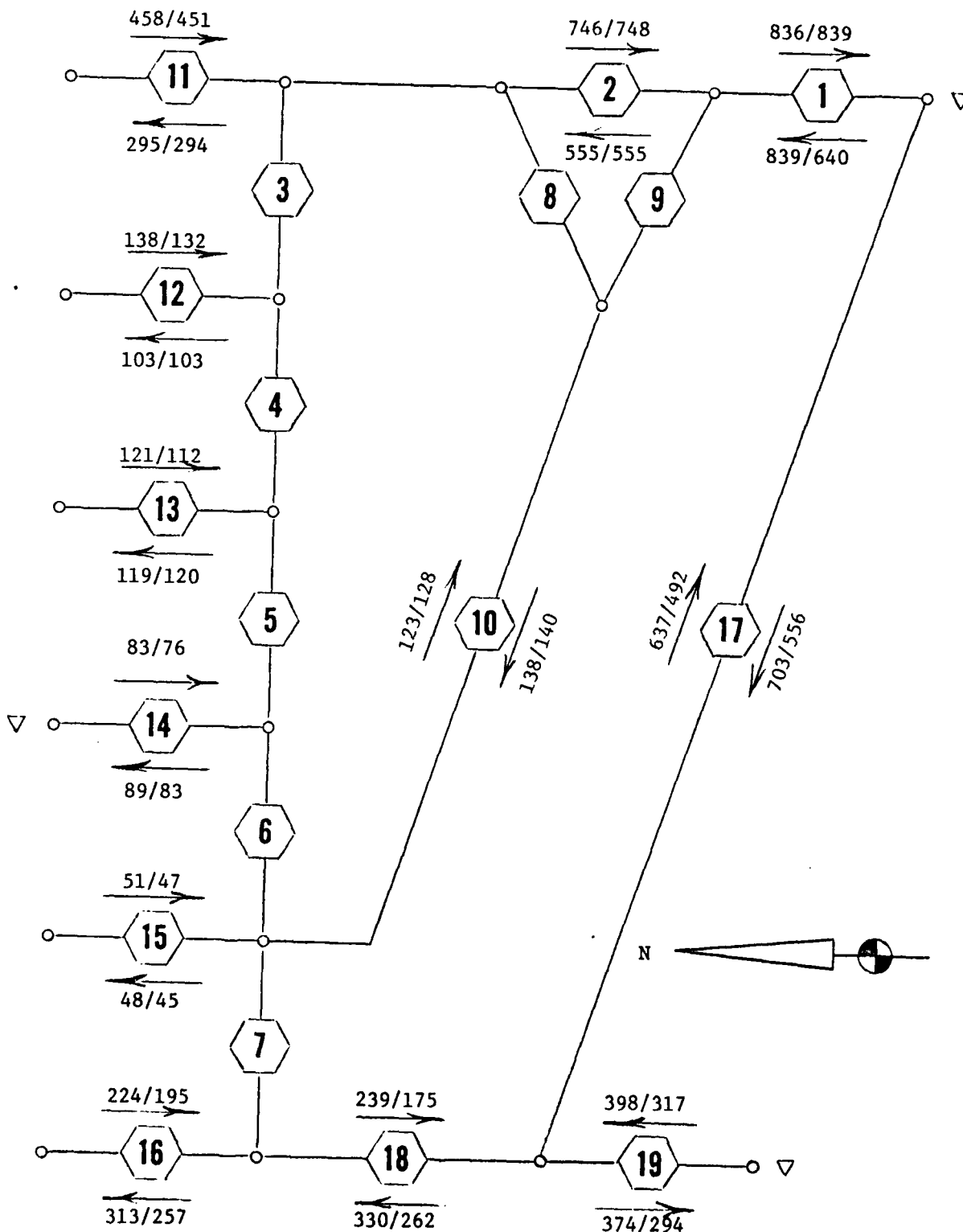

- NOTES:
1. Flows are in $10^6 \text{ ft}^3/\text{tide}$: modified/existing
 2. Total Ebb: 1075/1014
 3. Total Flood: 969/902

FIGURE 5
 EXCHANGE WITH NORTH BISCAYNE BAY
 EFFECT OF SHIP CHANNEL DREDGING
 SPRING TIDE

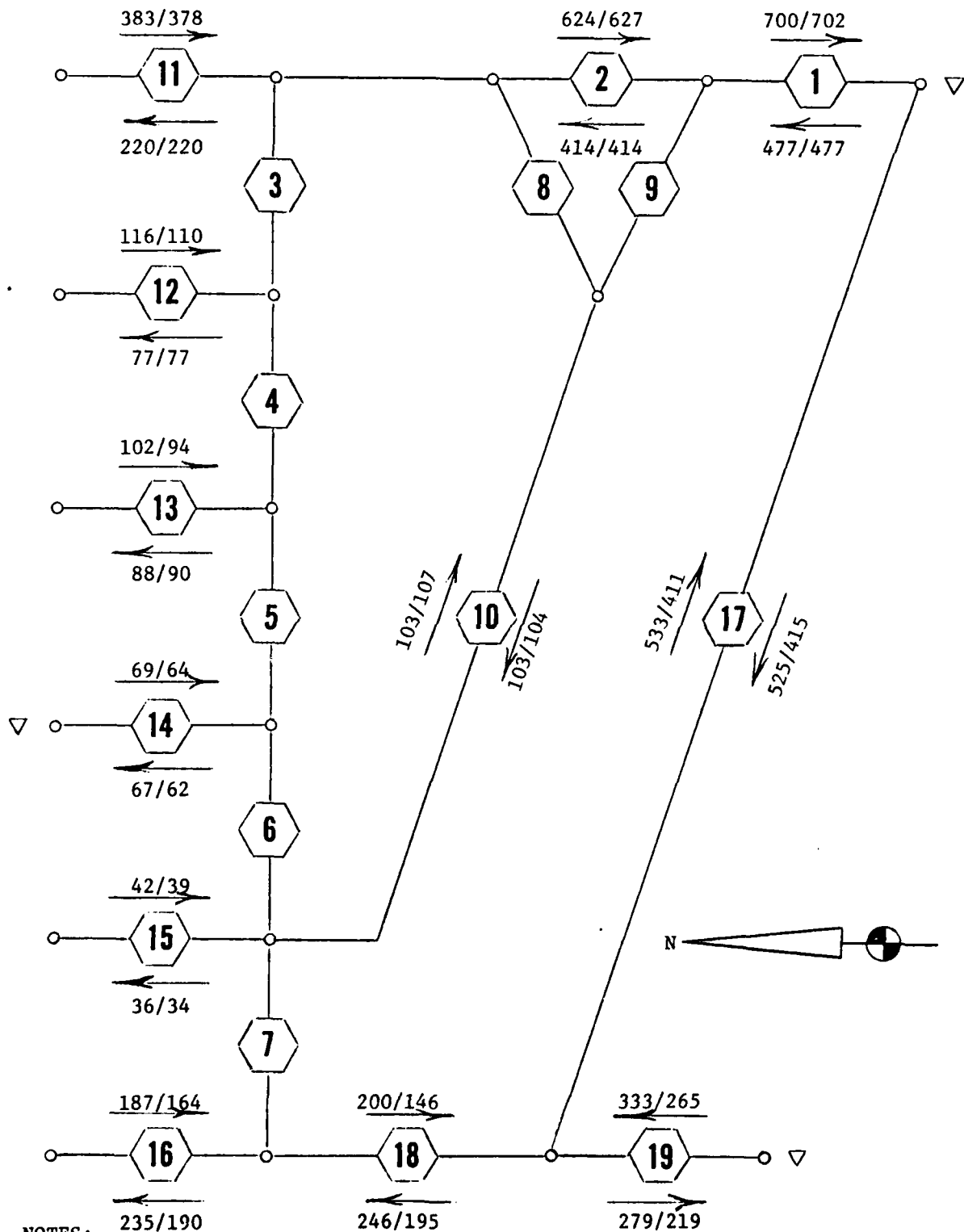

- NOTES:
1. Flows are in $10^6 \text{ft}^3/\text{tide}$: modified/existing
 2. Total Ebb: 900/848
 3. Total Flood: 723/672

FIGURE 6
EXCHANGE WITH NORTH BISCAYNE BAY
EFFECT OF SHIP CHANNEL DREDGING
NEAP TIDE

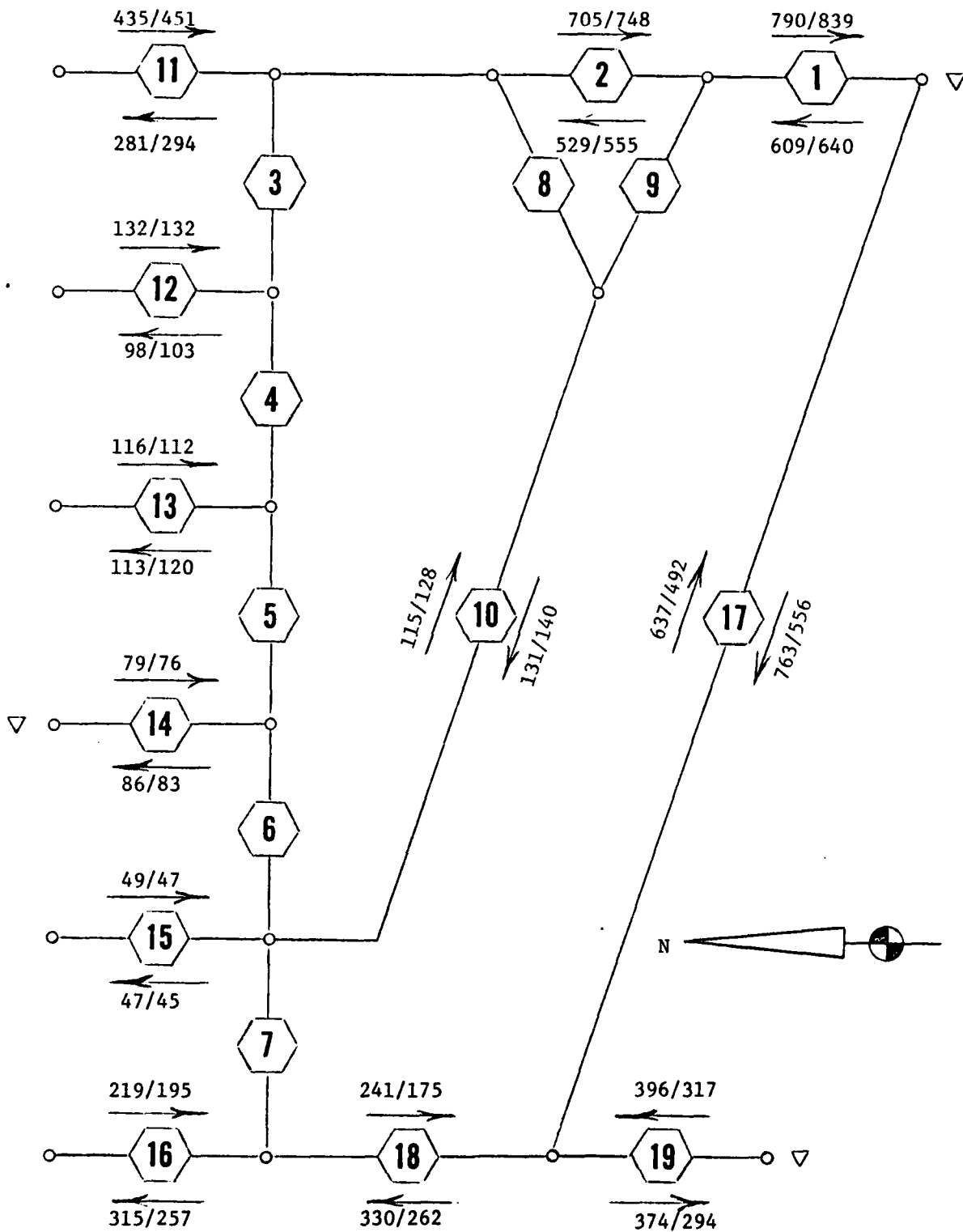
**NOTES:**

1. Flows are in $10^6 \text{ft}^3/\text{tide}$: modified/existing
2. Total Ebb: 1031/1014
3. Total Flood: 939/902

FIGURE 7
EXCHANGE WITH NORTH BISCAYNE BAY
CASE 1
SPRING TIDE

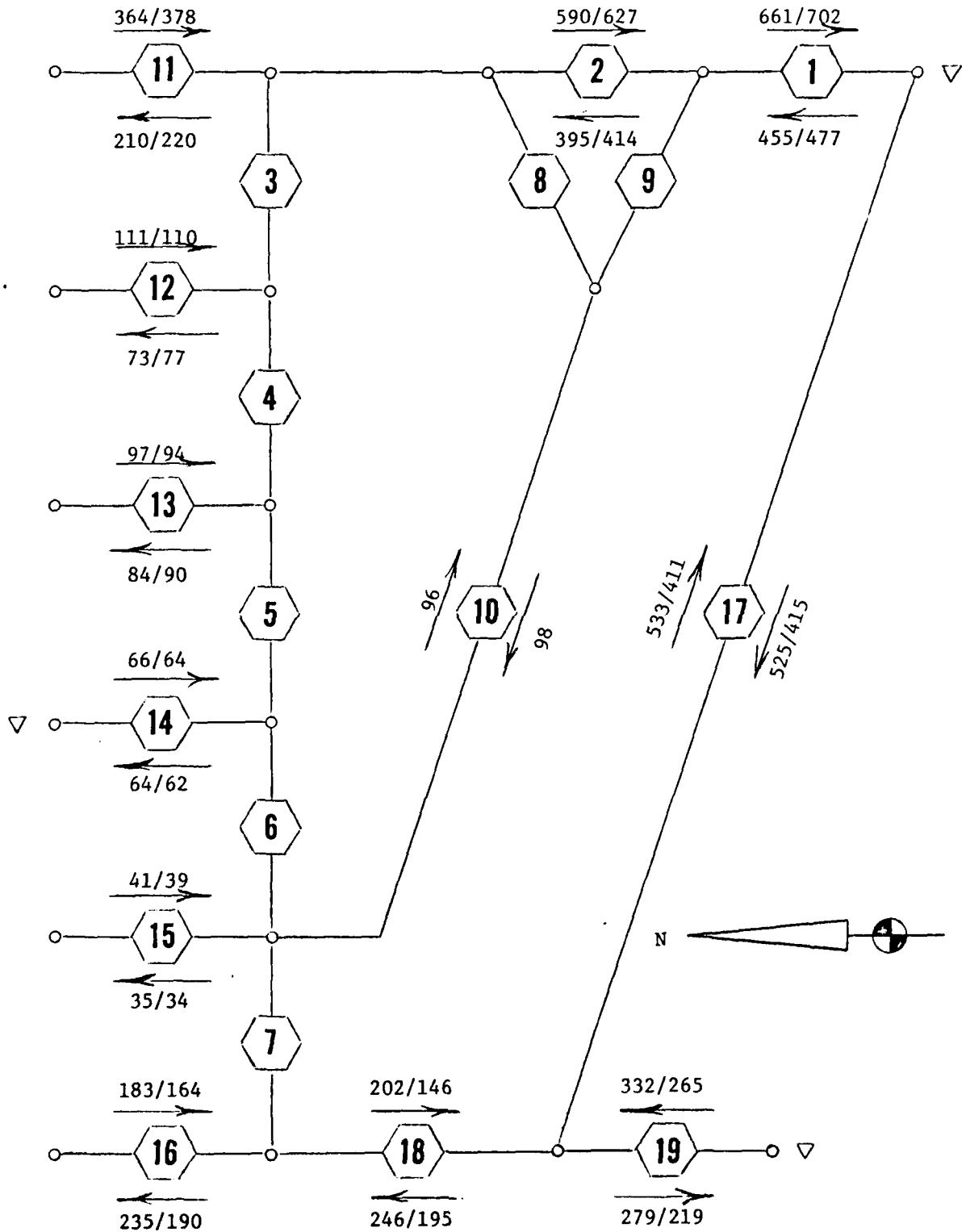

NOTES:

1. Flows are in $10^6 \text{ft}^3/\text{tide}$: modified/existing
2. Total Ebb: 863/848
3. Total Flood: 701/672

FIGURE 8
 EXCHANGE WITH NORTH BISCAYNE BAY
 CASE 1
 NEAP TIDE

the total exchange is still slightly greater than under existing conditions. This is caused by the improvement in the main ship channel.

The situation with complete enclosure of the marina, Case 2, is shown on Figure 9 and 10. Reductions in flow on the order of 30 percent in the easterly reaches can be noted while the westerly reaches are unaffected.

As this report neared completion it was decided to investigate another proposal for the marina construction which we have designated as Case 3. This proposal is identical to Case 1 as shown on Figure 4 except that the deep channel along the Miami Beach shore is to be filled to an elevation of -12 feet, mean low water. This solution would reduce the cost of the marina by facilitating construction of piers. It would also result in a reduction of the tidal current velocity through the marina. Figures 11 and 12 show the results of the model run. Results as far as circulation goes are much better than for Case 2, but not quite as good as for Case 1. Reductions in flow in the easterly part of the system are on the order of 10 percent while the total ebb flow is reduced by 4 percent and the total flood flow is unchanged.

Tables 4, 5 and 6 provide detailed results of the analysis of Cases 1, 2 and 3 under spring and neap conditions for the ebb and flood tide.

Conclusions

As a result of this study, we have arrived at the following conclusions:

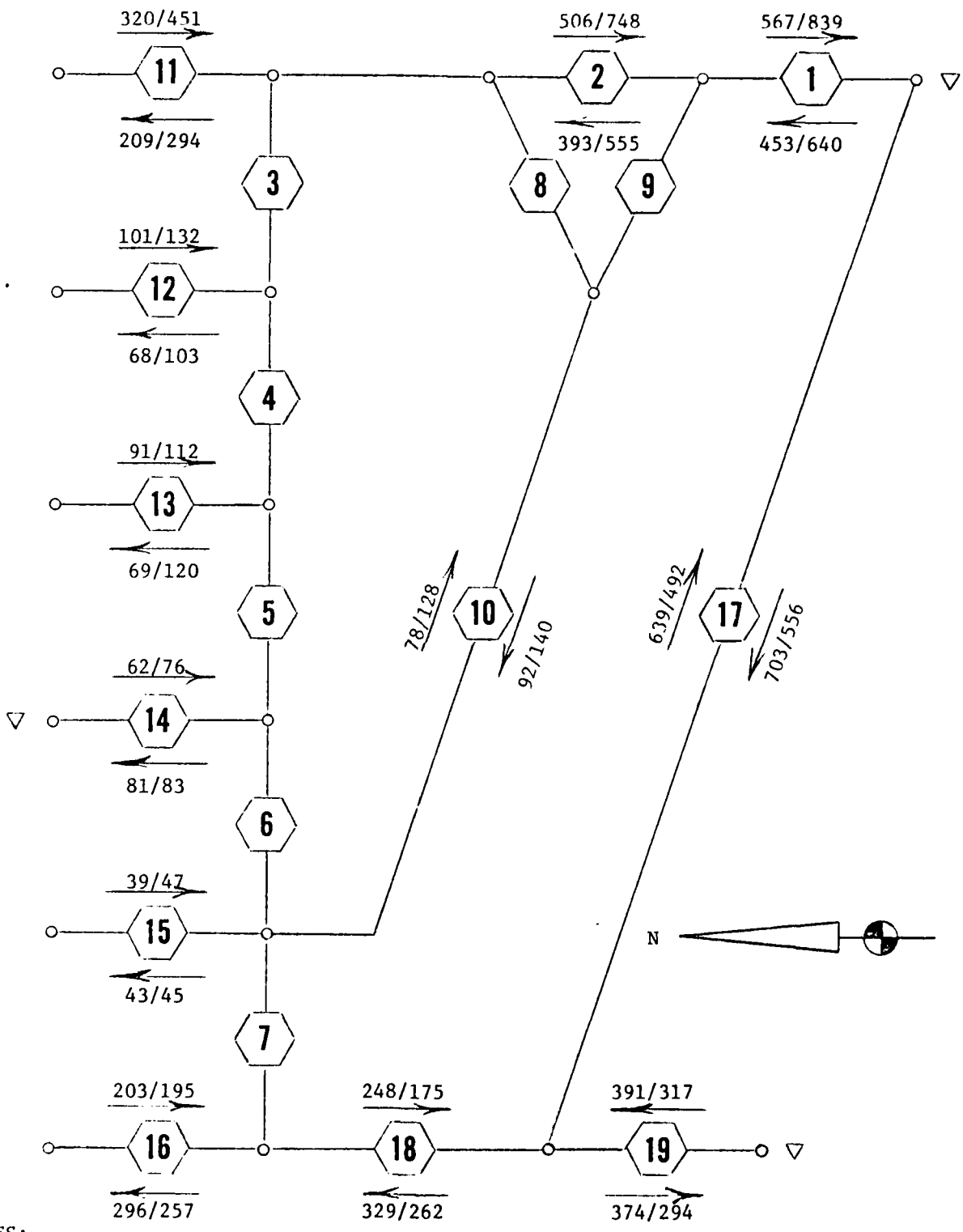

- NOTES:
1. Flows are in $10^6 \text{ ft}^3/\text{tide}$: modified/existing
 2. Total Ebb: 815/1014
 3. Total Flood: 782/902

FIGURE 9
EXCHANGE WITH NORTH BISCAYNE BAY
CASE 2
SPRING TIDE

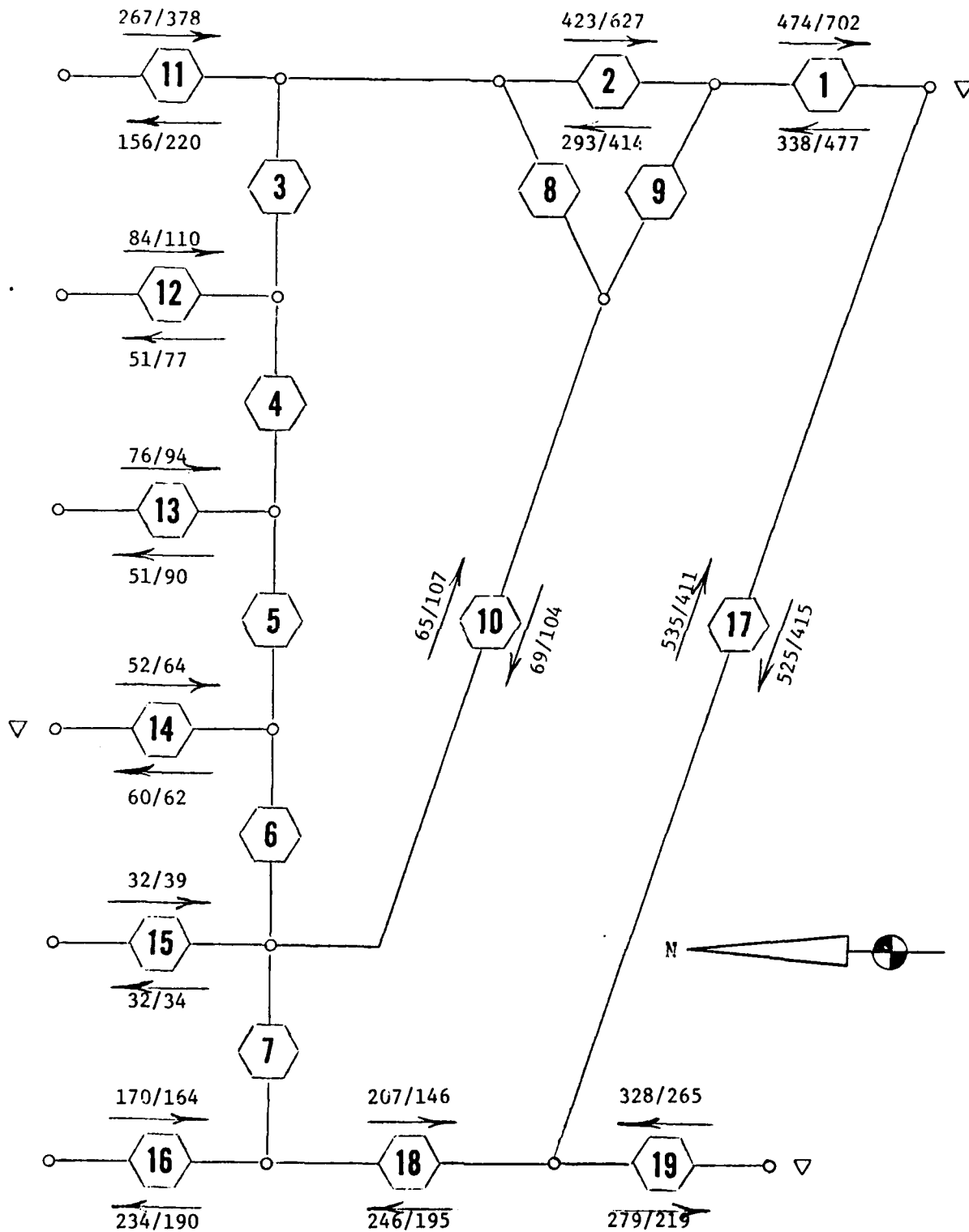

NOTES:

1. Flows are in $10^6 \text{ ft}^3/\text{tide}$: modified/existing
2. Total Ebb: 681/848
3. Total Flood: 584/672

FIGURE 10
 EXCHANGE WITH NORTH BISCAYNE BAY
 CASE 2
 NEAP TIDE

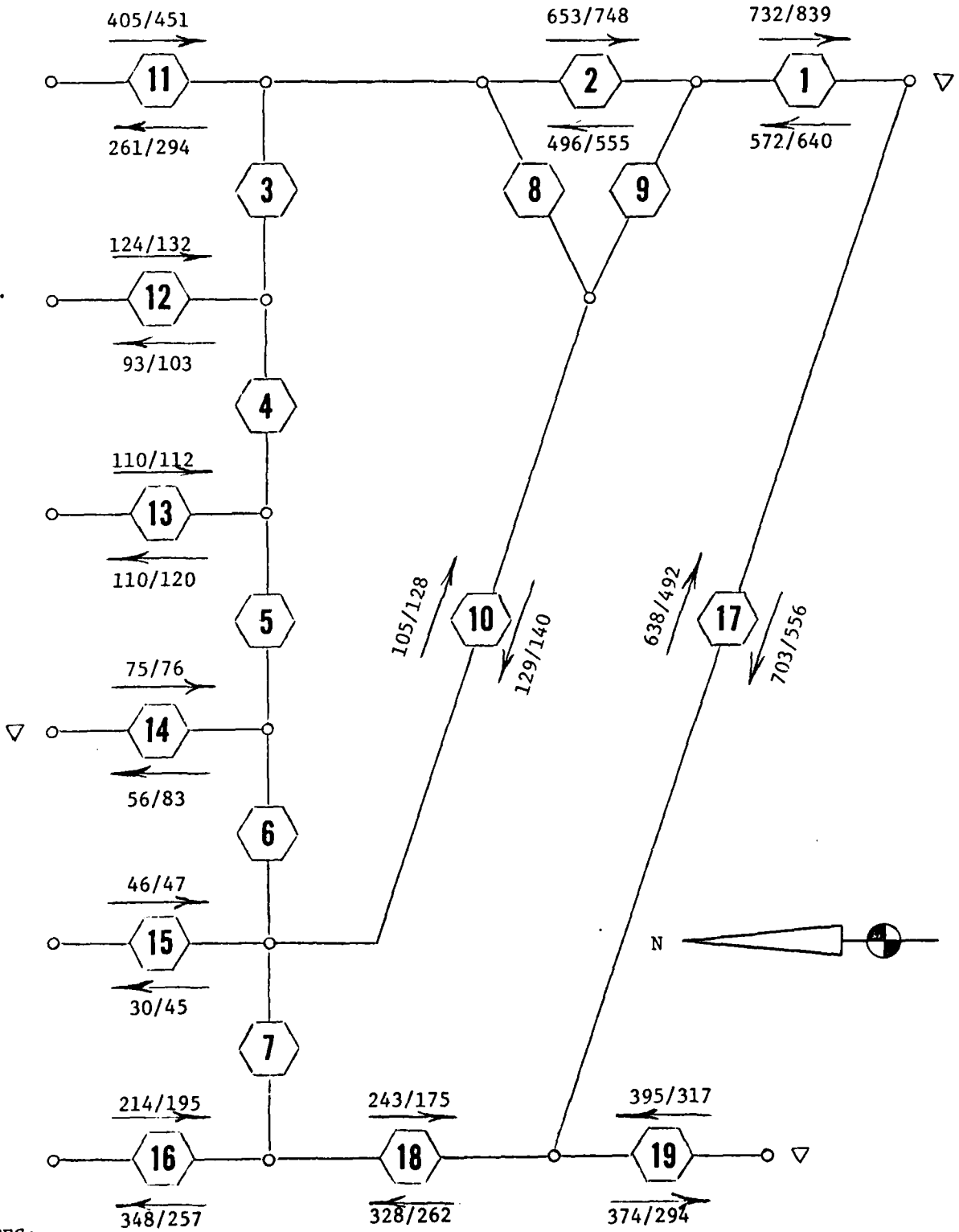

NOTES:

1. Flows are in $10^6 \text{ ft}^3/\text{tide}$: modified/existing
2. Total Ebb: 975/1014
3. Total Flood: 899/902

FIGURE 11
 EXCHANGE WITH NORTH BISCAYNE BAY
 CASE 3
 SPRING TIDE

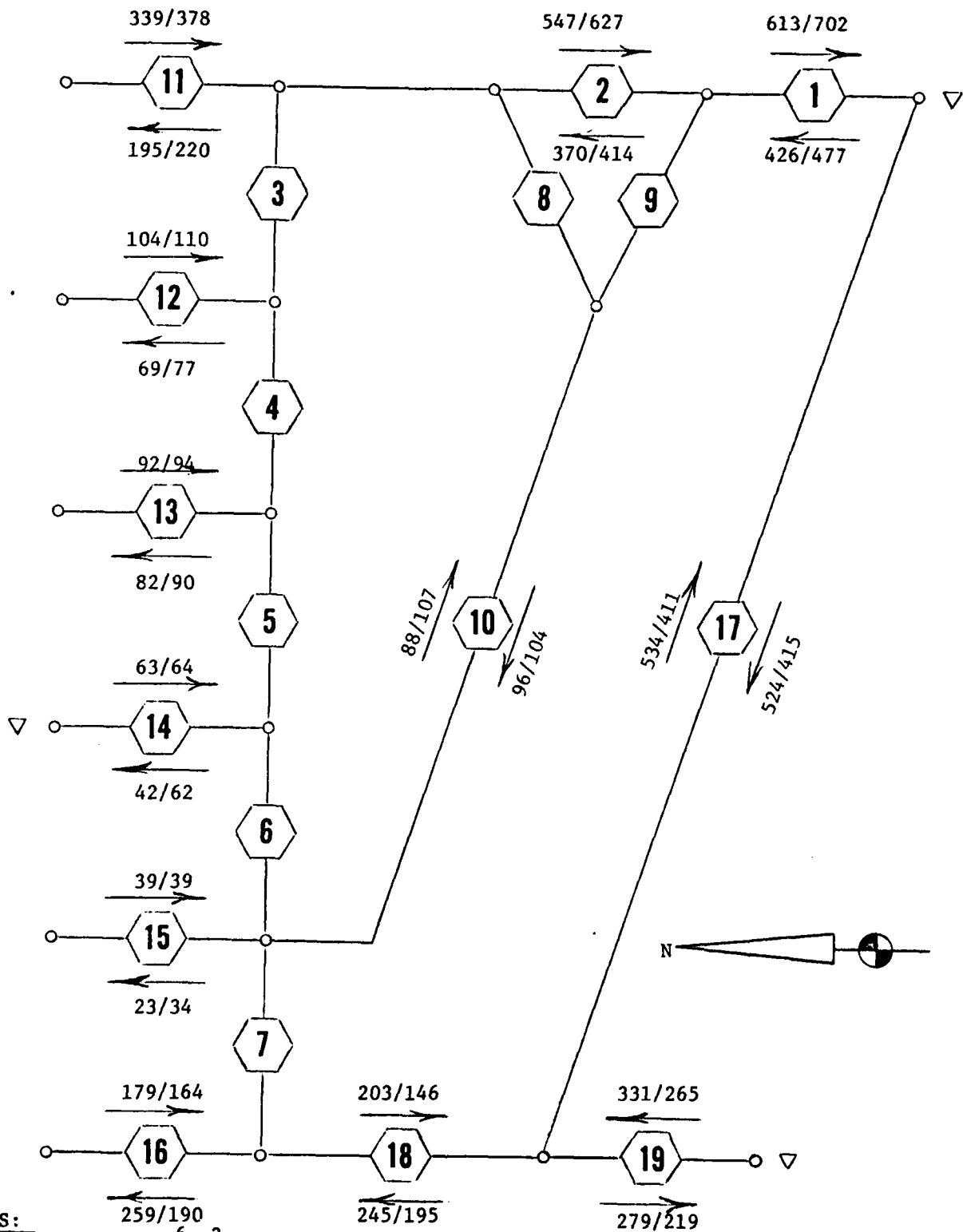

NOTES:

1. Flows are in $10^6 \text{ft}^3/\text{tide}$: modified/existing
2. Total Ebb: 816/848
3. Total Flood: 617/672

FIGURE 12
 EXCHANGE WITH NORTH BISCAYNE BAY
 CASE 3
 NEAP TIDE

TABLE 4
 COMPARISON OF ALTERNATE MARINA PLANS
 WITH EXISTING CONDITIONS

REACH	EXISTING CONDITIONS				CASE 1			
	SPRING		NEAP		SPRING		NEAP	
	EBB	FLOOD	EBB	FLOOD	EBB	FLOOD	EBB	FLOOD
1	839	640	702	477	790	610	661	455
2	748	555	627	414	705	530	590	395
3	260	205	218	153	240	194	201	144
4	129	102	108	76	108	94	90	70
5	16	18	13	14	-8	23	-7	17
6	60	101	51	76	88	85	74	63
7	-21	7	-17	5	22	19	18	14
8	37	56	31	41	30	57	25	42
9	91	84	76	63	85	81	71	60
10	128	140	107	104	115	137	96	102
11	451	294	378	220	435	279	364	208
12	132	103	110	77	132	99	111	74
13	112	120	94	90	117	118	98	88
14	76	83	64	62	79	61	67	46
15	47	45	39	34	49	33	41	25
16	195	254	164	190	219	348	184	259
17	492	556	411	415	638	703	534	524
18	175	262	146	195	241	328	202	245
19	317	294	265	219	397	375	332	279
TOTAL FLOW:								
	1013	899	849	673	1031	938	865	700

NOTE: FLOWS ARE IN MILLIONS OF CUBIC FEET PER TIDE.

TABLE 5

COMPARISON OF ALTERNATE MARINA PLANS
WITH EXISTING CONDITIONS

REACH	EXISTING CONDITIONS				CASE 2			
	SPRING		NEAP		SPRING		NEAP	
	EBB	FLOOD	EBB	FLOOD	EBB	FLOOD	EBB	FLOOD
1	839	640	702	477	567	453	474	338
2	748	555	627	414	506	393	423	293
3	260	205	218	153	169	151	141	113
4	129	102	108	76	68	83	57	62
5	16	18	13	14	-22	-15	-18	-11
6	60	101	51	76	84	66	71	49
7	-21	7	-17	5	45	16	37	12
8	37	56	31	41	17	33	14	24
9	91	84	76	63	61	60	51	44
10	128	140	107	104	78	92	65	69
11	451	294	378	220	320	209	267	156
12	132	103	110	77	101	68	84	51
13	112	120	94	90	91	69	76	51
14	76	83	64	62	62	81	52	60
15	47	45	39	34	39	43	32	32
16	195	254	164	190	203	314	170	234
17	492	556	411	415	639	703	535	525
18	175	262	146	195	248	329	207	246
19	317	294	265	219	391	374	328	279
TOTAL FLOW:								
	1013	899	849	673	816	784	681	584

NOTE: FLOWS ARE IN MILLIONS OF CUBIC FEET PER TIDE.

TABLE 6
 COMPARISON OF ALTERNATE MARINA PLANS
 WITH EXISTING CONDITIONS

REACH	EXISTING CONDITIONS				CASE 3			
	SPRING		NEAP		SPRING		NEAP	
	EBB	FLOOD	EBB	FLOOD	EBB	FLOOD	EBB	FLOOD
1	839	640	702	477	732	572	613	426
2	748	555	627	414	653	496	547	370
3	260	205	218	153	221	181	185	135
4	129	102	108	76	97	88	81	66
5	16	18	13	14	-13	22	-10	16
6	60	101	51	76	88	78	73	58
7	-21	7	-17	5	29	20	24	15
8	37	56	31	41	26	53	22	40
9	91	84	76	63	79	75	66	56
10	128	140	107	104	105	129	88	96
11	451	294	378	220	405	261	339	195
12	132	103	110	77	124	93	104	69
13	112	120	94	90	110	110	92	82
14	76	83	64	62	75	56	63	42
15	47	45	39	34	46	30	39	23
16	195	254	164	190	214	348	179	259
17	492	556	411	415	638	703	534	524
18	175	262	146	195	243	328	203	245
19	317	294	265	219	395	374	331	279
TOTAL FLOW:								
	1013	899	849	673	975	899	816	671

NOTE: FLOWS ARE IN MILLIONS OF CUBIC FEET PER TIDE.

1. The large reductions in tidal flow caused by complete enclosure of the marina as shown on Case 2 would probably cause deleterious effects to north Biscayne Bay.

2. Case 1 would have very slight effects on the circulation since the modification of the flows is small compared with seasonal variations and the total flow to north Biscayne Bay is greater than under existing conditions.

3. Case 3 would have a greater effect on circulation than Case 1. Nevertheless, the modifications due to the construction are considerably smaller than the variation between spring and neap tide. The acceptability of this system should be weighed carefully and considered in the light of benefits to navigation and construction rather than circulation only.

REFERENCES

- (1) Michel, John F. "A Study of the Hydrodynamic Effects to be Considered in the Design of a Marina at Miami Beach, Florida," Greenleaf-Telesca, March 1973
- (2) 1973 Tide Tables, High and Low Water Predictions, East Coast of North and South America, U.S. Department of Commerce, National Oceanic and Atmospheric Administration, National Ocean Survey.