

AD-A094 196

TENNESSEE UNIV SPACE INST TULLAHOMA  
PROCEEDINGS: ANNUAL WORKSHOP ON METEOROLOGICAL AND ENVIRONMENTAL--ETC(U)  
MAR 80 W FROST, D W CAMP

F/G 1/2

UNCLASSIFIED

NASA-CP-2139

NL

1 of 3

NO. A  
0-49-196

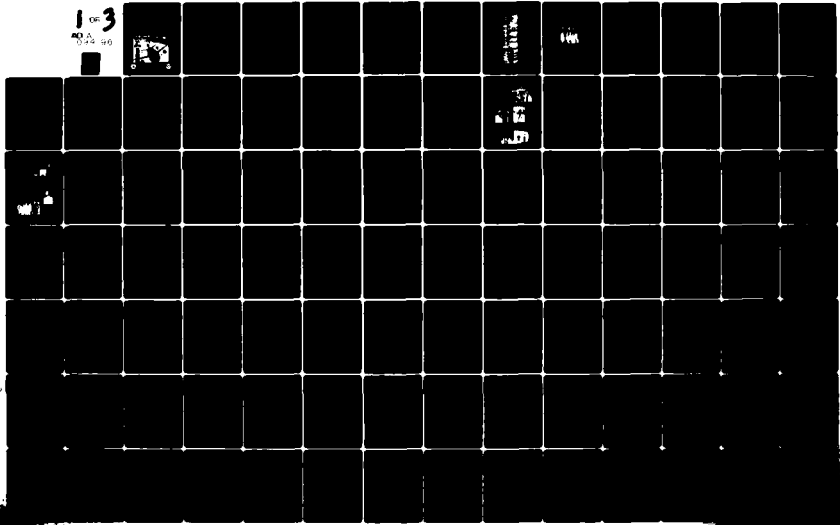

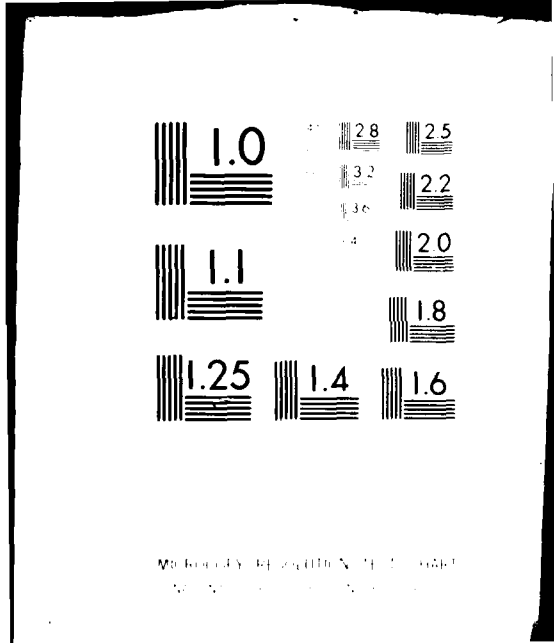

MILITARY RESOLUTION TEST CHART  
1963-A

TW

**NASA**  
National Aeronautics and  
Space Administration

**LEVEL** 12

NASA CP-2139

**PROCEEDINGS: FOURTH ANNUAL  
WORKSHOP ON METEOROLOGICAL AND  
ENVIRONMENTAL INPUTS TO  
AVIATION SYSTEMS**

MARCH 25-27, 1980

UNIVERSITY OF TENNESSEE SPACE INSTITUTE

EDITORS: WALTER FROST  
DENNIS W. CAMP

OTIC  
RECEIVED  
MAY 27 1981

AD A094196

DDC FILE COPY

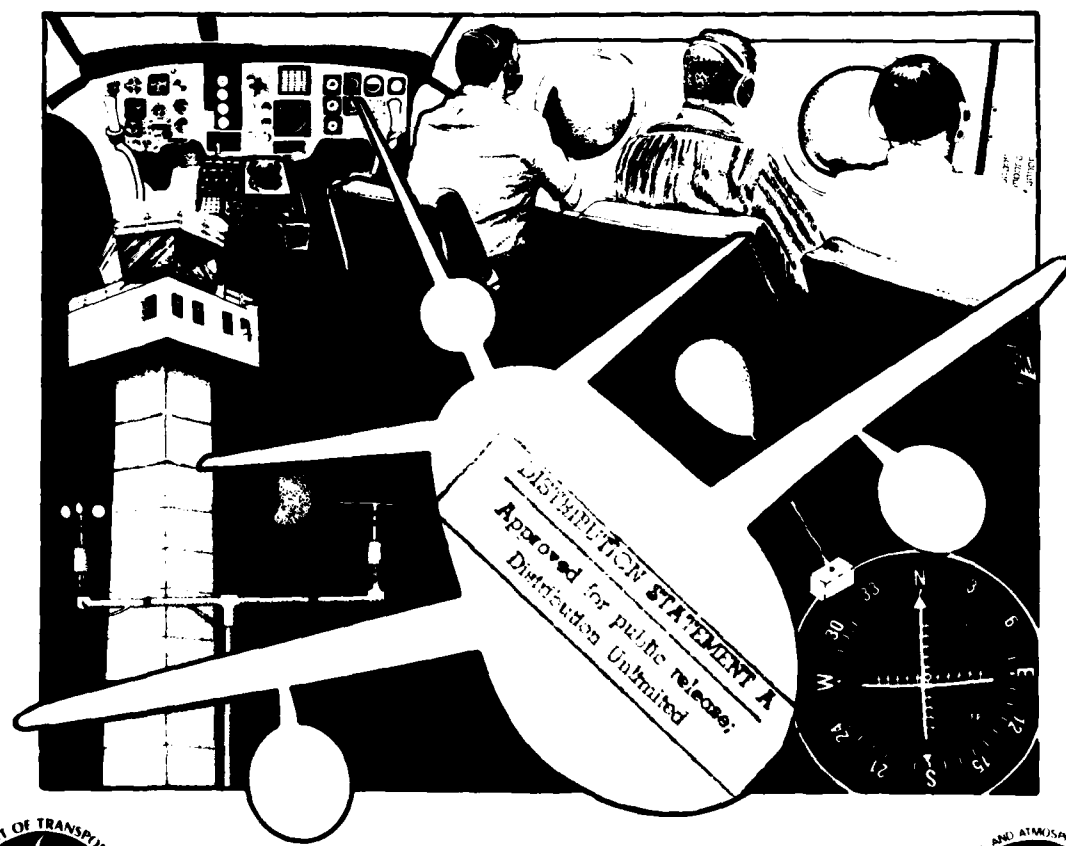

TECHNICAL EDITOR: REBECCA A. DUROCHER



FAA-RD-80-67

81 1 26 1980

APPROVAL

PROCEEDINGS: FOURTH ANNUAL WORKSHOP ON METEOROLOGICAL  
AND ENVIRONMENTAL INPUTS TO AVIATION SYSTEMS

Edited by Walter Frost and Dennis W. Camp

The information in this report has been reviewed for technical content. Review of any information concerning Department of Defense or nuclear energy activities or programs has been made by the MSFC Security Classification Officer. This report, in its entirety, has been determined to be unclassified.

  
CHARLES A. LUNDQUIST  
Director, Space Sciences Laboratory

① VASA, FAA-RD 19 CP-2139, X-167

TECHNICAL REPORT STANDARD TITLE PAGE

1. REPORT NO. NASA CP-2139 / FAA-RD-80-67		2. GOVERNMENT ACCESSION NO. AD-A094 296		3. RECIPIENT'S CATALOG NO.	
4. TITLE AND SUBTITLE 6) Proceedings: <del>Fourth</del> Annual Workshop on Meteorological and Environmental Inputs to Aviation Systems (4th), March 25-27, 1980		5. REPORT DATE March 1980		6. PERFORMING ORGANIZATION CODE	
		7. AUTHOR(S) 10) <del>Edited by</del> Walter Frost* and Dennis W. Camp**		8. PERFORMING ORGANIZATION REPORT # 15-27-27-2928	
9. PERFORMING ORGANIZATION NAME AND ADDRESS The University of Tennessee Space Institute Tullahoma, Tennessee 37388		10. WORK UNIT NO. 11/11/11		11. CONTRACT OR GRANT NO. NAS8-32692	
12. SPONSORING AGENCY NAME AND ADDRESS NASA/Marshall Space Flight Center, Alabama 35812 DOT/Federal Aviation Administration, Washington, D.C. 20553 DOC/National Oceanic and Atmospheric Administration, Rockville, Maryland 20850		13. TYPE OF REPORT & PERIOD COVERED 9) Conference Publication		14. SPONSORING AGENCY CODE	
15. SUPPLEMENTARY NOTES  * UTSI, Tullahoma, Tennessee 37388 ** NASA/Marshall Space Flight Center, Alabama 35812					
16. ABSTRACT The proceedings of a workshop on meteorological and environmental inputs to aviation systems held at The University of Tennessee Space Institute, Tullahoma, Tennessee, March 25-27, 1980, are reported. The workshop was jointly sponsored by NASA, NOAA, and FAA and brought together many disciplines of the aviation communities in round table discussions. The major objectives of the workshop are to satisfy such needs of the sponsoring agencies as the expansion of our understanding and knowledge of the interaction of the atmosphere with aviation systems, the better definition and implementation of services to operators, and the collection and interpretation of data for establishing operational criteria relating the total meteorological inputs from the atmospheric sciences to the needs of aviation communities. The unique aspects of the workshop were the diversity of the participants and the achievement of communication across the interface of the boundaries between pilots, meteorologists, training personnel, accident investigators, traffic controllers, flight operation personnel from military, civil, general aviation, and commercial interests alike. Representatives were in attendance from government, airlines, private agencies, aircraft manufacturers, Department of Defense, industries, research institutes, and universities. Full-length papers from invited speakers addressed topics on icing, turbulence, wind and wind shear, ceilings and visibility, lightning, and atmospheric electricity. These papers are contained in the proceedings together with the committee chairmen's reports on the results and conclusions of their efforts on similar subjects.					
17. KEY WORDS Aviation Safety Meteorology Air Traffic Control Training Flight Operations General Aviation Aviation Weather Research and Services			18. DISTRIBUTION STATEMENT Document is available to the U.S. public through the National Technical Information Service, Springfield, VA 22161.  STAR Category 47		
19. SECURITY CLASSIF. (of this report) Unclassified		20. SECURITY CLASSIF. (of this page) Unclassified		21. NO. OF PAGES 284	22. PRICE

TABLE OF CONTENTS

I. EXECUTIVE SUMMARY . . . . . 1

II. WELCOME REMARKS . . . . . 15

III. TOPIC AREA PRESENTATIONS . . . . . 21

    Survey of Workshops on Meteorological and Environmental  
    Inputs to Aviation Systems  
    Walter Frost and Dennis W. Camp . . . . . 23

    Aviation Meteorology Research and Development:  
    A Status Report  
    John H. Enders . . . . . 40

    Federal Aviation Administration and National Weather  
    Service Aviation Research and Development  
    John W. Connolly . . . . . 45

    Icing Instrumentation  
    William Olsen . . . . . 49

    Aircraft Icing Instrumentation--Unfilled Needs  
    Phyllis F. Kitchens . . . . . 61

    Turbulence: From a Pilot's Viewpoint  
    Charles L. Pocock . . . . . 66

    Clear Air Turbulence: Historical Comments  
    L. J. Ehernberger . . . . . 71

    Winds and Wind Shear In-Situ Sensors  
    R. Craig Goff . . . . . 82

    Remote Probing of Wind and Wind Shears  
    J. T. Lee . . . . . 109

    Ceiling and Visibility Instrumentation Within Government  
    Agencies  
    Robert S. Bonner . . . . . 125

    Observing Lightning from Ground-Based and Airborne Stations  
    John C. Corbin, Jr. . . . . 130

    Aeronautical Concerns and National Aeronautics and Space  
    Administration Atmospheric Electricity Needs  
    William W. Vaughan . . . . . 140

Accession For	By	Distribution/	Dist
NTIS GRA&I	Availability Codes	Avail and/or	Special
DTIC TAB			
Unannounced			
Justification			
<input type="checkbox"/>			
<input type="checkbox"/>			
<input type="checkbox"/>			

IV. BANQUET PRESENTATION . . . . .	161
Measuring Weather for Aviation Safety in the 1980's Robert W. Wedan . . . . .	162
V. IMPROMPTU PRESENTATIONS . . . . .	169
1979 Clear Air Turbulence Flight Test Program Edwin A. Weaver . . . . .	171
Very Short Range Forecasts of Visibility and Ceiling Arthur Hilsenrod . . . . .	180
The Microburst: Common Factor in Recent Aircraft Accidents Fernando Caracena . . . . .	186
Dr. Fujita's Microburst Analysis at Chicago John McCarthy . . . . .	201
Clear Air Turbulence Forecasting Techniques John L. Keller . . . . .	203
The Program of the Techniques Development Laboratory in Aviation Weather Forecasting William H. Klein . . . . .	209
Aviation Weather and the Commuter Airline Barry S. Turkel . . . . .	213
Charged Particle Fog Dispersal System Frank G. Collins . . . . .	215
Aviation Safety Uses for Leftover Space Hardware at National Aeronautics and Space Administration/Jet Propulsion Laboratory Bruce L. Gary . . . . .	221
VI. COMMITTEE SUMMARY REPORTS . . . . .	223
Summary Report: Atmospheric Electricity and Lightning Committee Andy D. Yates, Jr. . . . .	225
Summary Report: Fog, Visibility and Ceilings Committee Sepp J. Froeschl . . . . .	229
Summary Report: Icing and Frost Committee C. Dennis Wright . . . . .	239

VI. (Continued)

Summary Report: Turbulence Committee  
Neal M. Barr . . . . . 247

Summary Report: Winds and Wind Shear Committee  
William W. Melvin . . . . . 255

VII. CONCLUDING REMARKS . . . . . 261

Concluding Remarks  
John Blasic . . . . . 262

Concluding Remarks  
Dennis W. Camp . . . . . 263

Concluding Remarks  
John H. Enders . . . . . 264

Concluding Remarks  
Walter Frost . . . . . 267

Concluding Remarks  
Joseph F. Sowa . . . . . 268

APPENDICES . . . . . 269

Appendix A: Acronyms . . . . . 270

Appendix B: Roster of Workshop Participants . . . . . 276



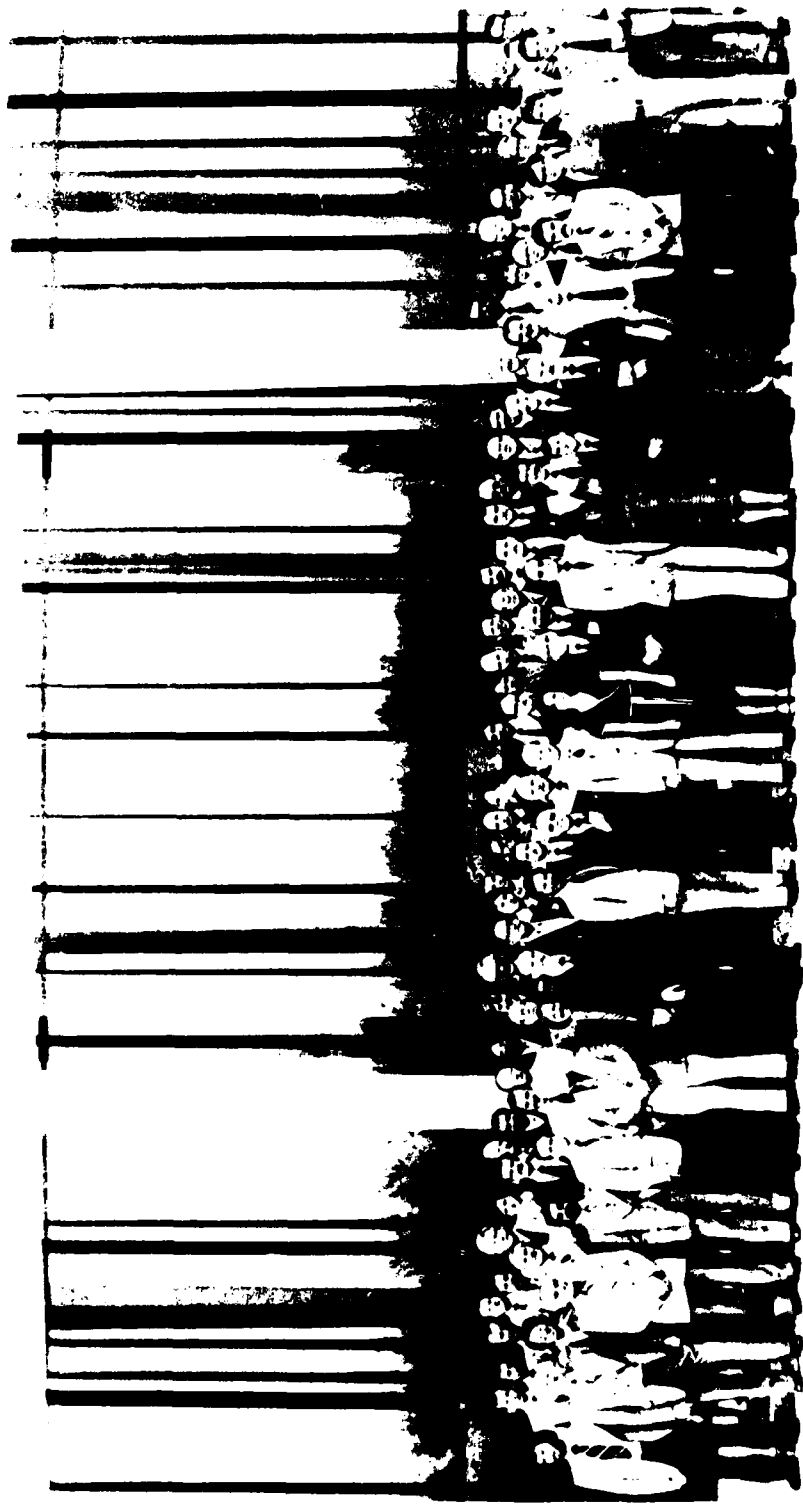

**WORKSHOP PARTICIPANTS**

# **SECTION I EXECUTIVE SUMMARY**



**MEMBERS OF THE ORGANIZATION COMMITTEE  
(FROM LEFT TO RIGHT)**

**JOSEPH F. SOWAR, FAA**

**WALTER FROST, UTSI**

**ALLAN R. TOBIASON, NASA**

**DENNIS W. CAMP, NASA**

**EDWARD M. GROSS, NOAA (NOT PICTURED)**

EXECUTIVE SUMMARY: FOURTH ANNUAL WORKSHOP ON  
METEOROLOGICAL AND ENVIRONMENTAL INPUTS TO AVIATION SYSTEMS

Dennis W. Camp, Walter Frost,  
Edward M. Gross, Joseph F. Sower, and Allan R. Tobiason  
Organization Committee

Introduction

Four Annual Workshops on Meteorological and Environmental Inputs to Aviation Systems have been jointly sponsored by the National Aeronautics and Space Administration (NASA), National Oceanic and Atmospheric Administration (NOAA), and Federal Aviation Administration (FAA) and hosted by The University of Tennessee Space Institute. The purpose of these workshops has been to bring together various disciplines of the aviation community with meteorologists and atmospheric scientists in round-table discussions in an effort to establish and identify the weather needs of the community and how these needs might best be satisfied. The results of the fourth annual workshop are briefly discussed in this summary.

Seventy-seven people from the government and private sectors attended the fourth workshop. These 77 people represented 32 organizations (see Table 1). The attendees were assigned to five specific working committees. Most of their time was spent in committee working sessions; however, overview and impromptu presentations were also given to the entire group. The topics for discussion by the committees were:

1. Winds and wind shear.
2. Turbulence.
3. Icing and frost.
4. Fog, visibility and ceilings.
5. Atmospheric electricity and lightning.

The major objective of this workshop was to satisfy the needs of the sponsors relative to:

1. Knowledge of the interaction of the atmosphere with aeronautical systems.
2. Better definition and implementation of meteorological services.
3. Collection and interpretation of data for establishing operational criteria relating the total meteorological inputs from the atmospheric sciences to the operational and educational needs of the aviation community.

TABLE 1  
ATTENDEE REPRESENTATION

GOVERNMENT (41)

National Aeronautics and Space Administration -- 17\*  
National Oceanic and Atmospheric Administration -- 4  
Federal Aviation Administration -- 12  
United States Army -- 2  
United States Air Force -- 4  
United States Navy -- 1  
National Transportation Safety Board -- 1

PRIVATE SECTOR (43)

University and Research -- 12  
    Georgia Institute of Technology  
    National Center for Atmospheric Research  
    University of Dayton Research Institute  
    University of Oklahoma  
    University of Tennessee Space Institute  
  
Consultants -- 3  
  
Foreign Representatives -- 1  
  
Industry -- 14  
    Alden Electronics  
    ARO, Inc.  
    Bell Helicopter Company  
    Boeing Commercial Airplane Company  
    Douglas Aircraft Company  
    FWG Associates, Inc.  
    MCS, Inc.  
    Spectron Development Laboratories  
  
Airlines -- 6  
    Continental Airlines  
    Flying Tiger Airline  
    Hughes Air West  
    United Airlines  
  
Associations -- 7  
    Aircraft Owners and Pilots Association  
    Air Line Pilots Association  
    Air Traffic Control Association, Inc.  
    Air Transport Association

\*Designates number of representatives from each respective agency.

While maintaining these major objectives, each workshop has had, in turn, an individual theme.

The first workshop, held in 1977, provided an opportunity for a mix of researchers, pilots, designers, forecasters, air traffic personnel, weather service specialists, and airline management to express their individual and collective views on weather problems relative to aviation systems. The second focused on a detailed examination of the most severe weather problems which were identified at the first workshop, with a view toward seeking consensus on appropriate public and private sector actions needed to solve these problems. It became apparent during the first two workshops that training and education throughout the community were important to achieving a better understanding of weather hazards and weather-tolerant designs and operations. The 1979 workshop was therefore organized to explore the training and educational questions resulting from the first two workshops. An evolutionary process was thereby established relative to workshop themes. The current fourth year's theme, "Measuring Weather for Aviation Safety in the 1980's," thus evolved from what took place at previous workshops.

In this workshop's committee sessions, efforts were concentrated on identifying the status of instrumentation and equipment systems currently in use, describing ongoing research relative to improving these systems, and identifying future work and programs necessary to bring the instrumentation and equipment up to the standards required for present and future aviation safety and operations.

In an effort to establish a common base for the committee efforts and to set the tempo of working sessions, the workshop began with overview papers which summarized results of previous workshops and their impact on the aviation community and which reviewed the current status of ongoing weather research (see Table 2). Also, nine invited papers reviewing the status of measuring weather for aviation safety in the 1980's, including operational capability, current research and development, and future needs, were presented (see Table 3). These papers were directed toward the specific weather phenomena of concern to the workshop.

During the course of the committee working sessions, time was allocated for the workshop participants to make an impromptu presentation if they desired. Presentations were made by nine attendees (see Table 4). The efforts discussed were concerned with ongoing or just-completed work which affected operations of the aviation community. These presentations also served to stimulate the various committee discussions.

In addition to the overview papers and impromptu presentations, Robert Wedan, Director of Systems Research and Development Service (SRDS), FAA, discussed at the banquet the efforts of the SRDS relative to atmospheric measurements; following one of the group dinners Peter Chesney, Chief of the Special Aviation Accident Branch, FAA, gave a presentation

TABLE 2  
OVERVIEW OF PREVIOUS WORKSHOPS

"Summary and Impact of Previous Workshops"

by

Walter Frost  
Atmospheric Science Division  
The University of Tennessee Space Institute

and

Dennis W. Camp  
Space Sciences Laboratory  
National Aeronautics and Space Administration  
Marshall Space Flight Center

"Summary of Current Aviation Meteorological Research"

by

John H. Enders  
Consultant (NASA Ret.)

and

John W. Connolly  
Consultant (NOAA Ret.)

TABLE 3

INVITED PRESENTATIONS

<p>ICING AND FROST:</p> <p>"Icing Instrumentation," by William Olsen, National Aeronautics and Space Administration, Lewis Research Center</p> <p>"Aircraft Icing Instrumentation Unfilled Needs," by Phyllis F. Kitchens, United States Army Test and Evaluation Command</p>
<p>TURBULENCE:</p> <p>"Turbulence--From a Pilot's Viewpoint," by Charles L. Pocock, Lockheed Aircraft Service Company</p> <p>"Clear Air Turbulence Technology--Historical Comments," by L. J. Ehernberger, National Aeronautics and Space Administration, Dryden Flight Research Center</p>
<p>WINDS AND WIND SHEAR:</p> <p>"Winds and Wind Shear In-Situ Sensors," by R. Craig Goff, Federal Aviation Administration, National Aviation Facilities Experimental Center</p> <p>"Remote Probing of Wind and Wind Shear," by J. T. Lee, National Severe Storms Laboratory</p>
<p>FOG, VISIBILITY AND CEILINGS:</p> <p>"Ceiling and Visibility Instrumentation Within Government Agencies," by Robert S. Bonner, United States Army, Atmospheric Sciences Laboratory</p>
<p>ATMOSPHERIC ELECTRICITY AND LIGHTNING:</p> <p>"Aeronautical Concerns and NASA Atmospheric Electricity Project," by William W. Vaughan, National Aeronautics and Space Administration, Marshall Space Flight Center</p> <p>"Observing Lightning from Ground-Based and Airborne Stations," by John C. Corbin, Jr., United States Air Force, Aeronautical Systems Division</p>

TABLE 4  
IMPROMPTU PRESENTATIONS

"1979 Clear Air Turbulence Flight Test Program," by Edwin A. Weaver, National Aeronautics and Space Administration, Marshall Space Flight Center

"Five-, Ten-, and Fifteen-Minute Forecasts of Runway Visual Range Ceilings and Visibility," by Arthur Hilsenrod, Federal Aviation Administration

"Microbursts," by Fernando Caracena, National Oceanic and Atmospheric Administration

"Dr. Fujita's Microburst Analysis at Chicago," by John McCarthy, National Center for Atmospheric Research

"Clear Air Turbulence Forecasting Techniques," by John L. Keller, University of Dayton Research Institute

"The Program of the Techniques Development Laboratory in Aviation Weather Forecasting," by William H. Klein, Consultant (NOAA Ret.)

"Aviation Weather and the Commuter Airline," by Barry S. Turkel, The University of Tennessee Space Institute

"Charged Particle Fog Dispersal System," by Frank G. Collins, FWG Associates, Inc.

"Aviation Safety Uses for Leftover Space Hardware at NASA/Jet Propulsion Laboratory," by Bruce Gary, National Aeronautics and Space Administration, Jet Propulsion Laboratory



concerning the Air New Zealand DC-10 accident at Mt. Erebus, Antarctica; and John Corbin of the U.S. Air Force Aeronautical Systems Division gave a slide presentation identifying some problems the Air Force has had relative to lightning. The special presentations provided by Peter Chesney and John Corbin are not available for publication in this year's proceedings.

The main feature of the annual workshops is the committee working sessions. In an effort to enhance the benefits resulting from these sessions, some goals were established. For this fourth workshop, the theme of measuring weather was to be considered in the broadest sense. That is, the committees were to consider not only precise measuring instruments for meteorological research, but also all existing equipment and methods as well as future requirements for monitoring, analyzing, disseminating and interpreting weather information for the users in the aeronautical community. This includes, for example, ground-based and on-board systems for detecting and warning of wind shear, turbulence, icing, frost, lightning, fog, and visibility; computer networks and other equipment for transmittal of information from weather service centers to user areas; communication and displays at Air Traffic Control (ATC) facilities, such as radars and weather displays; pilot briefing displays and remote information terminals; and data base and retrieval systems for use in such fields as accident investigation, flight training simulator development, flight control systems design (e.g., CAT III landing systems), ice removal systems, etc. The committees were requested to identify the status of routine instrumentation and equipment systems currently in use; to define deficiencies and voids in the current systems; to describe and indicate the status of ongoing research relative to improvement of these systems; and to identify future work and programs necessary to bring the instrumentation and equipment to the standards required for present and future aviation safety and operations. The needs were to be ordered as to importance.

#### Winds and Wind Shear

The Winds and Wind Shear Committee stated at the onset that Doppler radar inputs are needed to develop four-dimensional models for use in definition and analysis of wind shears. However, for simulator use the models will probably be two-dimensional. The use of simulator studies is needed to determine hazard thresholds for each type of aircraft.

The committee members recommended that uniform terminology be developed and disseminated. They believe very strongly that there is a need for a description of shear in terms of expected reaction from the aircraft, such as undershoot and overshoot, increasing and decreasing performance, etc.

They encouraged the evaluation and use of any instrumentation that provides pilots with better information for wind shear assessment. Since the opinion was that airborne Doppler would never have the

sensitivity to detect shear in clear air conditions, they support the application of ground-based Doppler radar, provided the system would be located at or near the terminal, the information would be for the approach and departure path and would include prediction of aircraft performance based on measured shear, and the system would be suitable for uplink to the cockpit.

They encouraged: greater use of pilot reports (PIREPS) and improvement of terminology used in the PIREPS; full use of the low-level wind alert system (LLWAS); and development of a capability to read wind at the end of the runway and of a data link capability for aircraft flying across country. They saw a need for improvement in training and recommended that ground schools stress operational approaches with regard to wind shear. They believe there is a definite need to improve wind shear models for use in simulators.

#### Icing and Frost

The Icing and Frost Committee members concerned themselves with basically three broad categories of icing instrumentation. Under these categories they considered the status of seven sensors (see Table 5) and the need for improvements in each relative to use in support of the aviation community. Under the research category, the committee discussed whether existing sensors satisfy the requirements of the researchers regarding accuracies, resolution, etc. The certification category was concerned with Parts 23 and 25 of the Federal Aviation Regulations (FAR's); namely, the certification of airframes for flight into known icing conditions. Under the operations category, the committee considered routine instrumentation used in aircraft operations.

The committee believes further development is required on liquid water content (LWC) sensors for all three categories. Outside air temperature (OAT) sensors appear to be adequate for the three categories. Development is needed for the ice accretion sensor in the research and operation categories but is not applicable to certification. The relative humidity sensor appears to be satisfactory for research, not applicable for certification, and required in terms of engine operations for development. Development of instruments is required for research purposes relative to ice crystals, but there was some question by the committee as to whether they will ever be needed for certification or operation. Drop size sensor development is required for the research category, appears to be satisfactory for certification, and does not seem applicable for operations. With regard to solar radiation sensors, there was no agreement as to whether research is needed. The committee did not, however, believe the sensors to be applicable to the other two categories.

#### Atmospheric Electricity and Lightning

The Atmospheric Electricity and Lightning Committee made a few general comments on the areas suggested for consideration and presented

TABLE 5

## ICING AND FROST COMMITTEE COMMENTS AND RECOMMENDATIONS

Instrument	Research	Certification	Operation
Liquid Water Content	DR	DR (Helo)	DR
Outside Air Temperature	OK	OK	OK
Ice Accretion Sensor	NV (Helo)	N/A	NV (Engines)
Relative Humidity	OK	N/A	DR (Engines)
Ice Crystals (%)	DR	?	?
Drop Size	DR	OK	N/A
Solar Radiation	?	N/A	N/A

Legend: DR = Development Required  
 OK = Okay  
 NV = Needs Verification  
 NA = Not Applicable

several recommendations. With regard to forecasting and dissemination, they recommended: 1) separate studies to forecast lightning probability, in addition to studies conducted with regard to thunderstorm occurrences; 2) study of the potential use of satellite and Doppler radar techniques to detect thunderstorms and forecast the probability of lightning; and 3) review of existing dissemination systems with regard to data collected from all sources and to increased speed and quantity of data dissemination.

In the research area, they made three recommendations: 1) to establish a National Flying Lightning Laboratory to serve the total needs of the aviation community; 2) to research the definition of airborne lightning strike models; and 3) to research the transition of electrical field data into application.

Two recommendations were made relative to the data base and retrieval area; namely, to improve the reporting of lightning strikes on aircraft for a statistical data base and to include a lightning data bank at the National Weather Record Center in Asheville, North Carolina.

The recommendations for the ground-based and on-board instrumentation area were to develop ground-based and airborne sensors to measure electrical fields for the purpose of predicting lightning probability and avoidance of lightning strikes and to develop an on-board instrument to detect lightning strike current path.

There were also two recommendations for the training area. First, there is a need for training with emphasis on instrument susceptibility with regard to the interpretation of electrical field measuring devices, lightning detectors, Doppler and weather radar, and post-strike procedures. The second recommendation, with regard to the training of pilots, was for face-to-face meetings between pilots and meteorologists relative to lightning.

The last recommendation by this committee, in the flight control systems area, was for development of positive design efforts and techniques to protect modern flight control and avionic systems.

#### Fog, Visibility and Ceilings

At the onset of his summary presentation, the chairman of the Fog, Visibility and Ceilings Committee made a general but very appropriate statement, namely, "...in complete agreement with panelists, committee members and participants of all previous workshops, our committee noted that the need exists to investigate the usefulness and validity of the meteorological criteria of visual and instrument flight rules (VFR's and IFR's). The concept of VFR's based on the fundamental thinking of 'to see and be seen' has to be questioned, and consequently the criteria for VFR's with respect to visibility should be reconsidered and possibly adjusted to accommodate: 1) aircraft characteristics of our day, and 2) congested terminal areas."

This committee's comments on slant visual range (SVR) were that: 1) current research in SVR is minimal; 2) the need for SVR is not firmly established; 3) the need for SVR product decreases and approaches the zero mark as landing operations move into CAT III conditions; and 4) due to state-of-the-art sensors and the cost of developmental and operational testing, the need for SVR should be reaffirmed by user groups, and regulatory procedures should be proposed and accepted by the user groups before SVR system development continues.

With regard to prevailing visibility, the committee believes that the term "prevailing visibility" requires a clear definition since it is one of the most important elements of an aviation weather observation made by either an observer or an automated system. They recommended adoption of the definition proposed by the Subcommittee on Basic Meteorological Services' Panel on Automated Meteorological Observation Systems, namely, that "the horizontal visibility near the earth's surface be representative of the visibility conditions in the vicinity of the point of observation, ground visibility being the same as prevailing visibility."

Concerning automation, they endorse the concept of the Joint Automated Weather Observation System (JAWOS) in order that observations can be obtained at more airports with an established approach procedure. They also recommended that short-term (0-60 minutes) parameter forecasts be included in automated weather observations.

The committee's comments on fog dispersal touched on three systems: thermokinetic, thermodynamic and charged particle. The thermokinetic is operational at two airports; is working very well; and involves relatively high installation costs, reasonable operating costs and some pollution, including noise. The thermodynamic system developed by the U.S. Air Force is not operational and has the problem of large electrical power consumption. The charged particle system has never been successfully demonstrated; however, the committee recommends that a systematic, step-by-step research and development effort be performed to determine whether this technique can be made operational.

The committee also believes that the problems expressed in the past concerning ambiguity of definitions and terminology remain; that a concentrated effort should be undertaken to resolve confusion between operational and regulatory literature; and that it is imperative that this problem be resolved before the advent of the automated weather message.

### Turbulence

The types of turbulence considered by the Turbulence Committee were low-level, clear air (CAT), and wake turbulence. Like the other committees, the Turbulence Committee made a few general comments at the onset of their summary presentation. One comment is especially noteworthy, namely, that although many forecasting tools are used today, including those that are devised by individual companies for their own use, very

little is generally known about these techniques. This committee believes there should be more interplay with regard to these forecasting techniques.

With regard to the data base and retrieval system for turbulence, this committee believes the base of information on the existence of turbulence is inadequate and that many reports of turbulence are too old to be useful when they reach the user. Future systems must correct this problem.

The best direct indicator of turbulence, whether ground-based or on-board instrumentation is considered, seems to be the PIREP; and it has the problem of subjectivity. It should be noted, however, that systems which are secondary methods have potential as turbulence indicators. Some of these are radar, lightning detectors, etc. It is recommended that further work be accomplished on each of these.

In the training area, the committee believes that the theoretical content of weather training is adequate for the commercial carrier regime but that more emphasis on interpretation of weather data is desirable. However, they believe that for general aviation, weather training relative to turbulence is marginal or inadequate, even though literature which adequately covers the subject is available for use.

Several systems were listed by this committee with regard to researching new turbulence detectors. It is the committee's recommendation that research of each system be continued. Some of the systems mentioned were: the infrared (IR) passive water vapor radiometer, the microwave passive vertical temperature radiometer, airborne lidar, and ground-based, high-power VHF and UHF radars. They also recommended that efforts continue on research relative to modeling turbulence. An example is the diagnostic Richardson number tendency analysis.

For new and future programs, the flow of information required for pilot decisions is currently inadequate. This process, including PIREPS, should be automated so that turbulence forecasts and nowcasts can be assessed in the cockpit by a pilot as needed. The most serious problems occur physically in the vicinity of terminals where high traffic density complicates aviation operations. The presence of thunderstorm-related turbulence in this area is not adequately reported. Deployment of detection devices, such as Doppler radar with telemetry to the cockpit by data processing computers, may eliminate this problem. Programs such as the FAA Discrete Address Beacon System (DABS) are certainly encouraging. Accurate on-board turbulence detection instrumentation is needed, not only for detecting and warning, but also for severity estimation and for formulating avoidance strategy.

**SECTION II  
WELCOME  
REMARKS**

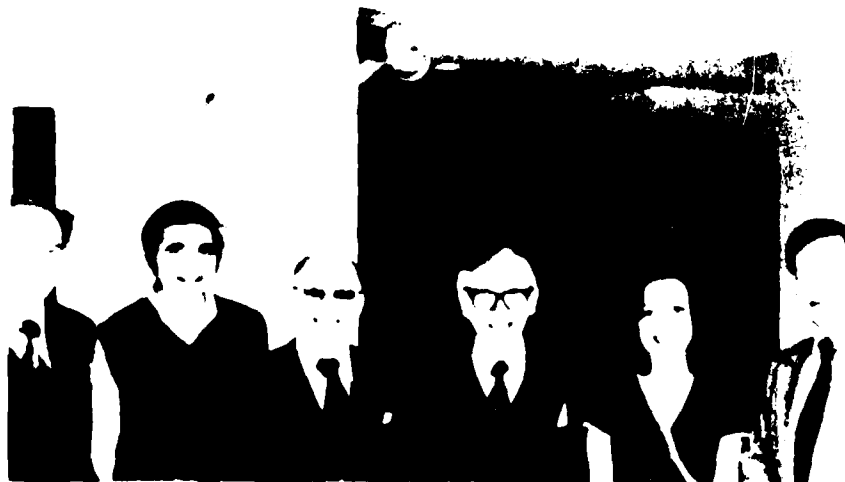

## WELCOME REMARKS

James M. Sisson

NASA/Marshall Space Flight Center

Good morning. Our southern sunshine didn't make it this morning, did it? Welcome on behalf of the National Aeronautics and Space Administration (NASA) and the Marshall Space Flight Center, as well as the Space Sciences Laboratory. Dr. Lundquist sends his regrets; he was looking forward to meeting with you for a day or two. He had a last-minute crisis arise which involved some principal investigators on a major scientific experiment; they will be doing some redefinition. I think he does plan to attend the workshop Thursday if possible.

We at NASA and Marshall attribute a great deal of importance and significance to these workshops. Through the broad range of participation here, we have experts in about every field, and we certainly appreciate your time. Through the conduct of the space program I think we sometimes put our focus too much on engineering. For instance, science kind of came last with the Apollo program; maybe that was necessary to get it off the ground. Now, though, I think it is important to have workshops such as this one so that we can focus technology on the things we need to get into to broaden the fields and advance the technology we have in hand, i.e., where do we need to use it? People who are experts in various disciplines such as you are and who are willing to spend their time can certainly make significant progress in this area.

At the Space Sciences Laboratory, and also with NASA, one of the specific objectives is to broaden that technology and be able to use it. At the Space Sciences Laboratory, as well as in other areas of the Marshall Center, we are involved in specific flight experiments that will fly on the Shuttle; and, from a science standpoint, that is the major thrust of some of our work. Dr. Vaughan, from whom you will be hearing in a few moments, is Division Chief of our Atmospheric Sciences Division, and he will be glad to discuss with you any of our work. He has a very active program in the severe storm area with which I am sure some of you are familiar.

The reason I bring up these points is that the science experiments we perform on the Shuttle and also the technology that forms the basis for coming up with those experiments come, in large part I think, out of workshops such as this. I think we can all benefit from the results of these sessions.

Our activity at the Marshall Center is much broader than just the science activity or science experiments. We are working on some very exciting things, of which Dr. Vaughan's division is a major part. With our Solar-Terrestrial Physics Division of the laboratory we are pursuing



investigations into earth-sun interactions and their effect on the earth's environment. We think in future years this will be a very exciting field to explore.

With that I will close. I certainly thank you for coming, and hopefully we will have a very productive two and one-half days.

## WELCOME REMARKS

Allan R. Tobiason

NASA Headquarters

On behalf of the Workshop Organization Committee and the co-sponsoring agencies--the Federal Aviation Administration (FAA), the National Oceanic and Atmospheric Administration (NOAA), and the National Aeronautics and Space Administration (NASA)--welcome to the Fourth Annual Workshop on Meteorological and Environmental Inputs to Aviation Systems. I am told that this particular workshop concept is the only forum that gets together all the actors in the aviation community--meteorologists, atmospheric scientists, pilots, and users--to periodically exchange ideas and, more importantly, to critique our programs, establish a basis for common needs, and develop recommendations for future research and operational requirements. As mentioned in Walter Frost's introductory remarks, I joined NASA Headquarters just a month and a half ago, after two and a half years with the National Transportation Safety Board (NTSB) as an aeronautical engineer. During that time I met many of you, including Bill Melvin and Andy Yates, who are committee chairmen here, as well as Jack Enders, Joe Stickle, John Blasic and quite a few others of you whom I met from previous assignments at the FAA or NTSB. I feel at home in today's environment and in this week's activities.

Last year, Jack Enders reported on the impact of this workshop on some of NASA's meteorological research, particularly in icing and frost research. I can assure you that NASA participation in each of the committees this week strongly influences research conducted by each center, and it is also very important to our interactions with other government agencies. In Washington it is very important to be able to say that NASA has coordinated its research programs with the FAA, NOAA, and the aviation community.

I am sure that John Blasic and Jerry Uecker from NOAA and Joe Sower from the FAA could also make very strong statements on the value of this workshop to their individual and coordinated research programs in meteorology.

In the program we have in Washington for aviation safety research, meteorology accounts for about \$3 million a year, i.e., about half of this year's \$6 million program for aviation safety. This funding level does not include NASA salaries; about half of the research is done on contract. We have been asked to put together a five-year plan of what we might do for new research initiatives. We have identified icing and severe storms, which would include destructive turbulence and lightning, as new starts. If that funding were approved it would virtually double what is now being spent annually in meteorology research. There is no guarantee of how much additional money we will get, but that is the kind

of emphasis the researchers at the centers and the workshops participants have related to NASA Headquarters.

I would like to mention some other ways of having programs endorsed. On March 3, 1980, Cliff von Kann, Vice President of the Air Transportation Association, commented on the NASA FY 81 research and technology program. General von Kann pointed out several NASA research programs related to meteorology that are of particular interest to the airlines, and I believe Bili Melvin and Andy Yates would second these kinds of comments. Quoting from von Kann's statement, he said, "Unforecast and unexpected clear air turbulence encounters continue to be a problem. An effective airborne warning system is needed to prevent injury to passengers and crew members and to maximize passenger comfort. Continued research into promising detection techniques such as the use of microwave radiometers should be pursued in cooperation with the FAA. Collection of additional data on low altitude gust gradient and wind shear encounters should be continued to improve the ability to forecast hazardous conditions during takeoff and landing operations. Research into the effect of lightning discharges on composite aircraft structures, microprocessors and other micro-electronic systems should be continued in view of the increased use of these materials and systems in new aircraft." That is more of what we are talking about this week; in fact, he named most of the committees which are here this week.

This is my first participation in the workshop. In reviewing the attendee list I see a wide range of people from all aspects of the aviation community who have a wide range of interests and a great deal of enthusiasm. But more importantly, I think we have here a cast of people who are the aviation community's experts, a one-and-only type of opportunity. We have some "old hands" who have been through this before and know how the workshops operate; they can probably streamline the operation and make it very productive. We also have the "new hands" who are going to learn a lot and are going to be heavily influenced by the proceedings of these workshops.

I know we are going to have a busy, stimulating week, and I am certainly anxious to see the end results. But I would also like to say in closing that we owe a great deal of appreciation to people like Jack Enders, Jack Connelly, Joe Sowa, Dennis Camp and Walter Frost for organizing and keeping these workshops going, and to you individually for participating in them. People have a hard time getting money and getting away; and your presence shows a dedication to these kinds of workshops which is very important. We in NASA are beneficiaries of this whole process. I would also like to thank Becky Durocher for compiling the proceedings in an easily readable form, which makes them even more useful. Thank you for coming, and I know you will have a busy, productive and enjoyable week.

## WELCOME REMARKS

Arthur A. Mason

The University of Tennessee Space Institute

We are very pleased to have you with us this morning. On behalf of Dr. Weaver, who is the Dean of the Space Institute, I would like to welcome you to The University of Tennessee, and especially to our facilities here at the Space Institute. I hope you will take advantage of your stay here to get acquainted with us, with our faculty and students, and with some of the things that are going on at the Institute. I know you are going to be very busy; I looked at Dr. Frost's schedule, and it includes about four days packed into two and one half, so I don't think you will have a great deal of time to wander around. Take what time you do have, though, to see what is going on here and to meet with some of our faculty.

I notice that this particular workshop brings together people of many different disciplines; there are engineers, meteorologists, physical scientists, accident investigators, and designers. This is the kind of meeting that we like to bring together because it gives people an opportunity to pollinate across different lines and to find out what is taking place in other fields that may be useful to them as individuals. This is basically the way the Institute operates; it is an interdisciplinary organization. We are part of the graduate school of The University of Tennessee, Knoxville, organized around research divisions, of which Walter Frost heads the Atmospheric Science Division. Each division is composed of groups of people; faculty members, engineers and students; from several different disciplines who work together to solve particular problems in which they have a common interest.

With that in mind, I will say, once again, that we are very pleased to have you here at the Space Institute. If there is anything we can do to make your stay more pleasant and more worthwhile and profitable, please do not hesitate to call on me or Walter Frost or Jules Bernard, the Manager of our Short Course and Workshop Program. Thank you.

# SECTION III TOPIC AREA PRESENTATIONS



SURVEY OF WORKSHOPS ON  
METEOROLOGICAL AND ENVIRONMENTAL INPUTS TO AVIATION SYSTEMS

Walter Frost\* and Dennis W. Camp\*\*

Introduction

In order to best survey the impact of the past three Annual Workshops on Meteorological and Environmental Inputs to Aviation Systems, the findings of previous committee discussions are summarized under the categories of: (1) winds and wind shear; (2) turbulence; (3) fog, visibility and ceilings; (4) icing and frost; and (5) atmospheric electricity and lightning. Simulation, an important discussion topic considered at the first workshop, is also reviewed.

Winds and Wind Shear

Seriousness of the problem. All committees throughout the past three years have agreed that the wind shear effect in terminal operations is one of the most serious problems in aviation meteorology. Existing data on turbulence and wind shear from aircraft and towers should be exploited to the fullest, and support is needed for atmospheric boundary layer research to improve knowledge and understanding of wind shear. Past programs on wind shear have by no means accomplished everything. Efforts to obtain more real-time wind and temperature information is desired.

Measuring wind shear. The committees in general agree that detection of wind shear along a glide slope is a most important research area and that the wind anemometer array is an interim solution at best. The committees further agreed that the state of the art for carrying out measurements of wind and wind shear is advancing. Doppler radar systems, both ground-based and airborne, can observe vital wind information. The ground-based systems appear particularly attractive to the air traffic controller groups and are of paramount importance to general aviation pilots.

The application and testing of on-board scanning radiometer devices also holds a near-term potential for detecting important operational wind shear. Further research on the application of scanning radiometers is recommended. Airborne methods to indicate wind differences at flight altitude and at touchdown should be pursued, including airborne Doppler.

Laser technology requires further investigation before it can make a positive contribution to wind shear measurements.

---

\*The University of Tennessee Space Institute

\*\*NASA/Marshall Space Flight Center

Procedures after detection. When wind shear detection systems have been developed and installed at major airports, manufacturers as well as the Federal Aviation Administration (FAA) must determine specific actions to be taken after wind shear has been detected. These procedures must address aircraft limitations and compensative maneuvers to be made by the crew members.

Data uplink of Doppler radar-derived information on winds and wind shear directly to an aircraft is feasible. Accessing Doppler wind measurements and categorizing these according to acceptable operation envelopes for given aircraft could expedite flow of information. The system of a data uplink is particularly attractive to air traffic controllers where the number of aircraft which can be controlled is reduced due to air-to-ground frequency saturation and the diversion of a controller's attention from the control of the aircraft to that of interpreting and relaying weather information. Thus, transferring the wind shear on a real-time basis using a data link system, a visual display in the cockpit, and Air Traffic Control (ATC) facilities is an attractive system.

In developing such a system, however, a human factors study should be conducted to assure that pilots and controllers are not being provided more information than can be absorbed in a given time, i.e., can a continuously updated weather display be monitored in addition to other information already in the cockpit and/or in the control room?

Aids for general aviation. Observed winds should be made available to the general aviation community as early as possible, and both the availability of the data and instructions on what to do with it when it is received should be publicized through appropriate publications. FAA Advisory Circular 00-02A (Advisory Circular Checklist) should be mailed to all newly certified airmen. A number of existing FAA information and training materials (videotapes, films, printed materials) are available. In particular, Advisory Circular 00-50A (Wind Shear) has recently been published. Airmen must be made aware of the existence of these materials.

The Air Traffic Control Committee believes that to establish operation procedures, research should be conducted to determine how close an aircraft can fly to wind shear without actually becoming involved in it. At the same time, research should continue to determine the intensity of wind shear which an aircraft, categorized as to type, can withstand if actually penetrating a system. They noted that wind shear intensity should be reduced to a numerical value. A pilot could then use the value to determine if the intensity of the system is too great for his type of aircraft to penetrate. Such information is invaluable to the controller and the pilot in planning traffic flow.

Winds aloft. Winds for flight planning require better forecasting relative to fuel economy, based on computerized flight plans and on interim flight paths for optimum climbout and letdown.

Major problems in dealing with winds aloft are:

1. Inadequate reporting by the National Weather Service (NWS), i.e., 12-hour reports.
2. Inaccurate forecasting below 100 m, mostly due to terrain changes.
3. Lack of updates on a real-time or an exception basis.

Recommendations to increase winds aloft reporting accuracy are:

1. Direct input to and from the ATC Center to the aircraft for updating and reporting actual winds aloft.
2. Plotting actual winds from determined pilot reports (PIREPS) in the same manner as forecast winds. This would make the necessary briefing information available to general aviation.
3. Increasing the number of soundings made by the NWS back to 6-hour reports.

Training for wind shear. A conflict on how to best teach the phenomenon of wind shear arose during the committee discussions. Whether to teach extensive theory or to simply teach recognition and procedures was not resolved. It was agreed, however, that teaching should include interpretation of severe weather reports and should educate users as to the availability of these reports within the National Airspace System (NAS). Teaching should also incorporate suitable use of flight simulators, and written pilot certification exams should include weather.

In dissemination of wind shear information, standard terminology is desperately needed. Simplified oral communication, with all weather information (i.e., PIREPS, weather briefers, forecasts, file clearances, etc.) being available from one telephone call is needed. Also, it is suggested that a checklist for acquiring various types of weather information during given stages of flight be implemented.

Aircrews' understanding and training relative to meteorological conditions which may create a low-level wind shear hazard should be continuously updated. Equal emphasis should be given to both the cold air outflow region of a thunderstorm and the gust front conditions. Also, frontal zones and low-level jet stream conditions should not be neglected.

### Turbulence

Turbulence models. Available design methods and flight control analyses utilizing existing turbulence models are generally valid far from the ground, but our understanding of the nonstationary, patchy or intermittent nature and of the spatial distribution of turbulence near the ground, both over the airplane and along the flight path, is poor. More data are needed on eddy size, spanwise gradients, lateral gusts,



cross-correlations, and other turbulence statistics. In addition to not accounting for low altitude effects, the current models have not been proven adequate for future generation aircraft designed with new concepts, e.g., composite structures with large deflections having different frequencies and modes.

The committee recommended continued research to develop more realistic and comprehensive models of turbulence. Fruitful areas of research recommended in this regard include:

1. Continuation of the National Aeronautics and Space Administration (NASA) Measurement of Atmospheric Turbulence (MAT) programs to study spanwise gradients or distributed gust velocities.
2. Equal effort given to discrete gust models as is given to spectral density models, therefore, recommendation to reinstate earlier VGH programs.
3. Low altitude flight measurements along typical glide slopes with emphasis given to probing worst case conditions.
4. Further investigation of severe low altitude turbulence through tower-based measurements.
5. Research work to identify turbulence levels and location in thunderstorms using time microwave Doppler instead of instrumented aircraft.

Additional comments relative to design.

1. Structural design should be based on the design envelope for critical conditions rather than on the mission analysis approach.
2. Standard models of turbulence and wind shear are required for flight quality validation and should include effects of visibility, precipitation, and other such climatological factors.

Clear Air Turbulence (CAT)

Forecasting CAT. CAT forecasting is still in the primitive stages. There are, however, some specialized CAT forecasts available to commercial and military aircraft which are not available to general aviation aircraft.

Acknowledging the impreciseness of turbulence forecasting and detecting and the lack of such information to general aviation pilots, the single most real-time means of identifying the presence of turbulence, its locations, and its relative intensity comes from the pilot. The passing of PIREPS should be stressed by management and given full support by pilots.

In reporting CAT there is a need for standard terminology to:

1. Be simple (indices).
2. Be consistently understandable (quantitative).
3. Account for aircraft response characteristics.

Turbulence warnings issued to pilots are frequently false alarms. Conversely, many turbulence encounters occur with no advance warning. The number of false alarms and misses are particularly high for general aviation pilots (90% false alarms and 20% misses). The committee felt that until more accurate forecasts are available, a good interim step is improvement of recording systems and gathering techniques. This would involve the use of Significant Meteorological Advisories (SIGMET's) and PIREPS by:

1. Plotting them on a map.
2. Tracking them.
3. Setting specific guidelines for transmitting standardized and timely reports back to the pilot.

CAT turbulence measurements. Priority should be given to the development of on-board sensors for detecting and warning prior to CAT encounters, such as:

1. Airborne pulse Doppler lidar CAT detectors (NASA/Marshall Space Flight Center).
2. Airborne infrared (IR) radiometer CAT detectors (National Oceanic and Atmospheric Administration, NOAA).

Training in turbulence. The committee noted that it is particularly important for general aviation pilots to receive training in turbulence. However, there is generally no live practice flight training in turbulence. A suggested technique to achieve such training is to practice in fair weather cumulus. Also, a need was expressed for training in turbulence while flying on instruments.

Turbulence appears to be more critical for light aircraft in terms of aircraft structure and response; therefore, there is an increased likelihood of upset. Wind shear, on the other hand, is a greater hazard to large aircraft due to long spool-up times and increased aircraft mass. This fact points to the need for upset training in simulators for general aviation pilots; a type of training which is currently nonexistent.

Many general aviation pilots within the committees expressed concern for the lack of textbook training on turbulence, i.e., information on where turbulence is to be found or expected and how to recognize cues indicating probable encounters. Also lacking is a description of turbulence and its effect on aircraft response.

The committee urged that until a more precise system for detecting and predicting turbulence becomes available, the importance of remaining clear of areas of forecast turbulence if its intensity exceeds the limits of the aircraft must be stressed both in the classroom and at pilot briefings. Study results and the introduction of accurate detection equipment may later be used to develop a policy considered realistic enough to be adhered to by all pilots.

### Fog, Visibility and Ceilings

Most of the committee discussions dealt with visibility, therefore the following summary will focus on that subject.

Prevailing visibility. General aviation has a continuing and critical need for prevailing visibility data. In this regard, they feel that the projected closing of several Federal Service Stations (FSS's), coupled with the shift toward systems automation, establishes a clear requirement for a sensor system to provide visibility information reliably and automatically. Prevailing visibility affects general aviation in a regulatory fashion and is used by the military in training and combat operations to determine visual flight rule (VFR) requirements and weapons delivery minimums.

There is a justifiable requirement for an Automated Low-Cost Weather Observation System (ALWOS) which will measure ceiling and visibility, since some 1,000 airports in the United States have approved instrument flight rules (IFR) approaches but little or no weather observation data.

Slant range visibility (SVR). The general concensus of the previous committees is that there is a valid requirement for a system to determine SVR. Research and development of a system to measure SVR looks feasible and promising; however, at the present time the developmental funds are being directed to higher priority projects. During this slowdown in SVR development, some policy decision is needed as to the future use of SVR:

1. Will SVR become a regulatory value used for minimums, thus replacing Runway Visual Range (RVR)?
2. Will SVR be used in an advisory fashion?

RVR trend data. RVR trend data is valuable, but before adoption it must be extensively tested and verified. Currently, a pilot making an approach based on improving RVR trend data may arrive at minimums and discover the trend did not materialize.

Category III (CAT III) visibility. The committee expressed concern that with twelve major airports planning to go to CAT IIIB operation, there is insufficient weather data to determine the frequency of CAT III weather.

Additional data on the occurrence of CAT II and III weather, down to 300 ft RVR and below, is needed to establish the frequency of marginal landing conditions at airports, thus justifying the requirement for automatic landing systems through CAT IIIC and/or for fog modification systems.

Visibility measuring equipment to provide RVR measurement below 600 ft and at less than the present 200 ft intervals are needed.

If CAT III operations are implemented, a need for landing runway guidance once on the ground becomes necessary. Additional problems include cockpit cutoff, particularly in jumbo jets, and improvement in the windshield field of view, i.e., reduction of reflection and improved visual properties.

Regulations. The current VFR standards may not be adequate in light of the high performance aircraft in use today. These rules may endanger aviation safety in highly congested areas plagued by pollution; therefore, the Fog, Visibility and Ceilings Committee recommends the VFR standards be reviewed and revised if they are no longer adequate. The review of VFR should consider:

1. Genesis of VFR criteria.
2. Current air traffic conditions as related to modern speeds, closure rates, low profiles, and visibility over congested areas which is reduced, yet above legal visibility (i.e., the glare problem and the inability to readily identify aircraft during haze and smog, but in a legal VFR environment).
3. Both controlled and uncontrolled areas where Mach 1 aircraft are mixed with 100 mph aircraft operating legally under one-mile visibility.

Education and training. Flight training experience with the actual or simulated conditions surrounding low-visibility flight and approach is important. For simulation this requires accurate eye positioning, familiarization with the available visual information and ground cues, and familiarization with specific cockpit cutoff angle of the aircraft being operated. For optimum training value and cost-effectiveness, it is highly desirable to identify and utilize those ground features which have maximal effect on a pilot's decision to continue VFR flight or to make an IFR approach.

Experience through realistic simulation of transition from instrument meteorological conditions (IMC) to visual meteorological conditions (VMC), or from VMC to IMC, and the use of available information and cues are at this time difficult to obtain.

Continued research is needed towards developing advanced displays using electronic techniques, such as forward-looking visual systems; low-light/low-visibility TV images of the ground environment; flight

path angle and ground speed profile descent displays; and SVR measurements, particularly as an instantaneously available readout to the pilot.

Responsibility for training is at present spotty and rests primarily with the operators and independent training organizations.

### Icing and Frost

General needs. Instruments are needed for icing research, certification flight tests, and operational usage to measure:

1. Cloud liquid water content (LWC).
2. Droplet size.
3. Outside air temperature (OAT).
4. Cloud ice crystal content.

Facilities. Simulation facilities are necessary because testing in natural conditions for icing certification purposes is very costly, time-consuming, and uncertain. Improvement of existing simulation facilities is recommended. NASA, FAA, and the military services should determine the proper mix of simulation facilities. Development of modeling techniques to supplement or reduce facility requirements is also needed.

Forecasting icing conditions. Improvement in the capability to forecast icing conditions is urgently needed. Ice forecasting is judged to be accurate approximately 50 percent of the time. Additional effort should be devoted to the application of forecast models. Icing severity level should be stated in quantitative rather than subjective terms. The installation of icing severity indication systems on an aircraft fleet would benefit in acquiring needed data for improvement of icing forecasts. These authors believe there is insufficient attention given to ground facilities which provide a consistent network of measuring stations.

Meteorological data base. The meteorological data base is considered inadequate for real-time and flight planning determination of:

1. Frequency of occurrence.
2. Severity levels below 1,500 ft.
3. Forecast modeling.

NOAA and the Air Weather Service (AWS) should determine the most cost-effective method of filling the data needs and implementing the necessary programs.

Design criteria. Reassessment of meteorological design criteria contained in the Federal Aviation Regulations (FAR's) and Military Specifications (MIL-SPEC's) for the various aircraft categories by a joint government agencies program (led by NASA) is needed. Also needed is a thorough study to determine the most effective tools for completing certification testing.

Effects on general aviation. Research into the effects of icing and frost on general aviation should be continued relative to:

1. Potential use of ice-phobic coatings on airfoils to prevent large and rapid accumulations of ice.
2. Development of inexpensive ice detection and cloud parameter instrumentation.
3. Definition of the sensitivity of each aircraft design to ice accretion.

Since the performance penalties to general aviation aircraft are so great, the committee's recommendation is that NASA, in their development of rotorcraft protection, keep in mind that the same requirements for a light-weight, low-cost, low-power system apply to general aviation. Studies of the aerodynamics of those shapes that are found to be less sensitive to ice accretion should be pursued.

Relative to frost, research is needed to establish the severity of the frost problem for various airfoil configurations by means of an accurate quantization of frost-induced aerodynamic penalties versus frost thickness and density. The possibility of takeoff within an adequate safety margin for an aircraft with a frost-coated airfoil by reducing gross weight, by lengthening the runway, or by using a modified takeoff procedure should be determined. Development of an inexpensive and effective frost removal process for general aviation aircraft is needed. Present carburetor ice detectors should be evaluated, and a reliable, accurate and inexpensive ice detector should be developed.

Influence on air traffic control. Because jet aircraft have a high rate of climb and cruise at high altitudes, limited study of the effect of ice and frost on jet aircraft has been carried out. However, jet aircraft in holding patterns are normally at low altitudes, at low indicated airspeeds, and in a nose-up high altitude position, which exposes a large cross section of the aircraft to the effects of icing. Therefore, more study is needed in this area.

Review of FAR's concerning tail icing for extended lengths of time during holding patterns of carrier-type aircraft is needed. Also, there is a general lack of controller knowledge regarding the effects aircraft anti-icing systems have on aircraft descent profile. Consequently, jet aircraft using their anti-icing systems frequently have difficulty complying with ATC descent instructions because of the higher power settings required to support the anti-icing system. Knowledge of what

anti-icing capabilities are available on an aircraft should be made available to the controller so he can adjust traffic flow/patterns accordingly. A general study to determine the operating characteristics of jet aircraft under icing and frost conditions should be made. Additional studies should be made to identify characteristics peculiar to each type of aircraft.

A near-term solution to this problem is for the pilots to advise the controllers of the anti-icing capability of their aircraft, when the anti-icing system is in use, and what intensity icing can affect or is affecting their aircraft. A long-term solution would be development of an aircraft transponder linked to the airborne ice detection system which could indicate by alphanumeric symbols on the controller's scope when an aircraft is encountering icing which is beyond the aircraft system's ability to handle.

Forecasting. Continued and expanded efforts to improve all phases of icing forecasts are strongly recommended. The inability to accurately forecast/detect icing frequently results in the controller first being notified of its presence through a PIREP. Such PIREPS from pilots operating in one or more holding patterns in a high density terminal area results in a traffic flow realignment and the establishment of new landing priorities. These last-minute reactions could be avoided if areas of icing were known in advance. Therefore, a method should be established of reporting all general aviation icing encounters to air traffic controllers in a reliable and timely fashion. Presently, the air traffic controller tends to receive only those icing reports which are issued from aircraft experiencing significant difficulties.

Training. A modified program of pilot instruction concerning problems associated with ice accretion is needed. It is recommended that the present training programs be reviewed and analyzed with respect to factors such as:

1. Recognition of the effects of ice accretion on aircraft performance.
2. Possible use of simulators programmed with aerodynamic penalties representing ice accretion.
3. Related secondary problems, such as increased fuel consumption.

Because the problem of frost on the airfoil is regional within the United States, training programs should be reviewed to assure that pilots from frost-free areas are adequately prepared to deal with the problem when flying in colder regions of the country. Relative to carburetor icing and the meteorological conditions under which it is most likely to occur, training is needed in recognizing carburetor icing symptoms and following the proper procedures for corrective measures. Training procedures should also be established to assure that pilots recognize the hazard and understand the appropriate reaction when engine ice ingestion occurs. Flight schools and flight instructors for both

the FAA and the general aviation industries/associations should be encouraged to provide flight training in actual IMC whenever possible and appropriate.

### Atmospheric Electricity and Lightning

General comments. An adequate lightning protection technology base, as well as personnel with sufficient experience to apply it, exists within the design organization for most military and transport category aircraft presently being built. Adequate formal, comprehensive standards and specifications, however, do not exist. Moreover, an adequate understanding of lightning protection technology does not generally exist among designers of general aviation aircraft. Whereas lightning has not been considered a serious problem to these aircraft in the past, greater use under IFR conditions has increased their susceptibility, and the number of reported lightning strike incidents is increasing.

The Air Traffic Control Committees feel that lightning, as a phenomenon, is reasonably well understood; this knowledge, however, does not appear to have been fully applied to the construction of ground systems, including the computers which serve the ATC system. Studies of systems' resistance to electromagnetic pulse (nuclear hardening) may be directly applicable to "lightning hardening" of both ground-based and airborne systems. A specific item desirable for ground installations is a system which can warn of an impending lightning strike in time for activation of standby systems, or protection of primary ones. A composite "hazard warning" system providing alerts for dangerous lightning, turbulence, precipitation and wind shear conditions, although difficult to achieve, would certainly be desirable.

Potential hazards for all categories of future aircraft increase as the trend increases toward use of nonmetallic structural materials and adhesive bonding techniques, and as reliance upon sensitive electronics to perform flight control functions increases. Therefore, new protection technology must be developed, documented, and made available to designers.

Research and development should continue in defining lightning hardening designs for avionics; ground computers, communications, NAVAID installations; and composite structures.

Forecasting. Development of lightning forecast methodology needs to address four basic concerns:

1. Timeliness of reporting (real-time versus delayed reporting).
2. Standardization of communication (terminology).
3. Quantity of information required.
4. Accessibility of information to general aviation.



Data base. A central data base must be established in order to track lightning strikes to aircraft. For large aircraft, the data base may be established using information from commercial airlines, manufacturers, and government agencies. For general aviation, the information may come from repair facilities, commuter airlines, and government agencies. In the area of accident investigation, a recording system is needed to provide lightning strike evidence. This is of particular concern for fly-by-wire systems, which now pose lightning problems in military aircraft and may do so in civil aircraft several years from now.

Training. Pilots of all aircraft need a better understanding of the conditions under which lightning strikes can occur and of the effects they may have on their aircraft. A better understanding would improve avoidance procedures, equip pilots to react knowledgeably when a strike occurs, and enable better information to be derived from PIREPS of in-flight strike incidents. Not only would pilots be benefited, but also accident investigators would benefit from training in the effects of lightning on aircraft. Another area in which all pilots in general need training is lightning awareness.

There is a need for education concerning the lightning/precipitation static (p-static) environment and its effect on systems. Many problems in communication can be traced to inadequately maintained p-static lead devices, emphasizing the need for adequate training in the importance of p-static lead devices and the effect of faulty equipment for both pilots and maintenance and electronic repair personnel.

Eight areas of technical need were identified by the Atmospheric Electricity and Lightning Committee. The nature and impact of each problem, timeliness of solution, degree of effort required, and roles of government and industry in achieving solutions were prioritized and are summarized in Table 1.

#### Simulation

A wide range of simulator types are currently available, from software models of a system with a pilot to hardware research simulators which allow complete studies of flight dynamics, handling qualities, control systems, guidance systems, navigation, ATC interface, certification criteria development, failure mode analyses, displays, and human factors to be carried out. In addition, more and more use is being made of the piloted simulator to recreate the critical flight situation for aircraft accident investigations. One must be aware, however, that the ability of simulators to duplicate motion cues is highly variable, depending upon the specific simulator and its degree-of-freedom and "wash-out" program. Very few simulators can duplicate the very high acceleration associated with severe turbulence environments, especially the low frequency, large amplitude portion of the response spectrum. Visual displays also limit and exhibit lags if driven outside the nominal frequency envelope.

TABLE 1  
TECHNICAL NEEDS RELATIVE TO ATMOSPHERIC ELECTRICITY AND LIGHTNING

	1	2	3	4	5	6	7	8
<b>NEED</b>	In-flight data on lightning electrical parameters <ul style="list-style-type: none"> <li>• direct strikes</li> <li>• nearby strikes</li> <li>• static electricity</li> </ul>	Technology base and design guidelines for protection of advanced aircraft systems and structures	Improved test techniques for: <ul style="list-style-type: none"> <li>• induced effects</li> <li>• blast effects</li> </ul>	Analysis techniques for predicting induced effects	More lightning strike incident data from general aviation	Lightning detection systems	Obtain pilot reports of lightning strikes to aircraft	Better training or awareness for pilots of all aircraft
<b>NATURE OF PROBLEM</b>	Lack of data	Lack of design data, R&D	R&D	R&D	Operational	R&D	Operational and procedural	Operational and procedural
<b>TIME REQUIRED</b>	2-4 years	2-6 years	2 years	3 years	1 year	2 years	3 years	---
<b>IMPACT OF PROBLEM</b>	Uncertain test and design parameters	Increased safety hazards; decreased use of advanced technology	Increased hazards; decreased efficiency	More cut-and-dry	Decreased reliability	Continued hazard to air/ground personnel and operations	Increased strikes	---
<b>COST BENEFIT</b>	Increased flight safety, especially under IFR conditions; quicker and more confident introduction of new technologies							
<b>EFFORT REQUIRED</b>	New effort	Some knowledge in hand and major new effort required	Continued effort	Some new effort	Additional reporting effort	Some new effort	In hand, education needed	New
<b>PARTICIPANTS</b>	Major role: government Supporting role: Contractors	Government/contractors; improved data base airframe manufacturers; specific applications	Government and industry	Government and industry	General aviation industry	Government and industry	Operators	All

Wind models. Ground level mean wind data and models are generally adequate for simulation. However, models of low-level wind shear for unique site characteristics, such as buildings, terrain features, aircraft carriers and nonaviation ships, are not readily available, although work is in progress. A simulation of existing and additional data is needed to model shears in warm fronts, inversion conditions, gust fronts and thunderstorms. More accurate data on these types of wind shear are needed to scope the magnitude and characteristics which can be expected in aircraft operations.

Atmospheric turbulence models are reasonably reliable, although there are too many models and standardization is needed. Additional data and analysis of existing data is desirable. Data is needed for VTOL aircraft operations and to simulate spatial distribution of turbulence. Specific problem areas identified are:

1. Definitions of terms need standardization, e.g., what is the difference between turbulence and wind shear? (Terminology for wind shear should be standardized.)
2. The considerable amount of meteorological data gathered over the years needs to be analyzed and translated into simple, yet generalized models in a format suitable for aircraft applications.
3. Turbulence models need to be standardized.

Attention must be given to mechanization of atmospheric disturbances and related modeling of aircraft responses to these disturbances, i.e., axis system to which turbulence and wind speed are referenced. Many airline training simulators need to be reprogrammed to properly simulate representative shear profiles. Also, industry should be encouraged to develop a low-cost flight simulator capable of realistic simulation of turbulence, the effects of icing on induction systems and structures, and low ceiling/visibility conditions. When this generation of simulators becomes available, flight schools should develop syllabi and training scenarios to afford the most effective use thereof.

#### General Comments

Measurement and transferral of weather information. Weather measuring equipment, PIREPS, weather observer and control tower observations are the principal sources of weather information. A variety of transfer mechanisms are employed in relaying information to the pilot and the controller, i.e., telephone, tele-autograph, closed-circuit TV, air-to-ground radio, digital RVR equipment, etc. While these transfer methods are satisfactory under most weather conditions, they do not satisfy the requirement for timely information during rapidly changing weather conditions. Weather information, particularly visibility, is extremely perishable. Thus, the transfer mechanism becomes all-important and is the element which is most frequently criticized during rapidly changing weather situations, when the transfer mechanism becomes

relatively slow because of the excessive workload of the pilot, forecaster, and controller. Coupled with this are the relatively slow methods of relaying the information, i.e., transposing observations onto a tele-autograph and relaying data from the tele-autograph to the pilot. A faster, more accurate method of relaying information should be through use of a data link from the equipment observer directly to the pilot and controller. This would reduce controller workload and air-to-ground frequency congestion. It may, however, present too much information in the cockpit. Moreover, the expense would likely be prohibitive to general aviation pilots.

In the area of instrumentation, airborne weather probes that are an integral part of the airframe are needed. Probes similar to the transponder and automatic altitude readout equipment would provide pertinent weather data to the appropriate ground dissemination system without any pilot input. This information could also be utilized in advising subsequent aircraft during landing approach.

Proposed study on weather information transferral. A study of pilot and controller actions during severe weather operations should be conducted. The study should include behavioral factors and should have as its objective the identification of:

1. Specific information required by the pilot and/or controller upon which to base their decision to continue along the planned route of flight or to proceed along an alternate route.
2. The time frame within which this information must be made available.
3. The format which will provide the information in the most concise, easily understood manner.
4. What effect this information will have on pilot and controller workload and their ability to interpret and use the continual flow of weather information.

Accident investigation. Aircraft accident investigators lack the necessary meteorological information to develop valid findings and recommendations about a specific accident. A centralized listing of all sources of weather information in federal, state and local governments, as well as in private concerns observing weather on a frequent basis, should be established. This up-to-date, consolidated listing of weather observing stations could be kept at a centralized location and consulted for a listing of agency names and telephone numbers of weather observing stations within a certain radius of an accident location. A better method of retrieving all pertinent and often perishable data, such as satellite pictures, local observations, and automatic observations, is also needed.

Making weather information useful to pilots. Pilot perception of what the weather actually is from a presentation of the weather information is currently poor. Sequence reports, notices to airmen (NOTAMS), PIREPS, and verbal briefings need to be made clearly understandable to pilots. Some suggestions for improvement are:

1. Use airport names instead of the three-letter identifiers.
2. State severe weather conditions in plain language instead of in symbolic language.
3. Make briefings slow and understandable, particularly where the briefer does not have eye contact with the receiver, and give the recipient several opportunities for questions.

Airports. Relative to the subject of fog dispersal at airports, the Airport Committee recommended that following completion of the literature search underway by NASA on the topic, the two most promising techniques should be field-tested.

Rain. There is a need for research on the effects of rain on aircraft performance similar to the research being conducted on frost. Another area which might need investigation is the differences between FAA requirements and MIL-SPEC requirements for engine water ingestion.

Standardization. Standardization of data is currently one of the largest problems which must be tackled. Improvements are still pending in the following areas:

1. Standardization of measurements from facsimile charts to terminal weather reports.
2. Specific standards and accountability for aviation forecasts.
3. Standardized training and proficiency checks for new and current pilots, dealing with terminology and use of existing systems.
4. A systems approach in implementing the new communication systems. Included in this task should be an effort to standardize the symbology presently used to depict weather information. Consistency in depicting given phenomena on all types of displays would be a valuable asset.

Computer-assisted instruction. For any automated system, computer-assisted instruction should be included as an integral part of the design. Such a system would allow the user to reference explanatory material to refresh his memory or to amplify briefing material in areas where doubt exists. This mode should be easily accessed to enhance utility.

An important need exists for communication between various groups serving the aviation community with weather information. These groups include: NWS, FSS, Air Route Traffic Control Center meteorologists, terminal controllers, and airline weather centers.

A study is needed to support what appears to be a requirement for additional observers/forecasters in control centers to amend, update, and otherwise provide timely information which reflects rapidly changing weather conditions.

## AVIATION METEOROLOGY RESEARCH AND DEVELOPMENT:

### A STATUS REPORT

John H. Enders

Consultant (NASA Ret.)

#### Introduction

The dynamic and rapid growth in our collective knowledge of weather problems as they affect aviation is dependent upon continued interaction between the operations community and the research and development community. The constant iteration between "what you should expect" and "here's what I ran into" provides the healthy environment for the nurturing of a sound information base of weather and its effects upon aircraft operations.

This Fourth Annual Workshop continues to provide information feedback and "feedforward" between the operators' real world and the research and development (R&D) community. This information linkage has been found by most participants to be vital to improving safety and economy of air operations through a constant open dialogue between the many members of the greater aviation community.

Virtually all of the R&D efforts described in the status reports presented at this workshop were undertaken because of the perception of flaws in operations. Occasionally, a tragic accident results because we did not know the intensity or extent of a weather hazard, or because we were unable to communicate information in a timely manner to a flight crew, or because the designer did not anticipate the stress Mother Nature chose to impose on an airplane at a particular time.

Jack Connolly and I will provide a brief overview of the present status of aviation meteorology research in the National Aeronautics and Space Administration (NASA), National Oceanic and Atmospheric Administration (NOAA), and Federal Aviation Administration (FAA). Hopefully, this will set the stage for the topic papers and the working sessions which will follow.

Most of NASA's aviation meteorology R&D is concerned with measurement of weather phenomena which can present hazards to aircraft flight. Projects recently completed or currently underway in NASA encompass some aspects of the following:

- Automatic voice advisory for small airports
- Clear air turbulence detection (airborne)
- Wind shear detection (airborne)
- Severe storms measurement

- Lightning-generated environment (in-flight measurements)
- Lightning direct strike to aircraft measurement
- Atmospheric temperature profiles and water burden measurement
- Mesoscale atmospheric storm prediction
- Development of methods for weather-related accident analysis
- Updating of icing hazards technology data base
- Helicopter rotor ice protection
- Ozone contamination in aircraft cabins study
- High altitude gust measurements
- Temporal and spatial continuity of gust gradient in-flight measurements
- Objective mesoscale analysis
- Warm fog dissipation and modification
- Frost formation modeling

I will discuss the status of some of these efforts in a generalized form, according to the committee arrangement for the workshop.

#### Winds and Wind Shear

According to Jim McLean of the National Transportation Safety Board (NTSB), winds, wind shear and associated turbulence accounted for one fatal and 11 nonfatal commercial airline accidents in 1977. General aviation suffered 75 fatal and 470 nonfatal accidents due to this cause. (Overall, in 1977 there were a total of 441 fatal and 826 nonfatal general aviation accidents due to all causes.) Mainly a terminal area hazard, winds and wind shear result typically in damaged structure, such as wing tips, landing gear and bent propellers, on up to complete structural destruction. In extreme cases, such as in the Eastern Airlines Flight 66 accident, a large transport aircraft is unable to cope with the shear encounter. Factors affecting our inability to deal effectively with winds and wind shear are: lack of adequate observation, lack of quick response instrumentation, timeliness in transmitting available information to the cockpit, short duration nature of some shears at a given location on or near the airport, and lack of pilot training in this area.

NASA work in wind and wind shear measurement is concerned with both ground-based and airborne instrumentation research. Objectives of this effort are twofold: To develop better instrumentation for the study of weather problems and to develop operational instrumentation concepts. Tower anemometry at Wallops Flight Center and atmospheric boundary layer modeling at Marshall Space Flight Center are aimed at a better understanding of atmospheric processes which prevail in mesoscale space. At Wallops, an effort is underway to examine the feasibility of using existing on-board weather radar and other



airborne equipment to provide aircraft ground speed and wind information necessary for detecting hazardous wind shear conditions below 1500 feet altitude. This project includes evaluations and tests of state-of-the-art pulse, solid-state CW, coded CW, and pulse-Doppler radar as a means of determining aircraft ground speed and wind shear profiles in rain, and as a possible means of providing ground speed/wind speed uplinks to the aircraft.

An infrared (IR) radiometer Low Altitude Wind Shear (LAWS) flight test/development cooperative program with NOAA is continuing at Ames Research Center with good success. It shows promise of a flight-rated wind shear detection and warning system.

### Icing and Frost

McLean (NTSB), in his 1977 study, noted that there were no fatal commercial accidents due to airframe icing or frost, but during the same period there were 22 fatal and 69 nonfatal general aviation accidents attributable to carburetor and airframe icing.

The renewal of interest in icing was brought into focus at a NASA/FAA-sponsored Workshop on Aircraft Icing held about two years ago. This workshop, which resulted in great part from discussions that took place during the Second Annual Workshop on Meteorological and Environmental Inputs to Aviation Systems in 1978, was followed shortly thereafter by a Tripartite Helicopter Icing Symposium in London. Subsequent to this activity, and based upon it, the Air Force Flight Dynamics Laboratory sponsored a Workshop on Icing problems encountered in low-level tactical operations. As a result of this renewed interest, NASA has mounted a program of icing research aimed at updating the data base and advancing the technology for coping with operational icing. Led by Lewis Research Center, other Centers with specific roles and missions will conduct supportive research, e.g., wind tunnel airframe ice testing, propulsion systems, flight testing, basic meteorology, etc. As an example, Ames Research Center, in cooperation with the Army, is evaluating concepts for helicopter rotor ice protection, including a new abrasion-resistant polyurethane elastomeric pneumatic boot. The Jet Propulsion Laboratory is experimenting with a sea surface sensor which measures vertical temperature profile and water burden of the atmosphere directly above it. A possible application would be to measure icing hazards. Through Marshall Space Flight Center, University of Dayton Research Institute has completed a mathematical model to predict overnight frost formation on an airfoil for any wind, temperature, humidity and radiation condition. It also calculates frost dissipation during takeoff.

### Atmospheric Electricity and Lightning

Accidents due directly to atmospheric electricity or lightning are few indeed. Growing appreciation of induced electrical effects due to lightning strikes to aircraft shows that careful attention to design is necessary to avoid hazard.

NASA's lightning research is aimed at developing protection concepts for aircraft relative to composite materials, bonded metal structures, advanced digital systems, and fly-by-wire systems (Langley Research Center). NASA's Severe Storms Program at Langley Research Center includes an effort to characterize lightning hazards at aircraft operating altitudes for design purposes by measurement of direct strike current and magnetic effects, assessment of induced effects, and collection of frequency-of-occurrence data. An instrumented F-106 aircraft is being flown at Langley to capture direct strike transients and high frequency data. Data from penetration of moderate intensity thunderstorms is being correlated with ground-based measurements.

F-106 on-board instrumentation includes the direct strike measurement experiment, an atmospheric chemistry experiment, a composite fin cap, gusts and winds sensors, a data logger, an X-ray, and lightning optical signature instruments. Ground-based facilities include: Wallops Flight Center's SPANDAR, LDAR to provide operational vectoring, electric fields measurements, and UHF Doppler weather radar; National Severe Storms Laboratory's Doppler weather radar, lightning location instruments, and electric fields measurements; and National Aviation Facilities Experimental Center's Doppler weather radar.

#### Fog, Visibility and Ceilings

This is a terminal area hazard which Jim Mclean (NTSB) found accounted for one fatal commercial accident, as well as 245 fatal and 128 nonfatal general aviation accidents, in 1977.

NASA or NASA-sponsored work in fog and fog dissipation is carried out through Marshall Space Flight Center. Over many years, NASA has searched for means of practically manipulating fog to the extent that visual contact with runways could be guaranteed during the final pre-touchdown phases of the approach. Following the extensive work with CALSPAN in the 1960's, Marshall concentrated on improving the understanding of fog physics with a view towards eventual warm fog modification. This is just plain hard research--grinding away on basic principles, looking for breakthroughs. Numerical modeling of advective fog is being conducted to simulate fog formation, to microscopically describe atmospheric aerosols, to simulate modification of advection fog, and to determine means of chemically or thermally modifying fog. This effort is continuing.

Another study is concerned with the effect of turbulence on the life cycle of warm fog. Field measurements are underway. Another effort is concerned with exploring means of operationally economical dispersion of warm fog at United States airports, especially employing charged particle techniques. A feasibility report has just been published by FWG Associates, Inc., on warm fog dispersion and is available from NASA (Christensen and Frost, 1980).

## Turbulence

Storm turbulence and clear air turbulence (CAT) accounted for one fatal and four nonfatal commercial accidents and for 19 fatal and 21 nonfatal general aviation accidents in 1977.

NASA's severe storms research at Langley Research Center, as described earlier, builds on earlier NOAA and Air Force thunderstorm research and complements their current efforts.

A major task over the past decade or more has been associated with a search for practical means of airborne detection of CAT and for characterization of CAT. Airborne tests have been conducted for Doppler lidar aboard NASA's Convair 990 and for the NASA/NOAA IR radiometer aboard NASA's Lear Jet, C-144, and CV-990.

The Doppler lidar, an elegant technique which is accurate to the extreme, is a victim of the cleanliness of cruise altitude air. Operating on backscatter principles, it is dependent upon aerosols present in the air, but jet transport cruise altitudes have turned out to be cleaner than the Environmental Protection Agency models would have us believe. At altitudes below 20,000 feet, Doppler lidar works well. It can also detect wake vortices at cruise altitudes, due to entrained engine exhaust products. The IR radiometer, on the other hand, detects water vapor concentration gradients which correlate well with the presence of CAT. Out of 141 total alarms in the CV-990 test series, 83 percent were verified encounters; only 17 percent were false alarms. The false alarms were largely very light turbulence encounters, while the heavy turbulence was almost always detected. More work to refine the instrument and technique is continuing, using NASA's Lear Jet.

## Conclusion

This is a very quick pass-through of NASA and NASA-sponsored work in aviation meteorology measurement. At this workshop, either the NASA project managers for this work or other knowledgeable people who can answer detailed questions on these projects are present.

FEDERAL AVIATION ADMINISTRATION AND NATIONAL WEATHER SERVICE  
AVIATION RESEARCH AND DEVELOPMENT

John W. Connolly  
(NOAA Ret.)

At the First Annual Workshop on Meteorological and Environmental Inputs to Aviation Systems which took place in March, 1977, I presented a brief overview of aviation weather services. During that presentation I not only attempted to define aviation weather services as they existed in 1977 but I also speculated on where we might be heading in the future.

I think the magnitude of the problem we face in providing adequate weather services to the wide variety of users has been established by a large number of organizations, including this Tullahoma forum. So it is not my intention today to again justify the need for better aviation weather services. Instead, I will touch very briefly on what the National Oceanic and Atmospheric Administration (NOAA), particularly the National Weather Service (NWS), and the Federal Aviation Administration (FAA) are doing in research and development to satisfy these needs.

In my 1977 discussion, I stated that both FAA and NWS had agreed that dissemination of aviation weather information was the number one priority development item. Here is an update on where we stand. The NWS Automated Field Observation System (AFOS) was scheduled for operation in late 1979 and early 1980. The system experienced difficulties in both hardware and software so that implementation of the system is delayed approximately one year. Since user requirements have been a problem, the American Meteorological Society is now sponsoring an informal users' group to insure that the needs of the users of aviation weather services are continuously put before the NWS as it implements AFOS. Both air carrier and general aviation are represented.

Turning now to the FAA, the Flight Service Station (FSS) Modernization Program Office has recently let contracts with three companies for development of a prototype dissemination system. These contractors have until early 1981 to produce a working system. At that time FAA will select the best system and a production contract will be let. This schedule calls for implementation of the Model #1 Alpha-Numeric System in fifty-eight FSS's by 1983. Graphic capability will be implemented in the 1983-1985 time period. Implementation plans beyond fifty-eight FSS's are not yet finalized. That is the status of NWS and FAA internal dissemination systems; we do not yet know how the information will get to the users.

Relative to surface weather observations, the obvious need of the future is automation. NWS and FAA are both involved in these

programs, so I will not try to differentiate responsibilities. There are a whole variety of automatic weather stations running the gamut from relatively simple measurements of wind and altimeter setting all the way to complex and complete weather observations.

#### Wind, Altimeter and Voice Equipment (WAVE)

WAVE was tested at Frederick, Maryland, last year and proved successful. A Technical Data Package will be available in April, 1980, and procurement of twenty-three WAVE systems is included in the 1981 budget.

#### Aviation Automatic Weather Observation System (AV-AWOS)

AV-AWOS was tested at Patrick Henry International Airport, Newport News, Virginia, in 1978. Using three conventional ceilometers and three videograph equipment sets in conjunction with other mostly conventional weather sensors, this test proved the concept of an automatic weather station capable of providing a complete aviation weather observation. Obviously AV-AWOS will be the most costly of the series of automated observing systems.

#### Automatic Low-Cost Weather Observing System (ALWOS)

Between these two approaches of WAVE and AV-AWOS is ALWOS. In relation to the term "low-cost," about the best one can say at the moment is that ALWOS will be less costly than AV-AWOS. This system may well be the workhorse of the aviation weather automation program. It is modular in design and has the flexibility of providing as simple an observation as WAVE or as complete an observation as AV-AWOS using single cloud base height and visibility sensors. ALWOS is scheduled for installation at Dulles in April, 1980. A Technical Data Package is scheduled for completion in October, 1980. Procurement plans for ALWOS are not yet complete.

#### Joint Aviation Weather Observation System (JAWOS)

Finally, FAA and NWS are planning to establish JAWOS. This joint approach to automatic weather station development and procurement apparently has the support, and perhaps the urging, of The Office of Management and Budgets (OMB).

#### Next Generation Weather Radar (NEXRAD)

Another major weather detection system of vital interest to the aviation community is NEXRAD. This is a joint development of Doppler weather radar by FAA, NWS and Air Weather Service (AWS) to replace the aging weather detection radar network. A joint Systems Project Office (SPO) has been established to manage the development of this next generation weather radar. An inter-agency plan is expected in April, 1980; procurement specifications are scheduled for April, 1981; and a procurement contract will be let in April, 1982. The first system

test is now planned for April, 1984, and implementation of the total system will take place between 1986 and 1990.

In addition to the joint project, FAA also plans to test and evaluate the capability of Doppler weather radar to provide terminal area coverage. A test will be conducted at Will Rogers Airport using both the Norman and Cimmaron Doppler radars. It may well be that even an extensive Doppler weather radar network will not be able to provide all of the services required in the terminal area.

#### Automated Thunderstorm and Associated Hazards Forecasts

In the area of forecast development, NWS is pursuing an FAA-sponsored project for automated forecasts of thunderstorms and associated hazards in the 0-2 hour time period, updated every 10 minutes. The obvious use of such a system is to assist air traffic controllers in expediting the movement of aircraft safely and to assist pilots and dispatchers in flight planning. It has been demonstrated that through the use of digital computers and weather radar data processing algorithms it is now possible to make convective cell movement and intensity change predictions with a significant degree of skill.

The next phase of this program, which begins this spring, is to further improve forecasts of convective weather for 10, 20 and 30 minute projections based on three years of archived data at Oklahoma City. This will be followed by a similar phase to develop improved 40, 50 and 60 minute projections.

FAA will test and evaluate these NWS objective techniques for 0-1 hour forecasts of thunderstorms and severe convective weather at the National Aviation Facilities Experimental Center (NAFEC) during 1980 and 1981.

#### Real-Time Upper-Air Wind Information

FAA is also looking into the possibility of obtaining real-time upper-air wind information in the terminal area by processing Direct Address Beacon System (DABS) derived track/ground speed (from a ground sensor) and true airspeed/heading data linked from the aircraft.

#### Gulf of Mexico Weather Services

A program is underway to improve Gulf of Mexico weather services for helicopter operations. The off-shore oil industry has caused a tremendous expansion in aviation weather needs in the Gulf area. Using observations from a number of platforms, NWS will issue Gulf area forecasts from New Orleans.

### Lightning Detection Systems

There is also a plan to test and evaluate lightning detection systems for thunderstorm location and tracking in the operational environment as an alternative to no coverage in the non-radar covered areas. A system will be installed in the Gulf area with outputs at the Lafayette and New Orleans FSS's.

### Icing Observations

To assist in the process of certifying helicopters for flight into icing conditions, FAA will obtain data on natural environmental icing conditions below 8,000 feet in order to establish airworthiness standards. Data will be obtained on liquid water content, drop size distribution and temperature.

### Prototype Regional Observation and Forecast System (PROFS)

In the Denver terminal area, FAA will participate with NWS in the terminal area weather support subsystem of PROFS. PROFS is being developed by NOAA through the Environmental Research Laboratories at Boulder, Colorado. If successful, the PROFS output will be used as a critical input to the terminal area subsystem of the aviation weather system.

### Conclusion

Finally, there are a number of forecast technique developments which will have an impact on improved aviation weather services in such areas as surface wind forecasting, severe local storm prediction, medium range forecasting, and probability forecasting, to name a few.

I have attempted to present a brief overview of what is going on in FAA and NOAA that will be useful for aviation in the future. I have been sketchy in detail, but there is a sufficient number of experts attending this workshop to answer any questions. So if you want more details, please see me during the next few days and I will point you to the experts.

## ICING INSTRUMENTATION

William Olsen

NASA/Lewis Research Center

### Introduction

This discussion will primarily consider the instrumentation used in icing simulation facilities. Phyllis Kitchens, in her presentation on "Aircraft Icing Instrumentation--Unfilled Needs," will discuss the instrumentation used in helicopter flight tests and on production aircraft.

Table 1 lists the types and usage categories of icing instrumentation. Somewhat different groupings of instruments are used in each instrument usage category. For example, in meteorological research an aircraft may fly through a cloud with most of the first six types of instruments, and a production aircraft would require only a few of them, e.g., outside air temperature (OAT), airspeed, liquid water content (LWC) or ice accretion, and some performance instruments. However, tests in an icing simulation facility or in flight tests for certification, etc., may require using all the types of instruments.

### State of the Art

Let us now briefly consider the state of the art for some of the icing instruments listed in Table 1. The discussion will be somewhat biased toward ground facilities for icing tests.

Temperature. Aircraft icing occurs over a fairly narrow range of ambient OAT, which means good accuracy is required for any temperature measurement. Today's technology is adequate for measuring the OAT outside the cloud, provided the probe never encounters--or it separates out--any small amount of entrained water in the airstream (Von Glahn, 1955). Measuring the temperature inside the cloud has been successfully accomplished (e.g., Keller, 1978), but this is much more difficult because the probe must separate out many droplets and negate the heat transfer due to phase changes. The technology for airfoil surface temperature measurement is also adequate, if applied with care.

Airspeed. The existing technology, using anti-iced probes, is adequate. Velocity survey rakes, consisting of electrically heated total and static tubes, have been used successfully in the past (Von Glahn, 1955), but they are difficult to make.

Relative humidity. The air in natural clouds is usually considered to be saturated (Willbanks and Schultz, 1973). The very cold air in most icing simulation facilities can be anywhere from dry to saturated. An unsaturated condition inside the icing cloud results in additional



TABLE 1  
ICING INSTRUMENTATION

<u>Types</u>
Temperature (OAT, surface, in-cloud)
Airspeed (V)
Relative humidity (or dew point and frost point)
Drop size (volume median and distribution)
Liquid water content (LWC)
Phase (supercooled liquid, snow, etc.)
Ice accretion (thickness scales, photos, etc.)
Aircraft performance changes (drag increases, fuel consumption, etc.)
Anti-deicing system performance (to protect aircraft and instruments)
<u>Usage</u>
Meteorological research
Simulation facility tests
Flight tests (certification, research and development)
Production aircraft instruments

mass and heat transfer, as compared to saturated air. Measurement of relative humidity (or frost point or dew point) inside the icing cloud is not simple; one must often rely on a measurement outside the cloud and a calculation of conditions inside the cloud. Analyses and experiments are being performed at the National Aeronautics and Space Administration (NASA) in order to determine the consequences of an unsaturated cloud. Sublimation is sometimes offered as the reason aircraft report losing ice after leaving a natural or a simulated icing cloud, especially when the sun is out. This explanation was partially checked out experimentally in the NASA Icing Research Wind Tunnel (IRT). It was found that the ice loss rate (from sublimation and/or shedding) in dry air--even in the presence of simulated terrestrial sunlight--was too slow to explain the ice loss during flight tests. Additional experiments and analyses are planned.

Ice crystal percentage. Most icing simulation facilities can control the spray nozzle pressures and spray fluid temperatures so that the test model or aircraft is in a cloud composed of adequately supercooled droplets with no ice crystals. An oil slide or laser holograph

is usually used to visually check for ice crystals. It has been reported that ice crystals, occurring in natural icing clouds, affect the ice accretion and the ice properties (Adams, 1977). Therefore, it appears that icing simulation facilities may have to be able to produce controlled levels of ice crystals.

Drop size. Droplet size mainly affects the extent of the surface where ice will accumulate. Until recently the aircraft icing spray tankers have produced excessively large droplets in their sprays, i.e., the volume median drop sizes ranging from 30 to 200 microns. Standard design practice is to calculate the ice accretion on an airfoil for 20 micron droplets and to calculate the maximum extent of the ice coverage with 40 micron droplets in order to account for the naturally occurring drop size distribution. This suggests that a reasonable volume median drop size goal for all icing facilities would be 20 microns. The tankers do not appear to meet that goal; as a result, the ice coverage on a test aircraft is in error. Recent experiments in the NASA/Lewis IRT have proven that there is a commercial spray nozzle which should permit tankers to produce the desired 20 micron drop size with reasonable spray nozzle air flows.

But let us return to our main concern, measuring the drop size, and discuss two pertinent questions: 1) How accurately does the drop size have to be measured? and 2) How accurate and practical are the existing instruments?

The standard design practice mentioned above, i.e., 20 microns for accretion and 40 microns for extent of ice coverage, suggests that for most icing tests the drop size should be known to better than  $\pm 5$  microns. Let us compare that minimum accuracy goal to the accuracy of drop size instruments. The accuracy estimates will be inferred by comparisons between the indications of old and new instruments. We really do not know whether the old and/or new instruments are correct, but if their measurements agree within about 5 microns, we can take some comfort in that agreement.

The older instruments for measuring drop size were the rotating cylinder and variations of the oil slide. In recent years, various types of laser spectrometers have been used extensively to measure the drop size histogram and volume median drop size in natural and in simulated icing clouds. They can be used over a large range of temperatures and over an airspeed range of approximately 50 to 200 mph. However, compared to the older methods, spectrometers are expensive, and they require constant maintenance and adjustments. They also have very subtle errors, which are described by Jeck (1979). Two instruments are required to cover the drop size range in icing clouds. The accuracy of the widely used laser spectrometer [Axial Scattering Spectrometer Probe (ASSP), drop size range of 3 to 45 microns] has recently been estimated to be no worse than  $+3$  to  $+6$  microns by several workers (Jeck, 1979; Hunt, 1978; Keller, 1978; and Olsen, herein). All observed that a given instrument unit had excellent repeatability during a given

test program. Let us look at some of these recent comparisons in more detail.

The oil slide was compared to the laser holograph at Arnold Engineering Development Center (Gall and Floyd, 1971) and to the ASSP laser spectrometer by Keller (1978). Figure 1 shows that the two laser methods were in close agreement. The oil slide consistently indicated larger droplet sizes than either laser method. Keller (1978) discussed the causes of this significant bias. On the other hand, the oil slide can also be subject to the human error of not counting the occasional big droplet. Keller (1978) also compared rotating cylinders to the laser spectrometer (not shown); he found this old method to be in substantial agreement with the laser.

Another drop size comparison was recently made by NASA and Meteorological Research, Inc. (MRI), in the NASA IRT. The experimental setup is shown in Figure 2; the test was similar to one reported by Keller (1978). Two instruments of different drop size ranges [the Axially Scattering Probe (ASP), 3 to 45 microns; and the Cloud Probe (CP), 30 to 300 microns] were used. Measurements were taken over most of the operating range of the IRT spray nozzles (see Figure 2); however, the velocity range was limited to 150 mph by the strength of the traverse mechanism and to 50 mph by the instrument. Although the test program was not exhaustive, the results are nevertheless informative, because the IRT was the facility used in the 40's and 50's to formulate most of the aircraft icing technology.

In Figure 3(a) the old IRT calibration of the 50's (made with rotating cylinders) is compared to a more recent calibration of the IRT by Lockheed (done in 1969, also with rotating cylinders). The drop sizes indicated in the Lockheed recalibration are very close to the line of perfect agreement. Keep in mind that both the old calibration line and the Lockheed line are averages of data with considerable scatter. The drop sizes indicated by the laser spectrometers scatter only about  $\pm 1$  micron from a straight line correction to the old IRT calibration. This 1 micron scatter is the same as the repeatability of the laser that was noted in repeatability checks. The very small scatter suggests that the old IRT calibration, i.e., drop size as a function of air and water spray nozzle pressures, along with tunnel air speed, is correct with the exception of a possible linear correction. Of course, we do not know whether the laser and/or rotating cylinders are correct. The line of perfect agreement is within 1 to 6 microns of the laser data. Therefore, even if the rotating cylinder were correct, the laser error would be no more than +3 to +6 microns. For most aircraft icing tests, this uncertainty would be acceptable.

It was also noted that the drop size changed less than 1 micron in traverses across the tunnel spray, i.e., drop size was the same for each nozzle. This fact, plus the fact that the drop size did not

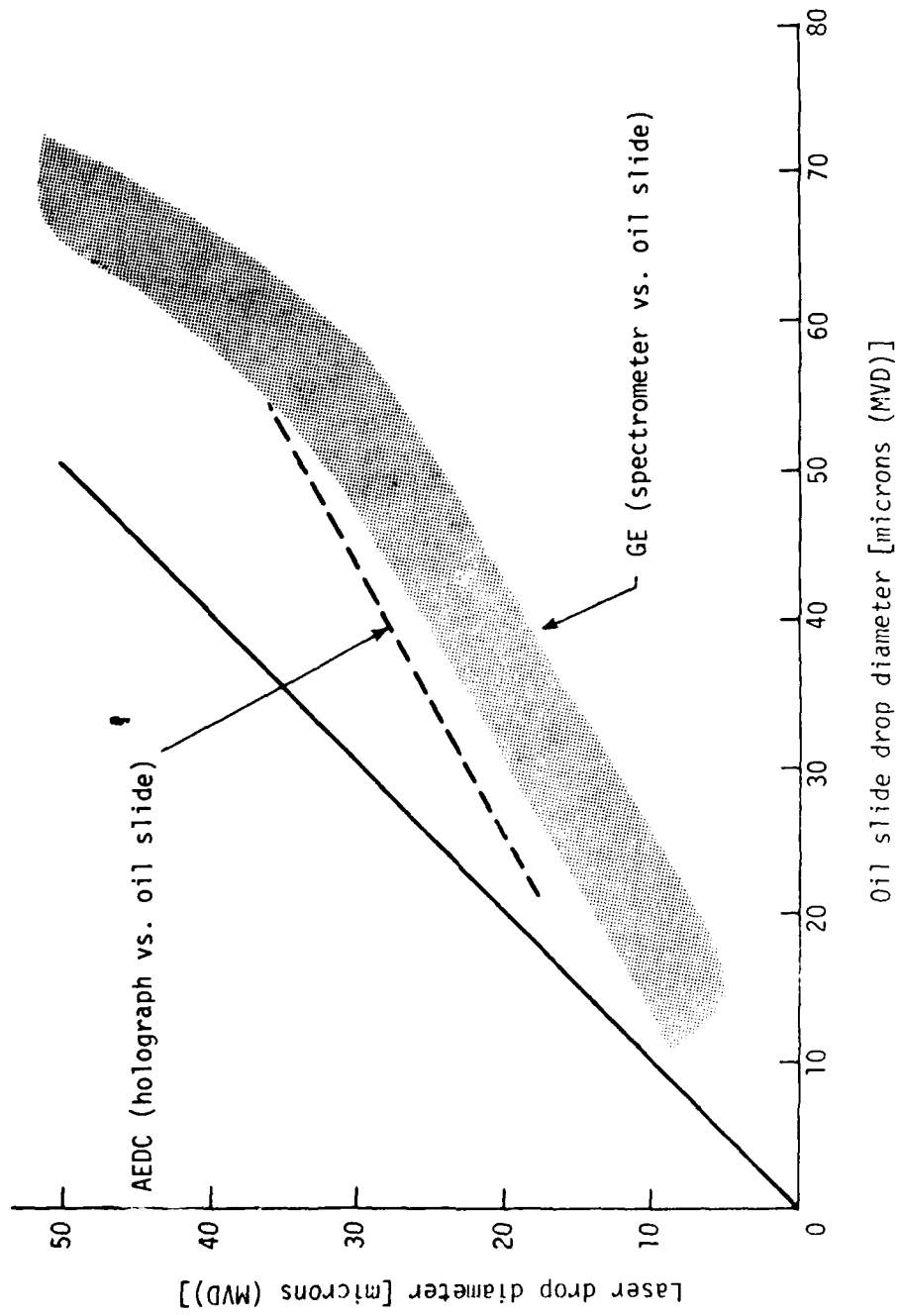

Figure 1. Drop size comparison (Keller, 1978)

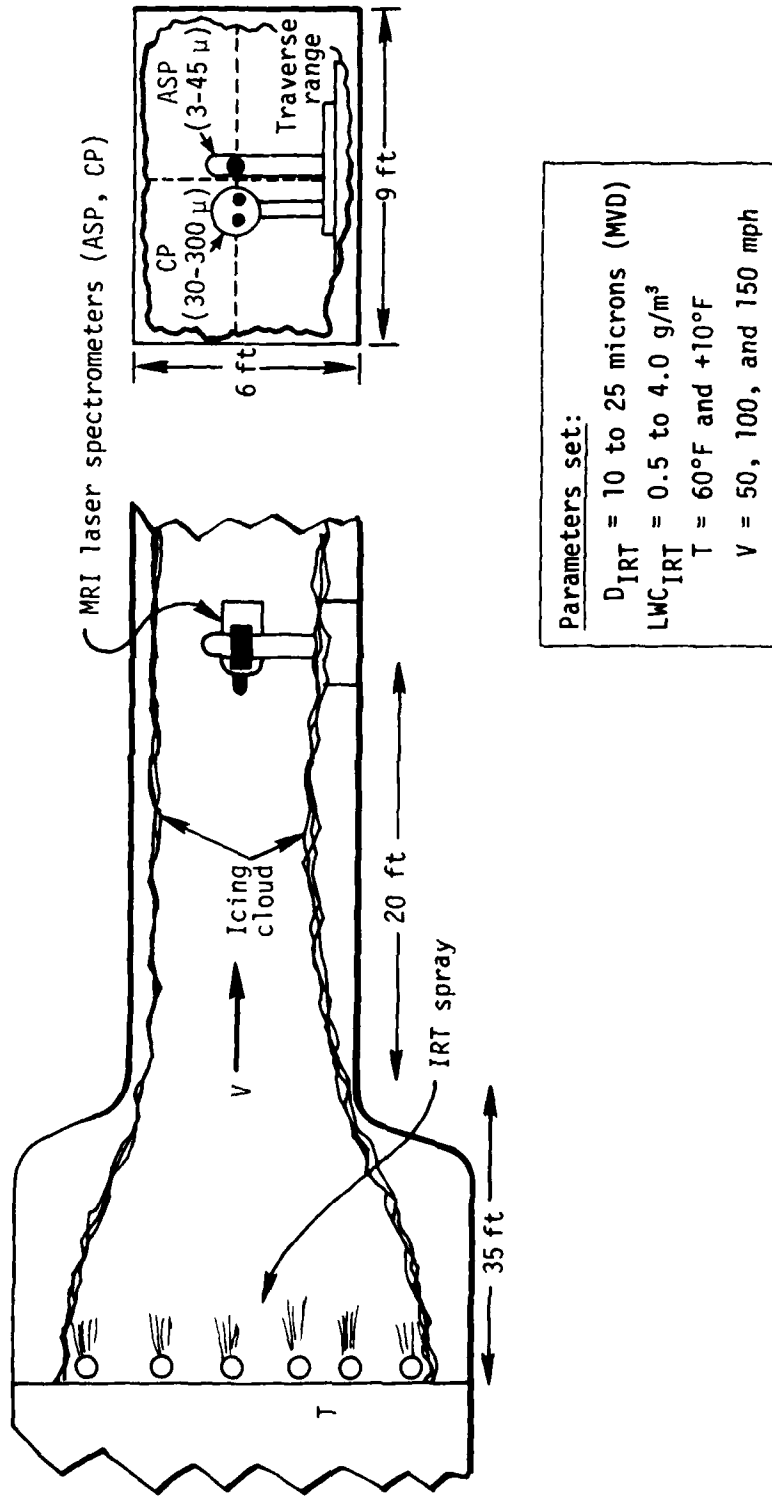
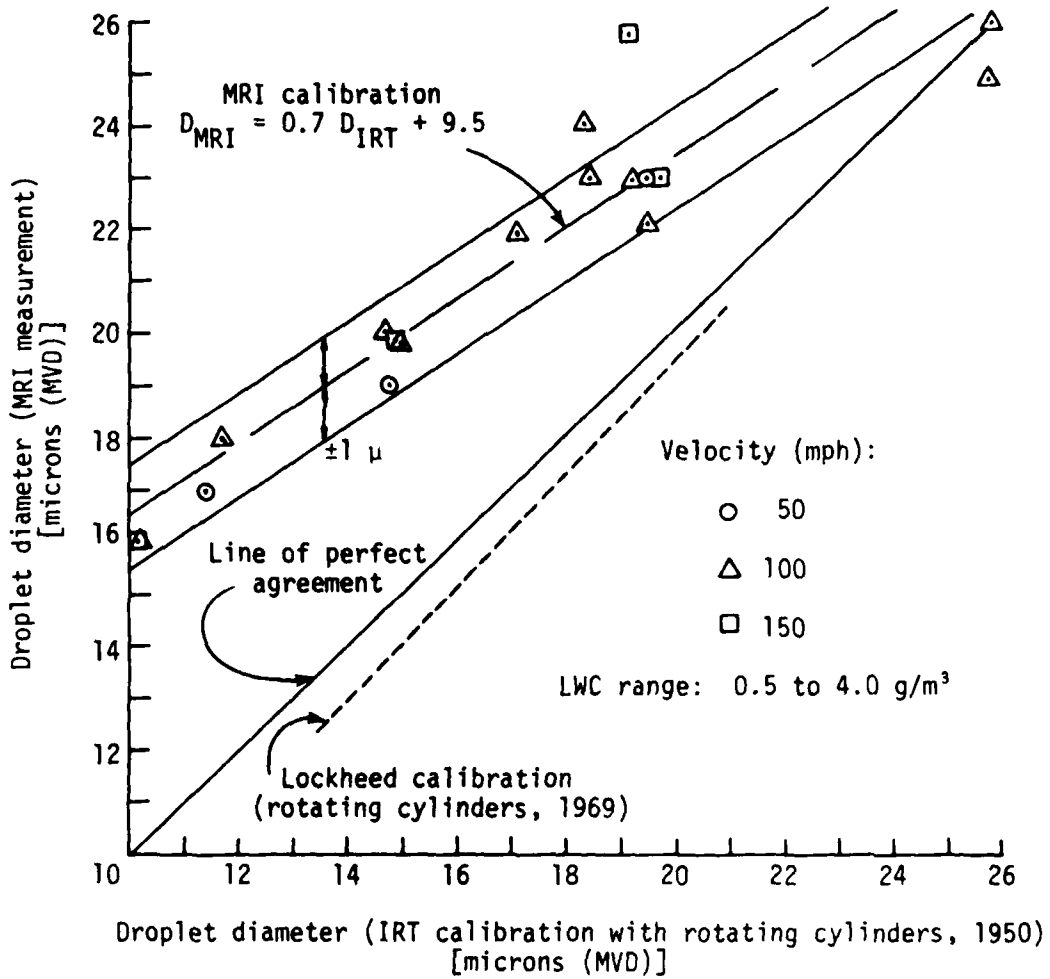

Figure 2. Setup for calibration of IRT spray.



(a) Droplet diameter comparison

Figure 3. Comparison of old and new instruments for drop size and LWC. (Tunnel air temperature, +10°F)

change measurably in 20 years, even though there was only minimal maintenance of the nozzles and demineralized water was used, indicates that the drop size does not necessarily have to be measured very often in an icing simulation facility.

Results from a different type of laser (not shown) were below the line of perfect agreement; the tunnel calibration equations were again confirmed except for a linear correction (below). Similar comparisons have been made in other ground facilities with similar results. Sometimes the correction was above, sometimes below.

Based on the above, this writer recommends that one small icing facility be used as a reference standard so that these laser instruments would be in agreement when they are used in various test programs.

Liquid water content. Let us now consider instruments to measure LWC in natural or simulated icing clouds. LWC is the primary parameter affecting the rate of ice accretion, i.e., icing severity. There are many types of LWC instruments; Table 2 contains a partial list. Some have a remote electrical readout, others are manual; both types have been used in both ground and flight icing tests. Electrical ice accretion rate meters measure the time it takes ice to accumulate to some preset thickness. All automatically turn on electric heaters to deice the sensing probe after some ice thickness is attained and then begin the detection cycle again. The Leigh and the Hot Rod use a light beam which is interrupted by the growing ice layer on a small rod. The Rosemount detects changes in the resonant frequency of the vibrating sensing element as ice accumulates on it. The United Controls probe employs Beta radiation, which is attenuated as the ice accumulates. The other instruments with electrical readouts do not permit ice to accumulate. The J&W and the Normalaire-Garrett probes are basically hot wire probes; they essentially use the greatly increased heat transfer coefficient that results from droplets impinging upon the sensor surface. In the case of the J&W probe, the surface temperature (i.e., the electrical resistance is measured) is held constant and the heat flux, i.e., electrical power to the surface heater, is measured. The Normalaire-Garrett probe is similar. Both use an "always-dry" sensor as a reference. The laser spectrometer calculates the LWC from the same drop size histogram data that it uses to calculate the volume median drop size. With the manual cylinder and the thin blade, ice accumulation is measured with a micrometer. For the sphere, ice growth is visually determined by rough comparison to a set of inscribed reference marks; the icing severity depends on how fast the ice accumulates. The sphere has been proposed as an inexpensive icing severity meter for general aviation aircraft by Newton (1978).

In response to the question of the accuracy and practicality of these instruments for various tasks, only a very incomplete answer can be given for a number of reasons. First, data for comparisons are limited. Second, there is no standard for LWC measurement; therefore, the LWC calibrations of icing facilities may not be comparable. Third,

TABLE 2  
LWC INSTRUMENTS

Electrical Readout	Manual Readout
<u>Instruments Employing Ice Accretion:</u> Leigh Hot Rod Rosemount United Control Rotating Disk	<u>Instruments Employing Ice Accretion:</u> Rotating Cylinder Thin Blade Sphere
<u>Instruments Not Employing Ice Accretion:</u> J & W Normalaire-Garrett Laser Spectrometer	

the measurement of the appropriate LWC is made more difficult in those facilities that do not have a uniform icing cloud. This problem is especially acute in icing tanker tests where the test aircraft oscillates transversely across an undulating and nonuniform spray cloud. Fortunately, the ice buildup is a time-averaging process over many oscillations. Therefore, this error can be minimized if the LWC instrument is near the test surface of interest and has an adequate sampling time.

A reasonable accuracy goal for LWC instruments would be between +10 and 20 percent. Let us now compare this goal with the indicated accuracy of several LWC instruments. As before, with the drop size instruments, we shall have to rely upon comparisons between instruments and repeatability checks to estimate the accuracy of LWC instruments. Keller (1978) compared the rotating cylinder to the laser spectrometer; the rotating cylinder reading proved to be 10 to 20 percent lower than the laser readings. Figure 3(b) shows a number of comparisons that were made between the old IRT calibration, which was made in the 50's with a small rotating cylinder, and other more recent measurements of the LWC in the NASA IRT. In 1969, Lockheed made some measurements with the rotating cylinder; the average of those results is close to the line of perfect agreement in Figure 3(b). The open symbols in Figure 3(b) are the LWC values indicated by the laser spectrometer (ASSP operated by Meteorological Research, Inc.). The data scatter about the line of



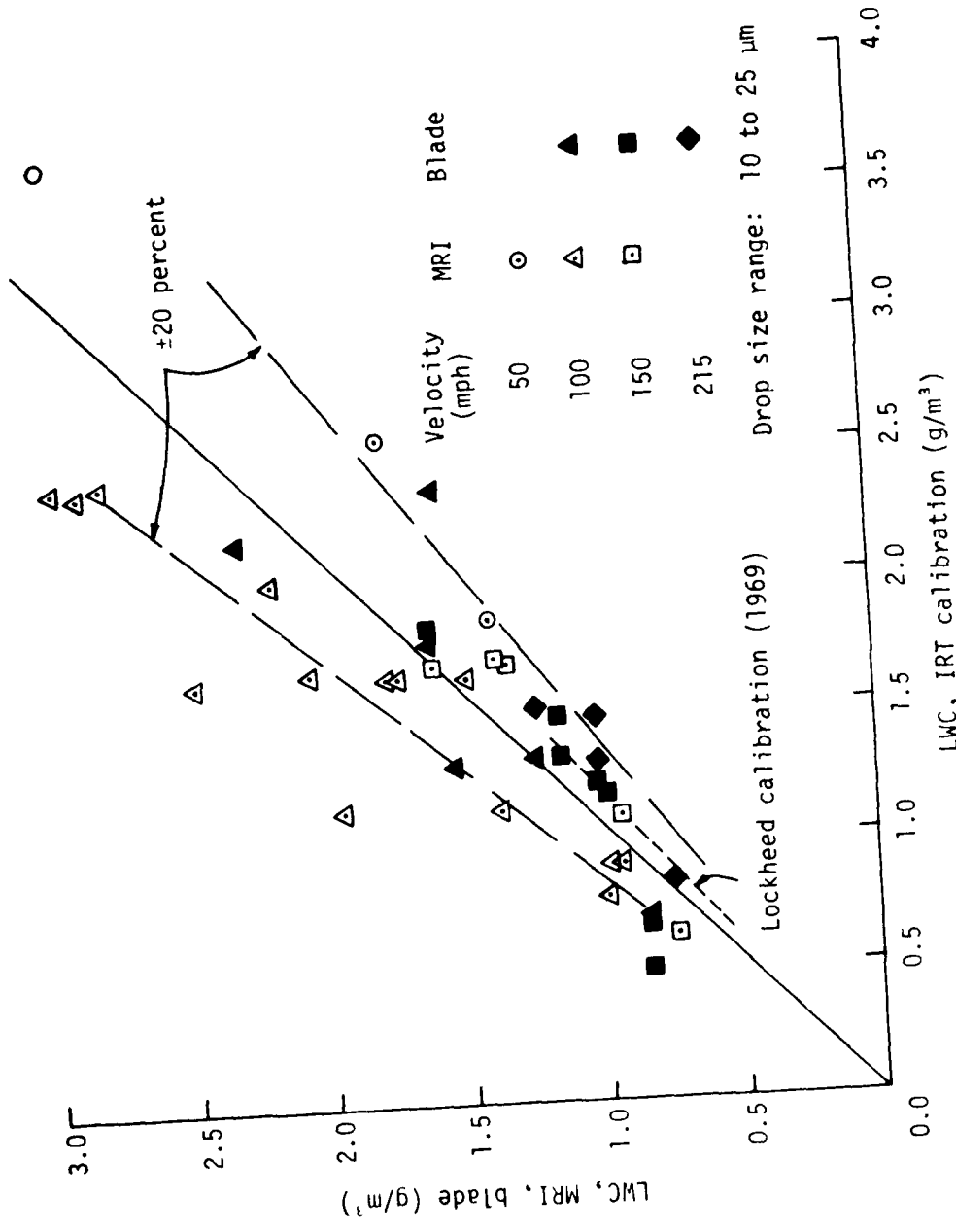

(b) LWC comparison

Figure 3 (continued)

perfect agreement; the scatter is about  $\pm 30$  percent. This droplet volume error corresponds to a drop diameter error of 10 percent. The dark symbols are the LWC values obtained with a thin blade. The data lie within  $\pm 20$  percent of the line of perfect agreement, and the repeatability of the blade was better than  $\pm 10$  percent. Stallabrass (1978) noted an error of less than 15 percent. The blade has been suggested as an inexpensive comparison standard for all ground icing facilities to insure that their LWC readings would be comparable. So far, the British and the Canadians have compared their facilities. The blade results shown in Figure 3(b) indicate that the LWC data in the IRT are comparable to those of the British and the Canadians. These limited results and discussions with other experimenters suggest that the accuracy of LWC instruments is somewhere between  $\pm 10$  percent and  $\pm 30$  percent. A 10 percent accuracy would certainly be adequate, but a 30 percent accuracy would not be adequate for many icing applications. The practicality of these instruments is another matter of concern. For example, many of the electrical ice accretion rate instruments do not have enough deicing heat for a cloud of high LWC. Indeed, these instruments appear to have a host of individual problems which could be ironed out in a comprehensive test program including a number of the instruments listed in Table 2. Such a test should be performed in an icing tunnel where conditions can be well controlled and the instruments subjected to a large variation in LWC. This writer suggests that such a test program be initiated to iron out the bugs and to then determine the accuracy, limitations and practicality of these instruments for the various uses listed in Table 1.

#### References

- Adams, R., 1977: An Assessment of Icing Definitions, presented to USARADOC Seminar on Helicopter Ice Protection, Ft. Rucker, Alabama.
- Gall, E., and F. Flloyd, 1971: Icing Test Capability of the Engine Test Facility Propulsion Development Test Cell J-1, AEDC-TR-71-94.
- Hunt, J., 1978: Engine Icing Measurement Capabilities at the AEDC, AGARD Conference Proceedings 236.
- Jeck, R., 1979: Performance of the PMS Axially Scattering Spectrometer Probe, Aerosol Measurement, University of Florida Press.
- Keller, R., 1978: Measurement and Control of Simulated Environmental Icing Conditions in an Outdoor Free Jet Engine Testing Ground Facility, AGARD Conference Proceedings 236.
- Newton, D., 1978: An Integrated Approach to the Problem of Aircraft Icing, AIAA Paper No. 77-1218.

Stallabrass, J., 1978: An Appraisal of the Single Rotating Cylinder Method of Liquid Water Content Measurement, NRS Low Temperature Laboratory Report No. LTR-LT-92.

Von Glahn, U., 1955: The Icing Problem: Current Status of NACA Techniques and Research, Ottawa AGARD Conference.

Willbanks, C., and R. Schultz, 1973: Analytical Study of Icing Simulation for Turbine Engines in Altitude Test Cells, AEDC-TR-73-144 (AD770069).

## AIRCRAFT ICING INSTRUMENTATION--UNFILLED NEEDS

Phyllis F. Kitchens

U.S. Army Test and Evaluation Command

### Introduction

A discussion of the unfilled icing instrumentation needs must be based upon an understanding of what we want to measure and why. The "usual" icing parameters are generally thought of as outside air temperature (OAT), liquid water content (LWC), and droplet size and distribution. For a flight test program, complete time histories of each of these parameters while in-cloud should be mandatory. Each of these measurements requires a high degree of accuracy and repeatability. There are a large variety of instruments currently available to provide this type of information.

In addition to the "usual" icing parameters, there are a number of related ones for which there is an unfilled instrumentation need. The type of instrumentation which is required is strongly dependent on the purpose for which it will be used. For icing the purposes are generally described as research and development (R&D), certification (or qualification, as it is called in the military), and operations.

The following discussion is a "shopping list" of instrumentation requirements which are presented for consideration and discussion during this workshop. Because of the Army's helicopter orientation, many of the suggestions are specific to rotary wing aircraft; however, some of the instrumentation would also be suitable for general aviation aircraft.

### Instrument Requirements

Rotor blade photography. It is highly desirable, and should probably be mandatory, to obtain photographic documentation of rotor blade ice accretion, i.e., chordwise and spanwise extent and ice shapes, types, and shedding characteristics. Actual pictures of blade ice accretion are currently needed to fill gaps in aircraft icing instrumentation. Researchers in Great Britain have successfully built hub- and fuselage-mounted rotor blade cameras for the Wessex helicopter, but there is no corresponding development for United States helicopters. Rotor blade cameras are need for R&D and certification.

Improved cloud characterization devices. For the last two years, the U.S. Army Applied Technology Laboratory (ATL) has contracted for use of a particle measuring system (PMS) axially scattering spectrometer probe (ASSP), as well as cloud (CPS) and precipitation (PPS) particle probes. Our contractor effort has also included complete technical support for instrumentation maintenance and data acquisition and

reduction. The cloud characterization system used on the ATL ice-protected UH-1H is relatively heavy (ASSP weighs 24 lbs, CPS and PPS each weigh 45 lbs); and the particle probes are fairly large cylinders (28 inches long by 6 1/2 inches diameter, with two extensions each 20 inches long by 1 inch diameter), all of which can create significant installation problems on small aircraft. In our flight tests, and in at least one other, the ASSP has experienced probe icing which resulted in a loss of data. This is very costly when one considers the overall paucity of natural icing opportunities in a given season.

Other drawbacks of the currently available systems are that the apparatus is very sophisticated and complex, well beyond the capabilities of the "average" Army flight test personnel to operate, maintain and interpret the results; and the equipment is relatively expensive to own, especially when one considers the normal annual 60 to 90-day flight test period which historically seems to be the limit of Army funding for icing flight tests. (Before continuing, it must be stated that ATL has no reservations about the fine support our contractor has provided. The point is merely that there is a need for improvements in the instrumentation and for development of an in-house capability to increase overall testing effectiveness.)

Based on the ATL test experience, there appears to be a need for lighter weight, more compact and less complex instrumentation for measurement of cloud parameters such as droplet diameter and distribution. The instrumentation needs to be highly reliable as well as affordable, and a complete software package needs to be provided for data processing. These miniaturized versions need to be at least as accurate as the present systems (estimated to be  $\pm 10$  percent) and, desirably, offer some improvements. One question which needs to be addressed is the effect of nonspherical water droplets on probe accuracy; the inclusion of a capability to discriminate and characterize ice crystals is also desirable, as explained in more detail below.

Ice crystal content. The presence of ice crystals along with supercooled liquid water is the so-called "mixed condition," which is suspected of being an important element in the heat balance equation for rotor blade ice accretion. Although icing tunnel experiments have been performed to determine ice accretion shapes under mixed conditions, very little is currently known about the prevalence of this condition or how crystals actually affect a helicopter. At one time it was postulated that the effect was extreme because of otherwise unexplainable high torque rises which were experienced during United Kingdom icing flight tests. The Royal Aircraft Establishment (RAE) Farnborough is developing a simple instrument using polarized light which will detect the presence of ice crystals but will not actually measure the concentration. The RAE is also sponsoring efforts to develop ice particle counters, one by the University of Washington and the other by Mee Industries. No information was found on the current status of the devices. The United Kingdom has used the Knollenberg optical array probes, suitably modified with polarizing optics and detection circuits, to discriminate between ice crystals and water; however, only 20 to

30 percent of the ice particles were identified correctly. At present there appears to be no flight test instrument which gives reliable discrimination between ice and water over the entire particle size range. Many of the available devices are prone to identifying large, nonspherical water droplets as ice or are strongly droplet-size dependent. Development of such instrumentation is applicable to research, development and certification. It may even be a necessity for operations, if mixed conditions are shown to present a significant hazard increase.

Relative humidity. This parameter is not an unusual one to measure, and there are devices on the market, such as the EG&G (Cambridge) frost point hygrometer, which can be used. However, the interest in this parameter as it relates to icing is relatively new, at least from the standpoint of ATL. During the 1980 icing flight tests a dew point hygrometer was borrowed from the Naval Research Laboratory (NRL) and installed in the test UH-1H helicopter. The purpose of using this instrument was to gather information on atmospheric humidity, along with the previously described LWC data, to determine if there are significant differences between the simulated icing cloud and the natural icing cloud. If significant differences are found which materially affect the accuracy of the icing simulation, measures will have to be devised to overcome these in order to use in-flight simulations most productively for R&D and certification.

Solar radiation. This year ATL wanted to measure the amount of solar radiation received by the test UH-1H in the simulated icing cloud and in natural icing because tests of the UH-1H in the Ottawa spray rig have revealed differences in ice shedding characteristics during tests conducted at the same OAT and LWC, but under different sky conditions. Because of the relatively "thin" cloud produced by an in-flight icing simulator, it is necessary to determine if there is any enhancement of a helicopter's tolerance to icing due to the relatively greater solar radiation experienced under simulated icing conditions. If this enhancement is significant, measures will have to be devised to offset the effect.

Unfortunately, no satisfactory method for using the available Bentley pyrliometer has been found. The device requires a stable mount so that the angle relative to the sun is constant; this was not achievable on the test helicopter. In addition, there is the unanswered question of what effect, if any, the chopping of the rotor blades would have on the accuracy of the device. A flight test instrument for measuring insolation on a helicopter is an R&D need and may also be a certification need.

Freezing precipitation. As stated many times at various conferences, there is a current need to verify or improve the icing meteorological data base. The Federal Aviation Administration (FAA) is undertaking a program to establish the validity of the supercooled cloud certification criteria contained in Federal Aviation Regulation (FAR) 25, Part C, for helicopters and other nontransport category aircraft. However, FAR 25 does not include consideration of snow, freezing

rain and drizzle, or hail. Under an ATL contract, Lockheed-California Company reviewed statistical data and developed recommended helicopter ice protection design criteria for snow and freezing rain. The Lockheed-generated design criteria still require verification. There is a need to quantify all of the freezing precipitation conditions, to establish valid ice protection design criteria, if they are necessary, and to design testing/certification criteria.

Freezing rain is of particular interest because many of the operational encounters with "icing" which are described by U.S. Army helicopter pilots are really with freezing rain. Some very limited flight tests conducted by the Army and Navy have failed to demonstrate the drastic effects expected from freezing rain on helicopters, making the need to quantify the exposure imperative. With the clearance of helicopters for flight in icing (supercooled cloud) conditions, it becomes more likely that freezing rain will be encountered. Therefore, the limit of an aircraft in freezing rain needs to be established during the certification process. Finally, the pilot needs a cockpit indicator to identify the condition in which he is flying so that he can determine whether he is "safe" or should exit the condition. Therefore, freezing precipitation requires instrumentation for use in R&D, certification and operations.

Instrumentation for total damage assessment. In this category, which mainly affects operations, we have a drastic departure from the normal icing instrumentation which measures cloud parameters. Instead of being interested in LWC per se, we are looking for the gross effect which flying through an icing condition has on any particular helicopter. There are two currently known approaches to accomplishing this objective of providing the pilot with a "total damage" assessment, i.e., integrating rate units and torque monitoring.

*Integrating rate units.* On the ATL test UH-1H there is an instrument called an integrating rate unit (IRU) which processes signals from the Leigh Mark 10 ice detector. (An IRU for the Leigh Mark 12 detector is in development.) The IRU actually integrates the fluctuating LWC as a function of the time the helicopter is passing through the condition and produces an output imaginatively termed integrated rate units. This term is a pure number which can be correlated to the thickness of ice which will have accreted at the main rotor blade midspan. On the ATL helicopter, the electrothermal deicing system is controlled by the IRU, automatically deicing the rotor blades when a particular number of units, corresponding to 1/4 inch ice thickness, is reached. The IRU then resets to zero and the integration process begins again. To date this method of control has been effective and quite satisfactory in our tests; however, additional testing, particularly by NRL, indicates that there may be another factor to take into account when arriving at the total damage done to a helicopter because of ice.

It appears that the detrimental effect of ice on a rotor blade is a function of LWC, time of exposure, and *temperature*. Apparently, temperature is important because it affects ice type and shape and

spanwise coverage. First for R&D and later for operational use, a new type of IRU is needed to integrate LWC and temperature with respect to time. Also, a cockpit display is needed to allow the pilot to monitor the effect icing is having on the helicopter so that he has the opportunity to exit the environment or to insure operating limitations are not exceeded for "partially cleared" aircraft. This new type of IRU could also be used to control the ice protection systems for aircraft which have full icing clearances.

*Torque monitoring.* Currently the French Puma and the German BO-105 helicopters rely on torque increases to cycle their rotor blade deicing systems; both aircraft use standard aircraft meters to provide the control input. Although this method uses the total damage concept, it is not completely satisfactory because the torque instruments do not have the high degree of accuracy required. The United Kingdom is working to develop a measurement of the "pure" torque change caused by rotor ice accretion. This is an extremely complex problem because so many factors can affect the power requirement (engine torque, blade lead and lag angles, blade stress, rotor shaft torque, airspeed, stick positions, attitude, rate of climb or descent, etc.). If such a system can be developed to monitor the true effect ice has on rotor power, it will negate the need to measure meteorological parameters for operational aircraft.

#### Conclusions

There are a number of areas in which in-flight icing instrumentation needs improvement. The suggestions made here can probably be expanded by other researchers and operators familiar with icing problems. The challenge has been presented--now it is up to industry and government, as represented by those attending this workshop, to respond.



## TURBULENCE: FROM A PILOT'S VIEWPOINT

Charles L. Pocock

Lockheed Aircraft Service Company

Since the turn of this century, when modern man started serious experimentation with heavier-than-air flying machines, atmospheric turbulence has been one of his greatest fears. Many early accidents were, in fact, attributed to what became known as "puffy air." This is not too surprising, considering that when flying one of these early wood and wire wonders, only a very few knots separated stall speed from maximum design dive speed. The safe operating envelope of these early craft was extremely sensitive to minor atmospheric perturbations.

A few years later, in the 1930's, the term "air pockets" emerged. This descriptive word conveniently fit the physical sensation without burdening the mental capacity of either aircrew or passengers with a detailed explanation of the turbulence phenomena. It should be mentioned that in this same era, night flight was becoming common and Captain Billy Mitchell had successfully demonstrated instrument flight from takeoff to landing. While aircraft performance had improved, man was again challenging the unknown and unseen. As pilots flew their frail machines into unannounced cumulus clouds, air pockets were conveniently blamed for a variety of accidents.

Today we take a much more sophisticated and learned approach. The terms "puffy air" and "air pockets" have been replaced with "wind shear," "chop," and "clear air turbulence (CAT)." These terms are much less frightening, but more precise, more descriptive, and of course more sophisticated.

Today I want to discuss measurement of turbulence, from a pilot's viewpoint. Measurement falls into two areas, frequency and severity, i.e., how often and how bad.

In thinking about this subject, I have made two assumptions: First, pilots will try to avoid turbulence when given a choice. Second, when a pilot encounters turbulence, there is nothing he can do about its severity; he can only attempt to minimize its effect on his airplane.

Let us begin by looking at the accepted turbulence criteria. I have taken some liberty by presenting velocities and acceleration levels from an Air Weather Service (AWS) study, along with the criteria from the Airman's Information Manual and the Department of Defense (DOD) Flight Information publication (Table 1). From this information we can see that we already have a nice, neat system to measure and classify turbulence, right?

TABLE 1  
TURBULENCE MEASUREMENT CRITERIA

Intensity	Aircraft Reaction	Reaction Inside Aircraft
5 to 20 ft/sec peak gust increments with accelerations of $\pm 0.2$ to $0.5$ "g"	<p><u>Light turbulence:</u> Momentarily causes slight, erratic changes in altitude and/or attitude.</p> <p><u>Light chop:</u> Causes slight, rapid and somewhat rhythmic bumpiness without appreciable changes in altitude or attitude.</p>	Occupants may feel a slight strain against seat belts or shoulder straps. Unsecured objects may be displaced slightly. Food service may be conducted and little or no difficulty is encountered in walking.
20 to 35 ft/sec peak gust increments with accelerations of $\pm 0.5$ to $1.0$ "g"	<p><u>Moderate turbulence.</u> Causes changes in altitude and/or attitude, but with the aircraft remaining in positive control at all times. Usually causes variations in indicated airspeed.</p> <p><u>Moderate chop.</u> Causes rapid bumps or jolts without appreciable changes in aircraft altitude or attitude.</p>	Occupants feel definite strains against seat belts or shoulder straps. Unsecured objects are dislodged. Food service and walking are difficult.
35 to 50 ft/sec peak gust increments with accelerations of $\pm 1$ to $2$ "g"	<u>Severe turbulence.</u> Causes large, abrupt changes in altitude and/or attitude. Usually causes large variations in indicated airspeed. Aircraft may be momentarily out of control.	Occupants are forced violently against seat belts or shoulder straps. Unsecured objects are tossed about. Food service and walking are impossible.
> 50 ft/sec peak gust increments with accelerations of $2$ "g"	<u>Extreme turbulence.</u> Aircraft is violently tossed about and is practically impossible to control. May cause structural damage.	

Frequency: Occasional (less than 1/3 of the time); intermittent (1/3 to 2/3 of the time); continuous (more than 2/3 of the time)

Wrong! It might be right if we followed Calvin Coolidge's suggestion about military airplanes: "Why don't we just buy one airplane and let everyone take turns flying it?" The fact is different airplanes behave differently in turbulence. Even the same airplane at different gross weights will react differently to the same gust load. Moreover, different pilots perceive the same turbulence differently.

Aircraft tolerance to turbulence is so basic to safe flying that it should be one of the first ten things a pilot learns. As a brief example, consider a gust reacting on the wing of a transport airplane. We will call it the airplane on which you last flew. The airplane is descending for landing after a long flight. Most of the fuel has burned off and the airplane weighs only about half of its designed maximum gross weight. Under this condition the wing has a low angle of attack and a low wing loading. The airplane then encounters a moderate to severe upward vertical gust, which suddenly increases the wing angle of attack several degrees and dramatically increases the lift being produced by the wing. Because of this large increase in lift on the light airplane, the passengers feel like they have been kicked by a Tennessee mule. The pilot reports severe turbulence like the book says.

Now imagine the same airplane has landed and been refueled with a full load of fuel. It has a full load of passengers and cargo, has just taken off, and is climbing out at maximum gross weight, but at the same airspeed as when descending. During climb-out, the wing has a very high angle of attack and high wing loading. It then encounters the same vertical gust. The angle of attack increase is the same, only this time the increased lift is reacting on twice as much airplane weight and the passengers feel only a moderate jolt, say an Arkansas mule kick--perhaps half of a "g" instead of a full "g" acceleration. This time the pilot reports light to moderate turbulence.

On which airplane would you rather be? Light turbulence is better than severe turbulence, right?

Wrong again! The second airplane is operating much closer to stall speed. It is seeing much greater structural loads, and because of its increased weight and inertia, the pilot's controls are less responsive.

As a rule we can say that airplanes with high wing loading are less sensitive to gusts. I have seen a look of total frustration on a forecaster's face when his severe turbulence forecast, reinforced by pilot reports (PIREPS) from general aviation pilots, is shrugged off by a fighter pilot. What is severe turbulence to a low wing loaded Cessna 182 may be only moderate chop to a high wing loaded F-16.

I have purposefully kept my comments simple and have stayed away from talking about low level wind shear, CAT, and wake turbulence, because I am sure they will be mentioned several times during this workshop.

I am also certain that most of you know much more about these topics than I.

I have given you a neat package for measuring turbulence, then I have taken some of that warm feeling away by showing that the system is not very meaningful. Now I would like to point out a few aerospace industry areas of promise for helping pilots solve the turbulence problem.

One of the major areas of promise is airplane design, within which there are two subareas. First is the area of basic design. Research indicates that turbulence tolerance is influenced by the phugoid oscillation frequency and magnitude in different airplanes, i.e., some airplanes are more turbulence tolerant than others, depending on the phugoid mode. For example, the longer C-141B is more tolerant than the shorter C-141A. Pilot-induced phugoid coupling is also known to influence the magnitude of turbulence-induced disturbances. When these factors are better known and better understood, future airplanes can be designed to minimize the problem. Phugoid oscillations are the long wave pitching motions along the longitudinal axis with only moderate changes in angle of attack. Less pronounced are the oscillations about the other axes. But these too may be improved by better design.

But you might say, "That is okay for future airplanes, but how about the airplane I am flying now? I can't wait for a new airplane." That notion leads to the second part of the design solution. How about fooling the airplane so that it thinks it has different characteristics? That is what the automatic lift distribution control systems on the C-5 and the L-1011-500 do. Through a series of accelerometers, they sense the lift generated by gust loads and, by way of a small computer program, deflect the ailerons to minimize the disturbances from straight and level flight. As the turbulence causes airplane reactions, the ailerons rapidly move to damp and counter the reactions like shock absorbers on your car. While the basic purpose of these systems is fuel conservation and structural life extension, a very beneficial by-product is a smoother ride in a more controllable airplane. Research is continuing to determine the payoffs of using the same techniques on the rudder and elevator systems.

Another area of potential help is related to the work being done to improve fuel consumption. By a computer analysis of airplane performance characteristics and of meteorological forecasts, best altitudes and routes are determined. A computer flight plan is then produced and distributed over a worldwide network to wherever there might be a pilot who needs one.

Since turbulence has a direct influence on fuel consumption, turbulence forecasting is an important data input. Jetplan, which is Lockheed's flight planning service, has been used successfully by the U.S. Navy for several years in their anti-submarine patrol mission. The Jetplan service was recently bought by the Air Force Military

Airlift Command for their strategic airlift forces, replacing their own computer flight plan service.

A third area which has only been scratched by the research community is the use of flight data recorders for gathering actual aircraft performance information. Digital flight data recorders are carried as mandatory equipment on all wide-body aircraft and on many narrow-body aircraft. Recording between 21 and 120 parameters each second, these recorders are measuring and recording for the world's airlines a variety of signals, including quantitative data on the effect of the turbulence. The data is easily recovered and is computer compatible, just waiting to be used by someone. In the past, Eastern Airlines has had several small contracts to reduce flight data for various users and is eager for new business. A well-documented example is the CAT data they collected for the National Aeronautics and Space Administration (NASA) several years ago.

There can be no doubt that atmospheric turbulence continues to be one of the most severe challenges to aviation. We have come a long way since Kittyhawk; but we still have a long way to go before we understand and overcome the impact of turbulence on aircraft. Hopefully, during this workshop you who are participating will make a substantial contribution.

## CLEAR AIR TURBULENCE: HISTORICAL COMMENTS

L. J. Ehernberger

NASA/Dryden Flight Research Center

### Introduction

Aviation history has been concerned with turbulence since the earliest days of powered flight (Hunsaker and Wilson, 1915). Mother Nature did not hesitate to provide the pioneering flight experimenters with gusts to provoke a fair share of stability and control problems as well as structural difficulties. Our early aviation pioneers gained an awareness of basic boundary layer concepts and optimistically anticipated that the predicaments imposed by rough air would be alleviated as soon as they could fly their aircraft above the earth's friction layer. Subsequent aircraft have flown at altitudes that have increased from above the friction layer to levels above convective air motions, above the cloud layers, and even above the jet stream. In spite of these higher and higher flight altitudes, some degree of turbulence has persisted at all flight levels. However, much of the hazard due to turbulence has been alleviated by advances in engineering and meteorological knowledge. The body of this paper cites the basic reference material for gust design criteria; discusses the status of clear air turbulence (CAT) meteorology (forecasting and detection); and indicates the directions future research and technology (R&T) might take. In addition, I am certain that the workshop sessions these next two days will accomplish a great amount in directing our future efforts to reduce turbulence hazards to aviation.

Before discussion of the historical aspects, it is important to bear in mind that the primary purpose of CAT technology is aviation safety. You are all aware that the achievement of aviation safety is a culmination of several processes. Information on weather conditions and statistics on the meteorological hazards to aviation are basic to the training of all personnel involved in the air transportation system. Such information is also fundamental to the design of airframes, power plants, and flight control systems. Once an airplane is in flight, weather conditions are perceived by the pilot and encountered by the aircraft, and the resulting level of safety depends on their combined capability to contend with the hazards present (Figure 1). The frequency of turbulence in aviation accidents/incidents is shown in Table 1 in relation to other weather factors.

### Gust Design Considerations

Both airplane stability and structural integrity are critical factors to successful flight through rough air. Satisfactory stability and control characteristics are necessary for safe flight in smooth air as well as in turbulence. As structural design practices were

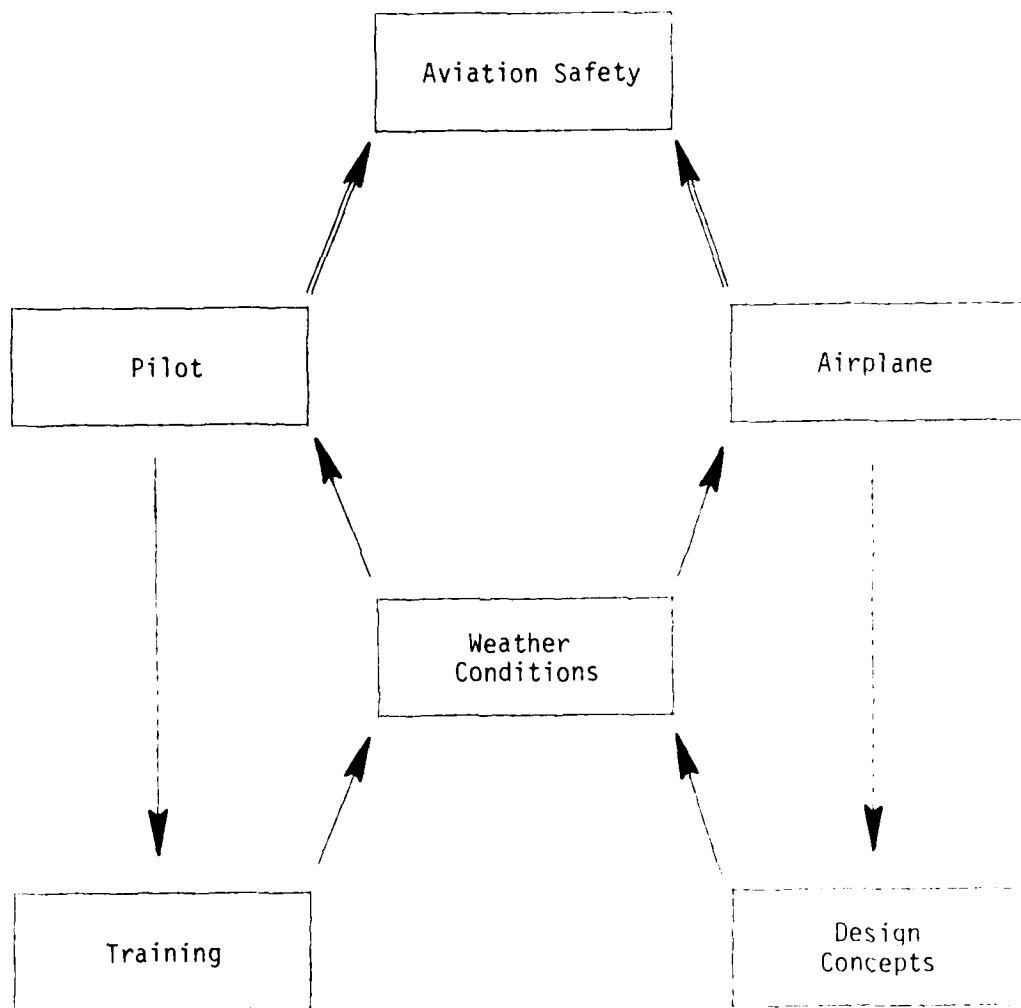

Figure 1. Weather condition input routes to aviation safety.

TABLE 1  
APPROXIMATE WEATHER FACTOR FREQUENCIES

Cause/Factor	General Aviation		Air Carrier
	Fatal (%)	Nonfatal (%)	All (%)
Any one or more	36.6	16.7	57.0
Low ceiling	23.6	1.5	5.0
Fog	14.6	---	4.0
Rain	9.5	0.8	4.4
Snow	4.4	---	1.7
Turbulence, cloud or thunderstorm	3.5	---	29.0
Thunderstorm activity	3.1	---	6.0
Ice, freezing precip.	2.7	---	0.8
Downdrafts/updrafts	2.2	1.3	1.1
Unfavorable winds	---	8.4	4.0
Carburetor ice conditions	---	1.2	---
Sudden wind shift	---	0.6	0.2
Sample size	5,535 (9 yrs)	47,093 (11 yrs)	306 (11 yrs)



refined, attention soon focused on the maximum gust load and the number of load cycles to be expected in order to assess structural strength and fatigue life requirements. Attention to these needs resulted in the discrete gust concept (Donley, 1949) and the derived equivalent gust velocity ( $U_{de}$ ) which relate the airplane normal acceleration load factor to the discrete gust velocity, airspeed, weight, wing area, and lift curve (Pratt and Walker, 1953). The National Advisory Committee on Aeronautics (NACA) Langley Laboratory initiated a sustained program to survey gust loads (i.e., the derived equivalent gust velocity values) as a function of flight altitude and geographical area using the VGH recorder (Richardson, 1951). This program has established a broad and repeatable data base which gives the statistical frequency of derived equivalent gust velocity as a function of  $U_{de}$  magnitude and altitude (Steiner, 1966, and Zalovcik, et al., 1977).

As airplane design progressed, flight dynamics became more complex, and simulation exercises began to use a wide range of gust wavelengths to depict the wide variation of gust characteristics found in the natural atmosphere. The analysis of structural dynamics also became more sophisticated and required the treatment of gust velocity as a continuous random variable. Specially instrumented aircraft were used to obtain measurements of true gust velocity. These data were analyzed in terms of both their root-mean-square gust velocity and their power-spectral-density (PSD) in the frequency domain. In addition, transfer function methods for airplane response were developed (Houbolt, et al., 1964), as described by Houbolt at the 1977 Workshop (Houbolt, 1977).

PSD design criteria were generated in terms of the portion of flight distance in smooth air, in nonstorm turbulence, and in storm turbulence for which the combinations of root-mean-square gust velocity and altitude agreed with the previous VGH data base (Press and Steiner, 1958, and Houbolt, et al., 1966). The PSD techniques represented an important advance in gust design procedures. However, during the 1970's several refinements were initiated. These included methods to represent the nonstationary and non-Gaussian turbulence occurrences, (Reeves, et al., 1976; Sidwell, 1978) and improved measurement methods to refine our knowledge of the turbulence scale length (Rhyne, et al., 1976; and Mark and Fischer, 1976). Most of our present true gust velocity data were sampled in straight and level flight and therefore do not indicate the full range of turbulence variation that can be encountered when stratified wind shear and atmospheric stability layers are penetrated on a sloping flight path. Data from sloping flight paths are needed for direct use in simulator studies as well as for analysis of their statistical properties.

Another current requirement is the need to refine our information on combinations of gust inputs acting simultaneously on separate vehicle response axes, as described by Houbolt at the 1979 Workshop (Houbolt, 1979). Data on the gust velocity gradients across the airframe are needed for this purpose. To address this need, the National Aeronautics and Space Administration (NASA) is planning a gust gradient measurement

to obtain data on both level and sloping flightpaths. This program will use the Measurement of Atmospheric Turbulence (MAT) program's B-57B airplane and instrumentation (Rhyne, et al., 1976, and Meissner, 1976) described by Rhyne at the 1979 Workshop.

#### Status of CAT Meteorology

As aircraft development progressed, reciprocating engine aircraft began to be equipped with superchargers and to fly at considerably higher altitudes. At this time meteorologists had relatively few observations of the atmospheric features and jet stream patterns at these flight altitudes. The turbulence these aircraft encountered away from clouds and terrain, i.e., CAT, presented its share of mystery. By the 1960 era, a meaningful understanding of the atmospheric conditions associated with CAT was acquired. At that time the U.S. Air Force Project Jet Stream was being completed; rawinsonde observations routinely extended into the lower stratosphere, and turbine engine transport aircraft activity was rapidly expanding. During this era CAT forecasting guidance relied primarily on wind speed, shear, and curvature considerations, with an allowance for greater severity above rough terrain.

The problem of swept-wing jet transport upsets due to CAT arose and stimulated several separate avenues of investigation. The earliest and perhaps most productive solution to the upset problem was the modification of flight control systems, pilot displays, and piloting procedures (Soderlind, 1964; Andrews, et al., 1965; and Bray and Larsen, 1965). The jet upset problem also stimulated efforts to avoid CAT encounters by improved forecasting techniques and remote detection devices.

Significant contributions to the study of CAT have been forthcoming from all segments of meteorology: studies by on-the-job forecasters; documentaries by airborne meteorological observers; research from the academic community; and field projects from the government sector (as indicated by the extensive list of references at the end of this paper). For example, descriptions of synoptic patterns and jet stream structures associated with CAT were provided by George (1960), Endlich (1964), and Reiter (1964). Kadlec (1966) and Sowa added their perceptive abilities to airborne observation and research. Analytical solutions to mountain wave motions were obtained by Wurtele (1970), Long (1958), and others. Harrison (1966) collaborated with Sowa in the preparation of extensive forecast guidance material for mountain wave CAT over the western United States. Colson (1963) compiled results from extensive CAT reporting efforts. Helvey (1967) demonstrated Richardson number reduction in mountain waves, and several investigators documented CAT production by Kelvin-Helmholtz instability in gravity waves. Our national emphasis on CAT meteorology peaked in the 1966-1970 time frame and is accounted for in several comprehensive references and conference proceedings (Proceedings of National Air Meeting on Clear Air Turbulence, 1966; Pao and Goldberg, 1969; Saxton, 1969; and Proceedings of the

RAeS/CASI/AIAA International Conference on Atmospheric Turbulence, 1971). Aspects of CAT meteorology are briefly summarized in Table 2.

TABLE 2  
ASPECTS OF CAT METEOROLOGY

<p><u>Forecasting</u></p> <p>Jet streams Synoptic patterns Mountain wave activity Baroclinic zones</p>
<p><u>Physical Aspects</u></p> <p>Vertical motion Decreased Richardson number Mountain wave tilt Kelvin-Helmholtz instability Fluid shear layer instability</p>

The pursuit of improved CAT forecasting methods has been both fascinating and frustrating. At one time the operational requirement and the technical intrigue associated with CAT were thought to merit lifelong dedication on the part of meteorologists. Significant advances in CAT forecasting state of the art were made; however, the budget squeezes of the 1970's made an impact, particularly on the operational practice of forecasting. Manpower limitations have simply precluded the application of state-of-the-art skills for operational CAT forecasting in most organizations. The wisdom of permitting this situation to persist should be examined by both aircraft operations and meteorological service organizations.

For several years we have anticipated the development of remote CAT detection devices which would alleviate the CAT forecasting requirements. Since the early 1960's we have witnessed the evolution of a wide variety of CAT detection concepts (Table 3). These concepts were stimulated by the achievements of weather radar, by visual observations from the flight deck, and by the relationships between CAT and in-flight temperature changes explored by Kadlec (1966). The validity of the CAT detection concept was demonstrated, but an ideal

level of perfection was not attained. Again, operational needs were not established, and efforts at CAT detection subsided for a period of years. However, in the late 1970's, Kuhn's work reawakened interest in CAT detection. His work dealt with the infrared water vapor bands and innovative signal processing algorithms. Other related in-flight experiments with lidar velocimeters and microwave temperature profile measurements will also be discussed later in this workshop by Ed Weaver and Bruce Gary, respectively.

TABLE 3  
CAT DETECTION METHODS

Weather radar
Visual clues: Clouds and contrails
Kadlec $\Delta T$ algorithms
Acoustic and electric field methods
Radiometry: Remote $\Delta T$
Lidar techniques
Dynamic radiometry
Temperature structure radiometry

Fundamental work in fluid dynamics has also improved the description of conditions that are critical to the development of turbulence in two-dimensional shearing flows, both with and without buoyancy effects. In addition, computational fluid dynamics has provided new tools for the description of small-scale meteorological flows, such as gravity waves, convective processes, local turbulence and shears associated with flow around buildings, and storm outflow gust fronts. These recent advances can potentially have significant impact on operational meteorology and forecasting. However, to take advantage of these tools it will be necessary to team the expertise of several separate disciplinary areas: fluid dynamics, computational methodology, instrumentation technology, mesoscale meteorology, forecasting, data processing, and aerodynamics. A team organization or project effort could effectively narrow the gap between theory and actual CAT forecast studies. Examples of CAT regions which could be addressed by such team effort include deep shear layers (in which forecast CAT is not often encountered), turbulence in anticyclonic flows, the hydraulic jump area in mountain waves, and the critical level behavior for vertically propagating wave energy. In summary, two types of efforts are required to maintain as well as to advance the state of the art for CAT meteorology. First, disciplinary studies focusing on

individual facets of CAT are needed continually to maintain the technical know-how for both research and operational applications. Second, in order to advance the technology, concerted interdisciplinary team projects are required periodically to gather and interpret data on CAT and the related meteorological processes.

#### Closing Remarks

Our present data base has established a solid foundation for gust design criteria, and CAT meteorology has also made considerable progress. However, significant potential exists for improving technology in both of these areas by the application of interdisciplinary team effort. Specific refinements in our gust design data base can be achieved by precise measurements of gust gradient characteristics and by obtaining a representative ensemble of true gust velocity time histories from sloping flight paths for direct use in simulation studies and training. In regard to CAT meteorology, previous observational limitations have dictated that forecast studies and detection experiments be based on empirical results rather than on fundamental knowledge and measurements. The resulting gap between practice and theory can be narrowed by the application of an interdisciplinary R&T project team incorporating state-of-the-art skills in instrument technology, computational methods, numerical modeling, and fluid dynamics, as well as skills in meteorology.

#### References

- Andrews, William H., Stanley P. Butchart, Thomas R. Sisk, and Donald L. Hughes, 1965: Flight Tests Related to Jet-Transport Upset and Turbulent-Air Penetration, Proceedings of the Conference on Aircraft Operating Problems, Langley Research Center, May 10-12, 1965, NASA SP-83, pp. 123-135.
- Ball, J. T., 1970: Cloud and Synoptic Parameters Associated with Clear Air Turbulence, NASA CR-111778.
- Bray, Richard S., and William E. Larsen, 1965: Simulator Investigations of the Problems of Flying a Swept-Wing Transport Aircraft in Heavy Turbulence, Proceedings of the Conference on Aircraft Operating Problems, Langley Research Center, May 10-12, 1965, pp. 137-148.
- Clark, James M., 1970: Laboratory Investigations of Atmospheric Shear Flows Using an Open Water Channel, Aerodynamics of Atmospheric Shear Flows, AGARD Conference Proceedings No. 48, Section 15.
- Colson, DeVer, 1963: Summary of High Level Turbulence over the United States, Monthly Weather Review, Vol. 91, No. 12, pp. 605-609.
- Donley, Philip, 1949: Summary of Information Relating to Gust Loads on Airplanes, NACA Report 997.

- Dutton, John A., 1971: Clear-Air Turbulence, Aviation, and Atmospheric Science, *Reviews of Geophysics and Space Physics*, Vol. 9, No. 3.
- Endlich, R. M., 1964: The Mesoscale Structure of Some Regions of Clear-Air Turbulence, *Journal of Applied Meteorology*, Vol. 3, pp. 261-276.
- George, J. J., 1960: *Weather Forecasting for Aeronautics*, Academic Press, New York, 673 pp.
- Harrison, Henry T., 1965: *The Mountain Wave*, NASA CR-135.
- Harrison, Henry T., and Daniel F. Sowa, 1966: Mountain Wave Exposure on Jet Routes of Northwest Airlines and United Air Lines, *United Air Lines Meteorology Circular No. 60*.
- Helvey, Roger A., 1967: Observations of Stratospheric Clear Air Turbulence and Mountain Waves over the Sierra Nevada Mountains, Final Report, Contract AF 19(628)-4146, Department of Meteorology, University of California, Los Angeles.
- Hoblit, Frederick M., Neil Paul, Jerry D. Shelton, and Frances E. Ashford, 1966: Development of a Power-Spectral Gust Design Procedure for Civil Aircraft, FAA-ADS-53.
- Houbolt, John C., Roy Steiner, and Kermitt G. Pratt, 1964: Dynamic Response of Airplanes to Atmospheric Turbulence Including Flight Data on Input and Response, NASA TR R-199.
- Houbolt, John C., 1977: Airplane Design for Gusts, *Proceedings: First Annual Workshop on Meteorological Inputs to Aviation Systems*, NASA CP 2028/FAA-RD-77-173, pp. 58-71.
- Houbolt, John C., 1979: Effect of Spanwise Gust Variations, *Proceedings: Third Annual Workshop on Meteorological and Environmental Inputs to Aviation Systems*, NASA CP-2104/FAA-RD-79-49, pp. 72-79.
- Hunsaker, J. C., and E. B. Wilson, 1915: Report on Behavior of Aeroplanes in Gusts, NACA Report No. 1.
- Kadlec, Paul W., 1966: Flight Observations of Atmospheric Turbulence, Eastern Air Lines, Inc., Final Report, Contract No. FA66WA-1449.
- Long, Robert R., 1958: Tractable Models of Steady-State Stratified Flow with Shear, *Quarterly Journal of the Royal Meteorological Society*, Vol. 84(360).
- Mark, William D., and Raymond W. Fischer, 1976: Investigation of the Effects of Nonhomogeneous (or Nonstationary) Behavior on the Spectra of Atmospheric Turbulence, NASA CR-2745.

- Meissner, Charles W., Jr., 1976: A Flight Instrumentation System for Acquisition of Atmospheric Turbulence Data, NASA TN D-8314.
- Panofsky, Hans A., John A. Dutton, Kurt H. Hemmerich, G. McCreary, and N. V. Loving, 1968: Case Studies of CAT in the Troposphere and Stratosphere, *Journal of Applied Meteorology*, Vol. 7, pp. 384-389.
- Pao, Y. H., and A. Goldberg, eds., 1969: Clear Air Turbulence and Its Detection, Seattle, Washington, August 14-16, 1968, Plenum Press, New York.
- Pratt, Kermit G., and Walter G. Walker, 1953: A Revised Gust-Load Formula and a Re-evaluation of V-G Data Taken on Civil Transport Airplanes from 1933 to 1953, NACA Report 1206.
- Press, Harry, and Roy Steiner, 1958: An Approach to the Problem of Estimating Severe and Repeated Gust Loads for Missile Operations, NASA TN 4332.
- Proceedings of National Air Meeting on Clear Air Turbulence, February 23-24, 1966: ION/SAE, Washington, DC.
- Proceedings of the RAeS/CASI/AIAA International Conference on Atmospheric Turbulence, May 18-21, 1971: Royal Aeronautical Society, London.
- Reeves, Paul M., Robert G. Joppa, and Victor M. Ganzer, 1976: A Non-Gaussian Model of Continuous Atmospheric Turbulence for Use in Aircraft Design, NASA CR-2639.
- Reiter, Elmar R., and Abele Nania, 1964: Jet-Stream Structure and Clear Air Turbulence, *Journal of Applied Meteorology*, Vol. 3, No. 3, pp. 247-260.
- Rhyné, Richard H., Harold N. Murrow, and Kenneth Sidwell, 1976: *Atmospheric Turbulence Power Spectral Measurements to Long Wavelengths for Several Meteorological Conditions*, Paper presented at the Aircraft Safety and Operating Problems Conference, NASA Langley Research Center, Hampton, Virginia, October 18-20, 1976, NASA SP-416.
- Richardson, Norman R., 1951: NACA VGH Recorder, NASA TN 2265.
- Saxton, J. A., ed., 1969: Proceedings of Colloquium on Spectra of Meteorological Variables, Stockholm, June 9-19, 1969, *Radio Science*, Vol. 4, No. 12.
- Sidwell, Kenneth, 1978: Analysis of Dynamic System Response to Product Random Processes, NASA TM-78667.

- Soderlind, Paul A., 1964: Jet Transport Operation in Turbulence, American Institute of Aeronautics and Astronautics, First Annual Meeting, June 29 - July 2, 1964, Washington, DC, Paper 64-353.
- Steiner, Roy, 1966: A Review of NASA High-Altitude Clear Air Turbulence Sampling Programs, Journal of Aircraft, Vol. 3, No. 1.
- Wurtele, Morton G., 1970: Meteorological Conditions Surrounding the Paradise Airline Crash of 1 March 1964, Journal of Applied Meteorology, Vol. 9, No. 5, pp. 787-795.
- Zalovcik, John A., Joseph W. Jewel, Jr., and Garland J. Morris, 1977: Comparison of VGH Data from Wide-Body and Narrow-Body Long-Haul Turbine-Powered Transports, NASA TN D-8481.



## WINDS AND WIND SHEAR IN-SITU SENSORS

R. Craig Goff

FAA Technical Center

### Definition of the Problem

The problem of future development of instrumentation for providing wind speed and direction information directly or indirectly to a pilot in the cockpit is somewhat dependent on identifying what and how much information is needed. There would be no wind speed and direction data from a single sensor located at the airfield midpoint. This information is currently available from all high-use airports.

But the pilot needs much more. The pilot needs horizontal wind information at touchdown, at liftoff, in approach and departure corridors, and even occasionally in flight outside the terminal area. The pilot may also need information about the vertical component of the wind,  $w$ , especially near the ground, and he needs frequent updates of the ever-changing wind.

Conceivably such information could be provided with state-of-the-art remote sensing devices located, say, on the ground about every 50 miles or on board every aircraft. Such systems collectively would be prohibitively expensive in terms of initial and upkeep costs. There would be high costs for processors and display devices, and data communication links would be required for ground-based systems. The cost-benefit ratio precludes such implementation. Remote sensors will soon be operational, but not as extensively as the above "needs" suggest. Before more sophisticated and expensive sensors are deployed, however, we must look closer at this wind phenomenon to be sure we do not overestimate or underestimate the problem.

For any given point in space, there are for a given coordinate system three wind components, all of which impinge upon aircraft which happen to be at that point:  $u$ , longitudinal,  $v$ , lateral, and  $w$ , vertical. The horizontal wind components,  $u$  and  $v$ , can be resolved into horizontal wind speed and direction through appropriate trigonometric relationships, or through coordinate rotation they can be thought of as longitudinal and lateral components relative to an aircraft. Except for the adverse effects of landing in a strong crosswind, the actual magnitudes of  $u$  and  $v$  are really unimportant in terms of a potential aviation hazard. After all, large aircraft have enough power to fly in the strongest of *maintained* winds (e.g., 200 knots) at jet stream heights.

The character of the vertical wind speed, however, may be very important to pilots, but it has been a very difficult parameter to measure. From a point measurement, large magnitude vertical motions (both + and -) are observed in most cases but are neither spatially extensive nor long-lived. When observed, the vertical wind fields have bubble-like shapes

or occur in elongated narrow bands. Those that have a larger horizontal extent such that an aircraft can respond fully to their effects are generally weak. A distinction is drawn here between those vertical wind fields to which an aircraft responds fully (up and downdrafts, w) and the very small-scale vertical motion changes that are characterized as turbulence. Outside updraft and downdraft pockets and turbulence zones, the vertical speed is typically near zero.

If one desires knowledge of the change of wind between two points in space, the measurement problem becomes much more complex. Now *nine* components or combinations of wind component changes over the three spatial directions x, y and z must be considered:

$$\begin{array}{ccc} \frac{\partial u}{\partial x} & \frac{\partial u}{\partial y} & \frac{\partial u}{\partial z} \\ \frac{\partial v}{\partial x} & \frac{\partial v}{\partial y} & \frac{\partial v}{\partial z} \\ \frac{\partial w}{\partial x} & \frac{\partial w}{\partial y} & \frac{\partial w}{\partial z} \end{array}$$

Assuming x is directed along the major axis of the aircraft, y is normal, and z is up, the significant or potentially unflyable *wind change* (or shear) are large organized changes in the u and v component over large horizontal spatial planes referred to as  $\partial u/\partial x$  and  $\partial v/\partial x$  in this paper. Turbulence consisting of high frequency changes in w referred to as  $(\partial w/\partial x)$  is rarely unflyable except in thunderstorms, but it causes passenger discomfort and may, in extreme cases, cause structural damage, especially to light aircraft.

Because conventional (non-VTOL) aircraft travel at least 10 times farther in the horizontal than in the vertical on any sloped flight path, vertical shear ( $\partial u/\partial z$ ,  $\partial v/\partial z$ ) does not produce unflyable conditions. Vertical changes in u and v are never so great that they cannot be easily handled by a pilot who is prepared for the transition. Even if the vertical shear is 10 knots per 100 feet, which is an extreme value, the pilot making a 100-foot descent in approximately 10 seconds should have no problem handling a 10-knot change over this time period (one knot per second relative to the aircraft). What pilots have identified as a vertical wind shear problem is very likely a horizontal wind shear or possibly a strong change in the vertical wind component along the flight path.

The remainder of the nine components are not considered real meteorological hazards, assuming an important caveat for two of these terms. The terms  $\partial w/\partial y$  and  $\partial u/\partial y$  are large in wake vortices and in severe thunderstorms produce "roll and yaw" effects due to the wind variation across the span of the aircraft. If we assume pilots will utilize proper separation standards and will not penetrate severe thunderstorms, such shears are deemed unimportant. The terms  $\partial w/\partial z$  and  $\partial v/\partial y$ , regardless of scale, do not represent shears hazardous to aircraft.

To summarize this lengthy section on wind problems, a subjective ranking of the potential wind hazards to aviation is given in Table 1. In this ranking, horizontal wind shear and up/downdrafts are considered the most significant hazards. However, up/downdrafts may be ranked too high as we shall attempt to show in the following section. Turbulence is ranked as moderately important and the other components are ranked low. Please note, however, the qualification associated with the V-component (crosswind) of the wind.

The next question is one of scale. It relates to the terms discussed above. Wind shear occurs everywhere and at all times in the atmosphere. Sometimes, the change in wind is more or less uniformly over a long distance thus having a long spatial scale. Sometimes the changes are over a short distance producing short spatial scales. Most often, these scales are mixed; that is, small eddies are imbedded in large eddies. Wind oscillations, even large amplitude waves, occurring over a long distance produce no serious consequences for pilots. This is because the change occurs so slowly relative to the aircraft that the effect can be controlled. Conversely, wind changes occurring over a very small distance are so spatially minute relative to a moving aircraft that the large mass body cannot respond. Somewhere in between, aircraft respond fully and quickly to wind fluctuations. This critical scale range is between 500 m to 2 km. A B-727 aircraft takes seven to 28 seconds to traverse these distances on a typical approach. The hazard curve (Figure 1) probably reaches a maximum for waves having a period of 20 seconds relative to the aircraft. The aircraft phugoid period (also important) is roughly twice this value. The sensor problem is now apparent in that we need to have observations every quarter to half mile to resolve the potentially hazardous wind changes, and for ground-based in-situ sensors, this is not cost-effective.

Relying on scale definitions proposed by Orlanski (1975), we can also rank aircraft hazards according to scale as in Table 2. This ranking is also subjective.

#### The Character of Vertical Motion Near the Ground

In several recent commercial air carrier accidents and incidents attributed to hazardous winds, downdrafts have been named as a contributing factor. In all these cases, the aircraft have been close to the ground when the meteorological hazard was encountered. In most of the cases, accident investigators have had to work with meager data from flight data recorders.

One method employed to deduce the vertical wind field at the time the subject aircraft encountered difficulty is to analyze data from the on-board vertical accelerometer. This sensor measures, in g's, the aircraft sink or ascent rate. In the technique, the aircraft vertical acceleration is integrated with respect to time, making adjustments for

TABLE 1

RELATIVE IMPORTANCE OF WIND AND SHEAR COMPONENTS TO AVIATION

Importance	Component	Description	Remarks
High	1. $\frac{\partial u}{\partial x}, \frac{\partial v}{\partial x}$	Horizontal wind shear (or turbulence)	May be unflyable.
	2. $\pm w$	Up/down drafts	May be ranked too high.
Medium	3. $\frac{\partial w}{\partial x}$	Turbulence	Rarely unflyable, passenger discomfort, structural effects.
Low	4. $\frac{\partial u}{\partial z}, \frac{\partial v}{\partial z}$	Vertical wind shear	Assumed flyable.
	5. $u, v^{(1)}$	Horizontal wind	Flyable, except large $v$ hinders landing ability.
Insignificant	6. $\frac{\partial w}{\partial y}, \frac{\partial u}{\partial y}$	"Roll and yaw" shear	Assumes avoidance of severe thunderstorms and wake vortices.
	7. $\frac{\partial w}{\partial z}, \frac{\partial v}{\partial y}$	---	---

Coordinates w.r.t. aircraft:

x: Longitudinal  
y: Lateral  
z: Vertical

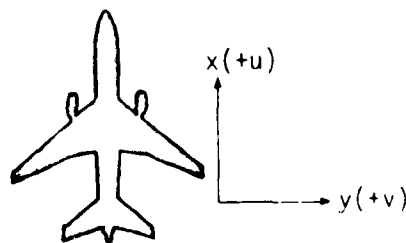

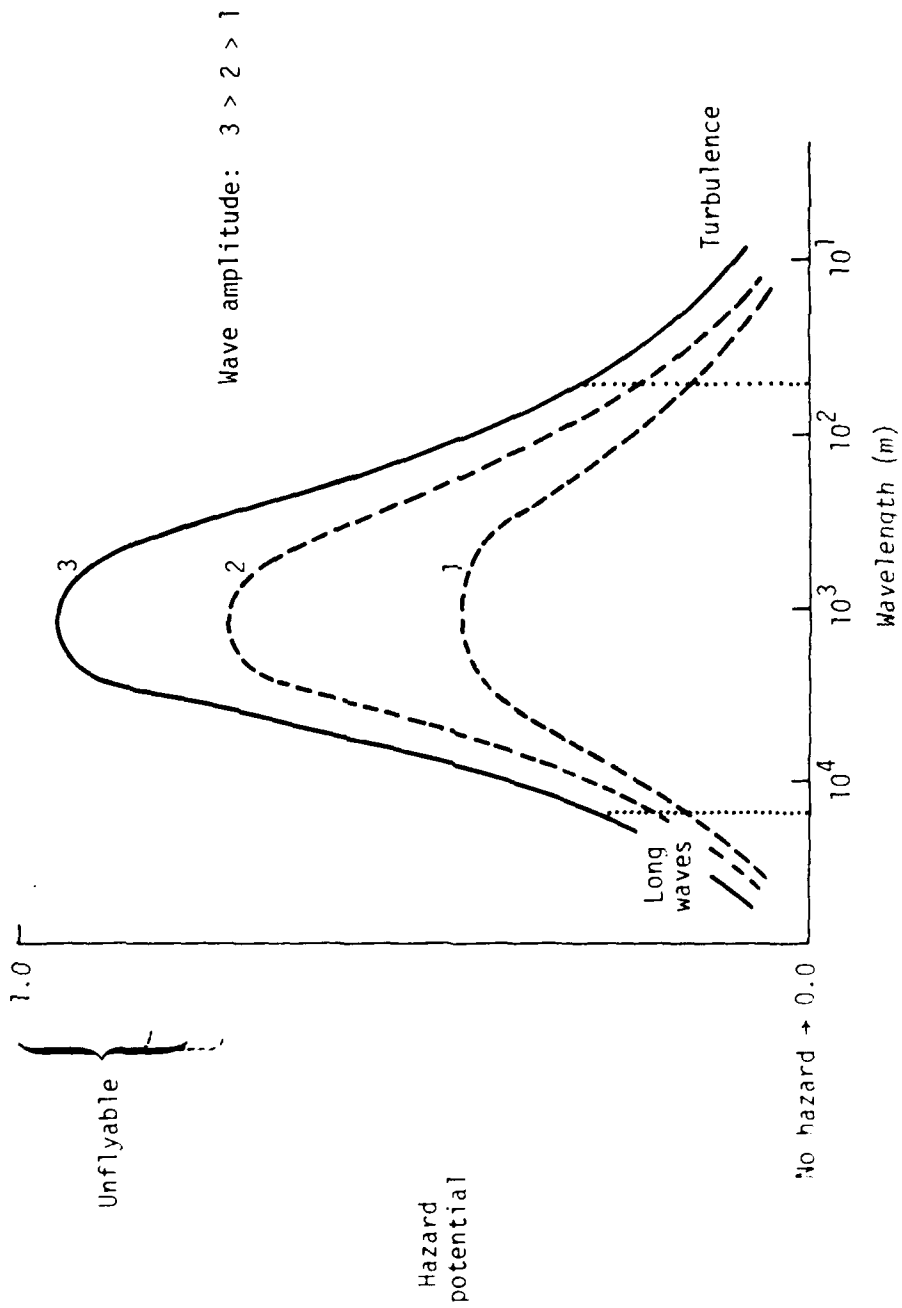

Figure 1. Hazard potential relative to wind perturbation scale length (wavelength). Subjective.

TABLE 2  
 ATMOSPHERIC SCALES (ORLANSKI, 1975)  
 AND THEIR RELATIVE HAZARD TO AVIATION

Rank	Scale Name	Scale Length	Wind Hazard
1	$\alpha$ micro	200-2000 m	Horizontal wind shear, up/downdrafts, turbulence
2	$\gamma$ meso	2-20 km	---
3	$\beta$ meso $\alpha$ meso	20-2000 km	Vertical wind shear
4	$\beta$ micro	20-200 m	"Roll and yaw" shear
5	macro $\gamma$ micro	>2000 km <20 m	None

the expected sink (climb) rate and the initial vertical motion field. The result is an estimate of the ambient vertical motion field through which the aircraft is flying. However, this technique is subject to *large* error for two reasons. First, consider Table 3, which shows in a very general way typical aircraft responses to meteorological inputs. Only four of the eight possible scenarios are shown. As meteorologists know, the horizontal wind and vertical wind are often coupled; i.e., changes in one coincide with changes in the other. Therefore, scenario 3 can be a frequently observed meteorological hazard. Note that both scenarios 1 and 2 result in a loss of altitude. It is imperative, if scenario 3 occurs, to determine the contribution of the horizontal shear to altitude loss in order to accurately deduce the vertical motion field that causes the resultant altitude loss. This is not done with precision in accident investigations that attempt to piece together the meteorological events from flight data recorder information. It is believed that horizontal shears are grossly underestimated using the methods employed.

Second, calculations of the vertical motion are based on integrations corrected by an integrated pressure altimeter factor. Considering the small-scale pressure variations characteristic of thunderstorms, this technique is highly questionable. Atmospheric pressures typically increase in thunderstorms, causing the pressure altimeter to read low. Integrations enhance the error.

Using these methods, an investigation following an incident at Atlanta in 1979 resulted in downdraft estimates of 68 feet per second ( $21 \text{ ms}^{-1}$ ) at 700 feet above ground. This is an exceedingly high value compared to what is typically observed in thunderstorms at this height. In fact, based on information now available on the vertical wind field in

TABLE 3

## AIRCRAFT RESPONSES TO METEOROLOGICAL INPUTS

Meteorological Inputs	Aircraft Responses	
	Altitude	Airspeed
1. Horizontal shear only (headwind loss)	Loss	Loss
2. Downdraft only (headwind steady)	Loss	Negligible effects
3. Horizontal shear (loss of headwind) with downdraft	Loss	Loss
4. Horizontal shear (gain of headwind) with downdraft	Compensating effects	Gain

thunderstorms, and considering the questionable investigation techniques used, it may be that downdraft estimates here are overstated by up to 300 percent and that the horizontal shear factor is significantly understated.

There is another technique sometimes used to estimate downdrafts which is fraught with error. This is the method of integrating a simplified continuity equation using data from a single sensor (anemometer or single Doppler). Figure 2 shows results of this method of estimating the vertical wind component compared with actual observations. Obviously, calculated values of downdrafts are poor compared with observations, whereas updraft calculations are quite favorable. Poor downdraft estimates occur because two-dimensional divergence cannot be assumed close to the ground. On the other hand, two-dimensionality can be assumed for convergent fields, even close to the ground, because the resulting updraft field is moving away from the solid boundary. Additionally this analysis relies on the Taylor's hypothesis being valid in severe storms which has not been proven.

The behavior of the vertical motion field close to the ground in thunderstorms is not completely understood. However, a study will be published soon which will shed light on the probability distribution of the vertical wind component, magnitude in the lower atmosphere. Some results of this study are presented here. The data, collected over a 14-month period, came from a 444 meter tower in Oklahoma. Thirty thunderstorms and fifteen strong cold fronts are included in the study. For brevity, the analysis method is not explained.

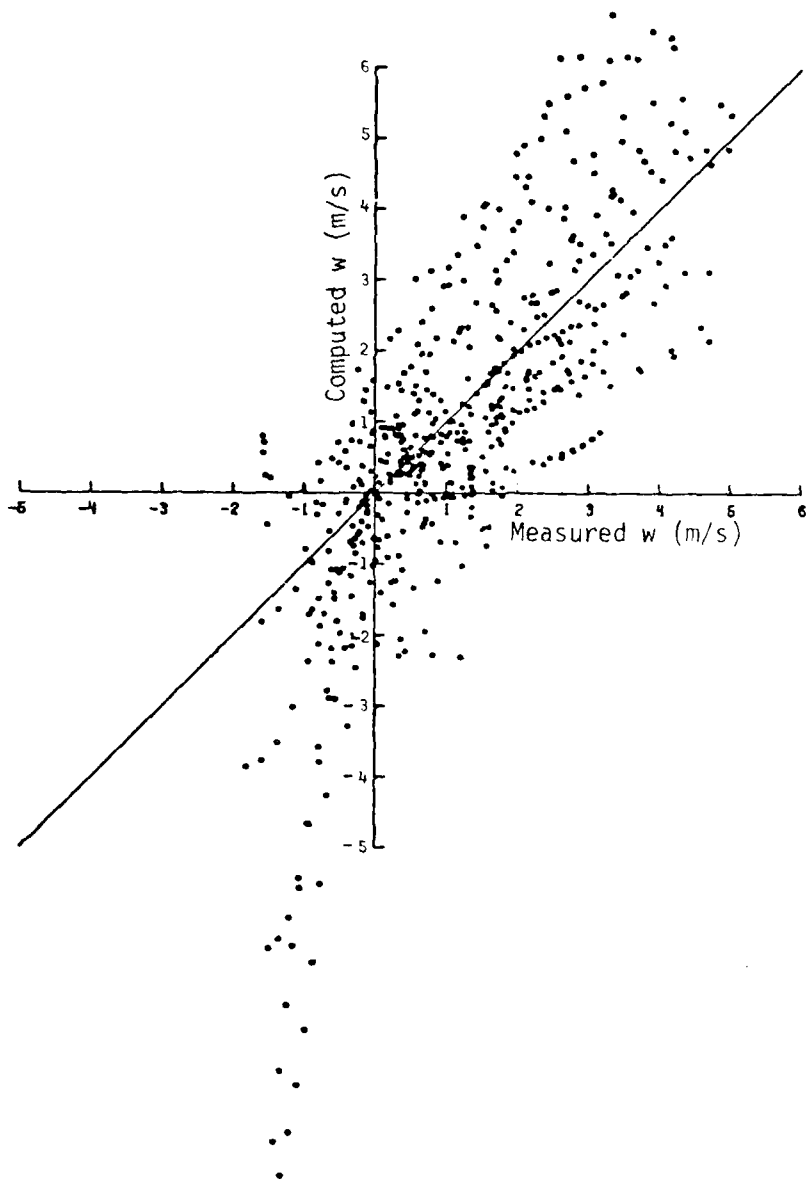

Figure 2. Vertical speeds determined by integrating the continuity equation ( $\partial u/\partial x + \partial w/\partial z = 0$ ) with respect to  $z$  compared with measured values (i.e.,  $w = \int^z \partial u/\partial x dz$ ). Oklahoma tower, all levels.



In Tables 4 through 6 frequency distributions of various class intervals of downdrafts are presented. Three levels are shown: the bottom level (26 m or 86 ft), the middle level (177 m or 581 ft), and the top level (444 m or 1,450 ft). There are nearly four million discrete observations. A time-to-space transformation was made. Only the largest downdraft class intervals are shown in the tables.

TABLE 4

DOWNDRAFT FREQUENCY DISTRIBUTION--26 METERS (86 FEET)--OKLAHOMA CITY  
(3,963,462 OBSERVATIONS)

Downdraft Magnitude ( $\text{ms}^{-1}$ )	Width (m)					
	< 100	100-200	200-300	300-400	400-600	600-800
10.0						
9.1 to 10.0						
8.1 to 9.0						
7.1 to 8.0						
6.1 to 7.0						
5.1 to 6.0	0					
4.1 to 5.0	1	0				
3.1 to 4.0	12	1	0			
2.1 to 3.0	176	51	5	0	0	
1.1 to 2.0	5241	1797	237	50	11	0

The data show clearly that large magnitude and spatially extensive downdrafts are virtually nonexistent. Only the very weak downdrafts have great width, and only the very narrow downdraft fields are strong regardless of level. The frequency of observations decreases markedly from the 177 meter level to the 26 meter level. The Atlanta aircraft incident analysis departs radically from these results. If the Atlanta analysis results were included in the 177 meter Oklahoma distribution, there would be non-zero values in the class intervals marked with an "X" in Table 5. One should note that Oklahoma thunderstorms are some of the most severe on earth, and all indications (other than the aircraft data investigation) are that the Atlanta storm was nothing more than average intensity for that area. Obviously, there is great inconsistency here.

TABLE 5

DOWNDRAFT FREQUENCY DISTRIBUTION--177 METERS (581 FEET)--OKLAHOMA CITY  
(3,781,594 OBSERVATIONS)

Downdraft Magnitude ( $\text{ms}^{-1}$ )	Width (m)							
	< 100	100- 200	200- 300	300- 400	400- 600	600- 800	800- 1000	1000- 1200
10.0	X	X	X	X	X	X		
9.1 to 10.0	1	X	X	X	X	X		
8.1 to 9.0	1	X	X	X	X	X	X	
7.1 to 8.0	10	X	X	X	X	X	X	X
6.1 to 7.0	15	1	X	X	X	X	X	X
5.1 to 6.0	26	2	X	X	X	X	X	X
4.1 to 5.0	51	9	2	X	X	X	X	X
3.1 to 4.0	143	24	6	3	X	X	X	X
2.1 to 3.0	1852	435	82	18	8	X	X	X
1.1 to 2.0	28948	10617	3012	1121	489	95	37	18

X = Class intervals that would be non-zero if the Atlanta case, as analyzed in the incident report was to fit into this distribution.

To complete our discussion of the lower atmosphere's wind characteristics in potentially hazardous flying weather, we present some results from another study which is to be published shortly. Using the same Oklahoma tower data set, a spectrum analysis was performed for all thunderstorm and post-cold front cases that were deemed potentially hazardous to flight. Thirty-four cases were included in the study. Spectra were computed for assumed aircraft longitudinal, lateral, and vertical components of the wind using data from the 444 meter level of the tower. One of these cases, assumed to be representative of thunderstorm flow, was selected for presentation here. The u, v and w spectra for this case are shown in Figures 3 through 5.

The data show that  $\gamma$  meso waves dominate all spectra. Most importantly, though, spectra for both horizontal wind components exhibit several times more kinetic energy than the w spectrum at scales critical to aircraft (10-second to 2-minute periods with respect to aircraft). In fact, in 100% of the thirty-four cases analyzed did the vertical component exceed either of the horizontal components at these critical periods. Again, there is great inconsistency between these

AD-A094 196

TENNESSEE UNIV SPACE INST TULLAHOMA  
PROCEEDINGS: ANNUAL WORKSHOP ON METEOROLOGICAL AND ENVIRONMENTAL--ETC(U)  
MAR 80 W FROST, D W CAMP

F/O 1/2

NAS8-32692

UNCLASSIFIED

NASA-CP-2139

NL

2 of 3

NOV 1994-96

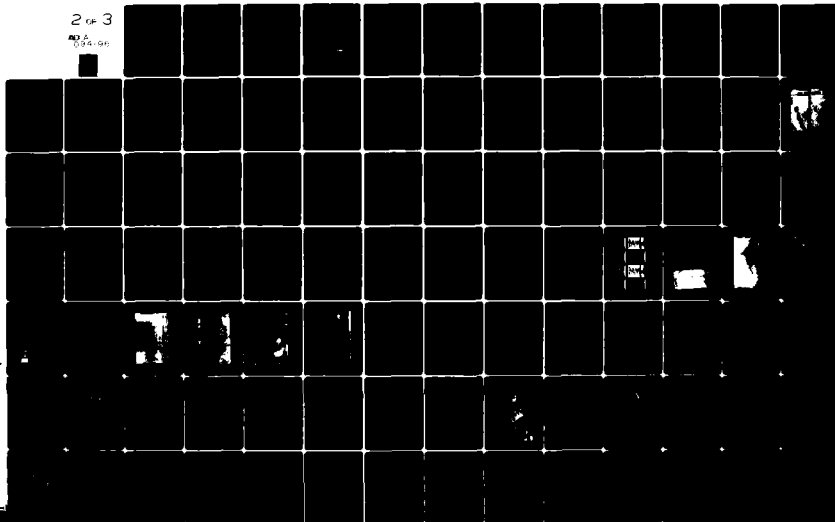

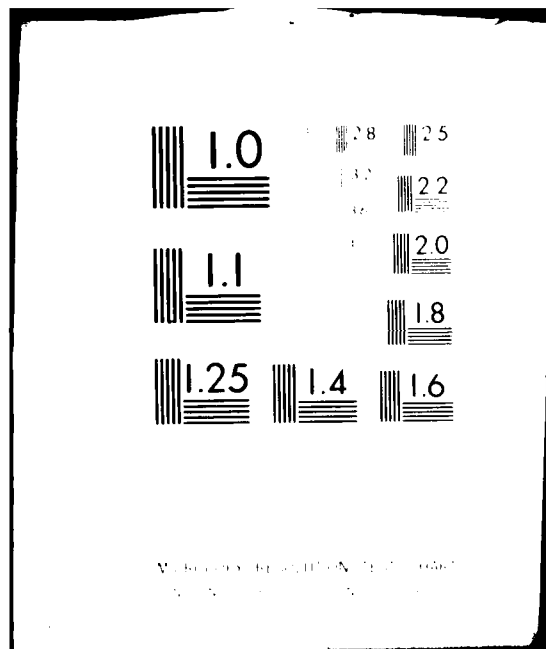

Resolution Test Chart  
1.0 1.1 1.25 1.4 1.6 1.8 2.0 2.2 2.5 2.8 3.2 3.6

TABLE 6

DOWNDRAFT FREQUENCY DISTRIBUTION--444 METERS (1456 FEET)--OKLAHOMA CITY  
(3,961,960 OBSERVATIONS)

Downdraft Magnitude (ms <sup>-1</sup> )	Width (m)							
	< 100	100-200	200-300	300-400	400-600	600-800	800-1000	1000-1200
10.0	2	9						
9.1 to 10.0	4	1	0					
8.1 to 9.0	8	2	0					
7.1 to 8.0	20	2	1	0				
6.1 to 7.0	27	4	1	0				
5.1 to 6.0	49	12	4	0	0			
4.1 to 5.0	97	25	12	5	2	0	0	
3.1 to 4.0	259	51	19	12	5	3	1	0
2.1 to 3.0	1593	459	133	56	33	10	4	0
1.1 to 2.0	17763	7405	2777	1261	672	208	76	30

results and those of several recent accident investigations. The conclusions drawn from the studies using Oklahoma data are that downdrafts are much less prevalent close to the ground than many believe. Horizontal wind shear appears to be the prime culprit in many accidents and incidents where pilots have encountered "adverse winds." Further confirmation of this result is important because it will be much easier to provide closely spaced horizontal wind observations (from which horizontal shears can be accurately calculated) than it will be to provide closely spaced measurements of the vertical motion field.

#### In-Situ Sensors

In-situ sensors used to measure or infer the horizontal wind and wind shear are divided into two categories: ground-based sensors and airborne sensors. Most of the ground-based sensors are well known and have been used extensively. However, a special application of one sensor type has recently been operationally implemented, and another ground-based sensor type is undergoing field testing for possible operational usage. Other than these two developments, there is no new technology in this area.



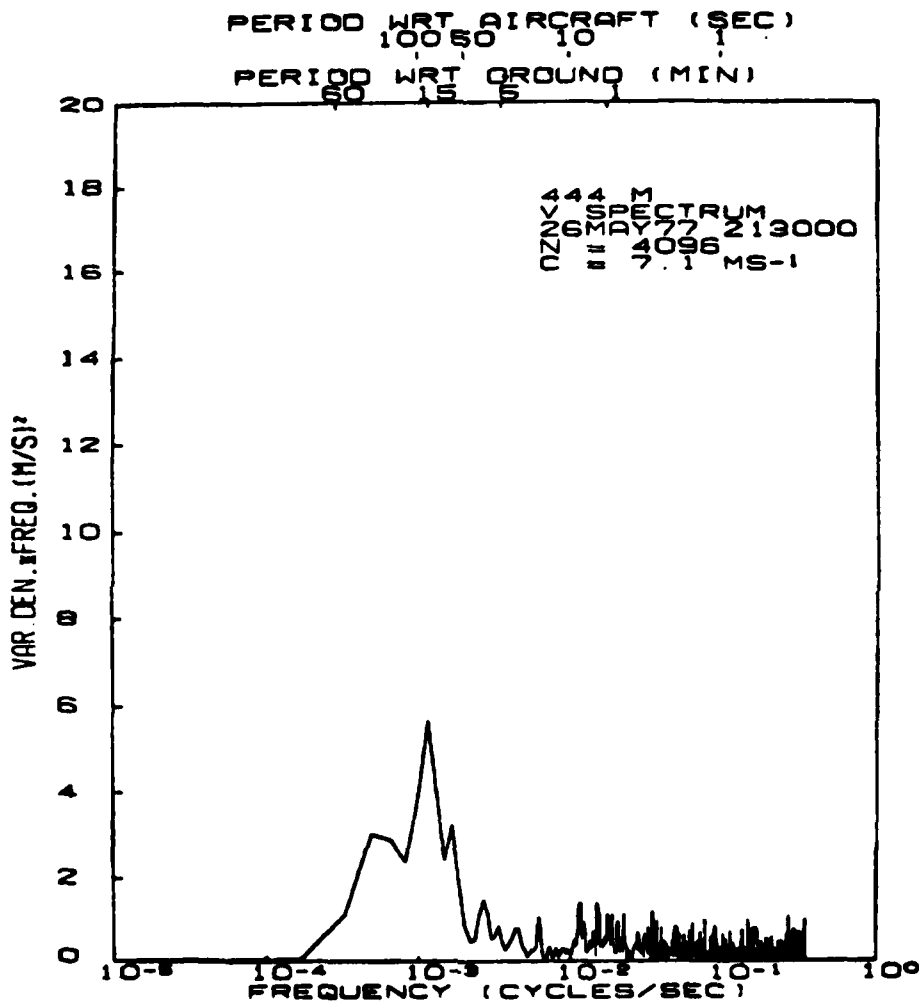

Figure 4.  $v$  spectrum (lateral component, where  $n$  = the number of observations in the time series, and  $c$  = the mean tower wind speed).





Ground-based sensing methods. Five ground-based sensing methods will be discussed below:

1. Radiosonde/Pibal/Rocket
2. Anemometer (on mast or tethered balloon)
3. Pressure Jump Sensor
4. Wind Sock
5. Kite

Ground-based sensing methods are generally the least expensive, compared with in-situ airborne or remote methods. However, there are definite limitations.

*Radiosonde.* The radiosonde or rawinsonde network employing balloon-borne sensor packages released twice daily by the National Weather Service (NWS) is quite adequate for determining macroscale winds but is not amenable to sensing winds at scales important to pilots. Rawinsonde and pibal programs are very labor-intensive, and there is considerable data reduction. This method, however, is currently the only method of routinely obtaining upper atmospheric winds. Rocket-borne sensor packages are not employed operationally. They are obviously not amenable for use at busy airports. These sensors are considered ground-based because of the location of the tracking equipment.

*Anemometer.* The anemometer has been used to measure the wind for many decades. There are many types, some quite complex and expensive. Low-cost anemometers are the cup and vane type or the propeller and vane type. All high-use airports have at least one anemometer, and recently the Federal Aviation Administration (FAA) has embarked on a program to equip certain airports with several anemometers in a network to measure low-level horizontal wind shear (Low-Level Wind Shear Alert System, LLWSAS). Whereas a single anemometer is relatively inexpensive, anemometer networks used to measure shear can be expensive, since elaborate signal conditioning, processing, and displaying wind equipment is necessary. Anemometer networks can be set up to measure shear at whatever scale is desired, but each sensor must be capable of measuring representative winds. Therefore, sensor siting is important, and in some cases good sensor sites are difficult to find.

*Pressure jump sensor.* The pressure jump system is a network of sensitive pressure change transducers which trigger alarms if a large pressure *increase* is observed over a short period of time. The pressure increase, or jump, is indicative of sudden changes in the total mass in a column of air over the sensor, and this mass increase is a function of a drop in the average temperature. Wind changes (shears) usually accompany these temperature or mass changes. Since the low temperature air is close to the ground, the heavier or more dense air is in the lower part of the column and thus the most influence on pressure jumps

observed at ground level. The network has been used successfully to detect shears associated with thunderstorm gust fronts and with strong cold fronts. It is presently being tested by the FAA at Atlanta. The network is low-cost and not site-sensitive, but the false alarm and missed alarm rate are not known, nor is the actual magnitude of the shear measured. Therefore, the system remains a research and development system until these factors can be resolved.

*Wind sock.* The wind sock, of course, does not output a quantitative value of the wind; however, the device is so low-cost and virtually maintenance free that it is attractive for certain applications. The device may be underutilized, as it appears to have potential (especially at general aviation airports) as a wind shear indicator. Consider the placement of wind socks suggested in Figure 6. Socks are positioned at quarter-mile intervals on either side of the centerline axis. The cross-centerline spacing increases with distance from the runway, as the pilot's lateral view is more restricted as his altitude increases. Each wind sock mast would be equipped with a set of lights so the sock would be visible at night, and the socks would need to be higher than any nearby obstructions. In the schematic diagram, a tailwind-to-headwind shear is depicted.

*Kite.* The kite sensor method, while low-cost and portable, is impractical for operational use at airports. The kite does not fly in light winds and requires a manual re-release when winds return to strength. The kite will serve as an antenna for lightning and is easily damaged in strong winds. It appears to have some application as a research tool, however.

Airborne sensing methods. Airborne in-situ sensors have some promise in alleviating the pilot's problem of coping with adverse winds in flight. The advantage of on-board sensors to detect hazardous winds is the ability to quickly transfer information from sensor to cockpit display without the need of routing data through ground facilities. In other words, the pilot has direct information.

However, there are serious disadvantages. One is that no on-board in-situ sensor is fully capable of detecting the wind hazard *before* the aircraft encounters it (although the acceleration margin technique (see appendix) is quasi-predictive). There is also the cost factor; on-board sensor systems are expensive, and sensor costs rule out wide acceptance of airborne sensor systems for privately piloted aircraft. Even for commercial aircraft, owners will be required to spend perhaps millions of dollars to equip their fleet if they opt for on-board wind shear sensors. Finally, some ground speed measuring equipment requires ground-based transmitters (localizer, DME) which may not be available when needed.

Airborne in-situ sensors and sensor systems are given in the outline below:

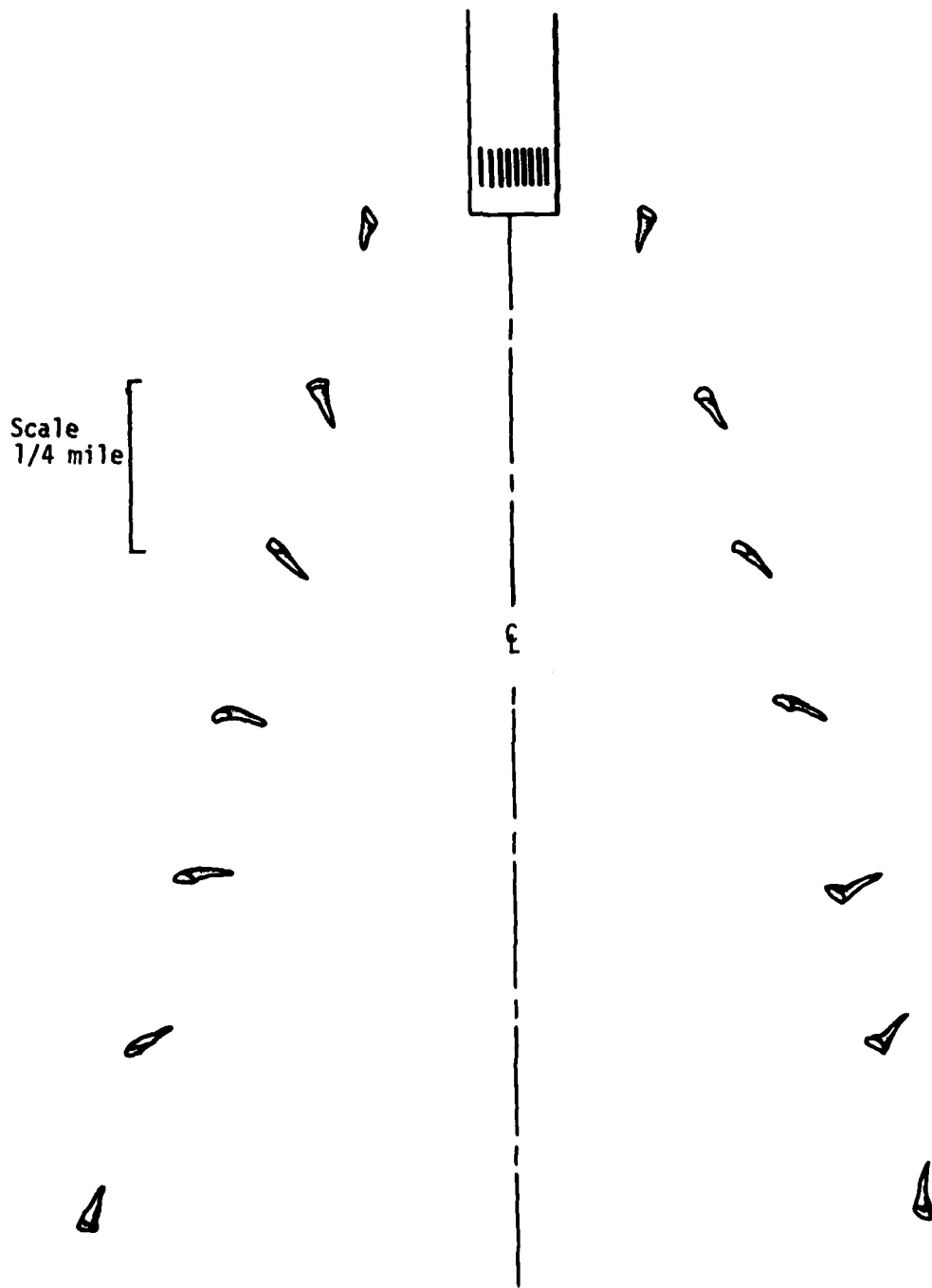

Figure 6. Placement of wind socks for wind shear indication.

1. Modified Flight Director (MFD)
2. Airspeed/Ground Speed Procedure ( $\Delta V$ )
  - a. ILS Localizer Monitoring
  - b. Range Rate Technique
  - c. Correlation Velocity Technique
  - d. Inertial Navigation System
  - e. Longitudinal Acceleration Method
3. Acceleration Margin ( $\Delta A$ )

Methods 1, 2 and 3 are described in the appendix to this report provided by Leo Garodz. The ILS localizer and range rate methods require ground-based equipment. The correlation velocity method is attractive because it requires no ground-based equipment. This method utilizes a pulsed radar altimeter to determine ground speed. The inertial navigation system is expensive but accurate. These four systems output the ground speed, which the pilot must compare with the true airspeed (not indicated airspeed) to determine flight degradation. The longitudinal acceleration method automates the computation of ground speed and true airspeed changes, displaying on a cockpit indicator an index of the wind hazard. This methodology is also incorporated in the so-called Head-Up Display (HUD) being evaluated by the FAA.

Discrete Address Beacon System (DABS). There is one other means of providing wind hazard information to pilots that is presently in a development stage. This technique, the DABS derived wind method, is a combined airborne and ground-based sensor package. True airspeed and heading information are to be obtained from every aircraft equipped with a TAS computer. The data are sent to the DABS tracking system via the DABS data link. Within a processor interfaced to the DABS system, true airspeed, heading, ground speed, and track are combined to produce a wind vector. By accumulating wind vector information from a number of aircraft and objectively analyzing the data, one may conceivably obtain a horizontal wind field and frequent updates over the whole airspace. This information can then be uplinked to the cockpit via the DABS data link.

The success of this method depends on a number of unresolved factors: extensive deployment of DABS, a large number of appropriately equipped aircraft, data accuracy, and adequate objective analysis schemes. Even if successful, the method has one serious drawback: at least one aircraft must penetrate a potentially hazardous wind field in order for the numerical method to position the hazard. However, this objection may be overcome by combining other sensor outputs (e.g., microwave Doppler) with the DABS outputs. In fact, this approach also overcomes a major weakness in a low power microwave Doppler system, its inability to sense wind fields in clear air.

Summary

To summarize the in-situ sensors that have been discussed, it is appropriate to weight each sensor or sensor method according to critical operational factors: the atmospheric scale the sensor system is capable of resolving (Table 2), equipment cost to provide data to one pilot at one airport (Table 7), sensor accuracy (Table 8), maintenance and operating requirements (Table 9), the density of observations the sensor is capable of providing (Table 10), certain operational constraints (Table 11), and system prediction capability (Table 12). It is assumed that a single sensor is not capable of resolving atmospheric waves (especially in near-real time). Single, immobile sensors are, therefore, assigned an atmospheric scale weight factor of five. Additional explanations are provided in the tables where necessary.

TABLE 7  
EQUIPMENT COST (INITIAL) PER SYSTEM\*

Rank	Cost (Dollars)
1	< 5 K
2	5 to 10 K
3	10 to 50 K
4	50 to 100 K
5	> 100 K

\*Includes sensor and auxiliary equipment.

TABLE 8  
SENSOR ACCURACY

Rank	Accuracy
1	1 ms <sup>-</sup> /1°
2	2 ms <sup>-</sup> /2°
3	3 ms <sup>-</sup> /5°
4	4 ms <sup>-</sup> /10°
5	Estimates only

TABLE 9  
 MAINTENANCE AND OPERATING REQUIREMENTS

Rank	Requirement
1	Very low < 0.1 manyears
2	Low 0.1 to 0.5 manyears
3	Moderate 0.5 to 1.5 manyears
4	High 1.5 to 3.0 manyears
5	Extremely high > 3.0 manyears

TABLE 10  
 DENSITY OF OBSERVATIONS

Rank	Density of Observations
1	Virtually "infinite" within sensor range (three-dimensional).
2	Limited, yet three-dimensional.
3	Virtually "infinite" in a plane (usually horizontal).
4	Limited within a plane or "infinite" along a line.
5	One observation only.

Note: "Infinite" implies a large number.

TABLE 11  
OPERATIONAL CONSTRAINTS FOR SENSOR DEVELOPMENT

Rank	Constraint
1	None
2	Weak
3	Moderate
4	Strong
5	Prohibitive

TABLE 12  
SYSTEM PREDICTION CAPABILITY

Rank	Prediction Capability
1	Excellent
2	Good
3	Fair
4	Poor
5	None

Note: "Excellent" capability assumes hazardous event can be initially detected as soon as or soon after it occurs and pilots can, thereby, be forewarned. System predictability, therefore, may relate to the scale criterion; i.e., the event must be resolvable. False alarm and missed rates downgrade the system.

The results of combining all these criteria are shown in Table 13. One remote sensor (microwave Doppler) is shown for comparison. The average of all criteria is provided in the right-hand column of Table 13. Although the weights are *subjective* and the values for each sensor debatable, the in-situ ground-based anemometer and pressure jump networks and the microwave Doppler have the lowest averages, although the anemometer network has a slightly lower average. Airborne in-situ sensors suffer mostly because of their inability to predict the hazard

TABLE 13  
EVALUATION OF WIND SENSORS AND SENSOR SYSTEMS

Sensor or Sensor System Type	Weighing Criteria (Table No.)										
	Atmo- spheric Scale (2)	Cost (7)	Accuracy (8)	Oper./ Maint. Req. (9)	Density of Obs. (10)	Oper. Con- straints (11)	Predict- ability (12)	Average (lowest is best)			
Rawinsonde/pibal/rocket network (2 obs./day)	3	5	3	5	2	2(f)	4	3.43			
Radiosonde/single pibal/single rocket (2 obs./day)	5	3	3	3	4	2(f)	5	3.57			
Anemometer, single	5	1	2	1	5	3(a)(f)	5	3.14			
Anemometer network (LLWSAS configuration)	1	4	2	2	3	2(a)	3	2.43			
Pressure jump (Atlanta configuration)	1	3	5	2	3	1	3	2.57			
Wind sock, single	5	1	5	1	5	3(a)(f)	5	3.57			
Wind sock, network	1	3	5	1	3	3(a)(f)	5	3.00			
Kite	5	1	3	5	5	5(b)	5	4.14			
Kite network	1	3	3	5	3	5(b)	4	3.43			
Modified flight director	1	5	2	2	N/A	1	5	2.67			
Ground speed (ILS, range rate)	1	3	3	3	4	3(c)(f)	5	3.00			
Ground speed (correlation velocity)	1	3	2	2	4	2(f)	5	2.71			
Ground speed (long. accel.)	1	4	2	2	4	1	5	2.71			
Acceleration margin	2	4	3	2	4	2(c)	3	2.85			
Air/ground method with DABS	2	5	3	3	2	2(d)	2	2.71			
Microwave Doppler	2	5	3	3	1	3(e)	1	2.57			

Note: (a) Siting problems; (b) Very strong wind and near calm wind sensor incapacitation; (c) Requires ground equipment or information which may not be available; (d) Data sparse regions are likely; (e) Ground clutter, range folding, output in precipitation only (assumed); (f) Increases pilot workload by forcing pilot to evaluate data to determine hazard.



and because of their cost. Several sensor systems are obviously poor for aviation wind hazard detection. On the other hand, the microwave Doppler, with improvements to eliminate ground clutter, range folding and sensing outside precipitation, will qualify as the best sensor of those named.

All the listed sensors or systems measure or estimate the horizontal wind or horizontal wind shear. No vertical speed sensors or systems have been named (there are few), but it is emphasized that identifying the location of the horizontal wind shear zones and measuring their intensity should be sufficient in also inferring the location of vertical speed zones. The horizontal wind fields that are tagged as aviation hazards are almost always collocated with vertical wind fields that might be considered hazardous. The extra cost and effort that would be required for a separate system (or sizeable add-on to an existing or proposed system) to measure the vertical wind field does not appear warranted.

Whatever sensor or sensor system is chosen for future use, it is suggested that a comparison similar to the one shown in Table 13 be performed. It is believed that combinations of two or more of the sensor systems named might be a very attractive possibility, especially if weaknesses in one system could be compensated by strengths in a companion system.

#### References

Orlanski, I., 1975: A Rational Subdivision of Scales for Atmospheric Processes, Bulletin of the American Meteorological Society, Vol. 56, No. 5, pp. 527-530.

## APPENDIX

Leo Garodz

FAA Technical Center

### Airborne Wind Shear Systems

Previous FAA manned flight simulation experiments have shown the following systems to be very effective in aiding the pilot to detect and cope with hazardous low-level wind shear. When used in combination, they constitute an airborne solution to the wind shear problem:

1. Modified Flight Director (MFD)
2. Airspeed/Ground Speed Procedure ( $\Delta V$ )
3. Acceleration Margin ( $\Delta A$ )

### Modified Flight Director

Flight director systems typical of those used in modern air carrier operations are rather loosely coupled to the flight path. In an extremely dynamic situation, such as wind shear, these systems are not as effective as they could be in preventing excursions from the flight path during wind shear encounters. The MFD system incorporates control laws which more tightly couple the aircraft to the glideslope with the incorporation of normal (vertical) acceleration. These modifications have been demonstrated to be effective in enabling pilots to maintain the intended flight path during approaches with hazardous wind shear encounters, including severe downdrafts, without adversely affecting the pilot workload. Some pilots have even commented that the modified pitch steering makes it easier to track the glideslope and, thereby, reduces workload.

In addition to the modified steering commands, the fast/slow indicator is augmented with ground speed error during approach. This procedure enables the pilot to store the energy needed to traverse the shear and is merely the airspeed/ground speed ( $\Delta V$ ) procedure discussed below.

In the go-around mode, in addition to the quickened steering, the MFD control laws have been changed to remove the normal pitch command limit and programmed to extract the maximum performance from the aircraft during a shear encounter. During a go-around in normal conditions, there may be no detectable difference in the MFD and the standard flight director system. However, in a go-around through a shear, in order to prevent loss of altitude, the pitch command will cause the pilot to exchange kinetic energy for potential energy (reduce airspeed to stop a rate of descent, for instance). As a result, the pilot may see higher pitch commands than he is accustomed to seeing (we have seen as much

as 25° pitch-up during some of the more severe shears), and the airspeed may be reduced to as low as 1.1  $V_S$  (1.1 stall). This speed is just a knot or two above stick-shaker, and depending on smoothness of control and the presence of turbulence, stick-shaker may or may not be intermittently encountered. Once 1.1  $V_S$  is reached, there is no more kinetic energy to be safely traded, so the MFD will command this airspeed, even at the expense of reducing pitch, until either ground impact occurs or the aircraft flies out of the shear. The MFD will never command a pitch attitude that will obtain less than 1.1  $V_S$ .

The procedure for using the MFD is the same as for the standard flight director system. The pitch and bank steering bars and the fast/slow indicator are command information and the rest of the instruments are raw data to back up the commands.

#### Airspeed/Ground Speed Procedure

The normal procedure for flying an approach typical of those used in air carrier operations requires the pilot to fly a specified indicated airspeed throughout the approach. This airspeed is usually  $V_{app}$ , where:

$$V_{app} = V_{ref} + \text{additives (such as for wind and gusts)}$$

$$V_{ref} = 1.3 V_S$$

$$V_S = \text{stall speed for the existing configuration}$$

The problem with this procedure, however, is that in a significant wind shear, the sudden wind change may cause a sudden loss of airspeed and lift, possibly causing the aircraft to stall or to exceed a safe rate of descent close to the ground. Some severe shears are known to have exceeded the performance capability of the aircraft to accelerate to overcome the shear. In order to prevent this, the airspeed/ground speed ( $\Delta V$ ) procedure was developed. Essentially, the  $\Delta V$  procedure causes the pilot to bank the energy (in the form of stored excess airspeed) that will be required to traverse the shear without adversely affecting landing performance. To use the  $\Delta V$  procedure, two reference speeds are calculated as follows:

1.  $V_{app}$  = same as above
2.  $G_{ref} = V_{ref} \text{ (true)} - HWg$

where:

$$V_{app} = \text{indicated approach speed}$$

$G_{ref}$  = reference ground speed

$V_{ref}$  =  $V_{ref}$  converted to true airspeed

HWg = headwind component of runway wind

Then, a normal approach is flown, except that neither the airspeed nor the ground speed is allowed to fall below its computed reference speed ( $V_{app}$  and  $G_{ref}$ , respectively). In this simulation, both airspeed and ground speed are presented on the same instrument. In addition, the fast/slow indicator on the ADI is programmed with both airspeed and ground speed error to give command information to maintain the proper speed.

To the pilot, using this procedure means that in a performance decreasing condition (decreasing headwind, increasing tailwind, or headwind to tailwind) he will be flying ground speed and the airspeed will be indicating above  $V_{ref}$  by the amount of wind change (or airspeed loss) which he will encounter between present position and touchdown. Conversely, in a performance increasing condition (decreasing tailwind, increasing headwind, or tailwind to headwind) he will be flying airspeed and the ground speed will be indicating above  $G_{ref}$  by the amount of wind change (or airspeed gain) which he will encounter between position and touchdown. In any case, maintaining the fast/slow indicator centered will insure that the proper speed (airspeed or ground speed) is flown and that the airspeed is never allowed to fall below  $V_{app}$ .

#### Acceleration Margin

Even though the  $\Delta V$  procedure is used, and the excess energy is available to traverse the shear, it is still advisable to avoid those severe shear conditions which may approach or exceed the performance capability of the aircraft. For this, the pilot needs timely go-around guidance based on aircraft performance. To this end, acceleration margin ( $\Delta A$ ) was developed and is computed as follows:

$$\Delta A = A_a - [(TAS - GNS) - HWg] \cdot \frac{\dot{H}}{H}$$

where:

$A_a$  = acceleration capability of the aircraft (go-around thrust, drag devices removed, landing flaps, gear down, level flight)

TAS = true airspeed

GNS = ground speed

HWg = headwind component of runway wind

$\dot{H}$  = vertical velocity

H = altitude

The quantity within the brackets is merely the wind difference ( $\Delta W$ ) between the headwind components at present position and touchdown, so that the equation can be written as:

$$\Delta A = A_a - \Delta W \frac{\dot{H}}{H}$$

The last term in the equation is the acceleration that will be required for a safe go-around in the shear, and the difference between this quantity and the acceleration capability of the aircraft is the margin of acceleration that the aircraft possesses above that which will be needed. As was the case with  $\Delta V$ , the  $\Delta A$  procedure is predictive in that the computation is based on what is ahead of the aircraft.

In this simulation,  $\Delta A$  is implemented as follows. The quantity

$$\Delta W \frac{\dot{H}}{H}$$

is presented on a vertical tape instrument mounted close to the airspeed/ground speed instrument. In addition, the quantity is set on this tape to represent the go-around,  $A_a$ , value (point at which continuing the approach may preclude a safe go-around). Whenever the indicator is reading above zero, this indicates an increasing performance condition, and the pilot should be aware of the possibility of a hot landing and should monitor ground speed accordingly. Whenever the indicator is reading below zero, this indicates a performance decreasing condition (which is a normal condition for approaches in a decreasing headwind). When the indicator reaches the no-go area, the go-around light will be illuminated, and this is a go-around command. To continue the approach beyond this point may mean entering a condition which will exceed the performance capability of the aircraft.

## REMOTE PROBING OF WIND AND WIND SHEARS

J. T. Lee

National Severe Storms Laboratory

In recent years, great progress has been made in demonstrating the ability of various types of remote probes to measure wind. Remote probes have two important advantages over *in-situ* sensors: their ability to measure atmospheric parameters without disturbing the air flow, and their ability to scan through large volumes of the atmosphere with relative ease. In his discussion of "Winds and Wind Shear In-Situ Sensors," Craig Goff detailed the direct measurement sensors, such as the anemometer and wind vane, and his comments should be kept in mind as the following remote sensors are discussed.

For the purpose of this presentation, let us categorize these into two groupings, active and passive. In the first group we have systems such as the acoustic radar, microwave radar, and lidar, and in the latter groups there are systems such as typified by the infrared (IR) radiometers.

Acoustic echo sounders were proposed to measure detailed profiles of the winds at low levels more than a decade ago (Little, 1969). Monostatic (colocated transmitter and receivers) and bistatic (transmitter and receiver separated by some distance) systems were developed and tested (Beran and Clifford, 1972). Figure 1 illustrates a basic system tested in Colorado and at Dulles International Airport, Washington, DC. The volume scanned is approximately vertical through a depth of 0.5 km. Acoustic Doppler radars can provide wind observations with satisfactory accuracy under low surface wind and when no precipitation is occurring. Noise contamination by high wind, rain and hail and by aircraft are serious problems which limit the use of acoustic sounders.

Another system which can measure wind in air clear to the naked eye is the Doppler lidar. Considerable progress has been made in the field of coherent Doppler lidar. DiMarzio, et al. (1979) have reported on ground-based system trials at Oklahoma City, Oklahoma, and at the Kennedy Space Center (KSC), Florida. The system incorporates a pulsed CO<sub>2</sub> laser Doppler velocimeter operating at 10.6  $\mu\text{m}$ . A light pulse reflected by particles naturally present in the atmosphere returns to the receiver. The frequency of the pulse has been shifted by an amount proportional to the velocity of the reflecting particles. The KSC's one-month test period recorded well-defined gust fronts associated with three storms. The wind shears were reported to be clearly visible both in real-time velocity versus azimuth plots and in post processing displays. The system has a range of 5 km but is strongly attenuated in moderate or greater precipitation. Bilbro and Vaughan (1978) have proposed the use of such a system on an aircraft. During a recent trip

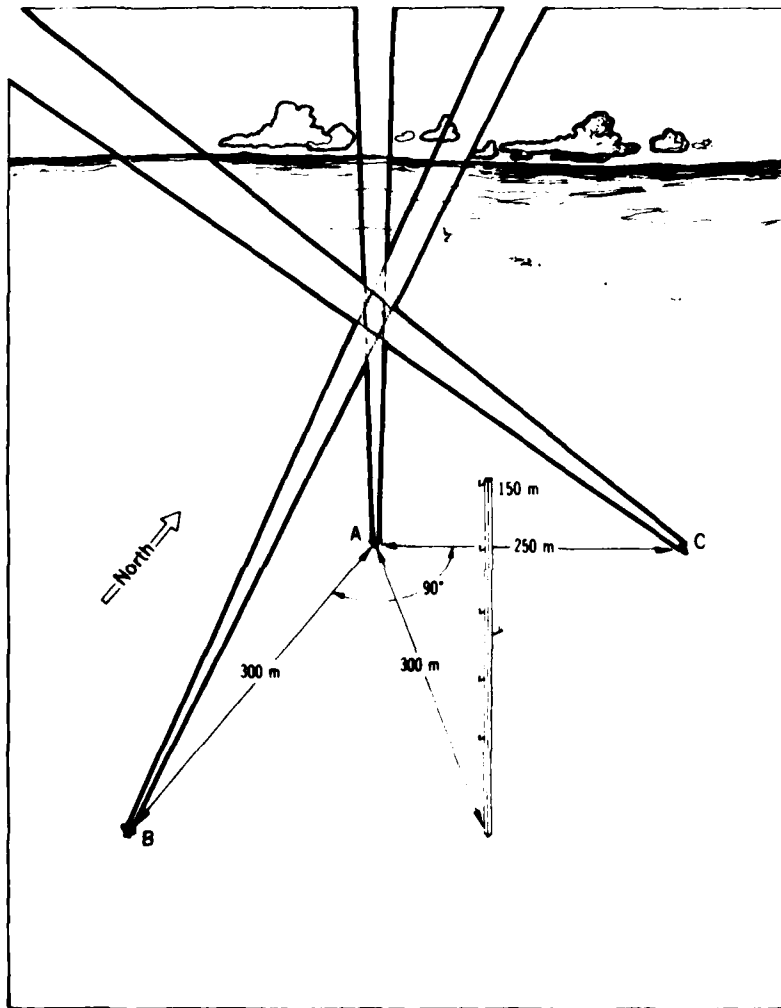

Figure 1. Basic acoustic system schematic (A, transmitter; B and C, receivers). (From Gaynor, 1977)

to England, I had the privilege of visiting the Royal Aircraft Establishment site at Bedford. There, a similar lidar had completed ground testing and was to be installed in an aircraft. The system's relatively short range presents a limitation, but they propose that a suitable coupling between the lidar wind measurements and the autopilot can result in a very effective combination for flight through a wind shear region.

A recent communication with Milton Huffaker, of the National Oceanic and Atmospheric Administration (NOAA), Wave Propagation Laboratory (WPL), brought to light a recent advancement in lidar. Under WPL contract, a group at United Technology Research Center has been able to reliably obtain measurements at 25 km (16 mi) using a Transverse Excited Atmospheric (TEA) laser. In January, 1980, ranges up to 32 km (20 mi) were consistently obtained using 6-inch optics. Plans are now being formulated for an airborne system in 1982 which will have a 100-200 km (60-120 mi) capability.

For a moment, I would like to skip discussion of microwave Doppler radars and look instead at passive systems. Kuhn and Caracena have demonstrated the ability of a passive IR detector to sense clear air turbulence (CAT) at jet flight altitudes (Kuhn, 1978). Their successes at altitude lead them to investigating the possible use of an IR band-pass filter in the CO<sub>2</sub> band. This IR system remotely senses large temperature fluctuations (> 1°C) in a horizontal, forward-looking direction along the glide slope. The thunderstorm downdraft and subsequent outflow are colder than the surrounding air; thus, these features should be observed by the equipment if the outflow is in the aircraft's path. A test of a modified system was conducted during Project SESAME 1979, but for a variety of reasons, a complete data set was not obtained. Further tests are required, and an operational system is probably years away.

Now let us consider microwave Doppler radars. They are probably the most advanced remote probes at the present time. The National Center for Atmospheric Research (NCAR) in Boulder, Colorado, has two C-band systems; the CHILL Doppler is a joint project between the University of Chicago and the Illinois State Water Survey (operating at C- and S-bands); Dr. Lhermitte, at the University of Miami, has two 10 cm S-band transportable systems; the Air Force Geophysical Laboratory (AFGL) has a C-band system and is acquiring a 10 cm system; and the National Severe Storms Laboratory (NSSL) has two 10 cm systems. Through observations by these unics, much has been learned about the air motion in thunderstorms and in clear air (Doviak, et al., 1979). These radars sense both intensity and radial velocity of precipitation, and trace airflow in the optically clear air. Doppler radar also offers the first practical method for measuring wind fields in optically clear air for virtually continuous profiling of the horizontal winds at various altitudes. Identifiable Doppler wind features are related to turbulent areas, wind shears and other hazards, such as mesoscale vortices--the forerunners of tornadoes.



Since a single Doppler radar measures only the target velocity toward or away from the radar, two widely spaced units are generally required for determination of true wind. In many cases, however, the full detail provided by combining observations from two radars is not required, and one radar provides sufficient information for important operational decisions.

Before proceeding, let us briefly look at one guiding consideration that permeates microwave Doppler radar applications. This is range and velocity ambiguities. Target range ( $r_a$ ) becomes ambiguous when the range exceeds  $r_a = cT_s/2$ , where  $c$  is the speed of light and  $T_s$  is the pulse repetition time. Target maximum unambiguous velocity ( $v_a$ ) is given by the expression  $\pm \lambda/4T_s$ , where  $\lambda$  is the radar wavelength. Thus the product of the unambiguous range and velocity is  $r_a \cdot v_a = c\lambda/8$  and typifies the ambiguity resolution capabilities of conventional Doppler radars which have uniform pulse spacing. If one studies the above equation, one sees an advantage in using longer wavelengths. That is, the right-side term will be increased, resulting in an increase in the allowable product of  $r_a$  and  $v_a$ . The Doppler radar at NSSL operates at a 10 cm wavelength and in normal operation has an  $r_a$  of 114 km (62 n mi) and a  $v_a$  of 34 m s<sup>-1</sup> (68 kts).

In the Next Generation Weather Radar Program (NEXRAD), this problem is being addressed, and possible solutions, such as use of a multiple frequency radar, will be examined. NEXRAD; a joint effort of the Federal Aviation Administration (FAA), the Air Force, the National Aeronautics and Space Administration (NASA), and the National Oceanic and Atmospheric Administration (NOAA); considers incorporation of Doppler features into the joint-use replacement weather radar as a requirement. The following illustrates expected operational uses of the new system.

#### Gust Front Detection

To illustrate Doppler radar's ability to determine gust fronts and wind shear, several examples are presented.

On May 19, 1977, a large squall line extending more than 300 km (162 n mi) in a north-south orientation passed through central Oklahoma; its gust front embedded in light precipitation reached the tower at 1557 CST.

The gust frontal zone was characterized by moderate shear in the wind speed component normal to the front and by sharp temperature discontinuity. An updraft larger than 4 m s<sup>-1</sup> at 1557 CST was followed by a downdraft exceeding 2 m s<sup>-1</sup>, thus creating a somewhat turbulent zone just behind the gust front. Little surface pressure discontinuity was associated with the gust front. Light precipitation began a few minutes ahead of the front. Figures 2 and 3 show the low level (center of beam is 250 m above ground) dual-Doppler derived winds at 1526 and 1532 CST. Superimposed are the tower winds at the 444 m level and the surface

HEIGHT 0.00KM  
1000  
1M/S

19 MAY 1977 DUAL DOPPLER WINDS 152535-152709

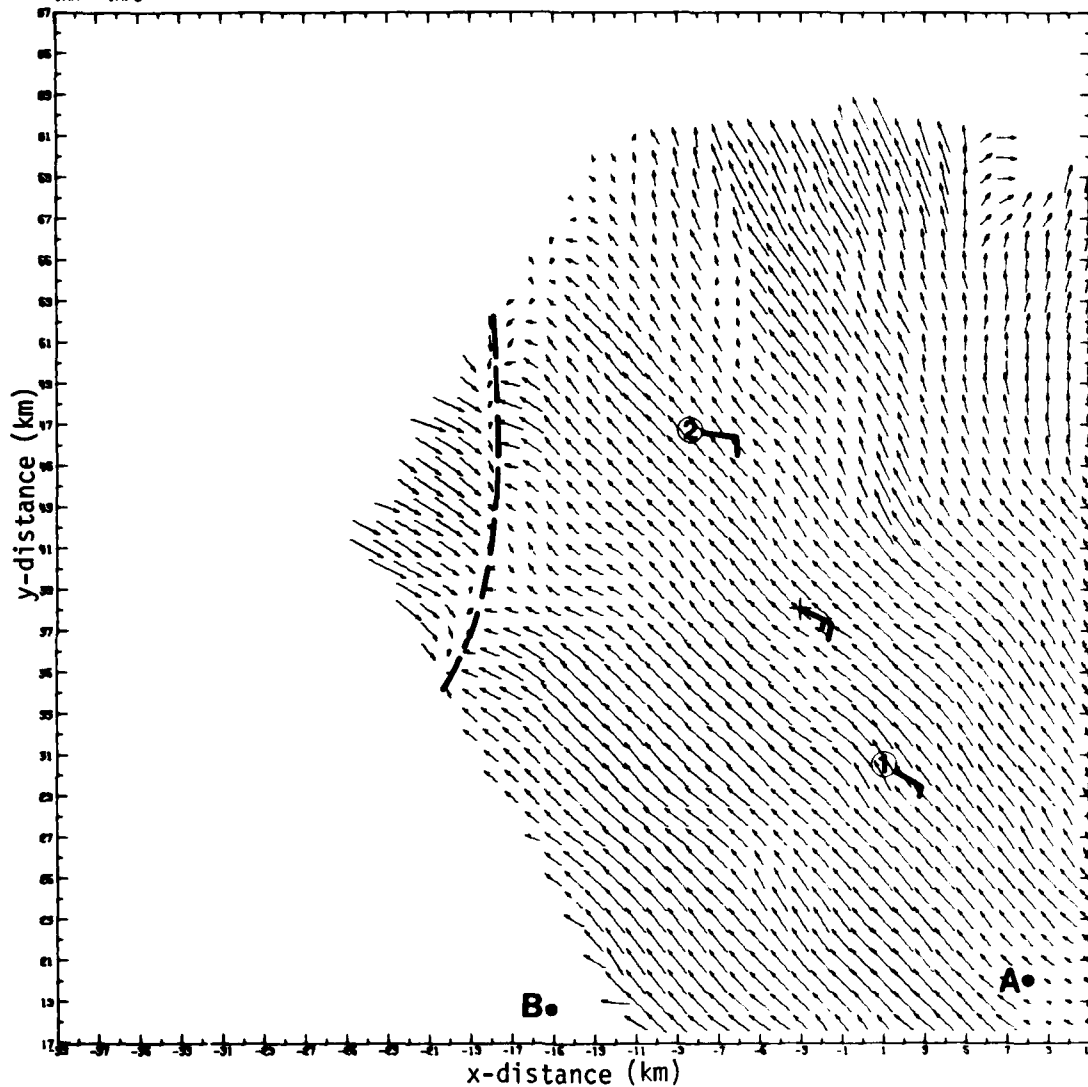

Figure 2. Dual-Doppler wind field of a gust front 19 May 1977, 1526 CST. Wind speeds are indicated by length of arrow; gust front by dashed line; tower site by "+" Coltrane surface site by "(1)" Pennsylvania Avenue site by "(2)"; Tinker Air Force Base by "A" Will Rogers International Airport by "B".

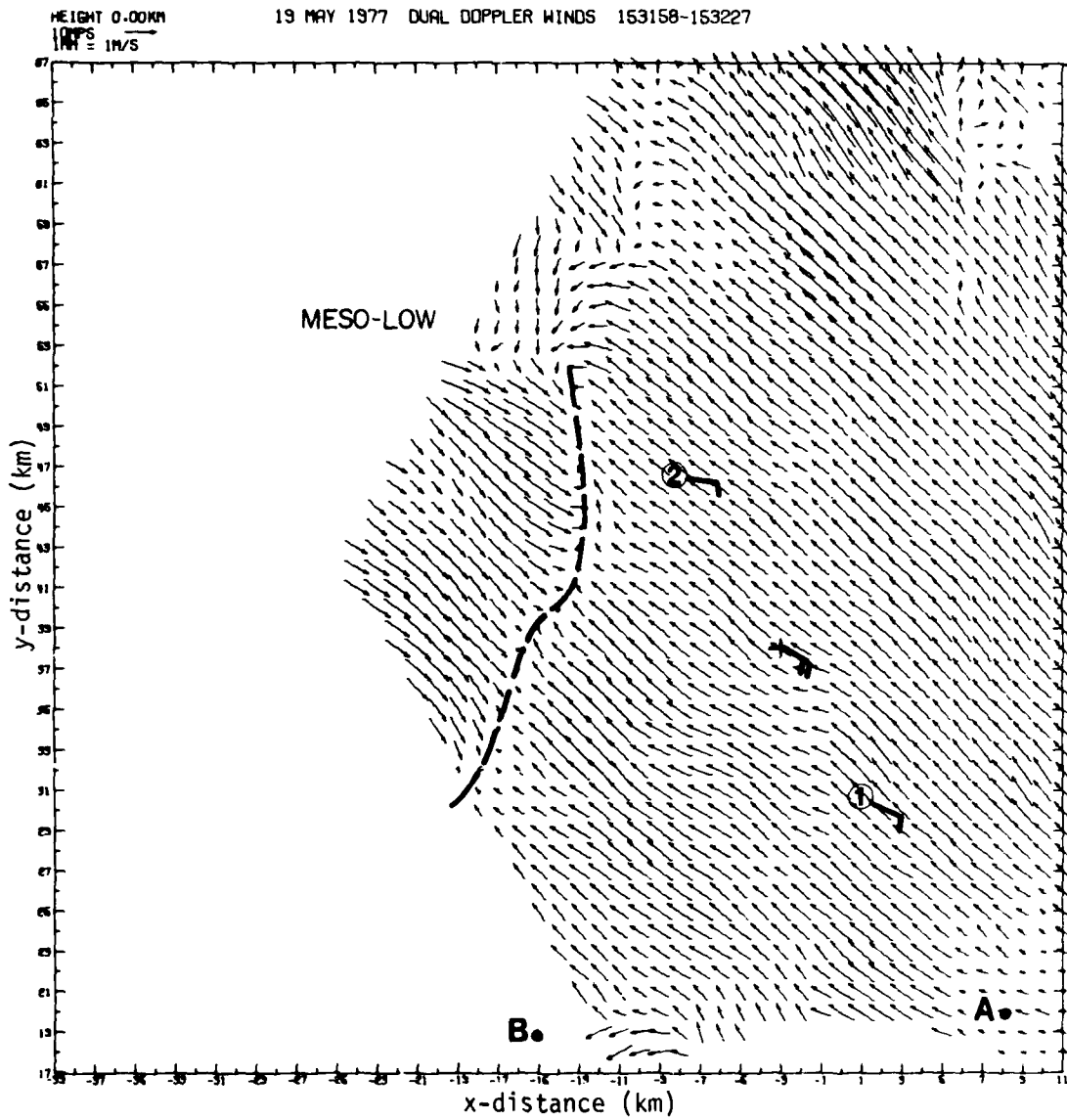

Figure 3. Same as Figure 2 except time is 1532 CST.

winds at the Pennsylvania Avenue (10 km NW of tower) and Coltrane Road (9 km SE of tower) sites. Note how well-defined is the small mesolow at the north end of the gust front in Figure 3. This characteristic pattern is similar to that shown by Goff, et al. (1977).

The F-4-C, flying at 460 m (1500 ft) above ground level (AGL) just north of the tower on east-west flight paths, measured horizontal and vertical winds and turbulence. Only light turbulence was reported by the pilot.

Another gust front situation is shown in Figure 4, the time-height cross section of a gust front passage at the KTVY-TV tower on June 12, 1977, and in Figure 5, the real-time single-Doppler radar display at a corresponding time. Surface gusts at the tower reached  $28 \text{ m s}^{-1}$  after passage of the gust frontal boundary. A sharp temperature discontinuity is evident across the front as the temperature dropped about  $6^\circ\text{C}$  in five minutes. Pre-gust front updrafts are greater than  $6 \text{ m s}^{-1}$ . The Norman Doppler real-time display is taken when the squall line leading edge is about 10 km away from the tower. The reflectivity pattern is typical with weaker values along the edge of the squall line and with numerous embedded cores. Central core values are greater than 40 dBZ. The velocity display shows clear evidence of strong outflow winds ( $\geq 32 \text{ m s}^{-1}$  toward the radar) along the forward edge of the line. These velocity maxima are displaced from the reflectivity cores by an appreciable amount. From the reflectivity display above, one may have judged the center portion of the squall line to be weaker than the extremities. The Doppler velocity display, however, shows this area having strong winds (gust front). This is an excellent example of how Doppler radar can detect outflow winds. Wind and lightning damage from this squall line was confined to disruption of an electric power distribution system.

A third case involves gust front detection in optically clear air. The use of the NSSL Doppler to obtain such data has been under trial for several years. The first observations of a clear air gust front by a Doppler radar occurred on May 26, 1976. Data were obtained from eight to twelve elevation angles scanned at selected azimuths. Recording started at 0819, or 20 minutes after the windshift but 30 minutes before the rain reached Norman. Data were abstracted at 1 km intervals along each elevation angle and analyzed, and cross sections were produced (Figure 6). Negative numbers indicate motion toward the radar. The illustrated cross section corresponds closely to the u component depicted in the tower cross section (Figure 7).

#### Observations in Clear Air

Echoes from clear air have been seen almost from the inception of radar observations. These "angel echoes" were at first mystifying but were often actually associated with birds and insects. Clear air echoes which were not related to any visible object in the atmosphere were conclusively proven to emanate from refractive index fluctuations

28JUN77 1700

1 km



STREAMLINE ANALYSIS

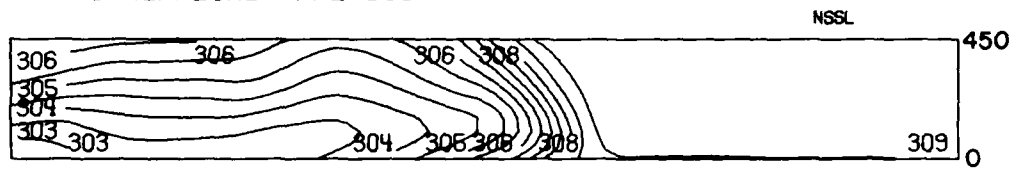

POTENTIAL TEMPERATURE

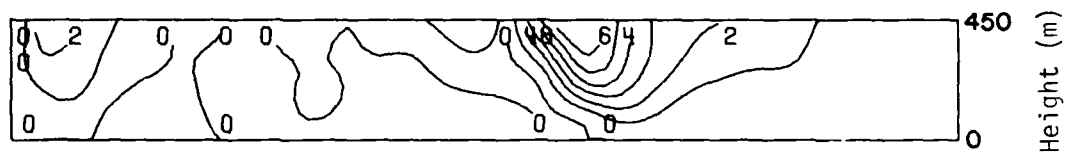

VERTICAL VELOCITY

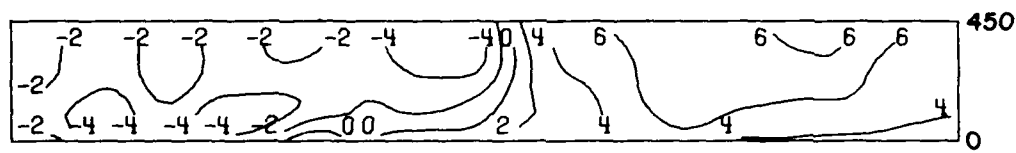

WIND SPEED PARALLEL TO FRONT



RELATIVE WIND SPEED, COMPONENT NORMAL TO FRONT

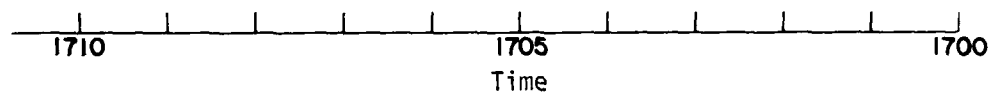
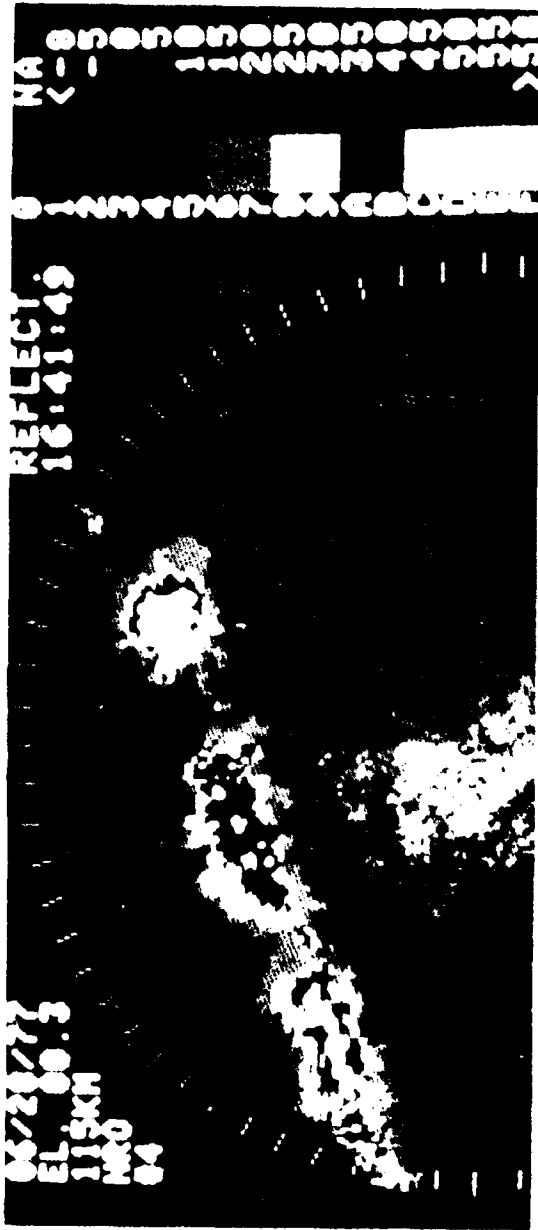
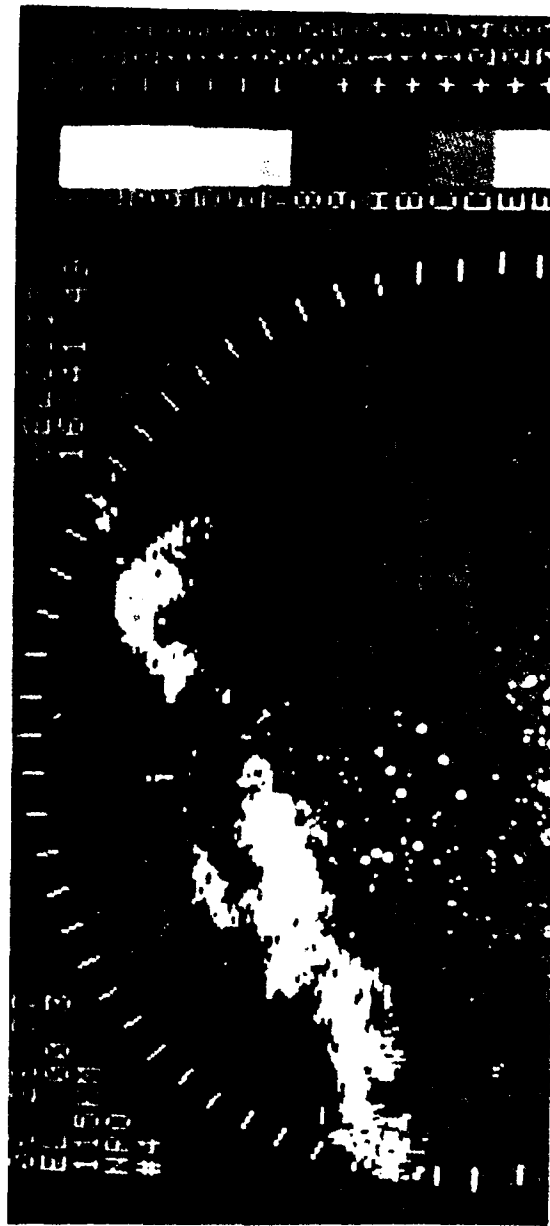

Figure 4. Gust front time-height cross sections 28 June 1977, as recorded at the KTVY-TV tower.



(a) Radar reflectivity pattern with reflectivity factor (dBZ) given at right.



(b) Doppler radial velocity with velocity scale ( $\text{m s}^{-1}$ ) given at right.

Figure 5. Real-time Doppler radar display. (Elevation angle is zero degrees.)

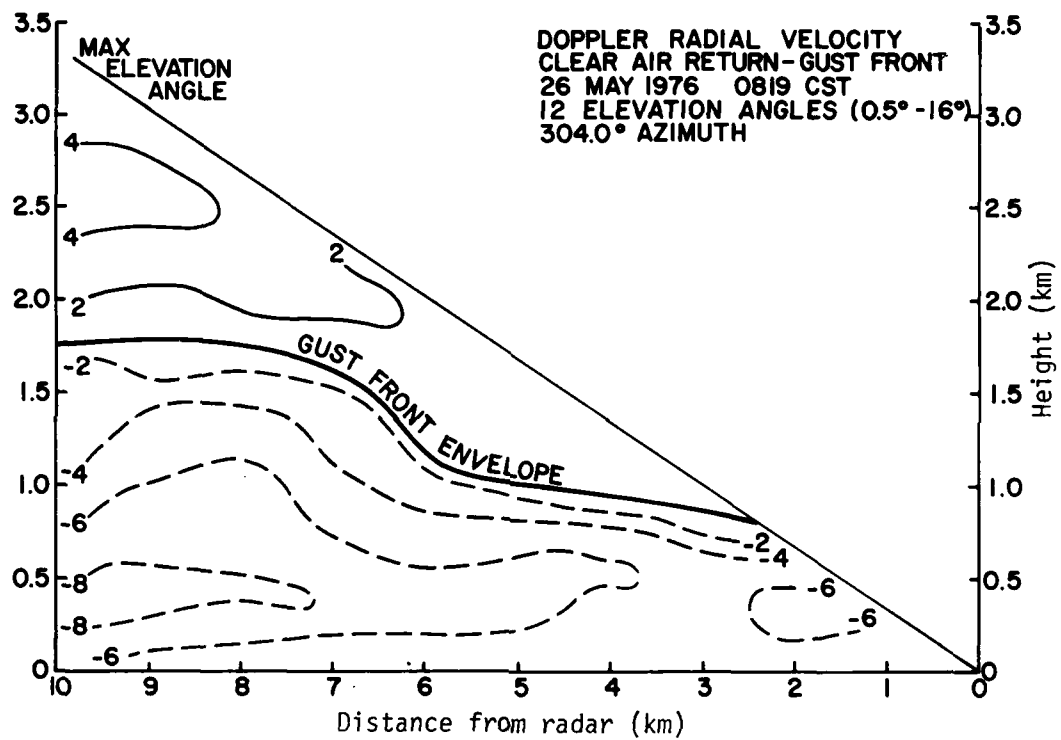

Figure 6. Clear air single Doppler wind cross section of gust front along 304° radial 26 May 1976. Positive (away from radar isotachs,  $\text{m s}^{-1}$ ) are solid, negative isotachs, dashed.

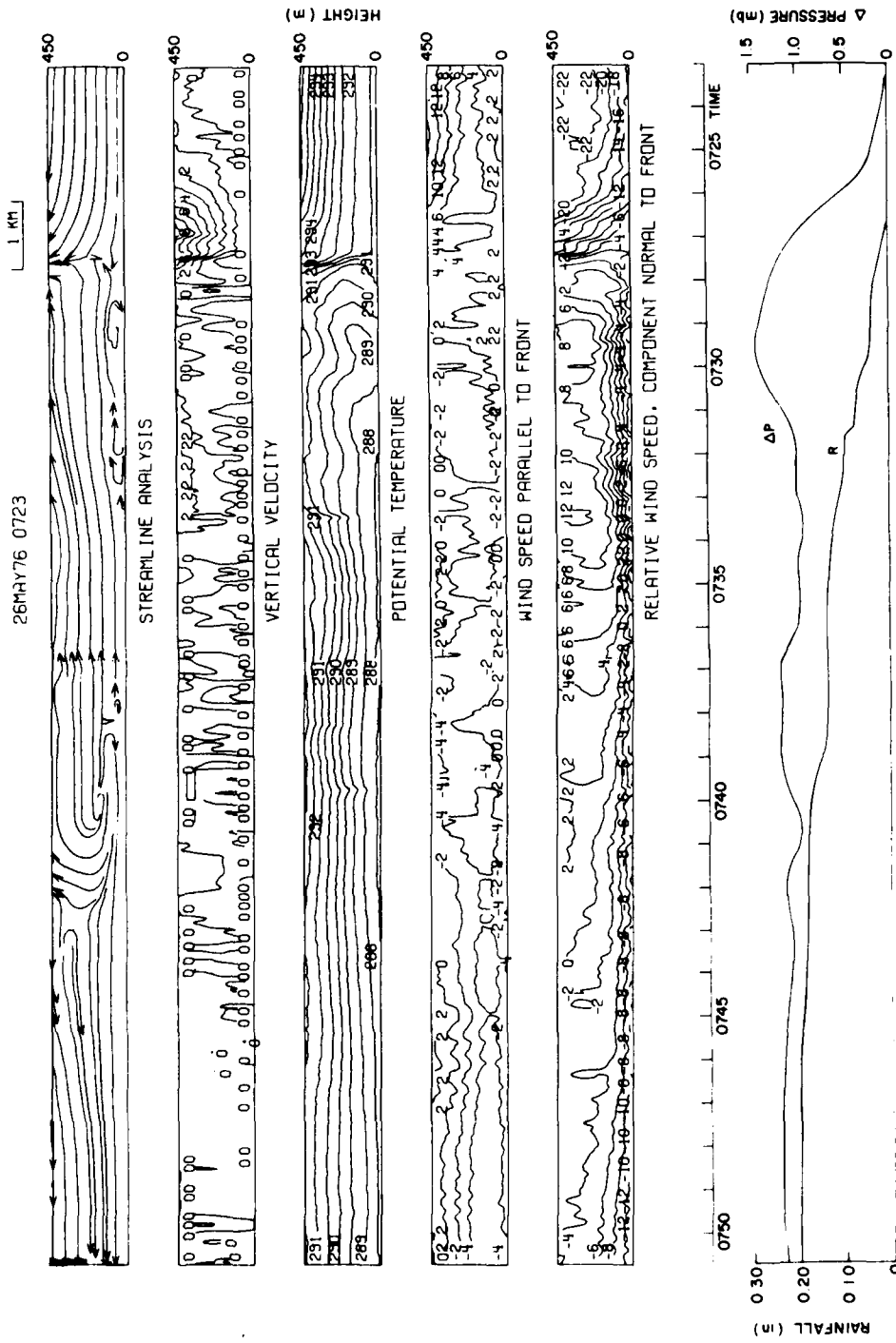

Figure 7. Time-height cross section of tower data 26 May 1976. Units are  $\text{m s}^{-1}$  and  $^{\circ}\text{K}$ .



through use of multi-wavelength radars at Wallops Island (Hardy, et al., 1966).

Whenever turbulence mixes air in which there are gradients of potential temperature and water vapor density, the turbulence causes spatial fluctuations in the refractive index  $n$ . The fluctuations are small, e.g., one part in a million; nevertheless, sensitive microwave radars detect the very faint echoes returned from these irregularities in what otherwise (without turbulence) would be a smoothly changing  $n$  with negligible backscatter.

In the 1960's, ultrasensitive incoherent radars were used to remotely detect and resolve clear air atmospheric structure, and these studies are well reviewed by Hardy and Katz (1969). These radars showed meteorological phenomena such as convective thermals, sea and land breezes, and Kelvin-Helmholtz waves. Doppler processing of coherent radar echoes can improve target detection; hence, medium resolution radars can have detection capabilities matching that associated with large aperture antennas.

On April 27, 1977, a day marked by strong nondirectional shear and curvature in the wind profile, NSSL's Doppler radar echo power measurement showed evidence of clear air convective streets, an observation that should signify the presence of roll vortices. The winds were fairly uniform from the southwest on this day, but there were small perturbations from the mean wind having a magnitude of about one order less than the mean wind itself. The  $x$  direction and  $u$  component of wind are along the mean wind and the  $y$  direction and  $v$  component are normal to the mean wind.

The synthesized perturbation wind (at one of the six levels from a tilt sequence) is shown in Figures 8(a) and 8(b). A band-pass filter was applied in the  $y$  direction to emphasize the 4 km wave feature for visual display. A low pass filter was applied in the  $x$  direction along which no dominant wavelength was noted.

Figure 8(b) is a vertical cross section perpendicular to the mean wind. Vertical velocities were derived by integrating the mass continuity equation using wind fields from the six horizontal surfaces. Vertical grid spacing is 250 m. Readily apparent are counter-rotating vortices (roll vortices) having approximately 4 km wavelengths whose maximum vertical velocities are of the order of  $1 \text{ m s}^{-1}$ .

Another utilization of Doppler radar has been simulated in an experiment conducted jointly by the University of Oklahoma, NASA, FAA and NSSL (McCarthy, et al., 1979; Albery, et al., 1979) during which instrumented aircraft made simulated instrument landing system (ILS) approaches to Max Westheimer Field (Norman Doppler radar location). The Doppler radar was pointed up the glide slope and concurrent data were obtained. Figure 9 shows the good correlation between the head-wind component of the aircraft-measured winds and the Doppler radar-observed winds obtained in clear air with no clouds present.

DUAL DOPPLER WINDS

27 APR 1977 144645-144935 CST

HEIGHT .75 km

10 mps

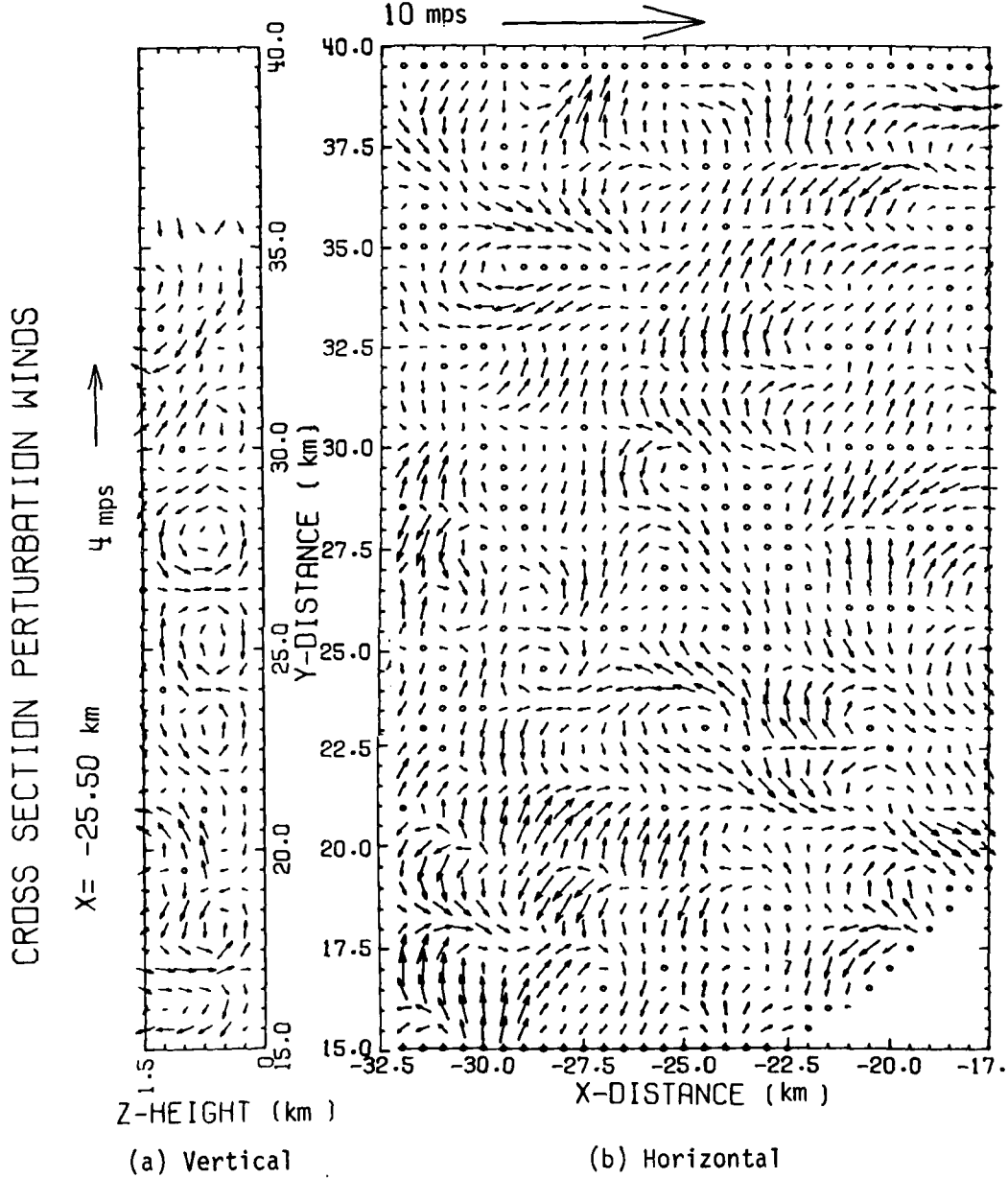

Figure 8. Cross sections of band-pass-filtered wind data that highlight the clear air role structure seen in the spectra of unfiltered data.

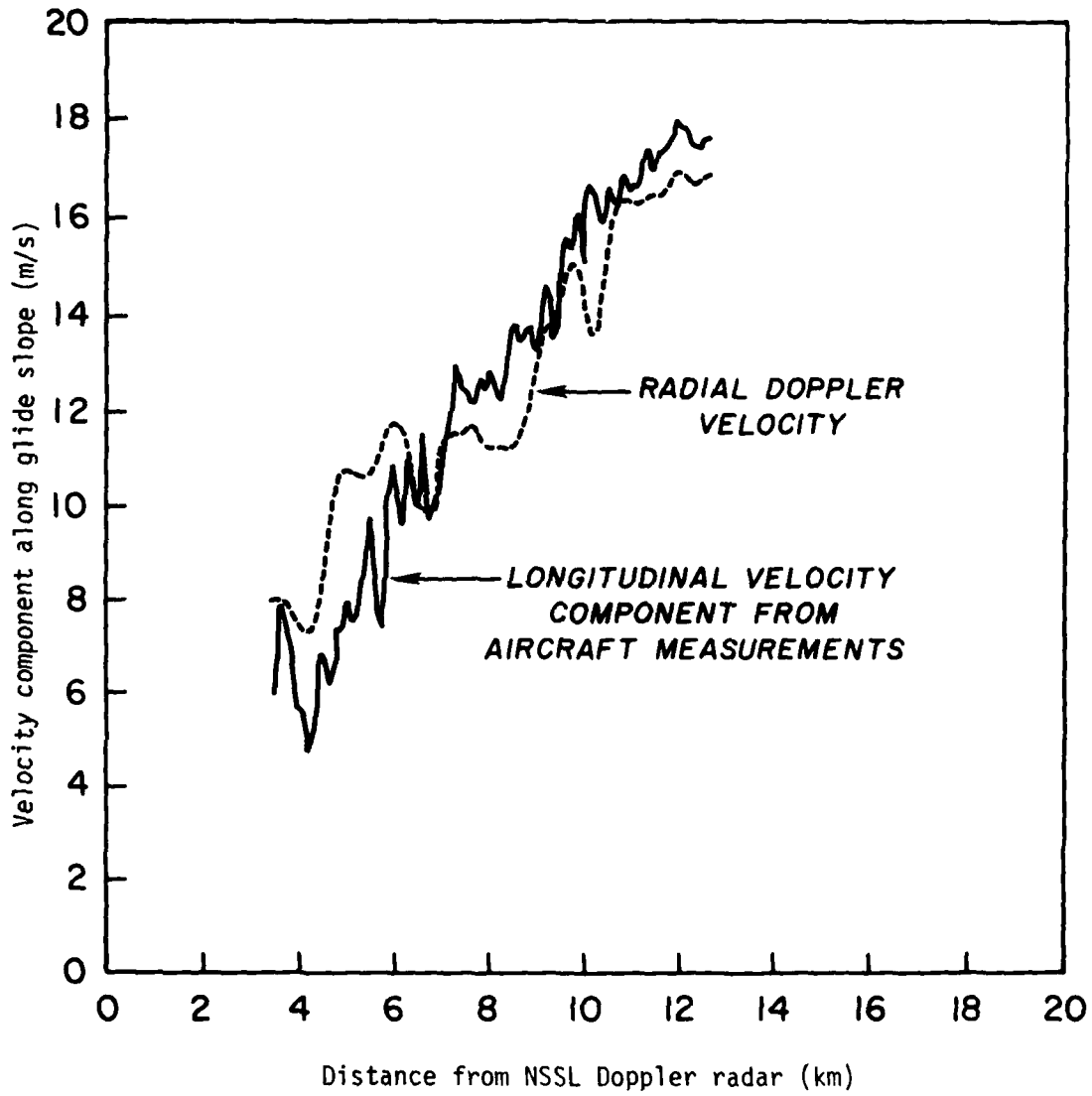

Figure 9. Comparison of Doppler-observed winds and aircraft-measured winds recorded during a simulated approach.

## Conclusion

Thus, we have an insight into Doppler radar's potential for measuring wind and wind shear under clear or cloudy conditions.

Mention must also be made of airborne Doppler radar systems. Tests have been conducted using a modified C-band radar on board NOAA's P-3 aircraft. The results are encouraging and are continuing.

We must conclude that while a number of remote sensors have a strong potential for use as wind and wind shear measuring devices, their cost-effectiveness needs further evaluation. Also, a timetable for their operational application is still in the draft stage. Therefore, it is prudent to implement--in the interim--a short-range program such as has been done by the FAA. These *in-situ* measuring devices cannot provide all the required information since sensing the wind in only a few locations does not adequately describe the shear located between sensors. Thus, the situation described by Dr. Fujita in "Downburst and Microburst - An Aviation Hazard" (1980) and the incident near Atlanta on August 22, 1979, show that shear will continue to be a hazard until these remote sensors reach an operational status or until pilots avoid flying through the center of thunderstorms during an approach to an airport.

## References

- Alberty, R. L., D. W. Burgess, C. E. Hane, and J. F. Weaver, 1979: SESAME 1979 Operations Summary, NOAA-ERL, 253 pp.
- Beran, D. W., and S. F. Clifford, 1972: Acoustic Doppler Measurements of the Total Wind Vector, Second Symposium on Meteorological Observations and Instrumentation, March 27-30, 1972, San Diego, California, pp. 100-106.
- Bilbro, J. W., and W. W. Vaughan, 1978: Wind Field Measurements in the Nonprecipitous Regions Surrounding Severe Storms by an Airborne Pulsed Doppler Lidar System, Bulletin of the American Meteorological Society, Vol. 59, No. 9, pp. 1095-1100.
- DiMarzio, C., C. Harris, J. W. Bilbro, E. A. Weaver, D. C. Burnham, and J. H. Hallock, 1979: Pulsed Laser Doppler Measurements of Wind Shear, Bulletin of the American Meteorological Society, Vol. 60, No. 9, pp. 1061-1066.
- Doviak, R. J., D. S. Zrnica, and D. Sirmans, 1979: Doppler Weather Radar, Proceedings of the IEEE, Vol. 67, No. 11, pp. 1522-1553.
- Fujita, T. T., 1980: Downbursts and Microbursts - An Aviation Hazard, Preprint, 19th Conference on Radar Meteorology, Miami Beach, Florida, 8 pp.

- Gaynor, J. E., 1977: Acoustic Doppler Measurements of Atmospheric Boundary Layer Velocity Structure Functions and Energy Dissipation Rates, *Journal of Applied Meteorology*, Vol. 16, No. 2, pp. 148-155.
- Goff, R. C., J. T. Lee, and E. A. Brandes, 1977: Gust Front Analytical Study, Final Report, FAA-RD-77-119, 120 pp.
- Hardy, K. R., D. Atlas, and K. M. Glover, 1966: Multiwavelength Backscatter from the Clear Atmosphere, *Journal of Geophysical Research*, Vol. 71, No. 6, pp. 1537-1552.
- Hardy, K. R., and I. Katz, 1969: Probing the Clear Atmosphere with High Power, High Resolution Radars, *Proceedings of the IEEE*, Vol. 57, pp. 468-480.
- Kuhn, P. M., 1978: Detection of CAT and Low Altitude Wind Shear by On-board Aircraft IR Sensors - An Update, *Proceedings, 16th Annual SAFE Symposium, San Diego, California*, pp. 181-184.
- Little, C. G., 1969: Acoustic Methods for Remote Probing of the Lower Atmosphere, *Proceedings of the IEEE*, Vol. 57, pp. 571-578.
- McCarthy, J., E. F. Blick, and R. R. Bensch, 1979: Jet Transport Performance in Thunderstorm Wind Shear Condition, *NASA Report 3207*, 54 pp.

CEILING AND VISIBILITY INSTRUMENTATION  
WITHIN GOVERNMENT AGENCIES

Robert S. Bonner

U.S. Army Atmospheric Sciences Laboratory

Ceilometers

Key system requirements. The key requirements for ceilometer systems are as follows:

1. Range must be 10,000 ft.
2. Laser emission must conform to the Bureau of Radiological Health Class I performance.
3. System must detect two lowest cloud layers.
4. Display must be in either English or metric units.
5. System must be capable of self-monitoring and testing performance.

Based upon the above requirements, Hughes Aircraft Corporation and Sanders Associates have been awarded contracts to build competitive prototype Cloud Height Indicator (CHI) systems. Witness evaluation tests will be conducted on them at their respective manufacturers' facilities in March, 1980. An evaluation report will be written in April, and a contract award for the initial production of a few units for operational testing will occur in late FY80.

*Hughes system.* The Hughes system consists of a transceiver unit which is located on the airfield, a maintenance unit which is remotely located from the transceiver, and remote readout units.

The transceiver has the following characteristics:

1. Is contained in a cylindrical enclosure.
2. Has built-in test capability to monitor operation of its major subsystems.
3. Has environmental control for subsystems and window heaters.
4. Uses a 1.54  $\mu\text{m}$  laser transmitter.
5. Uses a germanium photo detector.
6. Uses laser rangefinder principle to find cloud height, i.e., time of travel for light pulse to and from the target.

The maintenance unit has the following characteristics:

1. Contains microprocessor-based command and control for the transceiver.
2. Controls timing of cloud height measurements and built-in test data from transceiver.
3. Commands initiation of test sequences.

The maintenance unit commands the transceiver to perform a series of cloud height measurements in a one-minute period. These measurements are stored in memory and are correlated to reduce false alarms. The transceiver then performs the built-in test sequence upon command from the maintenance unit. Cloud height and built-in test data for the last series of measurements are then transmitted to the maintenance unit. The maintenance unit subsequently delivers the cloud height data to the readout units. When this sequence is complete, the transceiver is ready to repeat the cycle upon command from the maintenance unit.

Status and malfunction indicators are provided in the maintenance unit for quick response on maintenance.

*Sanders Associates system.* The Sanders Associates system consists of basically the same units as the Hughes system, namely, a transceiver, a maintenance unit and a remote readout unit.

The transceiver unit has the following characteristics:

1. Is contained in a large weather-proof enclosure similar in appearance to a house with a peaked roof.
2. Uses the roof of the enclosure to serve as windows for the transmitter and receiver.
3. Has 16-inch cassegrain telescopes for transmitter and receiver optics.
4. Has a 1.73  $\mu\text{m}$  Q-switched laser.
5. Has a germanium photodetector receiver.
6. Contains a microprocessor which controls cloud height measurement sequence timing, processes first two cloud-base returns to eliminate false data, and converts the measurements to either feet or meters.

The maintenance unit has the following characteristics:

1. Is rack mountable.
2. Provides remote control and monitoring of the transceiver unit.
3. Provides interface between transceiver and display units.
4. Has built-in self- and line-monitoring capability.
5. Has functional monitoring with a microprocessor which provides error correction techniques, less system downtime, and ease of maintenance.

The display unit controls will indicate intensity and cloud height (in feet or meters). They will also activate or deactivate the display unit power.

This system operates in basically the same manner as the Hughes unit, with the exception that all of the timing control, self-check functions, and data processing are accomplished in the transceiver unit. The maintenance unit acts only as an interface to the display units and as an error corrector and fault indicator.

#### Government programs.

*National Weather Service.* Mr. Tom Giff of Giff Company, California, has left with the National Weather Service (NWS) a prototype laser ceilometer for testing. Features include two ranges (10,000 and 20,000 ft), 10-inch optics for transmitter and receiver, digital and analog output, remote readout, GaAs laser transmitter, receiver, and associated optics which are fitted into a machined aluminum block. The whole unit is housed in a 2 ft x 2.5 ft x 1 ft box and is estimated to cost about \$4,000. Initial test results are favorable.

NWS is initiating a program to include ceiling and visibility data in the VHF Omni-Directional Range (VOR) at Dulles. The ceilometer to be used is a Gallium Arsenide laser ceilometer built by Impulsphysik.

*United States Air Force.* The United States Air Force (USAF) has an active program to improve hardware and software components to make measurements more reliable and accurate. They are pursuing a program this spring at Otis Air Force Base (AFB) to determine how representative a single point measurement is of the entire cloud base. Two rotating beam ceilometers (RBC's) will be separated by one mile, then comparisons will be made of simultaneous measurements of the base. This is a similar program to the one performed at Wright Patterson AFB a few years ago, but their three RBC's were placed at points of an equilateral triangle five to seven miles on each side. Otis test results will be available in June, 1981.

*United States Army.* The second prototype visioceilometer should be delivered in August, 1980. We are hoping to have another unit delivered by October, 1980. Testing and subsequent demonstrations will commence in the following months.

This is a hand portable system weighing approximately 5 lbs that will use the same laser (1.06  $\mu$ m) as in the AN/GVS-5 laser rangefinder. The hand-held portion will be approximately the size of a pair of 10 x 50 binoculars. The operator will aim it as nearly vertical as possible and fire the laser; the distance to the cloud base will be displayed in meters in the viewfinder.



## Visibility Sensors

### Government programs.

*Federal Aviation Administration.* The TASCAR 500 system is a dual baseline transmissometer which utilizes a visible light transmitter and two detectors. One detector is located a distance of 40 ft from the transmitter and the other is located 250 ft from the transmitter on the same axis as the 40 ft detector. When the visibility reaches a point between 40 ft and 250 ft, the system automatically changes from one detector to the other.

This system is being tested at the Arcata Airport. The preliminary 250 ft baseline comparisons with the AN/GMQ-10 transmissometer of the same baseline indicate good correlation of 700 ft to 900 ft Runway Visual Range (RVR). However, the 40 ft baseline data have no meaningful transmissometer comparisons since there are no 40 ft baseline transmissometers.

Operational tests will commence at one of the properly equipped CAT III terminals sometime in 1983.

The current AN/GMQ-10 transmissometers seem to be somewhat labor intensive. It is estimated that one man-year of effort is expended for each three transmissometers.

Mr. Eric Mandel, Federal Aviation Administration (FAA) representative, stated at the February, 1980, meeting of the Federal Panel on Automatic Meteorological Observing Systems (PAMOS) that the Artege Company has developed a new visibility system and desires FAA endorsement. However, this creates a dilemma since there are no test standards or criteria which could be used in an evaluation of this sort.

Current concensus on the use of the EG&G, Inc., forward scatter meter is that it may possibly be used for both RVR and prevailing visibility measurements.

*National Weather Service.* The NWS at Sterling, Virginia, is doing comparisons of the Videograph, the EG&G forward scatter meter, the AN/GMQ-10 transmissometer, and a telephotometer to determine which one is best suited for automated use. The group at Sterling are also involved in developing algorithms to satisfy automated visibility measurement requirements. There seems to be a need to report the type of visibility measurement in definable terms as input to an automated system. There is also a need for terminology that will differentiate instrument measurements from observer data.

*United States Air Force.* A program to reduce the size and weight of the EG&G forward scatter meter to a device the size of the MRI, Inc., visiometer is underway. The concept for use of this miniaturized system is around tactical airfields. The transmitter and receiver will be remoted from the processing electronics (approximately 15 ft maximum).

*United States Army.* Visibility measurements can also be made with the visioceilometer. A selector switch changes from cloud height measurements to visibility measurements.

#### Deficiencies

There are still no effective, eye-safe remote sensors for slant visual range (SVR) measurements.

There is no accurate comparison basis for the 40 ft baseline transmissometer.

There is a need to obtain more statistical test comparison data on laser remote monostatic visibility sensors with standard visibility instruments.

OBSERVING LIGHTNING FROM GROUND-BASED  
AND AIRBORNE STATIONS

John C. Corbin, Jr.

Air Force Aeroanautical Systems Division

Introduction

Before I prepared this presentation, I found out that Bill Vaughan's discussion of "Aeronautical Concerns and National Aeronautics and Space Administration Atmospheric Electricity Projects" would touch on the subject of lightning surveillance from space. Thus forewarned, I prepared a complementary paper on observing lightning from ground-based and airborne stations. Since I was not intimately familiar with recent work conducted in this area, I telephoned a number of people working in the area to provide me information suitable for such an overview. The response I received was most gratifying. For the information they supplied, I wish to personally thank Paul Ryan of Ryan Stormscope; Lee Parker of Lee Parker, Inc.; Ed Hay of the Bureau of Mines; Dick Johnson of Southwest Research Institute; Rodney Bent of Atlantic Scientific Corporation; Phil Krider and Leon Byerly of Lightning Location and Protection, Inc.; Don Fitzgerald of the Air Force Geophysics Laboratory (AFGL); Carl Lennon of the National Aeronautics and Space Administration (NASA)/Kennedy Space Center; Felix Pitts of NASA/Langley Research Center; Craig Hayenga of New Mexico Institute of Mining and Technology; Paul Smith of South Dakota School of Mines and Technology; Captain Rob Baum of the Air Force Flight Dynamics Laboratory (AFFDL); and Captain Pete Rustan of the Air Force Institute of Technology.

The Need for Lightning Detection

There are many important reasons for detecting lightning from a distance. One reason which applies particularly to ground-based operations is that warnings of lightning development enable measures to be taken to discontinue operations that might endanger life or that might be impaired by lightning's presence. In many situations early detection of lightning is almost a necessity; e.g., refueling of aircraft and loading and unloading of explosive stores should not be conducted in a weather environment conducive to lightning development. Landing and takeoff of aircraft should also be avoided under lightning conditions if at all possible.

Recently, the Bureau of Mines funded a study to evaluate a number of different lightning warning systems (Southwest Research Institute, 1979). An analysis of mining explosive accident reports indicated a need for clear and ample warning of approaching electrical storms to reduce injuries/fatalities due to lightning-induced premature

detonation. Mine safety standards specify that "when electric detonators are used, charging (of blastholes) shall be suspended...and men withdrawn to a safe location upon the approach of an electrical storm." The study has been completed (Johnson, et al., 1980), and results will be reported at the Symposium on Lightning Technology at Langley Research Center in late April, 1980.

The public utility companies also need to know about the approach of electrical storms. Not only do they need to alert power line and equipment repair crews in advance, but they also need to alert control centers as to probable areas of trouble in transmission and distribution networks within the power system. Power outages are costly to the companies and can cause serious problems to consumers (e.g., in hospitals and traffic control), in addition to short-term inconveniences (e.g., no electricity with which to cook, no lighting, etc.). A number of research studies over and above lightning detection are in progress to evaluate protective systems for transmission lines, substations, and distribution equipment, such as lines, transformers, and protective lightning arresters (Darveniza and Uman, 1979).

Each year thousands of forest fires in the United States are started by lightning. The lightning fire hazard is particularly serious in remote areas of Alaska and in portions of our western states, where it is more difficult to detect fires quickly. Thus, there has been a need for lightning detection systems which can locate lightning, particularly discharges to ground, over rather large areas, thereby aiding fire fighting personnel and simplifying fire management. In the past few years, the Bureau of Land Management of the U.S. Department of the Interior has installed a network of lightning detection stations in interior Alaska and in the northwest Great Basin States (Vance and Krider, 1978). As a result of these installations, detection aircraft can be dispatched to active lightning areas and can report fires in their early stages so that they can be much more effectively confined by fire fighting crews.

In terms of potential loss of life, perhaps the greatest need for an early warning lightning detection system is on aircraft. For example, within the U.S. Air Force (USAF) over the past ten years, seven USAF aircraft have been lost due to confirmed lightning strikes, 153 serious lightning-related mishaps have been reported, and 773 lightning strikes have been documented by the USAF. In 1978 alone, two aircraft were lost with eight fatalities. USAF pilots presently rely on the familiar airborne weather radar system to locate thunderstorms and areas of heavy precipitation. The system operates by reflecting microwaves from precipitation-sized cloud particles; however, care is required in interpreting the observed reflectivity. For example, reflection from a moderate rain cloud in front of a severe storm can mask the severe storm behind it and can lead to a false interpretation that the storm is weak. This so-called "wipeout factor" is frequency-dependent. Another limitation of airborne weather radar is the relatively weak return from ice particles which usually occur in the upper parts of severe storms.

An actual lightning strike incident reported in September, 1979, to a USAF propeller-driven aircraft in the vicinity of McGuire Air Force Base (AFB) in New Jersey emphasizes the limitation of airborne weather radar in detecting lightning potential. The weather briefing received by the crew indicated a "potential" for thunderstorms along the route of flight; but no surface observations taken during flight indicated thunderstorms, lightning, or rain showers within twenty miles of the flight path. At the approximate time of the incident, the nearest thunderstorm detected by ground-based weather radar was more than twenty miles from the course line. The aircraft weather radar did not detect any variation from the light rain pattern already being experienced. The crew reported flight conditions varied from mist to very light rain during the entire flight. The aircraft was struck by lightning, and damage occurred to navigation lights, the electrical system, the engine propeller, the left flap, and the transponder, resulting in repair costs in excess of \$7,000.

#### Airborne Detection Systems

The only system presently in use for airborne applications is the Ryan Stormscope, which was introduced to general aviation at the Reading Air Show in 1976. The Stormscope is a four-component solid-state receiving system which provides bearing and range information between aircraft and electrical discharges. Radio frequency (RF) signals, generated by electrical discharges, are picked up by a single flat-pack antenna which provides both the V and H direction loop antennas and an electrical sense antenna followed with a signal amplifier. The antenna signals are routed to the receiver, where processing and control functions take place. The receiver is broadband-tuned with a center frequency of 50 KHz. Azimuth of the discharge is determined from the ratio of the two crossed-loop antenna inputs. Polarization of the fields is detected and processed, and signals from horizontal discharges are rejected. The range of the discharge is obtained by computer evaluation of signal strength, time to peak, decay time, spectral content, and comparison of electric and magnetic field amplitudes. (Note: The details of the physical concept of this evaluation could not be found in the open literature and are not provided by the company.) Bearing information is displayed on a CRT monitor over 360° (or, if selected by the operator, over the forward 180°). Range is selected in three steps of 40, 100 and 200 nautical miles (NM). Maximum displayed range is 260 NM. The system records and displays up to 128 individual electrical discharges (as small green dots on the CRT) and automatically updates the "oldest" discharge information with the "newest." In this manner, the display is constantly updated. If the dots are not replaced by new data, each is automatically erased after five minutes. Also, dots may be manually erased by the operator. Changes in heading and position of the aircraft will not affect data already displayed, so periodic clearing is necessary to maintain an accurate presentation with respect to the changing position of the aircraft in flight (Ryan Stormscope WX-7A Weather Mapping System, 1980).

Some thought has been given to combining airborne weather radar with the Stormscope display. There are probably two ways this could be accomplished. The first approach would have both radar and Stormscope on at the same time, overlaid on each other. However, this would eliminate two-thirds to three-fourths of the coverage area of Stormscope, since radar has only a 90° to 120° view and Stormscope has a full 360° view. A color difference between radar and Stormscope information displayed would likely be necessary to avoid confusion. A second approach would have a mode selection of either the radar or the Stormscope display. This would allow comparison between the two systems and would maintain the full 360° capability of Stormscope.

Several years ago, the AFFDL conducted an in-flight test program to evaluate the Stormscope performance in conjunction with a Bendix X-band airborne weather radar and a ground-based LDAR detection system (Note: LDAR is described later in this paper.) which were operated at Kennedy Space Center (Baum and Seymore, 1979). The USAF 4950th Test Wing provided a T-39B as the test bed aircraft. Partial funding for the program was provided by the Federal Aviation Administration (FAA). The flight test phase of the program took place July 5-27, 1978, at Patrick AFB.

Comparisons between Stormscope and LDAR indicated: (1) more isolated discharges with Stormscope than with LDAR; (2) differences in centroid range, with Stormscope tending to depict activity more distant than did LDAR; (3) some differences in centroid azimuth, with no consistent angular bias evident in one direction or another; and (4) Stormscope activity areas somewhat larger than corresponding LDAR areas.

Comparisons between Stormscope and on-board radar indicated that: (1) Stormscope activity typically occurs in regions which are depicted as isolated second and third level precipitation contours on radar, (2) Stormscope activity rate correlates primarily with radar precipitation gradient (i.e., abrupt first/third level interface areas) rather than with precipitation intensity itself, and (3) weather avoidance paths based on the location of second and third level precipitation contour areas show good agreement with avoidance paths based on high electrical activity displayed by Stormscope. Several cases were noted in which the 360° field of view available from Stormscope provided potentially valuable avoidance information not shown on radar.

One of the recommendations of this report was to obtain additional data on Stormscope by performing direct penetration flights into thunderstorm formations using a test aircraft that is armored, protected from the effects of hail, turbulence, and direct lightning attachment, and instrumented with Stormscope, radar, turbulence measuring devices and photographic recording equipment. I am happy to report that this recommendation will come to fruition in 1980. The T-28 thunderstorm penetration aircraft operated by the Institute of Atmospheric Sciences of South Dakota School of Mines and Technology (Prodan, 1979) will be equipped with a Stormscope supplied at no cost by Ryan Stormscope for the 1980 flight season.

### Ground-Based Detection Systems

A number of ground-based systems for detecting electrical discharges have been developed during the past few years. Described below are two examples of difference-in-time-of-arrival (DTOA) systems for detecting spherics from discharges in electrified clouds: (1) Lennon's Lightning Detection and Ranging (LDAR) system and (2) Taylor's lightning mapping system. Next, an interferometric system adapted to lightning location by Warwick and Hayenga will be discussed. Finally, I will review systems that are based upon crossed-loop magnetic direction finding principles but which have been refined and improved to accurately locate lightning discharges to ground.

Lightning Detection and Ranging (LDAR) system. The basic LDAR system was built, installed and operated at Kennedy Space Center during the 1974-1975 period to detect potential hazardous electrical activity that might impair missile launch operations. LDAR is a DTOA system that determines the location as well as the elevation of an electrical discharge in the atmosphere from the times of arrival of emitted electromagnetic signals in the 60-80 MHz band at four stations positioned in a Y-configuration with a baseline of approximately 10 km. A mini-computer, using the times of arrival as input, solves the hyperbolic equations and plots the range/azimuth position of the electrical discharges on a PPI plot. The height of the discharges is plotted separately as a function of range on a range/height indicator (RHI). The range/height data of discharges north of the central LDAR site (i.e., in the azimuth range  $270^\circ$  to  $90^\circ$ ) are plotted separately from range/height data of discharges south of the central LDAR site (in the azimuth range  $90^\circ$  to  $270^\circ$ ). For each data point in the PPI plot, a corresponding point appears on the range/height plot.

Each LDAR dot represents an electrical discharge in the atmosphere produced by the electrical breakdown of the air preceding and accompanying lightning activity. LDAR does not register the instantaneous ground stroke, since the electromagnetic radiation during the ground stroke occurs at much lower frequency ( $< 10$  MHz) than the 60-80 MHz input frequency range of the LDAR system. In terms of lightning activity detection and warning, this is a fine point of limited practical importance, since each ground stroke is accompanied by 50 to 100 LDAR discharges within milliseconds of the ground stroke.

An accuracy analysis of the LDAR system has shown that the symmetrical Y-configuration produces a uniformly low measurement error with an x,y position accuracy within the baseline (10 km) of the system of less than one percent. At distances greater than the baseline length, the accuracy decreases with distance. However, quite usable data can still be obtained at distances as far out as 110 NM based on available GEOS satellite infrared (IR) photographs of thunderstorms. Within the baseline, azimuth position can be measured typically with an error of less than 0.1 degree. Because of the planar orientation of the LDAR receiving stations, height is measured with a lesser accuracy than

azimuth or range. Height is measured most accurately above 1,000 ft, but the height measurement accuracy decreases below that level. Typically, the height error is less than 100 m (Peohler, 1978).

In 1978, correlation between LDAR, radar echo, and updraft/downdraft wind velocity and turbulence were measured by an armored T-28 aircraft (Prodan, 1979) flying through thunderclouds near Kennedy Space Center. Comparison of LDAR with Kennedy radars showed electrical activity was present over only a portion of the precipitation echo. In general, only a portion of the precipitation echo corresponds to an electrified thunderstorm cloud. Comparison of turbulence data indicated a close correlation with electrical activity. High updraft/downdraft activity and increased values of the turbulence parameters corresponded to high electrical activity. No LDAR response indicated a lack of thunderstorm and updraft/downdraft activity.

Since 1976, the LDAR system has gradually been upgraded to improve its capability, reliability and accuracy. The addition of electric field sensors gave the system the capability to determine the position, waveshape, rate of rise, and peak current of ground strokes. The addition of two new ground stations to form a second Y-configuration gave the system an improvement in reliability and accuracy by providing a completely independent hyperbolic system with which to check the LDAR data (Poehler and Lennon, 1979). The LDAR system will be located at Wallops Flight Center in 1980 and will be used in conjunction with a Langley F-106 flight program to obtain in-flight data on lightning electrical parameters. Information on the program is given by Pitts, et al. (1979).

Taylor's lightning mapping system. A VHF technique for space-time mapping of lightning discharge processes was described by Taylor (1978). The technique uses the time difference of arrival of VHF impulses from lightning discharge processes to determine azimuth from a pair of horizontally spaced antennas and elevation from a pair of vertically spaced antennas. Using an antenna spacing of approximately 14 m, it was possible to achieve elevation and azimuth angle accuracies within  $\pm 0.5^\circ$ . A cathode ray tube was used to view and photograph in real time radiating impulse sources up to  $30^\circ$  in elevation and up to  $60^\circ$  in azimuth. The instrumentation used permitted response to impulse rates up to 25,000/sec. To achieve range information, two stations were needed to determine the source location of each impulse received from a lightning discharge element.

During 1976, a two-station wideband system that would respond to received impulses over the frequency range 20-80 MHz was installed at Kennedy Space Center as part of the Thunderstorm Research International Program (TRIP 76) with the stations located about 17.8 km apart. Since that time, the system has been employed at the National Severe Storms Laboratory (NSSL) at Norman, Oklahoma, for use in conjunction with a number of experimental research programs.



Interferometer system. Interferometers have been used in radio astronomy to accurately locate extraterrestrial sources of radio frequency emission. The technique has been adapted by Warwick and Hayenga for lightning location and for measuring the characteristics of VHF sources in nearby lightning discharges (Warwick, et al., 1979). They have built a single baseline, two-element interferometer to test this technique in one angular coordinate of the lightning flash. In a paper to be published in 1980, they describe an upgraded crossed-baseline system.

The relative phases of signals arriving at a pair of omnidirectional antennas contain the desired information regarding the direction of arrival of the signals. The accuracy in determining the source direction depends on the accuracy with which the relative phase can be determined. The determination is simplified by mixing the outputs of the antennas with local oscillator signals so that there is an offset frequency much lower than the received frequency. The signals are then mixed with each other to produce an interference pattern with a sinusoidal modulation at the offset frequency. The phase of the modulation, which can be determined accurately from successive zero-crossing times of the signal, is directly related to the relative phase of the received frequency signals arriving at the two antennas.

In the version tested, they used a sharply tuned receiver operating at 34.3 MHz (this frequency chosen because it is relatively free from man-made interference) to receive VHF radiation emitted by breakdown processes occurring at the stepped leader front. Based upon the time duration of the step, its length, and its wavelength, an antenna spacing of 80 m was chosen. This results in determining position to within  $0.3^\circ$ . Positions of a stepped leader 2 km away can be determined to within about 10 m.

The inherent high accuracy of source direction determination by this method is limited in part by the observation time (time of averaging) of a given train of waves. The method assumes that the train of waves is sufficiently long to produce an interference pattern, and that the radiation comes from a single source of small size during the time of observation. If the radiation comes from multiple sources, the direction determination may be in error. Hence, the received radiation is averaged over a sufficiently short time interval to minimize the possibility of confusion with other sources. In the version tested, this time interval is of the order of 1-2 microseconds. Thus, pulses separated by two or more microseconds and their associated sources can be resolved.

From the above phase shift, one infers the polar angle of the source with respect to the baseline direction. This determines one angle. Crossed baselines (two elements on each line) give the vector direction (both azimuth and elevation). Using two groups widely separated can yield the source position by triangulation.

Improved crossed-loop lightning detection systems. Crossed-loop magnetic direction finders have been used since the 1920's to determine the directions to lightning discharges. The accuracy of these systems is determined by four factors: (1) the location and orientation of the lightning channel source (2) the characteristics of the propagating field, (3) the antenna location, and (4) the detection system and method of display.

Magnetic direction finders that are designed for operation on lightning beyond several hundred kilometers operate typically in the VLF frequency range of 10-30 KHz. These systems have generally poor operating characteristics at distances less than 200 km because of poor angular resolution ( $\pm 10^\circ$  typical), due in part to antenna pickup of undesired components of horizontal channel sections and atmospheric reflections.

Several years ago, an improved magnetic direction finder system with angular resolution accuracies of  $1^\circ$  to  $2^\circ$  or better for close lightning return strokes was developed and demonstrated by Krider, et al. (1976). The system operates by sampling only the initial few microseconds of wideband (1 KHz to 1 MHz) return stroke magnetic fields. Bearing errors are minimized because, near the ground, most channels tend to be straight and vertical with no large branches or horizontal sections. By detecting only the lightning ground wave, source polarization errors are minimized, as are ionospheric reflections. Tests on a number of lightning storms at distances of 10-100 km indicated angular resolution to be in the range of  $1^\circ$  to  $2^\circ$  with little or no systematic dependence on azimuth or distance.

The system can be made relatively insensitive to intracloud discharges, which is a distinct advantage when detection and location of lightning-caused forest fires or of possible interruptions in electric power distribution systems are desired. Most intracloud discharges can be rejected by proper choice of trigger level and sample gate width in the electronics.

At the present time two companies, Lightning Location and Protection, Inc., and Atlantic Scientific Corporation, market packaged systems which are based upon the above discussed direction-finding principle for detecting lightning discharges to ground.

#### Summary

In reviewing what has been accomplished during the past five or six years, it is obvious that a number of very intelligent, hard-working people have used their imaginations and expertise to make substantial advances in the state of the art of lightning detection. I have focused attention on some of the more important "commercial" applications for these systems, yet I do not want to overlook the importance of these new and improved systems for obtaining fundamental data on basic atmospheric phenomena. I am sure that a report on this subject five or six years from now will reflect on even greater accomplishments.

## References

- Baum, R. K., and T. J. Seymour, 1979: In-Flight Evaluation of a Severe Weather Avoidance System for Aircraft, AFFDL-TM-79-45-FES.
- Darveniza, M., and M. A. Uman, 1979: Lightning Studies of Distribution Systems, IEEE Power Engineering Society Conference on Overhead and Underground Transmission and Distribution, April, 1979.
- Johnson, R. L., J. E. Janota, and J. E. Hay, 1980: A Study of the Comparative Performance of Six Lightning Warning Systems, Symposium on Lightning Technology, NASA/Langley Research Center, Hampton, Virginia, April 22-24, 1980.
- Krider, E. P., R. C. Noggle, and M. A. Uman, 1976: A Gated, Wideband Magnetic Direction Finder for Lightning Return Strokes, Journal of Applied Meteorology, Vol. 15, pp. 301-306.
- Pitts, F. L., M. E. Thomas, R. E. Campbell, R. M. Thomas, and K. P. Zaepfel, 1979: Inflight Lightning Characteristics Measurement System, FAA/FIT Workshop on Grounding and Lightning Technology, March, 1979, FAA-RD-79-6.
- Poehler, H. A., 1978: A Preliminary Test of the Application of the Lightning Detection and Ranging System (LDAR) as a Thunderstorm Warning and Location Device for the FAA, Including a Correlation with Updrafts, Turbulence, and Radar Precipitation Echoes, NASA CR-154629.
- Poehler, H. A., and C. L. Lennon, 1979: Lightning Detection and Ranging System (LDAR): System Description and Performance Objectives, NASA Technical Memorandum 74105.
- Prodan, J., 1979: The T-28 Thunder/Hailstorm Penetration Aircraft, Proceedings of the Third Annual Workshop on Meteorological and Environmental Inputs to Aviation Systems, NASA CP-2104/FAA-RD-79-49.
- Ryan Stormscope WX-7A Weather Mapping System, 1980: Installation and Technical Manual No. 377A200, Revision 2.
- Southwest Research Institute, 1979: Evaluation and Improvement of Electrical Storm Warning Systems, Final Report prepared for United States Department of the Interior, Bureau of Mines, Contract No. J0387207.
- Taylor, W. L., 1978: A VHF Technique for Space-Time Mapping of Lightning Discharge Process, Journal of Geophysical Research, Vol. 83, pp. 3575-3583.
- Vance, D. L., and E. P. Krider, 1978: Lightning Detection Systems for Fire Management, Fifth Joint Conference on Fire and Forest Meteorology, March, 1978.

Warwick, J. W., C. O. Hayenga, and J. W. Brosnahan, 1979: Interferometric Directions of Lightning Sources at 34 MHz, Journal of Geophysical Research, Vol. 84, pp. 2457-2468.

AERONAUTICAL CONCERNS AND NATIONAL AERONAUTICS  
AND SPACE ADMINISTRATION ATMOSPHERIC ELECTRICITY PROJECTS

William W. Vaughan

NASA/Marshall Space Flight Center

Relative to the subject of lightning, some comments were made earlier today that very few aircraft accidents are caused by lightning, even though the U.S. Air Force (USAF) has had a number of encounters. Oftentimes meteorological elements do not constitute an operational concern. When one does start running into weather-related problems, however, the lack of knowledge in the area of meteorology becomes apparent. Since I have been working in the interface area of science-engineering and operations, I have noticed that people tend to ignore the meteorological area until it starts causing a problem. Lightning is no exception to this trend.

Lightning is a phenomenon that is still very mysterious to most people, including myself. Frankly speaking, we do not know an awful lot about it, what causes it, why it does what it does, or why it does not do some of the things we think it should. I believe the National Science Foundation (NSF), Office of Naval Research (ONR), and National Aeronautics and Space Administration (NASA) sponsor most of the disciplinary research in the country relative to lightning. The Department of Defense (DOD) and the Federal Aviation Administration (FAA) are also supplying quite a bit of information relative to the engineering problems and the associated aircraft hazards. (Many people are not aware which agencies are supplying the resources for this research.)

Jim Dodge, who was originally scheduled to give this presentation, heads up the Severe Storms and Local Weather Research Program in NASA Headquarters. We at Marshall Space Flight Center (MSFC) have been working with him, trying to identify and assess the merits of a satellite lightning mapper system. I will discuss that work briefly, but in order to provide background for the working sessions, I will also discuss a number of points related to aeronautical interests.

A NASA report with which those of you who have an interest in lightning may be familiar is NASA RP 1008, entitled "Lightning Protection from Aircraft," by Franklin Fisher and Andy Plumer. It is a very informative document, some 500 pages long, so you will need more than an afternoon to review it. Ten percent of the report discusses the ambient environment.

Let me ask you: How many of you have been in an aircraft which has been struck by lightning? Twice I have had this very interesting experience. I am not sure I was in much danger, but I certainly felt like I was for a few moments. In the past, aircraft seemed to

have an ability to accommodate these strikes due to component capabilities, bonding, etc. However in the future, with the composite structures and the micro-electronics being used on aircraft, it will be a different story. This prospect is encouraging a lot of research in the atmospheric electricity area.

My colleagues tell me that in a presentation about lightning, the speaker should always show pictures\* of lightning, so I have a few to show for a frame of reference. Figure 1 depicts what happens in a cloud-to-ground discharge. As you may well know, a leader goes down and then the actual discharge, which you see visually, comes up from the ground. All this takes place in a matter of less than a second. Cloud-to-cloud discharges are characterized by the fact that you see no leader coming from them. Lightning is a phenomenon from the thunderstorm itself, with its intensity depending upon the relative difference of potential between the ground and the cloud, or cells within the cloud.

Figure 2 shows a dramatic display of lightning. Displays such as this may contribute to the fact that we do not have too many aircraft encounters, because a pilot can certainly see phenomena like these before he reaches the area. This fact may answer why pilots, especially those in commercial and general aviation, stay away from thunderstorms as much as possible. I believe the USAF is also adopting this policy to avoid lightning problems, judging from what I hear with respect to their instructions on new aircraft.

Figures 3-9 were photographed in Switzerland. Figure 3 shows a dramatic intracloud discharge near Mt. San Salvatore, and Figure 4 illustrates the very significant amount of electrical energy moving along the channel of this discharge near Mt. San Salvatore which had the appearance of a loop. In Figure 5, taken near Mt. Brè, the European Ash being struck by lightning is only 60 meters from where the picture was taken. I suspect the photographer had a traumatic encounter also.

Also taken near Mt. San Salvatore, Figure 6 shows a lightning flash to the side of the mountain; and Figure 7 illustrates an upward triggered flash. Figures 8 and 9 show cloud-to-ground flashes near Mt. Brè, with the spectrum displayed on the right-hand side in Figure 9. Figure 10, the final photograph of lightning, is a cloud-to-water flash off the coast of Cocoa Beach, Florida.

Figure 11 is a common chart to many of us in the atmospheric area; it is the thunderstorm day chart compiled by the National Weather Service (NWS) a number of years ago. As you can see, the concentration of

\*Photo credits:

Figures 1, 2 - NOAA.

Figures 3, 4, 5, 6, 7, 8, 9, 10 - Dr. R. Orville, State University of New York.

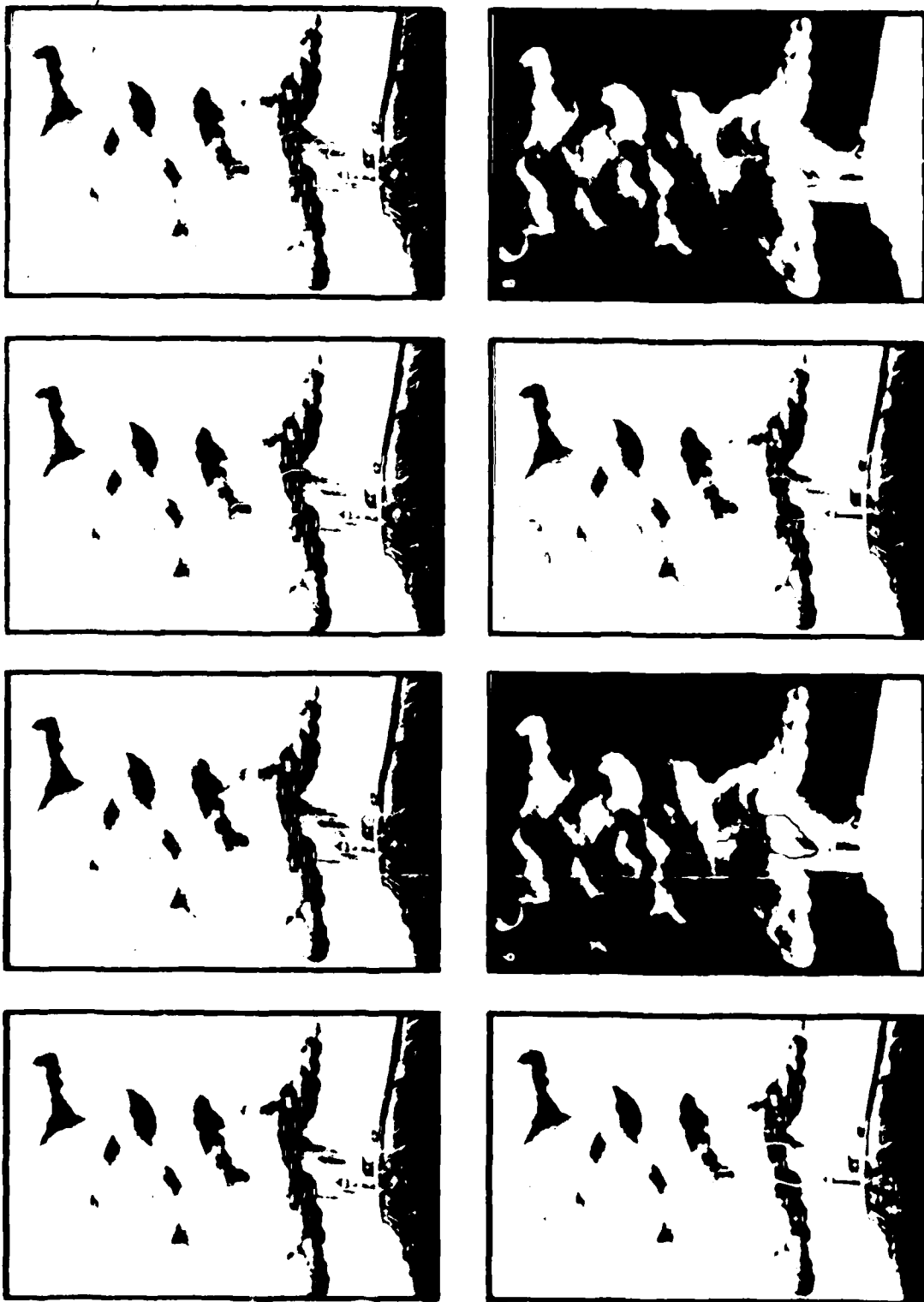

Figure 1. Life cycle of a lightning stroke. As thunderstorm induces growing positive charge in earth, potential between cloud and ground increases (1) until pilot leader starts a conductive channel toward ground (2) followed by step leaders (3) which move downward for short intervals (4) until met by streamers from ground. Return stroke from ground illuminates branches (5) and seems to come from cloud. Main stroke is followed by sequence of dart leaders and re-returns (6,7) until potential is reduced or ionized path is dispersed (8). Elapsed time: 1 sec.



Figure 1. Summer of the forest fire in the area.





Figure 1. Intracavitary lightning strike, Mt. San Salvatore, Switzerland.



Figure 3. Ground-to-cloud triggered lightning which has the appearance of a loop in the channel path.  
Mt. San Salvatore (1969).





View of the Alps from the side of Mt. San Salvatore, Lugano, Switzerland. Bright spot below flesh

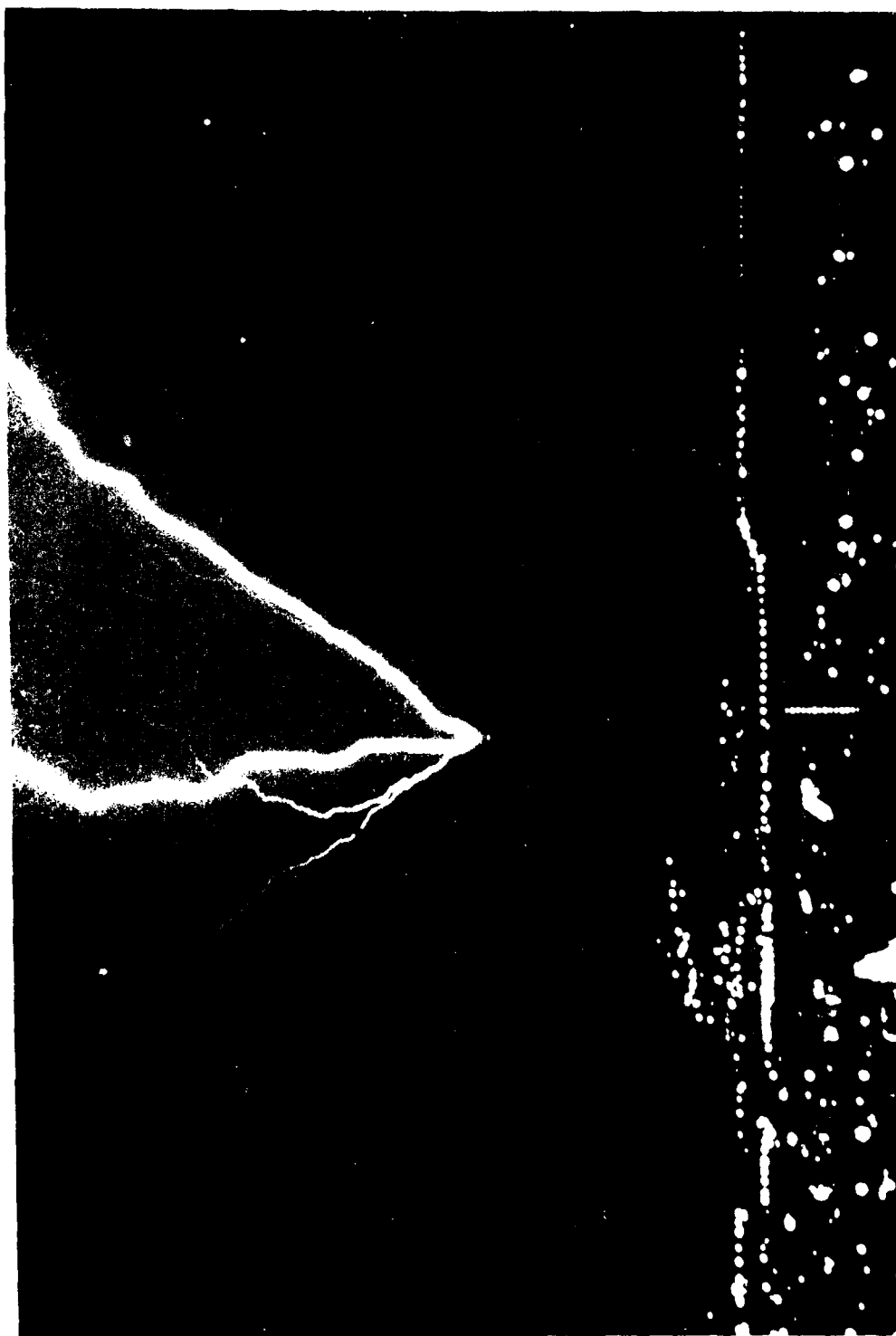

Figure 7. Upward triggered lightning flash from Mt. San Salvatore. (Maras)



Figure 9. Cloud-to-ground flash near Mt. Brè, Switzerland. (1967)



Figure 9. Cloud-to-ground flash near wt. bré, Switzerland. Spectrum is displayed on the right side.



Figure 10. Cloud-to-water flash off the coast of Cocoa Beach, Florida. (1977)



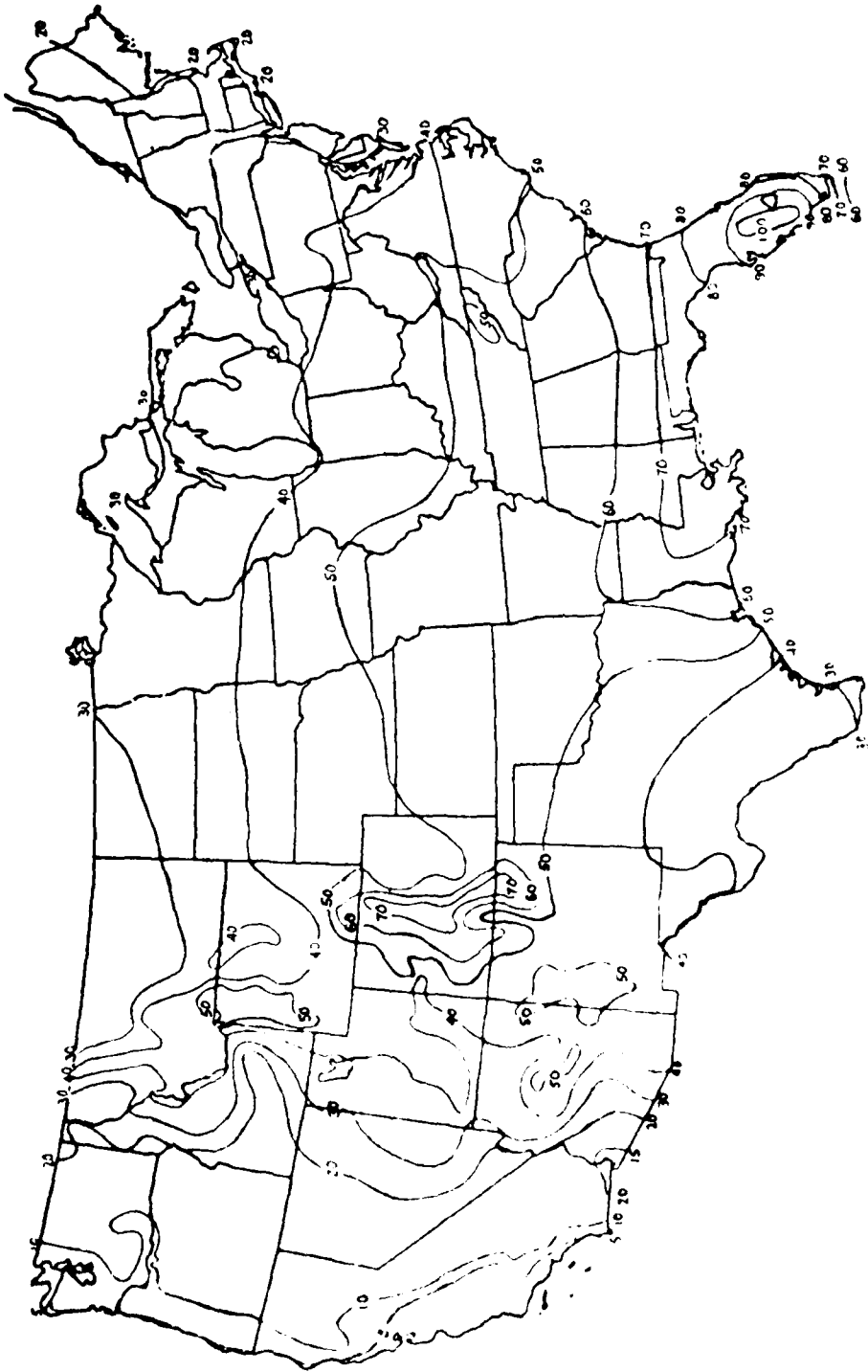

Figure 11. Thunderstorm days (isothermic level) within the continental United States as reported by the U.S. Weather Bureau. (Mean annual number of days with thunderstorms.)

thunderstorm days is in Florida and in the western part of the country, with the annual 50 line running through Kentucky and swinging up through Illinois. Although this is good information on thunderstorm days, it tells us nothing about the number of thunderstorms that actually occurred on each of those days. Tables 1 and 2 may help illustrate this point. Much analysis of lightning hazards has been done using thunderstorm day statistics, e.g., NASA has done a lot of work with respect to the environment at Kennedy Space Center (KSC) in connection with the early launches, the Shuttle program, and the Apollo program. You will note in these tables that the data from KSC covers an 11-year period and shows the number of days in which there were from one to six thunderstorms. A day during which there are six thunderstorms would still be categorized as one thunderstorm day in the data records; therefore, a one-to-one correlation does not exist between the statistics on thunderstorm days, the number of thunderstorms which occurred on those days, and the number of lightning discharges.

Figure 12 is again a frame of reference for those of you who are not familiar with a lightning discharge model. This model, which was developed for use in designing the Space Shuttle, is considered an extreme level design model, showing 200,000 amps of current flowing in a very short period of time. (Therefore, NASA does not expect any atmospheric electricity difficulty with the Space Shuttle, but we still anticipate staying out of thunderstorms.) As much as 200,000 amps or even more current may flow in some discharges, with the potential for causing tremendous effects. Generally speaking, a discharge usually measures 20,000 amps and above; and the continuing currents in these strokes, which can last up to hundreds of milliseconds, can run from 200 to 2,000 amps. Obviously then, from an aircraft electrical hazards point of view, considerable damage can result. Cloud-to-cloud discharges, I might add, run much lower in current intensities than do the cloud-to-ground discharges.

#### Measurement Techniques

The three basic techniques used to measure atmospheric electricity are acoustic, optical and radio frequency (RF). The platforms used for these techniques are ground, towers, balloons, rockets, dropsondes, airplanes and satellites. Art Low at MIT has done a bit of work in the acoustical area, listening to thunder in an attempt to derive signatures and relate them to electrical discharges and severe storm activity. Not too much work is going on in that area. Dick Orville and his associates at State University of New York, the flight in our division at MSFC, and others have done work in the area of optical techniques, including the spectrographic area and the visual counting of lightning discharges. The RF area is the one in which the majority of people in aircraft research are involved, especially in-situ measurements. Therefore, much work has been done in this area. With the RF technique one can distinguish between cloud-to-cloud and cloud-to-ground discharges. The very low frequency unit that Phil Frider, Martin Uman and others have installed in the western part of the country

TABLE 1

FREQUENCIES OF OBSERVED NUMBER OF DAYS THAT EXPERIENCED x THUNDERSTORM EVENTS AT KSC FOR THE 11-YEAR PERIOD JANUARY 1957 THROUGH DECEMBER 1967

x	JAN	FEB	MAR	APR	MAY	JUN	JUL	AUG	SEP	OCT	NOV	DEC	SPRING	SUMMER	FALL
0	335	295	308	299	266	187	177	185	228	311	321	334	873	540	860
1	4	9	20	18	43	77	80	89	54	17	6	3	81	246	77
2	2	4	9	10	25	40	47	30	33	9	3	2	44	117	45
3		2	3	3	3	17	26	24	12	4		2	9	67	16
4			1		3	6	9	10	3				4	25	3
5					0	2	2	3					0	7	
6					1	1							1	1	
n	341	310	341	330	341	330	341	341	330	341	330	341	1012	1012	1001

TABLE 2

RELATIVE FREQUENCY OF DAYS THAT EXPERIENCED AT LEAST ONE THUNDERSTORM EVENT AT KSC

	JAN	FEB	MAR	APP	MAY	JUN	JUL	AUG	SEP	OCT	NOV	DEC	SPRING	SUMMER	FALL
	0.013	0.043	0.097	0.094	0.222	0.433	0.481	0.457	0.309	0.088	0.027	0.021	0.137	0.458	0.141

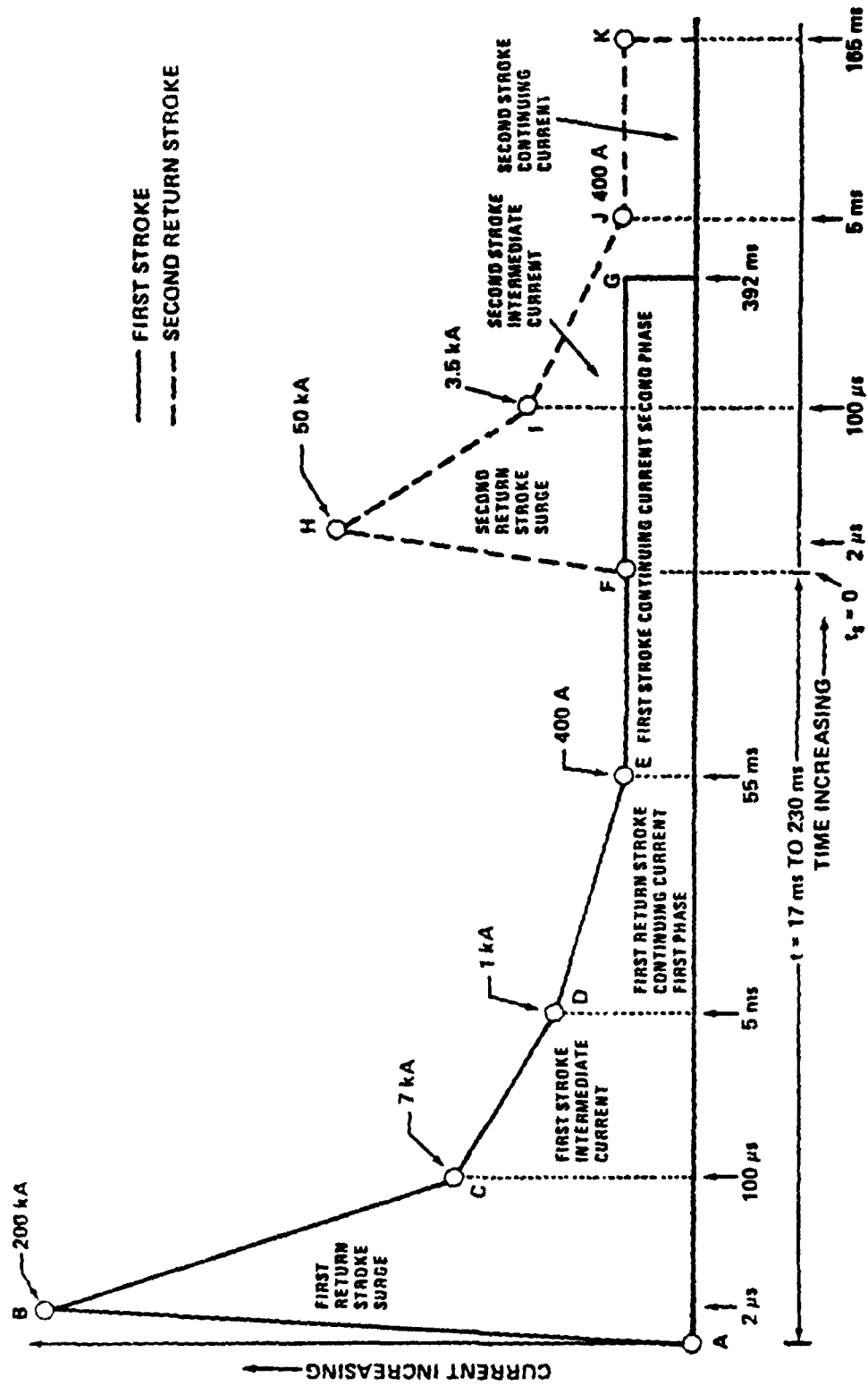

Figure 12. Diagrammatic representation of a very severe lightning model (Model 1). (Note that the diagram is not to scale.) January 1979 revision.

(probably the largest network going at this time) measures cloud-to-ground discharges because they are identified in the lower frequency part of the spectrum.

#### Aircraft Measurements

Joe Stickle and Norm Crabill in our audience have certainly had their share of experiences with the F-106 at Langley Research Center. Norm tells me they occasionally have problems with it, although I think it is one of the best instrumented aircraft in use today. Ralph Markson has an aircraft with which he has done a lot of work. The ONR is in the process of developing further work with the Schweitzer aircraft. They currently have one in New Mexico, and I believe another one is going to be instrumented primarily for external storm use. A number of other aircraft have been instrumented by DOD and others over the years.

#### Satellite Measurements

In the area of satellites, the VEGA had on it a sensor which was to detect and monitor atomic clandestine explosions or bursts. Unfortunately, lightning discharges were also being recorded. This led to the USAF's pursuing the subject further with the DMSP satellites, which had some small piggyback and very inexpensive (relatively speaking) instruments on board. They have demonstrated the ability to detect lightning from a satellite. The Workshop on the Need for Lightning Observations from Space held this past year at The University of Tennessee Space Institute (UTSI) led to NASA's decision to pursue the idea, conceptually at least, and we have three teams working on it today. Phil Krider at the University of Arizona is working along with others on the RF section; Bill Wolfe, also of the University of Arizona, is working the optical part; and Art Few of Rice University is rescrubbing the requirements of all the users, including aircraft, utilities, etc., to be sure we have a strong frame of reference for what is really needed and what can be used. In the summer of 1980 we plan a review at NASA Headquarters to determine which way to go with the program. I suspect next year we will still continue to work on the technology base with people like Phil Krider, Dave Rust and Marx Brook working with us on this program. I believe we will succeed in having a meaningful satellite sensor system. One of the things we have almost concluded, based on results to date, is that satellite spectrographic techniques may be difficult to use for sorting out cloud-to-cloud and cloud-to-ground discharges. The lines and spectral intensities from cloud-to-cloud and cloud-to-ground appear to be nearly the same. However, this does not appear to be a critical item for the effective use of the satellite measurements. In overflying storms with the U2 during 1979 and 1980, we have noted through observation that the origin of lightning discharges, whether they go to ground or not, appears to be in the upper part of the storm. This tends to negate the statements of some of our adversaries who say we cannot use satellite observations because the real action is occurring near and under the cloud. Our experiments seem to be proving otherwise, which is an encouragement for more research in that area.

NASA Efforts

Our colleagues at Langley Research Center and we at Marshall Space Flight Center are both engaged in atmospheric electricity and lightning work. The Langley work is primarily concerned with aircraft effects and in-situ measurements, design factors and protection. The Marshall work is primarily concerned with the concept of using the satellite as a lightning mapper with aircraft overflights, with space vehicle design, and with remote optical and RF measurements relative to severe storm research (Table 3). Langley and Marshall will collaborate on efforts as the work progresses. Some work is going on at Kennedy Space Center, but that has slowed down in the past couple of years. Kennedy's LDAR system has been moved to Wallops Flight Center; however, Kennedy has an aircraft they plan to instrument. Goddard Space Flight Center also has a small RF research effort in progress.

TABLE 3  
NASA EFFORTS

<p><u>Marshall Space Flight Center</u></p> <p>Satellite lightning mapper</p> <p>Aircraft overflights of storms and ground research efforts</p> <p>Space vehicle design</p> <p>Remote measurements</p>
<p><u>Langley Research Center</u></p> <p>Aircraft effects</p> <p>Protection</p> <p>Design factors</p> <p>In-situ measurements</p>

In Table 4, I have listed the RF techniques which seem to be most applicable to the aeronautical area. Naval Research Laboratory (NRL) has taken the initiative to take Heinz Kasemir's cylindrical field mill concept and try to overcome some of the operational difficulties of the prototype system. I suspect this is probably the newest development in the field mill area. NASA, in a modest way, is contributing to that development.

Three types of field mills can be used as instruments for electrical field measurements: radioactive collectors, shutter mills, and

TABLE 4  
SOME RF TECHNIQUES

<p><u>Electric Field</u></p> <p>Field mills or flux meters</p>
<p><u>Electric Field Change</u></p> <p>Field change meter</p> <p>Aerials with proper frequency response</p> <p>Shielded crossed loop antenna with sufficient bandwidth</p>
<p><u>Wave Shapes of Currents</u></p> <p>Shunt measurements</p> <p>Induction coils</p> <p>Cathode ray oscillograph</p>
<p><u>Lightning Flash Density</u></p> <p>Spherics counter</p> <p>Lightning flash counters</p> <p>Counts of field changes <math>&gt; 5 \text{ V m}^{-1}</math></p>

cylindrical mills. The radioactive collector and the shutter mill each have their own merits and limitations. The cylindrical mill appears capable of overcoming most of the limitations of those two systems, as well as giving two or perhaps three components of the electrical field. *During the working sessions I am sure Lothar Ruhnke will be glad to go into some of those details.*

There will be a symposium April 22-24, 1980, at Langley Research Center on the subject of lightning technology relative to aircraft. Listed in Table 5 are the major topics of the sessions, which will be covered over a period of three days. I encourage those of you who have an interest in this area to participate in that symposium. For those of you who have ample travel funds and wish to have a little time off this summer, you might wish to attend an international atmospheric electricity (lightning) conference which will be held in Manchester, England, at the end of July and the first of August.

TABLE 5

LIGHTNING TECHNOLOGY  
(DOT-NASA SYMPOSIUM, APRIL 22-24, 1980, LANGLEY RESEARCH CENTER)

Topics for Discussion

Phenomenology of lightning  
Lightning instrumentation and measurements  
Lightning detection and tracking  
Protection of ground systems  
Lightning interaction and simulation  
Lightning and static interactions with aircraft  
Aircraft lightning protection design and testing

At the Manchester conference, in which NASA, ONR and others are involved, a considerable amount of work will be reported, especially in the disciplinary areas relative to lightning and atmospheric electricity.

Conclusion

Lightning has been around a long, long time. I guess Ben Franklin gets the credit to a certain degree for being one of the first people to try to make some measurements and look at lightning objectively, but we still do not know much about it. However, consideration of the three points in Table 6 will help us direct our efforts.

TABLE 6

CONCLUDING REMARKS

- Lightning is an extremely variable phenomenon.
- Measurements are needed to provide more realistic and statistically significant comparisons.
- Phenomenon as a whole needs study, i.e., lightning intensity, synoptic situation, and meteorological aspects.

Efforts are continuing under the various government agencies' sponsorship, and under the sponsorship of the utilities in particular.



I think we are going to see some rather dramatic changes in information and understanding of this phenomenon in the future. Hopefully, what NASA is doing in the satellite area will contribute to solution of the related aviation problems, even though aviation's requirements are the most strenuous from both a temporal and a spatial point of view.

**SECTION IV**  
**BANQUET PRESENTATION**



## MEASURING WEATHER FOR AVIATION SAFETY IN THE 1980'S

Robert W. Wedan

FAA/Systems Research and Development Service

Ladies and gentlemen, I sincerely appreciate the opportunity to speak to you this evening. Mr. Quentin Taylor, our Federal Aviation Administration (FAA) Deputy Administrator, sends his regrets that he was unable to attend. Fortunately, from my point of view, he asked me to stand in for him as the banquet speaker. I am sure that Quent doesn't know what a beautiful place this is. Had he known, he probably would have sent me on his other assignment and attended this one himself. Be that as it may, I am pleased to be with you and pleased to have this particular audience to address, because it includes many familiar faces.

I have a personal as well as a professional interest in the subject of this workshop. As some of you know, my wife and I own an airplane. In fact, we used it on this trip, and we are vitally interested in the upgrading of weather sensing and distribution of aviation weather information. This includes improvements pertaining to pre-flight briefings, but also includes improvements related to in-flight operations. For instance, we want to know where the thunderstorms are as real-time information. We are interested in what is directly ahead of us for purposes of tactical activity--where are the soft spots?--should we continue straight ahead or deviate left or right? For in-flight strategic planning, we want to know where the storms are and where they are forecast to be in the general direction of our flight. On-board radar will not provide this, and even if it could, it is too expensive a solution for us. But thunderstorms are not everything. In the fall and winter we want to know where the icing levels are. We also want to know more accurately when frontal passages will take place en route and at our destination. Some of our destinations have special problems, such as sea fog at New England airports, where we want to know if the airport will remain above minimums--both visual flight rules (VFR) and instrument flight rules (IFR)--at our planned landing time. Regarding our planned landing time, it would be very helpful to have real-time winds aloft data available, as compared to six-hour old forecast winds.

Perhaps you have guessed that the aviation weather program to provide this capability is one of my favorites in government research and development.

Every one here was invited because of his or her special interest or special knowledge in aviation matters. You are specialists in flight operations, instrumentation, communications, meteorology, and almost any other profession dealing with aviation weather that one can imagine. The FAA exists to further the growth and safety of aviation, and since your interests are along the same lines, we hopefully are tuned to the

same frequency and can talk the same language. You are all aware that there have been three previous workshops here at The University of Tennessee Space Institute (UTSI) regarding environmental and meteorological inputs to aviation systems and that the results of those workshops have influenced the research and development (R&D) programs of the three sponsoring agencies. This search for "what needs to be done" and "what can be done" and determining the priorities for doing it without inventing the wheel over and over again is a never-ending search on the part of those of us in the government responsible for serving the best interests of all the users of the National Airspace System (NAS).

One such search was initiated almost two years ago when FAA Administrator Langhorne Bond asked the aviation community for its ideas on the direction we should take in engineering and development as we look into the future. That effort, which we called "New Engineering and Development Initiatives--Policy and Technology Choices," led to a document published in March, 1979, which summarized the user community views. To develop this document, approximately 260 experts of the aviation community, representing 60 organizations and organized into five topic groups, held 60 meetings over a seven-month period. All major sectors of the aviation community were represented, including airline pilots, trunk and commuter airline operators, owners and pilots of the entire spectrum of general aviation aircraft, air traffic controllers, airport operators, helicopter owners, operators and pilots, and aircraft and equipment manufacturers.

The topic groups were organized to evaluate the critical issues in five specific areas:

1. Productivity and automation.
2. Airport capacity.
3. Freedom of airspace.
4. Safety and flight control.
5. Non- or low-capital policies to improve efficiency.

Aviation weather problems appear to have been one of the favorite subjects in the overall study. Four of the five topic groups made recommendations relative to the need for better weather inputs to both controllers and pilots. The report expressed a true sense of urgency for aviation weather system improvements and warned us (the FAA) not to delay getting something going right now rather than waiting for added sophistication or precision, which always seems to be just over the horizon.

In all, there were 20 separate recommendations for FAA actions to improve the aviation weather system. In some cases, several of the topic groups made very similar recommendations. We viewed these repeated endorsements as strong reinforcements for the need of the efforts.

We analyzed all the recommendations very carefully and found that we could group them under three key requirements.

You might ask what all this has to do with measuring weather for aviation safety, which is the theme of this presentation and of this workshop. I think it has a lot to do with that theme; you certainly do not want to measure anything unless you can use the data. A sound, logical pattern tells us to first understand our requirements and to then identify what is needed to meet the requirements. When we have that all set, we match dollars available with the priorities established and get on with the work.

When one follows this logical pattern, the wheat gets separated from the chaff. Missing links are isolated, and R&D efforts are concentrated on alleviating known deficiencies. The value of an initiatives study like the one I have described is that it permits us to move out of the "wondering-what-we-ought-to-do" phase into the "knowing-what-we-ought-to-do" phase.

Taking the three key requirements that resulted from this study one at a time, let us see if they give us some clues on priorities for measuring weather parameters.

Requirement #1: The Urgent Need for Weather Observations at All Airports with Instrument Approaches

You are probably aware that a family of modular automated surface weather observing systems are under joint FAA/National Weather Service (NWS)/Air Weather Service (AWS) development to meet this requirement and that excellent progress is being made. However, instrumentation for measuring some of the weather elements is still not fixed, such as the ceilometer, the visibility sensor, the present weather sensor or sensors, and the thunderstorm detector and tracker. We have some ideas on the types of sensors to use, and we are experimenting with a variety of them, but it is still open season on making final selections, and an open area for innovation in sensor design. Our ultimate success in this program is dependent upon our ability to sense and measure automatically nearly all elements of weather. As a case in point, incidentally, those of us who flew into Tullahoma Municipal Airport yesterday or today are aware that the published approach descent minima are dependent on a local altimeter reading by the fixed based operator, conveyed over the UNICOM frequency. If not available, e.g., after dark, the Nashville altimeter reading applies--with a penalty. What does this mean? Well, 100 miles away, at Crossville, the ceiling this morning was broken at 600 feet. At Tullahoma, the published approach minima is 500 feet using the local altimeter setting, but has a 220-foot penalty if the Nashville setting is used. Now, picture this: If we had 600 feet, broken ceiling at Tullahoma and had descended to our minimum of 620 feet (using Nashville's altimeter setting), we might see the ground through the holes in the broken ceiling but still be in the clouds. Like the Sirens tempting the sailors of Ulysses' time to founder on the

rocks, these holes tempt pilots to "duck under." Does it happen? Yes. As we all know, this presents a major safety problem.

Requirement #2: The Need for More Accurate and Timely Radar Detection of Weather Elements Hazardous to Aviation

In this area, as with the automated weather observation system (AWOS) program, we have a joint FAA/National Oceanic and Atmospheric Administration (NOAA)/Air Force program underway to develop the next generation weather radar (NEXRAD). There is general agreement that a Doppler radar is needed to measure the weather elements hazardous to aviation. Information derivable from Doppler radar data includes quantitative measures of precipitation intensity, areas of associated turbulence, freezing level in areas of precipitation, short-term cell track predictions and, in some cases, clear air turbulence. Coverage from ground up and detection of low level anomalies such as turbulence and wind shear are critical in terminal operations, and these requirements tend to dictate rather stringent constraints on such factors as siting, scan rate, pulse repetition frequency, etc., which may force some tradeoffs in the final design. Determining these tradeoffs, and the optimum processing of the raw Doppler data for displaying information on the hazardous elements in an operationally meaningful manner for a variety of final users, provides a tremendous challenge over the next few years, for those involved in this joint effort. A national network of Doppler weather radars will undoubtedly be the number one priority weather measuring system for the 1980's.

Requirement #3: The Need for Better Methods of Timely Distribution of Both Pilot Reports and Ground Weather Data

The study groups recommended several important initiatives relative to this requirement, such as acceleration of discrete address beacon system (DABS) data link applications for air-to-ground and ground-to-air weather information distribution, development of automatic airborne weather sensing systems for automatic transmission to ground via DABS data link, and improvement of pilot report (PIREP) handling and use in conjunction with the ground system to improve forecasts.

This is the area in which we expect the biggest pay-off from our aviation weather system (AWES) development. AWES development is an effort to upgrade the full range of weather services being provided to the aviation community. Our plan is for the system to evolve as an integral part of the air traffic control, flight service station, and other systems rather than as a separate, parallel system. It will use, whenever practical, existing and planned air traffic control and flight service station system components, elements, subsystems, facilities and resources in the collection, distribution, processing and dissemination of operationally significant weather information. Some improvements in this area have recently been made, or will be made in the near term, such as implementation of the center weather service units (CWSU's), where NWS meteorologists are on duty in our air route

traffic control centers, and the provision of color weather radar displays for use by center controllers and the NWS meteorologists manning the CWSU's.

For the future, an enhanced flight service station data processor (FSDPS) will give us access to the national aviation weather data base and will enable us to automate the functions of the CWSU's. DABS will provide a data link to send digital and graphic weather information to the cockpit and will permit the sending of both manual and automated PIREPS to the ground. Initially, we plan to have runway winds and runway visual range available for terminal operations. PIREPS have already been structured for easy entry and breakdown by processors, and automatic PIREPS are available today, to a limited degree, from inertial navigation-equipped aircraft participating in the National Aeronautics and Space Administration (NASA)/NOAA aircraft-to-satellite data relay system (ASDAR). This system automatically provides aircraft position, time and altitude, along with temperature and wind speed and direction, to the National Meteorological Center and Airline Meteorological Office through a satellite-to-ground relay. These data are used in flight planning and over-ocean weather forecasting. Because of their limited numbers, we cannot depend solely upon inertial navigation-equipped aircraft for wind data over the continental United States, so we are investigating a technique to use non-inertial navigation-equipped aircraft true airspeed and heading, downlinked (via DABS), along with ground-derived aircraft track and ground speed to calculate upper air winds. If this technique is successful, we should be able to develop a broad base of near real-time upper air winds to be used not only for improving forecasts, but also for use in air traffic control metering, spacing and flow control. It will also satisfy one of the in-flight information needs that I mentioned earlier.

When we talk about measuring weather for aviation safety relative to this third requirement, I think we have to take it further than just measuring to come up with priority work efforts. True, we need a compact, low-cost airborne weather sensing system that can feed automatic PIREPS to the ground via the DABS data link system, but we also need to develop the ground-based system to handle automatically these observations for improving forecasts and for the many other uses planned. Corollary to this is the problem of using the data link to get the improved, more timely weather information products to the cockpit. We see the major challenge to our inventiveness right in the cockpit itself. How do we provide the simplest means for the pilot to feed information into the downlink system? More importantly, how do we display the uplinked weather data so that the cockpit is not loaded with displays, printers, and what-have-you? And finally, how do we present the information to the pilot in a form and format that requires little or no interpretation and that does not detract him from his piloting duties? These questions do not have easy answers; there is still a great deal of work to do before solutions are in hand.

### Conclusion

So there you have it--FAA's priorities for measuring weather for aviation safety in the 1980's include:

1. Both ground-based and airborne automated weather observation stations.
2. A national Doppler weather radar network.
3. A system to move the acquired weather data through the necessary processing and on to the final users in the shortest time possible and in a form and format that has real operational utility.

It is our sincerest hope that your deliberations during this workshop will provide new insights, solutions and approaches to resolve some of these questions we have raised.



## SECTION V

### IMPROMPTU PRESENTATIONS



## 1979 CLEAR AIR TURBULENCE FLIGHT TEST PROGRAM

Edwin A. Weaver

NASA/Marshall Space Flight Center

The National Aeronautics and Space Administration (NASA) Clear Air Turbulence (CAT) Flight Test Program in 1979 was funded by NASA's Aviation Safety Technology Branch and was a test of four advanced technology CAT instruments and detailed CAT forecasting techniques. Earlier, this branch sponsored the development of four CAT instrument systems which employ different approaches to the CAT problem. One measures velocity, another measures temperature structure, and two measure water vapor but at different wavelengths. Each of these developments showed promise in their approach, but they all had some potential limitations. The flight test conducted during January through March, 1979, provided a common test platform to determine performance or feasibility of each CAT sensor in different CAT and non-CAT conditions at a wide range of flight levels and atmospheric conditions. Each instrument was evaluated at the state of development achieved at the time of the test, so for two of them it was an initial concept feasibility test. The data from the test provided supporting proof for many detailed forecasting techniques. It also provided the basis to determine the instrument performance. The results of the analyses will be used to define the further development necessary for these or similar instrument systems that may be used toward resolving the CAT problem.

The NASA Convair 990 aircraft, NASA 712, shown in Figure 1, is based at the Ames Research Center. It is a flying laboratory. All the flight parameters that are available in the cockpit plus other pertinent flight data are sent to a computer in the experiments or passenger area. These data are available for display to the experimenters at any time throughout the flight. In addition, the computer will collect data from the different experiments and will plot the data in real time or near real time during a mission.

The objective of the 1979 Clear Air Turbulence Flight Test was to evaluate and test four different sensors in the detection and measuring of CAT and other meteorological targets of opportunity that relate to turbulence (Table 1). The primary types of CAT investigated were mountain wave CAT, jetstream CAT, CAT in cirrus clouds, and CAT in frontal wind shears, troughs and ridges. There were four investigators. Ed Weaver had the CO<sub>2</sub> pulsed Doppler lidar. Jack Ehernberger was co-investigator for CAT forecasting. Bruce Gary had two microwave radiometers. One, at a frequency of 55.5 GHz, looked at atmospheric temperature structure. The other, at a frequency of 180.1 GHz, looked at atmospheric water vapor and investigated the feasibility of measuring at the microwave frequency the turbulence features seen in the infrared (IR) frequencies. Bruce concludes that the sensitivity of the water vapor microwave radiometer is insufficient at this point in its



Figure 1. The NASA Convair 990 aircraft.

TABLE 1

OVERVIEW OF THE 1979 CLEAR AIR TURBULENCE FLIGHT TEST PROGRAM

OBJECTIVE:

- Evaluate four (4) sensors for the detection and measurement of CAT and meteorological targets of opportunity.

TYPES OF CAT:

- Mountain wave
- Jet stream
- CAT in cirrus clouds
- CAT in frontal wind shears, troughs, ridges, etc.

SPONSOR:

- NASA/Aviation Safety Technology Branch

INVESTIGATORS:

- Principal Investigator: NASA/Marshall Space Flight Center  
E. A. Weaver  
Doppler lidar, 10.6 micrometers
- Co-Investigator: NASA/Dryden Flight Research Center  
L. J. Ehernberger  
CAT forecasting techniques
- Co-Investigator: NASA/Jet Propulsion Laboratory  
B. Gary  
Microwave radiometers, 55.5 and 180.1 GHz
- Co-Investigator: DOC/NOAA/Environmental Research Laboratories  
P. M. Kuhn  
Infrared radiometer, 27-33 micrometers

development to make the kind of turbulence measurements of interest. Pete Kuhn had his IR radiometer at 27-33 micrometers wavelength as the fourth sensor. The IR radiometer successfully detected CAT at all flight levels. The pulsed Doppler lidar, as Jack Enders mentioned in "Aviation Meteorology Research and Development: A Status Report," of this proceedings, needs aerosols for tracers; but this is not necessarily a drawback since the atmosphere is not as dirty from the use of aerosols as some want us to believe.

Several groups participated in the test (Table 2): six NASA groups; the Department of Transportation (DOT); several industrial firms, e.g., the Raytheon Company which is the prime contractor for the pulsed Doppler lidar; three groups from the National Oceanic and Atmospheric Administration (NOAA); five Department of Defense (DOD) groups, including three Air Force and two Navy groups; and three universities. The involvement of so many organizations resulted in the large test crew of 25 shown in Figure 2. Not pictured are the pilots, the ground crew, the data reduction group, and the meteorological support group.

Figure 3 shows the test region. The aircraft was based at Moffett Field, Mountain View, California. Beginning there, the search for CAT covered an area bounded by Yuma, Arizona, to El Paso, Texas, on the south, Denver, Colorado, on the east, and Great Falls, Montana, to Portland, Oregon, on the north. Two missions with a different major objective, with CAT detection as a secondary objective, were flown all the way down to 20°N latitude off the Baja, California, peninsula. On those two missions we crossed the subtropical jetstream and collected some interesting wind and CAT data which will be discussed later.

The highlights of the test program are outlined in Table 3. Approximately an hour and a half into the first flight, a pilot report (PIREP) of moderate CAT was received from a United Airlines flight between Los Angeles and San Francisco at flight level 310 over Big Sur, California. When we arrived at that region nearly fifteen minutes later, CAT was still present, although not as intense. The IR radiometer detected and predicted the CAT, however, an electrical power problem prevented lidar operation during that mission. On this initial flight checkout of the microwave radiometers they were not yet prepared for real-time data use. Near a line from about Grand Junction, Colorado, to Hanksville, Utah, we encountered extensive moderate CAT in a convergence region of the polar and subtropical jetstreams. We probed the area approximately two hours at four or five different flight levels. Several commercial aircraft flying through that area also encountered about 30 minutes of light to moderate CAT. Crossing the subtropical jetstream, we encountered extensive light to moderate CAT in the cirrus clouds. Wind speeds greater than 100 knots (50 meters per second) were measured for nearly 600 nautical miles (1100 kilometers) to the south. This turbulence region was expected to be small, but during the crossing of the jetstream, which was from the west, there were many small changes in wind speed and direction. These wind changes, actually shears within the jetstream, probably caused the turbulence. Light CAT at the

TABLE 2  
 PARTICIPANTS IN THE 1979 CLEAR AIR TURBULENCE FLIGHT TEST PROGRAM

<u>NATIONAL AERONAUTICS AND SPACE ADMINISTRATION</u>	<u>DEPARTMENT OF COMMERCE</u>
NASA Headquarters	National Oceanic and Atmospheric Administration
Ames Research Center	Environmental Research Labs
Dryden Flight Research Center	National Environmental Satellite Service
Jet Propulsion Laboratory	National Weather Service
Lewis Research Center	
Marshall Space Flight Center	
<u>DEPARTMENT OF TRANSPORTATION</u>	<u>DEPARTMENT OF DEFENSE</u>
Federal Aviation Administration - Air Traffic and Airway Facilities	U.S. Air Force
Transportation Systems Center	Air Weather Service
	Edwards - Air Force Flight Test Center
	Global Weather Center
<u>INDUSTRY</u>	U.S. Navy
Barnes Engineering Company	Moffett Field - Naval Weather Detachment
Computer Sciences Corporation	Monterey - Fleet Numerical Weather Center
Exotic Materials	
Informatics PMI	<u>UNIVERSITIES</u>
M & S Computing, Inc.	Alabama A & M University
Northrup Services	University of Colorado
Raytheon Company	University of Oregon
SRI International, Inc.	
United Airlines	

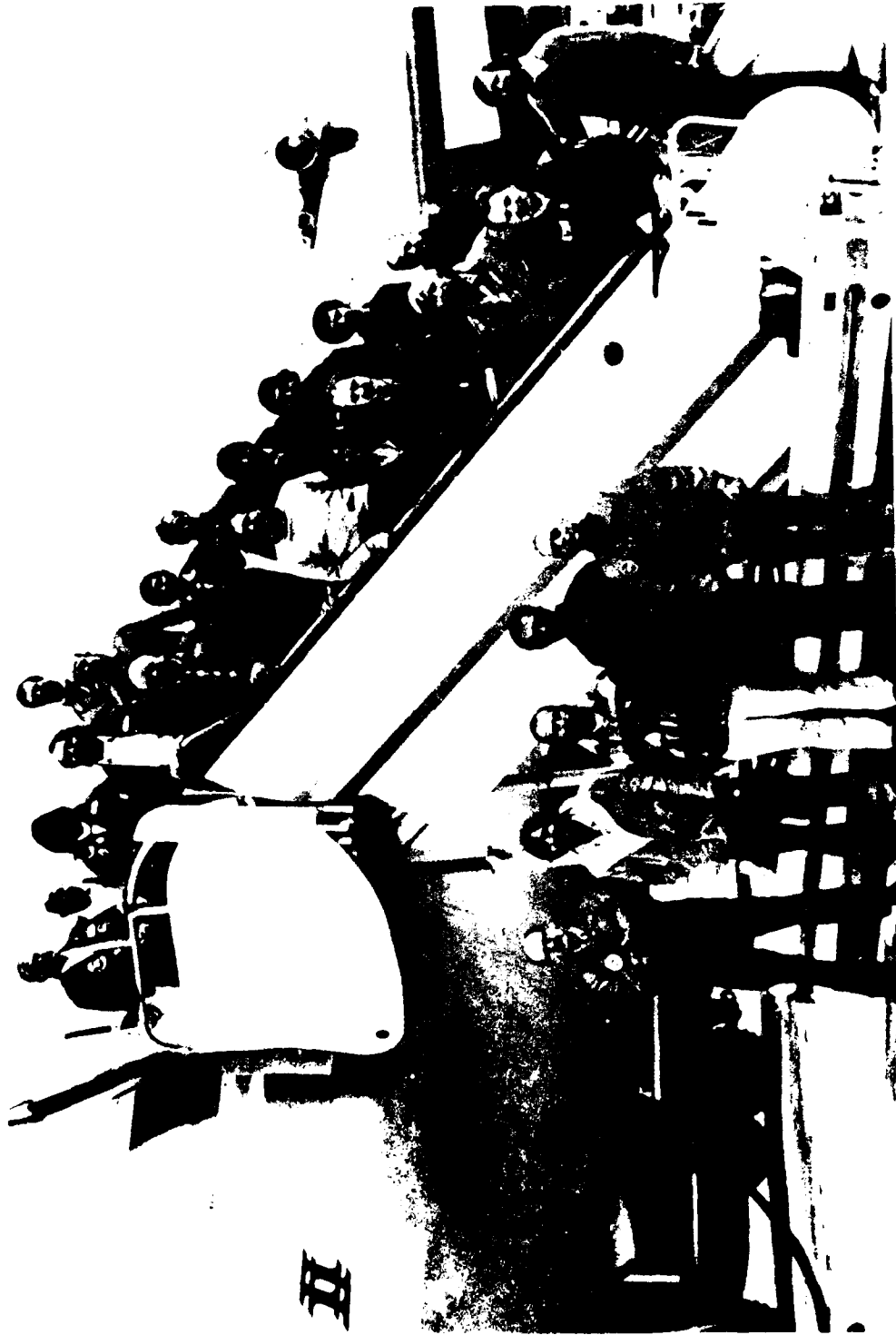

Figure 2. Test crew of the 1979 CAT Flight Test Program.

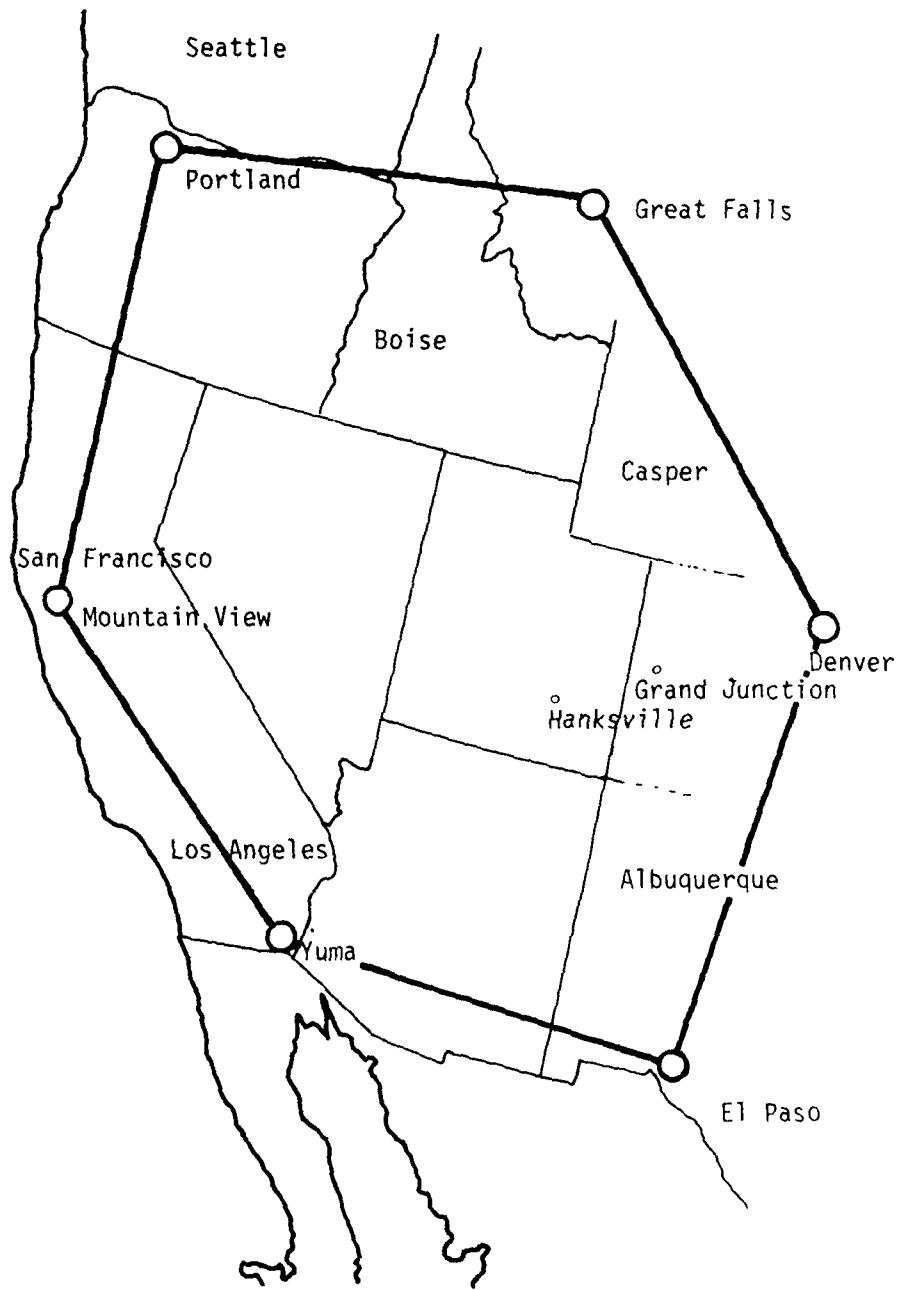

Figure 3. Flight test region for clear air turbulence.



TABLE 3

HIGHLIGHTS OF THE 1979 CLEAR AIR TURBULENCE FLIGHT TEST PROGRAM

- Predicted and encountered CAT:
  - Jet stream at 31,000 feet; first flight; by IR radiometer; PIREP used.
  - Extensive moderate CAT in convergence region of polar and subtropical jets.
  - Crossing subtropical jet; extensive light to moderate CAT in cirrus.
  - Several cases of low altitude mountain wave CAT.
  - Light CAT at tropopause in cirrus.
- DC-10 aircraft vortices detected by lidar at 31,000 feet.
- IR radiometer appears to predict CAT at all flight levels.
- Temperature structure radiometer worked well at all flight levels.
- Atmospheric aerosol content was much lower than model predictions.

tropopause was encountered several times, and there were many encounters of low altitude (below 10,000 feet) mountain wave CAT. I should emphasize that the winter of 1979 was not a good mountain wave CAT season because on clear days the winds were not perpendicular to the mountain ridge lines in either the High Sierras or the Rocky Mountains as required for intense mountain wave CAT. The many wet, turbulent fronts during that season covered the entire western United States; therefore, the aerosol tracers above 0.5 micrometers required for the lidar were continually being removed from the atmosphere, even in the southwestern desert regions. During this test season, it was quite clear above flight level 70; there were very few tracers other than cirrus ice crystals for use as reflectors or targets for the 10.6 micrometer radiation. Because of this finding, we are working on a small flight test program to determine some of the extremes in the seasonal and altitude variation of the aerosol density over a variety of geographical regions, as well as the backscatter coefficient of these aerosols at the  $CO_2$  wavelength of 10.6 micrometers. The lidar detected an unusual velocity spread in the path of a DC-10 heading toward San Francisco at flight level 310 in a jet lane over Utah. We plan to examine these data, possibly a result of the DC-10's vortices, after the atmospheric CAT data analyses are completed. These velocity data are presently somewhat difficult to explain, considering the low aerosol density.

The IR radiometer appears to predict CAT well at all flight levels. This was the first test program to employ this radiometer at a variety of altitudes, some as low as flight level 50. The IR radiometer's alert capability is shorter at these lower altitudes, but it does detect the turbulence ahead of the encounter. In view of its 83 percent prediction rate, as discussed by Jack Enders, this sensor appears worthy of further development, which is, in fact, proceeding. A flight prototype which may be ready for testing this year is now being developed for United Airlines.

The temperature structure radiometer also worked well at all flight levels. A plot of temperature change with altitude over many flight levels above and below the aircraft is constructed from its data. These data show when the atmospheric temperature conditions are favorable for CAT occurrence. This does not mean that CAT will always be there; however, these data should be helpful in CAT avoidance.

The final highlight, discussed earlier, was that the atmospheric aerosol content was much lower at all altitudes than predicted in the models for CO<sub>2</sub> wavelength. This must be taken into consideration if extensive use is to be made of the CO<sub>2</sub> pulsed Doppler lidar technology at flight altitudes or from above the troposphere.

In conclusion, thirty missions totaling 140 hours were flown. One hundred hours were dedicated to the CAT program. That amount of time generates a mountain of data. Even though much of it was available in near real time, the instrument performance analyses are taking substantially longer than planned. Prior to the test we envisioned completing all the routine processing by July, 1979. Oh, how we dreamed! The test has now been finished for one year, yet we are still trying to read and understand some parts of the data. As we learn more from the data, we find more things we still need to know from it. Hopefully, in another six months we will be ready to prepare a comprehensive report on the results of the test program.

Question and Answer Discussion:

Joseph F. Sower, FAA: What is the normal range of detection of CAT with the IR radiometer?

Edwin A. Weaver, NASA: At standard flight levels, approximately 28,000 ft and up, it would be about four to six minutes warning.

## VERY SHORT RANGE FORECASTS OF VISIBILITY AND CEILING

Arthur Hilsenrod

Federal Aviation Administration

Low ceilings and visibilities cause considerable delay to aircraft in the National Airspace System. Reliable, very short range, i.e., 0-5, 0-10 and 0-15 minute, forecasts of the beginning or ending of restrictive visibilities or ceilings at airports could be used to avoid delays and expedite the movement of air traffic. For example, a 15-minute forecast would offer the pilot of a 550 mph (true airspeed) aircraft (i.e., a 727-100 at cruise) information for a decision to continue to his destination or proceed to an alternate up to 140 miles from his destination.

### 1, 2, 3,-----24 Hour Probability Forecasts

Miller, et al., (1977) has developed a practical conditional climatology by taking into account the set of all locally observed meteorological probability distributions. It provides accurate and reliable forecasts not only of ceiling and visibility each hour after a weather observation but also of other parameters of the hourly aviation weather observation. He utilizes the Generalized Equivalent Markov (GEM) model to provide the hourly probability forecasts for each hour out to 24 hours of meteorological parameters including the aviation parameters which are part of the hourly observation. Table 1 is a transformation of the probability forecasts into categorical forecasts. The numbers in each cell refer to intervals or categories of the weather variables utilized in these forecasts, as shown in Table 2 (Miller, 1979).

Utilizing the category breakdown in Table 2, the forecast for 1300 hours is:

Wind direction	NNW-N
Wind speed	15 to 17 kts
Sea level pressure	1020.1 to 1030 mb
Dry bulb temperature	37 to 38°F
Dew point depression	16°F or higher
Sky cover	Broken
Visibility	7 statute miles to unlimited
Weather, any type	None
Pressure change	-1.9 to -1.0 mb
Ceiling	15,100 ft to unlimited

TABLE 1

CATEGORICAL FORECASTS OF GENERALIZED EQUIVALENT MARKOV MATRIX (GEMTRIX)\*

Category	OBS	24 Hourly Forecasts after OBS (Local Standard Time)																								
		10	11	12	13	14	15	16	17	18	19	20	21	22	23	24	1	2	3	4	5	6	7	8	9	10
WIND DIR	8	6	6	6	6	6	6	6	6	6	6	6	6	6	6	6	6	6	6	6	6	6	6	6	6	6
WIND SPD (KTS)	6	6	6	6	6	6	6	6	6	6	6	6	6	6	6	6	6	6	6	6	6	6	6	6	6	6
SLP (MB)	6	6	6	6	6	6	6	6	6	6	6	6	6	6	6	6	6	6	6	6	6	6	6	6	6	6
DB TEMP (DEG F)	8	8	8	8	8	8	8	8	8	8	8	8	8	8	8	8	8	8	8	8	8	8	8	8	8	8
DPT DPR (DEG F)	7	7	7	7	7	7	7	7	7	7	7	7	7	7	7	7	7	7	7	7	7	7	7	7	7	
SKY CVR	4	4	4	3	3	3	3	2	2	1	1	1	1	1	1	1	1	1	1	1	1	1	1	1	1	
VSBY (ST MI)	12	12	12	12	12	12	12	12	12	12	12	12	12	12	12	12	12	12	12	12	12	12	12	12	12	
WEATHER	1	1	1	1	1	1	1	1	1	1	1	1	1	1	1	1	1	1	1	1	1	1	1	1	1	
FOG,IF	1	1	1	1	1	1	1	1	1	1	1	1	1	1	1	1	1	1	1	1	1	1	1	1	1	
GROUND FOG	1	1	1	1	1	1	1	1	1	1	1	1	1	1	1	1	1	1	1	1	1	1	1	1	1	
K,H,D,KH,KD,HD,KHD	1	1	1	1	1	1	1	1	1	1	1	1	1	1	1	1	1	1	1	1	1	1	1	1	1	
BS,BD,BN,BY	1	1	1	1	1	1	1	1	1	1	1	1	1	1	1	1	1	1	1	1	1	1	1	1	1	
DRIZZLE	1	1	1	1	1	1	1	1	1	1	1	1	1	1	1	1	1	1	1	1	1	1	1	1	1	
RAIN	1	1	1	1	1	1	1	1	1	1	1	1	1	1	1	1	1	1	1	1	1	1	1	1	1	
RAIN SHOWERS	1	1	1	1	1	1	1	1	1	1	1	1	1	1	1	1	1	1	1	1	1	1	1	1	1	
SNOW,IC	1	1	1	1	1	1	1	1	1	1	1	1	1	1	1	1	1	1	1	1	1	1	1	1	1	
SNOW SHOWERS,IP	1	1	1	1	1	1	1	1	1	1	1	1	1	1	1	1	1	1	1	1	1	1	1	1	1	
FREEZING DRIZZLE	1	1	1	1	1	1	1	1	1	1	1	1	1	1	1	1	1	1	1	1	1	1	1	1	1	
FREEZING RAIN	1	1	1	1	1	1	1	1	1	1	1	1	1	1	1	1	1	1	1	1	1	1	1	1	1	
THUNDERSTORM,A-	1	1	1	1	1	1	1	1	1	1	1	1	1	1	1	1	1	1	1	1	1	1	1	1	1	
CLD CVR 200 FT	1	1	1	1	1	1	1	1	1	1	1	1	1	1	1	1	1	1	1	1	1	1	1	1	1	
CLD CVR 500 FT	1	1	1	1	1	1	1	1	1	1	1	1	1	1	1	1	1	1	1	1	1	1	1	1	1	
CLD CVR 1000 FT	1	1	1	1	1	1	1	1	1	1	1	1	1	1	1	1	1	1	1	1	1	1	1	1	1	
CLD CVR 3000 FT	1	1	1	1	1	1	1	1	1	1	1	1	1	1	1	1	1	1	1	1	1	1	1	1	1	
PRES CHG (.1 MB)	8	8	8	4	3	3	4	5	7	7	8	8	7	7	6	5	5	5	5	5	5	5	7	7	6	
CIG (100'S FT)	15	15	15	15	15	15	15	15	15	15	15	15	15	15	15	15	15	15	15	15	15	15	15	15	10	

\*Categorical GEMTRIX, Techniques Development Laboratory, for Station DCA, valid for 24 hours after March 12, 10 local.

TABLE 2

INTERVALS AND CATEGORIES OF WEATHER VARIABLES UTILIZED IN THE HOURLY FORECASTS (MILLER, 1979)

Category	Breakdown of Categories
WIND DIR	1=CALM 2=NNE-NE 3=ENE-E 4=ESE-SE 5=SSE-S 6=SSW-SW 7=WSW-W 8=WNW-NW 9=NNW-N
WIND SPD	1=0-3 2=4-7 3=8-9 4=10-12 5=13-14 6=15-17 7=18-22 8=23-27 9=28-32 10=33-45
SLP	1=980.1-990. 2=990.1-000. 3=000.1-005. 4=005.1-010. 5=010.1-020. 6=020.1-030. 7=030.1-090.
DB TEMP	1=-99-14 2=15-23 3=24-27 4=28-29 5=30-31 6=32 7=33-34 8=35-36 9=37-38 10=39-40 11=41-42 12=43-50 13=51-59 14=60-68 15=69-77 16=78-86 17=87-140
DPT DPR	1=0 2=1 3=2-4 4=5-6 5=7-11 6=12-15 7=16-99
SKY CVR	1=CLR 2=SCT 3=BKN 4=OVC
VSBY	1=.00-.49 2=.50-.74 3=.75-.99 4=1.0-1.49 5=1.5-1.99 6=2.0-2.49 7=2.5-2.99 8=3.0-3.99 9=4.0-4.99 10=5.0-5.99 11=6.0-6.99 12=7.0-99.0
WEATHER	1=NO 2=YES
FOG,IF	1=NO 2=YES
GROUND FOG	1=NO 2=YES
K,H,D,KH,KD,HD,KHD	1=NO 2=YES
BS,BD,BY,BY	1=NO 2=YES
DRIZZLE	1=NO 2=L-
RAIN	1=NO 2=R- 3=R 4=R+
RAIN SHOWERS	1=NO 2=RW- 3=RW 4=RW+
SNOW,IC	1=NO 2=S-,IC- 3=S,IC 4=S+,IC+
SNOW SHOWERS,IP	1=NO 2=SW-,IP-,SP- 3=SW,IP,SP
FREEZING DRIZZLE	1=NO 2=ZL-
FREEZING RAIN	1=NO 2=ZR-
THUNDERSTORM,A-	1=NO 2=T,A-
CLD CVR < 200 FT	1=CLR 2=OVC
CLD CVR < 500 FT	1=CLR 2=SCT 3=BKN 4=OVC
CLD CVR < 1000 FT	1=CLR 2=SCT 3=BKN 4=OVC
CLD CVR < 3000 FT	1=CLR 2=SCT 3=BKN 4=OVC
PRES CHG	1=-900--40 2=-39--30 3=-29--20 4=-19--10 5=-9-0 6=1-9 7=10-19 8=20-29 9=30-39 10=40-900
CIG	1=0-1 2=2-4 3=5-6 4=7-9 5=10-14 6=15-19 7=20-24 8=25-29 9=30-39 10=40-49 11=50-59 12=60-74 13=75-99 14=100-150 15=151-UNL

### 0-10, 0-20 and 0-30 Minute Forecasts

Short range forecasts of ceiling and visibility of one hour or less, e.g., five or 30 minutes, immediately after a series of local observations can be expected to be more accurate and reliable than any forecast of more than one hour. These forecasts can be accomplished by the operational implementation of fully automated aviation observations systems (AWOS), which has been the goal of agencies associated with providing airport weather for aviation use.

### The Air Force Geophysical Laboratory (AFGL) Experiment

AFGL developed a computer-based observing system and demonstrated the feasibility of automated observation and forecasting techniques using low-cost microprocessors at Scott Air Force Base (Tahk and Lynch, 1978).

Probability forecasts of ceiling and visibility 15, 30, 60 and 180 minutes in advance of a series of observations were developed utilizing station observations and a 20 year climatology from visibility and ceiling surface observations at Scott AFB.

A Markov stochastic model was used to generate exceedance probabilities of given thresholds. Table 3 diagrams a display of a visibility forecast at Scott AFB. At the completion of the experiment, in January 1979, this system was dismantled.

TABLE 3

VISIBILITY FORECAST DISPLAY IN AFGL AUTOMATED OBSERVATION SYSTEM

Probability Forecasts		
Time after Last Observation (minutes)	Probable Visibility Less Than (%)	
	0.75 miles	0.25 miles
+15	98	60
+30	78	28
+60	45	5

## Federal Aviation Administration (FAA) Plans

The AFGL experiment and the work of Miller (1979) provide the basis for the implementation of very short range forecasts within a few years.

Both the NWS and the FAA are pursuing the development of fully automated aviation observation systems (AWOS). The results of one recent test of an AWOS have been published (National Weather Service, 1979). A test of a modular AWOS developed by the FAA will be initiated this summer at Dulles Airport. It will have the capability of recording the entire observation. Another AWOS capable of withstanding a salt environment is planned for installation on an offshore platform in the Gulf of Mexico in 1981. It, too, will record the observations. The digital tape recordings will be at one-minute intervals, with the ceiling and visibility being the average of three 15-second observations.

The availability of these recorded observations and the statistical techniques developed by Miller will provide the basis of five, 10 and 20 minute forecasts of ceiling, visibility, wind speed, wind direction, or any other observed parameter that is desired. The exact format of parameters to be used and methods of presentation (categorical or probabilistic) have yet to be determined.

It should be noted that mesometeorological networks have not significantly improved visibility forecasts over the persistence technique (Entreken, 1968; Tahnk, 1975; and Chisholm, 1976). Chisholm concluded that the utility of mesometeorological networks to improve ceiling and visibility forecasts for the aviation community at Hanscom AFB based on 27 fully automated observation stations in the vicinity is marginal at best.

## Runway Visual Range (RVR) and Slant Visual Range (SVR) Forecasts

Forecasts of RVR two, five and 10 minutes after the last observation, utilizing the GEM technique, are yet to be developed for airport operations. A two-year data base of RVR is required to initiate the development of the forecast.

Geisler (1979) has demonstrated that the GEM technique can provide accurate and short range, i.e., five, 10 and 30 minute, forecasts of SVR.

## References

- Chisholm, Donald A., 1976: Objective Prediction of Mesoscale Variations of Sensor Equivalent Visibility During Advection Situations, AFGl-TR-76-0132, Air Force Geophysical Laboratory, Hanscom Air Force Base, Massachusetts.
- Entreken, J. E., J. W. Wilson, K. D. Hage, 1968: Evaluation of the Atlantic City Mesonet for Short Range Prediction of Aviation Terminal Weather, Travelers Research Center, Inc., Hartford, Connecticut, FAA-SRDS Report, #68-40.

- Geisler, Edward B., 1979: Development and Evaluation of a Tower Slant Visual Range System, AFGL-TR-79-0209, Air Force Geophysical Laboratory, Hanscom Air Force Base, Massachusetts.
- Miller, Robert G., Robert C. Whiton, Michael J. Kelly, Jr., 1977: Results of Single Station Forecasting Experiment, AWS-TR-77-273, Air Weather Service, Scott Air Force Base, Illinois, pp. 101-107.
- Miller, Robert G., 1979: Conditional Climatology Given the Local Observation, National Weather Digest (November), National Weather Service, National Oceanic and Atmospheric Administration, Silver Spring, Maryland.
- National Weather Service, 1979: Aviation Automated Weather Observation System (AV-AWOS), FAA-RD-79-63, Federal Aviation Administration, Washington, District of Columbia.
- Tahnk, William R., 1975: Objective Prediction of Fine Scale Variations in Radiation Fog Intensity, AFCRL-TR-75-0269, Air Force Cambridge Research Laboratories, Hanscom Air Force Base, Massachusetts.
- Tahnk, W. R., and R. H. Lynch, 1978: The Development of a Fixed Base Automated Weather Sensing and Display System, AFGL-TR-78-009, Air Force Geophysical Laboratory, Hanscom Air Force Base, Massachusetts.



THE MICROBURST:  
COMMON FACTOR IN RECENT AIRCRAFT ACCIDENTS

Fernando Caracena

NOAA/Environmental Research Laboratories

The severe downdraft as an aircraft safety hazard is getting to be an old topic now, but we have learned about it the hard way. Over the last five years there have been a number of aircraft accidents that have occurred at bases of strong thunderstorm downdrafts. Fujita (1978) has defined two terms referring to strong downdrafts: downburst and microburst. He defines a downburst as a strong localized downdraft that generates an outward burst of damaging winds on or near the surface. For the purpose of aircraft safety, he defines the downburst as a strong localized downdraft that generates a divergence in surface wind field of  $0.04 \text{ s}^{-1}$  or greater. The surface divergence is inversely related to the aircraft performance because it governs the rate of change of the head-to-tail wind component of an aircraft as it flies across the base of a downdraft. The greater the surface divergence, the greater will be the rate of loss of airspeed of the penetrating aircraft. Fujita defines a microburst as a microscale downburst with a damage path length of 5 km (3 mi) or less.

The aircraft safety hazard of the base area of a strong downdraft was first recognized by Melvin (1975) in a Flight Safety Foundation report. In this report he showed that the diverging wind field first gives an aircraft approaching the base of the downdraft, at low levels, an increasing headwind as the aircraft comes under the influence of the outflow. Then, as the aircraft penetrates the base of the downdraft, the headwind diminishes rapidly and becomes a tailwind. A variety of changes in the wind are possible which give the same effect, a rapid erosion of airspeed.

A brief review of a number of recent, downdraft-related accidents shows that a microburst has been the common factor in every case.

Fujita and Beyers (1977), in their analysis of the Eastern 66 crash at J. F. Kennedy International Airport, found that three separate microbursts moved across the approach to runway 22L as fourteen aircraft landed or attempted to land through the thunderstorm onto this runway. Their analysis is depicted in Figure 1. Despite the innocuous appearance of this storm, the low level encounter of Eastern Flight 66 with a microburst resulted in a major disaster.

At Stapleton International Airport on August 7, 1975, a microburst downed Continental Flight 426 on an attempted takeoff. A time-space section in Figure 2 depicts the outflow pattern that affected three aircraft which took off under this thunderstorm along runway 35L at approximately two-minute intervals apart. As is depicted in Figure 3,

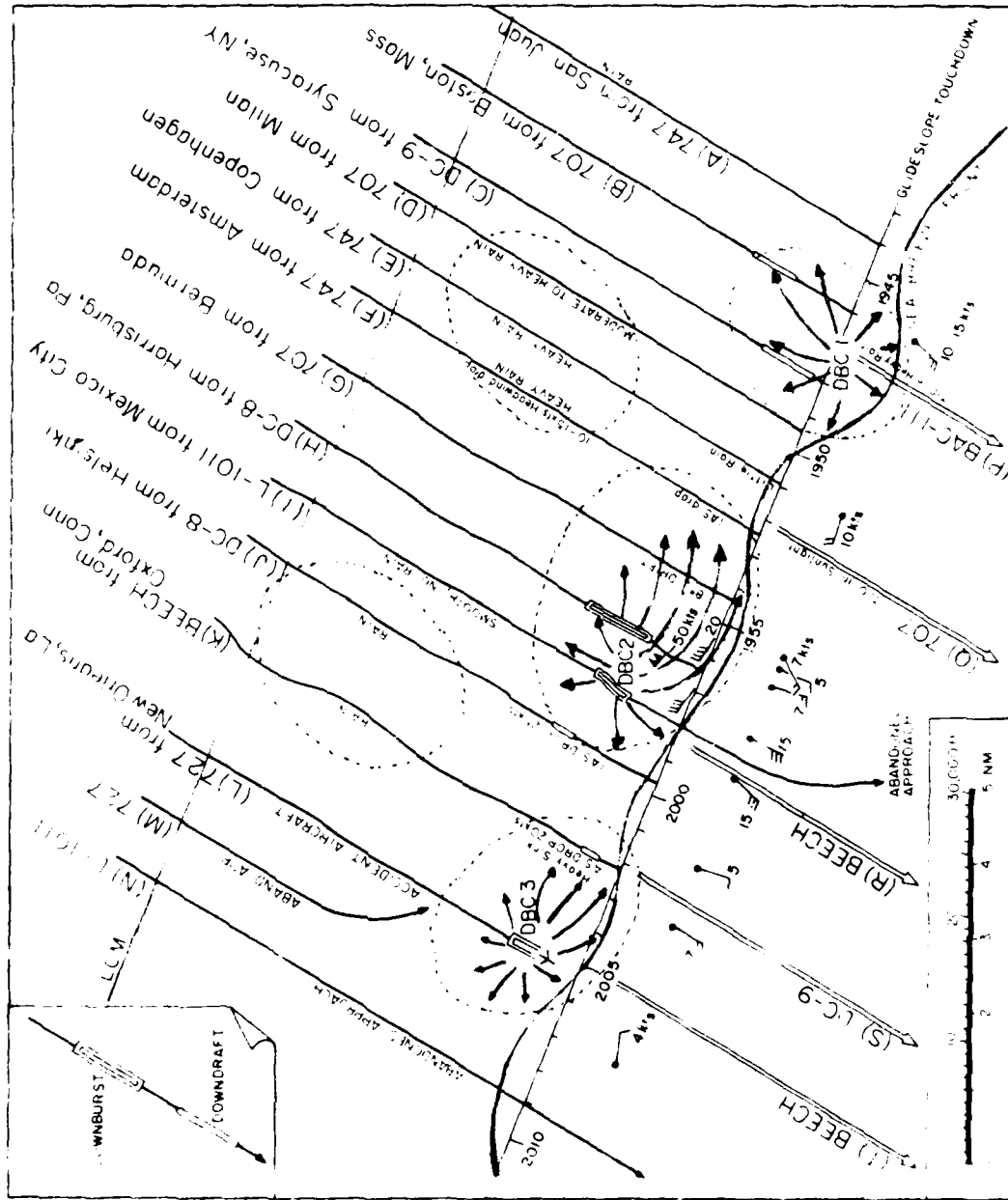

Figure 1. Analysis by Fujita and Beyers (1977) of three microbursts that presented a variety of wind shear hazards to 14 aircraft landing or attempting to land on runway 22L, J. F. Kennedy International Airport, June 24, 1975.

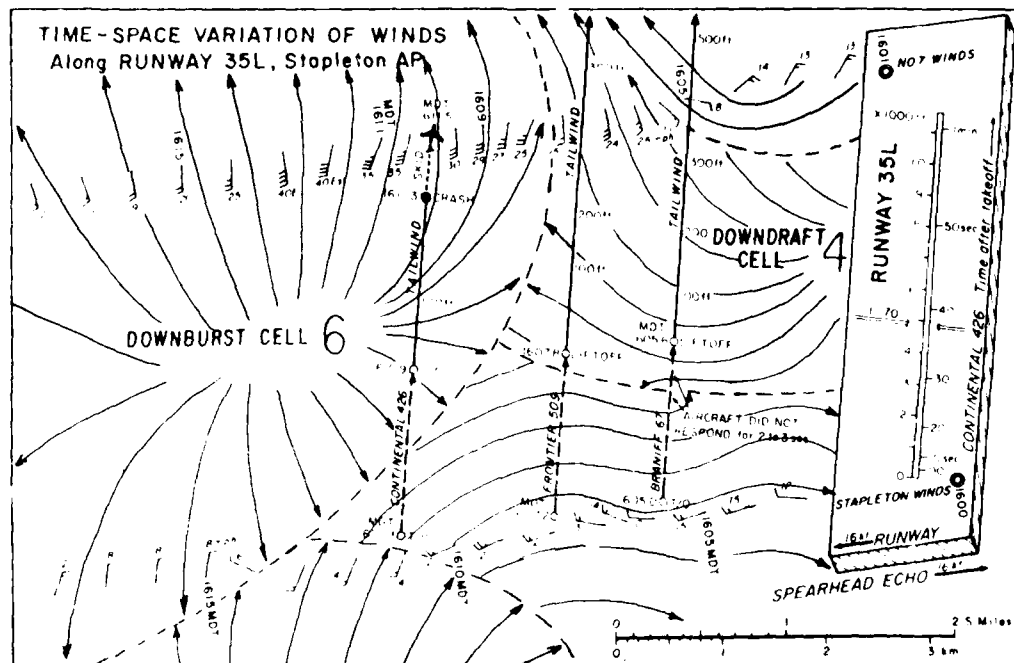

Figure 2. A time-space section by Fujita and Caracena (1977) of the winds across runway 35L of Stapleton International Airport on August 7, 1975, during the crash of Continental Flight 426.

each aircraft progressively encountered wind shear of increasing severity, culminating with the crash of Flight 426. Unfortunately, the maximum wind gusts were not measured in this case because anemometers north of Stapleton were set to record a maximum of 30 mph. The anemometers affected by the microburst were pegged, however, and wind damage at a construction site nearby gave evidence of wind gusts in excess of 48 kts.

Not far away from the departure end of runway 35L, near parallel runway 35R that was under construction, there was a large construction shed fashioned of two large vans bolted together with steel I-beams. Onto these steel I-beams were bolted wooden timbers that supported a roof. The construction shed, which was open to the south, had been on this site for two years and had withstood gusts up to 48 kts from the south and stronger gusts from other directions. The microburst that caused this accident blew the roof off that construction shed and impaled some of the 2 x 4's from the roof into a nearby metal construction shed. Meanwhile, not far away, at the south end of runway 35L, the center field anemometer was indicating a wind from the southwest of 10 to 15 kts. An airline captain driving to Stapleton at the time was crossing under runway 35L on I-70 when his car was almost blown

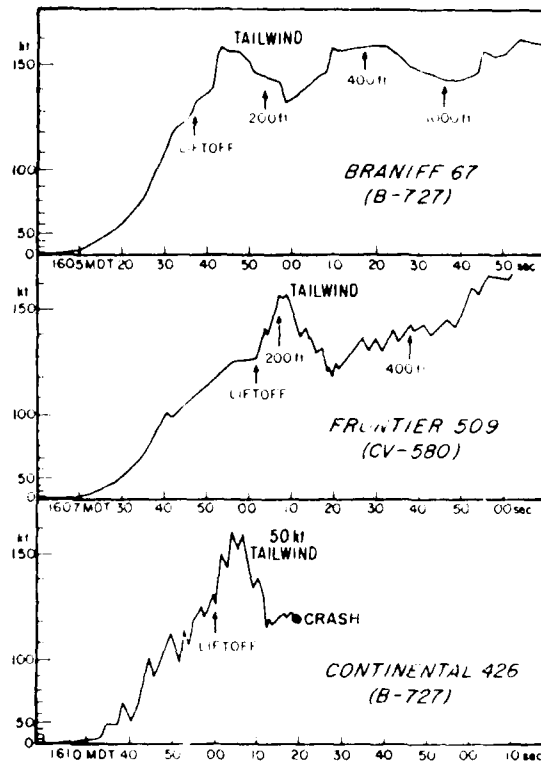

Figure 3. Flight recorder airspeed traces from the three aircraft penetrating the storm that downed Continental Flight 426. The airspeed scale is proportional to the square of the speed to depict energy.

against the median guard rail by a strong gust from the north. This indicates how localized the severe winds were at the time of the accident. At the north end of runway 35L there were damaging southerly winds; at about mid-runway there were strong winds from the north; and at the south end of the runway there was a breeze from the southwest. A complex airflow pattern such as this over a small area is very typical during the occurrence of a microburst.

Another low level encounter with a microburst resulted in the crash of Allegheny Flight 121 at Philadelphia International Airport on the afternoon of June 23, 1976. The aircraft was attempting to land on runway 27R. Two transmissometers and one recording gauge showed, through dips in visibility and a peak in rainfall rate, that a rain shaft came from the southwest and moved across the approach end of runway 27R (see Figure 4). Eyewitness accounts indicate that when the aircraft was on the approach, very strong winds and very heavy rain

AD-A094 196

TENNESSEE UNIV SPACE INST TULLAHOVA  
PROCEEDINGS: ANNUAL WORKSHOP ON METEOROLOGICAL AND ENVIRONMENTAL--ETC(U)  
MAR 80 W FROST, D W CAMP

F/6 1/2

NAS8-32692

UNCLASSIFIED

NASA-CP-2139

NL

3 OF 3

40 2  
100 06

END  
DATE  
FILMED

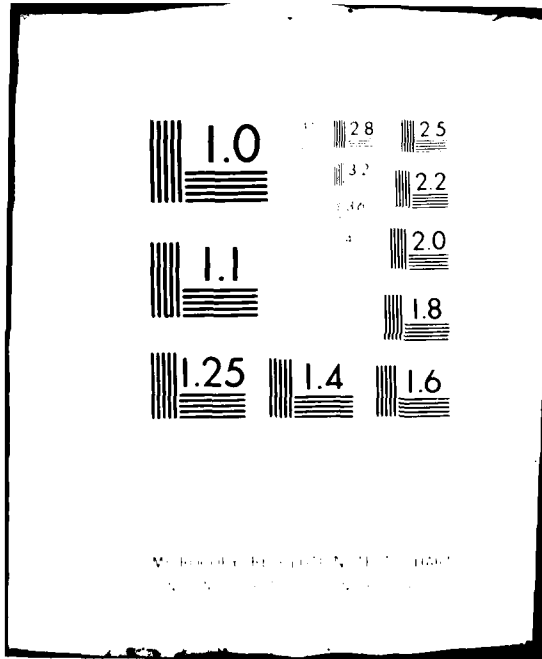

Resolution Test Chart No. 1010  
Copyright © 1963 by National Bureau of Standards

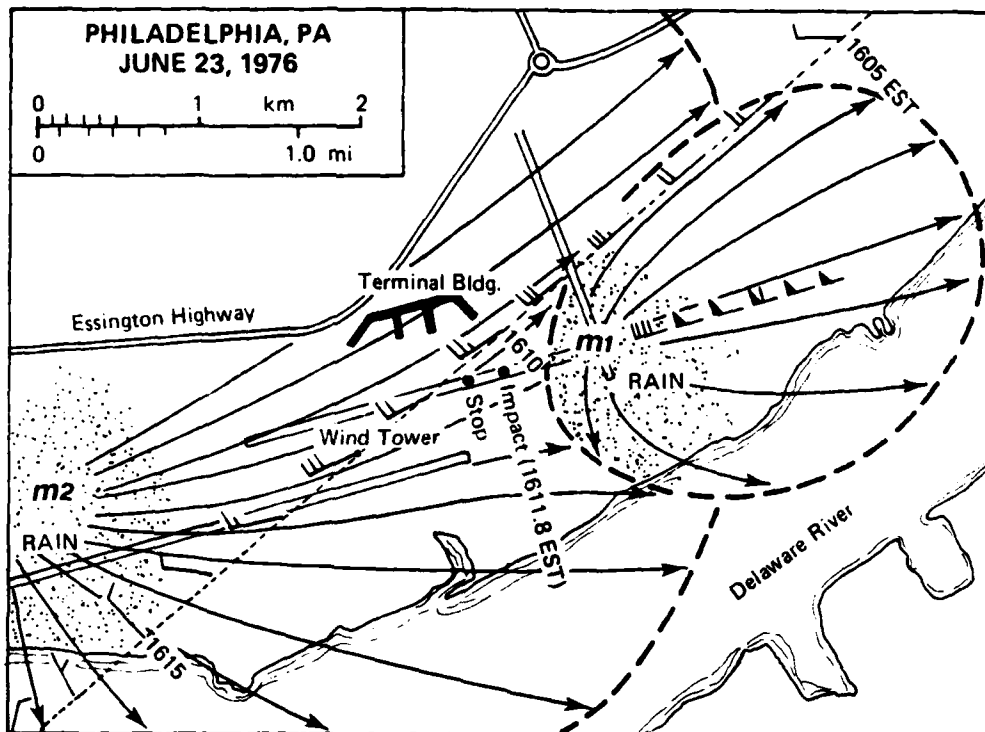

Figure 4. The path of Allegheny Flight 121 in relation to two microbursts, m1 and m2, at Philadelphia International Airport on June 23, 1976.

were moving across the airport south of the tower. An airline captain waiting to take off on parallel runway 27L reported that the rain had deposited about half an inch of water on the runway and that the winds were driving foam streaks on the surface of that standing water. From his standpoint it appeared to be a very dangerous storm, and there was no way that he was about to take off. He was riding his brake because he had the sensation of moving forward in the storm as the wind drove streaks of rain on his windshield and buffeted his aircraft. Meanwhile Allegheny Flight 121 was on the approach and had the runway in sight. That gives an indication of just how localized the storm was.

On parallel runway 27L the storm was really violent, while the captain on Allegheny Flight 121 had runway 27R in sight. He elected to go around, not because the weather looked bad but because the reported cross winds at the surface were just too strong. When he made that decision, he was 60 ft above the surface. He rotated the aircraft and climbed to about 260 ft, where the rain became heavy and the visibility went to almost zero. Very shortly thereafter he crashed on the runway in a nose-high attitude as reported by Capt. Bonn waiting at taxiway "Charlie." Capt. Bonn saw Allegheny Flight 121 falling rapidly from

the back of a very heavy rainshaft that he described as having the appearance of a "wall of water." After the aircraft crashed, it slid toward him and, fortunately, narrowly missed colliding with his aircraft, thereby avoiding a major disaster in Philadelphia.

An attempted takeoff of Continental Flight 63 across the base of a microburst resulted in another commercial airline accident at Tucson (see Figure 5). Microbursts were rendered visible that day by ring-shaped dust clouds. One eyewitness reported seeing a column of virga with a ring-shaped dust cloud about its base moving toward the airport just before the accident happened.

After taxiing onto runway 21, the captain of Continental Flight 63 waited for a cloud of dust to clear. A strong wind in excess of 40 kts tightly stretched out a nearby wind sock. As the dust cleared, the wind remained at about 40 kts. He had a good headwind when he began his takeoff. Near liftoff time, a wind sock opposite the airplane was observed to hang limply, but the aircraft was barely able to lift off. Eyewitnesses reported seeing a cloud of dust blowing out ahead of the aircraft on liftoff. The aircraft was unable to climb, and it suffered a rapid erosion of airspeed. At an altitude of about 30 ft, the aircraft ran into some power lines and began descending to about 15 ft above the surface. The aircraft would have crashed, but suddenly it experienced a very rapid increase in airspeed and shot up into the air as it penetrated the gust front. The damaged aircraft went around and managed to land on another runway.

From comparing eyewitness accounts, I estimate that this microburst was only about one or two minutes old when the accident occurred. A man who witnessed the accident through his rear view mirror had been driving southward on the Nogales highway. The flight path of Flight 63 crossed over this highway. For a distance of about one mile before observing the accident, this man had been fighting a strong cross wind from the southwest. At the time he saw the accident, he noticed that the wind had calmed. At that point he apparently was very near the gust front that was coming out of the microburst from the opposite direction. Behind this gust front there was a northwesterly wind of about 50 kts. Other witnesses who saw the accident were affected by a severe wind storm beginning on the order of one minute before the accident.

Eyewitnesses located just north-northeast of the accident site had trouble with strong wind gusts that caused two large cargo planes loaded with fire-retardant chemicals to jump their chocks just before the accident occurred. One of these aircraft, weathervaning into the wind, spun around through 180° driving a wing into the side of a hangar.

There are indications that much more severe microbursts have occurred than those we have discussed in connection with aircraft accidents. On areal damage surveys, Dr. Fujita (1978) of the University of Chicago has photographed downburst wind damage swaths in forests



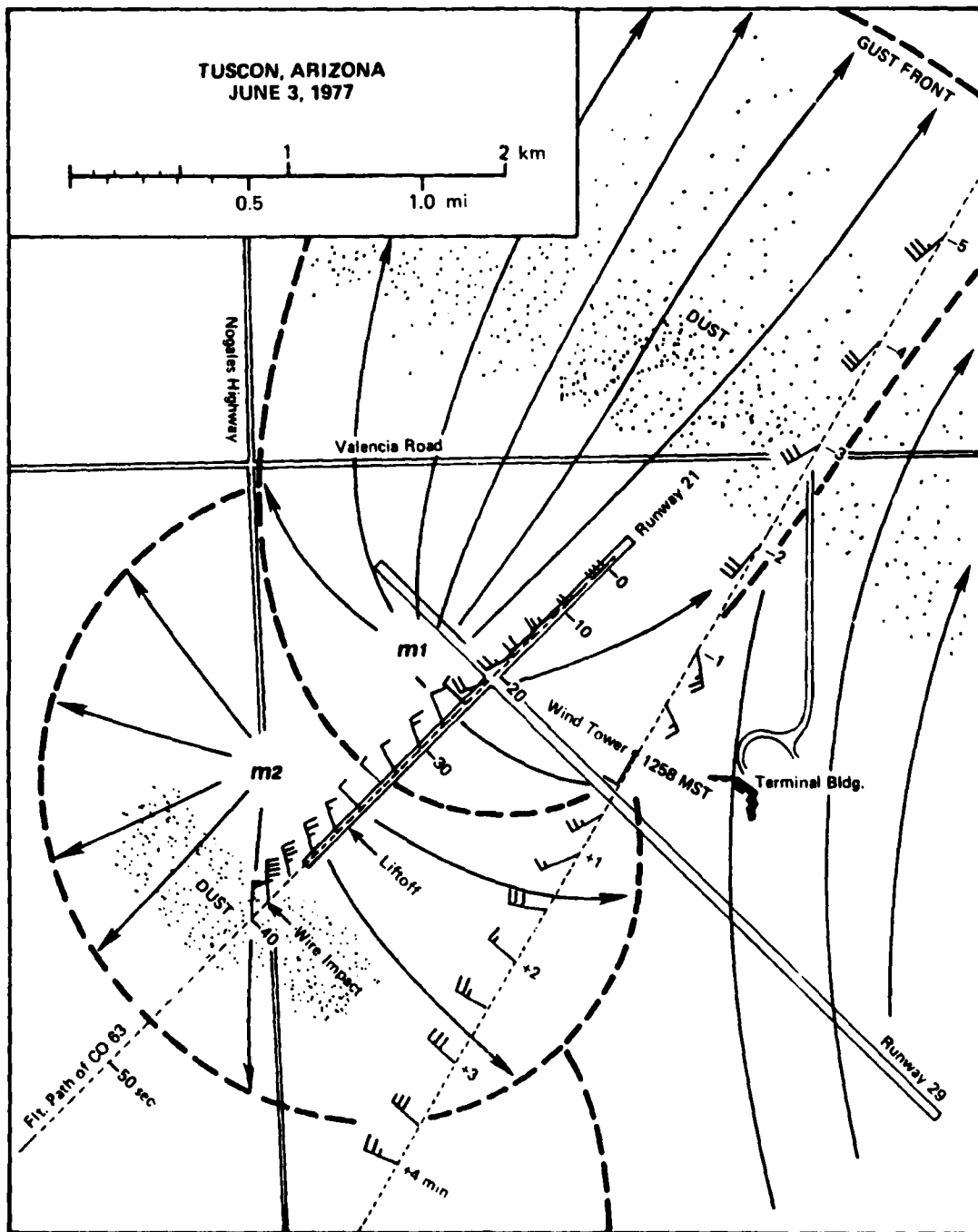

Figure 5. Continental Flight 63 took off toward the southwest under a microburst, m1, with a 40 kt headwind and attempted to lift off as another microburst, m2, was making its first surface contact.

or cornfields where the wind has been strong enough to blow down trees or corn. A number of these damage swaths showed pronounced diverging patterns in the direction of blown down trees. One particular storm in northern Wisconsin produced a damage swath 17 miles wide by about 166 miles long, within which Fujita was able to count 25 separate downburst centers. Fujita (1978) has also surveyed damage patterns of microbursts where swaths of felled trees are only a few hundred meters across and less than two miles in length. Microburst winds can approach the severity of the weaker end of the tornadic wind scale. Within a few square miles and for a few minutes, the strength of the wind within a microburst may rival the winds of a hurricane.

Microbursts are probably not as rare as tornadoes, but they occur rarely enough that few have occurred within meteorological mesonetworks. To my knowledge the only one which has been identified is a microburst that made an almost direct hit during a thunderstorm on the Field Observing Station (FOS) of the Florida Area Cumulus Experiment near the southern shore of Lake Okechobee on July 1, 1975. Because of a tornado-like roar, this microburst was at first mistaken for a tornado by meteorological observers on duty at the time. Figure 6 depicts some of the damage produced by this microburst. Helium bottles, weighing slightly over 100 lbs each were toppled by an estimated 60 kt wind.

The meteorological evidence assembled after the event showed that the severe winds were associated with a microburst; not with a tornado as had first been supposed.

Just after the storm a damage survey was conducted by Maier (Caracena and Maier, 1979), one of the observers on duty at the time. He mapped the direction of sugar cane fall in the fields surrounding the FOS. This map, depicted in Figure 7, shows a diverging pattern of fallen sugar cane about the FOS. It is the type of pattern that one would expect to be generated in the outflow of a severe downdraft.

Pressure and rainfall data also gave evidence of a strong downdraft. Figure 8 shows the pressure trace recorded at the FOS and the rainfall rate computed from a recording rain gauge located less than a mile away from the FOS. The period of damaging winds corresponded to an upward spike in the pressure trace of 2.4 mb that lasted for less than five minutes. This upward spike in pressure was caused by a thunderstorm pressure nose, which is known to be associated with a downdraft. Notice that the pressure nose corresponds to a gust of torrential rain that reached  $80 \text{ mm h}^{-1}$  ( $3.2 \text{ in h}^{-1}$ ).

A subsequent mesoanalysis of this event by Caracena and Maier (1979) using data from the entire mesonetwork showed that the microburst occurred at the beginning of a new downdraft. This downdraft was of a longer time scale and larger spatial scale than the microburst itself. In this analysis it was estimated that the downdraft was almost  $10^\circ\text{C}$  cooler than the thunderstorm environment. This amount of cooling in the downdraft was enough to make the microburst energetically

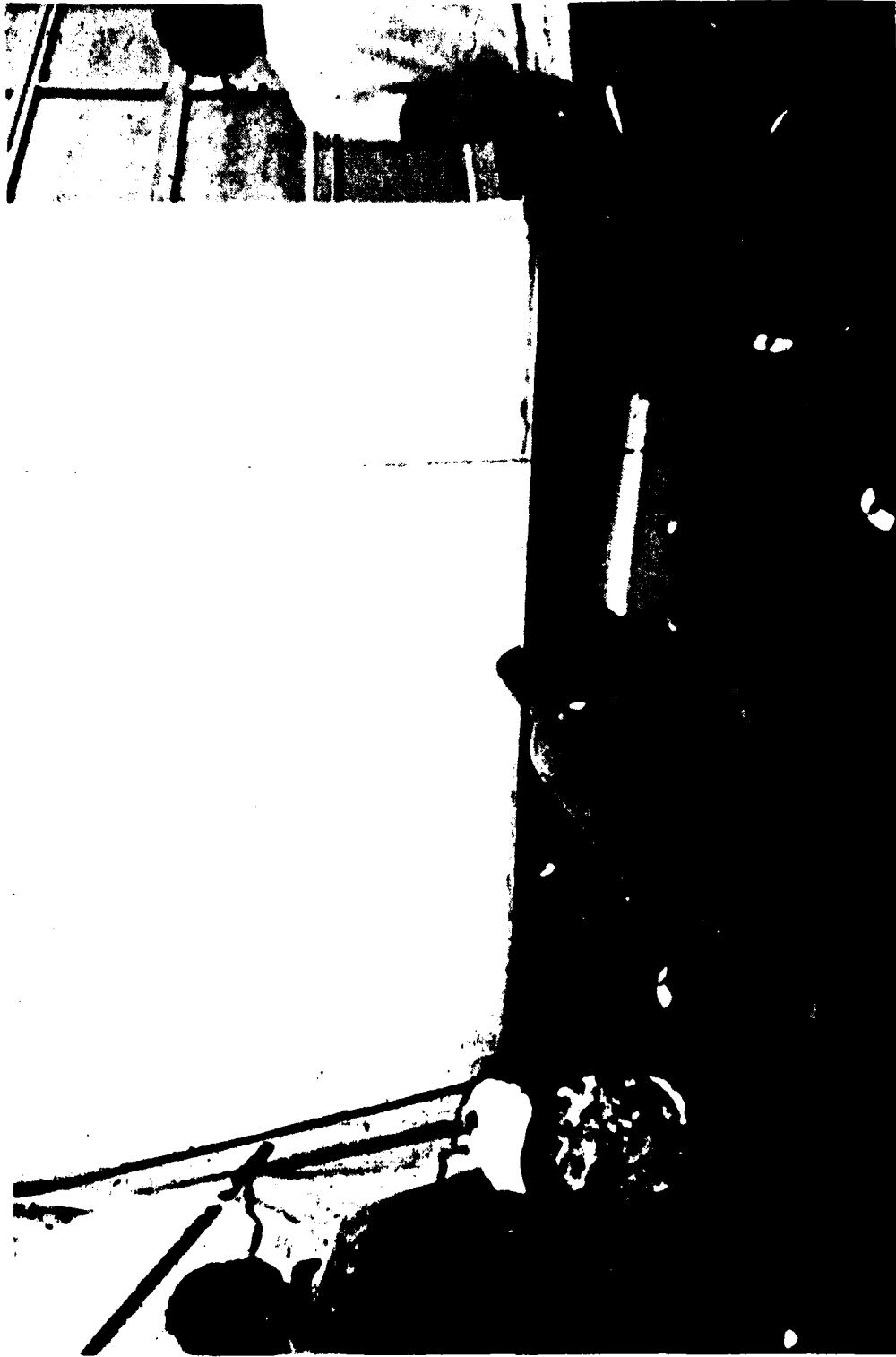

Figure 6. Damage caused by a microburst July 1, 1975, at the FOS of the Florida Area Cumulus Experiment.

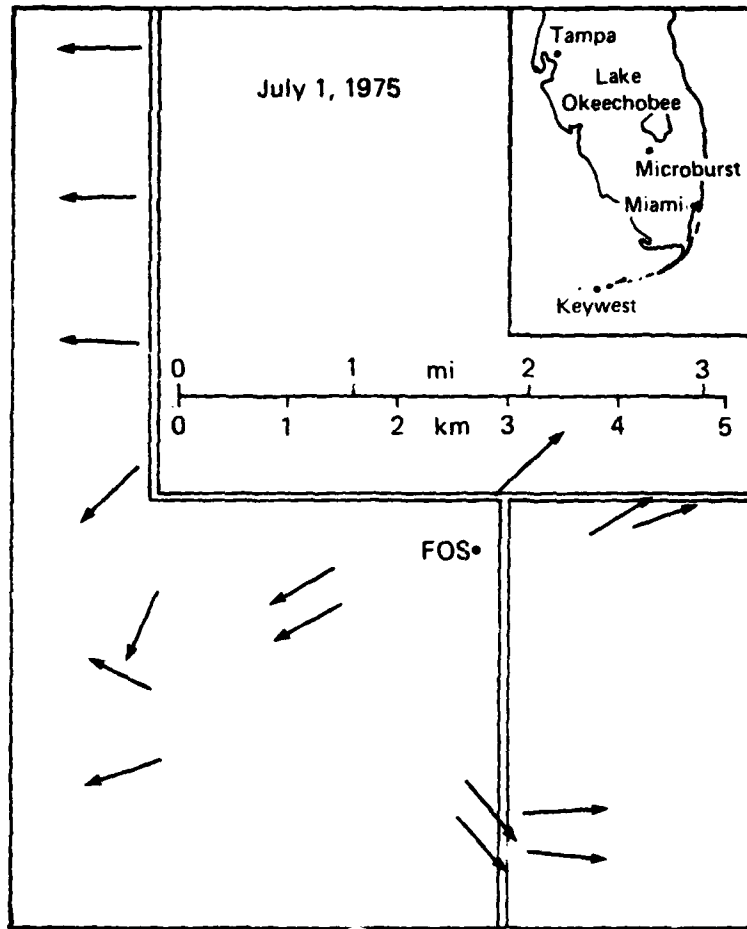

Figure 7. Map drawn by Maier (Caracena and Maier, 1979) of the sugar cane fall pattern shortly after the microburst made an almost direct hit on the FOS of the Florida Area Cumulus Experiment on July 1, 1975.

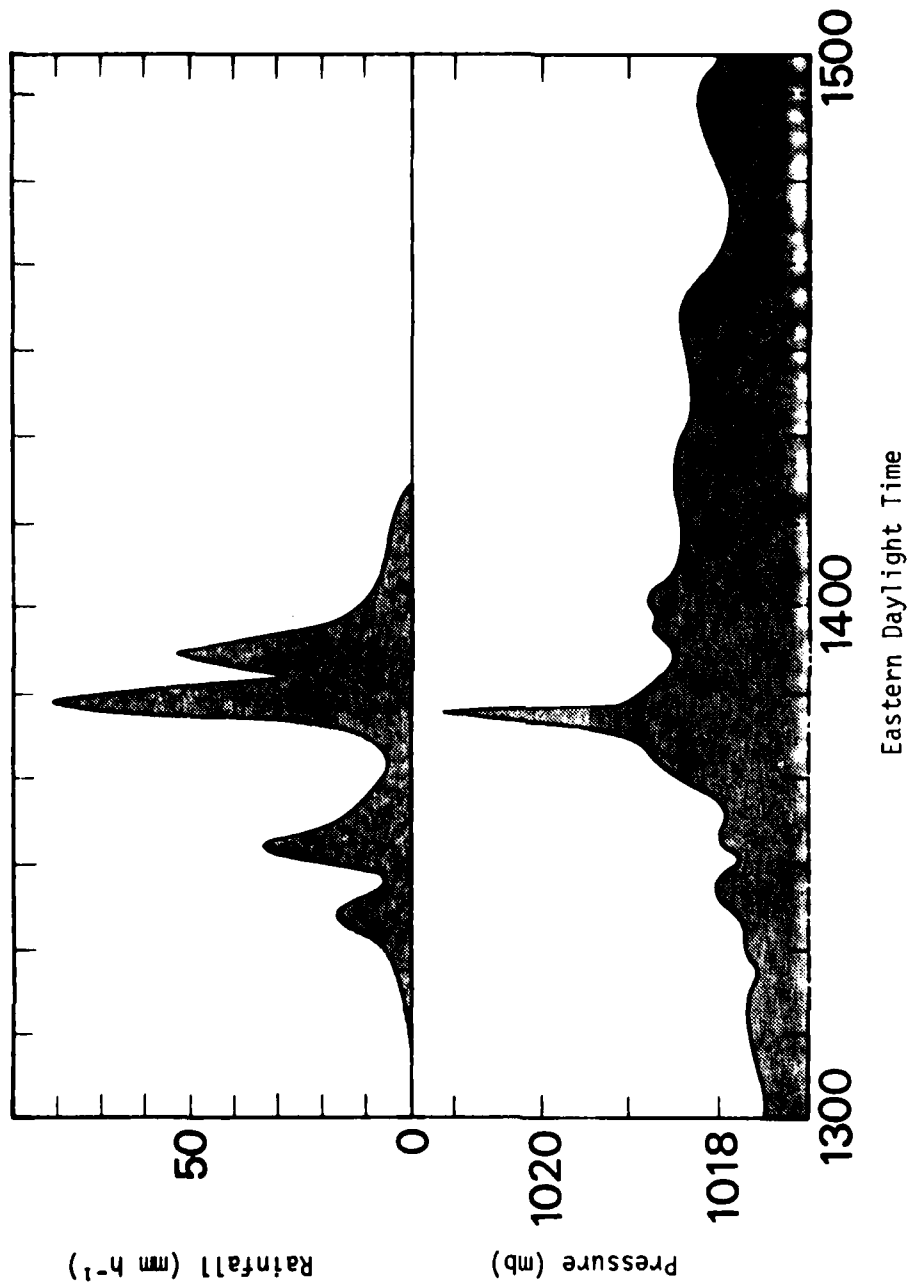

Figure 8. Pressure and rainfall rates associated with the microburst at the FOS of the Florida Area Cumulus Experiment on July 1, 1975.

possible on the basis of the negative buoyancy developed in a vertical column containing the precipitation.

From the foregoing discussion it is apparent that microbursts are a serious threat to air safety. They are a great hazard because they develop severe wind shear and because there is a great element of surprise in their occurrence. Without warning, an innocuously appearing air mass thunderstorm can produce a microburst where a few minutes earlier there was no problem, and the problem may vanish a few minutes later. A couple of miles away there may not have been any indication whatsoever of a hazardous wind shear event.

Because microbursts are small, short-lived, and invisible, they are easily overlooked. However, they last long enough and extend over a sufficiently large area to crash a commercial jetliner. This is the great challenge to us in air safety. We need to be able to detect these small, short-lived, invisible, but powerful objects and to warn pilots that they are there, in real time. A minute's delay in alerting the pilot may be fatal.

Dr. Kuhn and I at the Environmental Research Laboratories in Boulder have been concerned with the challenge of remote sensing of wind shear in thunderstorms. We think that a low-cost infrared (IR) radiometer can be used for this purpose. Studies of severe wind events by Fawbush and Miller (1954) show that the peak wind gust in thunderstorms is correlated with the temperature contrast of the outflow to the thunderstorm's environment at the surface (e.g., see Figure 9). The cooler the outflow, the stronger is the most probable peak gust.

In his discussion of the "1979 Clear Air Turbulence Flight Test Program," Ed Weaver mentioned an IR remote sensor of clear air turbulence (CAT) that was developed by Kuhn. This instrument detects CAT through IR radiation anomalies in the molecular water vapor band. Up to the present, testing of this instrument indicates that it can detect CAT with low failure and false alarm rates. As this instrument continues to be tested, present indicators are that it will probably be developed commercially in the not-too-distant future.

A simple design change in the presently existing IR CAT detector can render it a dual CAT/wind shear sensor. With a pressure-activated sensor mechanism, the CAT IR filter can be replaced with an IR filter in the carbon dioxide band.

The concept behind the wind shear remote sensing portion of this instrument is illustrated in Figure 10. An incoming IR signal in one carbon dioxide pass band is compared with a signal in another pass band. These two signals are processed to give a quantitative estimate of the forward, horizontal temperature gradient. The effective range of this instrument is about 10 km. When the forward temperature gradient exceeds a certain threshold, an alarm is activated (e.g., yellow light). At a second threshold this alarm is upgraded (e.g., red light).

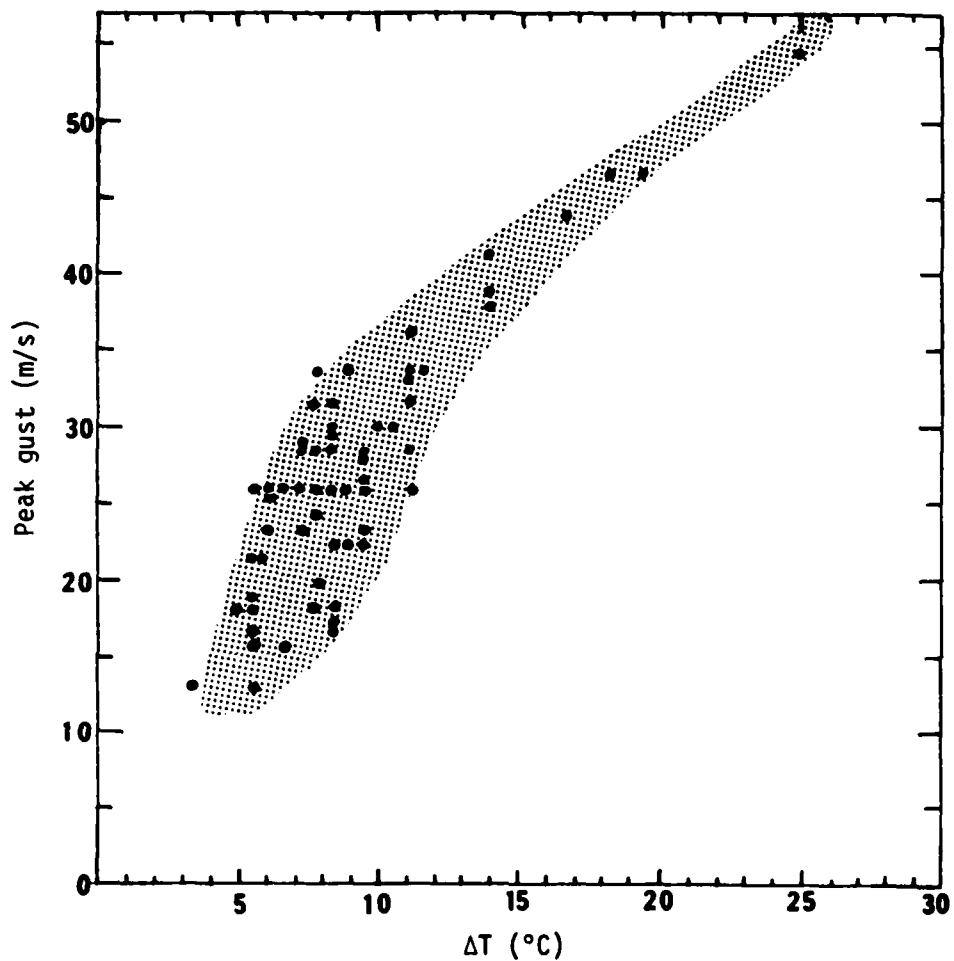

Figure 9. The relation of peak gusts in thunderstorms and the temperature deficit of the downdraft from Fawbush and Miller (1954). ( $\Delta T$  is the difference between the surface temperature just preceding the storm minus that just after the first heavy shower).

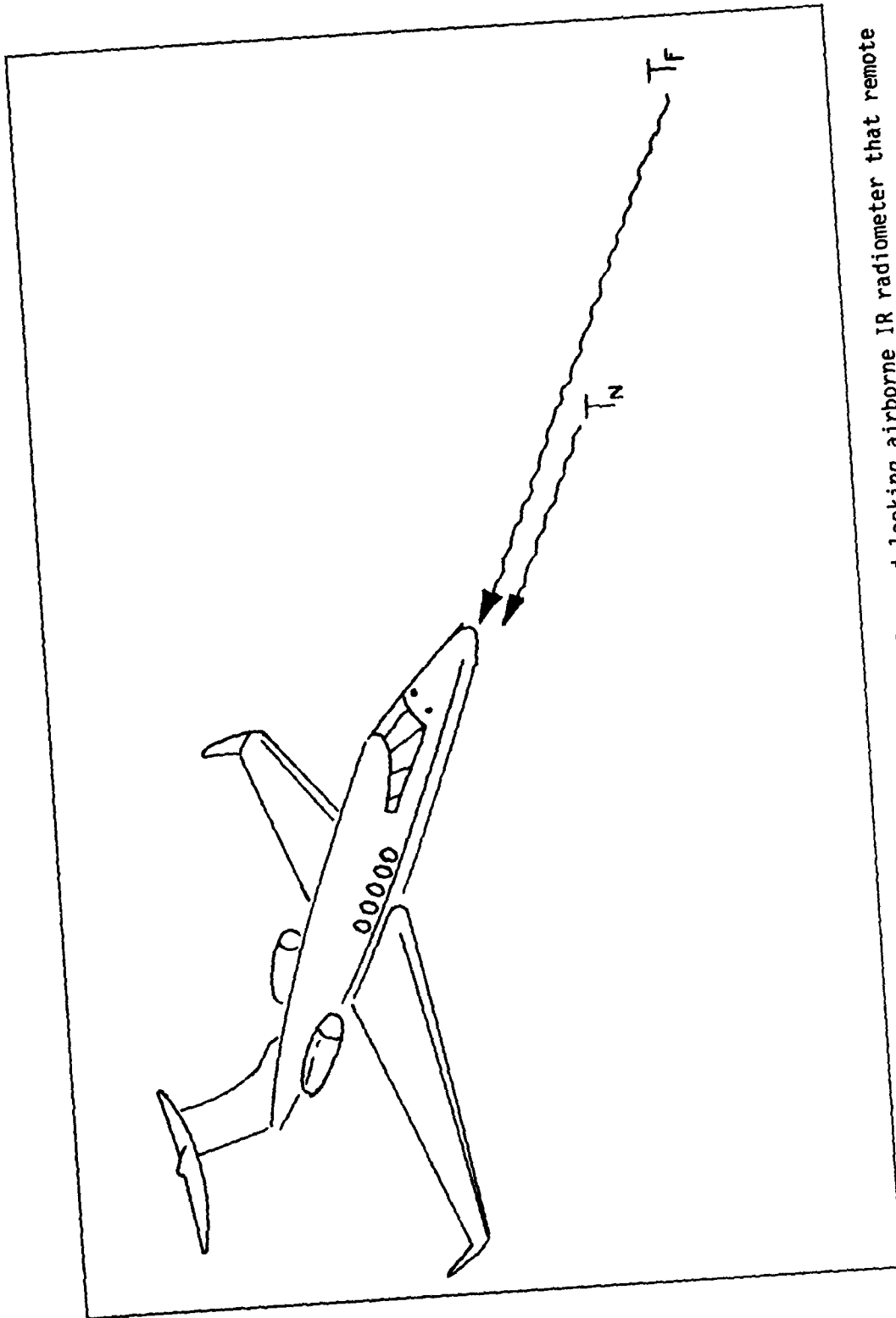

Figure 10. Schematic of incoming IR signals to a forward-looking airborne IR radiometer that remote senses low level wind shear.



The dual CAT/wind shear remote sensor described above is a very attractive instrument from the standpoint of air safety. It will have the advantage of being a low-cost instrument, and at present it offers the only hope for an airborne detector of severe wind shears such as the ones spawned in microbursts.

#### References

- Caracena, F., and M. Maier, 1979: Analysis of a Microburst in the FACE Meteorological Mesonet, preprint, 11th Conference on Severe Local Storms, Kansas City, Missouri, pp. 279-286.
- Fawbush, E.J., and R.C. Miller, 1954: A Basis for Forecasting Peak Wind Gusts in Nonfrontal Thunderstorms, Bulletin of the American Meteorological Society, Vol. 35, pp. 14-19.
- Fujita, T.T., 1978: A Manual of Downburst Identification for Project NIMROD, SMRP Research Paper No. 156, University of Chicago.
- Fujita, T.T., and H.R. Beyers, 1977: Spearhead Echo and Downburst in the Crash of an Airliner, Monthly Weather Review, Vol. 105, pp. 129-146.
- Fujita, T.T., and F. Caracena, 1977: An Analysis of Three Weather-Related Aircraft Accidents, Bulletin of the American Meteorological Society, Vol. 58, pp. 1164-1181.
- Melvin, W.W., 1975: Effects of Wind Shear in the Base Area of Down-drafts, Flight Safety Facts and Reports, Flight Safety Foundation, Inc., Sept. 1975, pp. 6-7.

## DR. FUJITA'S MICROBURST ANALYSIS AT CHICAGO

John McCarthy

National Center for Atmospheric Research

Fujita [1], University of Chicago, has just recently analyzed an intense wind shear occurrence on May 29, 1978, during the NIMROD experiment. Three Dopplers were available for this study, but the spacing was so large that Dr. Fujita had to rely on single Doppler to obtain the necessary resolution of the wind shear. Several important items should be emphasized. This case represents a single Doppler radar analysis; the vertical velocity fields to be shown are obtained by making certain assumptions regarding cross-radial wind components. While some would question the general validity of such assumptions, I do not doubt the presence of an incredibly strong low level jet outflow component of the microburst event. This one reaches a  $31 \text{ m s}^{-1}$  outflow, approximately 60 knots, only 50 meters above the surface! I have looked at the single Doppler data for this case, and there is no question in my mind that the outflow portion of it is valid. A 60 knot jet at 50 meters above the surface represents an extraordinarily serious hazard for aviation. Finally, the microburst event occurs on a much smaller scale than the mesoscale, which is usually considered.

Figure 1 shows a downdraft center. At approximately the 50 meter level, a vertical velocity downdraft of only 10 or 12 knots is indicated, which is not too far out of line from what you might expect with a tall instrumented tower, i.e., the National Severe Storms Laboratory tower. Again, I am not going to try to justify the assumptions regarding vertical velocity calculation, but my personal examination of the raw Doppler data suggests the validity of this case.

Figure 2 depicts this microburst outflow with several different approach and departure profiles superimposed. The strong outflow near the surface, with its abrupt boundary, represents a severe problem for the aircraft.

A major point here is to recognize that microbursts can be quite small-scale features and that they can occur in rather significant thunderstorms. However, evidence suggests they more typically occur in very weak thunderstorms that have hardly reached thunderstorm stage. I think the Atlanta case reported by Dr. Fujita represents a case where a very small storm produced a microburst, when standard detection and warning techniques would suggest no serious problem. That is, a microburst potentially can destroy an aircraft, yet may not produce damage on the ground. If we look for our traditional standards of severe storms, many severe wind shear situations will be ignored. Furthermore, the current low level wind shear alert and pressure jump systems presumably would have a difficult time detecting such intense but small-scale hazards.

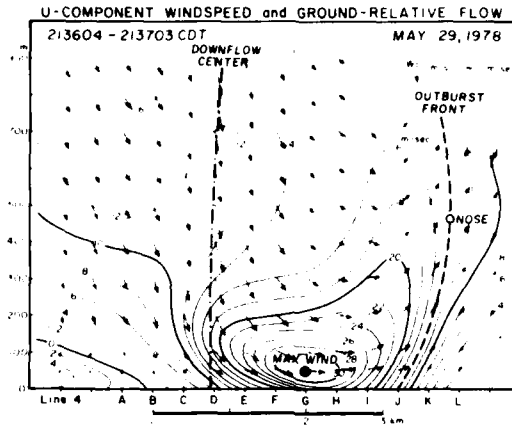

Figure 1. Isotachs of horizontal windspeeds through microburst event which occurred on 29 May 1978 during the NIMROD experiment. Vectors show x-z wind field. Maximum horizontal windspeed of  $31 \text{ m s}^{-1}$  is estimated to occur at 50 m or lower. (Courtesy of Dr. Fujita)

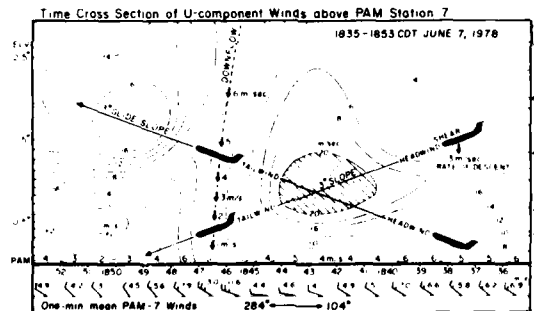

Figure 2. Hypothetical penetration through the maximum-wind core along 3-deg slopes. The headwind shear (headwind increase with time) is experienced during the approach to the core, while the tailwind shear (headwind decrease or tailwind increase with time) is encountered while flying away from the core. A strong tailwind shear results in a loss of airspeed which endangers both landing and takeoff operations. (Courtesy of Dr. Fujita)

#### Reference

- [1] Fujita, T.: Personal communication.

## CLEAR AIR TURBULENCE FORECASTING TECHNIQUES

John L. Keller

University of Dayton Research Institute

I would like to describe a promising way to improve National Weather Service (NWS) clear air turbulence (CAT) forecasting by more effectively using the currently operational Rawinsonde (RW) system. The method is called the Diagnostic Richardson Number Tendency (DRT) technique, its development was supported by NASA/Marshall Space Flight Center. The technique does not attempt to use the RW (or RAOB) as a direct detector of the turbulent motion or even of the CAT mechanism structure but rather senses the synoptic scale "centers of action" which provide the energy to the CAT mechanism at the mesoscale level.

The DRT algorithm is deterministic rather than statistical in nature, using the hydrodynamic equations ("equations of motion") relevant to the synoptic scale. However, interpretation, by necessity, is probabilistic. What is most important with respect to its operational implementation is that this method uses the same input data as currently used by the operational National Meteorological Center (NMC) prognostic models. These models provide the products used by general and aviation weather forecasters.

Some verification studies of the DRT have been carried out. The initial case study and its original formulation were done by Oard (1974). He very laboriously and meticulously generated an input data set for the eastern part of the United States. Using these data he resolved fairly substantial turbulence which had been documented in an observational study performed in the spring of 1970. Although the technique seemed to perform well, the laborious procedure for generating input limited Oard to but one case study.

Some additional case studies of documented CAT encounters were carried out by Dutton (1979) of the British Meteorological Office. The results thus far seem somewhat promising and are certainly worthy of consideration for eventual implementation to operational status.

The primary parameter in the DRT technique is the time required (idealistically) for a particular volume of the atmosphere to reach the critical Richardson number,  $t_{cr}$ . Since we are dealing with the synoptic scale, the interpretation of the critical Richardson number is not in the strict sense of the classical meaning which is relevant to infinitesimal layers. The Richardson number in the classical sense has a critical value of  $1/4$ .

Plotted in Figure 1, for the 250 mb (31,000-35,000 ft) level, is the location and time of each CAT encounter to the west of and over Europe.

250 mb (31,000-35,000 ft)

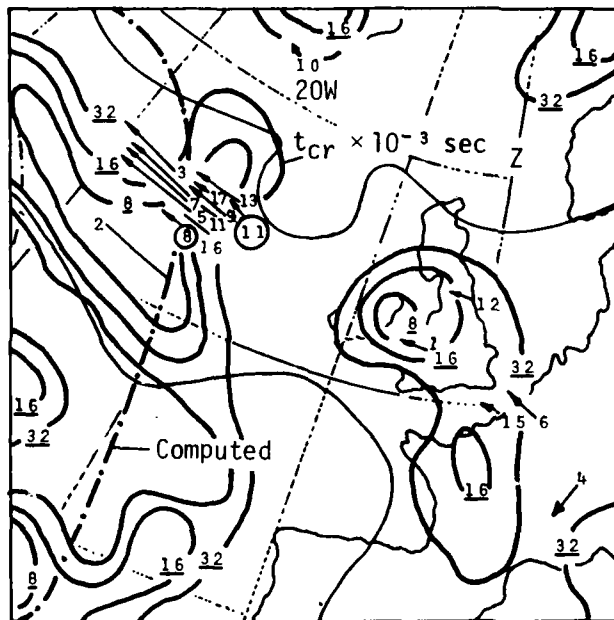

<u>Encounter/Time</u>	
1	1044-1047 Z
2	1107-1131
3	1237-1306
4	1325-1335
5	1351-1434
6	1405-1419
7	1428-1458
8	1444-1502
9	1456-1521
10	1509-1511
11	1513-1530
12	1537-1545
13	1545-1621
14	1559-1659
15	1640-1650
16	1648-1703
17	1708-1720

12 Z 18 March 1976

Figure 1. CAT encounters to the west of and over Europe.

The under lined numbers represent lines of constant  $t_{cr}$  in units of seconds multiplied by 1000. The region of high CAT potential as calculated by Dutton is indicated by a dot-dashed line. Listed on the right-hand side, in order of increasing time, are the encounters of CAT, starting shortly before the analysis time. The length of each arrow is the distance over which turbulence was encountered. Generally, these encounters seem to be clustered adjacent to the "centers of action."

Two of the encounters in this figure were described as being severe and are delineated by circles. Of course, the interpretation of CAT severity levels is known to be very subjective. In order to restrict this evaluation to significant turbulence, I used only reports described as at least moderate. I could then be confident that the pilot was substantially impressed by the "bumpiness" he was experiencing. This application is for the high levels used by commercial airlines; however, the analysis is not limited to these levels. This information can be made available to aircraft using lower altitudes.

Figures 2 and 3 illustrate a vertical cross section from 5,000 to 45,000 ft which passes through the center of the large concentration of encounters between 21°W and 34°W longitude and 55°N latitude in Figure 1. Upon inspection of these figures it can be seen that as the "center of action" propagate eastward and downward, so does the CAT encounters.

Figure 4 shows another case which occurred March 24, 1976. The level is lower (350 mb) and tends to pick up more encounters over Europe where flight paths tend to be lower. Also, since more planes are likely to be in the air at one time, there are more chances for encounters. The "center of action" in this case is in eastern Europe.

In summarizing, I must first mention that the NMC analyses, which supply the input data are now made at twice the horizontal resolution as the input data used here. Thus, more detailed representations, horizontally at least, are presently possible. Second, I think the DRT technique represents a great improvement over the highly qualitative CAT forecast products currently available. It requires no special data system and only some rather simple developmental work and computer code streamlining is needed to make it routinely available at modest cost.

#### References

- Dutton, M. J. O., 1979: Performance of Conventional Operational Forecasts of Clear-Air Turbulence During the 1976 Turbulence Survey, *The Meteorology Magazine*, Vol. 108, pp. 61-76.
- Oard, M. J., 1974: Application of a Diagnostic Richardson Number Tendency to a Case Study of CAT, *Journal of Applied Meteorology* Vol. 13, No. 7, pp. 771-777.

Encounter/Time	
1	0220-0240 Z
2	0300-0320
3	0448-0521
4	0537-0544
5	0640-0705
6	0650-0654

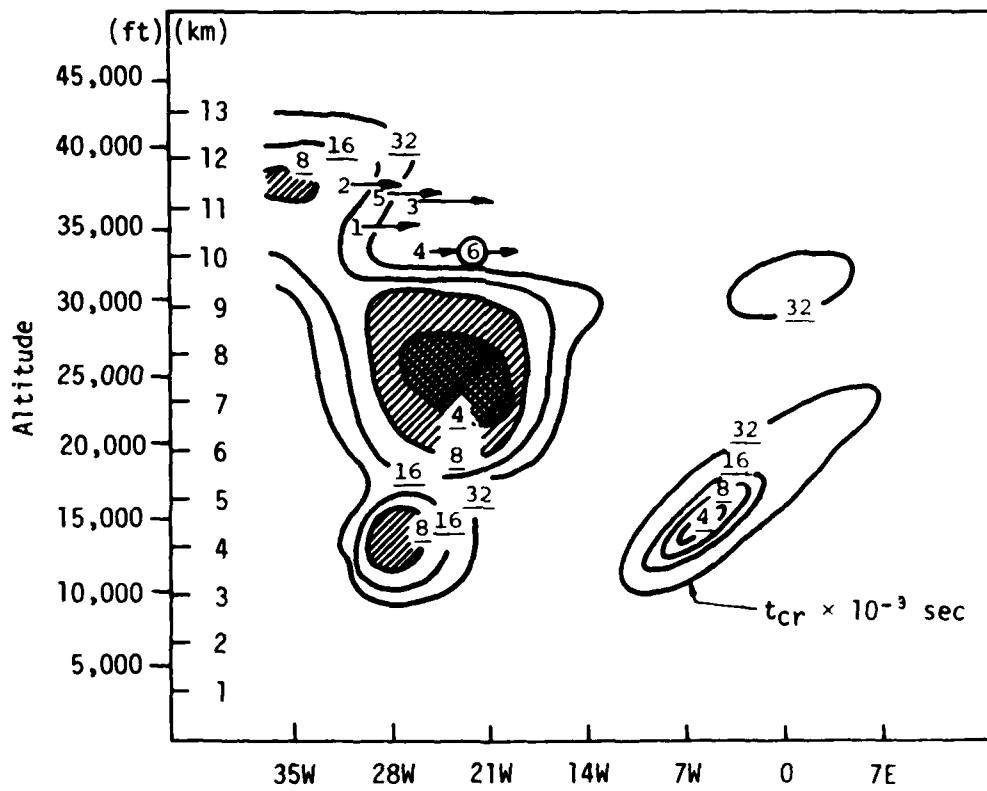

0 Z 18 March 1976

Figure 2. Vertical cross section of CAT.

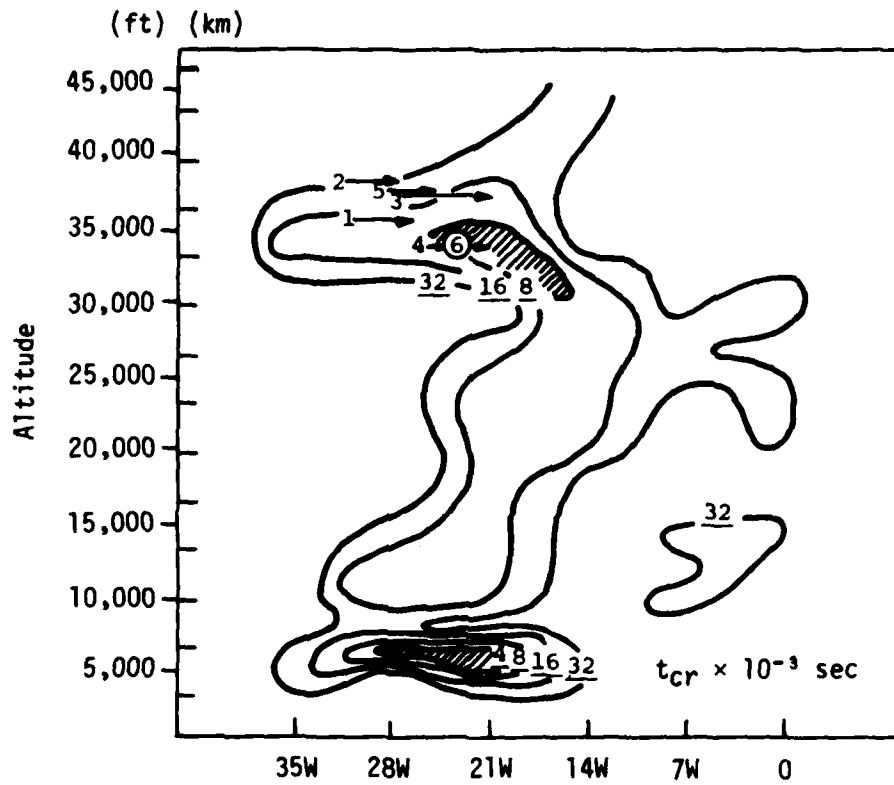

12 Z 18 March 1976

Figure 3. Vertical cross section of CAT.



350 mb (23,000-28,000 ft)

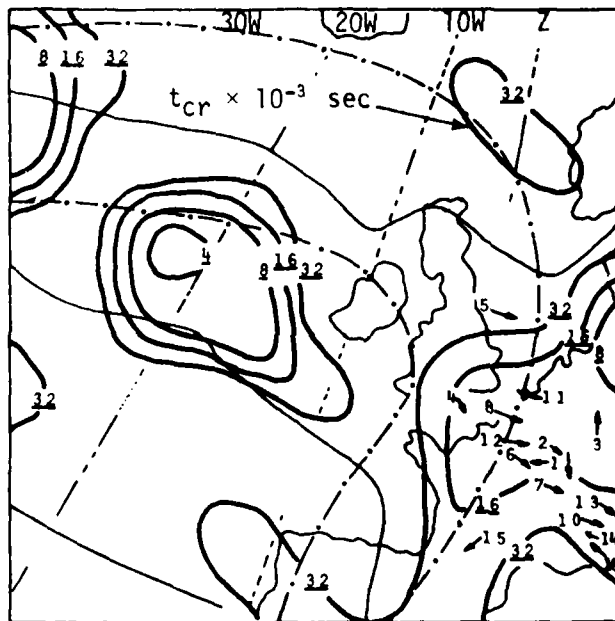

Encounter/Time	
1	0955-1018 Z
2	1000-1005
3	1000-1010
4	1100-1105
5	1100-1111
6	1114-1124
7	1159-1205
8	1206-1216
9	1334-1335
10	1357-1404
11	1437-1442
12	1534-1540
13	1626-1629
14	1753-1756
15	1805-1809
16	1815-1826

12 Z 24 March 1976

Figure 4. CAT encounters at a lower level.

THE PROGRAM OF THE TECHNIQUES DEVELOPMENT LABORATORY  
IN AVIATION WEATHER FORECASTING

William H. Klein

Intercon Weather Consultants, Inc. (NOAA Ret.)

It would be very beneficial for the attendees of this workshop to review the program of the Techniques Development Laboratory (TDL) in aviation forecasting because much of it is relevant to the discussions which are taking place here. In fact, some of it has already been mentioned in the first two days.

Currently Operational Products

The main contribution of TDL has been the development of a technique known as model output statistics (MOS), by means of which they turn out operational products shown in Table 1. Forecasts are prepared twice a day at the National Meteorological Center (NMC), Suitland, Maryland, for approximately 230 cities around the country for each of the weather elements I have listed in Table 1. Some of you may have seen these forecasts, but they are not usually available to people outside the weather forecast offices. The products include surface wind every six hours, i.e., wind speed and direction; cloud cover given as scattered, broken, clear or overcast every six hours; ceiling and visibility given in six categories; surface temperature valid every three hours; probability of precipitation in six and twelve hour periods (like the conventional radio forecast); probability of precipitation type, which tells whether the precipitation will be rain, snow or freezing rain and is of quite a bit of interest to aviation; probability of heavy snow, which can also be a serious aviation problem; and probability of thunderstorms and severe local storms in two forms, 1) a facsimile map covering the period from 12-36 hours in advance over the eastern two thirds of the United States and 2) a teletype plot from two to six hours in advance which is made four times a day and corresponds to the watches issued by the National Severe Storms Forecast Center (NSSFC), Kansas City. All of these products have an accuracy which is well within the state of the art. TDL feels they are the best available guidance to our forecasters, who have a very hard time improving on them. The essence of the method is to combine numerical or dynamical models like the limited area fine mesh (LFM) model run at NMC with the best statistical techniques we have developed and with local climatological records at each of these stations.

New Experimental Products

Some new experimental products are now in various stages of research and development, and these are listed in Table 2.

TABLE 1  
TECHNIQUES DEVELOPMENT LABORATORY OPERATIONAL PRODUCTS

- Wind
- Cloud Cover
- Ceiling
- Visibility
- Surface Temperature
- Probability of Precipitation (POP)
- Probability of Precipitation Type (POPT)
- Probability of Heavy Snow (POSH)
- Probability of Thunderstorms (POT) and Severe Local Storms (SELS)
  - 12-36 hours
  - 2-6 hours

TABLE 2  
TECHNIQUES DEVELOPMENT LABORATORY EXPERIMENTAL PRODUCTS

- Surface Dew Point (MOS)
- Obstructions to Vision (MOS)
- Boundary Layer Model (BLM)
- Computer-Worded Terminal Forecast (CWFT)
- Terminal Alerting Procedure (TAP)
- Generalized Equivalent Markov (GEM)
- Radar Forecasts (0-2 hours)
- Local AFOS MOS Program (LAMP)

Surface dew point. This is actually going to become operational in April, 1980, and will appear on the standard FOUS-12 message containing the products listed in Table 1. Surface dew point forecasts, which have been developed by the MOS technique, are valid at each of 230 cities every three hours and are prepared twice daily. They can easily be combined with the three-hourly temperature forecasts to produce relative humidity forecasts, which would have many applications, although relative humidity would not be of great interest to the aviation community.

Obstructions to vision. Type of obstruction will be listed in terms of the probability in four categories: no obstruction at all, smoke or haze, fog of any type, and blowing phenomena such as blowing sand, snow or dust. This would be issued twice a day.

Boundary layer model. This numerical dynamical model, which has been mentioned at previous workshops, is already being run on a quasi-operational basis twice a day. Since it has rather high resolution in the lower levels of the atmosphere, it will be quite useful in giving forecasts of low level wind shear, low level temperature inversions, and type of precipitation, including tip-offs to snow, freezing rain, etc. It covers only the eastern two thirds of the United States now, but is being extended to cover the entire country.

Computer-worded terminal forecast. This program will automate the terminal forecast (FT) and will have the computer express the FT in words just like the standard FT our forecasters prepare today. This will save a lot of time and effort in typing, etc. This program will begin operating within a year, but only on communication lines provided by Automation of Field Operations and Services (AFOS). Otherwise, the large quantity of material which will be transmitted would swamp existing teletype lines. So as soon as AFOS becomes operational, this program too will become operational, going out from NMC to each of the state aviation terminals. It will be based on all the forecasts that I listed before as well as some others to be forecast by the computer.

Terminal alerting procedure (TAP). TAP will compare the latest FT with the latest observation. Whenever there is a discrepancy, the forecaster will be alerted by the sound of a alarm or by a flashing bright light. An automated guidance forecast will be produced to tell the forecaster just how to amend his forecast when that is necessary. This program also requires the AFOS environment to be operational. We originally developed a method of doing this which is now being supplemented by a second method, listed as the Markov (GEM), which was discussed by Art Hilsenrod in his presentation "Very Short Range Forecasts of Visibility and Ceiling." Basically, it is a new statistical technique to develop FT's each hour from the hourly observations, and it can be developed for each city based on the previous record. This will probably be run on the AFOS mini-computers at each forecast station and combined with the TAP program. Once

the alert is sounded, the GEM program will be the one to give the new guidance forecast, including ceiling, visibility, wind, thunderstorms, etc., i.e., the whole surface observation.

Radar forecasts. As mentioned in Jack Connolly's discussion of "Federal Aviation Administration (FAA) and National Weather Service (NWS) Aviation Research and Development," FAA plans to conduct at the National Aviation Facilities Experimental Center (NAFEC) a test of this technique, which develops 0-2 hour forecasts of echo motions on digitized radar screens. This computer technique forecasts the location and intensity of the echoes and converts them into probabilities of thunderstorms and severe local storms, but it is not yet operational.

Local AFOS MOS program (LAMP). The idea of LAMP is to update the MOS forecasts, which are keyed to the NMC cycle and are issued only twice daily when the radiosondes are sent up. But we need aviation forecasts any time of the day. LAMP would key the forecasts to local observations and the latest data, updating on the AFOS mini-computers by means of the late radar data and late satellite data. This could all be worked into statistical equations which would be combined with a MOS forecast. LAMP also involves elaborate objective analysis of all surface observations and a very simple numerical model that can be run on the mini-computer which will advect these fields over the stations. It will eventually be applied to the entire nation, and TDL thinks it will provide the best possible guidance for the 0-24 hour period.

## AVIATION WEATHER AND THE COMMUTER AIRLINE

Barry S. Turkel

The University of Tennessee Space Institute

We have gathered here to talk about aviation weather and the aviation industry, and in so doing we must not forget about the commuter airlines. Recently there has been increased government concern over commuter airline operations safety, and this has prompted special National Transportation Safety Board (NTSB) hearings and Federal Aviation Administration (FAA) hearings and, subsequently, stricter operating requirements. Now this may not sound like an important issue to most people who deal in some fashion with large commercial airlines or pleasure flying. But it *is* important to the total U.S. aviation industry. Commuter airlines have been filling the gaps left in the U.S. air system by deregulation, which caused many large commercial airlines to pull out of less economical routes. There was even recent discussion at the Southeastern Airport Managers Association Conference about starting a commuter hub in the Southeast with extended service throughout the Southeast.

Nevertheless, as the need for widespread commuter service increases, safety in commuter flight operations must also increase. It must keep up with the pace.

The following NTSB statistics have been used to indicate that commuter airlines have an accident rate six times higher than that of the certificated carriers. In 1978, in accidents per 100,000 departures, commuters averaged 2.57 as opposed to 0.40 for the certificated carriers, a ratio of over six to one (Aviation Week and Space Technology, 1979).

While these statistics are used to show gross differences in safety between the commuters and the certificated carriers, it should still be noted that as commuter operations increase (at least until profitable market builds) flight through adverse weather will also increase due to increased exposure. Commuters will operate at higher operational levels with their smaller, less sophisticated, less equipped aircraft; they will continue to operate at less equipped airports with respect to on-site forecasters, shorter and ungrooved runways, lower airport maintenance capability (snow removal, etc.) and with limited funds and/or time for lesser experienced flight crews to properly train for adverse weather flight.

Now to adequately determine if, in fact, the commuters are presently weather-safe and where any problems might exist, the following work must be done.

First, NTSB's commuter airlines statistics must be more closely studied to locate specific weather problems. For example, what weather causes were most frequently cited? I think there should be some special consideration about fog and low ceilings; that is probably a major cause. Second, which phases of operation are affected most? The answer seems to be: mostly landing, final approach, leveling off and some takeoff, and perhaps initial climb. Third, are the commuter aircraft performance standards accurate, especially with the commuter airliner in use long after it is first broken in? Does it still conform to the operator's and the manufacturer's standards of performance? Are the federal standards--Visual Flight Rules, Instrument Flight Rules, minimums--feasible? Are they applicable to these kinds of aircraft with lesser equipment? Fourth, were the airports or facilities serving the commuters at fault in these accidents? And most important, I think there is a need to conduct a survey through the Commuter Airline Association of America to determine what precautions or safety programs they are presently using in their operational procedures, if any; which ones are working; and what can be done to improve current procedures. The result of this work would be a commuter operations safety manual for safe weather flight. I think that would be a beneficial thing for the commuter segment of the aviation industry to have, especially in light of the statistics that have been put against it.

#### References

Aviation Week and Space Technology, 1979: Commuters Fear Federal Talks May Yield Tighter Safety Rules, Vol. 111, No. 24, pp. 27-29.

## CHARGED PARTICLE FOG DISPERSAL SYSTEM

Frank G. Collins

FWG Associates, Inc.\*

Recently at FWG Associates, Inc., we have been studying the charged particle warm fog dispersal technique. This brief discussion of the technique is for the benefit of those of you who are perhaps not familiar with it.

Figure 1 illustrates the principle of the technique. Neutral particles, typically water droplets, are passed through a corona discharge; in the corona discharge region they pick up charges. They are then accelerated through a nozzle to high speeds and discharged into the fog. The charges are then transferred to the fog droplets.

A nozzle system that was actually used in some tests performed some years ago is illustrated in Figure 2. In this case, the saturated air passed through the sonic region of the nozzle and then through a corona discharge. The saturated air became super-saturated and droplets were formed. The droplets picked up charges in the corona discharge and then were accelerated to a Mach number of approximately 1.35, after which they were discharged into the fog.

The idea for use of the charged particle dispersal system in an airport is shown in Figure 3. An array of nozzles would be distributed along the runways, taxiways, etc., and each nozzle would send up charged particles into the fog. The charges would be transferred from the droplets in the jets to the fog, and then the charged fog would be driven along electric field lines to the ground and/or the fog droplets would precipitate out as rain.

Many questions remain as to how to successfully design such a system. The results of the field tests performed in the past were inconclusive. There are many design parameters that must be examined before exactly how to build such a system can be determined. Figure 4 shows a model we propose to review which would allow a theoretical examination of the effect of various parameters upon the design of this system. In this case, the charged particle beam is emitted into a wind having the profile shown. The mechanism of charge dispersal into the fog and the entrainment of the surrounding air with the jets need to be examined. The effects of space charge generation and of coalescence and precipitation of the fog need to be known. The effect of different fog particle size distributions and nozzle droplet distributions upon the effectiveness of the system need to be examined, which can best be accomplished through a very careful and complete numerical modeling of the system shown in Figure 4. We propose to continue our work through

---

\*Consultant from The University of Tennessee Space Institute



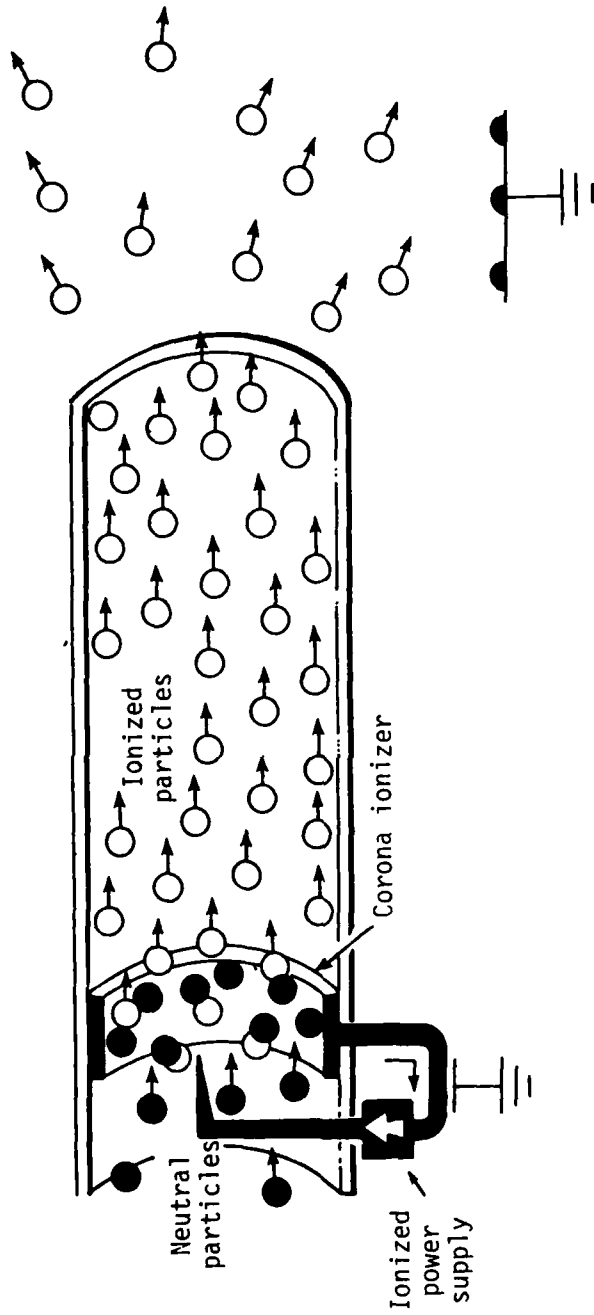

Figure 1. Illustration of fog dispersal principle.

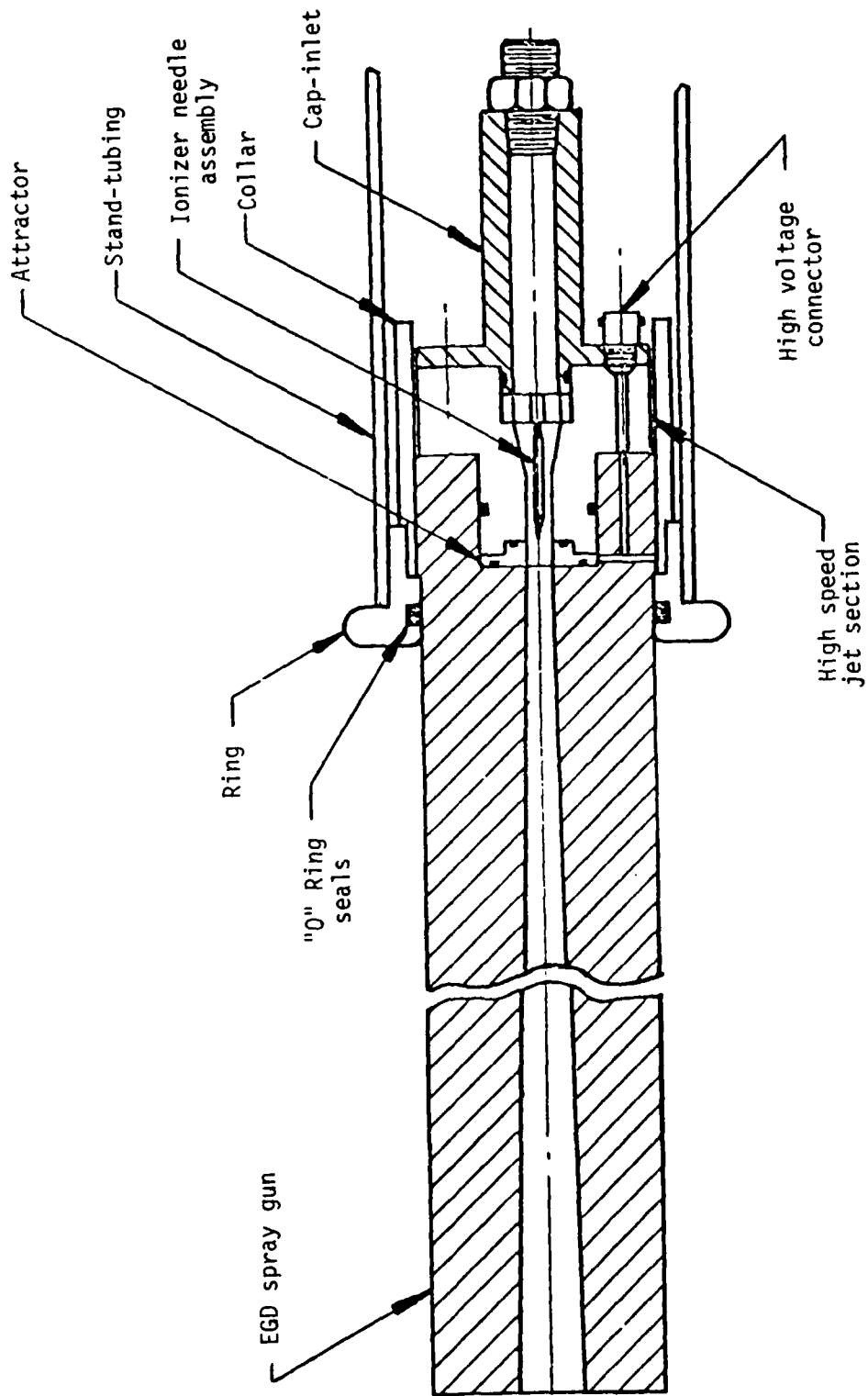

Figure 2. Schematic of nozzle used by Gourdine (Chang, 1973; Wright and Clark, 1973).

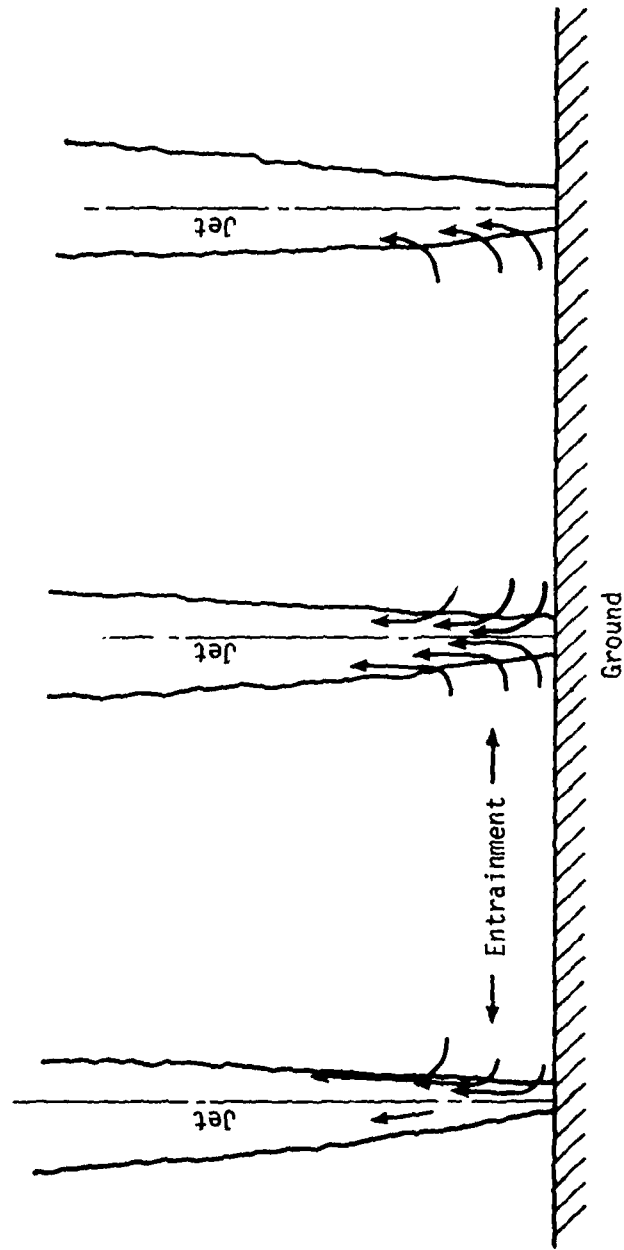

Figure 3. Application of charged particle fog dispersal system to fog dispersal at an airport.

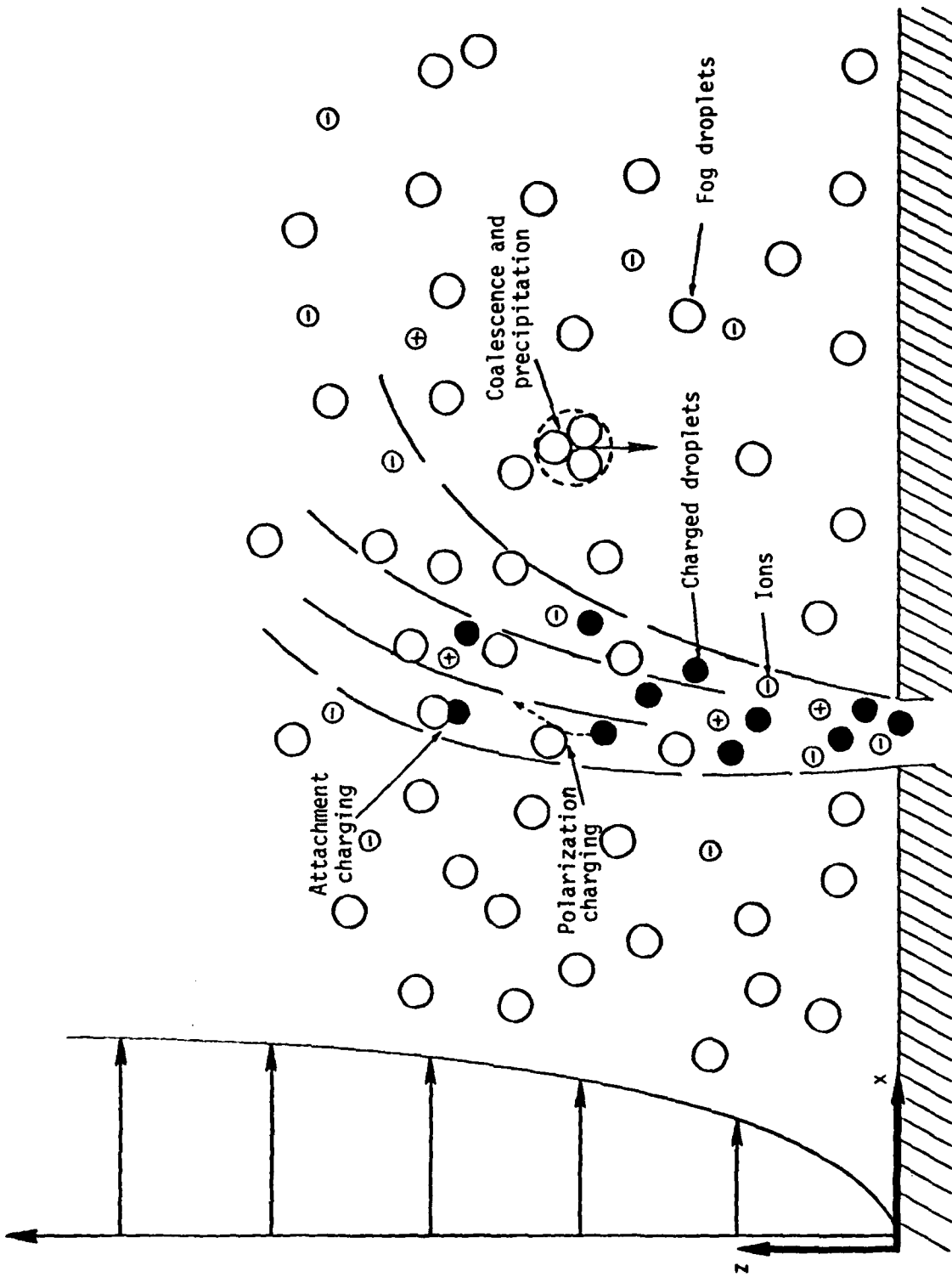

Figure 4. Phenomenon occurring in interaction of charged jet and warm fog.

this kind of numerical examination of the complete charged particle fog dispersal system. Once this has been accomplished and the most feasible design parameters have been determined, a field test to examine the results of the analysis will be proposed.

References

Chang, P.K., 1973: Field Evaluation of an Electrostatic Fog Dispersal Concept, Part I, FAA-RD-73-33.

Wright, T., and R. Clark, 1973: Field Evaluation of an Electrostatic Fog Dispersal Concept, Part I, FAA-RD-73-33.

AVIATION SAFETY USES FOR LEFTOVER SPACE HARDWARE AT  
NATIONAL AERONAUTICS AND SPACE ADMINISTRATION/JET PROPULSION LABORATORY

Bruce L. Gary

NASA/Jet Propulsion Laboratory

I feel that some information concerning the work we are doing at the Jet Propulsion Laboratory (JPL) should be of interest to this group because it may tie in to other work of those in attendance. Our work is largely unpublished, so this may be the first time that many of you will become aware of some of our capabilities. At JPL we are using leftover space hardware and identifying aviation safety uses for it. This hardware is microwave and passive, i.e., it is not radar. It has certain all-weather attributes due to the fact that it is microwave. Our sensors can be configured to sense three things: liquid water burden (the integral of liquid water along a line-of-sight), water vapor burden, and temperature versus altitude. There are three main configurations for this type of hardware: land-based, sea-based, and airborne. In April, 1980, JPL will be starting on a system for deep-ocean moored buoys for monitoring temperature versus altitude and vapor and liquid content, with funding from the National Oceanic and Atmospheric Administration (NOAA) and the National Aeronautics and Space Administration (NASA). The land-based system will be mounted in a van and will eventually have some mobility. The observed atmospheric properties will be displayed on television monitors. An airborne system which was flown in 1979 on a clear air turbulence (CAT) mission using NASA's Convair 990 was discussed by Ed Weaver in his discussion of the "1979 Clear Air Turbulence Flight Test Program." The airborne configuration senses temperature versus altitude for an altitude regime centered on the airplane's altitude. It scans up and down in elevation angle and retrieves temperature versus altitude a few thousand feet above and below the airplane. A search is made for unusual temperature structures, such as inversion layers and tropopause temperature inflections. Since this is done about every ten seconds, some assessment can be made of the dynamic state of these inversion layer and tropopause features. The sensor is intended to provide CAT avoidance and, perhaps, severity forecasting. This does not rule out forecasting CAT occurrence, but that is not the intended use of our sensor at this time.

Some other potential uses have been identified, though we are still trying to identify the best future for leftover space hardware. One of the potential uses is gust front and downburst cell detection, both airborne and land-based, i.e., airport. This would employ the same infrared technique that the NOAA/Wave Propagation Lab is using. Another potential is icing hazard monitoring, which would use a land-based system that monitors, in real time, the total liquid content of cloud material, as well as how super-cooled the cloud material is.

I believe these cloud properties are the two principal ingredients that determine the level of icing hazard. There may be some tie-in of this sensing capability to fog dispersal, since our sensor could characterize fog in a quantitative way. In fact, ours is the only sensor that can remotely determine how much liquid water is in a line-of-sight, and that at a one-second time scale besides! Finally, these sensors have uses in meteorology research, which is the direction from which we have come. Two years were spent doing meteorology research on stratus cloud formation/dissipation processes in conjunction with The University of California at Los Angeles. However, this technology is ready for application to more practical matters, and I believe aviation safety stands to benefit the most from these applications.



## **SECTION VI COMMITTEE SUMMARY REPORTS**







SUMMARY REPORT: ATMOSPHERIC ELECTRICITY AND LIGHTNING COMMITTEE

Andy D. Yates, Jr.

Air Line Pilots Association

Members: Andy D. Yates, Jr., Chairman; Air Line Pilots Association  
Robert E. Carr, NASA/Wallops Flight Center  
John C. Corbin, Jr., Air Force Aeronautical Systems Division  
W. R. Durrett, NASA/Kennedy Space Center  
Preston Geren, Boeing Commercial Airplane Company  
William H. Klein, Intercon Weather Consultants, Inc.  
Nickolus O. Rasch, FAA/National Aviation Facilities Experimental Center  
Lothar H. Ruhnke, Naval Research Laboratory  
Charles F. Schafer, NASA/Marshall Space Flight Center  
Joseph W. Stickle, NASA/Langley Research Center

Introduction

The Atmospheric Electricity and Lightning Committee became aware right at the outset of our discussions that interdisciplinary communications are lacking, i.e., much of the information available in the field of atmospheric electricity and lightning does not find its way into the hands of the aviation disciplines who could use it. In several instances our committee work was halted so that brief tutorial sessions could be held, and this helped a great deal in laying groundwork for discussions in our committee's areas of interest.

Discussion

Forecasting and dissemination of weather information. Forecasting the probability of high electrical energy fields and lightning is presently accomplished by measuring and tracking areas of activity and then predicting future movements and changes of intensity based on that information. Large-area and long-term forecasting is usually accomplished at National Weather Service (NWS) Centers and U.S. Air Force bases or at other military bases. The equipment used for taking measurements is essentially the same as that which has been employed for several years, although there have been some improvements made on the equipment over the years. In recent years some equipment has been introduced, such as infrared (IR) sensors, Doppler radar and field mills. Much of this type of equipment used in forecasting is still in the research stage. Dissemination of weather information however, has improved considerably over the years.

Research. In the past, a number of programs for probing areas of high electrical energy fields have been cancelled because of the lack of interest by high-level management and because of the fiscal considerations. However, new interest is being shown by the military, industry and government agencies. The U.S. Air Force and the National Aeronautics and Space Administration (NASA) have programs to characterize lightning that strikes aircraft. Research is ongoing to determine areas of probable lightning strikes to aircraft, rockets and the Shuttle orbiter. The effect of lightning strikes on composite materials and bonded materials is being examined; there is considerable concern that as aircraft are built using more composites, they may not be properly protected from the effects of lightning strikes.

Data base. The data base for in-flight lightning strike data is scant, so there was very little for our committee to discuss in that regard.

Ground-based and on-board instrumentation. Ground-based instrumentation consists of weather radars, storm scopes, and meteorological observations stations, both automatic and personnel-operated. In our discussion regarding the digitized radar located in a number of Air Traffic Control (ATC) Centers, terminals, and NWS Centers, it was brought out that ATC Centers and terminals have no weather depiction in their digitized weather radars and that older types of radar can detect only the most intense rainfall areas. The use of field mills for measuring electrical energy fields is becoming prevalent in both ground and flight research.

Training. Training appears to be inadequate in the interpretation of data collected from and presented by the following systems: electrical field measuring devices, storm scopes, weather radar, and Next Generation Weather Radar (NEXRAD, which is Doppler). Training is also lacking in post-strike procedures, particularly in the area of the effects of lightning strikes on instrumentation.

Flight control systems. In our brief discussion of flight control systems, concern was expressed as to the effects of lightning on fly-by-wire and fly-by-light control systems.

### Recommendations

Our committee's recommendations, listed under each discussion topic considered, are as follows:

#### Forecasting and dissemination:

1. Conduct separate studies on forecasting the probability of lightning in addition to those conducted with regard to thunderstorm occurrences.

2. Study the potential use of satellite and Doppler radar techniques to detect thunderstorms and forecast the probability of lightning.
3. Review existing dissemination systems with regard to data collected from all sources so as to increase speed and quantity of data disseminated to users.

Research:

1. Establish a National Flying Lightning Laboratory. NASA currently has a program using the F-106, but our committee feels that the F-106 alone will not serve the needs of all the users.
2. Research the definition of airborne lightning theoretical and experimental strike models.
3. Research the best way to apply electrical field data to operations.

Data base:

1. Improve the reporting of lightning strikes to aircraft in order to develop a statistical data base. Currently, it appears that a large number of lightning strikes to aircraft are not reported at all.
2. Include a lightning strikes data bank at the National Weather Record Center in Asheville, North Carolina, so this information will be available to all users.

Ground-based and on-board instrumentation:

1. Develop ground-based and airborne instrumentation to measure electrical fields for the purpose of lightning probability prediction and lightning strike avoidance.
2. Develop on-board instruments to detect lightning strike current path on the aircraft.

Training:

1. Train users in the interpretation of electrical field measuring devices, lightning detectors, and Doppler and weather radar. Also improve training in post-strike procedures, with emphasis on instrument susceptibility.
2. Train pilots and introduce face-to-face meetings between pilots and meteorologists in flight planning. With the trend toward automation in flight services, this may seem like an outdated recommendation, but we feel it is worthy of serious consideration.

Flight control systems:

Design positive hardening techniques to protect modern flight control and avionic systems.

Question and Answer Discussion:

Did I understand that the F-106 would not meet the needs of the user community?

Andy D. Yates, ALPA: Yes, it appears that the desires of many of the committee members were such that the F-106 would not fill all the needs they would have, or fill their needs expeditiously. They would rather see a dedicated aircraft with a national input, a vehicle accessible to everyone.

Jean T. Lee, NSSL: Relative to your recommendation for a lightning data bank, do I assume correctly that you are talking about lightning strikes to aircraft only?

Andy D. Yates, ALPA: That is correct.

SUMMARY REPORT: FOG, VISIBILITY AND CEILINGS COMMITTEE

Sepp J. Froeschl

Canadian Atmospheric Environment Service

Members: Sepp J. Froeschl, Chairman; Canadian Atmospheric Environment Service  
Edwin W. Abbott, Air Transport Association  
Robert S. Bonner, U.S. Army Atmospheric Sciences Laboratory  
Peter Chesney, FAA/Special Aviation Accident Branch  
Frank G. Collins, The University of Tennessee Space Institute  
Paul W. Kadlec, Continental Airlines  
Ronald H. Kohl, The University of Tennessee Space Institute  
Eric Mandel, FAA/Airports Group  
Byron B. Phillips, NCAR/Research Aviation Facility  
Ernest E. Schlatter, FAA/National Aviation Facilities Experimental Center  
August Stasio, Air Line Pilots Association  
Jerald Uecker, NOAA/National Weather Service  
Otha H. Vaughan, Jr., NASA/Marshall Space Flight Center  
Edwin A. Weaver, NASA/Marshall Space Flight Center

Introduction

It was a great honor and my pleasure to be called upon to chair the Fog, Visibility and Ceilings Committee during this Fourth Annual Workshop on Meteorological and Environmental Inputs to Aviation Systems. Let me also congratulate the Organization Committee for the preparation and the running of this workshop and thank the members of my committee for their cooperation. Before summarizing the deliberations and discussions of our committee, let me comment that I find this gathering of so many specialists, experts and scientists from a great variety of disciplines and faculties related to and involved in aviation and aerospace a formidable forum to communicate across interface boundaries and a great opportunity for the participants to exchange knowledge and experience.

Despite tremendous technological progress, visibility and ceiling and a combination thereof constitute a very important restrictive phenomenon in aviation, both civil and military; and it is a pity to say that the visibility/ceiling syndrome remains the foremost contributor to weather-related accidents.

During our initial deliberations we found ourselves plagued with a problem common to all the committees, that is, terminology and definitions. The committee also noted, much to our regret, that the findings documented by last year's Fog, Visibility and Ceilings Committee are still applicable and understandably even more timely. In general, problems expressed by our predecessors still remain as problems, more so since there seems to exist no coordinated mechanism for initiating applied research and development efforts.

Following working schedules and proceedings from the committees of preceding workshops, we singled out the following topics for this final report:

1. Slant Visual Range (SVR)
2. Prevailing Visibility and Automation
3. Fog Dispersal Systems

Before handling these subjects in detail we would like to stress the need for clearing up the confusion between the terms "visual meteorological conditions" (VMC) versus "visual flight rules" (VFR) and "instrument meteorological conditions" (IMC) versus "instrument flight rules" (IFR) and to encourage proper usage of these terms. In complete agreement with panelists, committee members and participants of all the previous workshop, our committee noted that the need exists to investigate the usefulness and validity of the meteorological criteria for VFR and IFR. The concept of VFR, being based on the fundamental thinking of "to see and be seen," has to be questioned, and consequently the criteria for VFR with respect to visibility should be reconsidered and possibly adjusted to accommodate:

1. Aircraft characteristics of our day.
2. Congested terminal areas.

#### Slant Visual Range (SVR)

Current research in the SVR area is minimal. After twenty years of intermittent research, an operational system still does not exist, although problem areas have certainly been better identified.

Past committee recommendations on the need for further SVR research efforts prompted considerable discussion during our meetings and some diversity of opinion, as could be expected among a group with such varied backgrounds. Consensus was reached, however, that the need for SVR is not firmly established and that further research should be limited to the development of an "approach" sensor capable of sampling that volume of airspace through which the pilot looks. This would have immediate application in improving existing Runway Visual Range (RVR) measurements upon which the delineation of airport landing minimums now depend. During this development period, the

refinement and acceptance of electronic landing systems might obviate any requirement for an SVR measuring and reporting system.

The need for an SVR product decreases and approaches the zero mark as landing operations move into Category III (CAT III) conditions, as the decision height rule applies regardless of SVR advisory information. CAT I and CAT II and the wide spectrum of IFR-rated pilot operations find SVR information useful, but regulation procedures should be established as to whether SVR will be advisory only or will become a basis for airport minimums in lieu of or in conjunction with decision height and/or RVR. Due to state-of-the-art sensors and the cost of developmental and operational testing, this year's panel feels that the need for SVR should be reaffirmed by user groups and that regulatory procedures should be proposed and accepted by user groups before SVR system development continues.

Much discussion centered around the fact that many airports are being rated or are close to being rated for CAT III operations, yet the visibility problem addressed as early as the Second Annual Workshop still awaits a solution. In other words, under CAT III conditions the plane lands safely on the runway, but the problems start once it has reached the end of the runway.

#### Prevailing Visibility and Automation

With respect to prevailing visibility and automation, the committee feels that the term "prevailing visibility" requires a clear definition since it is one of the most important elements of an aviation weather observation made by either an observer or an automated system. It is therefore recommended that the definition proposed by the Subcommittee on Basic Meteorological Services (SC/BMS) Panel on Automated Meteorological Observation Systems be adopted. We were fortunate enough to have a member of this panel on our committee. This proposed definition for prevailing visibility/oblique ground visibility (the question immediately arises as to why we start with an ambiguity in terminology) reads as follows: ". . . the horizontal visibility near the earth's surface representative of the visibility conditions in the vicinity of the point of observation, ground visibility being the same as prevailing visibility." The committee endorses the concept of the Joint Automated Weather Observation System (JAWOS) in order that observations can be obtained at more airports with an established instrument approach procedure. It is further recommended to include in the automated weather observation short-term (0-60 minutes) parameter forecasts.

#### Fog Dispersal Systems

Finally, with respect to fog dispersal systems, we were very fortunate to have in our group Paul Kadlec of Continental Airlines, who is really very knowledgeable and experienced in this field, and Frank Collins of The University of Tennessee Space Institute (UTSI), who is closely related to a new system which we considered to be more than worthwhile for further development. (Having our meeting at UTSI did



not influence this opinion.) Starting with the current operational requirements with respect to fog dispersal systems as defined by the Los Angeles Department of Airports and the Air Transport Association (ATA) with the concurrence of the Federal Aviation Administration (FAA), we accepted their requirements stating that any fog dispersal system should clear runway visibility to RVR of 1200 feet and increase visibility in the area of the final glide slope at the decision height to about 165 feet to accommodate the current widebodied fleet of transport aircraft. With the permission of Paul Kadlec, the committee is including as a reference an earlier report summary prepared by Continental Airlines for the ATA.

The present state of the art with respect to fog dispersal systems follows.

System I--Thermokinetic. This system is operational at two airports. From my own personal experience I would say these two systems are working very well, more than satisfactorily. The installation cost is relatively high, but, on the other hand, operation of the gear is relatively reasonable. There is some air pollution involved, but if the system is run on natural gas, it is operated on a cleaner basis. The noise pollution is fairly high, but still within limits, i.e., a 75 decibal maximum with 600 feet on either side of the row of engines. The clearing can be localized over the runways for all wind directions, and the system can be operated for short periods for each landing, making this system practical and relatively inexpensive to operate. Another system, which was developed by the U.S. Air Force, is closely akin to the thermokinetic system; its engines, including blowers and combustors to produce heat, are buried in the ground or stand just above it. This system, however, is not yet operational.

System II--Thermodynamic. A thermodynamic system, actually the opposite of the thermokinetic, is a kind of refrigerator. It has been shown to work in research development but has never been tested in operation. One of its setbacks, especially in this energy-stricken world, is that it is demanding on electrical power consumption. On the other hand, it is clean, and it humidifies and adds some heat to the air.

System III-Charged particle. This system has never been successfully demonstrated. However, after being briefed by Frank Collins, who is involved in its development, our committee recommends that systematic, step-by-step research and development be performed to determine whether this technique can be made operational. Research should include the examination of bipolar jets which could aid coalescence and improve visibility. This technique is estimated to have lower installation and operational costs than other methods. However, one of the problems at this stage is that the clearing height of this system is below 70 feet, and of course that is not enough at present. It is physically clean but has an unknown effect on the airport and aircraft electronic environment. So these unknowns must be studied before any further decisions regarding this system are made.

### Conclusion

The Fog, Visibility and Ceilings Committee feels that the problems expressed in the past concerning ambiguity of definitions and terminology remain and that a concentrated effort should be undertaken to resolve confusion between operational and regulatory literature. It is imperative that this ambiguity be resolved before the advent of the automated weather message.

## APPENDIX

Paul W. Kadlec

### Continental Airlines

At the request of Paul Leonard, Regional Vice President, ATA, Los Angeles, Mr. C. M. Stubben, Vice President - Flight Operations, and I were asked to study the various warm fog dispersal techniques that are currently in use or under development and report this information to the airlines serving Los Angeles. For the past three months I have been collecting reports and data from all the vendors, research organizations and government agencies currently involved in developing a practical, cost-effective warm fog dispersal system. Results of the investigation indicate that there are four techniques or methods, either in full operational use, or under various stages of development. These are: (1) the Turboclair System, developed by Bertin & Cie, (2) Ultraclear, developed by Ultrasystems, (3) the Linde AG Fog Dispersal Process, and (4) the Gourdine Electrogasdynamic Fog Dispersal System.

Since Orly and Charles de Gaulle Airports in Paris have the only warm fog dispersal system currently in use, Mr. Stubben and I visited Paris in mid-November, 1977, to obtain first-hand information on the operation of the Turboclair System. Initial development work was begun in 1958 at Bertin & Cie using outdated military jet engines in the 6,000 pound thrust class in an installation above ground. Further research and testing during the next 12 years led to final approval in 1972 by the Department of Civil Aviation of the Ministry of Transport of the French Republic to operate Turboclair at Orly. Development work conducted at Orly resulted in the eventual installation of 14 engines underground in specially designed pits along one side of the runway and extending into the approach zone to the area of the middle marker. Airline operations required an improvement in visibility to Category II limits of 1,200 feet runway visual range (RVR) and clearance to a decision height of approximately 150 feet.

Each engine is connected to a large duct or diffuser that directs the exhaust gas vertically through a grill and system of louvers mounted on a concrete pad. Since it is necessary to change the direction of movement of the hot gas plume, the pad can be rotated approximately 45° to compensate for variations in wind direction and velocity. The hot 600°C exhaust gases spread along the ground from the exhaust grill to the runway and mix with the surrounding ambient air. By the time the exhaust gases reach the runway, the temperature of the gas and forward thrust have been diminished so that warm air begins to rise vertically over the runway. The ascending volume of air is only 2-3°C warmer than the surrounding air. However, this is sufficient to lower the relative humidity of the air below saturation and cause evaporation, which in turn, improves the runway visibility to 1,200 feet or more. Design of the grill work which controls the velocity and angle of

movement of the exhaust gases is quite critical since it must prevent the warm air from rising too rapidly before it reaches the runway. Fuel to operate Turboclair is obtained from the airport fuel facility and is piped from a large storage tank near the end of the runway to each of the 14 underground sites.

The operation of all engines is controlled by a technician located in a small control facility a few hundred feet south of Runway 07. Upon receiving information from the airport control tower that fog is forecast or is forming, the technician starts all 14 engines and keeps them running at idle thrust during the entire period that fog is present. When the pilot of an inbound aircraft asks for a "FDS" (Fog Dispersal System) approach, the technician increases thrust to approximately 80 percent. Within approximately 60 seconds, clearing to at least 1,200 feet visibility occurs and the airplane lands immediately thereafter. Unless another airplane is following close behind, power is reduced to idle thrust and the system remains in standby mode until the next request for a FDS approach. Once a week, the entire system is run up to full power for approximately 15 minutes to make sure that all components are operational. If problem areas are found during this operational test, they are corrected immediately so that Turboclair is always ready for use.

A similar system was installed in conjunction with the construction of the new Charles de Gaulle Airport. However, there are only 13 underground units at de Gaulle. Also, a computer controls the entire start/stop and check-out functions of the Turboclair System. This has some advantages since the tower operator can run Turboclair from the control tower cab without contacting a technician near the runway station. However, when operational problems occur, it is more difficult for the control tower operator to troubleshoot the system.

Since we were also interested in talking with airlines that had used the Turboclair System, we interviewed Captain Claude Girard, Staff Vice President, Flight Operations, Overseas Division of Trans World Airlines. Captain Girard reported that TWA has had very good success with Turboclair during the three years it has been operational at Charles de Gaulle. TWA has used Turboclair on about 55 landings during this period. He stated that after initial problems primarily with the computer and automatic controls were resolved, they have had no complaints with the system in the last two years. Captain Girard has a standard practice of requesting pilot reports each time the system is used. He indicated that TWA has had no problem in getting adequate clearing during any approach when Turboclair was operating. Furthermore, TWA has had no problem with low-level turbulence from the jet exhaust with either the B707 or B747. The only operating limitation they have found with Turboclair is that it does not clear the entire runway so that it cannot also be used for takeoffs. Furthermore, there are no provisions for clearing the taxiways and there are no center-line taxiway lights to assist the pilot in taxiing to the terminal.

If a technical failure of the FDS should occur and be reported prior to reaching the decision height of 100 feet, TWA procedures call for immediate pull-up and execution of a go-around. If a failure in the FDS occurs after the aircraft has passed the decision height, the Captain may continue the approach if the required visual references are available.

Noise generated by Turboclair, of course, is of interest to the communities in the immediate proximity of any airport. Maximum noise levels reach approximately 75 dBA at Orly and Charles de Gaulle Airports. This sound level extends approximately 600 feet on either side of the row of engines. According to Bertin, the airport has not received any complaints of noise from the communities near the two Paris airports.

Ultrasystems, Inc., of Irvine, California, has also developed a fog dispersal technique that uses heat to improve visibility. Ultraclear is a system of heat-producing units spaced along both sides of the runway to be cleared. The main difference between Ultraclear and Turboclair is the heat source. While Turboclair uses hot exhaust gases and thrust from jet engines, the Ultraclear System consists of an array of units that utilize propellers attached to a diesel engine and combustion cans to produce thrust and heated air. The diesel engine is centered between two propellers that are attached to a drive shaft that extends from both ends of the engine. Outboard of the propellers are combustion cans or burners to generate heat. The propellers provide air for the combustion process and direct the resulting heat into exhaust ducts mounted on each end of the unit. The heated exhaust air passes through an elbow and upward in a vertical plane through the duct before passing through grates located at ground level. The design of the grate causes the warm exhaust air to move nearly horizontally toward the runway and mix with the surrounding air as in the Turboclair System. Kerosene or diesel fuel is used to operate the diesel engines and combustors.

There are two basic sizes of the units; the smaller, underground units are designed for installation along both sides of the runway while the larger, above ground units are used to clear fog in the runway approach zone.

Development of Ultraclear has been sponsored by Ultrasystems and the U.S. Air Force. Initial field tests to study the behavior of the heated plume under varying wind and combustor configurations without using any thrust augmentation to direct the heat, were first conducted at Vandenberg Air Force Base, California, in 1972. At the present time, the Air Force is planning installation of a prototype model of Ultraclear at Otis Air Force Base, Massachusetts. Operational testing is scheduled to begin in March, 1979. Results of this test and evaluation will determine the capability of Ultraclear to disperse warm fog although the test will not be full-scale at an operational air field.

In 1970, the Linde Company in Munich, West Germany, began development of a technique utilizing thermodynamic principles to produce a heat pump system to dissipate fog. The Linde Fog Dispersal System draws foggy air through the various components of a conventional refrigeration system which lowers the humidity and causes the fog droplets to evaporate sufficiently to improve the visibility. Foggy air which is drawn into the system by means of blowers, flows through an evaporator, droplet separator and condenser which lowers the humidity and raises the temperature before being exhausted back into the atmosphere. In the evaporator or inlet heat exchanger stage, the air temperature is lowered about 5-7°F which causes a considerable amount of water to condense out of the air. A droplet separator extracts additional moisture from the air before it passes through the condenser or outlet heat exchanger. In other words, the heat energy removed from the air in the evaporator stage is now restored by the condenser. In addition, the drier air is also heated another 8-10°F before it is exhausted into the atmosphere with a resulting relative humidity of about 50 percent. The Linde System does not use any fossil fuel, only electrical power to run the compressor and blowers to produce heated, dry air. An operational system would consist of a series of underground units placed along both sides of a runway and in the approach zone. The warm, dry air would be blown through a distribution channel and exhausted through a ground level grill with adjustable louvers and out into the airspace above the runway.

Initial field tests of the Linde System *pilot model* were conducted at an airport in south Germany near Munich in 1971. With the support of the government of West Germany, two larger units were produced and tested during the 1973-1974 fog season. Results indicated that visibility could be improved to Category II limits. At the present time, there are no plans for further testing unless financial support from the German government or other sources becomes available. The Linde Fog Dispersal System is environmentally acceptable since it merely recirculates foggy air through a refrigeration cycle to lower the humidity and raise the temperature slightly to improve visibility.

The fourth technique that was investigated was the Electrogas-dynamic Fog Dispersal System (EGD) developed by Dr. Meredith Gourdine. The EGD method utilizes negatively charged, submicron size water droplets that are propelled vertically into the atmosphere at near supersonic speeds by a jet of compressed air. The charged water droplets create an electrical field in the foggy air and charge the larger fog droplets causing them to migrate downward following electric field lines of force to the ground. In the EGD System a small nozzle made of dielectric material extends vertically from a self-contained mobile unit. A thin needle is centered axially in the nozzle and inside a conducting metal ring imbedded in the nozzle near the tip end of the needle. A high voltage power supply is connected between the needle and the metal ring which produces a corona that discharges small ions into the jet of compressed air. When air saturated with water vapor passes through the discharge nozzle, submicron size droplets are formed and given a negative charge as they pass the needle and through the

conducting metal ring. The charged water droplets are propelled about 100 feet into the atmosphere by the stream of compressed air. As they ascend, the charged droplets collide with the larger fog droplets and become attached or transfer the negative charge to the fog droplets. The charged fog droplets then drift downward to the ground and visibility improves. A rather large amount of charge must be generated for the system to disperse fog effectively above a height of approximately 30 feet. Research indicates that the nozzle must provide an electric field at ground level of at least  $10^6$  volts per meter to obtain clearing at sufficient altitude for this system to be operationally practical.

The proposed EGD System will utilize several hundred individual self-contained units placed in a rectangular grid approximately three-fourths of a mile wide by two and three-fourth miles long around the runway and adjacent areas of the airport to create the required electrical field. A prototype fog dispersal unit has been developed that is powered by a four horsepower propane fuelled engine that utilizes a DC starter/generator and automotive type starter battery. The engine drives a simple three cylinder air compressor which discharges high velocity air into the nozzle. A water injector adds an appropriate amount of water to the air stream and a AC/DC convertor supplies high voltage to produce the corona at the needle point in the nozzle. Storage tanks hold fuel and water sufficient for about a year of normal operations.

The EGD System was field tested in the Panama Canal Zone over five years ago. Results were inconclusive and further tests have not been conducted. Since it has been observed that the electrical charge decays rapidly above the discharge nozzle, questions have been raised regarding the ability of the EGD System to clear fog much above 30 feet. However, it might be practical to install this type of system near taxiways where clearing to a decision height of 100 feet or more is not required. In 1977, Bendix Environmental and Process Instruments Division assumed development and marketing activities of the EGD System.

A briefing describing these four systems will be given to representatives of the various airlines that serve Los Angeles on January 24th, 1978. The purpose of this briefing is to acquaint operations and administrative executives with the results of the investigation that has been conducted during the past four months. Following this meeting, the Air Transport Association will determine if the member airlines will support the Los Angeles Department of Airports' plan to go out on public bid for proposals from industry to install a warm fog dispersal system for Los Angeles International Airport.

1/12/78

SUMMARY REPORT: ICING AND FROST COMMITTEE

C. Dennis Wright

Aircraft Owners and Pilots Association

Members: C. Dennis Wright, Chairman; Aircraft Owners and Pilots Association

William D. Bachalo, Spectron Development Labs

Sam Brindley, Bell Helicopter Company

Ralph E. Brumby, Douglas Aircraft Company

H. J. Coffman, Bell Helicopter Textron

L. J. Ehernberger, NASA/Dryden Flight Research Center

Arthur Hilsenrod, FAA/Systems Research and Development Service

Jay D. Hunt, Sverdrup/ARO, Inc.

Phyllis F. Kitchens, U.S. Army Test and Evaluation Command

Robert L. Klapprott, FAA/Systems Engineering

James K. Luers, University of Dayton Research Institute

Richard L. Newman, Private Consultant

William Olsen, NASA/Lewis Research Center

Thomas C. West, FAA

Andy White, Air Force Wright Aeronautical Laboratories

Introduction

This year's Icing and Frost Committee focused attention on icing instrumentation, unlike last year's committee which possessed expertise in the areas relating to slush, snow, and slushy, snowy runways and which made recommendations accordingly. As this year's discussions progressed, three broad categories of icing instrumentation emerged, each category possessing different individual requirements for accuracy, resolution repeatability, etc. The three categories are:

1. Instrumentation for use in icing research
2. Instrumentation for use during aircraft certification
3. Instrumentation for use in aircraft operations

In each category of endeavor, our committee discussed the current status and deficiencies of the instrumentation. The results of these discussions are summarized in Table 1.



TABLE 1

## ICING AND FROST COMMITTEE COMMENTS AND RECOMMENDATIONS

Instrument	Research	Certification	Operation
Liquid Water Content	DR	DR (Helo)	DR
Outside Air Temperature	OK	OK	OK
Ice Accretion Sensor	NV (Helo)	N/A	NV (Engines)
Relative Humidity	OK	N/A	DR (Engines)
Ice Crystals (%)	DR	?	?
Drop Size	DR	OK	N/A
Solar Radiation	?	N/A	N/A

Legend: DR = Development Required  
 OK = Okay  
 NV = Needs Verification  
 NA = Not Applicable

## Instrumentation Used in Icing Research

Current status and deficiencies. With regard to icing instrumentation used in research, the Icing and Frost Committee felt that the overview paper presented by Phyllis F. Kitchens, "Aircraft Icing Instrumentation--Unfilled Needs," was a good detailed discussion of the current status and deficiencies of icing instrumentation. To summarize, the unfilled needs are as follows:

1. There is no reliable, simple way to obtain dewpoint.
2. There is no convenient way to instrument induction systems for temperature measurement. Temperature probes in the induction system freestreams can cause ice themselves.
3. Liquid water content devices need research to obtain correlation data.
4. Instruments for measuring icing and ice accretion data do not provide a desirable degree of agreement.

Additionally, two areas of ongoing research need to be mentioned and emphasized: The feasibility of developing ice-phobic coatings for use on leading edges of aircraft structures as well as in induction systems, and a camera that can photograph rotor blades during icing tests.

A ranking of roughly 100 commercial greases, oils and waxes considered to be ice-phobic materials was obtained from the U.S. Army Cold Region's Research and Engineering Laboratory (CRREL) under contract to the Air Force Wright-Patterson Aeronautical Laboratories (AFWAL), specifically, the Flight Dynamics Laboratory (FDL). The ranking was based on shearing ice release force under laboratory conditions. Of the 100 commercial materials tested, nine candidates were selected to be subjected to ice tunnel testing during FY 80, and maybe FY 81.

Future directions. One major manufacturer offered to develop a coating for use specifically as an ice-phobic. The Icing and Frost Committee encourages this course of action among all interested manufacturers.

Assessment of ice-phobic technology. There will probably never be the perfect ice-phobic material, but it has been proven that the use of an ice-phobic coating does reduce ice release force. Therefore, the use of an ice-phobic coating in concert with an active anti-icing system is suggested. We should thus realize a reduction in power, size and weight of the active systems. We envision the hybrid anti-deice concept as the technology of the future.

## Current Status and Deficiencies of Instrumentation Used in Aircraft Certification

The committee noted that standards for certification for flight into known icing conditions already exist in Federal Aviation Regulations Parts 23 and 25. The researchers in our group pointed out that these certification standards are based on data collected in research conducted during the 1930's and that research done with more modern instrumentation and aircraft structures may point to the need to re-evaluate the current certification standards.

## Instrumentation Used in Aircraft Operations

Current status and deficiencies. Two types of instrumentation are required to support aircraft operations: those needed to forecast icing conditions and those needed on the aircraft to provide icing information to the aircraft crew.

While an accurate, reliable icing forecast may well continue to be an impossibility, a prediction of icing conditions is within reach. Basically, two parameters are needed: liquid water content (LWC) and ambient air temperature. Of the two, LWC data are nonexistent for real-time forecast purposes.

Our data collection methods leave much to be desired. The primary source for upper atmosphere data is balloon-borne telemetry in the form of radiosonde and rawinsonde. These are launched at 12-hour intervals, with station locations rather sparsely distributed throughout the country. A data grid is established by extrapolation. Additionally, radiosonde balloons are, by necessity, assumed to ascend vertically when, of course, they do not. At best, the real-time, three-dimensional data network is a rough approximation of the true state of the atmosphere.

The intention is that pilot reports (PIREPS) of meteorological conditions become part of the weather data network to provide local forecasters with guidance. However, PIREPS have special inherent problems. They are.

1. Infrequent.
2. Sometimes inaccurate or incomplete.
3. Sometimes meaningless or unintelligible.
4. Sometimes just plain wrong.
5. Sometimes discounted or ignored by forecasters.

Automated PIREPS (APIREPS) are being studied and are in early stages of employment by the Air Force and some commercial carriers. APIREPS, when deployed on a large scale, will supplement radiosonde/rawinsonde data, but there are currently no plans for automated collection of LWC data.

While the budgetary constraints are recognized, the necessity for the ability to forecast icing conditions dictates the establishment of a dense data network, with the collection of LWC data a must.

The APIREP concept is heartily endorsed. It is hoped that a channel devoted to LWC data may be established.

Aeronautical penalties. Assuming that it is possible to provide a totally ice-protected aircraft, it becomes less important for the pilot to know the severity of the icing conditions. However, for unprotected aircraft or aircraft that have "limited" icing capability, it is paramount that the pilot have instrumentation that provides information as to the icing conditions and that he be able to relate this information to the "catch" characteristics of his aircraft.

In the case of the rotorcraft, the "catch" characteristics can be very complicated due to the configuration and motions of the main rotor. An ice detector on the fuselage may not indicate the ice buildup on the lift-generating structures or main rotor. Therefore, it is necessary to equate ice detector indications to the actual ice accretion on the flying surfaces or main rotor, as well as on engine inlets, induction systems, tail rotors and other primary systems.

In the case of the main rotor, several situations can result due to ice buildup. The most significant of these are:

1. Torque changes for powered flight.
2. Main rotor vibrations.
3. Thrust changes for powered and autorotative flight.

Icing and rotor systems. Main rotor torque increases are typical when the rotor blades become iced. Some agencies, e.g., Civil Aviation Authority (CAA), have accepted this torque increase as a criterion for determining the extent of main rotor ice accretion. However, there are possible risks in this assumption. In normal level flight at stable airspeed, there is a torque decrease with weight reduction due to fuel burnoff; and if the ice buildup-related torque increase is equal to the fuel burnoff torque decrease, the pilot may not be aware of the ice buildup.

Rotor systems - vibration. Rotor system ice buildup will normally manifest itself to the pilot by an increase in the rotor-induced vibrations due to:

1. Asymmetric buildup of ice, causing span and/or chord unbalance.
2. Buildups that spoil the aerodynamic shape of the main rotor blade, possibly causing the blade to approach stall and thus increasing the number per revolution vibrations.
3. Main rotor blade ice buildup, which eventually leads to asymmetric shedding, causing rotor unbalance which can become severe.

*Rotor systems -  $\Delta$  thrust.* Helicopter main rotor systems generally have a blade tip speed of Mach 8 or greater; consequently, there is significant heating in the outboard section. This heating, coupled with vibration and/or flexing, will frequently cause the outboard portion to remain ice free or to shed ice so as to maintain the integrity of its airfoil. Since a large part of the powered flight rotor thrust is produced by the outboard third of the main rotor blade, there is little, if any, apparent loss of performance even though the inboard portion of the blades may be severely iced. This condition can become disastrous if an automation descent and landing are required because during autorotative flight, the main rotor thrust is produced by the inboard portion of the main rotor blade. Since the helicopter rotor provides not only lift but also most of the pitch and roll control, the consequences of impairing these controls can be uncontrolled autorotative flight.

#### Recommendations for Future Work

1. Need comparison test of existing LWC instruments in a ground icing facility where the icing conditions are well controlled. These tests would determine the accuracy, limitations and practicability of these instruments for research, certification and operational uses.
2. Need evaluation of aircraft icing systems probabilities. For example, icing is a low probability event; therefore, an icing instrument system must be very reliable in turning on (or not turning on) a deicing system in order to protect an aircraft adequately.
3. Although meteorological data are now being collected at low altitudes in a Federal Aviation Administration (FAA)/Naval Research Laboratory (NRL) program, no data are being collected in this program below 3,000 feet. Need to obtain data down to 1,000 feet and near the ground.
4. Need a sensor or package of sensors that monitor ice accretion and removal and that provide the flight crew with information on total damage to the aircraft's airworthiness.
5. As described earlier, need a more desirable degree of agreement in instruments for measuring icing rate and ice accretion. Currently these sensors are chiefly employed as warning devices, but if developed to adequate performance standards, they could also provide quantitative inputs for PIREPS and, subsequently, aviation weather forecasting. Future work should include comparison experiments and engineering analyses to determine relative sensitivities of these icing instruments and any aerodynamic scaling effects due to droplet size, airspeed, dynamic pressure, etc.

6. Need comparison testing of LWC instruments in ground icing facilities to determine accuracy, limitations and practicability.
7. Need systematic measurement of the effectiveness of induction system icing detectors. The evaluation should compare the detector output with the formation of ice that can affect the engine operation. This applies equally to carburetor piston engines and turbine engines.
  - a. Existing certified carburetor ice detectors should be directly compared for effectiveness and reliability. This could be accomplished in flight or on dynometers.
  - b. Research is required to define the optimum location for ice detectors in carburetors.
  - c. Continued development of effective, reliable turbine inlet ice detectors is essential.
8. Need the development and dissemination of pilot training aids to assure proper pilot techniques in the use of anti-icing and deicing equipment.
  - a. Pilot advisory material and operating manuals should be prepared to ensure pilot awareness of the proper use of engine anti-ice systems (carburetor heat and turbine anti-ice). This discussion should cover the environmental conditions conducive to engine icing as well as actual operation of the equipment.
  - b. Instructional material covering the proper use of pneumatic deicing boots should be prepared for the general aviation pilot.
  - c. These training aids should include discussion of the instrumentation available on the aircraft.
9. Need to develop an inexpensive and effective frost removal process for general aviation.
10. Need to develop ice-phobic coatings for use with other established deicing devices to provide better icing protection.

Question and Answer Discussion:

John McCarthy, NCAR: As used in your report, what does the word certification mean?

C. Dennis Wright, AOPA: It means the certification of airframes for flight into known icing conditions as dealt with in FAR, Part 23 and Part 25.

John McCarthy, NCAR: When you say that in the area of drop size distribution under the category of certification, the present instrumentation is okay, does that mean that you are satisfied with the determination of drop size for certification processes?

C. Dennis Wright, AOPA: We had a long discussion about that. There are criteria in FAR, Parts 23 and 25, concerning the drop size in which you can fly an airplane in order to have the airplane certified for flight into known icing conditions; and the instrumentation used today to determine whether or not you are seeing the appropriate drop size seemed, in the opinion of the committee, to be okay.

John McCarthy, NCAR: The last question I have concerns outside air temperature. In your chart that was okay across the board.

C. Dennis Wright, AOPA: In our discussion of outside air temperature (correct me if I am wrong), we felt that an outside air temperature gauge having a resolution of  $\pm 1^\circ\text{C}$  was sufficiently adequate for all three categories.

John McCarthy, NCAR: I am involved in outside air temperature in research, and I can say that a sensor that gets wet, such as the Rosemont on a jet or a stick probe on most of the small aircraft, cannot give temperatures inside a degree, as far as I know, with supercooled water cloud icing conditions.

## SUMMARY REPORT: TURBULENCE COMMITTEE

Neal M. Barr

Boeing Commercial Airplane Company

Members: Neal M. Barr, Chairman; Boeing Commercial Airplane Company  
Warren Campbell, NASA/Marshall Space Flight Center  
Don S. Cornwall, Air Line Pilots Association  
Joseph G. Gamble, FAA/Systems Research and Development Service  
Bruce L. Gary, NASA/Jet Propulsion Laboratory  
John L. Keller, University of Dayton Research Institute  
James I. Metcalf, Georgia Institute of Technology  
Vernon W. Ramsey, NASA/Marshall Space Flight Center  
S. T. Wang, FWG Associates, Inc.

### Introduction

The primary types of turbulence considered in our discussions were low level, severe storms, clear air (CAT), and wake. Each type was considered with respect to: 1) analysis and forecasting; 2) needs of general and commercial aviation; 3) on-board and ground-based detection systems; and 4) communications.

### Current Status of Routinely Used Instrumentation and Equipment

Forecasting and dissemination of weather information. There is no ground-based or airborne instrumentation or equipment presently in operational use to measure turbulence directly, that is, to obtain initial data upon which to base analyses and forecasts. Pilot reports (PIREPS), which are at best very subjective in nature, are the only means to confirm the presence or absence of CAT and to measure its intensity. Many areas of turbulence are unreported because no flights traverse them. Presently available operational weather radars, both ground-based and airborne, do not directly measure turbulence in thunderstorms. Other than PIREPS, the parameters from which turbulence is forecast are largely based upon information derived from upper air observations, primarily by radiosonde (RAOB). The horizontal distance between RAOB stations and the infrequency of observations (once every 12 hours) make the locating of expected turbulence, especially CAT, very difficult. Over-forecasting, i.e., forecasting large areas where turbulence patches might be found, is too often required to denote "possible turbulence" areas. Since CAT patches may change very rapidly, in both time and space, forecasting is a real problem. Therefore, turbulence forecasts have a fairly low



skill, especially in the case of CAT. Upper air observations every six hours would help correct this, but most likely could not be justified based on the improvement of turbulence forecasting alone.

Various CAT forecasting tools are used today, including those that are devised by the individual airlines for their own flight crews. Little is known about these techniques, and we believe there should be more cooperation in discussing and developing them for the benefit of the entire aviation community.

Present ground-based systems used to collect and disseminate the raw and processed weather information needed for turbulence warnings are obsolete because of their slow speed. Improvements are on the way, including the Automation of Field Operations and Services (AFOS) system, but these will not be fully deployed for several years. This lack of immediate improvements in information dissemination contributes to a subsequent lack of forecasting improvements.

Present Air Route Traffic Control (ARTC) systems are not capable of meeting the weather dissemination needs of aircraft under air traffic control. There is no adequate system for collecting and collating PIREPS, and most that are received within an ARTC Center are never relayed outside it to assist the National Weather Service (NWS) and other pilots. Controllers who receive reports of turbulence often do volunteer such information to other pilots in the vicinity. They will also relay the information when asked; however, the ARTC Center meteorologist does not speak directly with the pilots.

Data base and retrieval systems. For reasons already stated, the data base of information on existence of turbulence is inadequate. Many reports are too old to be used before they reach the NWS facilities and the user. Present dissemination systems do not allow direct retrieval of turbulence observations and PIREPS. Future NWS systems such as AFOS will, hopefully, provide this capability.

Ground-based and on-board instrumentation. Presently there is only one direct CAT indicator, the PIREP. Here subjectivity is the problem, since CAT affects each airplane type differently. Airport and other ground-based radars are important for thunderstorm detection, but there are serious problems with them such as attenuation, a factor in recent severe storm incidents. Another severe storm indicator is the lightning detection system. Its accuracy and effectiveness are being evaluated. Still another indirect indicator is the monitoring of in-flight temperature. Detection of strong temperature gradients can assist in the analysis and forecasting of CAT. But these are secondary methods; they are not measuring the turbulence per se, they are measuring other parameters often associated with turbulence.

Training. For the commercial carriers, there is a six-month mandatory training requirement, which includes approximately two hours on weather. We feel that the theoretical content is adequate, but we

desire more emphasis on interpretation of weather data. General aviation weather training is marginal or inadequate. The literature is generally adequate, but the fact is that it is seldom read or assimilated. Specialized ground school sessions are good but not always widely available or utilized.

Flight control systems. An active flight control system for automatic aileron deflection when encountering turbulence is now being installed in the L-1011-500 airplane. In addition to providing a smoother ride, there should be an increase in the fuel efficiency as well. Although there is no other flight control system available at the moment, there will be in the future, because fuel efficiency provides additional impetus for the development of new instrumentation systems.

#### Deficiencies and Voids in the Turbulence Instrumentation Field

PIREPS are a present resource of weather information; potentially they should be available for documentation and automatic transmission to flights by one means or another. Our committee had no specific ideas on this, but we do suggest that the PIREPS be available to the pilot as quickly as possible.

Thunderstorm turbulence information in the approach zone prior to landing is poor because the volume of air traffic control information at the busiest airports is often too great to allow transmission of meteorological information. Many airports have inadequate surface wind indicators, which are one means of wake vortex detection. A method as simple as installing several wind socks around the airport would be an improvement over the present centrally located wind vane.

As mentioned, there are no on-board turbulence sensors in use at the present time. There exists no direct remote CAT detection system outside the PIREPS. The present radiosonde network is inadequate for analysis and forecasting of turbulence.

Aviation weather information available to the pilot often greatly lags the observation times. This is especially a problem with respect to turbulence forecasts. Turbulence information for the general aviation community is currently meager, at best, and is primarily PIREPS.

#### Ongoing Research

Research is progressing on several systems to fill the gaps just outlined. The infrared (IR) passive water vapor radiometer will provide warning of CAT in the altitude range between 5,000 and 45,000 feet, and it is close to commercial airplane/airline evaluation and exploitation.

A microwave passive "vertical temperature structure radiometer" operating at 57 GHz will provide "altitude avoidance" guidance--sometimes. It remains to be demonstrated how much of the time useful guidance can

be expected. Also, it may provide "severity" warning, but this remains to be demonstrated quantitatively. It does not have much promise as a forecaster of when turbulence will be encountered.

A microwave passive water vapor radiometer operating at 180 GHz is not technologically ready for application; but the technology is advancing, and this concept may someday warrant further consideration.

The airborne lidar (10.6  $\mu$ ) detects particulates in the turbulent air sometimes as much as one minute ahead of encounter; but winter air is much cleaner than researchers anticipated, and equipment is not yet simplified and miniaturized enough to warrant near-future operational use.

Ground-based, high-power VHF and UHF radars are being developed and tested for probing CAT and winds throughout the troposphere and stratosphere. These should contribute to our understanding of CAT generation as well as being an observing tool, but their en route coverage is so limited that operational use cannot be expected from them.

Doppler radar is presently being used for severe storm identification and should locate the areas of winds and turbulence within thunderstorms.

Numerical modeling studies are contributing to our understanding of CAT generation. The use of radiosonde data sets for probabilistic CAT location on a synoptic scale, such as the "Diagnostic Richardson Number Tendency" analysis, show promise.

These and similar techniques are projects we are hoping will be studied further so the best ones can be implemented soon.

#### New and Future Programs

The needs. The flow of information required for pilot decisions is currently inadequate. This process, including the use of PIREP's, should be automated so that turbulence information can be assessed in the cockpit by the pilot as needed.

The most serious turbulence problems occur physically in the vicinity of terminals where high density traffic complicates aviation operations. There the presence of thunderstorm-related turbulence is not adequately reported. Deployment of Doppler radar with telemetry to the cockpit by data processing computers may alleviate this problem. Programs such as the Federal Aviation Administration (FAA) Discrete Address Beacon System (DABS) are certainly to be encouraged.

Accurate on-board turbulence detection instrumentation is needed, not only for warning detection but also for severity estimation and for formulating avoidance strategy.

The needs for and the problems in deploying these various systems for general aviation were recognized. A government-sponsored program to initiate deployment should be investigated, if it is not already in progress.

Improved forecasting of turbulence should be based not only on NWS products but also on processed flight recorder-type information and inputs from the private sector. Novel approaches such as the Diagnostic Richardson Number Tendency analysis, discussed by John Keller in his presentation "Clear Air Turbulence Forecasting Techniques," should be encouraged and continued.

Airline pilot evaluation of the IR passive water vapor radiometer is imminent. The microwave vertical temperature structure radiometer will soon be flight-tested to gain statistics on avoidance and severity prediction capabilities. Numerical modeling tools can continue to be used for gaining insight into CAT generation; and the 180 GHz microwave sensor should be reconsidered soon for possible flight evaluation.

Responsible agencies for continuing and spurring research should include, among others, the FAA, the National Aeronautics and Space Administration (NASA), the National Atmospheric and Oceanic Administration (NOAA), and the Department of Defense (DOD).

#### Interim Measures

The present Aviation Satellite Data Relay (ASDAR) system used by Pan Am could be an aid to automatically transmitting meteorological information to the ground and to other airplanes in the reporting airplane's vicinity. Airport weather radars can be useful in the terminal and sector areas for storm avoidance. Airborne radar could be color-coded for better storm definition. Dissemination of PIREPS and forecasts could be improved, as could the communication links between the pilot and the ARTC Center. Hopefully, the ARTC Center meteorologists or another aviation meteorologist can be contacted by the pilot on occasion.

#### Conclusions

PIREPS are still not used to their potential. Perhaps more automation is needed in their collection and dissemination. No airborne or ground-based turbulence sensor is currently operational for either CAT or severe storm turbulence avoidance. IR and microwave airborne sensors hold promise for providing warnings of CAT occurrence, severity and avoidance. Doppler radar looks promising for convective storm turbulence location observation and local short range forecasting. Synoptic forecasting techniques require much improvement if they are to be useful for CAT forecasting.

With all the automation that has been mentioned, there is yet a definite place for the pilot in the loop; after all, he is the one

who flies the airplane, and he is the one who has to make the decisions. So, we feel that the pilot should continue to have "voice" as well as automated contact with ground control and with other pilots. Some of the routine tasks should be automated so that he can concentrate on those in which he is the important cog in the decision making wheel.

Question and Answer Discussion:

Andy D. Yates, ALPA: There is a problem with PIREPS given either to the ATC controller or to a company. Once a PIREP gets to the company, it does not go out to other users. I know of a case in which a pilot flying 10 minutes behind another pilot was not given information the pilot in front had reported a few minutes earlier.

Neal M. Barr, Boeing Commercial Airplane Co.: The communication of PIREPS is one of the most significant problems we discussed.

Norman L. Crabill, NASA: Regarding PIREPS, general aviation uses them with the Enroute Flight Advisory System. Low altitude turbulence is a problem. Some pilots use the Flight Watch frequency (122.0 MHz), which works in general aviation because all they do is tune in, and if anything is in their area, they will hear the air-to-ground communication. Flight records can be used for gust loads research. NASA has programs with airlines to study gust loads and operational usage; these results will later be reported to the general aviation community.

Neal M. Barr, Boeing: Some data have been collected. In particular, Eastern Airlines collected data for a while.

Jean T. Lee, NSSL: In regard to the forecasting of CAT this past year, 1979, on three occasions in cooperation with other people, 20 additional radiosonde stations were established east of the Rockies. Data for 24-hour periods at 3-hour intervals were taken. This data could be used for CAT forecasting.

Neal M. Barr, Boeing: Will these data be reported, then, to the general community?

Jean T. Lee, NSSL: This information is available through Robert E. Turner and Dennis W. Camp of NASA/Marshall Space Flight Center.

Neal M. Barr, Boeing: Thank you. That is useful information.

Paul W. Kadlec, Continental Airlines: With regard to PIREPS, we find that a majority of the reports from airline pilots are received by their own company when they are not transmitted in a strict computer-acceptable format. However, many are lost because they are not transmitted in the proper format by the ARINC operator on the ground or because they contain remarks that are appended to the PIREP. Since it is difficult to get all pilots to transmit a PIREP in a strict

computer-acceptable format, we must rely on the ARINC operator handling airline communications to do this for us. We know that many reports are lost or rejected by the computer when the format is incorrect, but the ATA and the FAA are trying to rectify the situation. Regarding radar, did your committee make any recommendations on the number of radar intensity levels that should be displayed in the cockpit?

Neal M. Barr, Boeing: No, but we did decide they need color intensity levels.

William W. Melvin, ALPA: In our discussions, some thought three levels would be enough. Doppler readings with turbulence levels are needed. Many end up with incompatible equipment now.

John McCarthy, NCAR: We need simple displays of intensity. Telemeter uplinking of single Doppler from ground to airplane may be possible.

William W. Melvin, ALPA: How many levels should be displayed?

Jean T. Lee, NSSL: I still feel that the fewer the better. More than the absolutely necessary ones are much too confusing.

Don S. Cornwall, ALPA: We are working with basically black and white now. A pilot can interpret the black to mean two different things.

Anonymous: More could be done to consolidate turbulence PIREPS.

L. J. Ehernberger, NASA: Was COMEDS covered in your committee discussions?

Neal M. Barr, Boeing: No.

L. J. Ehernberger, NASA: During the 990 CAT mission, COMEDS was found to be very convenient to use. The USAF COMEDS system, which is used at Edwards AFB and at Moffet Field Naval Air Station, saves the fore-caster time. The United States is divided into six or more regions, and you request the regions you need. You get an updated bulletin of PIREPS when you request it. Users in the AMS users group for the AFOS system should consider COMEDS as a possible model for a civilian counterpart.

Jerald Uecker, NOAA/NWS: Maybe we should begin breaking down PIREPS into categories, one for the FAA to distribute on an individual PIREP basis, and one for those that would be grouped for later display by graphics. It would be slow to transmit graphics now, but that will eventually improve when AFOS is implemented.

William W. Melvin, ALPA: Regarding standardizing data, I suggest that data furnished to the pilot be standardized in the English language. Everyone insists on their own sequence today. People in the cockpit do not know what it all means. Such a pilot has to land, then ask someone else what the information meant. When that person, in turn

does not know, he has to ask somebody else. Why can't we just use a language that we understand? Communications today try to make a pilot a computer which puts information into proper order. Pilots today are ignoring data because they do not know what it means.

SUMMARY REPORT: WINDS AND WIND SHEAR COMMITTEE

William W. Melvin

Air Line Pilots Association

Members: William W. Melvin, Chairman; Air Line Pilots Association  
James R. Banks, Air Traffic Control Association, Inc.  
John Blasic, NOAA/National Weather Service  
Edward F. Blick, University of Oklahoma School of Aerospace  
Mechanical and Nuclear Engineering  
John H. Bliss, Flying Tiger Line  
Fernando Caracena, NOAA/Environmental Research Laboratories  
Norman L. Crabill, NASA/Langley Research Center  
R. Craig Goff, FAA/National Aviation Facilities Experimental  
Center  
Bud Laynor, National Transportation Safety Board  
J. T. Lee, NOAA, National Severe Storms Laboratory  
John McCarthy, National Center for Atmospheric Research  
William H. Reinhoehl, Hughes Air West  
Fred Ross, United Airlines Flight Training Center  
Robert Serafin, National Center for Atmospheric Research  
Edward A. Spitzer, DOT/Transportation Systems Center  
David L. Stoddard, Hughes Air West  
Barry S. Turkel, FWG Associates, Inc.  
Harry A. Verstynen, FAA/Langley Research Center  
Fred Watts, United Airlines

Descriptions of Wind Shear

The Winds and Wind Shear Committee feels that Doppler radar inputs are needed for four-dimensional models of wind shear. This does not mean that these models will go into simulators, but for analysis we do need to define the shears themselves in four-dimensional models. For simulators the models will probably be two-dimensional. Simulator studies are needed to determine hazard thresholds for each type of aircraft that will possibly encounter the shear. We feel that pilot transfer functions need to be developed and included in simulator studies. Considerable work has been done on this by Walter Frost and others, but we feel that further work is needed and that the results



need to be included in the simulator models. Some of the previous studies have included fixed stick mode for the simulation, but we feel that is not realistic compared to pilot input.

Terminology. Uniform terminology should be developed and disseminated. The Federal Aviation Administration (FAA) has a glossary of wind shear; however, there are some things we feel are somewhat conflicting and therefore need some work. Some members of our committee are going to go back to their own shops, brainstorm this problem, and correspond with us about their ideas. We very strongly feel that along with uniform terminology we need descriptions of shears in terms of the expected reaction upon aircraft that are opposite in effect. Some terms that have been used are: Undershoot and overshoot, used in Australia; performance increase and performance decrease, used by Continental Airlines; positive and negative, a discarded set of terms; and airspeed increase and airspeed decrease, which are not satisfactory even though they have also been used.

#### Detection of Wind Shear

Observation network. In the area of forecasting, we need a denser observation network with a data link to inertial navigation system (INS)-equipped aircraft. Our finest observation devices are INS-equipped aircraft, which fly through weather all the time and could data-link the wind information back. This is not a new proposal; it was proposed last year and it has been proposed before. This idea has never gotten anywhere, but if put into operation it would give us a tremendous amount of capability for wind determination. It could be used in the upper altitudes as well as the lower altitudes, and especially in the terminal areas.

Aircraft instrumentation. We encourage the evaluation and use of any available instrumentation that provides pilots with better information for wind shear assessment. Such presently available off-the-shelf instrumentation includes the airspeed/ground speed method, the acceleration margin method, and heads-up displays with gamma reference or flight path angle reference.

The infrared (IR) sensor shows some promise of detecting the presence of microbursts, but some committee members expressed concern over the false alarms from conditions other than microbursts. It was generally conceded that the false alarms should occur in meteorological conditions not conducive to microbursts and that the value of a valid warning during conditions conducive to microbursts should be further explored. The IR sensor has further use in detecting clear air turbulence by using different filter circuits.

We need airborne weather radar, which should be improved. We feel unanimously that the use of C-band radar for commercial aircraft would be advantageous; presently there is apparently only one airline in the world which uses C-band radar. The use of multi-level, multi-color

sensing with color displays would also be advantageous. Doppler, both airborne and ground-based, would be very useful, but we feel the fact should be recognized that due to very high power requirements airborne Doppler will probably never have the sensitivity necessary to detect wind shear in clear air conditions. Therefore, we support the application of ground-based, pulsed microwave Doppler radar which is located at or near the terminal to provide detection capability of wind shear along approach and departure paths in clear air. This system can provide shear detection prior to aircraft entering the terminal airspace. It will include prediction of aircraft performance based on measured shear conditions, and it will be suitable for uplink to the cockpit. Data link to the cockpit occurs in many of our recommendations, because some of our best sensing will be on the ground, but the information will need to be used in the cockpit. We think this data link is inevitable.

Pilot reports. We encourage greater use and approved terminology, which should help in pilot reports as well as in education.

Low level wind shear alert system (LLWSAS). We encourage full use of this system, and we encourage evaluating it for effectiveness. We strongly support recording the data, a recommendation also voiced by last year's committee.

#### Information Transfer

Presently, once an aircraft is airborne we have only voice radio transmission. We recommend data link for the weather, both local and remote. For local use we recommend at least the capability of reading the wind at the end of the runway. Remote use might include WSR57 or next generation radar pictorials in the cockpit, maybe 500 to 1,000 miles ahead of the aircraft. If a suspected squall line is there, the pilot could call in and look at the pictorials while his plane proceeds across the country. Of course, the data link is needed for the Doppler radar from ground and for relaying the hazard level to pilots.

Training. We recommend that ground schools stress operational approaches. We think there is considerable advantage to telling the pilots about past accidents and incidents.

Simulators. We feel there is a definite need to improve the models in simulators. We find that many simulators do not have realistic models and that pilots are getting somewhat negative training by flying the simulators.

Recognition. We feel that there is a need to improve the recognition of wind shear. This would go along with ground school pictorial information of hazards, which would help pilots to be more cognizant of the hazards. We already have cases where pilots have avoided serious wind shear encounters because they recognized the clues, and there were cases in former accidents where pilots flew into these hazards because they did not recognize the clues.

As an addition to this report we are including a matrix of remote sensing wind shear detector developments provided by Norman Crabill (Figure 1). Essentially, it is a compendium of what they feel is available now.

	Ground-Based	Airborne
Lidar	Pulsed Doppler (AFGL) Pulsed/CW Doppler (MSFC) CW Doppler (Lockheed) CW Doppler (Raytheon) CW Doppler (RAE, UK)	Pulsed/CW Doppler (MSFC/Raytheon) CW Doppler (RSRE, UK)
Radar	Pulsed Doppler (AFGL) Pulsed Doppler (NSSL, NCAR, CHILL) FM CW Doppler (WPL) Mod. ASR-8 Doppler (NAFEC) 35 GHz Dual Polar. Doppler (WPL) NEXRAD	X-Band - FFT (bendix) C and X Band PPP (Collins) KuBand FFT & PPP (LaRC) PPB X-Band (NOAA/WPL)
Lidar/Radar	Pulsed CO <sub>2</sub> Doppler (TSC) X-Band Doppler	
Radiometers	IR (NOAA) Microwave (JPL)	IR (NOAA) Microwave (JPL)
Others	Anemometer Network (FAA) Anemometer/Pressure Sensor (FAA, NGA)	Modified Flight Director Airspeed/Ground Speed Comp. Acceleration Margin Wind Shear Computer (Safe Flight) SODAR

Figure 1. Matrix of Remote Sensing Wind Shear Detection



**SECTION VII**  
**CONCLUDING**  
**REMARKS**



PRECEDING PAGE BLANK-NOT FILMED

CONCLUDING REMARKS

John Blasic\*

National Oceanic and Atmospheric Administration

The National Oceanic and Atmospheric Administration (NOAA) was delighted to jointly sponsor and participate in the Fourth Annual Workshop on Meteorological and Environmental Inputs to Aviation Systems. We apologize for our somewhat limited participation due to travel restrictions, however, we were gratified that we had such expertise from our National Severe Storms Laboratory, Wave Propagation Laboratory, and Environmental Research Laboratories. NOAA/National Weather Service finds these workshops to be beneficial for bringing together various aviation disciplines and for helping us direct our research and operational efforts. We look forward to future participation in these workshops.

---

\*For Edward M. Gross

## CONCLUDING REMARKS

Dennis W. Camp

NASA/Marshall Space Flight Center

Those of you who were here last year will remember that my concluding comments were very short. They will be short again this year, even though I am incorporating additional comments from Dick Tobiason.

Let me call your attention to the beginning session of the workshop when Walter Frost said I would have responsibility for the weather during this workshop. The weather was overcast and gloomy the first two days so you could work without distraction, and now it is sunny so you can enjoy the weather as you are leaving. Harry Verstynen and Joe Stickle pointed out this morning that those of you heading west will be returning to gloomy weather, and those of you heading northeast will have a headwind. We are trying to impede your departure and convince you to stay.

Dick Tobiason asked me to express his appreciation and comment that without you and your participation we could not have had this workshop. The Organization Committee cannot have a successful workshop without you and your expertise, your desire, your support. Dick would like to have stayed, but he had another engagement at the National Aviation Facilities Experimental Center today.

I sincerely appreciate the support and participation of each and every one of you. Use the word of mouth to spread information about the workshop, and tell your cohorts and fellow workers at your organizations about the benefits you have received. If you feel something could be done to increase the benefits to workshop participants, tell us so we can improve future workshops.

## CONCLUDING REMARKS

John H. Enders

Consultant (NASA Ret.)

Someone once said that we are no more civilized than our caveman (or caveperson) ancestors; we are just civilized more of the time. I was reminded of that comment today as you were passing that dead microphone back and forth. I conjured up images of ancient tribes where kings passed the scepter back and forth to signify the right to talk. I was also reminded of a recent occasion. I have a small volcanic rock from Hawaii on my desk, and one day Fred Haise picked up that rock and started to talk. I started to interrupt, but he said, "No, no. I've got the stone. You see, in Indian Guides we have a talking stone to limit all superfluous conversation; only the person holding the stone is allowed to talk, and I have it right now." We seem to have been applying that same principle today.

On behalf of The University of Tennessee Space Institute (UTSI), Atmospheric Science Division staff, I would like to thank the National Aeronautics and Space Administration (NASA), National Oceanic and Atmospheric Administration (NOAA), and Federal Aviation Administration (FAA) for their co-sponsorship of this workshop. Thanks also go to all of you who individually supported this workshop with your attendance and participation, particularly the speakers and chairmen. The committee chairmen always have a tough job making order out of chaos.

This workshop represents a lot of hard work by a dedicated group of people who I think are representative of the best in the aviation meteorology research and operations business. Maybe we do not realize it when we sit around the table arguing with one another, but we are really a distillation of a pretty powerful community voice in aviation meteorology. As was noted many times during the workshop, attendance is off this year, primarily because of travel funding problems, but I am delighted to see the accident investigation groups represented by Bud Laynor and Peter Chesney. There were some deficiencies in representation of the corporate, air taxi and commuter groups, who could probably use some of the lessons we have traded back and forth. The other disappointment is a lack of FAA operational and regional people. In future efforts we need to get some of the airworthiness people to attend and participate, in particular those at headquarters and in the regions who are concerned with the rule-making process. We have been light in that area through all four annual workshops. Air traffic control representation could be strengthened somewhat--that gets back to the problem of communications and standardization of terminology to which we have repeatedly referred during this workshop. The U.S. Coast Guard intended to send a representative this year, but at the last minute they had to cancel. If there is anyone who flies in weather regularly and routinely, it is the Coast



Guard. They would be interested in what is going on the research and development community, and we would be grateful for the lessons they could teach us about coastal weather.

How do we tackle this lack of representation from these groups? One answer is for each of you to think of himself as a missionary designated to go out and have conversations with members of these groups, tell them about the workshops and let them know what they have missed. Try to butter them up so that when the next announcement goes out, they will be more receptive to the idea of attending. Another option is to spread the word about related conferences, such as the upcoming Montreal Conference on the Aviation Weather System which was mentioned by Sepp Froeschl and the AIAA Meeting in January, 1981, which was mentioned by Craig Goff. This group can be a good clearing house for that kind of information and can keep everyone else informed of what is going on in this area.

This year we chose a theme: "Measuring Weather for Aviation Safety in the 1980's." The Organization Committee felt it was a good idea, and we welcome your comments as to whether it is a good idea for a workshop like this to focus attention on a particular problem.

Some of you have expressed the opinion that in the fourth year of these workshops things are getting repetitive. This has been a concern to the Organization Committee the last couple of years and is one reason we went to the theme this year. I do not know how to answer that except to suggest that you assess the value of the workshop in a broader sense than what each of you individually learns from it. The interaction with peer groups seems to be worthwhile even if you do not learn any specific new thing that will help you in your specialty. There has been some discussion about going to a semiannual workshop and having a tutorial short course for airline and pilot personnel in the off year with lecturers drawn from this group. That might break the repetitive aspect, but I am wondering if that would also break the momentum that has been built up by this group. The Organization Committee would appreciate your thoughts on that.

Another possibility to break the repetitiveness is a method already employed by one manufacturer who is represented here. Every year they send one or two people, but different people from different parts of the organization so that corporate-wise, the company has had in attendance nearly a dozen people from flight control, design, simulation, lightning, etc. You might use that idea in encouraging colleagues to attend. I would like to single out the Air Line Pilots Association (ALPA) and congratulate them for getting enough people here the last couple of years to participate in all the committees, thereby bringing into the working sessions the personal experiences of the flight deck.

The discussion this year has centered around impressive budget problems, staff shortages (in the government, at least), and the need for more coordination and consolidation of national programs to prevent

duplication of effort. The national programs always profess to be seeking that goal, but a group as broad as this can keep the process honest and keep the pressure on to carry out that goal. Unless there is pressure from an outside expert group, the tendency is for each agency and university to explore what it finds interesting without considering the right balance of what is really needed.

There has also been a pretty good balance of conceptual thinking at this workshop, participants looking down the road in terms of what the future system will permit in information transfer, not in terms of just what we have now. For example, the DABS data link coming along in three or four years will possess a tremendous new amount of power in getting information transmitted around the system at a much faster pace than now. However, it will be necessary to guard against loading it with a lot of useless information, causing users to ignore the transmissions completely.

Some of you have remarked that we are making the same recommendations now as we made the last two years, but maybe more patience is required. Four years, when looked at it perspective, is not really a long time. Remember, in carrying out any program, you have many steps. First you must organize the new thoughts and generate program planning and justification rationale. You then have to seek budget approval in a very competitive budget atmosphere and in the midst of interminable budget cycles. These new programs must be introduced two to three years ahead of time to wedge the new ideas into the budget, and when the budget is finally approved, you must then conduct the program. So you can see that four years of workshops has barely scratched the surface. Our first workshop served as a venting session where the participants expressed their views of the problems, and it was not until the second and third workshops that we really began coming to grips with the hard problems. These are tough problems, ones that have eluded solution for a long time. Maybe we need these consistent, repetitive reports to emphasize the importance of our recommendations. I think the consistent year after year reminder that there are still problems in existence that cost lives, delays and unnecessary expense and complications in the aviation systems is something this group can help accomplish.

Please collect your thoughts on improving the workshop and on how often it should be held. If you have ideas for themes, relay them to the Organization Committee. Relative to current budget restrictions, you might let the Organization Committee know whether rescheduling the workshop to fall at the beginning of a fiscal quarter rather than at the end would be helpful in securing approval to attend.

We look forward to hosting the fifth workshop in this series, whether it is held in 1981 or 1982, and we look forward to your participation and support.

CONCLUDING REMARKS

Walter Frost

The University of Tennessee Space Institute

As hosts of this workshop, we at The University of Tennessee Space Institute would like to express our appreciation for your continued support of this annual event. I would also like to recognize the efforts of K. H. Huang and M. C. Lin, who operated the audio-visual equipment this year. Relative to Jack Enders' comments about the dead microphones; I want to thank Becky Durocher for taking over as stenographer when our recording system failed.

In closing, the Organization Committee feels that if Dennis Camp liked the weather during this year's workshop, we will recommend someone else to be in charge of weather next year.

## CONCLUDING REMARKS

Joseph F. Sower

Federal Aviation Administration

This is my third workshop out of four, and it is always a pleasure to be here. At these workshops we gain valuable information about what is going on across the interface of various aviation professions.

I found as I "floated" from committee to committee during their working sessions that this year's sessions went very well. The Winds and Wind Shear Committee was red hot. Actually, it was good that the wind shear game was boiling a little, because the feeling in the country is that the wind shear problem is solved. Even within some of the agencies, the feeling is that we have gone about as far as we ought to go. Personally, I do not feel that way, and I think the discussions in the wind shear group proved we have quite a bit further to progress before we get the wind shear problem totally under control. All the committees had interesting and lively discussions.

The Federal Aviation Administration always considers the new ideas that come from workshops like this one, and we gear our programs to tackle some of the problems you present. Therefore, we thank you for your participation in this year's workshop.

# APPENDICES

APPENDIX A

ACRONYMS

ADI	ATTITUDE DIRECTION INDICATOR
AFB	AIR FORCE BASE
AFFDL	AIR FORCE FLIGHT DYNAMICS LABORATORY
AFGL	AIR FORCE GEOPHYSICAL LABORATORY
AFOS	AUTOMATION OF FIELD OPERATIONS AND SERVICES
AFWAL	AIR FORCE WRIGHT AERONAUTICAL LABORATORIES
ALPA	AIR LINE PILOTS ASSOCIATION
ALWOS	AUTOMATIC LOW-COST WEATHER OBSERVING SYSTEM
APIREP	AUTOMATED PILOT REPORT
ARTC	AIR ROUTE TRAFFIC CONTROL
ASDAR	AVIATION SATELLITE DATA RELAY
ASP	AXIALLY SCATTERING PROBE
ASSP	AXIALLY SCATTERING SPECTROMETER PROBE
ATA	AIR TRANSPORT ASSOCIATION
ATC	AIR TRAFFIC CONTROL
ATCA	AIR TRAFFIC CONTROL ASSOCIATION
ATA	AIR TRANSPORT ASSOCIATION
ATL	APPLIED TECHNOLOGY LABORATORY
AV-AWOS	AVIATION AUTOMATIC WEATHER OBSERVATION SYSTEM
AWES	AVIATION WEATHER SYSTEM
AWS	AIR WEATHER SERVICE
BLM	BOUNDARY LAYER MODEL
CAA	CIVIL AVIATION AUTHORITY
CAT	CLEAR AIR TURBULENCE

CAT III	CATEGORY III
CHI	CLOUD HEIGHT INDICATOR
CHILL	UNIVERSITY OF CHICAGO AND THE ILLINOIS STATE WATER SURVEY
COMEDS	CONTINENTAL UNITED STATES METEOROLOGICAL DISTRIBUTION SYSTEM
CP	CLOUD PROBE
CPS	CLOUD PARTICLE PROBE
CRREL	COLD REGION'S RESEARCH AND ENGINEERING LABORATORY
CWFT	COMPUTER-WORDED TERMINAL FORECAST
CWSU	CENTER WEATHER SERVICE UNIT
DABS	DISCRETE ADDRESS BEACON SYSTEM
DCA	D.C. AIRPORT
DME	DISTANCE MEASURING EQUIPMENT
DMSP	DEFENSE METEOROLOGICAL SATELLITE PROGRAM
DOD	DEPARTMENT OF DEFENSE
DOT	DEPARTMENT OF TRANSPORTATION
DTOA	DIFFERENCE IN TIME OF ARRIVAL
EGD	ELECTROGASDYNAMIC
FAA	FEDERAL AVIATION ADMINISTRATION
FAR	FEDERAL AVIATION REGULATION
FDL	FLIGHT DYNAMICS LABORATORY
FDS	FOG DISPERSAL SYSTEM
FFT	FAST FOURIER TRANSFORM
FM CW	FREQUENCY MODULATED CONTINUOUS WAVE
FOS	FIELD OBSERVING STATION
FOUS	FORECAST, UNITED STATES
FSDPS	FLIGHT SERVICE STATION DATA PROCESSOR

FSS	FEDERAL SERVICE STATION
FT	TERMINAL FORECAST
GEM	GENERALIZED EQUIVALENT MARKOV
GOES	GEOSTATIONARY OPERATIONAL ENVIRONMENTAL SATELLITE
HUD	HEAD-UP DISPLAY
IFR	INSTRUMENT FLIGHT RULES
ILS	INSTRUMENT LANDING SYSTEM
IMC	INSTRUMENT METEOROLOGICAL CONDITIONS
IR	INFRARED
IRT	ICING RESEARCH WIND TUNNEL
IRU	INTEGRATING RATE UNIT
JAWOS	JOINT AVIATION WEATHER OBSERVATION SYSTEM
JPL	JET PROPULSION LABORATORY
KSC	KENNEDY SPACE CENTER
LAMP	LOCAL AFOS MOS PROGRAM
LAWS	LOW ALTITUDE WIND SHEAR
LDAR	LIGHTNING DETECTION AND RANGING
LFM	LIMITED AREA FINE MESH
LLWAS	LOW-LEVEL WIND ALERT SYSTEM
LLWSAS	LOW-LEVEL WIND SHEAR ALERT SYSTEM
LWC	LIQUID WATER CONTENT
MAT	MEASUREMENT OF ATMOSPHERIC TURBULENCE
MFD	MODIFIED FLIGHT DIRECTOR
MIL-SPEC	MILITARY SPECIFICATION
MOS	MODEL OUTPUT STATISTICS
MRI	METEOROLOGICAL RESEARCH, INC.



MSFC	MARSHALL SPACE FLIGHT CENTER
NACA	NATIONAL ADVISORY COMMITTEE ON AERONAUTICS
NAFEC	NATIONAL AVIATION FACILITIES EXPERIMENTAL CENTER
NAS	NATIONAL AIRSPACE SYSTEM
NASA	NATIONAL AERONAUTICS AND SPACE ADMINISTRATION
NCAR	NATIONAL CENTER FOR ATMOSPHERIC RESEARCH
NEXRAD	NEXT GENERATION WEATHER RADAR
NMC	NATIONAL METEOROLOGICAL CENTER
NOAA	NATIONAL OCEANIC AND ATMOSPHERIC ADMINISTRATION
NOTAM	NOTICE TO AIRMEN
NRC	NUCLEAR REGULATORY COMMISSION
NRL	NAVAL RESEARCH LABORATORY
NSF	NATIONAL SCIENCE FOUNDATION
NSSFC	NATIONAL SEVERE STORMS FORECAST CENTER
NSSL	NATIONAL SEVERE STORMS LABORATORY
NTSB	NATIONAL TRANSPORTATION SAFETY BOARD
NWS	NATIONAL WEATHER SERVICE
OAT	OUTSIDE AIR TEMPERATURE
OBS	OBSERVATION
OMB	OFFICE OF MANAGEMENT AND BUDGETS
ONR	OFFICE OF NAVAL RESEARCH
PAMOS	PANEL ON AUTOMATIC METEOROLOGICAL OBSERVING SYSTEMS
PIREP	PILOT REPORT
PMS	PARTICLE MEASURING SYSTEM
POP	PROBABILITY OF PRECIPITATION
POPT	PROBABILITY OF PRECIPITATION TYPE

POSH            PROBABILITY OF HEAVY SNOW  
POT            PROBABILITY OF THUNDERSTORMS  
PPP            POLYPULSE PAIR PROCESSING  
PPS            PRECIPITATION PARTICLE SENSOR  
PROFS          PROTOTYPE REGIONAL OBSERVATION AND FORECAST SYSTEM  
PSD            POWER SPECTRAL DENSITY  
R&D            RESEARCH AND DEVELOPMENT  
R&T            RESEARCH AND TECHNOLOGY  
RAE            ROYAL AIRCRAFT ESTABLISHMENT  
RAOB          RADIOSONDE  
RBC            ROTATING BEAM CEILOMETER  
RF             RADIO FREQUENCY  
RHI            RANGE/HEIGHT INDICATOR  
RSRE          ROYAL SIGNALS AND RADAR ESTABLISHMENT  
RVR            RUNWAY VISUAL RANGE  
SC/BMS        SUBCOMMITTEE ON BASIC METEOROLOGICAL SERVICES  
SELS          SEVERE LOCAL STORMS  
SESAME        SEVERE ENVIRONMENTAL STORMS AND MESOSCALE EXPERIMENT  
SIGMET        SIGNIFICANT METEOROLOGICAL ADVISORY  
SPO            SYSTEMS PROJECT OFFICE  
SRDS          SYSTEMS RESEARCH AND DEVELOPMENT SERVICE  
SVR            SLANT VISUAL RANGE  
TAP            TERMINAL ALERTING PROCEDURE  
TAS            TRUE AIR SPEED  
TDL            TECHNIQUES DEVELOPMENT LABORATORY  
TEA            TRANSVERSE EXCITED ATMOSPHERIC

TRIP	THUNDERSTORM RESEARCH INTERNATIONAL PROGRAM
TSC	TRANSPORTATION SYSTEMS CENTER
UK	UNITED KINGDOM
USAF	UNITED STATES AIR FORCE
UTSI	UNIVERSITY OF TENNESSEE SPACE INSTITUTE
VFR	VISUAL FLIGHT RULES
VMC	VISUAL METEOROLOGICAL CONDITIONS
VTOL	VERTICAL TAKEOFF AND LANDING
WAVE	WIND, ALTIMETER AND VOICE EQUIPMENT
WPL	WAVE PROPAGATION LABORATORY

APPENDIX B

FOURTH ANNUAL WORKSHOP ON  
METEOROLOGICAL AND ENVIRONMENTAL INPUTS TO AVIATION SYSTEMS

Roster of Workshop Participants

<u>Name</u>	<u>Address</u>	<u>Phone Number</u>
Edwin W. Abbott	Manager - Operations Air Transport Association 1709 New York Avenue, NW Washington, DC 20006	(202)626-4012
William D. Bachalo	Senior Scientist Spectron Development Labs 3303 Harbor Boulevard, G-3 Costa Mesa, CA 92626	(714)549-8477
James R. Banks	President Air Traffic Control Association, Inc. Suite 410 2020 North 14th Arlington, VA 22201	(703)522-5717
Neal M. Barr	Meteorologist Boeing Commercial Airplane Co. Orgn. B-8404, MS 73-07 PO Box 3707 Seattle, WA 98005	(206)237-8113
John Blasic	NWS Representative to FAA DOC/NOAA/NWS 800 Independence Avenue, SW Washington, DC 20591	(202)426-3223
Edward F. Blick	Professor School of Aerospace Mechanics and Nuclear Engineering University of Oklahoma 865 Asp, Room 211 Norman, OK 73019	(405)325-5011
John H. Bliss	Flying Tiger Line 2740 Graysby Avenue San Pedro, CA 90732	(213)831-1813
Robert S. Bonner	Physicist U.S. Army Atmospheric Sciences Lab White Sands Missile Range, NM 88002	(505)678-1801

Name	Address	Phone Number
Sam Brindley	Project Engineer Bell Helicopter Co. PO Box 482 Ft. Worth, TX 76101	(817)280-3231
Ralph E. Brumby	Senior Staff Engineer Douglas Aircraft Co. 3855 Lakewood Boulevard, M/C 36-81 Long Beach, CA 90846	(213)593-1902
Dennis W. Camp	Aerospace Engineer NASA/Marshall Space Flight Center ES82 AL 35812	(205)453-2087
Warren Campbell	Aerospace Engineer NASA/Marshall Space Flight Center ES82 AL 35812	(205)453-1886
Fernando Caracena	Physicist Dept. of Commerce/NOAA NOAA/ERL/APCL, R31 Boulder, CO 80302	(303)497-6269 FTS 323-6269
Robert E. Carr	Supervisory Physicist NASA/Wallops Flight Center Wallops Island, VA 23337	(804)824-3411 x488
Peter Chesney	Chief, Special Aviation Accident Branch FAA 800 Independence Avenue, SW Washington, DC 20591	(202)426-3120
H. J. Coffman	Project Engineer Bell Helicopter Textron 3205 Woodford Drive Arlington, TX 76013	(817)280-3691
Frank G. Collins	Research Associate FWG Associates, Inc. RR 2, Box 271-A Tullahoma, TN 37388	(615)455-1982
John W. Connolly	Director, Government Operations Alden Electronics 6311 Golf Course Square Alexandria, VA 22307	(703)765-1948

Name	Address	Phone Number
John C. Corbin, Jr.	Electromagnetic Interference and Compatibility Branch Air Force Aeronautical Systems Div. Wright-Patterson AFB, OH 45433	(153)255-5078 255-5986
Don S. Cornwall	ALPA/Delta Air Lines 10181 Jefferson Highway Baton Rouge, LA 70809	(504)292-8165
Norman L. Crabill	Aerospace Technologist NASA/Langley Research Center MS 247 Hampton, VA 23665	(804)827-3274 FTS 928-3274
W. R. Durrett	Branch Head, Telemetry NASA/Kennedy Space Center Code DL-NED-3 FL 32899	(305)867-4438
L. J. Ehernberger	NASA/Dryden Flight Research Center Box 273 Edwards, CA 93523	(805)258-3311 x154
John H. Enders	Consultant 6406 Rockhurst Road Bethesda, MD 20034	(301)530-8118
George H. Fichtl	Chief, Fluid Dynamics Branch NASA/Marshall Space Flight Center ES82 AL 35812	(205)453-0875
Sepp J. Froeschl	Supervisor CPQ Dept. of Env. - A.E.S. Canada 100 Alexis Nihon Ville St. Laurent Quebec, Canada H9P 1X5	(514)333-3070
Walter Frost	Director, Atmospheric Science Division The University of Tennessee Space Institute Tullahoma, TN 37388	(615)455-0631 x218
Joseph G. Gamble	Meteorologist FAA ARD-410 400 7th Street, SW Washington, DC 20590	(202)426-8427

Name	Address	Phone Number
Bruce L. Gary	Senior Scientist Jet Propulsion Laboratory 138-205 4800 Oak Grove Drive Pasadena, CA 91103	(213)354-3198 FTS 792-3198
Preston Geren	Engineer Boeing Commercial Airplane Co. MS 47-31 Seattle, WA 98124	(206)655-8123
R. Craig Goff	Research Meteorologist FAA Technical Center ANA 4B, Bldg 14 Atlantic City, NJ 08405	(609)641-8200 x2284
Arthur Hilsenrod	Meteorologist FAA/ARD-413 400 7th Street, SW Washington, DC 20950	(202)426-8427
Jay D. Hunt	Senior Research Engineer Sverdrup/ARO, Inc. ETF/TAB Arnold AFS, TN 37389	(615)455-2611 x562
Paul W. Kadlec	Flight Planning Representative Continental Airlines 28631 Quail Hill Drive Rancho Palos Verdes, CA 90274	(213)377-5272
John L. Keller	Research Meteorologist University of Dayton Research Institute College Park Avenue Dayton, OH 45469	(513)229-3921
Phyllis F. Kitchens	Aerospace Engineer U.S. Army Test & Evaluation Command Attn: DRSTE-CT-A Aberdeen Proving Ground, MD 21028	(301)278-2426 AV 823-2426
Robert Klapprott	Chief Systems Engineer FAA Engineering Office 43 Mid Continent Airport Wichita, KS 67037	(316)942-4281

Name	Address	Phone Number
William H. Klein	Intercon Weather Consultants, Inc. 4700 Auth Place Camp Springs, MD 20023	(301)423-6776
Ronald H. Kohl	Associate Professor of Physics The University of Tennessee Space Institute Tullahoma, TN 37388	(615)455-0631 x234
Bud Laynor	Chief, Vehicle Factors Division Bureau of Technology National Transportation Safety Board FOB 10A Washington, DC 20594	(202)472-6114
J. T. Lee	Program Coordinator National Severe Storms Lab 1313 Halley Circle Norman, OK 73069	(405)360-3620 FTS 736-4916
James Luers	Research Scientist University of Dayton Research Institute College Park Avenue Dayton, OH 45469	(513)229-3921
Eric Mandel	Meteorologist FAA ARD-411 400 7th Street, SW Washington, DC 20590	(202)426-8427
John McCarthy	Visiting Scientist National Center for Atmospheric Research/Field Observing Facility PO Box 3000 Boulder, CO 80307	(303)497-0651 FTS 322-7651
William W. Melvin	Chairman, Airworthiness & Performance Committee Air Line Pilots Association 1625 Massachusetts Avenue, NW Washington, DC 20036	(800)424-2470
James I. Metcalf	Georgia Institute of Technology EES/RAD Atlanta, GA 30332	(404)424-9626



<u>Name</u>	<u>Address</u>	<u>Phone Number</u>
Richard L. Newman	Consultant PO Box 481 Yellow Springs, OH 45387	(513)767-9279
William Olsen	Research Engineer Icing Research Section NASA/Lewis Research Center 21000 Brookpark Road Cleveland, OH 44135	(216)433-4000 x6122
Byron B. Phillips	Manager, Research Aviation Facility National Center for Atmospheric Research PO Box 3000 Boulder, CO 80303	(303)494-5151 x7850 FTS 322-5151 x7850
Vernon W. Ramsey	NRC Research Associate NASA/Marshall Space Flight Center ES82 AL 35812	(205)453-3104
Nickolus O. Rasch	Project Manager FAA/NAFEC ANA 340 Atlantic City, NJ 08405	(609)641-8200 x3740
William H. Reinhoehl	Manager, Simulator Maintenance Hughes Air West PO Box 2966 Phoenix, AZ 85062	(602)273-9231
Fred Ross	Instructor United Airlines Flight Training Center Stapleton International Airport Denver, CO 80207	(303)398-4041
Lothar H. Ruhnke	Branch Head Naval Research Lab Code 4320 Washington, DC 20375	(202)767-2951
Charles F. Schafer	Physicist NASA/Marshall Space Flight Center ES82 AL 35812	(205)453-1886

<u>Name</u>	<u>Address</u>	<u>Phone Number</u>
Ernest E. Schlatter	Research Meteorologist FAA/NAFEC Atlantic City, NJ 08405	(609)641-8200 x2644
Robert Serafin	Manager, Field Observing Facility National Center for Atmospheric Research PO Box 3000 Boulder, CO 80301	(303)497-0648
James M. Sisson	Deputy Lab Director Space Sciences Lab ED01 NASA/Marshall Space Flight Center AL 35812	(205)453-2524
Joseph F. Soward	Chief, Aviation Weather Branch FAA 400 7th Street, SW Washington, DC 20591	(202)426-8427
Edward A. Spitzer	Engineer DOT/TSC Kendall Square Cambridge, MA 02142	(617)494-2088
August Stasio	ALPA/United Air Lines PO Box 8523 San Francisco, CA 94128	(415)876-4882
Joseph W. Stickle	Asst. Chief, Flight Mechanics Division NASA/Langley Research Center Hampton, VA 23665	(804)827-2037
David L. Stoddard	Manager, DC-9 Flight Training Hughes Air West PO Box 2966 Phoenix, AZ 85062	(602)273-9231
Allan R. Tobiason	Manager, Aviation Safety Technology NASA Headquarters RJT-2 Washington, DC 20546	(202)755-3003
Barry Turkel	Research Engineer FWG Associates, Inc. RR 2, Box 271-A Tullahoma, TN 37388	(615)455-1982

<u>Name</u>	<u>Address</u>	<u>Phone Number</u>
Jerald Uecker	Domestic Aviation Program Specialist NWS/Aviation Branch 8060 13th Street Silver Spring, MD 20910	(301)427-7726
Otha H. Vaughan, Jr.	Space Scientist NASA/Marshall Space Flight Center ES83 AL 35812	(205)453-5218
William W. Vaughan	Chief, Atmospheric Sciences Division NASA/Marshall Space Flight Center ES81 AL 35812	(205)453-3100
Harry A. Verstynen	Chief, FAA/Langley E&D Field Office MS-250 NASA/Langley Research Center Hampton, VA 23665	(804)827-4595
S. T. Wang	Research Engineer FWG Associates, Inc. RR 2, Box 271-A Tullahoma, TN 37388	(205)883-4737
Fred Watts	Engineering Test Pilot United Air Lines Stapleton International Airport Denver, CO 80207	(303)398-4556
Edwin A. Weaver	Optics Engineer NASA/Marshall Space Flight Center EC32 AL 35812	(205)453-1597
Robert W. Wedan	Director, Systems Research & Development Service FAA Washington, DC 20590	(202)426-3200
Thomas C. West	Program Manager FAA 400 7th Street, SW Washington, DC 20590	(202)426-3406
Andy White	Staff Meteorologist AFWAL/Flight Dynamics Lab AFWAL/WEF Wright-Patterson AFB, OH 45433	(513)255-6756

<u>Name</u>	<u>Address</u>	<u>Phone Number</u>
C. Dennis Wright	Director, Technical Planning Dept. Aircraft Owners & Pilots Association PO Box 5800 Washington, DC 20014	(301)951-3921
Andy D. Yates, Jr.	Air Line Pilots Association 7413 Park Terrace Drive Alexandria, VA 22307	(703)765-7423

\*U.S. GOVERNMENT PRINTING OFFICE: 1980-0-722-239/372

**DATE**  
**ILME**