

AD-A091 730

COASTAL ENGINEERING RESEARCH CENTER FORT BELVOIR VA F/6 8/3  
INSTRUMENTATION AT CERC'S FIELD RESEARCH FACILITY, DUCK, NORTH --ETC(U)  
OCT 80 H C MILLER  
CERC-MR-80-8

NL

UNCLASSIFIED

1 of 1  
AD-A091 730

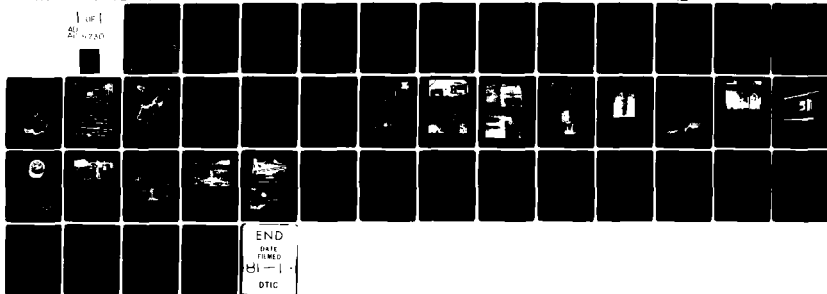

LEW # 12

MR 80-8

# Instrumentation at CERC's Field Research Facility, Duck, North Carolina

by  
H. Carl Miller

MISCELLANEOUS REPORT NO. 80-8  
OCTOBER 1980

AD A091730

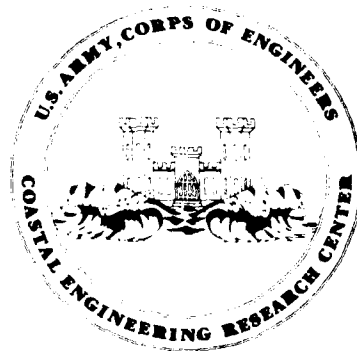

DTIC  
ELECTE  
NOV 20 1980  
A

Approved for public release;  
distribution unlimited.

U.S. ARMY, CORPS OF ENGINEERS  
COASTAL ENGINEERING  
RESEARCH CENTER

Kingman Building  
Fort Belvoir, Va. 22060

DDC FILE COPY

Reprint or republication of any of this material shall give appropriate credit to the U.S. Army Coastal Engineering Research Center.

Limited free distribution within the United States of single copies of this publication has been made by this Center. Additional copies are available from:

*National Technical Information Service  
ATTN: Operations Division  
5285 Port Royal Road  
Springfield, Virginia 22161*

Contents of this report are not to be used for advertising, publication, or promotional purposes. Citation of trade names does not constitute an official endorsement or approval of the use of such commercial products.

The findings in this report are not to be construed as an official Department of the Army position unless so designated by other authorized documents.

14 UNCLASSIFIED  
SECURITY CLASSIFICATION OF THIS PAGE (When Data Entered)

| CERC - REPORT DOCUMENTATION PAGE   |   | READ INSTRUCTIONS<br>BEFORE COMPLETING FORM |
|--|---|---|
| 1. REPORT NUMBER<br>MR-86-8  | 2. GOVT ACCESSION NO.<br>AD-A091 730                                  | 3. RECIPIENT'S CATALOG NUMBER               |
| 4. TITLE (and Subtitle)<br>INSTRUMENTATION AT CERC'S FIELD RESEARCH FACILITY, DUCK, NORTH CAROLINA   | 5. TYPE OF REPORT & PERIOD COVERED<br>Miscellaneous Report            | 6. PERFORMING ORG. REPORT NUMBER            |
| 7. AUTHOR(s)<br>H. Carl Miller   | 8. CONTRACT OR GRANT NUMBER(s)  |   |
| 9. PERFORMING ORGANIZATION NAME AND ADDRESS<br>Department of the Army<br>Coastal Engineering Research Center (CERRE-CO)<br>Kingman Building, Fort Belvoir, Virginia 22060  | 10. PROGRAM ELEMENT, PROJECT, TASK AREA & WORK UNIT NUMBERS<br>A31537 |   |
| 11. CONTROLLING OFFICE NAME AND ADDRESS<br>Department of the Army<br>Coastal Engineering Research Center<br>Kingman Building, Fort Belvoir, Virginia 22060   | 12. REPORT DATE<br>October 1980                                       | 13. NUMBER OF PAGES<br>42                   |
| 14. MONITORING AGENCY NAME & ADDRESS (if different from Controlling Office)<br>12 42   | 15. SECURITY CLASS. (of this report)<br>UNCLASSIFIED                  |   |
| 15a. DECLASSIFICATION/DOWNGRADING SCHEDULE   |   |   |
| 16. DISTRIBUTION STATEMENT (of this Report)<br>Approved for public release; distribution unlimited.  |   |   |
| 17. DISTRIBUTION STATEMENT (of the abstract entered in Block 20, if different from Report)   |   |   |
| 18. SUPPLEMENTARY NOTES  |   |   |
| 19. KEY WORDS (Continue on reverse side if necessary and identify by block number)<br>Coastal Engineering Research Center      Meteorological instruments<br>Duck, North Carolina                              Oceanographic instruments<br>Field Research Facility  |   |   |
| 20. ABSTRACT (Continue on reverse side if necessary and identify by block number)<br>Report describes the oceanographic and meteorological instrumentation used for the collection of environmental data at the Coastal Engineering Research Center's (CERC) Field Research Facility (FRF) at Duck, North Carolina; the necessary information for proper interpretation of the instrument data is also presented. An appendix contains installation summaries for each instrument described in the report. |   |   |

UNCLASSIFIED  
SECURITY CLASSIFICATION OF THIS PAGE (When Data Entered)  
037050

PREFACE

This report provides a basic description of the oceanographic and meteorological instrumentation used for the collection of environmental data at the Coastal Engineering Research Center's (CERC) Field Research Facility (FRF) at Duck, North Carolina; it also provides the information necessary for proper interpretation of the instrument data. The report is intended as a reference for subsequent reports which will contain summaries of the data collected from the instruments. The work was carried out under the CERC's waves and coastal flooding program.

The report was prepared by H. Carl Miller, Oceanographer, under the supervision of Dr. C.L. Vincent, Chief, Coastal Oceanography Branch and C. Mason, Chief, Field Research Facility Group, Research Division.

The author acknowledges the helpful review comments from M.G. Mattie of CERC, R. Masterson, National Ocean Survey (NOS), and J. O'Brien, National Weather Service (NWS), National Oceanic and Atmospheric Administration (NOAA).

Comments on this publication are invited.

Approved for publication in accordance with Public Law 166, 79th Congress, approved 31 July 1945, as supplemented by Public Law 172, 88th Congress, approved 7 November 1963.



TED E. BISHOP  
Colonel, Corps of Engineers  
Commander and Director

|               |                                     |
|---------------|-------------------------------------|
| Accession For |                                     |
| DTIC GRA&I    | <input checked="" type="checkbox"/> |
| DTIC          | <input type="checkbox"/>            |
| DTIC          | <input type="checkbox"/>            |
| Justification |                                     |
| By            |                                     |
| Date          |                                     |
| Approved      |                                     |
| Special       |                                     |

A

CONTENTS

|   | Page |
|---|------|
| CONVERSION FACTORS, U.S. CUSTOMARY TO METRIC (SI) . . . . . | 6    |
| I INTRODUCTION . . . . .                                    | 7    |
| II INSTRUMENTATION AT THE FRF . . . . .                     | 7    |
| 1. Oceanographic Instruments . . . . .                      | 7    |
| 2. Meteorological Instrumentation. . . . .                  | 23   |
| III SAMPLING INFORMATION AND SUMMARY DESCRIPTIONS. . . . .  | 31   |
| 1. Digital Wave Data . . . . .                              | 31   |
| 2. Current Meter Data. . . . .                              | 31   |
| 3. Conductivity and Temperature Data . . . . .              | 31   |
| 4. Monthly Tide Summaries. . . . .                          | 31   |
| 5. Meteorological Observations . . . . .                    | 37   |
| IV DATA REQUESTS. . . . .                                   | 37   |
| LITERATURE CITED . . . . .                                  | 40   |
| APPENDIX INSTRUMENT INSTALLATION CHART. . . . .             | 41   |

FIGURES

|  |    |
|--|----|
| 1 FRF location map . . . . .   | 8  |
| 2 Instrument locations at FRF. . . . .                                       | 9  |
| 3 Baylor wave staff gage and support system. . . . .                         | 11 |
| 4 Water depth envelope along the FRF pier. . . . .                           | 12 |
| 5 Waverider buoys. . . . .   | 12 |
| 6 Waverider moorings . . . . .   | 13 |
| 7 Pressure wave gage . . . . .   | 14 |
| 8 T-bracket used for current meter and pressure gage installations . . . . . | 15 |
| 9 Current meter installation . . . . .                                       | 17 |
| 10 Hydrolab Model TC-2 conductivity probe . . . . .                          | 18 |
| 11 Hydrolab Model T-4 temperature probe . . . . .                            | 18 |
| 12 Hydrolab temperature and conductivity meters . . . . .                    | 19 |
| 13 NOS control station at end of pier . . . . .                              | 19 |
| 14 Leupold-Stevens tide gage. . . . .  | 20 |
| 15 Bristol pressure tide gage . . . . .                                      | 20 |

CONTENTS

FIGURES--Continued

|  | Page |
|--|------|
| 16 Fischer-Porter tide gage . . . . .  | 21   |
| 17 Metercraft pressure tide gage. . . . .  | 21   |
| 18 Stilling well. . . . .  | 22   |
| 19 A model F420C anemometer used to measure wind speed and direction. . . . .  | 23   |
| 20 Wind speed and direction gages . . . . .  | 24   |
| 21 Microbarograph . . . . .  | 25   |
| 22 NWS barometer. . . . .  | 26   |
| 23 Hygrothermograph . . . . .  | 26   |
| 24 Wood shelter which houses the hygrothermograph . . . . .  | 27   |
| 25 Recording rain gage. . . . .  | 28   |
| 26 Six-inch plastic rain gage . . . . .  | 29   |
| 27 Sling psychrometer . . . . .  | 30   |
| 28 Mechanical pyranograph . . . . .  | 30   |
| 29 Example of the CERC monthly wave data summary for significant wave heights and periods . . . . .                  | 32   |
| 30 Example of the CERC monthly wave data summary for distribution of significant wave height versus period . . . . . | 33   |
| 31 Example of graph showing significant wave height and period versus time . . . . .                                 | 34   |
| 32 Example of spectrum plot . . . . .  | 34   |
| 33 Example of NOS tide summary. . . . .  | 35   |
| 34 Example of meteorological observations recorded on CERC Form 78-236. . . . .                                      | 38   |
| 35 Example of daily meteorological observation summaries. . . . .  | 39   |

## CONVERSION FACTORS, U.S. CUSTOMARY TO METRIC (SI) UNITS OF MEASUREMENT

U.S. customary units of measurement used in this report can be converted to metric (SI) units as follows:

| Multiply           | by                      | To obtain                               |
|--------------------|-------------------------|---|
| inches             | 25.4                    | millimeters                             |
|                    | 2.54                    | centimeters                             |
| square inches      | 6.452                   | square centimeters                      |
| cubic inches       | 16.39                   | cubic centimeters                       |
| feet               | 30.48                   | centimeters                             |
|                    | 0.3048                  | meters                                  |
| square feet        | 0.0929                  | square meters                           |
| cubic feet         | 0.0283                  | cubic meters                            |
| yards              | 0.9144                  | meters                                  |
| square yards       | 0.836                   | square meters                           |
| cubic yards        | 0.7646                  | cubic meters                            |
| miles              | 1.6093                  | kilometers                              |
| square miles       | 259.0                   | hectares                                |
| knots              | 1.852                   | kilometers per hour                     |
| acres              | 0.4047                  | hectares                                |
| foot-pounds        | 1.3558                  | newton meters                           |
| millibars          | $1.0197 \times 10^{-3}$ | kilograms per square centimeter         |
| ounces             | 28.35                   | grams                                   |
| pounds             | 453.6                   | grams                                   |
|                    | 0.4536                  | kilograms                               |
| ton, long          | 1.0160                  | metric tons                             |
| ton, short         | 0.9072                  | metric tons                             |
| degrees (angle)    | 0.01745                 | radians                                 |
| Fahrenheit degrees | 5/9                     | Celsius degrees or Kelvins <sup>1</sup> |

<sup>1</sup>To obtain Celsius (C) temperature readings from Fahrenheit (F) readings, use formula:  $C = (5/9) (F - 32)$ .

To obtain Kelvin (K) readings, use formula:  $K = (5/9) (F - 32) + 273.15$ .



INSTRUMENTATION AT CERC'S FIELD RESEARCH FACILITY,  
DUCK, NORTH CAROLINA

by  
H. Carl Miller

I. INTRODUCTION

The Coastal Engineering Research Center's (CERC) Field Research Facility (FRF) is located on the Outer Banks, North Carolina, near the village of Duck (Fig. 1). The FRF provides a means for obtaining high-quality field data, particularly during storms, in support of the U.S. Army Corps of Engineers coastal research missions. The FRF consists of an 1,840 foot-long concrete research pier supported on 3-foot-diameter steel piles. The pier deck is 20 feet wide, 25 feet above mean sea level (MSL), and extends from behind the dunes to approximately the 25-foot depth contour. In addition, the main building contains offices, a technical library, an instrument repair shop, and a data acquisition room.

A Basic Environmental Measurements (BEM) program has been established to collect, analyze, and disseminate data on selected oceanographic and meteorological conditions at the FRF. Weekly bottom profiles along both sides of the pier and periodic bathymetric surveys (from behind the dune to 1 or 2 miles from shore) along ranges as far as 2.5 miles north and south of the pier are also performed as part of the BEM.

This report describes the instrumentation maintained at the FRF for the BEM study and the types of data that are obtained as part of that program. It is intended as a reference report to provide users with information necessary for an understanding of how and where the data are collected. Subsequent reports will summarize the data collected by the instruments described herein.

Section II describes the instruments and their locations. Section III describes the data sampling procedure and the format of each type of data summary; Section IV discusses how to request data from CERC. An Appendix contains installation summaries for each instrument described in this report.

II. INSTRUMENTATION AT THE FRF

CERC maintains most of the oceanographic and meteorologic instrumentation in the vicinity of the FRF. However, tide gages have been installed by the National Ocean Survey (NOS), National Oceanic and Atmospheric Administration (NOAA) to monitor water levels in the ocean along the pier and in the sound adjacent to the FRF. The NOS Tides Branch at Rockville, Maryland, prepares monthly water level summaries from selected gages. In addition, the National Weather Service (NWS), NOAA, maintains wind measuring anemometers at the facility.

1. Oceanographic Instruments.

The location of each oceanographic instrument at the FRF (described below) is shown in Figure 2; station numbers in the figure correspond to the distance (in feet) from a reference base line to the installation. The shore end of the pier is at station number 1+20.

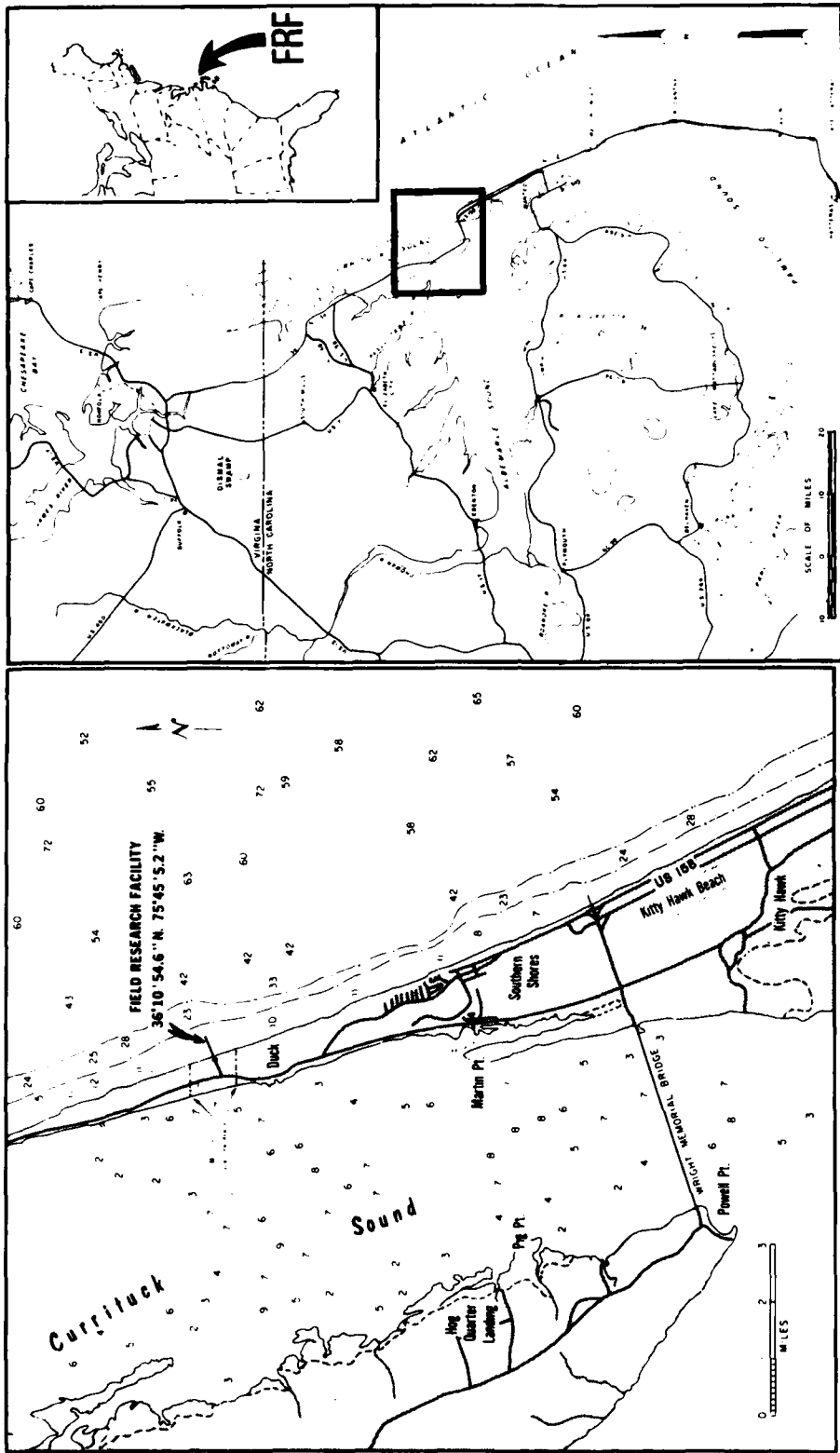

Figure 1. FRF location map.

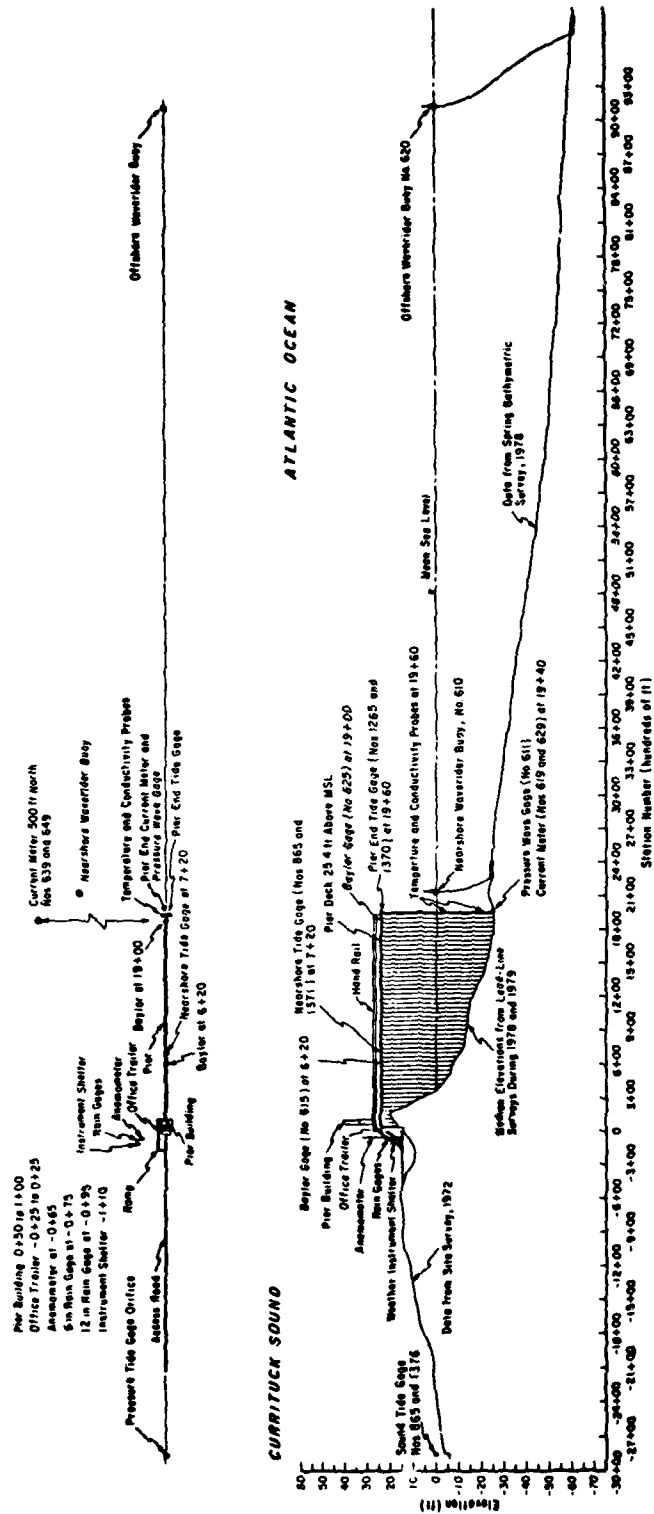

Figure 2. Instrument Locations at FRRF.

a. Staff Wave Gages. Three staff gages are used to collect wave data as part of the BEM. Two gages are located at stations 6+20 and 19+00; the third gage is located at Jennette's fishing pier (about 25 miles south of the FRF), Nags Head, North Carolina.

The wave staffs are parallel inductive cable types manufactured by the Baylor Company, Houston, Texas (Fig. 3). Each wave staff consists of two wire ropes 0.5 inch in diameter held parallel under tension 9 inches apart. Associated with each staff is a transducer element which yields an electrically linear (direct current) output that is proportional to the amount of cable above a short circuit on the staff caused by the conducting characteristics of seawater. The gage is designed for an accuracy and resolution of 1 and 0.1 percent full scale, respectively. (For additional details on the wave staffs, refer to Baylor Company, 1970.) The gage installations at stations 6+20 and 19+00 use a hanger bracket support at the top and an anchor system on the bottom which are centered under the pier deck midway between adjacent pilings (Fig. 3). The Nags Head staff has rigid top and bottom supports connected directly to a wooden piling on the north side of the pier.

The water depth at each gage fluctuates as a function of both the water level and bottom elevation. Figure 4 shows the maximum and minimum bottom elevations observed along the FRF pier between 27 July 1977 and 4 January 1979.

b. Wave Measuring Buoys. Two Datawell Waverider buoy wave sensors are deployed at the FRF (Fig. 5). One sensor is located near the seaward end of the pier in about 23 feet of water; the other sensor is 1.3 miles due east of the end of the pier in about 60 feet of water (Fig. 2). The Waverider is a buoy which follows the movement of the water surface with internal electronics that measure the vertical acceleration of the buoy. The signal is integrated twice to produce a surface displacement signal which is telemetered to a shore receiving station.

The mooring used to fix the buoy in position is an integral part of the wave measuring system, designed to allow the buoy to move freely with the sea surface but strong enough to withstand the large forces caused by storm waves. Figure 6 shows the nearshore and offshore Waverider mooring systems at the FRF. The mooring components and their dimensions are a function of the water depth where the buoys are deployed. The offshore mooring system (deployed in about 60 feet of water) consists of a black rubber stretch cord, a buoyant polypropylene white rope, and a nylon-covered, stainless-steel rope covered with an air compressor hose cut into 8-inch lengths (foreground of photo in Fig. 6). The air compressor hose protects the rope from abrasion as it is dragged back and forth on the ocean bottom. The nearshore mooring system consists only of the rubber cord for deployment in depths of 25 feet or less (background of photo in Fig. 6). Additional details on the buoy operation and mooring configuration are in Van Breugel, Verhagen, and Gerritzen (1972).

c. Pressure Wave Gage. A single pressure gage is installed under the seaward end of the FRF pier. The gage sensor consists of a transducer (manufactured by I.C. Transducers, Inc., San Jose, California), coupled to a Bellofram gage protector and enclosed in a PVC housing (Fig. 7). With this arrangement, the pressure is sensed by the diaphragm in the gage protector and transmitted by an oil-filled cavity to the transducer. (Additional details on the transducer may be obtained from the manufacturer.) The gage is located at station 19+40 in approximately 27 feet of water (Fig. 2). The pressure sensor is attached to a special T-shaped bracket anchored to the bottom (Fig. 8).

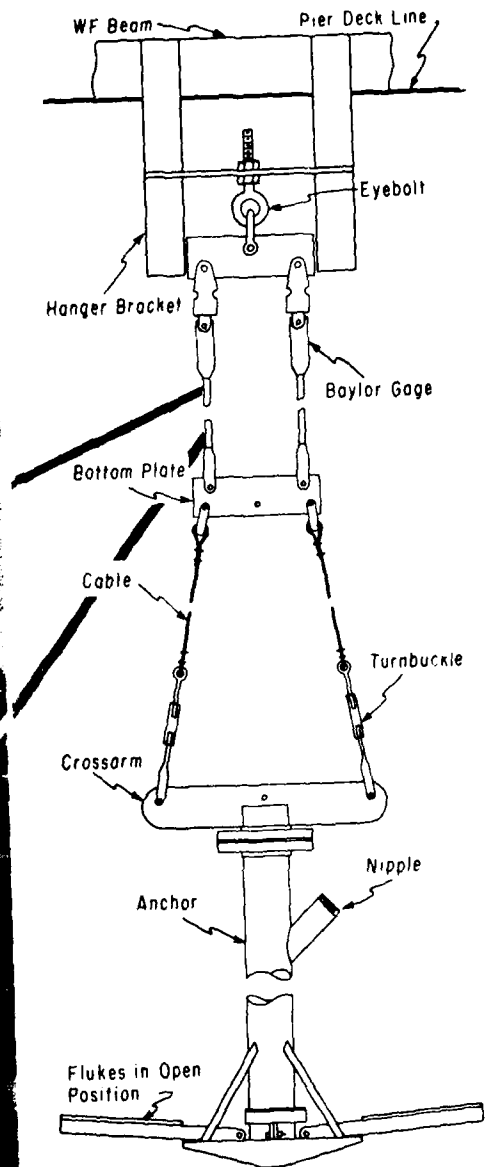

Figure 3. Baylor wave staff gage and support system.

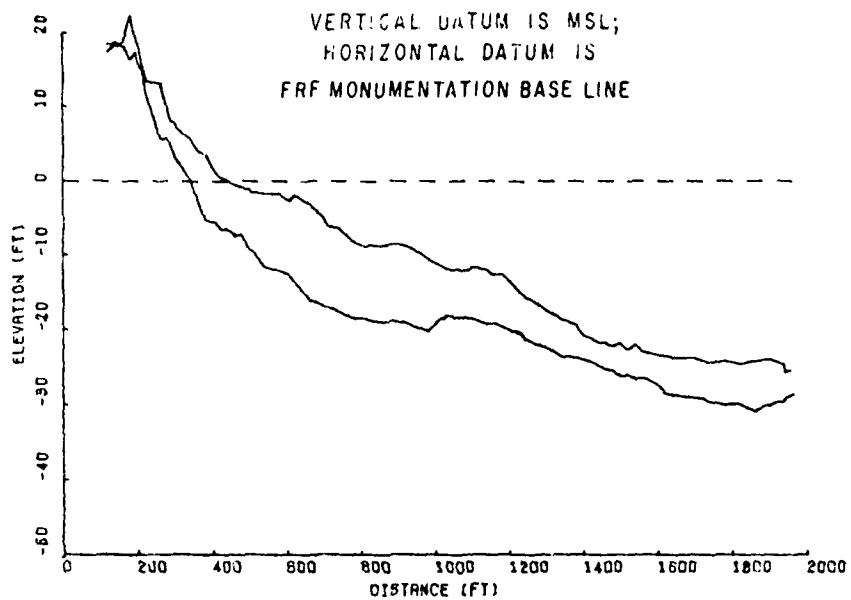

Figure 4. Water depth envelope along the FRF pier, 27 July 1977 to 4 January 1979.



Figure 5. Waverider buoys.

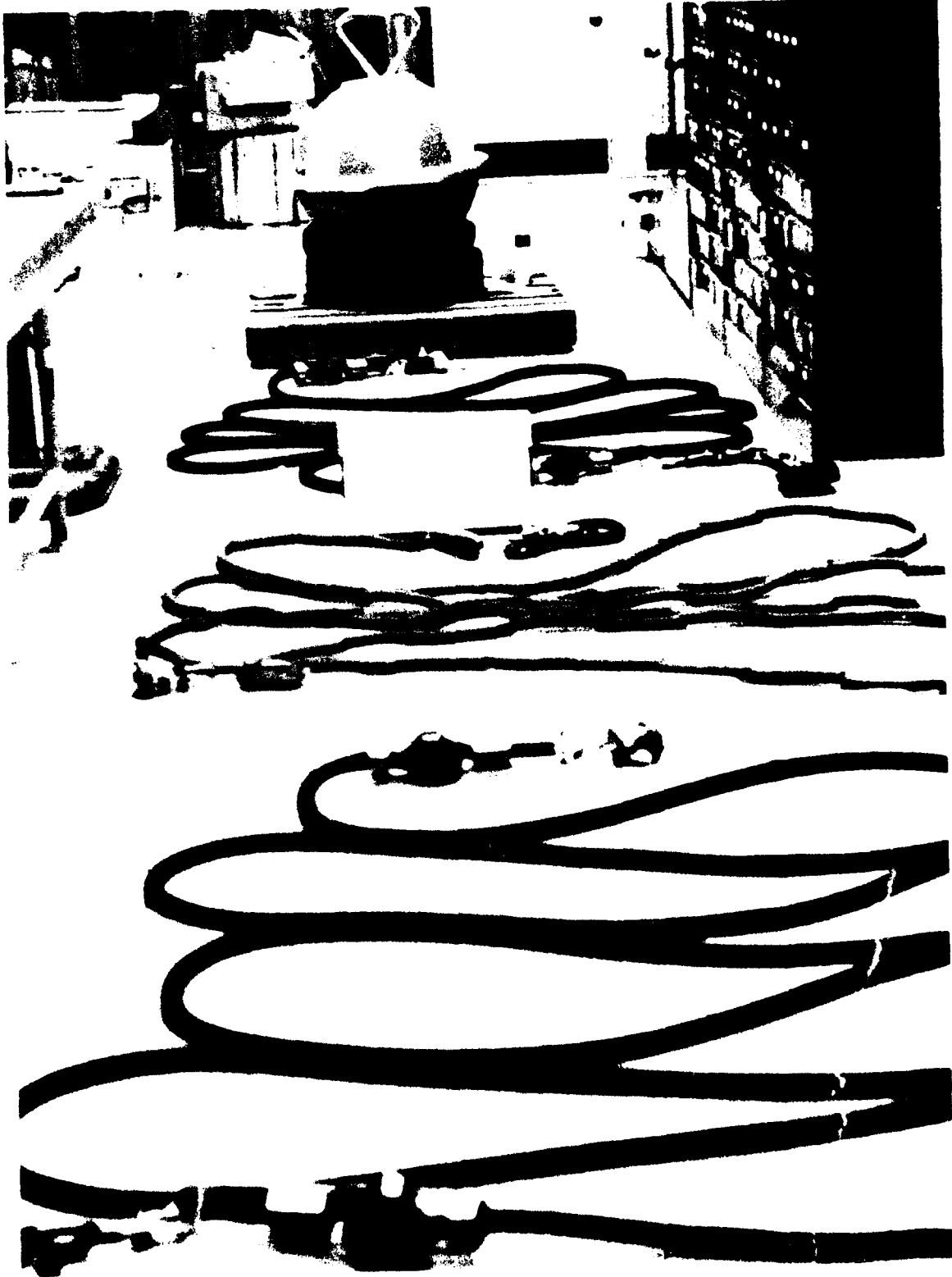

Figure 6. Waverider moorings.

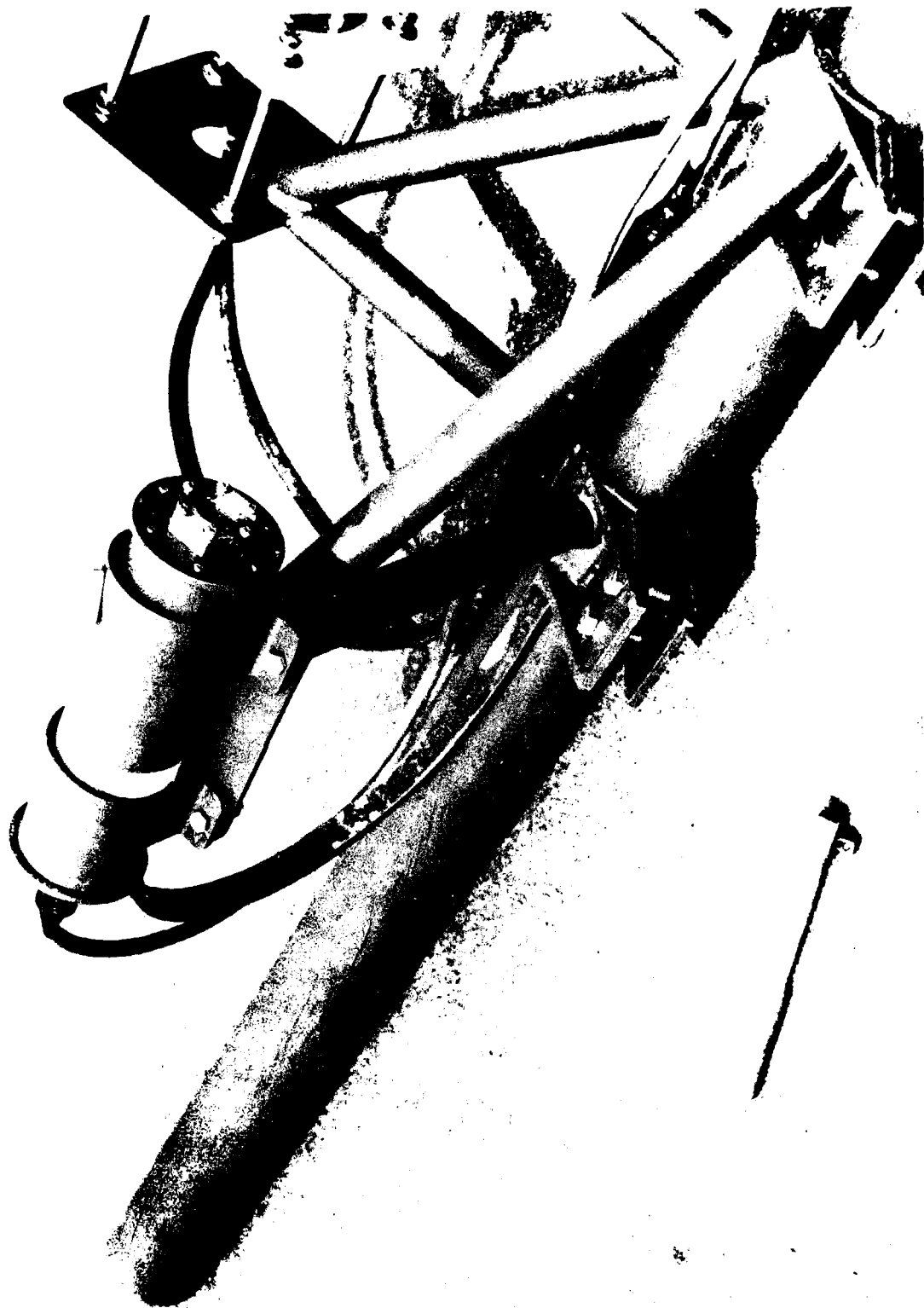

Figure 7. Pressure wave gage.



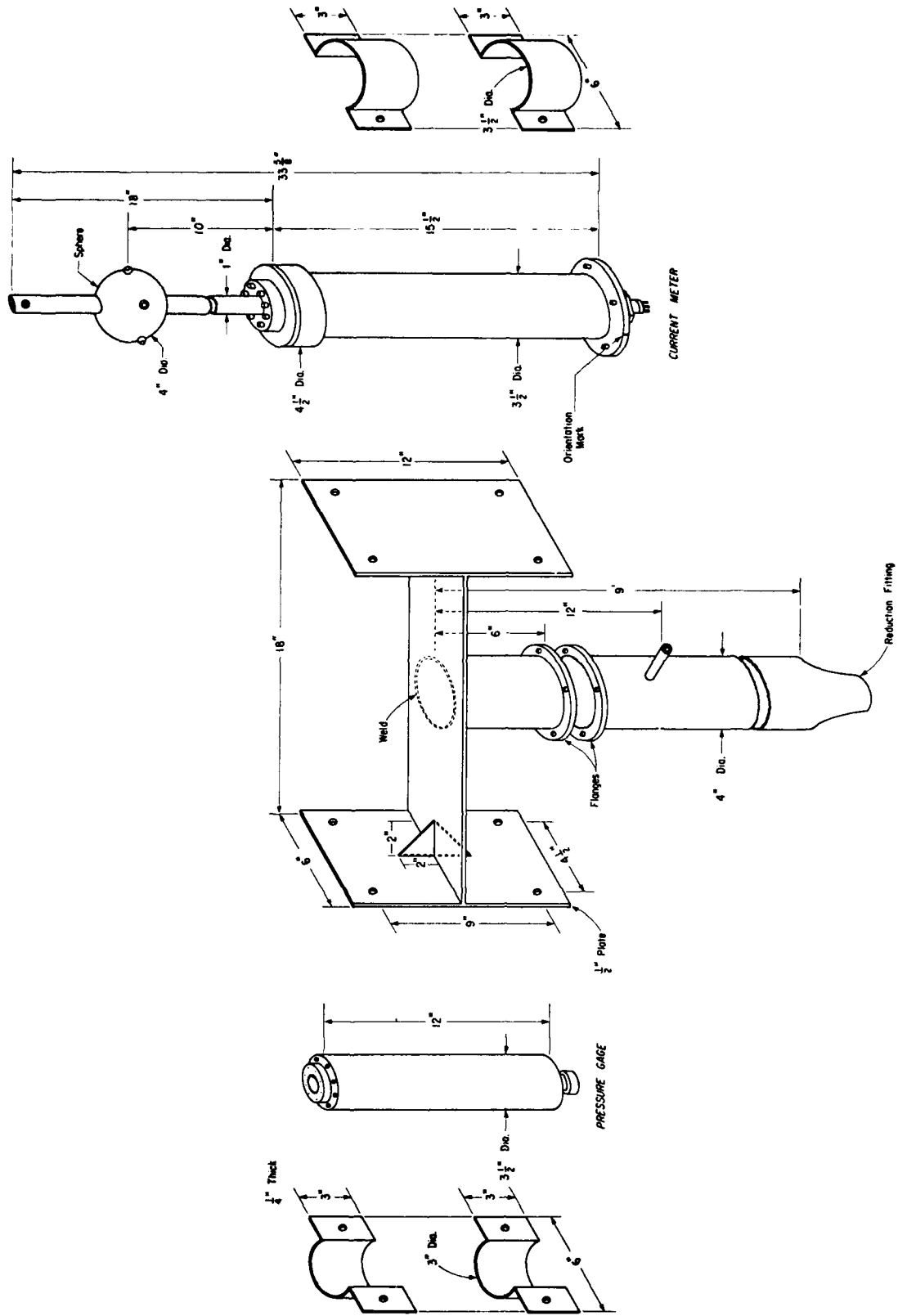

Figure 8. T-bracket used for current meter and pressure gage installation.

d. Current Meters. Two Marsh-McBirney (MMI) 551 electromagnetic current meters are deployed at the FRF, one at station 19+40 under the seaward end of the pier and the other at approximately the same distance from shore but 500 feet north of the pier (Fig. 2). The meter under the pier is attached to the T-bracket shown in Figure 8; the other meter installation is shown in Figure 9. The MMI current meters are solid-state instruments with no moving parts. The meter's operation is based on Faraday's principle of electromagnetic induction, i.e., a conductor moving through a magnetic field will produce a voltage proportional to the speed of the conductor. The probe for the meter consists of a 4-inch-diameter sphere which contains an electromagnet and two pairs of electrodes. The two orthogonal electrode pairs sense the vector component voltages induced when the water moves through the magnetic field produced by the electromagnet. The instrument range is  $\pm 10$  feet per second with an accuracy of  $\pm 2$  percent or  $\pm 0.07$  foot per second and a 0.2-second time constant; zero drift is less than 0.07 foot per second. Additional details on the MMI 551 meters are in Marsh-McBirney, Inc. (1978).

e. Conductivity and Temperature Meters. Two Hydrolab Model TC-2 conductivity probes (Fig. 10) and two Hydrolab Model T-4 temperature probes (Fig. 11) are located under the seaward end of the pier at station 1960. One conductivity and one temperature probe is 10 feet below MSL; the other pair is 22 feet below MSL. The TC-2 determines the total concentration of ions in solution using the four-electrode method of conductivity measurement. The method consists of separating the electrodes that supply the current in the conductivity cell from the electrodes that measure the voltage produced in the solution by passage of the current through the cell. This technique eliminates errors due to cable resistance and electrode polarization, and diminishes the effects of electrode fouling (Garner, 1972). Measurements of conductivity also vary with temperature; the TC-2 instruments are electronically corrected to  $25^{\circ}$  Celsius for temperature variations. Water temperature is measured by the TC-2 using a precision thermistor temperature sensor contained in the conductivity probe. The conductivity output data signal is stated to be accurate to within 2.5 percent of the reading and the temperature readings to within  $\pm 0.5^{\circ}$  Celsius. Mounted a few inches above the TC-2 probes are T-4 Marine Hydrographic thermometers which have a range from  $-2^{\circ}$  to  $49^{\circ}$  Celsius. The conductivity and temperature values are obtained by reading Hydrolab meters located in a stainless-steel box on the pier deck (Fig. 12). (Additional details on the conductivity and temperature probes may be obtained from the Hydrolab Corporation, Austin, Texas.)

f. Tide Gages. Three NOS tide stations consisting of four gages are installed at the FRF. The NOS control station (Fig. 13) at the seaward end of the research pier (Fig. 2) consists of a Leupold-Stevens gage (Fig. 14; manufactured by Leupold and Stevens, Inc., Beaverton, Oregon) and a Bristol pressure gage (Fig 15; manufactured by the Bristol Company, Waterbury, Connecticut). The second tide station (located at station 7+20) has a Fischer-Porter tide gage (Fig. 16; manufactured by Fischer and Porter Company, Warminster, Pennsylvania). The third station (located about 1,000 feet west of the shore in the Currituck Sound) has a Metercraft pressure tide gage (Fig. 17; manufactured by Metercraft Corporation, Perry Hall, Maryland).

Both the Leupold-Stevens and Fischer-Porter analog-to-digital recorders (ADR) are float-activated, negator-spring, counterpoised instruments that mechanically convert the vertical motion of a float into a coded, punched

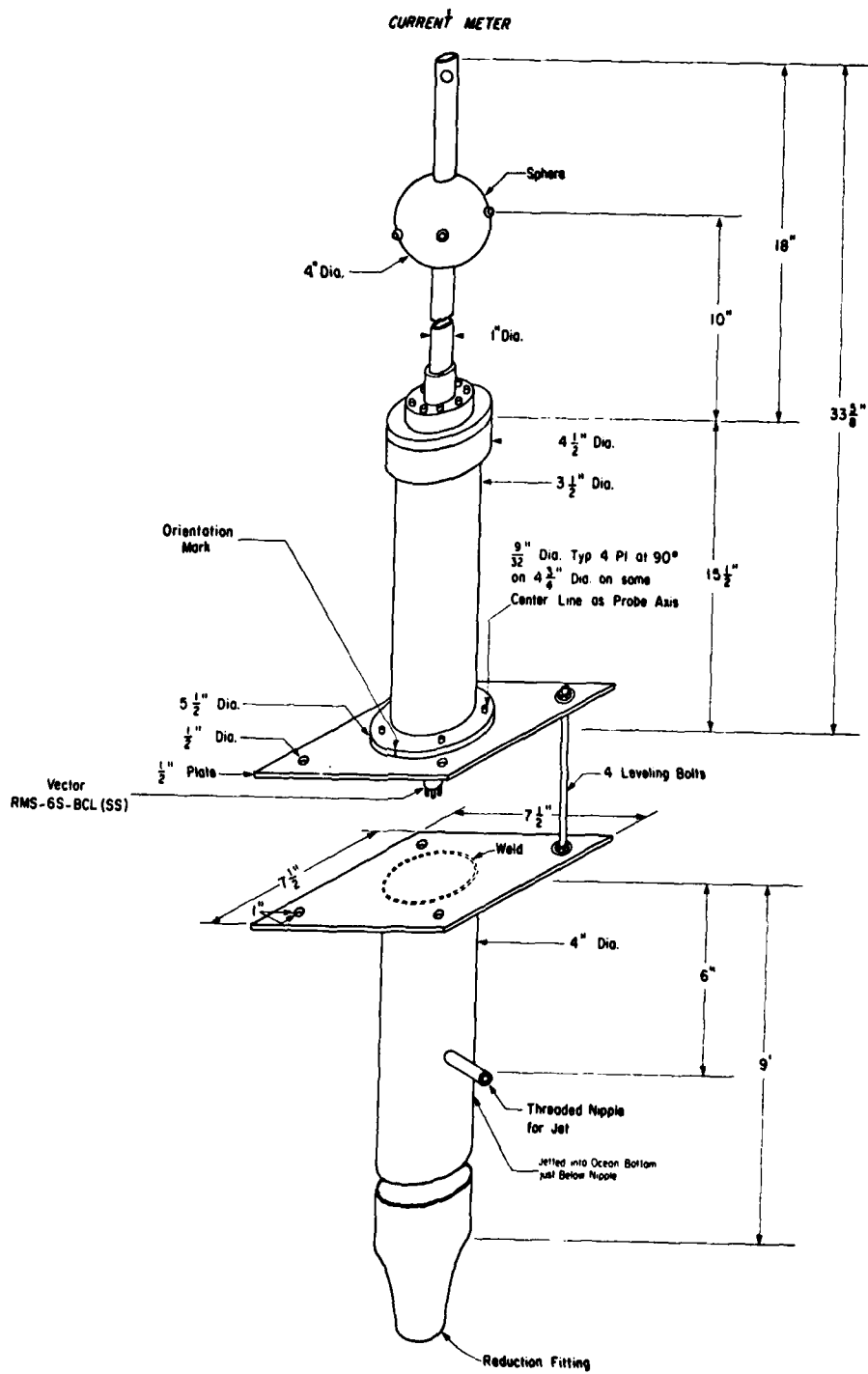

Figure 9. Current meter installation.

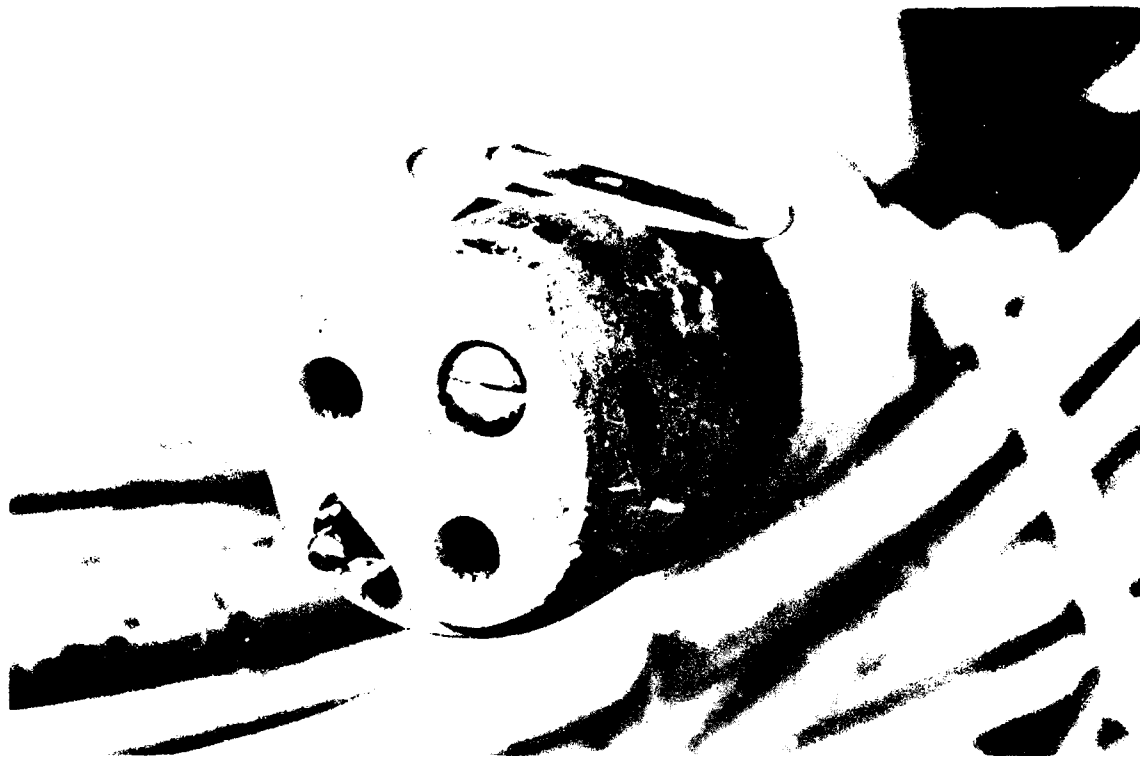

Figure 10. Hydrolab Model TC-2 conductivity probe.



Figure 11. Hydrolab Model T-4 temperature probe.

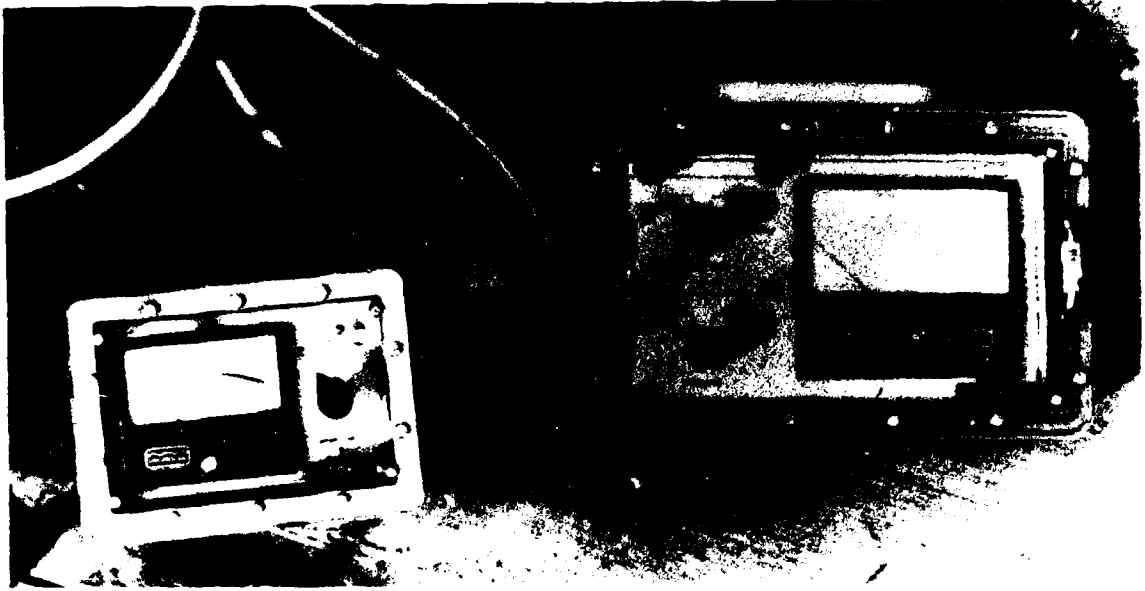

Figure 12. Hydrolab temperature and conductivity meters.



Figure 13. NOS control station at end of pier.

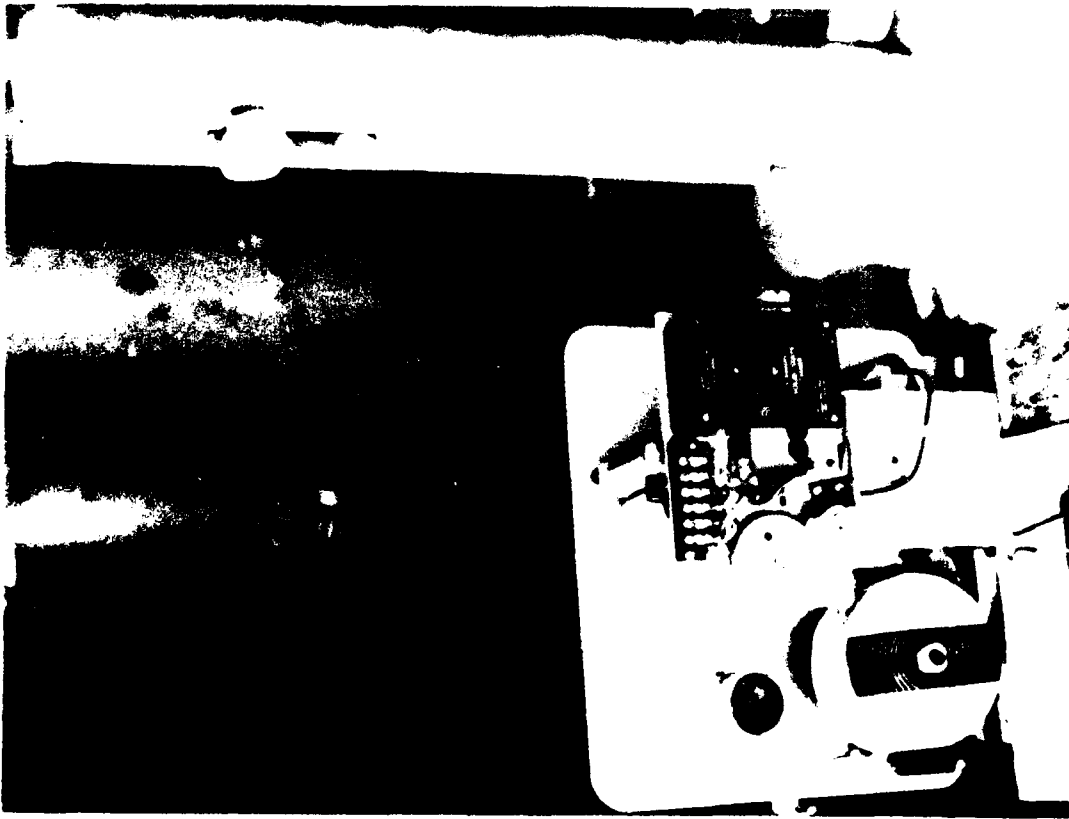

Figure 14. Leupold-Stevens tide gage.

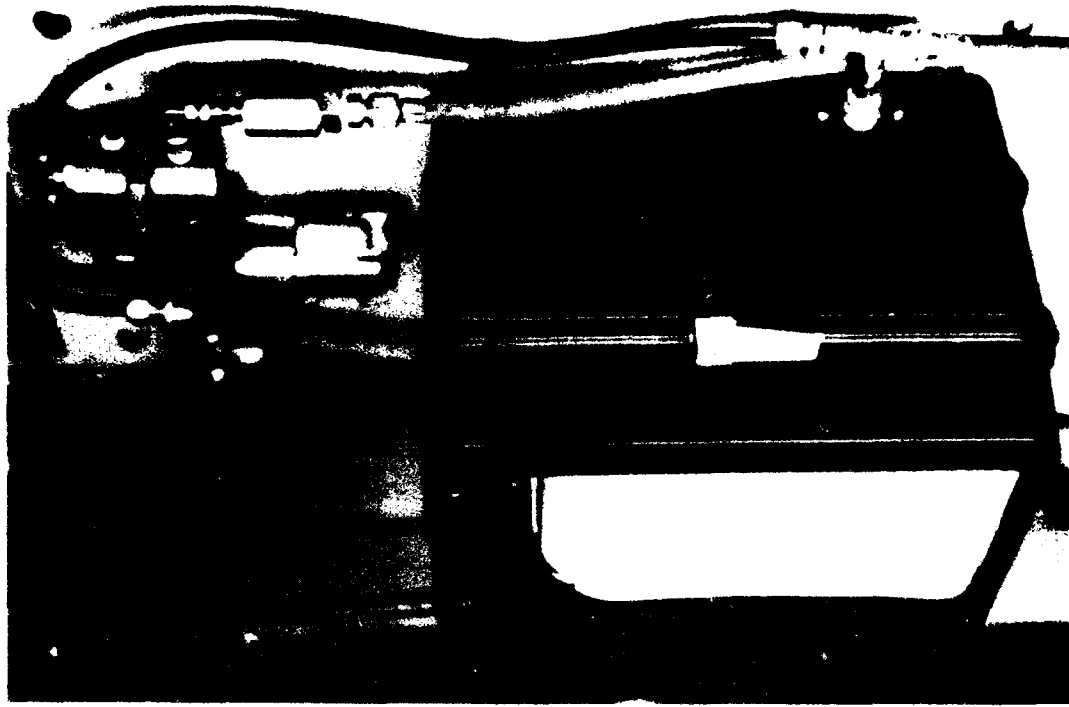

Figure 15. Bristol pressure tide gage.

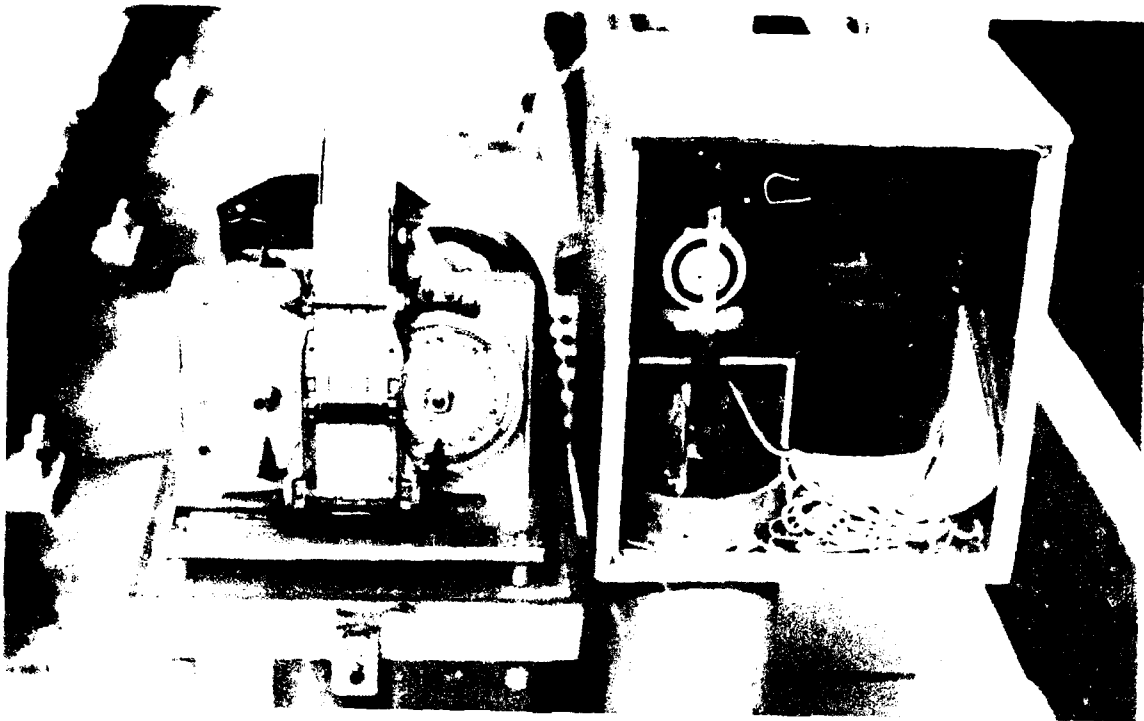

Figure 16. Fischer-Porter tide gage.

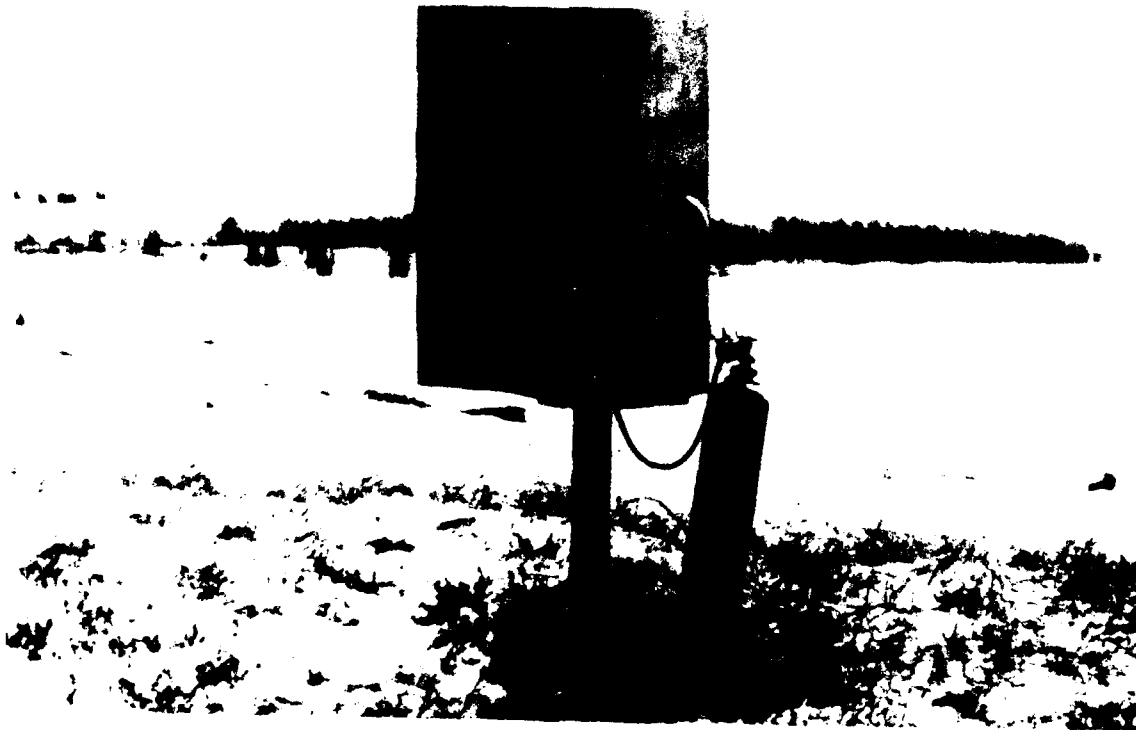

Figure 17. Metercraft pressure tide gage.

paper-tape record. The below-deck installations at stations 19+60 and 7+20 consist of 12-inch-diameter stilling wells with a 1-inch orifice and 0.5-inch orifice, respectively, and an 8.5-inch float (Fig. 18). The stilling well acts as a high-frequency filter to dampen the effects of waves, thereby giving accuracy to the measurements of water level fluctuations produced by the tide. The float, which responds to any variation in the water column within the stilling well, is coupled to a float-wire takeup drum and input shaft assembly via a stainless-steel wire. The angular position of the input shaft is recorded on paper tape every 6 minutes in a standard binary-decimal code.



Figure 18. Stilling well.

The Bristol and Metercraft pressure gages measure the hydrostatic pressure created by a column of water above a submerged orifice. The orifice and the recording instrument are linked by a nitrogen-filled, plastic supply line. Any change in the hydrostatic pressure, such as that caused by the rise and fall of the tide, is transmitted to the recorder where the pressure variations are recorded on a strip chart as changes in water depth.

To monitor tide gage operation and provide datum information, electric tape gages have been installed at stations 19+60 and 7+20 in lieu of a tide staff. The operating principle of the tape gage is based on the electrical conductivity of seawater. The gage consists of a stainless-steel tape on a takeup reel, 6-inch-diameter stilling well, voltmeter, and battery. The weighted tape, graduated to hundredths of a foot, completes an electrical circuit upon contact with the seawater inside the metal stilling well. The distance to the water level at that instant is measured below a reading mark on the tape. The reading mark



has a known elevation relative to tidal bench marks and the National Geodetic Vertical Control Network. The electric tape gage readings are compared with the automatically recorded tide record. Additional details on each gage may be obtained from the respective manufacturer.

## 2. Meteorological Instrumentation.

To monitor the meteorological conditions at the FRF, various equipment has been installed by the NWS and CERC. Figure 2 shows the location of the meteorological instruments. Although CERC is responsible for collecting the data, NWS provides guidance on installations and maintains the anemometer. In addition to any permanent records obtained from the devices with recording capabilities, each instrument is read daily (at approximately 0700 hours). Additional details on the instruments described below may be obtained from the respective manufacturer or from NWS.

a. Anemometer. A model F420C anemometer is used to measure wind speed and direction (Fig. 19). A cup rotor and a spread-tail wind vane were installed on a 21-foot-high tower about 65 feet from a temporary office trailer. The anemometer is coupled to wind speed and direction gages inside the trailer to monitor the onshore wind conditions (Fig. 20). The gages are manufactured by the Electric Speed Indicator Company, Cleveland, Ohio.



Figure 19. A model F420C anemometer used to measure wind speed and direction.

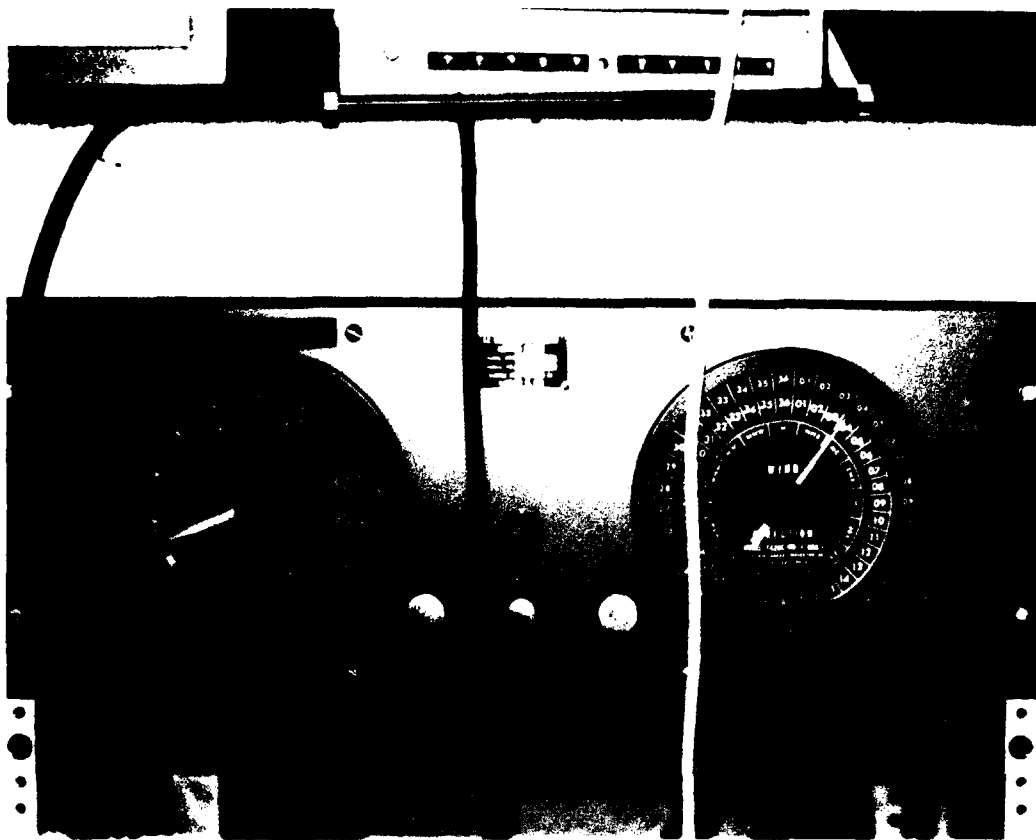

Figure 20. Wind speed and direction gages.

The accuracy of the speed transmitter and indicator assemblies is  $\pm 1$  knot from 2- to 100-knot winds and  $\pm 2$  knots for 100- to 200-knot winds at  $20^{\circ}$  to  $25^{\circ}$  Celsius. The wind-direction transmitter and indicator assemblies are accurate to  $\pm 5^{\circ}$  at an airspeed of 5 knots or greater for any horizontal direction at  $20^{\circ}$  to  $25^{\circ}$  Celsius.

The wind-direction transmitter assembly includes a direction transmitter body and a spread-tail wind vane. The transmitter body consists of a 12-volt (direct current) synchro transmitter coupled to the wind-vane shaft. The moment of inertia of the vane is approximately 583,000 gram-centimeters squared. The synchro transmitting element gives a minimum resistance to the electrical current when the vane is directed to due north and increases the resistance as the vane turns away from north. Two potentiometers are used to determine which direction the vane has turned with respect to north.

The windspeed transmitter includes a windspeed transmitter body and a cup rotor. A direct-current magneto is coupled to the cup rotor and provides a voltage-versus revolution-per-minute ratio of 0.004007 with an electrical load of 428.6 ohms. The terminal resistance of the magneto is 40 ohms  $\pm 1$  ohm; the moment of inertia of the cup rotor and magneto armature is 70,700 gram-centimeters squared (maximum). National Weather Service (1979) provides additional details on the wind measuring system. In late 1979, an analogue recorder was installed to provide continuous records of the wind speed and direction.

b. Microbarograph. This instrument, manufactured by the Belfort Instrument Company, Baltimore, Maryland, is located inside the building and is used to measure the atmospheric pressure and pressure tendency (Fig. 21). The device is an aneroid sensor which responds to pressure changes on the order of 0.005 inches of mercury. The pressure tendency can be determined from the chart record; i.e., the total change in pressure over a 3-hour period and the direction of change (increasing, decreasing, or some combination).



Figure 21. Microbarograph.

c. Barometer. A NWS barometer is also used for monitoring atmospheric pressure (Fig. 22). This device is an aneroid barometer with a 2-inch-diameter bimetallic wafer which expands or contracts with changes in pressure. The pressure (in inches) is read directly off the gage. Additional details on the barometer can be provided by the Basic Observations Branch, NWS.

d. Hygrothermograph. The hygrothermograph (Fig. 23) is located in an outdoor, ventilated instrument shelter (Fig. 24). This instrument, also manufactured by the Belfort Instrument Company, is used to measure and record both air temperature and relative humidity. The temperature sensor consists of a bimetal assembly made from two dissimilar metals which react to temperature changes at different rates. The recording styles (or pens) are driven by the expansion or contraction of the assembly. The relative humidity is sensed by

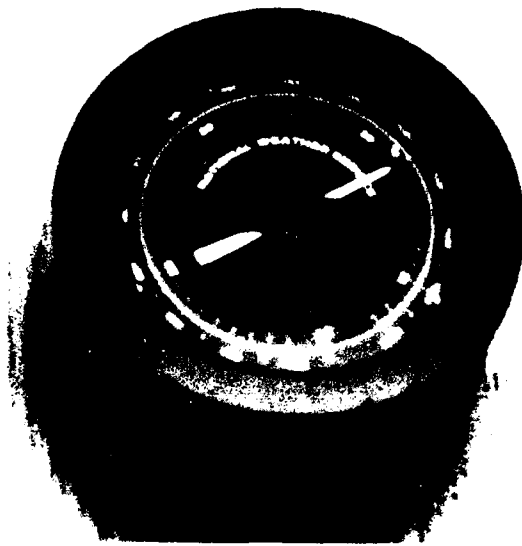

Figure 22. NWS barometer.



Figure 23. Hygrothermograph.



Figure 24. Wood shelter which houses the hygrothermograph.

a banjo-spread human hair element which expands when the humidity increases and contracts when it decreases, causing the second recording pen to deflect appropriately. In addition to the daily observations, a 7-day continuous chart record is produced.

e. Maximum and Minimum Thermometers. The NWS thermometers (housed in the instrument shelter) are used to determine the daily extreme temperatures (Fig. 24). A constriction in the capillary of the maximum thermometer prevents the mercury from flowing back into the bulb. The mercury is forced past the constriction as the temperature rises but does not return through it when the temperature falls, causing a thread of mercury to remain in the tube at the highest temperature reached. The thermometers are held in a special mounting device called a Townsend Support (see Fig. 23) which allows a reset of the thermometers without removal. The high temperature thermometer is reset by spinning it in the Townsend Support, thereby causing enough centrifugal force to force the mercury back through the constriction.

The minimum thermometer has a small, dark glass index in the thermometer bore which is pulled toward the bulb by the surface tension of the mercury meniscus as the temperature drops and remains stationary when the temperature rises. The thermometer is mounted horizontally except when the instrument is reset. Resetting is facilitated by the Townsend Support and consists of raising the bulb of the thermometer, thus causing the index to slide downward (toward higher temperatures) in the tube. The thermometers are read and reset once a day. Additional details on the thermometers can be provided by the Basic Observations Branch, NWS.

f. Twelve-Inch Weighing Rain Gage. This gage (manufactured by the Belfort Instrument Company, Baltimore, Maryland) is used to measure and record the daily amount of precipitation (Fig. 25), and is located near the instrument shelter (Fig. 2). The gage sensor consists of a 1-foot-high collection bucket (8 inches in diameter), a weighing mechanism connected to the recorder pen, and a chart drive for continuously recording the amount of precipitation. The weighing device is a spring scale connected through a lever mechanism to a pen that moves across the chart. The rain capacity is expressed in inches but is measured in terms of weight; i.e., 1 inch is 29.02 ounces at 62.56° Celsius. The manufacturer's specifications indicate that the instrument accuracy is 0 to 6 inches  $\pm 0.5$  percent ( $\pm 0.03$  inch of precipitation) and 6 to 12 inches  $\pm 1.0$  percent ( $\pm 0.06$  inch of precipitation). Daily observations of the total precipitation are recorded and the chart records are retained for future reference.



Figure. 25. Recording rain gage.

g. Six-Inch Plastic Rain Gage. The 6-inch rain gage (a True Check Rain Gage manufactured by the Edwards Manufacturing Company, Alberta Tea, Minnesota) (Fig. 26) is located about 25 feet from the 12-inch weighing rain gage (Fig. 2). The gage is simply a catch with a calibrated scale and is used as a check for the 12-inch weighing rain gage. Daily totals are recorded and the gage is manually (emptied) reset.



Figure 26. Six-inch plastic rain gage.

h. Sling Psychrometer. A sling psychrometer is used to measure relative humidity and to determine the dew point (Fig. 27). The psychrometer has two thermometers mounted in a frame which can be rotated rapidly. A moistened muslin wick is attached to the bulb of one of the thermometers and the device is whirled to ventilate both thermometers. The temperature is read from both the "wet" and the "dry" bulb thermometers and a set of tables is used to obtain the relative humidity and dew point values from the different temperatures. The dew point is recorded daily along with the other meteorological observations. Additional details on the sling psychrometer can be provided by the Basic Observations Branch, NWS.

i. Mechanical Pyranograph. This device, located on top of the weather instrument shelter and made by the Weather Measure Corporation, Sacramento, California, provides a continuous record of the intensity of the sun and sky radiation (Fig. 28). Two black and two white bimetallic strips are coupled together with the black strips attached through a linkage to the recording pen. As the radiation heats the black strips, the pen deflects. The white strips provide compensation for ambient temperature changes. The area under the curve on the chart record is a measure of the total radiation. The chart records are collected and stored without analysis.



Figure 27. Sling psychrometer.



Figure 28. Mechanical pyranograph.



### III. SAMPLING INFORMATION AND SUMMARY DESCRIPTIONS

#### 1. Digital Wave Data.

Routinely, four digital records per day at times near 0100, 0700, 1300, and 1900 e.s.t. are obtained from the CERC wave gages. Each record is 20 minutes long with a sample frequency of four data points per second. Thompson (1977) describes the method used to analyze the digital data records. Monthly summaries of significant wave height and peak spectral period are available for dissemination.

For the pressure-wave gage, the surface pressure record is attenuated with depth. In order for the pressure record sensed by the gage to reflect surface conditions, linear wave theory is used to compensate for the hydrodynamic attenuation; Esteva and Harris (1970) provide a discussion of the compensation technique used by CERC. These data are sampled at 4 hertz for a 20-minute period as are the other wave sensors.

The FRF wave data are summarized in the standard CERC monthly wave data summary format which consists of (a) a listing of the significant wave height and peak spectral wave period by day and time (Fig. 29), (b) a joint distribution of significant wave height versus peak spectral period (Fig. 30), and (c) a graph of the significant wave height and peak spectral period versus time (Fig. 31). When requested, the spectral energy distribution as a function of wave frequency can be printed or plotted (Fig. 32).

#### 2. Current Meter Data.

The current meter data are obtained as x and y components of velocity four times a day for 20 minutes at a frequency of four data points per second. The statistical package is designed to treat the data exactly like wave height information. Consequently, for each current component the mean of the data record, the standard deviation, and the spectral energy distribution are computed. The only summarization is in the form of Figure 29 where a listing of the mean current, standard deviation, and peak spectral period as a function of the day and time is generated.

#### 3. Conductivity and Temperature Data.

The conductivity and temperature gages are read once daily and the data are recorded as notes on the CERC Littoral Environmental Observation (LEO) forms for the pier end LEO site. The LEO visually observed data are summarized by computer after the data have been punched on cards. An analog recorder (installed in April 1980) is used for continuously recording the water conductivity and temperature.

#### 4. Monthly Tide Summaries.

The paper tapes and strip-chart records are sent to the NOS, Rockville, Maryland, where monthly tabulations of hourly tide heights and high and low water level summaries are prepared. Copies of the tabulated summaries are forwarded to CERC. Tidal datums at the FRF are computed by the NOS office. An example of the NOS hourly and high and low water summaries for 1 month of data is shown in Figure 33.

| DAY/TIME                                    | 0100   |        | 0700  |        | 1300  |        | 1900   |        |                                |
|---|--------|--------|-------|--------|-------|--------|--------|--------|--------------------------------|
|   | M(CM)  | T(SEC) | M(CM) | T(SEC) | M(CM) | T(SEC) | M(CM)  | T(SEC) |                                |
| 1   | 170.69 | 5.60   | 6.79  | 170.26 | 5.16  | 8.79   | 162.15 | 5.32   | 10.84                          |
| 2   | 91.44  | 3.00   | 10.84 | 76.81  | 2.52  | 10.84  | 95.10  | 3.12   | 10.84                          |
| 3   | 67.06  | 2.20   | 12.26 | 62.18  | 2.04  | 10.84  | 76.61  | 2.52   | 4.31                           |
| 4   | 60.96  | 5.01   | 5.01  | 95.10  | 3.12  | 5.01   |        |        |                                |
| 5   | 42.67  | 1.40   | 5.29  | 30.48  | 1.00  | 10.84  |        |        |                                |
| 6   | 52.43  | 1.72   | 6.38  | 40.23  | 1.52  | 5.61   | 47.55  | 1.56   | 6.85                           |
| 7   | 95.10  | 3.12   | 6.03  | 108.31 | 3.56  | 6.03   | 124.36 | 4.08   | 9.71                           |
| 8   | 178.00 | 5.84   | 4.79  | 220.68 | 7.24  | 12.26  | 114.60 | 3.76   | 10.84                          |
| 9   | 82.91  | 2.72   | 12.26 | 78.03  | 2.56  | 12.26  |        |        |                                |
| 10  | 60.47  | 2.64   | 4.75  | 151.18 | 4.96  | 6.38   |        |        |                                |
| 11  | 49.99  | 1.64   | 14.12 | 40.23  | 1.32  | 14.12  | 37.80  | 1.24   | 14.12                          |
| 12  | 49.99  | 1.44   | 12.26 | 60.47  | 2.64  | 3.95   | 121.92 | 4.00   | 8.03                           |
| 13  | 249.94 | 6.20   | 12.26 | 199.95 | 6.56  | 12.26  | 152.40 | 5.00   | 12.26                          |
| 14  | 113.39 | 3.72   | 10.84 | 129.24 | 4.24  | 10.84  | 151.18 | 4.96   | 10.84                          |
| 15  | 89.00  | 2.92   | 12.26 | 75.59  | 2.48  | 10.84  | 77.71  | 2.32   | 12.26                          |
| 16  | 58.52  | 1.92   | 10.84 | 64.92  | 2.12  | 12.26  | 91.44  | 3.00   | 4.75                           |
| 17  | 197.51 | 6.08   | 9.71  | 135.33 | 4.44  | 10.84  | 110.95 | 3.64   | 10.84                          |
| 18  | 153.62 | 5.04   | 4.75  | 106.51 | 5.56  | 5.01   | 170.99 | 5.60   | 9.71                           |
| 19  | 264.57 | 8.68   | 6.85  | 207.26 | 6.60  | 6.79   | 129.24 | 4.24   | 10.84                          |
| 20  | 132.99 | 4.36   | 9.71  | 74.37  | 2.44  | 9.71   | 74.37  | 2.44   | 10.84                          |
| 21  | 73.17  | 2.00   | 12.26 | 119.88 | 3.92  | 12.26  | 121.92 | 4.00   | 12.26                          |
| 22  | 75.54  | 2.48   | 12.26 | 76.03  | 2.56  | 12.26  | 93.88  | 3.08   | 12.26                          |
| 23  | 65.84  | 2.16   | 10.84 | 65.84  | 2.16  | 10.84  |        |        |                                |
| 24  | 53.64  | 1.76   | 9.71  | 57.40  | 1.68  | 9.71   | 85.34  | 2.80   | 9.71                           |
| 25  | 153.62 | 5.04   | 9.71  | 206.84 | 6.76  | 9.71   | 110.95 | 3.64   | 8.79                           |
| 26  | 82.91  | 2.72   | 10.84 | 60.96  | 2.00  | 9.71   | 93.88  | 3.08   | 10.84                          |
| 27  | 34.14  | 1.12   | 10.84 | 40.23  | 1.32  | 16.65  | 69.99  | 1.64   | 9.71                           |
| 28  | 65.34  | 2.80   | 5.01  | 78.03  | 2.56  | 5.97   | 49.99  | 1.64   | 7.39                           |
| 29  | 70.71  | 2.32   | 5.29  | 60.96  | 2.00  | 5.61   | 67.06  | 2.20   | 5.61                           |
| 30  | 69.49  | 2.28   | 6.38  |        |       |        | 40.22  | 2.96   | 5.97                           |
| 31  |        |        |       |        |       |        | 74.37  | 2.84   | 5.61                           |
| COL AVG                                     | 101.52 | 3.33   | 9.30  | 100.10 | 3.28  | 9.73   | 97.16  | 3.19   | 9.37                           |
| AVERAGE SIGNIFICANT WAVE HEIGHT = 3.23 FEET |        |        |       |        |       |        |        |        | AVERAGE WAVE PERIOD = 9.52 SEC |
|   |        |        |       |        |       |        |        |        | 112 OBSERVATIONS               |

Figure 29. Example of the CERC monthly wave data summary for significant wave heights and periods.

WAVE CLIMATE FOR 025 FRF, DUCK, NC FOR 1 MONTH - JAN 78  
 DISTRIBUTION OF SIGNIFICANT HEIGHT VS PERIOD ( IN OBSERVATIONS PER 1000 OBS )  
 FOR 112 OBSERVATIONS OF NON-CALM CONDITIONS - 0 OBSERVATIONS OF CALM CONDITIONS HAVE NOT BEEN INCLUDED

| PERIOD<br>(SECS) | SIGNIFICANT HEIGHT |       |      |      |       |      |      |       |      |      |       | TOTAL | ACC. RUN |       |       |      |
|------------------|--------------------|-------|------|------|-------|------|------|-------|------|------|-------|-------|----------|-------|-------|------|
|                  | 0=1                | 1=2   | 2=3  | 3=4  | 4=5   | 5=6  | 6=7  | 7=8   | 8=9  | 9=10 | 10=11 |       |          | 11=12 | 12=13 | 13+  |
| 0.0 - .9         |                    |       |      |      |       |      |      |       |      |      |       |       |          |       | 0.00  |      |
| 1.0 - 1.9        |                    |       |      |      |       |      |      |       |      |      |       |       |          |       | 0.00  |      |
| 2.0 - 2.9        |                    |       |      |      |       |      |      |       |      |      |       |       |          |       | 0.00  |      |
| 3.0 - 3.9        |                    |       |      |      |       |      |      |       |      |      |       |       |          |       | 0.00  |      |
| 4.0 - 4.9        |                    |       |      |      |       |      |      |       |      |      |       |       |          |       | 0.00  |      |
| 5.0 - 5.9        |                    |       |      |      |       |      |      |       |      |      |       |       |          |       | 0.00  |      |
| 6.0 - 6.9        |                    |       |      |      |       |      |      |       |      |      |       |       |          |       | 0.00  |      |
| 7.0 - 7.9        |                    |       |      |      |       |      |      |       |      |      |       |       |          |       | 0.00  |      |
| 8.0 - 8.9        |                    |       |      |      |       |      |      |       |      |      |       |       |          |       | 0.00  |      |
| 9.0 - 9.9        |                    |       |      |      |       |      |      |       |      |      |       |       |          |       | 0.00  |      |
| 10.0 - 10.9      |                    |       |      |      |       |      |      |       |      |      |       |       |          |       | 0.00  |      |
| 11.0 - 11.9      |                    |       |      |      |       |      |      |       |      |      |       |       |          |       | 0.00  |      |
| 12.0 - 12.9      |                    |       |      |      |       |      |      |       |      |      |       |       |          |       | 0.00  |      |
| 13.0 - 13.9      |                    |       |      |      |       |      |      |       |      |      |       |       |          |       | 0.00  |      |
| 14.0 - 14.9      |                    |       |      |      |       |      |      |       |      |      |       |       |          |       | 0.00  |      |
| 15.0 - 15.9      |                    |       |      |      |       |      |      |       |      |      |       |       |          |       | 0.00  |      |
| 16.0 - 16.9      |                    |       |      |      |       |      |      |       |      |      |       |       |          |       | 0.00  |      |
| 17.0 - 17.9      |                    |       |      |      |       |      |      |       |      |      |       |       |          |       | 0.00  |      |
| 18.0 - 18.9      |                    |       |      |      |       |      |      |       |      |      |       |       |          |       | 0.00  |      |
| 19.0 - 19.9      |                    |       |      |      |       |      |      |       |      |      |       |       |          |       | 0.00  |      |
| 20.0 - 20.9      |                    |       |      |      |       |      |      |       |      |      |       |       |          |       | 0.00  |      |
| 21.0 +           |                    |       |      |      |       |      |      |       |      |      |       |       |          |       | 0.00  |      |
| TOTAL            | 187                | 393   | 352  | 107  | 71    | 62   | 9    | 18    |      |      |       |       |          |       | 1000  | 3.29 |
| ACC. TOTAL       | 187                | 580   | 732  | 839  | 911   | 973  | 982  | 1000  | 1000 | 1000 | 1000  | 1000  | 1000     | 1000  | 1000  | 3.29 |
| COL. AVG.        | 0.00               | 10.21 | 8.95 | 9.74 | 10.04 | 9.00 | 9.07 | 12.50 | 9.50 | 0.00 | 0.00  | 0.00  | 0.00     | 0.00  | 0.00  | 9.48 |

AVERAGE SIGNIFICANT WAVE HEIGHT = 3.23 FT AVERAGE WAVE PERIOD = 9.52 SEC  
 VARIANCE OF SIGNIFICANT WAVE HEIGHT = 2.71 FT SU VARIANCE OF WAVE PERIOD = 8.12 SEC SU  
 STANDARD DEVIATION OF SIG. HEIGHT = 1.65 FT STANDARD DEVIATION OF PERIOD = 2.65 SEC  
 (FOR THE ABOVE 3 LINES, CALM IS COUNTED AS 0.0 FEET FOR WAVE HEIGHT AND IS OMITTED FOR WAVE PERIOD)

RECORD OBTAINED WITH A BAYLON STAFF wave gage located at station 19+00 (FRF pier).  
 DATA OBTAINED BY ANALYSIS OF A 1024-SECOND DIGITAL RECORD.

Figure 30. Example of the CERC monthly wave data summary for distribution of significant wave height versus period.

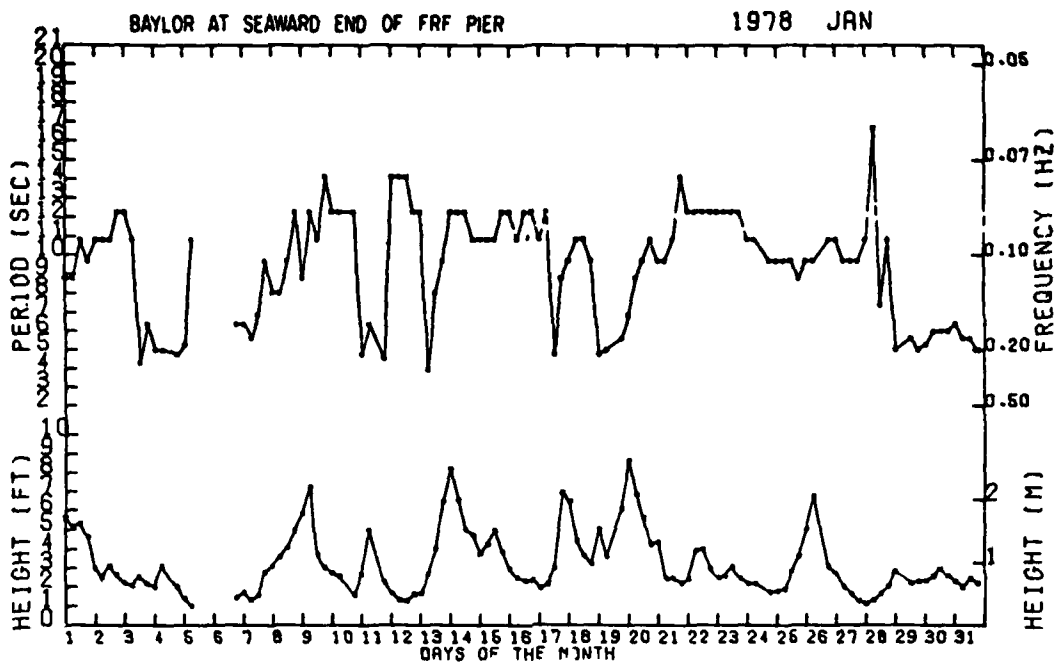

Figure 31. Example of graph showing significant wave height and period versus time.

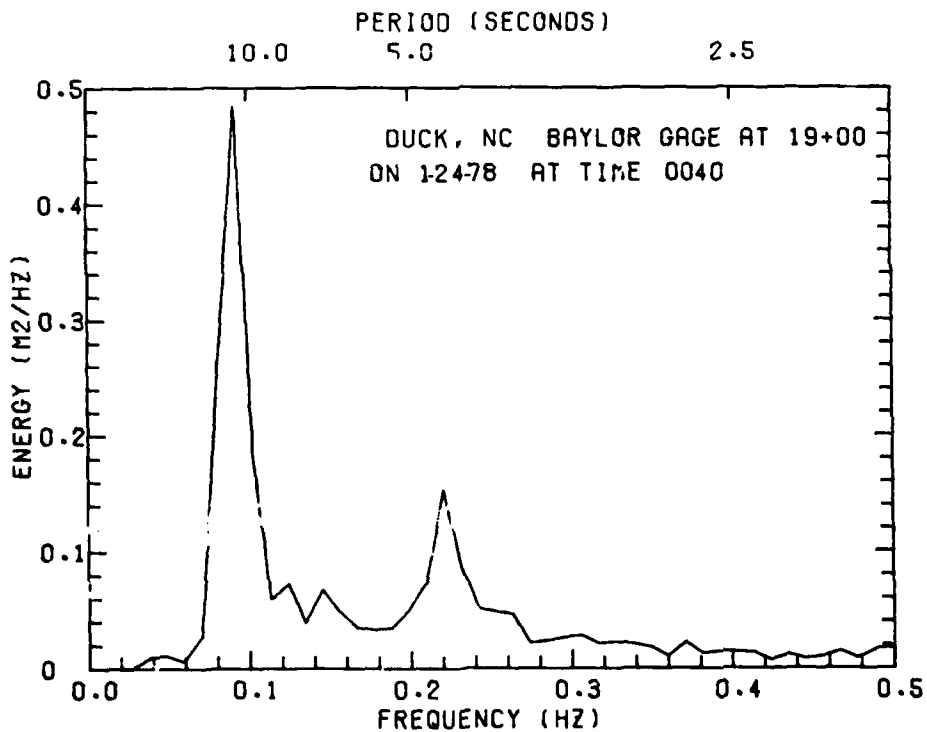

Figure 32. Example of spectrum plot.

NATIONAL OCEAN SURVEY (NOAA)  
TIDES, HIGH AND LOW WATERS (FEET)

0651370 DUCK PRF NC (OUTSIDE)

SEP 1974 TM 75M

0651370 DUCK PRF NC (OUTSIDE)

SEP 1974 TM 75M

| DAY | HIGH | TIME | LOW   | HIGH  | TIME | LOW  | DAY | HIGH  | TIME | LOW  | HIGH  | TIME  | LOW |
|-----|------|------|-------|-------|------|------|-----|-------|------|------|-------|-------|-----|
| 1   | 6.2  | 0.6  | 21.32 | 18.37 | 17.3 | 1.2  | 17  | 7.3   | 19.4 | 13.8 | 22.73 | 17.87 |     |
| 2   | 18.7 | 11.9 | 22.25 | 18.02 | 19.6 | 1.9  | 18  | 7.9   | 20.5 | 14.4 | 22.75 | 18.21 |     |
| 3   | 19.1 | 13.1 | 22.36 | 18.94 | 20.5 | 2.6  | 19  | 8.7   | 20.9 | 15.1 | 23.01 | 18.37 |     |
| 4   | 19.4 | 13.6 | 22.41 | 19.00 | 20.9 | 3.1  | 20  | 9.7   | 21.1 | 16.3 | 23.50 | 18.50 |     |
| 5   | 20.2 | 14.3 | 22.44 | 19.72 | 22.1 | 4.3  | 21  | 10.1  | 21.5 | 17.1 | 23.55 | 19.41 |     |
| 6   | 21.1 | 14.9 | 22.42 | 20.68 | 22.8 | 5.9  | 22  | 11.5  | 23.7 | 17.6 | 21.60 | 18.72 |     |
| 7   | 21.8 | 15.8 | 21.98 | 21.84 | 23.7 | 7.6  | 23  | 12.1  | 24.1 | 8.9  | 23.21 | 19.70 |     |
| 8   | 22.9 | 16.6 | 21.51 | 22.74 | 24.1 | 8.7  | 24  | 13.0  | 24.6 | 9.1  | 22.37 | 20.13 |     |
| 9   | 23.5 | 17.7 | 22.15 | 23.38 | 24.6 | 9.1  | 25  | 13.7  | 25.2 | 9.9  | 22.48 | 20.25 |     |
| 10  | 24.0 | 18.8 | 22.57 | 24.65 | 25.2 | 10.2 | 26  | 14.2  | 25.9 | 10.9 | 22.57 | 19.66 |     |
| 11  | 24.7 | 19.9 | 22.22 | 25.35 | 25.9 | 11.5 | 27  | 15.9  | 26.5 | 12.3 | 22.53 | 19.66 |     |
| 12  | 25.7 | 21.1 | 21.48 | 26.34 | 26.5 | 12.3 | 28  | 16.7  | 27.2 | 13.8 | 22.32 | 19.69 |     |
| 13  | 26.7 | 22.4 | 21.09 | 27.28 | 27.2 | 14.0 | 29  | 17.7  | 28.0 | 15.4 | 22.60 | 19.65 |     |
| 14  | 27.7 | 23.8 | 20.79 | 28.18 | 28.0 | 15.7 | 30  | 18.1  | 28.6 | 17.7 | 22.57 | 19.75 |     |
| 15  | 28.7 | 25.2 | 20.50 | 29.04 | 28.6 | 17.7 |     | 18.1  | 29.1 | 20.3 | 22.35 | 19.82 |     |
| 16  | 29.7 | 26.6 | 20.22 | 29.86 | 29.1 | 20.3 |     | 22.51 | 29.6 | 22.3 | 22.35 | 19.82 |     |
| 17  | 30.7 | 28.0 | 20.00 | 30.64 | 29.6 | 22.3 |     | 22.51 | 30.1 | 24.9 | 22.35 | 19.82 |     |
| 18  | 31.7 | 29.4 | 19.82 | 31.38 | 30.1 | 24.9 |     | 22.51 | 30.6 | 27.2 | 22.35 | 19.82 |     |
| 19  | 32.7 | 30.8 | 19.68 | 32.08 | 30.6 | 27.2 |     | 22.51 | 31.1 | 29.6 | 22.35 | 19.82 |     |
| 20  | 33.7 | 32.2 | 19.58 | 32.74 | 31.1 | 29.6 |     | 22.51 | 31.6 | 32.1 | 22.35 | 19.82 |     |
| 21  | 34.7 | 33.6 | 19.50 | 33.36 | 31.6 | 32.1 |     | 22.51 | 32.1 | 34.6 | 22.35 | 19.82 |     |
| 22  | 35.7 | 35.0 | 19.44 | 33.94 | 32.1 | 34.6 |     | 22.51 | 32.6 | 37.1 | 22.35 | 19.82 |     |
| 23  | 36.7 | 36.4 | 19.40 | 34.48 | 32.6 | 37.1 |     | 22.51 | 33.1 | 39.6 | 22.35 | 19.82 |     |
| 24  | 37.7 | 37.8 | 19.38 | 35.00 | 33.1 | 39.6 |     | 22.51 | 33.6 | 42.1 | 22.35 | 19.82 |     |
| 25  | 38.7 | 39.2 | 19.38 | 35.48 | 33.6 | 42.1 |     | 22.51 | 34.1 | 44.6 | 22.35 | 19.82 |     |
| 26  | 39.7 | 40.6 | 19.40 | 35.94 | 34.1 | 44.6 |     | 22.51 | 34.6 | 47.1 | 22.35 | 19.82 |     |
| 27  | 40.7 | 42.0 | 19.44 | 36.38 | 34.6 | 47.1 |     | 22.51 | 35.1 | 49.6 | 22.35 | 19.82 |     |
| 28  | 41.7 | 43.4 | 19.50 | 36.80 | 35.1 | 49.6 |     | 22.51 | 35.6 | 52.1 | 22.35 | 19.82 |     |
| 29  | 42.7 | 44.8 | 19.58 | 37.20 | 35.6 | 52.1 |     | 22.51 | 36.1 | 54.6 | 22.35 | 19.82 |     |
| 30  | 43.7 | 46.2 | 19.68 | 37.58 | 36.1 | 54.6 |     | 22.51 | 36.6 | 57.1 | 22.35 | 19.82 |     |
| 31  | 44.7 | 47.6 | 19.80 | 37.94 | 36.6 | 57.1 |     | 22.51 | 37.1 | 59.6 | 22.35 | 19.82 |     |

MHW 22.60 MLW 19.08 PSL 20.75 MN 3:32 PTL 20.74  
 MTL-HSL -0.01 MHM 22.58 PLLM 18.93 DMQ 0.18 DLQ 0.15  
 GT 3.65 (DRL)TL 20.75 (CRL)TL-HSL -0.00  
 GHWI 12.29 HRS GHLWI 6.18 HRS  
 HIGHEST TIDE 23.98 16.9 HRS SEP 13  
 LOWEST TIDE 17.87 1.2 HRS SEP 17 DATUM IS .....

74 M 30 ( 7/31 8 ) ( 9/ 1 15 ) 0.11 248.9 \* ( ) INFERRED  
 74 M 30 ( 9/ 1 20 ) ( 10/ 1 7 ) 0.14

NATIONAL OCEAN SURVEY (NOAA)  
TIDES, NEAPLY HEIGHTS (FEET)

0651370 DUCK PRF NC (OUTSIDE)

SEP 1974 TM 75M

| HOUR | 1     | 2     | 3     | 4     | 5     | 6     | 7     | 8     | 9     | 10    | 11    |
|------|-------|-------|-------|-------|-------|-------|-------|-------|-------|-------|-------|
| 0    | 18.49 | 19.21 | 19.40 | 19.78 | 20.30 | 20.88 | 21.25 | 21.21 | 21.64 | 22.09 | 21.73 |
| 1    | 18.54 | 19.03 | 18.95 | 18.91 | 19.42 | 19.97 | 20.37 | 20.56 | 21.59 | 22.08 | 21.91 |
| 2    | 18.82 | 19.29 | 19.02 | 18.70 | 18.54 | 19.23 | 19.55 | 19.90 | 21.05 | 21.71 | 21.95 |
| 3    | 19.39 | 19.73 | 19.44 | 19.02 | 18.87 | 18.87 | 18.88 | 19.21 | 20.31 | 21.07 | 21.76 |
| 4    | 20.27 | 20.56 | 20.09 | 19.44 | 18.16 | 18.95 | 18.62 | 18.79 | 19.50 | 20.44 | 21.22 |
| 5    | 20.99 | 21.23 | 20.76 | 20.15 | 18.77 | 19.61 | 18.77 | 18.71 | 19.11 | 19.78 | 20.45 |
| 6    | 21.29 | 21.95 | 21.70 | 21.18 | 20.67 | 20.03 | 19.34 | 18.93 | 19.07 | 19.43 | 19.75 |
| 7    | 21.24 | 22.28 | 22.27 | 22.04 | 21.60 | 21.03 | 20.01 | 19.64 | 19.27 | 19.39 | 19.34 |
| 8    | 21.17 | 22.11 | 22.30 | 22.34 | 22.18 | 21.88 | 20.84 | 20.36 | 19.72 | 19.59 | 19.17 |
| 9    | 20.40 | 21.62 | 21.98 | 22.34 | 22.32 | 22.22 | 21.78 | 21.33 | 20.59 | 20.16 | 19.31 |
| 10   | 19.83 | 20.88 | 21.37 | 21.77 | 22.05 | 22.19 | 22.08 | 22.16 | 21.66 | 20.83 | 19.86 |
| 11   | 19.14 | 20.00 | 20.41 | 21.00 | 21.55 | 21.88 | 21.92 | 22.38 | 22.32 | 21.78 | 20.67 |
| 12   | 18.62 | 19.33 | 19.72 | 20.30 | 20.65 | 21.22 | 21.49 | 22.31 | 22.49 | 22.30 | 21.56 |
| 13   | 18.82 | 19.03 | 19.16 | 19.53 | 19.87 | 20.35 | 20.79 | 21.96 | 22.54 | 22.54 | 22.16 |
| 14   | 19.29 | 19.18 | 19.08 | 19.14 | 19.24 | 19.58 | 20.06 | 21.30 | 22.17 | 22.40 | 22.52 |
| 15   | 19.97 | 19.65 | 19.39 | 19.20 | 18.94 | 19.02 | 19.21 | 20.53 | 21.45 | 22.05 | 22.20 |
| 16   | 20.74 | 20.38 | 20.05 | 19.67 | 19.19 | 18.99 | 18.89 | 19.91 | 20.67 | 21.50 | 21.82 |
| 17   | 21.61 | 21.36 | 20.83 | 20.24 | 19.59 | 19.25 | 18.79 | 19.53 | 20.10 | 20.60 | 21.17 |
| 18   | 22.05 | 22.04 | 21.71 | 21.19 | 20.24 | 19.72 | 19.02 | 19.38 | 19.82 | 20.00 | 20.19 |
| 19   | 22.19 | 22.34 | 22.38 | 21.98 | 21.26 | 20.38 | 19.45 | 19.81 | 19.68 | 19.57 | 19.37 |
| 20   | 21.91 | 22.28 | 22.41 | 22.41 | 21.83 | 21.27 | 20.22 | 20.36 | 19.93 | 19.47 | 18.82 |
| 21   | 21.35 | 21.81 | 22.14 | 22.28 | 22.12 | 21.83 | 20.95 | 20.99 | 20.53 | 19.74 | 18.66 |
| 22   | 20.60 | 21.05 | 21.53 | 21.88 | 22.03 | 21.96 | 21.38 | 21.68 | 21.23 | 20.32 | 18.84 |
| 23   | 19.88 | 20.26 | 20.74 | 21.17 | 21.66 | 21.71 | 21.55 | 22.02 | 21.86 | 21.14 | 19.45 |

Figure 33. Example of NOS tide summary.

NATIONAL OCEAN SURVEY (NOAA)  
TIDES, FLOWLY HEIGHTS (FEET)

SEP 1978 7M 75M

8651370 DUCK FRF NC (OUT:CEI)

DA / CF MONTH

| HOUR | 12    | 13    | 14    | 15    | 16    | 17    | 18    | 19    | 20    | 21    | 22    | 23    | 24    | 25    | 26    | 27    | 28    | 29    | 30    |
|------|-------|-------|-------|-------|-------|-------|-------|-------|-------|-------|-------|-------|-------|-------|-------|-------|-------|-------|-------|
| 0    | 20.26 | 19.32 | 20.13 | 19.76 | 18.29 | 18.38 | 19.33 | 20.13 | 21.87 | 21.57 | 21.36 | 21.34 | 22.27 | 21.50 | 20.81 | 20.62 | 20.06 | 19.83 | 19.42 |
| 1    | 20.90 | 20.16 | 20.74 | 19.27 | 18.19 | 17.97 | 18.52 | 19.01 | 20.67 | 20.87 | 20.91 | 21.13 | 22.30 | 21.67 | 21.36 | 21.15 | 20.50 | 20.18 | 19.55 |
| 2    | 21.39 | 21.05 | 21.74 | 19.55 | 18.71 | 18.17 | 18.31 | 18.47 | 20.12 | 20.05 | 20.23 | 21.04 | 22.11 | 21.77 | 21.83 | 21.72 | 21.19 | 21.00 | 20.21 |
| 3    | 21.47 | 21.60 | 22.65 | 21.16 | 19.73 | 18.88 | 18.72 | 18.38 | 19.77 | 19.37 | 19.54 | 20.57 | 21.73 | 21.60 | 21.70 | 22.13 | 21.73 | 21.74 | 20.90 |
| 4    | 21.19 | 21.79 | 23.24 | 22.11 | 20.59 | 19.87 | 19.27 | 18.67 | 19.83 | 19.11 | 18.85 | 20.07 | 21.12 | 21.22 | 21.55 | 22.12 | 22.02 | 22.20 | 21.64 |
| 5    | 20.72 | 21.59 | 23.33 | 22.26 | 22.62 | 21.20 | 20.39 | 19.43 | 20.20 | 19.20 | 18.70 | 19.69 | 20.56 | 20.66 | 21.43 | 21.89 | 21.99 | 22.51 | 22.18 |
| 6    | 20.00 | 21.07 | 23.11 | 22.89 | 22.45 | 22.29 | 21.64 | 20.53 | 20.67 | 19.57 | 18.65 | 20.08 | 20.20 | 20.15 | 20.99 | 21.63 | 21.82 | 22.49 | 22.39 |
| 7    | 19.21 | 20.25 | 22.30 | 22.50 | 22.70 | 22.70 | 22.47 | 21.69 | 21.56 | 20.34 | 19.34 | 20.22 | 20.13 | 19.82 | 20.44 | 20.86 | 21.28 | 22.03 | 22.22 |
| 8    | 18.69 | 19.49 | 21.42 | 21.71 | 22.30 | 22.57 | 22.72 | 22.49 | 22.87 | 21.18 | 20.02 | 20.80 | 20.28 | 19.69 | 20.10 | 20.22 | 20.63 | 21.46 | 21.60 |
| 9    | 18.41 | 18.92 | 20.26 | 20.55 | 21.39 | 22.07 | 22.52 | 22.54 | 23.40 | 22.05 | 20.73 | 21.51 | 20.64 | 19.83 | 20.04 | 19.69 | 20.02 | 20.78 | 20.89 |
| 10   | 18.73 | 18.95 | 19.45 | 19.51 | 20.25 | 21.22 | 21.99 | 22.36 | 23.50 | 22.48 | 21.57 | 22.33 | 21.23 | 20.29 | 20.30 | 19.81 | 19.71 | 20.10 | 20.06 |
| 11   | 19.34 | 19.25 | 19.09 | 18.70 | 18.15 | 20.06 | 21.07 | 21.79 | 23.24 | 22.36 | 21.77 | 22.84 | 21.94 | 20.81 | 20.70 | 20.05 | 19.63 | 19.73 | 19.46 |
| 12   | 20.23 | 19.89 | 19.47 | 18.39 | 18.33 | 18.95 | 19.89 | 20.98 | 22.45 | 22.02 | 21.70 | 23.22 | 22.30 | 21.35 | 21.17 | 20.50 | 19.95 | 19.71 | 19.24 |
| 13   | 21.18 | 21.05 | 20.12 | 18.67 | 18.19 | 18.33 | 18.81 | 19.82 | 21.51 | 21.45 | 21.35 | 23.05 | 22.48 | 21.83 | 21.82 | 21.00 | 20.47 | 20.15 | 19.39 |
| 14   | 21.87 | 22.32 | 20.91 | 19.37 | 18.51 | 18.30 | 18.35 | 18.95 | 20.39 | 20.66 | 20.74 | 22.80 | 22.33 | 22.00 | 22.25 | 21.63 | 21.12 | 20.73 | 19.94 |
| 15   | 22.19 | 23.28 | 22.06 | 20.48 | 19.30 | 18.59 | 18.40 | 18.78 | 19.64 | 19.81 | 20.13 | 22.29 | 22.08 | 21.97 | 22.48 | 22.11 | 21.81 | 21.47 | 20.73 |
| 16   | 22.12 | 23.85 | 23.06 | 21.87 | 20.50 | 19.48 | 18.93 | 18.84 | 19.45 | 19.27 | 19.37 | 21.68 | 21.59 | 21.80 | 22.39 | 22.33 | 22.23 | 22.17 | 21.61 |
| 17   | 21.71 | 23.99 | 23.47 | 22.62 | 21.80 | 20.77 | 19.68 | 19.66 | 19.47 | 19.10 | 18.96 | 21.08 | 21.06 | 21.29 | 22.10 | 22.16 | 22.29 | 22.52 | 22.12 |
| 18   | 20.96 | 23.75 | 23.42 | 23.02 | 22.61 | 21.84 | 20.87 | 20.53 | 19.81 | 19.22 | 18.90 | 20.69 | 20.52 | 20.74 | 21.64 | 21.24 | 22.09 | 22.56 | 22.30 |
| 19   | 20.01 | 23.02 | 22.84 | 22.76 | 22.85 | 22.61 | 21.90 | 21.69 | 20.56 | 19.62 | 19.05 | 20.63 | 20.10 | 20.14 | 20.91 | 21.25 | 21.58 | 22.22 | 22.39 |
| 20   | 19.04 | 21.82 | 21.75 | 22.16 | 22.55 | 22.64 | 22.37 | 22.61 | 21.46 | 20.33 | 19.57 | 20.66 | 19.94 | 19.71 | 20.34 | 20.48 | 20.90 | 21.56 | 21.84 |
| 21   | 18.43 | 20.88 | 20.70 | 21.05 | 21.82 | 22.34 | 22.34 | 23.01 | 22.14 | 21.08 | 20.07 | 21.02 | 20.16 | 19.69 | 20.05 | 19.54 | 20.28 | 20.80 | 21.13 |
| 22   | 18.33 | 20.32 | 19.62 | 19.83 | 20.43 | 21.61 | 21.88 | 22.77 | 22.22 | 21.61 | 20.83 | 21.49 | 20.48 | 19.87 | 20.07 | 19.68 | 19.92 | 20.02 | 20.41 |
| 23   | 18.71 | 19.99 | 18.93 | 18.78 | 19.61 | 20.50 | 21.25 | 22.49 | 22.14 | 21.72 | 21.47 | 21.98 | 20.96 | 20.32 | 20.25 | 19.77 | 19.76 | 19.45 | 19.35 |

DATUM IS ..... MSL 20.75 1994.74

Figure 33. Example of NOS tide summary.--Continued

#### 5. Meteorological Observations.

The meteorological instruments are read daily and the data are recorded on CERC Form 78-236 (Fig. 34). Daily monitoring of the instruments facilitates rapid identification of problems with the equipment as well as obtaining climatological information. An example of the daily meteorological observation summaries for 1 month of data from the FRF is shown in Figure 35.

#### IV. DATA REQUESTS

The Coastal Engineering Information and Analysis Center (CEIAC) is responsible for storing and disseminating most data collected at the FRF under the BEM. All data requests should be in writing and addressed to: Coastal Engineering Research Center, Corps of Engineers, Kingman Building, Fort Belvoir, Virginia 22060. Tidal data other than summaries should be obtained directly from the Tides Branch, National Ocean Survey, Rockville, Maryland 20850. A complete explanation of the exact data desired for specific dates or times will expedite filling any request. The request should also explain how the data will be used to help determine if other relevant data are available. For information regarding the availability of data, contact CEIAC at (202) 325-7386. Costs for collecting, copying, and mailing will be borne by the requestor.

| OBSERVER |   | TITLE<br>WEATHER OBSERVATIONS AT THE FRF<br>DUCK, N.C. |   |   |   |   |   |   |   |   |   |   |   |   |   |   | PROGRAMMER |   |   |   |   | DATE | SHEET<br>-- OF -- |   |   |   |   |   |   |   |   |   |   |   |             |   |         |   |
|----------|---|--|---|---|---|---|---|---|---|---|---|---|---|---|---|---|------------|---|---|---|---|------|-------------------|---|---|---|---|---|---|---|---|---|---|---|-------------|---|---------|---|
| Y        | R | D  | M | N | S | V | W | E | N | I | I | P | D | H | P | T | D          | W | W | W | W | W    | S                 | K | R | A | M | T | P | R | S | C | O | O | TASK NUMBER |   | REMARKS |   |
|          |   |  |   |   |   |   |   |   |   |   |   |   |   |   |   |   |            |   |   |   |   |      |                   |   |   |   |   |   |   |   |   |   |   |   | 1           | 2 | 1       | 2 |
| 1        | 8 | 1  | 0 | 1 | 0 | 1 | 0 | 1 | 0 | 1 | 0 | 1 | 0 | 1 | 0 | 1 | 0          | 1 | 0 | 1 | 0 | 1    | 0                 | 1 | 0 | 1 | 0 | 1 | 0 | 1 | 0 | 1 | 0 | 1 | 0           | 1 | 0       |   |
| 2        | 8 | 1  | 0 | 1 | 0 | 1 | 0 | 1 | 0 | 1 | 0 | 1 | 0 | 1 | 0 | 1 | 0          | 1 | 0 | 1 | 0 | 1    | 0                 | 1 | 0 | 1 | 0 | 1 | 0 | 1 | 0 | 1 | 0 | 1 | 0           | 1 | 0       |   |
| 3        | 8 | 1  | 0 | 1 | 0 | 1 | 0 | 1 | 0 | 1 | 0 | 1 | 0 | 1 | 0 | 1 | 0          | 1 | 0 | 1 | 0 | 1    | 0                 | 1 | 0 | 1 | 0 | 1 | 0 | 1 | 0 | 1 | 0 | 1 | 0           | 1 | 0       |   |
| 4        | 8 | 1  | 0 | 1 | 0 | 1 | 0 | 1 | 0 | 1 | 0 | 1 | 0 | 1 | 0 | 1 | 0          | 1 | 0 | 1 | 0 | 1    | 0                 | 1 | 0 | 1 | 0 | 1 | 0 | 1 | 0 | 1 | 0 | 1 | 0           | 1 | 0       |   |
| 5        | 8 | 1  | 0 | 1 | 0 | 1 | 0 | 1 | 0 | 1 | 0 | 1 | 0 | 1 | 0 | 1 | 0          | 1 | 0 | 1 | 0 | 1    | 0                 | 1 | 0 | 1 | 0 | 1 | 0 | 1 | 0 | 1 | 0 | 1 | 0           | 1 | 0       |   |
| 6        | 8 | 1  | 0 | 1 | 0 | 1 | 0 | 1 | 0 | 1 | 0 | 1 | 0 | 1 | 0 | 1 | 0          | 1 | 0 | 1 | 0 | 1    | 0                 | 1 | 0 | 1 | 0 | 1 | 0 | 1 | 0 | 1 | 0 | 1 | 0           | 1 | 0       |   |
| 7        | 8 | 1  | 0 | 1 | 0 | 1 | 0 | 1 | 0 | 1 | 0 | 1 | 0 | 1 | 0 | 1 | 0          | 1 | 0 | 1 | 0 | 1    | 0                 | 1 | 0 | 1 | 0 | 1 | 0 | 1 | 0 | 1 | 0 | 1 | 0           | 1 | 0       |   |
| 8        | 8 | 1  | 0 | 1 | 0 | 1 | 0 | 1 | 0 | 1 | 0 | 1 | 0 | 1 | 0 | 1 | 0          | 1 | 0 | 1 | 0 | 1    | 0                 | 1 | 0 | 1 | 0 | 1 | 0 | 1 | 0 | 1 | 0 | 1 | 0           | 1 | 0       |   |
| 9        | 8 | 1  | 0 | 1 | 0 | 1 | 0 | 1 | 0 | 1 | 0 | 1 | 0 | 1 | 0 | 1 | 0          | 1 | 0 | 1 | 0 | 1    | 0                 | 1 | 0 | 1 | 0 | 1 | 0 | 1 | 0 | 1 | 0 | 1 | 0           | 1 | 0       |   |
| 10       | 8 | 1  | 0 | 1 | 0 | 1 | 0 | 1 | 0 | 1 | 0 | 1 | 0 | 1 | 0 | 1 | 0          | 1 | 0 | 1 | 0 | 1    | 0                 | 1 | 0 | 1 | 0 | 1 | 0 | 1 | 0 | 1 | 0 | 1 | 0           | 1 | 0       |   |
| 11       | 8 | 1  | 0 | 1 | 0 | 1 | 0 | 1 | 0 | 1 | 0 | 1 | 0 | 1 | 0 | 1 | 0          | 1 | 0 | 1 | 0 | 1    | 0                 | 1 | 0 | 1 | 0 | 1 | 0 | 1 | 0 | 1 | 0 | 1 | 0           | 1 | 0       |   |
| 12       | 8 | 1  | 0 | 1 | 0 | 1 | 0 | 1 | 0 | 1 | 0 | 1 | 0 | 1 | 0 | 1 | 0          | 1 | 0 | 1 | 0 | 1    | 0                 | 1 | 0 | 1 | 0 | 1 | 0 | 1 | 0 | 1 | 0 | 1 | 0           | 1 | 0       |   |
| 13       | 8 | 1  | 0 | 1 | 0 | 1 | 0 | 1 | 0 | 1 | 0 | 1 | 0 | 1 | 0 | 1 | 0          | 1 | 0 | 1 | 0 | 1    | 0                 | 1 | 0 | 1 | 0 | 1 | 0 | 1 | 0 | 1 | 0 | 1 | 0           | 1 | 0       |   |
| 14       | 8 | 1  | 0 | 1 | 0 | 1 | 0 | 1 | 0 | 1 | 0 | 1 | 0 | 1 | 0 | 1 | 0          | 1 | 0 | 1 | 0 | 1    | 0                 | 1 | 0 | 1 | 0 | 1 | 0 | 1 | 0 | 1 | 0 | 1 | 0           | 1 | 0       |   |
| 15       | 8 | 1  | 0 | 1 | 0 | 1 | 0 | 1 | 0 | 1 | 0 | 1 | 0 | 1 | 0 | 1 | 0          | 1 | 0 | 1 | 0 | 1    | 0                 | 1 | 0 | 1 | 0 | 1 | 0 | 1 | 0 | 1 | 0 | 1 | 0           | 1 | 0       |   |
| 16       | 8 | 1  | 0 | 1 | 0 | 1 | 0 | 1 | 0 | 1 | 0 | 1 | 0 | 1 | 0 | 1 | 0          | 1 | 0 | 1 | 0 | 1    | 0                 | 1 | 0 | 1 | 0 | 1 | 0 | 1 | 0 | 1 | 0 | 1 | 0           | 1 | 0       |   |
| 17       | 8 | 1  | 0 | 1 | 0 | 1 | 0 | 1 | 0 | 1 | 0 | 1 | 0 | 1 | 0 | 1 | 0          | 1 | 0 | 1 | 0 | 1    | 0                 | 1 | 0 | 1 | 0 | 1 | 0 | 1 | 0 | 1 | 0 | 1 | 0           | 1 | 0       |   |
| 18       | 8 | 1  | 0 | 1 | 0 | 1 | 0 | 1 | 0 | 1 | 0 | 1 | 0 | 1 | 0 | 1 | 0          | 1 | 0 | 1 | 0 | 1    | 0                 | 1 | 0 | 1 | 0 | 1 | 0 | 1 | 0 | 1 | 0 | 1 | 0           | 1 | 0       |   |
| 19       | 8 | 1  | 0 | 1 | 0 | 1 | 0 | 1 | 0 | 1 | 0 | 1 | 0 | 1 | 0 | 1 | 0          | 1 | 0 | 1 | 0 | 1    | 0                 | 1 | 0 | 1 | 0 | 1 | 0 | 1 | 0 | 1 | 0 | 1 | 0           | 1 | 0       |   |
| 20       | 8 | 1  | 0 | 1 | 0 | 1 | 0 | 1 | 0 | 1 | 0 | 1 | 0 | 1 | 0 | 1 | 0          | 1 | 0 | 1 | 0 | 1    | 0                 | 1 | 0 | 1 | 0 | 1 | 0 | 1 | 0 | 1 | 0 | 1 | 0           | 1 | 0       |   |
| 21       | 8 | 1  | 0 | 1 | 0 | 1 | 0 | 1 | 0 | 1 | 0 | 1 | 0 | 1 | 0 | 1 | 0          | 1 | 0 | 1 | 0 | 1    | 0                 | 1 | 0 | 1 | 0 | 1 | 0 | 1 | 0 | 1 | 0 | 1 | 0           | 1 | 0       |   |
| 22       | 8 | 1  | 0 | 1 | 0 | 1 | 0 | 1 | 0 | 1 | 0 | 1 | 0 | 1 | 0 | 1 | 0          | 1 | 0 | 1 | 0 | 1    | 0                 | 1 | 0 | 1 | 0 | 1 | 0 | 1 | 0 | 1 | 0 | 1 | 0           | 1 | 0       |   |
| 23       | 8 | 1  | 0 | 1 | 0 | 1 | 0 | 1 | 0 | 1 | 0 | 1 | 0 | 1 | 0 | 1 | 0          | 1 | 0 | 1 | 0 | 1    | 0                 | 1 | 0 | 1 | 0 | 1 | 0 | 1 | 0 | 1 | 0 | 1 | 0           | 1 | 0       |   |
| 24       | 8 | 1  | 0 | 1 | 0 | 1 | 0 | 1 | 0 | 1 | 0 | 1 | 0 | 1 | 0 | 1 | 0          | 1 | 0 | 1 | 0 | 1    | 0                 | 1 | 0 | 1 | 0 | 1 | 0 | 1 | 0 | 1 | 0 | 1 | 0           | 1 | 0       |   |
| 25       | 8 | 1  | 0 | 1 | 0 | 1 | 0 | 1 | 0 | 1 | 0 | 1 | 0 | 1 | 0 | 1 | 0          | 1 | 0 | 1 | 0 | 1    | 0                 | 1 | 0 | 1 | 0 | 1 | 0 | 1 | 0 | 1 | 0 | 1 | 0           | 1 | 0       |   |
| 26       | 8 | 1  | 0 | 1 | 0 | 1 | 0 | 1 | 0 | 1 | 0 | 1 | 0 | 1 | 0 | 1 | 0          | 1 | 0 | 1 | 0 | 1    | 0                 | 1 | 0 | 1 | 0 | 1 | 0 | 1 | 0 | 1 | 0 | 1 | 0           | 1 | 0       |   |
| 27       | 8 | 1  | 0 | 1 | 0 | 1 | 0 | 1 | 0 | 1 | 0 | 1 | 0 | 1 | 0 | 1 | 0          | 1 | 0 | 1 | 0 | 1    | 0                 | 1 | 0 | 1 | 0 | 1 | 0 | 1 | 0 | 1 | 0 | 1 | 0           | 1 | 0       |   |
| 28       | 8 | 1  | 0 | 1 | 0 | 1 | 0 | 1 | 0 | 1 | 0 | 1 | 0 | 1 | 0 | 1 | 0          | 1 | 0 | 1 | 0 | 1    | 0                 | 1 | 0 | 1 | 0 | 1 | 0 | 1 | 0 | 1 | 0 | 1 | 0           | 1 | 0       |   |
| 29       | 8 | 1  | 0 | 1 | 0 | 1 | 0 | 1 | 0 | 1 | 0 | 1 | 0 | 1 | 0 | 1 | 0          | 1 | 0 | 1 | 0 | 1    | 0                 | 1 | 0 | 1 | 0 | 1 | 0 | 1 | 0 | 1 | 0 | 1 | 0           | 1 | 0       |   |
| 30       | 8 | 1  | 0 | 1 | 0 | 1 | 0 | 1 | 0 | 1 | 0 | 1 | 0 | 1 | 0 | 1 | 0          | 1 | 0 | 1 | 0 | 1    | 0                 | 1 | 0 | 1 | 0 | 1 | 0 | 1 | 0 | 1 | 0 | 1 | 0           | 1 | 0       |   |

CERC Form 235-79  
5/75-79

Figure 34. Example of meteorological observations recorded on CERC Form 78-236.



Daily meteorological observations at the Field Research Facility, Duck, N.C.

| MONTH 11 |      | YEAR 74 |   |
|----------|------|---------|---|
| 01       | 7300 | 0       | 0 |
| 02       | 7300 | 0       | 0 |
| 03       | 7300 | 0       | 0 |
| 04       | 7300 | 0       | 0 |
| 05       | 7300 | 0       | 0 |
| 06       | 7300 | 0       | 0 |
| 07       | 7300 | 0       | 0 |
| 08       | 7300 | 0       | 0 |
| 09       | 7300 | 0       | 0 |
| 10       | 7300 | 0       | 0 |
| 11       | 7300 | 0       | 0 |
| 12       | 7300 | 0       | 0 |
| 13       | 7300 | 0       | 0 |
| 14       | 7300 | 0       | 0 |
| 15       | 7300 | 0       | 0 |
| 16       | 7300 | 0       | 0 |
| 17       | 7300 | 0       | 0 |
| 18       | 7300 | 0       | 0 |
| 19       | 7300 | 0       | 0 |
| 20       | 7300 | 0       | 0 |
| 21       | 7300 | 0       | 0 |
| 22       | 7300 | 0       | 0 |
| 23       | 7300 | 0       | 0 |
| 24       | 7300 | 0       | 0 |
| 25       | 7300 | 0       | 0 |
| 26       | 7300 | 0       | 0 |
| 27       | 7300 | 0       | 0 |
| 28       | 7300 | 0       | 0 |
| 29       | 7300 | 0       | 0 |
| 30       | 7300 | 0       | 0 |

| WEATHER CONDITIONS | KEYNOTES ON WEATHER OBSERVATIONS |
|--------------------|----------------------------------|
| 00                 | 00 = CLOUD                       |
| 01                 | 01 = COVER VISIB                 |
| 02                 | 02 = WATER SPOUT                 |
| 03                 | 03 = THUNDERSTORM                |
| 04                 | 04 = FREEZING DRIZZLE            |
| 05                 | 05 = FOG                         |
| 06                 | 06 = SMOG                        |
| 07                 | 07 = HAIL                        |
| 08                 | 08 = SNOW                        |
| 09                 | 09 = RAIN                        |
| 10                 | 10 = DRIZZLE                     |
| 11                 | 11 = HAZE OR SMOKE               |
| 12                 | 12 = INTENSITY OF                |
| 13                 | 13 = WEATHER CONDITIONS          |
| 14                 | 14 = (C) UNUSUALLY INTERESTING   |
| 15                 | 15 = (C) MILD CONDITIONS         |
| 16                 | 16 = (C) UNUSUALLY INTERESTING   |
| 17                 | 17 = (C) MILD CONDITIONS         |
| 18                 | 18 = (C) UNUSUALLY INTERESTING   |
| 19                 | 19 = (C) MILD CONDITIONS         |
| 20                 | 20 = (C) UNUSUALLY INTERESTING   |
| 21                 | 21 = (C) MILD CONDITIONS         |
| 22                 | 22 = (C) UNUSUALLY INTERESTING   |
| 23                 | 23 = (C) MILD CONDITIONS         |
| 24                 | 24 = (C) UNUSUALLY INTERESTING   |
| 25                 | 25 = (C) MILD CONDITIONS         |
| 26                 | 26 = (C) UNUSUALLY INTERESTING   |
| 27                 | 27 = (C) MILD CONDITIONS         |
| 28                 | 28 = (C) UNUSUALLY INTERESTING   |
| 29                 | 29 = (C) MILD CONDITIONS         |
| 30                 | 30 = (C) UNUSUALLY INTERESTING   |

Figure 35. Example of daily meteorological observation summaries.

LITERATURE CITED

- BAYLOR COMPANY, "Handbook HB-13528," Houston, Tex., Mar. 1970.
- ESTEVA, E., and HARRIS, D.L., "Comparison of Pressure and Staff Wave Gage Records," *Proceedings of the 12th Coastal Engineering Conference*, American Society of Civil Engineers, Ch. 7, 1970, pp. 101-115 (also Reprint 2-71, U.S. Army, Corps of Engineers, Coastal Engineering Research Center, Washington, D.C., NTIS 732 637).
- GARNER, W., Jr., "Four-Electrode Conductivity Measurements," Hydrolab Technical Note 1, Austin, Tex., Dec. 1972.
- MARSH-McBIRNEY, INCORPORATED, "Model 551 Electromagnetic Water Current Meter," TWX No. 710-828-0083, Gaithersburg, Md., 1978.
- THOMPSON, E.F., "Wave Climate at Selected Locations Along U.S. Coasts," TR 77-1, U.S. Army, Corps of Engineers, Coastal Engineering Research Center, Fort Belvoir, Va., Jan 1977.
- NATIONAL WEATHER SERVICE, "Specification No. F420C-SP001, Wind Measuring System," Silver Spring, Md., Sept. 1970.
- VAN BREUGEL, J.G.A., VERHAGEN, C.M., and GERRITZEN, P.L., "Operation and Service Manual for Waverider," Haarlem, Netherlands, 1972.

APPENDIX  
INSTRUMENT INSTALLATION CHART

| Sensor No.                               | Sensor type                               | Data type                             | Location  | Medium depth (MSL) at sensor (ft) | Sensor range (ft) | Initial installation (date) |
|--|---|---------------------------------------|---|-----------------------------------|-------------------|-----------------------------|
| 615                                      | Baylor staff continuous wire              | Wave                                  | Station 620 FRF pier                                | 7.5                               | 28                | 23 Nov. 1977                |
| 625                                      | Baylor staff continuous wire              | Wave                                  | Station 1900 FRF pier                               | 27                                | 31                | 11 Nov. 1977                |
| 112                                      | Baylor staff continuous wire              | Wave                                  | Jennette's Fishing Pier, Nags Head, N.C.            | 17                                | 25                | Nov. 1977                   |
| 610                                      | Waverider buoy                            | Wave                                  | 350 ft NE. of seaward end of FRF pier               | 23                                | 32                | 25 July 1978                |
| 620                                      | Waverider buoy                            | Wave                                  | 1.3 mi. E. of seaward end of FRF pier               | 60                                | 32                | 25 July 1978                |
| 611                                      | Pressure gage                             | Wave                                  | Station 1940 FRF pier                               | 27                                | 25                | 23 Nov. 1977                |
| 619, 629 (channels X and Y respectively) | Electromagnetic current meter             | Mean and wave-induced bottom currents | Station 1940 FRF pier                               | 27                                | ±10 ft/s          | 19 Nov. 1977                |
| 639, 649 (channels X and Y respectively) | Electromagnetic current meter             | Mean and wave-induced bottom currents | 500 ft N. of FRF pier at approximately Station 1940 | 21                                | ±10 ft/s          | 19 Nov. 1977                |
| 612                                      | Temperature probe                         | Water temperature                     | 9.6 ft below MSL at station 1960, FRF pier          | 27                                |                   | 20 Nov. 1977                |
| 613                                      | Conductivity probe                        | Conductivity of seawater              | 9.6 ft below MSL at station 1960, FRF pier          | 27                                |                   | 20 Nov. 1977                |
| 602                                      | Temperature probe                         | Water temperature                     | 22 ft below MSL at station 1960, FRF pier           | 27                                |                   | 20 Nov. 1977                |
| 603                                      | Conductivity probe                        | Conductivity of seawater              | 22 ft below MSL at station 1960, FRF pier           | 27                                |                   | 20 Nov. 1977                |
| 865-1376                                 | Leupold-Stevens float-activated tide gage | Water level information               | FRF pier end at station 1960                        | 27                                |                   | 14 Jan. 1979                |
| 865-1371                                 | Fischer-Porter float-activated gage       | Water level information               | FRF pier at station 720                             | 11                                |                   | 17 Dec. 1977                |
|  | Bubbler (pressure) tide gage              | Water level information               | 1,000 ft W. of shore in Currituck Sound at FRF      | 5                                 |                   | 28 Oct. 1977                |
|  | Fischer-Porter float-activated tide gage  | Water level information               | 1,000 ft W. of shore in Currituck Sound at FRF      | 5                                 |                   | 28 Oct. 1977                |

## APPENDIX

| Sensor No.             | Sensor type                    | Data type  | Location  | Medium depth(MSL) at sensor (ft) | Sensor range (ft) | Initial installation (date) |
|------------------------|--------------------------------|--|---|----------------------------------|-------------------|-----------------------------|
| 865-1376               | Meteorcraft pressure tide gage | Water level information  | 1,000 ft W. of shore in Currituck Sound at FRF    |                                  | 4                 | 15 July 1978                |
|                        | Anemometer                     | Wind speed and direction                                       | 190 ft behind the dune                            |                                  |                   | 25 Feb. 1978                |
|                        | Microbarograph                 | Continuously records the atmospheric pressure                  | Inside office trailer                             |                                  |                   | 4 Mar. 1978                 |
|                        | Barometer                      | Atmospheric pressure   | Inside office trailer                             |                                  |                   | 4 Mar. 1978                 |
|                        | Hygrothermograph               | Continuously records the air temperature and relative humidity | Located in the instrument shack, 300 ft from dune |                                  |                   | 4 Mar. 1978                 |
|                        | Maximum thermometer            | Maximum air temperature  | Instrument shelter                                |                                  |                   | 4 Mar. 1978                 |
|                        | Minimum thermometer            | Minimum air temperature  | Instrument shelter                                |                                  |                   | 4 Mar. 1978                 |
|                        | 12-inch weighing rain gage     | Continuously records the amount of precipitation               | 285 ft behind the dune                            |                                  |                   | 4 Mar. 1978                 |
|                        | 6-inch rain gage               | Precipitation  | 270 ft behind the dune                            |                                  |                   | 4 Mar. 1978                 |
|                        | Sling psychrometer             | Dew point  | Used at instrument shelter                        |                                  |                   | 11 Dec. 1978                |
| Mechanical pyranograph | Solar radiation                | Mounted on top of instrument shelter                           |   |                                  | 18 Jan. 1979      |                             |

Miller, H. Carl  
Instrumentation at CERC's Field Research Facility, Duck North Carolina / by H. Carl Miller. -- Fort Belvoir, Va. : U.S. Coastal Engineering Research Center ; Springfield, Va. : available from National Technical Information Service, 1980.  
[42] p. : ill. : 27 cm. -- (Miscellaneous report -- U.S. Coastal Engineering Research Center ; no. 80-8)  
Includes bibliographical references.

Report describes the oceanographic and meteorological instrumentation used for the collection of environmental data at the Coastal Engineering Research Center's (CERC) Field Research Facility (FRF) at Duck, North Carolina; the necessary information for proper interpretation of the instrument data is also presented. Installation summaries for each instrument described are in an appendix.

1. Duck, North Carolina. 2. Engineering research. 3. Meteorological instruments. 4. Oceanographic instruments. I. Title. II. U.S. Coastal Engineering Research Center. III. Series: U.S. Coastal Engineering Research Center. Miscellaneous report no. 80-8.  
TC203 .U581mr no. 80-8 627

Miller, H. Carl  
Instrumentation at CERC's Field Research Facility, Duck North Carolina / by H. Carl Miller. -- Fort Belvoir, Va. : U.S. Coastal Engineering Research Center ; Springfield, Va. : available from National Technical Information Service, 1980.  
[42] p. : ill. : 27 cm. -- (Miscellaneous report -- U.S. Coastal Engineering Research Center ; no. 80-8)  
Includes bibliographical references.

Report describes the oceanographic and meteorological instrumentation used for the collection of environmental data at the Coastal Engineering Research Center's (CERC) Field Research Facility (FRF) at Duck, North Carolina; the necessary information for proper interpretation of the instrument data is also presented. Installation summaries for each instrument described are in an appendix.

1. Duck, North Carolina. 2. Engineering research. 3. Meteorological instruments. 4. Oceanographic instruments. I. Title. II. U.S. Coastal Engineering Research Center. III. Series: U.S. Coastal Engineering Research Center. Miscellaneous report no. 80-8.  
TC203 .U581mr no. 80-8 627

Miller, H. Carl  
Instrumentation at CERC's Field Research Facility, Duck North Carolina / by H. Carl Miller. -- Fort Belvoir, Va. : U.S. Coastal Engineering Research Center ; Springfield, Va. : available from National Technical Information Service, 1980.  
[42] p. : ill. : 27 cm. -- (Miscellaneous report -- U.S. Coastal Engineering Research Center ; no. 80-8)  
Includes bibliographical references.

Report describes the oceanographic and meteorological instrumentation used for the collection of environmental data at the Coastal Engineering Research Center's (CERC) Field Research Facility (FRF) at Duck, North Carolina; the necessary information for proper interpretation of the instrument data is also presented. Installation summaries for each instrument described are in an appendix.

1. Duck, North Carolina. 2. Engineering research. 3. Meteorological instruments. 4. Oceanographic instruments. I. Title. II. U.S. Coastal Engineering Research Center. III. Series: U.S. Coastal Engineering Research Center. Miscellaneous report no. 80-8.  
TC203 .U581mr no. 80-8 627

Miller, H. Carl  
Instrumentation at CERC's Field Research Facility, Duck North Carolina / by H. Carl Miller. -- Fort Belvoir, Va. : U.S. Coastal Engineering Research Center ; Springfield, Va. : available from National Technical Information Service, 1980.  
[42] p. : ill. : 27 cm. -- (Miscellaneous report -- U.S. Coastal Engineering Research Center ; no. 80-8)  
Includes bibliographical references.

Report describes the oceanographic and meteorological instrumentation used for the collection of environmental data at the Coastal Engineering Research Center's (CERC) Field Research Facility (FRF) at Duck, North Carolina; the necessary information for proper interpretation of the instrument data is also presented. Installation summaries for each instrument described are in an appendix.

1. Duck, North Carolina. 2. Engineering research. 3. Meteorological instruments. 4. Oceanographic instruments. I. Title. II. U.S. Coastal Engineering Research Center. III. Series: U.S. Coastal Engineering Research Center. Miscellaneous report no. 80-8.  
TC203 .U581mr no. 80-8 627