

UNCLASSIFIED  
UNCLASSIFIED

MEMORANDUM 79021 ✓



MEMORANDUM 79021

AD A091625

LEVEL II

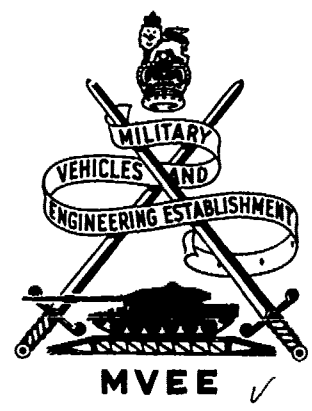

SDTIC  
ELECTE  
NOV 17 1980  
E

# TEST TRACK FACILITIES

DECEMBER 1979

UNCLASSIFIED

DDC FILE COPY

Procurement Executive  
Ministry of Defence  
MVEE  
Chobham Lane  
Chertsey  
Surrey KT16 OEE  
United Kingdom

UNCLASSIFIED

80 10 31 066

**THIS DOCUMENT IS THE PROPERTY OF HER BRITANNIC MAJESTY'S GOVERNMENT, and is issued for the information of such persons only as need to know its contents in the course of their official duties. Any person finding this document should hand it to a British forces unit or to a police station for its safe return to the**

**MINISTRY OF DEFENCE, HQ SECURITY, LONDON SW1A 2HB**

**with particulars of how and where found. THE UNAUTHORISED RETENTION OR DESTRUCTION OF THE DOCUMENT IS AN OFFENCE UNDER THE OFFICIAL SECRETS ACTS OF 1911 — 1939. (When released to persons outside Government Service, this document is issued on a personal basis and the recipient to whom it is entrusted in confidence, within the provisions of the Official Secrets Acts 1911 — 1939, is personally responsible for its safe custody and for seeing that its contents are disclosed only to authorised persons.)**

**THIS DOCUMENT MUST NOT BE  
REPRODUCED WHOLLY OR IN PART  
WITHOUT THE WRITTEN CONSENT  
OF THE DIRECTOR MVEE**

**This Document has been written primarily for the records of the Establishment and is not necessarily to be regarded as a formal expression of MVEE opinion.**

**Limited circulation is authorised outside MVEE.**

- 1 (a)**
- 1 (b)**
- 1 (c)**
- 1 (d)**

UNCLASSIFIED

MILITARY VEHICLES AND ENGINEERING ESTABLISHMENT

MVEE MEMORANDUM No 79021

11 December 1979

14 MVEE MEMO-79021

6 TEST TRACK FACILITIES

Originating Branch:

TRIALS BRANCH

1286

SUMMARY

This Memorandum provides a general description and detailed specification of each separate vehicle test facility situated at the three separate test track sites under the control of MVEE Chertsey. It provides guidance for those whose duty it is to plan vehicle trials and it replaces MVEE Memorandum 71061 of December 1975.

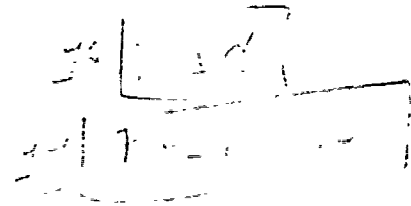

Accession For	
NTIS CANAL	<input checked="" type="checkbox"/>
DDC TAB	<input type="checkbox"/>
Unannounced	<input type="checkbox"/>
Justification	
By _____	
Distribution/	
Availability Codes	
Dist.	Avail and/or special
A	

Branch File Reference: FVE/40/12 ✓

Copyright © HMSO London 1979

UNCLASSIFIED

406799

5213

# RECORD OF AMENDMENTS

Particulars of all amendments are to be entered below.

No.	DATED	DETAIL	SIGNATURE	DATE

## DISTRIBUTION

	No of Copies
<b>Internal</b>	
D/MVEE	1
TSO/D	1
DD/PR	1
MA/DD/PR	1
DD/TE	1
Heads of Division (2 copies each 1 for PTA's)	8
SO-H/EED	1
Assistant Directors (1 copy each)	17
Secretary	1
PPTO's, PSO's, and Lt Col's (distributed via AD's)	61
Quality Officer	1
Automotive Wing Sections	6
Publications Officer MVEE (Christchurch)	10
Head of DO (Christchurch)	2
Principal Photographer	1
Senior Illustrator	1
SAO	1
AT/PTS	5
Chief Test Track Controller	5
Man Acct	1
Library (Chertsey, and Christchurch) (2 copies each)	4
SO Trials (For further distribution)	500
<b>External</b>	
DRPB	1
DRIC	3
Libraries: RARDE	1
RAE	1

## CONTENTS

	Page	Test Track Facility Map Reference No
1. Introduction	7	
2. MVEE Chertsey Location Sketch Map	9	
3. Longcross Test Track	11	
3.1 Facility Location Map	13	
3.2 Main Track	15	21
3.3 Snake Course	16	25
3.4 Rough Road Demonstration Course	18	23
3.5 Rain Test Facility	20	35
3.6 Slip Pad	23	31
3.7 Tilt Platform	26	32
3.8 Articulation Gauges (Multi Axle)	32	40
Simple		
3.9 Articulation Gauges (Multi Axle)	34	36
Compound		
3.10 Articulation Gauges Single Wheel	36	33
3.11 Belly Clearance Gauge	38	38
3.12 Drop Simulator	40	44
3.13 Loading Gauges	42	41/43
3.14 Step Obstacles	44	37
3.15 Variable Gap Crossing	46	37
3.16 Test Gradients	48	16/19
3.17 Offset Towing Course	52	20
3.18 Straight and Level course	56	22
3.19 Suspension Courses	58	9
a. Pavé	58	8
b. Boulder	59	7
c. Camera Track	59	
d. Setts	59	5/6'
3.20 Wading Pool	66	34
3.21 Field Dynamometer	68	39
3.22 Winch Test Facility	70	10
3.23 General Vehicle (Dynamometer)	73	4
Building		
4. Bagshot Test Track	74	
4.1 Facility Location Map	75	
4.2 Water Splash	78	
5. Long Valley Test Track	80	
5.1 Facility Location Map	81	
5.2 Sand Trials Facility	86	
5.3 Rocky Terrain Profile	88	
6. Commercial Hire Guide	91	

PRECEDING PAGE BLANK-NOT FILMED

# MILITARY VEHICLES AND ENGINEERING ESTABLISHMENT

MVEE MEMORANDUM No 79021

## 1. Introduction

\* The Military Vehicles and Engineering Establishment is situated near Chertsey in Surrey, approximately 30 miles south west of London. The Establishment is responsible for the Research, Design and Development of tracked and wheeled vehicles to meet the requirements of the Armed Services and certain other Government Departments, and for Engineering and Bridging equipment. Development trials are carried out by the Establishment to prove designs, both from the technical and User aspects, after which equipments are offered to the Service Departments for official Acceptance.

The testing facilities in this brochure include facilities for the static testing of complete vehicles and components, and road, rough road, and cross country test courses which allow vehicles to be tested for durability and reliability under selected severe service conditions.

There are 3 main test track complexes under MVEE Chertsey's control:

LONGCROSS - All hard surface tracks and static test facilities,

BAGSHOT - Wheeled vehicle rough road and Alpine circuits, and

LONG VALLEY - Separate tracked and wheeled cross country circuits.

NOTE: Other test track facilities, not listed herein, are available at MVEE Christchurch. These are shown in a separate publication which may be obtained from MVEE Christchurch, Christchurch, Dorset, England.

Standard trials methods for the use of all the facilities shown in this publication are recorded in the MVEE (FVRDE Publication) Trials Manual.

For further details of all facilities and requests for the exchange of commercial hire contracts, application should be made to the Director, MVEE, Chobham Lane, Chertsey, Surrey KT16 0EE.

PRECEDING PAGE BLANK-NOT FILMED







### 3. Longcross Test Track

The Longcross Test Track complex consists of a 35 ft (10.67 m) wide 50% stone rolled asphalt main course of 2 miles (3.22 km) length with banked curves. The maximum speed is normally restricted to 70 mile/h (110 km/h).

Other courses (all described in greater detail under their own headings) are:

**Snake Circuit** An asphalt high speed steering and stability course of approximately 1135 yards (1038 m) which may be incorporated with the outer circuit. Maximum gradients are 15.9% (1 in 6.3).

**Slip Pad** There is a central 510 ft (155.28 m) diameter slightly domed asphalt circular area which may be used for brake tests, turning circles, jack-knifing trials, cut-in of trailers and angles of vision. There is a 1 in 10 slope running down to this facility.

**Suspension Courses** There are multiple suspension courses with runs of 1175 ft (332.7 m) consisting of various heights of concrete randomly set blocks and Pavé. Full details are given in the main booklet on pages 12 and 15.

**Other Facilities** Other 'running' facilities include 4 test gradients (1 in 4 - 1 in 1.73), a Straight and Level course 1000 ft (305 m) long and a Rough Road course.

**Static Facilities** The complex also includes a large number of static facilities, including a tilt platform (capable of tilting a loaded tank transporter trailer), simple and compound articulation and belly clearance gauges, a wading pool, a rain-maker, a winch test facility (300 yards/274 m long) with anchor points of 50 and 100 tons, together with various gap crossing and vertical climbing facilities.

The Tracks have been in use since August 1953 and were designed for Heavy Transporters (100-120 Tons) and Tracked Vehicles of 80 Tons. The main track, snake circuit and slip pad have a foundation of stabilised soil with a 23 cm (9") layer of Tar Macadam and a final layer of 5 cm (2") 50% Stone Rolled Asphalt. The remainder has a 35% Stone Rolled Asphalt, with the exception of the Marshalling Area. The west side of the Marshalling Area is a refuelling area and this surface is 50% Stone Pitch Mastic and the East End 45% Stone Mastic Asphalt.

#### Navigation Points

The track has two Survey Points used for accuracy checks on on-board vehicle navigation systems. These are situated at:

Track Marshalling Area

Eastings 498321.2 m  
Northings 165641.9 m

Circular metal insert flush with tarmac and surrounded by yellow paint circle.

Junction east end  
Straight and Level and main  
circuits

Eastings 499072.5 m  
Northings 166060.1 m

Circular metal nail flush  
with tarmac surrounded by  
yellow paint circle.

# MVEE CHERTSEY - LONGCROSS TEST

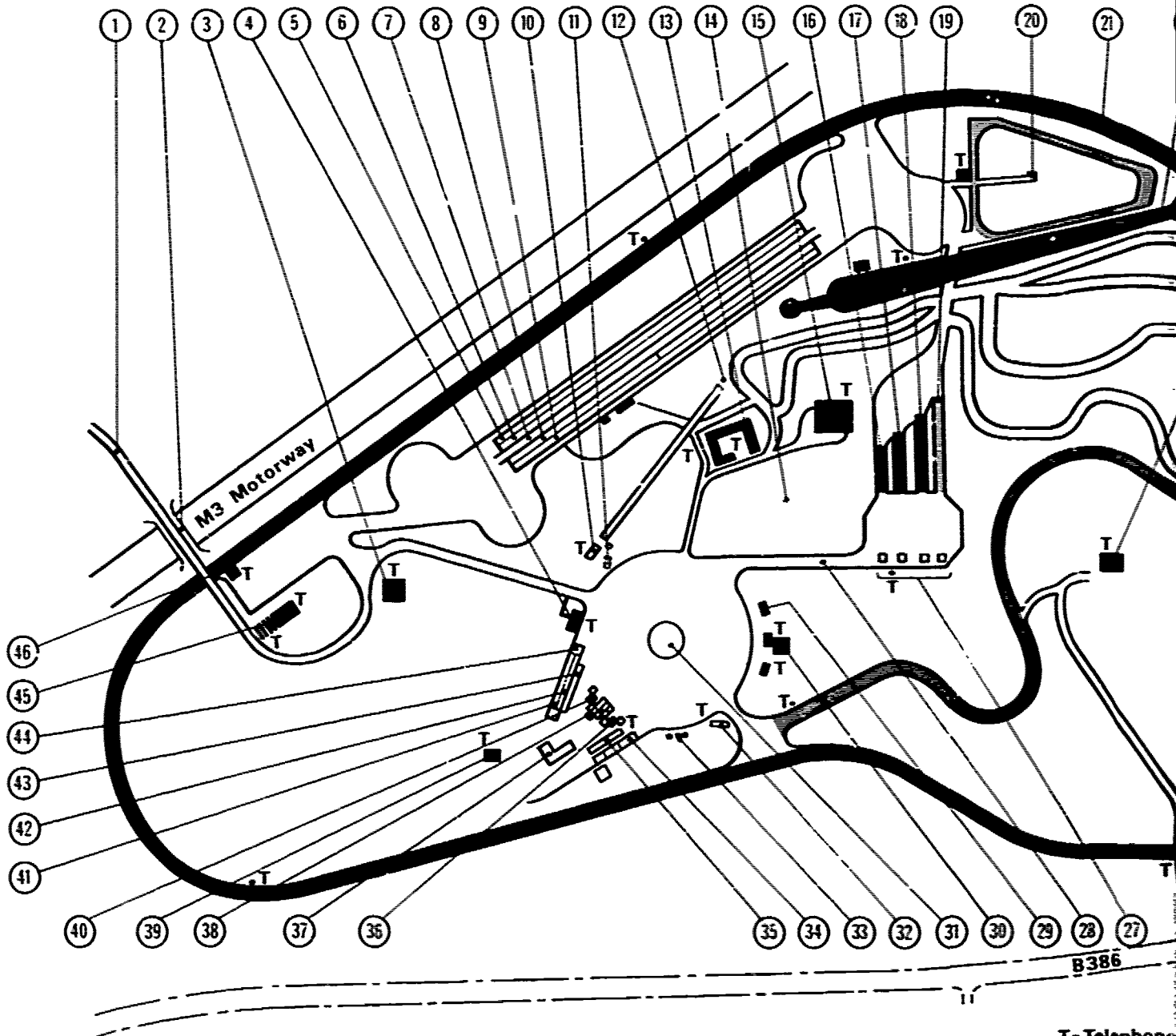

REVISED FEB. 79

T = Telephone

B386

# CROSS TEST TRACK

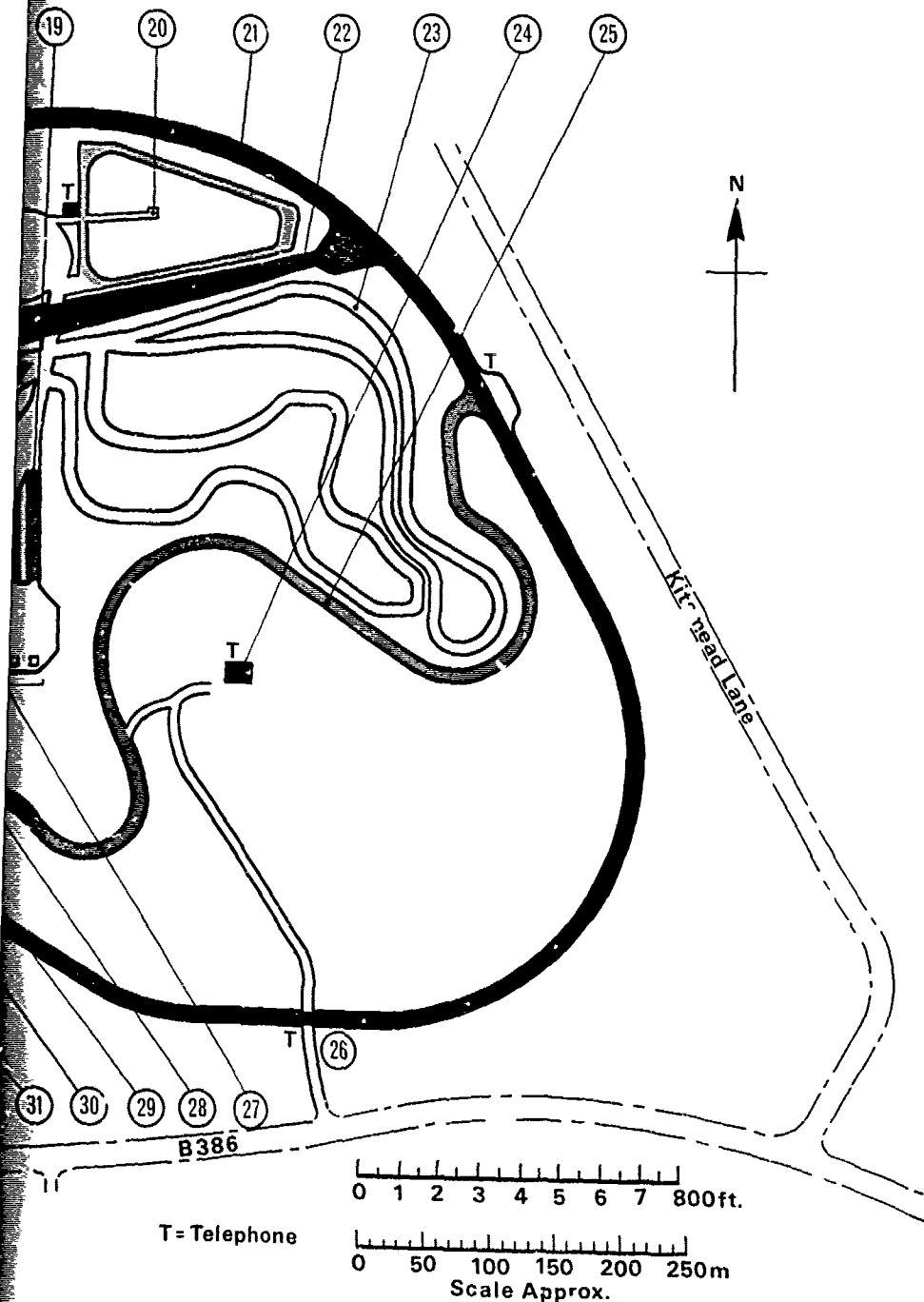

## Key

- 1 MAIN ENTRANCE (VIA LOWER MAIN GATE)
- 2 M3 OVERBRIDGE
- 3 DRIVERS REST ROOM/TRACK STORE
- 4 AUTOMOTIVE TRIALS/PERFORMANCE TRIAL SECTION (AT/PTS)
- 5 SUSPENSION COURSE CORRUGATED 50.8 mm (2 in) HIGH
- 6 SUSPENSION COURSE CORRUGATED 25.4 mm (1 in) HIGH
- 7 CAMERA TRACK PLAIN LEVEL SURFACE TO ENABLE HIGH SPEED CAMERA RECORDS OF SUSPENSION MOVEMENTS TO BE TAKEN
- 8 SUSPENSION COURSE BOULDER
- 9 SUSPENSION COURSE PAVE
- 10 WINCH TEST HOUSE
- 11 71.1 TONNE (70 TON) VERTICAL ANCHOR FACILITY
- 12 ANCHOR BLOCK FOR WINCH TEST HOUSE 101.6 TONNE (100 TON)
- 13 HOME FARM SPLASH RANGE
- 14 DEMONSTRATION CROSS COUNTRY AREA
- 15 PLANT TROOP HANGAR
- 16 TEST GRADIENT 57.8 PERCENT GRADE (1 IN 1.73)
- 17 TEST GRADIENT 50 PERCENT GRADE (1 IN 2)
- 18 TEST GRADIENT 33.3 PERCENT GRAD (1 IN 3)
- 19 TEST GRADIENT 25 PERCENT GRADE (1 IN 4)
- 20 OFFSET TOWING SUSPENSION COURSE
- 21 OUTER TRACK 3220 m (2 MILES) LONG BANKED AT CORNERS INCLUDES A FLAT LEVEL MEASURED 402 m (¼ mile)
- 22 STRAIGHT AND LEVEL TRACK 305 m (1000 ft)
- 23 ROUGH ROAD DEMONSTRATION COURSE
- 24 BARROW HILLS OFFICERS MESS
- 25 SNAKE COURSE
- 26 MANSION CROSSING (RESTRICTED ENTRANCE)
- 27 ANCHOR BLOCKS FOR TEST GRADIENT 50.8 TONNE (50 TON)
- 28 TEST GRADIENT 10 PERCENT GRADE 1 IN 10
- 29 CONTROL HUTS/CHALETs
- 30 TOILETS
- 31 SLIP PAD (HELICOPTER LANDING SITE GR SU 987656)
- 32 TILTING PLATFORM
- 33 ARTICULATION GAUGES SINGLE WHEEL (3 GAUGES)
- 34 WADING POOL
- 35 RAIN MAKING FACILITY
- 36 ARTICULATION GAUGES COMPOUND (3 GAUGES)
- 37 VARIABLE GAP CROSSING AND STEP OBSTACLES
- 38 CELLY CLEARANCE GAUGES (3 GAUGES)
- 39 STATIC DYNAMOMETER TEST HOUSE
- 40 ARTICULATION GAUGES SIMPLE (3 GAUGES)
- 41 LOADING GAUGE LST 3
- 42 LOADING GAUGE LCT 8
- 43 LOADING GAUGE AIRCRAFT
- 44 DROP SIMULATOR
- 45 DRIVER TRAINING SECTION
- 46 TEST TRACK CONTROL BUILDING

FV884867

PRECEDING PAGE BLANK-NOT FILLED

### 3.2 Longcross - Main Track

Facility No 21



#### *General Description*

This is the main stone rolled asphalt circuit with a 3.22 km (2 mile) centreline measurement. It is 10.67 m (35 ft) wide with banking to represent 65 km/h (40 mile/h) at its eastern end, and 95 km/h (60 mile/h) at its western end (hands off speed). Incorporated into the circuit along its northern course, is a 400 m straight approximately 2.5 cm (1 inch) out of level. The approaches to this are marked with 400m and 800m approach boards

Speeds on this circuit are normally restricted to 112.7 km/h (70 mile/h) due to the manually operated crossing gates situated on the south side of the circuit.

The Snake Mountain circuit leaves and rejoins the main track in either direction.

The eastern end of the Snake and the Straight and Level course are connected by a hard surfaced road which can provide an inner undulating course separate from the outer more level course if required. This will only be used with the authority of Chief Test Track Controller.

### 3.3 Longcross - Snake Course

Facility No 25

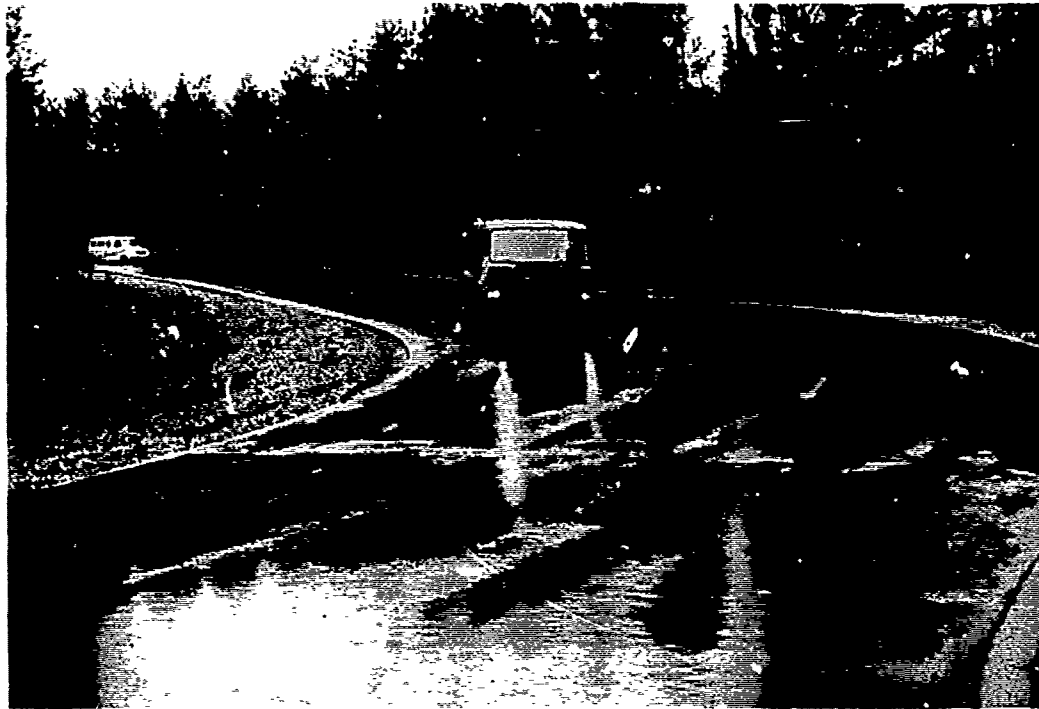

For a line diagram showing Technical Specifications - see opposite.

#### *General Description*

This course has a similar surface to that of the main outside track. It is 1135 yards (1038 m) long, leaves and rejoins the main circuit and may be used in either direction. Its purpose is to provide a steering and stability test course for all types of tracked and wheeled vehicles. The maximum gradients are, in an anti-clockwise direction, 15.9% (1 in 6.3), and clockwise 10.5% (1 in 9.5). The gradients and curved nature should ensure that this is a severe handling course for the larger wheeled and tracked vehicles.

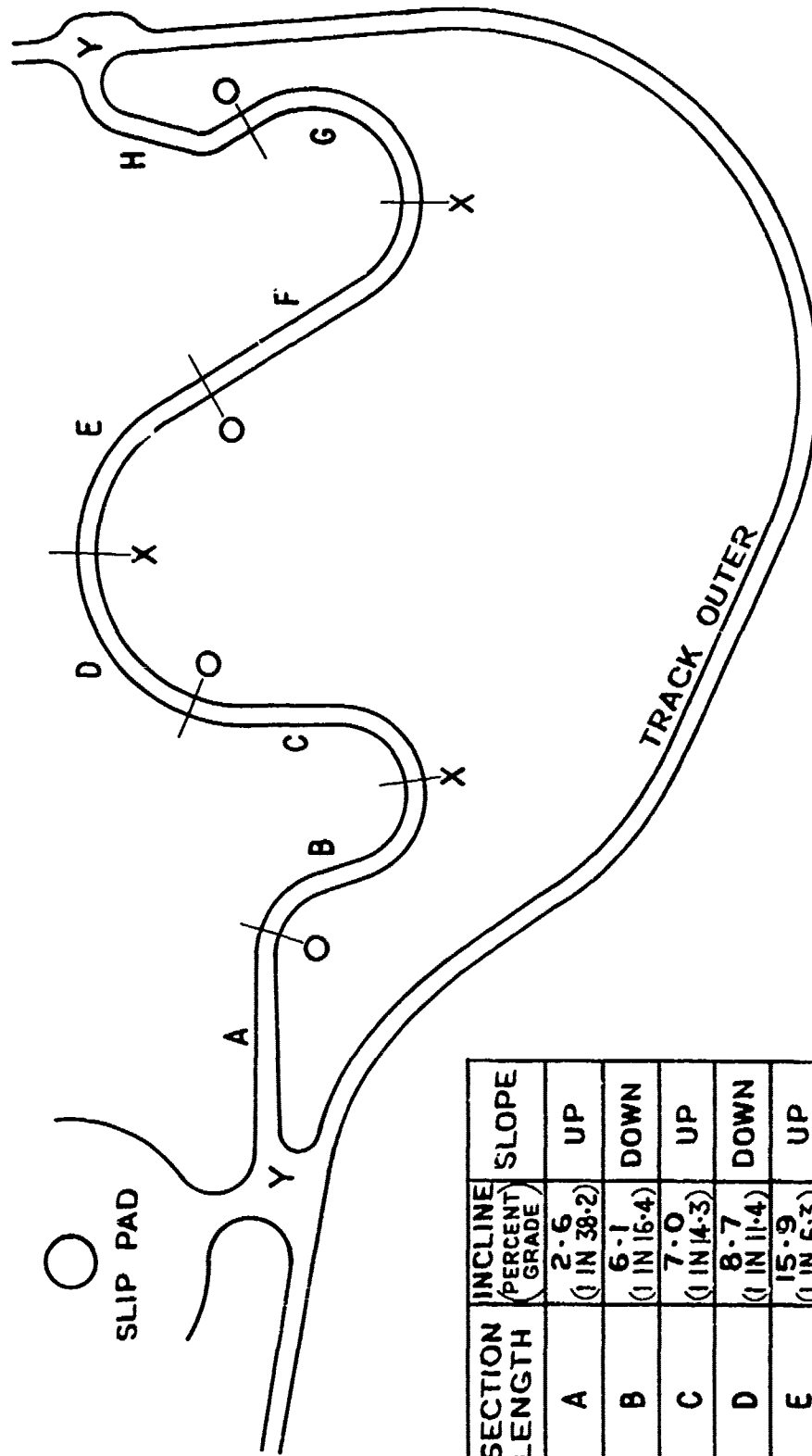

SECTION LENGTH	INCLINE (PERCENT GRADE)	SLOPE
A	2.6 (1 IN 38.2)	UP
B	6.1 (1 IN 16.4)	DOWN
C	7.0 (1 IN 14.3)	UP
D	8.7 (1 IN 11.4)	DOWN
E	15.9 (1 IN 6.3)	UP
F	10.5 (1 IN 9.5)	DOWN
G	3.5 (1 IN 28.6)	UP
H	9.6 (1 IN 10.4)	DOWN

LENGTH OF COURSE BETWEEN POINTS MARKED Y Y 1038 m

O TOP OF SLOPE  
X BOTTOM OF SLOPE

SLAKE COURSE





For a line diagram showing Technical Specifications - see opposite.

*General Description*

A series of demonstration rough roads, surfaced similar to the main rough road facility at Bagshot Test Track, and surfaced with natural flint ballast bound in its own hoggin, are provided for demonstration and short duration rough road vehicle trials. The loose nature of the surface, together with the effect of flying flintstones results in severe wear to the tyres, brake pipes and all other fittings found underneath a vehicle chassis. The stresses imposed on the vehicle chassis and suspension make this an "accelerated testing" course

This course can be graded, rolled or infilled for specific military trials should it be necessary. It is not normally available for vehicles larger than Landrover size because of the severe radius of its turns and the restricted load bearing surface of its foundations.

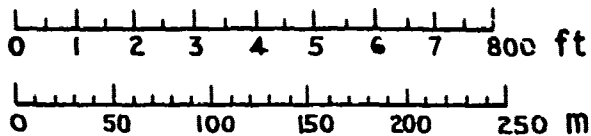

SCALE  
APPROX

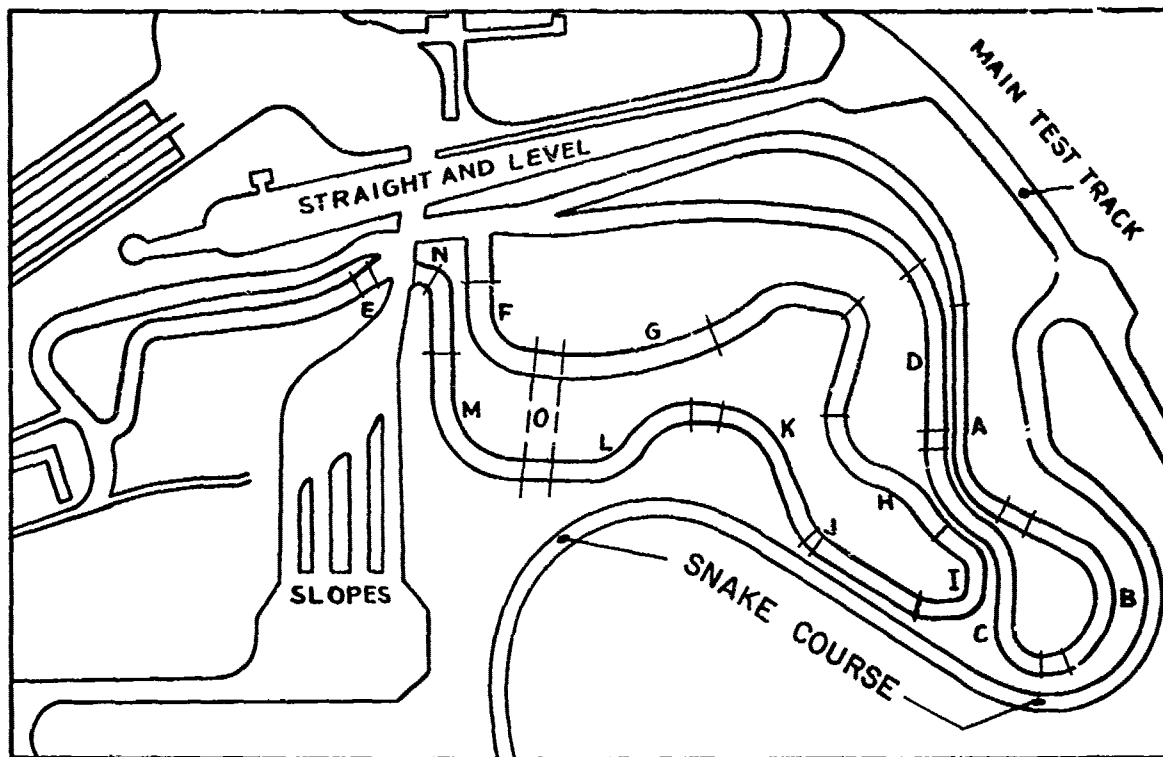

STAGE	SECTION	LENGTH OF SECTION	INCLINE PERCENT GRADE	LENGTH OF STAGE
1	A	100 m	21.3 (1 IN 4.7)	1280 m
	B	100 m	15.9 (1 IN 6.3)	
	C	130 m	17.6 (1 IN 5.7)	
	D	80 m	21.3 (1 IN 4.7)	
	E	10 m	15.9 (1 IN 6.3)	
2	F	60 m	15.9 (1 IN 6.3)	1033 m
	G	75 m	7.0 (1 IN 14.3)	
	H	80 m	14.0 (1 IN 7.1)	
	I	80 m	10.5 (1 IN 9.5)	
	J	90 m	8.7 (1 IN 11.4)	
	K	80 m	21.3 (1 IN 4.7)	
	L	80 m	21.3 (1 IN 4.7)	
	M	80 m	25.0 (1 IN 4)	
	N	12 m	28.7 (1 IN 3.5)	
	O	40 m	36.4 (1 IN 2.7)	

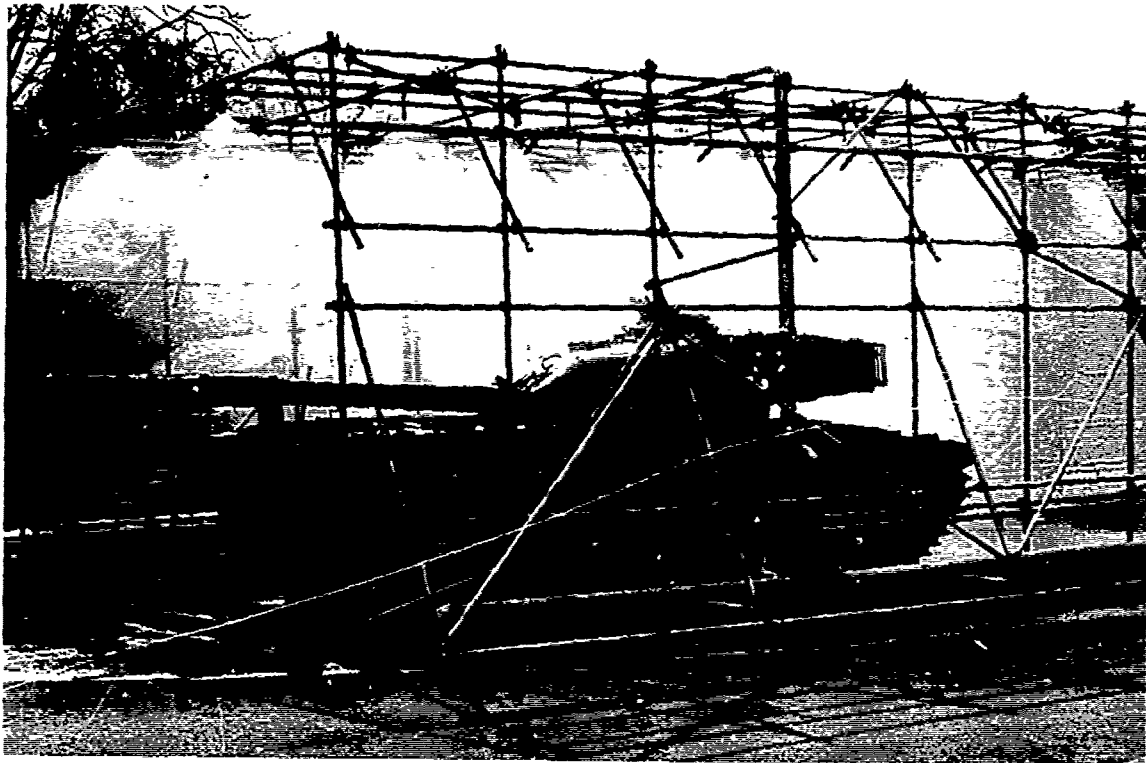

For a line diagram showing Technical Specifications - see opposite

*General Description*

This facility consists of a hollow, framed tubular pipe construction with rainmaking water nozzles. It is designed to subject vehicles and equipment to controlled rainfall conditions in order to check for water ingress and its effect on the operation of the equipment under test. The water producing pipework is 30 m (98 ft) long and vehicles may be either static or driven through the test facility.

Typical tests include the checking of water ingress into vehicle cabs and AFV compartments, the effects of water ingress into such items as engine ignition systems and the evaluation of waterproof clothing.

*Technical Specification*

Range of rainfall:	10 - 6705.6 mm per hour (.4 - 264 in per hour)
Frame size: Length:	30 m (98 ft)
Width:	6 m (19.7 ft)
Height:	4.6 m (15 ft)

MAX INTENSITY OF SIMULATED RAIN 1300mm/h  
 TESTS NORMALLY CONDUCTED TO DEF STAN 00-1

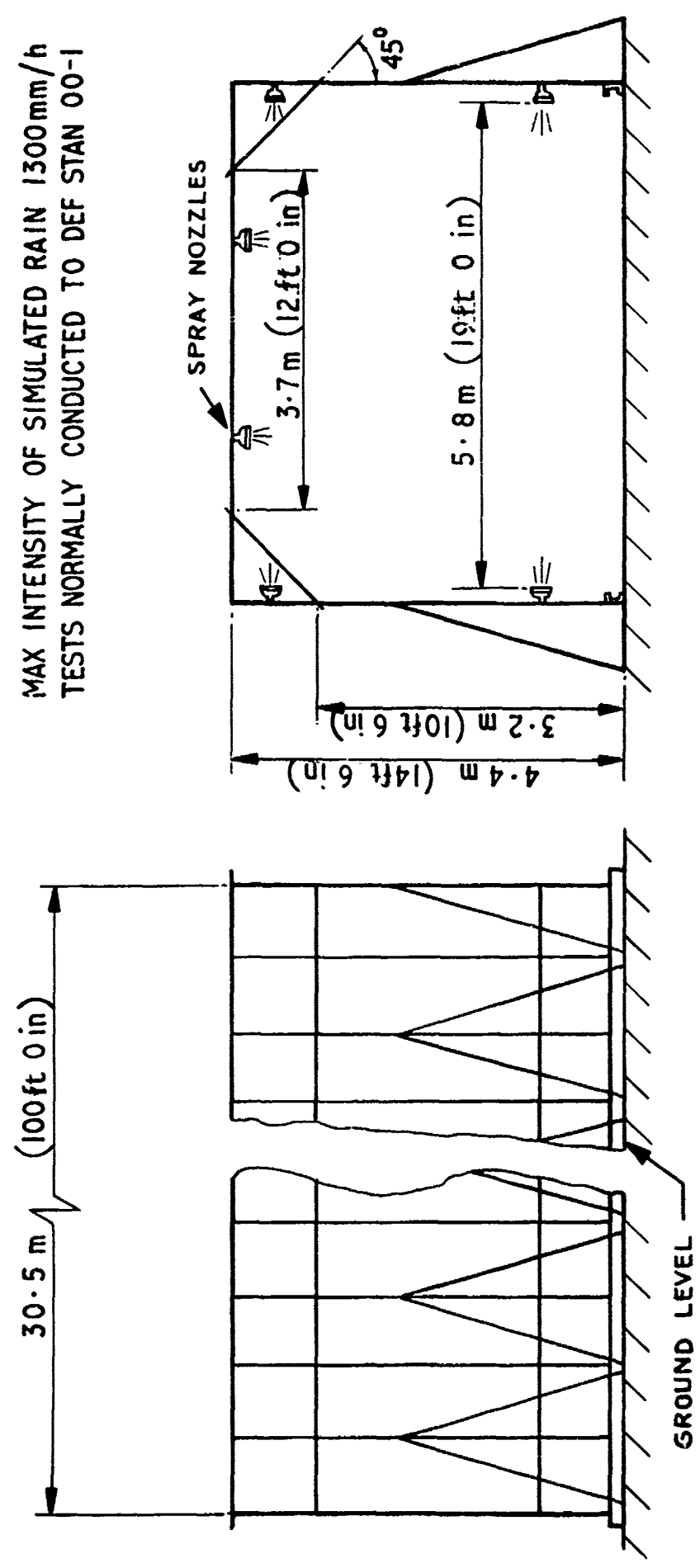

RAIN MAKING FACILITY

### 3.6 Longcross - Slip Pad

Facility No 31



For a line diagram showing Technical Specifications - see overleaf.

#### *General Description*

A large circular tarmac area which is the main general manoeuvring and static test location. A 1 in 10 slope connects this facility with the top of the Test Slope area.

General trials include:

- a. Brake Tests
- b. Angles of Vision
- c. Minimum turning circles
- d. Relationship between stability, turning circle and speed.
- e. Relationship between 'cut-in of trailer' and turning circle of prime mover.

*Dimensions*

155.28 m (520') Diameter - slightly conical the centre being higher than the periphery.

*Markings*

From the centre 3 m circle there are 9 further circles 3 m apart and then 3 circles at 45 m, 60 m and 70 m. (Each white line is 10 cm wide).

*Associated Facilities*

There are 3 buildings on the eastern edge, each heated, equipped with tables and chairs and capable of housing approx 30 people. One building is equipped to show films. They are booked through track control. There is a fully equipped male and female toilet behind these buildings. (Capacity approx 10 people of each sex).

*Helicopter Landing Pad*

See attached Sketch Map. Book through Staff Officer Trials.

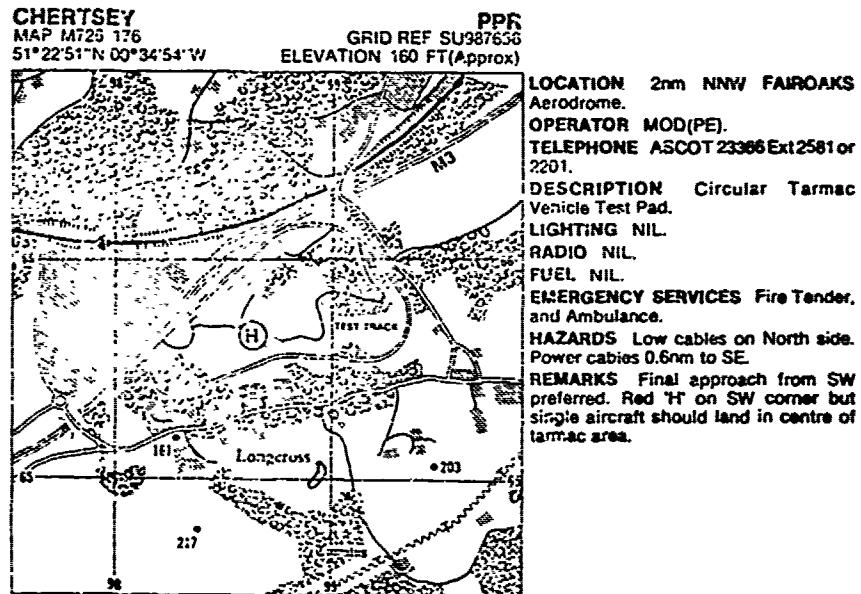

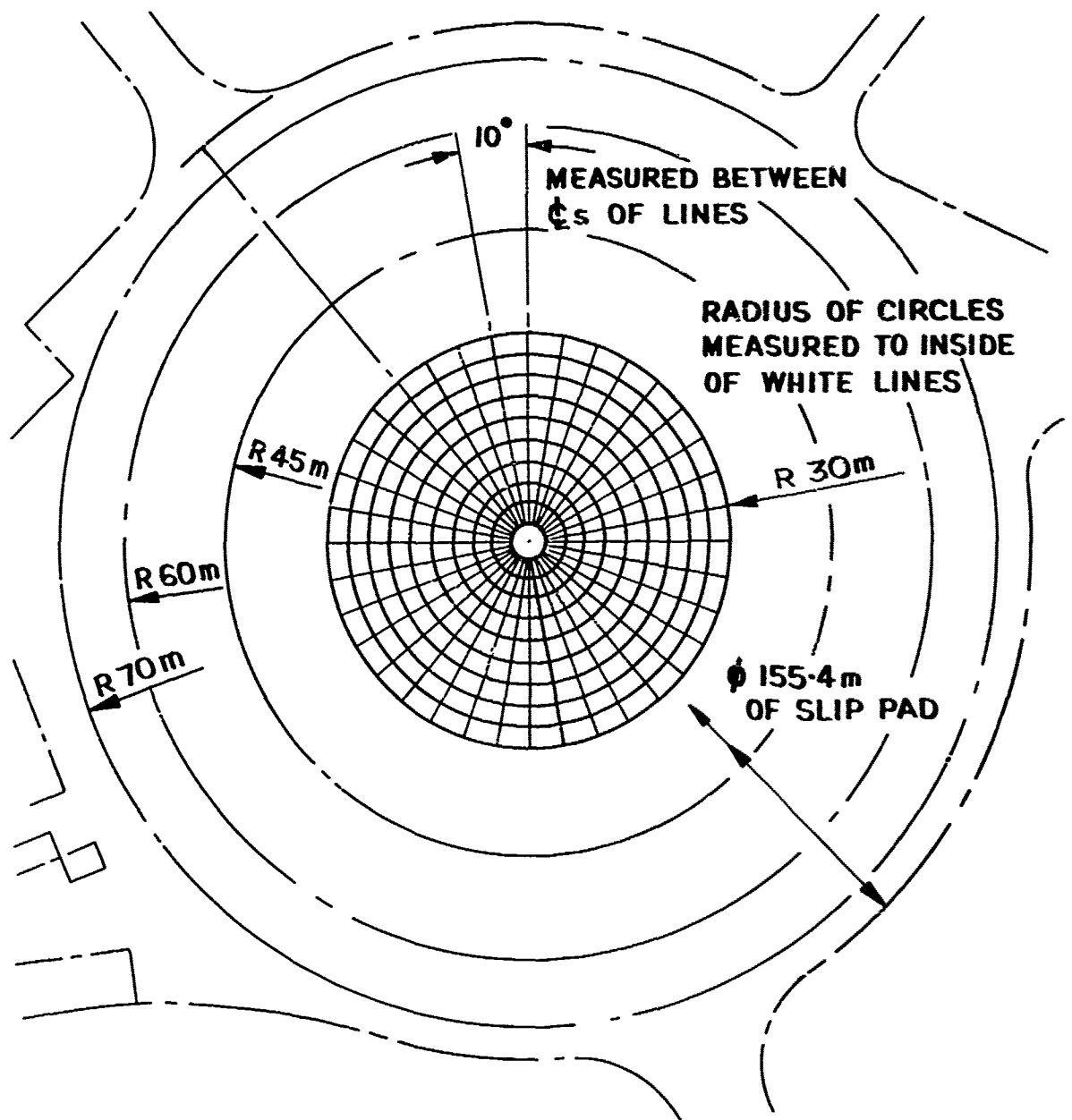

10 - WHITE PAINTED CIRCLES - CENTRE CIRCLE OF 3m RADIUS THEN 9 CIRCLES EACH 3m APART. 3 CIRCLES AT 45m, 60m AND 70m RADII FROM THE CENTRE POINT. EACH LINE 100mm WIDE. TO ASSIST IN:-

- a. DETERMINATION OF MINIMUM TURNING CIRCLES
- b. ESTABLISHING RELATIONSHIP BETWEEN STABILITY, TURNING CIRCLE AND SPEED

36 - WHITE PAINTED RADIAL LINES 10° APART, 50mm WIDE AND STARTING FROM THE CENTRE CIRCLE TO ASSIST IN:-

- a. ESTABLISHING RELATIONSHIP BETWEEN 'CUT-IN' OF TRAILER AND TURNING CIRCLE OF TRACTOR.

SURFACE OF SLIP PAD IS SLIGHTLY CONICAL, CENTRE IS 300mm HIGHER THAN PERIPHERY

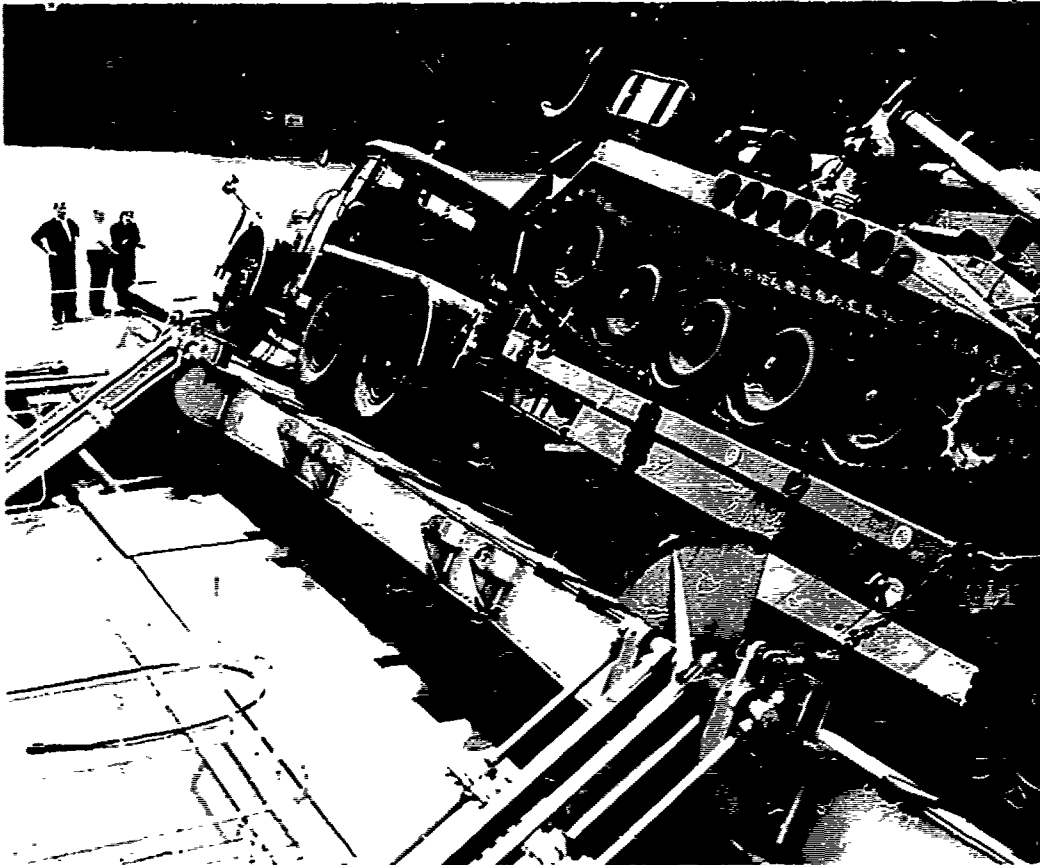

For a line diagram showing Technical Specifications - see opposite.

*General Description*

The platform can tilt vehicles to a maximum of 50°. There are overhang plates at either end and on the downward side (see diagram) which allow for large load overhangs to be accommodated, for example a loaded tank transporter.

*Technical Details*

Maximum safe working load 91.5 tonnes (automatic cut-out)  
Average tilt rate 6° per minute.  
The platform is operated by 8 hydraulic rams at a pressure of 1600 psi (110 Bars) from an electrically driven (440 volts 3 phase) pump.

*Platform Measurements* Length 16.5 m Width 4.3 m

*Safety* Maximum vehicle Wheelbase 47 ft 6 in (14.47 m) maximum  
Track 12 ft 8 in (3.861 m).

A combined chain and wire rope (manual winch operated) restraining system is used and manually operated safety cut-outs are positioned around the facility.

*General Comment*

The tilt platform is always operated by members of the Establishment (AT/PTS) and is booked separately from the other facilities via Track Control.





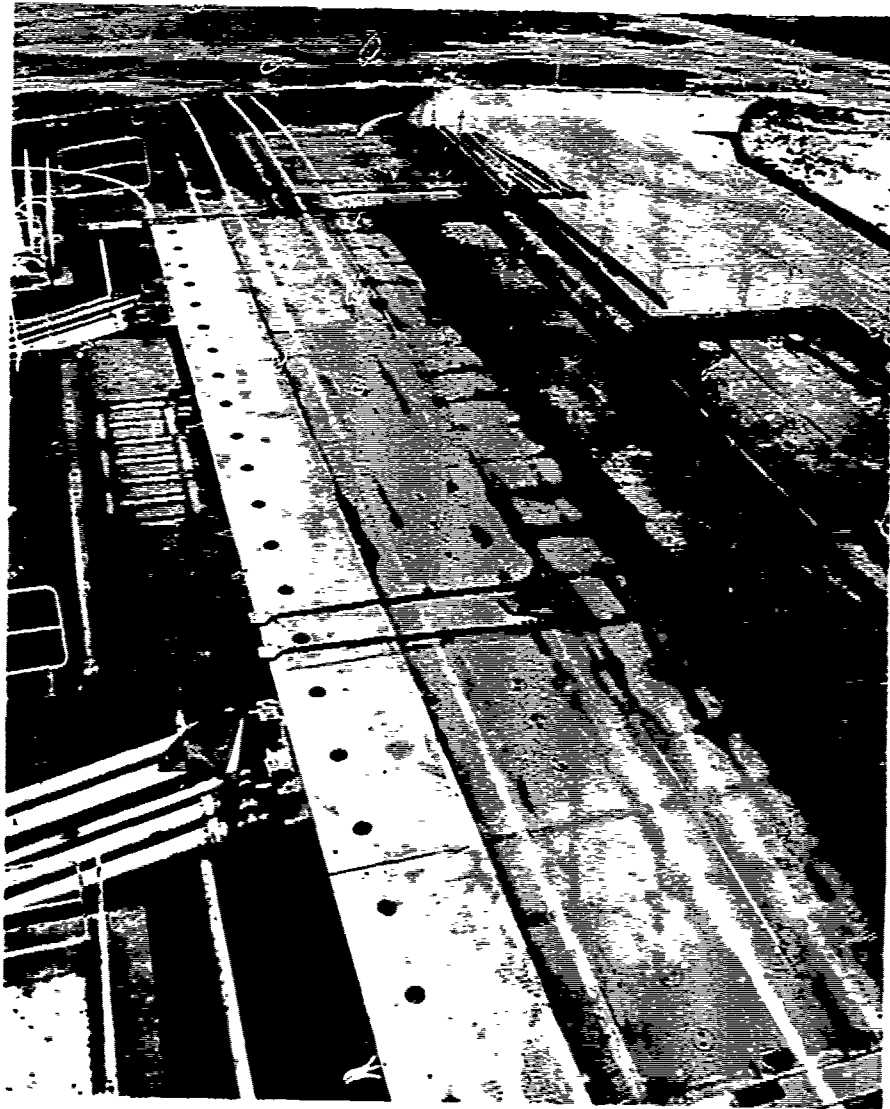

Tilt Platform - Ready for use



Tilt Platform - In Operation

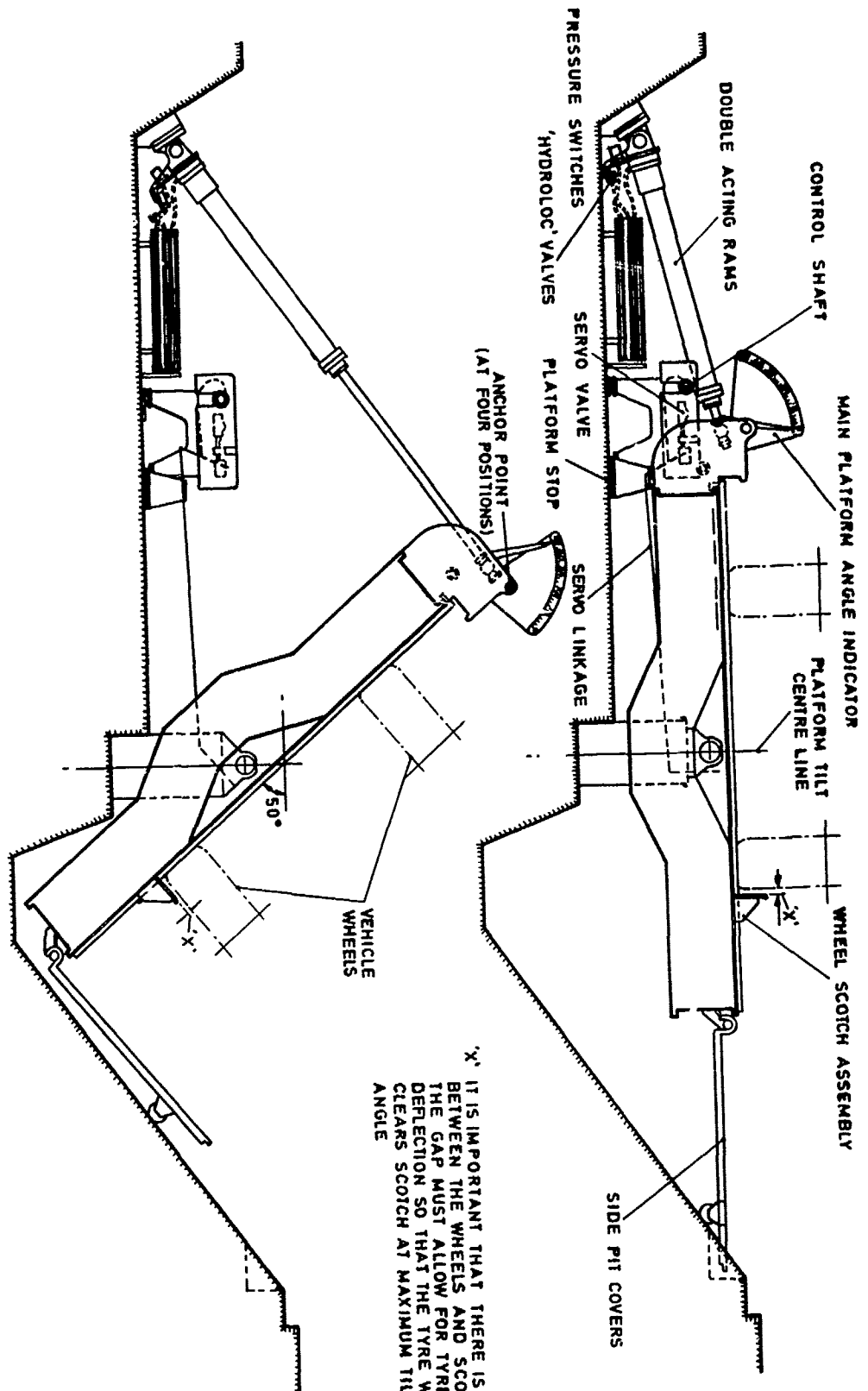

'X' IT IS IMPORTANT THAT THERE IS A GAP BETWEEN THE WHEELS AND SCOTCHES THE GAP MUST ALLOW FOR TYRE DEFLECTION SO THAT THE TYRE WALL CLEARS SCOTCH AT MAXIMUM TILT ANGLE

FIG.3 MAIN PLATFORM TILT ANGLES

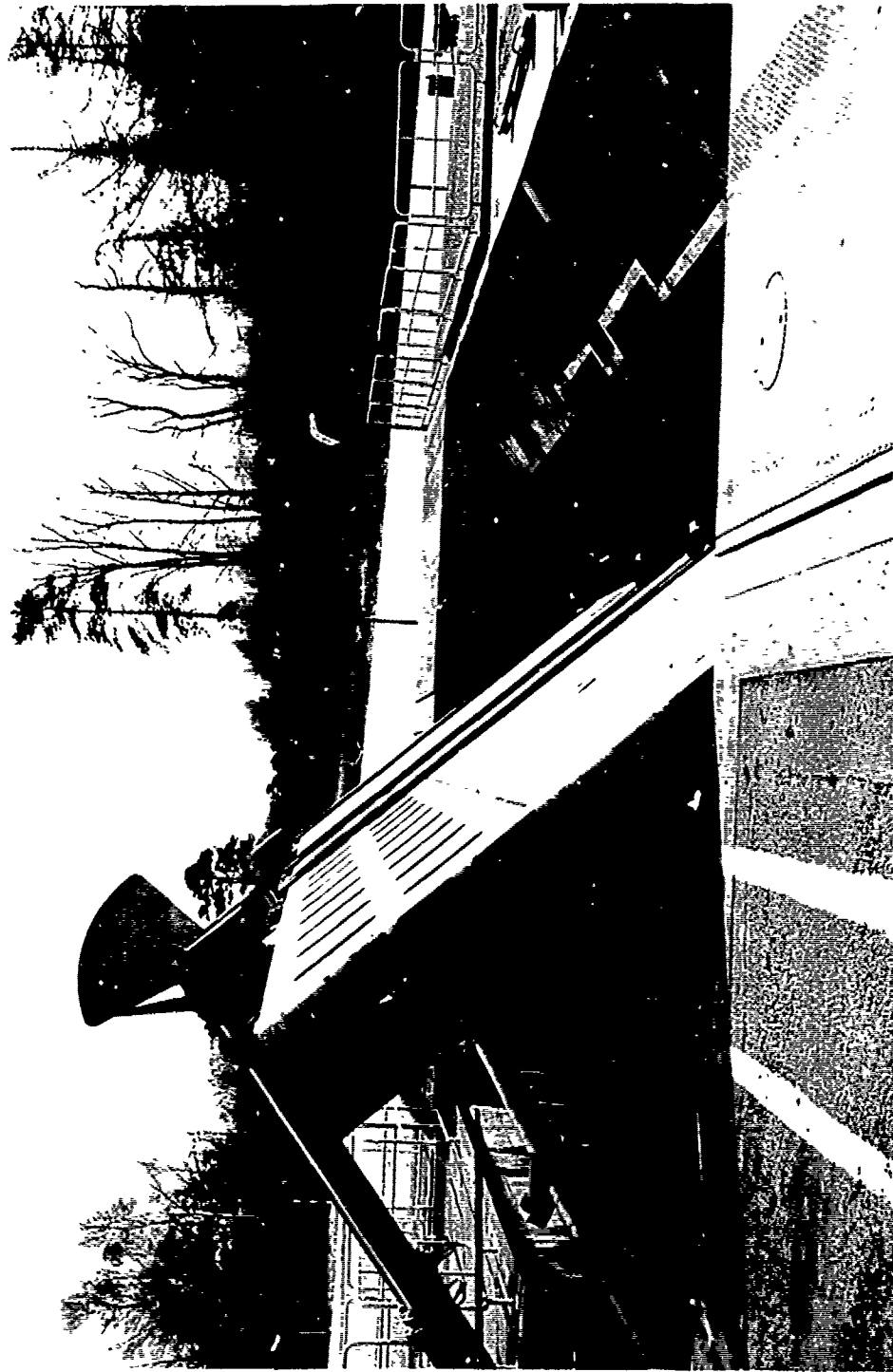

TILT PLATFORM AT MAXIMUM ANGLE 50°

3.8 Longcross - Articulation Gauges (Multi Axle) - Simple

Facility No 40



For a line diagram showing Technical Specifications - see opposite.

*General Description*

All wheels on the same axle will be either raised or lowered. The gauge will exercise the spring assemblies of close coupled axles and measurement of axle vertical travel and clearance of associated assemblies between chassis/body work and axle/spring assemblies can be made.

For dimensions see diagram.

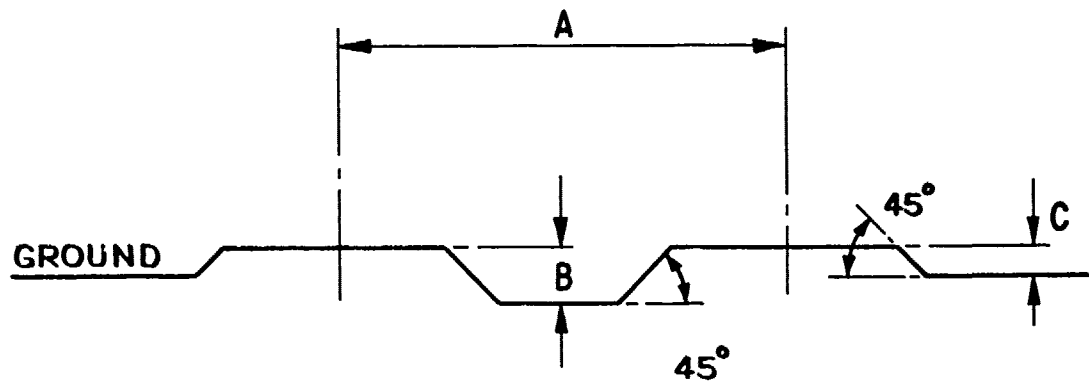
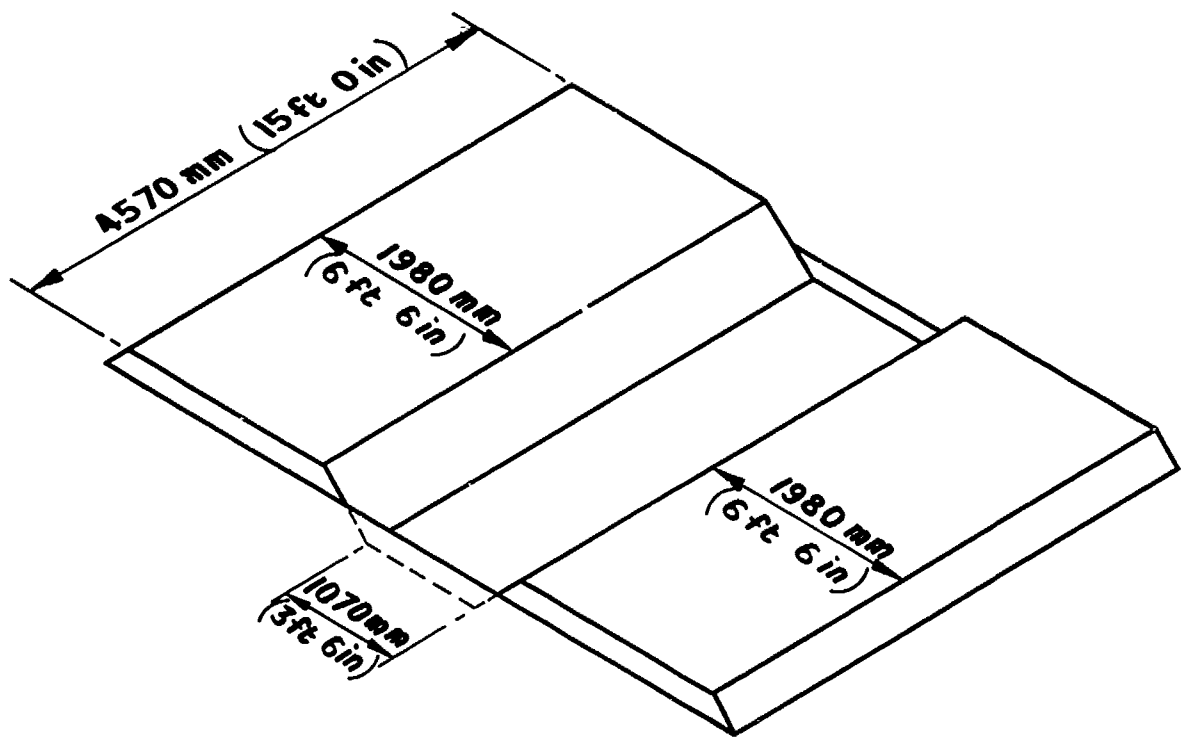

GAUGE	A	B	C
1	3660 mm (12ft 0in)	305 mm (1 ft 0in)	152 mm (6 in)
2	3960 mm (13ft 0in)	460 mm (1 ft 6in)	230 mm (9 in)
3	4270 mm (14 ft 0in)	610 mm (2ft 0in)	305 mm (1 ft 0in)

3.9 Longcross - Articulation Gauges (Multi Axle) Compound

Facility No 36



For a line diagram showing Technical Specifications - see opposite.

*General Description*

The opposite wheel(s) on any given axle are raised/lowered in opposition to each other. Close coupled multi axles will be exercised on opposite extremes of travel (see picture). Static measurements of wheel, axle and spring assembly travel and clearance of related assemblies between suspension and body on extreme axle travel movement can be made.

For measurements see diagram.



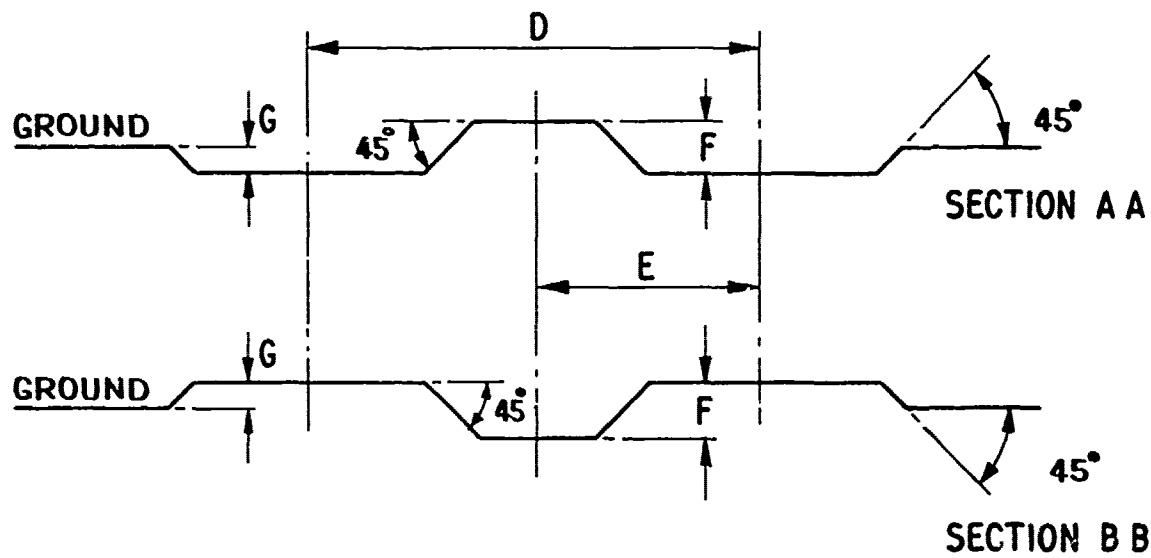
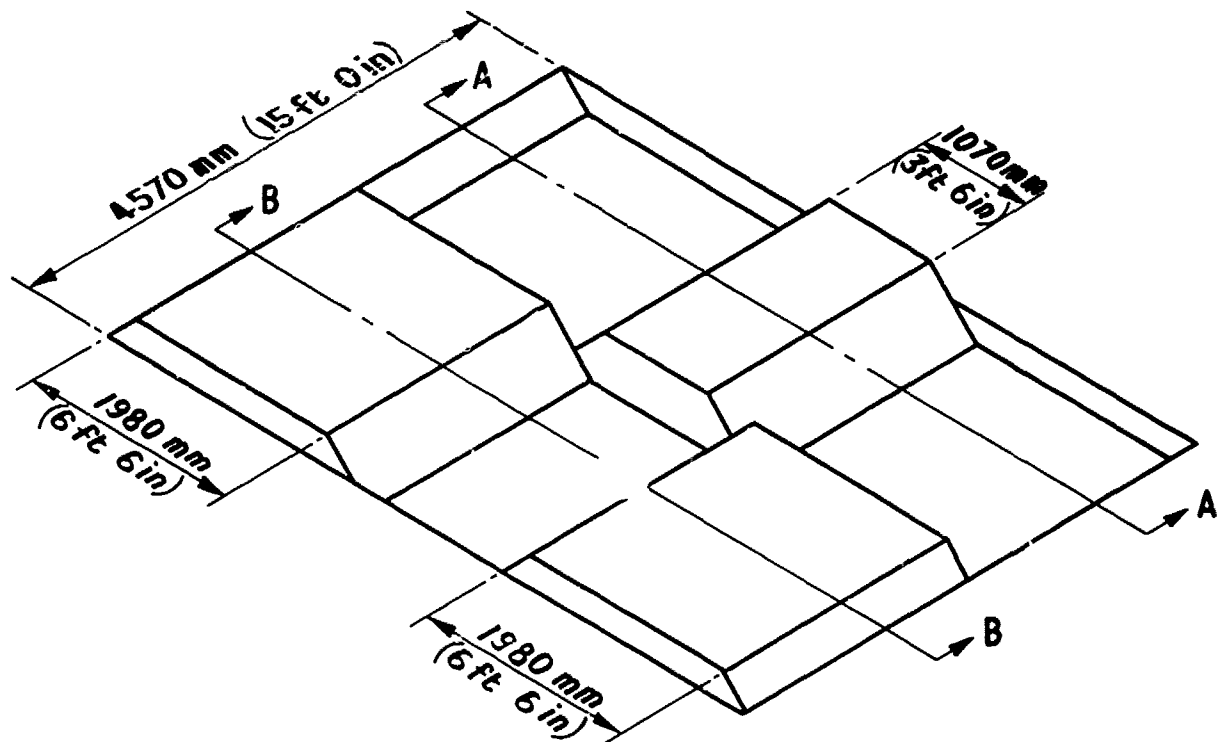

GAUGE	D	E	F	G
1	3660 mm (12 ft 0 in)	1830 mm (6 ft 0 in)	305 mm (1 ft 0 in)	152 mm (6 in)
2	3960 mm (13 ft 0 in)	1980 mm (6 ft 6 in)	460 mm (1 ft 6 in)	230 mm (9 in)
3	4270 mm (14 ft 0 in)	2135 mm (7 ft 0 in)	610 mm (2 ft 0 in)	305 mm (1 ft 0 in)

ARTICULATION GAUGES COMPOUND

3.10 Longcross - Articulation Gauges Single Wheel

Facility No 33



For a line diagram showing Technical Specifications - see opposite.

*General Description*

The wheel(s) on one side of the front axle are raised whilst the opposite side rear axle(s) unit(s) are positioned below ground level. Static measurements of vehicle tilt, twist and axle/wheel clearance can be made.

For measurements see diagram.

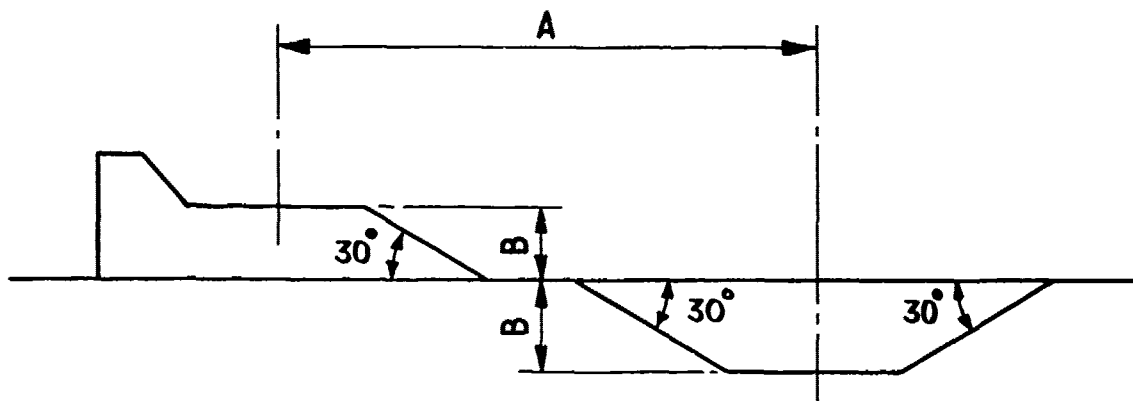
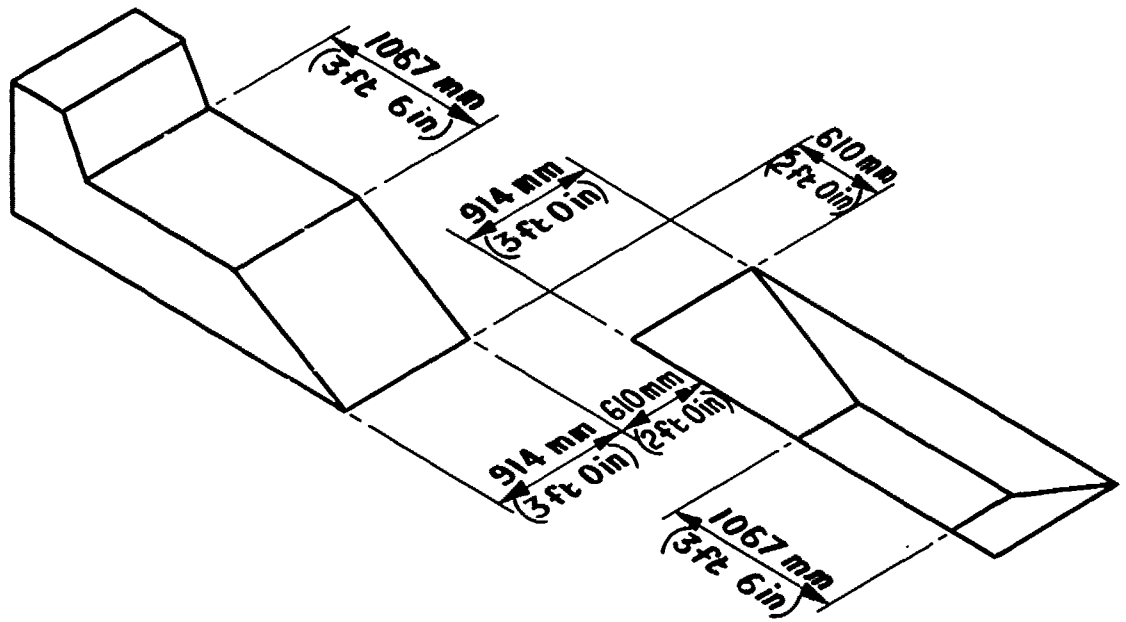

GAUGE	A	B
1	2743 mm (9 ft 0 in)	305 mm (1 ft 0 in)
2	3277 mm (10 ft 9 in)	457 mm (1 ft 6 in)
3	3810 mm (12 ft 6 in)	310 mm (2 ft 0 in)



For a line diagram showing Technical Specifications - see opposite.

*General Description*

To determine the maximum convex gradient changes (ie hill summits etc) on cross country driving that a vehicle can negotiate.

The ability of a vehicle or vehicle train to negotiate rises in ground surface is dependent on the interrelationship between the vehicle's wheel base and belly clearance or the interface between vehicle and trailer. The purpose made hump back of specific dimensions should be used to assess the vehicle/vehicle train's capability in this respect.

For dimensions see diagrams.

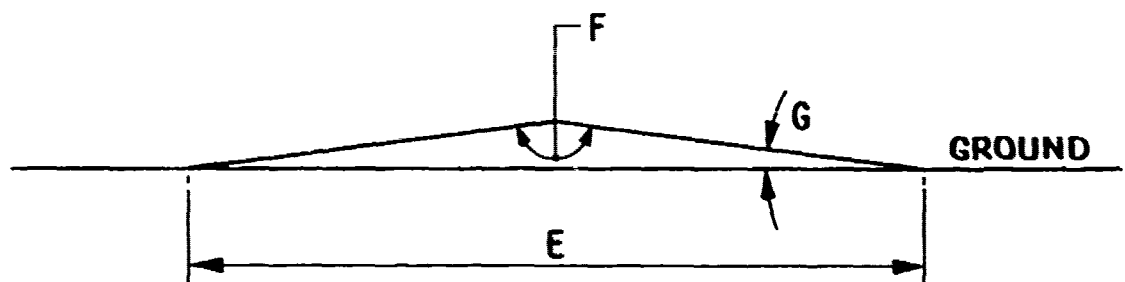
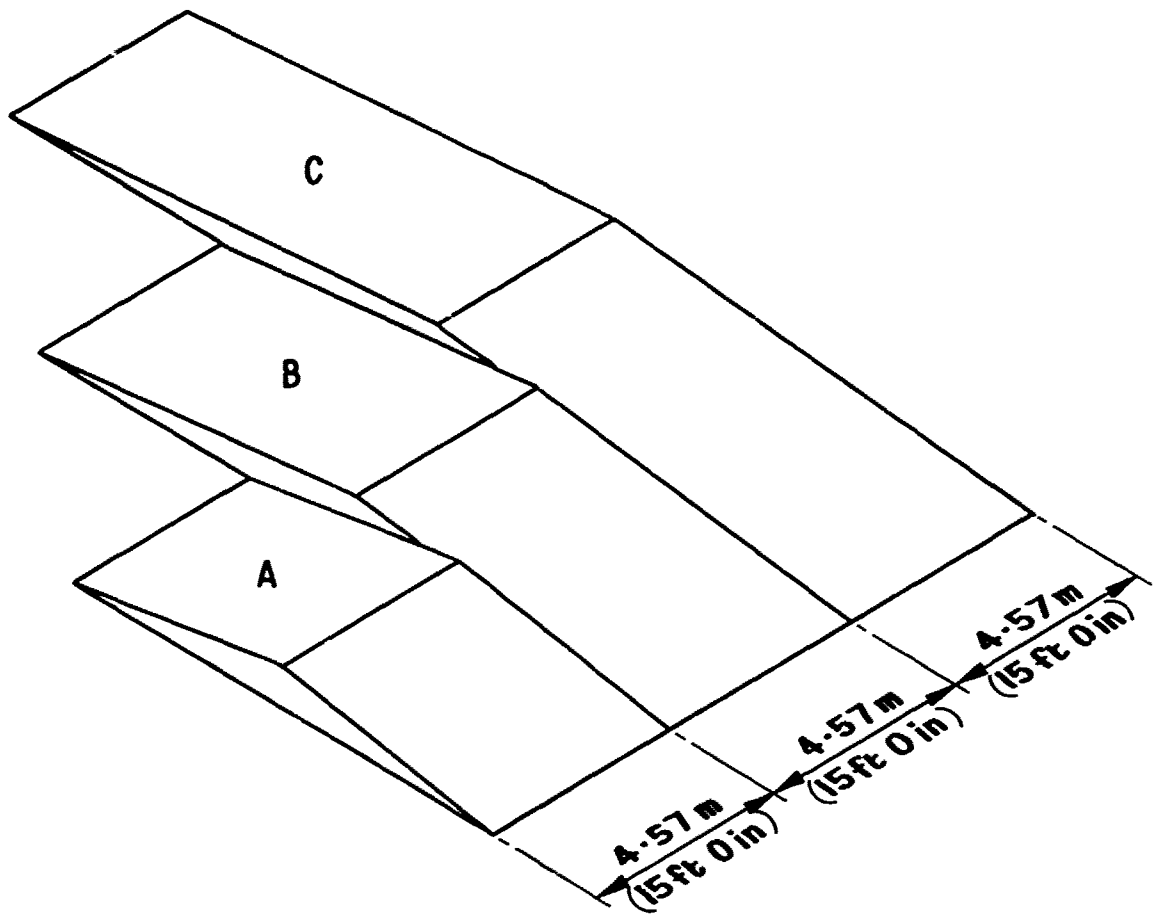

GAUGE	E	F	G PERCENT GRADE
A	10.7 m (35 ft 0 in)	161°	16.7 (1 IN 6)
B	16.0 m (52 ft 6 in)	167°	11.4 (1 IN 8-8)
C	21.3 m (70 ft 0 in)	171°	7.9 (1 IN 12-7)

### BELLY CLEARANCE GAUGES



For a line diagram showing Technical Specifications - see opposite

*General Description*

This is a crane gantry (SWL 15.2 Tonnes) which is used to hoist loads to a maximum height of 25 ft above ground level. A quick release hook then allows the load to be dropped on to a reinforced concrete base (or other material under test placed thereon). High speed cameras and other instrumentation (not normally available for hire) may be incorporated into the trial.

The facility can be used for testing the landing decelerations of 'air dropped' loads (including cargo/vehicle platforms) and the suitability of vehicle 'roll over' protection kits.

LIFTING CAPACITY — SWL (15.2 tonnes)

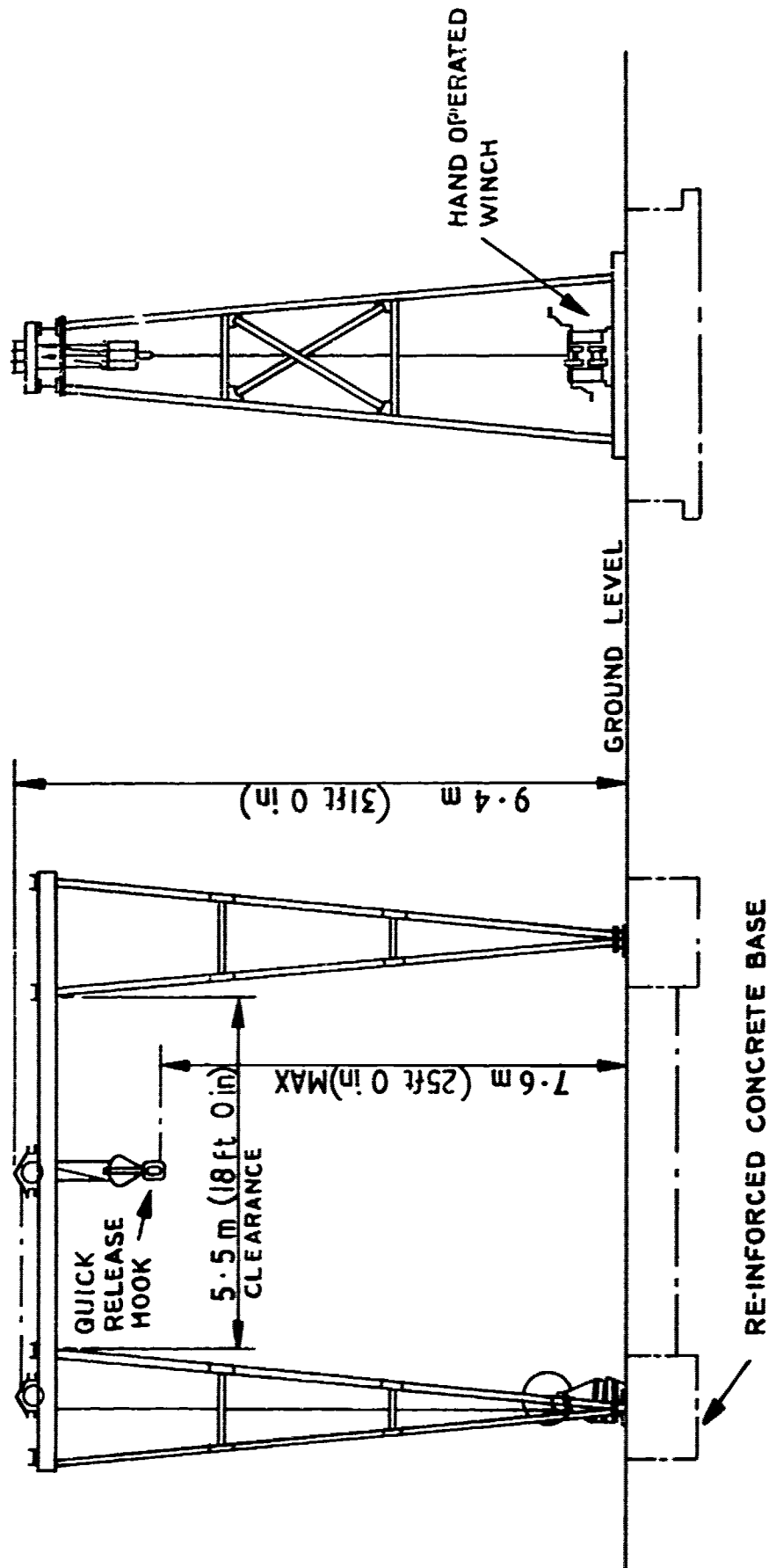

DROP SIMULATOR

### 3.13 Longeross - Loading Gauges

Facility No 41/43



For a line diagram showing Technical Specifications - see opposite.

#### *General Description*

Two ship bow ramp gauges, a Landing Craft Tank (LCT) and Landing Ship Tank (LST) which are both obsolescent and a compound representative 'air-craft' loading ramp gauge. The two ships gauges have 'landing points' of gravel to represent beaches. One is due to be modified to represent the bow ramp of a Landing Craft Logistic (LCL) now in MOD Service with the RCT Fleet

The gauges allow the gradeability, stability and ground clearance of vehicles and trailers to be determined for loading and unloading. For the ship gauges there are metal inserts to represent the actual vessel and these ramps may be 'pre-wetted' to simulate sea conditions.

The gauges are now mainly used for miscellaneous trials of static vehicles on known ramp angles - eg engine oil starvation, AFV turret traversing etc.



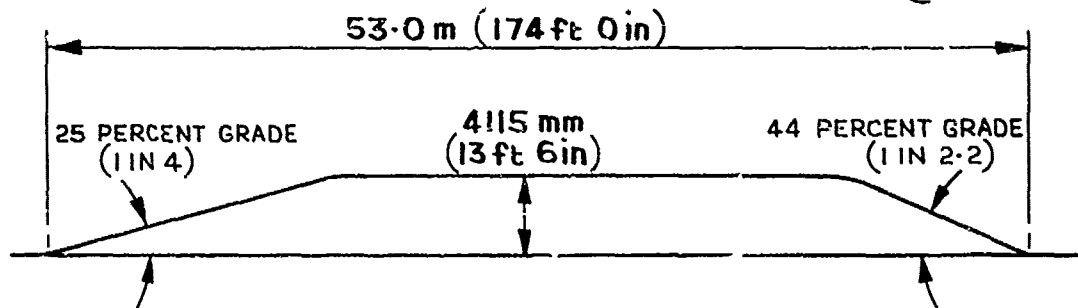
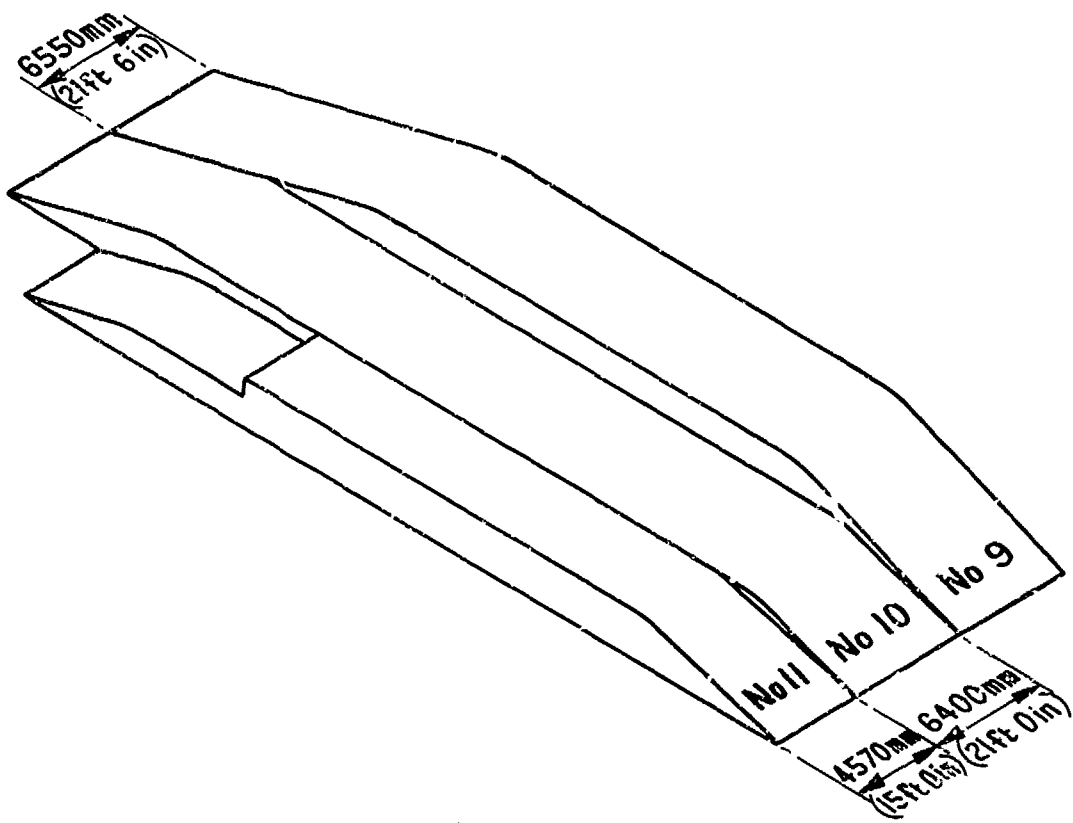

LST 3

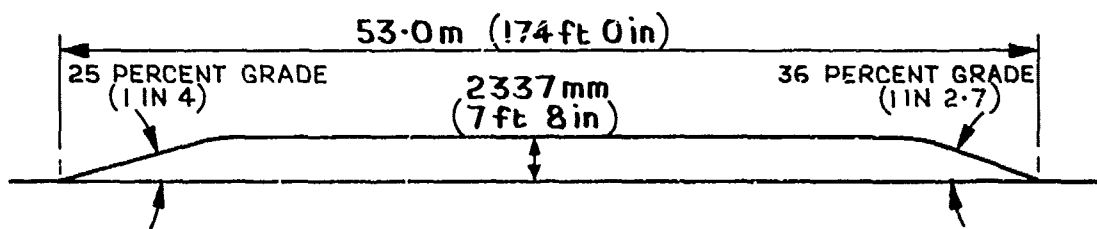

LCT 8

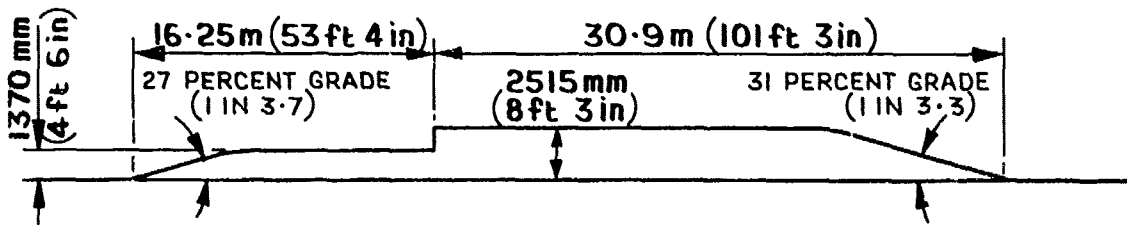

AIRCRAFT

LOADING GAUGE

### 3.14 Longe.oss - Step Obstacles

Facility No 37



For a line diagram showing Technical Specifications - see opposite.

#### *General Description*

There are 3 concrete ramps on tarmac surrounds. They test the ability of a vehicle to climb a vertical obstacle from rest which is dependent on vehicle ground clearance, tractive efficiency and engine power. Tests are conducted on progressively increasing step heights

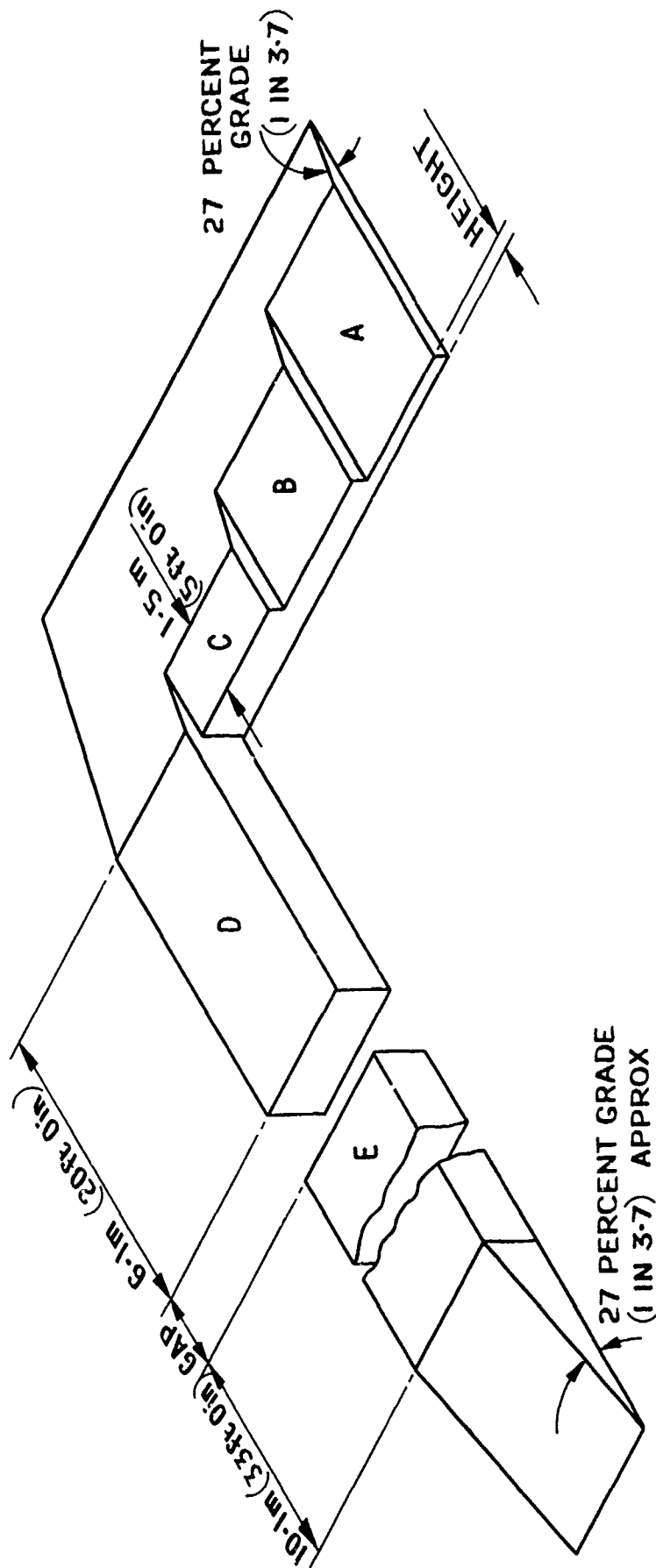

STEP OBSTACLES

	WIDTH	HEIGHT	REMARKS
A	4.42 m (14 ft 6 in)	279 mm (11.0 in) 406 mm (1 ft 4 in)	1 SLEEPER ADDED
B	4.42 m (14 ft 6 in)	533 mm (1 ft 9 in) 660 mm (2 ft 2 in) 787 mm (2 ft 7 in)	1 SLEEPER ADDED 2 SLEEPERS ADDED
C	5.18 m (17 ft 0 in)	914 mm (3 ft 0 in)	

GAP CROSSING

	WIDTH	HEIGHT	REMARKS
D	5.18 m (17 ft 0 in)	1.22 m (4 ft 0 in)	FIXED
E	5.18 m (17 ft 0 in)	1.22 m (4 ft 0 in)	MOVEABLE

GAP 1.219m (4ft 0in) MIN - 3.353m (11ft 0in) MAX  
 ADJUSTABLE IN 50.8mm (2.0in) STAGES  
 BY MOVING E

### 3.15 Longcross - Variable Gap Crossing (Tracked Vehicles only)

Facility No 37



For a line diagram showing Technical Specifications - see previous page.

#### *General Description*

The ability of a slow moving tracked vehicle to traverse a gap between two horizontal surfaces at the same level is dependent on the length of track in contact with the ground, and angles of approach and departure.

The variable gap crossing facility consists of two platforms of the same height, one fixed and the other movable so that the gap between them can be varied.

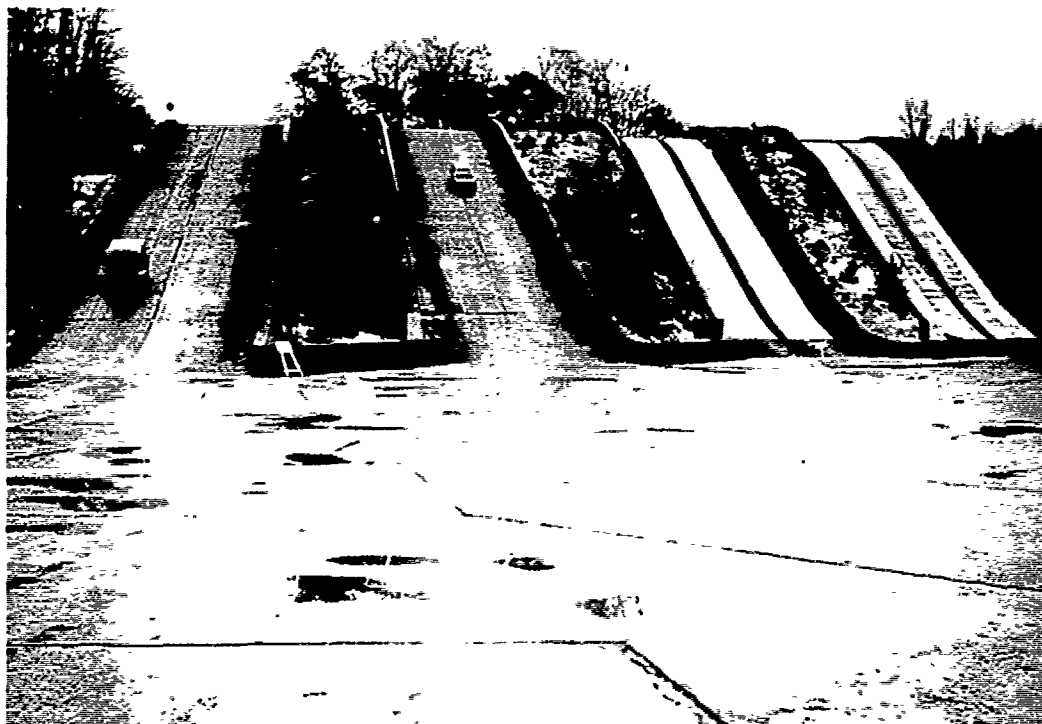

For a line diagram showing Technical Specifications - see opposite.

*General Description*

There are four Test Gradients of concrete construction with entry and exit areas of tarmac. The two steepest gradients have surface inserts - 1 in 2 of continuous timber and 1 in 7.3 of ribbed steel plate.

They test the ability of a vehicle to negotiate steep slopes and are therefore an indication as to its mobility. Associated tests include:

Determination of gradient and speed attainable in differing gears.  
Stopping, holding and re-starting characteristics.  
Determination of engine and lubrication performance.

*Safety*

Only the 1 in 4 and 1 in 3 slopes are normally open. Traffic ascends the 1 in 4 and descends the 1 in 3, (direction signs may only be changed with Track Control authority).

All tests on the two steepest slopes are to be conducted under the direction of Track Control and AP/TS if required.

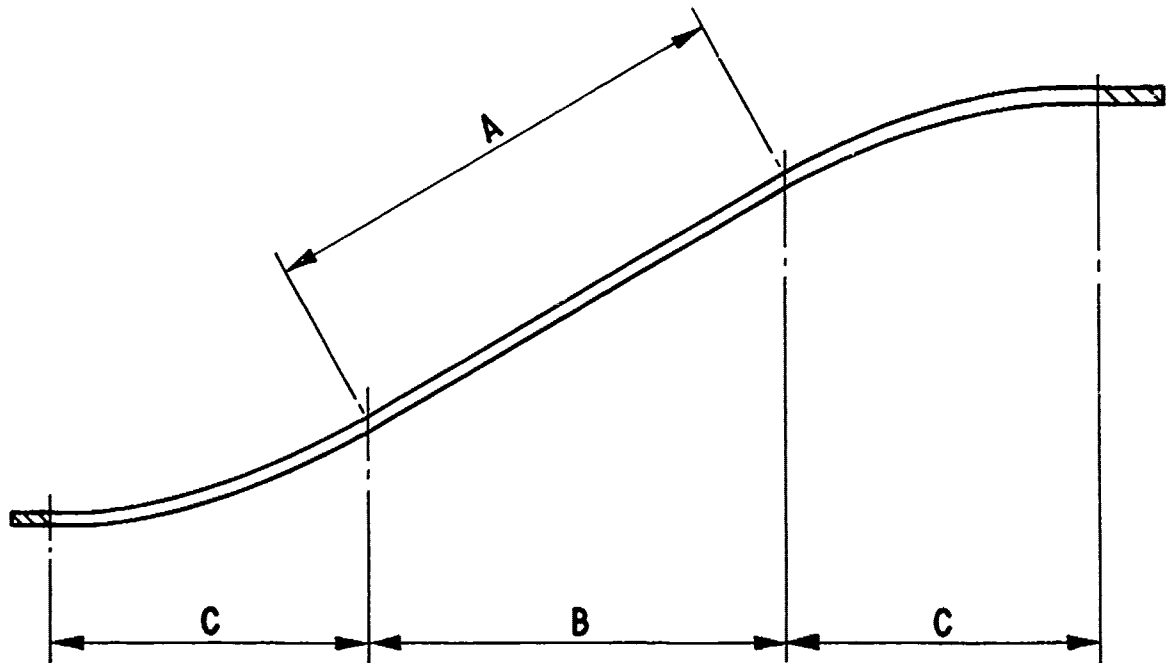

REF No	GRADIENT (PERCENT GRADE)	A	B	C
21	25.0 (1 IN 4)	59.7m (196 ft)	58.2m (191 ft)	14.9m (49 ft)
22	33.3 (1 IN 3)	42.7m (140 ft)	40.2m (132 ft)	14.6m (48 ft)
23	50.0 (1 IN 2)	25.6m (84 ft)	22.9m (75 ft)	14.3m (47 ft)
24	57.8 (1 IN 1.73)	21.3m (70 ft)	18.3m (60 ft)	14.0 (46 ft)

ALL SLOPES ARE 9.1m (30ft) WIDE

SLOPE REF No 24 HAS A RIBBED ARMOURD STEEL PLATE SURFACE

SLOPE REF No 23 HAS CONTINUOUS WOODEN SLEEPER SURFACE

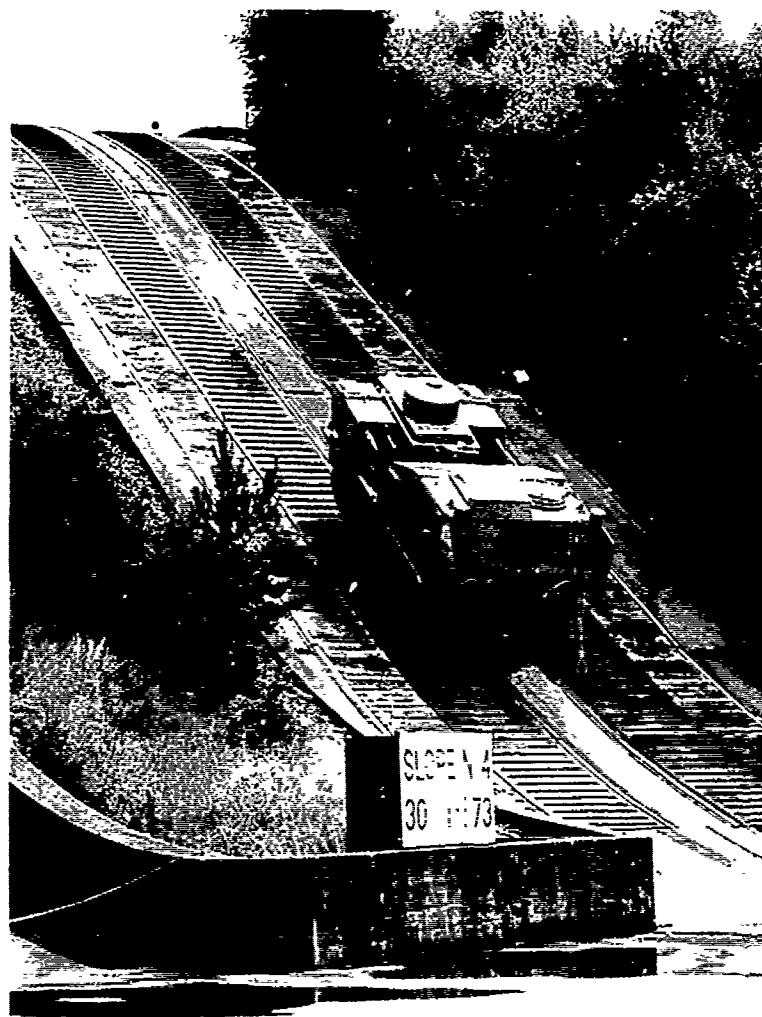





### 3.17 Longcross - Offset Towing Course

Facility No 20



For a line diagram showing Technical Specifications - see opposite.

#### *General Description*

A circular course consisting of a number of differing 'obstacles' - see diagrams - which act as a severe suspension course for towed equipments. The course is entirely set in a concrete base and the prime mover - of suitable wheel base - fitted with an offset towing assembly - runs in a parallel level trackway. This course is for 'accelerated testing' purposes.

FOR SECTIONAL VIEWS SEE OVERLEAF

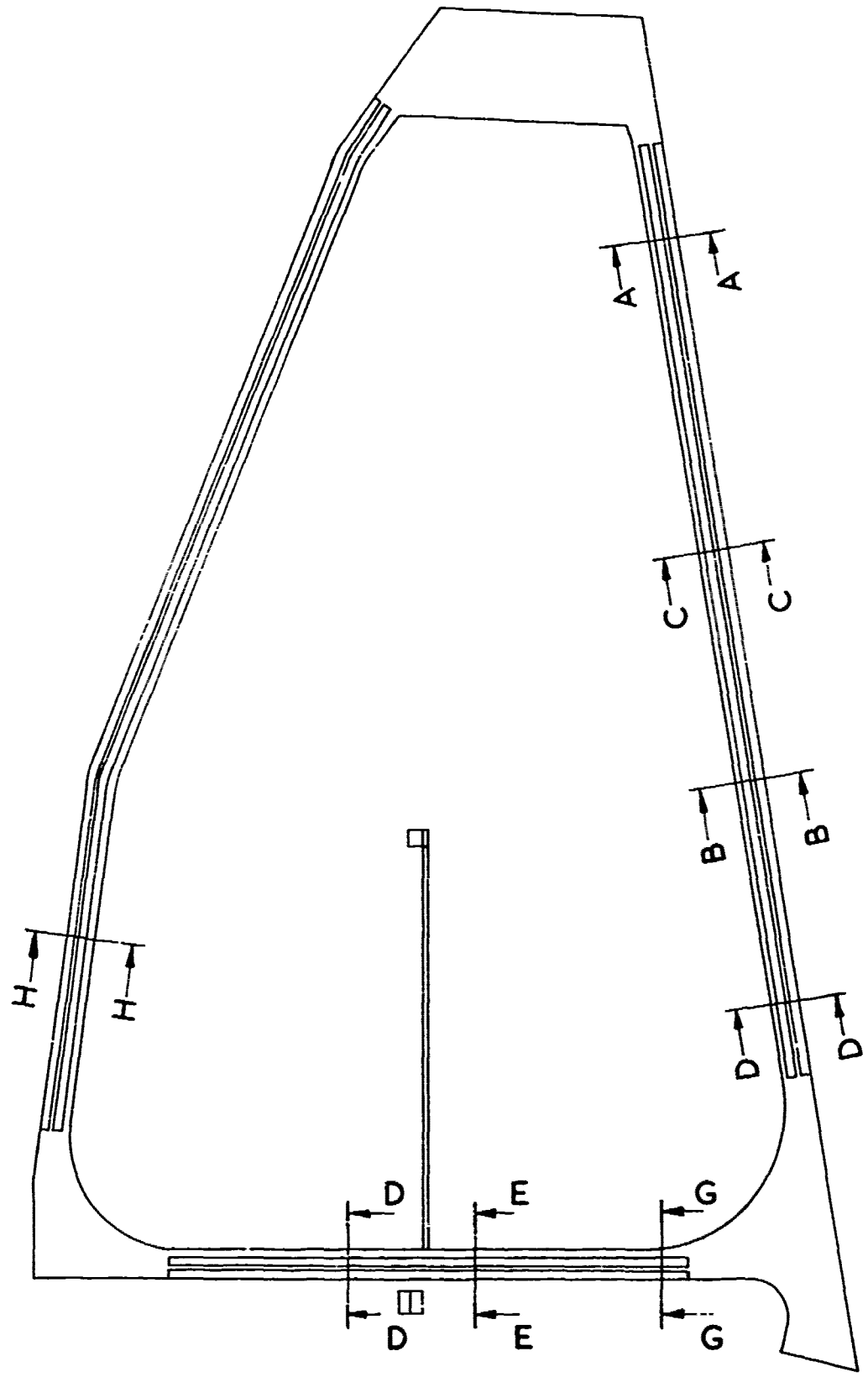

OFFSET TOWING COURSE

OFFSET TOWING COURSE

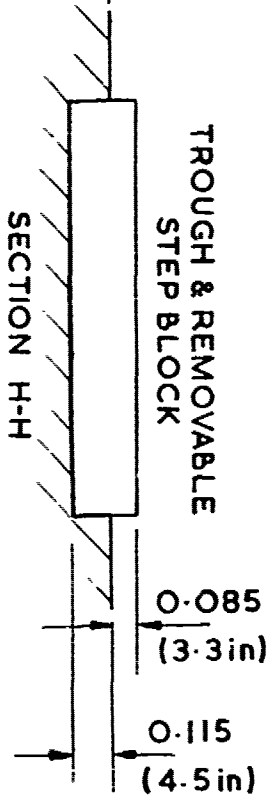
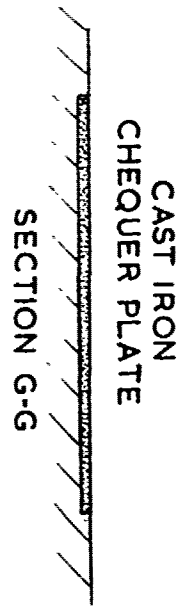
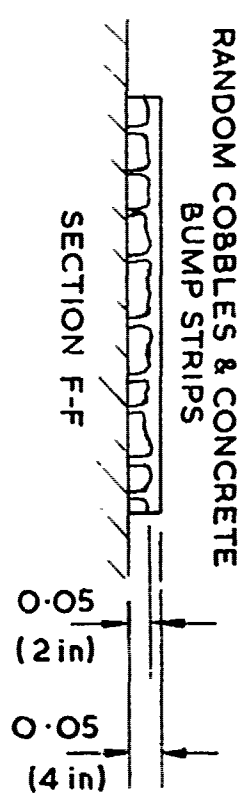
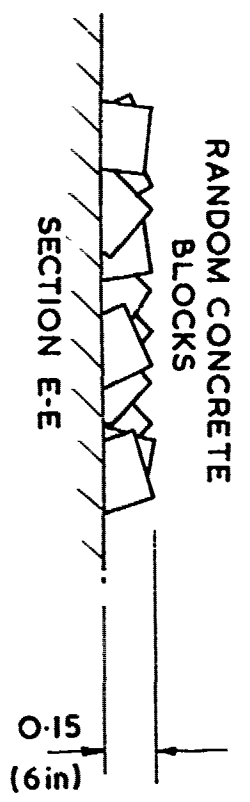
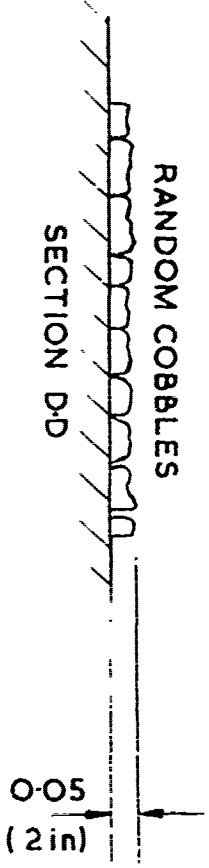
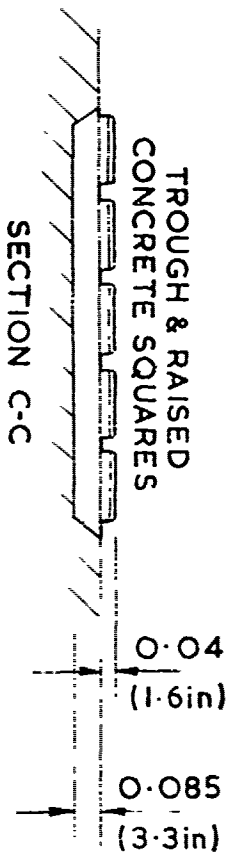
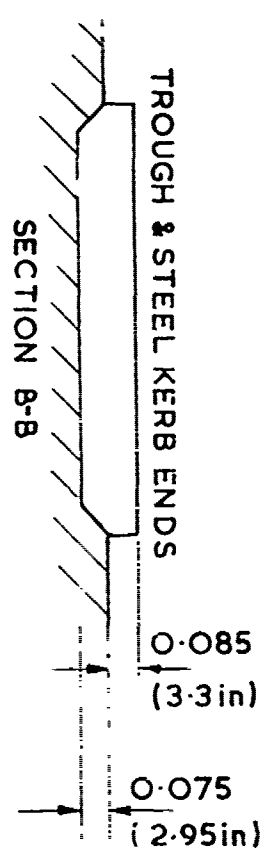
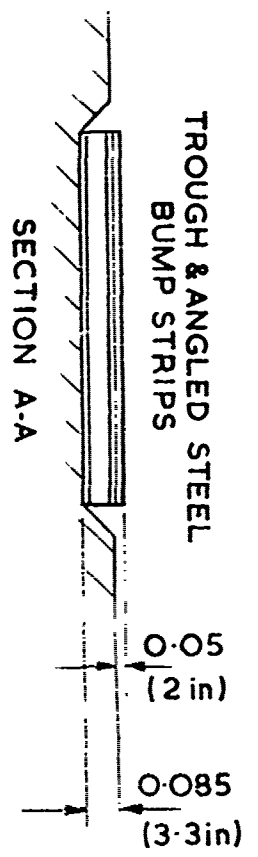

NOTE: TYPICAL WIDTH 1.2m (3ft. 11in)

3.18 *Longeross - Straight and Level Course*

Facility No 22



For a line diagram showing Technical Specifications - see opposite.

*General Description*

A tarmac course approx 1000 foot in length and level to within plus or minus an eighth of an inch on which braking, rolling resistance, steering drift, and other suspension tests using portable metal ramps may be conducted.

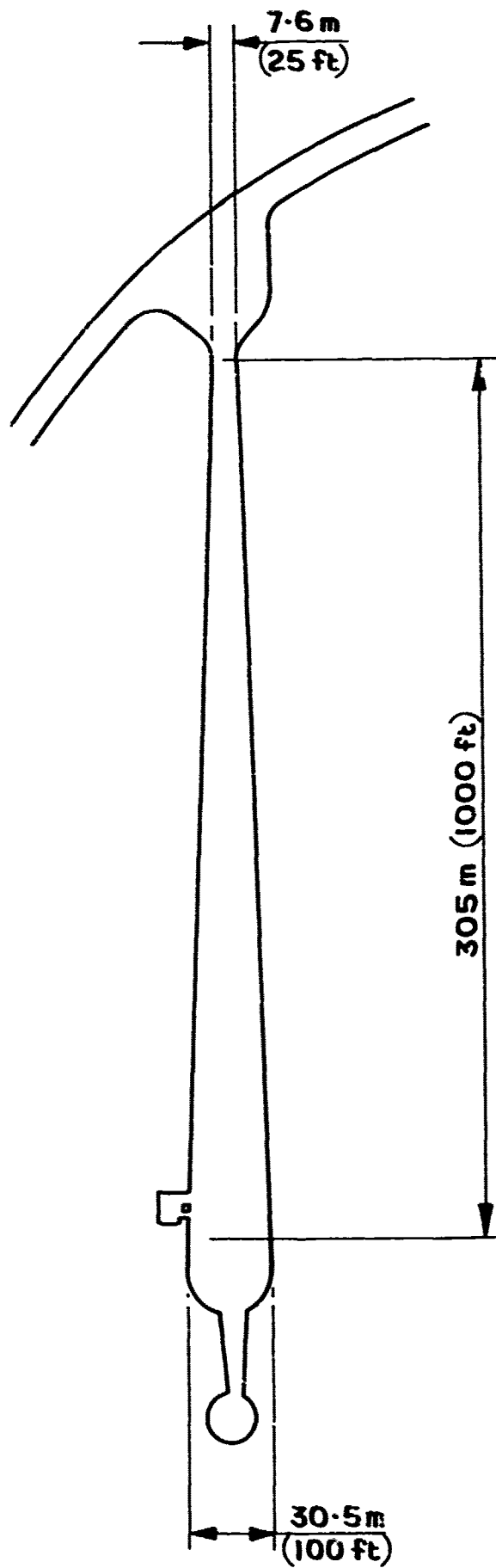

STRAIGHT AND LEVEL TRACK

### 3.19 *Longeross Suspension Courses*

Facility No 5/9



For a line diagram showing Technical Specifications - see overleaf.

#### *General Description*

The Suspension Course complex consists of four parallel courses running East/West with an approximate 'run length' of 1170 ft (for all detailed measurements see diagrams). Each course has an attached turning area of similar material at each end to allow for continuous 'on surface' running. A tarmac level surfaced course (max capacity 4 tonnes GVW), which enables filming from moving chase vehicles, runs between the suspension courses.

*The Courses consist of (from South to North)*

#### a. Pavé

(For use by wheeled and light tracked vehicles) Granite blocks of uniform size approx 6" x 9" set in parallel lines but with a varying and random 'pot hole' effect. There are two broadly differing areas of severity.

b. Boulder

(For use by all vehicles) Granite blocks of irregular shape approx 2 ft square. This course is only 628 ft in length having a firm sand (with occasional iron 'mushroom' inserts) run up to the East.

c. Camera Track

Tarmac, 4 tonnes Gross Vehicle Weight.

d. Setts

(For use by wheeled vehicles only) Two tracks with concrete 'sleepers' set in a firm tarmac/concrete base. Each sleeper approx 2 ft by 4 inches and on one course set proud by 1 inch and on the other by 2 inches. The pitch and phase of each sleeper varies and is shown on the attached diagram.

These courses all produce a form of 'accelerated testing'.

3.19.1

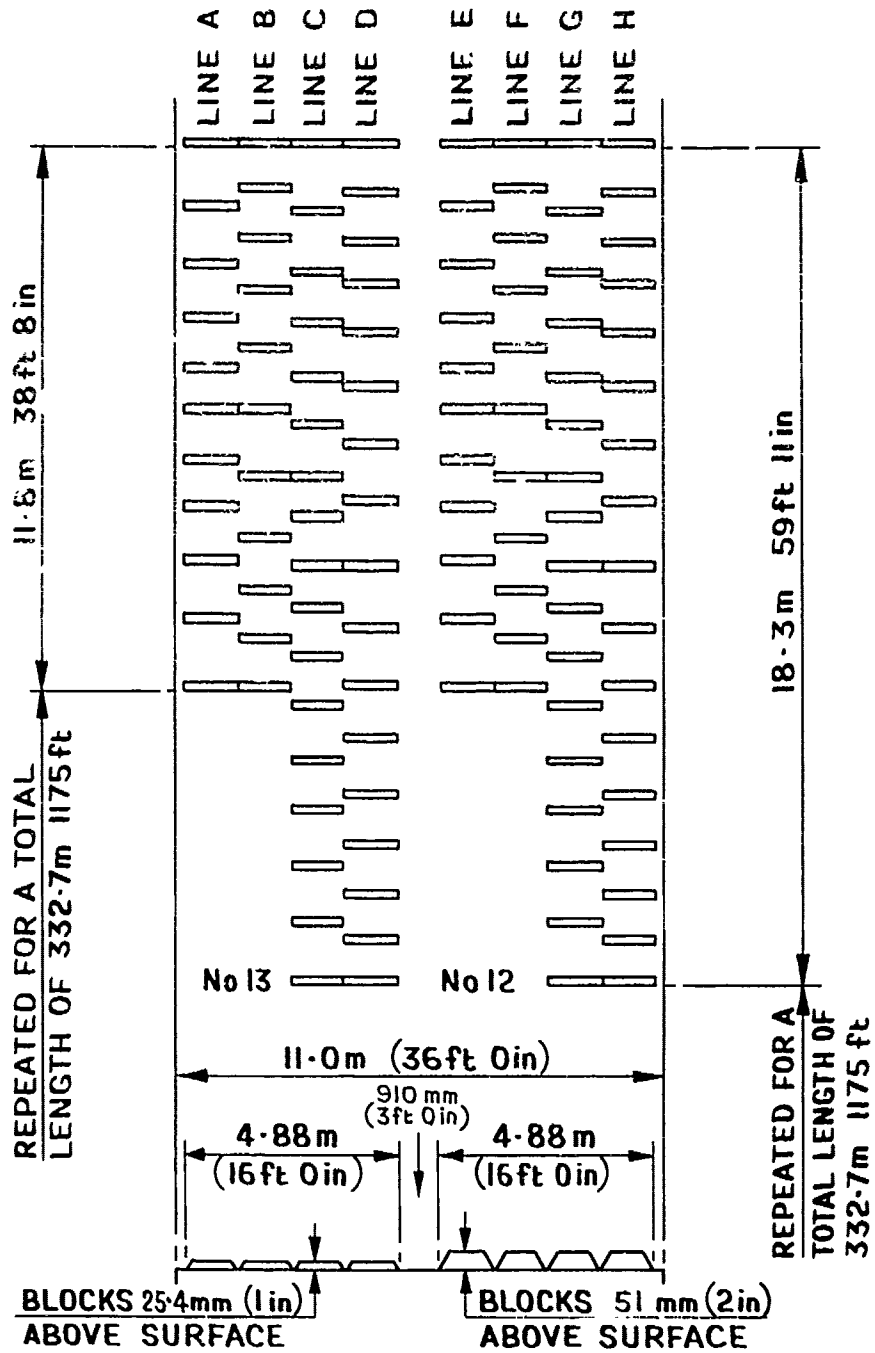

**BLOCKS IN LINES**

A & B ARE PITCHED ALIKE BUT PHASED DIFFERENTLY  
 E & F ARE PITCHED & PHASED LIKE A & B RESPECTIVELY

C & D ARE PITCHED ALIKE BUT PHASED DIFFERENTLY  
 G & H ARE PITCHED & PHASED LIKE C & D RESPECTIVELY

PITCHING OF LINES A, B, E & F DIFFER FROM PITCHING OF LINES  
 C, D, G & H

AT EACH END OF COURSE 25.4 MM (1 IN) HIGH BLOCKS ARE CONTINUED  
 FOR 47.6 M (156 FT) AT 1.22 M (4 FT) INTERVALS TO ENABLE A TURN  
 ROUND FOR CONTINUOUS RUNNING





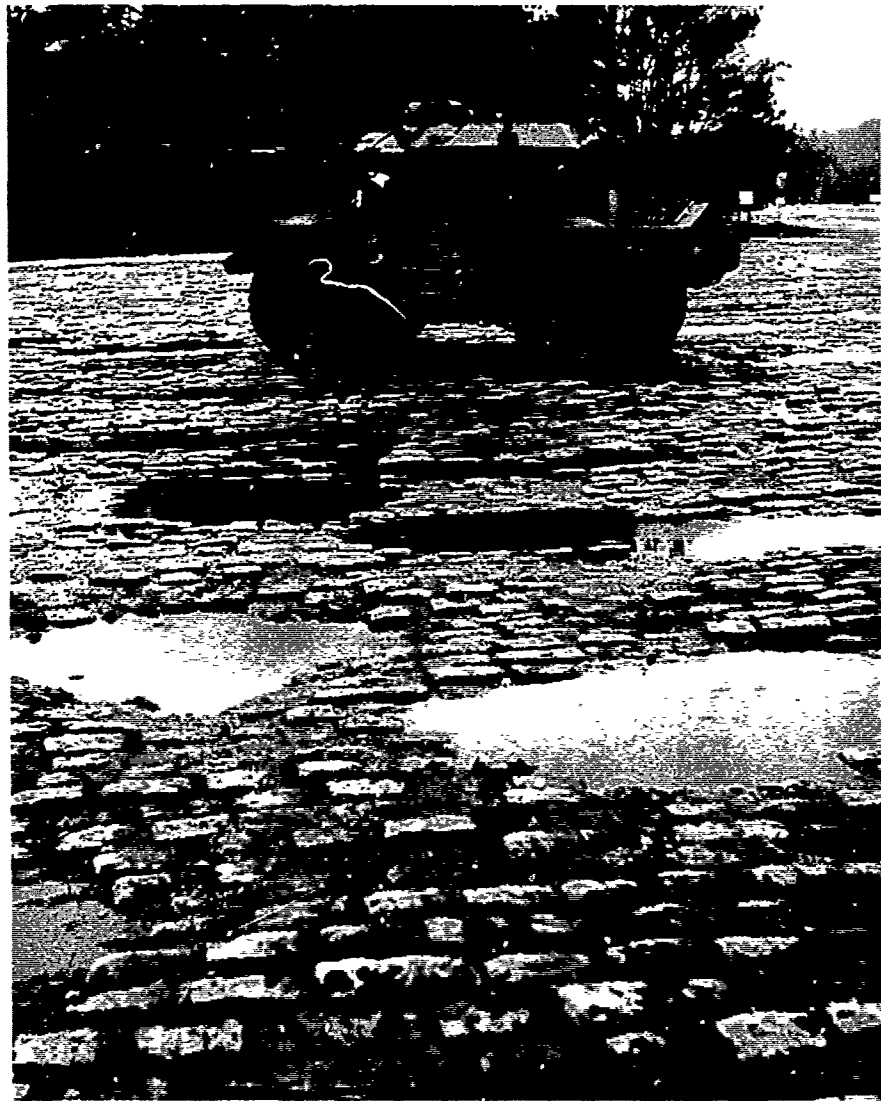

3.19.2

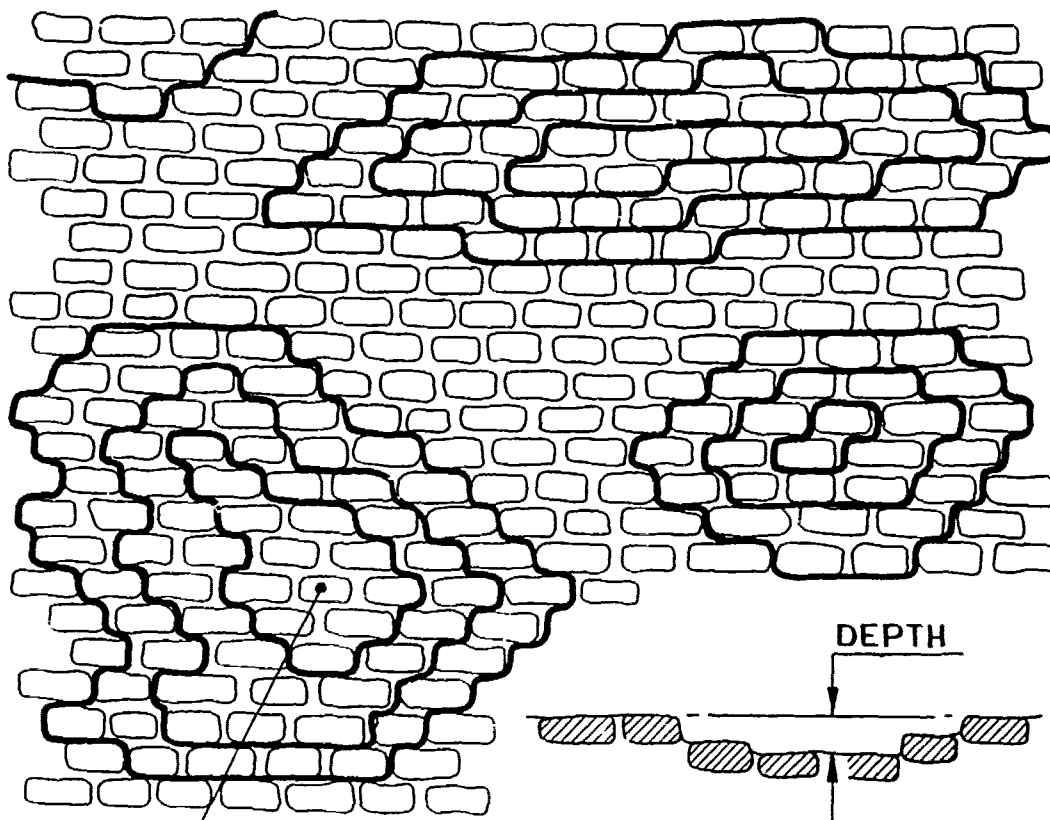

**RANDOM DEPRESSIONS**

- 1 COURSE 356.6 m (1170 ft 0 in) LONG, NO GRADIENT ALONG ITS LENGTH  
6.1 m (20 ft 0 in) WIDE
- 2 THERE ARE 2 SECTIONS  
SECTION A 201.2 m (660 ft 0 in) LONG  
SECTION B 155.5 m (510 ft 0 in) LONG
- 3 DEPRESSIONS ARE IN THE FORM OF POT HOLES, ROUGHLY ELIPTICAL IN SHAPE WITH MAJOR AX.I.S ACROSS THE COURSE

DEPRESSIONS (POT HOLES)	SECTION A	SECTION B
PITCH	VARIES FROM 610 - 1524 mm (2 - 5 ft)	
NUMBER	16 - 17 PER EACH 9.15 m (30 ft 0 in)	
DEPTH	75 mm (3.0 in) MAX	GENERALLY 75-90 mm (3 - 3½ in) OCCASIONALLY 115-130 mm (4½ - 5 in)
AREA	—————	BETWEEN 15% & 30% GREATER THAN 'A' ON ABOUT 50% OF THE NUMBER
TOP SURFACE BETWEEN DEPRESSIONS	FAIRLY LEVEL NO GREAT VARIATIONS IN HEIGHT BETWEEN SETS	ROUGHER THAN 'A' SET HEIGHTS VARY ± 25-38 mm (1 - 1½ in)
JOINTS BETWEEN SETS	25 mm ± 19 mm WIDE (1 in ± ¾ in)	50% AREA 25 mm ± 6 mm (1 in ± ¼ in) 50% AREA 25 - 50 mm (1 - 2 in)
ENTRY & EXIT FROM DEPRESSION	SETS ARRANGED SQUARE STEPS 25-38 mm (1 - 1½ in)	GENERALLY AS 'A' MANY SETS 25 - 65 mm (1 - 2½ in) HIGH

- 4 COURSE IS EXTENDED AT EACH END TO PERMIT A TURN ROUND FOR CONTINUOUS RUNNING

3.19.3

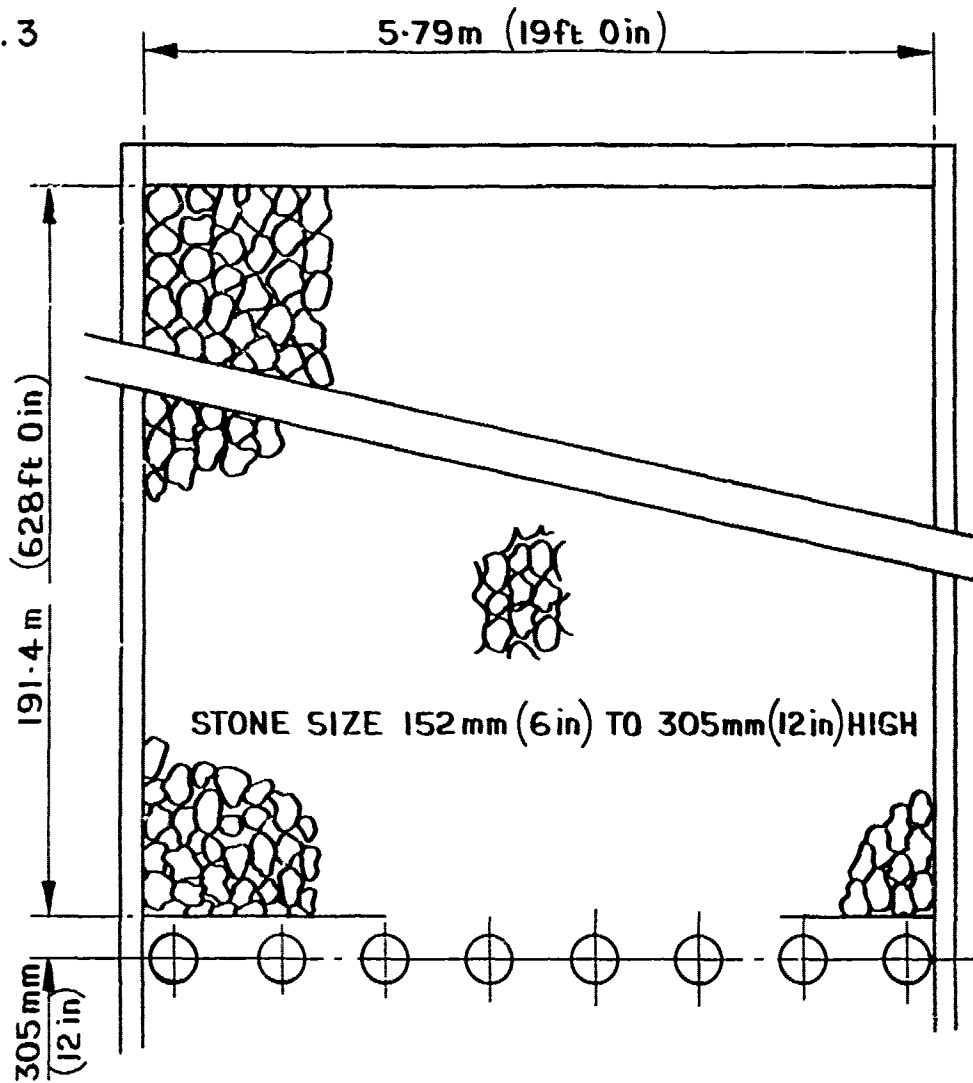

TYPICAL CROSS SECTION THROUGH COURSE

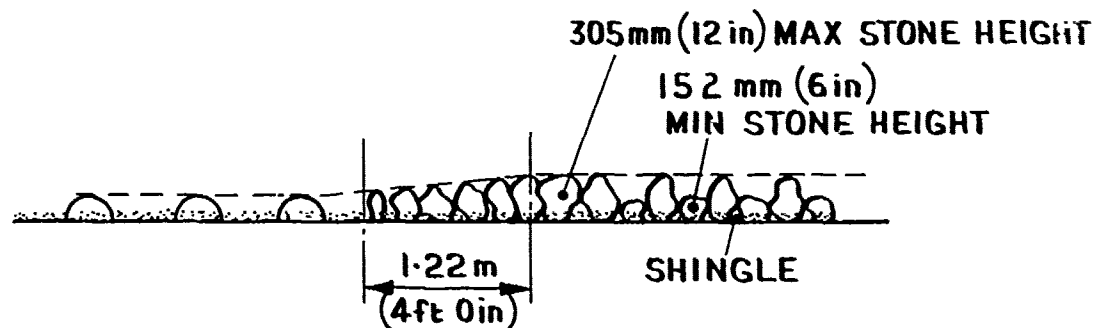

LONGITUDINAL SECTION SHOWING CHANGEOVER FROM BOULDER TO MUSHROOM  
STONE SIZE INCREASED GRADUALLY OVER 1.22 m (4ft 0in) TO A HEIGHT OF 305 mm (12in)



### 3.20 Longcross - Wading Pool

Facility No 34

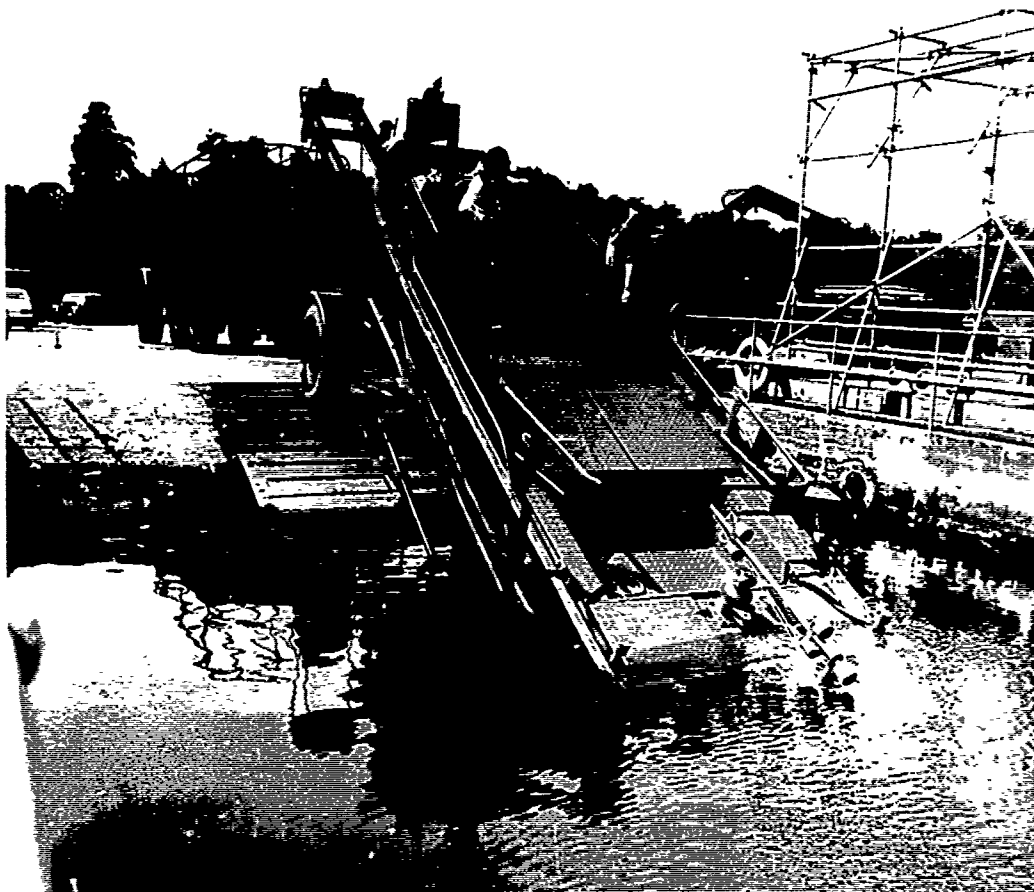

For a line diagram showing Technical Specifications - see opposite.

#### *General Description*

The structure consists of a concrete tank 30 ft wide and 50 ft long at its base, and 155 ft long at its top edge. The maximum depth of water is 16 ft and this may be varied by pumping to or from the adjacent Green Braithwaite tanks at a rate of approximately 12 inches per 20 minutes. The facility may be used for either full flotation trials or shallow and deep wading trials. The permanently built in ramp angles were originally provided as representative of those to be found on a Landing Ship Tank 3 (LST 3) now no longer in Ministry of Defence service.

The minimum water depth obtainable is 18 inches.

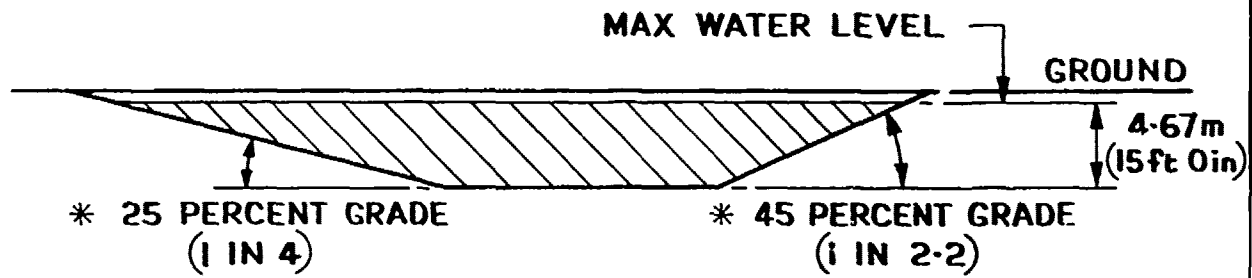
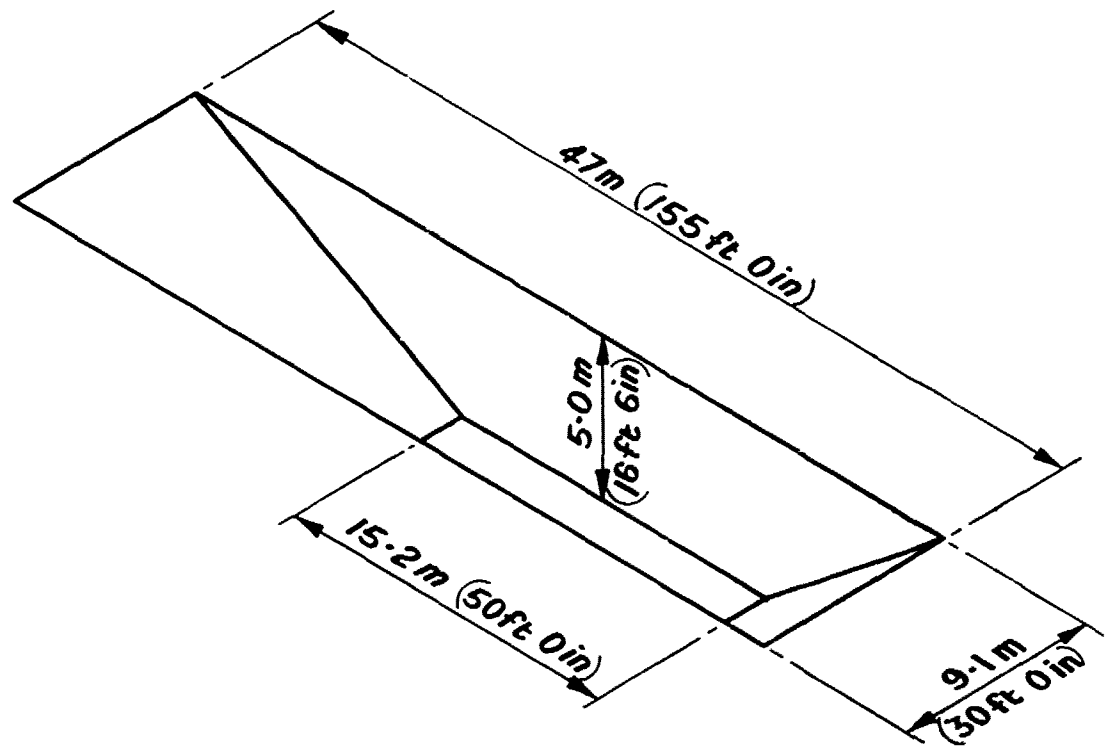

\* SAME AS LST 3

WADING POOL

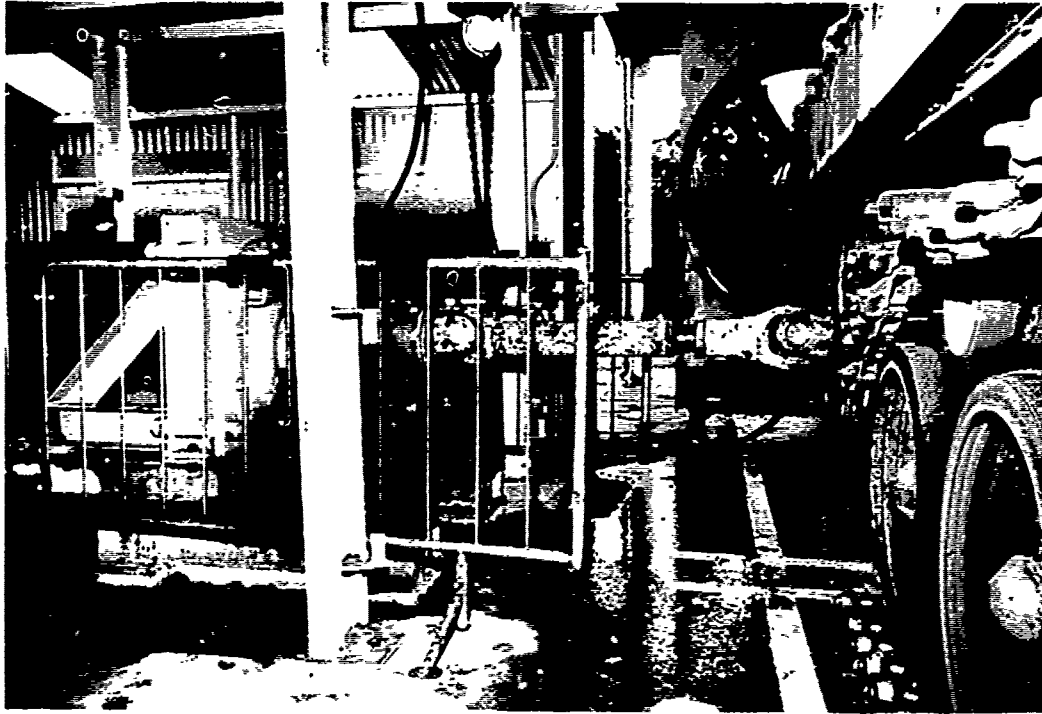

For a line diagram showing Technical Specifications - see opposite.

*General Description*

This facility consists of 2 DPY non-reversible water brake dynamometers housed in a covered area with a separate control cabin. The facility is specially designed for testing tracked vehicle power outputs. The dynamometer is capable of absorbing inputs of over 800 BHP. The control cabin contains instrumentation and recording equipment from which can be determined the vehicle's power curves over a wide speed and gear ratio range.



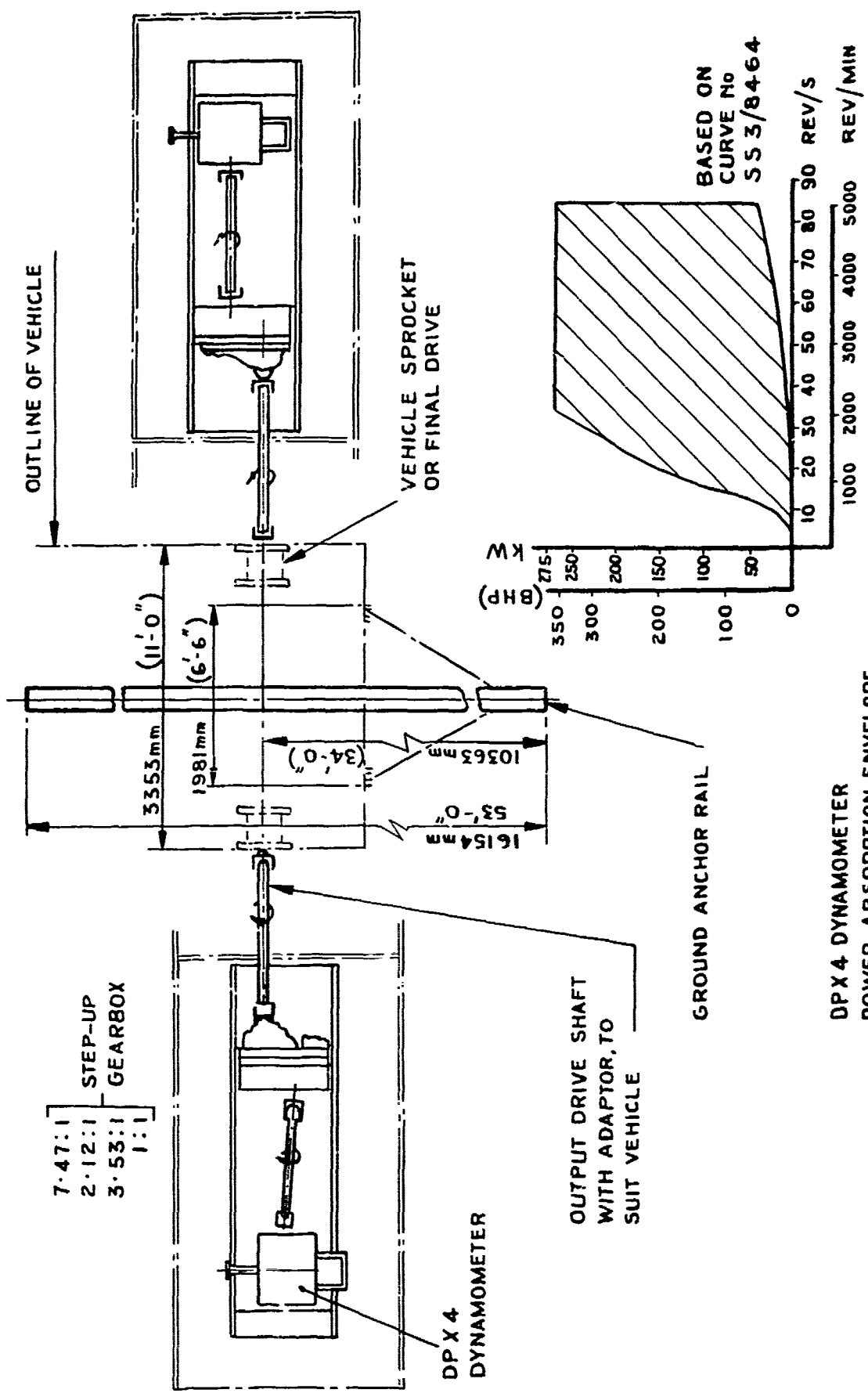

DPX 4 DYNAMOMETER  
POWER ABSORPTION ENVELOPE

FIELD DYNAMOMETER



For a line diagram showing Technical Specifications - see opposite.

*General Description*

The Winch Test Facility consists of a static winch housed in a covered building, a cable run area of 440 ft (134.1 m) with a further overrun area of 165 ft (50.3 m) behind which is an anchor attachment block of a 100 tonne capacity. A further 50 tonne anchor block assembly is positioned within the main rope run area for multiple block and tackle pulls.

The winch test allows vehicle-borne winches to be proved under controlled conditions. The winch test assembly is housed on a floating bed which is coupled to a dynamic load cell that directly indicates the pull on the winch rope under test. The length of the rope run allows the test vehicle's winch rope can be trialled up to its fully payed-out length. The vehicle under test can either be restrained using its own means (eg spade attachment) or by being coupled to the 100 tonne anchor point, in which case the vehicle is normally parked on the concrete hard standing at the end of the main winch rope run. The winch itself can exert a direct pull up to 35 tonnes on the vehicle winch under test, or it can act as a winch load by means of coupling an electrical load bank to the static test winch drum assembly.

The complete Winch Test Facility is due to be updated in the early 1980's.

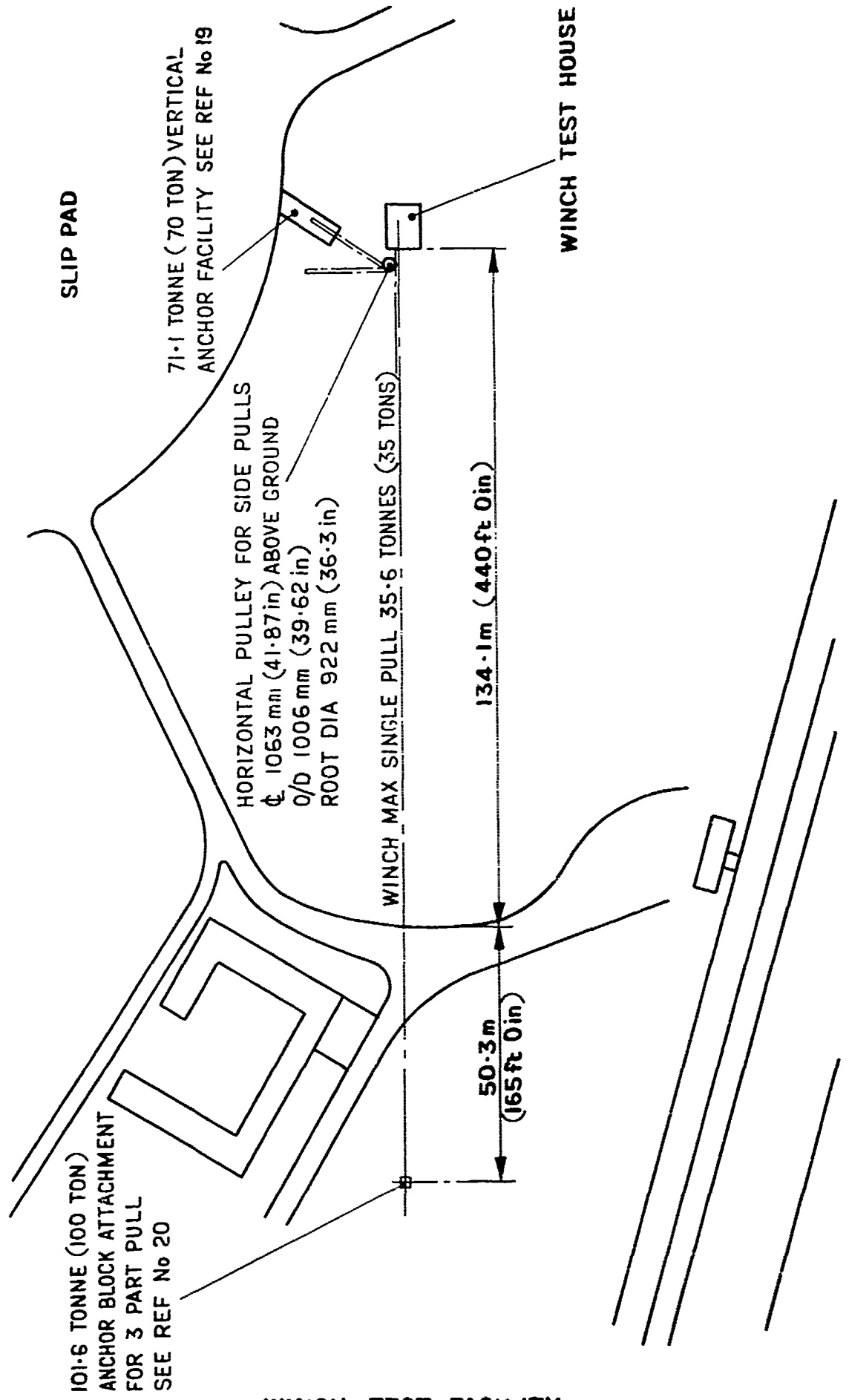

WINCH TEST FACILITY

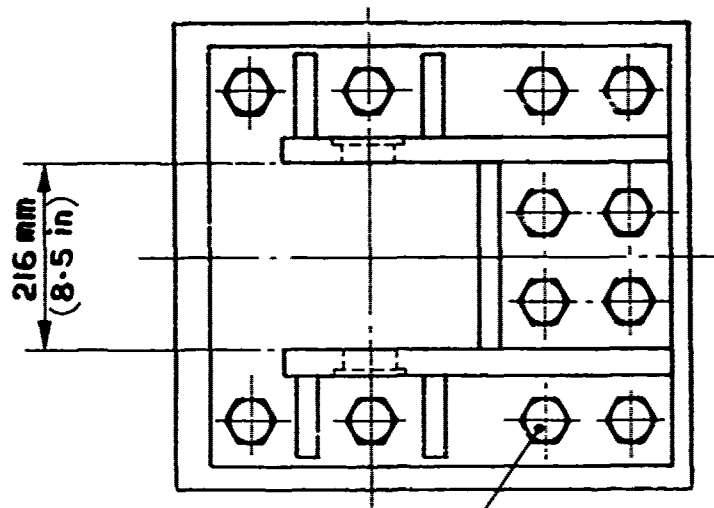

HOLE  $\phi$  64 mm (2.515 in)      12- $\frac{1}{4}$  in DIA HOLDING DOWN BOLTS

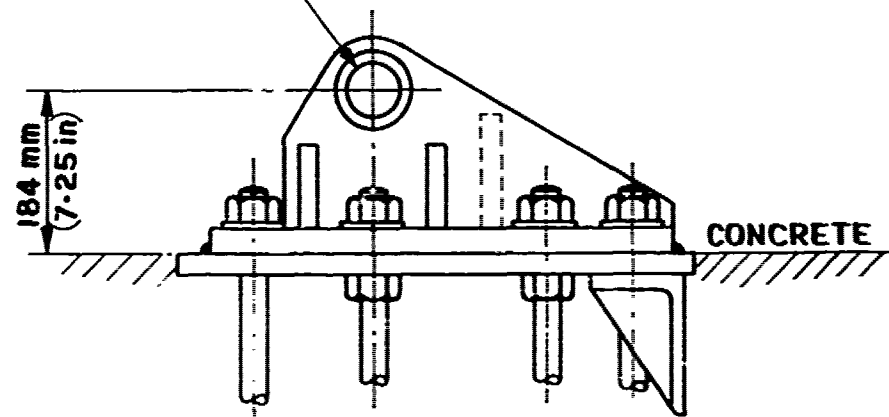

THE 50.8 AND 101.6 TONNE (50 AND 100 TON) ANCHOR BLOCKS DIFFER ONLY IN THE LENGTH OF HOLDING DOWN BOLTS AND DEPTH OF CONCRETE

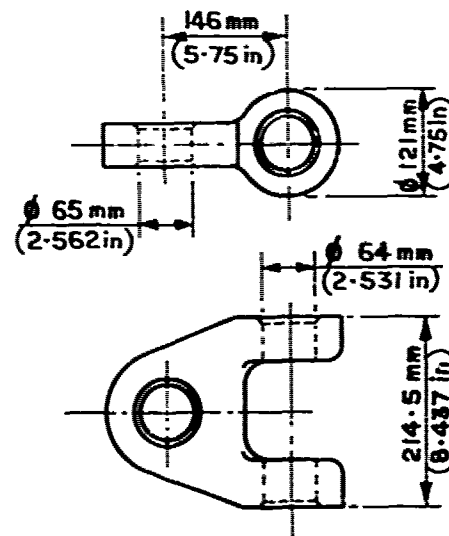

TOWING EYE  
FV 62775

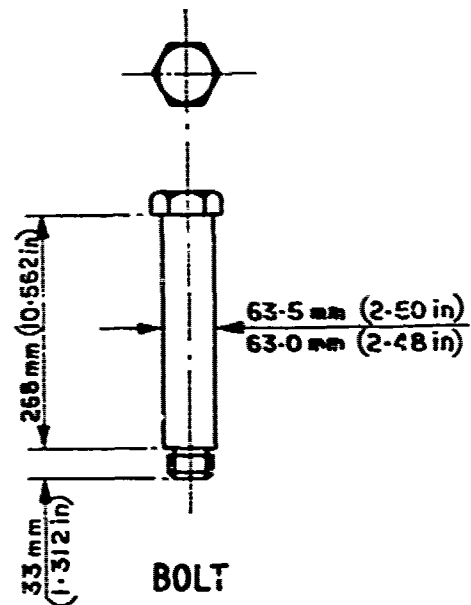

BOLT  
FV 62776



For a line diagram showing Technical Specifications - see overleaf.

*General Description*

This large modern hangar complex is situated at the western edge of the Slip Pad. It houses Automotive Trials/Performance Trials Section (AT/PTS) who are responsible for instrumenting vehicles before certain tests (eg brake test) and conducting all trials on the Tilt Platform, Winch Test Facility, Field Dynamometer, Gap Crossing Gauge, Steep Slopes and various other facilities. The building also contains the following test facilities.

A 15 m square flat floor used for vehicle measurement accuracy checks, tyre deflections, and other steering geometry static trials.

An electronic individual axle wheel weighing system which produces instant print outs of a vehicle's individual axle (max load 20 tonnes per axle) and gross vehicle weights. This facility is suitable for all types of wheeled vehicles. Individual portable wheel station weighing systems (Max load 20 tonnes).

#### 4. Bagshot Test Course Complex

The Bagshot test course complex is approximately 8 miles south-west of the main Establishment. There are 3 courses:

##### *The main course*

This is a 3.7 mile rough road course suitable for wheeled vehicles of all sizes (including loaded tank transporters). Rough Road indicates a graded, compacted surface of flintstones (up to 6 inches in diameter) with a clay and sand binding. With use, the road becomes rutted and covered with potholes and this combination provides a very severe test for suspension systems and tyres. The course is regularly maintained but dependant on weather, the surface condition may display marked differences.

##### *Alpine Course*

This is a narrower, steeper (up to 1 in 2.7 gradients) 3.5 mile circuit constructed with the same mixture of flint, clay and sand. The last four up gradients are additionally surfaced with "Somersetfield Trackway", a combination of wire netting and bars staked into the ground. The course is suitable for all-wheel drive vehicles normally not larger than the 1 tonne Landrover size.

##### *Cross Country Area*

There is a central, approximately 1 km square, cross country driving area consisting of sand and mud between heather and small trees. This is suitable only for all wheeled vehicles and may only be used on an occasional basis to stop the degradation of the area.

#### Navigation Points

There are 2 Navigation Points for use in accuracy checks of on-board vehicle navigational systems:

Rough Road roundabout	Eastings 490681.0 m Northings 160822.5 m	Metal rod set in concrete and marked with yellow paint
Alpine Course - lower Curley	Eastings 490912.7 m Northings 161720.4 m	Metal rod set in concrete and marked with yellow paint

#### Administrative Facilities

There are toilets, a drivers rest room and a small kitchen.

A small conference room may be made available by special request.

A covered hangar area, with inspection pit, may be available, on request, when not in use for Establishment work.

Cold water high pressure air/water mix wash down facilities are available on request.

Telephone Camberley 26262.

M.V.E.E. TRIALS AREA BAGSHOT HEATH

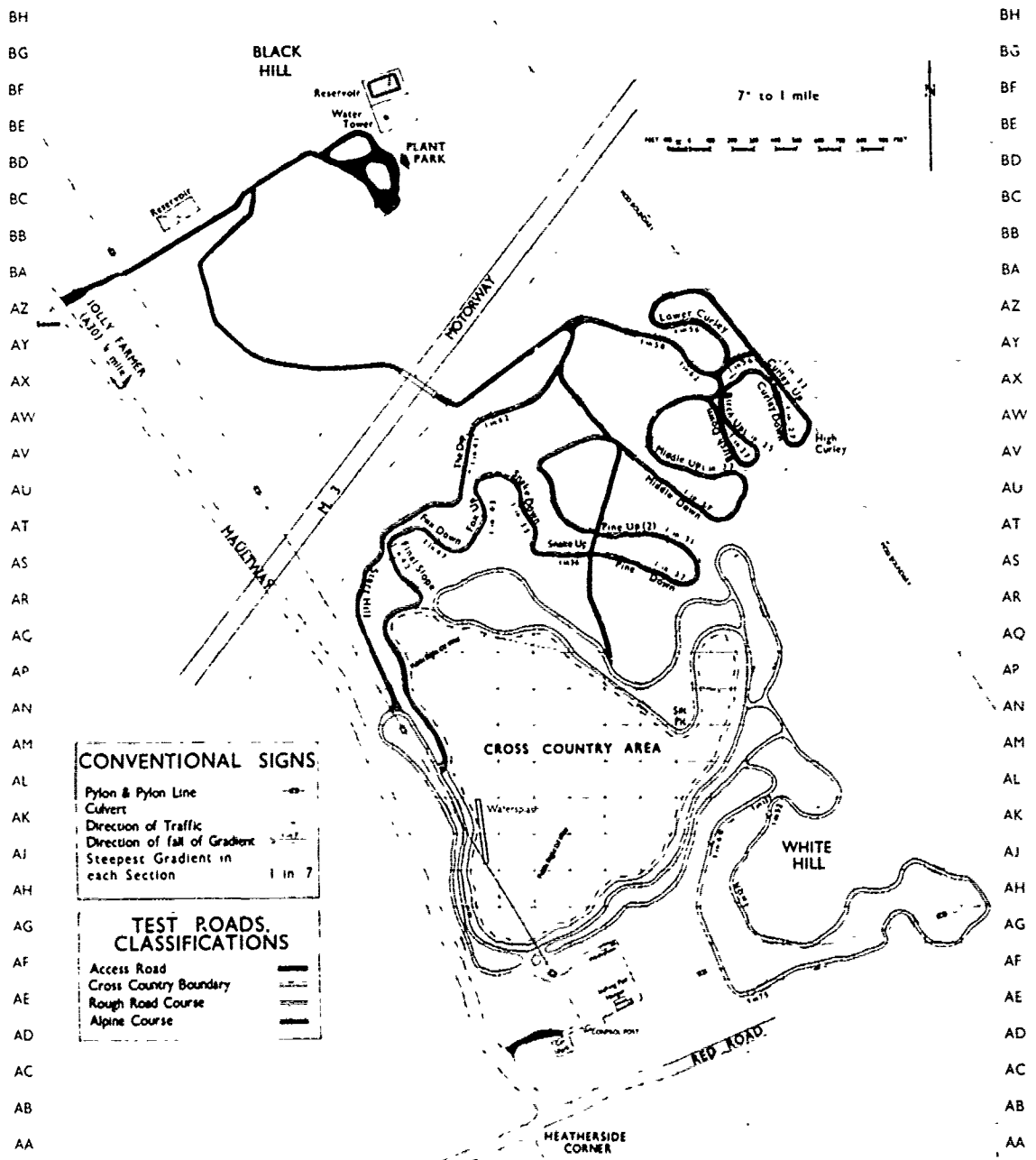

Produced by 42 Survey Engineer Regiment in 1970 from ground revision carried out in 1969  
 Reprinted with minor amendments by 42 Survey Engineer Regiment in 1976  
 Reprinted with minor amendments by Mapping and Charting Establishment RE in 1979

Reprinted by Mapping and Charting Establishment RE



SCAMMEL 'COMMANDER' TANK TRANSPORTER ON  
MAIN BAGSHOT ROUGH ROAD COURSE





FODEN ON BAGSHOT ROUGH ROAD



4.2 Bagshot - Water Splash



For a line diagram showing Technical Specifications - see opposite.

*General Description*

This consists of a concrete, shallow fording facility approximately 320 ft (97.5 m) long and 17 ft (5.2 m) wide.

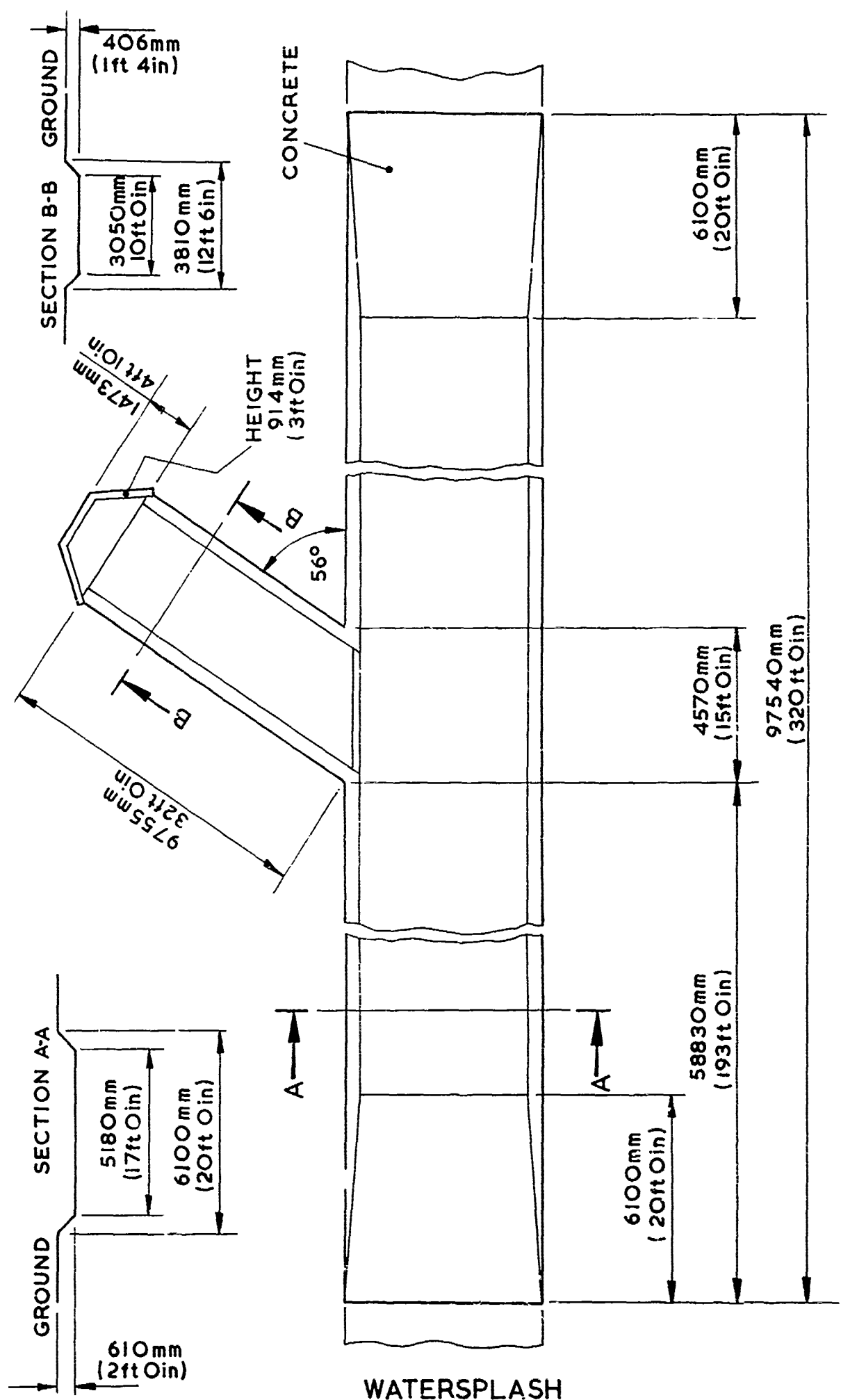

WATERSPLASH

## 5. Long Valley Test Courses

The Long Valley test course complex is situated approximately 17 miles south-west of the main Establishment. It forms part of a large Army Department-owned Training Area (Aldershot Garrison Training Area B4). MVEE Chertsey has three separate courses here:

### *Cross Country Area for Tracked Vehicles*

This is approximately 2 km square and is left in its natural state which consists of large potholes full of water with fairly extensive rutting. These are sometimes frozen hard in winter, very slippery during the spring and autumn and can be very dusty during the summer. The area is suitable only for heavy tracked vehicles.

### *Cross Country Course Wheeled Vehicles*

This is approximately 4 miles long and consists of both sandy and gravel sections. In the main it is left in its natural state though the worst ruts are occasionally levelled. It is suitable for all-wheel drive and improved low mobility wheeled vehicles, together with light tracked AFVs.

### *Rough Road*

A short (approximately 1.5 km) rough road graded course similar in construction to that found at the main rough road course complex at Bagshot. This is soon to be extended to a more acceptable length incorporating several gradients.

## Navigation Points

The track has 3 survey points (to 12 figure grid references) suitable for use in accuracy checks of vehicle navigation systems. The exact locations are:

- a. Junction of approach road to main test course,  
Eastings - 484436.5 m  
Northings - 152420.9 m  
Metal rod set in a buried concrete block with wooden post surrounding
- b. Miles Hill (north west corner of test track),  
Eastings - 483468.5 m  
Northings - 152249.6 m  
Metal rod set in a buried concrete block surrounded by wooden guard poles.
- c. Long Hill (south west corner of test track),  
Eastings - 483299.3 m  
Northings - 151668.7 m  
Metal rod set in a buried concrete block with surrounding wooden posts situated by metal oil drums.

## Administrative Facilities

There are, at present, very limited facilities available. These consist of a hot water shower and toilet block and a small kitchen and communal rest room.

A small office is sometimes available for use on a limited basis.

Cold water high pressure washdown facilities are available.

Telephone Aldershot 21777

# M. V. E. E. LONG VALLEY

SERIES GSGS 5329  
SHEET M.V.E.E. LONG VALLEY  
EDITION 1-6SGS

This map supersedes UKLF Misc 78

## TRACK INFORMATION/SUITABILITY LEGEND

	Cross country		Wheeled & light tracked vehicles
	Approach road		Tracked vehicles
	Mini Alpine		
	Sand patch		
	Cross country		
	Approach road		
	Rough road		
	Extension		
	Plantation fences with stiles shown		

BLACK NUMBERED LINES INDICATE THE 100 METRE BRITISH NATIONAL GRID  
AIRY SPHEROID

## MAGNETIC INFORMATION (1980)

For 50° 16' N, 0° 48' W

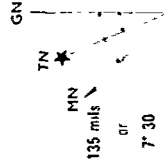

Annual Change 1 ml or 4" East

Prepared by Ordnance Survey in 1979 from O.S. 1:10,000 Series Sheet SU 85 SW dated 1978 with overprint information supplied by UKLF

GRAPHICS PRODUCED UNDER THE DIRECTION OF THE DIRECTOR OF MILITARY SURVEY ARE NOT TO BE TAKEN AS NECESSARILY REPRESENTING THE VIEW OF THE UK GOVERNMENT ON BOUNDARIES OR POLITICAL STATUS

Produced under the direction of the Director of Military Survey, Ministry of Defence, United Kingdom 1979

Copyright © HMSO LONDON 1979

Printed for the Director of Military Survey, Ministry of Defence, United Kingdom by Ordnance Survey

2000117/917058/83

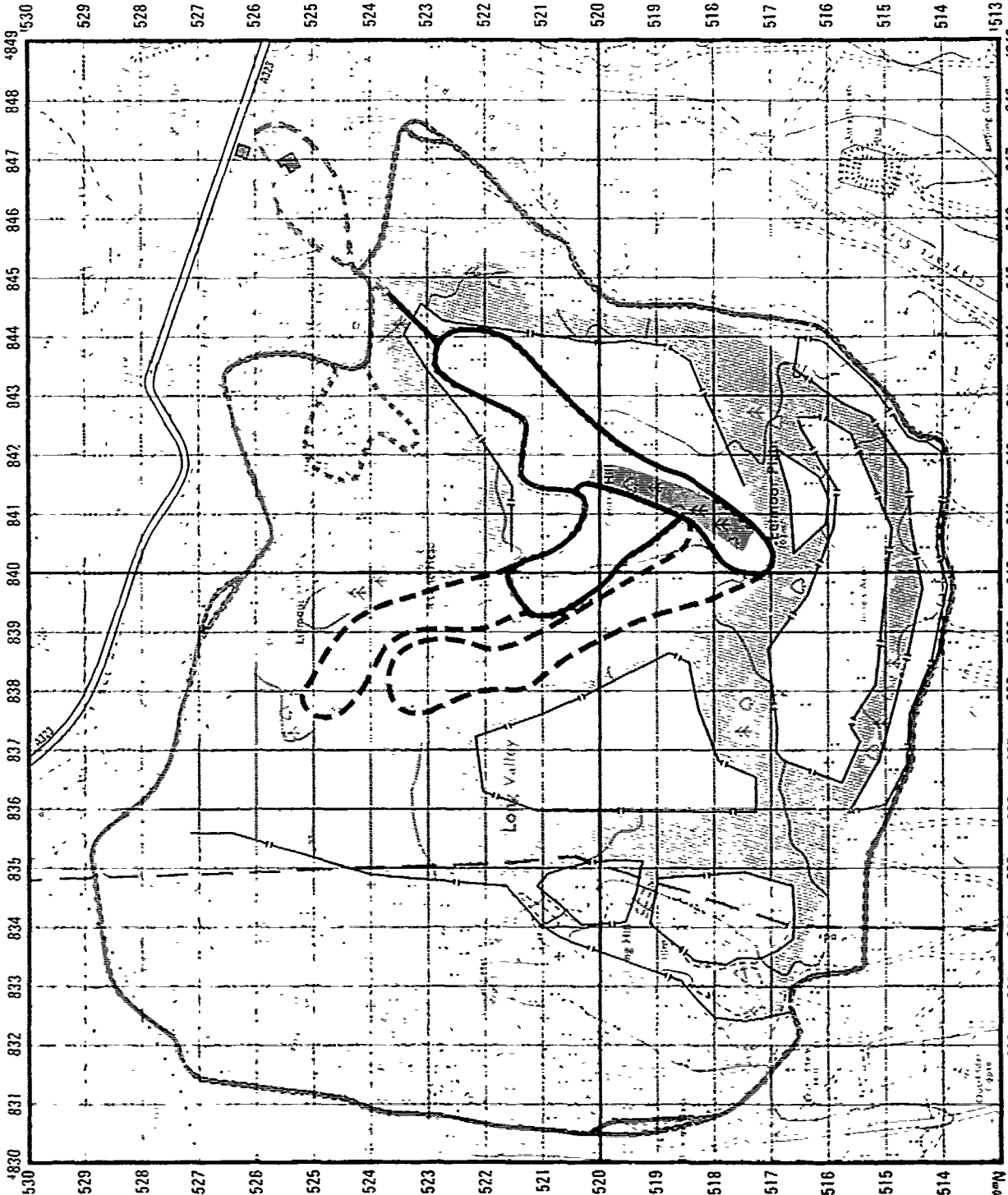

SCALE 1:10 000

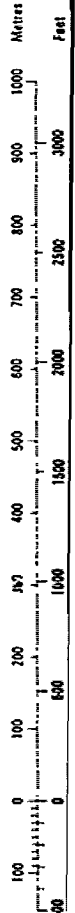

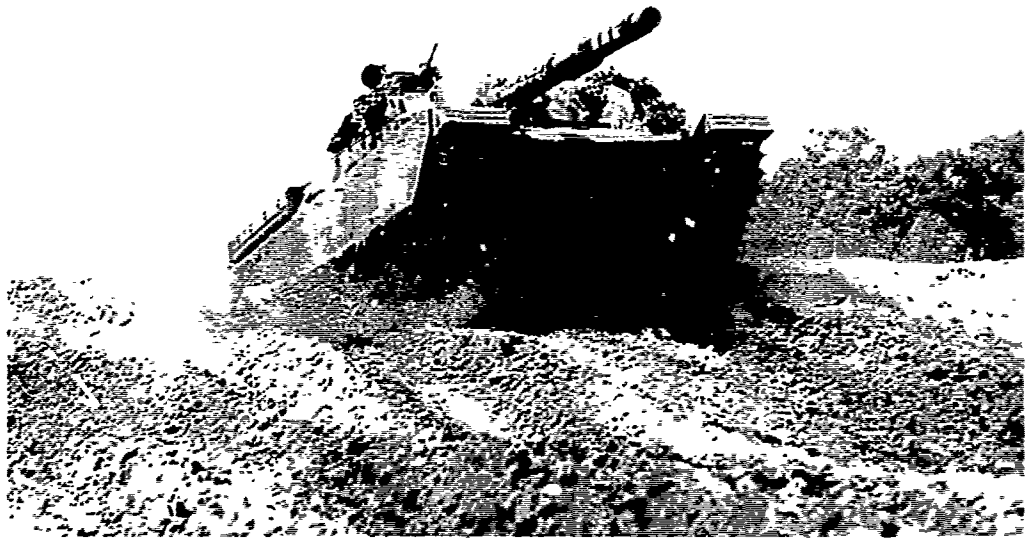

LONG VALLEY MAIN AFV CROSS COUNTRY COURSE  
AND SCORPION CVR(T)

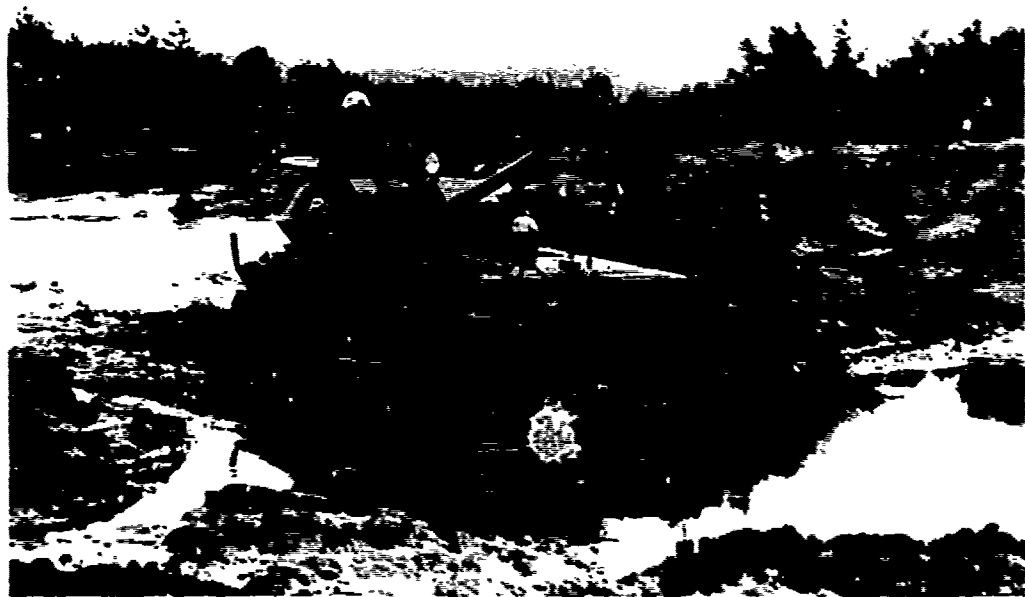

FOX ON WHEELED CROSS . UNTRY





LONG VALLEY - WHEELED CROSS COUNTRY COURSE  
FODEN FH70 GUN TRACTOR



## 5.2 Long Valley - Sand Trials Facility



For a line diagram showing Technical Specifications - see opposite.

### *General Description*

This is an area of imported sand containing 2 level and 1 sloping sections. It is used for trials involving the performance of wheeled and tracked vehicles in varying sand conditions. The facility may be harrowed or rolled to achieve the exact required load-bearing surface.

Representative trials are the determining of wheel and vehicle sand tyre performance and the track shedding characteristics of tracked vehicles undergoing sharp turns.

SAND

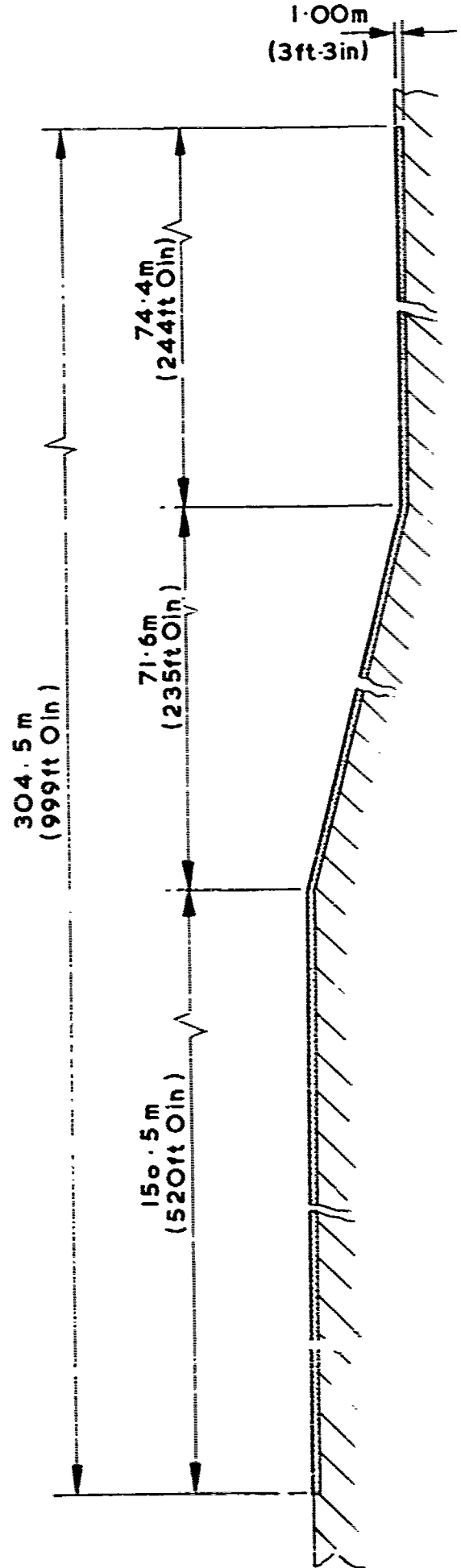
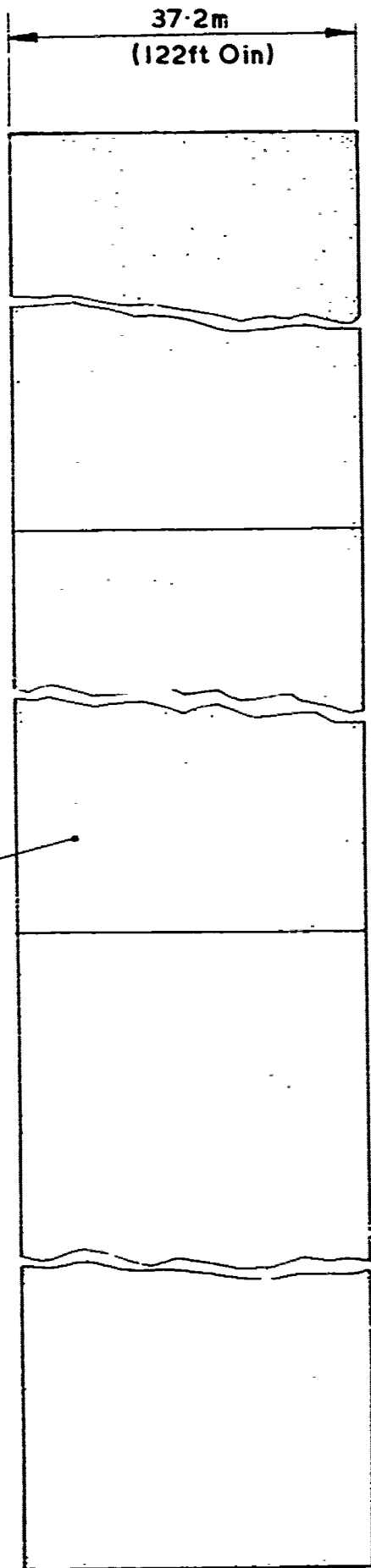

### 5.3 Long Valley - Rocky Terrain Profile

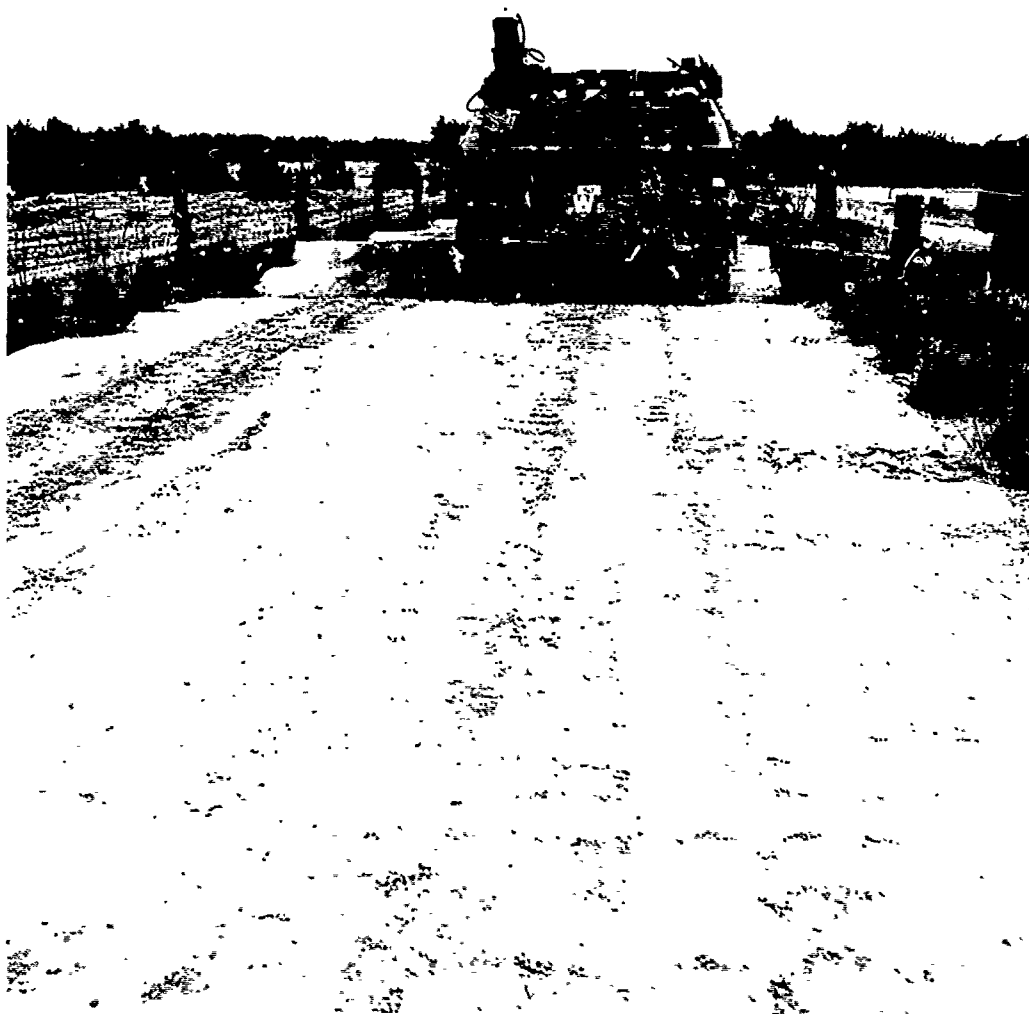

For a line diagram showing Technical Specifications, - see opposite.

#### *General Description*

This facility consists of a specially constructed, severe, closely undulating concrete course of approximately 300 ft (91.4 m) for heavy tracked vehicles. The facility is so positioned that either high or low speed runs may be undertaken over it. It is a very severe test of tracked suspension systems. The facility is sometimes referred to as the "Iranian river bed". It is positioned on the eastern side of the test course complex between the main AFV and outside wheeled cross country area/circuit, adjacent to the southern end of the EELMOOR driver training circuit.

ASHPHALT

GRANITE

ASHPHALT

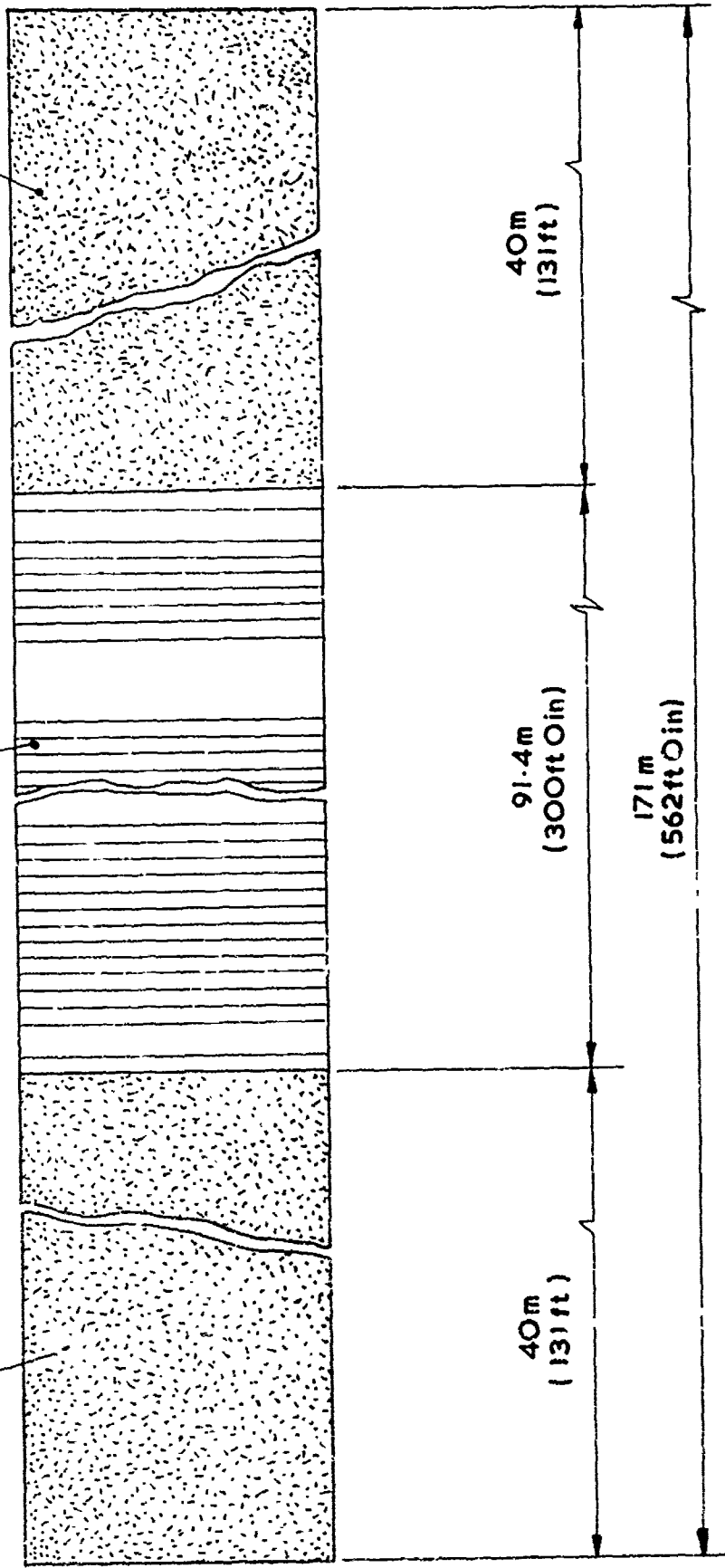

ROCKY TERRAIN PROFILE

6. General Restrictions of Use for Commercial Hire of MVEE Chertsey Test Track Facilities

These restrictions are in addition to, or amplify, but in no case replace, the formal contract.

6.1 *MVEE Contacts - Ascot 23366*

6.1.1 Initial Queries, Policy matters, liaison with the Ministry of Defence and Bookings - Staff Officer Trials Branch - ext 2581.

6.1.2 Detailed Queries and Bookings - Duty Test Track Controller.

Longcross - ext 2202 (for Tilt Platform Bookings then ask for ext 20).

6.1.3 Outstation - Contact Numbers

Long Valley - Aldershot 21777. Bagshot - Camberley 26262

Note: All queries and details on bookings are to be referred to Test Track Control at Longcross.

6.2 *Usage*

6.2.1 Shared

The most usual and flexible usage. Test Track Staff will co-ordinate and only previous day notice is required. However on occasions late notice requests maybe denied. Other vehicles, both commercial and Military, from Tanks to Go-carts must be expected as co-users.

6.2.2 Semi Exclusive

Certain facilities eg slip pad - Huts - Snake course, Straight and level etc maybe reserved for sole use. At least 14 days prior notice is required and the facility is normally only available on this basis for one working day.

6.2.3 Note

MVEE always reserves the right to delay/cancel commercial work for Priority Ministry Trials, without warning. however, every endeavour is made by the Test Track Staff to accommodate a hirer's requirements.

6.2.4 MVEE will give no 'Commercial in Confidence' guarantee though all Track users are asked to be discreet.

### 6.3 *Photography*

#### 6.3.1 *General*

No Military Vehicles, building or Personnel may normally feature even in a background capacity, in any photography. The Test Track Controller can advise further.

Commercial users are asked NOT to take advantage of concurrent activity by other firms without the latter's permission.

#### 6.3.2 *Stills*

May be taken by the customer of his own equipment/vehicles only provided that the Duty Test Track Controller is previously consulted on the day in question.

#### 6.3.3 *Cine*

This must be previously cleared at least 72 hours ahead with the Test Track Controller. Dependent upon content (ie all non-technical and PR work) this must be cleared by the Staff Officer Trials Branch with the Ministry of Defence and a written request from the customer may be called for.

### 6.4 *Press Release/Publicity*

6.4.1 No mention of the Ministry of Defence, or of MVEF must be made in voice recorded or pictorial matter that in any way implies Official recognition or acceptance of the product under test.

6.4.2 Unofficial verbal comments by MVEE Staff must not be subsequently quoted as Official Ministry Observations.

6.4.3 Printed material used at a MVEE site (for example during a publicity event on a Test Track) must have the following printed disclaimer:

'The Test Circuit has been provided by MVEE on the strict understanding that no mention of MVEE or the Ministry of Defence is made in any written or recorded matter and that no military vehicles or buildings may appear in any photographs taken. MVEE and the Ministry of Defence also disclaim any connection with, or interest in, the vehicles being demonstrated.'

### 6.5 *Visitors*

#### 6.5.1 *UK Nationals*

The test track controller should be informed of the names of UK nationals visiting the Test Track before commencement of work on the Test Track'

#### 6.5.2 Foreign Nationals

Visits by foreign nationals with their names, countries of origin and organisation represented, must be passed to the Chief Test Track Controller at least 72 hours before the intended visit.

#### 6.5.3 Foreign Nationals Representing Their Government (In any Official Capacity)

Names, government appointments and reason for the visit must be sent, in writing, to the Staff Officer Trials Branch at least one week ahead of the intended visit.

#### 6.5.4 Visits by any foreign nationals may be cancelled or restricted without warning.

### 6.6 Charges

6.6.1 An up-to-date scale of charges is held by the Test Track Staff. Only vehicles actually under trial are 'booked' - support vehicles may be brought in at no additional cost. Vehicle/Trailer combinations count as one vehicle.

6.6.2 Vehicles under test should book on and off for each session with the relevant Track Controller. Bills are normally invoiced monthly and queries should be raised with the clerical officer (Contracts) on Extension 2582.

### 6.7 Track Rules

#### 6.7.1 Control

All vehicles using the Test Tracks are under the control of the Test Track Controller.

#### 6.7.2 Track Discipline

Observe the directional circuit signs.

Vehicles are not to leave the surfaced area of the track.

Speed is limited to 70 mile/h (112 km/h).

Track direction on the main circuit and Snake Roads is normally reversed between 1240 and 1300 hours daily. The direction is indicated by traffic direction signs at all intersections.

#### Overtaking

Slow moving vehicles are to keep to the inside of the track and all overtaking is to be done towards the outside. Vehicles displaying warning signs of any type (eg Brake Test, Vehicle Steering under Test, etc) are not to be overtaken on any curved section of the track. Following vehicles should not drive closely behind vehicles displaying warnings signs.

UNCLASSIFIED

Brake Tests

Vehicles undergoing Brake Tests are to display a notice on the rear of the vehicle which may be obtained from Track Control.

Parking

Do not park so as to obstruct any circuit.  
No parking is permitted on the snake circuit.

6.7.3 Specific Restrictions

The following rules are to be observed:-

Refuelling

All refuelling operations are to take place on the petrol-proof asphalt area indicated by notice boards (Longcross Only) or other areas specially designated by the Track Control Staff.

Suspension Course Camera Track

Vehicles over 4 tonnes may not use this course.

Test Slopes

Wheeled vehicles are always to go UP the 1 in 4 (left hand end facing southward) slope and DOWN the 1 in 3 unless the track control are informed and special warning signs are displayed at the top and bottom of the slopes

6.7.4 General Warning

It is not advisable to travel close behind any tracked vehicle as the rubber track pads may be shed at any time causing a potential hazard to windscreens, bonnets, etc.

Take care when standing on any track or parking area - other vehicles may be moving in the vicinity.