

AD-A091 089

MARTIN MARIETTA AEROSPACE ORLANDO FL

F/G 1/3

PERFORMANCE VERIFICATION OF THE 'SUPERJET' LAMINAR ANGULAR RATE--ETC(U)

MAY 80 B W CURRY

DAAK40-79-D-0017

UNCLASSIFIED

OR-16127

NADC-80081-60

NL

3

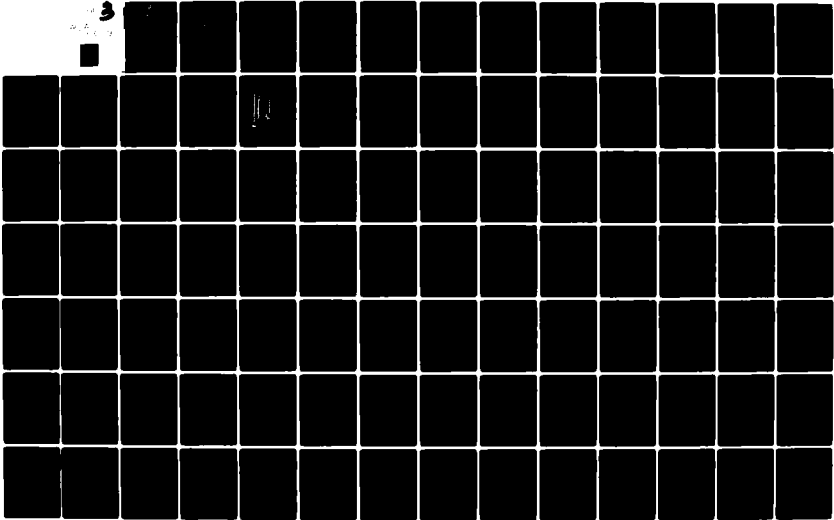

OF

3

AD. A

091089

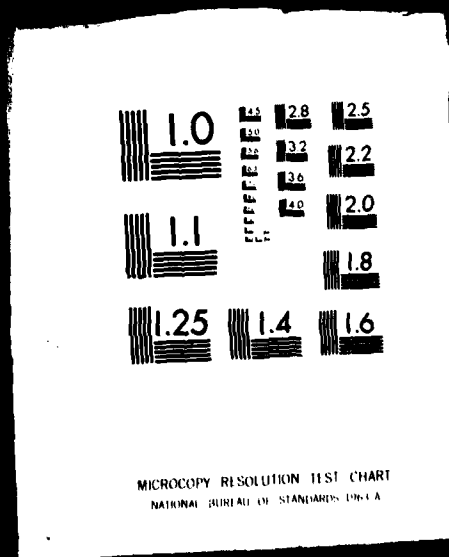

TECHNICAL REPORT
NADC 80081-60

LEVEL

12
P.S.



PERFORMANCE VERIFICATION OF THE "SUPERJET" LAMINAR ANGULAR RATE SENSOR

Boyd W. Curry, Jr.
Martin Marietta Corporation
Orlando Aerospace
Post Office Box 5837
Orlando, Florida 32855

May 1980

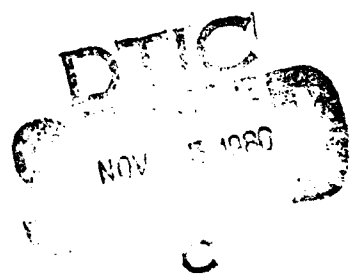

FINAL REPORT

Approved for Public Release:
Distribution Unlimited

THIS DOCUMENT IS BEST QUALITY PRACTICABLE.
THE COPY FURNISHED TO DDC CONTAINED A
SIGNIFICANT NUMBER OF PAGES WHICH DO NOT
REPRODUCE LEGIBLY.

NAVAL AIR DEVELOPMENT CENTER (6013)
AIRCRAFT AND CREW SYSTEMS TECHNOLOGY DIRECTORATE
WARMINSTER, PENNSYLVANIA 18974

80 11 03 176

AD A091089

DDC FILE COPY

DISCLAIMER NOTICE

THIS DOCUMENT IS BEST QUALITY PRACTICABLE. THE COPY FURNISHED TO DTIC CONTAINED A SIGNIFICANT NUMBER OF PAGES WHICH DO NOT REPRODUCE LEGIBLY.

(16) 741400

SECURITY CLASSIFICATION OF THIS PAGE (When Data Entered)

19 REPORT DOCUMENTATION PAGE		READ INSTRUCTIONS BEFORE COMPLETING FORM	
1 REPORT NUMBER NADC 80081-60	2 GOVT ACCESSION NO. AD A091089	3 RECIPIENT'S CATALOG NUMBER	
4 TITLE (and Subtitle) PERFORMANCE VERIFICATION OF THE "SUPERJET" LAMINAR ANGULAR RATE SENSOR.		5 TYPE OF REPORT & PERIOD COVERED FINAL rept. 5 NOV 79 - 5 MAY 80	
7 AUTHOR(s) BOYD W. CURRY, JR.		6 PERFORMING ORG. REPORT NUMBER OR-16 127	
9 PERFORMING ORGANIZATION NAME AND ADDRESS MARTIN MARIETTA CORPORATION POST OFFICE BOX 5837 ORLANDO, FLORIDA 32855		8 CONTRACT OR GRANT NUMBER(s) CONTRACT DAAK40-79-D-0017 D.O. 0006	
11 CONTROLLING OFFICE NAME AND ADDRESS AIRCRAFT AND CREW SYSTEMS TECHNOLOGY DIRECTORATE (6013) NAVAL AIR DEVELOPMENT CENTER WARMINSTER, PENNSYLVANIA 18974		10 PROGRAM ELEMENT, PROJECT, TASK AREA & WORK UNIT NUMBERS 62241N F41 400 000	
14 MONITORING AGENCY NAME & ADDRESS (if different from Controlling Office)		12 REPORT DATE MAY 80	
(12) 205		13 NUMBER OF PAGES	
16 DISTRIBUTION STATEMENT (of this Report) APPROVED FOR PUBLIC RELEASE, DISTRIBUTION UNLIMITED.		15 SECURITY CLASS. (of this report) UNCLASSIFIED	
17 DISTRIBUTION STATEMENT (of the abstract entered in Block 20, if different from Report)		15a DECLASSIFICATION/DOWNGRADING SCHEDULE	
18 SUPPLEMENTARY NOTES			
19 KEY WORDS (Continue on reverse side if necessary and identify by block number) SUPERJET RATE SENSOR ENVIRONMENTAL TESTING ESCAPE SYSTEM EJECTION SEAT			
20 ABSTRACT (Continue on reverse side if necessary and identify by block number) This report covers work accomplished under contract DAAK40-79-D-0017-0006, "Performance Verification of the Superjet Angular Rate Sensor" for potential application on the Maximum Performance Escape System (MPES) Program. Three Hamilton Standard Superjet Angular Rate Sensors (9304100-099) were subjected to a test program.			

DD FORM 1 JAN 73 1473

EDITION OF 1 NOV 68 IS OBSOLETE
S/N 0102-LF-014-6601

UNCLASSIFIED 403238
SECURITY CLASSIFICATION OF THIS PAGE (When Data Entered)

Handwritten signature

The performance data collected from this test can be summarized as follows:

PERFORMANCE

Full Scale Rate At $\pm 2\%$ Linearity	500 ± 100 deg/sec
Scale Factor	.0062 \pm .0002 deg/sec
Null Bias (calculated)	± 2 deg/sec
Hysteresis	± 0.6 deg/sec
Threshold	< 0.1 deg/sec
Resolution	< 0.1 deg/sec
Readytime	80 milliseconds maximum
Drift	± 0.76 deg/sec/min
Null Offset (measured)	± 2 deg/sec
G-Sensitivity	1.68 deg/sec/g/maximum
High Temperature Tested	$+165^{\circ}\text{F}$
Low Temperature Tested	-30°F
Sensitivity to Jerk	Negligible
Acoustic Sensitivity	Negligible
Vibration Sensitivity	± 2 deg/sec at approx. 2,000 Hz

Additional information obtained regarding the three units tested as follows:

Null Bias Drift @ 72°F	.166 deg/sec over 15 minute period
Reliability	
Storage Failure	$< .9906$
Operating Failure	$< .9999995$
Weight	12.0 ounces
Volume	1.5 x 3.5 x 5.0

It is recommended that additional investigation of the g-sensitivity effects be performed when the requirements of the MPES program are defined.

EXECUTIVE SUMMARY

This report covers work accomplished under contract DAAK40-79-D-0017-006, "Performance Verification of the Superjet Angular Rate Sensor," for potential application on the Maximum Performance Escape System (MPES) Program. Three Hamilton Standard Superjet Angular Rate Sensors (9304100-099) were subjected to a test program.

The performance data collected from this test can be summarized as follows:

PERFORMANCE

Full Scale Rate At $\pm 2\%$ Linearity	500 ± 100 deg/sec
Scale Factor	.0062 $\pm .0002$ deg/sec
Null Bias (calculated)	± 2 deg/sec
Hysteresis	± 0.6 deg/sec
Threshold	<0.1 deg/sec
Resolution	<0.1 deg/sec
Readytime	80 milliseconds maximum
Drift	+0.76 deg/sec/min
Null Offset (measured)	± 2 deg/sec
G-Sensitivity	1.68 deg/sec/g/maximum
High Temperature Tested	+165°F
Low Temperature Tested	-30°F
Sensitivity to Jerk	Negligible
Acoustic Sensitivity	Negligible
Vibration Sensitivity	± 2 deg/sec at approx. 2,000 Hz

Additional information obtained regarding the three units tested as follows:

Null Bias Drift @ 72°F	.166 deg/sec over 15 minute period
Reliability	
Storage Failure	<.9906
Operating Failure	<.9999995
Weight	12.0 ounces
Volume	1.5 x 3.5 x 5.0

It is recommended that additional investigation of the g-sensitivity effects be performed when the requirements of the MPES program are defined.

Accession For	
NTIS	
DTIC	
Unannounced	
Justification	
BY	
Distribution/	
AVAILABILITY	
DATE	

A 203
144

CONTENTS

Executive Summary	1
1.0 Introduction	9
2.0 Design and Analysis	10
2.1 Design	10
2.1.1 Description	10
2.1.2 Concept	10
2.2 Operational Mode	11
2.2.1 Four Second Scenario	11
2.2.2 Fifteen Minute Scenario	11
2.3 Reliability	12
2.4 Maintainability	12
2.5 Weight and Volume	12
3.0 Performance Tests	18
3.1 Baseline Tests	18
3.1.1 Test Setup and Procedure	18
3.1.2 Test Results	19
3.1.3 Data Evaluation	20
3.2 Acceleration Sensitivity	34
3.2.1 Test Setup and Procedure	34
3.2.2 Test Results	34
3.2.3 Data Evaluation	57
3.3 High Temperature Sensitivity	60
3.3.1 Test Setup and Procedure	60
3.3.2 Test Results	60
3.3.3 Data Evaluation	60
3.4 Low Temperature Sensitivity	78
3.4.1 Test Setup and Procedure	78
3.4.2 Test Results	78
3.4.3 Data Evaluation	78
3.5 Jerk Sensitivity	92
3.5.1 Test Setup and Procedure	92
3.5.2 Test Results	92
3.5.3 Data Evaluation	93
3.6 Acoustic Sensitivity	120
3.6.1 Test Setup and Procedure	120
3.6.2 Test Results	120
3.6.3 Data Evaluation	120
3.7 Vibration	140
3.7.1 Test Setup and Procedure	140
3.7.2 Test Results	140
3.7.3 Data Evaluation	141

4.0 Conclusions and Recommendations 154

List of Terms 155

Appendixes

 A. Test Procedures A-1

 B. Test Plan B-1

 C. Least Squares Fit Algorithm and Output Drift C-1

ILLUSTRATIONS

2.1-1	Superjet Sensor Cross Section	13
2.1-2	Superjet Angular Rate Sensor Schematic	14
2.3-1	Copperhead Reliability	16
2.5-1	Superjet Rate Sensor	17
3.1.2-1	Output vs. Input Initial Baseline Test	30
3.1.2-2	Readytime Plot (Typical)	31
3.3.2-1	Output vs. Input +165°F Test Run	75
3.4.2-1	Output vs. Input -30°F Test Run	89
3.5.3-1	Jerk Data, S.N 355, +X Direction, CCW Rotation	94
3.5.3-2	Jerk Data, S/N 373, +X Direction, CCW Rotation	95
3.6.2-1	Acoustic Specification Octave Analysis	122
3.6.2-2	Octave Analysis Calibration	123
3.6.2-3	Octave Analysis Microphone No. 1	124
3.6.2-4	Octave Analysis Microphone No. 2	125
3.6.2-5	Octave Analysis Microphone No. 3	126
3.6.2-6	Null Output vs. Acoustic Environment	127

TABLES

2.1-I	Superjet Rate Sensor Specification	15
3.1.2-I	Initial Baseline Test Results	21
3.1.2-II	Initial Baseline Test Results	22
3.1.2-III	Initial Baseline Test Results	23
3.1.2-IV	Initial Baseline Test Results	24
3.1.2-V	Initial Baseline Test Results	25
3.1.2-VI	Initial Baseline Test Results	26
3.1.2-VII	Initial Baseline Test Results	27
3.1.2-VIII	Initial Baseline Test Results	28
3.1.2-IX	Initial Baseline Test Results	29
3.1.3-I	Baseline Test Data Summary	32
3.1.3-II	Baseline Drift and Readytime	33
3.2.2-I	G-Sensitivity Comparison	35
3.2.2-II	G-Sensitivity Comparison	36
3.2.2-III	G-Sensitivity Comparison	37
3.2.2-IV	G-Sensitivity Comparison	38
3.2.2-V	G-Sensitivity Comparison	39
3.2.2-VI	G-Sensitivity Comparison	40
3.2.2-VII	G-Sensitivity Comparison	41
3.2.2-VIII	G-Sensitivity Comparison	42
3.2.2-IX	G-Sensitivity Comparison	43
3.2.2-X	G-Sensitivity Comparison	44
3.2.2-XI	G-Sensitivity Comparison	45
3.2.2-XII	G-Sensitivity Comparison	46
3.2.2-XIII	G-Sensitivity Comparison	47
3.2.2-XIV	G-Sensitivity Comparison	48
3.2.2-XV	G-Sensitivity Comparison	49
3.2.2-XVI	G-Sensitivity Comparison	50
3.2.2-XVII	G-Sensitivity Comparison	51
3.2.2-XVIII	G-Sensitivity Comparison	52
3.2.2-XIX	G-Sensitivity Comparison	53
3.2.2-XX	G-Sensitivity Comparison	54
3.2.2-XXI	G-Sensitivity Comparison	55
3.2.2-XXII	G-Sensitivity Comparison	56
3.2.3-I	G-Sensitivity Comparison	58
3.2.3-II	G-Sensitivity Data	59
3.3.2-I	High Temperature Test Results	62
3.3.2-II	High Temperature Test Results	63
3.3.2-III	High Temperature Test Results	64
3.3.2-IV	High Temperature Test Results	65
3.3.2-V	High Temperature Test Results	66
3.3.2-VI	High Temperature Test Results	67
3.3.2-VII	High Temperature Test Results	68

3.3.2-VIII	High Temperature Test Results	69
3.3.2-IX	High Temperature Test Results	70
3.3.2-X	High Temperature Test Results	71
3.3.2-XI	High Temperature Test Results	72
3.3.2-XII	High Temperature Test Results	73
3.3.2-XIII	High Temperature Test Results	74
3.3.3-I	High Temperature Test Data Summary	76
3.3.3-II	High Temperature Drift and Readytime Summary	77
3.4.2-I	Low Temperature Test Results	80
3.4.2-II	Low Temperature Test Results	81
3.4.2-III	Low Temperature Test Results	82
3.4.2-IV	Low Temperature Test Results	83
3.4.2-V	Low Temperature Test Results	84
3.4.2-VI	Low Temperature Test Results	85
3.4.2-VII	Low Temperature Test Results	86
3.4.2-VIII	Low Temperature Test Results	87
3.4.2-IX	Low Temperature Test Results	88
3.4.3-I	Cold Temperature Test Data	90
3.4.3-II	Cold Temperature Test Data	91
3.5.2-I	Jerk Test Results	96
3.5.2-II	Jerk Test Results	97
3.5.2-III	Jerk Test Results	98
3.5.2-IV	Jerk Test Results	99
3.5.2-V	Jerk Test Results	100
3.5.2-VI	Jerk Test Results	101
3.5.2-VII	Jerk Test Results	102
3.5.2-VIII	Jerk Test Results	103
3.5.2-IX	Jerk Test Results	104
3.5.2-X	Jerk Test Results	105
3.5.2-XI	Jerk Test Results	106
3.5.2-XII	Jerk Test Results	107
3.5.2-XIII	Jerk Test Results	108
3.5.2-XIV	Jerk Test Results	109
3.5.2-XV	Jerk Test Results	110
3.5.2-XVI	Jerk Test Results	111
3.5.2-XVII	Jerk Test Results	112
3.5.2-XVIII	Jerk Test Results	113
3.5.2-XIX	Jerk Test Results	114
3.5.2-XX	Jerk Test Results	115
3.5.2-XXI	Jerk Test Results	116
3.5.2-XXII	Jerk Test Results	117
3.5.2-XXIII	Jerk Test Results	118
3.5.2-XXIV	Jerk Test Results	119
3.6.2-I	Post Acoustic Baseline Test Results	128
3.6.2-II	Post Acoustic Baseline Test Results	129
3.6.2-III	Post Acoustic Baseline Test Results	130
3.6.2-IV	Post Acoustic Baseline Test Results	131
3.6.2-V	Post Acoustic Baseline Test Results	132
3.6.2-VI	Post Acoustic Baseline Test Results	133

3.6.2-VII Post Acoustic Baseline Test Results 134
 3.6.2-VIII Post Acoustic Baseline Test Results 135
 3.6.2-IX Post Acoustic Baseline Test Results 136
 3.6.2-X Post Acoustic Baseline Test Results 137
 3.6.3-I Post Acoustic Test Data Summary 138
 3.6.3-II Post Acoustic Drift and Readytime 139
 3.7.2-I Severe Resonance Frequencies 141
 3.7.2-II Post Vibration Baseline Test Results 142
 3.7.2-III Post Vibration Baseline Test Results 143
 3.7.2-IV Post Vibration Baseline Test Results 144
 3.7.2-V Post Vibration Baseline Test Results 145
 3.7.2-VI Post Vibration Baseline Test Results 146
 3.7.2-VII Post Vibration Baseline Test Results 147
 3.7.2-VIII Post Vibration Baseline Test Results 148
 3.7.2-IX Post Vibration Baseline Test Results 149
 3.7.2-X Post Vibration Baseline Test Results 150
 3.7.2-XI Post Vibration Baseline Test Results 151
 3.7.3-I Post Vibration Baseline Test Results Data Summary . 152
 3.7.3-II Post Vibration Drift and Readytime 153

NADC 80081-60

THIS PAGE INTENTIONALLY LEFT BLANK.

1.0 INTRODUCTION

↓
The need exists for small rugged rate sensors applicable to the Navy's Maximum Performance Escape System². A recent study indicated that a prime candidate for this system is the Superjet² rate sensor used on the U.S. Army Copperhead Program.²

The Superjet performance verification contract DAAK 40-79-D-0017/006 was initiated on September 1979 by the U.S. Army Missile Command, Redstone Arsenal, Alabama. The program is under the technical direction of the Naval Air Development Center (NADC), Aircraft and Crew Systems Technology Directorate, Warminster, PA. Mr. R. L. McGiboney is the cognizant Project Engineer for this program.

↓
The purpose of this performance verification task is to determine through test and analyses the suitability of the Hamilton-Standard Superjet angular rate sensor for the possible application in NADC's Maximum Performance Escape System (MPES) program.

↖
For NADC to make that determination, a test plan (Appendix B) was submitted and approved. The results of the tests are presented in this report.

In addition, technical tasks described in the statement of work 60134-12, Paragraph 3.2, are discussed in the text. These tasks include operational mode, (4 second or 15 minute performance duration), reliability, maintainability, weight and volume.

1 Reference: Fluidic Gyro Development, Martin Marietta OR15,646 prepared under contract N00019-78-C-0298. Prepared for:

Department of the Navy
Naval Air Systems Command
Advanced Technology Section
AIR-5162C
Washington, DC 20360

2.0 DESIGN AND ANALYSIS

2.1 Design

2.1.1 Description

The Superjet rate sensor is manufactured by Hamilton Standard, Farmington, Connecticut, Part Number 9304100-099. The package includes a pump which directs a stream of helium between two resistive elements. The change in cooling of these elements by the gas stream is sensed to indicate angular rate. The package also includes the required electronics (analog type); so all that is required is a ± 15 V.D.C. power supply and a voltmeter. Output of the device is ± 6 V.D.C.

The three Superjet rate sensors used during this evaluation were serial numbers 0100355, 0100373, and 0100381, which will be referred to as serial numbers 355, 373, and 381, respectively. A drawing describing the Superjet package is shown in Figure B.2-1, Appendix A, Part B of this report.

A cross section of the Superjet sensor is shown in Figure 2.1-1.

The Copperhead program roll rate sensor specification may be found in Martin Marietta document SPC10200000-004.

The vendor specifications for Superjet are listed in Table 2.1-I.

2.1.2 Concept

The principle of operation of the Superjet may be most readily visualized by referring to Figure 2.1-2. As illustrated in this figure, a laminar flow gas jet flows with an average velocity V_j , from a nozzle located at one end of the case. A jet position sensor, located a distance, L , from the nozzle mouth is used to detect any lateral deflection, y , of the gas jet from the center position. In the presence of an angular rate ω_I , along the input axis of the case, the jet will be deflected away from its normal center position in proportion to the magnitude of the rate, and in a direction corresponding to the clockwise or counterclockwise direction of the angular rate. The amount of this deflection may be calculated by double integration of the Coriolis acceleration of the jet as it flows toward the jet position sensor:

$$\ddot{y} = 2\omega_I V_j \quad \text{Eq (1)}$$

$$\dot{y} = 2\omega_I V_j T \quad \text{Eq (2)}$$

$$y = \omega_I V_j T^2 \quad \text{Eq (3)}$$

At the position sensor:

$$y = \omega_I V_j T^2 = \omega_I L T = \omega_I \frac{L^2}{V_j} \quad \text{Eq (4)}$$

where $L = V_j T$

Thus, it can be seen from the above equation that the gas jet deflects in proportion to the input angular rate perpendicular to the axis of the jet. Moreover, the deflection is proportional to the product of the length of the jet, L , and the transit time of the jet, T , or to the length squared divided by the jet velocity. The above computation is based on small angle approximations which can be shown to be valid for actual Superjet design parameters.

Constant translational velocities of the sensor in any direction do not cause jet deflections relative to the jet position sensor. Translational acceleration is claimed also not to introduce any first order error since the laminar gas flow jet is essentially buoyantly supported within the free gas space. Acceleration does produce density gradients, however, which may cause second order errors. These, however, are claimed to be an order of magnitude smaller than comparable errors for equivalent mechanical gyros.

In order to maintain gas jet stability and produce a low noise signal, the jet must be kept within the laminar flow regime. This is achieved by limiting the Reynolds number to a value below 1,000. Laminar flow is most readily produced with a gas having a low density and high viscosity since Reynolds number is proportional to density and inversely proportional to the viscosity of the gas. Also, from the standpoint of obtaining maximum frequency response, it is desirable to have the gas jet velocity as high as possible consistent with laminar flow criteria. Conversely, it should be recalled from the previous equations that lateral deflection is inversely proportional to the velocity. Thus, the selected design velocity represents a compromise between frequency response and sensitivity.

Conversion of the jet deflection into an electrical signal proportional to the input rate is accomplished by symmetrically mounting two temperature sensitive resistors on either side of the jet stream and connecting them by means of a bridge circuit. As the jet deflects to the left or right, the differential cooling of the temperature sensitive resistors produces an output voltage that varies linearly with input rate, over a limited range of angular rate input.

2.2 Operational Mode

The accuracy of the roll rate sensors does not change under any of the two MPES scenarios considered.

2.2.1 Four Second Scenario

The Superjet rate sensor is best suited for this scenario. There is virtually no shift in the null bias for this short time frame. It is known, however, that the electronics of the Superjet package is not temperature compensated beyond a range of -25° to $+145^{\circ}\text{F}$.

2.2.2 Fifteen Minute Scenario

The null bias at $72^{\circ}\text{F} \pm 5^{\circ}\text{F}$ has a shift of about 1 mv over a 15 minute period which is equivalent to .166 degrees per second rate, which was indicated by observing the units throughout the test program. Drift test data are reported for one minute periods, in Sections 3.1, 3.3, 3.4, 3.6 and 3.7.

2.3 Reliability

The only moving mechanical part in the Superjet Angular Rate Sensor is the vibrating pump diaphragm. This diaphragm consists of a ceramic piezo-electric crystal which is flexibly mounted around its periphery and has electrically excited faces perpendicular to the mounting plane. Stress levels induced under normal operating amplitude conditions are approximately 17 percent of rated fatigue strength. As a result, the crystal may vibrate indefinitely without limiting the life of the sensor.

Life tests on five experimental models have exceeded 34,000 hours each or a cumulative total of over 170,000 hours without failure. The complete absence of wear limited components in both the jet sensor and the electronics has made it possible to attain a virtually unlimited unit life.

The environmental resistance of the sensor assembly has been analysed for a broad spectrum of vibration, shock and acceleration dynamic conditions.

The Superjet Angular Rate Sensor is exceptionally tolerant to angular rate overranging. This is a consequence of the fact that overranging does not produce an internal mechanical force on stops, gimbal suspensions, or spin bearings as in conventional rate gyroscopes. Thus, the unit will recover from any degree of overranging without degradation of performance.

Electronic oscillator driver and bridge output amplifier circuits are extremely simple. Failure rates for these components were derived from MIL-HDBK-217A, using 71°C ambient temperature and environmental stress factors for manned aircraft. The predicted failure rate of the complete circuitry totals four failures per million hours, or an equivalent MTBF of 250,000 hours. This gives an operating probability of success 0.999996.

The "Superjet" roll rate sensor is currently used on the "Copperhead" program which is a cannon launched guided projectile. Early reliability predictions on Copperhead, for the roll rate sensor, produce the following probability of success:

Storage Failure	<.9906
Operating Failure	<.9999995

This was based on the reliability math model as shown in Figure 2.3-1, (Reference: Copperhead (CLGP) Reliability (RAM-D) Report, Eleventh Bimonthly, CK1 SRP 00801000-011, Figure 1, Page 151).

2.4 Maintainability

The Superjet rate sensor is a hermetically sealed unit fabricated by Hamilton Standard. There are no outside moving parts and there is no maintenance requirement. If there is a malfunction, on the Copperhead program, the sensor is replaced, and sent back to the manufacturer for refurbishment.

2.5 Weight and Volume

The total weight of the Superjet package is 12.0 ounces and the total volume does not exceed 1.5" x 3.5" x 5". Figure 2.5-1 shows the outline of the sensor package.

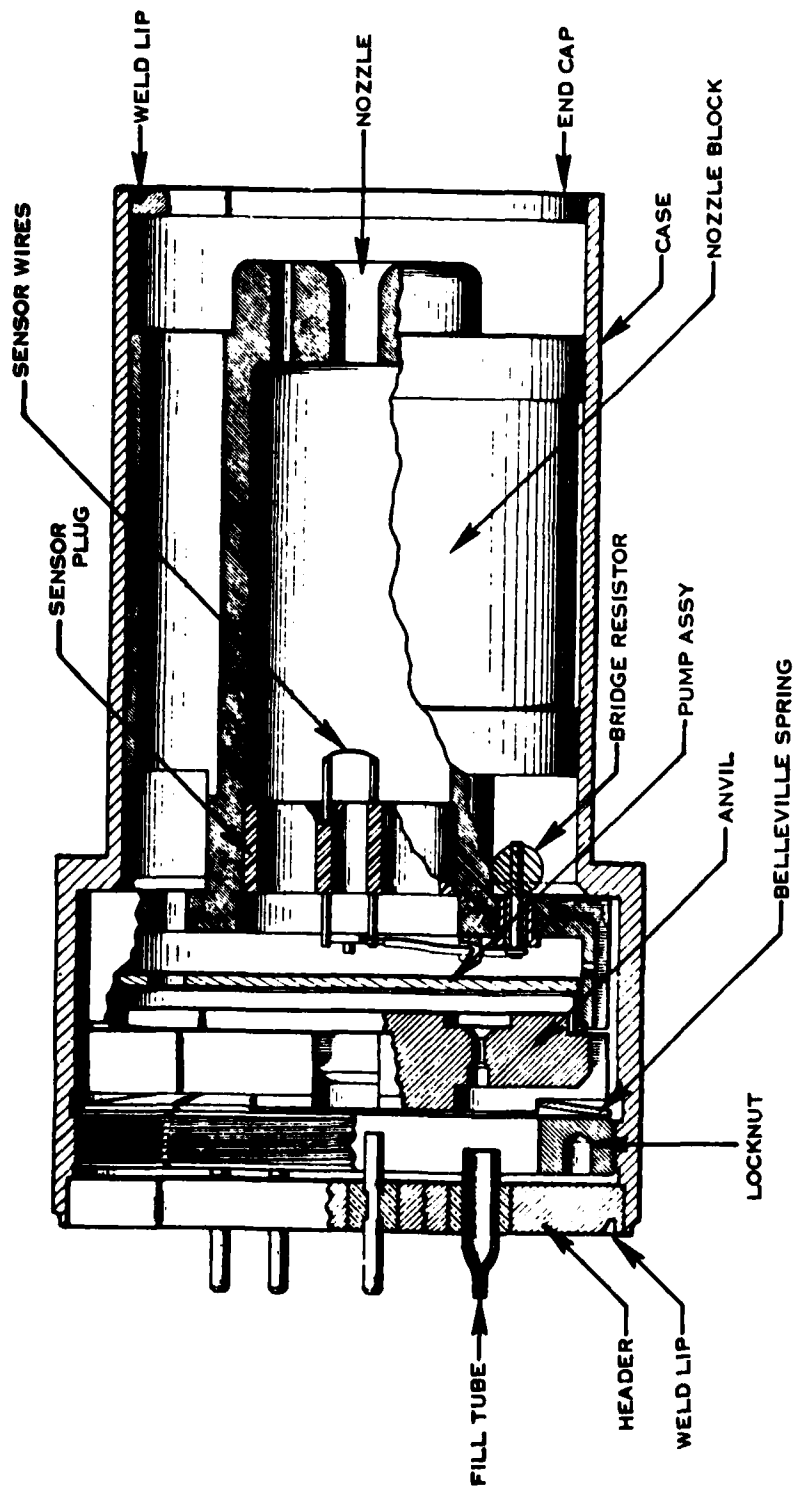

FIGURE 2.1-1
SUPERJET SENSOR CROSS SECTION

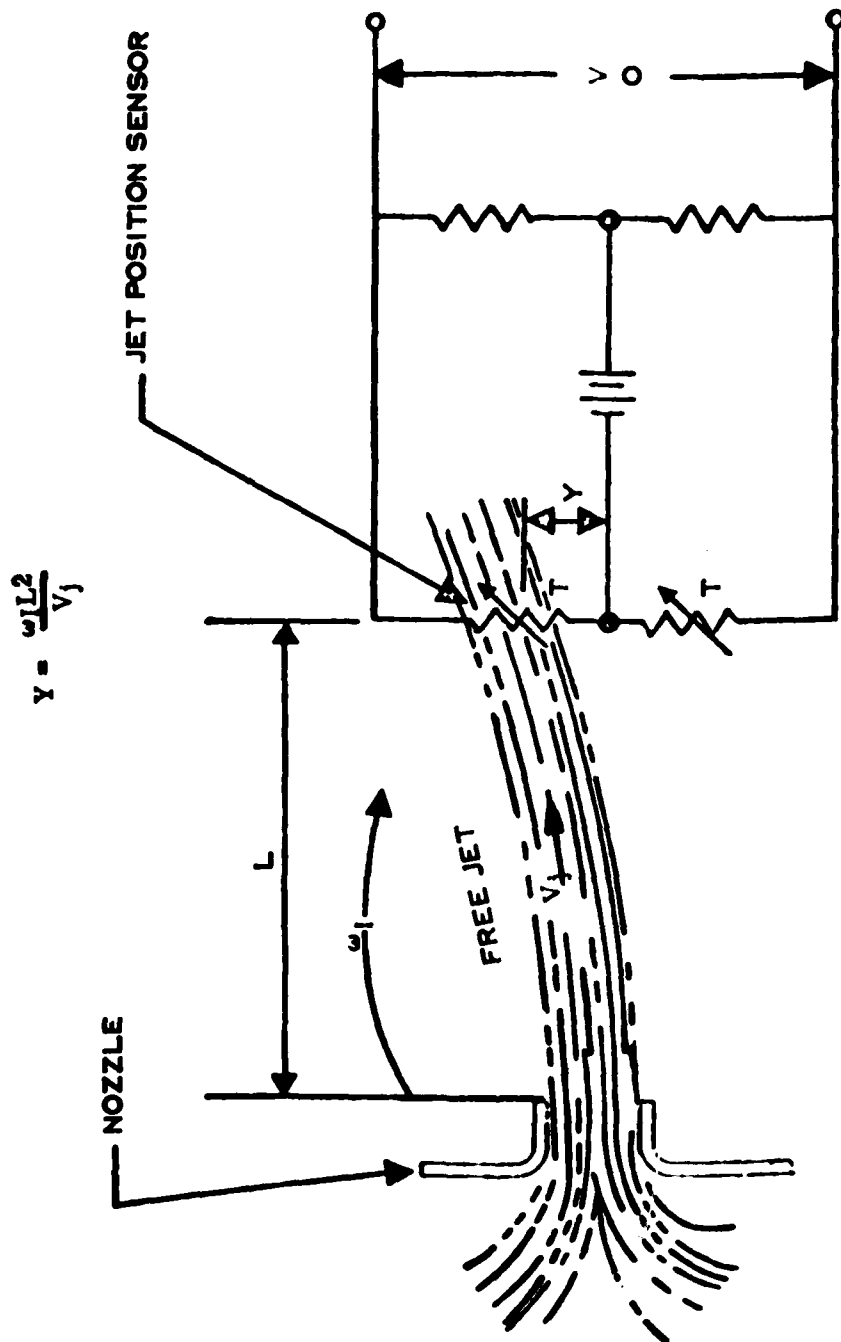
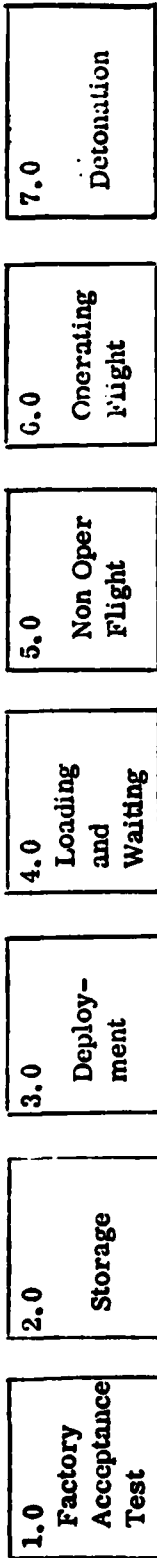

FIGURE 2.1-2 SUPERJET ANGULAR RATE SENSOR SCHEMATIC

SUPERJET RATE SENSOR SPECIFICATIONHAMILTON STANDARD

Weight of jet:	3.8 oz
Weight of total package:	12.0 oz
Input voltage:	+15V at 80 mA -15V at 7 mA
Rate range:	500 deg/s
Scale factor:	Rate - 6 mV/deg/s Angle - 120 mV/deg Null stability - ± 0.6 deg/s (when bias is stored during rates) Scale factor - 15% (absolute, linearity, environment, and symmetry)
Linear acceleration sensitivity:	0.02 deg/s/g
Frequency response:	>40 Hz
Input axis alignment:	< $\frac{1}{2}$ degree
Environmental capacity:	Temperature: -25 ^o F to +155 ^o F Vibration: 7.6g rms Shock: 10,000g

TABLE 2.1-I



$$P_R = R_{1.0} \times t_S \times e^{-\left[(\lambda_{NO}) (t_1) (K_S) + (\lambda_{NO}) (t_2) (K_D) + (\lambda_{NO}) (t_3) (K_L) + (\lambda_{NO}) (t_4) (K_W) + (\lambda_{NO}) (t_5) (K_F) + (\lambda_{OP}) (t_6) \right]}$$

P_R Expected or Predicted Reliability of One Roll Rate Sensor.

R^{*} 1.0 = 0.99999 based on the Roll Rate Sensor being capable of 100% acceptance testing of all functional requirements. The Roll Rate Sensor contains no one shots.

e Base for Natural or Napierian Logarithms = 2.71828.

λ_{NO} Non-operating or Storage Failure Rate (Time Dependent Elements) = 1.0691 x 10⁻⁷ (see Table D).

t₁ Storage Duration = 87,600 hours (10 years covered storage) maximum.

K_S Storage Environmental Factor = 1.0.

t₂ Deployment Duration (t₂ = 36 hours).

K_D Deployment Environment Factor = 5.0.

t₃ Loading Duration = 0.0055 hours.

K_L Loading Environmental Factor = 5.0.

t₄ Waiting Duration = 0.0167 hours.

K_W Waiting Environmental Factor = 1.0.

t₅ Flight Duration Non-operating = 0.0047 hours (midrange flight).

K_F Firing Environmental Factor = 1000.0.

λ_{OP} Operating Failure Rate Including K Factors (Time Dependent Elements) = 3.90566 x 10⁻⁵ (see Table II).

t₆ Flight Duration Operating = 0.0119 hours (midrange flight).

R_S Reliability of Structure and Pump Diaphragm = .99999.

FIGURE 2.3-1

COPPERHEAD RELIABILITY MATH MODEL

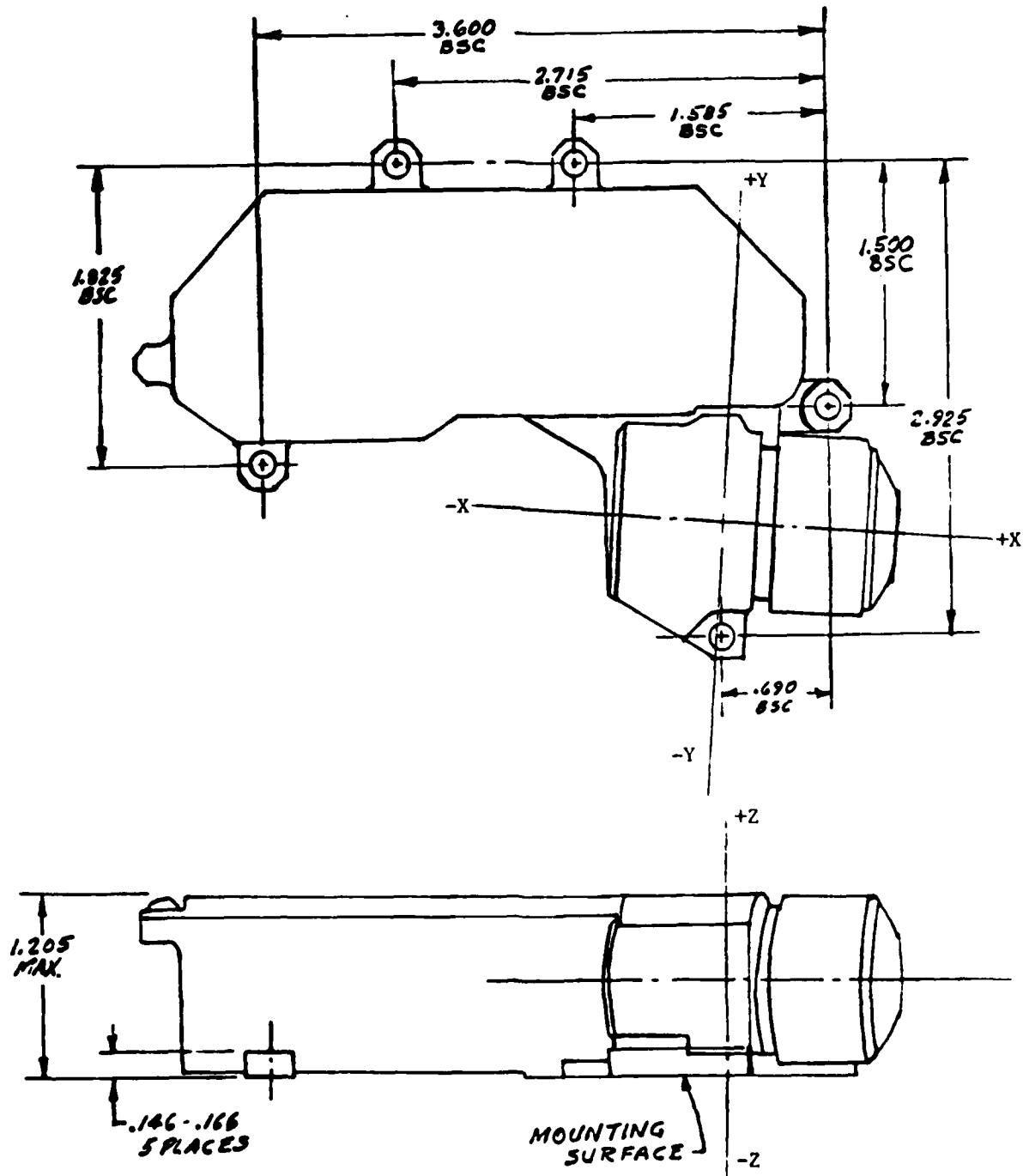

FIGURE 2.5-1
SUPERJET RATE SENSOR

3.0 PERFORMANCE TESTS

Three Superjet roll rate sensors were subjected to a series of baseline tests consisting of the following:

- input voltage (volts)
- input current (amps)
- full scale range at 2% linearity (degrees/seconds)
- hysteresis (millivolts)
- threshold (degrees/seconds)
- resolution (degrees/seconds)
- output drift (degrees/seconds)
- ready time (seconds)
- null offset (add after initial baseline testing) (millivolts)

The sensors were then monitored for various environmental factors which included the following:

- Sensitivity to acceleration (degrees/second/G)
- Temperature sensitivity at +165°F
- Temperature sensitivity at -30°F
- Sensitivity to jerk (\dot{a})
- Acoustic sensitivity
- Vibration environment

A majority of the performance testing was conducted in Martin Marietta's Precision Inertial Laboratory. The acoustic and vibration environments were generated in the Environmental Test Lab of the Orlando Division. Barometric pressure was $30.00 \pm .08$ in Hg throughout the test program.

A Hewlett Packard 9500 test set was used in the Inertial Lab, to program the Genisco 1100-2 rate table. The rate table was wired to the computer such that all power input to the Superjet test unit occurred simultaneously. This allowed the Superjet sensor to experience the actual procedure involved during a real ejection situation.

3.1 Baseline Tests

3.1.1 Test Setup and Procedure

Three "Superjet" rate sensor packages were tested in the Precision Inertial Laboratory on the Genisco series 1100-2 rate table. This rate table is programmable by paper tape reader or automatic test set for automatic operation. Speed accuracy is 0.01%; the table servo has a peak torque of 22 ft.-lbs.

The Hewlett Packard 9500A-145 test set was used to program the rate table. The test set includes a Hewlett Packard HP2116C computer controlling two 50-volt and two 100-VDC programmable power supplies as well as five non-programmable 20-ampere, 40 VDC power supplies controlling a programmable counter, oscilloscope, a volt-ohm meter and a modular switch for control of these devices.

Each test unit was centrally located on the rate table by using a standard 8"x8"x8" test cube in the lab. The input axis of the sensor coincided with the rotation axis of the rate table.

The computer in the test set was programmed to increment the rate table (usually in 50 degree/second increments) to the maximum counterclockwise rate and back through zero to the maximum clockwise rate and back to zero rate. The actual rate and output of the sensor was recorded at each rate increment. Each data point represented an average of 40 readings taken within approximately 1.6 seconds or less. The maximum rate was varied by 50 degrees/second intervals until the non-linearity exceeded $\pm 2\%$ of full scale, as calculated using a least-squares-fit straight line.

The output drift of each unit was measured on the rate table with the computer programmed to give a readytime plot, wait 15 seconds and take an average of 40 readings of the output, and repeat for a one minute time period, at 15 second intervals. This was done for rates of 100, 200, 300, 400 and 500 degrees/second.

Threshold and resolution was derived by rotating the rate table from 0.0 degrees/second to 1.0 degrees/second in 0.1 degree/second increments. And 5.0 degrees/second to 6.0 degrees/second in 0.1 degree/second increments, respectively.

A test schematic for the baseline test is shown in Appendix A, Figure A.2-1 of this report.

The test program was conducted under the guidance of the Test Plan (see Appendix B) prepared by Jerome C. Salmons, November 1979 which was approved by NADC on January 11, 1980. A detailed procedure for the baseline tests is shown in Appendix A, Part A of this report.

The algorithm used for calculating the least-squares-fit data and output drift may be found in Appendix C.

3.1.2 Baseline Test Results

The scale factor was computed as the slope of the least-squares-fit straight line. Percentage error from both fullscale and "ideal" (actual reading) was calculated for each data point.

The full scale rate of the sensor was determined by the $\pm 2\%$ linearity error requirement. Hysteresis values for clockwise and counterclockwise rates were calculated. The bias shown on the data sheets was determined as the Y-intercept of the least-squares-fit straight line.

A typical plot of voltage output vs. rate is shown in Figure 3.1.2-1 for S/N 355. Since the hysteresis error is so small (.002% of full scale) the plot is a straight line. This figure was transposed from Table 3.1.2-1. The scale factor program printouts are shown for all three serial numbers in Tables 3.1.2-I through 3.1.2-VI.

The first column in this table is the actual rate of the rate table as recorded by the computer with an accuracy within .01%. The second column is the average of 40 readings taken while dwelling at a known rate. The third column is the calculated value of the output using the curve fitting technique of the least squares fit straight line. The fourth column is the error of the particular data point as percentage of the full scale rate (from the least squares fit straight line). The fifth column is the error of each data point as a percentage of the corresponding output from the least squares fit straight line. A test summary is provided at the bottom of each table for individual evaluation.

Tables 3.1.2-VII through 3.1.2-IX show the results of the output drift. The first reading for each rate input is the output value after 15 seconds. The next reading is the value after 30 seconds. The third and fourth readings are the values for 45 and 60 seconds respectively. The third column is the mean divided by the actual rate. This was used to evaluate the drift since there were small changes in rates.

A typical readytime plot is shown in Figure 3.1.2-2. Readytime is defined as the time required for the device to reach 95% of its steadystate output without any electronic warmup, at any rate.

Threshold and resolution for the "Superjet" rate sensor was found to be less than 0.1 degrees/second. The actual value was not obtained due to the limited accuracy of the equipment used. It is believed that for the maximum performance escape system, a threshold and resolution of 0.1 degree second for this device will not impair the expected system performance significantly. The specification made by the Copperhead program at Martin Marietta called for Superjet threshold and resolution to be 0.03 degree/second maximum.

3.1.3 Data Evaluation

Baseline test data for the three Superjet rate sensor packages tested produces the following worst case evaluation:

1. Full scale rate at <u>+2%</u> linearity	475 <u>+75</u> degrees/second
2. Scale Factor	.0061 <u>+ .0001</u> V/degrees/second
3. Bias	<u>+ .26</u> degrees/second
4. Hysteresis	<u>+ .56</u> degrees/second
5. Threshold	<u>< .1</u> degrees/second
6. Resolution	<u>< .1</u> degrees/second
7. Readytime	.068 second maximum
8. Drift	+ .55 degrees/second/minute max.

The values for each unit may be evaluated from Table 3.1.3-I (baseline test data) and Table 3.1.3-II (baseline drift and readytime test data).

RATE SENSOR TEST PROGRAM

NADC 80081-60

DATE...2-18-80.....

RUN...Initial Baseline.....

TEMP...72°F...50%RH..

SER#...355.....

RATE (DEG/SEC)	V OUT (VDC)	V CALC (VDC)	Z FS	Z IDEAL
-49.989	.2953	.3057	.342	-3.418
-99.8422	.5898	.609	.628	-3.147
-149.639	.8873	.9119	.81	-2.706
* -199.549	1.1873	1.2155	.929	-2.328
-249.455	1.4913	1.5191	.915	-1.834
-299.286	1.7996	1.8223	.746	-1.246
-349.236	2.1134	2.1261	.418	-.598
-399.008	2.4332	2.4289	-.143	.179
-448.893	2.7598	2.7324	-.901	1.003
-498.808	3.093	3.036	-1.872	1.876
-448.988	2.7613	2.733	-.93	1.036
-399.032	2.4354	2.4291	-.21	.263
-349.182	2.1163	2.1258	.312	-.447
-299.329	1.8029	1.8225	.645	-1.077
-249.395	1.4945	1.5188	.796	-1.596
-199.499	1.1906	1.2152	.808	-2.025
-149.69	.8906	.9122	.711	-2.375
-99.7762	.5929	.6086	.513	-2.573
-49.9797	.2975	.3056	.268	-2.683
49.8369	-.2926	-.3016	-.297	-2.933
* 99.7095	-.5881	-.605	-.557	-2.792
149.589	-.8862	-.9084	-.731	-2.445
199.43	-1.1863	-1.2116	-.834	-2.092
249.322	-1.4899	-1.5152	-.83	-1.664
299.192	-1.7976	-1.8185	-.687	-1.147
349.056	-2.11	-2.1219	-.392	-.562
398.962	-2.4282	-2.4255	.091	.114
448.814	-2.7528	-2.7287	.791	.882
498.677	-3.0835	-3.0321	1.691	1.696
448.862	-2.7533	-2.729	.799	.89
398.921	-2.4291	-2.4252	.126	.158
349.087	-2.1114	-2.1221	-.35	-.501
299.178	-1.7988	-1.8184	-.645	-1.078
249.374	-1.4914	-1.5155	-.792	-1.587
199.459	-1.188	-1.2118	-.784	-1.966
149.545	-.888	-.9082	-.663	-2.216
99.7078	-.5903	-.605	-.483	-2.421
49.8523	-.2944	-.3017	-.24	-2.409

TEST SUMMARY

FULL SCALE RATE (DEG/SEC): 500
 SCALE FACTOR (V/DEG/SEC): -6.08342E-03
 BIAS (VOLTS) : 1.57557E-03
 HYSTERESIS, NEG RATES (VDC): -3.37982E-03
 HYSTERESIS, POS RATES (VDC): 2.23863E-03

TEST ENGINEER.....

[Handwritten Signature]
 2-18-80

READY

TABLE 3.1.2-1

RATE SENSOR TEST PROGRAM

NADC 80081-60

DATE...2-18-80.....

RUN Initial Baseline

TEMP...72°F...50%RH..

SER#...355.....

RATE (DEG/SEC)	V OUT (VDC)	V CALC (VDC)	% FS	% IDEAL
-49.9388	.2951	.3073	.362	-3.984
-99.8574	.5896	.6124	.68	-3.748
-149.648	.8863	.9168	.908	-3.339
* -199.549	1.1858	1.2219	1.072	-2.953
-249.487	1.4898	1.5271	1.11	-2.447
-299.272	1.7978	1.8315	1.001	-1.84
-349.167	2.1117	2.1365	.738	-1.162
-399.037	2.4313	2.4413	.299	-.412
-448.851	2.7573	2.7459	-.34	.416
-498.805	3.0903	3.0512	-1.161	1.28
-548.737	3.42993	3.35652	-2.183	2.188
-498.766	3.0918	3.051	-1.213	1.338
-448.95	2.7598	2.7465	-.398	.488
-399.057	2.4343	2.4415	.212	-.292
-349.147	2.115	2.1364	.635	-1
-299.296	1.8017	1.8316	.889	-1.634
-249.444	1.4938	1.5269	.984	-2.171
-199.492	1.19	1.2215	.938	-2.587
-149.678	.8899	.917	.804	-2.956
-99.8151	.5927	.6122	.581	-3.199
-49.9625	.2971	.3074	.305	-3.362
49.8529	-.2924	-.3028	-.309	-3.41
99.7061	-.5876	-.6075	-.591	-3.26
149.584	-.885	-.9124	-.815	-2.998
199.444	-1.1847	-1.2172	-.968	-2.669
249.349	-1.4881	-1.5223	-1.018	-2.245
* 299.215	-1.7952	-1.8271	-.949	-1.745
349.153	-2.1076	-2.1324	-.738	-1.162
398.94	-2.4257	-2.4368	-.328	-.452
448.792	-2.7502	-2.7415	.259	.318
498.706	-3.0811	-3.0466	1.026	1.131
548.615	-3.41805	-3.35169	1.974	1.979
498.693	-3.0821	-3.0466	1.058	1.167
448.853	-2.7519	-2.7419	.298	.365
398.968	-2.4279	-2.4369	-.268	-.37
349.126	-2.1103	-2.1322	-.652	-1.027
299.217	-1.7979	-1.8271	-.869	-1.596
249.349	-1.4906	-1.5223	-.942	-2.079
199.481	-1.1872	-1.2175	-.899	-2.478
149.578	-.8876	-.9124	-.739	-2.716
99.6536	-.5902	-.6072	-.504	-2.784
49.8472	-.2943	-.3027	-.251	-2.766

TEST SUMMARY

FULL SCALE RATE (DEG/SEC): 550
 SCALE FACTOR (V/DEG/SEC): -6.11309E-03
 BIAS (VOLTS) : 1.98895E-03
 HYSTERESIS, NEG RATES (VDC): -4.12464E-03
 HYSTERESIS, POS RATES (VDC): 2.72226E-03

TABLE 3.1.2-II

TEST ENGINEER

[Handwritten signature]
2-18-80

READY

RATE SENSOR TEST PROGRAM

NADC 80081-60

DATE...2-18-80..... RUN..Initial Baseline.....

TEMP...72°F...50%RH.. SER#...373.....

RATE (DEG/SEC)	V OUT (VDC)	V CALC (VDC)	% FS	% IDEAL
-49.9477	.2945	.3058	.461	-3.69
-99.766	.5947	.6122	.712	-2.853
* -149.737	.8985	.9196	.856	-2.288
-199.612	1.2061	1.2263	.823	-1.65
-249.448	1.519	1.5328	.563	-.904
-299.355	1.8379	1.8398	.078	-.105
-349.235	2.1641	2.1466	-.711	.815
-399.093	2.4978	2.4532	-1.814	1.818
-349.206	2.1648	2.1464	-.748	.857
-299.35	1.8391	1.8398	.027	-.036
-249.453	1.5206	1.5329	.501	-.803
-199.555	1.2079	1.226	.734	-1.471
-149.71	.9006	.9194	.765	-2.044
-99.8404	.5966	.6127	.656	-2.63
-49.9325	.2957	.3058	.41	-3.28
49.8582	-.3034	-.308	-.187	-1.5
99.7501	-.6034	-.6149	-.467	-1.873
* 149.591	-.9055	-.9214	-.645	-1.725
199.483	-1.2111	-1.2282	-.696	-1.395
249.359	-1.521	-1.535	-.568	-.912
299.221	-1.8359	-1.8417	-.233	-.312
349.141	-2.1575	-2.1487	.359	.411
399.028	-2.4857	-2.4555	1.226	1.229
349.109	-2.1581	-2.1485	.39	.446
299.222	-1.8371	-1.8417	-.188	-.251
249.374	-1.5221	-1.5351	-.53	-.85
199.539	-1.2126	-1.2286	-.652	-1.307
149.561	-.9074	-.9212	-.563	-1.505
99.7179	-.6047	-.6147	-.406	-1.628
49.8778	-.3043	-.3081	-.154	-1.234

TEST SUMMARY
 FULL SCALE RATE (DEG/SEC): 400
 SCALE FACTOR (V/DEG/SEC): -6.15037E-03
 BIAS (VOLTS) : -1.35492E-03
 HYSTERESIS, NEG RATES (VDC): -2.08056E-03
 HYSTERESIS, POS RATES (VDC): 1.84214E-03

TEST ENGINEER *[Signature]*
 2-18-80

READY

TABLE 3.1.2-III

RATE SENSOR TEST PROGRAM

NADC 80081-60

DATE 2-18-80..... RUN Initial Baseline
 TEMP 72°F..... 50%RH SER#..... 373

RATE (DEG/SEC)	V OUT (VDC)	V CALC (VDC)	Z FS	Z IDEAL
-49.9608	.2946	.3096	.538	-4.849
* -99.8506	.5953	.6187	.837	-3.771
-149.648	.8998	.9272	.98	-2.948
-199.546	1.2078	1.2363	1.022	-2.305
-249.431	1.5213	1.5453	.861	-1.554
-299.318	1.8406	1.8543	.492	-.74
-349.196	2.1668	2.1633	-.124	.16
-399.035	2.5006	2.4721	-1.024	1.154
-448.954	2.8432	2.7813	-2.22	2.225
-399.108	2.5015	2.4725	-1.041	1.173
-349.235	2.1677	2.1635	-.15	.193
-299.368	1.8417	1.8546	.464	-.697
-249.512	1.5225	1.5458	.834	-1.504
-199.587	1.2095	1.2365	.969	-2.186
-149.759	.9017	.9278	.939	-2.822
-99.8219	.5975	.6185	.754	-3.398
-49.9438	.2961	.3095	.482	-4.339
49.8885	-.3035	-.3089	-.194	-1.746
99.7585	-.6037	-.6179	-.509	-2.295
149.572	-.9061	-.9265	-.728	-2.191
* 199.422	-1.2117	-1.2353	-.845	-1.907
249.369	-1.5219	-1.5447	-.817	-1.474
299.209	-1.8371	-1.8534	-.585	-.88
349.117	-2.1588	-2.1626	-.135	-.174
398.963	-2.4875	-2.4714	.577	.651
448.943	-2.8236	-2.781	1.529	1.532
399.009	-2.488	-2.4717	.587	.662
349.112	-2.16	-2.1626	-.092	-.118
299.219	-1.8384	-1.8535	-.542	-.815
249.379	-1.5232	-1.5447	-.773	-1.395
199.412	-1.2134	-1.2352	-.783	-1.768
149.654	-.9078	-.927	-.688	-2.07
99.7332	-.6049	-.6177	-.458	-2.066
49.8699	-.3044	-.3088	-.158	-1.423

TEST SUMMARY
 FULL SCALE RATE (DEG/SEC): 450
 SCALE FACTOR (V/DEG/SEC): -6.19478E-03
 BIAS (VOLTS) : 1.14196E-04
 HYSTERESIS, NEG RATES (VDC): -2.13492E-03
 HYSTERESIS, POS RATES (VDC): 1.65558E-03

TEST ENGINEER

[Handwritten Signature]
 27 15 80

READY

TABLE 3.1.2-IV

RATE SENSOR TEST PROGRAM

DATE... 2-21-80..... RUN... Initial Baseline
 TEMP... 72°F 50%RH..... SER#... 381.....

RATE (DEG/SEC)	V OUT (VDC)	V CALC (VDC)	Z FS	Z IDEAL
-49.9772	.2977	.3086	.323	-3.555
-99.7863	.594	.6153	.626	-3.453
-149.725	.8933	.9227	.868	-3.189
-199.543	1.1952	1.2294	1.008	-2.777
* -249.421	1.5011	1.5364	1.042	-2.298
-299.279	1.8115	1.8433	.94	-1.728
-349.155	2.1272	2.1504	.684	-1.078
-399.025	2.4486	2.4574	.259	-.357
-448.908	2.7762	2.7645	-.346	.424
-498.769	3.1088	3.0714	-1.103	1.216
-548.666	3.44492	3.37865	-1.957	1.962
-498.778	3.1093	3.0715	-1.117	1.232
-448.879	2.7775	2.7643	-.391	.479
-399.065	2.4508	2.4576	.202	-.278
-349.214	2.1299	2.1508	.617	-.971
-299.287	1.8144	1.8434	.857	-1.576
-249.445	1.504	1.5366	.962	-2.121
-199.527	1.1979	1.2293	.927	-2.555
-149.715	.8959	.9226	.789	-2.898
-99.7643	.5962	.6151	.559	-3.081
-49.9782	.2985	.3086	.3	-3.305
49.8389	-.2951	-.3059	-.316	-3.49
99.7213	-.5926	-.6129	-.602	-3.318
149.615	-.8923	-.9201	-.821	-3.019
199.41	-1.1942	-1.2266	-.958	-2.643
249.344	-1.5001	-1.534	-1.003	-2.212
299.168	-1.8101	-1.8408	-.907	-1.667
349.094	-2.1251	-2.1481	-.678	-1.069
* 398.914	-2.4456	-2.4548	-.271	-.374
448.85	-2.772	-2.7622	.289	.355
498.659	-3.1036	-3.0688	1.026	1.131
548.515	-3.43916	-3.3757	1.874	1.879
498.693	-3.1043	-3.069	1.042	1.149
448.814	-2.7736	-2.762	.344	.422
398.953	-2.4482	-2.455	-.202	-.279
349.129	-2.1276	-2.1483	-.612	-.963
299.188	-1.8123	-1.8409	-.843	-1.549
249.324	-1.5023	-1.5339	-.932	-2.056
199.447	-1.1964	-1.2269	-.899	-2.478
149.654	-.8944	-.9203	-.764	-2.809
99.7027	-.5945	-.6128	-.542	-2.989
49.8288	-.2965	-.3058	-.274	-3.028

TEST SUMMARY
 FULL SCALE RATE (DEG/SEC): 550
 SCALE FACTOR (V/DEG/SEC): -6.15610E-03
 BIAS (VOLTS) : 9.52902E-04
 HYSTERESIS, NEG RATES (VDC): -2.85959E-03
 HYSTERESIS, POS RATES (VDC): 2.57397E-03

TABLE 3.1.2-V

TEST ENGINEER.....

[Handwritten signature]
 2-21-80

RATE SENSOR TEST PROGRAM

DATE...2-21-80..... RUN Initial Baseline NADC 80081-60
 TEMP...72° F 50%RH SER#...381.....

RATE (DEG/SEC)	V OUT (VDC)	V CALC (VDC)	% FS	% IDEAL
-49.9646	.2978	.3105	.342	-4.11
-99.8151	.5948	.6193	.659	-3.958
-149.69	.8941	.9282	.917	-3.674
* -199.492	1.1965	1.2366	1.08	-3.247
-249.402	1.5028	1.5457	1.155	-2.778
-299.306	1.8132	1.8548	1.12	-2.245
-349.142	2.1292	2.1635	.921	-1.583
-398.988	2.4506	2.4722	.582	-.875
-449.006	2.7779	2.782	.11	-.148
-498.82	3.1105	3.0905	-.538	.647
-548.624	3.44725	3.39903	-1.298	1.419
-598.524	3.78638	3.70809	-2.107	2.112
-548.659	3.44843	3.39925	-1.324	1.447
-498.79	3.1123	3.0903	-.591	.71
-448.879	2.7802	2.7812	.027	-.036
-399.103	2.4531	2.4729	.532	-.8
-349.137	2.1316	2.1634	.858	-1.475
-299.338	1.8155	1.855	1.064	-2.132
-249.424	1.5052	1.5459	1.095	-2.635
-199.524	1.1991	1.2368	1.015	-3.053
-149.666	.8963	.928	.853	-3.419
-99.8218	.5965	.6193	.613	-3.683
-49.9053	.2987	.3101	.308	-3.702
49.8445	-.2957	-.3077	-.321	-3.87
99.7399	-.5934	-.6167	-.627	-3.772
149.561	-.8934	-.9253	-.859	-3.444
* 199.42	-1.1955	-1.2341	-1.039	-3.126
249.337	-1.5016	-1.5432	-1.12	-2.694
299.178	-1.812	-1.8519	-1.075	-2.156
349.044	-2.1274	-2.1608	-.899	-1.546
398.884	-2.4478	-2.4695	-.583	-.877
448.799	-2.7745	-2.7786	-.111	-.149
498.743	-3.1059	-3.088	.484	.582
548.62	-3.44174	-3.39681	1.209	1.322
598.466	-3.77955	-3.70554	1.992	1.997
548.562	-3.4427	-3.39646	1.244	1.361
498.721	-3.1075	-3.0878	.529	.636
448.857	-2.7759	-2.779	-.083	-.111
398.899	-2.4497	-2.4696	-.533	-.802
349.051	-2.1292	-2.1608	-.851	-1.463
299.198	-1.8139	-1.8521	-1.027	-2.06
249.344	-1.5038	-1.5433	-1.062	-2.556
199.464	-1.1977	-1.2343	-.986	-2.966
149.632	-.8952	-.9257	-.822	-3.296
99.6367	-.5952	-.6161	-.563	-3.388
49.8377	-.2969	-.3076	-.288	-3.47

TEST SUMMARY
 FULL SCALE RATE (DEG/SEC): 600
 SCALE FACTOR (V/DEG/SEC): -6.19356E-03
 BIAS (VOLTS) : 1.04026E-03
 HYSTERESIS, NEG RATES (VDC): -2.58541E-03
 HYSTERESIS, POS RATES (VDC): 2.23064E-03

TABLE 3.1.2-V1

TEST ENGINEER.....

[Handwritten Signature] 2-21-80

RATE SENSOR PROGRAM: OUTPUT DRIFT

NADC 80081-60

DATE...2-19-80..... RUN...Initial Baseline

TEMP...72°F.....50%RH SER#...355.....

TIME (SEC)	OUTPUT DRIFT IN 15 SEC INTERVALS		
	RATE (DEG/SEC)	MEAN (VDC)	SCALE FACTOR (VOLTS/DEG/SEC)
15	99.8056	.592772	5.93927E-03
30	99.8325	.59322	5.94215E-03
45	99.8305	.59357	5.94578E-03
60	99.8634	.594153	5.94966E-03
15	199.592	1.18991	5.96172E-03
30	199.557	1.19068	5.96663E-03
45	199.567	1.19153	5.97059E-03
60	199.59	1.19221	5.97330E-03
15	299.339	1.80431	6.02766E-03
30	299.342	1.80549	6.03154E-03
45	299.337	1.80621	6.03404E-03
60	299.318	1.80705	6.03723E-03
15	399.056	2.44222	6.11999E-03
30	399.09	2.44294	6.12126E-03
45	399.065	2.44408	6.12452E-03
60	399.112	2.44519	6.12658E-03
15	498.868	3.10689	6.22788E-03
30	498.909	3.1081	6.22980E-03
45	498.824	3.10925	6.23316E-03
60	498.847	3.11066	6.23569E-03

READY

Ray W. Long
2-19-80

*Data Shown are for t = 15, 30, 45, and 60 seconds for each of five nominal rate inputs of 100, 200, 300, 400, and 500 degrees/second.

TABLE 3.1.2-VII

RATE SENSOR PROGRAM: OUTPUT DRIFT

NADC 80081-60

DATE..2-19-80..... RUN..Initial Baseline
 TEMP..72°F..50%RH... SER#...373.....

OUTPUT DRIFT IN 15 SEC INTERVALS

RATE (DEG/SEC)	MEAN (VDC)	SCALE FACTOR (VOLTS/DEG/SEC)
99.8112	.591919	5.93039E-03
99.864	.592952	5.93760E-03
99.8498	.593578	5.94471E-03
99.8284	.594043	5.95064E-03
199.589	1.20507	6.03772E-03
199.578	1.20608	6.04316E-03
199.581	1.20674	6.04638E-03
199.538	1.20752	6.05156E-03
299.308	1.84101	6.15090E-03
299.316	1.84205	6.15420E-03
299.338	1.8429	6.15659E-03
299.338	1.84376	6.15946E-03
399.1	2.50633	6.27997E-03
399.115	2.50797	6.28383E-03
399.072	2.50887	6.28676E-03
399.079	2.50979	6.28896E-03
498.88	3.20376	6.42191E-03
498.89	3.20515	6.42456E-03
498.908	3.20679	6.42761E-03
498.927	3.20789	6.42958E-03

READY

Handwritten signature and date: 2-19-80

TABLE 3.1.2-VIII

RATE SENSOR PROGRAM: OUTPUT DRIFT

NADC 80081-60

DATE...2-19-80..... RUN Initial Baseline

TEMP...72°F...50%RH.. SER#...381.....

OUTPUT DRIFT IN 15 SEC INTERVALS

RATE (DEG/SEC)	MEAN (VDC)	SCALE FACTOR (VOLTS/DEG/SEC)
99.8467	.592919	5.93829E-03
99.7802	.593474	5.94781E-03
99.8533	.593904	5.94777E-03
99.7711	.594278	5.95642E-03
199.599	1.19523	5.98817E-03
199.61	1.19608	5.99208E-03
199.599	1.19674	5.99573E-03
199.583	1.19772	6.00113E-03
299.316	1.81507	6.06406E-03
299.346	1.81605	6.06674E-03
299.359	1.81723	6.07042E-03
299.322	1.81789	6.07336E-03
399.073	2.45741	6.15779E-03
399.069	2.45848	6.16053E-03
399.103	2.45948	6.16253E-03
399.071	2.46072	6.16613E-03
498.804	3.12312	6.26122E-03
498.83	3.12489	6.26444E-03
498.83	3.1261	6.26687E-03
498.859	3.12645	6.26720E-03

READY

Boyd A. Smith
2-19-80

TABLE 3.1.2-IX

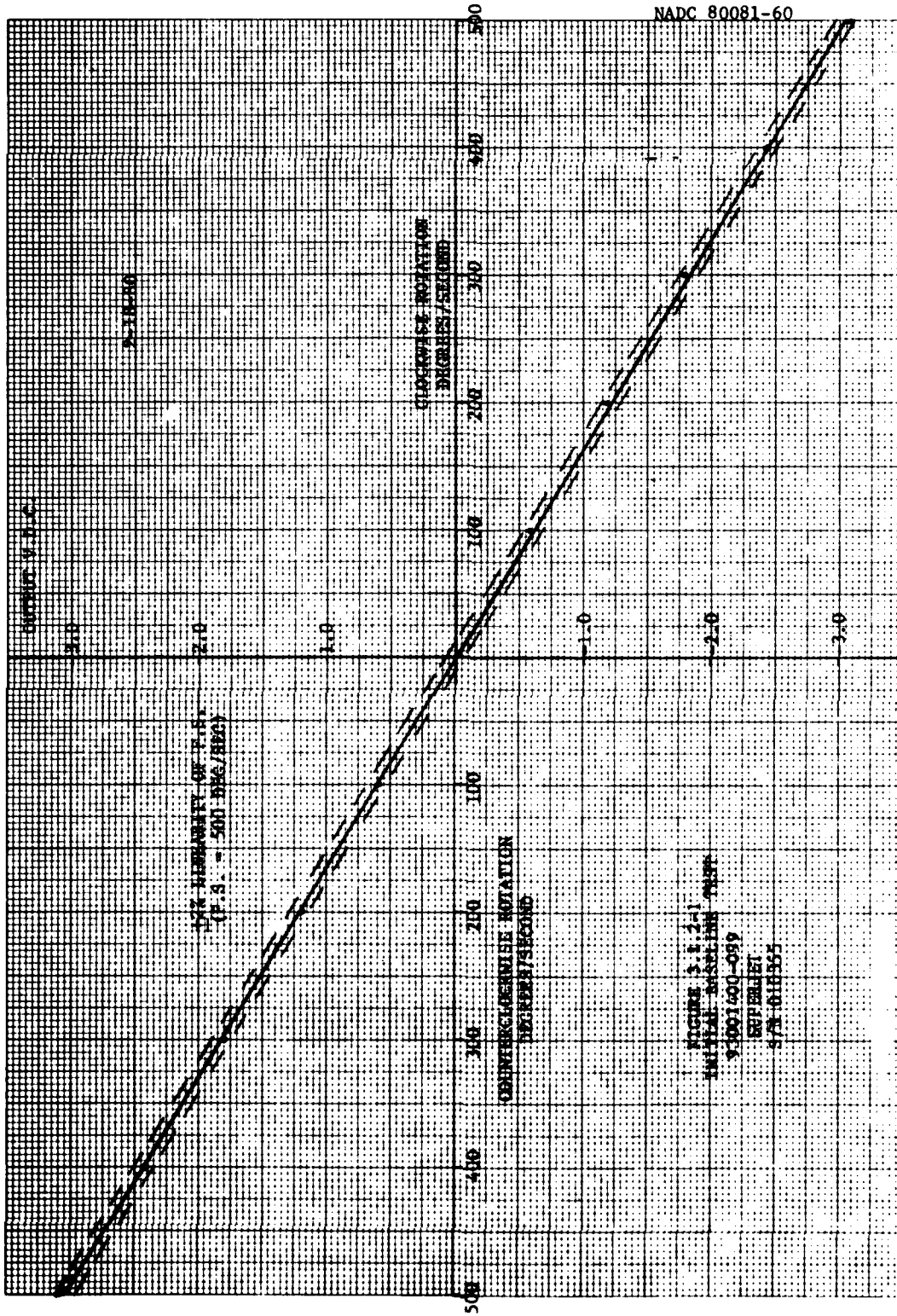

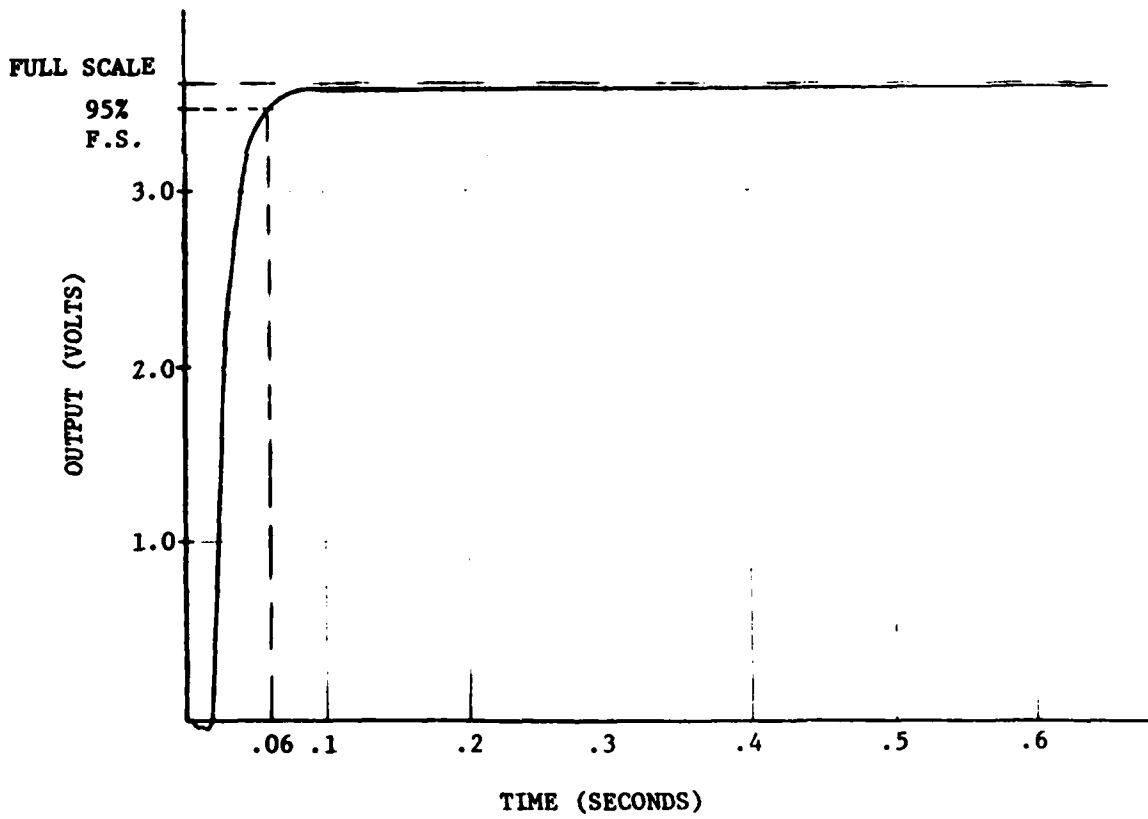

FIGURE 3.1.2-2
TYPICAL READYTIME PLOT

PARAMETER	S/N 355	S/N 373	S/N 381
FULL SCALE RATE (DEG/SECOND) AT +2% LINEARITY ERROR	500	400	550
SCALE FACTOR (MV/DEG/SEC)	-6.08	-6.15	-6.15
BIAS (DEG/SECOND)	-.26	+ .22	-.15
HYSTERESIS CCW (DEG/SECOND)	+ .56	+ .34	+ .47
HYSTERESIS CW (DEG/SECOND)	-.37	-.30	-.42
THRESHOLD (DEG/SECOND)	< .10	< .10	< .10
RESOLUTION (DEG/SECOND)	< .10	< .10	< .10
READYTIME (SECONDS) AVG. OF 5 RATES*	+ .038	+ .050	+ .047
DRIFT (DEG/SEC/MIN) AVG. OF 5 RATES*	+ .22	+ .19	+ .18

*100, 200, 300, 400, AND 500 DEGREES/SECOND
(See Table 3.1.3-II)

TABLE 3.1.3-I

BASELINE TEST DATA SUMMARY

RATE (DEG/SEC)	OUTPUT DRIFT (DEG/SEC/MIN)			READYTIME (SECONDS)		
	355	373	381	355	373	381
100	+ .22	+ .33	+ .29	.032	.035	.045
200	+ .25	+ .23	+ .21	.035	.045	.035
300	+ .31	+ .14	+ .15	.035	.050	.045
400	+ .14	+ .14	+ .13	.040	.068	.045
500	+ .17	+ .13	+ .10	.046	.055	.065

TABLE 3.1.3-II
BASELINE DRIFT AND READYTIME

3.2 Acceleration Sensitivity

3.2.1 Test Setup and Procedure

The "Superjet" rate sensors (one at a time) were mounted on the Genisco model 1100-2 rate table in the Precision Inertial Laboratory. The rate table was again controlled by the Hewlett Packard 9500A test set. The scale factor test program (see Section 3.1) was used and a maximum rate of 500 degrees/second was used as a baseline. The rate sensors were subjected to constant accelerations in each direction along the three mutually perpendicular axes, (See Figure B.2-1 in Appendix A).

The X and Y axes were accelerated with the input axis or Z axis of the sensor parallel to the rate table spin axis. The Z axis was accelerated with the X axis or jet axis parallel to the rate table spin axis.

The acceleration tests were conducted per Appendix A Part B of this test report. The tests deviate from the test plan (Appendix B) for which the desired maximum acceleration level was 30g.

Due to the saturation of the "Superjet" exceeding a 2% error beyond 500 degrees/second, the maximum acceleration applied was 4.74g which is equivalent to a rate of 500 degrees/second.

The orientation of Superjet while subjected to acceleration was made to be rate sensitive. The manufacturer performed acceleration tests with the Superjet oriented to be rate in-sensitive. The performance of the "Maximum Performance Escape System" depends on the g-sensitivity in any direction of acceleration, where the worst case appears to be a rate sensitive orientation.

3.2.2 Test Results

By using the scale factor test program, the voltage output of the "Superjet" was recorded at 250 and 500 degrees per second. This was done for six different orientations at a zero arm and approximately a twenty-four inch arm. The data used for the X and Y axis at the zero arm was obtained from the baseline post acoustic test results, (see Tables 3.5.2-I, IV and V). Tables 3.2.2-I through 3.2.2-XXI represent data obtained during testing for each axis accelerated. Using the underlined values, Table 3.2.2-XXII was constructed for evaluation.

RATE SENSOR TEST PROGRAM

NADC 80081-60

DATE...3-28-80..... RUN...+X...R=24 in...
 TEMP...72°F...50%RH... SER#...355.....

RATE (DEG/SEC)	V OUT (VDC)	V CALC (VDC)	% FS	% IDEAL
-53.0432	.3045	.3149	.334	-3.334
-99.8811	.6065	.626	.627	-3.14
-149.813	.9115	.9378	.842	-2.91
* -199.697	1.2192	1.2492	.956	-2.4
-249.624	1.5314	1.5628	.942	-1.866
-299.477	1.8465	1.872	.753	-1.258
-349.399	2.1715	2.1837	.391	-.56
-399.313	2.5005	2.4953	-.168	.21
-449.182	2.8362	2.8266	-.847	1.354
-499.093	3.1784	3.1102	-1.929	1.933
-449.248	2.837	2.837	-.86	1.69
-399.284	2.5319	2.4951	-.218	.273
-349.362	2.1732	2.1835	.33	-.473
-299.517	1.8528	1.8723	.688	-1.148
-249.583	1.534	1.5636	.852	-1.737
-199.715	1.2218	1.2493	.879	-2.2
-149.778	.914	.9375	.756	-2.522
-99.8777	.6286	.626	.559	-2.787
-53.01	.3355	.3147	.295	-2.948
49.7383	-.299	-.3263	-.299	-2.889
99.6807	-.6019	-.6197	-.572	-2.367
149.577	-.9273	-.9312	-.767	-2.565
* 199.439	-1.2149	-1.2425	-.885	-2.217
249.348	-1.5266	-1.5541	-.879	-1.762
299.246	-1.8429	-1.8655	-.726	-1.213
349.175	-2.1643	-2.1772	-.414	-.583
399.134	-2.4913	-2.4883	.088	.122
448.94	-2.825	-2.8	.831	.892
498.821	-3.165	-3.1114	1.715	1.72
448.88	-2.8264	-2.7997	.858	.956
399.351	-2.4933	-2.4886	.152	.191
349.133	-2.1666	-2.177	-.334	-.473
299.228	-1.8449	-1.8654	-.657	-1.392
249.437	-1.5292	-1.5544	-.837	-1.618
199.456	-1.2175	-1.2426	-.832	-2.211
149.571	-.9295	-.9312	-.695	-2.324
99.6892	-.6038	-.6198	-.511	-2.564
49.7656	-.3251	-.3383	-.261	-2.621

TEST SUMMARY
 FULL SCALE RATE (DEG/SEC): 520
 SCALE FACTOR (V/DEG/SEC): -6.04262E-33
 BIAS (VOLTS) : 2.52845E-33
 HYSTERESIS, NEG RATES (VDC): -2.62234E-33
 HYSTERESIS, POS RATES (VDC): 2.67243E-33
 FULL OFFSET (VDC): 3.95268E-33

TEST ENGINEER

Boyd W. King
 : 3-28-80

READY

TABLE 3.2.2-1

RATE SENSOR TEST PROGRAM

NADC 80081-60

DATE: 3-28-80.....

RUN: X...R#24.4n.

TEMP: 72°F...507RH..

SER#...355.....

RATE (DEG/SEC)	V OUT (VDC)	V CALC (VDC)	% FS	% IDEAL
-54.3125	.3036	.3149	.361	-3.613
-99.6708	.6455	.6252	.653	-3.272
-149.773	.9102	.9371	.963	-2.872
-199.648	1.2181	1.2481	.962	-2.41
* -249.61	1.53	1.5597	.953	-1.909
-299.461	1.8474	1.8736	.745	-1.244
-349.332	2.1692	2.182	.411	-.588
-399.316	2.498	2.4934	-.146	.193
-449.121	2.8333	2.804	-.938	1.444
-499.292	3.1743	3.1157	-1.893	1.296
-449.280	2.8347	2.835	-.952	1.26
-399.28	2.5305	2.4932	-.934	.293
-349.45	2.173	2.1824	.332	-.433
-299.5	1.851	1.8709	.637	-1.064
-249.576	1.5347	1.5585	.798	-1.508
-199.68	1.2226	1.2483	.896	-2.368
-149.79	.9146	.9372	.725	-2.422
-99.854	.6094	.6257	.523	-2.621
-49.9917	.3061	.3142	.277	-2.772
49.7846	-.2883	-.3275	-.984	-2.955
99.7146	-.6013	-.6189	-.564	-2.83
* 149.503	-.9362	-.9882	-.76	-2.54
199.444	-1.2141	-1.2459	-.859	-2.154
249.366	-1.5256	-1.5523	-.85	-1.734
299.3	-1.8414	-1.8637	-.716	-1.197
349.231	-2.1622	-2.1751	-.413	-.591
399.341	-2.4867	-2.4858	.096	.12
449.326	-2.8217	-2.7975	.777	.866
499.228	-3.1606	-3.1387	1.662	1.666
449.965	-2.8229	-2.7971	.826	.92
399.111	-2.4834	-2.4662	.136	.17
349.165	-2.1645	-2.1747	-.326	-.467
299.249	-1.8436	-1.8634	-.635	-1.26
249.442	-1.5232	-1.5527	-.786	-1.575
199.523	-1.2168	-1.2413	-.785	-1.868
149.621	-.9389	-.9301	-.678	-2.265
99.6621	-.6339	-.6186	-.472	-2.368
49.6181	-.3324	-.3277	-.234	-2.353

TEST SUMMARY

FULL SCALE RATE (DEG/SEC): 520
 SCALE FACTOR (V/DEG/SEC): -6.23678E-33
 BIAS (VOLTS) : 0.968442-23
 HYSTERESIS, NEG RATES (VDC): -4.64272E-33
 HYSTERESIS, POS RATES (VDC): 2.67529E-33
 NULL OFFSET (VDC): 3.54195E-33

TEST ENGINEER



3-28-80

READY

TABLE 3.2.2-II

RATE SENSOR TEST PROGRAM

NADC 80081-60

DATE... 3-28-80... RUN TIME... 4-24.14.
 TEMP. 77.29F... 504RA... SER#... 355.....

RATE (DEG/SEC)	V OUT (VDC)	V CALC (VDC)	Z FS	Z IDEAL
-50.001	.3033	.3136	.330	-3.323
-99.9149	.6244	.6237	.624	-3.105
-149.8	.9379	.9339	.937	-2.794
* -199.656	1.2143	1.2437	.949	-2.376
-249.573	1.5252	1.554	.926	-1.855
-299.35	1.8400	1.8634	.725	-1.211
-349.34	2.1615	2.1741	.433	-.577
-399.206	2.4894	2.484	-.173	.017
-449.233	2.8234	2.7948	-.921	1.025
-499.200	3.1643	3.1044	-1.926	1.93
-449.126	2.8246	2.7943	-.975	1.205
-399.226	2.4912	2.4841	-.222	.285
-349.373	2.1642	2.1743	.324	-.464
-299.489	1.8434	1.8642	.672	-1.121
-249.558	1.5281	1.5539	.831	-1.665
-199.686	1.2173	1.2439	.856	-2.144
-149.83	.9107	.9341	.752	-2.511
-99.9183	.6264	.6237	.56	-2.802
-49.9929	.3043	.3135	.297	-2.968
49.7961	-.298	-.3067	-.28	-2.810
99.6316	-.5998	-.6164	-.536	-2.689
149.556	-.9037	-.9267	-.741	-2.476
199.452	-1.2122	-1.2362	-.658	-2.151
* 249.334	-1.5233	-1.5469	-.854	-1.713
299.229	-1.8342	-1.857	-.714	-1.193
349.117	-2.1546	-2.1671	-.4	-.572
399.367	-2.4799	-2.4775	.077	.397
448.885	-2.8116	-2.7871	.782	.877
498.784	-3.149	-3.0973	1.665	1.67
448.982	-2.8125	-2.7877	.795	.886
398.992	-2.4812	-2.477	.135	.17
349.141	-2.1566	-2.1672	-.34	-.487
299.239	-1.837	-1.857	-.644	-1.377
249.379	-1.5229	-1.5472	-.782	-1.562
199.469	-1.2125	-1.2369	-.785	-1.968
149.569	-.9058	-.9268	-.676	-2.20
99.6480	-.6217	-.6165	-.478	-2.389
49.7961	-.2992	-.3067	-.24	-2.486

TEST SUMMARY
 FULL SCALE RATE (DEG/SEC): 500
 SCALE FACTOR (V/DEG/SEC): -6.21531E-23
 BIAS (VOLTS) : 2.81463E-23
 HYSTERESIS, NEG RATES (VDC): -3.07298E-23
 HYSTERESIS, POS RATES (VDC): 2.52247E-23
 FULL OFFSET (VDC): 3.51720E-23

TEST ENGINEER *[Signature]*
 3-28-80

READY

TABLE 3.2.2-III

RATE SENSOR TEST PROGRAM

NADC 80081-60

DATE... 3-28-80.....

RUN... 7... R-2A. in..

TEMP... 72°F... 50%RH..

SER#... 355.....

RATE (DEG/SEC)	V OUT (VDC)	V CALC (VDC)	% FS	% IDEAL
-49.9225	.3022	.312	.316	-3.161
-99.8354	.6034	.6224	.612	-3.367
* -149.676	.907	.9324	.917	-2.73
-199.585	1.2138	1.2427	.93	-2.329
-249.5	1.5247	1.5532	.915	-1.934
-299.439	1.84	1.8636	.758	-1.265
-349.332	2.1613	2.1738	.434	-.579
-399.25	2.4864	2.4845	-.125	.156
-449.316	2.8224	2.794	-.914	1.312
-498.235	3.1626	3.1344	-1.27	1.874
-449.291	2.8232	2.7944	-.926	1.331
-399.143	2.4889	2.4837	-.197	.247
-349.338	2.1635	2.1741	.34	-.427
-299.367	1.8426	1.8633	.666	-1.113
-249.549	1.5274	1.5535	.84	-1.632
-199.626	1.2166	1.243	.751	-2.131
-149.739	.9397	.9322	.742	-2.477
-99.7722	.6358	.622	.518	-2.621
-49.9333	.3039	.3121	.265	-2.652
49.8621	-.2983	-.3235	-.322	-3.292
99.7327	-.6033	-.6185	-.585	-2.933
149.687	-.9043	-.9293	-.914	-2.687
* 199.493	-1.2113	-1.2391	-.995	-2.237
249.456	-1.5222	-1.5496	-.822	-1.721
299.28	-1.8371	-1.8596	-.726	-1.212
349.185	-2.1577	-2.17	-.396	-.567
399.073	-2.4841	-2.4803	.123	.154
449.211	-2.8171	-2.7923	.844	.84
498.914	-3.1554	-3.1312	1.744	1.746
449.362	-2.8178	-2.7911	.857	.854
399.137	-2.4858	-2.4825	.17	.213
349.128	-2.1622	-2.17	-.317	-.453
299.374	-1.8422	-1.8632	-.645	-1.072
249.473	-1.5251	-1.5499	-.797	-1.597
199.539	-1.2145	-1.2394	-.831	-2.227
149.655	-.9073	-.9291	-.702	-2.346
99.7619	-.6027	-.6189	-.519	-2.631
49.8765	-.2999	-.3086	-.279	-2.831

TEST SUMMARY
 FULL SCALE RATE (DEG/SEC): 500
 SCALE FACTOR (V/DEG/SEC): -6.21895E-03
 BIAS (VOLTS) : 1.55324E-03
 HYSTERESIS, NEG RATES (VDC): -2.73639E-03
 HYSTERESIS, POS RATES (VDC): 3.13735E-03
 FULL OFFSET (VDC): 2.94272E-03

TEST ENGINEER *Boyd W. Long*
 3-28-80

READY

TABLE 3.2.2-IV

RATE SENSOR TEST PROGRAM

NADC 80081-60

DATE...4-1-80.....

RUN...T...R=23.6 1h.

TEMP...72°F...507RM..

SER#...355.....

RATE (DEG/SEC)	V OUT (VDC)	V CALC (VDC)	% FS	% IDEAL
* -49.9384	.0033	.0035	-1.049	13.506
-99.8117	-.0011	-.001	-.33	1.653
-149.693	-.0026	-.0025	-.712	2.379
-199.576	-.004	-.004	.137	-3.43
-249.58	-.0054	-.0056	.955	-1.914
-299.489	-.0068	-.0071	1.741	-3.375
-349.341	-.0083	-.0086	2.161	-3.086
-399.199	-.0097	-.0101	2.774	-3.475
-449.05	-.0111	-.0116	3.412	-3.799
-499.013	-.0125	-.0131	3.836	-3.814
-449.898	-.0111	-.0116	3.142	-3.487
-399.142	-.0098	-.0101	2.11	-2.644
-349.353	-.0084	-.0086	1.374	-1.907
-299.389	-.007	-.0071	.298	-.495
-249.556	-.0056	-.0056	-.47	.942
-199.637	-.0043	-.004	-1.768	4.429
-149.683	-.003	-.0025	-3.385	13.305
-99.8488	-.0015	-.001	-3.456	17.306
-49.9511	-.0002	.0005	-4.384	43.9023
* 49.8931	.0006	.0005	-5.981	-59.8346
99.7586	.0041	.005	-5.935	-29.747
149.703	.0057	.0065	-5.749	-19.201
199.578	.0074	.008	-4.571	-11.459
249.508	.009	.0096	-3.712	-7.439
299.363	.0107	.0111	-2.197	-3.669
349.342	.0126	.0126	.041	.059
399.133	.0144	.0141	2.034	2.761
449.092	.0164	.0156	5.265	5.899
498.902	.0184	.0171	2.681	2.7
449.171	.0165	.0156	5.779	6.433
399.158	.0146	.0141	3.542	4.437
349.344	.0128	.0126	1.623	2.323
299.327	.0111	.0111	.539	.931
249.559	.0095	.0096	-.474	-.951
199.611	.0078	.008	-1.379	-3.455
149.677	.0063	.0065	-1.478	-4.938
99.7856	.0048	.005	-1.463	-7.329
49.9322	.0033	.0035	-1.483	-14.86

TEST SUMMARY

FULL SCALE RATE (DEG/SEC): 500
 SCALE FACTOR (V/DEG/SEC): 3.02311E-05
 BIAS (VOLTS) : 1.99878E-03
 HYSTERESIS, NEG RATES (VDC): -9.99934E-09
 HYSTERESIS, POS RATES (VDC): 0
 NULL OFFSET (VDC): 2.13032E-03

TEST ENGINEER

[Signature]
 3-8-80

READY

TABLE 3.2.2-V

RATE SENSOR TEST PROGRAM

NADC 80081-60

DATE..4-1-80.....

RUN...Z...B*24.4.in.

TEMP...72°R...50%RH..

SER#..355.....

RATE (DEG/SEC)	V OUT (VDC)	V CALC (VDC)	Z FS	Z IDEAL
* -49.9470	.0033	.0034	-1.126	11.073
-99.8489	-.001	-.0039	-.978	4.896
-149.758	-.0034	-.0071	-1.975	6.259
-199.508	-.0037	-.0134	-2.313	5.799
-249.553	-.0048	-.0246	-1.573	3.150
-299.434	-.006	-.0359	-.585	.977
-349.397	-.0071	-.0572	.029	-1.187
-399.309	-.0081	-.0884	2.566	-3.213
-449.017	-.0091	-.0997	4.971	-5.530
-499.031	-.0099	-.0109	7.346	-7.363
-449.040	-.0091	-.0097	4.568	-5.350
-399.194	-.0082	-.0084	1.65	-2.367
-349.026	-.0072	-.0072	-.327	.469
-299.302	-.0062	-.0059	-2.130	3.571
-249.424	-.005	-.0046	-3.049	6.110
-199.654	-.0039	-.0034	-3.963	9.729
-149.741	-.0020	-.0021	-3.926	13.130
-99.8400	-.0014	-.0009	-4.17	20.704
-49.8391	-.0001	.0004	-3.776	37.3204
* 49.8685	.0026	.0029	-2.484	-24.91
99.7552	.0039	.0042	-1.926	-9.653
149.601	.0054	.0054	-.764	-2.550
199.491	.0067	.0067	.591	.739
249.412	.0081	.0081	1.291	2.567
299.297	.0094	.0092	1.606	2.684
349.239	.0106	.0105	2.072	2.907
399.105	.012	.0110	1.855	2.324
449.109	.0132	.013	1.678	1.800
498.846	.0144	.0143	1.125	1.127
449.112	.0132	.013	1.824	2.03
399.387	.012	.0110	2.072	2.634
349.222	.0107	.0105	1.529	2.129
299.308	.0094	.0092	1.535	2.563
249.457	.0081	.008	.636	1.274
199.62	.0067	.0067	-.445	-1.115
149.723	.0053	.0055	-1.038	-3.560
99.723	.004	.0042	-1.630	-8.214
49.6604	.0026	.0029	-2.414	-24.9

TEST SUMMARY
 FULL SCALE RATE (DEG/SEC): 50.0
 SCALE FACTOR (V/DEG/SEC): 2.50748E-05
 BIAS (VOLTS) : 1.66616E-03
 HYSTERESIS, NEG RATES (VDC): -9.99924E-09
 HYSTERESIS, POS RATES (VDC): 8.85053E-05
 FULL OFFSET (VDC): 2.23165E-03

TEST ENGINEER

Ray W. Long
4-1-80

READY

TABLE 3.2.2-VI

RATE SENSOR TEST PROGRAM

NADC 80081-60

DATE..4-1-80..... RUN..2.....R=0.16..
 TEMP..72°F..507RA... SER#...333.....

RATE (DEG/SEC)	V OUT (VDC)	V CALC (VDC)	Z FS	Z IDEAL
* -49.9239	.0001	0	1.435	-14.308
-99.7863	-.0004	-.0005	2.388	-11.97
-149.72	-.0011	-.001	-1.869	3.571
-199.654	-.0016	-.0015	-.956	2.393
-249.556	-.002	-.002	-.398	.196
-299.431	-.0025	-.0026	.402	-.672
-349.402	-.003	-.0031	1.266	-1.511
-399.296	-.0034	-.0036	3.345	-3.213
-449.209	-.0038	-.0041	5.263	-5.058
-499.05	-.0043	-.0046	6.512	-6.53
-449.213	-.0039	-.0041	4.597	-5.116
-399.236	-.0035	-.0036	2.153	-2.626
-349.379	-.003	-.0031	.682	-.99
-299.399	-.0026	-.0026	-1.395	1.828
-249.587	-.0022	-.002	-2.497	5.221
-199.641	-.0017	-.0015	-3.158	7.91
-149.832	-.0012	-.001	-4.216	14.072
-99.8371	-.0007	-.0005	-4.726	23.67
-49.9398	-.0003	0	-5.484	54.918
49.6831	.0027	.0011	-6.254	-62.9772
99.7856	.0013	.0016	-5.17	-25.905
149.677	.0019	.0021	-4.328	-13.66
199.572	.0024	.0026	-3.927	-9.832
249.532	.0031	.0031	-1.43	-2.865
299.469	.0036	.0037	-.293	-.49
349.266	.0043	.0042	1.525	2.183
399.231	.0048	.0047	2.936	3.677
* 449.114	.0055	.0052	4.996	5.562
499.112	.006	.0057	6.341	6.351
449.126	.0055	.0052	4.871	5.423
399.21	.0049	.0047	3.548	4.444
349.32	.0043	.0042	2.007	2.872
299.427	.0037	.0037	.675	1.128
249.54	.0031	.0031	-.632	-1.067
199.583	.0025	.0026	-1.717	-4.322
149.696	.002	.0021	-2.893	-9.664
99.7636	.0015	.0016	-1.982	-9.934
49.8821	.0009	.0011	-2.641	-26.473

TEST SUMMARY
 FULL SCALE RATE (DEG/SEC): 500
 SCALE FACTOR (V/DEG/SEC): 1.03679E-05
 RIAS (VOLTS) : 5.50441E-04
 HYSTERESIS, NEG RATES (VDC): -9.99931E-09
 HYSTERESIS, POS RATES (VDC): 6.34769E-06
 NULL OFFSET (VDC): 9.86603E-04

TEST ENGINEER

B. W. Cough
 4-1-80

READY

TABLE 3.2.2-VII

RATE SENSOR TEST PROGRAM

NADC 80081-60

DATE 3-28-80 RUN 374 1P..
 TEMP. 72°F / 307RH ... SER# 373

RATE (DEG/SEC)	V OUT (VDC)	V CALC (VDC)	% FS	% IDEAL
-49.9921	.2975	.3151	.559	-5.587
-99.9268	.6023	.6311	.91	-4.551
-149.756	.9106	.9464	1.132	-3.779
-199.685	1.2228	1.2623	1.25	-3.128
* -249.512	1.5407	1.5776	1.165	-2.335
-299.519	1.8652	1.894	.91	-1.519
-349.399	2.1968	2.2096	.407	-.582
-399.269	2.5363	2.5252	-.353	.442
-449.211	2.884	2.8412	-1.355	1.536
-499.125	3.2383	3.157	-2.569	2.574
-449.211	2.8851	2.8412	-1.387	1.544
-399.35	2.5378	2.5257	-.382	.479
-349.411	2.1986	2.2297	.351	-.522
-299.48	1.8668	1.8938	.854	-1.425
-249.634	1.5429	1.5782	1.116	-2.255
-199.732	1.2247	1.2624	1.192	-2.985
-149.813	.9122	.9462	1.294	-3.65
-99.8929	.6041	.6329	.846	-4.232
-53.3342	.2926	.3154	.532	-5.312
49.7701	-.3094	-.3161	-.212	-2.126
99.6431	-.6136	-.6316	-.564	-2.83
149.591	-.9205	-.9477	-.62	-2.82
199.437	-1.2327	-1.2631	-1.325	-2.571
* 249.412	-1.5493	-1.5794	-1.376	-2.156
299.256	-1.8659	-1.8947	-.91	-1.521
349.129	-2.1932	-2.2133	-.54	-.774
399.024	-2.5274	-2.5226	.345	.356
448.995	-2.8697	-2.8422	.87	.266
498.926	-3.2187	-3.1581	1.915	1.912
449.014	-2.8726	-2.8423	.896	.997
399.207	-2.5225	-2.5264	.007	.384
349.144	-2.1946	-2.2104	-.498	-.713
299.268	-1.8677	-1.8948	-.856	-1.43
249.439	-1.5477	-1.5795	-1.325	-2.214
199.449	-1.2326	-1.2632	-.867	-2.423
149.623	-.9223	-.9479	-.832	-2.731
99.7213	-.6151	-.6322	-.54	-2.71
49.8417	-.31	-.3163	-.198	-1.951

TEST SUMMARY

FULL SCALE RATE (DEG/SEC): 500
 SCALE FACTOR (V/DEG/SEC): -6.32743E-03
 BIAS (VOLTS) : -1.18439E-03
 HYSTERESIS, NEG RATES (VDC): -2.14008E-03
 HYSTERESIS, POS RATES (VDC): 2.37274E-03
 GULL OFFSET (VDC): -5.29595E-03

TEST ENGINEER

[Signature]
 3-28-80

READY

TABLE 3.2.2-VIII

RATE SENSOR TEST PROGRAM

NADC 80081-60

DATE ~~3-28-80~~ 3-28-80

RUN. ~~45~~ R-24 1p.

TEMP. ~~72.7~~ 50.7RH

SER# ~~373~~

RATE (DEG/SEC)	V OUT (VDC)	V CALC (VDC)	Z FS	Z IDEAL
-53.0083	.2985	.3175	.621	-6.025
-99.8917	.6043	.6342	.944	-4.723
-149.746	.9141	.9527	1.153	-3.849
* -199.693	1.2278	1.2677	1.261	-3.158
-249.59	1.547	1.5846	1.184	-2.372
-299.443	1.8725	1.9011	.898	-1.5
-349.411	2.2356	2.2183	.401	-.573
-399.299	2.5464	2.535	-.359	.45
-449.277	2.8946	2.8523	-1.334	1.484
-499.118	3.2494	3.1687	-2.542	2.547
-449.169	2.8959	2.8516	-1.397	1.555
-399.186	2.5489	2.5343	-.459	.575
-349.483	2.2384	2.2187	.325	-.465
-299.472	1.8757	1.9312	.806	-1.346
-249.612	1.5522	1.5847	1.076	-2.176
-199.666	1.2311	1.2676	1.15	-2.88
-149.727	.9173	.9506	1.248	-3.492
-99.925	.6373	.6344	.854	-4.272
-49.9929	.3574	.3174	.537	-5.379
49.7969	-.3097	-.3161	-.2	-2.337
* 99.6655	-.6154	-.6327	-.546	-2.738
149.52	-.9235	-.9422	-.848	-2.741
199.479	-1.2346	-1.2663	-1.331	-2.539
249.425	-1.5543	-1.5834	-1.244	-2.392
299.249	-1.8714	-1.8997	-.893	-1.491
349.178	-2.1994	-2.2167	-.545	-.78
399.338	-2.5343	-2.5332	.432	.24
449.953	-2.8763	-2.8501	.823	.917
498.858	-3.2253	-3.167	1.839	1.843
449.314	-2.8771	-2.8535	.838	.933
399.294	-2.5349	-2.5336	.441	.351
349.153	-2.2307	-2.2166	-.531	-.717
299.242	-1.8728	-1.8997	-.848	-1.417
249.425	-1.552	-1.5834	-.991	-1.926
199.484	-1.2363	-1.2664	-.947	-2.373
149.517	-.9252	-.9422	-.755	-2.524
99.7112	-.6172	-.633	-.498	-2.497
49.7937	-.3112	-.3161	-.155	-1.554

TEST SUMMARY
 FULL SCALE RATE (DEG/SEC): 500
 SCALE FACTOR (V/DEG/SEC): -6.3485E-23
 BIAS (VOLTS): 4.14044E-25
 HYSTERESIS, NEG RATES (VDC): -3.35729E-23
 HYSTERESIS, POS RATES (VDC): 1.82721E-23
 NULL OFFSET (VDC): -5.30325E-23

TEST ENGINEER *[Signature]*
 3-28-80

READY

TABLE 3.2.2-IX

RATE SENSOR TEST PROGRAM

NADC 80081-60

DATE...3-28-80.....

RUN...XY...R-24...in..

TEMP...72°F...50ZRH..

SER#...373.....

RATE (DEG/SEC)	V OUT (VDC)	V CALC (VDC)	% FS	% IDEAL
-49.9922	.0991	.3183	.604	-6.241
* -99.9149	.6355	.6353	.939	-4.699
-149.727	.9155	.9516	1.137	-3.790
-199.676	1.2294	1.2688	1.242	-3.111
-249.576	1.5489	1.5857	1.16	-2.324
-299.428	1.8744	1.9323	.878	-1.467
-349.319	2.2081	2.2191	.345	-.493
-399.214	2.5485	2.5359	-.396	.496
-449.209	2.8975	2.8534	-1.382	1.545
-499.315	3.2527	3.1627	-2.615	2.62
-449.142	2.8977	2.953	-1.428	1.567
-399.22	2.5489	2.5364	-.396	.496
-349.306	2.2085	2.219	.332	-.475
-299.514	1.8753	1.9322	.866	-1.445
-249.536	1.5496	1.5854	1.13	-2.264
-199.675	1.2305	1.2688	1.237	-3.324
-149.764	.9169	.9518	1.1	-3.672
-99.854	.6371	.6349	.876	-4.326
-50.3442	.3031	.3183	.575	-5.751
49.7942	-.3121	-.3154	-.169	-1.697
99.6689	-.6150	-.6321	-.52	-2.61
149.593	-.9236	-.9492	-.836	-2.695
* 199.446	-1.2345	-1.2652	-.985	-2.468
249.358	-1.5522	-1.5827	-1.223	-2.352
299.3	-1.871	-1.8929	-.938	-1.517
349.19	-2.199	-2.2167	-.556	-.796
399.046	-2.5338	-2.5333	.016	.021
448.926	-2.8761	-2.8531	.82	.914
498.887	-3.2249	-3.1673	1.812	1.816
448.977	-2.8766	-2.8534	.825	.919
399.031	-2.5344	-2.5332	.032	.048
349.171	-2.2	-2.2166	-.521	-.746
299.234	-1.8722	-1.8995	-.859	-1.435
249.386	-1.5513	-1.5829	-.996	-1.997
199.462	-1.2357	-1.2659	-.95	-2.351
149.589	-.9246	-.9492	-.774	-2.526
99.6723	-.6162	-.6322	-.485	-2.433
49.8113	-.3128	-.3155	-.148	-1.461

TEST SUMMARY
 FULL SCALE RATE (DEG/SEC): 500
 SCALE FACTOR (V/DEG/SEC): -6.35336E-03
 BIAS (VOLTS) : 7.82692E-04
 HYSTERESIS, NEG RATES (VDC): -1.61731E-03
 HYSTERESIS, POS RATES (VDC): 1.21263E-03
 FULL OFFSET (VDC): -5.72215E-03

TEST ENGINEER

Boyd W. Cherry
 3-28-80

READY

TABLE 3.2.2-X

RATE SENSOR TEST PROGRAM

NADC 80081-60

DATE 13-28-80

RUN # 24 In..

TEMP 72.27 307.11

SER# 373

RATE (DEG/SEC)	V OUT (VDC)	V CALC (VDC)	% FS	% IDEAL
-49.9245	.096	.313	.536	-5.366
-99.8134	.6035	.6287	.892	-4.466
* -149.734	.9085	.9447	1.143	-3.815
-199.551	1.2208	1.2599	1.338	-3.121
-249.507	1.5385	1.5761	1.186	-2.378
-299.37	1.8626	1.8917	.918	-1.533
-349.272	2.1939	2.2075	.43	-.615
-399.162	2.5328	2.5232	-.334	.38
-449.028	2.8792	2.8388	-1.278	1.423
-498.92	3.2322	3.1545	-2.455	2.46
-449.123	2.881	2.8394	-1.314	1.463
-399.172	2.5349	2.5233	-.366	.461
-349.258	2.1965	2.2174	.345	-.493
-299.373	1.8655	1.8914	.717	-1.365
-249.482	1.5471	1.5759	1.37	-2.145
-199.637	1.2247	1.2633	1.126	-2.99
-149.675	.9124	.9443	1.337	-3.364
-99.8349	.634	.6287	.78	-3.929
-49.9239	.2982	.313	.467	-4.674
49.8534	-.3096	-.3185	-.279	-2.785
99.7636	-.6142	-.6343	-.635	-3.112
149.633	-.9215	-.9491	-.892	-2.992
199.535	-1.232	-1.2651	-1.366	-2.671
249.449	-1.5473	-1.5816	-1.385	-2.174
* 299.338	-1.8679	-1.8972	-.925	-1.545
349.265	-2.1957	-2.2133	-.559	-.8
399.127	-2.5325	-2.5229	.35	.462
448.84	-2.8732	-2.8442	.916	1.291
498.857	-3.2228	-3.1631	1.984	1.962
449.339	-2.8747	-2.8446	.95	1.257
399.131	-2.533	-2.5229	.127	.16
349.197	-2.1988	-2.2129	-.446	-.638
299.351	-1.8715	-1.8975	-.822	-1.372
249.434	-1.5537	-1.5816	-.974	-1.952
199.52	-1.2353	-1.2657	-.959	-2.434
149.652	-.9246	-.9531	-.833	-2.662
99.7937	-.6166	-.6345	-.566	-2.836
49.8671	-.3129	-.3187	-.246	-2.47

TEST SUMMARY

FULL SCALE RATE (DEG/SEC): 500
 SCALE FACTOR (V/DEG/SEC): -6.32868E-03
 BIAS (VOLTS) : -.002968
 HYSTERESIS, NEG RATES (VDC): -3.91519E-03
 HYSTERESIS, POS RATES (VDC): 3.53336E-03
 NULL OFFSET (VDC): -6.62715E-03

TEST ENGINEER

[Handwritten Signature]
 3-28-80

READY

TABLE 3.2.2-XI

RATE SENSOR TEST PROGRAM

NADC 80081-60

DATE **4-1-80**.....

RUN **+Z**...R=**23.6 in.**

TEMP **72°F**...50%RH...

SER#...**373**.....

RATE (DEG/SEC)	V OUT (VDC)	V CALC (VDC)	Z FC	Z IDEAL
* -49.9361	-.3109	-.3118	2.12	-21.226
-99.7897	-.3156	-.3162	1.349	-6.794
-149.714	-.3233	-.3236	.659	-2.001
-199.624	-.325	-.325	-.113	.232
-249.466	-.3297	-.3293	-.325	1.654
-299.439	-.3343	-.3337	-1.436	2.341
-349.279	-.3388	-.3381	-1.842	2.639
-399.244	-.3434	-.3425	-2.15	2.73
-449.13	-.3477	-.3469	-2.494	2.853
-499.333	-.352	-.3512	-1.662	1.671
-549.172	-.3478	-.3469	-2.359	2.656
-599.167	-.3435	-.3425	-2.255	2.625
-649.275	-.3389	-.3381	-1.93	2.763
-699.431	-.3344	-.3337	-1.441	2.437
-749.544	-.3297	-.3293	-.842	1.620
-799.614	-.325	-.325	-.158	.322
-849.717	-.3205	-.3206	.238	-.784
-899.8536	-.3157	-.3162	1.257	-0.295
-949.9433	-.311	-.3119	1.695	-18.262
* 49.9215	-.3019	-.2931	2.765	27.622
99.686	-.2926	-.2913	2.827	14.678
149.684	-.287	-.2857	2.49	1.654
199.583	-.2813	-.281	2.546	7.13
249.473	-.2754	-.2744	2.291	4.191
299.349	-.2698	-.2689	2.5	1.471
349.279	-.2626	-.2632	-1.336	-1.441
399.138	-.2561	-.2576	-3.364	-4.214
449.122	-.2494	-.252	-5.937	-0.628
499.222	-.2425	-.2363	-8.663	-0.622
549.136	-.2395	-.232	-5.62	-6.257
599.259	-.2363	-.2276	-2.56	-3.512
649.219	-.2331	-.2232	-1.274	-.383
699.329	-.2296	-.2191	1.879	3.132
749.429	-.2258	-.2144	3.325	6.823
799.547	-.222	-.2131	4.342	13.1
849.582	-.2179	-.2057	4.97	10.619
899.7586	-.2135	-.2013	5.379	25.454
949.901	-.2091	-.2031	4.791	48.312

TEST SUMMARY

FULL SCALE RATE (DEG/SEC): 500
 SCALE FACTOR (V/DEG/SEC): 0.77455E-05
 BIAS (VOLTS) : -7.45430E-03
 HYSTERESIS, NEG RATES (VDC): -9.99940E-09
 HYSTERESIS, POS RATES (VDC): 0
 FULL OFFSET (VDC): -0.16147E-03

TEST ENGINEER

[Handwritten Signature]
 4-1-80

READY

TABLE 3.2.2-XII

RATE SENSOR TEST PROGRAM

NADC 80081-60

DATE...4-1-80.....

RUN...Z...R=24.4 in.

TEMP...72°F...50%RH...

SER#...373.....

RATE (DEG/SEC)	V OUT (VDC)	V CALC (VDC)	Z FS	Z IDEAL
* -49.8338	-.3139	-.3118	2.496	-21.893
-99.6352	-.3155	-.316	.876	-4.891
-149.725	-.3231	-.3231	-.25	.169
-199.543	-.3247	-.3242	-1.183	2.963
-249.516	-.3292	-.3284	-1.97	3.248
-299.428	-.3335	-.3325	-2.397	3.995
-349.213	-.3379	-.3367	-3.349	4.365
-399.224	-.3419	-.3406	-2.742	3.434
-449.151	-.3458	-.345	-1.923	2.141
-499.867	-.3493	-.3491	-.514	.515
-449.12	-.3457	-.345	-1.826	2.333
-399.24	-.3418	-.3408	-2.587	3.24
-349.284	-.3378	-.3367	-2.786	3.278
-299.414	-.3335	-.3325	-2.32	3.891
-249.582	-.329	-.3284	-1.454	2.912
-199.597	-.3244	-.3242	-.449	1.224
-149.769	-.3196	-.3231	.63	-2.771
-99.6739	-.3151	-.316	2.441	-14.317
-49.8515	-.3135	-.3118	3.149	-31.591
* 49.8322	-.3115	-.3135	4.912	49.2311
99.7156	.309	.3136	5.388	27.354
149.628	.317	.3148	5.284	17.657
199.491	.311	.3129	4.924	12.482
249.447	.3147	.313	3.875	7.767
299.271	.3181	.3172	2.807	3.657
349.283	.3212	.3213	-.371	-.531
399.163	.3238	.3255	-3.784	-4.74
449.378	.3265	.3286	-7.614	-8.47
499	.3282	.3338	-11.754	-11.777
449.665	.3264	.3296	-7.733	-8.577
399.112	.3239	.3255	-3.843	-4.815
349.221	.3211	.3213	-.563	-.236
299.351	.318	.3172	1.858	3.134
249.444	.3146	.313	3.715	7.447
199.493	.3119	.3109	4.737	11.796
149.572	.3068	.3048	4.971	16.617
99.2465	.3027	.3006	5.135	25.566
49.8332	-.3015	-.3035	4.752	47.672

TEST SUMMARY

FULL SCALE RATE (DEG/SEC): 500
 SCALE FACTOR (V/DEG/SEC): 2.30347E-05
 BIAS (VOLTS) : -7.66345E-13
 HYSTERESIS, DEG RATES (VDC): -4.35332E-34
 HYSTERESIS, DEG RATES (VDC): 1.39182E-34
 FULL OFFSET (VDC): -6.36923E-13

TEST ENGINEER

[Handwritten Signature]
4-1-80

READY

TABLE 3.2.2-XIII

RATE SENSOR TEST PROGRAM

NADC 80081-60

DATE...4-1-80..... RUN...Z...R=0 in...
 TEMP...72°F...50%RH... SER#...373.....

RATE (DEG/SEC)	V OUT (VDC)	V CALC (VDC)	Z IS	Z IDEAL
-49.9878	-.0103	-.0119	4.767	-47.6795
* -99.6422	-.0141	-.0152	3.448	-17.268
-149.6422	-.0178	-.0185	2.117	-6.7
-199.689	-.0217	-.0218	.976	-.686
-249.58	-.0255	-.0251	-1.393	2.791
-299.475	-.0293	-.0284	-2.869	4.78
-349.431	-.033	-.0317	-4.357	5.806
-399.343	-.0365	-.0349	-4.795	6.334
-449.274	-.04	-.0382	-5.321	5.922
-499.133	-.0433	-.0415	-5.466	5.476
-449.162	-.04	-.0382	-5.532	6.125
-399.27	-.0365	-.0349	-4.827	6.32
-349.433	-.0329	-.0317	-3.935	5.587
-299.462	-.0292	-.0284	-2.479	4.138
-249.541	-.0254	-.0251	-.82	1.844
-199.637	-.0215	-.0218	.714	-1.735
-149.635	-.0176	-.0185	2.691	-8.922
-99.854	-.0136	-.0152	4.173	-22.286
-49.9635	-.0141	-.0119	5.478	-54.127
49.8881	-.0222	-.0253	7.676	76.932
99.7619	-.0225	-.022	7.745	31.817
149.739	-.0237	-.0212	7.512	25.39
199.66	-.0267	-.0145	6.582	16.527
249.537	-.0294	-.0278	4.832	2.825
299.437	-.0118	-.0111	2.054	3.451
* 349.336	-.0139	-.0144	-1.547	-2.157
399.254	-.0156	-.0177	-6.191	-7.752
449.139	-.0172	-.021	-11.581	-12.383
499.135	-.0125	-.0243	-17.412	-17.443
449.112	-.0171	-.021	-11.638	-12.957
399.215	-.0156	-.0177	-6.282	-7.976
349.338	-.0138	-.0144	-1.792	-2.574
299.449	-.0118	-.0111	2.031	3.725
249.536	-.0094	-.0078	4.844	2.737
199.631	-.0067	-.0045	6.612	16.74
149.637	-.0038	-.0012	7.73	25.827
99.811	-.0007	-.002	8.358	41.176
49.9461	-.0027	-.0053	7.983	79.576

TEST SUMMARY
 FULL SCALE RATE (DEG/SEC): 5.01
 SCALE FACTOR (V/DEG/SEC): 6.593367-25
 BIAS (VOLTS) : -0.60338E-03
 HYSTERESIS, NEG RATES (VDC): -2.30226E-04
 HYSTERESIS, POS RATES (VDC): 9.78220E-25
 FULL OFFSET (VDC): -6.45033E-03

TEST ENGINEER

[Signature]
 4-1-80

READY

TABLE 3.2.2-XIV

RATE SENSOR TEST PROGRAM

NADC 80081-60

DATE..3-28-80..... RUN.#X..R=24 ip..
 TEMP..72°F...50ZRH... SER#...381.....

RATE (DEG/SEC)	V OUT (VDC)	V CALC (VDC)	Z FS	Z IDEAL
-49.9377	.2869	.2957	.285	-2.153
-99.8574	.5879	.6057	.573	-2.071
-149.761	.8914	.9155	.779	-2.596
-199.563	1.1977	1.2247	.807	-2.173
-249.461	1.5061	1.5346	.853	-1.711
* -299.392	1.8222	1.8446	.7	-1.162
-349.284	2.1432	2.1543	.36	-.516
-399.172	2.4692	2.4641	-.163	.024
-449.018	2.8035	2.7736	-.867	.966
-498.95	3.1366	3.0836	-1.705	1.739
-449.272	2.8314	2.7739	-.884	.984
-399.157	2.4697	2.464	-.184	.23
-349.272	2.1442	2.1543	.326	-.467
-299.412	1.8241	1.8447	.663	-1.137
-249.47	1.5093	1.5346	.817	-1.637
-199.582	1.199	1.2249	.833	-2.352
-149.727	.8924	.9152	.733	-2.447
-99.81	.589	.6054	.529	-2.649
-49.9222	.2873	.2955	.266	-2.665
49.8577	-.3144	-.3239	-.327	-2.374
99.7924	-.6128	-.6339	-.583	-2.223
149.73	-.9186	-.9432	-.72	-2.624
199.531	-1.2262	-1.253	-.863	-2.164
249.425	-1.5365	-1.563	-.854	-1.712
* 299.352	-1.8512	-1.873	-.721	-1.171
349.224	-2.1713	-2.1926	-.365	-.523
399.063	-2.4962	-2.4922	.142	.125
449.014	-2.8274	-2.8022	.112	.934
498.864	-3.163	-3.1112	1.646	1.65
449.222	-2.8227	-2.8022	.154	.92
399.227	-2.4923	-2.4923	.122	.24
349.153	-2.1732	-2.1822	-.272	-.322
299.22	-1.8541	-1.8722	-.522	-.922
249.476	-1.5392	-1.5633	-.776	-1.522
199.544	-1.2254	-1.2533	-.82	-2.122
149.678	-.9215	-.9437	-.713	-2.322
99.721	-.6172	-.6334	-.52	-2.622
49.8762	-.3147	-.324	-.222	-3.122

TEST SUMMARY
 FULL SCALE RATE (DEG/SEC): 500
 SCALE FACTOR (V/DEG/SEC): -6.23194E-03
 BIAS (VOLTS) : -1.43357E-02
 HYSTERESIS, NEG RATES (VDC): -1.27329E-03
 HYSTERESIS, POS RATES (VDC): 2.89773E-03
 FULL OFFSET (VDC): -1.23491E-02

TEST ENGINEER *Ray W. Lacey*
 3-28-80

READY

TABLE 3.2.2-XV

RATE ERROR TEST PROGRAM

NADC 80081-60

DATE...3-28-80.....

RUP...X...R=24 in..

TEMP...72°F...50%RH..

SER#...381.....

DATE (DD/SS/CC)	V OUT (VDC)	V CALC (VDC)	DIFF	PERCENT
-48.9178	.8651	.8945	.323	-3.630
-88.1106	.5048	.7333	.990	-1.987
-118.6088	.4875	.918	.791	-2.541
-188.585	1.1988	1.287	.8	-2.258
-248.465	1.5324	1.5285	.874	-1.751
-288.378	1.8168	1.838	.689	-1.177
-348.155	2.1355	2.1471	.375	-.537
-388.164	2.4635	2.4558	-.148	.150
-448.113	2.7943	2.7644	-.838	-.833
-488.087	3.1244	3.2731	-1.658	-1.661
-448.116	2.7815	2.7651	-.351	-.948
-388.145	2.4683	2.4558	-.298	-.961
-348.178	2.1385	2.1478	.291	-.433
-288.207	1.8198	1.8383	.587	-.898
-248.235	1.5360	1.5287	.76	-1.524
-188.265	1.1967	1.2218	.791	-1.917
-148.276	.8913	.9118	.667	-2.03
-88.3134	.5882	.6338	.699	-2.448
-48.3187	.2873	.2845	-.285	-.353
88.3261	-.3131	-.3231	-.895	-3.20
88.7388	-.814	-.6317	-.57	-.888
148.883	-.9178	-.9874	-.748	-2.498
188.582	-1.3988	-1.2853	-.858	-2.148
248.487	-1.8388	-1.5588	-.831	-1.668
288.687	-1.8388	-1.8668	-.664	-1.188
348.201	-2.1666	-2.1758	-.365	-.508
388.134	-2.4887	-2.4645	.133	.167
448.173	-2.818	-2.7838	.787	.870
488.820	-3.1514	-3.1891	-1.588	-1.588
448.887	-2.8189	-2.7631	.837	.838
388.118	-2.4834	-2.4838	.018	.008
348.265	-2.1668	-2.1758	-.28	-.418
288.857	-1.8484	-1.8668	-.588	-.888
248.388	-1.5347	-1.5578	-.748	-1.488
188.813	-1.2253	-1.2498	-.774	-1.84
148.687	-.8188	-.8488	-.684	-2.018
88.7318	-.6168	-.6318	-.188	-.248
48.1748	-.318	-.3831	-.868	-2.868

TEST SUMMARY
 FULL SCALE RATE (DEG/SEC): 5'
 SCALE FACTOR (V/DEG/SEC): -0.118778E-13
 IBS (VOLTS) : -1.83861E-12
 HYSTERIC, POS RATE (VDC): -2.78750E-13
 HYSTERIC, NEG RATE (VDC): 0.41343E-13
 FULL OFFSET (VDC): -1.0141E-10

TEST MACHINE

B. H. ...
 3-28-80

TABLE

TABLE 3.2.2-XVI

RATE SENSOR TEST PROGRAM

NADC 80081-60

RATE...3-28-80..... RUP...+Y...R=24 in..
 TEMP...72°F...50%RH... SER#...381.....

RATE (DEG/SEC)	V OUT (VDC)	V CALC (VDC)	Z ZS	Z IDEAL
-54.017	.8002	.2961	.39	-3.197
-89.971	.5063	.6956	.623	-3.117
-149.103	.8083	.8147	.80	-2.737
-199.666	1.1053	1.2238	.999	-2.319
-249.530	1.5051	1.533	.897	-1.798
-299.433	1.8199	1.8423	.782	-1.236
-349.34	2.1388	2.1517	.381	-.546
-399.155	2.4657	2.4625	-.167	.239
-449.120	2.7967	2.7733	-.85	.946
-499.242	3.1323	3.3782	-1.697	1.7
-449.13	2.7984	2.7733	-.934	1.327
-399.03	2.4683	2.461	-.835	.295
-349.422	2.1436	2.1523	.81	-.462
-299.477	1.824	1.8426	.6	-1.332
-249.531	1.5096	1.533	.754	-1.511
-199.649	1.1997	1.2237	.774	-1.84
-149.6	.8936	.8147	.69	-2.275
-89.6829	.5197	.6953	.574	-2.584
-54.0173	.3079	.2961	.264	-2.646
54.7614	-.3134	-.3225	-.294	-2.296
99.6970	-.6148	-.632	-.554	-1.770
149.989	-.9155	-.9414	-.736	-2.467
199.435	-1.2200	-1.2593	-.825	-2.104
249.393	-1.5345	-1.56	-.728	-1.653
299.11	-1.8484	-1.8687	-.655	-1.181
349.116	-2.1675	-2.1783	-.349	-.5
399.179	-2.4915	-2.4979	.117	.180
449.91	-2.8012	-2.7871	.779	.600
499.766	-3.1151	-3.1261	1.592	1.580
449.833	-2.8023	-2.787	.315	.93
399.871	-2.483	-2.4973	.103	.23
349.171	-2.1691	-2.1736	-.310	-.467
299.258	-1.8531	-1.8691	-.615	-1.19
249.347	-1.5359	-1.5587	-.77	-1.542
199.450	-1.2261	-1.2524	-.764	-1.826
149.584	-.9231	-.9413	-.681	-2.105
99.7061	-.6165	-.6321	-.583	-2.382
54.7975	-.3147	-.3227	-.250	-2.572

TEST SUMMARY
 FULL SCALE RATE (DEG/SEC): 511
 SCALE FACTOR (V/DEG/SEC): -0.158097E-03
 BIAS (VOLTS) : -1.39543E-02
 HYSTERESIS, NEG RATES (VDC): -4.45219E-03
 HYSTERESIS, POS RATES (VDC): 1.68077E-03
 FULL OFFSET (VDC): -1.24147E-02

TEST ENGINEER *Byrd W. Cuyler*
 3-28-80

REPLY

TABLE 3.2.2-XVII

RATE SENSOR TEST PROGRAM

NADC 80081-60

DATE...3-28-80.....

RUP...Y...R=24 in..

TEMP...72°F...507RH..

SER#...381.....

RATE (DEG/SEC)	V OUT (VDC)	V CALC (VDC)	Z FS	Z IDEAL
-49.9926	.2874	.2958	.271	-2.725
-99.8895	.5888	.6358	.548	-2.742
-149.847	.8923	.9161	.768	-2.501
-199.697	1.1920	1.2258	.876	-2.194
* -249.554	1.5082	1.5352	.944	-1.692
-299.419	1.8242	1.8452	.675	-1.123
-349.321	2.1442	2.1552	.354	-.537
-399.225	2.47	2.4652	-.154	.193
-449.136	2.8009	2.7752	-.828	.921
-498.993	3.1358	3.0849	-1.639	1.643
-448.191	2.8017	2.7756	-.84	.935
-399.24	2.4708	2.4653	-.178	.223
-349.320	2.1458	2.1552	.303	-.433
-299.461	1.826	1.8455	.626	-1.345
-249.558	1.5115	1.5355	.774	-1.55
-199.687	1.201	1.2257	.795	-1.991
-149.768	.894	.9156	.696	-2.325
-99.9376	.5901	.6061	.514	-2.57
-50.0015	.288	.2959	.255	-2.548
49.7812	-.3141	-.3239	-.316	-3.17
99.6384	-.6159	-.6336	-.571	-2.866
149.584	-.92	-.9439	-.768	-2.566
199.457	-1.2268	-1.2537	-.967	-2.174
* 249.366	-1.5375	-1.5637	-.844	-1.692
299.268	-1.8524	-1.8737	-.684	-1.143
349.295	-2.1727	-2.1832	-.339	-.485
399.319	-2.4978	-2.4933	.144	.12
448.98	-2.8288	-2.8337	.809	.931
498.931	-3.164	-3.1132	1.617	1.62
448.838	-2.8332	-2.8334	.864	.962
399.365	-2.4998	-2.4936	.2	.25
349.287	-2.1748	-2.1839	-.295	-.422
299.28	-1.8551	-1.8738	-.6	-1.332
249.363	-1.5424	-1.5637	-.751	-1.526
199.434	-1.2294	-1.2535	-.777	-1.947
149.569	-.9224	-.9432	-.68	-2.326
99.6029	-.6177	-.6334	-.537	-2.543
49.7983	-.3152	-.324	-.285	-2.962

TEST SUMMARY

FULL SCALE RATE (DEG/SEC): 500
 SCALE FACTOR (V/DEG/SEC): -6.21177E-03
 BIAS (VOLTS) : -1.47093E-02
 HYSTERESIS, NEG RATES (VDC): -2.53034E-03
 HYSTERESIS, POS RATES (VDC): 2.86007E-03
 NULL OFFSET (VDC): -1.19394E-02

TEST ENGINEER

Boyd W. Curry
3-28-80

READY

TABLE 3.2.2-XVIII

RATE SENSOR TEST PROGRAM

NADC 80081-60

DATE **4-1-80**..... RUN **+Z/ R=24.4 in.**
 TEMP **72°F 50%RH**... SER# **381**.....

RATE (DEG/SEC)	V OUT (VDC)	V CALC (VDC)	% FS	% IDEAL
* -48.8313	-.016	-.0162	1.194	-11.892
-99.61	-.0179	-.0182	1.639	-8.212
-149.676	-.02	-.0202	.962	-3.213
-199.629	-.022	-.0222	.849	-2.122
-249.48	-.0238	-.0241	1.249	-2.574
-299.492	-.0258	-.0261	1.499	-2.532
-349.319	-.0278	-.0281	1.449	-2.374
-399.175	-.0298	-.0301	1.534	-1.921
-449.133	-.0318	-.0321	1.225	-1.364
-499.095	-.0338	-.034	1.031	-1.323
-449.027	-.0319	-.0321	1.016	-1.131
-399.091	-.0299	-.0301	.698	-.874
-349.263	-.028	-.0281	.534	-.764
-299.426	-.0261	-.0261	.033	-.255
-249.487	-.0242	-.0241	-.279	.559
-199.609	-.0224	-.0222	-.99	2.481
-149.742	-.0205	-.0202	-1.537	5.131
-99.8252	-.0187	-.0182	-2.439	12.212
-49.9184	-.0168	-.0162	-2.993	22.777
* 49.8946	-.013	-.0123	-3.623	-36.3322
99.6841	-.011	-.0103	-3.792	-19.322
149.687	-.009	-.0083	-3.417	-11.415
199.581	-.0069	-.0063	-2.771	-6.942
249.473	-.0047	-.0043	-2.283	-4.174
299.358	-.0026	-.0024	-1.363	-2.777
349.29	-.0004	-.0004	-.052	-.075
399.156	.0018	.0016	1.259	1.777
449.138	.0042	.0036	3.164	3.523
499.267	.0065	.0055	4.865	4.675
449.132	.0042	.0036	3.321	3.697
399.222	.0019	.0016	1.632	2.248
349.227	-.0002	-.0004	.833	1.15
299.41	-.0024	-.0024	-.25	-.418
249.452	-.0045	-.0043	-.769	-1.542
199.552	-.0069	-.0063	-.637	-1.597
149.667	-.0085	-.0083	-.946	-3.152
99.7416	-.0105	-.0103	-1.272	-6.378
49.8699	-.0124	-.0123	-.721	-7.227

TEST SUMMARY
 FULL SCALE RATE (DEG/SEC): 502
 SCALE FACTOR (V/DEG/SEC): 3.96685E-05
 BIAS (VOLTS) : -1.42458E-02
 HYSTERESIS, NEG RATES (VDC): -9.99945E-09
 HYSTERESIS, POS RATES (VDC): 2
 FULL OFFSET (VDC): -1.36152E-02

TEST ENGINEER

Boyd W. Curry
 4-1-80

READY

TABLE 3.2.2-XIX

RATE SENSOR TEST PROGRAM

NADC 80081-60

DATE..4-1-80..... RUN..2...R=24.4 in.

TEMP..72°F...507RH... SER#.....381.....

DATE (DEG/SEC)	V. OUT (VDC)	V. CALC (VDC)	I. FS	I. IDEAL
-48.8362	-.3158	-.3157	-.714	0.15
-98.6117	-.3177	-.3174	-1.473	7.43
-148.38	-.3186	-.3182	-2.323	7.75
-198.1517	-.3212	-.3208	-1.966	4.61
-248.043	-.3229	-.3226	-1.632	3.212
-298.478	-.3246	-.3244	-1.32	1.72
-348.291	-.3261	-.3261	.437	-.582
-398.177	-.3275	-.3279	1.826	-2.412
-448.014	-.329	-.3296	3.675	-4.351
-498.881	-.3307	-.3313	6.014	-6.33
-548.719	-.3323	-.3326	4.336	-4.352
-598.587	-.3375	-.3379	1.965	-2.336
-648.474	-.3361	-.3361	.15	-.66
-698.372	-.3346	-.3344	-1.169	1.246
-748.283	-.3329	-.3327	-1.682	3.39
-798.208	-.3313	-.3322	-2.244	5.151
-848.145	-.3197	-.3192	-3.116	11.47
-898.089	-.318	-.3174	-2.91	13.815
-948.046	-.3162	-.3157	-2.69	20.291
-998.016	-.3126	-.3122	-1.8	-11.31
-1048.756	-.3117	-.3119	-1.826	-6.147
-1098.784	-.3097	-.3097	-.96	-1.61
-1148.821	-.3077	-.3077	.957	.731
-1198.874	-.3051	-.3053	.873	1.21
-1248.837	-.3032	-.3035	1.153	3.913
-1298.833	-.3013	-.3013	1.21	2.732
-1348.857	-.3003	-.3001	.995	0.505
-1398.919	-.2991	-.2997	0.141	0.355
-1448.988	-.2937	-.2937	1.11	1.112
-1498.835	-.292	-.2917	1.743	1.841
-1548.139	-.2902	-.2901	1.421	1.72
-1598.318	-.2816	-.2816	1.147	1.642
-1648.376	-.2835	-.2835	.346	.57
-1698.361	-.2854	-.2853	-.931	-1.409
-1748.395	-.2872	-.287	-.845	-2.366
-1798.475	-.2891	-.2897	-1.225	-6.134
-1848.637	-.2882	-.2885	-2.433	-11.237
-1898.799	-.2897	-.2892	-2.63	-22.375

TEST SUMMARY
 FULL SCALE RATE (DEG/SEC): 500
 SCALE FACTOR (V/DEG/SEC): 3.42493E-05
 IAS (VOLTS) : -.31294
 SYSTEMIC, POC RATES (VDC): -0.3695E-05
 SYSTEMIC, POC RATES (VDC): 2.735E-09
 GELL OFFSET (VDC): -1.35112E-09

TEST OPERATOR *[Signature]*
 4-1-80

MAPY

TABLE 3.2.2-XX

RATE SENSOR TEST PROGRAM

NADC 80081-60

DATE..4-1-80..... RUN..Z...R=0.in..
 TEMP..72°F...50%RH... SER#...381.....

RATE (DEG/SEC)	V. OUT (VDC)	V. CALC (VDC)	Z FS	Z IDEAL
-50.8125	-.3151	-.3147	-3.691	30.1878
-99.8794	-.3163	-.3158	-3.836	19.745
-149.883	-.3173	-.3169	-3.88	13.90
-199.631	-.3183	-.318	-2.824	7.479
-249.627	-.3194	-.3191	-2.149	4.335
-299.563	-.3207	-.3202	-.239	.399
-349.436	-.321	-.3213	3.104	-4.442
* -399.329	-.3219	-.3224	5.117	-6.416
-449.117	-.3225	-.3235	8.754	-9.740
-499.175	-.3232	-.3246	13.863	-13.895
-549.219	-.3235	-.3235	9.38	-13.146
-599.284	-.3218	-.3224	5.640	-7.37
-649.363	-.3211	-.3213	2.417	-3.459
-699.495	-.3223	-.3222	-.377	.569
-749.626	-.3193	-.3191	-1.979	3.863
-799.715	-.3175	-.318	-4.341	13.117
-849.827	-.3176	-.3169	-5.970	19.944
-899.8149	-.3166	-.3152	-7.238	36.2212
-949.829	-.3150	-.3147	-7.963	78.625
-999.865	-.3134	-.3125	-7.630	-76.5090
99.723	-.3122	-.3114	-6.9	-34.5205
149.721	-.311	-.3133	-5.595	-12.609
199.528	-.3097	-.3093	-4.362	-13.93
* 249.489	-.3083	-.3082	-1.747	-5.931
299.338	-.3071	-.3071	-.236	-.361
349.285	-.3057	-.306	2.304	4.314
399.198	-.3042	-.3049	5.931	7.333
449.147	-.3027	-.3038	9.386	13.449
499.965	-.3012	-.3027	13.272	13.3
549.133	-.3008	-.3039	9.27	13.62
599.156	-.3042	-.3049	6.175	7.735
649.495	-.3057	-.306	2.92	4.330
699.359	-.307	-.3071	.30	.631
749.484	-.3084	-.3092	-2.554	-5.110
799.557	-.3096	-.3093	-4.922	-12.332
849.627	-.311	-.3134	-5.849	-19.545
899.7772	-.3127	-.3114	-6.890	-34.5649
949.8619	-.3135	-.3125	-7.124	-71.2339

TEST SUMMARY
 FULL SCALE RATE (DEG/SEC): 500
 SCALE FACTOR (V/DEG/SEC): 2.19745E-35
 BIAS (VOLTS) : -1.56382E-32
 HYSTERESIS, NEG RATES (VDC): -5.21725E-35
 HYSTERESIS, POS RATES (VDC): 1.87252E-35
 FULL OFFSET (VDC): -1.35644E-32

TEST ENGINEER *[Signature]*
 4-1-80

READY

TABLE 3.2.2-XXI

G - SENSITIVITY DATA
VOLTAGE OUTPUT (VOLTS)

AXIS ACCELER. X, Y, OR Z	RATE DEG/SEC	G	S/N 355			S/N 373			S/N 381					
			AT RADIUS CCV	AT RADIUS CV	ZERO* CV	AT RADIUS CCV	AT RADIUS CV	ZERO* CV	AT RADIUS CCV	AT RADIUS CV	ZERO CV			
+X	250	1.184	1.5327	-1.5279	1.5485	-1.5431	1.5418	-1.5465	1.5589	-1.5624	1.5087	-1.5379	1.5286	-1.5430
	500	4.736	3.1784	-3.1665	3.2095	-3.194	3.2383	-3.2187	-	-	3.1366	-3.163	3.1669	-3.1748
NULL OFFSET MV**			+3.95		+2.73		-5.30		-5.55		-12.35		-7.85	
SCALE FACTOR MV/DEG/SEC			-6.24		-6.30		-6.32		-6.35		-6.21		-6.28	
-X	250	1.184	1.5324	-1.5270	1.5485	-1.5431	1.5486	-1.5512	1.5589	-1.5624	1.5043	-1.5336	1.5286	-1.5430
	500	4.736	3.1748	-3.1606	3.2095	-3.1940	3.2494	3.2253	-	-	3.1244	-3.1514	3.1669	-3.1748
NULL OFFSET MV			+3.50		+2.73		-5.38		-5.55		-12.85		-7.85	
SCALE FACTOR MV/DEG/SEC			-6.24		-6.30		-6.34		-6.35		-6.18		-6.28	
+Y	250	1.184	1.5266	-1.5216	1.5485	-1.5431	1.5493	-1.5508	1.5589	-1.5624	1.5074	-1.5352	1.5286	-1.5430
	500	4.736	3.1643	-3.149	3.2095	-3.1940	3.2527	-3.2249	-	-	3.1323	-3.1551	3.1669	-3.1748
NULL OFFSET MV			3.52		2.73		-5.70		-5.55		-12.42		-7.85	
SCALE FACTOR MV/DEG/SEC			-6.22		-6.30		-6.35		-6.35		-6.20		-6.28	
-Y	250	1.184	1.5274	-1.5236	1.5485	-1.5431	1.5493	-1.5490	1.5589	-1.5624	1.5102	-1.5389	1.5286	-1.5430
	500	4.736	3.1626	-3.1554	3.2095	-3.1940	3.2322	-3.2228	-	-	3.1358	-3.1640	3.1669	-3.1748
NULL OFFSET MV			2.94		2.73		-6.61		-5.55		-11.99		-7.85	
SCALE FACTOR MV/DEG/SEC			-6.22		-6.30		-6.33		-6.35		-6.21		-6.28	
+Z	250	1.1643	-1.2056	+0.0093	-0.0002	+0.0031	-0.0297	+0.0157	-0.0255	+0.0094	-0.0241	-0.0047	-0.0194	-0.0084
	500	4.6571	-0.2125	+0.0184	-0.0043	+0.0060	-0.0520	+0.0325	-0.0433	+0.0185	-0.0338	+0.0065	-0.0232	-0.0012
NULL OFFSET MV			2.10		0.98		-6.20		-6.40		-13.60		-13.60	
SCALE FACTOR MV/DEG/SEC			-6.22		-6.30		-6.33		-6.35		6.21		6.28	
-Z	250	1.2037	-0.2049	+0.0081	-0.0002	+0.0031	-0.0291	+0.0147	-0.0255	+0.0094	-0.0229	-0.0052	-0.0194	-0.0084
	500	4.8149	-0.2099	+0.0144	+0.0043	+0.0060	-0.0492	+0.0289	-0.0433	+0.0185	-0.0302	+0.0037	-0.0232	-0.0012
NULL OFFSET MV			2.20		0.98		-6.40		-6.40		-13.50		-13.60	
SCALE FACTOR MV/DEG/SEC			NA		NA		NA		NA		NA		NA	

*DATA OBTAINED FROM POST ACQUISITION BASELINE TEST FOR +X, -Y, +Y AND -Y AXES.
**MV IS MILLIVOLTS

TABLE 3.2.2-XXII

3.2.3 Data Evaluation

Using Table 3.2.2-XXII, the acceleration sensitivity of the "Superjet" was calculated for the "Maximum Performance Escape System" scenario

The G-sensitive terms were reduced as follows:

$$G_s = \frac{\frac{(V-NO)}{(SF)} \text{At Radius} - \frac{(V-NO)}{(SF)} \text{Zero Arm}}{G} \quad \text{Eq (5)}$$

where:

- G_s = Acceleration Sensitivity (deg/sec/g)
- V = Voltage Output Counterclockwise or Clockwise
- NO = Null Offset
- SF = Scale Factor at Zero or at Radius (volts/deg/sec)
- G = Acceleration Level in Units of Gravity g (where g = 32.17 ft/sec²)

The G-sensitivity was calculated and is compared with the manufacturer's G-sensitivity data as shown in Table 3.2.3-I. The values obtained by Martin Marietta represent the worst case for each individual axis. The manufacturer's data was evaluated by accelerating the axes at 20.0g and positioning the rate sensor on a rate table to be rate insensitive. This was done on a 4.0 inch arm at 2500 degrees/second clockwise and counterclockwise. The G-sensitivity data was calculated as shown for rate insensitive orientations:

$$G_s = \frac{V_{cw} + V_{ccw}}{2G(SF)} = \text{degrees/second/g} \quad \text{Eq (6)}$$

where:

- G_s = G-sensitivity
- V_{cw} = Voltage Output Clockwise
- V_{ccw} = Voltage Output Counterclockwise
- G = 20 g where g = 32.174 ft/sec²
- SF = Scale Factor (nominally 0.006 v/degrees/second)

G-SENSITIVITY COMPARISON

AXIS ACCELERATED	MMC		MANUFACTURER	
	DEG/SEC/G	G	DEG/SEC/G	G
X	1.33	1.184g	0.13	20g
Y	1.68	1.184g	0.14	20g
Z	0.90	1.164g	0.02	20g

TABLE 3.2.3-I

It is questionable whether it is correct to calculate the G-sensitivity term by averaging the clockwise and counterclockwise rate outputs, without considering the rate outputs in the absence of acceleration, since these outputs are not necessarily equal to each other.

For tests that have the rate sensor input axis parallel to the rate table axis of rotation, the rate sensor would gradually go into saturation at rates above 500 deg/s so that the difference in output would strictly be a matter of difference in saturation and not necessarily due to linear acceleration.

The G-sensitivity data for each direction and g level is shown in Table 3.2.3-II along with the manufacturers data. Included in the table are sketches showing sensor orientations with respect to the acceleration vector and centerline of the rate table. The sensor sketch shows the wires and jet axis orientation. The arrow inside the block is the jet axis.

G-SENSITIVITY = DEG/SFC/G

AXIS ACCELERATED	MHC		355	373	381	NOTE	HAMILTON STANDARD
+X		ccw	-0.311	-1.331	+0.235	1	
		ccw	-0.060	-	+0.326	2	
		cw	+0.100	-1.108	+1.022	3	
		cw	+0.090	-	+0.646	4	
-X		ccw	-0.291	-1.067	+0.706	1	
		ccw	-0.167	-	+0.446	2	
		cw	-0.082	-1.011	+1.373	3	
		cw	-0.074	-	+0.753	4	
+Y		ccw	-0.416	-1.257	+0.401	1	
		ccw	-0.179	-	+0.355	2	
		cw	-0.147	-1.563	+0.979	3	
		cw	-0.123	-	+0.547	4	
-Y		ccw	-0.228	-1.683	+0.390	1	
		ccw	-0.217	-	+0.286	2	
		cw	+0.046	-1.275	+1.206	3	
		cw	+0.075	-	+0.692	4	
+Z		ccw	+0.902	+0.605	+0.659	5	
		ccw	+0.324	+0.306	+0.370	6	
		cw	+0.705	+0.834	+0.520	7	
		cw	+0.392	+0.471	+0.271	8	
-Z		ccw	+0.793	+0.408	+0.490	9	
		ccw	+0.230	+0.201	+0.249	10	
		cw	+0.508	+0.702	+0.422	11	
		cw	+0.242	+0.344	+0.165	12	

Notes:

- | | | |
|--------------------|---------------------|----------------------|
| 1) 250°/n, 1.184 R | 5) 250°/n, 1.1643 R | 9) 250°/n, 1.8037 R |
| 2) 500°/n, 4.736 R | 6) 500°/n, 4.657 R | 10) 500°/n, 4.815 R |
| 3) 250°/n, 1.184 R | 7) 250°/n, 1.645 R | 11) 250°/n, 1.2037 R |
| 4) 500°/n, 4.736 R | 8) 500°/n, 4.657 R | 12) 500°/n, 4.8149 R |

TABLE 3.2.3-11

3.3 High Temperature Sensitivity

3.3.1 Test Setup and Procedure

The test setup for the $+165^{\circ}\text{F} \pm 5^{\circ}\text{F}$ temperature sensitivity environment is the same as the baseline test setup except for the addition of heat.

A thermistor was mounted under one of the rate sensor mounting screws. A portable environmental chamber was mounted over the 8"X8"X8" test cube on the Genisco 1100-2 rate table. The heating coils located on the test cube were then connected to a temperature controller located in the rate table controller test console. After temperature equalization and soaking for 45 minutes minimum, the tests were run.

The temperature was monitored and controlled continuously throughout the test. A test schematic is shown in Figure C.3-1 of Appendix A, Part C.

The procedure is outlined in Appendix A Part C of this report. There were no deviations from the test plan.

3.3.2 Test Results

The test results are presented in the same form as the baseline test. The scale factor test program results are shown in Tables 3.3.2-I through 3.3.2-X. Tables 3.3.2-XI through 3.3.2-XIII show the output drift characteristics at different rates. The null offset measurement was added to the printout to monitor variations from setup to setup and day to day. From Table 3.3.2-I, a plot was made to show typically the high temperature effect on the output vs. input. This is shown in Figure 3.3.2-1 for S/N 355 and can be compared to the baseline data at room temperature recorded in Figure 3.1.2-1.

Readytime, threshold, and resolution were measured in the same manner as the baseline test.

3.3.3 Data Evaluation

The high temperature ($+165^{\circ}\text{F} \pm 5^{\circ}\text{F}$) sensitivity data for the 3 Superjet rate sensors tested produce the following worst case evaluation:

1. Full Scale Rate at $\pm 2\%$ Linearity Error	625 \pm 75 deg/sec
2. Scale Factor	.0062 \pm .0002 V/deg/sec
3. Bias	± 3.24 deg/sec
4. Hysteresis	$\pm .25$ deg/sec
5. Threshold	<.1 deg/sec
6. Resolution	<.1 deg/sec
7. Readytime	.068 sec maximum
8. Drift	$\pm .36$ deg/sec/min maximum

A breakdown of tests data for each serial number is shown in Tables 3.3.3-I and 3.3.3-II.

It is evident that the high temperature increases the full scale rate at +2% linearity and null bias appreciably. This is due to the fact that the Superjet sensors tested are not temperature compensated above +145°F. Readytime increased slightly but is well within the 0.100 second requirement.

RATE SENSOR TEST PROGRAM

NADC 80081-60

DATE...3-12-80..... RUN...HOT.....
 TEMP...165°F..... SER#...355.....

RATE (DEG/SEC)	V OUT (VDC)	V CALC (VDC)	% FS	% IDEAL
-49.9545	.302	.3111	.3	-3.336
-99.8308	.5985	.6145	.526	-2.636
-149.773	.8971	.9181	.691	-2.336
-199.746	1.1981	1.222	.783	-1.973
-249.642	1.5025	1.5255	.756	-1.514
-299.612	1.8138	1.8293	.639	-1.316
-349.51	2.1236	2.1328	.341	-.43
-399.296	2.4413	2.4355	-.191	.239
* -449.402	2.7649	2.7432	-.211	.902
-499.045	3.0942	3.0433	-1.672	1.675
-449.367	2.7658	2.74	-.848	.943
-399.36	2.4421	2.4358	-.232	.253
-349.587	2.1241	2.1332	.332	-.432
-299.565	1.8113	1.822	.983	-.873
-249.663	1.503	1.5256	.742	-1.486
-199.751	1.1988	1.2221	.765	-1.916
-149.759	.8977	.918	.67	-2.232
-99.842	.5991	.6151	.525	-2.622
-49.9888	.3022	.3113	.341	-3.336
49.8538	-.2899	-.2958	-.194	-1.849
* 99.7569	-.5864	-.5993	-.426	-2.134
149.664	-.8846	-.9328	-.597	-1.996
199.574	-1.1849	-1.2363	-.735	-1.765
249.559	-1.4825	-1.5133	-.716	-1.435
299.495	-1.7856	-1.814	-.602	-1.326
349.352	-2.1368	-2.1172	-.342	-.429
399.251	-2.4226	-2.4226	.066	.083
449.234	-2.744	-2.7246	.638	.711
499.132	-3.0734	-3.222	1.393	1.395
449.228	-2.7447	-2.7249	.652	.726
399.246	-2.4234	-2.4226	.091	.114
349.354	-2.1376	-2.1172	-.314	-.449
299.444	-1.7963	-1.8137	-.57	-.952
249.576	-1.4895	-1.5134	-.686	-1.374
199.689	-1.1861	-1.227	-.689	-1.722
149.738	-.8857	-.9033	-.579	-1.932
99.8438	-.5876	-.5996	-.393	-1.969
49.8648	-.2849	-.2959	-.165	-1.651

TEST SUMMARY
 FULL SCALE RATE (DEG/SEC): 500
 SCALE FACTOR (V/DEG/SEC): -6.88122E-33
 BIAS (VOLTS) : 7.32315E-33
 HYSTERESIS, NEG RATES (VDC): -9.82176E-34
 HYSTERESIS, POS RATES (VDC): 1.26636E-33
 NULL OFFSET (VDC): 6.43392E-33

TEST ENGINEER *Roy W. Curry*
 3-12-80

READY

TABLE 3.3.2-1

RATE SENSOR TEST PROGRAM

NADC 80081-60

DATE... 3-12-80..... RUN... HOT.....
 TEMP... 164°F..... SER#... 355.....

RATE (DEG/SEC)	V OUT (VDC)	V CALC (VDC)	% FS	% IDEAL
-54.0066	.2978	.3081	.311	-3.419
-99.9217	.5903	.6094	.578	-3.18
* -149.851	.8849	.9139	.782	-2.87
-199.766	1.1819	1.2122	.913	-2.515
-249.732	1.4821	1.5138	.955	-2.104
-299.56	1.7869	1.8146	.835	-1.534
-349.563	2.0953	2.1165	.637	-1.203
-399.436	2.4091	2.4176	.256	-3.53
-449.468	2.7289	2.7196	-.23	.343
-499.358	3.0543	3.0208	-1.009	1.111
-549.314	3.38489	3.32245	-1.881	1.883
-499.28	3.055	3.0203	-1.244	1.151
-449.389	2.7308	2.7192	-.35	.428
-399.451	2.4116	2.4177	.184	-.253
-349.543	2.0975	2.1164	.569	-.895
-299.573	1.789	1.8147	.775	-1.424
-249.705	1.4848	1.5137	.87	-1.915
-199.692	1.1844	1.2117	.824	-2.27
-149.857	.8878	.9109	.697	-2.559
-99.9284	.5926	.6095	.529	-2.824
-54.0332	.2993	.3081	.265	-2.919
49.8536	-.2859	-.2947	-.265	-2.929
99.7772	-.5791	-.5961	-.512	-2.925
* 149.831	-.8739	-.8921	-.75	-2.679
199.668	-1.1712	-1.1991	-.84	-2.315
249.594	-1.4716	-1.5006	-.873	-1.825
299.516	-1.7749	-1.802	-.816	-1.408
349.532	-2.0829	-2.1039	-.632	-.994
399.433	-2.3956	-2.405	-.223	-.329
449.368	-2.7138	-2.7066	.217	.266
499.227	-3.0373	-3.0076	.896	.908
549.197	-3.36596	-3.3092	1.71	1.712
499.153	-3.038	-3.0074	.924	1.212
449.281	-2.715	-2.7061	.269	.329
399.452	-2.3971	-2.4053	-.245	-.357
349.466	-2.0848	-2.1035	-.564	-.988
299.483	-1.777	-1.8017	-.746	-1.37
249.628	-1.4737	-1.5006	-.813	-1.792
199.637	-1.1735	-1.199	-.769	-2.113
149.759	-.8763	-.8979	-.65	-2.387
99.7399	-.5811	-.5959	-.445	-2.453
49.9074	-.2874	-.2951	-.23	-2.535

TEST SUMMARY
 FULL SCALE RATE (DEG/SEC): 550
 SCALE FACTOR (V/DEG/SEC): -6.03694E-03
 BIAS (VOLTS) : 6.21719E-03
 HYSTERESIS, NEG RATES (VDC): -2.66031E-03
 HYSTERESIS, POS RATES (VDC): 2.38895E-03
 NULL OFFSET (VDC): 6.42287E-03

TABLE 3.3.2-11

TEST ENGINEER

B. W. Cuyler
 7-12-80

RATE SENSOR TEST PROGRAM

DATE... 3-12-80..... RUN... HOT..... NADC 80081-60
 TEMP... 164°F..... SER#... 355.....

RATE (DEG/SEC)	V OUT (VDC)	V CALC (VDC)	% FS	% IDEAL
-49.979	.321	.3139	.352	-4.222
-99.9318	.5962	.6193	.63	-3.78
-149.905	.8935	.9248	.852	-3.411
-199.761	1.1923	1.2295	1.002	-3.009
-249.671	1.4959	1.5346	1.058	-2.541
* -299.582	1.8024	1.8397	1.018	-2.039
-349.551	2.1141	2.1452	.848	-1.456
-399.519	2.4305	2.4507	.549	-.825
-449.387	2.7528	2.7555	.073	-.093
-499.353	3.0807	3.0609	-.539	.647
-549.27	3.41375	3.36614	-1.298	1.418
-599.226	3.75133	3.67152	-2.176	2.179
-549.275	3.41371	3.36617	-1.296	1.416
-499.329	3.0809	3.0608	-.548	.658
-449.445	2.7535	2.7559	.065	-.366
-399.516	2.4314	2.4506	.525	-.783
-349.56	2.115	2.1453	.826	-1.417
-299.597	1.8033	1.8393	.995	-1.994
-249.724	1.4966	1.535	1.046	-2.512
-199.758	1.1936	1.2295	.979	-2.94
-149.832	.8942	.9243	.821	-3.287
-99.9048	.5971	.6191	.602	-3.614
-50.0005	.3215	.3141	.344	-4.125
49.8772	-.2882	-.2965	-.226	-2.714
99.7399	-.5835	-.6013	-.485	-2.919
149.718	-.8824	-.9068	-.72	-2.886
* 199.638	-1.1794	-1.212	-.888	-2.668
249.552	-1.4817	-1.5171	-.966	-2.322
299.52	-1.7872	-1.8225	-.964	-1.931
349.468	-2.0971	-2.1279	-.839	-1.44
399.285	-2.4114	-2.4324	-.572	-.36
449.256	-2.7314	-2.7379	-.175	-.234
499.165	-3.0566	-3.043	.372	.447
549.182	-3.38697	-3.34867	1.044	1.141
599.127	-3.72146	-3.65399	1.84	1.842
549.18	-3.38781	-3.34866	1.068	1.166
499.292	-3.0574	-3.0437	.373	.448
449.332	-2.7324	-2.7383	-.163	-.217
399.391	-2.4125	-2.4331	-.562	-.844
349.545	-2.0981	-2.1283	-.823	-1.413
299.51	-1.7885	-1.8225	-.926	-1.856
249.599	-1.4833	-1.5174	-.931	-2.237
199.687	-1.1811	-1.2123	-.85	-2.553
149.786	-.8821	-.9072	-.686	-2.747
99.767	-.5849	-.6015	-.451	-2.71
49.8976	-.2894	-.2966	-.196	-2.361

TEST SUMMARY
 FULL SCALE RATE (DEG/SEC): 600
 SCALE FACTOR (V/DEG/SEC): -6.11297E-33
 BIAS (VOLTS) : 8.41362E-03
 HYSTERESIS, NEG RATES (VDC): -9.17435E-04
 HYSTERESIS, POS RATES (VDC): 1.69754E-03
 NULL OFFSET (VDC): 6.63767E-03

TABLE 3.3.2-III

TEST ENGINEER.....

RATE SENSOR TEST PROGRAM

NADC 80081-60

DATE...3-13-80..... RUN....HOT.....

TEMP...165°F..... SER#...373.....

RATE (DEG/SEC)	V OUT (VDC)	V CALC (VDC)	% FS	% IDEAL
-49.8987	.328	.338	.392	-3.142
-99.8015	.6401	.6556	.612	-2.453
* -149.734	.9549	.9735	.73	-1.949
-199.575	1.2735	1.2908	.681	-1.365
-249.431	1.5967	1.6282	.452	-.725
-299.397	1.9253	1.9262	.737	-.349
-349.253	2.2598	2.2436	-.635	.727
-399.125	2.6	2.5611	-1.529	1.532
-349.218	2.2604	2.2434	-.666	.763
-299.326	1.9258	1.9258	0	0
-249.456	1.5973	1.6283	.435	-.697
-199.556	1.274	1.2907	.654	-1.31
-149.759	.9557	.9737	.706	-1.885
-99.81	.6437	.6557	.589	-2.36
-49.9443	.3284	.3383	.387	-3.1
49.8832	-.2935	-.2972	-.146	-1.169
* 99.7518	-.6348	-.6147	-.39	-1.563
149.593	-.9186	-.932	-.525	-1.424
199.557	-1.2348	-1.25	-.597	-1.197
249.42	-1.5552	-1.5675	-.48	-.77
299.275	-1.8799	-1.8848	-.193	-.258
349.198	-2.2099	-2.2326	.286	.328
398.967	-2.5455	-2.5194	1.323	1.326
349.182	-2.2125	-2.2325	.312	.357
299.271	-1.8837	-1.8848	-.161	-.215
249.439	-1.5561	-1.5676	-.449	-.721
199.574	-1.2359	-1.2531	-.561	-1.124
149.672	-.9196	-.9325	-.505	-1.35
99.7619	-.6059	-.6147	-.348	-1.395
49.8748	-.2944	-.2972	-.11	-.88

TEST SUMMARY
 FULL SCALE RATE (DEG/SEC): 403
 SCALE FACTOR (V/DEG/SEC): -6.36587E-03
 BIAS (VOLTS) : 2.03222E-02
 HYSTERESIS, NEG RATES (VDC): -7.75695E-04
 HYSTERESIS, POS RATES (VDC): 1.12939E-03
 NULL OFFSET (VDC): 1.76674E-02

TEST ENGINEER

Bob W. Long
 3-13-80

READY

TABLE 3.3.2-IV

RATE SENSOR TEST PROGRAM

NADC 80081-60

DATE...3-13-80..... RUN....HOT.....
 TEMP...+165°F..... SER#...373.....

RATE (DEG/SEC)	V OUT (VDC)	V CALC (VDC)	Z FS	Z IDEAL
-49.9442	.3267	.3424	.492	-4.922
-99.7982	.638	.6624	.761	-3.813
-149.678	.9523	.9825	.941	-3.142
* -199.527	1.27	1.3224	1.308	-2.526
-249.477	1.5926	1.6229	.944	-1.893
-299.373	1.9226	1.9432	.704	-1.175
-349.252	2.2545	2.2632	.272	-.389
-399.145	2.5944	2.5834	-.343	.43
-449.028	2.9395	2.9036	-1.12	1.247
-498.967	3.2872	3.224	-1.967	1.971
-448.82	2.9398	2.9035	-1.133	1.262
-399.157	2.5952	2.5835	-.365	.458
-349.263	2.256	2.2633	.228	-.326
-299.27	1.922	1.9425	.637	-1.364
-249.492	1.5942	1.623	.899	-1.822
-199.517	1.2717	1.3223	.954	-2.38
-149.736	.9538	.9827	.9	-3.225
-99.8366	.6394	.6624	.719	-3.631
-49.9281	.3276	.3423	.46	-4.633
49.8846	-.2933	-.2982	-.154	-1.539
99.6976	-.6339	-.6179	-.435	-2.132
149.615	-.9169	-.9382	-.665	-2.223
199.471	-1.2324	-1.2582	-.832	-2.311
* 249.431	-1.552	-1.5786	-.928	-1.661
299.3	-1.876	-1.8988	-.713	-1.191
349.266	-2.2055	-2.2195	-.437	-.626
399.448	-2.54	-2.539	.834	.342
448.979	-2.8821	-2.8594	.645	.717
498.82	-3.2239	-3.1793	1.39	1.393
448.93	-2.8848	-2.8591	.678	.755
399.441	-2.5412	-2.5389	.07	.387
349.143	-2.2267	-2.2187	-.375	-.538
299.31	-1.8772	-1.8989	-.676	-1.129
249.412	-1.5536	-1.5787	-.781	-1.567
199.523	-1.2338	-1.2585	-.772	-1.933
149.647	-.9182	-.9384	-.631	-2.132
99.7585	-.6352	-.6183	-.426	-2.335
49.864	-.294	-.2981	-.128	-1.285

TEST SUMMARY
 FULL SCALE RATE (DEG/SEC): 500
 SCALE FACTOR (V/DEG/SEC): -6.41750E-03
 BIAS (VOLTS): 2.19196E-02
 HYSTERESIS, NEG RATES (VDC): -.001683
 HYSTERESIS, POS RATES (VDC): 1.56927E-03
 NULL OFFSET (VDC): .016964

TEST ENGINEER: *[Signature]*
 3-13-80

READY

TABLE - 3.3.2-V

RATE SENSOR TEST PROGRAM

NADC 80081-60

DATE..3-13-80..... RUN....HQT.....

TEMP..+165°F..... SER#...373.....

RATE (DEG/SEC)	V OUT (VDC)	V CALC (VDC)	Z FS	Z IDEAL
-49.912	.3264	.3446	.513	-5.652
-99.7998	.6377	.6664	.809	-4.457
-149.632	.9523	.9879	1.233	-3.685
* -199.566	1.2698	1.31	1.132	-3.121
-249.422	1.5925	1.6316	1.131	-2.428
-299.331	1.9205	1.9535	.93	-1.738
-349.267	2.2545	2.2756	.594	-.935
-399.116	2.5942	2.5972	.083	-.114
-449.094	2.9392	2.9195	-.555	.679
-498.956	3.28703	3.2412	-1.291	1.423
-547.769	3.63494	3.56255	-2.34	2.045
-498.84	3.28789	3.2404	-1.336	1.473
-448.906	2.9403	2.9183	-.618	.757
-398.115	2.5956	2.5972	.343	-.259
-349.226	2.256	2.2753	.547	-.361
-299.299	1.9219	1.9533	.886	-1.622
-249.492	1.5942	1.632	1.267	-2.351
-199.543	1.2715	1.3296	1.38	-2.978
-149.649	.9536	.988	.97	-3.565
-99.8252	.6391	.6666	.776	-4.273
-49.9208	.3273	.3447	.49	-5.398
49.8697	-.2932	-.299	-.163	-1.802
99.7281	-.6341	-.6236	-.467	-2.576
149.581	-.917	-.9422	-.711	-2.613
199.466	-1.2327	-1.264	-.882	-2.432
249.41	-1.5524	-1.5862	-.952	-2.298
299.297	-1.8764	-1.938	-.889	-1.634
* 349.237	-2.2056	-2.2301	-.691	-1.388
398.979	-2.5406	-2.5539	-.29	-.4
448.821	-2.8809	-2.8737	.231	.246
498.87	-3.2245	-3.1953	.823	.937
548.775	-3.56964	-3.51716	1.479	1.482
498.811	-3.2253	-3.1949	.856	.944
448.95	-2.8816	-2.8733	.233	.286
398.848	-2.542	-2.5514	-.265	-.366
349.17	-2.2072	-2.2297	-.633	-.997
299.285	-1.8777	-1.9279	-.851	-1.564
249.488	-1.5539	-1.5861	-.91	-2.336
199.532	-1.2343	-1.2644	-.849	-2.34
149.581	-.9186	-.9422	-.665	-2.447
99.6706	-.6054	-.6203	-.418	-2.339
49.8513	-.2941	-.2989	-.136	-1.483

TEST SUMMARY
 FULL SCALE RATE (DEG/SEC): 550
 SCALE FACTOR (V/DEG/SEC): -6.45053E-33
 BIAS (VOLTS) : 2.26589E-32
 HYSTERESIS, NEG RATES (VDC): -1.62777E-33
 HYSTERESIS, POS RATES (VDC): 1.62782E-33
 NULL OFFSET (VDC): 1.67427E-32

TABLE 3.3.2-VI

TEST ENGINEER

Ray W. King 3-13-80

RATE SENSOR TEST PROGRAM

NADC 80081-60

DATE... 3-12-80..... RUN..... HOT.....

TEMP... 165°F..... SER#... 381.....

RATE (DEG/SEC)	V OUT (VDC)	V CALC (VDC)	% FS	% IDEAL
-49.9822	.2801	.2883	.241	-2.647
-99.9064	.5811	.5961	.441	-2.429
-149.9	.8841	.9044	.599	-2.197
-199.742	1.1887	1.2117	.68	-1.873
* -249.732	1.4966	1.52	.69	-1.52
-299.597	1.8078	1.8275	.581	-1.267
-349.546	2.1225	2.1355	.382	-.632
-399.516	2.4405	2.4436	.392	-.127
-449.434	2.7614	2.7514	-.296	.362
-499.363	3.0838	3.0593	-.722	.795
-549.294	3.4051	3.36724	-1.128	1.13
-499.282	3.0843	3.0589	-.751	.827
-449.335	2.7623	2.7511	-.33	.434
-399.419	2.4415	2.443	.045	-.062
-349.535	2.1237	2.1352	.34	-.536
-299.61	1.8088	1.8276	.552	-1.313
-249.73	1.4979	1.52	.652	-1.436
-199.793	1.1898	1.212	.656	-1.825
-149.886	.8851	.9043	.566	-2.278
-99.8827	.582	.596	.41	-2.26
-50.8858	.2837	.2884	.228	-2.539
49.9249	-.3208	-.3271	-.286	-2.272
* 99.7941	-.6221	-.6353	-.39	-2.15
149.713	-.925	-.9431	-.536	-1.968
199.672	-1.2299	-1.2512	-.628	-1.729
249.626	-1.5374	-1.5591	-.64	-1.411
299.459	-1.8478	-1.8665	-.553	-1.317
349.398	-2.1615	-2.1745	-.382	-.632
399.388	-2.4782	-2.4827	-.132	-.182
449.39	-2.7981	-2.7911	.228	.255
499.246	-3.1191	-3.0985	.607	.669
549.224	-3.43956	-3.40662	.971	.973
499.193	-3.1196	-3.0982	.633	.698
449.236	-2.799	-2.7901	.261	.319
399.347	-2.4794	-2.4822	-.084	-.115
349.486	-2.1627	-2.175	-.363	-.572
299.531	-1.849	-1.8668	-.525	-.964
249.616	-1.5387	-1.5592	-.635	-1.333
199.671	-1.2312	-1.2512	-.59	-1.626
149.669	-.9263	-.9429	-.487	-1.79
99.7602	-.6236	-.6351	-.339	-1.866
49.8565	-.3223	-.3274	-.149	-1.646

TEST SUMMARY
 FULL SCALE RATE (DEG/SEC): 550
 SCALE FACTOR (V/DEG/SEC): -6.16636E-33
 BIAS (VOLTS) : -1.99573E-32
 HYSTERESIS, NEG RATES (VDC): -1.27745E-33
 HYSTERESIS, POS RATES (VDC): 1.54114E-33
 NULL OFFSET (VDC): -1.96618E-32

TABLE 3.3.2-VII

TEST ENGINEER: *[Signature]*
 3-12-80

RATE SENSOR TEST PROGRAM

DATE...3-12-80.....
 TEMP...163°F.....

RUN.....HOT.....
 SER#.....381.....

NADC 80081-60

RATE (DEG/SEC)	V OUT (VDC)	V CALC (VDC)	% FS	% IDEAL
-50	.2821	.2894	.251	-3.215
-99.8845	.5827	.5978	.46	-2.765
-149.798	.8834	.9063	.618	-2.475
-199.752	1.1821	1.2151	.727	-2.183
-249.697	1.4964	1.5238	.74	-1.779
-299.566	1.8076	1.8321	.661	-1.324
-349.583	2.122	2.1413	.519	-.891
* -399.45	2.4397	2.4495	.263	-.396
-449.389	2.7608	2.7582	-.07	.093
-499.294	3.0835	3.2667	-.455	.546
-549.255	3.40516	3.37555	-.798	.872
-599.167	3.72361	3.68408	-1.066	1.067
-549.363	3.40573	3.37622	-.796	.869
-499.307	3.0841	3.2668	-.468	.562
-449.411	2.7616	2.7583	-.088	.118
-399.505	2.4408	2.4498	.243	-.365
-349.594	2.123	2.1413	.494	-.848
-299.602	1.8081	1.8323	.653	-1.308
-249.702	1.4971	1.5238	.722	-1.735
-199.79	1.1892	1.2153	.706	-2.119
-149.788	.8843	.9062	.592	-2.372
-99.8997	.5816	.5979	.437	-2.625
-49.9899	.2825	.2893	.239	-2.868
49.8533	-.3208	-.3278	-.189	-2.272
* 99.7957	-.6218	-.6365	-.398	-2.394
149.738	-.9245	-.9452	-.558	-2.237
199.579	-1.2294	-1.2533	-.646	-1.942
249.596	-1.5369	-1.5625	-.691	-1.661
299.542	-1.847	-1.8712	-.654	-1.31
349.459	-2.1607	-2.1798	-.516	-.886
399.334	-2.4777	-2.4881	-.279	-.419
449.26	-2.7973	-2.7967	.317	.023
499.221	-3.1133	-3.1055	.343	.413
549.173	-3.43281	-3.41426	.662	.723
599.127	-3.75621	-3.72305	.894	.795
549.212	-3.43951	-3.4145	.674	.737
499.286	-3.1191	-3.1059	.354	.425
449.42	-2.7981	-2.7977	.011	.015
399.396	-2.4786	-2.4885	-.265	-.398
349.479	-2.1621	-2.1799	-.481	-.826
299.476	-1.8483	-1.8708	-.608	-1.218
249.574	-1.5382	-1.5624	-.653	-1.569
199.645	-1.2309	-1.2537	-.616	-1.851
149.649	-.9264	-.9447	-.493	-1.977
99.7484	-.6237	-.6362	-.338	-2.233
49.8944	-.3223	-.3281	-.155	-1.859

TEST SUMMARY
 FULL SCALE RATE (DEG/SEC): 600
 SCALE FACTOR (V/DEG/SEC): -6.18139E-03
 BIAS (VOLTS) : -1.96605E-02
 HYSTERESIS, NEG RATES (VDC): -1.10579E-03
 HYSTERESIS, POS RATES (VDC): 1.93787E-03
 NULL OFFSET (VDC): -1.93361E-02

TABLE 3.3.2-VIII

TEST ENGINEER.....

Boyd W. Long 3-12-80

RATE SENSOR TEST PROGRAM

DATE..3-12-80..... RUN...MOJ.....
 TEMP...164°F..... SER#...381.....

RATE (DEG/SEC)	V OUT (VDC)	V CALC (VDC)	% FS	% IDEAL
-49.9743	.2793	.2895	.252	-3.272
-99.9149	.5802	.5989	.465	-3.024
-149.788	.883	.9078	.617	-2.679
-199.758	1.1875	1.2174	.744	-2.421
-249.675	1.4953	1.5267	.78	-2.031
* -299.619	1.8061	1.8361	.744	-1.613
-349.522	2.121	2.1452	.602	-1.12
-399.482	2.4393	2.4547	.384	-.625
-449.482	2.7603	2.7645	.103	-.15
-499.326	3.0826	3.0733	-.232	.302
-549.319	3.40475	3.38307	-.538	.637
-599.096	3.72346	3.69145	-.795	.863
-649.15	4.03508	4.03154	-.833	.834
-599.208	3.72403	3.69214	-.792	.059
-549.257	3.40568	3.38269	-.571	.676
-499.368	3.0839	3.0736	-.257	.335
-449.423	2.7614	2.7641	.068	-.098
-399.466	2.4407	2.4547	.347	-.564
-349.514	2.1225	2.1452	.564	-1.05
-299.592	1.8078	1.8359	.699	-1.517
-249.724	1.4968	1.527	.75	-1.952
-199.725	1.1889	1.2172	.703	-2.289
-149.915	.8842	.9086	.606	-2.629
-99.9166	.5812	.5989	.438	-2.052
-50.3181	.2799	.2897	.244	-3.171
49.8755	-.3214	-.3291	-.192	-2.507
99.8025	-.6224	-.6384	-.398	-2.595
149.659	-.9254	-.9473	-.545	-2.366
199.687	-1.23	-1.2572	-.677	-2.204
249.571	-1.5374	-1.5663	-.717	-1.866
* 299.515	-1.8475	-1.8757	-.701	-1.521
349.429	-2.1614	-2.1849	-.584	-1.387
399.464	-2.4782	-2.4949	-.414	-.673
449.356	-2.7979	-2.804	-.15	-.217
499.253	-3.1192	-3.1131	.151	.197
549.122	-3.44318	-3.422	.452	.534
599.139	-3.75765	-3.73186	.64	.695
648.975	-4.06903	-4.04061	.706	.707
599.104	-3.75061	-3.73164	.67	.727
549.239	-3.44173	-3.42253	.464	.549
499.3	-3.1236	-3.1134	.18	.234
449.336	-2.7997	-2.8038	-.104	-.15
399.342	-2.48	-2.4941	-.351	-.571
349.463	-2.1632	-2.1851	-.544	-1.011
299.547	-1.8494	-1.8759	-.657	-1.427
249.574	-1.5393	-1.5663	-.67	-1.744
199.62	-1.2318	-1.2568	-.62	-2.013
149.797	-.9272	-.9481	-.52	-2.258
99.8448	-.6243	-.6387	-.357	-2.324
49.8912	-.3229	-.3292	-.156	-2.037

TEST SUMMARY
 FULL SCALE RATE (DEG/SEC): 650
 SCALE FACTOR (V/DEG/SEC): -6.19521E-03
 BIAS (VOLTS): -2.31262E-02
 HYSTERESIS, NEG RATES (VDC): -1.62220E-03
 HYSTERESIS, POS RATES (VDC): 1.94240E-03
 NULL OFFSET (VDC): -1.93609E-02

TEST ENGINEER

[Handwritten Signature]
 3-12-80

TABLE 3.3.2-IX

RATE SENSOR TEST PROGRAM

NADC 80081-60

DATE...3-12-80..... RUN....HOT.....

TEMP...164°F..... SER#...381.....

RATE (DEG/SEC)	V OUT (VDC)	V CALC (VDC)	% FS	% IDEAL
-99.8895	.5798	.6319	.511	-3.578
-199.749	1.1866	1.2193	.756	-2.65
-299.575	1.8042	1.8364	.744	-1.739
* -399.502	2.4364	2.4542	.413	-.723
-499.26	3.0795	3.071	-.198	.277
-599.192	3.72075	3.68884	-.737	.861
-699.069	4.3338	4.30632	-.635	.636
-599.148	3.72154	3.68857	-.762	.39
-499.351	3.0807	3.0715	-.213	.298
-399.46	2.4377	2.454	.377	-.66
-299.578	1.8055	1.8365	.716	-1.674
-199.756	1.1872	1.2193	.743	-2.603
-99.8828	.5804	.6319	.496	-3.476
99.8245	-.6225	-.6328	-.284	-1.99
199.638	-1.2268	-1.2499	-.533	-1.37
299.527	-1.8432	-1.8674	-.561	-1.31
* 399.363	-2.4726	-2.4846	-.278	-.487
499.19	-3.113	-3.1018	.259	.363
599.05	-3.75153	-3.71914	.749	.875
698.951	-4.28764	-4.33677	-1.135	-1.137
599.109	-3.75269	-3.7195	.767	.296
499.188	-3.1145	-3.1018	.294	.412
399.314	-2.4744	-2.4743	-.009	-.432
299.537	-1.8448	-1.8675	-.524	-1.224
199.61	-1.2284	-1.2497	-.493	-1.728
99.8042	-.6222	-.6327	-.243	-1.703

TEST SUMMARY
 FULL SCALE RATE (DEG/SEC): 700
 SCALE FACTOR (V/DEG/SEC): -6.18237E-33
 BIAS (VOLTS) : -.015642
 HYSTERESIS, NEG RATES (VDC): -1.28984E-03
 HYSTERESIS, POS RATES (VDC): 1.80912E-03
 NULL OFFSET (VDC): -1.95895E-02

TEST ENGINEER: *[Signature]*
 3-12-80

READY

TABLE 3.3.2-X

RATE SENSOR PROGRAM: OUTPUT DRIFT NADC 80081-60

DATE...3-13-80..... RUN....HQT.....

TEMP...+165°F..... SER#...355.....

OUTPUT DRIFT IN 15 SEC INTERVALS

RATE (DEG/SEC)	MEAN (VDC)	SCALE FACTOR (VOLTS/DEG/SEC)
99.8386	.596905	5.97870E-03
99.8168	.597292	5.98389E-03
99.7797	.597534	5.98853E-03
99.7493	.597599	5.99131E-03
199.541	1.19771	6.33235E-03
199.556	1.19799	6.33327E-03
199.564	1.1983	6.32460E-03
199.544	1.19875	6.30745E-03
299.334	1.81288	6.35639E-03
299.308	1.81301	6.35735E-03
299.35	1.81355	6.35829E-03
299.33	1.81406	6.36239E-03
399.111	2.44711	6.13140E-03
399.078	2.44846	6.13529E-03
399.067	2.44944	6.13791E-03
399.109	2.44974	6.13802E-03
498.896	3.1049	6.22354E-03
498.799	3.10592	6.22679E-03
498.957	3.10605	6.22508E-03
498.854	3.10636	6.22698E-03

NULL OFFSET (VDC): 4.85412E-03

READY

Boyd W. Long
3-13-80

TABLE 3.3.2-XI

RATE SENSOR PROGRAM: OUTPUT DRIFT NADC 80081-60

DATE...3-13-80..... RUN...HOT.....

TEMP...163°F..... SER#...373.....

OUTPUT DRIFT IN 15 SEC INTERVALS

RATE (DEG/SEC)	MEAN (VDC)	SCALE FACTOR (VOLTS/DEG/SEC)
99.8172	.63623	6.37395E-03
99.7848	.636856	6.38229E-03
99.7756	.636906	6.38338E-03
99.7782	.637496	6.38512E-03
199.542	1.26872	6.35817E-03
199.581	1.26943	6.36047E-03
199.563	1.27043	6.36606E-03
199.57	1.27093	6.36837E-03
299.293	1.92227	6.42268E-03
299.339	1.92247	6.42238E-03
299.34	1.92299	6.42412E-03
299.297	1.92375	6.42754E-03
399.106	2.59895	6.51194E-03
399.094	2.59987	6.51444E-03
399.091	2.60449	6.51602E-03
399.107	2.60119	6.51752E-03
498.849	3.29585	6.60690E-03
498.919	3.29692	6.60812E-03
498.848	3.29744	6.61313E-03
498.938	3.29846	6.61096E-03

NULL OFFSET (VDC): 1.63632E-02

READY

Boyd W. Lewis
3-13-80

TABLE 3.3.2-XII

RATE SENSOR PROGRAM: OUTPUT DRIFT NADC 80081-60

DATE..3-13-80..... RUN....HOT.....

TEMP..165°F..... SER#...381.....

OUTPUT DRIFT IN 15 SEC INTERVALS

RATE (DEG/SEC)	MEAN (VDC)	SCALE FACTOR (VOLTS/DEG/SEC)
99.9279	.57377	5.74184E-03
99.9183	.574024	5.74493E-03
99.9609	.574516	5.74740E-03
99.935	.574479	5.74853E-03
199.76	1.17852	5.89967E-03
199.757	1.17897	5.90201E-03
199.758	1.17893	5.90178E-03
199.752	1.17928	5.90372E-03
299.574	1.79536	5.99303E-03
299.534	1.7955	5.99431E-03
299.534	1.79605	5.99614E-03
299.628	1.79699	5.99740E-03
399.391	2.4287	.006081
399.39	2.4289	6.00152E-03
399.433	2.42895	.006081
399.412	2.42972	6.00324E-03
499.185	3.07446	6.15895E-03
499.263	3.07449	6.15826E-03
499.302	3.07462	6.15782E-03
499.212	3.0749	6.15951E-03

NULL OFFSET (VDC): -.022159

READY

Boyd W. Long Jr
3-13-80

TABLE 3.3.2-XIII

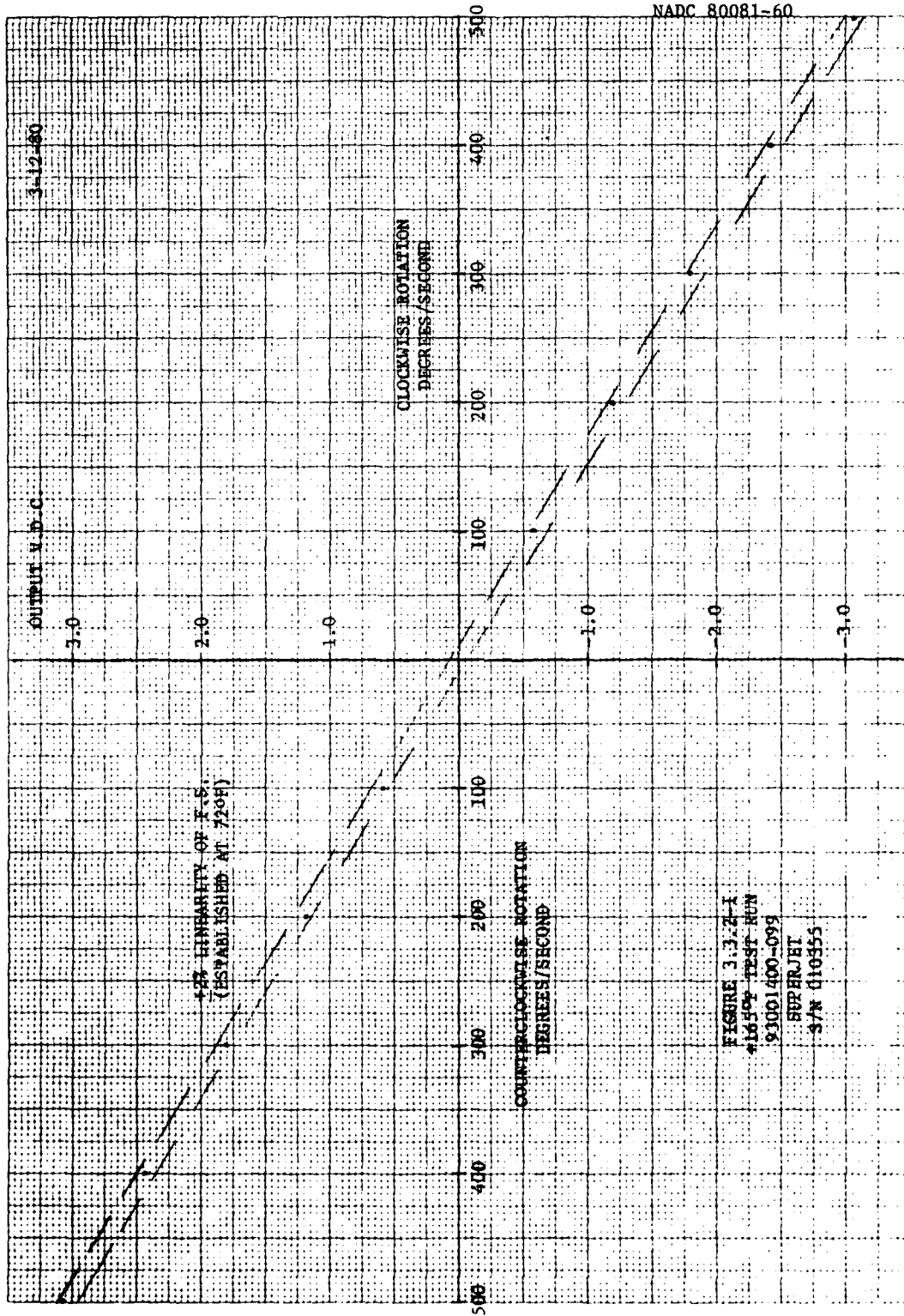

HIGH TEMPERATURE TEST DATA SUMMARY
(+165°F ±5°F)

PARAMETER	S/N 355	S/N 373	S/N 381
FULL SCALE RATE (DEG/SECOND) AT ±2% LINEARITY ERROR	550	500	700
SCALE FACTOR (MV/DEG/SEC) AT BASELINE FACTOR	-6.08	-6.37	-6.17
BIAS (DEG/SECOND)	-1.20	-3.19	+3.24
HYSTERESIS CCW (DEG/SECOND)	+1.15	+1.12	+1.21
HYSTERESIS CW (DEG/SECOND)	-1.21	-1.18	-1.25
NULL OFFSET (DEG/SECOND)	-1.05	-2.77	+3.19
THRESHOLD (DEG/SECOND)	<.10	<.10	<.10
RESOLUTION (DEG/SECOND)	<.10	<.10	<.10
READYTIME (SECONDS) AVG. OF 5 RATES*	.059	.065	.068
DRIFT (DEG/SEC/MIN) AVG. OF 5 RATES*	.14	.14	.08

*100, 200, 300, 400, AND 500 DEGREES/SECOND
(See Table 3.3.3-II)

TABLE 3.3.3-I

HIGH TEMPERATURE DRIFT AND READYTIME SUMMARY
 (+1650F ±5°F)

RATE (DEG/SEC)	OUTPUT DRIFT (DEG/SEC/MIN)			READYTIME (SECONDS)		
	355	373	381	355	373	381
100	+ .27	+ .23	+ .14	.068	.065	.065
200	+ .11	+ .21	+ .08	.052	.062	.067
300	+ .09	+ .10	+ .09	.062	.062	.075
400	+ .15	+ .12	+ .05	.060	.068	.060
500	+ .08	+ .08	+ .01	.052	.070	.075

TABLE 3.3.3-II

3.4 Low Temperature Sensitivity

3.4.1 Test Setup and Procedure

The test setup for the -30°F $\pm 5^{\circ}\text{F}$ temperature sensitivity environment is the same as the baseline test setup except for the addition of cooling.

A thermocouple was mounted under one of the rate sensor mounting screws. A portable environmental chamber was mounted over the 8"X8"X8" test cube on the Genisco 1100-2 rate table.

A tank of liquid nitrogen was used for cooling by pressurizing with dry nitrogen. The dry nitrogen pressure was controlled by a solenoid to maintain a constant temperature. After temperature stabilization and a 45 minute soak, the test was run. The thermocouple was disconnected prior to each run. This was done due to the absence of thermocouple wiring in the rate table slip rings.

This test deviates from the -65°F $\pm 5^{\circ}\text{F}$ described in the test plan. This was discussed and approved by NADC at the mid-task review.

A test schematic is shown in Figure C.3-2 of Appendix A, Part C.

3.4.2 Test Results

The test results are presented in the same manner as the baseline test. The results are shown in tables 3.4.2-I through 3.4.2-IX. From table 3.4.2-II, a plot was made to typically show the low temperature effect on the output of the units. This is compared to the baseline data obtained at room temperature as shown in Figure 3.1.2-1. This particular plot is for S/N 355 sensor at 500 degrees/second maximum rate.

Readytime, threshold and resolution were measured exactly as done during the baseline test.

3.4.3 Data Evaluation

The cold temperature (-30°F $\pm 5^{\circ}\text{F}$) sensitivity data for the Superjet rate sensors tested produced the following worst case evaluation:

1. Full Scale Rate at $\pm 2\%$ Linearity Error	425 ± 25 deg/sec
2. Scale Factor	.0058 \pm .0001 V/deg/sec
3. Bias	± 1.66 deg/sec
4. Hysteresis	± 2.44 deg/sec
5. Threshold	< 0.1 deg/sec
6. Resolution	< 0.1 deg/sec
7. Readytime	.069 sec max.
8. Drift	random (± 4.8 deg/sec/min)

The data recorded for each serial number is shown in Tables 3.4.3-I and 3.4.3-II.

The full scale rate decreases with cold temperature along with a scale factor reduction of approximately 10%. The hysteresis error increased substantially on serial number 355 while the other two units hardly changed.

Threshold, resolution and readytime were virtually unchanged while the drift characteristics were random. This may have been caused by the heating and cooling of the wires located in the sensor.

RATE SENSOR TEST PROGRAM

NADC 80081-60

DATE...3-17-80..... RUN...COLD.....
 TEMP...-30°F..... SER#...355.....

RATE (DEG/SEC)	V OUT (VDC)	V CALC (VDC)	% FS	% IDEAL
-49.9135	.2867	.2933	.26	-2.343
-99.7846	.5624	.5737	.447	-2.315
-149.663	.8369	.8541	.679	-2.341
-199.5	1.1128	1.1342	.847	-1.929
-249.409	1.3956	1.4148	.76	-1.371
-299.367	1.6811	1.6957	.574	-.863
* -349.159	1.9732	1.9756	.396	-.123
-398.971	2.2808	2.2556	-.997	1.125
-448.864	2.5903	2.5361	-2.144	2.15
-399.34	2.2758	2.256	-.784	.884
-349.155	1.9836	1.9756	-.316	.428
-299.286	1.6876	1.6952	.321	-.453
-249.404	1.3958	1.4148	.748	-1.35
-199.489	1.1129	1.1342	.841	-1.897
-149.622	.8341	.8538	.839	-2.824
-99.7812	.5518	.5736	.863	-3.891
-49.9168	.2754	.2933	.726	-6.365
* 49.8251	-.2632	-.2674	-.284	-2.566
99.7632	-.5326	-.5481	-.615	-2.772
149.631	-.8098	-.8283	-.732	-2.221
199.427	-1.0917	-1.1084	-.664	-1.498
249.352	-1.3747	-1.3891	-.571	-1.331
299.246	-1.6601	-1.6696	-.375	-.563
349.114	-1.9503	-1.95	.014	.312
398.875	-2.242	-2.2297	.485	.547
448.811	-2.5414	-2.5104	1.226	1.229
398.931	-2.2374	-2.23	.293	.33
349.148	-1.942	-1.9501	-.323	-.416
299.168	-1.6535	-1.6692	-.62	-.932
249.395	-1.3739	-1.3894	-.612	-1.104
199.44	-1.095	-1.1085	-.535	-1.236
149.643	-.816	-.8286	-.498	-1.496
99.7721	-.5405	-.5482	-.393	-1.368
49.8652	-.2751	-.2676	.295	2.664

TEST SUMMARY
 FULL SCALE RATE (DEG/SEC): 450
 SCALE FACTOR (V/DEG/SEC): -5.62178E-03
 BIAS (VOLTS) : 1.26843E-02
 HYSTERESIS, NEG RATES (VDC): -1.74251E-02
 HYSTERESIS, POS RATES (VDC): 1.48815E-02
 NULL OFFSET (VDC): 1.73858E-03

TEST ENGINEER

Ray W. Cuyler
 3-17-80

READY

TABLE 3.4.2-1

RATE SENSOR TEST PROGRAM

NADC 80081-60

DATE...3-17-80..... RUN...GOLD.....
 TEMP...-30°F..... SER#...355.....

RATE (DEG/SEC)	V OUT (VDC)	V CALC (VDC)	Z FS	Z IDEAL
-49.9178	.2763	.2822	.556	-5.57
-89.8134	.552	.5768	.867	-4.345
-149.69	.8337	.8612	1.273	-3.563
-199.563	1.1126	1.1457	1.161	-2.822
-249.443	1.3985	1.4322	1.275	-2.155
-299.325	1.6917	1.7141	.789	-1.312
-349.194	1.9875	1.9882	.41	-.587
-399.335	2.2896	2.2834	-.217	.272
* -448.888	2.5931	2.5678	-.889	.99
-498.822	2.9225	2.8526	-2.451	2.456
-449.556	2.636	2.5685	-1.316	1.465
-399.363	2.2918	2.2834	-.295	.369
-349.186	1.9842	1.9921	.525	-.751
-299.316	1.6916	1.7147	.839	-1.351
-249.355	1.4375	1.4297	.777	-1.552
-199.48	1.123	1.1452	.78	-1.256
-149.648	.8417	.861	.675	-2.257
-89.7457	.5628	.5764	.476	-2.367
-49.9396	.2777	.2823	.513	-5.132
49.8655	-.273	-.277	-.132	-1.324
99.7213	-.5483	-.5613	-.457	-2.291
149.633	-.826	-.846	-.7	-2.341
199.52	-1.1257	-1.1325	-.572	-2.126
249.366	-1.388	-1.4148	-.241	-1.227
299.215	-1.6741	-1.6992	-.272	-1.467
349.389	-1.9679	-1.9837	-.553	-.751
* 398.922	-2.2636	-2.2678	-.146	-.13
448.823	-2.5626	-2.5531	.546	.632
498.762	-2.8822	-2.8373	1.575	1.579
448.836	-2.58	-2.5526	.863	1.273
398.316	-2.2775	-2.2624	.319	.4
349.119	-1.9756	-1.9838	-.229	-.413
299.183	-1.6729	-1.689	-.67	-1.12
249.425	-1.3911	-1.4151	-.839	-1.622
199.425	-1.107	-1.13	-.728	-2.226
149.535	-.8273	-.8454	-.637	-2.122
99.7365	-.5516	-.5614	-.343	-1.722
49.8626	-.2641	-.2769	-.451	-4.525

TEST SUMMARY
 FULL SCALE RATE (DEG/SEC): 523
 SCALE FACTOR (V/DEG/SEC): -5.73372E-23
 BIAS (VOLTS) : 7.45839E-23
 HYSTERESIS, NEG RATES (VDC): -1.22493E-22
 HYSTERESIS, POS RATES (VDC): 1.32395E-22
 FULL OFFSET (VDC): 2.47325E-23

TEST ENGINEER.....

[Handwritten Signature]
 3-17-80

READY

TABLE 3.4.2-II

RATE SENSOR TEST PROGRAM

NADC 80081-60

DATE..3-14-80..... RUN...COLD.....
 TEMP...-30°F..... SER#.....373.....

	RATE (DEG/SEC)	V OUT (VDC)	V CALC (VDC)	% FS	% IDEAL
*	-49.9432	.292	.3245	.529	-4.238
	-99.8269	.5839	.5988	.631	-2.520
	-149.632	.8781	.8926	.615	-1.645
	-199.511	1.1729	1.1869	.591	-1.184
	-249.419	1.4722	1.4813	.384	-.615
	-299.326	1.7752	1.7757	.024	-.033
	-349.182	2.0884	2.2699	-.788	.932
	-399.035	2.4095	2.3638	-1.938	1.943
	-349.116	2.0874	2.0695	-.761	.372
	-299.291	1.7745	1.7755	.045	-.36
	-249.468	1.4677	1.4816	.586	-.94
	-199.536	1.1695	1.187	.741	-1.486
	-149.676	.8746	.8929	.775	-2.07
	-99.8134	.5813	.5987	.738	-2.959
	-49.9442	.2892	.3245	.646	-5.176
*	49.834	-.2864	-.2842	.096	.767
	99.7129	-.5744	-.5784	-.171	-.687
	149.53	-.8657	-.8723	-.281	-.753
	199.449	-1.1584	-1.1668	-.356	-.713
	249.278	-1.4534	-1.4628	-.315	-.505
	299.224	-1.7511	-1.7555	-.186	-.249
	348.994	-2.0549	-2.0491	.245	.281
	398.995	-2.3667	-2.3441	.956	.959
	349.122	-2.0525	-2.0497	.116	.132
	299.163	-1.7435	-1.7551	-.492	-.657
	249.324	-1.4421	-1.4611	-.834	-1.29
	199.489	-1.1469	-1.1671	-.857	-1.718
	149.53	-.8584	-.8723	-.592	-1.584
	99.7298	-.5718	-.5785	-.285	-1.143
	49.8531	-.2868	-.2843	.127	.859

TEST SUMMARY
 FULL SCALE RATE (DEG/SEC): 400
 SCALE FACTOR (V/DEG/SEC): -5.80959E-03
 BIAS (VOLTS) : 9.82129E-03
 HYSTERESIS, NEG RATES (VDC): -9.99900E-09
 HYSTERESIS, POS RATES (VDC): 3.84152E-04
 NULL OFFSET (VDC): 1.11750E-03

TEST ENGINEER.....

[Signature]
 3-14-80

READY

TABLE 3.4.2-III

RATE SENSOR TEST PROGRAM

NADC 80081-60

DATE...3-14-80..... RUN...COLD.....

TEMP...-28°F..... SER#...373.....

	RATE (DEG/SEC)	V OUT (VDC)	V CALC (VDC)	% FS	% IDEAL
*	-49.9183	.2668	.2893	.55	-4.958
	-99.8337	.5394	.5625	.908	-4.393
	-149.743	.8145	.8439	1.159	-3.482
	-199.478	1.0964	1.1248	1.121	-2.527
	-249.438	1.3824	1.4068	.959	-1.731
	-299.313	1.6735	1.6882	.58	-.271
	-349.136	1.9731	1.9694	-.146	.128
	-398.998	2.278	2.2538	-1.072	1.239
	-448.917	2.5886	2.5325	-2.237	2.212
	-399.21	2.2754	2.2509	-.965	1.088
	-349.179	1.9721	1.9697	-.096	.124
	-299.382	1.6764	1.6886	.481	-.722
	-249.417	1.3884	1.4067	.718	-1.295
	-199.553	1.1042	1.1252	.827	-1.865
	-149.719	.8229	.844	.83	-2.494
	-99.7982	.5458	.5623	.648	-2.921
	-49.934	.27	.2839	.429	-3.862
*	49.8157	-.2742	-.2821	-.339	-2.795
	99.6892	-.5471	-.5635	-.645	-2.91
	149.542	-.8242	-.8442	-.814	-2.45
	199.342	-1.103	-1.1259	-.933	-2.339
	249.23	-1.3863	-1.4077	-.845	-1.525
	299.131	-1.6752	-1.6891	-.545	-.82
	348.987	-1.9715	-1.9734	.041	.053
	398.88	-2.2714	-2.252	.763	.861
	448.791	-2.5755	-2.5337	1.647	1.651
	398.872	-2.2641	-2.2519	.477	.532
	348.994	-1.9655	-1.9735	-.195	-.251
	299.132	-1.6739	-1.6891	-.6	-.933
	249.337	-1.3873	-1.4079	-.812	-1.466
	199.358	-1.1059	-1.126	-.792	-1.787
	149.633	-.8281	-.8452	-.672	-2.321
	99.7399	-.5532	-.5638	-.418	-1.885
	49.8384	-.2796	-.2822	-.132	-.916

TEST SUMMARY
 FULL SCALE RATE (DEG/SEC): 450
 SCALE FACTOR (V/DEG/SEC): -5.64348E-03
 BIAS (VOLTS) : -9.26244E-04
 HYSTERESIS, NEG RATES (VDC): -2.43811E-03
 HYSTERESIS, POS RATES (VDC): 6.04451E-03
 NULL OFFSET (VDC): -5.69418E-03

TEST ENGINEER

Boyd W. Long
 3-14-80

READY

TABLE 3.4.2-IV

RATE SENSOR TEST PROGRAM

NADC 80081-60

DATE...3-17-80..... RUN...COLD.....
 TEMP...-30°F..... SER#...381.....

RATE (DEG/SEC)	V OUT (VDC)	V CALC (VDC)	% FS	% IDEAL
-49.8873	.272	.2812	.364	-3.281
-99.7795	.5467	.5622	.61	-2.749
-149.631	.8225	.843	.837	-2.427
-199.563	1.1035	1.1242	.816	-1.841
-249.426	1.3861	1.435	.749	-1.351
* -299.349	1.6732	1.686	.546	-.761
-349.12	1.969	1.9665	-.095	.122
-398.959	2.2698	2.2473	-.888	1.032
-448.891	2.5723	2.5285	-1.729	1.734
-399.315	2.266	2.2476	-.728	.821
-349.231	1.9681	1.967	-.042	.054
-299.272	1.6761	1.6858	.381	-.573
-249.436	1.389	1.4349	.629	-1.135
-199.477	1.1047	1.1237	.748	-1.688
-149.663	.8249	.8431	.722	-2.17
-99.7745	.5496	.5622	.496	-2.235
-49.9227	.2737	.2814	.331	-2.714
* 49.855	-.2763	-.2836	-.17	-1.536
99.6384	-.5526	-.561	-.333	-1.502
149.65	-.8288	-.8427	-.55	-1.653
199.478	-1.1063	-1.1233	-.67	-1.512
249.368	-1.3889	-1.4343	-.609	-1.327
299.254	-1.6776	-1.6853	-.344	-.457
349.111	-1.9682	-1.9661	.021	.135
399.343	-2.2646	-2.2473	.68	.766
448.845	-2.565	-2.5279	1.466	1.469
398.999	-2.258	-2.2471	.432	.427
349.171	-1.9588	-1.9665	-.3	-.387
299.256	-1.6664	-1.6853	-.748	-1.125
249.337	-1.3819	-1.434	-.87	-1.57
199.484	-1.1053	-1.1234	-.714	-1.612
149.532	-.8282	-.842	-.522	-1.57
99.7467	-.5511	-.5616	-.416	-1.279
49.8288	-.277	-.2835	-.137	-1.234

TEST SUMMARY
 FULL SCALE RATE (DEG/SEC): 453
 SCALE FACTOR (V/DEG/SEC): -9.63233E-03
 BIAS (VOLTS) : 1.88592E-04
 HYSTERESIS, NEG RATES (VDC): -2.96712E-03
 HYSTERESIS, POS RATES (VDC): 7.01904E-04
 NULL OFFSET (VDC): -2.17223E-03

TEST ENGINEER *[Signature]*
 3-17-80

READY

TABLE 3.4.2-V

RATE SENSOR TEST PROGRAM

NADC 80081-60

DATE...3-17-80..... RUN....COLD.....

TEMP...-30°F..... SER#...381.....

RATE (DEG/SEC)	V OUT (VDC)	V CALC (VDC)	% FS	% IDEAL
-49.8992	.2799	.2945	.511	-5.119
* -99.8536	.5569	.5798	.8	-4.337
-149.666	.8371	.8643	.953	-3.182
-199.524	1.124	1.1491	.876	-2.196
-249.432	1.4118	1.4339	.774	-1.551
-299.243	1.7236	1.7186	.524	-.876
-349.177	1.9996	2.0038	.149	-.213
-399.338	2.3001	2.2886	-.432	.534
-448.947	2.6071	2.5737	-1.171	1.304
-498.808	2.9195	2.8584	-2.139	2.144
-448.841	2.6315	2.5731	-.997	1.11
-398.942	2.2927	2.2881	-.163	.235
-349.177	1.9929	2.0038	.452	-.647
-299.289	1.6962	1.7189	.792	-1.324
-249.428	1.4068	1.4341	.955	-1.915
-199.555	1.1244	1.1492	1.338	-2.525
-148.661	.8383	.8643	.873	-2.917
-99.7542	.5609	.5792	.641	-3.211
-49.9396	.282	.2947	.443	-4.438
* 49.8491	-.2716	-.2753	-.129	-1.294
99.7632	-.5485	-.5633	-.415	-2.079
149.591	-.8342	-.845	-.518	-1.732
199.534	-1.1296	-1.1382	-.723	-1.811
249.349	-1.3931	-1.4147	-.756	-1.516
299.261	-1.6802	-1.6998	-.687	-1.147
349.095	-1.974	-1.9844	-.366	-.524
399.027	-2.2711	-2.2695	.253	.367
448.911	-2.5775	-2.5546	.823	.895
498.757	-2.8865	-2.8393	1.654	1.658
448.858	-2.572	-2.5543	.622	.693
398.97	-2.2656	-2.2693	-.13	-.163
348.134	-1.9662	-1.9845	-.641	-.918
298.163	-1.6734	-1.6993	-.934	-1.511
248.437	-1.3875	-1.4151	-.964	-1.933
198.452	-1.1053	-1.1297	-.857	-2.149
148.687	-.8271	-.8455	-.646	-2.158
98.767	-.5537	-.5634	-.339	-1.698
48.8638	-.2771	-.2754	.262	.62

TEST SUMMARY
 FULL SCALE RATE (DEG/SEC): 500
 SCALE FACTOR (V/DEG/SEC): -5.71161E-03
 BIAS (VOLTS) : 9.44667E-03
 HYSTERESIS, NEG RATES (VDC): -4.00674E-03
 HYSTERESIS, POS RATES (VDC): 5.53429E-03
 NULL OFFSET (VDC): 4.23338E-03

TEST ENGINEER.....

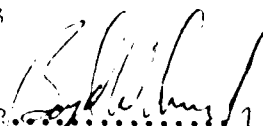

3-17-80

READY

TABLE 3.4.2-VI

RATE SENSOR PROGRAM: OUTPUT DRIFT NADC 80081-60

DATE...3-17-80..... RHO...COLD.....
 TEMP...-30°F..... SER#...355.....

OUTPUT DRIFT IN 15 SEC INTERVALS		
RATE (DEG/SEC)	MEAN (VDC)	SCALE FACTOR (VOLTS/DEG/SEC)
99.8523	.562269	5.63131E-33
99.7665	.561388	5.62792E-33
99.6836	.565372	5.66465E-33
99.8274	.564995	5.65972E-33
199.57	1.12914	5.65784E-33
199.542	1.12587	5.64231E-33
199.511	1.12734	5.65054E-33
199.547	1.12459	5.63573E-33
299.324	1.71252	5.71461E-33
299.275	1.70941	5.71144E-33
299.271	1.74163	5.68583E-33
299.273	1.74779	5.73644E-33
399.361	2.3251	5.77638E-33
399.346	2.34705	5.78117E-33
399.353	2.3051	5.77642E-33
399.35	2.32322	5.82242E-33
498.215	2.95225	5.91412E-33
498.743	2.96332	5.94168E-33
498.266	2.97112	5.95575E-33
498.792	2.95392	5.89927E-33

FULL OFFSET (VDC): 1.47319E-33

READY

Raydill
3-17-80

TABLE 3.4.2-VII

RATE SENSOR PROGRAM: OUTPUT DRIFT NADC 80081-60

DATE...3-14-80..... RUN...COLD.....
 TEMP...-30°F..... SER#...373.....

OUTPUT DRIFT IN 15 SEC INTERVALS

RATE (DEG/SEC)	MEAN (VDC)	SCALE FACTOR (VOLTS/DEG/SEC)
99.7721	.561648	5.62931E-03
99.8254	.556452	5.57426E-03
99.8279	.561911	5.62879E-03
99.7812	.570312	5.71562E-03
199.529	1.14836	5.75534E-03
199.525	1.1543	5.78526E-03
199.539	1.14438	5.73512E-03
199.577	1.15338	5.77913E-03
299.271	1.7706	5.91638E-03
299.265	1.7494	5.84566E-03
299.238	1.72554	5.76645E-03
299.22	1.71062	5.71695E-03
399.046	2.31766	5.80799E-03
399.076	2.33096	5.84309E-03
399.051	2.3263	5.82958E-03
399.047	2.33229	5.84466E-03
498.778	2.99902	6.01273E-03
498.835	3.01079	6.03566E-03
498.747	2.98534	5.98567E-03
498.792	2.96457	5.94349E-03

HULL OFFSET (VDC): -1.76195E-03

READY

Boyd W. Curry, Jr.
3-14-80

TABLE 3.4.2-VII

RATE SENSOR PROGRAM: OUTPUT DRIFT NADC 80081-60

DATE..3-17-80..... RUN...GOLD.....

TEMP..300%..... SER#..381.....

OUTPUT DRIFT IN 15 SEC INTERVALS

RATE (DEG/SEC) MEAN (VDC) SCALE FACTOR (VOLTS/DEG/SEC)

99.7462	.543208	5.44591E-03
99.8239	.54366	5.44619E-03
99.7665	.543851	5.45123E-03
99.7452	.543602	5.44991E-03
199.541	1.1005	5.51514E-03
199.511	1.10699	5.54851E-03
199.539	1.10554	5.54345E-03
199.508	1.10587	.305543
299.252	1.68249	5.61564E-03
299.275	1.68279	5.61619E-03
299.276	1.68285	5.62308E-03
299.337	1.68351	5.62413E-03
398.995	2.27936	.005712
399.217	2.27265	5.69562E-03
399.039	2.26967	5.68734E-03
399.036	2.2709	5.69497E-03
498.795	2.89099	5.79594E-03
498.827	2.88462	5.78281E-03
498.737	2.88183	5.77826E-03
498.752	2.87971	5.77382E-03

NULL OFFSET (VDC): -3.88153E-03

READY

Boyd W. Curly
3-17-80

TABLE 3.4.2-IX

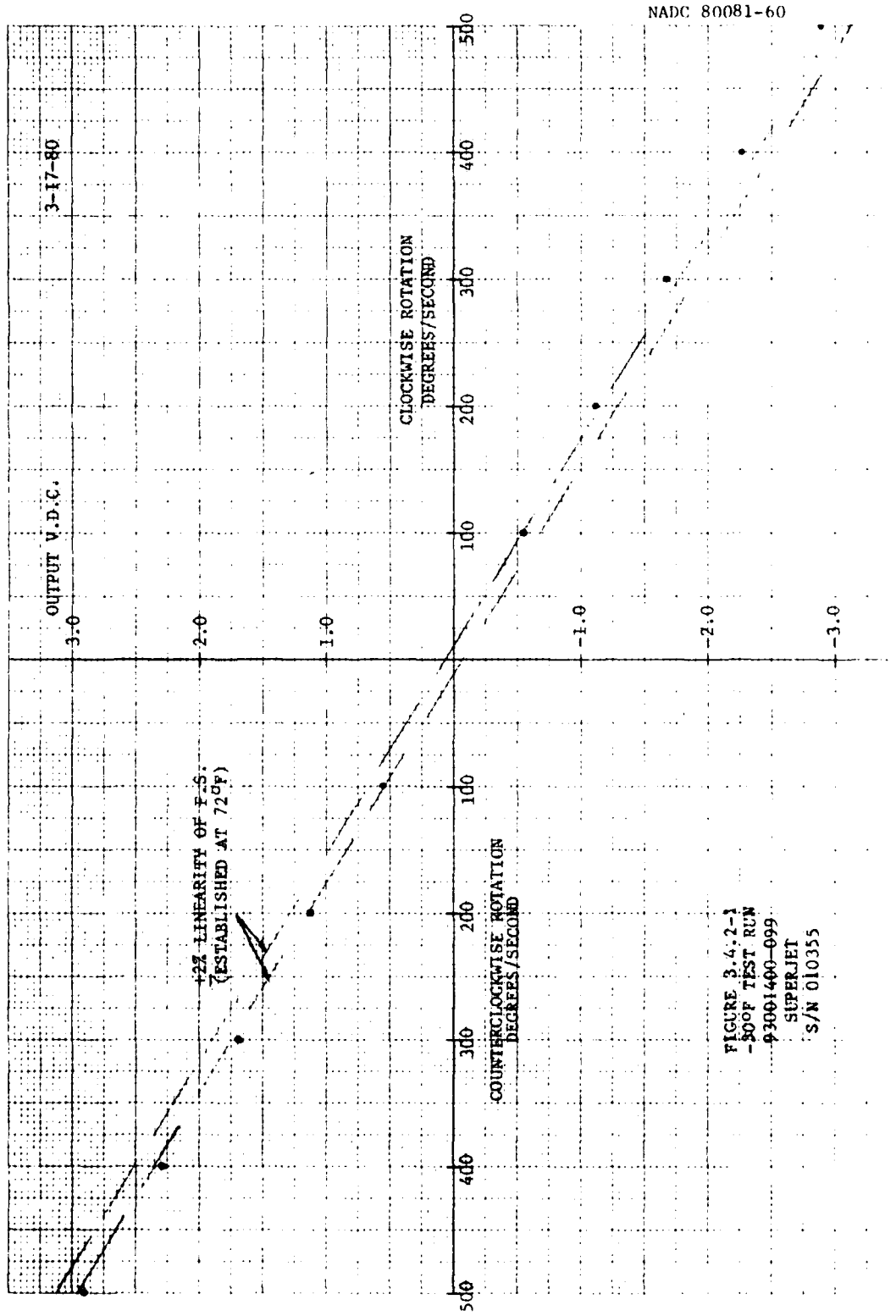

FIGURE 3.4.2-1
-500F TEST RUN
93001400-099
SUPERJET
S/N 010355

COLD TEMPERATURE TEST DATA
(-30°F)

PARAMETER	S/N 355	S/N 373	S/N 381
FULL SCALE RATE (DEG/SECOND) AT +2% LINEARITY ERROR	450	400	450
SCALE FACTOR (MV/DEG/SEC) AT BASELINE RATE	-5.70	-5.90	-5.71**
BIAS (DEG/SECOND)	-1.31	-1.66	-1.65
HYSTERESIS CCW (DEG/SECOND)	2.25	.17	.70
HYSTERESIS CW (DEG/SECOND)	-2.44	-.65	-.97
NULL OFFSET (DEG/SECOND)	-.43	-.19	-.84
THRESHOLD (DEG/SECOND)	<0.10	<0.10	<0.10
RESOLUTION (DEG/SECOND)	<0.10	<0.10	<0.10
READYTIME (SECONDS) AVG. OF 5 RATES*	.067	.069	.068
DRIFT (DEG/SEC/MIN) AVG. OF 5 RATES*	+1.08 (RANDOM)	+1.82 (RANDOM)	+1.61 (RANDOM)

*100, 200, 300, 400, AND 500 DEGREES/SECOND (See Table 3.4.3-II)

**DATA FROM 500 DEG/SEC RUN

TABLE 3.4.3-I

COLD TEMPERATURE DRIFT AND READYTIME
 (-30°F)

RATE (DEG/SEC)	OUTPUT DRIFT (DEG/SEC/MIN)			READYTIME (SECONDS)		
	355	373	381	355	373	381
100	+2.65	+4.79	+0.19	.068	.068	.070
200	+0.52	-3.40	+2.34	.068	.070	.065
300	-1.81	-4.51	+0.19	.065	.069	.070
400	+3.20	+0.82	+0.85	.068	.070	.070
500	+1.32	+3.12	-0.52	.065	.070	.065

TABLE 3.4.3-II

3.5 Sensitivity Jerk

3.5.1 Test Setup and Procedure

The test setup for the constant change in acceleration is the same as in the acceleration sensitivity test. The only difference is in the computer programming. A test schematic is shown in Figure D.2-1 in Appendix A.

The computer was programmed to accelerate the rate table from 0 degrees/second to 1000 degrees/second by incrementing the angular rates in 0.015 degree/second increments. The units were subjected to counterclockwise and clockwise rates.

The angular velocity was then incremented by .030 degree/second increments to double the jerk rate. Three more increments were used, i.e. .045, .060, and .075 degree/second. This method allowed each unit to be subjected to 5 different jerk rates. Data was taken at approximately 250 degrees/second and 500 degrees/second rates, only since higher rates cause saturation. The test procedure is discussed in Appendix A, Part D.

3.5.2 Test Results

Data could only be taken at multiples of the rate increments. As a result, the actual rates for each jerk are:

<u>RATE INCREMENT °/SEC</u>	<u>JERK</u>	<u>RUN TIME APPROXIMATE</u>	<u>250°/SEC</u>	<u>500°/SEC</u>
.015	1	11.7	250.5	501.0
.030	2	5.8	252.0	501.0
.045	3	3.9	252.0	504.0
.060	4	2.9	252.0	504.0
.075	5	2.4	255.0	502.5

Using the actual rates, the output may be corrected for evaluation by transforming all data to the nominal rates. This is done by using the nominal scale factor of each unit. It is not known if the scale factor remains constant from one jerk value to the next. However, if the scale factor changes by +1%, the output would change only by +.01%. Historical data shows the scale factor on sensor serial number 355 at 500 degrees/second maximum rate changes by 3.6% which is equivalent to .1 degree/second for 250 degrees/second rate and .18 degree/second for 500 degrees/second rate.

However, the repeatability of the sensor has varied up to 19 millivolts at 500 degrees/second (post acoustic baseline, S/N 381), which enters into the Jerk evaluation.

The data collected for each direction and serial number is shown in Tables 3.5.2-I through 3.5.2-XXIV. Data was obtained at 750, 500 and 250 degrees/second rates.

AD-A091 089

MARTIN MARIETTA AEROSPACE ORLANDO FL F/G 1/3
PERFORMANCE VERIFICATION OF THE 'SUPERJET' LAMINAR ANGULAR RATE--ETC(U)
MAY 80 B W CURRY DAAK40-79-D-0017
OR-16127 NADC-80081-60 NL

UNCLASSIFIED

2.3

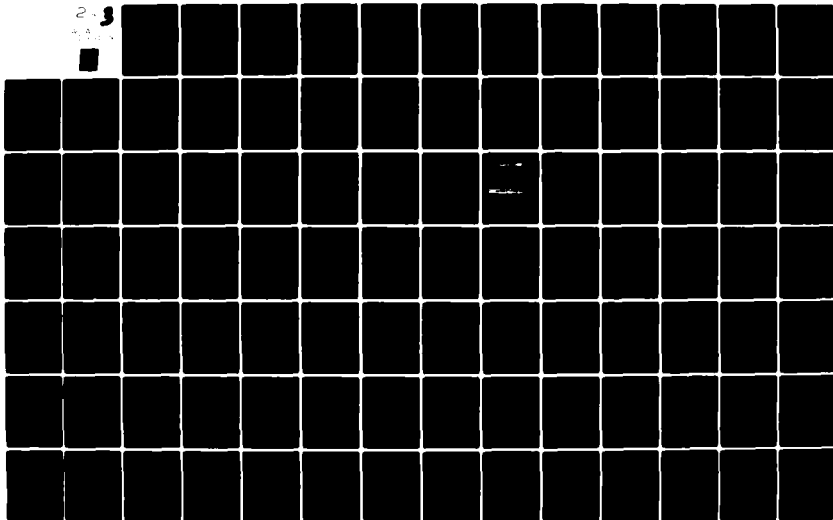

2 OF 3

AD A

091089

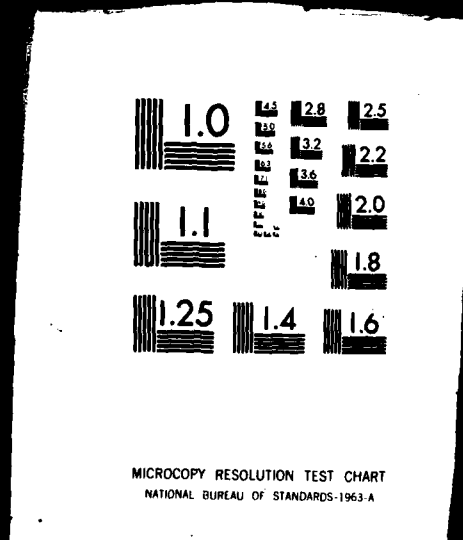

3.5.3 Data Evaluation

It is evident that the change of acceleration (jerk) sensitivity on the Superjet is so small that it is concealed in the repeatability of each sensor, which has been measured to be 31 mv at 500 degrees/second rate from one setup to another setup.

This is shown typically by Figures 3.5.3-1 and 3.5.3-2, which is for the positive X direction rotating counterclockwise and for serial numbers 355 and 373.

Serial number 355 shows a large delta between the zero arm run and the 24 inch arm, but the gap is constant, therefore indicating negligible jerk sensitivity. The gap on serial number 373 is small which also indicates negligible jerk sensitivity.

The slope of the data points do suggest that there may be an angular acceleration sensitivity. The highest value of the two sensors occurs for serial number 373 at the 500 degrees/second reading. The change in output is = 22.0 millivolts which is equivalent to 3.47 degrees/second shift from $\dot{\omega} = 87 \text{ degrees/second}^2$ to $427 \text{ degrees/second}^2$. This reduces to an angular acceleration sensitivity of 0.01 degrees/second/degree/second².

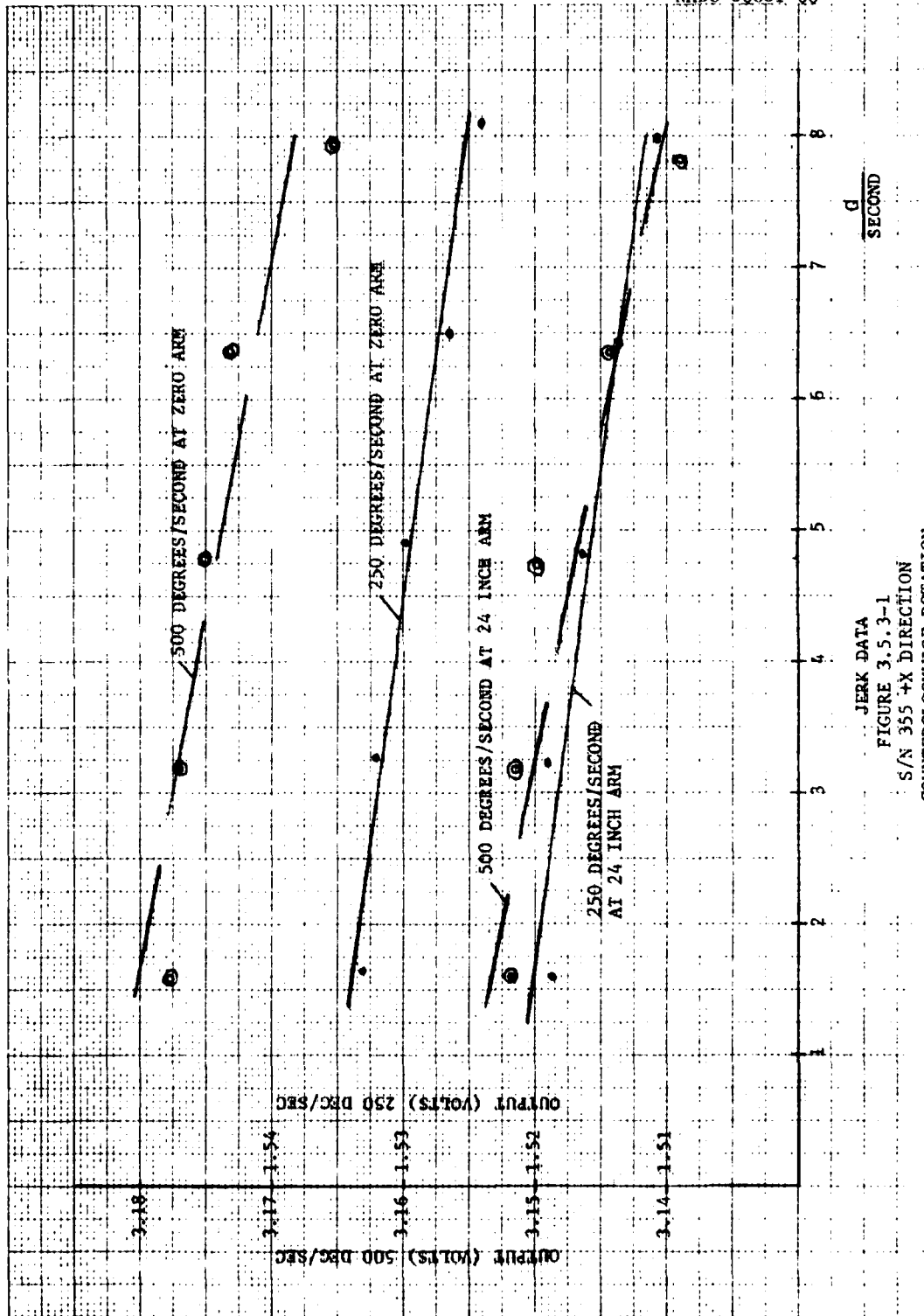

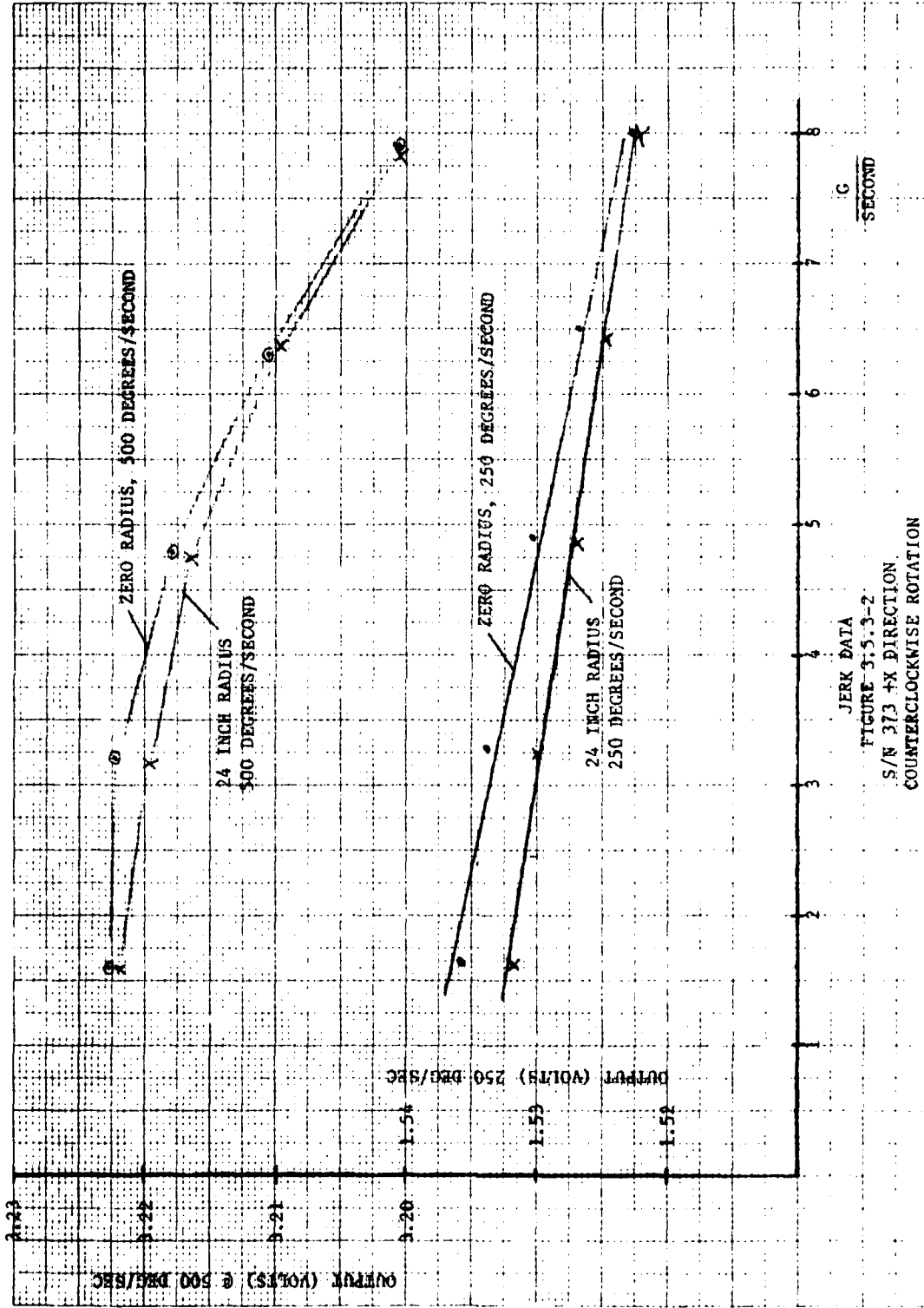

JERK DATA
FIGURE 3;5.3-2
S/N 373 +X DIRECTION.
COUNTERCLOCKWISE ROTATION

3-20-80 R = 24 in.
 SER# 355 AXIS NULL VOLTS 29.00V

NADC 80081-60

ENTER 1 FOR CCW ROTATION; -1 FOR CW ROTATION ?1

27.533
 TIME MEAS TIME V OUT (VDC) G DOT
 10.148 9.085 4.0007 1.5591
 6.001 2.675 4.0005 3.11462
 4.373 3.106 4.0004 4.65014
 3.206 2.541 4.0071 6.18954
 2.466 1.939 4.014 7.60345

READY
 SER# AXIS NULL VOLTS

ENTER 1 FOR CCW ROTATION; -1 FOR CW ROTATION ?-1

27.533
 TIME MEAS TIME V OUT (VDC) G DOT
 12.161 9.289 -4.0258 1.55744
 6.1 4.69 -4.0269 3.13492
 4.386 3.136 -4.0272 4.65534
 3.071 2.359 -4.0274 6.16737
 2.473 1.915 -4.0277 7.65071

READY
 SER# AXIS NULL VOLTS

ENTER 1 FOR CCW ROTATION; -1 FOR CW ROTATION ?1

25.333
 TIME MEAS TIME V OUT (VDC) G DOT
 11.898 6.213 3.1582 1.59186
 5.966 3.131 3.1578 3.17466
 3.998 2.116 3.1749 4.73737
 3.284 1.598 3.1694 6.33453
 2.42 1.209 3.1546 7.80645

READY
 SER# AXIS NULL VOLTS

ENTER 1 FOR CCW ROTATION; -1 FOR CW ROTATION ?-1

25.333
 TIME MEAS TIME V OUT (VDC) G DOT
 11.938 6.230 -3.1284 1.58653
 5.986 3.141 -3.129 3.16435
 4.312 2.123 -3.1466 4.72034
 3.016 1.634 -3.1415 6.27984
 2.403 1.269 -3.1269 7.80366

READY
 SER# AXIS NULL VOLTS

ENTER 1 FOR CCW ROTATION; -1 FOR CW ROTATION ?1

20.522
 TIME MEAS TIME V OUT (VDC) G DOT
 11.659 3.135 1.5218 1.6245
 5.848 1.6 1.5317 3.23371
 3.018 1.284 1.529 4.8341
 2.945 .825 1.5261 6.43124
 2.371 .676 1.5418 7.9819

READY
 SER# AXIS NULL VOLTS

ENTER 1 FOR CCW ROTATION; -1 FOR CW ROTATION ?-1

20.522
 TIME MEAS TIME V OUT (VDC) G DOT
 11.699 3.135 -1.5406 1.61094
 5.869 1.636 -1.5103 3.20713
 3.932 1.387 -1.5167 4.81079
 2.955 .827 -1.5139 6.43946
 2.382 .679 -1.53 7.98799

READY

JERK DATA
 TABLE 3.5.2-1

3-20-60 R + 24 in.
 SER# 355 AXIS HULL VOLTS 20V.

ENTER 1 FOR CCW ROTATION; -1 FOR CW ROTATION ?1

77.533

RUN TIME	MEAS TIME	V OUT (VDC)	G DOT
12.148	9.295	4.2703	1.5591
6.381	4.675	4.2853	3.11462
4.073	3.106	4.2695	4.65214
3.36	2.351	4.2537	6.18954
2.466	1.928	4.2970	7.68245

READY
 RUN
 SER# AXIS HULL VOLTS

ENTER 1 FOR CCW ROTATION; -1 FOR CW ROTATION ?-1

77.533

RUN TIME	MEAS TIME	V OUT (VDC)	G DOT
12.163	9.299	-4.2265	1.55718
6.1	4.69	-4.2276	3.10492
4.286	3.136	-4.228	4.65534
3.371	2.359	-4.2282	6.16737
2.473	1.915	-4.2286	7.65871

READY
 RUN
 SER# AXIS HULL VOLTS

ENTER 1 FOR CCW ROTATION; -1 FOR CW ROTATION ?1

75.333

RUN TIME	MEAS TIME	V OUT (VDC)	G DOT
11.896	6.217	3.1544	1.59213
5.967	3.131	3.1521	3.17412
3.998	2.116	3.1715	4.73737
3.226	1.599	3.1691	6.33273
2.40	1.285	3.1513	7.92645

READY
 RUN
 SER# AXIS HULL VOLTS

ENTER 1 FOR CCW ROTATION; -1 FOR CW ROTATION ?-1

75.333

RUN TIME	MEAS TIME	V OUT (VDC)	G DOT
11.938	6.238	-3.131	1.59653
5.936	3.141	-3.1333	3.16435
4.311	2.122	-3.1486	4.72531
3.318	1.634	-3.1433	6.27874
2.428	1.289	-3.1202	7.83266

READY
 RUN
 SER# AXIS HULL VOLTS

ENTER 1 FOR CCW ROTATION; -1 FOR CW ROTATION ?1

77.533

RUN TIME	MEAS TIME	V OUT (VDC)	G DOT
11.613	2.928	1.2145	1.63293
5.825	1.283	1.2198	3.2515
3.923	.822	1.2233	4.85268
2.934	.678	1.2314	6.45535
2.363	.548	1.2198	8.0583

READY
 RUN
 SER# AXIS HULL VOLTS

ENTER 1 FOR CCW ROTATION; -1 FOR CW ROTATION ?-1

77.533

RUN TIME	MEAS TIME	V OUT (VDC)	G DOT
11.659	2.537	-1.2053	1.62533
5.745	1.290	-1.206	3.24339
3.916	.874	-1.2134	4.83657
2.944	.68	-1.2197	6.43342
2.371	.55	-1.2063	8.0319

READY
 JERK DATA
 TABLE 3.5.2-II

3-20-80 R = 24 in. NADC 50081-60
 RUN 358
 SER# AXIS NULL VOLTS 14.500

ENTER 1 FOR CCW ROTATION; -1 FOR CW ROTATION ?1
 77.500
 RCDR
 RUN TIME MEAS TIME V OUT (VDC) G DOT
 12.123 9.269 4.8817 1.56232
 6.001 4.675 4.8993 3.11462
 4.373 3.126 4.8824 4.65014
 3.86 2.351 4.8679 6.18954
 2.469 1.909 4.9117 7.60357

READY
 RUN
 SER# AXIS NULL VOLTS

ENTER 1 FOR CCW ROTATION; -1 FOR CW ROTATION ?-1
 77.500
 RCDR
 RUN TIME MEAS TIME V OUT (VDC) G DOT
 12.162 9.299 -4.8249 1.55731
 6.121 4.69 -4.8259 3.10441
 4.386 3.136 -4.8264 4.63534
 3.871 2.359 -4.8266 6.16737
 2.473 1.915 -4.827 7.65671

READY
 RUN
 SER# AXIS NULL VOLTS

ENTER 1 FOR CCW ROTATION; -1 FOR CW ROTATION ?1
 75.303
 RCDR
 RUN TIME MEAS TIME V OUT (VDC) G DOT
 11.898 6.218 3.1564 1.59186
 5.966 3.131 3.1568 3.17466
 3.998 2.116 3.1738 4.73737
 3.384 1.998 3.1697 6.38493
 2.42 1.285 3.1556 7.82645

READY
 RUN
 SER# AXIS NULL VOLTS

ENTER 1 FOR CCW ROTATION; -1 FOR CW ROTATION ?-1
 75.300
 RCDR
 RUN TIME MEAS TIME V OUT (VDC) G DOT
 11.938 6.238 -3.1284 1.58653
 5.987 3.141 -3.1279 3.16352
 4.311 2.122 -3.1452 4.72201
 3.815 1.604 -3.1486 6.28192
 2.428 1.289 -3.1258 7.80066

READY
 RUN
 SER# AXIS NULL VOLTS

ENTER 1 FOR CCW ROTATION; -1 FOR CW ROTATION ?1
 72.502
 RCDR
 RUN TIME MEAS TIME V OUT (VDC) G DOT
 11.699 3.135 1.5232 1.6245
 5.846 1.6 1.5324 3.23871
 3.917 1.063 1.5385 4.83533
 2.945 .825 1.5295 6.43124
 2.372 .676 1.5458 7.98482

READY
 RUN
 SER# AXIS NULL VOLTS

ENTER 1 FOR CCW ROTATION; -1 FOR CW ROTATION ?-1
 79.503
 RCDR
 RUN TIME MEAS TIME V OUT (VDC) G DOT
 11.699 3.145 -1.529 1.61894
 5.869 1.606 -1.5193 3.22713
 3.932 1.087 -1.5171 4.81629
 2.955 .827 -1.514 6.40948
 2.38 .679 -1.5299 7.95798

READY

JERK DATA
 TABLE 3.5.2-III

RUN 3-20-80 R = 24 in.
 SER# 365 AXIS NULL VOLTS 11.20V..

NADC 80081-60

ENTER 1 FOR CCW ROTATION; -1 FOR CW ROTATION ?1

TCDR
 77.500
 RUN TIME MEAS TIME V OUT (VDC) G DOT
 10.149 9.295 4.8067 1.55898
 6.081 4.675 4.8954 3.11462
 4.872 3.125 4.8014 4.65128
 3.06 2.351 4.8664 6.18954
 2.465 1.909 4.9000 7.68357

READY
 RUN
 SER# AXIS NULL VOLTS

ENTER 1 FOR CCW ROTATION; -1 FOR CW ROTATION ?-1

TCDR
 77.500
 RUN TIME MEAS TIME V OUT (VDC) G DOT
 12.163 9.299 -4.828 1.55718
 6.181 4.69 -4.829 3.10441
 4.886 3.136 -4.8294 4.63534
 3.071 2.359 -4.8296 6.16737
 2.474 1.915 -4.8299 7.69562

READY
 RUN
 SER# AXIS NULL VOLTS

ENTER 1 FOR CCW ROTATION; -1 FOR CW ROTATION ?1

TCDR
 75.000
 RUN TIME MEAS TIME V OUT (VDC) G DOT
 11.898 6.218 3.1582 1.59186
 9.967 3.131 3.1597 3.17412
 3.998 2.116 3.1749 4.73737
 3.036 1.599 3.1789 6.30073
 2.42 1.285 3.1586 7.82645

READY
 RUN
 SER# AXIS NULL VOLTS

ENTER 1 FOR CCW ROTATION; -1 FOR CW ROTATION ?-1

TCDR
 75.000
 RUN TIME MEAS TIME V OUT (VDC) G DOT
 11.938 6.238 -3.1382 1.58653
 9.988 3.141 -3.1381 3.16299
 4.012 2.123 -3.153 4.72884
 3.016 1.604 -3.1497 6.27984
 2.428 1.289 -3.1347 7.80066

READY
 RUN
 SER# AXIS NULL VOLTS

ENTER 1 FOR CCW ROTATION; -1 FOR CW ROTATION ?1

TCDR
 72.500
 RUN TIME MEAS TIME V OUT (VDC) G DOT
 11.699 3.135 1.5234 1.6245
 9.848 1.6 1.5332 3.23871
 3.917 1.083 1.5309 4.83533
 2.945 .825 1.5281 6.43124
 2.372 .676 1.5441 7.98482

READY
 RUN
 SER# AXIS NULL VOLTS

ENTER 1 FOR CCW ROTATION; -1 FOR CW ROTATION ?-1

TCDR
 72.500
 RUN TIME MEAS TIME V OUT (VDC) G DOT
 11.699 3.145 -1.512 1.61894
 9.869 1.606 -1.5215 3.22713
 3.932 1.037 -1.519 4.81689
 2.955 .827 -1.5174 6.42948
 2.38 .679 -1.5328 7.99788

READY

JERK DATA
 TABLE 3.5.2-IV

RUN 3-20-80 R = 24.4 in.
 SER# 355AXIS.....NULL VOLTS.....3.7W...

ENTER 1 FOR CCW ROTATION; -1 FOR CW ROTATION ?1

RUN TIME	MEAS TIME	V OUT (VDC)	G DOT
12.103	9.27	-.009929	1.64143
6.202	4.676	-.010677	3.27179
4.374	3.127	-.039050	4.88439
3.361	2.350	-.038541	6.53302
2.467	1.91	-.030141	8.26637

READY
 RUN
 SER#AXIS.....NULL VOLTS.....

ENTER 1 FOR CCW ROTATION; -1 FOR CW ROTATION ?-1

RUN TIME	MEAS TIME	V OUT (VDC)	G DOT
12.225	9.340	.017775	1.6304
6.144	4.733	.018233	3.23877
4.387	3.137	.016232	4.86889
3.372	2.36	.015202	6.47754
2.474	1.916	.015245	8.04329

READY
 RUN
 SER#AXIS.....NULL VOLTS.....

ENTER 1 FOR CCW ROTATION; -1 FOR CW ROTATION ?1

RUN TIME	MEAS TIME	V OUT (VDC)	G DOT
11.941	6.261	-.007024	1.66644
5.967	3.132	-.006489	3.33484
3.999	2.117	-.005477	4.97599
3.305	1.599	-.034967	6.62196
2.401	1.286	-.004302	8.21933

READY
 RUN
 SER#AXIS.....NULL VOLTS.....

ENTER 1 FOR CCW ROTATION; -1 FOR CW ROTATION ?-1

RUN TIME	MEAS TIME	V OUT (VDC)	G DOT
11.98	6.281	.014991	1.66132
6.33	3.184	.015071	3.3
4.213	2.124	.012995	4.95863
3.317	1.635	.012093	6.59562
2.429	1.29	.01171	8.19226

READY
 RUN
 SER#AXIS.....NULL VOLTS.....

ENTER 1 FOR CCW ROTATION; -1 FOR CW ROTATION ?1

RUN TIME	MEAS TIME	V OUT (VDC)	G DOT
11.731	3.178	-.002239	1.70362
5.849	1.631	-.001161	3.40212
3.918	1.084	-.030595	5.07887
2.946	.829	-.030116	6.75458
2.373	.677	.000461	8.38559

READY
 RUN
 SER#AXIS.....NULL VOLTS.....

ENTER 1 FOR CCW ROTATION; -1 FOR CW ROTATION ?-1

RUN TIME	MEAS TIME	V OUT (VDC)	G DOT
11.741	3.188	.009748	1.69403
5.912	1.649	.009028	3.34507
3.933	1.090	.027606	5.05595
2.956	.828	.007162	6.73173
2.381	.68	.004578	8.35741

READY

JERK DATA
 TABLE 3.5.2-V

RUN 3-20-80 R = 23.6 in.
SER#.....355.....AXIS.....Z.....NULL VOLTS.....4.0V..

ENTER 1 FOR CCW ROTATION; -1 FOR CW ROTATION ?1

27.500

RUN TIME	MEAS TIME	V OUT (VDC)	G DOT
10.124	9.27	-.318536	1.53609
6.382	4.676	-.319367	3.36248
4.116	3.169	-.3184	4.52527
3.133	2.394	-.318453	6.33058
2.538	1.952	-.318773	7.42663

READY
RUN
SER#.....AXIS.....NULL VOLTS.....

ENTER 1 FOR CCW ROTATION; -1 FOR CW ROTATION ?-1

27.500

RUN TIME	MEAS TIME	V OUT (VDC)	G DOT
12.206	9.343	.328024	1.52597
6.120	4.691	.329303	3.25244
4.387	3.137	.329749	4.55738
3.372	2.36	.330377	6.06315
2.474	1.916	.331032	7.5287

READY
RUN
SER#.....AXIS.....NULL VOLTS.....

ENTER 1 FOR CCW ROTATION; -1 FOR CW ROTATION ?1

25.300

RUN TIME	MEAS TIME	V OUT (VDC)	G DOT
11.941	6.261	-.309559	1.55984
6.31	3.174	-.310141	3.09917
4.341	2.159	-.310161	4.60925
3.249	1.642	-.310373	6.13889
2.463	1.328	-.310596	7.56232

READY
RUN
SER#.....AXIS.....NULL VOLTS.....

ENTER 1 FOR CCW ROTATION; -1 FOR CW ROTATION ?-1

25.300

RUN TIME	MEAS TIME	V OUT (VDC)	G DOT
11.982	6.281	.318655	1.5545
5.988	3.142	.319551	3.11855
4.313	2.124	.320174	4.64142
3.417	1.635	.320595	6.17368
2.429	1.29	.32101	7.66818

READY
RUN
SER#.....AXIS.....NULL VOLTS.....

ENTER 1 FOR CCW ROTATION; -1 FOR CW ROTATION ?1

22.500

RUN TIME	MEAS TIME	V OUT (VDC)	G DOT
11.701	3.178	-.322606	1.59183
5.891	1.643	-.322788	3.16177
3.961	1.127	-.322777	4.70235
2.988	.868	-.322952	6.2336
2.415	.72	-.323002	7.71263

READY
RUN
SER#.....AXIS.....NULL VOLTS.....

ENTER 1 FOR CCW ROTATION; -1 FOR CW ROTATION ?-1

22.500

RUN TIME	MEAS TIME	V OUT (VDC)	G DOT
11.740	3.180	.310634	1.58627
5.87	1.637	.311534	3.17328
3.933	1.388	.312174	4.73502
2.956	.880	.312213	6.33138
2.381	.60	.312602	7.82076

READY
JERK DATA
TABLE 3.5.2-VI

NADC 80081-60

RUN
 ENTER 1 FOR CCW ROTATION; -1 FOR CW ROTATION ?1
 77.522 S/N 355 R = 0 in.
 RUN MEAS V OUT G DOT +3.9MM
 TIME TIME (VDC) X and Y Axis

12.321	9.214	4.9058	1.57558
6.35	4.647	4.9210	3.14396
4.238	3.187	3.9069	4.69044
3.334	2.337	4.8917	6.24258
2.445	1.898	4.9344	7.74640

READY
 RUN
 ENTER 1 FOR CCW ROTATION; -1 FOR CW ROTATION ?-1
 77.522
 RUN MEAS V OUT G DOT
 TIME TIME (VDC)

12.26	9.244	-4.8311	1.57048
6.349	4.662	-4.8321	3.1311
4.322	3.117	-4.8325	4.67423
3.345	2.345	-4.8327	6.22203
2.453	1.904	-4.8331	7.72116

READY
 RUN
 ENTER 1 FOR CCW ROTATION; -1 FOR CW ROTATION ?1
 75.000
 RUN MEAS V OUT G DOT
 TIME TIME (VDC)

11.768	6.181	3.1841	1.63945
5.922	3.113	3.1833	3.23928
3.955	2.123	3.2006	4.78887
2.973	1.989	3.1982	6.37367
2.393	1.277	3.1828	7.91475

READY
 RUN
 ENTER 1 FOR CCW ROTATION; -1 FOR CW ROTATION ?-1
 75.032
 RUN MEAS V OUT G DOT
 TIME TIME (VDC)

11.828	6.201	-3.1636	1.604
5.922	3.123	-3.1624	3.19824
3.967	2.11	-3.1796	4.77439
2.982	1.994	-3.1731	6.35144
2.401	1.281	-3.1597	7.82838

READY
 RUN
 ENTER 1 FOR CCW ROTATION; -1 FOR CW ROTATION ?1
 72.523
 RUN MEAS V OUT G DOT
 TIME TIME (VDC)

11.5	3.116	1.5362	1.64696
5.77	1.591	1.5447	3.2225
3.864	1.077	1.5423	4.93166
2.905	.82	1.539	6.51979
2.34	.673	1.5552	8.09402

READY
 RUN
 ENTER 1 FOR CCW ROTATION; -1 FOR CW ROTATION ?-1
 72.520
 RUN MEAS V OUT G DOT
 TIME TIME (VDC)

11.541	3.126	-1.5243	1.64111
5.789	1.596	-1.534	3.27172
3.879	1.081	-1.5313	4.8827
2.916	.822	-1.5284	6.4952
2.348	.675	-1.5433	8.06644

READY

JERK DATA
 TABLE 3.5.2-VII

RUN
 ENTER 1 FOR CCW ROTATION; -1 FOR CW ROTATION ?1 S/N 355 R = 0 in.
 77.500 +3.1 MV
 Z Axis

RUN TIME	MEAS TIME	V OUT (VDC)	G DOT
12.03	9.214	-.005661	1.5744
6.335	4.648	-.005699	3.13036
4.042	3.108	-.005309	4.6098
3.338	2.338	-.005929	6.23436
2.448	1.899	-.006481	7.73693

READY
 RUN
 ENTER 1 FOR CCW ROTATION; -1 FOR CW ROTATION ?-1

RUN TIME	MEAS TIME	V OUT (VDC)	G DOT
12.111	9.286	.011204	1.56387
6.356	4.663	.010696	3.12748
4.356	3.118	.010364	4.66963
3.049	2.346	.010593	6.21187
2.456	1.905	.011011	7.71173

READY
 RUN
 ENTER 1 FOR CCW ROTATION; -1 FOR CW ROTATION ?1

RUN TIME	MEAS TIME	V OUT (VDC)	G DOT
11.828	6.223	-.00241	1.60108
5.911	3.113	-.002609	3.2042
3.962	2.104	-.002671	4.70041
2.978	1.59	-.002688	6.35997
2.439	1.32	-.003025	7.76548

READY
 RUN
 ENTER 1 FOR CCW ROTATION; -1 FOR CW ROTATION ?-1

RUN TIME	MEAS TIME	V OUT (VDC)	G DOT
11.868	6.243	.008308	1.59539
5.932	3.124	.00831	3.19285
3.975	2.111	.008308	4.76478
2.988	1.595	.008481	6.33869
2.406	1.282	.008439	7.87199

READY
 RUN
 ENTER 1 FOR CCW ROTATION; -1 FOR CW ROTATION ?1

RUN TIME	MEAS TIME	V OUT (VDC)	G DOT
11.57	3.159	.000283	1.63699
5.784	1.592	.000232	3.27455
3.875	1.078	.0004	4.88774
2.955	.863	.000295	6.40948
2.347	.673	.000356	8.06988

READY
 RUN
 ENTER 1 FOR CCW ROTATION; -1 FOR CW ROTATION ?-1

RUN TIME	MEAS TIME	V OUT (VDC)	G DOT
11.612	3.17	.006073	1.63107
5.834	1.597	.006035	3.26327
3.888	1.081	.00593	4.8714
2.923	.823	.005797	6.47964
2.355	.676	.005765	8.04246

READY

JERK DATA
 TABLE 3.5.2-VII

RUN 3-20-80 R = 24 in.
 SER#377.....AXIS.....%.....NULL VOLTS.....%..... NADC 80081-60

ENTER 1 FOR CCW ROTATION; -1 FOR CW ROTATION ?1

77.500
 RUN MEAS V OUT G DOT
 TIME TIME (VDC)
 12.148 9.295 4.9422 1.5591
 6.081 4.675 4.9482 3.11462
 4.273 3.126 4.9315 4.65214
 3.26 2.351 4.9132 6.18954
 2.466 1.929 4.9521 7.68045

READY
 RUN
 SER#AXIS.....NULL VOLTS.....

ENTER 1 FOR CCW ROTATION; -1 FOR CW ROTATION ?-1

77.500
 RUN MEAS V OUT G DOT
 TIME TIME (VDC)
 12.163 9.299 -4.2351 1.55718
 6.101 4.69 -4.2361 3.12441
 4.286 3.136 -4.2365 4.63534
 3.271 2.359 -4.2367 6.16737
 2.473 1.915 -4.237 7.65871

READY
 RUN
 SER#AXIS.....NULL VOLTS.....

ENTER 1 FOR CCW ROTATION; -1 FOR CW ROTATION ?1

75.000
 RUN MEAS V OUT G DOT
 TIME TIME (VDC)
 11.898 6.218 3.2283 1.59186
 5.967 3.131 3.2259 3.17412
 3.998 2.116 3.2419 4.73737
 3.205 1.599 3.2359 6.38283
 2.42 1.285 3.2192 7.82645

READY
 RUN
 SER#AXIS.....NULL VOLTS.....

ENTER 1 FOR CCW ROTATION; -1 FOR CW ROTATION ?-1

75.000
 RUN MEAS V OUT G DOT
 TIME TIME (VDC)
 11.938 6.238 -3.2326 1.58653
 5.986 3.141 -3.1986 3.16425
 4.212 2.123 -3.2155 4.72284
 3.216 1.604 -3.2287 6.27984
 2.428 1.289 -3.192 7.80266

READY
 RUN
 SER#AXIS.....NULL VOLTS.....

ENTER 1 FOR CCW ROTATION; -1 FOR CW ROTATION ?1

72.500
 RUN MEAS V OUT G DOT
 TIME TIME (VDC)
 11.659 3.135 1.5348 1.6245
 5.848 1.6 1.5427 3.23871
 3.917 1.083 1.5396 4.83533
 2.945 .825 1.5374 6.43124
 2.371 .677 1.5530 7.98482

READY
 RUN
 SER#AXIS.....NULL VOLTS.....

ENTER 1 FOR CCW ROTATION; -1 FOR CW ROTATION ?-1

72.500
 RUN MEAS V OUT G DOT
 TIME TIME (VDC)
 11.699 3.145 -1.5364 1.61894
 5.869 1.606 -1.5442 3.22713
 3.932 1.087 -1.5417 4.81689
 2.955 .827 -1.5384 6.42948
 2.38 .679 -1.5543 7.95798

READY
 JERK DATA
 TABLE 3.5.2-IX

RUN 3-20-80 R = 24 in.
 SER# 373AXIS.....NULL VOLTS...-5.20V.

NADC 80081-60

ENTER 1 FOR CCW ROTATION; -1 FOR CW ROTATION ?1
 27.500
 RUN MEAS V OUT G DOT
 TIME TIME (VDC)
 12.100 9.269 4.9319 1.56245
 6.481 4.675 4.9447 3.11462
 4.373 3.126 4.9273 4.65814
 3.06 2.351 4.9114 6.18954
 2.466 1.909 4.9401 7.69045

READY
 RUN
 SER#AXIS.....NULL VOLTS.....

ENTER 1 FOR CCW ROTATION; -1 FOR CW ROTATION ?-1
 27.500
 RUN MEAS V OUT G DOT
 TIME TIME (VDC)
 12.162 9.299 -4.8362 1.55731
 6.101 4.69 -4.8371 3.18441
 4.086 3.136 -4.8376 4.63534
 3.071 2.359 -4.8377 6.16737
 2.473 1.915 -4.833 7.69871

READY
 RUN
 SER#AXIS.....NULL VOLTS.....

ENTER 1 FOR CCW ROTATION; -1 FOR CW ROTATION ?1
 25.200
 RUN MEAS V OUT G DOT
 TIME TIME (VDC)
 11.897 6.217 3.2368 1.592
 5.966 3.131 3.2345 3.17466
 3.998 2.116 3.2492 4.73737
 3.005 1.599 3.2427 6.30283
 2.42 1.285 3.2245 7.82645

READY
 RUN
 SER#AXIS.....NULL VOLTS.....

ENTER 1 FOR CCW ROTATION; -1 FOR CW ROTATION ?-1
 25.200
 RUN MEAS V OUT G DOT
 TIME TIME (VDC)
 11.938 6.238 -3.228 1.58653
 5.987 3.141 -3.2055 3.16352
 4.012 2.123 -3.2198 4.72084
 3.016 1.624 -3.2131 6.27984
 2.428 1.289 -3.1972 7.80066

READY
 RUN
 SER#AXIS.....NULL VOLTS.....

ENTER 1 FOR CCW ROTATION; -1 FOR CW ROTATION ?1
 22.500
 RUN MEAS V OUT G DOT
 TIME TIME (VDC)
 11.659 3.135 1.5483 1.6245
 5.848 1.6 1.5482 3.23871
 3.917 1.083 1.5447 4.83533
 2.945 .825 1.542 6.43124
 2.372 .676 1.5573 7.98482

READY
 RUN
 SER#AXIS.....NULL VOLTS.....

ENTER 1 FOR CCW ROTATION; -1 FOR CW ROTATION ?-1
 22.500
 RUN MEAS V OUT G DOT
 TIME TIME (VDC)
 11.699 3.145 -1.5433 1.61894
 5.849 1.626 -1.5489 3.22713
 3.932 1.087 -1.5453 4.81609
 2.955 .827 -1.5423 6.42948
 2.38 .679 -1.5583 7.95798

READY

JERK DATA
 TABLE 3.5.2-X

RUN 3-20-80 R = 24 in.
 SER# 373 AXIS NULL VOLTS...-5.7V.

NADC 80081-60

ENTER 1 FOR CCW ROTATION; -1 FOR CW ROTATION ?1

77.500
 RUN MEAS V OUT G DOT
 TIME TIME (VDC)
 12.123 9.269 4.9356 1.56232
 6.281 4.675 4.9489 3.11462
 4.373 3.126 4.9333 4.65014
 3.26 2.351 4.9157 6.18954
 2.466 1.589 4.9536 7.68245

READY
 RUN
 SER# AXIS NULL VOLTS.....

ENTER 1 FOR CCW ROTATION; -1 FOR CW ROTATION ?-1

RCDR
 77.500
 RUN MEAS V OUT G DOT
 TIME TIME (VDC)
 12.162 9.299 -4.8332 1.55731
 6.1 4.69 -4.8341 3.10492
 4.086 3.136 -4.8349 4.63534
 3.271 2.359 -4.8347 6.16737
 2.473 1.915 -4.835 7.65871

READY
 RUN
 SER# AXIS NULL VOLTS.....

ENTER 1 FOR CCW ROTATION; -1 FOR CW ROTATION ?1--

75.000
 RUN MEAS V OUT G DOT
 TIME TIME (VDC)
 11.898 6.218 3.2286 1.59186
 5.967 3.131 3.2248 3.17412
 3.998 2.116 3.242 4.73737
 3.025 1.599 3.236 6.30283
 2.42 1.285 3.2173 7.82645

READY
 RUN
 SER# AXIS NULL VOLTS.....

ENTER 1 FOR CCW ROTATION; -1 FOR CW ROTATION ?-1

RCDR
 75.000
 RUN MEAS V OUT G DOT
 TIME TIME (VDC)
 11.938 6.238 -3.1981 1.58653
 5.986 3.141 -3.1929 3.16425
 4.012 2.123 -3.21 4.72084
 3.016 1.684 -3.2033 6.27984
 2.428 1.289 -3.1892 7.80066

READY
 RUN
 SER# AXIS NULL VOLTS.....

ENTER 1 FOR CCW ROTATION; -1 FOR CW ROTATION ?1

72.500
 RUN MEAS V OUT G DOT
 TIME TIME (VDC)
 11.658 3.135 1.5342 1.62464
 5.848 1.6 1.5417 3.23871
 3.917 1.083 1.538 4.83533
 2.945 .825 1.5344 6.43124
 2.372 .677 1.5518 7.98482

READY
 RUN
 SER# AXIS NULL VOLTS.....

ENTER 1 FOR CCW ROTATION; -1 FOR CW ROTATION ?-1

RCDR
 72.500
 RUN MEAS V OUT G DOT
 TIME TIME (VDC)
 11.699 3.145 -1.5336 1.61894
 5.869 1.626 -1.5421 3.22713
 3.932 1.087 -1.5395 4.81689
 2.955 .827 -1.5398 6.40948
 2.38 .678 -1.5527 7.95798

READY

JERK DATA
 TABLE 3.5.2-XI

N
 3-20-80 R = 24 in.
 SER# 373AXIS.....NULL VOLTS.....6.70V.

NADC 80081-60

ENTER 1 FOR CCW ROTATION; -1 FOR CW ROTATION ?1

77.500
 RUN MEAS V OUT G DOT
 TIME TIME (VDC)
 12.148 9.295 4.9237 1.5591
 6.281 4.675 4.9338 3.11462
 4.372 3.125 4.912 4.65128
 3.26 2.351 4.894 6.18854
 2.466 1.829 4.9338 7.68345

READY
 RUN
 SER#AXIS.....NULL VOLTS.....

ENTER 1 FOR CCW ROTATION; -1 FOR CW ROTATION ?-1

77.500
 RUN MEAS V OUT G DOT
 TIME TIME (VDC)
 12.162 9.299 -4.2333 1.55731
 6.131 4.69 -4.8344 3.13441
 4.286 3.136 -4.8348 4.63534
 3.071 2.359 -4.835 6.16737
 2.473 1.915 -4.2353 7.65071

READY
 RUN
 SER#AXIS.....NULL VOLTS.....

ENTER 1 FOR CCW ROTATION; -1 FOR CW ROTATION ?1

75.300
 RUN MEAS V OUT G DOT
 TIME TIME (VDC)
 11.898 6.218 3.2285 1.59186
 5.966 3.131 3.2173 3.17466
 3.998 2.116 3.2352 4.73737
 3.205 1.599 3.226 6.30283
 2.42 1.285 3.2287 7.82645

READY
 RUN
 SER#AXIS.....NULL VOLTS.....

ENTER 1 FOR CCW ROTATION; -1 FOR CW ROTATION ?-1

75.300
 RUN MEAS V OUT G DOT
 TIME TIME (VDC)
 11.930 6.238 -3.1994 1.58653
 5.987 3.141 -3.1966 3.16352
 4.312 2.123 -3.2123 4.72884
 3.216 1.624 -3.2056 6.27984
 2.428 1.289 -3.1891 7.80066

READY
 RUN
 SER#AXIS.....NULL VOLTS.....

ENTER 1 FOR CCW ROTATION; -1 FOR CW ROTATION ?1

72.500
 RUN MEAS V OUT G DOT
 TIME TIME (VDC)
 11.699 3.135 1.5347 1.6245
 5.848 1.6 1.5425 3.23871
 3.917 1.003 1.5388 4.83533
 2.945 .825 1.5362 6.43124
 2.372 .676 1.5321 7.98482

READY
 RUN
 SER#AXIS.....NULL VOLTS.....

ENTER 1 FOR CCW ROTATION; -1 FOR CW ROTATION ?-1

72.500
 RUN MEAS V OUT G DOT
 TIME TIME (VDC)
 11.699 3.145 -1.5352 1.61894
 5.869 1.626 -1.544 3.22713
 3.937 1.037 -1.541 4.81679
 2.955 .827 -1.5369 6.42948
 2.38 .679 -1.5334 7.95798

READY

JERK DATA
 TABLE 3.5.2-XII

RUN 3-20-80 R = 23.6 in
 SER#.....373.....AXIS.....%.....NULL VOLTS.....6.8V

NADC 80081-60

ENTER I FOR CCW ROTATION; -I FOR CW ROTATION ?I

77.583
 RUN MEAS V OUT G DOT
 TIME TIME (VDC)
 12.151 9.297 -.271795 1.5328P
 6.174 4.718 -.372166 3.8414R
 4.116 3.169 -.472315 4.52527
 3.104 2.395 -.571864 6.03364
 2.508 1.952 -.872947 7.42663

READY
 RUN
 SER#.....AXIS.....NULL VOLTS.....

ENTER I FOR CCW ROTATION; -I FOR CW ROTATION ?-I

RCRR
 77.500
 RUN MEAS V OUT G DOT
 TIME TIME (VDC)
 12.163 9.3 .836632 1.53137
 6.143 4.733 .836302 3.83287
 4.129 3.179 .8361 4.51182
 3.114 2.402 .835952 5.98137
 2.516 1.958 .836396 7.48302

READY
 RUN
 SER#.....AXIS.....NULL VOLTS.....

ENTER I FOR CCW ROTATION; -I FOR CW ROTATION ?I

75.800
 RUN MEAS V OUT G DOT
 TIME TIME (VDC)
 11.941 6.261 -.851583 1.55984
 6.011 3.175 -.851291 3.89865
 4.342 2.159 -.851586 4.68812
 3.349 1.642 -.851605 6.18889
 2.463 1.328 -.851381 7.56232

READY
 RUN
 SER#.....AXIS.....NULL VOLTS.....

ENTER I FOR CCW ROTATION; -I FOR CW ROTATION ?-I

RCRR
 75.300
 RUN MEAS V OUT G DOT
 TIME TIME (VDC)
 11.982 6.281 .82747 1.5545
 6.029 3.184 .827739 3.8894
 4.355 2.166 .827718 4.59534
 3.359 1.647 .828026 6.0889P
 2.471 1.332 .827717 7.53784

READY
 RUN
 SER#.....AXIS.....NULL VOLTS.....

ENTER I FOR CCW ROTATION; -I FOR CW ROTATION ?I

72.500
 RUN MEAS V OUT G DOT
 TIME TIME (VDC)
 11.701 3.178 -.828887 1.59183
 5.892 1.644 -.829088 3.16184
 3.961 1.127 -.829079 4.72235
 2.988 .868 -.829188 6.2336
 2.415 .72 -.82933 7.71263

READY
 RUN
 SER#.....AXIS.....NULL VOLTS.....

ENTER I FOR CCW ROTATION; -I FOR CW ROTATION ?-I

RCRR
 72.500
 RUN MEAS V OUT G DOT
 TIME TIME (VDC)
 11.742 3.188 .813207 1.58627
 5.912 1.649 .813135 3.15894
 3.975 1.13 .812934 4.68579
 2.998 .87 .812743 6.21281
 2.423 .722 .813286 7.68717

READY

JERK DATA
 TABLE 3.5.2-XIII

3-20-80 R = 24.4 in.
 373AXIS.....Z.....NULL VOLTS...-6.0V

ENTER 1 FOR CCW ROTATION; -1 FOR CW ROTATION ?1

77.500

RUN TIME	MEAS TIME	V OUT (VDC)	G DOT
12.124	9.27	-.262862	1.64129
6.123	4.718	-.263503	3.24988
4.116	3.169	-.263977	4.83455
3.134	2.395	-.263172	6.41376
2.589	1.953	-.263012	7.93135

READY
 RUN
 SER#.....AXIS.....NULL VOLTS.....

ENTER 1 FOR CCW ROTATION; -1 FOR CW ROTATION ?-1

77.500

RUN TIME	MEAS TIME	V OUT (VDC)	G DOT
12.235	9.342	.029515	1.6334
6.144	4.733	.029838	3.23877
4.129	3.179	.029284	4.81933
3.114	2.402	.029893	6.39817
2.516	1.958	.030049	7.9089F

READY
 RUN
 SER#.....AXIS.....NULL VOLTS.....

ENTER 1 FOR CCW ROTATION; -1 FOR CW ROTATION ?1

75.330

RUN TIME	MEAS TIME	V OUT (VDC)	G DOT
11.941	6.261	-.248714	1.66644
6.31	3.174	-.248593	3.31298
4.841	2.159	-.248976	4.92428
3.849	1.642	-.24891	6.5264
2.463	1.328	-.248264	8.07917

READY
 RUN
 SER#.....AXIS.....NULL VOLTS.....

ENTER 1 FOR CCW ROTATION; -1 FOR CW ROTATION ?-1

75.300

RUN TIME	MEAS TIME	V OUT (VDC)	G DOT
11.981	6.281	.025832	1.6608F
6.35	3.184	.025178	3.3
4.855	2.166	.025287	4.90727
3.859	1.647	.024836	6.52507
2.471	1.332	.025079	8.05301

READY
 RUN
 SER#.....AXIS.....NULL VOLTS.....

ENTER 1 FOR CCW ROTATION; -1 FOR CW ROTATION ?1

72.500

RUN TIME	MEAS TIME	V OUT (VDC)	G DOT
11.721	3.178	-.028385	1.70062
5.892	1.644	-.028375	3.37729
3.961	1.127	-.028707	5.02373
2.988	.868	-.028585	6.65964
2.415	.72	-.028912	8.23975

READY
 RUN
 SER#.....AXIS.....NULL VOLTS.....

ENTER 1 FOR CCW ROTATION; -1 FOR CW ROTATION ?-1

72.530

RUN TIME	MEAS TIME	V OUT (VDC)	G DOT
11.741	3.138	.013089	1.69483
5.912	1.649	.013974	3.36587
3.974	1.13	.013993	5.0273
2.998	.87	.013386	6.63742
2.424	.720	.013389	8.23916

READY

JERK DATA
 TABLE 3.5.2-XIV

NADC 80081-60

RUN
 ENTER 1 FOR CCW ROTATION; -1 FOR CW ROTATION ?1
 ??,500 S/N 373 R = 0 in.
 RUN -6.5W
 TIME MEAS TIME V OUT (VDC) G DOT X and Y Axis
 12.02 9.214 4.9292 1.57571
 6.03 4.647 4.9464 3.14096
 4.338 3.137 4.9285 4.69044
 3.034 2.337 4.9387 6.24258
 2.445 1.898 4.9487 7.74642

READY
 RUN
 ENTER 1 FOR CCW ROTATION; -1 FOR CW ROTATION ?-1
 ??,500
 RUN MEAS TIME V OUT (VDC) G DOT
 12.06 9.244 -4.8372 1.57048
 6.349 4.662 -4.8382 3.1311
 4.352 3.117 -4.8386 4.67423
 3.345 2.345 -4.8389 6.22003
 2.453 1.904 -4.8391 7.72116

READY
 RUN
 ENTER 1 FOR CCW ROTATION; -1 FOR CW ROTATION ?1
 ??,300
 RUN MEAS TIME V OUT (VDC) G DOT
 11.794 6.207 3.2338 1.6059
 5.902 3.113 3.229 3.22908
 3.955 2.103 3.243 4.78887
 2.973 1.589 3.235 6.37067
 2.393 1.277 3.2197 7.91475

READY
 RUN
 ENTER 1 FOR CCW ROTATION; -1 FOR CW ROTATION ?-1
 ??,300
 RUN MEAS TIME V OUT (VDC) G DOT
 11.808 6.201 -3.2056 1.604
 5.922 3.123 -3.2031 3.19824
 3.967 2.11 -3.2183 4.77439
 2.983 1.594 -3.2117 6.34931
 2.4 -1.281 -3.195 7.89167

READY
 RUN
 ENTER 1 FOR CCW ROTATION; -1 FOR CW ROTATION ?1
 ??,500
 RUN MEAS TIME V OUT (VDC) G DOT
 11.5 3.116 1.539 1.64696
 5.77 1.591 1.5466 3.2825
 3.864 1.077 1.543 4.98166
 2.905 .82 1.5394 6.51979
 2.34 .673 1.5544 8.09402

READY
 RUN
 ENTER 1 FOR CCW ROTATION; -1 FOR CW ROTATION ?-1
 ??,500
 RUN MEAS TIME V OUT (VDC) G DOT
 11.54 3.126 -1.54 1.64125
 5.79 1.596 -1.5473 3.27116
 3.878 1.08 -1.5442 4.98396
 2.916 .822 -1.5405 6.4952
 2.348 .675 -1.5561 8.06644

JERK DATA
TABLE 3.5.2 -XV

RUN
 ENTER 1 FOR CCW ROTATION; -1 FOR CW ROTATION ?1
 27.500
 S/N 373 R = 0 in.
 -6.2 MW
 Z Axis

RUN TIME	MEAS TIME	V OUT (VDC)	G DOT
12.272	9.256	-.054157	1.56892
6.277	4.69	-.05421	3.11667
4.284	3.15	-.054414	4.63761
3.081	2.381	-.054396	6.14735
2.49	1.941	-.054896	7.62643

READY
 RUN
 ENTER 1 FOR CCW ROTATION; -1 FOR CW ROTATION ?-1
 27.500

RUN TIME	MEAS TIME	V OUT (VDC)	G DOT
12.113	9.287	.016855	1.56361
6.256	4.663	.016281	3.12748
4.056	3.118	.015863	4.66963
3.249	2.346	.01644	6.21187
2.456	1.905	.016551	7.71173

READY
 RUN
 ENTER 1 FOR CCW ROTATION; -1 FOR CW ROTATION ?1
 25.300

RUN TIME	MEAS TIME	V OUT (VDC)	G DOT
11.828	6.223	-.040132	1.62128
5.953	3.155	-.039801	3.18159
4.303	2.146	-.039996	4.73145
3.32	1.632	-.040111	6.27152
2.439	1.32	-.039936	7.76548

READY
 RUN
 ENTER 1 FOR CCW ROTATION; -1 FOR CW ROTATION ?-1
 25.300

RUN TIME	MEAS TIME	V OUT (VDC)	G DOT
11.869	6.244	.015467	1.59575
5.932	3.124	.015383	3.19285
3.975	2.111	.01532	4.76478
2.988	1.595	.015043	6.33869
2.405	1.282	.015255	7.87526

READY
 RUN
 ENTER 1 FOR CCW ROTATION; -1 FOR CW ROTATION ?1
 22.500

RUN TIME	MEAS TIME	V OUT (VDC)	G DOT
11.572	3.16	-.023495	1.63671
5.825	1.634	-.023523	3.2515
3.917	1.12	-.023523	4.83533
2.956	.863	-.023544	6.40731
2.389	.716	-.023518	7.928

READY
 RUN
 ENTER 1 FOR CCW ROTATION; -1 FOR CW ROTATION ?-1
 22.500

RUN TIME	MEAS TIME	V OUT (VDC)	G DOT
11.611	3.169	.007952	1.63121
5.804	1.597	.0078	3.26327
3.888	1.081	.007748	4.8714
2.923	.823	.007719	6.47964
2.355	.676	.007778	8.04246

JERK DATA
 TABLE 3.5.2-XVI

RUN 3-20-80 R = 24 in.
SER# 301 AXIS 71 NULL VOLTS -11.90V

ENTER 1 FOR CCW ROTATION; -1 FOR CW ROTATION ?1
77.500

RUN TIME	MEAS TIME	V OUT (VDC)	G DOT
12.148	9.295	4.7724	1.5591
6.381	4.675	4.7790	3.11462
4.375	3.126	4.7632	4.65314
3.36	2.351	4.7425	6.18954
2.466	1.939	4.779	7.68345

READY
RUN
SER#AXIS.....NULL VOLTS.....

ENTER 1 FOR CCW ROTATION; -1 FOR CW ROTATION ?-1

77.500

RUN TIME	MEAS TIME	V OUT (VDC)	G DOT
12.162	9.299	-3.999	1.55731
6.131	4.69	-4.8001	3.13441
4.286	3.136	-4.3005	4.63534
3.371	2.359	-4.3006	6.16737
2.475	1.915	-4.801	7.65871

READY
RUN
SER#AXIS.....NULL VOLTS.....

ENTER 1 FOR CCW ROTATION; -1 FOR CW ROTATION ?1

77.500

RUN TIME	MEAS TIME	V OUT (VDC)	G DOT
11.897	6.217	3.1297	1.592
5.967	3.131	3.1291	3.17412
3.998	2.116	3.1404	4.73737
3.305	1.599	3.1346	6.30283
2.42	1.285	3.1286	7.82645

READY
RUN
SER#AXIS.....NULL VOLTS.....

ENTER 1 FOR CCW ROTATION; -1 FOR CW ROTATION ?-1

77.500

RUN TIME	MEAS TIME	V OUT (VDC)	G DOT
11.938	6.238	-3.1436	1.58653
5.976	3.141	-3.1424	3.16435
4.312	2.123	-3.1546	4.72084
3.316	1.694	-3.1474	6.27984
2.426	1.289	-3.1324	7.80066

READY
RUN
SER#AXIS.....NULL VOLTS.....

ENTER 1 FOR CCW ROTATION; -1 FOR CW ROTATION ?1

77.500

RUN TIME	MEAS TIME	V OUT (VDC)	G DOT
11.698	3.135	1.583	1.62464
5.847	1.6	1.5187	3.25927
3.917	1.083	1.5874	4.83533
2.945	.825	1.5846	6.43124
2.372	.676	1.5233	7.98482

READY
RUN
SER#AXIS.....NULL VOLTS.....

ENTER 1 FOR CCW ROTATION; -1 FOR CW ROTATION ?-1

77.500

RUN TIME	MEAS TIME	V OUT (VDC)	G DOT
11.699	3.145	-1.5249	1.61094
5.869	1.626	-1.5339	3.22713
3.932	1.087	-1.5326	4.81609
2.959	.827	-1.5274	6.43948
2.38	.679	-1.5427	7.99798

READY

JERK DATA
TABLE 3.5.2-XVII

N
 RUN 3-20-80 R = 24 in.
 SER#981.....AXIS.....X.....MULL VOLTS.....J1.98.

NADC 80081-60

ENTER 1 FOR CCW ROTATION; -1 FOR CW ROTATION ?1

27.500
 RUN MEAS V OUT G DOT
 TIME TIME (VDC)
 12.123 9.269 4.7474 1.56232
 6.381 4.675 4.7615 3.11462
 4.372 3.125 4.7441 4.65128
 3.326 2.351 4.7272 6.18854
 2.466 1.909 4.7632 7.68345

READY
 RUN
 SER#AXIS.....MULL VOLTS.....

ENTER 1 FOR CCW ROTATION; -1 FOR CW ROTATION ?-1

27.502
 RUN MEAS V OUT G DOT
 TIME TIME (VDC)
 12.162 9.299 -3.9989 1.55731
 6.1 4.69 -4 3.12492
 4.286 3.136 -4.2033 4.63534
 3.371 2.359 -4.2033 6.16737
 2.473 1.915 -4.2002 7.65871

READY
 RUN
 SER#AXIS.....MULL VOLTS.....

ENTER 1 FOR CCW ROTATION; -1 FOR CW ROTATION ?1

25.000
 RUN MEAS V OUT G DOT
 TIME TIME (VDC)
 11.898 6.218 3.1263 1.59186
 5.967 3.131 3.1245 3.17412
 3.998 2.116 3.1397 4.73737
 3.304 1.596 3.1343 6.30493
 2.42 1.285 3.1175 7.82645

READY
 RUN
 SER#AXIS.....MULL VOLTS.....

ENTER 1 FOR CCW ROTATION; -1 FOR CW ROTATION ?-1

25.000
 RUN MEAS V OUT G DOT
 TIME TIME (VDC)
 11.938 6.238 -3.1404 1.58653
 5.987 3.141 -3.1379 3.16352
 4.212 2.123 -3.1523 4.72884
 3.316 1.634 -3.1468 6.27934
 2.422 1.289 -3.1301 7.83366

READY
 RUN
 SER#AXIS.....MULL VOLTS.....

ENTER 1 FOR CCW ROTATION; -1 FOR CW ROTATION ?1

22.500
 RUN MEAS V OUT G DOT
 TIME TIME (VDC)
 11.659 3.135 1.5034 1.6245
 5.847 1.6 1.5129 3.23927
 3.917 1.303 1.51 4.83533
 2.945 .825 1.5069 6.43124
 2.372 .677 1.5232 7.98482

READY
 RUN
 SER#AXIS.....MULL VOLTS.....

ENTER 1 FOR CCW ROTATION; -1 FOR CW ROTATION ?-1

22.500
 RUN MEAS V OUT G DOT
 TIME TIME (VDC)
 11.699 3.145 -1.5256 1.61894
 5.869 1.636 -1.5325 3.22713
 3.932 1.387 -1.5282 4.71689
 2.955 .827 -1.5259 6.43948
 2.38 .679 -1.5416 7.95798

READY

JERK DATA
 TABLE 3.5.2-XVII

3-20-60 R=24 in.
 381.....AXIS.....#Y.....NULL VOLTS...-(12.1)V

ENTER 1 FOR CCW ROTATION; -1 FOR CW ROTATION ?1

TIME	MEAS TIME	V OUT (VDC)	G DOT
12.149	9.225	4.7668	1.55890
6.281	4.675	4.7734	3.11462
4.372	3.125	4.7503	4.65128
3.26	2.351	4.7412	6.18954
2.466	1.939	4.7777	7.68345

READY
 RUN
 SER#.....AXIS.....NULL VOLTS.....

ENTER 1 FOR CCW ROTATION; -1 FOR CW ROTATION ?-1

TIME	MEAS TIME	V OUT (VDC)	G DOT
12.162	9.299	-3.999	1.55731
6.121	4.69	-4.2001	3.12441
4.286	3.136	-4.2004	4.63534
3.271	2.359	-4.2005	6.16737
2.473	1.915	-4.2009	7.65871

READY
 RUN
 SER#.....AXIS.....NULL VOLTS.....

ENTER 1 FOR CCW ROTATION; -1 FOR CW ROTATION ?1

TIME	MEAS TIME	V OUT (VDC)	G DOT
11.898	6.218	3.1301	1.59186
5.967	3.131	3.1312	3.17412
3.998	2.116	3.1444	4.73737
3.236	1.599	3.1397	6.32073
2.42	1.285	3.1225	7.82645

READY
 RUN
 SER#.....AXIS.....NULL VOLTS.....

ENTER 1 FOR CCW ROTATION; -1 FOR CW ROTATION ?-1

TIME	MEAS TIME	V OUT (VDC)	G DOT
11.938	6.238	-3.1429	1.58653
5.986	3.141	-3.1422	3.16435
4.212	2.123	-3.1534	4.72084
3.216	1.624	-3.1479	6.27984
2.428	1.289	-3.1317	7.80366

READY
 RUN
 SER#.....AXIS.....NULL VOLTS.....

ENTER 1 FOR CCW ROTATION; -1 FOR CW ROTATION ?1

TIME	MEAS TIME	V OUT (VDC)	G DOT
11.659	3.135	1.5233	1.6245
5.848	1.6	1.5126	3.23871
3.217	1.283	1.529	4.83533
2.245	.825	1.5266	6.43124
2.372	.677	1.5223	7.98482

READY
 RUN
 SER#.....AXIS.....NULL VOLTS.....

ENTER 1 FOR CCW ROTATION; -1 FOR CW ROTATION ?-1

TIME	MEAS TIME	V OUT (VDC)	G DOT
11.699	3.145	-1.5259	1.61894
5.862	1.626	-1.5325	3.22713
3.232	1.287	-1.5203	4.81689
2.255	.827	-1.523	6.42948
2.38	.679	-1.5225	7.99798

READY

JERK DATA
 TABLE 3.5.2-XIX

RUN 3-20-80 R = 24 in.
SER# 301AXIS.....NULL VOLTS.....J.J.00%

ENTER 1 FOR CCW ROTATION; -1 FOR CW ROTATION ?1

27.533

RUN TIME	MEAS TIME	V OUT (VDC)	G DOT
10.148	9.295	4.7518	1.5591
6.381	4.675	4.7577	3.11462
4.073	3.126	4.7411	4.65214
3.36	2.351	4.7239	6.18954
2.466	1.929	4.7596	7.68345

READY
RUN
SER#AXIS.....NULL VOLTS.....

ENTER 1 FOR CCW ROTATION; -1 FOR CW ROTATION ?-1

27.533

RUN TIME	MEAS TIME	V OUT (VDC)	G DOT
12.162	9.299	-3.9997	1.55731
6.131	4.69	-4.2028	3.13441
4.386	3.136	-4.2011	4.65534
3.371	2.359	-4.2312	6.16737
2.473	1.915	-4.2317	7.65271

READY
RUN
SER#AXIS.....NULL VOLTS.....

ENTER 1 FOR CCW ROTATION; -1 FOR CW ROTATION ?1

25.333

RUN TIME	MEAS TIME	V OUT (VDC)	G DOT
11.898	6.218	3.1262	1.59186
5.967	3.131	3.1248	3.17412
3.898	2.116	3.1383	4.75737
3.335	1.599	3.1328	6.32283
2.42	1.285	3.1158	7.82645

READY
RUN
SER#AXIS.....NULL VOLTS.....

ENTER 1 FOR CCW ROTATION; -1 FOR CW ROTATION ?-1

25.333

RUN TIME	MEAS TIME	V OUT (VDC)	G DOT
11.938	6.238	-3.146	1.58653
5.987	3.141	-3.1445	3.16352
4.311	2.122	-3.1577	4.72231
3.316	1.634	-3.1555	6.27984
2.423	1.239	-3.1376	7.82366

READY
RUN
SER#AXIS.....NULL VOLTS.....

ENTER 1 FOR CCW ROTATION; -1 FOR CW ROTATION ?1

22.533

RUN TIME	MEAS TIME	V OUT (VDC)	G DOT
11.659	3.135	1.5846	1.6245
5.848	1.6	1.5125	3.23871
3.917	1.283	1.539	4.83533
2.945	.825	1.5357	6.43124
2.372	.676	1.5227	7.98482

READY
RUN
SER#AXIS.....NULL VOLTS.....

ENTER 1 FOR CCW ROTATION; -1 FOR CW ROTATION ?-1

22.533

RUN TIME	MEAS TIME	V OUT (VDC)	G DOT
11.698	3.145	-1.5263	1.61236
5.869	1.606	-1.5344	3.22713
3.932	1.287	-1.5313	4.71629
2.955	.827	-1.5279	6.43948
2.38	.679	-1.5427	7.95786

READY

JERK DATA
TABLE 3.5.2-XX

3-20-80 R = 23.6 in.
 SER# AXIS NULL VOLTS 12.2V.

ENTER 1 FOR CCW ROTATION; -1 FOR CW ROTATION ?1

77.500

RUN TIME	MEAS TIME	V OUT (VDC)	G DOT
10.124	9.27	-.34362P	1.53629
6.124	4.712	-.34373P	3.34142
3.116	3.169	-.343357	4.52527
3.144	2.395	-.343747	6.20364
2.538	1.952	-.343835	7.42663

READY
 RUN
 SER# AXIS NULL VOLTS

ENTER 1 FOR CCW ROTATION; -1 FOR CW ROTATION ?-1

77.500

RUN TIME	MEAS TIME	V OUT (VDC)	G DOT
12.226	9.343	.02269	1.52597
6.101	4.691	.02128	3.25294
4.287	3.137	.021213	4.55738
3.072	2.36	.022126	6.06315
2.474	1.916	.022468	7.5287

READY
 RUN
 SER# AXIS NULL VOLTS

ENTER 1 FOR CCW ROTATION; -1 FOR CW ROTATION ?1

75.300

RUN TIME	MEAS TIME	V OUT (VDC)	G DOT
11.941	6.261	-.029817	1.55984
6.21	3.174	-.029751	3.09917
4.242	2.159	-.029882	4.60812
3.349	1.642	-.030125	6.10889
2.463	1.328	-.029866	7.56232

READY
 RUN
 SER# AXIS NULL VOLTS

ENTER 1 FOR CCW ROTATION; -1 FOR CW ROTATION ?-1

75.300

RUN TIME	MEAS TIME	V OUT (VDC)	G DOT
11.981	6.281	.008142	1.55463
5.988	3.142	.008612	3.11255
4.312	2.123	.008861	4.64257
3.316	1.635	.009339	6.17573
2.429	1.29	.009494	7.66818

READY
 RUN
 SER# AXIS NULL VOLTS

ENTER 1 FOR CCW ROTATION; -1 FOR CW ROTATION ?1

72.530

RUN TIME	MEAS TIME	V OUT (VDC)	G DOT
11.701	3.178	-.020764	1.59183
5.892	1.644	-.020881	3.16124
3.861	1.127	-.021123	4.70235
2.889	.868	-.021149	6.23192
2.416	.72	-.021186	7.70944

READY
 RUN
 SER# AXIS NULL VOLTS

ENTER 1 FOR CCW ROTATION; -1 FOR CW ROTATION ?-1

72.530

RUN TIME	MEAS TIME	V OUT (VDC)	G DOT
11.740	3.188	-.002627	1.58627
5.87	1.637	-.002266	3.17323
3.833	1.186	-.001893	4.73572
2.856	.822	-.001562	6.30133
2.371	.68	-.001623	7.82276

READY

JERK DATA
 TABLE 3.5.2-XXI

3-20-80 R = 24.4 in.
 381.....SIG.....2.....NULL VOLTS:12.0V..

ENTER 1 FOR CCW ROTATION; -1 FOR CW ROTATION ?1

27.533
 27.533

TIME	SEAS TIME	V OUT (VDC)	G DOT
12.165	9.312	-.231675	1.63576
6.382	4.676	-.331191	3.27179
4.116	3.169	-.332469	4.93455
3.461	2.352	-.32222	6.53222
2.466	1.91	-.322395	8.26934

READY
 27.533
 27.533.....AXIS.....NULL VOLTS.....

ENTER 1 FOR CCW ROTATION; -1 FOR CW ROTATION ?-1

27.533
 27.533

TIME	SEAS TIME	V OUT (VDC)	G DOT
12.235	9.342	.214412	1.6334
6.144	4.733	.213368	3.23877
4.387	3.137	.211995	4.86225
3.372	2.36	.21116	6.47754
2.474	1.916	.212629	8.24325

READY
 27.533
 27.533.....AXIS.....NULL VOLTS.....

ENTER 1 FOR CCW ROTATION; -1 FOR CW ROTATION ?1

25.333
 25.333

TIME	SEAS TIME	V OUT (VDC)	G DOT
11.941	6.261	-.227379	1.66644
5.967	3.132	-.226582	3.33424
4.341	2.159	-.226923	4.92428
3.349	1.642	-.228138	6.5264
2.421	1.286	-.229396	8.21933

READY
 25.333
 25.333.....AXIS.....NULL VOLTS.....

ENTER 1 FOR CCW ROTATION; -1 FOR CW ROTATION ?-1

25.333
 25.333

TIME	SEAS TIME	V OUT (VDC)	G DOT
11.981	6.281	.206146	1.66388
6.03	3.184	.205899	3.3
4.212	2.123	.203855	4.95987
3.217	1.625	.203667	6.59562
2.429	1.229	.20224	8.19222

READY
 25.333
 25.333.....AXIS.....NULL VOLTS.....

ENTER 1 FOR CCW ROTATION; -1 FOR CW ROTATION ?1

22.533
 22.533

TIME	SEAS TIME	V OUT (VDC)	G DOT
11.731	3.178	-.222852	1.72262
5.892	1.644	-.222884	3.37729
3.961	1.127	-.222922	5.02373
2.988	.868	-.222962	6.65964
2.415	.72	-.221176	8.23975

READY
 22.533
 22.533.....AXIS.....NULL VOLTS.....

ENTER 1 FOR CCW ROTATION; -1 FOR CW ROTATION ?-1

22.533
 22.533

TIME	SEAS TIME	V OUT (VDC)	G DOT
11.742	3.188	-.233329	1.69469
5.912	1.649	-.233477	3.36537
3.933	1.203	-.23356	5.0595
2.956	.822	-.23634	6.73173
2.321	.68	-.236442	8.35741

READY

JERK DATA
 TABLE 3.5.2-XXII

NADC 80081-60

RUN
 ENTER 1 FOR CCW ROTATION; -1 FOR CW ROTATION ?1
 77.500
 S/N 381 R = 0 in.
 -11.8MV
 X and Y Axis

RUN TIME	MEAS TIME	V OUT (VDC)	G DOT
12.02	9.214	4.7526	1.57571
6.03	4.647	4.7649	3.14096
4.038	3.107	4.7476	4.69044
3.034	2.337	4.7301	6.24258
2.445	1.898	4.7655	7.74642

READY
 RUN
 ENTER 1 FOR CCW ROTATION; -1 FOR CW ROTATION ?-1
 77.500

RUN TIME	MEAS TIME	V OUT (VDC)	G DOT
12.061	9.244	-3.9969	1.57035
6.049	4.662	-3.9981	3.13111
4.051	3.117	-3.9984	4.67539
3.045	2.345	-3.9986	6.22033
2.453	1.904	-3.999	7.72116

READY
 RUN
 ENTER 1 FOR CCW ROTATION; -1 FOR CW ROTATION ?1
 75.000

RUN TIME	MEAS TIME	V OUT (VDC)	G DOT
11.768	6.181	3.143	1.60945
9.902	3.113	3.1414	3.20908
3.955	2.103	3.1538	4.78887
2.973	1.509	3.147	6.37067
2.393	1.277	3.1318	7.91475

READY
 RUN
 ENTER 1 FOR CCW ROTATION; -1 FOR CW ROTATION ?-1
 75.000

RUN TIME	MEAS TIME	V OUT (VDC)	G DOT
11.808	6.201	-3.1641	1.604
9.922	3.123	-3.150	3.19824
3.968	2.11	-3.1724	4.77318
2.982	1.594	-3.1653	6.35144
2.4	1.281	-3.1492	7.89167

READY
 RUN
 ENTER 1 FOR CCW ROTATION; -1 FOR CW ROTATION ?1
 72.500

RUN TIME	MEAS TIME	V OUT (VDC)	G DOT
11.5	3.116	1.5121	1.64696
9.77	1.591	1.5197	3.2825
3.864	1.077	1.5152	4.90166
2.905	.82	1.512	6.51979
2.34	.673	1.5258	8.09402

READY
 RUN
 ENTER 1 FOR CCW ROTATION; -1 FOR CW ROTATION ?-1
 72.500

RUN TIME	MEAS TIME	V OUT (VDC)	G DOT
11.542	3.127	-1.5379	1.64096
9.79	1.596	-1.5434	3.27116
3.878	1.08	-1.5402	4.88396
2.916	.822	-1.536	6.4952
2.348	.675	-1.5311	8.06644

JERK DATA
TABLE 3.5.2-XXIII

NADC 80081-60

RUN
 ENTER 1 FOR CCW ROTATION; -1 FOR CW ROTATION ?1
 77.500 S/W 381 R = 0 in.
 RUN -13.2MV
 TIME MEAS V OUT G DOT Z Axis
 TIME TIME (VDC)
 12.275 9.269 -.218633 1.56853
 6.472 4.69 -.01842 3.11924
 4.281 3.15 -.018491 4.64132
 3.278 2.381 -.218446 6.15335
 2.488 1.941 -.018582 7.61254

READY
 RUN
 ENTER 1 FOR CCW ROTATION; -1 FOR CW ROTATION ?-1
 77.500
 RUN MEAS V OUT G DOT
 TIME TIME (VDC)
 12.104 9.287 .001857 1.56477
 6.25 4.663 .001763 3.13058
 4.294 3.16 .002322 4.62628
 3.346 2.346 .002044 6.21799
 2.454 1.905 .001186 7.71001

READY
 RUN
 ENTER 1 FOR CCW ROTATION; -1 FOR CW ROTATION ?1
 75.000
 RUN MEAS V OUT G DOT
 TIME TIME (VDC)
 11.811 6.224 -.018204 1.63359
 5.945 3.156 -.018204 3.18587
 3.998 2.147 -.018325 4.73737
 3.315 1.632 -.018173 6.28192
 2.437 1.321 -.018311 7.77185

READY
 RUN
 ENTER 1 FOR CCW ROTATION; -1 FOR CW ROTATION ?-1
 75.000
 RUN MEAS V OUT G DOT
 TIME TIME (VDC)
 11.351 6.244 -.003791 1.59818
 5.965 3.166 -.004055 3.17519
 3.969 2.111 -.004192 4.77198
 3.225 1.637 -.00441 6.26116
 2.442 1.282 -.004596 7.8851

READY
 RUN
 ENTER 1 FOR CCW ROTATION; -1 FOR CW ROTATION ?1
 72.500
 RUN MEAS V OUT G DOT
 TIME TIME (VDC)
 11.545 3.16 -.016278 1.64354
 5.812 1.634 -.016278 3.25877
 3.908 1.12 -.016449 4.84647
 2.949 .863 -.016557 6.42252
 2.383 .716 -.016421 7.94796

READY
 RUN
 ENTER 1 FOR CCW ROTATION; -1 FOR CW ROTATION ?1-
 ?
 STOP

READY
 RUN
 ENTER 1 FOR CCW ROTATION; -1 FOR CW ROTATION ?-1
 72.500
 RUN MEAS V OUT G DOT
 TIME TIME (VDC)
 11.585 3.17 -.009092 1.63487
 5.79 1.597 -.009357 3.27116
 3.88 1.082 -.009538 4.80144
 2.917 .823 -.009621 6.49297
 2.349 .676 -.009697 8.06331

JERK DATA
 TABLE 3.5.2-XXIV

3.6 Acoustic Sensitivity

3.6.1 Test Setup and Procedure

The sensor units were mounted (one at a time) on a cantilever beam (aluminum channel) and positioned in the throat of the acoustic chamber. The jet axis (X - axis) of the sensor coincided with the direction of acoustic wave propagation and with the horizontal centerline of the chamber.

The unit was energized and a series of eight acoustic pulses (approximately 155 db for 10 seconds) were applied to the test area. Three microphones were placed within the test area under procedures outlined in MIL-STD-810C, Method 515.2. The null output of the unit was monitored throughout testing along with the input to the acoustic chamber.

A test schematic is shown in Figure E.2-1 of Appendix A, Part E of this report, with the test procedure.

The baseline tests were repeated to discover any anomalies caused by the acoustic environment. These tests were done as in Section 3.1 of this report.

3.6.2 Test Results

The octave analysis specification for the category D, 165 db acoustic test is shown in Figure 3.6.2-1.

The calibration of the acoustic chamber is shown in the octave analysis shown in Figure 3.6.2-2.

The octave analysis for the three microphones placed around the test specimen indicated an overall acoustic level of 155 db. (See Figures 3.6.2-3 to 3.6.2-5) This level was the highest that could be obtained for this setup. One of the acoustic drivers had to be replaced due to failure caused by pushing the limit of the equipment.

The output of the device was recorded on an oscillograph. A typical graph is shown in Figure 3.6.2-6.

The post acoustic baseline test results are shown in Tables 3.6.2-I through 3.6.2-X. The data is in the same form as the initial baseline test data.

3.6.3 Data Evaluation

The acoustic environment had no effect on the null output of the device except for the increase in noise level. All three devices had a pretest noise level of 6.0 millivolts peak to peak. The overall average noise level during testing was 12.0 millivolts with no shift in the null D.C. output. The noise level of the null output was 6.0 millivolts after the acoustic pulses, indicating no adverse effects on the Superjet sensor.

The worst case baseline data obtained for the three test units after the acoustic environmental test is as shown below:

1. Full Scale Rate at $\pm 2\%$ Linearity Error	500 ± 100 deg/sec
2. Scale Factor	$-.00630 \pm .00002$ V/deg/sec
3. Bias	$+1.07$ deg/sec
4. Hysteresis	$+0.46$ deg/sec
5. Threshold	<0.10 deg/sec
6. Resolution	<0.10 deg/sec
7. Readytime	.071 seconds maximum
8. Drift	$+0.75$ deg/sec/min maximum
9. Null Offset	± 1.25 deg/sec

The fullscale rate increased by 9% on S/N 381 and the scale factor increased by 0.2 millivolts/degrees/second. The only substantial increase in the bias parameter occurred in S/N 381 as also shown in the null offset measurement. The null offset measurements were not taken during the initial baseline test. The calculated bias (least squares fit) value relates to null offset which is the voltage measured before the actual test sequence. Readytime has increased typically 50% over the initial baseline test but remains the same as measured in the hot and cold temperature tests. The drift of the sensors have increased approximately 265% over the initial baseline measurements. This may have been caused by the temperature test environments.

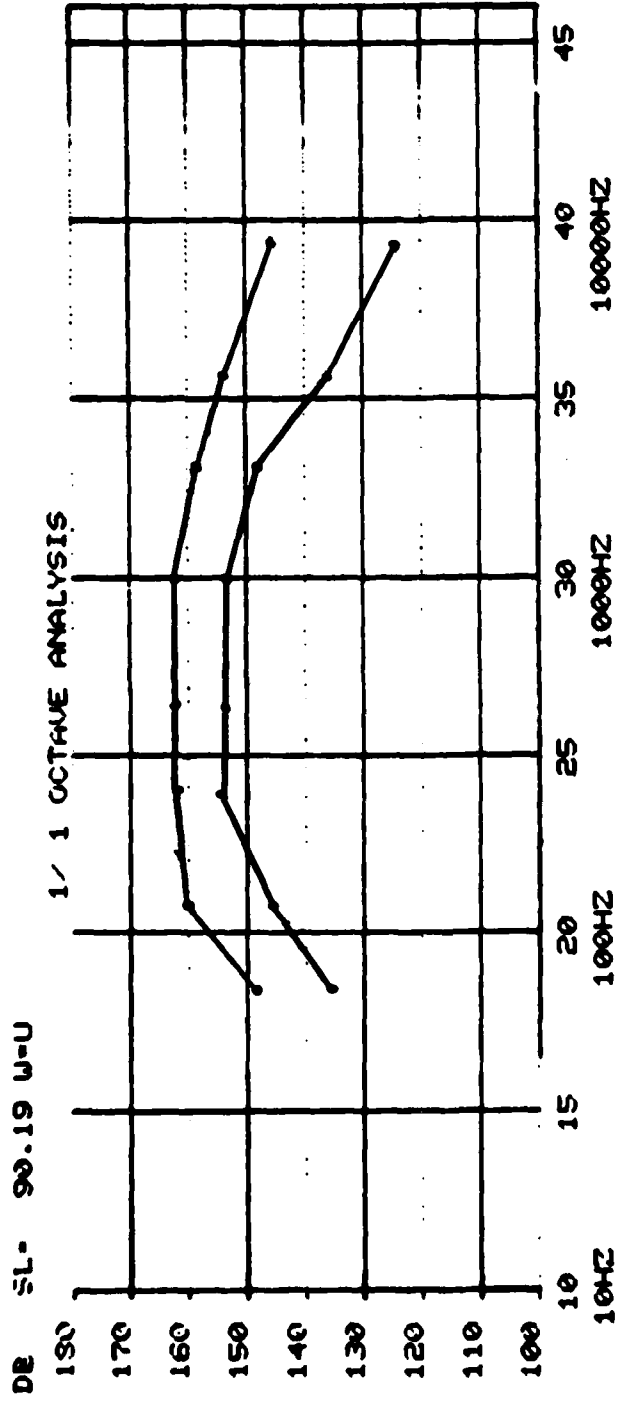

FIGURE 3.6.2-1

SPECIFICATION
MIL-STD-810C
METHOD 515.2
CATEGORY D

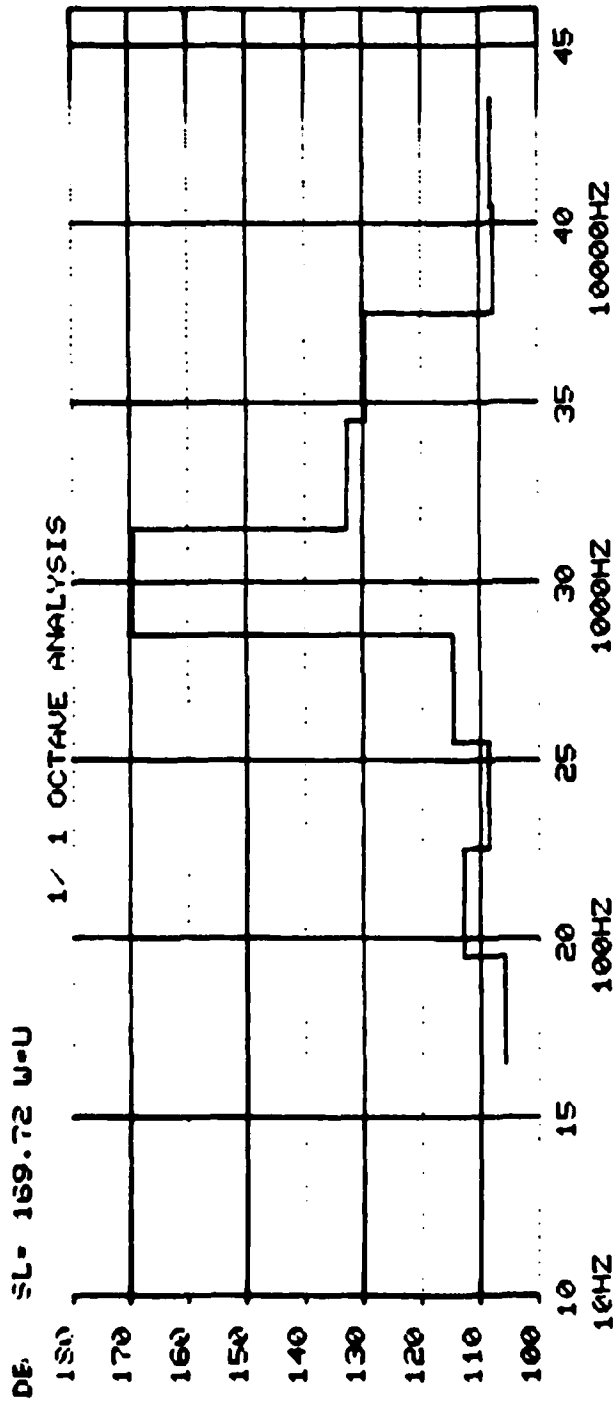
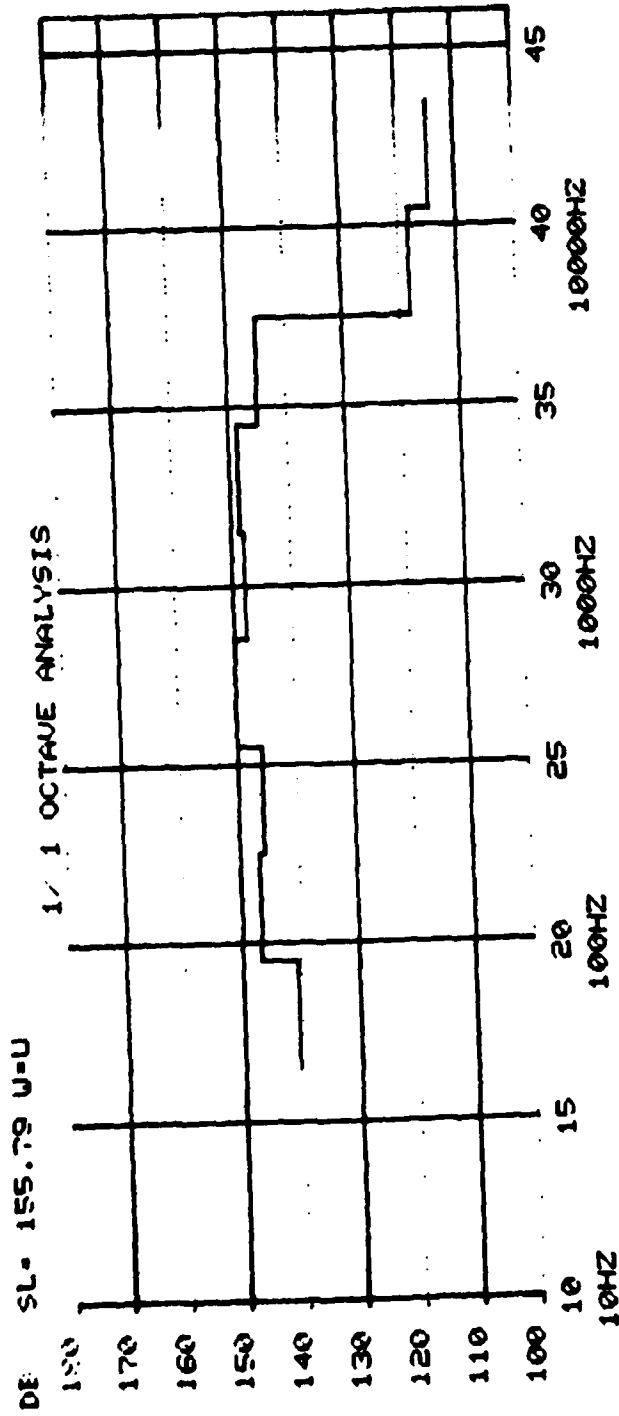

FIGURE 3.6.2-2
 CALIBRATION 170 db
 3-27-80
 ACOUSTIC CHAMBER

W-U A-LI N= 4 (4) SL= 169.72

15.0	63.0	105.92
21.0	125.0	112.77
24.0	250.0	108.50
27.0	500.0	114.65
30.0	1000.0	169.71
33.0	2000.0	132.92
36.0	4000.0	129.76
39.0	8000.0	107.50
42.0	16000.0	138.16



M-U A-LI U- 4) SL- 155.79

15.0	53.0	140.74
21.0	125.0	145.88
24.0	250.0	145.96
27.0	500.0	150.11
30.0	1000.0	148.08
33.0	2000.0	148.80
36.0	4000.0	145.22
39.0	8000.0	118.38
42.0	16000.0	114.57

FIGURE 3.6.2-3

MICROPHONE NO. 1 CALIBRATION
3-27-80

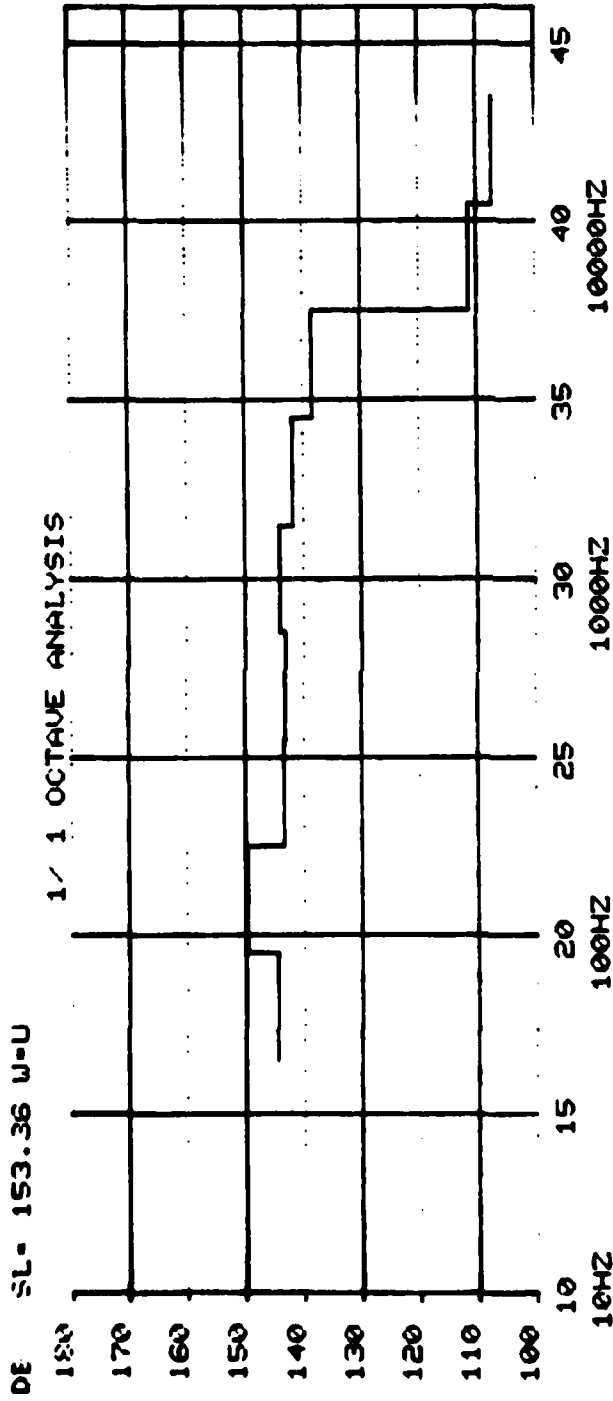

W-U W-LI H= 4 (4) SL- 153.36

10.0	63.0	144.61
21.0	125.0	149.80
24.0	250.0	143.50
27.0	500.0	143.25
30.0	1000.0	144.22
33.0	2000.0	141.93
36.0	4000.0	139.44
39.0	8000.0	111.49
42.0	16000.0	107.25

FIGURE 3.6.2-4
MICROPHONE NO. 2 CALIBRATION
3-27-80

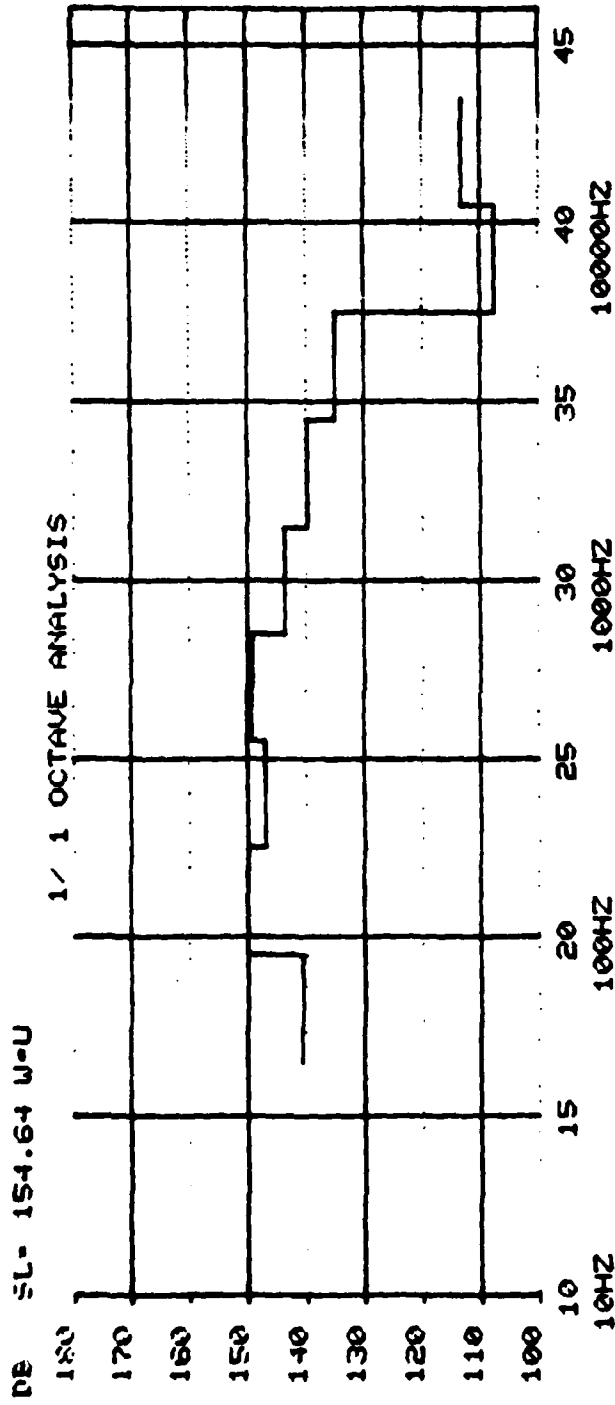

W-U A-LI N- 4 (4) SL- 154.64

18.0	63.0	140.84
21.0	125.0	150.06
24.0	250.0	147.18
27.0	500.0	149.43
30.0	1000.0	143.79
33.0	2000.0	139.85
36.0	4000.0	135.14
39.0	8000.0	107.59
42.0	16000.0	113.35

FIGURE 3.6.2-5

MICROPHONE NO. 3 CALIBRATION
3-27-80

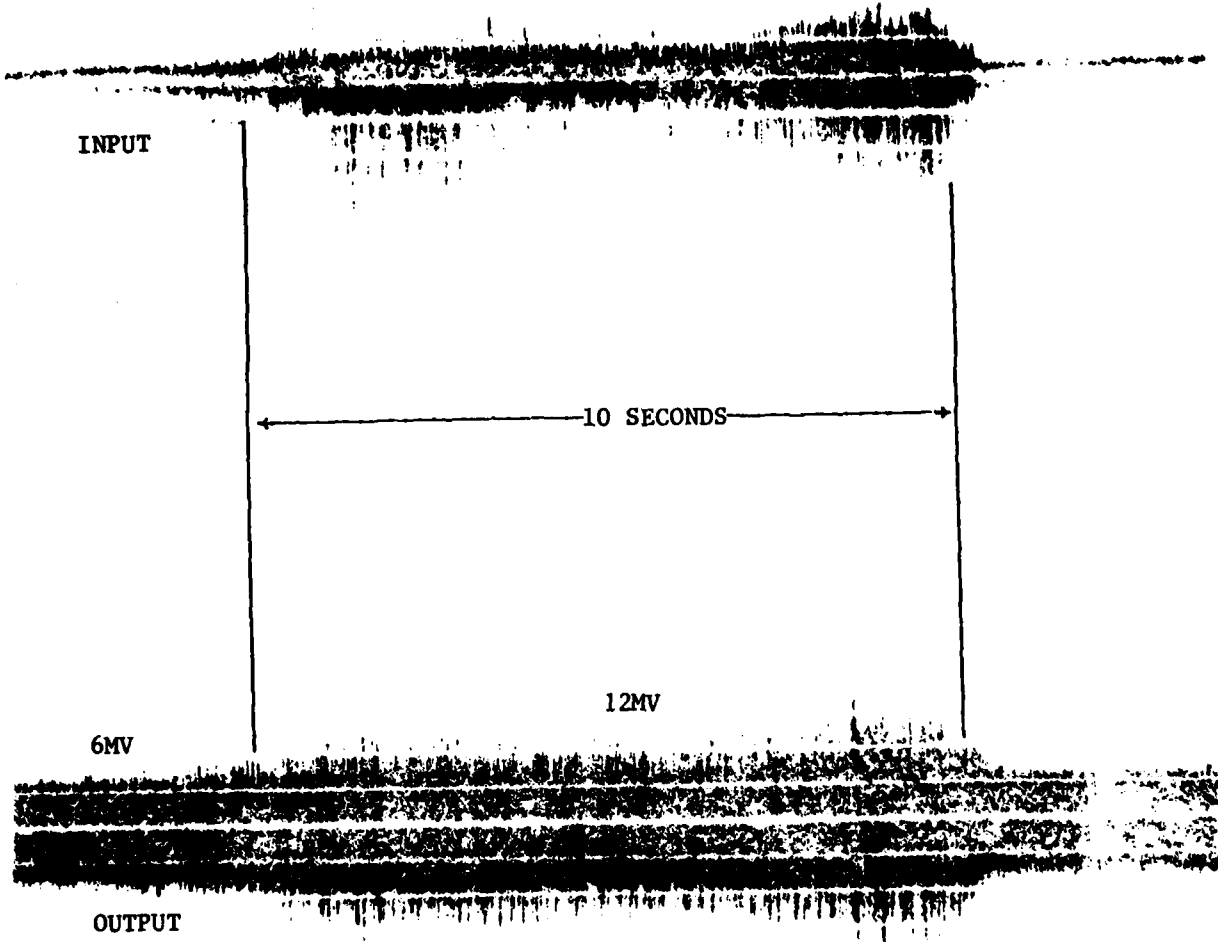

FIGURE 3.6.2-6

NULL OUTPUT VS. ACOUSTIC ENVIRONMENT
(TYPICAL)

RATE SENSOR TEST PROGRAM

POST ACOUSTIC

NADC 80081-60

DATE 3-22-80.....

RUN BASELINE.....

TEMP 72°F 50%RH....

SER# 355.....

RATE (DEG/SEC)	V OUT (VDC)	V CALC (VDC)	% FS	% IDEAL
-48.9280	.3068	.3181	.36	-3.637
-98.1935	.6122	.6327	.649	-3.253
-149.676	.9206	.947	.836	-2.793
-199.587	1.2316	1.2616	.953	-2.307
* -249.518	1.5471	1.5764	.93	-1.863
-299.427	1.8673	1.8929	.749	-1.257
-349.263	2.1935	2.2052	.371	-.531
-399.121	2.5257	2.5195	-.196	.246
-449.064	2.8644	2.8343	-.954	1.362
-499.957	3.2095	3.1489	-1.924	1.929
-449.15	2.8658	2.8349	-.979	1.39
-399.189	2.5271	2.5198	-.289	.287
-349.204	2.1956	2.2053	.338	-.441
-299.388	1.8699	1.8928	.663	-1.122
-249.548	1.55	1.5766	.844	-1.69
-199.628	1.2343	1.2617	.868	-2.174
-149.735	.9231	.9471	.761	-2.543
-99.8371	.6145	.6327	.572	-2.897
-49.8575	.3081	.3183	.324	-3.245
49.8579	-.3026	-.311	-.264	-2.644
99.6976	-.6387	-.6252	-.523	-2.623
149.62	-.9168	-.9399	-.731	-2.444
* 199.574	-1.2275	-1.2548	-.867	-2.171
249.452	-1.5421	-1.5692	-.86	-1.723
299.276	-1.861	-1.8833	-.738	-1.183
349.236	-2.1854	-2.1983	-.439	-.585
399.11	-2.5155	-2.5127	.088	.111
449.336	-2.8518	-2.8275	.773	.861
499.928	-3.194	-3.142	1.649	1.653
449.98	-2.8526	-2.8272	.828	.9
399.125	-2.5167	-2.5127	.127	.16
349.17	-2.187	-2.1979	-.344	-.492
299.31	-1.8628	-1.8636	-.659	-1.121
249.425	-1.544	-1.5691	-.796	-1.596
199.542	-1.2293	-1.2546	-.821	-2.322
149.637	-.9184	-.94	-.684	-2.225
99.7636	-.6103	-.6256	-.486	-2.435
49.8628	-.3038	-.311	-.227	-2.273

TEST SUMMARY

FULL SCALE RATE (DEG/SEC): 500
 SCALE FACTOR (V/DEG/SEC): -6.33421E-03
 BIAS (VOLTS) : 3.35272E-03
 HYSTERESIS, NEG RATES (VDC): -2.89790E-03
 HYSTERESIS, POS RATES (VDC): 1.85776E-03
 NULL OFFSET (VDC): 2.72875E-03

TEST ENGINEER: *Boyd W. Camp Jr*

3-22-80

READY
 END
 SCALE FACTOR PROGRAM

TABLE 3.6.2-1

RATE SENSOR TEST PROGRAM

POST ACOUSTIC

NADC 80081-60

DATE...3-27-80.....

RUN...BASELINE.....

TEMP...72°F 50%RH....

SEN#...355.....

RATE (DEG/SEC)	V OUT (VDC)	V CALC (VDC)	Z FS	Z IDEAL
-49.9462	.3054	.3189	.39	-4.09
-99.8201	.61	.6342	.694	-3.825
-149.724	.9173	.9496	.93	-3.417
-199.592	1.2276	1.2642	1.271	-2.951
* -249.524	1.540	1.5825	1.125	-2.435
-299.431	1.8614	1.8959	.994	-1.906
-349.311	2.1865	2.2112	.749	-1.117
-399.269	2.5179	2.527	.663	-.362
-449.123	2.8557	2.842	-.394	.482
-498.964	3.1996	3.1572	-1.219	1.344
-548.837	3.5483	3.47247	-2.196	2.2
-498.990	3.2004	3.1574	-1.237	1.364
-449.272	2.8569	2.8412	-.434	.531
-399.218	2.5195	2.5267	.216	-.283
-349.284	2.1867	2.211	.644	-1.413
-299.456	1.8639	1.8961	.924	-1.682
-249.532	1.5442	1.5820	1.222	-2.265
-199.617	1.2333	1.265	.999	-2.751
-149.764	.9199	.9499	.862	-3.167
-99.8371	.6123	.6343	.633	-3.427
-49.9362	.3068	.3129	.347	-3.824
49.8518	-.302	-.3119	-.223	-3.127
99.7298	-.6271	-.6272	-.577	-3.121
149.571	-.9144	-.9422	-.2	-2.842
199.51	-1.2244	-1.2579	-.965	-2.659
249.469	-1.5301	-1.5737	-1.225	-2.26
* 299.273	-1.8558	-1.8885	-.938	-1.724
349.175	-2.1794	-2.2039	-.726	-1.113
399.275	-2.5083	-2.5193	-.317	-.437
449.212	-2.8438	-2.835	.252	.328
498.299	-3.1851	-3.1533	.999	1.131
548.833	-3.53172	-3.46592	1.694	1.892
498.87	-3.186	-3.1532	1.031	1.137
448.955	-2.8451	-2.8346	.322	.37
399.263	-2.512	-2.5193	-.261	-.36
349.232	-2.1813	-2.2243	-.661	-1.341
299.275	-1.858	-1.8885	-.878	-1.613
249.423	-1.5399	-1.5733	-.958	-2.114
199.461	-1.2262	-1.2576	-.922	-2.486
149.523	-.9163	-.9423	-.748	-2.742
99.6976	-.6287	-.627	-.527	-2.925
49.8504	-.3231	-.3119	-.252	-2.779

TEST SUMMARY

FULL SCALE RATE (DEG/SEC): 553
 SCALE FACTOR (V/DEG/SEC): -6.32122E-03
 BIAS (VOLTS): 3.22861E-03
 HYSTERESIS, NEG RATES (VDC): -2.78258E-03
 HYSTERESIS, POS RATES (VDC): 2.11167E-03
 NULL OFFSET (VDC): 2.22923E-03

TABLE 3.6.2-II

TEST ENGINEER

[Signature]
 3-27-80

RATE SENSOR TEST PROGRAM

NADC 80081-60

DATE **3-22-80** RUN **POST ACOUSTIC**
BASELINE
 TEMP. **72.5 F** SER# **373**

RATE (DEG/SEC)	V OUT (VDC)	V CALC (VDC)	% FS	% IDEAL
-49.9431	.3212	.3137	.494	-3.958
-99.8472	.61	.6289	.75	-3.335
* -149.68	.922	.9437	.86	-2.229
-199.553	1.2381	1.2588	.819	-1.641
-249.532	1.5598	1.5744	.575	-.922
-299.421	1.8882	1.8897	.258	-.378
-349.292	2.2238	2.2348	-.751	.861
-399.172	2.5669	2.5199	-1.861	1.865
-349.284	2.2244	2.2347	-.781	.894
-299.365	1.8892	1.8894	.334	-.326
-249.535	1.5615	1.5744	.539	-.816
-199.612	1.2398	1.2592	.768	-1.54
-149.78	.9238	.9444	.816	-2.178
-99.8269	.6115	.6286	.683	-2.739
-49.9614	.3323	.3138	.453	-3.627
49.8533	-.3123	-.3162	-.176	-1.439
99.7327	-.6233	-.6317	-.451	-1.839
149.618	-.9337	-.947	-.645	-1.726
* 199.518	-1.2441	-1.2622	-.712	-1.44
249.337	-1.5624	-1.577	-.576	-.925
299.271	-1.8861	-1.8924	-.25	-.334
349.156	-2.2165	-2.2376	.353	.434
399.256	-2.5539	-2.5223	1.232	1.235
349.143	-2.2172	-2.2375	.385	.441
299.275	-1.8869	-1.8924	-.218	-.291
249.412	-1.5636	-1.5774	-.549	-.851
199.474	-1.2456	-1.262	-.642	-1.3
149.574	-.9317	-.9467	-.594	-1.589
99.6976	-.6214	-.6316	-.426	-1.63
-49.8131	-.3131	-.3165	-.135	-1.381

TEST SUMMARY
 FULL SCALE RATE (DEG/SEC): 400
 SCALE FACTOR (V/DEG/SEC): -6.31732E-03
 BIAS (VOLTS) : -1.80916E-03
 HYSTERESIS, NEG RATES (VDC): -1.75536E-03
 HYSTERESIS, POS RATES (VDC): 1.49465E-03
 NULL OFFSET (VDC): -5.62225E-03

TEST ENGINEER *Ray W. King*
 3-22-80

READY

TABLE 3.6.2-III

RATE SENSOR TEST PROGRAM

NADC 80081-60

POST ACOUSTIC

DATE 3-27-80.....

RUN# BASELINE.....

TEMP. 72°F...507RH..

SER#...373.....

RATE (DEG/SEC)	V OUT (VDC)	V CALC (VDC)	Z FS	Z IDEAL
-49.9340	.3008	.316	.534	-4.808
-99.6784	.6091	.6332	.845	-3.805
-149.688	.9208	.9496	1.208	-3.332
* -199.634	1.2363	1.2666	1.46	-2.39
-249.424	1.5578	1.5831	.886	-1.598
-299.421	1.8857	1.9006	.521	-.783
-349.27	2.2212	2.2173	-.137	.177
-399.182	2.5641	2.5343	-1.043	1.176
-449.139	2.9147	2.8514	-2.214	2.219
-399.169	2.565	2.5342	-1.078	1.215
-349.304	2.2223	2.2175	-.169	.218
-299.385	1.8876	1.9204	.45	-.676
-249.475	1.56	1.5834	.818	-1.476
-199.585	1.2386	1.2665	.976	-2.2
-149.764	.9228	.9501	.955	-2.868
-99.7998	.6139	.6327	.765	-3.447
-49.956	.3018	.3162	.502	-4.524
49.8599	-.3125	-.3178	-.186	-1.683
99.7585	-.6201	-.6348	-.514	-2.312
149.616	-.9303	-.9514	-.74	-2.225
199.535	-1.2436	-1.2683	-.863	-1.946
* 249.4	-1.5616	-1.5852	-.825	-1.489
299.288	-1.885	-1.9021	-.597	-.898
349.16	-2.2152	-2.2182	-.127	-.164
399.061	-2.5524	-2.5358	.581	.655
448.973	-2.8872	-2.8522	1.555	1.558
399.097	-2.5531	-2.536	.589	.675
349.234	-2.2163	-2.2193	-.104	-.134
299.334	-1.8862	-1.9024	-.565	-.85
249.378	-1.5631	-1.5851	-.768	-1.385
199.539	-1.2451	-1.2685	-.818	-1.845
149.623	-.9318	-.9515	-.689	-2.273
99.7162	-.6215	-.6345	-.455	-2.354
49.8536	-.3132	-.3178	-.158	-1.435

TEST SUMMARY

FULL SCALE RATE (DEG/SEC): 450
 SCALE FACTOR (V/DEG/SEC): -6.35151E-03
 BIAS (VOLTS) : -1.13828E-03
 HYSTERESIS, NEG RATES (VDC): -2.29526E-03
 HYSTERESIS, POS RATES (VDC): 1.51515E-03
 HULL OFFSET (VDC): -5.55075E-03

TEST ENGINEER

[Signature]
3-27-80

READY

TABLE 3.6.2-IV

RATE SENSOR TEST PROGRAM

NADC 80081-60

POST ACOUSTIC

DATE 3-27-80.....

RUN BASELINE.....

TEMP 72°F..... 50%RH.....

SER# 381.....

RATE (DEG/SEC)	V OUT (VDC)	V CALC (VDC)	Z FS	% IDEAL
-49.9665	.2949	.3074	.36	-3.961
-99.8641	.5988	.621	.642	-3.536
-149.692	.955	.9342	.832	-3.256
-199.639	1.2145	1.2482	.875	-2.677
-249.549	1.5277	1.5619	.99	-2.181
-299.353	1.8453	1.8749	.859	-1.572
x -349.345	2.1679	2.1892	.615	-.868
-399.189	2.4962	2.5226	.183	-.252
-449.076	2.8296	2.8161	-.391	.479
-498.949	3.1669	3.1296	-1.281	1.192
-548.886	3.52613	3.4435	-1.812	1.815
-499.315	3.1681	3.13	-1.134	1.217
-449.169	2.7311	2.8166	-.417	.511
-399.225	2.4977	2.5327	.146	-.231
-349.316	2.17	2.189	.549	-.865
-299.432	1.8471	1.8753	.813	-1.494
-249.578	1.5294	1.5621	.845	-2.282
-199.653	1.2161	1.2423	.931	-2.564
-149.715	.9367	.9344	.871	-2.943
-99.8642	.6222	.621	.622	-3.317
-49.9452	.2957	.3372	.333	-3.669
49.8687	-.3122	-.3222	-.262	-2.957
99.7399	-.6149	-.6337	-.541	-2.985
149.586	-.921	-.947	-.75	-2.752
199.496	-1.2226	-1.2637	-.899	-2.472
* 249.447	-1.5421	-1.5747	-.942	-2.272
299.297	-1.8586	-1.888	-.85	-1.562
349.171	-2.1802	-2.2015	-.615	-.969
399.32	-2.5369	-2.5152	-.24	-.33
449.322	-2.8389	-2.822	.285	.35
498.897	-3.1748	-3.1426	.929	1.324
548.826	-3.51313	-3.45644	1.64	1.643
498.931	-3.1754	-3.1429	.941	1.337
449.326	-2.8397	-2.8292	.334	.372
399.375	-2.5061	-2.5152	-.224	-.282
349.197	-2.1816	-2.2317	-.58	-.914
299.335	-1.8632	-1.8881	-.826	-1.431
249.376	-1.5439	-1.5742	-.872	-1.937
199.5	-1.2313	-1.2637	-.852	-2.342
149.615	-.9227	-.9472	-.722	-2.625
99.6858	-.6162	-.6333	-.495	-2.733
49.8528	-.3112	-.3231	-.232	-2.629

TEST SUMMARY
 FULL SCALE RATE (DEG/SEC): 553
 SCALE FACTOR (V/DEG/SEC): -6.26574E-33
 BIAS (VOLTS) 9 -6.71413E-33
 HYSTERESIS, NEG RATES (VDC): -2.87712E-33
 HYSTERESIS, POS RATES (VDC): 1.77813E-33
 FULL OFFSET (VDC): -7.84673E-23

TABLE 3.6.2-V

TEST ENGINEER

Boyd W. King
 3-27-80

RATE SENSOR TEST PROGRAM

DATE...3-27-80.....

RUN Post Acoustic B/L

NADC 80081-60

TEMP. 72°F.....51%RH..

SER#.....381.....

RATE (DEG/SEC)	V OUT (VDC)	V CALC (VDC)	Z FS	Z IDEAL
-49.9431	.2883	.3212	.342	-4.127
-99.8523	.5908	.6154	.651	-3.913
-149.827	.8958	.9298	.922	-3.611
-199.571	1.2035	1.2431	1.247	-3.143
-249.451	1.5155	1.5571	1.1	-2.645
* -299.419	1.8317	1.8716	1.257	-2.117
-349.291	2.1534	2.1855	.852	-1.463
-399.16	2.4805	2.4995	.531	-.754
-449.069	2.8127	2.8136	.225	-.233
-498.964	3.1491	3.1277	-.566	.681
-548.933	3.4877	3.4423	-1.222	1.314
-598.751	3.82568	3.75989	-1.842	1.852
-548.923	3.4887	3.44224	-1.23	1.344
-498.326	3.1506	3.128	-.592	.719
-449.357	2.8147	2.8136	-.229	.339
-399.221	2.4829	2.4997	.445	-.669
-349.377	2.1559	2.1861	.799	-1.371
-299.428	1.8344	1.8717	.933	-1.979
-249.482	1.518	1.5573	1.241	-2.533
-199.617	1.2059	1.2434	.992	-2.983
-149.71	.8979	.9292	.831	-3.329
-99.8337	.5924	.6153	.625	-3.635
-49.9687	.289	.3214	.329	-3.942
49.8714	-.3157	-.3271	-.323	-3.641
99.7196	-.6183	-.6409	-.586	-3.526
149.623	-.924	-.955	-.821	-3.294
199.556	-1.2317	-1.2693	-.997	-2.997
249.471	-1.5433	-1.5835	-1.066	-2.563
* 299.3	-1.8589	-1.8972	-1.213	-2.232
349.178	-2.1799	-2.2112	-.828	-1.422
399.127	-2.5058	-2.5255	-.522	-.784
448.979	-2.837	-2.8394	-.364	-.086
498.87	-3.1723	-3.1535	.5	.631
548.826	-3.51031	-3.46774	1.127	1.232
598.647	-3.84686	-3.78148	1.731	1.735
548.813	-3.51124	-3.46779	1.145	1.252
498.914	-3.1735	-3.1537	.523	.629
449.322	-2.8384	-2.8396	-.229	-.339
399.122	-2.5076	-2.5256	-.476	-.715
349.275	-2.1817	-2.2118	-.797	-1.37
299.324	-1.8639	-1.8974	-.964	-1.932
249.469	-1.5451	-1.5835	-1.218	-2.449
199.547	-1.2335	-1.2693	-.947	-2.846
149.693	-.9255	-.9555	-.794	-3.121
99.7484	-.6221	-.6411	-.556	-3.345
49.847	-.3165	-.3269	-.277	-3.336

TEST SUMMARY

FULL SCALE RATE (DEG/SEC): 633
 SCALE FACTOR (V/DEG/SEC): -6.29483E-03
 BIAS (VOLTS) : -1.31749E-32
 HYSTERESIS, NEG RATES (VDC): -2.66266E-23
 HYSTERESIS, POS RATES (VDC): 2.22203E-03
 NULL OFFSET (VDC): -1.22466E-32

TABLE 3.6.2-VI

TEST ENGINEER

Raymond L. Curry
 7-21-80

RATE SENSOR TEST PROGRAM

DATE 3-27-80..... RUN Post Acoustic 8/L
 TEMP. 72°F..... 51%RH. SER#...381.....

RATE (DEG/SEC)	V OUT (VDC)	V CALC (VDC)	% FS	% IDEAL
-49.947	.2883	.3258	.426	-5.549
-99.8434	.5937	.6203	.721	-4.695
-149.741	.8959	.9348	.951	-4.13
-199.58	1.2037	1.249	1.126	-3.632
-249.507	1.5154	1.5637	1.179	-3.371
-299.406	1.8317	1.8783	1.137	-2.467
-349.36	2.1534	2.1932	.971	-1.837
* -399.182	2.48	2.5073	.665	-1.382
-449.13	2.8125	2.8221	.235	-.34
-499.011	3.149	3.1366	-.323	.394
-548.893	3.48734	3.45127	-.885	1.248
-598.822	3.8254	3.76581	-1.454	1.578
-648.661	4.15825	4.37999	-1.925	1.929
-598.723	3.82631	3.76586	-1.495	1.623
-548.947	3.48937	3.45141	-.919	1.288
-499.079	3.1509	3.137	-.34	.443
-449.116	2.8149	2.822	.174	-.252
-399.139	2.4827	2.5073	.621	-.979
-349.322	2.1557	2.1928	.926	-1.606
-299.389	1.8341	1.8782	1.277	-2.338
-249.507	1.5175	1.5637	1.128	-2.938
-199.619	1.2052	1.2493	1.26	-3.453
-149.78	.8976	.9351	.914	-3.967
-99.8354	.5923	.6202	.682	-4.443
-49.9547	.289	.3058	.411	-5.349
49.8739	-.3156	-.3235	-.193	-2.521
99.7332	-.6184	-.6378	-.473	-3.281
149.598	-.9238	-.9521	-.692	-3.237
199.495	-1.2314	-1.2667	-.861	-2.826
249.447	-1.543	-1.5816	-.942	-2.455
* 299.327	-1.8584	-1.8959	-.914	-1.926
349.182	-2.1792	-2.2133	-.759	-1.413
399.095	-2.505	-2.5249	-.487	-.792
449.051	-2.836	-2.8398	-.393	-.135
498.907	-3.1714	-3.1541	.423	.551
548.633	-3.5095	-3.46879	.993	1.177
598.754	-3.84584	-3.78342	1.522	1.652
648.63	-3.99415	-4.09789	-2.532	-2.537
598.821	-3.84683	-3.78378	1.539	1.67
548.83	-3.51274	-3.46877	1.024	1.213
498.943	-3.173	-3.1543	.455	.592
449.046	-2.8379	-2.8398	-.347	-.267
399.165	-2.5071	-2.5254	-.446	-.727
349.229	-2.1813	-2.2124	-.712	-1.326
299.303	-1.8635	-1.8959	-.862	-1.872
249.435	-1.5448	-1.5315	-.895	-2.333
199.539	-1.2332	-1.267	-.825	-2.687
149.547	-.9254	-.9518	-.644	-2.8
99.7281	-.6199	-.6378	-.435	-2.837
49.8469	-.3165	-.3233	-.167	-2.172

TEST SUMMARY
 FULL SCALE RATE (DEG/SEC): 653
 SCALE FACTOR (V/DEG/SEC): -6.33381E-03
 BIAS (VOLTS) : -9.13134E-03
 HYSTERESIS, NEG RATES (VDC): -2.64645E-23
 HYSTERESIS, POS RATES (VDC): 2.12765E-03
 NULL OFFSET (VDC): -.212814

TEST ENGINEER: *[Signature]*
 3-27-80

TABLE 3.6.2-VII

RATE SENSOR PROGRAM: OUTPUT DRIFT
POST ACOUSTIC

NADC 80081-60

DATE . 3-28-80 RUN . BASELINE
TEMP . 72°F . . . 50%RH . . . SER# . . . 355

OUTPUT DRIFT IN 15 SEC INTERVALS

RATE (DEG/SEC)	MEAN (VDC)	SCALE FACTOR (VOLTS/DEG/SEC)
99.797	.633486	6.31737E-33
99.799	.633221	6.34416E-33
99.8132	.633935	6.35365E-33
99.8295	.634545	6.35578E-33
199.597	1.21344	6.36438E-33
199.571	1.21503	6.38823E-33
199.592	1.21698	6.39737E-33
199.62	1.21822	6.41172E-33
299.463	1.8367	6.13455E-33
299.42	1.84345	6.15674E-33
299.473	1.8458	6.16528E-33
299.364	1.84766	6.17195E-33
399.196	2.48574	6.22686E-33
399.214	2.49577	6.25173E-33
399.236	2.49899	6.25991E-33
399.232	2.50121	6.26541E-33
499.338	3.16141	6.33531E-33
499.359	3.17348	6.35882E-33
499.969	3.17755	6.36823E-33
499.314	3.17981	6.37218E-33

FULL OFFSET (VDC): 2.27038E-33

Boyd W. Cough
3-28-80

TABLE 3.6.2-VIII

RATE SENSOR PROGRAM: OUTPUT DRIFT POST ACOUSTIC NADC 80081-60
 DATE . 3-28-80 RUN . BASELINE
 TEMP . 72°F 50%RH SER# 373

OUTPUT DRIFT IN 15 SEC INTERVALS

RATE (DEG/SEC)	MEAN (VDC)	SCALE FACTOR (VOLTS/DEG/SEC)
99.8188	.599355	6.34438E-33
99.8254	.601539	6.32561E-33
99.831	.602466	6.33486E-33
99.8369	.603056	6.34244E-33
199.618	1.21929	6.13813E-33
199.588	1.22421	6.13369E-33
199.605	1.22556	6.13994E-33
199.596	1.22655	6.14512E-33
299.364	1.86141	6.21797E-33
299.392	1.86836	6.24253E-33
299.411	1.87325	6.24633E-33
299.407	1.8715	6.25367E-33
399.198	2.53146	6.34137E-33
399.221	2.54137	6.36537E-33
399.217	2.54413	6.37279E-33
399.22	2.54638	6.37764E-33
499.973	3.23239	6.47809E-33
499.986	3.24514	6.50347E-33
499.918	3.24863	6.51734E-33
499.944	3.25369	6.51385E-33

BULL OFFSET (VDC): -6.42718E-33

Boyd W. Curry Jr
 3-28-80

TABLE 3.6.2-IX

RATE SENSOR PROGRAM: OUTPUT DRIFT
POST ACOUSTIC

NADC 80081-60

DATE...3-27-80.....

RUN BASELINE.....

TEMP./20F...51RH...

SER#...381.....

OUTPUT DRIFT IN 15 SEC INTERVALS

RATE (DEG/SEC)	MEAN (VDC)	SCALE FACTOR (VOLTS/DEG/SEC)
99.8289	.58428	5.85281E-33
99.866	.586314	5.87131E-33
99.8614	.587333	5.87847E-33
99.8792	.587252	5.87863E-33
199.636	1.19246	5.96316E-33
199.622	1.19474	5.98551E-33
199.633	1.19587	5.99123E-33
199.589	1.19657	5.99513E-33
299.36	1.81238	6.25423E-33
299.394	1.81898	6.27521E-33
299.365	1.82384	6.28233E-33
299.427	1.82156	6.28349E-33
399.211	2.45457	6.14654E-33
399.179	2.46417	6.17317E-33
399.187	2.46667	6.17924E-33
399.188	2.46818	6.18299E-33
499.945	3.11943	6.25225E-33
499.803	3.13142	6.27535E-33
499.834	3.13445	6.28124E-33
499.838	3.13584	6.28376E-33

MULL OFFSET (VDC): -9.57715E-33

Boyd W. Camp
3-27-80

TABLE 3.6.2-X

POST ACOUSTIC TEST DATA SUMMARY

PARAMETER	S/N 355	S/N 373	S/N 381
FULL SCALE RATE (DEG/SECOND) AT +2% LINEARITY ERROR	500	400	600
SCALE FACTOR (MV/DEG/SEC) AT BASELINE RATE	-6.30	-6.32	-6.29
BIAS (DEG/SECOND)	-0.53	+0.29	+1.07
HYSTERESIS CCW (DEG/SECOND)	+0.46	+0.28	+0.33
HYSTERESIS CW (DEG/SECOND)	-0.29	-0.24	-0.28
NULL OFFSET (DEG/SECOND)	-0.43	+0.89	+1.25
THRESHOLD (DEG/SECOND)	<0.10	<0.10	<0.10
RESOLUTION (DEG/SECOND)	<0.10	<0.10	<0.10
READYTIME (SECONDS) AVG. OF 5 RATES*	.061	.069	.071
DRIFT (DEG/SEC/MIN) AVG. OF 5 RATES*	+0.75	+0.75	+0.65

*100, 200, 300, 400, AND 500 DEGREES/SECOND
(SEE TABLE 3.6.3-II)

TABLE 3.6.3-I

POST ACOUSTIC DRIFT AND READYTIME

RATE (DEG/SEC)	OUTPUT DRIFT (DEG/SEC/MIN)				READYTIME (SECONDS)		
	355	373	381	355	373	381	
100	+ .82	+ .76	+ .57	.062	.070	.070	
200	+ .79	+ .78	+ .67	.060	.070	.070	
300	+ .79	+ .69	+ .62	.060	.070	.070	
400	+ .58	+ .76	+ .73	.060	.068	.070	
500	+ .78	+ .75	+ .67	.062	.068	.075	

TABLE 3.6.3-II

3.7 Vibration

3.7.1 Test Setup and Procedure

The Superjet rate sensors were individually subjected to a sinusoidal mechanical vibration along each of its mutually perpendicular axis as described in Figure B.2-1 in Appendix A, Part B of this report.

A test fixture was fabricated by the environmental lab to accept the hole pattern of the Superjet assembly. The test fixture was installed on a test cube that is part of the C-60 vibration test set. A control accelerometer was mounted on the test fixture to monitor the vibration input along the vertical axis of the test set. The unit was then mounted on the test fixture. The 2222B accelerometer was mounted on the unit along the sensitive axis using Eastman 910 adhesive. A resonance search from 10 Hz to 3000 Hz was conducted at 3 g rms to find the three most severe resonances. This part of the test deviates from the test plan which describes the search from 10 to 5000 Hz. The maximum frequency available at the Martin facility is 3000 Hz. MIL-STD-810C procedures defines 10 to 2000 Hz as the resonance search frequencies. After the severe resonances were determined, the unit was subjected to each resonance frequency for a period of 10 minutes at 5.2 g rms. The unit was then tested for the other axes in the same manner.

After the vibration test, the baseline test was performed for all three units. This is the final test of the program and the results were compared to the post-acoustic baseline test as described in Section 3.6.

3.7.2 Test Results

A dyna-monitor was used to fine tune the most severe frequencies for dwelling. The output accelerometer was installed on the fibre cap of the sensor for S/N 373, and 355 when vibrating the X-axis (jet axis). Upon removal of the accelerometer the fibre cap of S/N 355 separated from its bond joint. This caused concern and the accelerometer was installed on a block on the top of the sensor. This explains the differences of frequencies established along the X-axis. The accelerometer was continued to a hard mount on the sensor for the Y and Z axes. The frequencies for each axis and serial number that were searched at 3.0 g rms and occurred again at 5.2 g rms are shown in Table 3.7.2-I. Also shown is the accelerometer output in units of g (gravity)

AXIS	S/N 355		S/N 373		S/N 381	
	f Hz	g	f Hz	g	f Hz	g
X	605	7.0	605	5.0	605	4.0
	850	11.8	970	9.8	950	5.5
	1075	9.5	1125	7.8	2500	14.0
Y	620	7.0	605	7.2	605	7.0
	925	8.2	1000	12.0	1150	13.2
	1840	9.6	2300	15.0	2150	9.2
Z	575	7.0	1025	7.3	560	6.0
	975	9.0	2225	10.0	1100	6.2
	1950	14.0	2650	18.0	2350	18.0

TABLE 3.7.2-I
SEVERE RESONANCE FREQUENCIES

The results from the baseline tests are shown in Tables 3.7.2-II through 3.7.2-XI.

3.7.3 Data Evaluation

The Superjet rate sensor is virtually unaffected by vibration along the X and Z axes except for a small increase in null noise level.

However, when the rate sensor is subjected to a vibration along the Y-axis, (normal to jet-axis and input axis), a null shift occurs at a very high frequency. This was evident on S/N 355 and S/N 381, which occurred at 1995 Hz and 2150 Hz respectively, during the resonance search. A null shift also occurred on S/N 373, but this was detected only on the dwell sequence since a sweep was not performed. A sweep was not performed due to the use of a dynamometer to tune in the resonance frequency.

The worst case baseline data was reduced to yield the following:

- | | |
|---|-------------------------------|
| 1. Full Scale Rate at $\pm 2\%$ Linearity Error | 500 ± 100 deg/sec |
| 2. Scale Factor | .00625 $\pm .00002$ V/deg/sec |
| 3. Bias | ± 2.19 deg/sec |
| 4. Hysteresis | $\pm .56$ deg/sec |
| 5. Threshold | < 0.10 deg/sec |
| 6. Resolution | < 0.10 deg/sec |
| 7. Readytime | .080 seconds maximum |
| 8. Drift | $\pm .76$ deg/sec/min maximum |
| 9. Null Offset | ± 2.08 deg/sec |

Readytime increased by 12% and the bias shifted by 104% on S/N 381. Since the other units did not change appreciably, the effects of vibration is predicted to be undamaging.

RATE SENSOR TEST PROGRAM

NADC 80081-60

DATE 4-7-80..... RUN POST VIBRATION
 TEMP 72°F 50%RH..... SER# 355.....
 BASELINE

RATE (DEG/SEC)	V OUT (VDC)	V CALC (VDC)	% FS	% IDEAL
-49.9437	.334	.3153	.367	-3.627
-99.8128	.6375	.6284	.667	-3.337
-149.739	.9139	.941	.866	-2.891
-199.531	1.2032	1.2532	.957	-2.398
* -249.467	1.5366	1.5665	.948	-1.9
-299.301	1.8551	1.8781	.756	-1.263
-349.159	2.1796	2.1914	.379	-.543
-399.057	2.5099	2.5043	-.177	.002
-448.995	2.8477	2.8174	-.965	1.375
-498.849	3.191	3.13	-1.944	1.948
-448.039	2.8487	2.8177	-.980	1.1
-399.077	2.512	2.5244	-.742	.304
-349.252	2.1826	2.192	.3	-.43
-299.277	1.8585	1.8787	.645	-1.077
-249.504	1.5433	1.5666	.84	-1.682
-199.632	1.2264	1.2537	.871	-2.181
-149.697	.9167	.9438	.767	-2.563
-99.8125	.61	.6285	.589	-2.949
-49.9538	.3253	.3154	.321	-3.239
49.8514	-.3321	-.3134	-.264	-2.649
99.7281	-.6062	-.6232	-.54	-2.738
x 149.593	-.9126	-.9358	-.74	-2.473
199.452	-1.2217	-1.2484	-.854	-2.14
249.347	-1.5346	-1.5613	-.852	-1.732
299.205	-1.8515	-1.8739	-.715	-1.194
349.112	-2.1742	-2.1866	-.474	-.575
398.97	-2.5023	-2.4994	.093	.116
448.897	-2.8368	-2.8125	.776	.864
498.787	-3.1773	-3.1253	1.657	1.661
448.899	-2.8376	-2.8125	.799	.89
398.999	-2.5334	-2.4996	.12	.151
349.121	-2.1756	-2.1869	-.36	-.516
299.232	-1.8532	-1.8741	-.666	-1.113
249.3	-1.5361	-1.561	-.794	-1.593
199.51	-1.2233	-1.2488	-.812	-2.234
149.55	-.9144	-.9355	-.673	-2.25
99.7292	-.6079	-.6232	-.485	-2.434
49.8273	-.3032	-.3126	-.237	-2.379

TEST SUMMARY
 FULL SCALE RATE (DEG/SEC): 500
 SCALE FACTOR (V/DEG/SEC): -6.27315E-03
 BIAS (VOLTS): 2.15551E-03
 HYSTERESIS, NEG RATES (VDC): -3.52833E-03
 HYSTERESIS, POS RATES (VDC): 1.83224E-03
 NULL OFFSET (VDC): 1.96227E-03

TEST ENGINEER

Boyd W. Curry, Jr.
 4-7-80

READY

TABLE 3.7.2-II

RATE SENSOR TEST PROGRAM

NADC 80081-60

POST VIBRATION

DATE 4-7-80.....

RUN BASELINE.....

TEMP 72°F 50%RH....

SER# 355.....

RATE (DEG/SEC)	V OUT (VDC)	V CALC (VDC)	Z- FS	Z IDEAL
-49.985	.3340	.3178	.393	-4.33
-99.4117	.6379	.6321	.699	-3.859
-149.68	.9143	.9467	.933	-3.427
* -199.595	1.2237	1.2615	1.389	-3.021
-249.466	1.5377	1.5761	1.139	-2.444
-299.341	1.856	1.8937	1	-1.837
-349.225	2.1844	2.2054	.719	-1.133
-399.134	2.511	2.52	.259	-.357
-448.933	2.848	2.8343	-.395	.484
-498.859	3.1914	3.1493	-1.210	1.341
-548.678	3.54247	3.46357	-2.217	2.222
-498.868	3.1925	3.1493	-1.243	1.371
-448.888	2.8498	2.8349	-.428	.524
-398.118	2.5128	2.5201	.239	-.289
-348.191	2.1827	2.2052	.647	-1.019
-298.34	1.8588	1.8907	.92	-1.689
-248.494	1.5406	1.5763	1.03	-2.27
-198.549	1.2267	1.2612	.996	-2.744
-148.656	.917	.9465	.851	-3.126
-98.854	.6103	.6324	.636	-3.524
-48.9843	.3055	.3178	.354	-3.892
48.8545	-.3023	-.312	-.279	-3.081
98.7518	-.6066	-.6267	-.58	-3.198
* 148.588	-.9127	-.9411	-.817	-3.235
198.474	-1.222	-1.2558	-.973	-2.683
248.373	-1.5351	-1.5705	-1.022	-2.254
298.271	-1.8524	-1.8853	-.947	-1.74
348.143	-2.1753	-2.1998	-.727	-1.114
398.984	-2.5038	-2.5142	-.3	-.414
448.892	-2.8332	-2.8291	.264	.323
498.809	-3.1766	-3.1439	.998	1.131
548.674	-3.52484	-3.45842	1.914	1.919
498.775	-3.1794	-3.1437	1.329	1.135
448.942	-2.8391	-2.8291	.287	.352
398.846	-2.5051	-2.5146	-.275	-.379
348.187	-2.1771	-2.2021	-.664	-1.246
298.283	-1.8544	-1.8854	-.893	-1.641
248.33	-1.5372	-1.5702	-.952	-2.299
198.5	-1.2244	-1.2559	-.907	-2.5
148.574	-.9153	-.941	-.74	-2.721
98.7619	-.6084	-.6268	-.53	-2.923
48.8775	-.3034	-.3121	-.251	-2.765

TEST SUMMARY

FULL SCALE RATE (DEG/SEC): 55.4
 SCALE FACTOR (V/DEG/SEC): -6.3279E-03
 BIAS (VOLTS) : 2.53893E-03
 HYSTERESIS, NEG RATES (VDC): -2.94518E-03
 HYSTERESIS, POS RATES (VDC): 2.59483E-03
 NULL OFFSET (VDC): 2.25735E-03

Boyd W. King
 4-7-80

TABLE 3.7.2-III

TEST ENGINEER.....

RATE SENSOR TEST PROGRAM

POST VIBRATION

DATE 4-7-80.....

RUN BASELINE.....

TEMP 72°F... 50%RH !

SER#... 373.....

RATE (DEG/SEC)	V OUT (VDC)	V CALC (VDC)	% FS	% IDEAL
-49.955	.2973	.3095	.488	-3.936
-99.8151	.6023	.6209	.746	-2.989
-149.702	.9107	.9327	.878	-2.345
* -199.614	1.2231	1.2443	.95	-1.733
-249.49	1.5411	1.5559	.991	-.947
-299.223	1.8658	1.8665	.93	-.24
-349.162	2.1975	2.1785	-.763	.274
-399.128	2.5372	2.4936	-1.865	1.869
-349.25	2.1983	2.179	-.773	.885
-299.416	1.867	1.8677	.93	-.239
-249.438	1.5429	1.5555	.944	-.309
-199.597	1.225	1.2442	.77	-1.544
-149.632	.9124	.9321	.79	-2.111
-99.832	.604	.621	.682	-2.732
-49.9777	.2984	.3096	.447	-3.577
49.8457	-.3097	-.3139	-.169	-1.359
99.767	-.6141	-.6258	-.466	-1.867
149.559	-.9209	-.9368	-.635	-1.699
* 199.444	-1.231	-1.2484	-.697	-1.397
249.422	-1.5457	-1.5636	-.595	-.953
299.271	-1.8656	-1.872	-.253	-.338
349.136	-2.1923	-2.1835	.355	.426
399.053	-2.5262	-2.4953	1.238	1.241
349.126	-2.1932	-2.1834	.393	.45
299.261	-1.8666	-1.8719	-.213	-.284
249.401	-1.547	-1.5605	-.54	-.867
199.547	-1.2324	-1.248	-.667	-1.337
149.603	-.9222	-.9371	-.594	-1.588
99.789	-.6154	-.6259	-.422	-1.69
49.8636	-.3136	-.314	-.14	-1.121

TEST SUMMARY

FULL SCALE RATE (DEG/SEC): 400
 SCALE FACTOR (V/DEG/SEC): -6.24649E-33
 BIAS (VOLTS) : -2.57981E-33
 HYSTERESIS, NEG RATES (VDC): -1.86441E-33
 HYSTERESIS, POS RATES (VDC): 1.37997E-33
 FULL OFFSET (VDC): -5.85245E-33

TEST ENGINEER

Boyd W. Perry, Jr.
4-7-80

READY

TABLE 3.7.2-IV

RATE SENSOR TEST PROGRAM

NADC 80081-60

DATE 4-7-80

POST VIBRATION

RUN BASELINE

TEMP 72°F 50%RH

SER# 373

RATE (DEG/SEC)	V OUT (VDC)	V CALC (VDC)	Z FS	Z IDEAL
-49.8533	.2962	.3158	.516	-4.666
-99.8526	.6302	.6237	.834	-3.757
-149.747	.9277	.9366	1.022	-3.372
* -199.618	1.2181	1.2482	1.067	-2.425
-249.448	1.5363	1.5617	.899	-1.622
-299.377	1.8587	1.8747	.534	-.832
-349.252	2.1926	2.1874	-.111	.143
-399.126	2.5229	2.5631	-1.321	1.151
-448.945	2.8759	2.8125	-2.246	2.251
-399.116	2.5298	2.5231	-1.252	1.190
-349.281	2.1821	2.1877	-.156	.231
-299.316	1.8612	1.8743	.445	-.668
-249.433	1.5326	1.5616	.813	-1.467
-199.61	1.2217	1.2492	.976	-2.2
-149.72	.9291	.9364	.943	-2.833
-99.8438	.6224	.6237	.753	-3.393
-49.8614	.2976	.3132	.472	-4.252
49.8643	-.3091	-.315	-.249	-1.385
99.7399	-.6122	-.6277	-.53	-2.39
149.625	-.9127	-.9435	-.771	-2.318
199.439	-1.2281	-1.2522	-.677	-1.92
x 249.326	-1.542	-1.566	-.842	-1.532
299.2	-1.8614	-1.8783	-.589	-.9
349.289	-2.1877	-2.1912	-.124	-.16
399.227	-2.521	-2.5341	.6	.677
448.97	-2.8618	-2.8173	1.575	1.579
399.243	-2.5217	-2.5343	.617	.626
349.149	-2.1891	-2.1915	-.224	-.126
299.231	-1.8633	-1.8785	-.537	-.828
249.432	-1.5442	-1.5663	-.782	-1.41
199.535	-1.2322	-1.2534	-.823	-1.855
149.567	-.9229	-.9431	-.621	-2.25
99.679	-.6146	-.6273	-.452	-2.341
49.8435	-.3122	-.3149	-.164	-1.482

TEST SUMMARY

FULL SCALE RATE (DEG/SEC): 450
 SCALE FACTOR (V/DEG/SEC): -6.26991E-43
 BIAS (VOLTS) : -2.34913E-43
 HYSTERESIS, NEG RATES (VDC): -2.52536E-43
 HYSTERESIS, POS RATES (VDC): 2.17795E-43
 NULL OFFSET (VDC): -6.14822E-43

TEST ENGINEER

Boyd W. Long
4-7-80

READY

TABLE 3.7.2-V

RATE SENSOR TEST PROGRAM

POST VIBRATION

DATE 4-7-80..... RUN BASELINE.....

TEMP. 72°F. 50%RH.... SER# 381.....

DATE (DEG/SEC)	V OUT (VDC)	V CALC (VDC)	Z-FS	Z IDEAL
-49.9897	.086	.0979	.345	-3.797
-99.7173	.5868	.6000	.640	-3.556
* -1-9.769	.89	.9199	.871	-3.199
-199.591	1.1963	1.2331	.985	-2.714
-299.140	1.5060	1.5411	1.236	-2.218
-399.39	1.8210	1.8523	.895	-1.645
-349.189	2.1413	2.1629	.63	-.990
-399.394	2.4667	2.4739	.249	-.288
-449.305	2.7979	2.7649	-.375	.46
-499.847	3.133	3.2950	-1.399	1.233
-548.663	3.47121	3.43614	-1.898	1.933
-498.964	3.1339	3.0963	-1.490	1.238
-449.371	2.7988	2.7853	-.399	.481
-399.138	2.468	2.4741	.178	-.245
-349.255	2.1431	2.1630	.588	-.925
-299.345	1.8231	1.8501	.847	-1.555
-249.403	1.5083	1.541	.952	-2.1
-199.599	1.198	1.2334	.945	-2.624
-149.755	.8919	.9194	.838	-2.948
-99.8483	.5883	.6004	.588	-3.241
-49.9355	.2867	.2970	.317	-3.491
49.481	-.3140	-.3240	-.299	-3.22
99.7721	-.6158	-.6359	-.577	-3.18
149.569	-.9182	-.9459	-.75	-2.869
199.538	-1.2250	-1.2570	-.933	-2.573
* 249.43	-1.535	-1.5683	-.971	-2.142
299.354	-1.849	-1.8795	-.88	-1.635
349.138	-2.1686	-2.1898	-.62	-.876
399.39	-2.4927	-2.5211	-.246	-.339
448.846	-2.8224	-2.8119	.338	.377
498.813	-3.1503	-3.1227	.978	1.079
548.711	-3.49387	-3.43368	1.756	1.76
498.843	-3.1571	-3.1229	.997	1.099
448.846	-2.8233	-2.8173	.321	.393
399.343	-2.4937	-2.5219	-.21	-.29
349.19	-2.1697	-2.1931	-.596	-.939
299.315	-1.8535	-1.8793	-.838	-1.54
249.464	-1.5367	-1.5686	-.928	-2.045
199.539	-1.2268	-1.2574	-.891	-2.455
149.643	-.9201	-.9464	-.745	-2.739
99.6858	-.6171	-.635	-.521	-2.877
49.9156	-.3155	-.3240	-.27	-2.876

TEST SUMMARY

FULL SCALE RATE (DEG/SEC): 552
 SCALE FACTOR (V/DEG/SEC): -6.23289E-03
 BIAS (VOLTS) : -1.36726E-02
 HYSTERESIS, NEG RATES (VDC): -1.95563E-03
 HYSTERESIS, POS RATES (VDC): 1.73748E-03
 FULL OFFSET (VDC): -1.29399E-02

3.7.2-VI

TEST ENGINEER

Boyd W. King, Jr. 4-7-80

RATE SENSOR TEST PROGRAM

POST VIBRATION

DATE...4-7-80.....

RUN...BASELINE.....7

NADC 80081-60

TEMP. 72°F.....50%RH.....

SER#...381.....

RATE (DEG/SEC)	V OUT (VDC)	V CALC (VDC)	% FS	% IDEAL
-49.9386	.286	.2991	.348	-4.175
-99.8354	.5868	.6116	.661	-3.97
-149.825	.8699	.9246	.923	-3.698
-199.571	1.1961	1.2363	1.071	-3.221
-249.411	1.5063	1.5485	1.123	-2.722
-299.375	1.8209	1.8615	1.28	-2.164
* -349.231	2.1407	2.1738	.88	-1.511
-399.186	2.466	2.4867	.55	-.827
-449.082	2.7971	2.7992	.057	-.076
-498.91	3.1325	3.1113	-.563	.678
-548.747	3.47083	3.42354	-1.258	1.376
-598.644	3.80909	3.73600	-1.943	1.947
-548.795	3.47181	3.42384	-1.276	1.395
-498.849	3.1342	3.1109	-.62	.745
-448.995	2.7993	2.7987	-.016	.021
-399.077	2.4682	2.486	.472	-.71
-349.229	2.1434	2.1736	.826	-1.385
-299.414	1.8235	1.8617	1.212	-2.04
-249.492	1.5087	1.549	1.074	-2.584
-199.546	1.1983	1.2362	1.008	-3.332
-149.67	.8921	.9238	.843	-3.379
-99.8424	.5885	.6117	.617	-3.726
-49.9459	.2869	.2991	.326	-3.92
49.8716	-.3147	-.3261	-.332	-3.638
99.7298	-.6161	-.6364	-.594	-3.576
* 149.611	-.9193	-.9508	-.839	-3.366
199.532	-1.2255	-1.2635	-1.313	-3.345
249.464	-1.5354	-1.5763	-1.089	-2.618
299.29	-1.8493	-1.8884	-1.04	-2.384
349.209	-2.1685	-2.2011	-.866	-1.488
399.068	-2.4927	-2.5134	-.55	-.827
448.987	-2.8225	-2.826	-.093	-.125
498.833	-3.1568	-3.1383	.494	.594
548.731	-3.49442	-3.45077	1.161	1.27
598.615	-3.83134	-3.76323	1.812	1.816
548.789	-3.49535	-3.45113	1.176	1.286
498.831	-3.1581	-3.1383	.527	.634
449.011	-2.8241	-2.8262	-.056	-.074
399.075	-2.4945	-2.5134	-.502	-.755
349.143	-2.1703	-2.2007	-.807	-1.386
299.329	-1.8512	-1.8886	-.996	-1.997
249.439	-1.5373	-1.5761	-1.233	-2.485
199.491	-1.2273	-1.2633	-.958	-2.86
149.576	-.9213	-.9536	-.781	-3.131
99.7627	-.6175	-.6386	-.563	-3.386
49.8479	-.3158	-.3259	-.271	-3.264

TEST SUMMARY

FULL SCALE RATE (DEG/SEC): 600
 SCALE FACTOR (V/DEG/SEC): -6.26373E-23
 BIAS (VOLTS) : -1.37173E-32
 HYSTERESIS, NEG RATES (VDC): -2.63329E-33
 HYSTERESIS, POS RATES (VDC): 1.92114E-33
 FULL OFFSET (VDC): -1.29701E-32

3.7.2-VII

TEST ENGINEER.....

Boyd W. King 4-7-80

RATE SENSOR TEST PROGRAM POST VIBRATION
 DATE...4-7-80..... RUN...BASELINE...
 TEMP 72°E....50XPH.. SER#...381.....

RATE (DEG/SEC)	V OUT (VDC)	V CALC (VDC)	Z FS	Z IDEAL
-49.8396	.2853	.3024	.42	-5.469
-99.81	.5853	.6149	.726	-4.729
-149.744	.8881	.9278	.975	-4.231
-199.544	1.1934	1.2399	1.142	-3.72
-249.45	1.503	1.5526	1.217	-3.171
* -299.368	1.8168	1.8654	1.195	-2.594
-349.23	2.1363	2.1779	1.021	-1.9
-399.147	2.4611	2.4907	.726	-1.182
-449.332	2.7914	2.8333	.292	-.422
-498.9	3.1263	3.1158	-.26	.338
-548.812	3.46414	3.42858	-.873	1.334
-598.644	3.80222	3.74284	-1.507	1.636
-648.59	4.13696	4.05322	-2.341	2.346
-598.649	3.83356	3.74328	-1.539	1.671
-548.918	3.46625	3.42924	-.909	1.376
-498.893	3.1288	3.1157	-.322	.42
-449.238	2.7943	2.8331	.216	-.313
-399.393	2.4642	2.4903	.641	-1.344
-349.279	2.1395	2.1782	.949	-1.766
-299.279	1.82	1.8649	1.1	-2.389
-249.543	1.506	1.5532	1.159	-3.22
-199.59	1.1962	1.2402	1.379	-3.515
-149.648	.8905	.9272	.902	-3.918
-99.8286	.5873	.615	.68	-4.431
-49.9489	.2863	.3025	.396	-5.153
49.8914	-.3142	-.3232	-.22	-2.86
99.7315	-.6149	-.6355	-.506	-3.296
149.699	-.918	-.9486	-.752	-3.263
199.567	-1.2235	-1.2611	-.923	-3.328
249.369	-1.5328	-1.5732	-.991	-2.584
* 299.298	-1.8463	-1.8861	-.975	-2.118
349.222	-2.1652	-2.1989	-.827	-1.539
399.285	-2.489	-2.5114	-.55	-.895
449.331	-2.8189	-2.8243	-.135	-.195
498.87	-3.1523	-3.1367	.383	.5
548.686	-3.48972	-3.44877	1.025	1.191
598.721	-3.8264	-3.76231	1.573	1.738
648.498	-3.98751	-4.27423	-2.129	-2.134
598.667	-3.82694	-3.76197	1.595	1.732
548.792	-3.49372	-3.44944	1.313	1.2
498.824	-3.154	-3.1362	.436	.562
449	-2.8235	-2.8242	-.291	-.131
399.368	-2.4914	-2.5113	-.488	-.794
349.237	-2.168	-2.1987	-.756	-1.437
299.292	-1.8492	-1.886	-.925	-1.965
249.431	-1.5354	-1.5734	-.934	-2.433
199.523	-1.2258	-1.2627	-.858	-2.795
149.733	-.92	-.9486	-.723	-3.352
99.7295	-.6166	-.6354	-.462	-3.329
49.87	-.3153	-.323	-.191	-2.493

TEST SUMMARY
 FULL SCALE RATE (DEG/SEC): 658
 SCALE FACTOR (V/DEG/SEC): -6.26639E-03
 BIAS (VOLTS) : -1.3544CE-02
 HYSTERESIS, NEG RATES (VDC): -3.26322E-03
 HYSTERESIS, POS RATES (VDC): 2.84352E-03
 NULL OFFSET (VDC): -1.31849E-02

TEST ENGINEER.....

TABLE 3.7.2-VIII

Boyd W. Long
 4-7-80

RATE SENSOR PROGRAM : OUTPUT DRIIFT
 POST VIBRATION NADC 80081-60
 DATE...4-7-80..... RUN BASELINE.....
 TEMP...72°F...50%RH... SER#...355.....

OUTPUT DRIIFT IN 15 SEC INTERVALS

RATE (DEG/SEC)	MEAN (VDC)	SCALE FACTOR (VOLTS/DEG/SEC)
99.8345	.623328	6.34338E-33
99.8457	.625652	6.26588E-33
99.8478	.626267	6.27195E-33
99.8376	.626612	.626376
199.598	1.21324	6.26142E-33
199.611	1.21363	6.12525E-33
199.622	1.22221	6.11266E-33
199.6	1.22298	6.11714E-33
299.397	1.84496	6.14688E-33
299.386	1.84771	6.17166E-33
299.458	1.85352	6.17958E-33
299.421	1.85231	6.18533E-33
399.2	2.49331	6.23749E-33
399.184	2.49831	6.26136E-33
399.198	2.50242	6.26861E-33
399.192	2.50452	6.27397E-33
499.331	3.165	6.34232E-33
499.323	3.1772	6.36803E-33
499.365	3.18113	6.37418E-33
499.366	3.18396	6.37933E-33

FULL OFFSET (VDC): 2.45548E-33

Boyd W. Curry Jr
4-7-80

TABLE 3.7.2-IX

RATE SENSOR PROGRAM: OUTPUT DRIFT
 POST VIBRATION NADC 80081-60
 DATE... 4-7-80..... RUN... BASELINE.....
 TEMP... 72°F 50%RH..... SER#... 373.....

OUTPUT DRIFT IN 15 SEC INTERVALS

RATE (DEG/SEC)	HEAT (VDC)	SCALE FACTOR (VOLTS/DEG/SEC)
99.8490	.63146	6.32305E-33
99.855	.633570	6.34573E-33
99.8596	.634355	6.35530E-33
99.83	.634714	6.35744E-33
199.617	1.22157	6.11484E-33
199.612	1.22482	6.13022E-33
199.619	1.220	6.14167E-33
199.622	1.22722	6.14774E-33
299.43	1.86054	6.21362E-33
299.441	1.86709	6.23526E-33
299.407	1.86902	6.24241E-33
299.441	1.87333	6.24636E-33
399.231	2.5287	6.33443E-33
399.221	2.53813	6.35771E-33
399.19	2.54077	6.36487E-33
399.191	2.54222	6.36931E-33
499.987	3.22597	6.46523E-33
499.980	3.2380	6.48953E-33
499.989	3.24146	6.49593E-33
499.980	3.24395	6.50066E-33

FULL OFFSET (VDC): 4.56691E-32

Boyd W. Coughlin
 4-7-80

TABLE 3.7.2-X

RATE SENSOR PROGRAM: OUTPUT DRIFT
 POST VIBRATION NADC 80081-60

DATE...4-7-80..... RUN#...BASELINE.....
 TEMP. 72°F...50%RH... SER#...381.....

OUTPUT DRIFT IN 15 SEC INTERVALS

RATE (DEG/SEC)	MEAN (VDC)	SCALE FACTOR (VOLTS/DEG/SEC)
99.8345	.584426	5.85395E-33
99.8675	.586381	5.87154E-33
99.8944	.586943	5.87504E-33
99.8782	.587049	5.87765E-33
199.63	1.19246	5.96333E-33
199.632	1.19457	5.99300E-33
199.631	1.19552	5.99864E-33
199.639	1.19611	5.99135E-33
299.45	1.8133	6.34541E-33
299.448	1.81712	6.36810E-33
299.396	1.81874	6.37471E-33
299.414	1.81985	6.37535E-33
399.212	2.45169	6.14182E-33
399.224	2.46121	6.16499E-33
399.210	2.46363	.336171
399.234	2.46515	6.17470E-33
499.982	3.11433	6.24276E-33
499.993	3.12579	6.26440E-33
499.992	3.1285	6.26964E-33
499	3.1336	6.27375E-33

FULL OFFSET (VDC): -1.34531E-0

Boyd W. Curry Jr
 4-7-80

TABLE 3.7.2-XI

POST VIBRATION TEST DATA SUMMARY

PARAMETER	S/N 355	S/N 373	S/N 381
FULL SCALE RATE (DEG/SECOND) AT +2% LINEARITY ERROR	500	400	600
SCALE FACTOR (MV/DEG/SEC) AT BASELINE RATE	-6.27	-6.25	-6.23
BIAS (DEG/SECOND)	-0.34	+0.41	+2.19
HYSTERESIS CCW (DEG/SECOND)	+0.56	+0.30	+0.31
HYSTERESIS CW (DEG/SECOND)	-0.29	-0.22	-0.27
NULL OFFSET (DEG/SECOND)	-0.32	+0.94	+2.08
THRESHOLD (DEG/SECOND)	<0.10	<0.10	<0.10
RESOLUTION (DEG/SECOND)	<0.10	<0.10	<0.10
READYTIME (SECONDS) AVG. OF 5 RATES*	.070	.070	.080
DRIFT (DEG/SEC/MIN) AVG. OF 5 RATES*	+0.76	+0.72	+0.63

*100, 200, 300, 400 AND 500 DEGREES/SECOND.
(See Table 3.7.3-II)

TABLE 3.7.3-I

POST VIBRATION DRIFT AND READYTIME

RATE (DEG/SEC)	OUTPUT DRIFT (DEG/SEC/MIN)				READYTIME (SECONDS)				
	355	373	381	355	373	381	355	373	381
100	+ .70	+ .72	+ .51	.072	.072	.085	.072	.072	.085
200	+ .76	+ .70	+ .61	.070	.072	.078	.070	.072	.078
300	+ .77	+ .69	+ .64	.068	.068	.075	.068	.068	.075
400	+ .78	+ .72	+ .70	.068	.070	.075	.068	.070	.075
500	+ .80	+ .75	+ .70	.072	.070	.090	.072	.070	.090

TABLE 3.7.3-II

4.0 CONCLUSIONS AND RECOMMENDATIONS

The data collected and evaluated produced the following information on the 3 Superjet Angular Rate Sensors tested:

SUPERJET TEST DATA (Worst Case)

1. Full Scale Rate at <u>+2%</u> Linearity	500 <u>+100</u> deg/sec
2. Scale Factor	.0062 <u>+.0002</u> V/deg/sec
3. Null Bias (calculated)	<u>+2</u> deg/sec
4. Hysteresis	<u>+0.6</u> deg/sec
5. Threshold	<0.1 deg/sec
6. Resolution	<0.1 deg/sec
7. Readytime	80 milliseconds maximum
8. Drift	<u>+0.76</u> deg/sec/min
9. Null Offset (measured)	<u>+2</u> deg/sec
10. G-Sensitivity	1.68 deg/sec/g maximum
11. High Temperature Tested	+165°F
12. Low Temperature Tested	-30°F
13. Sensitivity to Jerk	Negligible
14. Acoustic Sensitivity	Negligible
15. Vibration Sensitivity	<u>+2</u> deg/sec at approx. 2,000 Hz

The low temperature environment -30°F changes the scale factor by -10%. The reduction of the scale factor by 10% shifts the least squares fit straight line out of the +2% linearity limits of the baseline performance, (See Figure 3.4.2-1).

The Superjet rate sensor/electronic package needs to be better temperature compensated for the requirements of the Maximum Performance Escape System.

It is difficult to determine the impact of a (worst case) 1.68 deg/second/g G-sensitivity effects of the Superjet, without a clearer definition of the MPES requirements. A conceivable 10 g environment would generate a 10 degree/second error.

Considering the results of this test program, it appears that the Superjet angular rate sensor is a viable candidate for the Maximum Performance Escape System. Additional testing should be performed to verify the unexpected high G-sensitivity.

LIST OF TERMSACOUSTIC SENSITIVITY:

Acoustic Sensitivity is the effect of acoustic vibration on an operating sensor (output change vs. frequency) and the shift in performance parameters after a known acoustic environment.

BIAS:

Bias is the null or zero offset evaluated as the output at zero input as calculated using the method of least squares to input-output data obtained by varying the input cyclically over the input span. This excludes outputs due to hysteresis and acceleration.

DRIFT:

Drift is the change in output at a given rate over a specified period of time (degrees/second/minute).

G-SENSITIVITY:

G-Sensitivity is the effect of acceleration on the output of the sensor. (degrees/second/g)

HYSTERESIS:

Hysteresis is the difference between output signals for increasing and decreasing inputs at that input for which the difference is maximum, measured after cycling through the input span (degrees/second).

JERK:

The constant rate of change of acceleration.

NON-LINEARITY:

Non-linearity is a term which describes the systematic deviations from the least squares straight line for input-output relationships which nominally can be represented by a linear equation. In this case non-linearity is +2% full scale.

NULL OFFSET:

Null offset is the sensor output when the input rate is zero, generally expressed as an equivalent input rate. It excludes outputs due to hysteresis and acceleration (degrees/second).

READYTIME:

Readytime is the time required for the sensor to measure 95% of its steady-state output, at all rates, without any electronic warmup.

RELIABILITY:

Reliability is the probability that a sensor will meet specified performance requirements under specified environmental conditions throughout a specified operating or storage life.

RESOLUTION:

Resolution is the largest value of the minimum change in input, for inputs greater than the threshold, which produces a change in output equal to some specified percentage (at least fifty percent) of the change in output expected using the nominal scale factor (degrees/second).

SCALE FACTOR:

Scale factor is the ratio of change in output to a change in the input intended to be measured. Scale factor is generally evaluated as the slope or the straight line that can be fitted by the method of least squares to input-output data obtained by varying the input cyclically over the input span (volts/degree/second).

THRESHOLD:

Threshold is the largest absolute value of the minimum input that produces an output equal to some specified percentage (at least fifty percent) of the output expected using the nominal scale factor (degree/second).

VIBRATION SENSITIVITY:

Vibration sensitivity is the effect of vibration on an operating sensor (output change vs. frequency) and the shift in performance parameters after a known vibration environment.

APPENDIX A

Introduction

This test procedure outlines the details and order of events to evaluate the performance of Hamilton-Standard's "SUPERJET" Rate Sensor for application to a Navy Air Development Center (NADC) Program. This procedure is in accordance with "Test Plan, for Performance Verification Tests, on the SUPERJET Angular Rate Sensor, Contract No. DAAK40-79-D-0017, November, 1979", prepared by Jerome C. Salmons. The test plan has been approved by NADC as of January 11, 1980.

A. Baseline Test

A.1 Parameters to be measured are:

- Input Voltage (Volts)
- Input Current (Amps)
- Full Scale Range at 2% Linearity (Degrees/Seconds)
- Hysteresis (VDC)
- Threshold (Degrees/Seconds)
- Resolution (Degrees/Seconds)
- Output Drift (Degrees/Seconds/Minutes)
- Ready Time (Seconds)
- Null Offset (VDC)

A.2 Test Setup

The baseline tests are conducted at 77°F \pm 10°F and less than 90% relative humidity.

The equipment used for baseline performance was:

- Genisco 1100-2 Rate Table & Controller
- BWCO32580-001 Test Plate
- BWCO32580-002 Test Plate
- 8"X8"X8" Cube Test Fixture
- Honeywell 1858 Visicorder
- Hewlett Packard 9500A Test Set :
 - 1 - HP 2116C Computer
 - 2 - 50 Volt Power Supplies
 - 2 - 100 Volt Programmable Power Supplies
 - 5 - 40 Volt Power Supplies
 - 1 - Programmable Counter
 - 1 - Oscilloscope
 - 1 - Volt - Ohmmeter
- Modular Switch Panel

A test schematic is shown in Figure A.2-1.

A.3 Test Procedure

1. Install test plate BWC032580-001 to top of Genisco 1100-2 Rate Table. Insure that "connector" stamped on plate is near connector located on rate table.
2. Install test plate BWC032580-002 onto 8"X8"X8" cube test fixture.
3. Install Superjet sensor on test plate BWC032580-002 and install cube on table so that sensor is located on the rate table centerline. (Input axis parallel to rate table axis.)
4. Connect wires on rate table to sensor.
5. Load "scale factor" program in 9500A computer test set and turn on rate table controller.
6. Engage Switch 1 on computer switch panel, (See Figure A.3-1).
7. If hysteresis measurement at each rate increment is desired, engage Switch 14.
8. To abort test Switch 15 should be engaged.
9. Run program.
10. Check voltage and current requirements on printout. The values shall be:

Voltage	+15.0V	+0.5V
	-15.0V	+0.5V
Current - Positive	85.0	+5.0 ma
Negative	11.0	+1.0 ma
11. Check temperature reading (if high or low temperature extremes) and null offset.
12. Disengage Switch 1 on computer switchboard.
13. Insert maximum rate desired and rate increment, (degrees/second, example: 500, 50), into computer.
14. Make test run.
15. Obtain data printout. Check test summary:

- *Full Scale Rate
- *Scale Factor*
- *Bias*
- *Hysteresis, Negative Rates
- *Hysteresis, Positive Rates
- *Null Offset**

*Determined by least squares fit.
**Added after first run of baseline test.

16. Note temperature, relative humidity, date, and barometric pressure.
17. Check percent of full scale linearity error to be less than +2%.
18. Rerun program at new maximum rate until linearity error exceeds +2%.
19. For this program rate increments have been set at 50 degrees/second.
20. Repeat Steps 1 thru 19 for other Rate Sensor units.
21. Load "Output Drift/Ready Time/Threshold/Resolution" program in the 9500A Computer Test Set and turn on Rate Table Controller.
22. Connect the Honeywell 1858 Visicorder to the patch panel on the Hewlett Packard 9500A Test Set. The remote drive on the Visicorder is connected to D21 and D22 on the patch panel. Set time lines to .1 seconds and chart speed to 8 in/second. Using a channel on the Visicorder with a sensitivity of 500 millivolts per division, connect the signal line to L27 on the patch panel. The computer is programmed to run recorder for 250 milliseconds, turn on the sensor and measure output for 750 milliseconds, for readytime measurements.
23. Run program.
24. When bells ring, set sensitivity on recorder to 100 mv/division for 100 degree/sec. rate. This must be done within two minutes after sounding bell.
25. When bells ring, set sensitivity to 200 mv/division for 200 degree/second rate - two minute wait.
26. When bells ring, set sensitivity to 500 mv/div. This will be setting for 300, 400, and 500 degrees/second rates.
27. Data printout:
 Output Drift
 Null Offset
28. Repeat Steps 23 thru 27 for other units.
29. Engage switch 1 on computer switchboard and run program.
30. Set sensitivity of recorder to 5 MV full scale. It may be required to use an external power generator to offset the null offset voltage of any sensor.

31. Set recorder drive to manual and set at .8 in./sec. chart speed with time lines at 10 second intervals.
32. Operate the rate table controller manually from zero degree/second to 1.0 degree/second in 0.1 degree/second increments. Allow each increment to run 1 second minimum. (Threshold test, ref.).
33. Operate the rate table controller manually from 5.0 to 6.0 degrees/second in 0.1 degrees/second increment. Allow each increment to run 1 second minimum. (Resolution test, ref.).
34. Repeat Steps 30 thru 33 for other units.
35. Stop program.

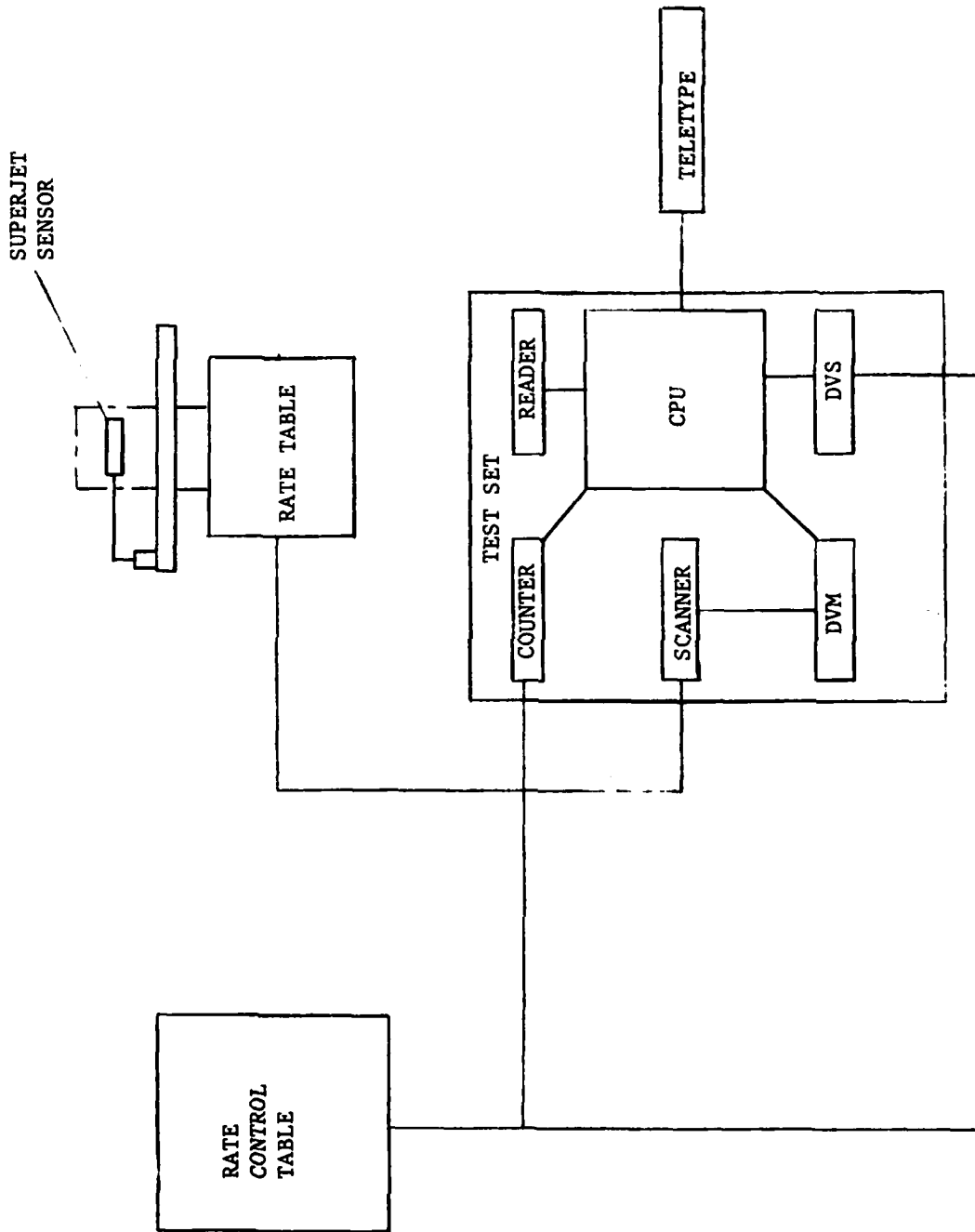

FIGURE A.2-1
BASELINE TEST SCHEMATIC

APPENDIX A - PART B

B. ACCELERATION SENSITIVITY

B.1 Parameters to be measured:

Output vs. Acceleration (in units of gravity g)
Null Offsets

B.2 Test Setup

The acceleration test was conducted at 77°F \pm 10°F and less than 90% relative humidity.

The equipment used for the acceleration test was:

- Hewlett Packard 9500A Test Set
- Genisco G1100-2 Rate Table and Controller
- 8"X8"C8" Test Cube
- BWC032580-001 Test Plate
- BWC032580-002 Test Plate
- BWC032580-003 Arm
- BWC032580-004 Angle (used for acceleration of Z axis)
- BWC032580-005 Plate (used for acceleration of X and Y axis)

The test setup schematic is shown in Figure B.2-1, which is the baseline test schematic. Axis orientation is shown in Figure B.2-1.

B.3 Test Procedure

The acceleration test was performed by the following steps:

1. Install test plate BWC032580-001 to top of Genisco 1100-2 rate table. Insure that "connector" is stamped on plate near connector located on rate table.
2. Install test plate BWC032580-002 into 8"X8"X8" cube test fixture.
3. Install Superjet sensor on test plate BWC032580-002 insuring that sensor is located on the rate table centerline.

Mount cube test fixture as follows:

AXIS ACCELERATED	HOLE PATTERN USED ON BWC032580-001 TEST PLATE
X	1
Y	1
Z	3 (jet axis down)

Check to see that sensor centerline is on rate table centerline.

4. Connect wires on rate table to sensor.
5. Load "scale factor" program in 9500A computer test set and turn on rate table controller.
6. Disengage switch 1 on computer switchboard.
7. Engage switch 14.
8. To abort test switch 15 should be engaged.
9. Run program.
10. Input maximum rate of 500 degrees per second and 50 degrees per second rate increment. i.e. 500, 50.
11. Test run.
12. Data printout.
13. Note temperature, relative humidity, date, and barometric pressure.
14. Repeat steps 3 through 13 for each axis and unit, (should be 6 runs for 3 units since X and Y axis runs are identical).
15. Remove test plates and test cube from rate table.
16. Attach BWC032580-003 arms to rate table.
17. Attach units to either BWC032580-004 angle or BWC032580-005 plate depending on which axis is accelerated (make sure that both sides are identical for maintaining proper rate table balance).
18. Connect electrical pigtail to one of the units.
19. Run program.
20. Input maximum rate of 500 degrees/second.
21. Test run.
22. Data printout.
23. Note temperature, relative humidity, date and barometric pressure.
24. Repeat steps 17 through 23 for all configurations.
25. End of testing.

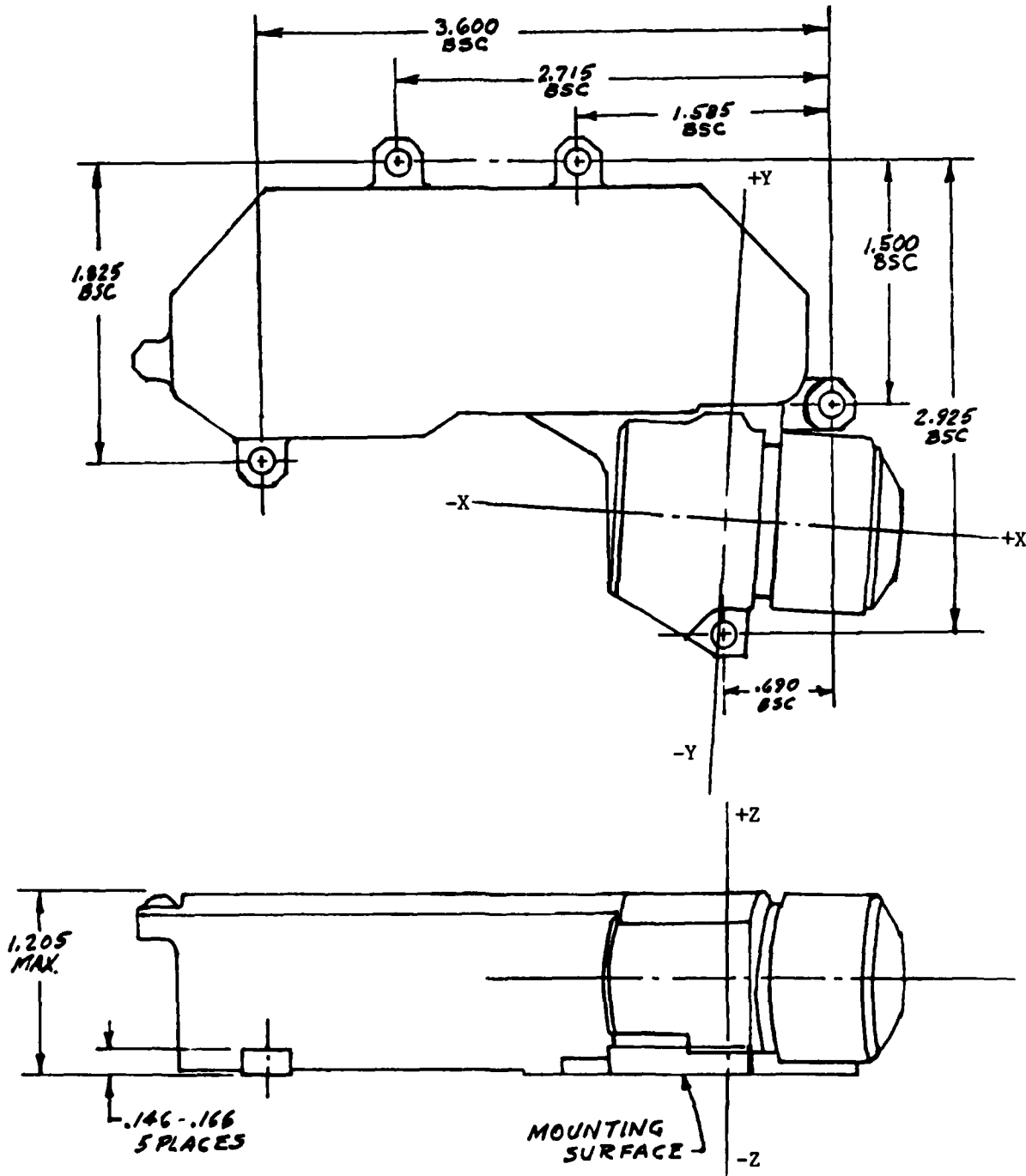

FIGURE B.2-1

SENSOR ORIENTATION

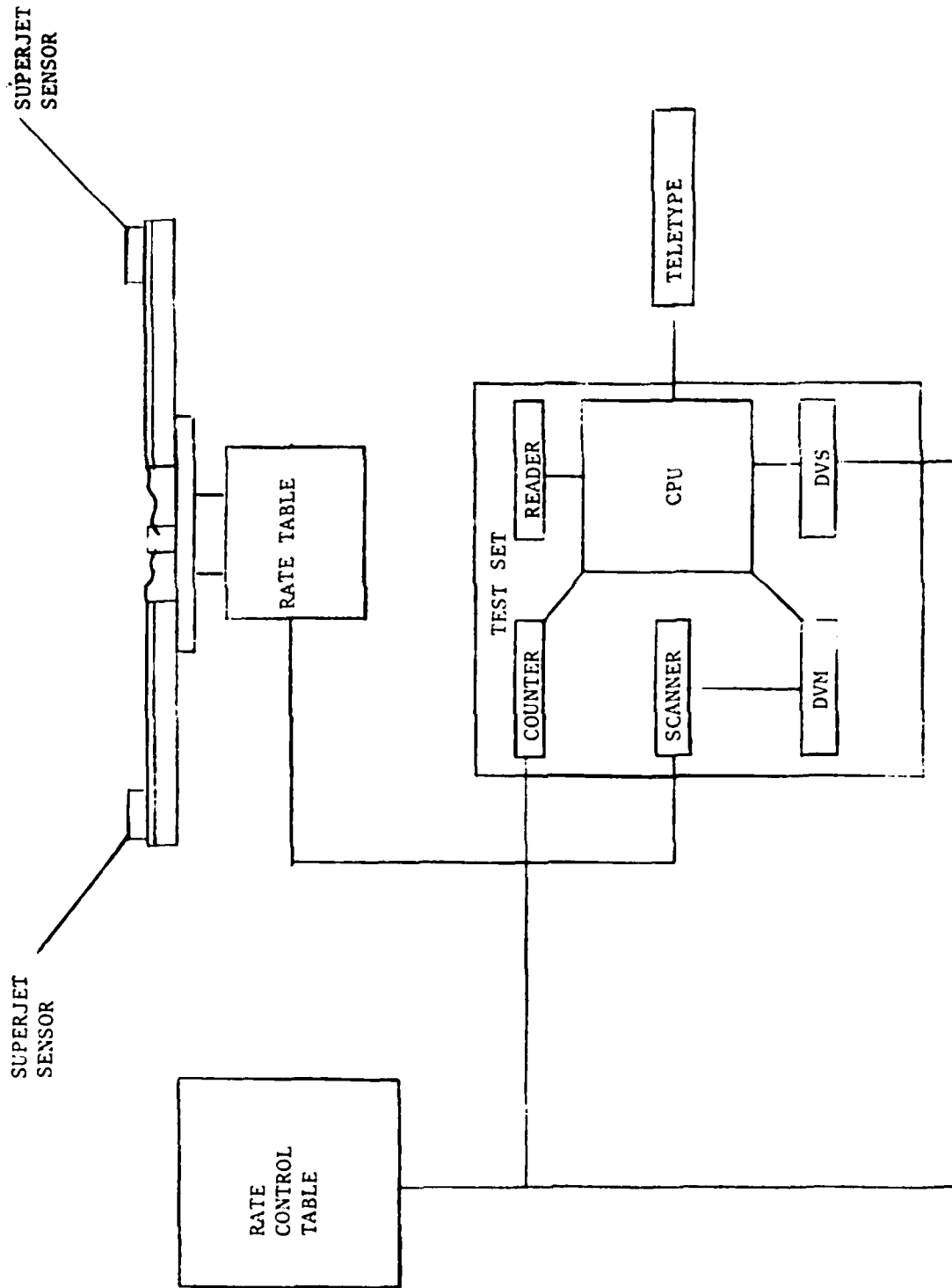

FIGURE B.2-2

ACCELERATION TEST SCHEMATIC

APPENDIX A - PART C

C. TEMPERATURE SENSITIVITY

C.1 Parameters to be measured are:

Input Voltage
Input Current
Full Scale Range at +2% Linearity
Hysteresis
Threshold
Resolution
Output Drift
Readytime
Null Offset

C.2 Test Setup

The temperature sensitivity tests were conducted at -30°F $+5^{\circ}\text{F}$ and $+165^{\circ}\text{F}$ $+5^{\circ}\text{F}$. The equipment used for this test was:

Hewlett Packard 9500A Test Set
Genisco G1100-2 Rate Table and Controller
8"X8"X8" Test Cube
BWC032580-001 Test Plate
BWC032580-002 Test Plate
Martin Marietta Temperature Controller
Fenwal UUT 45J1 Thermistor
Martin Marietta Environmental Chamber (Portable)
Honeywell 1858 Visicorder
Liquid Nitrogen Bottle
Iron-constantine Thermocouple Wire

C.3 Test Procedure

This procedure may be used for both hot and cold temperature testing. The only difference is the external setup. Figure C.3-1 shows the test schematic for the high temperature testing. The cold temperature test schematic is shown in Figure C.3-2. The test procedure for either hot or cold environments is as follows:

1. Bring test unit to temperature and soak for 45 minutes.
2. Load "scale factor" program in 9500A computer test set and turn on rate table controller.
3. Engage switch 1 on computer switchboard.
4. If hysteresis at each rate is desired, engage switch 14.
5. To abort test switch 15 should be engaged.

6. Run program.
7. Check voltage and current requirements on print out. The values shall be:

Voltage	+15.0V	+0.5V
	-15.0V	+0.5V
Current - Positive	85.0	+5.0 ma
Negative	11.0	+1.0 ma

8. Check temperature reading and null offset.
9. If satisfied with temperature and null offset disengage switch 1 on computer switchboard.
10. Insert maximum rate desired and rate increment (degrees/second). Example: 500, 50.
11. Run test.
12. Check data printout and test summary:

```

*Full Scale Rate
*Scale Factor*
*Bias*
'Hysteresis, Negative Rates
'Hysteresis, Positive Rates
*Null Offset**

```

*Determined by least squares fit.

**Added after initial baseline test.

13. Note temperature, relative humidity, date, and barometric pressure.
14. Check percent of full scale linearity to be less than 2%.
15. Rerun program at new maximum rate until linearity error exceeds 2%.
16. For this program rate increments have been set at 50 degrees/second.
17. Load "output drift/readytime/threshold/resolution" program into the 9500A computer test set and turn on rate table controller.
18. Connect the Honeywell 1858 Visicorder to the patch panel on the Hewlett Packard 9500A test set. The remote drive on the visicorder is connected to D21 and D22 on the patch panel. Set time lines to .01 seconds and chart speed to 8 inches/second. Using a channel on the visicorder with a sensitivity of 500 millivolts per division, connect the signal line to D29 and the return line to L27 on the patch panel. The remote drive is programmed to run recorder for 250 milliseconds, turn on the sensor and measure output for 750 milliseconds.

19. Run program.
20. When bells ring, set sensitivity on recorder to 100 mv/division for 100 deg/sec. This must be done within two minutes after sounding bell.
21. When bells ring, set sensitivity to 200 mv/division for 200 degrees/second - two minute wait.
22. When bells ring, set sensitivity to 500 mv/division. This will be setting for 300, 400, and 500 degrees/second rates.
23. Data Printout:
Output Drift
Null Offset
24. Engage Switch 1 on computer switchboard and run program.
25. Set sensitivity of recorder to 5mv full scale. It may be required to use an external power generator to offset the null offset voltage of any sensor.
26. Set recorder drive to manual and set at .8 inches/second, chart speed with time lines at 10 second intervals.
27. Operate the rate table controller manually from zero degree/second to 1.0 degree/second in 0.1 degree/second increments. Allow each increment to run 1 second minimum.
28. Operate the rate table controller manually from 5.0 to 6.0 degrees/second in 0.1 degrees/second increment. Allow each increment to run 1 second minimum.
29. Stop program.
30. Repeat Steps 1 thru 29 for other units.
31. For 165^oF, connect heater wires and monitor thermistor until resistance is 6750 OHMS +200 OHMS. Soak unit for 45 minutes.

For -30^oF, connect liquid nitrogen hose to top of chamber and monitor flow and dry nitrogen pressure until thermocouple wire is -30^oF +5^oF. Soak for 45 minutes.

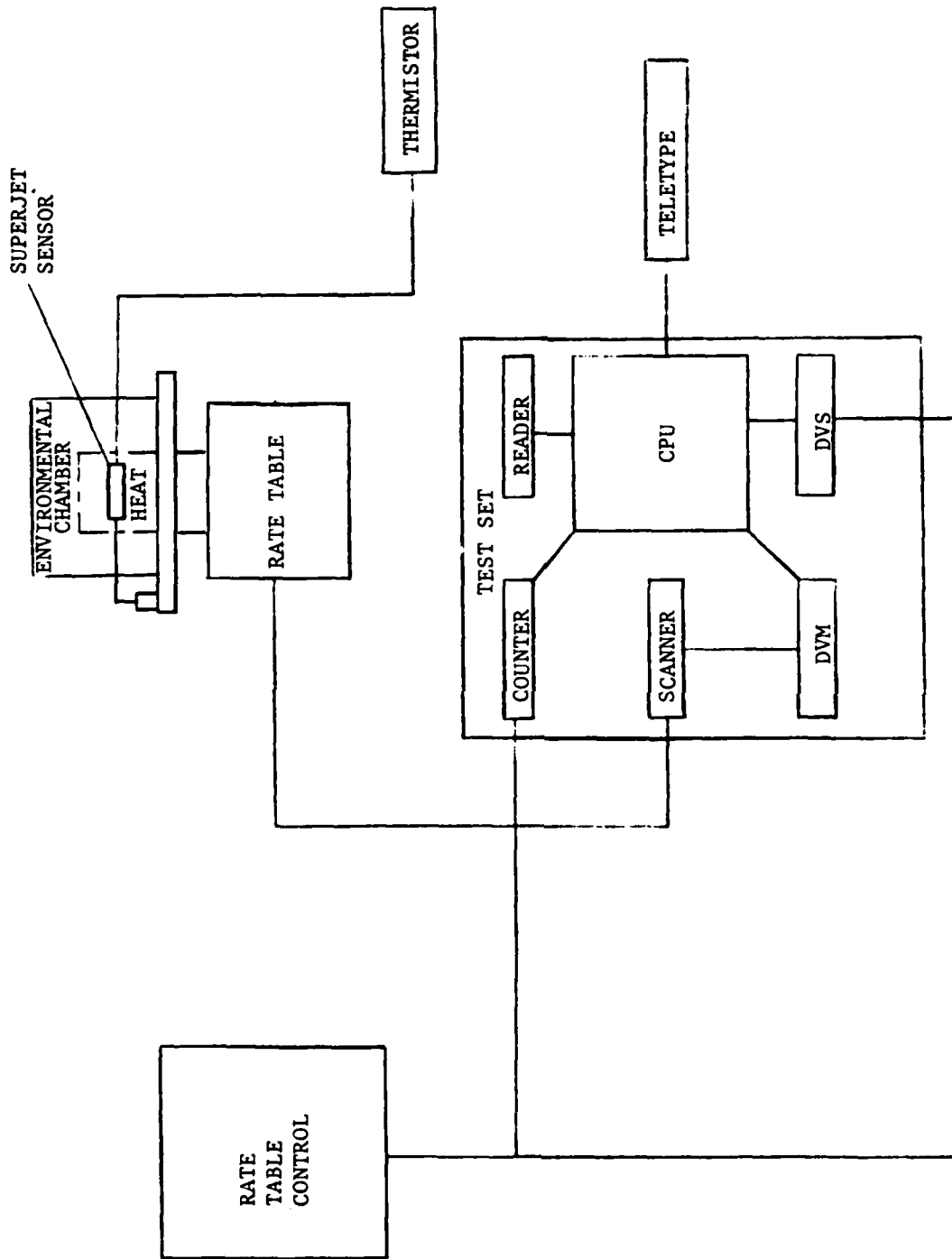

FIGURE C.3-1

HIGH TEMPERATURE TEST SCHEMATIC

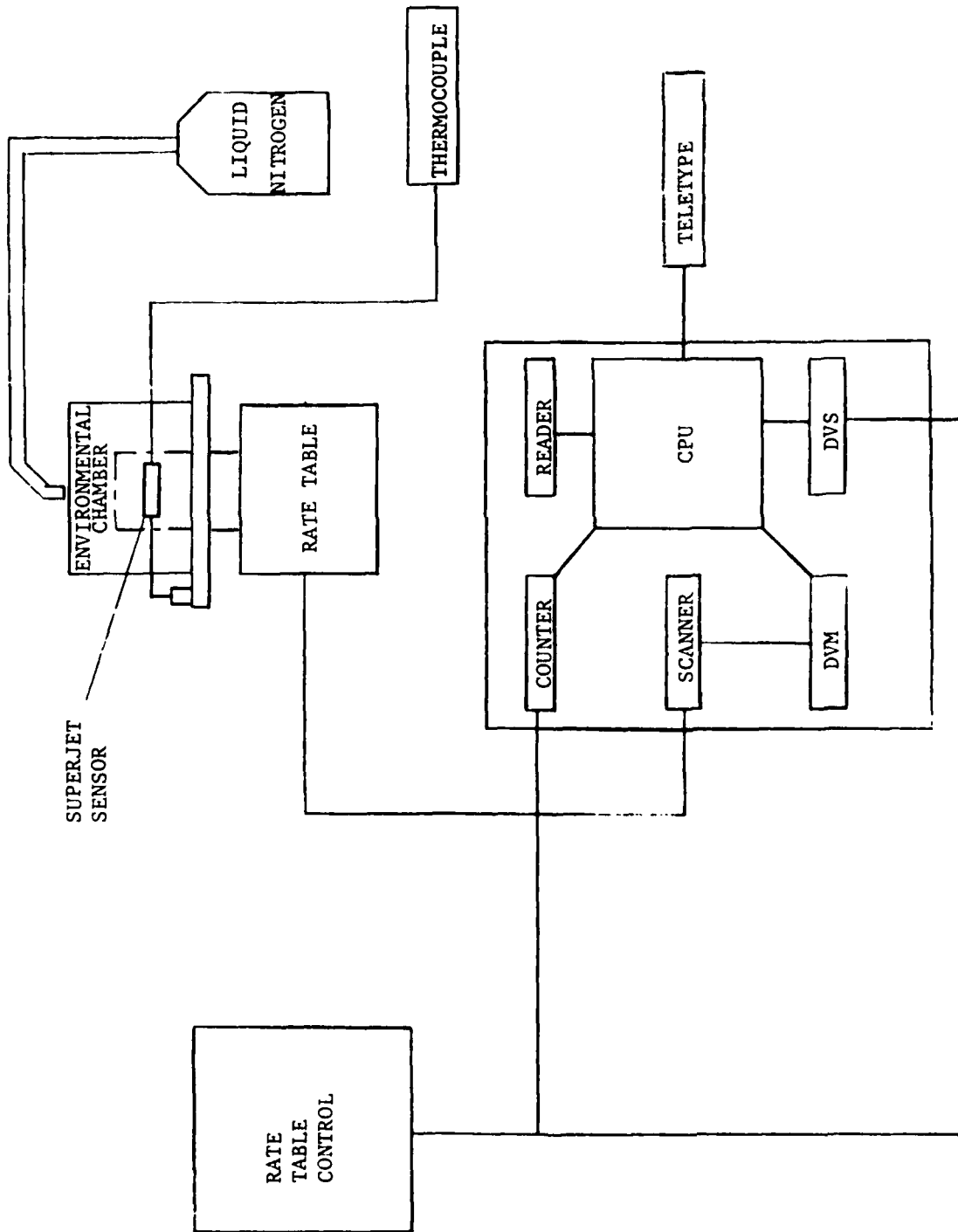

FIGURE C.3-2
LOW TEMPERATURE TEST SCHEMATIC

D. JERK SENSITIVITY

D.1 Parameters to be measured:

Output at Various Jerk Rates
Null Offset

D.2 Test Setup

The Jerk tests are to be conducted at 77°F \pm 10°F and less than 90% relative humidity. The following equipment is to be used:

Hewlett Packard 9500A Test Set
Genisco G1100-2 Rate Table and Controller
BWC 032580-003 Arm
BWC 032580-004 Angle
BWC 032580-005 Plate
BWC 032580-001 Test Plate
BWC 032580-002 Test Plate
8"x8"x8" Test Cube

A test schematic is shown in Figure D.2-1.

D.3 Test Procedure

The jerk test was performed by the following steps:

1. Install test plate BWC 032580-001 to top of Gensico 1100-2 rate table. Insure that "connector" stamped on plate in near connector located on rate table.
2. Install test plate BWC 032580-003 into 8"x8"x8" cube test fixture.
3. Install Superjet sensor on test plate BWC 032580-002 insuring that sensor is located on the rate table centerline.

Mount cube test fixture as follows:

AXIS ACCELERATED	HOLE PATTERN USED ON BWC 032580-002 TEST PLATE
X	1
Y	1
Z	3 (Jet Axis Down)

Check to see that sensor centerline is on rate table centerline.

4. Connect wires on rate table to sensor.
5. Load "jerk test" program in 9500A computer test set and turn on rate table controller.

6. Disengage Switch 1 on computer switchboard.
7. Engage Switch 14.
8. To abort test switch 15 should be engaged.
9. Run program.
10. Insert measurement rate of 250 or 500 degrees per second and direction of rotation.
11. Run test.
12. Check data printout.
13. Note temperature, relative humidity, date and barometric pressure.
14. Repeat steps 3 through 13 for each axis and unit, (should be 6 runs for 3 units since X and Y axis runs are identical).
15. Remove test plates and test cube from rate table.
16. Attach BWC 032580-003 arms to rate table.
17. Attach units to either BWC 032580-004 angle or BWC 032580-005 plate depending on which axis is accelerated (make sure that both sides are identical for maintaining proper rate table balance).
18. Connect electrical pigtails to one of the units.
19. Run program.
20. Input measurement rate of 250 or 500 degrees/second.
21. Run test.
22. Check data printout.
23. Note temperature, relative humidity, date and barometric pressure.
24. Repeat steps 17 through 23 for all configurations.

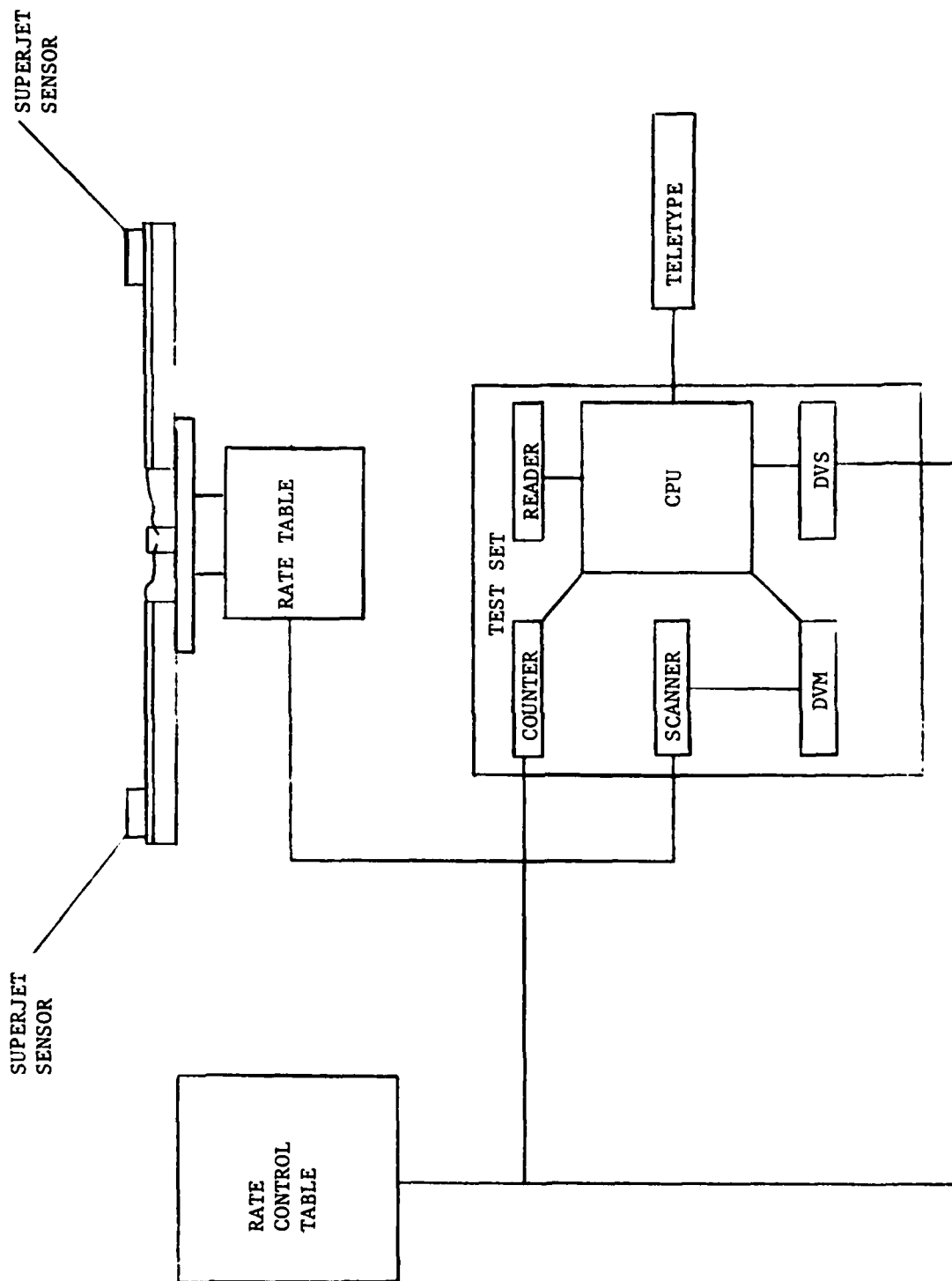

FIGURE D.2-1
JERK TEST SCHEMATIC

E. ACOUSTIC SENSITIVITY

E.1 Parameters to be measured:

Overall Decibel Level
Null Output

E.2 Test Setup

The acoustic test was conducted at 72°F and less than 90% relative humidity. The equipment used was:

Martin Marietta Acoustic Chamber
Hewlett Packard Model 5451B Acoustic Analyzer
Honeywell 1858 Visicorder
Martin Marietta Control Box
Digitec 262C Multimeter
Philbrick Researches PR-300 Power Supply

A test schematic is shown in Figure E.2-1.

A test schematic describing the monitoring of each unit is shown in Figure E.2-2.

E.3 Test Procedure

The acoustic test was performed by the following steps:

1. Install unit on beam support and position in acoustic chamber throat area.
2. Position three microphones surrounding the test article as described in MIL-STD-810C method 515.2 paragraph 3.5.2.1.
3. Connect test unit to control box.
4. Connect +15 V.D.C. and -15 V.D.C. to control box.
5. Connect white wire on test unit to (+) signal on digital multimeter (must be floating DMM, Ref 6V) and on visicorder.
6. Connect grey wire on test unit to common on DMM, and on visicorder.
7. Connect real time noise analyzer to recorder and set at 170 db full scale.
8. Turn on DMM and set sensitivity to read millivolts.
9. Turn on recorder set at 0.8 inches/second chart speed and 10 second time lines.

10. Turn on test unit by turning power switch to "warmup" on control box.
11. Apply acoustic environment of eight 10 second +8 second pulses and achieve the maximum overall db level, but do not exceed 165 db.
12. End test.
13. Repeat steps 1 through 12 for other units.

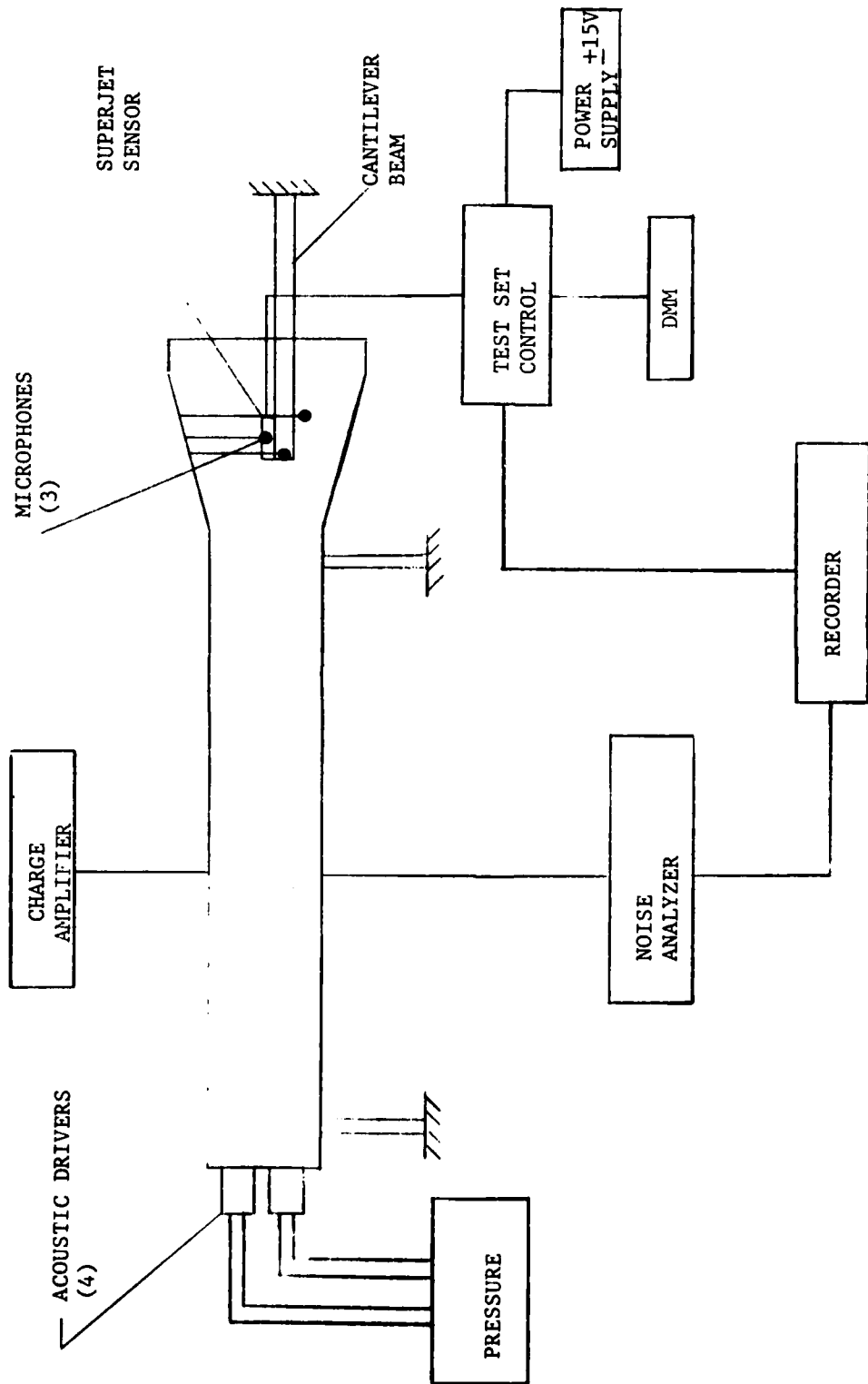

FIGURE E.2-1
ACOUSTIC TEST SCHEMATIC

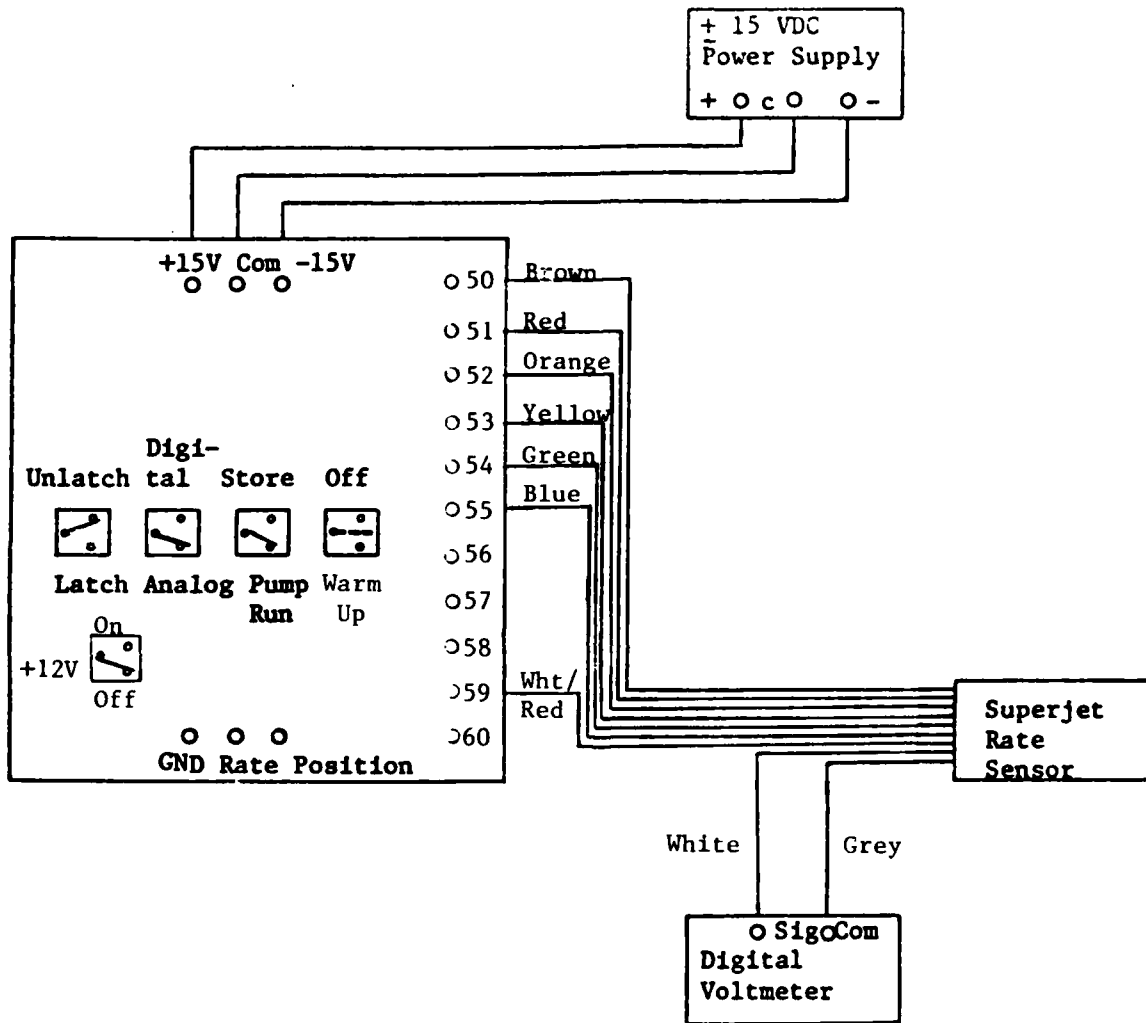

FIGURE E.2-2
TEST SET CONTROL

APPENDIX A - PART F

F. VIBRATION

F.1 Parameters to be measured:

Most Severe Resonances (3)
Null Output

F.2 Test Setup

The vibration test was conducted at 70°F and less than 90% relative humidity. The test was performed in the environmental test laboratory at Martin Marietta. The equipment used was:

C-60 Vibration Test Set
10 - 3000 Hz capability
Endevco Dynamometer Model 2702B
Accelerometer 2222B S/N FX15
(.3% sensitivity)
Honeywell 1858 Visicorder
Martin Marietta Control Box
Digitec 262C Multimeter
Philbrick Researches PR-300 Power Supply

The test setup is illustrated schematically by Figure F.2-1, and Figure E.2-2.

F.3 Test Procedure

Each test run was based on the following step-by-step procedure:

1. Install unit on test fixture mounted on test cube located on the C-60 Vibration Test Set.
2. Annotate orientation.
3. Connect control accelerometer to monitor vibration input (3.0 or 5.2g rms).
4. Mount accelerometer 2222B on Superjet sensor in a manner to monitor the output of the axis under vibration.
5. Connect control accelerometer to visicorder. Set sensitivity to 10 g/in.
6. Connect output accelerometer to visicorder to 10 g/in.
7. Connect unit to control box.
8. Connect +15.0VDC and -15.0VDC and common to control box.
9. Connect white wire on test unit to the (+) on digital multimeter (must be floating DMM, Ref. 6V).

10. Connect grey wire on test unit to *common* on DMM.
11. Connect white and grey wires to visicorder. Set sensitivity to 20 mv/in.
12. Connect frequency counter on C-60 test set to visicorder. Set sensitivity to 5 v/in.
13. Set chart speed to 0.1 in/sec and timelines to 10 second intervals.
14. Start visicorder.
15. Turn on unit at control box (power switch to "warmup").
16. Apply resonance search at 3g rms from 10 to 3000 Hz over a period of 3.5 minutes.
17. Stop visicorder.
18. Select the three most severe resonances and annotate.
19. Start visicorder.
20. Dwell unit for 10 minutes at each selected resonance.
21. Stop visicorder.
22. Turn off unit.
23. Repeat test for each orientation and other units.
24. Repeat baseline test per Part A.

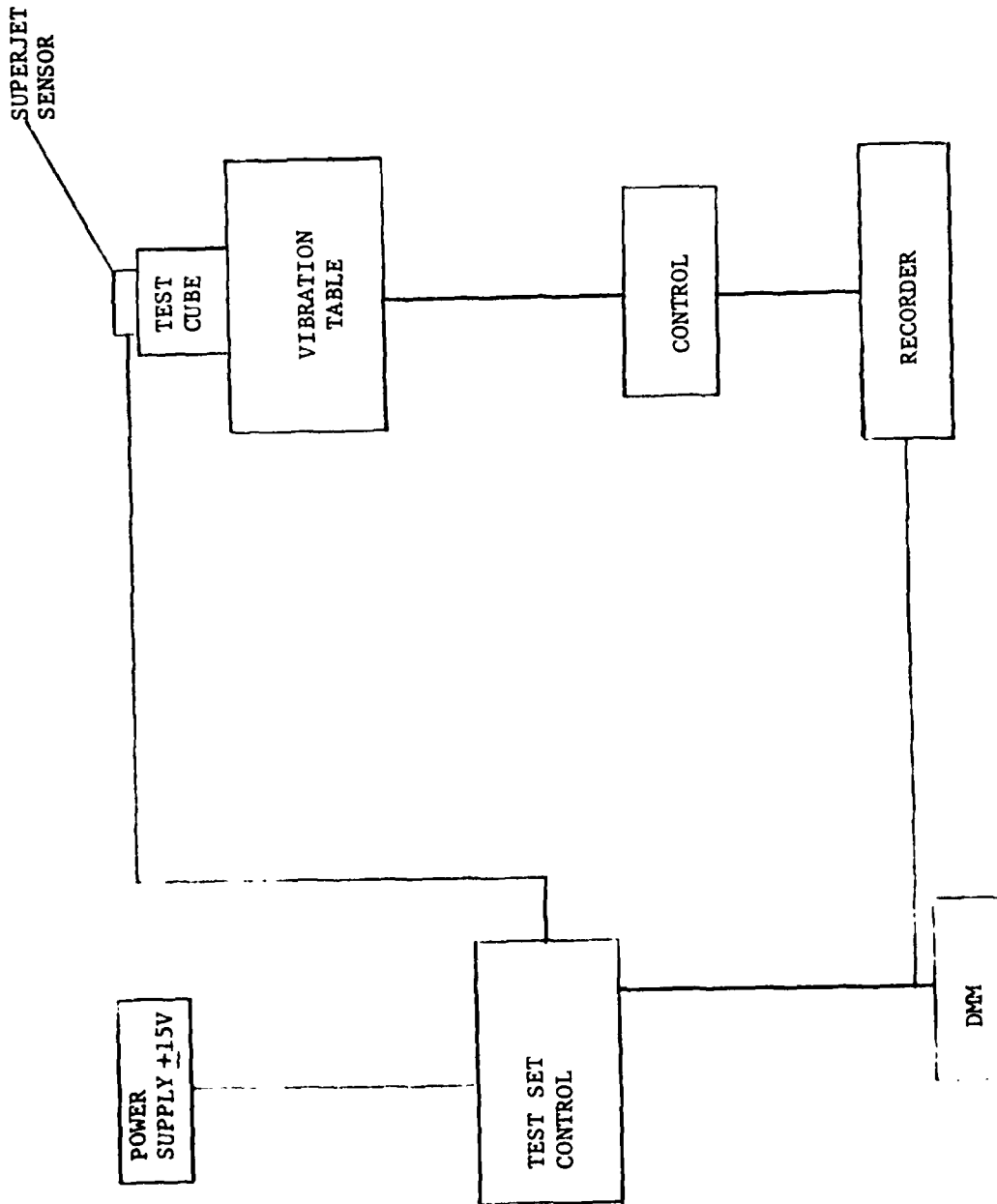

FIGURE F.2-1

APPENDIX B

TEST PLAN
for
Performance Verification Tests
on the
SUPERJET Angular Rate Sensor
Contract No. DAAK40-79-D-0017
November, 1979

Prepared by
Jerome C. Salmons
Dept. 5463

Martin Marietta Corporation
Orlando, Florida

FOREWORD

This document is prepared to fulfill the requirements of paragraphs 3.2.1.5 and 3.2.1.6 of Statement of Work 60134-12 dated 7 August 1979 which describes the effort authorized under Operations Directive No. 3-0017-00-375-15. This O. D., issued 19 October 1979, implements contract number DAAK40-79-D-0017 with the Naval Air Development Center Aircraft and Crew Systems Technology Directorate, Warminster, Pa. 18974. Under the terms of the referenced contract Martin Marietta is to evaluate the Hamilton-Standard SUPERJET angular rate sensor for possible application in the Maximum Performance Escape System (MPES) Program being conducted by the Naval Air Development Center (NADC). A major portion of the evaluation effort will involve performance tests under various environmental conditions. This document describes the test program to be conducted and gives a time schedule for the accomplishment of major milestones.

CONTENTS

Para. No.	Page
Title Page	1
Forward	2
Table of Contents	3
List of Tables and Illustrations	4
Summary	5
1. Introduction	6
1.1 Purpose	6
1.2 Test Objectives	6
2. APPLICABLE DOCUMENTS	7
3. TEST APPROACH	8
3.1 Test Facilities	8
3.2 Test Equipment	8
3.3 Test Articles	8
3.4 Test Descriptions	10
4.0 TEST IMPLEMENTATION	15
4.1 Test Procedures	15
4.2 Failure Documentation	15
4.3 Data Requirements	16
4.4 Schedule and Milestones	17
5.0 Definitions	19
Appendix A	
Typical Test Data Sheet	20

TABLES

NO.	PAGE
1. Test Equipment	9

ILLUSTRATIONS

1. RRS Mounting Dimensions and Orientation	12
2. Roll Rate Sensor Test Schedule	18

SUMMARY

This test plan document describes the scope of effort to be expended in evaluating the performance of Hamilton-Standard's SUPERJET roll rate sensor (RRS) for application to a Navy Air Development Center (NADC) Program. The tests to be conducted are described, the number of test units to be employed is given and the test levels for each test are specified. Test schedules and data formats for each test are presented. Measurements to be made are listed and test apparatus to be used is specified.

1. INTRODUCTION

1.1 Purpose

The SUPERJET is an angular rate sensor produced by the Hamilton Standard Division of United Technologies, Inc. One version of this device containing associated electronics for shaping and correcting the output and providing switching and null bias functions is being developed for use on the Copperhead projectile as a roll rate sensor.

In a previous study conducted by Martin Marietta Corp., Orlando, Florida, the potential application of the SUPERJET to air crew ejection systems was recognized. The final report of this study effort (OR 15646) recommended further evaluation of the SUPERJET to better define its potential for such application. The purpose of this test plan is to describe the test activities involved in the evaluation effort and to establish a time schedule for performing the test effort.

1.2 Test Objectives

The major objectives of this test program are to demonstrate feasibility of less than 2 deg/s bias error with 0.1s ready time and linearity of 1 percent over the rate range of ± 500 deg/s at any temperature between -65° F and $+165^{\circ}$ F.

Secondary objectives will be to determine the effects on sensor output of high and low temperature, linear acceleration, rate of change of acceleration, vibration and acoustic environments.

Where it can be determined that tests equivalent to those specified herein have been conducted on other programs, the data from such tests may be presented in lieu of duplicating those tests.

2. APPLICABLE DOCUMENTS

2.1 Authorizing Documents

- | | |
|--|------------------|
| 1. Contract | DAAK40-79-D-0017 |
| 2. Statement of Work, NADC No. | 60134-12 |
| 3. Operations Directive, Martin Marietta No. | 3-0017-00-375-15 |

2.2 References

- | | |
|--|--------------------------|
| 1. Martin Marietta Reports | |
| Fluidic Gyro Development, August, 1979 | OR15,646 |
| 2. Military Standards | |
| Environmental Test Methods | MIL-STD-810C
Change 4 |
| 3. Specifications, Martin Marietta | |
| Roll Rate Sensor | SPC 10200000-004 |

3. TEST APPROACH

3.1 Test Facilities

The test program described herein is to be conducted by various laboratories of Martin Marietta Corp., Orlando, Florida. Room temperature performance tests will be conducted on a rate table in the Fluidics Lab or Precision Inertial Laboratory. The Dynamics Lab and the Environmental Test Lab will provide equipment for generating vibration and acoustic environments and shall provide all necessary measurement and recording equipment for these tests. Temperature chambers mounted on a rate table will be used for creating the high and low temperature environments during rate tests. At this time it is proposed to use thermostatically controlled electric heaters for creating the high temperature environment. The low temperature environment will be created by flowing gaseous nitrogen from a liquid N₂ supply through an insulated chamber on the rate table.

3.2 Test Equipment

Test equipment necessary for conducting this test program is given in Table 1.

3.3 Test Articles

The roll rate sensors to be tested are identified as Hamilton Standard P/N 9304100099. Serial number 0100196 and 0100142 are presently available from a previous test program. Additional units of the same part number will be obtained by transfer or consignment from the Copperhead program, or purchased from Hamilton Standard should it prove impractical to use Copperhead units.

AD-A091 089

MARTIN MARIETTA AEROSPACE ORLANDO FL

F/G 1/3

PERFORMANCE VERIFICATION OF THE 'SUPERJET' LAMINAR ANGULAR RATE--ETC(U)

MAY 80 B W CURRY

DAAK40-79-D-0017

UNCLASSIFIED

OR-16127

NADC-80081-60

NL

3 3

4 3



END
DATE
FILMED
12-80
DTIC

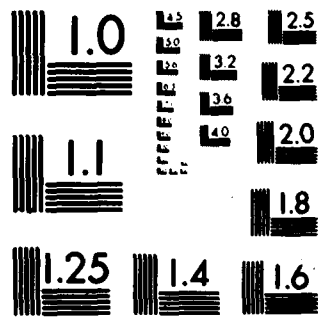

MICROCOPY RESOLUTION TEST CHART
NATIONAL BUREAU OF STANDARDS-1963 A

TABLE 1
Test Equipment¹

Model No/ Part No.	Description/Manufacturer	Accuracy (%)
	Power Supply +5v	+1.00
	Power Supply +11.5v	+1.00
	Power Supply +15.0v	+1.00
	Power Supply -15.0v	+1.00
HP3440 or HP3465B	Digital voltmeter-Hewlett Packard High Impedence 0-100 mv range	0.25
	RRS Test Set	----
	Acoustic chamber-Martin Marietta	----
Model	MB Shaker	
Model G-1100	Rate table-Genisco	----
	Rate table controller- test set-Hewlett Packard	----
	Temperature control chamber Martin	----
Model 1054	Precision Centrifuge- Martin-Genisco	----

¹ Similar equipment having adequate performance characteristics for the usage intended may be substituted. Test data sheets shall note the actual equipment used.

3.4 Test Descriptions

3.4.1 Base Line Performance Tests

These tests shall be performed at room ambient conditions of 77°F \pm 10°F and less than 90% relative humidity. The unit under test (UUT) shall be at a stable temperature prior to test. Unless otherwise implied or specified, the following tests will be made while the sensor is motionless with its base in contact with a horizontal support surface:

1. Input voltage and current requirements will be measured at the power supplies.
2. Output drift - the sensor output change with time shall be determined for constant rate inputs.
3. Output scale factor - (volts/deg/sec)
4. Full scale range for 2% linearity
5. Threshold
6. Resolution
7. Hysteresis

3.4.2 Ready Time

A test for "ready time" shall be made by recording the output characteristic of the sensor as the unit is activated. The recording shall be measured to determine the steady state output level. "Ready time" is the time required for the unit to respond to the activation signal and develop and output equal to 95 % of the steady state level.

3.4.3 Acceleration Sensitivity Tests

3.4.3.1 Constant Acceleration

The unit will be oriented on a centrifuge and subjected to constant accelerations in each direction along each of the three mutually perpendicular axes (reference Figure 1). Various levels of acceleration shall be applied up to a maximum of 30g. The sensitivity of the sensor output to the applied acceleration shall be determined.

3.4.3.2 Constant Jerk

The centrifuge will be programmed to produce linearly varying accelerations by linearly changing the rate of rotation. The rate of change of acceleration shall be varied in increments from zero to 10g/sec. The sensitivity of the sensor output to the applied rate of change of acceleration (jerk) shall be determined. The acceleration vectors shall be oriented in each direction along the three test axes shown in Figure 1.

3.4.4 Vibration Tests

The sensitivity of the unit to vibration environments will be evaluated by tests conducted in accordance with MIL -STD-810C procedures. Vibration will be applied along the three axes defined in Figure 1.

A resonance search will be performed at a maximum level of 3g from 10 to 5000 Hz in each axis. The three most severe resonances in each axis will be selected. The unit will then be vibrated at each of the three selected frequencies in each axis for 10 minutes. The test level shall be 5.2g.

Null output shall be monitored during vibration.

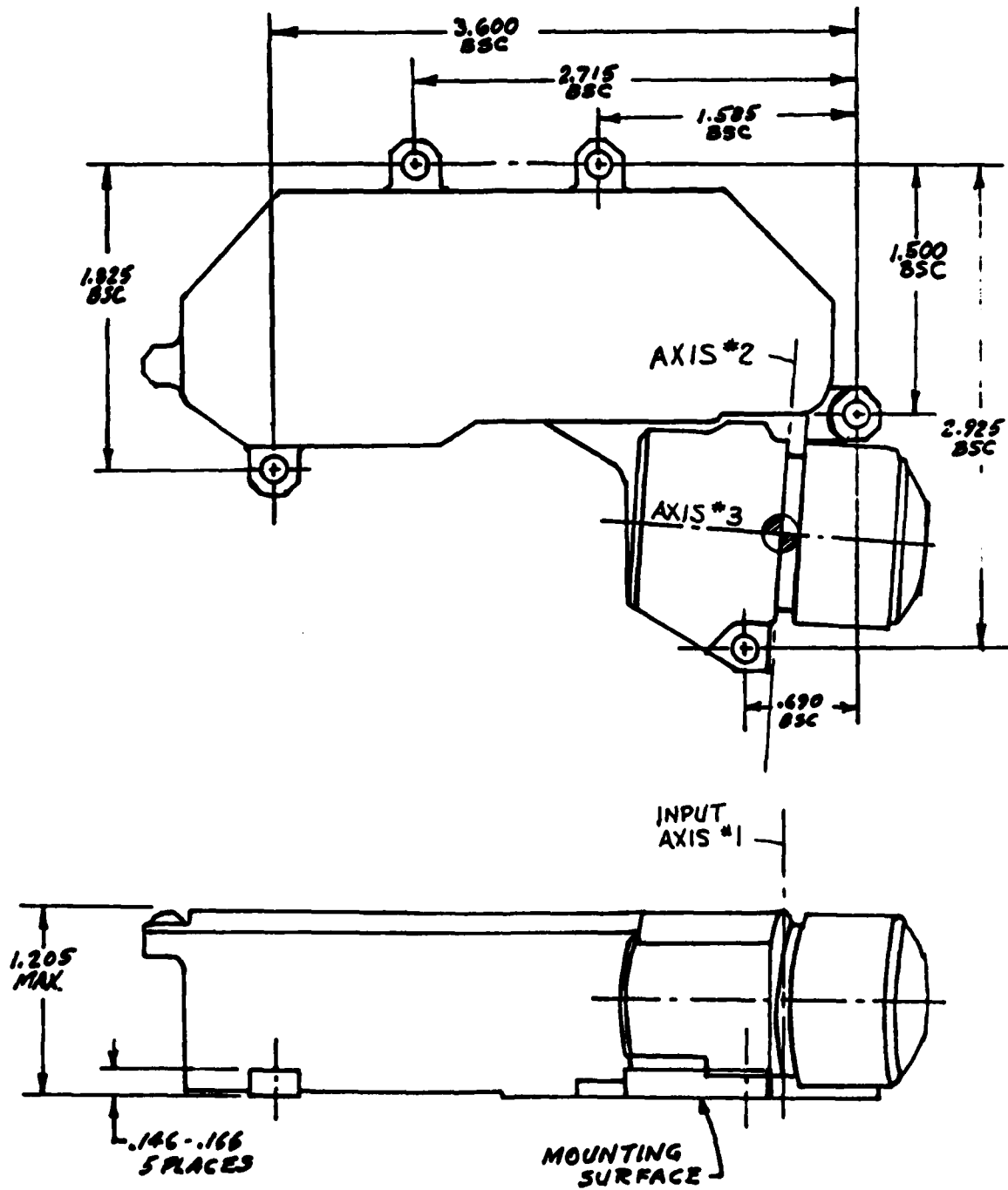

Figure 1 RRS Mounting Dimensions and Orientation

3.4.5 Acoustic Sensitivity

The sensitivity of the RRS to high level acoustic environment will be evaluated by tests conducted in general conformity to MIL-STD-810C. The RRS will be suspended in an acoustic chamber on elastic cords having a natural frequency less than 25 Hz. Procedure 1 of MIL-STD-810C will be used as a guide. A category B test will be conducted (150 db for 30 minutes) to evaluate the effects of longer term acoustic environment on the RRS output. Measurements of the RRS output will be made at intervals no greater than 5 minutes during this test. A category D test will be conducted for limited time periods. A minimum sound pressure level of 165 db will be applied in "pulses" of approximately 1 second duration. The sound pressure level will be brought up to the maximum level in the minimum time period consistent with laboratory operating procedures and equipment capabilities. Following the sound "pulse" the pressure level will be allowed to decay in accordance with inherent equipment characteristics. This short duration acoustic pulse will be applied to the energized RRS a minimum of 8 times. The output will be continuously recorded. Acoustic effects on the RRS output will be determined by comparing the recorded null output during and following the acoustic pulse to the output recorded just prior to application of the acoustic environment. In addition, results of post-environment performance tests will be compared to pre-environment performance baseline tests.

3.4.6 Temperature Sensitivity Tests

The baseline performance tests will be conducted at $-65^{\circ}\text{F} \pm 5^{\circ}\text{F}$ and at $+165^{\circ}\text{F} \pm 5^{\circ}\text{F}$. The temperature chamber shall be stabilized at the test temperature preceding the testing. Data from these tests shall be compared to room temperature test data to determine temperature sensitivity.

4. TEST IMPLEMENTATION

4.1 Test Procedures

The major tests necessary in the conduct of this test program are as follows:

1. Baseline performance tests.
2. High temperature test.
3. Low temperature test.
4. Acceleration test.
5. Rate of acceleration (jerk) test.
6. Vibration test.
7. Acoustic sensitivity test.

A detailed test procedure shall be written giving the steps to follow in conducting the above tests. The procedure will define the order of testing, when the RRS is to be operated, how and when the environmental exposure is to be applied, the parameters to be measured and recorded, and the frequency or time of measurement. Baseline performance will be established prior to and following environmental exposures.

4.2 Failure Documentation

In case of equipment failure appropriate entries as to schedule impact and corrective action shall be made in the test logs by the test program engineer.

In case of failure of the Unit Under Test, a full description of the test conditions and nature of the failure will be given in the test report. Failure analysis, failure testing and failure reports are beyond the scope of this program.

4.3 Data Requirements

4.3.1. Photographic Documentation

Photographs will be employed as necessary to supplement drawings, sketches, and descriptive material in the test report, such that test set-ups may be reconstructed or duplicated. Orientation of the test specimen during environmental exposures is of particular interest and must be fully documented.

4.3.2. Data Sheets

Data sheets similar to the example shown in Appendix A will be prepared for use with each test procedure and shall contain as a minimum the following entries in addition to sections for recording observed performance data.

Name of Test

Place of Test

Part number & serial number of test article

Pertinent test equipment model/serial numbers

Date

Test conditions @ Start Finish

Time of day

Temperature

Baro. press

Humidity

Test Engineer(s) attesting signature

4.3.3 Oscillograph Records

Oscillograph records shall be annotated to indicate trace identification, scale factors, and time of events and shall be identified with the entries listed in paragraph 4.3.2.

4.4 Schedule and Milestones

A schedule for conducting the tests described herein is shown in Figure 2. It is planned that all testing shall be completed by 1 April 1980. Test data reduction, analysis, evaluation and presentation and preparation of descriptive test results will be completed by 1 May 1980. Test results will be made available to NADC on or before 15 May 1980. The formal test report will be a part of the program final report.

5. DEFINITIONS

Scale Factor - slope of best fitting straight line to test data.

Linearity - the deviation of the output data from the best straight line fit to the data and through the zero rate point.

Null Bias - output of rate sensor at zero rate input. Also termed "offset".

Hysteresis - the difference in output at any rate when approached in opposite directions.

Figure 2 ROLL RATE SENSOR TEST SCHEDULE

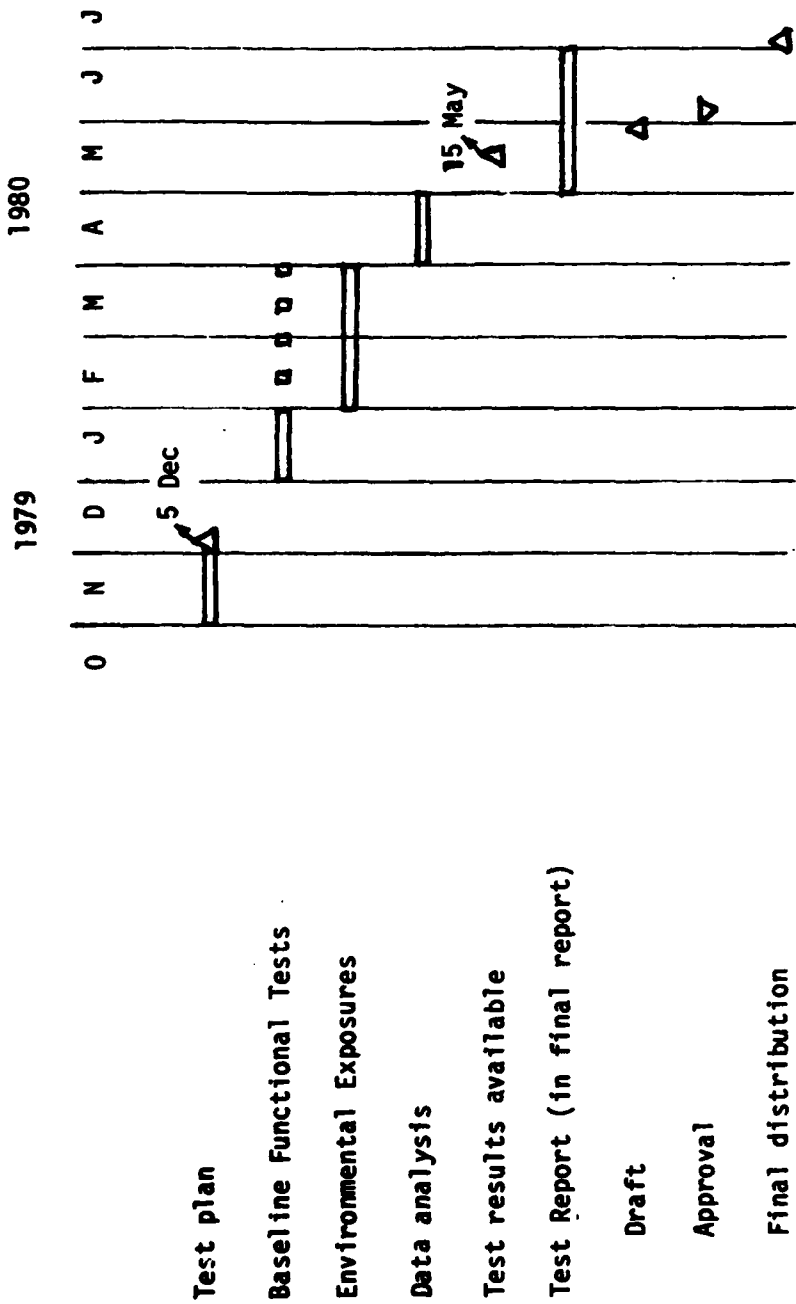

APPENDIX A
TYPICAL DATA SHEET

Test: _____
Run No.: _____

Date: _____	Time: _____	Start _____	Finish _____
Laboratory: _____	Temp: _____	_____	_____
Test Machine: _____	Baro. Press: _____	_____	_____
	Relative Humidity: _____	_____	_____
Test Article I. D.	Input: Voltage _____		
Name: _____	Current _____		
Part No.: _____	Power _____		
Model No.: _____			
Serial No.: _____			

NOTES:

DATA		DATA ANALYSIS RESULTS
Input	Output	
This test conducted in accordance with paragraph ____ of TPL _____ and paragraph ____ of TPR _____ except as noted. Test Engineer: _____ Signature _____		Scale Factor _____
		Null Bias _____
		Hysteresis _____
		Threshold _____
		Resolution _____

APPENDIX C

LEAST SQUARES FIT ALGORITHM

Scale factor, bias and linearity:

$$\begin{aligned} Z &= B + Ax \\ B &= (Q - (A \cdot S))/H9 \\ A &= ((H9 \cdot P) - (S \cdot Q))/((H9 \cdot T) - (S \cdot S)) \\ H9 &= (4 \cdot (R1/R2))/2 \end{aligned}$$

Where:

A = Slope of Least Squares Fit Straight Line (volts/degrees/second)
 B = Bias (Y - Intercept of Least Squares Fit Line (volts))
 H9 = Number of Data Points
 P = Sum of Inputs Times Outputs (volts/degrees/second)
 Q = Sum of the Outputs (volts)
 R₁ = Maximum Rate (degrees/second)
 R₂ = Rate Increment (degrees/second)
 S = Sum of the Inputs (degrees/second)
 T = Sum of the Inputs Squared (degrees/second)²
 X = Input (degrees/second)
 Z = Least Squares Fit Straight Line (volts)

Hysteresis: Maximum

$$M = Y_1 - Y_2$$

Where:

M = Hysteresis (volts)
 Y₁ = Output Recorded Approaching Maximum Rate
 Y₂ = Output Recorded Approaching Zero Rate

OUTPUT DRIFT ALGORITHM

$$D = \frac{SF_H - SF_L}{SF_{NOM}} \times \frac{60}{t} \times 100$$

Where: SF_H = Highest scale factor at rate
 SF_L = Lowest scale factor at rate
 SF_{NOM} = Nominal baseline scale factor
 t = Time in seconds between high and low scale factors