

AD-A090 985

FOREIGN TECHNOLOGY DIV WRIGHT-PATTERSON AFB OH  
DEVICE WHICH TRIGGERS HIGH-VOLT PULSE GENERATOR, (U)  
FEB 80 I P PEKAR  
FTD-IDIRS)T-1934-79

F/6 9/5

UNCLASSIFIED

NL

1 of 1  
11-80  
DTIC



END  
JAN  
11-80  
DTIC

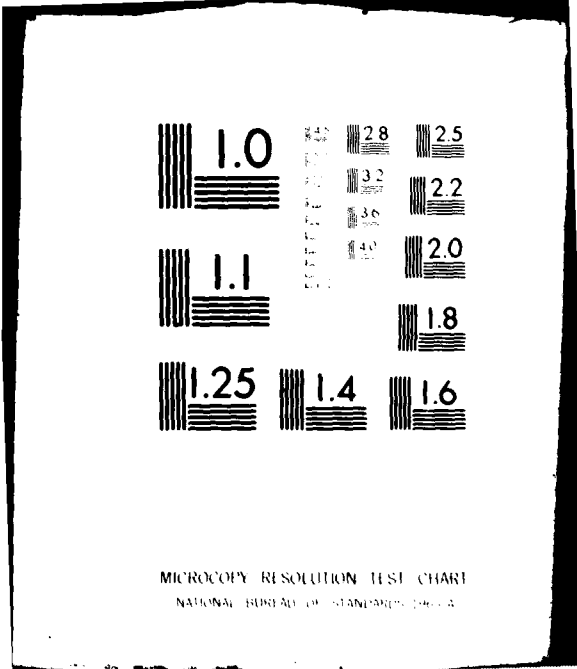

PHOTOGRAPH THIS SHEET

AD A 090985

DTIC ACCESSION NUMBER



LEVEL

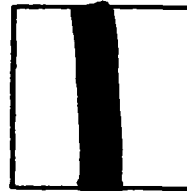

INVENTORY

FTD-ID(RS)T-1934-79

DOCUMENT IDENTIFICATION

DISTRIBUTION STATEMENT A

Approved for public release;  
Distribution Unlimited

DISTRIBUTION STATEMENT

ACCESSION FOR	
NTIS	GRA&I <input checked="" type="checkbox"/>
DTIC	TAB <input type="checkbox"/>
UNANNOUNCED	<input type="checkbox"/>
JUSTIFICATION	<input type="checkbox"/>
BY	
DISTRIBUTION /	
AVAILABILITY CODES	
DIST	AVAIL AND/OR SPECIAL
A	

DISTRIBUTION STAMP

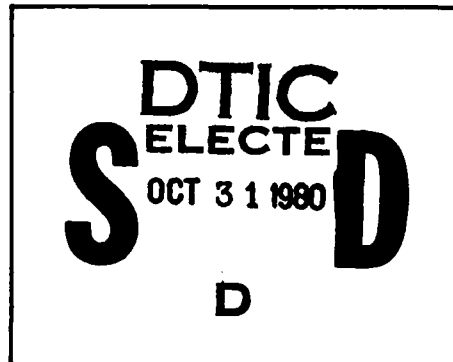

DATE ACCESSIONED

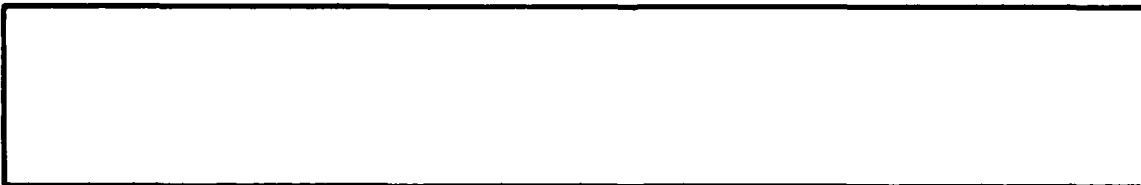

DATE RECEIVED IN DTIC

PHOTOGRAPH THIS SHEET AND RETURN TO DTIC-DDA-2

AD A 090985

# FOREIGN TECHNOLOGY DIVISION



DEVICE WHICH TRIGGERS HIGH-VOLT PULSE GENERATOR

By

I. P. Pekar'



Approved for public release;  
distribution unlimited.



80 7 1 178

## EDITED TRANSLATION

FTD-ID(RS)T-1934-79

11 February 1980

MICROFICHE NR: FTD-80-C-000202

DEVICE WHICH TRIGGERS HIGH-VOLT PULSE GENERATOR

By: I. P. Pekar'

English pages: 5

Source: USSR Patent Nr. 341150, 5 June 1972,  
pp. 1-2

Country of Origin: USSR

Translated by: Marilyn Olacchia

Requester: FTD/TQTD

Approved for public release; distribution unlimited.

THIS TRANSLATION IS A RENDITION OF THE ORIGINAL FOREIGN TEXT WITHOUT ANY ANALYTICAL OR EDITORIAL COMMENT. STATEMENTS OR THEORIES ADVOCATED OR IMPLIED ARE THOSE OF THE SOURCE AND DO NOT NECESSARILY REFLECT THE POSITION OR OPINION OF THE FOREIGN TECHNOLOGY DIVISION.

PREPARED BY:

TRANSLATION DIVISION  
FOREIGN TECHNOLOGY DIVISION  
WP.AFB, OHIO.

U. S. BOARD ON GEOGRAPHIC NAMES TRANSLITERATION SYSTEM

Block	Italic	Transliteration	Block	Italic	Transliteration
А а	<i>А а</i>	A, a	Р р	<i>Р р</i>	R, r
Б б	<i>Б б</i>	B, b	С с	<i>С с</i>	S, s
В в	<i>В в</i>	V, v	Т т	<i>Т т</i>	T, t
Г г	<i>Г г</i>	G, g	У у	<i>У у</i>	U, u
Д д	<i>Д д</i>	D, d	Ф ф	<i>Ф ф</i>	F, f
Е е	<i>Е е</i>	Ye, ye; E, e*	Х х	<i>Х х</i>	Kh, kh
Ж ж	<i>Ж ж</i>	Zh, zh	Ц ц	<i>Ц ц</i>	Ts, ts
З з	<i>З з</i>	Z, z	Ч ч	<i>Ч ч</i>	Ch, ch
И и	<i>И и</i>	I, i	Ш ш	<i>Ш ш</i>	Sh, sh
Й й	<i>Й й</i>	Y, y	Щ щ	<i>Щ щ</i>	Shch, shch.
К к	<i>К к</i>	K, k	Ъ ъ	<i>Ъ ъ</i>	"
Л л	<i>Л л</i>	L, l	Ы ы	<i>Ы ы</i>	Y, y
М м	<i>М м</i>	M, m	Ь ь	<i>Ь ь</i>	'
Н н	<i>Н н</i>	N, n	Э э	<i>Э э</i>	E, e
О о	<i>О о</i>	O, o	Ю ю	<i>Ю ю</i>	Yu, yu
П п	<i>П п</i>	P, p	Я я	<i>Я я</i>	Ya, ya

\*ye initially, after vowels, and after ъ, ь; e elsewhere.  
When written as ë in Russian, transliterate as yë or ë.

RUSSIAN AND ENGLISH TRIGONOMETRIC FUNCTIONS

Russian	English	Russian	English	Russian	English
sin	sin	sh	sinh	arc sh	sinh
cos	cos	ch	cosh	arc ch	cosh
tg	tan	th	tanh	arc th	tanh
ctg	cot	cth	coth	arc cth	coth
sec	sec	sch	sech	arc sch	sech
cosec	csc	csch	csch	arc csch	csch

Russian      English

rot          curl  
lg          log

DEVICE WHICH TRIGGERS HIGH-VOLT PULSE GENERATOR

I.P. Pekar' (inventor)

Submitted by Khar'kov [Order of Lenin] Polytechnical Institute.

This is an invention in the field of high-volt pulsed voltage and current generators.

We are familiar with a device designed to trigger a high-volt pulse generator. It consists of spark dischargers, a resistive voltage divider, charging and switching capacitors and additional capacitors connected to a bus switched through a resistor to one lead of the storage capacitor. The time required to trigger the generator, however, depends on the magnitude of the voltage applied to it.

The object of this invention is to increase reaction time independently of the voltage which is applied.

The object is achieved as follows: The bus of this device is switched to a second lead of the charging capacitor through the switching capacitor and trigatron. A circuit consisting of series-connected protective resistor and additional high-voltage source are connected in parallel to the trigatron.

The scheme is shown in the figure.

Between electrodes 1 spark gaps 2 are formed. These are shunted by high-ohmic resistors 3 and interelectrode parasitic capacitors 4.

Outer electrodes 1 are connected (one through resistor 5 of the load and the other directly) to the charging capacitor 6, which is charged through protective resistor 7 from regulated high-voltage source 8. Load resistor 5 is shunted by parasitic capacitor 9. Additional capacitors 10, whose common connection point is connected to trigatron 12 through igniting capacitor 11 and through resistor 13 to the lead of charging capacitor 6, are switched to electrodes 1. From additional source 14 unregulated high voltage, equal in amplitude to the nominal charge voltage of capacitor 6, is conducted through resistor 15 to igniting capacitor 11.

The trigatron is started by means of generator 16. The following condition must be observed:



$$C_6 > C_{11} > C_{10} > C_4$$

where  $C_6$  is the capacitance value of capacitor 6;  $C_{11}$  - value of igniting capacitor 11;  $C_{10}$  - value of additional capacitors 10,  $C_4$  - value of parasitic interelectrode capacitance 4.

Charging voltage  $U_8$  from source 8 applied to electrodes 1 is distributed evenly between spark gaps 2. The common point of connection of additional capacitors 10 through resistor 13 receives the potential from the lead or left electrode 1. Igniting capacitor 11, which is connected to additional source 14, is charged to a voltage of

$$U_{11} = U_{14} - U_8$$

where  $U_{14}$  is the nominal voltage of source 14.

For triggering of the device the pulse from generator 16 is supplied to trigatron 12. After the breakdown of trigatron 12 the difference in potentials between the common point of connection of the additional capacitors 10 and left electrode 1 increases to  $U_{14} + U_8$  regardless of the magnitude of the charge voltage of generating capacitor 6. Since  $C_{10} > C_4$ , almost all of the voltage which develops between left electrode 1 and the common point of attachment of

additional capacitors 10 is applied to left spark gap 2, which causes it to break down, then to the following spark gap, causing it to break down, etc.

The multiplicity factor of excess voltage on the left gap is approximately equal to the number of spark gaps.

Simultaneously with the increase in voltage on the left spark gap 2 there develops an excess voltage on the last gap and a pulse arises on load resistor 5.

#### Object of the Invention

The triggering device for the high-volt pulse generator consists of spark dischargers, a resistive voltage divider, charging capacitor, switching capacitor, and additional capacitors connected to a bus which is connected through a resistor to one lead of the charging capacitor. It is distinguished by the fact that, for the purpose of increasing reaction time independently of applied voltage, the bus is switched to the second lead of the charging capacitor through the switching capacitor and trigger. A circuit consisting of series-connected protective resistor and additional high-voltage

source is connected parallel to the trigatron.

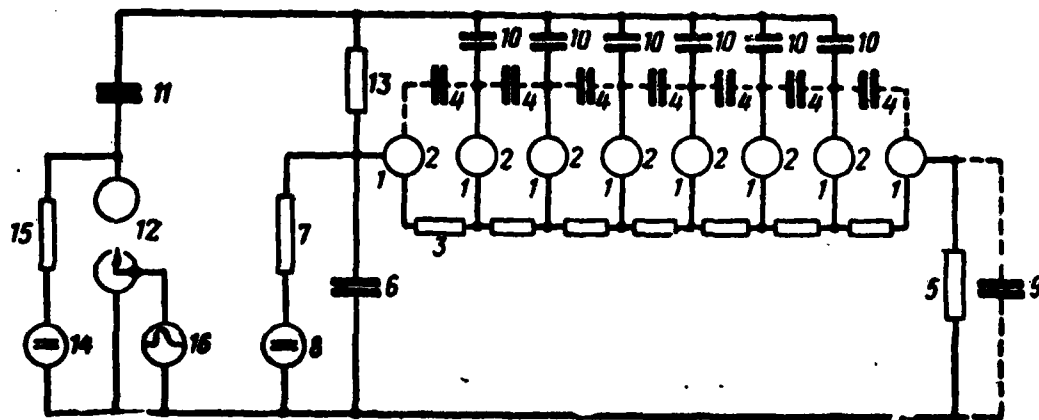

**DISTRIBUTION LIST**

**DISTRIBUTION DIRECT TO RECIPIENT**

<u>ORGANIZATION</u>	<u>MICROFICHE</u>	<u>ORGANIZATION</u>	<u>MICROFICHE</u>
A205 DMATC	1	E053 AF/INAKA	1
A210 DMAAC	2	E017 AF/RDXTR-W	1
B344 DIA/RDS-3C	9	E403 AFSC/INA	1
C043 USAMIIA	1	E404 AEDC	1
C509 BALLISTIC RES LABS	1	E408 AFWL	1
C510 AIR MOBILITY R&D LAB/FIO	1	E410 ADTC	1
C513 PICATINNY ARSENAL	1	FTD	
C535 AVIATION SYS COMD	1	CCN	1
C591 FSTC	5	ASD/FTD/NIIS	3
C619 MIA REDSTONE	1	NIA/PHS	1
D008 NISC	1	NIIS	2
H300 USAICE (USAREUR)	1		
P005 DOE	1		
P050 CIA/CRB/ASD/SD	2		
NAVORDSTA (50L)	1		
NASA/NST-44	1		
AFIT/LD	1		
LLL/Code L-389	1		
NSA/1213/TDL	2		