

AD-A090 824

TEXAS DEPT OF PUBLIC SAFETY AUSTIN DIV OF DISASTER E--ETC F/6 15/3  
TEXAS EMERGENCY RESOURCE MANAGEMENT, VOLUME II.(U)  
SEP 79 A C ELEDGE, R L ORTON, S O MERZ

DCPA01-78-C-0321

NL

UNCLASSIFIED

1 of 4  
2/10/24

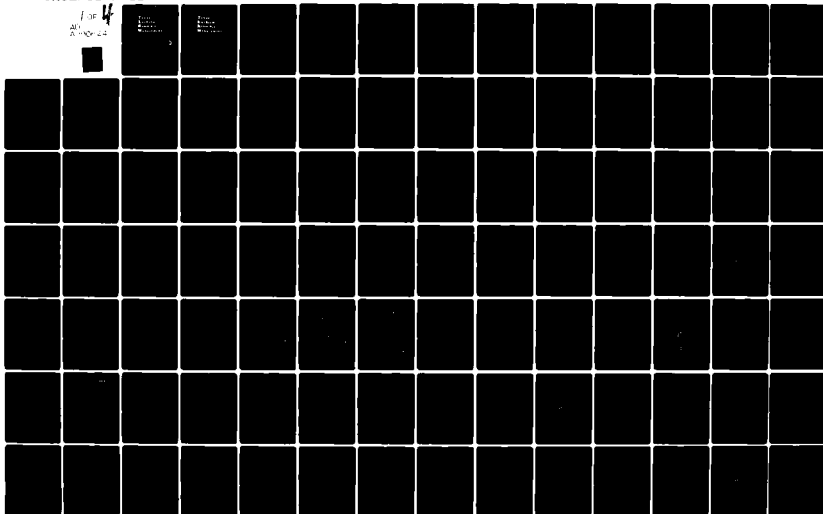

**LEVEL III**

12

3

A STUDY IN:

# TEXAS EMERGENCY RESOURCE MANAGEMENT

VOL. II

AD A090824



DTIC  
ELECTE  
OCT 27 1980  
S D  
A

DDC FILE COPY

Final Report

Contract DCPA 01-78-C-0321  
Work Unit 4351-E

Approved for Public Release  
Distribution Unlimited

September 1979

Division of Disaster Emergency Services  
Texas Department of Public Safety  
Austin, Texas

80 10 23 44

A STUDY IN:

6

# TEXAS EMERGENCY RESOURCE MANAGEMENT

Vol. II

Vol. II

10 by  
Ashley C. Eledge  
Robert L. Orton  
Soon O. Merz

11-24-79  
10-15-79

For  
Federal Emergency Management Agency  
Washington, D.C. 20472  
Final Report, September 1979

11-24-79

15  
Contract DCPA 01-78-C-0321  
Work Unit 4351-E

FEMA REVIEW NOTICE: This report has been reviewed in the Federal Emergency Management Agency and approved for publication. Approval does not signify that the contents necessarily reflect the views and policies of the Federal Emergency Management Agency.

Approved for Public Release; Distribution Unlimited

Division of Disaster Emergency Services  
Texas Department of Public Safety  
5805 North Lamar Boulevard  
Austin, Texas 78752

411774

42

Unclassified

SECURITY CLASSIFICATION OF THIS PAGE (When Data Entered)

REPORT DOCUMENTATION PAGE		READ INSTRUCTIONS BEFORE COMPLETING FORM
1. REPORT NUMBER FEMA Work Unit 4351-E	2. GOVT ACCESSION NO. AD-A090 824	3. RECIPIENT'S CATALOG NUMBER
4. TITLE (and Subtitle) TEXAS EMERGENCY RESOURCE MANAGEMENT Volume II		5. TYPE OF REPORT & PERIOD COVERED Final Report 10-1-78 to 9-30-79
		6. PERFORMING ORG. REPORT NUMBER
7. AUTHOR(s) Ashley C. Eledge                      Soon O. Merz Robert L. Orton		8. CONTRACT OR GRANT NUMBER(s) DCPA 01-78-C-0321
9. PERFORMING ORGANIZATION NAME AND ADDRESS Texas Department of Public Safety Division of Disaster Emergency Services 5805 North Lamar, Austin, Texas 78752		10. PROGRAM ELEMENT PROJECT, TASK AREA & WORK UNIT NUMBERS Emergency Resources Management
11. CONTROLLING OFFICE NAME AND ADDRESS Federal Emergency Management Agency Washington, DC 20472		12. REPORT DATE September 30, 1979
		13. NUMBER OF PAGES 269
14. MONITORING AGENCY NAME & ADDRESS (if different from Controlling Office)		15. SECURITY CLASS (of this report) Unclassified
		15a. DECLASSIFICATION/DOWNGRADING SCHEDULE
16. DISTRIBUTION STATEMENT (of this Report) Approved for Public Release; Distribution Unlimited		
17. DISTRIBUTION STATEMENT (of the abstract entered in Block 20, if different from Report)		
18. SUPPLEMENTARY NOTES		
19. KEY WORDS (Continue on reverse side if necessary and identify by block number) Emergency Resources Management      In-Place Shelter Crisis Relocation                      Presidential Option Risk Areas                                  Resources Priority Board Host Areas                                  Disaster Emergency Services Council		
20. ABSTRACT (Continue on reverse side if necessary and identify by block number) This document is Volume II of Texas Emergency Resource Management (TERM). Part A covers emergency management of resources and contains overall State policies and guidance for the provision and use of essential resources to meet urgent needs in the State in a nuclear attack emergency or crisis relocation of the population. It also describes the system and identifies roles of Federal, State and local government organizations for the emergency management of essential		

(Cont.)

Unclassified

SECURITY CLASSIFICATION OF THIS PAGE(When Data Entered)

19. (Cont.)

Economic Stabilization  
Health and Medical  
Petroleum, Gas and Solid Fuel  
Electric Power, Water  
Industrial Production  
Manpower, Transportation

20. (Cont.)

Resources available to the State. Part B includes separate resource sections containing specific provisions and procedures to implement overall State resource policies and guidance in the following resource categories:

- I. Economic Stabilization
- II. Construction
- III. Electric Power
- IV. Food
- V. Petroleum, Gas and Solid Fuels
- VI. Health and Medical
- VII. Industrial Production
- VIII. Manpower
- IX. Transportation
- X. Water
- XI. Housing

These separate resource sections include emergency actions, action documents and organizational arrangement to carry on State management roles in particular resource fields.

Accession For	
NTIS GRA&I	<input checked="" type="checkbox"/>
DTIC TAB	<input type="checkbox"/>
Unannounced	<input type="checkbox"/>
Justification	
By _____	
Distribution/	
Availability Codes	
Dist	Avail and/or Special
A	

Unclassified

SECURITY CLASSIFICATION OF THIS PAGE(When Data Entered)

## EXECUTIVE SUMMARY

With the introduction of Crisis Relocation Planning into Civil Preparedness, a need arose to update State emergency resource management plans to reflect structure changes that have occurred in State government and industry in recent years so as to make the plans more responsive to the conditions that result from execution of population relocation protection options.

The findings in this report, published in two volumes, are based on the Texas Emergency Resource Management (TERM) Plan and incorporate information and ideas from seven of nine states queried relative to emergency resources management during the crisis relocation mode. An analysis and evaluation of the effectiveness of existing emergency resource management plans was made to determine if basic operational concepts contained therein are compatible with and applicable to FEMA guidance on Crisis Relocation Planning. Volume I includes a discussion of State organization and emergency resources management, State agency functional assignments and a discussion of other States' problems in emergency resources management planning. Volume II, appropriate and applicable specifically to the State of Texas, is a model state emergency resources management plan.

This document is Volume II of Texas Emergency Resource Management (TERM). Part A covers emergency management of resources and contains overall State policies and guidance for the provision and use of essential resources to meet urgent needs in the State in a nuclear attack emergency or crisis relocation of the population. It also describes the system and identifies roles of Federal, State and local government organizations for the emergency

management of essential resources available to the State. Part B includes separate resource sections containing specific provisions and procedures to implement overall State resource policies and guidance in the following resource categories:

- I. Economic Stabilization
- II. Construction
- III. Electric Power
- IV. Food
- V. Petroleum, Gas and Solid Fuels
- VI. Health and Medical
- VII. Industrial Production
- VIII. Manpower
- IX. Transportation
- X. Water
- XI. Housing

These separate resource sections include emergency actions, action documents and organizational arrangement to carry on State management roles in particular resource fields.

FORWARD

This document was prepared and published by the Division of Disaster Emergency Services, Texas Department of Public Safety at Austin, Texas.

Funds were provided by Defense Civil Preparedness Agency (DCPA)  
Contract 01-78-C-0321.

This Texas Emergency Resource Management (TERM) Plan represents an in-depth revision of the initial one published in 1965. The Presidential option of crisis relocation is considered throughout this revised version.

The results of our work is offered as an effort to provide a stimulant for similar actions by other states in updating their own plans.

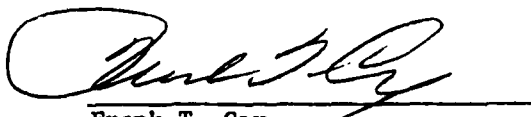

Frank T. Cox  
Chief, Disaster Emergency  
Services  
Department of Public Safety

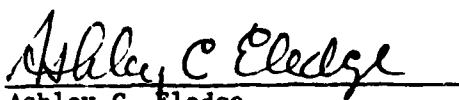

Ashley C. Eledge  
Senior Emergency Resources  
Management Planner



Robert L. Orton  
Emergency Resources Management  
Planner



Soon O. Merz  
Emergency Resources Management  
Planner



STATE OF TEXAS  
EMERGENCY RESOURCE MANAGEMENT PLAN

Table of Contents

	<u>Page</u>
<u>Part A</u>	
BASIC PLAN	
Introduction	A-1
Purpose	A-2
Activation	A-2
Major Policies	A-2
Organization	A-2
Emergency Actions	A-4
Control and Communications	A-5
Annex A - Authority	A-A-1
Annex B - Organization	A-B-1
Annex C - Emergency Action Documents	A-C-1
Annex D - Resource Specialists	A-D-1
 <u>Part B</u>	
I - ECONOMIC STABILIZATION	
Introduction	B-I-1
Purpose	B-I-1
Activation	B-I-1
Major Policies	B-I-1
Emergency Actions	B-I-2
Administration	B-I-A-1
Annex A - Organization	B-I-A-1
Annex B - Flow Charts	B-I-B-1
Annex C - Emergency Action Documents	B-I-C-1
Annex D - Money, Credit and Banking	B-I-D-1
Annex E - Wage and Salary Stabilization	B-I-D-1
Annex F - Ration Board Instructions	B-I-D-1
Annex G - Rent Board Instructions and Determining Ceiling Prices	B-I-D-1
Annex H - Price Board Instructions and Services	B-I-D-1
 II - CONSTRUCTION	
Introduction	B-II-1
Purpose and Activation	B-II-1
Concept of Operation	B-II-1
Resource Management Execution	B-II-3
Emergency Actions	B-II-3
Annex A - Organization	B-II-A-1
Annex B - Emergency Action Documents	B-II-B-1
 III - ELECTRIC POWER	
Introduction	B-III-1
Purpose	B-III-1
Activation	B-III-2
Authority and Related Documents	B-III-2
Federal Government	B-III-2
State Government	B-III-2
Electric Power Industry	B-III-2
Responsibilities	B-III-2
Annex A - Emergency Documents	B-III-A-1
 IV - FOOD	
Purpose	B-IV-1
Authority	B-IV-1
Activation of the Plan	B-IV-1
Organization	B-IV-1
Major Policies	B-IV-2
Emergency Actions	B-IV-A-1
Annex A - Organizational Chart	B-IV-A-1
Annex B - Emergency Action Documents	B-IV-B-1
Annex C - Reference Documents	B-IV-C-1



XI - HOUSING

Introduction  
Purpose and Activation  
Concept of Operation  
Resource Management Execution  
Emergency Actions  
    Annex A - Organization  
    Annex B - Emergency Action Documents  
    Annex C - Reference Documents

Page

B-XI-1  
B-XI-1  
B-XI-1  
B-XI-3  
B-XI-3  
B-XI-A-1  
B-XI-B-1  
B-XI-C-1

**PART A - RESOURCE MANAGEMENT**

**PART A  
BASIC PLAN**

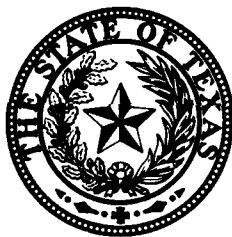

**Texas  
Emergency  
Resource  
Management**

**PLAN**

## INTRODUCTION

Part A of Appendix 8, Annex AA of the State of Texas Disaster Plan covers emergency management of resources and contains overall State policies and guidance for the provision and use of essential resources to meet urgent needs in the State in a nuclear attack emergency or crisis relocation of the population. It also describes the system and identifies roles of Federal, State and local government organizations for the emergency management of essential resources available to the State.

This part of the plan includes organizational and staffing arrangements to provide, on behalf of the Governor, central coordination and policy direction to the State government organizations with emergency assignments in particular resource fields. Also included is a roster of key officials selected and designated preattack to serve on the Resource Priorities Board, the coordinating and advisory body to the Governor for resource activities in a nuclear attack emergency. Some of these key officials are heads of regular departments and agencies of the State government; others are selected from industry and business to bring into State emergency government special knowledge, skills and experience in resource fields not normally a direct concern of State government.

The executive order was issued with the adoption of this portion of the plan making specific resource assignments and authorizing existing and emergency State organizations to manage designated resources on behalf of the Federal Government when Federal capability is absent. In other cases, specified State resource organizations are called upon to represent State interests and needs and to provide information and support to certain Federal organizations functioning in the State.

Although it is conceivable, it is improbable that the emergency resource management portion of the State Disaster Plan will be implemented without first the State being under the operational provisions of the State of Texas Disaster Plan, under which, upon proper notification certain portions of the population will relocate or upon warning of an attack, the entire population will take cover in in-place shelters. Following emergence from shelter, local governments take actions directed in the State of Texas Disaster Plan and local emergency plans and additionally insure conservation of available local resources. Local governments direct the use of local resources to carry on emergency operations and to meet needs immediately necessary for survival and defense. Civil defense facilities, personnel and organizations will be utilized as necessary in establishing and continuing emergency management of resources to insure smooth and effective transition into immediate or eventual Federal emergency control.

State level resource officials are immediately concerned postattack or upon initiating crisis relocation with implementing State-wide policies and providing guidance to local governments on the conservation, distribution and use of the resources immediately available to them and arranging for continuing resupply of goods and services to meet local emergency needs. Local governments, however, must have developed their own resource management plans based on existing National and State plans. Urgent needs for resources that cannot be met from locally available supplies are reported to the district or the State headquarters. State resource officials arrange with industry, either directly or through Federal Government agencies functioning in the State, for deliveries of goods or provision of services to meet these local shortages.

As soon as possible, once this immediate supply process is underway, the State acts to assure the longer range continuing provision and efficient use of resources available to the State. On direction of the Governor, the State resource organizations exchange information on anticipated supplies and essential continuing requirements for resources. These requirements include, in addition to the direct civilian and military needs, the resources required on a continuing basis to support essential industrial and commercial activities. Such resources are the petroleum products needed to operate transportation systems or the electric power, water and manpower needed by manufacturing plants to maintain the production of essential items. Decisions are made by or on behalf of the Governor on the essential activities to be maintained in the State and the assignment of available resources to support them. Arrangements are made either directly or through Federal organizations with industry and commerce to provide and distribute essential goods and services to meet essential continuing needs in the State.

-0-

Part B of the State plan includes separate resource sections containing specific provisions and procedures to implement overall State resource policies and guidance in the following resource categories:

- I. Economic Stabilization
- II. Construction
- III. Electric Power
- IV. Food
- V. Petroleum, Gas and Solid Fuels
- VI. Health and Medical
- VII. Industrial Production
- VIII. Manpower
- IX. Transportation
- X. Water
- XI. Housing

These separate resource sections include emergency actions, action documents and organizational arrangements to carry on State management roles in particular resource fields. They are concerned primarily with actions and arrangements to assure supplies of essential resources and services to meet immediate and continuing needs in the State. The procedures the State resource organizations follow to obtain resupply of local inventories and to provide services to meet local needs are included in these resource sections. They also include State policies and guidance for the operation of a State-wide system for rationing items to individual consumers and for stabilizing prices and rents.

STATE OF TEXAS  
EMERGENCY RESOURCE MANAGEMENT PLAN  
PART A  
RESOURCE MANAGEMENT

1. Purpose:

This plan provides for the supply and resupply of resources to meet urgent survival and military needs immediately following nuclear attack or crisis relocation and to provide for the ongoing management of resources available to the State to meet continuing survival and recovery needs thereafter. It establishes the organization and prescribes the actions and measures necessary for the emergency provision, distribution and use of goods and services and the utilization of manpower for essential purposes.

2. Activation:

The provisions of this plan will be activated by the Governor of the State of Texas or his legal successor upon implementing crisis relocation or declaration of a national emergency for civil defense purposes by the President of the United States, or upon receipt of a notice that an attack is underway. (Annex A. "Authority")

3. Major Policies:

a. Federal: Federal policies for the mobilization, management and use of resources in crisis relocation situation or a nuclear emergency are set forth in the National Plan.

b. State: In accordance with Federal policy, the following State policies have been adopted and are in effect in the State of Texas upon activation of this plan as provided for in paragraph 2, above:

- (1) In the event the Federal Government is not able to manage primary resources, State and local governments will manage and direct the use of such resources as necessary, until the Federal Government resumes its responsibilities.
- (2) The Governor and chief executives of local governments will exercise such control and guidance, during emergency operations, of government and civilian forces and resources subject by law to their authority as is necessary to assure the proper functioning of the economy in response to State and national needs. This includes those Federal civilian employees and material resources made available to the State and local governments.
- (3) The Governor is vested with emergency power and authorities to manage all resources under the jurisdictional control of the State in a civil defense emergency. (See Annex A.)
- (4) Emergency operations will be carried out principally at the local level. Emergency operations continue in all communities of the State until the Federal government again takes over.
- (5) All military resources employed in support of civil defense and resource management programs will remain at all times under military command and control.
- (6) State and local governments will place maximum reliance upon such resources available and closest to the point of need.
- (7) State and local governments will plan to assist adjacent areas in need.
- (8) The leaders of industry, agriculture, labor and finance--existing business and commercial managements--are responsible, in cooperation with appropriate government agencies, for planning and executing measures designed to assure the continued functioning or rapid restoration of the essential elements of the national economy.
- (9) Individuals and families are responsible to the extent possible for their own emergency needs and for participation in the general survival and recovery effort.
- (10) All public organizations are expected to make such contributions to State or community preparedness and survival operations as possible and appropriate.
- (11) Wherever possible, emergency assignments have been made to governmental organizations in being before the emergency. These assignments are related to the peacetime functions or emergency capabilities of the governmental units involved. Only where this is not possible have special emergency agencies been created. Further, volunteers are to be used to augment governmental structure and volunteer organizations used to supplement organizations with emergency functions.

4. Organization:

a. State: Emergency resource management is controlled at State level through the Director, Disaster Emergency Services, as directed in the executive order providing for the administration of resource management and certain economic stabilization programs.

Guidance in resource management is provided by a Resource Priorities Board composed of the coordinators of the State resource organizations as well as representatives of major users of resources and also liaison representatives of Federal agencies carrying on Federal resource management functions in the State of Texas. The Resource Priorities Board may meet jointly with the State Disaster Emergency Services Council or as an independent entity. Augmentation to State, regional and districts staffs is provided by designated resource specialists, (Annex E) "Resource Specialists".

b. District: The State of Texas is divided into 17 Disaster Districts which correspond to the boundaries of the Texas Highway Patrol Districts and Subdistricts. The Department of Public Safety Highway Patrol commanding officer in each district and subdistrict has been designated, by gubernatorial Executive Order W.B.C. 11, dated August 15, 1979, Chairman, Disaster District Committee and will report directly to the Director or State Coordinator on matters relating to this appendix. Counterparts of State departments and agencies represented on the Resources Priority Board and the Disaster Emergency Services Council will constitute the membership of the Disaster District Committee.

c. Local: Federal and State policy assumes that most essential economic activity will continue as regular and voluntary effort by and under existing business and commercial management.

This is particularly true at local and operating level. However, at local level there necessarily must be a centralized official or office from whom or through which any necessary governmental control will be exercised. Unless specifically excepted elsewhere in this plan, the government will be represented at local level by the county judge (for the county) and by the mayor (for incorporated cities and towns), who will be supported by governmental agencies and services of each political subdivision, and by auxiliary forces assigned for emergency resources management purposes.

d. Specific Responsibilities:

(1) State Department of Highways and Public Transportation:

(a) Develop and maintain emergency construction management plans related to the construction, repair and modification of emergency facilities (exclusive of community facilities related to housing); advise on and prepare guidance relative to emergency construction; be prepared to implement emergency plans; all in cooperation with the Associated General Contractors, Texas Highway-Heavy Branch.

(b) Develop and maintain emergency housing and community facilities plans and provide for assumption of assigned responsibilities; be prepared to implement emergency plans; be prepared to control the repair, conversion and construction and the management of emergency housing and community facilities; all in cooperation with the Texas Association of Home Builders.

(2) Public Utility Commission of Texas:

Maintain plans for establishing priorities for electric power and be prepared to provide the organization to implement emergency plans for establishment of priorities and curtailments and the enforcement of curtailments.

(3) Texas Department of Agriculture:

Develop and maintain emergency food and feeding plans and be prepared to implement existing plans; be prepared to control and supervise the distribution of secondary resources consistent with Federal and State objectives.

(4) Texas Railroad Commission:

Develop and maintain emergency transportation and petroleum, gas and solid fuels plans; provide for resource support for the operation of essential transportation, petroleum and gas and solid fuels facilities and equipment located in the State; provide for the emergency distribution of petroleum, gas and solid fuels within the State; provide for the support of the petroleum and gas industries within the State; and insure the proper use of intrastate and interstate transportation and solid, gaseous and liquid fuels.

(5) State Department of Health:

Develop and maintain emergency health and medical plans and provide for the distribution of health resources, including civilian health manpower, available for use in the State; provide for emergency sewage control and waste disposal, prevention and alleviation of water pollution.

(6) Texas Industrial Commission:

In cooperation with the Bureau of Business Research, maintain emergency industrial production plans, records and statistical data, and be prepared to provide a skeleton-staff organization upon which to expand in the event of a declared emergency; be prepared to provide for resource support for the operation of essential industrial production and distribution facilities within the State.

(7) Texas Employment Commission:

Maintain emergency manpower resource plans (exclusive of health manpower) to include recruitment, classification and utilization of civilian manpower.

(8) Texas Department of Water Resources:

Maintain emergency water resource plans to include distribution and use of water available for use in the State and the preservation and conservation of existing water supplies; be prepared to provide resource support for the operation of water utilities and suppliers located in the State.

(9) Banking Department of Texas and the Division of Disaster Emergency Services:

Develop and maintain price stabilization, rent stabilization and consumer rationing emergency plans; advise on and provide guidance relative to these assigned responsibilities; be prepared to conduct price stabilization, rent stabilization and consumer rationing functions during an emergency.

(10) Texas Department of Public Safety:

Provide emergency communications and administrative support, i.e., personnel, facilities and supplies for the conduct of the emergency resource management function; provide storage of reference documents and emergency and alternate site building facility.

(11) Local and District Organizations:

Assess, record and report local damage and provide on-the-spot analysis of increased (decreased) requirements of specific resources; prepare emergency plans and programs and direct efforts to the saving of life and property, to the conservation and management of resources and to the support of defense and retaliatory operations; provide for maximum self-sufficiency and continuity of operation.

(12) Governmental and Nongovernmental Units:

Take measures authorized by law to prepare for emergency before it arises to include: Training in self-protection and performance of emergency assignments; prepare and maintain plans and procedures; provide for periodic tests and improve organizational ability to carry out assignments; properly locate and maintain facilities, manpower equipment, communications and supplies.

5. Emergency Actions:

The following actions are taken by the Governor or officials designed by him to act on his behalf at State and district levels to provide overall State policies, guidance and direction for the management of resources in this State in a nuclear attack emergency or crisis relocation.

The emergency action and reference documents contained here have been prepared and pre-positioned with appropriate State and district officials during the pre-emergency planning process.

a. Actions for Immediate Supply:

- (1) Direct compliance with the Federal General Freeze Order. (Appendix 1, "Governor's Order Directing Compliance with Federal General Freeze Order," to Annex C, "Emergency Action Documents.")
- (2) Direct assumption of emergency duties by elements of the State emergency resource management organization. (Appendix 2, "Implementation of Resource Management Order," to Annex C, "Emergency Action Documents.")
- (3) Announce to the public the establishment and functions of the State emergency resource management organization. (Appendix 3, "Public Announcement," to Annex C, "Emergency Action Documents.")
- (4) Announce to the public the provisions of the Federal General Freeze Order and point out the need for individuals to conserve essential items. (Appendix 4, "Public Announcement," to Annex C, "Emergency Action Documents.")
- (5) Issue State policy on the priorities which will govern the provision and use of resources within the State. (Appendix 5, "Policy on Priority Use of Resources," to Annex C, "Emergency Action Documents.")
- (6) Issue Governor's proclamation announcing that State resource policies are in effect throughout the State and providing guidance to local governments on the implementation of these State policies. (Appendix 6, "Governor's Proclamation on State Resource Policies and Guidance," to Annex C, "Emergency Action Documents.")
- (7) Designate essential items to be distributed through the consumer rationing system. (Appendix 7, "Essential Items to be Rationed," to Annex C, "Emergency Action Documents.")

b. Actions for Continuing Supply: As soon as actions have been taken to conserve local use of essential resources and to resupply secondary inventories to meet essential needs in the localities, the following actions are taken to anticipate needs and to arrange for the continuing supply of essential resources to meet these needs:

- (1) Authorize the coordinators of the State resource organizations to apportion resources available to the State among essential needs and to take actions to arrange for the provision of these essential needs. (Appendix 8, "Delegation of Resource Authority," to Annex C, "Emergency Action Documents.")
- (2) Direct the coordinators of the State resource organizations to refer to the Resource Priorities Board for recommendations to the Governor on the adjudication of unresolved conflicts resulting from inability to meet needs from expected resources available under their jurisdiction. (Appendix 9, "Adjudication of Resource Conflicts," to Annex C, "Emergency Action Documents.")



6. Control and Communications:

a. Control:

- (1) Control and coordination of State emergency resources management activities will be exercised through normal communications channels or through the State emergency operating center communication system, if the situation warrants, and in accordance with instructions and guidance provided in the State of Texas Disaster Plan. As the defense and disaster relief activities decrease and the emergency provision, distribution and use of goods, services and manpower develop in urgency, the State resource management staff will expand beyond the space limitation of the emergency operating center. At that time, suitable additional space will be allocated if various participating agencies are unable to return to their former offices.
- (2) Unless specifically excepted elsewhere in this plan, the Department of Public Safety district and subdistrict organizations will be used as State control measures by emergency resource management as an extension of civil defense use of the area concept.
- (3) Alternate headquarters site will conform to that prescribed in the State of Texas Disaster Plan.

b. Communications:

- (1) Normal communication facilities will be used to the extent possible. When damage to existing systems is so vast as to restrict communications to emergency systems, the State emergency operating center employing the communications network of the Texas Department of Public Safety, supplemented however and wherever possible, will be used in conjunction with Department of Public Safety and civil defense traffic. Priority determination: Director of Public Safety as Director, Disaster Emergency Services Division.
- (2) Warnings: As prescribed in State of Texas Disaster Plan.

ANNEXES:

- A -- Authority
- B -- Organization for Emergency Management of Resources
- C -- Emergency Action Documents
- D -- Resource Specialists

ANNEX A  
AUTHORITY

Actions taken under this Emergency Resource Management Plan are in consonance with:

1. Sovereign authority of the State of Texas expressed in the State Constitution.
2. Emergency Interim Public Office Succession Act: An act to provide for temporary emergency interim succession to State and local public offices, except those of Governor, the Judiciary and members of the legislature, in order to assure continuity of government in periods of emergency caused by attack upon the United States; providing for severability; and declaring an emergency.
3. Texas Disaster Act of 1975: An act relating to the development of a civil defense and disaster relief plan for this State and its political subdivision; granting necessary powers to State and local governments of this State to cope with emergencies threatening life and property within the State; authorizing cooperative and mutual aid agreements for relief work between this and other States; and for related purposes; and providing a means for financing of such program by counties, towns and cities, repealing all laws in conflict; providing a saving clause; and declaring an emergency.
4. Ratification by the Legislature of the State of Texas of a compact on behalf of the State of Texas under the consent, by the Congress of the United States of America, to civil defense compacts by an act entitled "Federal Civil Defense Act of 1950, as amended" (Public Law 920, Eighty-First Congress, Second Session, Approved January 12, 1965): An act providing that the State of Texas may enter into a compact with any other state of the United States or of the United Mexican States - with the consent and approval of the government of the United States - for mutual helpfulness in meeting any civil defense emergency or disaster; containing a saving clause; and declaring an emergency.
5. Executive Order of the Governor W.P.C. 11, August 15, 1979, designates the Disaster Emergency Services Council and it's Chairman as well as Disaster Districts covering the State and the Disaster District Committee for each district. It further designates the mayors of each municipal corporation and county judge of each county as the Disaster Director/Coordinator for their respective jurisdictions.

This executive order also provides a closely knit organization of State representatives for field duty both in the planning and operating phases of the State Division of Disaster Emergency Services Program. It establishes State Disaster Districts and Subdistricts which parallel the Highway Patrol Districts and Subdistricts of the Department of Public Safety. District Emergency Operations Centers (EOC's) will be located in the District Headquarters of the Highway Patrol, or in such other place as may be designated and agreed upon by the State representatives constituting the organization in each District. The State personnel in each State Disaster District EOC shall consist of: The District Highway Patrol Commanding Officer, who shall serve as the Chairman and for purposes of organization and coordination. Designated representatives from the following agencies and departments: State Department of Highways and Public Transportation, Health Department, Department of Human Resources, Adjutant General, State Board of Insurance, Employment Commission, and American Red Cross.

6. State of Texas Disaster Plan: (December, 1976, as revised). Purpose: To describe the organization, the staff, the facilities and the techniques to effectively implement the Texas Disaster Act of 1975 and Federal statutes pertaining to Disaster Emergency Services. Responsibility: Planning and operation on the local level is the responsibility of the county judge for the county, and of the mayor for incorporated cities and towns, supported by governmental agencies and services of each political subdivision (County or City) has the primary responsibility for civilian activities for Disaster Emergency Services within its jurisdiction. It is further assumed that if the local plan becomes unable to cope with the disaster situation, the county or city concerned will make its needs known to the State Director of Disaster Emergency Services through the District headquarters. The State Director of Disaster Emergency Services will, when the situation demands, call upon the Regional Officer of Federal Emergency Management Agency for additional assistance.
7. Article 4413 (14); Law creating the Department of Public Safety and specifically defining when the Governor shall command the Department: Upon the occurrence of a public disaster, riot, or insurrection, or the formation of a dangerous resistance to the enforcement of the law, or for the purpose of performing his constitutional duty to cause the laws to be enforced, the Governor of this State shall have the authority to assume command of and direct the activities and functions of the Commission and of Department during the existence of such emergency or necessity.
8. Executive Order of the Governor Number 11, August 15, 1979; Transfer of the function of Disaster Emergency Services from the Governor's Office to the Department of Public Safety and giving the Director, Department of Public Safety, an additional title of Director, Disaster Emergency Services. The transfer was predicated upon the Department of Public Safety's attributes of rapid communications, trained personnel, and the strategic placement of its manpower and equipment.
9. Opinion Number C-455 of the Attorney General, State of Texas, dated June 13, 1965. (Appendix 1, Annex A)

**EXTRACT  
OPINION NO. C-455  
ATTORNEY GENERAL, STATE OF TEXAS  
JUNE 15, 1965**

Re: Does the Governor, in time of national emergency, have the authority to direct the implementation of the submitted Emergency Resources Management Plan. If not, what legislation will be necessary to give him the authority, and allied questions.

\*\*\*\*\*

The caption of House Bill 784, Acts 1951, 52nd Leg., p. 529, Ch. 311, which is codified by Vernon as Article 6889-4, states in part:

"An Act relating to the development of a civil defense and disaster relief plan for this State and its political subdivisions; granting necessary powers to State and local governments of this State to cope with emergencies threatening life and property within the State; . . . ." (Emphasis added)

Section 2 states:

"The Governor shall provide for the organization and coordination of a program of civil defense and disaster relief adequate to protect life and property in this State in case of natural disaster, enemy action, or the threat thereof.

"He may establish by executive proclamation a State Defense and Disaster Relief Council, consisting of the representatives of such State agencies, departments, and institutions of the State whose legal functions relate to important phases of this activity and representatives of public or quasi-public relief organizations, and who may be designated by the Governor."

Section 3 states:

"The Governor, or upon his designation, the State Defense and Disaster Relief Council, may issue, within the limits of constitutional power, such directives and executive orders as may be necessary to effectuate the purpose of this Act, which directives shall be filed in the office of the Secretary of State and shall receive widespread publicity and notice unless such notice will be of aid and comfort to the enemy."

Section 4 states in part:

"The Governor, or upon his designation, the State Defense and Disaster Relief Council, is further authorized and empowered:

" . . .

"(b) To provide for the organization and operation of Mobile Support Units for use by him in dispatching outside aid to stricken areas;

"(c) To coordinate the negotiation of civil defense mutual aid agreements between political subdivisions of the State and to direct, if necessary, the coordination of civil defense activity under such agreements;

"(d) Through appropriate State agencies and State Disaster District Control Centers to direct evacuation plans and operations;

"(e) To prescribe uniform signals, warnings, alerts, credentials, insignia, and civil defense operational plans throughout the State and to provide for dimouts or other precautionary measures deemed necessary to prevent or minimize loss of life or injury to persons or property from enemy action or other catastrophe or the threat thereof;

" . . . " (Emphasis added)

Section 8 states:

"In carrying out the provisions of this Act, the Governor and the executive officers or governing bodies of the political subdivisions of the State are authorized to utilize the services, equipment, supplies and facilities of existing departments, offices, and agencies of the State and of the political subdivisions thereof to the maximum extent practicable, and the officers and personnel of all such departments, offices, and agencies are directed to cooperate with and extend such services and facilities to the Governor and to the civil defense organization of the State upon request."

Section 10 states:

"It shall be the duty of every organization for civil defense established pursuant to this Act and of the officers thereof to execute and enforce such orders, rules and regulations as may be made by the Governor and/or the State Defense and Disaster Relief Council, under authority of this Act."

There have been no cases construing the above mentioned statute and therefore, this opinion is based upon our construction of the statute, together with the plans as submitted.

. . . under Article 6889-4, we are of the opinion that the Governor, in time of national emergency, has the authority to direct the implementation of the plan submitted.

. . . we are of the opinion that under the above quoted provisions of Article 6889-4, the Governor has the authority to direct certain State agencies to assume responsibility under this plan, both during peace and emergency.

Under Section 2 of Article 6889-4, which states:

"The Governor shall provide for the organization and coordination of a program of civil defense and disaster relief adequate to protect life and property in this State in case of natural disaster, enemy action, or the threat thereof.

". . ."

The Governor has authority to create a State Executive Reserve under the plan submitted. However, there is not authority which we can find that will allow payment to the individuals so selected for such training in the executive reserve, and the persons so selected would have to serve without compensation.

SUMMARY

1. In time of national emergency, the Governor has the authority to direct implementation of the Emergency Resources Management Plan, under Article 6889-4, Vernon's Civil Statutes.
2. Under Article 6889-4, the Governor has the authority to direct certain State agencies to assume responsibilities under provisions of this plan, both in peace and during emergencies.
3. We can find no additional State authorities governing the plan as submitted, except those set out in Annex A.
4. The Governor has the authority to create a State Executive Reserve, under Article 6889-4, and the plan as submitted, provided such reserves serve without compensation.

Yours very truly,  
WAGGONER CARR  
Attorney General

(Signed by): John H. Banks  
Assistant

JHB:sj

APPROVED: OPINION COMMITTEE

W. V. Geppert, Chairman; Pat Bailey; John Reeves; J. C. Davis; H. Grady Chandler

APPROVED FOR THE ATTORNEY GENERAL BY: T. B. Wright

ANNEX B

ORGANIZATION FOR EMERGENCY MANAGEMENT OF RESOURCES

1. The Governor is vested with emergency powers and authorities to manage all resources under the jurisdictional control of the State of Texas in a civil defense emergency. (Annex A, Authority)
2. The Governor has:
  - a. Assigned responsibility for administering emergency resource management and economic stabilization programs to specified departments and agencies of the State government and to certain emergency organizations established where existing agencies are not adequate for the purpose. (Executive Order Number 71-1, dated February 22, 1971, Providing for the Administration of Resource Management and Economic Stabilization Programs)
  - b. Established a Resource Priorities Board to advise him on emergency resource management and economic stabilization policies and on decisions governing the allocation and use of essential resources to meet the most urgent needs. (Appendix 1, Annex B)
  - c. Appointed an official to act as his principal assistant and adviser on emergency resource management and economic stabilization activities and to act on his behalf in coordinating the emergency resource management and economic stabilization activities of the departments and agencies of the State government. (Executive Order Number 71-1, dated February 22, 1971, Providing for the Administration of Resource Management and Economic Stabilization Programs)
  - d. Assigned the responsibility for providing administrative support for the conduct of the resource management function. (Appendix 2, "Administrative Support, Resource Management," to Annex B)
3. The State of Texas is divided into 17 emergency resource management districts which parallel the Highway Patrol districts and subdistricts of the State Department of Public Safety. District planning is carried out by executives for the State Director, Disaster Emergency Services, resource specialists and counterparts of other State departments and agencies who combine to constitute the district committees of this organization. Planning and plan implementation at district level will conform throughout this appendix for emergency resources management to the districts shown on Appendix 3, unless specifically excepted elsewhere in this Appendix.
4. Planning and operations for emergency resource management on the local level, unless specifically excepted elsewhere in this disaster plan, is the responsibility of the county judge for the county and of the mayor for incorporated cities and towns, supported by governmental agencies and services of each political subdivision, and by auxiliary forces that are assigned for emergency resources management purposes.

APPENDIX 1  
(FUNCTIONS AND MEMBERSHIP  
OF THE STATE RESOURCE PRIORITIES BOARD)  
TO ANNEX B  
(ORGANIZATION FOR EMERGENCY  
MANAGEMENT OF RESOURCES)

The Resource Priorities Board meets on call of the Chairman (Director, Disaster Emergency Services) when problems arise requiring the collective consideration and advice of its members. Normally, the coordinators of the resource organizations dispose of problems concerning resources under their jurisdiction on their own initiative and refer to the Board only those problems they are unable to resolve by direct negotiation.

Initially, most of the problems and actions to direct the distribution of locally available resources to meet immediate and urgent needs will take place at local levels and create requirements for State action at State or local area levels to resupply resources to meet local needs.

As soon as information is available, the Resource Priorities Board serves as a coordinating body in the development by the State resource organizations of estimates of future continuing requirements and expected supplies of resources that will be available for use in the State. It makes recommendations to the Governor for resolution of conflicts and allocation of resources when expected supplies will not be adequate to meet all essential programs and needs.

1. The Resource Priorities Board advises the Governor on resource management and economic stabilization activities in the State in a nuclear attack emergency, including the resolution of conflicting claims for scarce resources.
2. Members of the Resource Priorities Board are the coordinators of the several resource organizations, as well as members representative of principal users of resources. In addition to representing to the Board the status of their resource in the State, the resource organization heads also present their claims upon other resources under the jurisdiction of other State resource organizations.
3. Federal agency officials participating with the State in the management of certain resources as a Federal responsibility serve as liaison representatives to the Resource Priorities Board, both in their capacity as managers of resources under Federal jurisdiction and as claimants on resources under State jurisdiction.
4. Chart at Tab A diagrams the Emergency Resource Management organization. Chart at Tab B shows functional arrangements of the Resource Priorities Board. Chart at Tab C shows the composition and membership of the Resource Priorities Board.

---

APPENDIX 2  
(ADMINISTRATIVE SUPPORT  
RESOURCE MANAGEMENT)  
TO ANNEX B  
(ORGANIZATION FOR EMERGENCY  
MANAGEMENT OF RESOURCES)

1. The Governor of the State of Texas has assigned to the Department of Public Safety the responsibility for providing administrative support, i.e., personnel, facilities and supplies for the conduct of the resource management function. Copies of the Disaster Plan and all action and reference documents have been placed and are immediately available in the emergency operating center of the Department of Public Safety and in the seventeen district offices.
2. Upon implementation of this appendix, the Director, Disaster Emergency Services, and such key staff members as he prescribes establish headquarters at the emergency operating center, Department of Public Safety, or at such location as directed by the Governor.
3. Lines of succession to insure continuity of key staff are provided in the roster of key personnel contained in Part C and will be maintained current by existing membership.

# STATE OF TEXAS EMERGENCY RESOURCES MANAGEMENT FUNCTIONAL CHART

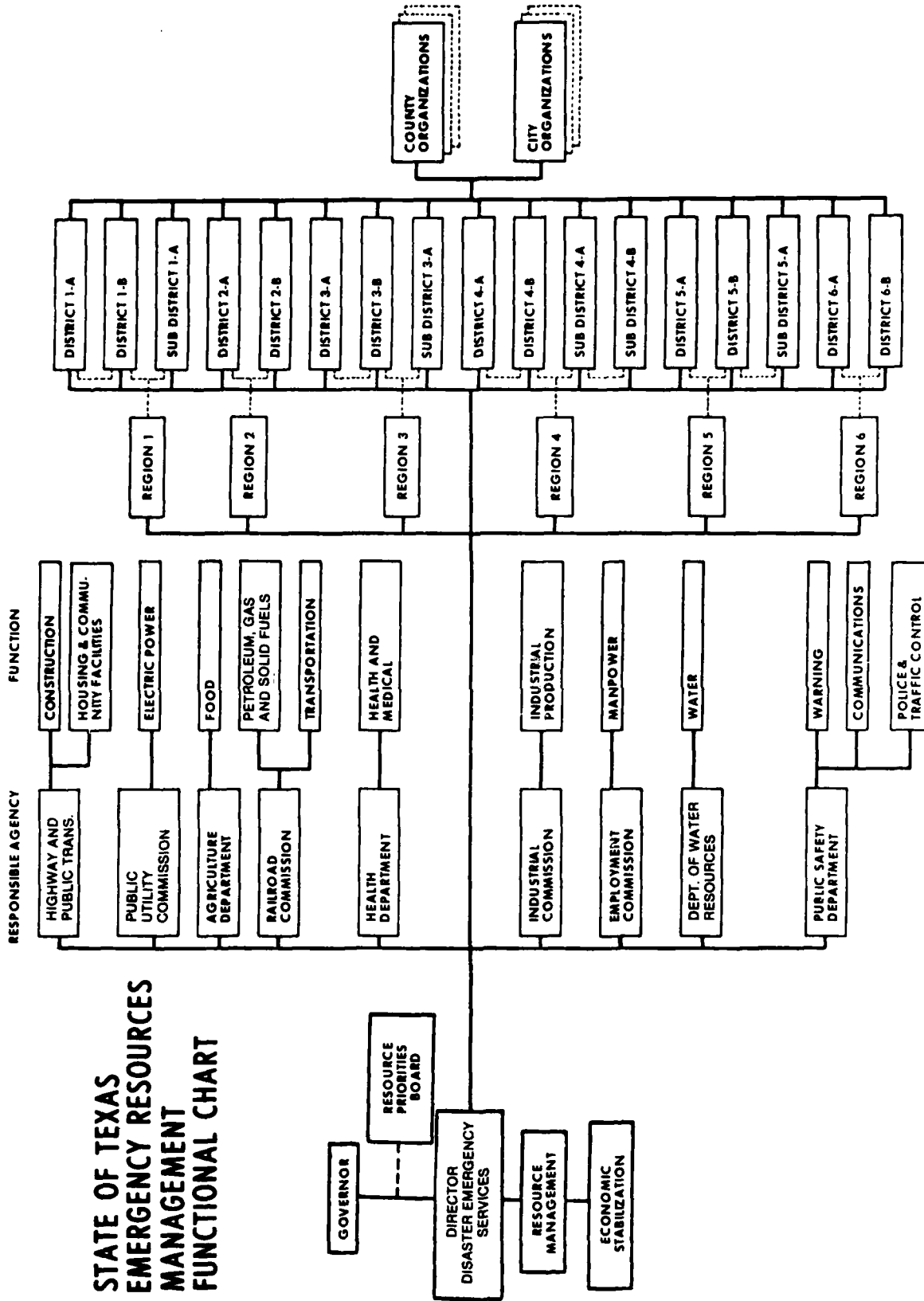

Tab B  
FUNCTIONAL CHART

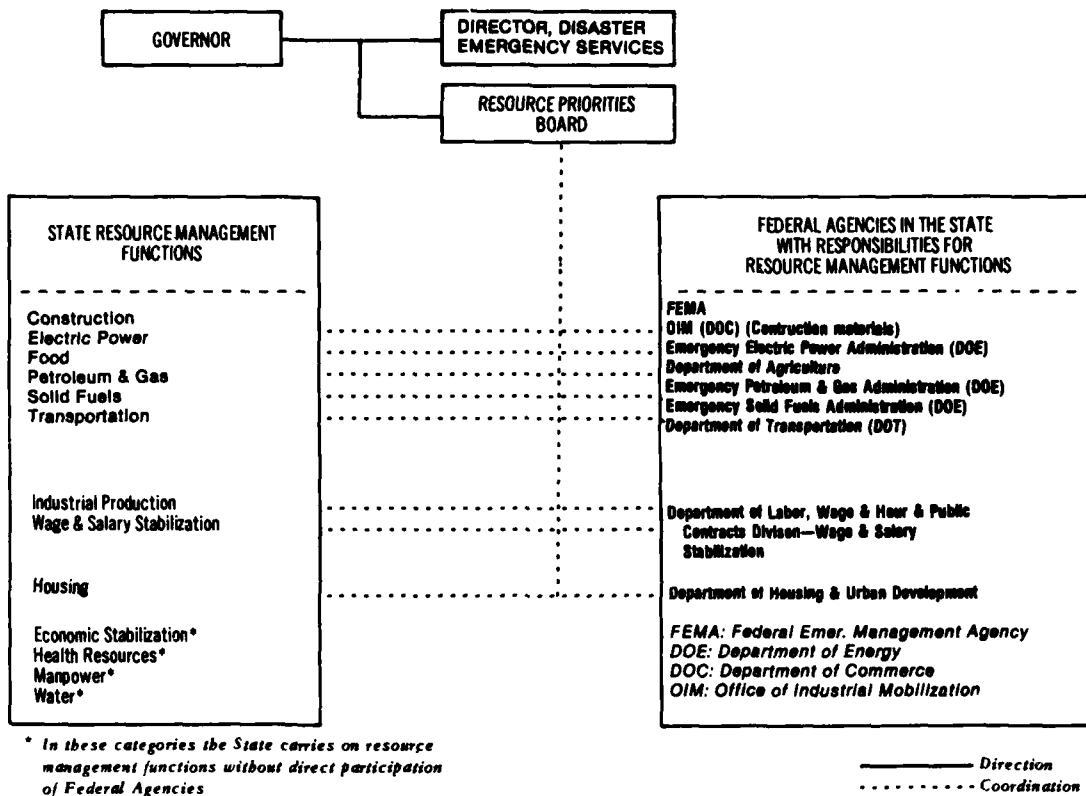

Tab C  
COMPOSITION OF RESOURCE PRIORITIES BOARD

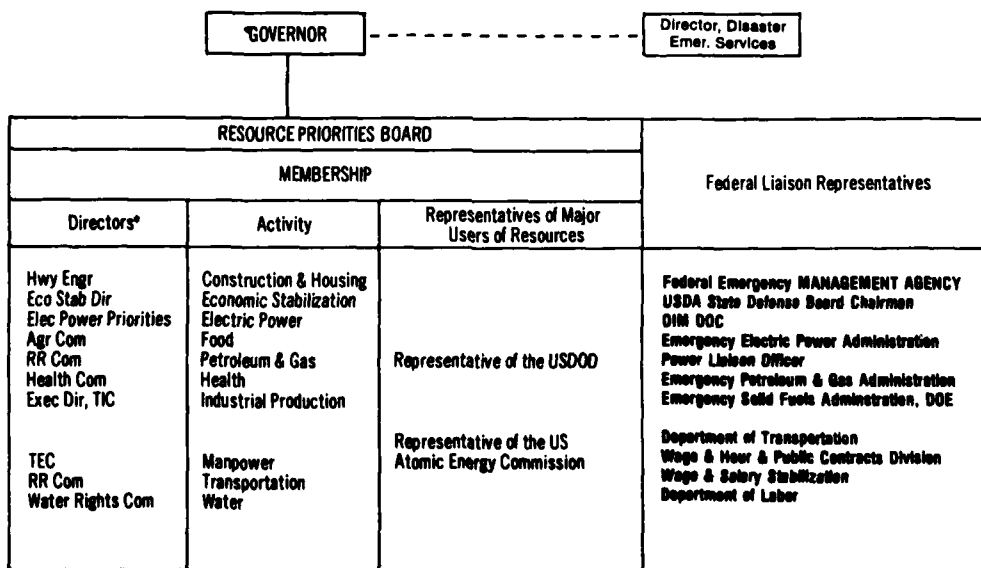

\* These State Resource Directors, in addition to seeking to meet the needs of the direct claimants and those sponsored by Federal Liaison representatives, also claim on other State resource agencies for resources needed to support the operation of industries and services under their jurisdiction.

# DIVISION OF DISASTER EMERGENCY SERVICES DISASTER DISTRICT BOUNDARIES

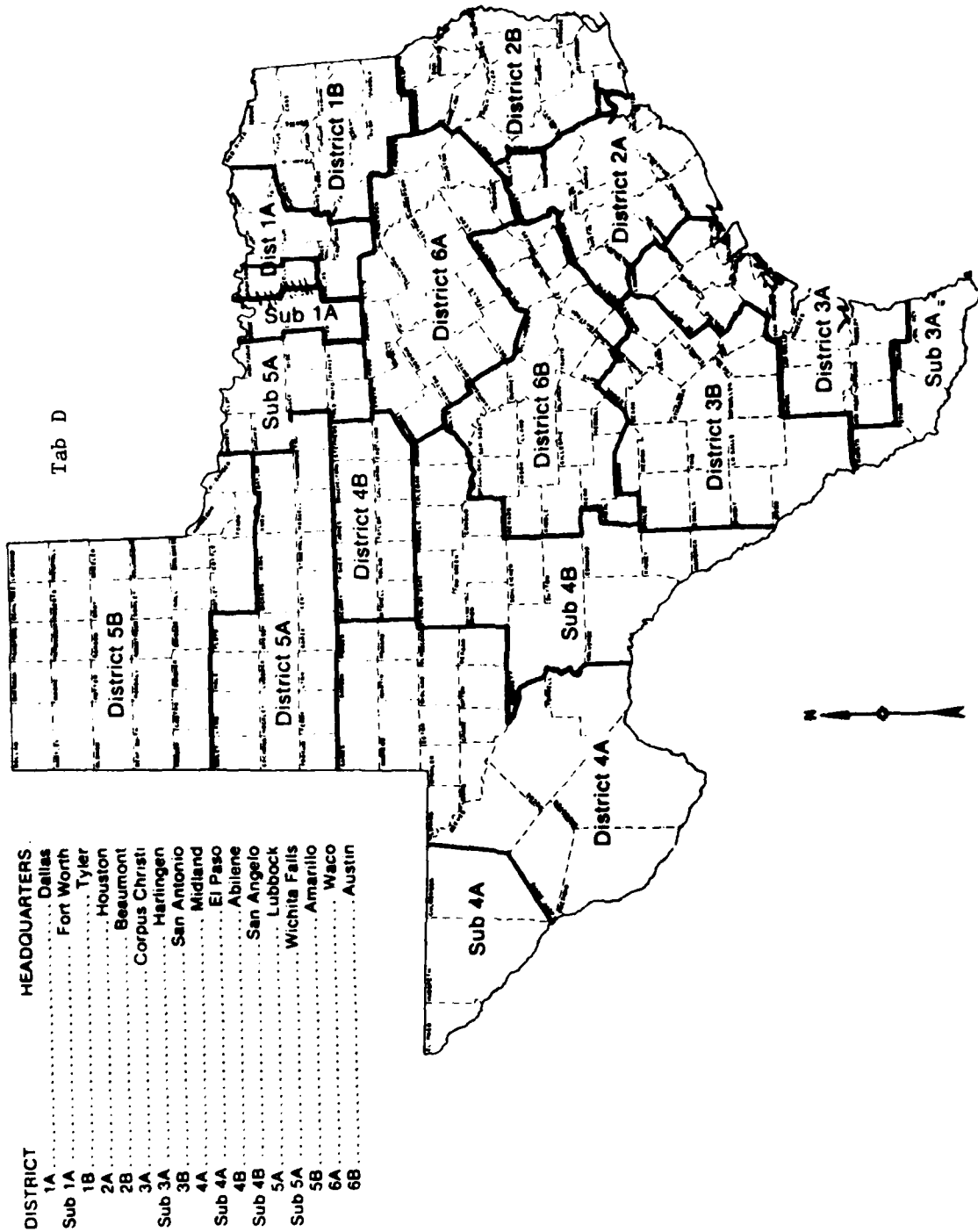

A-B-2

Tab D



DEPARTMENT OR AGENCY	ECONOMIC STABILIZATION		CONSTRUCTION	ELECTRIC POWER	FOOD	PETROLEUM AND GAS	HEALTH	HARBORS	TRANSPORTATION	WATER	HOUSING	INDUSTRIAL PRODUCTION (Coal & Uranium)	SOLID FUEL	BUDGET RESOURCE	MANAGEMENT	PERSONNEL	RESOURCES PRIORITY BOARD	CONSULTING SERVICES BOARD	DES COUNCIL	
	P	S																		
Division of Disaster Emergency Services																				
Department of Highways and Public Transportation																				
Public Utilities Commission																				
Department of Agriculture																				
Railroad Commission																				
Department of Health																				
Industrial Commission																				
Texas Employment Commission																				
Department of Water Resources																				
Comptroller of Public Accounts																				
Attorney General																				
Banking Commission																				

R-Railroad  
 V-Motor Vehicle  
 I-Inland Waterway  
 A-Air Transport Services

B-Monetary, Banking and Consumer Credit  
 W-Wage and Salary Stabilization  
 T-Price, Consumer Rationing and Rent Control

DEPARTMENT OR AGENCY	ECONOMIC STABILIZATION		CONSTRUCTION	ELECTRIC POWER	FOOD	PETROLEUM AND GAS	HEALTH	HARBOUR	TRANSPORTATION			HOUSING	INDUSTRIAL PRODUCTION	SOLID FUEL (Coal & Uranium)	ENERGY MANAGEMENT BUREAU	RESOURCES PRIORITY BOARD	CONSULTING SERVICES BOARD	DPS OFFICE
	A	B							A	B	C							
State Treasurer																		
Secretary of State																		
Adjutant General's Department																		
Texas Aeronautics Commission										P								M
Texas Air Control Board						S												M
State Auditor																		M
Board of Control																		M
Texas Education Agency																		M
State Board Of Insurance																		M
General Land Office																		M
Texas Department of Mental Health and Mental Retardation																		M
Texas Parks and Wildlife Department																		M

R-Railroad  
 V-Motor Vehicle  
 I-Inland Waterway  
 A-Air Transport Services

B-Monetary, Banking and Consumer Credit  
 W-Wage and Salary Stabilization  
 T-Price, Consumer Nationing and Rent Control



**ANNEX C  
EMERGENCY ACTION DOCUMENTS**

- Appendix 1: Governor's Order Directing Compliance with Federal Freeze Order
- Appendix 2: Implementation of Resource Management Order
- Appendix 3: Public Announcement, State Resource Organization
- Appendix 4: Public Announcement, General Freeze Order
- Appendix 5: Policy on Priority Use of Resources
- Appendix 6: Governor's Proclamation on State Resource Policies and Guidance
- Appendix 7: Essential Items to be Rationed
- Appendix 8: Delegation of Resources Authority
- Appendix 9: Adjudication of Resource Conflicts

**APPENDIX 1 TO ANNEX C  
GOVERNOR'S ORDER DIRECTING COMPLIANCE  
WITH  
FEDERAL GENERAL FREEZE ORDER**

---

To All Concerned:

By virtue of the authority vested in me in a nuclear attack emergency by the laws of the State of Texas it is hereby ordered:

All persons shall comply with the provisions of the attached Federal General Freeze Order (Economic Stabilization) dealing with ceilings on prices, rents, the prohibition of retail sales and the rationing of essential consumer items. In accordance with this Federal General Freeze Order I have designated essential consumer items that are to be distributed in this State through the consumer rationing system. These essential consumer items are listed in Appendix 7, "Essential Items to be Rationed," which is issued concurrently with this order.

The Executive Heads of governing bodies of local governments are authorized to make exceptions to the "Freeze" provisions to permit retail sales to meet the immediate needs of designated essential local users and to maintain operations of designated essential facilities. They shall enforce compliance with all provisions of the Federal General Freeze Order and any subordinate regulations, orders or directives issued by State or local governments.

This order, the Federal General Freeze Order, and Appendix 7, "Essential Items to be Rationed," shall be published and made known to all affected persons by use of all media available for the purpose.

By the Governor of the State of Texas.

In witness whereof I set my hand and seal this \_\_\_\_\_ day  
of \_\_\_\_\_, 19\_\_\_\_\_.

SEAL

\_\_\_\_\_  
Governor

\_\_\_\_\_  
Secretary of State

Tab 1 - Federal General Freeze Order

**TAB 1 TO APPENDIX 1, ANNEX C TO PART A  
FEDERAL GENERAL FREEZE ORDER  
(ECONOMIC STABILIZATION)**

Whereas, the President has proclaimed the existence of an unlimited national emergency and of a civil defense emergency, and has found that it is necessary to provide for resource conservation and control and for the stabilization of the civilian economy;

Now, therefore, by virtue of the authority vested in me by the President, it is hereby ordered as follows:

**Section 1. General Freeze.**

All prices, wages and salaries and rents are hereby frozen at the levels specified in Section 2 of this Order.

**Section 2. Prohibitions.**

- (a) No person may charge, receive, or pay more for commodities and services than the highest prices which were in effect during the one-month base period prior to the base date.
- (b) No employer shall pay and no employee shall receive a wage, salary or other form of compensation at a rate higher or lower than that paid or received as of the base date.
- (c) No person shall demand or receive, nor shall any person pay more than the following rent ceilings:
  - (1) The rent in effect on the base date for any housing accommodation, commercial, or industrial unit which was rented on the base date;
  - (2) The last rent in effect during the base period for any house, apartment, flat, commercial, or industrial unit which was not rented on the base date but was rented at any time during the base period;
  - (3) The ceiling rent established by regulation, directive, or order issued pursuant to this Order for houses, apartments, flats, commercial, and industrial units, for rooms of all types, and for any rented structure, unit, or space.
- (d) No owners of any interest in real property shall demand or receive, and no purchaser shall pay more than the sales price ceilings which shall be:
  - (1) The sale price specified in a sales contract signed by both parties on or before the base date; or
  - (2) Where there is no such sales contract, the fair market value of the property in the rent-control area as of the base date, as established by an authorized appraiser, subject to the approval of the local rent administrator.

**Section 3. Consumer Rationing.**

For a period of five days from the effective date of this Order, all retail sales, except perishable foods or any health item dispensed under prescribed procedures, shall be prohibited. Thereafter, rationing of selected essential consumer items will be imposed as rapidly as possible.

**Section 4. Definitions.**

- (a) "Base Date": Base date means the date of the first nuclear attack on the United States.
- (b) "Base Period": Base period means the one-month period prior to the base date as to ceiling prices, and the three months prior to and ending on the base date as to rents.
- (c) "Persons": Persons shall include any individual, corporation, partnership, firm or any other entity.
- (d) "Price": Price shall include rentals, commissions, margins, rates, fees, charges or other forms of prices paid or received for the sale or use of commodities or services or for the sale of real property, but shall not include prices on finished military items produced for the armed forces.
- (e) "Commodity": Commodity means all commodities, articles, products, and materials, including those provided by public utilities services, such as electricity, gas, and water.
- (f) "Services": Services means all services rendered, other than as an employee, in connection with the processing, distribution, storage, installation, repair, or negotiation or purchases or sales of a commodity, or in connection with the operation of any service establishment for the servicing of a commodity, or privileges including professional services. (The term "services" shall not be construed to authorize the regulation of compensation paid by an employer to any of his employees.)
- (g) Wage, salary, or other form of compensation includes all forms of remuneration to an employee by an employer for personal services including, but not limited to, premium overtime rate payments, night shift, year-end and other bonus payments, incentive payments, commissions, vacation and holiday payments, employer contributions to or payment of insurance or welfare benefits or pension funds or annuities, and other payments in kind. Regardless of any right or contract heretofore or hereafter existing, no change or adjust-

ment shall be made in such rates of wages, salaries, or other forms of compensation except as may be permitted or required by regulations, orders, or directives issued under this Order.

- (h) "Sale": Sale includes sales, dispositions, exchanges, and other transfers and contracts and offers to do any of the foregoing.
- (i) "Authorized Appraiser": Authorized appraiser means qualified appraiser designated by the local rent administrator to make appraisals in connection with the establishment of sales price ceilings for real property.
- (j) "Essential Consumer Items": Essential consumer items means items that are used to satisfy essential needs of individual consumers, such as food, clothing, petroleum products and other items as indicated in Section 5, (b).
- (k) "Retail": Retail (sometimes referred to as secondary) means the level at which commodities, products and materials are sold directly to the consumer.
- (l) "Rent": Rent includes charges for any building, structure or part thereof, or land appurtenant thereto, or services, furnishings, furniture, equipment, facilities, and improvements connected with the use or occupancy of such property.

#### **Section 5. Interim Administration.**

Until such time as a Federal emergency stabilization agency is created and is capable of administering the provisions of this Order, interim operations include the following:

- (a) The Secretary of Labor is delegated authority to administer those provisions of this Order dealing with wages, salaries and other compensation (and the resolution of any labor disputes that may arise) and to issue such regulations, orders or directives as he deems necessary to such administration. He is further authorized to redelegate this authority to such officers of his Department as he deems appropriate.
- (b) It is expected that the Governor of each State through such State offices or agencies, local authorities including civil defense and other emergency organizations as he may designate will exercise such emergency authorities as are available to him under State law, to provide for the administration of those provisions of this Order dealing with ceilings on prices, rents, the prohibition of all retail sales, and the rationing of essential consumer items. In the course of such administration, the Governor through such designees is expected to make such essential exceptions to the prohibition-of-sales provisions of this Order as he finds necessary and shall designate those essential consumer items to be distributed through the consumer rationing system.
- (c) It is further expected that the governor of each state, pursuant to the laws of his state and supported by local authorities, will provide for the interim enforcement of ceilings established by this Order and of any regulations, orders or directives issued pursuant to this section.

#### **Section 6. Record Keeping.**

- (a) Commodities and Services: All records in existence on the date of this Order reflecting prices which were charged for the commodities or services during the base period, together with all other records of any kind or description shall be preserved. All records hereafter required to be kept pursuant to regulations or directives issued hereunder shall be preserved.
- (b) Rents: All persons subject to this Order shall preserve and maintain all records which are necessary to show the manner by which the ceiling rentals were determined and the record of payments made by persons in occupancy of real property or any part thereof.
- (c) Wages and Salaries: All employers shall preserve and maintain all records which reflect the rates of wages, salaries or other forms of compensation paid on the base date, together with all other records of any kind or description.

#### **Section 7. Applicability.**

The provisions of this Order shall be effective immediately and are applicable to the United States, its territories and possessions, the Commonwealth of Puerto Rico, and the District of Columbia.

#### **Section 8. Termination.**

This interim Order shall expire when replaced by subsequent executive or administrative Economic Stabilization Agency orders.

Dated \_\_\_\_\_

\_\_\_\_\_  
Designated Federal Official

(Note: For planning purposes, it is assumed that such an order will be issued by the Federal Government in a nuclear attack emergency.)

**APPENDIX 2 TO ANNEX C  
IMPLEMENTATION OF RESOURCE MANAGEMENT ORDER**

To All Concerned:

By virtue of the authority vested in me in time of extreme emergency and it having been determined that a grave emergency does in fact now exist, it is hereby ordered that the State of Texas Emergency Resource Management Plan be implemented as an order and the provisions of the Plan be enforced under the supervision of the Director, Disaster Emergency Services as the designated Resource Assistant to the Governor.

By the Governor of the State of Texas.

In witness whereof I set my hand and seal this \_\_\_\_\_  
day of \_\_\_\_\_, 19\_\_\_\_\_.

\_\_\_\_\_  
Governor

SEAL

\_\_\_\_\_  
Secretary of State

**APPENDIX 3  
(PUBLIC ANNOUNCEMENT, STATE RESOURCES ORGANIZATION)  
TO ANNEX C  
(EMERGENCY ACTION DOCUMENTS)**

To: Heads of all State Departments, Offices and Agencies, Executive Heads of County and City Governments, Designated Resource Specialists, Directors of Civil Defense and Citizens of the State of Texas.

The Official Emergency Resource Management Plan for the State of Texas, adopted the 25th day of November, 1966, is hereby invoked as an order providing for the emergency management of resources and economic stabilization activities in this State. The Director, Disaster Emergency Services, will supervise the implementation of the order and will head the Resource Priorities Board, composed of coordinators of the State resource organizations and representatives of major users of resources as well as liaison representatives of Federal agencies carrying on Federal resource management functions in the State.

It is hereby directed that each individual agency and activity discharge the responsibilities entrusted to it.

I earnestly request all political subdivisions in our State to support this operation. Citizens of the State should cooperate fully so that our State and Nation will recover from this disaster.

By the Governor of the State of Texas.

In witness whereof I set my hand and seal this \_\_\_\_\_ day of \_\_\_\_\_, 19\_\_\_\_\_.

\_\_\_\_\_  
Governor

SEAL

\_\_\_\_\_  
Secretary of State

**APPENDIX 4  
(PUBLIC ANNOUNCEMENT, GENERAL FREEZE ORDER)  
TO ANNEX C  
(EMERGENCY ACTION DOCUMENTS)**

Austin, Texas

Governor \_\_\_\_\_ announced today that a Federal General Freeze Order has been placed in effect in the State of Texas. This action imposes ceilings on prices, wages, salaries, rent and rental property and provides for consumer rationing. The Order became effective at \_\_\_\_\_ (A.M.) (P.M.) today and will remain in effect for an indefinite period.

The Governor deemed the action necessary because of the grave emergency now existing which threatens to undermine the national economy, impede the national defense and disrupt civilian morale.

Governor \_\_\_\_\_ announced further that conservation of all essential resources on a full austerity basis is necessary. Consequently, he has activated the State Resource Priority Board under the coordination of Colonel \_\_\_\_\_ the Director of Disaster Emergency Services, his Resource Assistant. Colonel \_\_\_\_\_ is advisor to the Governor on emergency resource management and economic stabilization activities under the jurisdiction of the State and its political subdivisions.

**APPENDIX 5 TO ANNEX C  
POLICY ON PRIORITY USE OF RESOURCES**

To: State Resource Directors and Executive Heads of Government in the Subdivisions in the State of Texas.

1. **Priority Activities in Immediate Postattack Period:** The following activities in the State of Texas are to be accorded priority over all other claims for resources. There is no significance in the order of listing—all are important. The order in which and the extent to which they are supported locally may vary with local conditions and circumstances. If local conditions necessitate the establishment of an order of priority among these activities, that order shall be based on determinations of relative urgency among the activities listed, the availability of resources for achieving the actions required and the feasibility and timeliness of the activities in making the most rapid and effective contribution to national survival.
  - a. **The immediate defense and retaliatory combat operations of the Armed Forces of the United States and its Allies:** This includes support of military personnel and the production and distribution of military and atomic weapons, materials and equipment required to carry out these immediate defense and retaliatory combat operations.
  - b. **Maintenance or Re-establishment of Government Authority and Control:** To restore and preserve order and to assure direction of emergency operations essential for the safety and protection of the people in the State of Texas. This includes:
    - (1) Police protection and movement direction;
    - (2) Fire defense, rescue and debris clearance;
    - (3) Warnings;
    - (4) Emergency information and instructions;
    - (5) Radiological detection, monitoring and decontamination.
  - c. **Production and Distribution of Survival Items and Provision of Services:** Essential to continued survival and rapid recovery in the State of Texas. These include:
    - (1) Expedient shelter;
    - (2) Food, including necessary processing and storage;
    - (3) Feeding, clothing, lodging and other welfare services;
    - (4) Emergency housing and community services;
    - (5) Emergency health services, including medical care, public health and sanitation;
    - (6) Water, fuel and power supply;
    - (7) Emergency repair and restoration of damaged vital facilities.
  - d. **Essential Communications and Transportation Services:** Needed to carry out the above activities.
  - e. **Provision of Supplies and Equipment to Produce and Distribute Goods:** Needed for the above activities.
2. **Assignment of Resources:** Resources required for essential uses, including manpower, will be assigned to meet the emergency requirements of the priority activities indicated above. The principal objectives are to use available resources to serve essential needs promptly and effectively and to:
  - a. Protect and to prevent waste or dissipation of resources prior to their assignment to priority activities.
  - b. Support production of essential goods. Other production will be permitted to continue only from inventories on hand and when there is no emergency requirement for the resources vital to this production.
  - c. Support construction for emergency repair and restoration, construction of facilities needed for survival, or the conversion of facilities to survival use, where this can be accomplished quickly. Other construction already underway should be stopped, and no new construction started unless it can be used immediately for essential purposes upon completion.

By the Governor of the State of Texas.

In witness whereof I set my hand and seal this \_\_\_\_\_ day of \_\_\_\_\_,  
19\_\_\_\_\_.

\_\_\_\_\_  
Governor

SEAL

\_\_\_\_\_  
Secretary of State



## ATTACHMENT 1 TO APPENDIX 5

This document contains a listing of items considered essential to sustain life at a productive level to assure national survival in an emergency.

The items are arranged by seven major groups:

- (1) Health Supplies and Equipment
- (2) Food
- (3) Body Protection and Household Operations,
- (4) Electric Power and Fuels,
- (5) Sanitation and Water Supply,
- (6) Emergency Housing and Construction Materials and Equipment, and
- (7) General Use Items.

Survival items are defined as "those items without which large segments of the population would die or

have their health so seriously impaired as to render them both burdensome and non-productive." The items have been classified into Group A or Group B, with Group A representing end products consumed or used directly by the population, and Group B consisting of those items essential to the effective production and utilization of the Group A items, which are consumed or used directly by the people.

There are no Group B items in the categories of Health Supplies and Equipment, Body Protection and Household Operations, and Emergency Housing and Construction Materials and Equipment. All of these items are considered to be consumed directly and any attempt to separate them in to A and B groupings would be too arbitrary to be meaningful.

### LIST OF ESSENTIAL SURVIVAL ITEMS

#### I. Health Supplies and Equipment:

##### GROUP A

#### 1. Pharmaceuticals:

Alcohol.  
Analgesics, non-narcotic.  
Antibiotics and antibacterials.  
Antidiabetic agents, oral.  
Antihistamines.  
Antimalarials.  
Atropine.  
Blood derivatives.  
Carbon dioxide absorbent.  
Cardiovascular depressants.  
Cardiovascular stimulants.  
Corticosteroids.  
Diuretics.  
General anesthetics.  
Hypnotics.  
Insulin.  
Intravenous solutions for replacement therapy.  
Local anesthetics.  
Lubricant, surgical.  
Morphine and substitutes.  
Oral electrolytes.  
Oxygen.  
Surgical antiseptics.  
Sulfa drugs.  
Synthetic plasma volume expanders.  
Vitamin preparations, pediatric.  
Water for injection.

#### 2. Blood Collecting and Dispensing Supplies:

Blood collecting and dispensing containers.  
Blood donor sets.  
Blood grouping and typing sera.  
Blood recipient sets.  
Blood shipping containers.

#### 3. Biologicals:

Diphtheria toxoid.  
Diphtheria antitoxin.  
Diphtheria and tetanus toxoids and pertussis vaccine.  
Gas gangrene antitoxin.  
Poliomyelitis vaccine, oral.  
Rabies vaccine.  
Smallpox vaccine.

Tetanus antitoxin.  
Tetanus toxoid, absorbed.  
Typhoid vaccine.  
Typhus vaccine, epidemic.  
Yellow fever vaccine.

#### 4. Surgical Textiles:

Adhesive plaster.  
Bandage, gauze.  
Bandage, muslin.  
Bandage, plaster of paris.  
Cotton, USP.  
Surgical pads.  
Stockinette, surgical.  
Wadding, cotton sheet.

#### 5. Emergency Surgical Instruments and Supplies:

Airway, pharyngeal.  
Anesthesia apparatus.  
Basin, wash, solution.  
Blade, surgical knife.  
Brush, scrub, surgical.  
Catheter, urethral.  
Containers for sterilization.  
Chisel, bone.  
Drain, Penrose.  
Dusting powder.  
Forceps, dressing.  
Forceps, hemostatic.  
Forceps, obstetrical.  
Forceps, tissue.  
Gloves, surgeon's.  
Handles, surgical knife.  
Holder, suture needle.  
Inhaler, anesthesia, Yankauer (ether mask).  
Intravenous injection sets.  
Knife, cast cutting.  
Lamps, for diagnostic instruments.  
Lamps, for surgical lights.  
Laryngoscope.  
Light, surgical, portable.  
Litter.  
Mallet, bone surgery.  
Needles, hypodermic, reusable.  
Needles, suture, eyed.  
Otoscope and ophthalmoscope set.

Probe, general operating.  
Razor and blades (for surgical preparation).  
Retractor, rib.  
Retractor set, general operating.  
Rongeur, bone.  
Saw, amputating.  
Saw, bone cutting, wire (Gigli).  
Scissors, bandage.  
Scissors, general surgical.  
Sigmoidoscope  
Speculum, vaginal.  
Sphygmomanometer.  
Splint, leg, Thomas.  
Splint, wire, ladder.  
Sterilizer, pressure, portable.  
Stethoscope.  
Sutures, absorbable.  
Sutures, absorbable, with attached needle.  
Sutures, nonabsorbable.  
Sutures, nonabsorbable, with attached needle.  
Syringes, Luer, reusable (hypodermic syringes).  
Thermometers, clinical.  
Tracheotomy tube.  
Tube, nasogastric  
Tubing, rubber or plastic, and connectors.  
Vascular prostheses.  
Webbing, textile, with buckle.

#### 6. Laboratory Equipment and Supplies:

Bacteriological culture media and apparatus.  
Balance, laboratory with weights.  
Blood and urine analysis instruments, equipment and supplies  
Chemical reagents, stains and apparatus.  
Glassware cleaning equipment  
Laboratory glassware.  
Microscope and slides.  
Water purification apparatus.

GROUP B None.

## II. Food:

### GROUP A

1. **Milk Group.** Milk in all forms, milk products. Important for calcium, riboflavin, protein, and other nutrients.

2. **Meat and Meat Alternate Group.** Meat, poultry, fish, eggs; also dry beans, peas, nuts. Important for protein, iron, and B-vitamins.

3. **Vegetable-Fruit Group,** including. 1. Dark green and yellow vegetables. Important for Vitamin A. 2. Citrus fruit or other fruit or vegetables. Important for Vitamin C. 3. Other fruits and vegetables, including potatoes.

4. **Grain Products.** Especially enriched, restored cereal and cereal products, and bread, flours, and meals. Important for energy, protein, iron, and B-vitamins.

5. **Fats and Oils.** Including butter, margarine, lard, and other shortening oils. Important for palatability and food energy; some for Vitamin A and essential fatty acids.

6. **Sugars and Syrups.** Important for palatability and food energy.

7. **Food Adjuncts.** Certain food adjuncts should be provided to make effective use of available foods. These include antioxidants and other food preservatives, yeast, baking powder, salt, soda, seasonings and other condiments. In addition, coffee, tea, and cocoa are important for morale support.

### GROUP B

Food containers.

Nitrogenous fertilizers.

Seed and livestock feed.

Salt for livestock.

#### Veterinary Medical Items:

Anthrax vaccine.

Black leg vaccine.

Hog cholera vaccine.

Newcastle vaccine.

## III. Body Protection and Household Operations:

### GROUP A

#### 1. Clothing:

Gloves and mittens.

Headwear.

Hosiery.

Outerwear.

Shoes and other footwear.

Underwear.

Waterproof outer garments.

#### 2. Personal Hygiene Items:

Diapers, all types.

Disposable tissues.

First aid items (included on Health Supplies and Equipment List).

Nipples.

Nursing bottles, all types.

Pins.

Sanitary napkins.

Soaps, detergents, and disinfectants.

Toilet Tissue.

#### 3. Household Equipment.

Bedding.

Canned heat.

Cots.

Hand sewing equipment.

Heating and cooking stoves.

Incandescent hand portable lighting equipment (including flashlights, lamps, batteries).

Kitchen, cooking, and eating utensils.

Lamps (incandescent medium base) and lamp holders.

Matches.

Nonelectric lighting equipment.

Sleeping bags.

### GROUP B

None.

## IV. Electric Power and Fuels:

#### 1. Electric Power.

### GROUP A

Electricity.

### GROUP B

Conductors (copper and/or aluminum), including bare cable for high voltage lines and insulated wire or cable for lower voltage distribution circuits.

Switches and circuit breakers.

Insulators.

Pole line hardware.

Poles and crossarms.

Transformers (distribution, transmission, and mobile).

Tools for live-circuit operations, including rubber protective equipment, and linemen's tools. Utility repair trucks, fully equipped.

Prime mover generator sets up to 501 kilowatts and 2400 volts, including portable and mobile sets up to 150 kilowatts and 110/220/440 volts, 3-phase, 60-cycle complete with fuel tank and switchgear in self-contained units.

#### 2. Petroleum Products.

### GROUP A

Gasoline.

Kerosene.

Distillate fuel oil.

Residual fuel oil.

Liquefied petroleum gas.

Lubricating oil.

Grease.

### GROUP B

Storage tanks.

Pumps for loading and unloading.

Pressure containers and fittings for liquefied petroleum gas.

#### 3. Gas.

### GROUP A

Natural gas.

Manufactured gas.

### GROUP B

Various sizes of pipe (mostly steel).

Various sizes of valves, fittings, and pressure regulators.

Specialized repair trucks and equipment.

#### 4. Solid Fuels.

### GROUP A

Coal, coke, and uranium

### GROUP B

Conveyor belting.

Insulated trail cables.

Trolley feeder wire.

Roof bolts.

## V. Sanitation and Water Supply:

### GROUP A

1. Water.
2. Water Supply Materials:
  - a. Coagulation:
    - Ferric chlororide.
    - Ferrous sulfate.
    - Ferric sulfate.
    - Chlorinated copperas.
    - Filter alum.
    - Hydrated lime.
    - Pulverized limestone.
    - Soda ash.
  - b. Disinfection Chemicals:
    - High-test hypochlorites (70 percent) in drums, cans, ampules.
    - Iodine tablets.
    - Liquid chlorine, including containers.
    - Chlorine compounds (not gas).
  - c. Miscellaneous Materials:
    - Diatomaceous earth.
    - Activated carbon.
3. Chemical, Biological, and Radiological (CBR) Detection, Protection, and Decontamination Items:
  - Calibrators.
  - Chemical agent detection kits, air, food, and water.
  - Dosimeters and chargers.
  - Protective masks, clothing, helmets.
  - Survey meters (Alpha, Beta, Gamma).
  - Warning signs—biological, chemical, and radiological contamination.
4. Insect and Rodent Control Items:
  - a. Insecticides:
    - DDT, water dispersible powder (75 percent).
    - Lindane powder, dusting (1 percent).
    - Malathion, liquid, emulsifiable concentrate (57 percent).
    - Deet (diethyltoluamide) 75 percent in denatured alcohol.
    - Pyrethrum.
  - b. Rodenticides:
    - Anticoagulant type, ready-mixed bait.
    - "1080" (sodium monofluoroacetate) for controlled use only).
5. General Sanitation:
  - Lye.

### GROUP B

1. General Supplies and Equipment:
  - Chemical feeders.
  - Mobile and portable pressure filters.
  - Chlorinators (gas and hypochlorites).
  - Pumps and appurtenances, Hand—Electric—Gasoline—Diesel.
  - Well-drilling equipment, including well casing, drive pipe and drive points.
2. Storage and Transport Equipment:
  - Lyster bags.
  - Storage tanks, collapsible and portable.
  - Storage tanks, rigid, transportable.
  - Storage tanks, wood stave, knock-down.
3. Laboratory Equipment and Supplies:
  - Membrane filter kits with filters and media.
  - Chlorine and pH determination equipment.

## 4. Sanitation Equipment:

Hand sprayer, continuous type.  
Hand sprayer, compression type.  
Hand duster, plunger type.  
Spraying equipment for use with helicopter, fixed-wing light aircraft, high-speed fixed-wing attack aircraft, and cargo-type aircraft.

## VI. Emergency Housing and Construction Materials and Equipment

### GROUP A

Asphalt and tar roofing and siding products.  
Builders hardware—hinges, locks, handles, etc.  
Building board, including insulating board, laminated fiberboard, hardpressed fiberboard, gypsum board, and asbestos cement (flat sheets and wallboard).  
Building papers.  
Plastic patching, couplings, clamps, etc. for emergency repairs.  
Plumbing fixtures and fittings.  
Prefabricated emergency housing.  
Rough hardware—nails, bolts, screws, etc.  
Sewer pipe and fittings.  
Tents and tarpaulins; canvas, plastics, and other similar materials.  
Lumber and allied products: Lumber, principally 1-inch and 2-inch, minor quantities of small and large timbers; siding and flooring; plywood; millwork, doors, and windows.  
Masonry products—brick, cement, lime, concrete block, hollow tile, etc.  
Translucent window coverings.  
Water pipe and hose, plus fittings—all types, including fire hose.

### GROUP B

None.

## VII. General Use Items.

### GROUP A

None.

### GROUP B

Batteries, wet and dry cell.  
Bulldozers.  
Fire fighting equipment.  
Light equipment and hand tools (including electric powered) for carpentry, masonry, plumbing, and excavation.  
Pipe installation materials and equipment.  
Refrigerators, mechanical.  
Rigging tools—cables, ropes, tackle, hoists, etc.  
Tank railroad cars.  
Tank trucks and trailers.  
Tires.  
Trenching equipment.  
Truck tractors and trailers, including low bed.  
Trucks up to five tons (25 percent equipped with power takeoff).  
Welding equipment and supplies (electric and acetylene).

(F.R. Doc. 64-11454: Filed, Nov. 9, 1964; 8:46 a.m.)

**APPENDIX 6 TO ANNEX C**  
**GOVERNOR'S PROCLAMATION ON STATE RESOURCE POLICIES AND GUIDANCE**

To: Executive Heads of All Political Subdivisions in This State.

It is essential that the resources available to this State during the immediate postattack situation be carefully conserved and channeled into the most urgent uses and activities.

I have issued overall policies and guidance on the use of essential resources. Copies of these policy and guidance documents are contained in the State Plan for the Emergency Management of Resources and have been provided to the executive heads and governing bodies of all of the political subdivisions in the State. Included is a list of specific items considered essential for survival.

I hereby proclaim these policies and guidance in effect throughout this State.

I have instructed the coordinators of the several State resource organizations to provide to you more specific guidance on the application of State policies for the distribution and use of resources.

Facilities in your jurisdiction which produce or distribute items or provide services essential for local, State and national survival and which must be supported with locally available resources to maintain operations have been identified for you by the State resource officials.

You are requested to authorize essential local users and essential facilities in your jurisdictions to use the following certification on their purchase orders or requests on their suppliers to obtain resources, or in placing contracts or work orders with construction contractors, in accordance with the specific provisions contained in policies and guidance provided to you, on my behalf, by the several State Resource Coordinators.

" This is an essential order  
authorized by the State of  
Texas.

\_\_\_\_\_  
Signature of Purchaser"

Please advise local employment offices to act on requests and arrange for the assignment of manpower needed by essential local users and essential facilities.

You are to inform secondary suppliers of essential survival items in your jurisdictions that they are prohibited from selling items in their inventories unless (1) excepted by the Federal General Freeze Order, or (2) to fill authorized demands under the consumer rationing system, or (3) to meet other essential needs authorized by you pursuant to specific guidance provided to you by the coordinators of the several State resource organizations. Secondary suppliers and secondary inventories of resources are defined and designated in the separate resource sections of the State Plan for the Emergency Management of Resources.

If supplies of essential survival items available for use to meet essential needs in your jurisdictions are inadequate you are to restrict further their delivery and use to those needs which, in your judgment, are most urgent and request appropriate State officials to arrange for an increased resupply to make up local deficiencies.

Federal emergency regulations contain provisions for persons operating essential facilities or providing essential services to use Federal certifications on delivery orders to obtain production materials, capital equipment; and maintenance, repair and operating supplies. The Office of Industrial Mobilization of the U.S. Department of Energy has issued these regulations and State production officials have distributed and publicized them. You should advise the management of essential facilities to make use of these Federal authorities to obtain production materials; capital equipment; and maintenance, repair, and operating supplies where these are applicable; all other essential needs are to be met through State certified orders.

You are to inform persons engaged in essential local activities or operating essential facilities how to obtain emergency credit from local banks and financial institutions in accordance with Federal emergency regulations. A copy of the Federal Emergency Banking Regulation has been provided to you preattack by the State Emergency Stabilization organization.

As soon as possible you are requested to arrange for rationing of designated essential consumer items.

Governor of the State of Texas.

In witness whereof I set my hand and seal this \_\_\_\_\_ day of \_\_\_\_\_,  
19\_\_\_\_\_.

SEAL

\_\_\_\_\_  
Governor

\_\_\_\_\_  
Secretary of State

**ATTACHMENT 1 TO APPENDIX 6 TO ANNEX C  
GOVERNOR'S PROCLAMATION ON STATE RESOURCE POLICIES AND GUIDANCE**

**Essential Users:**

- (1) Individuals, both civilian and military, engaged in producing or providing essential items, products, care or services, e.g., doctors providing professional medical diagnoses, treatment and services, farmers producing essential food; military personnel engaged in immediate retaliatory or defense operations.
- (2) Organizations or establishments engaged in essential activities or providing essential items or services.

**Essential Facilities:**

- (1) Military establishments engaged in immediate retaliatory or defense operations;
- (2) Electric power, gas and water utility systems;
- (3) Industrial plants producing or processing essential items;
- (4) Major wholesale establishments storing or distributing essential items; and
- (5) Transportation or communication systems providing essential services.

**Individual Consumers:**

Individuals who depend on local distribution systems (retailers and dealers) for essential supplies for individual and family use.

---

**APPENDIX 7 TO ANNEX C  
ESSENTIAL ITEMS TO BE RATIONED**

To: Executive Heads of Political Subdivisions

You are hereby directed to provide for the distribution, through the consumer rationing system, of such essential consumer items as will influence or will be influenced by prescribed policy on priority use of resources (Appendix 5 to Annex C). Items listed in Attachment 1 to Appendix 5, Annex C will be used as an initial and immediate guide and conditions prevailing in each region, district and county will be the final factor for an initial determination of specific items to be rationed.

You will be advised by the Director, Disaster Emergency Services, of specifically designated items to be introduced into the consumer rationing system upon completion of a survey to determine ration needs.

---

Effective Date

(Signed)

Governor

**APPENDIX 8 TO ANNEX C  
DELEGATION OF RESOURCES AUTHORITY**

(Note: This action document should not be issued until immediate actions to supply and resupply local needs are under way. The precise point in time postattack for its issuance cannot be precisely identified preattack. The action must be based on a judgment that information upon which reasonably sound estimates of future requirements and anticipated future resources supplies is obtainable by the coordinators of the several resource organizations.)

To: Resource Coordinators

With respect to the particular resources assigned to your jurisdiction you are hereby authorized to decide on the division of such supplies during the 90-day period commencing           (date)          , among essential needs for these resources. In reaching these decisions you will review estimates of requirements presented to you by civil defense officials, representatives of the United States Department of Defense, the United States Atomic Energy Commission, and other appropriate Federal agencies functioning in the State, and making decisions on the division or allocation of resources by Appendix 5, Policy on Priority Use of Resources.

You are to notify representatives of major users of resources (claimants) of the quantities of resources allocated to carry on activities under their particular jurisdiction during the prescribed 90-day period.

You will authorize such claimants to use and in turn to authorize others to use the following certification on purchase orders to procure quantities of resources within the amount allocated to them:

<p>"This is an emergency order authorized by the Coordinator of the State of Texas</p> <p>_____</p> <p style="text-align: center;">(Name of resource organization)</p> <p>_____</p> <p style="text-align: center;">(Signature)</p>
--

_____	_____
Effective Date	(Signed) Governor

**APPENDIX 9 TO ANNEX C  
ADJUDICATION OF RESOURCE CONFLICTS**

To: Resource Coordinators

You are hereby directed to report to your Governor, through the Director, Disaster Emergency Services conflicts resulting from actual or anticipated inability to meet needs for resources from supplies expected to be available during the 90-day period commencing           (date)          . This report must indicate the total estimated supply of the resources and of the demands placed upon them, together with your recommendations to resolve conflicts.

_____	_____
Effective Date	(Signed) Governor

**ANNEX D**  
**Concept of Operations Wherein Selected Experts**  
**Will Be Involved As Resource Specialists In Pre-**  
**Attack Planning and Postattack Operations**  
**In The Promulgation and Implementation of**  
**The State Emergency Resource Management Plan**

**GENERAL:**

Certain individuals, recognized as outstanding in their fields of endeavor, have been selected from various segments of the civilian economy and from government to be employed in executive positions in the State government during periods of emergency under the provisions of the State of Texas Emergency Resource Management Plan.

The Dir., Dis. Emerg. Serv., develops policies and plans and coordinates the activities of individuals who are designated to work with various State agencies and departments. Agencies and departments designated by the Governor have authority to recommend persons from private life and from government to serve in their departments. Responsibility for selection of these persons will be retained by the Governor. Training of these Resource Specialists is carried out consistent with regulations and standards set up by the Director, Disaster Emergency Services. Resource Specialists will be used to augment the Resource Priorities Boards at State, region and district levels under provisions of the State of Texas Emergency Resource Management Plan and may be used to supplement the staff at district levels.

**SPECIFIC:**

Section 1. Under Provisions of the Emergency Resource Management Plan there is recognized need

in the Executive Branch of the Government for the talents and abilities of persons in various segments of the civilian economy and from government to serve on a volunteer basis and to be trained for employment in executive positions in the State government during periods of emergency.

Section 2. The Director, Disaster Emergency Services should institute and administer the program; coordinate the activities of other agencies in establishing units of Specialists; provide for appropriate standards of recruitment and training; and issue necessary rules and regulations in connection with the use of Resource Specialists.

Sec. 3 The Director, Disaster Emergency Services in carrying out his responsibilities under this concept, may utilize the services of other departments and agencies in the maintenance of agency and centralized rosters and in the development of training programs and materials.

Section 4. Heads of departments and agencies of the government designated by the Governor, should recommend persons to serve as members. Responsibility for selection of these persons will be retained by the Governor.

Section 5. Activities of persons by reason of designation as Resource Specialists under this concept shall not include acting or advising on any matter pending before any department or agency but shall be limited to receiving training for employment under the provisions of the State of Texas Emergency Resource Management Plan.

**APPENDIX 1**  
**(STATEMENT OF UNDERSTANDING)**  
**TO ANNEX D**

As a State Resource Specialist, I accept the following responsibilities:

I. In Time of Peace or International Tension, I agree to:

- (1) Maintain close liaison with the part of the State government to which I am assigned.
- (2) Attend called training meetings or courses whenever possible.
- (3) Attend war games or exercises where possible.
- (4) Participate in the review of Emergency Resource Management Plans and Programs.

II. In Time of General War,

I agree to be immediately available for full-time employment to the State of Texas, except for priority obligations to the Federal Government, in the event of attack on the United States.

III. I agree to serve as a State of Texas Resource Specialist in time of Peace or International Tension and hereby agree to waive any and all pay or compensation for such service for myself, heirs and assigns. In the event of general war, I shall have the option of serving with compensation from the State of Texas or on an uncompensated basis (with continued receipt of compensation from my private employer) pending establishment of regular personnel procedures for the emergency.

Name \_\_\_\_\_ Title \_\_\_\_\_  
(Print or Type)

Signature \_\_\_\_\_ Date \_\_\_\_\_

Approved:  
Company or Organization \_\_\_\_\_

By \_\_\_\_\_ Title \_\_\_\_\_  
(Print or Type)

Signature \_\_\_\_\_

**PART B - RESOURCE SECTIONS**

**I. Economic Stabilization**

**B-I**  
Economic Stabilization

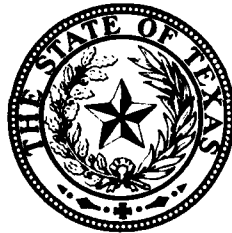

**Texas  
Emergency  
Resource  
Management**

**PLAN**



## INTRODUCTION

The Governor of Texas has issued general policy on the use of essential resources in the immediate postattack period. These policies are set forth in Part A of the State Emergency Resource Management Plan. These plans have been furnished to appropriate officials of the political subdivisions of the State.

In general, these State policies provide for temporary freezing of retail inventories of essential items and immediate and continuing release of these items to meet urgent military and civil defense needs and to maintain operation of facilities essential to continued survival and recovery. They provide for continuing resupply of local secondary inventories as well as inventories of essential facilities which obtain their supplies from wholesale and primary sources. This is true for risk and host areas alike.

### Definitions:

#### a. Essential Users:

- (1) Individuals, both civilian and military, engaged in producing or providing essential items, products, care or services, e.g., doctors providing professional medical diagnoses, treatment and services; farmers producing essential food; military personnel engaged in immediate retaliatory or defense operations.
- (2) Organizations or establishments engaged in essential activities or providing essential items or services.

#### b. Essential Facilities:

- (1) Military establishments engaged in immediate retaliatory or defense operations;
- (2) Electric power, gas and water utility systems;
- (3) Industrial plants producing or processing essential items;
- (4) Major wholesale establishments storing or distributing essential items; and
- (5) Transportation or communication systems providing essential services.

#### c. Individual Consumers: Individuals who depend on local distribution systems (retailers and dealers) for essential supplies for individual and family use.

---

STATE OF TEXAS  
EMERGENCY RESOURCE MANAGEMENT PLAN  
PART B-RESOURCE SECTIONS  
I-ECONOMIC STABILIZATION

### 1. Purpose:

This section of the State of Texas Resource Management Plan contains State policies, guidance and techniques for the rationing of food, petroleum and other essential items to consumers and the stabilization of prices and rents including sales prices of real property in a nuclear attack emergency or during the period of crisis relocation.

The purpose of this section and the principal objective of emergency stabilization is to establish and maintain the economic base for coordinated mobilization under any contingency, including national survival and recovery in event of attack, wherein it will be necessary to:

Restrain and combat inflation, whether resulting from shortages, maldistribution or speculation.

Maintain confidence in public and private financial institutions and continue a money economy, avoiding substitution of other systems of exchange.

Assure conservation and equitable sharing of available goods and services.

### 2. Activation:

The provisions of this section will be activated by the Governor of the State of Texas or his legal successor upon declaration of a national emergency for civil defense by the President of the United States, or upon receipt of a notice that an attack is underway or the implementation of the Presidential option of crisis relocation. (See Annex A, Part.A).

### 3. Major Policies:

#### a. Federal Government

The Federal Government has made available to the State national policies, guidance and techniques for initiating and carrying on activities in the State and its subdivisions for the rationing of food, petroleum products and other essential items to consumers and for stabilizing prices and rents including sales prices on real property postattack.

#### b. State Government

The State economic stabilization organization (State Banking Department and Disaster Emergency Services), on behalf of the Governor, provides State policies, guidance and techniques consistent with national policies, for the operation of consumer rationing systems and price and rent stabilization measures in subdivisions of the State until the Federal Government can absorb and administer, on a national basis, stabilization systems and measures.

c. Local Governments

Emergency plans of the State, consistent with Federal and State policy, contain specific organizational arrangements and procedures for county administration of consumer rationing and price and rent stabilization functions within their jurisdictions immediately postattack or in the event of crisis relocation is implemented.

d. Financial, Monetary, Banking and Credit Responsibilities

(1) Federal Government

Measures to maintain the solvency and functioning of the surviving banking and monetary system are a Federal Government responsibility. The United States Treasury Department, through Federal financial agencies such as those in the Federal Reserve System and the Federal Home Loan System, is responsible for the preparedness and administration of postattack banking, monetary, credit and tax programs. Self-triggering postattack operating programs and orders have pre-positioned with banks and other financial institutions at all levels throughout the State.

(2) State Government

The State has made known preattack to its counties and cities the postattack and crisis relocation provisions of these programs and orders.

(3) Local Governments

Local governments are responsible for advising persons engaged in carrying on essential survival activities or managing essential facilities in their jurisdictions of the general provisions of these programs and orders. Officials of local banks and financial institutions can provide specific information on how to obtain necessary credit to carry on emergency local functions and operations not only postattack but during crisis relocation as well. (NOTE: Annex D identifies the Federal Emergency Financial Operating Plan. Emergency Banking Regulation 1 of that plan (Appendix 6) provides specific guidance with respect to the procurement of credit for essential purposes. Further information with respect to the maintenance of the money, credit and banking system can be obtained from the Emergency Planning Officer of the Federal Reserve Bank serving the State.)

e. Wage and Salary Stabilization

The field offices of the Wage and Hour and Public Contracts Division of the United States Department of Labor are responsible for planning for and administering, on an interim basis, measures for postattack and crisis relocation stabilization of wages and salaries throughout the State. State and county stabilization officials provide necessary supporting resources to this Federally administered program and coordinate the timing and application of local price and rent stabilization measures with the related Federal actions to stabilize wages and salaries.

(NOTE: Annex E identifies the Federal operating instructions for Wage and Salary Stabilization. This document lists the locations of representatives of the Wage and Hour and Public Contracts Division of the United States Department of Labor who are responsible for actions to stabilize wages and salaries.)

4. Emergency Actions:

The following actions are taken at State and district levels to provide State policies, guidance and techniques to coordinate and support the administration of economic stabilization systems and measures throughout the State. These emergency actions are effective immediately upon implementation everywhere physically possible or feasible--and particularly in all towns, cities or communities which escape major damage or are free of intolerable fallout.

- a. Assure that designated county authorities publicize and enforce "Governor's Order Directing Compliance with General Freeze Order," the Federal General Freeze Order. (See Appendix 1 to Annex C, Part A.)
- b. Assure that State economic stabilization organizations and programs are in effect throughout the State in undamaged areas free of intolerable fallout. (Appendix 2, "State Economic Stabilization Policy and Guidance," to Annex C, "Emergency Action Documents")
- c. Issue any changes in the pre-positioned Governor's order designating items to be rationed to individual consumers and, after consultation with State organizations, inform local governments on behalf of the Governor, of initial use levels for items to be distributed to individual consumers through the rationing system. (See Appendix 7, "Essential Items to be Rationed," to Annex C, "Emergency Action Documents," to Part A.)
- d. Request county authorities to report on numbers of individual consumers registered and to be provided food, petroleum products and other items distributed under the consumer rationing system and furnish this information to appropriate State resource organizations as a basis for determining future resource requirements.
- e. Upon approved modification by State resource organizations, inform county officials, on behalf of the Governor, of adjustments in the use level to conform to the expected availability of supplies for distribution to individual consumers in the State under local consumer rationing systems.
- f. Take such other actions as are necessary to provide guidance for county administration.

3. Administration:

- a. Area economic stabilization offices (paragraph 2a, Annex A; and Tabs A and B, Annex A) are located in control centers at points which have been established for regional emergency operations. These locations are such that coordination can be achieved expeditiously with Federal stations listed in Annex E (See Note to paragraph 3a, above).
- b. Actions necessary to provide for the continuity of operation of the State economic stabilization organization:
  - (1) The Governor of the State of Texas has assigned to the Office of the Director, Disaster Emergency Services, the responsibility for providing administrative support, i.e., personnel, facilities and supplies for the operation of the State economic stabilization organization. Copies of this plan are immediately available in the State control centers and in the Department of Public Safety and its relocation and alternate sites.
  - (2) Upon activation of this plan, the Coordinator and key staff with emergency assignments to the State economic stabilization organization establish headquarters at the State control centers and in the Department of Public Safety or its relocation and alternate sites.
  - (3) Lines of succession to assure continuity of key staff for the operation of the State economic stabilization organization are provided in the roster of key personnel.
- c. Consumer rationing reproduction proofs have been pre-positioned with county judges for use as prescribed in Annex F. These proofs are to be safeguarded, registered and inventoried to insure control.
- d. County judges, upon assuming office, will thoroughly brief themselves on the provisions of this plan.
- e. County judges, when leaving office, will insure that their successors are thoroughly briefed on the provisions of this plan.

ANNEX A

ECONOMIC STABILIZATION ORGANIZATION

1. State:

a. Organization

The State economic stabilization organization is headed by a Coordinator, a resource specialist appointed by the Governor, serving without pay at the pleasure of the Governor on an "as needed" basis. He is supported by not less than twelve (12) additional resource specialists who compose the emergency staff of the economic stabilization organization. The permanent staff is headed by an executive director assisted by personnel of sufficient number to accomplish prescribed tasks. This staff is assigned to and works with the staff of the Director, Disaster Emergency Services, except during an emergency when the economic stabilization organization is mobilized to full operating strength. The Coordinator is supported by a Deputy Coordinator, also a resource specialist, who coordinates the activities of the three divisions of the State staff. These three divisions, shown in Tab A, are: Price, Consumer Rationing and Rent Operations.

b. Functions

(1) Price Operations

- (a) Be familiar with Federal and State emergency economic stabilization policies, objectives and plans, with particular reference to price stabilization.
- (b) Participate in continuing development of overall State programs in field of emergency economic stabilization.
- (c) Work with appropriate authorities at operating levels regarding the appointment of knowledgeable individuals to serve as price stabilization officers and as members of price stabilization panels.
- (d) Provide continual technical information and guidance to appropriate operating authorities including publicity, emergency executive orders, proclamations and other materials necessary for advancing capability to administer an interim local emergency price stabilization program.
- (e) Schedule and conduct periodic training conferences involving appropriate operating level personnel.
- (f) Meet jointly and periodically to assess the status of preparedness of the State-wide price stabilization program.
- (g) Maintain liaison with appropriate Federal officials and counterpart organizations.
- (h) Sponsor State-wide periodical tests to determine adequacy of capabilities to administer this program.

(2) Rationing Operations

- (a) Be familiar with Federal emergency economic stabilization policies, objectives, plans and the State role, with particular reference to consumer rationing programs.
- (b) Participate in the development and coordination of overall State programs in the field of emergency economic stabilization.

- (c) Work with appropriate authorities at operating levels regarding the appointment of knowledgeable individuals to serve as rationing officers and as members of rationing panels.
- (d) Provide continual technical information and guidance to appropriate operating authorities including publicity, emergency executive orders, proclamations and other materials necessary for advancing capability to impose emergency local rationing programs.
- (e) Schedule and conduct periodic training conferences involving appropriate operating personnel.
- (f) Meet jointly and periodically to assess the status of preparedness of the State-wide rationing program.
- (g) Maintain liaison with appropriate Federal officials and counterpart organizations.
- (h) Participate as required in the determination of normal requirements of survival items for each operating level in conjunction with appropriate State and Federal agencies.
- (i) Participate as required in the collection and maintenance of selected supply and replenishment data on State-wide basis in conjunction with appropriate State and Federal supply and allocating agencies.
- (j) Plan for State-wide support of local registration for rationing.
- (k) Sponsor State-wide periodical tests to determine adequacy of rationing capabilities.

(3) Rent Operations

- (a) Be familiar with Federal emergency economic stabilization policies, objectives and plans and the State role, with particular reference to rent stabilization and sales control programs of real property.
- (b) Participate in development and coordination of overall State plans in the field of emergency economic stabilization.
- (c) Work with appropriate authorities at operating levels regarding the appointment of competent individuals to serve as rent officers and as members of rent panels.
- (d) Provide continual technical information and guidance to appropriate operating authorities including publicity, emergency executive orders, proclamations and materials necessary for local operations.
- (e) Schedule and conduct periodic training conferences involving appropriate operating personnel.
- (f) Meet jointly and periodically to assess the status of preparedness of the State-wide rent stabilization program.
- (g) Maintain liaison with appropriate Federal officials and counterpart State organizations.
- (h) Provide for dissemination of proclamations, notices, instructions and forms needed for implementing the rent stabilization program.

2. Region:

a. General

For purposes of economic stabilization, the State of Texas is divided into 17 disaster districts which conform precisely with the Highway Patrol districts and subdistricts of the Texas Department of Public Safety (See Tab B).

b. Organization

The organization of the economic stabilization staff at region headquarters will conform to the State staff structure and the personnel to man these staffs will be appointed in appropriate numbers by the Governor.

c. Functions

(1) Price Operations

- (a) Become familiar with Federal and State emergency economic stabilization policies, objectives and plans, with particular reference to price stabilization.
- (b) Collaborate with the State office in development of a county organization consistent with size and population of operating area to be served.
- (c) Maintain liaison with appropriate Federal officials, State and counterpart test organizations.

- (d) Organize price control advisory group from representative retailers, wholesalers and service organizations within the operating area for purpose of establishing community ceiling prices on essential items.
  - (e) Participate in development of overall community plans in field of emergency economic stabilization.
  - (f) Provide for enforcement of price controls.
  - (g) Provide continual technical information and guidance to all price control boards including publicity, emergency executive orders and technical materials necessary for local price stabilization administration.
  - (h) Act as arbitrators in local price stabilization disputes.
- (2) Consumer Rationing Operations
- (a) Become familiar with Federal and State policies, objectives and overall plans involving emergency economic stabilization programs.
  - (b) In collaboration with the State office, develop local ration organizations consistent with size and population of operating level to be served.
  - (c) Maintain liaison with State and counterpart organizations in adjoining political subdivisions.
  - (d) With appropriate State and local agencies, participate in the determination of local supply and the normal requirements of essential survival items.
  - (e) Provide overall guidance and assistance including technical materials to local rationing organizations.
  - (f) Participate in development of overall community plans in the field of emergency economic stabilization,
  - (g) In the event of attack or upon advice from higher authority, institute plans to insure austere distribution of essential survival items.
  - (h) Provide for enforcement of rationing measures.
  - (i) Provide continual technical information and guidance to all local ration organizations including publicity, emergency executive orders and technical materials necessary for local rationing.
  - (j) Keep local industry, retail, etc., advised of emergency operating programs and their role (e.g., retail stores should be familiar with the "freeze" and the operating program to supplement the freeze.)
  - (k) Set up the mechanics for resolving possible disputes between county rationing organizations.
  - (l) In conjunction with the State or on an independent basis, conduct periodic tests to determine capability to administer emergency rationing programs.
- (3) Rent Operations
- (a) Become familiar with Federal and State policies, objectives and overall plans involving emergency economic stabilization programs.
  - (b) Collaborate with the State office in development of county organizations consistent with size and population of operating level to be served.
  - (c) Maintain liaison with State and counterpart organization in adjoining political subdivisions.
  - (d) Participate in development of overall community plans in the field of emergency economic stabilization.

- (e) Provide overall guidance and assistance to the local rent stabilization organizations in the development of an emergency program to control the sale price of real property.
- (f) Prescribe programs for the enforcement of rent stabilization and related measures.
- (g) Provide continual technical information and guidance to all rent stabilization organizations including publicity, emergency executive orders and technical materials necessary for administering local rent stabilization and related measures.

### 3. County:

#### a. General

A local structure for the control of prices, rents and rationing is established at county level. The county judge is responsible for economic stabilization at that level. As director, he establishes adjudicating panels as needed or delegates such authority to designated persons. The county judge will appoint an executive director for each of the three stabilization functions. Additionally, a citizen's advisory committee is established at county level to provide local guidance for the three stabilization functions, particularly with respect to developing public support and compliance and disseminating information. In organizing stabilization panels and committees, guidance is provided by the Federal and State governments and includes, but is not limited to, the following:

Rationing, rent control and price control instructional material, developed, reproduced and distributed by either the Federal or State government, has been and will continue to be issued to all key personnel involved in the stabilization on each appropriate board or committee. Committees and panels will be representative of the community and will include consumers, businessmen, laborers, minority leaders, etc. All adjudicatory panels will include at least one attorney.

#### b. Specific

##### (1) Price Operations

###### (a) Organizations:

Director, price panels and advisory committee.

###### (b) Director:

1. Become familiar with Federal, State and local policies, objectives and plans involving economic stabilization programs.
2. Enlist active and continuing support from the public and industry in developing local techniques and procedures to administer price stabilization.
3. Be prepared to institute and administer price stabilization programs.

4. Set up machinery to make known in an attack situation the prevailing ceilings for important commodities and services.
5. Set up in accordance with Federal policy the mechanics for handling emergency adjustments.
6. Set up mechanics for checking on potential sources of violation.

###### (c) Adjudicatory Panels:

1. Establish and adjust ceiling prices in accordance with Federal and State policy.
2. Adjudicate disputes regarding prices and ceilings.
3. Conduct compliance hearings.
4. Be guided by instructions in Annex H.

##### (2) Consumer Rationing

###### (a) Organization:

Director, rationing panels and advisory committee.

###### (b) Director:

1. Become familiar with Federal, State and local policies, objectives and plans.
2. Enlist active and continuing support from the public and the business community in developing local techniques and procedures of control.
3. Be prepared to undertake preparations to institute and administer interim postattack local consumer rationing.
4. Provide local Ration Panels with appropriate operating instructions and conduct periodic surveys of the status of the rationing program.
5. Provide standby notice and instructions to dealers and the public.
6. Support periodic tests to determine capability to administer emergency rationing program.

###### (c) Adjudicatory Panels:

1. Subject to State or area office decisions, determine essential items for local rationing.
2. Subject to State or area office decisions, establish and adjust rationing quantities.
3. Adjudicate rationing disputes.
4. Conduct compliance hearings.
5. Be guided by instructions in Annex F.

##### (3) Rent Operations

###### (a) Organization:

Director, rent panels and advisory committee.

###### (b) Director:

1. Become familiar with Federal, State and local policies, objectives and plans involving economic stabilization programs.

2. Enlist active and continuing support from the public and the real estate interest in developing local techniques and procedures to administer the rent stabilization and related real property sales control programs.
3. Be prepared to institute and administer rent stabilization programs immediately postattack.
4. Provide mechanics, including adjudicatory panels, for reviewing eviction notices, approving rents on the basis of residential units never before rented, additional occupancy, conversion of commercial and industrial space, etc.

(c) Adjudicatory Panels:

1. Approve rents for residential units never before rented, additional occupancy, conversion of commercial and industrial space, etc.
2. Approve eviction notices.
3. Adjudicate disputes between tenants and owners.
4. Approve prices for real estate sales.
5. Conduct compliance hearings in cases of complaint of violation of rent ceilings.
6. Be guided by instructions in Annex G.

**STATE OF TEXAS  
EMERGENCY ECONOMIC STABILIZATION ORGANIZATION**

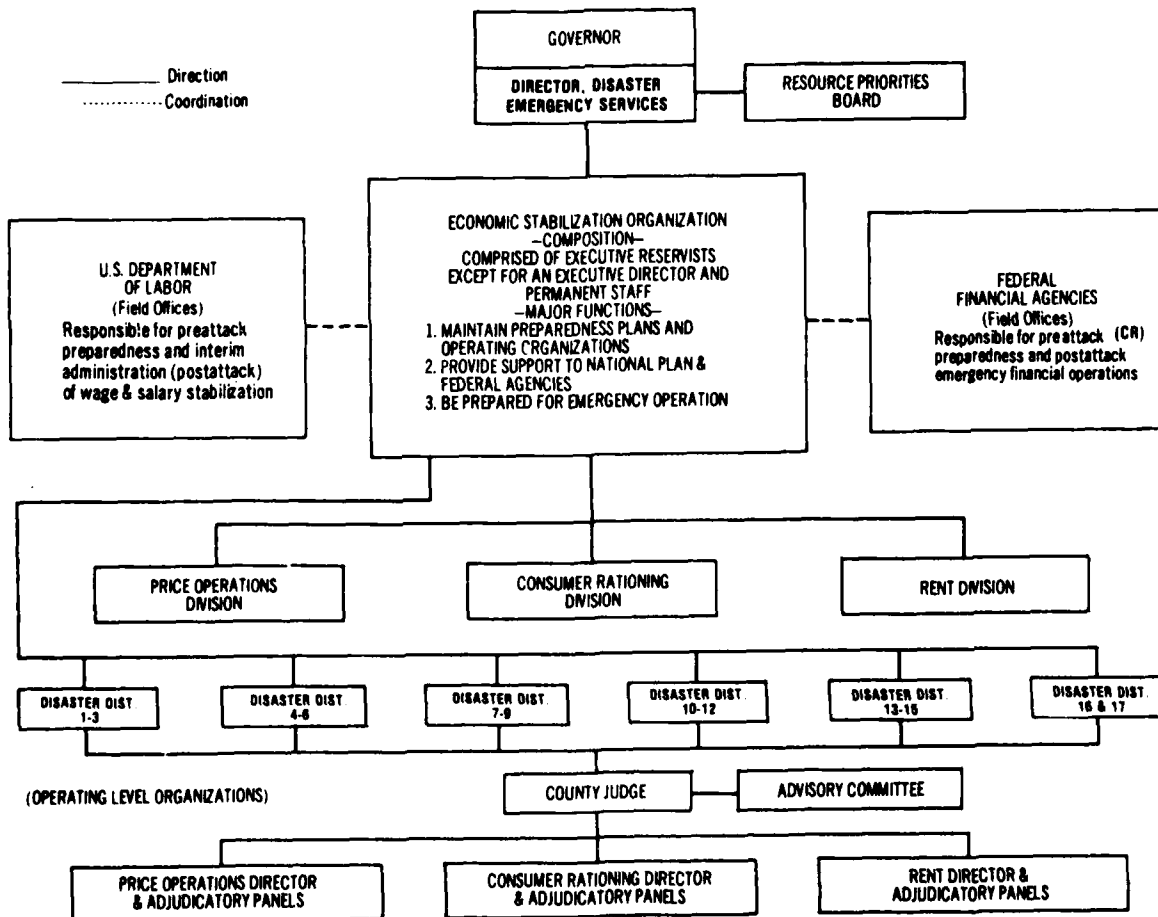

# DIVISION OF DISASTER EMERGENCY SERVICES DISASTER DISTRICT BOUNDARIES

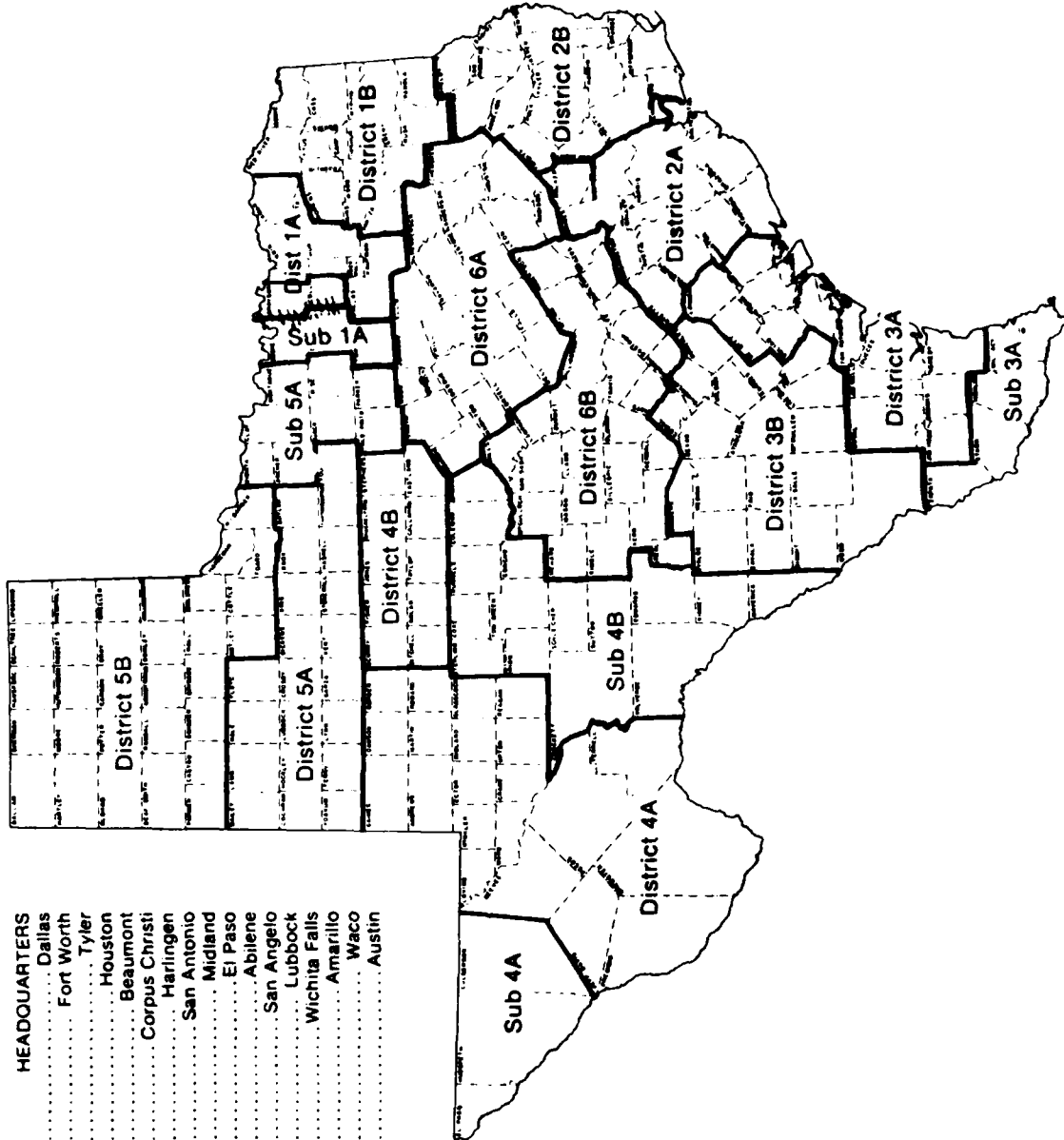

DISTRICT	HEADQUARTERS
1A	Dallas
Sub 1A	Fort Worth
1B	Tyler
2A	Houston
2B	Beaumont
3A	Corpus Christi
Sub 3A	Harlingen
3B	San Antonio
4A	Midland
Sub 4A	El Paso
4B	Abilene
Sub 4B	San Angelo
5A	Lubbock
Sub 5A	Wichita Falls
5B	Amarillo
6A	Waco
6B	Austin

B-I-A-4  
Tab B



**ANNEX B  
ECONOMIC STABILIZATION  
FLOW CHARTS**

**Flow Charts**

Following are three flow charts and accompanying functional statements for the consumer rationing, price stabilization and rent stabilization programs.

**Chart Number 1**

Indicates the various control levels involved in the flow and distribution of essential survival items in secondary inventories and their relationship to the consumer rationing system.

**Chart Number 2**

Indicates the responsibility of the various control levels with respect to the price stabilization programs.

**Chart Number 3**

Indicates the responsibility of the various control levels with respect to the rent stabilization program.

Tab A  
**PLAN FOR THE EMERGENCY MANAGEMENT OF RESOURCES**  
Flow Chart No. 1 Economic Stabilization (Consumer Rationing)

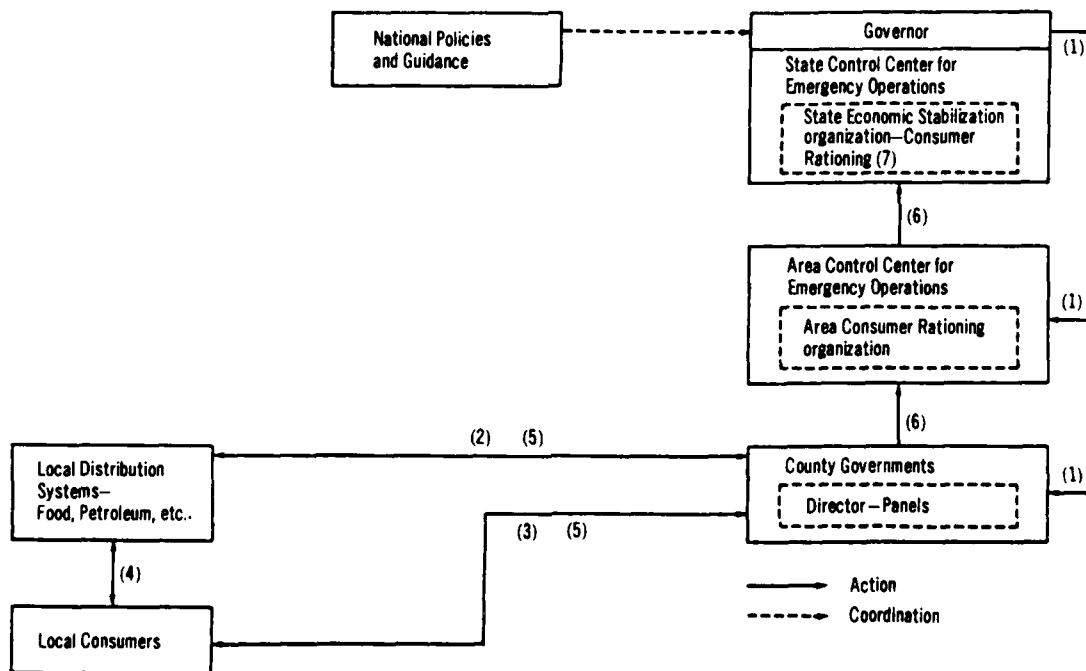

**Legend for Flow Chart No. 1 - Consumer Rationing**  
Functions and Coordination Responsibilities

- (1) Announce that State consumer rationing policy and guidance is in effect.
- (2) Issue instructions for rationing operations to the local distribution system.
- (3) Provide rationing evidence and instruct consumers on use.
- (4) Place Orders—obtain deliveries.
- (5) Report shortages of supplies available to meet designated levels of consumer use.
- (6) Local governments—reduce local use—request State assistance.
- (7) Request State resource organizations to increase resupply to meet local shortages.

Tab B

**PLAN FOR THE EMERGENCY MANAGEMENT OF RESOURCES**  
**Flow Chart No. 2 Economic Stabilization (Price Stabilization)**

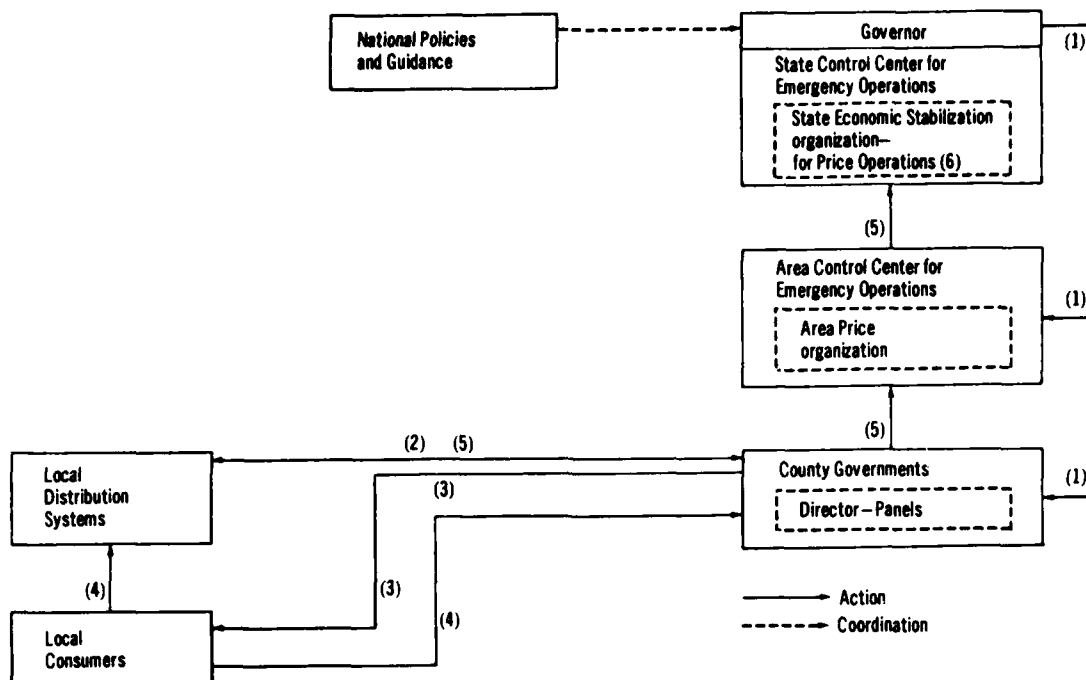

**Legend for Flow Chart No. 2-Price Stabilization**  
**Functions and Responsibilities**

- (1) Assure that all local and area Price Control Boards have implemented the procedures outlined in "Price Board Instructions for Postattack Price Stabilization."
- (2) Issue instructions imposing ceiling prices on all goods and services to local distribution systems (retailers and dealers).
- (3) Advise the public on ceiling prices.
- (4) Place orders and report violations to local governments.
- (5) Report requests for adjustments of local price ceilings and ask for State decisions.
- (6) Maintain a constant interchange of information with the appropriate State representative of the Federal Wage and Salary Stabilization Agency and with the State Rent Stabilization Staff to ensure coordinated operations and adherence to the "freeze date" levels prescribed.

**PLAN FOR THE EMERGENCY MANAGEMENT OF RESOURCES**  
**Flow Chart No. 3 Economic Stabilization (Rent Stabilization)**

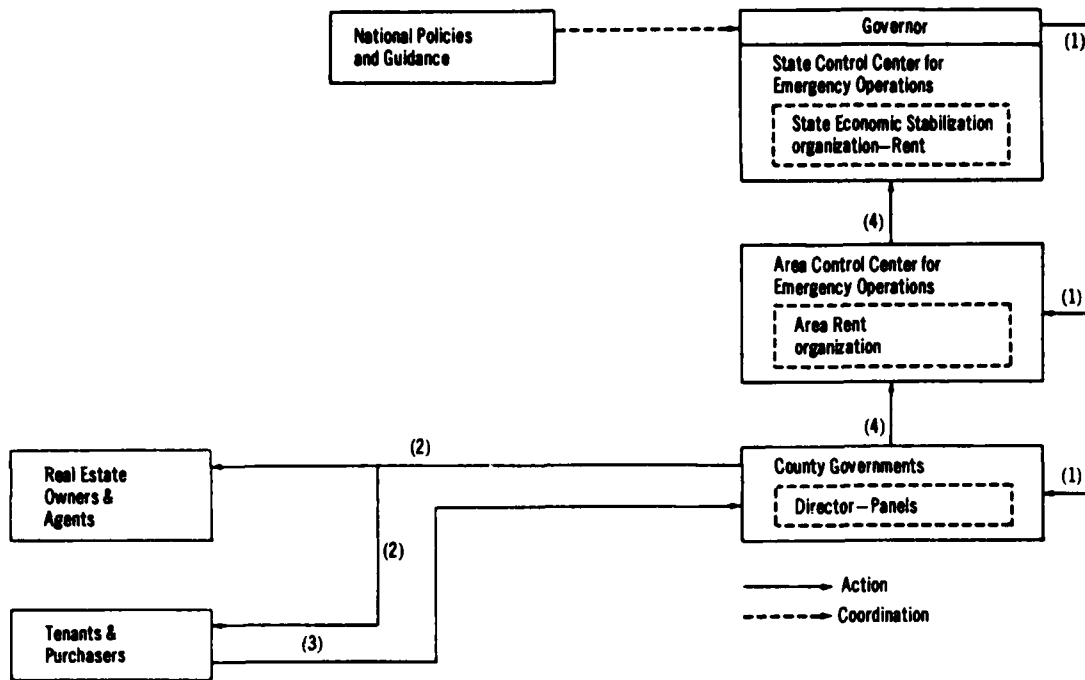

**Legend for Flow Chart No. 3-Rent Stabilization**  
**Functions and Responsibilities**

- (1) Assure that all local Rent Control Boards have implemented the procedure outlined in "Rent Board Instructions for Postattack Rent Stabilization and Sales Prices of Real Property."
- (2) Announce the imposition of rent ceilings and ceilings on sales of real estate.
- (3) Report alleged violations to local government.
- (4) Report to the State that controls on rent and sales prices of real property have been imposed.

**ANNEX C  
ECONOMIC STABILIZATION  
EMERGENCY ACTION DOCUMENTS  
State Economic Stabilization Policy and Guidance**

TO: Regional Directors and County Judges:

**Guidance for Local Governments:** The Governor has issued general policy on the use of essential resources in the immediate postattack period. These policies are set forth in Part A of the State Plan. It is essential that food, petroleum products, and other items essential for the survival of people available for use in this State be carefully conserved and restricted to immediate and urgent needs until the continuing supply for use in the State can be assessed and the supplies to be available for less essential needs determined.

In accordance with the Governor's general policy, it is necessary to (1) ration essential items to individual consumers, (2) stabilize prices, and (3) stabilize rents including prices of real property. Consequently, appropriate and previously designated officials of government are requested to take the following actions:

1. Publicize and enforce the temporary freeze on retail inventories of designated essential items.
2. Announce items to be rationed to individual consumers.
3. Announce use levels for items to be rationed.
4. Upon request, report to the State the numbers of individual consumers who are to be provided continuing supplies of food, petroleum products, and other essential items under local rationing systems.
5. Announce items that are to be distributed through the use of individually issued ration certificates such as batteries, automobile tires, fuel oil, etc.
6. Advise the public how and where to register to receive rationing evidence and how to use this evidence to obtain rationed items from distributors.
7. Inform local retail distributors on their roles under the local rationing system.
8. Enforce rationing regulations.
9. Announce and enforce price and rent ceilings including sales prices of real property at levels in effect at the time of or just prior to the attack.

In the event resupply of local inventories is inadequate to meet essential local needs, including consumers under the rationing system, local government will cut back authorized uses, including consumer use levels. Concurrently, they will report local shortages and request appropriate officials of State government to take actions to increase supplies available to the locality.

\_\_\_\_\_  
Date

\_\_\_\_\_  
Governor of the State of Texas

By: \_\_\_\_\_  
State Economic Stabilization  
Coordinator

B-I-C-1

**ANNEX D**  
**ECONOMIC STABILIZATION**  
**MONEY, CREDIT AND BANKING PROBLEMS IN A POSTATTACK EMERGENCY**  
(To be supplied by the Federal Government)

---

**ANNEX E**  
**ECONOMIC STABILIZATION**  
**WAGE AND SALARY STABILIZATION PROGRAMS IN A POSTATTACK EMERGENCY**  
(To be supplied by the Federal Government)

---

**ANNEX F**  
**ECONOMIC STABILIZATION**  
**RATION BOARD INSTRUCTIONS FOR POSTATTACK CONSUMER RATIONING**  
  
**Instructions To Local Authorities**  
(To be supplied by the Federal Government)

---

**ANNEX G**  
**ECONOMIC STABILIZATION**  
**RENT BOARD INSTRUCTIONS FOR STABILIZING RENTS AND DETERMINING**  
**CEILING PRICES OF REAL PROPERTY IN A POSTATTACK EMERGENCY**  
  
**Instructions To Local Authorities**  
(To be supplied by the Federal Government)

---

**ANNEX H**  
**ECONOMIC STABILIZATION**  
**PRICE BOARD INSTRUCTIONS FOR STABILIZING PRICES AND SERVICES**  
**IN A POSTATTACK EMERGENCY**  
  
**Instructions To Local Authorities**  
(To be supplied by the Federal Government)

**PART B - RESOURCE SECTIONS**

**II. Construction**

**B-II**  
Construction



**Texas  
Emergency  
Resource  
Management**

**PLAN**

## INTRODUCTION

Emergency construction in the State involves two series of actions. First, the crisis relocation phase; the use of highway department equipment or contractor services to improve existing fallout protection in "host areas" by "crisis upgrading" actions -- that is, by adding earth to previously identified buildings in the "Host Area Shelter Surveys". Second, the postattack phase; essential immediate needs for construction of facilities to provide mass care and reception facilities, medical facilities and emergency housing, etc., to carry an essential civil defense emergency operations for the survival of people and protection of property are identified and actions are taken to meet these needs.

### Definitions

- a. **Crisis Relocation:** The orderly relocation of people, in time of international crisis, from areas of potentially high risk from the direct effects of nuclear weapons to low risk areas -- and their reception, care and protection in the host areas.
- b. **Construction Activity:** Includes the emergency repair and modification of existing facilities and the construction of new facilities. It also includes the use of construction resources for the performance of emergency operations such as debris clearance, decontamination, highway repair, etc.
- c. **Construction Resources:** Include contractor services such as general contractors, builders, and specialty contractors who provide the management skill and direction required for the execution of a construction project. They also include the construction and building materials and equipment, and the manpower, fuels, transportation, and other resources and services used to complete a construction project.
- d. **Construction Contracts and Orders:** Include contracts for the repair, modification or construction of a facility and work orders to obtain the use of contractor services to carry on emergency operations.
- e. **Facilities:** Include facilities to provide essential services and protection for people including emergency housing, welfare, and health services facilities. They also include industrial plants and commercial facilities producing or distributing essential items, food production and processing facilities, transportation and communications systems and facilities, electric power, gas and water utility systems and facilities, essential public works facilities, and essential military facilities.
- f. **Certified Orders:** Purchase orders, contracts, or other requests for resources which bear a signed certification that the order is an essential order authorized pursuant to Federal Government emergency regulations or State authorizations.
- g. **Construction Industry:** General contractors, builders, special trade contractors, and related professional skills such as design organizations who provide the management skill and direction required for execution of projects.
- h. **Essential Users:**
  - (1) Individuals, both civilian and military, engaged in producing or providing essential items, products, care or services, e.g., doctors providing professional medical diagnoses, treatment and services; farmers producing essential food, military personnel engaged in immediate retaliatory or defense operations.
  - (2) Organizations or establishments engaged in essential activities or providing essential items or services.
- i. **Essential Facilities**
  - (1) Military establishments engaged in immediate retaliatory or defense operations;
  - (2) Electric power, gas and water utility systems;
  - (3) Industrial plants producing or processing essential items;
  - (4) Major wholesale establishments storing or distributing essential items; and
  - (5) Transportation or communication systems providing essential services.
- j. **Individual Consumers:** Individuals who depend on local distribution systems (retailers and dealers) for essential supplies for individual and family use.

STATE OF TEXAS  
EMERGENCY RESOURCE MANAGEMENT PLAN  
PART B-RESOURCE SECTIONS  
II-CONSTRUCTION

### 1. Purpose and Activation:

#### a. Purpose:

The purpose of this section of the State Resource Management Plan is to provide policies, guidance and actions to meet essential construction needs in the State in a nuclear attack emergency.

#### b. Activation:

This plan will become effective upon a declaration of a civil defense emergency by the President of the United States, the Congress of the United States, or the Governor of Texas or with a nuclear attack upon the United States.

### 2. Concept of Operation:

Federal, State and local governments have roles in the emergency management and supply of construction resources.

a. Federal Government:

The Federal Government has provided National policies and guidance and preattack assistance to the State in the development of this plan and the preparations to implement it in an emergency.

b. State Government:

The State construction organization and its area offices develop in cooperation with other organizations of the State government and provide, on behalf of the Governor, policies and guidance, consistent with State and Federal construction objectives. The purpose of these policies and guidance is to assure application throughout the State of compatible measures to assure that the most essential construction needs are identified and met within the resources available. The State construction organization and its area offices work with the construction industry at State and area levels to arrange for contractor services and their materials and equipment to undertake construction projects and services in the localities when locally available contractor services are inadequate to meet urgent and essential construction needs in the immediate postattack situation. As soon as possible after the attack, the State construction organization in cooperation with other State organizations representing major activities in the State that involve the construction or repair and modification of facilities, anticipate continuing construction needs and arrange for construction resources to meet these ongoing construction needs.

c. Local Government:

Operational Survival Plans of the State of Texas and its political subdivisions contain provisions for authorizing essential local construction and the use of construction contractor services and supporting resources to meet essential needs in the localities. These plans also provide for local government decisions and guidance, consistent with State policies, for construction contractor functions in the localities and acquisition by them of the manpower, construction material and equipment, petroleum products, and other supporting construction resources and services.

d. Flow Chart:

Following is a flow chart showing the process and the actions to be taken by State and local governments to assure that essential construction needs in the State are met in a nuclear attack emergency. The legend accompanying the chart identifies:

- A. Actions to be taken immediately to provide for the construction of facilities and use of contractor services for survival, and
- B. Actions to be taken as soon as possible to anticipate continuing needs and to channel construction resources to meet the most urgent construction needs for continuing survival and recovery.

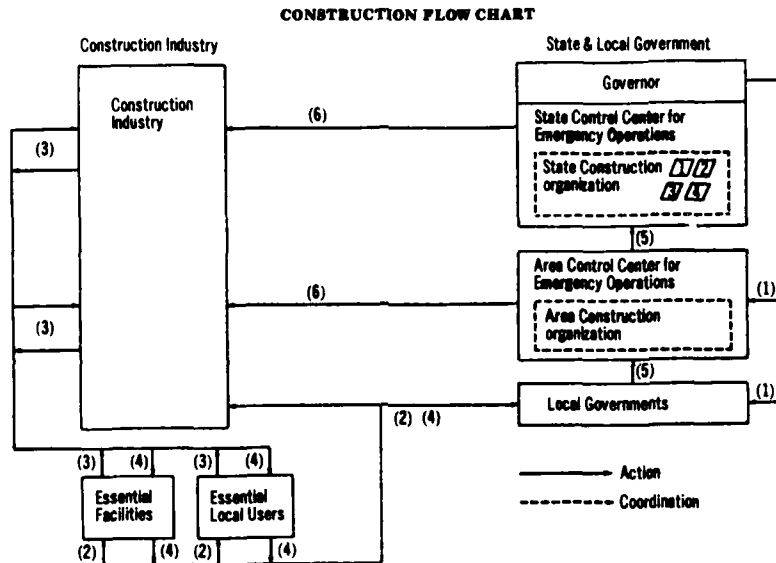

**A. ACTIONS TO PROVIDE IMMEDIATE CONSTRUCTION**

- (1) Issue State construction policy.
- (2) Authorize placement and acceptance of work orders for contractor services and placement and acceptance of construction contracts for essential construction.
- (3) Place essential orders and construction contracts with construction contractors.
- (4) Report inability to place orders or contracts or nonperformance on orders or contracts.
- (5) Anticipate local construction shortages -- request State assistance.
- (6) Expedite placement and performance on essential construction contracts.

**B. ACTIONS TO PROVIDE CONTINUING CONSTRUCTION**

- 17 Estimate future construction requirements and construction contractor capabilities.
- 18 Estimate construction industry requirements for supporting resources--present to appropriate State resource agencies.
- 19 Adjust State construction policy.
- 20 Allocate future construction capability among resource and claimant agencies.



### 3. Resource Management Execution

#### a. State

- (1) The Governor of the State of Texas has assigned to the State Department of Highways and Public Transportation (SDHPT) the responsibility for providing administrative support--personnel, facilities and supplies--for the operations of the State construction organization. Direction will be provided through assignment of a nucleus of key SDHPT people to carry out these responsibilities in close cooperation with and assistance from the Associated General Contractors. It must be kept in mind that high priority must be retained by SDHPT operating personnel, equipment and supplies for emergency and continuing highway repair, reconstruction and construction during the postattack period. Copies of this plan have been placed and are immediately available in State control centers and in headquarter and district offices of the SDHPT and Associated General Contractors.
- (2) Upon activation of this plan, the Construction Coordinator and key staff with emergency assignments to the State construction organization will establish headquarters at the Austin office of the SDHPT or its relocation or alternate sites.
- (3) Coordination with other resource organizations will be handled at State level.
- (4) A roster of key personnel is contained in Part C of this Plan

#### b. Construction Areas

- (1) The eleven construction area offices will be activated and established in the appropriate SDHPT district offices as indicated in Annex A. Activation will be on direction from the State Construction Coordinator.
- (2) Area offices will maintain liaison with the following within the geographic boundaries of their area: SDHPT district offices, disaster district and subdistrict offices, and appropriate local offices at county and city levels.
- (3) Coordination with other area offices will be through the State Construction Coordinator.
- (4) Communication will be by the fastest available methods; i.e., telephone, SDHPT teletype, SDHPT or Department of Public Safety radio.
- (5) Area offices are responsible for establishing and keeping current a tabulation of construction resource materials, equipment and services available within the area.
- (6) Area offices are responsible for determining local needs and taking the necessary steps to meet those needs within the scope of policy established by the State Construction Coordinator. In other words, to the maximum extent feasible area offices are to function as self-sufficient units, keeping in mind that records and documentation of actions are essential to later evaluation of operations after Federal control has been restored.
- (7) Needs beyond the capacity of the area office to meet will be referred to the State Construction Coordinator.
- (8) It is the responsibility of the area offices to keep the State Construction Coordinator continually informed of area construction resources in excess of area needs.
- (9) Local communities and counties are expected to provide for their own emergency needs to the maximum extent feasible before calling on the area director for assistance.

#### 4. Emergency Actions:

The following actions are taken on behalf of the Governor at State and area levels by State construction officials to provide policies and guidance applicable throughout the State on the provision and use of contractor services and construction resources to meet essential local needs.

The emergency action and reference documents contained here have been prepared and placed with appropriate State and local officials during the preattack planning process.

##### a. Actions to Provide Immediate Construction:

- (1) Issue, on behalf of the Governor, policies and guidance applicable throughout the State covering the provision of contractor services and available construction resources within the State. (Con-1, State Construction Policy and Guidance, Annex B).
- (2) Arrange with the construction industry at area and State levels for the provision of contractor services and construction resources to meet local needs based on local government reports of deficiencies in locally available contractor services and construction resources. (Con-2, State Assistance to Local Governments, and Con-3, Request for Assistance to Expedite Deliveries of Construction Resources, Annex B).

##### b. Actions to Provide Continuing Construction

As soon as construction activity for urgent immediate needs in the localities is underway, the State construction organization takes the following actions to anticipate continuing needs and to arrange for continuing construction services to meet these needs.

- (1) Consult with State civil defense officials, Federal military officials, and appropriate Federal and State resource officials to estimate continuing requirements for construction that will be needed in the State during the ensuing 90-day period. (Con-4, Estimate of Continuing Construction Requirements, Annex B).
- (2) Consult with the construction industry and estimate construction contractor services that can be supplied for continuing use in the State during the ensuing 90-day period.

- (3) Estimate continuing requirements of building and construction supplies and equipment, petroleum products, construction manpower, transportation, and other supporting construction resources and services that will be needed to carry on required construction activities in the State during the ensuing 90-day period. Present these requirement estimates to appropriate State resource organizations. (Con-5, Construction Industry Support Requirements, Annex B).
- (4) If anticipated construction capabilities are inadequate to meet the estimated requirements and adjustments in requirements cannot be negotiated, refer to the Resource Priorities Board for recommendations to the Governor on the allocation of anticipated capability among competing programs.
- (5) Issue revised State policy on the use of construction capabilities in the State to conform with the Governor's decision. (Con-6, Revised State Construction Policy, Annex B).
- (6) Authorize civil defense officials, Federal military officials, and appropriate Federal and State resource officials to place or authorize others to place construction contracts. (Con-7, Construction Program Authorizations, Annex B).

ANNEX A - EMERGENCY ORGANIZATION

STATE CONSTRUCTION ORGANIZATION

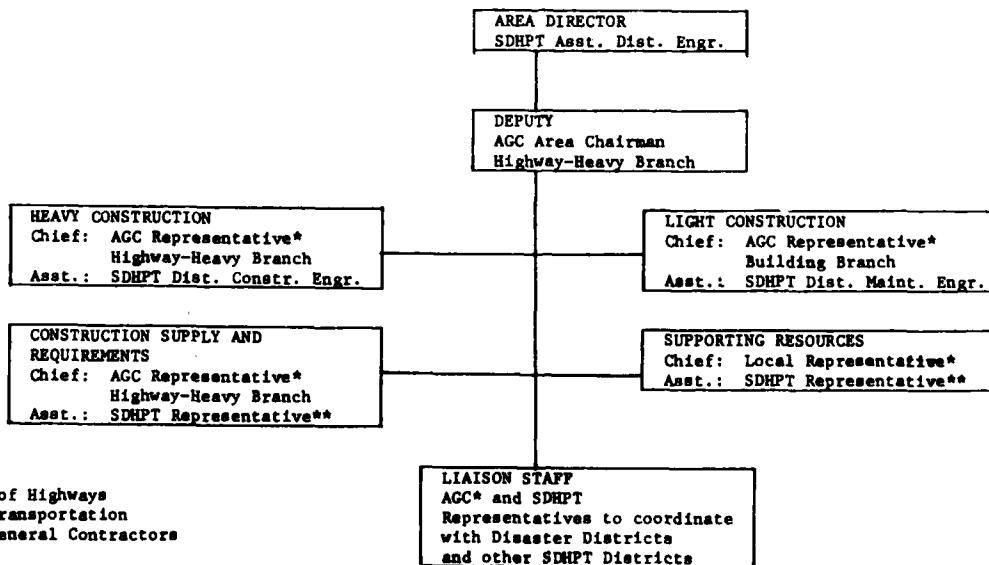
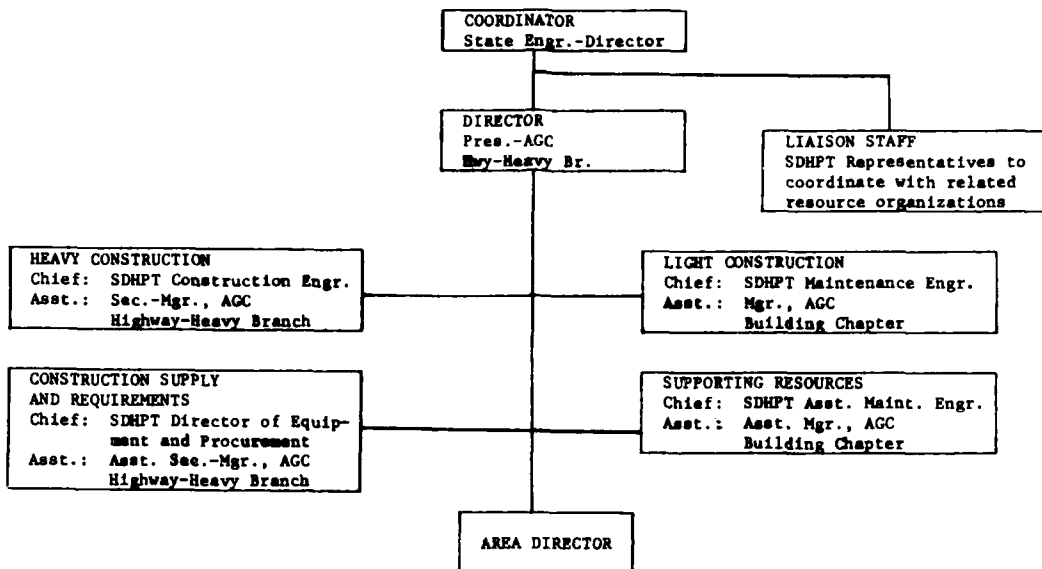

SDPT-State Dept. of Highways  
and Public Transportation  
AGC-Associated General Contractors

\*-To be selected by Deputy Area Director

\*\* -To be selected by Area Director

The area construction offices shown in the organization chart will be located in control centers in the district offices of the SDHPT whose addresses and telephone numbers are as follows:

<u>Area</u>	<u>City</u>	<u>SDHPT District Number</u>	<u>Address</u>	<u>Phone</u>	<u>Zip</u>
1	Amarillo	4	Box 2708	355-5671	79105
2	Fort Worth	2	Box 6868	292-6510	76115
3	Dallas	18	Box 3067	321-6421	75221
4	Tyler	10	Box 2031	593-0111	75710
5	Houston	12	Box 1386	869-4571	77001
6	Waco	9	Box 1010	799-6261	76703
7	San Antonio	15	Box 29928	696-1110	78284
8	Pharr	21	Drawer EE	787-2771	78577
9	San Angelo	7	Box 5500	944-1501	76902
10	El Paso	24	Box 10278	778-4254	79994
11	Corpus Christi	16	Box 7708	855-8281	78415

Coordination with disaster district offices, as adopted in Part A of the Emergency Resource Management Plan, and with other SDHPT district offices will be provided as set out in the following table:

<u>Construction Area Office</u>	<u>Liaison with State Highway District Numbers</u>	<u>Liaison with State Disaster District Numbers</u>
No. 1, Amarillo	4-Amarillo 5-Lubbock 25-Childress	5-A, Lubbock 5-B, Amarillo
No. 2, Fort Worth	2-Fort Worth 3-Wichita Falls	Sub 1-A, Fort Worth Sub 5-A, Wichita Falls
No. 3, Dallas	1-Paris 18-Dallas	1-A, Dallas Sub 1-A, Fort Worth
No. 4, Tyler	10-Tyler 11-Lufkin 19-Atlanta	1-B, Tyler 2-B, Beaumont
No. 5, Houston	12-Houston 20-Beaumont	2-A, Houston 2-B, Beaumont
No. 6, Waco	9-Waco 14-Austin 17-Bryan	6-A, Waco 6-B, Austin
No. 7, San Antonio	15-San Antonio	3-B, San Antonio
No. 8, Pharr	21-Pharr	3-A, Corpus Christi 3-B, San Antonio Sub 3-A, Harlingen
No. 9, San Angelo	6-Odesa 7-San Angelo 8-Abilene 22-Del Rio	4-A, Midland 4-B, Abilene Sub 4-B, San Angelo
No. 10, El Paso	24-El Paso	4-A, Midland Sub 4-A, El Paso
No. 11, Corpus Christi	12-Yoakum 16-Corpus Christi	3-A, Corpus Christi

The following State county outline maps show appropriate boundar

Map 1 - Construction Areas

Map 2 - SDHPT Districts

Map 3 - State Disaster Districts

**CONSTRUCTION AREAS**

- Area 1 - Panhandle and South Plains
- Area 2 - Fort Worth
- Area 3 - Dallas
- Area 4 - North East Texas
- Area 5 - Upper Gulf Coast
- Area 6 - Central Texas
- Area 7 - San Antonio
- Area 8 - Lower Rio Grande Valley
- Area 9 - West Central Texas
- Area 10 - West Texas Area Council
- Area 11 - Middle Coast

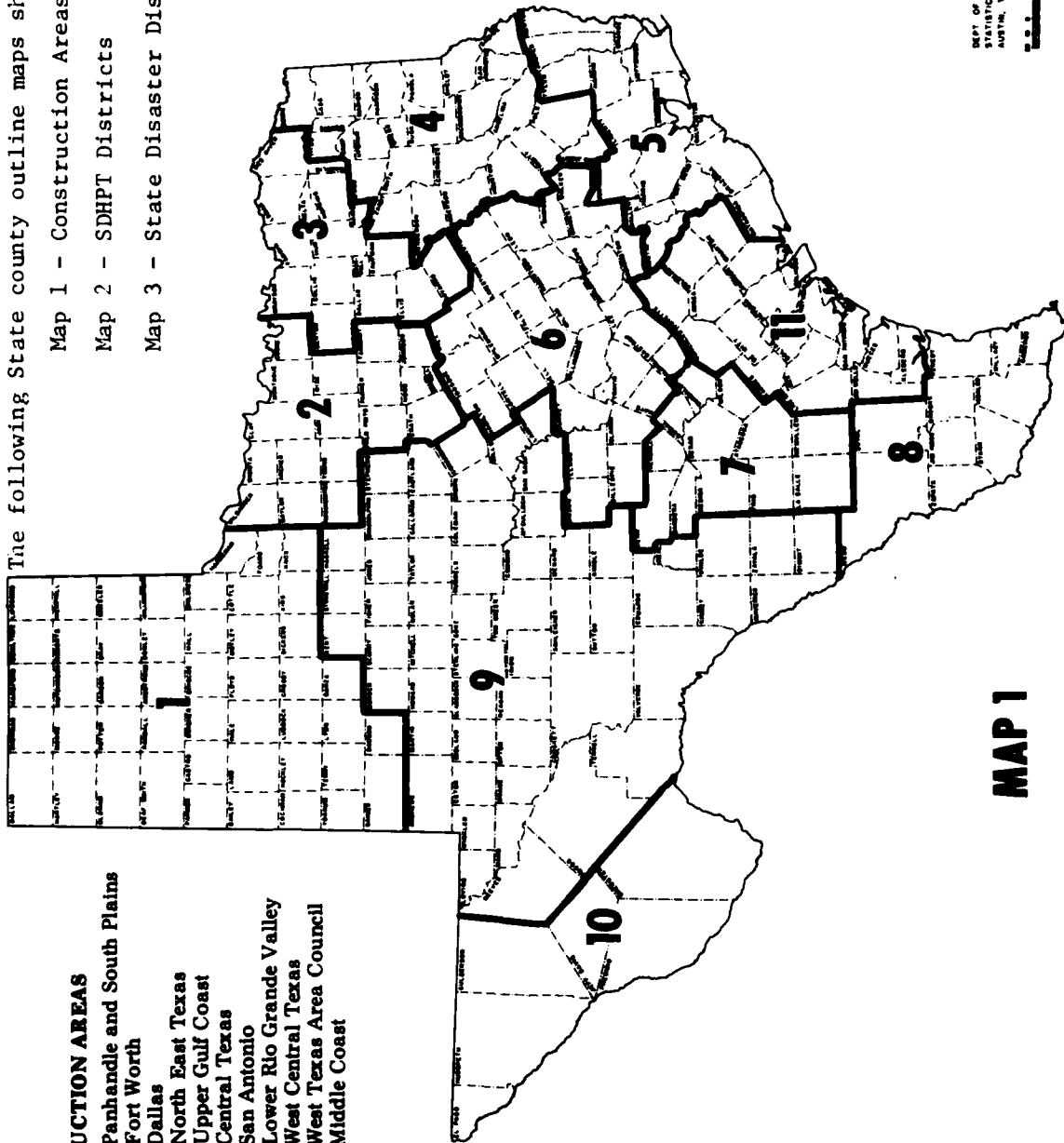

DEPT. OF PUBLIC SAFETY  
STATISTICAL DIVISION  
AUSTIN, TEXAS



**MAP 1**

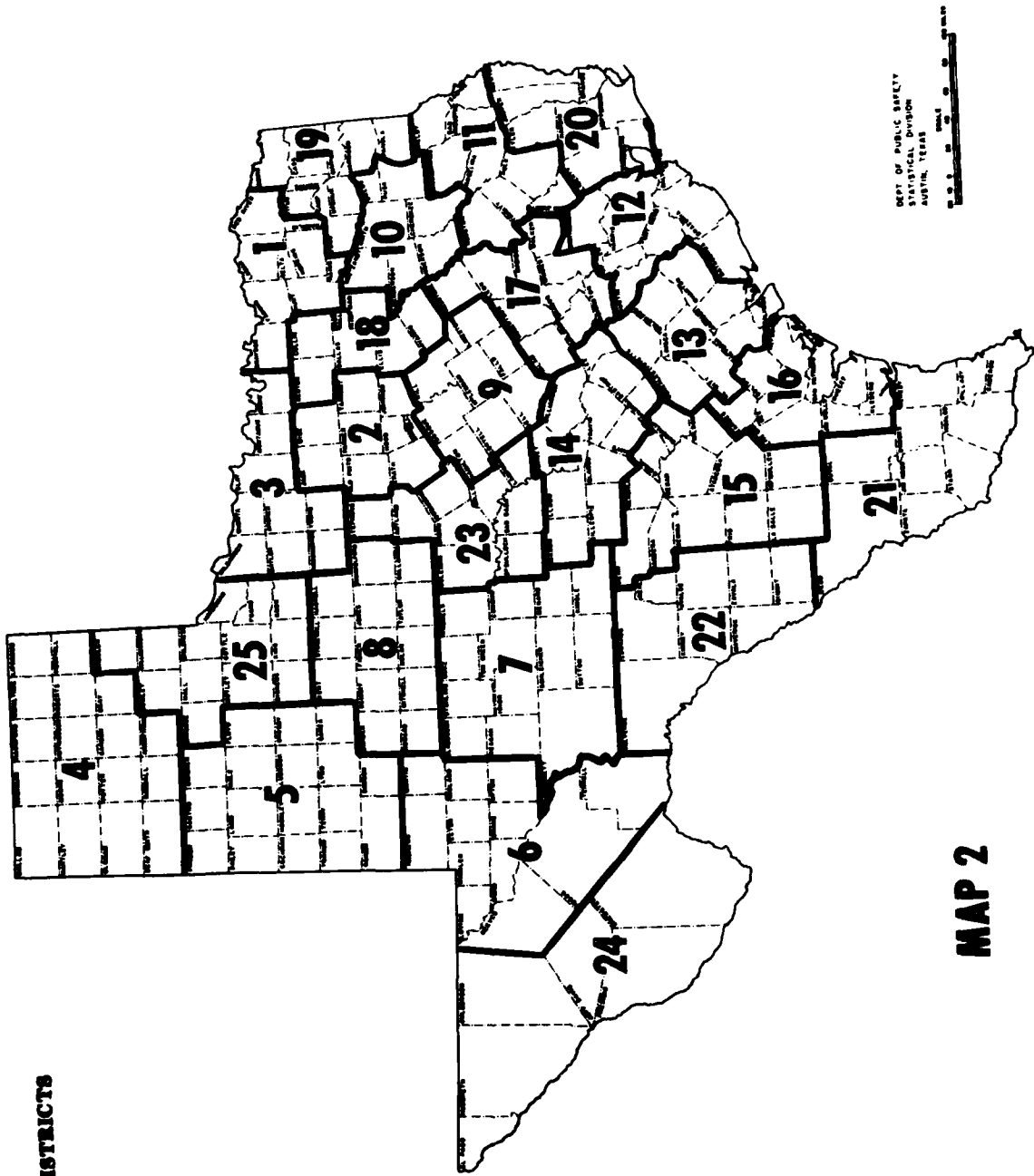

DEPT. OF PUBLIC SAFETY  
STATISTICAL DIVISION  
AUSTIN, TEXAS



**HIGHWAY DISTRICTS**

**MAP 2**

**DIVISION OF DISASTER EMERGENCY SERVICES  
DISTRICTS AND SUBDISTRICTS BOUNDARIES**

DISTRICT	HEADQUARTERS
1A	Dallas
Sub 1A	Fort Worth
1B	Tyler
2A	Houston
2B	Beaumont
3A	Corpus Christi
Sub 3A	Harlingen
3B	San Antonio
4A	Midland
4A	El Paso
4B	Abilene
Sub 4B	San Angelo
5A	Lubbock
Sub 5A	Wichita Falls
5B	Amarillo
6A	Waco
6B	Austin

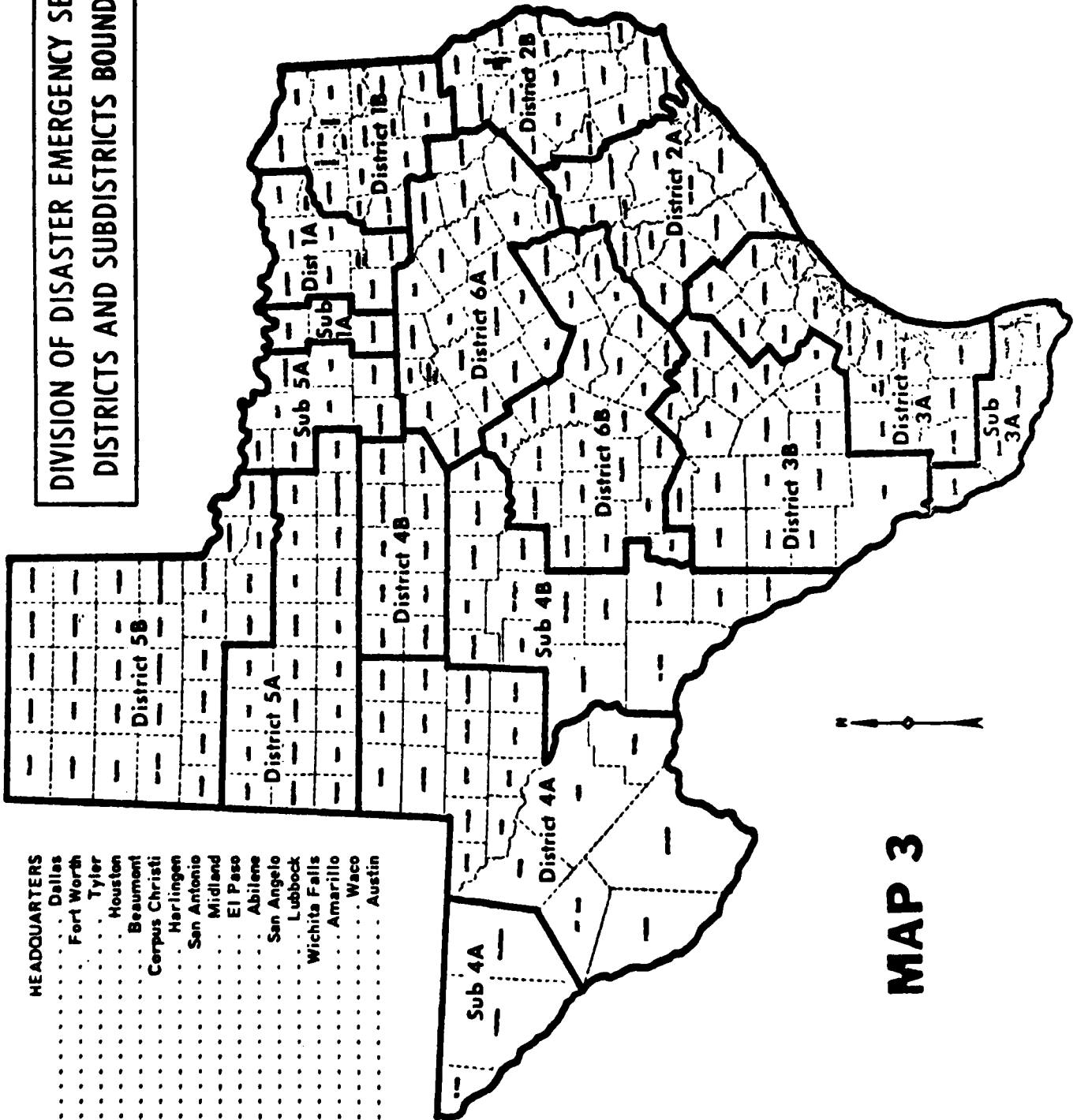

**MAP 3**

ANNEX B  
EMERGENCY ACTION DOCUMENTS

- Con-1, State Construction Policy and Guidance
- Con-2, State Assistance to Local Governments
- Con-3, Request for Assistance to Expedite Deliveries of Construction Resources
- Con-4, Estimate of Continuing Construction Requirements
- Con-5, Construction Industry Support Requirements
- Con-6, Revised State Construction Policy
- Con-7, Construction Program Authorizations

---

Con-1, State Construction Policy and Guidance

To: Heads of Political Subdivisions

Guidance for Local Governments: It is essential that construction capabilities available for use in this State be carefully conserved and restricted to immediate and urgent use for local, State, and National survival and recovery until continuing construction capability can be assessed and contractor services and construction resources that will be available can be determined.

In order to prevent waste and dissipation of construction resources and to provide adequate construction capability to meet immediate and urgent needs, appropriate officials of local government are requested to take the following actions:

1. Provide instructions to local construction contractors on the kinds of construction contracts and work orders they are to accept to meet essential local needs.
2. Authorize essential local users and essential facilities to place certified work orders and contracts with construction contractors.
3. Enforce the Governor's policy by stopping nonessential construction underway and prohibiting new construction starts, unless authorized as essential.

In the event available construction resources are inadequate to meet all essential needs, local governments should cut back on authorized local construction. Concurrently they should report shortages and request appropriate officials of State government to take actions to increase the availability of construction resources to the local jurisdiction.

\_\_\_\_\_  
Effective Date

\_\_\_\_\_  
Governor of the State of Texas

By: \_\_\_\_\_  
State Construction Coordinator

Con-1, Attachment 1

Background Information

The Governor has issued general policy on the use of essential resources in the immediate postattack period. These policies are set forth in Part A of the State plan. They have been furnished to appropriate officials of the political subdivisions of the State.

In general, these State policies provide for temporary freezing of retail inventories of essential items and immediate and continuing release of these items to meet urgent military and civilian needs and to maintain operations of facilities essential to continued survival and recovery. They provide for continuing resupply of local secondary inventories as well as inventories of essential facilities which obtain their supplies from wholesale and primary sources.

The general State policy calls for the following types of construction:

- (1) Emergency repair, restoration, or construction of facilities needed for survival, such as essential production, essential services, and emergency housing.
- (2) Conversion of facilities to survival use, where this can be accomplished quickly.

Other construction already started should be stopped, and no new construction started unless it can be used immediately for essential purposes upon completion.

---

Con-2, State Assistance to Local Governments

To: \_\_\_\_\_

In accordance with your request for assistance following are the names, addresses, and telephone numbers of construction and building contractors that can undertake the construction or provide contractor services to correct the deficiencies you reported under date of

Name

Address

Telephone Number

I have checked with appropriate government officials of the jurisdictions in which these contractors are located and have agreements that their services can be diverted to your locality.

\_\_\_\_\_  
Coordinator of Area or State Construction Organization



Con-3, Request for Assistance to Expedite Deliveries of Construction Resources

to: (State or Area Resource Organization, e.g., Industrial Production Organization)

You are requested to arrange with suppliers to make deliveries on certified orders received from construction contractors or from local distributors in the following localities in the following quantities:

<u>Locality</u>	<u>Item</u>	<u>Unit</u>	<u>Quantity</u>
Rockport	Concrete	Cubic Yards	100
Fulton			

State (or Area) Construction Organization Coordinator

Con-4, Estimate of Continuing Construction Requirements

Attached are lists of and descriptions of construction projects that are required to be started in this State during the 90-day period commencing

These requirements have been estimated and submitted by claimant and resource organizations to provide essential facilities needed to carry on activities under their cognizance by the following categories:

Civilian Requirements include the construction projects needed to carry on emergency civil defense operations and to maintain essential local community activities. These civilian requirements estimates are provided by appropriate civil defense officials.

Military Requirements include the construction projects needed to carry on military activities and to maintain and operate military installations and equipment. These military requirements estimates are provided by appropriate military officials.

Resource Support Requirements included the construction projects needed to repair, modify, or construct essential facilities under the cognizance of Federal and State resource organizations functioning in the State. These support resource requirements are provided by appropriate State resource organizations.

Attach lists of required projects submitted by claimant and resource organizations.

Con-5, Construction Industry Support Requirements

Estimate of Construction Industry Support Requirements for 90-Day Period Commencing _____ (Date) _____				
Resource	Unit of Measure	First 30 Days	Following 60 Days	Total 90 Days
Electric Power				
Water				
Transportation				
Gas				

Con-6, Revised State Construction Policy

This document will be, in essence, a Revised Con-1, State Construction Policy and Guidance, contained here.  
It will be prepared to meet the needs and fit the conditions as they exist in the postattack period.

---

Con-7, Construction Program Authorizations

To: (Name of claimant or resource organization)

This is confirmation of the list of construction projects that have been determined feasible of accomplishment in accordance with the Governor's policy or program decisions.

You are authorized to place construction contracts or to authorize others to place construction contracts with contractors.

These construction contracts are to bear the following certification:

"This is an essential contract authorized  
by the State Construction Coordinator.

(signed)  
(person placing contract)"

Construction contractors are to be instructed to use this certification or the appropriate Federal certification on purchase orders for supporting construction resources.

---

(Effective Date)

(signed)  
(State Construction Coordinator)

---

Con-7, Attachment 1

List and Description of Construction Projects:

<u>Project (Description)</u>	<u>Location</u>	<u>Starting Date</u>	<u>Completion Date</u>
------------------------------	-----------------	----------------------	------------------------

**PART B - RESOURCE SECTIONS**

**III. Electric Power**

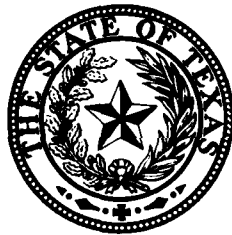

**Texas  
Emergency  
Resource  
Management**

**PLAN**

**B-III**  
Electric Power

## INTRODUCTION

This section of the State of Texas Resource Management Plan contains policies, guidance and actions to provide electric power to meet essential needs in the State in a national emergency for civil defense.

The process for managing resources in the State in a nuclear emergency involves two series of actions. First, essential immediate needs are identified and actions taken to supply these needs. Secondly, and as soon as possible, continuing needs and expected future supplies are estimated. Decisions are made and actions are taken to channel these expected future supplies to meet recovery of the State of Texas and the Nation.

### Definitions:

- a. Electric Power: The generation, transmission, distribution and use of electrical energy. The term is applied to all electric power capability, regardless of ownership, except that of plants owned and operated by the Federal Government at military bases and Nuclear Regulatory Commission installations.
- b. Essential Users:
  - (1) Individuals, both civilian and military, engaged in producing or providing essential items, products, care or services, e.g., doctors providing professional medical diagnoses, treatment and services; farmers producing essential food; military personnel engaged in immediate retaliatory or defense operations.
  - (2) Organizations or establishments engaged in essential activities or providing essential items or services.
- c. Essential Facilities:
  - (1) Military establishments engaged in immediate retaliatory or defense operations;
  - (2) Electric power, gas and water utility systems;
  - (3) Industrial plants producing or processing essential items;
  - (4) Major wholesale establishments storing or distributing essential items; and
  - (5) Transportation or communication systems providing essential services.
- d. Individual Consumers: Individuals who depend on local distribution systems (retailers and dealers) for essential supplies for individual and family use.
- e. Curtailment: Restriction of electric power usage based on conservation of resources or inability to serve.

### Policy:

The distribution of fuel and energy, to include electricity, will continue through normal channels to the extent practicable during a national emergency. Although subject to emergency controls and regulations, the provision of electrical energy and the construction, operation and maintenance of fuel and energy facilities would remain the responsibility of owners and operators of electric power systems.

State and local governments will not assume responsibility for the performance of any function reserved to EEPA unless the required action could not be carried out by EEPA. Nor will the State and local governments assume responsibility for technical direction of electric power generation, transmission or distribution operations, except those in which they are normally engaged.

### Special Considerations:

Electric power is a dynamic and ever changing resource. It is incapable of being warehoused or stored in any manner. Electric generating plants are dispersed throughout the United States and the State of Texas. Generating plants of an electric utility system usually are connected by transmission lines and operated as an integrated system. The Texas Public Utility Regulatory Act certificated service area of a utility, interconnected system, or power pool frequently does not coincide with local, State or Federal regional jurisdictions.

Some electric power generating plants, substations, distribution systems and transmission lines will be destroyed or damaged by a nuclear attack. These losses probably would be offset by reduced demands. In some undamaged areas, power requirements could increase from refugee needs and production requirements.

STATE OF TEXAS  
EMERGENCY RESOURCE MANAGEMENT PLAN  
PART B-RESOURCE SECTIONS  
III-ELECTRIC POWER

### 1. Purpose

The purpose of this plan is to:

- a. Define the procedures to be followed during a national emergency that may be required in providing electric service for essential needs.
- b. Delineate the function and responsibility of the Federal, State and local governments.

- c. Delineate the function and responsibility of the electric power systems, including power pools.
  - d. Establish the organization and describe the procedures for carrying out the mission of supplying electric service during a national emergency.
2. Activation:
- The provisions of this plan are to be activated by the Governor of the State of Texas or his legal successor upon declaration of a national emergency for civil defense by the President or upon receipt of notice that an attack is underway. The plan is to be terminated at the end of the national emergency.
3. Authority and Related Documents:
- a. Executive Order Number 10480
  - b. Executive Order Number 10997
  - c. Electric Power Emergency Operations Handbook
  - d. Part A - Resource Management and authority cited therein
4. Federal Government:
- The Federal Government will review the supply of available resources and allocate to essential users on an equitable basis. The Emergency Electric Power Administration (EEPA) is an agency of the Federal Government established by the Secretary of Energy to become fully operational under him immediately upon declaration of a civil defense emergency. There are nineteen (19) EEPA areas, each headed by a Director, a Deputy and an alternate. The EEPA organization in Texas, which is in EEPA Area 12, is composed of a State Liaison Officer, a Deputy for North Texas, a Deputy for South Texas and a Deputy for West Texas, each with alternates. (See Part C for EEPA Roster.)
5. State Government
- The State of Texas will conserve resources and utilize available supplies to meet all essential needs. The State organization for electric power consists of the Coordinator of Priorities for Electric Power and three Deputies, one from North Texas, one from West Texas, and one from South Texas. The Coordinator is from the Texas Public Utility Commission and the Deputies are reservists from industry serving without compensation. The Coordinator will report to the Chairman, Resource Priorities Board, and serve as a member of that board.
6. Electric Power Industry:
- In a national emergency the electric utilities will provide power service within their capabilities for essential needs and comply with Federal, State and local government orders and directives. For purposes of electric power management, the State of Texas may be assumed to be divided into twelve (12) areas. (See attached map.) Each of these twelve (12) areas has an Electric Power Liaison Officer. In addition, the local representative of the company serving each town or area will serve as Electric Power Liaison for that town or area.
7. Responsibilities:
- a. Federal Government (EEPA):
    - (1) Area Power Director
      - (a) Order curtailment of nonessential uses of electric power when necessary to comply with requests of State and local governments.
      - (b) When communications with higher headquarters are lost during postattack periods, exercise with respect to the power area the authority delegated by the Secretary of Energy.
      - (c) At all times act as agent of Department of Energy in performing the following functions for the Federal Government:
        1. If interconnections between utility systems are necessary, make such requirements known to the affected utilities.
        2. Aid, on request, each affected utility in the restoration, repair, inspection and construction of essential facilities.
        3. Keep the record of materials and equipment on inventory that may be available within the power area.
        4. Exercise authority with appropriate agencies in obtaining and retaining the essential manpower, facilities and materials for the electric power industry.
    - (2) State Power Liaison (EEPA Designated)
      - (a) Advise the State Coordinator of Priorities for Electric Power on, but not limited to, matters concerning electric power, electric power utilization and the need for evoking priority measures within the State.

- (b) Coordinate activities concerning electric power with and between utility systems, local power liaison and the Area Power Director.
- (c) When communications with Area Power Director, Deputy or Alternate is lost, continue to perform EEPA functions; but, if necessary, with the authority of the State.
- (d) Serve as consultant to Resource Priority Board and as advisor to State Coordinator of Priorities for Electric Power.

b. State:

(1) State Power Organization

- (a) A State Coordinator from the Public Utility Commission (PUC) and three reservists from industry (serving without compensation). The three Deputies shall be one from North Texas, one from West Texas and one from South Texas. Their duties shall be:

- 1. Evaluate requirements and determine priority of use among customers in event of a shortage of power supply.
- 2. Issue orders approving or denying claims as passed by the Resource Priorities Board.
- 3. Issue curtailment and other orders.
- 4. Assist utilities to obtain or retain manpower, equipment and supplies needed to produce electric power for essential use.

- (b) Coordinator of Priorities for Electric Power

- 1. In addition to serving on the State Power Organization, the Coordinator of Priorities for Electric Power shall serve as a member of the Resource Priorities Board.
- 2. Develop, advise on and administer policies, measures and activities required to protect, conserve and provide for the effective use of electric power resources available for use within the State.
- 3. During the emergency period, the State Coordinator of Priorities for Electric Power shall, in cooperation with the EEPA organization, periodically assess electric power available from all sources within the State, analyze requirements and estimated requirements, identify problem areas, and issue priority and curtailment orders to provide maximum benefit from available electric power.

(2) State and Local Governments

- (a) Refer matters concerning electric power on the State level to the EEPA State Power Liaison Officer. Refer matters concerning electric power on the local level to the local electric power liaison officer, who, in most cases, will be the local manager of the electric power organization.
- (b) Inform appropriate liaison officer of the essential needs that must be met.
- (c) Determine and enforce priorities for the use of electric power within their respective jurisdictions.
- (d) Assist in issuing curtailment orders and enforce such orders.
- (e) In the immediate postattack period, facilitate acquisition of materials needed by electric utilities for emergency restoration and repair to serve essential needs.
- (f) Permit electric utilities to retain for their use their wholly owned communications facilities and those leased for their exclusive use.
- (g) Permit electric utilities to retain for their use all equipment normally used in the production and distribution of electric power, as well as other equipment used in the operation and maintenance of the electric systems; including, but not limited to, transportation equipment, tools, materials and supplies.

c. Electric Power Industry:

- (1) Maintain adequate preparedness and civil defense plans to minimize the effect of overt and covert attack and maintain continuity of operations.
- (2) Through the use of appropriate utility personnel establish and maintain liaison with all levels of government within the service area of each system.
- (3) Cooperate with Federal, State and local governments in maintaining emergency plans for electric power.
- (4) Within their capabilities comply with request from local, State and Federal officials, as appropriate, for supply of electric power for essential uses.
- (5) Call on other utilities for mutual assistance when necessary.
- (6) If power is not available for all essential uses, request State Power Liaison Coordinator to obtain necessary curtailment orders for nonessential uses whenever necessary and notify affected government headquarters through appropriate power liaison personnel.
- (7) Submit conflicting demands for electric power as follows:
  - (a) If within the jurisdiction of a single local government - through the local liaison officer to the local government.
  - (b) If involving two or more local governments in the State - through the State Liaison Officer to the State government.

# TAB A

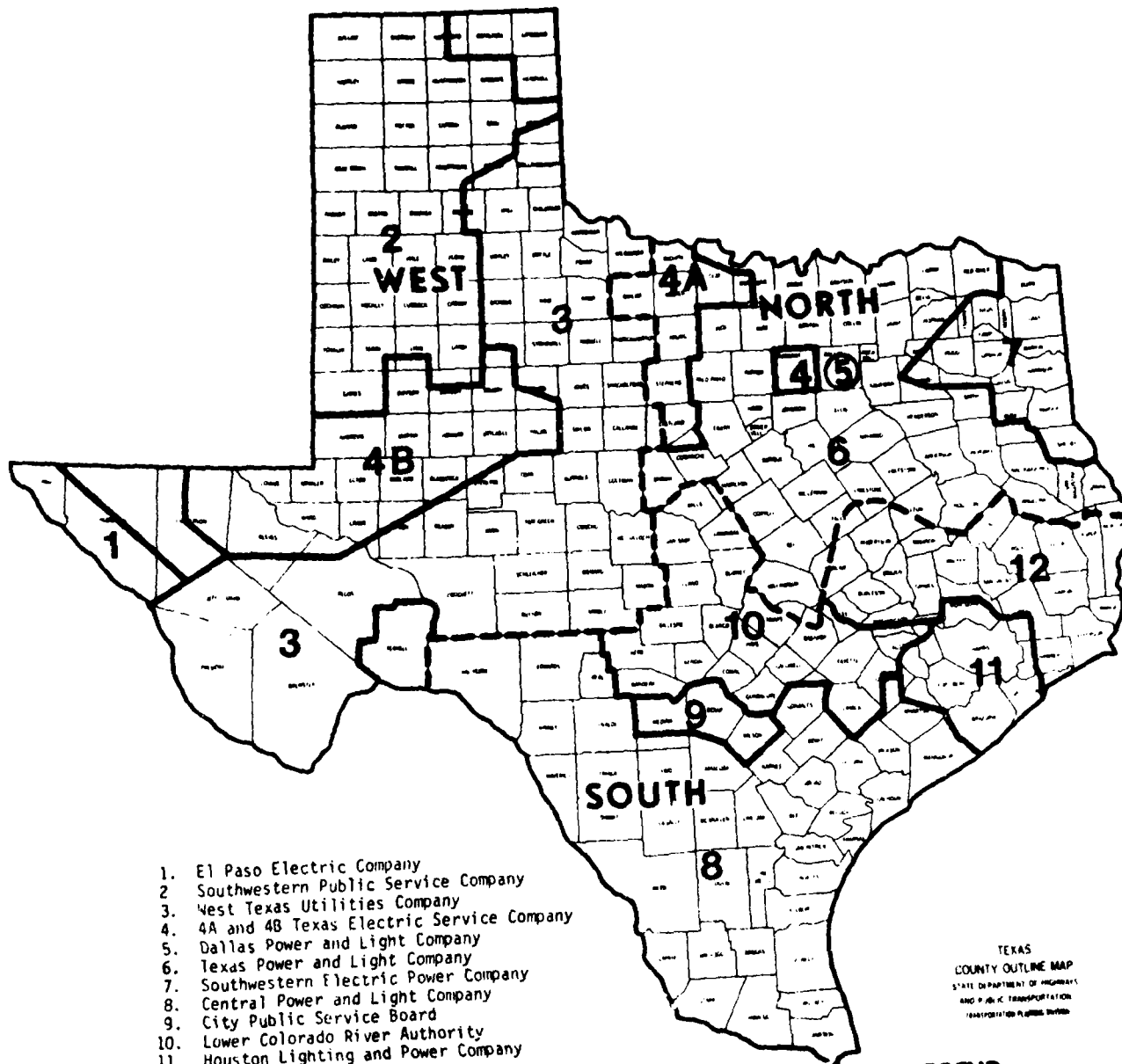

1. El Paso Electric Company
2. Southwestern Public Service Company
3. West Texas Utilities Company
4. 4A and 4B Texas Electric Service Company
5. Dallas Power and Light Company
6. Texas Power and Light Company
7. Southwestern Electric Power Company
8. Central Power and Light Company
9. City Public Service Board
10. Lower Colorado River Authority
11. Houston Lighting and Power Company
12. Gulf States utilities

Other companies, co-operative and municipals are distributed throughout the State and included in general areas shown.

TEXAS  
COUNTY OUTLINE MAP  
STATE DEPARTMENT OF HIGHWAYS  
AND PUBLIC TRANSPORTATION  
TRANSPORTATION PLANNING DIVISION

## LEGEND

----- Boundaries of EEPA organization  
in Texas; North, South, and West.

————— Electric power management  
areas in Texas.

Tab B

FLOW CHART

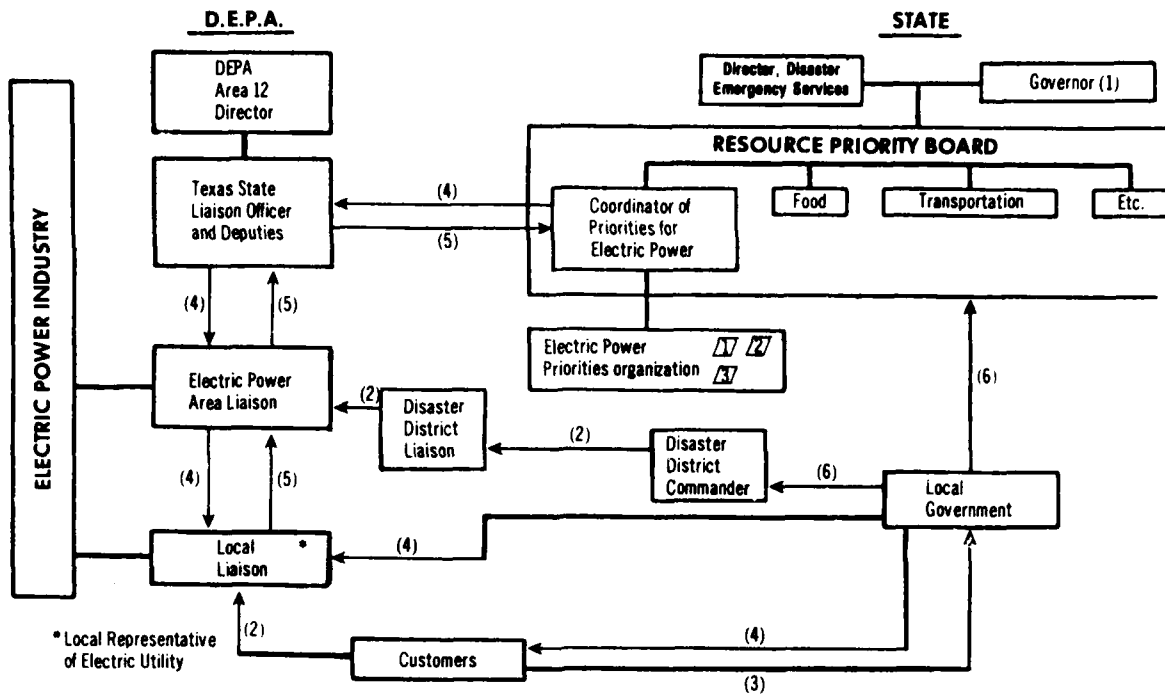

ACTIONS FOR IMMEDIATE SUPPLY

- (1) Issue State Electric Power Policy
- (2) Requests for Power
- (3) Requests for Priority
- (4) Priority and Curtailment Orders and Enforcement
- (5) Report Surplus or Deficiency of Power Supply
- (6) Request Assistance

ACTIONS FOR CONTINUING SUPPLY

- 1 Evaluate Requirements and Determine Priority of Use Among Customers
- 2 Issue Orders Approving or Denying Claims Passed by Resource Board
- 3 Assist Utilities to Obtain Supporting Resources

Tab C

RELATIONSHIP CHART  
STATE OF TEXAS-ELECTRIC INDUSTRY-D.E.P.A.

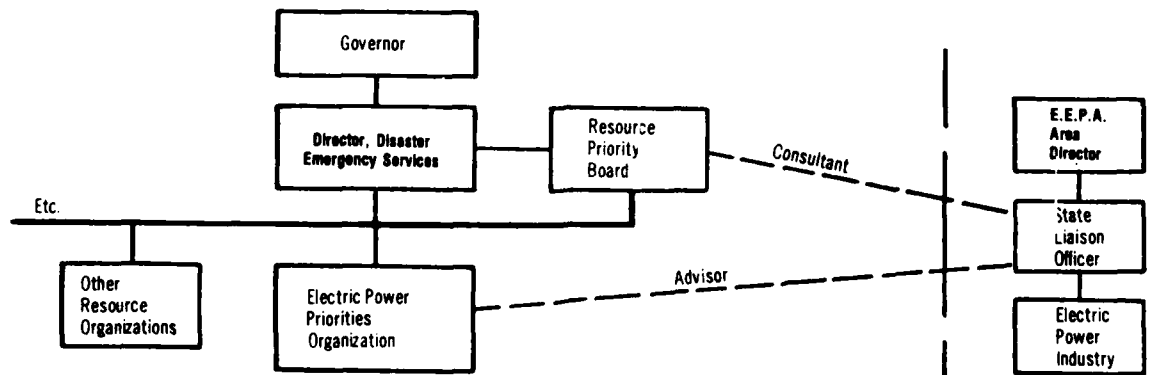

DUTIES:

- Priority of use
- Issuing claims & orders approved by Priority Board
- Help secure resource support
- Enforce curtailment & other orders

DUTIES:

- Operation
- Management
- Production
- Transmission
- Distribution
- Ability & Capability



ANNEX A

EMERGENCY ACTION DOCUMENTS

- Elec-1, State Electric Power Policy and Guidance
- Elec-2, Request for State Assistance
- Elec-3, Request for Industry Assistance
- Elec-4, Estimate of Continuing Electric Power Requirements
- Elec-5, Authorization to Electric Power Systems and Facilities to Obtain Supporting Resources

---

Elec-1, State Electric Power Policy and Guidance

To: Chief Executives, Texas Political Subdivision

Subject: Emergency Electric Policy and Guidance

It is essential that electric power available for use in this State and its localities be carefully conserved and restricted to essential local users, essential facilities, and the minimum needs of individual consumers until the continuing supply can be assessed and the supply that will be available for less essential needs can be determined.

In accordance with the general policy to (1) prevent waste and dissipation of electric power, (2) provide supplies of electric power to meet needs of essential local users and maintain operation of essential facilities, (3) meet minimum electric power needs of individual consumers, and (4) assure continuing supply of electric power, local governments when they have been advised by the local electric power system of a shortage of electric power are requested to take the following actions:

1. Curtail nonessential local uses of electric power (Attachment 1);
2. Enforce priorities on local use of electric power (Attachment 2).

In the event of advice by the local electric power system that electric power supply is not adequate to meet all essential local needs, local governments will decide and cut back authorized local uses. Concurrently they will report local shortages and request appropriate officials of State government to take actions to increase the supply of electric power to the local jurisdictions.

---

Effective Date

---

Governor of the State of Texas

By: \_\_\_\_\_ (Signature)  
Title

(This form to be issued immediately upon activation of this plan.)

---

Elec-1, Attachment 1

Curtailment of Electric Power Service:

In accordance with the Governor's policy, curtailment on local use of electric power is suggested by a series of seven steps, which are listed below. When Steps I through VI are taken they are enforced by appropriate local government authorities. Step VII is carried out by the utility. The public is to be informed and instructed through available communication media. Modification at the discretion of local government of the curtailment steps to suit local conditions is to be effected as required.

If, in the restoration of electric power, service cannot be provided for all uses, restoration shall be in reverse order of the steps listed below.

Step I - Discontinue:

- a. All exterior advertising, decorative, and flood lighting.
- b. All show window lighting.
- c. All interior display and showcase lighting.
- d. All comfort air conditioning.
- e. The use of electric ovens and broilers in home cooking, and reduce use of electricity for other home cooking to an absolute minimum.
- f. The use of all residential electrical appliances except refrigerators, ranges and television or radio receivers.
- g. Nonresidential cooking and baking on electrical equipment except for essential staple foods, and reduce nondomestic use of electricity for all cooking and baking to an absolute minimum.

Step II - Reduce:

- a. Elevator service to an absolute minimum.
- b. Public lighting to the absolute minimum essential for safety.
- c. Thermostat settings for comfort heating, utilizing electricity, to a maximum of 65 degrees daytime and 50 degrees nighttime temperatures.
- d. The use of hot water heated by electricity to minimum requirements.
- e. General illumination by 50% in all commercial and residential establishments.
- f. Electric transportation facility heating by 50%.
- g. The use of radio and television receivers to the minimum necessary to receive civil defense information and instructions.

Step III - Discontinue the use of electricity except for preservation of equipment:

- a. In all places of amusement.
- b. In nonessential public places (such as museums, galleries, etc.)
- c. In schools other than those with pupils attending pursuant to requirements of the Compulsory Education Law and institutions of higher learning.

Step IV - Discontinue the use of electricity except for preservation of equipment:

- a. In all commercial wholesale and retail establishments except those engaged in the distribution of controlled-temperature storage of foods, fuel, medical supplies and medicines.
- b. In all industrial establishments not engaged in the manufacture, processing or controlled-temperature storage of staple foods, medicines and medical supplies, or specifically designated by the State as essential facilities.
- c. In all office buildings not engaged in communications, utilities, police, fire, health, water supply, public works, welfare and transportation services.

Step V - Discontinue industrial use of electricity by all essential industrial facilities except those engaged in the manufacturing, processing, controlled-temperature storage and distribution of staple foods, fuel and medical supplies.

Step VI - Discontinue use of electricity to preferred services.

Step VII - If electric power service cannot be rendered with safety, the utility shall disconnect all power supply.

Priorities on Local Use of Electric Power

In accordance with the Governor's policy the following essential local uses having more direct application of electric service shall have first preference for service or restoration of service:

Electric utilities power requirements needed for rendering service for essential uses

- Military reprisal facilities
- Hospitals and emergency hospitals
- Water pumping and sewage disposal plants
- Emergency shelters and community facilities for displaced persons
- Control centers (civil defense, police, fire, light, water, etc.)
- Food production, processing, storing and distribution
- Dairy farms for milking and cooling
- Ice and dry ice plants
- Communication utilities:
  - Radio services
  - Telegraph services
  - Television services
  - Telephone services
- Solid fuels, petroleum and gas
- Transportation utilities
- Doctors' offices and clinics
- Essential government services
- Plants manufacturing survival items

Elec-2, Request for State Assistance

To: State Electric Power Coordinator

Supply of electric power in this local jurisdiction is inadequate to meet present and anticipated needs of essential local users, essential facilities and individual consumers.

Authorized local uses have been cut back as far as possible by local government action.

Assistance is needed to increase the level of supply to this local jurisdiction as quickly as possible.

Request for State Assistance to Supply Electric Power	
Unit of Measure	Increase in Daily Supply
Kilowatts	
Kilowatt Hours	

Date \_\_\_\_\_

Location \_\_\_\_\_

(Name of Head of Local Government) \_\_\_\_\_

By: \_\_\_\_\_ (Signature)  
Local Electric Power Official

(To be used by local governments if requirements cannot be satisfied at local liaison level.)

**Elec-3, Request for Industry Assistance**

To: State Power Liaison Representatives

Shortages of electric power have been reported from the following localities in this State:

Summary of Local Deficiencies in Daily Supply of Electric Power		
Locality	Kilowatts	Kilowatt Hours

You are requested to arrange with the electric power industry to correct these deficiencies by taking steps to increase power supply to these localities.

Please advise this office of the increased power supply that has been made available to these localities.

\_\_\_\_\_

Date

\_\_\_\_\_

State Coordinator of Priorities  
for Electric Power  
State of Texas

**Elec-4, Estimate of Continuing Electric Power Requirements**

Forms 1 and 2 attached to this emergency action document contain data on quantities of electric power that will be required in this State for the 90-day period commencing \_\_\_\_\_.

The requirements stated include the quantities of electric power to meet needs of essential users, essential facilities and individual consumers throughout the State.

The purpose of these State requirements estimates is to determine and anticipate quantities of electric power needed from the industry during this 90-day period.

These forms are for the use of the Coordinator of Priorities for Electric Power.

**Definitions**

- a. **Civilian Requirements:** Include the electric power needed to carry on emergency civil defense operations, to maintain essential local activities, and to supply individual consumers. These civilian requirements estimates are provided by appropriate civil defense officials.
- b. **Military Requirements:** Include the electric power needed to carry on military activities and to maintain and operate military installations and equipment. These military requirements estimates are provided by appropriate military officials.
- c. **Resource Support Requirements:** Include the electric power needed to maintain operation of essential facilities located in the State. These support resource requirements are provided by appropriate Federal and State resource organizations.

**Elec-4, Form 1**

Summary Estimates of Continuing Requirements for Electric Power for 90-Day Period Commencing _____.		
Requirement Categories	Kilowatt Demand	Kilowatt Hours
Civilian 90 days		
First 30 days		
Following 60 days		
Military 90 days		
First 30 days		
Following 60 days		
Supporting Resource Requirements 90 days		
First 30 days		
Following 60 days		
Total Requirements 90 days		
First 30 days		
Following 60 days		

**Elec-4, Form 2**

Estimate of Continuing Supporting Resource Requirements for Electric Power by Resource Program for 90-Day Period Commencing _____.		
Resource Programs	Kilowatt Demand	Kilowatt Hours
Production 90 days		
First 30 days		
Following 60 days		
Transportation 90 days		
First 30 days		
Following 60 days		
Etc.		
Total 90 days		
First 30 days		
Following 60 days		

**Elec-5, Authorization to Electric Power Systems and Facilities to Obtain Supporting Resources**

To: (Name of Company)

You are hereby authorized to obtain the supporting resources in the quantities specified in the attached list.

Resource	Unit of Measure	First 30 Days	Following 60 Days	Total
Petroleum Products				
Water				
Transportation				
Solid Fuels				
Gas				

In placing orders for the above supporting resources, you are authorized to use the following certification:

"This is an essential order authorized  
by the State Electric Power Coordinator.

\_\_\_\_\_  
(signed)  
(Purchaser)

\_\_\_\_\_  
Effective Date

\_\_\_\_\_  
State Coordinator of Priorities  
for Electric Power

**PART B - RESOURCE SECTIONS**

**IV. Food**

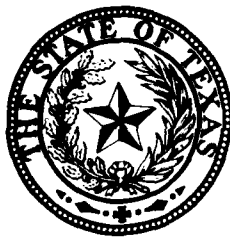

**Texas  
Emergency  
Resource  
Management**

**PLAN**

**B-IV  
Food**

STATE OF TEXAS  
EMERGENCY RESOURCES  
MANAGEMENT PLAN  
PART B-RESOURCE SECTIONS  
IV-FOOD

1. Purpose

- a. To conserve and direct distribution of secondary food resources<sup>1</sup> available to the State of Texas in the event of nuclear attack emergency or crisis relocation.
- b. To provide guidance and an operating basis for State and local governments to carry out their assigned food responsibilities.
- c. To assist local governments in acquisition and equitable distribution of food for emergency needs.

2. Authority:

a. Federal (U. S. Department of Agriculture)

- (1) Actions taken to control production, processing, storage and wholesale distribution of food are taken pursuant to Federal emergency authorities.
  - (a) Federal Defense Production Act of 1950 as amended.
  - (b) Presidential Executive Order 10480.
  - (c) Presidential Executive Order 10998.
  - (d) Presidential Executive Order 10958.
- (2) State-U.S.D.A. Memorandum of Understanding (See Appendix, Food 15) placing all primary food resources<sup>2</sup> under Federal authority.

b. State

- (1) Actions to be taken to control distribution of secondary food resources available to the State of Texas will be taken pursuant to applicable State emergency authorities, directives issued or to be issued by the Governor or his authorized representatives, and the policies set forth in this document and Part A, Emergency Resources Management Plan.
- (2) State-U.S.D.A. Memorandum of Understanding placing all secondary food resources under State authority.

c. Local

- (1) Actions to be taken by local political jurisdiction for emergency food management will be taken in consonance with and will be subject to applicable State emergency authorities.
- (2) In emergency situations when communications with higher State authority is impossible, officially designated county and local authorities will be authorized to take whatever actions are necessary and feasible to insure the equitable distribution of available retail food supplies to surviving populations in their respective political jurisdictions.

3. Activation of the Plan:

This Food Plan is activated by direction of the Governor or by appropriate Federal authority or by directives prescribed or to be prescribed in the event of crisis relocation or an enemy attack upon any part of the United States.

4. Organization:

a. Federal

The United States Department of Agriculture has established in the State of Texas a U.S.D.A. State Defense Board, and for each county a County Defense Board to carry on Federal functions and activities for the production and management of primary food resources.

b. State (Annex A)

- (1) The Governor of the State of Texas has established a State food organization under the supervision of the Commissioner of Agriculture, as State Food Coordinator to plan functions and activities for the management of secondary food resources available to the State. The State food organization will develop plans, determine policies, and prepare recommended procedures for management of these food resources.
- (2) Execution of State Food Plan provisions, except for emergency mass feeding operations, will be carried out at the State and district level by the Texas Department of Agriculture. When normal communications systems become inadequate or inoperative preappointed personnel from the Texas Department of Agriculture will be prepared to report to each of 17 disaster district headquarters or to other alternate locations where facilities will be provided. (See Part A.)

<sup>1</sup>Secondary food resources: Food in homes, retail stores, restaurants, and other commercial eating places, schools, hospitals, and other institutions (except Federal), and cold storage lockers for use by owner.

<sup>2</sup>Primary food resources: Food on farms, livestock feed, and seed at all levels, including retail, plus food in transit and processor and warehouse stocks (distribution, commercial storage, cold storage at wholesale levels).



- (3) The Texas Department of Human Resources, subject to approval of its director, will, through its Commodity Distribution Service, be responsible for supplying all emergency mass feeding operations. Where practical, such emergency feeding operations will be conducted through the use of school lunchroom facilities and other similar facilities not already designated for emergency use. In all instances, however, local authorities will remain in charge of actual operation of such facilities. Department of Human Resources personnel will operate from each of the 17 disaster district headquarters in conjunction with other State food organization officials.
- (4) An executive committee of five persons designated as State Resource Specialists will be appointed to assist the Commissioner of Agriculture in the administration of this plan.

c. Local

(1) County Jurisdiction

First authority for local administration of emergency management of secondary food resources will rest with office of the county judge.

(2) Local Jurisdiction

Within each county, subject to approval of the county judge, authority for administration of the Food Plan at the local level will be preassigned to county or district school superintendents or to such other local authority the county judge may designate.

5. Major Policies:

a. Federal Government

- (1) The Federal Government is responsible for working with the food industry to assure needed production, processing, and distribution of food in primary inventories to meet essential needs of the surviving population of the United States. Generally, the U. S. Department of Agriculture, State and County Defense Boards carry out these Federal food responsibilities in their respective jurisdictions.
- (2) In an emergency, the U.S.D.A. Defense Boards work with producers, processors, and wholesalers to conserve and direct food supplies available from these sources to where they are most needed. These Boards are authorized to make supplies of food available from primary sources:
  - (a) To the State for feeding civilian population (after distribution controls are in effect.)
  - (b) To the Department of Defense.
  - (c) For essential industrial uses.
  - (d) For meeting other urgent needs outside the State.
- (3) U.S.D.A. Defense Boards issue orders controlling primary food resources. The initial orders permit the free flow of certain types of food, chiefly perishables; restrict the flow of such storable foods as canned goods; place specific limitations on the flow of foods likely to be extremely short in supply; and limit the distribution of the remaining foods to specified percentages to preattack rates. This system permits the food industry to continue the orderly conduct of its regular business to the extent possible under the circumstances.
- (4) Defense Boards authorize food facilities whose stocks are under U.S.D.A. control to continue food deliveries to regular customers, both intrastate and interstate and subject to appropriate control orders, as soon as adequate State or local food rationing and distribution controls are in effect. In the event of breakdown in commercial operations, the U.S.D.A. State Defense Boards arrange through National headquarters or, where direction from higher authority is unavailable, with its counterparts in other States, for inshipment of food to make up local deficiencies in food supplies. Food so received will usually be channeled by U.S.D.A. into the wholesale distribution system.
- (5) Food producers and operators of food processing, storage and wholesale distribution facilities will obtain uncontrolled requisites<sup>1</sup> necessary to essential production and services from their usual suppliers of these requisites. For essential controlled requisites, they will seek procurement authorization from the governmental authority having local jurisdiction over the requisite. When they are unable to obtain essential requisites in the above manner they will request assistance from the U.S.D.A. County or Metropolitan Area Defense Boards.
- (6) U.S.D.A. County Defense Boards will work with local governments to obtain supplies of requisites needed for food production, processing, storage, and distribution. Where essential needs cannot be met the County Defense Board will advise the U.S.D.A. State Defense Board of its problem. The State Defense Board works with appropriate Federal agencies and State government officials to obtain necessary assistance.
- (7) Wholesomeness of food is essentially a Federal responsibility, carried out at State and local levels by cooperative program arrangements with the U.S. Department of Health, Education and Welfare which will provide preattack guidance, standards, and plans for emergency inspections. Persons now inspecting foods for wholesomeness will continue to have this responsibility following an attack.

<sup>1</sup>Requisites are supporting resources such as manpower, materials, equipment, supplies and services needed for food production, processing, storage and distribution.

b. State Government

- (1) The State food organization develops, in cooperation with other organizations of the State Government and the U.S. Department of Agriculture, and provides, on behalf of the Governor, policies and guidance for control of secondary food resources consistent with Federal and State objectives. The purpose of these policies and guidance is to assure application throughout the State of measures compatible with National and State plans for the conservation, distribution, and use of secondary inventories of food to prevent their dissipation and waste and to assure that essential needs for food are identified and met within the supplies of food available to the State.
- (2) The State food organization issues all policies, orders and instructions relative to use or sale of secondary foods.
- (3) The State food organization, acting within the framework of the National Emergency Food Consumption Standard (see attachment), also receives and acts upon requests for assistance from local government officials. Upon a showing of necessity and evidence of effective rationing, U.S.D.A. may be requested to arrange for additional supplies. Upon activation of this plan, the State food organization anticipates future continuing needs for food in the State and requests the U.S.D.A. to make arrangements with the primary industry to provide food to meet ongoing needs in the State.
- (4) Operators of facilities having secondary food resources obtain uncontrolled requisites from their customary suppliers in the customary manner. If requisites are controlled, operators of such food establishments go to their local government control agency for requisites such as petroleum, fuel, manpower, electric power, transportation, and other items controlled by these local civil authorities. To the extent possible, local civil authorities meet such needs. When requisites cannot be obtained in this manner, food handlers subject to State control over their food stocks request assistance from the State food organization. State food organization representatives work with appropriate local civil agencies to develop the best possible distribution of items in short supply. When it becomes possible, appropriate resource agencies will allocate additional requisites to meet essential local needs on a continuing basis.
- (5) However remote, the possibility of a temporary breakdown of U.S.D.A. control in some geographic areas must be recognized. Should the established U.S.D.A. network be incapable of functioning postattack, the State food organization would undertake responsibility for working directly with the primary food industry until U.S.D.A. informs the State it has resumed control over primary food resources.

c. Local Government

- (1) Operational Survival Plans of the State of Texas and its political subdivision contain provisions for the rationing and use of food at retail levels within the State.
- (2) Survival plans also provide for local government decisions guidance, consistent with State policies, for the functioning of the secondary food management system as applied to local government levels in the State.
- (3) Local governments will also request State assistance to obtain deliveries of food to meet local shortages.

d. Flow Chart

- (1) Following is a flow chart showing the process and actions to be taken by Federal, State and local governments to assure a continuing flow of food supplies to meet essential needs in the State in a nuclear attack emergency. The legend accompanying the chart identifies:

- (a) Actions to be taken immediately to supply immediate needs essential for survival.
- (b) Actions to be taken, as soon as possible, to anticipate continuing needs and to channel food supplies to meet the most urgent needs for continuing survival and recovery.

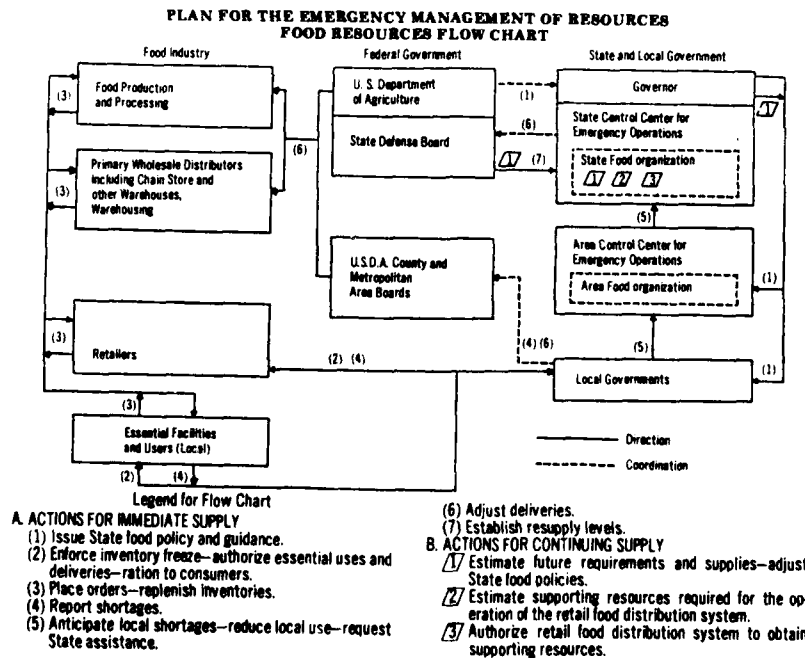

6. Emergency Actions:

The State food organization will:

- (a) Issue, on behalf of the Governor, the State Food Freeze Order. This State Order must be parallel and supplemental to the Federal General Freeze Order. (Annex B, Food-2)
- (b) Issue and publish an Emergency Food Release Order directing retail food distributors to make emergency releases of food to meet urgent and immediate demands as exceptions to the five-day Federal General Freeze Order on retail inventories. (Annex B, Food-3)
- (c) Request food retailers to inventory and report to the State food organization, through local food authorities, quantities of food in their stocks. This inventory and report is to be completed during the five-day Federal General Freeze. (Annex B, Food-1, Policy on Retail Sale of Food, Inventory)
- (d) Summarize information on food supplies in inventories of food retailers. (Annex B, Food-11)
- (e) Based on the National Emergency Food Consumption Standard (Annex C, Food-5), obtain estimates of quantities of food that will be needed for mass feeding of people in reception centers and for use in the food rationing program to feed people in homes, institutions, (except Federal) and commercial feeding establishments. (Annex B, Food-10)
- (f) Maintain a tabulation on State food supplies and requirements for 30-60-90 day periods and provide the U.S.D.A. State Defense Board with this information. (Annex B, Food-11, Food-12)
- (g) Request the U.S.D.A. State Defense Board to advise on items and quantities of primary food supplies that can be made available to overcome deficiencies in available supplies.
- (h) Apportion secondary food supplies available during crisis relocation or the first 90 days after attack for consumer rationing distribution and mass feeding purposes.
- (i) Establish in consultation with the U.S.D.A. State Defense Board the consumption standards, i.e., items and amounts of food, to be used by the rationing agency in operating State and local food rationing systems.
  - (1) The rationing level will be determined from the numbers of people to be fed and the supplies available for this purpose.
  - (2) Items to be made available for consumption should be, to the greatest extent possible, those which are the least storable and most difficult to transport. Canned and other storable foods should be conserved to the utmost.
- (j) Make all pertinent information available to rationing authorities.
- (k) Authorize officials responsible for conducting mass feeding operations to certify purchases for food assigned for this use as needed during the first 90 days. (See Part A, Emergency Action Documents, Appendix 6 to Annex C.)
- (l) Collaborate and work closely with the U.S.D.A. in obtaining precise information regarding the State food situation.
- (m) Accumulate and summarize needed requisites in performance of State food organization responsibilities.
- (n) Cooperate with all Texas emergency resources organizations to insure proper coordination of policies and efficient operation.

ANNEX A  
ORGANIZATIONAL CHART

State Food Organization - Major Functions

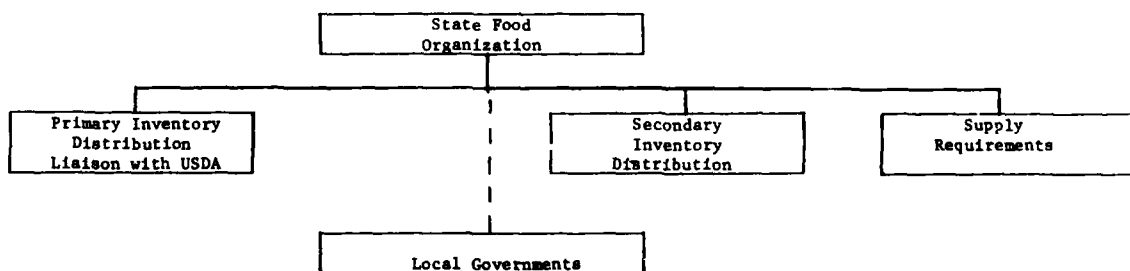

## ANNEX B

### EMERGENCY ACTION DOCUMENTS

Documents for emergency implementation of this plan have been prepared and will be placed in the hands of officials of all political subdivisions having emergency food responsibilities. Samples of all documents are found in the Appendix.

- Food- 1, State Food Policy and Guidance
- Food- 2, Food Freeze Order
- Food- 3, Emergency Food Release Order
- Food- 4, Authorization for Public Eating Places
- Food- 5, National Emergency Food Consumption Standard
- Food- 6, Food Resupply Program Guidance
- Food- 7, Sample Commodity Order
- Food- 8, Instructions for Resupply of Requisites
- Food- 9, Request for Increase in Food Deliveries
- Food-10, Estimate of Current Food Requirements
- Food-11, Estimate of Current Stocks of Secondary Food Resources
- Food-12, Estimate of Continuing Food Requirements

---

#### Food-1, State Food Policy and Guidance

To. Heads of Political Subdivisions and Designated County and Local Emergency Food Organizations

**Guidance for Local Governments:** It is essential that food be carefully conserved and restricted to immediate and urgent needs for local, State, and National survival until the continuing supply of food that will be available for distribution can be determined.

In order to prevent waste and dissipation of food in local secondary inventories, provide supplies of food to meet immediate and urgent needs, assure continuing resupply of local secondary inventories of food, and ration food to meet minimum essential needs of individual consumers, appropriate officials of local government shall take the following actions:

- (1) Provide policies on the sale and resupply of food.
- (2) Announce the provisions of the Food Freeze Order governing retail stocks of nonperishable foods.
- (3) Announce and enforce the Emergency Food Release Order and instructions to local food retailers for release of food as authorized in this order.
- (4) Announce general authorization regarding public eating places.
- (5) Announce restrictions on the use of commodities in critically short supply.
- (6) Announce that the National Emergency Food Consumption Standard will be utilized as the general guide for the distribution and use of food.

In the event resupply from primary suppliers of food is not adequate to meet all essential needs, local governments should cut back authorized levels of distribution. Concurrently they should report shortages to the U.S.D.A. County Defense Board and request them to increase the supply of food to the local jurisdiction. When unable to obtain necessary quantities in this manner, request assistance of the State food organization.

\_\_\_\_\_  
Date

\_\_\_\_\_  
Governor of the State of Texas

By: \_\_\_\_\_  
State Food Coordinator

## Food-1, Attachment 1

### Background Information

The Governor of Texas has issued general policy on the use of essential resources in the immediate postattack period. These policies are set forth in Part A of the State Plan. They have been furnished to appropriate officials of the political subdivisions of the State.

In general, these State policies provide for temporary freezing of retail inventories of essential items and immediate and continuing release of these items to meet urgent military and civil defense needs and to maintain operation of facilities essential to continued survival and recovery. They provide for continuing resupply of local secondary inventories as well as inventories of essential facilities which obtain their supplies from wholesale and primary sources.

#### Essential Users:

- (1) Individuals, both civilian and military, engaged in producing or providing essential items, products, care of services, e.g., doctors providing professional medical diagnoses, treatment and services; farmers producing essential food; military personnel engaged in immediate retaliatory or defense operations.
- (2) Organizations or establishments engaged in essential activities or providing essential items or services.

#### Essential Facilities:

- (1) Military establishments engaged in immediate retaliatory or defense operations;
- (2) Electric power, gas and water utility systems;
- (3) Industrial plants producing or processing essential items;
- (4) Major wholesale establishments storing or distributing essential items; and
- (5) Transportation or communication systems providing essential services.

**Individual Consumers:** Individuals who depend on local distribution systems (retailers and dealers) for essential supplies for individual and family use.

**Primary and Secondary Food Resources:** All food in all locations. The division between primary and secondary resources is governed by the State U.S.D.A. Memorandums of Understanding with resources under State control<sup>1</sup> being secondary food resources and Federally controlled food resources being the primary food resources. The common division is as follows:

- (1) **Primary Food Resources:** Are food on farms, livestock feed, and seed at all levels including retail, plus food in transit and processor and warehouse stocks (distribution, commercial storage, and wholesale cold storage).
- (2) **Secondary Food Resources:** Are food in homes, retail stores, restaurants, and other commercial eating places, schools, hospitals, and other institutions (except Federal), and cold storage lockers (for use by owner).
- (3) **Distribution Controls:** A general term used to denote any kind of orderly process which promotes conservation and equitable distribution of food at rates consistent with supplies, but not to exceed the National Emergency Food Consumption Standard. Such processes may range from mass feeding to a formalized procedure, such as a point-rationing system, or lesser arrangements which nonetheless will prevent uncontrolled dissipation of food stocks or permit any one individual or concern obtaining an unfair advantage over another.
- (4) **Requisites:** Supporting resources such as manpower, materials, equipment, supplies, and services needed for food production, processing, storage, and distribution.

---

<sup>1</sup> "Under State control" is used broadly to mean not only the State level food organization (including its area officers) but also local political jurisdictions whose emergency food management activities are carried out in consonance with policies announced by the Governor.

## **Food-1, Attachment 2**

### **Policy on Retail Sale of Food:**

The following policies are provided, on behalf of the Governor, for use and guidance of local governments until such time as more detailed guidance can be provided. Copies of this statement should be supplied pre-emergency to local food stores:

- (1) **Inventory:** During the freeze on sales of nonperishables, take inventory of stocks and remove from display areas items which are not to be sold. (It may be necessary to package foods which are not in ration size units or approximate multiple thereof.) Local food authorities will either authorize food stores to stay open to sell only perishables or give the store manager directions on how to dispose of them.
- (2) **Sale of Rationed Foods:** As soon as a food rationing program is put into effect (presumably within five days), food stores will reopen to sell foods that are rationed and items exempt from rationing and the inventory freeze. Stocks of certain reserved foods will be retained until directions for their use are received. Generally these will be nonperishables which the State and local authorities may need for emergency use in other areas (canned foods).

---

## **Food-2, Food Freeze Order**

### **Section 1 - Purpose**

The purpose of this Order is to control sales, transfers, disposition and the use of secondary food stocks until such time as appraisals are made of the food supply situation, and more refined food management programs are instituted to provide appropriate and adequate distribution of food supplies.

### **Section 2 - Scope**

This Order applies to all food retailers throughout the State of Texas regardless of location.

### **Section 3 - Definitions**

"Secondary food resources" subject to this Order shall be defined to include food in all retail positions, including retail stores, hotels, schools, restaurants, institutions, (except Federal institutions) and homes and for the food stocks of processors such as confectioners, delicatessens, local fluid milk distributors, retail bakers, and other whose distribution in any case is retail in nature and subject to rationing.

### **Section 4 - Regulatory Provisions**

In keeping with the general Freeze Order promulgated by the Federal Government and confirmed by the Governor, it is hereby ordered as follows:

1. For a period of five days from the effective date of this Order, or until consumer food rationing shall have been established, sales and transfers of all secondary food resources shall be prohibited.
2. No person engaged in the business of handling secondary food resources shall sell, assign, divert, deliver, barter, give away, exchange, or otherwise dispose of, or permit the disposal of, any food which is or becomes subject to his custody or physical control, irrespective of ownership; nor shall any person contract to do any of the foregoing.

### **Section 5 - Exceptions**

Exceptions to this Order may be made to meet urgent and immediate survival needs as specified in this State's Emergency Food Release Order or amendments thereto. The State Food Coordinator is hereby authorized to make such exceptions as he deems necessary and appropriate.

### **Section 6 - Requests for Release of Food**

Requests for the release of food stocks subject to this Order shall be addressed to the Chief of Secondary Inventory Distribution, of the State Food Organization, to his alternates or to the Coordinator of the State Food Organization in Austin or his alternates.

### **Section 7 - Violations**

Any person who violates or conspires to violate any provision of this Order or any requirement pursuant to this Order, will be subject to the full penalties of applicable laws and regulations.

---

Effective Date

---

Governor of the State of Texas

By: \_\_\_\_\_  
State Food Coordinator

Food-3, Emergency Food Release Order

Acting on the authority delegated to me by the Governor of the State in order to meet urgent and immediate survival needs, I \_\_\_\_\_, Coordinator of the State Food Organization authorize all food retailers to release secondary food resources as provided below:

1. The following foods which are exempt from rationing: (Insert list prepared to fit conditions at the time of issuance.)
2. Special dietary foods and other special foods as needed to provide diets for specific individuals when prescribed in writing by recognized medical authorities. (When a rationing program is in effect, they will be supplied in place of the standard ration.)
3. Canned and packaged baby foods for babies in accordance with special ration plans developed by local civil authorities.<sup>1</sup> (Since quantities available for resupply are likely to be limited, care should be exercised in development of such plans and quantities shall be provided for no more than a week at a time.)
4. Such food as may be determined by me or my designee to be needed for emergency feeding purposes.
5. Perishable foods in danger of spoilage. (In areas without refrigeration, this will include frozen foods.)

Any person who violates or conspires to violate any provision of this order or any requirement pursuant to this Order, will be subject to the full penalties of applicable law and regulations.

Effective Date \_\_\_\_\_

\_\_\_\_\_  
Governor of the State of Texas

By: \_\_\_\_\_  
State Food Coordinator

<sup>1</sup> These should be supplied only to persons that the local rationing authorities certified as eligible (having children under two years of age.)

Food-4, Authorization for Public Eating Places

In order to meet the food needs of persons who normally eat in public eating places and those who are away from home, the following types of public eating places are authorized to feed people of the categories indicated prior to issuance of food ration cards.

1. Hospitals and public institutions are authorized to feed resident patients and inmates and staff in residence or while on duty at the institution.<sup>1</sup>
2. Cafes, cafeterias, restaurants, hotels and motels are authorized to sell meals to out-of-town customers and to local persons known to eat regularly at the facility.
3. Educational institutions may continue to feed students in residence. Day schools normally providing a noon meal may continue to do so for students and faculty.<sup>1</sup>

Food service shall be limited to regular meals. Quantities served per person shall be limited to \_\_\_\_\_ percent of preattack/precrisis quantities of rationing foods.<sup>2</sup> Use of canned foods shall be held to a minimum and no resupply of such items shall be requested. Frozen foods will be available only in areas where electric power failure makes it impossible to store locally available supplies of frozen foods. Public eating places serving meals in compliance with this Order may request their regular suppliers to provide them with foods available pursuant to applicable regulations. They may order the following foods in quantities not in excess of the percentages of preattack/precrisis rates specified:

Item	Percent of Preattack/Precrisis Rate
a. _____	In this space insert table of specified percentages applied to specific items.
b. _____	
c. _____	

Requests for permission to order increased quantities of food will be considered by the State food organization when such a request is accompanied by records indicating that the number of meals served is materially greater than preattack/precrisis.

Each public eating place shall make an inventory of food on hand as of the time the Food Freeze Order was issued, and keep a record of the number of meals while operating under this Order for presentation to the State food organization on request.

Date \_\_\_\_\_

By: \_\_\_\_\_  
Texas State Food Organization

<sup>1</sup> Note: When rationing begins, the ration cards of all individuals who consume meals at their place of work or study will be adjusted in the same manner as those individuals who eat certain meals in public eating places.

<sup>2</sup> Insert appropriate percentage. If no guidance is available, use 67.

## **Food-5, National Emergency Food Consumption Standard**

**Introduction.** The National Emergency Food Consumption Standard is the standard for food consumption promulgated nationally for use by governmental authorities at all levels to assure the conservation and equitable distribution of the food supply among the population remaining postattack. It establishes the maximum distribution level for consumer food rationing and mass feeding operations during the immediate postattack period of between 2000 and 2500 calories per person per day depending upon the foods selected. The Standard also shall be the basic guide for establishing distribution levels for categories of various foods, for evaluating requests made upon the U.S.D.A. for food, and for making other food management decisions. The Standard is established at a level which will maintain a reasonable degree of health and vigor for a limited time.

The Standard contains three tables. Table 1 shows the food allowance per person per week under emergency conditions. Table 2 prescribes acceptable substitutions which may be made among the foods in Table 1. Table 3 prescribes the substitution rates for canned, dry and concentrated foods. However, the canned, dry and concentrated foods in Table 3 may be used only after maximum utilization has been made of nonstorable foods.

In utilizing the National Emergency Food Consumption Standard the following shall be observed:

- a. **Special dietary foods** and other special foods may be released by local authorities as needed to provide diets for specific individuals as prescribed by recognized medical authorities.
- b. **Canned and packaged baby foods** may be released for babies in accordance with special ration plans that may be developed by local civil authorities. (Since quantities available are likely to be limited, care should be exercised in development of such plans.)
- c. **Special military packaged rations** shall be released only to the military.
- d. The Standard may be exceeded only after maximum substitutions have been made within the framework of the Standard and there still remain substantial quantities of food in danger of spoilage if not used immediately.
- e. **Canned meats** (including fish and poultry) and canned mixed foods containing meat and canned cheese may be released only if the total quantity of fresh, frozen and cured items in the meat group that are available for distribution falls below 1-1/2 lbs. per person per week. In such case, sufficient quantities of these items may be released to increase the total of the meat group items to 2 lbs. per person per week.
- f. **Dry and canned milk** (including malted milk and all products containing 50 percent or more of dry milk) will be released only for use by (a) children under 6 years of age and (b) pregnant women and nursing mothers, and then only if the total supply of usable fresh milk that is available in the area is less than the amount that is necessary to supply these two groups with 7 pints per person per week. The amount of dry and canned items released will be only enough to make up the deficiency below 7 pints per woman or child in categories (a) and (b) above.



National Emergency Food Consumption Standard  
 Table 1 - Food Allowance  
 Per Person Per Week

Food Groups and Food Items	Amt. Per Week
Meat and Meat Alternates (Fresh, Frozen, and cured meat, poultry, fish, shellfish, cheese; and nuts)	3 lbs.
Eggs	6 eggs
Milk (Fluid, whole)	7 pints
Cereals and Cereal Products (Flour including mixes, fresh bakery products, corn meal, rice, hominy, macaroni, and breakfast cereals)	4 lbs.
Fruits and Vegetables Fresh and frozen	4 lbs.
Food Fats and Oils (Butter, margarine, lard, shortening, salad and cooking oils)	1/2 lb.
Potatoes (white and sweet)	2 lbs.
Sugars, Syrups, Honey & other sweets	1/2 lb.

National Emergency Food Consumption Standard  
 Table 2 - Acceptable Substitutes  
 (Among Foods in Table 1)

Unit	Equivalent Unit	Substitute Foods or Food Groups
Meat and Meat Alternates	1/2 lb. 1/4 lb.	Cereals & Cereal Products Food Fats and Oils
1 lb.	12 2-3/4 lb. 2-1/2 pts.	Eggs Potatoes Milk (Fluid, whole)
Eggs	1/2 lb. 1/4 lb.	Meat and Meat Alternates Cereals & cereal products
6 eggs	1 pt.	Milk (Fluid, whole)
Milk (Fluid, Whole)	2/5 lb. 1/5 lb.	Meat and Meat Alternates Cereals & Cereal products
1 pint		
Cereals and Cereal Products	2 lbs. 5 lbs.	Meat and Meat Alternates Potatoes (white & sweet)
1 lb.		
Food Fats and Oils	4 lbs. 2 lbs.	Meat and Meat Alternates Cereals & cereal products
1 lb.		
Potatoes	1/5 lb. 2 lbs.	Cereal & cereal products Fruits and Vegetables
1 lb.		

National Emergency Food Consumption Standard  
 Table 3 - Substitution Rates for Canned, Dry  
 and Concentrated Foods

Unit	Equivalent Unit	Substitute Foods or Food Groups
Meat and Meat Alternates	1 lb. 2 lbs. 2 lbs.	Canned meats, poultry & fish Canned pork and beans Canned meat mixtures such as hash, chili, stew, spaghetti and meatballs, etc.
1 lb.	1 lb.	Dry beans and peas
Milk (Fluid, whole)	8 ozs. 3 ozs. 2 ozs. 3 ozs. 3 ozs.	Canned evaporated milk Canned condensed milk Dried milk, whole Dried milk, non-fat solids Malted milk, dry powder
1 pt.		
Fruits and Vegetables	2/3 lb.	Canned fruits & vegetables
1 lb.		
Food Fats and Oils	1 lb.	Canned Food Fats and Oils
1 lb.		

Food-6, Food Resupply Program Guidance

Close cooperation between Federal and State governments will be essential upon activation of this plan to assure adequate and equitable distribution of available food supplies. The program which it is desirable for the State to follow is summarized below. This is compatible with U.S.D.A. plans for control of food processing and wholesale distribution.

1. Temporary Resupply Arrangements. Immediately following plan activation local governments will authorize food retailing facilities to obtain and distribute food subject to the following requirements:
  - a. The following foods may be received without restriction and may be distributed in accordance with applicable rationing regulations.
    - (1) Fresh (not frozen) fruits and vegetables (except potatoes)
    - (2) Milk for fluid consumption
    - (3) Bakery products (no sweet goods may be produced postattack)
  - b. The following foods may be neither received nor distributed:
    - (1) Canned goods not requiring refrigeration
    - (2) Dehydrated and dried fruits and vegetables including dry edible beans and peas.
  - c. Because of expected short supplies, the following foods shall be subject to individual controls with respect to use by processors and/or to percentage restrictions on quantities which wholesalers may supply: sugar, yeast, coffee and tea, fats and oils, imported spices, and any other foods in short supply.
  - d. All foods not falling in one of the categories listed above shall be treated as a group and users may order from wholesalers or other suppliers who normally supplied them at a percent of the preattack/precrisis rate to be announced by the State food organization in collaboration with the U. S. Department of Agriculture.

This plan would authorize resupply to retailers by their regular suppliers at a fixed percentage of the preattack/precrisis transportation level. The State food organization may request the U.S.D.A. to authorize release of reserve stock held by sources under U.S.D.A. control for some specific disposition or use. The State food organization will require food retailers to maintain records of transactions in food.

To the extent necessary the State food organization may modify the above procedure to meet unforeseen critical situations with respect to transactions between food retailers and secondary food wholesalers and processors.

To the extent that the State food organization finds that the application of standard procedure is inequitable because of a situation resulting from crisis relocation or an attack (e.g., influx of refugees or loss of supply source) the State food organization and the appropriate U.S.D.A. Defense Board shall arrange for appropriate adjustments. These adjustments may include: (a) Administrative establishment of a new "base"; (b) modification of the distribution percentage; (c) authorization of a single delivery specifying supplier, recipient, items and quantity; (d) authorization of release of a specific quantity of some food(s) on the restricted list; or (e) other appropriate adjustments. The State food organization shall advise U.S.D.A. Defense Board of any food establishments which have failed to follow State and local food control orders so that U.S.D.A. may take action to insure the discontinuation of food shipments to these establishments.

Long-Range Postattack Resupply Arrangements. As quickly as administratively feasible, a State or Federal food rationing program will be developed with a resupply plan based on sales under the ration program. The temporary system previously discussed will be in effect until this more precise program can be put into effect.

**Food-7, Sample Commodity Order<sup>1</sup>**

**Restrictions on Use of Sugar:**

Under authority delegated to me by the Governor, I hereby direct all users and distributors of sugar and other natural sweeteners in the State to abide by such regulations as may be issued by the U. S. Department of Agriculture pertaining to the use of such goods. If no such regulation has been issued by the U. S. Department of Agriculture I direct that:

1. Use of sugar by public eating places be held to no more than \_\_\_\_\_ percent of preattack/precrisis levels per day.
  2. No sugar be used by bakeries, dairies or soft drink manufacturers until specifically authorized by me.
  3. Sugar used in other types of food processing shall be only as specifically authorized by me.
- All questions relative to this order shall be made to local government food officials. This Order will be replaced by regulations governing sugar rationing.

\_\_\_\_\_ Date

\_\_\_\_\_ Texas State Food Organization

<sup>1</sup> Similar orders may be required governing use of any foods found in short supply.

**Food-8, Instructions for Resupply of Requisites**

Farmers and operators of all food facilities obtain uncontrolled requisites from their customary suppliers in the customary manner. If requisites are controlled, these users go to their local government control agency for such requisites as petroleum fuels, manpower, electric power, and other items controlled by these civil authorities. To the extent possible, these local civil authorities meet such needs.

When requisites cannot be obtained in this manner, operators of facilities subject to State control (i.e., secondary food resources) request assistance from the State food organization. State food organization representatives work with appropriate local civil agencies (and, as necessary, with other State resource control agencies) to develop the best possible distribution of items in short supply.

When farmers and operators of food processing, storage, and wholesale distribution facilities (i.e., primary food resources) cannot obtain requisites as outlined in paragraph 1 above, they request assistance from the U.S.D.A. County Defense Boards. These Boards work with appropriate local civil authorities to obtain needed quantities of items in short supply. Where essential needs cannot be met, the U.S.D.A. County Defense Board advises the U.S.D.A. State Defense Board of its problem. The U.S.D.A. State Defense Board works with appropriate Federal agencies and State government officials to obtain necessary assistance.

When it becomes possible to install a more sophisticated system for distribution of controlled requisites, appropriate resource organizations will allocate additional requisites to meet essential local needs on a continuing basis.

**Food-9, Request for Increase in Food Deliveries**

To: U. S. D. A. State Defense Board

Shortages in food supplies are being reported by local governments in this State.

Following is an estimate of the increased amounts of food needed to meet essential needs in the named localities in the State.

Locality	Meat	Eggs	Cereals	Potatoes	Etc.

\_\_\_\_\_ Date

\_\_\_\_\_ State Food Coordinator

**Food-10, Estimate of Current Food Requirements**

To: State Food Coordinator

Food in this local jurisdiction is inadequate to meet present and anticipated needs under the rationing system.

Local use levels have been cut back as far as possible by local government decision and action.

The U.S.D.A. \_\_\_\_\_ County Defense Board has been requested but is unable to arrange for adequate deliveries from primary food sources.

Assistance is needed to increase the level of resupply to this local jurisdiction as quickly as possible.

Following are estimated increases in weekly deliveries required to meet essential local needs for food.

Request for State Assistance Resupply of Food		
Item	Unit of Measure	Increase in Weekly Deliveries
Meat	lbs.	
Eggs	doz.	
Cereals	lb.	
Milk	gal.	
Potatoes	lbs.	

\_\_\_\_\_  
Date

\_\_\_\_\_  
County Judge

By: \_\_\_\_\_  
Local Food Official

**Food-11, Estimate of Current Stocks of Secondary Food Resources**

To: U. S. D. A. State Defense Board

It is estimated that the following quantities of food will be available from secondary sources during the next 30-60-90 days.

Estimate of Current Stocks of Secondary Food Resources			
Item	30 Days	60 Days	90 Days
Meat and Meat Alternates			
Eggs			
Etc.			

(Note: Report quantities available using the same categories contained in Food-12.)

\_\_\_\_\_  
Date

\_\_\_\_\_  
State Food Coordinator

**Food-12, Estimate of Continuing Food Requirements**

To: U. S. D. A. State Defense Boards

Following is an estimate of the number of civilians to be fed in this State during the 30-60-90 day period commencing \_\_\_\_\_.

Number of persons to be fed— 30 days \_\_\_\_\_; 60 days \_\_\_\_\_; 90 days \_\_\_\_\_.

The following level of feeding for these people is desired:

**Food Ration Level Per Person Per Week**

<b>Food Groups and Food Items</b>	<b>Amount Per Week<sup>1</sup></b>
<b>Meat and Meat Alternates</b> (fresh, frozen, and cured meat, poultry, fish, shellfish; cheese; and nuts)	3 lbs.
<b>Eggs</b>	6 eggs
<b>Milk (fluid, whole)</b>	7 pints
<b>Cereals and Cereal Products</b> (flour including mixes, fresh bakery products, corn meal, rice, hominy, macaroni, and breakfast cereals)	4 lbs.
<b>Fruits and Vegetables</b> (fresh and frozen)	4 lbs.
<b>Food Fats and Oils</b> (butter, margarine, lard, shortening, salad and cooking oils)	1/2 lb.
<b>Potatoes (white and sweet)</b>	2 lbs.
<b>Sugars, Syrups, Honey and Other Sweets</b>	1/2 lb.

<sup>1</sup> This may be adjusted to meet local conditions but not in excess of the National Emergency Food Consumption Standard.

Please advise if food that can be provided from primary sources and made available for civilian use in this State during this 30-60-90 day period will be adequate to meet these requirements. If not adequate, advise the food allowance per person per week that available supplies will permit.

\_\_\_\_\_  
Date

\_\_\_\_\_  
State Food Coordinator

## RETAIL INVENTORY REPORT

To: County Food Organization Director

From: (Name and Address of Retail Institution)

Date:

Following is a general inventory report on current stocks in my establishment, estimated within 5 percent of accuracy. In addition to a report of quantities, an estimate of days' supply on hand, based on normal consumption, is included. Notation is included on items in critically short supply.

Item	Quantity (Use Normal Measure)	Days' Supply	Retailer's Notes
All Beef			
All Pork			
Poultry			
Cheese			
Milk			
Eggs			
Bread			
Flour and Meal			
Dried Vegetables			
Fresh Produce			
Fresh Fruits			
Dried Fruits			
Frozen Vegetables			
Frozen Fruits			
Frozen Breads and Pastries			
Canned Vegetables			
Canned Fruits			

---

 Name and Title

**ANNEX C  
REFERENCE DOCUMENTS  
REFERENCE DOCUMENT NUMBER 1**

**MEMORANDUM OF UNDERSTANDING  
ON THE FEDERAL-STATE DIVISION OF POSTATTACK  
FOOD MANAGEMENT RESPONSIBILITIES**

**1. Purpose:**

The purpose of this Memorandum of Understanding is:

- a. To provide an understanding between the U. S. Department of Agriculture (U.S.D.A.) and the State of Texas as to the emergency management of food stocks following a national emergency caused by the threat of or an actual enemy attack.
- b. To provide a means for enhancing the survival of the citizens of the State of Texas through the orderly management of food supplies to support State food rationing in an emergency period;
- c. To give recognition to the principle that certain food stocks are part of a national supply and must be available as such to accomplish the most equitable distribution possible under conditions of crisis relocation or postattack emergency;
- d. To foster close working relationships between U.S.D.A. and the State of Texas in both the pre-emergency and postattack periods;
- e. To form a basis for eliciting the cooperation and assistance of the food industry in the planning to cope with a national emergency; and

1. To facilitate the carrying out of the responsibilities assigned to U.S.D.A. and the States by the National Food Plan (Annex 31 to the National Plan for Civil Defense and Defense Mobilization.)

2. Emergency Food Management Objectives of U.S.D.A.:

In exercising distribution control of certain food stocks within the State, it is the U.S.D.A. objective and intent to provide the State and its citizens with an appropriate share of those stocks under emergency conditions. Moreover, in the management of food supplies at locations outside the State, it will be the U.S.D.A. objective and intent to utilize such foods in such manner as to meet the needs of all survivors, including those in the State of Texas.

3. Scope:

This Memorandum of Understanding pertains to the management responsibility for food stocks of wholesalers (including chain store warehouses) and processors located in the State of Texas. It provides a basis for both pre-emergency planning and the management in a crisis relocation or a postattack period of food stocks of such wholesalers and processors.

4. Understandings Reached:

Discussions between duly authorized representatives of the State of Texas and of U.S.D.A. have resulted in the following understandings:

a. Responsibility for Food Stocks

It is understood that U.S.D.A. will retain all responsibility for crisis relocation or postattack distribution control of the food stocks of wholesalers (including chain store warehouses) and of all processors except those in the categories described in Item B control in full cooperation with the State of Texas and in consideration of the needs of its surviving population.

b. State Control of Certain Processor Food Stocks

It is understood that the State of Texas will assume responsibility for crisis relocation or postattack distribution control of food in all retail positions including retail stores, hotels, schools, restaurants, institutions (except Federal institutions), and homes and for the food stocks of processors such as confectioners, delicatessens, local fluid milk distributors, retail bakers, and other whose distribution in any case is retail in nature and subject to rationing.

c. Distribution of Food

It is understood that food stocks from sources under distribution control of the State of Texas and such foods as may be made available to the State of Texas by U.S.D.A., shall be distributed at a rate which will not result in an amount in excess of that necessary to meet the National Emergency Food Consumption Standard.

d. Food in Transit

Food in transit is understood to be part of the national food reserve and subject to U.S.D.A. management. It is understood also that both State and Federal authorities will facilitate its continued movement to destination to the extent possible, as provided by the National Food Plan.

e. Identification of Facilities

It is understood that, in the interest of the welfare of its surviving population, the State of Texas will assist U.S.D.A. as necessary and possible in the identification and listing of food wholesalers and processors whose stocks would be important in the crisis relocation or postattack period.

f. Facilities and Claimancy

It is understood that U.S.D.A. will retain responsibility during crisis relocation or postattack for facilities and will serve as claimant for materials, equipment, manpower, and services that may be needed during crisis relocation or postattack by food wholesalers (including chain store warehouses) and processors.

5. Modification of Understandings:

In the event that future developments require modifications of the understandings summarized herein, representatives of the State of Texas and U.S.D.A. will hold such discussions as are necessary to arrive at informal mutual agreement concerning necessary changes. Such changes will be summarized and subscribed to as addenda to or revisions of this Memorandum of Understanding.

October 5, 1962

S/ W. Lewis David  
Chairman, Texas U.S.D.A. State Defense Board

CONCURRENCE

S/ James H. Garner  
State Coordinator

September 20, 1962

State of Texas

**PART B - RESOURCE SECTIONS**

**V. Petroleum & Gas**

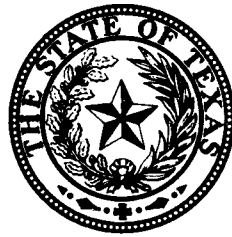

**Texas  
Emergency  
Resource  
Management**

**PLAN**

**B-V**  
Petroleum & Gas &  
Solid Fuels



## INTRODUCTION

In normal times, petroleum, petroleum products, gas, coal and uranium move freely within the State of Texas and to other states in the United States. Many areas of the United States are dependent upon products and raw materials as well as natural gas originating in the State of Texas. To insure the distribution of available supplies of such petroleum, petroleum products, natural gas, coal and uranium to areas both within the State of Texas and to other states of the United States, it is necessary that the operations of the petroleum, gas and solid fuels industries within the State of Texas be directed in accordance with an integrated plan. Since pipelines, railroads and motor transports move this material across State and regional boundaries, it is necessary that their control be exercised at the highest possible point. Damage to or operational stoppage of pipelines, refineries, mines storage and distribution operations at one point in the system requires quick adjustment elsewhere to prevent waste or danger of fire and explosion. For these reasons, petroleum, gas and solid fuels operations must be controlled on an interstate system-wide basis by an agency having overall responsibility for petroleum, gas and solid fuel supply. It will be necessary for the State of Texas and local authorities to have their Emergency Petroleum and Gas Plans in accord with the policies and plans of the Emergency Petroleum and Gas Administration and Emergency Solid Fuels Administration, U. S. Department of Energy.

This section of the State Resource Management Plan sets forth policies, guidance and states actions to be taken to provide for the management of the petroleum, gas and solid fuel resources of the State of Texas in a nuclear attack emergency or crisis relocation of population when the Emergency Petroleum and Gas Administration or Emergency Solid Fuels Administration is unable to function.

In the event of a nuclear attack emergency or crisis relocation resulting in the Emergency Petroleum and Gas Administration and/or Emergency Solid Fuels Administration being unable to perform their prescribed functions in the State of Texas, the Texas Railroad Commission will perform, within and in behalf of the State, those duties and functions during the interim period until such administration is able to reassume these functions.

### Definitions:

- a. The term "petroleum" means crude oil and synthetic liquid fuel, their products and associated hydrocarbons, including pipelines for their movement and facilities specially designed for their storage.
- b. The term "gas" means natural gas (including helium) and manufactured gas, including pipelines for the movement and facilities specially designed for their storage.
- c. The term "solid fuels" means coal and uranium, their products including methods for their distribution and facilities specially designed for their storage.
- d. Primary petroleum inventories are all crudes, condensates, natural gas liquids, natural gasolines and unfinished oils and those petroleum products in storage at refineries or large storage terminals which receive their supplies by either pipeline, tanker or barge for distribution to bulk plants or large consumers. All stocks in transit from or to a primary inventory are considered a part of such inventory.
- e. Secondary petroleum inventories are those petroleum products in storage at (1) bulk plants supplied primarily by tank car and tank truck (rather than by pipeline, tanker or barge) for distribution to retailers, industrial accounts, farms and individual small consumers; (2) service stations, jobbers or small distributors having petroleum stocks in bulk storage, and (3) refineries or primary inventories where segregated for exclusive delivery to consumers listed in (2).  
(Note: Military stocks are secondary inventories but are not available for distribution for nonmilitary uses except by agreement with the military authorities.)
- f. The gas industry facilities are divided into primary and secondary facilities:
  - (1) Primary facilities are those related to producing, processing and transmission of natural gas.
  - (2) Secondary facilities are those related to distribution of natural gas to consumers.
  - (3) Facilities for delivery from transmission lines to industrial consumers are considered primary facilities.
- g. Certified orders are purchase orders, contracts or other requests for resources which bear a signed certification that the order is an essential order authorized pursuant to Federal Government emergency regulations or State authorization.
- h. Local authorities are any authorities within the State itself and not under Federal control (i.e., county, city, town, etc.) are considered a local authority.

STATE OF TEXAS  
EMERGENCY RESOURCES  
MANAGEMENT PLAN  
PART B-RESOURCE SECTIONS  
V-PETROLEUM, GAS AND SOLID FUELS

### 1. Purpose:

The purpose of this plan is to provide policies, guidance and State actions to be taken to provide for management of petroleum, solid fuel and gas resources of the State of Texas in the event of national emergency, crisis relocation, limited war or general war with attack on the United States.

### 2. Activation:

This plan will become effective upon a declaration of a civil defense emergency by the President of the United States, the Congress of the United States, or the Governor of Texas or a nuclear attack on the United States.

AD-A090 824 TEXAS DEPT OF PUBLIC SAFETY AUSTIN DIV OF DISASTER E--ETC F/G 15/3  
TEXAS EMERGENCY RESOURCE MANAGEMENT, VOLUME II.(U)  
UNCLASSIFIED SEP 79 A C ELEDGE, R L ORTON, S O MERZ DCPA01-78-C-0321 NL

204  
ALL INFORMATION CONTAINED  
HEREIN IS UNCLASSIFIED

The majority of the page is obscured by a large grid of blacked-out cells, indicating that the original content has been redacted. The grid consists of approximately 15 columns and 10 rows of solid black squares.

3. Authorities:

- (1) Federal Civil Defense Act of 1950--Public Law 920
- (2) Defense Production Act of 1959--Public Law 774
- (3) Executive Order 10480
- (4) Executive Order 10997
- (5) State of Texas Disaster Plan

4. References:

- (1) National Plan for Emergency Preparedness--Chapter 10
- (2) Emergency Operations Manual for the National Gas Transmission Industry

5. Concept of Operation:

a. Federal

The President of the United States has delegated to the Secretary of Energy the responsibility for preparing plans for the petroleum, gas and solid fuel industry to insure adequate supplies of petroleum, gas and solid fuels to meet the needs of essential users, essential facilities and consumers. The Secretary of Energy has established the Emergency Petroleum and Gas Administration and Emergency Solid Fuel Administration for the purpose of discharging his duties in regard to the responsibilities assigned to him by the President of the United States.

The Emergency Petroleum and Gas Administration and Emergency Solid Fuel Administration have a responsibility for the management of primary petroleum, gas and solid fuel resources.

Under the plan prepared by the Department of Energy, the states and local government have the responsibility for management of the distribution to users and consumers being supplied by local utilities and petroleum distribution sources. Military and large industrial users supplied by transmission lines or from primary inventory terminals will look to the Emergency Petroleum and Gas Administration and Emergency Solid Fuel Administration for their supply of essential needs of gas, petroleum and solid fuel products.

b. State

In the State of Texas, the Texas Railroad Commission will, in addition to its normal operations regarding drilling of oil and gas wells and setting allowables for production of oil and gas, serve as the agency of the Governor in providing policy and guidance within the State of Texas for the conservation, distribution and use of petroleum products, gas and solid fuels to assure that the needs of the essential users, essential facilities and consumers are met.

c. Industry

The petroleum, gas and solid fuel industry within the State of Texas will to the maximum extent possible under the policies and guidance of the Texas Railroad Commission fill the essential needs of consumers, essential users and essential facilities for secondary petroleum, gas and solid fuel resources. Guidance on use of secondary sources of petroleum products will be furnished by the Texas Railroad Commission where the total volume available will not meet the demand from essential users, essential facilities and consumers.

d. Local Authority

The local authority will determine allocations and priorities for consumers, essential facilities and essential users located within their jurisdictions in accordance with State policies.

e. Flow Chart (Petroleum Products)

Following is a flow chart showing the process and the actions to be taken by Federal, State and local governments to assure a continuing flow of petroleum products to meet essential needs in the State in a nuclear attack emergency. The Legend accompanying the chart identifies:

### PETROLEUM FLOW CHART

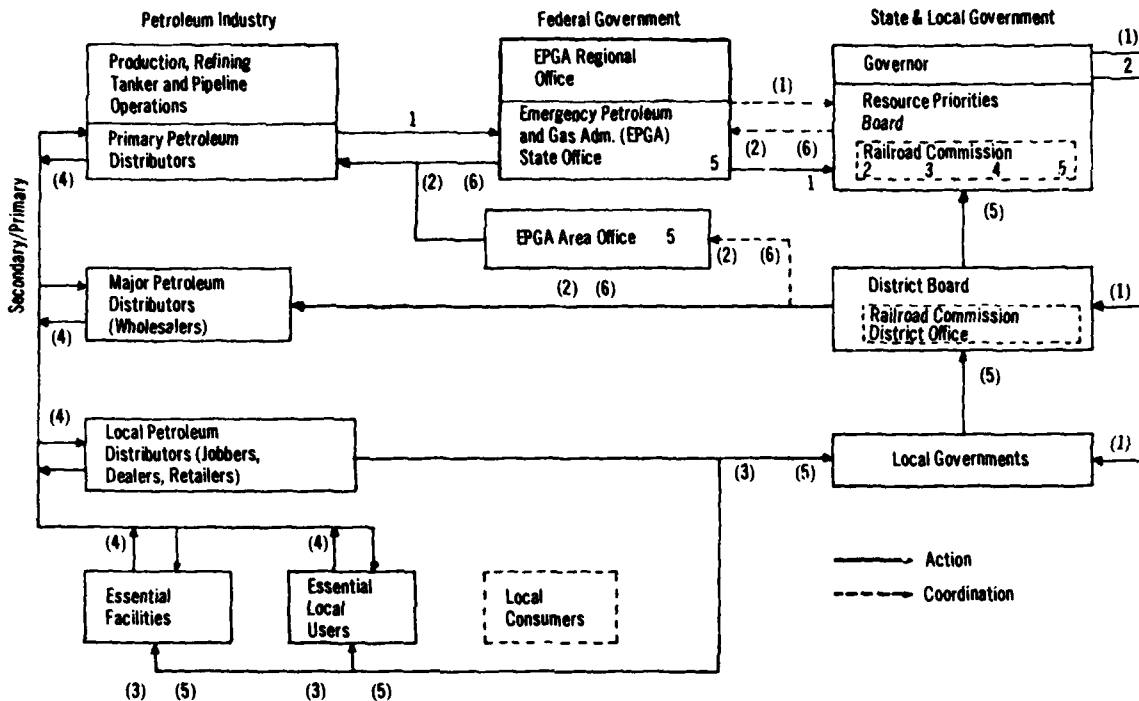

#### LEGEND FOR FLOW CHART

##### A. ACTIONS FOR IMMEDIATE SUPPLY

- (1) Issue State Petroleum Policy—list of essential petroleum items—list of essential petroleum facilities.
- (2) Authorize initial delivery quotas.
- (3) Enforce inventory freeze—authorize essential uses and deliveries—ration to consumers.
- (4) Place orders—resupply inventories—report shortages.
- (5) Anticipate local shortages—reduce local use—request State assistance.
- (6) Adjust delivery quotas.

##### B. ACTIONS FOR CONTINUING SUPPLY

- 1 Report deliveries—future delivery capabilities.
- 2 Estimate future requirements and supplies—adjust State petroleum policies.
- 3 Allocate future supplies to resource and claimant agencies.
- 4 Estimate petroleum industry requirements for supporting resources—present to appropriate State resource agencies.
- 5 Authorize primary petroleum facilities and major petroleum distributors to obtain supporting resources.

## GAS FLOW CHART Federal Government

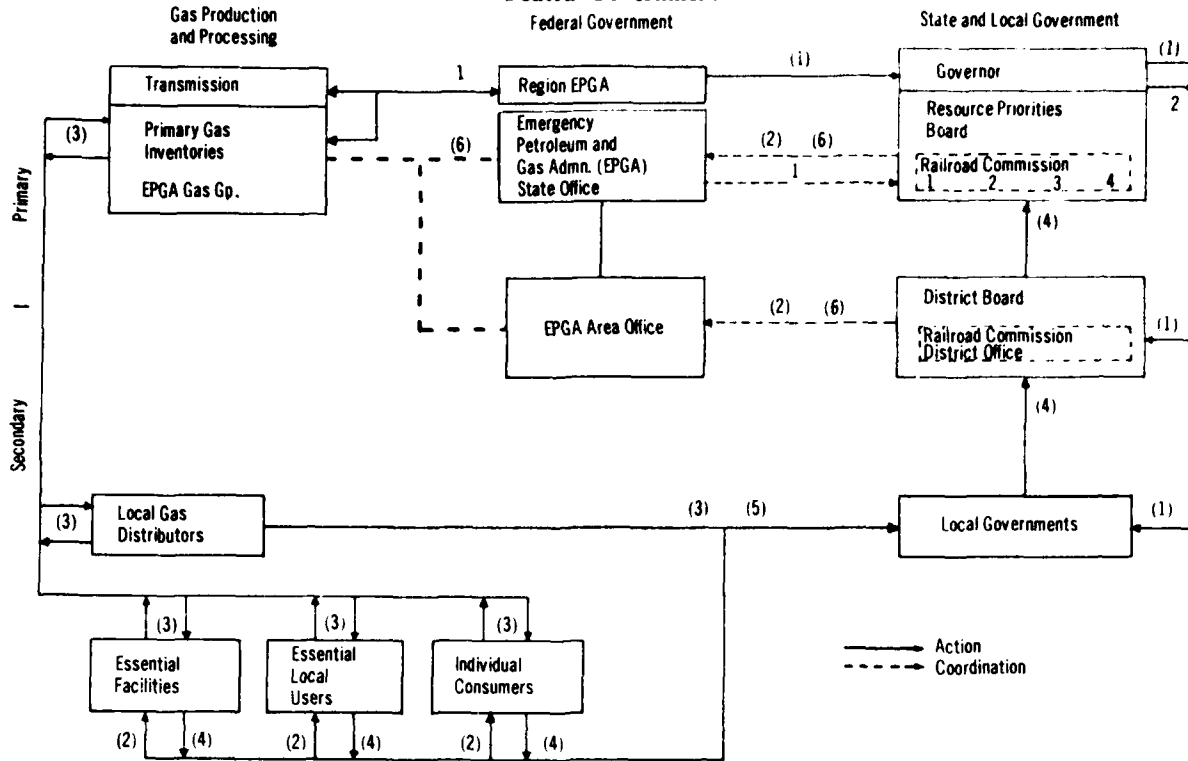

### LEGEND FOR FLOW CHART

#### A. ACTIONS FOR IMMEDIATE SUPPLY

- (1) Issue State Gas Policy—list of essential gas facilities.
- (2) Enforce curtailment order—authorize essential uses.
- (3) Resupply inventories—report shortages.
- (4) Anticipate local shortages—reduce local use—request State assistance.
- (5) Adjust usage levels.
- (6) Adjust supply quotas.

#### B. ACTIONS FOR CONTINUING SUPPLY

- 1 Estimate future requirements and supplies—adjust State Gas policies.
- 2 Estimate gas industry requirements for supporting resources—present to appropriate State resource agencies.
- 3 Allocate future supplies to resource and claimant agencies.
- 4 Authorize primary gas facilities to obtain supporting resources.

#### 6. Responsibilities:

##### a. State

- (1) The Texas Railroad Commission will be responsible for allocation of production allowable to the various oil and gas wells within the State of Texas. The Emergency Petroleum and Gas Administration will be responsible for informing the Texas Railroad Commission as to the desired total production allowable for Texas.
- (2) The Texas Railroad Commission will be responsible for the supervision and processing of drilling and recompletion applications within the State of Texas. The Emergency Petroleum and Gas Administration will be responsible for the establishment of recommended rules for the Texas Railroad Commission on utilization of materials and manpower.
- (3) The Texas Railroad Commission through their local representatives will exercise control over petroleum products, distribution from all secondary inventories not under military control, and those primary inven-

tories located within the State of Texas which by prior agreement have been preallocated to the State of Texas.

In exercising this control, the Texas Railroad Commission will be guided by policy directives defining essentiality of use (Annex D-DMO, 8500.1, Guidance on Priority Use of Resources in Immediate Postattack Period), and by directives from the Region 5 or Federal Emergency Petroleum and Gas Administrations relating to the utilization of such products.

- (4) The Texas Railroad Commission will be responsible for the supervision of execution of the Emergency Petroleum and Gas Plan in Texas and will maintain liaison with those sections of the industry over which they do not exercise direct control.
- (5) The Texas Railroad Commission will exercise the responsibilities assigned to the State Emergency Petroleum and Gas Administration as they pertain to the State of Texas in the event that that agency is not able to exercise these responsibilities.

#### b. Local Government

- (1) Local government will be responsible for the allocation of petroleum products from secondary inventories within its jurisdiction in accordance with priorities furnished by State authorities.
- (2) Local government will allocate to the most important emergency uses natural gas available to local utilities, assisting the local utility in informing their customers of the necessary curtailment, and resolving any conflicts between essential local users on the basis of policy directives providing priority guidance or relatively urgencies issued by the State government.

#### c. Industry

- (1) The oil and gas producing segments of the oil industry in Texas will be responsible for drilling, completing, and producing oil and gas wells in accordance with orders, directives, and allocations as set out by the Texas Railroad Commission.
- (2) The oil and products transmission companies within Texas will be responsible for transporting and delivering crude oil and products in accordance with the policies and directives furnished by the Emergency Petroleum and Gas Administration.
- (3) The gas transmission industry within Texas will be responsible for transporting and delivering natural gas in accordance with the directives received from their gas group headquarters.
- (4) The oil refining industry in Texas will be responsible for processing and producing petroleum products in accordance with policies and directives furnished by the Region 5 Emergency Petroleum and Gas Administration.
- (5) The natural gas processing plants in Texas will be responsible for processing natural gas and producing natural gas liquids in accordance with policies and directives furnished by the Region 5 Emergency Petroleum and Gas Administration.
- (6) The local gas utilities within Texas will be responsible for delivering gas to the consumers in the State of Texas in accordance with policies and directives issued by the local authorities.
- (7) The petroleum products distribution (bulk dealers) and liquids petroleum and gas distributors within Texas will be responsible for delivery of petroleum products to the local product sales or consumer in accordance with the policies and directions received from agents of the Texas Railroad Commission.
- (8) The local petroleum products sales (service stations) within Texas will be responsible for delivery of petroleum products to consumers in accordance with policies and directives received from the local authorities.
- (9) Normal means and methods of delivery will be utilized to the maximum.

#### 7. Emergency Actions:

##### a. Petroleum

The following actions are taken on behalf of the Governor at State and area levels by State petroleum officials to provide policies and guidance applicable throughout the State on the distribution and use of petroleum products and to arrange for resupply of secondary inventories from major wholesale and primary sources to meet essential local needs.

The emergency action and reference documents contained here have been prepared and placed with appropriate State and local officials during the preattack planning process.

##### (1) Actions for Immediate Supply

- (a) Issue, on behalf of the Governor, policies and guidance, applicable throughout the State covering the distribution and use of secondary inventories of petroleum products within the State. (Pet-1, State Petroleum Policy and Guidance, Appendix 1 to Annex B)
- (b) Confirm with the State office of the Emergency Petroleum and Gas Administration arrangements made with primary petroleum distributors to make deliveries on certified orders received from customers in the State. (Pet-2, Request for Release of Primary Inventories, Appendix 2 to Annex B)
- (c) Area offices of the State petroleum organization confirm arrangements with major petroleum distributors (wholesalers) for initial delivery, pursuant to initial quotas, to communities in their distribution areas and authorize them to certify orders on suppliers to resupply their inventories. (Pet-3, Release and Resupply of Major Wholesale Inventories, Appendix 3 to Annex B)
- (d) Arrange with major petroleum distributors for adjustments of delivery quotas to meet local shortages in petroleum supplies reported by local governments. (Pet-4, Adjustment of Delivery Quotas, Appendix 4 to Annex B)
- (e) Request the State office of the Emergency Petroleum and Gas Administration to arrange for increases where needed in delivery quotas of primary petroleum distributors to resupply wholesale and local inventories to meet shortages reported by local governments. (Pet-5, Adjustment of Primary Distributor Delivery Quotas, Appendix 5 to Annex B)

##### (2) Actions for Continuing Supply

As soon as resupply of secondary inventories to meet essential immediate needs in the localities is well underway the State petroleum organization takes the following actions to anticipate continuing needs and to arrange for continuing supply to meet these needs.

- (a) Consult with State civil defense supply officials, Emergency Petroleum and Gas Administration military officials, and appropriate State resource officials to esti-

mate continuing requirements of petroleum products that will be needed in the State during the ensuing 90-day period. (Pet-6, Estimate of Continuing Petroleum Requirements, Appendix 6 to Annex B)

- (b) Obtain from the Emergency Petroleum and Gas Administration estimates of quantities of petroleum products that can be supplied by primary petroleum distributors for continuing use in the State during the ensuing 90-day period.
- (c) If anticipated supplies are inadequate to meet the estimated requirements and adjustments in requirements cannot be negotiated, refer to the Resource Priorities Board for recommendations to the Governor on the allocation of anticipated supplies among competing programs. (Pet-7, Allocation of Petroleum Supplies, Appendix 7 to Annex B)
- (d) Issue revised State policies on the use of petroleum in the State to conform with the Governor's decision. (Pet-8, Revised State Petroleum Policy, Appendix 8 to Annex B)
- (e) Consult with the Emergency Petroleum and Gas Administration and develop estimates of continuing requirements for electric power, for manpower, for transportation, and for other operating supplies, equipment, and services that will be needed to maintain operations of essential petroleum facilities in the State during the ensuing 90-day period. Present these requirements estimates to appropriate State resource organizations. (Pet-9, Petroleum Industry Support Requirements, Appendix 9 to Annex B)
- (f) Consult with the Emergency Petroleum and Gas Administration and develop estimates of emergency repair and construction of essential petroleum facilities that will be required during the ensuing 90-day period and present these requirements estimates to the State construction organization. (Pet-10, Petroleum Industry Construction Requirements, Appendix 10 to Annex B)
- (g) Inform the Emergency Petroleum and Gas Administration State office of supplies of supporting resources that will be available in the State for acquisition and use by the primary petroleum industry to maintain essential operations during the ensuing 90-day period. (Pet-11, Allocation of Supporting Resources to Primary Petroleum Industry, Appendix 11 to Annex B)
- (h) Authorize major petroleum distributors (wholesalers) to certify purchase orders to obtain specified quantities of supporting resources and services during the ensuing 90-day period. (Pet-12, Authorization to Major Petroleum Distributors to Obtain Supporting Resources, Appendix 12 to Annex B)

## b. Gas

The following actions are taken on behalf of the Governor at State and area levels by State gas officials to provide policies and guidance applicable throughout the State on the distribution and use of gas and to arrange for resupply of secondary inventories from primary sources to essential local needs.

The emergency action and reference documents contained here have been prepared and placed with appropriate State and local officials during the preattack planning process.

### (1) Actions for Immediate Supply

- (a) Issue, on behalf of the Governor, policies and guidance, applicable throughout the State covering the provision, distribution and use of secondary inventories of gas supplies within the State. (Gas-1, State Gas Policy and Guidance, Appendix 13 to Annex B)
- (b) Arrange with the Emergency Petroleum and Gas Administration for adjustments in deliveries from primary sources to meet local shortages in gas supplies as reported by local governments. (Gas-2, Adjustment of Delivery Quotas, Appendix 14 to Annex B)

### (2) Actions for Continuing Supply

As soon as resupply of secondary inventories to meet essential immediate needs in the localities is underway, the State gas organization takes the following actions to anticipate continuing needs and to arrange for continuing supply to meet these needs.

- (a) Consult with State civil defense supply officials, Federal military officials and appropriate State resource officials to estimate continuing requirements of gas that will be needed in the State during the ensuing 90-day period. (Gas-3, Estimate of Continuing Gas Requirements, Appendix 15 to Annex B)
- (b) Obtain from Emergency Petroleum and Gas Administration estimates of quantities of gas that can be supplied from primary sources for continuing use in the State during the ensuing 90-day period.
- (c) If anticipated supplies are inadequate to meet the estimated requirements and adjustments in requirements cannot be negotiated, refer to the Resource Priorities Board for recommendations to the Governor on the allocation of anticipated supplies among competing programs. (Gas-4, Allocation of Gas Supplies, Appendix 16 to Annex B)
- (d) Issue revised State policies on the use of gas in the State to conform with the Governor's decision. (Gas-5, Revised State Gas Policy, Appendix 17 to Annex B)
- (e) Consult with the Emergency Petroleum and Gas Administration and develop estimates of continuing requirements for

electric power, manpower, transportation, petroleum products, and solid fuels and other operating supplies, equipment, and services that will be needed to maintain operation of essential gas facilities in the State during the ensuing 90-day period. Present these requirements estimates to appropriate State resource organizations. (Gas-6, Gas Industry Support Requirements, Appendix 18 to Annex B)

- (f) Consult with the Emergency Petroleum and Gas Administration and develop estimates of emergency repair and construction of essential gas facilities that will be required during the ensuing 90-day period and present these requirements estimates to the State construction organization. (Gas-7, Gas Industry Construction Requirements, Appendix 19 to Annex B)
- (g) Inform the Emergency Petroleum and Gas Administration State office of supplies of supporting resources that will be available in the State for acquisition and use by the primary gas industry to maintain essential operations during the ensuing 90-day period. (Gas-8, Allocation of Supporting Resources to Primary Gas Industry, Appendix 20 to Annex B)

c. Liquefied Petroleum Gas

(1) Function and Purpose

- (a) The function and purpose of the Liquefied Petroleum Gas (LP-Gas) Division is the development and enforcement of safety rules and regulations pertaining to the storage, transportation and dispensing of liquefied petroleum gas and the installation of related equipment which will protect or tend to protect the health, welfare and safety of the general public. The LP-Gas Division does not have jurisdiction over refineries, railroad tank cars or pipeline companies.
- (b) The LP-Gas Division has a part of its responsibility, records and information on LP-gas tank location, size ownership and classification of various installations including registration of all LP-gas truck and transport units, emergency standby fuel systems for large commercial and industrial installations, schools, hospitals and public installations when LP-gas is used.

(2) Readiness

- (a) The LP-Gas Division has 13 field inspectors (see Tab 3, LP-Gas Districts) located throughout the state, which if aware of a potential disaster, could assist in giving warnings through areas involved by use of two way radio communication systems installed at most LP-gas licensee's base station and on LP-gas trucks. This same system could be used to dispatch a field inspector to problem areas involving the consuming public.
- (b) The LP-Gas Division has a mobile van emergency unit which contains gas detecting and sensing equipment. This emergency unit could be dispatched from the Austin base to any disaster area as a command post from which the field inspector can be dispatched by two way radio. Each field inspector is equipped with a State automobile which could be used to evacuate or transport injured.

(3) Emergency Operations

The LP-Gas Division, during actual emergencies, could provide information in crisis relocation of population situations as well as advise fire fighting personnel and DPS personnel in handling LP-gas emergencies. They can also render areas involved, safe after an accident or disaster.

(4) Recovery Operations

- (a) The LP-Gas Division district inspectors can assess damage, supervise repairs and restore gas systems. The Division director could coordinate efforts of the LP-gas dealers to meet demands of disaster area for bottle gas. An ample supply is on hand and could be tapped from storage inventory through an area and transported to the disaster. Portable heaters, stoves, tanks and piping could also be supplied.
- (b) All repairs found necessary to damaged containers, tanks and LP-gas equipment would be channeled back to a licensed fabricator for repairs through the LP-Gas Division inspection reports.



ANNEX A  
ORGANIZATION

1. National

- a. The agency having responsibility for execution and supervision of the emergency petroleum and gas operations within the United States is the Emergency Petroleum and Gas Administration (EPGA).
- b. The agency having responsibility for execution and supervision of the emergency solid fuels operations within the United States is the Emergency Solid Fuels Administration (ESFA).

2. Region 5

The agency having responsibility for supervision and execution of emergency petroleum, gas and solid fuels operations within Region 5 (Arkansas, Louisiana, New Mexico, Oklahoma and Texas) is the Region 5 Emergency Petroleum and Gas Administration (REPGA) and Emergency Solid Fuels Administration (RESFA).

3. State

- a. Within the State of Texas, the Texas Railroad Commission will be responsible for the supervision and execution of the Emergency Petroleum and Gas Plan as it pertains to production and gathering of oil and gas and to the distribution and sale of petroleum products and gas as outlined under "Responsibilities". The Texas State Emergency Petroleum and Gas Manager will be responsible for supervision and execution of the Texas Emergency Petroleum and Gas Plan as it pertains to allocation of petroleum products from primary inventories.
- b. Reference documents include:
  - (1) A list of primary petroleum storage installations together with locations, normal inventories and names of operators, this list developed and maintained current through informal consultation of Office of Oil and Gas officials. State authorities and operators of primary storage facilities; and
  - (2) A list of major wholesale distributors of petroleum products compiled and maintained in like manner. Those supplies in a primary petroleum facility which are normally distributed as secondary inventories should be included in the listing of primary petroleum inventories because in an emergency they will be made available to State officials for distribution as secondary inventories. These supplies are noted for consideration as secondary inventories even though located in a primary inventory facility.

4. Local

The agency responsible for the execution of that part of the plan pertaining to allocation, certification and rationing is the local authority.

5. Local Emergency Petroleum and Gas Administrations will be established in districts as shown on map at Tab 1.

6. Gas Groups

- a. To facilitate the transmission of natural gas, the transmission systems of the United States have been divided into nine (9) operating groups called Gas Group Areas which are based on marketing areas served. An EPGA Gas Group Office has been established in each area and charged in an emergency with the direction and control of the transmission systems comprising the Group, subject to the authority of an appropriate EPGA Regional Office.
- b. Gas Group 4 will be responsible for the operation of gas transmission and distribution in those counties in East and South Texas as indicated on map at Tab 1.
- c. Gas Group 5 will be responsible for the operation of gas transmission and distribution in those counties as indicated on map at Tab 1.
- d. Gas Group 7 will be responsible for the operation of gas transmission and distribution in Dallam, Hartley and Sherman Counties.
- e. Gas Group 8 will be responsible for the operation of gas transmission and distribution in El Paso and Hudspeth Counties.

7. Industry

Each of the segments of the petroleum and gas industries within the State of Texas will, within their capabilities, produce, transport, process, refine and manufacture quantities of their products or services to meet essential needs in accordance with the orders and directives of the Federal, State and local authorities assigned responsibility for their area of capability.

GAS GROUP 7

Tab 1

**OIL AND GAS DIVISION  
RAILROAD COMMISSION OF TEXAS**

GAS GROUP 5

GAS GROUP 8

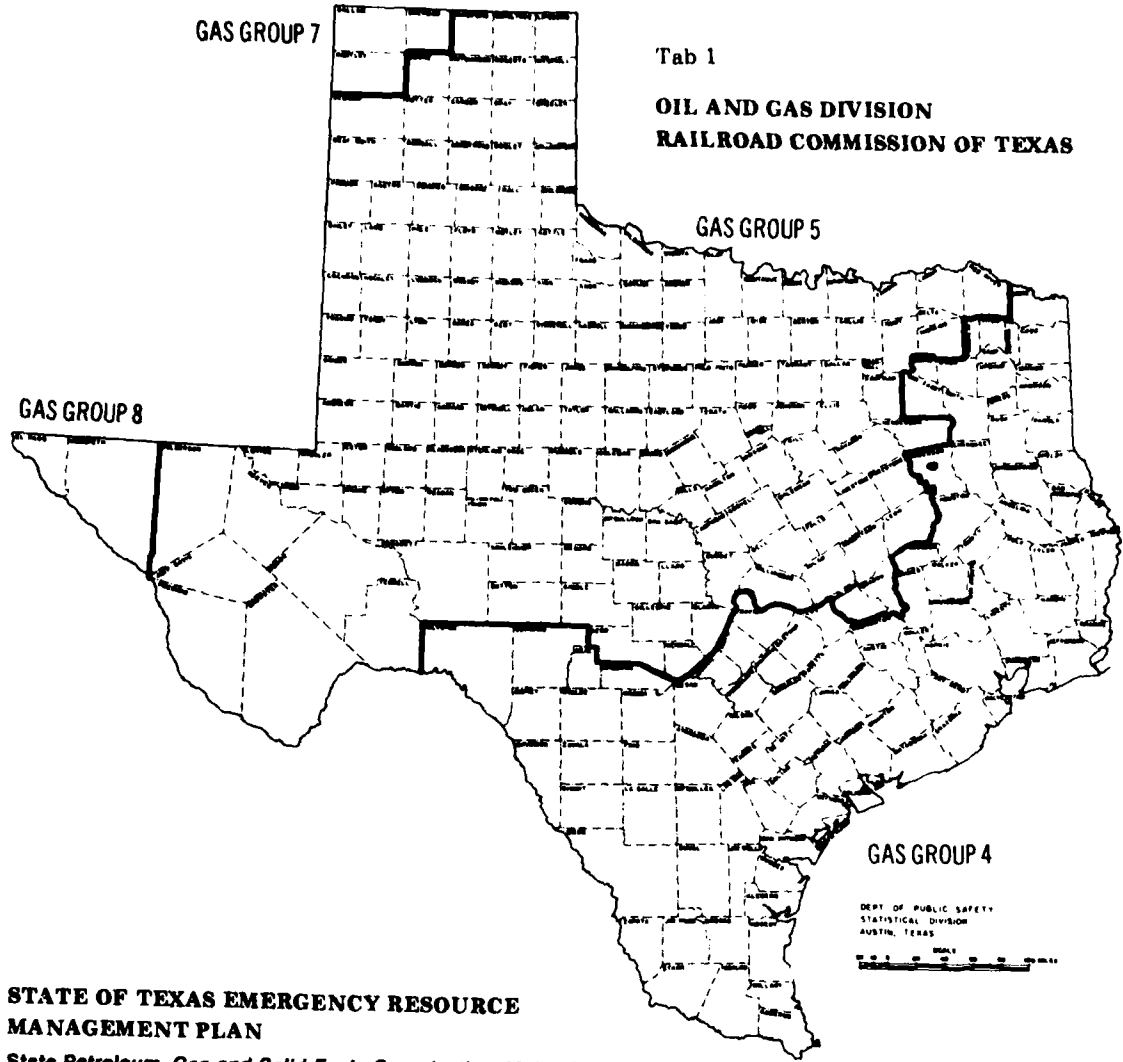

**STATE OF TEXAS EMERGENCY RESOURCE  
MANAGEMENT PLAN**

State Petroleum, Gas and Solid Fuels Organization-Major Functions

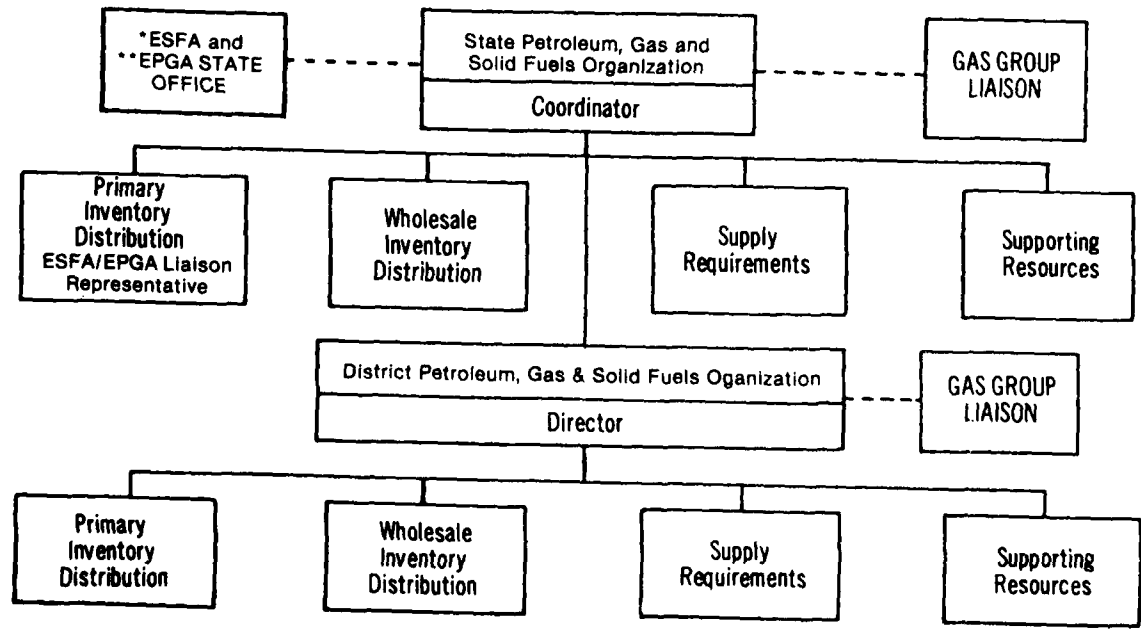

\* Emergency Solid Fuels Administration  
\*\* Emergency Petroleum and Gas Administration

**APPENDIX 1 TO ANNEX A  
DISTRICT ORGANIZATION**

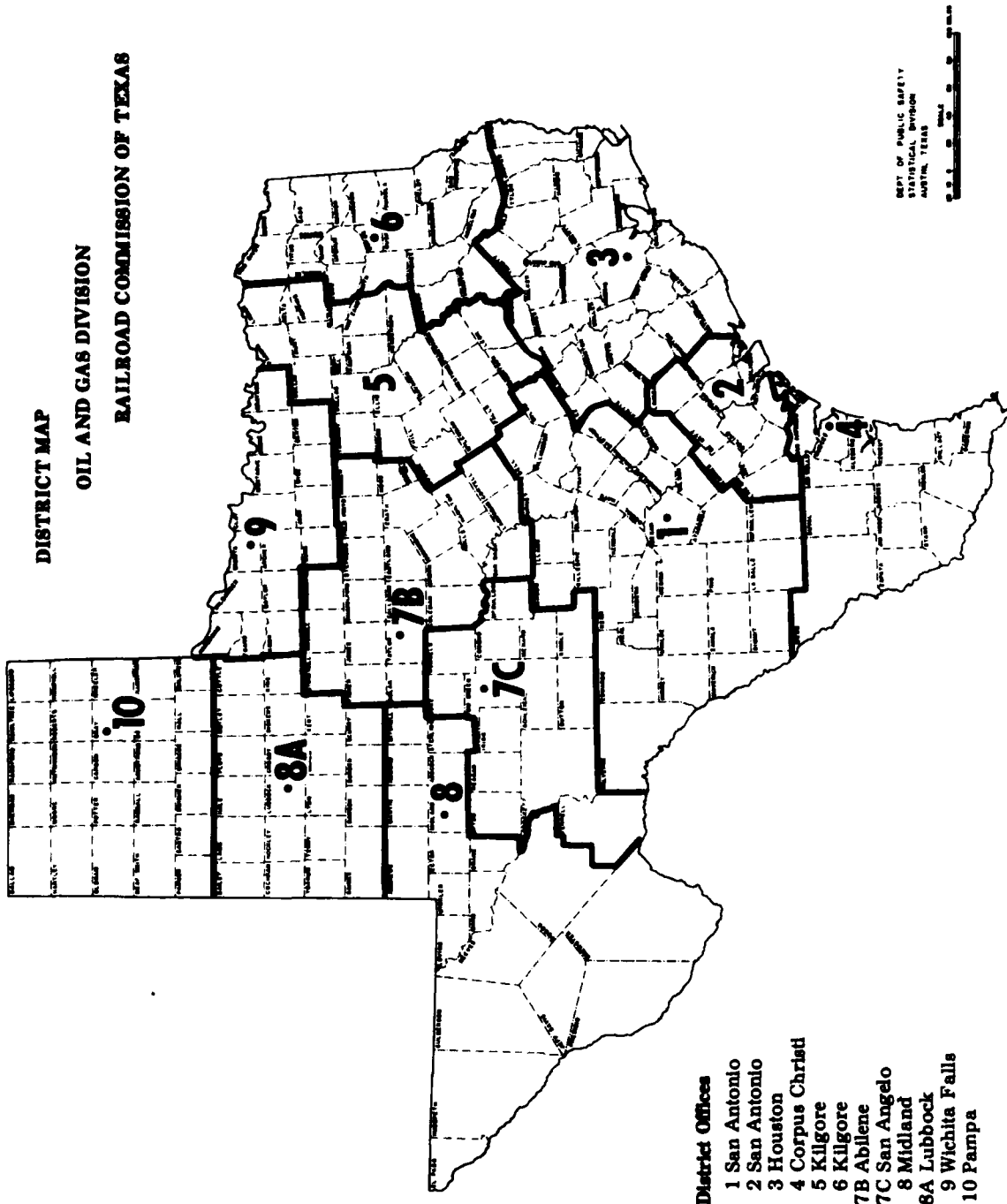

B-V-A-3

Tab 2

DISTRICT MAP  
LIQUEFIED PETROLEUM GAS DIVISION  
RAILROAD COMMISSION OF TEXAS

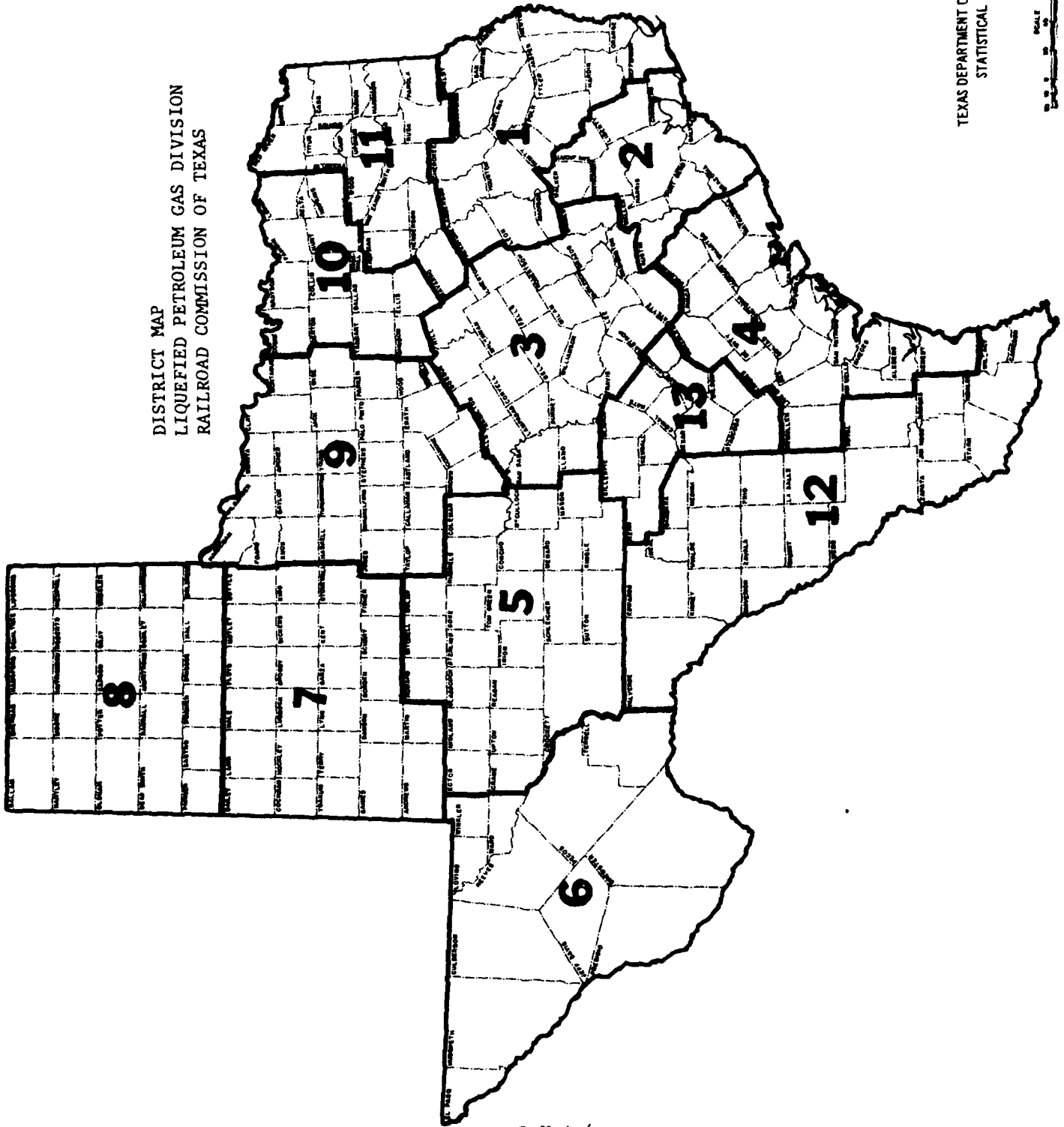

TEXAS DEPARTMENT OF PUBLIC SAFETY  
STATISTICAL SERVICES



B-V-A-4  
Tab 3

URANIUM MINING OPERATIONS  
STATE OF TEXAS

SURFACE MINING AND  
RECLAMATION DIVISION

RAILROAD COMMISSION OF TEXAS

<u>NAME OF MINE</u>	<u>LOCATION</u>
Site 1 (Thomas-Knandel-Dybowski)	Gonzales County
Site 2 (Winerich)	Karnes County
Site 3 (Kotzur)	Karnes County
Site 4 (Fort Worth National Bank)	Karnes County
Site 5 (Rosenbrock-Carmody)	Karnes County
Site 6 (Moczygmba)	Karnes County
Site 7 (Hurt)	Atascosa County
Site 8 (House-Seale-Taylor)	Live Oak County
Site 9 (Zamsow)	Karnes County
Site 10 (Labus-Hoffman)	Karnes County
Site 11 (Franklin-Swiere)	Karnes County
Site 12 (Nieschwietz)	Karnes County
Site 13 (Dichson-Pawelek)	Karnes County
Site 14 (Garcia)	Karnes County
Site 15 (Korth-Hartmann-Finch)	Karnes County
Site 16 (Steinmann-Lotta-Swanson)	Karnes County
Site 17 (Smith)	Gonzales County
Site 18 (Griffin)	Gonzales County
Site 21 (House)	Live Oak County
Site 22 (Knispel-Vaughn-Taylor)	Live Oak County
Site 23 (Korzechwa-Nieschwietz)	Karnes County
Site 24 (S. Dzuik)	Karnes County
Site 25 (Banduch-Cochran)	Karnes County
Site 26 (Dzuik-Lysey)	Karnes County
Site 27 (Dobie)	Live Oak County
Site 28 (Chapman)	Live Oak County
Site 30 (Weddington)	Karnes County
Site 31 (Sickanius)	Karnes County
Site 32 (Pawelek-Lysey-Butler)	Karnes County
Mill (Mill Site)	Karnes County

RAILROAD COMMISSION OF TEXAS  
Surface Mining and Reclamation Division

COAL MINING OPERATIONS

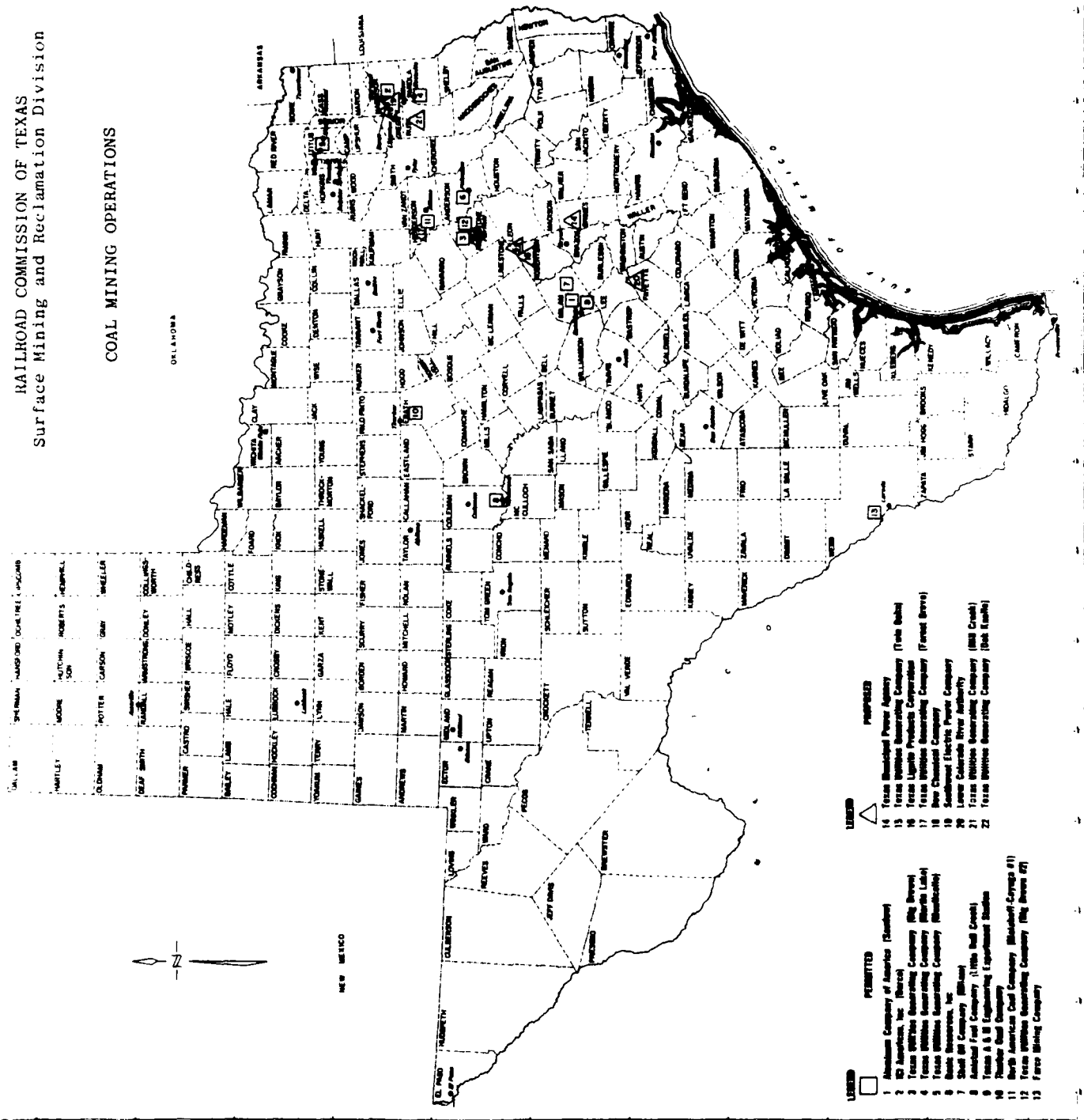

B-V-A-6  
Tab 5

**ANNEX B  
EMERGENCY ACTION DOCUMENTS**

Following are emergency action documents to implement the emergency actions directed in paragraph 4, basic document.

During the process of expediting deliveries to meet urgent local needs, the quickest means of communication between levels of government and with industry will be used. The suggested forms illustrate the kind of information to be transmitted over telephone or other available means of fast communication.

---

**APPENDIX 1 TO ANNEX B**

**Pet-1, State Petroleum Policy and Guidance**

**To: Heads of Political Subdivisions**

**Guidance for Local Governments.** It is essential that petroleum products available for use in this State be carefully conserved and restricted to immediate and urgent uses for local, State, and National survival and recovery until the continuing supply of petroleum products can be assessed and the supplies that will be available for less essential needs can be determined.

In order to (1) prevent waste and dissipation of petroleum products in local secondary inventories, (2) provide supplies of petroleum products to meet immediate and urgent needs, (3) assure continuing resupply of local secondary inventories of petroleum products, and (4) ration petroleum products to meet most essential needs of individual consumers, appropriate officials of local government are requested to take the following actions:

1. Announce and enforce temporary freeze on inventories of local secondary distributors of petroleum products (jobbers, dealers, retailers).
2. Provide instructions to secondary distributors on how to release inventories to meet essential needs.
3. Authorize essential local users to obtain immediate and urgent supplies of petroleum products from secondary distributors.
4. Authorize essential facilities to certify purchase orders for petroleum products needed to maintain their operations. Instruct essential facilities to place these certified orders on their customary sources of supply. (Local governments have been provided by the State with a list of the essential facilities located in their jurisdictions.)
5. As soon as possible, ration petroleum products to individual consumers and inform these individual consumers how to obtain supplies under the ration system. (Procedures prescribed in Section II (Economic Stabilization).)
6. Inform local secondary distributors of petroleum products of their roles under the ration system.

In the event resupply from major wholesale distributors or primary distributors of petroleum products is not adequate to meet all essential needs, local governments should decide and cut back authorized local uses. Concurrently they should report shortages and request appropriate officials of State government to take actions to increase the local supply of petroleum products.

(Effective Date)

(Name)

\_\_\_\_\_  
Governor of the State of Texas

By: \_\_\_\_\_

(Signature)

State Petroleum Coordinator

**Pet-1, Attachment 1**

**Background Information**

The Governor has issued general policy on the use of essential resources in the immediate post-attack period. These policies are set forth in Part A of the State plan. They have been furnished to appropriate officials of the political subdivisions of the State.

In general, these State policies provide for temporary freezing of retail inventories of essential items and immediate and continuing releases of these items to meet urgent military and civil defense needs and to maintain operation of facilities essential to continued survival and recovery. They provide for continuing resupply of local secondary inventories as well as inventories of essential facilities which obtain their supplies from wholesale and primary sources.

In addition, the Governor has issued a proclamation requesting the executive heads of the political subdivisions in this State to provide resources from locally available supplies to carry on immediate and urgent activities for survival and to maintain the operation of essential facilities. In accordance with this direction from the Governor, local governments are requested to inform essential users of resources and persons engaged in the operation of essential facilities how to identify their purchase orders, contracts, and other purchase arrangements to obtain deliveries of supplies and services.

Attached to this section of the State plan is a list of essential petroleum facilities that must continue in operation to assure an adequate flow of petroleum products for local, State and national survival and recovery. Names and addresses of these facilities located in the political subdivisions have been provided to the local governments concerned.

Local governments, upon attack, notify the management of these facilities to certify their purchase orders and contracts to obtain production materials, capital equipment, and maintenance, repair, and operating supplies or to place contracts for essential repair and construction as follows:

1. Essential petroleum facilities use the following State certification to identify:
  - a. purchase orders for supplies of electric power, gas, and transportation services, and
  - b. construction contracts for repair and construction of facilities.

"This is an essential order  
authorized by the State of Texas

\_\_\_\_\_  
(Signature of purchaser)"

2. Essential petroleum facilities identify their purchase orders in accordance with the rating and certification provisions of Federal emergency regulations issued by the Business and Defense Services Administration of the U. S. Department of Commerce upon attack, for supplies of production materials, capital equipment, and other maintenance, repair, and operating supplies. The State production organization publicizes and makes known these Federal regulations to local governments and industry immediately following an attack.

Retail and wholesale distributors use the State certification on purchase orders to supply their inventories from primary petroleum distributors.

**Essential Users:**

- (1) Individuals, both civilian and military, engaged in producing or providing essential items, products, care or services, e.g., doctors providing professional medical diagnoses, treatment and services; farmers producing essential food; military personnel engaged in immediate retaliatory or defense operations.
- (2) Organizations or establishments engaged in essential activities or providing essential items or services.

**Essential Facilities:**

- (1) Military establishments engaged in immediate retaliatory or defense operations;
- (2) Electric power, gas and water utility systems;
- (3) Industrial plants producing or processing essential items;
- (4) Major wholesale establishments storing or distributing essential items; and
- (5) Transportation or communication systems providing essential services.

**Individual Consumers:**

Individuals who depend on local distribution systems (retailers and dealers) for essential supplies for individual and family use.



**APPENDIX 2 TO ANNEX B**

**Pet-2, Request for Release of Primary Inventories**

To: Regional or State Office of the Emergency Petroleum and Gas Administration

Local governments in this State, in accordance with State policies and guidance, have identified essential local users and essential facilities in their jurisdictions and authorized them to certify their purchase orders for petroleum products with the following certification:

"This is an emergency order  
authorized by the State of Texas

\_\_\_\_\_  
(Signature of Purchaser)"

Retail and wholesale petroleum distributors have been instructed to accept and make deliveries to fill these certified orders. They have in turn been authorized to use this same certification on their purchase orders to resupply their inventories.

You are requested to arrange with primary distributors of petroleum products for acceptance and deliveries against these State-certified orders within the quantities of petroleum products in their inventories that are available for use in this State.

\_\_\_\_\_  
(Effective Date)

\_\_\_\_\_  
(Signature)

State Coordinator or Area Petroleum Director  
State of Texas

**APPENDIX 3 TO ANNEX B**

**Pet-3, Release and Resupply of Major Wholesale Inventories**

To: \_\_\_\_\_  
(Name of Wholesale Petroleum Distributor)

Local governments in this State, in accordance with State policies and guidance, have identified essential local users and essential facilities in their jurisdictions and authorized them to certify their purchase orders for petroleum products with the following certification:

"This is an emergency order  
authorized by the State of Texas

\_\_\_\_\_  
(Signature of purchaser)"

Retail petroleum distributors have been instructed to accept and make deliveries to fill these certified orders and to use the same certification on their purchase orders to resupply their inventories.

You are to accept and make deliveries against these State-certified orders subject to the quotas governing your deliveries to the separate localities in your distribution area. You are prohibited from making deliveries on any other orders that do not bear this State certification.

Initially you will establish local delivery quotas on the basis of the percentage of your inventory delivered to the separate localities during the week immediately preceding the attack. At the end of ten (10) days after the attack you will release reserved inventories under these local quotas to fill certified orders received from other localities.

You will receive from time to time directions from the State or Area Petroleum Directors to adjust your deliveries to meet shortages reported in particular localities.

You are authorized to use the certification contained herein to certify your purchase orders on primary petroleum distributors to resupply your inventories.

If you are unable to obtain adequate resupply to meet certified orders placed on you, notify this office promptly.

\_\_\_\_\_  
(Effective Date)

\_\_\_\_\_  
(Signature)

State Coordinator or Area Petroleum Director  
State of Texas



## APPENDIX 5 TO ANNEX B

### Pet-5, Adjustment of Primary Distributor Delivery Quotas

To: Regional or State Office of the Emergency Petroleum and Gas Administration

Shortages in petroleum supplies are being reported by local governments in this State.

You are requested to arrange with primary petroleum distributors to increase their delivery quotas to meet certified orders received from customers in this State.

Following is an estimate of the increased amounts of petroleum products in primary inventories that will be needed to meet essential needs in the State.

#### Request for Adjustment of Primary Petroleum Distributor Delivery Quotas

The following increases in deliveries from primary distributors are requested:

(See Chart in Pet-4)

---

## APPENDIX 6 TO ANNEX B

### Pet-6, Estimate of Continuing Petroleum Requirements

Forms 1 and 2 attached to this emergency action document contain data on quantities of petroleum products that will be required in this State for a 90-day period commencing \_\_\_\_\_ (date) \_\_\_\_\_.

The requirements stated include the quantities of petroleum products to be supplied by major petroleum distributors (wholesalers) and local petroleum distributors (jobbers, dealers, and retailers) to fill authorized orders of essential users, essential facilities, and consumers under the consumer rationing system.

These requirements do not include quantities of petroleum products needed by essential facilities such as large military installations and bases and large industrial facilities that obtain their requirements directly from primary petroleum distributors. These latter requirements are the responsibility of the EPGA. Procedures for claims, allocations, and supply arrangements are included in the emergency plans of the EPGA.

The purpose of these State requirements estimates is to determine and anticipate quantities of petroleum products needed from primary sources under Federal jurisdiction to resupply secondary distributors under State and local government jurisdiction.

#### Definitions

"Civilian Requirements" include the petroleum products needed to carry on emergency civil defense operations, to maintain essential local activities, and to supply individual consumers under the consumer rationing system. These civilian requirements estimates are provided by appropriate civil defense officials.

"Military Requirements" include the petroleum products needed to carry on military activities and to maintain and operate military installations and equipment. They include only the supplies that are to be obtained from wholesale and retail distributors. These military requirements estimates are provided by appropriate military officials.

"Resource Support Requirements" include the petroleum products needed to maintain operation of essential facilities under the cognizance of Federal and State resource organization functioning in the State. These support resource requirements are provided by appropriate State resource organizations.

**Pet-6, Form 1**

Summary Estimate of Continuing Requirements for Petroleum Products for 90-Day Period, Commencing _____ (date) _____ (in gallons)					
Requirement Categories	Gasoline	Distillates	Kerosene	Lube Oils and Greases	Residual Fuel Oils
Civilian 90 days					
First 30 Days					
Following 60 Days					
Military 90 Days					
First 30 Days					
Following 60 Days					
Supporting Resource Requirements 90 Days					
First 30 Days					
Following 60 Days					
Grand Total 90 Days					
First 30 Days					
Following 60 Days					

**Pet-6, Form 2**

Estimate of Continuing Supporting Resource Requirements for Petroleum Products By Resource Program for 90-Day Period Commencing _____ (date) _____ (in gallons)					
Resource Programs	Gasoline	Distillates	Kerosene	Lube Oils and Greases	Residual Fuel Oils
Production 90 Days					
First 30 Days					
Following 60 Days					
Transportation 90 Days					
First 30 Days					
Following 60 Days					
Etc.					
Grand Total 90 Days					
First 30 Days					
Following 60 Days					

**APPENDIX 7 TO ANNEX B**

**Pat-7, Allocation of Petroleum Supplies, Form 1**

Allocation of Expected Continuing Supplies of Petroleum Products for 90-Day Period Commencing _____ (date) _____ (in gallons)					
Major Use Categories	Gasoline	Distillates	Kerosene	Lube Oils and Greases	Residual Fuel Oils
<b>Civilian 90 Days</b>					
First 30 Days					
Following 60 Days					
<b>Military 90 Days</b>					
First 30 Days					
Following 60 Days					
<b>Supporting Resource Requirements 90 Days</b>					
First 30 Days					
Following 60 Days					
<b>Total 90 Days</b>					
First 30 Days					
Following 60 Days					

**Pet-7-Allocation of Petroleum Supplies, Form 2**

Allocation of Expected Continuing Supplies of Petroleum Products by Resource Program for 90-Day Period Commencing _____ (date) _____ (in gallons)					
Resource Programs	Gasoline	Distillates	Kerosene	Lube Oils and Greases	Residual Fuel Oils
Production 90 Days					
First 30 Days					
Following 60 Days					
Transportation 90 Days					
First 30 Days					
Following 60 Days					
Etc.					
Grand Total 90 Days					
First 30 Days					
Following 60 Days					

**APPENDIX 8 TO ANNEX B**

**Pet-8, Revised State Petroleum Policy**

(Note: The content and substance of the revised petroleum policy will depend on the situation and the supplies expected to be available to meet continuing essential needs. Necessarily, this document will not be completed except in a test of the plan or at the appropriate point in a postattack situation.)

This document will be, in essence, a Revised Pet-1, State Petroleum Policy and Guidance, contained here.

**APPENDIX 9 TO ANNEX B**

**Pet-9, Petroleum Industry Support Requirements**

Estimate of Petroleum Industry Support Requirements For 90-Day Period Commencing _____ (date) _____.				
Resource	Unit of Measure	First 30 Days	Following 60 Days	Total 90 Days
Electric Power				
Water				
Transportation				
Gas				

**APPENDIX 10 TO ANNEX B**

**Pet-10, Petroleum Industry Construction Requirements**

To: State Construction Organization

Following is a list and description of major construction, repair, and modification of facilities that will be required to maintain desired production and distribution of petroleum products during the 90-day period commencing \_\_\_\_\_ (date) \_\_\_\_\_.

**Construction Projects**

1. Name, location, type, and size of construction project; start and completion dates.

(If project is underway or a construction contract has been prepared, attach a copy of the contract document and summary bill of materials.)

2.

3.

4.

**APPENDIX 11 TO ANNEX B**

**Pet-11, Allocation of Supporting Resources to Primary Petroleum Industry**

To: Emergency Petroleum and Gas Administration

Attached is a list and the quantities of supporting resource have been allocated for maintaining essential operations of primary petroleum facilities.

This is furnished as a basis for authorizing these facilities to obtain continuing supplies of these resources during the allocation period.

(Attach list.)

**APPENDIX 12 to ANNEX B**

**Pet-12, Authorization to Major Petroleum Distributors to Obtain Supporting Resources**

To: (Name of Major Petroleum Distributor)

You are hereby authorized to obtain the supporting resources in the quantities specified in the attached list.

Resource	Unit of Measure	First 30 Days	Following 60 Days	Total
Electric Power				
Water				
Transportation				
Gas				

In placing orders or in making commitments for continuing supplies of the above supporting resources, you are authorized to use the following certification:

"This is an essential order authorized by the State Petroleum Coordinator.

(signed)  
\_\_\_\_\_  
(Purchaser)

(signed)  
\_\_\_\_\_  
State Petroleum Coordinator

**APPENDIX 13 TO ANNEX B**

**Gas-1, State Gas Policy and Guidance**

To: Heads of Political Subdivisions

**Guidance for Local Governments.** It is essential that gas available for use in this State be carefully conserved and restricted to immediate and urgent uses for local, State, and National survival and recovery until the continuing supply of gas can be assessed and the supplies that will be available for less essential needs can be determined.

In order to (1) prevent waste and dissipation of gas in local secondary inventories, (2) provide supplies of gas to meet needs of essential local users and to maintain operation of essential facilities, (3) meet minimum gas needs of individual consumers, and (4) assure continuing re-supply of local secondary inventories of gas, appropriate officials of local governments are requested to take the following actions:

1. Curtail nonessential and unsafe local use of gas. (Attachment 2)
2. Enforce priorities on local use of gas. (Attachment 3)

In the event gas supply is not adequate to meet all essential local needs, local governments will decide and cut back authorized local uses. Concurrently, they will report local shortages and request appropriate officials of State government to take actions to increase the supply of gas to the local jurisdictions.

(Effective Date)  
\_\_\_\_\_

(Name)  
\_\_\_\_\_  
Governor of the State of Texas

By: \_\_\_\_\_  
(Signature)  
State Gas Coordinator



**Gas-1, Attachment 1**

**Background Information**

The Governor has issued general policy on the use of essential resources in the immediate post-attack period. These policies are set forth in Part A of the State Plan. They have been furnished to appropriate officials of the political subdivisions of the State.

In general, these State policies provide for temporary freezing of retail inventories of essential items and immediate and continuing release of these items to meet urgent military and civil defense needs and to maintain operations of facilities essential to continued survival and recovery. They provide for continuing resupply of local secondary inventories as well as inventories of essential facilities which obtain their supplies from wholesale and primary sources.

In addition, the Governor has issued a proclamation requesting the executive heads of the political subdivisions in this State to provide resources from locally available supplies to carry on immediate and urgent activities for survival and to maintain the operation of essential facilities. In accordance with this direction from the Governor, local governments are requested to inform essential users of resources and persons engaged in the operation of essential facilities how to identify their purchase orders, contracts, and other purchase arrangements to obtain deliveries of supplies and services.

Attached to this section of the State Plan is a list of essential gas facilities that must continue in operation to assure an adequate flow of gas for local, State, and National survival and recovery.

Local governments, upon attack, notify the management of these facilities to certify their purchase orders and contracts to obtain production materials, capital equipment, and maintenance, repair, and operating supplies or to place contracts for essential repair and construction as follows.

1. Essential gas facilities use the following State certification to identify:
  - a. purchase orders for supplies of electric power, petroleum products, solid fuels, and transportation services, and
  - b. construction contracts for repair and construction of facilities.

"This is an essential order  
authorized by the State of Texas

(signature of purchaser) "

---

2. Essential gas facilities identify their purchase orders in accordance with the rating and certification provisions of Federal emergency regulations issued by the Business and Defense Services Administration of the U. S. Department of Commerce upon attack, for supplies of production materials, capital equipment, and other maintenance, repair, and operating supplies. The State industrial production organization publicizes and makes known these Federal regulations to local governments and industry immediately following an attack.

Retail distributors use the State certification on purchase orders to supply their inventories from primary gas distributors.

**a. Essential Local Users:**

- (1) Civilian organizations engaged in essential civil defense activities including persons, equipment and facilities providing essential survival care and services to people;
- (2) Military organizations engaged in essential military activities; and
- (3) Farmers producing essential food and local establishments providing essential items and services to people. Less essential individual consumers are not included except those requiring immediate supplies for individual or family survival.

**b. Essential Facilities:**

- (1) Military establishments engaged in immediate retaliatory or defense operations;
- (2) Electric power, gas and water utility systems;
- (3) Industrial plants producing or processing essential items;
- (4) Major wholesale establishments storing or distributing essential items; and
- (5) Transportation or communication systems providing essential services.

**c. Individual Consumers:**

Consumers not included in defined Essential Local Users or Essential Facilities.

**Gas-1, Attachment 2**

**Curtailment of Gas Service**

In accordance with the Governor's policy, curtailment on the local use of gas is suggested by the following steps.

**Step I— Discontinue:**

- a. All comfort air conditioning.
- b. All residential uses except refrigeration, cooking, space heating, and water heating.
- c. Use in coin-operated laundries for drying purposes.

**Step II— Reduce:**

- a. Thermostat settings for comfort heating to a maximum of 65 degrees daytime and 50 degrees nighttime temperatures.
- b. Use of hot water heated by gas to minimum requirements.

\_\_\_\_\_  
(Date)

\_\_\_\_\_  
(Signed)  
Coordinator, State Gas Organization

**Gas-1, Attachment 3**

**Priorities on Local Use of Gas**

In accordance with the Governor's policy the following essential local uses having more direct application to gas shall have first preference for service or restoration of service:

- Gas utilities power requirements needed for rendering services for essential uses
- Military reprisal facilities
- Hospitals and emergency hospitals
- Emergency shelters and community facilities for displaced persons
- Control centers (civil defense, police, fire, light, water, etc.)
- Food production, processing, storing and distribution
- Dairy farms for milking and cooling
- Ice and dry ice plants
- Solid fuels, petroleum, and electricity
- Transportation utilities
- Doctors' offices and clinics
- Essential government services
- Plants manufacturing survival items

**APPENDIX 14 TO ANNEX B**

**Gas-2, Adjustment of Primary Distributor Delivery Quotas**

To: Area Office of the Emergency Petroleum and Gas Administration

Shortages in gas supplies are being reported by local governments in this State.

You are requested to arrange with the primary gas industry to increase their deliveries to meet certified orders received from customers in this State.

Following is an estimate of the increased amounts of gas from primary sources that will be needed to meet essential needs in the State:

Summary of Local  
Deficiencies in Daily  
Resupply of Gas

Locality	Gas (in 1000 cubic ft. per day)
Maud	
Maypearl	
Medicine Mound	
Date	

\_\_\_\_\_  
(Signature)  
State Coordinator or Area Gas Director  
State of Texas

**Gas-2, Attachment 1**

<b>Request for State Assistance Resupply of Gas</b> <hr/>	
<u>(Name of Locality)</u>	
<b>Gas</b>	<b>Increase in Daily Deliveries (in 1000 cubic ft. per day)</b>
Date _____	
<u>(Name of Head of Local Government)</u>	
By: _____ (signature) Local Gas Official	

**APPENDIX 15 TO ANNEX B**

**Gas-3, Estimate of Continuing Gas Requirements**

Forms 1 and 2 attached to this emergency action document contain data on quantities of gas that will be required in this State for a 90-day period commencing                     (date)                    .

The requirements stated include the quantities of gas needed to fill authorized orders of essential users, essential facilities, and consumers.

These requirements do not include quantities of gas needed by essential facilities such as large military installations and bases and large industrial facilities that obtain their requirements directly from primary gas distributors. These latter requirements are the responsibility of the Emergency Petroleum and Gas Administration. Procedures for claims, allocations, and supply arrangements are included in the emergency plans of this Federal Administration.

The purpose of these State requirements estimates is to determine and anticipate quantities of gas needed from primary sources under Federal jurisdiction to resupply secondary distributors under State and local government jurisdiction.

**Definitions**

**Civilian Requirements:** Include the gas needed to carry on emergency civil defense operations, to maintain essential local activities, and to supply individual consumers. These civilian requirements estimates are provided by appropriate civil defense officials.

**Military Requirements:** Include the gas needed to carry on military activities and to maintain and operate military installations and equipment. They include only the supplies that are to be obtained from secondary distributors. These military requirements estimates are provided by appropriate military officials.

**Resource Support Requirements:** Include the gas needed to maintain operation of essential facilities under the cognizance of Federal and State resource organizations functioning in the State. These support resource requirements are provided by appropriate State resource organizations.

**Gas-3, Form 1**

Summary Estimate of Continuing Requirements for Gas for 90-Day Period Commencing _____ (date)	
Requirement Categories	1000 Cubic Feet Per Day
<b>Civilian 90 Days</b>	
First 30 Days	
Following 60 Days	
<b>Military 90 Days</b>	
First 30 Days	
Following 60 Days	
<b>Supporting Resource Requirements 90 Days</b>	
First 30 Days	
Following 60 Days	
<b>Total Requirements 90 Days</b>	
First 30 Days	
Following 60 Days	

**Gas-3, Form 2**

Estimate of Continuing Supporting Resource Requirements for Gas by Resource Program for 90-Day Period Commencing _____ (date)	
Resource Programs	1000 Cubic Feet Per Day
<b>Production 90 Days</b>	
First 30 Days	
Following 60 Days	
<b>Transportation 90 Days</b>	
First 30 Days	
Following 60 Days	
<b>Etc.</b>	
<b>Total 90 Days</b>	
First 30 Days	
Following 60 Days	

**APPENDIX 16 TO ANNEX B**

**Gas-4, Allocation of Gas Supply, Form 1**

Allocation of Expected Continuing Supplies of Gas for 90-Day Period Commencing _____ (date)	
Major Use Categories	1000 Cubic Feet Per Day
Civilian 90 Days	
First 30 Days	
Following 60 Days	
Military 90 Days	
First 30 Days	
Following 60 Days	
Supporting Resource Requirements	
First 30 Days	
Following 60 Days	
Total 90 Days	
First 30 Days	
Following 60 Days	

**Gas-4, Allocation of Gas Supply, Form 2**

Allocation of Expected Continuing Supplies of Gas by Resource Program for 90-Day Period Commencing _____ (date)	
Resource Programs	1000 Cubic Feet Per Day
Production 90 Days	
First 30 Days	
Following 60 Days	
Transportation 90 Days	
First 30 Days	
Following 60 Days	
Etc.	
Total 90 Days	
First 30 Days	
Following 60 Days	

**APPENDIX 17 TO ANNEX B**

**Gas-5, Revised State Gas Policy**

(Note: The content and substance of the revised gas policy will depend on the situation and the supplies expected to be available to meet continuing essential needs. Necessarily, this document will not be completed except in a test of the plan or at the appropriate point in a postattack situation.)

This document will be, in essence, a Revised Gas-1, State Gas Policy and Guidance, contained here.

**APPENDIX 18 TO ANNEX B**

**Gas-6, Gas Industry Support Requirements**

Estimate of Gas Industry Support Requirements for 90-Day Period Commencing _____ (date)				
Resource	Unit of Measure	First 30 Days	Following 60 Days	Total 90 Days
Petroleum Products				
Electric Power				
Transportation				
Water				

**APPENDIX 19 TO ANNEX B**

**Gas-7, Gas Industry Construction Requirements**

To: State Construction Organization

Following is a list and description of major construction, repair, and modification of facilities that will be required to maintain desired production, transmission, and distribution of gas during the 90-day period commencing \_\_\_\_\_ (date) .

**Construction Projects**

1. Name, location, type and size of construction project; start and completion dates.

(If project is underway or a construction contract has been prepared, attach a copy of the contract document and summary bill of materials.)

2.

3.

4.

**APPENDIX 20 TO ANNEX B**

**Gas-8, Allocation of Supporting Resources to Primary Gas Industry**

To: Emergency Petroleum and Gas Administration

Attached is a list and the quantities of supporting resources that have been allocated for maintaining essential operations of primary gas facilities.

This is furnished as a basis for authorizing these facilities to obtain continuing supplies of these resources during the allocation period.

(Attach list.)

ANNEX C

REFERENCE DOCUMENTS

Activities of refineries, crude oil storage, gasoline plants, other gas plants operations and cycling plants in Texas are published by the Railroad Commission of Texas in the Oil and Gas Division Annual Report. These statistics are updated monthly and as such are available and considered part of this plan.

**PART B - RESOURCE SECTIONS**

**VI. Health**

**B-VI**  
**Health**

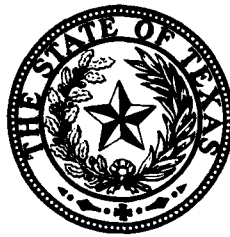

**Texas  
Emergency  
Resource  
Management**

**PLAN**



## INTRODUCTION

This section of the Texas Emergency Resource Management Plan contains policies, guidance and actions to provide health and medical resources to meet essential needs in Texas in a nuclear attack emergency or crisis relocation phase.

**Disaster Health and Medical Services:** Medical and dental care for the civilian population in all of their specialties and adjunct therapeutic fields and the planning, provision and operation of collecting stations, hospitals and clinics; preventive health services including detection, identification and control of communicable diseases, their vectors and other public health hazards; inspection and control of purity and safety of food, drugs and biologicals; food and milk sanitation, preservation of public water supply, sewage and other waste disposal; registration and disposal of the dead; prevention and alleviation of water pollution; vital statistics services; preventive and curative care related to human exposure to radiological, chemical and biological warfare agents; and rehabilitation and related services for disabled survivors.

**Health and Medical Resources:** Manpower, material and facilities required to prevent the impairment of, and to improve and restore the physical and mental health conditions of, the civilian population in support of the disaster health and medical services as defined above.

**Health and Medical Manpower:** Physicians, dentists, sanitary engineers, registered professional nurses, and occupations included in the List of Health Manpower Occupations (Attachment 2 of the Action Document Health--I).

**Primary Inventories:** Health and medical end items in storage at the Federal Emergency Management Agency Offices, General Services Administration, Public Health Service, and Veteran's Administration Depots. Also included are stocks of the Bureau of Narcotics and stocks at producers plants.

**Secondary Inventories:** Health and medical end items at retail outlets and intrastate and interstate wholesale outlets. (It must be emphasized that through mutual assistance programs between states a preallocation of the interstate wholesale stocks must be made for planning purposes.) Producers stock at regional producer warehouses also are considered secondary inventories and are preallocated by mutual agreement between states.

**Certified Orders:** Purchase orders, contracts, or other requests for resources which bear a signed certification that the order is an essential order authorized pursuant to Federal Government emergency regulations or State authorizations.

**Disaster Districts:** Geographical subdivisions of the State of Texas designed for the control of the State Disaster Health and Medical Care Program. These districts, totaling 17 in number, correspond to the State Department of Public Safety districts (See Tab A.)

**Collecting Stations:** The first medical treatment facility with which casualties will normally come in contact. These collecting stations should be located along natural arteries of traffic flow, normally between 7 to 11 miles from the center of a potential risk area or target city.

**Hospital Disaster Zone.** An area in which a number of supporting hospitals designed to support a specific zone control hospital are blocked.

**Zone Control Hospital:** An existing general hospital located along a natural artery of traffic flow, generally between 15 and 35 miles from the city limits of a potential target city. A zone control hospital is normally the first fixed medical facility to which a casualty is admitted.

**Zone Support Hospital:** An existing hospital so situated as to logically provide hospital support to a zone control hospital.

**Zone Support and Liaison Hospital:** A supporting hospital which, because of its location, is situated in two or more hospital disaster zones. These hospitals will provide the liaison function of coordinating the evacuation of patients from one zone to medical facilities in an adjacent zone.

**Hospital Disaster Zone Coordinator:** A person assigned the responsibility for coordinating the reception, processing, hospitalization and movement of casualties, both interzone and intrazone. This includes initial operation of the collecting station or stations assigned to his zone. Moreover, the zone coordinator's office should be located at the zone control hospital in order to effect maximum coordination and control of casualty flow and processing.

**Packaged Disaster Hospital:** An austere but completely functional 200-bed, general field hospital, designed to be set up within a preselected structure, such as a school, church building or community center. The Packaged Disaster Hospital (PDH) is designed to augment existing medical care facilities near or adjacent to zone control hospitals or zone support hospitals in the event of a major disaster. (See Tab D, Annex A-Location of PDH's.)

**Casualty Coordination Control:** The coordination, supervision and control of the flow and processing of casualties into, within and between hospital zones and their medical care installations. Casualty coordination control will be exercised by specific assignment to the potential target area District Disaster Medical Care Directors and their zone coordinators.

**Administrative Control:** The coordination, supervision and control of personnel activities and supply operations in the field of disaster health and medical care. Personnel activities include the following:

4. Procurement of additional personnel necessary for the effective conduct of planned disaster health and medical operations.

- b. Assignment of health, medical, paramedical and administrative personnel where and when most needed.
- c. Training of all health, medical paramedical and administrative personnel in their disaster duties.
- d. Administrative control over all health facilities in each district shall be exercised by the Disaster Health Director (Public Health Regional Director) concerned.

Supply operations embody the following:

- a. Procurement and distribution of adequate health and medical supplies through preliminary planning designed to identify sources and approximate estimates of normal stock levels carried at each source. Prior arrangements related to a mutually agreeable procedure for release of and reimbursement for these supplies to and by proper authorities will tend to preclude delays and major breakdowns in the procurement of health and medical supplies.
- b. Provisions for adequate food, clothing and shelter is the responsibility of civil defense welfare authorities. Prior planning and coordination with these authorities is essential to insure that these necessities are provided for both patients, medical and health personnel when and where needed.
- c. Provision for requisite transportation is the responsibility of civil defense transportation authorities. Prior planning and coordination with these authorities is vital to insure that sufficient transportation is provided for both patients, medical and health personnel and supplies when and where most needed.
- d. Provision for necessary communications is the responsibility of civil defense communications authorities. However, adequate communications between health and medical installations and facilities can only be assured through prior planning and coordination with these communications authorities.

STATE OF TEXAS  
EMERGENCY RESOURCE MANAGEMENT PLAN

VI-HEALTH AND MEDICAL RESOURCES

PART B-RESOURCE SECTIONS

1. General

The process of managing resources in the State of Texas in a nuclear emergency involves two series of actions. First, essential immediate needs are identified and actions taken to supply these needs. Secondly, and as soon as possible, continuing needs and expected future supplies are estimated. Decisions are made and actions are taken to channel these expected future supplies to meet the continuing needs that are most essential to survival and recovery of the State and the Nation.

Following is a brief description of Federal, State and city-county government roles in the emergency management and supply of health and medical resources in the State of Texas:

- a. Federal Government. The United States Department of Health, Education and Welfare is responsible for national plans for the management of health and medical resources in an emergency.
- b. State Government. The State health and medical resources organization (disaster health and medical services) and its district organizations will develop, in coordination with other organizations of the State government, and provide, on behalf of the Governor, policies and guidance consistent with State and Federal objectives. The purpose of these policies and guidance is to assure application throughout the State of compatible measures for the conservation, distribution and use of health and medical resources to prevent dissipation and waste and to assure that essential needs are identified and met within the supplies available. The State health and medical resources organization will work with wholesalers on the conservation and release of inventories and the employment of inventories from the producers. The State health and medical resources organization and its district organizations will act on request for State level assistance from local government disaster health and medical officials and arrange with distributors of secondary stocks to adjust deliveries of health and medical end items to correct local shortages in supply. As soon as possible after the attack, the State health and medical resources organization will anticipate continuing needs and make arrangements to provide health and medical end items to meet ongoing demands for authorized essential users.
- c. City-County Government. Annex L, Disaster Health and Medical Services, of the State of Texas Disaster Plan, contains provisions for the conservation, distribution and use of local supplies of health and medical end items within the State. These plans also provide for local government decisions and guidance consistent with State policies for the functioning of the retail health end item distribution system and the localities in the State.
- d. Essential Health and Medical End Items Facilities. Referenced as Reference Document Number 1 is a publication listing manufacturers producing health and medical end items with their locations which are essential to National and State survival and which must be kept in operation to assure a continuing flow of health items to meet essential needs for survival and recovery. Preattack arrangements will be made with appropriate authorities of local governments to assure provision of electric power, manpower, transportation, water, fuels and other locally available requisites for the continuing operation of these essential health and medical end item facilities.
- e. Production and Distribution of Health and Medical End Items. The management of production of health and medical end items throughout the State of Texas will be the responsibility of the State Industrial Production Resource Agency. Distribution of these manufactured health and medical end items will also be handled by the State Industrial Production Resource Agency; however, the State Coordinator of the health and medical resource organization (disaster health and medical services) will furnish recommendations to the Director of the Industrial Production Resources Agency for the distribution of all health and medical end items included in Part I of the List of Essential Survival Items of Appendix I to the Defense Mobilization Order 8500.1 dated November 4, 1964.
- f. Federal Nonmilitary Health Care Facilities. Facilities of this nature are to be utilized as a local resource during an emergency. Administrators of these facilities will retain control over the facility and staff. When directed by higher authority, the Federal facility will be recalled to a Federal mission.
- g. Nonmedical Facilities. Certain nonmedical facilities, such as school buildings, hotels, etc., will be designated by agreement with the proper authorities as emergency health care facilities. Requests for the allocation of a facility to health activities should be processed through the Civil Defense Director.

2. Mission

To coordinate a State-wide disaster health and medical resources management organization whose existence would insure the most effective and efficient use of the total available health and medical resources in order to provide the following essential services during periods following a nuclear attack:

- a. Medical care
- b. Environmental health
- c. Protection of survivors against effects of chemical, biological and radiological warfare
- d. Post disaster mortuary activities and vital records pertaining thereto.

### 3. Resource Management Execution

#### a. General

- (1) The effects of a nuclear attack on this country cannot be predicted with precision. For that reason, medical stockpile goals are based on assumed postattack situations which are reasonable under current concepts. Severe losses to production potentials and to normal inventories at all levels of distribution of medical supplies and equipment probably would occur. Projected losses are: 88 percent of preattack inventory at manufacturers' sites, 94 percent of manufacturers' distribution points 64 percent of wholesale houses, 51 percent at retail pharmacies and 52 percent at hospitals.
- (2) Stockpile objectives include the creation of widely distributed reserves of essential health and medical items which will provide, in accordance with a national plan of utilization, first the materials to meet immediate community needs, and second, sufficient additional backup reserves to bridge the gap until production capability can match State and national needs.

#### b. State

- (1) The State Coordinator of the Disaster Health and Medical Services and each of the associate directors are responsible for ascertaining needs and making overall plans for the management of disaster health and medical personnel, equipment, supplies, materials and transportation relating to their specific fields of responsibilities. The State Coordinator of Disaster Health and Medical Services is also the State Health and Medical Resources Coordinator.
- (2) To assist the associate directors in the procurement of necessary personnel and logistic support for their operations, there will be four basic resource management elements. These are: the Medical Supplies and Equipment Division and the Medical Personnel Processing Division of the Disaster Medical Care Services which will provide requisite medical personnel and logistic support to those services. A health supply and equipment element will be included within the General Services and Supply Division plus a manpower procurement and control element of the Personnel and Manpower Division which will provide required logistic and personnel support to the Environmental Health Services, the Communicable Diseases Control Services, and the Laboratory Services. These supply division chiefs will be directly responsible to the associate director concerned for coordinating and assisting the several segments of their respective organizations in planning, initiating and conducting such activities as may be essential for the procurement and management of all necessary health and medical resources.

#### c. Districts

- (1) Within each of the 17 districts, health and medical resource coordinators will be designated by the district disaster health and medical services directors to coordinate supply, transportation and resource management problems in his area with the State Coordinator for Disaster Health and Medical Services in order that resources may be moved where the patient load is heaviest at any particular time.
- (2) This district health and medical resource coordinator will be responsible for establishing procedures for estimating the supply of resources available, for determining the demands for such resources, and for making recommendations of the assignment of resources to the most essential activities. The basic elements of the procedures needed at both district and local levels are outlined below:
  - (a) Estimate the supply of the resources (e.g., maintain information on the quantities of resources including transportation available in the area).
  - (b) Determine resources needs (e.g., estimate the quantity of supplies, equipment and transportation that will be required to carry out the operations).
  - (c) Identify and take action on shortages (e.g., compare the supply of resources with demands and identify shortages. Where there are indicated shortages of a resource, it will be necessary to adjust either the supply or the demand by reassessment of priorities. Reduction of shortages can be facilitated by obtaining additional resources from other communities or from Federal sources).
- (3) The following factors provide guidance in developing the estimates of supplies and equipment referred to above:
  - (a) The management of national resources of health and medical material in a national emergency is primarily the responsibility of the Federal Government and under limited or cold war conditions, the Federal Government will exercise these functions. In the event of nuclear attack, Federal efforts will be directed toward the establishment of effective national control as soon as possible.
  - (b) Local communities, which are primary source of health protection services, will have to perform their functions with the resources on hand until aid from other localities, the State or Federal Government, becomes available. Each community will control retail stocks of health end items.
  - (c) Producers' plant and wholesalers' facilities, together with their inventories of health end items, are considered a national resource.
  - (d) Each local community is responsible for evaluating the health situation and assessing the resources of health and medical material within its political jurisdiction. When local resources of health end items are insufficient to meet essential needs and conflicts involve two or three neighboring political jurisdictions within the State, the

District Director of Disaster Health and Medical Services will exercise priority and allocation authority. When two or more districts are involved, the State Disaster Health and Medical Services Coordinator will determine the priority.

- (4) One of the initial actions that the area health and medical resource coordinators must take in the immediate postattack period is to recommend that local authorities put an immediate freeze on all essential survival items which would be included in the category of health/medical supplies and equipment. Immediately thereafter, provisions should be made for the equitable distribution of survival items as needed.
- (5) If a well organized health and medical resource management planning staff is developed within each district and community, and if the district disaster health and medical services directors are cognizant of the close coordination required among themselves, their resource management counterparts and the State Coordinator of Disaster Health and Medical Services, an effective and efficient disaster health and medical resource management program can be realized at all levels.

d. Transportation—Health and Medical

- (1) It should be assumed that all public and private transportation located within the State at the time of an emergency will be available for controlled utilization. The State Coordinator of Transportation through the State Emergency Transportation Office will direct the utilization of those facilities which are normally available for intercity use in accordance with Section IX, (Transportation), Part B. Obviously, taxicabs, local delivery trucks and private vehicles will come under the supervision of local authorities. The operational control of transportation equipment and facilities used and the dispatching and operating responsibilities of the same will remain with the legally constituted owners and/or operators, under the supervision of the State, through the State Transportation Coordinator.
- (2) The district coordinators for health and medical resources will also be responsible for all transportation requirements in his particular field of activity, i.e., health protection, or medical care. In this capacity they must coordinate jointly with the transportation coordinator as well as commissions or agencies responsible for regulating transportation within the area in normal times.
- (3) Disaster health and medical resource coordinators at all levels will have to consider the following procedures in order to achieve realistic health and medical transportation requirement planning:
  - (a) Estimate transportation availability (e.g., obtain quantitative data and statistics on health and medical transportation equipment and facilities in the target and hospital disaster zone areas and evaluate these data with regard to base of operations, routes, of heaviest travel or concentration, etc. Determine the capabilities of these resources to move persons and goods. Develop a capability to analyze and assess the probably availability of remaining transportation in a postattack period.)
  - (b) Estimate requirements (e.g., in cooperation with appropriate civil defense, military, and other resource agencies, estimate the likely health/medical demands to be made on the transportation services.)
  - (c) Identify and take action on shortages and problem areas (e.g., compare estimates of locally available health and medical transport capability with requirements of users in order to identify problem areas, bottlenecks, shortages, etc. Recommend adoption or adaption of Federal control measures applicable to the district or local area, such as priorities, allocations, permit procedures, etc. Where interarea industrial systems remain operable, support their continuation under existing management and where disruption has necessitated assumption of temporary operational control by resource management officials, recommend release and restoration of private and public systems as soon as possible.)
  - (d) Preplanned medical evacuation transportation should be designated down to and including names of trucking and transit firms. Specific designations of carriers to medical facilities, to include collecting stations, zone control hospitals, and Packaged Disaster Hospitals for transportation within the supporting hospital zone and between adjoining zones should be included in a well defined plan and must be thoroughly coordinated and included as an integral part of the area transportation plan.
  - (e) Maximum utilization of railways should be exploited to tie in with collecting stations, zone control hospitals, supporting hospitals and areas adjoining hospital zones. Consideration should also be given to the utilization of private aircraft, as well as commercial airlines, as much as is feasible in order to augment surface transportation.

4. Control

- a. The State Coordinator of Disaster Health and Medical Services is directly responsible to the Governor, through the State Director, Disaster Emergency Services, for all disaster health and medical resource management activities enumerated in this plan.
- b. The activities of the disaster health and medical services organization will be conducted and controlled through the established chain of command as described in this plan.

- c. The 17 disaster health and medical districts will be under the coordination control of the State Coordinator of Disaster Health and Medical Services as indicated in this plan.
- d. The emergency lines of direction and succession for the State disaster health and medical services are:
  - (1) State Coordinator for Disaster Health and Medical Services (State Commissioner of Health)
  - (2) Deputy State Coordinator for Disaster Health and Medical Services (Deputy State Commissioner of Health)
  - (3) Associate State Director for Disaster Medical Care Services (Chairman of Texas Medical Association's Committee on Disaster Medical Care)
  - (4) Associate State Director for Administrative Support Services.
- e. In the event of a absence, disability or death of the State Coordinator or of the director of any subdivision of the organization at any level, the senior staff member present will serve as acting coordinator (director) until the next in line of succession arrives at the control center.
- f. For purposes of coordination and control, the disaster health and medical services organization (health and medical resources management organization) will utilize the established State disaster districts as described in the State Emergency Operations Plan and indicated in Tab A, Annex A.
- g. The State Disaster Health and Medical Control Center (HMCC) will be located in the Texas State Department of Health building at 1100 West 49th Street, Austin, Texas.
- h. Alternate State Health and Medical Control Center (HMCC) will be established at: Waco, Texas--U. S. Veteran's Administration Hospital.
- i. Only designated State officials may authorize the expenditure of State government funds.

5. Emergency Actions

The following actions are taken on behalf of the Governor at State and district levels by State health and medical resources (disaster health and medical services) officials to provide policies and guidance applicable throughout the State on the management and use of health resources.

The emergency action and reference documents contained here have been prepared and will be placed with appropriate State and local officials during the preattack planning process.

a. Actions for Immediate Supply

- (1) Issue, on behalf of the Governor, policies and guidance, applicable throughout the State covering the provision and distribution of health and medical resources within the State. (Health-1, State Health and Medical Resources Policy and Guidance.)
- (2) Confirm arrangements with producers and wholesalers of health and medical end items to make deliveries on certified orders received from customers in the State. (Health-2, Request for Release of Health and Medical End Items Inventories.)
- (3) Arrange with health and medical end item distributors for adjustments of deliveries to meet local shortages in health supplies reported by local governments. (Health-3, Adjustment of Deliveries.)
- (4) Arrange for transfer of health and medical manpower in the State to meet urgent shortages reported by local governments. (Health-4, Request for Health and Medical Manpower.)

b. Actions for Continuing Supply

As soon as resupply of secondary inventories to meet essential immediate needs in the localities is under way the State health and medical resources (disaster health and medical services) organization takes the following actions to anticipate continuing needs and to arrange for continuing supply to meet these needs.

- (1) Consult with State civil defense supply officials, district directors of disaster health and medical services, Federal military officials and appropriate State resources officials to estimate continuing requirements of health and medical end items that will be needed in the State during the ensuing 90-day period. (Health-5, Estimate of Continuing Health and Medical End Items Requirements.)
- (2) Obtain from producers and wholesalers estimates of health and medical end items that can be supplied for continuing use in the State during the ensuing 90-day period.
- (3) If anticipated supplies are inadequate to meet the estimated requirements and adjustments in requirements cannot be negotiated, refer to the Resource Priorities Board for recommendations to the Governor on the allocation of anticipated supplies among competing programs. (Health-6, Allocation of Health Supplies.)
- (4) Issue revised State policies on the use of health resources in the State to conform with the Governor's decision. (Health-7, Revised State Health Resources Policy.)
- (5) Consult with wholesalers of health end items and district directors of disaster health and medical services and develop estimates of continuing requirements for electric power, manpower, transportation, petroleum products, and other operating supplies, equipment, and services that will be needed to maintain operations in the State during the ensuing 90-day period. Present these requirements estimates to appropriate State resource organizations. (Health-8, Health Services Support Requirements.)
- (6) Consult with wholesalers of health and items and district directors of disaster health and medical services and develop estimates of emergency repair and construction of essential health and medical services facilities that will be required

during the ensuing 90-day period and present these requirements estimates to the State construction organization. (Health-9, Health Services Construction Requirements.)

- (7) Inform wholesalers of health end items and district directors of disaster health and medical services of supplies of supporting resources that will be available in the State for acquisition and use by them to maintain essential operations during the ensuing 90-day period. (Health-10, Allocation of Supporting Resources.)
- (8) Authorize wholesalers of health end items and district directors of disaster health and medical services to certify purchase orders to obtain specified quantities of supporting resources and services during the ensuing 90-day period. (Health-11, Authorization to Obtain Supporting Resources.)

ANNEX A  
ORGANIZATION

1. Supporting Agencies and Organizations

- a. In the event of a nuclear attack, the following Federal and State agencies will maintain liaison with and will support State disaster health and medical resource management operations within the limits of their capabilities:

Federal Agency

Federal Emergency Management Agency (FEMA)

U. S. Department of Labor  
U. S. Department of Commerce

U. S. Department of Interior

U. S. Department of Agriculture

U. S. Housing and Home Finance Agency  
U. S. Department of Health, Education and Welfare

State Agency

Governor's Division of Disaster Emergency Services  
Adjutant General's Department  
Texas Employment Commission  
Texas Railroad Commission  
State Department of Highways and Public Transportation  
Texas Aeronautics Commission  
Texas Parks and Wildlife Department  
Texas Forest Services  
Texas Department of Water Resources  
State Department of Agriculture  
A & M University Extension Service  
Texas Department of Health  
Texas Department of Human Resources  
Texas Education Agency

- b. State-wide Medical and Paramedical Organizations

- (1) Texas Medical Association
- (2) Texas Osteopathic Association
- (3) Texas Dental Association
- (4) Texas Veterinary Medical Association
- (5) Texas Nurses Association
- (6) Licensed Vocational Nurses Association of Texas
- (7) Texas League for Nursing
- (8) Texas Hospital Association
- (9) Texas Pharmaceutical Association
- (10) Texas Funeral Directors and Embalmers Association
- (11) Texas Nursing Home Association
- (12) Various medical, laboratory, X-ray, etc., technicians' organizations.

2. Health and Medical Resource Organization

- a. General

- (1) All disaster health and medical operations in the State of Texas including health and medical resources management will be under the general coordination of the State Coordinator of Disaster Health and Medical Services (State Commissioner

of Health). That portion related to disaster medical care will be coordinated by the Chairman of the Texas Medical Association's Committee on Disaster Medical Care (Associate State Director for Disaster Medical Care).

- (2) The disaster health and medical services of the State will include two general operational fields and a support field. These are:
  - (a) Disaster medical care
  - (b) Disaster health protection
  - (c) Administrative and support activities.
- (3) The resources, cooperation and services of the members of the professional medical and related groups are brought to bear through the State Advisory Committee on the Health and Medical Aspects of Civil Defense.
- (4) Administrative and support activities, including health and medical resource management, as indicated in Tabs B and C, will be conducted as joint support operations for all elements of disaster health and medical services.
- (5) The disaster health and medical services organization, assignments and functions are illustrated by the enclosed charts, Tabs B and C. The services consist of the State Coordinator and headquarters staff, and the field operating echelons of district and city/county disaster health and medical staffs. The State headquarters organization is made up of all elements of the State Department of Health and consists of the Office of the Director and five major services. These are: the Administrative Support Services, the Environmental Health Services, the Communicable Diseases Control Services, the Disaster Medical Care Services and the Laboratory Services.

b. Office of the State Coordinator

The Office of the State Coordinator for Disaster Health and Medical Services will consist of the State Coordinator, the Deputy State Coordinator, the Office of Planning and Coordination, and the Office of Public Information. The State Advisory Committee on the Health and Medical Aspects of Civil Defense will furnish guidance and assistance to the State Coordinator and State Deputy Coordinator on civil defense health and medical plans and policies.

c. Disaster Support Operations

- (1) The Associate State Director for the Disaster Administrative Support Services is also the State Coordinator of Health and Medical Resources and will be responsible to the State Coordinator of Disaster Health and Medical Services for the planning and coordination of all administrative, support and resource management activities not specifically assigned to either Disaster Health Protection Operations or Disaster Medical Care Operations. (See Tab B.) The Administrative and Support Section will maintain liaison as necessary with the other sections of the disaster health and medical services.
- (2) The Administrative Support Services will consist of four basic support divisions. These are: the Fiscal Division, the Legal Division, the General Services and Supply Division, and the Personnel and Manpower Procurement and Assignment Pool which will function under the control of the Personnel Division and will consist of all those elements of the Texas Department of Health not previously assigned to other disaster services.

d. Environmental Health Services

The Environmental Health Services will consist of seven basic operating divisions. These are: the Sanitary Engineering Division, the Veterinary Public Health Division, the Water Pollution Control Division, the Food and Drug Division, the Vital Records and Mortuary Division, the Radiological Warfare Defense Division, and the Chemical Warfare Defense Division. The Water Pollution Control Division will work in close coordination and cooperation with the State Water Rights Commission in assuring the preservation of a safe, adequate and continuing public water supply during the recovery period.

e. Communicable Diseases Control Services

The Communicable Diseases Control Services comprises three basic divisions. These are: the Investigation and Reporting Division, the Biological Warfare Defense Division, and the Public Health Nursing Division.

f. Disaster Medical Care Operations

- (1) The Associate State Director for the Disaster Medical Care Services will be responsible to the State Director of Disaster Health and Medical Services for planning and coordination of all activities related to the State-wide care of the sick and injured during and immediately following a nuclear attack or major disaster. This service will be responsible for the procurement, management and assignment of medical care personnel, equipment and supplies as required. In addition, the disaster medical care services will maintain liaison with the other segments of the disaster health and medical organization as required.



- (2) The Disaster Medical Care Services will consist of three basic operating divisions. These operating divisions are: the Hospital and Medical Installations Division, the Medical Personnel Procurement and Assignment Division, and the Medical Supplies and Equipment Division.

g. Laboratory Services

The Laboratory Services will consist of the nine basic divisions of the present Texas Department of Health Laboratory Section augmented with necessary personnel for continuous and prolonged laboratory operations.

h. District Disaster Health and Medical Operations

- (1) Disaster health and medical districting within the State conforms to the 17 disaster districts as established. There will be a district director for disaster health protection and a district director for disaster medical care in each of the 17 disaster districts. These health and medical directors will serve on the staff of the Disaster District Committee and will be responsible for planning and coordination in accordance with the State plan in their respective health/medical resource management fields.
- (2) Counties and cities within each district should plan and conduct their health/medical resource management operations in consonance with the district plan.
- (3) Guidance, coordination and integration of all disaster health and medical support plans and operations throughout the State is the responsibility of the State Coordinator of Disaster Health and Medical Services. He will be responsible for encouraging and assisting each district and local area in the development of disaster health and medical care plans including management of health and medical resources.
- (4) The field organization which will carry out those disaster health and medical services as required is composed of three major echelons. These field elements are: the district disaster health and medical directors and their staffs, the city/county disaster health and medical directors and their staffs, and the hospital disaster zones and their supporting facilities.
- (5) Hospital disaster zones will be established throughout the State in direct support of a pre-designated potential target area. Each hospital disaster zone will be composed of a zone coordinator and assistant coordinator with requisite staff, plus each medical care installation within the zone. Included in these zones are: the zone control hospitals from which the zone coordinator will operate; the support hospitals within the zone; the support liaison hospitals which form the coordination link with other hospital disaster zones; the Packaged Disaster Hospitals which will augment existing facilities where needed; and the casualty collecting stations servicing their assigned hospital disaster zones.
- (6) In order to accomplish this support mission, all medical facilities within a hospital disaster zone will be under the casualty coordination control of a disaster zone coordinator. Each zone will be in direct support of the zone's assigned target area. Hospital disaster zones will be necessary transcend disaster health and medical district boundaries. but all medical facilities within a given disaster medical district will be under the administrative control of the district director of disaster medical care for that district.
- (7) One of the basic planning assumptions of the hospital disaster zone concept is that all health and medical installations and facilities within all target zones will be destroyed. However, it is impossible to predict which target cities will be hit and which target cities will be spared. In the event a target city is not subject to attack, the health and medical resources of that area will be placed in direct support of a stricken area as directed by the State Coordinator for Disaster Health and Medical Services. In order to accomplish this, each potential target city must develop plans wherein all medical and health facilities of the community are organized into one or more hospital disaster zones to receive and care for casualties from stricken areas. The number of hospital disaster zones comprising each target area will depend on the number of hospital facilities available in the community.
- (8) Each of the 17 disaster health and medical districts of the State will have a director for disaster health protection and a director for disaster medical care, with alternate directors for each. These district directors and their alternates will be appointed by the State Coordinator of Disaster Health and Medical Services (State Commissioner of Health). Adequate operating staffs will be organized by each of the district disaster health and medical directors to meet the requirements of the plan.
- (9) There should be a city/county disaster health protection director and a disaster medical care director assigned each city/county resource management staff by the local director, to implement this plan.
- (10) This, then, is the general concept of providing area and State-wide medical care and handling of mass casualties and management of health and medical resources. The echelons of medical treatment-collecting stations, zone control hospitals, supporting hospitals and the linking of supporting hospital disaster zones by liaison hospitals-included every general hospital and all available medical and paramedical personnel and material resources in the State.

# DIVISION OF DISASTER EMERGENCY SERVICES DISASTER DISTRICT BOUNDARIES

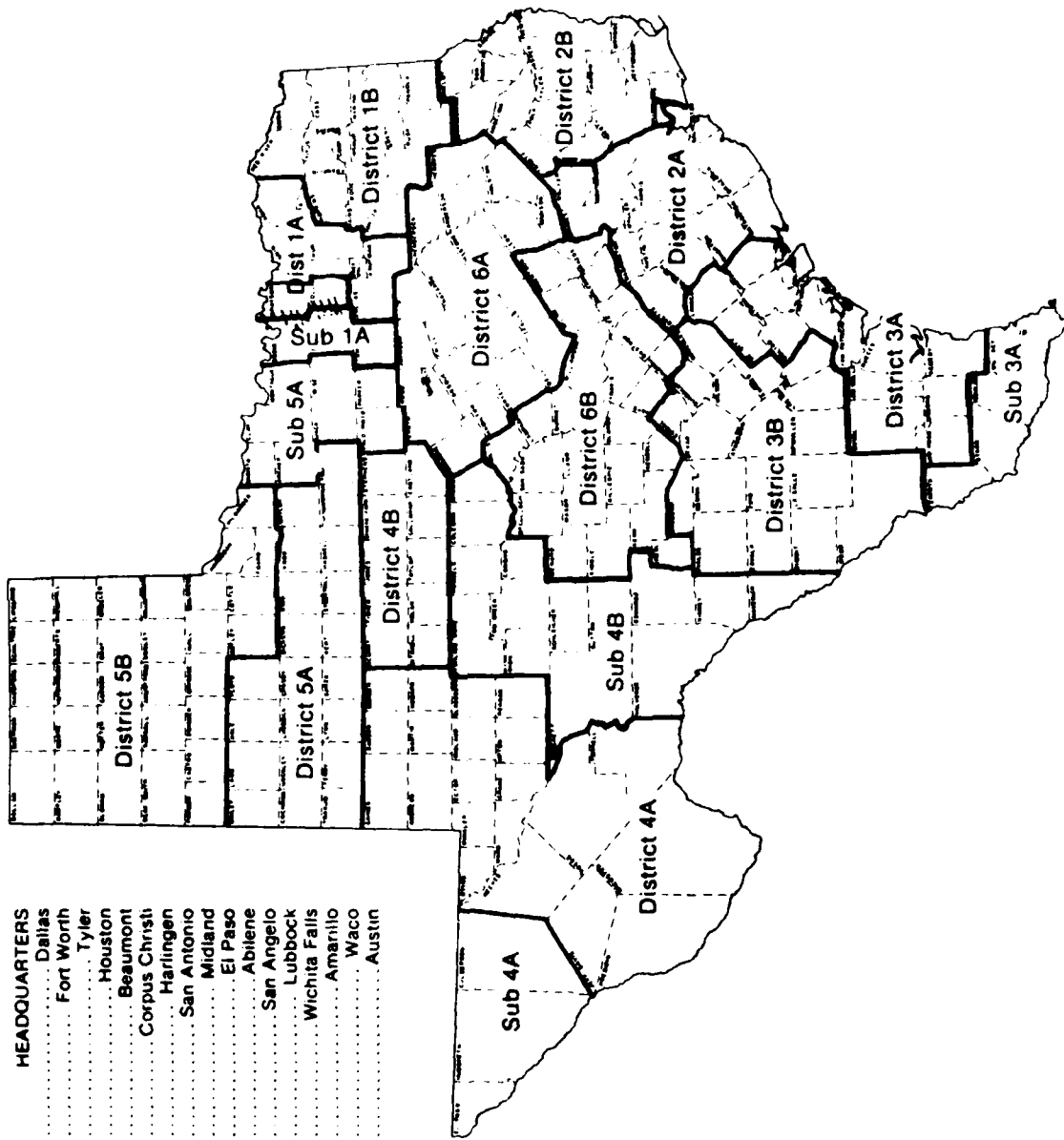

DISTRICT	HEADQUARTERS
1A	Dallas
Sub 1A	Fort Worth
1B	Tyler
2A	Houston
2B	Beaumont
3A	Corpus Christi
Sub 3A	Harlingen
3B	San Antonio
4A	Midland
Sub 4A	El Paso
4B	Abilene
Sub 4B	San Angelo
5A	Lubbock
Sub 5A	Wichita Falls
5B	Amarillo
6A	Waco
6B	Austin

**Tab B  
DISASTER HEALTH AND MEDICAL SERVICES  
ORGANIZATIONAL AND FUNCTIONAL CHART**

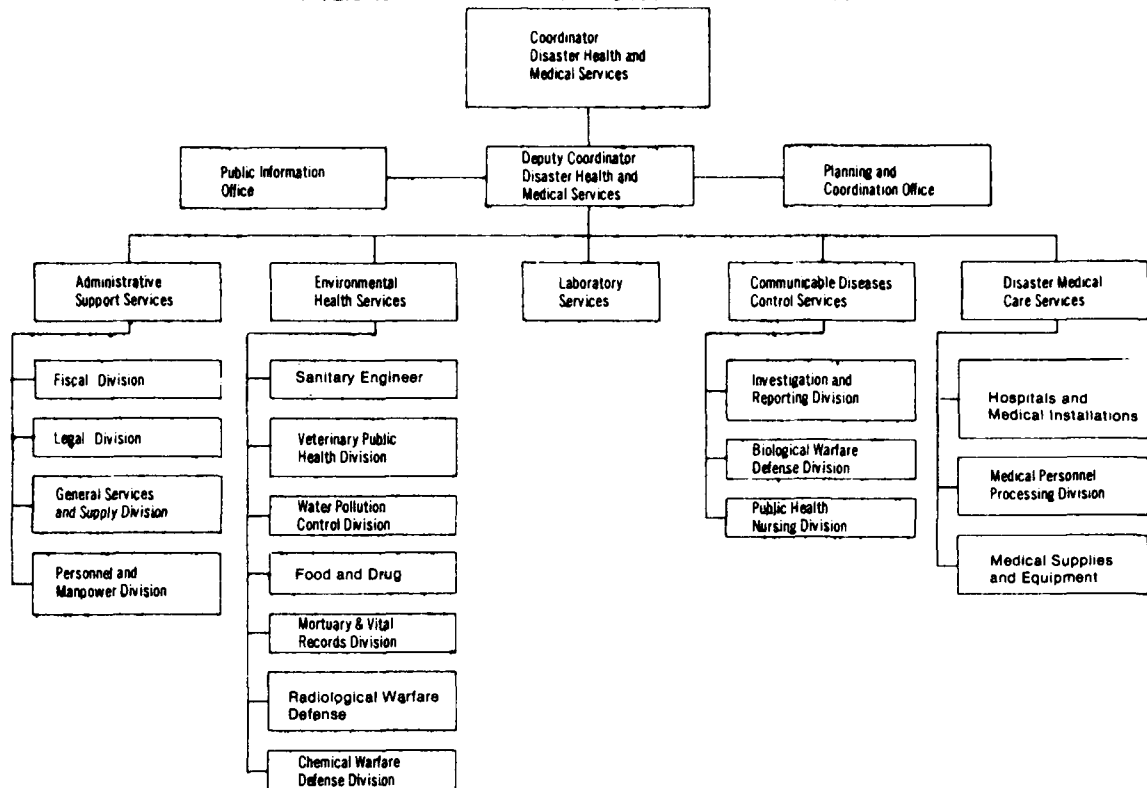

**Tab C  
STATE HEALTH AND MEDICAL RESOURCES FUNCTIONAL ORGANIZATION**

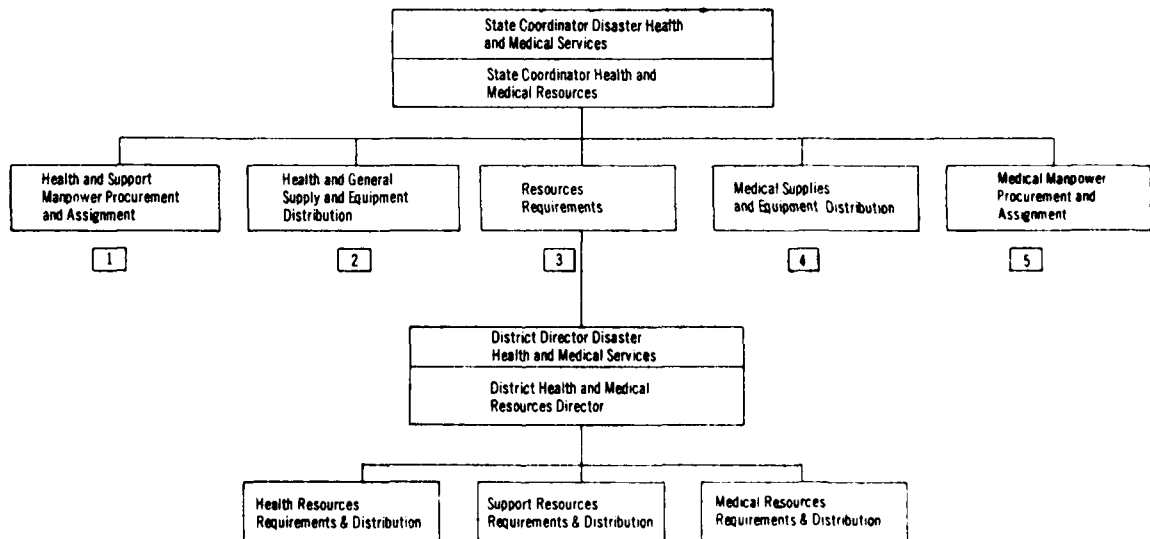

- |  |   |
|--|---|
| <p>(1) Performed by Personnel and Manpower, Administrative Support Services</p> <p>(2) Performed by General Services and Supply, Administrative Support Services</p> <p>(3) Received and processed by the Office of the Associate Director for Administrative Support Services</p> | <p>(4) Performed by Medical Supplies and Equipment, Disaster Medical Care Services</p> <p>(5) Performed by Medical Personnel Processing, Disaster Medical Care Services</p> |
|--|---|

TAB D  
PACKAGED DISASTER HOSPITALS  
LOCATIONS

Abilene  
Amarillo (2)  
Anahuac  
Arcadia  
Ballinger  
Baytown  
Beeville  
Bellville  
Bertram  
Big Lake  
Boerne  
Borger  
Bowie  
Brenham  
Bryan  
Camp Wood  
Childress  
Cleburne  
Coleman  
Columbus  
Conroe  
Corpus Christi  
Corsicana  
Dalhart  
Dallas (2)  
Denton  
Duncanville  
Eagle Pass  
Edinburg  
El Campo  
Eldorado  
El Paso  
Ennis  
Fort Stockton  
Gainesville  
Gorman  
Graham  
Grand Prairie  
Hallettsville  
Harlingen  
Hillsboro  
Hondo  
Keene  
Kermit  
Kingsville  
Knox City  
La Grange  
Lamesa  
Lancaster  
Laredo  
League City

Leakey  
Levelland  
Liberty  
Lipan  
Livingston  
Longview  
Lubbock  
Luling  
Marlin  
Marshall  
McKinney  
Mexia  
Mt. Pleasant  
Nacogdoches  
Navasota  
New Braunfels  
Odessa  
Palestine  
Paris  
Pasadena  
Pearsall  
Perryton  
Rockport  
Rosenberg  
San Angelo  
Schulenburg  
Sealy  
Seguin  
Sherman  
Snyder  
Stephenville  
Strawn  
Sweetwater  
Temple  
Terrell  
Three Rivers  
Uvalde  
Victoria  
Wellington  
Weslaco  
West Columbia

NATURAL DISASTER  
HOSPITALS  
LOCATIONS

Amarillo  
Edinburg  
Floresville  
Texarkana  
Wichita Falls



ANNEX B  
EMERGENCY ACTION DOCUMENTS

- Health- 1, State Health Resources Policy and Guidance
- Health- 2, Request for Release of Health End Items Inventories
- Health- 3, Adjustment of Deliveries
- Health- 4, Request for Health Manpower
- Health- 5, Estimate of Continuing Health End Items Requirements
- Health- 6, Allocation of Health Supplies
- Health- 7, Revised State Health Resource Policy
- Health- 8, Health Services Support Requirements
- Health- 9, Health Services Construction Requirements
- Health-10, Allocation of Supporting Resources
- Health-11, Authorization to Obtain Supporting Resources

---

Health-1, State Health Resources Policy and Guidance

To: Heads of Political Subdivision, State of Texas

Guidance for Local Governments. It is essential that health resources available for use in this State be carefully conserved and restricted to immediate and urgent uses for local, State, and National survival and recovery. Consequently, appropriate officials of local government are requested to take the following actions:

1. Advise all health and medical manpower not ordered to military service to continue, if possible, in their regular work relationships unless requested to perform other emergency health activities by local health authorities.
2. Notify supporting manpower who are integral to health operations and who are employed at time of attack by medical facilities or laboratories or government health agencies to remain with the employing organization if not ordered to military service.
3. Announce and enforce restrictions on release and sale of inventory of local secondary distributors of health end items except as authorized by you.
4. Implement instructions to secondary distributors on how to release inventories to meet essential needs.
5. Authorize essential local users to obtain immediate and urgent health end items from secondary distributors.
6. Authorize essential health facilities to certify purchase orders for health supplies needed to maintain their operations. Instruct essential facilities to place these certified orders on their customary sources of supply.
7. In the event locally available health resources are not adequate to meet all essential needs, local governments should decide and cut back authorized local uses. Concurrently they should report shortages and request district disaster health and medical services officials to take actions to increase the supply of health resources to the local jurisdiction.

\_\_\_\_\_  
(Effective Date)

\_\_\_\_\_  
(Name)  
Governor of the State of Texas

\_\_\_\_\_  
State Health Resources Coordinator  
(Coordinator of Disaster Health and  
Medical Services)

## Health-1, Attachment 1

### Background Information

The Governor has issued general policy on the use of essential resources in the immediate post-attack period. These policies are set forth in Part A of the State plan. They have been furnished to appropriate officials of the political subdivisions of the State.

In general, these State policies provide for temporary freezing of retail inventories of essential items and immediate and continuing release of these items to meet urgent military and civil defense needs and to maintain operations of facilities essential to continued survival and recovery. They provide for continuing resupply of local secondary inventories of essential facilities which obtain their supplies from wholesale and primary sources.

In addition, the Governor has issued a proclamation, Appendix 6 to Annex C, Part A, requesting the executive heads of the political subdivisions in this State to provide resources from locally available supplies to carry on immediate and urgent activities for survival and to maintain the operation of essential facilities. In accordance with this direction from the Governor, local governments are requested to inform essential users of resources and persons engaged in the operation of essential facilities how to identify their purchase orders, contracts, and other purchase arrangements to obtain deliveries of supplies and services.

Attached to this section of the State plan is a list of end items production and distribution facilities that must continue in operation to assure an adequate flow of health end items for local, State, and National survival and recovery. Names and addresses of these facilities located in the political subdivisions have been provided to the local governments concerned.

Local governments, upon attack, notify the management of these facilities to certify their purchase orders and contracts to obtain production materials, capital equipment, and maintenance, repair, and operating supplies or to place contracts for essential repair and construction as follows:

1. Health services use the following State certification to identify:
  - a. Purchase orders for supplies of electric power, petroleum products, gas, solid fuels, and transportation services, and
  - b. Construction contracts for repair and construction of facilities.

"This is an essential order  
authorized by the State of Texas

\_\_\_\_\_  
(signature of purchaser)"

2. Health services identify purchase orders in accordance with the rating and certification provisions of Federal emergency regulations issued by the Business and Defense Services Administration of the U. S. Department of Commerce upon attack, for supplies of production materials, capital equipment, and other maintenance, repair, and operating supplies. The State production organization publicizes and makes known these Federal regulations to local governments and industry immediately following an attack.

Retail and wholesale distributors use the Federal rating and certification on purchase orders to supply their inventories from primary distributors.

To: Coordinator of State Disaster Health and Medical Services Organization and Executive Heads of Government

1. Purpose. This Order issues the List of Health Manpower Occupations and assigns responsibilities in regard thereto.
2. Definitions. The Federal Government has defined health manpower as "physicians (including osteopaths), dentists, sanitary engineers, registered professional nurses; and such other occupations as may be included in the List of Health Manpower Occupations," issued by appropriate authority. The list issued by the this Order is consistent with Federal Government usage as established in Defense Mobilization Order 8540.1 issued by the Director, Office of Emergency Planning, March 11, 1964.
3. Responsibilities. Civilian manpower mobilization planning responsibilities are assigned to the Texas Employment Commission and civilian health manpower mobilization planning responsibilities are assigned to the Texas State Department of Health.

State and local health officials have the primary responsibility for planning the organization, training, and utilization of civilian health manpower. The facilities of the Texas Employment Commission and its local offices will be utilized in carrying out the health program (e.g., recruitment, referral, and other manpower measures).

The skills identified in the attached List of Health Manpower Occupations are those which will be immediately required for the provision of essential emergency public health and medical services. Persons possessing the listed skills and allocated by appropriate officials to meet nonmilitary requirements will be made available to health services. However, as health hazards are brought under control and medical care loads permit, health officials will release for utilization in other essential activities the health manpower that is no longer critically needed.

Supporting manpower, integral to health operations, e.g., hospitals, sanitation, and laboratory helpers, and engineering, clerical, food service and custodial personnel, is not listed. Such civilian manpower employed at the time of attack by a medical facility or laboratory or governmental health agency, will, if not ordered to military service, remain with the employing organization. All others will be provided according to priorities established by the manpower agency or ranking governmental official.

4. Effective Date. This Order is effective the date of issuance.

---

Governor

Attachment



LIST OF HEALTH MANPOWER  
OCCUPATIONS (1\*)

Based on Defense Mobilization Order 8540.1  
Office of Emergency Planning  
Executive Office of the President

<u>Occupational Title</u>	<u>Department of Labor Occupational Code Number</u>	<u>Occupation Title</u>	<u>Department of Labor Occupational Code Number</u>
Audiologist (2*)	0-39.925	Nurse Aide (Med. Serv.)	2-42.20
Biochemist	0-07.02	Nurse, Licensed Vocational	0-62.83
Clinical Radioisotope Technician	(3*)	Nurse, Practical	2-38.20
Dental Hygienist	0-50.07	Nurse, Professional	0-33
Dental Technician (Sub. Serv.)	0-50.06	Occupational Therapist	9-32.04
Dentist	0-13.	Optometrist	0-39.92
Food and Drug Inspector (Govt. Serv.)	0-95.11	Orderly (Med. Serv.)	2-42.10
Health Physicist	(4*)	Orthopedic Technician	5-09.410
Medical Physiologist	0-26.50	Osteopathic Physician	0-39.96
Medical Record Librarian	0-23.25	Pharmacist (Prof. and Kindred)	0-25.10
Medical Technician (Med. Serv.)	0-50.01	Podiatrist (9*)	0-39.901
Medical Technologist (Med. Serv.)	0-50.01	Psychologist, Clinical (7*)	0-36.22
Bacteriology Technician	0-50.01	Physicians and Surgeons	0-26
Biochemistry Technician	0-50.01	Physical Therapist (Med. Serv.)	0-52.00
Bloodbank Technician	0-50.01	Sanitarian (8*)	0-39.976
Cytology Technician	0-50.01	Sanitary Engineer	0-16.01
Hematology Technician	0-50.01	Social Worker, Medical	0-27.20
Parasitology Technician	0-50.01	Social Worker, Psychiatric	0-27-20
Serology Technician	0-50.01	Speech Pathologist	0-32.07
Tissue Technician	0-50.01	Superintendent, Hospital (Med. Serv.)	0-99.84
Virology Technician	0-50.01	Veterinarian (6*)	0-34
Midwife	2-38.20	X-ray Technician (Med. Serv.)	0-50.04
Natural Scientists (N.E.C.)	0-35.		
Anatomist (Prof. and Kindred)	0-35.36		
Biophysicist (5*)	0-35.49		
Dairy Bacteriologist	0-35.33		
Food Bacteriologist	0-35.33		
Hematologist	0-35.38		
Histopathologist	0-35.37		
Medical Bacteriologist	0-35.33		
Parasitologist, Medical	0-35.31		
Pharmaceutical Bacteriologist	0-35.33		
Pharmacologist	0-35.34		
Public Health Bacteriologist	0-35.33		
Veterinarian Bacteriologist (6*)	0-35.33		

(1\*) Includes students, trainees, and interns whose training or education leading to any of the indicated skill is sufficiently advanced to qualify them to contribute to the technical tasks of providing health services.

(2\*) Unpublished definition and code.

(3\*) Coding and nomenclature not yet received from Department of Labor.

(4\*) Health Physicist. *Devises and directs a research training and monitoring program to protect plant personnel from radiation hazards. Conducts research to develop inspection standards, radiation exposure limits for personnel, safe work methods, and decontamination procedures and tests surrounding areas to assure that releases to environment are not in excess of permissible radiation standards. Designs or modifies health physics equipment, such as detectors and counters to improve radiation protection. Assists in developing standards of permissible concentrations of radioisotopes in liquids and gases. Directs testing and monitoring of equipment and recording of personnel radiation exposure dates.*

Requests special bioassay samples of individuals believed to be exposed. Consults with scientific personnel regarding new experiments to determine that equipment or plant design conforms to health physics standards for protection of personnel. Supervises radiation monitoring and directs monitoring of plant areas and work sites. Requisitions and maintains inventory of instruments. Records location and quantity of radioactive sources assigned to departments. Instructs personnel in principles, policies, rules, and regulations related to radiation hazards. Assigns film badges and dosimeters to personnel and recommends changes in assignment for health reasons. May advise public authorities on methods of dealing with radiation hazards and procedures to be followed in radiation incidents and assists in civil defense planning. Reports findings and recommends improvements in safety measures. A bachelor's degree with a major in physics, chemistry, engineering, or a biological science, plus at least one year

of specialized training in health physics is required.

- (5\*) Biophysicist. Studies the physical principles of living cells and organisms, including mechanics, heat, light, radiation, sound, and electricity. Is trained in both physics and biology. May specialize, for example, in the field of radiobiology which includes such activities as the study and use of radiation and nuclear particles in the treatment of cancer or the use of atomic isotopes in discovering the transformation of substances in cells.
- (6\*) Veterinarian Bacteriologist. Though current planning provides that many veterinarians be utilized in casualty care and preventive medicine activities in the immediate postattack period, veterinarians will continue to be needed to perform services of a strictly veterinary nature after most of the human casualties have been cared for temporarily. Such veterinary activities will include protection of food animals against diseases and the effects of atomic, biological, and chemical warfare; meat and poultry inspection and supplementing food inspection forces for certain food processing plants, and food storage facilities.
- (7\*) Clinical Psychologist. Diagnoses mental and emotional disorders of individuals in clinics, hospitals, prisons, and other institutions and administers program of treatment. Interviews patient, studies medical and social case history, observes patient in play or other situations, and selects, administers, and interprets projective and other psychological tests to diagnose disorder and formulate plan of treatment. Treats psychological disorders to effect improved adjustment through psychodrama, play therapy, and other techniques of individual and group therapy. Selects approach to use in individual therapy such as directive, nondirective, and supportive therapy and plans frequency, intensity, and duration of therapy.

May collaborate with PSYCHIATRIST, PEDIATRICIAN, SOCIAL WORKER, PSYCHIATRIC, and other specialist in developing treatment program for patients, based on analysis of clinical data. May instruct and direct students serving psychological internships in hospitals and clinics. May develop experimental design and conduct research in field of personality development and adjustment and on problems of diagnosis, treatment, and prevention of mental illness. May serve as consultant to social, educational, welfare and other agencies on individual cases or in evaluation, planning and development of mental health programs. May specialize on one of the following: behavior problems, crime and delinquency, group therapy, individual diagnosis and therapy, mental deficiency, objective tests, projective techniques, and speech pathology. A Clinical Psychologist is identified as an individual who is working in the field of clinical psychology and who meets one of the following criteria: (1) is a diplomat in clinical psychology of the American Board of Examiners in Professional Psychology; (2) is a fellow of the Division of Clinical and Abnormal Psychology of the American Psychological Association; or (3) holds a Ph.D. degree in clinical psychology.

- (8\*) Sanitarian. Interprets and enforces sanitation laws and regulations to protect and promote public health. Inspects and investigates sanitation facilities and conditions in such places as dwellings, water supply and sewerage plants, recreational areas, industrial plants, barber shops, beauty salons, and food processing and serving establishments to determine compliance with standards. Takes samples of such materials as water, food, and air and performs or orders a variety of chemical, physical or biological tests for contamination. Formulates plans and oversees notices and orders, and follows up on compliance. Collaborates with public health personnel in epidemiology survey, analyses, and control programs. Reviews and makes recommendations on sanitary laws and regulations. Plans, organizes and conducts training programs in sanitary practices for such personnel as food handling, pest extermination and recreational workers. Confers with governmental, community, industrial, and civil defense personnel and organizations to interpret and promote sanitation standards and practices. In some states, may be required to hold license or be registered. When employed by public health agency, is known as PUBLIC HEALTH SANITARIAN. In large public agencies, and in industry, may be designated according to specialization, as FOOD AND INDUSTRIAL SANITARIAN (profess. and kin.), HOUSING SANITARIAN (profess. and kin.), MILK SANITARIAN (profess. and kin.).
- (9\*) Podiatrist (Medical ser.) 0-39.901. Chiropodist, Foot Specialist. Diagnoses and treats diseases and deformities of human foot. Diagnoses foot ailments such as tumors, ulcers, fractures, skin or nail diseases, and congenital or acquired deformities, utilizing such medically accepted methods as urinalysis, blood tests, and X-ray analysis. Treats deformities such as flat or weak feet and foot imbalance by mechanical methods such as whirlpool or paraffin baths, or by electrical methods such as short wave and low voltage currents. Treats conditions such as corns, calluses, ingrowing nails, tumors, shortened tendons, cysts, and abscesses by surgical methods including suturing, medications, and administration of local anesthetics. Does not perform amputations of the foot. Corrects deformities by means of plaster casts and strappings. Makes and fits prosthetic appliances. Prescribes corrective footwear. Refers patients to PHYSICIAN when symptoms observed in feet and legs evidence systemic disorders such as arthritis, heart disease, diabetes or kidney trouble. May treat bone, muscle and joint disorders limits to feet and be known as PODIATRIST; children's foot diseases and be known as PODOPEDIATRICIAN; or perform surgery and be known as PODIATRIC SURGEON.

Health-2, Request for Release of Health End Item Inventories

To: Producers and Wholesalers of Health End Items

Local governments in this State, in accordance with State policies and guidance, have identified and authorized health facilities in their jurisdictions to certify their purchase orders for health end items.

Retail distributors have been instructed to accept and make deliveries to fill these certified orders. They have been authorized to certify their purchase orders to resupply their inventories.

Wholesale distributors have been instructed to accept and make deliveries to fill certified orders received from retailers and institutions and to certify their purchase orders on producers.

Producers are requested to accept and deliver against these certified orders within the quantities of health end items in their inventories that are available for use in this State.

\_\_\_\_\_  
(Effective Date)

\_\_\_\_\_  
(Signature)

State Coordinator or District Director  
of Disaster Health and Medical Services

Health-3, Adjustment of Deliveries, Form 1

To: Wholesaler of Health End Items

Shortages in supplies of health end items have been reported from the following localities in your distribution area:

Summary of Local Deficiencies in Weekly Resupply of Health End Items	
Locality	Name of Item
Fairlie Fairview Fairy Etc.	
<p>You are directed to adjust your local deliveries to correct the deficiencies indicated above.</p> <p>Please advise this office the increase in deliveries you can make in this way to the named communities.</p> <p>_____ (Date)</p> <p>_____ (Signature) State Coordinator or District Director of Disaster Health and Medical Services</p>	

Health-3, Adjustment of Deliveries, Form 2

To: State Coordinator or District Director of Disaster Health and Medical Services

Resupply of recondary inventories of health end items in this local jurisdiction is inadequate to meet present and anticipated needs of essential health facilities and essential local users.

Authorized local uses and use levels have been cut back as far as possible by local government decision and action.

Assistance is needed to increase the level of resupply to this local jurisdiction as quickly as possible.

Following are estimated increases in weekly deliveries required to meet essential local needs for health end items.

Request for State Assistance Resupply of Health End Items		
Health End Items	Unit of Measure	Increase in Weekly Deliveries
1. (name of item)		
2.		
3.		

\_\_\_\_\_  
(Date)

\_\_\_\_\_  
(Name of Head of Local Government)

By: \_\_\_\_\_  
(Signature)  
Local Disaster Health and Medical  
Services Official

Health-4, Request for Health Manpower

To: State Coordinator or District Director of Disaster Health and Medical Services

The supply of health manpower in this local jurisdiction is inadequate to meet present and anticipated needs for health manpower.

Assistance is needed as quickly as possible.

Following is a detailed list of the needs for health manpower.

Request for Health Manpower	
Number	Occupational Code Number
	(Note: It is intended that the U.S. Department of Labor's occupational code be used here. The relevant part of this code is included in Attachment 2, of Health-1.)

\_\_\_\_\_  
(Date)

\_\_\_\_\_  
(Name of Head of Local Government)

By: \_\_\_\_\_  
(Signature)  
Local Disaster Health and Medical  
Services Official

Health-5, Estimate of Continuing Health End Item Requirements

Form 1 attached to this emergency action document contains data on quantities of health end items that will be required in each Disaster Health and Medical District for a 90-day period commencing           (date)          .

The requirements stated include the quantities of health end items to be supplied by producers, wholesalers, and local distributors to fill authorized orders of essential health facilities, and individual consumers.

These requirements do not include quantities of health end items needed by essential facilities such as large military installations and bases that obtain their requirements directly from producers. These latter requirements are the responsibility of the relevant Federal agency.

These estimates will be prepared by each District Director of Disaster Health and Medical Services and will be forwarded to the State Coordinator of Disaster Health and Medical Services as soon as practicable.

The purpose of these State requirements estimates is to determine and anticipate quantities of health end items needed from primary sources under Federal jurisdiction to resupply secondary stocks under State and local government jurisdiction.

Definitions

**Civilian Requirements:** Include the health and items needed to carry on emergency civil defense operations to maintain essential local activities and to supply individual consumers under the consumer rationing system. These civilian requirements estimates are provided by appropriate health officials.

**Military Requirements:** Include the health end items needed to carry on military activities. They include only the supplies that are to be obtained from wholesale and retail distributors. These military requirements estimates are provided by appropriate military officials.

Health-5, Form 1

Summary of Continuing Requirements for Health End Items for District <u>                    </u> For 90-Day Period Commencing <u>          (date)          </u>									
	Civilian			Military			Total		
	Total 90 Days	First 30 Days	Following 60 Days	Total 90 Days	First 30 Days	Following 60 Days	Total 90 Days	First 30 Days	Following 60 Days
Name of Item									
Name of Item									
(Add Items as Necessary)									

Health-6, Allocation of Health End Items

Allocation of Expected Continuing Supplies of Health End Items For the 90-Day Period Commencing _____ (date)									
	Civilian			Military			Total		
	Total 90 Days	First 30 Days	Following 60 Days	Total 90 Days	First 30 Days	Following 60 Days	Total 90 Days	First 30 Days	Following 60 Days
Name of Item									
Name of Item									
(Add Items as Necessary)									

Health-7, Revised State Health Resources Policy

(Note: The content and substance of the revised health resources policy will depend on the situation and the supplies of health resources. Necessarily, this document will not be completed except in a test of the plan or at the appropriate point in a postattack situation.)

This document will be, in essence, a Revised Health-1, State Health Resources Policy and Guidance, contained here.

Health-8, Health Services Support Requirements

Estimate of Health Services Support Requirements for District _____ For 90-Day Period Commencing _____ (date)				
Resource	Unit of Measure	First 30 Days	Following 60 Days	Total 90 Days
Electric Power				
Petroleum Products				
Transportation				
Gas				
Water				

Health-9, Health Services Construction Requirements

To: State Construction Organization

Following is a list and description of major construction, repair and modification of facilities that will be required to maintain desired supply of health resources during the 90-day period commencing \_\_\_\_\_ (date).

Construction Projects

1. Name, location, type and size of construction project. Start and completion dates. (If project is underway or a construction contract has been prepared, attach a copy of the contract document and summary bill of materials.)
- 2.
- 3.
- 4.

Health-10, Allocation of Supporting Resources to Health Services

To:

Attached is a list and the quantities of supporting resources that have been allocated for maintaining essential health services.

This is furnished as a basis for authorizing these facilities to obtain continuing supplies of these resources during the allocation period.

(Attach list.)

---

Health-11, Authorization to Obtain Supporting Resources

To: (Name of Wholesale Distributor)

You are hereby authorized to obtain the supporting resources in the quantities specified in the attached list.

Resource	Unit of Measure	First 30 Days	Following 60 Days	Total 90 Days
Electric Power				
Petroleum Products				
Transportation				
Gas				
Water				

In placing orders for the above supporting resources, you are authorized to use the following certification:

"This is an essential order authorized by the State Coordinator of Disaster Health and Medical Services."

\_\_\_\_\_  
(signed)  
Purchaser

\_\_\_\_\_  
(signed)  
State Coordinator of Disaster Health and Medical Services

---

Reference Document Number 1

End Item Producer Facilities in the State

See: Directory of Texas Manufacturers  
Bureau of Business Research  
The University of Texas

**PART B - RESOURCE SECTIONS**

**VII. Industrial Production**

**B-VII**  
Industrial Production

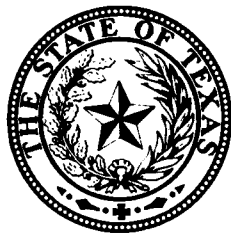

**Texas  
Emergency  
Resource  
Management**

**PLAN**



## INTRODUCTION

### General

This section of the State Emergency Resource Management Plan contains policies, guidance and actions to provide essential items to meet urgent needs in the State in a nuclear attack emergency or crisis relocation of the population.

The process for managing industrial resources in the State in a nuclear attack emergency or crisis relocation involves two series of actions. First, essential immediate needs are identified and actions taken to supply these needs. Secondly, and as soon as possible, continuing needs and expected future supplies are estimated. Decisions are made and actions are taken to channel these expected future supplies to meet the continuing needs that are most essential to survival and recovery of the State and the Nation.

This plan prescribes certain emergency actions and contains a more detailed discussion of the problems to be solved and the actions to be taken in the following functional areas:

Administration

Distribution

Production

The description of each of the functional areas is presented in two parts, preattack actions and postattack actions.

Before the plan can be considered to be operational, additional preparation, as prescribed in the advance planning sections for each functional area, must be completed. After the advance planning is accomplished, detailed advance preparation must be done. This, also, is described for each functional area. Finally, the necessary postattack actions are described.

### Definitions

- a. Essential items. See Annex A
- b. Primary essential item inventories. Essential items in producer and interstate wholesale distributor inventories.
- c. Secondary essential item inventories. Essential items in intrastate wholesale distributor and retail inventories.
- d. Certified orders. Purchase orders, contracts or other requests for resources which bear a signed certification that the order is an essential order authorized pursuant to Federal Government emergency regulations or State authorizations.
- e. Essential Users: (1) Individuals, both civilian and military, engaged in producing or providing essential items, products, care or services, e.g., doctors providing professional medical diagnoses, treatment and services; farmers producing essential food; military personnel engaged in immediate retaliatory or defense operations. (2) Organizations or establishments engaged in essential activities or providing essential items or services.
- f. Essential Facilities: (1) Military establishments engaged in immediate retaliatory or defense operations; (2) electric power, gas and water utility systems; (3) industrial plants producing or processing essential items; (4) major wholesale establishments storing or distributing essential items; and (5) transportation or communication systems providing essential services.
- g. Individual Consumers: Individuals who depend on local distribution systems (retailers and dealers) for essential supplies for individual and family use.

STATE OF TEXAS  
EMERGENCY RESOURCE MANAGEMENT PLAN  
PART B-RESOURCE SECTIONS  
VII-INDUSTRIAL PRODUCTION

### 1. Purpose and Activation

- a. The purpose of the instructions contained in this section is to establish an emergency organization to prepare, provide and supervise policies and guidance and to prescribe actions to insure provision, to the extent possible, of essential items to meet urgent needs in the State in a nuclear attack emergency.
- b. The provisions of this plan will be activated by the Governor of the State of Texas or his legal successor upon declaration of a national emergency for civil defense purposes. (See Part A.)

### 2. Concept of Operation

Federal, State and local governments have specific roles in the emergency management and supply of essential items in the State, and government at each level must be prepared to function independently of the others in event of a nuclear catastrophe.

#### Federal Government

The Federal Government is responsible for working with industry to assure maximum production and the release of essential items in producer and interstate wholesale inventories in the State to meet essential needs of the State of Texas as well as to meet essential needs of other States which depend on these inventories for essential item supplies. The Federal government is also responsible for arranging for the distribution of essential items in primary inventories in other states to meet essential needs in the State of Texas when this is necessary in an emergency.

The Office of Industrial Mobilization (OIM) of the United States Department of Commerce has 40 field offices throughout the country and, in addition, has designated officials in the states for this purpose. These Federal representatives arrange with producers of essential items for maximum production. They also work with these producers and interstate wholesalers to assure a continuing supply of essential items to meet essential needs in this State as well as in other states.

OIM has the responsibility for actions with respect to the production and distribution of products, materials, facilities and services related to production and construction, except for food and the domestic distribution of farm equipment and commercial fertilizer which are the responsibility of the Department of Agriculture, and petroleum, gas, solid fuels, electric power and certain minerals which are the responsibility of the Department of the Energy. Appendix 1 to Annex A contains a list of the items which have been determined to be essential for survival.

OIM performs its emergency responsibilities by exercising the priority and allocation powers under the Defense Production Act of 1950, as amended. The broad authority provided by the Defense Production Act permits OIM to direct and control industrial production, distribution and construction by taking the following types of actions:

- a. Issuance of regulations and orders controlling the production, use and distribution of products, materials, and the construction and use of related facilities.
- b. Authorization of the use of priorities.
- c. Establishment of mandatory preference in the performance of contracts or orders.
- d. Mandatory rescheduling of production and deliveries.
- e. Issuance of mandatory "set-aside" orders requiring suppliers to reserve part of production or stocks for designated purposes.
- f. Allocation of facilities for specified production.
- g. Establishment of inventory restrictions including freezing of inventories.
- h. Allocation of materials to designated purchasers or classes of purchasers.
- i. Issuance of production and distribution directives to require specific actions on the part of individuals or individual companies.

In taking any of the foregoing types of actions to carry out its emergency responsibilities, OIM cooperates closely with the State resource organization, if and when both are functioning, and looks to them for full support. OIM will issue Emergency Regulations in an emergency which will:

- a. Provide automatic purchase priorities for the use of companies and persons producing survival items and furnishing essential service to obtain maintenance, repair and operating supplies; capital equipment; and production materials. These regulations will require neither the submission of applications nor specific government authorization and will serve as an interim emergency measure.
- b. Limit the distribution of inventories of selected finished survival items to the filling of priority orders or by specific authorization of appropriate government authority in order to avoid dissipation of existing supplies.

In addition, OIM, in cooperation with the State Industrial Production Resource Agency, will provide emergency assistance to essential government activities, producers of essential items and suppliers of essential services in locating sources of supply and expediting deliveries of needed products, materials and services.

Federal plans provide that immediately postattack, OIM, as the emergency production agency, puts into effect emergency regulations designed to implement National policy. These emergency regulations are issued by authorized OIM officials at the Department of Commerce regional or field office level, under the authority delegated by OIM Emergency Delegation Number 1. These emergency regulations provide automatic purchase priorities for producers of essential items and suppliers of essential services to obtain production materials, maintenance, repair and operating supplies and capital equipment. These regulations freeze inventories of selected finished essential items and provide for their release to fill priority orders or under specific authorization of appropriate governmental authority.

During this initial period in which great dependence may be placed on automatic Federal controls, the State Industrial Production Resource Agency will be called upon to provide full support to the State civil defense authority, the State rationing authority, producers of essential items, and providers of essential services in locating sources of supply within the State. As soon as conditions permit and national control has been re-established, OIM will call upon the State Industrial Production Resource Agency to furnish data relating to remaining supplies of and requirements for essential items within the State. On the basis of the supply-requirements data provided by each State, OIM will determine the supplies which can be allocated to each State for emergency distribution within its jurisdiction.

The OIM has arranged through the Employment and Training Administration (ETA) of the U. S. Department of Labor for the various State Employment Security Agencies to provide aid to the State Industrial Production Resource Agency in obtaining information concerning surviving production capabilities and survival item inventories in a postattack situation. Within the State of Texas, the Texas Employment Commission performs the functions of the State Employment Security Agency.

#### State Government

The State Industrial Production Resource Agency and its 6 region and 17 district organizations will develop, in cooperation with other organizations of the State government, and provide, on behalf of the Governor, policies and guidance consistent with State and Federal objectives. The purpose of these policies and guidance is to assure application throughout the State of compatible measures for the conservation, distribution and use of essential items to prevent dissipation and waste and to assure that

essential needs for these essential items are identified and met within the supplies available.

The industrial production resource organization will act upon requests for State level assistance from local government officials and arrange through OIM representatives, subject to the availability of that agency, with producers and interstate wholesalers to adjust deliveries of essential items to correct local shortages in supply. When the OIM organization or its control is ineffective, the State agency performs this task. The State Industrial Production organization will also work with intrastate wholesale distributors and retailers to correct these local shortages. As soon as possible after an attack, the State Industrial Production Resource Agency, in collaboration with other State agencies representing major activities within the State that consume essential items, will anticipate future continuing needs and work with available OIM representatives to assure that arrangements are made with the primary industry to provide essential items to meet ongoing demands of authorized essential users.

The State Industrial Production Resource Agency is responsible for assisting and cooperating with OIM in carrying out Federal policy with respect to the emergency management of industrial production and distribution. It is also responsible for directing the distribution and use of essential items with respect to supplies of such items allocated by OIM to the State of Texas, by the assignment of such supplies to the various State of Texas emergency organizations for distribution to ultimate users.

In the event OIM is unable to function in the State in the immediate postattack period, the State Industrial Production Resource Agency assumes, on behalf of the Federal Government, the responsibility for working directly with the producers and interstate wholesalers of essential items until Federal capability is re-established.

The State Industrial Production Resource Agency will be expected to coordinate its activities with those of neighboring states in correcting deficiencies of essential survival items. This action would be in accordance with the authority noted in Paragraph 4 of Annex A to Part A of the State Texas Emergency Resource Management Plan.

The Texas Employment Commission will provide assistance to the State Industrial Production Resource Agency in obtaining information concerning surviving production capabilities and survival item inventories in a postattack situation.

#### Local Government

The State of Texas Disaster Plan and Emergency Operations Plans of its political subdivision contain provisions for the conservation, distribution and use of essential items in secondary inventories within the State. These plans also provide for local government decisions and guidance, consistent with State policies, for the functioning of the secondary essential item distribution system in the localities in the State. Local governments, when implementing the provisions of the State of Texas Emergency Resource Management Plan, will be familiar with the provisions of Section VII, Industrial Production, and the State organization established therein, and insure coordination therewith.

### 3. Emergency Actions

The following actions are taken on behalf of the Governor at State, region and district levels by State industrial production officials to provide policies and guidance applicable throughout the State on the distribution and use of essential items and to arrange for resupply of secondary inventories from primary sources to meet essential local needs.

The emergency actions, as listed in this section, have been expanded in greater detail in Annex B, specifically as pertains to:

- A. Administration
- B. Distribution
- C. Production

The emergency action and reference documents contained here have been prepared and placed with appropriate State and local officials during the preattack planning process by the State Industrial Production Resource Agency.

#### a. Preattack Actions

The Coordination of the State Industrial Production Resource Agency shall:

##### (1) As soon as possible after this plan is adopted:

- (a) Prepare a roster of the interstate wholesale distributors of the essential items. (Refer to Procedures B, Appendix 1 to Annex B to this plan.)
- (b) Prepare preprinted inventory forms to develop inventory information. (Refer to Procedures, B, Appendix 1 to Annex B.)
- (c) Prepare and maintain rosters of the Texas producers of essential survival items. (Refer to Procedures C, Appendix 1 to Annex B.)
- (d) Make arrangements with the other resource agencies for the proper requisitioning of emergency resources to support industrial production. (Preattack-1, Emergency Resources Requirements--refer to Procedures C, Appendix 1 to Annex B to this plan.)
- (e) Provide claimant agencies with the list of essential survival items for which industrial production is responsible (Appendix 2 to Annex A) and the forms to be used in estimating essential items requirements. (Preattack-2, Essential Items Requirements--refer to Procedures B, Appendix 1 to Annex B to this plan.)
- (f) Make a survey of the production capabilities of the producers of essential items. (Pre-attack-3, Production Capability, Annex C--refer to Procedures C, Appendix 1 to Annex B to this plan.)
- (g) Prepare all necessary emergency communications. (Refer to Appendix 1 to Annex A to this plan.)

- (h) Assure the appointment of qualified personnel to all positions within the organization through the level of Managers of District Production Sections and Managers of District Distribution Sections. (Refer to Procedures A, Appendix 1 to Annex B.)
- (2) At a time of imminent danger, and at the direction of the Governor:
  - (a) Place a supply of production capability forms and inventory forms in the offices of the producers and wholesale distributors of essential items. (Preattack-4, Supply of Essential Survival Items, Annex C--refer to Procedures B and C, Appendix 1 to Annex B to this plan.) This communication also will include an alerting of the producers and wholesalers of essential items and local government officials.
  - (b) Obtain a copy of the roster of the interstate wholesale distributors of the essential items from the Regional Office of the OIM. (Refer to Procedures B, Appendix 1 to Annex B to this plan.)
  - (c) Place a supply of the forms to estimate requirements of essential items in the offices of claimants. (Refer to Procedures B, Appendix 1 to Annex B to this plan.)

b. Postattack Actions

(1) Actions for Immediate Supply

The Coordinator of the State Industrial Production Resource Agency shall:

- (a) Issue, on behalf of the Governor, policies and guidance, applicable throughout the State, covering the provision, distribution, and use of essential items within the State. (Prod-1, Essential Items Policy, Annex C--refer to Procedures A, Appendix 1 to Annex B.)
- (b) Notify all elements of the Industrial Production Resource Agency of the activation of the plan. (Prod-2, Emergency Communications, Annex C--refer to Procedures A, Appendix 1 to Annex B.)
- (c) Notify all producers and interstate wholesale distributors of the activation of the plan. (Prod-3, Supply of Essential Survival Items, Annex C--refer to Procedures A, Appendix 1 to Annex B.)
- (d) Confirm with the State office of OIM that the Federal emergency regulations have been issued requiring producers and interstate wholesalers to make deliveries on authorized orders received from customers in the State.  
Assist the OIM in the distribution of Federal emergency regulations to acquaint authorized persons with the provisions of these regulations. (Prod-4, Request for Release of Primary Inventories, Annex C--refer to Procedures B, Appendix 1 to Annex B to this plan.)
- (e) Make an assessment of secondary inventories in intrastate wholesale distributor and retail stocks. (Prod-8, Inventories Annex C--refer to Procedures B, Appendix 1 to Annex B.)
- (f) Request the State office of OIM to arrange for increases where needed in deliveries by producers and interstate wholesalers of essential items to resupply local inventories to meet shortages reported by local governments. (Prod-5, Adjustment of Primary Deliveries, Annex C--refer to Procedures B, Appendix 1 to Annex B to this plan.)
- (g) Provide emergency assistance to locate sources of supply and to expedite deliveries of industrial products, materials, and services needed to maintain operations of essential local users and essential facilities. (Prod-6, Request for Immediate Needs of Essential Items, Annex C--refer to Procedures B and C, Appendix 1 to Annex B to this plan.)

(2) Actions for Continuing Supply

As soon as resupply of secondary inventories to meet essential immediate needs in the localities is underway, the State industrial production organization will take the following actions to anticipate continuing needs and to arrange for continuing supply to meet these needs:

- (a) Consult with State civil defense officials, Federal military officials, and appropriate State resource officials to estimate continuing requirements of essential items that will be needed in the State during the ensuing 90-day period. (Prod-7, Estimate of Continuing Essential Items Requirements, Annex C--refer to Procedures B, Appendix 1 to Annex B to this plan.)
- (b) Obtain reports from producers and interstate wholesalers on quantities of essential items in inventories and additional supplies of the items that can be furnished from new production in the State during the ensuing 90-day period. (Prod-8, Inventory of Essential Survival Items and Prod-9, Production Capability Form, Annex C--refer to Procedures B and C, Appendix 1 to Annex B to this plan.)
- (c) Request OIM to decide on and allocate quantities of essential items for use in the State during the ensuing 90-day period. (Refer to Procedures B, Appendix 1 to Annex B to this plan.)
- (d) If anticipated supplies are inadequate to meet the estimated requirements and adjustments in requirements cannot be negotiated, refer to the Resource Priorities Board for recommendations to the Governor on the allocation of anticipated supplies among competing programs. (Refer to Procedures B, Appendix 1 to Annex B to this plan.)
- (e) Issue revised State policy on the use of essential items in the State to conform with the Governor's decision. (Prod-10, Revised State Essential Items Policy, Annex C--refer to Procedures B, Appendix 1 to Annex B to this plan.)

- (f) Assign quantities of essential items available in the State to appropriate agencies and authorize them to use, or to authorize others to use, certified orders to procure from wholesale and retail distributors quantities of the items assigned to them. (Prod-11, Assignment of Essential Items, Annex C--refer to Procedures B, Appendix 1 to Annex B to this plan.)
- (g) Develop estimates of continuing requirements for electric power, manpower, transportation, petroleum products and other operating supplies, equipment and services that will be needed to maintain operations of essential item production and wholesale facilities in the State during the ensuing 90-day period.
- Consult with OIM as to the most practical methods and the most expeditious techniques for securing this information. Present these requirements estimates to appropriate State resource organization. (Prod-12, Essential Items Industry Support Requirements, Annex C--refer to Procedures C, Appendix 1 to Annex B to this plan.)
- (h) Develop estimates of emergency repair and construction of primary essential item facilities that will be required during the ensuing 90-day period and present these requirements estimates to the State construction organization. Consult with OIM as to the most practical methods and the most expeditious techniques for securing this information. (Prod-13, Essential Items Industry Construction Requirements, Annex C--refer to Procedures C, Appendix 1 to Annex B to this plan.)
- (i) Inform the OIM State office of supplies of supporting resources that will be available in the State for acquisition and use by essential items producers and wholesalers to maintain essential operations during the ensuing 90-day period. (Prod-14, Allocation of Supporting Resources to Essential Items Production and Interstate Wholesale Distribution Industry, Annex C--refer to Procedures B, Appendix 1 to Annex B to this plan.)

ANNEX A  
ESSENTIAL ITEMS

"Essential Items" are processed or manufactured products and materials that are required for consumption and use by people for survival or are required to carry on essential survival and recovery activities in a nuclear attack emergency. The essential items with which the State Industrial Production Resource Agency (SIPRA) is directly concerned include health supplies and equipment, body protection and household operation equipment and supplies, light, power, and fuels equipment and supplies, sanitation and water supply items, and emergency housing and lodging materials and equipment. In order to clarify the responsibility of the Industrial Production Resource Agency with respect to the production and distribution of "Essential Items," two appendices define: First, essential survival items list as published by the U. S. Department of Commerce; Second, the essential survival items for which industrial production is responsible. The only items which are in the Department of Commerce list but which are excluded from industrial production responsibility are the following:

Category II

Group A -- All items are the responsibility of the Food Agency.

Group B -- Seed and livestock feed are the responsibility of the Food Agency.

Category IV

1. Electric Power

Group A -- Electricity - This is the responsibility of the Electric Power Agency.

2. Petroleum Products

Group A -- All items are the responsibility of the Petroleum and Gas Agency.

3. Gas

Group A -- All items are the responsibility of the Petroleum and Gas Agency.

4. Solid Fuels

Group A -- All items are the responsibility of the Petroleum and Gas Agency.

Category V

Group A -- Water - This is the responsibility of the Water Agency.

Essential Items Production and Interstate Wholesale Facilities

Reference Documents No. 1 and No. 2, shown in Annex E of this section, are roster of producers and interstate wholesale distributors of essential items located in this State which must be kept in operation to assure a continuing flow of essential items to meet survival and recovery needs. Preattack arrangements are to be made with appropriate authorities to assure provision of electric power, manpower, petroleum products, transportation, water, fuels and other locally available requisites for the continuing operation of these identified essential item facilities.

Health and Medical Resources

The production organization has been assigned responsibility for the production of all health and medical essential items. The physical distribution of these essential items also is the responsibility of the production organization; however, the Health and Medical Agency will determine the point of delivery. Coordination shall be between the District Distribution Directors and the District Health and Medical Resources Directors.

APPENDIX I TO ANNEX A

Defense Mobilization Order 8500.1A  
November 4, 1964  
EXECUTIVE OFFICE OF THE PRESIDENT  
OFFICE OF EMERGENCY PLANNING  
Washington, D. C. 20504  
DMO 8500.1A--GUIDANCE ON PRIORITY USE  
OF RESOURCES IN IMMEDIATE POSTATTACK  
PERIOD

1. Purpose. This Order (1) states the policy of the Federal Government on use of resources in the period immediately following a nuclear attack on the United States, (2) provides general guidance for Federal, State, and local government officials on activities to be accorded priority in the use of postattack resources, and (3) lists those items essential to national survival in the immediate postattack period.

2. Cancellation. Defense Mobilization Order 8500.1, Guidance on Priority Use of Resources in Immediate Postattack Period, dated April 24, 1964 (29 F. R. 5796) is hereby superseded.

3. General Policy. In an immediate postattack period all decisions regarding the use of resources will be directed to the objective of national survival and recovery. In order to achieve this objective, postattack resources will be assigned to activities concerned with the maintenance and saving of lives, immediate military defense and retaliatory operations, and economic activities essential to continued survival and recovery.

This guidance is designed to achieve a degree of national equity in the use of resources and to assign and conserve resources effectively in the immediate postattack period. Until more specific instructions are available, these are the general guidelines within which managerial judgment and common sense must be used to achieve national objectives under widely differing emergency conditions.

4. Responsibilities. As stated in The National Plan for Emergency Preparedness, the direction of resources mobilization is a Federal responsibility. However, in the period immediately following an attack, certain geographical areas may be temporarily isolated, and State and local governments will assume responsibility for the use of resources remaining in such areas until effective Federal authority can be restored. State and local governments will not assume responsibility for resources under the jurisdiction of a Federal agency where the Federal agency is able to function.

As soon as possible after an attack and until specific national direction and guidance on the use of resources is provided, Federal, State, and local officials will determine what resources are available, to what needs they can be applied, how they are to be used, and the extent to which resources are deficient or in excess of survival needs. They will base determinations as to the relative urgency for use of resources primarily upon the importance of specific needs of defense, survival, and recovery.

5. Priority activities in immediate postattack period. The following activities are to be accorded priority over all other claims for resources. There is no significance in the order of the listing--all are important. The order in which and the extent to which they are supported locally may vary with local conditions and circumstances. If local conditions necessitate the establishment of an order of priority among these activities, that order shall be based on determinations of relative urgency among the activities listed, the availability of resources for achieving the actions required, and the feasibility and timeliness of the activities in making the most rapid and effective contribution to national survival.

a. The immediate defense and retaliatory combat operations of the Armed Forces of the United States and its Allies: This includes support of military personnel and the production and distribution of military and atomic weapons, materials and equipment required to carry out these immediate defense and retaliatory combat operations.

b. Maintenance or reestablishment of Government authority and control to restore and preserve order and to assure direction of emergency operations essential for the safety and protection of the people: This includes:

- (1) Police protection and movement direction;
- (2) Fire defense, rescue and debris clearance;
- (3) Warnings;
- (4) Emergency information and instructions;
- (5) Radiological detection, monitoring and decontamination.

c. Production and distribution of survival items and provision of services essential to continued survival and rapid recovery. (For list of survival items, see Tab A to this order.) These include:

- (1) Expedient shelter;
- (2) Food, including necessary processing and storage;
- (3) Feeding, clothing, lodging, and other welfare services;
- (4) Emergency housing and community services;
- (5) Emergency health services, including medical care, public health and sanitation;
- (6) Water, fuel, and power supply;
- (7) Emergency repair and restoration of damaged vital facilities.

d. Essential communications and transportation services needed to carry out the above activities.

e. Provision of supplies, equipment, and repair parts to produce and distribute goods needed for the above activities.

6. Assignment of resources. Resources required for essential uses, including manpower, will be assigned to meet the emergency requirements of the priority activities indicated above. The principal objectives are to use available resources to serve essential needs promptly and effectively, and to:

- a. Protect and to prevent waste or dissipation of resources prior to their assignment to priority activities;

b. Support production of essential goods. Other production will be permitted to continue only from inventories on hand and when there is no emergency requirement for the resources vital to this production.

c. Support construction for emergency repair and restoration, construction of facilities needed for survival, or the conversion of facilities to survival use where this can be accomplished quickly. Other construction already under way should be stopped, and no new construction started unless it can be used immediately for essential purposes upon completion.

Dated: November 4, 1964.

Effective date: This order is effective the date of issuance.

EDWARD A. McDERMOTT,  
Director, Office of Emergency Planning.

Reprinted from the FEDERAL REGISTER of November 10, 1964 (29 F. R. 15123)

U. S. DEPARTMENT OF COMMERCE  
Washington, D. C.

ESSENTIAL SURVIVAL ITEMS LIST  
Tab 5

(DMO 8500.1A - November 4, 1964)

This document contains a listing of items considered essential to sustain life at a protected level to assure national survival in an emergency. The list identifies items to which major attention should be given in all phases of preattack planning to insure the availability of basic essentials for a productive economy in the event of a nuclear attack. Additionally, the items are identified to four digits of the Standard Industrial Classification (SIC) Code. Supply-requirements studies and assessments for these items will be made to disclose critical deficiencies or other problems that can be anticipated. Revisions will be made as necessary to keep the items as up-to-date as possible.

The items are arranged by seven major groups:

- (1) Health Supplies and Equipment
- (2) Food,
- (3) Body Protection and Household Operations,
- (4) Electric Power and Fuels
- (5) Sanitation and Water Supply
- (6) Emergency Housing and Construction Materials and Equipment, and
- (7) General Use Items.

Survival items are defined as "those items without which large segments of the population would die or have their health so seriously impaired as to render them both burdensome and non-productive." The items have been classified into Group A or Group B, with Group A representing end products consumed or used directly by the population, and Group B consisting of those items essential to the effective production and utilization of the Group A items, which are consumed or used directly by the people.

There are no Group B items in the Categories of Health Supplies and Equipment, Body Protection and Household Operations, and Emergency Housing and Construction Materials and Equipment. All of these items are considered to be consumed directly and any attempt to separate them into A and B groupings would be too arbitrary to be meaningful.

It is important to keep in mind the fact that while the items listed are the basic essentials necessary for maintaining a viable economy during the first six months following an attack, not all of them would create problems that would require government action preattack to insure adequate supplies. The aforementioned supply-requirements studies will be undertaken to identify the problem areas. In developing supply data, all available production capacity, existing inventories, and possible substitutions will be considered. For example, in analyzing clothing items, all available supplies would be considered from sport to dress shirts, from overalls to dress suits. However, new production would be limited to the simplest form of the basic item which can be produced. The final determination as to which of the items are most critical and which may require preattack actions by the Government, as well as the type of actions which must be taken, can be made only after a comprehensive supply-requirements analysis is completed.

LIST OF ESSENTIAL SURVIVAL ITEMS

<u>Item</u>	<u>SIC Number</u>	<u>Item</u>	<u>SIC Number</u>	<u>Item</u>	<u>SIC Number</u>
I. Health Supplies and Equipment		Blood derivatives	2831	Morphine and substitutes	2834
		Carbon dioxide absorbent	2834	Oral electrolytes	2834
		Cardiovascular depressants	2834	Oxygen	2834
Group A		Cardiovascular stimulants	2834	Surgical antiseptics	2834
		Corticosteroids	2834	Sulfa drugs	2834
1. Pharmaceuticals:		Diuretics	2834	Synthetic plasma volume expanders	2831
Alcohol	2834	General Anesthetics	2834	Vitamin preparations, pediatric	2834
Analgesics, non-narcotic.	2834	Hypnotics	2834	Water for injection	2831
Antibiotics and antibacterials	2834	Insulin	2834	2. Blood Collecting and Dispensing Supplies:	
Antidiabetic agents, oral	2834	Intravenous solutions for replacement therapy	2831	Blood collecting and dispensing containers (glass)	3221
Antihistamines	2834	Local anesthetics	2834		
Antimalarials	2834	Lubricant, surgical	2834		
Atropine	2834				

Blood donor sets	3841
Blood grouping and typing sera	2831
Blood recipient sets	3841
Blood shipping containers	2653
3. Biologicals:	
Diphtheria toxoid	2834
Diphtheria antitoxin	2834
Diphtheria and tetanus toxoids and pertussis vaccine	2834
Gas gangrene antitoxin	2834
Polio myelitis vaccine, oral	2834
Rabies vaccine	2834
Smallpox vaccine	2834
Tetanus antitoxin	2834
Tetanus toxoid, absorbed	2834
Typhoid vaccine	2834
Typhus vaccine, epidemic	2834
Yellow fever vaccine	2834
4. Surgical Textiles:	
Adhesive plaster	3842
Bandage, gauze	3842
Bandage, muslin	3842
Bandage, plaster of paris	3842
Cotton, USP	3842
Surgical pads	3842
Stockinette, surgical	3842
Wadding, cotton sheet	3842
5. Emergency Surgical Instruments and Supplies:	
Airway, pharyngeal	3841
Anesthesia apparatus	3841
Basin, wash, solution	3461
Blade, surgical knife	3841
Brush, scrub, surgical	3981
Catheter, urethral	3841
Containers for sterilization	3461
Chisel, bone	3841
Drain, Penrose	3069
Dusting powder	2834
Forceps, dressing	3841
Forceps, hemostatic	3841
Forceps, obstetrical	3841
Forceps, tissue	3841
Gloves, surgeon's	3069
Handles, surgical knife	3841
Holder, suture needle	3841
Inhaler, anesthesia, Yankauer (ether mask)	3841
Intravenous injection sets	3841
Knife, cast cutting	3841
Lamps, for diagnostic instruments	3641
Lamps, for surgical lights	3641
Laryngoscope	3841
Light, surgical, portable	3841
Litter	3842
Mallet, bone surgery	3841
Needles, hypodermic, reusable	3841
Needles, suture, eyed	3841
Otoscope and ophthalmoscope set	3841
Probe, general operating	3841
Razor and blades (for surgical preparation)	3421
Retractor, rib	3841
Retractor set, general operating	3841
Rongeur, bone	3841
Saw, amputating	3841
Saw, bone cutting, wire (Gigli)	3841
Scissors, bandage	3841
Scissors, general surgical	3841
Sigmoidoscope	3841
Speculum, vaginal	3841
Sphygmomanometer	3841
Splint, leg, Thomas	3842
Splint, wire, ladder	3842

Sterilizer, pressure, portable	3842
Stethoscope	3841
Sutures, absorbable	3842
Sutures, absorbable, with attached needle	3842
Sutures, nonabsorbable	3842
Sutures, nonabsorbable, with attached needle	3842
Syringes, Luer, reusable (hypodermic syringes)	3841
Thermometers, clinical	3821
Tracheotomy tube	3841
Tube, nasogastric	3069
Tubing, rubber or plastic, and connectors	3069
Vascular prostheses	3842
Webbing, textile, with buckle	2241
6. Laboratory Equipment and Supplies:	
Bacteriological culture media and apparatus	3811
Balance, laboratory with weights	3811
Blood and urine analysis instruments, equipment and supplies	3811
Chemical reagents, stains and apparatus	2815
	2899
	3811
Glassware cleaning equipment	2818
	2819
Laboratory glassware	3231
Microscope and slides	3831
Water purification apparatus	3811
Group B	
None	
II. Food:	
Group A	
1. Milk Group	
Milk in all forms, milk products. Important for calcium, riboflavin, protein, and other nutrients.	
2. Meat and Meat Alternate Group	
Meat, poultry, fish, eggs; also dry beans, peas, nuts. Important for protein, iron, and B-vitamins.	
3. Vegetable-Fruit Group, including	
1. Dark green and yellow vegetables. Important for Vitamin A.	
2. Citrus fruit or other fruit or vegetables. Important for Vitamin C.	
3. Other fruits and vegetables, including potatoes.	
4. Grain Products	
Especially enriched, restored, cereal and cereal products, and bread, flours, and meals. Important for energy, protein, iron, and B-vitamins.	
5. Fats and Oils	
Including butter, margarine, lard, and other shortening oils. Important for palatability and food energy; some for Vitamin A and essential fatty acids.	
6. Sugars and Syrups	
Important for palatability and food energy.	
7. Food Adjuncts	
Certain food adjuncts should be	

provided to make effective use of available foods. These include antioxidants and other food preservatives, yeast, baking powder, salt, soda, seasonings and other condiments. In addition, coffee, tea, and cocoa are important for morale support.

#### Group B

#### Food containers:

Glass	3221
Metal Cans	3411
Nitrogenous fertilizers	2871
Seed and livestock feed	0113
Salt for livestock	2899
Veterinary Medical Items:	
Anthrax vaccine	2834
Black leg vaccine	2834
Hog cholera vaccine	2834
Newcastle vaccine	2834

#### III. Body Protection and Household Operations:

#### Group A

#### 1. Clothing:

Gloves and mittens (all leather)	3151
(Knit)	2259
(Except knit and leather)	2381
Headwear	3151
Hosiery	2352
	2251
	2252

#### Outerwear:

Knit	2253
Men's, Youths' & Boys' suits, coats & overcoats	2311
Men's, etc. shirts (except workshirts)	2321
Men's etc. separate trousers	2327
Workclothing	2328
Men's, etc. outerwear n.e.c.	2329
Women, misses, juniors blouses, waists & shirts	2331
Womens, misses & juniors dresses	2335
Womens, etc. suits, skirts & coats, except fur coats and raincoats	2337
Women's etc. outerwear n.e.c.	2339
Girls, childrens & infants dresses, blouses, waists and shirts	2361
Girls, etc. coats & suits	2363
Girls, etc. outerwear, n.e.c.	2369
Shoes and other footwear:	
Rubber	3021
Leather	3141
Underwear:	
Knit (in knitting mills)	2254
Mens, youths, & boys	2322
Womens, misses, childrens & infants	2341



Corsets and all bed garments	2342	Switches and circuit breakers	3613	Trolley feeder wire	3357
Waterproof outer garments (rubber)	2389	Insulators	3229	Roof bolts	3452
			3264		
2. Personal Hygiene Items:		Pole line hardware	3644	V. Sanitation and Water Supply:	
Diapers, all types	2211	Poles and crossarms	2411	Group A	
Disposal tissues	2399	Transformers (distribution, transmission and mobile)	3612	1. Water	4941
First aid items (included on Health Supplies and Equip. List)	2647	Tools for live-circuit operations, including rubber protective equipment, and linemen's tools	3423	4971	
Nipples	3069	Utility repair trucks, fully equipped	3537	2. Water Supply Materials:	
Nursing bottles, all types	3229		3713	a. Coagulation:	
	3079	Prime mover generator sets up to 501 kilowatts and 2400 volts, including portable and mobile sets up to 150 kilowatts and 110/220/440 volts, 3-phase, 60-cycle complete with fuel tank and switchgear in self-contained units	3717	Ferric chloride	2819
Pins	3964			Ferrous sulfate	2819
Sanitary napkins	2649	2. Petroleum Products		Ferric sulfate	2819
Soaps, detergents and disinfectants	2841	Group A		Chlorinated copperas	2819
	2842	Gasoline	2911	Filter alum.	2819
Toilet tissue	2647	Kerosene	2911	Hydrated lime	3274
3. Household Equipment:		Distillate fuel oil	2911	Pulverized limestone	3295
Bedding:		Liquefied petroleum gas	2911	Soda ash	2812
Blanketing & blankets	2211	Lubricating oil	2911	b. Disinfection Chemicals:	
	2221	Grease	2911	High-test hypochlorites (70 percent) in drums, cans	
	2231	Residual fuel oil	2911	ampules	2819
Sheets & pillowcases	2211			Iodine tablets	2842
	2221	Group B		Liquid chlorine, including containers	2812
	2392	Storage tanks	3443	Chlorine compounds (not gas)	2819
Pillows	2392	Pumps for loading and unloading	3561	c. Miscellaneous Materials:	
Comforters, padded quilts, and sleeping bags	2399	Pressure containers and fittings for liquefied petroleum gas	3443	Diatomaceous earth	3295
Canned heat	2899	3. Gas		Activated carbon	2819
Cots	2514	Group A		3. Chemical, Biological, and Radiological (CBR) Detection, Protection, and Decontamination Items:	
Hand sewing equipment	3964	Natural gas	1311	Calibrators	3821
Heating and cooking stoves	3433		4923	Chemical agent detection kits air, food, and water	3811
	3631	Manufactured gas	2911	Dosimeters and chargers	3821
Incandescent hand portable lighting equipment (including flashlights, lamps, batteries)	3642		4925	Protective masks, clothing helmets	3842
Kitchen, cooking, and eating utensils	3262	Group B	5983	Survey meters (Alpha, Beta, Gamma)	3821
	3421	Various sizes of pipe (mostly steel)	3317	Warning signs-biological, chemical, & radiological contamination	3993
	3461	Various sizes of valves, fittings, and pressure regulators	3494	4. Insect and Rodent Control Items:	
	3914	Specialized repair trucks and equipment	3713	a. Insecticides:	
	3079		3717	DDT, water dispersible powder (75 percent)	2879
Lamps (incandescent medium base) and lamp holders	3641	4. Solid Fuels		Lindane powder, dusting (1 percent)	2879
Matches	3983	Group A		Malathion, liquid, emulsifiable concentrate (57 percent)	2879
Nonelectric lighting equipment	3642	Coal	1111	Deet (diethyltoluamide) 75 percent in denatured alcohol	2842
Sleeping bags	2399	Coke	2911	Phrethrum	2879
			3312	b. Rodenticides:	
Group B				Anticoagulant type ready-mixed bait	2842
None		Conveyor belting	3069	"1080" (sodium monofluoroacetate) (for controlled use only)	
IV. Electric Power and Fuels:		Insulated trail cables	3535	5. General Sanitation:	
1. Electric Power			3357	Lye	2812
Group A				Group B	
Electricity	4911			1. General Supplies and Equipment:	
Group B				Chemical feeders	3559
Conductors (copper and/or aluminum), including bare cable for high voltage lines and insulated wire or cable for lower voltage distribution circuits	3357			Mobile and portable pressure filters	3569
				Chlorinators (gas and hypochlorites)	3589

Pumps and appurtenances, Hand-Electric-Gasoline- Diesel	3561	Lumber and allied products: Rough lumber	2421	Pipe installation materials and equipment	3423
Well-drilling equipment	3533	Dressed "inc. siding, ceiling	2421	Refrigerators, mechanical	3632
Well casing	3321	Other lumber, inc. soft flooring	2421		3585
	3317	Hardwood flooring	2426		
Drive pipe endpoints	3317	Plywood	2432		
2. Storage and Transport Equipment:		Millwork	2431		
Lyster bags	3069	Windows	2431		
Storage tanks, collapsible and portable	3069	Doors	2431		
Storage tanks, rigid, trans- portable	3443	Other Millwork	2431		
Storage tanks, wood stave, knock-down	2499	Masonry products-brick, cement, lime, concrete block, hollow tile, etc.	3251 3271 3241		
3. Laboratory equipment and Supplies:		Translucent window coverings	2821 3079		
Membrane filter kits with filters and media	3811	Water pipe and hose, plus fit- tings-all types including fire hose	3069 3079 3272		
Chlorine and pH determin- ation equipment	3811		3292 3321 3317 3321 3351 3569		
4. Sanitation Equipment:		Group B			
Hand sprayer, continuous type	3522	None			
Hand sprayer, compression type	3522				
Hand duster, plunger type	3522				
Spraying equipment for use with helicopter, fixed- wing light aircraft, high- speed fixed-wing attack aircraft, and cargo type aircraft	3522				
VI. Emergency Housing and Construction Materials and Equipment		VII. General Use Items			
Group A		Group A			
Asphalt and tar roofing and siding products	2952	Group B			
Builders hardware-hinges, locks, handles, etc.	3429	Batteries, wet and dry cell	3692		
Building board, including in- sulating board, and lamin- ated fiberboard	2661	Bulldozers	3531		
Hard pressed fiberboard	2499	Fire fighting equipment	3713 3717		
Gypsum board	3275	Light equipment and hand tools (including electric powered)	3423		
Asbestos cement (flat sheets & wallboard)	3292	for carpentry, masonry, plumbing, and excavation	3548		
Building papers	2661	Rigging tools-cables, ropes, tackle, hoists, etc.	3429		
Plastic patching	3079	Tank railroad cars	3742		
Couplings, clamps, for emergency repairs	3429	Tank trucks and trailers	3715		
Plumbing fixtures and fittings	3432	Tires	3011		
Prefabricated emergency housing	2433	Trenching equipment	3531		
Rough hardware-nails, bolts screws, etc.	3452	Truck tractors and trailers, including low bed	3715 3717		
Sewer pipe and fittings	3321 3259 3272	Trucks up to five tons (25 percent equipped with power takeoff)	3717 3537		
Tents and tarpaulins; canvas, plastics, and other similar materials	2211 2394	Welding equipment and sup- plies (electric and acety- lene)	3623 3548		

ESSENTIAL SURVIVAL ITEMS  
FOR WHICH INDUSTRIAL PRODUCTION IS RESPONSIBLE

<u>OIM Industry Division</u>	<u>Essential Survival Item</u>	<u>Code Numbers</u>
AGRICULTURAL, CONSTRUCTION, MINING, AND OIL FIELD EQUIPMENT:		
Agricultural Machinery and Implements (AGRI)	Hand sprayer, continuous type	3522
	Hand sprayer, compression type	3522
	Hand duster, plunger type	3522
	Spraying equipment for use with helicopter, fixed-wing light aircraft, high-speed fixed-wing attack aircraft, and cargo- type aircraft.	3522
Construction Machinery and Equip- ment (CMEQ)	Bulldozers	3531
	Trenching Equipment	3531
Mining Equipment (MMEQ)	Conveyor belting	3069
Oil Field Equipment (OFME)	Storage Tanks	3443
ALUMINUM AND MAGNESIUM (ALUM)	Well-drilling equipment	3553
	Conductors (copper and/oraluminum), including bare cable for high voltage lines and insulated wire or cable for lower voltage distribution circuits)	3357
AUTOMOTIVE AND TRANSPORTATION EQUIPMENT:		
Automotive (AUTO)	Truck tractors and trailers including low bed	3715 3717
	Trucks up to five tons (25 percent equipped with power takeoff)	3717
	Specialized repair trucks and equipment	3713
	Utility repair trucks, fully equipped	3713
	Fire Fighting equipment	3713
Shipbuilding (SHIP)	none	
Ordnance (ORDN)	none	
Railroad Equipment (RAIL)	Tank railroad cars	3742
	Tank trucks and trailers	3715
Aircraft (AIRC)	None	
BUILDING MATERIALS (BLDG)	Sewer pipe and fittings	3321
	Plumbing fixtures and fittings	3432
	Masonry products-brick, cement, lime, concrete, block hollow tile, etc.	3271
	Asphalt and tar roofing and siding products	2952
	Builders hardware-hinges, locks, handles, etc.	3429
	Plastic patching	3079
	Prefabricated emergency housing	2433
	Translucent window coverings	2821 3079
	Building board, including insulating board, and laminated fiberboard	2661
	Hard pressed fiberboard	2499
	Gypsum board	3275
	Asbestos cement (flat sheets and wallboard)	3292
BUSINESS EQUIPMENT AND SERVICE INDUSTRIES (SERV)	Warning signs-biological, chemical, and radiological contamination	3993
CHEMICAL AND RUBBER: Chemicals (CHEM)	Analgesics, non-narcotic	2834
	Antibiotics and antibacterials	2834
	Antidiabetic agents, oral	2834
	Antihistamines	2834
	Antimalarials	2834
	Atropine	2834
	Blood derivatives	2831
	General anesthetics	2834
	Hypnotics	2834
	Insulin	2834
	Morphine and substitutes	2834
	Oral electrolytes	2834
	Oxygen	2834
	Surgical antiseptics	2834
	Diphtheria toxoid	2834
	Diphtheria antitoxin	2834
	Diphtheria and tetanus toxoids and pertussis vaccine	2834
	Gas gangrene antitoxin	2834
	Poliomyelitis vaccine, oral	2834
	Rabies vaccine	2834
	Smallpox vaccine	2834
	Tetanus antitoxin	2834
	Tetanus toxoid, absorbed	2834
	Typhoid vaccine	2834
	Typhus vaccine, epidemic	2834

OIM Industry Division

Essential Survival Item

Code Numbers

	Yellow fever vaccine	2834
	Dusting powder	2834
	Chemical reagents, stains and apparatus	2819
	Bacteriological culture media and apparatus	2831
	Nitrogenous fertilizers	2871
	Salt for livestock	2899
	Anthrax vaccine	2834
	Black leg vaccine	2834
	Hog cholera vaccine	2834
	Newcastle vaccine	2834
	Soaps, detergents, and disinfectants	2841, 2842
	Ferric chloride	2819
	Ferrous sulfate	2819
	Ferric sulfate	2819
	Hydrated lime	3274
	Soda ash	2812
	Iodine tablets	2842
	Chlorine compounds (not gas)	2819
	Activated carbon	2819
	DDT, water dispersible powder (75 percent)	2879
	Pyrethrum	2879
	Lye	2812
	Alcohol	2834
	Carbon dioxide absorbent	2834
	Cardiovascular depressants	2834
	Cardiovascular stimulants	2834
	Corticosteroids	2834
	Diuretics	2834
	Intravenous solutions for replacement therapy	2831
	Local anesthetics	2834
	Lubricant, surgical	2834
	Sulfa drugs	2834
	Synthetic plasma volume expanders	2831
	Vitamin preparations, pediatric	2834
	Water for injection	2831
	Blood grouping and typing sera	2831
	Canned heat	2899
	Chlorinated copperas	2819
	Filter Alum	2819
	High-test hypochlorites (70 percent) in drums, cans, ampules	2812
	Liquid chlorine, including containers	2812
	Lindane powder, dusting (1 percent)	2879
	Malathion, liquid, emulsifiable concentrate (57 percent)	2879
	Deet (diethyltoluamide) 75 percent in denatured alcohol	2842
	Anticoagulant type, ready-mixed bait "1080" (sodium monofluoroacetate) (for controlled use only)	2842
	Glassware cleaning equipment	2818
	First aid items (included on Health Supplies and Equipment List)	2834
Rubber (RUBR)	Gloves, surgeon's	3069
	Tubing, rubber or plastic, and connectors	3069
	Waterproof outer garments	2385
	Nipples	3069
	Conveyor belting	3069
	Tires	3011
	Nursing bottles, all types	3229
	Lyster bags	3069
	Storage tanks, collapsible and portable	3069
	Water pipe and hose, plus fittings-all types, including fire hose	3069
		3079*
		3272*
		3292*
		3312*
		3317*
		3021
	Shoes and other footwear	
* OIM also lists these under CHEM, BLDG, MSMN, and STEE	Drain, Penrose	3069
	Tube, nasogastric	3069
COMMUNICATIONS (COMM)	None, Support to survival items	
CONSTRUCTION INDUSTRY (CSTN)	None, Covered by another resource agency	
CONSUMER DURABLE GOODS (CDGS)	Brush, scrub, surgical	3981
	Lamps, for diagnostic instruments	3641
	Lamps, for surgical lights	3641
	Razor and blades (for surgical preparation)	3421
	Laboratory glassware	3231
	Nursing bottles, all types	3229

	Pins	3964
	Cots	2511
	Heating and cooking stoves	3433
		3631
	Incandescent hand portable lighting equipment (including flashlights, lamps, batteries)	3642
	Kitchen, cooking, and eating utensils	3262
		3421
	Nonelectric lighting equipment	3642
	Refrigerators, mechanical	3632
	Hand sewing equipment	3964
	Basin, wash, solution	3461
	Insulators	3229
CONTAINERS AND PACKAGING (CONT)	Food containers	3221
	Storage tanks, rigid, transportable	3443
	Containers for sterilization	3461
	Blood collecting and dispensing containers	3221
	Blood shipping containers	2653
	Pressure containers and fittings for liquefied petroleum gas	3443
COPPER (COPR)	Conductors (copper and/or aluminum, including bare cable for high voltage lines and insulated wire or cable for lower voltage distribution circuits)	3357
	Lamps (incandescent medium base) and lamp holders	3464
ELECTRICAL EQUIPMENT (ELEC)	Pole line hardware	3644
	Transformers, (distribution, transmission, and mobile)	3612
	Batteries, wet and dry cell	3692
	Conductors (copper and/or aluminum) including bare cable for high voltage lines and insulated wire or cable for lower voltage distribution circuits)	3357
	Switches and circuit breakers	3613
	Insulated trail cables	3357
	Trolley feeder wire	3357
ELECTRONICS (ETRX)	None at present. Items are anticipated to be placed under this industry in the future	
FOOD INDUSTRIES (FOOD)	None. Covered by another resource agency	
FOREST PRODUCTS:		
Lumber and Wood Products (LUMB)	Matches	3983
	Poles and crossarms	2411
	Storage tanks, wood stove, knock-down	2499
	Lumber and allied products:	
	Rough Lumber	2421
	Dressed lumber inc. siding, ceiling	2421
	Other lumber, inc. soft flooring	2421
	Hardwood flooring	2426
	Plywood	2432
	Millwork:	
	Windows	2431
	Doors	2431
	Other Millwork	2431
Pulp, Paper, and Paperboard (PAPR)	Sanitary napkins	2649
	Toilet tissue	2647
	Disposable tissues	2647
	Building papers	2661
GENERAL INDUSTRIAL EQUIPMENT AND COMPONENTS:		
General Components (GCOH)	Tools for live-circuit operations, including rubber protective equipment, and linemen's tools	3423
	Roof bolts	3452
	Rough hardware-nails, bolts, screws, etc.	3452
	Various sizes of valves, fittings and pressure regulators	3494
	Light equipment and hand tools (including electric powered) for carpentry, masonry, plumbing and excavation	3423
	Pipe installation materials and equipment	3229
	Rigging tools-cables, ropes, tackle, hoists, etc.	3429
General Industrial Equipment (GIEQ)	Pumps for loading and unloading	3561
	Chemical feeders	3559
	Mobile and portable pressure filters	3569
	Pumps and appurtenances, hand-electric-gasoline-diesel	3561
	Couplings, clamps, for emergency repairs	3429
	Conveyor belting	3069
	Refrigerators, mechanical	3632
IRON AND STEEL (STEE)	Sewer pipe and fittings	3321
	Various sizes of pipe (mostly steel)	3317
	Well casing	3312
	Drive pipe and drive points	3317
LEATHER, SHOES, AND ALLIED PRODUCTS (LEAT)	Shoes and other footwear	3141
	Gloves and mittens	3151
METALWORKING EQUIPMENT (MWEQ)	Welding equipment and supplies (electric and acetylene)	3623
	Light equipment and hand tools (including electric powered) for carpentry, masonry, plumbing, and excavation	3548

MISCELLANEOUS METALS AND MINERALS  
(MSMN)

POWER EQUIPMENT (POWR)

PRINTING AND PUBLISHING (PRIN)

SCIENTIFIC, MOTION PICTURE AND  
PHOTOGRAPHIC PRODUCTS:

Motion Picture and Photographic  
Products (MOTP)  
Scientific Instruments and  
Technical Equipment (SITE)

Diatomaceous earth	3295
Pulverized limestone	3295
Prime mover generator sets up to 501 kilowatts and 2400 volts, including portable and mobile sets up to 150 kilo- watts and 110/220/440 volts, 3-phase, 60-cycle complete with fuel tank and switchgear in self-contained units	3621
Chlorinators (gas and hypochlorites)	3589
Warning signs-biological, chemical, and radiological contamination	3993
None	
Adhesive plaster	3842
Bacteriological culture media and apparatus	3811
Bandage, gauze	3842
Bandage, muslin	3842
Bandage, plaster of paris	3842
Blood recipient sets	3841
Surgical pads	3842
Stockinette, surgical	3842
Airway, pharyngeal	3841
Anesthesia apparatus	3841
Blade, surgical knife	3841
Chisel, bone	3841
Forceps, dressing	3841
Forceps, hemostatic	3841
Forceps, obstetrical	3841
Forceps, tissue	3841
Handles, surgical knife	3841
Holder, suture needle	3841
Laryngoscope	3841
Light, surgical, portable	3841
Litter	3842
Mallet, bone surgery	3841
Needles, hypodermic, reusable	3841
Needles, suture, eyed	3841
Otoscope and ophthalmoscope set	3841
Probe, general operating	3841
Retractor set, general operating	3841
Saw, amputating	3841
Saw, bone cutting, wire (Gigli)	3841
Scissors, bandage	3841
Scissors, general surgical	3841
Sigmoidoscope	3841
Speculum, vaginal	3841
Sphygmomanometer	3841
Splint, leg, Thomas	3842
Splint, wire, ladder	3842
Sterilizer, pressure, portable	3842
Stethoscope	3841
Sutures, absorbable	3842
Sutures, absorbable, with attached needle	3842
Sutures, nonabsorbable	3842
Sutures, nonabsorbable, with attached needle	3842
Syringes, Luer, reusable (hypodermic syringes)	3841
Thermometers, clinical	3821
Balance, laboratory with weights	3811
Microscope and slides	3831
Blood donor sets	3841
Intravenous injection sets	3841
Knife, cast cutting	3421
Retractor, rib	3841
Rongeur, bone	3841
Tracheotomy tube	3841
Vascular prostheses	3842
First aid items (included on Health Supplies and Equipment List)	3841
Calibrators	3821
Chemical agent detection kits, air, food, and water	3811
Dosimeters and chargers	3821
Protective masks, clothing, helmets	3842
Survey meters (Alpha, Beta, and Gamma)	3821
Membrane filter kits with filters and media	3811
Chlorine and pH determination equipment	3811
Catheter, urethral	3841
Inhaler, anesthesia, Yankauer (ether mask)	3841
Water purification apparatus	3811
Cotton, USP	3842

TEXTILES AND CLOTHING (TEXT)

Wadding, cotton sheet	2293
Blood and urine analysis instruments, equipment and supplies	3811
Headwear	2352
Hosiery	2251
Outerwear:	
Knit	2253
Men's, Youths' & Boys' suits, coats, & overcoats	2311
Men's, etc. shirts (except workshirts)	2321
Men's etc. separate trousers	2327
Workclothing	2328
Men's etc. outerwear, n.e.c.	2329
Women, misses, juniors blouses, waists, & shirts	2331
Women's misses, & juniors dresses	2335
Women's etc. suits, skirts & coats, except fur coats and raincoats	2337
Women's etc. outerwear n.e.c.	2339
Girls, childrens & infants dresses, blouses, waists & shirts	2361
Girls, etc. coats & suits	2363
Girls, etc. outerwear, n.e.c.	2369
Underwear:	
Knit (in knitting mills)	2254
Mens, youths, & boys	2322
Womens, misses, childrens & infants	2341
Corsets & all bed garments	2342
	2389
Diapers, all types	2211
Bedding	2211
Webbing, textile, with buckle	2241
Tents and tarpaulins; canvas, plastics, and other similar materials	2394
Sleeping bags	2399

WATER AND SEWERAGE INDUSTRY  
AND UTILITIES (WATR)

None. Covered by another resource agency

ANNEX B

EMERGENCY ORGANIZATION

The Texas Industrial Commission will provide administrative support; i.e., personnel, facilities and supplies for the operation of the State Industrial Production Resource Agency. Copies of this plan and all action and reference documents are immediately available in the EOC, Texas Department of Public Safety, Austin, Texas; in the office of the Industrial Commission, Austin, Texas; in the office of the Federal Emergency Management Agency Office, Denton, Texas; and in the relocation and alternate sites prescribed in the Civil Defense Emergency Operations Plan.

Upon activation of this plan the Coordinator of the Industrial Production Resource Agency and key staff with emergency assignments to the State Industrial Production Resource Agency will establish headquarters at the site prescribed by the Director, Disaster Emergency Services.

Lines of succession to assure continuity of key staff for operation of the State Industrial Production Resource Agency are provided in the roster of key personnel contained in the organizational provisions of this section.

The organization chart (Tab A) on the following page identifies functional areas involved in the management of essential survival items in the State of Texas in an emergency. The functional duties of each position shown on the chart are explained in Appendix 1.

The Coordinator of the Industrial Production Resource Agency is the Executive Director of the Texas Industrial Commission. The Texas Industrial Commission shall, in cooperation with the Bureau of Business Research, maintain emergency industrial production plans, records and statistical data, and be prepared to provide a skeleton-staff organization upon which to expand in event of a declared emergency.

The State of Texas is divided into 17 Disaster Districts which conform to the State Department of Public Safety (DPS) Highway Patrol Districts and Subdistricts. The DPS Highway Patrol Commander in each district or subdistrict is designated Chairman of the Disaster Committee. Counterparts of other State departments and agencies represented on the Resource Priorities Board will constitute the remaining members of the district Disaster Committee.

Within each district's District Production Offices and District Distribution Offices shall be established corresponding to the 17 Disaster Emergency Services Districts. The headquarters location of these offices shall be the same as the headquarters location of the Disaster Emergency Services Districts. A map showing the boundaries of each district are shown in Appendix 2. The counties within each district are identified in Appendix 3.

Each District Production Office and each District Distribution Office shall contain individual sections which are responsible for the assurance of a continuing supply of specific groups of the essential survival items. Each specific group of the essential survival items shall correspond to one of twenty of the Industry Divisions of the Office of Industrial Mobilization (OIM). These sections shall be established in accordance with the occurrence of producers or distributors of the essential survival items within the district. The establishment of these sections shall be accomplished as preattack advance planning by the Texas Industrial Commission.

A list of the OIM Industry Divisions and their corresponding essential survival items and SIC code numbers is included in Appendix 2 to Annex A, of this plan.

The producers of the essential survival items in each of the districts are identified in Reference Document No. 1, Annex D to this plan. Correspondingly, the interstate wholesale distributors are identified in Reference Document No. 2, Annex D.

The District Distribution Directors and the District Production Directors shall exercise autonomous authority for situations existing within their districts so long as their operations are not in conflict with other provisions of this plan. The District Distribution Directors shall take action to resupply secondary inventories from primary inventories within their districts without prior approval from the Region or State offices. Both the District Production Directors and the District Distribution Directors shall take action to assure a continuity of supply by obtaining supporting resources and materials from sources within their districts without prior approval from the Region or State offices. Requests for essential items, supporting resources and supporting materials which are not available within the Districts shall be submitted to the Region office.

When District resources are insufficient to meet essential needs and conflicts involve two or more districts within their regions, the Region Distribution Director will exercise priority and allocation authority. When two or more regions are involved, the Assistant Director for Distribution in the State office will determine the priority.



Tab A

INDUSTRIAL PRODUCTION RESOURCE AGENCY — STATE OF TEXAS

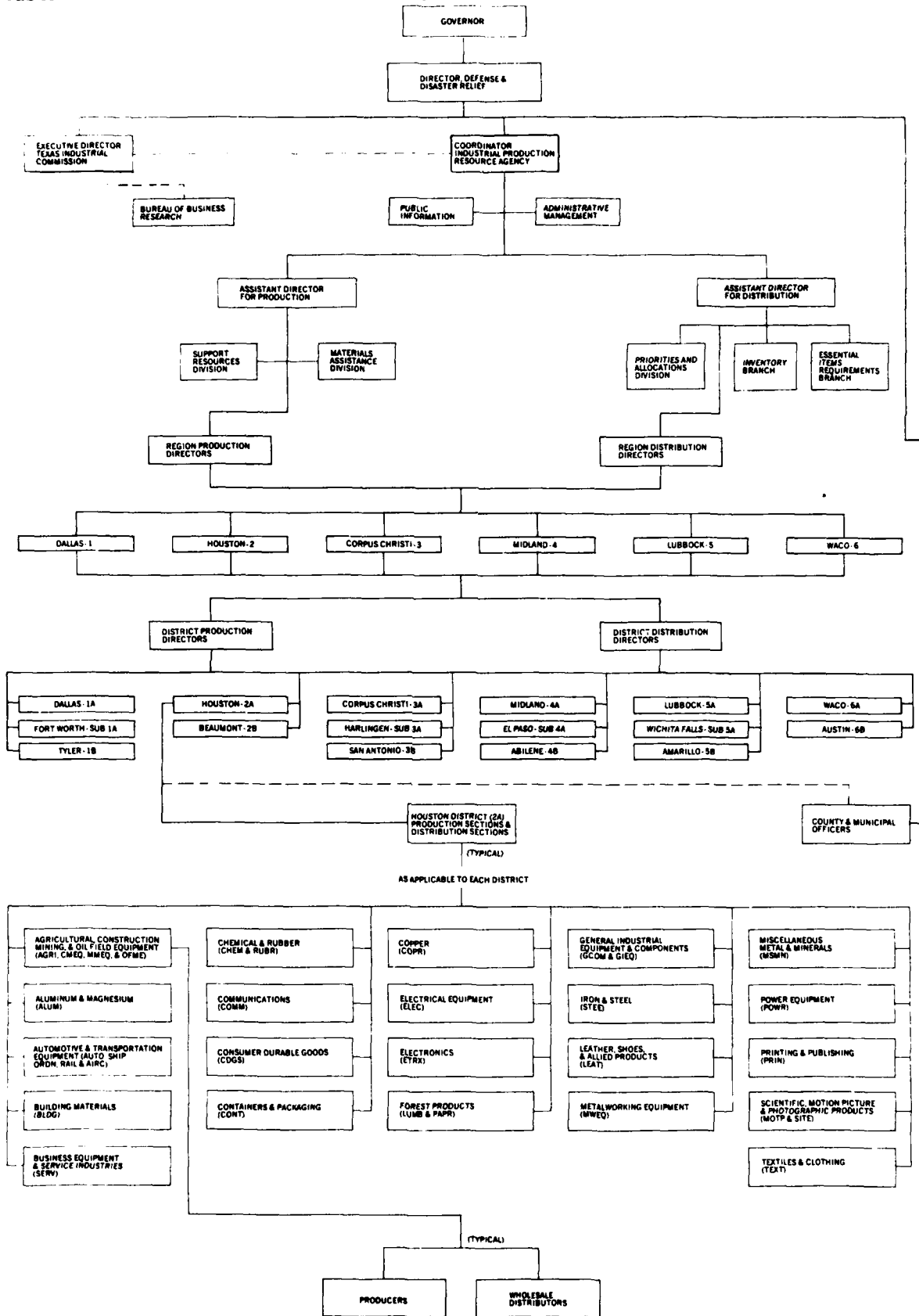

APPENDIX 1  
(Functions of the Industrial Production  
Resource Agency)  
TO ANNEX B, EMERGENCY ORGANIZATION

Coordinator of Industrial Production Resource Agency (Executive Director, Texas Industrial Commission)

1. Advises the Governor, the Director, Disaster Emergency Services and all departments of the State having emergency responsibilities with respect to production, inventories, distribution, requirements and allocation of essential items.
2. Makes final determinations on recommended allocations of essential items within the State received from official in charge of distribution.
3. Provides OIM with information concerning supplies of essential items within the State available for allocation to other states.
4. Establishes and supervises maintenance of close working relationship between all elements of Industrial Production Resource Agency and OIM.
5. Supervises the liaison with the other State resource organizations.
6. Serves as a member of the State Resource Priorities Board.

Texas Industrial Commission

The Texas Industrial Commission shall:

1. Preattack: In cooperation with the Bureau of Business Research, maintain emergency industrial production plans, records and statistical data as directed in Procedures A, B, and C (attached) and be prepared to provide a skeleton-staff organization upon which to expand; be prepared to provide for resource support for the operation of essential industrial production and distribution facilities within the State.
2. Postattack. On order, provide for the operation of the industrial production organization and implement appropriate industrial production plans as directed; insure distribution of specified essential items within the State; provide resource support for the operation of essential industrial production and distribution facilities located in the State.

Bureau of Business Research (The University of Texas)

The Bureau of Business Research shall supply data as requested by the Texas Industrial Commission to maintain a current assessment of production capability in the State. The Bureau also shall assist the Texas Industrial Commission in making surveys of industrial producers. These duties are described fully in Procedures B and C of this plan.

Director of Public Information

1. Provides information for industry and the public through the State Emergency Public Information Officer concerning all activities of the State industrial production organization.
2. Provides the State Emergency Public Information Officer with information about emergency policies, regulations, orders, procedures, and other matters to assure public knowledge and cooperation.
3. Answers incoming inquiries directly or by reference to appropriate official.
4. Prepares and releases communications in accordance with instructions from the Coordinator, Industrial Production Resource Agency to include: Preattack--4; Prod--1; Prod--2; Prod--3; Prod--4 and Prod--10.

Administrative Management Official

The Administrative Management Official shall serve as Administrative Assistant to the Coordinator of the Industrial Production Resource Agency.

Assistant Director for Production (See Procedures C, attached)

1. Principal adviser to the Coordinator, Industrial Production Resource Agency on all matters concerned with the achievement of maximum production of essential items and supporting industrial production resources within the State.
2. Provides OIM with information on production capabilities and assists OIM in locating production sources within the State as necessary.

Assistant Director for Distribution (See Procedures B, attached)

1. Principal adviser to the Coordinator, Industrial Production Resource Agency concerning distribution of essential items to meet emergency needs.
2. Maintains close working relationships with the other State claimant organizations responsible for preparing estimates of requirements for essential items.
3. Recommends to the Coordinator, Industrial Production Resource Agency allocations of available supplies of essential items to State claimant organizations to fill emergency needs within the State and recommends sources outside the State for obtaining additional supplies, when needed.

4. Recommends to the Coordinator, Industrial Production Resource Agency distribution of surplus supplies of essential items to other states.

Manager of Support Resources Division

1. Assists producers of essential items in obtaining support resources such as manpower, electric power, water and transportation within the State.
2. Maintains close working relationship with the other State resource organizations for this purpose.
3. Works closely with OIM in aiding producers of essential items to obtain support resources from outside the State. Takes direct action in this regard if control is not possible through OIM.

Manager of Materials Assistance Division

1. Works closely with OIM and producers of essential items to assist them in locating sources of supply of production materials and equipment within the State.
2. Utilizes producers' inventories of spare parts as sources of supply for production equipment.
3. Assists OIM in expediting production of essential items through close cooperation with production sources within the State.
4. Works closely with OIM in aiding producers of essential items to obtain support materials from sources outside the State. Takes direct action in this regard if control is not possible through OIM.

Manager of Priorities and Allocations Division  
(See Procedures B, attached)

1. Assembles information on available supplies of essential items in intrastate wholesale and retail inventories and interstate wholesale inventories within the State from Inventory Branch.
2. Assembles information on available supplies of essential items in producers' inventories from Regional Production Directors.
3. Determines total potential supplies of essential items within the State from above sources.
4. Assembles requirements for essential items from Essential Items Requirements Branch.
5. Determines shortages or overages in essential items within the State.
6. Prepares statements of supplies, requirements, shortages and overages for each essential item.
7. Where shortages are disclosed, consults with the other State claimant organizations concerning possible reduction or deferral of requirements to achieve balance of requirements with available supplies. If such adjustments appear infeasible, consults with OIM concerning availability of additional supplies from sources outside the State. Takes direct action with sources outside the State if control is not possible through OIM.
8. On the basis of this consultation, prepares recommendations for allocation of available supplies to the State claimant organization for Distribution.
9. Submits reports of overages of individual essential items to Assistant Director for submission to Assistant Director for Distribution.
10. Upon approval by the Coordinator, Industrial Production Resource Agency, issues allocations of essential items to the State claimant organizations for distribution to users.

Manager of Inventory Branch

Assembles and maintains on a current basis complete information concerning inventories of essential items within the State, using Region Production Offices and Region Distribution Offices to collect this information and provides such information to Priorities and Allocations Division.

Manager of Essential Items Requirements Branch

1. Assembles requirements for essential items.
2. Provides statements of requirements for essential items to Priorities and Allocations Division.

Director of Region Production Office

1. Assembles and maintains on a current basis complete information concerning production capabilities within the region, using the Production Districts within the region to collect this information.
2. Provides information on current production capabilities and current producers' inventories of essential items to other elements of the Industrial Production Resource Agency.
3. Provides OIM with production capabilities data and assistance in locating production sources within the region.
4. Works through the Support Resources Division and Materials Assistance Division to assist producers of essential items within the region to obtain necessary resources and materials to continue production.

#### Director of Region Distribution Office

1. Adviser to the Assistant Director for Distribution concerning the distribution of essential items within the region to meet emergency needs.
2. Provides information to the Inventory Branch concerning inventories of essential items in interstate and intrastate wholesale distributors and retail outlets within the region.
3. Communicates with the Priorities and Allocations Division concerning the distribution of essential items from producers and from inventories in interstate wholesale distributor outlets within the region.
4. Exercises priority and allocation authority to resolve conflicts concerning needs of essential items within the region.

#### Director of District Production Office

1. Assembles and maintains on a current basis complete information concerning production capabilities within the district, using the production sections within the district to collect this information.
2. Provides information on current production capabilities and current producers' inventories of essential items to the Region Production Office.
3. Provides OIM with production capabilities data and assistance in locating production sources within the district.
4. Maintains liaison as affects industrial production with county and municipal officials within the district.
5. Works through the Region Production Office to assist producers of essential items to obtain necessary resources and materials to continue production.
6. Provides Materials Assistance Division with information when requested concerning producers' inventories of spare parts which could be available for emergency use.

#### Manager of District Production Section

1. Assembles and maintains on a current basis complete information concerning production capabilities of a specific commodity within the district, using the producers within the district to collect this information.
2. Provides information on current production capabilities and current producers' inventories of specific essential items to the District Production Director.
3. Maintains liaison with producers of specific essential items in the district.
4. Provides Director of District Production Office with information when requested concerning producers' inventories of spare parts which could be available for emergency use.

#### Director of District Distribution Office

1. Adviser to the Region Distribution Director concerning the distribution of essential items within the district to meet emergency needs.
2. Provides information to the Region Distribution Office concerning inventories of essential items in interstate and intrastate wholesale distributor and retail outlets within the district.
3. Communicates with Region Distribution Office concerning the distribution of essential items from producers and from inventories in interstate wholesale distributor outlets within the district.
4. Maintains liaison as affects distribution of essential items with county and municipal officials within the district.
5. Exercises priority and allocation authority to resolve conflicts concerning needs of essential items within the district.

#### Manager of District Distribution Section

1. Assembles and maintains on a current basis complete information concerning inventories of a specific commodity within the district, using the interstate and intrastate wholesale distributors and retailers within the district to collect this information.
2. Provides information on current inventories of specific essential items to the District Distribution Director.
3. Maintains liaison with interstate wholesale distributors of specific essential items in the district.
4. Communicates with the Director of the District Distribution Office concerning the distribution of specific essential items from producers and from inventories in interstate wholesale distributor outlets within the district.

#### County and Municipal Officials

This plan assigns direct responsibility for the control of the producers and interstate wholesale distributors of certain essential survival items to the State Industrial Production Resource Agency. Local control is assigned to the District Production Directors and District Distribution Directors. This control is exercised only in the event of loss of communications with the Federal Government, principally the OIM.

This plan recognizes that the most efficient control of the "secondary essential item inventories" is through local government. These local governments will control the distribution from intrastate wholesale distributor and retail inventories.

Close coordination with county and municipal officials will be mandatory. This shall be accomplished by the District Directors.

It is anticipated that the Governor will request county and municipal officials to develop local plans for the management of emergency resources. As these plans are developed the relationships of the District Directors to local officials will be defined to meet specific needs of the geographic areas.

PROCEDURES A (ADMINISTRATION) TO  
APPENDIX 1 (FUNCTIONS) ANNEX B,  
EMERGENCY ORGANIZATION

1. PREATTACK ACTIONS

a. Advance Planning

(1) Maintenance of the Organization

The Coordinator of the Industrial Production Resource Agency shall assure that all positions within the organization through the level of Managers of District Production Sections and Managers of District Distribution Sections are filled by competent personnel.

Part C to this plan contains nominations for individuals for all positions through the level of District Production Directors and District Distribution Directors. Before the full district organizations can be described, it will be necessary that the occurrence of producers and distributors of essential survival items within each district be determined. Part of the information needed for this determination may be found in Reference Document No. 1, Annex D, Roster of Producers of Essential Items. The remainder must be determined through the development of a roster of interstate wholesale distributors. (See Procedures B-Distribution.)

Whenever a producer or an interstate wholesale distributor of an essential survival item is found to be located in a district, then a Manager of a District Production Section and/or a Manager of a District Distribution Section shall be appointed with responsibility for the particular commodity. The sections shall correspond to one of the twenty Industry Divisions of the OIM.

The Coordinator of SIPRA shall obtain from the Director, Disaster Emergency Services, the length of appointive terms for all positions within the Industrial Production Resource Agency. The Coordinator of SIPRA shall supply nominations for all positions, when needed, to the Director, Disaster Emergency Services.

(2) Preparation of Emergency Communications

The Coordinator of the Industrial Production Resource Agency shall assure that all emergency communications are in a state of readiness. (Refer to Appendix 1 to Annex A to this plan.)

b. Advance Preparation

(1) Release of Alert Letter

At a time of imminent danger, and at the direction of the Governor, the Coordinator of SIPRA shall release an alert letter to the producers and interstate wholesale distributors of essential items and to local government officials. A suggested form for this letter is shown as Preattack-4.

2. POSTATTACK ACTIONS

a. Actions for Immediate Supply

The Coordinator of the State Industrial Production Resource Agency shall:

- (1) Issue, on behalf of the Governor, policies and guidance, applicable throughout the State, covering the provision, distribution, and use of essential items within the State. (Prod-1, Essential Items Policy, Annex C.)
- (2) Notify all elements of the Industrial Production Resource Agency of the activation of the plan. (Prod-2, Emergency Communications, Annex C.)
- (3) Notify all producers and interstate wholesale distributors of the activation of the plan. (Prod-3, Supply of Essential Survival Items, Annex C.)

b. Actions for Continuing Supply

As soon as resupply of secondary inventories to meet essential immediate needs in the localities is underway, the State industrial production organization will take actions to anticipate continuing needs and to arrange for continuing supply to meet these needs.

PROCEDURES B (DISTRIBUTION) TO  
APPENDIX 1 (FUNCTIONS), ANNEX B,  
EMERGENCY ORGANIZATION

The flow chart at Tab A shows the process and the actions to be taken by Federal, State and local governments to assure a continuing supply of essential items to meet essential needs in the State in a nuclear attack emergency. The legend accompanying the chart identifies:

1. Actions to be taken immediately to supply immediate needs essential for survival, and
2. Actions to be taken as soon as possible to anticipate future continuing needs and to channel essential item supplies to meet the most urgent needs for continuing survival and recovery.

The Assistant Director for Distribution shall have the responsibility for:

1. Priority allocation, against
2. Availability of inventory, or
3. Production

A network of districts is to be established throughout the State, each under a District Distribution Director. Administrative control of each district will be exercised by one of 6 regions, under a Region Distribution Director.

The responsibility for effecting the flow of supplies as depicted on the flow chart on the following page, rests within the distribution organization.

1. Preattack Actions

a. Advance Planning

(1) Preparation of Rosters of Interstate Wholesale Distributors of Essential Survival Items

Inventories of essential survival items are the only immediate source of supplies in a postattack situation and will continue to be until production channels are re-established.

It is of the utmost importance that a listing of sources stocking primary inventories within the State and adjacent areas be made well in advance of a nuclear attack emergency. The list must be maintained up-to-date. The locations of such inventories must be immediately available for reference and use if required under postattack conditions.

The Texas Industrial Commission (TIC) shall prepare and maintain rosters of the interstate wholesale distributors of essential survival items in Texas and those in the adjacent areas serving Texas. The lists shall be revised annually, or at more frequent intervals if such is required.

A listing of interstate wholesale distributors of essential survival items, so far as can be determined from the three-digit SIC code system currently used by the Texas Employment Commission, has been prepared and is incorporated in Reference Document No. 2 shown in Annex E. This roster, however, is not considered suitable for use in an emergency. Therefore, the Texas Industrial Commission shall develop and maintain, on coded cards and on computer tapes, a proper list of interstate wholesale distributors, using the standard SIC four-digit code classification system which will be required for immediate use in case of a nuclear attack emergency. The Texas Employment Commission will assist in the preparation of this roster (refer to Procedures C-Production, section 1.a.(6)).

Duplicates of the cards and computer tapes of this list, developed by TIC, shall be submitted to the Office of Federal Emergency Management Agency, Denton Federal Center, Denton, Texas.

The data cards used by the Texas Industrial Commission in preparing these rosters will be those of International Business Machines.

The existing roster shown as Reference Document No. 2 in Annex E also shall be placed on duplicate cards and computer tapes and submitted to the Office of Federal Emergency Management Agency, Denton, Texas.

(2) Inventory Forms

The Texas Industrial Commission shall prepare preprinted forms in sets which will develop the required inventory information. A suggested sample form is incorporated in this portion of the plan as Prod-8.

These forms shall be held in the offices of the Texas Industrial Commission and the Texas Employment Commission in Austin in a state of readiness for use.

The Texas Industrial Commission shall maintain from separate sources information as to intrastate wholesaler and retail inventories; and shall take information on producers' inventories from the tabulations prepared by the Bureau of Business Research in connection with the survey of production capabilities.

(3) Preparations for Requesting Essential Items for Industrial Production

The Texas Industrial Commission shall perform preparatory work for the requesting of essential items as outlined below:

(a) Uniform Listings of Essential Items

A uniform listing of essential items, prepared by categories, using the four-digit standard Industrial Classification Code, is included in the plan as Appendix 2 to Annex A.

The identification of the essential items is to be simplified through the use of standard units of measure. The Texas Industrial Commission shall develop such units through the OIM. Upon receipt from the OIM of standard units for these items, the Texas Industrial Commission will incorporate the information as an addition to Appendix 2 to Annex A of this plan.

The Texas Industrial Commission will distribute the list of essential survival items, including the code numbers and standard units, to the other State claimant agencies. When it is transmitted to those agencies, they shall be requested to review it periodically to insure that it keeps pace with technological advances.

The maintenance of this listing is the responsibility of the Texas Industrial Commission.

Changes in the list of essential items shall be promptly communicated in writing to all interested state agencies by the Texas Industrial Commission.

(b) Transmittal of List and Transmittal of Forms for Claiming Essential Items

A suggested letter of transmittal is incorporated in the plan as Preattack-2.

Enclosed with the letter will be two forms for use in claiming the essential survival items. Form A (Prod-7) will estimate the requirements of the claimant agency for a three-month period. Form B (Prod-6) will be used to claim immediate requirements.

The Texas Industrial Commission shall be responsive to comments and suggestions of the claimant agencies regarding methods of working together.

The SIC code numbers and standard units will always be employed. In the case of equipment such as pumps, where there is great diversity of sizes and forms, technical designations standard to the industry will be used.

(c) Arrangements for Emergency Transportation

The industrial production plan must be coordinated with the transportation plan to assure availability of transportation for the distribution of essential items.

The Director of the Texas Industrial Commission shall meet annually, or more often if necessary, with a representative of the Railroad Commission to maintain a current plan.

(4) Liaison Between SIPRA and Claimants

Each claimant agency shall designate an official who will be in charge of the claims submitted to the State Industrial Production Resource Agency. These agencies shall notify the Texas Industrial Commission when this is done. (See Tab C, Annex B to Part A, Emergency Resource Management Plan.)

The Director of the Texas Industrial Commission is responsible for maintaining a current list of such officials, and will further be responsible for furnishing such officials with a list of key TIC personnel. This list will include their home addresses and telephone numbers. In return, he will request those claimant agencies for similar lists of their key personnel.

As soon as the claimant agencies have designated their claim officials, the Assistant Director for Distribution of SIPRA shall meet with them and they shall thoroughly discuss their jobs, with the view of establishing mutually acceptable methods of operations.

At these meetings, the productive capacities which will likely be available in Texas will be distributed, to all concerned, (see Procedures C-Production) and in return, each will provide available information as to the likely requirements of his agency.

Where possible, charts and maps showing locations of productive capacities and places where they will be needed will be prepared and distributed at these meetings and to the Office of Federal Emergency Management Agency, Denton Federal Center, Denton, Texas.

Such meetings will be held on an annual basis, or more often if deemed desirable.

b. Advance Preparation

(1) Request for Federal Roster of Interstate Wholesale Distributors

When, in the judgment of the Governor of Texas, a situation of probable emergency is impending, the Director of the Texas Industrial Commission shall officially request the roster of interstate wholesale distributors which is on file in the Regional Office of OIM.

If at that time the OIM will provide a copy of the roster to the State Emergency Organization, it shall then be used by the Texas Industrial Commission and the Texas Employment Commission to survey and prepare inventory reports, as required by the State Industrial Production Resource Agency.

Tab B

**STATE OF TEXAS—EMERGENCY MANAGEMENT OF RESOURCES  
INDUSTRIAL PRODUCTION FLOW CHART**

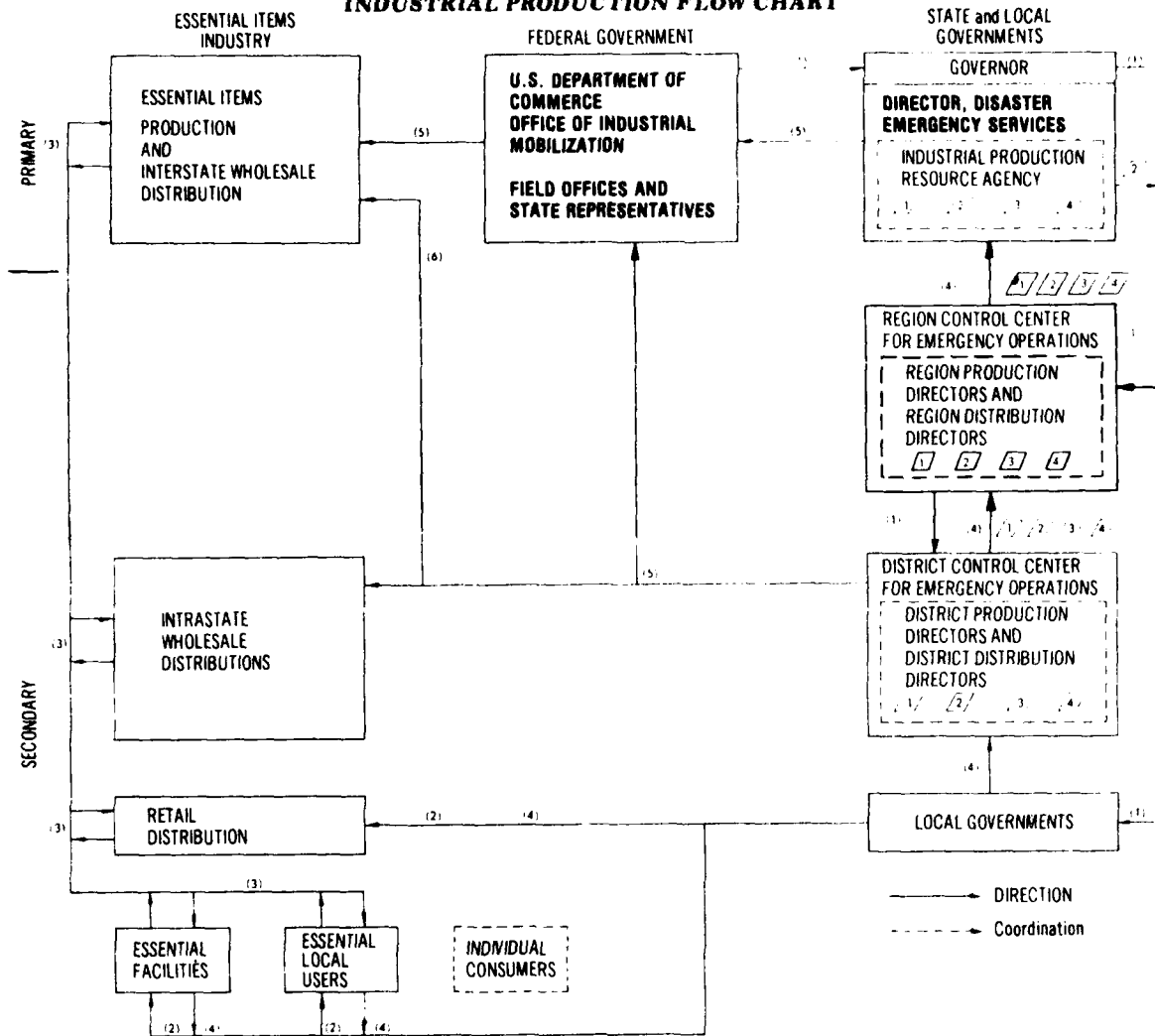

**LEGEND**

**A. ACTIONS FOR IMMEDIATE SUPPLY**

- (1) Issue State Production Policy—list of essential items—list of essential production and distribution facilities.
- (2) Enforce State inventory freeze—authorize essential uses and deliveries—ration to consumers.
- (3) Place orders—resupply inventories—report shortages.
- (4) Anticipate local shortages - reduce local use - request State assistance.
- (5) Expedite deliveries.
- (6) Expedite deliveries in event of loss of communications with BDSA.

**B. ACTIONS FOR CONTINUING SUPPLY**

- 1 Report production capabilities and producer and wholesaler inventories.
- 2 Estimate, with other emergency organizations assisting, future requirements and supplies - adjust State production and distribution policies (adjustment to be made by State office based on information received from Region and District Offices.)
- 3 Estimate production industry requirements for supporting resources - present to appropriate State resource agencies.
- 4 Authorize essential item production facilities to obtain supporting resources.

**ESSENTIAL LOCAL USERS** are (1) civilian organizations engaged in essential civilian activities including persons, equipment and facilities providing essential survival care and services to people, (2) military organizations engaged in essential military activities, and (3) farmers producing essential food and workers employed in essential facilities or local establishments providing essential items and services to people. Less essential individual consumers are not included except those requiring immediate supplies for individual or family survival.

**ESSENTIAL FACILITIES** are (1) military establishments engaged in immediate retaliatory or defense operations, (2) electric power, gas, and water utility systems, (3) industrial plants producing or processing essential items, (4) major wholesale establishments storing or distributing essential items, and (5) transportation and communications systems providing essential services.

**INDIVIDUAL CONSUMERS** are individuals not included in defined Essential Facilities or Essential Local Users who receive essential items under the consumer rationing system. The process for rationing essential items to consumers is shown in the flow chart in the Economic Stabilization Section of the Plan.



If it is not made available, the Texas Industrial Commission shall use the roster which it has previously developed.

(2) Pre-positioning of Inventory Forms

Preparation shall be made, insofar as possible, for making an inventory of essential survival items.

Using the addressing and mailing facilities of the Texas Employment Commission, the Texas Industrial Commission shall pre-position the inventory forms with the interstate wholesale distributors. The mechanism for accomplishing this is discussed in detail in Procedures C-Production, Section 1.a.(6).

(3) Pre-positioning of Claim Forms

The forms used to request supplies of essential items from SIPRA (Prod-6 and Prod-7) shall be placed in the hands of all claimants. The forms shall be placed with the other resource agencies, with all producers of essential items, with all interstate wholesale distributors, with all essential local users, with all other essential facilities, and with all representatives of local governments. This shall be the responsibility of the Texas Industrial Commission.

2. Postattack Actions

a. Actions for Immediate Supply

- (1) The Assistant Director for Distribution shall confirm with the State office of OIM that the Federal emergency regulations have been issued requiring producers and interstate wholesalers to make deliveries on authorized orders received from customers in the State.

The Assistant Director for Distribution shall, through the Region and District Distribution Directors, assist the OIM in the distribution of Federal emergency regulations to acquaint authorized persons with the provisions of these regulations. Following this action, the Coordinator of SIPRA shall request the release of primary inventories through the OIM. A recommended letter for this purpose is enclosed as Prod-4.

- (2) The existing secondary inventories in intrastate wholesale distributor and retail stocks shall be assessed by the District Distribution Directors through communications with county and municipal officials.
- (3) The Priorities and Allocations Division shall request the State office of OIM to arrange for increases where needed in deliveries by producers and interstate wholesalers for essential items to resupply secondary inventories to meet shortages reported by local governments. A recommended form for this communication is enclosed as Prod-5.
- (4) The District Distribution Directors shall work through the Essential Items Requirements Branch and the Priorities and Allocations Division in replenishing shortages in secondary inventories as reported by local governments. Agencies of local government shall report their shortages on the enclosed form Prod-6.
- (5) The District Distribution Directors shall work through the Essential Items Requirements Branch and the Priorities and Allocations Division in replenishing shortages reported by essential local users and essential facilities. These requirements will be reported on the same form (Prod-6) by the essential local users and essential facilities through the District Distribution Directors to the Essential Items Requirements Branch.

b. Actions for Continuing Supply

- (1) The primary inventories in interstate wholesale distributor stocks and in producer stocks shall be assessed. Each District Distribution Director shall make an assessment of his district; in addition, the Bureau of Business Research shall compile an inventory for the entire State. The State inventory shall be forwarded to the Inventory Branch. The facilities of the Texas Employment Commission will be used in initiating the survey. The mechanism for accomplishing the inventory is presented in detail in Procedures C-Production, Section 1.a.(6).

Two surveys shall be made. The first will be to determine existing inventories. The second will be to determine inventories which will be available during the 90-day period. The assessment of producers' stocks shall be made by the District Production Directors, (refer to Procedures C-Production).

- (2) The Priorities and Allocations Division shall balance the continuing needs of essential items for the 90-day period as reported to the Essential Items Requirements Branch against the inventories as reported to the Inventory Branch and the production capabilities as reported by the Assistant Director for Production. (Refer to Procedures C-Production.) After having analyzed needs against supplies, the Priorities and Allocations Branch shall forward its recommendations to OIM for allocations during the ensuing 90-day period.
- (3) If anticipated supplies are inadequate to meet the requirements and if adjustments in requirements cannot be negotiated, the Coordinator of SIPRA shall refer to the Resource Priorities Board for recommendations to the Governor on the allocations of anticipated supplies among competing programs.
- (4) If internal adjustments are necessary, the Coordinator of SIPRA shall issue the revised state policy on the use of essential items to conform with the Governor's decisions. (Prod-10, Revised State Essential Items Policy.)
- (5) Using the information which it has developed and has gained from the OIM, and, if necessary, the Resource Priorities Board, the Priorities and Allocations Division shall announce, for the Coordinator of SIPRA, the allocations made of the essential items. Quantities of essential items available in the State shall be assigned to appropriate agencies. The agencies shall be authorized to use, or in turn, authorize others to use, certified orders to procure from intrastate wholesale and retail distributors quantities of the items assigned them. A suggested form for this use (Assignment of Essential Items) is enclosed as Prod-11.

- (6) The District Distribution Directors shall obtain from the interstate wholesale distributors their requirements for supporting resources and supplies during the 90-day period. These requirements shall be forwarded to the Support Resources Division, if not available within the district. Similarly, requirements for equipment and materials other than the essential items shall be prepared by the interstate wholesale distributors and forwarded through the District Distribution Directors to the Materials Assistance Division, if not available within the district. (Refer to Procedures C-Production.)
- (7) The District Distribution Directors shall obtain from the interstate wholesale distributors their estimates of requirements for emergency construction and repair during the 90-day period. These shall be transmitted to the Support Resources Division, if not available within the district. (Refer to Procedures C-Production.)
- (8) The Priorities and Allocations Division shall inform OIM of supplies of supporting resources that will be available in the State for acquisition and use by essential items producers and interstate wholesalers to maintain operations during the ensuing 90-day period. A suggested letter, Allocation of Supporting Resources to Essential Items and Interstate Wholesale Distribution Industry, is enclosed as Prod-14.

PROCEDURES C (PRODUCTION) TO APPENDIX 1  
(FUNCTIONS), ANNEX B.  
EMERGENCY ORGANIZATION

1. Preattack Actions

a. Advance Planning

(1) Preparation of Rosters of Texas Producers of Essential Survival Items

Rosters of the Texas producers of Essential Survival Items shall be maintained in a state of readiness by the Texas Industrial Commission for use by the State Industrial Production Resource Agency.

The Bureau of Business Research of the University of Texas has prepared and shall maintain rosters of Texas producers of essential survival items coded by order of listing as follows:

- (a) Administrative district or subdistrict in which the producer is located.
- (b) OIM Industry Division which contains the particular essential survival items.
- (c) County in which producer is located.
- (d) City in which producer is located.
- (e) Standard Industrial Classification (SIC) code number of the essential survival items.

Corollary information in the roster shall include the number of people employed by the producer and whether the producer covers an intrastate or interstate territory.

(2) Revisions of Rosters

The rosters shall be revised and brought up-to-date on an annual basis, or at more frequent intervals if such is required, by appropriate State officials. This is the responsibility of the Texas Industrial Commission.

The Bureau of Business Research of the University of Texas is the designated State agency for providing the Texas Industrial Commission with the data for keeping these rosters current. The rosters shall include some indication of the productive capacity of the manufacturers. Initially, this will be the number of persons employed.

The Bureau of Business Research shall make the necessary surveys to provide the required information to the Texas Industrial Commission and shall maintain close liaison with that commission.

As changes are made by authorized Government agencies in the list of essential survival items, or other changes take place which affect the rosters or organizations, they shall be transmitted immediately to the Director of the Bureau of Business Research by the Director of the Texas Industrial Commission, and necessary revisionary work shall take place promptly.

Financial transactions between the two organizations, or between them and State Industrial Production Resource Agency, will be handled by standard State Interagency Cooperation Act, unless otherwise provided for by appropriate authorities.

(3) Distribution of Rosters, Directories, Data Cards, and Tapes

The rosters, as well as the latest copy of the annual Directory of Texas Manufacturers (which is published by the Bureau of Business Research), shall be maintained in the office of the Texas Industrial Commission in Austin and be made available to the State Industrial Production Resource Agency, as required.

Copies of the required rosters, prepared by the Bureau of Business Research, together with the Directory of Texas Manufacturers, are referenced in this plan in Annex E.

The data cards used by the Bureau of Business Research in preparing these rosters are those made by International Business Machines.

The information on the coded cards shall also be put on computer tapes. One set of the tapes shall be maintained by the Bureau of Business Research. Another set shall be maintained in the Office of Federal Emergency Management Agency, Denton Federal Center, Denton, Texas.

(4) Requesting Resources from Other Resource Agencies

The SIPRA's requirements for necessary resources from other resource organizations shall be determined by the Coordinator of SIPRA, on the basis of recommendations made to him by the Assistant Directors for Production and Distribution.

Forms suitable to the resource agencies upon which the claims will be made must be developed. The Texas Industrial Commission is responsible for seeing that this is done.

A suggested letter to be sent to these agencies, with attached form, is incorporated in the plan as Preattack-1, and Prod-11.

(5) Preattack Survey of the Producers of Essential Survival Items in Texas

A preattack survey as required by this plan is outlined below. It shall be made and filed as indicated.

A preattack survey of producers shall be made both to acquaint the manufacturers with the requirements of the State Industrial Production Resource Agency and to test the adequacy of this portion of the State Plan.

The Director, Disaster Emergency Services, shall issue a letter to essential-item producers which will outline and explain the survey which is being conducted. Appropriate preprinted survey forms shall accompany each such letter. Utilizing the mailing facilities of the Bureau of Business Research, the Texas Industrial Commission will conduct the survey.

A suggested letter and as a sample preprinted data survey form are incorporated in this portion of the plan as Preattack-5 and Prod-9.

The manufacturers shall return the forms by mail to the Bureau of Business Research. The Bureau of Business Research shall compile and analyze the data and transmit the information to the Texas Industrial Commission for transmission to the State Industrial Production Agency, or to the Director, Disaster Emergency Services, as may be required. Each of these three agencies shall maintain copies of the preattack survey in readily reproducible form.

The Bureau of Business Research shall be responsible for expediting when information fails to come from certain companies. When there is no mail response to the efforts of the Bureau of Business Research as regards key producers, designated personnel of the Office of the Director, Disaster Emergency Services, shall make personal contact with those companies to secure the required information.

A study shall be made by the Bureau of Business Research, the Texas Industrial Commission, and the Office of the Director, Disaster Emergency Services, of changes which are indicated by the results of this preattack survey.

(6) Arrangements With Texas Employment Commission for Postattack Survey of Production Capabilities and Inventories

As the result of an arrangement between the OIM and the Employment and Training Administration, the Texas Employment Commission is in a position to provide assistance in the assessment of postattack production capability and producers' inventories.

Joint responsibilities for this assessment are as follows:

(a) Responsibilities of the Texas Industrial Commission

1. The TIC will provide the Texas Employment Commission with the list of essential survival items for which industrial production is responsible (Appendix 2 to Annex A of this plan) as soon as possible after this plan is adopted. The TIC will take steps to assure that the list is correct and current at all times.
2. The TIC will supply the following items to the Texas Employment Commission for storage and use in an emergency.
  - a. A sufficient number of blank envelopes for mailing to the producers, intrastate wholesale distributors, and interstate wholesale distributors of the essential survival items.
  - b. A sufficient number of letters and forms properly prepared ahead of time for the firms to execute and mail to the Bureau of Business Research and to the appropriate District Production Director and appropriate District Distribution Director. The suggested examples are Preattack-4 along with Prod-8 and Prod-9.
  - c. A sufficient number of letters advising the firms of the activation of the Emergency Resource Management Plan and requesting return of the forms. A suggested letter is enclosed as Prod-3.
  - d. A sufficient number of two sets of preaddressed return envelopes for mailing by the respondent firms. One set of the return envelopes will be preaddressed to the Bureau of Business Research. The other will be preaddressed to the District Headquarters, Industrial Production Resource Agency, leaving the city and street to be inserted by the firm.

(b) Responsibilities of the Texas Employment Commission

1. The Texas Employment Commission will inform the TIC of the number of firms for which envelopes will be required.

2. The Texas Employment Commission will store the mailing material provided by the TIC so that it will be available for immediate use in a nuclear emergency.
3. At the request of the Texas Industrial Commission, the Texas Employment Commission will arrange for the pre-positioning of the required forms through the mailing of the letter Preattack-4, forms Prod-8 and Prod-9 and other attachments. The Texas Employment Commission will use its addressing equipment to address the envelopes, or labels to be used on the envelopes, to the firms involved. The Texas Employment Commission will stuff the envelopes with the letters, forms, enclosures and preaddressed envelopes and mail them.
4. In the event of a nuclear attack, upon an area of the United States, without further instruction, the Texas Employment Commission will release the letter, Prod-3, with enclosures to the firms. As in 3 above, the Texas Employment Commission will address, insert, and mail the letters.

b. Advance Preparation

(1) Pre-Positioning of Forms with Producers

A stock of preprinted data survey forms is to be maintained by the Bureau of Business Research for all required survival items and shall be pre-positioned with the appropriate Texas producers at a time judged to be wise by the Governor of Texas. A suggested letter for use is incorporated as Preattack-4 in this portion of the plan for use in pre-positioning the forms. The Texas Industrial Commission is responsible for seeing that this is done through the use of the services of the Texas Employment Commission as outlined in 1.a.(6), above.

c. Postattack Action

a. Actions for Assessing Production Capability

(1) A compilation shall be made as outlined below of the State's production capabilities and inventories.

(a) Notification

Producers, like other persons and establishments covered by the State Emergency Resources Management Plan, will be notified of any nuclear attack emergency via public communications (newspaper, radio and television), and this announcement will be followed up by official written communications. A suggested letter of notification is incorporated in the plan as Prod-3.

(b) Return of Forms

The producers shall return the forms to the Bureau of Business Research and to the appropriate District Director for Production by the most rapid means available. The appropriate District Director for Production is responsible for following up and securing delayed responses from producers, but may call upon the Assistant Director for Production for personal contact work when necessary.

(c) Report Information

From the collected data, the Assistant Director for Production (using the services of the Bureau of Business Research) shall be responsible for compiling reports showing:

1. The maximum production capability of Texas producers for 90 days.
2. Run-out production from supplies of production materials on hand.
3. Present inventory of finished items.

(d) Types of Reports

These reports shall be compiled by:

1. The 17 districts.
2. Essential survival items and their code numbers.

(2) Assessment of Postattack Production Capability

Using the above production capability reports, the Coordinator of the State Industrial Production Resource Agency is responsible for preparing a postattack supply and production situation report. He shall present this information to the Resources Priority Board for use.

b. Actions for Continuing Supply

(1) After resupply to meet immediate needs is underway, SIPRA will take action to anticipate continuing needs.

Consultation shall proceed with all claimant agencies. These claimant agencies are the other resource agencies, the essential local users, and the essential local facilities. The pre-positioned form "Estimate of Continuing Essential Items Requirements" (Prod-7) shall be transmitted from claimants, as follows:

- (b) From essential local users and essential facilities to the District Distribution Directors. If the requirements cannot be obtained within the district, the requests will be forwarded through the region office to the Essential Items Requirements Branch.
- (2) The producers and interstate wholesalers of essential items shall determine their needs for supporting resources, operating supplies, equipment and services that will be needed to maintain operations during the ensuing 90-day period. This shall be accomplished as follows:
- (a) The producers shall use the forms which have been prepared by the other resource agencies (Prod-12) to report their requirements for manpower, electric power, water, etc., to the District Production Directors. If the requirements cannot be obtained within the district, the requests will be forwarded through the region office to the Support Resources Division.
- (b) The interstate wholesalers shall report their requirements for supporting resources on the same forms (Prod-12) to the District Distribution Directors. Once again, if the requirements cannot be obtained within the district, the requests will be forwarded through the region office to the Support Resources Division.
- (c) The producers' and interstate wholesalers' needs for essential items to continue operations will have been reported previously under (1) above. However, the producers and interstate wholesalers also may need any operating supplies, materials and types of equipment which are not in the current listing of essential items. These requirements shall be reported on the same form as the "Estimate of Continuing Essential Items Requirements" (Prod-7). The SIC code numbers from the OIM Product Assignment Directory, Reference Document No. 4, shown in Annex E, shall be used in the report. Producers' requirements shall be transmitted to the District Production Directors. Interstate wholesalers' requirements shall be transmitted to the District Distribution Directors. Requirements which cannot be filled within the district will be forwarded through the region office of the Materials Assistance Division.
- (3) Estimates shall be made of the requirements for emergency repair and construction of the physical plants of the producers and interstate wholesale distributors of essential items. The estimates shall be prepared by the producers and forwarded to the District Production Directors. Similar estimates for the interstate wholesale distributors shall be forwarded to the District Distribution Directors. Requirements which cannot be filled within the district will be forwarded through the region office to the Support Resources Division.

The Support Resources Division shall submit the estimates, after review by the Priorities and Allocations Division, to the State Construction Agency. A suggested report form is enclosed, Prod-13.

# DIVISION OF DISASTER EMERGENCY SERVICES DISASTER DISTRICT BOUNDARIES

Appendix 2 to Annex B

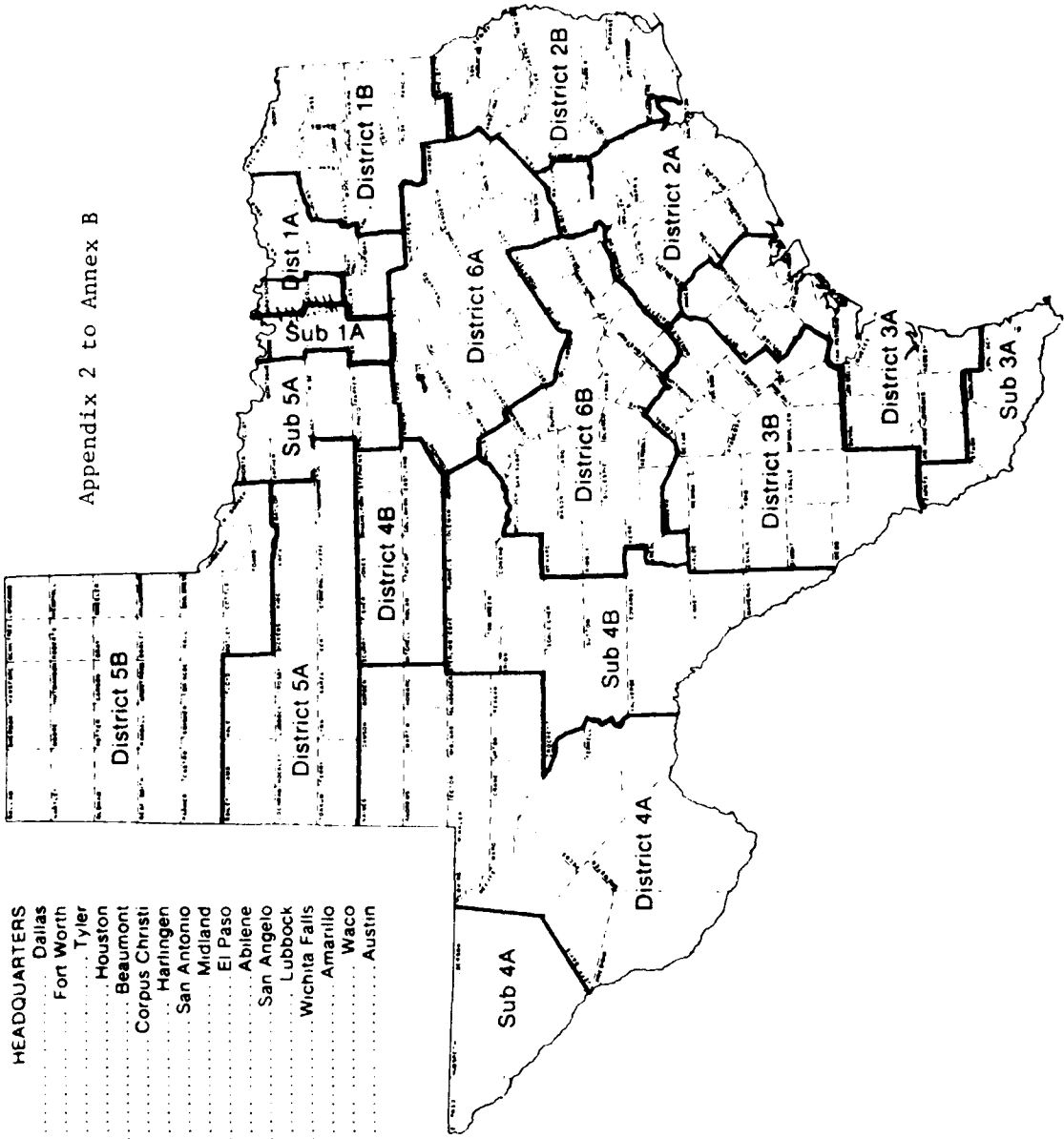

DISTRICT	HEADQUARTERS
1A	Dallas
Sub 1A	Fort Worth
1B	Tyler
2A	Houston
2B	Beaumont
3A	Corpus Christi
Sub 3A	Harlingen
3B	San Antonio
4A	Midland
Sub 4A	El Paso
4B	Abilene
Sub 4B	San Angelo
5A	Lubbock
Sub 5A	Wichita Falls
5B	Amarillo
6A	Waco
6B	Austin

APPENDIX 3  
(COUNTIES WITHIN DISTRICT AND  
SUBDISTRICT BOUNDARIES)  
TO ANNEX B (EMERGENCY ORGANIZATION)

<u>DISTRICTS and SUBDISTRICTS</u>	<u>COUNTIES</u>	<u>DISTRICTS and SUBDISTRICTS</u>	<u>COUNTIES</u>
District 1A (Dallas headquarters)	Grayson Fannin Lamar Collin Hunt	Delta Dallas Rockwall Kaufman	El Paso Hudspeth Culberson
Subdistrict 1A (Fort Worth headquarters)	Cooke Denton	Tarrant	Scurry Fisher Jones Shackelford Stephens Mitchell Nolan Taylor Callahan Eastland Coleman Brown
District 1B (Tyler headquarters)	Red River Bowie Hopkins Franklin Titus Morris Cass Camp Rains	Wood Upshur Marion Van Zandt Smith Gregg Harrison Rusk Panola	Subdistrict 4B (San Angelo headquarters) Sterling Coke Runnels Irion Tom Green Kinney Maverick Crockett
District 2A (Houston headquarters)	Grimes Walker Montgomery Washington Waller Harris Austin	Fayette Colorado Fort Bend Wharton Matagorda Brazoria Galveston	District 5A (Lubbock headquarters) Bailey Lamb Hale Floyd Cochran Hockley Lubbock Crosby Dickens King Knox Baylor Yoakum Terry Lynn Garza Kent Stonewall Haskell Throckmorton Young
District 2B (Beaumont headquarters)	Shelby Nacogdoches San Augustine Sabine Angelina Trinity Polk Tyler	Jasper Newton San Jacinto Liberty Hardin Orange Jefferson Chambers	Subdistrict 5A (Wichita Falls headquarters) Wichita Archer Clay Montague Jack Wise Palo Pinto Parker
District 3A (Corpus Christi headquarters)	Lavaca De Witt Victoria Jackson Goliad Calhoun Refugio San Patricio	Duval Jim Wells Nueces Kleberg Jim Hogg Brooks Kenedy Aransas	District 5B (Amarillo headquarters) Dallas Sherman Hansford Ochiltree Donley Lipscomb Hartley Moore Hutchinson Roberts Hemphill Oldham Potter Carson Gray Wheeler Foard Deaf Smith Randall Armstrong Donley Collingsworth Farmer Castro Swisher Briscoe Hall Childress Mottley Cottle Hardeman Wilbarger
Subdistrict 3A (Harlingen headquarters)	Zapata Starr Hidalgo	Willacy Cameron	
District 3B (San Antonio headquarters)	Bandera Comal Uvalde Medina Bexar Guadalupe Gonzales Wilson Karnes	Zavala Frio Atascosa Dimmit La Salle McMullen Live Oak Bee Webb	District 6A (Waco headquarters) Comanche Erath Hood Somervell Johnson Ellis Hamilton Bosque Hill Navarro Henderson Corvell McLennan Limestone Freestone Anderson Cherokee Bell Falls Leon Houston Madison
District 4A (Midland headquarters)	Gaines Dawson Borden Andrews Martin Howard Loving Winkler Ector Midland Glasscock	Reeves Ward Crane Upton Reagan Jeff Davis Pecos Presidio Brewster Terrell	District 6B (Austin headquarters) Mills McCulloch San Saba Lampasas Menard Mason Llano Burnet Williamson Milam Robertson Kimble Gillespie Blanco Travis Lec Burleson Brazos Kerr Kendall Hays Caldwell Bastrop Real

ANNEX C  
EMERGENCY ACTION DOCUMENTS

1. PREATTACK

- Preattack-1: Emergency Resource Requirements (Letter) w/Encl.
- Preattack-2: Essential Items Requirements (Letter) w/3 Encls.
- Preattack-3: Production Capability (Letter) w/2 Encls.
- Preattack-4: Supply of Essential Survival Items (Letter) w/8 Encls.

2. POSTATTACK

- Prod-1: State Essential Items Policy and Guidance (Letter)
- Prod-2: Emergency Communications (Letter)
- Prod-3: Supply of Essential Survival Items (Letters) w/3 Encls.
- Prod-4: Request for Release of Primary Inventories (Letter)
- Prod-5: Adjustment of Primary Deliveries (Letter & Form)
- Prod-6: Request for Essential Items - Immediate Needs (Form)
- Prod-7: Estimate of Continuing Essential Items Requirements (Form)
- Prod-8: Inventory of Essential Survival Items (Form)
- Prod-9: Production Capability (Form)
- Prod-10: Revised State Essential Items Policy (Letter)
- Prod-11: Assignment of Essential Items (Form)
- Prod-12: Essential Items Industry Support Requirements (Form)
- Prod-13: Essential Items Industry Construction Requirements (Letter)
- Prod-14: Allocation of Supporting Resources to Essential Items and Interstate Wholesale Distribution Industry (Letter)



Preattack-1  
(Emergency Resource Requirements)

Texas Industrial Commission  
Austin, Texas

---

TO: State Resource Coordinator  
Emergency Resource Management Organization

Gentlemen:

In the event the Emergency Resource Management Plan is activated, the State Industrial Production Resource Agency will make claims upon certain of you for resources necessary to carry out our emergency assignments.

Enclosed herewith is a form which has been suggested for making such claims upon your agencies.

You may need other information beyond that called for in the suggested form, and I am, therefore, submitting it to you for comments and revisions, if necessary.

Please let me hear from you within two weeks.

(Signature)  
Director

1 Enclosure  
Essential Items Industry Support Requirements (Prod-12)

---

Preattack-2  
(Essential Items Requirements)

Industrial Production Resource Agency  
State of Texas  
Austin, Texas

Office of the Coordinator

---

TO: Representative of the State  
Disaster Emergency Services Organization  
Representative of the U. S. Atomic Energy Commission  
State Resource Coordinator

Gentlemen:

Transmitted to you with this letter is a list of essential survival items coded to four digits, using the Standard Industrial Classification System. Please review this upon an annual basis to see that it is abreast of technological advances in your field. If you feel changes are needed write me.

In the event of a nuclear attack emergency, you, as claimant agencies, may call upon the inventories and productive capabilities of the State of Texas for necessary supplies of these essential survival items. You will be expected to use two types of standard forms to requisition essential items. Copies of these forms are attached so that you and your organization may familiarize yourself with them.

Form A would estimate your requirements for a three-month period.

Form B would give your immediate requirements. Normally, such immediate requests would be handled by telephone, and Form B would provide a record of these communications.

Form B, as sent you with this letter, contains an example of the method in which it should be prepared.

(Signature)  
Coordinator

3 Enclosures  
1-Essential Survival Items  
2-Form A (Prod-7)  
3-Form B (Prod-6)

Preattack-3  
(Production Capability)

Director, Disaster Emergency Services

---

TO: Producers of Essential Survival Items

Gentlemen:

Governor \_\_\_\_\_ has announced that studies are being made under the Emergency Resource Management Plan for use in the event of a nuclear attack. The Texas Industrial Commission, with the assistance of the Bureau of Business Research of the University of Texas, is now engaged in making surveys of producers' capabilities and inventories covering a list of essential survival items. You, as a producer of one or more of these items, are requested to submit certain production and inventory data needed for this program, in order that Texas will be prepared.

A list of the items in which the Texas Industrial Commission is concerned is enclosed. Multi-product manufacturers may not receive at the same time survey forms for all the essential survival items they produce. In this connection, if you produce any item on the enclosed list for which you have not yet received a preprinted survey form at the time of your report, please indicate the item(s) in the "Remarks" section of the report.

If the need should ever arise, the Director, Disaster Emergency Services, with technical advice and assistance from other State Agencies, including the Texas Industrial Commission, will be responsible for determining requirements for the items under attack conditions. These requirements, together with related state and neighboring area needs, will be matched against inventories (including wholesale and retail inventories, which will be developed through other surveys) and production data to enable a measurement of the ability of Texas to meet its needs for such items. Thereafter, measures will be considered to remedy the potential postattack short-supply situations.

At this particular time, the need for planning activities of this type may not seem to be urgent, but the situation could change abruptly. If it does, sufficient time for planning may not be available.

The information required is confidential and only for use in defense mobilization activities. The unauthorized publication or disclosure of individual company information is prohibited by law, and persons having access to such information are subject to fine and imprisonment for unauthorized disclosure.

Questions concerning your report should be addressed to the Director, Texas Industrial Commission, Austin, Texas. Reports should be returned to the Bureau of Business Research, University of Texas, Austin, Texas, which is serving as the collecting agency for the Texas Industrial Commission.

(Signature)

\_\_\_\_\_  
Director, Disaster Emergency Services

2 Enclosures

- 1-Essential Survival Items
- 2-Production Capability (Prod-9)

Preattack-4  
(Supply of Essential Survival Items)

Industrial Production Resource Agency  
State of Texas  
Austin, Texas

Office of the Coordinator

---

TO: Producers and Wholesale Distributors  
of Essential Survival Items

cc:  
County Judges of Texas  
Mayors or City Executives of Texas  
Region Production Directors  
Region Distribution Directors  
District Production Directors  
District Distribution Directors

Gentlemen:

In light of the present critical situation, Governor \_\_\_\_\_ has deemed it prudent to alert you to the possibility that he may be compelled to activate the State Emergency Resource Management Plan, in case a nuclear attack emergency should isolate Texas from Federal control.

Although such an emergency has not arisen, and may never arise, I am writing under instructions from the Governor to request that you hold yourself and the resources of your organization in a state of readiness.

Detailed plans have been prepared to cope with such an emergency. You who are producers will recall surveys which have been made of your productive capacity and inventories of essential survival items. They were required as part of the planning activities which began in 1965, when the State of Texas prepared such a plan under contract to the Office of Emergency Planning, now the Federal Emergency Management Agency, of the Federal Government. A list of these essential survival items and a copy of Defense Mobilization Order 8500.1A are enclosed for your guidance.

The Federal Government has already instituted controls over essential production, and these will continue in effect until further official notice.

Insofar as production and inventories are concerned, the State Plan calls for the establishment of 6 Region Production and Distribution Directorates and 17 District Production and Distribution Directorates. Maps showing the boundaries of these areas and rosters of the administrative headquarters are attached.

You will be contacted by appropriate personnel of the State Industrial Production Resource Agency without delay, if the Governor activates the Emergency Resource Management Plan. If you are a producer, your immediate point of contact will be the District Director of Production in your district. If you are a distributor, your contact will be the District Director of Distribution within your district.

The county judges and mayors within the 17 districts of Texas will represent the Governor of Texas locally and receive instructions through the office of the Director, Disaster Emergency Services.

Forms requesting certain information regarding your capabilities to produce certain essential survival items and/or your stocks on hand are enclosed.

These forms are sent as a planning measure at this time, so that you will have them in hand and know what information will be required of you in the event the Governor must place the State Emergency Resource Management Plan into effect.

This is not a rehearsal or a drill.

You are certainly aware of the perilous situation. Be prepared to respond immediately if the United States encounters a nuclear attack emergency.

After you are notified of such an emergency, transmit your forms with the required information to the Bureau of Business Research, the University of Texas, Austin, Texas, and to your District Director by the most rapid means at your command.

This information will be used in the United States and Texas by the State Emergency Resource Management Organization, under the immediate supervision of Governor \_\_\_\_\_.

(Signature)  
Coordinator

- 8 Enclosures  
1-Map of Region Boundaries  
2-Map of District Boundaries  
3-Roster of District Directors  
4-List of Essential Survival Items for Which Industrial Production is Responsible  
5-DMO 8500.1A  
6-Production Capability (Prod-9)  
7-Inventory (Prod-8)  
8-Envelopes

Prod-1  
(State Essential Items Policy and Guidance)

State of Texas

TO: Heads of Political Subdivisions

Guidance for Local Governments

It is important that essential items available for use in this State be carefully conserved and restricted to immediate and urgent uses for local, State, and National survival and recovery until the continuing supply of these items can be assessed and the supplies that will be available for less essential needs can be determined.

In order to (1) prevent waste and dissipation of essential items in secondary inventories, (2) provide supplies of essential items to meet immediate and urgent needs, (3) assure continuing resupply of local secondary inventories of essential items, and (4) ration essential items to meet most essential needs of individual consumers, appropriate officials of local government are requested to take the following actions:

1. Announce and enforce the temporary freeze on inventories of local secondary distributors of designated essential items.
2. Provide instructions to secondary distributors on how to release and resupply their inventories to meet essential needs.
3. Authorize essential local users to obtain immediate and urgent supplies of essential items from secondary distributors.
4. Authorize essential facilities to certify purchase orders on secondary distributors for essential items needed to maintain their operations. Instruct essential facilities to place these certified order on their customary sources of supply. (Local governments have been provided by the State with a list of the essential facilities located in their jurisdiction.)
5. Inform essential local users and essential facilities how to identify their purchase orders on primary producers and distributors of essential items.
6. As soon as possible, ration designated essential items to individual consumers and inform these individual consumers how to obtain supplies under the ration system.
7. Inform local secondary distributors of essential items as to their roles under the ration system.

In the event resupply from producers and wholesalers of essential items is not adequate to meet all essential needs, local governments should decide and cut back authorized local uses. Concurrently, they should report shortages and request District Distribution Directors to take actions to increase the supply of essential items to the local jurisdiction.

Effective Date: \_\_\_\_\_

(Name)  
Governor of the State of Texas

By: \_\_\_\_\_  
(Signature)  
Coordinator, Industrial Production Resource  
Agency

Prod-2  
(Emergency Communications)

Industrial Production Resource Agency  
State of Texas  
Austin, Texas

Office of the Coordinator

---

TO: Assistant Director for Production  
Assistant Director for Distribution  
Director of Public Information  
Administrative Assistant  
Region Production Directors  
Region Distribution Directors  
District Production Directors  
District Distribution Directors  
Director, Texas Industrial Commission  
Director, Bureau of Business Research, University of Texas

Gentlemen:

The Governor of Texas, the Honorable \_\_\_\_\_, has advised the appropriate State and Federal officials that he has activated the Emergency Resource Management Plan.

The authority of the State has therefore superseded that of the Federal Government, until such time as the Federal Government re-establishes control.

You are hereby directed to execute the provisions of the Emergency Resource Management Plan as affects industrial production.

(Signature)  
\_\_\_\_\_  
Coordinator

Prod-3  
(Supply of Essential Survival Items)

Industrial Production Resource Agency  
State of Texas  
Austin, Texas

Office of the Coordinator

---

TO: Producers and Wholesale Distributors  
of Essential Survival Items

cc:  
County Judges of Texas  
Mayors or City Executives of Texas  
Region Production Directors  
Region Distribution Directors  
District Production Directors  
District Distribution Directors

Gentlemen:

The Governor of Texas, the Honorable \_\_\_\_\_, has activated the State Emergency Resource Management Plan, effective \_\_\_\_\_.

The authority of the State of Texas has therefore superseded that of the Federal Government, until such time as the Federal Government re-establishes control.

The regulations and controls previously instituted by the Federal Government remain in effect, but will be administered by the State of Texas.

You will be contacted by the District Director who has authority over your operations.

Previously you received preprinted forms to report your production capability or supply of the essential survival items. Please complete and return these forms to the Bureau of Business Research, University of Texas, Austin, Texas, and to your District Director by the quickest means available.

A second supply of the forms and envelopes are enclosed for your use.

Your wholehearted cooperation in this emergency is required.

(Signature)  
Coordinator

3 Enclosures  
1-Inventory (Prod-8)  
2-Production Capability (Prod-9)  
3-Envelopes

Prod-4  
(Request for Release of Primary Inventories)

Industrial Production Resource Agency  
State of Texas  
Austin, Texas

Office of the Coordinator

TO: State Office of the Federal Business and Defense Services Administration

The District Distribution Directors in Texas and local governments in this State, in accordance with National and State policies and guidance, have advised essential local users, essential facilities, and secondary distributors to certify their purchase orders placed with their suppliers of essential items.

You are requested to arrange with producers and interstate wholesalers of essential items for acceptance and delivery against these orders within the quantities of essential items in their inventories that are available for use in this State.

Effective Date: \_\_\_\_\_

\_\_\_\_\_  
(Signature)  
Coordinator

Prod-5  
(Adjustment of Primary Deliveries)

Industrial Production Resource Agency  
State of Texas  
Austin, Texas

TO: State Office of the Federal Office of Industrial Mobilization

Shortages in essential item supplies are being reported by local governments and by District Distribution Directors in this State.

Authorized local uses have been cut back as far as possible by local government decision and action.

You are requested to arrange with producers and interstate wholesalers to increase deliveries to meet authorized orders received by them from these localities.

Attached are requested increased in deliveries of specified essential items to named localities.

Necessary Increases of Essential Item Deliveries		
Name of Locality _____		
Essential Item	Unit of Measure	Increase in Deliveries

\_\_\_\_\_  
(Signature)  
Manager, Priorities and Allocations Division

Prod-6  
 (Request for Essential Items-Immediate Needs)

Form B  
 (Request for Essential Items-Immediate Needs)

(1) DATE OF REQUEST:  (2) TO: Industrial Production Resource Agency-Essential Items Requirements Branch (address) (city)  (3) CLAIMANT: (agency name) (address) (city) PHONE NO.:  (4) ESSENTIAL SERVICE INDUSTRY DESIGNATION:  Water	(12) Date Received: _____ No.  Checked By:  Title:  Date:
--	--

Line (5)	Item (6)	Code (7)	Technical Designation; Model; Type; Packaging; etc. (8)	Unit (9)	Required Quantity (10)
1	Hypochlorite - 70%	2819	100 lb. cannisters	lb.	500 lbs.
2	Pump - centrifugal	3561	4x3 horiz. splitcase; 140' tdh 300 gpm	ea.	1
3	Motor-induction-polyphase AC	3621	20 hp; 3 ph; 440 v.A.C.; for pump in Item 2	ea.	1
4	Cast iron pressure pipe	3321	6" mechanical joint Class 150	ft.	2,000 ft.

(11) REMARKS

(13) REQUEST PREPARED BY: (name)  
 (title)  
 (signature)

INSTRUCTIONS  
 FORM "B"

- Item 1: DATE OF REQUEST: Date on which request was prepared.
  - Item 2: TO: State Industrial Production Resource Agency. This could be preprinted.
  - Item 3: CLAIMANT: Full name of originating claimant agency, with complete mailing address and telephone number.
  - Item 4: ESSENTIAL SERVICE INDUSTRY DESIGNATION: Show user group classification for which claimant agency's request is made, i.e.: Gas; Petroleum; Water; Food Resources; etc.
  - Item 5: LINE: Item Number: 1, 2, 3, etc.
  - Item 6: ITEM: Name of item as it appears in standard governmental listings, such as "Official Class B Product List and Product Assignment Directory."
  - Item 7: CODE: Number of item as it appears in "Official Class B Product List and Product Assignment Directory."
  - Item 8: TECHNICAL DESIGNATION, etc.: Give a brief, precise, accurate description of requested item if there is more than one form, type or kind available.
  - Item 9: UNIT: Show the usual measurement of each item, such as pounds, feet, U. S. gallons, etc.
  - Item 10: REQUIRED QUANTITY: The total number of units of an item.
  - Item 11: REMARKS: A brief explanatory statement, if necessary, to avoid any possible misinterpretation or misunderstanding of the nature of the requested item or items.
  - Item 12: This space is for the receiving office. It should show disposition of request. (A specific format is not offered for this form although it could be set up as part of a final coordinating effort with other affected branches.)
  - Item 13: This is to be completed by person preparing request.
- THE ARTICLES LISTED ON LINES 1 TO 5 ARE FOR ILLUSTRATIVE PURPOSES ONLY AS PART OF THIS EXHIBIT.



Form A  
 (Estimate of Continuing Essential Items Requirements)

THREE MONTHS BEGINNING \_\_\_\_\_

<p>(1) DATE OF REQUEST: _____</p> <p>(2) TO: Industrial Production Resource Agency          -Essential Items Requirements Branch-          (address) (city)</p> <p>(3) CLAIMANT: (agency name)          (address)          (city)          PHONE NO. _____</p> <p>(4) ESSENTIAL SERVICE INDUSTRY DESIGNATION: _____</p>	<p>(12) Date Received: _____ No: _____</p> <p>Checked By: _____</p> <p>Title: _____</p> <p>Date: _____</p>
---	--

Line (5)	Item (6)	Code (7)	Technical Designation; Type; Packaging; etc. (8)	Unit (9)	Estimated Requirements		
					1st Mo (10)	2nd Mo (10)	3rd Mo (10)

(11) REMARKS: \_\_\_\_\_

(13) REQUEST PREPARED BY: (name)  
 (title)  
 (signature)

INSTRUCTIONS  
 FORM "A"

This form is to be prepared and submitted by the claimant agency. It is a reasonable estimate of that agency's requirements for an ensuing three-month period.

- Item 1: DATE OF REQUEST: Date on which requirements estimate was prepared.
- Item 2: TO: State Industrial Production Resource Agency. This could be preprinted.
- Item 3: CLAIMANT: Full name of originating claimant agency, with complete mailing address and telephone number.
- Item 4: ESSENTIAL SERVICE INDUSTRY DESIGNATION: Show user group classification for which claimant agency's request is made, i.e.: Gas; Petroleum; Water, Food Resources; etc.
- Item 5: LINE: Item number: 1, 2, 3, etc.
- Item 6: ITEM: Name of item as it appears in standard governmental listings, such as "Official Class B Product List and Product Assignment Directory."
- Item 7: CODE: Number of item as it appears in "Official Class B Product List and Product Assignment Directory."
- Item 8: TECHNICAL DESIGNATION, etc.: Give a brief, precise, accurate description of item if there is more than one form, type or kind available.
- Item 9: UNIT: Show the usual measurement of each item, such as pounds, feet, U. S. gallons, etc.
- Item 10: ESTIMATED REQUIREMENTS: For each item set forth, show number of units estimated as being needed in each month of the covered period, according to the best reasonable estimate that can be made.
- Item 11: REMARKS: Give a brief statement of the methods used for estimating requirements. Also, if needed, a brief explanatory statement to avoid possible misinterpretation or misunderstanding of the nature of a particular item.
- Item 12: This space is for the receiving office. It should show disposition of request. (A specific format is not offered for this form although it could be set up as part of a final coordinating effort with other affected branches.)
- Item 13: This is to be completed by person preparing estimate.



AD-A090 824 TEXAS DEPT OF PUBLIC SAFETY AUSTIN DIV OF DISASTER E--ETC F/6 15/3  
TEXAS EMERGENCY RESOURCE MANAGEMENT. VOLUME II.(U)  
SEP 79 A C ELEDGE, R L ORTON, S O MERZ DCPA01-78-C-0321  
NL

UNCLASSIFIED

3 of 4  
21  
2100124

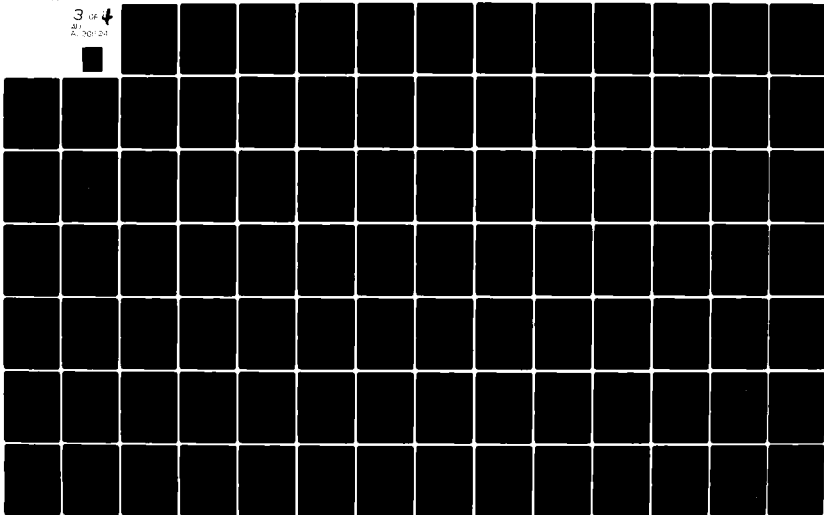

(Instructions--Inventories of  
Essential Survival Items)

Mailing - File one (1) copy of this report with the above address as soon as possible after receipt, in the enclosed envelope which requires no postage. Retain File Copy for your files.

Additional copies of this reporting form are available upon request to the Industrial Production Resource Agency, or you may reproduce copies yourself.

1. Name and address of company - List detailed mailing address of General Office of Company. Show both street address and P. O. Box (if any), and underline preferred address for mail.
  2. Plant location - Fill out a separate report for each location which has one or more of the items listed in inventory. In reporting locations, give the street address and name the boundary streets between which the stock lies. If the warehouse does not have a street address, the location may be specified as distance and direction from a town or a state or federal highway.
  3. Col. (a)-Item - From list of essential survival items, list those items on hand in the stock being reported upon. (Note:-Forms could be preprinted listing essential survival items by subgroup i.e.-Pharmaceuticals, Blood Collecting and Dispensing Supplies, Biologicals, etc.-by Industry Division. See sample form for Water Supply Materials.)
  4. Col. (b)-Code No. - OIM Officials Class B Product List and Product Assignment Directory (Note: These product codes could be preprinted in this column, same as preprinting of Item.)
  5. Col. (c)-Unit of Measure - Normal measurement of item-i.e. Each, pounds, tons, gallons, etc.
  6. Col (d)-Stocks on Hand
  7. Col (e)-Normal Inventory
- IF EXACT DATA CANNOT BE COMPUTED WITH REASONABLE EFFORT, CAREFUL ESTIMATES ARE ACCEPTABLE PROVIDED THEY ARE SO LABELED.

Prod-9--Sheet 1 of 2  
(Production Capability)

SAMPLE FORM	(Production Capability)
From Industrial Production Resource Agency Bureau of Business Research (Collecting Agency)  SURVIVAL ITEMS PROGRAM  Water Supply Materials	Due in Austin  30 DAYS AFTER RECEIPT  1. Name and Address of Company   Phone No.
Return To Bureau of Business Research University of Texas Austin, Texas	2. Name and Address of Plant (Street, City, State, Zip Code)   Phone No.

Instructions  
(See Sheets Attached)

MAXIMUM PRODUCTION, PRODUCTION RUN-OUT AND INVENTORY						
Item (a)	Code No. (b)	Unit of Measure (c)	Maximum Production Capability 90 days (d)	Production Run-Cut (e)	Present Inventory Finished Items (f)	
<b>a. Coagulation:</b>						
Ferric Chloride	2819					
Ferrous Sulphate	2819					
Ferric Sulphate	2819					
Chlorinated Copperas	2819					
Filter alum	2819					
Hydrated Lime	3274					
Pulverized Limestone	3295					
Soda Ash	2812					
<b>b. Disinfection Chemicals:</b>						
High-test hypochlorites (70X) in drums, cans, ampules	2819					
Iodine Tablets	2842					
Liquid Chlorine, incl. containers	2812					
Chlorine Compounds (not gas)	2819					
<b>c. Miscellaneous Materials:</b>						
Diatomaceous Earth	3295					
Activated Carbon	2819					

REMARKS:

(use additional sheet, if necessary)

EMERGENCY ADDRESS AND TELEPHONE  
NUMBER IF DIFFERENT FROM REVERSE  
SIDE

PREPARED BY: \_\_\_\_\_  
(Print Name and Title)

SIGNATURE: \_\_\_\_\_

DATE: \_\_\_\_\_

(Instruction-Production Capability)

Mailing - File one (1) copy of this report with the above address not later than 30 days after receipt, in the enclosed envelope which requires no postage. Retain file copy for your files.

Additional copies of this reporting form are available upon request to the Bureau of Business Research, the University of Texas, Austin, Texas.

1. Name and address of company - List detailed mailing address of General Office of Company. Show both street address and P. O. Box (if any), and underline preferred address for mail.
2. Plant location - Fill out a separate report for each plant making one or more of the items listed. In reporting plant location, give the street address and name and boundary streets between which the plant lies. If the plant does not have a street address, the location may be specified as distance and direction from a town or a state or federal highway.

3. Col.(a)-Item - Form list of essential survival items, list those items produced by the plant being reported upon. (Note- Forms should be preprinted, listing essential survival items by subgroup, i.e.-Pharmaceuticals, Blood Collecting and Dispensing Supplies, Biologicals, etc.,-by Industry Division. See sample form for Water Supply Materials.)
4. Col.(b)-Code No. - OIM Official Class B Product List and Produce Assignment Directory. (Note: These product codes should be preprinted in this column, same as preprinting of Item.)
5. Col.(c)-Unit of Measure - Normal measurement of item-i.e. Each, pounds, tons, gallons, etc.
6. Col.(d)-Maximum Production Capability 90 Days - Report your best estimate of the maximum production possible of each item listed in Col. (a) for the 90-day period following receipt of this report. In estimating maximum production:
  - a. Assume that there will be no change from the present availability of materials and components.
  - b. Take into account building facilities and machinery which are available or will be added during the 90-day period for which estimates are to be made.
  - c. Assume that production of items of a strictly military nature which you may now be making will be continued at the present rate. Do not take into account additional commitments you may have made in connection with the Planning Program. (These assumptions are not to be considered as an invalidation of any military production plans that may have been negotiated by your plant.)
  - d. Take into account the utilization of labor, machinery, and materials presently employed in the production of items not listed in Col.(a), or nonmilitary items
  - e. If you have production capacity to make any of the items listed in Col. (a) which you do not now produce, you should estimate maximum possible production of such items under the assumptions contained in this instruction.
  - f. In estimating your maximum production of the items you are now producing and the items you could produce, which you are not now making, you should use that product mix which maximizes production of each individual item.
  - g. In reply to this question, you should take into consideration the availability of additional personnel in your area, the training time required, and the additional machinery downtime resulting from operating at capacity levels.
7. Col.(e)-Production Run-Out - Assuming your outside supply lines were completely shut off, estimate quantity of goods you could produce based on the amount of raw materials, semifinished and finished components and subassemblies on hand. Finished items received from outside suppliers awaiting packaging, labeling, etc., should be included.
8. Col.(f)-Present Inventory - List quantity of finished items, Col.(a), on hand at time of receipt of this report, located at the plant or adjacent warehouse.

IF EXACT DATA CANNOT BE COMPUTED WITH REASONABLE EFFORT, CAREFUL ESTIMATES ARE ACCEPTABLE, PROVIDED THEY ARE SO LABELED.

Prod-10

(Revised State Essential Items Policy)

(Note: The content and substance of the revised essential items policy will depend on the situation and the supplies expected to be available to meet continuing urgent needs. Necessarily this document will not be completed except in a test of the plan or at the appropriate point in a postattack situation.)

This document will be, in essence a revision to Prod-1. State Essential Items Policy and Guidance.

**Prod-11  
(Assignment of Essential Items)**

Industrial Production Resource Agency  
State of Texas  
Austin, Texas

TO: \_\_\_\_\_  
\_\_\_\_\_  
\_\_\_\_\_

Allocation of Essential Items  
(See Instructions on Reverse Side)

1. CLAIMANT

\_\_\_\_\_  
(Agency Name)  
\_\_\_\_\_  
(Address)  
\_\_\_\_\_  
(City)

2. DATE \_\_\_\_\_

3. Allocations for the period from \_\_\_\_\_ to \_\_\_\_\_.

Line (4)	Item (5)	Code (6)	Technical Designation; Type; Packaging, etc. (7)	Unit (8)	Quantity Allocated		
					30 days (9)	60 days (10)	90 days (11)
REMARKS (12)							

Released By: \_\_\_\_\_ (Signature)  
Manager, Priorities and Allocations  
Division

Instructions - Assignment of Essential Items

**Distribution**- This report shall be released as soon as the information has been developed. Distribution shall be:

- Two Copies to State Claimant
- One Copy to Director of Disaster Emergency Serv.
- Two Copies to Office of FEMA, Denton Federal Center, Denton, Texas.
- Two Copies to OIM Denton Federal Center, Denton Texas
- One Copy to following SIPRA Groups:  
Coordinator, SIPRA  
Assistant Director for Production  
Assistant Director for Distribution  
Essential Items Requirements Branch  
Director of Production for Region  
Director of Distribution for Region  
Director of Production for District  
Director of Distribution for District

1. State Claimant- The claimant will be one of the following:

- (a) Another Resource Agency
- (b) An Essential Local User
- (c) An Essential Facility

2. Date- Enter date of release of the allocation.

3. Allocations for the period from \_\_\_\_\_ to \_\_\_\_\_  
The time period involved will be for 30 days, 60 days or 90 days.

4. Line: Entry number: 1, 2, 3, etc.

5. Item: Name of item as it appears in the "Official Class B Product List and Product Assignment Directory."

6. Code: Code number of item as it appears in the "Official Class B Product List and Product Assignment Directory."

7. Technical Designation: Give a brief, precise, accurate description of item if there is more than one form, type, or kind available. This applies particularly to machinery, such as pumps or compressors.

8. Unit: Show the standard units in use by the BDSA. If this is not available show the usual measurement, such as pounds, linear feet, U.S. gallons, etc.

9, 10, and 11. Quantity Allocated: Show the number of units allocated for the particular time interval.

12. Remarks: State reasons for denying requested amounts, if applicable. Explain any substitutions made.

**Prod-12**  
**(Essential Items Industry Support Requirements)**

Estimate of Essential Item Industry Support Requirements for 90-Day Period Commencing _____.				
Resource	Unit of Measure	First 30 days	Following 60 days	Total 90 days
Electric power				
Manpower				
Transportation				
Petroleum				

**Prod-13**  
**(Essential Items Industry Construction Requirements)**

Industrial Production Resource Agency  
 State of Texas  
 Austin, Texas

TO: State Construction Agency

cc: Director of Production for Region \_\_\_\_\_  
 Director of Distribution for Region \_\_\_\_\_  
 Director of Production for District \_\_\_\_\_  
 Director of Distribution for District \_\_\_\_\_

Following is a list and description of major construction, repair and modification of facilities that will be required to maintain desired production and distribution of essential items during the 90-day period commencing \_\_\_\_\_.

**Construction Projects**

1. Name, location, type, and size of construction project; start and completing dates.

(If project is underway or a construction contract has been prepared, attach a copy of the contract document and summary bill of materials.)

- 2.
- 3.
- 4.

(Signature)  
 \_\_\_\_\_  
 Manager, Materials Assistance Division



Prod-14  
(Allocation of Supporting Resources to Essential  
Items and Interstate Wholesale Distribution Industry)

Industrial Production Resource Agency  
State of Texas  
Austin, Texas

---

TO: State Office of the Federal Office of Industrial  
Mobilization

cc: Region Production Directors  
Region Distribution Directors  
District Production Directors  
District Distribution Directors

Attached is a list and the quantities of supporting resources that have been allocated for maintaining urgent operations of producers' and interstate wholesalers' essential items facilities.

This is furnished as a basis for authorizing these facilities to obtain continuing supplies of these resources during the allocation period.

(Signature)

Manager, Priorities and Allocations Division

---

ANNEX D

(REFERENCE DOCUMENTS)

1. COMPUTERIZED LIST OF ESSENTIAL ITEMS
2. ROSTER OF INTERSTATE WHOLESALE DISTRIBUTORS OF ESSENTIAL ITEMS  
(To be furnished by the Department of Commerce and supplied by the Federal Government.)
3. DIRECTORY OF TEXAS MANUFACTURERS  
(Published by the Bureau of Business Research, The University of Texas)
4. OFFICIAL CLASS B PRODUCT LIST AND PRODUCT ASSIGNMENT DIRECTORY  
(Supplied by the Federal Government as published by the U. S. Government Printing Office for the Department of Commerce; last publication issued October 1, 1960.)

**FORMAT FOR  
ROSTER OF PRODUCERS  
OF ESSENTIAL ITEMS**

<u>Name and Address</u>	<u>Date of Establishment</u>	<u>Distribution</u>	<u>Employee Code</u>	<u>SIC No.</u>	<u>Home Office</u>	<u>County No.</u>	<u>City No.</u>	<u>Alpha No.</u>	<u>District Code</u>	<u>BDSA Code</u>
-------------------------	------------------------------	---------------------	----------------------	----------------	--------------------	-------------------	-----------------	------------------	----------------------	------------------

**Name and Address**- This entry is self-explanatory.

**Date of Establishment**- This is the date on which the company or corporation was formed and began business.

**Distribution**- The entry under distribution indicates the area of distribution of products manufactured by the firm. The following alphabetical code is used:

L - Local	R - Regional (more than one state)
C - County	N - National
D - District (several counties)	I - International
S - State	

**Employee Code**- The numerical code under this entry indicates the number of employees working for the firm.

1 - Under 8	4 - 50 to 99	7 - 500 to 999
2 - 8 to 24	5 - 100 to 249	8 - 1,000 to 4,999
3 - 25 to 49	6 - 250 to 499	9 - 5,000 and over

**SIC No.**- This is the Standard Industrial Classification code number for the essential item involved. The SIC number is taken from the Official Class B Product List and Product Assignment Directory (OIM). This document is enclosed as Annex H to the plan. The SIC numbers are listed for each essential item for which Industrial Production is responsible. A list of these essential items is contained in Appendix 2 to Annex A of the Industrial Production Plan.

**Home Office**- Relationship to a home office at another address, or to affiliated plants, is indicated by an asterisk (\*).

**County No.**- This numerical code refers to the county in which the firm is located. A list of these code numbers is enclosed on Page B-VII-D-3.

**City No.**- The numerical code refers to the city in which the firm is located. The city code is given in the Directory of Texas Manufacturers; however, a cross reference is not necessary in that the city is already listed under "Name and Address."

**Alpha No.**- The alpha number is an entry necessary for computer processing and contains no meaning as far as the roster is concerned.

**District Code**- This numerical code refers to the Defense and Disaster Relief district or subdistrict in which the firm is located. A list of the code numbers for the districts is shown on Page B-VII-D-4.

**BDSA Code**- This code number refers to the OIM Industry Division under which the essential item is listed. The code numbers for the OIM Industry Division are shown on Page B-VII-D-5. The grouping of essential items into the OIM Industry Divisions is shown on the same page.

In order to enable a full understanding of the roster, the information listed for the first firm will be explained. The first firm listed is the Jamaka Company, 349 E. Virginia, McKinney, Texas.

**Date of Establishment**- The firm began operation in 1959.

**Distribution**- The alphabetical entry "N" is given. This indicates that the Jamaka Company distributes its products nationally throughout the U.S.A.

**Employee Code**- The numerical entry "2" is listed. The firm has between 8 and 24 employees.

**SIC No.**- The numerical entry "3522" is given. Reference to Appendix 2 to Annex A of this plan shows that the firm manufactures agricultural machinery and implements.

**Home Office**- In that no asterisk is shown, the conclusion is that the home office of the firm is in McKinney, Texas.

**County No.**- The numerical entry "043" is listed. The firm is located in Collin County, Texas.

**District Code**- The numerical entry "1" is given. The county is located within District 1A of the Defense and Disaster Relief district or subdistrict.

**BDSA Code**- The numerical entry "1" is listed. The essential item is within the Agricultural, Construction, Mining, and Oil Field Equipment Division of the BDSA.

TEXAS COUNTIES WITH DTM CODE NUMBERS

Anderson	001	Ector	068	King	135	Sabine	202
Andrews	002	Edwards	069	Kinney	136	San Augustine	203
Angelina	003	Ellis	070	Kleberg	137	San Jacinto	204
Aransas	004	El Paso	071	Knox	138	San Patricio	205
Archer	005	Erath	072	Lamar	139	San Saba	206
Armstrong	006	Falls	073	Lamb	140	Schleicher	207
Atascosa	007	Fannin	074	Lampasas	141	Scurry	208
Austin	008	Fayette	075	La Salle	142	Shackelford	209
Bailey	009	Fisher	076	Lavaca	143	Shelby	210
Bandera	010	Floyd	077	Lee	144	Sherman	211
Bastrop	011	Foard	078	Leon	145	Smith	212
Baylor	012	Fort Bend	079	Liberty	146	Somervell	213
Bee	013	Franklin	080	Limestone	147	Starr	214
Bell	014	Freestone	081	Lipscomb	148	Stephens	215
Bexar	015	Frio	082	Live Oak	149	Sterling	216
Blanco	016	Gaines	083	Llano	150	Stonewall	217
Borden	017	Galveston	084	Loving	151	Sutton	218
Bosque	018	Garza	085	Lubbock	152	Swisher	219
Bowie	019	Gillespie	086	Lynn	153	Tarrant	220
Brazoria	020	Glasscock	087	McCulloch	154	Taylor	221
Brazos	021	Goliad	088	McLennan	155	Terrell	222
Brewster	022	Gonzales	089	McMullen	156	Terry	223
Briscoe	023	Gray	090	Madison	157	Throckmorton	224
Brooks	024	Grayson	091	Marion	158	Titus	225
Brown	025	Gregg	092	Martin	159	Tom Green	226
Burleson	026	Grimes	093	Mason	160	Travis	227
Burnet	027	Guadalupe	094	Matagorda	161	Trinity	228
Caldwell	028	Hale	095	Maverick	162	Tyler	229
Calhoun	029	Hall	096	Medina	163	Upshur	230
Callahan	030	Hamilton	097	Menard	164	Upton	231
Cameron	031	Hansford	098	Midland	165	Uvalde	232
Camp	032	Hardeman	099	Milam	166	Val Verde	233
Carson	033	Hardin	100	Mills	167	Van Zandt	234
Cass	034	Harris	101	Mitchell	168	Victoria	235
Castro	035	Harrison	102	Montague	169	Walker	236
Chambers	036	Hartley	103	Montgomery	170	Waller	237
Cherokee	037	Haskell	104	Moore	171	Ward	238
Childress	038	Hays	105	Morris	172	Washington	239
Clay	039	Hemphill	106	Motley	173	Webb	240
Cochran	040	Henderson	107	Nacogdoches	174	Wharton	241
Coke	041	Hidalgo	108	Navarro	175	Wheeler	242
Coleman	042	Hill	109	Newton	176	Wichita	243
Collin	043	Hockley	110	Nolan	177	Wilbarger	244
Collingsworth	044	Hood	111	Nueces	178	Willacy	245
Colorado	045	Hopkins	112	Ochiltree	179	Williamson	246
Comal	046	Houston	113	Oldham	180	Wilson	247
Comanche	047	Howard	114	Orange	181	Winkler	248
Concho	048	Hudspeth	115	Palo Pinto	182	Wise	249
Cooke	049	Hunt	116	Panola	183	Wood	250
Coryell	050	Hutchinson	117	Parker	184	Yoakum	251
Cottle	051	Irion	118	Parmer	185	Young	252
Crane	052	Jack	119	Pecos	186	Zapata	253
Crockett	053	Jackson	120	Polk	187	Zavala	254
Crosby	054	Jasper	121	Potter	188		
Culberson	055	Jeff Davis	122	Presidio	189		
Dallam	056	Jefferson	123	Rains	190		
Dallas	057	Jim Hogg	124	Randall	191		
Dawson	058	Jim Wells	125	Reagan	192		
Deaf Smith	059	Johnson	126	Real	193		
Delta	060	Jones	127	Red River	194		
Denton	061	Karnes	128	Reeves	195		
De Witt	062	Kaufman	129	Refugio	196		
Dickens	063	Kendall	130	Roberts	197		
Dimmit	064	Kenedy	131	Robertson	198		
Donley	065	Kent	132	Rockwall	199		
Duval	066	Kerr	133	Runnels	200		
Eastland	067	Kimble	134	Rusk	201		

DISTRICT CODE

<p><b>01 DISTRICT 1A</b> Collin Dallas Delta Fannin Grayson Hunt Kaufman Lamar Rockwall</p>	<p><b>05 DISTRICT 2B</b> Angelina Chambers Hardin Jasper Jefferson Liberty Nacogdoches Newton Orange Polk Sabine San Augustine San Jacinto Shelby Trinity Tyler</p>	<p><b>09 DISTRICT 4A</b> Andrews Borden Brewster Crane Dawson Ector Gaines Glasscock Howard Jeff Davis Loving Martin Midland Pecos Presidio Reagan Reeves Terrell Upton Ward Winkler</p>	<p><b>13 DISTRICT 5A</b> Bailey Baylor Cochran Crosby Dickens Floyd Garza Hale Haskell Hockley Kent King Knox Lamb Lubbock Lynn Stonewall Terry Throckmorton Yoakum Young</p>	<p><b>16 DISTRICT 6A</b> Anderson Bell Bosque Cherokee Comanche Coryell Ellis Erath Falls Freestone Hamilton Henderson Hill Hood Houston Johnson Leon Limestone Madison McLennan Navarro Rockwall Somervell</p>
<p><b>02 SUB. 1A</b> Cooke Denton Tarrant</p>	<p><b>06 DISTRICT 3A</b> Aransas Brooks Calhoun De Witt Duval Goliad Jackson Jim Hogg Jim Wells Kenedy Kleberg Lavaca Nueces Refugio San Patricio Victoria</p>	<p><b>10 SUB. 4A</b> Culberson El Paso Hudspeth</p>	<p><b>14 SUB. 5A</b> Archer Clay Jack Montague Palo Pinto Parker Wichita Wise</p>	<p><b>17 DISTRICT 6B</b> Bastrop Blanco Brazos Burleson Burnet Caldwell Gillespie Hays Kendall Kerr Kimble Lampasas Lee Llano Mason McCulloch Menard Milam Mills Real Robertson San Saba Travis Williamson</p>
<p><b>03 DISTRICT 1B</b> Bowie Camp Cass Franklin Gregg Harrison Hopkins Marion Morris Panola Rains Red River Rusk Smith Titus Upshur Van Zandt Wood</p>	<p><b>07 SUB. 3A</b> Cameron Hidalgo Starr Willacy Zapata</p>	<p><b>11 DISTRICT 4B</b> Brown Callahan Coleman Eastland Fisher Jones Mitchell Nolan Scurry Shackelford Stephens Taylor</p>	<p><b>15 DISTRICT 5B</b> Armstrong Briscoe Carson Castro Childress Collingsworth Cottle Dallam Deaf Smith Donley Foard Gray Hall Hansford Hardeman Hartley Hemphill Hutchison Lipscomb Moore Motley Ochiltree Oldham Parmer Potter Randall Roberts Sherman Swisher Wheeler Wilbarger</p>	
<p><b>04 DISTRICT 2A</b> Austin Brazoria Colorado Fayette Fort Bend Galveston Grimes Harris Matagorda Montgomery Walker Waller Washington Wharton</p>	<p><b>08 DISTRICT 3B</b> Atascosa Bandera Bee Bexar Comal Dimmit Frio Gonzales Guadalupe Karnes La Salle Live Oak McMullen Medina Uvalde Webb Wilson Zavala</p>	<p><b>12 SUB. 4B</b> Coke Concho Crockett Edwards Irion Kinney Maverick Runnels Schleicher Sterling Sutton Tom Green Val Verde</p>		

OFFICE OF INDUSTRIAL MOBILIZATION (OIM)  
INDUSTRY DIVISIONS

01	Agricultural, constuction, mining, and oil field equipment	11	Forest products
02	Aluminum and magnesium	12	General industrial equipment and components
03	Automotive and transportation equipment	13	Iron and steel
04	Building materials	14	Leather, shoes, and allied products
05	Business equipment and service industries	15	Metalworking equipment
06	Chemical and rubber	16	Miscellaneous metals and minerals
07	Consumer durable goods	17	Power equipment
08	Containers and packaging	18	Printing and publishing
09	Copper	19	Scientific, motion picture and photographic products
10	Electrical equipment	20	Textiles and clothing

OIM INDUSTRY DIVISIONS

01	3069	3021	11	2411	18	3993	
	3443	3069		2421			
	3522	3079		2426	19	2293	
	3531	3229		2431		3421	
	3553	3272		2432		3811	
02	3357	3274		2499		3821	
03	3713	3292		2647		3831	
	3715	3312		2649		3841	
	3717	3317		2661		3842	
	3742			3983			
04	2433	07	2511				
	2499		3229	12	3069	20	2211
	2661		3231		3229		2241
	2821		3262		3423		2251
	2952		3421		3429		2253
	3079		3433		3452		2254
	3271		3461		3494		2311
	3275		3631		3559		2321
	3292		3632		3561		2322
	3321		3641		3569		2327
	3429		3642		3632		2328
	3432		3964				2329
05	3993		3981	13	3312		2331
06	2385	08	2653		3317		2335
	2812		3221		3321		2337
	2818		3443				2339
	2819		3461	14	3141		2341
	2831	09	3357		3151		2342
	2834						2352
	2841	10	3357	15	3548		2361
	2842		3464		3623		2363
	2871		3612	16	3295		2369
	2879		3613	17	3443		2389
	2899		3644		3589		2394
	3011		3692		3621		2399

**PART B - RESOURCE SECTIONS**

**VIII. Manpower**

**B-VIII**  
Manpower

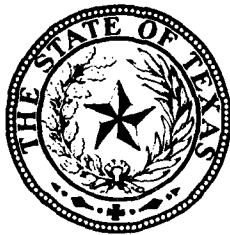

**Texas  
Emergency  
Resource  
Management**

**PLAN**

## INTRODUCTION

This section of the Texas Emergency Resource Management Plan contains policies, guidance and actions to provide civilian manpower to carry on essential activities in the State in a nuclear attack emergency. It prescribes the organizational arrangement to carry on State management roles in the manpower resource field and is concerned primarily with actions and arrangements to assure manpower support and service to meet immediate and continuing needs of the State. Although this plan is primarily focused on postattack, it will also provide and will constitute as guidance should crisis relocation be implemented prior to an attack. The following definitions and abbreviations are supplied to insure clarity:

### Definitions:

- a. Manpower includes everyone capable of effort which will contribute to the survival of the Nation.
- b. Health Manpower includes those occupations listed in the List of Health Manpower Occupations based on Defense Mobilization Order 8540.1, Federal Emergency Management Agency. It includes physicians (including osteopaths), dentists, sanitary engineers, registered professional nurses and certain other occupations.
- c. Manpower Priorities are staff instructions issued by manpower officials to carry out executive guidance by the Governor or head of local government or their authorized agents in the assignment of available manpower. Such executive guidance is referred to as relative urgency guidance.
- d. Military Manpower includes military reserves and Selective Service inductees.
- e. Postattack Period is the 90-day (more or less) period following attack.

### Abbreviations:

ETA - Employment and Training Administration

DPS - Texas Department of Public Safety

DES - Disaster Emergency Services

LCDA - Local Civil Defense Authority

FEMA - Federal Emergency Management Agency

OMPC - Office of Manpower Planning and Coordination

TEC - Texas Employment Commission

ERA - Economic Research and Analysis Department of the Texas Employment Commission

STATE OF TEXAS  
EMERGENCY RESOURCE MANAGEMENT PLAN  
PART B-RESOURCE SECTIONS  
VIII-MANPOWER

### 1. Assumptions:

This Plan is based upon a general war situation following a nuclear attack on the Continental United States. It considers the preattack period a time of development of operational readiness and the postattack period as a time for individual survival and the implementing of postattack operational plans. A nuclear attack on the State of Texas will disrupt all normal operations within the area of the blast; communications will be broken, transportation will be lacking or in short supply and manpower will be immobilized by radioactive fallout. TEC employees and their families will be scattered. If the attack is extensive, many TEC offices will be completely isolated. Psychological, chemical and biological warfare and sabotage will follow to increase confusion, impair morale, reduce the will to resist and delay recovery operations. Water will be unpotable and food will be in short supply.

Faced with such a situation, manpower service personnel at all levels will be called upon to operate, for a time at least, under delegated authority with little or no assistance or guidance. All possible emergency actions should, therefore, be planned now, leaving a minimum of decisions to be made in the postattack period.

### 2. Mission

The Texas Employment Commission will:

- a. Be prepared to operate independently at State and district levels in accordance with postattack plans and procedures in the case of a failure of communications or a breakdown in the chain of command due to enemy attack;
- b. Recruit and channel the manpower of the State of Texas (and with prior reciprocal arrangements, the manpower of other states) to fill existing approved requirements of war production and other essential activities;
- c. Make payments to the eligible members of the labor force who are unemployed;

- d. Serve as agent of the U. S. Department of Labor in the operation of any national emergency unemployment-payments plan;
  - e. Determine and report manpower resources and requirements;
  - f. Assist in the maximum survival of the people and continue to operate as an integral part of the Government of the State of Texas.
3. Authority:
- a. The Federal Civil Defense Act of 1950, as amended by Public Law 606, 85th Congress.
  - b. The Texas Civil Protection Act of 1951, as amended.
  - c. Executive Order of the President Number 10480, dated August 14, 1953.
  - d. Executive Order of the President Number 10952, dated July 20, 1961.
  - e. Public Law 87-296, 87th Congress, approved September 22, 1961.
  - f. U. S. Department of Labor, Secretary's Order 27-64.
  - g. Executive Order of the President Number 11000, dated February 16, 1962.
  - h. The National Plan for Emergency Preparedness, December, 1964.
  - i. Sovereign Authority of the State of Texas as expressed in the State Constitution and various emergency and statutory authorities.
  - j. The State of Texas Disaster Plan.
  - k. Executive Order of the Governor Number 1, dated January 17, 1963, placing the Division of Defense and Disaster Relief (now Disaster Emergency Services) under the Texas Department of Public Safety.
  - l. State of Texas Emergency Resource Management Plan, Part A, Resource Management.
4. Command and Control:
- a. The planning relationship for preattack operations of the Texas Employment Commission (TEC) to the several authorities and departments of government listed below is as follows:
    - (1) Office of the Governor:
 

Preattack: The TEC is subject to the administrative control of the Governor of the State of Texas and the planning coordination of the State Director of Disaster Emergency Services in all matters connected with defense and disaster relief and emergency resource management.

Postattack: The Chairman and Executive Director of the TEC will become the State Manpower Coordinator and he or his representative will be an operational member of the Resource Priorities Board which will be activated under the authority of the Governor at such time as the Governor may decree.
    - (2) State Organization for Resource Management:
 

Preattack: The TEC acknowledges the coordinating authority for resource management planning of the Director, Disaster Emergency Services.

Postattack: The TEC as a member of the Resource Priorities Board will participate in resource management functions. The Director, Disaster Emergency Services, will coordinate matters connected with priorities for manpower and movement of manpower in the immediate postattack period.
    - (3) U. S. Department of Labor:
      - (a) Employment and Training Administration (ETA):
 

Preattack: The functional authority of the ETA is acknowledged in matters pertaining to employment security, unemployment payments and fiscal administration.

Postattack: In the postsurvival period, the State Manpower Coordinator will operate under national manpower policies and the standards of the Secretary of Labor and the United States Employment Service. The TEC will deal directly with the regional office of the Employment and Training Administration on all postattack employment security programs and administrative matters if such communication channel remains uninterrupted.
      - (b) Office of Manpower Planning and Coordination:
 

Preattack: the TEC receives advise and information relating to defense and mobilization activities from the regional OMPC.

Postattack: The field operations of the Department of Labor will be carried out through its normal organizational structure and will be coordinated by the regional OMPC.

Department of Labor directive (Secretary's Order 27-64) provides, in event of an emergency, for eight OMPC regions with boundaries coterminous with FEMA regions.



## INTRODUCTION

This section of the Texas Emergency Resource Management Plan contains policies, guidance and actions to provide civilian manpower to carry on essential activities in the State in a nuclear attack emergency. It prescribes the organizational arrangement to carry on State management roles in the manpower resource field and is concerned primarily with actions and arrangements to assure manpower support and service to meet immediate and continuing needs of the State. Although this plan is primarily focused on postattack, it will also provide and will constitute as guidance should crisis relocation be implemented prior to an attack. The following definitions and abbreviations are supplied to insure clarity:

### Definitions:

- a. Manpower includes everyone capable of effort which will contribute to the survival of the Nation.
- b. Health Manpower includes those occupations listed in the List of Health Manpower Occupations based on Defense Mobilization Order 8540.1, Federal Emergency Management Agency. It includes physicians (including osteopaths), dentists, sanitary engineers, registered professional nurses and certain other occupations.
- c. Manpower Priorities are staff instructions issued by manpower officials to carry out executive guidance by the Governor or head of local government or their authorized agents in the assignment of available manpower. Such executive guidance is referred to as relative urgency guidance.
- d. Military Manpower includes military reserves and Selective Service inductees.
- e. Postattack Period is the 90-day (more or less) period following attack.

### Abbreviations:

ETA - Employment and Training Administration

DPS - Texas Department of Public Safety

DES - Disaster Emergency Services

LCDA - Local Civil Defense Authority

FEMA - Federal Emergency Management Agency

OMPC - Office of Manpower Planning and Coordination

TEC - Texas Employment Commission

ERA - Economic Research and Analysis Department of the Texas Employment Commission

STATE OF TEXAS  
EMERGENCY RESOURCE MANAGEMENT PLAN  
PART B-RESOURCE SECTIONS  
VIII-MANPOWER

### 1. Assumptions:

This Plan is based upon a general war situation following a nuclear attack on the Continental United States. It considers the preattack period a time of development of operational readiness and the postattack period as a time for individual survival and the implementing of postattack operational plans. A nuclear attack on the State of Texas will disrupt all normal operations within the area of the blast; communications will be broken, transportation will be lacking or in short supply and manpower will be immobilized by radioactive fallout. TEC employees and their families will be scattered. If the attack is extensive, many TEC offices will be completely isolated. Psychological, chemical and biological warfare and sabotage will follow to increase confusion, impair morale, reduce the will to resist and delay recovery operations. Water will be unpotable and food will be in short supply.

Faced with such a situation, manpower service personnel at all levels will be called upon to operate, for a time at least, under delegated authority with little or no assistance or guidance. All possible emergency actions should, therefore, be planned now, leaving a minimum of decisions to be made in the postattack period.

### 2. Mission

The Texas Employment Commission will:

- a. Be prepared to operate independently at State and district levels in accordance with postattack plans and procedures in the case of a failure of communications or a breakdown in the chain of command due to enemy attack;
- b. Recruit and channel the manpower of the State of Texas (and with prior reciprocal arrangements, the manpower of other states) to fill existing approved requirements of war production and other essential activities;
- c. Make payments to the eligible members of the labor force who are unemployed;

(4) Other State Government Agencies having Related Functions:

(a) State Department of Human Resources

Preattack: The TEC and the State Department of Human Resources maintain close liaison contact to assure the full knowledge of each agency regarding possible postattack manpower requirements.

Postattack: The TEC will continue the close working arrangements and will furnish manpower in accordance with Department of Human Resources needs and established priorities. The TEC will utilize the Department of Human Resources emergency registration form as a resource file in the recruitment of manpower at relocation sites. This form will be used in accordance with the recruiting procedures outlined in postattack placement operations procedures.

(b) State Department of Health:

Preattack: The TEC works closely with the State Department of Health to assist in their plans to meet postattack civilian health manpower mobilization requirements.

Postattack: The facilities of the TEC and its local offices will be utilized in carrying out the health program of the State Department of Health (e.g.,) recruitment, referral, and other manpower measures).

Supporting manpower, integral to health operations, will be recruited through and provided by the TEC in accordance with established priorities.

(5) Agencies of the Federal Government located within the State having Manpower Responsibilities:

(a) Department of Army and Federal Emergency Management Agency.

Preattack: The TEC receives civil defense and resource information and guidance through the OMPC, and indirectly receives information and guidance as furnished by the Department of Army and FEMA.

Postattack: The TEC will continue to be guided regarding manpower policies and priorities, unemployment insurance, and employment security fiscal matters from the regional office of ETA.

(b) Selective Service System:

Preattack: Arrangements have been made with the Selective Service to provide TEC local employment offices, in an emergency, the names of registrants, not subject to early induction, who have skills in needed occupational categories.

Postattack: The TEC local offices will keep the Selective Service local boards informed of occupational shortages. Selective Service local boards will identify their registrants in the needed occupational categories who are not subject to early induction. Local offices will contact workers in accordance with postattack placement operations procedures.

(c) United States Civil Service Commission:

Preattack: Arrangements have been made with the U. S. Civil Service Commission for the postattack "outstationing" of Civil Service representatives in TEC local offices located in important labor supply areas.

Postattack: Civil Service Commission representatives for whom preattack arrangements were made for stations in TEC local offices and who reached their assigned stations will establish whatever working relationships with the local employment office as may be feasible and mutually helpful under the existing circumstances.

The TEC local offices will work with the Civil Service Commission representatives in accordance with the policies and procedures as outlined in Mobilization Circular Number 35 and its Supplement Number 2. Civil Service representatives will be stationed in TEC local offices located in the following cities:

Amarillo	Houston
Austin	San Angelo
Corpus Christi	San Antonio
Dallas	Tyler
El Paso	Waco
Fort Worth	Wichita Falls

(6) The State Advisory Council established under the Texas Unemployment Compensation Act:

Preattack: This council, comprised of members representing employers, employees and the public, is available to assist in determining policies and planning in connection with civil defense and resource management.

Postattack: The duties and responsibilities of this council remain the same in the postattack period with such additional duties as they may be called upon to perform by the three members of the Commission, then constituting the "Manpower Policy and Priority Board" of the State Civil Defense Organization and the Emergency Resources Management Organization.

(7) Manpower Agencies of Other States:

Preattack: The responsibility of TEC consists of planning postattack operations of such activities as interstate clearance of workers, interstate unemployment insurance claims and appeals, interstate labor market area reports and interstate administrative arrangement for mutual assistance.

Postattack: The TEC will render such interstate assistance as planned in the preattack period which is within its capability to perform.

b. The postattack internal organization of the TEC is as follows:

- (1) As the manpower arm of the State organization for Emergency Resource Management, the lines of command originate with the Governor and extend through the Director, Disaster Emergency Services, the State Manpower Coordinator, the District Manpower Director to the manager of the TEC local office (Tab 2, Annex A). Direct contact between the State office and the local employment office, or vice versa, will be maintained except when precluded by an emergency.
- (2) The variations from normal organizational patterns of the Commission will be:
  - (a) State Office
    1. The formation of a Manpower Policy and Priority Board of the State organization for Emergency Resource Management composed of the three members of the TEC, to assist, when requested, in recommending solutions to manpower problems.
    2. The State Advisory Council, operating as the State Manpower Advisory Council, will assist, when requested, in recommending to the Manpower Policy and Priority Board solutions to manpower problems. Similar councils are authorized at district and lower levels.
    3. The Chairman and Executive Director of the TEC becomes the State Manpower Coordinator and head of all emergency manpower activities.
  - (3) Chiefs of the several departments will serve in their regular capacities in the postattack period, except as follows:
    - (a) The Chief of Special Programs Department will serve as Assistant Chief of Placement.
    - (b) The General Counsel and the Supervisor of Appeals will report to the State Manpower Coordinator and will serve in such capacities as he directs.

c. District and Local Offices:

- (1) Authority has been delegated to the district and local level to operate independently in emergency situations.
- (2) TEC districts, as presently constituted, will cease to operate upon the implementation of this plan, being replaced by the Emergency Resource Management District organization. (Tab-1, Annex A) Once Federal control has been re-established following the implementation of the State of Texas Emergency Resource Management Plan, the Texas Employment Commission reverts to its normal district organization and operation. (Tab-3, Annex A)
- (3) District directors and designated local office managers are listed on map (Tab-1, Annex A) will become Emergency Resource Management District (Subdistrict) Manpower Directors.

Note: Boundaries of the 17 State districts and subdistricts do not coincide with geographical areas of any TEC district. Local offices will, in many instances, find themselves serving under a District Manpower Director other than their regular TEC District Director.
- (4) Liaison contacts will be maintained for planning purpose with each agency of the State represented on the district council.
- (5) The personnel of the district office, not required by the TEC District Director in his capacity as District Manpower Director, will be assigned to the local office for duty with that unit subject to recall as needed.
- (6) The local office manager will report to the District Manpower Director in whose district his office is designated by the State district (subdistrict) organization. He also serves as local manpower director for the city and/or county in which his office is located.

5. Execution:

a. Plans in Being:

- (1) An Emergency Operating Manual has been published with State office, district and local office appendices.
- (2) Emergency procedures containing detailed postattack operating plans, instructions and arrangements for the TEC State office and district and local offices have been issued in the following fields:
  - (a) Postattack Unemployment Insurance Operations provide plans for:
    1. A postattack tax-collecting operation to go into effect as soon after the attack as the situation permits and for assigning excess Tax Department personnel to assist in benefit disbursement operations and placement operation.
    2. A decentralized unemployment payment program to go into effect when authorized by law to expend funds at the local level. The Program - UI Emergency Operational Plan - is based on the premise that there has been a failure in communications or a break in the chain of command between the local offices and the State office. It provides for decentralization of the unemployment insurance payment operation and allows each local office to act as an independent unit so far as UI payments are concerned. Local offices will accept claims, make and issue monetary and nonmonetary determinations and disburse payments on a decentralized basis. The local office will continue to operate as an independent unit until control and supervision of the unemployment

insurance program can be returned to the State Office Benefits Department.

3. A reconstruction program of insurance and tax files by ADP personnel to go into effect in the event essential insurance and tax records are destroyed.
- (b) Postattack Placement Operations provide plans for:
1. A postattack placement operation for State office, district and local office staff.
  2. State Office Placement Department postattack work shifts and personnel assignments, including tentative assignments to each work shift.
  3. Complete local office placement postattack operations, including:
    - a. Manpower Control and Priorities
    - b. Health Manpower
    - c. Registration of Workers
    - d. Occupational Classification
    - e. Emergency Order-taking
    - f. Recruitment
    - g. Selection and Referral
    - h. Clearance
    - i. Coordination of Placement Activities with the Selective Service and the U. S. Civil Service Commission
    - j. Agreement Between the TEC and the Railroad Retirement Board
- (c) Labor Supply Area Reports and Statistics Procedures provide plans for:
1. Identification of area labor requirements, shortages, and surpluses by specified industry, and by critical occupation.
  2. Location of workers to meet essential reconstruction and production needs.
  3. Assessing effects of bomb damage and radiation of work force, and for calculating effects of evacuation on work supply based on:
    - a. Bomb Damage Assessment and Estimate of Surviving Labor Force.
    - b. Evacuation Traffic Movement Study and Methods for Estimating Surviving Labor Force.
  4. Reporting above information on standard format.
- (d) Fiscal and Supply Emergency Plans and Procedures provide plans for:
1. Postattack delegation of authority to request and receive funds.
  2. Fund accounting.
    - a. Administrative fund balance determination

- b. Use of funds
- c. Request for funds

- 3. Financial reporting.
- 4. Continuity of the payroll function and instructions for obtaining forms, supplies and equipment.
- 5. Local office procurement and payroll preparation.
- 6. A decentralized fiscal program to go into effect when authorized by law to expend funds at the local level. The program — **Fiscal Emergency Operational Plan** — is based on the premise that there has been a failure in communications or a break in the chain of command between the local offices and the State office. It provides for decentralization of the fiscal operation and allows the payment of employee salaries and local purchases of necessary supplies and equipment. Local offices will continue to operate as an independent unit until control and supervision of the fiscal program can be returned to the State Office Fiscal Department.

(e) **Emergency Administrative Arrangements** provide plans for:

- 1. Delegation of authority to Emergency Resource Management Districts (Sub-districts) and local offices for independent action.
- 2. Chain telephone warning system.
- 3. Communications (procedures to be followed where normal communications facilities are inoperative).
- 4. General warning instructions to TEC employees.
- 5. Building protection and warden system.
- 6. Budget administration.
- 7. Personnel administration.
- 8. Premises administration.
- 9. Relocation sites for the State Office; records and materials stored in Brownwood; and target city district and local office relocation sites.
- 10. Resource Management Districts.
- 11. Local offices.
- 3) The Texas Employment Commission will serve as agent of the U. S. Department of Labor in the operation of any national emergency unemployment payments plan.
- (4) A chain telephone warning system has been developed at all levels and is maintained currently by each operating department, district and local office.
- (5) Lines of succession have been determined for all key positions in State office department, district offices and local offices and are on file in the State office and in each district and local office.

- (6) A building protection and warden system has been developed at all levels and personnel assignments are on file in the State office and maintained in current condition.
- (7) Essential records and supplies have been determined by department heads, district directors and local office managers and are being stored at designated relocation sites.
- (8) Department heads, district directors and local office managers are instructed to inform employees as to relocation assignments, escape routes, transportation arrangements, communications, etc.
- (9) Department heads, district directors and local office managers are responsible for:
  - (a) Assigning of emergency duties to their personnel.
  - (b) Maintaining "lines of succession" lists on all key positions in their offices.
  - (c) Conducting a continuing program of training in:
    - 1. Individual survival procedures;
    - 2. Mobilization functions of the units to which assigned;
    - 3. Postattack duty assignments and responsibilities.
- (10) Authority has been delegated for recruitment of additional district and local office staff as needed in an emergency situation.
- (11) The Texas Employment Commission local office at Brownwood, Texas has been designated as the relocation site for the State office. Alternate sites, in the event Brownwood is rendered incapable, are TEC local offices at San Angelo and Tyler.
- (12) Plans at all levels include identification of emergency bases from which office staff evacuated from target areas can operate within the framework of overall State and local survival plans.
- (13) The Texas Employment Commission plans to request, obtain, disburse, and account for administrative funds in an emergency situation in a manner consistent, as applicable, with recommendations and requirements set forth by the U. S. Department of Labor.
- (14) Necessary supplies, equipment and service required during the period when transportation and communication facilities are not available will be procured through the appropriate civil defense authority or as authorized in **Fiscal Emergency Operational Plan**.
- (15) Emergency Resource Management District Manpower Directors and local office managers will prepare emergency manpower plans for postattack operations. A copy of each plan will be on file in the State office and in the State office relocation site in Brownwood.

b. **Supply and Transportation:**

- (1) Supply:

Internal supply procedures and authority for local purchases will be in accordance

with emergency fiscal arrangements as outlined in **Fiscal Emergency Operational Plan**.

(2) **Transportation:**

Transportation will be arranged as needed at each level through motor pools under the control of **Emergency Resource Management transportation authorities**.

**c. Communications:**

Where normal communication facilities are not operative, all levels of the TEC operations will use the communications as provided by the **Communications Service (Annex B of the State Emergency Operations Plan)** and such supplemental communication services as may be arranged in accordance with **Emergency Administrative Arrangements**.

**d. Emergency Actions:**

The following postattack emergency actions for the management of civilian manpower will be taken by the **State Manpower Coordinator**.

(1) **Actions for Immediate Supply:**

- (a) Announce that State manpower policy and management measures are in effect and activate manpower plans. (Manpower-1, Annex B) Issue policies and guidance applicable throughout the State covering the management and utilization of manpower.
- (b) Confirm with the State Selective Service Headquarters the activation of joint plans to assist local offices when manpower shortages exist in the specific occupational groups for which records and lists have been prepared by local selective service boards. Advise the State Selective Service Headquarters of critical civilian requirements for manpower skills for use by the local selective service boards in administering deferments.
- (c) Arrange for the transfer of manpower available in the State, and if possible from other States, to meet shortages reported by local governments to the State Manpower Coordinator or to a local office of this agency.
- (d) Identify manpower skills in short supply and critically needed to staff essential activities and report the information in accordance with ERA procedures outlined in reports and statistics procedures.
- (e) Announce the State manpower policy and management measures with respect to health manpower. (Manpower-1, Annex B) Receive and act upon requests for assistance from health authorities in locating and referring health manpower.
- (f) Activate, in accordance with Section 15000, Volume II, of the TEC Employment Service Manual, arrangements for local consultation with representatives of labor and management through established area labor-management committees to obtain advice and guidance in meeting emergency manpower needs,

in preventing manpower problems, applying manpower controls, implementing employment stabilization procedures and disposition of appeals by employers and employees from manpower actions. (Manpower-2, Annex B)

(2) **Actions for Continuing Supply:**

As soon as activities to meet essential immediate manpower needs in the localities are under way, the Texas Employment Commission will take the following actions to anticipate future continuing needs and to arrange for continuing supply to meet these needs.

- (a) Consult with State civil defense officials, Federal military officials, and appropriate resource State officials to obtain their estimate of continuing requirements for civilian manpower that will be needed in the State during the ensuing 90-day period.
- (b) Obtain estimates from the State Selective Service Headquarters of probable draft calls in the State during the ensuing 90-day period.
- (c) Estimate civilian manpower that will be available in the State during the ensuing 90-day period.
- (d) If the estimated supply of manpower to meet requirements and adjustments in requirements cannot be negotiated, conflicting claims for manpower will be referred to the State of Texas Resource Priorities Board for recommendations to the Governor on relative urgencies among competing programs.
- (e) Issue revised State policy on the priority use of manpower to conform with the Governor's decision.

**e. Reporting Manpower Shortages**

- (1) In case of manpower shortages, local manpower officials will request guidance from the head of local government or his authorized agent on the referral of available supplies.
- (2) Manpower shortages will be reported by the most expeditious means of communication available through the Emergency Resource Management District Manpower Director, if feasible, who will take action to allocate available supplies of manpower as he has available. In the event a shortage still exists, either as a result of inadequate supplies of manpower available to the Emergency Resource Management District Manpower Director or the lack of communication through this agency, the shortage will be referred to the State Manpower Coordinator.
- (3) The State Manpower Coordinator may seek the advice of the Manpower Policy and Priority Board prior to making recommendations to and requesting guidance from the State Resource Priorities Board.

**f. Conflicting Claims for Manpower Resources**

(1) In case of conflicting claims for allocation of available manpower, the local manpower director will refer the problem to the head of local government or his authorized agent for resolution. In the event conflicting claims for allocation of available manpower cannot be resolved at local level, the problem will be forwarded, if possible, by the most expeditious means available to the Emergency Resource Management District Manpower Director who will resolve the problem, if possible. In the event the Emergency Resource

Management District Manpower Director is unable to resolve the conflicting claims or if such claims cannot be referred to him, the problem will be referred to the State Manpower Coordinator.

(2) The State Manpower Coordinator may seek the advice of the Manpower Policy and Priority Board prior to forwarding the conflicting claims to the State Resource Priorities Board for recommendation of resolution to Governor.

ANNEX A

Tab 1

DISTRICT ORGANIZATION

District	TEC REPRESENTATIVE (Manpower Director)
1-A Dallas	Director, Dallas
1-B Tyler	Director, Longview
2-A Houston	Director, Houston
2-B Beaumont	Director, Beaumont
3-A Corpus Christi	Director, Corpus Christi
3-B San Antonio	Director, San Antonio
4-A Midland	Manager, Midland
4-B Abilene	Manager, Abilene
5-A Lubbock	Manager, Lubbock
5-B Amarillo	Director, Amarillo
6-A Waco	Manager, Waco
6-B Austin	Director, Austin

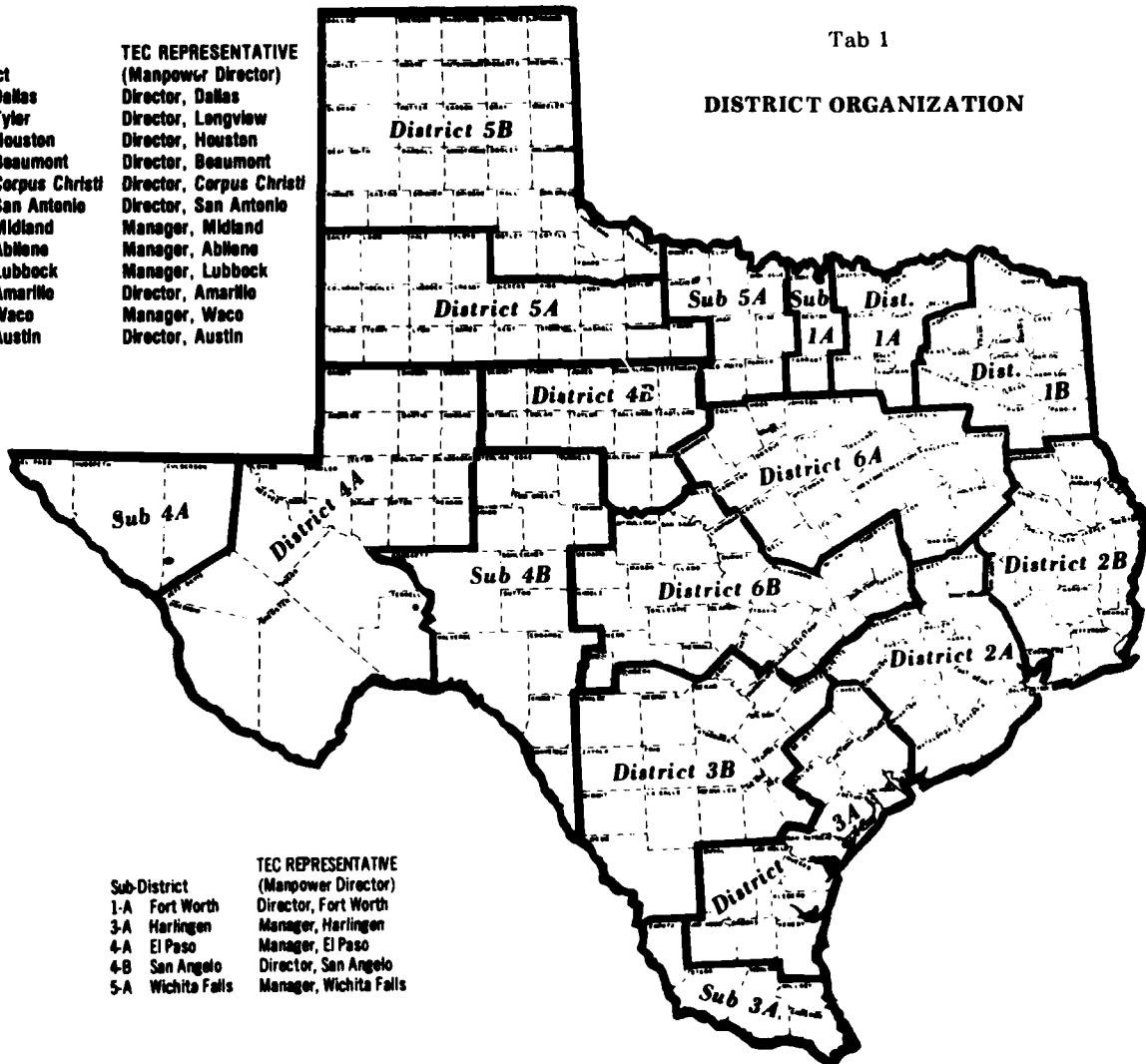

Sub-District	TEC REPRESENTATIVE (Manpower Director)
1-A Fort Worth	Director, Fort Worth
3-A Harlingen	Manager, Harlingen
4-A El Paso	Manager, El Paso
4-B San Angelo	Director, San Angelo
5-A Wichita Falls	Manager, Wichita Falls

**POST-ATTACK  
ORGANIZATION  
of the  
TEXAS EMPLOYMENT  
COMMISSION**

Tab 2

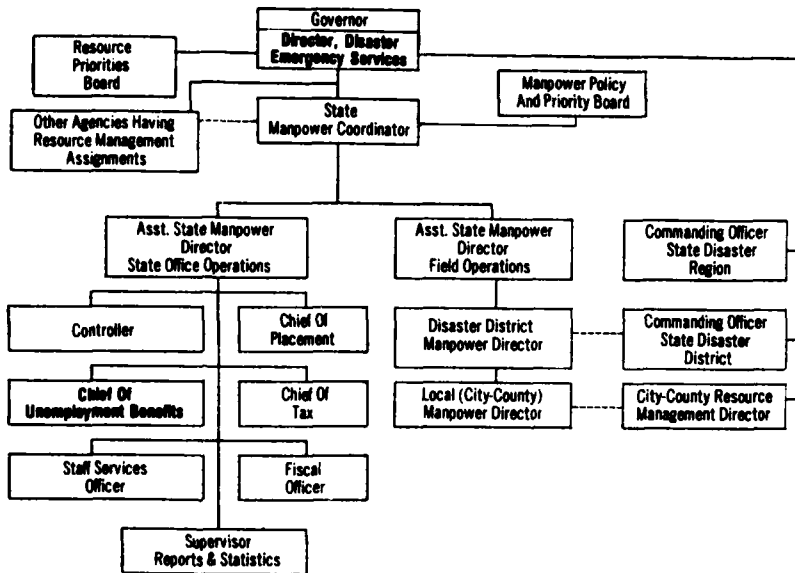



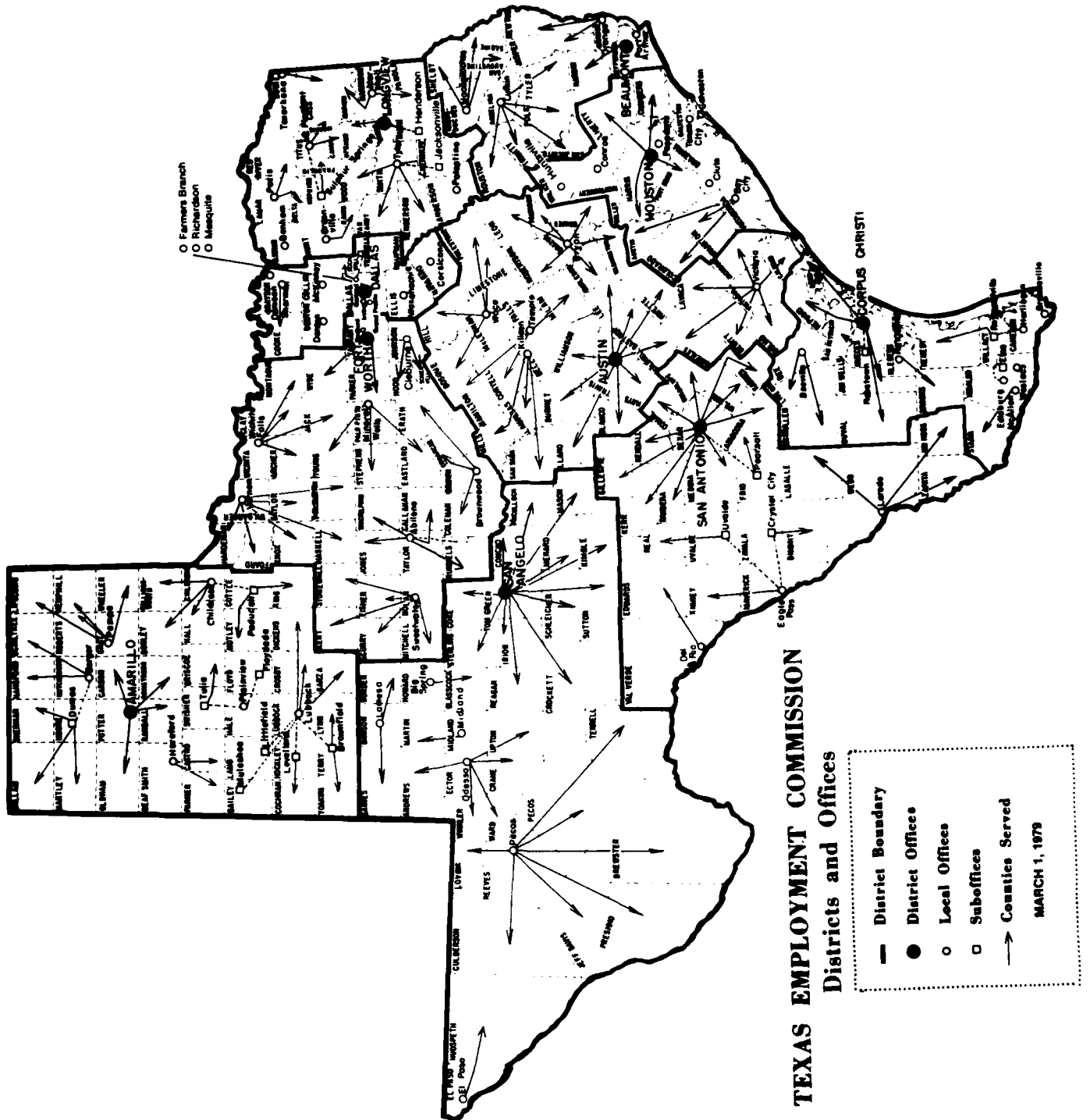

B-VIII-A-3  
 Tab 3

**ANNEX B**  
**EMERGENCY ACTION DOCUMENTS**

**Manpower-1, State Manpower Resources Policy and Guidance**  
**Manpower-2, Executive Guidance to TEC**

---

**Manpower-1, State Manpower Resources Policy and Guidance**

**Tg: Heads of Political Subdivisions, State of Texas**

**Guidance for Local Governments.** It is essential that manpower available for use in Texas be utilized for immediate and urgent activities for local, State, and National survival and recovery. Consequently, appropriate officials of local government are requested to take the following actions:

1. Advise employers and workers to continue, if possible, in their regular work relationships unless requested to perform other activities by civil authorities. Urge employers and employees to remain in contact with each other to the extent possible where normal activities are not feasible, pending action by local authorities.
2. Notify women, older people, youths, and others not normally in the labor force to register for employment when requested by local manpower authorities.
3. Assign health manpower in accordance with guidance of the appropriate health authorities. Supporting manpower integral to health operations employed at the time of attack by a medical facility or laboratory or governmental health agency will remain with the employing organization, unless ordered to military duty.
4. Authorize essential facilities and essential local users to recruit manpower to meet immediate and urgent needs, subject to applicable manpower controls. (Local governments have been provided by the State with a list of the essential facilities in their jurisdictions.)
5. Announce that the urgency of the situation may require imposition by manpower officials of measures such as employment ceilings, limitation of employment choices, and other measures as necessary to assure availability of manpower for survival and defense activities. Carry out arrangements for consultation with labor and management. Compensate and protect as appropriate workers accepting employment as requested.
6. In the event locally available manpower is not adequate to meet all essential needs, heads of local government or their authorized agents will establish relative urgencies for the guidance of manpower officials in assigning available supplies consistent with the **Guidance on Priority Use of Resources** (Appendix 1 to Annex C, Part A). Manpower officials will report shortages and request appropriate officials of State government to take actions to increase the supply of manpower to the local jurisdiction.

\_\_\_\_\_  
(Effective Date)

\_\_\_\_\_  
(Name)

Governor of the State of Texas

By: \_\_\_\_\_  
(Signature)

State Manpower Coordinator

**Manpower-1, Attachment 1**

To: Coordinator of State Manpower Organization and Executive Heads of Government

1. **Purpose.** This Order issues the List of Health Manpower Occupations and assigns responsibilities in regard thereto.
2. **Definitions.** The Federal Government has defined health manpower as "physicians (including osteopaths), dentists, sanitary engineers, registered professional nurses; and such other occupations as may be included in the List of Health Manpower Occupations," issued by appropriate authority. The list issued by this Order is consistent with Federal Government usage as established in Defense Mobilization Order 8540.1 issued by the Director, Office of Emergency Planning, March 11, 1964.
3. **Responsibilities.** Civilian manpower mobilization planning responsibilities are assigned to the Texas Employment Commission and civilian health manpower mobilization planning responsibilities are assigned to the Texas Department of Health.

State and local health officials have the primary responsibility for planning the organization, training, and utilization of civilian health manpower. The facilities of the Texas Employment Commission and its local offices will be utilized in carrying out the health program (e.g., recruitment, referral, and other manpower measures).

The skills identified in the attached List of Health Manpower Occupations are those which will be immediately required for the provision of essential emergency public health and medical services. Persons possessing the listed skills and allocated by appropriate officials to meet nonmilitary requirements will be made available to health services. However, as health hazards are brought under control and medical care loads permit, health officials will release for utilization in other essential activities the health manpower that is no longer critically needed.

Supporting manpower integral to health operations, e.g., hospital, sanitation, and laboratory helpers, and engineering, clerical food service and custodial personnel, is not listed. Such civilian manpower employed at the time of attack by a medical facility or laboratory or governmental health agency, will, if not ordered to military service, remain with the employing organization. All others will be provided according to priorities established by the manpower agency or ranking governmental official.

4. **Effective Date.** This Order is effective the date of issuance.

---

Governor

Attachment

Based on Defense Mobilization Order 8540.1  
Office of Emergency Planning  
Executive Office of the President

<u>Occupational Title</u>	<u>Occupational Code Number</u>
AUDIOLOGIST	076.101-010
BIOCHEMIST	041.061-026
NUCLEAR MEDICAL TECHNOLOGIST	078.361-018
DENTAL HYGIENIST	078.361-010
DENTAL-LABORATORY TECHNICIAN	712.381-018
DENTIST	072.101-010
FOOD AND DRUG INSPECTOR	168.267-042
HEALTH PHYSICIST	079.021-010
MEDICAL PHYSIOLOGIST	041.061-078
MEDICAL RECORD TECHNICIAN	079.367-014
MEDICAL-LABORATORY TECHNICIAN	078.381-014
MEDICAL TECHNOLOGIST	078.361-014
CHEMISTRY TECHNOLOGIST	078.261-010
BLOOD-BANK TECHNICIAN	078.381-014
CYTOTECHNICIAN	078.381-014
HEMATOLOGY TECHNICIAN	078.381-014
SEROLOGY TECHNICIAN	078.381-014
TISSUE TECHNICIAN	078.381-014
BIRTH ATTENDANT	354.377-010
Occupations In Biological Sciences 041	
ANATOMIST	041.061-010
BIOPHYSICIST	041.061-034
BACTERIOLOGIST, DAIRY	041.061-058
BACTERIOLOGIST, FOOD	041.061-058
HISTOPATHOLOGIST	041.061-054
BACTERIOLOGIST, MEDICAL	041.061-058

MEDICAL PARASITOLOGIST	041.061-070
BACTERIOLOGIST, PHAMACEUTICAL	041.061-058
PHARMACOLOGIST	041.061-074
PUBLIC-HEALTH MICROBIOLOGIST	041.261-010
VETERINARY BACTERIOLOGIST	073.061-018
NURSE AIDE	355.674-014
NURSE PRACTICAL	354.374-010
NURSE, PROFESSIONAL	TERM
OCCUPATIONAL THERAPTIST	076.121-010
OPTOMETRIST	079.101-018
ORDERLY	355.674-018
ORTHOTICS TECHNICIAN	712.381-034
OSTEOPATHIC PHYSICIAN	071.101-010
PHARMACIST	074.101-010
PODIATRIST	079.101-022
PSYCHOLOGIST, CLINICAL	045.107-022
Physicians and Surgeons 070	
PHYSICAL THERAPIST	076.121-014
SANITARIAN	079.117-018
SANITARY ENGINEER	005.061-030
SOCIAL WORKER, MEDICAL	195.107-030
SOCIAL WORKER, PSYCHIATRIC	195.107-034
SPEECH PATHOLOGIST	076.107-010
ADMINISTRATOR, HOSPITAL	187.117-010
VETERINARIAN	073.101-010
X-RAY TECHNICIAN	199.361-010

on individual cases or in evaluation, planning, and development of mental health programs. May specialize on one of the following: behavior problems, crime and delinquency, group therapy, individual diagnosis and therapy, mental deficiency, objective tests, projective techniques, and speech pathology. A Clinical Psychologist is identified as an individual who is working in the field of clinical psychology and who meets one of the following criteria: (1) is a diplomate in clinical psychology of the American Board of Examiners in Professional Psychology; (2) is a fellow of the Division of Clinical and Abnormal Psychology of the American Psychological Association; or (3) holds a Ph.D. degree in clinical psychology.

- (8\*) **Sanitarian.** Interprets and enforces sanitation laws and regulations to protect and promote public health. Inspects and investigates sanitation facilities and conditions in such places as dwellings, water supply and sewerage plants, recreational areas, industrial plants, barber shops, beauty salons, and food processing and serving establishments to determine compliance with standards. Takes samples of such materials as water, food, and air and performs or orders a variety of chemical, physical or biological tests for contamination. Formulates plans and oversees programs for insect and rodent extermination and control. Issues corrective notices and orders, and follows up on compliance. Collaborates with public health personnel in epidemiology survey, analyses, and control programs. Reviews and makes recommendations on sanitary laws and regulations. Plans, organizes and conducts training programs in sanitary practices for such personnel as food handling, pest extermination and recreational workers. Confers with governmental, community, industrial, and civil defense personnel and organizations to interpret and promote sanitation standards and practices. In some States, may be required to hold license or be registered. When employed by public health agency, is known as PUBLIC HEALTH SANITARIAN. In large public agencies, and in industry, may be designated according to specialization, as FOOD AND INDUSTRIAL SANITARIAN (profess. and kin.), HOUSING SANITARIAN (profess. and kin.), MILK SANITARIAN (profess. and kin.).
- (9\*) **Podiatrist (Medical Ser.) 0-39.901.** Chiropodist, Foot Specialist. Diagnoses and treats diseases and deformities of human foot. Diagnoses foot ailments such as tumors, ulcers, fractures, skin or nail diseases, and congenital or acquired deformities, utilizing such medically accepted methods as urinalysis, blood tests, and X-ray analysis. Treats deformities such as flat or weak feet and foot imbalance by mechanical methods such as whirlpool or paraffin baths, or by electrical methods such as short wave and low voltage currents. Treats conditions such as corns, calluses, ingrowing nails, tumors, shortened tendons, cysts, and abscesses by surgical methods including suturing, medications, and administration of local anesthetics. Does not perform amputations of the foot. Corrects deformities by means of plaster casts and strappings. Makes and fits prosthetic appliances. Prescribes corrective footwear. Refers patients to PHYSICIAN when symptoms observed in feet and legs evidence systemic disorders such as arthritis, heart disease, diabetes or kidney trouble. May treat bone, muscle and joint disorders limited to feet and be known as PODIATRIST; children's foot diseases and be known as PODOPEDIATRICIAN, or perform surgery and be known as PODIATRIC SURGEON.

---

#### Manpower-2, Executive Guidance to TEC

To: The Texas Employment Commission

1. The Texas Employment Commission shall, through its local offices, obtain the advice and guidance of management and labor in meeting emergency manpower needs, in preventing manpower problems, and in achieving prompt solution of these problems.
2. As soon as possible Labor-Management Advisory Committees, established under procedures set forth in the Basic Employment Security Manual, (Part II, Chapter 15000) issued by the TEA of the U. S. Department of Labor, shall be convened in appropriate areas for this purpose.
3. In situations where, for any reason, a Labor-Management Advisory Committee cannot be convened, the Texas Employment Commission shall, through its local offices, consult with representative leaders of labor and management pending the establishment of a Committee.
4. Consultation with labor and management shall be sought in any situation when in the judgment of local manpower officials such consultation is necessary or desirable in carrying out his responsibilities. Advice and assistance shall be obtained particularly on:
  - a. The application of manpower management controls;
  - b. The implementation of employment stabilization procedures;
  - c. The disposition of appeals by employees or employers from manpower actions.

---

Governor

**PART B - RESOURCE SECTIONS**

**IX. Transportation**

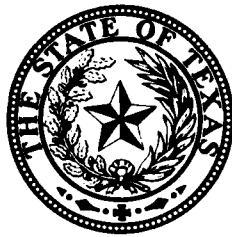

**Texas  
Emergency  
Resource  
Management**

**PLAN**

**B-IX**  
Transportation

## INTRODUCTION

This section of the State of Texas Emergency Resource Management Plan contains overall State policies and guidance for the provision and use of transportation services to meet essential needs in the State in a nuclear attack emergency or crisis relocation situation.

The process for furnishing transportation services in the State in a nuclear attack emergency or crisis relocation involves two series of actions. First, essential immediate needs are identified and actions are taken to supply these needs. Second, and as soon as possible, future continuing needs for transportation service and expected future transportation capability are estimated, following which decisions are made and actions are taken to direct these expected future capabilities to meet needs most essential to continued survival and recovery of the State and Nation.

### Definitions

For the purpose of this Plan a distinction is made between interstate (primary) transportation resources and intrastate (secondary) transportation resources.

- a. Interstate (primary) transportation resources: Those civil transportation facilities, equipment and services controlled or provided by operators generally engaged in interstate transportation and air carrier aircraft and their related facilities, equipment and services. The management and the provision of centralized control over the utilization of interstate (primary) transportation resources are the general responsibilities of the Office of Emergency Transportation and other appropriate Federal transportation agencies.
- b. Intrastate (secondary) transportation resources: Those civil transportation facilities, equipment and services provided or authorized for use primarily within a State, territory or the District of Columbia, excluding air carrier aircraft and their related facilities, equipment and services. Management and control of intrastate (secondary) transportation resources are the responsibilities of State and local governments.
- c. Certified requests: Transportation requests for service placed with carriers and other rendering transportation services, or their agents, bearing a signed certification that the request is for essential service authorized by the State. Carriers and others rendering transportation services, or their agents, are required to furnish the service specified in "certified requests," wherever possible.

STATE OF TEXAS  
EMERGENCY RESOURCE MANAGEMENT PLAN  
PART B-RESOURCE SECTIONS  
IX-TRANSPORTATION SERVICES

### 1. Purpose and Activation:

- a. The purpose of the instructions contained in this section is to establish an emergency organization to develop and supervise policies, guidance and actions to provide transportation services to meet essential needs in the State in a nuclear attack emergency.
- b. The provisions of this plan will be activated by the Governor of the State of Texas or his legal successor upon declaration of a national emergency for civil defense purposes. (See Part A.)

### 2. Concept of Operation:

Following is a brief description of Federal, State, local government and transportation industry roles in the emergency management and use of transportation services in the State.

#### a. Federal Government

The Federal Government is responsible for working with transportation industry - all modes, as appropriate - to assure maximum service and to provide transportation service to satisfy shortages at State and local government levels. The Department of Transportation has established intermediate offices or representatives at State and area levels where appropriate. Representatives of this Federal agency are available to the State transportation organization for assistance and guidance.

Transportation service is available to all users for essential movements in the interest of State and National defense. In accordance with Federal policy, users within the State may use interstate transportation services originating in or passing through the State for essential movements and the responsible State or local government agencies may claim for any transportation to meet the transportation requirements of the State.

Federal Government transport agencies work with the transportation industry to assure maximum transportation services and for the furnishing of interstate transportation services to meet essential needs in the State of Texas, as well as to meet essential needs in other States which also depend on these interstate transportation services.

#### b. State Government

The State transportation organization develops, in cooperation with other organizations of the State government, and provides, on behalf of the Governor, policies and guidance consistent with State and Federal objectives. The purpose of these policies and guidance is to assure application throughout the State of compatible measures for the conservation and use of transportation services and to assure that essential movement needs are identified and met within the transportation services available. The State transportation organization accepts requests for State level assistance from local government officials and arranges through the Federal transportation agencies with interstate transportation agencies with interstate transportation systems to provide service to correct local transportation shortages. As soon as possible after the attack, the State transportation organization, in cooperation with State organization representing major activities within the State that use transportation



services, anticipates continuing needs and works with the Office of Emergency Transportation State Representative to assure that arrangements are made to provide transportation services to meet ongoing demands of authorized essential users.

In the event of a breakdown in communications or area isolation, when the appropriate Federal agency representative responsible for control of a particular mode(s) is not available, the State exercises responsibility for the control of the affected mode(s) within the boundaries of that State, exclusive of air carrier aircraft. When Federal agency representation is available, control of transportation is the responsibility of the Federal agency representatives.

c. Local Government

Emergency Operations Plans of the State and its political subdivisions contain provisions for the conservation and use of transportation services available to the localities in the State. These plans also provide for requesting and obtaining State assistance to provide transportation to meet local shortages of transportation services.

d. Industries

Transportation industries function under their own managements and operate their systems and facilities so as to provide the maximum possible service within their capabilities and to fill essential needs as specified by appropriate Federal, State and local government authorities. This includes responsibility for continuity of management; protection of personnel and facilities; conservation of supplies; restoration of damaged lines and terminals; rerouting; expansion or improvement of operations; and the securing of necessary manpower, materials and services.

e. Users and Shippers

Users of transportation and shippers, including Government agencies, are responsible for their own internal transportation procedures and for arranging directly with carriers for the actual accomplishment of movements.

Transportation installations, facilities and equipment, so essential to National and State survival, must be kept in operation to assure provisions of transportation services to meet essential needs. Preattack arrangements have been made for transportation management of these facilities to submit equipment inventories (Tran-8, Annex B) and to identify their purchase orders for equipment, materials, maintenance, repair and operating supplies to assure acceptance and deliveries on these purchase orders by suppliers. Similar preattack arrangements have been made with appropriate authorities of local governments to assure provision of electric power, manpower, transportation, water, fuels and other locally available resources requisite to the continuing operation of these transportation facilities.

Local governments authorize local intrastate transportation companies in their jurisdictions to identify purchase orders to obtain maintenance, repair, operation supplies and equipment to assure continuous operations.

f. Flow Charts

Following are flow charts for the various modes of transportation (i.e., rail, motor, water and air) showing the process and the actions to be taken by Federal, State and local governments to assure a continuing provision of a transportation services to meet essential needs in the State in a nuclear attack emergency.

The legends accompanying the charts identify:

- A. Actions to be taken immediately to provide immediately needed transportation services essential for survival, and
- B. Actions to be taken as soon as possible to anticipate future continuing needs and to direct transportation services toward meeting the most urgent needs for continuing survival and recovery.

**FLOW CHART NUMBER 1**

**Introduction - Transportation (Railroad)**

Following is a brief description of Federal, State and local government roles in the provisions and use of rail transport services available to the State in a nuclear emergency.

**a. Federal Government**

The Federal Government is responsible for working with the interstate railroad industry to provide rail transport services to meet essential transportation needs in the State of Texas as well as to meet essential needs of other states which depend on these interstate systems for essential rail transport services.

The Interstate Commerce Commission, Bureau of Railroad Safety and Service, has designated a State Senior Executive Reservist to work with State transportation officials for this purpose. This Federal agency has also designated ICC Terminal Reservists at selected railroad terminal areas within the State to work with State and area transportation officials for the same purpose.

Attached is a list of the names, emergency locations and telephone numbers of these Federal officials.

**b. State Government**

The State transportation organization and its area organization have a rail transport division to work with Federal transportation officials to obtain interstate rail transportation services to meet shortages reported by local governments. As soon as possible after attack, the State rail transportation division, in collaboration with other State organizations representing major activities in the State that use transportation services, anticipates future interstate rail transport needs and arranges with Federal rail transportation officials for service to meet these ongoing needs.

The State has adopted for its use as State general orders the ICC General Orders, ICC-TM-1 through ICC-TM-13, listed by subject in Appendix 2, Annex C, attached to this plan. Such orders, therefore, are the governing policy applicable to the appropriate surface transportation mode in the State.

Emergency Operations Plans of the State of Texas and its political subdivisions contain provisions for authorizing essential local users and essential facilities to place certified transportation requests on carriers for essential rail transport services.

**EMERGENCY MANAGEMENT OF RESOURCES**  
Flow Chart No. 1 - Transportation (Railroad)

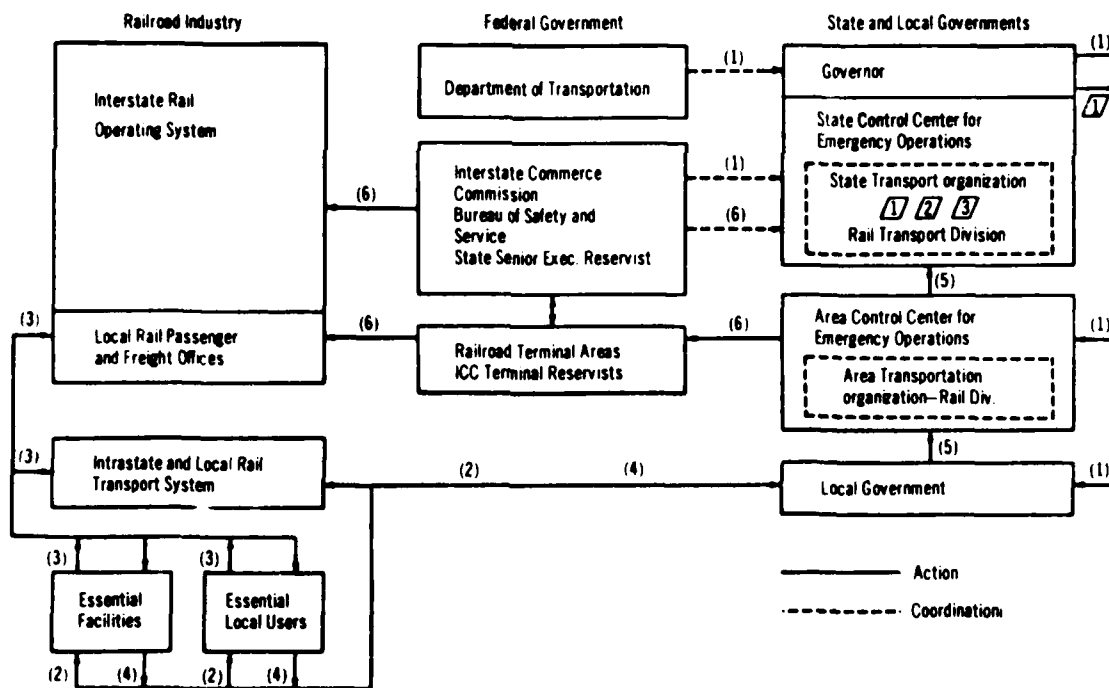

**A. Actions to Provide Immediate Railroad Transportation Services**

- (1) Issue State Policy on Use of Rail Transport Services—list of essential railroad facilities.
- (2) Authorize essential local uses of rail transportation services.
- (3) Place certified transportation requests for service.
- (4) Report shortages.
- (5) Anticipate local rail transport service shortages—reduce local use—request State assistance.
- (6) Arrange with railroad industry to overcome shortages of service.

**B. Actions to Provide Continuing Railroad Transportation Services**

- 1/ Estimate future needs—available continuing service—adjust State Transportation-Rail Transport policies.
- 2/ Estimate Rail industry requirements for supporting resources—present to appropriate State resource organizations.
- 3/ Allocate and authorize rail transport systems to obtain supporting resources.

FLOW CHART NUMBER 2

Introduction - Transportation (Motor)

Following is a brief description of Federal, State and local government roles in the provision and use of motor transport services available to the State in a nuclear emergency.

a. Federal Government

The Federal government is responsible for working with the interstate motor transport industry to provide motor transport services to meet essential transportation needs in the State of Texas as well as to meet essential needs of other states which depend on these interstate systems for essential motor transport services.

The Interstate Commerce Commission, Bureau of Operations and Compliance, has established a State representative located at San Antonio to work with State transportation officials for this purpose.

b. State Government

The State transportation organization and its area organizations have a motor transportation division to work with Federal transportation officials to obtain interstate motor transportation services to meet shortages reported by local governments. As soon as possible after attack the State motor transportation division, in collaboration with other State organizations representing major activities in the State that use transportation services, anticipates future interstate motor transport needs and arranges with Federal motor transportation official for service to meet these ongoing needs.

The motor transport division is comprised of an Emergency Motor Transport Board made up of a chairman designated by the Governor with representatives of the State motor transport regulatory commission, the ICC and the motor transport industry to advise and assist on motor transport matters in the State.

Where motor transportation is disrupted through enemy action, operations are directed from the assembly and control points of the various motor transportation headquarters within each county in accordance with direction from the Emergency Transport Board which is a part of the motor transport division of the State of Texas transportation organization.

The State has adopted for its use as State general orders the ICC General Orders, ICC-TM-1 through ICC-TM-3, listed by subject in Appendix 2, Annex C, attached to this plan. Such orders, therefore, are the governing policy applicable to the appropriate surface transportation mode in the State.

c. Local Government

Emergency Operations Plans of the State of Texas and its political subdivisions contain provisions for authorizing essential local users and essential facilities to place certified transportation requests on carriers for essential transport services.

EMERGENCY MANAGEMENT OF RESOURCES  
Flow Chart No. 2 - Transportation (Motor)

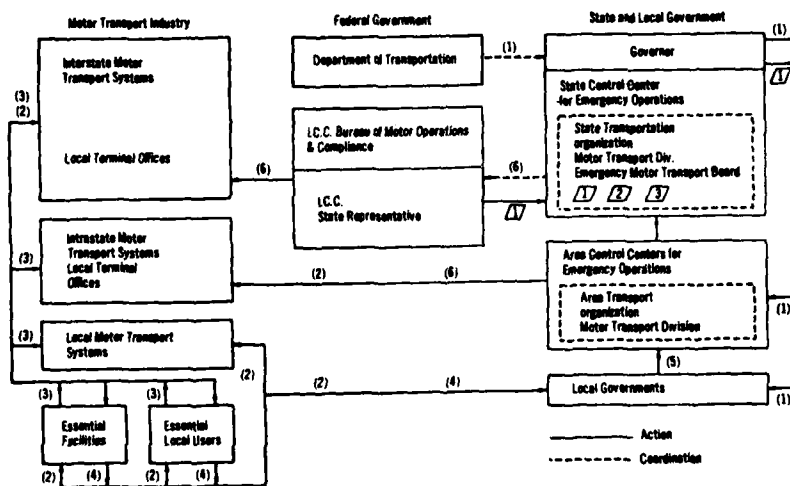

A. Actions to Provide Immediate Motor Transportation Services

- (1) Issue State Motor Transportation Policy—list of essential motor transport facilities.
- (2) Authorize essential local uses of motor transport services.
- (3) Place certified transportation requests for service—report shortages.
- (4) Report shortages.
- (5) Anticipate local motor transport service shortages—reduce local use—request State assistance.
- (6) Arrange with Motor Transport Industry to provide motor transport service to satisfy shortages.

B. Actions to Provide Continuing Motor Transportation Services

- 1/ Estimate future needs for service—available service—adjust State motor transport policy.
- 2/ Estimate motor transport industry requirements for supporting resources—present to appropriate State resource agencies.
- 3/ Allocate and authorize motor transport systems to obtain supporting resources.

**EMERGENCY MANAGEMENT OF RESOURCES**  
**Flow Chart No. 3—Transportation (Air)**

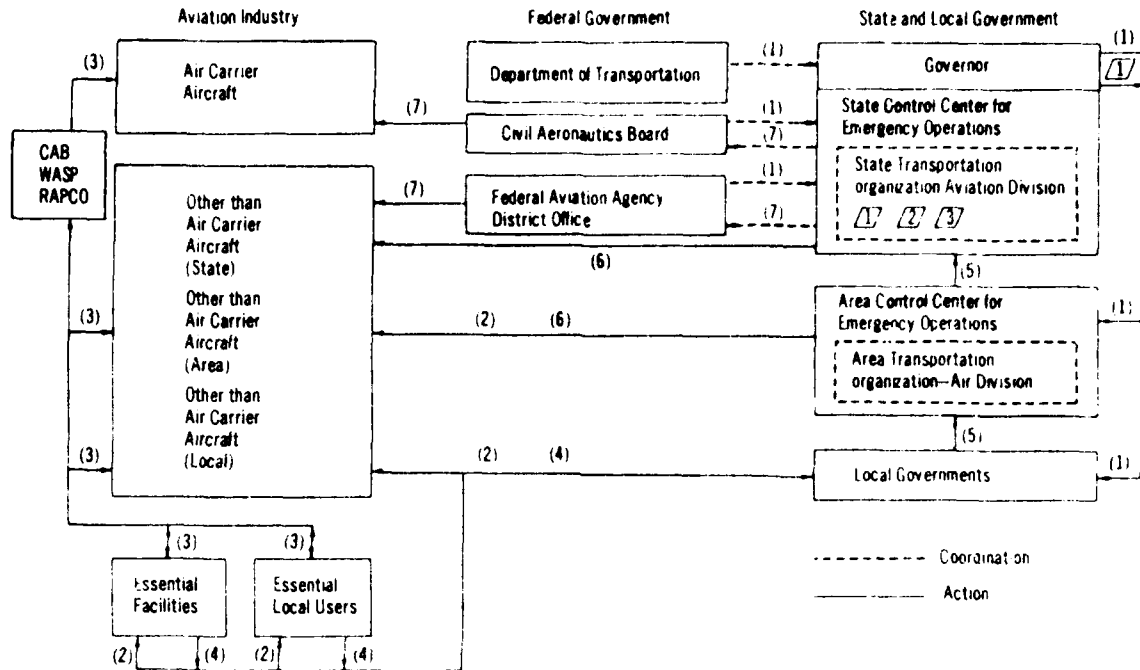

**A. Actions to Provide Immediate Air Transportation Services**

- (1) Issue Air Transportation Policy.
- (2) Authorize essential local uses of air transport services.
- (3) Place certified transportation requests for service.
- (4) Report shortages.
- (5) Anticipate local air transport service shortages—reduce local use—request State assistance.
- (6) Arrange with Aviation Industry to provide air transport service to satisfy shortages.
- (7) Request Federal transport agencies assistance.

**B. Actions to Provide Continuing Air Transportation Services**

- 1/ Estimate future needs—available continuing services—adjust State air transport policy.
- 2/ Estimate aviation industry requirements for supporting resources—present to appropriate State resource agencies.
- 3/ Allocate and authorize air transport systems to obtain supporting resources.

**FLOW CHART NUMBER 3**

**Introduction- Transportation (Air)**

Following is a brief description of Federal, State and local government roles in the provision and use of air transport services available to the State in a nuclear attack emergency.

**a. Federal Government**

The Federal Government is responsible for working with the air carrier industry to provide interstate air transport services to meet essential needs in the State as well as to provide air transport services to other states which depend on these interstate air carrier systems to meet essential air transport needs in a nuclear attack emergency.

The CAB-WASP-Regional Air Priorities Control Office (RAPCO) located in Dallas, Texas, will administer and control the WASP Air Priority for its region. State aviation officials will coordinate with the RAPCO in arranging for provision of air carrier services to meet essential air transportation needs of the State in accordance with procedures specified in the CAB-WASP Air Priorities Manual.

The Federal Aviation Agency has designated representation to work with State aviation officials

to assist in the provision of air transport services, provided by other than air carrier aircraft, to meet essential needs of the State as well as essential needs of other states. This Federal agency also assists the State in restoring and developing airports.

**b. State Government**

The State aviation organization and its area organizations develop, in cooperation with other organizations of State government, and provide, on behalf of the Governor, policies and guidance consistent with State and Federal air transport objectives. The purpose of these policies and guidance is to assure application throughout the State of compatible measures for identifying the most essential air transport needs and to meet these needs within the air transport service available to the State. The State aviation organization arranges through the CAB for the provision of air carrier service to meet shortages reported by local governments. The State aviation organization also works with companies operating other than air carrier aircraft charter services and individuals and companies owning other than air carrier aircraft for air trans-

port services to meet shortages reported by local governments.

As soon as possible after attack, the State aviation organization in cooperation with other State organizations representing major activities that use air transport services anticipates continuing needs and arranges with the Federal air transport agencies for air transport services to meet these ongoing needs.

Emergency Operations Plans contain provisions for authorizing essential users and essential facilities in their jurisdictions to place certified transportation requests on air carriers and on owners and operators of other than air carrier aircraft to obtain air transport services. Designated aviation officials of local government assist authorized local users to obtain air transport services and where necessary assign priorities on local use. When shortages in local service arise, local governments request State aviation officials to arrange for air transport services to meet local shortages.

**c. Local Government**

**EMERGENCY MANAGEMENT OF RESOURCES  
Flow Chart No. 4 — Transportation (Inland Water)**

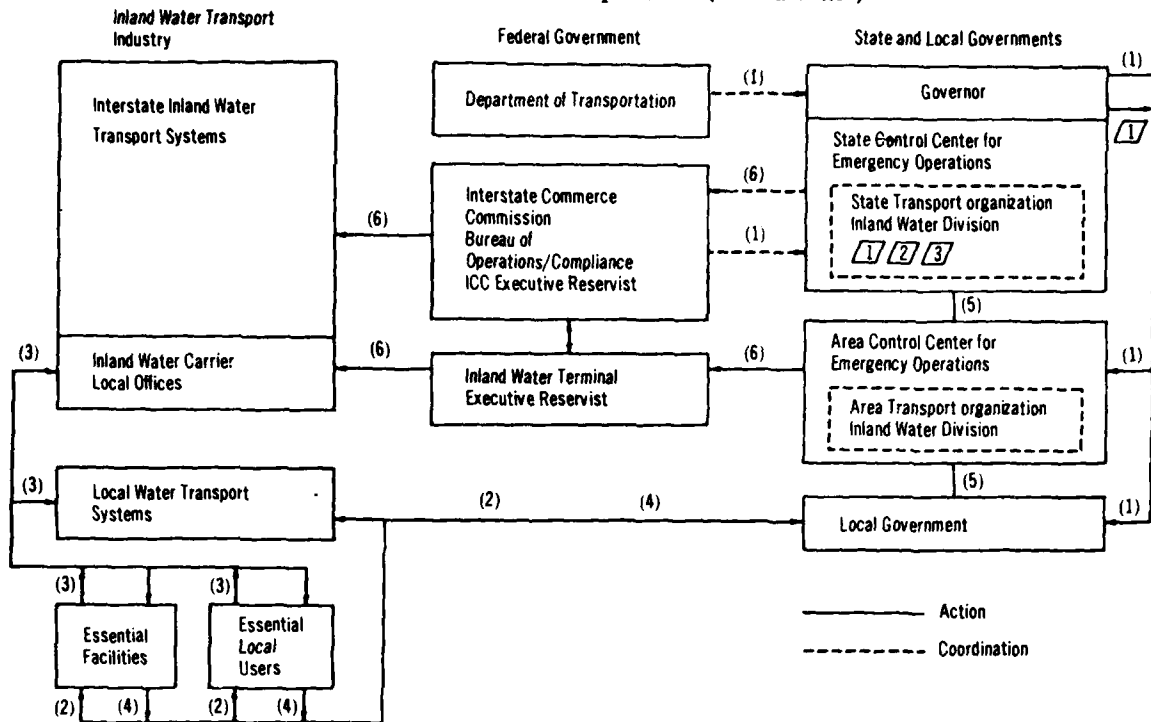

**A. Actions to Provide Immediate Inland Water Services**

- (1) Issue State Inland Water Transportation Policy—list of essential inland water facilities.
- (2) Authorize essential local uses of inland water transport services.
- (3) Place certified transportation requests for service.
- (4) Report shortages.
- (5) Anticipate local inland water service shortages—reduce local use—request State assistance.
- (6) Arrange with Inland Water Transport Industry to provide inland water transport services to satisfy shortages.

**B. Actions to Provide Continuing Inland Water Services**

- 1 Estimate future needs—available continuing service—adjust State inland water transport policy.
- 2 Estimate inland water transport industry requirements for supporting resources—present to appropriate State resource agencies.
- 3 Allocate and authorize inland water transport systems to obtain supporting resources.

**FLOW CHART NUMBER 4**

**Introduction - Transportation (Inland Water)**

Following is a brief description of Federal, State and local government roles in the provision and use of inland water transport services available to the State in a nuclear emergency.

**a. Federal Government**

The Federal Government is responsible for working with the interstate inland water transport in-

dustry to provide water transport services to meet essential transportation needs in the State of Texas as well as to meet essential needs of other states which depend on these interstate systems for essential water transport services.

The Interstate Commerce Commission, Bureau of Operations and Compliance, has established a State Senior Executive Reservist to work with State transportation officials for this purpose. This Federal

agency has also designated ICC Terminal Reservists within the State to work with State and area transportation officials for the same purpose.

(Note: Where inland water transportation is disrupted through enemy action, operations are directed from the assembly and control points of the various inland water transportation headquarters in coordination with the Regional Senior Inland Water Executive Reservist or his appropriate alternate.)

**b. State Government**

The State transportation organization and its area organizations have an inland water division to work with Federal transportation officials to obtain interstate water transportation services to meet shortages reported by local governments. As soon as possible after attack the State inland water transportation division, in collaboration with other State

organizations representing major activities in the State that use transportation services, anticipates future interstate inland water transport needs and arranges with Federal transportation officials for service to meet these ongoing needs.

The State has adopted for its use as State general orders, the ICC General Orders, ICC-TM-1 through ICC-TM-13, listed by subject in Appendix 2, Annex C, attached to this plan. Such orders, therefore, are the governing policy applicable to the appropriate surface transportation mode in the State.

**c. Local Government**

Emergency Operations Plans of the State of Texas and its political subdivisions contain provisions for authorizing essential local users and essential facilities to place certified transportation requests on carriers for essential inland water transport services.

**EMERGENCY MANAGEMENT OF RESOURCES**  
**Flow Chart No. 5 — Transportation (Ocean Ports and Ocean Shipping)**

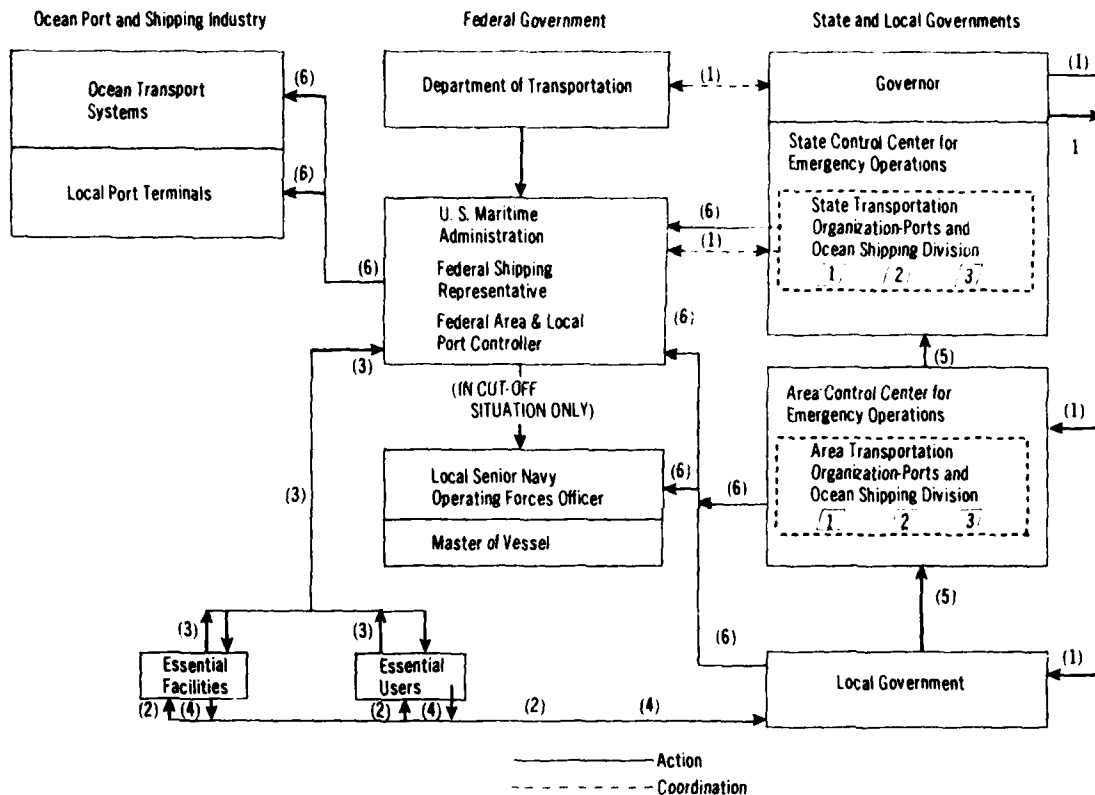

**A. Actions to Provide Immediate Oceans Port Terminal and Shipping Services**

- (1) Issue State Policy on use of Ocean Port Terminal and Shipping Services—list of essential facilities.
- (2) Authorize essential local uses of water transport service.
- (3) Place authorized transportation requests for service.
- (4) Report shortages.
- (5) Anticipate water transportation requirements, report shortages to State level and reduce local uses to most essential needs.
- (6) Request assistance in meeting shortages.

**B. Actions to Provide Continuing Ocean Port Terminal and Shipping Services.**

- 1 Estimate future needs—amount of continuing service available—and make necessary changes to State policies.
- 2 Estimate resource requirements for supporting resources and present to appropriate State resource organizations.
- 3 Authorize the allocation of supporting resources to ocean port terminal and shipping systems as required to maintain the required level of services.

## FLOW CHART NUMBER 5

### Introduction - Transportation (Ocean Ports and Ocean Shipping)

The following information describes the roles of Federal, State and local governments in the use of (a) ocean ports and their facilities and (b) ocean shipping services, in a national defense emergency. It also sets forth the manner in which State requirements for such use will be handled.

#### a. Federal Government

The Federal Government is responsible for worldwide allied shipping support, meeting U. S. military and civilian shipping requirements, and for working with the ocean port and shipping industry in fulfilling essential ocean transportation needs of the State and local governments.

In an emergency, ocean ports and shipping will be components of the National Transportation System and the utilization of these resources will be administered by the Maritime Administration, Department of Commerce. Shipping operations will be performed by or for the Federal Government which will likewise provide for the continued operation of ocean ports through local control of the utilization of port systems and their facilities. The Maritime Administration will have, in most ports, both shipping representatives and local Federal Port

Controllers to act on behalf of the Federal Government. A portion of this staff will be composed of pre-positioned Executive Reservists. In addition, U.S. steamship lines will be designated as General Agents for the Government in matters concerning the emergency operation of ocean shipping. These and other Federal officials within the State have been designated to work with the State and local transportation officials to assure emergency operation of ocean port terminals and shipping services.

#### b. State Government

The State transportation organization and its area divisions have a port and ocean shipping division to work with Federal transportation officials to obtain ocean port terminal and shipping services to meet shortages reported by local governments.

The State has adopted for its use, as State General Orders, the Maritime Administration General Orders listed below:

- MA-TPM-1 Restrictions upon the Transfer, Change in Use, or Terms Governing Utilization of Port Facilities
- MA-TPM-2 Restriction upon the Use of Port Facilities without a Ship Warrant
- MA-TPM-3 Removal of Export, Import, Coastwise and Intercoastal Freight from Port Area

### 3. Responsibilities:

#### a. State Emergency Transportation Coordinator: (See Annex A.)

- (1) Creates an effective emergency transportation organization.
- (2) Selects, staffs and operates supporting subordinate district staffs and organizations.
- (3) Provides guidance for establishment and operation of local transportation staffs.
- (4) Coordinates all interstate and intrastate emergency transportation.
- (5) Provides State policy on the use of all emergency transport services.
- (6) Estimates future transportation needs.
- (7) Estimates and provides continuing transportation services.
- (8) Estimates transportation industry requirements for supporting resources and presents to appropriate State resource organizations these requirements.
- (9) Allocates and authorizes transport systems to obtain supporting resources.

#### b. District Emergency Transportation Director:

- (1) Develops supporting operational transportation plans.
- (2) Represents the State Emergency Transportation Coordinator in assigned district.
- (3) Provides for settlement or arbitration of transportation conflicts at district and local level; forwards to the State Coordinator only those conflicts which cannot be adjudicated at district level.
- (4) Arranges with transportation companies to overcome shortages in services.

#### c. Local Directors:

- (1) Authorizes essential local uses of transportation services.
- (2) Reports shortages.
- (3) Anticipates local transport service shortages, reduces local use and requests, through district, State assistance.

#### d. Transportation Companies:

- (1) Under their own management, operate their systems and facilities so as to provide the maximum service to fill essential needs specified by State and local emergency transportation authorities.
- (2) Provides for:
  - (a) Continuity of management;
  - (b) Protection of personnel and facilities;
  - (c) Conservation of supplies;
  - (d) Restoration of damaged lines and terminals;
  - (e) Routing and rerouting;
  - (f) Expansion or improvement of operations; and
  - (g) Securing necessary manpower, materials and services.

#### e. The Texas State Department of Public Safety: Provides liaison with the State Emergency Transportation Office on matters pertaining to direction and control of motor vehicle traffic.

#### f. The SDHPT.

Provides liaison with the State Emergency Transportation Office on matters pertaining to highway traffic regulation and use of highways. For implementation and operational procedures of

highway traffic regulation, see Appendix 3 to Annex C, this document. The "Emergency Highway Traffic Regulation and Control Plan for the State of Texas," Appendix 3, was approved by the Bureau of Public Roads in 1961.

#### 4. Emergency Actions:

The following actions are taken on behalf of the Governor at State and area levels by State and area transportation officials to provide policies and guidance applicable throughout the State on the provision and use of transportation services.

The emergency action and reference documents contained here have been prepared and placed with appropriate State and local officials during the pre-attack planning process.

##### a. Actions to Provide Immediate Transportation Services

- (1) Issue on behalf of the Governor policies and guidance applicable throughout the State covering the provision and use of transportation services within the State for each mode of transportation as appropriate, i.e., rail, motor, water and air. (Tran-1, State Transportation Policy and Guidance, to Annex B)
- (2) Confirm with the State representatives of the various Federal Government transportation agencies arrangements with interstate transportation companies to furnish services on certified requests received from users or shippers in the State. (Tran-2, Request for Furnishing of Interstate (Primary) Transportation Service, to Annex B)
- (3) Authorize essential local users and essential facilities to certify requests for transportation services for all modes. (Tran-3, Authorization on Use of Intrastate Transportation Services, to Annex B)
- (4) Act on requests from local governments and arrange with interstate transportation carriers and through the Federal transportation agency representatives with interstate transportation carriers to furnish services to meet local shortages of transportation service. (Tran-4, Request State Assistance; and Tran-5, Request to Industry to Adjust Service to Meet Shortages at Local Levels, to Annex B)
- (5) Obtain from the management of transportation system inventories of available transportation, with capacities, capabilities and repair status. (Tran-8, Estimate Transportation Capability, to Annex B)

##### b. Actions to Provide Continuing Transportation Services

As soon as shortages of transportation service at local government levels are being satisfied through the furnishing of service by transportation systems, the State transportation organization takes the following actions to anticipate continuing needs for service and to make arrangements for furnishing service on a continuing basis to meet these needs.

- (1) Consult with State civil defense officials, Federal military officials and appropriate State resource officials to estimate the continuing transportation requirements for movement that will be needed in the State

during the ensuing 90-day period. (Tran-6, Estimate of Continuing Transportation Service Requirements, to Annex B)

- (2) Obtain from the State office of the appropriate Federal transportation agency estimates of transportation capacities and capabilities which can be furnished by interstate transportation systems for continuing use in the State during the ensuing 90-day period. (Tran-7, Estimate of Continuing Interstate Transportation Capability to Meet Transportation Service Requirements, to Annex B)
- (3) Obtain from the management of intrastate (Secondary) transportation systems estimates of transportation capacities and capabilities which can be furnished for continuing use in the State during the ensuing 90-day period. (Tran-8, Estimate of Continuing Intrastate and Local Transportation Capability, to Annex B)
- (4) If anticipated capabilities of the transportation systems are inadequate to meet the estimated requirements for transportation services, and adjustments in requirements cannot be negotiated, refer to the Resource Priorities Board for recommendations to the Governor on the allocation of anticipated transportation services among competing programs. (Tran-9, Allocation of Transportation Services, to Annex B)
- (5) Issue revised State policies on the use of transportation services in the State to conform with the Governor's decision. (Tran-10, Revised State Transportation Policies, to Annex B)
- (6) Consult with the State office of the Federal Office of Emergency Transportation and the management of intrastate transportation companies and develop estimates of continuing requirements for power, petroleum products, manpower, equipment, operating supplies and services that will be needed to maintain operations of essential transportation systems in the State during the ensuing 90-day period. Present these operating requirements estimates to appropriate State resource agencies. (Tran-11, Transportation Industry Support Requirements, to Annex B)
- (7) Consult with the State office of the Federal Office of Emergency Transportation and the management of intrastate transportation companies and develop estimates of emergency repair and construction of essential transportation systems and facilities that will be required during the ensuing 90-day period and present these requirements estimates to the State construction organization. (Tran-12, Transportation Industry Construction Requirements, to Annex B)
- (8) Inform the State office of the Federal Office of Emergency Transportation and the management of intrastate transportation companies of supplies of supporting resources that will be available in the State for acquisition and use by the transportation industry to maintain essential operations during the ensuing 90-day period. (Tran-13, Allocation of Supporting Resources to Interstate (Primary) Transportation Industry, to Annex B)



(9) Inform the State office of the Federal Office of Emergency Transportation and the management of intrastate transportation companies of approved construction and major repair projects.

(10) Authorize the management of intrastate transportation companies to certify purchase orders and construction contracts to obtain approved quantities of supporting resources and to arrange with contractors to undertake approved construction and major repair projects. (Tran-14, Authorization to Major Transportation Carriers and Facilities to Obtain Supporting Resources, to Annex B)

**5. Control and Communications:**

**a. Control:**

(1) Emergency transportation activities will be controlled through the established chain of command, with a line of succession as follows:

- (a) First and second alternate director
- (b) Director, Motor Transport Division
- (c) Director, Rail Transport Division
- (d) Director, Aviation Division

(2) Physical control and operation of privately owned vehicles will remain with the owner or operator, under the general supervision of the emergency transportation organization.

(3) Control of transportation will be in accordance with priorities established by the State Transportation Coordinator upon the advice and council of the industry advisory group and the State and Federal advisors.

**b. Communications:**

(1) Normal communications will be used to the maximum.

(2) Communications systems of the various types of vehicles will be used to the maximum, including:

- (a) Railroad telegraph service
- (b) Railroad radio service
- (c) Motor transport dispatching systems
- (d) Taxi dispatching systems
- (e) Aviation control systems

(3) When communication facilities in addition to the above are needed, the Disaster Emergency Services system will be used. This system includes, in addition to the Department of Public Safety system, the personnel and equipment of the State Parks and Wildlife Commission.

**6. Recruitment, Training and Maintenance:**

The State Transportation Coordinator is responsible on the State and district levels for providing, with the cooperation of the Texas Employment Commission, personnel to maintain his service and expand it in time of necessity. This he will accomplish by utilizing the State Resource Specialists prescribed in Annex E, Part A, Emergency Resource Management Plan.

**a. Personnel Recruitment Sources:**

- (1) Private fleet operators and associations
- (2) Industrial and commercial concerns operating truck fleets
- (3) Taxicab companies
- (4) Owners of private vehicles
- (5) Railroad associations and services, to include the Railroad Retirement Board, Dallas, Texas (See Part C.)
- (6) Railroad Brotherhoods
- (7) Commercial airlines
- (8) Industrial and commercial concerns operating airplanes
- (9) Flying schools and clubs
- (10) Military reservists not on active duty
- (11) Federal Executive Reservists

**b. Training and Maintenance:**

- (1) Staff personnel will participate in Stages I, II, III and IV Testing.
- (2) Staffs at each level will develop and maintain necessary plans and operating procedures.
- (3) Training will be directed toward maintaining an operating capability in changing situations.

**ANNEX A  
EMERGENCY ORGANIZATION  
FUNCTIONAL**

The organizational charts which follow identify the functional areas involved in the regulation of transportation resources in an emergency.

The area transportation terminal, county, and other substate level offices are located in control centers at points which have been established for area, regional or other substate level emergency operations. (See also Part A, Resource Management Plan.)

These are actions necessary to provide for the continuity of operations of the State transportation organization.

a. The Governor of the State of Texas has assigned to the Railroad Commission the responsibility for providing administrative support, i.e., personnel, facilities and supplies for the operations of the State transportation organizations. Copies of this

plan and all action and reference documents have been placed and are immediately available in the State control centers and in the office of the Railroad Commission and its relocation and alternate sites.

b. Upon activation of this plan, the State Transportation Coordinator and key staff with emergency assignments to the State transportation organization establish headquarters at the State control centers of the office of the Railroad Commission or its relocation or alternate site.

c. Lines of succession to assure continuity of key staff for the operation of the State transportation organization are provided in the roster of key personnel contained in the organizational provisions of this section. This roster is included in Part C of this plan.

**STATE TRANSPORTATION ORGANIZATION**

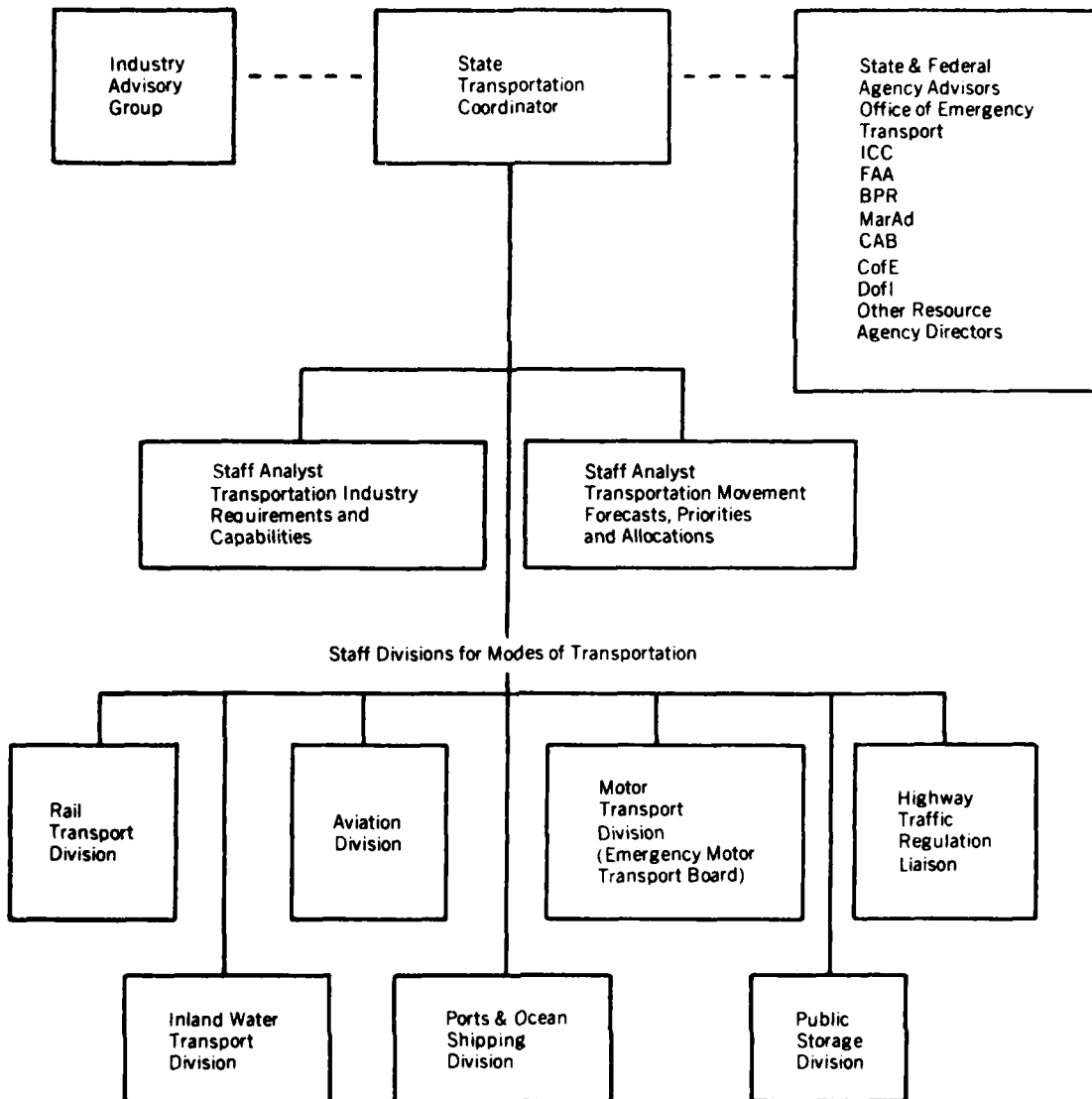

**STATE OF TEXAS**  
**TRANSPORTATION ORGANIZATION**

**1. The Coordinator of Transportation**

- a. Establishes an appropriate organization.
- b. Establishes suitable transportation operating centers.
- c. Activates divisions and branches of the State transportation organizations when directed by the Governor.
- d. Establishes effective operating procedures.
- e. Assists lower levels in the establishment of appropriate and uniform organizations and operation procedures.
- f. Directs the activities of the transportation organization.

**2. The Industry Advisory Group**

- a. Advises and assists the Coordinator on all matters pertaining to the availability, capability, procurement and regulation of transportation services.
- b. Advises and assists the Coordinator in the selection of an emergency operating staff of sufficient size and capabilities to handle the details of regulation of transportation services.
- c. Advises and assists the Coordinator of Transportation in establishing suitable local level transportation operating centers and effective operating procedures for such centers.

**3. The Interagency Advisory Group**

- a. Advises and assists the Coordinator on all matters pertaining to the coordination of governmental agency responsibilities and activities in respect to transportation.
- b. Maintains current information on all laws, regulations, directives, orders, etc., pertinent to the authority, responsibilities and limitations of the respective agency of each member affecting the mobilization and regulation of emergency defense transportation services.
- c. Individual members have the full authority to act for their agencies in the absence of communications.

**4. Directors of Rail, Aviation, Motor, Highway Traffic regulation, Water and Public Storage Divisions**

- a. Advise and assist the Coordinator of Transportation pertaining to their respective modes of transportation and storage.
- b. Coordinate the activities of the various segments of their respective modes of transportation and storage.
- c. Organize and direct the activities of the emergency operating staff of their respective divisions.
- d. Supervise the details of regulation of storage and transportation service of the mode of transport their divisions regulate.
- e. Advise and assist representatives of industry for their respective modes in emergency operations for the preservation, conservation and maximum utilization of transport service in an emergency.

---

**State Transportation Organization**  
**Rail Transport Division**

The Rail Transport Division is responsible to the Coordinator of State Transportation organization for railroad transportation facilities and equipment utilization within the State of Texas. The Rail Transport Division coordinates actions of an operational nature with the Regional Senior Executive Reservist and will be guided by his advice and counsel.

The Rail Transport Division in general mobilizes available rail transport and transportation facilities within the State of Texas for the purpose of effecting the maximum utilization of the industry for the movement of people, supplies and things in the event of a national emergency.

The Rail Transport Division, supplemented by railroad Executive Reservists, develops and maintains information as to the preattack rail transport equipment and facilities within the State of Texas.

In general, rail terminal reporting areas are established as determined to be necessary throughout the State of Texas.

Contacts with out-of-state emergency governmental elements, transportation associations, or specific railroad carriers are made primarily through the Rail Transport Division in the State of Texas. In an attack situation, decisions regarding the emergency use of railroad transportation, facilities, equipment or personnel rest with the ICC State Senior Rail Reservist in coordination with the Regional Senior Reservist or his designee.

The State is represented by a member of the State Railroad Commission charged with carrying out overall

State transportation policy and procedures and, among other duties, will:

1. Represent the State as a member of the Rail Transport Division;
2. Be responsible for the emergency coordination of railroad transportation with Federal, military and civilian representatives and the railroad industry.

The Interstate Commerce Commission, Bureau of Safety and Service Representative, provides support to the Rail Transport Division. The ICC member works closely with the railroad industry through the ICC Railroad Executive Reservist for coordination of Federal transport policy direction with State and local authorities.

The railroad industry is represented on the division by the State Senior Railroad Executive Reservist who has the primary responsibility for inventory and use of railroad transportation equipment throughout the State of Texas.

The State Senior Railroad Executive Reservist coordinates problems of an operational nature with the Regional Senior Railroad Executive Reservists. In attack situations he keeps the Rail Transport Division advised as to railroad conditions and operations in the State and region. He advises as to most effective use of surviving railroad equipment, manpower and facilities.

The Military Liaison Officer coordinates military matters which may affect rail transportation.

An ICC State Senior Railroad Reservist and an alternate have been appointed in the State of Texas. They are listed in Annex D.

In accordance with established plans, they utilize their transportation experience and managerial skills, to-

**State Transportation Organization  
Rail Transport Division**

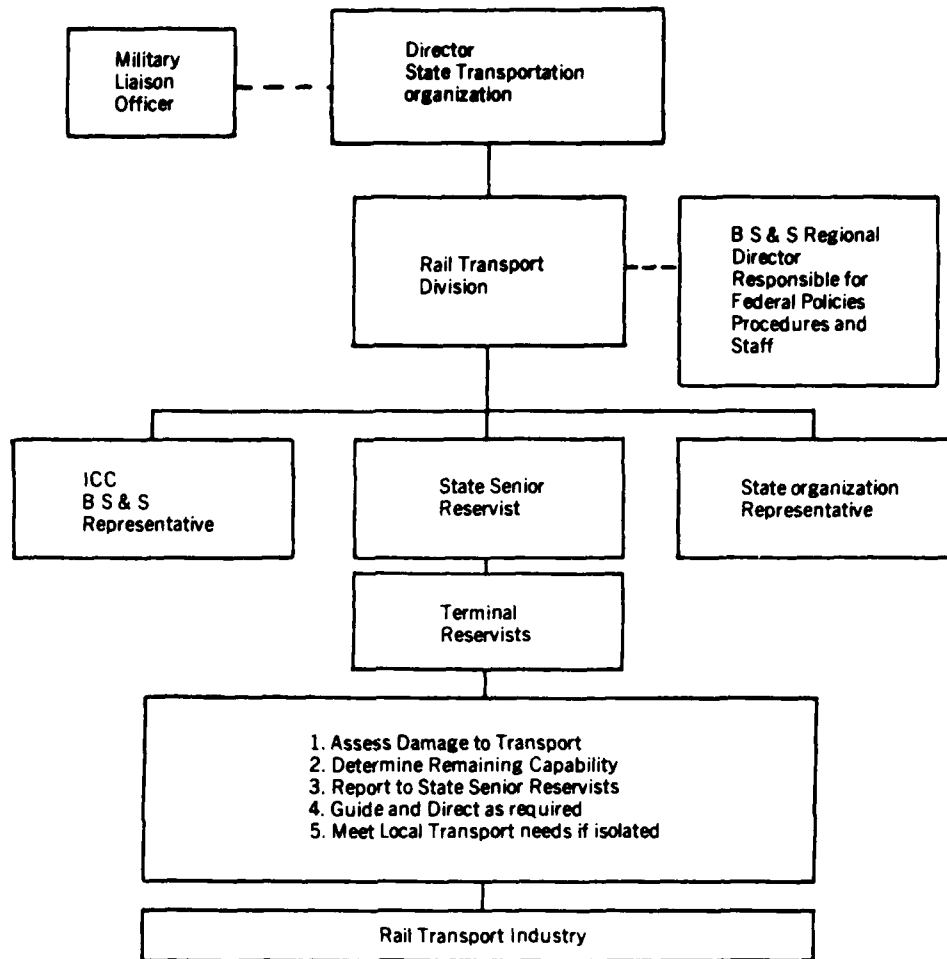

gether with their executive training, in assisting in carrying out the following functions:

1. Determining transportation capabilities in view of available transport equipment and facilities.
2. Analyzing demands for the movement of strategic goods and essential personnel.
3. Defending, maintaining and restoring of industry essential in providing the transport industry with the capability and supporting resources to accomplish its emergency mission.
4. Making effective arrangements to accomplish emergency transportation jobs.

Duties of the Railroad Terminal Executive Reservist are broadly defined as follows:

1. The terminal reservist is responsible to the State Senior Rail Executive Reservist for situation reports or analyses of conditions within his terminal area.
2. He maintains close working relationship with local civil defense authorities.

Rail terminal areas within the State of Texas have been designated and terminal reservists have been appointed with responsibilities enumerated under paragraphs above.

The selected terminal areas are as follows:

**List of Rail Terminal Areas**

Abilene	Marshall
Alice	Monahans
Amarillo	Orange
Austin	Port Arthur
Beaumont	San Antonio
Big Spring	Sherman
Corpus Christi	Slaton
Dallas	Smithville
Denison	Victoria
El Paso	Waco
Ennis	Wichita Falls
Fort Worth	
Freeport	
Galveston	
Hearne	
Houston	
Laredo	
Lubbock	
Lufkin	

**State Transportation Organization  
Motor Transport Division**

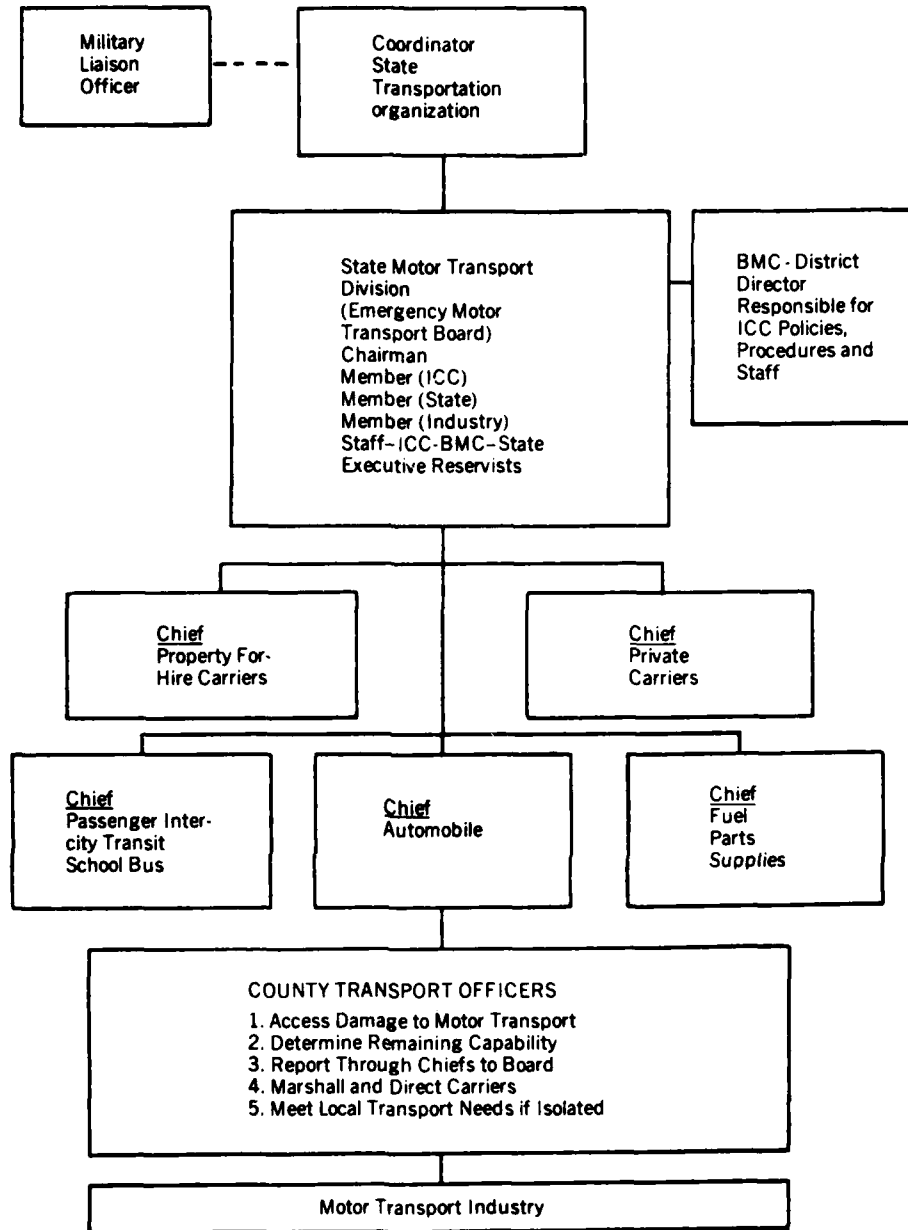

**State Transportation Organization  
Motor Transport Division**

The Emergency Motor Transport Board, within the State Motor Transport Division, is appointed by the Governor of the State and the Interstate Commerce Commission. It is an integral part of the Motor Transport Division of the State of Texas transportation organization.

The Motor Transport Division, comprising the Board, in general organizes all available motor transport and transportation facilities within the State of Texas for the purpose of effecting the maximum utilization of all motor transportation media for the movement of people, supplies and things in the event of an emergency or during a postattack period.

The Board, the Division Chiefs and the County Motor Transport Officers gather and maintain such information as is or becomes available concerning post-attack motor transport equipment and facilities within the State of Texas.

Motor transportation equipment dispersion and assembly areas are established in county seats or as otherwise determined to be necessary throughout the State of Texas.

Contacts with out-of-state agencies, civil defense organizations and other transportation establishments are made primarily through the Emergency Motor Transport Board in the State of Texas. If, for any reason, such as lack of communications, this arrangement becomes impractical, decisions for the use of motor transportation facilities, both within the county and

outside the State, rest with County Motor Transport Officer.

The duties of the Motor Transport Division and its entities are:

1. The Motor Transport Division is responsible for motor transportation facilities and vehicle utilization within the State of Texas, and is responsible to the Governor and the Interstate Commerce Commission through the Coordinator of the State transportation organization for transportation actions.
  2. The Emergency Motor Transport Board coordinates actions of an operational nature with the Motor Transport Industry for the State Motor Transport Division.
  3. The Chief of the Motor-For-Hire Property Carrier Branch is responsible for inventorying, assembling and the use of all motor-driven truck transportation throughout the State.
  4. The Chief of the Private Carrier Branch is responsible for inventorying, assembling and the use of all private carrier motor vehicles within the State.
  5. The Chief of Passenger Transportation Branch is responsible for the accumulation and use of all bus and taxicab transportation within the State of Texas, including interstate bus transportation, privately owned bus transportation, school bus transportation and taxicabs in the State.
  6. The Chief of Privately Owned Automobile Branch is responsible primarily for the assembling of abandoned private transportation on highways and the restoration of these vehicles to their rightful owners through the assistance of the chief law enforcement officer of the State of Texas. He is also responsible for the proper use and dispatch of these vehicles while under his control during the period that the owners are being identified and the equipment returned to the legal owner.
  7. The Chief of the Fuel, Parts and Supplies Branch, is responsible for claiming and making provision for the release of such items for essential transportation usage and keeping industry informed of such provisions.
  8. The Military Liaison Officer is responsible to the Motor Transport Division for close liaison with the military. He makes all arrangements with the Board and various branch chiefs to assist the military in the movement of troops and equipment when requested by the proper military authorities.
  9. The motor transportation areas for the State of Texas are the counties of the State. The County Motor Transport Officer is located at the county seat, unless some other place is designated during an emergency.
    - a. The county motor transport organization is in general the same as that of the State. It may be modified to meet local needs of terrain and concentration of populations within the county to satisfy emergency requirements.
    - b. Within the cities of the county, the City Motor Transportation Officer is responsible for the proper use of local transportation. The organization within the city may be modified to meet local needs.
- The Motor Transport Division, including the Emergency Motor Transport Board, is located in the City of Austin for the purpose of assisting motor transportation activities throughout the State.

**State Transportation Organization  
Aviation Division**

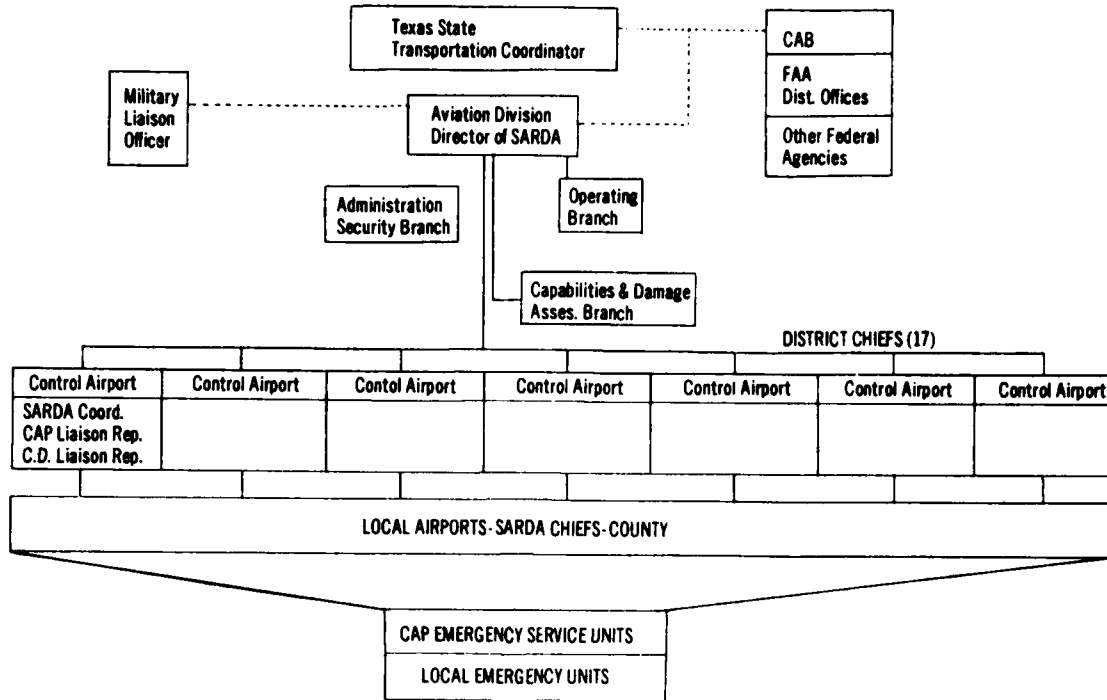

**Section I  
General**

The Aviation Division provides the Coordinator of the State Emergency Transportation Organization with direction and assistance in the managed air movement of persons and goods and in the use of special purpose type aircraft in support of national, regional, State and local essential activities. The Aviation Division functions as an element of the State Emergency Transportation Organization, under the direction of its Coordinator, in the management and control of civil airports, civil aviation operating and maintenance facilities, and civil aircraft other than air carrier aircraft available to the State in an emergency.

The National Program for the management and control of these nonair carrier resources is called the State and Regional Defense Airlift (SARDA). Thus the Aviation Division of the State Emergency Transportation Organization, referred to above, is intended to designate or identify that element of the State emer-

gency organization which is to carry out the SARDA program within the State.

Hereinafter, the term "Aviation Division" will be referred to as the "Texas SARDA," or simply, "SARDA." The term "Director of Aviation Division" will be referred to as "Director of SARDA for the State of Texas," or simply "State Director of SARDA," or "Director of SARDA."

**Authorities-Federal.** Actions taken by the Federal Aviation Agency in the control and utilization of SARDA resources are taken pursuant to the following Federal emergency authorities:

- Federal Civil Defense Act of 1950
- Federal Aviation Act of 1958, Sec. 302 (e)
- Executive Order Number 11003 of 1962

**Authority-State.** Actions taken by the State Emergency Transportation Organization, (the air portion of which is known as SARDA), in the control and utilization of SARDA resources are taken pursuant to appropriate State emergency authorities.

Section II  
ORGANIZATION

The Texas SARDA is organized at the State level into three branches: (1) Administrative and Security Branch, (2) Operating Branch, and (3) Capabilities and Damage Assessment Branch. Liaison is provided at this level with Federal agencies and various organizations of the civil aviation industry.

The three branches of the organization at State level perform the following functions:

Administrative and Security Branch

1. Issue and publish necessary documents to activate subordinate elements of the Texas SARDA and provide for the registration or reporting for duty of individuals throughout the State who are to perform aviation services during the emergency.
2. Provide appropriate authority to designated personnel to enable enforcement, if necessary, of security measures and other actions to implement the plan.
3. Provide appropriate liaison to the State Director, Disaster Emergency Services (DES) and Armed Forces. Establish and maintain liaison with SARDA Directors in adjoining States, and with representatives of appropriate FAA General Aviation District Offices and Airport District Offices. Arrange for presence of a suitable liaison representative at the State, area, and local emergency operations centers in time of emergency.
4. Assist in the establishment of a communications network for the dissemination of necessary directives and pertinent information to airports and personnel, and provide for necessary tests of facilities, training of personnel and simulated drills to determine the adequacy of the networks to perform the functions which they are assigned.
5. Assist and advise the State Director, DES in the development or modification of agreements for use of nonair carrier aircraft in support of civil defense missions.
6. Assist the SARDA designees and local Civil Defense Directors in developing plans for use of nonair carrier aircraft at area and local levels within the State to support civil defense missions.
7. Assisting the State Director, DES in making State financial arrangements for support of postattack civil defense assigned flight missions.
8. Providing for the appropriate support of national policies and programs.
9. Providing assistance to other states on a regional basis, as requested by the General Aviation District Office, when directed by the regional boards.

Operating Branch

1. Specify the duties and responsibilities of the Director of SARDA and those of the State, area and local officials or designees assigned defense readiness responsibilities in SARDA.
2. Provide the criteria and guidance for the establishment and operation of control airports and methods of securing and controlling the operation of aircraft from all landing areas within the State except military.
3. Define responsibilities and establish procedures and general instructions for the security control of civil air traffic within the State in cooperation with the Federal Aviation Agency and appropriate military services.
4. At all airports within the State, provide for the appropriate registration of all aircraft, maintenance of suitable charts, directories, and other data to assure proper pilot and/or flight crew briefing concerning operation of aircraft under security restrictions.
5. Provide for delegation of authority from State to area to local levels to carry out postattack operational missions as requested by the emergency transportation organization and the local Civil Defense Director in "cutoff" situations.
6. Estimate the quantities of resources required to maintain essential aviation services in support of authorized programs on a time-phased basis, and submit claims to proper resource allocation authorities.
7. Periodically arrange for and direct test exercises in conjunction with civil defense exercises and/or military exercises as appropriate. Arrange for or conduct the training of aviation personnel required to perform civil defense missions. Provide guidance for the conduct of training of personnel for performing civil defense support missions in coordination with the local Civil Defense Director.
8. Develop in conjunction with State Director, DES guidance material to be used by nonair carrier aircraft in developing standard operating procedures for carrying out special civil defense missions.
9. Prepare to carry out the postattack operational missions as arranged by the State Director, DES through the State emergency transportation organization.

Capabilities and Damage Assessment Branch

1. Maintain a record of all SARDA aviation resources within the State, including airmen, aircraft, repair facilities, airports, fixed-base operators, executive aircraft and other aeronautical activities and facilities, together with an indication of the availability on a voluntary basis for the participation in support of the State or national interests during an emergency.



2. Predetermine priorities and allocations for the use of aviation services and with adequate provisions to modify these as necessary to meet the essential actual requirements of the then existing situation. Assign or delegate, the assignment of aviation services to approved claimants on the basis of current priorities.
3. Prepare to obtain estimates of the surviving aviation resources within the State and to develop and maintain a supply-demand situation report.
4. Make arrangements to advise the State Coordinator of Emergency Transportation of the capability of the remaining SARDA resources to perform aviation services in response to essential requirements.
5. Prepare and maintain a functional analysis of available passenger and cargo airlift and aircraft suitable for special purposes, such as aerial spraying, radiological monitoring, reconnaissance, and others. Provide this information to the Coordinator of Emergency Transportation, Director, DES and other interested offices, including the General Aviation District Office assigned responsibility for this State.
6. Prepare to furnish such support as is available for the operation and control of aircraft flying civil defense missions in an emergency.

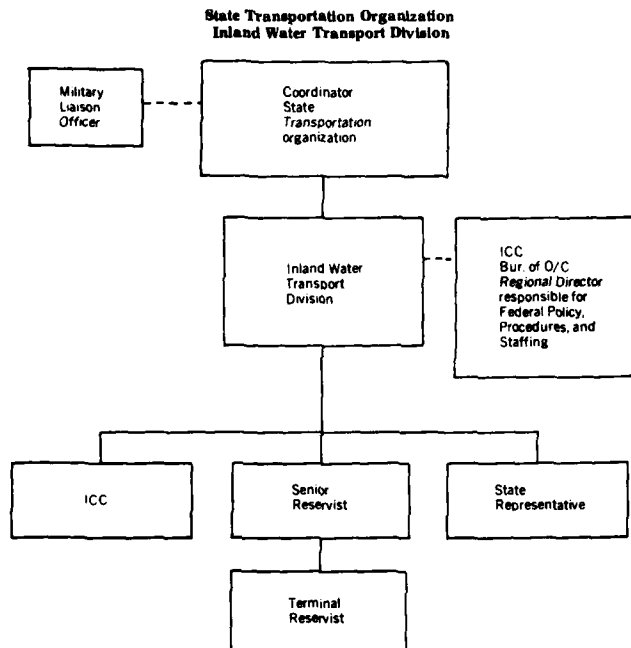

**State Transportation Organization Inland Water Transport Division**

The Inland Water Transport Division in general mobilizes available inland water transport and transportation facilities within the State of Texas for the purpose of effecting the maximum utilization of the inland water carrier industry for the movement of people and commodities in the event of a national emergency.

1. The Inland Water Transportation Division including the Inland Water Executive Reservists, develops and maintains such information as is available within the State of Texas relative to inland water transportation equipment and facilities.
2. Contacts with out-of-state emergency governments, transportation associations or specific inland water carriers are made primarily by the Inland Water Transportation Division. In attack situations, decisions for the emergency use of inland waterway transportation, facilities, equipment, or personnel rest with the Inland Water Port Executive Reservist in coordination with the Regional Senior Inland Water Reservist or his designee.
3. The Inland Water Transportation Division is responsible for inland water transportation facilities and equipment utilization within the State of Texas and is responsible to the Governor and the Interstate Commerce Commission, through the Coordinator of the State transportation organization for transportation actions. The division coordinates actions of an operational nature with the Regional Senior Executive Reservist (Inland Water) and is guided by his advice and counsel.
  - a. The State is represented by a member of the Texas Railroad Commission who is charged with overall responsibility for carrying out State transportation policy and procedures and among other duties:

Represents the State as head of the Inland Water Transport Division. Is responsible for the emergency coordination of inland water transportation with representatives of the Federal Government (civil and military).

- b. The Interstate Commerce Commission, Bureau of Operations and Compliance, provides liaison representation to the division. The ICC member:

Works closely with the inland water carrier industry through the ICC Inland Water Executive Reserve for coordination of Federal transport policy direction with State and local authority.

- c. The Inland Water Port Executive Reservist's responsibilities are broadly defined as follows:

- (1) Responsible to the Regional Senior Inland Water Reservist for situation reports or analyses of conditions within his terminal area.
- (2) Keeps the division advised as to conditions of inland waterways operations in the State and region. He advises the division as to the most effective use of surviving floating craft, manpower, terminal facilities and condition of the waterway.
- (3) Maintains a current inventory of manpower, equipment and facilities at his terminal.
- (4) Maintains close working relationship with local civil defense authorities.

- d. The military Liaison Officer is responsible to the division for coordination of military matters which may have an impact on inland water transportation.

**State Transportation Organization  
Ports and Ocean Shipping Division**

The Ports and Ocean Shipping Division provides State government direction and assistance in obtaining ocean port terminal and shipping services to move persons and cargo in support of State and local essential activities.

This division functions as a division of the State transportation organization under the direction of the Director of the Ports and Ocean Shipping Division.

The Director of the Ports and Ocean Shipping Division and his staff:

1. Specify, in conformance with Federal Maritime Administration policy, the duties and responsibilities of the Ports and Ocean Shipping Division and those of the area and local government officials.
2. Assist Federal MARAD port and ocean shipping officials by providing the resources necessary for the continued operation of these essential elements of the transportation system. (petroleum, manpower, fuel, etc.)
3. Assist Federal officials, including MARAD shipping representatives, port controllers and design-

nated general agents for the governments concerned with emergency operation of ocean shipping, in coordinating the local movement of export-import traffic that is scheduled to move from or through a congested or damaged port area. This is to assure that such traffic is not delayed by the movement of local domestic movements—by any mode.

4. Assist in the collection, evaluation and dissemination of damage assessment information.
5. Assist in the process of damage control, decontamination and restoration of essential ocean port terminal and shipping services.
6. Assemble the State requirements for ocean transportation for presentation to the nearest Federal Office of Emergency Transportation to obtain service.
7. Assist in furnishing replacements for Federal port controller casualties.

As soon as possible after an enemy attack, the State's Port and Ocean Shipping Division, in collaboration with other State organizations representing major activities in the State that use transportation services, estimates the future State needs for port and ocean shipping services and makes these requirements known to appropriate Federal officials.

**State Transportation Organization  
Ports and Ocean Shipping Division**

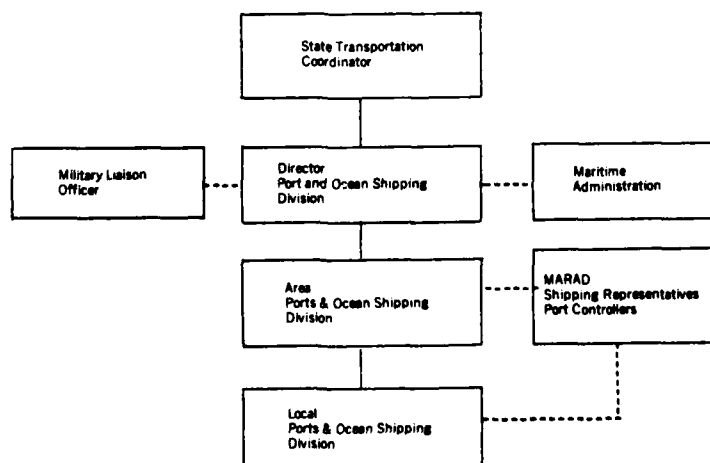

**State Transportation Organization  
Public Storage Division**

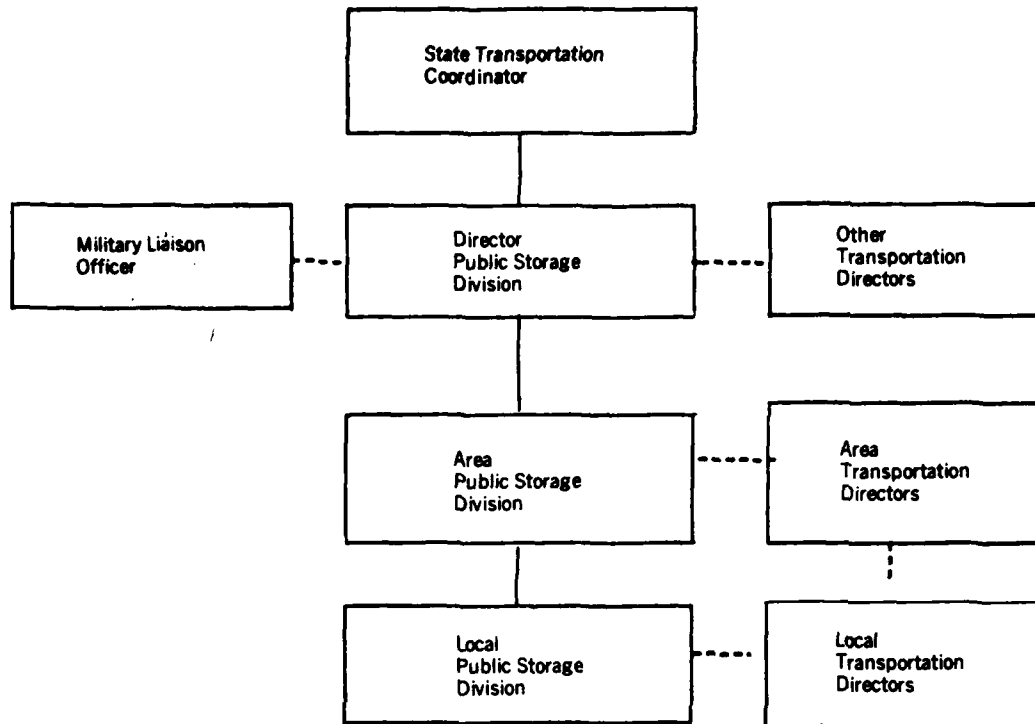

**State Transportation Organization  
Public Storage Division**

The Public Storage Division provides State government direction and assistance in obtaining public storage and warehousing services to stock cargo in support of State and local essential activities.

The division functions as a division of the State transportation organization under the direction of the Director of the Public Storage Division.

The Director of the Public Storage Division and his staff:

1. Specify the duties and responsibilities of the Public Storage Division and those of the area and local government officials.
2. Provide area and storage facilities necessary for the continued operation of essential elements of the transportation system.

3. Assist Federal and other officials in coordinating the storage of transit, temporary or consigned stocks. This is to assure that such stock is not damaged while in transit or in storage.
4. Assist in the collection, evaluation and dissemination of damage assessment information.
5. Assist in the process of damage control, decontamination and restoration of essential terminal and warehouse services.
6. Assemble the State requirements for storage and warehousing.
7. Assist in furnishing replacements for area or local warehousing casualties.

As soon as possible after an enemy attack, the State's Public Storage Division, in collaboration with other State organizations representing major activities in the State that use transportation services, estimates the future State needs for public storage services and makes these requirements known to appropriate officials.

**ANNEX A  
EMERGENCY ORGANIZATION  
GEOGRAPHIC**

For the purpose of this section of the resource plan, the State of Texas is divided into 17 geographic subdivisions, corresponding to DES Disaster Districts, each district headed by a representative of the State Railroad Commission responsive to the Commission headquarters in Austin. These representatives are for the most part resource specialists serving under the provisions shown in Annex E, Part A, Emergency Resource Management Plan.

The following listing of district designation and location of subordinate headquarters is amplified and constantly updated by the roster maintained in Part C of this plan.

District	Location
1A	Dallas (Region 1)
Sub 1A	Fort Worth
1B	Tyler
2A	Houston (Region 2)
2B	Beaumont
3A	Corpus Christi (Region 3)
Sub 3A	Harlingen
3B	San Antonio
4A	Midland (Region 4)
Sub 4A	El Paso
4B	Abilene
Sub 4B	San Angelo
5A	Lubbock (Region 5)
Sub 5A	Wichita Falls
5B	Amarillo
6A	Waco (Region 6)
6B	Austin

---

**ANNEX B  
EMERGENCY ACTION DOCUMENTS**

Following are emergency action documents to implement the emergency actions directed in paragraph 4, basic document.

During the process of expediting deliveries to meet urgent local needs, the quickest means of communication between levels of government and with industry will be used. The suggested forms illustrate the kind of information to be transmitted over telephone or other available means of fast communication.

**Index of Emergency Action Documents**

- Tran- 1, State Transportation Policy and Guidance
- Tran- 2, Request for Furnishing of Interstate (Primary) Transportation Services
- Tran- 3, Authorization on Use of Intrastate (Secondary) Transportation Services
- Tran- 4, Request State Assistance
- Tran- 5, Request to Industry to Adjust Service to Satisfy Shortages of Service at Local Levels
- Tran- 6, Estimate of Continuing Transportation Services Requirements
- Tran- 7, Estimate of Continuing Interstate (Primary) Transportation Capability to Meet Transportation Service Requirements
- Tran- 8, Estimate of Continuing Intrastate and Local Transportation Capability to Meet Transportation Service Requirements
- Tran- 9, Allocation of Transportation Services
- Tran-10, Revised State Transportation Policies
- Tran-11, Transportation Industry Support Requirements
- Tran-12, Transportation Industry Construction Requirements
- Tran-13, Allocation of Supporting Resources to Interstate (Primary) Transportation Industry
- Tran-14, Authorization to Major Transportation Carriers and Facilities to Obtain Supporting Resources
- Tran-15, Activation of the State and Regional Defense Airlift Plan (SARDA)

**Tran-1, State Transportation Policy and Guidance**

To: Heads of Political Subdivisions

**Guidance for Local Governments.** It is essential that transportation services available for use in this State be carefully conserved and restricted to immediate and urgent uses for local, State and National survival and recovery until the continuing transportation capability can be assessed and transportation services that will be available for less essential needs can be determined.

In order to (1) prevent waste and dissipation of transportation service throughout the State, (2) provide transportation services to meet immediate and urgent needs, and (3) to assure continuing transportation services for local uses, appropriate officials of local government are requested to take the following actions:

1. Announce and enforce restrictions on the use of transportation services.
2. Provide instructions to the transportation industry on how to meet essential needs.
3. Authorize essential local users to obtain transportation services for immediate and urgent needs.
4. Authorize essential facilities and essential local users to certify requests for necessary transportation services. Instruct essential facilities and essential local users to place these certified requests on their customary agents or companies.

In the event transportation services are not adequate to meet all essential needs, local governments should reduce authorized local uses. Concurrently they should report shortages of service and request appropriate officials of State government to take actions to increase transportation services to the local jurisdiction.

\_\_\_\_\_  
(Effective Date)

\_\_\_\_\_  
(Name)

Governor of the State of Texas

By: \_\_\_\_\_  
(Signature)

State Transportation Coordinator

**Tran-1, Attachment 1**

**Background Information**

The Governor has issued general policy on the use of essential resources in the immediate postattack period. These policies are set forth in Part A of the State plan. They have been furnished to appropriate officials of the political subdivisions of the State.

In general, these State policies provide for temporary freezing of retail inventories of essential items and immediate and continuing release of these items to meet urgent military and civilian needs and to maintain operations of facilities essential to continued survival and recovery. They provide for continuing resupply of local secondary inventories as well as inventories of essential facilities which obtain their supplies from wholesale and primary sources.

In addition, the Governor has issued a proclamation requesting the executive heads of the political subdivisions in this State to provide resources from locally available supplies to carry on immediate and urgent activities for survival and to maintain the operation of essential facilities. In accordance with this direction from the Governor, local governments are requested to inform essential users of resources and persons engaged in the operation of essential facilities how to identify their purchase orders, contracts, and other purchase arrangements to obtain deliveries of supplies and services.

Attached to this section of the State plan is a list of essential transportation facilities that must continue in operation to assure an adequate flow of transportation services for local, State, and National survival and recovery. Names and addresses of these facilities located in the political subdivisions have been provided to the local governments concerned.

Local governments, upon attack, notify the management of these facilities to certify their purchase orders and contracts to obtain production materials, capital equipment, and maintenance, repair and operating supplies or to place contracts for essential repair and construction as follows.

1. Essential transportation facilities use the following State certification to identify:
  - a. Purchase orders for supplies of electric power, gas, solid fuels, and transportation and communication services, and
  - b. Construction contracts for repair and construction of facilities.

"This is an essential order  
authorized by the State of Texas.

\_\_\_\_\_  
(signature of purchaser)"

2. Essential transportation facilities identify their purchase orders for supplies of production materials, capital equipment, and other maintenance, repair, and operating supplies in accordance with the rating and certification provisions of Federal emergency regulations issued by the Office of Industrial Mobilization (OIM) of the U. S. Department of Commerce upon at-

tack. The State industrial production organization publicizes and makes known these Federal regulations to local governments and industry immediately following an attack.

**Definitions:**

**a. Essential Users:**

- (1) Individuals, both civilian and military, engaged in producing or providing essential items, products, care or services, e.g., doctors providing professional medical diagnoses, treatment and services; farmers producing essential food; military personnel engaged in immediate retaliatory or defense operations.
- (2) Organizations or establishments engaged in essential activities or providing essential items or services.

**b. Essential Facilities:**

- (1) Military establishments engaged in immediate retaliatory or defense operations;
- (2) Electric power, gas and water utility systems;
- (3) Industrial plants producing or processing essential items;
- (4) Major wholesale establishments storing or distributing essential items; and
- (5) Transportation or communication systems providing essential services.

**c. Individual Consumers:** Individuals who depend on local distribution systems (retailers and dealers) for essential supplies for individual and family use.

---

**Tran-2, Request for Furnishing of Interstate (Primary) Transportation Services**

To: State and Area Offices of Appropriate Federal Transportation Agencies.

Local governments in this State, in accordance with State policy and guidance, have identified and authorized essential local users and essential facilities in their jurisdictions to certify their requests for transportation services with the following certification:

"This is an emergency transportation request authorized by the State of Texas.

(signature of shipper or user)"

Local and intrastate transportation industries and operators have been instructed to accept certified transportation requests and to furnish the services requested. They have in turn been authorized to use this same certification on their requests for services, equipment or operating supplies needed to supplement their regular transportation service.

You are requested to arrange with interstate transportation operating systems of your appropriate mode for acceptance of these State certified requests for transportation within their capabilities to furnish service.

(Effective Date)

(Signature)

State (Area) Transportation Coordinator  
State of Texas

---

**Tran-3, Authorization on Use of Intrastate (Secondary) Transportation Services**

To: \_\_\_\_\_

(Name of Each Intrastate Transportation Industry Company)

Local governments in this State, in accordance with State policy and guidance, have identified and authorized essential local users and essential facilities in their jurisdictions to certify their requests for transportation services with the following certification:

"This is an emergency transportation request authorized by the State of Texas.

(signature of shipper or user)"

You are to accept and furnish service when presented a State certified transportation request subject to your capability to furnish such service.

You will receive, from time to time, directions from the State or Area Transportation Directors (Coordinator) to adjust your services to meet shorages of service reported in particular localities.

You are authorized to use the certification quoted above to certify your purchase orders for equipment, services, and operating supplies needed for your continued operations.

If you are unable to obtain needed equipment, services, and supplies to meet the certified transportation requests placed on you, notify this office promptly.

(Effective Date)

(Signature)

State Transportation Coordinator  
State of Texas

**Tran-4, Request State Assistance**

To: State or Area Transportation Director (Coordinator)

Transportation services in this local jurisdiction are inadequate to meet present and anticipated needs of essential local users and essential facilities.

Authorized local uses and use levels have been cut back as far as possible by local government control and action. Assistance is needed to increase transportation services in this local jurisdiction as quickly as possible.

Following are estimated increases in weekly transportation services required to meet essential local needs.

Request for State Assistance to Provide Additional Transportation Service				
Transportation Services (As Appropriate)	Unit of Measure		Weekly Increase	
	Ton Miles	Passenger Miles	Ton Miles	Passenger Miles
Rail				
Motor				
Air				
Water				

\_\_\_\_\_  
(Date)

\_\_\_\_\_  
(Name of Head of Local Government)

By: \_\_\_\_\_  
(Signature)  
Local Transportation Officer

**Tran-5, Request to Industry to Adjust Service to Satisfy Shortages of Service at Local Levels**

To: Intrastate and Local Transportation Industry Companies

Shortages in transportation services have been reported from the following localities in the area where you furnish transportation services.

Summary of Local Deficiencies in Transportation Services								
Locality	Rail		Motor		Air		Water	
	Ton Mi.	Pass. Mi.	Ton Mi.	Pass. Mi.	Ton Mi.	Pass. Mi.	Ton Mi.	Pass. Mi.
Corpus Christi Metro. Area								
Aransas County Rural Area								
Etc.								

You are directed to adjust your services to correct the above deficiencies in services where, in your judgment, this can be done without creating unacceptable shortages in other localities in the area where you furnish transportation services.

Report to this office the increase in transportation service you can furnish to the above named communities.

\_\_\_\_\_  
(Date)

\_\_\_\_\_  
(Signature)  
State Transportation Coordinator  
State of Texas

## **Tran-6. Estimate of Continuing Transportation Services Requirements**

Form 1, attached to this emergency action document contains civil requirements movement data on transportation services which will be required in this State for a 90-day period commencing \_\_\_\_\_ (date).

The requirements stated include freight and passenger movements for which intrastate and local transportation industries will furnish movement services on authorized transportation requests from essential users and essential facilities.

Procedures for claims, allocations, and the furnishing of service arrangements are included in the emergency plans of the Federal transportation agencies.

The purpose of these State requirements-for-movement estimates is to determine and anticipate the ton miles and passenger miles of service needed from interstate transportation sources under Federal jurisdiction and to furnish transportation services to meet the shortages of intrastate and local transportation services.

### **Definitions:**

- a. **Civilian Requirements:** Include all needed movement to carry on emergency civil defense operations and to maintain essential local activities. These civilian requirements estimates are provided by appropriate civilian officials.
- b. **Military Requirements:** Include the movement requirements needed to carry on military activities and to maintain and operate military installations. These military movement estimates are provided by appropriate military officials.
- c. **Resource Support Requirements:** Include the transportation movement requirements needed to maintain operation of essential facilities under the cognizance of Federal and State resource organizations functioning in the State. These support resource movement requirements are provided by appropriate State resource organizations.

The steps to be taken in arriving at an estimate of continuing transportation movement requirements are as follows:

1. Locate the metropolitan areas within the State.
2. Measure the amount of products produced and consumed in each metropolitan area, in terms of weight and cube.
3. Determine the origin and destination of the traffic flow.
4. Measure the mileage by mode between the metro areas, using basing points located as near the center of traffic origin or destination in each area.
5. Determine ton mile and passenger mile movement requirements:
  - a. Inside each metro area;
  - b. Between metro areas inside the State;
  - c. Between origin and destination points into and out of the States; and
  - d. Between points in rural areas of the State.
6. Determine equipment needed.
7. Determine resources needed to support operations.

Following are the general categories of personnel and commodities to be included where appropriate. Other commodity breakdowns and classes may be employed so long as they are compatible with and convertible to these terms:

- a. **Passengers.** Persons to be moved, including totals of those moving as individuals and as groups.
- b. **General Cargo.** Any of the various goods and items hauled in usual lots or containers, such as boxes, crates, bales, bags, barrels, and which do not require special vehicle or vessel or special handling which would necessitate its being reported under one of the other categories.
- c. **Perishable Cargo.** That cargo requiring refrigeration or other temperature control or special protection from the elements to prevent deterioration or loss. Freeze cargo will be reported separately from chill cargo.
- d. **Explosives and Dangerous Cargo.** Those cargoes, such as ammunition and explosives, which, because of the hazards involved in their handling and shipment, require specialized and isolated loading and storage.
- e. **Bulk Dry Cargo.** Unpackaged dry grain, minerals, ores, and lumber which is to be loaded and transported in its "natural" bulk state. Edible products will not be grouped with inedible.
- f. **Bulk Liquid Cargo.** Petroleum products and other unpackaged liquids which are to be loaded and transported in bulk. Acids, chemicals, and other products requiring special care or conveyances should be separately listed. Edible oils and milk will be in separate listings from mineral products.
- g. **Uncreated Vehicles and Aircraft.** Any vehicle or aircraft processed for shipment without boxing or crating. Items above 35 short-tons will be separately reported or annotated.

(Continued on next page)



Trans-6 (Continued)

**h. Outsize Cargo.** That cargo which, because of its bulky size, weight, shape, or handling characteristics, requires special loading, bracing, and transport. Any items that exceed in any dimension 8' height, 8' width, 26' length, or 50,000 pounds in weight, or the loading requirements of standard vessels and craft.

Information which is not reportable under the above format, such as special routings or diversions and prospective abandonment, will be explained in footnotes or covering summary material.

**Tran-6, Form 1**

Summary Estimate of Continuing Transportation Movement Requirements  
by Modes for 90-Day Period Commencing \_\_\_\_\_ (date)

Categories of Service	Rail		Motor		Air		Water	
	P.M.	T.M.	P.M.	T.M.	P.M.	T.M.	P.M.	T.M.
Civilian 90 Days								
First 30 Days								
Following 60 Days								
Military 90 Days								
First 30 Days								
Following 60 Days								

**Tran-6, Form 2**

Summary Estimate of Transportation Movement Requirements  
by Areas for 90-Day Period Commencing \_\_\_\_\_ (date)

		Intrastate						Interstate					
		Metro Area #1		Metro Area #2		Rural		Imports		Exports		Total Outgoing	
From	To	P.M.	T.M.	P.M.	T.M.	P.M.	T.M.	P.M.	T.M.	P.M.	T.M.	P.M.	T.M.
Metro Area #1		1/	1/										
Metro Area #2				1/	1/								
Rural						2/	2/						
Imports								--	--	--	--		
Exports								--	--	--	--		
Total Incoming													

1/ Give movement total inside the Metro Area.

2/ Give movement total inside Rural Area.

**Tran-6, Form 3**

State of Texas  
Transportation Movements Requirements

Time Phase \_\_\_\_\_ Civil \_\_\_\_\_ Military \_\_\_\_\_ Date \_\_\_\_\_  
 Category of Passengers or Freight \_\_\_\_\_  
 Unit of Measure (Passenger Miles - Ton Miles) \_\_\_\_\_

		Intrastate			Interstate		
From \ To	Metro Area #1	Metro Area #2	Rural	Imports	Exports	Total Outgoing	
Metro Area #1	1/						
Metro Area #2		1/					
Rural			2/				
Imports				--	--		
Exports				--	--		
Total Incoming							

1/ Give movement total inside Metro Area.

2/ Give movement total inside Rural Area.

**Tran-7, Estimate of Continuing Interstate (Primary) Transportation Capability to Meet Transportation Service Requirements**

To: Appropriate Federal Transportation Agency State Office.

You are requested to submit estimates of transportation service capabilities which can be furnished by interstate transportation systems for continuing use in the State during the ensuing 90-day period.

Please submit such estimates by mode(s) in terms of ton miles for freight and cargo, and passenger miles for movement of persons.

\_\_\_\_\_  
(Date)

\_\_\_\_\_  
(Signature)

Coordinator of Transportation  
State of Texas

**Tran-7, Attachment 1**

**Background Information**

Governments at all levels must be prepared to determine the capability of the transportation system serving their particular jurisdiction and to assess any damage occurring to that system.

For local government, this might include bus services, local trucking, local automobiles, taxi fleets, etc. For a State, this might include intrastate bus, rail, air, and trucking lines, etc. For Federal Government, this must represent the capability of interstate (primary) transportation resources.

Such a task for any level of government involves the collection and analysis of significant amounts of data about transportation. To assist the States and local governments in the process of data collection, the Federal Government transport agency representatives in a State will provide factors which can be used to determine the capability of the transportation system. In most cases these factors will have to be adjusted to the local system before they can be utilized, because the Federally developed factors have been determined on the basis of national averages.

Capability analysis is defined as the procedure for determining the amount of transportation service which a system or area can feasibly produce on the basis of the available transportation equipment, facilities, travelways, manpower, and other resources. Generally speaking, the capability of a transportation vehicle (railway cars, aircraft, ships, trucks) is dependent upon the three major factors of load, speed, and utilization (time in motion). The capability of the system, simply stated, is the fleet average load, speed, and utilization (time in motion) multiplied by the number of vehicles in the fleet. It is normally expressed in terms of ton miles or passenger miles for some particular time period (hour, day, week, month, or year).

In addition to the three major factors that determine the capability of transport equipment, there

are several other factors that affect the productivity of transport equipment such as terminals, travelways, manpower, fuel, spare parts and other supplies, power, maintenance, and repair. In expressing the capability of a particular transportation system, it is not sufficient to state the number of tons or persons that can be carried over a given distance in a given time. Because the commodities carried vary significantly in their transport characteristics, special equipment has been developed for the carriage of these special commodities. For this reason the transportation service provided by a tank car cannot be equated with the service offered by a stock car or a freight car. This being the case, it is necessary for any capability analysis to include some breakdown of the transportation equipment into classes representing the general types of service provided by the equipment.

The steps to be taken in analysis of transportation capability follow:

1. Inventory the equipment, facilities, and travelways composing the system, and the manpower, fuel, and other resources needed to support the system;
2. Locate the inventory by geographical area of operation in accordance with metropolitan areas of the State and rural areas of the State;
3. Divide the equipment inventory into the general classes of usage.
4. Use peacetime rates of load, speed, and utilization to determine the system capability. Express the results in ton miles or passenger miles per time period for each class of equipment.
5. Determine the amounts of resources used or consumed in producing the amount of transportation service developed by the system.

**Tran-8, Estimate of Continuing Intrastate and Local Transportation Capability to Meet Transportation Service Requirements**

To: Intrastate and Local Transportation Industry Companies.

You are directed to submit information as to the service capability of your system, including equipment, fuel and maintenance situation, manpower situation, and condition of communications.

\_\_\_\_\_  
(Date)

\_\_\_\_\_  
Director of Appropriate Mode  
Division of the State  
Transportation Organization  
(i.e., Rail Transport Division,  
Motor Transport Division, Inland  
Water Transport Division, etc.)

Tran-8, Form 1

**State Transportation Organization  
Rail Transport**

**Evaluation Report Form**

- A. Date and Time: \_\_\_\_\_ Location: \_\_\_\_\_
- B. Operational Status: Good \_\_\_\_\_ Fair \_\_\_\_\_ Poor \_\_\_\_\_
- C. Available and Operational: **Rolling Stock**
1. Locomotives \_\_\_\_\_
  2. Freight Cars- Type and Capacity \_\_\_\_\_
  3. Passenger Cars- Type and Capacity \_\_\_\_\_
- D. Fuel and Maintenance Situation: (Quantity Available)
1. Diesel Fuel Supplies: Adequate \_\_\_\_\_ Inadequate \_\_\_\_\_
  2. Lubricant Supplies: Adequate \_\_\_\_\_ Inadequate \_\_\_\_\_
  3. Repair and Replacement Supplies: Adequate \_\_\_\_\_ Inadequate \_\_\_\_\_
  4. Miscellaneous Supplies: \_\_\_\_\_
- E. Manpower Situation: (Number Available)
1. Supervisors: Adequate \_\_\_\_\_ Inadequate \_\_\_\_\_ Surplus \_\_\_\_\_
  2. Engineers: Adequate \_\_\_\_\_ Inadequate \_\_\_\_\_ Surplus \_\_\_\_\_
  3. Mechanics: Adequate \_\_\_\_\_ Inadequate \_\_\_\_\_ Surplus \_\_\_\_\_
  4. Operating Personnel: Adequate \_\_\_\_\_ Inadequate \_\_\_\_\_ Surplus \_\_\_\_\_
- F. Communications: Good \_\_\_\_\_ Fair \_\_\_\_\_ Poor \_\_\_\_\_

State Transportation Organization  
Motor Transport

Evaluation Report Form

A. Date and Time: \_\_\_\_\_ Location: \_\_\_\_\_

B. Operational Status: Good \_\_\_\_\_ Fair \_\_\_\_\_ Poor \_\_\_\_\_  
Completely Out \_\_\_\_\_

C. Empty Vehicles Available and Operational:

1. Tractors - Type and Capacity \_\_\_\_\_

2. Trailers - Type and Capacity \_\_\_\_\_

3. Trucks - Type and Capacity \_\_\_\_\_

4. Refrigerators - Type and Capacity \_\_\_\_\_

D. Fuel and Maintenance Situation: (Quantity Available)

1. Diesel Fuel Supplies: Adequate \_\_\_\_\_ Inadequate \_\_\_\_\_

2. Gasoline Supplies: Adequate \_\_\_\_\_ Inadequate \_\_\_\_\_

3. Repair and Replacement Supplies: Adequate \_\_\_\_\_ Inadequate \_\_\_\_\_

4. Miscellaneous Supplies: \_\_\_\_\_

E. Manpower Situation: (Number Available)

1. Supervisors \_\_\_\_\_ Dispatchers \_\_\_\_\_

2. Drivers \_\_\_\_\_ Helpers \_\_\_\_\_

3. Mechanics \_\_\_\_\_ Helpers \_\_\_\_\_

4. Operating Personnel for Assembly Area \_\_\_\_\_

F. Communication Ability: Good \_\_\_\_\_ Fair \_\_\_\_\_ Poor \_\_\_\_\_  
Completely Out \_\_\_\_\_

G. Immediate Needs for Continued Operation: 1/

H. Loaded Vehicles and Contents Held for Disposition: 1/

1. Food for Humans \_\_\_\_\_ Perishables \_\_\_\_\_  
Food for Animals \_\_\_\_\_

2. Medicines \_\_\_\_\_ Related Commodities \_\_\_\_\_

3. Clothing \_\_\_\_\_ Related Commodities \_\_\_\_\_

4. Miscellaneous Commodities \_\_\_\_\_

I. General Remarks on Overall Situation:

1/ Designate trucks by symbol "T" and tractor-trailer by symbol "TT."

State Transportation Organization  
Inland Water Transport

Evaluation Report Form

- A. Date and Time: \_\_\_\_\_ Location: \_\_\_\_\_
- B. Operational Status: Good \_\_\_\_\_ Fair \_\_\_\_\_ Poor \_\_\_\_\_
- C. Empty Units Available and Operational:
1. Tug and Tow Boats- Horsepower \_\_\_\_\_
  2. Dumb Barges- Type and Capacity \_\_\_\_\_
  3. S. P. Tank Vessels- Capacity \_\_\_\_\_
  4. S. P. Dry Cargo Vessels- Capacity \_\_\_\_\_
- D. Fuel and Maintenance Situation: (Quantity Available)
1. Diesel Fuel Supplies: Adequate \_\_\_\_\_ Inadequate \_\_\_\_\_
  2. Lubricant Supplies: Adequate \_\_\_\_\_ Inadequate \_\_\_\_\_
  3. Repair and Replacement Supplies: Adequate \_\_\_\_\_ Inadequate \_\_\_\_\_
  4. Miscellaneous Supplies: \_\_\_\_\_
- E. Manpower Situation: (Number Available)
1. Master and Mates: Adequate \_\_\_\_\_ Inadequate \_\_\_\_\_ Surplus \_\_\_\_\_
  2. Marine Engineers: Adequate \_\_\_\_\_ Inadequate \_\_\_\_\_ Surplus \_\_\_\_\_
  3. Deck Personnel (Unlicensed): Adequate \_\_\_\_\_ Inadequate \_\_\_\_\_ Surplus \_\_\_\_\_
  4. Engine Personnel (Unlicensed): Adequate \_\_\_\_\_ Inadequate \_\_\_\_\_ Surplus \_\_\_\_\_
  5. Operating Personnel for Assembly Area: Adequate \_\_\_\_\_ Inadequate \_\_\_\_\_ Surplus \_\_\_\_\_
  6. Terminal Personnel: Adequate \_\_\_\_\_ Inadequate \_\_\_\_\_ Surplus \_\_\_\_\_
  7. Others: Adequate \_\_\_\_\_ Inadequate \_\_\_\_\_ Surplus \_\_\_\_\_
- F. Communications: Good \_\_\_\_\_ Fair \_\_\_\_\_ Poor \_\_\_\_\_

State Transportation Organization  
Air Transport

Evaluation Report Form

- A. Date and Time: \_\_\_\_\_ Location: \_\_\_\_\_
- B. Operational Status: Good \_\_\_\_\_ Fair \_\_\_\_\_ Poor \_\_\_\_\_
- C. Available and Operational: **Aircraft- Under 12,500 pounds**
1. Single Engine- 1 and 2 place \_\_\_\_\_, 3 to 5 place \_\_\_\_\_, 6 places or over \_\_\_\_\_.
  2. Twin Engine- 1 and 2 place \_\_\_\_\_, 3 to 5 place \_\_\_\_\_, 5 to 8 place \_\_\_\_\_.
- D. Available and Operational: **Aircraft- Over 12,500 pounds (List)**
1. Type \_\_\_\_\_ Number of Engines \_\_\_\_\_ Type of Engine (Propeller, Turbo, Jet), Passenger Capacity \_\_\_\_\_, Cargo Capacity \_\_\_\_\_ lb.
- E. Available and Operational: **Aircraft- Rotary Wing**
1. Type \_\_\_\_\_, Passenger Capacity \_\_\_\_\_, Cargo Capacity \_\_\_\_\_ lb.
  2. Type \_\_\_\_\_, Passenger Capacity \_\_\_\_\_, Cargo Capacity \_\_\_\_\_ lb.
- F. Fuel and Maintenance Situation: (Quantity Available)
1. Aviation Gasoline: Adequate \_\_\_\_\_, Inadequate \_\_\_\_\_.
  2. Jet Fuel: Adequate \_\_\_\_\_, Inadequate \_\_\_\_\_.
  3. Lubricants: Adequate \_\_\_\_\_, Inadequate \_\_\_\_\_.
  4. Repair and Replacement Parts: Adequate \_\_\_\_\_, Inadequate \_\_\_\_\_.
  5. Miscellaneous Other Supplies: (Detail)
- G. Manpower Situation: (Number Available)
1. Flight Operations:
    - a. Pilots: Adequate \_\_\_\_\_, Inadequate \_\_\_\_\_, Surplus \_\_\_\_\_.
    - b. Co-Pilots: Adequate \_\_\_\_\_, Inadequate \_\_\_\_\_, Surplus \_\_\_\_\_.
    - c. Flight Engineer Adequate \_\_\_\_\_, Inadequate \_\_\_\_\_, Surplus \_\_\_\_\_.
    - d. Navigator: Adequate \_\_\_\_\_, Inadequate \_\_\_\_\_, Surplus \_\_\_\_\_.
    - e. Steward(ess): Adequate \_\_\_\_\_, Inadequate \_\_\_\_\_, Surplus \_\_\_\_\_.
  2. Ground Operations:
    - a. Dispatcher (Passenger): Adequate \_\_\_\_\_, Inadequate \_\_\_\_\_, Surplus \_\_\_\_\_.
    - b. Dispatcher (Freight): Adequate \_\_\_\_\_, Inadequate \_\_\_\_\_, Surplus \_\_\_\_\_.
    - c. Aircraft Ground Maintenance: Adequate \_\_\_\_\_, Inadequate \_\_\_\_\_, Surplus \_\_\_\_\_.
    - d. Mechanics- A & E License: Adequate \_\_\_\_\_, Inadequate \_\_\_\_\_, Surplus \_\_\_\_\_.
    - e. Mechanics- General: Adequate \_\_\_\_\_, Inadequate \_\_\_\_\_, Surplus \_\_\_\_\_.
    - f. Miscellaneous Operating Personnel: Adequate \_\_\_\_\_, Inadequate \_\_\_\_\_, Surplus \_\_\_\_\_.
- H. Communications (Including Tower and GCA):  
Good \_\_\_\_\_, Fair \_\_\_\_\_, Poor \_\_\_\_\_
1. Personnel: Adequate \_\_\_\_\_, Inadequate \_\_\_\_\_, Surplus \_\_\_\_\_.
- I. Remarks:

State Transportation Organization  
Ports and Ocean Shipping

Evaluation Report Form

- A. Date and Time: \_\_\_\_\_ Location: \_\_\_\_\_
- B. Operational Status: Good: \_\_\_\_\_ Fair: \_\_\_\_\_ Poor: \_\_\_\_\_
- C. Empty Units Available and Operational:  
(List by Type and Capacity)
- D. Tug and Tow Boats - (Horsepower)
- E. Port Facilities:
1. Warehouses:  
(List by Type and Capacity)
  2. Wharf and Apron Space:
  3. Dry Cargo Docks:
  4. Dry Cargo Loading Facilities:
  5. Deep Sea Oil Docks:
  6. Oil Loading Facilities:
  7. Basin Capacity:
  8. General Facilities:
- F. Fuel and Maintenance Situation: (Quantity Available)
1. Diesel Fuel Supplies: Adequate \_\_\_\_\_ Inadequate \_\_\_\_\_
  2. Lubricant Supplies: Adequate \_\_\_\_\_ Inadequate \_\_\_\_\_
  3. Repair and Replacement Supplies: Adequate \_\_\_\_\_ Inadequate \_\_\_\_\_
  4. Miscellaneous Supplies:
- G. Manpower Situation (Number Available)
1. Master and Mates: Adequate \_\_\_\_\_ Inadequate \_\_\_\_\_ Surplus \_\_\_\_\_
  2. Marine Engineers: Adequate \_\_\_\_\_ Inadequate \_\_\_\_\_ Surplus \_\_\_\_\_
  3. Deck Personnel (Unlicensed): Adequate \_\_\_\_\_ Inadequate \_\_\_\_\_ Surplus \_\_\_\_\_
  4. Engine Personnel (Unlicensed): Adequate \_\_\_\_\_ Inadequate \_\_\_\_\_ Surplus \_\_\_\_\_
  5. Operating Personnel for Assembly Area: Adequate \_\_\_\_\_ Inadequate \_\_\_\_\_ Surplus \_\_\_\_\_
  6. Terminal Personnel: Adequate \_\_\_\_\_ Inadequate \_\_\_\_\_ Surplus \_\_\_\_\_
  7. Others: Adequate \_\_\_\_\_ Inadequate \_\_\_\_\_ Surplus \_\_\_\_\_
- H. Communications: Good: \_\_\_\_\_ Fair: \_\_\_\_\_ Poor: \_\_\_\_\_
- I. Immediate Needs for Continued Operations:
- J. General Remarks on Overall Situation:

**State Transportation Organization  
Warehouse and Public Storage**

**Evaluation Report Form**

- A. Date and Time: \_\_\_\_\_ Location: \_\_\_\_\_
- B. Operational Status: Good: \_\_\_\_\_ Fair: \_\_\_\_\_ Poor: \_\_\_\_\_  
Completely Out: \_\_\_\_\_
- C. Empty Warehouses Available and Operational:  
(List by Type and Capacity and Location)  
(Fireproof, refrigerated, grain, dry, liquid, etc.)
- D. Loading Equipment:
- E. Transfer Equipment:
- F. Fuel and Maintenance Situation: (Quantity Available)
1. Diesel Fuel Supplies: Adequate \_\_\_\_\_ Inadequate \_\_\_\_\_
  2. Gasoline Supplies: Adequate \_\_\_\_\_ Inadequate \_\_\_\_\_
  3. Repair and Replacement Supplies: Adequate \_\_\_\_\_ Inadequate \_\_\_\_\_
  4. Miscellaneous Supplies: \_\_\_\_\_
- G. Manpower Situation: (Number Available)
1. Supervisors \_\_\_\_\_ Dispatchers \_\_\_\_\_
  2. Crain Operators \_\_\_\_\_ Helpers \_\_\_\_\_
  3. Drivers \_\_\_\_\_ Helpers \_\_\_\_\_
  4. Cargo Loading Operators \_\_\_\_\_ Helpers \_\_\_\_\_
  5. Mechanics \_\_\_\_\_ Helpers \_\_\_\_\_
  6. Warehousemen \_\_\_\_\_
- H. Communications: Good: \_\_\_\_\_ Fair: \_\_\_\_\_ Poor: \_\_\_\_\_  
Completely Out: \_\_\_\_\_
- I. Immediate Needs for Continued Operation:
- J. Storage Held for Disposition:
1. Food for Humans \_\_\_\_\_ Perishables \_\_\_\_\_  
Food for Animals \_\_\_\_\_
  2. Medicines \_\_\_\_\_ Related Commodities \_\_\_\_\_
  3. Clothing \_\_\_\_\_ Related Commodities \_\_\_\_\_
  4. Miscellaneous Commodities \_\_\_\_\_
- K. General Remarks on Situation:

**Tran-9, Allocation of Transportation Services**

Allocation of Transportation Movement Services by Mode for 90-Day Period Commencing _____ (date)								
Categories of Service	Rail		Motor		Air		Water	
	P.M.	T.M.	P.M.	T.M.	P.M.	T.M.	P.M.	T.M.
Civilian 90 Days								
First 30 Days								
Following 60 Days								
Military 90 Days								
First 30 Days								
Following 60 Days								

(Note: Develop detailed allocation as appropriate.)



**Tran-10, Revised State Transportation Policies**

(Note: The content and substance of the Revised State Transportation Policy will depend on the situation and the transportation services expected to be available to meet continuing essential movement requirement needs. Necessarily, this document will not be completed except in a test of the plan or at the appropriate point in a postattack situation.)

This document will be in essence a Revised Tran-1, **State Transportation Policy and Guidance**, contained here.

**Tran-11, Transportation Industry Support Requirements**

Estimate of Transportation Industry Support Requirements for 90-Day Period Commencing _____ (date)				
Resource	Unit of Measure	First 30 Days	Following 60 Days	Total 90 Days
Manpower				
Fuel				
Spare Parts				
Other Supplies				
Power				
Miscellaneous				

**Tran-12, Transportation Industry Construction Requirements**

To: State Construction Organization

Following is a list and description of major construction, repair, and modification of facilities that will be required to maintain necessary transportation services during the 90-day period commencing \_\_\_\_\_ (date).

**Transportation Construction Projects**

1. Name, location, type, and size of construction project; start and completion dates.  
(If project is underway, or a construction contract has been prepared, attach a copy of the contract document and summary bill of materials.)
- 2.
- 3.
- 4.

**Tran-13, Allocation of Supporting Resources to Interstate (Primary) Transportation Industry**

To: Appropriate Federal Transportation Agency State Office

Attached is a list and the quantities of supporting resources that have been allocated for maintaining essential interstate transportation operations.

This is furnished as a basis for authorizing interstate transportation companies and their facilities to obtain, on a continuing basis, equipment, services, supplies, and materials from these resources during the allocation period.

(Attach list.)

\_\_\_\_\_  
(Date)

\_\_\_\_\_  
(Signature)

State Transportation Coordinator  
State of Texas

**Tran-14, Authorization to Major Transportation Carriers and Facilities to Obtain Supporting Resources**

To: Transportation Industry Companies and Their Facilities.

You are hereby authorized to obtain the supporting resources for your operations in the quantities specified in the attached list.

Resource	Unit of Measure	First 30 Days	Following 60 Days	Total
Petroleum Products				
Electric Power				
Manpower				
Etc.				

In placing orders for the above supporting resources, you are authorized to use either the applicable Federal certification or the following certification:

"This is an essential order authorized by  
the State Transportation Coordinator.

\_\_\_\_\_  
(Signed)  
Purchaser

\_\_\_\_\_  
(Signed)  
State Transportation Coordinator

**Tran-15, Activation of the State and Regional Defense Airlift Plan (SARDA)**

To: Owners and Operators of Nonair Carrier Aircraft Registered in the State of Texas

Notice is hereby given by the undersigned that pursuant to the authority vested in the State Transportation Organization, Aviation Division, by the Governor of this State to make most effective use of nonair carrier aircraft within the State and to meet the needs of the State for essential aviation services during the present emergency, all nonair carrier aircraft are herein mobilized for use until further notice.

All nonair carrier aircraft owners and operators will report to the \_\_\_\_\_  
(address of General Aviation

\_\_\_\_\_  
District Office, State, Area, or local controlling office as indicated by FAA or State)

\_\_\_\_\_ by the fastest means of communication, including: the present location of their aircraft, its permanent home base, availability of flight and maintenance crews, and the state of readiness of the aircraft for use.

All civil airmen not assigned to aviation services in support of Federally designated and controlled air operations (CRAF, WASP) will report to the \_\_\_\_\_

(address of GADO, State, Area, or local  
\_\_\_\_\_ by the fastest means of com-

\_\_\_\_\_ controlling office indicated by FAA or State)  
munications, including: name, airman certificate, ratings, current qualifications, present location and availability for immediate duty.

\_\_\_\_\_  
Director, Aviation Division

ANNEX C  
 (Reference Documents)  
 To  
 SECTION IX  
 (Transportation)

formation to complete those appendices of this annex which are lacking in detail will be compiled and incorporated herein when reporting operational plans are developed by regions, districts, counties and cities.

Additionally, it is proposed that this material will supplement the transportation equipment and facilities information on file with local, district, regional and State Civil Defense headquarters but will not duplicate that information.

APPENDIX 1 TO ANNEX C  
 (Reference Documents)  
 To  
 SECTION IX  
 (Transportation)  
 ESSENTIAL TRANSPORTATION INSTALLATIONS

Terminals, Passenger Arrival and Departure, Freight Loading and Unloading, by modes.

TRANSPORTATION SERVICE AVAILABILITY  
 IN SELECTED TEXAS COMMUNITIES, 1976\*

Population of Community	Number of Communities with					
	Number of communities	Air service	Intercity bus service	Motor freight service	Rail freight service	Rail passenger service
0-999.....	31	-	16	29	10	-
1,000 - 2,499.....	64	-	46	64	34	1
2,500 - 4,999.....	72	-	66	72	61	-
5,000 - 9,999.....	62	-	62	62	57	3
10,000 - 49,999.....	61	14	61	61	60	8
50,000 and up.....	21	21	21	21	21	8
Total.....	311	35	272	309	243	20

\* Includes the largest community in each of Texas' 254 counties, all county seats and six other selected significant cities.

Source: Compiled from Charles P. Zlatkovich, Texas Transportation Handbook (Austin: The University of Texas at Austin, Bureau of Business Research, 1976).

## RAILROADS IN TEXAS

1977

Railroads operating in Texas and the initials used to designate them are:

A & S	Abilene and Southern
A & NR	Angelina and Neches River
AT & SF	Atchison, Topeka and Santa Fe Railway Company
BRR	Belton Railroad
CRI & P	Chicago, Rock Island and Pacific
FW & D	Fort Worth and Denver
GH & H	Galveston, Houston and Henderson
GRR	Georgetown Railroad
KCS	Kansas City Southern
NKT	Missouri-Kansas-Texas
MP	Missouri Pacific
MC & SA	Moscow, Camden and San Augustine
PVS	Pecos Valley Southern
PC & N	Point Comfort and Northern
QA & P	Quanah, Acme and Pacific
RS & S	Rockdale, Sandow and Southern
RS & P	Roscoe, Snyder and Pacific
SLSF	St. Louis-San Francisco Railway Company
SLSW	St. Louis Southwestern
SP	Southern Pacific
TC	Texas Central
TM	Texas Mexican
TNM	Texas-New Mexico
T & N	Texas and Northern
TSE	Texas South-Eastern
WMW & NW	Weatherford, Mineral Wells and Northwestern

Source: Texas Almanac - 1978-1979

Of the 42 railroad properties in Texas, 17 were directly controlled by 10 major systems, 15 were unaffiliated and 10 were terminal companies. The major systems control 12,843 miles of mainline track, and the unaffiliated companies 460 miles. On January 1, 1974, track mileage owned by railroads in Texas was:

	Main Line	Switching	Other Track	Total Miles
Burlington.....	997	234	89	1,320
Frisco.....	201	80	21	302
Kansas City Southern.....	256	79	32	367
Katy.....	736	293	90	1,119
Missouri Pacific.....	1,786	568	205	2,559
Rock Island.....	623	193	66	882
*Texas and Pacific.....	1,160	345	212	1,717
Santa Fe.....	3,496	976	539	5,011
Southern Pacific.....	3,064	925	262	4,251
**Cotton Belt.....	524	109	54	687
Unaffiliated.....	460	151	22	633
Terminal.....	0	0	286	286
Total.....	13,303	3,953	1,878	19,134

\* Missouri Pacific affiliate  
 \*\* Southern Pacific affiliate

Source: Texas Almanac - 1976-1977

AIR TRANSPORTATION  
TEXAS ENPLANED TRAFFIC (1975)

Source: Texas Almanac - 1978-1979

<u>City</u>	<u>Aircraft Departures</u>	<u>Enplaned Passengers</u>	<u>Air Mail (Tons)</u>	<u>Cargo (Tons)</u>
<b>DOMESTIC</b>				
Abilene.....	1,592	27,378	29.59	29.59
Amarillo.....	6,558	212,777	368.61	684.55
Austin.....	8,757	370,701	1,277.42	1,277.42
Beaumont-Port Arthur.....	2,503	28,403	36.42	132.34
Brownsville-Harlingen-San Benito.....	2,104	95,340	17.02	957.09
Brownwood.....	734	3,436	.67	17.78
Corpus Christi.....	4,724	185,387	448.49	428.64
Dallas-Fort Worth.....	135,769	7,148,549	35,843.56	71,267.11
El Paso.....	13,622	553,501	1,526.66	6,329.11
Houston.....	55,280	2,884,613	12,924.82	39,512.83
Laredo.....	496	13,269	10.26	179.59
Longview-Kilgore-Gladewater.....	1,171	7,430	3.14	34.19
Lubbock.....	8,464	242,199	230.43	760.58
Lufkin.....	88	293	1.06	1.07
Midland-Odessa.....	7,788	241,306	521.48	1,104.73
Mission-McAllen-Edinburg.....	1,405	49,357	.38	312.14
Paris.....	626	1,758	---	32.57
San Angelo.....	822	20,246	.82	64.01
San Antonio.....	18,852	776,386	3,719.60	4,225.24
Temple.....	530	3,856	.19	135.30
Tyler.....	1,032	5,489	13.49	25.99
Waco.....	1,556	13,115	12.55	49.37
Wichita Falls.....	1,541	33,920	32.89	149.97
<b>INTERNATIONAL</b>				
Dallas-Fort Worth.....	2,019	147,701	371.55	1,521.23
Houston.....	782	54,197	34.24	977.40
San Antonio.....	1,092	62,350	193.43	277.58

FOREIGN AND DOMESTIC COMMERCE THROUGH TEXAS PORTS

CALENDAR YEAR 1975

	Total	Foreign		Coastwise		Domestic		Local
		Imports	Exports	Receipts	Shipments	Receipts	Shipments	
Sabine Pass.....	513,062	250	---	---	---	196,936	315,876	-
Orange.....	912,014	466	88,363	220	644	676,644	145,677	-
Beaumont.....	30,582,512	6,037,838	3,960,929	946,915	9,760,291	5,135,823	4,552,245	188,000
Port Arthur.....	26,597,557	8,179,138	2,158,450	2,158,450	7,300,120	1,326,447	4,831,703	11,000
Houston.....	83,674,039	18,273,391	18,000,891	3,315,300	19,541,554	10,994,880	9,838,437	3,709,500
Texas City.....	23,863,770	5,662,641	531,599	405,937	7,066,350	5,402,574	4,763,060	31,600
Galveston.....	5,971,160	854,359	3,091,981	59,694	1,157,845	338,074	468,831	-
Freeport.....	8,194,136	3,142,026	971,229	263,614	1,105,425	1,737,863	863,735	110,100
Corpus Christi.....	35,487,454	13,038,122	5,195,591	201,992	11,923,449	1,393,438	3,081,333	653,500
Port Isabel	255,938	1,035	566	---	---	24,738	229,599	-
Brownsville	2,829,009	1,146,137	492,602	4,420	19,446	550,999	615,405	-
Port Aransas (Harbor Island).....	6,348,824	2,722,142	3	28,319	866,469	578,890	2,153,001	-
Port Mansfield.....	29,438	---	---	---	---	---	---	-
TOTAL	225,258,913	59,057,545	34,492,274	8,017,033	58,741,593	28,357,306	31,858,902	4,704,800

APPENDIX 2 TO ANNEX C  
INTERSTATE COMMERCE COMMISSION TRANSPORT MOBILIZATION ORDERS

1. "Preference and Priority for Transportation by Carriers-For-Hire of U. S. Military Personnel, Accredited Civil Defense Personnel, Accredited Civil Defense Workers and United States Mail."
2. "Rail Freight Embargo-Appoint of Permit Agent."
3. "Motor Freight Embargo."
4. "Inland Waterways Freight Embargo."
5. "Disposal by Carriers of Undeliverable Shipments."
6. "Control of Railroad Tank Cars."
7. "Rerouting of Rail Traffic."
8. "Direction to Certain Over-the-Road Motor Carriers of Property Regarding Routes, Diversions and Services to Certain Destinations."
9. "Direction to Certain Intercity Common Carriers of Persons by Bus to Serve Certain Points."
10. "Control of Motor Transport Vehicles."
11. "Control of Freight Shipments to or Within Port or Storage Areas."
12. "Inventory and Disposition of Shipments of Food and Medical Supplies Requisitioned by Government in Possession of Railroads and Motor Carriers."
13. "Control of Liquid Transport Vessels."

APPENDIX 3 TO ANNEX C  
EMERGENCY HIGHWAY TRAFFIC  
REGULATION AND CONTROL  
FOR THE STATE OF TEXAS

al:

lear attack on this country or implementation of crisis relocation would create traffic problems which could be alleviated most tively by a workable traffic regulation plan.

ation can be described as the system of traffic management which facilitates the orderly flow of traffic under any emergency tion, including the evacuation and relocation of portions of the population, directed movement through dangerous areas, and the ation and control of priority traffic over routes of limited capacity.

urpose of highway traffic regulation is to plan, schedule, route and direct the actual use of highways in order to adequately the needs of the emergency.

riority:

Disaster Plan for the State of Texas outlines the responsibilities of the State Department of Highways and Public Transportation PT) within Engineering Services. The State Engineer-Director has been appointed State Chief of the engineering services organization which is composed of professional personnel of the SDHPT and other State agencies, public utilities, contractors in the field onstruction and maintenance, the professional engineering organizations, and the State engineering schools.

State of Texas is divided into seventeen (17) disaster districts which parallel the Highway Patrol districts as created by the rtement of Public Safety (DPS). The chief engineer of each of the disaster districts is the SDHPT District Engineer. The chief neer of each disaster district will select his staff and organize the staff similar to the State engineering services organization.

primary civil defense responsibilities of the SDHPT are the maintenance of existing highway facilities, construction of new ities as needed, radiological monitoring of the highway system, installing signs and barricades where needed, providing traffic rol stations, maintaining two-way radio communications along priority routes, debris clearance, demolition of dangerous structures tanding, coordinating of repair operations to the State's rail, road, airport and waterway transportation facilities, and ishing engineering assistance to other civil defense services upon request.

nization:

State Traffic Control Center:

This central State supervisory organization will be established in Austin and will operate from the DPS position in the State Emergency Operating Center. An alternate location will be designated in the event evacuation of Austin becomes necessary. The State traffic control center will be staffed by representatives from the SDHPT, as determined by the chief of engineering services, in cooperation with representatives of the DPS. This organization will direct and supervise State-wide traffic control and will cooperate with adjacent states and the Bureau of Public Roads on interstate traffic regulation problems.

District Traffic Regulation Center:

At each of the seventeen (17) disaster districts of the State of Texas a district traffic regulation center will be established. Its function will be to coordinate and supervise the highway transportation network within the disaster district and to work with and assist the State traffic control center. Personnel from the SDHPT and DPS within the disaster district will staff the district traffic regulation center.

District Traffic Regulation Sector:

The district traffic regulation center will establish these sectors and will supervise their operations. The district traffic regulation sectors will operate in and control a particular area, receiving instructions from and relaying information to the district traffic regulation center. The district sector may be composed of one or more counties with county law enforcement personnel assisting the staff.

#### 4. District Traffic Regulation Post:

Regulation posts are the basic groups located along highway routes at strategic points to provide information to highway users and to control and expedite the movement of traffic. The posts are subordinate to the district traffic regulation sector and provide such information as highway conditions, traffic movements and the presence of radiological fallout to higher authority.

#### 5. Metropolitan Traffic Regulation Sector:

The larger cities will be classified as metropolitan sectors and will regulate and control the movement of traffic through and within the city. This group should be staffed by personnel from the city's traffic and police departments and will coordinate operations with the district traffic regulation center.

#### 6. Metropolitan Traffic Regulation Post:

These metropolitan traffic posts will be established by and will be subordinate to the metropolitan traffic regulation sector, and will function within the limits of the city as the primary or basic groups located along evacuation or priority routes and at critical intersections.

The Texas highway traffic regulation suggested organization is shown in Attachment 1.

#### Scope:

The highway traffic regulations herein described will become effective upon direction of the chief of engineering services, or in the absence of specific instructions, immediately upon occurrence of a national emergency as a result of enemy attack or crisis relocation.

The implementation of this traffic regulation plan will be exercised on routes only where and so long as traffic demands exceed highway capacity and in restricted areas on routes where and so long as highway users must be protected from exposure to radiological or other hazards resulting from the use of modern weapons.

Interstate problems will normally be resolved by cooperative action of highway traffic regulation centers of adjoining states at either district or State level. Special problems which cannot be so resolved will be referred to the Bureau of Public Roads for action.

Military installations and areas will coordinate operations with the State traffic control center and district traffic regulation centers. Liaison will normally be effected by the staff transportation officer of the military field commander. Military Standing Operating Procedures for Highway Traffic Regulation are outlined in Attachment 2.

Military assistance to civil authorities in a civil defense emergency will be rendered by the military departments and agencies of the Department of Defense when such assistance is requested or directed in accordance with Public Law 920, 81st Congress, and Executive Order 10346, April 10, 1952.

#### Procedures:

##### A. Inventory of Highway Network:

1. The extent of highway damage and radioactive fallout should be determined as soon as possible after a nuclear attack in order to identify and evaluate the availability and capacity of the remaining highway network. State situation maps will be prepared at the State traffic control center showing damage to the highway

facility and radiation intensity on the principal highway routes in the State. Also, district traffic regulation centers and sectors will prepare situation maps indicating damage and radiation intensity on highway routes within their areas. Radiation points on these routes will be identified as follows:

- H plus 1 - 100 roentgens/hr.  
(safe for travel at D plus 1)
- H plus 1 - 375 roentgens/hr.  
(safe for travel at D plus 30)
- H plus 1 - 750 roentgens/hr.  
(safe for travel at D plus 90)

##### B. Selection and Regulation of Priority Routes:

1. Each district will determine highway capacity and tonnage capability for the available highway network within its jurisdiction and this information will be furnished to the State traffic control center where State-wide priority routes will be established. Alternate priority routes will be determined by the need for restoration and maintenance operations.
2. Periodic traffic counts will be made on the priority routes to determine whether the traffic volume is approaching capacity of the route. As capacity is reached, measures should be implemented to insure the movement of essential traffic. If such counts show that the traffic is not being effectively distributed over the 24-hour day, the need for corrective action should be brought to the attention of the groups utilizing these routes.
3. Route information for highways limited to essential movements of specific users and for highways in restricted areas will be disseminated to the highway users through the traffic regulation posts and other media including automobile associations, oil companies, press, radio, television and periodic condition maps.

##### C. Traffic Regulation:

1. Standard traffic regulation measures used in peacetime will continue to be used in periods of emergency. Of necessity, certain modifications will have to be made and the requirement for enforcement will be greater than normal.
2. Signing of routes through restricted and unrestricted areas will be in accordance with the Manual of Uniform Traffic Control Devices and the Bureau of Public Roads special sign standards for the emergency regulation of traffic.
3. Maximum speeds will be prescribed in keeping with the local highway conditions and the development of maximum highway capacity. In some cases, minimum speeds will be prescribed for radiological areas to reduce the radiation dosage to the driver and other occupants of the vehicle and to develop maximum capacity.
4. The type of movement generally will be unscheduled except on routes so congested that only essential priority traffic can move. When convoy movements and special movements of high security cargo must be introduced into the traffic stream they will be scheduled at appropriate intervals to insure they have a minimum effect on the capacity of the route.



5. When movement over a route must be limited to priority traffic special control of vehicles will be necessary. Road space will be allocated to using agencies within priorities established by emergency transportation agencies but care must be exercised to insure that capacity is not wasted. Users will normally retain responsibility for assigning priorities within their groups and will accomplish dispatching as necessary. Permits will be issued on basis of mission of the vehicle on a particular trip and not on the basis of ownership or general usage. Since convoys reduce the possible capacity of a route their use will be discouraged. Where convoys are necessary they should not exceed 15 vehicles in a single element. For adequate control and operation 4 to 8 vehicles are preferable.
6. Close coordination between SDHPT and the State and local police agencies will be maintained to insure the necessary patrol of routes, wrecker and escort service, direction of traffic and the required enforcement giving due regard to limitations in such activities because of radiation and other unusual hazards.
7. Where traffic must move in or through contaminated areas State or district highway traffic regulation centers will select a minimum number of routes. Traffic will be carefully regulated on these routes. All other routes will be denied to traffic and will be posted and/or barricaded. The basic criteria in operating routes through radiologically contaminated restricted areas is that people in transit should be exposed to no more than an average of 0.4 roentgens per day over the first year. Highway traffic regulation post personnel stationed at the edge of restricted areas will inform vehicle occupants of the radiological dosage they will accumulate in transit. They will also arrange for prompt evacuation of any stranded motorists.
8. Highway traffic regulation posts will be located at strategic locations on the networks in areas safe from radiological or other unusual hazards. Personnel at these posts will permit the passage of authorized traffic only, will check and report on status of movements and will request instructions from the appropriate highway traffic regulation center for diversion of movements when congestion develops. Once the daily schedules for road space have been established it is the responsibility of the post personnel to see that the schedules are strictly followed by the using groups.
9. Procedures for selection and operation of highway traffic regulation posts will be developed jointly by the SDHPT and DPS.

#### D. Cargo Protection:

1. Security of classified or high-priority movements will be provided upon request by State and local police when such security cannot be provided by shippers or carriers. While the highway traffic regulation centers will not have a direct responsibility in this respect, any plan of highway traffic regulation must make allowance for the necessary protective measures.

2. Liaison with respect to such matters should be maintained by the highway traffic regulation centers with the users and the local and State police agencies who will provide the necessary police protection.
3. Adequate protection normally can be most efficiently obtained by the use of convoys. Such convoys must have priority of movement and be carefully checked through highway traffic regulation posts.
4. Suitable measures must be taken for adequate protection and security of explosive and/or flammable materials. Standard procedures now in force should be followed when applicable or can be modified to fit the local conditions or new requirements.

#### E. Size and Weight Restrictions:

1. Vehicle movements on the routes of the several road systems should not exceed the ability of the routes to provide for sustained movement of traffic. Due consideration must be given to structural capacity, maintenance capabilities, frequency of movement of heavy axle or gross loads and/or oversized loads and traffic volumes of such magnitude that the capacity would be seriously restricted by slow moving vehicles. In many cases roads having structures of limited load capacity can be made available for carrying necessary traffic by strengthening the structures either by temporary or permanent means.
2. The issuance of special permits for oversized and/or overweight vehicles is a function of the SDHPT. Except when there is an overriding civilian or military necessity permits should be issued only where it is impracticable to transport the material on vehicles within the established weight limitations and the frequency of such loads will not result in damage to the highway facilities or result in excessive maintenance. Movements of oversized vehicles under special permit should have traffic escort where needed to provide for safety of movement and to prevent traffic congestion.
3. Enforcement activities relating to compliance of traffic to the size and weight limitations are accomplished by the State and local police agencies. These activities should be coordinated as necessary by the State and district highway traffic regulation centers to assure the most efficient movement of essential vehicular traffic.

**TEXAS HIGHWAY TRAFFIC REGULATION SUGGESTED ORGANIZATION**

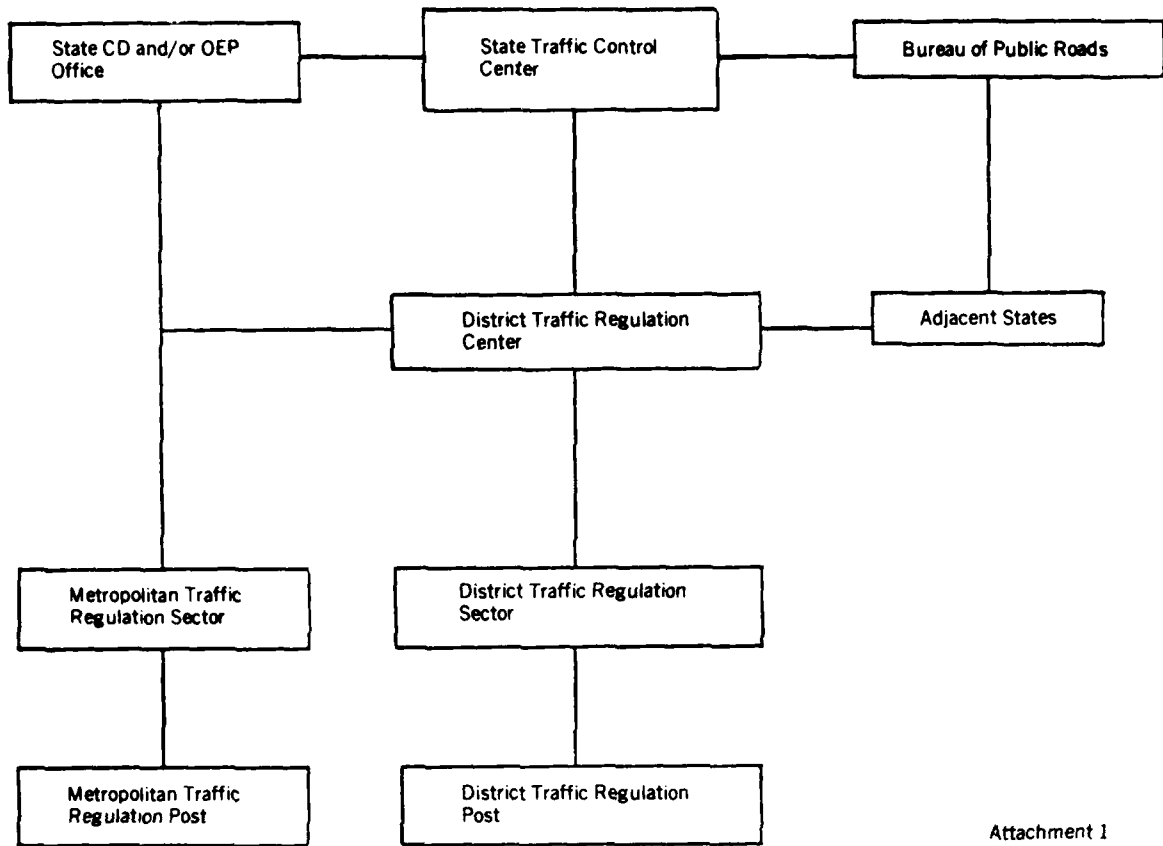

Attachment 1

Attachment 2

**STANDING OPERATING PROCEDURES  
FOR HIGHWAY TRAFFIC REGULATION  
SUMMARY STATEMENT ON HIGHWAY  
TRAFFIC REGULATIONS, ARMY**

- I. General. There will be organized within the field army, corps, division and within other major commands having area jurisdiction, an operating agency, or headquarters, for the purpose of coordinating and regulating the movement of vehicles and other traffic over roadways. The organization will be known as the Highway Traffic Headquarters.
- II. Mission. The mission of the Highway Traffic Headquarters is to plan, schedule, route, and direct the actual use of highways by vehicles, personnel afoot (including troops, refugees, and others) and animals, so as to meet military operational requirements. It provides a working level organization for the resolution of day-to-day problems of highway regulation and control. It seeks to anticipate traffic tie-ups and to overcome difficulties before they reach critical stage; it attempts to maintain a constant and orderly flow of troops and conveyances so that the full potential of the road net may be realized; it assures that the multitudinous traffic over military routes is responsive to command and that the changing needs of tactical forces are realized from hour to hour.

III. Responsibilities.

1. General staff supervision over the Highway Traffic Headquarters is the responsibility of the Assistant Chief of Staff, G-4, for logistical movements and Assistant Chief of Staff, G-3, for tactical movements.
2. The transportation officer has operational control of the Highway Traffic Headquarters.
3. The provost marshal has staff responsibility for traffic control and will assure the enforcement of traffic regulations in cooperation with the agency.
4. The engineer officer has responsibility for construction, maintenance and signing of highways, and for road and bridge reconnaissance.
5. Other staff members having responsibilities necessary to support the effective functioning of the agency include: the signal officer for communications, the ordnance officer for wrecker service and vehicle repair; the civil affairs/military government officer to coordinate the use of highways for non-military agencies.
6. The traffic officer is charged with the actual operation of the headquarters or agency and with the direct supervision of personnel assigned thereto.

#### IV. Organization.

1. The Highway Traffic Headquarters is organized as shown in Figure 1.
2. Transportation personnel of the organization are directly engaged in highway regulation functions of routing, scheduling and directing the use of roadways.
3. The military police officer is the agency's representative for traffic control and for maintaining liaison with the provost marshal to provide highway information and effecting enforcement of traffic directives.
4. The Corps of Engineers Officer provides the agency with timely and accurate route intelligence. He also coordinates matters relating to construction, maintenance and improving of essential highways and bridges, and the posting of permanent route signs.
5. In addition to assigned personnel, representatives of signal, ordnance and civil affairs/military government will be detailed to the agency on a day-to-day basis as required. They coordinate matters which are the primary responsibility of the staff office they represent.

#### V. Functions. The following are specific functions of the headquarters:

1. Planning.
  - a. Analyzes the route network by means of traffic surveys, capability studies, and route reconnaissance.
  - b. Classifies routes according to the degree of control to be exercised, as open, supervised, dispatch or reserved.
  - c. Develops the area traffic circulation plan, to include direction of flow, location of key check points, etc.
  - d. Maintains situation map of highway net and keeps posted up to the minute data on surface conditions, obstructions, detours, etc.
2. Routing and Scheduling.
  - a. Establishes and disseminates priorities for highway movements in accordance with commander's instructions.
  - b. Receives, logs, and disseminates as required, information from other traffic headquarters concerning highway movements into its area of jurisdiction.
  - c. Receives requests (proposed itineraries) for highway routings and scheduling over regulated routes from units within the area of jurisdiction.
  - d. Consolidates itineraries and march tables and schedules highway movements as necessary within the area.
  - e. Coordinates with other traffic headquarters highway movements terminating outside the area of jurisdiction.
3. Directing.
  - a. Prepares and disseminates traffic plans, orders, and related SOP.
  - b. Assigns serial numbers to units which is their authority to use certain routes within stated time periods.

- c. Receives from check posts hour-by-hour progress of movements over routes and information as to any anticipated tie-ups or delays. Keeps this information current on master march graphs.
- d. Effects changes in routes, schedules, or priorities as the situation dictates, and notifies unit or convoy commanders through check posts on the routes.

#### 4. Miscellaneous.

- a. Provides information to transportation officers regarding location of supply depots, installations, and terminals based on knowledge of availability and suitability of access routes and traffic requirements.
- b. Coordinates with engineer in obtaining highway route intelligence and on matters relative to posting permanent signs, construction and maintaining essential roads and related facilities.
- c. Coordinates with signal officer in planning for and providing the necessary communications for the operation of the traffic headquarters.
- d. Coordinates with ordnance officer relative to requirements and limitations of overweight and oversize vehicles, and for the provision of vehicle repair teams and wrecker evacuation service on routes.
- e. Coordinates with civil affairs/military government officer on matters concerning the use of highways by nonmilitary agencies, including the size, location, and direction of movements of refugees.

VI. Relationship to Transportation Movements. Transportation movements is the responsibility of the movements division, a staff division in the transportation section of a major command. The movements division is concerned with programming of movements of personnel and cargo so as to insure maximum utilization of all transport placed in general support of the command. The transportation movements program, based on priorities received from higher authority, specifies what is to be moved, where it is to be moved, when it is to move, which type of transportation will be used (water, rail, air, or highway), but not how the operating units will conduct the movements. The highway operating units contact the Highway Traffic Headquarters for schedules to meet the requirements of the movements program. The Highway Traffic Headquarters attempts to allocate schedules for road space as requested. When a conflict occurs between a schedule to meet the movement program and another movement having the same priority, the Highway Traffic Headquarters in coordination with the movements division, will contact higher authority to determine which movement will have priority.

Figure 1

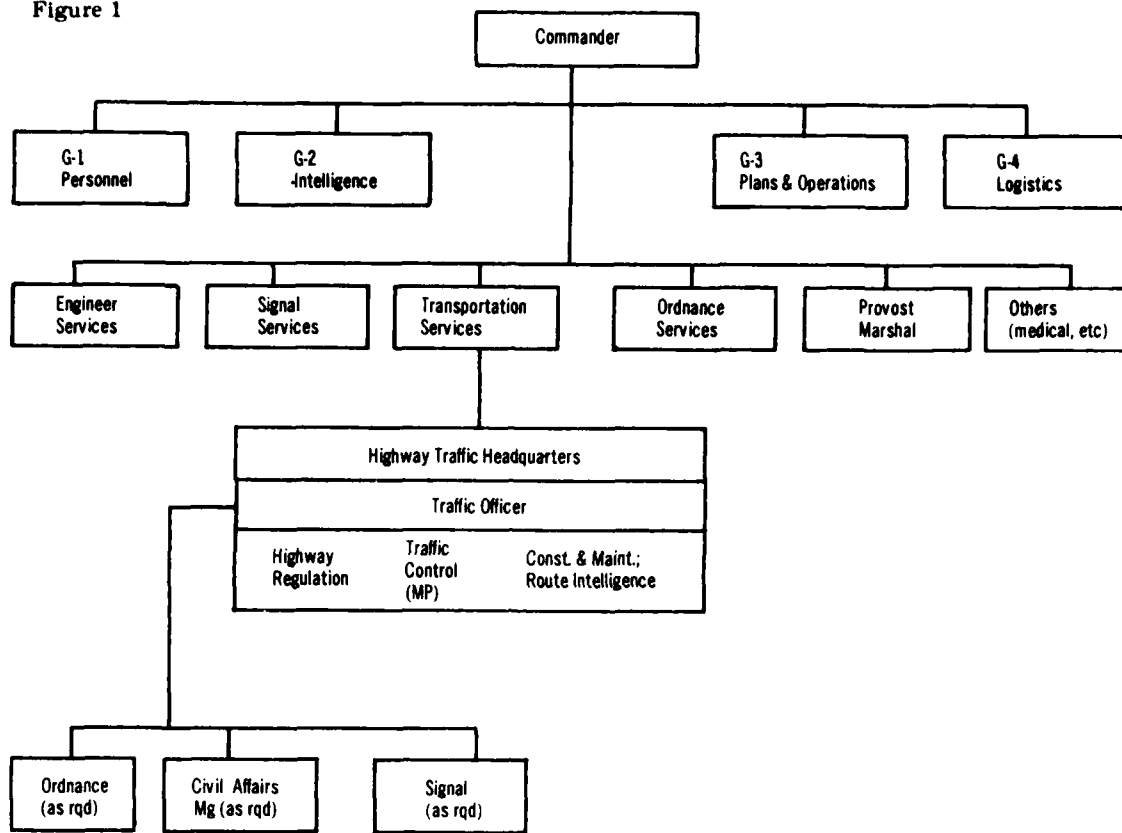

**APPENDIX 4 TO ANNEX C  
AUTHORITIES AND RELATED GUIDANCE**

**Federal Laws:**

Defense Production Act of 1950, as amended  
 Federal Civil Defense Act of 1950  
 Federal Aviation Act of 1958  
 Interstate Commerce Act

**Presidential Executive Orders:**

EO 10480	EO 11003
EO 10537	EO 11005
EO 10660	EO 11090
EO 10997	EO 11093
EO 10999	EO 11095

Chapter 6, Transportation, The National Plan for Emergency Preparedness  
 Chapter 2, Civil Defense, the National Plan for Emergency Preparedness  
 Transportation Appendices to State Survival Plans  
 Bureau of Public Roads Emergency Planning and Operations Manual  
 Bureau of Public Roads Order BPR-THM-1  
 Civil Aeronautics Board Air Transportation Mobilization Orders:  
 CAB ATM-1, General Order, Emergency Operating Authorizations  
 Interstate Commerce Commission Emergency Planning and Operations Manual

**APPENDIX 5 TO ANNEX C  
SUPPORTING PUBLICATIONS**

Reference documents for the State Transportation Coordinator not included as a part of the State plan:

State of Texas Highway Maps  
 Current Texas Railroad Map  
 Current Maps of Airlines Serving Texas  
 Current State Motor Vehicle Registration, by County  
 Annual **Carrier-For-Hire Listing** published by Texas Motor Transportation Association

**PART B - RESOURCE SECTIONS**

**X. Water**

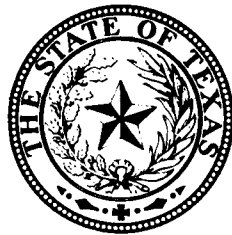

**Texas  
Emergency  
Resource  
Management**

**PLAN**

**B-X  
Water**

## INTRODUCTION

The process for managing water resources in the State in a nuclear attack emergency involves two series of actions. First, essential immediate needs are identified and actions taken to supply these needs. Secondly, and as soon as possible, continuing needs and expected future supplies are estimated. Decisions are made and actions are taken to channel these expected future supplies to meet continuing needs that are most essential to survival and recovery of the State and the Nation.

### Definitions:

"Water" is used in its commonly understood meaning. It includes water essential to our national survival.

"Public water supply" is any water supply regardless of ownership which serves two or more unrelated users.

"Water utility" or "water supply utility" includes public water supply systems whether publicly or privately owned and controlled.

"Primary water resources" are generally interstate or international sources of water supply which have a major interstate or international use.

"Secondary water resources" are generally intrastate sources of water supply which are available to meet essential needs within a single state.

"Federal reservoir projects" are dam and reservoir projects constructed by an agency of the Federal Government and usually operated and maintained by the constructing agency.

"State reservoir projects" are dam and reservoir projects constructed by an agency of the State or a local political subdivision and usually operated and maintained by the constructing agency.

"Local reservoir projects" are dam and reservoir projects constructed by a city or by an industry and usually operated and maintained by the constructing entity.

## STATE OF TEXAS EMERGENCY RESOURCE MANAGEMENT PLAN PART B-RESOURCE SECTIONS X-WATER

### Purpose, Activation, Authorities and References:

#### a. Purpose:

The purpose of this section of the State Resource Management Plan is to provide policies, guidance and actions for the provision and effective utilization of water resources and water supply equipment and materials to assure water of such quality and in sufficient quantity to meet essential needs in the State in a nuclear attack emergency.

#### b. Activation:

This plan will become effective upon a declaration of a civil defense emergency by the President of the United States, the Congress of the United States, or the Governor of Texas or with a nuclear attack upon the United States.

### Concept of Operation:

Federal, State and local governments have roles in the emergency management and supply of water and the provision of supporting water supply equipment and materials.

#### a. Federal Government:

The Department of Interior has the primary responsibility in the Federal Government to develop emergency plans and preparedness programs to assure the provision of emergency water supplies.

The Federal Government is responsible for the direct management of natural and artificial impoundments and water flow systems operated by the following Federal Government agencies:

Corps of Engineers/Department of the Army (Civil Works)  
U. S. Department of the Interior  
U. S. Department of Agriculture  
International Boundary and Water Commission

The management of these water sources arrange for the release of water to meet essential needs in the State of Texas as well as to meet essential needs of other states which depend on these primary sources for water supply. The Federal Government is also responsible for arranging for the release of water from primary sources in other states to meet essential needs in the State of Texas when possible.

In addition to this section of the State plan, shown in Annex C as Reference Document Number 1, is a list of water sources located in the State of Texas.

b. State Government:

The State water organization, in cooperation with other organizations of the State government, will develop and provide, on behalf of the Governor, water policies and guidance consistent with State and Federal objectives. The purpose of these policies and guidance is to assure application throughout the State of compatible measures for the conservation, distribution and use of water to prevent dissipation and waste and to assure that essential needs for water are met within the supplies available during the period of emergency. The State water organization also works with the management of natural and artificial impoundments and water flow systems under State government control. It furnishes guidance on the conservation and release of water from these State water sources and provides them with authority to obtain supporting water supply equipment and supplies. The State water organization acts on requests from local officials and arranges with appropriate entities for release of water to correct local shortages in supply. The State water organization also arranges with the State Industrial production organization for deliveries of water supply equipment and materials to correct shortages reported by local governments. As soon as possible after activation, the State water organization, in collaboration with other State organization representing major activities within the State that consume water, determines continuing needs and works with appropriate organizations to provide water to meet ongoing demands of authorized essential users.

c. Local Government:

Operational Survival Plans of the State of Texas, the Texas Water Utilities Association and political subdivisions will provide for the conservation, distribution and use of water supplied by local water utilities and sources. These plans will also provide for local government decisions and guidance, consistent with State policies, for the functioning of the water supply and distribution system in the localities in the State.

d. Essential Water Sources:

In Annex C to this section of the State of Texas plan is a summary of conservation storage conditions and shows locations of water sources which are essential to survival and which must be kept in operation to assure a continuing supply of water to meet essential needs for survival and recovery. Preattack arrangements have been made with appropriate authorities of local governments to assure provision of electric power, manpower, transportation, fuels and other locally available requisites for the continuing operation of these essential water facilities.

e. Flow Chart (Water)

Following is a flow chart showing the process and the actions to be taken by Federal, State and local governments to assure a continuing supply of water to meet essential needs in the State in a nuclear attack emergency. The legend accompanying the chart identifies

A. Actions to be taken immediately to supply immediate needs essential for survival, and

B. Actions to be taken as soon as possible to anticipate future continuing needs and to channel water supplies to meet the most urgent needs for continuing survival and recovery.

**STATE OF TEXAS PLAN FOR THE EMERGENCY MANAGEMENT OF RESOURCES  
WATER FLOW CHART**

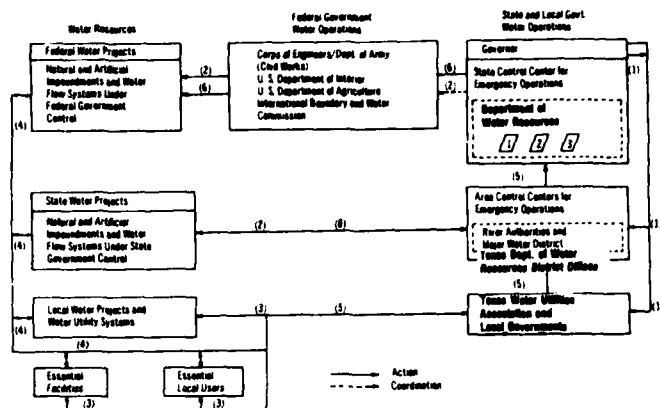

**A. Actions for Immediate Supply**

- (1) Issue State water policy—list of Federal and State water projects.
- (2) Provide State water policy to managers of Federal and State water sources—provide for procurement of capital equipment and maintenance, repair, and operating supplies.
- (3) Designate essential local uses and users of water—provide for procurement by local water facilities and utilities of essential capital equipment and maintenance, repair, and operating supplies.
- (4) Place orders—obtain deliveries.
- (5) Report water shortages—reduce local use—request State assistance.

**B. Actions for Continuing Supply**

- (1) Estimate future requirements and supplies—adjust State water policies.
- (2) Estimate water system future requirements for supporting resources—present to appropriate State resource organizations.
- (3) Allocate future water supplies to resource and claimant entities.

responsibilities:

State:

The Governor of the State of Texas has assigned to the Texas Department of Water Resources the responsibility for providing administrative support, i. e., personnel, facilities and supplies for the operations of the State water organization. Copies of this plan and all action and reference documents have been placed and are immediately available in the Office of the Department and its relocation and alternate sites.

Upon activation of this plan, the Water Coordinator and key staff with emergency assignments to the State water organization establish headquarters at the Office of the Water Rights Commission or its relocation or alternate site.

Health matters pertaining to water will be coordinated by the Coordinator, Water Organization, with the Coordinator, Health Organization, on an informal basis or during conferences of the Resource Priorities Board.

Region and District:

- (1) Staffs at these levels will include water representation nominated at these levels from major water districts and river authorities and approved by the Governor.
- (2) Staff representatives for water will attempt to solve problems at the lowest possible level. Only those problems which cannot be reconciled will be forwarded to higher headquarters.
- (3) Staff representatives for water will represent water resources at each level for the benefit of all Texas, coordinate with adjacent regions/districts on problems pertaining thereto and represent water utilities and water users within the region/district.

Local:

Mayors and county judges will avail themselves of services of technicians (Water) from Texas Water Utilities Association, local water utilities, districts and/or authorities.

Emergency Actions:

The following actions are taken on behalf of the Governor at State and area levels by State water officials to provide policies and guidance applicable throughout the State on the distribution and use of water and to arrange for the provision of water supply equipment and materials to maintain operations of essential water facilities.



The emergency action and reference documents contained here have been prepared and placed with appropriate State and local officials during the preattack planning process.

a. Actions for Immediate Supply:

- (1) Issue, on behalf of the Governor, policies and guidance covering the provision, distribution and use of water within the State. (Water-1, State Water Policy and Guidance, Annex B.)
- (2) Confirm with the State office of appropriate Federal agencies arrangements to release water from Federal water sources to meet essential needs in the State.
- (3) Confirm arrangements with State water projects for the release of water to supply essential needs in the State.
- (4) Arrange for interconnections with alternate sources of water of suitable quality to correct shortages in water supply reported by local governments. (Water-2, Increase in Local Water Supply, Annex B.)
- (5) Arrange for redistribution of water supply equipment and materials in inventories of water utilities that can be spared to correct deficiencies in local supplies reported by local governments. (Water-3, Redistribution of Inventories of Water Supply Equipment and Materials, Annex B.)

b. Actions for Continuing Supply:

As soon as arrangements to meet essential immediate needs in the localities are underway, the State water organization takes the following actions to anticipate continuing needs and to arrange for continuing supply to meet these needs.

- (1) Consult with State civil defense officials, Federal military officials and appropriate State resource officials to estimate continuing requirements for water that will be needed in the State during the ensuing 90-day period. (Water-4, Estimate of Continuing Water Requirements, Annex B.)
- (2) Obtain from appropriate Federal agency representatives, State water sources and local governments estimates of quantities of water that can be supplied for continuing use in the State during the ensuing 90-day period.
- (3) If anticipated supplies are inadequate to meet the estimated requirements and adjustments in requirements cannot be negotiated, refer to the Resource Priorities Board for recommendations to the Governor on the allocation of anticipated supplies among competing programs. (Water-5, Allocation of Water Supplies, Annex B.)
- (4) Issue revised State policies on the use of water in the State to conform with the Governor's decision. (Water-6, Revised State Water Policy, Annex B.)
- (5) Consult with appropriate Federal agency representatives in the State and State entities and develop estimates of continuing requirements for electric power, manpower, transportation, petroleum products and other operating supplies, equipment and services that will be needed to maintain operations of essential water facilities in the State during the ensuing 90-day period. Present these requirements estimates to appropriate State resource organizations. (Water-7, Water Industry Support Requirements, Annex B.)
- (6) Consult with appropriate Federal agency representatives in the State and State entities and develop estimates of emergency repair and construction of essential water facilities that will be required during the ensuing 90-day period and present these requirements estimates to the State construction organization. (Water-8, Water Industry Construction Requirements, Annex B.)
- (7) Inform appropriate Federal agency representatives and State entities of supply of supporting resources that will be available to them in the State for acquisition and use to maintain essential operations during the ensuing 90-day period. (Water-9, Allocation of Supporting Resources to Water Industry, Annex B.)

ANNEX A  
ORGANIZATION

Emergency Organization

1. The district offices in the chart for Texas water organization, attached, are located in control centers at points which have been established in Part A for district emergency operations.
2. The Texas Department of Water Resources will provide administrative support for the operations of the State water organization.

Upon activation of this plan, the Director, Texas Department of Water Resources, and key staff with emergency assignments to the State water organization establish headquarters at the Office of the Texas Department of Water Resources or its relocation or alternate site.

Lines of succession to assure continuity of key staff for the operation of the State water organization are provided in the roster of key personnel contained in Part C of this plan.

3. Personnel from the Department of Water Resources district offices will represent water interests and provide staff assistance to the disaster district chairman in matters pertaining to water.
4. At local level staff vacancies (Water) will be selected by mayors/county judges from individuals involved as members of Texas Water Utilities Association, local water utilities, districts or authorities.
5. Staff functions and responsibilities generally will be as shown below:

- a. Coordination

Coordinates water resource requirements with staffs of other resource coordinators; arranges for water transfers, when such is necessary, between subordinate water authorities; coordinates transport requirements, supervises manpower and accomplishes necessary personnel transfers; coordinates water responsibilities with the State Health Department and Railroad Commission.

- b. Distribution

Receives reports of local surveys of water conditions (shortages, damage to facilities, sources, etc.) and authorizes distribution of water resources by allocation of supply.

- c. Supply

Arranges for supply and resupply of parts, facilities, machinery and equipment.

**Texas Water Organization  
for  
Emergency Resource Management**

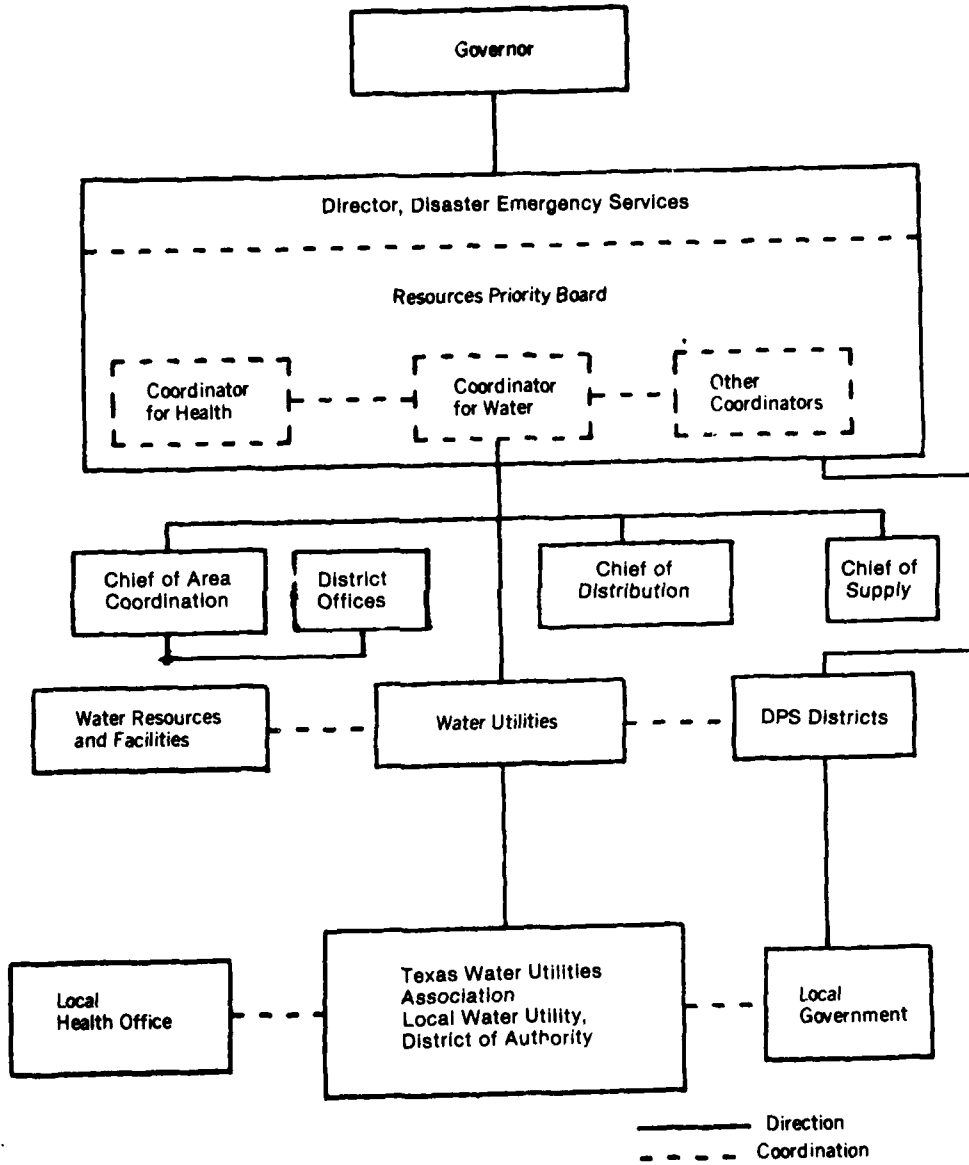

TEXAS DEPARTMENT OF WATER RESOURCES  
 ENFORCEMENT AND FIELD OPERATIONS DIVISION  
 DISTRICT OFFICES

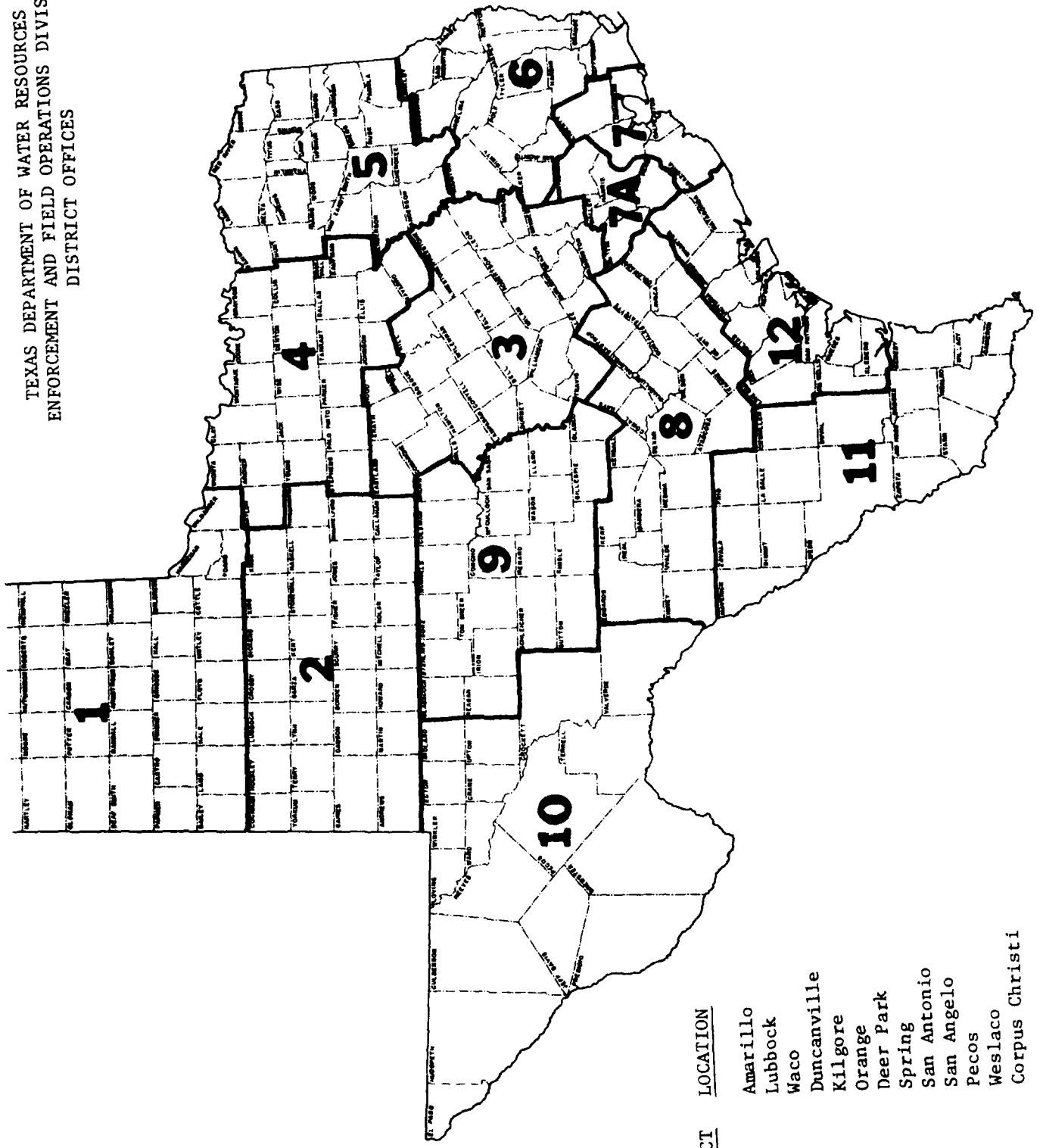

DISTRICT    LOCATION

- 1    Amarillo
- 2    Lubbock
- 3    Waco
- 4    Duncanville
- 5    Kilgore
- 6    Orange
- 7    Deer Park
- 7A    Spring
- 8    San Antonio
- 9    San Angelo
- 10    Pecos
- 11    Weslaco
- 12    Corpus Christi

B-X-A-3

**ANNEX B  
EMERGENCY ACTION DOCUMENTS**

**Index of Emergency Action Documents**

- Water-1, State Water Policy and Guidance
  - Water-2, Increase in Local Water Supply
  - Water-3, Redistribution of Inventories of Water Supply Equipment and Materials
  - Water-4, Estimate of Continuing Water Requirements
  - Water-5, Allocation of Water Supplies
  - Water-6, Revised State Water Policy
  - Water-7, Water Industry Support Requirements
  - Water-8, Water Industry Construction Requirements
  - Water-9, Allocation of Supporting Resources to Water Industry
- 

**Water-1, State Water Policy and Guidance**

**To: Heads of Political Subdivisions**

Guidance for Local Governments. It is essential that water available for use in this State be carefully conserved and restricted to immediate and urgent uses for local, State, and National survival and recovery until the continuing supply of water can be assessed and the supplies that will be available for less essential needs can be determined.

In order to (1) prevent waste and dissipation of local water supplies, (2) provide water to meet immediate and urgent needs, (3) assure continuing supply of water, and (4) to meet minimum essential needs of individual consumers, appropriate officials of local government are requested to take the following actions:

1. Announce and enforce water quality standards for emergency use.
2. Provide instructions to local water utilities and systems on the release of water to meet essential needs.
3. Authorize essential local users to obtain immediate and urgent supplies of water from local water utilities and systems.
4. Authorize essential facilities to certify purchase arrangements for water needed to maintain their operations. (Local governments have been provided by the State with a list of the essential facilities located in their jurisdictions.)
5. Announce and enforce curtailment of nonessential uses of water.

In the event local water supply is not adequate to meet all essential needs, local governments should decide to cut back authorized local uses. Concurrently they should report shortages and request appropriate officials of the State government to take actions to increase the supply of water to the local jurisdiction.

Effective Date \_\_\_\_\_

Governor of the State of Texas \_\_\_\_\_

By: \_\_\_\_\_  
Director, Texas Department of Water Resources

Background Information

The Governor has issued general policy on the use of essential resources in the immediate postattack or crisis relocation period. These policies are set forth in Part A of the State plan. They have been furnished to appropriate officials of the political subdivisions of the State.

In general, these State policies provide for temporary freezing of retail inventories of essential items and immediate and continuing release of these items to meet urgent military and civil defense needs and to maintain operations of facilities essential to continued survival and recovery. They provide for continuing resupply of local secondary inventories as well as inventories of essential facilities which obtain their supplies from wholesale and primary sources.

In addition, the Governor has issued a proclamation requesting the executive heads of the political subdivision in this State to provide resources from locally available supplies to carry on immediate and urgent activities for survival and to maintain the operation of essential facilities. In accordance with this direction from the Governor, local governments are requested to inform essential users of resources and persons engaged in the operation of essential facilities how to identify their purchase orders, contracts, and other purchase arrangements to obtain deliveries of supplies and services.

1. Essential water facilities use the following State certification to identify:

- a. Purchase orders for supplies of petroleum products, electric power, gas, solid fuels, and transportation services, and
- b. Construction contracts for repair and construction of facilities.

"This is an essential order authorized  
by the State of Texas.

\_\_\_\_\_  
(Signature of purchaser)"

2. Essential water facilities identify their purchase orders in accordance with the rating and certification provision of Federal emergency regulations issued by the Office of Industrial Mobilization of the U. S. Department of Commerce upon activation. For supplies of production materials, capital equipment, and other maintenance, repair, and operating supplies. The State industrial production organization publicizes and makes known these Federal regulations to local governments and industry immediately following activation of this plan.

a. Essential Users:

- (1) Individuals, both civilian and military, engaged in producing or providing essential items, products, care or services, e.g., doctors providing professional medical diagnoses, treatment and services; farmers producing essential food; military personnel engaged in immediate retaliatory or defense operations.
- (2) Organizations or establishments engaged in essential activities or providing essential items or services.

b. Essential Facilities:

- (1) Military establishments engaged in immediate retaliatory or defense operations;
- (2) Electric power, gas and water utility systems;
- (3) Industrial plants producing or processing essential items;
- (4) Major wholesale establishments storing or distributing essential items; and
- (5) Transportation or communication systems providing essential services.

c. Individual Consumers: Individuals who depend on local distribution systems (retailers and dealers) for essential supplies for individual and family use.

Water-2, Increase in Local Water Supply

(Name of State Water Source)

A shortage or impending shortage in water supply to meet essential needs has been reported by (name of local government).

The following are the recommendations of this local government to interconnect with alternate water sources to correct this local shortage:

1. To arrange with this locality and to provide skilled manpower and equipment to interconnect the local water source or sources to provide water of suitable quality for local use as soon as possible.

2. To complete this as this has been accomplished.

\_\_\_\_\_  
(signature)  
Director, Texas Department of Water Resources

**Water-3, Redistribution of Inventories of Water Supply Equipment and Materials**

To: (Name of Water Utility)

Shortages in water supply equipment and materials have been reported by  
(name of local government)

Following is a list of items and quantities required to maintain essential water supply.

You are requested to release from your inventories and ship these supplies to the  
(name of local water official) to correct this local shortage.

Please advise this office as soon as possible that the shipment has been made.

(signature)

Director, Texas Dept. of Water Resources

**Water-4, Estimate of Continuing Water Requirements**

The table of this emergency action document contains data on quantities of water that will be required in Texas for a 90-day period commencing (date).

The requirements stated include the quantities of water to be supplied by State sources to meet needs of essential users, essential facilities, and consumers.

**Definitions:**

**Civilian Requirements:** Include water needed to carry on emergency civil defense operations, to maintain essential local activities, and to supply individual consumers. These civilian requirements estimates are provided by appropriate civil defense officials.

**Military Requirements:** Include water needed to carry on military activities and to maintain and operate military installations and equipment. These military requirements estimates are provided by appropriate military officials.

**Resource Support Requirements:** Include water needed to maintain operation of essential facilities functioning in the State. These support resource requirements are provided by appropriate State resource organizations.

Requirement Categories	First 30 Days	Following 60 Days	Total 90 Days
Civilian			
Military			
Supporting Resources (Total)			
Production			
Electric Power			
Petroleum			
Etc.			

**Water-5, Allocation of Water Supplies**

Major Use Categories	First 30 Days	Following 60 Days	Total 90 Days
	Per Day Total	Per Day Total	
Civilian			
Military			
Supporting Resources (Total)			
Production			
Electric Power			
Petroleum			
Etc.			

**Water-6, Revised State Water Policy**

To: Heads of Political Subdivisions

(Note: The content and substance of the revised water policy will depend on the situation and the supplies expected to be available to meet continuing essential needs. Necessarily, this document will not be completed except in a test of the plan or at the appropriate point in a post-attack situation.)

This document will be, in essence, a Revised Water-1, State Water Policy and Guidance, contained here.

(signature)

Director, Texas Dept. of Water Resources

**Water-7, Water Industry Support Requirements**

Estimate of Water Industry Support Requirements for 90-Day Period Commencing _____ (date)				
Resource	Unit of Measure	First 30 Days	Following 60 Days	Total 90 Days
	Rate/Total Day	Rate/Total Day	Rate/Total Day	
Electric Power				
Petroleum Products				
Transportation				
Manpower				
Operating Supplies and Equipment				

Note: This form suggests the content that would be covered in estimating support requirements and should, of course, contain the necessary product breakdowns.

**Water-8, Water Industry Construction Requirements**

To: State Construction Organization

Following is a list and description of major construction, repair, and modification of facilities that will be required to maintain desired water supply during the 90-day period commencing \_\_\_\_\_ (date).

**Construction Projects**

1. Name, location, type, and size of construction project; start and completion dates.  
(If project is underway or a construction contract has been prepared, attach a copy of the contract document and summary bill of materials.)
- 2.
- 3.
- 4.

\_\_\_\_\_  
(signature)  
Director, Texas Dept. of Water Resources

**Water-9, Allocation of Supporting Resources to Water Industry**

To: Appropriate Federal Agency, Appropriate State Sources

Attached is a list and the quantities of supporting resources that have been allocated for maintaining essential operations of water facilities under the control of the \_\_\_\_\_ (name of agency source).

This is furnished as a basis for authorizing these facilities to obtain continuing supplies of these resources during the allocation period.

(Attach list.)

\_\_\_\_\_  
(signature)  
Director, Texas Dept. of Water Resources

**ANNEX C  
REFERENCE DOCUMENTS**

Ref Doc 1 - Summary of Conservation Storage Conditions (Published Monthly)



**PART B - RESOURCE SECTIONS**

**XI. Housing**

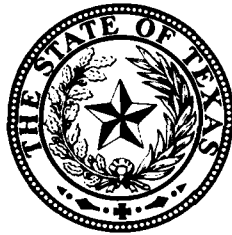

**Texas  
Emergency  
Resource  
Management**

**PLAN**

## INTRODUCTION

Emergency housing in the State involves two series of actions. First, immediately necessary emergency housing needs are identified and actions taken to meet these needs for the survival and protection of people. Secondly, and as soon as possible, future emergency housing needs are estimated and actions are taken to channel construction resources to meet the most essential housing needs for continued survival and recovery of the State and the Nation.

### Definitions:

- a. **Emergency Housing:** Additional dwelling accommodations provided by construction of housing, repair of damaged housing, or the conversion of nondwelling structures to dwelling use to meet the State and local housing needs. (Provisions for the emergency lodging or billeting of people in existing housing facilities are contained in the Operational Survival Plans of the State and its political subdivisions.) The post billeting use of existing housing and its management and conservation is also a part of emergency housing.
- b. **Emergency Community Facilities:** All installations necessary to furnish water, sewer, electricity, and gas resources between the housing unit or project and the nearest practical source.
- c. **Housing Management:** The provision by any level of government of management personnel and services for the operation of housing owned or operated by government housing and organizations. It also means the provision of management by government to direct the use of and to protect the

equity and interests of owners of private housing when for any reason the legal owners are not available in an emergency.

### d. Essential Users:

- (1) Individuals, both civilian and military, engaged in producing or providing essential items, products, care or services, e.g., doctors providing professional medical diagnoses, treatment and services; farmers producing essential food; military personnel engaged in immediate retaliatory or defense operations.
- (2) Organizations or establishments engaged in essential activities or providing essential items or services.

### e. Essential Facilities:

- (1) Military establishments engaged in immediate retaliatory or defense operations;
- (2) Electric power, gas and water utility systems;
- (3) Industrial plants producing or processing essential items;
- (4) Major wholesale establishments storing or distributing essential items; and
- (5) Transportation or communication systems providing essential services.

- f. **Individual Consumers:** Individuals who depend on local distribution systems (retailers and dealers) for essential supplies for individual and family use.

## STATE OF TEXAS EMERGENCY RESOURCE MANAGEMENT PLAN PART B-RESOURCE SECTIONS XI-HOUSING

### 1. Purpose and Activation:

#### a. Purpose:

The Housing Section of the State Resources Management Plan contains State policies, guidance and actions for the repair, conversion, construction and management of emergency housing to meet the needs of the State area nuclear attack emergency.

#### b. Activation:

This plan will become effective upon a declaration of a civil defense emergency by the President of the United States, the Congress of the United States, or the Governor of Texas or with a nuclear attack upon the United States.

### 2. Concept of Operation:

Following is a brief description of Federal, State and local government roles in the provision and management of emergency housing in the State in a nuclear emergency.

#### a. Federal Government

The Federal Government has provided National policies and guidance, and preattack assistance to the State in the development of this plan, and in the preparations to implement it in an emergency.

The Department of Housing and Urban Development (DHUD) has established a Federal emergency housing organization in this State with a State office located at San Antonio. The DHUD representative is empowered with the

authority of the Secretary of DHUD in the absence of effective national direction. Upon request of the State or local governments, this Federal agency provides technical guidance and undertakes the construction, management and financing of emergency housing where the State or local governments cannot provide additional essential housing capacity.

Procedures and forms for requesting Federal assistance to provide emergency housing are contained in Reference Document Number 1 attached to this section of the State plan.

Also, the Federal Government is responsible in cooperation with State and local governments for the emergency management of any part of the existing housing supply which in a postattack situation is left without effective ownership and management. This management will be for the purpose of insuring its greatest utility in connection with the survival and recovery of the Nation, and to conserve its value for the owners when they appear. This would occur after the housing is no longer needed for billeting. Basically, it would consist of housing upon which FHA had written mortgage insurance or VA had guaranteed mortgages, but would include any other "ownerless" housing.

#### b. State Government:

The State housing organization and the area housing organizations develop, in coordination with the State construction organization and

other State government organizations, and provide, on behalf of the Governor, policies and guidance consistent with State and Federal housing objectives. The purpose of these policies and guidance is to assure application throughout the State of compatible measures to assure that the most essential housing needs are identified and met within the resources available.

The State housing organization and the area organizations work with the State construction organization at State and area levels to arrange for contractor services and supporting resources when locally available construction resources are inadequate to meet urgent and essential housing needs in the immediate postattack situation.

As soon as possible after the attack, the State housing organization, in cooperation with other State organizations, anticipates continuing housing construction needs and requests the State construction organization to arrange for the provision of construction resources to meet these needs.

The State housing organization provides policies and where necessary provides management or assists local governments in the provision of management for emergency housing. It also, where necessary, requests the DH UD to provide Federal assistance and financing to construct emergency housing in the State.

**c. Local Government:**

Operational Survival Plans of the State of Texas and its political subdivisions contain provisions for authorizing essential local housing construction activities and the use of the homebuilding industry and supporting resources to meet essential needs in the localities. These plans also provide for local government decisions and guidance, consistent with State policies, for home builder operations in the localities and acquisition by them of the manpower, building materials and equipment, petroleum products and other supporting resources and services.

Local governments also include in their plans arrangements to provide manpower, water, transportation, fuels and other locally available resources for the provision of emergency housing and related community facilities.

Local government, in addition, will be called on to determine local emergency housing needs, prepare a local housing construction plan by selecting damaged housing for repair, structures for conversion, and sites for mobile housing or construction of new housing.

**d. Flow Chart:**

Following is a flow chart showing the process and the actions to be taken by Federal, State and local governments to assure that essential housing construction needs in the State are met in a nuclear attack emergency.

**STATE PLAN FOR THE EMERGENCY MANAGEMENT OF RESOURCES  
Housing Flow Chart**

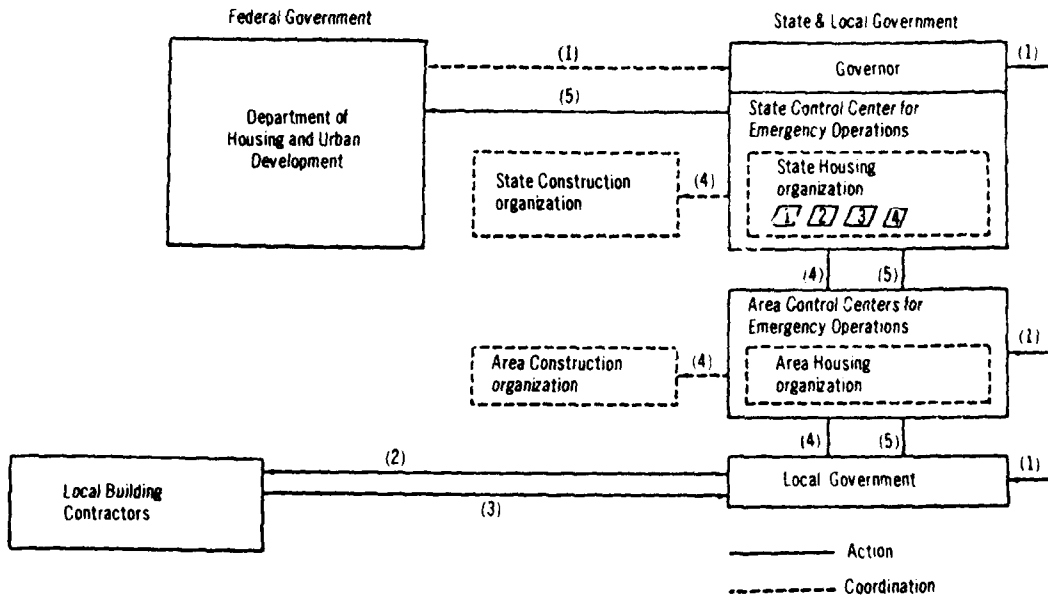

**Legend for Flow Chart**

- A. Actions to Provide Immediate Housing Construction and Management**
- (1) Issue State Housing Management and Construction Policy.
  - (2) Place contracts with local building contractors.
  - (3) Report shortages of contractor services and other construction resources.
  - (4) Request State assistance.
  - (5) Request financial assistance.

- B. Actions to Provide Continuing Housing Construction and Management**
- 1 Estimate future housing requirements.
  - 2 Present housing construction requirements to State Construction organization.
  - 3 Issue revised State Housing Construction and Management Policy.
  - 4 Authorize local governments to undertake future housing construction programs.

3. Resource Management Execution:

a. State:

In order to carry out purpose, responsibilities and functions of the State of Texas in regard to emergency housing and related community facilities, there is established a State housing organization as follows:

- (1) The State housing organization, for emergency planning purposes, will be under the State Department of Highways and Public Transportation (SDHPT) and headed by a SDHPT official familiar with housing and related community facilities. During this phase it will be supported by not less than twelve State Resource Specialists who compose the emergency staff of the housing organization. The staff of the Texas housing organization shall work with the staff of the State Division of Disaster Emergency Services (DES) during preattack planning.
- (2) Upon declaration of an emergency the Texas housing organization will be mobilized to full operation strength and will report directly to the Governor, coordinating its activities with the State Disaster Emergency Services Division and other resource organizations.

b. Housing Areas:

- (1) The twenty (20) housing area offices will be activated and established in the appropriate Department of Public Safety regional offices as indicated in Annex A. Activation will be on direction from the State Housing Coordinator.
- (2) Area offices will maintain liaison with the following within the geographic boundaries of their area: SDHPT district offices, disaster district and subdistrict offices, and appropriate local offices at county and city levels.
- (3) Coordination with other area offices will be through the State Housing Coordinator.
- (4) Communication will be by the fastest available methods; i.e., telephone, SDHPT teletype, SDHPT or Department of Public Safety radio.
- (5) Area offices are responsible for establishing and keeping current a tabulation of housing resource materials, equipment and services available within the area.
- (6) Area offices are responsible for determining local needs and taking the necessary steps to meet those needs within the scope of policy established by the State Housing Coordinator. In other words, to the maximum extent feasible, area offices are to function as self-sufficient units, keeping in mind that records and documentation of actions are essential to later evaluation of operations after Federal control has been restored.
- (7) Needs beyond the capacity of the area office to meet will be referred to the State Housing Coordinator.
- (8) It is the responsibility of the area offices to keep the State Housing Coordinator continuously informed of area construction resources in excess of area needs.
- (9) Local communities and counties are expected to provide for their own emergency needs to the maximum extent feasible before calling on the area director for assistance.

4. Emergency Actions:

The following actions are taken on behalf of the Governor of Texas and area levels by the Texas housing organization officials to provide policies and guidance applicable throughout the State on the management of existing housing and construction of emergency housing to meet essential local needs.

The emergency action documents contained herein have been prepared and placed with appropriate State and local officials during the preattack planning process.

a. Actions to Provide Immediate Housing Construction and Management:

- (1) Issue, on behalf of the Governor, policies and guidance applicable throughout the State covering the provision and management of emergency housing. (Housing-1, Annex B)
- (2) Request the State construction organization to arrange for contractor services and construction resources to meet deficiencies reported by local governments. (Housing-2, Annex B)
- (3) Request the State construction organization to undertake construction of emergency housing beyond the capacity of local governments when requested to do so by local governments.
- (4) Upon request by local governments arrange for State or Federal financing and the provision of management for local emergency housing projects.

b. Actions to Provide Continuing Housing Construction and Management:

As soon as emergency housing and management activity for urgent immediate needs in the localities is underway, the State housing organization takes the following actions to estimate future continuing needs and to arrange for continuing housing construction and management to meet these needs.

- (1) Consult with State civil defense officials, Federal military officials, and appropriate State and Federal resource officials to estimate continuing requirements for construction, conversion and repair of housing that will be needed in the State during the ensuing 90-day period. Present these future housing requirements to the State construction organization together with estimates of building materials and equipment and other construction resources required to meet the requirements. (Housing-3, Annex B)
- (2) Receive approved housing program for the ensuing 90-day period and authorize local governments to undertake housing construction.
- (3) Issue revised State policy on emergency housing, construction and management. (Housing-4, Annex B)
- (4) If the State intends to request Federal reimbursement, copies of each application should be prepared for submission as appropriate to the DHUD Emergency State Office for approval. (See Reference Document Number 1, Application for Reimbursement, Annex C.)

**ANNEX A  
ORGANIZATION**

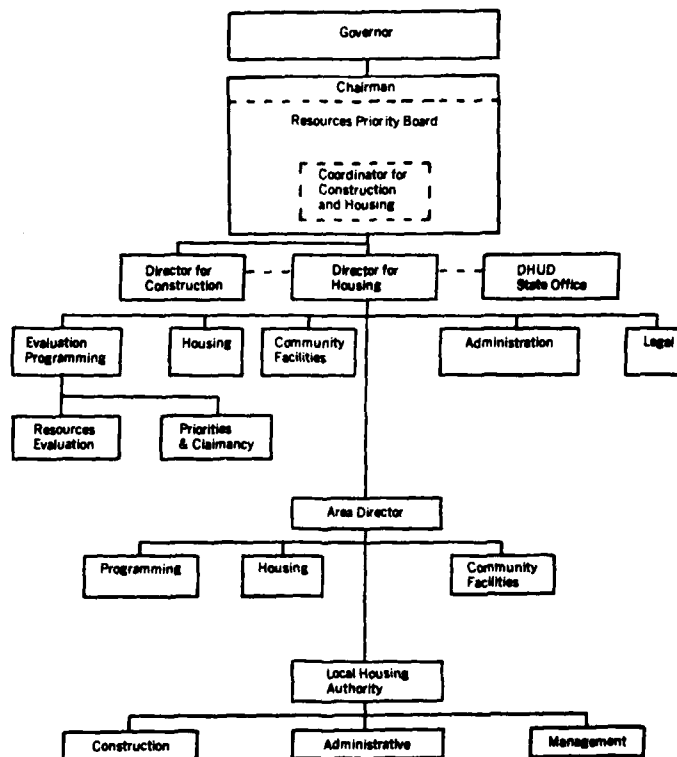

## **1. Functions of Texas Housing Organization:**

### **a. Preattack or Crisis Relocation:**

- (1) Prepare for continuity of operations.
- (2) Maintain liaison and coordinate preparedness measures with State Director, Disaster Emergency Services other resource organizations and the San Antonio Office of DHUD.
- (3) Familiarize selected staff members with plans, forms and documents involving emergency construction and management of housing and related community facilities.
- (4) See that local communities are familiar with local emergency housing services. (See DHUD Local Emergency Housing Services Guide, Item 6, Reference Document 2, Annex C.)
- (5) Participate in Civil Defense exercises and serve on committees to coordinate emergency housing with other emergency and survival programs.
- (6) Establish and maintain close working relationships with State and local welfare organizations in order to establish procedures for determining local housing requirements.

### **b. Postattack: The State of Texas housing organization will be activated and will carry out functions as follows:**

#### **(1) Coordinator:**

- (a) Administer emergency housing and community facility programs in accordance with emergency plans and operating guides.
- (b) Coordinate with other State resource organizations and the State DHUD Office as necessary to carry out the Texas Housing Plan.
- (c) Issue pre-positioning orders, as necessary.
- (d) Supervise area offices and local housing organizations.

#### **(2) Evaluation and Programming:**

- (a) Assess damage to housing and community facilities in the State and estimate remaining housing resources.
- (b) Review appraisals submitted by local or area offices for construction of housing or community facilities and recommend to the coordinator their approval, modification or rejection after coordination of minimum housing requirements with the Welfare Department.
- (c) Prepare claims for controlled material, equipment and manpower for Coordinator's use.
- (d) Allocate controlled material, equipment and manpower.
- (e) Recommend restoration or abandonment of attacked areas.

### **(3) Housing:**

- (a) Administer State-wide housing programs as directed.
- (b) Provide technical guidance on housing to area offices and local communities.
- (c) Prepare construction cost data and estimates for the Coordinator.
- (d) Assist Evaluation and Programming Division in claimancy and allocating by providing materials data based on specifications.
- (e) Provide management services as needed by local communities.

### **(4) Community Facilities Division:**

- (a) Assist communities and/or area offices with engineering and design services as necessary so as to provide emergency water and sanitary facilities.
- (b) Administer State-wide programs for emergency community facilities, as directed.
- (c) Prepare construction cost data and estimates on emergency community facilities for the Coordinator.
- (d) Provide:
  1. Evaluation and Programming Data with materials required for claimancy.
  2. Assist in assessing damage to water and sewer facilities.
  3. Recommend either abandonment or restoration of attacked areas.
- (e) Assist in preparation of applications for Federal assistance in connection with needed community facilities to support emergency housing.
- (f) Consult with State resource organizations on water, sewer, gas and electric power.

### **(5) Administrative Division:**

Provide customary administrative services—personnel, time, leave and payroll; budget and accounting; space and equipment.

### **(6) Legal Division:**

Provide legal services to the Coordinator on all matters having legal implications.

## **2. Area Division Organization:**

Will assist State office in carrying out functions as enumerated under State organization above.

## **3. Local Housing Service:**

Represent the State housing organization at the local level and administer local needs and requirements.

Coordination with Disaster District offices, as adopted in Part A of the Emergency Resource Management Plan, and with other State Dept. of Highways and Public Transportation District offices will be provided as set out in the following table:

<u>Housing Area Office</u>	<u>Liaison With State Highway District Numbers</u>	<u>Liaison With State Disaster District Numbers</u>
No. 1, Corpus Christi	16-Corpus Christi; 21-Pharr	3-A, Corpus Christi
No. 2, Victoria	13-Yoakum	3-A, Corpus Christi
No. 3, San Antonio	15-San Antonio; 22-Del Rio	3-B, San Antonio
No. 4, Austin	14-Austin	6-B, Austin
No. 5, Houston	12-Houston	2-A, Houston
No. 6, Galveston	12-Houston	2-A, Houston
No. 7, Beaumont	20-Beaumont	2-B, Beaumont
No. 8, Lufkin	11-Lufkin	2-B, Beaumont
No. 9, Dallas	18-Dallas	1-A, Dallas
No. 10, Waco	9-Waco	6-A, Waco
No. 11, Tyler	10-Tyler	1-B, Tyler
No. 12, Texarkana	19-Atlanta	1-B, Tyler
No. 13, Fort Worth	2-Fort Worth	Sub 1-A, Fort Worth
No. 14, Wichita Falls	3-Wichita Falls	Sub 5-A, Wichita Falls
No. 15, Abilene	8-Abilene	4-B, Abilene
No. 16, San Angelo	7-San Angelo	Sub 4-B, San Angelo
No. 17, Lubbock	5-Lubbock; 25-Childress	5-A, Lubbock
No. 18, Amarillo	4-Amarillo	5-B, Amarillo
No. 19, Midland	6-Odessa	4-A, Midland
No. 20, El Paso	6-Odessa; 24-El Paso	Sub 4-A, El Paso

The following State county outline maps show appropriate boundaries:

Map 1-Housing Areas

Map 2-State Highway Department Districts

Map 3-State Disaster Districts

AREA HOUSING ORGANIZATION

MAP 1

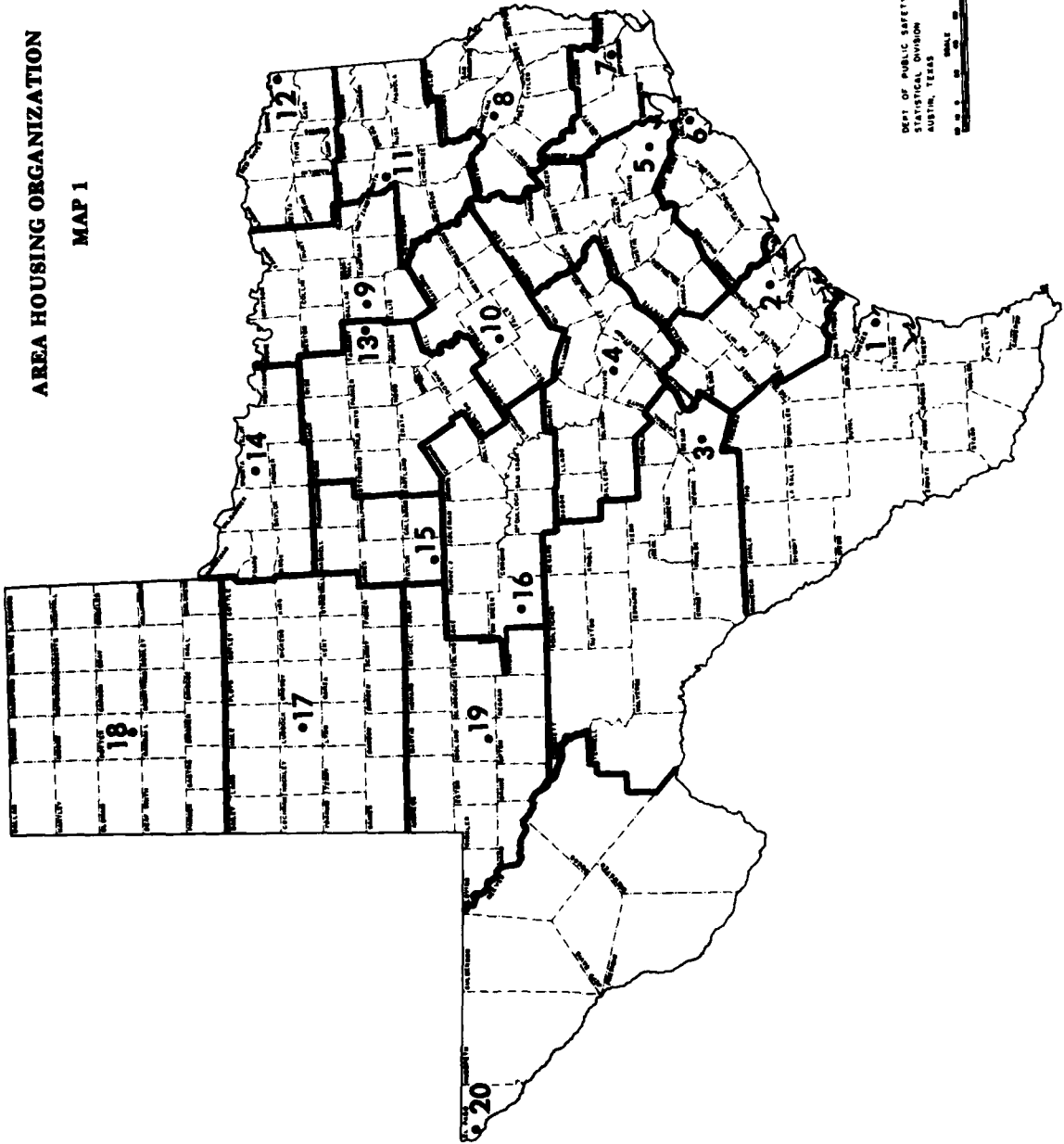



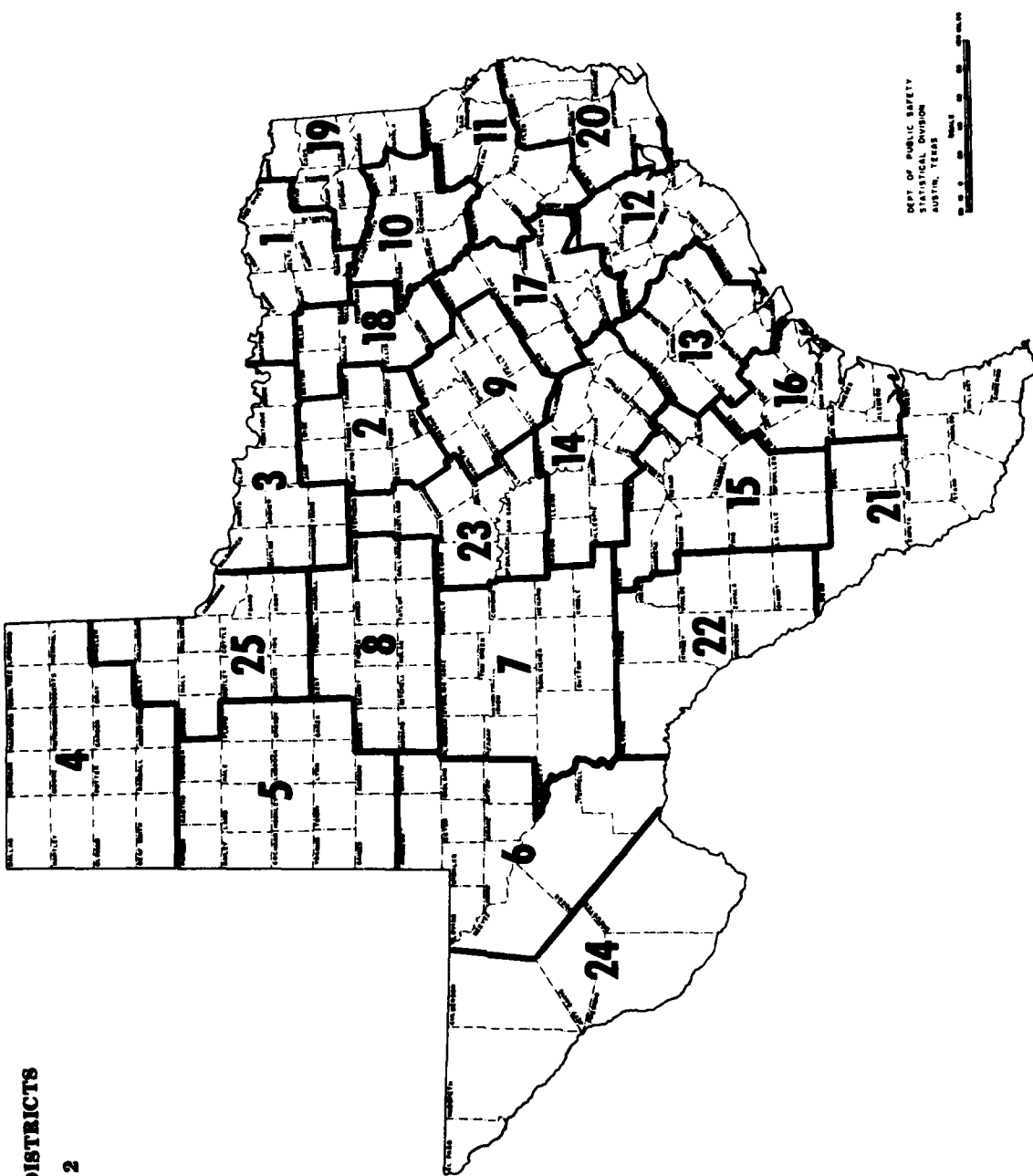

DEPT. OF PUBLIC SAFETY  
 STATISTICAL DIVISION  
 AUSTIN, TEXAS

**HIGHWAY DISTRICTS**  
**MAP 2**

**DIVISION OF DISASTER EMERGENCY SERVICES  
DISASTER DISTRICT BOUNDARIES**

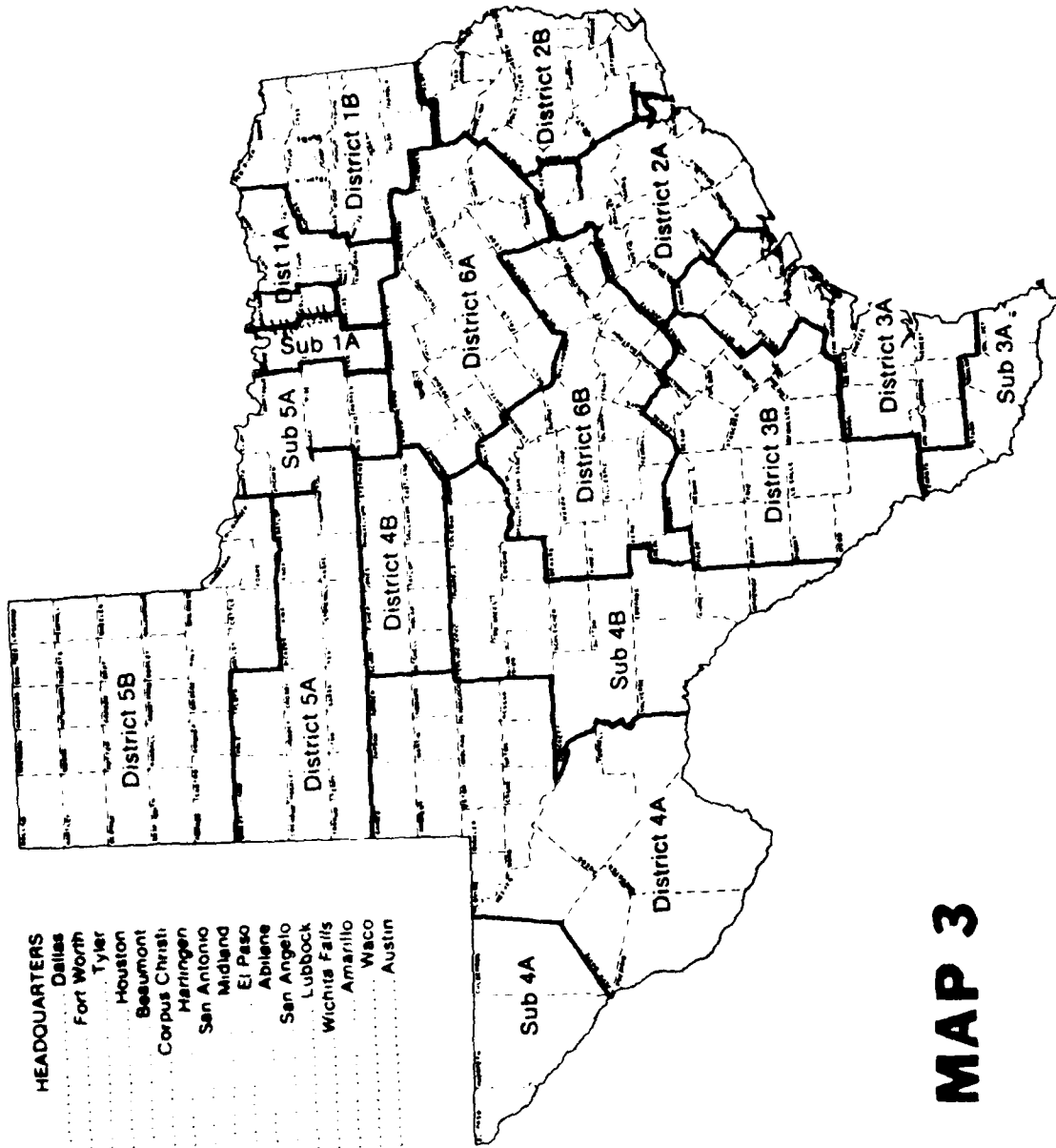

DISTRICT	HEADQUARTERS
1A	Dallas
Sub 1A	Fort Worth
1B	Tyler
2A	Houston
2B	Beaumont
3A	Corpus Christi
Sub 3A	Harrington
3B	San Antonio
4A	Midland
Sub 4A	El Paso
4B	Abiene
Sub 4B	San Angelo
5A	Lubbock
Sub 5A	Wichita Falls
5B	Amarillo
6A	Waco
6B	Austin

**MAP 3**

**ANNEX B  
EMERGENCY ACTION DOCUMENTS**

**Index of Emergency Action Documents**

Housing-1, State Housing Policy and Guidance  
Housing-2, State Assistance to Local Government  
Housing-3, Estimate of Continuing Housing Construction Requirements  
Housing-4, Revised State Housing Policy  
Housing-5, Construction and Housing Program Authorizations

---

**Housing-1, State Housing Policy and Guidance**

To: Heads of Political Subdivisions

**Guidance for Local Governments.** It is essential that capabilities for housing repair, conversion and construction, available for use in Texas, be carefully conserved and restricted to immediate and urgent uses for local, State and National survival and recovery until the continuing capability can be assessed and capabilities for less essential housing construction can be determined.

In order to prevent waste and dissipation of housing construction resources and to meet urgent and immediate local housing needs, appropriate officials of local government are requested to take the following actions:

1. Enforce State construction policies by stopping nonessential housing construction underway and prohibiting the start of nonessential housing repairs and construction.
2. Authorize home owners to undertake austere home repairs where this is essential for survival and immediate protection of occupants.
3. Determine housing needs that cannot be met by lodging and billeting in existing structures and establish a program for the conversion of existing structures, repair and construction of emergency type housing to meet these needs.
4. Establish austere housing construction plans and specifications and engage building contractors to undertake housing repair, conversion and construction.
5. Where necessary, request the State to provide assistance or to obtain from the Federal Government assistance to finance, provide and manage urgently needed housing.
6. Provide for the management and use of housing where owners or managers cannot be located and protect the equity of these absent owners in such housing.

The Construction Section of the State plan contains policies, guidance and actions on the provision and use of construction resources for necessary housing construction as well as all other types of essential construction. These have been provided to local governments.

In the event available housing construction resources are inadequate to meet essential local needs, local governments should cut back on authorized local emergency housing construction. Concurrently, they should report shortages and request appropriate officials of State government to take actions to increase the availability of housing construction resources to the local jurisdictions.

\_\_\_\_\_  
(Effective Date)

\_\_\_\_\_  
(Name)  
Governor of the State of Texas

By: \_\_\_\_\_  
(Signature)  
State Housing Coordinator

AD-A090 824

TEXAS DEPT OF PUBLIC SAFETY AUSTIN DIV OF DISASTER E--ETC F/6 15/3  
TEXAS EMERGENCY RESOURCE MANAGEMENT, VOLUME II.(U)  
SEP 79 A C ELEDGE, R L ORTON, S O MERZ DCPA01-78-C-0321  
NL

UNCLASSIFIED

4 of 4  
2009-14



END  
DATE  
FILMED  
42-80  
DTIC

**Housing-1, Attachment 1**

**Background Information:**

The Governor has issued general policy on the use of essential resources in the immediate post-attack period. These policies are set forth in Part A of the State plan. They have been furnished to appropriate officials of the political subdivisions in Texas.

In general, these State policies provide for temporary freezing of retail inventories of essential items and immediate and continuing release of these items to meet urgent military and civil defense needs and to maintain operations of facilities essential to continued survival and recovery. They provide for continuing resupply of local secondary inventories as well as inventories of essential facilities which obtain their supplies from wholesale and primary sources.

In addition, the Governor has issued a proclamation (Appendix 6, Annex C, Part A) requesting the executive heads of the political subdivisions in this State to provide resources from locally available supplies to carry on immediate and urgent activities for survival and to maintain the operation of essential facilities. In accordance with this direction from the Governor, local governments are requested to inform essential users of resources and persons engaged in the operation of essential facilities how to identify their purchase orders, contracts and other purchase arrangements to obtain deliveries of supplies and services.

In accordance with Federal policies and objectives State construction policies provide for the use of construction resources to support the following types of construction.

1. Emergency repair, restoration or construction of facilities needed for survival, such as essential production, essential services and emergency housing, and
2. Conversion of facilities to survival use, where this can be accomplished quickly.

Other construction already underway should be stopped, and no new construction started unless it can be used immediately for essential purposes upon completion.

Local governments, upon attack, certify their contracts to obtain essential repair and construction of housing with the following certification.

"This is an essential order authorized  
by the State of Texas.

\_\_\_\_\_  
(Signature of Official)"

**Housing-2, State Assistance to Local Government**

To: State Construction Organization

You are requested to take action to meet the following shortages of emergency housing as reported by local governments.

Location

Description of Project

\_\_\_\_\_  
(Date)

(Signed)

\_\_\_\_\_  
State Housing Coordinator

**Housing-3, Estimate of Continuing Housing Construction Requirements**

To: State Construction Organization

Attached are lists of and descriptions of building projects that are required to be started in this State during the 90-day period commencing \_\_\_\_\_ (date) \_\_\_\_\_.

<u>Location</u>	<u>Purpose</u>	<u>Description of Work</u>	<u>Start Date</u>	<u>Expected Completion Date</u>
Lot 27, Sq. 18	To construct housing units for 38	Complete construction including required facilities  (Note: Attach bill of materials and construction resources that will be required.)		

\_\_\_\_\_  
(Date)

(Signed)

\_\_\_\_\_  
State Housing Coordinator

**Housing-3, Attachment 1**

To: State or Local Housing Organization

Application Number \_\_\_\_\_

From \_\_\_\_\_  
(city or county)

\_\_\_\_\_  
(State)

**Application for Emergency (Barracks) Housing**

(Where necessary, use additional pages to provide required information.)

We hereby officially request permission to construct emergency barracks to meet a critical housing shortage as follows:

- a. Number of Emergency Barracks Structures (each to house 20 persons) \_\_\_\_\_
- b. Number of Utility Buildings \_\_\_\_\_
- c. Number of Mess Halls \_\_\_\_\_

**1. Housing Condition**

- a. Estimated number of people presently housed \_\_\_\_\_
- b. Estimated number of additional people expected \_\_\_\_\_
- c. Total \_\_\_\_\_
- d. Estimated total number of usable units in community occupied and vacant \_\_\_\_\_
- e. Average number of persons per room in occupied family units \_\_\_\_\_
- f. Estimated number of additional persons who can be absorbed in existing units \_\_\_\_\_
- g. Number of persons for whom additional housing must be constructed \_\_\_\_\_

**2. Materials and Labor**

- a. Are materials and equipment available locally for construction of the requested barrack structures? Yes \_\_\_\_\_ No \_\_\_\_\_  
If partial, state amount available. \_\_\_\_\_
- b. If YES, who controls said materials and equipment? \_\_\_\_\_  
(Indicate Federal, State, County or City official by name and title.)
- c. If not available locally, do you know where materials and equipment can be obtained? State where. \_\_\_\_\_
- d. Is labor available? \_\_\_\_\_

**3. Land**

- a. Is land available? \_\_\_\_\_
- b. How many acres? \_\_\_\_\_
- c. Who has title? \_\_\_\_\_
- d. Will land have to be requisitioned under emergency authority? \_\_\_\_\_
- e. Have appropriate officials agreed to requisition land? \_\_\_\_\_
- f. Name and title of these officials. \_\_\_\_\_

**4. Utilities**

- a. Is there sufficient public water supply for the increased population? \_\_\_\_\_
- b. If not, has application been made for increased water facilities? \_\_\_\_\_
- c. Are there sufficient public sewage disposal facilities for the increased population? \_\_\_\_\_
- d. If not, has application been made for increased sewage disposal facilities? \_\_\_\_\_

\_\_\_\_\_  
(Signature of Official making Application)

Title: \_\_\_\_\_

Date: \_\_\_\_\_

**Housing-4, Revised State Housing Policy**

(Note: The content and substance of the revised housing policy will depend on the situation and the supplies expected to be available to meet continuing essential needs. Necessarily, this document will not be completed except in a test of the plan or at the appropriate point in a post-attack situation.)

This document will be, in essence, a revised Housing-1, State Housing Policy and Guidance, contained here.

---

**Housing-5, Construction and Housing Program Authorizations**

To: (Name of claimant or resource organization)

In response to your requirements the attached list of housing projects have been determined feasible of accomplishment.

You are authorized to place contracts or to authorize others to place contracts with housing contractors.

These housing contracts are to bear the following certification:

"This is an essential  
contract authorized  
by the State Housing  
Coordinator.

(signed)  
\_\_\_\_\_  
" (person placing contract) "

Housing contractors are to be instructed to use this same certification on purchase orders for supporting resources not covered by Federal emergency regulation.

\_\_\_\_\_  
(Effective Date)

(signed)  
\_\_\_\_\_  
State Housing Coordinator

Attachment: List of projects

**ANNEX C**  
**REFERENCE DOCUMENTS**

**Reference Document Number 1, Application for Federal Reimbursement for Construction of Emergency Housing**

Application is hereby made for reimbursement of \_\_\_\_\_ percent\* of the cost of construction of emergency housing, including the cost of land, incurred by \_\_\_\_\_ (State or Local Government) \_\_\_\_\_.

The \_\_\_\_\_ (State or Local Government) hereby certifies that the emergency housing was necessary to take care of dislocated persons and/or employees of essential industries.

The emergency housing consists of (Describe in terms of units or square feet, as appropriate. Use additional sheets and attach them to this application to provide all essential details.)

and was constructed between (Insert starting and completion dates) \_\_\_\_\_. No prior application for authorization to construct the above described housing was submitted because \_\_\_\_\_

\_\_\_\_\_  
(State reasons, e.g., no communication possible; conditions would not permit delay.)

A detailed account of the total expense incurred is attached.

\_\_\_\_\_  
(Date)

\_\_\_\_\_  
(State or Local Government)

\_\_\_\_\_  
(Authorized Representative)

\*The cost of emergency construction of housing will be absorbed by the Federal Government to the extent consistent with operating details now being developed to support a national policy of postattack loss-sharing or indemnification.

**Reference Document Number 2, HUD Guidance Publications**

1. **Construction:** Plans, drawings, specifications and materials listed here have been developed for emergency barracks-type structures, each accommodating 20 persons. Some have been designed for use as mess halls and lavatories. Instructions for their use, covering administrative procedures, design criteria, construction and financing procedures, and sample forms, are contained in the document entitled "Emergency Housing Construction (Barracks)."
2. **Repair:** Emergency repairs to damaged housing means those repairs which can be done quickly with the materials and manpower available locally and under the control of, or readily obtainable by, the local government. They include only the minor repairs essential for restoring the damaged structures to housing use and may or may not include the repair of all damage sustained by the structure. The document entitled "Emergency Repair of Damaged Housing" contains criteria for determining which structures are repairable, as well as method, organization, sample contract forms and financing for housing repair programs.
3. **Conversions:** Conversion is only one of several methods of providing emergency housing. By definition, "conversion" is a term used to indicate a nondwelling structure which is physically altered by construction changes or additions so that it may be used as living quarters for people. The document entitled "Emergency Conversion of Nondwelling Structures to Dwelling Use" contains guidance and instructions for State and local officials, and includes standards for determining convertibility, methods, and financing, and sample forms.
4. **Tents and Trailers:** The document entitled "Emergency Use of Tents and Trailers" contains instructions for State and local governments on how to prepare and keep a current inventory, standards for occupancy, site selection, and preparation, financing, and management of existing stocks of tents and house trailers in the hands of dealers and manufacturers.
5. **Management:** The "Emergency Housing Management Manual" sets forth policies and procedures for the management of emergency housing, including tent eligibility standards; evictions; establishment, collection and use of rents; management personnel; and reporting.
6. **Service:** The "Local Emergency Housing Service" manual provides a guide to local governments for establishing and operating, as a part of local civil defense, an organization with authority and skill to assume emergency housing functions.
7. **Community Facilities:** The "Emergency Community Facilities Related to Housing" manual provides guidance to local, State and Federal governments in providing emergency community facilities related to housing in the event of necessity and additionally sets forth procedures showing how local governments may obtain Federal assistance, both technical and financial, in such undertaking.



DISTRIBUTION LIST

(Number of Copies--One unless otherwise indicated)

Federal Emergency Management Agency  
Mitigation and Research  
ATTN: Administrative Officer  
Washington, D.C. 20472 (60)

Assistant Secretary of the Army (R&D)  
ATTN: Assistant for Research  
Washington, D.C. 20301

Chief of Naval Research  
Washington, D.C. 20360

Commander, Naval Supply Systems  
Command (0421C)  
Department of the Navy  
Washington, D.C. 20376

Commander  
Naval Facilities Engineering Command  
Research and Development (Code 0322C)  
Department of the Navy  
Washington, D.C. 20390

Defense Technical Information Center  
Cameron Station  
Alexandria, Virginia 22314 (12)

Civil Defense Research Project  
Oak Ridge National Laboratory  
ATTN: Librarian  
P. O. Box X  
Oak Ridge, Tennessee 37830

Mr. Leonard Sullivan, Jr.  
Systems Planning Corporation  
1500 Wilson Boulevard  
Suite 1500  
Arlington, Virginia 22209

Mr. Howard Berger  
Analytical Assessments Corporation  
P. O. Box 9758  
Marina del Rey, California 90291

Mr. Robert Harker  
Systan, Inc.  
343 2nd Street  
P. O. Box U  
Los Altos, California 94022

The Council of State Governments  
Disaster Assistance Project  
1225 Connecticut Avenue, N.W.  
Suite 300  
Washington, D.C. 20036

Mr. Leo A. Hoegh  
Director, Council of State Governments  
Timpa Road  
Chipita Park, Colorado 80811

LTC David Thomas  
Defense Nuclear Agency  
ATTN: VLWS  
Washington, D.C. 20305

Jerome W. Weinstein  
Defense Intelligence Agency  
ATTN: DB-4N  
Washington, D.C. 20301

LTC Donald C. Anselm  
COPRA  
OJCS/SAGA  
Pentagon  
Washington, D.C. 20301

Dr. David W. Peterson  
Pugh-Roberts Associates, Inc.  
Five Lee Street  
Cambridge, MA 02139

Mr. Richard B. Foster  
Strategic Studies Center  
SRI International  
1611 N. Kent Street  
Arlington, Virginia 22209

General Leslie Bray  
The Analytic Sciences Corporation  
1601 N. Kent Street  
Suite 1201  
Arlington, Virginia 22209

Mr. Mark Earle, Jr.  
Director, Center for Economic Policy  
Research-Menlo Park  
SRI International  
333 Ravenswood  
Menlo Park, California 94025

Dr. Maynard M. Stephens  
152 Norgate  
3500 Division Street  
Letaire, Louisiana 70002

Dr. Gordon A. Saussy  
Director, Division of Business  
and Economic Research  
University of New Orleans  
Lake Front  
New Orleans, Louisiana 70122

Dr. Joseph E. Minor  
Director, Institute for Disaster Research  
College of Engineering  
Texas Tech University  
P. O. Box 4089  
Lubbock, Texas 79409

Mr. Harvey Lerner  
Cecchi and Company  
815 Connecticut Avenue, N. W.  
Washington, D.C. 20006

Research Triangle Institute  
ATTN: Mr. Robert Hendry  
Mr. Don Johnston  
P. O. Box 12194  
Research Triangle Park, North Carolina 27709

Boeing Company  
MASD Library  
ATTN: R. E. Shipp 23-99  
P. O. Box 3955  
Seattle, Washington 98124

Mr. Robert A. Merchant  
Chief, Emergency Planning Staff  
Office of the Secretary of the Treasury  
Washington, D.C. 20220

Mr. Harry Guintier  
Board of Governors for the Federal  
Reserve System  
Washington, D.C. 20551

Mr. Murray Rosenthal  
System Development Corporation  
2500 Colorado Avenue  
Santa Monica, California 90406

IITRI Institute  
ATTN: Mr. Arthur N. Takata  
10 West 35th Street  
Chicago, Illinois 60616

Stanford Research Institute  
ATTN: Mr. Francis W. Dresch  
Mr. Robert Rodden  
Menlo Park, California 94025

Institute for Defense Analysis  
400 Army-Navy Drive  
Arlington, Virginia 22202

Dikewood Corporation  
1009 Bradbury Drive, S. E.  
University Research Park  
Albuquerque, New Mexico 87106

Dr. William W. Chenault  
Human Sciences Research, Inc.  
Westgate Research Park  
7710 Old Springhouse Road  
McLean, Virginia 22101

Hudson Institute  
Quaker Ridge Road  
Croton-on-Hudson, New York 10520

Ohio State University  
Disaster Research Center  
127-129 West 10th Avenue  
Columbus, Ohio 43201

Defense Intelligence Agency  
ATTN: DS-4A2  
Washington, D.C. 20301

URS Research Company  
155 ovet Road  
San Mateo, California 94402

Mr. Richard K. Laurino  
Center for Planning and Research, Inc.  
750 Welch Road  
Palo Alto, California 94304

Office of Joint Chiefs of Staff, J-  
Pentagon 1D937A  
Washington, D.C. 20301

Mr. Gerald W. Collins, Executive Vice President  
National Defense Transportation Association  
1612 K Street, N. W.  
Suite 706  
Washington, D.C. 20006

Mr. Harvey Ryland  
Mission Research Corporation  
P. O. Drawer 719  
Santa Barbara, California 93102

Ms. Barbara Burroughs  
Technical Library  
U.S. Energy Research & Development Admin.  
Washington, D.C. 20545

General Research Corporation  
ATTN: Library/db  
7655 Old Spring House Road  
McLean, Virginia 22101

Dr. John Billheimer  
Systan, Inc.  
P. O. Box U  
Los Altos, California 94022

Mr. David L. Jones  
Bureau of Economics  
Room 38  
Interstate Commerce Commission  
Washington, D.C. 20423

Library, General Electric Company  
Space and REFD Divisions  
ATTN: Mr. L. I. Chasen, Manager  
Philadelphia, Pennsylvania 19104

Architectural and Engineering Development  
Information Center for Civil Defense  
540 Engineering Building  
University of Florida  
Gainesville, Florida 32601

Industrial College of the Armed Forces  
Washington, D.C. 20319

Director  
USAMC Intern Training Center  
Red River Army Depot  
ATTN: AMXMC-ITC-L  
Texarkana, Texas 75501

Central Intelligence Agency  
ATTN: CRS/DSB/IAS (Ms. Doris Lohmeyer)  
Washington, D.C. 20505

Commander  
Naval Ordnance Laboratory  
ATTN: Technical Library  
Silver Springs, Maryland 20910

Headquarters USAF (SAMI)  
ATTN: H. A. Quinn  
Pentagon 1D384  
Washington, D.C. 20330

Chief, National Military Command Systems  
Support Center  
(Code B210)  
The Pentagon  
Washington, D.C. 20310

**TEXAS EMERGENCY RESOURCE MANAGEMENT (TERM) Volume II**

Unclassified - TX DPS DES - September 1979 - 269 pages -

DCPA 01-78-c-0321, Work Unit 4351-E

**ABSTRACT**

This document is Volume II of Texas Emergency Resource Management (TERM). Part A covers emergency management of resources and contains overall State policies and guidance for the provision and use of essential resources to meet urgent needs in the State in a nuclear attack emergency or crisis relocation of the population. It also describes the system and identifies roles of Federal, State and local government organizations for the emergency management of essential resources available to the State. Part B includes separate resources sections containing specific provisions and procedures to implement overall State resource policies and guidance in the following resource categories:

- I. Economic Stabilization
- II. Construction

**TEXAS EMERGENCY RESOURCE MANAGEMENT (TERM) Volume II**

Unclassified - TX DPS DES - September 1979 - 269 pages -

DCPA 01-78-c-0321, Work Unit 4351-E

**ABSTRACT**

This document is Volume II of Texas Emergency Resource Management (TERM). Part A covers emergency management of resources and contains overall State policies and guidance for the provision and use of essential resources to meet urgent needs in the State in a nuclear attack emergency or crisis relocation of the population. It also describes the system and identifies roles of Federal, State and local government organizations for the emergency management of essential resources available to the State. Part B includes separate resources sections containing specific provisions and procedures to implement overall State resource policies and guidance in the following resource categories:

- I. Economic Stabilization
- II. Construction

**TEXAS EMERGENCY RESOURCE MANAGEMENT (TERM) Volume II**

Unclassified - TX DPS DES - September 1979 - 269 pages -

DCPA 01-78-c-0321, Work Unit 4351-E

**ABSTRACT**

This document is Volume II of Texas Emergency Resource Management (TERM). Part A covers emergency management of resources and contains overall State policies and guidance for the provision and use of essential resources to meet urgent needs in the State in a nuclear attack emergency or crisis relocation of the population. It also describes the system and identifies roles of Federal, State and local government organizations for the emergency management of essential resources available to the State. Part B includes separate resources sections containing specific provisions and procedures to implement overall State resource policies and guidance in the following resource categories:

- I. Economic Stabilization
- II. Construction

**TEXAS EMERGENCY RESOURCE MANAGEMENT (TERM) Volume II**

Unclassified - TX DPS DES - September 1979 - 269 pages -

DCPA 01-78-c-0321, Work Unit 4351-E

**ABSTRACT**

This document is Volume II of Texas Emergency Resource Management (TERM). Part A covers emergency management of resources and contains overall State policies and guidance for the provision and use of essential resources to meet urgent needs in the State in a nuclear attack emergency or crisis relocation of the population. It also describes the system and identifies roles of Federal, State and local government organizations for the emergency management of essential resources available to the State. Part B includes separate resources sections containing specific provisions and procedures to implement overall State resource policies and guidance in the following resource categories:

- I. Economic Stabilization
- II. Construction



- III. Electric Power
- IV. Food
- V. Petroleum, Gas and Solid Fuels
- VI. Health and Medical
- VII. Industrial Production
- VIII. Manpower
- IX. Transportation
- X. Water
- XI. Housing

These resource sections include emergency actions, action documents and organizational arrangement to carry on State management roles in particular resource fields.

- III. Electric Power
- IV. Food
- V. Petroleum, Gas and Solid Fuels
- VI. Health and Medical
- VII. Industrial Production
- VIII. Manpower
- IX. Transportation
- X. Water
- XI. Housing

These resource sections include emergency actions, action documents and organizational arrangement to carry on State management roles in particular resource fields.

- III. Electric Power
- IV. Food
- V. Petroleum, Gas and Solid Fuels
- VI. Health and Medical
- VII. Industrial Production
- VIII. Manpower
- IX. Transportation
- X. Water
- XI. Housing

These resource sections include emergency actions, action documents and organizational arrangement to carry on State management roles in particular resource fields.

- III. Electric Power
- IV. Food
- V. Petroleum, Gas and Solid Fuels
- VI. Health and Medical
- VII. Industrial Production
- VIII. Manpower
- IX. Transportation
- X. Water
- XI. Housing

These resource sections include emergency actions, action documents and organizational arrangement to carry on State management roles in particular resource fields.