

90499

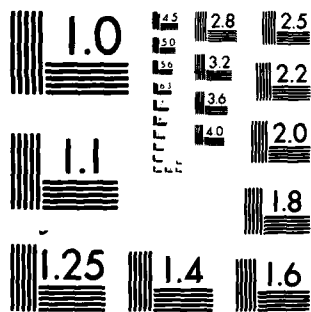

MICROCOPY RESOLUTION TEST CHART
NATIONAL BUREAU OF STANDARDS 1963-A

AIR FORCE



LEVEL *II*

2
uw

RECURSIVE FORECASTING SYSTEM
FOR PERSON-JOB MATCH

By

Donald E. Gustafson
Raman K. Mehra
William H. Ledsham
Salim Sajan
Scientific Systems, Inc.
Suite No. 309-310
186 Alewife Brook Parkway
Cambridge, Massachusetts 02138

MANPOWER AND PERSONNEL DIVISION
Brooks Air Force Base, Texas 78235

September 1980
Final Report

Approved for public release; distribution unlimited

SDTIC
SELECTED
OCT 15 1980

AD A090499

HUMAN RESOURCES

LABORATORY

DDC FILE COPY

AIR FORCE SYSTEMS COMMAND
BROOKS AIR FORCE BASE, TEXAS 78235

80 10 8 016

NOTICE

When U.S. Government drawings, specifications, or other data are used for any purpose other than a definitely related Government procurement operation, the Government thereby incurs no responsibility nor any obligation whatsoever, and the fact that the Government may have formulated, furnished, or in any way supplied the said drawings, specifications, or other data is not to be regarded by implication or otherwise, as in any manner licensing the holder or any other person or corporation, or conveying any rights or permission to manufacture, use, or sell any patented invention that may in any way be related thereto.

This final report was submitted by Scientific Systems, Inc., 186 Alewife Brook Parkway, Cambridge, Massachusetts 02138, under Contract F33615-78-C-0050, Project 2077, with Manpower and Personnel Division, Air Force Human Resources Laboratory (AFSC), Brooks Air Force Base, Texas 78235. Lt David K. Roberts (MPMD) was the Contract Monitor for the Laboratory.

This report has been reviewed by the Office of Public Affairs (PA) and is releasable to the National Technical Information Service (NTIS). At NTIS, it will be available to the general public, including foreign nations.

This technical report has been reviewed and is approved for publication.

NANCY GUINN, Technical Director
Manpower and Personnel Division

RONALD W. TERRY, Colonel, USAF
Commander

SUBJECT TO EXPORT CONTROL LAWS

This document contains information for manufacturing or using munitions of war. Export of the information contained herein, or release to foreign nationals within the United States, without first obtaining an export license, is a violation of the International Traffic in Arms Regulations. Such violation is subject to a penalty of up to 2 years imprisonment and a fine of \$100,000 under 22 U.S.C. 2778.

Accession For	
NTIS CMAI	<input checked="" type="checkbox"/>
DTIC TAB	<input type="checkbox"/>
Unannounced	<input type="checkbox"/>
Justification	
By _____	
Distribution/	
Availability Codes	
Dist	Avail and/or Special
A	

Unclassified

SECURITY CLASSIFICATION OF THIS PAGE (When Data Entered)

19 REPORT DOCUMENTATION PAGE		READ INSTRUCTIONS BEFORE COMPLETING FORM	
1. REPORT NUMBER AFHRL TR-79-83 ✓	2. GOVT ACCESSION NO. AD-A090499	3. RECIPIENT'S CATALOG NUMBER	
4. TITLE (and Subtitle) RECURSIVE FORECASTING SYSTEM FOR PERSON-JOB MATCH		5. TYPE OF REPORT & PERIOD COVERED Final Report	
6. AUTHOR(s) Donald E. Gustafson Salim/Sajan Raman K. Mehra William H. Ledsham		8. CONTRACT OR GRANT NUMBER(s) F33615-78-C-0050 NEW	
9. PERFORMING ORGANIZATION NAME AND ADDRESS Scientific Systems, Inc. Suite No. 309-310, 186 Alewife Brook Parkway Cambridge, Massachusetts 02138		10. PROGRAM ELEMENT, PROJECT, TASK AREA & WORK UNIT NUMBERS 62703F 20770411 1244	
11. CONTROLLING OFFICE NAME AND ADDRESS HQ Air Force Human Resources Laboratory (AFSC) Brooks Air Force Base, Texas 78235		12. REPORT DATE September 1980	
14. MONITORING AGENCY NAME & ADDRESS (if different from Controlling Office) Manpower and Personnel Division Air Force Human Resources Laboratory Brooks Air Force Base, Texas 78235		13. NUMBER OF PAGES 314	
15. SECURITY CLASS. (of this report) Unclassified		15a. DECLASSIFICATION/DOWNGRADING SCHEDULE	
16. DISTRIBUTION STATEMENT (of this Report) Approved for public release; distribution unlimited.			
17. DISTRIBUTION STATEMENT (of the abstract entered in Block 20, if different from Report)			
18. SUPPLEMENTARY NOTES			
19. KEY WORDS (Continue on reverse side if necessary and identify by block number) time series analysis Person-Job Match forecasting Kalman filtering adaptive filtering			
20. ABSTRACT (Continue on reverse side if necessary and identify by block number) The overall objective of this research effort was to investigate the applicability of time series analysis, state space modeling, and forecasting techniques to prediction of Person-Job Match (PJM) time series. This work was undertaken in order to provide more accurate input data for PJM and thereby yield higher payoffs to the Air Force. The approach taken was based on several new results in time series analysis and forecasting which allow one to automatically determine multivariate state space models empirically from input-output data. The state space approach is an extension of the Box-Jenkins method and gives superior results for multivariate time			

DD FORM 1 JAN 73 1473

393341

Unclassified

SECURITY CLASSIFICATION OF THIS PAGE (When Data Entered)

Handwritten initials/signature

Unclassified

SECURITY CLASSIFICATION OF THIS PAGE(When Data Entered)

Item 20 Continued

series. The form of the models is a Kalman filter/predictor. Once a model has been determined, predictions can be made based on this model and past data. Since the underlying dynamics of the time series may change in an unpredictable manner, provision has been made to estimate the parameters of the model recursively. This allows one, for example, to follow the effects of policy changes (fast rate of change of parameters) or more long-term changes which cannot be explicitly modeled.

The technical effort was divided into three major phases:

Phase I: PJM payoff matrix column mean data over a five-year period, beginning in January 1973, were collected and statistically analyzed. A total of 50 categories were selected to span the dimensions of sex, skill score and job area (*Administrative, Electronic, General and Mechanical*). A frequency analysis showed that various series contained significantly different spectra, with peaks at 6/year, 4/year, and 3/year. The semiannual component is probably tied to the academic year. A correlation analysis showed that most female high skill series move together. Female low skill series also showed the same trend, though not as marked. Male series were, in general, correlated, but were less so than the female series. Male and female series were essentially uncorrelated. A set of state space models was developed for the individual time series. A set of Kalman filter/predictors was then generated, based on the state space models.

Phase II: An adaptive Kalman filter methodology was developed for the PJM data. The adaptive filter was an approximate maximum likelihood estimator for the Kalman filter/predictor parameters. Two adaptation parameters were used: (a) an age weighting parameter to discount old data, and (b) an adaptation time constant to control the rate of change of the parameter estimates. The adaptation parameters were themselves varied recursively to minimize the mean-squared prediction errors. The dynamic coefficients of a linear Kalman filter/predictor were estimated causally from the data, along with the usual Kalman filter state estimates, and shown to give better performance than the non-adaptive (stationary) Kalman filter/predictor.

Phase III: An extended Kalman filter was developed for use on the PJM data. This filter was intended for use in estimating the parameters of the Kalman filter; i.e., the problem studied was that studied in Phase II. The extended filter did not appear as suitable for use on PJM data due to: (a) increased complexity, (b) its generally poor convergence properties, and (c) its generally decreased accuracy.

Unclassified

SECURITY CLASSIFICATION OF THIS PAGE(When Data Entered)

TABLE OF CONTENTS

	<u>page</u>
1. INTRODUCTION	6
2. PJM SYSTEM DESCRIPTION	8
2.1 Problem Statement	8
2.2 Problem Formulation	9
3. PAYOFF DATA ANALYSIS	12
3.1 Data Used in the Study	12
3.2 Preliminary Discussion of Basic Time Series Behavior	12
4. STATE SPACE MODELING AND PREDICTION FOR TIME SERIES DATA	15
4.1 Introduction	15
4.2 State Space Models	16
4.3 Recursive State Estimation and Kalman Filter Equations	20
4.4 Properties of Kalman Filters	22
5. STATE SPACE MODEL STRUCTURE DETERMINATION	26
5.1 Theoretical Basis	26
5.2 State Space Models	26
5.3 Stochastic Realization Theory	27
5.4 Transformation to Stationarity	28
5.5 Development of Kalman Filter from Canonical State Space Model	30
6. STATIONARY STATE SPACE MODELS - RESULTS	34
6.1 Introduction	34
6.2 Discussion of Results	34
7. ADAPTIVE KALMAN FILTERING METHODOLOGY FOR PJM PAYOFF DATA	36
7.1 Motivation	36
7.2 Approaches to Adaptive Filtering	43
7.3 Maximum Likelihood Estimation	43
7.4 Development of Adaptive Filtering Algorithm	45

8.	ADAPTIVE FILTERING OF PJM PAYOFF DATA	55
8.1	Nature of the Experiment	55
8.2	Determining γ and β	56
8.3	Results and Discussion	57
9.	CONCLUSIONS AND RECOMMENDATIONS	93
	REFERENCES	96
APPENDIX A	Payoff Data	99
APPENDIX B	Stationary State Space Model Data	164
APPENDIX C	An Extended Kalman Filter for PJM Time Series Data	243
C.1	Problem Formulation	243
C.2	Extended Filter Development	244
C.3	Comparison with Maximum Likelihood Adaptive Filter	247
APPENDIX D	Adaptive Filtering Tests Using Known Time Series Models	250
D.1	Adaptive Filter Algorithm Tests on Completely Observed Data	251
D.2	Adaptive Filter Tests on Partially Observed Data	253

LIST OF FIGURES

	<u>page</u>
4.1 State Vector Model	17
4.2 A Discrete-Time Kalman Filter in Two Dimensions	23
5.1 Flow Diagram of State Space Forecasting Program	29
7.1 12-Month Moving Average for F42333 Payoff	37
7.2 12-Month Moving Average for F20530 Payoff	38
7.3 12-Month Moving Average for M67232 Payoff	39
7.4 12-Month Moving Average for M27131 Payoff	40
7.5 12-Month Moving Average for F46330 Payoff	41
7.6 12-Month Moving Average for M30230 Payoff	42
8.1 Adaptive Filter One Month Predictions of F42333	61
8.2 Adaptive Filter One Month Prediction of F20530	62
8.3 Adaptive Filter One Month Prediction of M30230	63
8.4 Adaptive Filter One Month Prediction of F46330	64
8.5 Adaptive Filter One Month Prediction of M67232	65
8.6 Adaptive Filter One Month Prediction of M27131	66
8.7 Adaptive Filter One Month Prediction of TSK288	67
8.8 Adaptive Filter One Month Prediction of TSK287	68
8.9 Adaptive Filter 3-Month Prediction of F42333	69
8.10 Adaptive Filter 3-Month Prediction of F20530	70
8.11 Adaptive Filter 3-Month Prediction of M30230	71
8.12 Adaptive Filter 3-Month Prediction of F46330	72
8.13 Adaptive Filter 3-Month Prediction of M67232	73
8.14 Adaptive Filter 3-Month Prediction of M27131	74
8.15 Adaptive Filter 3-Month Prediction of ISK288	75
8.16 Adaptive Filter 3-Month Prediction of TSK287	76
8.17 Adaptive Filter 12-Month Prediction of F42333	77
8.18 Adaptive Filter 12-Month Prediction of F20530	78

8.19	Adaptive Filter 12-Month Prediction of M30230	79
8.20	Adaptive Filter 12-Month Prediction of F46330	80
8.21	Adaptive Filter 12-Month Prediction of M67232	81
8.22	Adaptive Filter 12-Month Prediction of M27131	82
8.23	Adaptive Filter 12-Month Prediction of TSK288	83
8.24	Adaptive Filter 12-Month Prediction of TSK287	84
8.25	γ and β Parameters Used in Filtering F42333	85
8.26	γ and β Parameters Used in Filtering F20530	86
8.27	γ and β Parameters Used in Filtering M30230	87
8.28	γ and β Parameters Used in Filtering F46330	88
8.29	γ and β Parameters Used in Filtering M67232	89
8.30	γ and β Parameters Used in Filtering M27131	90
8.31	γ and β Parameters Used in Filtering TSK288	91
8.32	γ and β Parameters Used in Filtering TSK287	92
9.1	Disturbance Filter Applied to Series F42333	95
A.1 - A.51	Payoff Data	99
B.1 - B.52	Stationary State Space Model Data	191
D.1 - D.47	Adaptive Filtering Test Data	252 266

LIST OF TABLES

	<u>page</u>
3.1 Series Analyzed in Data Set #1	14
7.1 Adaptive Filtering Algorithm	54
8.1 Prediction Error Summary of Adaptive Filter and Persistence Predictor	59
8.2 Adaptive Filter Performance on Series TSK288 Using Various γ and β	60
Appendix A, 1 - 2 Payoff Data	150
Appendix B, 1 - 27 Stationary State Space Model Data	164

1. INTRODUCTION

The computer-based Air Force Advanced Personnel Data System (APDS) and the Procurement Management Information System (PROMIS) utilize several advanced concepts from the field of statistics and operations research (Ward, Haney, Hendrix and Pina, 1978). In particular, the Person-Job Match (PJM) system is based on the development of a payoff matrix the $(i, j)^{th}$ element of which represents the predicted payoff to the Air Force of assigning the j^{th} job to the i^{th} individual. The purpose of the PJM system is to maximize the total payoff to the Air Force over all tasks and individuals. Since the PJM system is sequential, a job has to be assigned to a person at the current time without full knowledge of the availability of persons and their job skills in the future. For example, if the planning horizon is 9 months, the optimal allocation of jobs at the current time would depend on the statistics of the available pool of applicants over the next 9 months. In this sense, the PJM problem is one of stochastic optimization or of decision under uncertainty. The method by which this problem is being solved is discussed at greater length in Chapter 2. For the purposes of this discussion, it will suffice to state that the present algorithm relies on the column mean (average over task) of the payoff matrix. Due to the large number of transactions that occur in the system, it is not feasible to maintain current column means. The quantities used must thus be estimates of the current means given historical data. It is this problem of payoff mean time series estimation that this report will address.

Over the last 30 years, starting with the groundbreaking work of Bellman (1957) on Dynamic Programming and that of Kalman (1960) on prediction, a large amount of research has been done in the field of stochastic optimization and control. The state space representation of dynamic and multistage systems has played a key role in the solution of these problems. The earliest applications of these techniques took place . . . in the aerospace field where the state space models were easy to derive from known physical laws. The applications in the management and socio-economic areas have been slow to develop due to the difficulty of deriving state space models for such systems. However, recent work in the area of system identification (e.g., IEEE, 1974; Mehra and Lainiotis, 1976) has provided several methods for deriving state space models empirically from input-output data. This research has studied the application of the concepts for solving the PJM problem.

The specific method of approach consisted of four phases which progressed from the initial development of a linear Kalman filter/predictor (Phase I) for job column payoff means to its enhancement by using adaptive (Phase II) and extended (Phase III) Kalman filtering techniques, followed by a more general study of the PJM system for further improvements and applications of the state space techniques (Phase IV). Since the structure of the state space model and parameter values cannot be inferred directly from theoretical or first-principle considerations, techniques of system identification, parameter estimation and time series analysis (IEEE, 1974; Mehra and Lainiotis, 1976) have been used for building

predictive models. Scientific Systems, Inc. has utilized already-developed software for state space model structure determination using canonical correlations and for parameter estimation using the maximum likelihood method. A brief description of these programs is contained in Chapter 4. The state space forecasting program described in Chapter 4 also performs automatic detrending and deseasonalizing to convert non-stationary time series into stationary time series.

The models for the Kalman filter/predictor are based on historical data and a priori knowledge. Since the structure of the real system may change over time, it is important to detect these changes and adapt the Kalman filter accordingly. The exact form of the adaptive filter depends upon the expected structural changes, but the techniques of model validation and hypothesis testing (Chapter 4) can be used to detect changes in system structure, states and parameters. These techniques have been applied to the PJM time series.

Extended Kalman filters can provide improvements to the basic Kalman filter to account for non-Gaussian statistics, nonlinearities in the state and measurement equations and errors in independent variables (Mehra, 1976), which may be present in the PJM system. They can also provide an alternate adaptive filter methodology.

Application of stochastic control techniques for optimal assignment under uncertainty (e.g., to take into account confidence levels on forecasts and to use second order statistics of the payoff series) is one method of solving the PJM assignment problem.

This report is organized as follows. In Chapter 2, a basic description of the PJM system is given, and the problem of payoff matrix column mean prediction is discussed. Chapter 3 presents a statistical analysis of payoff data spanning a 5-year period, from January 1973. The notions of state space modeling and prediction for time series data are introduced in Chapter 4, including the formulation of the prediction problem in a Kalman filtering regime. Chapter 5 presents an efficient technique for model structure determination, based on recent results in stochastic realization theory. The methods in Chapter 5 are limited to stationary processes. State space models for selected PJM time series are given in Chapter 6; predictions based on these models are found and compared with persistence predictions. Analysis of PJM data has revealed significant nonstationarities in the parameters of the linear models. The nonstationary problem is attacked by using a parameter-adaptive Kalman filter predictor, developed in Chapter 7. This adaptive algorithm is an approximate maximum likelihood estimator. An alternative approach is to use an Extended Kalman filter for parameter adaptation. This method is discussed in Appendix C. The adaptive algorithms are applied to the problem of PJM time series prediction in Chapter 8 and to prediction for series with known mathematical structure in Appendix D. Numerical comparisons indicate that improvements can be obtained over the use of stationary time series models. Conclusions and recommendations for further work are given in Chapter 9.

2. PJM SYSTEM DESCRIPTION

2.1 Problem Statement

The assignment procedures in the Air Force Procurement Management Information System (PROMIS) are well described in Ward et al. (1977). The critical information for person-job matching is the Predicted Payoff Array, which contains payoff values estimated from a mathematical model using person-job information and the subjective judgement of Air Force managers (Ward, 1977). The assignment problem may be solved using optimal algorithms for batch assignment or near-optimum algorithms for sequential-constrained-choice assignment. It is more useful in practice to develop an allocation array using decision indices (Ward, 1959) since alternative assignments that are nearly optimal can also be indicated.

The PJM problem has mostly been formulated in the operations research literature as a static deterministic assignment problem. In practice, however, it is a stochastic dynamic problem in which decisions have to be made sequentially over time based on the best current information to optimize the payoff over a certain period of time. In this sense, the PJM problem is akin to the Secretary Problem (Bellman, 1957), but much larger in size and scope. Bayesian statistical decision theory and stochastic control provide suitable mathematical frameworks for such problems. The most elegant results in stochastic control and Bayesian decision analysis are available for the so-called Linear-Quadratic-Gaussian (LQG) problem, involving linear dynamics, Gaussian statistics and quadratic cost or payoff function (IEEE, 1971). The optimal decision law is a linear function of the optimal state estimate and the control law does not depend on the second and higher order moments of the state estimates (certainty equivalence principle). The optimal state estimate is given by a linear Kalman filter (Kalman, 1960).

The PJM problem does not satisfy all the assumptions of the LQG formulation, but its optimal solution in a constrained sequential mode would involve forecasting of job skill levels over the planning horizon. If we denote by $r_{i,j}(t)$ the payoff (or reward) at time t of matching individual i to job j , then the variation of $r_{i,j}(t)$ over the individuals (i.e., i 's) may be described by a probability distribution function $P_{j,t}(\bar{r})$. In other words, $P_{j,t}(\bar{r})$ denotes the fraction of applicants with payoff less than or equal to \bar{r} for job j and time t . If the pool of applicants is very large, $P_{j,t}(\bar{r})$ would tend to be a continuous function of \bar{r} and can be differentiated to obtain a probability density function $p_{j,t}(\bar{r}) = dP_{j,t}(\bar{r})/d\bar{r}$. In a sequential decision process, the optimal allocation of individuals to jobs would be done in such a way as to maximize the expected payoff, EP , with respect to all feasible feedback assignment rules $\{a_{i,j}(r_j(1), \dots, r_j(t))\}$ where

$$EP(a) = \sum_{t=1}^T \sum_{j \in J} \sum_{i \in I} E\{r_{ij}(t) a_{i,j}(r_j(1), \dots, r_j(t))\}$$

$E\{\cdot\}$ denotes expectation with respect to $P_{j,t}(r)$; $a_{i,j}(r_j(1), \dots, r_j(t))$ is a binary valued function (1 or 0) specifying an assignment at time t of individual i to job j based on the observed payoffs $\{r_j(1), \dots, r_j(t)\}$.*

In practice, this decision function is too complex to implement, so that certain statistics of the observed payoffs will be used, e.g., the mean value $\hat{m}_j(t-1) = \frac{1}{(t-1)} \sum_{\tau=1}^{t-1} r_j(\tau)$ and $r_j(t)$ may be used,** as is currently being done in the APDS-PROMIS system. Another choice would be $\{\hat{m}_j(t-1), \hat{\sigma}_j(t-1), r_j(t)\}$ where the assignment also takes into account the standard deviation, $\hat{\sigma}_j(t-1)$ around the mean $\hat{m}_j(t-1)$. Irrespective of how the decision function is defined, the optimal assignment still involves maximization of R with respect to assignment rules for future time periods. The exact formulation of this problem requires use of dynamic programming or backward induction (Bellman, 1957), which though useful from a conceptual point of view, is computationally impractical with current state of the art. A good suboptimal procedure at time t is to forecast the values of the future mean payoffs, namely, $\hat{m}_j(t+1), \dots, \hat{m}_j(T)$ and to solve a deterministic assignment problem assuming certainty equivalence, namely, the forecast mean values are the actual mean values. If the decision rule also includes the standard deviation $\hat{\sigma}_j(t)$, then these deviations may also be forecast and used for assignment. All the forecasts would be updated with each new applicant, using a recursive filter/predictor. The details of this procedure are discussed in the next chapter.

2.2 Problem Formulation

In the previous section, it was shown that a solution of the stochastic multistage PJM problem requires forecasting of future mean payoffs over the planning horizon (9 months in PROMIS). Since historical data on the mean payoffs are available, statistical model-building methods using state space or time series methods can be used for forecasting. The advantages of using state space methods are that multiple time series can be handled in essentially the same way as single time series, and control theory methods can be used for decision analysis. In addition, once a state vector model has been identified, Kalman filtering techniques can be used for recursive forecasting. The confidence intervals for forecasts are also obtained directly from the covariance calculations which are an integral part of the Kalman filter.

The basic payoff model for PJM at time of contract start was:

$$Y = b_0 Y_0 + b_3 Y_3 + b_{11} Y_{11} + b_{12} Y_{12} + b_{13} Y_{13} + b_2 Y_2 + b_3 Y_3$$

where

Y = payoff value of a particular person assigned to a particular job;

*If decision indices are used, $a_{i,j}$ will be a continuous variable.

**A hat over a quantity denotes its estimate.

- Y_0 = constant fill component, which is given to eligible person-job combinations so that each possible classification is assigned a positive payoff;
- Y_{13} = indicator of skill area preference (Mech, Admin, Gen, or Elect);
- Y_{11} = aptitude-difficulty component, which is a composite function of applicant aptitude and job difficulty;
- Y_{12} = technical school success component, which is a prediction of final technical school grades based on a regression of final grades of previous graduates onto their aptitude test scores, high school graduation status and high school courses taken;
- Y_2 = variable fill component, which is a function of time left until a particular enlistment date and of the proportion of a specific job quota for that date which has been filled. Typically, Y_2 is increased as the deadline approaches;
- Y_3 = minority/non-minority component, which is a function of percent minority/non-minority representation on a given job. Y_3 increases for jobs with lower than average representation.

The weights b_0, b_{11}, \dots control the priorities of the six components and are specified by managers and policy makers. The coefficients are adjusted so that the maximum payoff is 1000.

Given a set of payoffs $\{Y^{ij}; i=1, \dots, m; j=1, \dots, n\}$ for m people and n jobs, the payoff matrix is

$$\begin{bmatrix} Y^{11} & Y^{12} & \dots & \dots & Y^{1n} \\ \cdot & & & & \\ \cdot & & & & \\ \cdot & & & & \\ Y^{m1} & \dots & \dots & \dots & Y^{mn} \end{bmatrix}$$

and the column means are

$$\bar{Y}^j = \frac{1}{m} \sum_{i=1}^m Y^{ij}$$

The data available for this study included column means over a 5-year period (1973-1977) for the total payoff and for the components Y_{11} and Y_{12} . In addition, total number and eligible number of applicants data were supplied. Data for a total of 320 job categories (CAFSC) were supplied.

The accuracy of predicting column means is of particular importance for optimally assigning applicants in a sequential procedure such as PJM. No accurate dynamical models for this set of time series, based on economic modeling, presently exist, nor are they likely to be developed. The problem is compounded by high month-to-month variation which sometimes causes certain series to look like a white noise (i.e., completely unpredictable) process. However, the times at which policy changes which might affect the nature of the time series go into effect will be known. This information can be used to look for trends in the data at specific times. Thus, the prior information relating to possible structural properties of the PJM column means is minimal.

The best approach to the problem at present is to utilize empirical techniques based on stochastic realization theory, which are important generalizations of the well-known techniques of regression analysis.

The specific problem addressed in this report is development of a systematic methodology for time series prediction which will be applicable to PJM time series data. The techniques developed are quite general in nature, but will be demonstrated to possess merit for the specific problem studied. That is, they are demonstrated to offer improvements over traditional (stationary) time series analysis techniques when used to predict payoff column means.

3. PAYOFF DATA ANALYSIS

3.1 Data Used in the Study

The basic data sets used in this study consisted of two sets of time series. Both sets consisted of monthly averages or totals broken down by job category, Control Air Force Specialty Code (CAFSC), and spanned 5 years beginning with January 1973. There were thus 60 data points in each series analyzed. The first data set used consisted of monthly column means of the payoff data. The second data set consisted of the monthly means of two components that are used in computing the total payoff (known as Y_{11} and Y_{12}) and the monthly totals for eligible individuals and total individuals for each category. These last two quantities modulate the number of applicants for the various job categories and so may be seen to affect the variable fill component used in the payoffs.

Both data sets display much the same basic character. For this reason, this section and those that follow will emphasize the data set consisting of only monthly payoffs. Also, since the data set consists of 320 categories, only a representative sample of job categories was selected to span the various categories in their various dimensions of sex, skill score, and job area (Admistrative, Electronic, General and Mechanical)

A total of 50 payoff series were analyzed to determine their basic statistical behavior. These series are listed in Table 3.1.

3.2 Preliminary Discussion of Basic Time Series Behavior

It is often desirable to examine plots of the basic data to discover any underlying trends, similarities between series, etc. that may be tied to an understood phenomenon. A set of plots of the raw series, their 3-month moving averages and 12-month moving averages for a set of representative series are given in Appendix A, Figures A.1 - A.45. As may be seen, the series exhibit a variety of behaviors.

The E80F class data appear very noisy, indicating that prediction will be relatively difficult. The remaining E80F class data were smoother, with a single peak near December 1975. The E70F data are relatively smooth and show two peaks--one near December 1974 and one near December 1976. The E60F data match E70F closely, and E50F also looks similar to the E70F class. G60F data do not exhibit the peak near December 1976. M50F data are doubly peaked with the first peak somewhat lower and occurring earlier. The male series are, in general, smoother than the corresponding female series. All series should probably be regarded as nonstationary due to their lack of a long-term mean. Two general trends appear that are not well understood in terms of a causal event or policy change. The first trend is the rapid increase in the payoff beginning in January 1976. The second is the leveling off and falling of the payoff beginning in 1977. The 3-month averages also show the expected local peak of payoff in the summer months. The anticipated midwinter peak is often absent. These peaks have been historically associated with an increase in enlistments at the end of the first and second terms of the academic year.

For the remaining classes, G50F, G40F and A40F cluster and exhibit a rise in 1974, wide variation during 1975 and 1976, and a fall during 1977. Classes A50F and M40F exhibit unique shapes. These data suggest that only a few significantly different time series models may possibly represent most of the time series data.

Because of the fact that it is expected that cyclical variations will occur in the data due to academic year end, etc., it is also of interest to investigate the structure of the series. If this is done, a variety of behaviors is observed. A sample of these behaviors is given in Appendix A, Figures A.46-A.51. The series F30430 displays a frequency peak corresponding to a component with a 4-month period. F43130 shows a peak with subannual frequency, but also appreciable components at semiannual and quarterly periods. Similar behavior occurs in F27131 and F42333, but with diminished higher frequencies. In F20430, the higher frequencies are almost gone, while M23123 shows hardly any higher frequencies. The semiannual component is probably tied to the academic year. The cause of the higher frequencies is unknown, and the lower frequencies are probably the result of policy changes.

Due to the similarity in shapes between some of the time series, it is of interest to investigate the interclass correlation functions. These correlation functions are given for both the raw series and the movement (first difference) of the series in Tables 1 and 2 (Appendix A), respectively. Examining these tables, it is possible to make several observations: certain groups such as the E80 female jobs (variables 1 to 4) are highly correlated with themselves but not with most other jobs. The only significant correlation is a mild one with the female E70 job 46330 (variable 11). It is interesting to note that the E80F jobs do not show significant correlation with the E80M jobs. This may indicate that the variable fill component may dominate the payoff for certain groups since all the E80F jobs are competing for the same small pool of recruits. A similar behavior is observed for the A80M jobs (variables 30 and 31).

Interpretation of the correlation matrix of the series movement is that most female high skill series move only in unison with their group. That is, the A80F jobs will move as a group but are not strongly correlated with members of other groups. The low skill female series show a greater tendency to move in a correlated fashion with members of other female low skill groups. It is interesting to note that the movement of the female series is not significantly correlated with the movement of the male series. The male series show a higher tendency to be correlated with each other than do the female series.

This completes the basic time series analysis of the raw data. Because of the nonstationary behavior of the series, statistics such as means, variance, kurtosis, etc. have little or no applicability and will not be presented.

Table 3.1
Series Analyzed in Data Set #1

CAFSC	Skill Level	Series Name Used in this Report
30230	E80	X30230
30331	E80	X30331
30333	E80	X30333
30430	E80	X30430
67231	A80	X67231
67232	A80	X67232
20230	G80	X20230
20530	G80	X20530
20830	G80	X20830
25130	G80	X25130
46330	E70	X46330
46230	E60	X46230
20430	G60	X20430
54130	E50	X54130
54230	E50	X54230
54231	E50	X54231
54232	E50	X54232
54530	E50	X54530
99000	E50	TSK295 - Female, TSK296 - Male
43130	E50	X43130
42732	G50	X42732
99000	A50	TSK287 - Female, TSK288 - Male
23132	G40	X23132
27131	A40	X27131
42333	M50	X42333

X signifies that male series are prefixed by M, female series by F

4. STATE SPACE MODELING AND PREDICTION FOR TIME SERIES DATA

4.1 Introduction

In Chapter 2, the payoff $r_j(t)$ for job j was defined as a stochastic process in the sense that it is a function of time t and of a random variable s (e.g., skill) which varies over the population of applicants.* The probability distribution of $r_j(t)$ was denoted by $P_{j,t}(\bar{r}(t))$ where

$$P_{j,t}(\bar{r}) = \text{Prob}\{r_j(t) \leq \bar{r}\} \quad (4.1)$$

The mean payoff $m_j(t)$ over a given population of applicants is, therefore, defined as

$$m_j(t) = \int_{S_j} \bar{r} dP_{j,t}(\bar{r}) = E\{r_j(t)\} \quad (4.2)$$

where S_j denotes the set of all possible payoffs for job j . For a sequential-constrained solution of the PJM problem, one is interested in the time-evolution of the probability distribution function $P_{j,t}(\bar{r})$ or, more modestly, of the mean $m_j(t)$.** Assuming that the time evolution of $m_j(t)$ consists of deterministic (e.g., trend, seasonal) as well as stochastic components describable by a finite order Gauss-Markov process, one can construct a state vector model of the following type:

$$x_j(i+1) = \phi_j x_j(i) + v_j(i); \quad i = \text{sample number} \quad (4.3)$$

$$m_j(i) = H_j x_j(i) \quad (4.4)$$

Here $x_j(i)$ is an $n \times 1$ vector of state variables, where n is the sum of the orders of the deterministic and stochastic components. $v_m(i)$ is a Gaussian white noise (i.e., uncorrelated in time) sequence with mean \bar{v}_j and covariance Q_j . The matrices $\phi_j (n \times n)$ and $H_j (1 \times n)$ are known as the state-transition and output transformation matrices. The definition of the state vector $x_j(i)$ is not unique, and any other vector related to $x_j(i)$ by a nonsingular $n \times n$ transformation matrix is also a state vector. This fact can be used to simplify the structure of matrices ϕ_j and H_j to certain canonical forms. Once the canonical forms have been chosen, the

*To be more precise, payoff should be denoted as $r_j(s,t)$.

**An obvious extension would be to study the time evolution of both the mean and the variance of $r_j(t)$.

dimension of the state vector and consistent estimates for the parameters are obtained by using Akaike's Canonical Correlation Technique (Akaike, 1974).

The state vector model of Eq. (4.3) - (4.4) does not take into account lagged payoff correlations between jobs. For example, if the mean payoffs m_j and m_k on jobs j and k tend to be correlated with each other at different times, an augmented state space model may be defined as follows:

$$\begin{bmatrix} x_j(i+1) \\ x_k(i+1) \end{bmatrix} = \begin{bmatrix} \phi_j & \phi_{j,k} \\ \phi_{k,j} & \phi_k \end{bmatrix} \begin{bmatrix} x_j(i) \\ x_k(i) \end{bmatrix} + \begin{bmatrix} v_j(i) \\ v_k(i) \end{bmatrix} \quad (4.5)$$

$$\begin{bmatrix} m_j(i) \\ m_k(i) \end{bmatrix} = \begin{bmatrix} H_j, 0 \\ 0, H_k \end{bmatrix} \begin{bmatrix} x_j(i) \\ x_k(i) \end{bmatrix} \quad (4.6)$$

where the off-diagonal block matrices $\phi_{k,j}$ account for the interaction over time between job payoffs. The advantage of using Eq. (4.5) - (4.6) is that the predictions of $m_j(i)$ and/or $m_k(i)$ may be improved since one series may contain leading-indicator type of information for the other series.

Further improvements of the state space models may be obtained by including exogenous variables, denoted by vector u . Examples of possible exogenous variables that would influence payoffs are better educational background, increased standard of living, special training, incentive programs, improved salaries, advertising and special recruitment campaigns. The exogenous variables can be included in Eq. (4.3) - (4.4) as follows:

$$x_j(i+1) = \phi_j x_j(i) + G u_j(i) + v_j(i) \quad (4.7)$$

$$m_j(i) = H_j x_j(i) + D u_j(i) \quad (4.8)$$

where G is the input distribution matrix expressing the influence of exogenous variables on the state of the system.

We now discuss in detail the state space modeling methodology.

4.2 State Space Models

State space models of random processes are based on the Markov property which, in simple terms, implies the independence of the future of the process from its past, given the present state. In other words, the state of a Markov process summarizes all the information from the past that is necessary to predict its future. For obvious reasons, only the case where the state vector is finite dimensional is of practical interest. A general state vector model is typically specified in terms of the following five quantities (see Figure 4.1): (i) three vectors respectively of input $u(i)$, output $y(i)$ and internal state variables $x(i)$; (ii) a rule for

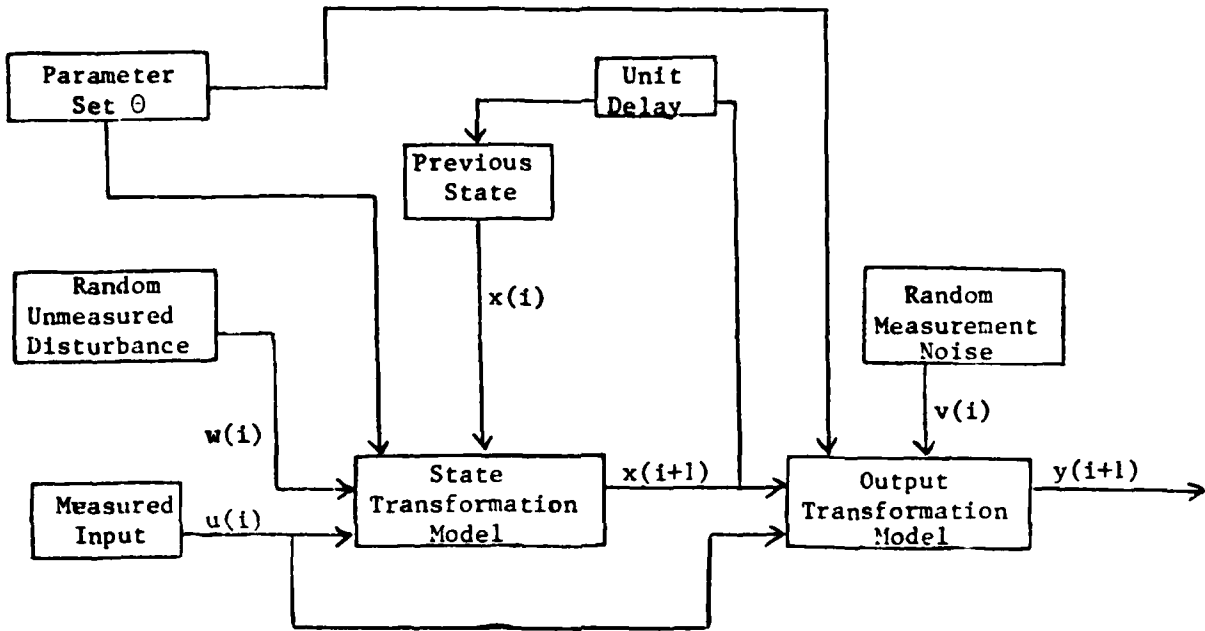

Figure 4.1. State Vector Model

transformation of the state vector from one time instant to the next; (iii) a relationship between the input-output and state variables; (iv) initial state $x(0)$ and (v) joint statistics of all random variables. Mathematically,

$$x(i+1) = f(x(i), u(i), \theta, i) + w(i) \quad (4.9)$$

$$y(i) = h(x(i), u(i), \theta, i) + v(i) \quad (4.10)$$

$$i = 0, 1, 2, \dots$$

where $x(i)$ is $n \times 1$ state vector, $u(i)$ is $r \times 1$ input vector, $w(i)$ is $q \times 1$ process noise vector, θ is $m \times 1$ parameter vector, $y(i)$ is $p \times 1$ output vector and $w(i)$ and $v(i)$ are assumed to be uncorrelated white noise sequences with known distributions. Similarly, the distribution of $x(0)$ is assumed known.

All mathematical models including the state vector model are only approximations to reality. It will be shown here that a number of models used in forecasting can be written in the form of Eq. (4.9) and (4.10). If the model is physical or conceptual, the state $x(i)$ has a physical meaning. In black-box or time series models, the state need not have a physical meaning. However, it still possesses an abstract mathematical meaning stated above for a Markov process.

When Eq. (4.9) and (4.10) are linear, then the model is known as a Gauss-Markov model. It is of special significance and is written as

$$x(i+1) = \Phi x(i) + Gu(i) + \Gamma w(i) \quad (4.11)$$

$$y(i) = Hx(i) + v(i) \quad (4.12)$$

$$i = 0, 1, 2, \dots$$

where $w(i)$ and $v(i)$ are assumed to be Gaussian white noise (GWN) sequences with zero mean and covariances Q and R . The initial state $x(0)$ is normally distributed with mean \hat{x}_0 and covariance P_0 . The matrices Φ , G , H , Γ , Q , R and P_0 are deterministic but may be time-varying. The main advantage of the representation (4.11) and (4.12) is that the mean, covariance and correlation functions for $x(i)$ and $y(i)$ can be computed recursively by solving a set of first order vector difference equations (Bryson and Ho, 1969). Furthermore, the posterior distribution $p(x(i)|y(i), y(i-1), \dots, y(1))$ turns out to be Gaussian and its first two moments are computed recursively by the Kalman filter.

Process and Measurement Noise

The state vector model (4.11) - (4.12) contains two white noise terms, namely, process noise $w(i)$ and measurement noise $v(i)$, which physically have quite different interpretations and effects. $v(i)$ represents the errors inherent in observing the true state of the system $x(i)$, whereas $w(i)$ represents random shocks during the evolution of $x(i)$. If we neglect $v(i)$ and assume for the time being that all the state variables can be observed, i.e., $y(i) = x(i)$ and all matrices are time-invariant, Eq. (4.11) may be written as

$$y(i+1) = \phi y(i) + Gu(i) + \Gamma w(i) \quad (4.13)$$

Eq. (4.13) represents a first-order autoregressive process with observed input (or exogenous variable) $u(i)$ and random errors $w(i)$ (Whittle, 1963). Chow (1975) and Mehra (1974) show how econometric simultaneous equations models may be written in the form of Eq. (4.13).

Consider now the case where there is no process noise, i.e., $w(i) \equiv 0$, and the initial state $x(0)$ is known perfectly. Then, given $\{u(i)\}$, the $\{x(i)\}$ process is deterministic and Eq. (4.12) represents a signal plus noise model. The prediction problem, in this case, consists essentially of separating the signal from the noise. Notice that this nice interpretation may be lost if $x(i) = y(i) - v(i)$ is substituted into Eq. (4.11) yielding

$$y(i+1) = \phi y(i) + Gu(i) + (v(i+1) - \phi v(i)) \quad (4.14)$$

Eq. (4.14) corresponds to a vector first order Autoregressive Moving Average (ARMA) model (Whittle, 1963). The same type of model is obtained even if the $w(i)$ term is kept in the model.

To show the modeling flexibility of the state vector form, we consider the following examples:

(i) Time Varying Regression Model. Consider a time varying regression model with $d(i)$ as the dependent variable and $z_1(i), \dots, z_m(i)$ as the independent variables.

$$d(i) = \sum_{k=1}^m a_k(i) z_k(i) + \eta(i) \quad (4.15)$$

Assume further that the time variation of each of the regression coefficients may be described by a first order scalar model with random shocks $\xi_k(i)$, namely

$$a_k(i+1) = \alpha_k a_k(i) + \xi_k(i) \quad (4.16)$$

$$k = 1, \dots, m$$

Eq. (4.15) and (4.16) may be expressed in the form (4.11) - (4.12) by defining

$$y(i) = d(i), \quad \eta(i) = v(i)$$

$$x^T(i) = [a_1(i), \dots, a_m(i)], \quad G = 0, \quad \Gamma = I$$

$$H(i) = [z_1(i), \dots, z_m(i)]$$

$$\phi = \begin{bmatrix} \alpha_1 & & & \\ & \alpha_2 & & \\ & & \ddots & \\ & & & \alpha_m \end{bmatrix} \quad w(i) = \begin{bmatrix} \xi_1(i) \\ \vdots \\ \xi_n(i) \end{bmatrix}$$

(ii) Error-in-Variable Model (EVM) with Correlated Independent Variables.
 Suppose that in Eq. (4.15) the independent variables $z_i(i)$ can only be observed as $b_k(i)$ with errors $e_k(i)$, i.e.,

$$b_k(i) = z_k(i) + e_k(i) \quad k = 1, \dots, m \quad (4.17)$$

Suppose further that $z_k(i)$ may be modeled as first order scalar Markov process, namely:

$$z_k(i+1) = \phi_k z_k(i) + \zeta_k(i) \quad (4.18)$$

The model of Eq. (4.15), (4.17) and (4.18) may be written in the linear state vector form (4.11) - (4.12) for the constant coefficient case and in the nonlinear form (4.9) - (4.10) for the time varying case. The state vector in the latter case consists of $(z_1(i), \dots, z_m(i), a_1(i), \dots, a_m(i))$. The evolution equation (4.9) is linear in both cases (i.e., Eq. (4.11)), but the output equation in the time varying case involves products of states. Models of this form can be used to develop adaptive Kalman filters, in which the desire is to track changing coefficients which vary in an unpredictable manner (i.e., track ϕ in Eq. (4.11)).

4.3 Recursive State Estimation and Kalman Filter Equations

Consider the model of Eq. (4.9) - (4.10) with Θ and $p(x(0))$ specified. Recursive equations to propagate conditional densities are derived as follows, starting from $p(x(0))$:

$$p(x(i)|Y^i) \xrightarrow{\text{(prediction)}} p(x(i+1)|Y^i) \xrightarrow{\text{(update)}} p(x(i+1)|Y^{i+1})$$

where $Y^i = \{y(i), y(i-1), \dots, y(1)\}$ denotes the set of all observations available at time t .

One-step-ahead prediction is done using the state equation as follows:

$$\begin{aligned} p(x(i+1)|Y^i) &= \int p(x(i+1), x(i)|Y^i) dx(i) \\ &= \int p(x(i+1)|x(i), Y^i) p(x(i)|Y^i) dx(i) \\ &= \int p_{w(i)}(x(i+1) - f(x(i), u(k), \Theta, i)) \times \\ &\quad p(x(i)|Y^i) dx(i) \end{aligned} \quad (4.19)$$

where $p_{w(i)}(\cdot)$ denotes the probability distribution of $w(i)$ and the integration is carried over the sample space of $x(i)$.

Measurement update is done using Bayes Rule as follows:

$$\begin{aligned}
p(x(i+1)|Y^{i+1}) &= p(x(i+1)|Y^i, y(i+1)) \\
&= \frac{p(y(i+1)|x(i+1))P(x(i+1)|Y^i)}{\int p(y(i+1)|x(i+1))p(x(i+1)|Y^i) dx(i+1)}
\end{aligned}
\tag{4.20}$$

Notice that

$$p(y(i+1)|x(i+1)) = p_{v(i+1)}(y(i+1) - h(x(i+1), u(i+1), \theta, (i+1)))$$

where $p_{v(i+1)}$ denotes the probability distribution of $v(i+1)$. Also, Eq. (4.19) may be used repeatedly for prediction more than one step ahead.

The actual forecasts are obtained by minimizing the loss function averaged with respect to the prediction densities. For example, if the loss function is mean square forecast (output) error one step ahead, then the mean of $p(x(i+1)|Y^i)$ is chosen as the best forecast. Other attributes of a density function commonly used in practice are the median and the mode, the former minimizing the absolute forecast error and the latter selecting the most probable value of the random variable. (For details, see Degroot (1970) and Bryson and Ho (1969).)

The computation of Eq. (4.19) and (4.20) is quite cumbersome due to the multi-dimensional integrations and the nonparametric specification of the density functions. By using the special case of the linear Gauss-Markov model (Eq. (4.11) and (4.12)), elegantly simple results are obtained due to the following facts:

- a) Linear transformations of Gaussian random variables are also Gaussian.
- b) The Gaussian family has the conjugate property that for Gaussian priors and Gaussian likelihood functions, the posterior distributions are also Gaussian.
- c) Gaussian distributions are completely specified by their first two moments, i.e., mean and covariance.

A justification for using the Gaussian assumption comes from the central limit theorem according to which the limiting sums of non-Gaussian independent random variables, under certain regularity conditions, have Gaussian distributions.

Kalman filter equations. Let the mean and the covariance of the Gaussian density function $p(x(i+1)|Y^i)$ be denoted by $\hat{x}(i+1|i)$ and $P(i+1|i)$, respectively. We would also denote the same as

$$p(x(i+1)|Y^i) \sim N(\hat{x}(i+1|i), P(i+1|i))$$

where $\sim N(a,b)$ signifies "distributed normally with mean a and covariance b ." Similarly, let

$$p(x(i)|Y^i) \sim N(\hat{x}(i|i), P(i|i))$$

Eq. (4.19) leads to the following two equations:

Prediction equations:

$$\hat{x}(i+1|i) = \phi(i)\hat{x}(i|i) + G(i)u(i) \quad (4.21)$$

$$P(i+1|i) = \phi(i)P(i|i)\phi^T(i) + \Gamma(i)Q(i)\Gamma^T(i) \quad (4.22)$$

Eq. (4.20) leads to the following equations:

Update equations:

$$\hat{x}(i+1|i+1) = \hat{x}(i+1|i) + K(i+1)v(i+1) \quad (4.23)$$

$$v(i+1) = y(i+1) - H(i+1)\hat{x}(i+1|i) \quad (4.24)$$

$$K(i+1) = P(i+1|i) H^T(i+1)\Sigma^{-1}(i+1) \quad (4.25)$$

$$\Sigma(i+1) = H(i+1)P(i+1|i)H^T(i+1) + R(i+1) \quad (4.26)$$

$$P(i+1|i+1) = [I - K(i+1)H(i+1)]P(i+1|i) \quad (4.27)$$

Initial conditions:

$$x(0|0) = x_0 \quad (4.28)$$

$$P(0|0) = P_0 \quad (4.29)$$

Eq. (4.21) - (4.27) constitute the basic Kalman filtering equations and they are solved recursively starting from the initial conditions (4.28) - (4.29) in the sequence (4.21), (4.22), (4.24), (4.26), (4.25), (4.23) and (4.27). For predictions more than one step ahead into the future, only Eq. (4.21) and (4.22) are used recursively. Since for Gaussian density functions, the mean, mode, and median are the same, the k-step-ahead forecasts $\hat{x}(i+k|i)$ will be optimal for a whole class of symmetric loss functions--that is, even functions of estimation error (Degroot, 1970). The covariance matrix $P(i+k|i)$ provides confidence limits for the forecasts $\hat{x}(i+k|i)$. The prediction and update steps are illustrated in Figure 4.2.

4.4 Properties of Kalman Filters

In addition to the optimality properties stated above in the Bayesian decision theory sense, the Kalman filters have a number of other interesting properties of practical significance. We mention these properties here without detailed proofs.

(i) Innovation property. The one-step ahead prediction error sequence $v(i) = y(i) - H\hat{x}(i|i-1)$ is known as the "innovation sequence" since it represents new information brought by observations $y(i)$ in addition to the information contained in the past observation history Y^{i-1} . The sequence $v(i)$ has the interesting property that for an optimal filter it is a zero mean Gaussian white noise sequence with covariance $\Sigma(i)$. It will be shown in the sequel how this property may be used to test the optimality of Kalman filters, to detect changes in the process model and to build adaptive and robust Kalman filters. It has been shown by Kailath (1968) that

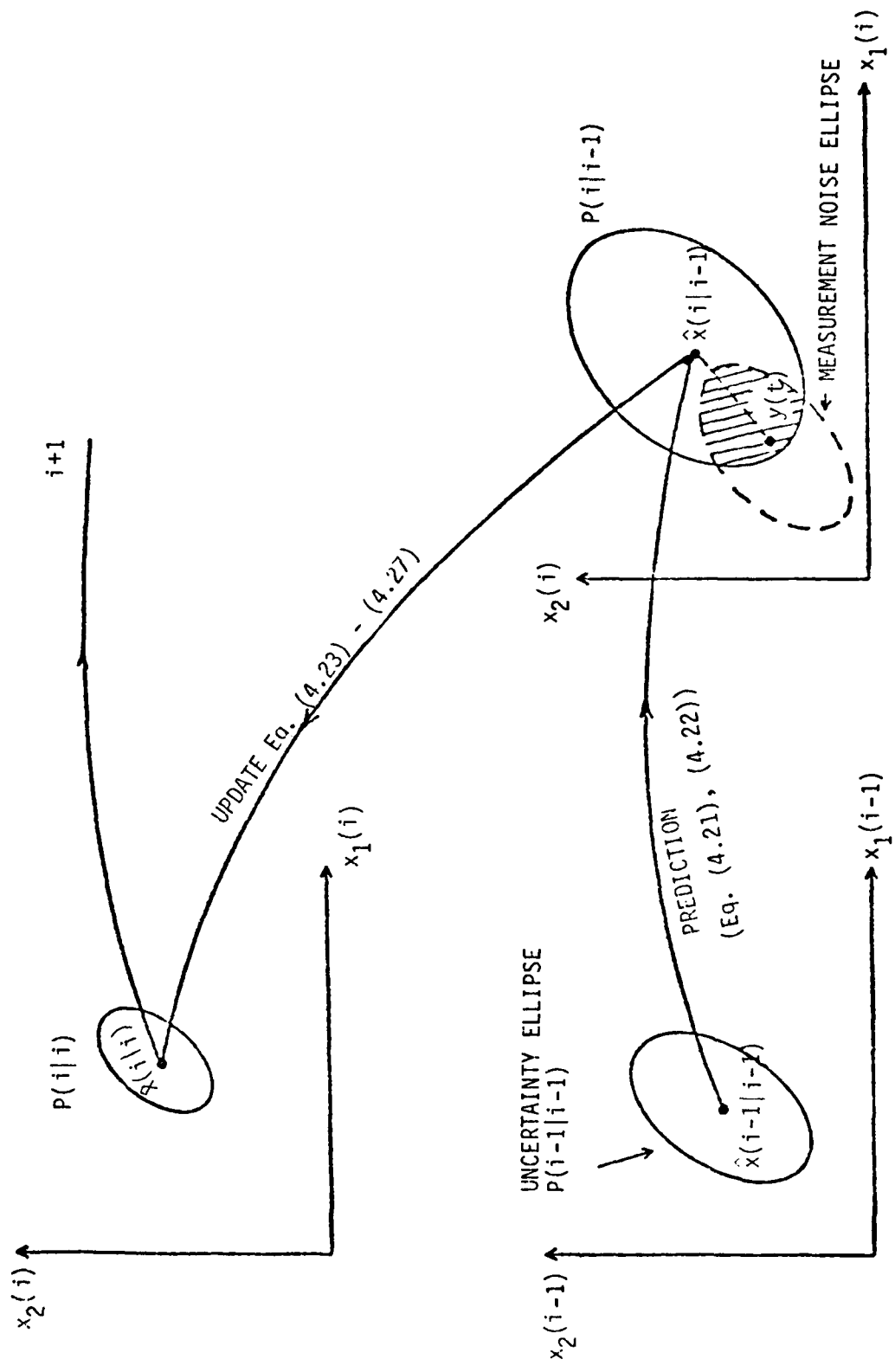

Figure 4.2. A Discrete-Time Kalman Filter in two Dimensions

the innovation property follows directly from the orthogonality principle of linear least squares estimation and that this property may be used as a starting point for the derivation of the Kalman filter. Furthermore, since $\{v(i)\}$ may be obtained from $\{y(i)\}$ by a causal and a causally-invertible transformation, the innovation sequence contains as much information as the original observation sequence.

(ii) Stability. It has been shown by Kalman (1963) and others that the Kalman filter possesses the property of global asymptotic stability for a completely controllable and observable system. The last two properties of the system are of central importance in modern system theory and relate to the structure of the system matrices Φ , Γ and H . For time invariant systems, necessary and sufficient conditions for the system of Eq. (4.11) - (4.12) to be completely controllable and observable are that the rank of the following two matrices be n , where n is the dimension of the state vector, i.e.,

$$\text{Rank}[\Gamma, \Phi\Gamma, \Phi^2\Gamma, \dots, \Phi^{n-1}\Gamma] = n \quad (4.30)$$

$$\text{Rank} [H^T, \Phi^T H^T, \dots, (\Phi^{n-1})^T H^T] = n \quad (4.31)$$

The physical interpretation of the observability property is that for a noise-free observable system, the initial state $x(0)$ can be reconstructed uniquely from the noise-free measurements at n time instants, that is,

$$\{y(1), \dots, v(n)\}$$

The controllability property implies the existence of a control sequence transferring the system from a given initial state to any other state in finite time and with finite control energy.

The practical significance of the controllability and observability conditions are that for time-invariant systems, the filter covariance matrices $(P(i|i), P(i|i))$ and Kalman gain $K(i)$ reach constant steady state values, independent of the initial conditions. Furthermore, since these matrices can be precomputed (without having observations $\{y(i)\}$), the real-time Kalman filter computations can be reduced to Eq. (4.21), (4.23) and (4.24). In many applications, the assumption of constant Kalman filter gain does not degrade filter performance by very much, but results in significant computational savings. Wiener filtering (Wiener, 1949) for stationary processes also corresponds to this case.

(iii) Numerical properties. The Kalman filter equations (4.21) - (4.27) can be written in different forms with different numerical properties. Unfortunately, the equations (4.21) - (4.27) known as the covariance form of the Kalman filter, though physically easiest to comprehend, are not best suited for numerical computation. In systems with widely separated eigenvalues of the filter covariance matrices, round-off errors can lead to non-negative definite covariance matrices. A solution to the problem is obtained by using Cholesky square roots of the covariance matrices by equations of the type:

$$P(i|i) = S(i|i)S^T(i|i) \quad (4.32)$$

Recursive equations are developed for $S(i|i)$, and Eq. (4.32) is used to compute $P(i|i)$. Another advantage of this approach is improved accuracy on finite bit machines since the condition number of $S(i|i)$ is half that of $P(i|i)$. In particular, the accuracy of single-precision square root Kalman filters is comparable to that of double-precision covariance Kalman filters. The triangular factorization of $P(i|i)$ offers several other advantages which are discussed in a recent book by Bierman (1976).

Kalman filter equations can also be written in terms of the information matrices which are defined as the inverses of the covariance matrices (see Schweppe, 1973). The information form has the nice property that the prior information P_0^{-1} can be set to zero without any numerical difficulties.

The information form also plays a role in square root filtering and in systems with Fisher-unknown inputs (Schweppe, 1973; Mehra, 1975). In the latter case, the limit $Q \rightarrow \infty I$ is considered to model input forcing functions that are deterministic but completely unknown (i.e., no prior information on $\{v(i)\}$).

Cases in which the measurement noise is correlated or some of the measurements are noise-free have been considered by Bryson and Henrickson (1968). It is possible to reduce the size of the Kalman filter in these cases. Other techniques for reducing the dimension of Kalman filters are discussed in Galdos and Gustafson (1977).

5. STATE SPACE MODEL STRUCTURE DETERMINATION

Multidimensional or multiple time series are encountered commonly in economic, sales, production, financial, scientific and engineering applications. Even so, one finds very few techniques in the literature for their modeling and forecasting. The univariate time series, on the other hand, has received considerable attention and has been used extensively by Box and Jenkins (1970) and others for modeling and prediction. Several attempts have been made over the last decade to extend the Box-Jenkins approach to multiple time series. However, most of these attempts have failed because the multiple time series case requires certain new concepts and techniques not present in the Box-Jenkins approach.

Recently certain groundbreaking developments in the field of systems identification and control theory (IEEE, 1974; Mehra and Lainiotis, 1976) have led to a new approach to the modeling and forecasting of multiple time series. This chapter describes the theory and application of a computer program based on the new approach which can analyze a large number of time series simultaneously, limited only by the size of the computer memory available for the storage of data. The program can perform differencing and choose the order of the model automatically so that user intervention is minimal. Even on univariate time series, the program has been found to be more convenient and faster to use than the Box-Jenkins method.

5.1 Theoretical Basis

The program is based on state space models, stochastic realization theory, statistical decision theory, canonical correlation analysis and Kalman filtering combined in a unique way for multiple time series analysis. A brief discussion of the technical aspects is given below. For full technical details, the reader should consult a chapter by Akaike in Mehra and Lainiotis (1976).

5.2 State Space Models

The state of a system is defined as a collection of all information from the present and past history of the process sufficient to predict its future behavior. The state vector may be defined from theoretical considerations or from an analysis of the past history of a process. The former approach leads to a theoretical or physical model such as the simultaneous equation models of economics (e.g., Klein's model of the U.S. economy), dynamical models of mechanics, or circuit models of electrical engineering. These models are too specialized to be made part of a general purpose program for multiple time series forecasting. In practice, there are many processes and systems for which theoretical models are not available, and statistical models have to be developed directly from the data. This chapter describes an approach which achieves this statistical model development by identifying the state of the system from a canonical correlation analysis of the observed data and by using state vector canonical models whose parameters are uniquely defined from the input-output

properties of the system.

Let $y(i)$, $i = 1, 2, 3, \dots, N$ be a p -dimensional vector of an observed time series. Then a state vector model of the process is of the form

$$x(i+1) = Fx(i) + Gv(i+1) \quad (5.1)$$

$$y(i) = Hx(i) \quad (5.2)$$

where $x(i)$ is an n -dimensional vector of state variables (generally $n \geq p$) and $v(i+1)$ is a p -dimensional vector of one-step-ahead prediction errors or "innovations" which is a zero mean white noise process. Matrices F , G , and H , respectively $n \times n$, $n \times p$, and $p \times n$, depend on the statistical properties of the process. The covariance matrix of $v(i)$ is denoted by Σ . The system of equations (5.1) and (5.2) is completely specified in terms of the quantities (n, F, G, H, Σ) . It is shown easily that the state vector model of Eq. (5.1) and (5.2) is equal to an ARMA model in the sense that both models will produce an output series $y(i)$ with identical statistical properties. However, there are several advantages in using state vector models instead of multidimensional ARMA models. These are:

(i) Once the state vector model is identified, prediction or forecasting is done trivially by setting $v_t \equiv 0$ for all future values of t .

The prediction of some of the series when the future values for the rest are known is also done easily by using a Kalman filter.

(ii) A multidimensional ARMA model of the type

$$y(i) + B_1 y(i-1) + \dots + B_m y(i-m) = u(k) + A_1 u(i-1) + \dots + A_L u(i-L)$$

is not unique in the sense that a large number of matrices $(B_1 \dots B_m, A_1 \dots A_L)$ may produce a $y(i)$ series with identical statistical properties. (This problem does not arise for univariate series.) The same problem exists for the state vector model but it is easily solved by restricting (F, G, H) to the so-called "canonical forms" (Mehra and Lainiotis, 1976). The restrictions on $(B_1 \dots B_m, A_1 \dots A_L)$ are more complicated and are difficult to incorporate easily in an identification program.

5.3 Stochastic Realization Theory

The problem of determining the internal structure of a state vector model, namely (n, F, G, H, Σ) given its external behavior, namely the correlation function $(C_0, C_1, C_2, \dots)^*$ of the output $y(i)$ is called the stochastic realization problem. Further conditions such as the minimality of n and the uniqueness of (F, G, H, Σ) are imposed to develop a parsimonious representation whose parameters can be identified uniquely from the data. It should be noted that stochastic realization theory by itself does not

*
$$C_k = \frac{1}{N-k} \sum_{i=k}^N y(i)y(i-k)^T$$

solve completely the problem of multiple time series modeling since the correlation function (C_0, C_1, \dots) is not known exactly and must be estimated from the observed time series ($y(1), y(2), \dots, y(N)$). This problem is solved by using tools of statistical decision theory and canonical correlation analysis, discussed by Akaike in Mehra and Lainiotis (1976).

Statistical decision theory is used in the development of the information criterion and the test statistic for selection of model order (Akaike, 1974). Autoregressive (AR) models of different orders are developed using a Levinson-Whittle-Wiggins-Robinson algorithm and are employed in tests of fit, determination of G , and in generating forecasts for cross-checking with the state vector model.

A flow diagram of the procedure is shown in Figure 5.1. The basic concept behind the method is that the state vector of a system at current time i may be defined as a basis vector for the space spanned by the current output and future predictions:

$$\{y(i), \hat{y}(i+1|i), \dots, \hat{y}(i+k|i), \dots\}$$

(This space is referred to as the "prediction space" of a system at time i , since $\hat{y}(i+k|i)$ is the predicted estimate of $y(i+k)$ based on observations up to time i .) It can be shown that this space is finite dimensional for a finite dimensional system and that the dimension of the system can be determined by examining the canonical correlations between two sets of variables U and V_k for $k = 1, 2, 3, \dots$ where

$$U = \{y^T(i), y^T(i-1), \dots, y^T(i-k)\}, \quad k \text{ sufficiently large, and}$$

$$V_k = \{y^T(i), y^T(i+1|i), \dots, y^T(i+k|i)\}$$

By increasing k one at a time and by considering elements of y in a given order, the state vector $x(t)$ of the system is determined as a subset of V_k as shown in Figure 5.1. Once the state vector is identified, the matrix F is determined simultaneously from the canonical variables. The purpose of fitting the AR model and computing the impulse response function is to estimate the Kalman gain matrix G and the innovation covariance matrix Σ . Notice that the procedure identifies the stationary Kalman filter model directly and does not involve solving Riccati equations.

5.4 Transformation to Stationarity

The program can perform automatic differencing and deseasonalizing to convert the given time series individually to stationary ones. The tests of stationarity and the choice of the seasonality period are based on the autocorrelation function. The automatic differencing (one period and seasonal) are continued until the transformed series passes the stationarity test.

The program has already been used successfully on a number of time series, both multivariate and univariate. It has the advantage that no cumbersome and time-consuming nonlinear searches are performed to estimate

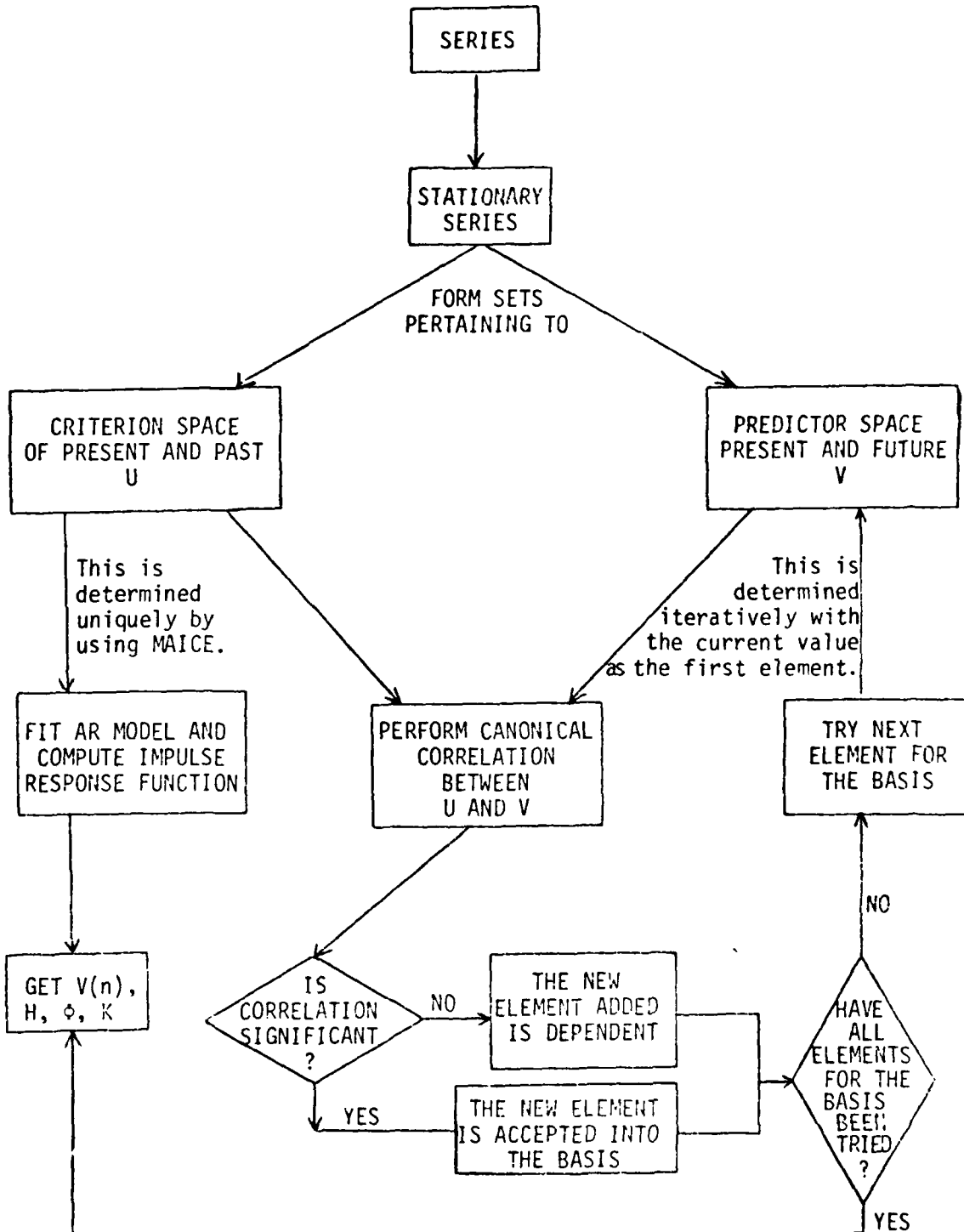

Figure 5.1. Flow Diagram of State Space Forecasting Program

the parameters. The canonical correlation and AR modeling techniques provide asymptotically efficient estimates of all system parameters (Mehra and Lainiotis, 1976).

5.5 Development of Kalman Filter from Canonical State Space Model

Once the state space model is specified, the next step is to derive the Kalman filter from it.

The Kalman filter is based on a system model of the form

$$x(i+1) = \phi x(i) + w(i+1) \quad (5.3)$$

$$y(i) = \Gamma x(i) + v(i) \quad (5.4)$$

where the initial state $x(0)$ is a Gaussian random variable with mean m_0 and covariance matrix P_0 and $w(i)$, $v(i)$ are mutually independent zero mean Gaussian white noise sequences with respective covariances W , V .

The Kalman filter produces the minimum-variance estimate recursively according to

$$\hat{x}(i+1|i) = \phi \hat{x}(i|i) \quad (5.5)$$

$$\hat{x}(i+1|i+1) = \hat{x}_1(i+1|i) + K(i+1)r(i+1) \quad (5.6)$$

where $\hat{x}(i+1|i)$ is the one-step-ahead prediction of x , and $r(i+1)$ is the one-step-ahead output prediction error

$$r(i+1) = y(i+1) - \Gamma \hat{x}(i+1|i) \quad (5.7)$$

The initial condition is $\hat{x}(0) = m$. The gain matrix $K(i+1)$ is computed according to

$$K(i+1) = P(i+1|i) \Gamma^T S(i+1)^{-1} \quad (5.8)$$

$$S(i+1) = \Gamma P(i+1|i) \Gamma^T + V \quad (5.9)$$

where $P(i+1|i)$, $S(i+1)$ are, respectively, the one-step-ahead state and output error covariance matrices. $P(i+1)$ is the covariance matrix of estimation errors which is computed recursively by

$$P(i+1|i) = \phi P(i|i) \phi^T + W \quad (5.10)$$

$$P(i+1|i+1) = P(i+1|i) - K(i+1) \Gamma P(i+1|i) \quad (5.11)$$

with initial condition $P(0|0) = P_0$. Since the state space model is a steady state one, we are interested in the steady state Kalman filter in which $K(i) = K \forall i$, $P(i|i) = P \forall i$, $S(i) = S \forall i$, $P(i+1|i) = P' \forall i$.

In this case the equations to be solved are

$$K = P' \Gamma^T S^{-1} \quad (5.12)$$

$$S = \Gamma P' \Gamma^T + V \quad (5.13)$$

$$P' = \phi P \phi^T + W \quad (5.14)$$

$$P = P' - K \Gamma P' \quad (5.15)$$

The Kalman filter has the desirable property that the sequence $\{v(i)\}$ is a zero-mean Gaussian white noise sequence with covariance matrix S_i .

By comparing the Kalman filter and state space models, the following correspondences are seen to hold:

State Space Model	F	G	H	Σ
Kalman Filter	ϕ	K	Γ	S

In order to proceed further, we will take advantage of the special form of the state space equations. The state vector $x(i)$ is of the form

$$x(i) = \begin{bmatrix} y(i) \\ y^r(i) \end{bmatrix} \quad (5.16)$$

where $y^r(i)$ is an $n-m$ vector which contains predicted values of the components of $y(i)$. Now we note that the state space model is of the form

$$\hat{x}(i+1|i+1) = \phi \hat{x}(i|i) + Gv(i+1) \quad (5.17)$$

$$v(i+1) = y(i+1) - \hat{y}(i+1|i) \quad (5.18)$$

$$y(i+1) = Hx(i+1) \quad (5.19)$$

where

$$\hat{x}(i|k) = E[x(i) | y(1), y(2), \dots, y(k)] \quad (5.20)$$

is the conditional expectation of $x(i)$, based on data up to $y(k)$. Since $\hat{y}(i+1|i+1) = y(i+1)$, K is of the form

$$K = \begin{bmatrix} I_{m \times n} \\ \hline K^r_{(n-m) \times m} \end{bmatrix} \quad (5.21)$$

ϕ is of the form

$$\phi = \begin{bmatrix} 0_{m \times m} & \vdots & \phi_{12}_{m \times (n-m)} \\ \hline \phi_{21}_{(n-m) \times m} & \vdots & \phi_{22}_{(n-m) \times (n-m)} \end{bmatrix} \quad (5.22)$$

and H is of the form

$$H = \begin{bmatrix} \Gamma_{m \times m} & | & 0_{m \times (n-m)} \end{bmatrix} \quad (5.23)$$

Eq. (5.17) - (5.19) correspond to the Kalman filtering equations for perfect measurements. Thus P assumes the form

$$P = \begin{bmatrix} 0_{m \times m} & | & 0_{m \times (n-m)} \\ \hline 0_{(n-m) \times m} & | & P^r_{(n-m) \times (n-m)} \end{bmatrix} \quad (5.24)$$

The remaining question is the form of P' and the driving noise covariance matrix W. Partition W as

$$W = \begin{bmatrix} W_{11} & | & W_{12} \\ \hline W_{12}^T & | & W_{22} \end{bmatrix} \quad (5.25)$$

and P' as

$$P' = \begin{bmatrix} P'_1 & | & P'_2 \\ \hline P'_2^T & | & P'_3 \end{bmatrix} \quad (5.26)$$

Then Eq. (5.12) - (5.15) yield

$$P^r = P'_3 - K^r \Sigma (K^r)^T \quad (5.27)$$

$$\Sigma = \phi_{12} P^r \phi_{12}^T + W_{11} \quad (5.28)$$

$$\Sigma (K^r)^T = \phi_{12} P^r \phi_{22}^T + W_{12} \quad (5.29)$$

$$P'_3 = \phi_{22} P^r \phi_{22}^T + W_{22} \quad (5.30)$$

$$P'_2 = \Sigma (K^r)^T \quad (5.31)$$

$$P'_1 = \Sigma$$

In these equations, there are $(n-m+1)(n-m)/2$ free variables which may be specified. One solution is to specify $W_{22} > 0$; for example

$$W_{22} = \sigma^2 I_{n-m} \quad (5.33)$$

However, there are constraints on W_{22} which need to be met. To see this,

write (5.30) in the form

$$P^r = \dot{\phi}_{22} P^r \phi_{22} + [W_{22} - K^r \Sigma (K^r)^T] \quad (5.34)$$

If ϕ_{22} is unstable, we can get a solution by picking

$$0 \leq W_{22} < K^r \Sigma (K^r)^T$$

On the other hand, if ϕ_{22} is stable, then we are assured of a solution if $W_{22} > K^r \Sigma (K^r)^T$. An approximate value of W_{22} can also be picked by statistical tests on the original data. For example, the covariance matrix of x , $\bar{X} = E[x(i)x(i)^T]$, may be calculated for the data ensemble and then W found from

$$W = \bar{X} - \phi \bar{X} \phi^T > 0$$

Note that this implies stability of ϕ , which we expect in practice since the payoffs are bounded. Using (5.25), W_{22} can then be estimated. A further check is that the two computed values of W_{12} should agree, at least approximately.

Once W_{22} is selected, P^r is found directly from (5.34) by solving a linear vector-matrix equation by writing out the components of P^r in vector form. The values of P_1^r , P_2^r , P_3^r , W_{11} and W_{12} are then computed directly, which completely specifies the parameters of the Kalman filter.

Given the model of (5.17) - (5.19), predictions can be easily made by noting that the predicted value of $y(i+k)$ given data $y(1), y(2), \dots, y(i)$ is

$$\hat{y}(i+k|i) = [I \ 0] \dot{\phi}^k \hat{x}(i|i); \quad k \geq 0 \quad (5.35)$$

The advantage of using the Kalman filter form is that some very powerful adaptive filtering techniques have been developed using this form and these may be easily mechanized for solving the PJM problem. We will discuss in Chapter 7 the adaptive filtering problem and then develop a specialized approach for the PJM problem.

6. STATIONARY STATE SPACE MODELS - RESULTS

6.1 Introduction

In order to apply the methodology of stationary state space model identification given in the preceding sections to the PJM payoff series, a number of stationary models were identified using the S²I state space identification program. This program implements the process of automatic differencing determination, canonical correlation analysis, model order determination, parameter identification and forecasting. It is capable of producing a number of outputs such as the identified model, forecasts with upper and lower 95 percent confidence limits, goodness-of-fit statistics, etc.

The models reported in this section will consist of models derived only for the payoff series dataset. Because of the large amount of output associated with each model, only a representative sample of outputs will be presented. A summary of the state space model error, 12-month moving average model error and persistence model error for 13 male and 13 female series is given in Table 1 of Appendix B. The state space models for these series were produced then by identifying the system on the first 4 years of data (1973-1976) and then predicting the series for the last year (1977).

The persistence model was taken to be the value of the series for December 1976 and forecasting no change over 1977. The moving average model was taken to be the average of the preceding 12 months (January 1976 to December 1976) with no change forecast for 1977.

A listing of the abbreviated output from the state space model program with plots of the historical data and 12-month predictions are given in Appendix B, Tables 2 through 27 and Figures B.1 through B.52. In these figures, the suffix PH stands for the one step ahead prediction of the history over the four-year fit set, P stands for the 12-month predictions, and PU and PL stand for the upper and lower 95 percent confidence limits on the predictions.

6.2 Discussion of Results

The results of the experiment cannot be termed encouraging. The models developed for all the male series and all but several of the female series do not contain leading terms as state variables and so are simple first-order models. For many of the male series and several of the female series, first order differencing was performed to obtain a more stationary behavior. In those cases, the state transition element value was quite small, often of magnitude 0.1 or 0.2. This fact, taken with the low order models, tends to indicate that the series have quasi-random walk character. This hypothesis is borne out when the performance of the state space models is evaluated against a persistence predictor which is optimum for predicting a random walk process. For the majority of the male series, the persistence predictor performs better than the state space model, even though the fit of the model over the earlier 4 years is good. In examining the series for which the state space model performance is poor, it is noted that the model tends to overestimate the series due to the unforeseen

leveling off and even decline in the series values during 1977. It is precisely this type of behavior that may violate the assumption of statistical stationarity for the PJ series payoff data and make the problem more suitable for treatment by the adaptive methods covered in later sections.

The performance of the state space models on the female time series data is superior to that of the male series when scored against a persistence predictor. The models produced, however, have much the same character as the male models except for the two series in which leading terms were found. The E80F series (F30230) was the worst to predict, with the model being basically series mean. Other models often achieved an R^2 of 0.8 or 0.9 against the original series data, but showed poor performance against the differenced data.

In summary, it should be concluded that the time-invariant state space models are probably not suitable for prediction of payoff series data due to the sudden shifts in the series. These series will probably be treated better by adaptive filters than any constant valued model.

7. ADAPTIVE KALMAN FILTERING METHODOLOGY FOR PJM PAYOFF DATA

7.1 Motivation

Although the Kalman filter has many desirable properties, it suffers from some fundamental limitations. One such limitation is that the matrices Φ , K must be known a priori. These matrices may be time varying, but if this time variation is known a priori, the Kalman filter remains optimal.

The situation changes, however, when Φ changes in an unpredictable manner or the statistics of the process noise changes. We may indicate this more precisely by writing the steady-state Kalman gain matrix in the form

$$K = P'H^T\Sigma^{-1} \quad (7.1)$$

where P' is the error covariance matrix for the estimate $\hat{x}(i+1|i)$ and Σ is the covariance matrix for the innovations (Σ is outputted directly by the state space modeling program). The matrix P' is given by

$$P' = \Phi P \Phi^T + W \quad (7.2)$$

where P is the error covariance matrix for the estimate $\hat{x}(i+1|i+1)$ and W is the covariance matrix for the process noise. Assuming a Markov process of the form

$$x(i+1) = \Phi x(i) + w(i) \quad (7.3)$$

where $x(i)$ is the true state, then

$$W = E[w(i)w^T(i)] \quad (7.4)$$

Using (7.3) as our model of the true state, P and P' are, respectively, the covariances of $\hat{x}(i|i) - x(i)$ and $\hat{x}(i+1|i) - x(i)$.

It is clear that the gain matrix K changes if Φ or W changes. Thus if the dynamics, modeled by Φ , or the process noise statistics, modeled by W , change with time in an unpredictable manner, we need to develop a technique for estimating them.

Previous numerical studies on the PJM payoffs have suggested that the underlying process changes with time. Figures 7.1-7.6 show the 12-month moving average for several payoffs during the period 1974-1977. It is clear that the dynamics change significantly over the entire 5-year period but tend to persist over at least several months. That is, the variation in the dynamics is not entirely random. The payoff for F42333 has dynamics which appear to change at discrete points--the middle of 1975 and the beginning of 1977. Otherwise, the dynamics for this payoff appear to be the same. For payoff F20530, the dynamics change abruptly at the middle of 1975, but change only gradually thereafter. The payoff for M67232 undergoes abrupt changes in dynamics in the middle of 1974, the middle of 1975 and the middle of 1976. The dynamics for the M27131 payoff

12 MONTH MOVING AVERAGE OF PAYOFF

F42333

A=AVER

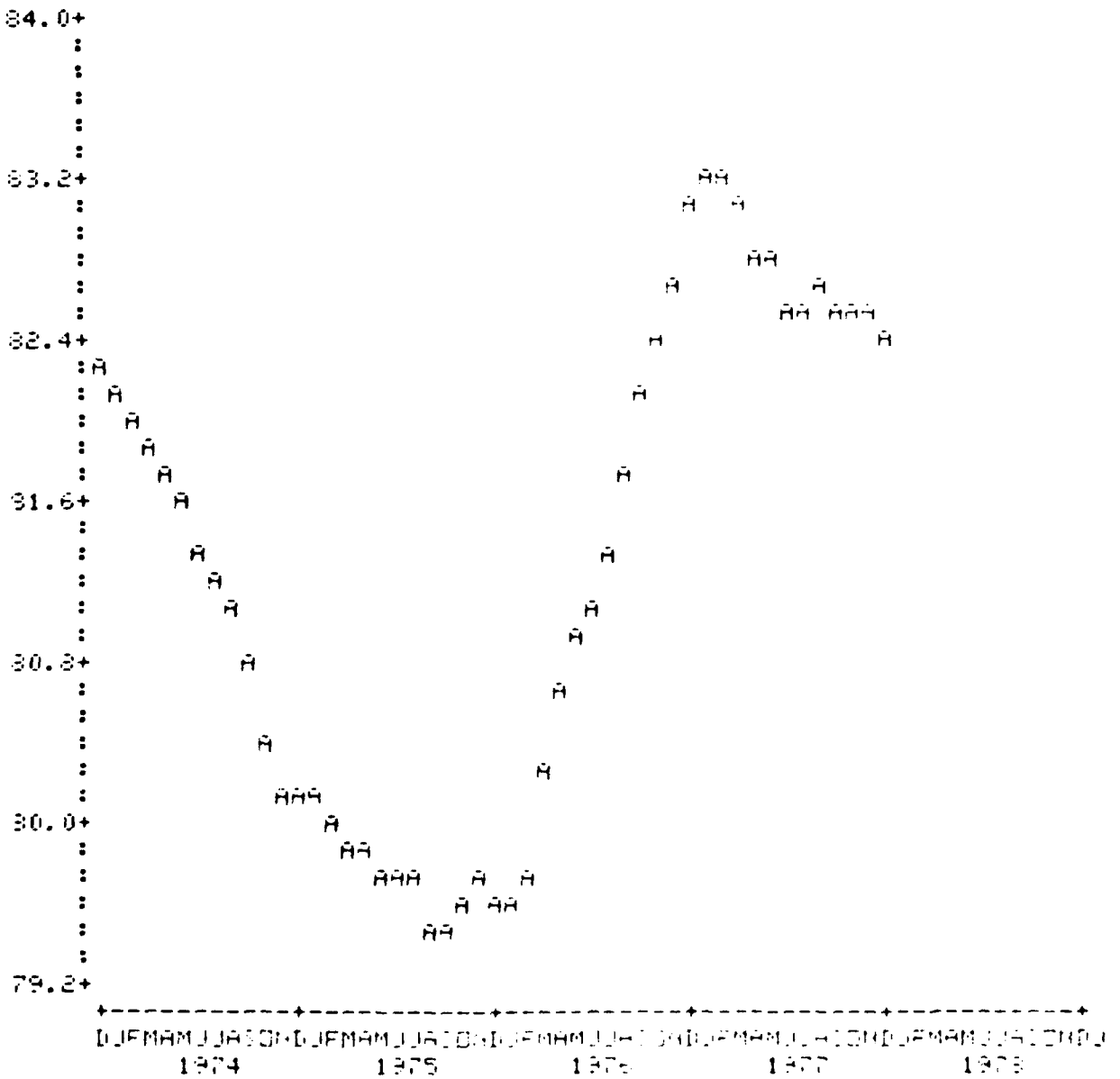

Figure 7.1. 12-Month Moving Average for F42333 Payoff

12 MONTH MOVING AVERAGE OF PAYOFF

F20530

A=AVER

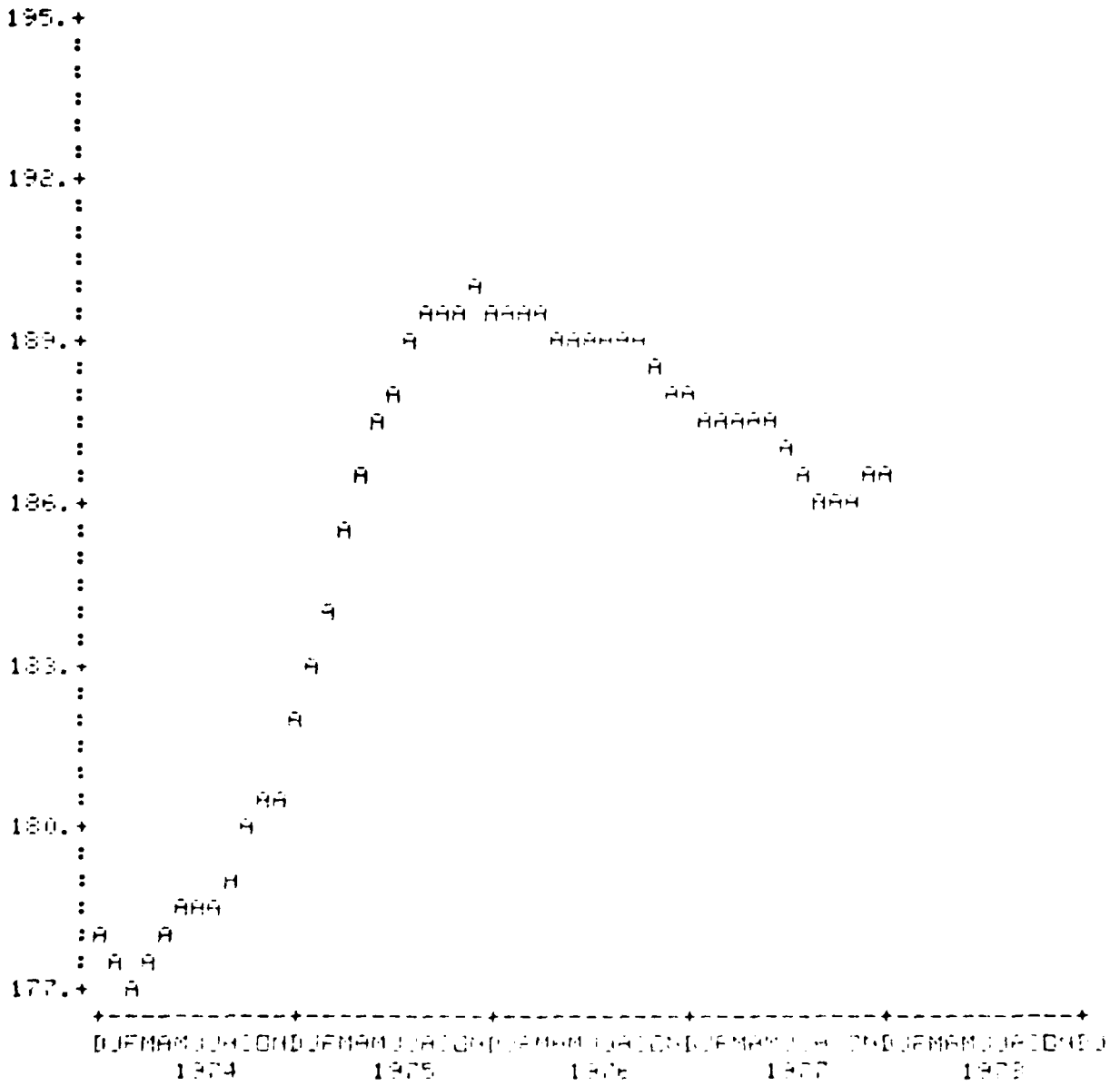

Figure 7.2. 12-Month Moving Average for F20530 Payoff

12 MONTH MOVING AVERAGE OF PAYOFF

M67232

A=AVER

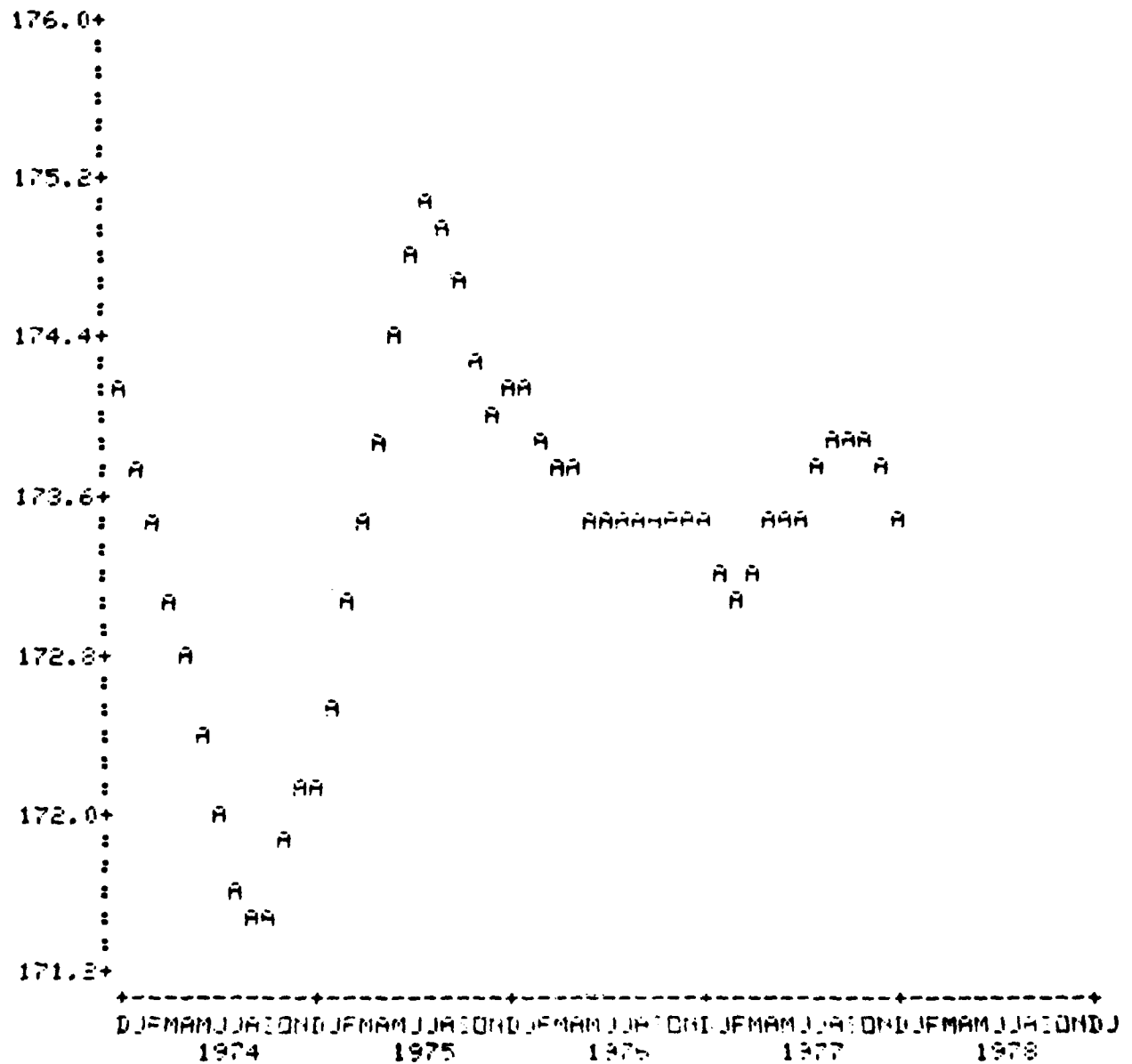

Figure 7.3. 12-Month Moving Average for M67232 Payoff

12 MONTH MOVING AVERAGE OF PAYOFF

M27131

A=AVR

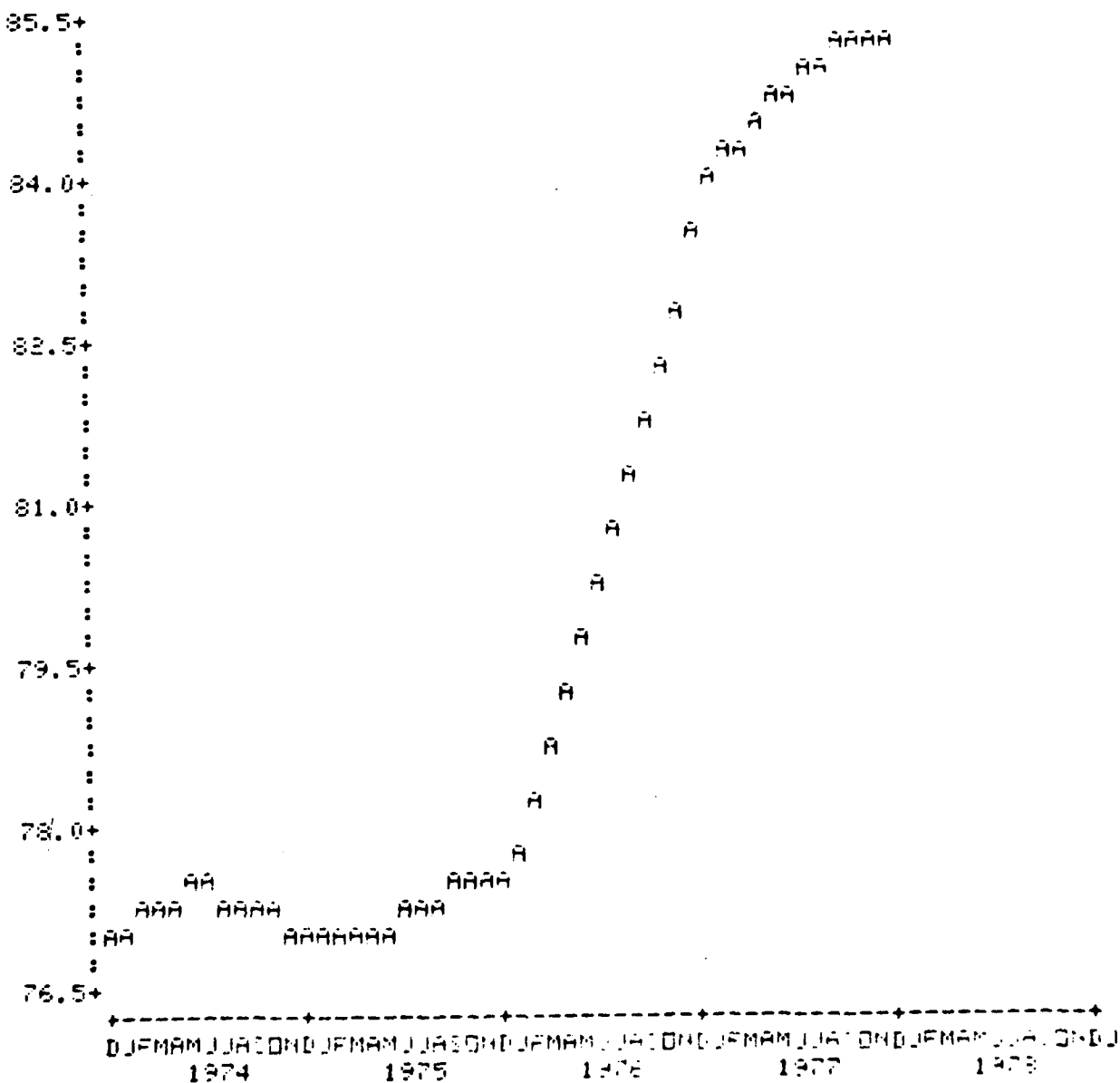

Figure 7.4. 12-Month Moving Average for M27131 Payoff

12 MONTH MOVING AVERAGE OF PAYOFF

F46330

A=AYER

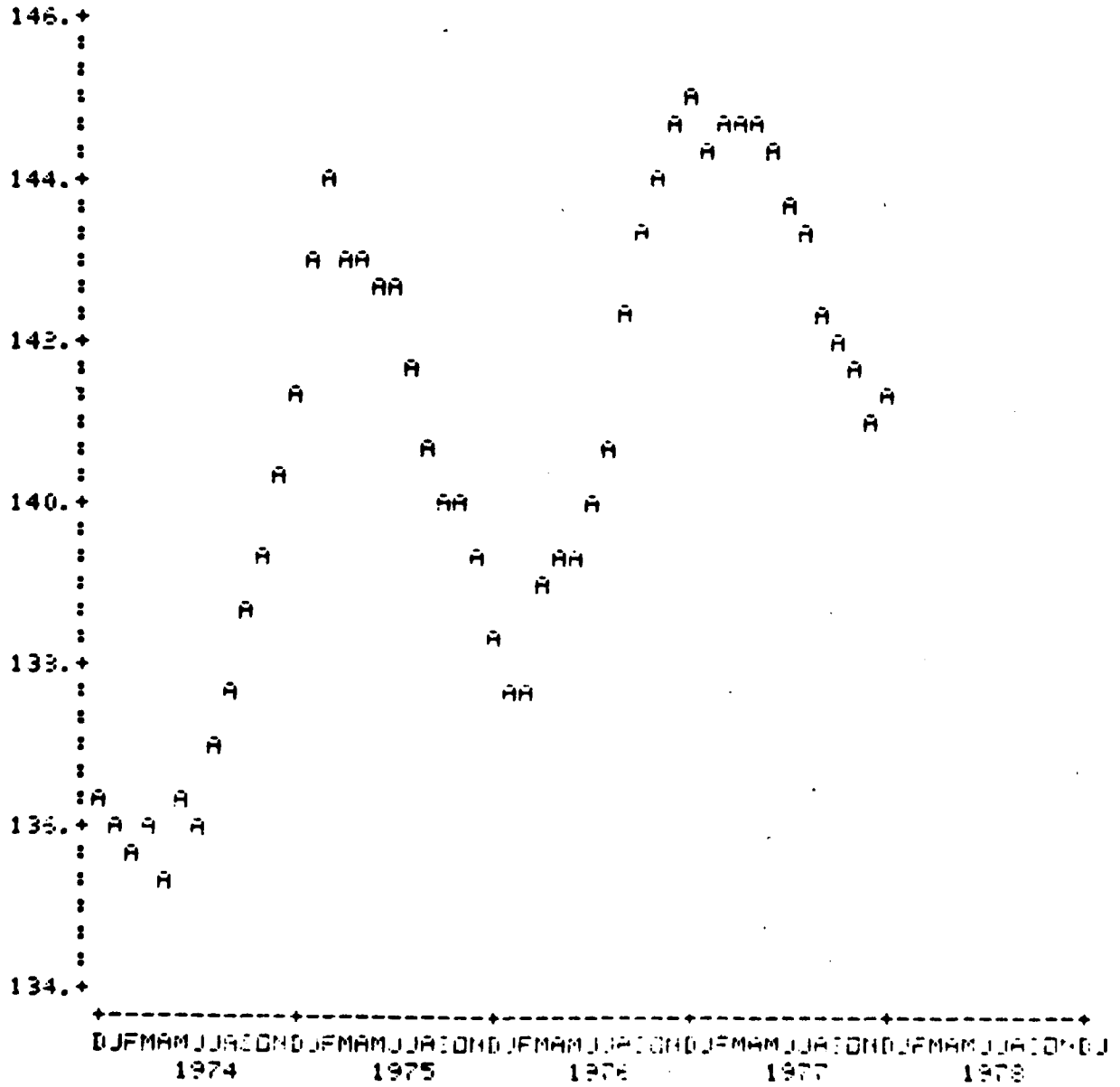

Figure 7.5. 12-Month Moving Average for F46330 Payoff

12 MONTH MOVING AVERAGE OF PAYOFF

M30230

A= AVER

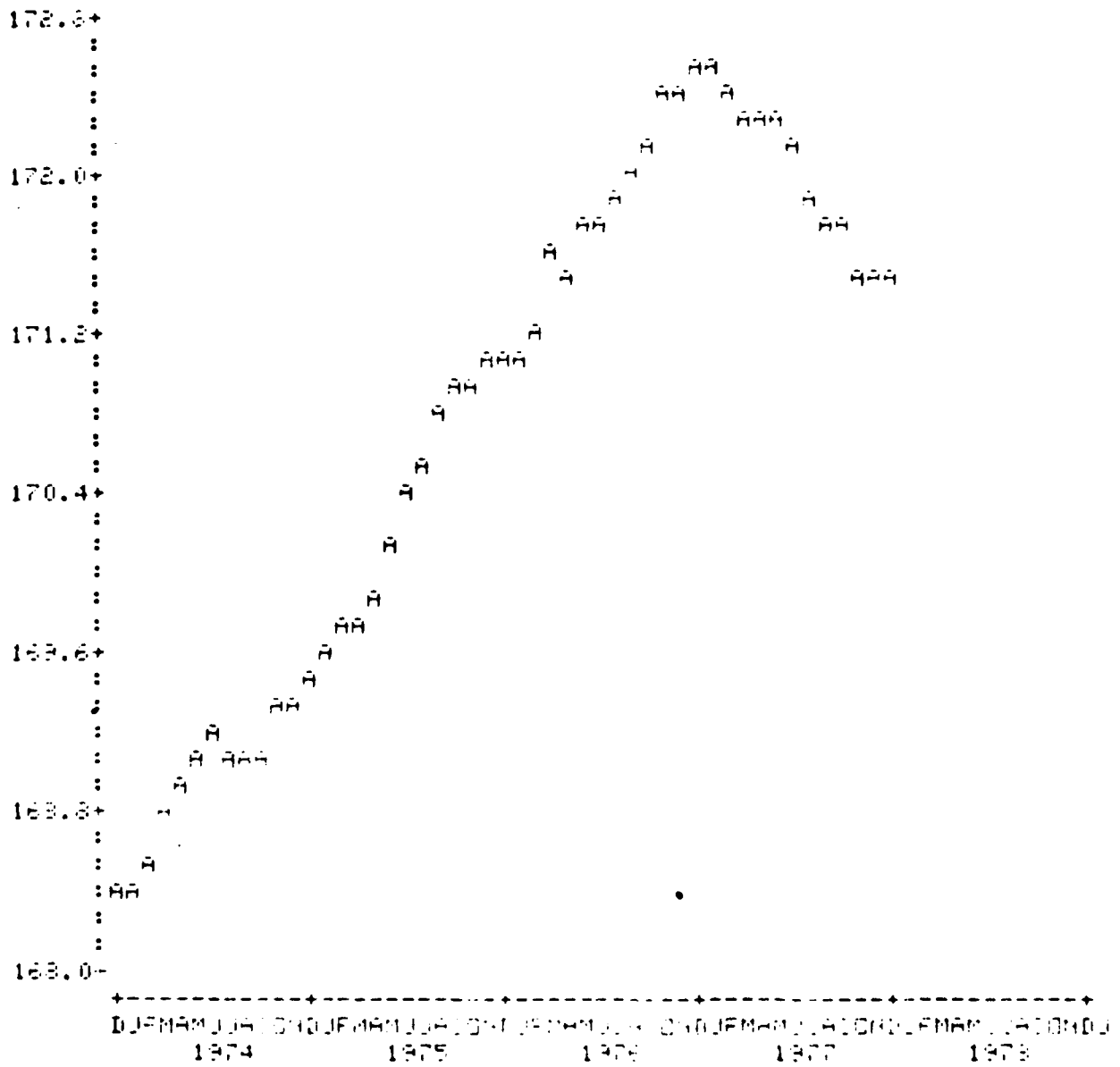

Figure 7.6. 12-Month Moving Average for M30230 Payoff

undergo an abrupt change in the beginning of 1976 and a gradual change during 1976 and 1977. The dynamics for the F46330 payoff are seen to undergo abrupt changes three, possibly four, times. Finally, the M30230 payoff dynamics are seen to change abruptly at the beginning of 1977. The nature of the changes in the dynamics of these series is not predictable; we cannot predict where or how fast the dynamics will change for any of them. This suggests that adaptive filtering techniques might be useful in building better prediction models for the payoffs. These results also suggest that we need to develop methods which can adapt to the following situations:

- (i) slow changes in parameters
- (ii) step changes in parameters

In the sequel, we develop an adaptive filter which can handle both types of situations by simply varying a single scalar parameter.

7.2 Approaches to Adaptive Filtering

The different possible methods of adaptive filtering may be divided into four general categories: 1) Bayesian estimation; 2) maximum likelihood; 3) correlation methods; and 4) covariance matching.

A discussion of these techniques and comparisons between them have been given by Mehra (1972). Of these four methods, the maximum likelihood approach is generally the most attractive since it produces (ideally) consistent, unbiased and efficient estimates for all parameters. One drawback of the maximum likelihood approach is that numerical solutions require solving difficult nonlinear programming problems (Gupta and Mehra, 1974). However, it is also possible to develop approximation techniques which lead to solutions which may be found recursively. This is the approach taken in the sequel.

7.3 Maximum Likelihood Estimation

Let α denote the set of parameters we wish to estimate. For example, if we wish to simultaneously estimate the matrices Φ and K , then

$$\alpha = \{\Phi, K\}$$

Now let $Y^k = \{y(1), y(2), \dots, y(k)\}$, with $y(i) = Hx(i)$. Then the marginal probability density of α , given Y^k , is

$$P(\alpha | Y^k) = \frac{P(Y^k | \alpha) P(\alpha)}{P(Y^k)} \quad (7.5)$$

where

$$\begin{aligned} p(Y^k | \alpha) &= p(Y^{k-1}, y(k) | \alpha) \\ &= p(y(k) | Y^{k-1}, \alpha) p(Y^{k-1} | \alpha) \\ &\quad \vdots \\ &= p(y(k) | Y^{k-1}, \alpha) p(y(k-1) | Y^{k-2}, \alpha) \dots p(y(1) | \alpha) \end{aligned} \quad (7.6)$$

Under the assumption that $y(i)$ is Gaussian, it follows that $p(y(i)|Y^{i-1}, \alpha)$ is Gaussian with mean $H\phi\hat{x}(i-1|i-1)$ and covariance Σ .

The maximum likelihood estimate can be obtained by maximizing

$$\begin{aligned} L(\alpha) &= \log p(\alpha|Y^k) \\ &= -\frac{k}{2} \sum_{i=1}^k [y(i) - H\phi\hat{x}(i-1|i-1)]^T \Sigma^{-1} [y(i) - H\phi\hat{x}(i-1|i-1)] \\ &\quad - \frac{k}{2} \log |\Sigma| + \log p(\alpha) + \text{constants} \end{aligned} \quad (7.7)$$

with respect to α .

In Eq. (7.7), the matrices ϕ , Σ and the estimates $\hat{x}(i-1|i-1)$ are all functions of α . If no a priori distribution on α is given, the term $\log p(\alpha)$ is dropped. We will make this assumption in the sequel.

The solution is found by solving, simultaneously, the first-order necessary conditions

$$\frac{\partial L(\alpha)}{\partial \alpha} = 0, \quad \frac{\partial L(\alpha)}{\partial \Sigma} = 0 \quad (7.8)$$

Denote the maximum likelihood estimates by $\hat{\alpha}$, $\hat{\Sigma}$. Then

$$\left. \frac{\partial L(\alpha)}{\partial \alpha} \right|_{\hat{\alpha}, \hat{\Sigma}} = \sum_{i=1}^k v^T(i) \Sigma^{-1} \left. \frac{\partial v(i)}{\partial \alpha} \right|_{\hat{\alpha}, \hat{\Sigma}} = 0 \quad (7.9)$$

$$\left. \frac{\partial L(\alpha)}{\partial \Sigma} \right|_{\hat{\alpha}, \hat{\Sigma}} = \text{tr} \left\{ k \Sigma^{-1} - \Sigma^{-1} \sum_{i=1}^k v(i) v(i)^T \Sigma^{-1} \right\} \Big|_{\hat{\alpha}, \hat{\Sigma}} = 0 \quad (7.10)$$

Eq. (7.10) gives

$$\hat{\Sigma} = \frac{1}{k} \sum_{i=1}^k v(i) v(i)^T \quad (7.11)$$

The remaining problem is to solve (7.9) for $\hat{\alpha}$. This is a nonlinear problem and we must resort to some type of iteration scheme. The method which appears to work best in general practice (Gupta and Mehra, 1974) is the Gauss-Newton iteration:

$$\hat{\alpha}^{l+1} = \hat{\alpha}^l - [I_F]^{-1} \left. \frac{\partial L(\alpha)}{\partial \alpha} \right|_{\hat{\alpha}^l} \quad (7.12)$$

where I_F is the Fisher information matrix

$$I_F = \sum_{i=1}^k \frac{\partial v(i)^T}{\partial \alpha} \Sigma^{-1} \frac{\partial v(i)}{\partial \alpha} \quad (7.13)$$

The maximum likelihood parameter identification algorithm may now be summarized as follows. Starting with initial estimates $\hat{\alpha}^0$ and $\hat{\Sigma}^0$, compute

$$(i) \quad \Gamma^\ell = \sum_{i=1}^k \frac{\partial v(i)^T}{\partial \alpha} \Sigma^{-1} v(i) \quad \left| \begin{array}{l} \alpha = \hat{\alpha}^\ell \\ \Sigma = \hat{\Sigma}^\ell \end{array} \right. \quad (7.14)$$

$$(ii) \quad I_F^\ell = \sum_{i=1}^k \frac{\partial v(i)^T}{\partial \alpha} \Sigma^{-1} \frac{\partial v(i)}{\partial \alpha} \quad \left| \begin{array}{l} \alpha = \hat{\alpha}^\ell \\ \Sigma = \hat{\Sigma}^\ell \end{array} \right. \quad (7.15)$$

$$(iii) \quad \hat{\alpha}^{\ell+1} = \hat{\alpha}^\ell - [I_F^\ell]^{-1} \Gamma^\ell \quad (7.16)$$

$$(iv) \quad \hat{\Sigma}^{\ell+1} = \frac{1}{k} \sum_{i=1}^k v(i)v(i)^T \quad \left| \begin{array}{l} \alpha = \hat{\alpha}^{\ell+1} \end{array} \right. \quad (7.17)$$

if $\|\hat{\alpha}^{\ell+1} - \hat{\alpha}^\ell\| > \epsilon$ go to (i), otherwise stop.

This iteration solves the estimation problem in a batch mode. We will adapt it to a more useful recursive form in the next section.

7.4 Development of Adaptive Filtering Algorithm

In this section, an adaptive filter suitable for on-line operation is developed. The arguments follow closely the work of DuVal (1976). In adapting the maximum likelihood estimator of Section 7.3 to adaptive filtering, several points must be kept in mind:

1. We wish to make the adaptive filter completely recursive.
2. We wish to discount old data which were subject to dynamics different from those of the present data. This will be done using age-weighting of the data.

3. We need to be aware of the fact that we are attempting, in reality, to solve a nonlinear filtering problem. Since the optimal solution cannot be found in practice, we must be careful to ensure that the approximations we make do not degrade the convergence properties of the algorithm. In particular, we will make the assumption that the innovations are linear in the parameters, when in fact the relationship is nonlinear. As a consequence, it is not a good idea to update the parameters to their optimal values at each sample. Rather, we will make only a partial correction to the parameter estimates at each sample using the following formula:

$$\alpha(k+1) = \alpha(k) + \beta[\hat{\alpha}(k) - \alpha(k)] \quad (7.18)$$

where $\alpha(k)$ is the actual parameter vector utilized in the filter and $\hat{\alpha}(k)$ is the "optimal" value computed in the adaptation process.

4. The innovations covariance matrix Σ is computed independently of the identification of the parameters. We may therefore use any constant weighting matrix W in place of Σ in the cost function $L(\alpha)$ and eliminate the need to identify Σ on-line. This may also lead to more robust adaptive filters since increased values of $v(i)$ are compensated in $L(\alpha)$ by increased values of Σ . By using a constant matrix W , we are exerting more positive control in keeping the innovations small.

With these points in mind, we now turn to the development of the adaptive filter. The cost function we will use is

$$J(k) = \frac{1}{2} \sum_{i=1}^k \gamma^{k-i} v(i)^T W^{-1} v(i) \quad (7.19)$$

where γ is a scalar age-weighting factor used to discount older data in a gradual fashion. We will make several assumptions:

- (1) The filter has reached a statistical steady state so that the optimal gains are constant.
- (2) The innovations are approximately linear functions of the parameters (the elements of ϕ and K).

We now make one important additional assumption, namely, that the gain K , as determined in the state space modeling program, remains close to optimum for the duration of the time series of interest. The PJM payoff data of Figures 7.1-7.6 suggest that greater changes are expected in ϕ than in K in most cases. For this reason, the following development will be based on adapting the transition matrix ϕ , but using a constant gain matrix K . This is equivalent to saying that following the trends in the data will be more important than estimating changes in its rms variation about the trend.

There are several possible approaches to on-line adaptation of ϕ . The simplest approach is to simply adapt each component independently, thus eliminating a high-order matrix inversion. However, this approach neglects the interactions between the elements of ϕ , which may be quite significant. If all components are adapted simultaneously, a matrix of dimension $n^2 \times n^2$ must be inverted. A different approach has been taken by DuVal and represents a compromise between these two extremes. This approach is based on adapting the components of ϕ one column at a time. The rationale for this approach is that each column of ϕ acts on a single component of the state vector, so that the column elements will be more highly correlated with each other than with the elements of other columns.

Let ϕ_i be the i^{th} column of ϕ ; i.e.,

$$\phi = [\phi_1 \mid \phi_2 \mid \dots \mid \phi_n]$$

Then, using the relations,

$$\hat{x}(i|i-1) = \Phi(i-1|i-1)\hat{x}(i-1|i-1) \\ v(i) = v(i) - H\hat{x}(i|i-1)$$

we have

$$\frac{\partial v(i)}{\partial \phi_j} = -H \frac{\partial \hat{x}(i|i-1)}{\partial \phi_j}$$

and

$$\begin{aligned} \frac{\partial \hat{x}(i|i-1)}{\partial \phi_j} &= \frac{\partial}{\partial \phi_j} [\Phi(i-1|i-1)] \\ &= \frac{\partial}{\partial \phi_j} \prod_{i=1}^n \Phi_i \hat{x}_i(i-1|i-1) \\ &= I \hat{x}_j(i-1|i-1) + \Phi \frac{\partial \hat{x}(i-1|i-1)}{\partial \phi_j} \end{aligned}$$

where $\hat{x}_j(i-1|i-1)$ is the j^{th} component of $\hat{x}(i-1|i-1)$. Now using

$$\hat{x}(i-1|i-1) = \hat{x}(i-1|i-2) + Kv(i-1)$$

we have

$$\frac{\partial \hat{x}(i-1|i-1)}{\partial \phi_j} = \frac{\partial \hat{x}(i-1|i-2)}{\partial \phi_j} + K \frac{\partial v(i-1)}{\partial \phi_j}$$

Combining these results and defining the sensitivity function

$$G_j(i) = \frac{\partial \hat{x}(i|i-1)}{\partial \phi_j}$$

gives the recursion

$$G_j(i) = I \hat{x}_j(i-1|i-1) + \Phi(I-KH)G_j(i-1) \quad (7.20)$$

Now define

$$S_j(i) = \frac{\partial v(i)}{\partial \phi_j} = -HG_j(i) \quad (7.21)$$

Using these results, we can compute the gradients of the cost function as

$$\Gamma_j(k) = \frac{\partial J(k)}{\partial \phi_j} = \sum_{i=1}^k \gamma^{k-i} S_j(i)^T W^{-1} v(i) \quad (7.22)$$

$$\Lambda_j(k) = \frac{\partial^2 J}{\partial \hat{\phi}_j \partial \hat{\phi}_j} = \sum_{i=1}^k \gamma^{k-1} S_j(i)^T W^{-1} S_j(i) \quad (7.23)$$

Then by analogy to (7.14) - (7.17), the maximum likelihood estimates of ϕ_j are found via the iteration

$$\hat{\phi}_j^{\ell+1}(k) = \hat{\phi}_j^{\ell}(k) - [\Lambda_j^{\ell}(k)]^{-1} \Gamma_j^{\ell}(k) \quad (7.24)$$

where

$$\Gamma_j^{\ell}(k) = \Gamma_j(k) \Big|_{\phi_j = \hat{\phi}_j^{\ell}(k)}$$

$$\Lambda_j^{\ell}(k) = \Lambda_j(k) \Big|_{\phi_j = \hat{\phi}_j^{\ell}(k)}$$

This iteration corresponds to a batch processor using the data Y^k . We wish to convert it to a recursive form. We start by noting that

$$\Gamma_j(k) = \gamma \Gamma_j(k-1) + S_j(k)^T W^{-1} v(k) \quad (7.25)$$

$$\Lambda_j(k) = \gamma \Lambda_j(k-1) + S_j(k)^T S^{-1} S_j(k) \quad (7.26)$$

We will make the additional assumption that only one iteration of the maximum likelihood equations will be made at each time step. This appears to be a reasonable assumption since we do not expect the matrix $\hat{\phi}$ to undergo a large jump at a single time but rather, that changes will occur over at least several successive time steps. Even if large changes did occur at only a single step, it would take several additional measurements of y to estimate the change. This assumption is also in keeping with the philosophy of "cautious" adaptation to minimize the effects of unmodeled uncertainties. With this assumption the adaptation equations (7.18) and (7.24) become

$$\hat{\phi}_j(k) = \hat{\phi}_j(k-1) - \Lambda_j(k)^{-1} \Gamma_j(k) \quad (7.27)$$

$$\hat{\phi}_j(k+1) = \hat{\phi}_j(k) + \beta [\hat{\phi}_j(k) - \hat{\phi}_j(k)] \quad (7.28)$$

In order to analyze this algorithm we first consider its performance under average steady-state conditions.

Steady-State Conditions

When the adaptor has converged, the following conditions hold, on the average (cf. (7.24)):

$$E[\Gamma_j(k)] = 0 \quad (7.29)$$

or

$$\sum_{i=1}^K E[S_j(i)W^{-1}v(i)] = 0 \quad (7.30)$$

We wish to investigate the conditions under which (7.29) holds. Now use

$$\begin{aligned} S_j(i) &= -HG_j(i) \\ v(i) &= -He(i|i-1) \end{aligned} \quad (7.31)$$

where

$$e(i|i-1) = \hat{x}(i|i-1) - x(i) \quad (7.32)$$

Then (7.28) becomes

$$\sum_{i=1}^k E[G_j(i)^T H^T W^{-1} He(i|i-1)] = 0$$

Assume, for simplicity, that y is a scalar. Then a sufficient condition for (7.30) to hold is

$$E[e(i|i-1)G_j(i)^T] = 0 \quad \forall i \quad (7.33)$$

Now

$$e(i+1|i) = (I-KH)e(i|i-1) - w(i+1) \quad (7.34)$$

Let

$$\bar{\Phi} = \Phi(I-KH)$$

Then

$$\begin{aligned} G_j(i+1) &= I\hat{x}_j(i|i) + \bar{\Phi}G_j(i) \\ e(i+1|i) &= \bar{\Phi}e(i|i-1) - w(i+1) \end{aligned}$$

Define

$$\begin{aligned} Q_j(i) &= E[e(i|i-1)G_j(i)^T] \\ Q_j(i+1) &= E\{[\bar{\Phi}e(i|i-1) - w(i+1)][I\hat{x}_j(i|i) + G_j(i)^T \bar{\Phi}^T]\} \\ &= \bar{\Phi}Q_j(i)\bar{\Phi}^T - E[w(i+1)\hat{x}_j(i|i)] - E[w(i+1)G_j(i)^T]\bar{\Phi}^T + \bar{\Phi}E[e(i|i-1)\hat{x}_j(i|i)] \end{aligned}$$

The terms involving $w(i+1)$ are zero since $w(i+1)$ is assumed independent of the past. Thus

$$Q_j(i+1) = \bar{\Phi} Q_j(i) \bar{\Phi}^T + \bar{\Gamma} E\{e(i|i-1)x_j(i|i)\} \quad (7.35)$$

If the filter has converged to a solution $\hat{\phi}$ after r time steps, we wish to have

$$Q_j(i) = 0; \quad i = r, r+1, \dots$$

This will be satisfied if

$$E\{e(i|i-1)\hat{x}(i|i)^T\} = 0; \quad i = r, r+1, \dots$$

This condition is equivalent to

$$E\{e(i|i-1)\hat{x}(i|i-1)^T\} = E\{e(i|i-1)e(i|i-1)^T\} H^T K^T = P' H K^T$$

Under optimal (Kalman) filtering the left-hand side is zero since the error and estimate are orthogonal. Thus, the algorithm will not converge, on the average, to a Kalman filter. This failure may be traced to the fact that the matrix Σ was not included in the cost. A simple modification leads to an algorithm which does converge, on the average, to the Kalman filter, if it converges at all. The modification is to use another recursion for $G_j(i)$:

$$G_j(i+1) = I \hat{x}_j(i|i-1) + \phi(k) [I - KH] G_j(i) \quad (7.36)$$

This form yields an "unbiased" adaptor, in the sense that (7.33) is satisfied for $i \geq r$. However, it does not necessarily yield a minimum variance estimate of ϕ .

We now consider another approximation we have used thus far, namely, that the value of ϕ is constant for all time steps since we have assumed batch processing of the data.

Accounting for Varying Reference Transition Matrices

The adaptation equation for ϕ_j (7.27) is based on the assumption that ϕ_j is fixed for all time steps. In practice, this will not be true and we need to account for the fact that ϕ_j is time varying. We may do this in the following manner. Let

$$J_0 = \frac{1}{2} \sum_{i=1}^k \gamma^{k-i} v(i)^T W^{-1} v(i) \Big|_{\phi_j(k)}$$

be the cost associated with the sequence $\phi_j(1), \phi_j(2), \dots, \phi_j(k)$. Viewing

this as a reference sequence we can expand the cost for using an estimate $\hat{\phi}_j(k)$ as a Taylor series to second order:

$$J(\hat{\phi}_j(k)) = J_0 + \sum_{i=1}^k \gamma^{k-i} [\hat{\phi}_j(k) - \phi_j(k)]^T S(i) T_W^{-1} v(i) \Big|_{\phi_j(i)} \\ + \sum_{i=1}^k \gamma^{k-i} [\hat{\phi}_j(k) - \phi_j(k)]^T S(i) T_W^{-1} S(i) [\hat{\phi}_j(k) - \phi_j(k)] \Big|_{\phi_j(i)}$$

The minimizing value $\hat{\phi}_j(k)$ satisfies:

$$\frac{\partial J(\hat{\phi}_j(k))}{\partial \hat{\phi}_j(k)} = \sum_{i=1}^k \gamma^{k-i} S(i) T_W^{-1} v(i) \Big|_{\phi_j(i)} \\ + \sum_{i=1}^k \gamma^{k-i} S(i) T_W^{-1} S(i) \Big|_{\phi_j(i)} [\hat{\phi}_j(k) - \phi_j(i)] = 0$$

Similarly, for the estimate $\hat{\phi}_j(k-1)$ we have

$$\sum_{i=1}^{k-1} \gamma^{k-i-1} S(i) T_W^{-1} v(i) \Big|_{\phi_j(i)} \\ + \sum_{i=1}^{k-1} \gamma^{k-i-1} S(i) T_W^{-1} S(i) \Big|_{\phi_j(i)} [\hat{\phi}_j(k-1) - \phi_j(i)] = 0$$

These may be converted, using (7.22) and (7.23), into the form

$$\Gamma_j(k) + \Lambda_j(k) \hat{\phi}_j(k) = \sum_{i=1}^k \gamma^{k-1} S(i) T_W^{-1} S(i) \phi_j(i) \\ \Gamma_j(k-1) + \Lambda_j(k-1) \hat{\phi}_j(k-1) = \sum_{i=1}^{k-1} \gamma^{k-i-1} S(i) T_W^{-1} S(i) \phi_j(i)$$

Combining these yields

$$\Gamma_j(k) - \gamma \Gamma_j(k-1) + \Lambda(k) \hat{\phi}_j(k) - \gamma \Lambda_j(k-1) \hat{\phi}_j(k-1) = S(k) T_W^{-1} S(k) \phi_j(k)$$

Now using (7.25) and (7.26) are rearranging gives

$$\begin{aligned}\hat{\phi}_j(k) &= \hat{\phi}_j(k-1) - \Lambda_j(k)^{-1} S(k)^T W^{-1} \{v(k) \\ &\quad - S(k) [\phi_j(k) - \hat{\phi}_j(k-1)]\}\end{aligned}\quad (7.37)$$

This equation is valid for time-varying reference values of ϕ_j .

This completes the major development of the adaptive filter. In summary, the adaptation equations are (7.28) and (7.37), while Λ is updated using (7.26). Note from (7.37) that an $n \times n$ matrix inversion is required to compute $\hat{\phi}_j(k)$. If n is large, this can cause numerical problems. This problem can be alleviated in most cases if m , the dimension of y , is less than n by using an alternate form that only requires inverting an $m \times m$ matrix. This may be done as follows.

Simplification for $m \times n$

By using the matrix inversion lemma (Bryson and Ho, 1969) and (7.26), we can write

$$\Lambda_j(k)^{-1} = \frac{1}{\gamma} [I - D_j(k) S_j(k)] \Lambda_j(k-1)^{-1} \quad (7.38)$$

where

$$D_j(k) = \Lambda_j(k-1)^{-1} S_j(k)^T M_j(k)^{-1} \quad (7.39)$$

$$M_j(k) = S_j(k) \Lambda_j(k-1)^{-1} S_j(k)^T + \gamma W \quad (7.40)$$

Another form for $D_j(k)$ is

$$D_j(k) = \Lambda_j(k)^{-1} S_j(k)^T W^{-1} \quad (7.41)$$

which gives, for (7.37),

$$\hat{\phi}_j(k) = \hat{\phi}_j(k-1) - D_j(k) \{v(k) - S(k) [\phi_j(k) - \hat{\phi}_j(k-1)]\} \quad (7.42)$$

Note that $\Lambda_j(k)^{-1}$ can be computed recursively using (7.38) - (7.40) by inverting only the $m \times m$ matrix $M_j(k)$.

We remark that the equation for updating $\hat{\phi}_j$ is in the form of a Kalman filter with $D_j(k)$ the Kalman gain matrix and

$$v(k) - S(k) [\phi_j(k) - \hat{\phi}_j(k-1)]$$

the innovations process. The matrix $\Lambda_j(k)$ is the covariance matrix of estimation errors of $\hat{\phi}_j$.

Summary of Adaptive Filtering Equations

The preceding development is summarized in Table 7.1, which presents the final form of the adaptive filtering algorithm. In the table,

$$\bar{\Lambda}_j(i) = \Lambda_j(i)^{-1}.$$

Table 7.1: Adaptive Filtering Algorithm

Initial conditions:	$J(0) = 0, \Phi(0), \bar{\Lambda}_j(-1), S_j(1) = 0, G_j(1) = 0,$ $\hat{x}(1 0) = \Phi(0)\hat{x}(0 0), \phi_j(1), \hat{\phi}_j(0)$
Filter:	$\begin{cases} v(i) = y(i) - H\hat{x}(i i-1) \\ \hat{x}(i i) = \hat{x}(i i-1) + Kv(i) \end{cases}$
Cost:	$J(i) = \gamma J(i-1) + v(i)^T W^{-1} v(i)$
A	$j = 1$
Adaptor Gain Propagation:	$\begin{cases} M_j(i) = S_j(i)\bar{\Lambda}_j(i-1)S_j(i)^T + \gamma W \\ D_j(i) = \bar{\Lambda}_j(i-1)S_j(i)^T M_j(i)^{-1} \\ \bar{\Lambda}_j(i) = \frac{1}{\gamma} [I - D_j(i)S_j(i)]\bar{\Lambda}_j(i-1) \end{cases}$
Adaptor:	$\begin{cases} \hat{\phi}_j(i) = \hat{\phi}_j(i-1) - D_j(i)\{v(i) - S_j(i)[\phi_j(i) - \hat{\phi}_j(i-1)]\} \\ \phi_j(i+1) = \phi_j(i) + \beta[\hat{\phi}_j(i) - \phi_j(i)] \end{cases}$
Sensitivity Propagation:	$\begin{cases} G_j(i+1) = I\hat{X}_j(i i-1) + \Phi(i)[I - KH]G_j(i) \\ S_j(i+1) = -HG_j(i+1) \end{cases}$
	$j = j+1$
	if $j = n+1$, go to A
Propagate State Estimate:	$\begin{cases} \Phi(i+1) = [\phi_1(i+1) \phi_2(i+1) \dots \phi_n(i+1)] \\ \hat{x}(i+1 i) = \Phi(i+1)\hat{x}(i i) \end{cases}$

8. ADAPTIVE FILTERING OF PJM PAYOFF DATA

8.1 Nature of the Experiment

In order to test the adaptive filter developed in the earlier sections of this report on actual PJM payoff data, a number of experiments were run. In these experiments, the filter was exercised on data that exhibited what might be thought of as "policy" changes; that is, those PJM payoff series that showed a behavior pattern for a reasonable length of time and then a change. This property of reasonably constant behavior over a period of time of either the original series or a series derived from the original by some differencing operation is important to the correct operation of the adaptive filter.

The adaptive filter has, in some sense, properties similar to that of a phase locked loop. That is, there will exist a bandwidth in the rate of signal change over which it will function properly. Exceeding this bandwidth will cause the filter to lose the "signal" (in this case the state transition matrix) and perform poorly. Like the loop filter in a phase locked loop, the adaptive filter has two parameters that control the bandwidth over which it will correctly track the signal. The first parameter is γ , the age weighting parameter. This parameter is similar to the settling time of the loop filter. Too long a time constant (γ high) will cause the filter to be sluggish in reacting to fast change in the transition matrix. Too short a time constant (γ low) will cause the filter to respond only to very recent data. The second parameter is β , the state transition matrix slow rate parameter. β should be set to a low value for highly random data and to a high value for smoothly varying data. This parameter is similar to the damping of the phase-lock filter, in that too high a value will cause the filter to overreact to a change and overshoot, bounce or even oscillate. Too low a value will cause the filter to adapt too slowly to a change in the inputs.

Ideally, these two parameters should be varied on-line in response to the local behavior of the signal. During periods of signal change, γ should be relatively low and β relatively high in order to track the change. During periods of constant behavior, the reverse should hold in order to filter out noise. The adaptive filter thus has within itself the problem of adapting its own parameters. The experiments of this section use a scheme for this which seems to give reasonable results. This scheme will be discussed later in this section.

In order to reduce the bandwidth of the change in the state transition matrix and reduce variations about underlying trends, experiments in this section used right-justified or causal moving averages of the PJM payoff data. The desire to reduce the bandwidth was motivated by two factors. The first factor was that the payoff series data were quantized or perhaps rounded to the nearest integral value. Thus, if the actual series was 100.9, 100, 98.9, ..., the quantized data available would have been 100, 100, 98. This results in a much higher bandwidth than was realistically expected in the data, with a large number of step changes. The second reason was to observe the response of the γ and β adaptation

algorithm to changes that could be more easily pinpointed.

8.2 Determining γ and β

There exist a number of approaches for determining γ and β . The first is to assume that the two variables are constant for the series. The values of γ and β that may be used can be found by evaluating the filter performance on some cost criteria for a historical dataset. A minimum cost point can be found and values of γ and β used for the future filtering problem. This approach has an obvious advantage and several disadvantages. The advantage is that it is probably more inexpensive to determine the values only once rather than determining them on-line. The disadvantage is that this approach is most likely to be very suboptimal. The optimum values of γ and β are most likely time varying quantities, so a single value will give locally poor performance. Either the filter will be too sluggish or else it will overshoot when viewed on a local level. Further, even if the optimum values of γ and β are constant over the historical data, there is no guarantee that they will be so in the future.

A second approach will be to filter for γ and β in some manner. To do this, we must construct some sort of model for the behavior of γ and β . A heuristically reasonable model for these parameters would be that they would be produced by a persistence plant. That is, that the values of γ and β are as likely to increase with time as they are to decrease. This assumption is violated at the boundaries zero and one, but will be accepted here. We thus will assume the model:

$$\begin{bmatrix} \gamma(t+1) \\ \beta(t+1) \end{bmatrix} = \begin{bmatrix} 1 & 0 \\ 0 & 1 \end{bmatrix} \begin{bmatrix} \gamma(t) \\ \beta(t) \end{bmatrix} + \begin{bmatrix} \eta_1(t) \\ \eta_2(t) \end{bmatrix}$$

where $\eta(t)$ is a white noise vector with zero mean and covariance matrix Q . For our purposes, it will suffice to assume that Q is $\sigma^2 I$ for some σ . This basically states that γ and β move independently of each other with increments of equal probability.

The total model is basically one of two-dimensional Brownian motion. Again, this will be violated at the boundaries, but is not totally unreasonable in the interior.

The next thing that must be assumed in the filter is a cost function. Since our ultimate desire is to minimize the error in the state variable predictions, a quadratic form on the one-step prediction innovation will be reasonable.

Finally, it is necessary to model the transfer function from γ and β to the predictions, and the additive noise on this transfer function. The transfer function itself is quite trivial, being the adaptive filter itself. That is, all else being constant, the prediction made by the adaptive filter is a function of γ and β . The noise, however, is not so straightforward. First, like the plant noise, it is not a Gaussian variable. Secondly, its variance is process noise dependent. That is, it depends on the plant and additive noises of the observed series, which in

general are unknown. If we assume an a priori "signal-to-noise" ratio of the γ and β plant to the additive noise in the adaptive filter, we may make some headway. Call this parameter $\alpha(i)$.

Given these assumptions, it is possible to design a filter that attempts to track γ and β . The algorithm is basically as follows:

1. Assuming a value for $\gamma(i)$ and $\beta(i)$, perform a prediction of $x(i)$ (the state variables) for time $i+1$, giving $x'(i+1)$.
2. Observing $y(i+1)$, calculate the actual cost function incurred.
3. Varying $\gamma(i)$ and $\beta(i)$ within a radius α , perform step 1 as if that value had been used to predict $x(i+1)$.
4. Evaluate the cost function of step 2 for these predictions.
5. Select as $\gamma(i+1)$ and $\beta(i+1)$ the minimum step 4 cost α and β .
6. Go to step 1 for time $i+1$.

This algorithm is motivated in terms of our earlier discussion as follows: step 6 is the prediction step of a Kalman filter. Steps 1 and 3 are the modulation steps in an extended Kalman filter. Steps 3 and 4 taken together find the direction of steepest descent of the cost function. This may be viewed as the sensitivity matrix computation of the extended Kalman filter. Step 5 in combination with step 3 is an update step in the filter. Although still somewhat ad hoc, this algorithm contains sufficient motivation to make it reasonable in practice.

8.3 Results and Discussion

The adaptive filter was run on a number of PJM payoff series. A list of some of the series with the prediction error summary of the adaptive filter and persistence predictor errors for 1, 3 and 12-month predictions are given in Table 8.1. Figures 8.1 - 8.8, 8.9 - 8.16, and 8.17 - 8.24 show the 1-month, 3-month and 12-month predictions with observed data respectively. Figures 8.25 - 8.32 show the values of γ and β determined by the program.

The performance of the adaptive filter's 1- and 3-month predictions are quite good when compared to the persistence predictor. The estimates are generally unbiased and the error covariance less than the persistence predictor. Examining the plots, we note an overshoot or undershoot at those times that the system changes, but this is an expected event.

The performance of the filter in its 12-month predictions is, at best, poor. While still relatively unbiased, the error covariance is large. Examination of the plots, in particular that of F46330, shows the cause. Basically, the filter is usually being asked to predict further into the future than the mean time between policy changes. In the worst case, its predictions become 180° out of phase with reality.

The plots of γ and β show that the algorithm is indeed changing these parameters on the basis of changes in the behavior of the series. For the majority of the series, however, the parameters are being modified in a counter-intuitive manner. At points of change in the series, γ

increases and β decreases. During periods of constant behavior, γ decreases and β increases. For this reason, the algorithm previously presented may have to be modified or superseded. It should be noted, however, that the algorithm yields results that are better than single choices of γ and β . Table 8.2 documents the performance of the adaptive filter in the varying γ and β mode versus several choices of a constant γ and β . The varying mode performs better.

The conclusion that may be drawn from these experiments is that the adaptive filter performs in a superior fashion to the persistence predictor for short and medium range predictions. For long range predictions beyond the mean time to a policy change, the filter performs in a manner inferior to a simple persistence predictor. Finally, the algorithm that varies γ and β gives better performance than a constant γ and β , but is probably suboptimum.

Table 8.1: Prediction Error Summary of Adaptive Filter and Persistence Predictor

Series	One-Step Prediction			Three-Step Prediction			Twelve-Step Prediction					
	Adaptive Filter		Persistence Predictor	Adaptive Filter		Persistence Predictor	Adaptive Filter		Persistence Predictor			
	μ	σ^2	μ	σ^2	μ	σ^2	μ	σ^2				
M27131	0.001	0.007	0.176	0.046	0.000	0.116	0.701	0.680	0.476	5.187	2.556	5.762
M67232	-0.012	0.040	-0.009	0.068	0.029	0.392	0.023	0.722	0.409	12.639	0.369	1.965
F46330	0.042	0.482	0.103	0.482	0.109	3.164	0.417	3.846	-0.584	76.743	1.453	13.021
M30230	0.001	0.014	0.064	0.016	-0.017	0.010	0.265	0.149	-0.259	1.530	1.090	0.542
F20530	0.017	0.128	0.181	0.252	0.044	0.802	0.755	3.013	-0.741	35.030	2.873	24.526
F42333	0.008	0.027	0.005	0.045	0.039	0.209	0.045	0.513	0.885	4.929	0.525	3.505
TSK287	0.008	0.014	0.225	0.012	-0.010	0.083	0.871	0.136	-0.118	1.378	2.899	0.699
TSK288	0.010	0.011	0.163	0.040	0.040	0.136	0.661	0.567	0.726	4.090	2.500	4.362

Table 8.2: Adaptive Filter Performance on Series TSK288 Using Various γ and β

γ	β	Mean Error	Error Covariance
Varying	Varying	0.010	0.0111
.5	.5	0.002	0.0148
.6	.4	0.004	0.0185
.4	.6	0.001	0.0123
.3	.7	0.163	0.0402
.5	.6	0.001	0.0135
.5	.7	0.001	0.0125

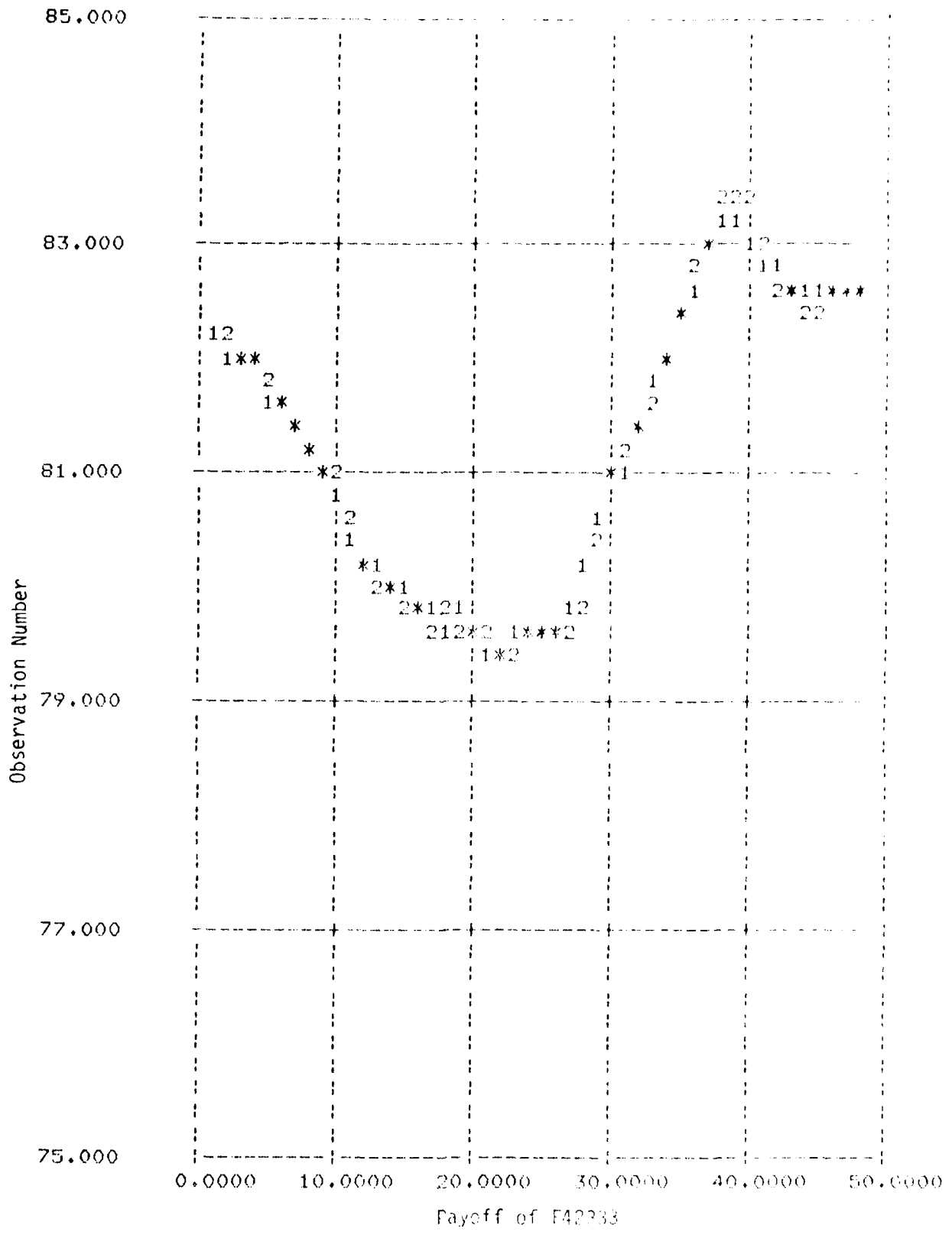

Figure 8.1. Adaptive Filter One Month Predictions at 1.055s.
 1 = Observed Data, 2 = One Month Prediction

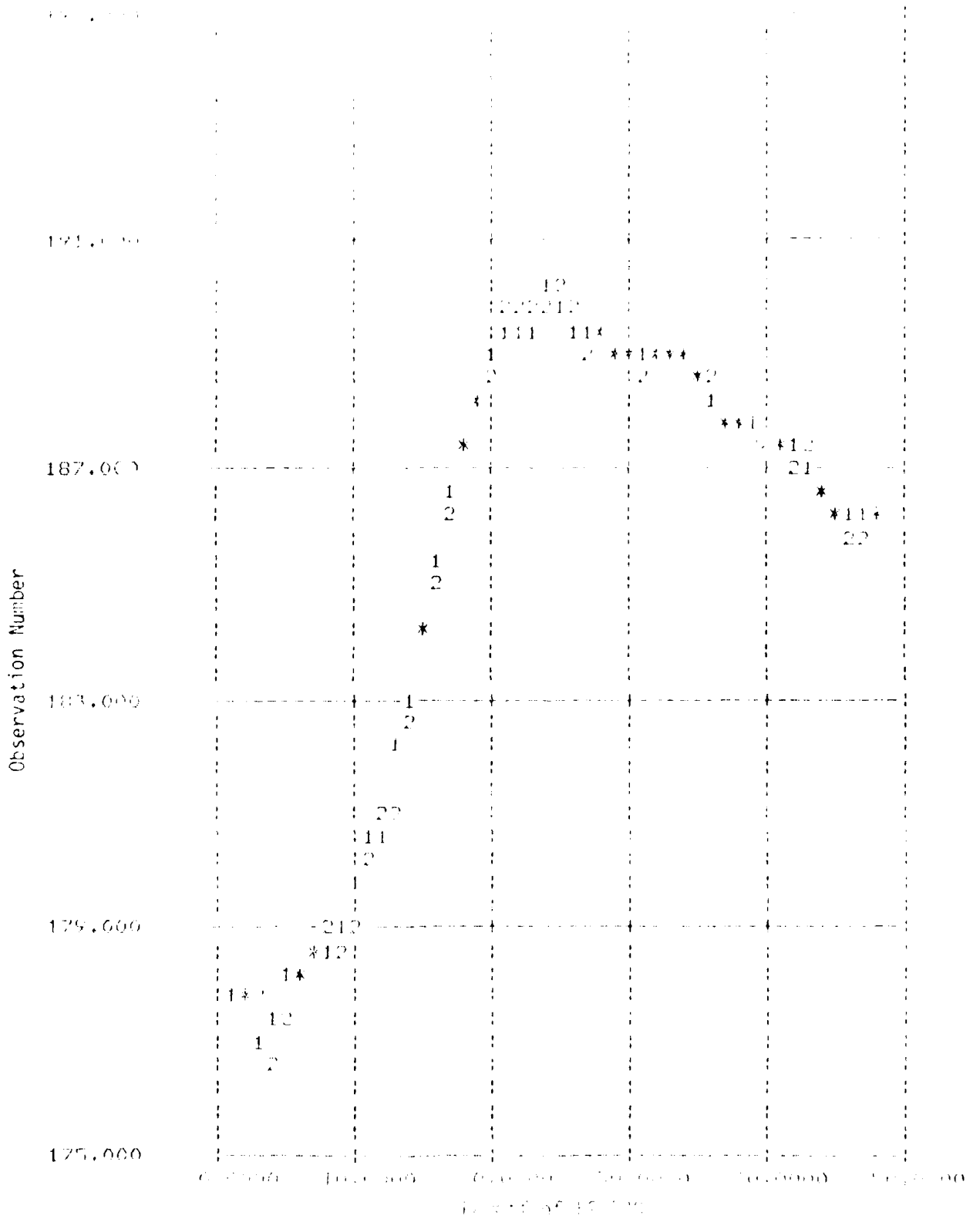

Figure 8.2. Adaptive Filter One Month Prediction of 120000.
 1 = Observed Data, 2 = One Month Prediction

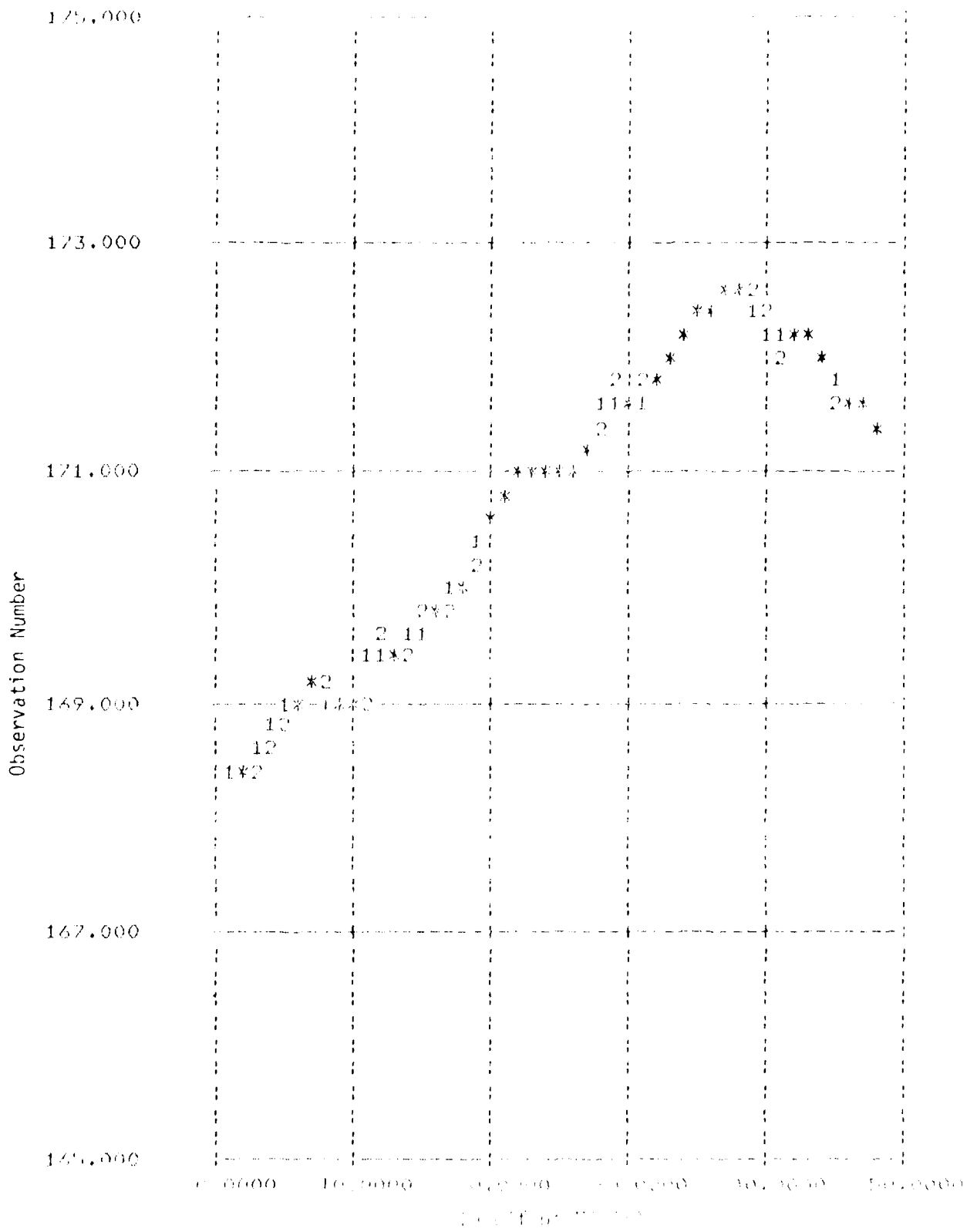

Figure 3.3. Adaptive Filter and Month Prediction of 230,000.
 1 = Observed data, 2 = one Month Prediction

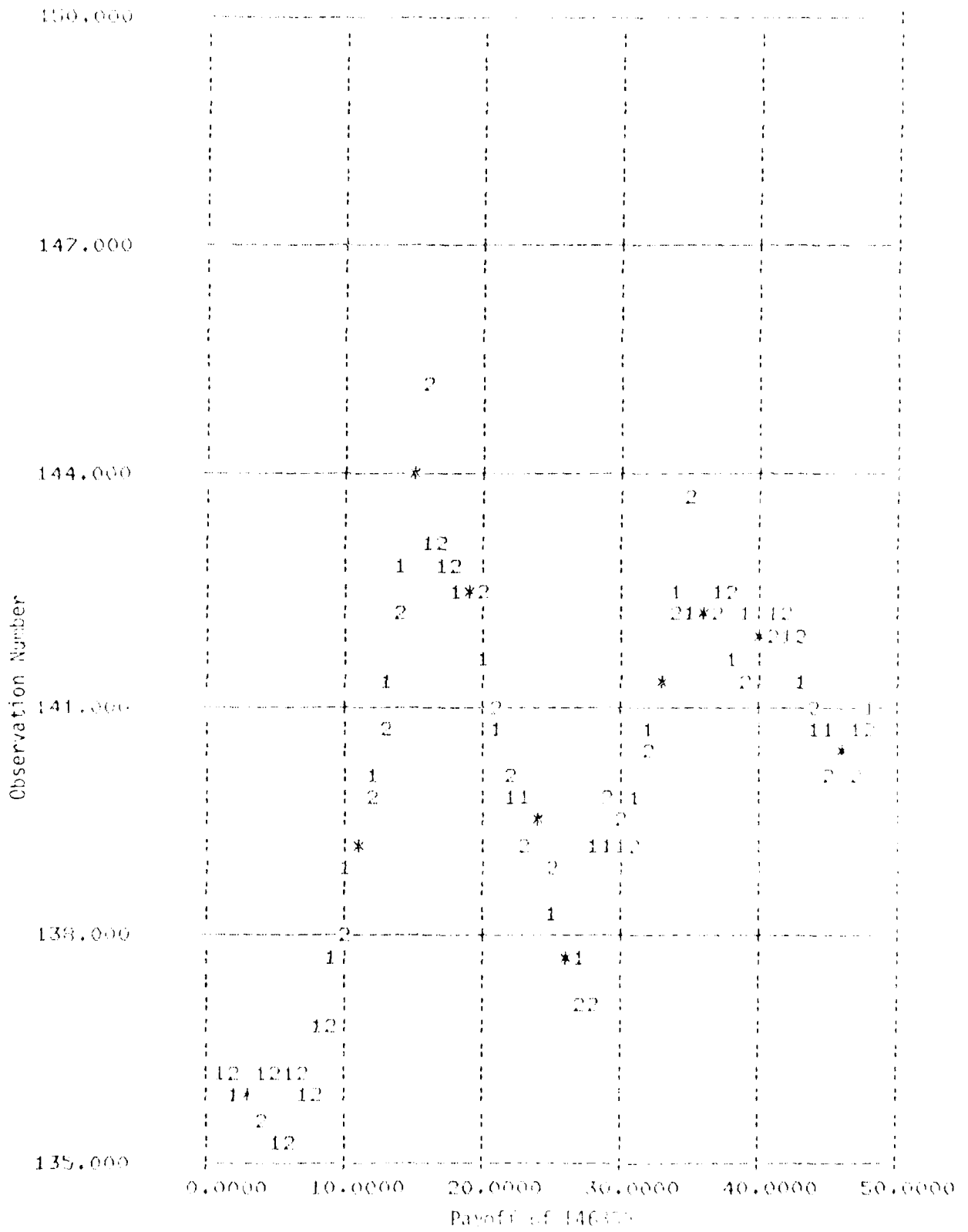

Figure 1.5. Scatter Plot Filter One Month Prediction of Fig. 1.4
 1 - Observed Data, 2 - One Month Prediction

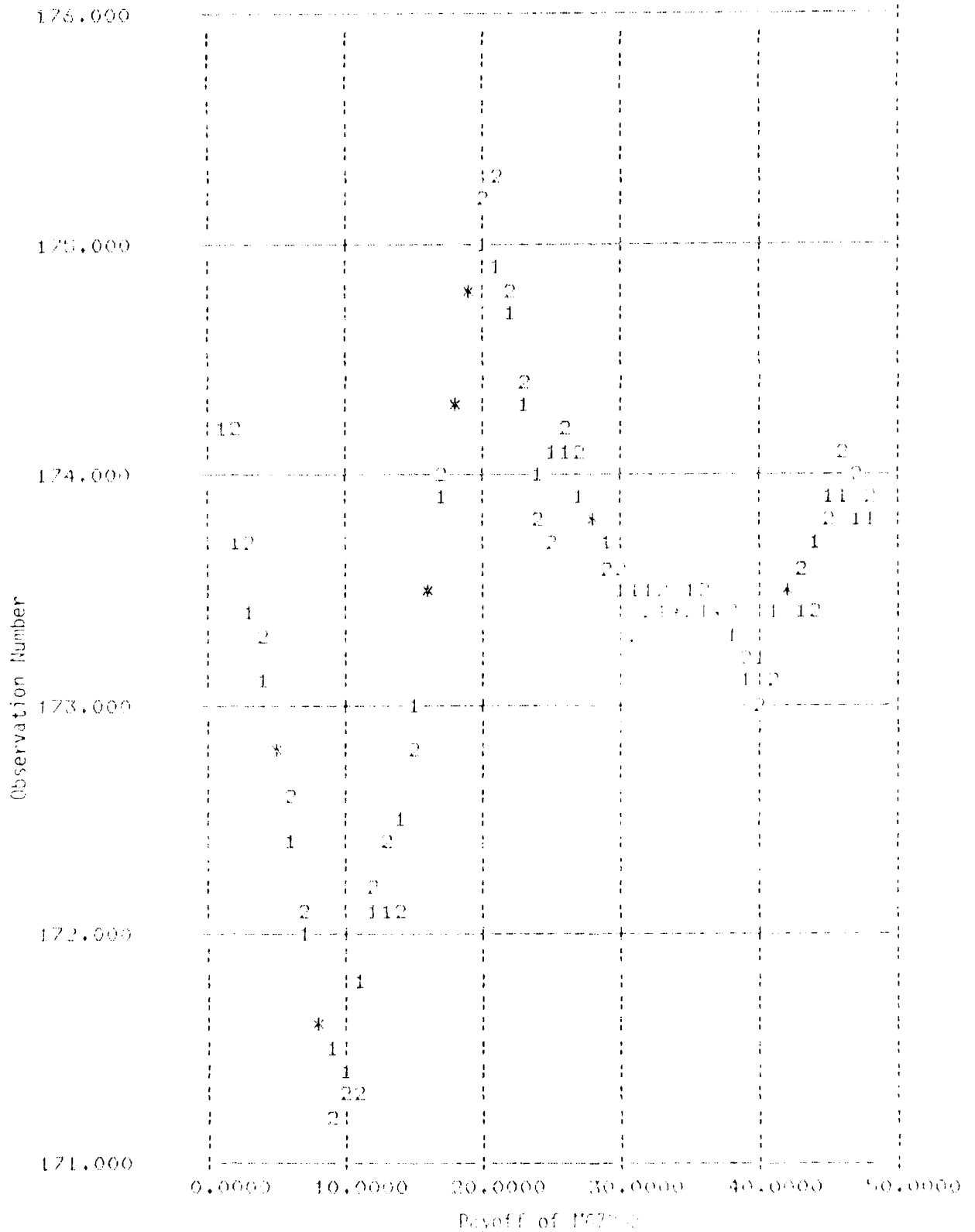

Figure 8.5. Adaptive Filter of Month Prediction and Observed
 1 = Observed Data, 2 = One Month Prediction

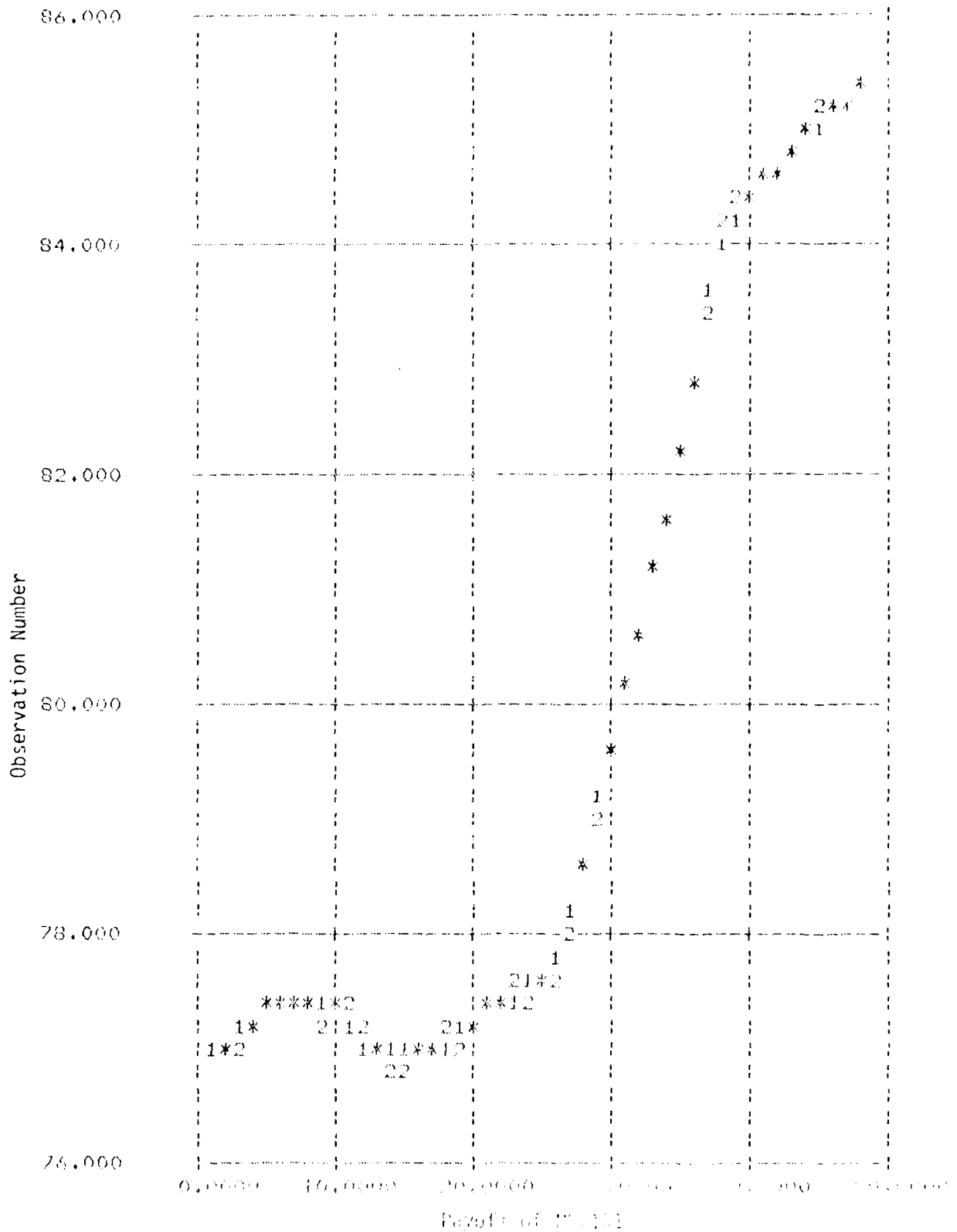

Figure 8.6. Adaptive Filter One Month Prediction of M7131
 1 = Observed Data, 2 = One Month Prediction

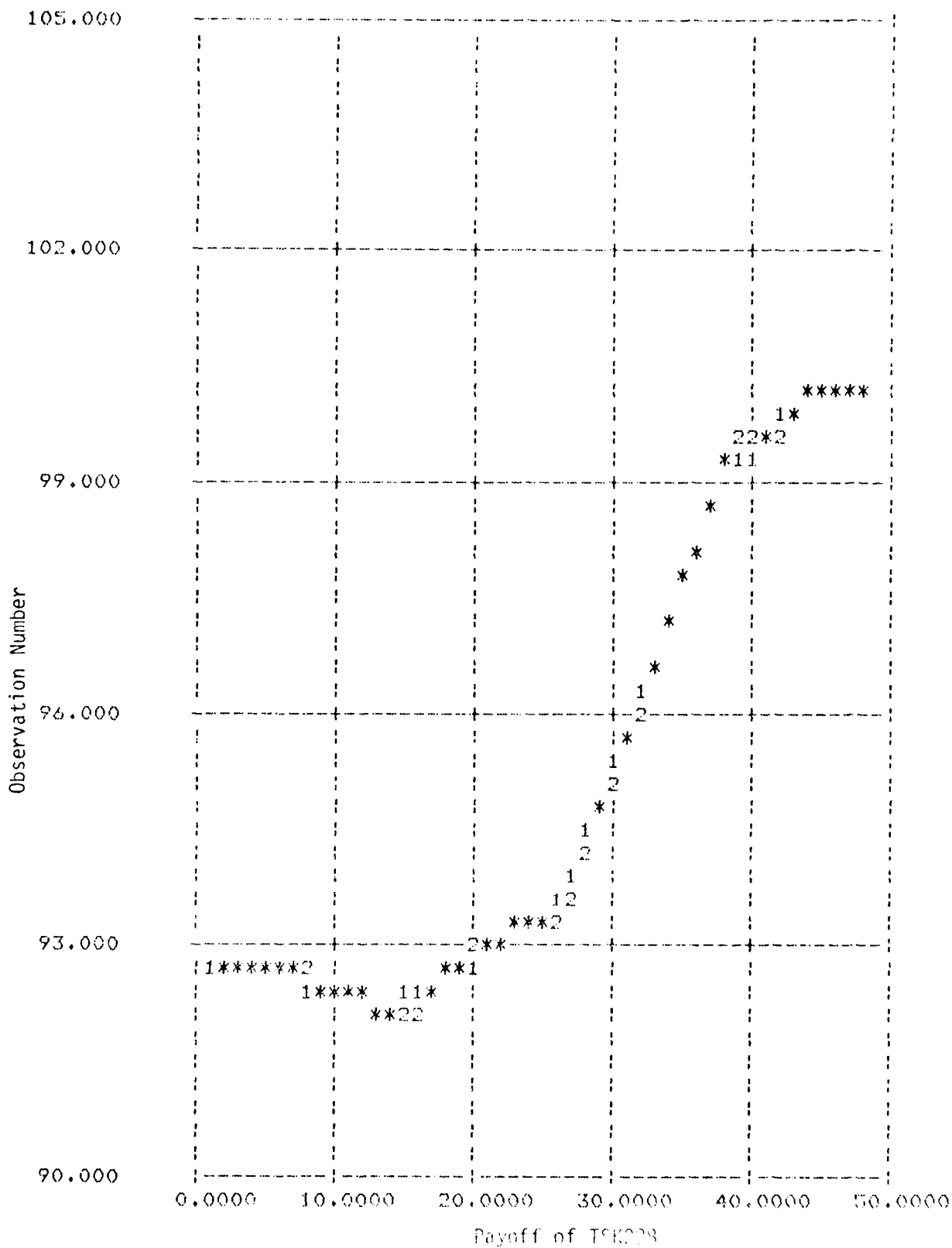

Figure 8.7. Adaptive Filter One Month Prediction of TSK288
 1 = Observed Data, 2 = One Month Prediction

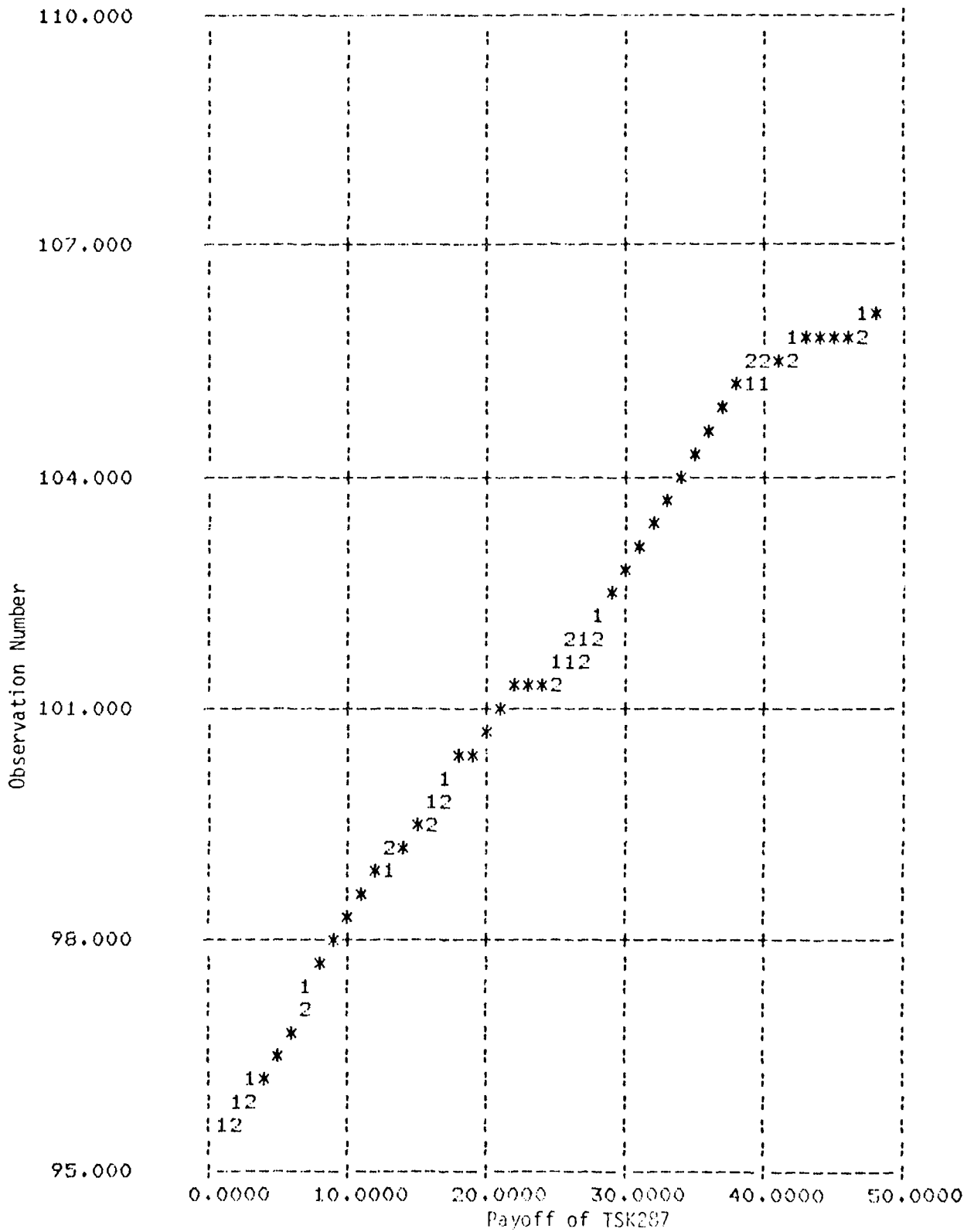

Figure 8.8. Adaptive Filter One Month Prediction of TSK287
 1 = Observed Data, 2 = One Month Prediction

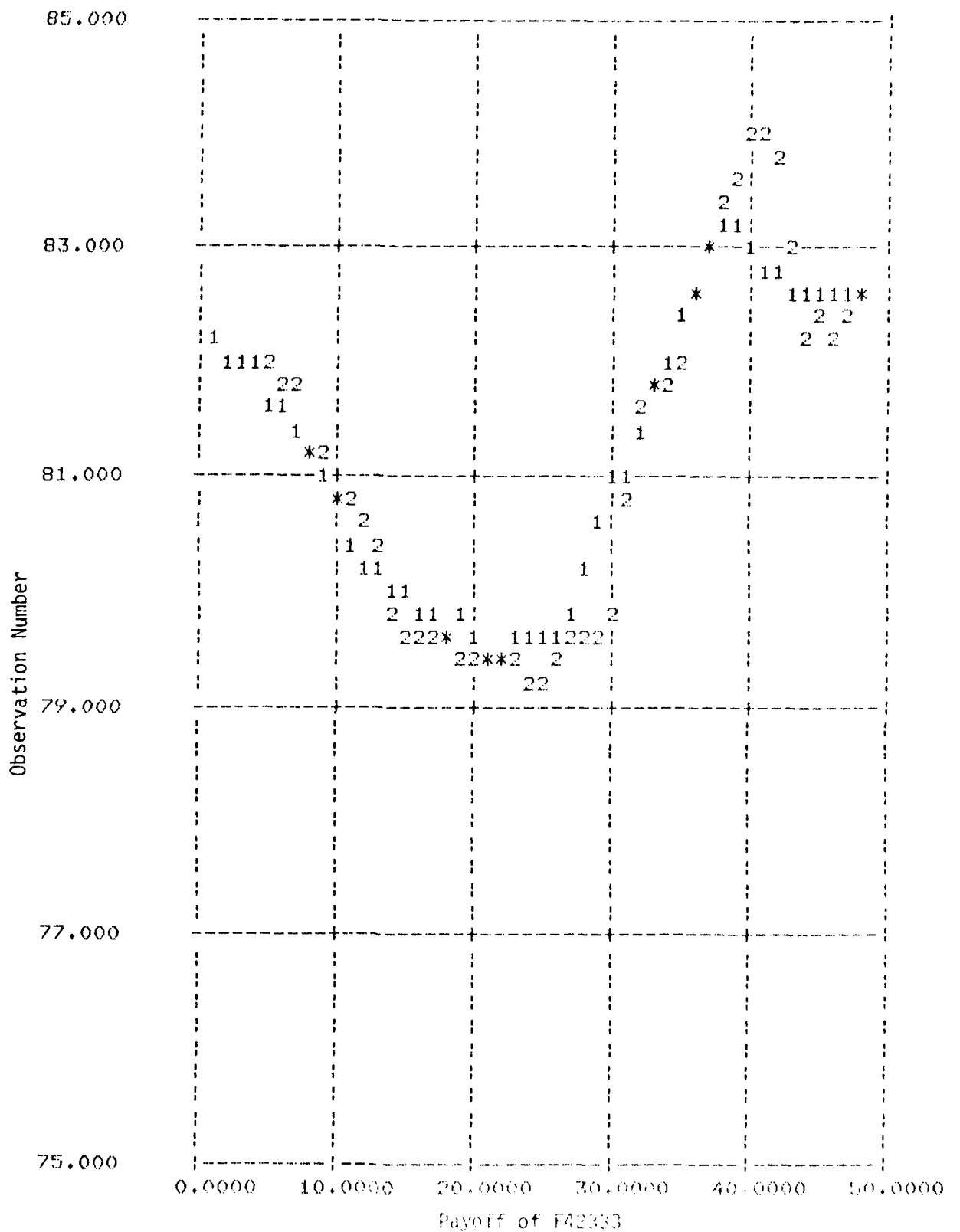

Figure 8.9. Adaptive Filter 3-Month Prediction of F42333
 1 = Observed Data, 2 = 3-Month Prediction

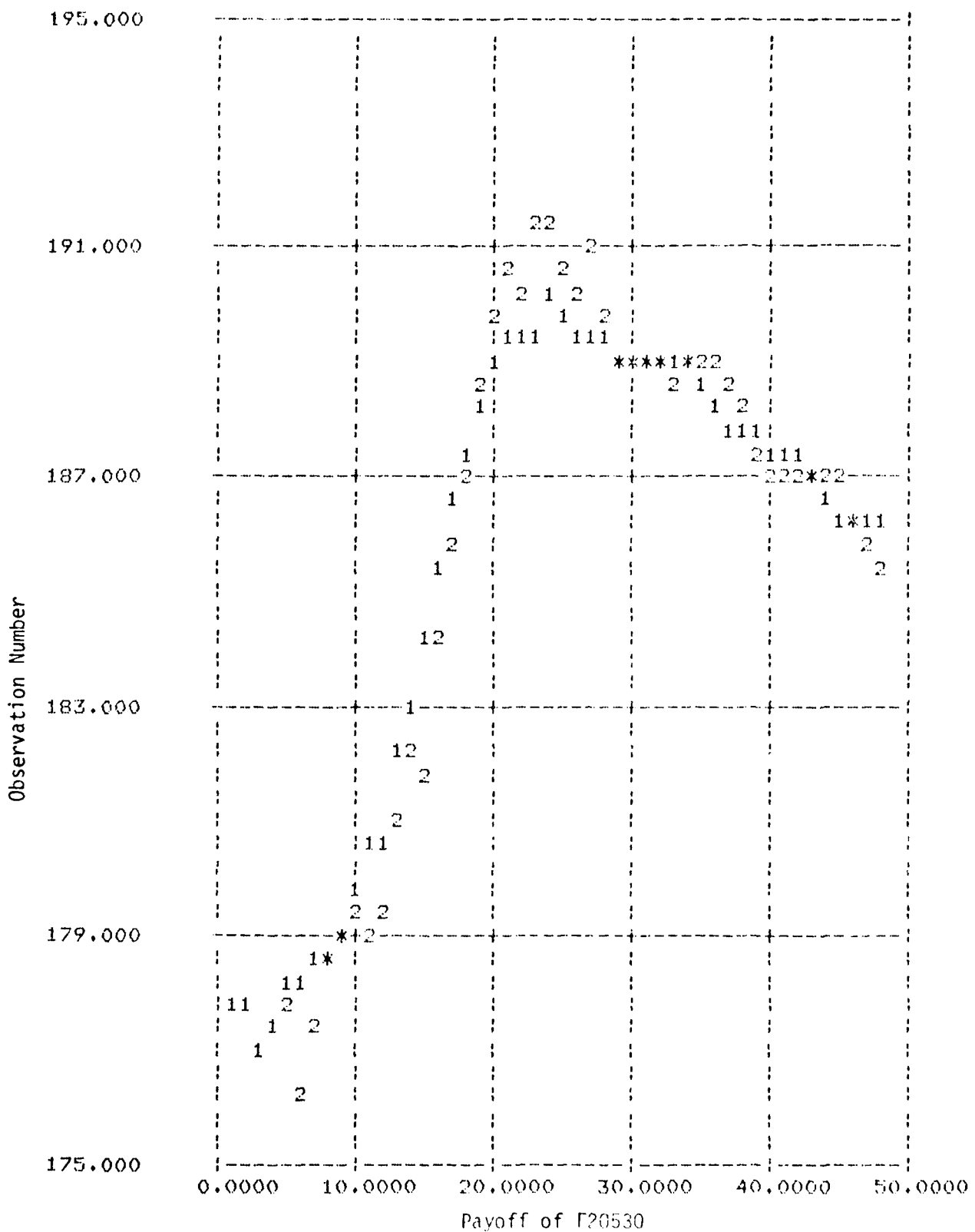

Figure 8.10. Adaptive Filter 3-Month Prediction of F20530
 1 = Observed Data, 2 = 3-Month Prediction

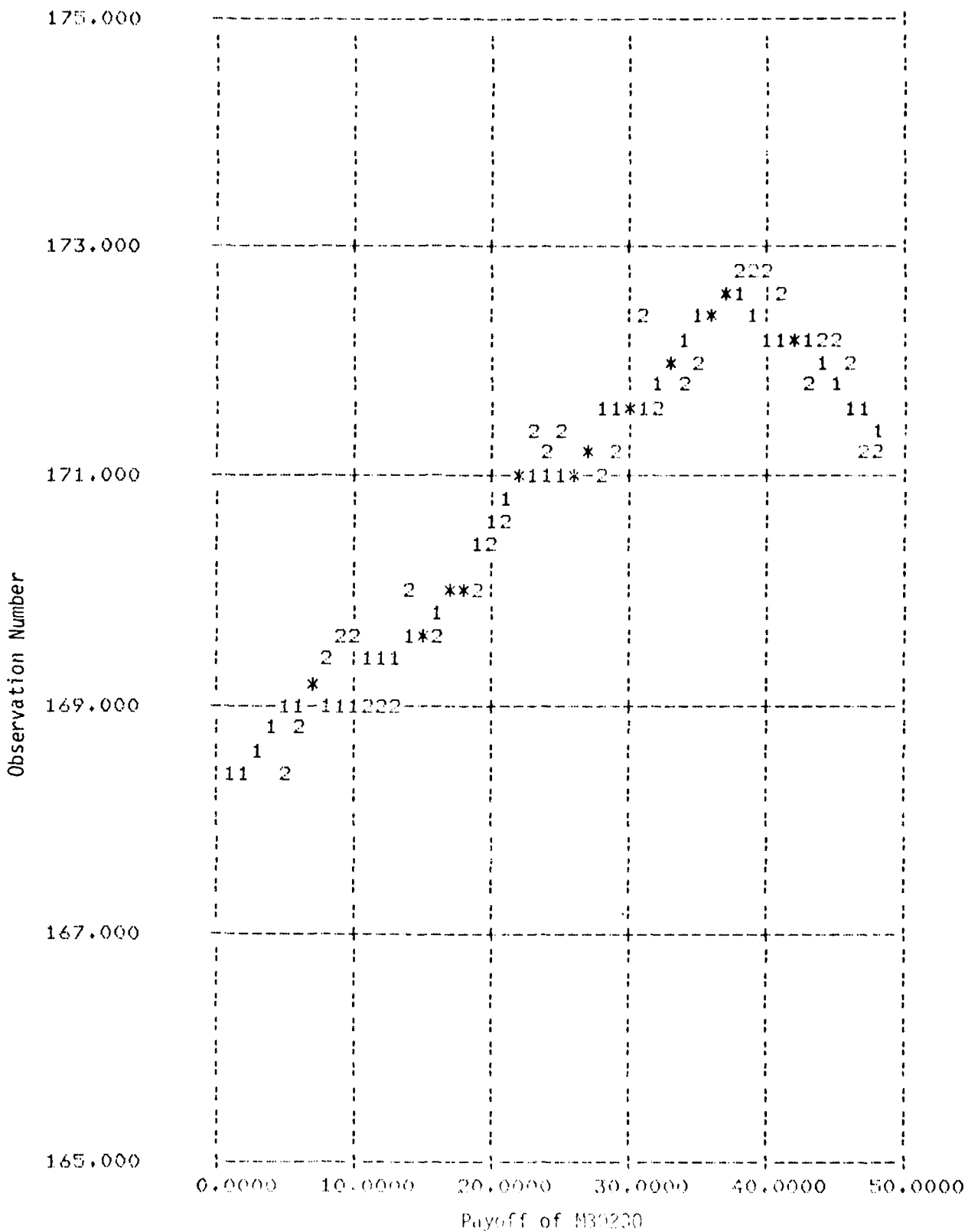

Figure 8.11. Adaptive Filter 3-Month Prediction of M30230
 1 = Observed Data 2 = 3-Month Prediction

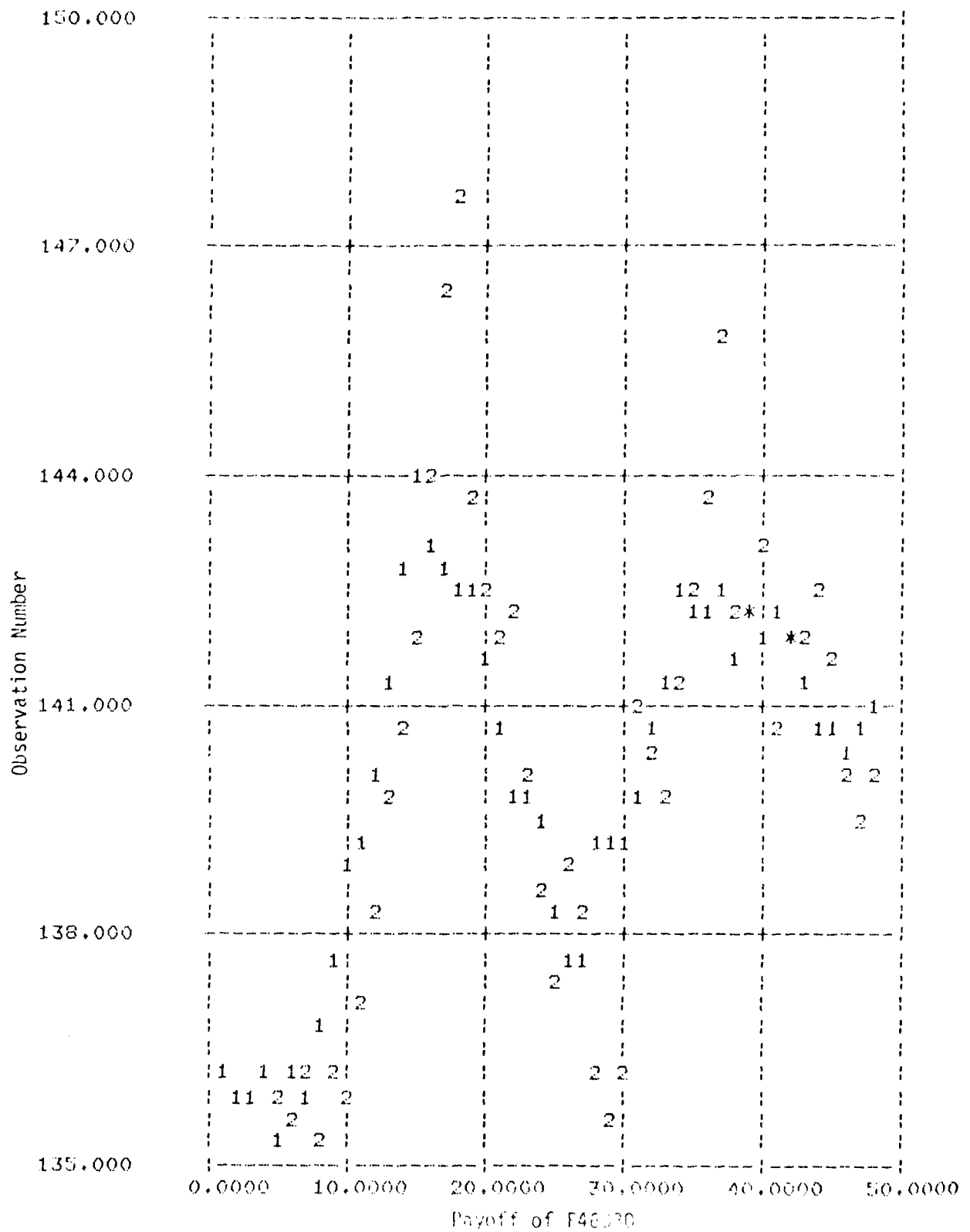

Figure 8.12. Adaptive Filter 3-Month Prediction of F46330
 1 = Observed Data, 2 = 3-Month Prediction

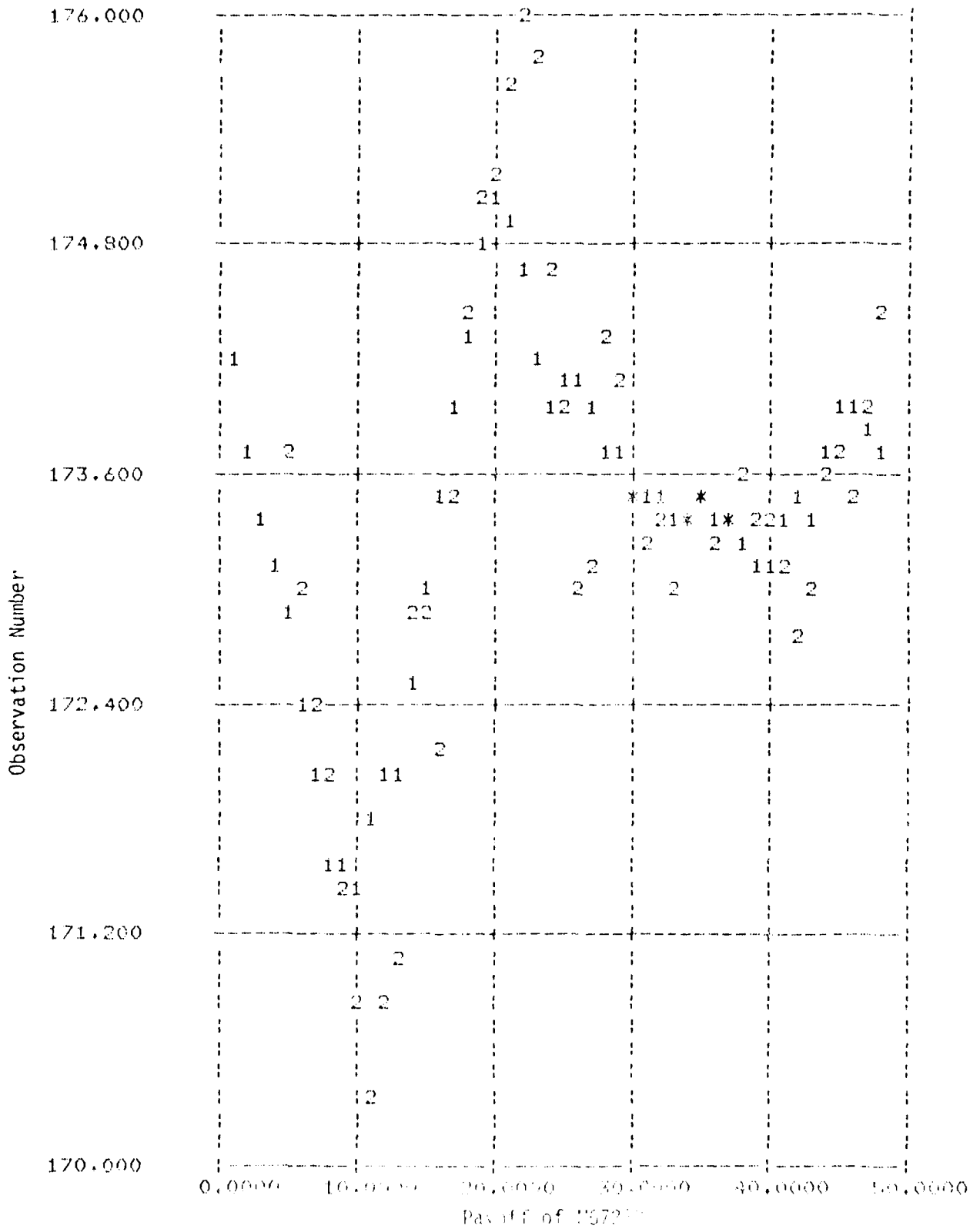

Figure 8.13. Adaptive Filter 3-Month Prediction of M67232
 1 = Observed Data, 2 = 3-Month Prediction

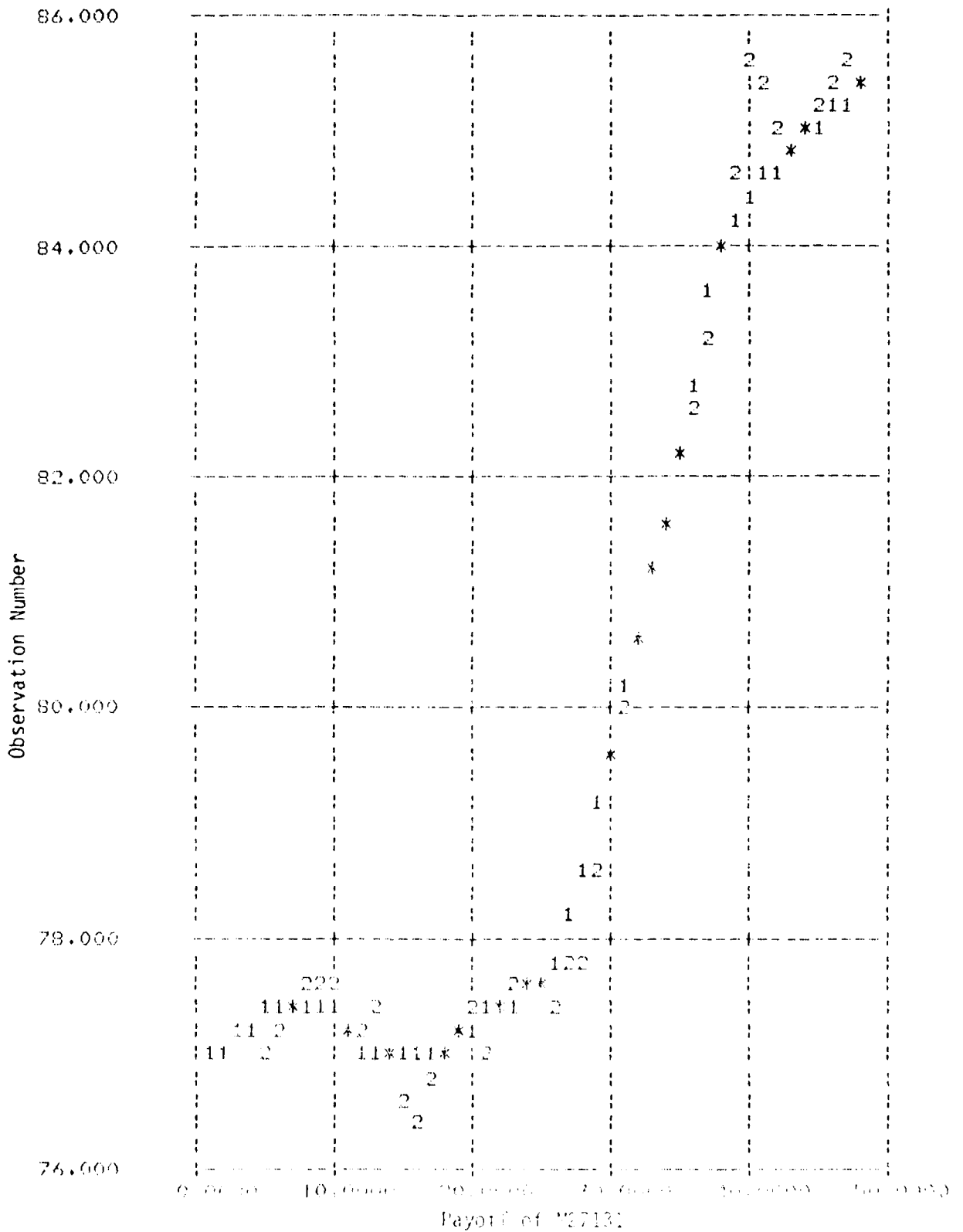

Figure 8.14. Adaptive Filter 3-Month Prediction of M27131
 1 = Observed Data, 2 = 3-Month Prediction

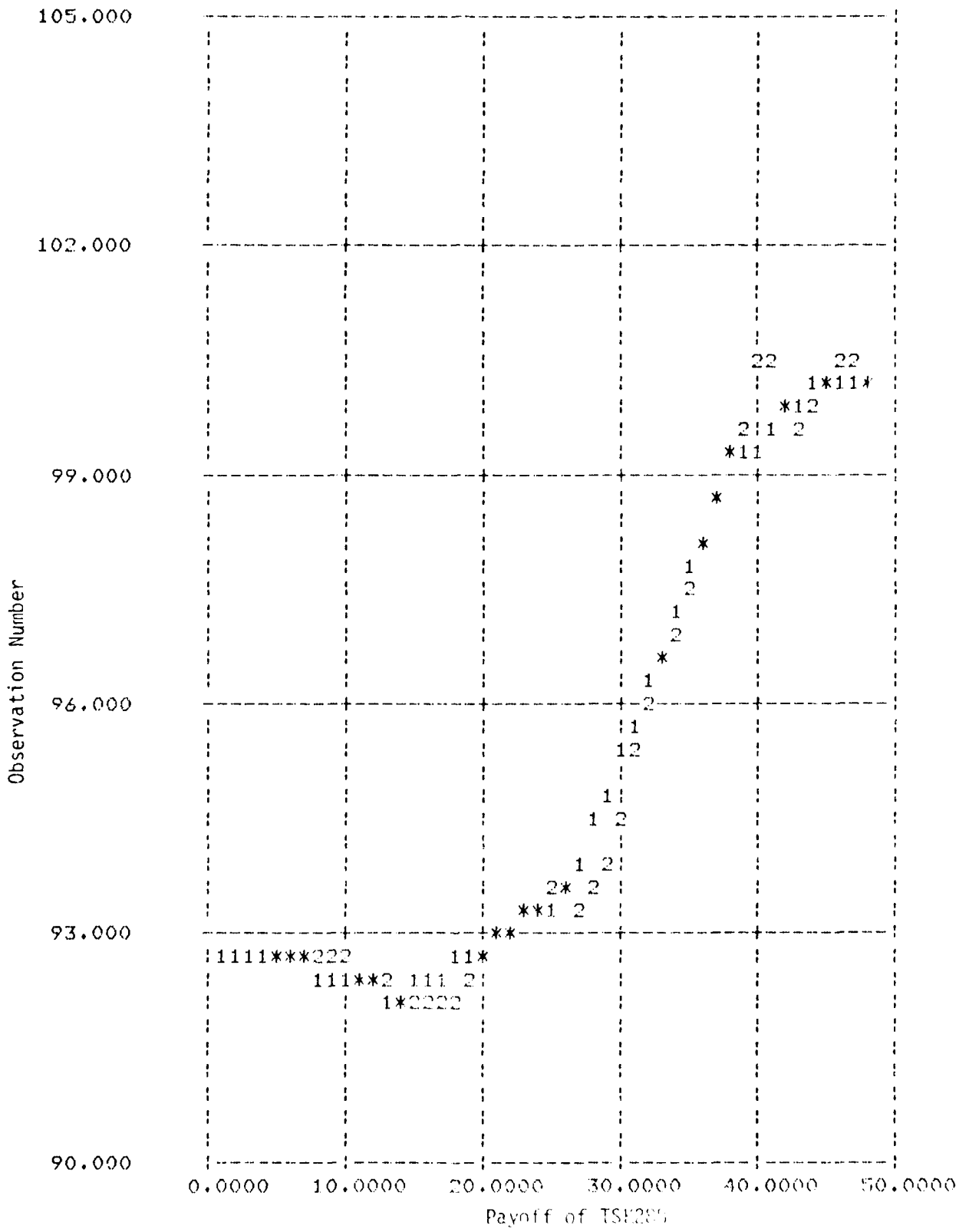

Figure 8.15. Adaptive Filter 3-Month Prediction of TSE285
 1 = Observed Data, 2 = 3-Month Prediction

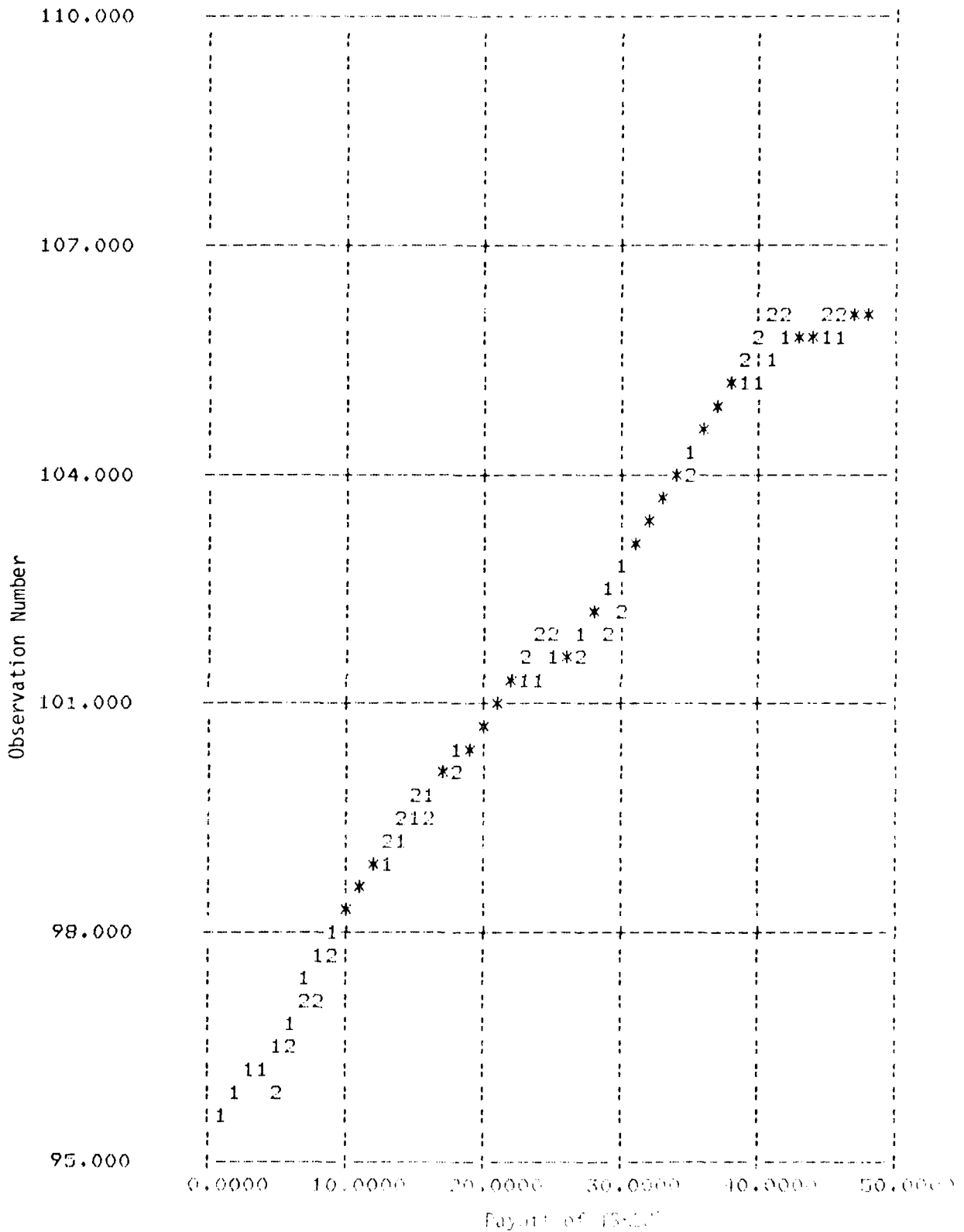

Figure 8.16. Adaptive Filter 3-Month Prediction of TSK287
 1 = Observed Data, 2 = 3-Month Prediction

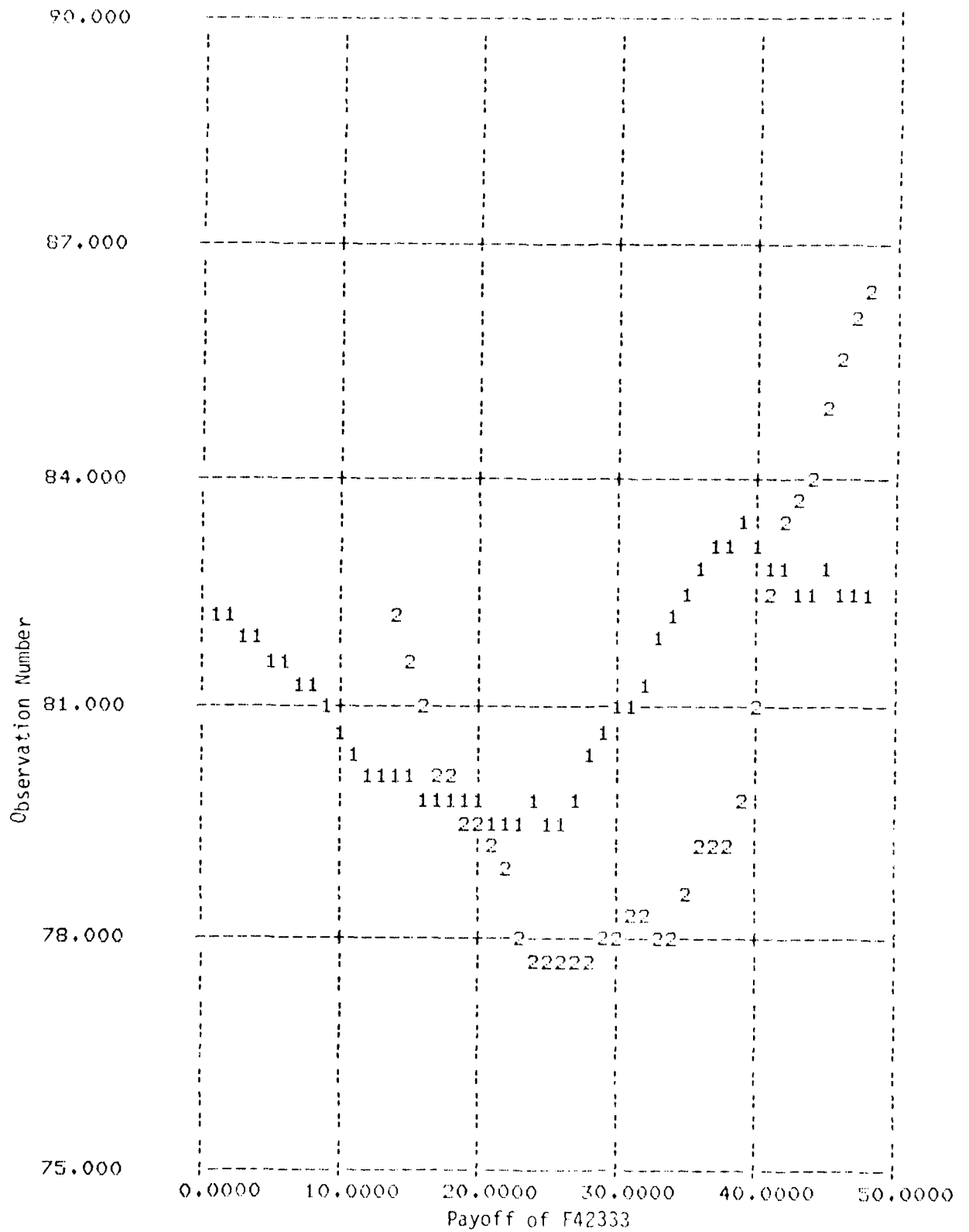

Figure 8.17. Adaptive Filter 12-Month Prediction of F42333
 1 = Observed Data, 2 = 12-Month Prediction

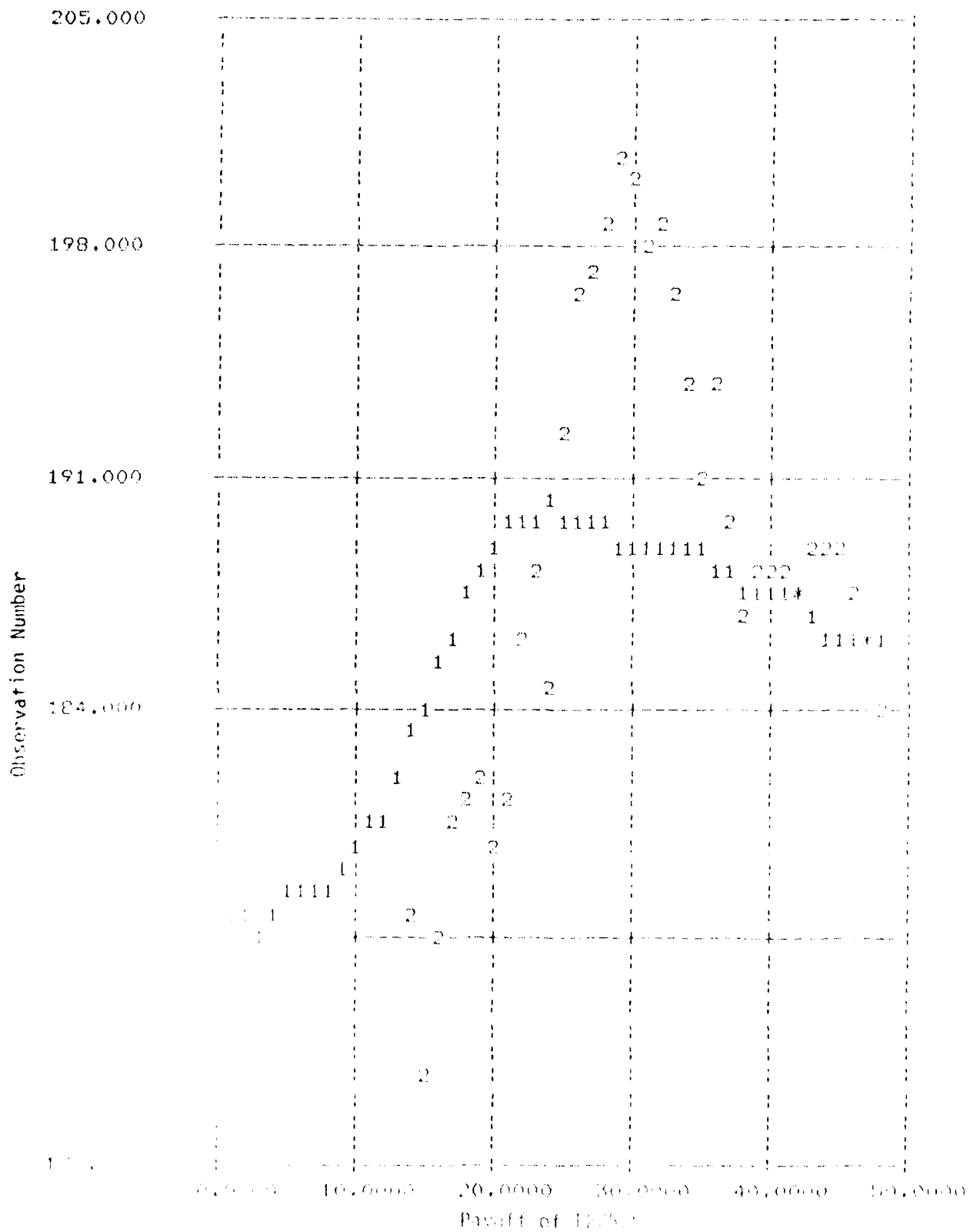

Figure 6.12. Adaptive Filter 12-Month Prediction of 1.0000
 1 = Observed Data, 2 = 12-Month Prediction

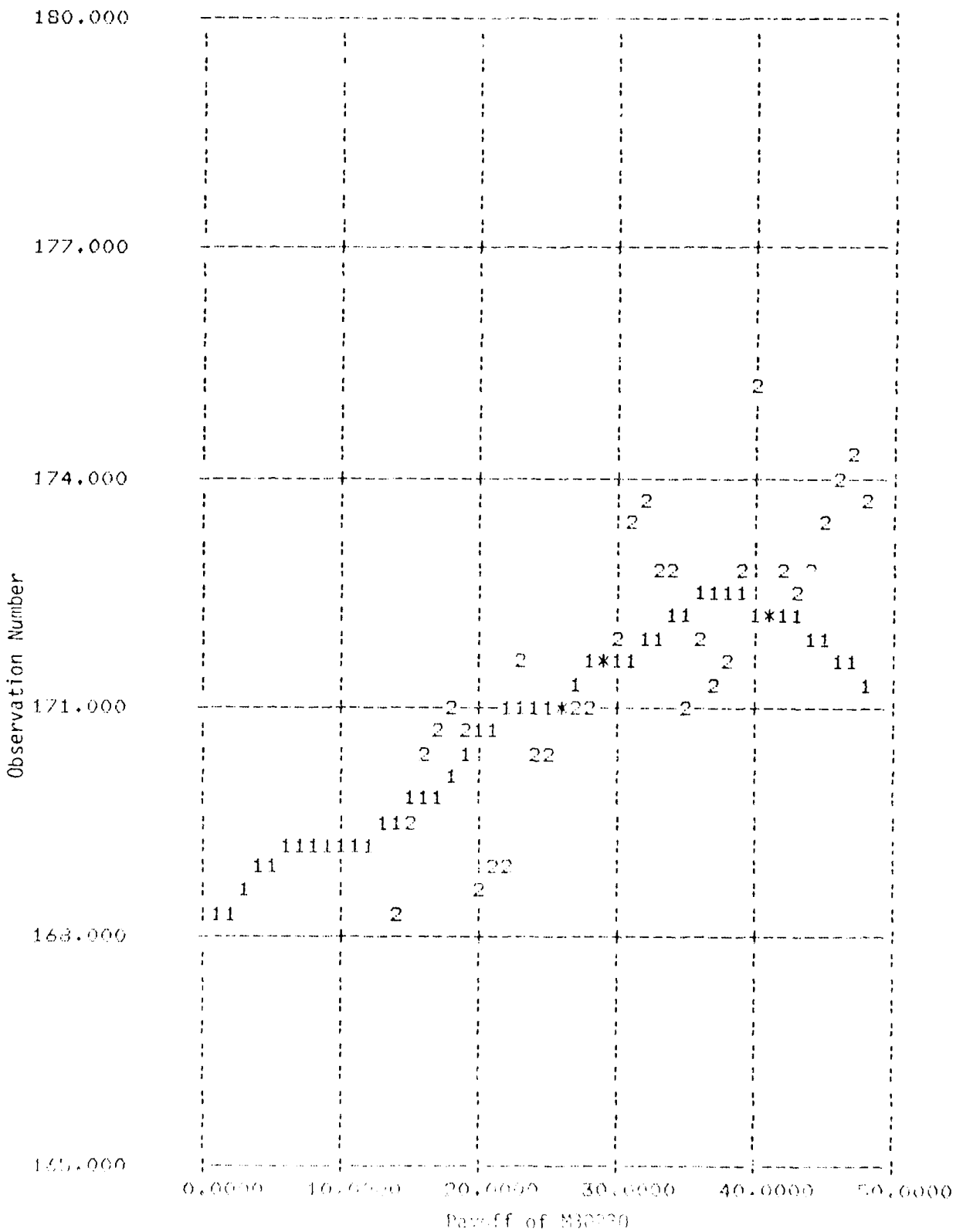

Fig. 19. Adaptive Filter 12-Month Prediction of N51236
 1 = Observed Data, 2 = 12-Month Prediction

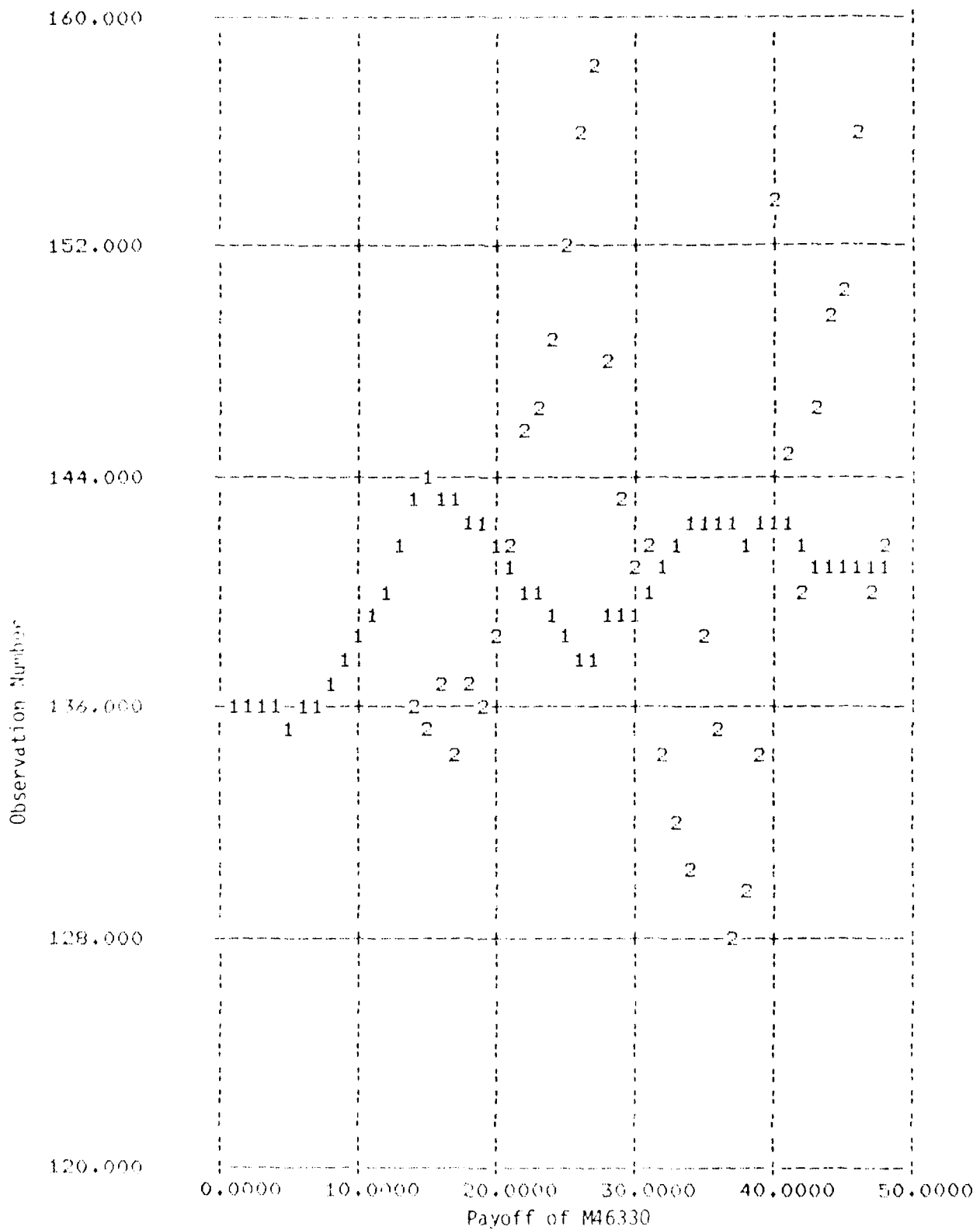

Figure 6.30. Adaptive Filter 12 Month Prediction of M46330
 1 - Observed Data, 2 - 12 Month Prediction

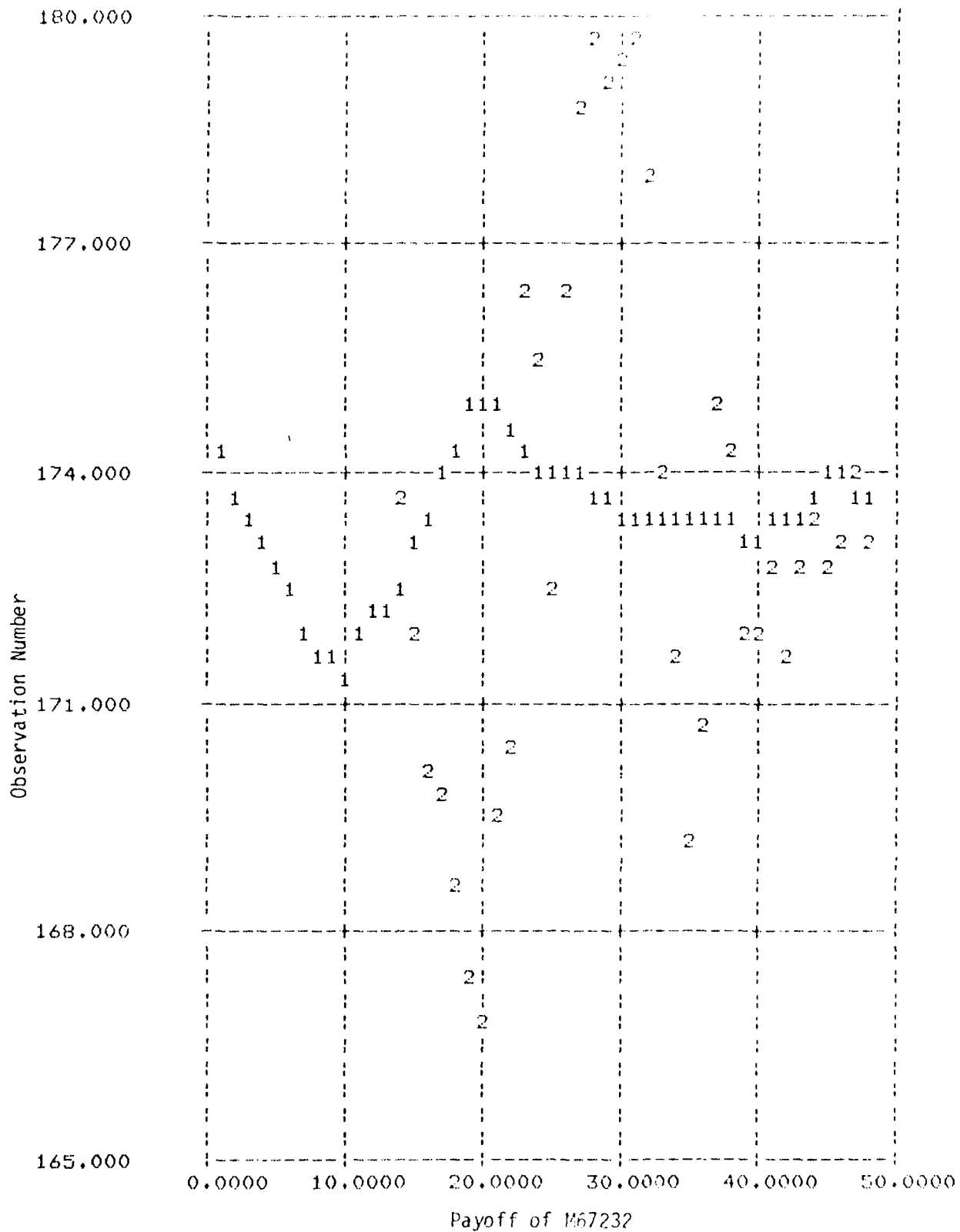

Figure 8.21. Adaptive Filter 12-Month Prediction of M67232
 1 = Observed Data, 2 = 12-Month Prediction

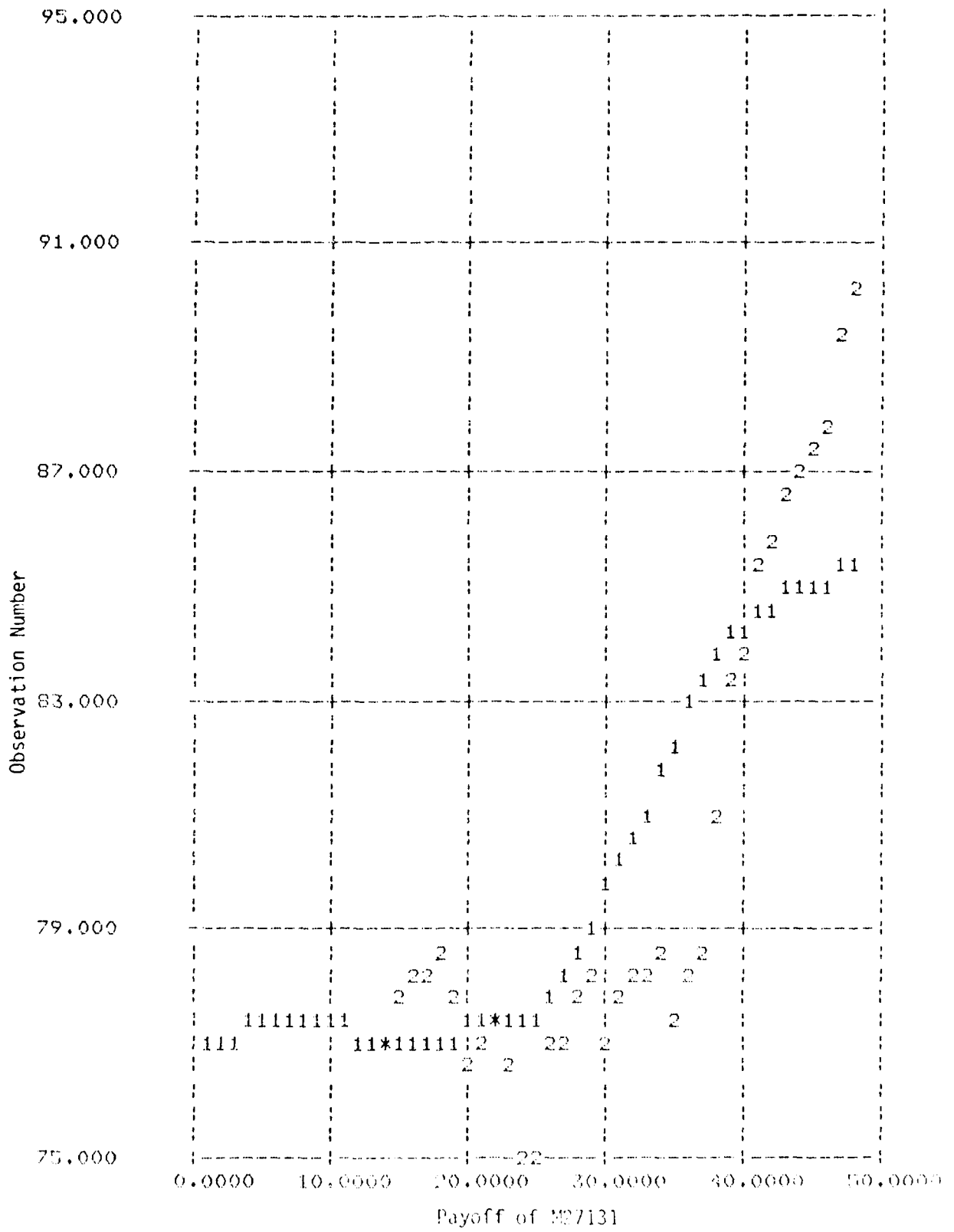

Figure 8.22. Adaptive Filter 12-Month Prediction of M27131
 1 = Observed Data, 2 = 12-Month Prediction

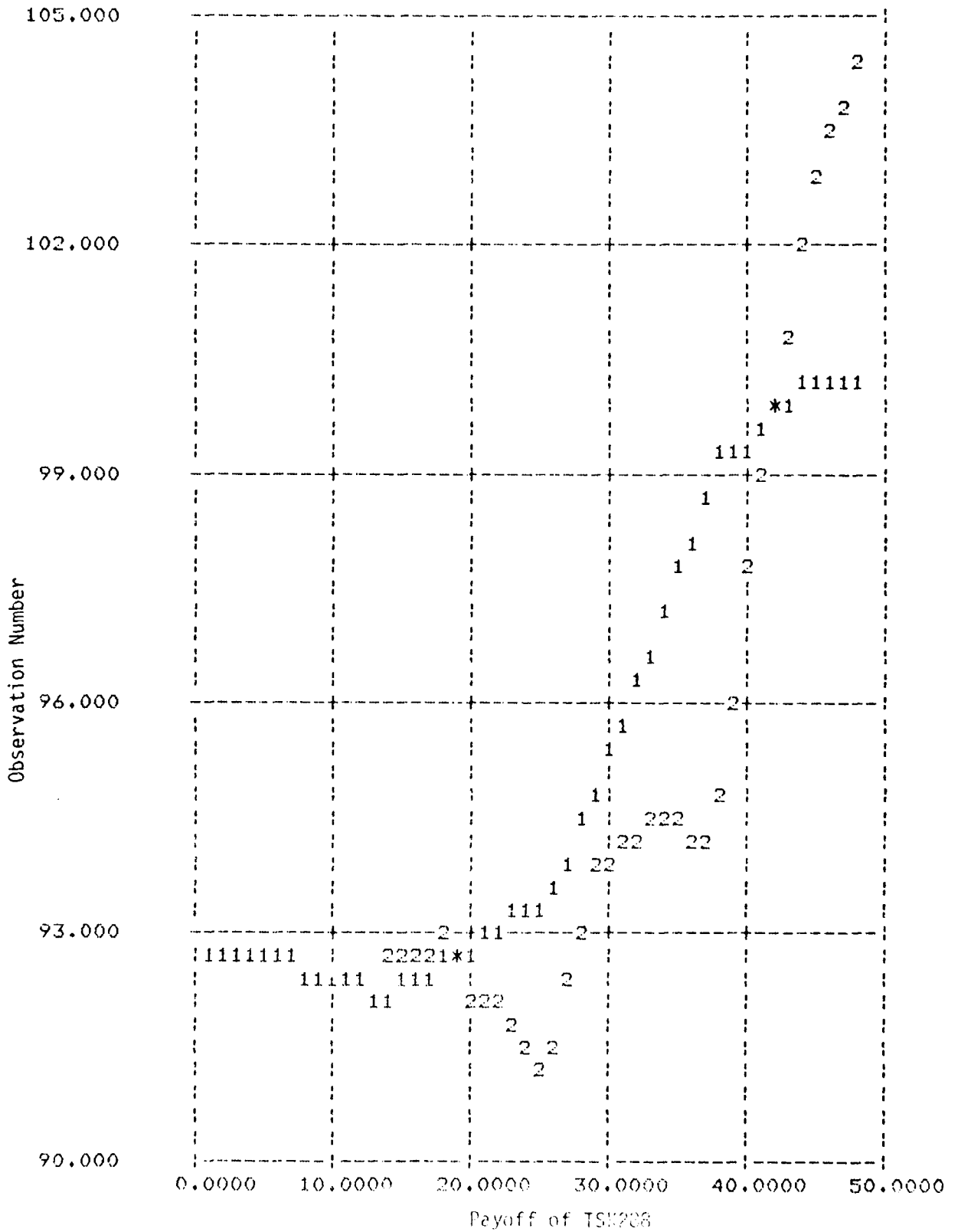

Figure 8.23. Adaptive Filter 12-Month Prediction of TSK288
 1 = Observed Data, 2 = 12-Month Prediction

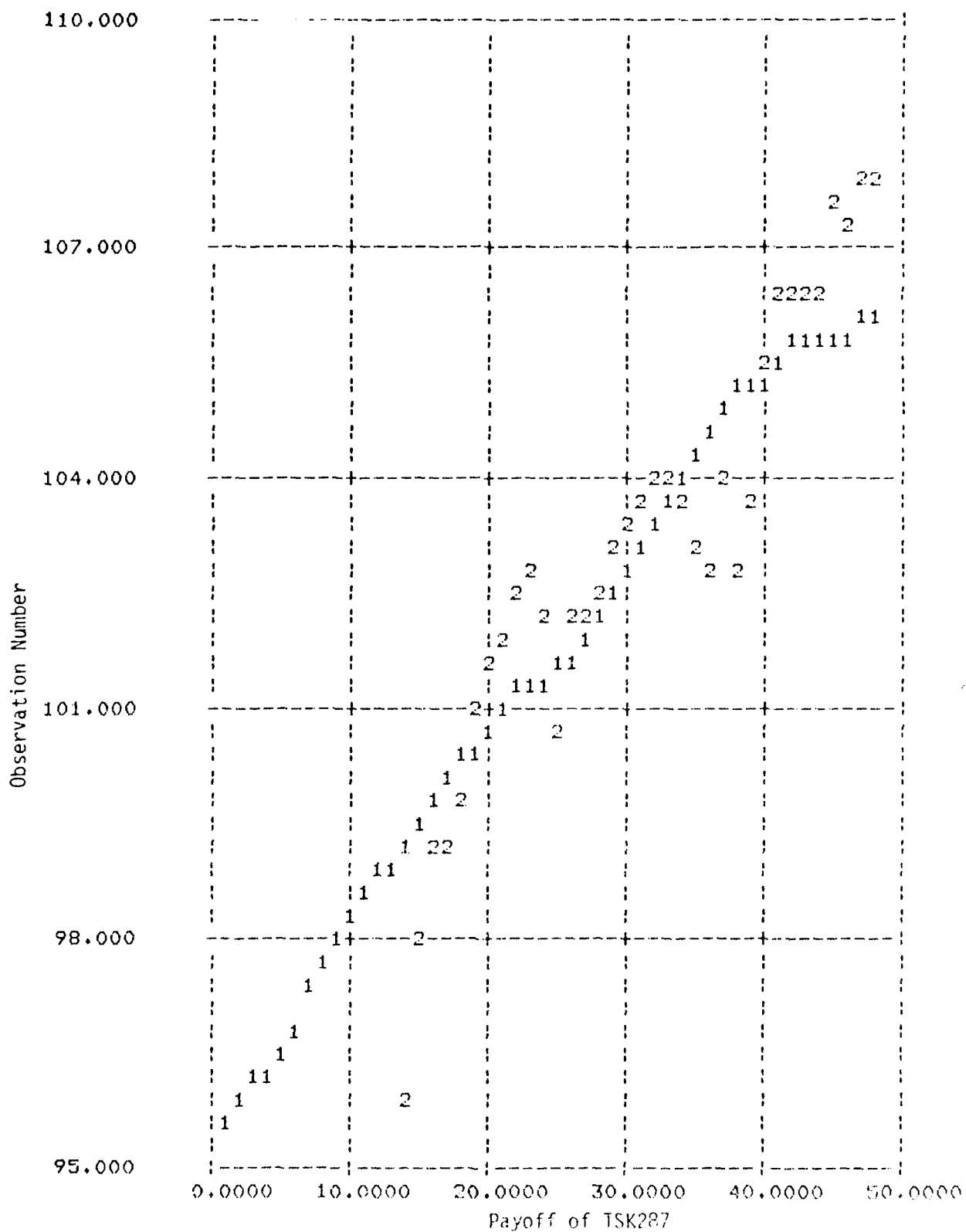

Figure 8.24. Adaptive Filter 12-Month Prediction of TSK287
 1 = Observed Data, 2 = 12-Month Prediction

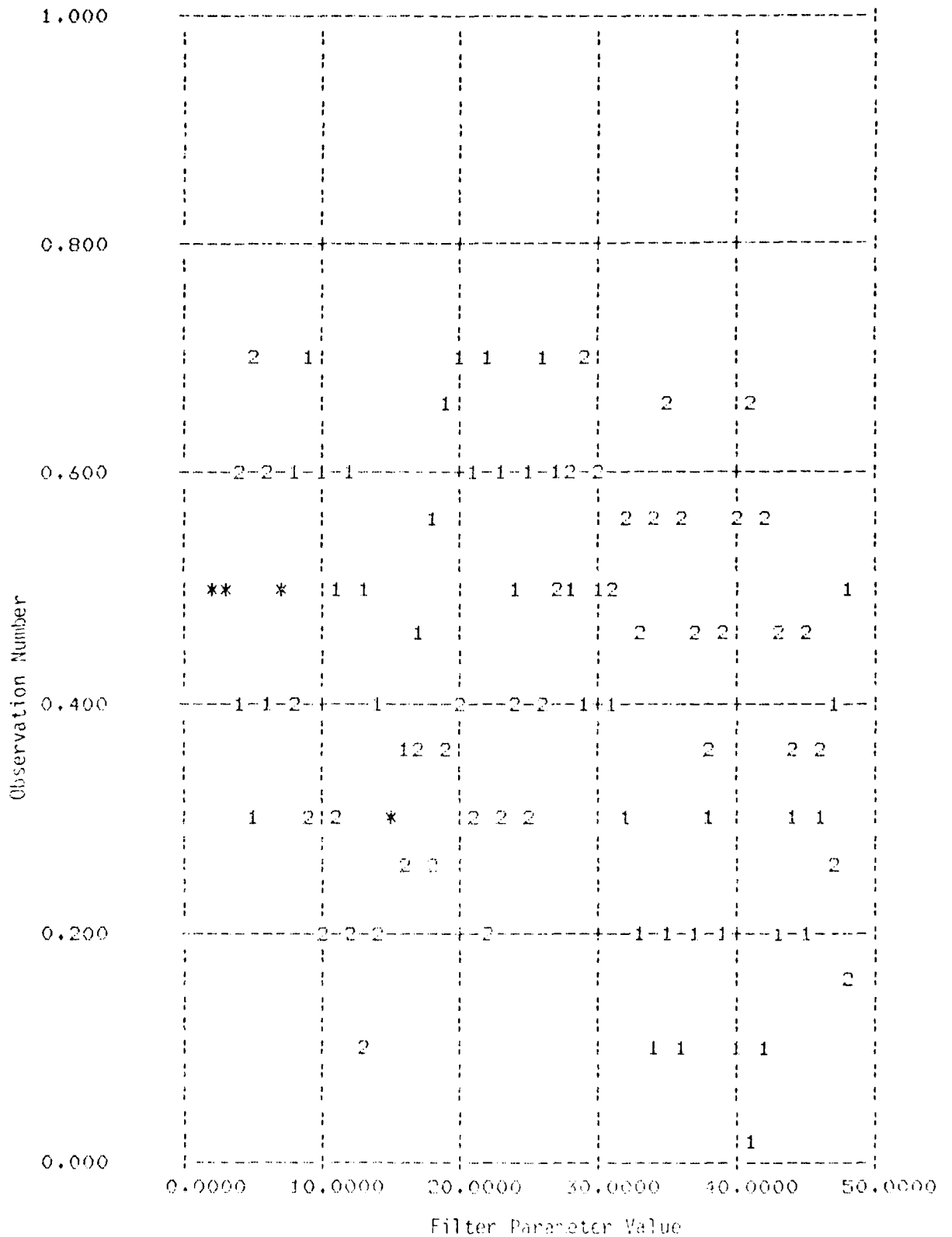

Figure 8.25. γ and β Parameters Used in Filtering Eq. 8.33. 1 = γ , 2 = β .

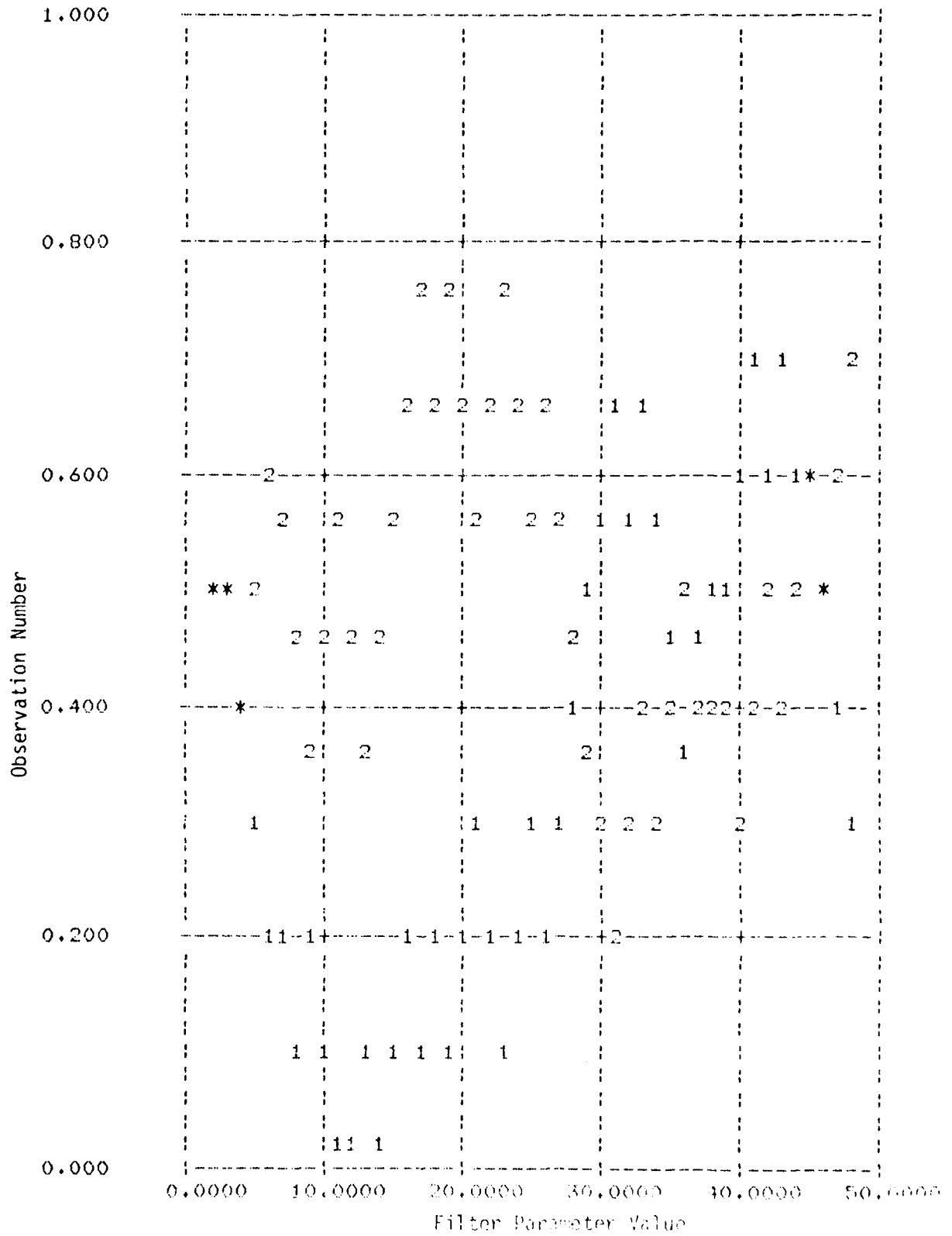

Figure 8.26. γ and β Parameters Used in Filtering F20530. 1 = γ , 2 = β

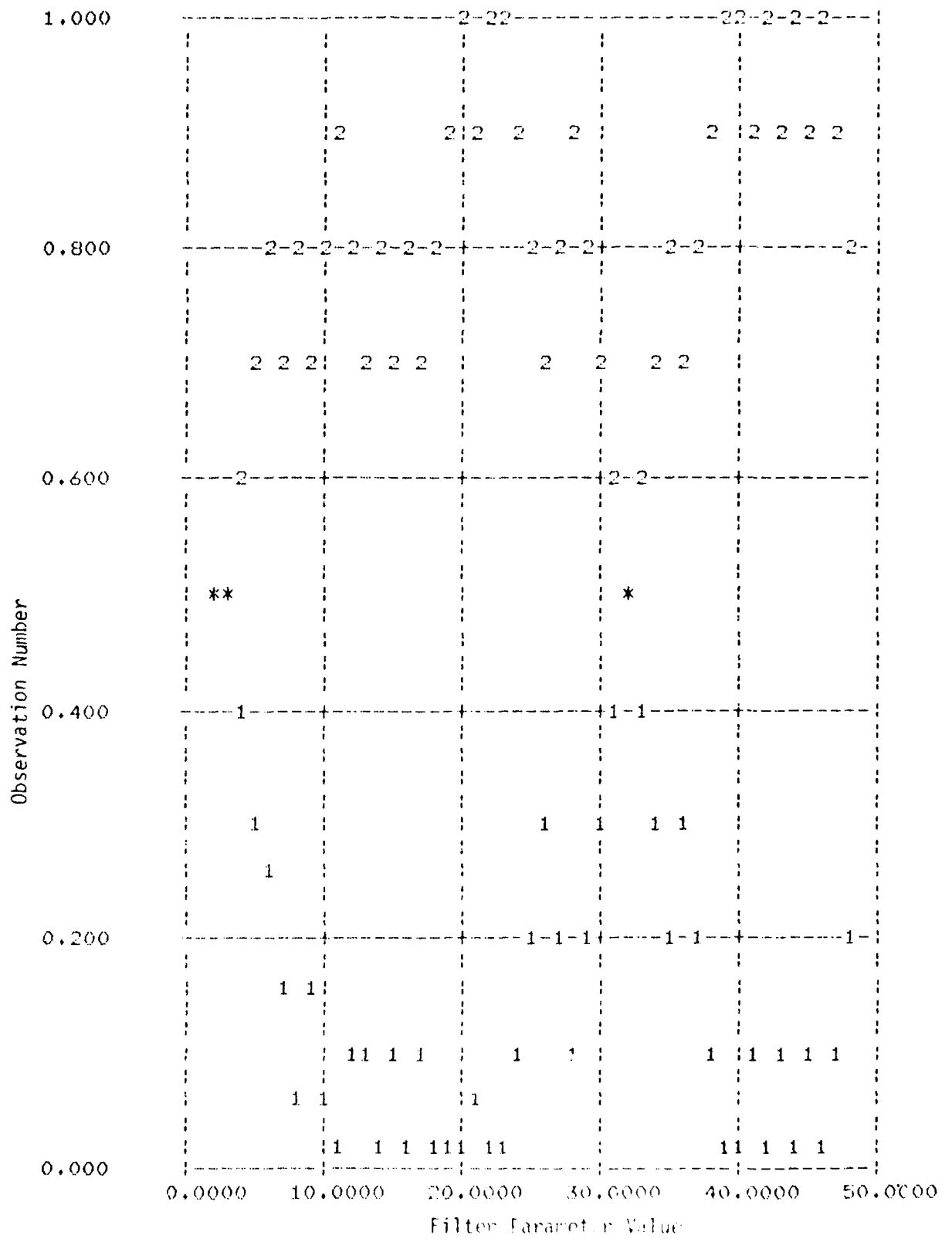

Figure 8.27. γ and β Parameters Used in Filtering (1 = γ , 2 = β)

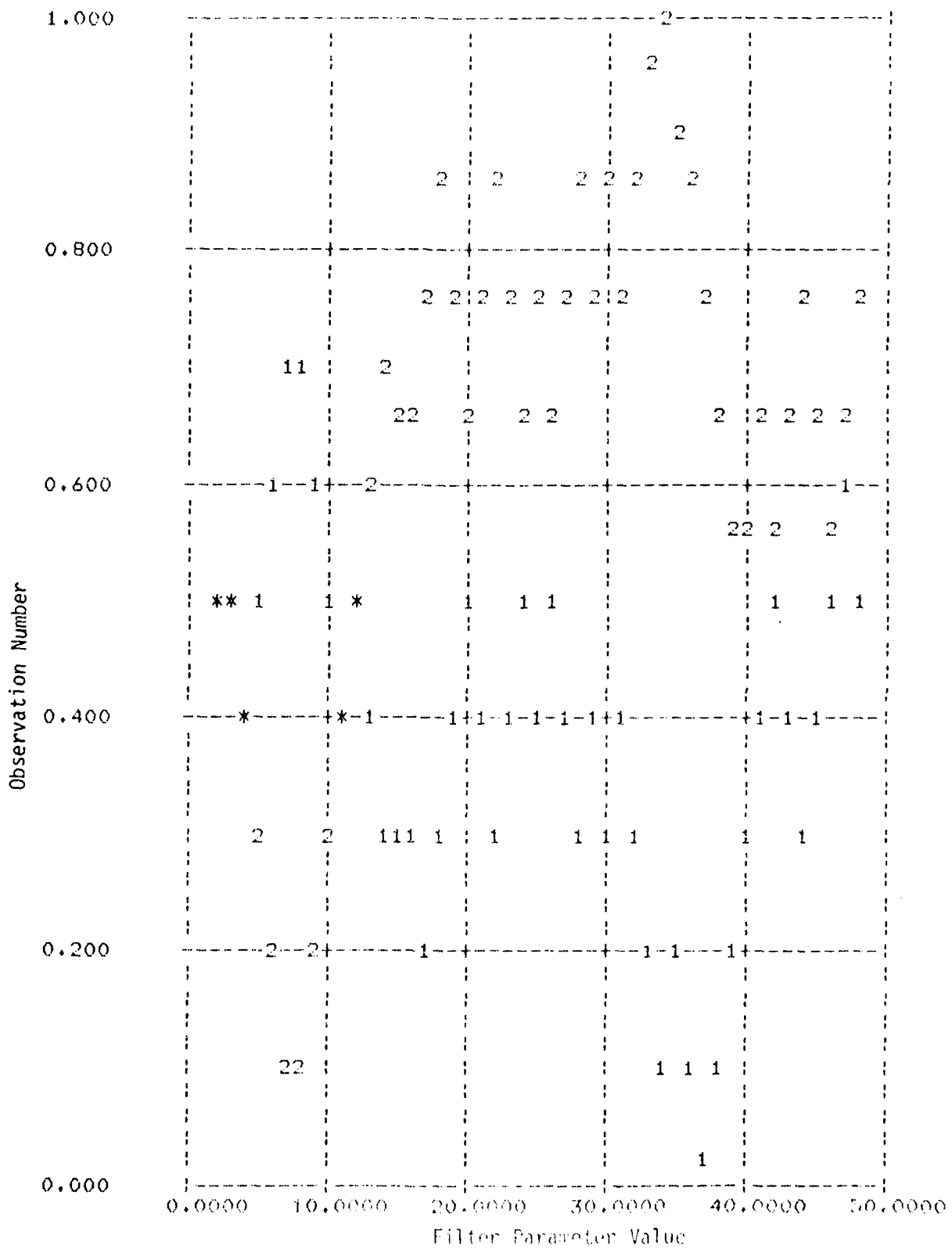

Figure 8.28. γ and β Parameters Used in Filtering F46330. 1 = γ , 2 = β

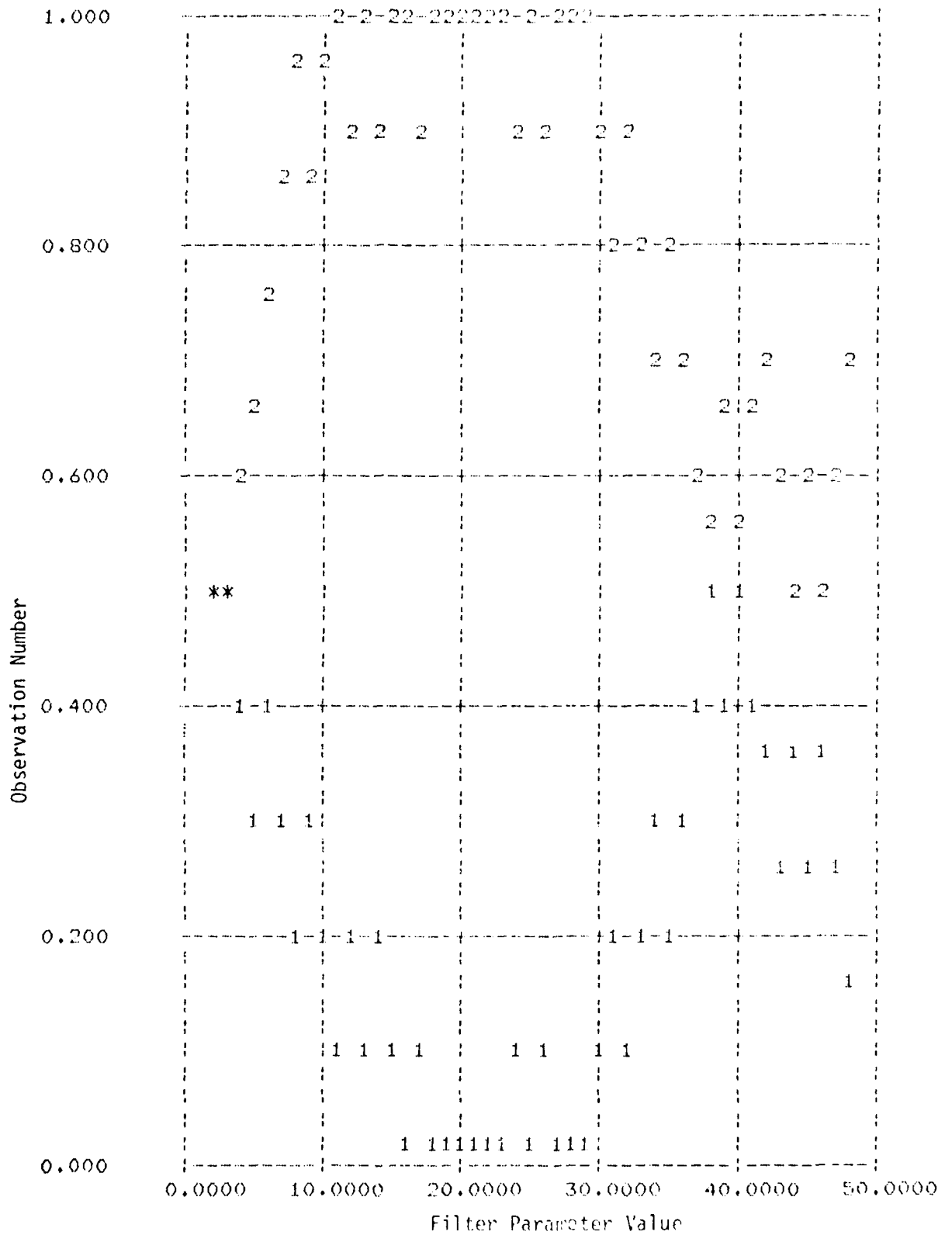

Figure 8.29. γ and β Parameters Used in Filter for M67232. 1 = γ , 2 = β .

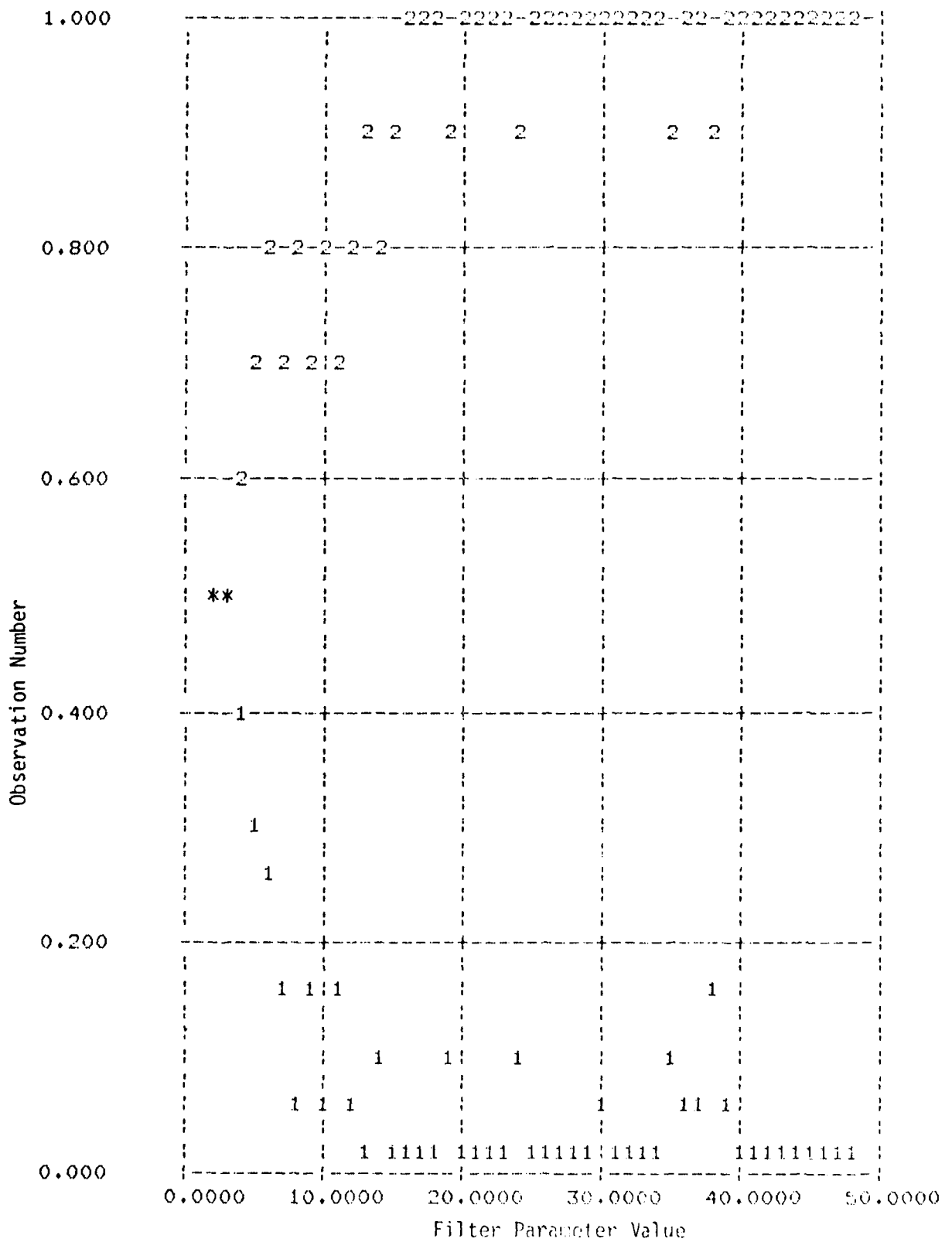

Figure 8.30. γ and β Parameters Used in Filtering M271M. 1 = γ , 2 = β

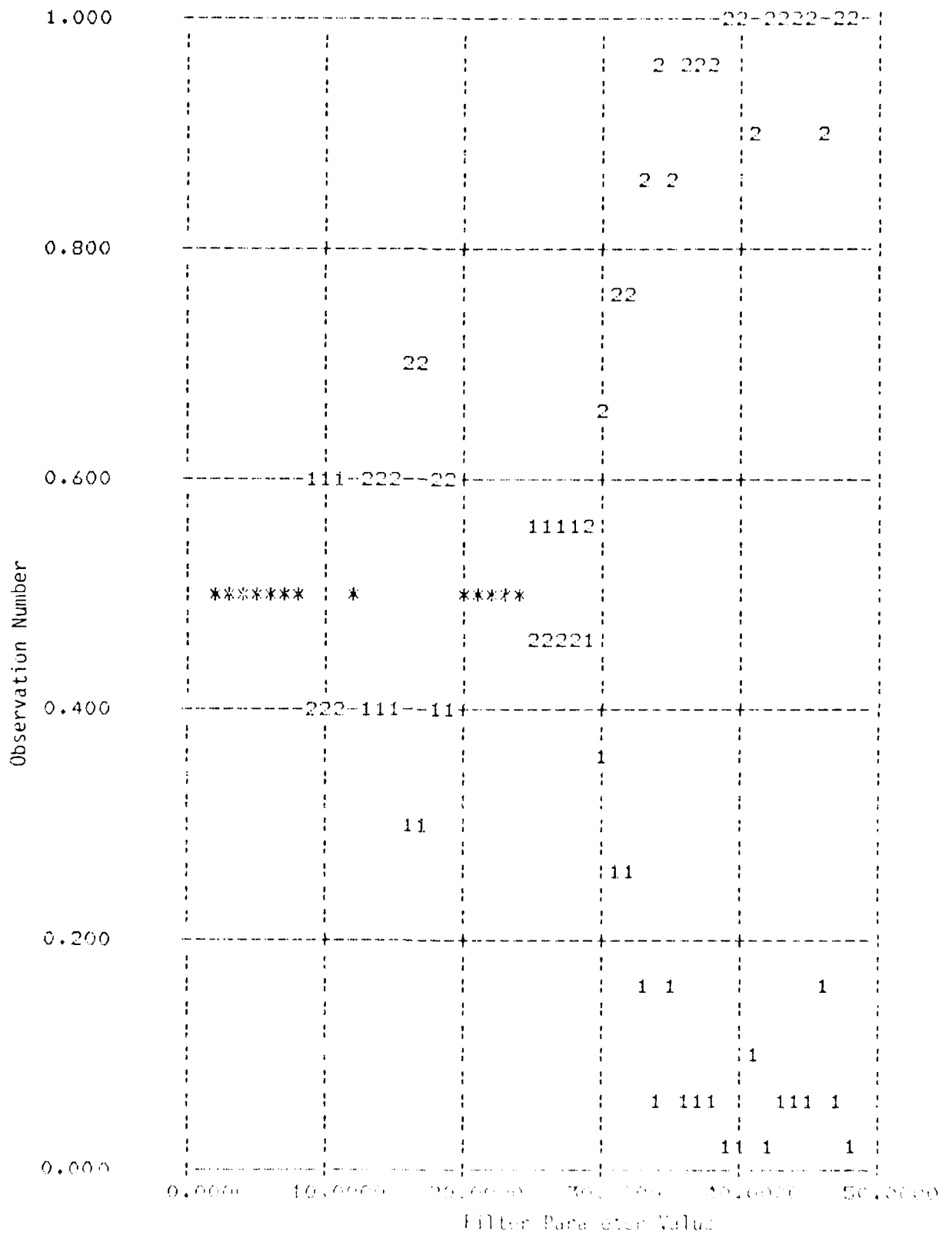

Figure 8.31. γ and β Parameters Used in Filtering TSK288. 1 = γ , 2 = β

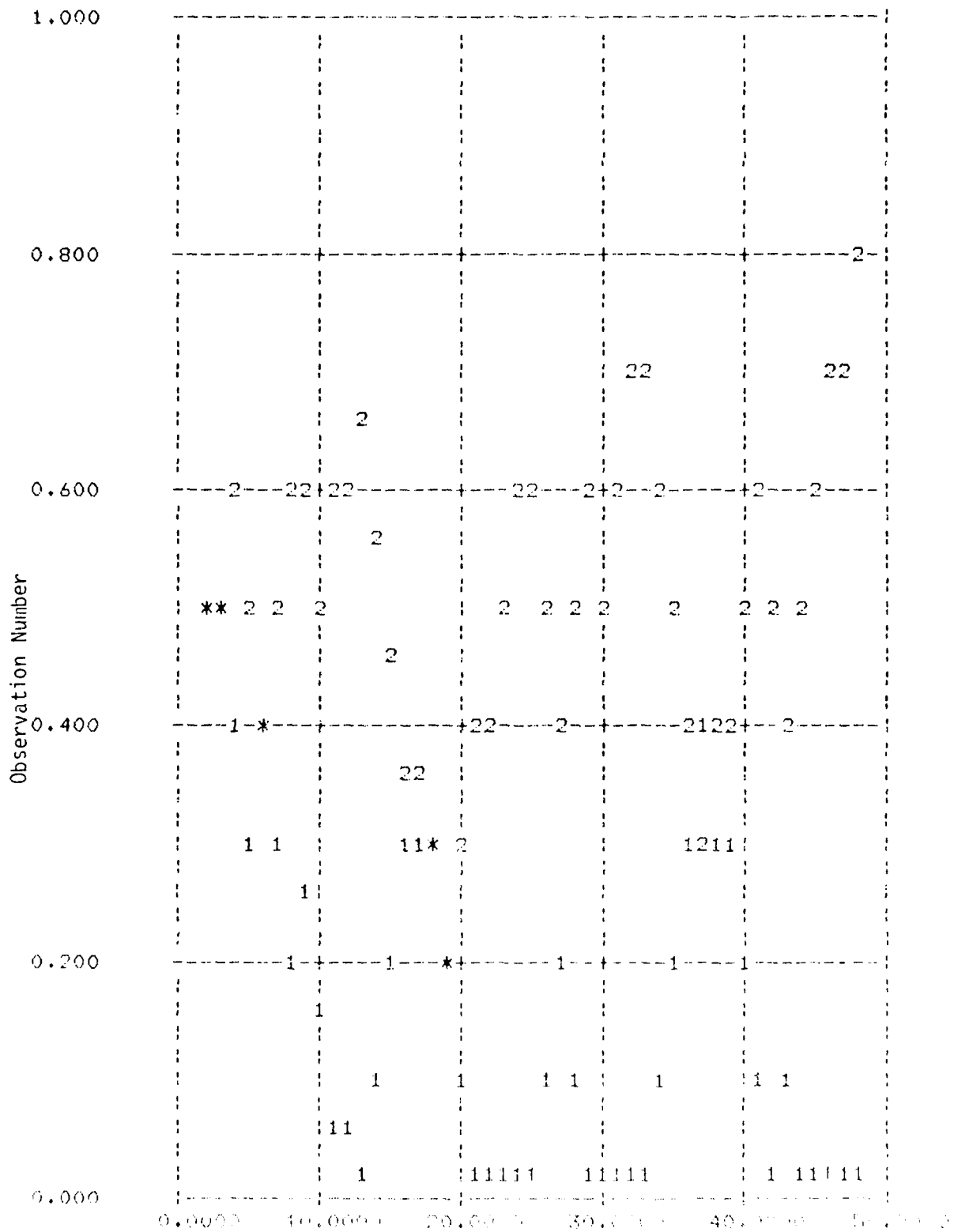

Figure 8.32. γ and β Parameters Used in Filtering TSP Data. $\gamma = 0.001$

AD-A090 499

SCIENTIFIC SYSTEMS INC CAMBRIDGE MA
RECURSIVE FORECASTING SYSTEM FOR PERSON-JOB MATCH. (U)
SEP 80 D E GUSTAFSON, R K MEHRA, W H LEDSHAM

F/6 5/9

Unclassified

F33615-78-C-0050
NL

SELDI-78-70-R3

6
AD-A090 499

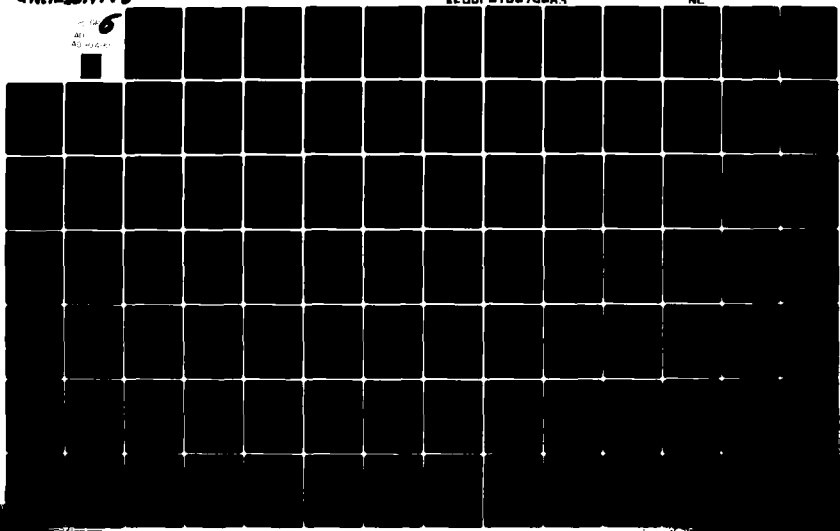

90499

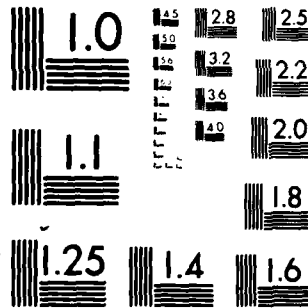

MICROCOPY RESOLUTION TEST CHART
NATIONAL BUREAU OF STANDARDS 1963-A

9. CONCLUSIONS AND RECOMMENDATIONS

This study has revealed certain characteristics of the PJM payoffs that can be exploited in developing efficient prediction schemes. First, series within particular groups tend to move together. For example, the E80F series are highly correlated as a group, but tend to be uncorrelated with other series. Series in the E80F group are not highly correlated with series within the E80M group. This may indicate that the variable fill component dominates for certain groups since, for example, all E80F jobs are competing for the same small pool of recruits. Similar behavior was seen for the A80M group. The female low skill series show a greater tendency to move in a correlated fashion with members of other female low skill groups. The male series tend to move together as a group more than the female series. However, the female and male series tend to move independently. These tendencies could be used to reduce the number and complexity of prediction models. For example, a single model may be used to represent an entire group. Many of the series within that group could perhaps be modeled with that model. Series which differ significantly could be modeled independently or models of their difference from the group model could be constructed.

A methodology was suggested for modeling the PJM time series, based on a multivariate state space representation in a Markovian setting. A powerful approach to model structure determination, based on recent results in stochastic realization theory, was discussed. An algorithm based on this theory was utilized to generate state vector models for a selected number of PJM series. The model was in the form of a time-invariant Kalman filter/predictor. Prediction of the series was found to be adequate in some cases and poor in others. The poor results were almost invariably caused by shifts in the nature of the time series. The implication from a modeling point of view is that the parameters of the state space models change in an unpredictable manner and time-invariant models are not adequate under such conditions.

In order to remedy this problem, an adaptive filtering technique was developed. The parameters of a Kalman filter/predictor of fixed structure were estimated recursively using an approximate maximum-likelihood approach. Based on an analysis of the PJM payoff data, it was concluded that only the transition matrix needed to be reestimated; the Kalman gain was assumed to be fixed. An extended Kalman filter was also considered for this parameter estimation problem but was discarded since, comparatively, it is less robust, less accurate and more complex.

Detailed numerical tests on PJM payoff data were performed. Comparison of prediction error statistics was made between the adaptive filter/predictor and a pure persistence predictor. The adaptive filter was found to give substantially better results. Additional tests were run using data generated from known stochastic dynamical models. Tradeoff studies demonstrated the robustness of the adaptive filter and qualitative bounds on adaptation parameters in order to maintain stability of the adaptation process.

Further development of the adaptive filter should be undertaken. More systematic techniques for varying the adaptation parameters on line

should be developed. In particular, γ should be a function of the smoothness of the estimated parameters. The Kalman gain should be adapted simultaneously with the transition matrix, being careful that their (nonlinear) interaction does not degrade stability properties of the adaptor. The possibility of adapting all of the elements of Φ simultaneously should be explored. The effect of using more than one iteration per time step should be examined. Comparisons with several other approaches, such as stochastic approximation, should be made. An extension to include prior information (size limitations on Φ , e.g.) should be made, possibly using a Bayesian formulation.

Another extension which should be explored is the use of disturbance models. For a model of the form

$$x(i+1) = \Phi x(i) + n(i+1)$$

where n is white noise, we may add a disturbance d to give

$$x(i+1) = \Phi x(i) + n(i+1) + d(i+1)$$

The disturbance may be modeled as an unknown constant, or may be slowly varying. A possible model is the first-order Markov process

$$d(i+1) = A d(i) + v(i+1)$$

with $v(i)$ a white noise process. Using an augmented state

$$x_a(i) = \begin{matrix} x(i) \\ d(i) \end{matrix}$$

this formulation may be handled by the general theory given in Chapters 4, 5 and 7 and Appendix C. As a simple example, a disturbance model was used for prediction of the 12-month moving average payoff series F42333. The model used was

$$\begin{aligned} x(i+1) &= x(i) + n(i+1) + d(i+1) \\ d(i+1) &= \frac{2}{3} d(i) + v(i+1) \end{aligned}$$

The Kalman gains were set to 2/3 for both x and d . The results are shown in Figure 9.1 and indicate that the disturbance filter gives much better performance than any first-order stationary model, due to the piecewise-stationary trends on the data.

12 MONTH MOVING AVERAGE OF PAYOFF

F42333

A=AVERAGE

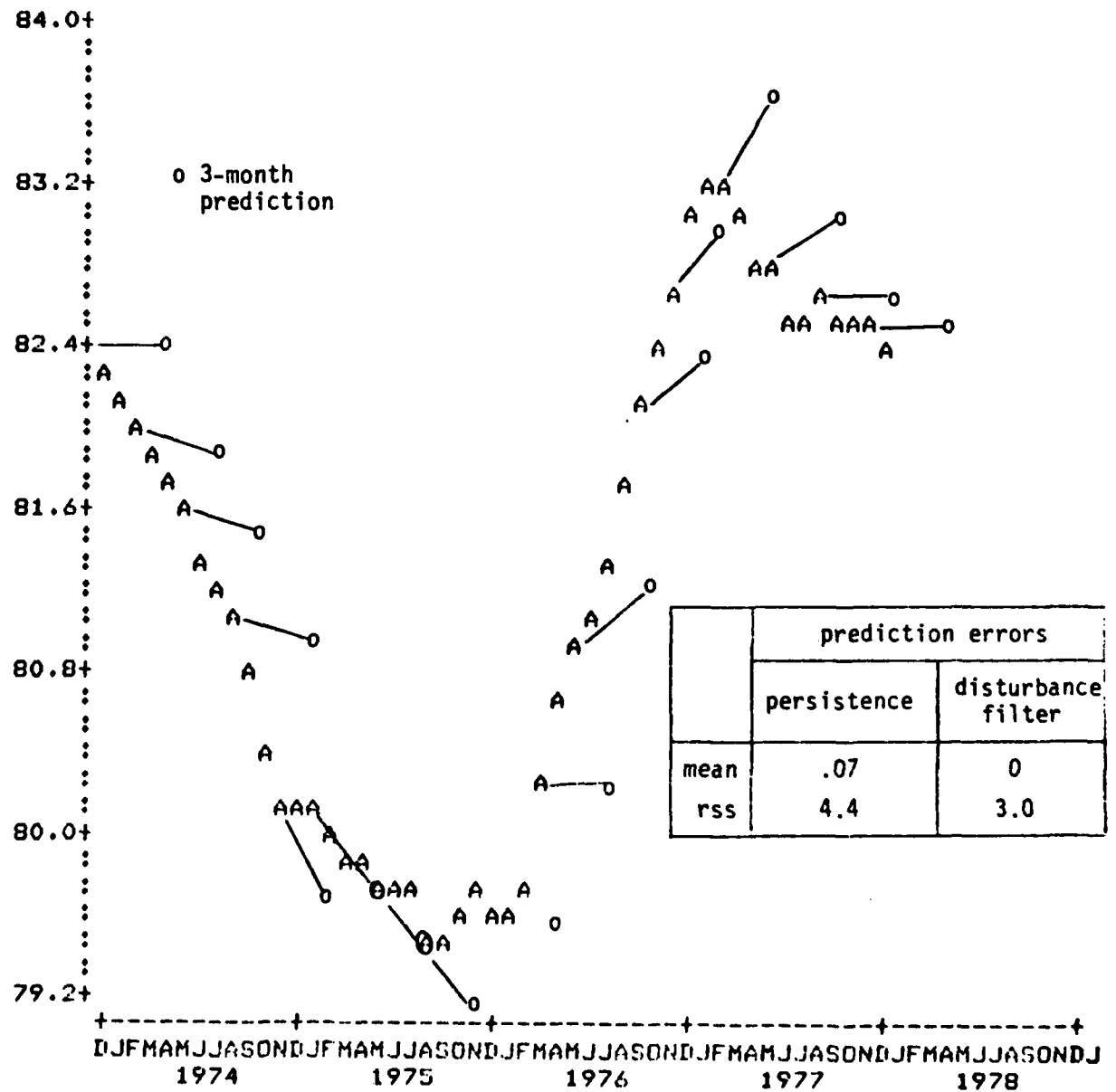

Figure 9.1. Disturbance Filter Applied to Series F42333

REFERENCES

1. Akaike, H., "A New Look at Statistical Model Identification," IEEE Trans. on Automatic Control, Vol. AC-19, pp. 716-723, 1974.
2. Astrom, K. J. and T. Bohlin, "Numerical Identification of Linear Dynamic Systems from Normal Operating Records," Proc. IFAC Symposium on Self-Adaptive Control Systems, pp. 96-110, 1965.
3. Bellman, R. E., Dynamic Programming, Princeton, N.J.: Princeton University Press, 1957.
4. Bierman, G. J., Factorization Methods for Discrete Sequential Estimation, New York: Academic Press, 1976.
5. Box, G. E. P. and G. M. Jenkins, Time Series Analysis, Forecasting and Control, San Francisco: Holden-Day, 1970.
6. Bryson, A. E. and Y. C. Ho, Applied Optimal Control, New York: Blaisdell, 1969.
7. Bryson, A. E. and L. J. Henrickson, "Estimation Using Sampled Data Containing Sequentially Correlated Noise," J. Spacecraft and Rockets, Vol. 5, pp. 662-665, 1968.
8. Chow, G., Analysis and Control of Dynamic Economic Systems, New York: Wiley, 1975.
9. Cox, H., "On the Estimation of State Variables and Parameters for Noisy Dynamic Systems," IEEE Trans. on Automatic Control, Vol. AC-9, pp. 5-12, 1964.
10. Degroot, M., Optimal Statistical Decisions, New York: McGraw-Hill, 1970.
11. DuVal, R. W., "A Rapidly Converging Adaptive Filter for On-Line Applications," PhD thesis, Stanford University, 1976.
12. Galdos, J. I. and D. E. Gustafson, "Information and Distortion in Reduced-Order Filter Design," IEEE Trans. on Information Theory, Vol. IT-23, pp. 183-194, 1977.
13. Gupta, N. K. and R. K. Mehra, "Computational Aspects of Maximum Likelihood Estimation and Reduction in Sensitivity Function Calculations," IEEE Trans. on Automatic Control, Vol. AC-19, pp. 774-783, 1974.
14. IEEE Special Issue on Linear Quadratic Gaussian Problems, December 1971.

15. IEEE Transactions on Automatic Control, Special Issue on System Identification, Vol. AC-19, December 1974.
16. Kailath, T, "An Innovations Approach to Least-Squares Estimation, Part I: Linear Filtering in Additive White Noise," IEEE Trans. on Automatic Control, Vol. AC-13, pp. 646-655, 1968.
17. Kalman, R. E., "A New Approach to Linear Filtering and Prediction Problems," J. Basic Engineering, Vol. 82, pp. 34-35, 1960.
18. Kalman, R. E., "New Methods in Wiener Filtering Theory," Proc. First Symposium on Engineering Applications of Random Function Theory and Probability (ed. J. L. Bogdanoff and F. Kozin), New York: Wiley, 1963.
19. Ljung, L., "The Extended Kalman Filter as a Parameter Estimator for Linear Systems," Report LITH-ISY-I-0154, Linkoping University, Sweden, 1977.
20. Mehra, R. K., "Approaches to Adaptive Filtering," IEEE Trans. on Automatic Control, Vol. AC-17, pp. 693-698, 1972.
21. Mehra, R. K., "Identification and Control of Econometric Systems, Similarities and Differences," Annals of Economic and Social Measurement, January 1974.
22. Mehra, R. K., "Sequential Estimation for Dynamic Systems with Unknown Deterministic Inputs and Duality with Singular Control," IEEE Trans. on Automatic Control, October, 1975.
23. Mehra, R. K., "Identification and Estimation of the Error-in-Variables Model (EVM) in Structural Form," Research Memo, International Institute for Applied Systems Analysis (IIASA), 1975.
24. Mehra, R. K. and D. G. Lainiotis (eds.), System Identification: Advances and Case Studies, New York: Academic Press, 1976.
25. Nelson, L. W. and E. Stear, "The Simultaneous On-Line Estimation of Parameters and States in Linear Systems," IEEE Trans. on Automatic Control, Vol. AC-21, pp. 438-442, 1976.
26. Orlic, D. G., M. Athans, J. Speyer and P. K. Houpt, "Dynamic Stochastic Control of Freeway Corridor Systems. Volume IV - Estimation via Extended Kalman Filter Methods," MIT, Electronic Systems Lab., Report ESL-R-611, 1975.
27. Saridis, G. N., "Comparison of Six On-Line Identification Algorithms," Automatica, Vol. 10, pp. 69-80, 1974.
28. Schweppe, F. C., Uncertain Dynamic Systems, New York: Prentice-Hall, 1973.

29. Ward, J. H., Use of a Decision Index in Assigning Air Force Personnel, WADC-TN-59-38, AD-214 600, Lackland AFB, Texas: Personnel Laboratory, Wright Air Development Center, Air Research and Development Command, April, 1959.
30. Ward, J. H., Creating Mathematical Models of Judgment Processes: From Policy-Capturing to Policy-Making, AFHRL-TR-77-47, AD-A048 983, Brooks AFB, Texas: Occupation and Manpower Research Division, Air Force Human Resources Laboratory, August, 1977.
31. Ward, J. H., D. L. Haney, W. H. Hendrix and M. Pina, Assignment Procedures in the Air Force Procurement Management Information System, AFHRL-TR-78-30, AD-A056 531, Brooks AFB, Texas, Occupation and Manpower Research Division, Air Force Human Resources Laboratory, July, 1978.
32. Whittle, P., Prediction and Regulation, Princeton, N.J.: Van Nostrand, 1963.
33. Wiener, N., The Extrapolation, Interpolation, and Smoothing Stationary Time Series with Engineering Applications, New York: Wiley, 1949.

APPENDIX A

PAYOFF DATA

F=F30230

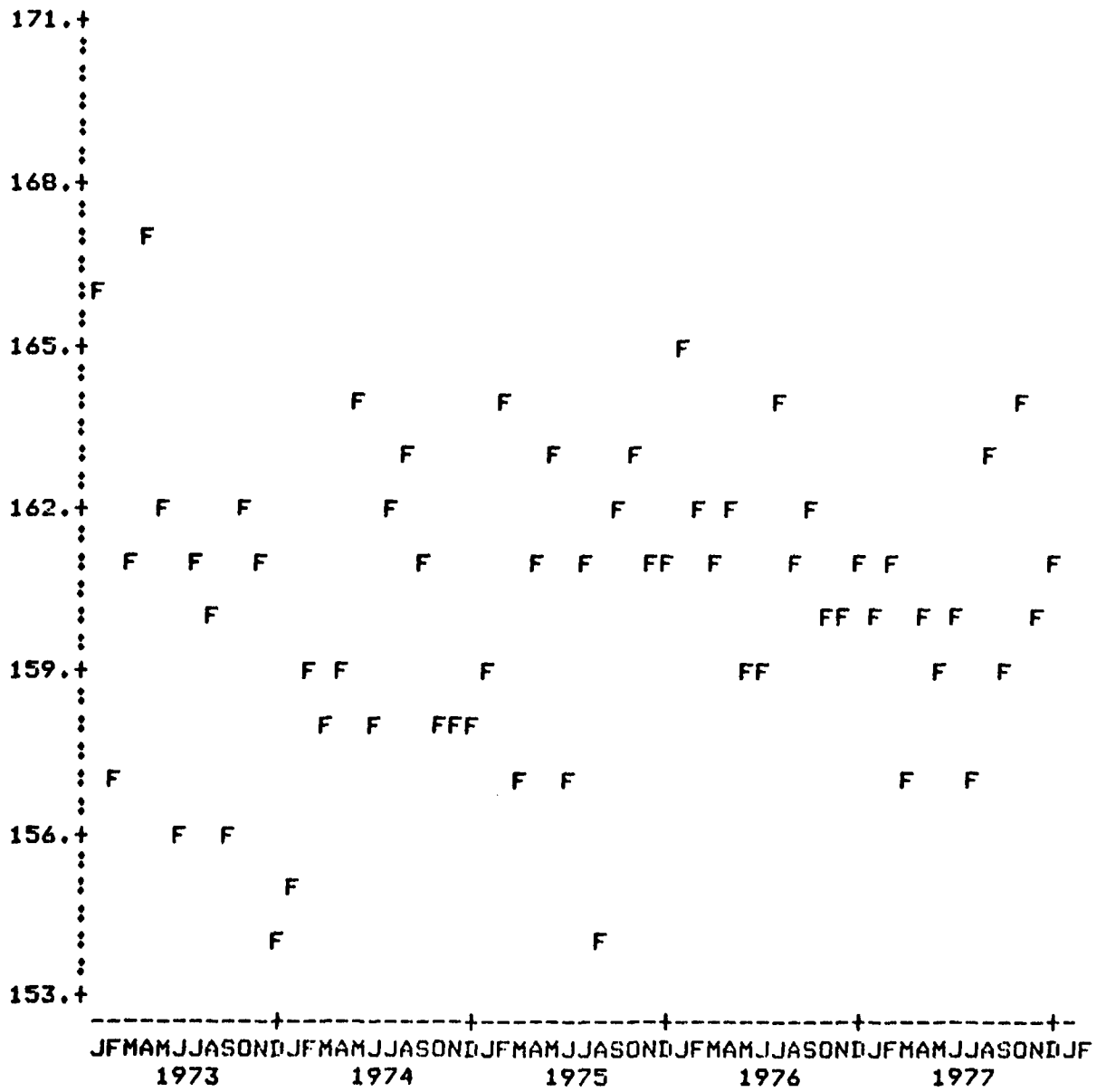

Figure A.1. Plot of Series F30230

M=M30230

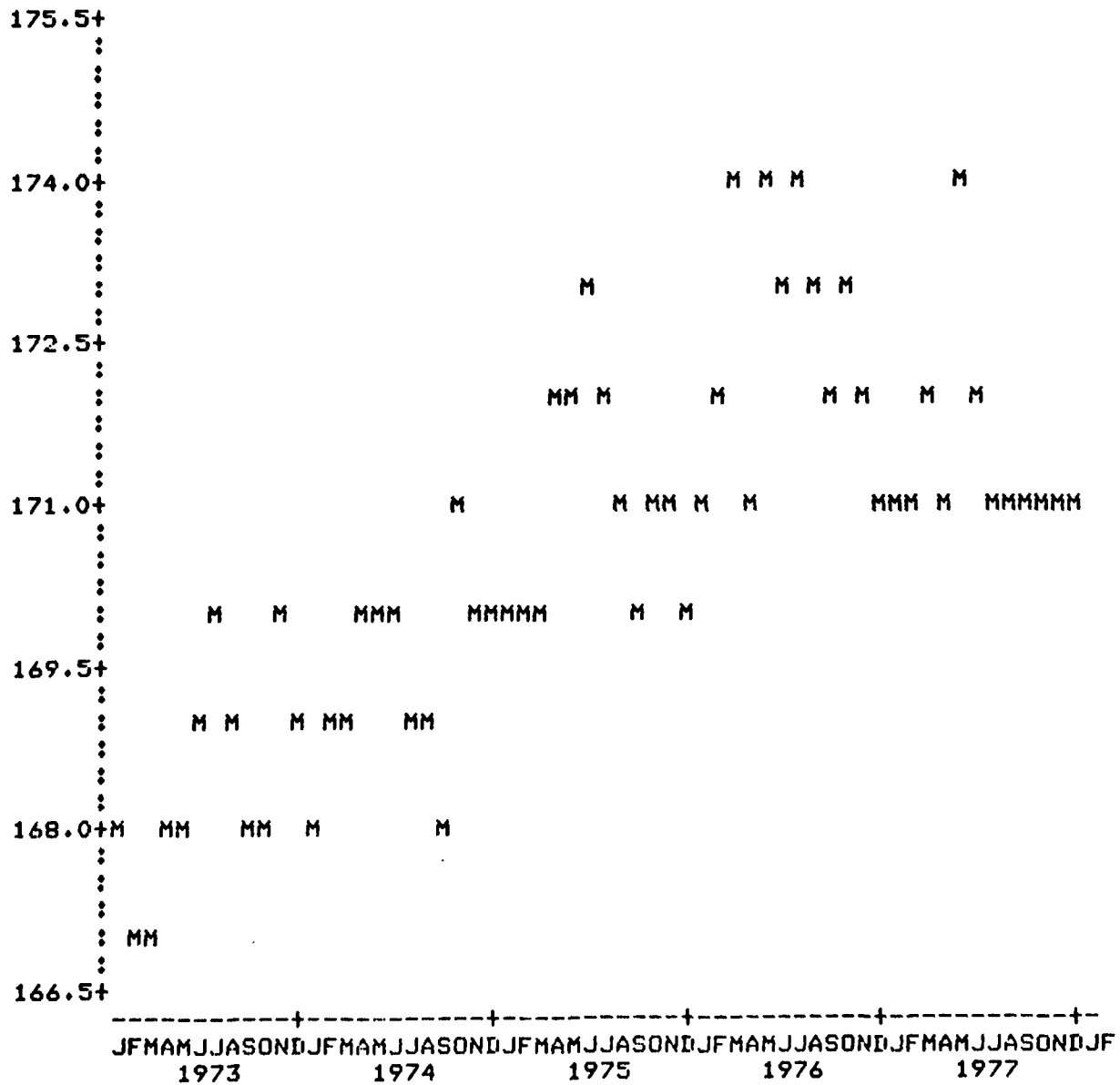

Figure A.2. Plot of Series M30230

F=F67231

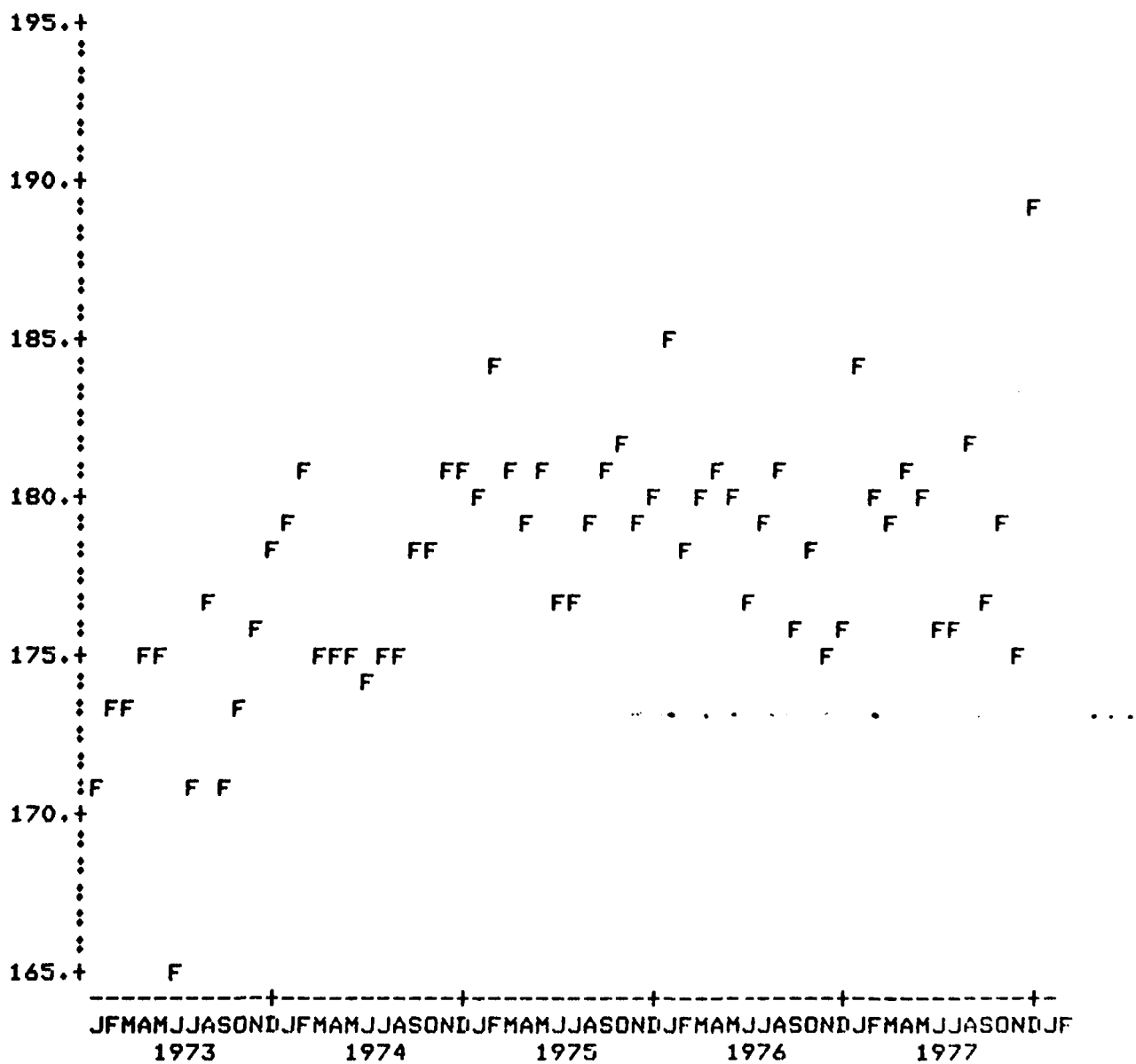

Figure A.3. Plot of Series F67231

M=M67231

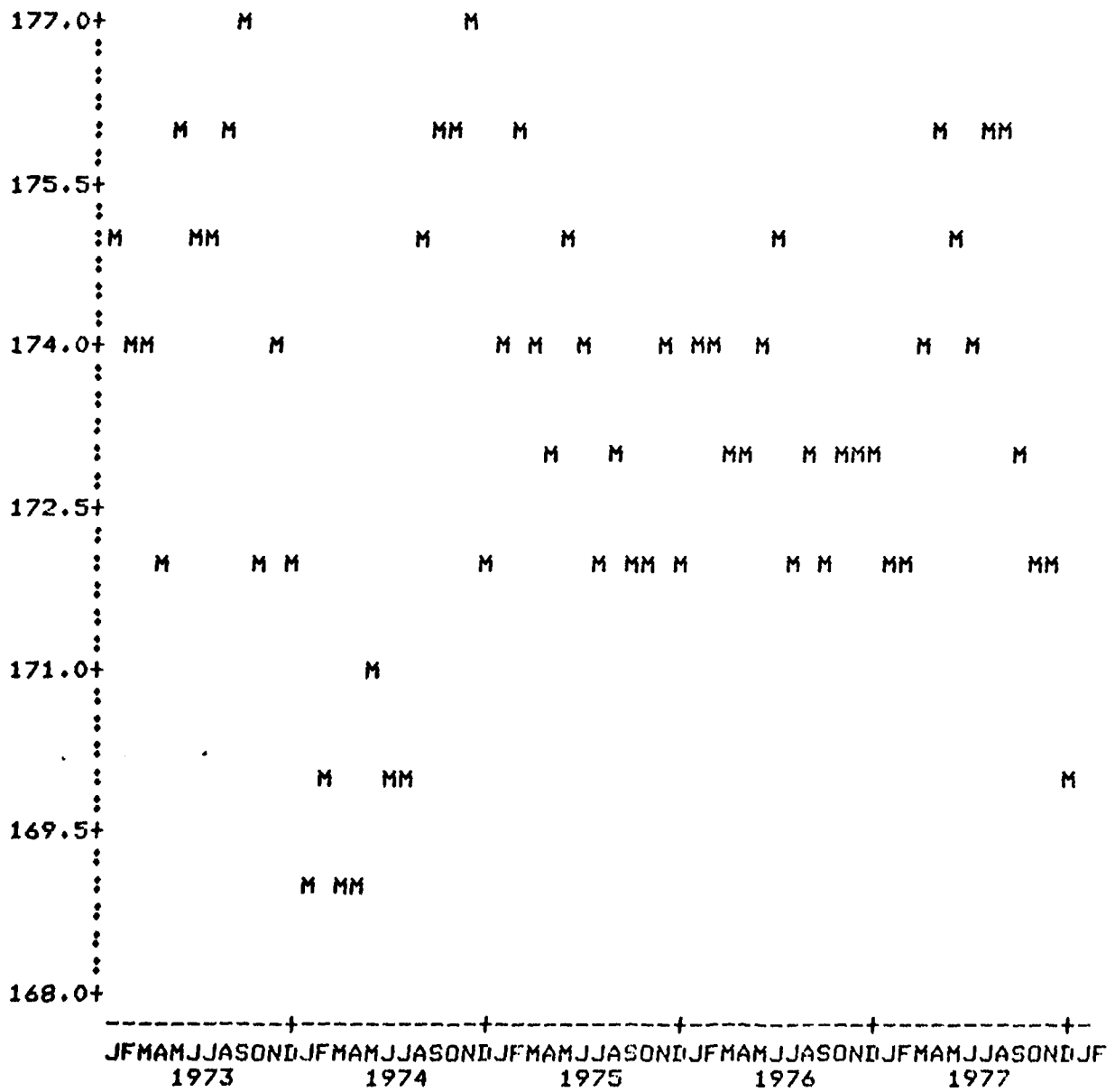

Figure A.4. Plot of Series M67231

F=F46330

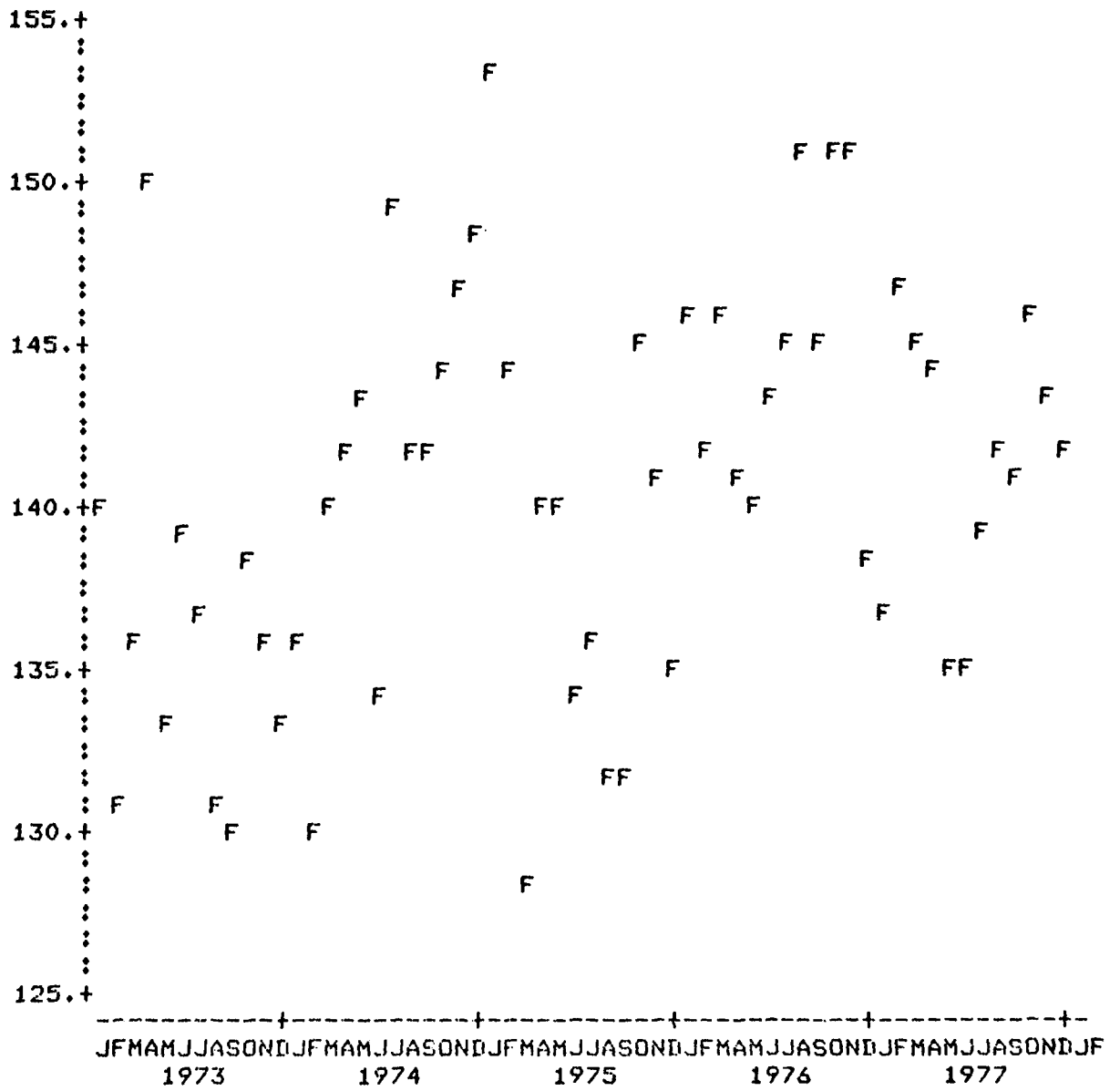

Figure A.5. Plot of Series F46330

F=F46230

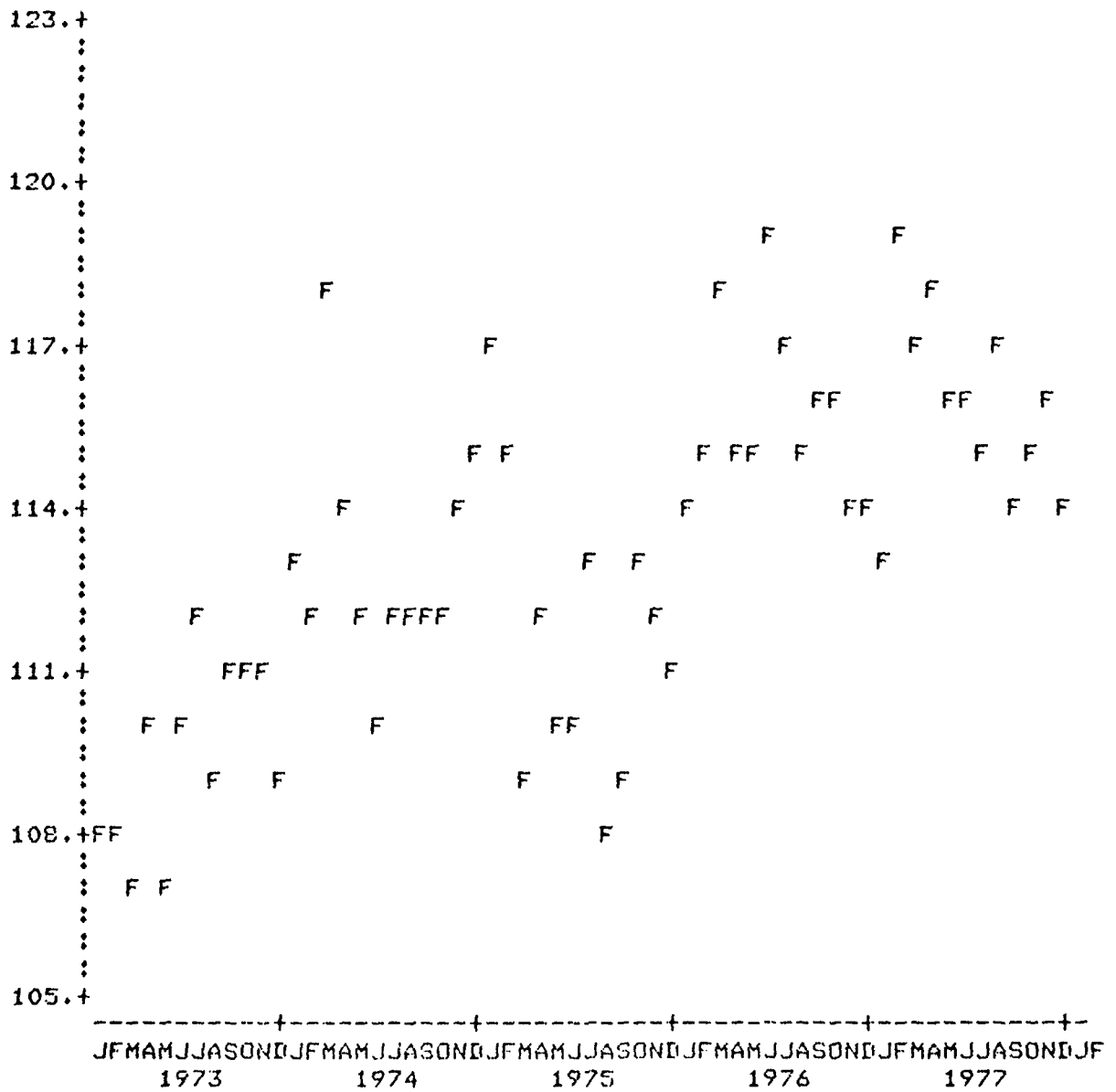

Figure A.6. Plot of Series F46230

F=F20430

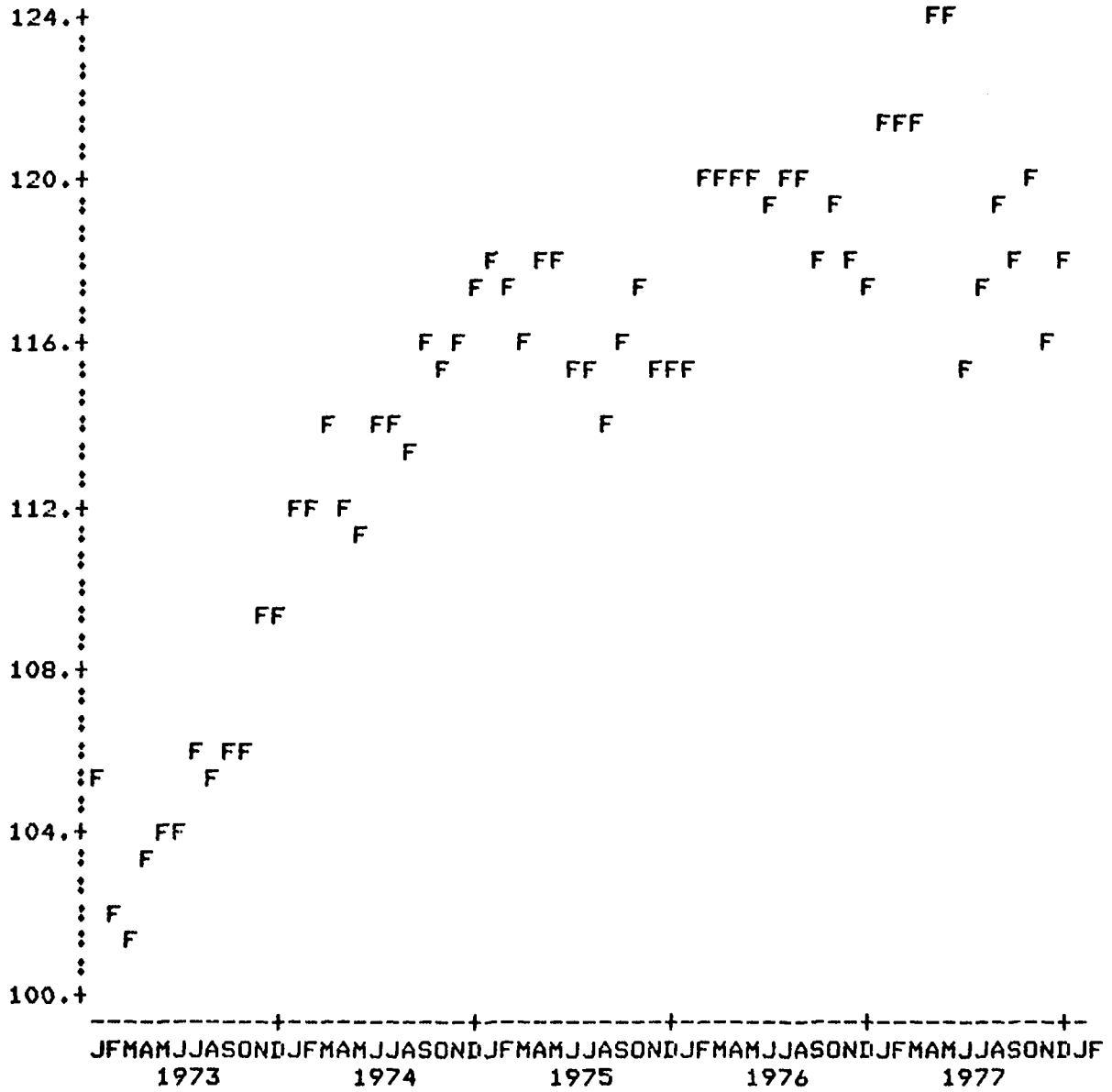

Figure A.7. Plot of Series F20430

F=F54130

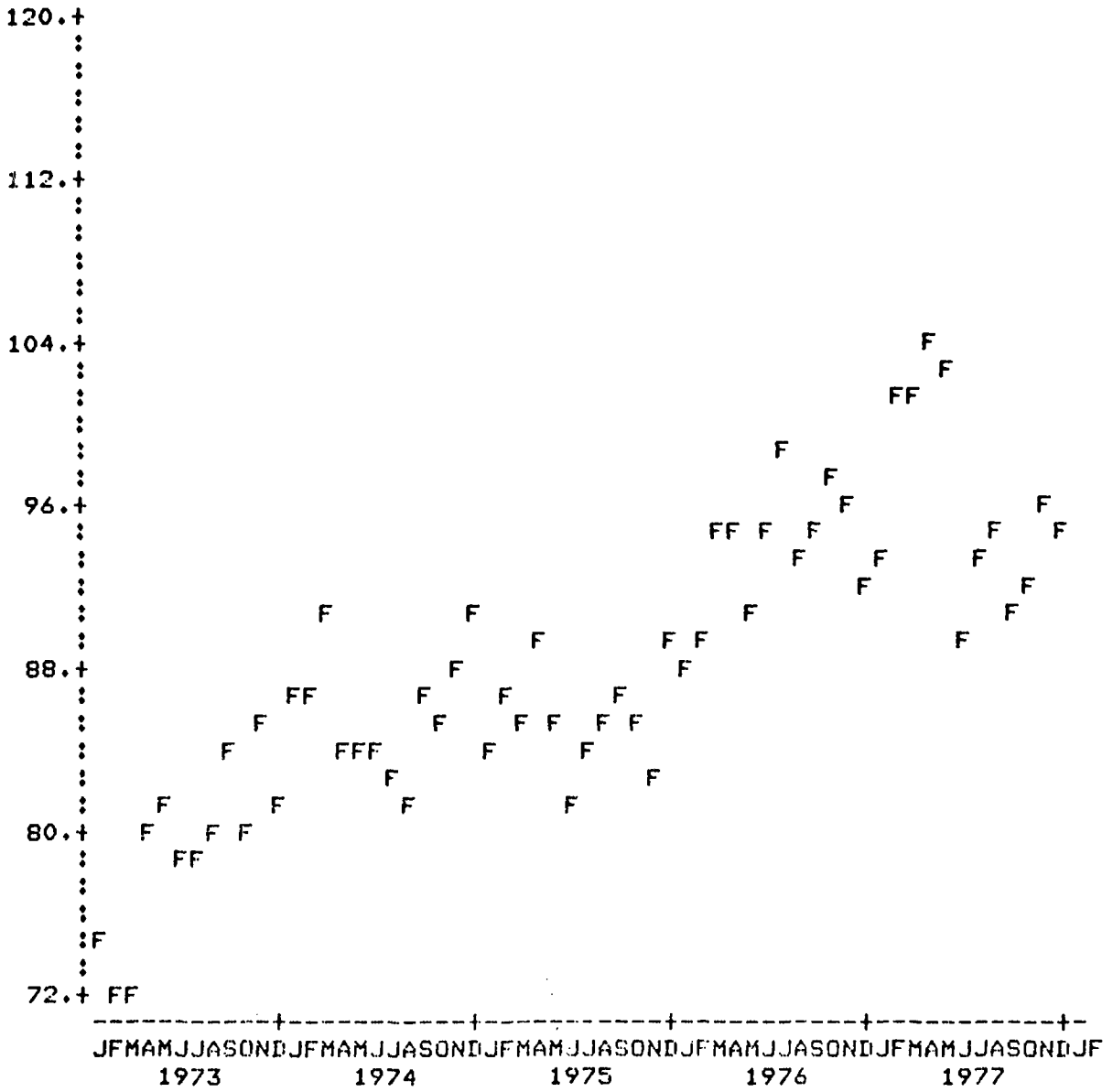

Figure A.8. Plot of Series F54130

T=TSK287

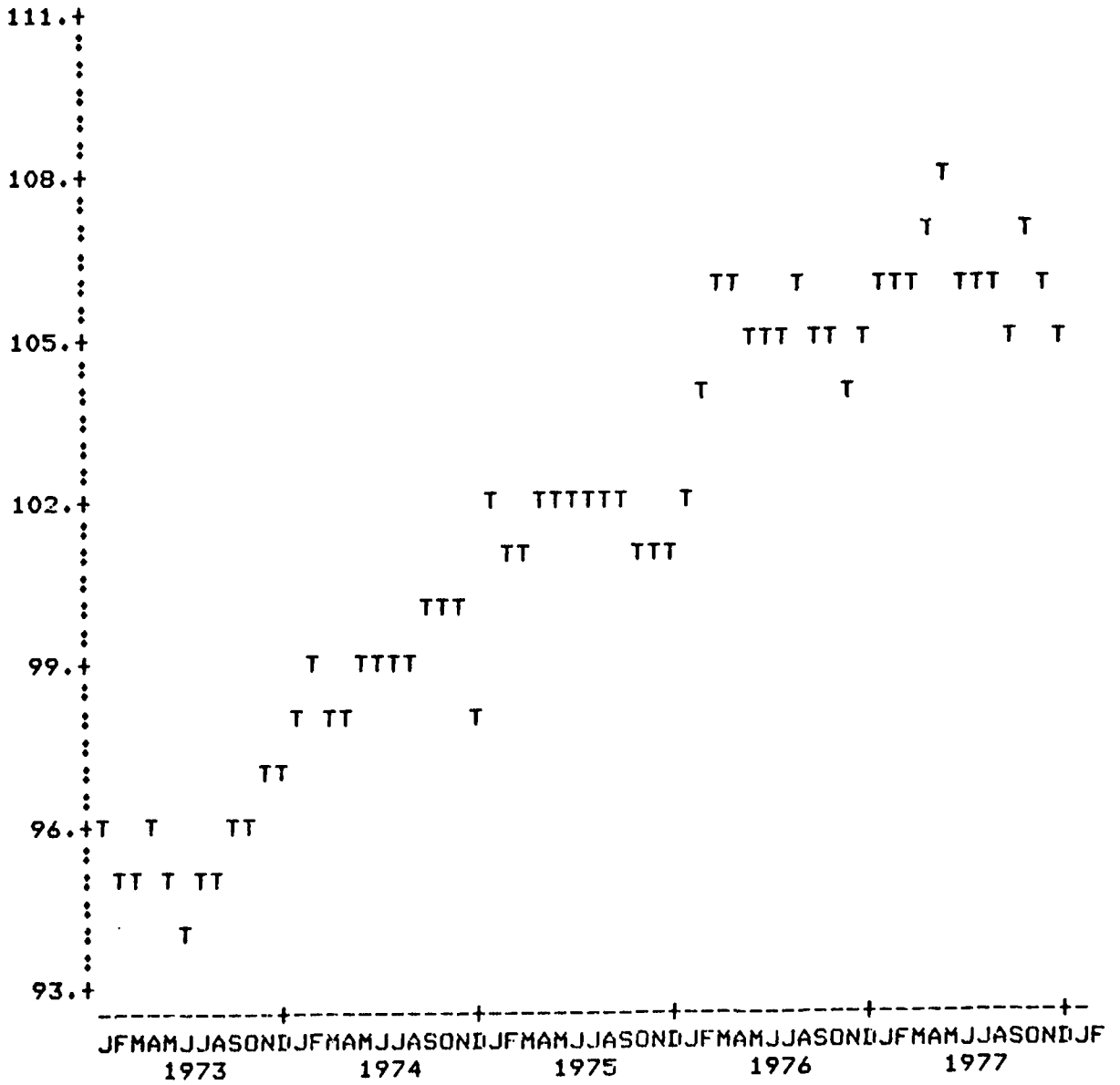

Figure A.9. Plot of Series TSK287

F=F43130

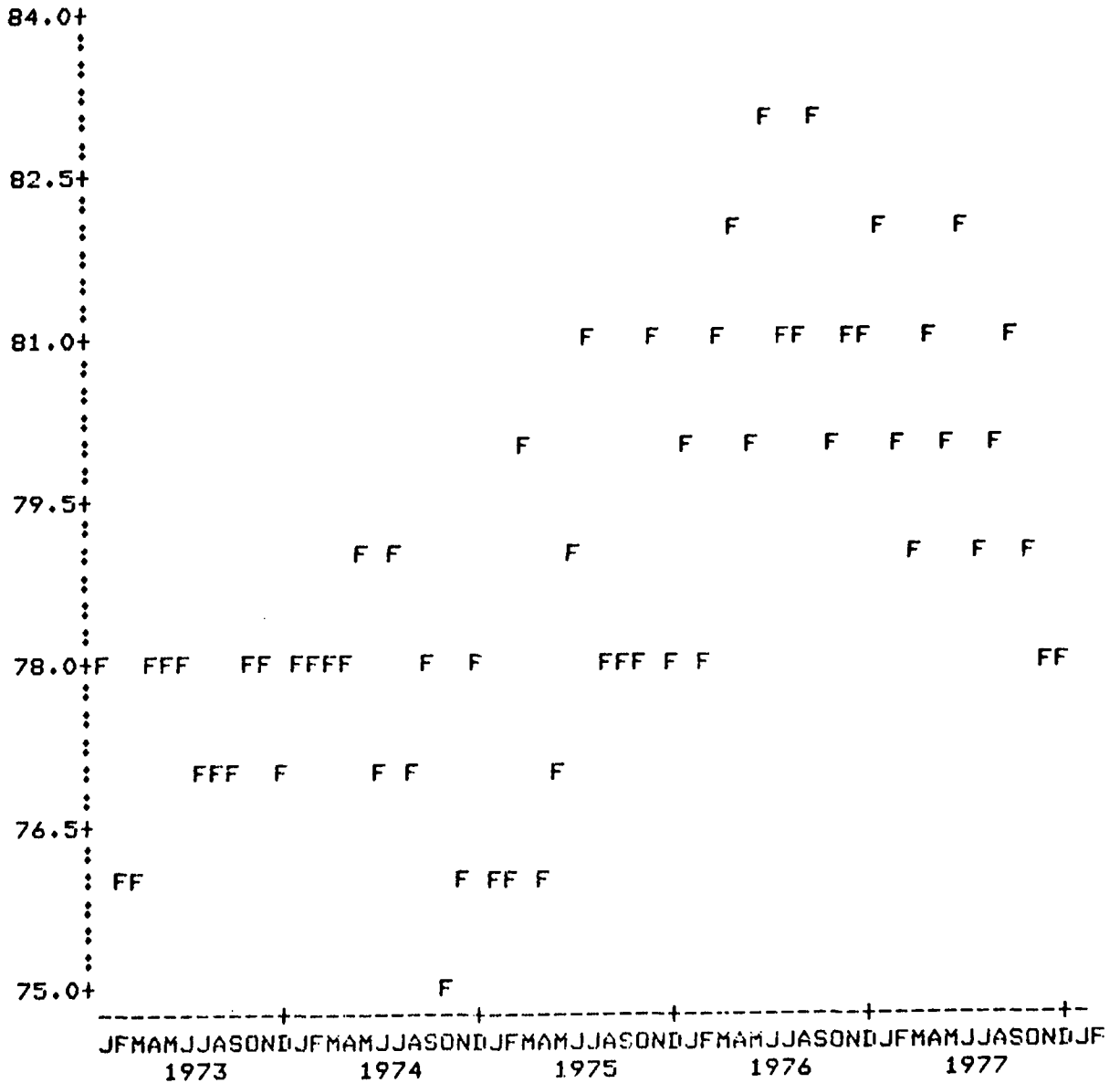

Figure A.10. Plot of Series F43130

F=F42732

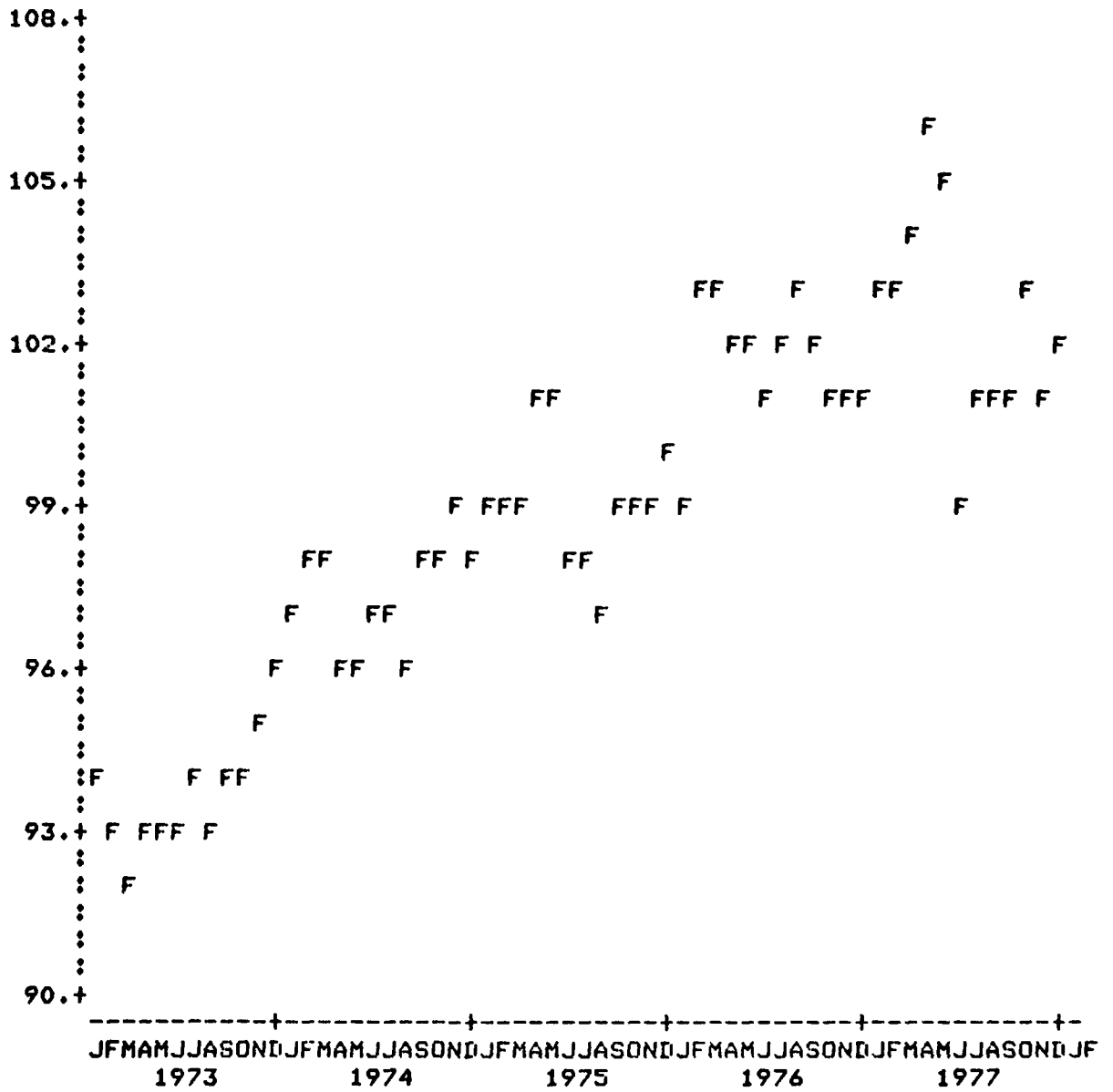

Figure A.11. Plot of Series F42732

F=F27131

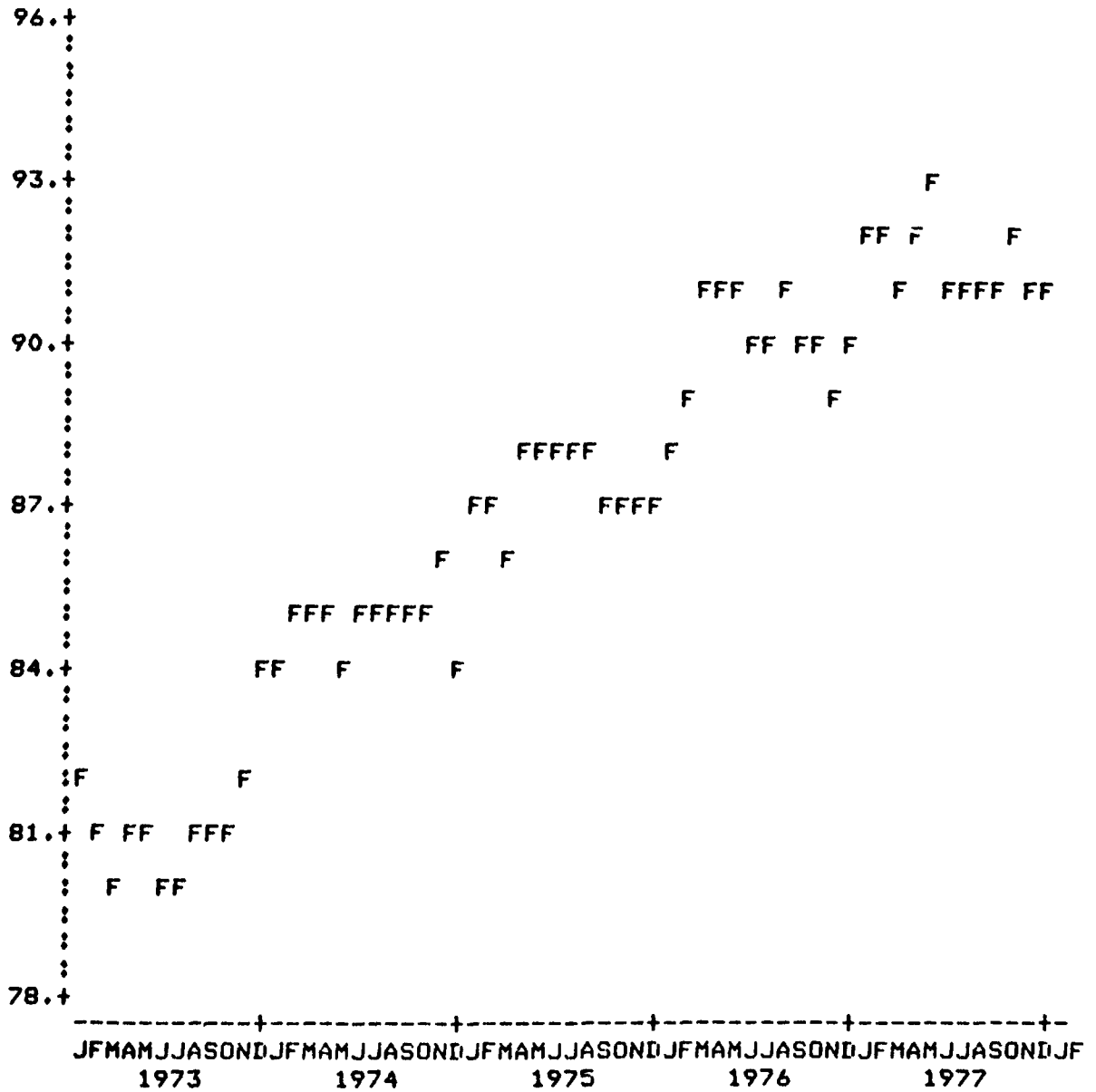

Figure A.12. Plot of Series F27131

F=F42333

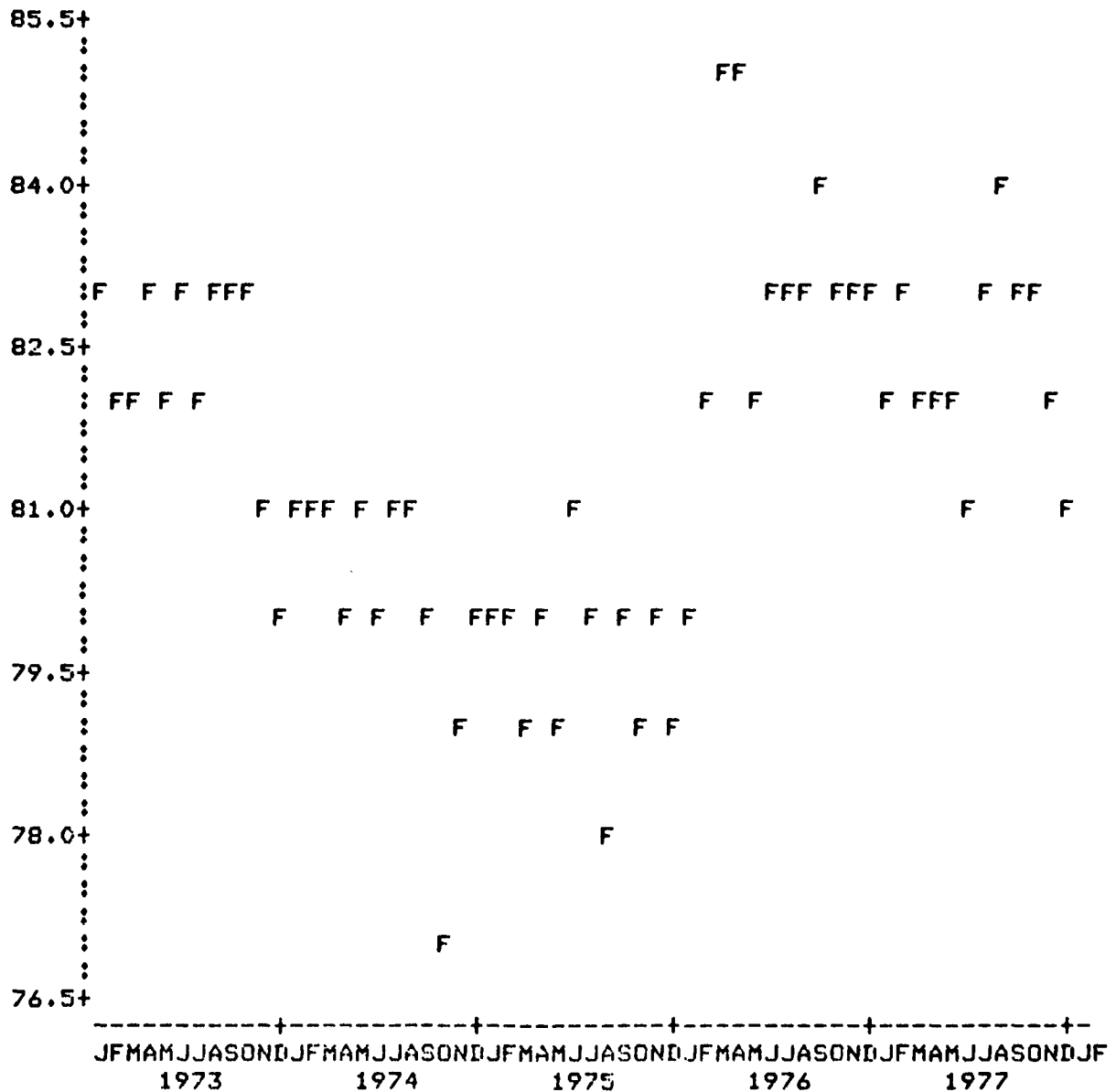

Figure A.13. Plot of Series F42333

F=F23132

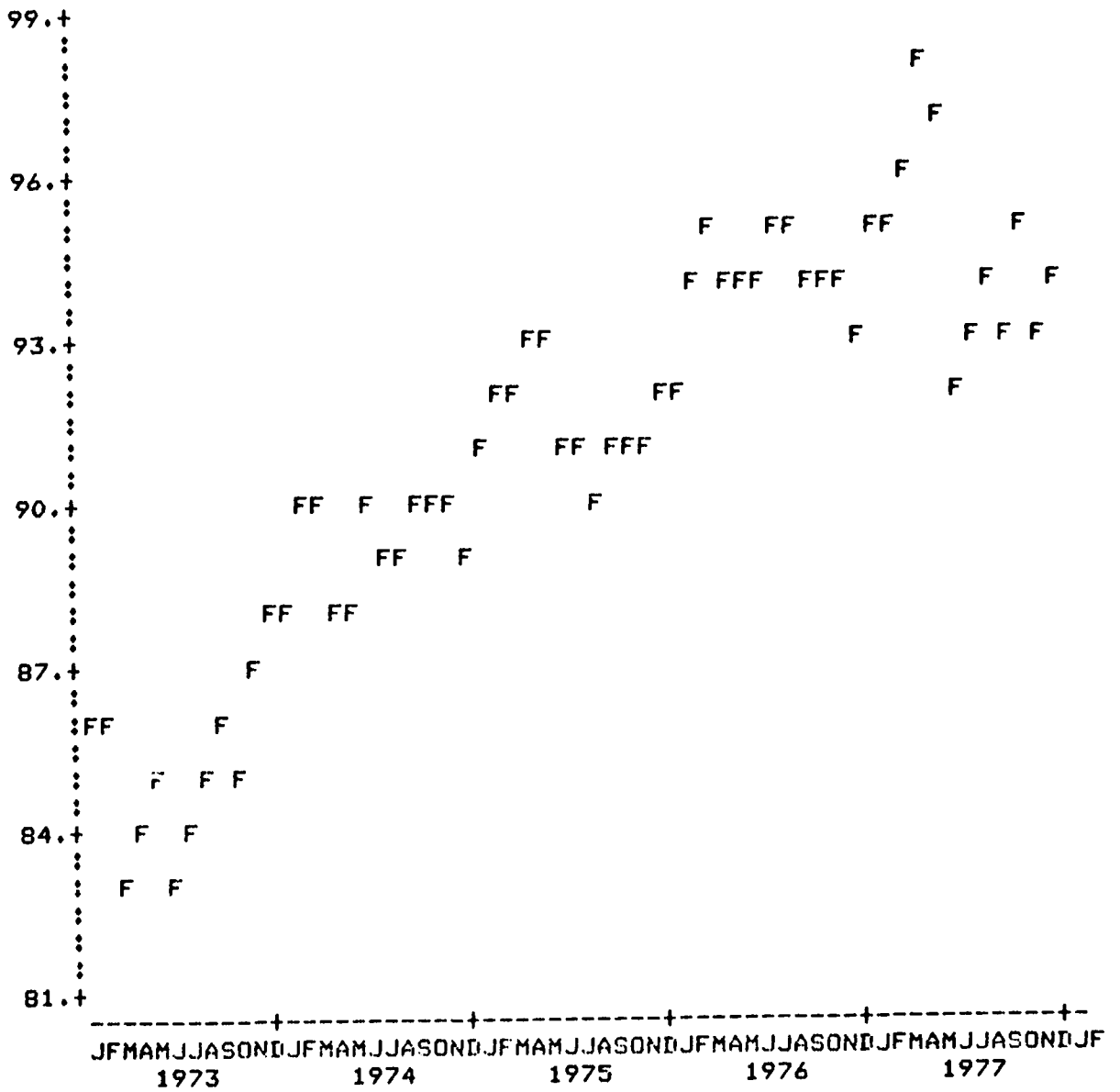

Figure A.14. Plot of Series F23132

M=M23132

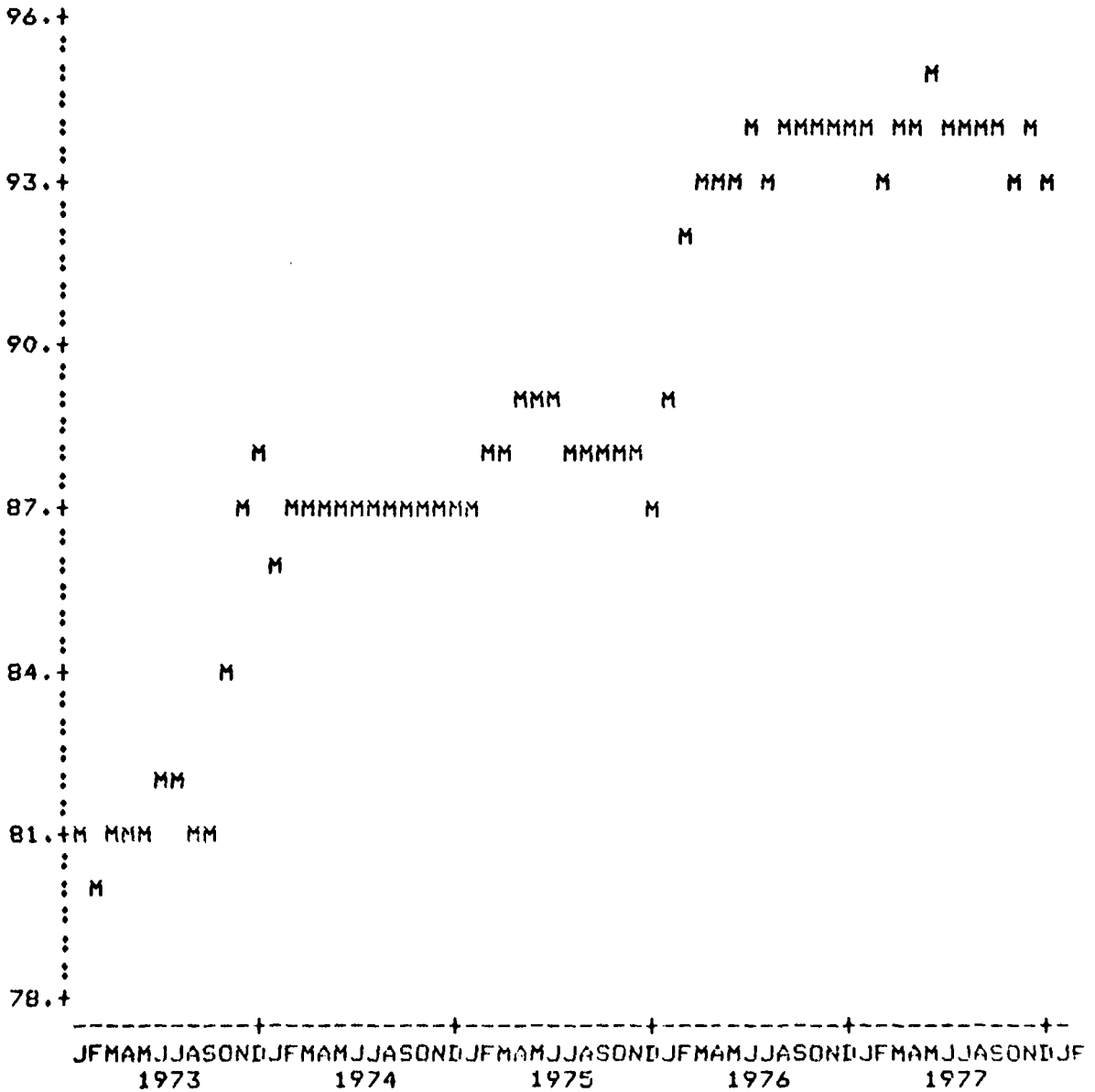

Figure A.15. Plot of Series N23132

3 MONTH MOVING AVERAGE OF PAYOFF

F30230

A=AVERAGE

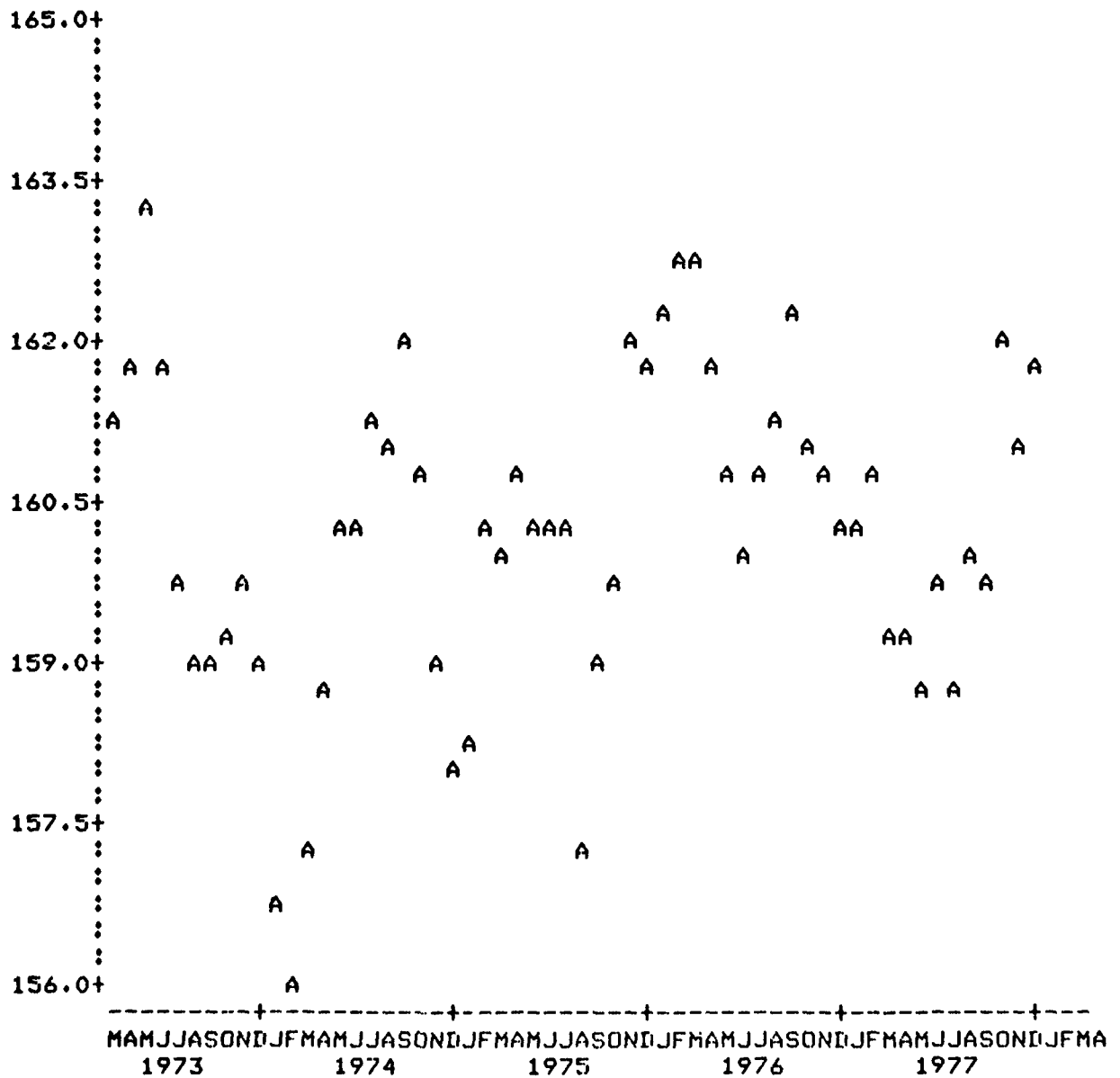

Figure A.16. Plot of 3-Month Moving Average of F30230

3 MONTH MOVING AVERAGE OF PAYOFF

M30230

A=AVERAGE

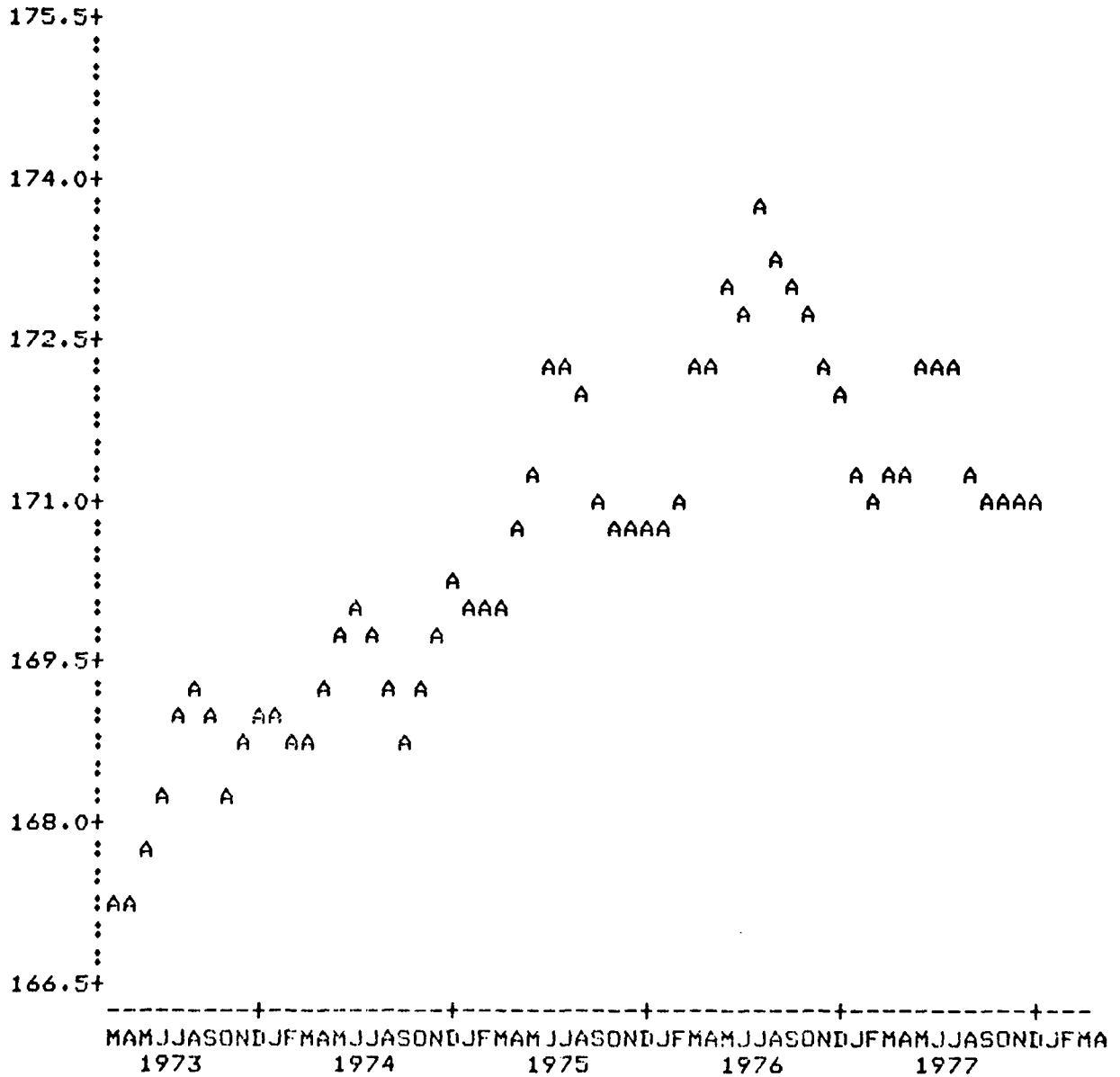

Figure A.17. Plot of 3-Month Moving Average of M30230

3 MONTH MOVING AVERAGE OF PAYOFF

F67231

A=AVERAGE

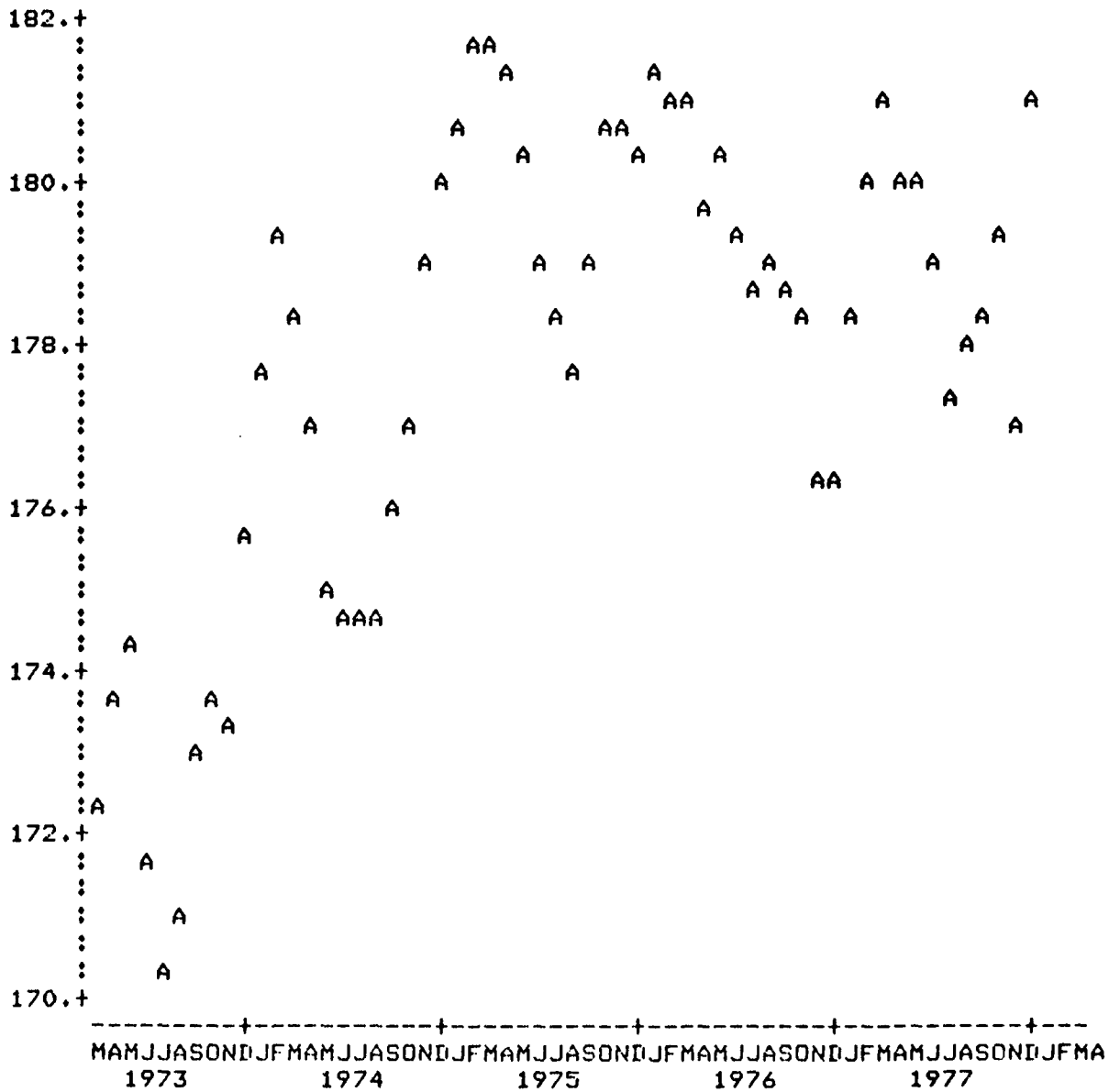

Figure A.18. Plot of 3-Month Moving Average of F67231

3 MONTH MOVING AVERAGE OF PAYOFF

M67231

A=AVERAGE

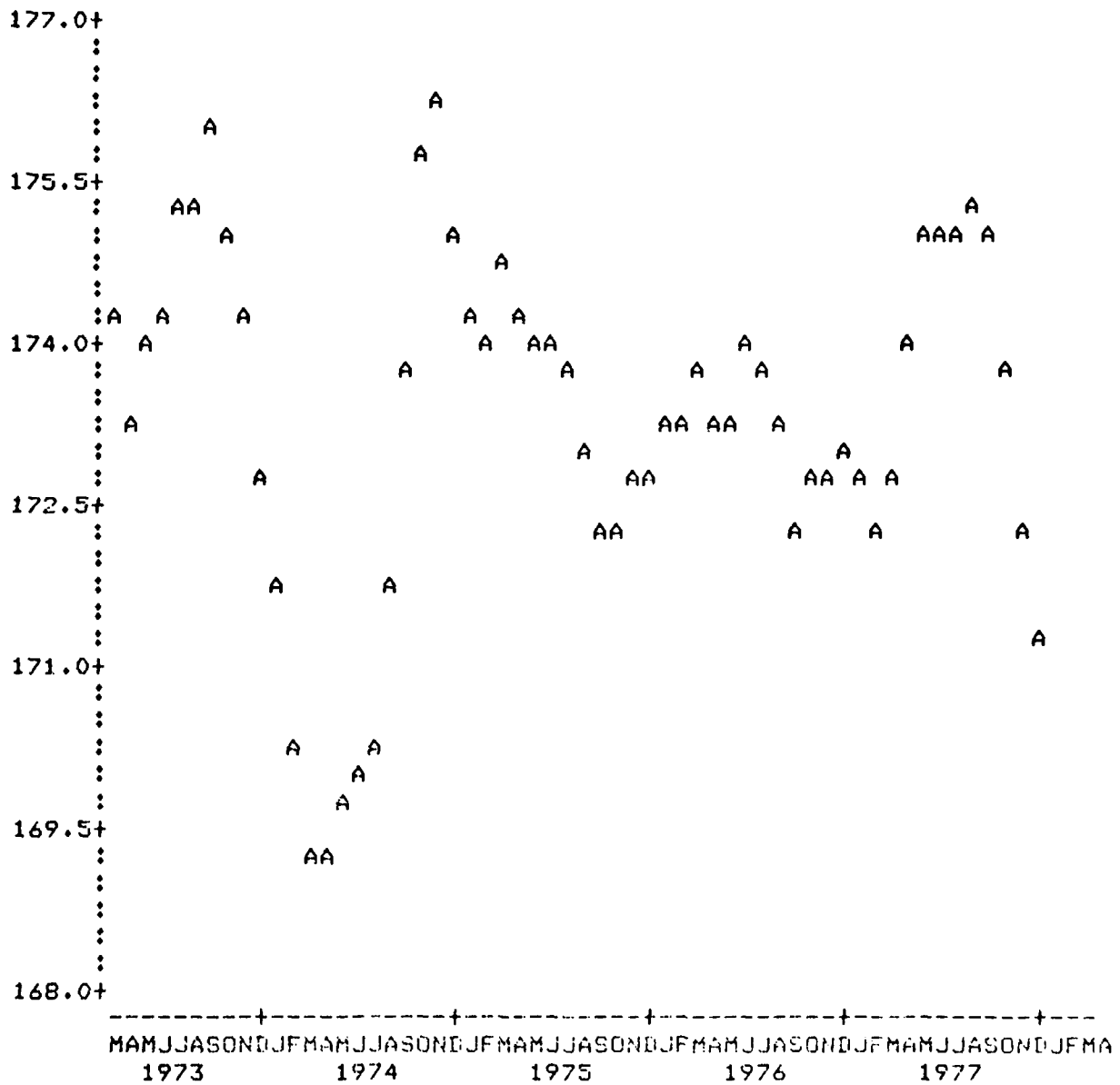

Figure A.19. Plot of 3-Month Moving Average of M67231

3 MONTH MOVING AVERAGE OF PAYOFF

F46330

A=AVERAGE

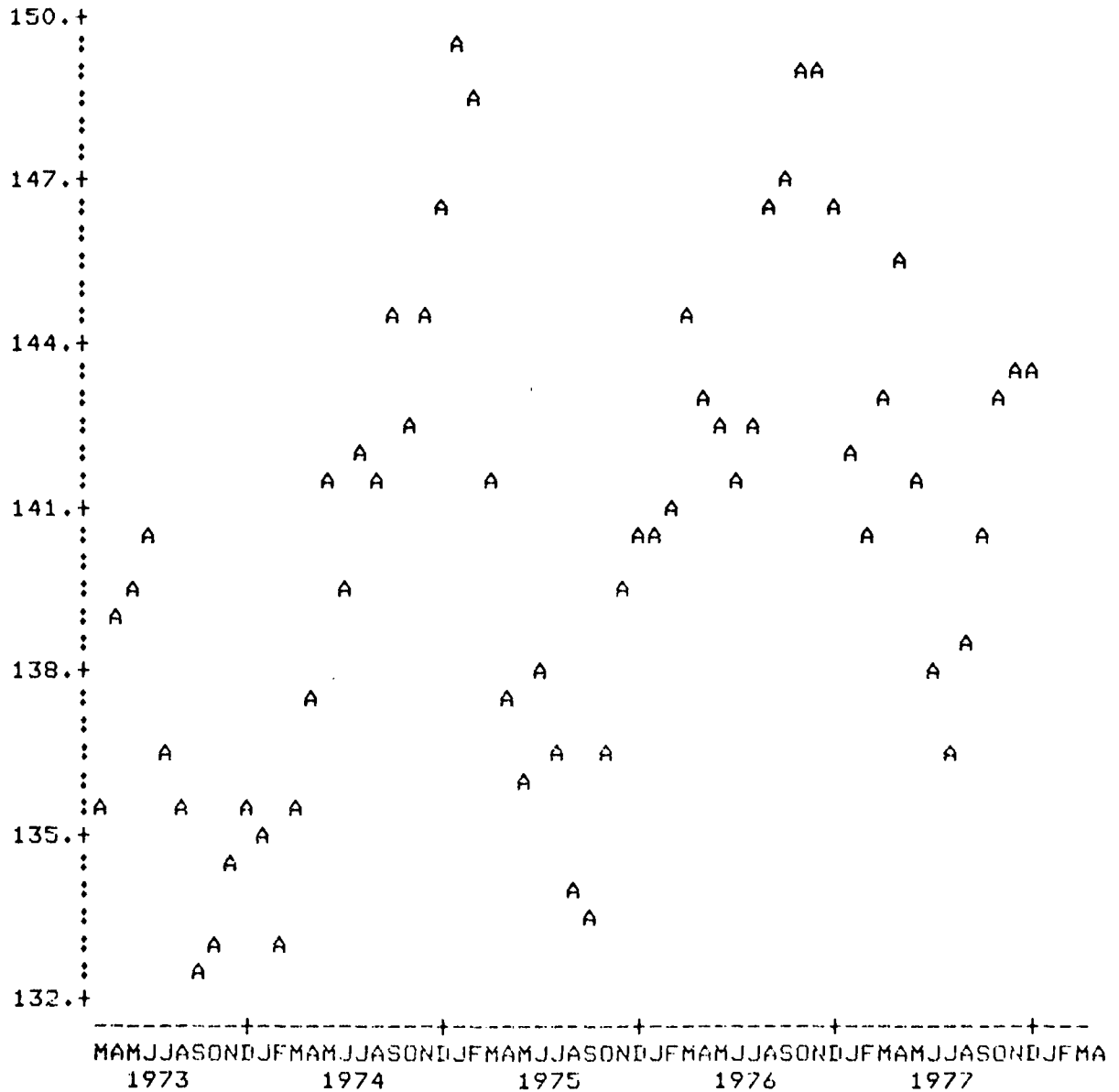

Figure A.20. Plot of 3-Month Moving Average of F46330

3 MONTH MOVING AVERAGE OF PAYOFF

F46230

A=AVERAGE

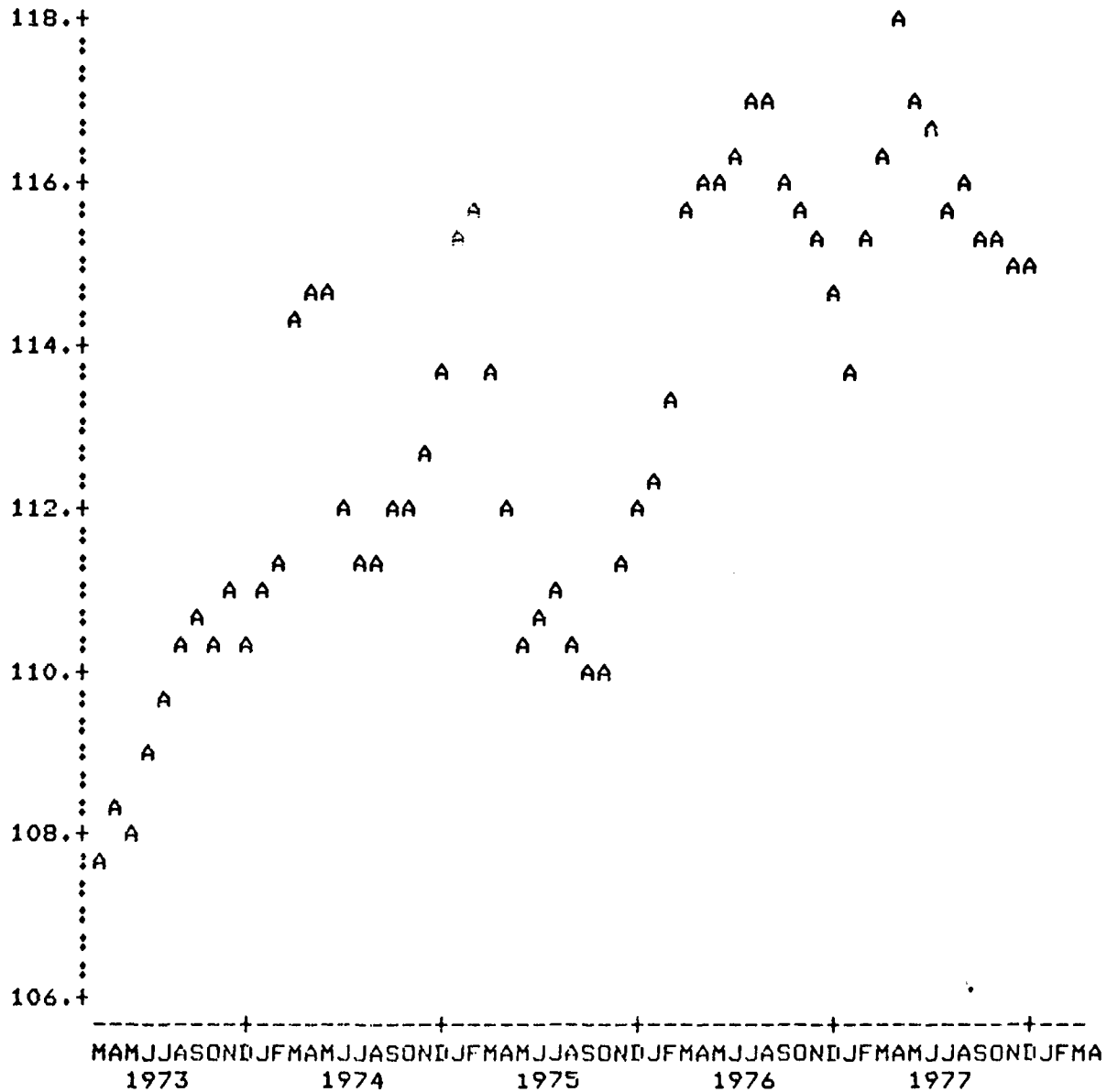

Figure A.21. Plot of 3-Month Moving Average of F46230

3 MONTH MOVING AVERAGE OF PAYOFF

F20430

A=AVERAGE

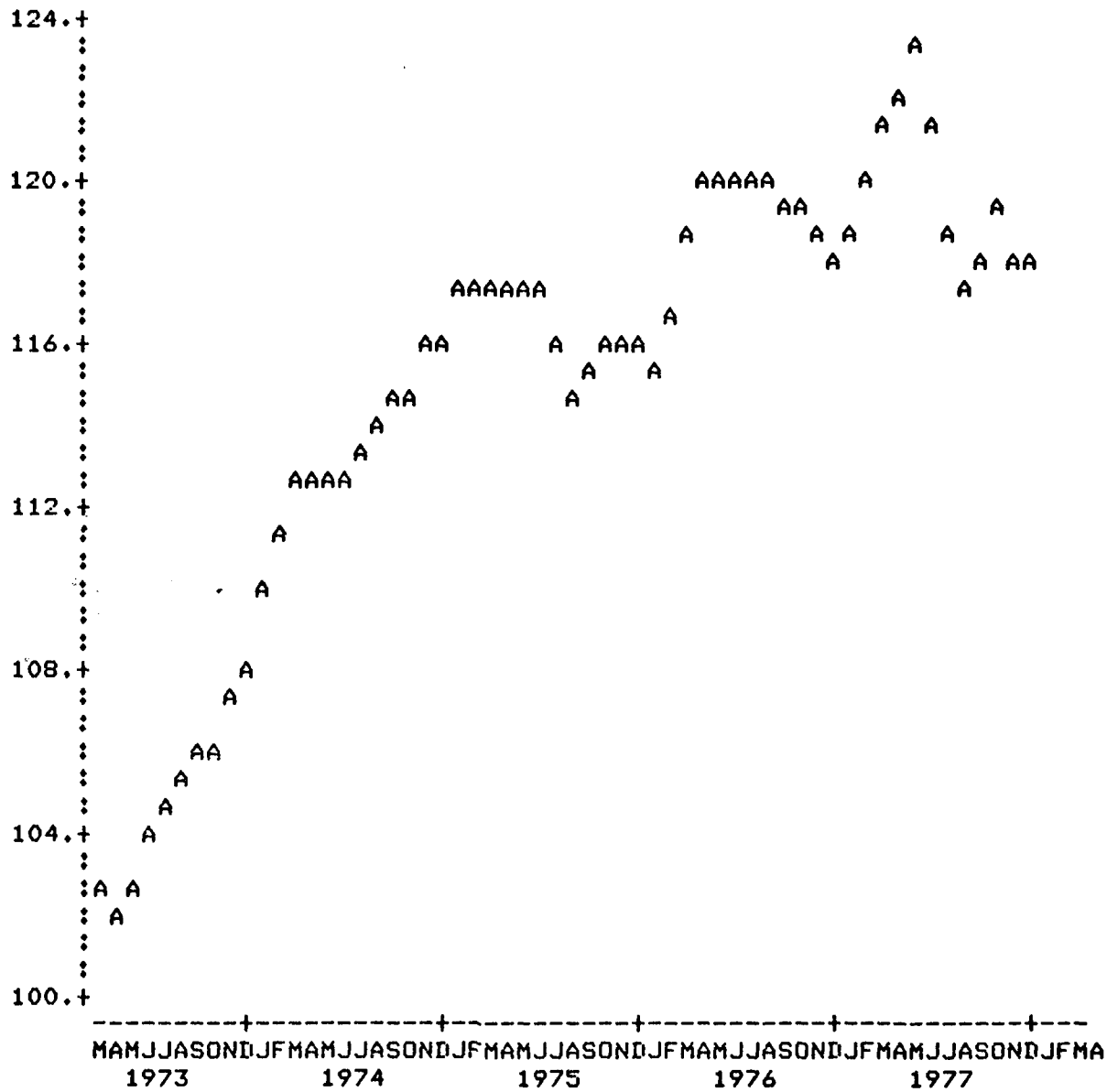

Figure A.22. Plot of 3-Month Moving Average of F20430

3 MONTH MOVING AVERAGE OF PAYOFF

F54130

A=AVERAGE

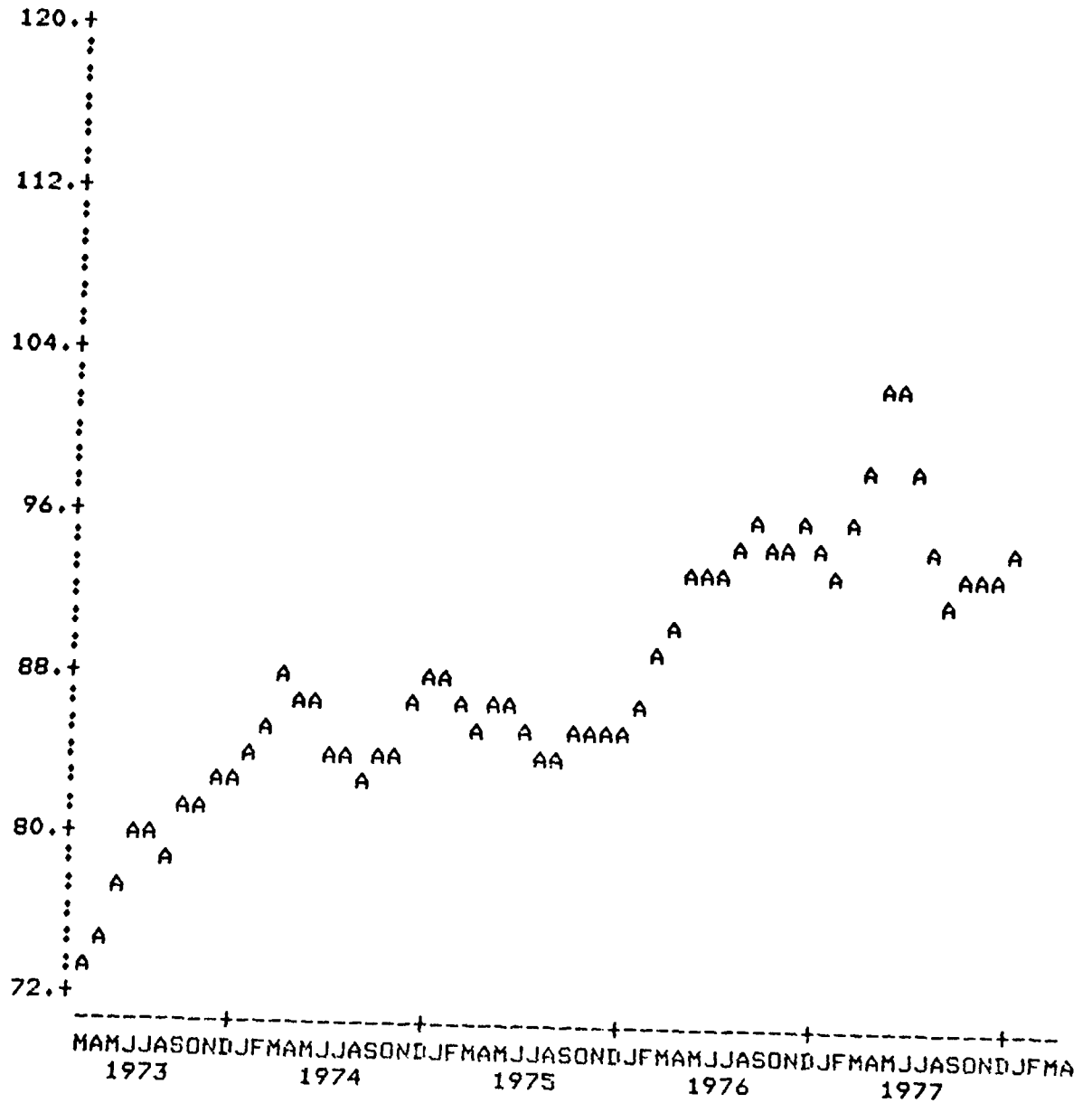

Figure A.23. Plot of 3-Month Moving Average of F54130

3 MONTH MOVING AVERAGE OF PAYOFF

TSK287

A=AVERAGE

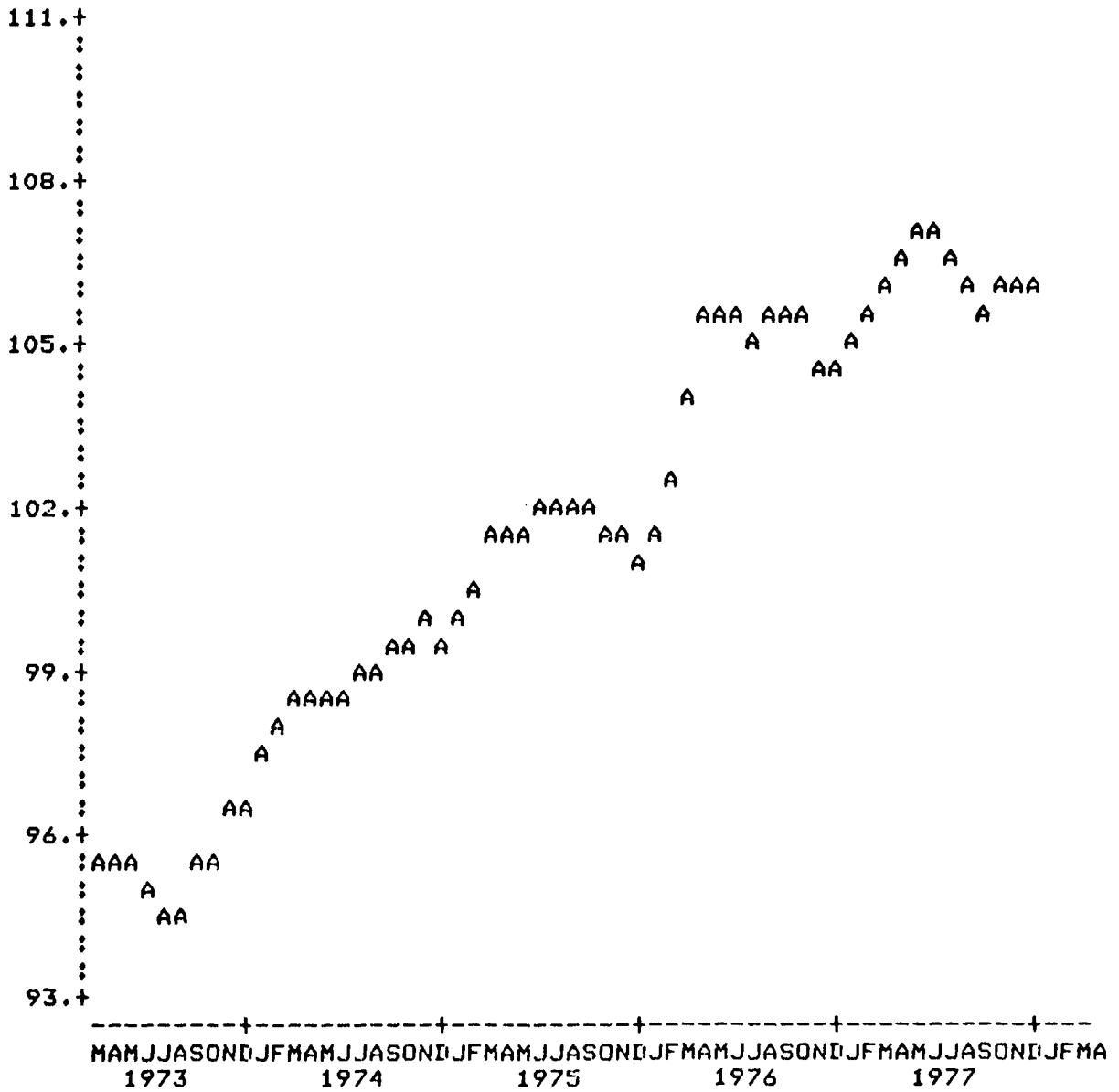

Figure A.24. Plot of 3-Month Moving Average of TSK287

3 MONTH MOVING AVERAGE OF PAYOFF

F43130

A=AVERAGE

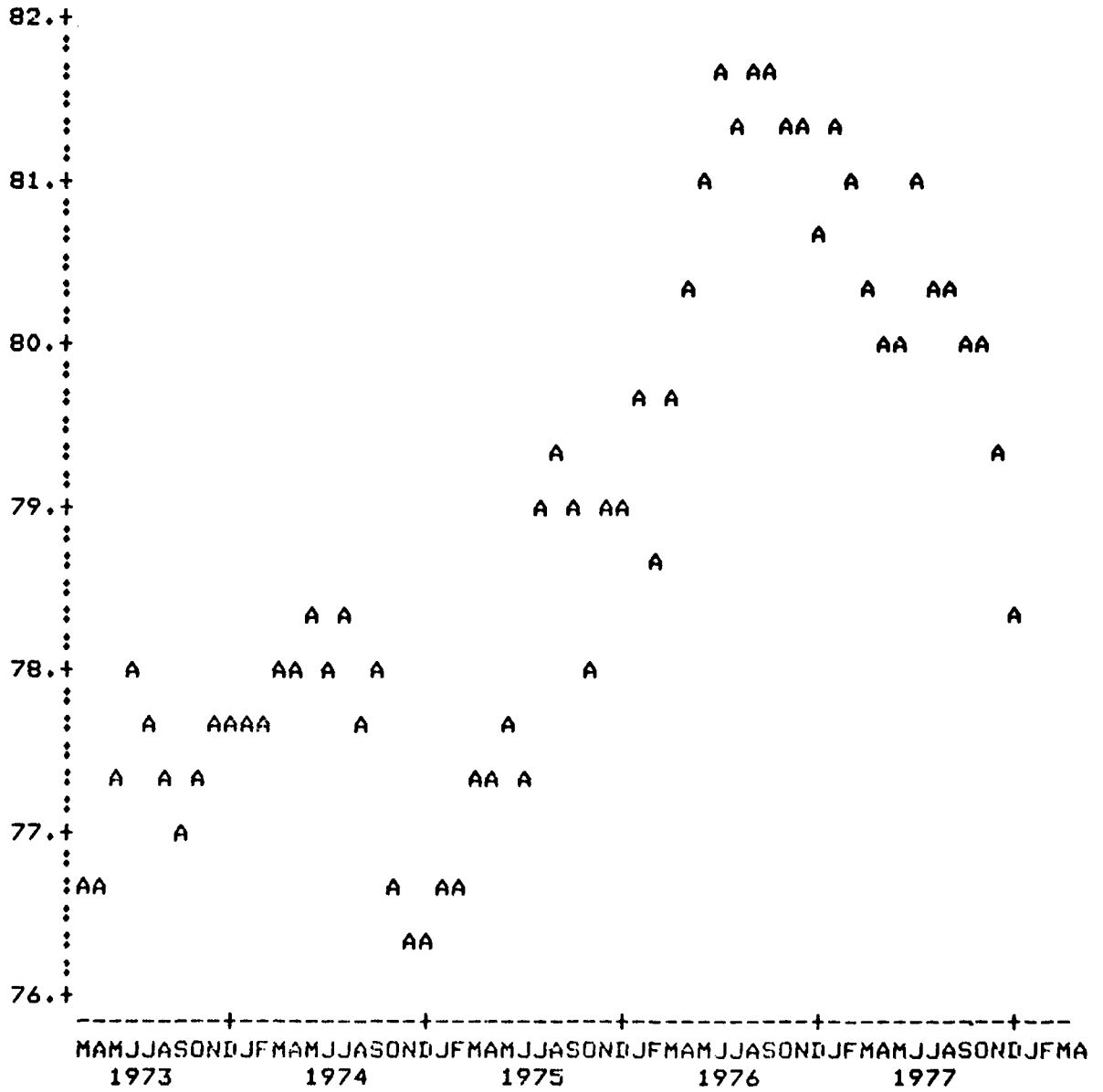

Figure A.25. Plot of 3-Month Moving Average of F43130

3 MONTH MOVING AVERAGE OF PAYOFF

F42732

A=AVERAGE

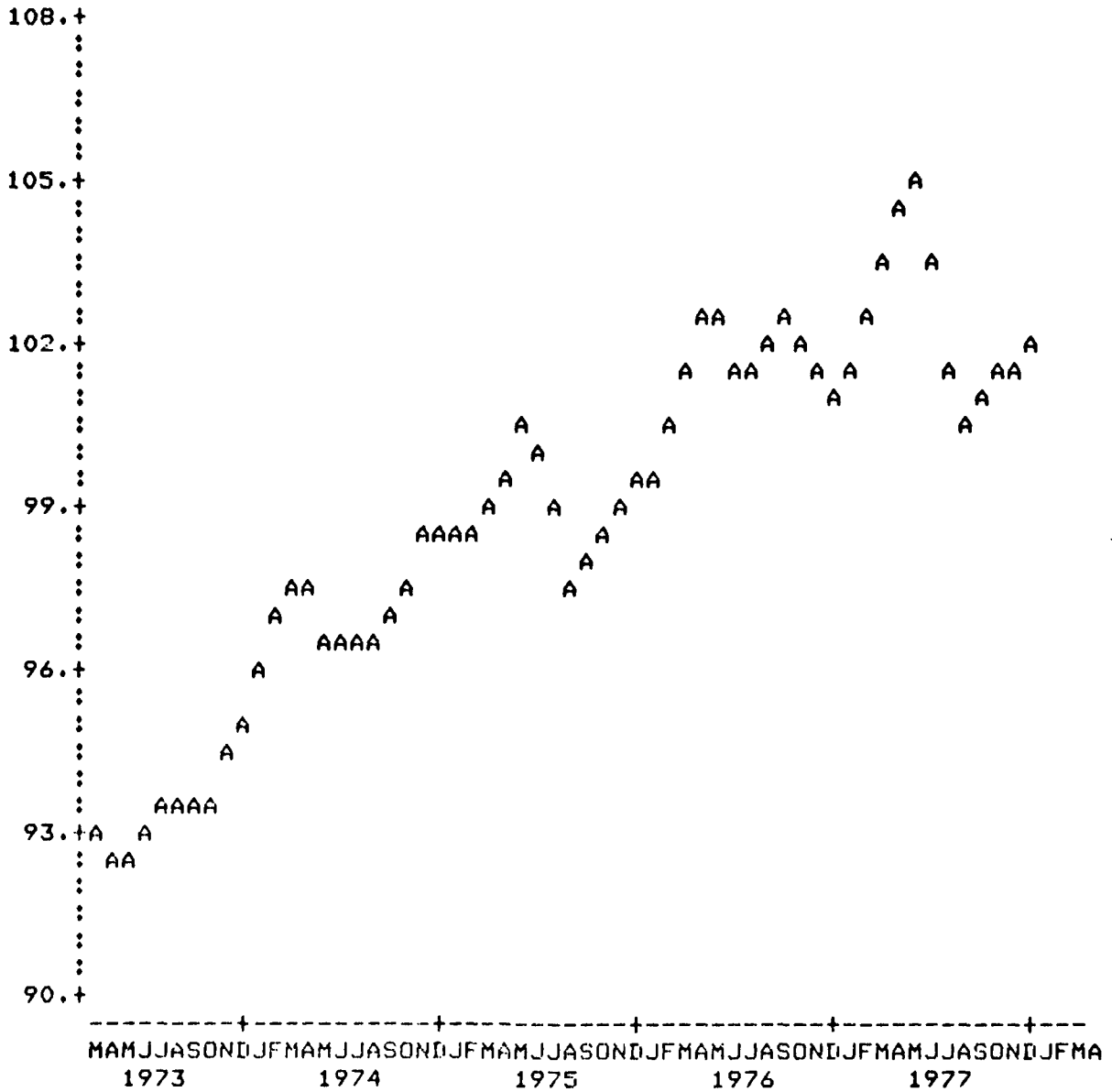

Figure A.26. Plot of 3-Month Moving Average of F42732

3 MONTH MOVING AVERAGE OF PAYOFF

F27131

A=AVERAGE

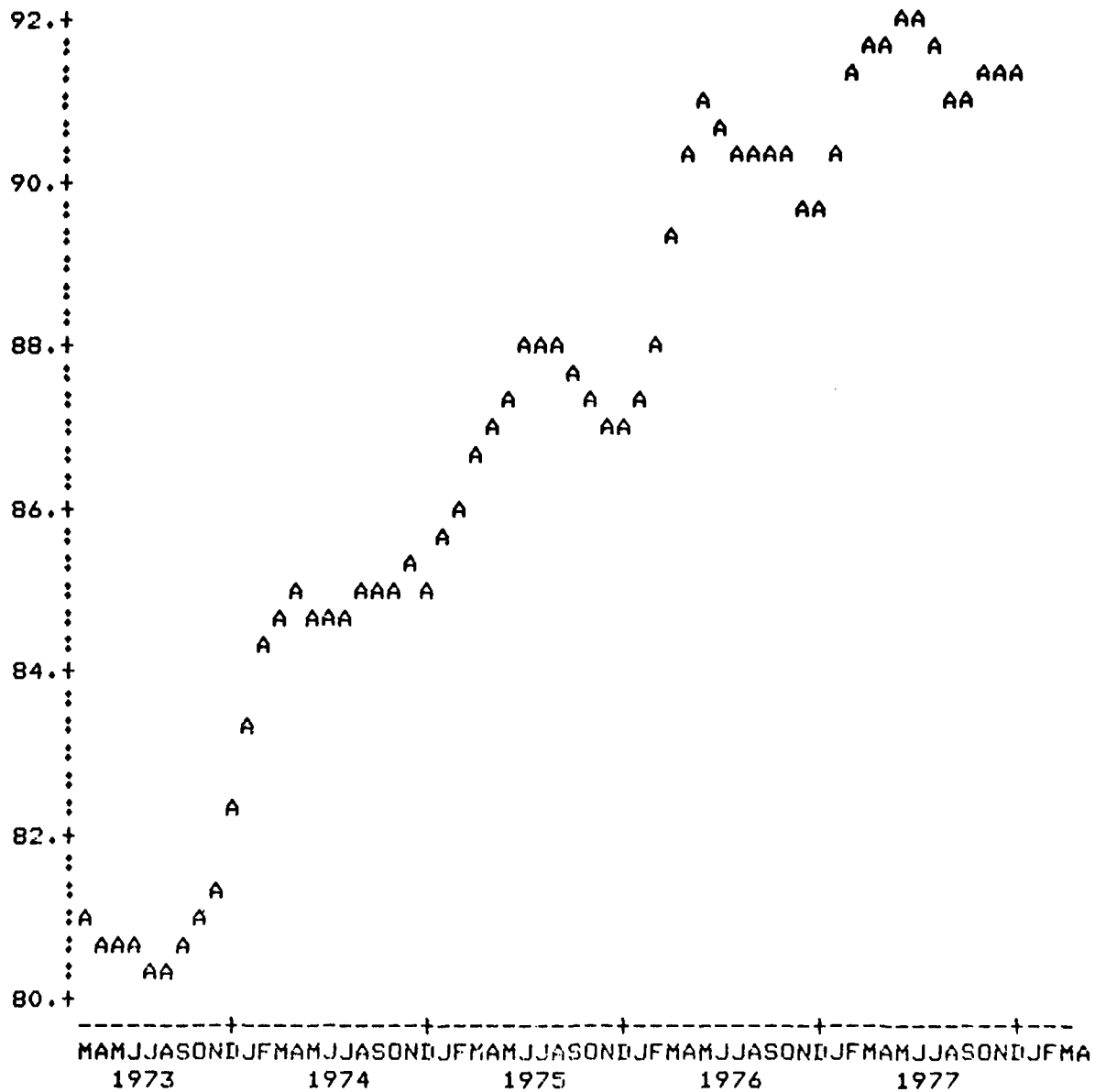

Figure A.27. Plot of 3-Month Moving Average of F27131

3 MONTH MOVING AVERAGE OF PAYOFF

F42333

A=AVERAGE

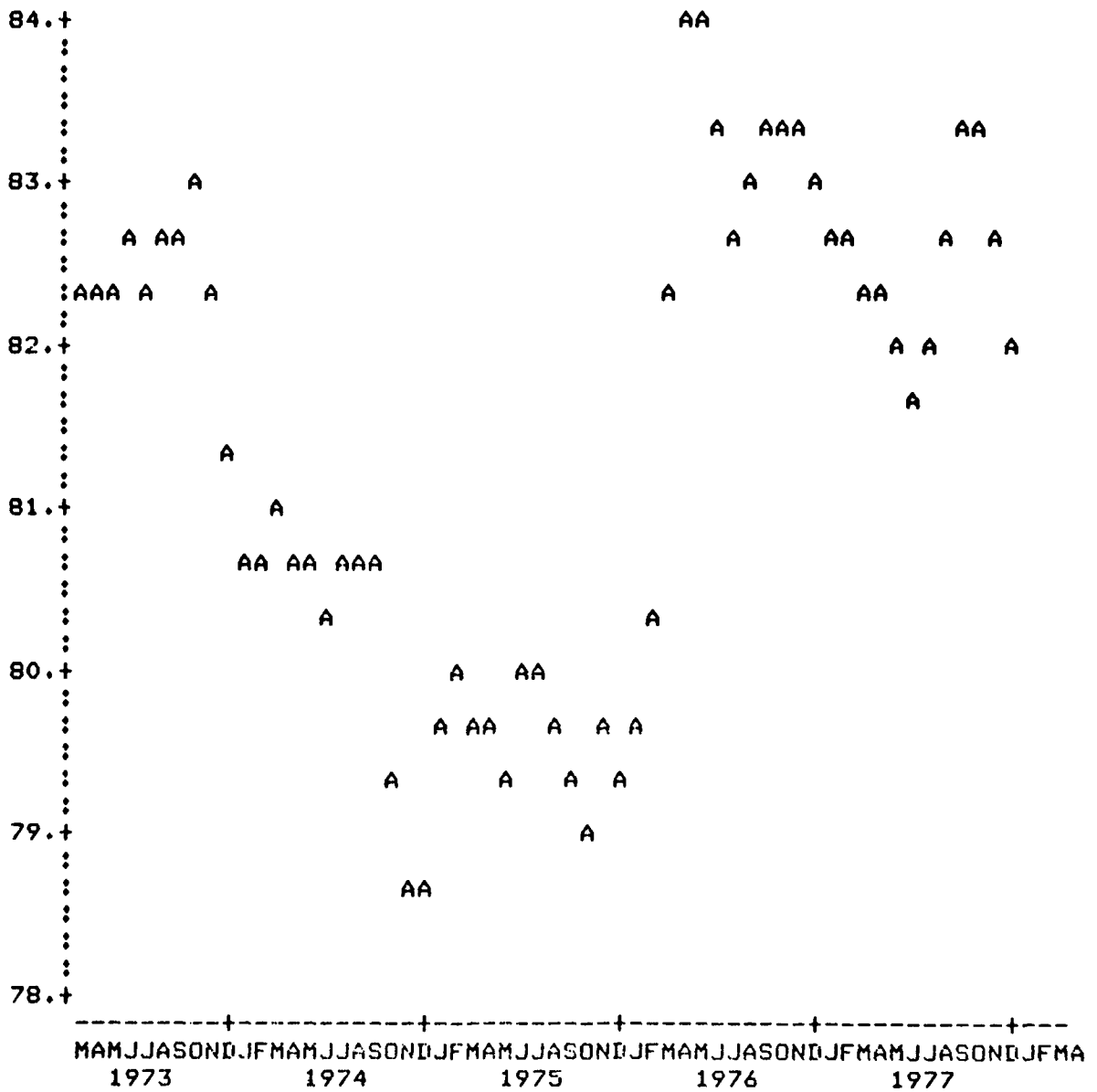

Figure A.28. Plot of 3-Month Moving Average of F42333

3 MONTH MOVING AVERAGE OF PAYOFF

F23132

A=AVERAGE

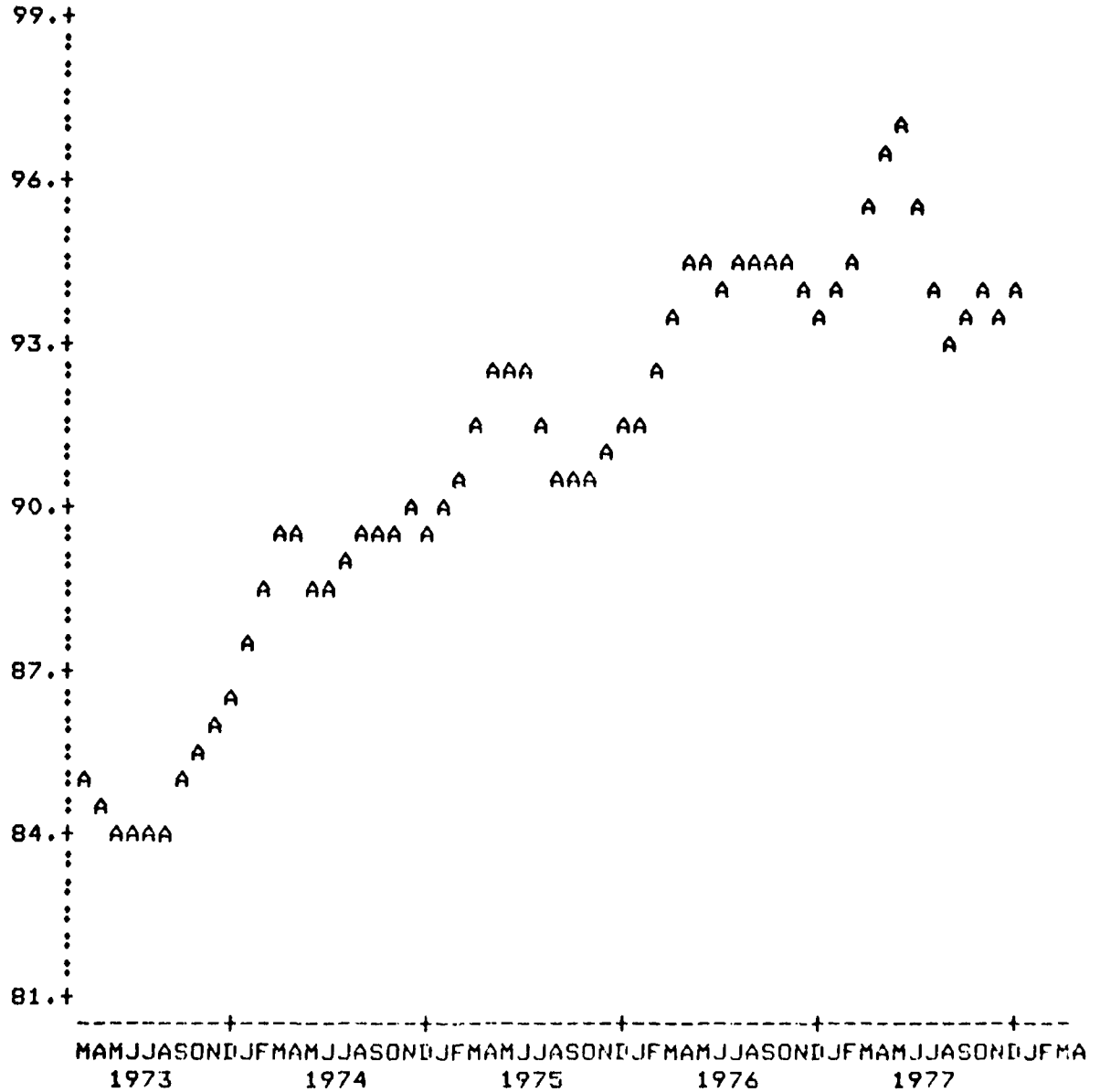

Figure A.29. Plot of 3-Month Moving Average of F23132

3 MONTH MOVING AVERAGE OF PAYOFF

M23132

A=AVERAGE

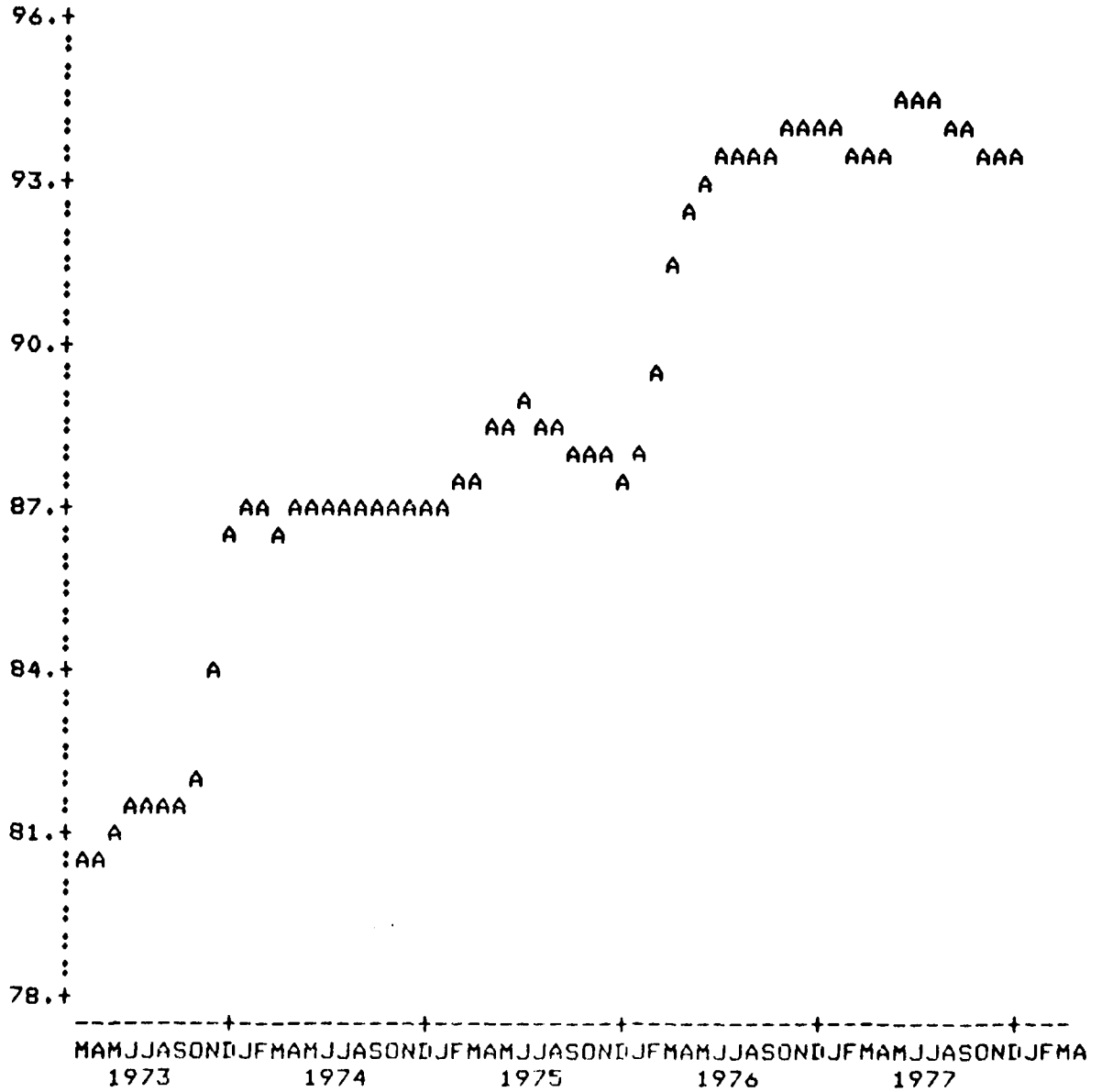

Figure A.30. Plot of 3-Month Moving Average of M23132

12 MONTH MOVING AVERAGE OF PAYOFF

F30230

A=AVERAGE

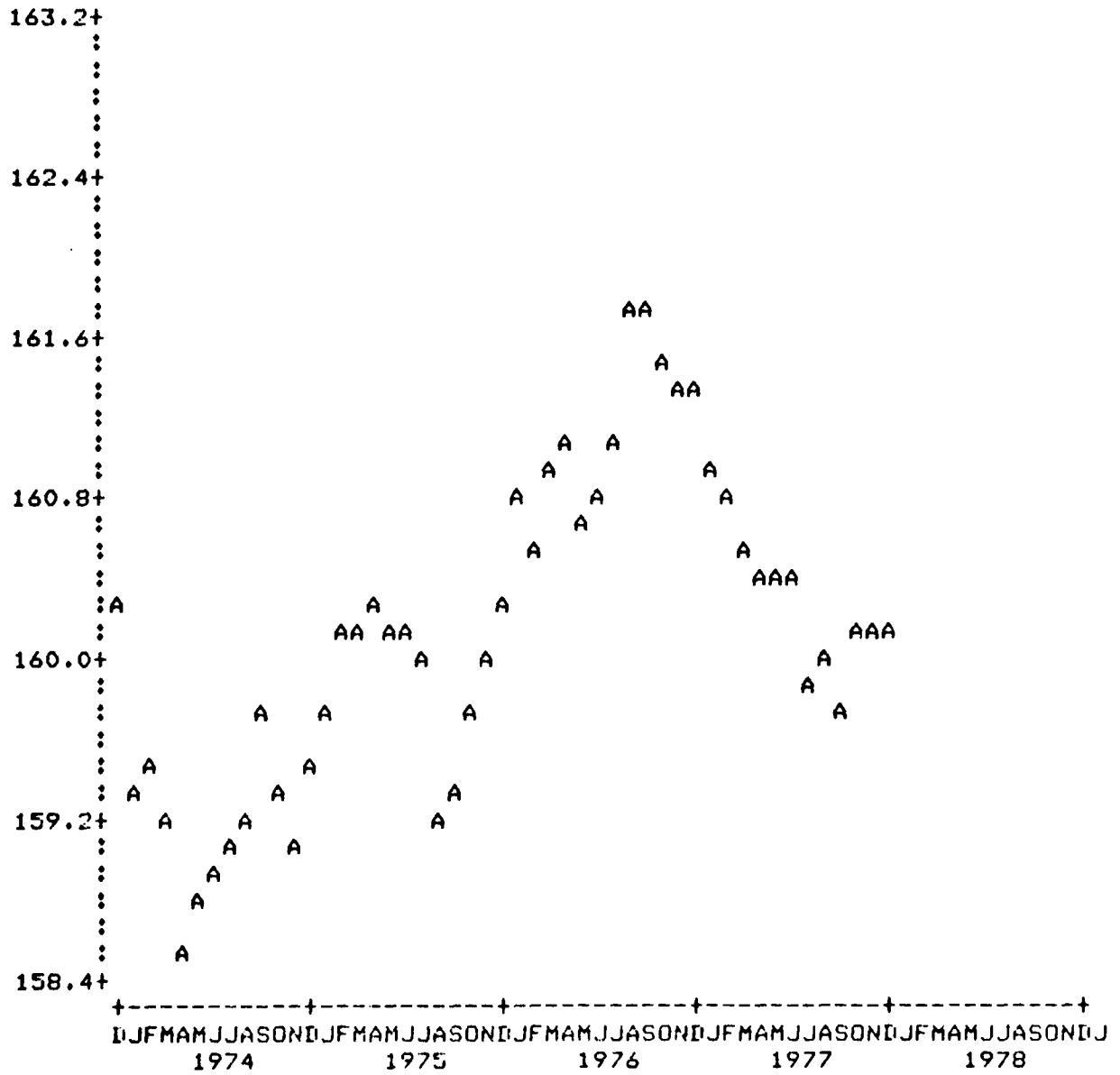

Figure A.31. Plot of 12-Month Moving Average of F30230

12 MONTH MOVING AVERAGE OF PAYOFF

M30230

A=AVERAGE

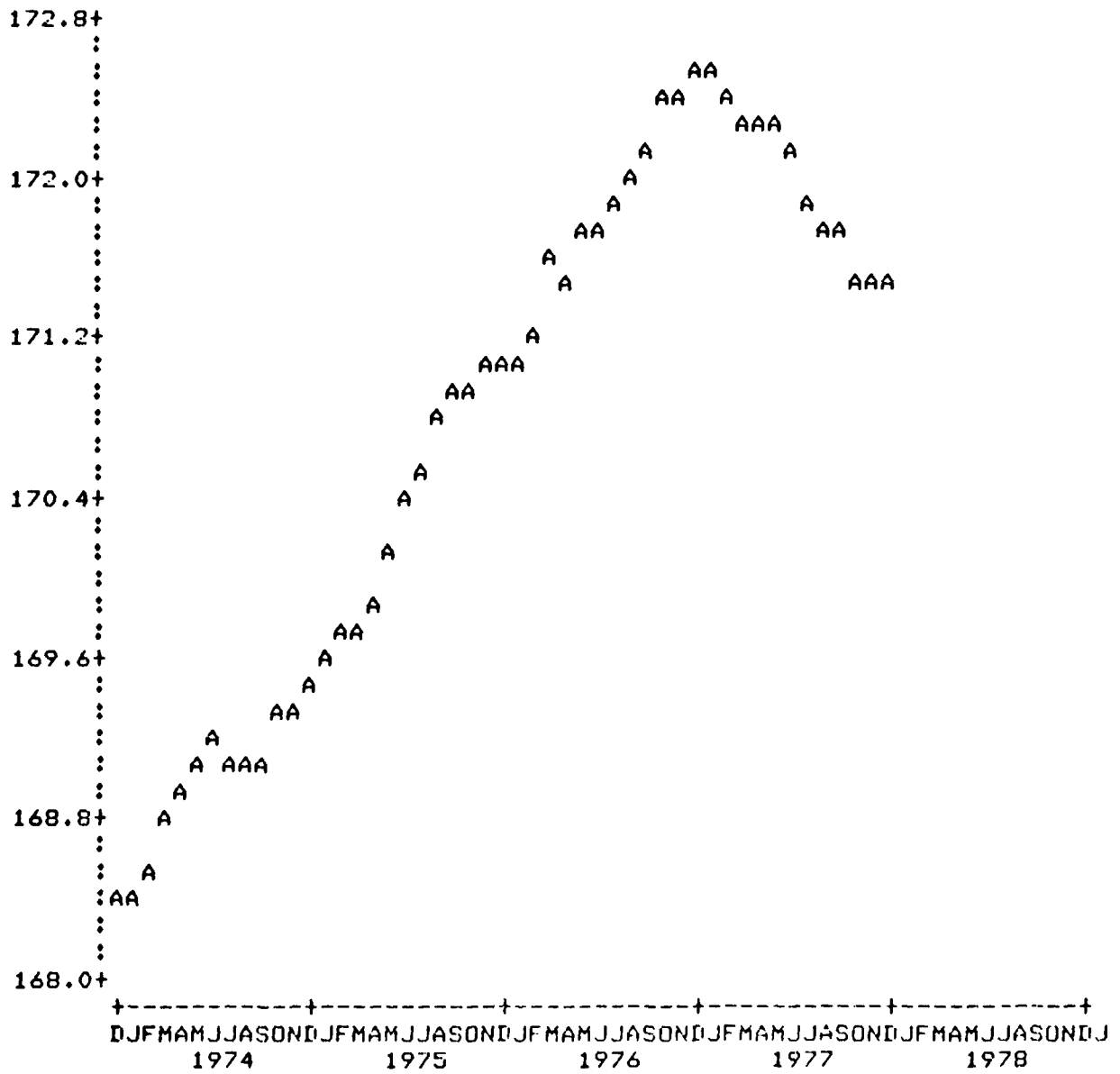

Figure A.32. Plot of 12-Month Moving Average of M30230

12 MONTH MOVING AVERAGE OF PAYOFF

F67231

A=AVERAGE

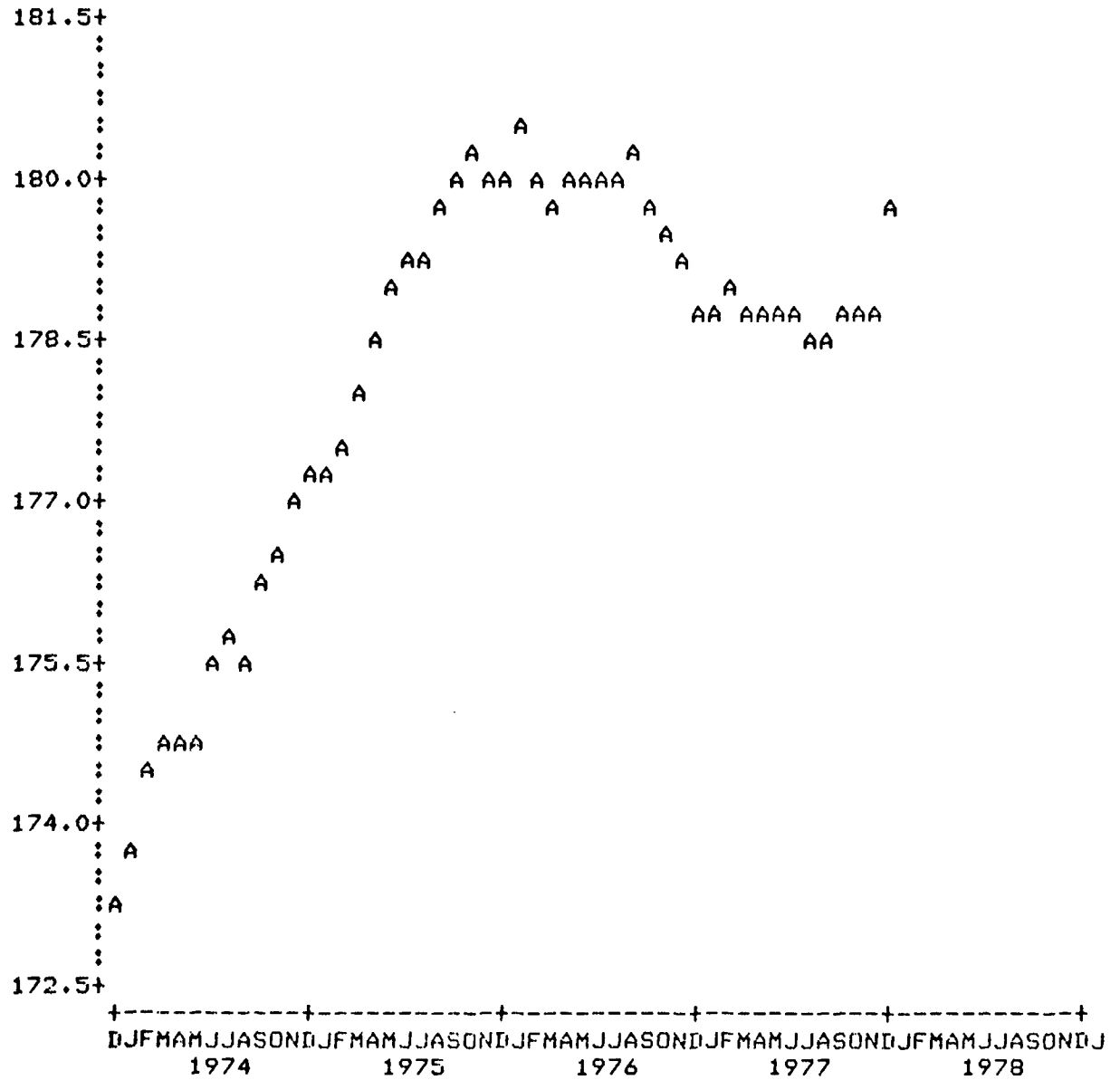

Figure A.33. Plot of 12-Month Moving Average of F67231

12 MONTH MOVING AVERAGE OF PAYOFF

M67231

A=AVERAGE

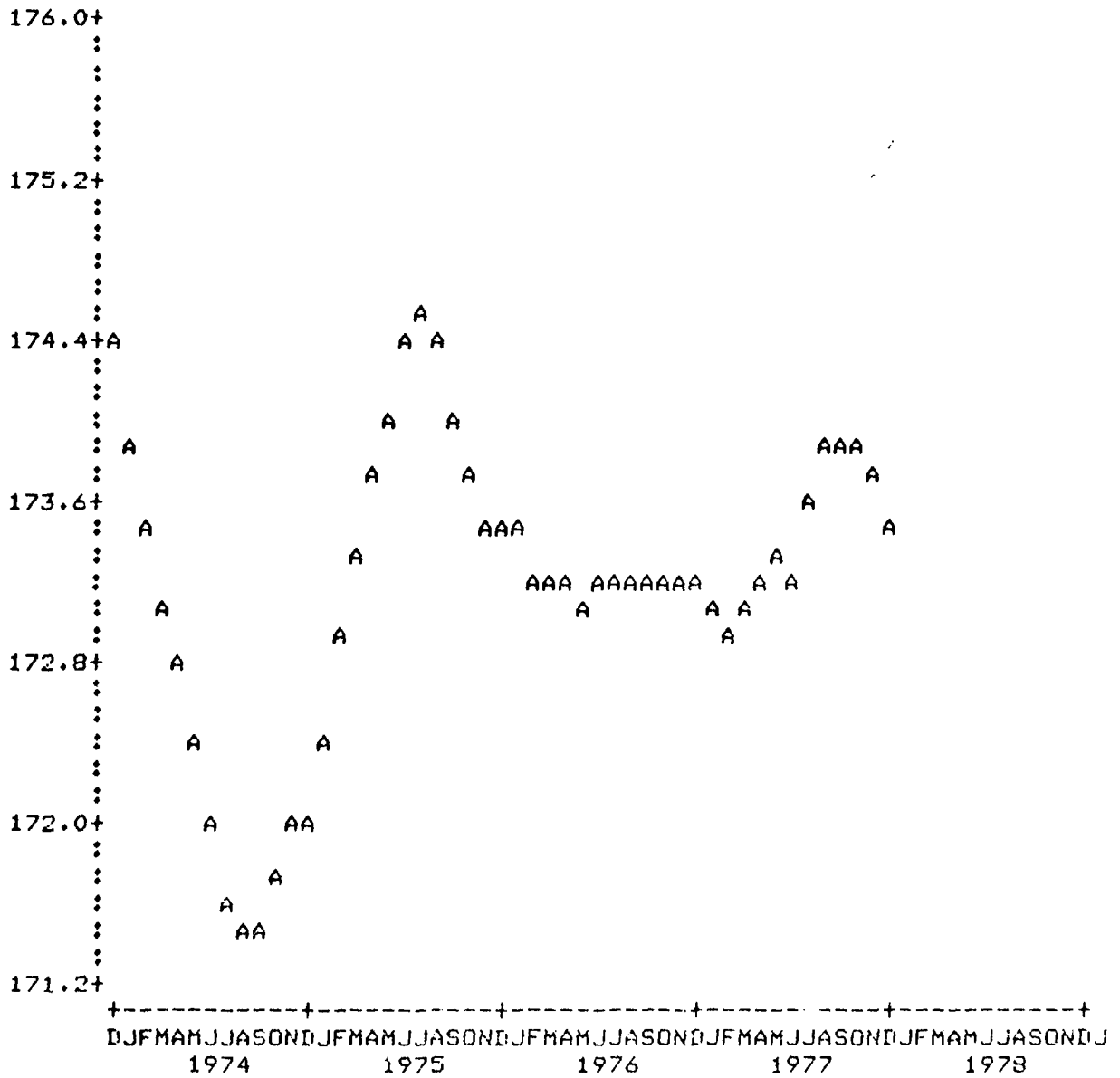

Figure A.34. Plot of 12-Month Moving Average of M67231

12 MONTH MOVING AVERAGE OF PAYOFF

F46330

A=AVERAGE

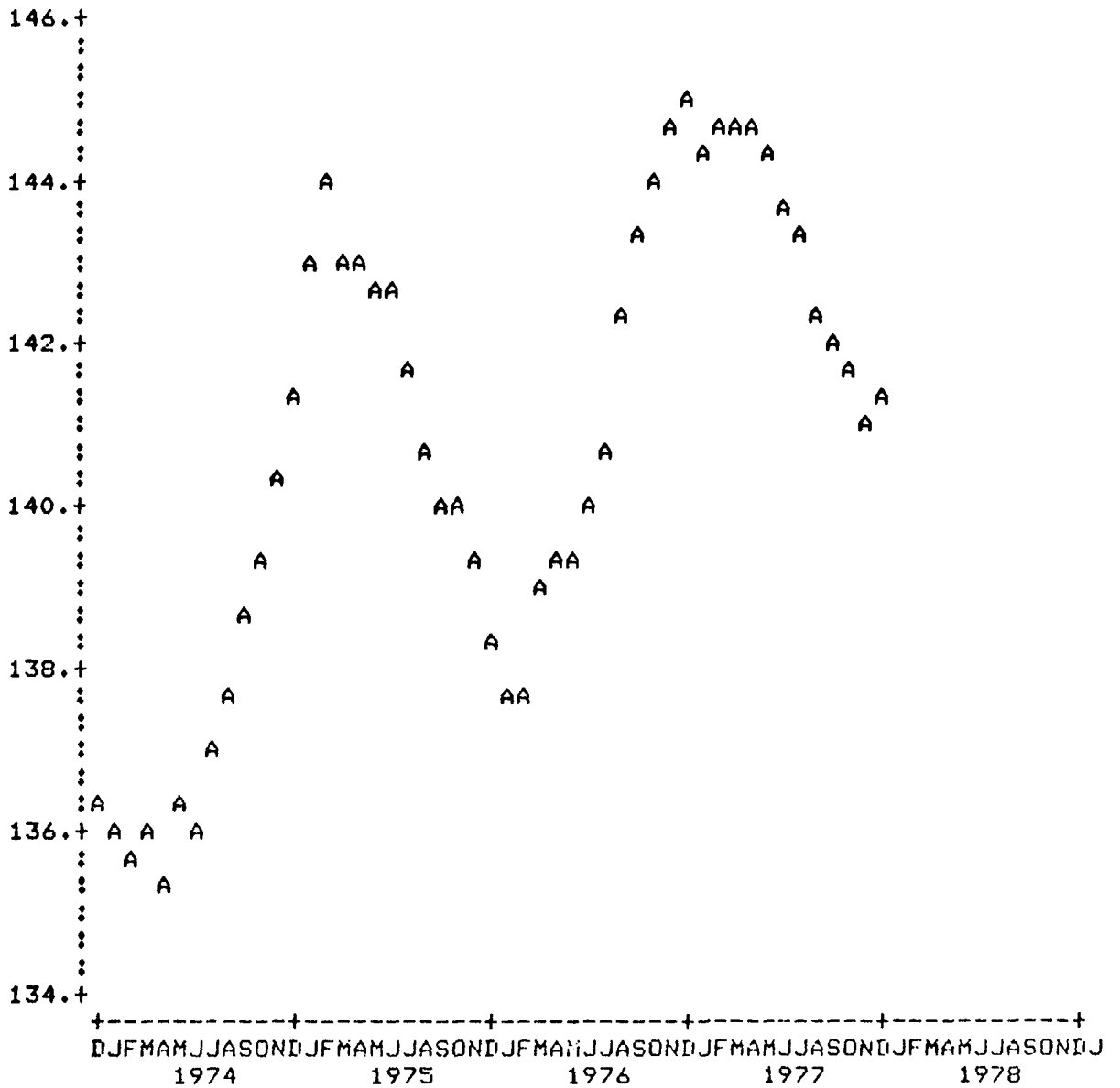

Figure A.35. Plot of 12-Month Moving Average of F46330

12 MONTH MOVING AVERAGE OF PAYOFF

F46230

A=AVERAGE

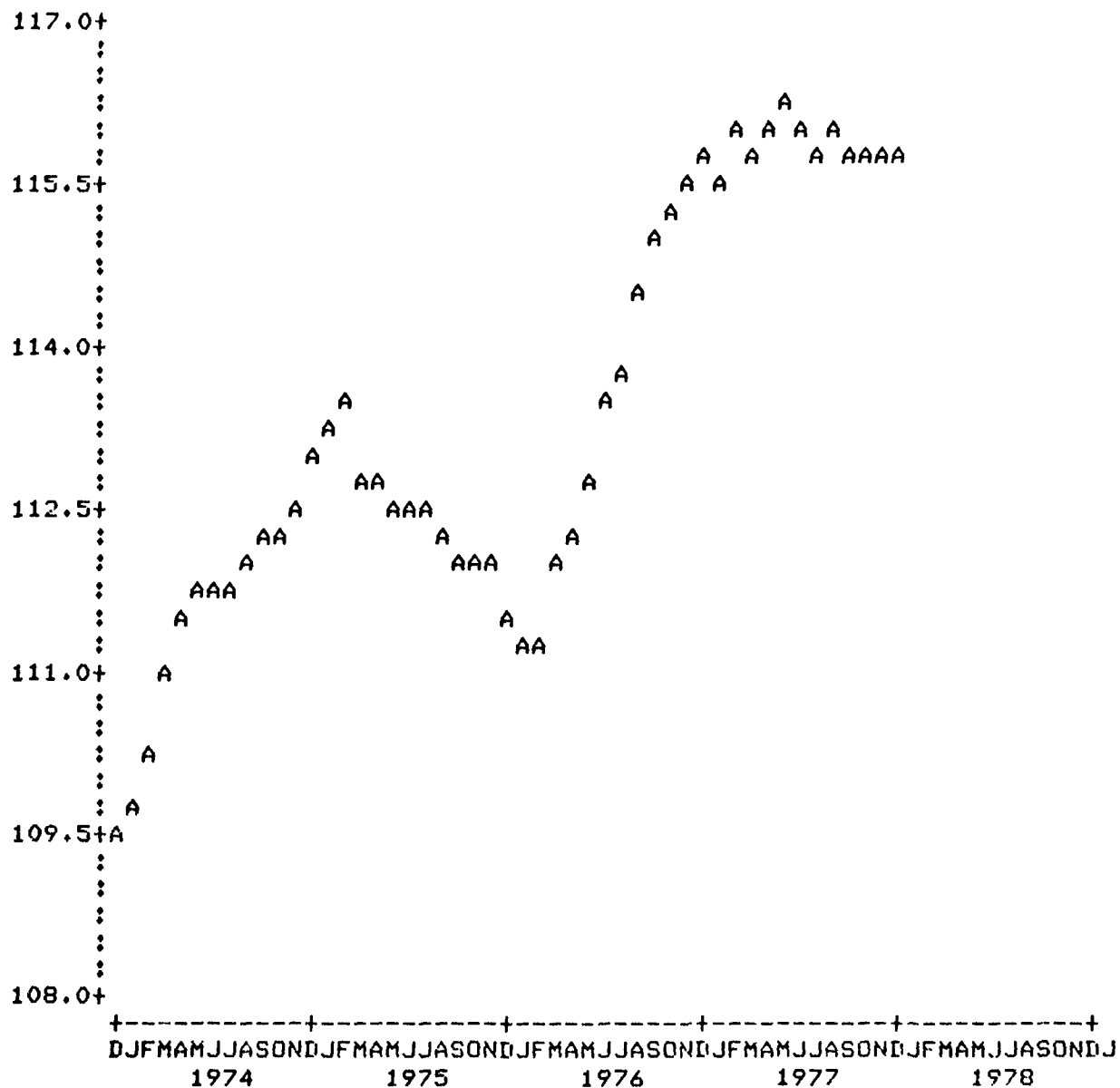

Figure A.36. Plot of 12-Month Moving Average of F46230

12 MONTH MOVING AVERAGE OF PAYOFF

F20430

A=AVERAGE

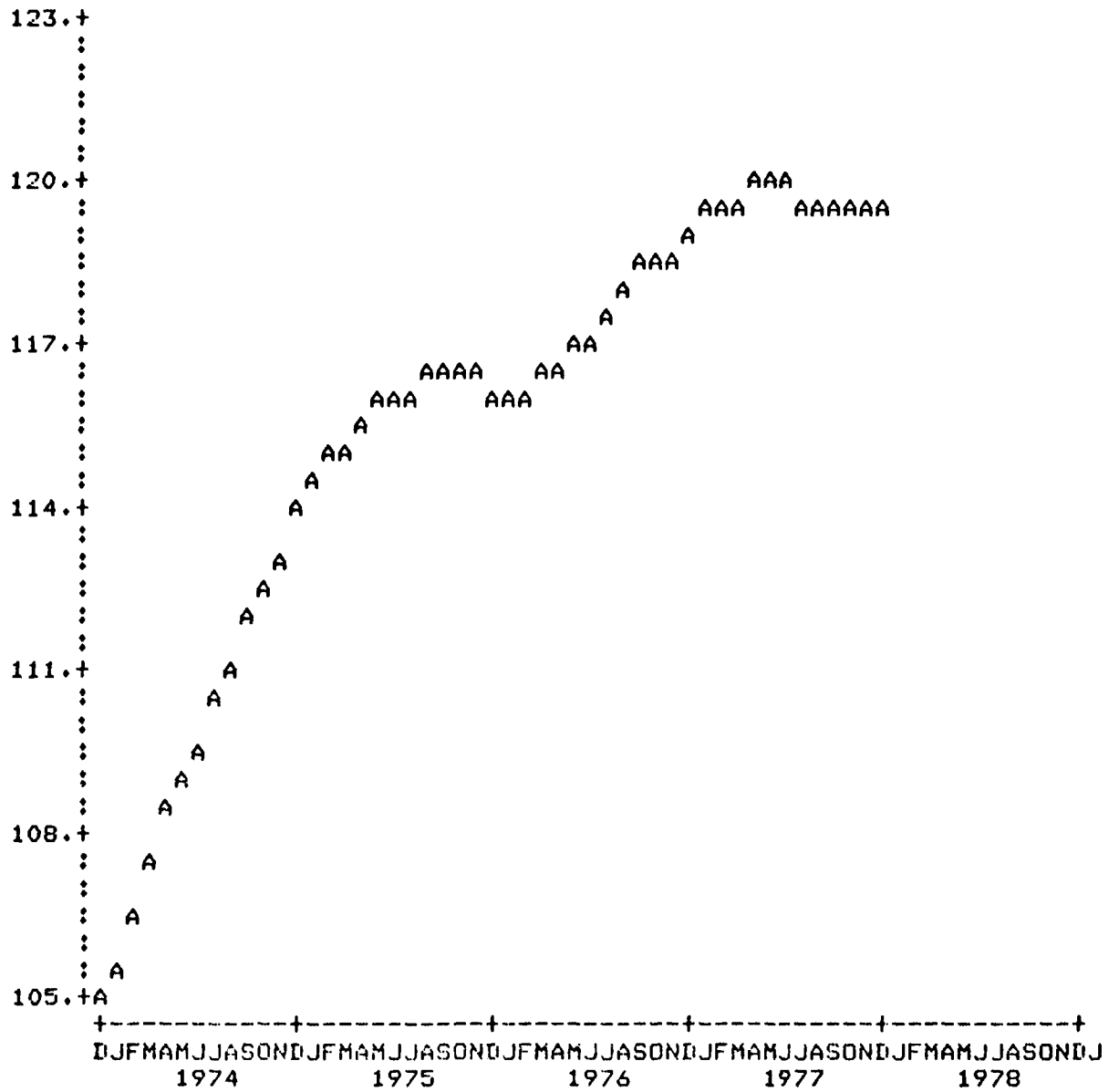

Figure A.37. Plot of 12-Month Moving Average of F20430

12 MONTH MOVING AVERAGE OF PAYOFF

F54130

A=AVERAGE

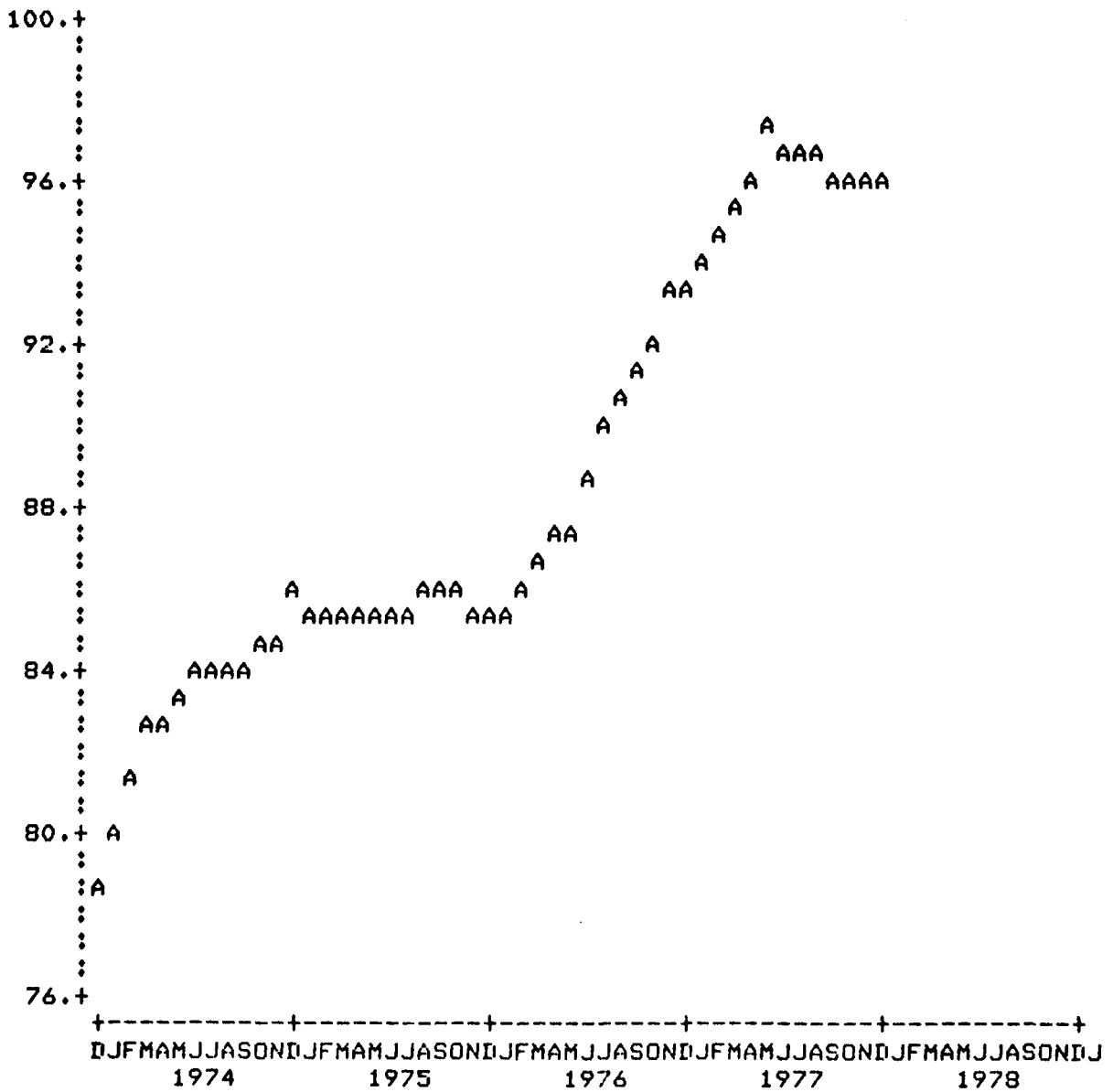

Figure A.38. Plot of 12-Month Moving Average of F54130

12 MONTH MOVING AVERAGE OF PAYOFF

TSK287

A=AVERAGE

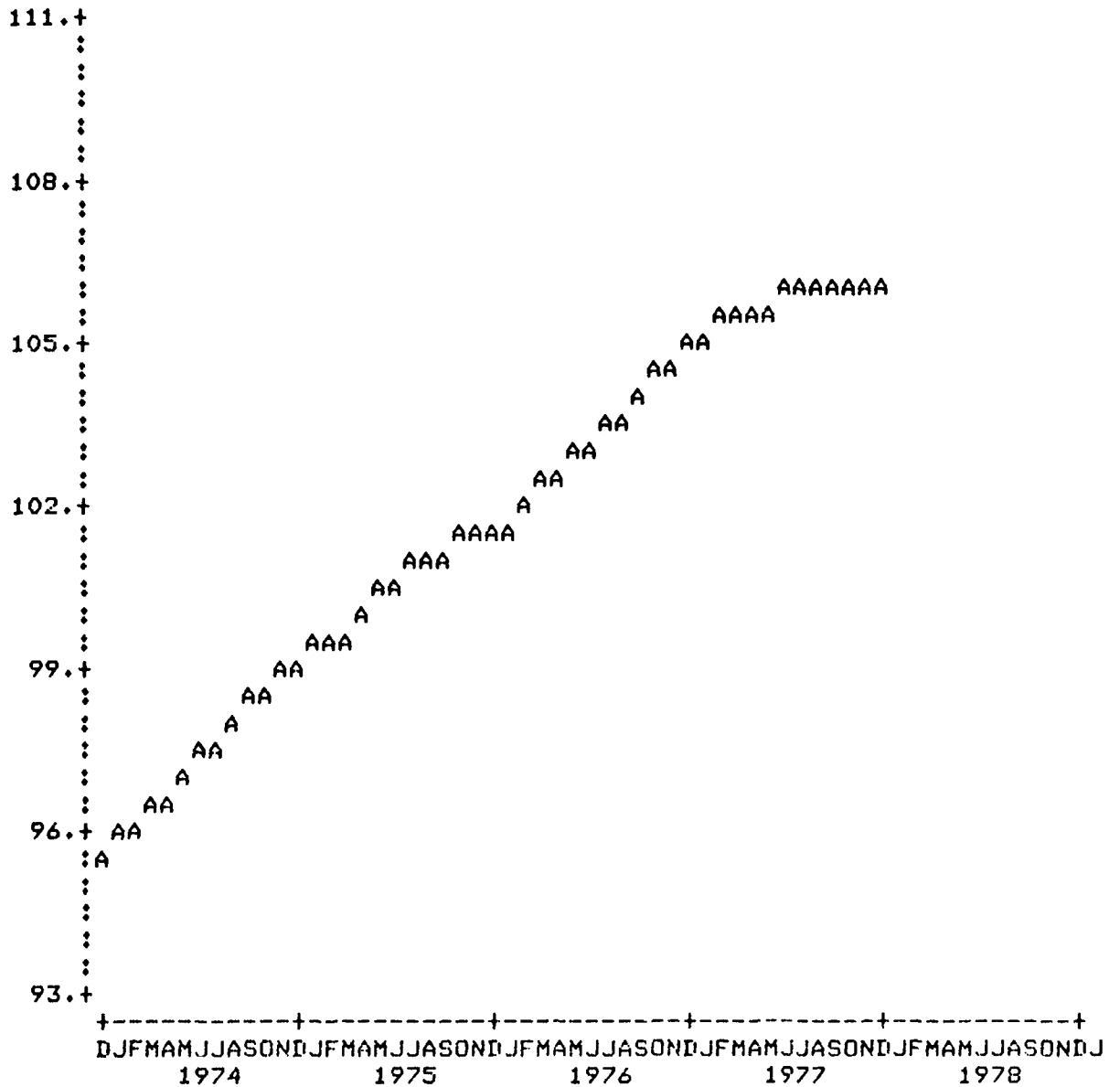

Figure A.39. Plot of 12-Month Moving Average of TSK287

12 MONTH MOVING AVERAGE OF PAYOFF

F43130

A=AVERAGE

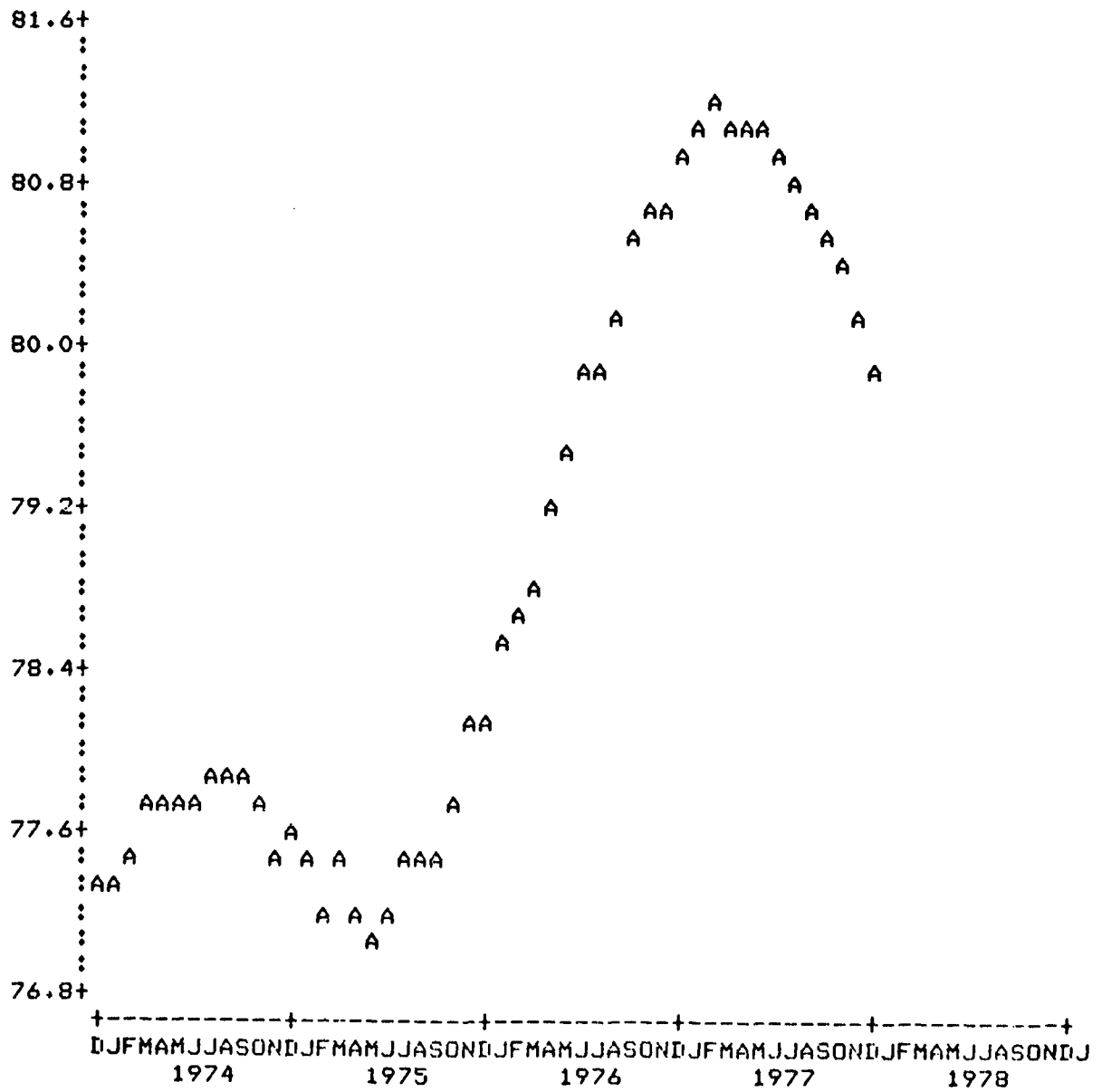

Figure A.40. Plot of 12-Month Moving Average of F43130

12 MONTH MOVING AVERAGE OF PAYOFF

F42732

A=AVERAGE

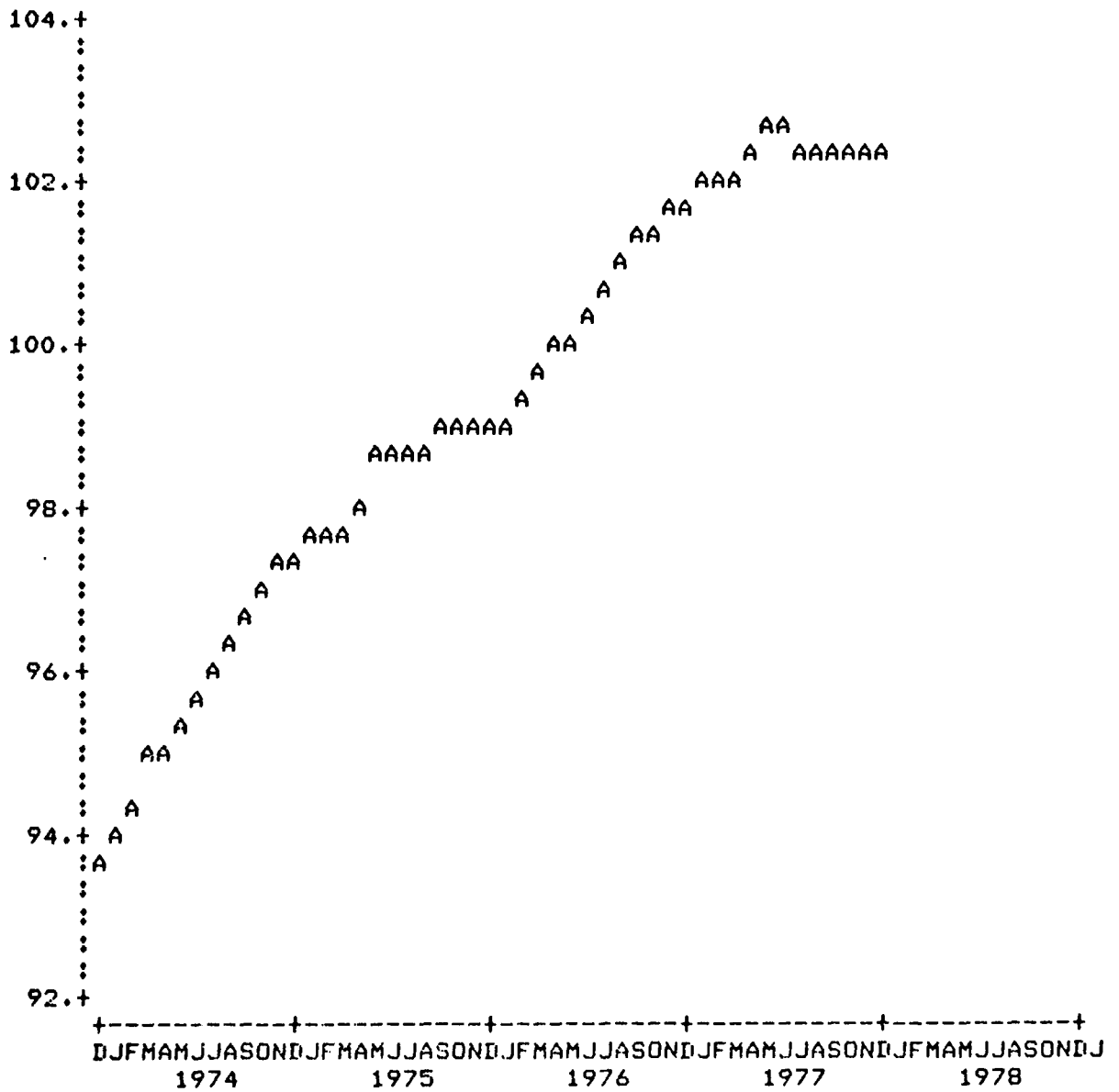

Figure A.41. Plot of 12-Month Moving Average of F42732

12 MONTH MOVING AVERAGE OF PAYOFF

F27131

A=AVERAGE

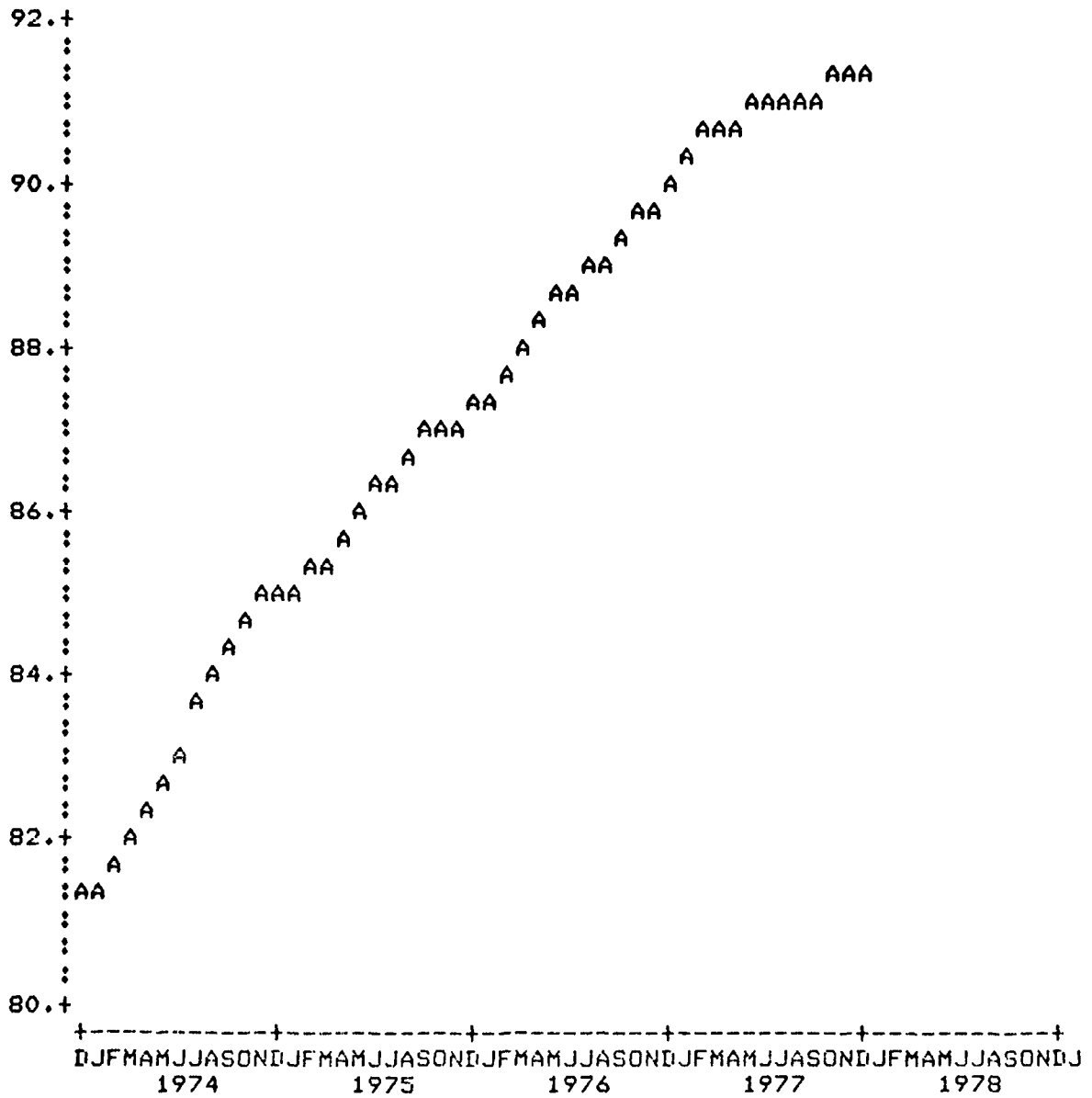

Figure A.42. Plot of 12-Month Moving Average of F27131

12 MONTH MOVING AVERAGE OF PAYOFF

F42333

A=AVERAGE

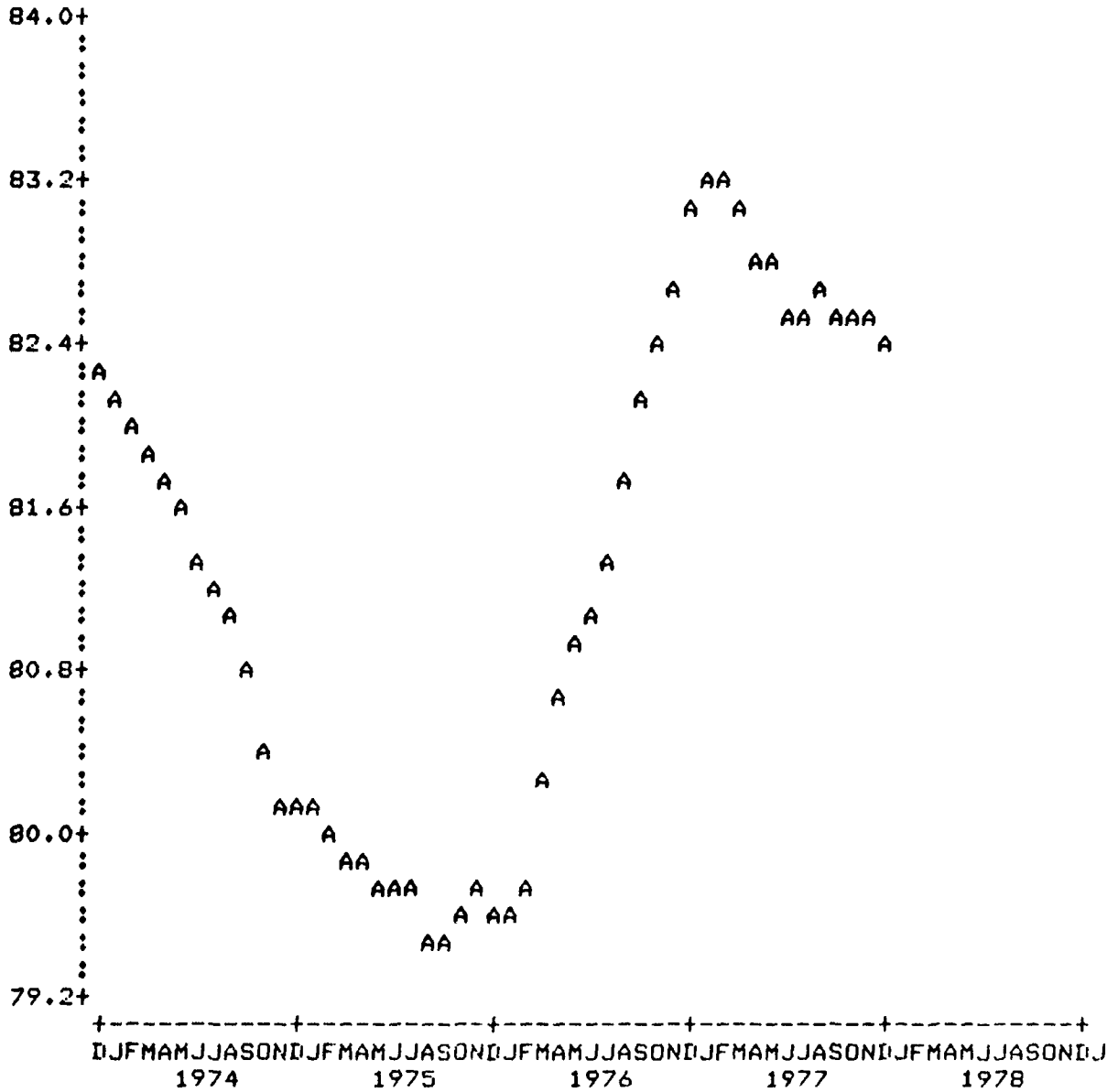

Figure A.43. Plot of 12-Month Moving Average of F42333

12 MONTH MOVING AVERAGE OF PAYOFF

F23132

A=AVERAGE

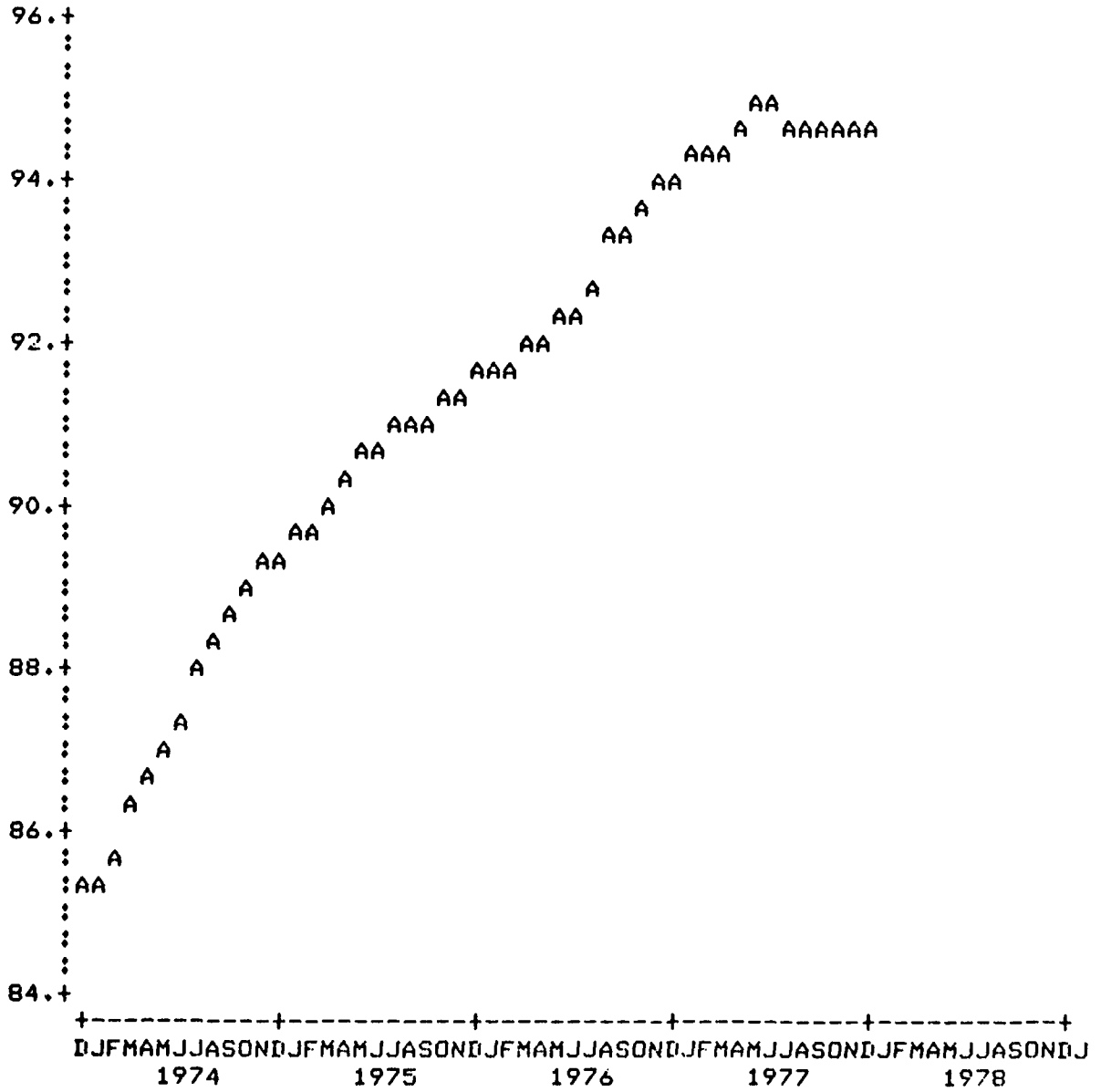

Figure A.44. Plot of 12-Month Moving Average of F23132

12 MONTH MOVING AVERAGE OF PAYOFF

M23132

1=AVERAGE

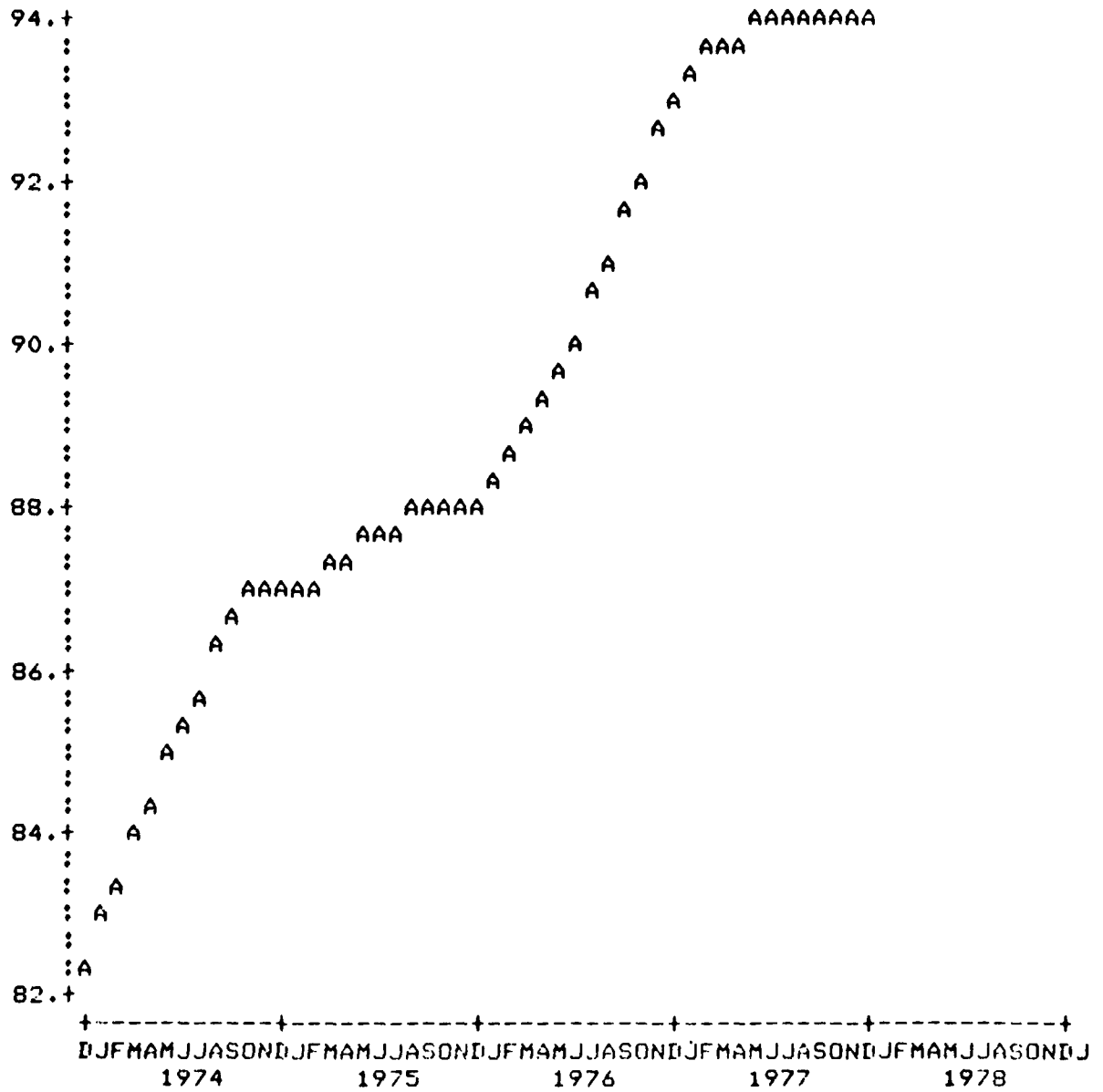

Figure A.45. Plot of 12-Month Moving Average of M23132

SUM OF DETRENDED DATA FOR
10

(AMPLITUDE NORMALIZED TO MAXIMUM COMPONENT)
(FREQUENCY IN CYCLES PER YEAR)

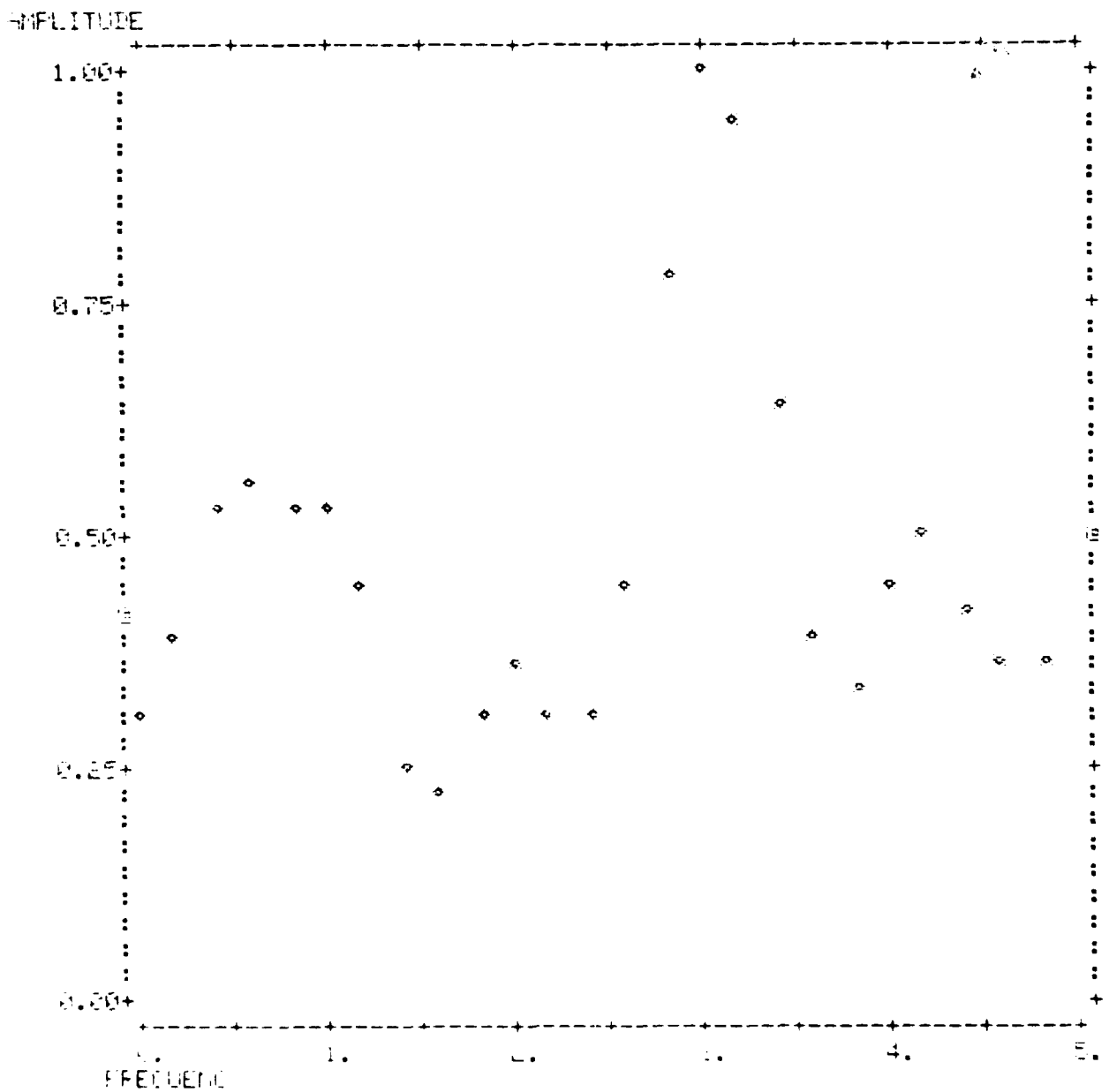

Figure A.46. Spectrum of Detrended Data for F30430

SPECTRUM OF DETRENDED DATA FOR
F43130

(AMPLITUDE NORMALIZED TO MAXIMUM COMPONENT)
(FREQUENCY IN CYCLES PER YEAR)

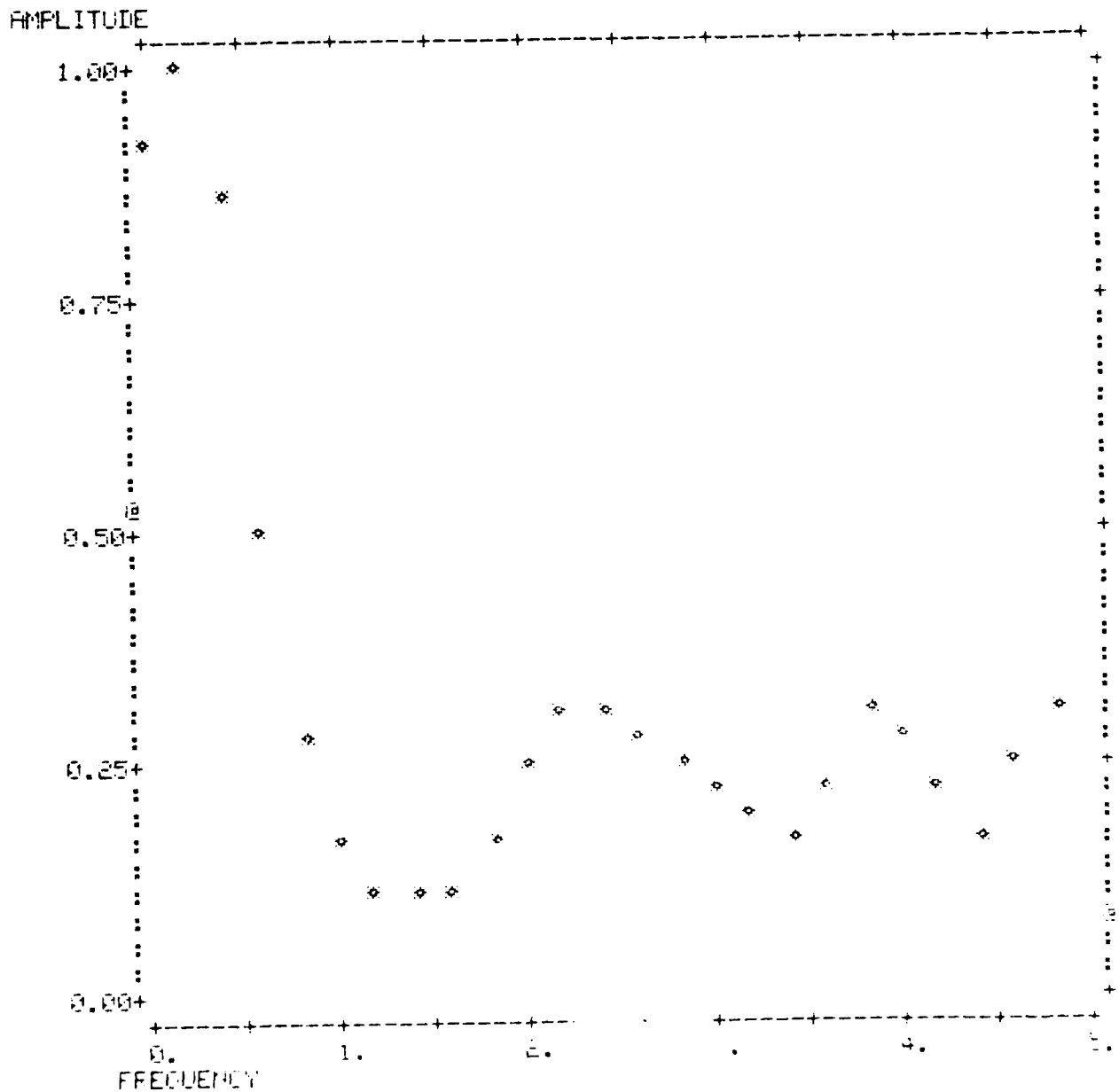

Figure A.47. Spectrum of Detrended Data for F43130

SPECTRUM OF DETRENDED DATA FOR
F27131

(AMPLITUDE NORMALIZED TO MAXIMUM COMPONENT)
(FREQUENCY IN CYCLES PER YEAR)

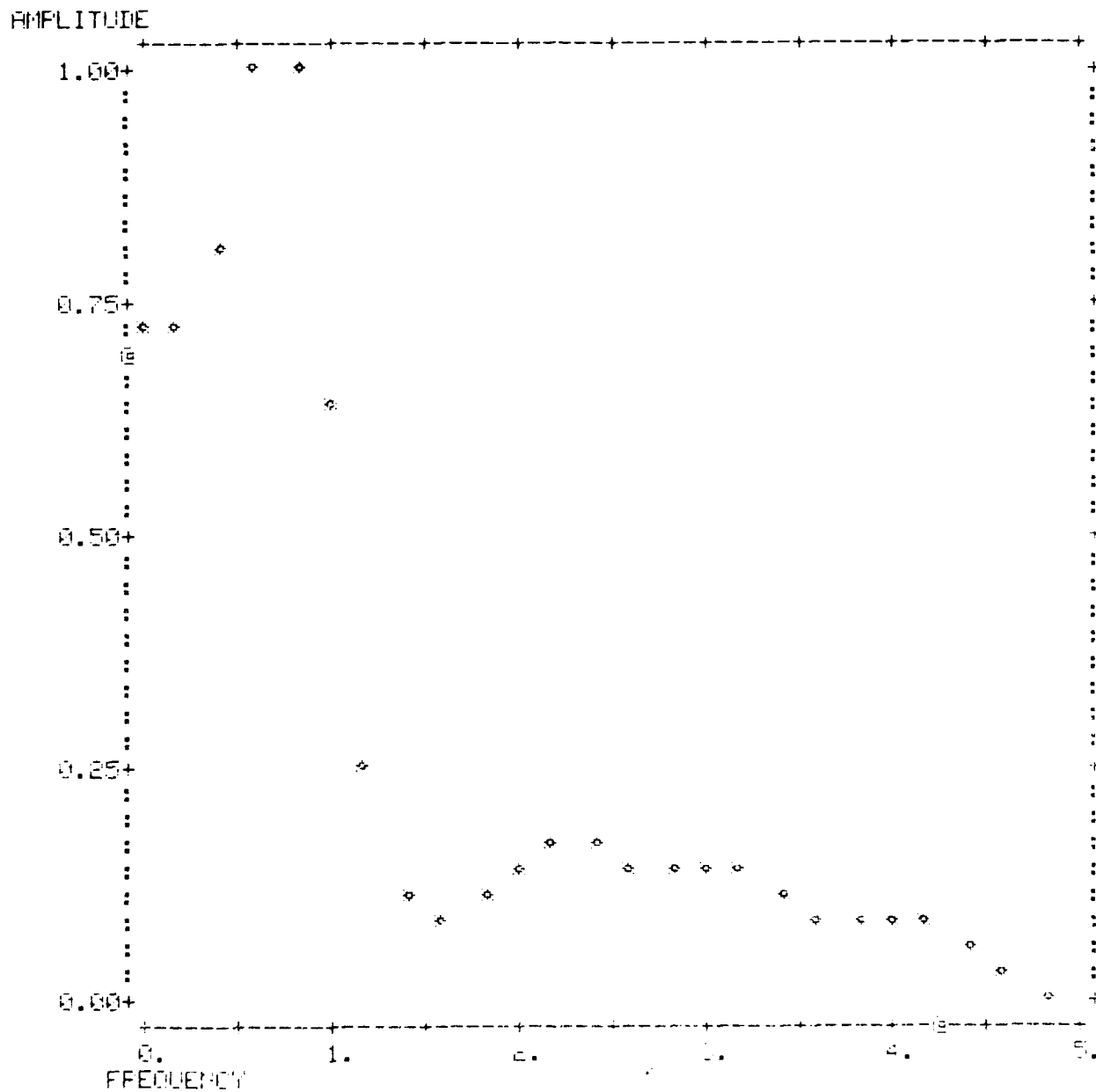

Figure A.48. Spectrum of Detrended Data for F27131

SPECTRUM OF DETRENDED DATA FOR
F42333

(AMPLITUDE NORMALIZED TO MAXIMUM COMPONENT)
(FREQUENCY IN CYCLES PER YEAR)

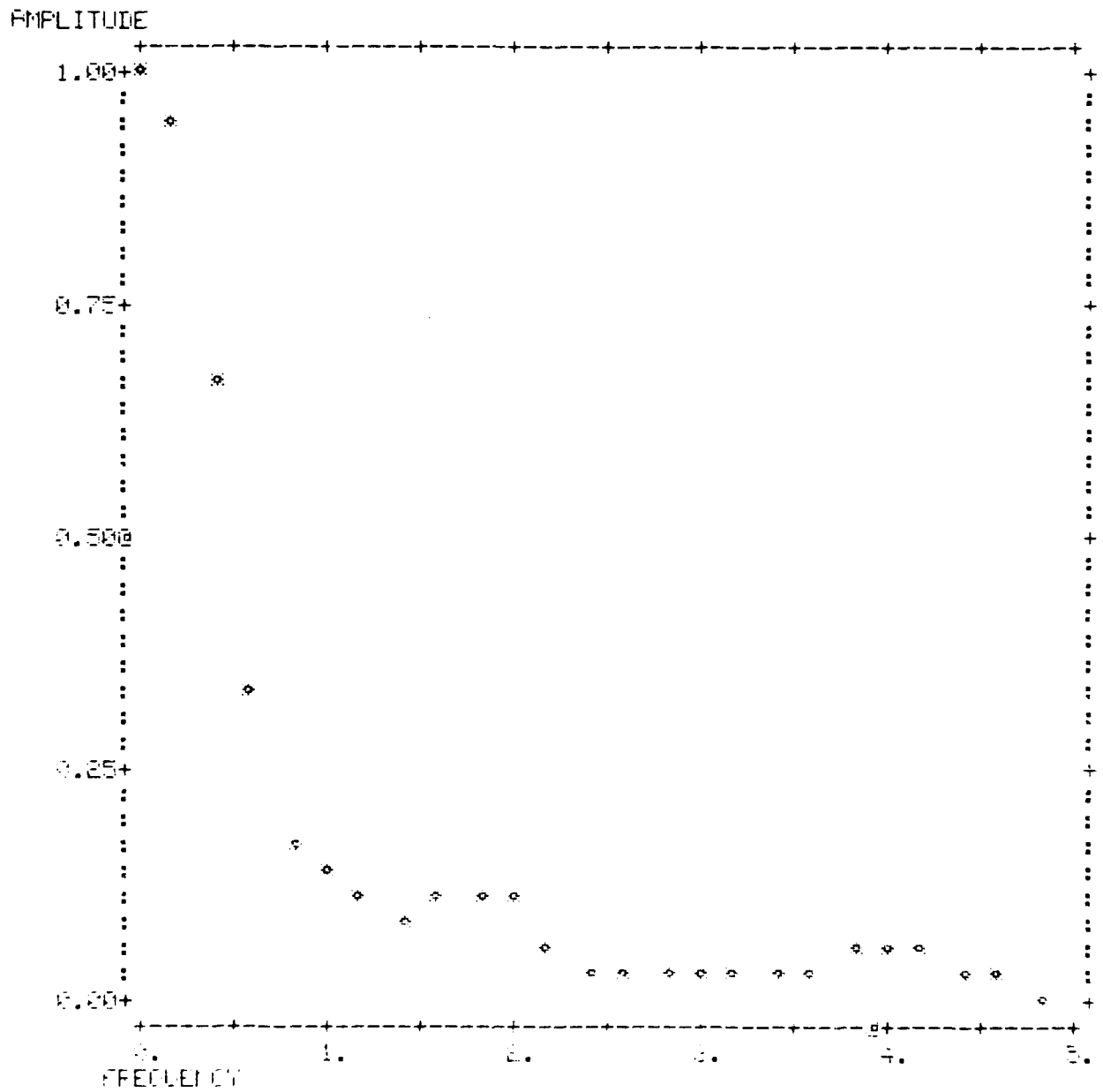

Figure A.49. Spectrum of Detrended Data for F42333

SPECTRUM OF DETRENDED DATA FOR
F20430

AMPLITUDE NORMALIZED TO MAXIMUM COMPONENT
(FREQUENCY IN CYCLES PER YEAR)

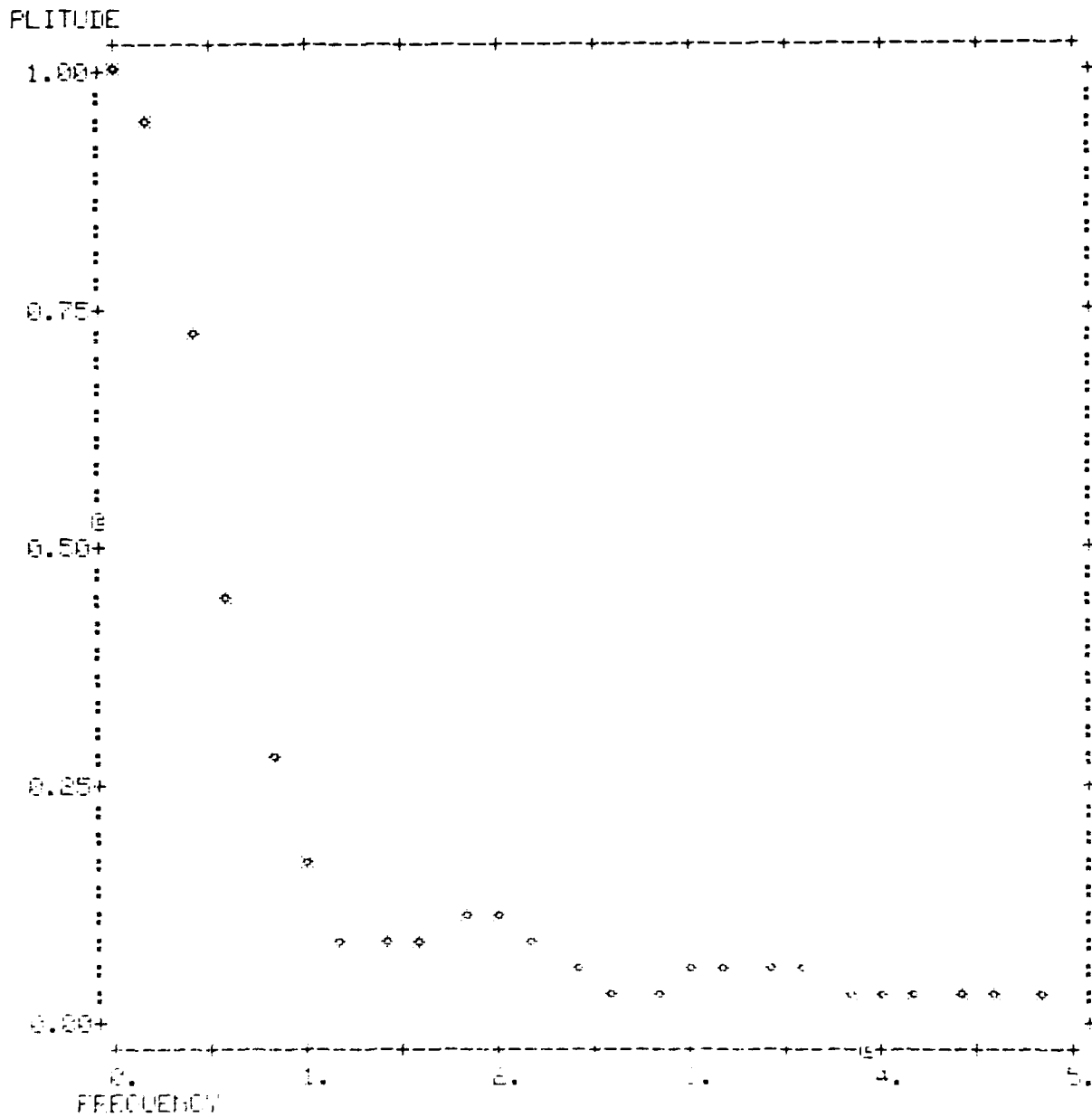

Figure A.50. Spectrum of Detrended Data for F20430

SPECTRUM OF DETRENDED DATA FOR
M23132

(AMPLITUDE NORMALIZED TO MAXIMUM COMPONENT)
(FREQUENCY IN CYCLES PER YEAR)

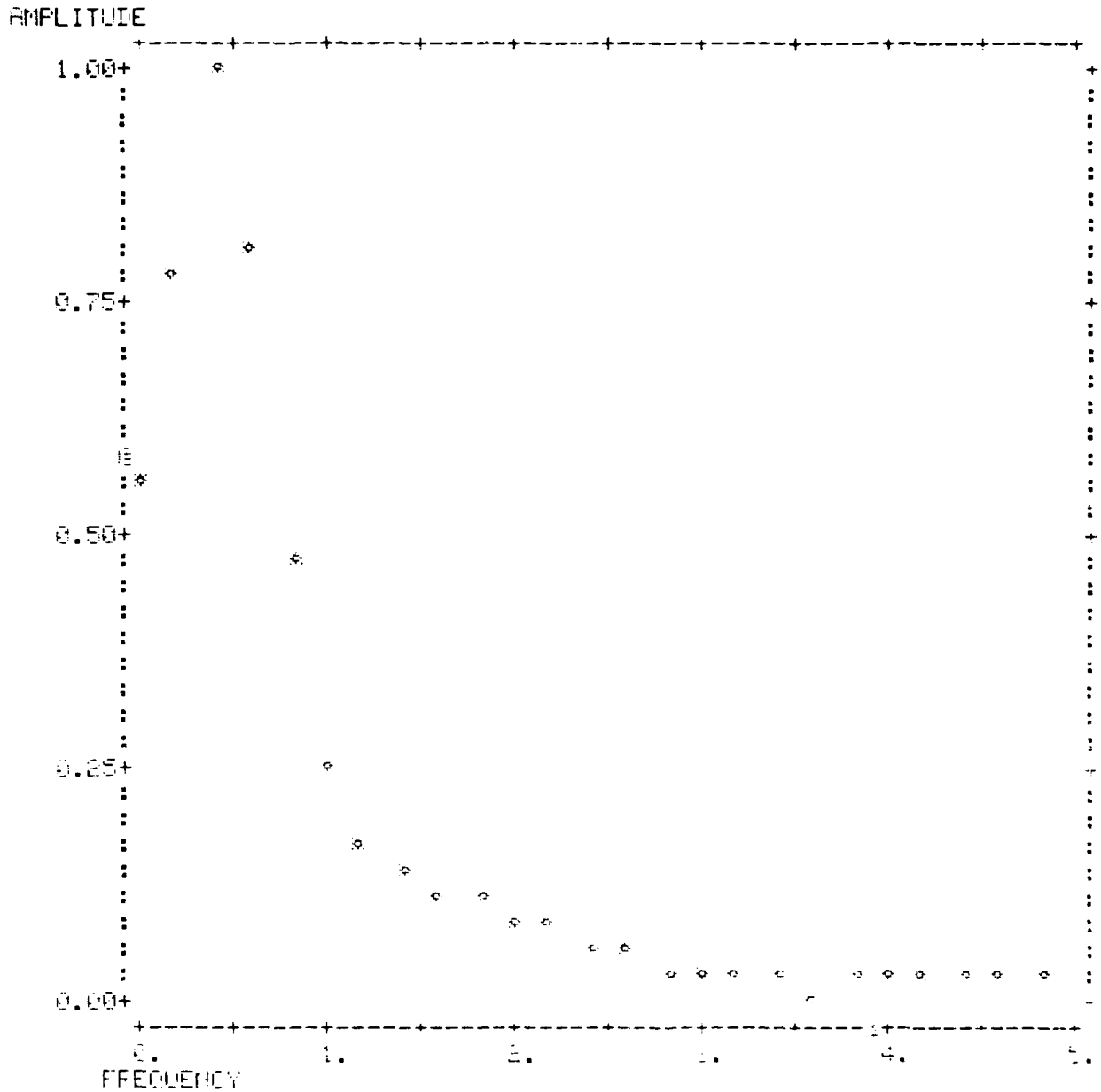

Figure A.51. Spectrum of Detrended Data for M23132

CORRELATION MATRIX

	Skill Level	1	2	3	4	5
1	F30230(T) E80F	1.0000				
2	F30331(T) E80F	0.9751	1.0000			
3	F30333(T) E80F	0.9804	0.9955	1.0000		
4	F30430(T) E80F	0.9875	0.9917	0.9945	1.0000	
5	F67231(T) A80F	0.1403	0.0065	0.0399	0.0750	1.0000
6	F67232(T) A80F	0.1237	-0.0222	0.0087	0.0504	0.9375
7	F20230(T) G80F	0.0865	-0.0518	-0.0308	0.0174	0.6022
8	F20530(T) G80F	0.0707	-0.0675	-0.0490	0.0006	0.6105
9	F20830(T) G80F	0.0950	-0.0372	-0.0269	0.0255	0.4835
10	F25130(T) G80F	0.0915	-0.0495	-0.0279	0.0204	0.6089
11	F46330(T) E70F	0.4001	0.3420	0.3404	0.3619	0.1988
12	F46230(T) E60F	0.0737	-0.0060	0.0094	0.0314	0.3481
13	F20430(T) G60F	0.0275	-0.1302	-0.0988	-0.0521	0.6590
14	F54130(T) E50F	-0.0033	-0.1036	-0.0804	-0.0570	0.5002
15	F54230(T) E50F	0.0065	-0.1064	-0.0797	-0.0532	0.5420
16	F54231(T) E50F	0.0158	-0.0962	-0.0661	-0.0428	0.5700
17	F54232(T) E50F	0.0402	-0.0721	-0.0461	-0.0199	0.5205
18	F54530(T) E50F	0.0043	-0.1031	-0.0761	-0.0546	0.4946
19	TSK295(T) E50F	-0.0154	-0.1219	-0.0948	-0.0716	0.5296
20	F43130(T) M50F	0.1429	0.0761	0.0926	0.1066	0.1785
21	F42732(T) G50F	0.0550	-0.0856	-0.0566	-0.0192	0.6211
22	TSK287(T) A50F	0.0871	-0.0432	-0.0130	0.0169	0.5555
23	F23132(T) G40F	0.0580	-0.0890	-0.0555	-0.0176	0.6380
24	F27131(T) A40F	0.0542	-0.0794	-0.0481	-0.0177	0.5903
25	F42333(T) M40F	0.2274	0.2945	0.2895	0.2596	-0.2617
26	M30230(T) E80M	0.0391	-0.1002	-0.0785	-0.0361	0.4051
27	M30331(T) E80M	0.0229	-0.1043	-0.0843	-0.0458	0.3615
28	M30333(T) E80M	0.0302	-0.1035	-0.0830	-0.0403	0.3888
29	M30430(T) E80M	0.0399	-0.1016	-0.0803	-0.0329	0.4108
30	M67231(T) A80M	0.0037	0.0253	0.0135	0.0072	-0.0984
31	M67232(T) A80M	0.0024	0.0074	-0.0014	-0.0015	-0.0511
32	M20230(T) G80M	0.1100	0.0285	0.0335	0.0554	0.3656
33	M20530(T) G80M	0.1140	0.0351	0.0374	0.0613	0.3252
34	M20830(T) G80M	0.0196	-0.0416	-0.0571	-0.0247	0.1011
35	M25130(T) G80M	0.1267	0.0441	0.0503	0.0710	0.3693
36	M46330(T) E70M	-0.0292	-0.1080	-0.0886	-0.0707	0.2470
37	M46230(T) E60M	0.0558	-0.0462	-0.0266	-0.0019	0.4316
38	M20430(T) G60M	0.0118	-0.1130	-0.0866	-0.0599	0.4664
39	M54130(T) E50M	0.0523	-0.0576	-0.0336	-0.0060	0.4598
40	M54230(T) E50M	0.0804	-0.0309	-0.0083	0.0197	0.4685
41	M54231(T) E50M	0.0775	-0.0354	-0.0108	0.0161	0.4738
42	M54232(T) E50M	0.0755	-0.0468	-0.0217	0.0101	0.5394
43	M54530(T) E50M	0.0614	-0.0632	-0.0390	-0.0049	0.5430
44	TSK296(T) E50M	0.0672	-0.0400	-0.0166	0.0097	0.4760
45	M43130(T) E50M	0.0728	-0.0401	-0.0173	0.0086	0.4834
46	M42732(T) G50M	0.0118	-0.1130	-0.0866	-0.0599	0.4664
47	TSK288(T) A50M	0.0779	0.0101	0.0265	0.0335	0.2877
48	M23132(T) G40M	0.0113	-0.1224	-0.0938	-0.0606	0.5059
49	M27131(T) A40M	0.0634	-0.0006	0.0184	0.0219	0.2795
50	M42333(T) M40M	0.0907	-0.0087	0.0124	0.0331	0.4442

Table 1: Correlation Matrix of Raw Payoff Data

	6	7	8	9	10
6 F67232(T)	1.0000				
7 F20230(T)	0.6383	1.0000			
8 F20530(T)	0.6457	0.9940	1.0000		
9 F20830(T)	0.5747	0.7850	0.7874	1.0000	
10 F25130(T)	0.6515	0.9958	0.9932	0.7903	1.0000
11 F46330(T)	0.1831	0.2602	0.2646	0.2784	0.2555
12 F46230(T)	0.3692	0.4653	0.4585	0.3356	0.4642
13 F20430(T)	0.6969	0.7769	0.7740	0.6247	0.7765
14 F54130(T)	0.5022	0.5522	0.5325	0.3659	0.5421
15 F54230(T)	0.5452	0.5940	0.5780	0.4192	0.5855
16 F54231(T)	0.5494	0.5896	0.5787	0.3847	0.5875
17 F54232(T)	0.5209	0.6070	0.5893	0.4069	0.5988
18 F54530(T)	0.4862	0.5734	0.5514	0.3670	0.5621
19 TSK295(T)	0.5229	0.5943	0.5771	0.3973	0.5841
20 F43130(T)	0.2224	0.3196	0.3001	0.2572	0.3342
21 F42732(T)	0.6344	0.7222	0.7134	0.5357	0.7185
22 TSK287(T)	0.5769	0.6806	0.6668	0.4331	0.6779
23 F23132(T)	0.6595	0.7419	0.7324	0.5607	0.7399
24 F27131(T)	0.6046	0.6728	0.6631	0.4339	0.6702
25 F42333(T)	-.2787	-.1299	-.1746	-.1637	-.1383
26 M30230(T)	0.4570	0.6746	0.6558	0.5503	0.6751
27 M30331(T)	0.3950	0.6579	0.6452	0.5424	0.6552
28 M30333(T)	0.4321	0.6917	0.6773	0.5595	0.6892
29 M30430(T)	0.4543	0.6936	0.6809	0.5722	0.6931
30 M67231(T)	-.0308	0.1696	0.1564	-.0010	0.1643
31 M67232(T)	0.0288	0.2614	0.2486	0.0931	0.2542
32 M20230(T)	0.3740	0.6089	0.5902	0.3723	0.6053
33 M20530(T)	0.3458	0.6057	0.5885	0.3990	0.6021
34 M20830(T)	0.2142	0.2534	0.2572	0.6265	0.2644
35 M25130(T)	0.3738	0.6146	0.5953	0.3797	0.6105
36 M46330(T)	0.2526	0.3430	0.3251	0.2502	0.3408
37 M46230(T)	0.4343	0.5342	0.5181	0.3627	0.5343
38 M20430(T)	0.4714	0.5399	0.5237	0.3466	0.5428
39 M54130(T)	0.4623	0.5811	0.5660	0.3642	0.5785
40 M54230(T)	0.4746	0.6006	0.5847	0.3730	0.5996
41 M54231(T)	0.4820	0.5974	0.5798	0.3671	0.5964
42 M54232(T)	0.5518	0.6629	0.6497	0.4504	0.6608
43 M54530(T)	0.5470	0.6450	0.6313	0.4380	0.6420
44 TSK296(T)	0.4802	0.5960	0.5794	0.3747	0.5934
45 M43130(T)	0.4812	0.5627	0.5468	0.3661	0.5605
46 M42732(T)	0.4714	0.5399	0.5237	0.3466	0.5428
47 TSK288(T)	0.2726	0.4251	0.3981	0.1593	0.4189
48 M23132(T)	0.5205	0.5964	0.5838	0.4167	0.5972
49 M27131(T)	0.2634	0.3987	0.3714	0.1454	0.3962
50 M42333(T)	0.4332	0.5444	0.5254	0.3443	0.5411

Table 1 (continued)

	11	12	13	14	15
11 F46330(T)	1.0000				
12 F46230(T)	0.5954	1.0000			
13 F20430(T)	0.4199	0.7410	1.0000		
14 F54130(T)	0.3903	0.8107	0.8540	1.0000	
15 F54230(T)	0.3848	0.8267	0.8963	0.9782	1.0000
16 F54231(T)	0.3588	0.7868	0.8759	0.9399	0.9572
17 F54232(T)	0.3968	0.8125	0.8893	0.9690	0.9909
18 F54530(T)	0.3730	0.8207	0.8677	0.9725	0.9879
19 TSK295(T)	0.3614	0.8282	0.8850	0.9730	0.9930
20 F43130(T)	0.1816	0.5055	0.5109	0.5775	0.6197
21 F42732(T)	0.3871	0.7404	0.9596	0.8955	0.9352
22 TSK287(T)	0.3547	0.7166	0.9073	0.8604	0.9007
23 F23132(T)	0.3488	0.7163	0.9596	0.8784	0.9240
24 F27131(T)	0.3383	0.7107	0.9185	0.8499	0.8987
25 F42333(T)	0.1775	0.3342	0.0130	0.2925	0.2863
26 M30230(T)	0.3189	0.6033	0.7822	0.6915	0.7257
27 M30331(T)	0.3070	0.5724	0.7499	0.6503	0.6968
28 M30333(T)	0.3156	0.5597	0.7654	0.6483	0.6913
29 M30430(T)	0.3047	0.5459	0.7746	0.6394	0.6825
30 M67231(T)	-.0651	-.0828	-.0623	-.0618	-.0510
31 M67232(T)	-.0917	-.0974	0.0044	-.0294	-.0202
32 M20230(T)	0.3139	0.4967	0.6482	0.6474	0.6843
33 M20530(T)	0.3253	0.4925	0.6251	0.6076	0.6474
34 M20830(T)	0.2000	0.0204	0.1104	-.0410	-.0228
35 M25130(T)	0.3299	0.5222	0.6570	0.6677	0.7016
36 M46330(T)	0.2517	0.5934	0.6525	0.7107	0.7454
37 M46230(T)	0.3900	0.7230	0.8214	0.8550	0.8847
38 M20430(T)	0.3553	0.7376	0.8513	0.8727	0.9007
39 M54130(T)	0.3643	0.6973	0.8440	0.8609	0.8914
40 M54230(T)	0.3684	0.6945	0.8407	0.8481	0.8823
41 M54231(T)	0.3643	0.6876	0.8437	0.8466	0.8813
42 M54232(T)	0.3787	0.6880	0.8793	0.8498	0.8840
43 M54530(T)	0.3957	0.7068	0.8862	0.8612	0.8944
44 TSK296(T)	0.3491	0.6847	0.8415	0.8484	0.8825
45 M43130(T)	0.4071	0.7258	0.8442	0.8720	0.8975
46 M42732(T)	0.3553	0.7376	0.8513	0.8727	0.9007
47 TSK288(T)	0.2941	0.6676	0.6743	0.8105	0.8305
48 M23132(T)	0.3682	0.7442	0.8955	0.8743	0.9078
49 M27131(T)	0.2697	0.6760	0.6735	0.8208	0.8394
50 M42333(T)	0.3990	0.7089	0.7963	0.8448	0.8752

Table 1 (continued)

	16	17	18	19	20
16 F54231(T)	1.0000				
17 F54232(T)	0.9510	1.0000			
18 F54530(T)	0.9542	0.9851	1.0000		
19 TSK295(T)	0.9581	0.9839	0.9903	1.0000	
20 F43130(T)	0.6399	0.6365	0.6453	0.6094	1.0000
21 F42732(T)	0.9014	0.9417	0.9179	0.9267	0.5571
22 TSK287(T)	0.8841	0.9233	0.8939	0.8884	0.6461
23 F23132(T)	0.9030	0.9302	0.9035	0.9164	0.5780
24 F27131(T)	0.8845	0.9130	0.8890	0.8866	0.6321
25 F42333(T)	0.2488	0.3115	0.3324	0.3009	0.5027
26 M30230(T)	0.6880	0.7270	0.7100	0.7020	0.5741
27 M30331(T)	0.6551	0.7053	0.6832	0.6756	0.5851
28 M30333(T)	0.6472	0.6981	0.6771	0.6670	0.5598
29 M30430(T)	0.6506	0.6901	0.6648	0.6558	0.5750
30 M67231(T)	-0.0740	-0.0453	-0.0436	-0.0304	-0.1232
31 M67232(T)	-0.0406	-0.0145	-0.0209	-0.0043	-0.1002
32 M20230(T)	0.6604	0.7232	0.6926	0.6636	0.6293
33 M20530(T)	0.6084	0.6824	0.6500	0.6243	0.6083
34 M20830(T)	-0.0447	-0.0456	-0.0809	-0.0594	0.1301
35 M25130(T)	0.6710	0.7393	0.7087	0.6808	0.6011
36 M46330(T)	0.7161	0.7496	0.7571	0.7355	0.6271
37 M46230(T)	0.8478	0.8976	0.8934	0.8771	0.7009
38 M20430(T)	0.8843	0.9142	0.9005	0.8859	0.6941
39 M54130(T)	0.8599	0.9139	0.8935	0.8765	0.6958
40 M54230(T)	0.8532	0.9066	0.8845	0.8689	0.7036
41 M54231(T)	0.8525	0.9059	0.8825	0.8653	0.6978
42 M54232(T)	0.8518	0.9055	0.8789	0.8687	0.6653
43 M54530(T)	0.8652	0.9138	0.8902	0.8777	0.6681
44 TSK296(T)	0.8513	0.9051	0.8849	0.8701	0.6898
45 M43130(T)	0.8675	0.9181	0.9004	0.8837	0.6892
46 M42732(T)	0.8843	0.9142	0.9005	0.8859	0.6941
47 TSK288(T)	0.8035	0.8612	0.8540	0.8253	0.6968
48 M23132(T)	0.8876	0.9199	0.8989	0.8911	0.6755
49 M27131(T)	0.8172	0.8668	0.8622	0.8368	0.7092
50 M42333(T)	0.8391	0.9007	0.8812	0.8610	0.7000

Table 1 (continued)

	21	22	23	24	25
21 F42732(T)	1.0000				
22 TSK287(T)	0.9437	1.0000			
23 F23132(T)	0.9823	0.9551	1.0000		
24 F27131(T)	0.9463	0.9893	0.9620	1.0000	
25 F42333(T)	0.1625	0.2450	0.1304	0.1947	1.0000
26 M30230(T)	0.7789	0.8013	0.7927	0.8000	0.1400
27 M30331(T)	0.7488	0.7794	0.7665	0.7846	0.1467
28 M30333(T)	0.7615	0.7802	0.7712	0.7871	0.1129
29 M30430(T)	0.7608	0.7880	0.7812	0.7945	0.0920
30 M67231(T)	-.0465	-.0116	-.0393	-.0649	0.0625
31 M67232(T)	0.0036	0.0328	0.0174	-.0176	-.0225
32 M20230(T)	0.7219	0.7923	0.7121	0.7629	0.3623
33 M20530(T)	0.6872	0.7509	0.6768	0.7274	0.3539
34 M20830(T)	0.0366	-.0405	0.0493	-.0430	-.0935
35 M25130(T)	0.7397	0.7959	0.7256	0.7645	0.3829
36 M46330(T)	0.7550	0.7626	0.7412	0.7726	0.4318
37 M46230(T)	0.8909	0.9221	0.8819	0.9176	0.3916
38 M20430(T)	0.8929	0.9461	0.8987	0.9386	0.3150
39 M54130(T)	0.9020	0.9598	0.9032	0.9501	0.3351
40 M54230(T)	0.9022	0.9607	0.9029	0.9504	0.3425
41 M54231(T)	0.9035	0.9655	0.9067	0.9564	0.3268
42 M54232(T)	0.9207	0.9665	0.9239	0.9608	0.2625
43 M54530(T)	0.9232	0.9641	0.9221	0.9596	0.2601
44 TSK296(T)	0.8992	0.9572	0.9007	0.9479	0.3394
45 M43130(T)	0.8991	0.9517	0.9010	0.9455	0.3457
46 M42732(T)	0.8929	0.9461	0.8987	0.9386	0.3150
47 TSK288(T)	0.7937	0.8769	0.7789	0.8489	0.3591
48 M23132(T)	0.9195	0.9579	0.9271	0.9564	0.2494
49 M27131(T)	0.7846	0.8737	0.7766	0.8460	0.5581
50 M42333(T)	0.8750	0.9334	0.8716	0.9231	0.4240

Table 1 (continued)

	26	27	28	29	30
26 M30230(T)	1.0000				
27 M30331(T)	0.9698	1.0000			
28 M30333(T)	0.9751	0.9808	1.0000		
29 M30430(T)	0.9738	0.9804	0.9878	1.0000	
30 M67231(T)	0.0243	-.0175	0.0197	-.0038	1.0000
31 M67232(T)	0.1090	0.0706	0.1096	0.0861	0.9762
32 M20230(T)	0.7663	0.7685	0.7775	0.7610	0.2954
33 M20530(T)	0.7680	0.7692	0.7814	0.7592	0.3205
34 M20830(T)	0.2709	0.2586	0.2651	0.2807	0.0399
35 M25130(T)	0.7659	0.7596	0.7694	0.7518	0.3115
36 M46330(T)	0.7374	0.7476	0.7223	0.7218	-.1018
37 M46230(T)	0.7898	0.7716	0.7628	0.7602	-.0494
38 M20430(T)	0.7916	0.7626	0.7501	0.7648	-.0639
39 M54130(T)	0.7909	0.7848	0.7780	0.7829	-.0321
40 M54230(T)	0.8023	0.7916	0.7887	0.7925	0.0002
41 M54231(T)	0.8027	0.7941	0.7922	0.7962	-.0008
42 M54232(T)	0.8192	0.8079	0.8111	0.8157	-.0191
43 M54530(T)	0.8176	0.8046	0.8056	0.8126	-.0517
44 TSK298(T)	0.7830	0.7767	0.7728	0.7744	0.0078
45 M43130(T)	0.7726	0.7619	0.7568	0.7609	-.0631
46 M42732(T)	0.7916	0.7626	0.7501	0.7648	-.0639
47 TSK288(T)	0.6885	0.6685	0.6537	0.6460	0.0684
48 M23132(T)	0.8019	0.7759	0.7690	0.7839	-.1049
49 M27131(T)	0.6689	0.6510	0.6268	0.6196	0.0383
50 M42333(T)	0.7776	0.7723	0.7625	0.7615	-.0432
	31	32	33	34	35
31 M67232(T)	1.0000				
32 M20230(T)	0.3333	1.0000			
33 M20530(T)	0.3602	0.9839	1.0000		
34 M20830(T)	0.1106	0.1699	0.2335	1.0000	
35 M25130(T)	0.3454	0.9918	0.9827	0.1649	1.0000
36 M46330(T)	-.0998	0.8690	0.6344	0.0060	0.6811
37 M46230(T)	-.0327	0.7787	0.7474	-.0336	0.7886
38 M20430(T)	-.0426	0.7480	0.7087	-.0382	0.7564
39 M54130(T)	-.0041	0.8005	0.7624	-.0722	0.8052
40 M54230(T)	0.0293	0.8201	0.7844	-.0576	0.8252
41 M54231(T)	0.0294	0.8216	0.7848	-.0606	0.8261
42 M54232(T)	0.0225	0.8076	0.7755	-.0114	0.8121
43 M54530(T)	-.0138	0.7974	0.7643	-.0173	0.8015
44 TSK298(T)	0.0339	0.8163	0.7829	-.0645	0.8221
45 M43130(T)	-.0470	0.7822	0.7461	-.0577	0.7883
46 M42732(T)	-.0426	0.7480	0.7087	-.0382	0.7564
47 TSK288(T)	0.0562	0.7871	0.7416	-.1875	0.8007
48 M23132(T)	-.0678	0.7166	0.6829	-.0238	0.7239
49 M27131(T)	0.0275	0.7639	0.7178	-.2052	0.7766
50 M42333(T)	-.0314	0.8178	0.7854	-.0354	0.8265

Table 1 (continued)

	36	37	38	39	40
36 M46330(T)	1.0000				
37 M46230(T)	0.8762	1.0000			
38 M20430(T)	0.8326	0.9597	1.0000		
39 M54130(T)	0.8346	0.9773	0.9725	1.0000	
40 M54230(T)	0.8281	0.9765	0.9674	0.9956	1.0000
41 M54231(T)	0.8341	0.9723	0.9680	0.9946	0.9962
42 M54232(T)	0.7945	0.9647	0.9543	0.9878	0.9900
43 M54530(T)	0.8031	0.9659	0.9638	0.9865	0.9864
44 TSK296(T)	0.8279	0.9761	0.9626	0.9948	0.9946
45 M43130(T)	0.8236	0.9751	0.9761	0.9898	0.9861
46 M42732(T)	0.8326	0.9597	1.0000	0.9725	0.9674
47 TSK288(T)	0.8237	0.9261	0.9171	0.9318	0.9336
48 M23132(T)	0.8014	0.9500	0.9856	0.9709	0.9643
49 M27131(T)	0.8138	0.9262	0.9220	0.9293	0.9277
50 M42333(T)	0.8328	0.9751	0.9572	0.9819	0.9790
	41	42	43	44	45
41 M54231(T)	1.0000				
42 M54232(T)	0.9881	1.0000			
43 M54530(T)	0.9863	0.9940	1.0000		
44 TSK296(T)	0.9933	0.9885	0.9842	1.0000	
45 M43130(T)	0.9846	0.9799	0.9828	0.9864	1.0000
46 M42732(T)	0.9680	0.9543	0.9638	0.9626	0.9761
47 TSK288(T)	0.9288	0.9913	0.8987	0.9297	0.9249
48 M23132(T)	0.9647	0.9659	0.9738	0.9584	0.9717
49 M27131(T)	0.9235	0.8832	0.8817	0.9275	0.9235
50 M42333(T)	0.9772	0.9685	0.9664	0.9799	0.9853
	46	47	48	49	50
46 M42732(T)	1.0000				
47 TSK288(T)	0.9171	1.0000			
48 M23132(T)	0.9856	0.8792	1.0000		
49 M27131(T)	0.9220	0.9910	0.8815	1.0000	
50 M42333(T)	0.9572	0.9470	0.9433	0.9427	1.0000

Table 1 (concluded)

CORRELATION MATRIX

	1	2	3	4	5
1 F30230(T)	1.0000				
2 F30331(T)	0.9900	1.0000			
3 F30333(T)	0.9917	0.9956	1.0000		
4 F30430(T)	0.9911	0.9952	0.9957	1.0000	
5 F67231(T)	0.3563	0.3085	0.3314	0.3244	1.0000
6 F67232(T)	0.3604	0.3072	0.3316	0.3266	0.9292
7 F20230(T)	0.0699	0.0623	0.0670	0.0600	0.1409
8 F20530(T)	0.0390	0.0357	0.0355	0.0287	0.1107
9 F20830(T)	0.1933	0.1753	0.1892	0.1865	0.1708
10 F25130(T)	0.1048	0.0920	0.0993	0.0898	0.1726
11 F46330(T)	0.4283	0.4486	0.4344	0.4340	0.0054
12 F46230(T)	0.3114	0.3571	0.3398	0.3410	-0.1993
13 F20430(T)	0.1694	0.1573	0.1660	0.1772	0.2927
14 F54130(T)	0.1592	0.1809	0.1725	0.1817	0.1030
15 F54230(T)	0.1734	0.1799	0.1793	0.1919	0.2129
16 F54231(T)	0.1866	0.1901	0.1985	0.1988	0.3553
17 F54232(T)	0.1742	0.1845	0.1789	0.1940	0.0814
18 F54530(T)	0.0818	0.0792	0.0800	0.0891	0.1445
19 TSK295(T)	0.0746	0.0866	0.0876	0.0928	0.1895
20 F43130(T)	0.1608	0.1576	0.1660	0.1649	-0.0122
21 F42732(T)	0.1250	0.1200	0.1251	0.1308	0.1941
22 TSK287(T)	0.2106	0.2181	0.2239	0.2197	0.1477
23 F23132(T)	0.0954	0.0840	0.0985	0.1030	0.3751
24 F27131(T)	0.0524	0.0606	0.0630	0.0522	0.3007
25 F42333(T)	0.2901	0.3306	0.3329	0.3251	-0.1494
26 M30230(T)	-0.0100	-0.0473	-0.0394	-0.0338	-0.0332
27 M30331(T)	-0.0756	-0.0985	-0.0956	-0.0902	-0.1319
28 M30333(T)	-0.0923	-0.1205	-0.1150	-0.1085	-0.1564
29 M30430(T)	-0.0554	-0.0920	-0.0880	-0.0738	-0.1153
30 M67231(T)	-0.0730	-0.0893	-0.0898	-0.0861	0.0344
31 M67232(T)	-0.0495	-0.0594	-0.0601	-0.0604	-0.0036
32 M20230(T)	-0.1066	-0.1053	-0.1289	-0.1221	0.0685
33 M20530(T)	-0.1284	-0.1163	-0.1460	-0.1333	-0.0862
34 M20830(T)	-0.0364	-0.0442	-0.0539	-0.0484	0.1150
35 M25130(T)	-0.0456	-0.0477	-0.0719	-0.0641	0.0751
36 M46330(T)	-0.1292	-0.1351	-0.1302	-0.1095	-0.0619
37 M46230(T)	-0.0448	-0.0270	-0.0444	-0.0295	-0.0428
38 M20430(T)	-0.0509	-0.1079	-0.1086	-0.0851	0.1097
39 M54130(T)	-0.0901	-0.0797	-0.0917	-0.0535	-0.1875
40 M54230(T)	0.0467	0.0567	0.0388	0.0649	-0.1278
41 M54231(T)	0.0429	0.0519	0.0376	0.0621	-0.0432
42 M54232(T)	0.0080	0.0164	0.0089	0.0218	-0.0224
43 M54530(T)	0.0416	0.0378	0.0228	0.0555	0.0467
44 TSK296(T)	-0.0335	-0.0221	-0.0370	-0.0122	-0.0383
45 M43130(T)	0.0441	0.0335	0.0182	0.0417	0.0423
46 M42732(T)	-0.0509	-0.1079	-0.1086	-0.0851	0.1087
47 TSK288(T)	0.0789	0.0619	0.0422	0.0511	-0.1762
48 M23132(T)	-0.0136	-0.0315	-0.0376	-0.0073	-0.1372
49 M27131(T)	0.1328	0.1345	0.1315	0.1238	0.1846
50 M47333(T)	-0.0279	-0.0271	-0.0271	-0.0271	-0.0271

Table 2: Correlation Matrix for Differenced Data

	6	7	8	9	10
6 F67232(T)	1.0000				
7 F20230(T)	0.0902	1.0000			
8 F20530(T)	0.0532	0.9765	1.0000		
9 F20830(T)	0.1527	0.6794	0.6502	1.0000	
10 F25130(T)	0.1315	0.9761	0.9729	0.6858	1.0000
11 F46330(T)	-.0272	-.0961	-.0799	-.0678	-.1071
12 F46230(T)	-.1963	0.1764	0.1846	0.0967	0.1473
13 F20430(T)	0.2880	0.3103	0.3215	0.3174	0.2879
14 F54130(T)	0.1307	0.2804	0.2615	0.1900	0.2294
15 F54230(T)	0.2040	0.2282	0.2244	0.2734	0.1817
16 F54231(T)	0.2910	0.2110	0.2250	0.1838	0.2138
17 F54232(T)	0.0764	0.2708	0.2566	0.3031	0.2269
18 F54530(T)	0.1028	0.3262	0.2978	0.2542	0.2553
19 TSK295(T)	0.1620	0.3130	0.3068	0.2318	0.2588
20 F43130(T)	-.0511	-.0380	-.0220	-.0745	0.0314
21 F42730(T)	0.1808	0.2426	0.2460	0.2742	0.2240
22 TSK287(T)	0.2547	0.0447	0.0362	0.0122	0.0246
23 F23132(T)	0.3850	0.3183	0.3116	0.2865	0.3138
24 F27131(T)	0.3480	-.0942	-.0843	-.0288	-.1199
25 F42333(T)	-.1658	0.0817	0.0217	0.1544	0.0440
26 M30230(T)	-.0142	0.0018	-.0021	-.0372	0.0137
27 M30331(T)	-.1677	-.0209	-.0019	-.0244	-.0176
28 M30333(T)	-.1799	-.0741	-.0699	-.0447	-.0691
29 M30430(T)	-.1431	-.0872	-.0850	-.0961	-.0782
30 M67231(T)	0.1375	-.0791	-.0856	-.2272	-.0762
31 M57232(T)	0.0917	-.0851	-.0891	-.2178	-.0794
32 M20230(T)	0.0144	-.1299	-.1256	-.1201	-.1039
33 M20530(T)	-.1064	-.1528	-.1356	-.0804	-.1421
34 M20930(T)	0.1435	-.0297	-.0238	0.1678	0.0008
35 M25130(T)	0.0210	-.0584	-.0470	-.0346	-.0394
36 M48370(T)	-.0750	-.1383	-.1316	-.0016	-.1526
37 M48230(T)	-.0464	-.1958	-.1302	-.0784	-.1518
38 M50430(T)	0.1475	-.1205	-.1001	-.0887	-.0803
39 M54130(T)	-.1565	-.2466	-.1891	-.1449	-.2354
40 M54230(T)	-.1152	-.2647	-.2176	-.1667	-.2261
41 M54231(T)	-.0118	-.2741	-.2441	-.1772	-.2295
42 M54232(T)	0.0072	-.1569	-.1231	-.0722	-.1465
43 M54530(T)	0.0482	-.2110	-.1912	-.1099	-.2136
44 TSK296(T)	-.0166	-.2042	-.1693	-.0720	-.2018
45 M43130(T)	0.0930	-.2202	-.2220	-.0716	-.2233
46 M42730(T)	0.1475	-.1785	-.1001	-.0887	-.0803
47 TSK290(T)	-.1225	-.0002	-.0126	-.0135	-.0422
48 M23132(T)	-.0908	-.1400	-.1198	0.0021	-.1349
49 M22131(T)	-.0583	0.1143	0.1373	0.1634	0.1564
50 M42333(T)	0.0345	-.1115	-.0754	0.0320	-.1133

Table 2 (continued)

	11	12	13	14	15
11 F46330(T)	1.0000				
12 F46230(T)	0.6270	1.0000			
13 F20430(T)	0.1965	0.2196	1.0000		
14 F54130(T)	0.1620	0.3780	0.5570	1.0000	
15 F54230(T)	0.1412	0.3782	0.6900	0.8420	1.0000
16 F54231(T)	0.1272	0.3034	0.4932	0.6148	0.7099
17 F54232(T)	0.1320	0.3839	0.6532	0.8261	0.9426
18 F54530(T)	0.1271	0.4009	0.6064	0.8253	0.9003
19 TSK295(T)	0.0860	0.3899	0.6647	0.8345	0.9504
20 F43130(T)	-.0041	0.0640	-.1946	-.1003	-.0314
21 F42732(T)	0.1076	0.1091	0.8630	0.4725	0.6179
22 TSK287(T)	0.1398	0.1468	0.4608	0.1853	0.2385
23 F23132(T)	-.0612	0.0564	0.7602	0.4842	0.6385
24 F27131(T)	0.1191	0.0915	0.4768	0.1063	0.2844
25 F42333(T)	0.2537	0.3850	0.1271	0.2600	0.2608
26 M30230(T)	0.1377	0.1014	0.1774	0.0545	0.0299
27 M30331(T)	0.1310	0.1297	0.1459	-.0127	0.0098
28 M30333(T)	0.0931	0.0947	0.1440	-.0036	0.0157
29 M30430(T)	0.0842	0.0572	0.1390	-.0276	-.0391
30 M67231(T)	-.1740	-.1003	-.0210	-.0215	-.0173
31 M67232(T)	-.2366	-.1500	-.0263	0.0282	0.0001
32 M20230(T)	0.0838	-.1594	0.1529	-.0285	0.0228
33 M20530(T)	0.0831	-.0490	0.1053	-.0047	0.0499
34 M20830(T)	0.1472	-.0249	0.2035	0.0759	0.1050
35 M25130(T)	0.0813	-.1078	0.2575	0.0601	0.1160
36 M46330(T)	0.0355	-.0569	0.2167	-.1156	-.0193
37 M46230(T)	0.1857	-.0776	0.0821	-.0832	-.0971
38 M20430(T)	-.0737	-.2181	0.1164	-.1523	-.1320
39 M54130(T)	0.0444	-.1667	0.0675	-.0886	-.1052
40 M54230(T)	0.0964	-.2103	-.0531	-.2324	-.2167
41 M54231(T)	0.0984	-.1907	0.0270	-.2094	-.1894
42 M54232(T)	0.1212	-.1778	0.0947	-.0320	-.0978
43 M54530(T)	0.1855	-.1178	0.2111	0.0430	0.0327
44 TSK225(T)	-.0556	-.2712	0.0610	-.1716	-.1675
45 M43130(T)	0.1201	-.1336	0.0094	-.0604	-.1394
46 M43230(T)	-.0737	-.2181	0.1164	-.1523	-.1410
47 TSK288(T)	0.1736	0.0545	0.0820	-.0597	-.0530
48 M23132(T)	0.0743	-.0016	0.1537	-.0500	0.0132
49 M27131(T)	-.0285	-.0068	0.0497	-.0686	-.0613
50 M42333(T)	0.2279	-.0486	0.1104	-.1205	-.1157

Table 2 (continued)

	16	17	18	19	20
16 F54231(T)	1.0000				
17 F54232(T)	0.6540	1.0000			
18 F54530(T)	0.7306	0.8829	1.0000		
19 TSK295(T)	0.7373	0.9150	0.9317	1.0000	
20 F43130(T)	0.2682	-.0340	0.1037	0.0066	1.0000
21 F42732(T)	0.4135	0.6444	0.5005	0.5981	-.2669
22 TSK287(T)	0.1827	0.2491	0.1560	0.2523	-.1195
23 F23132(T)	0.5087	0.6090	0.4996	0.6589	-.2443
24 F27131(T)	0.2311	0.1613	0.1513	0.2656	-.2226
25 F42333(T)	0.1879	0.2737	0.2889	0.2839	0.3155
26 M30230(T)	-.1260	-.0249	0.0273	0.0059	-.2617
27 M30331(T)	-.1561	-.0240	0.0169	0.0095	-.2333
28 M30333(T)	-.1883	-.0460	0.0142	-.0097	-.2528
29 M30430(T)	-.1714	-.0876	-.0196	-.0627	-.2095
30 M67231(T)	-.0025	-.0811	-.0758	0.0552	-.1463
31 M67232(T)	0.0010	-.0433	-.0581	0.0773	-.1419
32 M20230(T)	-.0116	0.0092	0.0305	0.0155	0.0956
33 M20530(T)	-.1116	0.0039	0.0108	0.0102	0.0458
34 M20830(T)	0.0310	0.0807	0.0085	0.0159	-.0092
35 M25130(T)	0.0065	0.1124	0.0846	0.0803	-.0450
36 M46330(T)	-.1343	-.0732	-.1104	-.0561	-.2701
37 M46330(T)	-.1864	-.1867	-.1270	-.1120	-.0068
38 M20430(T)	-.1164	-.1712	-.1533	-.1654	0.0079
39 M54130(T)	-.2269	-.1632	-.1602	-.1577	-.0542
40 M54230(T)	-.2566	-.2700	-.2945	-.2700	0.0691
41 M54231(T)	-.2689	-.2482	-.3146	-.2582	-.0461
42 M54232(T)	-.2373	-.1646	-.1425	-.1472	-.1418
43 M54233(T)	-.1203	-.0460	-.0700	-.0572	-.0708
44 TSK296(T)	-.2922	-.2340	-.2382	-.2136	-.0893
45 M43130(T)	-.2579	-.2311	-.1983	-.1820	-.0874
46 M42732(T)	-.1164	-.1712	-.1533	-.1654	0.0079
47 TSK288(T)	-.0594	-.0433	-.0384	-.0716	-.0354
48 M23132(T)	-.0465	-.0209	-.0212	-.0451	0.0394
49 M27131(T)	0.0107	-.0334	-.0863	-.0488	0.1577
50 M42333(T)	-.2711	-.2125	-.1549	-.1762	-.2198

Table 2 (continued)

	21	22	23	24	25
21 F42732(T)	1.0000				
22 TSK287(T)	0.5145	1.0000			
23 F23132(T)	0.8192	0.5270	1.0000		
24 F27131(T)	0.4811	0.7280	0.5807	1.0000	
25 F42333(T)	0.1277	0.2351	0.0337	0.0902	1.0000
26 M30230(T)	0.1050	0.1755	0.1551	0.2437	-.1628
27 M30331(T)	0.0548	0.0402	0.0727	0.1482	-.1215
28 M30333(T)	0.0823	0.0344	0.0574	0.1728	-.0803
29 M30430(T)	0.0543	0.0451	0.0660	0.1556	-.1106
30 M67231(T)	0.0232	0.2027	0.2074	0.1384	-.0609
31 M67232(T)	0.0439	0.2112	0.2301	0.1148	-.0867
32 M20230(T)	0.1814	0.1241	0.1162	0.1701	0.0406
33 M20530(T)	0.0929	0.0229	0.0177	0.1754	0.0760
34 M20830(T)	0.1928	0.1371	0.1366	0.2416	-.0695
35 M25130(T)	0.3046	0.1414	0.2286	0.2011	0.0097
36 M46330(T)	0.3061	0.0912	0.2299	0.2752	-.0391
37 M46230(T)	0.1011	0.0213	-.0190	0.1360	-.0274
38 M20430(T)	0.0530	0.1278	0.0568	0.1198	-.1819
39 M54130(T)	0.0468	0.0554	-.0648	0.0835	-.0689
40 M54230(T)	0.0034	0.0915	-.0933	0.1232	0.0150
41 M54231(T)	0.1080	0.1631	0.0127	0.2002	-.0404
42 M54232(T)	0.0667	0.1414	-.0552	0.1839	-.0511
43 M54530(T)	0.1454	0.0771	-.0744	0.0812	0.0056
44 TSK296(T)	0.0237	0.0487	-.0809	0.0881	-.0986
45 M43130(T)	-.0713	0.0121	-.1057	0.1142	0.0211
46 M42732(T)	0.0530	0.1278	0.0568	0.1198	-.1819
47 TSK288(T)	0.1798	0.3351	-.0129	0.2431	0.2128
48 M23132(T)	0.1648	0.2118	0.0710	0.2046	0.0934
49 M27131(T)	0.0829	0.3927	0.0361	0.1692	0.1405
50 M42333(T)	0.0277	0.0772	-.0478	0.2317	-.0808

Table 2 (continued)

	26	27	28	29	30
26 M30230(T)	1.0000				
27 M30331(T)	0.8825	1.0000			
28 M30333(T)	0.9078	0.9273	1.0000		
29 M30430(T)	0.9020	0.9314	0.9485	1.0000	
30 M67231(T)	0.0173	-.1138	-.0426	0.0132	1.0000
31 M67232(T)	0.0420	-.0872	-.0166	0.0255	0.9703
32 M20230(T)	0.2972	0.2944	0.2933	0.3304	0.2132
33 M20530(T)	0.3244	0.3082	0.3359	0.3232	0.2085
34 M20830(T)	-.0075	0.0201	0.0209	0.0432	0.0905
35 M25130(T)	0.3233	0.3005	0.3057	0.3374	0.2094
36 M46330(T)	0.4629	0.5829	0.5437	0.5811	0.0013
37 M46230(T)	0.3990	0.4088	0.4035	0.3982	-.0613
38 M20430(T)	0.3412	0.2844	0.2716	0.3987	0.2908
39 M54130(T)	0.2612	0.3222	0.3121	0.3566	0.0205
40 M54230(T)	0.2686	0.2822	0.2935	0.3329	0.0562
41 M54231(T)	0.3316	0.3682	0.3792	0.4306	0.1274
42 M54232(T)	0.4099	0.3982	0.4266	0.4259	-.0289
43 M54530(T)	0.3762	0.3649	0.3842	0.4209	-.0594
44 TSK296(T)	0.1449	0.2119	0.2129	0.2268	0.0834
45 M43130(T)	0.2918	0.3197	0.3590	0.3833	0.1033
46 M42732(T)	0.3412	0.2844	0.2716	0.3987	0.2908
47 TSK288(T)	0.2101	0.0892	0.1301	0.1529	0.2002
48 M23132(T)	0.3661	0.2963	0.3392	0.3768	0.1339
49 M27131(T)	0.1129	0.0330	-.0069	0.0077	0.1730
50 M42333(T)	0.3803	0.4314	0.4320	0.4455	-.0260
	31	32	33	34	35
31 M67232(T)	1.0000				
32 M20230(T)	0.2220	1.0000			
33 M20530(T)	0.2120	0.8868	1.0000		
34 M20830(T)	0.0942	0.4765	0.5012	1.0000	
35 M25130(T)	0.2238	0.9443	0.8951	0.4913	1.0000
36 M46330(T)	-.0220	0.2663	0.2068	0.0971	0.2820
37 M46230(T)	-.0502	0.4040	0.3758	0.0767	0.3398
38 M20430(T)	0.2471	0.3300	0.2655	0.2037	0.3239
39 M54130(T)	0.0305	0.2226	0.2075	0.0393	0.1820
40 M54230(T)	0.0731	0.3687	0.3351	0.0668	0.3124
41 M54231(T)	0.1249	0.3755	0.3107	0.1535	0.3313
42 M54232(T)	-.0110	0.3003	0.3003	0.0523	0.2670
43 M54530(T)	-.0925	0.3204	0.3108	0.0747	0.2956
44 TSK296(T)	0.0969	0.2866	0.3065	0.1472	0.2606
45 M43130(T)	0.0635	0.2478	0.2729	0.0790	0.2152
46 M42732(T)	0.2471	0.3300	0.2655	0.2037	0.3239
47 TSK288(T)	0.1609	0.1263	0.0888	-.0292	0.0955
48 M23132(T)	0.0997	0.1708	0.2067	0.0387	0.1702
49 M27131(T)	0.1935	0.1797	0.1239	0.0307	0.1477
50 M42333(T)	-.0621	0.2516	0.2702	0.1716	0.2414

Table 2 (continued)

	36	37	38	39	40
36 M46330(T)	1.0000				
37 M46230(T)	0.6112	1.0000			
38 M20430(T)	0.3813	0.4774	1.0000		
39 M54130(T)	0.5444	0.7852	0.5884	1.0000	
40 M54230(T)	0.5048	0.7958	0.5653	0.8904	1.0000
41 M54231(T)	0.6386	0.7642	0.5635	0.8307	0.8792
42 M54232(T)	0.4644	0.8214	0.5153	0.8658	0.8527
43 M54530(T)	0.5188	0.7582	0.5634	0.7566	0.7268
44 TSK296(T)	0.5032	0.7363	0.5019	0.8630	0.8318
45 M43130(T)	0.4403	0.6523	0.6156	0.7198	0.7157
46 M42732(T)	0.3813	0.4774	1.0000	0.5884	0.5653
47 TSK288(T)	0.2588	0.3415	0.4970	0.3989	0.4389
48 M23132(T)	0.4617	0.5834	0.7558	0.6922	0.6513
49 M27131(T)	0.0927	0.3607	0.4696	0.4174	0.4667
50 M42333(T)	0.4411	0.7077	0.5852	0.7053	0.6004
	41	42	43	44	45
41 M54231(T)	1.0000				
42 M54232(T)	0.8202	1.0000			
43 M54530(T)	0.7398	0.8281	1.0000		
44 TSK296(T)	0.7796	0.8398	0.7224	1.0000	
45 M43130(T)	0.6776	0.7629	0.7280	0.7239	1.0000
46 M42732(T)	0.5635	0.5153	0.5634	0.5019	0.6156
47 TSK288(T)	0.3950	0.3852	0.3868	0.3189	0.3735
48 M23132(T)	0.6165	0.6257	0.6655	0.5142	0.6655
49 M27131(T)	0.3579	0.3770	0.2728	0.3767	0.2462
50 M42333(T)	0.6358	0.7693	0.6402	0.6592	0.7713
	46	47	48	49	50
46 M42732(T)	1.0000				
47 TSK288(T)	0.4970	1.0000			
48 M23132(T)	0.7558	0.6208	1.0000		
49 M27131(T)	0.4696	0.6636	0.4870	1.0000	
50 M42333(T)	0.5852	0.3981	0.5777	0.3225	1.0000

Table 2 (concluded)

APPENDIX B

STATIONARY STATE SPACE MODEL DATA

TABLE 1
Error Statistics for Various Forecasting Schemes

Series	State Space		Persistence		Twelve Month Moving Average	
	μ	σ	μ	σ	μ	σ
F30230	-.23	2.065	-.92	2.065	-1.25	2.065
F67231	2.81	3.972	3.83	3.927	1.00	3.927
F20230	-.41	2.783	0.58	2.466	-1.50	2.466
F46330	1.23	4.048	3.33	4.075	-3.58	4.075
F46230	3.20	1.771	1.83	1.749	0.17	1.749
F20430	0.66	3.475	2.50	2.876	0.67	2.876
F43130	-1.51	1.664	-1.08	1.379	-1.00	1.379
F42732	0.43	2.269	1.42	1.975	0.75	1.975
TSK287	0.07	1.236	1.17	0.835	1.33	0.835
F54130	-.59	5.638	4.08	4.981	2.58	4.981
F23132	0.29	2.095	1.58	1.782	0.58	1.782
F27131	0.55	1.160	1.50	0.674	1.50	0.674
F42333	0.71	0.994	-.67	0.888	-.67	0.888
M30230	-.30	0.980	0.42	0.900	-1.08	0.900
M67231	0.27	1.968	0.50	1.977	0.25	1.977
M20230	1.37	1.267	2.17	1.267	-1.08	1.267
M46330	3.16	1.568	-.58	1.929	-.08	1.929
M46230	-2.27	1.739	-.83	1.115	0.17	1.115
M20430	-1.17	1.396	0.50	0.798	0.92	0.798
M43130	-2.17	1.106	-.75	0.622	0.50	0.622
M42732	-1.17	1.396	0.50	0.798	0.92	0.798
TSK288	-.83	0.966	0.25	0.622	1.50	0.622
M54130	-5.30	2.821	-2.08	1.379	1.75	1.379
M23132	-1.91	1.275	-.17	0.577	0.75	0.577
M27131	-1.07	1.032	0.25	0.622	1.75	0.622
M42383	-1.48	0.765	-.33	0.492	0.08	0.492

STATE SPACE FORECAST

48 OBSERVATIONS, 1 SERIES
 RANGE =JAN 73 -DEC 76

DIFFERENCING PERFORMED
 SERIES REGULAR SEASONAL
 F30230 0* 0*

* AUTOMATIC DIFFERENCING

THE FOLLOWING ARE THE ELEMENTS OF THE STATE VECTOR
 CANONICAL

CORRELATION 1.0000
 CHI SQUARE 9999.99
 D.F. 3
 INF. CRIT. 9993.99

F30230(T)
 STATE VECTOR DIMENSION IS AT LEAST 1

CANONICAL
 CORRELATION 1.0000 0.2882
 CHI SQUARE 9999.99 3.90
 D.F. 6 2
 INF. CRIT. 9987.99 -.10

NEGATIVE INFORMATION CRITERION ELIMINATES VARIABLE 1
 FROM USE AT HIGHER LEADS IN STATE VECTOR

F MATRIX

1 ROWS 1 COLUMNS
 ROW 1 -.0065

H MATRIX

1 ROWS 1 COLUMNS
 ROW 1 1.0000

G MATRIX

1 ROWS 1 COLUMNS
 ROW 1 1.0000

RESIDUAL MEAN VECTOR

1 ROWS 1 COLUMNS
 ROW 1 -.1186

RESIDUAL COVARIANCE MATRIX

1 ROWS 1 COLUMNS
 ROW 1 7.6515

GOODNESS OF FIT ORIGINAL DATA DIFFERENCED DATA
 (1 D.F.) 2.135 2.135

R SQUARED TEST ORIGINAL DATA DIFFERENCED DATA
 F30230 0.08213 0.08213

Table 2: State Space Model for F30230

DIFFERENCING PERFORMED
 SERIES LINEAR SEASONAL
 F67231 0* 0*

* AUTOMATIC DIFFERENCING

THE FOLLOWING ARE THE ELEMENTS OF THE STATE VECTOR

CANONICAL
 CORRELATION 1.0000
 CHI SQUARE 9999.99
 D.F. 4
 INF. CRIT. 9991.99
 F67231(T)
 STATE VECTOR DIMENSION IS AT LEAST 1

CANONICAL
 CORRELATION 1.0000 0.3614
 CHI SQUARE 9999.99 6.23
 D.F. 8 3
 INF. CRIT. 9983.99 0.23
 F67231(T+ 1)
 STATE VECTOR DIMENSION IS AT LEAST 2

CANONICAL
 CORRELATION 1.0000 0.3702 0.3235
 CHI SQUARE 9999.99 11.35 4.86
 D.F. 12 6 2
 INF. CRIT. 9975.99 -0.65 0.86
 NEGATIVE INFORMATION CRITERION ELIMINATES VARIABLE 1
 FROM USE AT HIGHER LEADS IN STATE VECTOR

F MATRIX
 2 ROWS 2 COLUMNS
 ROW 1 0.0000 1.0000
 ROW 2 -0.1463 1.0013

H MATRIX
 1 ROWS 2 COLUMNS
 ROW 1 1.0000 0.0000

G MATRIX
 2 ROWS 1 COLUMNS
 ROW 1 1.0000
 ROW 2 0.4592

RESIDUAL MEAN VECTOR
 1 ROWS 1 COLUMNS
 ROW 1 0.1704

RESIDUAL COVARIANCE MATRIX
 1 ROWS 1 COLUMNS
 ROW 1 7.5085

GOODNESS OF FIT ORIGINAL DATA DIFFERENCED DATA
 (3 D.F.) 23.497 23.497

R SQUARED TEST ORIGINAL DATA DIFFERENCED DATA
 F67231 0.45913 0.45913

Table 3: State Space Model for F67231

DIFFERENCING PERFORMED
 SERIES REGULAR SEASONAL
 F20230 1* 0*

* AUTOMATIC DIFFERENCING

THE FOLLOWING ARE THE ELEMENTS OF THE STATE VECTOR
 CANONICAL

CORRELATION 1.0000
 CHI SQUARE 9999.99
 D.F. 3
 INF. CRIT. 9993.99
 F20230(T)
 STATE VECTOR DIMENSION IS AT LEAST 1

CANONICAL
 CORRELATION 1.0000 0.3569
 CHI SQUARE 9999.99 6.00
 D.F. 6 2
 INF. CRIT. 9987.99 2.00
 F20230(T+ 1)
 STATE VECTOR DIMENSION IS AT LEAST 2

CANONICAL
 CORRELATION 1.0000 0.3627 0.0221
 CHI SQUARE 9999.99 6.16 0.02
 D.F. 9 4 1
 INF. CRIT. 9981.99 -1.84 -1.98
 NEGATIVE INFORMATION CRITERION ELIMINATES VARIABLE 1
 FROM USE AT HIGHER LEADS IN STATE VECTOR

F MATRIX

 2 ROWS 2 COLUMNS
 ROW 1 0.0000 1.0000
 ROW 2 -.2820 -.3754

H MATRIX

 1 ROWS 2 COLUMNS
 ROW 1 1.0000 0.0000

G MATRIX

 2 ROWS 1 COLUMNS
 ROW 1 1.0000
 ROW 2 -.5451

RESIDUAL MEAN VECTOR

 1 ROWS 1 COLUMNS
 ROW 1 0.0508

RESIDUAL COVARIANCE MATRIX

 1 ROWS 1 COLUMNS
 ROW 1 6.0265

GOODNESS OF FIT ORIGINAL DATA DIFFERENCED DATA
 (3 D.F.) 72.193 28.591

R SQUARED TEST ORIGINAL DATA DIFFERENCED DATA
 F20230 0.81058 0.52098

Table 4: State Space Model for F20230

STATE SPACE FORECAST

48 OBSERVATIONS, 1 SERIES
 RANGE =JAN 73 -DEC 76

DIFFERENCING PERFORMED
 SERIES REGULAR SEASONAL
 F46330 0* 0*

* AUTOMATIC DIFFERENCING

THE FOLLOWING ARE THE ELEMENTS OF THE STATE VECTOR
 CANONICAL

CORRELATION 1.0000
 CHI SQUARE 9999.99
 D.F. 3
 INF. CRIT. 9993.99
 F46330(T)

STATE VECTOR DIMENSION IS AT LEAST 1

CANONICAL

CORRELATION 1.0000 0.2750
 CHI SQUARE 9999.99 3.54
 D.F. 6 2
 INF. CRIT. 9987.99 -.46

NEGATIVE INFORMATION CRITERION ELIMINATES VARIABLE
 FROM USE AT HIGHER LEADS IN STATE VECTOR

F MATRIX

1 ROWS 1 COLUMNS
 ROW 1 0.3536

H MATRIX

1 ROWS 1 COLUMNS
 ROW 1 1.0000

G MATRIX

1 ROWS 1 COLUMNS
 ROW 1 1.0000

RESIDUAL MEAN VECTOR

1 ROWS 1 COLUMNS
 ROW 1 -.0119

RESIDUAL COVARIANCE MATRIX

1 ROWS 1 COLUMNS
 ROW 1 35.5306

GOODNESS OF FIT	ORIGINAL DATA	DIFFERENCED DATA
(1 D.F.)	4.429	4.429

R SQUARED TEST	ORIGINAL DATA	DIFFERENCED DATA
F46330	0.12536	0.12536

Table 5: State Space Model for F46330

STATE SPACE FORECAST

48 OBSERVATIONS, 1 SERIES
 RANGE =JAN 73 -DEC 76

DIFFERENCING PERFORMED
 SERIES REGULAR SEASONAL
 F46230 0* 0*

* AUTOMATIC DIFFERENCING

THE FOLLOWING ARE THE ELEMENTS OF THE STATE VECTOR
 CANONICAL

CORRELATION 1.0000
 CHI SQUARE 9999.99
 D.F. 3
 INF. CRIT. 9993.99
 F46230(T)

STATE VECTOR DIMENSION IS AT LEAST 1

CANONICAL
 CORRELATION 1.0000 0.1841
 CHI SQUARE 9999.99 1.55
 D.F. 6 2
 INF. CRIT. 9987.99 -2.45

NEGATIVE INFORMATION CRITERION ELIMINATES VARIABLE 1
 FROM USE AT HIGHER LEADS IN STATE VECTOR

F MATRIX
 1 ROWS 1 COLUMNS
 ROW 1 0.6229

H MATRIX
 1 ROWS 1 COLUMNS
 ROW 1 1.0000

G MATRIX
 1 ROWS 1 COLUMNS
 ROW 1 1.0000

RESIDUAL MEAN VECTOR
 1 ROWS 1 COLUMNS
 ROW 1 0.1126

RESIDUAL COVARIANCE MATRIX
 1 ROWS 1 COLUMNS
 ROW 1 5.0383

GOODNESS OF FIT ORIGINAL DATA DIFFERENCED DATA
 (1 D.F.) 25.587 25.587

R SQUARED TEST ORIGINAL DATA DIFFERENCED DATA
 F46230 0.43714 0.43714

Table 6: State Space Model for F46230

STATE SPACE FORECAST

48 OBSERVATIONS, 1 SERIES
 RANGE =JAN 73 -DEC 76

DIFFERENCING PERFORMED
 SERIES REGULAR SEASONAL
 F20430 1* 0*

* AUTOMATIC DIFFERENCING

THE FOLLOWING ARE THE ELEMENTS OF THE STATE VECTOR

CANONICAL
 CORRELATION 1.0000
 CHI SQUARE 9999.99
 D.F. 3
 INF. CRIT. 9993.99
 F20430(T)
 STATE VECTOR DIMENSION IS AT LEAST 1

CANONICAL
 CORRELATION 1.0000 0.1183
 CHI SQUARE 9999.99 0.62
 D.F. 6 2
 INF. CRIT. 9987.99 -3.38
 NEGATIVE INFORMATION CRITERION ELIMINATES VARIABLE 1
 FROM USE AT HIGHER LEADS IN STATE VECTOR

F MATRIX
 1 ROWS 1 COLUMNS
 ROW 1 -.1666

H MATRIX
 1 ROWS 1 COLUMNS
 ROW 1 1.0000

G MATRIX
 1 ROWS 1 COLUMNS
 ROW 1 1.0000

RESIDUAL MEAN VECTOR
 1 ROWS 1 COLUMNS
 ROW 1 0.0737

RESIDUAL COVARIANCE MATRIX
 1 ROWS 1 COLUMNS
 ROW 1 2.3940

GOODNESS OF FIT	ORIGINAL DATA	DIFFERENCED DATA
(1 D.F.)	117.150	3.668

R SQUARED TEST	ORIGINAL DATA	DIFFERENCED DATA
F20430	0.92075	0.11833

Table 7: State Space Model for F20430

Table 8: State Space Model for F43130

STATE SPACE FORECAST

48 OBSERVATIONS, 1 SERIES
 RANGE 1973 - DEC 76

DIFFERENTIATION PERFORMED
 SEASONAL REGULAR
 F43130 0* 3*

* ALL DIFFERENCING

THE FOLLOWING ARE THE ELEMENTS OF THE STATE VECTOR

CANONICAL STATE VECTOR
 COEFFICIENTS: 1.0000
 CHARACTERISTIC POLYNOMIAL: 9999.99
 D.F.: 5
 INITIAL STATE VECTOR: 9989.99
 STATE VECTOR DIMENSION IS AT LEAST 1

CANONICAL STATE VECTOR
 COEFFICIENTS: 1.0000 0.3923
 CHARACTERISTIC POLYNOMIAL: 9999.99 6.85
 D.F.: 10 4
 INITIAL STATE VECTOR: 9979.99 -1.15
 NELLER INFORMATION CRITERION ELIMINATES VARIABLE 1
 AT HIGHER LEADS IN STATE VECTOR

F
 1 ROWS 1 COLUMNS
 VALUE: -0.1382

H
 1 ROWS 1 COLUMNS
 VALUE: 1.0000

G
 1 ROWS 1 COLUMNS
 VALUE: 1.0000

MEAN VECTOR
 1 ROWS 1 COLUMNS
 VALUE: 0.0129

RESIDUAL COVARIANCE MATRIX
 1 ROWS 1 COLUMNS
 VALUE: 2.8036

COEFFICIENTS OF FIT ORIGINAL DATA DIFFERENCED DATA
 VALUE: 10.077 -1.069

FIT - RELATIVE GOODNESS OF FIT IS NEGATIVE

R-SQUARED TEST ORIGINAL DATA DIFFERENCED DATA
 VALUE: 0.23538 0.02048

STATE SPACE FORECAST

48 OBSERVATIONS, 1 SERIES
 RANGE =JAN 73 -DEC 76

DIFFERENCING PERFORMED
 SERIES REGULAR SEASONAL
 F42732 1* 0*

* AUTOMATIC DIFFERENCING

THE FOLLOWING ARE THE ELEMENTS OF THE STATE VECTOR

CANONICAL
 CORRELATION 1.0000
 CHI SQUARE 9999.99
 D.F. 3
 INF. CRIT. 9993.99
 F42732(T)

STATE VECTOR DIMENSION IS AT LEAST 1

CANONICAL
 CORRELATION 1.0000 0.1620
 CHI SQUARE 9999.99 1.17
 D.F. 6 2
 INF. CRIT. 9987.99 -2.83
 NEGATIVE INFORMATION CRITERION ELIMINATES VARIABLE 1
 FROM USE AT HIGHER LEADS IN STATE VECTOR

F MATRIX
 1 ROWS 1 COLUMNS
 ROW 1 -.1753

H MATRIX
 1 ROWS 1 COLUMNS
 ROW 1 1.0000

G MATRIX
 1 ROWS 1 COLUMNS
 ROW 1 1.0000

RESIDUAL MEAN VECTOR
 1 ROWS 1 COLUMNS
 ROW 1 0.0250

RESIDUAL COVARIANCE MATRIX
 1 ROWS 1 COLUMNS
 ROW 1 1.2902

GOODNESS OF FIT	ORIGINAL DATA	DIFFERENCED DATA
(1 D.F.)	92.123	0.502

R SQUARED TEST	ORIGINAL DATA	DIFFERENCED DATA
F42732	0.86502	0.05185

Table 9: State Space Model for F42732

STATE SPACE FORECAST

48 OBSERVATIONS, 1 SERIES
 RANGE =JAN 73 -DEC 76

DIFFERENCING PERFORMED
 SERIES REGULAR SEASONAL
 TSK287 1* 0*

* AUTOMATIC DIFFERENCING

THE FOLLOWING ARE THE ELEMENTS OF THE STATE VECTOR
 CANONICAL

CORRELATION 1.0000
 CHI SQUARE 9999.99
 D.F. 3
 INF. CRIT. 9993.99

TSK287(T)
 STATE VECTOR DIMENSION IS AT LEAST 1

CANONICAL
 CORRELATION 1.0000 0.1397
 CHI SQUARE 9999.99 0.87
 D.F. 6 2
 INF. CRIT. 9987.99 -3.13
 NEGATIVE INFORMATION CRITERION ELIMINATES VARIABLE 1
 FROM USE AT HIGHER LEADS IN STATE VECTOR

F MATRIX
 1 ROWS 1 COLUMNS
 ROW 1 -.2276

H MATRIX
 1 ROWS 1 COLUMNS
 ROW 1 1.0000

G MATRIX
 1 ROWS 1 COLUMNS
 ROW 1 1.0000

RESIDUAL MEAN VECTOR
 1 ROWS 1 COLUMNS
 ROW 1 0.0214

RESIDUAL COVARIANCE MATRIX
 1 ROWS 1 COLUMNS
 ROW 1 0.9224

GOODNESS OF FIT ORIGINAL DATA DIFFERENCED DATA
 (1 D.F.) 119.595 2.073

R SQUARED TEST ORIGINAL DATA DIFFERENCED DATA
 TSK287 0.92476 0.08500

Table 10: State Space Model for TSK287

DIFFERENCING PERFORMED
 SERIES REGULAR SEASONAL
 F54130 1* 0*

* AUTOMATIC DIFFERENCING

THE FOLLOWING ARE THE ELEMENTS OF THE STATE VECTOR

CANONICAL
 CORRELATION 1.0000
 CHI SQUARE 9999.99
 D.F. 3
 INF. CRIT. 9993.99
 F54130(T)
 STATE VECTOR DIMENSION IS AT LEAST 1

CANONICAL
 CORRELATION 1.0000 0.3408
 CHI SQUARE 9999.99 5.43
 D.F. 6 2
 INF. CRIT. 9987.99 1.43
 F54130(T+ 1)
 STATE VECTOR DIMENSION IS AT LEAST 2

CANONICAL
 CORRELATION 1.0000 0.3647 0.1547
 CHI SQUARE 9999.99 7.26 1.05
 D.F. 9 4 1
 INF. CRIT. 9981.99 -1.74 -1.95
 NEGATIVE INFORMATION CRITERION ELIMINATES VARIABLE 1
 FROM USE AT HIGHER LEADS IN STATE VECTOR

F MATRIX

2 ROWS 2 COLUMNS
 ROW 1 0.0000 1.0000
 ROW 2 -0.1387 -0.0450

H MATRIX

1 ROWS 2 COLUMNS
 ROW 1 1.0000 0.0000

G MATRIX

2 ROWS 1 COLUMNS
 ROW 1 1.0000
 ROW 2 -0.4554

RESIDUAL MEAN VECTOR

1 ROWS 1 COLUMNS
 ROW 1 0.2385

RESIDUAL COVARIANCE MATRIX

1 ROWS 1 COLUMNS
 ROW 1 9.5858

GOODNESS OF FIT ORIGINAL DATA DIFFERENCED DATA
 (3 D.F.) 56.778 6.594

R SQUARED TEST ORIGINAL DATA DIFFERENCED DATA
 F54130 0.73393 0.23489

Table 11: State Space Model for F54130

DIFFERENCING PERFORMED
 SERIES REGULAR SEASONAL
 F23132 1* 0*

* AUTOMATIC DIFFERENCING

THE FOLLOWING ARE THE ELEMENTS OF THE STATE VECTOR

CANONICAL
 CORRELATION 1.0000
 CHI SQUARE 9999.99
 D.F. 3
 INF. CRIT. 9993.99
 F23132(T)
 STATE VECTOR DIMENSION IS AT LEAST 1

CANONICAL
 CORRELATION 1.0000 0.3283
 CHI SQUARE 9999.99 5.02
 D.F. 6 2
 INF. CRIT. 9987.99 1.02
 F23132(T+ 1)
 STATE VECTOR DIMENSION IS AT LEAST 2

CANONICAL
 CORRELATION 1.0000 0.3658 0.0974
 CHI SQUARE 9999.99 6.66 0.41
 D.F. 9 4 1
 INF. CRIT. 9981.99 -1.34 -1.59
 NEGATIVE INFORMATION CRITERION ELIMINATES VARIABLE 1
 FROM USE AT HIGHER LEADS IN STATE VECTOR

F MATRIX
 2 ROWS 2 COLUMNS
 ROW 1 0.0000 1.0000
 ROW 2 -0.3366 -0.6699

H MATRIX
 1 ROWS 2 COLUMNS
 ROW 1 1.0000 0.0000

G MATRIX
 2 ROWS 1 COLUMNS
 ROW 1 1.0000
 ROW 2 -0.1738

RESIDUAL MEAN VECTOR
 1 ROW 1 COLUMNS
 ROW 1 0.0577

RESIDUAL COVARIANCE MATRIX
 1 ROWS 1 COLUMNS
 ROW 1 0.9939

GOODNESS OF FIT ORIGINAL DATA DIFFERENCED DATA
 (3 D.F.) 109.500 5.731

R SQUARED TEST ORIGINAL DATA DIFFERENCED DATA
 F23132 0.91435 0.22089

Table 12: State Space Model for F23132

STATE SPACE FORECAST

48 OBSERVATIONS, 1 SERIES
 RANGE =JAN 73 -DEC 76

DIFFERENCING PERFORMED
 SERIES REGULAR SEASONAL
 F27131 1* 0*

* AUTOMATIC DIFFERENCING

THE FOLLOWING ARE THE ELEMENTS OF THE STATE VECTOR
 CANONICAL

CORRELATION 1.0000
 CHI SQUARE 9999.99
 D.F. 3
 INF. CRIT. 9993.99
 F27131(T)

STATE VECTOR DIMENSION IS AT LEAST 1

CANONICAL

CORRELATION 1.0000 0.1322
 CHI SQUARE 9999.99 0.78
 D.F. 6 2
 INF. CRIT. 9987.99 -3.22

NEGATIVE INFORMATION CRITERION ELIMINATES VARIABLE 1
 FROM USE AT HIGHER LEADS IN STATE VECTOR

F MATRIX

1 ROWS 1 COLUMNS
 ROW 1 -.2202

H MATRIX

1 ROWS 1 COLUMNS
 ROW 1 1.0000

G MATRIX

1 ROWS 1 COLUMNS
 ROW 1 1.0000

RESIDUAL MEAN VECTOR

1 ROWS 1 COLUMNS
 ROW 1 0.0210

RESIDUAL COVARIANCE MATRIX

1 ROWS 1 COLUMNS
 ROW 1 0.8329

GOODNESS OF FIT ORIGINAL DATA DIFFERENCED DATA
 (1 D.F.) 120.409 2.016

R SQUARED TEST ORIGINAL DATA DIFFERENCED DATA
 F27131 0.92606 0.08189

Table 13: State Space Model for F27131

STATE SPACE FORECAST

48 OBSERVATIONS, 1 SERIES
 RANGE =JAN 73 -DEC 76

DIFFERENCING PERFORMED
 SERIES REGULAR SEASONAL
 F42333 0* 0*

* AUTOMATIC DIFFERENCING

THE FOLLOWING ARE THE ELEMENTS OF THE STATE VECTOR
 CANONICAL

CORRELATION 1.0000
 CHI SQUARE 9999.99
 D.F. 3
 INF. CRIT. 9993.99
 F42333(T)

STATE VECTOR DIMENSION IS AT LEAST 1

CANONICAL

CORRELATION 1.0000 0.1054
 CHI SQUARE 9999.99 0.50
 D.F. 6 2
 INF. CRIT. 9987.99 -3.50

NEGATIVE INFORMATION CRITERION ELIMINATES VARIABLE 1
 FROM USE AT HIGHER LEADS IN STATE VECTOR

F MATRIX

1 ROWS 1 COLUMNS
 ROW 1 0.7244

H MATRIX

1 ROWS 1 COLUMNS
 ROW 1 1.0000

G MATRIX

1 ROWS 1 COLUMNS
 ROW 1 1.0000

RESIDUAL MEAN VECTOR

1 ROWS 1 COLUMNS
 ROW 1 -.0100

RESIDUAL COVARIANCE MATRIX

1 ROWS 1 COLUMNS
 ROW 1 1.3778

GOODNESS OF FIT	ORIGINAL DATA	DIFFERENCED DATA
(1 D.F.)	36.988	36.988

R SQUARED TEST	ORIGINAL DATA	DIFFERENCED DATA
F42333	0.55615	0.55615

Table 14: State Space Model for F42333

STATE SPACE FORECAST

48 OBSERVATIONS, 1 SERIES
 RANGE =JAN 73 -DEC 76

DIFFERENCING PERFORMED
 SERIES REGULAR SEASONAL
 M30230 1* 0*

* AUTOMATIC DIFFERENCING

THE FOLLOWING ARE THE ELEMENTS OF THE STATE VECTOR
 CANONICAL

CORRELATION 1.0000
 CHI SQUARE 9999.99
 D.F. 3
 INF. CRIT. 9993.99

M30230(T)
 STATE VECTOR DIMENSION IS AT LEAST 1

CANONICAL
 CORRELATION 1.0000 0.2373
 CHI SQUARE 9999.99 2.55
 D.F. 6 2
 INF. CRIT. 9987.99 -1.45
 NEGATIVE INFORMATION CRITERION ELIMINATES VARIABLE 1
 FROM USE AT HIGHER LEADS IN STATE VECTOR

F MATRIX
 1 ROWS 1 COLUMNS
 ROW 1 -.3790

H MATRIX
 1 ROWS 1 COLUMNS
 ROW 1 1.0000

G MATRIX
 1 ROWS 1 COLUMNS
 ROW 1 1.0000

RESIDUAL MEAN VECTOR
 1 ROWS 1 COLUMNS
 ROW 1 0.0312

RESIDUAL COVARIANCE MATRIX
 1 ROWS 1 COLUMNS
 ROW 1 1.1887

GOODNESS OF FIT (1 D.F.)	ORIGINAL DATA 47.238	DIFFERENCED DATA 6.804
R SQUARED TEST M30230	ORIGINAL DATA 0.64923	DIFFERENCED DATA 0.16373

Table 15: State Space Model for M30230

STATE SPACE FORECAST

48 OBSERVATIONS, 1 SERIES
 RANGE = JAN 73 - DEC 76

DIFFERENCING PERFORMED
 SERIES REGULAR SEASONAL
 M67231 0* 0*

* AUTOMATIC DIFFERENCING

THE FOLLOWING ARE THE ELEMENTS OF THE STATE VECTOR

CANONICAL
 CORRELATION 1.0000
 CHI SQUARE 9999.99
 D.F. 8
 INF. CRIT. 9983.99
 M67231(T)
 STATE VECTOR DIMENSION IS AT LEAST 1

CANONICAL
 CORRELATION 1.0000 0.5033
 CHI SQUARE 9999.99 12.41
 D.F. 16 7
 INF. CRIT. 9967.99 -1.59
 NEGATIVE INFORMATION CRITERION ELIMINATES VARIABLE 1
 FROM USE AT HIGHER LEADS IN STATE VECTOR

F MATRIX
 1 ROWS 1 COLUMNS
 ROW 1 0.5454

H MATRIX
 1 ROWS 1 COLUMNS
 ROW 1 1.0000

G MATRIX
 1 ROWS 1 COLUMNS
 ROW 1 1.0000

RESIDUAL MEAN VECTOR
 1 ROWS 1 COLUMNS
 ROW 1 -.0393

RESIDUAL COVARIANCE MATRIX
 1 ROWS 1 COLUMNS
 ROW 1 2.8177

GOODNESS OF FIT ORIGINAL DATA DIFFERENCED DATA
 (1 D.F.) 16.051 16.051

R SQUARED TEST ORIGINAL DATA DIFFERENCED DATA
 M67231 0.31344 0.31344

Table 16: State Space Model for M67231

STATE SPACE FORECAST

48 OBSERVATIONS, 1 SERIES
 RANGE =JAN 73 -DEC 76

DIFFERENCING PERFORMED
 SERIES REGULAR SEASONAL
 M20230 1* 0*

* AUTOMATIC DIFFERENCING

THE FOLLOWING ARE THE ELEMENTS OF THE STATE VECTOR

CANONICAL
 CORRELATION 1.0000
 CHI SQUARE 9999.99
 D.F. 3
 INF. CRIT. 9993.99
 M20230(T)
 STATE VECTOR DIMENSION IS AT LEAST 1

CANONICAL
 CORRELATION 1.0000 0.1088
 CHI SQUARE 9999.99 0.52
 D.F. 6 2
 INF. CRIT. 9987.99 -3.48
 NEGATIVE INFORMATION CRITERION ELIMINATES VARIABLE 1
 FROM USE AT HIGHER LEADS IN STATE VECTOR

F MATRIX
 1 ROWS 1 COLUMNS
 ROW 1 -.2255

H MATRIX
 1 ROWS 1 COLUMNS
 ROW 1 1.0000

G MATRIX
 1 ROWS 1 COLUMNS
 ROW 1 1.0000

RESIDUAL MEAN VECTOR
 1 ROWS 1 COLUMNS
 ROW 1 0.0538

RESIDUAL COVARIANCE MATRIX
 1 ROWS 1 COLUMNS
 ROW 1 2.9879

GOODNESS OF FIT	ORIGINAL DATA	DIFFERENCED DATA
(1 D.F.)	70.399	1.971

R SQUARED TEST	ORIGINAL DATA	DIFFERENCED DATA
M20230	0.70570	0.08101

Table 17: State Space Model for M20230

STATE SPACE FORECAST

40 OBSERVATIONS, 1 SERIES
 RANGE =JAN 73 -DEC 76

DIFFERENCING*PERFORMED
 SERIES REGULAR SEASONAL
 M46330 0* 0*

* AUTOMATIC DIFFERENCING

THE FOLLOWING ARE THE ELEMENTS OF THE STATE VECTOR
 CANONICAL
 CORRELATION 1.0000
 CHI SQUARE 9999.99
 D.F. 3
 INF. CRIT. 9993.99
 M46330(T)
 STATE VECTOR DIMENSION IS AT LEAST 1

CANONICAL
 CORRELATION 1.0000 0.2298
 CHI SQUARE 9999.99 2.44
 D.F. 6 2
 INF. CRIT. 9987.99 -1.56
 NEGATIVE INFORMATION CRITERION ELIMINATES VARIABLE 1
 FROM USE AT HIGHER LEADS IN STATE VECTOR

F MATRIX
 1 ROWS 1 COLUMNS
 ROW 1 0.6663

H MATRIX
 1 ROWS 1 COLUMNS
 ROW 1 1.0000

G MATRIX
 1 ROWS 1 COLUMNS
 ROW 1 1.0000

RESIDUAL MEAN VECTOR
 1 ROWS 1 COLUMNS
 ROW 1 0.0939

RESIDUAL COVARIANCE MATRIX
 1 ROWS 1 COLUMNS
 ROW 1 5.1793

GOODNESS OF FIT ORIGINAL DATA DIFFERENCED DATA
 (1 D.F.) 28.362 28.362

R SQUARED TEST ORIGINAL DATA DIFFERENCED DATA
 M46330 0.46877 0.46877

Table 18: State Space Model for M46330

STATE SPACE FORECAST

48 OBSERVATIONS, 1 SERIES
 RANGE =JAN 73 -DEC 76

DIFFERENCING PERFORMED
 SERIES REGULAR SEASONAL
 M46230 1* 0*

* AUTOMATIC DIFFERENCING

THE FOLLOWING ARE THE ELEMENTS OF THE STATE VECTOR
 CANONICAL

CORRELATION 1.0000
 CHI SQUARE 9999.99
 D.F. 3
 INF. CRIT. 9993.99
 M46230(T)

STATE VECTOR DIMENSION IS AT LEAST 1

CANONICAL
 CORRELATION 1.0000 0.1271
 CHI SQUARE 9999.99 0.72
 D.F. 6 2
 INF. CRIT. 9987.99 -3.28

NEGATIVE INFORMATION CRITERION ELIMINATES VARIABLE 1
 FROM USE AT HIGHER LEADS IN STATE VECTOR

F MATRIX

1 ROWS 1 COLUMNS
 ROW 1 -.3199

H MATRIX

1 ROWS 1 COLUMNS
 ROW 1 1.0000

G MATRIX

1 ROWS 1 COLUMNS
 ROW 1 1.0000

RESIDUAL MEAN VECTOR

1 ROWS 1 COLUMNS
 ROW 1 0.0273

RESIDUAL COVARIANCE MATRIX

1 ROWS 1 COLUMNS
 ROW 1 1.7226

GOODNESS OF FIT ORIGINAL DATA DIFFERENCED DATA
 (1 D.F.) 87.440 3.941

R SQUARED TEST ORIGINAL DATA DIFFERENCED DATA
 M46230 0.85088 0.11875

Table 19: State Space Model for M46230

Table 20: State Space Model for M20430

STATE SPACE FORECAST

48 OBSERVATIONS, 1 SERIES
 RANGE =JAN 73 -DEC 76

DIFFERENCING PERFORMED
 SERIES REGULAR SEASONAL
 M20430 1* 0*

* AUTOMATIC DIFFERENCING

THE FOLLOWING ARE THE ELEMENTS OF THE STATE VECTOR

CANONICAL
 CORRELATION 1.0000
 CHI SQUARE 9999.99
 D.F. 3
 INF. CRIT. 9993.99
 M20430(T)
 STATE VECTOR DIMENSION IS AT LEAST 1

CANONICAL
 CORRELATION 1.0000 0.1811
 CHI SQUARE 9999.99 1.47
 D.F. 6 2
 INF. CRIT. 9987.99 -2.53
 NEGATIVE INFORMATION CRITERION ELIMINATES VARIABLE 1
 FROM USE AT HIGHER LEADS IN STATE VECTOR

F MATRIX
 1 ROWS 1 COLUMNS
 ROW 1 -.0618

H MATRIX
 1 ROWS 1 COLUMNS
 ROW 1 1.0000

G MATRIX
 1 ROWS 1 COLUMNS
 ROW 1 1.0000

RESIDUAL MEAN VECTOR
 1 ROWS 1 COLUMNS
 ROW 1 0.0270

RESIDUAL COVARIANCE MATRIX
 1 ROWS 1 COLUMNS
 ROW 1 1.4692

GOODNESS OF FIT ORIGINAL DATA DIFFERENCED DATA
 (1 D.F.) 108.640 -.737

NOTE: BIC(1) = RELATIVE GOODNESS OF FIT IS NEGATIVE

R SQUARED TEST ORIGINAL DATA DIFFERENCED DATA
 M20430 0.90502 0.01652

STATE SPACE FORECAST

48 OBSERVATIONS, 1 SERIES
 RANGE = JAN 73 - DEC 76

DIFFERENCING PERFORMED
 SERIES REGULAR SEASONAL
 M43130 1* 0*

* AUTOMATIC DIFFERENCING

THE FOLLOWING ARE THE ELEMENTS OF THE STATE VECTOR
 CANONICAL

CORRELATION 1.0000
 CHI SQUARE 9999.99
 D.F. 3
 INF. CRIT. 9993.99

M43130(T)
 STATE VECTOR DIMENSION IS AT LEAST 1

CANONICAL

CORRELATION 1.0000 0.1744
 CHI SQUARE 9999.99 1.36
 D.F. 6 2
 INF. CRIT. 9987.99 -2.64

NEGATIVE INFORMATION CRITERION ELIMINATES VARIABLE 1
 FROM USE AT HIGHER LEADS IN STATE VECTOR

F MATRIX

1 ROWS 1 COLUMNS
 ROW 1 -0.2180

H MATRIX

1 ROWS 1 COLUMNS
 ROW 1 1.0000

G MATRIX

1 ROWS 1 COLUMNS
 ROW 1 1.0000

RESIDUAL MEAN VECTOR

1 ROWS 1 COLUMNS
 ROW 1 0.0268

RESIDUAL COVARIANCE MATRIX

1 ROWS 1 COLUMNS
 ROW 1 0.6544

GOODNESS OF FIT ORIGINAL DATA DIFFERENCED DATA
 (1 D.F.) 128.509 2.537

R SQUARED TEST ORIGINAL DATA DIFFERENCED DATA
 M43130 0.93776 0.09202

Table 21: State Space Model for M43130

STATE SPACE FORECAST

48 OBSERVATIONS, 1 SERIES
 RANGE =JAN 73 -DEC 76

DIFFERENCING PERFORMED
 SERIES REGULAR SEASONAL
 M42732 1* 0*

* AUTOMATIC DIFFERENCING

THE FOLLOWING ARE THE ELEMENTS OF THE STATE VECTOR

CANONICAL
 CORRELATION 1.0000
 CHI SQUARE 9999.99
 D.F. 3
 INF. CRIT. 9993.99
 M42732(T)

STATE VECTOR DIMENSION IS AT LEAST 1

CANONICAL
 CORRELATION 1.0000 0.1811
 CHI SQUARE 9999.99 1.47
 D.F. 6 2
 INF. CRIT. 9987.99 -2.53

NEGATIVE INFORMATION CRITERION ELIMINATES VARIABLE 1
 FROM USE AT HIGHER LEADS IN STATE VECTOR

F MATRIX
 1 ROWS 1 COLUMN
 ROW 1 -.0618

H MATRIX
 1 ROWS 1 COLUMN
 ROW 1 1.0000

G MATRIX
 1 ROWS 1 COLUMN
 ROW 1 1.0000

RESIDUAL MEAN VECTOR
 1 ROWS 1 COLUMN
 ROW 1 0.0270

RESIDUAL COVARIANCE MATRIX
 1 ROWS 1 COLUMN
 ROW 1 1.4692

GOODNESS OF FIT ORIGINAL DATA DIFFERENCED DATA
 (1 D.F.) 108.640 -1.737

POOR MODEL FIT RELATIVE GOODNESS OF FIT IS NEGATIVE

RESIDUAL MEAN ORIGINAL DATA DIFFERENCED DATA
 M42732 0.0270 0.0270

Table 22: State Space Model for M42732

STATE SPACE FORECAST

48 OBSERVATIONS, 1 SERIES
 RANGE = JAN 73 - DEC 76

DIFFERENCING PERFORMED		
SERIES	REGULAR	SEASONAL
TSK288	1*	0*

* AUTOMATIC DIFFERENCING

THE FOLLOWING ARE THE ELEMENTS OF THE STATE VECTOR
 CANONICAL

CORRELATION	1.0000
CHI SQUARE	9999.99
D.F.	3
INF. CRIT.	9993.99
TSK288(T)	

STATE VECTOR DIMENSION IS AT LEAST 1

CANONICAL

CORRELATION	1.0000	0.1448
CHI SQUARE	9999.99	0.93
D.F.	6	2
INF. CRIT.	9987.99	-3.07

NEGATIVE INFORMATION CRITERION ELIMINATES VARIABLE 1
 FROM USE AT HIGHER LEADS IN STATE VECTOR

F MATRIX

	1 ROWS	1 COLUMNS
ROW	1	0.1159

H MATRIX

	1 ROWS	1 COLUMNS
ROW	1	1.0000

G MATRIX

	1 ROWS	1 COLUMNS
ROW	1	1.0000

RESIDUAL MEAN VECTOR

	1 ROWS	1 COLUMNS
ROW	1	0.0265

RESIDUAL COVARIANCE MATRIX

	1 ROWS	1 COLUMNS
ROW	1	0.6838

GOODNESS OF FIT	ORIGINAL DATA	DIFFERENCED DATA
(1 D.F.)	111.587	0.588

R SQUARED TEST	ORIGINAL DATA	DIFFERENCED DATA
TSK288	0.91079	0.05357

Table 23: State Space Model for TSK288

STATE SPACE FORECAST

48 OBSERVATIONS, 1 SERIES
 RANGE = JAN 73 - DEC 76

DIFFERENCING PERFORMED
 SERIES REGULAR SEASONAL
 M54130 1* 0*

* AUTOMATIC DIFFERENCING

THE FOLLOWING ARE THE ELEMENTS OF THE STATE VECTOR

CANONICAL
 CORRELATION 1.0000
 CHI SQUARE 9999.99
 D.F. 3
 INF. CRIT. 9993.99
 M54130(T)
 STATE VECTOR DIMENSION IS AT LEAST 1

CANONICAL
 CORRELATION 1.0000 0.1753
 CHI SQUARE 9999.99 1.37
 D.F. 6 2
 INF. CRIT. 9987.99 -2.63
 NEGATIVE INFORMATION CRITERION ELIMINATES VARIABLE 1
 FROM USE AT HIGHER LEADS IN STATE VECTOR

F MATRIX

1 ROWS 1 COLUMNS
 ROW 1 -.2504

H MATRIX

1 ROWS 1 COLUMNS
 ROW 1 1.0000

G MATRIX

1 ROWS 1 COLUMNS
 ROW 1 1.0000

RESIDUAL MEAN VECTOR

1 ROWS 1 COLUMNS
 ROW 1 0.0508

RESIDUAL COVARIANCE MATRIX

1 ROWS 1 COLUMNS
 ROW 1 3.9261

GOODNESS OF FIT	ORIGINAL DATA	DIFFERENCED DATA
(1 D.F.)	121.402	2.657

R SQUARED TEST	ORIGINAL DATA	DIFFERENCED DATA
M54130	0.99960	0.99993

Table 24: State Space Model for M54130

STATE SPACE FORECAST

48 OBSERVATIONS, 1 SERIES
 RANGE =JAN 73 -DEC 76

DIFFERENCING PERFORMED
 SERIES REGULAR SEASONAL
 M23132 1* 0*

* AUTOMATIC DIFFERENCING

THE FOLLOWING ARE THE ELEMENTS OF THE STATE VECTOR
 CANONICAL

CORRELATION 1.0000
 CHI SQUARE 9999.99
 D.F. 3
 INF. CRIT. 9993.99

M23132(T)
 STATE VECTOR DIMENSION IS AT LEAST 1

CANONICAL
 CORRELATION 1.0000 0.2712
 CHI SQUARE 9999.99 3.36
 D.F. 6 2
 INF. CRIT. 9997.99 -.64
 NEGATIVE INFORMATION CRITERION ELIMINATES VARIABLE 1
 FROM USE AT HIGHER LEADS IN STATE VECTOR

F MATRIX
 1 ROWS 1 COLUMNS
 ROW 1 0.1773

H MATRIX
 1 ROWS 1 COLUMNS
 ROW 1 1.0000

G MATRIX
 1 ROWS 1 COLUMNS
 ROW 1 1.0000

RESIDUAL MEAN VECTOR
 1 ROWS 1 COLUMNS
 ROW 1 0.0261

RESIDUAL COVARIANCE MATRIX
 1 ROWS 1 COLUMNS
 ROW 1 0.9003

GOODNESS OF FIT ORIGINAL DATA DIFFERENCED DATA
 (1 D.F.) 134.770 1.315

R SQUARED TEST ORIGINAL DATA DIFFERENCED DATA
 M23132 0.94557 0.00819

TABLE 73: State Space Model Summary

90490

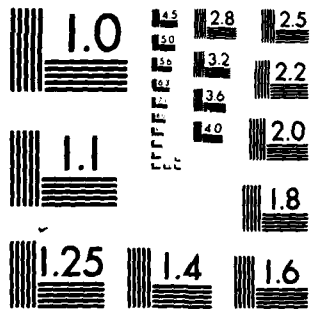

MICROCOPY RESOLUTION TEST CHART
NATIONAL BUREAU OF STANDARDS-1963 A

STATE SPACE FORECAST

48 OBSERVATIONS, 1 SERIES
 RANGE =JAN 73 -DEC 76

DIFFERENCING PERFORMED
 SERIES REGULAR SEASONAL
 M27131 1* 0*

* AUTOMATIC DIFFERENCING

THE FOLLOWING ARE THE ELEMENTS OF THE STATE VECTOR
 CANONICAL

CORRELATION 1.0000
 CHI SQUARE 9999.99
 D.F. 3
 INF. CRIT. 9993.99

M27131(T)
 STATE VECTOR DIMENSION IS AT LEAST 1

CANONICAL
 CORRELATION 1.0000 0.2066
 CHI SQUARE 9999.99 1.92
 D.F. 6 2
 INF. CRIT. 9987.99 -2.08

NEGATIVE INFORMATION CRITERION ELIMINATES VARIABLE 1
 FROM USE AT HIGHER LEADS IN STATE VECTOR

F MATRIX
 1 ROWS 1 COLUMNS
 ROW 1 0.2106

H MATRIX
 1 ROWS 1 COLUMNS
 ROW 1 1.0000

G MATRIX
 1 ROWS 1 COLUMNS
 ROW 1 1.0000

RESIDUAL MEAN VECTOR
 1 ROWS 1 COLUMNS
 ROW 1 0.0286

RESIDUAL COVARIANCE MATRIX
 1 ROWS 1 COLUMNS
 ROW 1 0.5110

GOODNESS OF FIT ORIGINAL DATA DIFFERENCED DATA
 (1 D.F.) 128.312 2.865

R SQUARED TEST ORIGINAL DATA DIFFERENCED DATA
 M27131 0.93750 0.09834

Table 26: State Space Model for M27131

STATE SPACE FORECAST

48 OBSERVATIONS, 1 SERIES
 RANGE =JAN 73 -DEC 76

DIFFERENCING PERFORMED
 SERIES REGULAR SEASONAL
 M42333 1* 0*

* AUTOMATIC DIFFERENCING

THE FOLLOWING ARE THE ELEMENTS OF THE STATE VECTOR

CANONICAL
 CORRELATION 1.0000
 CHI SQUARE 9999.99
 D.F. 3
 INF. CRIT. 9993.99
 M42333(T)
 STATE VECTOR DIMENSION IS AT LEAST 1

CANONICAL
 CORRELATION 1.0000 0.0956
 CHI SQUARE 9999.99 0.40
 D.F. 6 2
 INF. CRIT. 9987.99 -3.60
 NEGATIVE INFORMATION CRITERION ELIMINATES VARIABLE 1
 FROM USE AT HIGHER LEADS IN STATE VECTOR

F MATRIX
 1 ROWS 1 COLUMNS
 ROW 1 -.3049

H MATRIX
 1 ROWS 1 COLUMNS
 ROW 1 1.0000

G MATRIX
 1 ROWS 1 COLUMNS
 ROW 1 1.0000

RESIDUAL MEAN VECTOR
 1 ROWS 1 COLUMNS
 ROW 1 0.0260

RESIDUAL COVARIANCE MATRIX
 1 ROWS 1 COLUMNS
 ROW 1 0.6386

GOODNESS OF FIT ORIGINAL DATA DIFFERENCED DATA
 (1 D.F.) 120.939 4.734

R SQUARED TEST ORIGINAL DATA DIFFERENCED DATA
 M42333 0.92689 0.13349

Table 27: State Space Model for M42333

F=F30230
 2=F30230PH

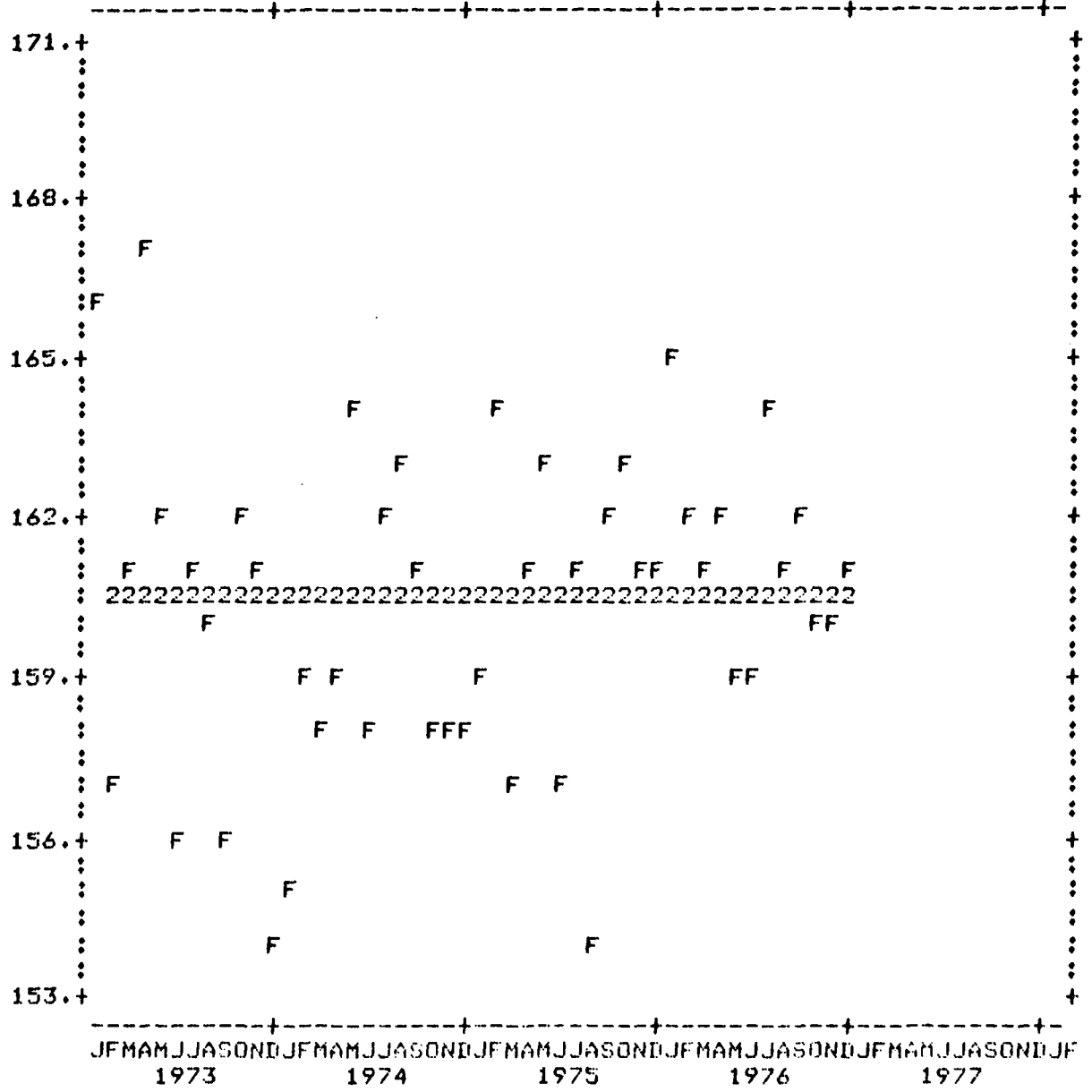

Figure B.1. Plot of One Step State Space Prediction for F30230 and Observed Data Over Fit Set

F=F30230
 2=F30230P
 3=F30230PU
 4=F30230PL

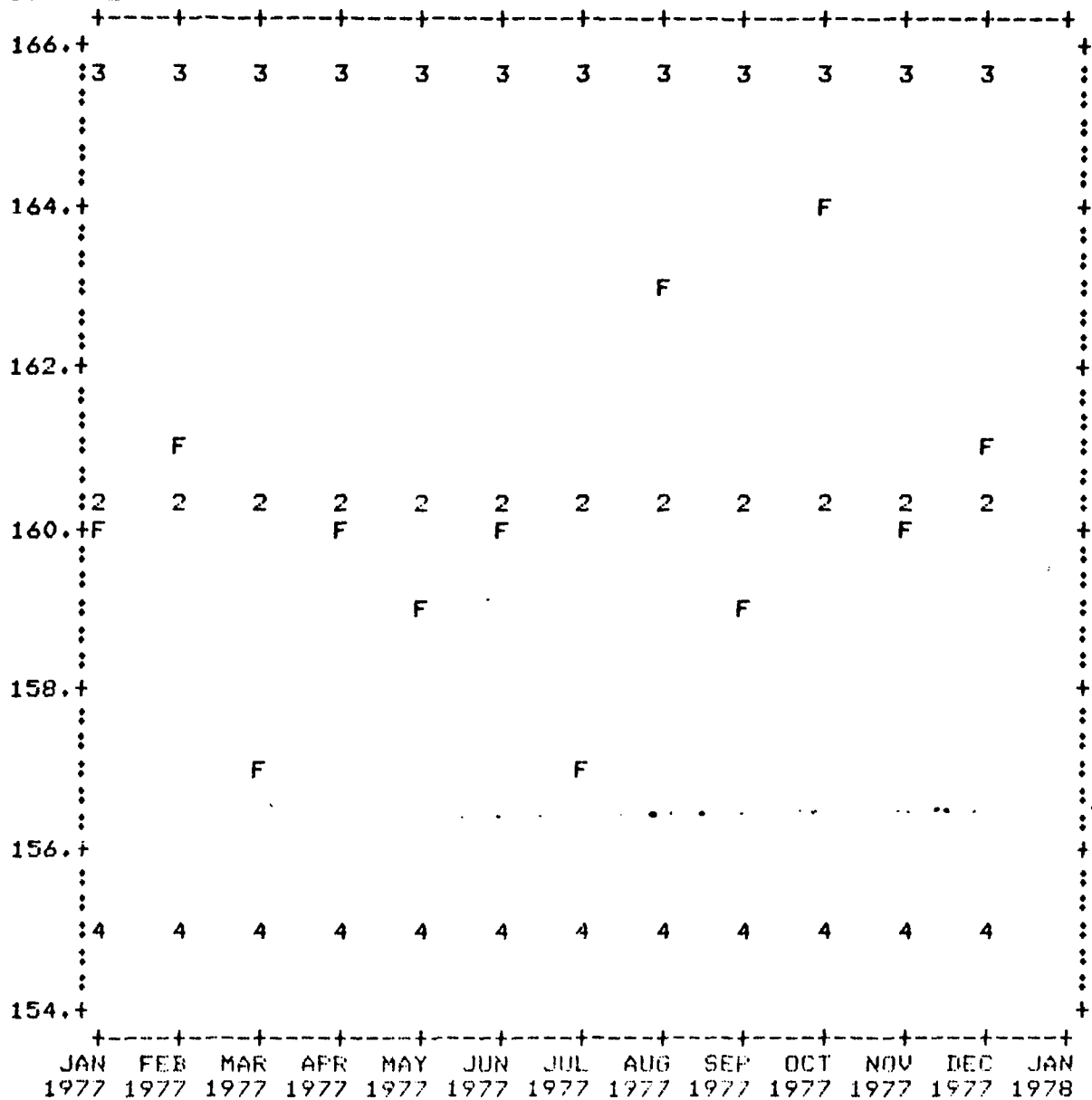

Figure B.2. Plot of 12-Month State Space Prediction and Actual Observed Data of F30230 for 1977

F=F67231
 2=F67231PH

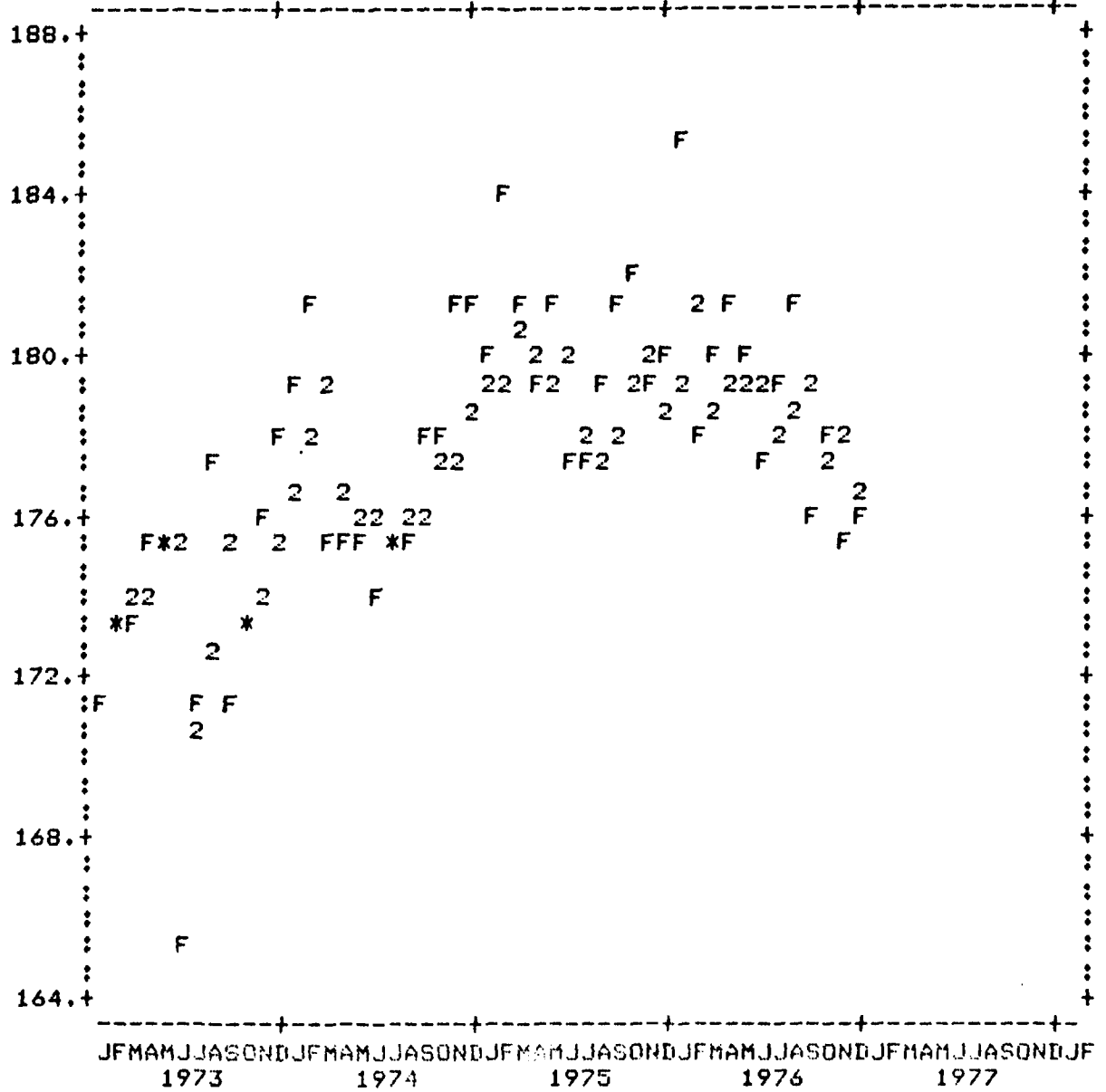

Figure B.3. Plot of One Step State Space Prediction for F67231 and Observed Data Over Fit Set

F=F67231
 2=F67231P
 3=F67231PU
 4=F67231PL

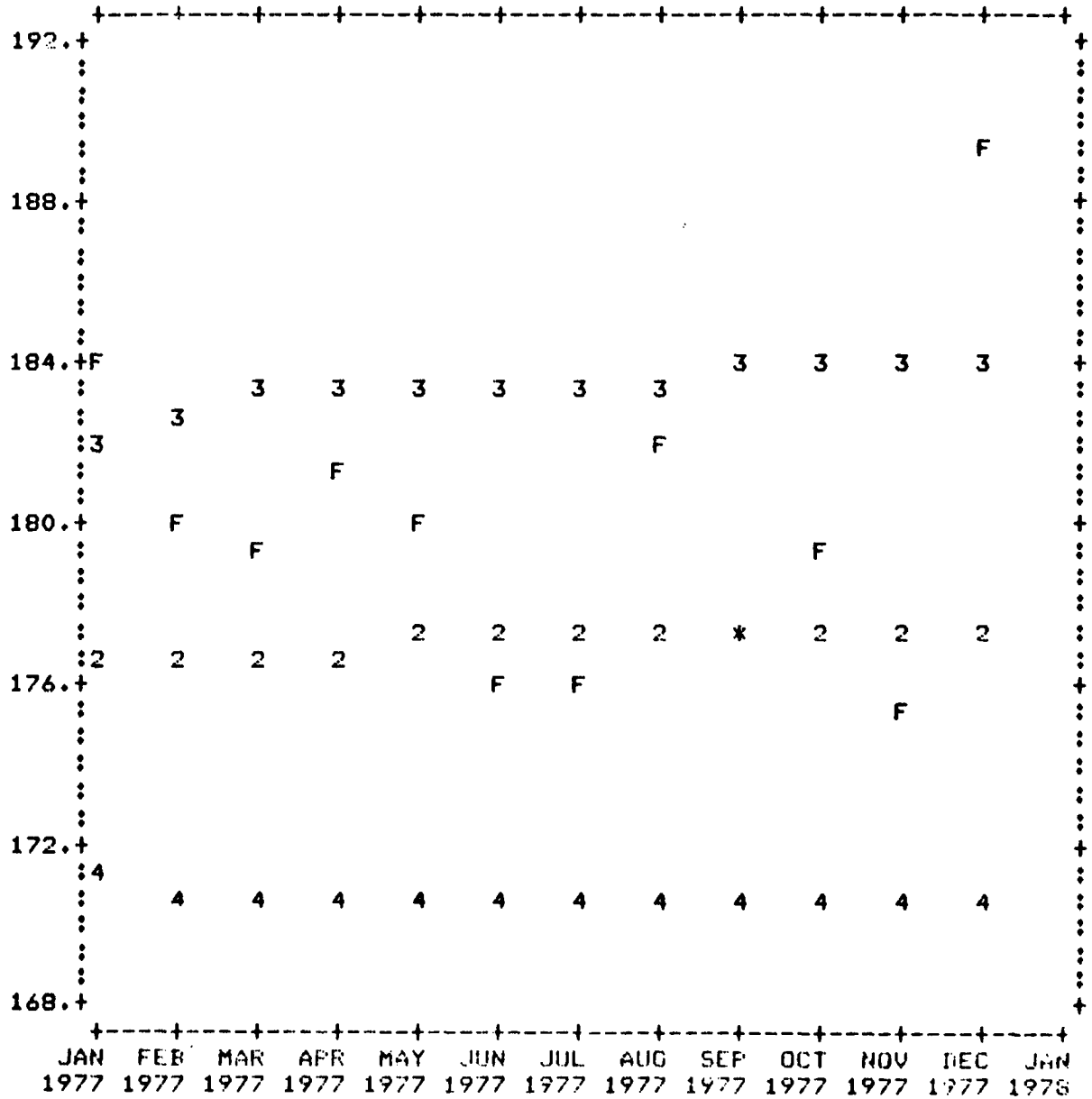

Figure B.4. Plot of 12-Month State Space Prediction and Actual Observed Data of F67231 for 1977

F=F20230
 2=F20230PH

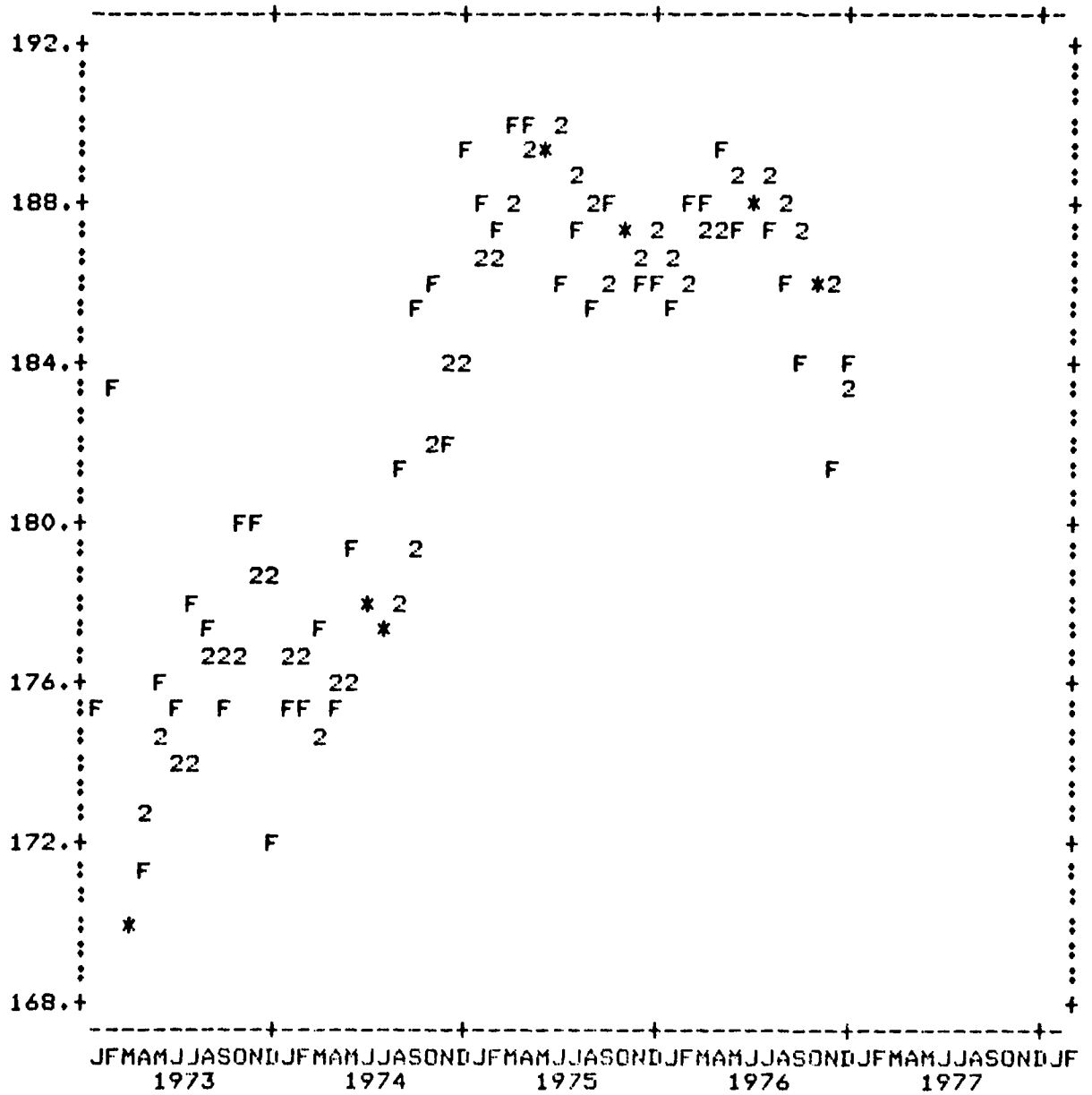

Figure B.5. Plot of One Step State Space Prediction for F20230 and Observed Data Over Fit Set

F=F20230
 2=F20230F
 3=F20230FU
 4=F20230PL

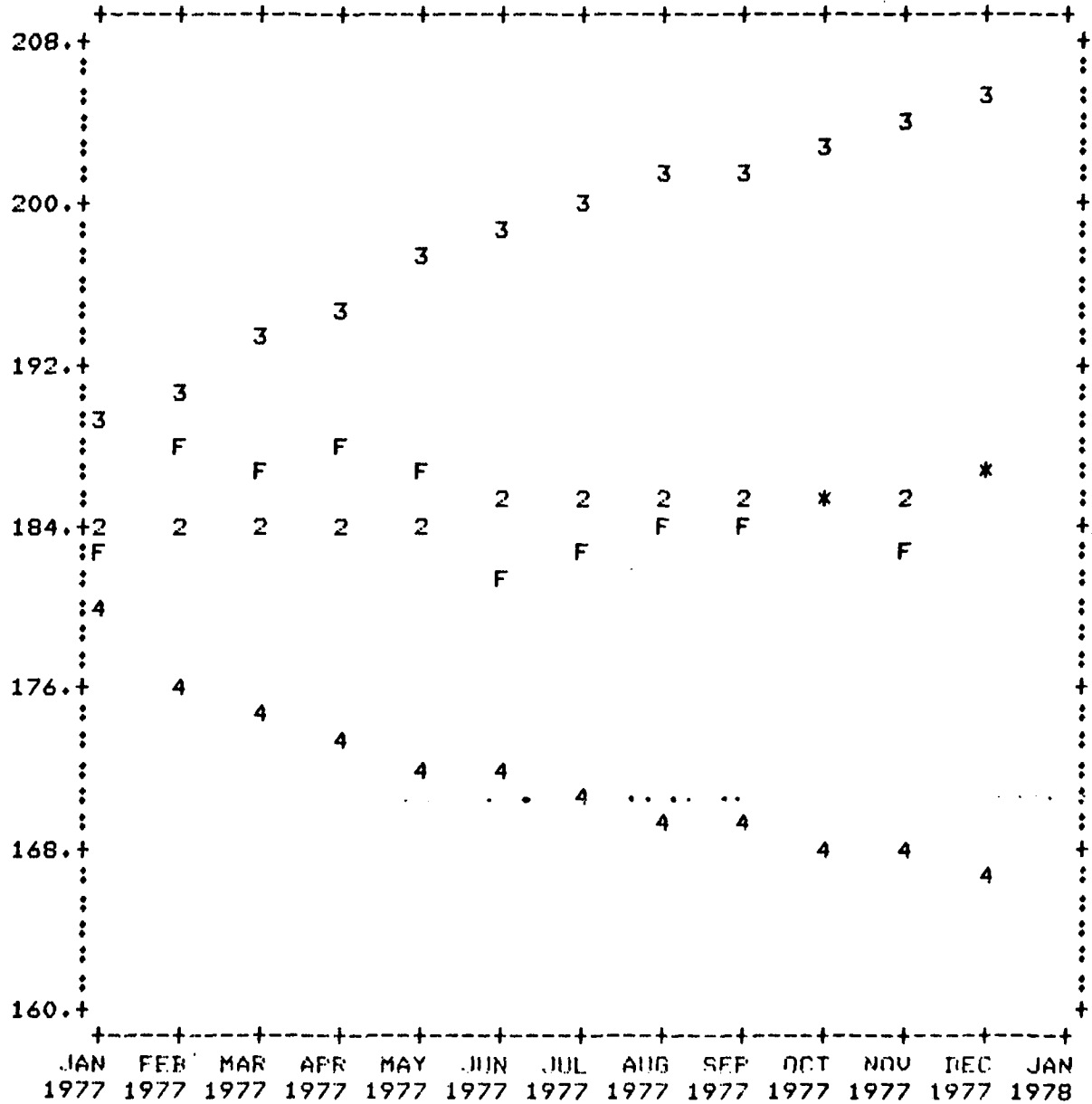

Figure B.6. Plot of 12-Month State Space Prediction and Actual Observed Data of F20230 for 1977

F=F46330
2=F46330PH

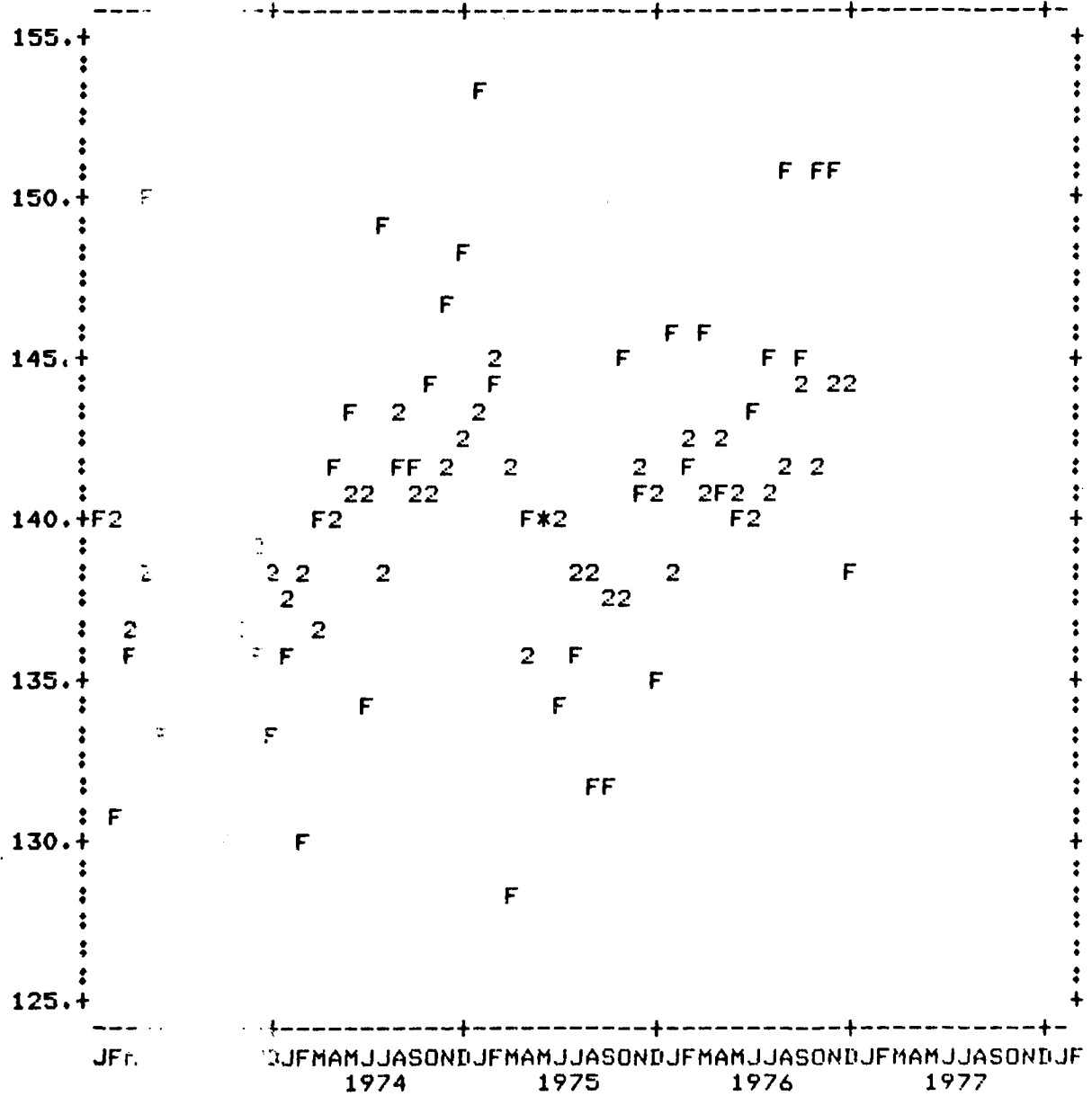

Figure 1. Plot of One Step State Space Prediction for F46330 and Observed Data Over Fit Set

F=F46330
 2=F46330F
 3=F46330FU
 4=F46330PL

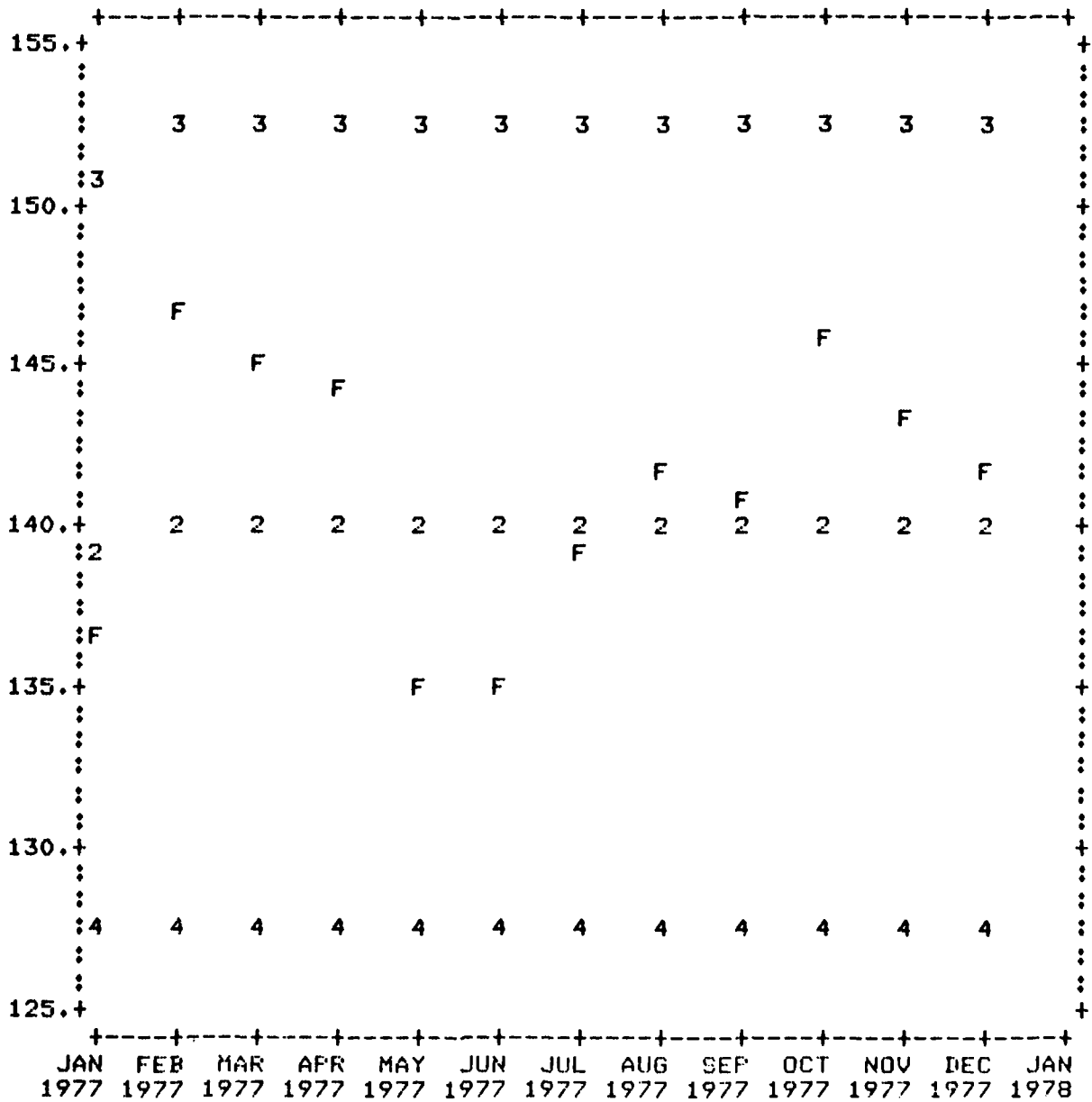

Figure B.8. Plot of 12-Month State Space Prediction and Actual Observed Data of F46330 for 1977

F=F46230
2=F46230PH

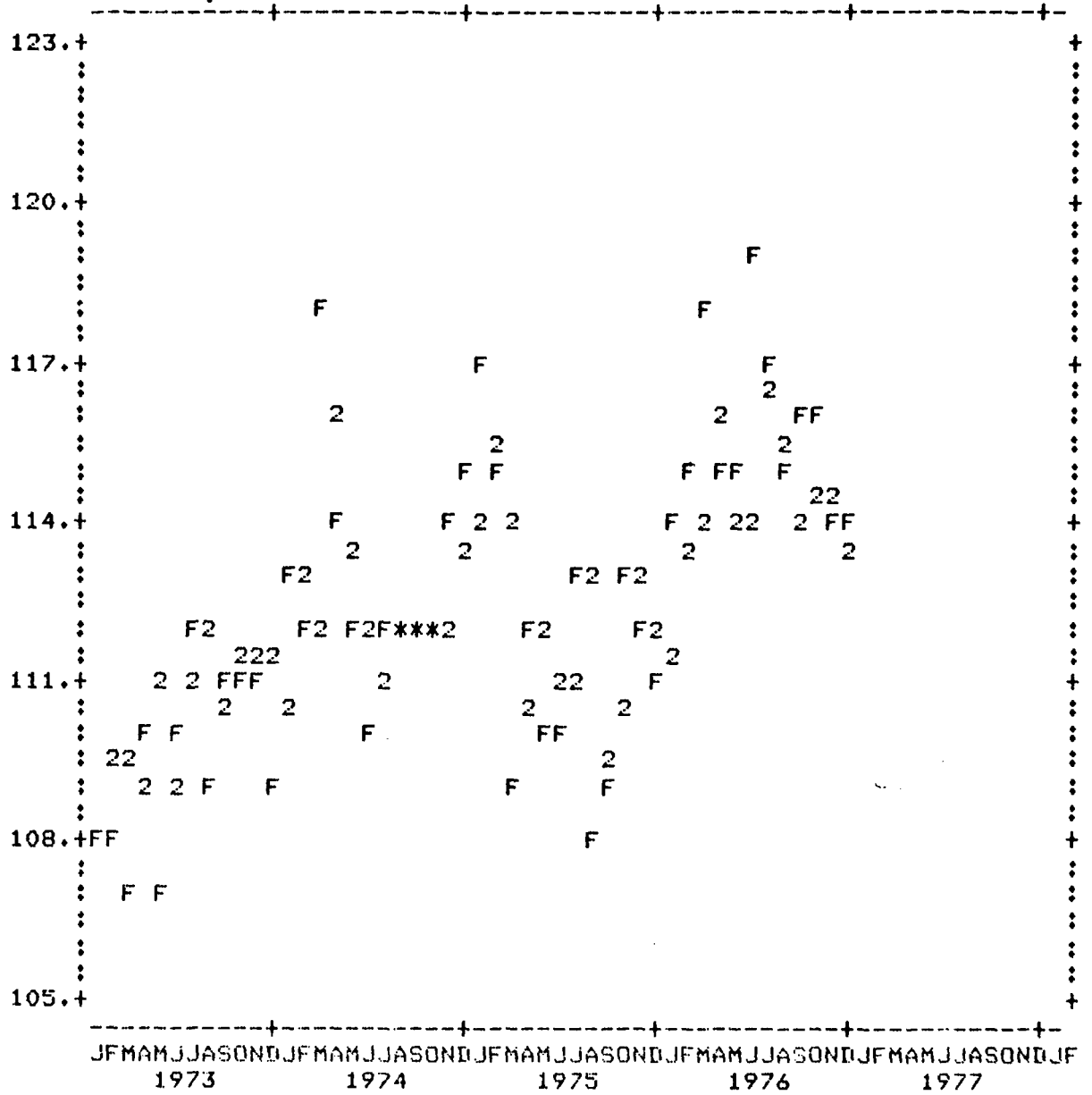

Figure B.9. Plot of One Step State Space Prediction for F46230 and Observed Data Over Fit Set

F=F46230
 2=F46230P
 3=F46230PU
 4=F46230PL

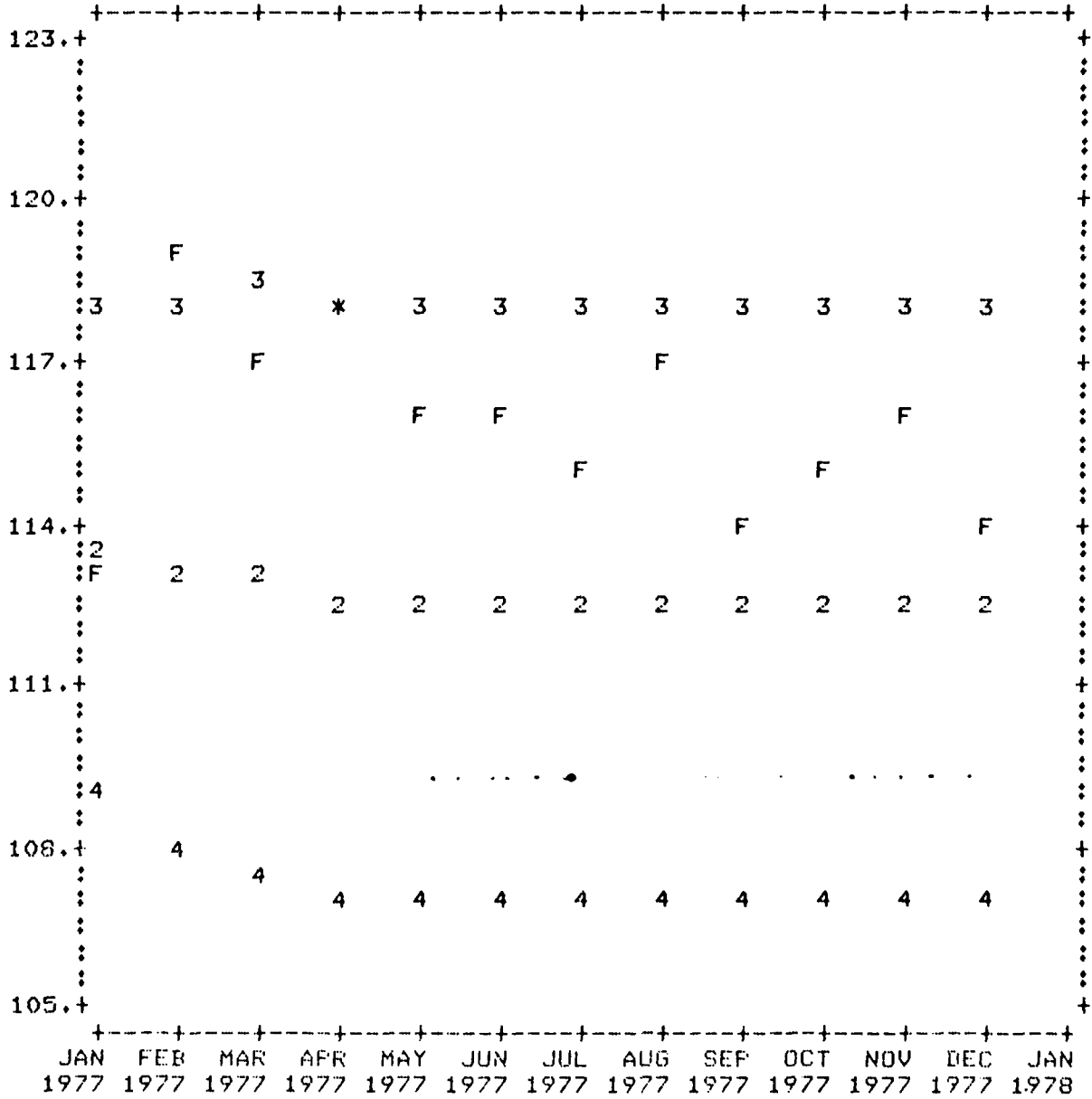

Figure B.10. Plot of 12-Month State Space Prediction and Actual Observed Data of F46230 for 1977

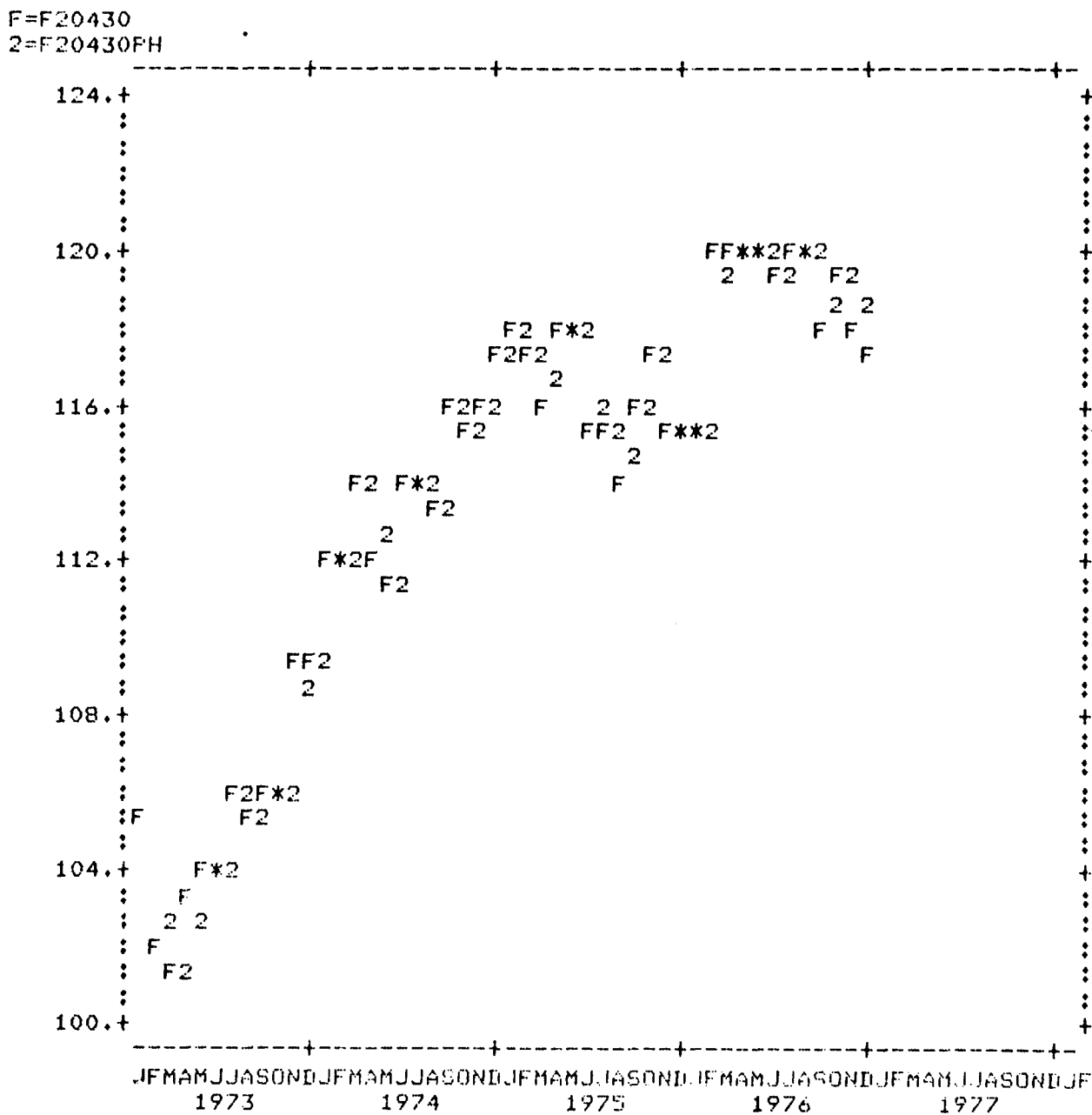

Figure B.11. Plot of One Step State Space Prediction for F20430 and Observed Data Over Fit Set

F=F20430
 2=F20430F
 3=F20430FU
 4=F20430FL

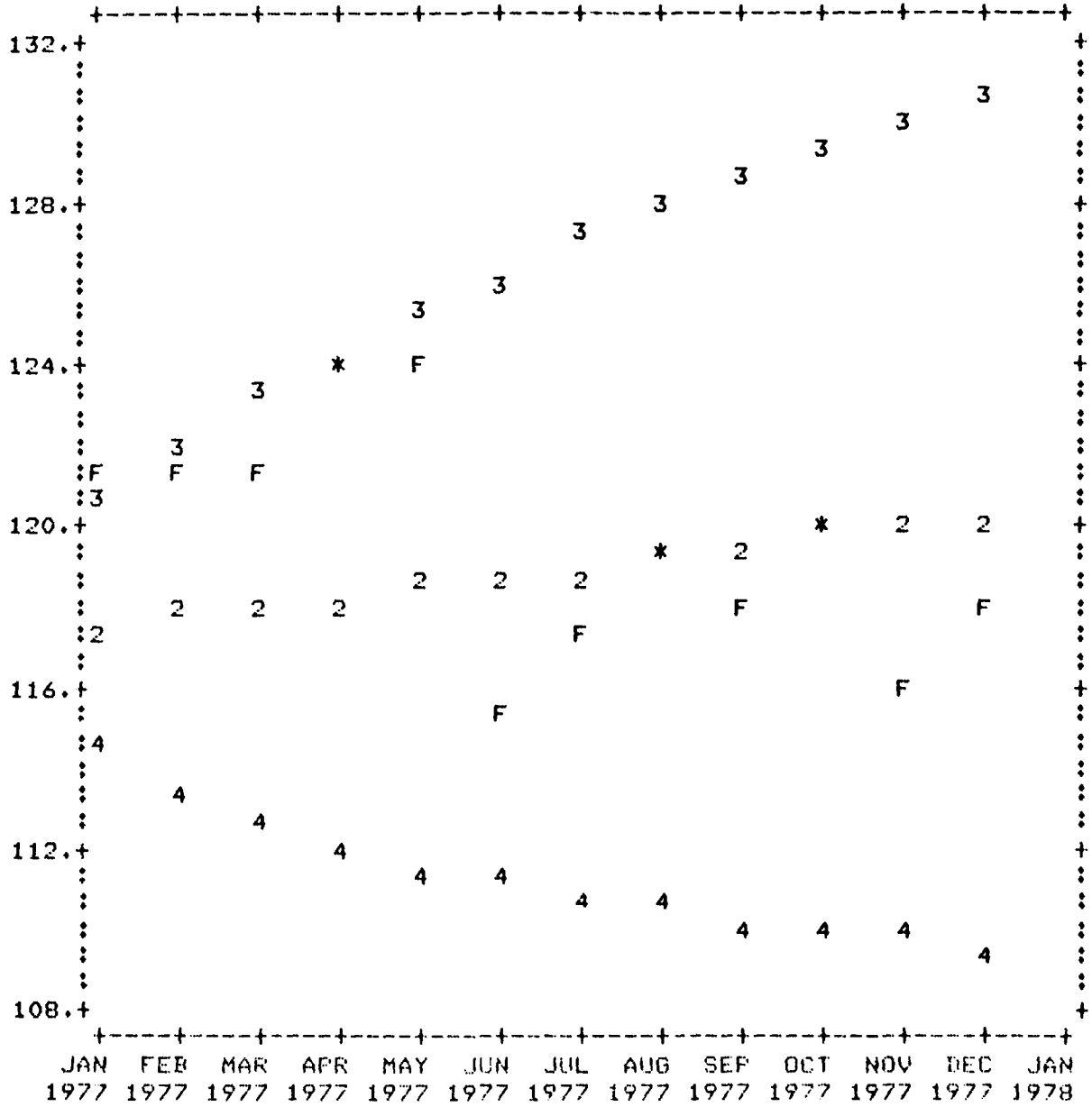

Figure B.12. Plot of 12-Month State Space Prediction and Actual Observed Data of F20430 for 1977

F=F43130
 2=F43130PH

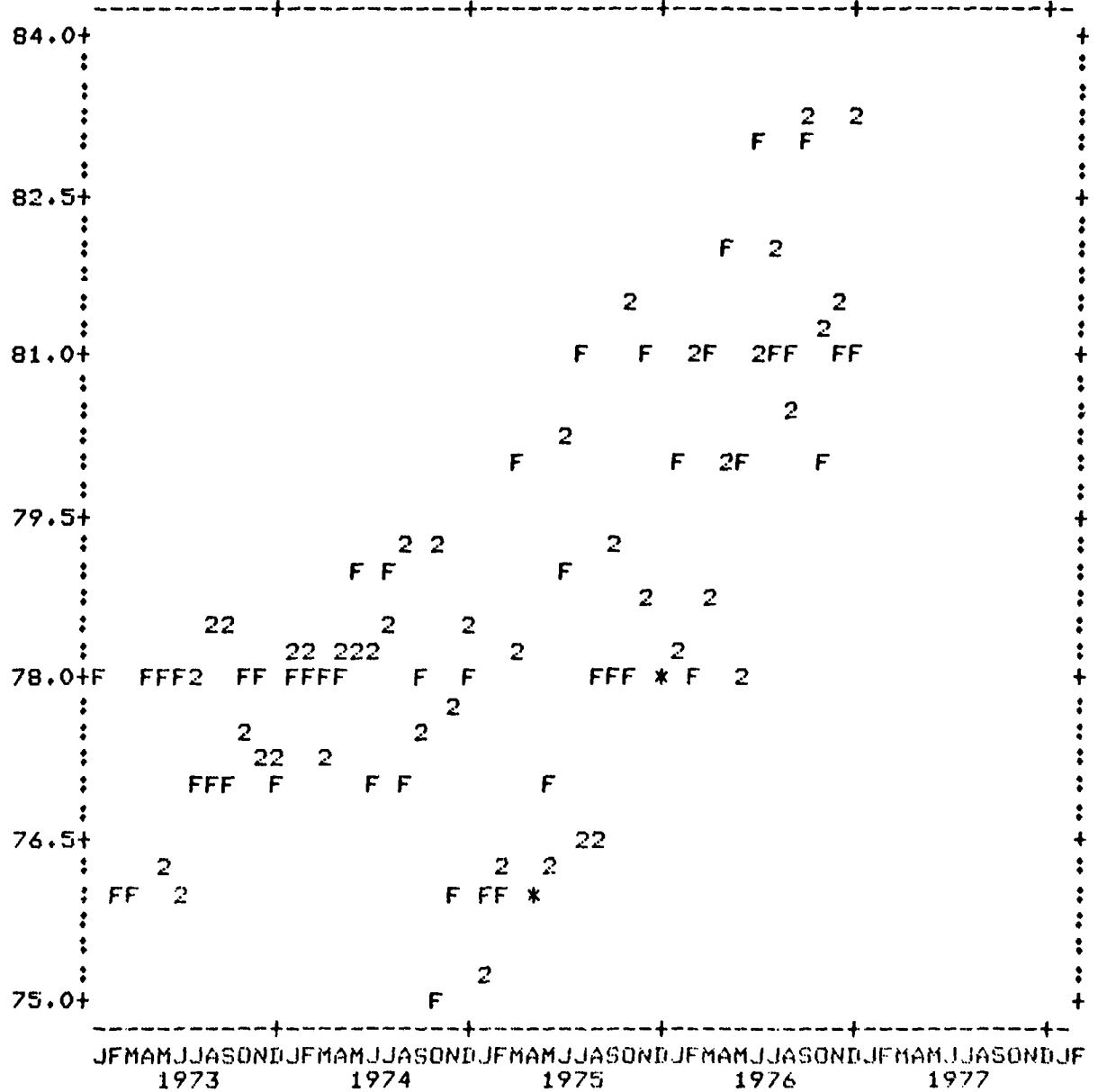

Figure B.13. Plot of One Step State Space Prediction for F43130 and Observed Data Over Fit Set

F=F43130
 2=F43130F
 3=F43130PU
 4=F43130PL

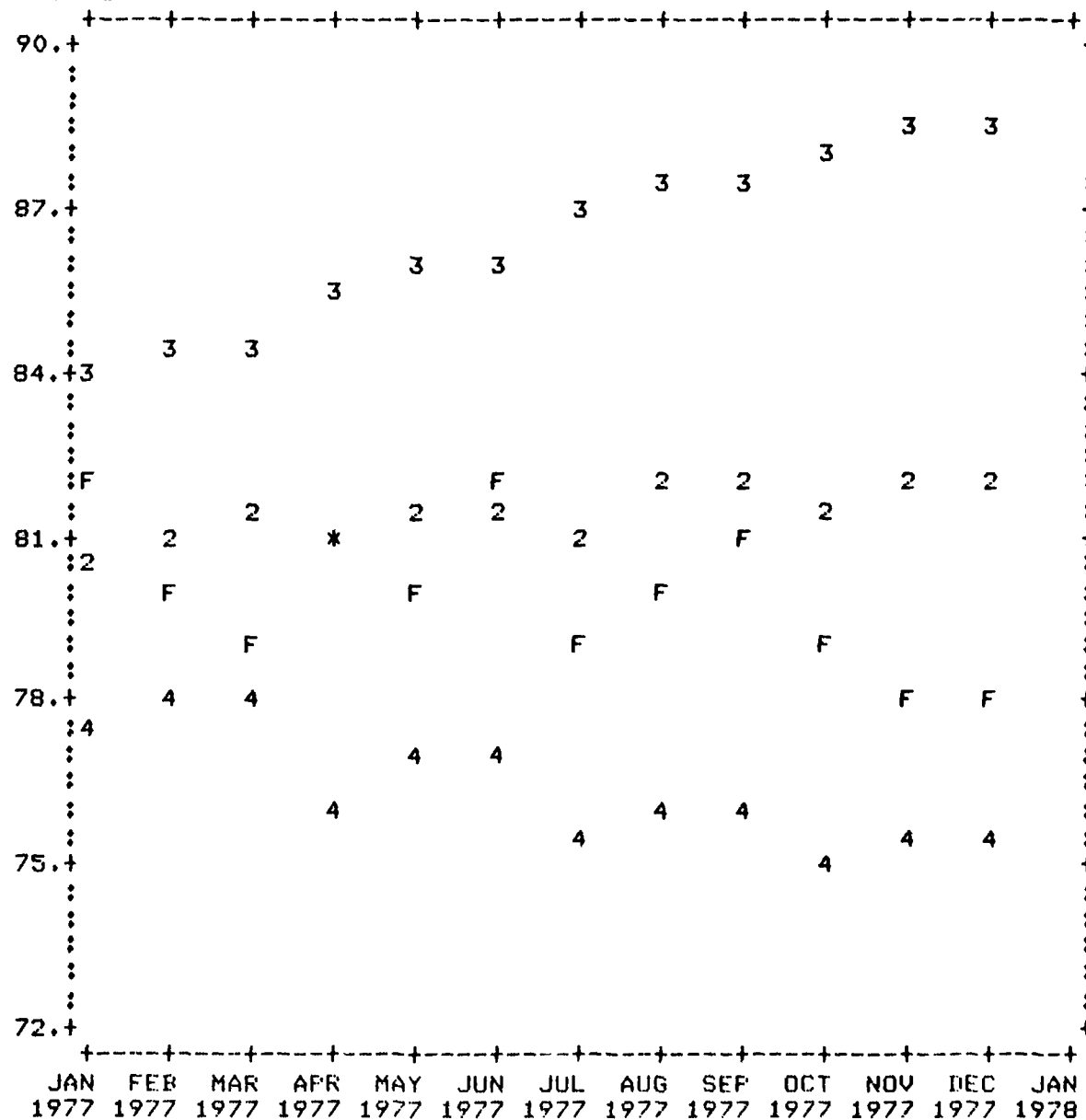

Figure B.14. Plot of 12-Month State Space Prediction and Actual Observed Data of F43130 for 1977

F=F42732
 2=F42732PH

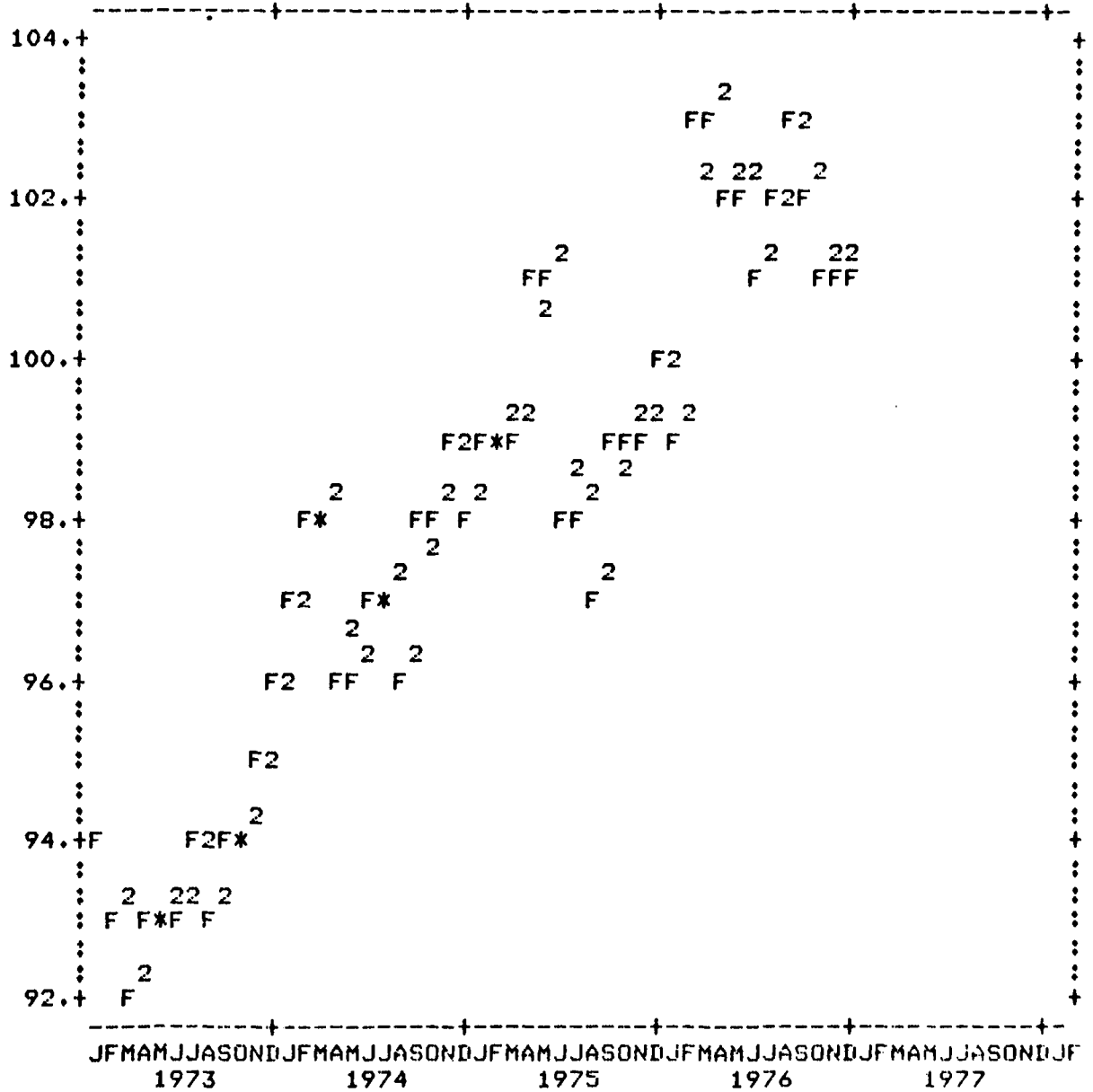

Figure B.15. Plot of One Step State Space Prediction for F42732 and Observed Data Over Fit Set

F=F42732
 2=F42732F
 3=F42732FU
 4=F42732PL

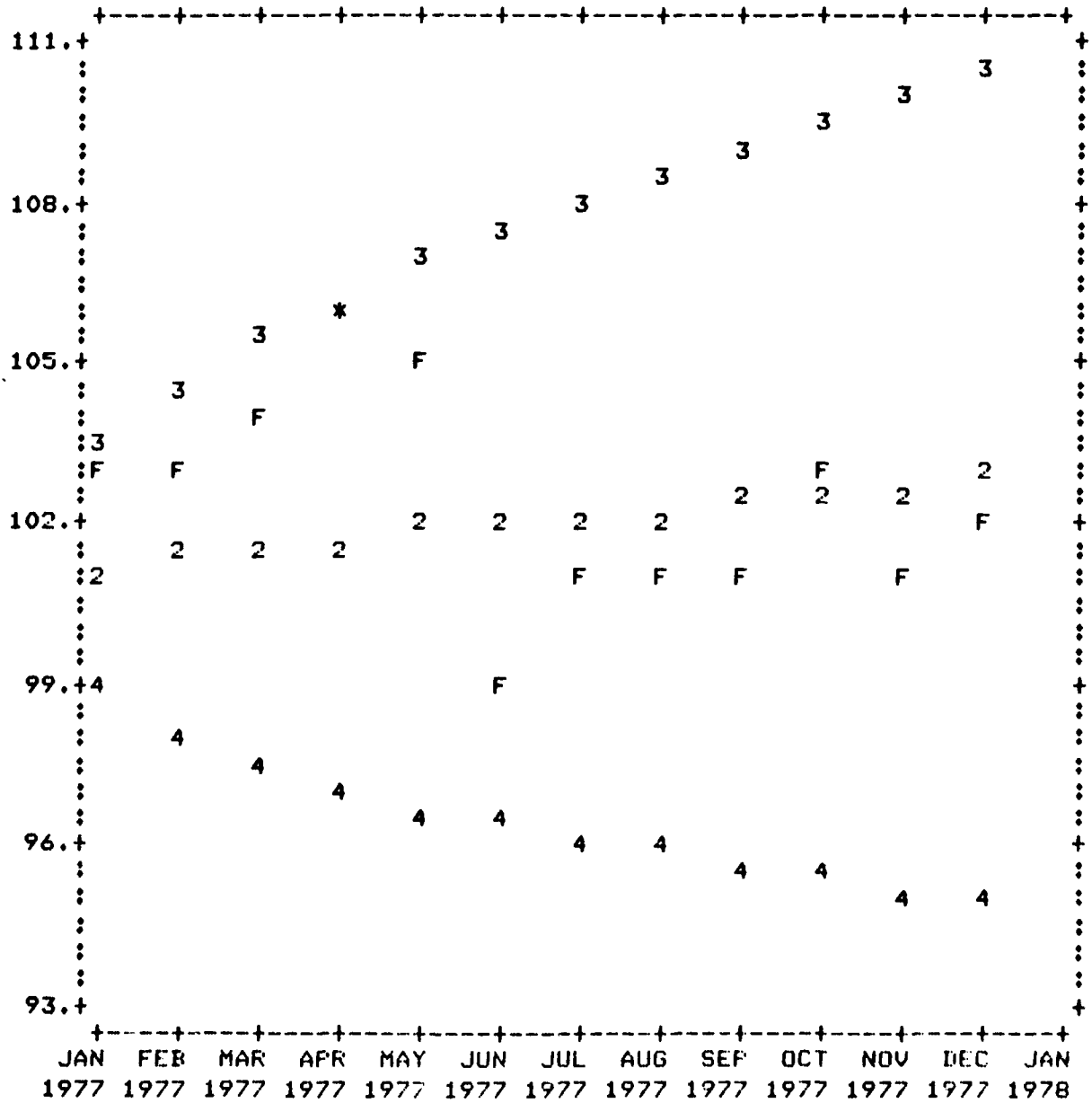

Figure B.16. Plot of 12-Month State Space Prediction and Actual Observed Data of F42732 for 1977

T=TSK287
2=TSK287PH

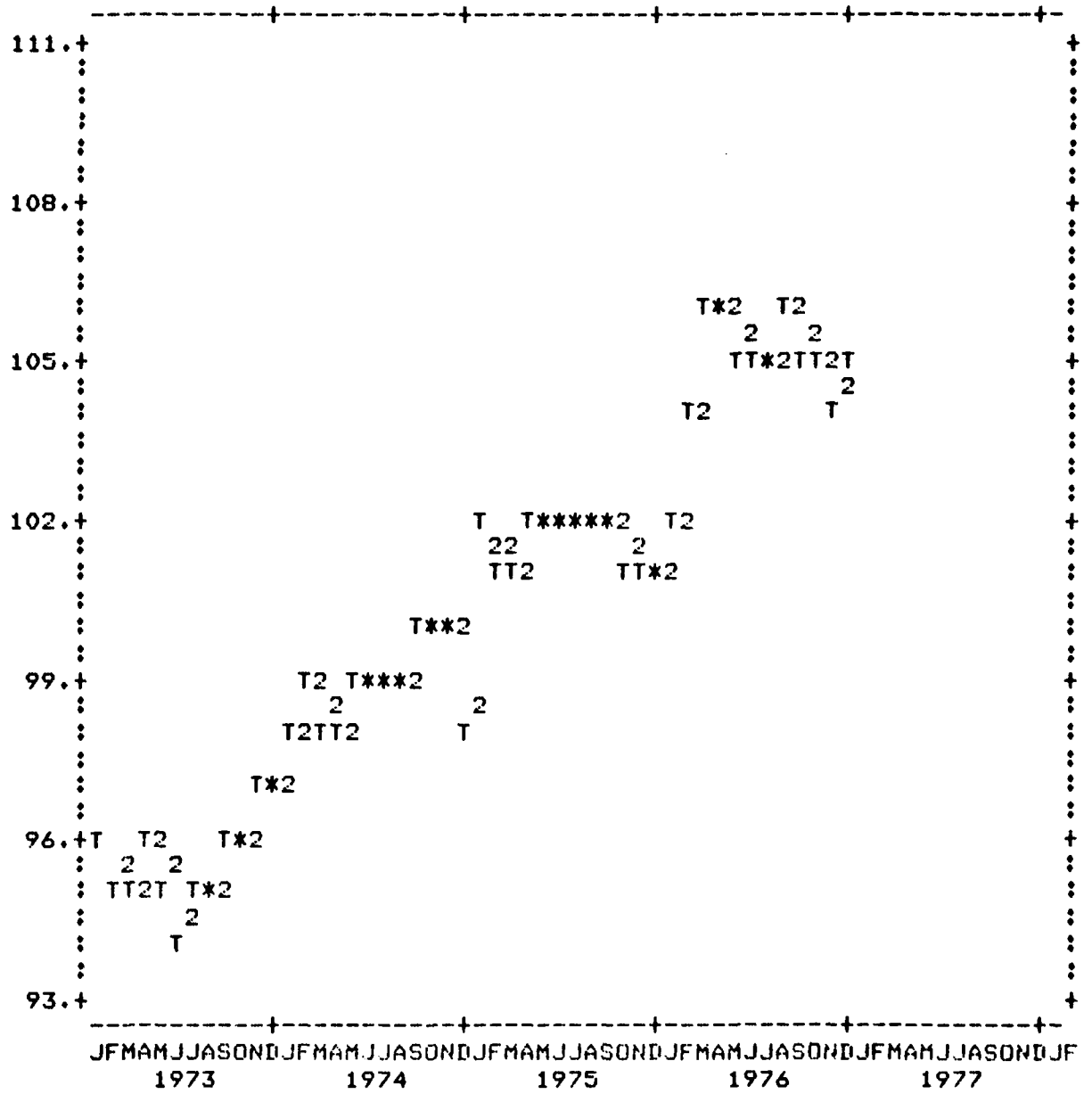

Figure B.17. Plot of One Step State Space Prediction for TSK287 and Observed Data Over Fit Set

T=TSK287
 2=TSK287P
 3=TSK287PU
 4=TSK287PL

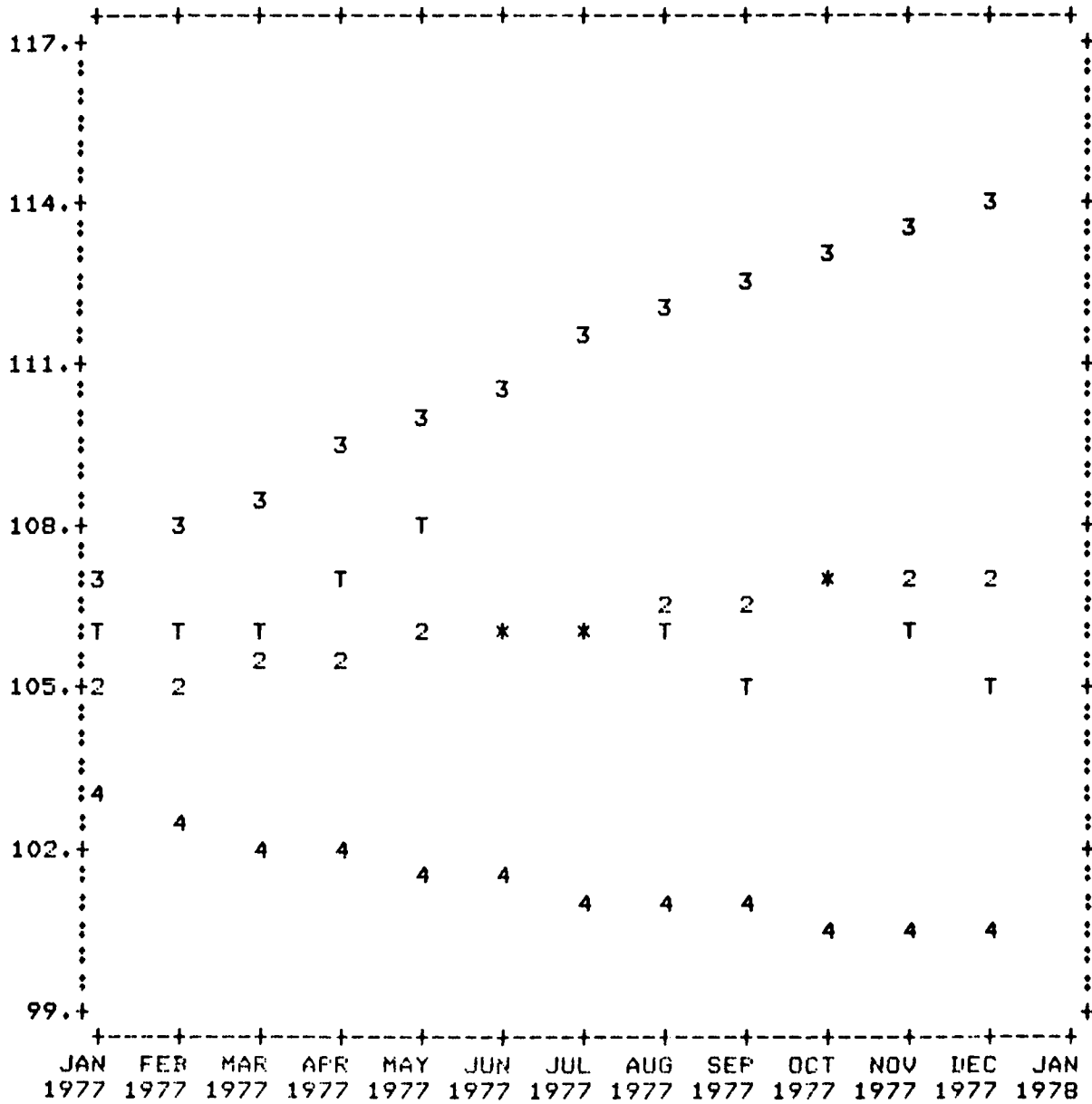

Figure B.18. Plot of 12-Month State Space Prediction and Actual Observed Data of TSK287 for 1977

F=F54130
 2=F54130FH

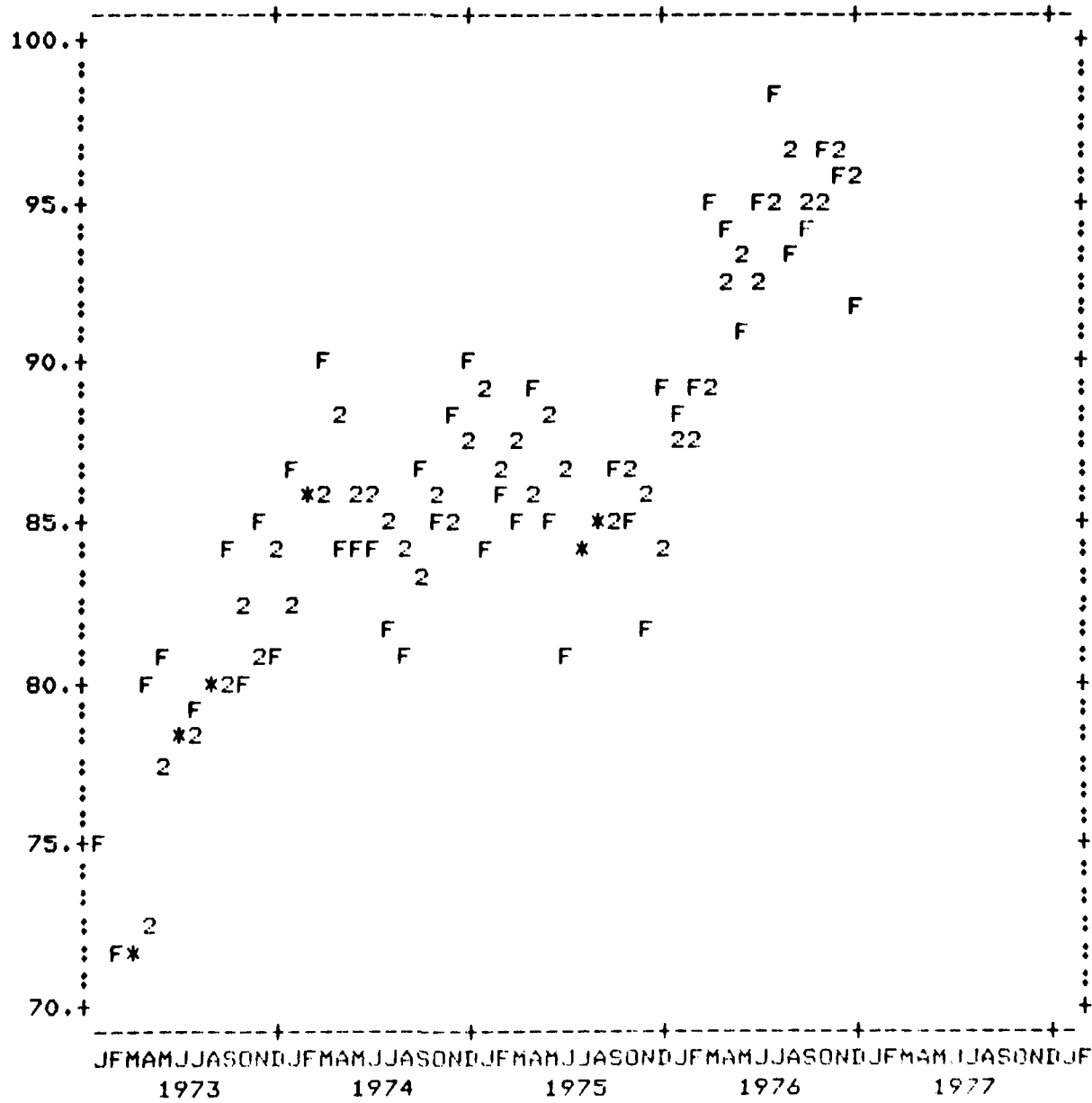

Figure B.19. Plot of One Step State Space Prediction for F54130 and Observed Data Over Fit Set

F=F54130
 2=F54130F
 3=F54130PU
 4=F54130PL

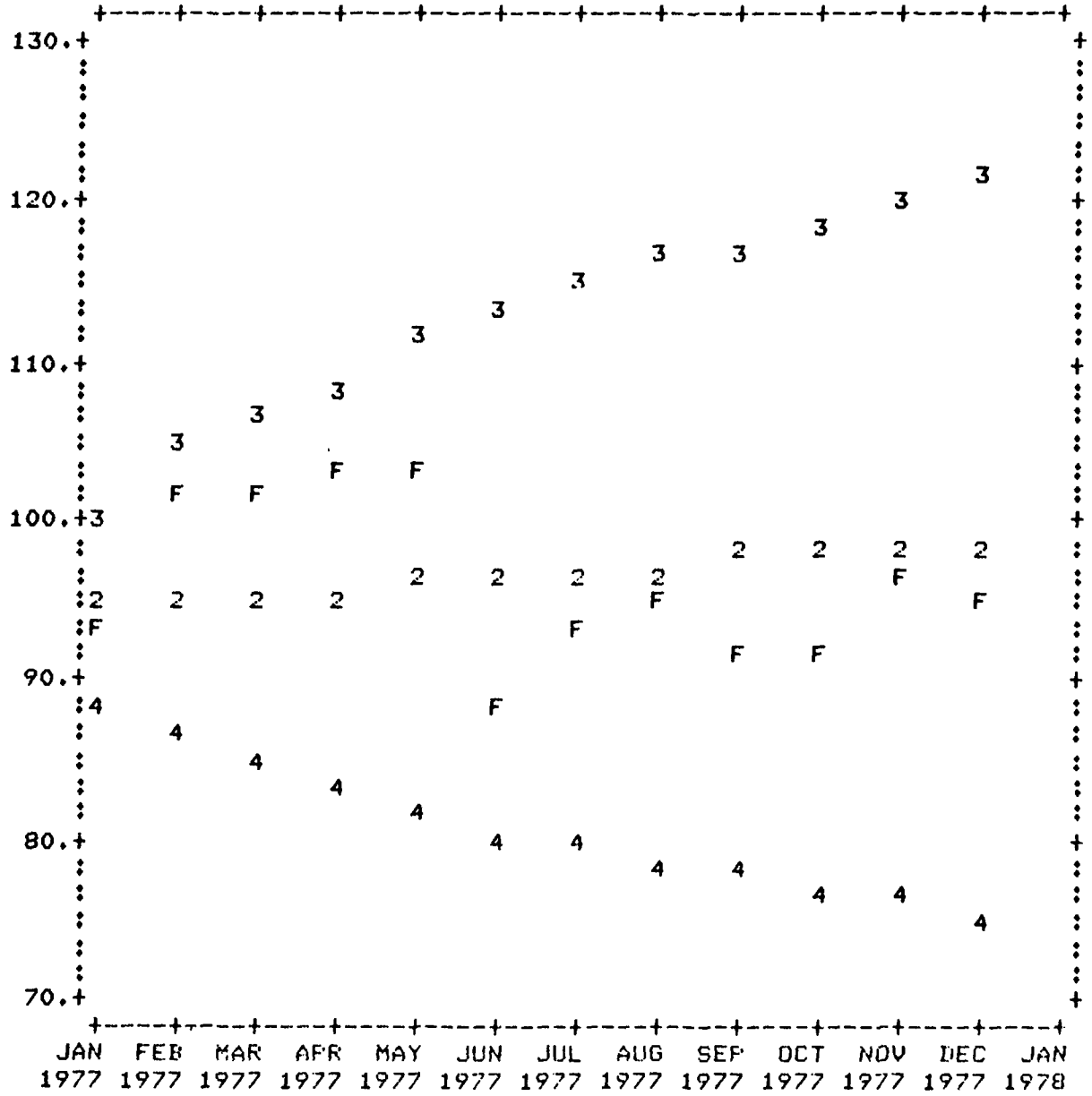

Figure B.20. Plot of 12-Month State Space Prediction and Actual Observed Data of F54130 for 1977

F=F23132
 2=F23132PH

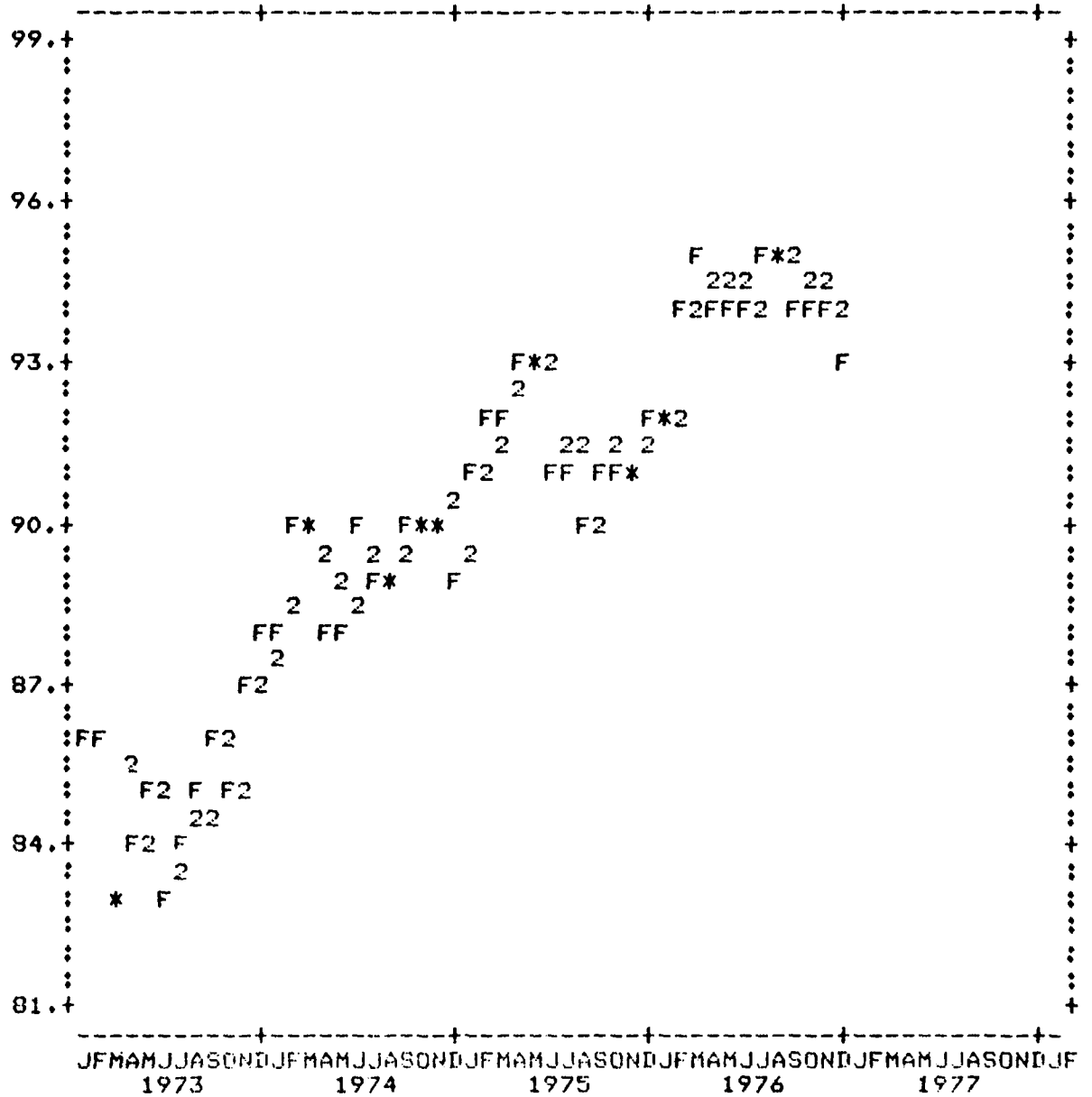

Figure B.21. Plot of One Step State Space Prediction for F23132 and Observed Data Over Fit Set

F=F23132
 2=F23132F
 3=F23132FU
 4=F23132FL

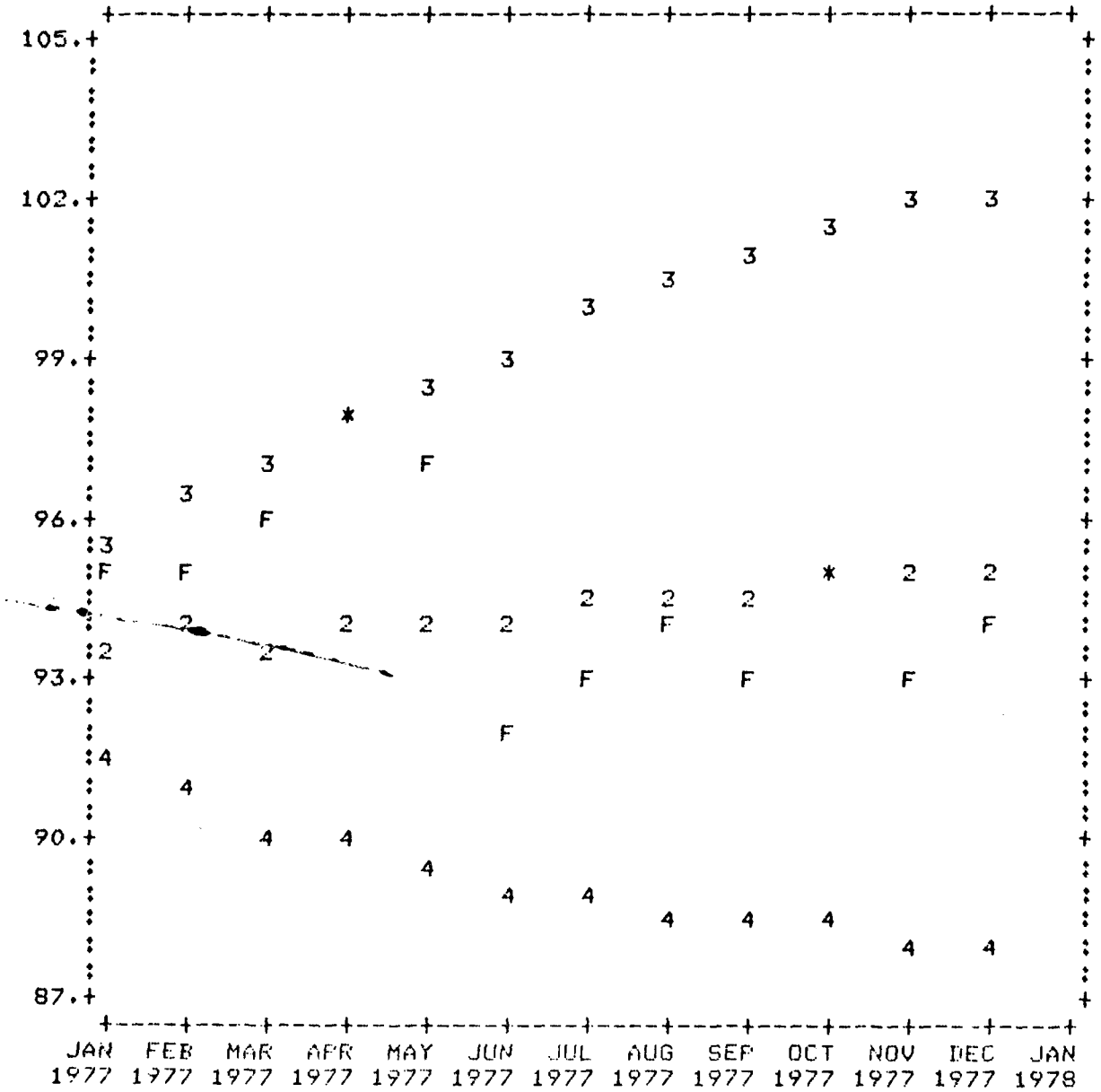

Figure B.22. Plot of 12-Month State Space Prediction and Actual Observed Data for F23132 for 1977

F=F27131
 2=F27131PH

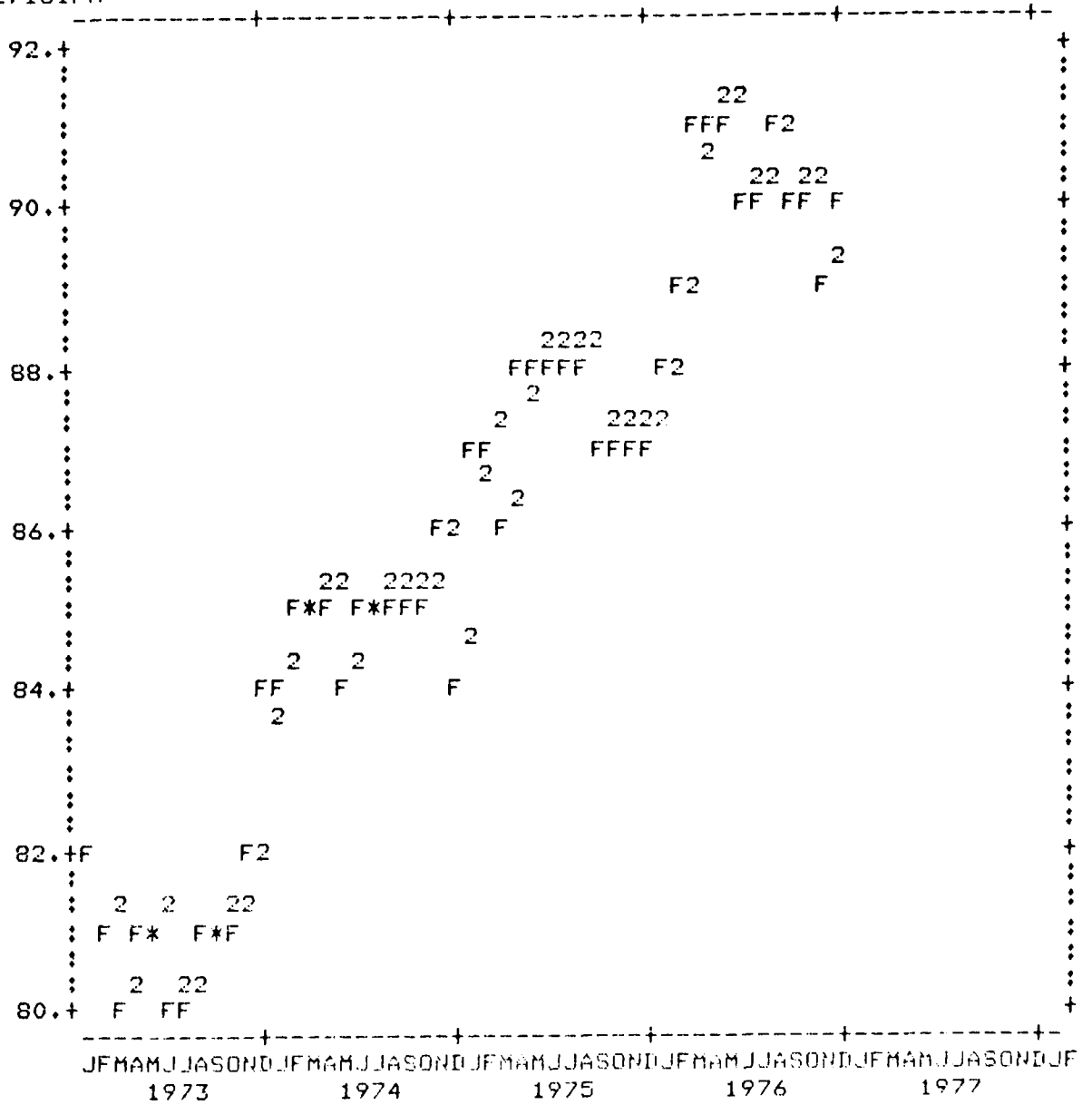

Figure B.23. Plot of One Step State Space Prediction for F27131 and Observed Data Over Fit Set

F=F27131
 2=F27131P
 3=F27131PU
 4=F27131PL

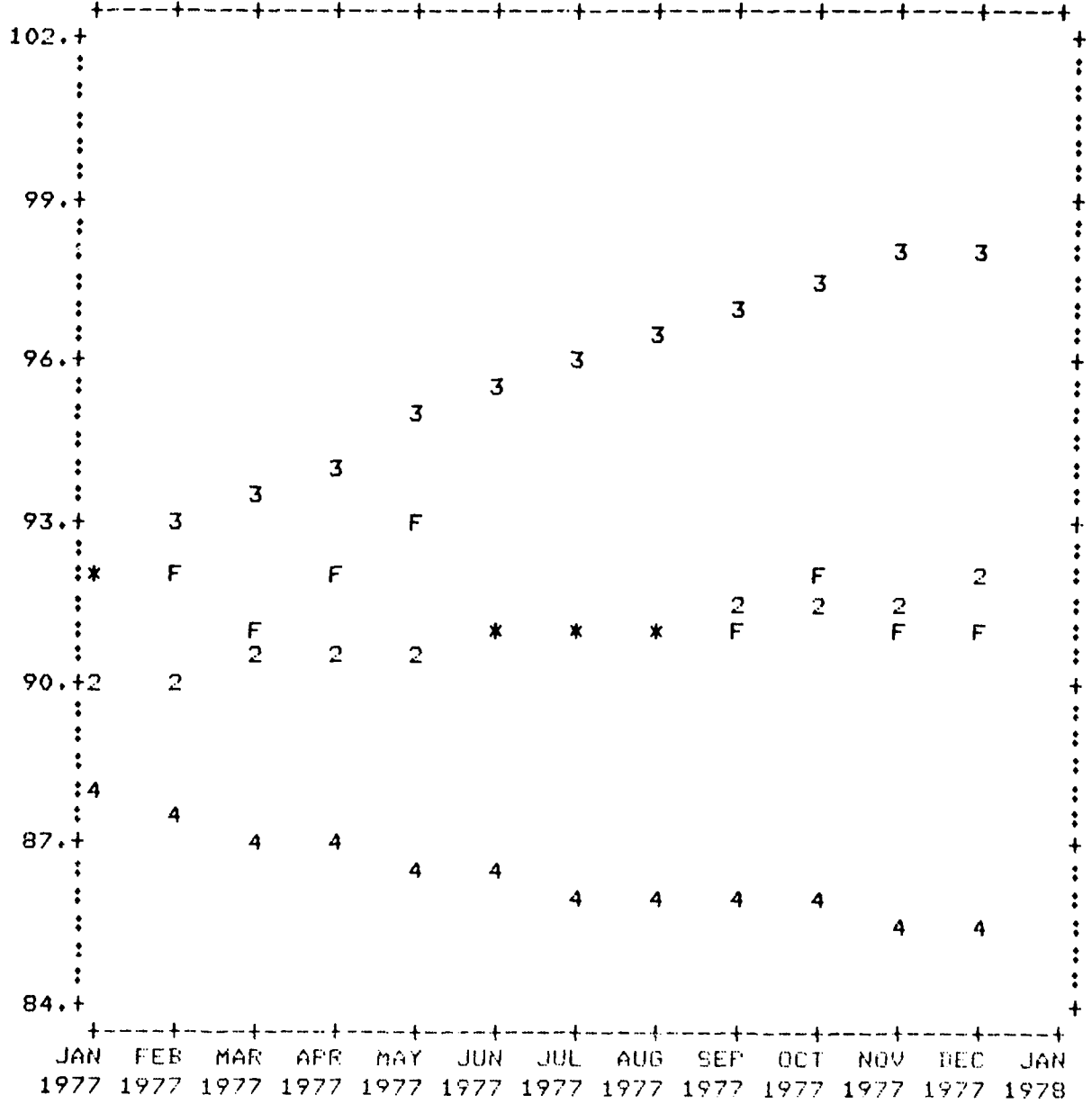

Figure B.24. Plot of 12-Month State Space Prediction and Actual Observed Data for F27131 for 1977

F=F42333
 2=F42333PH

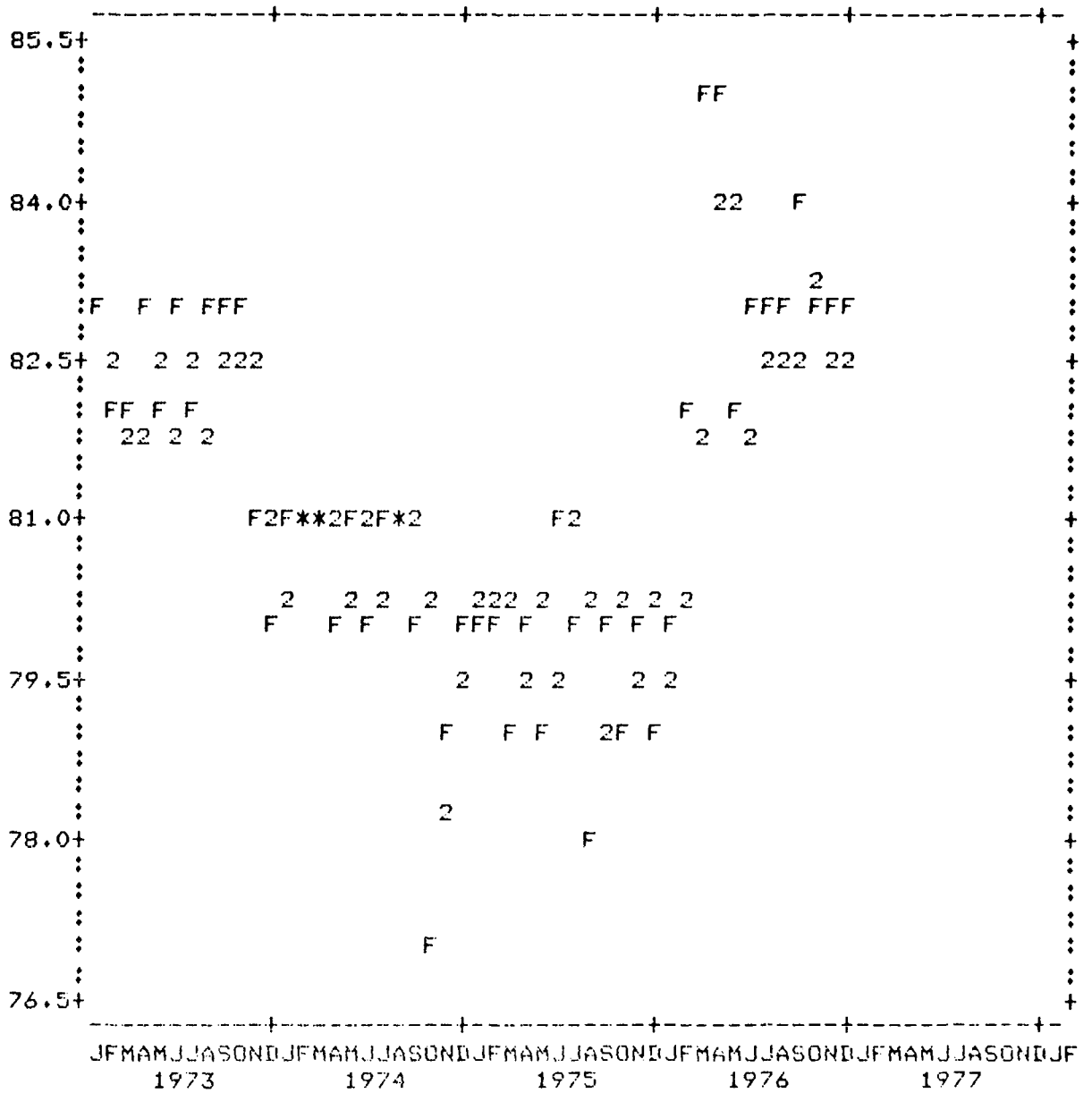

Figure B.25. Plot of One Step State Space Prediction for F42333 and Observed Data Over Fit Set

F=F42333
 2=F42333F
 3=F42333PU
 4=F42333PL

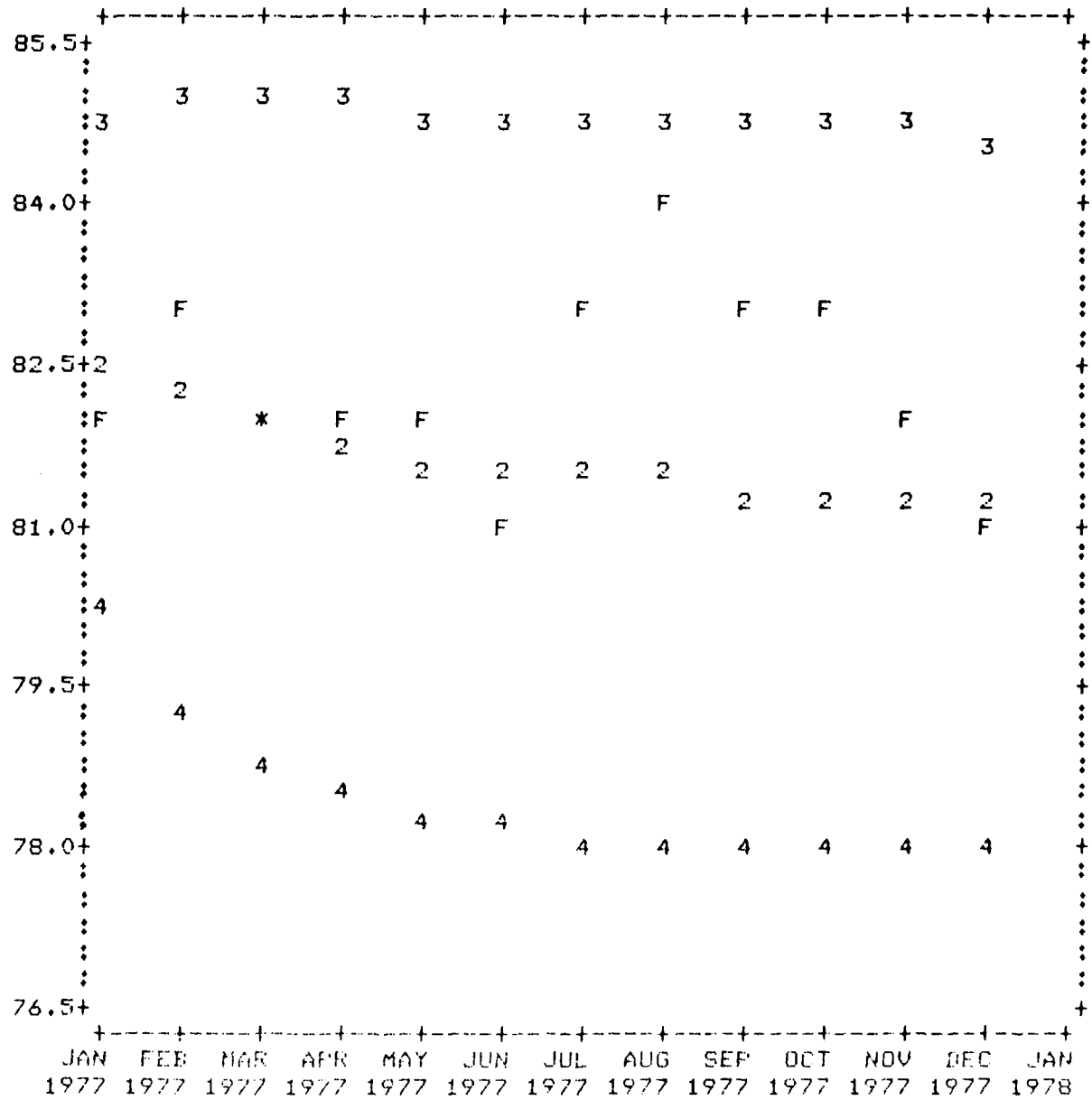

Figure B.26. Plot of 12-Month State Space Prediction and Actual Observed Data for F42333 for 1977

M=M30230
 2=M30230FH

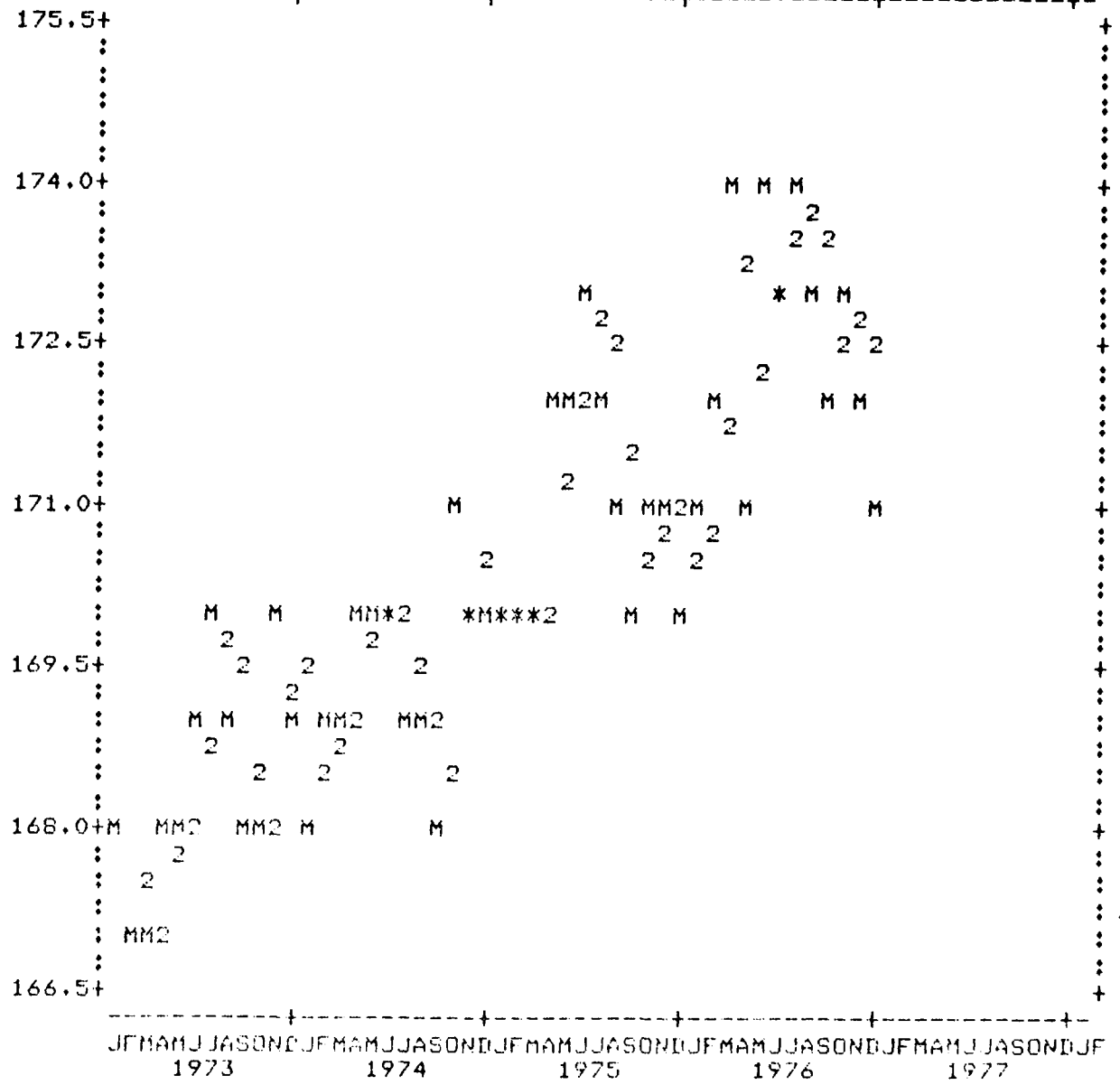

Figure B.27. Plot of One Step State Space Prediction for M30230 and Observed Data Over Fit Set

M=M30230
 2=M30230F
 3=M30230FU
 4=M30230FL

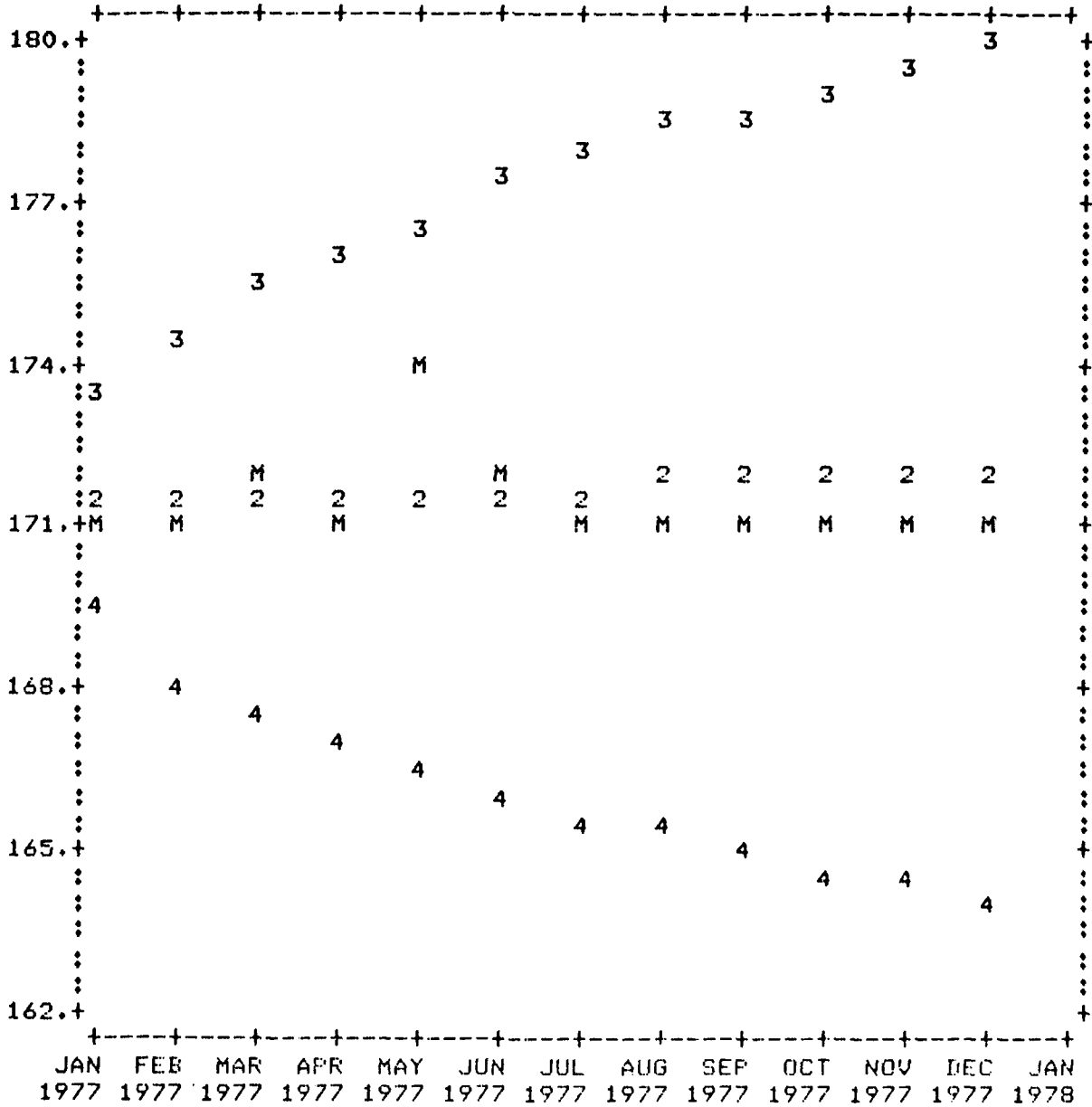

Figure B.28. Plot of 12-Month State Space Prediction and Actual Observed Data of M30230 for 1977

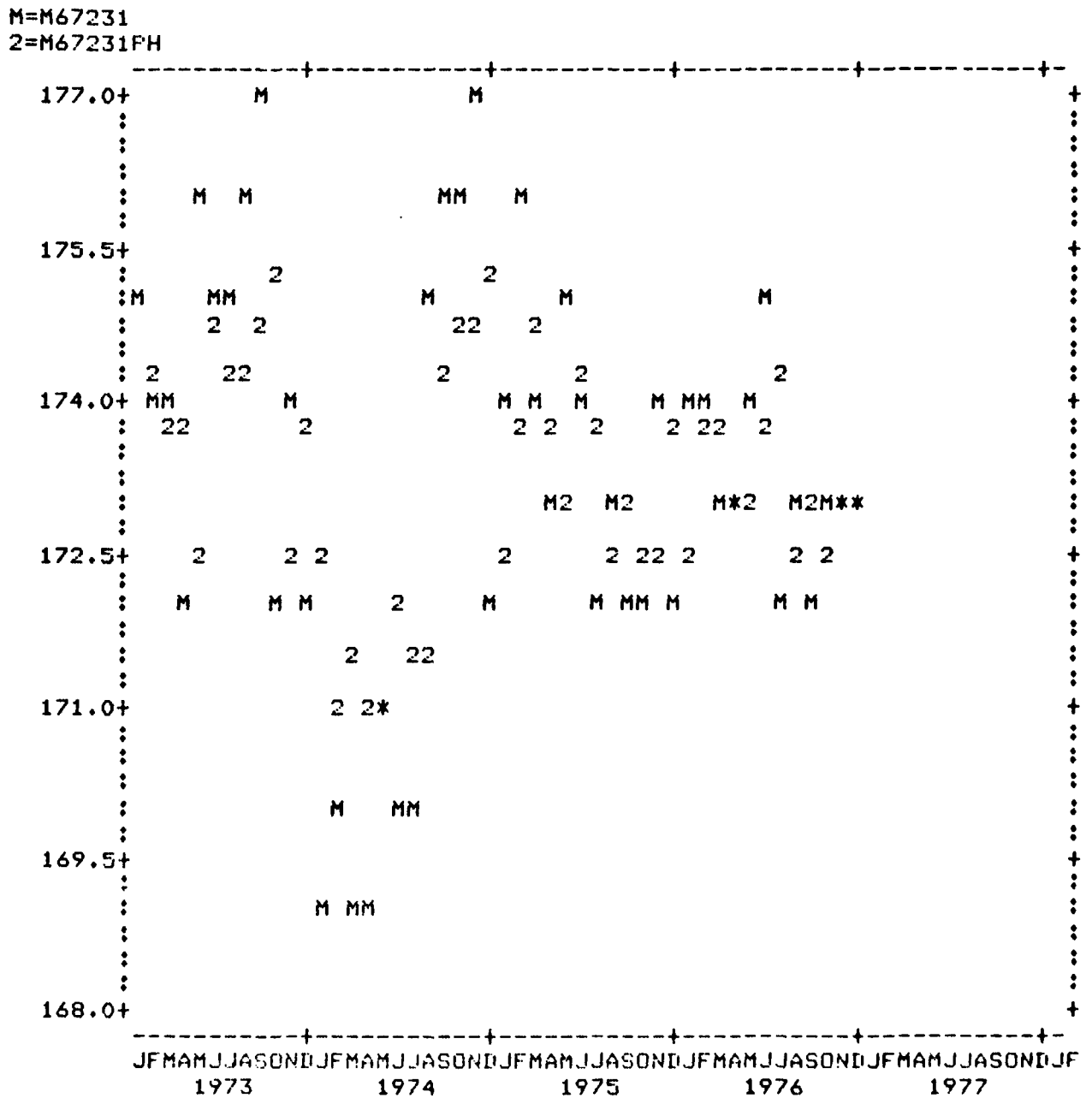

Figure B.29. Plot of One Step State Space Prediction for M67231 and Observed Data Over Fit Set

M=M67231
 2=M67231P
 3=M67231PU
 4=M67231PL

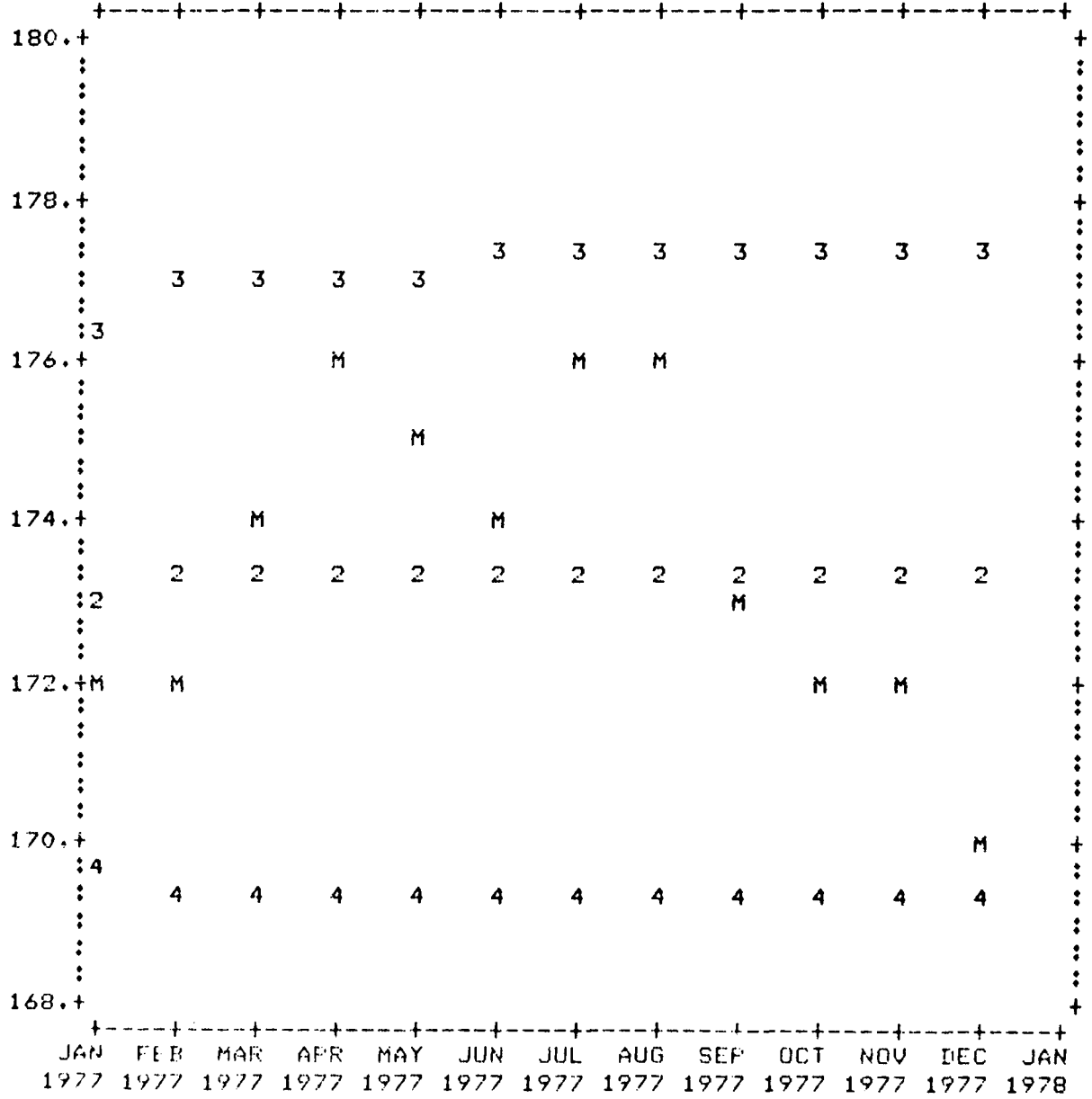

Figure B.30. Plot of 12-Month State Space Prediction and Actual Observed Data of M67231 for 1977

M=M20230
2=M20230PH

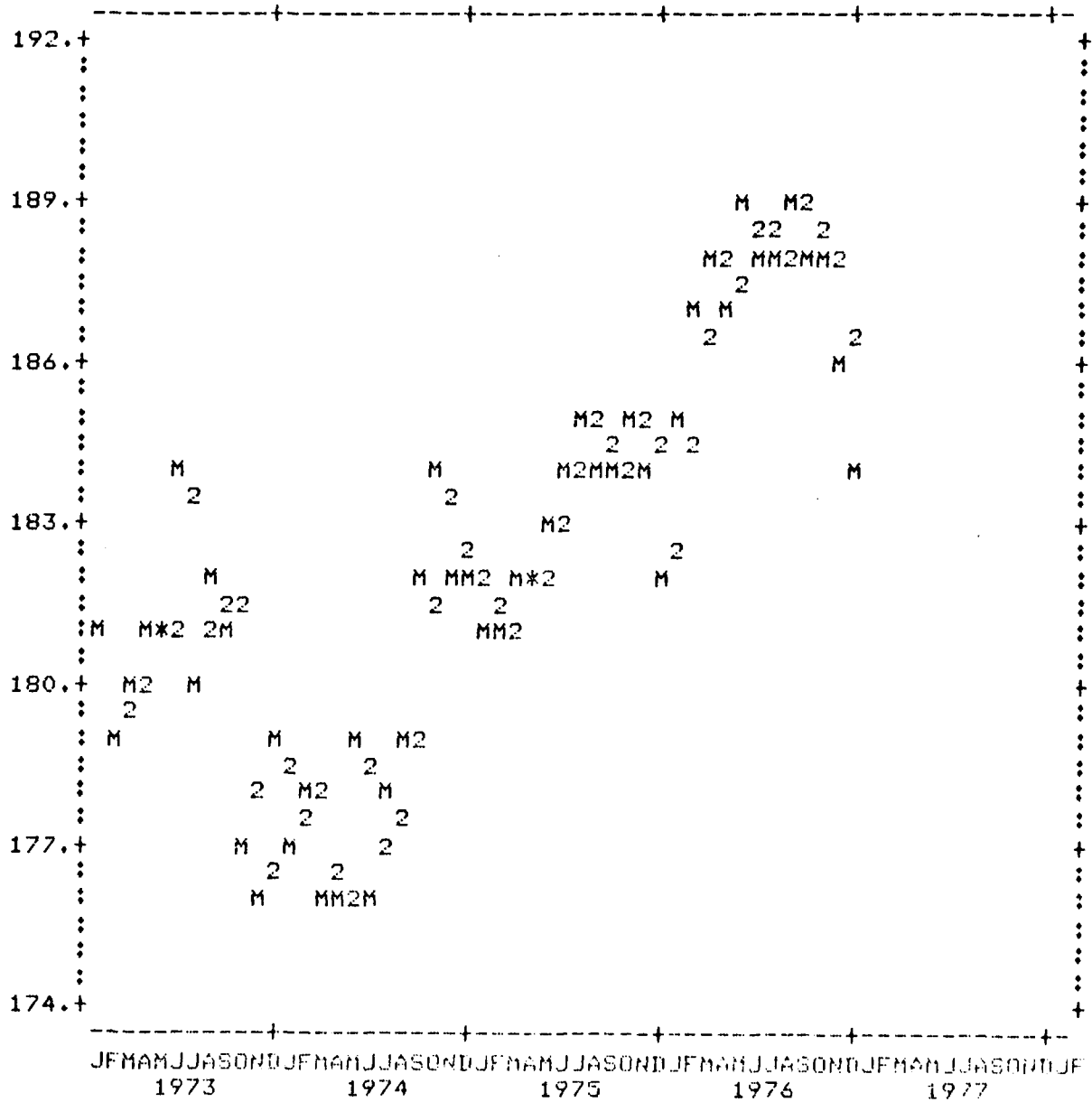

Figure B.31. Plot of One Step State Space Prediction for M20230 and Observed Data Over Fit Set

M=M20230
 2=M20230F
 3=M20230FU
 4=M20230PL

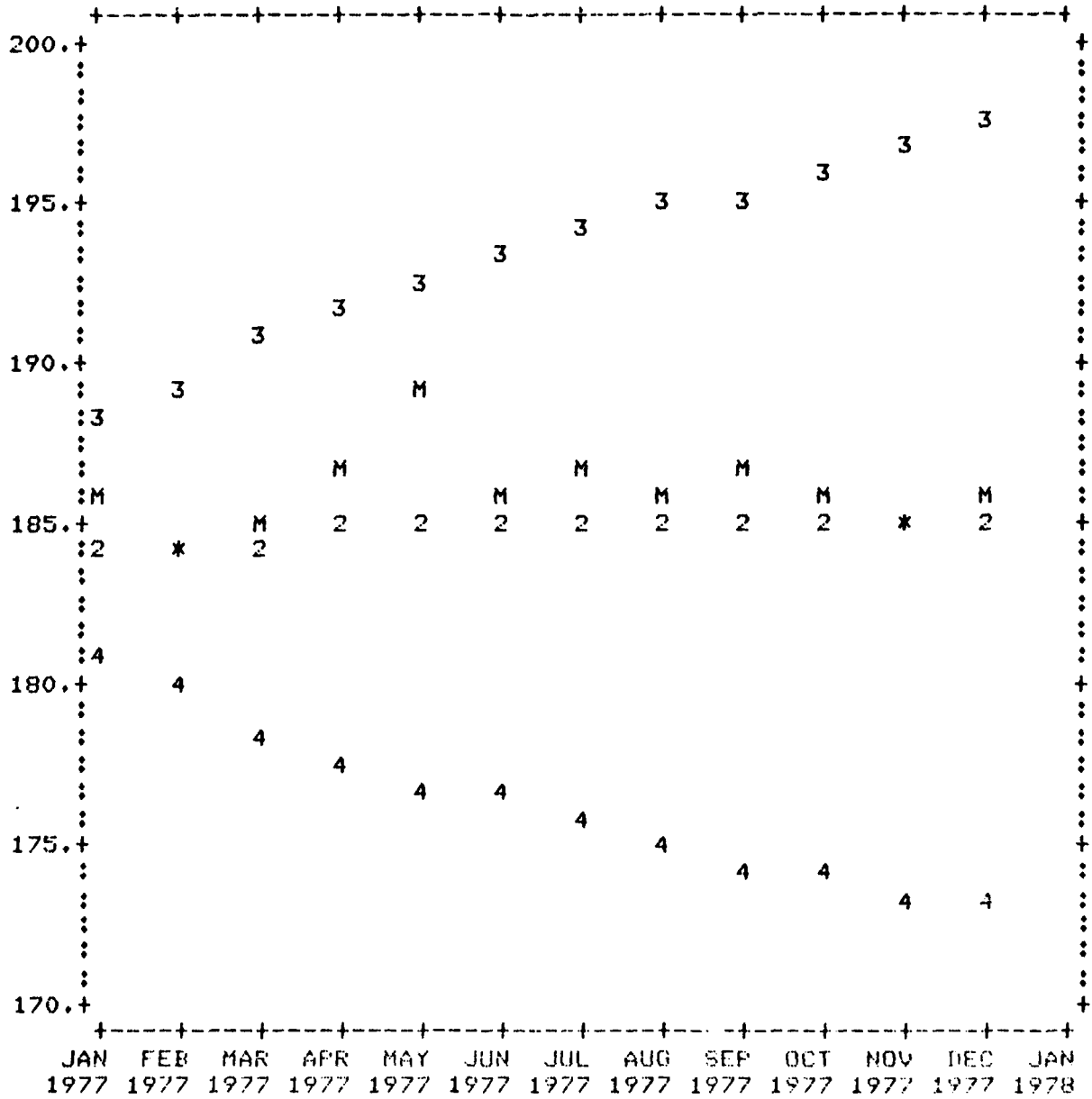

Figure B.32. Plot of 12-Month State Space Prediction and Actual Observed Data of M20230 for 1977

M=M46330
 2=M46330PH

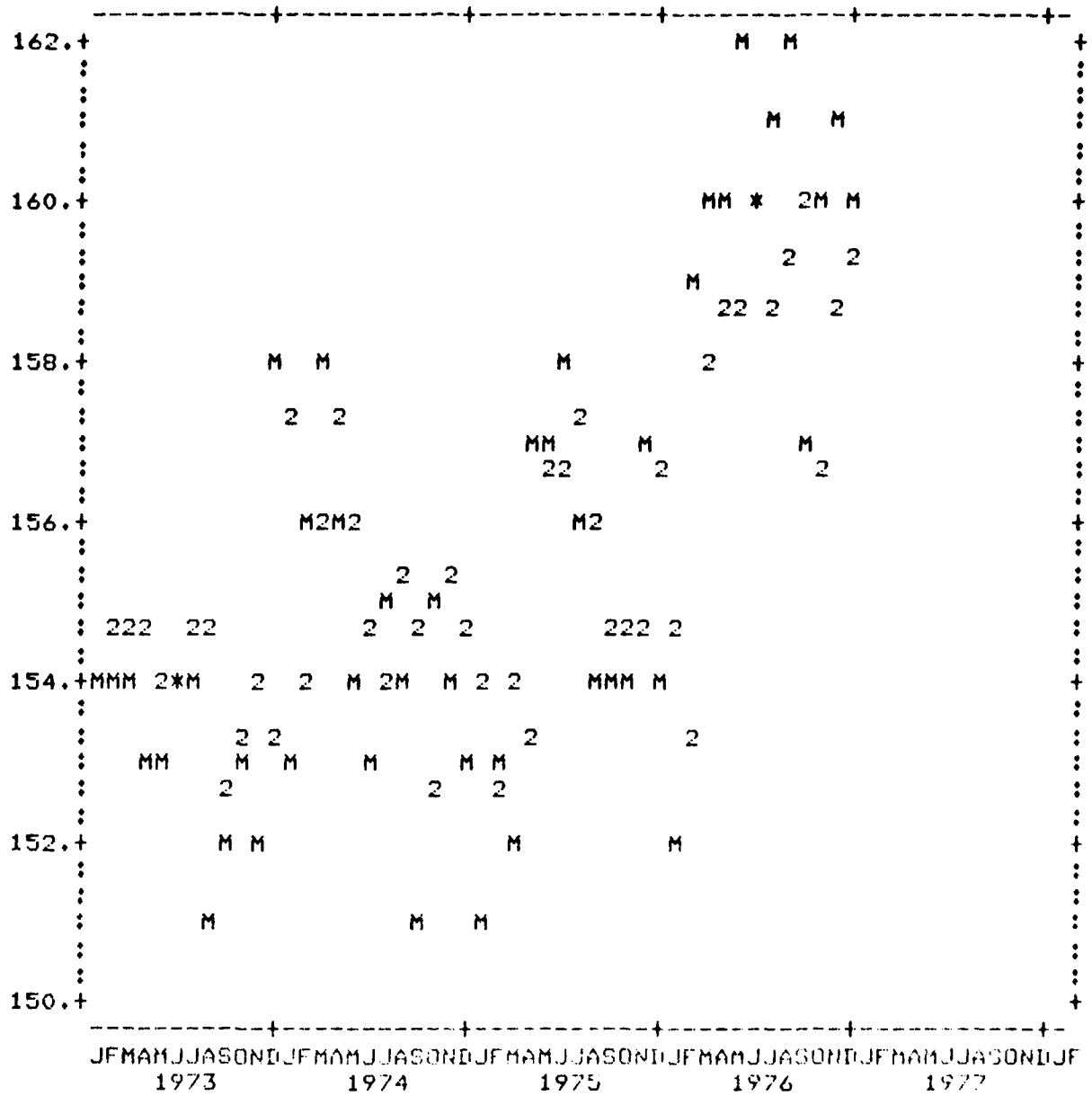

Figure B.33. Plot of One Step State Space Prediction for M46330 and Observed Data Over Fit Set

M=M46330
 2=M46330P
 3=M46330PU
 4=M46330PL

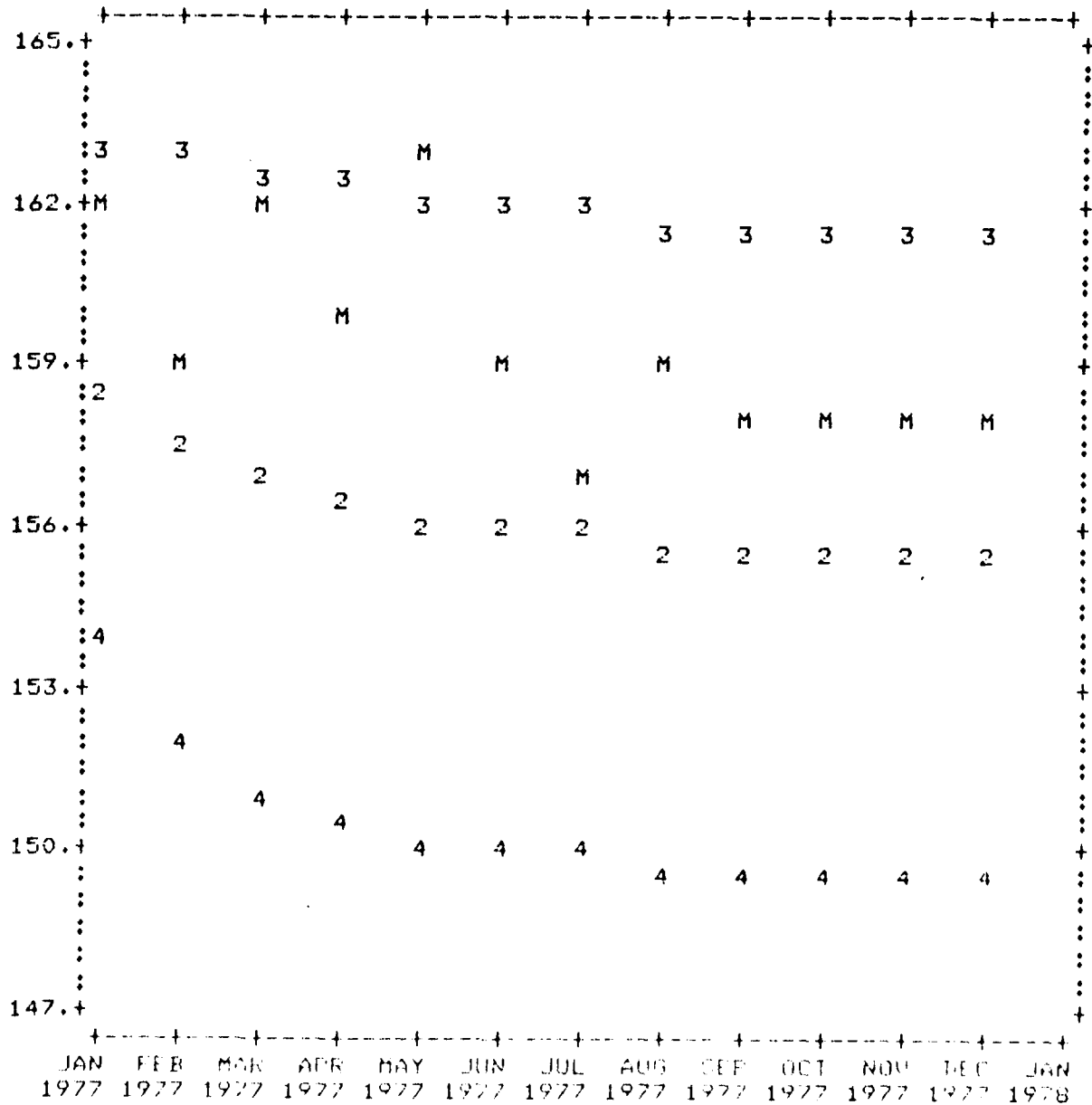

Figure B.34. Plot of 12-Month State Space Prediction and Actual Observed Data of M46330 for 1977

M=M46230
 2=M46230FH

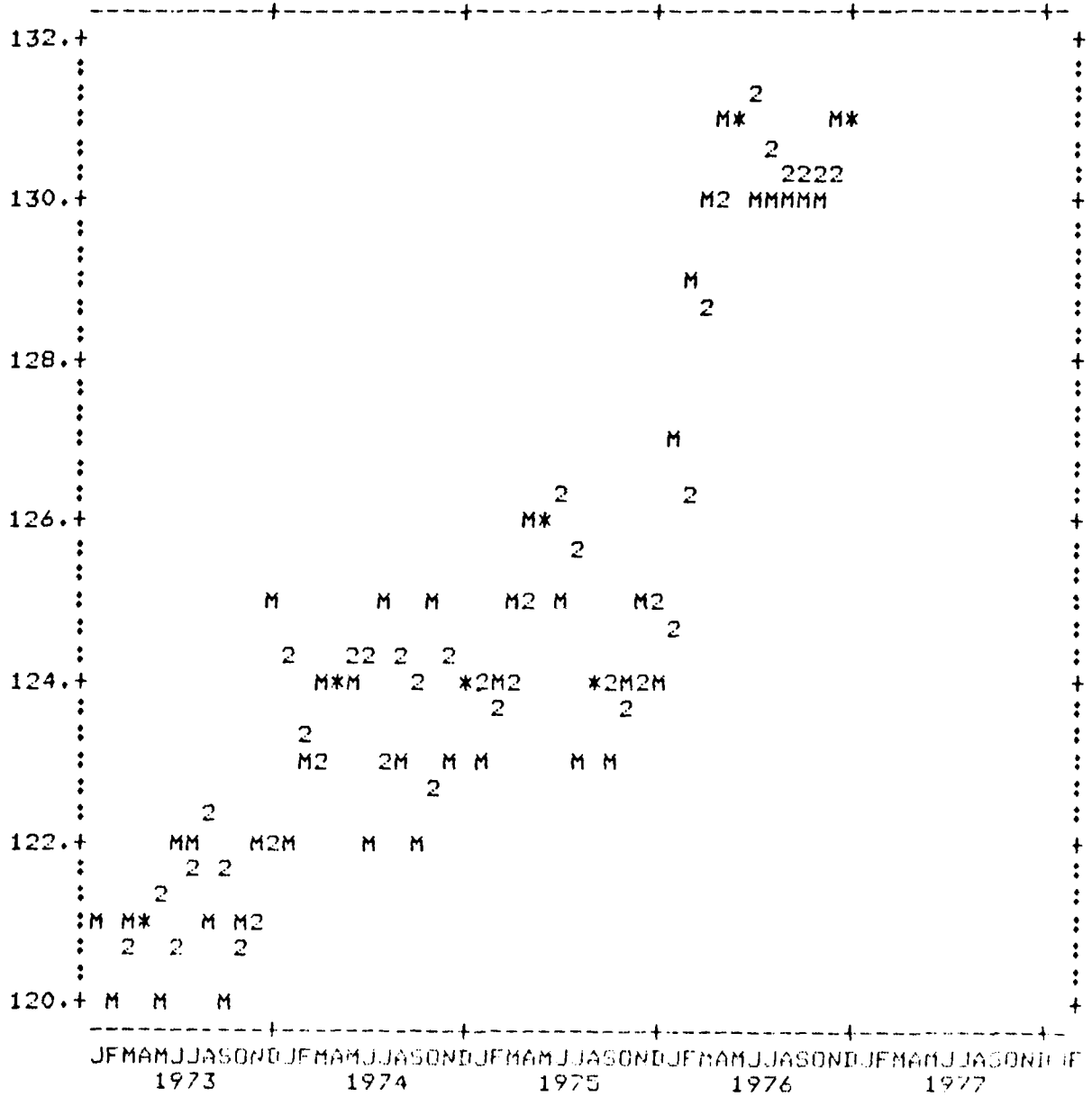

Figure B.35. Plot of One Step State Space Prediction for M46230 and Observed Data Over Fit Set

M=M46230
 2=M46230F
 3=M46230FU
 4=M46230FL

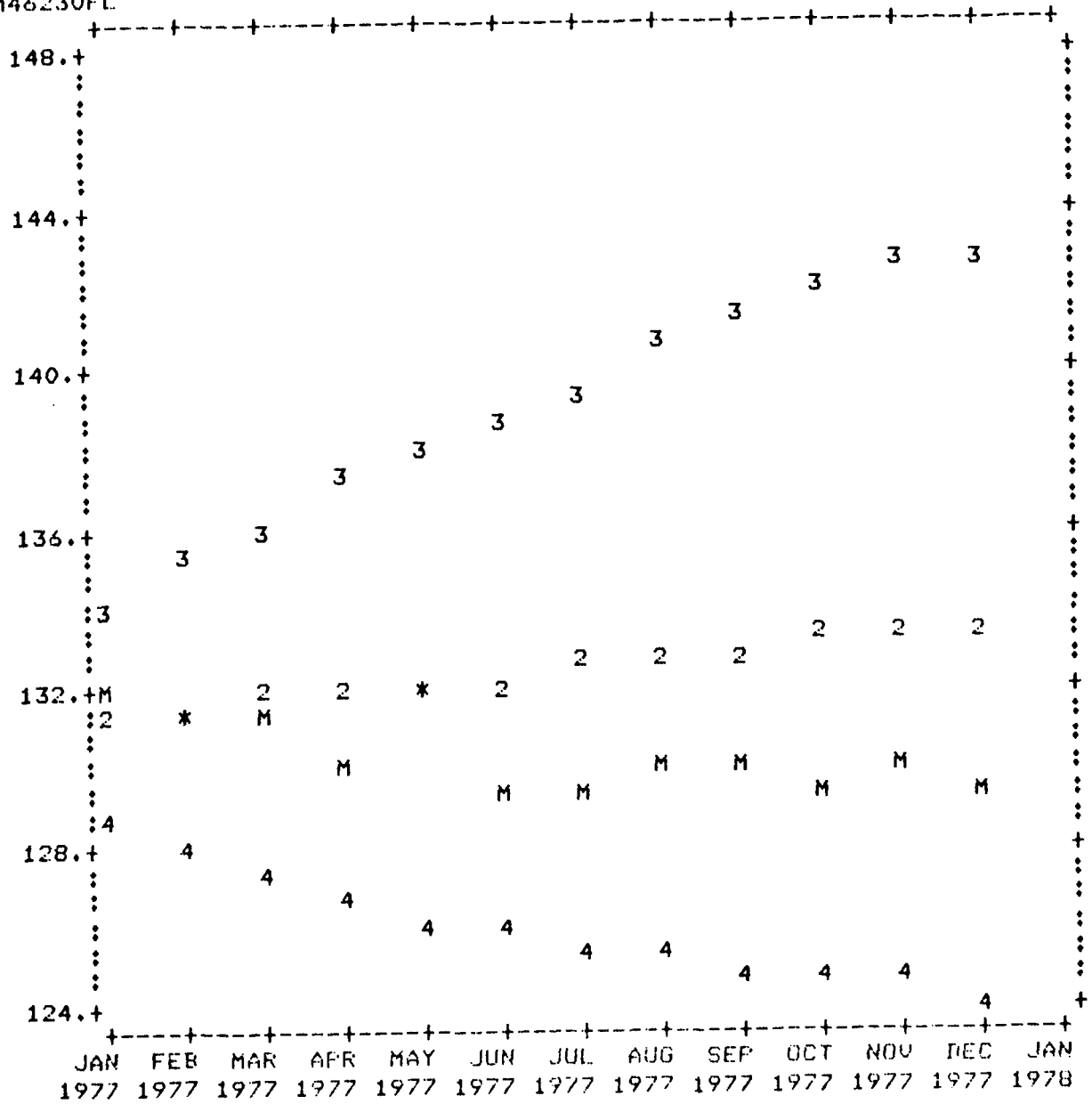

Figure B.36. Plot of 12-Month State Space Prediction and Actual Observed Data of M46230 for 1977

M=M20430
 2=M20430PH

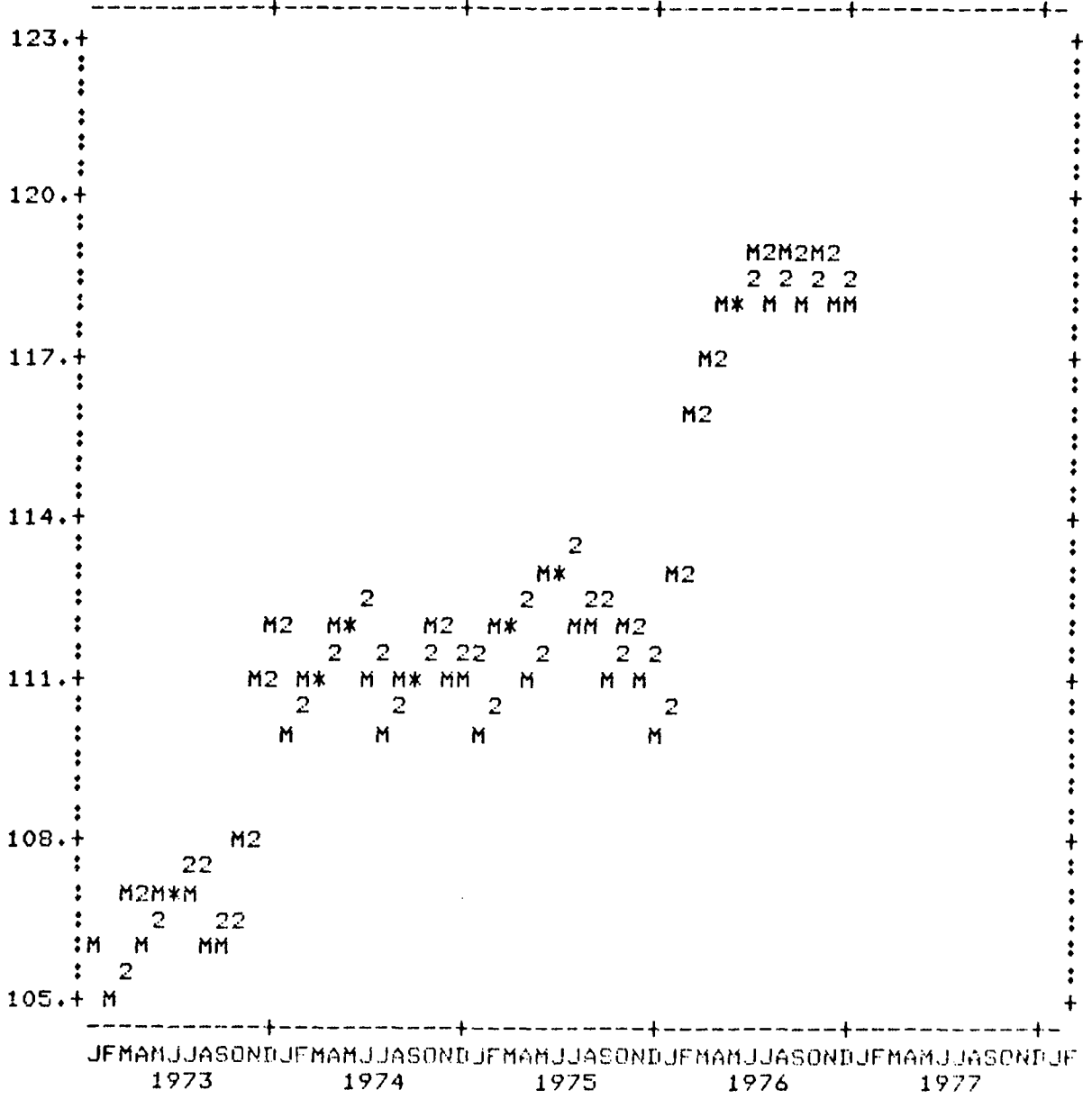

Figure B.37. Plot of One Step State Space Prediction for M20430 and Observed Data Over Fit Set

M=M20430
 2=M20430P
 3=M20430FU
 4=M20430PL

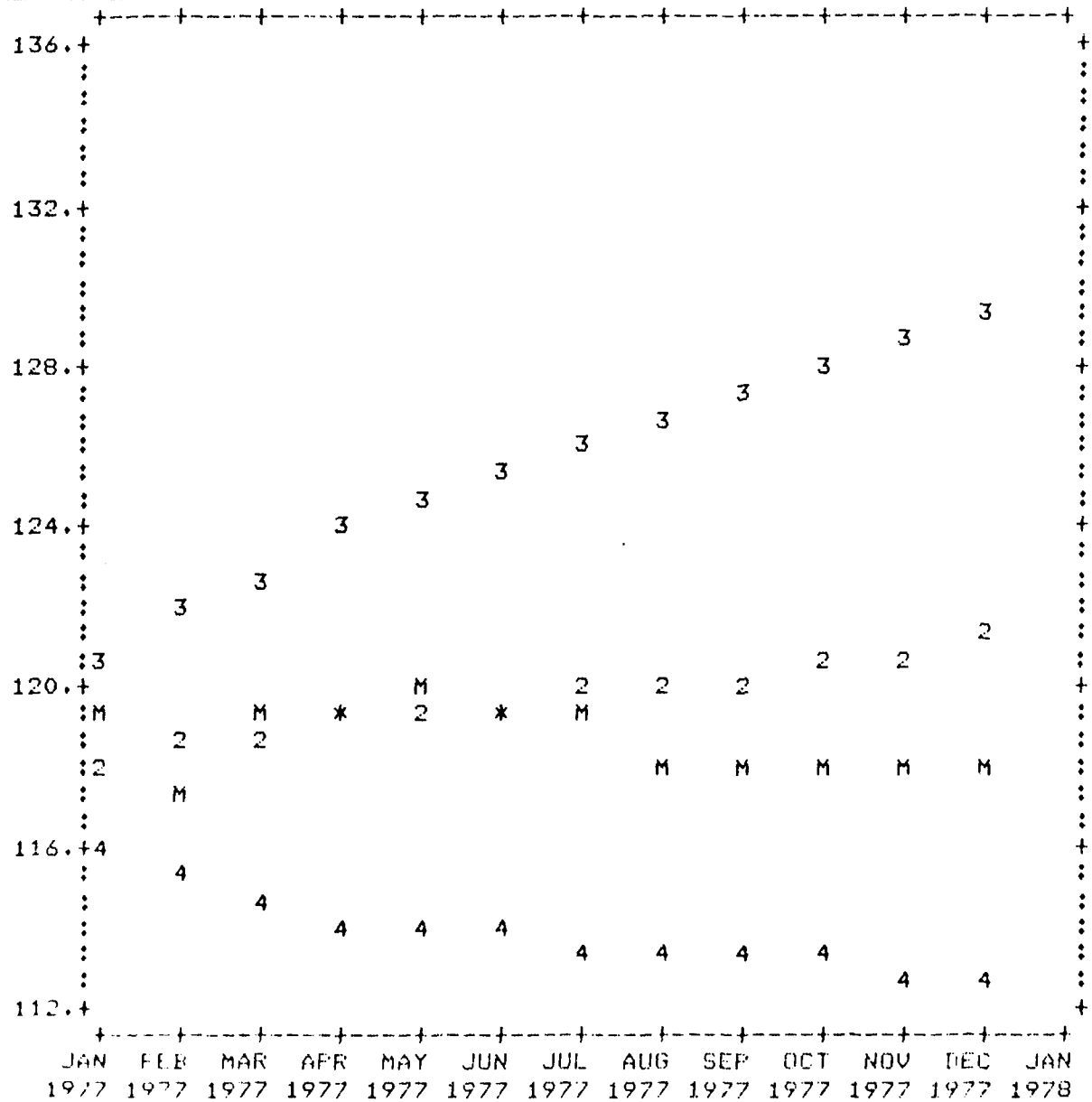

Figure B.38. Plot of 12-Month State Space Prediction and Actual Observed Data for M20430 for 1977

M=M43130
 2=M43130FH

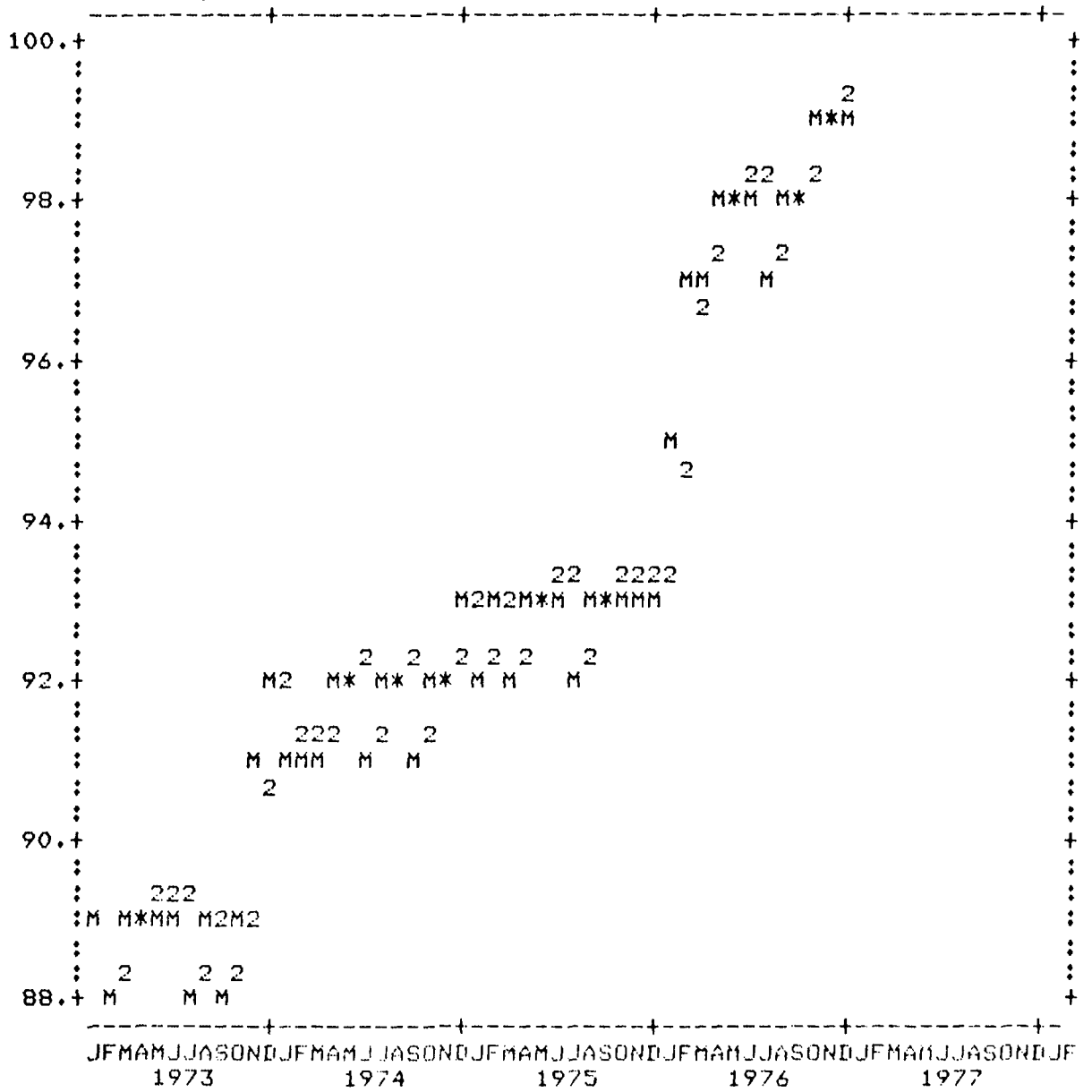

Figure B.39. Plot of One Step State Space Prediction for M43130 and Observed Data Over Fit Set

M=M43130
 2=M43130P
 3=M43130PU
 4=M43130FL

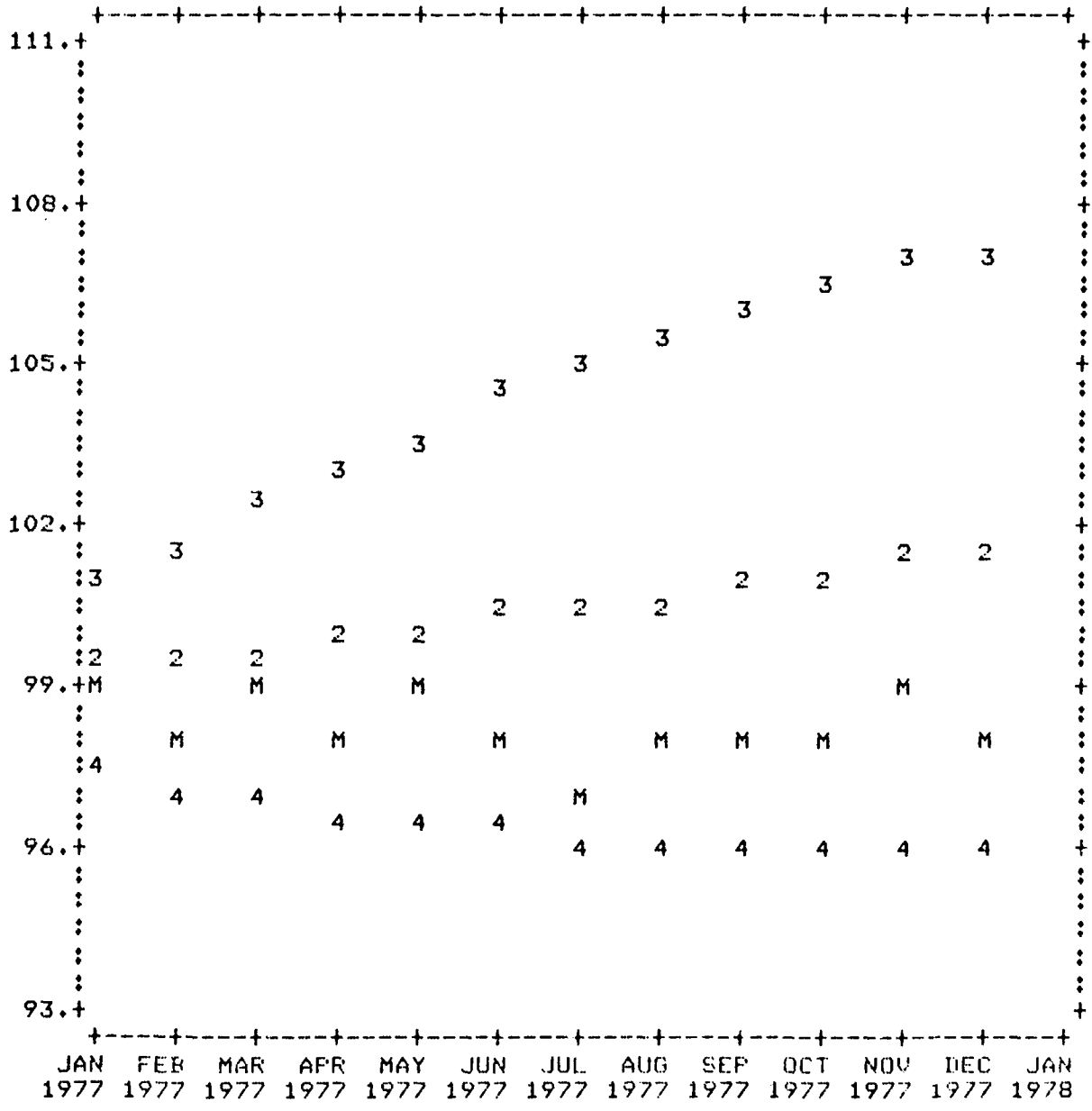

Figure B.40. Plot of 12-Month State Space Prediction and Actual Observed Data of M43130 for 1977

M=M42732
 2=M42732FH

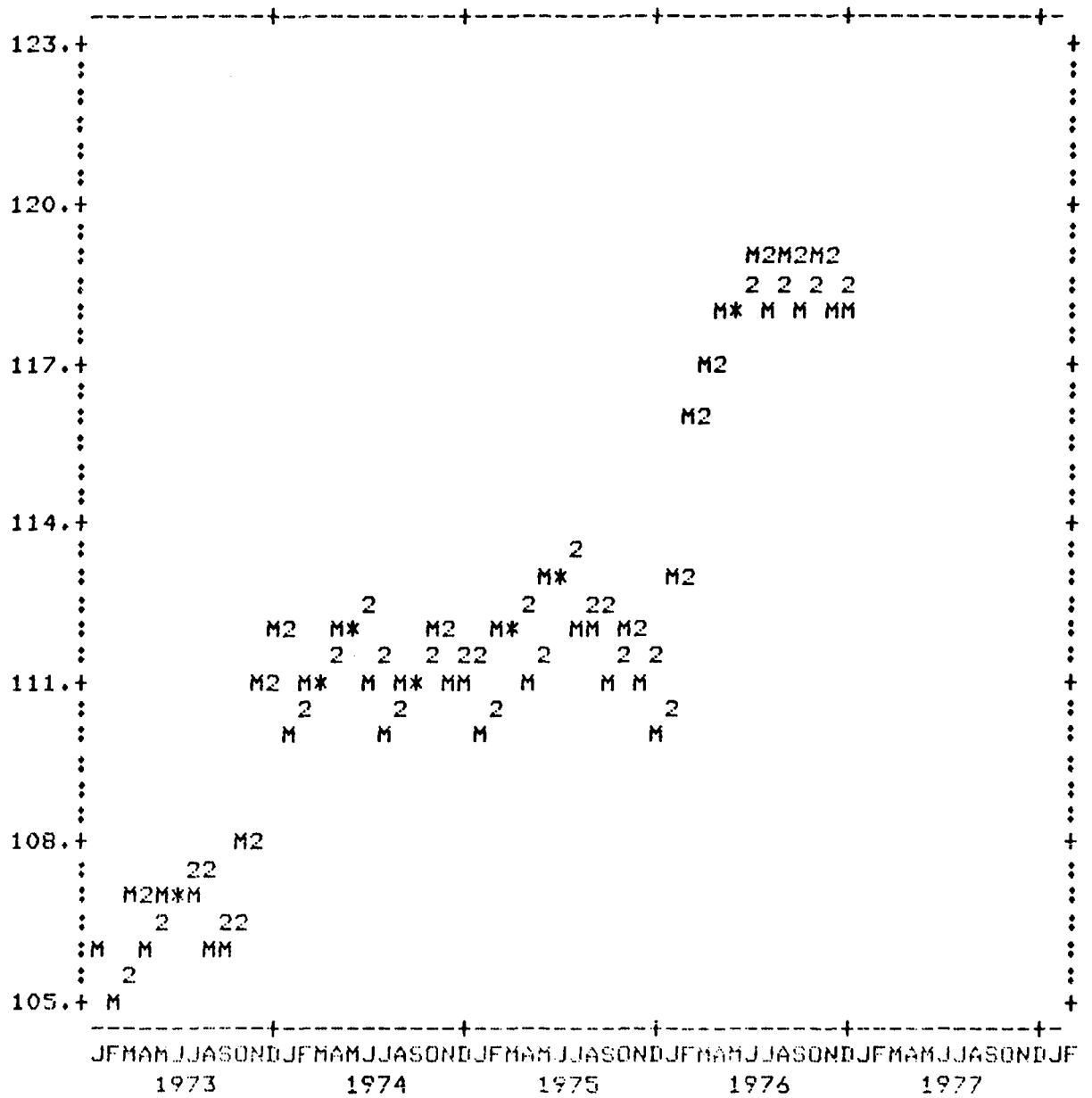

Figure B.41. Plot of One Step State Space Prediction for M42732 and Observed Data Over Fit Set

M=M42732
 2=M42732F
 3=M42732FU
 4=M42732FL

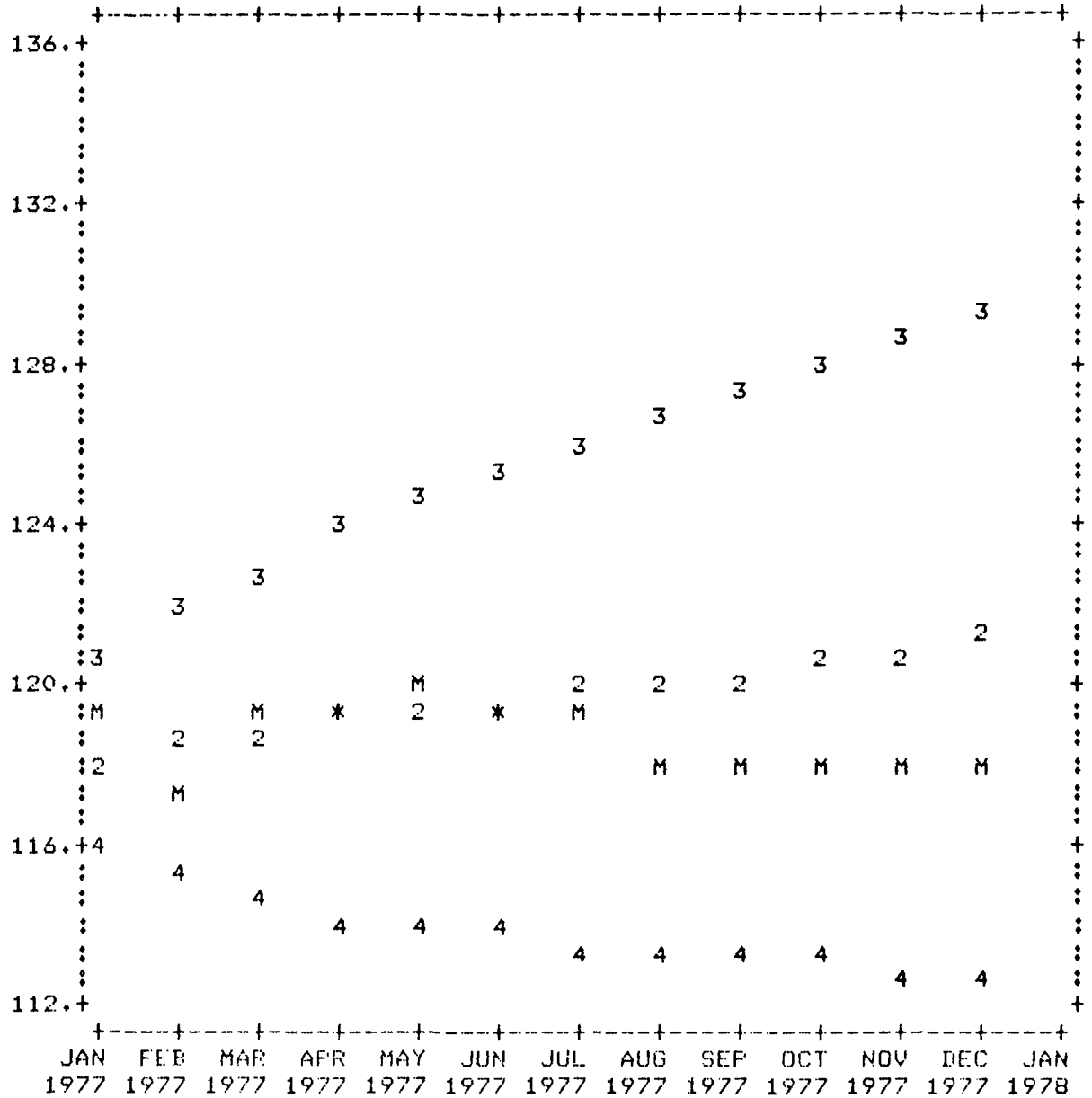

Figure B.42. Plot of 12-Month State Space Prediction and Actual Observed Data of M42732 for 1977

T=TSK288
 2=TSK288FH

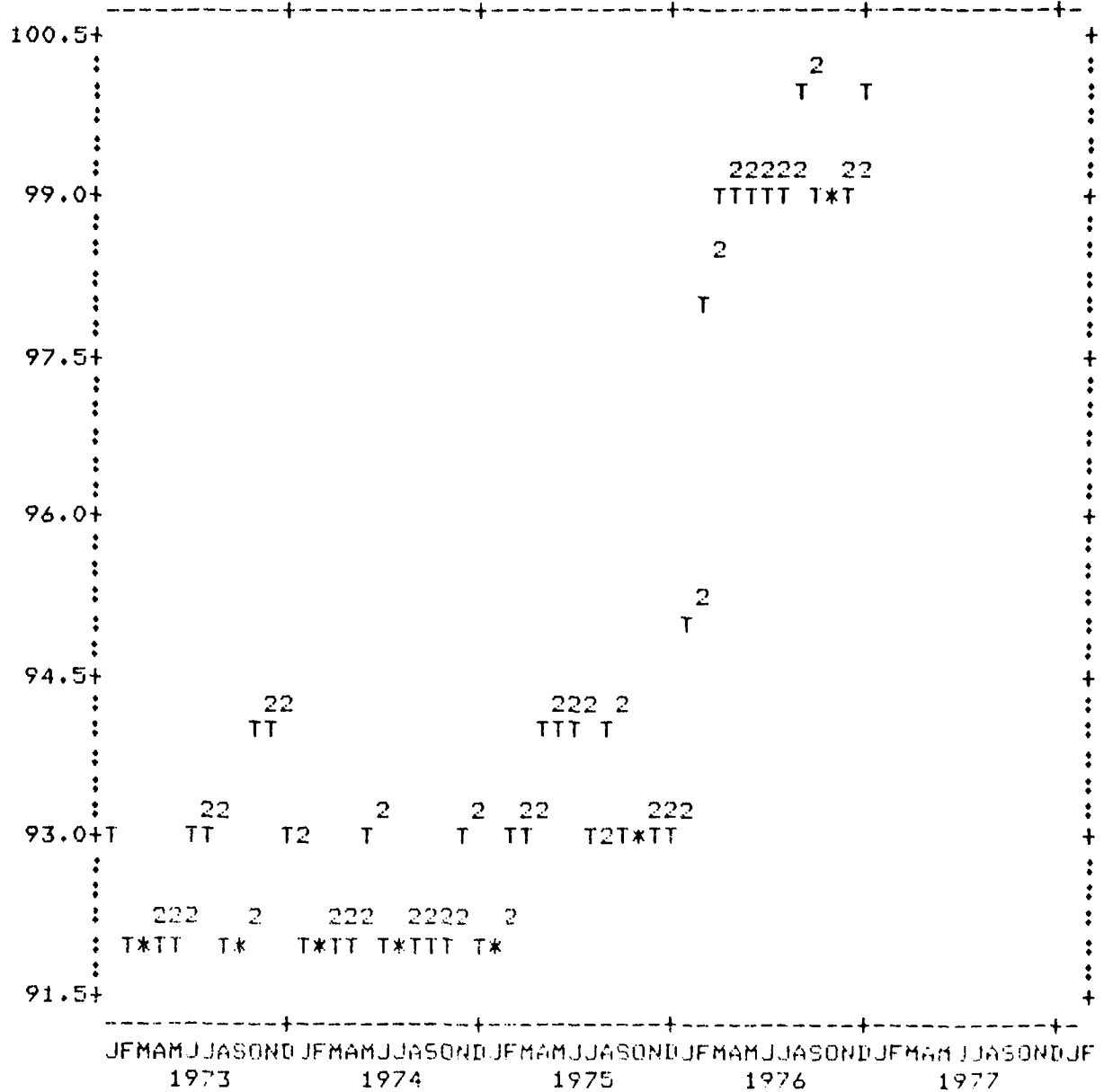

Figure B.43. Plot of One Step State Space Prediction for TSK288 and Observed Data Over Fit Set

T=TSK288
 2=TSK288F
 3=TSK288FU
 4=TSK288FL

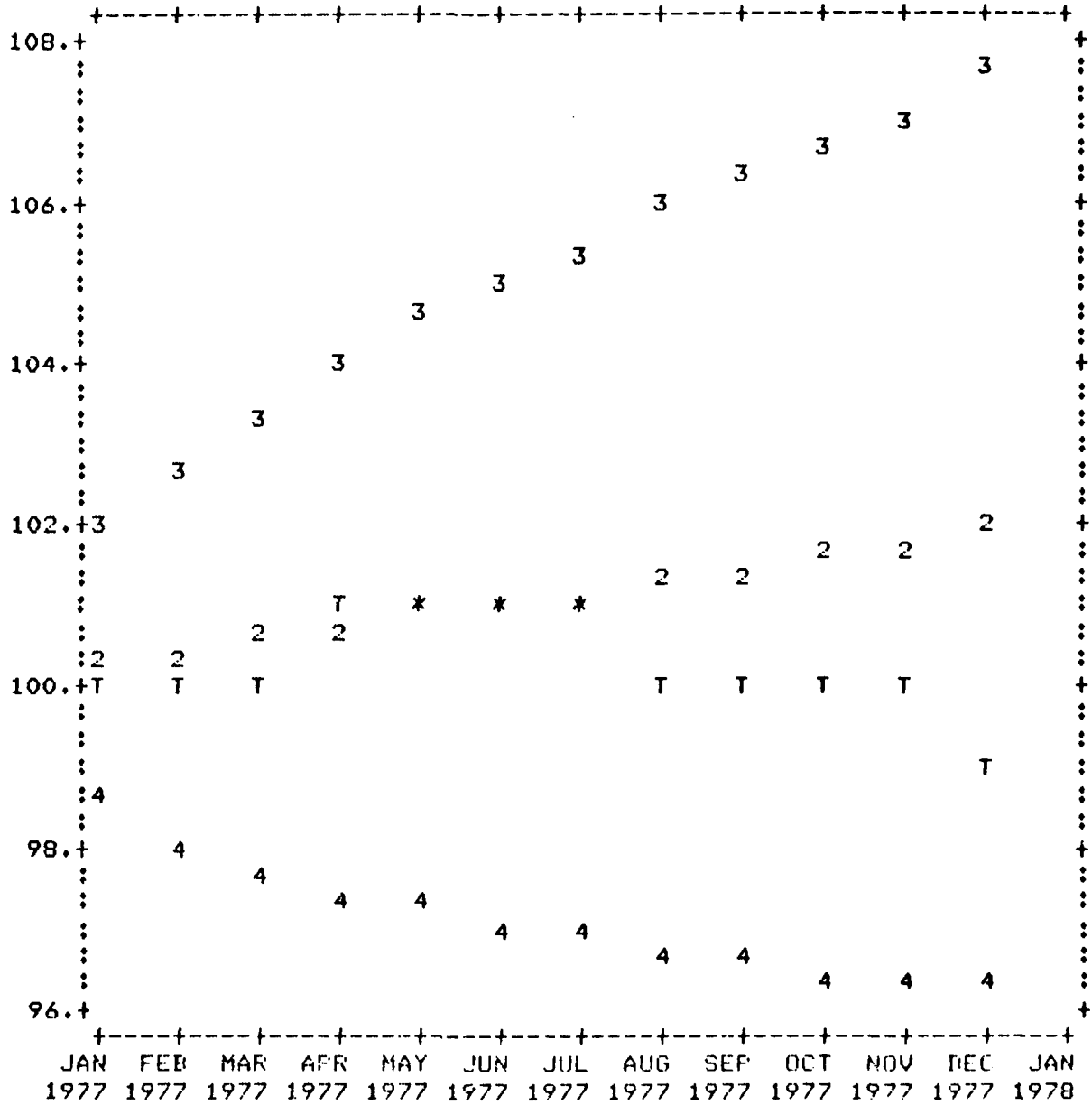

Figure B.44. Plot of 12-Month State Space Prediction and Actual Observed Data for TSK288 for 1977

M=M54130
 2=M54130FH

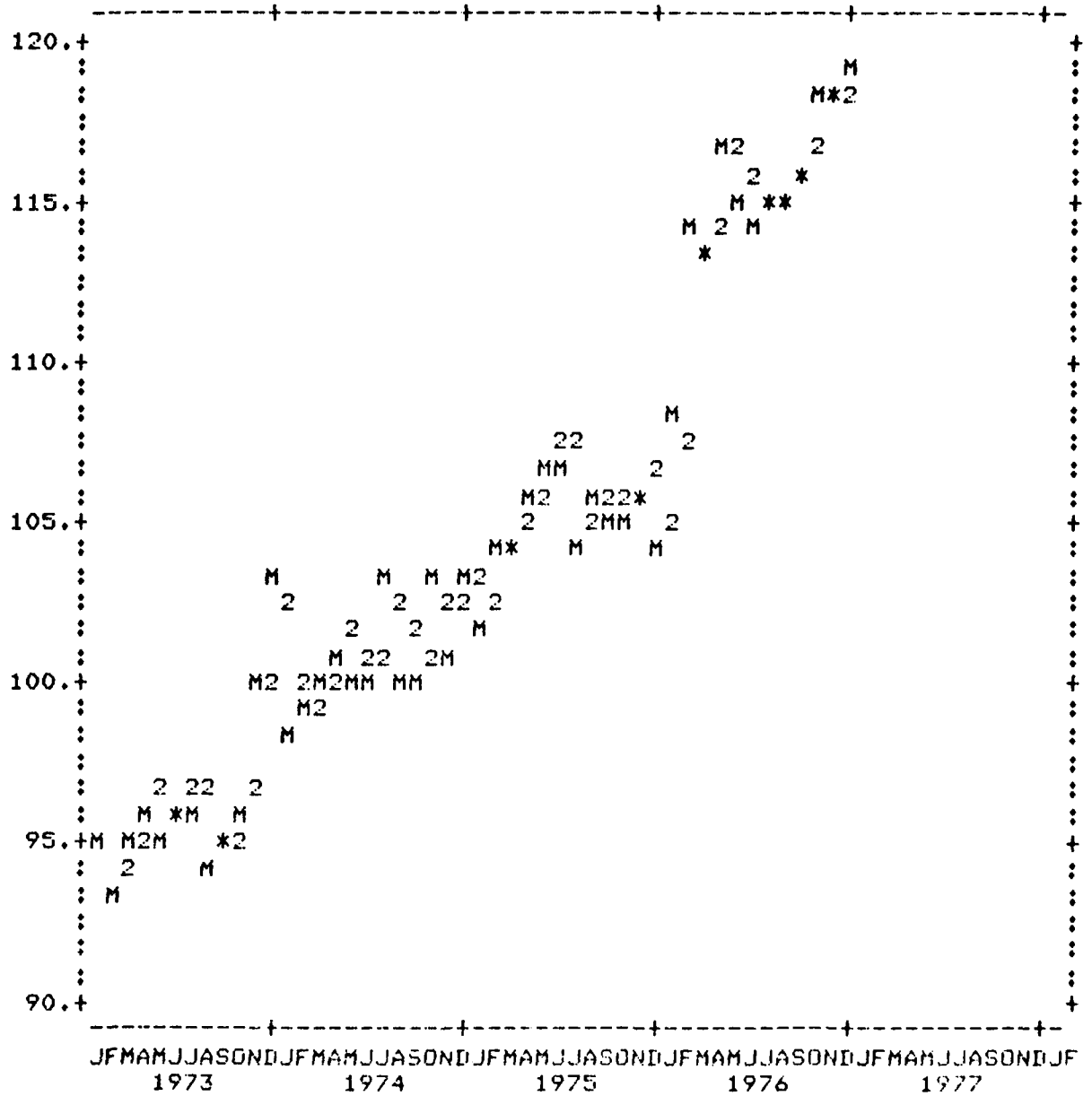

Figure B.45. Plot of One Step State Space Prediction for M54130 and Observed Data Over Fit Set

M=M54130
 2=M54130P
 3=M54130FU
 4=M54130PL

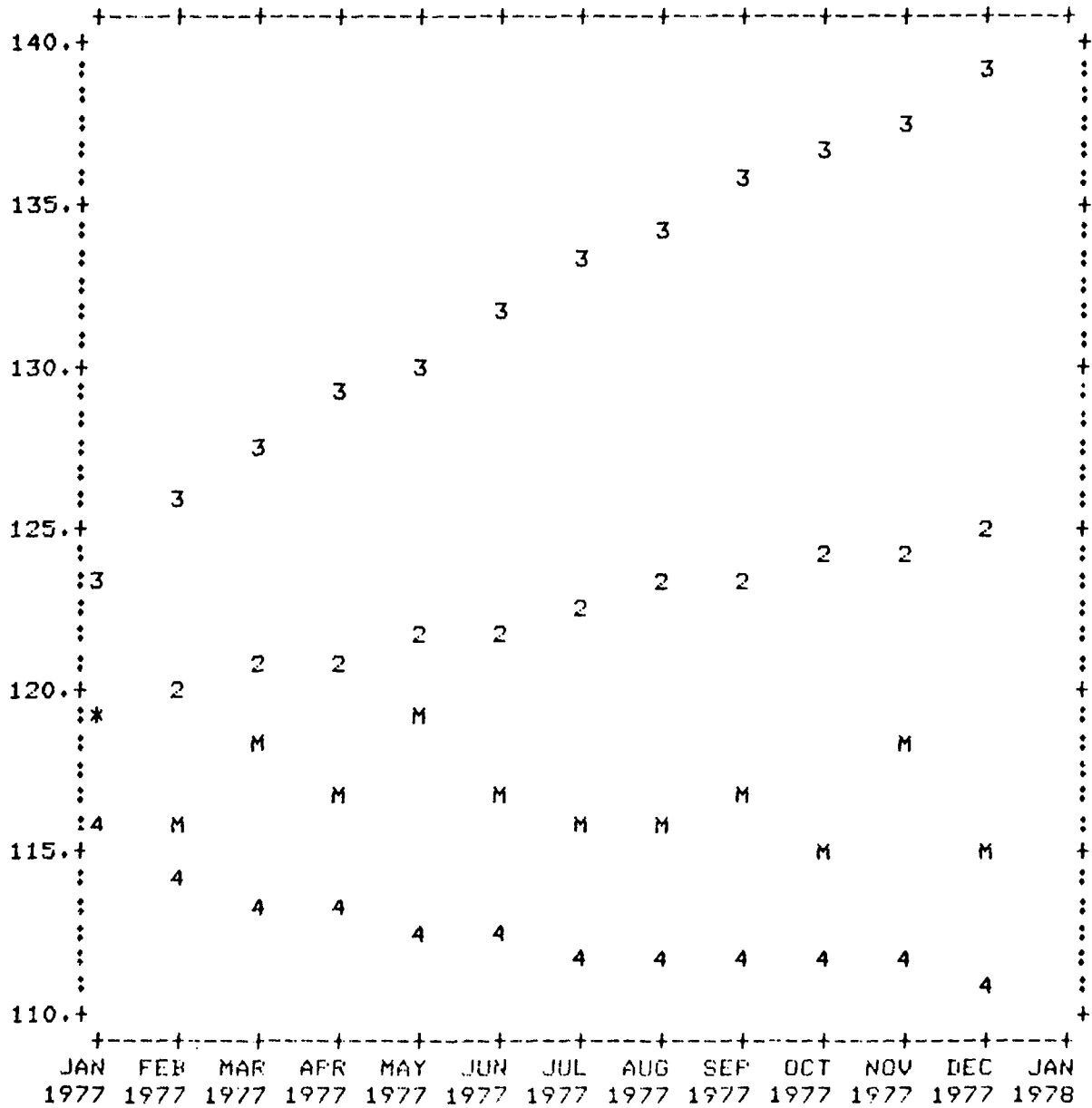

Figure B.46. Plot of 12-Month State Space Prediction and Actual Observed Data of M54130 for 1977

M=M23132
 2=M23132FH

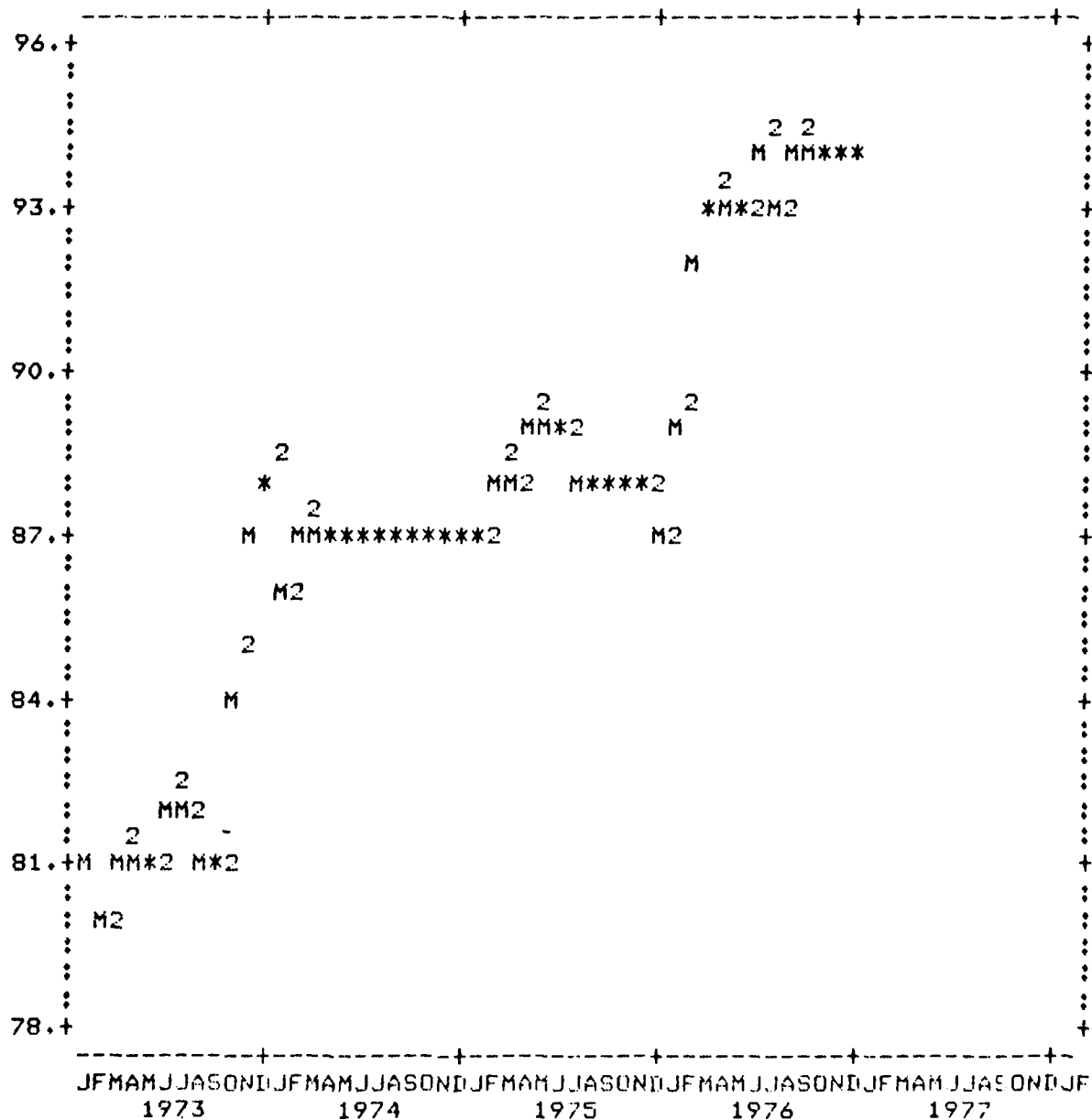

Figure B.47. Plot of One Step State Space Prediction for M23132 and Observed Data Over Fit Set

M=M23132
 2=M23132P
 3=M23132PU
 4=M23132PL

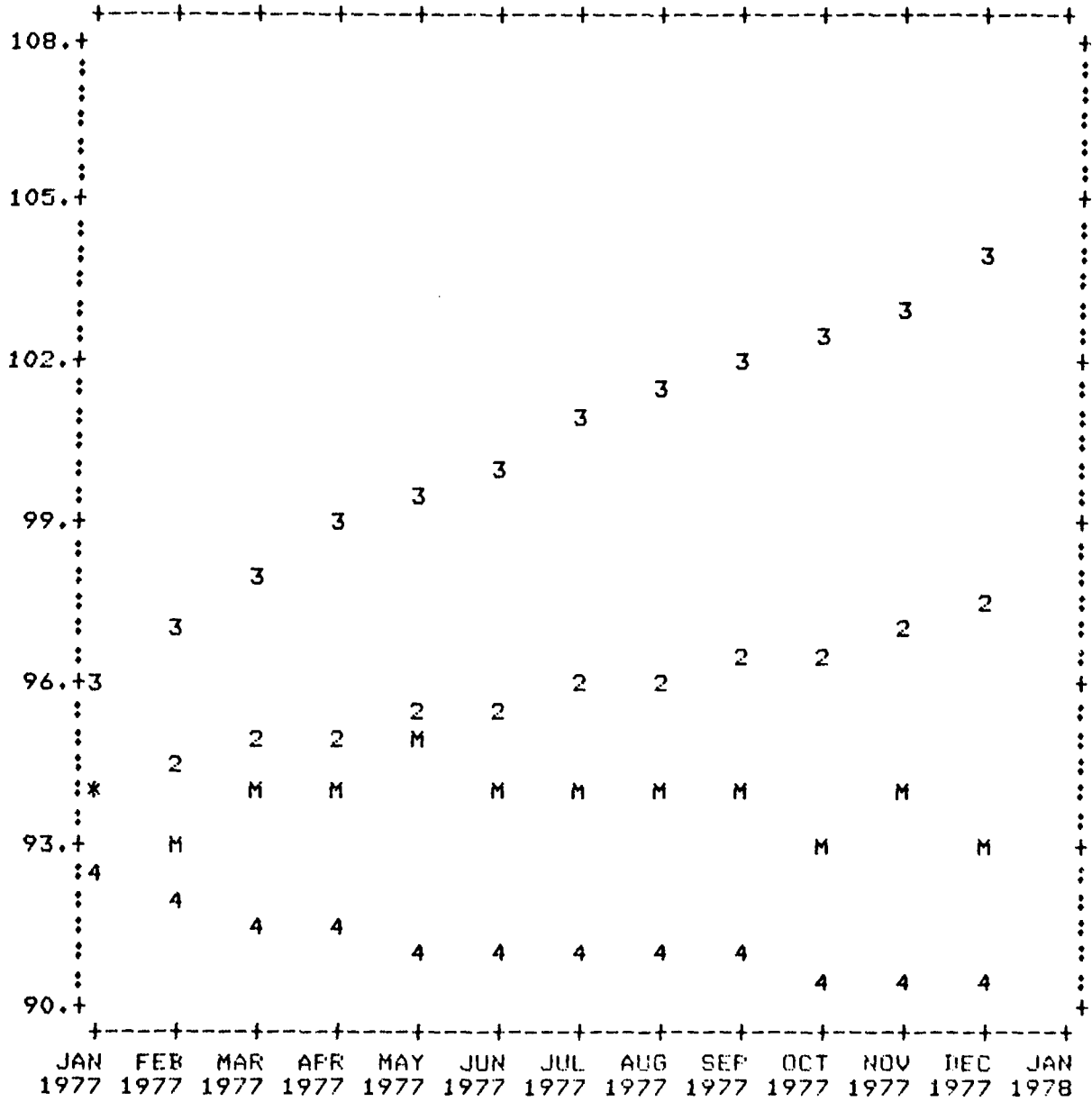

Figure B.48. Plot of 12-Month State Space Prediction and Actual Observed Data of M23132 for 1977

M=M27131
2=M27131PH

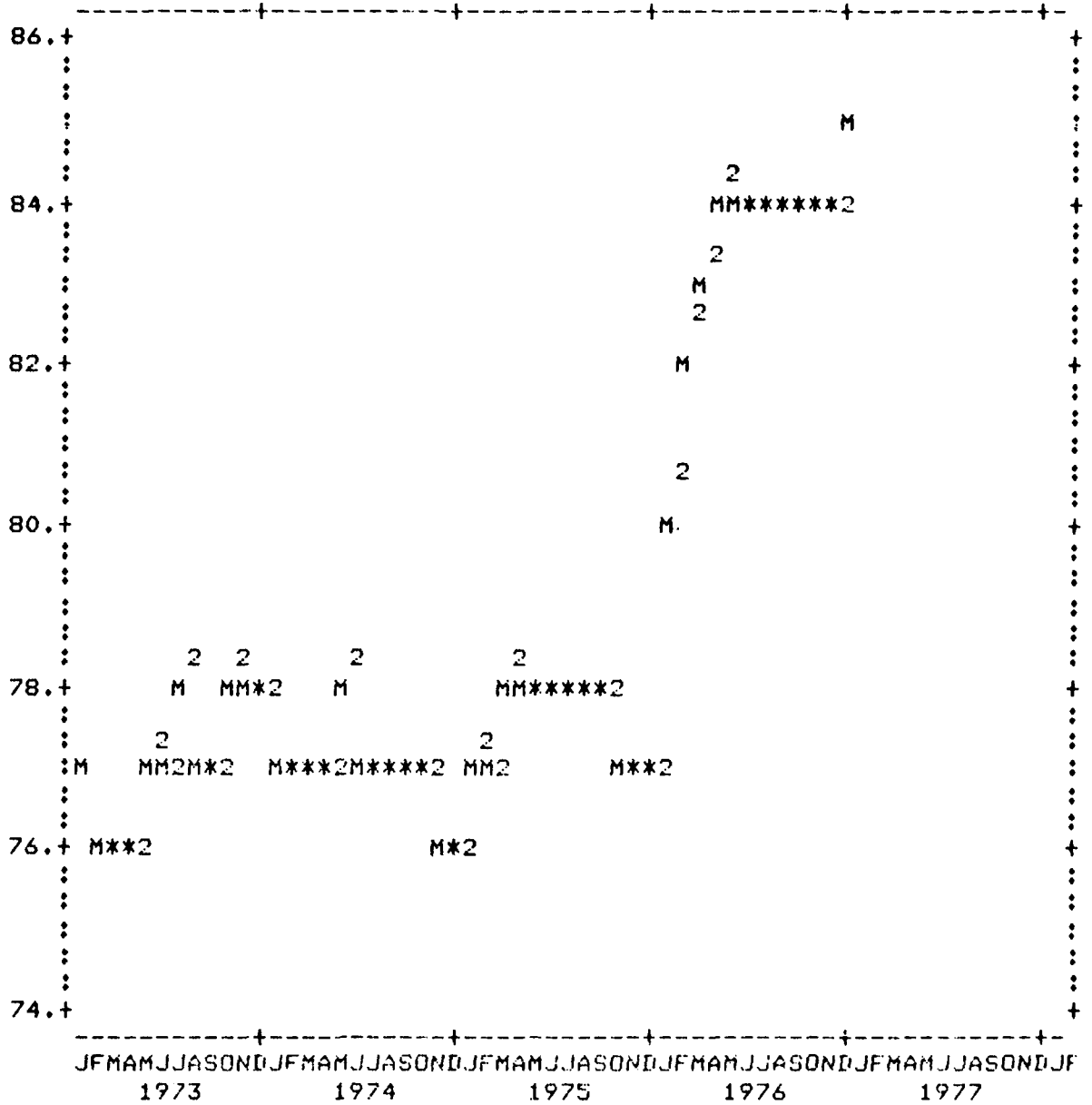

Figure B.49. Plot of One Step State Space Prediction for M27131 and Observed Data Over Fit Set

M=M27131
 2=M27131F
 3=M27131FU
 4=M27131FL

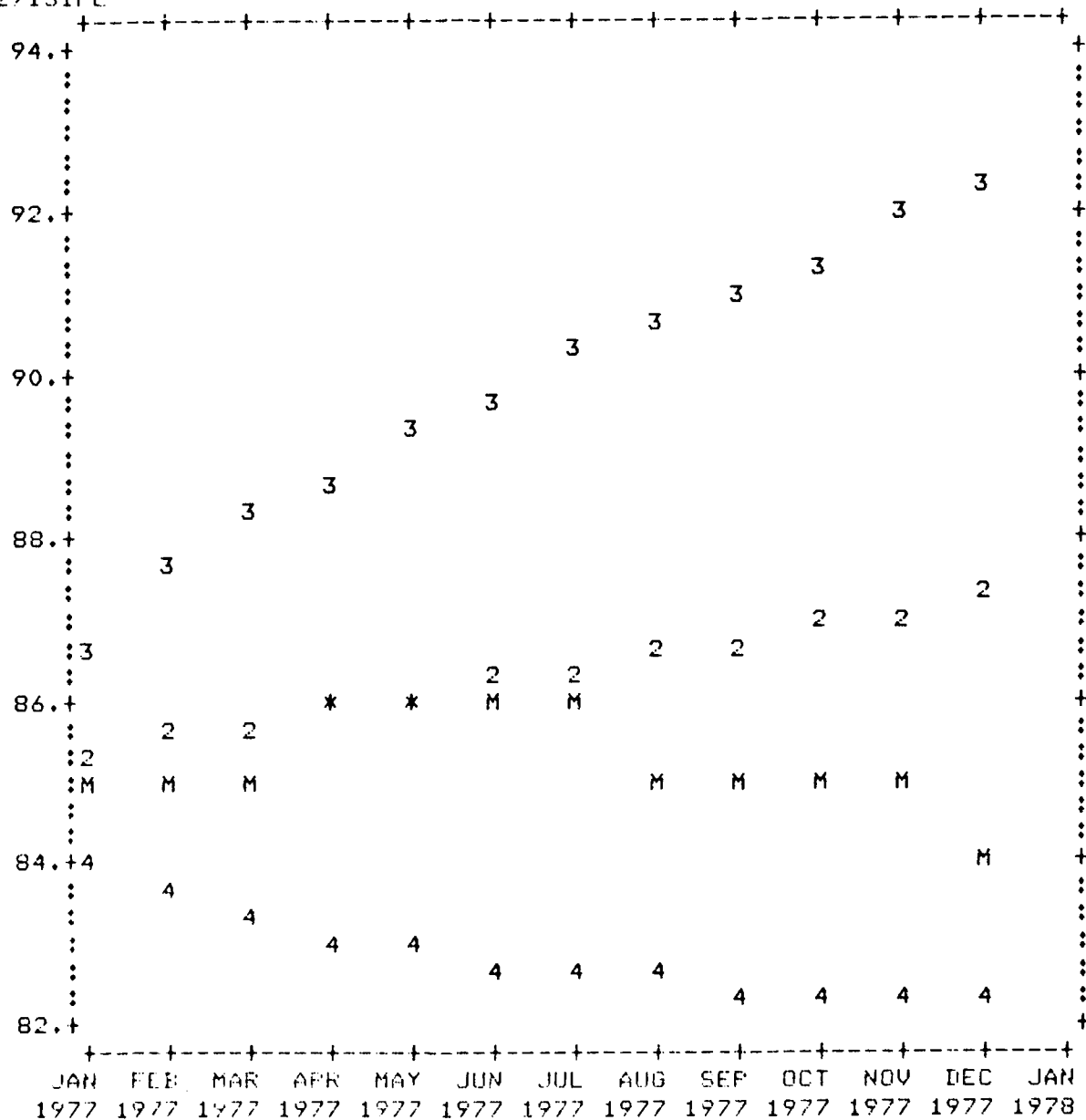

Figure B.50. Plot of 12-Month State Space Prediction and Actual Observed Data of M27131 for 1977

M=M42333
 2=M42333FH

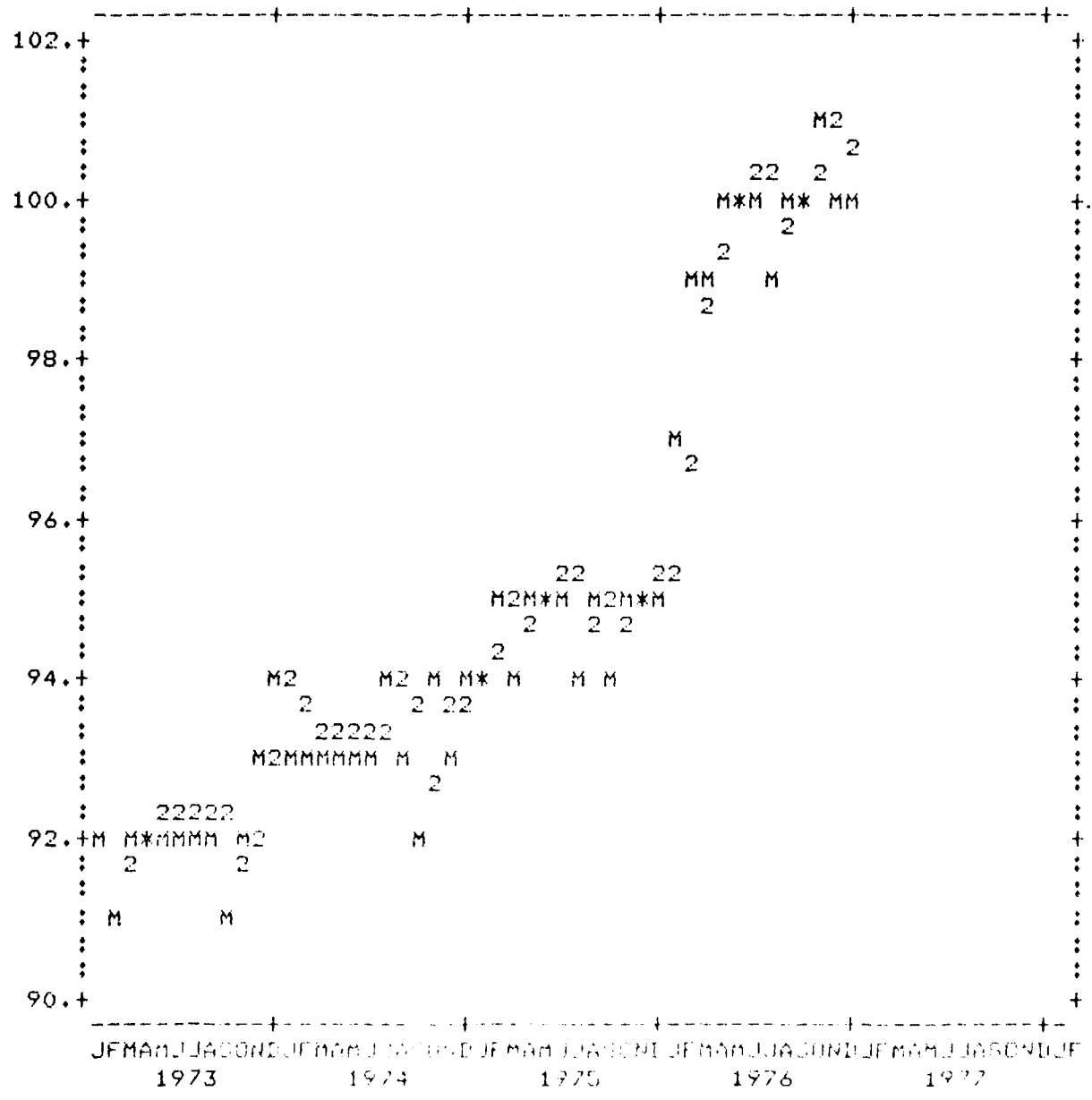

Figure B.51. Plot of One Step State Space Prediction for M42333 and Observed Data Over Fit Set

M=M42333
 2=M42333P
 3=M42333FU
 4=M42333PL

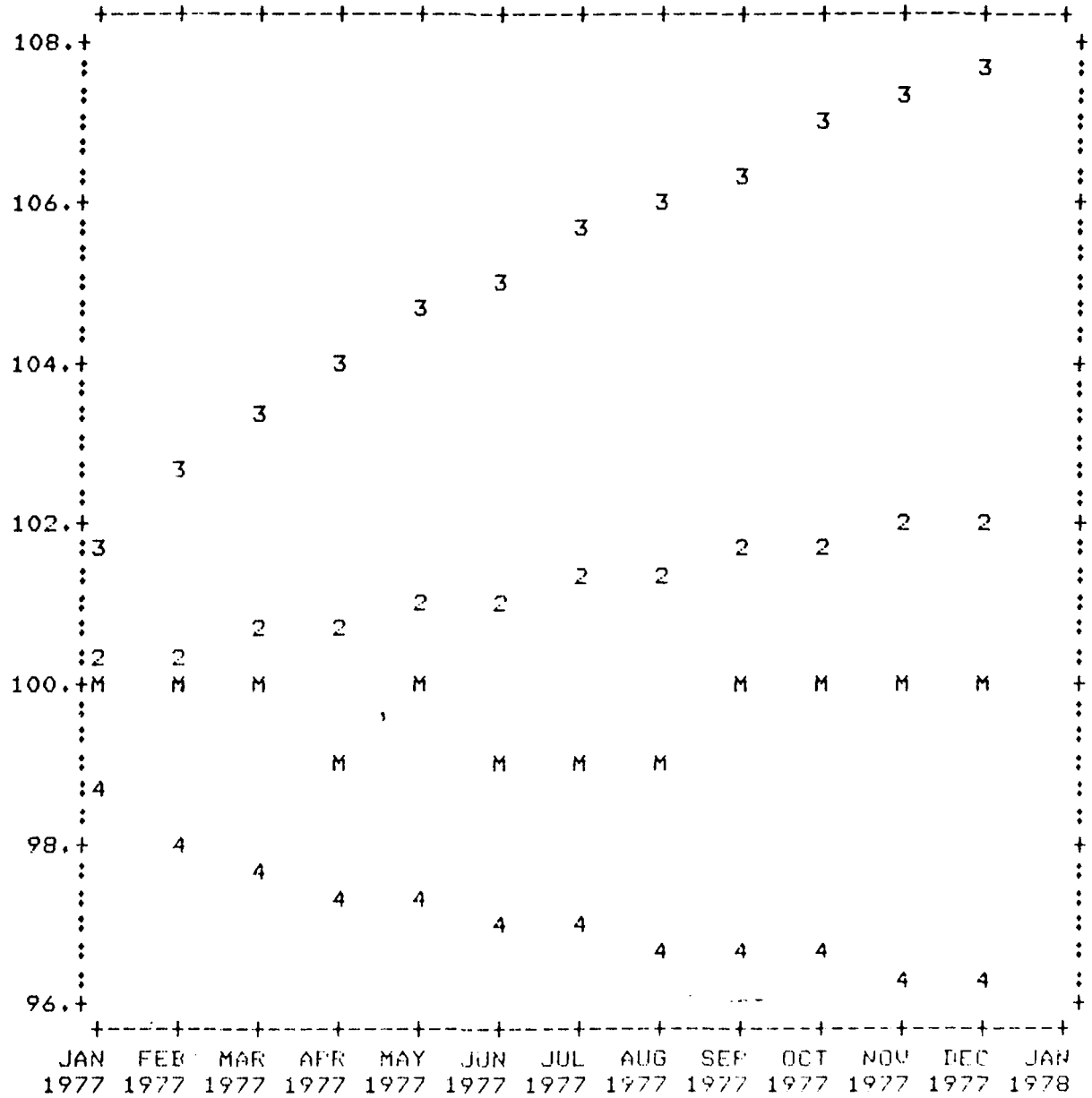

Figure B.52. Plot of 12-Month State Space Prediction and Actual Observed Data for M42333 for 1977

APPENDIX C

AN EXTENDED KALMAN FILTER FOR PJM TIME SERIES DATA

C.1 Problem Formulation

An extended Kalman filter is generally used in cases where one of the following is present: (i) nonlinear terms in the model; (ii) error statistics which are nongaussian; (iii) parameters which are unknown and time-varying; or (iv) errors in independent variables.

The extended Kalman filter is an approximate filter for nonlinear systems which is based on a first-order linearization method. It is the best known and most often used method of nonlinear estimation. It has the advantage of being a very straightforward approach to nonlinear estimation in that the usual Kalman filter can be applied to the linearized system. However, it suffers from several important disadvantages. First, it is only a first-order method; consequently, it does not have strong convergence properties in general (Nelson and Stear, 1976). Ljung (1977) has given convergence conditions and suggested a modification of the filter to improve convergence properties. Extended Kalman filters are known to give biased estimates (Orlhac, Athans, Speyer and Houpt, 1975). In this appendix, we develop an extended filter applicable to the PJM problem and compare it with the adaptive filter of Chapter 7.

The data analysis and filter developments of Chapters 3 and 7 have indicated that condition (iii), mentioned above, is the most significant departure from the Kalman filter assumptions. Hence, the extended Kalman filter for the PJM data will be an adaptive filter designed to estimate both the states and system parameters at the same time.

Detailed analyses of PJM data, as discussed in Chapter 7, have indicated that the most significant source of modeling uncertainty leading to prediction errors is the uncertainty in the transition matrix. For this reason, the exposition below is restricted to development of an extended filter to simultaneously estimate the state and the elements of the transition matrix.

Consider the problem of estimating simultaneously the state x and the j^{th} column, ϕ_j , of the transition matrix ϕ . The usual state equation is

$$x(i+1) = \phi x(i) + w(i) \quad (\text{C.1})$$

with observation

$$y(i) = Hx(i) + r(i) \quad (\text{C.2})$$

where

$$\phi = [\phi_1 \quad \vdots \quad \dots \quad \vdots \quad \phi_j \quad \vdots \quad \dots \quad \vdots \quad \phi_n]$$

x , ϕ_i are $n \times 1$ vectors, y , r are $m \times 1$ vectors and $w(k)$, $r(k)$ are zero-mean

uncorrelated white noise processes with known covariance matrices W and R , respectively.

C.2 Extended Filter Development

The extended filter uses the augmented state

$$z_j(i) = \begin{bmatrix} x(i) \\ \phi_j(i) \end{bmatrix} \quad (C.3)$$

The uncertainty in $\phi_j(i)$ will be accounted for here by modeling $\phi_i(k)$ by a Markov process of the form

$$\phi_j(i+1) = A_j \phi_j(i) + q_j(i) \quad (C.4)$$

where A_j is a fixed known $n \times n$ matrix and q_j is a zero-mean white noise process with known covariance matrix Q_j . It is explicitly assumed that $w(i)$, $r(i)$ and $q_j(i)$ are uncorrelated.

The augmented state z_i evolves as a nonlinear Markov process according to

$$z_j(i+1) = f(z_j(i)) + u_j(i) \quad (C.5)$$

where

$$f(z_j(i)) = \begin{bmatrix} \sum_{k=1}^n \phi_k(i) x_k(i) \\ \text{---} \\ A_j \phi_j(i) \end{bmatrix} \quad (C.6)$$

and

$$u_j(i) = \begin{bmatrix} w(i) \\ \text{---} \\ q_j(i) \end{bmatrix} \quad (C.7)$$

In the linear Gaussian case, $z_j(i+1)$ is a Gaussian random variable and the condition mean (minimum-variance estimate) was found using the Kalman filter. In the nonlinear case (Eq. (C.5)), the problem becomes more difficult. The conditional mean \hat{z}_j is

$$\hat{z}_j(i+1|i) = \int f(z_j(i)) p(z_j(i)) dz_j(i) \quad (C.8)$$

where $p(z_j(i))$ is the probability density functions for $z_j(i)$, given data $y(1), \dots, y(i)$. Thus, in order to compute $\hat{z}_j(i+1|i)$, $p(z_j(i))$, which is nongaussian in general, must be known.

In practice, it is not possible to solve Eq. (C.8) and alternative approaches must be sought. An attractive alternative, which is the basis of the extended Kalman filter, is based on a linearization technique. The dynamical equation (C.5) is expanded in a Taylor series about the prior estimate $\hat{z}_j(i|i)$ as

$$z_j(i+1) = f(\hat{z}_j(i|i)) + \left. \frac{\partial f}{\partial z} \right|_{z=\hat{z}_j(i|i)} (z_j(i) - \hat{z}_j(i|i)) + \dots \quad (C.9)$$

Taking the expectation of both sides of Eq. (C.9) produces

$$\hat{z}_j(i+1|i) = f(\hat{z}_j(i|i)) + 0 + \dots \quad (C.10)$$

Now we use the notation

$$e_j(i|i) = z_j(i) - \hat{z}_j(i|i) \quad (C.11)$$

$$\Psi_j(i) = \left. \frac{\partial f}{\partial z} \right|_{z=\hat{z}_j(i|i)} \quad (C.12)$$

where $e_j(i|i)$ is the estimation error at sample i using measurements up to $y(i)$; to write Eq. (C.9) as

$$z_j(i+1) = f(\hat{z}_j(i|i)) + \Psi_j(i)e_j(i|i) \quad (C.13)$$

It follows that the estimation error $e_j(i+1|i) = z_j(i+1) - \hat{z}_j(i+1|i)$ has mean zero and covariance matrix

$$P_j(i+1|i) = \Psi_j(i)P_j(i)\Psi_j(i)^T + U_j \quad (C.14)$$

where U_j is the covariance matrix of $u_j(i)$.

The measurement $y(i)$ is linear in the states $z_j(i)$:

$$y(i) = [H \ 0]z_j(i) \quad (C.15)$$

and thus, the update equations at a measurement are precisely those of the Kalman filter (cf. Eq. (5.5) through (5.11)).

We now summarize the complete set of equations for the extended Kalman filter, noting that

$$\Psi_j(i) = \begin{bmatrix} \Phi(i) & | & I_n x_j(i) \\ \hline 0 & | & A_j \end{bmatrix} \quad (C.16)$$

where $x_j(i)$ is the j^{th} component of $x(i)$ and I_n is the $n \times n$ identity matrix. The following notation will be used:

$$P'_j(i) = P_j(i|i-1), \quad P_j(i) = P_j(i|i)$$

and the covariance matrices will be partitioned as

$$P = \begin{bmatrix} P_{xx} & | & P_{\phi x}^T \\ \hline P_{\phi x} & | & P_{\phi\phi} \end{bmatrix}$$

With these definitions, the extended Kalman filter is as follows.

Propagation

$$\hat{x}(i+1|i) = \hat{\Phi}(i)\hat{x}(i|i) \quad (C.17)$$

$$\hat{\Phi}_j(i+1|i) = A_j \hat{\Phi}_j(i|i); \quad j = 1, 2, \dots, n \quad (C.18)$$

$$P'_{xx_j}(i+1) = \hat{\Phi}(i)P_{xx_j}(i)\hat{\Phi}(i)^T + \hat{\Phi}(i)P_{\phi_j x}(i)^T \hat{x}_j(i|i) \\ + P_{\phi_j x}(i)\hat{\Phi}(i)^T \hat{x}_j(i|i) + P_{\phi_j \phi_j}(i)\hat{x}_j(i|i)^2 + W \quad (C.19)$$

$$P'_{\phi_j x}(i+1) = A_j P_{\phi_j x}(i)\hat{\Phi}(i)^T + A_j P_{\phi_j \phi_j}(i)\hat{x}_j(i|i) \quad (C.20)$$

$$P'_{\phi_j \phi_j}(i+1) = A_j P_{\phi_j \phi_j}(i)A_j^T + Q \quad (C.21)$$

Measurement Incorporation

$$v(i) = y(i+1) - H\hat{x}(i+1|i) \quad (C.22)$$

$$\hat{x}(i+1|i+1) = \hat{x}(i+1|i) + K_{x_j}(i+1)v(i+1) \quad (C.23)$$

$$\hat{\Phi}_j(i+1|i+1) = \hat{\Phi}_j(i+1|i) + K_{\phi_j}(i+1)v(i+1) \quad (C.24)$$

$$K_{x_j}(i+1) = P'_{xx_j}(i+1)H^T \Sigma_j(i+1)^{-1} \quad (C.25)$$

$$K_{\phi_j}(i+1) = P'_{\phi_j x}(i+1)H^T \Sigma_j(i+1)^{-1} \quad (C.26)$$

$$\Sigma_j(i+1) = HP'_{xx_j}(i+1)H^T + R \quad (C.27)$$

$$P_{xx_j}(i+1) = [I - K_x(i+1)H]P'_{xx_j}(i+1) \quad (C.28)$$

$$P_{\phi_j x}(i+1) = [I - K_{\phi_j}(i+1)H]P'_{\phi_j x}(i+1) \quad (C.29)$$

$$P_{\phi_j \phi_j}(i+1) = [I - K_{\phi_j x}(i+1)H]P'_{\phi_j \phi_j}(i+1) \quad (C.30)$$

$$\hat{\phi}(i+1) = [\hat{\phi}_1(i+1); \dots; \hat{\phi}_j(i+1); \dots; \hat{\phi}_n(i+1)] \quad (C.31)$$

These equations are predicated on updating the j^{th} column of ϕ only. For updating all n columns, they may be processed sequentially as follows:

- (i) Compute $\hat{x}(i+1|i)$ and $v(i)$.
- (ii) Evaluate Eqs. (C.18) through (C.21) for $j=1,2,\dots,n$.
- (iii) Evaluate Eqs. (C.24) through (C.30) for $j=1,2,\dots,n$, storing $K_{x_j}(i+1)$ at each step.
- (iv) Compute the arithmetic means:

$$\bar{\Sigma}(i+1) = \frac{1}{n} \sum_{j=1}^n \Sigma_j(i+1)$$

$$\bar{P}'_{xx}(i+1) = \frac{1}{n} \sum_{j=1}^n P'_{xx_j}(i+1)$$

$$\text{and the gain } \bar{K}_x(i+1) = \bar{P}'_{xx}(i+1)H^T \bar{\Sigma}(i+1)^{-1}.$$

- (v) Update estimated ϕ using Eq. (C.31) and estimated $x(i+1)$ using $\hat{x}(i+1|i+1) = \hat{x}(i+1|i) + \bar{K}_x(i+1)v(i+1)$.

C.3 Comparison with Maximum Likelihood Adaptive Filter

The extended Kalman filter of Eqs. (C.17) through (C.31) is much more complex than the adaptive filter of Fig. 7.1, due principally to the fact that prior information is included in the extended filter, which is based on a Bayesian formulation. In addition, if it is desired to estimate all of the columns, the complexity increases by about a factor of n .

The relationship between the two filters can be seen more clearly by neglecting certain of the terms in the extended Kalman filter. For updating the state, we assume

$$P_{xx_j}(i) \gg P_{\phi_j \phi_j}(i), \quad P_{xx_j}(i) \gg P_{\phi_j x}(i)$$

Then Eq. (C.19) becomes

$$P'_{xx}(i+1) = \hat{\phi}(i)P_{xx}(i)\hat{\phi}(i) + W \quad (C.32)$$

Since $\Sigma_j(i)$ becomes independent of j , Eqs. (C.17), (C.22), (C.23), (C.27) and (C.32) comprise the usual Kalman filter for x , based on the estimated transition matrix $\hat{\phi}(i)$.

For estimating $\phi_j(i)$, we now assume

$$P_{\phi_j\phi_j}(i) \gg P_{xx_j}(i), \quad P_{\phi_j\phi_j}(i) \gg P_{\phi_j x}(i), \quad A_j = a_j I, \\ Q = 0, \quad W = 0$$

Then the equations for estimating ϕ_j become

$$\hat{\phi}_j(i+1|i+1) = a_j \hat{\phi}_j(i|i) + K_{\phi_j}(i+1)v(i+1) \quad (C.33)$$

$$K_{\phi_j}(i+1) = a_j P_{\phi_j\phi_j}(i) \hat{x}_j(i|i) H^T \tilde{\Sigma}_j(i+1)^{-1} \quad (C.34)$$

$$\tilde{\Sigma}_j(i+1) = H \hat{x}_j(i|i) P_{\phi_j\phi_j}(i+1) \hat{x}_j(i|i) H^T + R \quad (C.35)$$

$$P_{\phi_j\phi_j}(i+1) = a_j^2 [I - K_{\phi_j}(i+1)H] P_{\phi_j\phi_j}(i) \quad (C.36)$$

The relationship between these equations and those for the adaptive filter of Table 7.1 is striking. Note that the equations for updating $\phi_j(i)$ become identical if, in Table 7.1, we use $\hat{x}_j(i|i)$ rather than $\hat{x}_j(i|i-1)$, assume $\gamma = 1$ (no age weighting), $G_j(i) = 0$ and set $a_j = 1$ in Eqs. (C.33) through (C.36).

Several studies have been made of the extended filter and its relation to other parameter-adaptive methods. Ljung (1977) showed theoretically that the well-known divergence problem associated with the extended filter can be traced to the fact that the effect on the Kalman gain of a change in the parameters is not appropriately accounted for. This is particularly important if the noise covariances change, but is important even if they do not. He suggested a technique for modifying the gain to improve convergence. However, this technique requires extensive computations and it is not yet clear that this is warranted for the PJM problem. Saridis (1974) has compared the extended filter to several other causal* parameter-adaptive algorithms. A fourth-order system was studied with \ddagger in companion form

$$\phi = \begin{bmatrix} 0 & 1 & 0 & 0 \\ 0 & 0 & 1 & 0 \\ 0 & 0 & 0 & 1 \\ \phi_1 & \phi_2 & \phi_3 & \phi_4 \end{bmatrix}$$

*Causality implies that $\phi_j(i)$ is estimated using only past data $y(1), \dots, y(i)$.

and $H = [1 \ 0 \ 0 \ 0]$. The methods studied included a non-causal maximum likelihood method (Astrom and Bohlin, 1965), a causal modification of this algorithm (similar to the algorithm developed in Chapter 7), two stochastic approximation algorithms and a maximum a posteriori probability filter (Cox, 1964). Of these, the causal maximum likelihood filter gave the least mean squared errors in estimating the ϕ_j 's. However, the global convergence properties were not quite as good as the stochastic approximation algorithms. It is interesting to note that the non-causal algorithm yielded no better error performance, but required considerably more computation. We emphasize here that non-causal estimation is not appropriate for the PJM problem, since our objective is predicting future values of the time series of interest.

The above discussion indicates that there is a tradeoff between robustness and performance in parameter-adaptive algorithms. This phenomenon is quite well known and appears to be a universal characteristic. The design of the most appropriate algorithm for a particular problem depends on the problem itself and no single adaptive filter is best for all problems.

The conclusion of this appendix is that extended Kalman filters do not appear to be the most appropriate technique for parameter adaptation of PJM time series. For this reason, no numerical results are given for this method in this report.

APPENDIX D

ADAPTIVE FILTERING TESTS USING KNOWN TIME SERIES MODELS

The numerical results given in Chapter 8 were based on prediction of PJM time series. The performance measure was, of necessity, based entirely upon the prediction error statistics. Since the "true" dynamical models for producing the PJM time series data are unknown, it is not possible to examine the ability of the adaptive filter to correctly identify the dynamics (i.e., the transition matrix in this case) using PJM data. We may, of course, make certain inferences concerning the performance of the adaptive filter from these results. For example, we can study stability properties directly by varying γ and β and the initial conditions to get some idea of robustness and stability bounds. Nevertheless, a more complete analysis is not possible. The properties of the adaptive filter developed in Chapter 7 can be studied more thoroughly by using data generated by known dynamical models.

The adaptive filter developed in Chapter 7 is an approximate maximum-likelihood estimator for the components of the transition matrix. A true maximum-likelihood estimator produces estimates which are consistent, asymptotically Gaussian and asymptotically efficient, under the assumption that the disturbances are white Gaussian sequences. It is also necessary that the system is "persistently excited," which implies that all modes of the system are excited at all times by the white noise disturbance. As a simple example, consider the system

$$\mathbf{x}(i+1) = \Phi \mathbf{x}(i)$$

where

$$\mathbf{x}(0) = \begin{bmatrix} 1 \\ 1 \end{bmatrix}$$

The transition matrix

$$\Phi = \begin{bmatrix} a & | & 1-a \\ - & | & - \\ b & | & 1-b \end{bmatrix}$$

yields $\mathbf{x}(i) = \begin{bmatrix} 1 \\ 1 \end{bmatrix}$ for all i . Thus, with respect to the given initial condition Φ is not uniquely identifiable with no disturbance input since the parameters a and b are free. The state space program discussed in Chapter 5 uses a special canonical form for Φ . In the two-dimensional case

$$\Phi = \begin{bmatrix} 0 & | & 1 \\ - & | & - \\ b & | & 1-b \end{bmatrix}$$

reducing the number of free parameters to one. Identifiability of ϕ is enhanced, since there is one instead of two free parameters. However, both states must be persistently excited to ensure identifiability.

In this appendix we consider a simple two-dimensional dynamical system. This system was chosen to be roughly neutrally stable to match qualitatively the character of PJM payoff data. Changes are introduced in the dynamics, and the signal-to-noise ratio is varied. Measurements of one and then both states are taken. Initial conditions are varied to study the identifiability problem. Sensitivity to changes in the Kalman gain is evaluated and the effects of varying the adaptation parameters are studied. The overall result is that the adaptive filter works quite well and appears to be quite robust to variations in system parameters.

D.1 Adaptive Filter Algorithm Tests on Completely Observed Data

Here we present tests using a two-dimensional series where both states are observed for a neutrally stable $\phi(t)$. The series was generated recursively by

$$x(t+1) = \phi(t+1)x(t) + n(t+1) \quad (D.1)$$

where $x(0) = \begin{bmatrix} 0 \\ 0 \end{bmatrix}$ and $n(t)$ is pseudo white noise, normally distributed with zero mean and covariance matrix

$$Q = \begin{bmatrix} 0.0025 & 0 \\ 0 & 0.0025 \end{bmatrix} = \sigma_N^2 I$$

A neutrally stable $\phi(t)$ has eigenvalues that lie on the unit circle in the z-plane. As the white noise in the system may render the time series unstable, eigenvalues of magnitude 0.99 were chosen so as to lie just within the unit circle. Figure D.1 shows the location of the eigenvalues in the z-plane as a function of θ . The corresponding ϕ matrix is given by

$$\phi = \begin{bmatrix} 0 & 1 \\ -0.98 & 1.98\cos\theta \end{bmatrix} \quad (D.2)$$

$\phi(t)$ was varied every 15 time periods in a step manner by changing θ so that ϕ remained neutrally stable. Values of θ chosen were 72° , 36° , and 0° . The corresponding $\hat{\phi}(t)$ obtained was used in Eq. (D.1) to generate time series over 45 time periods. The adaptive filter was run on the series and initialized with the following boundary conditions:

$$\Lambda(0) = \begin{bmatrix} 1 & 0 \\ 0 & 1 \end{bmatrix}, \quad W = \begin{bmatrix} 1 & 0 \\ 0 & 1 \end{bmatrix}, \quad \hat{\phi}(0) = \phi(0) = \begin{bmatrix} .1 & .9 \\ -.7 & .8 \end{bmatrix}$$

The algorithm used was presented in Table 7.1.

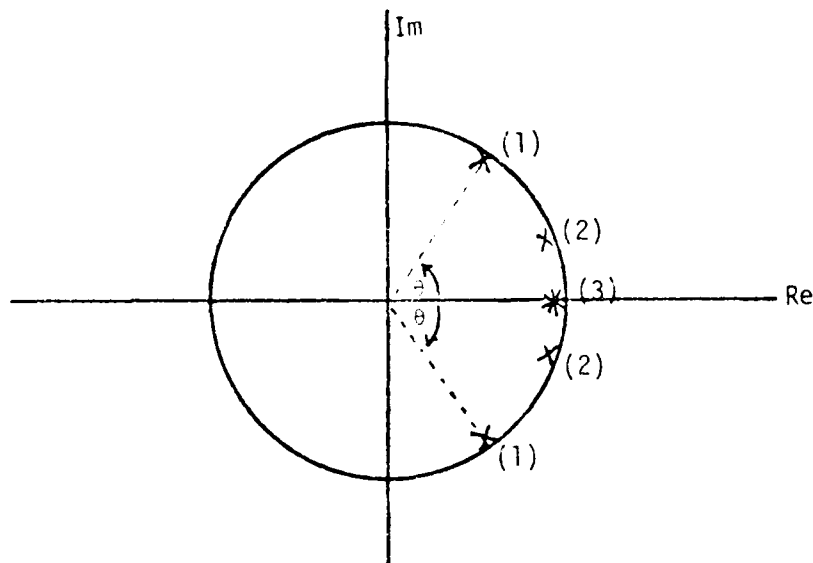

Figure D.1. Eigenvalues of Neutrally Stable $\Phi(t)$ Varied in a Step Manner from (1) to (2) to (3).

The parameters γ and β in the algorithm control the speed of adaptation. Several different tests were implemented using the adaptive filter and the results for the one-step-ahead prediction errors are summarized in Table D.1. In each case the adaptive root sum square vector is derived for comparison with the persistence root sum square vector. It is clearly seen that the adaptive filter does a better job than persistence. Cases (1) to (5) are tests using different values for γ and β with noise standard deviation of 0.05. Cases (1) and (5) represent better choices of γ and β . Case (6) is similar to Case (1) except that $x(0) = \begin{bmatrix} 0 \\ 0 \end{bmatrix}$. Case (7) uses $\gamma = .5$, $\beta = .5$ but with reduced $\sigma_N = 0.025$. As expected the adaptive filter performs better than in Case (6) where $\sigma_N = 0.05$. Case (8) uses observations generated from $\Phi^T(t)$ * varied in the same manner as in the other cases. Note in this case the adaptive filter does considerably better than persistence. Figures D.2-D.9 show the adaptation of the elements of $\hat{\Phi}$ for Cases (6) and (7). In Figures D.10-D.25, the actual states are plotted over the 45 time periods together with the one-step-ahead predicted states for each of the Cases (1)-(8). As expected from comparison in Table D.1, Cases (1) and (5) achieve the best one-step-ahead predictions out of the first five cases. Figures D.24 and D.25 reveal that the system with transition matrix = Φ^T in Case (8) becomes unstable; however, the adaptive filter tracks well.

*The eigenvalues of $\hat{\Phi}(t)$ and $\Phi^T(t)$ are identical.

D.2 Adaptive Filter Tests on Partially Observed Data

The properties of the adaptive filter of Chapter 7 were further studied using partially observed data. A two-dimensional time series was generated using the model of (D.1) and (D.2) with

$$Q = \sigma^2 \begin{bmatrix} 1 & 0 \\ 0 & 1 \end{bmatrix}$$

In this case, however, only the first component of $x(t)$ was observed. As in Section D.1, $\phi(t)$ was varied every 15 time periods in a step manner by changing θ so that ϕ remained neutrally stable. Various sets of data were generated using (D.1) with different choices of θ and σ . The adaptive filter was run on these sets of data, always initialized with the following boundary conditions:

$$\Lambda(0) = \begin{bmatrix} 1 & 0 \\ 0 & 1 \end{bmatrix}, \quad W = \begin{bmatrix} 1 & 0 \\ 0 & 1 \end{bmatrix}, \quad \phi(0) = \begin{bmatrix} 0 & 1 \\ -.7 & 1 \end{bmatrix} \quad \text{or} \quad \begin{bmatrix} 0 & 1 \\ -.7 & .3 \end{bmatrix}$$

Note that the adaptive filter was required to identify only the elements of the second row of ϕ . The elements of the first row were set to 0 and 1 respectively to satisfy identifiability conditions.

Test Cases

1. Noise-free data: $\theta = 50^\circ, 40^\circ, 30^\circ$, respectively

- (a) 45 data points generated by decreasing θ every 15 steps from 50° through 30° . The x vector in (D.1) was initialized using $x(0) = \begin{bmatrix} 1 \\ -1 \end{bmatrix}$. Various combinations of γ and β were used with the gain matrix, $K = \begin{bmatrix} 1 \\ 1 \end{bmatrix}$. Results appear in Table D.2, where it can be seen that the best choice of parameters was $\gamma = .95$, $\beta = .95$. A high value of γ is optimal since the elements of the transition matrix, ϕ , do not change drastically; in fact, only $\phi(2,2)$ changes as θ is moved through three 10° steps. Since the data are noise-free, a high value of β is expected to be optimal so that the rate of adaptation is high. Case 5 shows the deterioration in the performance of the filter when the gain matrix, K , is changed to $\begin{bmatrix} 1 \\ 0 \end{bmatrix}$. Also note that the adaptive filter does a better job than persistence prediction of $x(1)$.
- (b) Using the same values of θ as in (a), a second two-dimensional time series was generated with $x(0) = \begin{bmatrix} 1 \\ 1 \end{bmatrix}$ which allows the magnitudes of the two states to remain closer to each other than with $x(0) = \begin{bmatrix} 1 \\ -1 \end{bmatrix}$. The results using this data appear in Table D.3. Figures D.26 and D.27 show the adaptation of $\phi(2,1)$ and

$\phi(2,2)$ for $\gamma = .9$, $\beta = .8$. Note that identifiability of the elements of $\hat{\phi}$ is poorer here than in (a), since the data have less dynamics due to the choice of $x(0)$.

2. Noisy data: $\theta = 50^\circ, 40^\circ, 30^\circ$, respectively

- (a) The data were generated as in 1.a above but with $\sigma = .05$, producing a signal-to-noise ratio* of approximately 1100. Again, various combinations of γ and β were used and the results are presented in Table D.4. As in 1.a, the best choice of parameters was again $\gamma = .95$, $\beta = .95$. This is not surprising as the signal-to-noise ratio is high. Note the poorer performance of the filter in Case 14 where β was reduced to $.2$. Since the noise level is low, a high rate of adaptation is expected to be optimal. In Figures D.28 and D.29, the actual states are plotted over the 45 time periods together with the one-step-ahead predicted states for Case 11. Figures D.30 and D.31 show the adaptation of the elements of $\hat{\phi}$ for Case 11. Figures D.32 - D.35 are similar plots for Case 14. Note that in Case 16 where $\gamma = .5$ and $\beta = .95$, the system goes unstable. This is because the loop gain (β) $\hat{\phi}$ is too high in this non-linear system. Cases 17 to 21 use $\begin{bmatrix} 1 \\ k \end{bmatrix}$ for the gain matrix K where k was calculated as the steady-state Kalman gain using the one-step-ahead prediction of $\hat{\phi}$ from the adaptive filter. The performance of the filter was not as good as in the $K = \begin{bmatrix} 1 \\ 1 \end{bmatrix}$ cases. Since the prediction $\hat{\phi}$ itself depends upon the value of the Kalman gain matrix K, the filter can perform worse than with $K = \begin{bmatrix} 1 \\ 1 \end{bmatrix}$ if the $\hat{\phi}$ prediction is not accurate.
- (b) Similar data to (a) were generated but with $\sigma = .25$ producing an average signal-to-noise ratio of approximately 100. Cases 23 to 32 in Table D.5 cover the different combinations of γ and β used. Best results were obtained with $\gamma = .95$, $\beta = .2$. Since the signal-to-noise ratio here is lower than in (a), a lower value of β is expected to be optimal so that the rate of adaptation is slowed down. In Figures D.36 and D.37 the actual states and the one-step-ahead predicted states are plotted for Case 25 ($\gamma = .95$, $\beta = .2$) and Figures D.38 and D.39 show the adaptation of the elements of $\hat{\phi}$.
- (c) A third set of data was generated as in (a) and (b) but with $\sigma = 1.25$ producing an average signal-to-noise ratio of approximately 30. Various combinations of γ and β were used in Cases 34 to 38 in Table D.6 and the optimal values were found to be $\gamma = .95$, $\beta = .05$ in Case 35. Since the noise level is higher here than in (b), a lower β is expected to be optimal. Figures D.40 to D.43 show the actual and the one-step-ahead predicted states and the adaptation of the elements of $\hat{\phi}$.

*Signal-to-noise ratio was computed as the average value of $(x(i))^T x(i) / \text{tr } Q$.

3. Noise-free data: $\theta = 72^\circ, 36^\circ, 0^\circ$, respectively

45 data points were generated by decreasing θ every 15 steps from 72° to 36° to 0° , using $x(0) = \begin{bmatrix} 1 \\ 1 \end{bmatrix}$ as in (1). This set of data points was used to show the poor performance of the filter when the data have little dynamics and are almost static with $\theta = 0^\circ$ in the transition matrix, when

$$\phi \approx \begin{bmatrix} 0 & 1 \\ -1 & 2 \end{bmatrix}$$

That is,

$$x_1(K+1) \approx x_2(K)$$

$$x_2(K+1) \approx -x_1(K) + 2x_2(K) \approx x_2(K)$$

Hence, all the dynamics in the data are suppressed (see Table D.7). Figures D.44 and D.45 show the adaptation of $\hat{\zeta}(2,1)$ and $\hat{\phi}(2,2)$. In Case 40 it is not surprising, given the nature of the data, that identifiability is very bad; in fact the filter identifies the transition matrix $\begin{bmatrix} 0 & 1 \\ 1 & 0 \end{bmatrix}$ approximately which also gives: $x_1(K+1) = x_2(K) = x_2(K+1)$. Figures D.46 and D.47 show the actual and one-step-ahead predicted states. Note that toward the end of the simulation where $\theta = 0^\circ$, the filter is doing a good job of predicting the states since the $\hat{\phi}$ matrix it has identified produces the same prediction of the static states as the actual $\hat{\zeta}$ matrix would.

Case #	$x(0)$	β	σ_N	Mean Adaptive Error Vector	Mean Persistence Error Vector	
1	$\begin{pmatrix} 0. \\ 0. \end{pmatrix}$.5	.5	.05	$\begin{pmatrix} .007 \\ .002 \end{pmatrix}$	$\begin{pmatrix} 0.010 \\ 0.015 \end{pmatrix}$
2	$\begin{pmatrix} 0. \\ 0. \end{pmatrix}$.5	.8	.05	$\begin{pmatrix} .004 \\ .006 \end{pmatrix}$	$\begin{pmatrix} 0.010 \\ 0.015 \end{pmatrix}$
3	$\begin{pmatrix} 0. \\ 0. \end{pmatrix}$.3	.5	.05	$\begin{pmatrix} .001 \\ .002 \end{pmatrix}$	$\begin{pmatrix} 0.010 \\ 0.015 \end{pmatrix}$
4	$\begin{pmatrix} 0. \\ 0. \end{pmatrix}$.3	.3	.05	$\begin{pmatrix} .003 \\ .003 \end{pmatrix}$	$\begin{pmatrix} 0.010 \\ 0.015 \end{pmatrix}$
5	$\begin{pmatrix} 0. \\ 0. \end{pmatrix}$.75	.9	.05	$\begin{pmatrix} .005 \\ .003 \end{pmatrix}$	$\begin{pmatrix} 0.010 \\ 0.015 \end{pmatrix}$
6	$\begin{pmatrix} .1 \\ .1 \end{pmatrix}$.5	.5	.05	$\begin{pmatrix} .003 \\ .003 \end{pmatrix}$	$\begin{pmatrix} 0.006 \\ 0.014 \end{pmatrix}$
7	$\begin{pmatrix} .1 \\ .1 \end{pmatrix}$.5	.5	.025	$\begin{pmatrix} -.001 \\ .003 \end{pmatrix}$	$\begin{pmatrix} 0.001 \\ 0.006 \end{pmatrix}$
8	$\begin{pmatrix} .1 \\ .1 \end{pmatrix}$.5	.5	.025	$\begin{pmatrix} .003 \\ .003 \end{pmatrix}$	$\begin{pmatrix} 0.004 \\ -0.101 \end{pmatrix}$

Transition Matrix = I

Table 2.1 Comparison of Adaptive and Persistence Prediction Methods for Various Cases

Case #	Adaptive Covariance Matrix	Persistence Covariance Matrix	Adaptive Root Sum Square Vector	Persistence Root Sum Square Vector
1	$\begin{bmatrix} 0.0027 & 0.0004 \\ 0.0004 & 0.0044 \end{bmatrix}$	$\begin{bmatrix} 0.0141 & 0.0062 \\ 0.0062 & 0.0111 \end{bmatrix}$	$\begin{pmatrix} .052 \\ .066 \end{pmatrix}$	$\begin{pmatrix} .119 \\ .106 \end{pmatrix}$
2	$\begin{bmatrix} 0.0030 & 0.0005 \\ 0.0005 & 0.0047 \end{bmatrix}$	$\begin{bmatrix} 0.0141 & 0.0062 \\ 0.0062 & 0.0111 \end{bmatrix}$	$\begin{pmatrix} .055 \\ .069 \end{pmatrix}$	$\begin{pmatrix} .119 \\ .106 \end{pmatrix}$
3	$\begin{bmatrix} 0.0039 & 0.0015 \\ 0.0015 & 0.0048 \end{bmatrix}$	$\begin{bmatrix} 0.0141 & 0.0062 \\ 0.0062 & 0.0111 \end{bmatrix}$	$\begin{pmatrix} .100 \\ .069 \end{pmatrix}$	$\begin{pmatrix} .119 \\ .106 \end{pmatrix}$
4	$\begin{bmatrix} 0.0037 & 0.0017 \\ 0.0017 & 0.0052 \end{bmatrix}$	$\begin{bmatrix} 0.0141 & 0.0062 \\ 0.0062 & 0.0111 \end{bmatrix}$	$\begin{pmatrix} .061 \\ .072 \end{pmatrix}$	$\begin{pmatrix} .119 \\ .106 \end{pmatrix}$
5	$\begin{bmatrix} 0.0022 & 0.0004 \\ 0.0004 & 0.0050 \end{bmatrix}$	$\begin{bmatrix} 0.0141 & 0.0062 \\ 0.0062 & 0.0111 \end{bmatrix}$	$\begin{pmatrix} .047 \\ .071 \end{pmatrix}$	$\begin{pmatrix} .119 \\ .106 \end{pmatrix}$
6	$\begin{bmatrix} 0.0034 & 0.0005 \\ 0.0005 & 0.0033 \end{bmatrix}$	$\begin{bmatrix} 0.0116 & 0.0050 \\ 0.0050 & 0.0079 \end{bmatrix}$	$\begin{pmatrix} .058 \\ .062 \end{pmatrix}$	$\begin{pmatrix} .108 \\ .090 \end{pmatrix}$
7	$\begin{bmatrix} 0.0013 & 0.0004 \\ 0.0004 & 0.0011 \end{bmatrix}$	$\begin{bmatrix} 0.0041 & 0.0016 \\ 0.0016 & 0.0027 \end{bmatrix}$	$\begin{pmatrix} .036 \\ .033 \end{pmatrix}$	$\begin{pmatrix} .064 \\ .052 \end{pmatrix}$
8	$\begin{bmatrix} 0.0009 & 0.0003 \\ 0.0003 & 0.0059 \end{bmatrix}$	$\begin{bmatrix} 0.0458 & -0.0362 \\ -0.0362 & 0.0457 \end{bmatrix}$	$\begin{pmatrix} .031 \\ .077 \end{pmatrix}$	$\begin{pmatrix} .234 \\ .236 \end{pmatrix}$

Table D.1 continued

CASE #	DATA	γ	β	K	MEAN ADAPTIVE ERROR VECTOR	ADAPTIVE COVARIANCE MATRIX	ADAPTIVE ROOT SUM SQUARE VECTOR
1	45 data points with θ varied every 15 steps: $\theta = 50^\circ, 40^\circ, 30^\circ$, respectively; noise-free; $x(0) = \begin{bmatrix} 1 \\ -1 \end{bmatrix}$.9	.8	$\begin{bmatrix} 1 \\ 1 \end{bmatrix}$	$\begin{bmatrix} .015 \\ .021 \end{bmatrix}$	$\begin{bmatrix} .6255 & 0 \\ 0 & .3133 \end{bmatrix}$	$\begin{bmatrix} .791 \\ .560 \end{bmatrix}$
2		.95	.95	$\begin{bmatrix} 1 \\ 1 \end{bmatrix}$	$\begin{bmatrix} .018 \\ .029 \end{bmatrix}$	$\begin{bmatrix} .6174 & 0 \\ 0 & .2824 \end{bmatrix}$	$\begin{bmatrix} .786 \\ .532 \end{bmatrix}$
3		1.	1.	$\begin{bmatrix} 1 \\ 1 \end{bmatrix}$	$\begin{bmatrix} .020 \\ .036 \end{bmatrix}$	$\begin{bmatrix} .6202 & 0 \\ 0 & .2924 \end{bmatrix}$	$\begin{bmatrix} .788 \\ .542 \end{bmatrix}$
4		.5	.5	$\begin{bmatrix} 1 \\ 1 \end{bmatrix}$	$\begin{bmatrix} -.051 \\ -.229 \end{bmatrix}$	$\begin{bmatrix} 1.6248 & 0 \\ 0 & 2.4132 \end{bmatrix}$	$\begin{bmatrix} 1.276 \\ 1.570 \end{bmatrix}$
5		.95	.95	$\begin{bmatrix} 1 \\ 0 \end{bmatrix}$	$\begin{bmatrix} .246 \\ .285 \end{bmatrix}$	$\begin{bmatrix} 3.7385 & 0 \\ 0 & 3.2508 \end{bmatrix}$	$\begin{bmatrix} 1.949 \\ 1.825 \end{bmatrix}$
6					Mean persistence error = .038	Persistence covariance = 1.079	Persistence root sum square = 1.04

Table D.2: Adaptive Filter Performance with Noise-Free Data
 $\theta = 50^\circ, 40^\circ, 30^\circ$; $x(0) = (1, -1)$

Test #	DATA	y	F	K	VECTOR	PERSISTENCE MATRIX	VECTOR
7	45 data points with θ varied every 15 steps: $\theta = 50^\circ, 40^\circ, 30^\circ$, respectively; noise-free; $x(0) = \begin{bmatrix} 1 \\ 1 \end{bmatrix}$.9	.8	$\begin{bmatrix} 1 \\ 1 \end{bmatrix}$	$\begin{bmatrix} .025 \\ .055 \end{bmatrix}$	$\begin{bmatrix} .1492 & 0 \\ 0 & .1067 \end{bmatrix}$	$\begin{bmatrix} .387 \\ .331 \end{bmatrix}$
8		.9	.5	$\begin{bmatrix} 1 \\ 1 \end{bmatrix}$	$\begin{bmatrix} .034 \\ .073 \end{bmatrix}$	$\begin{bmatrix} .1503 & 0 \\ 0 & .1100 \end{bmatrix}$	$\begin{bmatrix} .389 \\ .340 \end{bmatrix}$
9				Persistence prediction of observed state	Mean persistence error = -.001	Persistence covariance = .2427	Persistence root sum square = .493

Table D.3: Adaptive Filter Performance with Noise-Free Data
 $\theta = 50^\circ, 40^\circ, 30^\circ$; $x(0) = (1, 1)$

CASE #	DATA	γ	β	K	MPFH ADAPTIVE ERROR VECTOR	ADAPTIVE COVARIANCE MATRIX	ADAPTIVE ROOT SUM SQUARE VECTOR
10	45 data points with θ varied every 15 steps: $\theta = 50^\circ, 40^\circ, 30^\circ$, respectively; white noise S.D. = .05, signal to noise ratio approximately 1100; $x(0) = \begin{bmatrix} 1 \\ -1 \end{bmatrix}$.9	.8	$\begin{bmatrix} 1 \\ 1 \end{bmatrix}$	$\begin{bmatrix} .012 \\ 0 \end{bmatrix}$	$\begin{bmatrix} .7496 & 0 \\ 0 & .4451 \end{bmatrix}$	$\begin{bmatrix} .866 \\ .667 \end{bmatrix}$
11		.95	.95	$\begin{bmatrix} 1 \\ 1 \end{bmatrix}$	$\begin{bmatrix} .016 \\ .011 \end{bmatrix}$	$\begin{bmatrix} .7370 & 0 \\ 0 & .3902 \end{bmatrix}$	$\begin{bmatrix} .859 \\ .625 \end{bmatrix}$
12		1.	1.	$\begin{bmatrix} 1 \\ 1 \end{bmatrix}$	$\begin{bmatrix} .022 \\ .028 \end{bmatrix}$	$\begin{bmatrix} .7406 & 0 \\ 0 & .3941 \end{bmatrix}$	$\begin{bmatrix} .861 \\ .628 \end{bmatrix}$
13		.5	.5	$\begin{bmatrix} 1 \\ 1 \end{bmatrix}$	$\begin{bmatrix} -.164 \\ -.313 \end{bmatrix}$	$\begin{bmatrix} 1.5400 & 0 \\ 0 & 3.0698 \end{bmatrix}$	$\begin{bmatrix} 1.252 \\ 1.780 \end{bmatrix}$
14		.9	.2	$\begin{bmatrix} 1 \\ 1 \end{bmatrix}$	$\begin{bmatrix} -.002 \\ -.029 \end{bmatrix}$	$\begin{bmatrix} .7438 & 0 \\ 0 & .4238 \end{bmatrix}$	$\begin{bmatrix} .862 \\ .652 \end{bmatrix}$
15		.9	.5	$\begin{bmatrix} 1 \\ 1 \end{bmatrix}$	$\begin{bmatrix} .004 \\ -.015 \end{bmatrix}$	$\begin{bmatrix} .7502 & 0 \\ 0 & .4506 \end{bmatrix}$	$\begin{bmatrix} .866 \\ .671 \end{bmatrix}$
16		.5	.95	$\begin{bmatrix} 1 \\ 1 \end{bmatrix}$		UNSTABLE	

Table D.4: Adaptive Filter Performance with Noisy Data
 SNR = 1100; $\theta = 50^\circ, 40^\circ, 30^\circ$; $x(0) = (1, -1)$

CASE #	DATA	γ	β	K	MEAN ADAPTIVE ERROR VECTOR	ADAPTIVE COVARIANCE MATRIX	ADAPTIVE ROOT SUM SQUARE VECTOR
17	45 data points with θ varied every 15 steps: $\theta = 50^\circ, 40^\circ, 30^\circ$, respectively; white noise S.D. = .05; signal to noise ratio approximately 1100; $x(0) = \begin{bmatrix} 1 \\ -1 \end{bmatrix}$.95	.95	$\begin{bmatrix} 1 \\ k \end{bmatrix}$	$\begin{bmatrix} .043 \\ .056 \end{bmatrix}$	$\begin{bmatrix} .7602 & 0 \\ 0 & .4393 \end{bmatrix}$	$\begin{bmatrix} .873 \\ .665 \end{bmatrix}$
18		.9	.5	$\begin{bmatrix} 1 \\ k \end{bmatrix}$	$\begin{bmatrix} .001 \\ -.025 \end{bmatrix}$	$\begin{bmatrix} .7659 & 0 \\ 0 & .4719 \end{bmatrix}$	$\begin{bmatrix} .875 \\ .687 \end{bmatrix}$
19		.9	.8	$\begin{bmatrix} 1 \\ k \end{bmatrix}$	$\begin{bmatrix} .032 \\ .033 \end{bmatrix}$	$\begin{bmatrix} .7692 & 0 \\ 0 & .4904 \end{bmatrix}$	$\begin{bmatrix} .878 \\ .701 \end{bmatrix}$
20		1.	1.	$\begin{bmatrix} 1 \\ k \end{bmatrix}$	$\begin{bmatrix} .048 \\ .071 \end{bmatrix}$	$\begin{bmatrix} .7676 & 0 \\ 0 & .4450 \end{bmatrix}$	$\begin{bmatrix} .877 \\ .671 \end{bmatrix}$
21		.9	.2	$\begin{bmatrix} 1 \\ k \end{bmatrix}$	$\begin{bmatrix} -.004 \\ -.033 \end{bmatrix}$	$\begin{bmatrix} .7562 & 0 \\ 0 & .4197 \end{bmatrix}$	$\begin{bmatrix} .870 \\ .649 \end{bmatrix}$
22							

Table D.4 concluded

CASE #	DATA	Y	B	K	MEAN ADAPTIVE ERROR VECTOR	ADAPTIVE COVARIANCE MATRIX	ADAPTIVE ROOT SUM SQUARE VECTOR
23	45 data points with θ varied every 15 steps: $\theta = 50^\circ, 40^\circ, 30^\circ$, respectively; white noise S.D. = .25; signal to noise ratio approximately 100	.95	.95	$\begin{bmatrix} 1 \\ 1 \end{bmatrix}$	$\begin{bmatrix} .034 \\ -.006 \end{bmatrix}$	$\begin{bmatrix} 1.6648 & 0 \\ 0 & 1.6813 \end{bmatrix}$	$\begin{bmatrix} 1.291 \\ 1.297 \end{bmatrix}$
24		.95	.5	$\begin{bmatrix} 1 \\ 1 \end{bmatrix}$	$\begin{bmatrix} .027 \\ -.021 \end{bmatrix}$	$\begin{bmatrix} 1.6631 & 0 \\ 0 & 1.6707 \end{bmatrix}$	$\begin{bmatrix} 1.290 \\ 1.293 \end{bmatrix}$
25		.95	.2	$\begin{bmatrix} 1 \\ 1 \end{bmatrix}$	$\begin{bmatrix} .010 \\ -.058 \end{bmatrix}$	$\begin{bmatrix} 1.6008 & 0 \\ 0 & 1.4277 \end{bmatrix}$	$\begin{bmatrix} 1.265 \\ 1.196 \end{bmatrix}$
26		.95	.1	$\begin{bmatrix} 1 \\ 1 \end{bmatrix}$	$\begin{bmatrix} .029 \\ -.015 \end{bmatrix}$	$\begin{bmatrix} 1.6259 & 0 \\ 0 & 1.4871 \end{bmatrix}$	$\begin{bmatrix} 1.275 \\ 1.220 \end{bmatrix}$
27		.95	.3	$\begin{bmatrix} 1 \\ 1 \end{bmatrix}$	$\begin{bmatrix} .009 \\ -.061 \end{bmatrix}$	$\begin{bmatrix} 1.6219 & 0 \\ 0 & 1.5233 \end{bmatrix}$	$\begin{bmatrix} 1.274 \\ 1.236 \end{bmatrix}$
28		1.	.1	$\begin{bmatrix} 1 \\ 1 \end{bmatrix}$	$\begin{bmatrix} .044 \\ .023 \end{bmatrix}$	$\begin{bmatrix} 1.6384 & 0 \\ 0 & 1.4799 \end{bmatrix}$	$\begin{bmatrix} 1.281 \\ 1.217 \end{bmatrix}$

Table D.5: Adaptive Filter Performance with Noisy Data
 SNR = 100; $\theta = 50^\circ, 40^\circ, 30^\circ$; $x(0) = (1, -1)$

CASE #	DATA	γ	β	K	MEAN ADAPTIVE ERROR VECTOR	ADAPTIVE COVARIANCE MATRIX	ADAPTIVE ROOT SUM SQUARE VECTOR
29	45 data points with θ varied every 15 steps; $\theta = 50^\circ, 40^\circ, 30^\circ$, respectively; white noise S.D. = .25; signal to noise ratio approximately 100	.5	.2	$\begin{bmatrix} 1 \\ 1 \end{bmatrix}$	$\begin{bmatrix} .483 \\ .975 \end{bmatrix}$	$\begin{bmatrix} 3.5657 & 0 \\ 0 & 8.9992 \end{bmatrix}$	$\begin{bmatrix} 1.949 \\ 3.154 \end{bmatrix}$
30		.9	.2	$\begin{bmatrix} 1 \\ 1 \end{bmatrix}$	$\begin{bmatrix} .003 \\ -.082 \end{bmatrix}$	$\begin{bmatrix} 1.6449 & 0 \\ 0 & 1.6747 \end{bmatrix}$	$\begin{bmatrix} 1.283 \\ 1.297 \end{bmatrix}$
31		.95	.25	$\begin{bmatrix} 1 \\ 1 \end{bmatrix}$	$\begin{bmatrix} .008 \\ -.063 \end{bmatrix}$	$\begin{bmatrix} 1.6097 & 0 \\ 0 & 1.4725 \end{bmatrix}$	$\begin{bmatrix} 1.269 \\ 1.215 \end{bmatrix}$
32		.5	.95	$\begin{bmatrix} 1 \\ 1 \end{bmatrix}$		UNSTABLE	
33			Persistence prediction of observed state		Mean persistence error = .066	Persistence covariance = 2.320	Persistence root sum square = 1.525

Table D.5 concluded

CASE #	DATA	γ	β	K	MEAN ADAPTIVE ERROR VECTOR	ADAPTIVE COVARIANCE MATRIX	ADAPTIVE ROOT SUM SQUARE VECTOR	
34	45 data points with θ varied every 15 steps: $\theta = 50^\circ, 40^\circ, 30^\circ$, respectively; white noise S.D. = 1.25; signal to noise ratio approximately 30	.95	.2	$\begin{bmatrix} 1 \\ 1 \end{bmatrix}$	$\begin{bmatrix} .146 \\ -.052 \end{bmatrix}$	$\begin{bmatrix} 15.418 & 0 \\ 0 & 22.464 \end{bmatrix}$	$\begin{bmatrix} 3.929 \\ 4.740 \end{bmatrix}$	
35		.95	.05	$\begin{bmatrix} 1 \\ 1 \end{bmatrix}$	$\begin{bmatrix} .156 \\ -.024 \end{bmatrix}$	$\begin{bmatrix} 15.274 & 0 \\ 0 & 21.143 \end{bmatrix}$	$\begin{bmatrix} 3.911 \\ 4.598 \end{bmatrix}$	
36		1.	.05	$\begin{bmatrix} 1 \\ 1 \end{bmatrix}$	$\begin{bmatrix} .202 \\ .092 \end{bmatrix}$	$\begin{bmatrix} 15.394 & 0 \\ 0 & 20.811 \end{bmatrix}$	$\begin{bmatrix} 3.929 \\ 4.563 \end{bmatrix}$	
37		.5	.2	$\begin{bmatrix} 1 \\ 1 \end{bmatrix}$	$\begin{bmatrix} .57 \\ .917 \end{bmatrix}$	$\begin{bmatrix} 29.662 & 0 \\ 0 & 72.087 \end{bmatrix}$	$\begin{bmatrix} 5.476 \\ 8.540 \end{bmatrix}$	
38		.5	.95	$\begin{bmatrix} 1 \\ 1 \end{bmatrix}$	UNSTABLE			
39			Persistence prediction of observed state		Mean persistence error = .176	Persistence covariance = 16.325	Persistence root sum square = 4.044	

Table D.6: Adaptive Filter Performance with Noisy Data
SNR = 30; $\theta = 50^\circ, 40^\circ, 30^\circ$; $x(0) = (1, -1)$

CASE #	DATA	γ	B	K	MEAN ADAPTIVE ERROR VECTOR	ADAPTIVE COVARIANCE MATRIX	ADAPTIVE ROOT SUM SQUARE VECTOR
40	45 data points with α varied every 15 steps: $\alpha = 72^\circ, 36^\circ, 0^\circ$, respectively; noise-free; $x(0) = \begin{bmatrix} 1 \\ 1 \end{bmatrix}$.9	.6	$\begin{bmatrix} 1 \\ 1 \end{bmatrix}$	$\begin{bmatrix} -.029 \\ -.058 \end{bmatrix}$	$\begin{bmatrix} .2369 & 0 \\ 0 & .2009 \end{bmatrix}$	$\begin{bmatrix} .486 \\ .452 \end{bmatrix}$
41		.9	.2	$\begin{bmatrix} 1 \\ 0 \end{bmatrix}$	$\begin{bmatrix} -.587 \\ -.632 \end{bmatrix}$	$\begin{bmatrix} 1.1979 & 0 \\ 0 & 1.0587 \end{bmatrix}$	$\begin{bmatrix} .242 \\ 1.208 \end{bmatrix}$
42		.9	.2	$\begin{bmatrix} 1 \\ 1 \end{bmatrix}$	$\begin{bmatrix} -.107 \\ -.182 \end{bmatrix}$	$\begin{bmatrix} .2993 & 0 \\ 0 & .3229 \end{bmatrix}$	$\begin{bmatrix} .557 \\ .597 \end{bmatrix}$
43			Persistence prediction of observed state		Mean persistence error = -0.04	Persistence covariance = .3547	Persistence root sum square = .597

Table D.7: Adaptive Filter Performance with Noise-Free Data
 $\theta = 72^\circ, 36^\circ, 0^\circ$; $x(0) = (1, 1)$

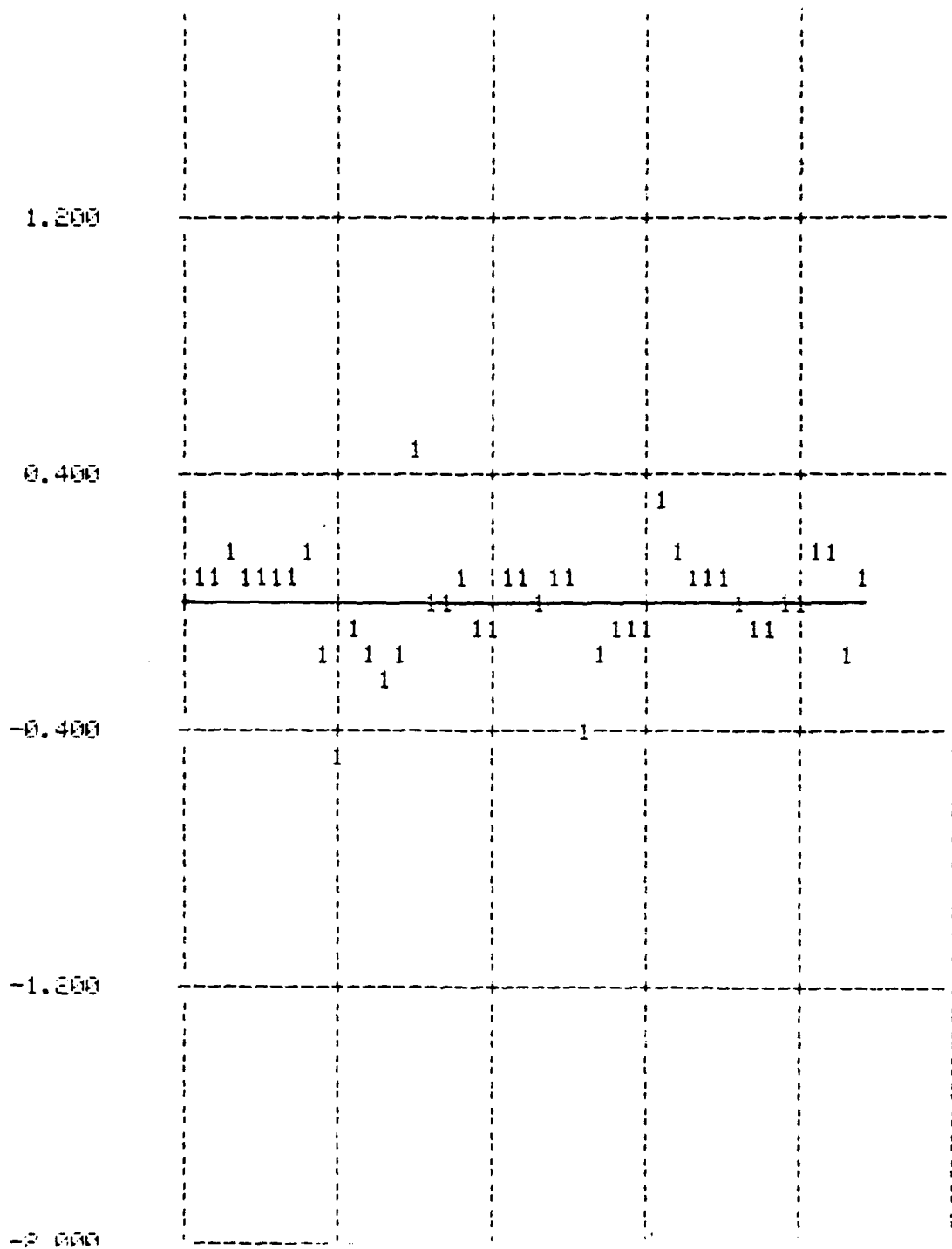

Figure D.2. Case (6). Adaptation of $\phi(1,1)$

— Actual $\phi(1,1)$
 1 1 1 Adapted $\phi(1,1)$

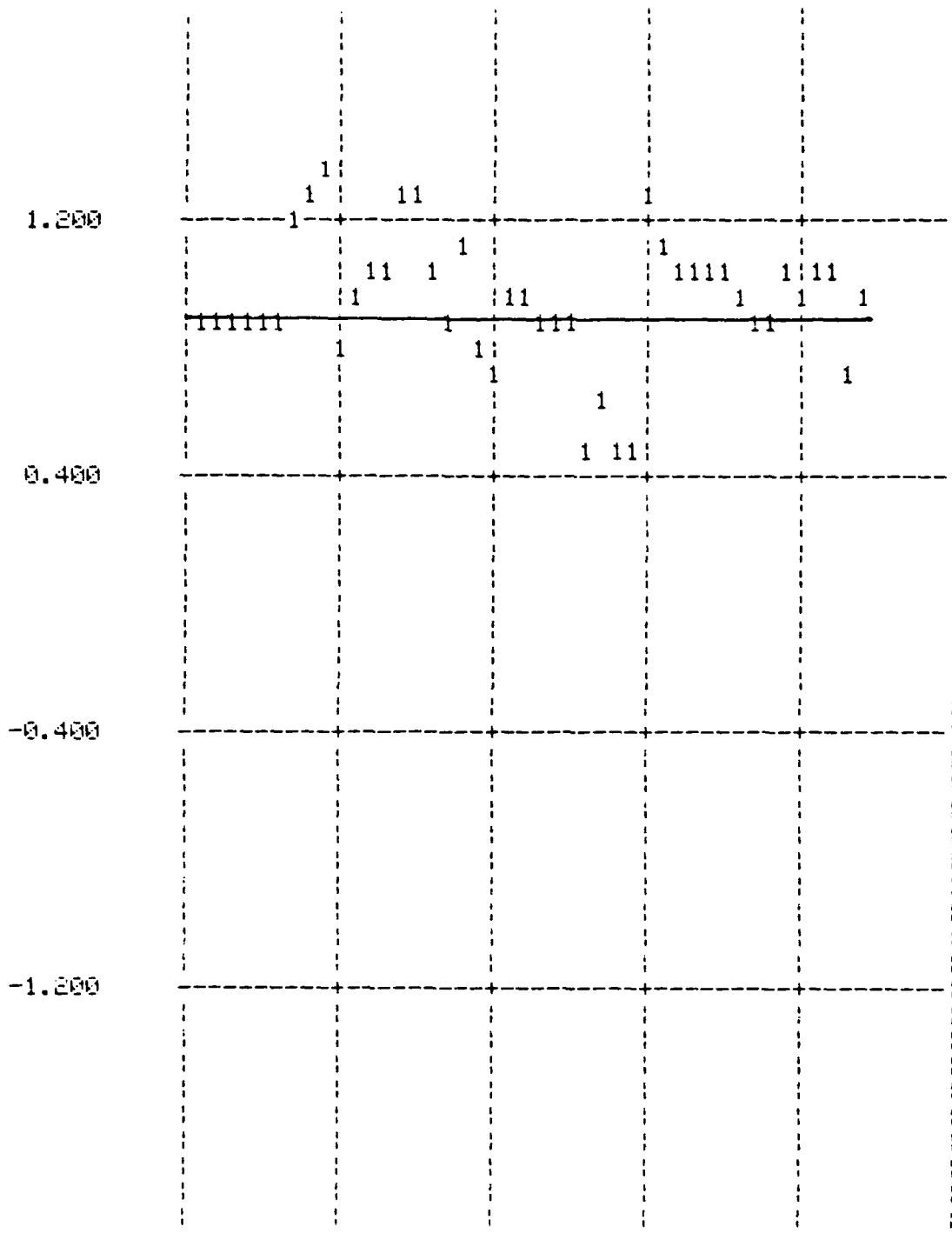

Figure D.3. Case (6). Adaptation of $\phi(1,2)$ —— Actual $\phi(1,2)$
--- Adapted $\phi(1,2)$

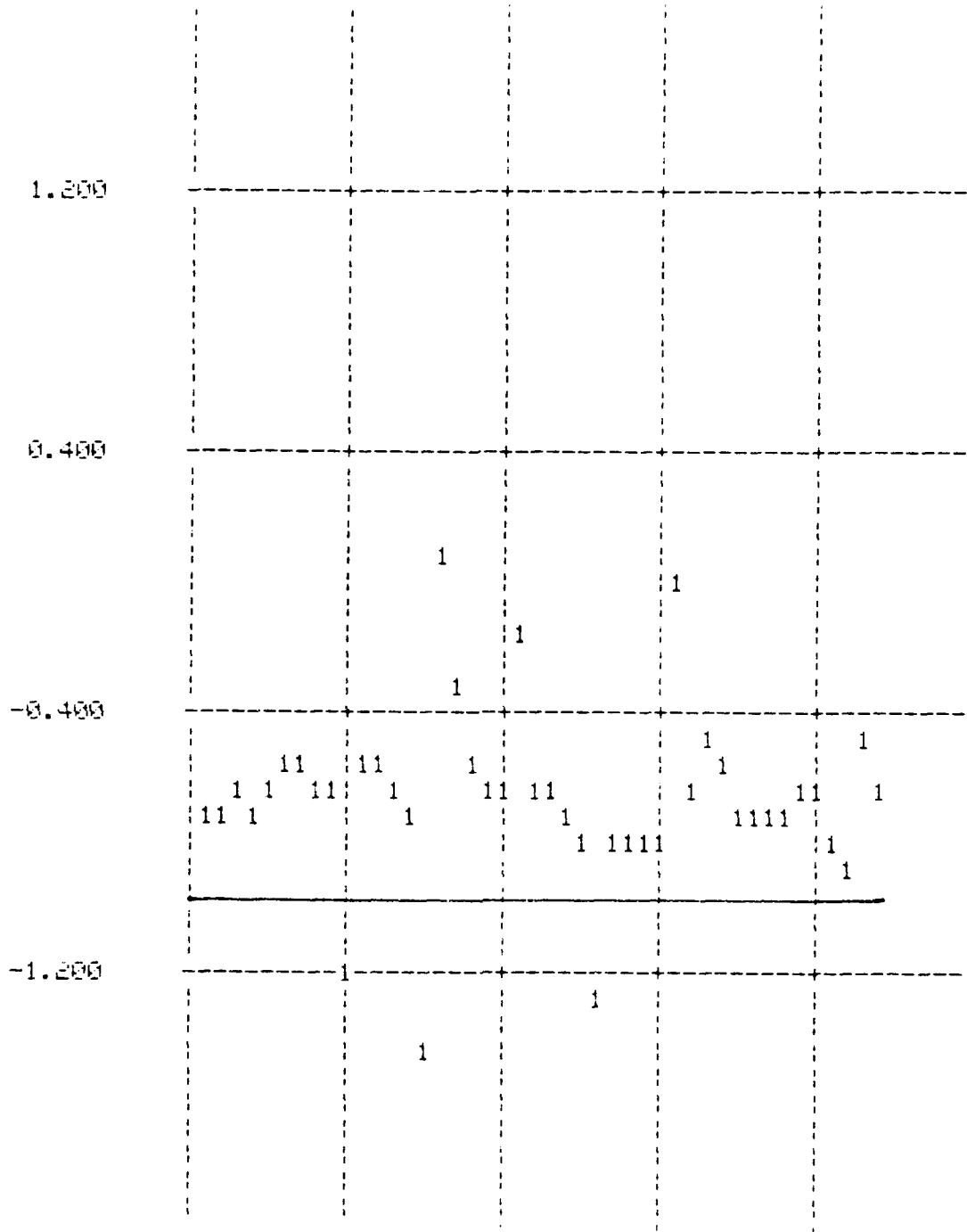

Figure D.4. Case (6), Adaptation of $\zeta(2,1)$
 ——— Actual $\zeta(2,1)$, 111 Adapted $\zeta(2,1)$

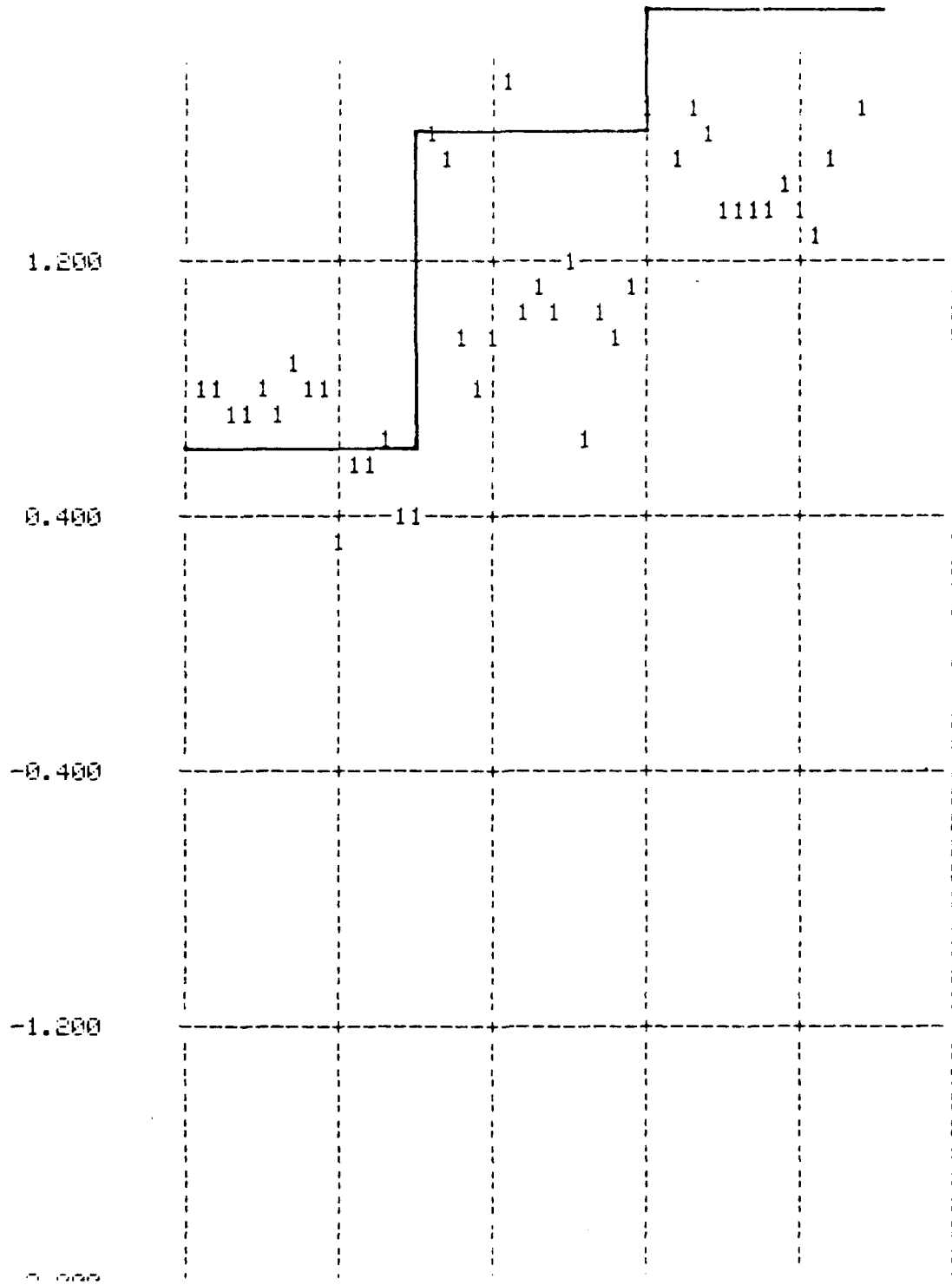

Figure D.5. Case (6), Adaptation of $\phi(2,2)$. — Actual $\phi(2,2)$
 111 Adapted $\phi(2,2)$

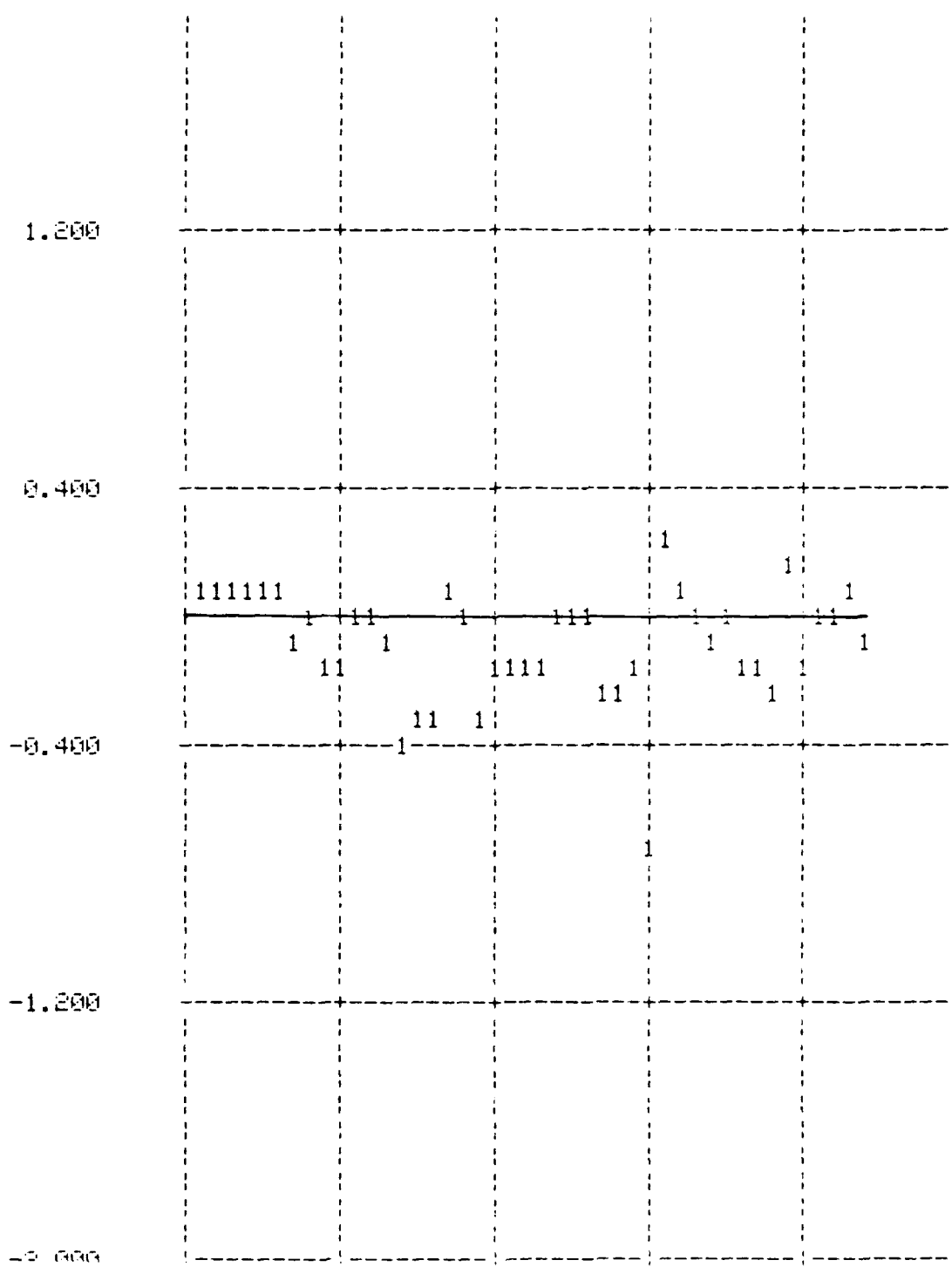

Figure D.6. Case (7), Adaptation of $\phi(1,1)$. — Actual $\phi(1,1)$
 1 1 1 Adapted $\phi(1,1)$

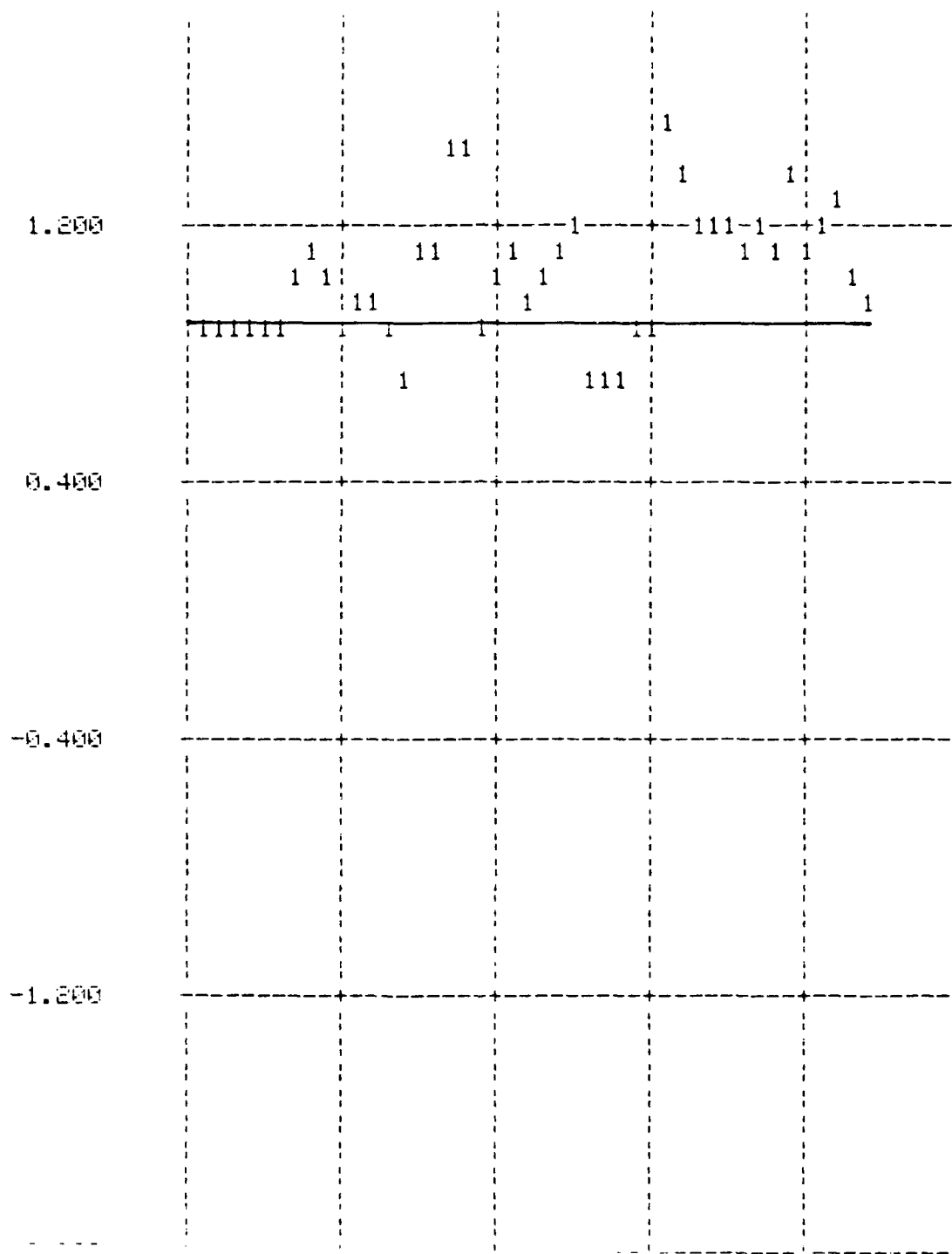

Figure D.7. Case (7), Adaptation of $\phi(1,2)$. — Actual $\phi(1,2)$
 - - - Adapted $\phi(1,2)$

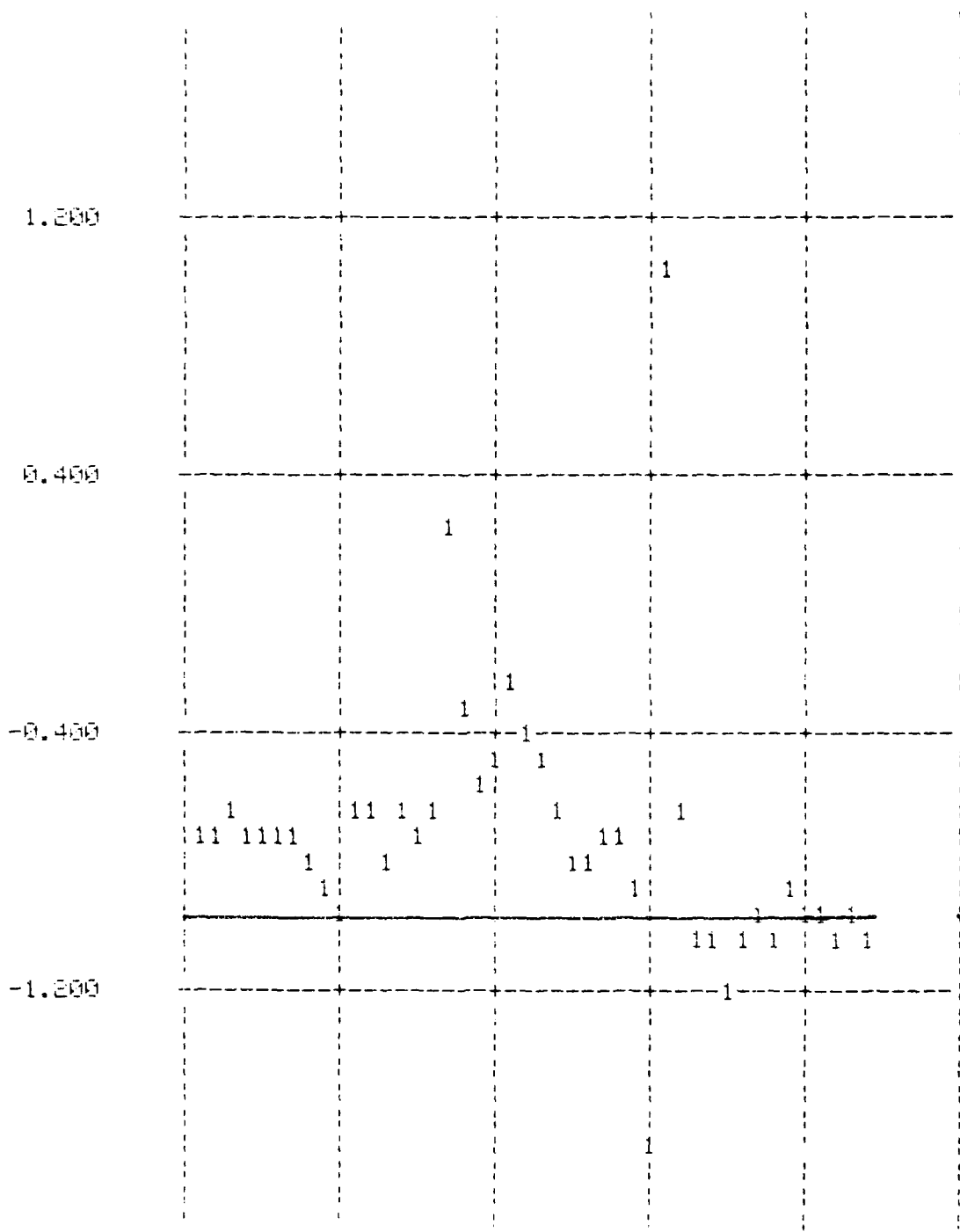

Figure D.8. Case (7), Adaptation of $\phi(2,1)$.
 ----- Actual $\phi(2,1)$
 111 Adapted $\phi(2,1)$

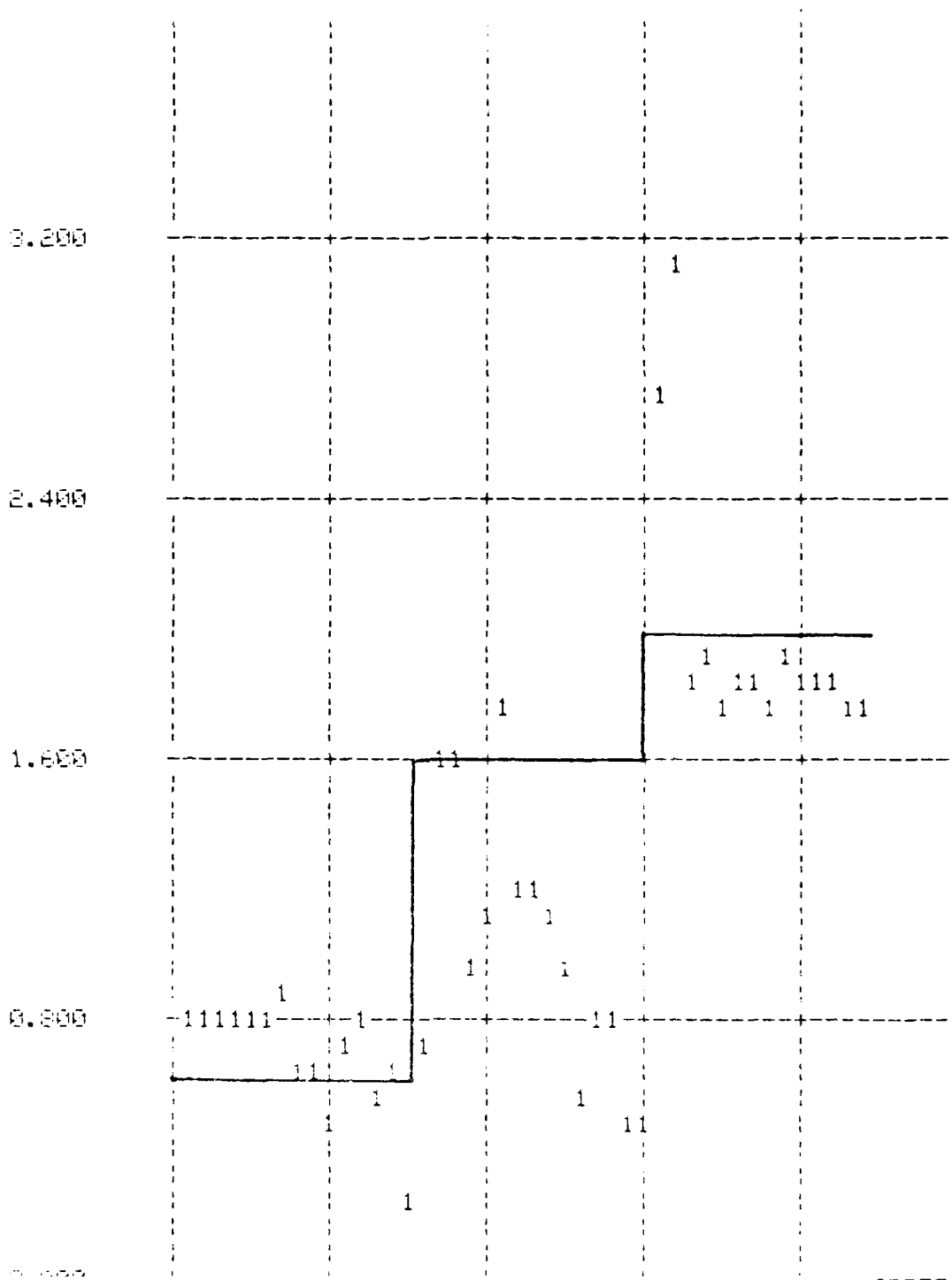

Figure D.9. Case (7), Adaptation of $f(2,2)$.
 ----- Actual $f(2,2)$
 1 1 1 Adapted $f(2,3)$

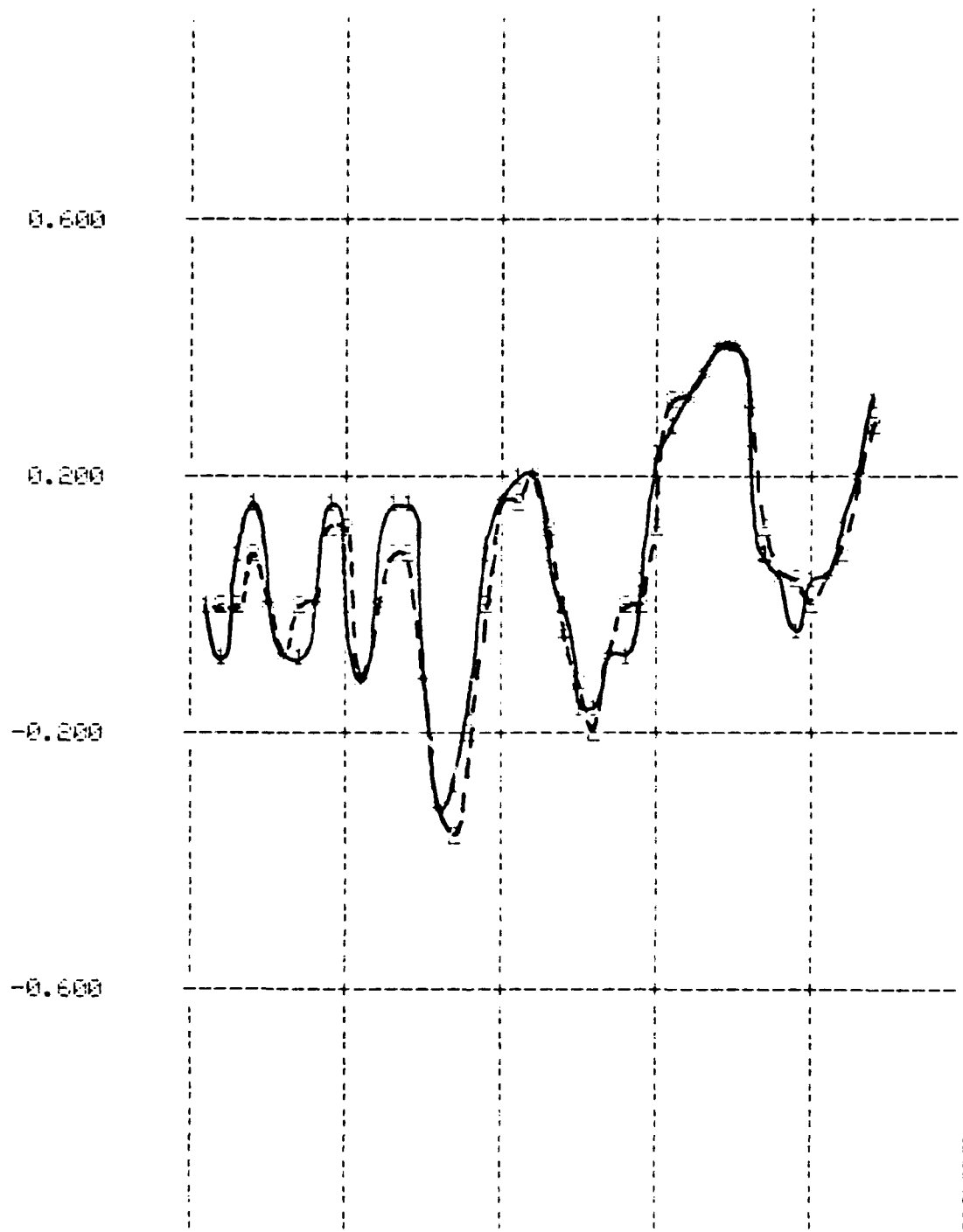

Figure D.10. Case (1). --- Actual $x(1)$; - - - One-step-ahead predicted $x(1)$

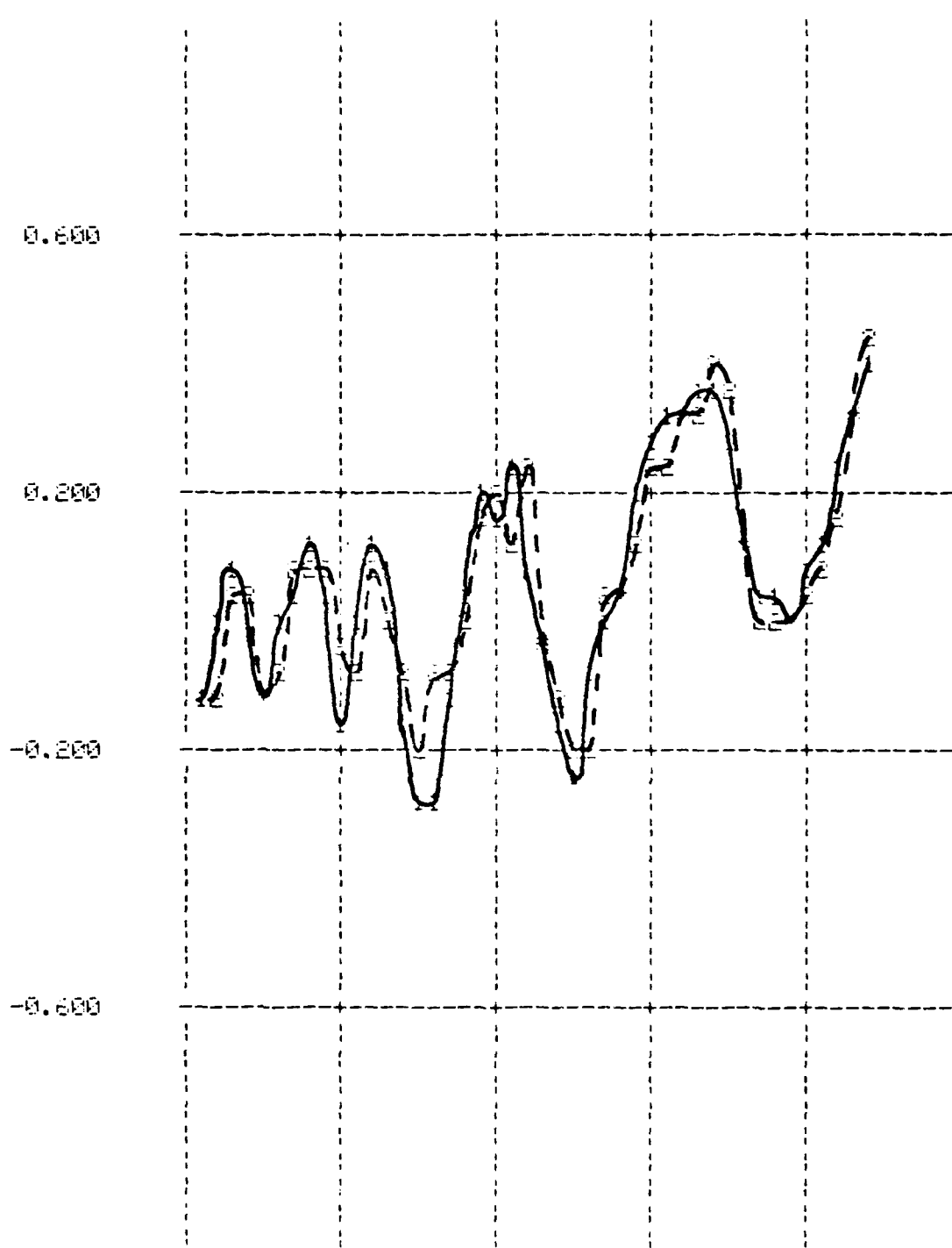

Figure D.11. Case (1). $+-+-$ Actual $x(2)$; $- - -$ One-step-ahead predicted $x(2)$

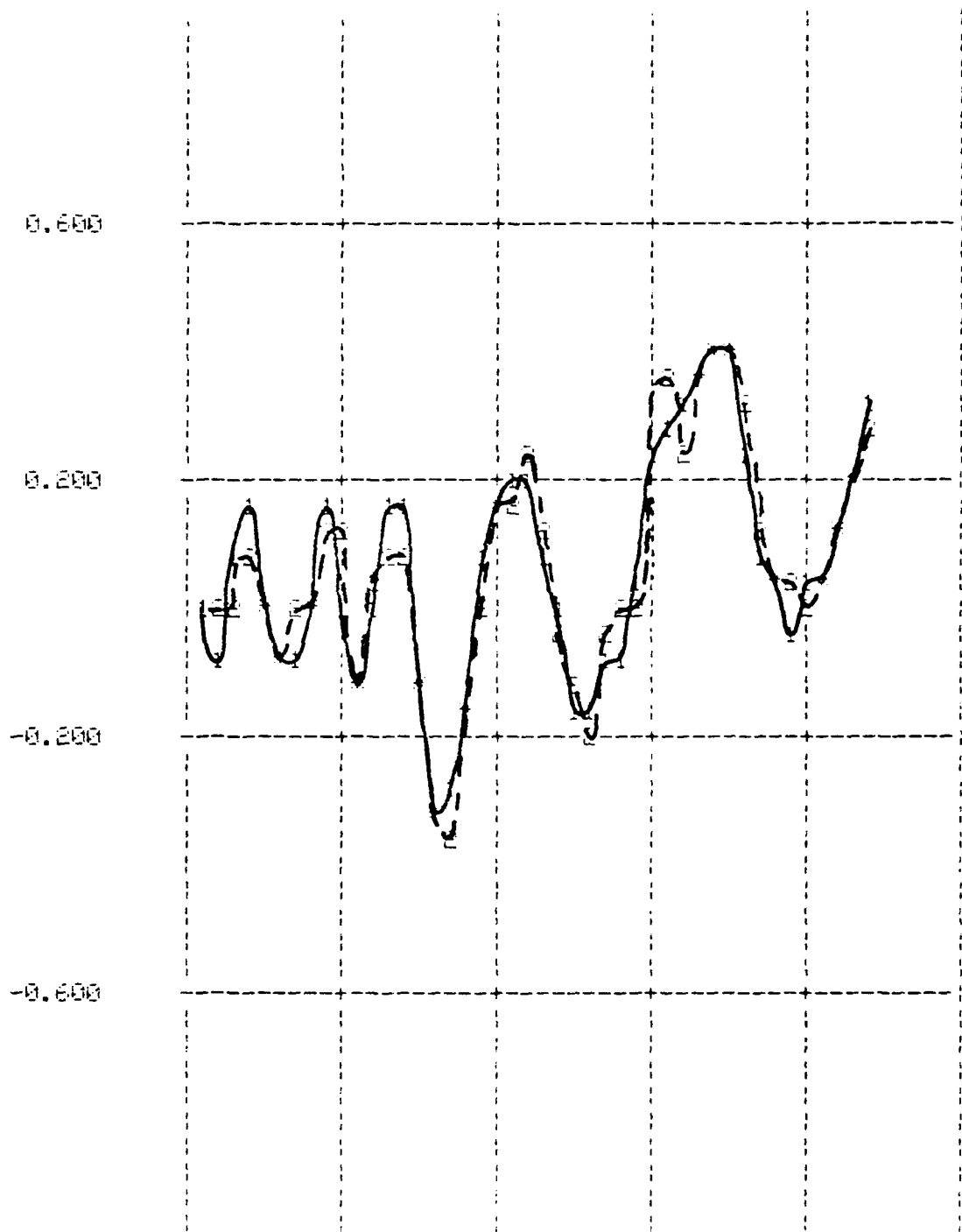

Figure D.12. Case (2). $+$ $+$ $+$ Actual $x(1)$; $-$ $-$ $-$ One-step-ahead predicted $x(1)$

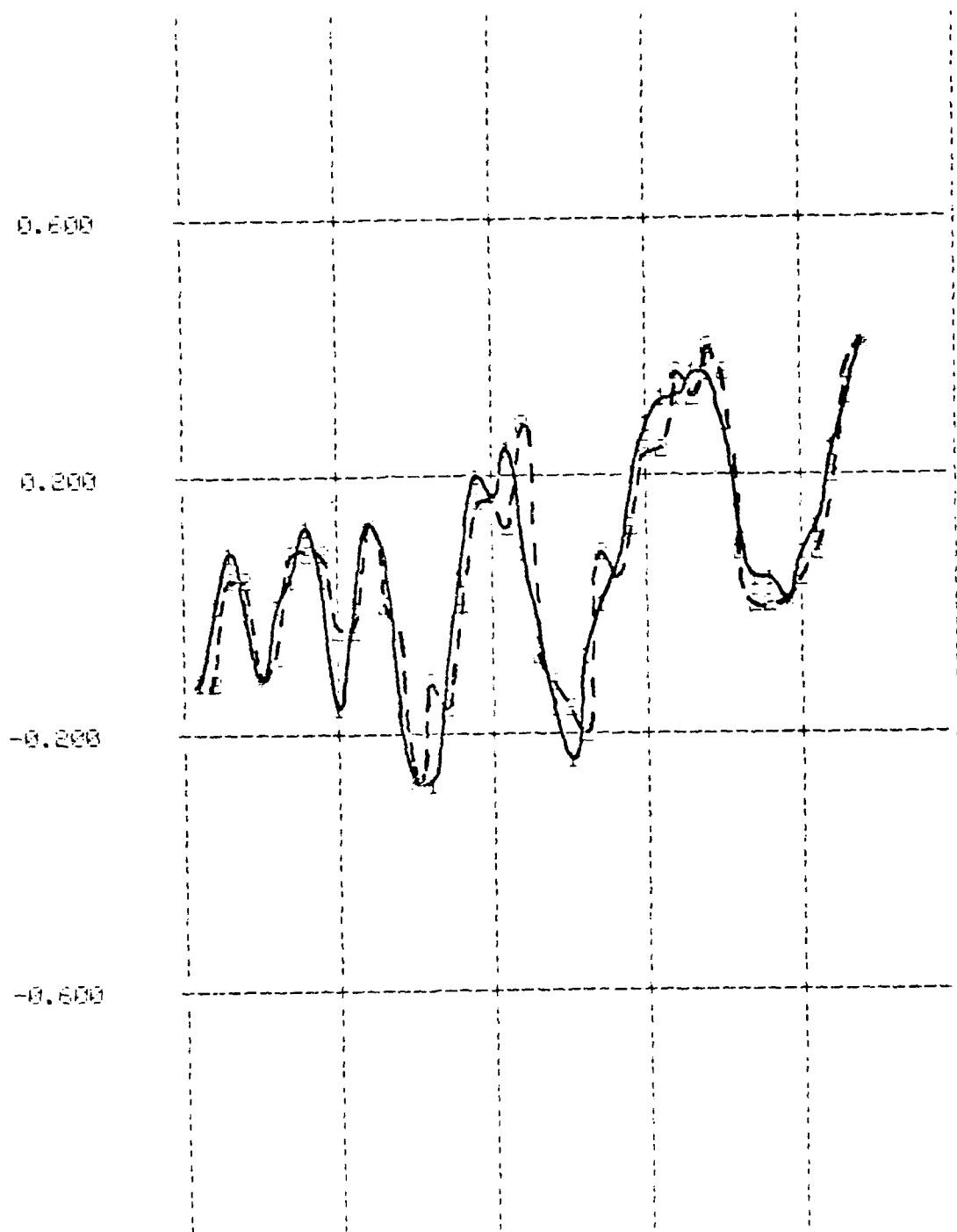

Figure D.12. Case (1). \bullet — \bullet Actual $x(t)$; $- - -$ One-step-ahead predicted $x(t)$

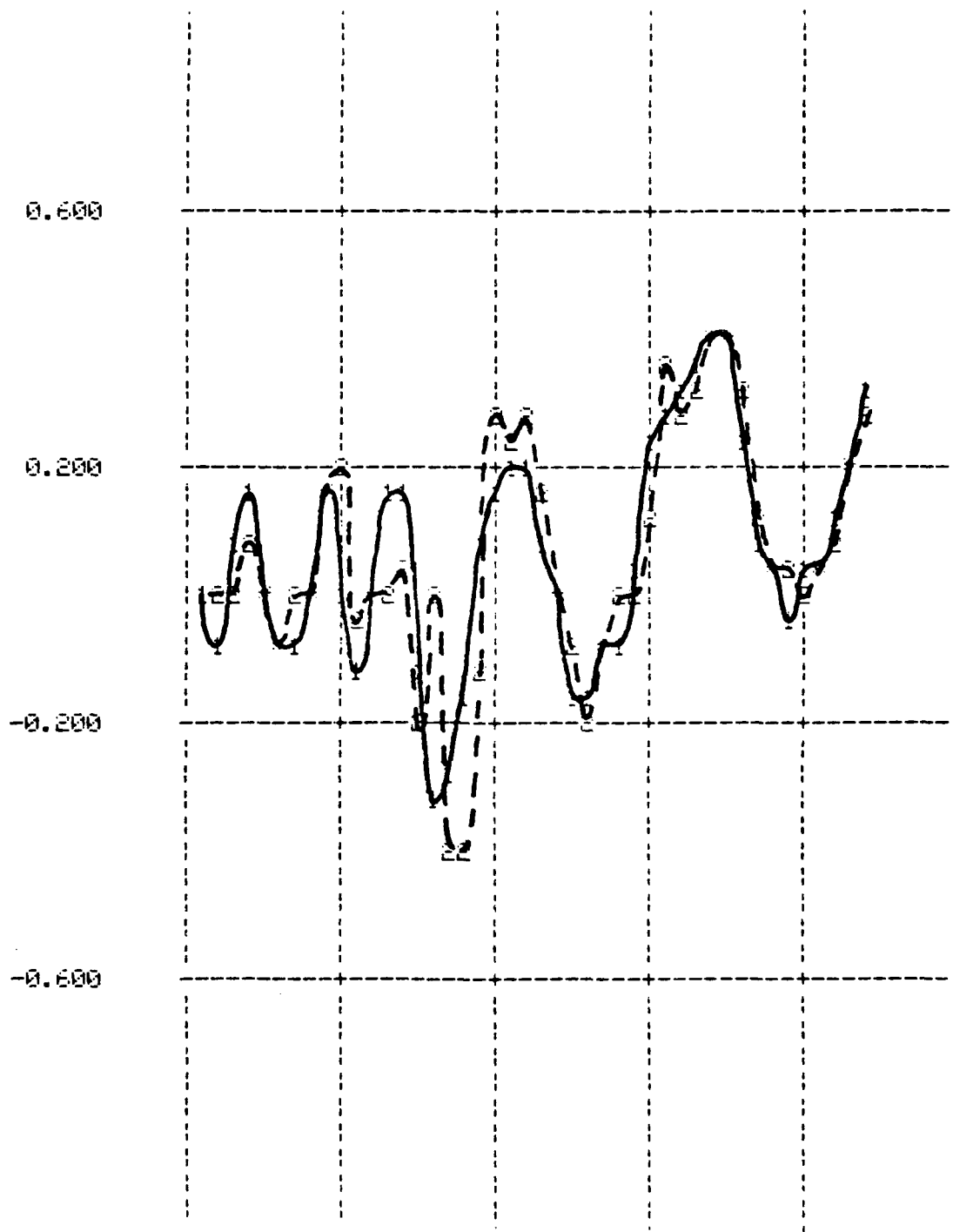

Figure D.14. Case (3). $+-+-$ Actual $x(1)$; $- - -$ One-step-ahead predicted $x(1)$

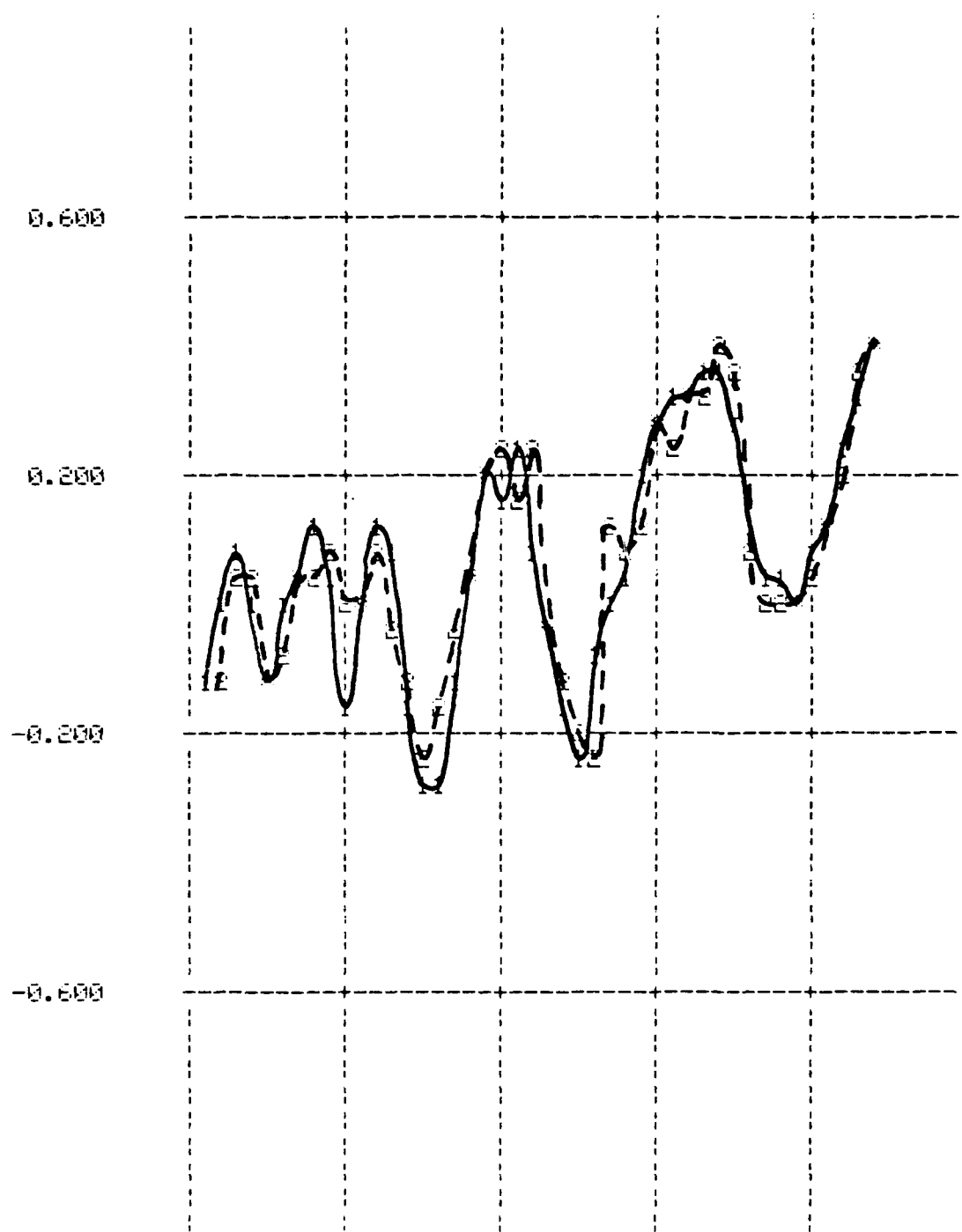

Figure D.15. Case (3). $+$ $+$ $+$ Actual $x(2)$; $-$ $-$ $-$ One-step-ahead predicted $x(2)$

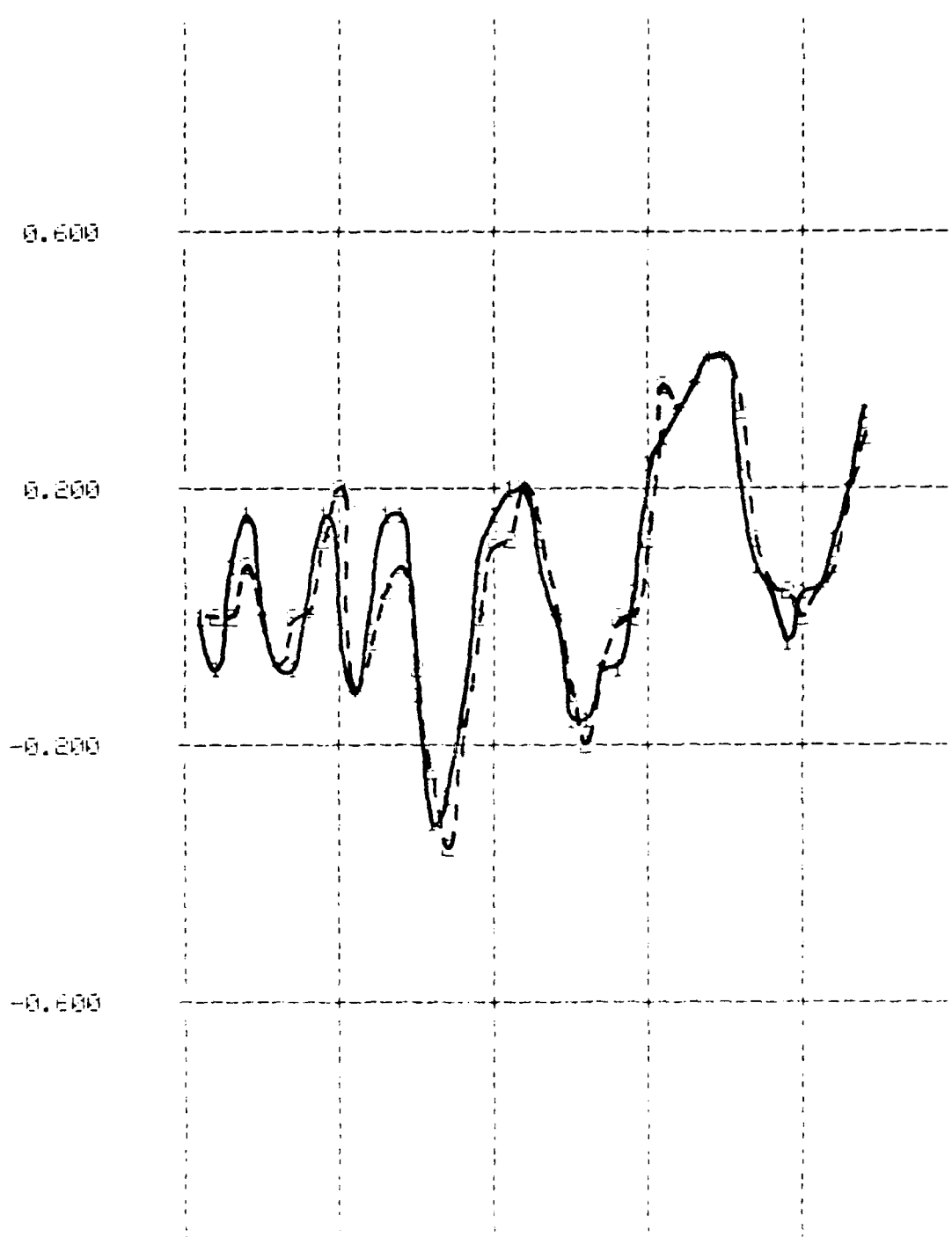

Figure D.16. Case (4). $+1+1$ Actual $x(1)$; $2+2-2$ One-step-ahead predicted $x(1)$

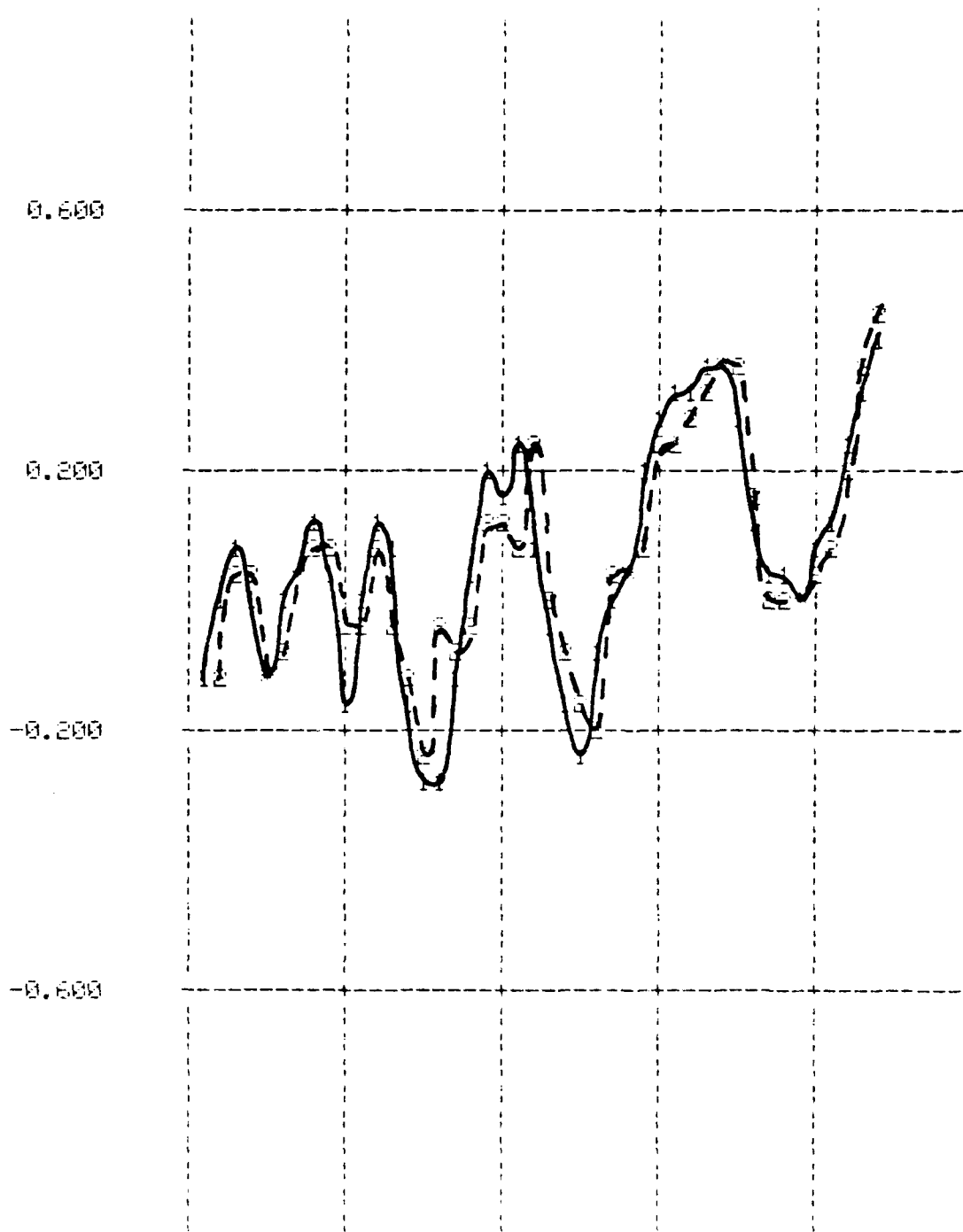

Figure D.17. Case (4). +++ Actual $x(2)$; --- One-step-ahead predicted $x(2)$

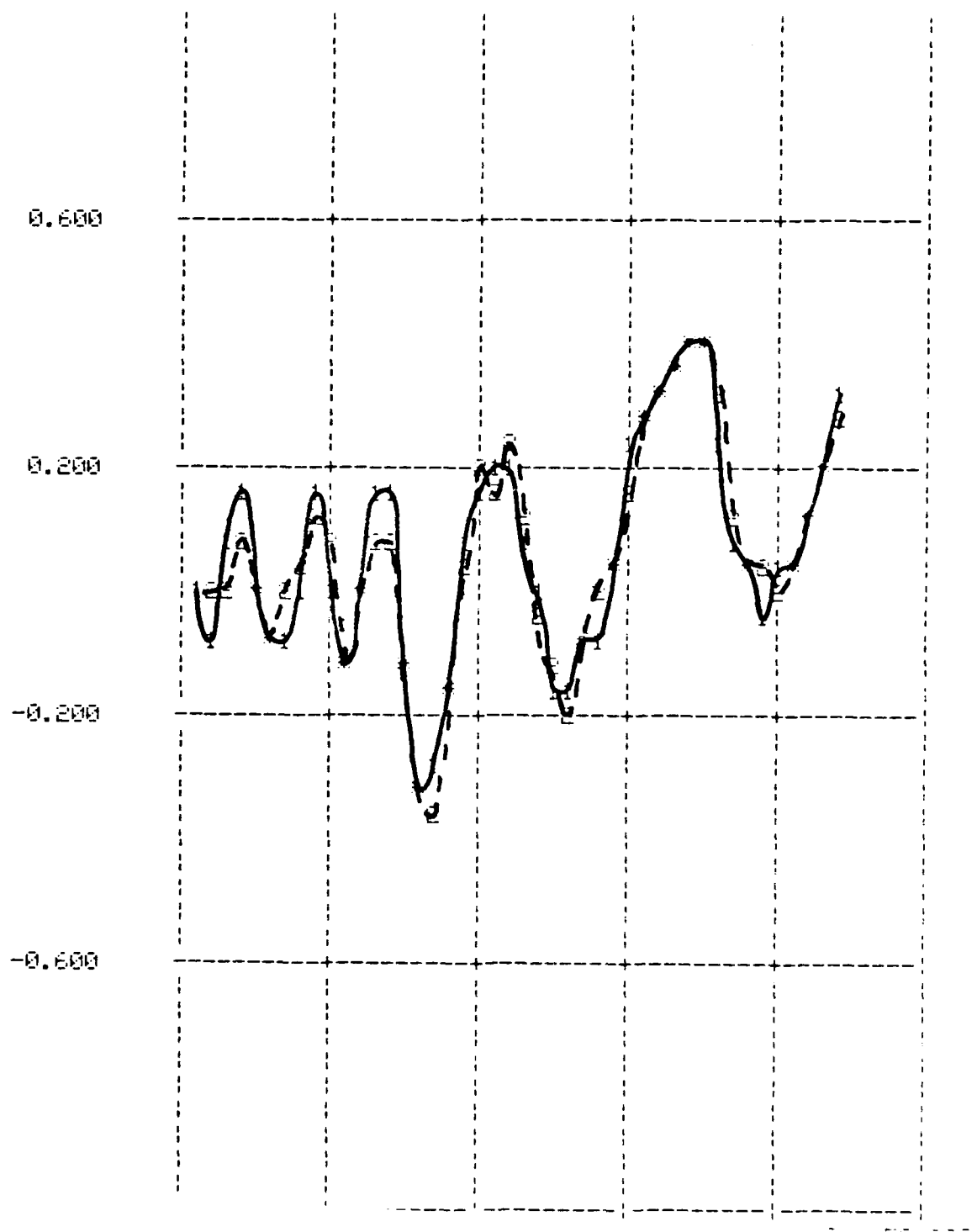

Figure D.18. Case (5). $+$ - $+$ - $+$ Actual $x(1)$; $-$ - $-$ One-step-ahead predicted $x(1)$

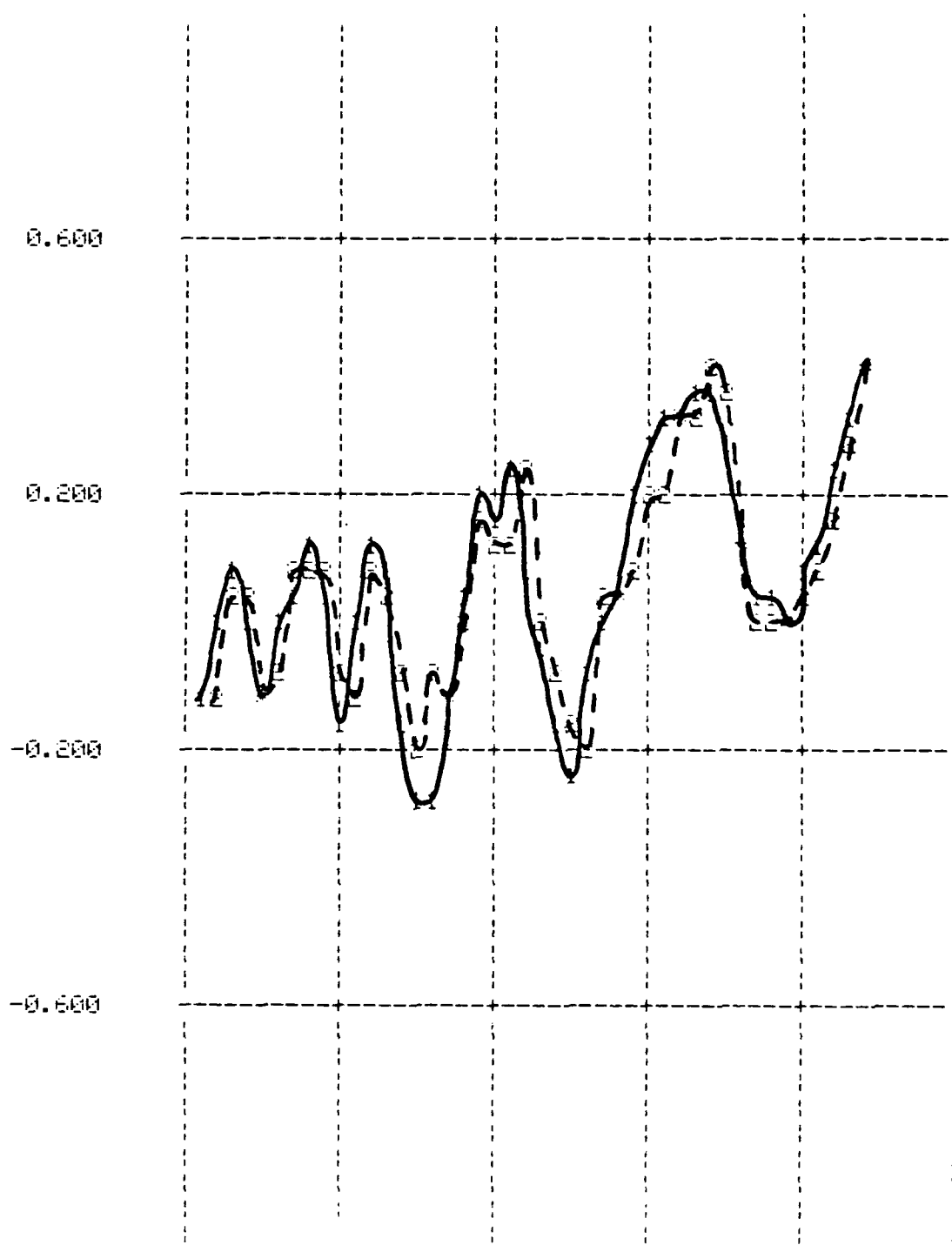

Figure D.19. Case (5). +++ Actual $x(2)$; --- One-step-ahead predicted $x(2)$

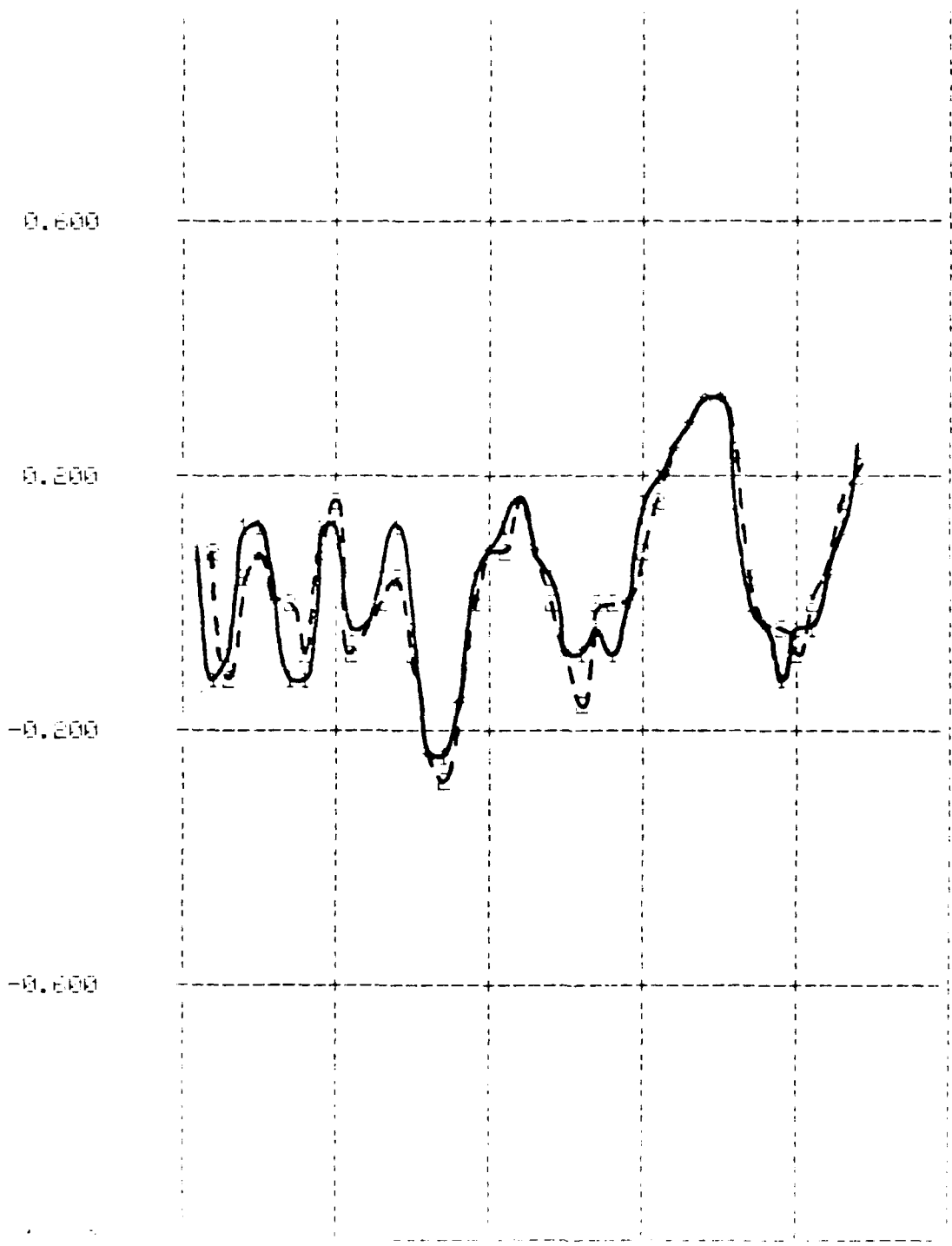

Figure 2. (a) (b) (c) (d) (e) (f) (g) (h) (i) (j) (k) (l) (m) (n) (o) (p) (q) (r) (s) (t) (u) (v) (w) (x) (y) (z) (aa) (ab) (ac) (ad) (ae) (af) (ag) (ah) (ai) (aj) (ak) (al) (am) (an) (ao) (ap) (aq) (ar) (as) (at) (au) (av) (aw) (ax) (ay) (az) (ba) (bb) (bc) (bd) (be) (bf) (bg) (bh) (bi) (bj) (bk) (bl) (bm) (bn) (bo) (bp) (bq) (br) (bs) (bt) (bu) (bv) (bw) (bx) (by) (bz) (ca) (cb) (cc) (cd) (ce) (cf) (cg) (ch) (ci) (cj) (ck) (cl) (cm) (cn) (co) (cp) (cq) (cr) (cs) (ct) (cu) (cv) (cw) (cx) (cy) (cz) (da) (db) (dc) (dd) (de) (df) (dg) (dh) (di) (dj) (dk) (dl) (dm) (dn) (do) (dp) (dq) (dr) (ds) (dt) (du) (dv) (dw) (dx) (dy) (dz) (ea) (eb) (ec) (ed) (ee) (ef) (eg) (eh) (ei) (ej) (ek) (el) (em) (en) (eo) (ep) (eq) (er) (es) (et) (eu) (ev) (ew) (ex) (ey) (ez) (fa) (fb) (fc) (fd) (fe) (ff) (fg) (fh) (fi) (fj) (fk) (fl) (fm) (fn) (fo) (fp) (fq) (fr) (fs) (ft) (fu) (fv) (fw) (fx) (fy) (fz) (ga) (gb) (gc) (gd) (ge) (gf) (gg) (gh) (gi) (gj) (gk) (gl) (gm) (gn) (go) (gp) (gq) (gr) (gs) (gt) (gu) (gv) (gw) (gx) (gy) (gz) (ha) (hb) (hc) (hd) (he) (hf) (hg) (hh) (hi) (hj) (hk) (hl) (hm) (hn) (ho) (hp) (hq) (hr) (hs) (ht) (hu) (hv) (hw) (hx) (hy) (hz) (ia) (ib) (ic) (id) (ie) (if) (ig) (ih) (ii) (ij) (ik) (il) (im) (in) (io) (ip) (iq) (ir) (is) (it) (iu) (iv) (iw) (ix) (iy) (iz) (ja) (jb) (jc) (jd) (je) (jf) (jg) (jh) (ji) (jj) (jk) (jl) (jm) (jn) (jo) (jp) (jq) (jr) (js) (jt) (ju) (jv) (jw) (jx) (jy) (jz) (ka) (kb) (kc) (kd) (ke) (kf) (kg) (kh) (ki) (kj) (kk) (kl) (km) (kn) (ko) (kp) (kq) (kr) (ks) (kt) (ku) (kv) (kw) (kx) (ky) (kz) (la) (lb) (lc) (ld) (le) (lf) (lg) (lh) (li) (lj) (lk) (ll) (lm) (ln) (lo) (lp) (lq) (lr) (ls) (lt) (lu) (lv) (lw) (lx) (ly) (lz) (ma) (mb) (mc) (md) (me) (mf) (mg) (mh) (mi) (mj) (mk) (ml) (mm) (mn) (mo) (mp) (mq) (mr) (ms) (mt) (mu) (mv) (mw) (mx) (my) (mz) (na) (nb) (nc) (nd) (ne) (nf) (ng) (nh) (ni) (nj) (nk) (nl) (nm) (nn) (no) (np) (nq) (nr) (ns) (nt) (nu) (nv) (nw) (nx) (ny) (nz) (oa) (ob) (oc) (od) (oe) (of) (og) (oh) (oi) (oj) (ok) (ol) (om) (on) (oo) (op) (oq) (or) (os) (ot) (ou) (ov) (ow) (ox) (oy) (oz) (pa) (pb) (pc) (pd) (pe) (pf) (pg) (ph) (pi) (pj) (pk) (pl) (pm) (pn) (po) (pp) (pq) (pr) (ps) (pt) (pu) (pv) (pw) (px) (py) (pz) (qa) (qb) (qc) (qd) (qe) (qf) (qg) (qh) (qi) (qj) (qk) (ql) (qm) (qn) (qo) (qp) (qq) (qr) (qs) (qt) (qu) (qv) (qw) (qx) (qy) (qz) (ra) (rb) (rc) (rd) (re) (rf) (rg) (rh) (ri) (rj) (rk) (rl) (rm) (rn) (ro) (rp) (rq) (rr) (rs) (rt) (ru) (rv) (rw) (rx) (ry) (rz) (sa) (sb) (sc) (sd) (se) (sf) (sg) (sh) (si) (sj) (sk) (sl) (sm) (sn) (so) (sp) (sq) (sr) (ss) (st) (su) (sv) (sw) (sx) (sy) (sz) (ta) (tb) (tc) (td) (te) (tf) (tg) (th) (ti) (tj) (tk) (tl) (tm) (tn) (to) (tp) (tq) (tr) (ts) (tt) (tu) (tv) (tw) (tx) (ty) (tz) (ua) (ub) (uc) (ud) (ue) (uf) (ug) (uh) (ui) (uj) (uk) (ul) (um) (un) (uo) (up) (uq) (ur) (us) (ut) (uu) (uv) (uw) (ux) (uy) (uz) (va) (vb) (vc) (vd) (ve) (vf) (vg) (vh) (vi) (vj) (vk) (vl) (vm) (vn) (vo) (vp) (vq) (vr) (vs) (vt) (vu) (vv) (vw) (vx) (vy) (vz) (wa) (wb) (wc) (wd) (we) (wf) (wg) (wh) (wi) (wj) (wk) (wl) (wm) (wn) (wo) (wp) (wq) (wr) (ws) (wt) (wu) (wv) (ww) (wx) (wy) (wz) (xa) (xb) (xc) (xd) (xe) (xf) (xg) (xh) (xi) (xj) (xk) (xl) (xm) (xn) (xo) (xp) (xq) (xr) (xs) (xt) (xu) (xv) (xw) (xx) (xy) (xz) (ya) (yb) (yc) (yd) (ye) (yf) (yg) (yh) (yi) (yj) (yk) (yl) (ym) (yn) (yo) (yp) (yq) (yr) (ys) (yt) (yu) (yv) (yw) (yx) (yy) (yz) (za) (zb) (zc) (zd) (ze) (zf) (zg) (zh) (zi) (zj) (zk) (zl) (zm) (zn) (zo) (zp) (zq) (zr) (zs) (zt) (zu) (zv) (zw) (zx) (zy) (zz)

AD-A090 499

SCIENTIFIC SYSTEMS INC CAMBRIDGE MA

F/6 5/9

RECURSIVE FORECASTING SYSTEM FOR PERSON-JOB MATCH.(U)

declassified

SEP 80 D E GUSTAFSON, R K MEHRA, W H LEDSHAM F33615-78-C-0050

ACLUJ-TR-78-R3

NL

4-6

SEP 80

1

END
PAGE
R 30
DTIC

CONT.

4 OF 6

AD

4090499

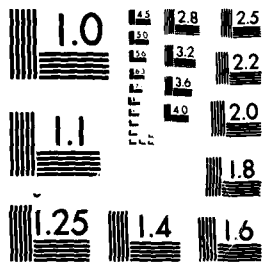

MICROCOPY RESOLUTION TEST CHART
NATIONAL BUREAU OF STANDARDS 1963 A

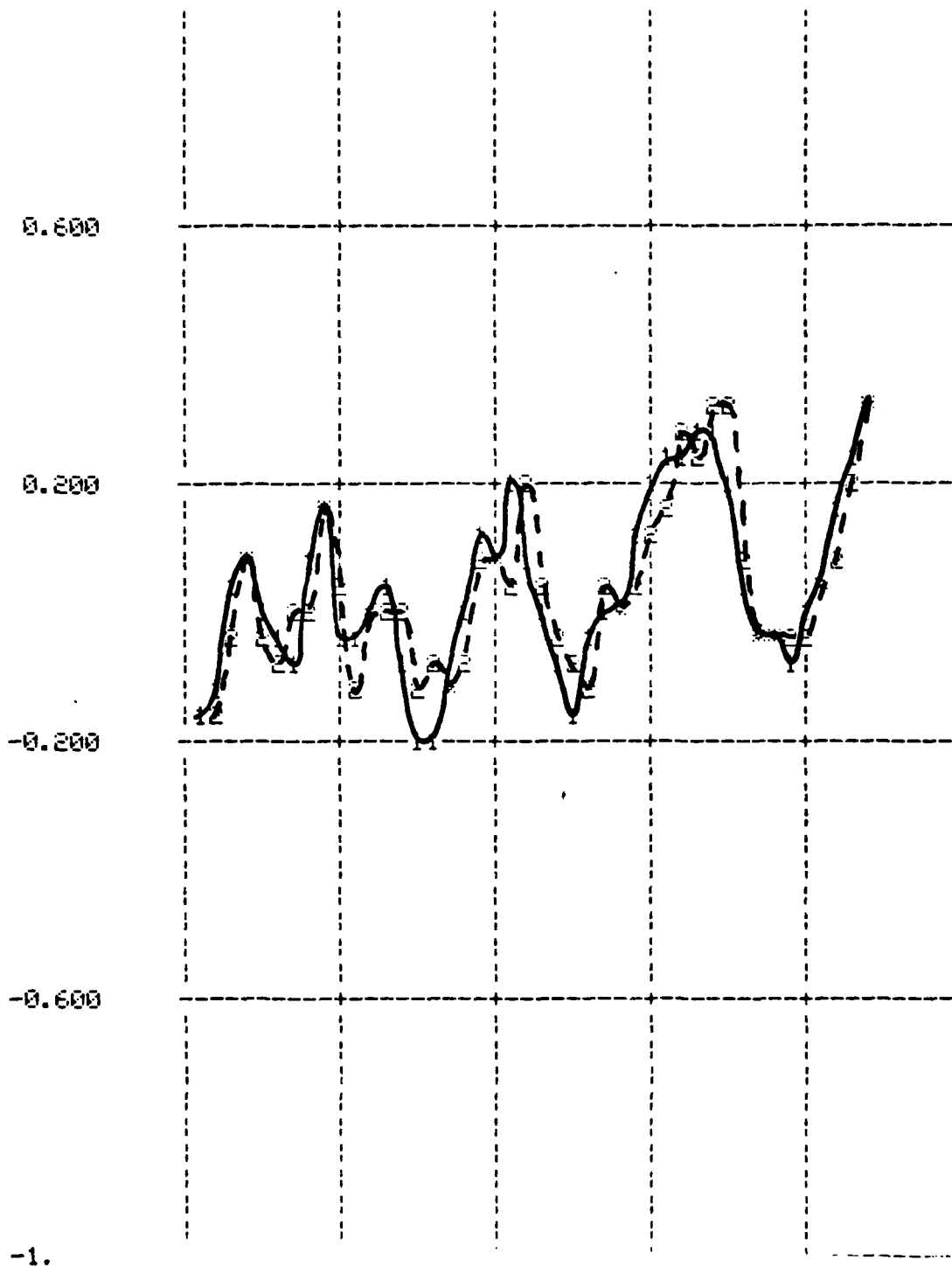

Figure D.21. Case (6). $+$ $+$ $+$ Actual $x(2)$; $-$ $-$ $-$ One-step-ahead predicted $x(2)$

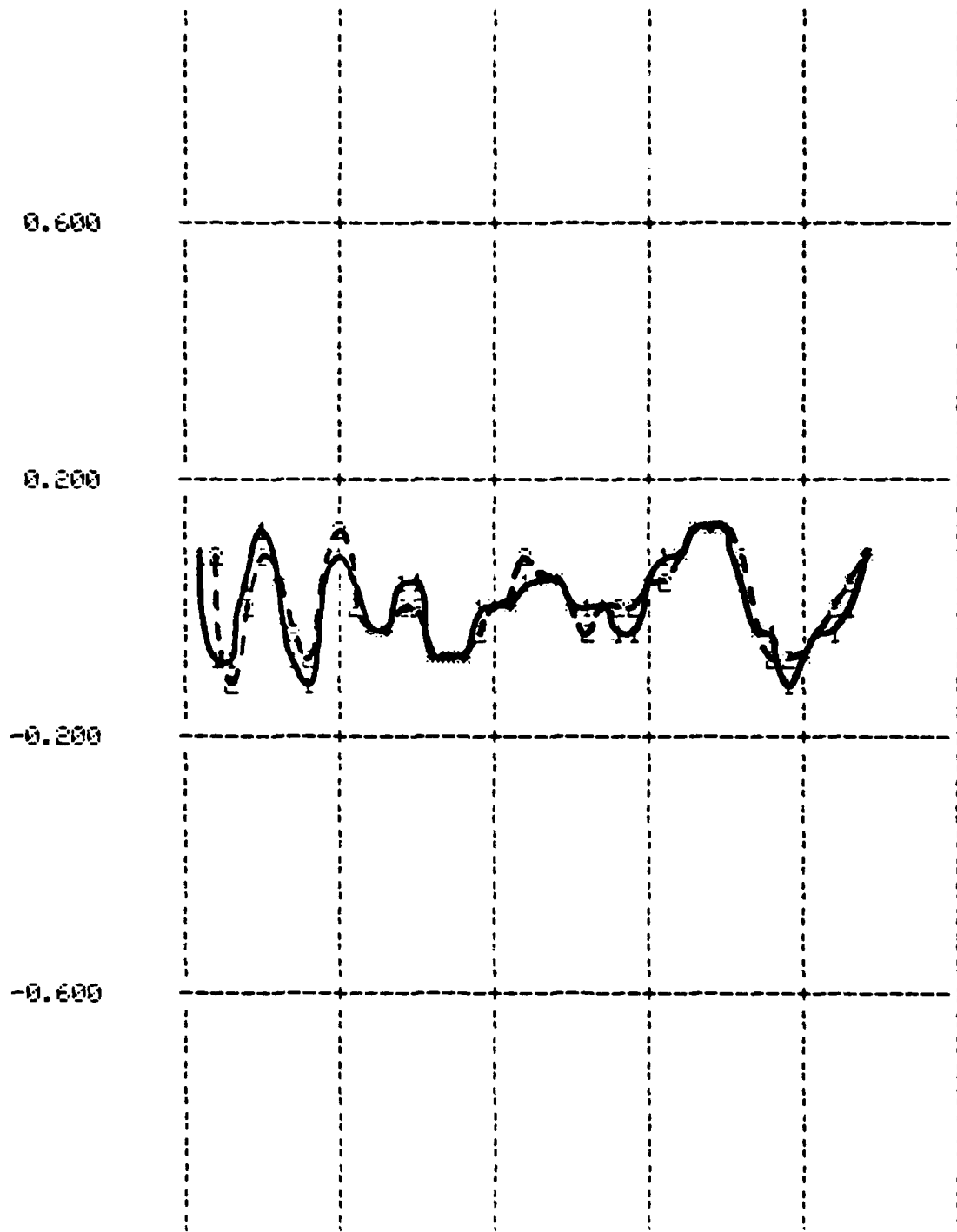

Figure D.22. Case (7). $+ + +$ Actual $x(1)$; $- - -$ One-step-ahead predicted $x(1)$

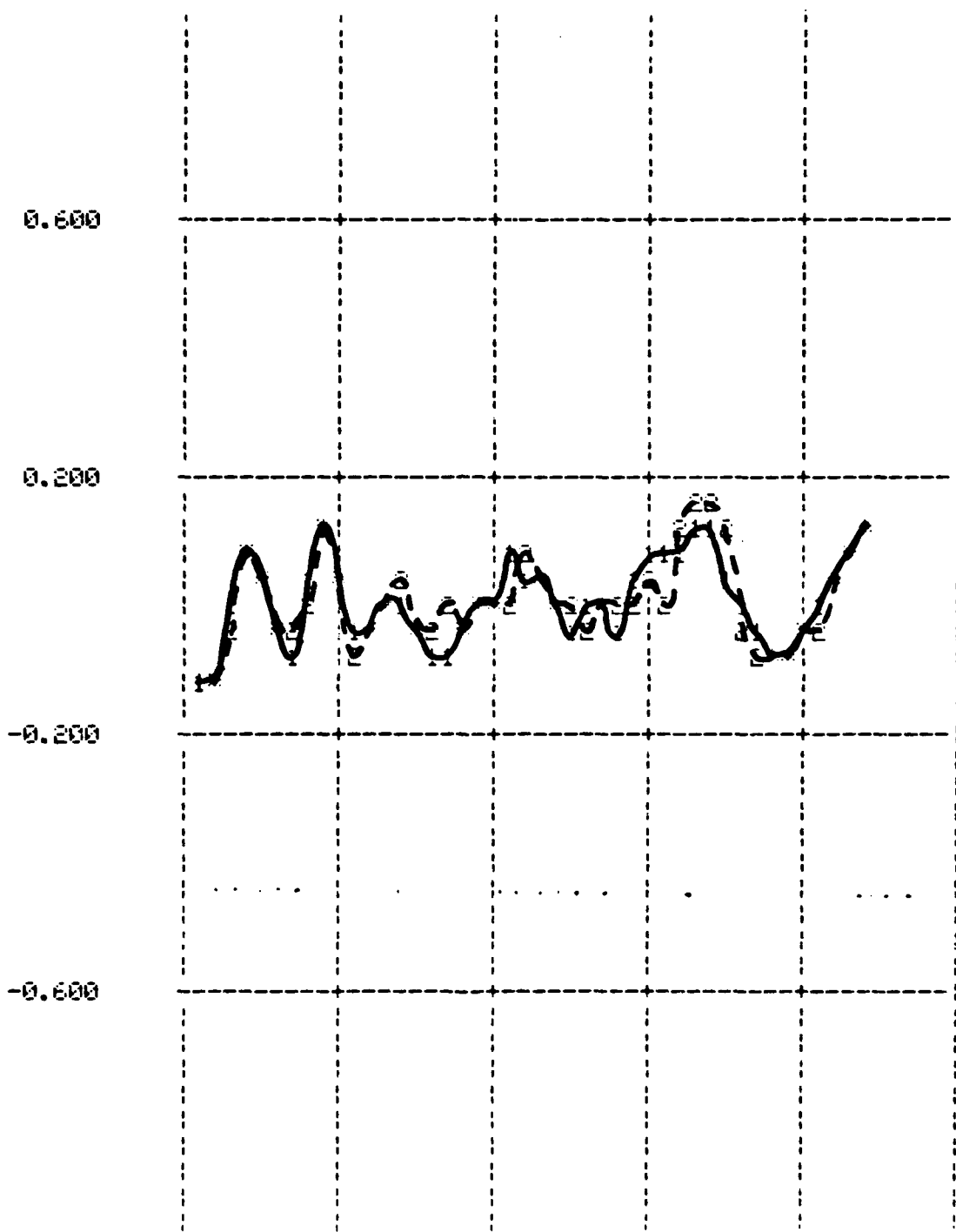

Figure D.23. Case (7). $\text{---}\text{---}\text{---}$ Actual $x(2)$; $\text{---}\text{---}\text{---}$ One-step-ahead predicted $x(2)$

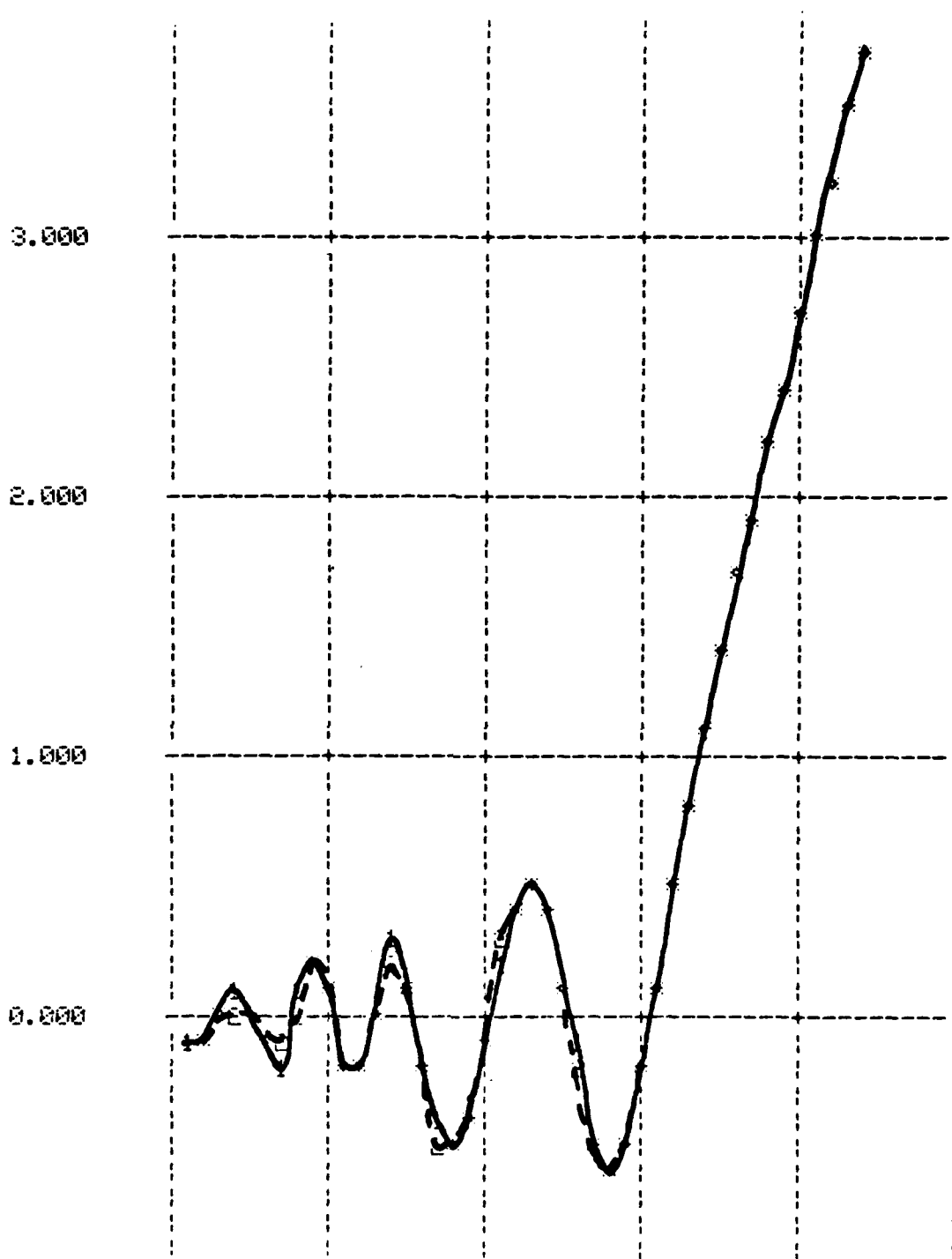

Figure D.24. Case (8). +--+ Actual $x(1)$; -x-x One-step-ahead predicted $x(1)$

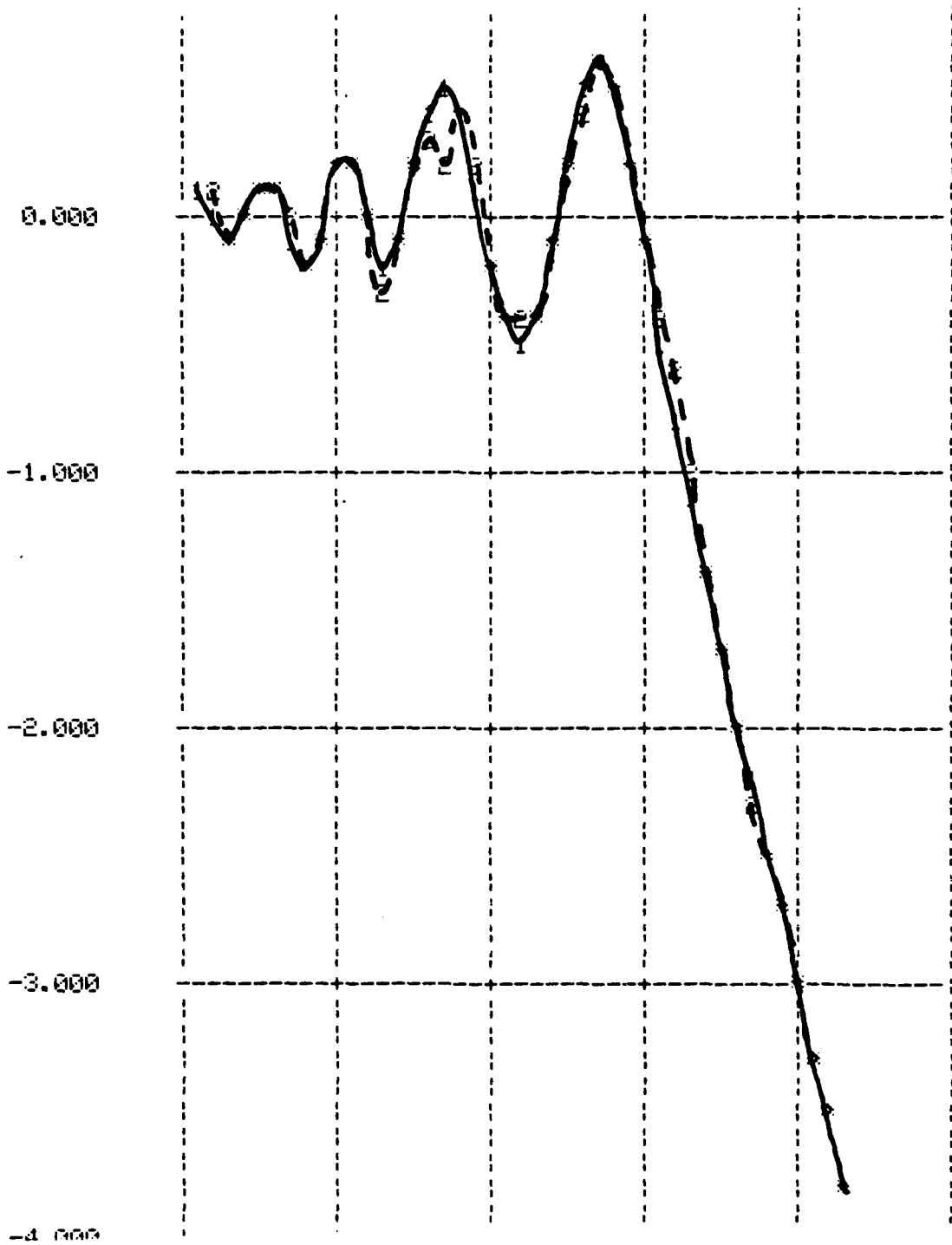

Figure D.25. Case (8). $+ + +$ Actual $x(2)$; $x x x$ One-step-ahead predicted $x(2)$

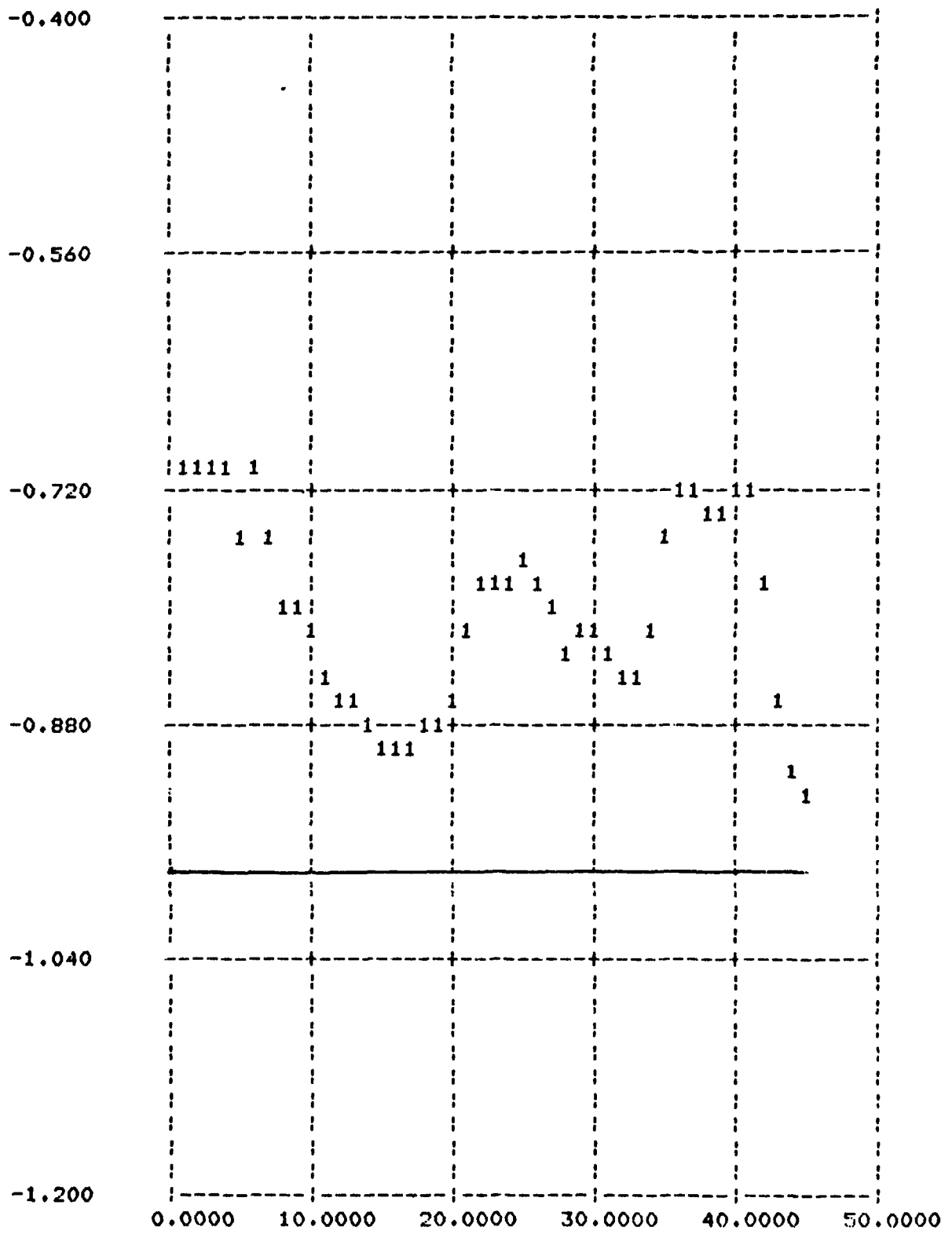

Figure D.26. Case (7) ($\gamma = .9, \beta = .8$). 1 1 1. One-step-ahead predicted $\phi(2,1)$
 ——— Actual $\phi(2,1)$

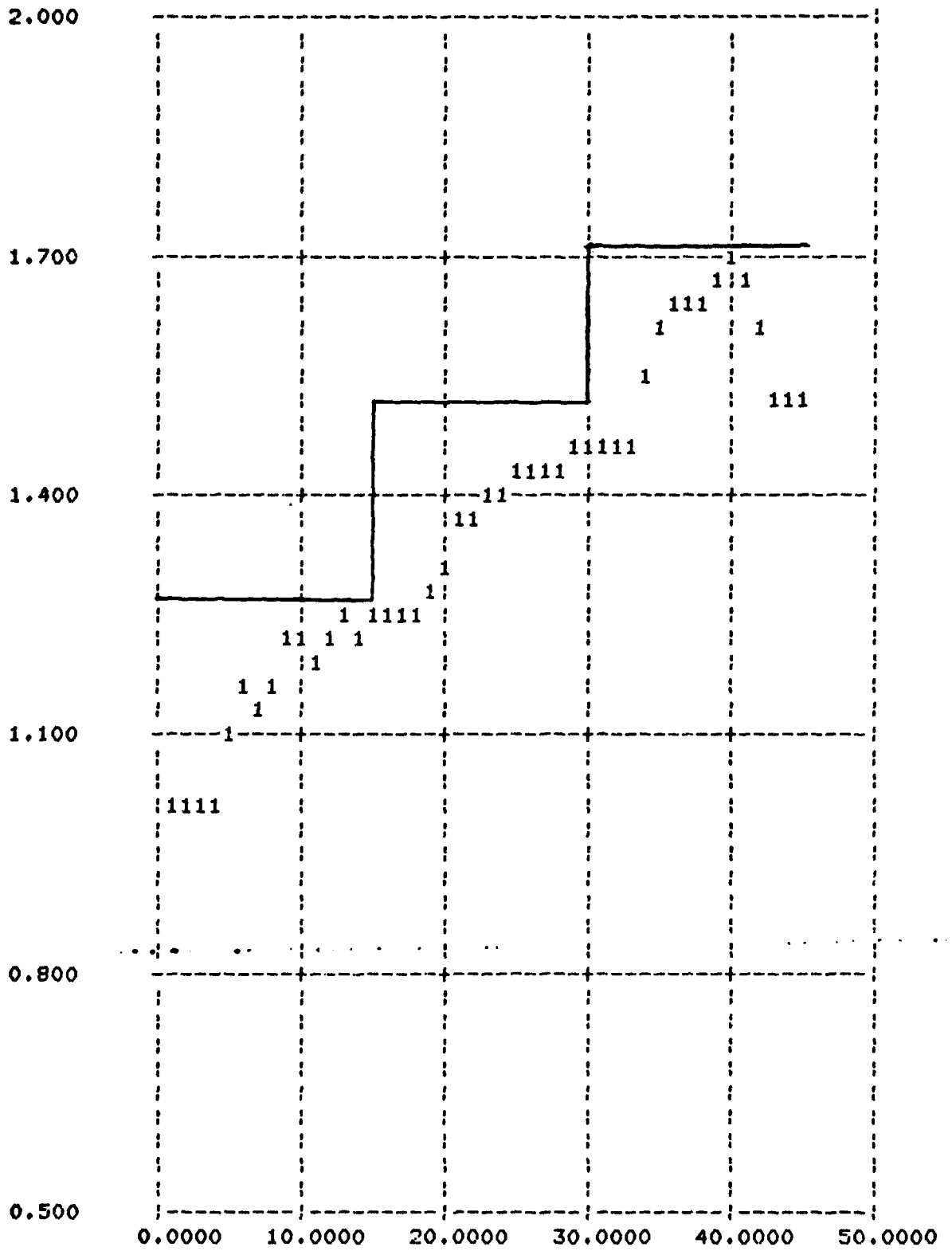

Figure D.27. Case (7) ($\gamma = .9$, $\beta = .8$). 1 1 1 One-step-ahead predicted $\phi(2,2)$
 ——— Actual $\phi(2,2)$

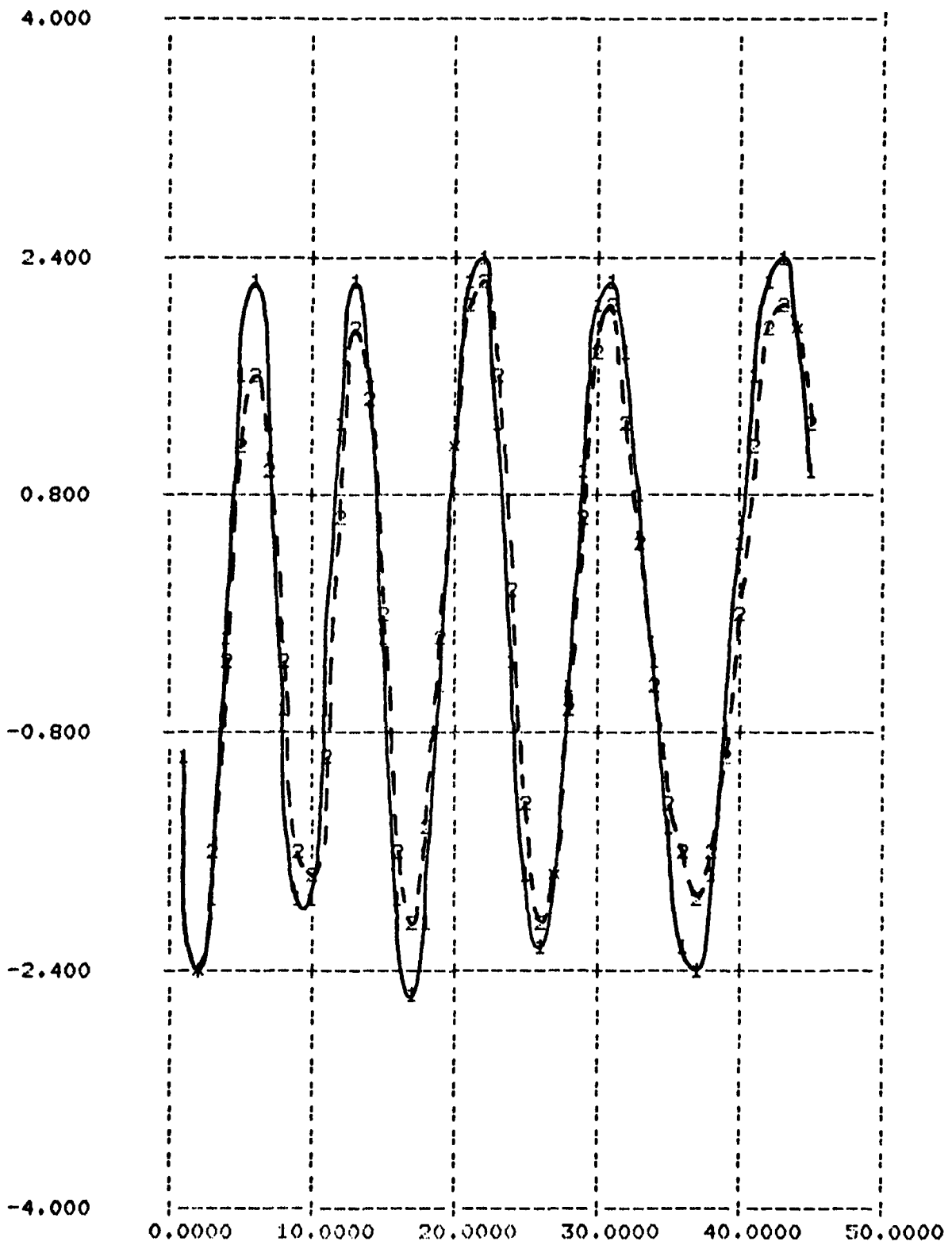

Figure D.28. Case (11) ($\gamma = .95$, $\beta = .95$)
 Observed state: x Actual $x(1)$; o One-step-ahead
 predicted $x(1)$

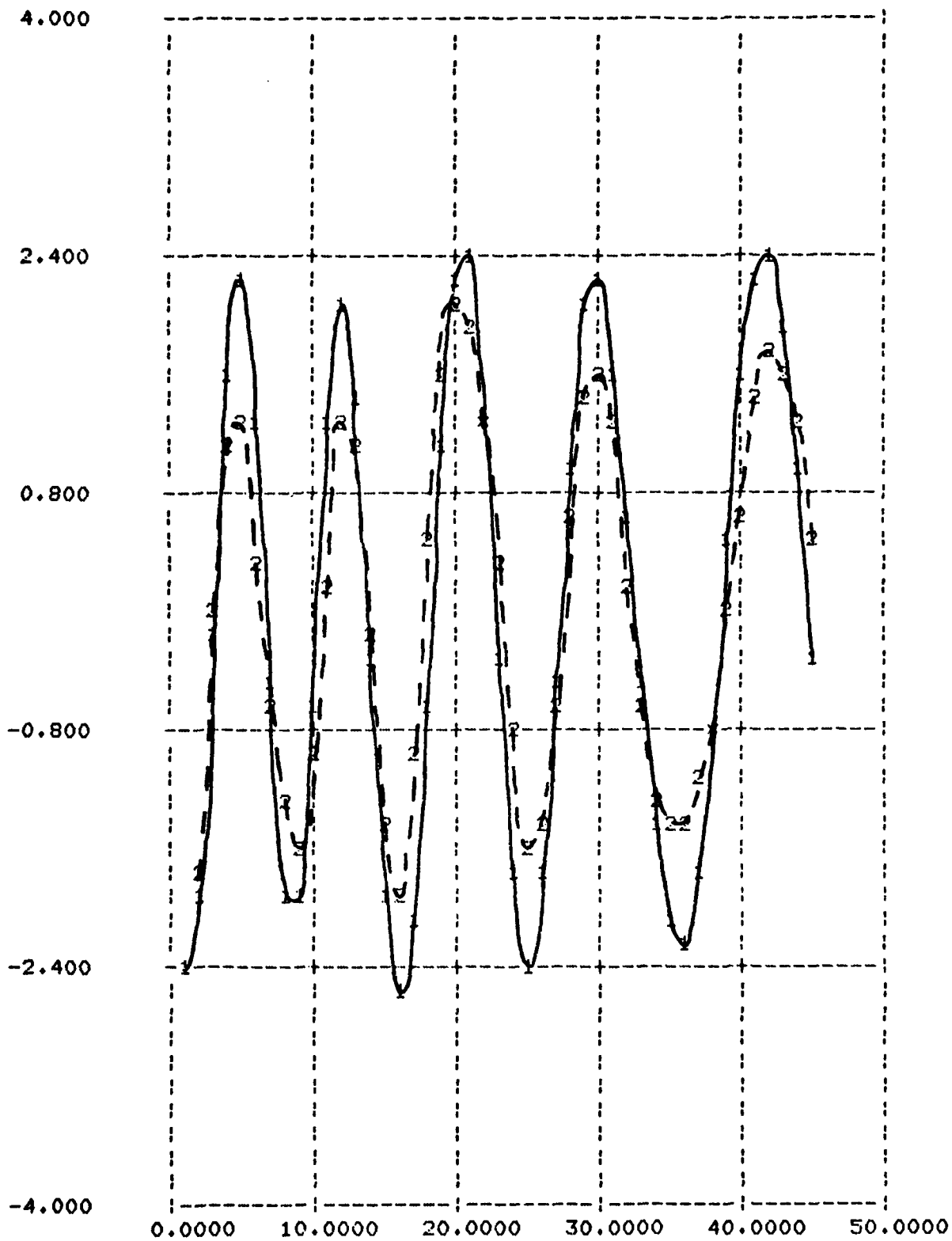

Figure D.29. Case (11) ($\gamma = .95$, $\beta = .95$). Unobserved state:
 --- Actual $x(2)$
 — One-step-ahead predicted $x(2)$

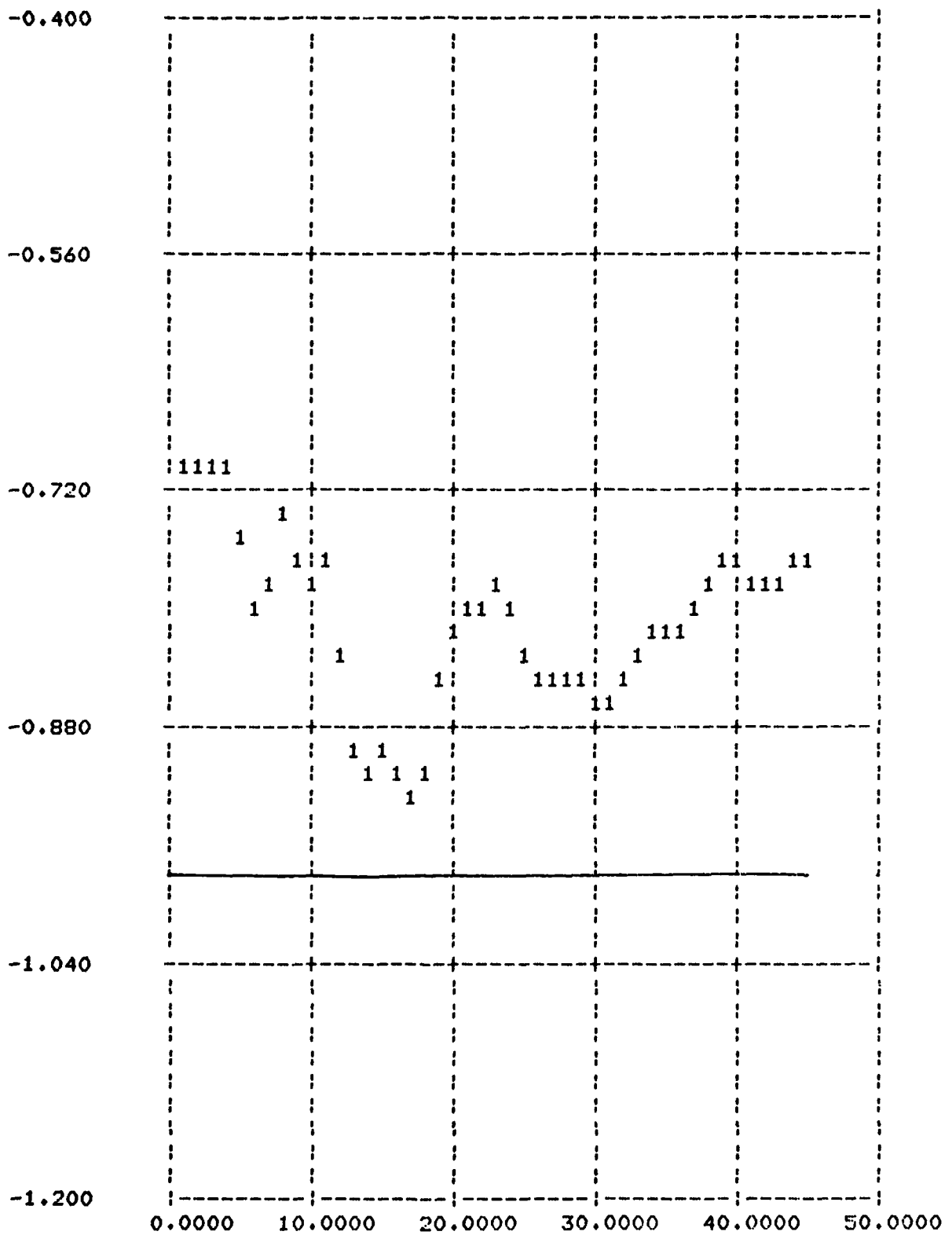

Figure D.30. Case (11) ($\gamma = .95$, $\beta = .95$). 1 1 1 One-step-ahead predicted $\phi(2,1)$
 — Actual $\phi(2,1)$

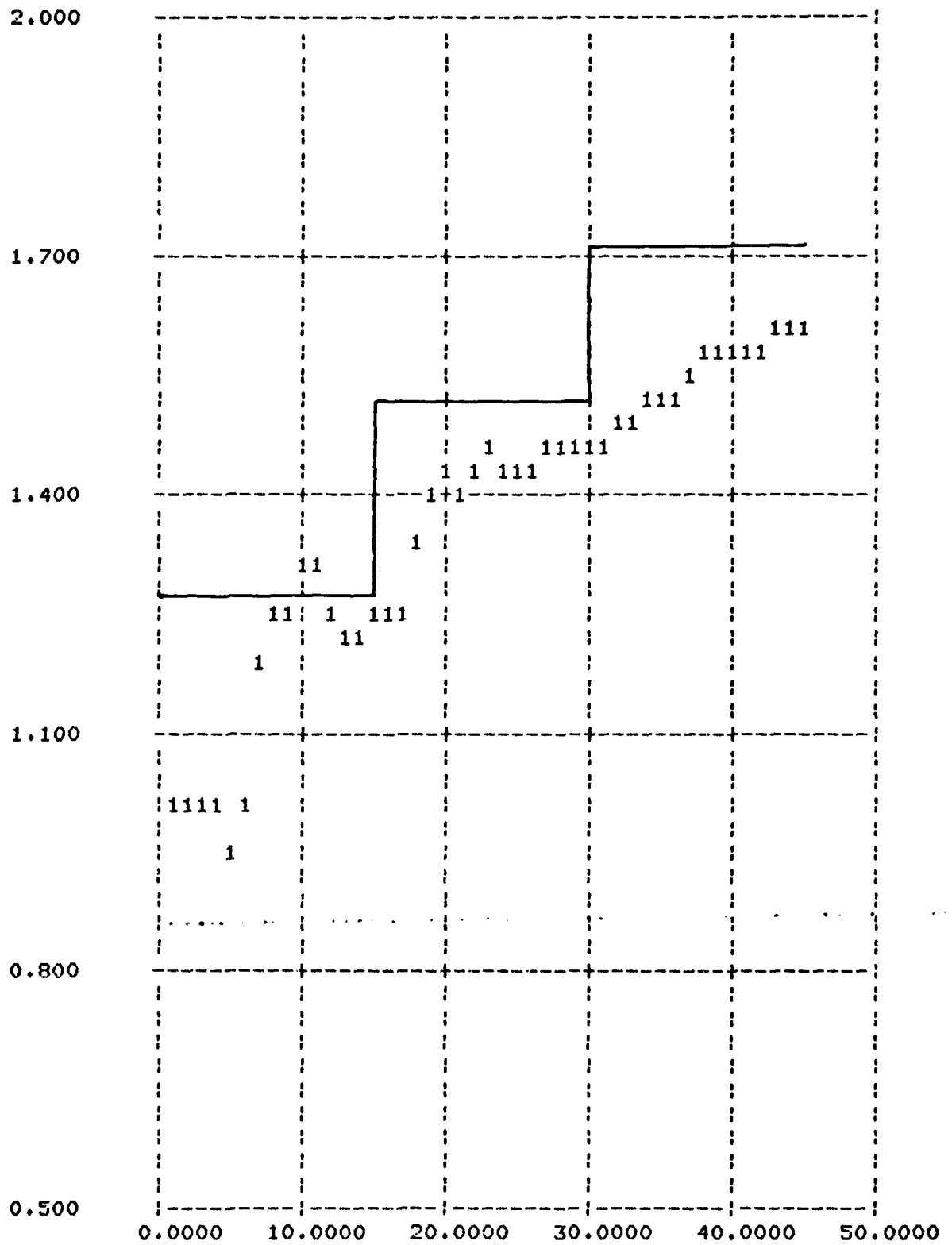

Figure D.31. Case (11) ($\gamma = .95$, $\beta = .95$). 111 One-step-ahead predicted $\phi(2,2)$
 — Actual $\phi(2,2)$

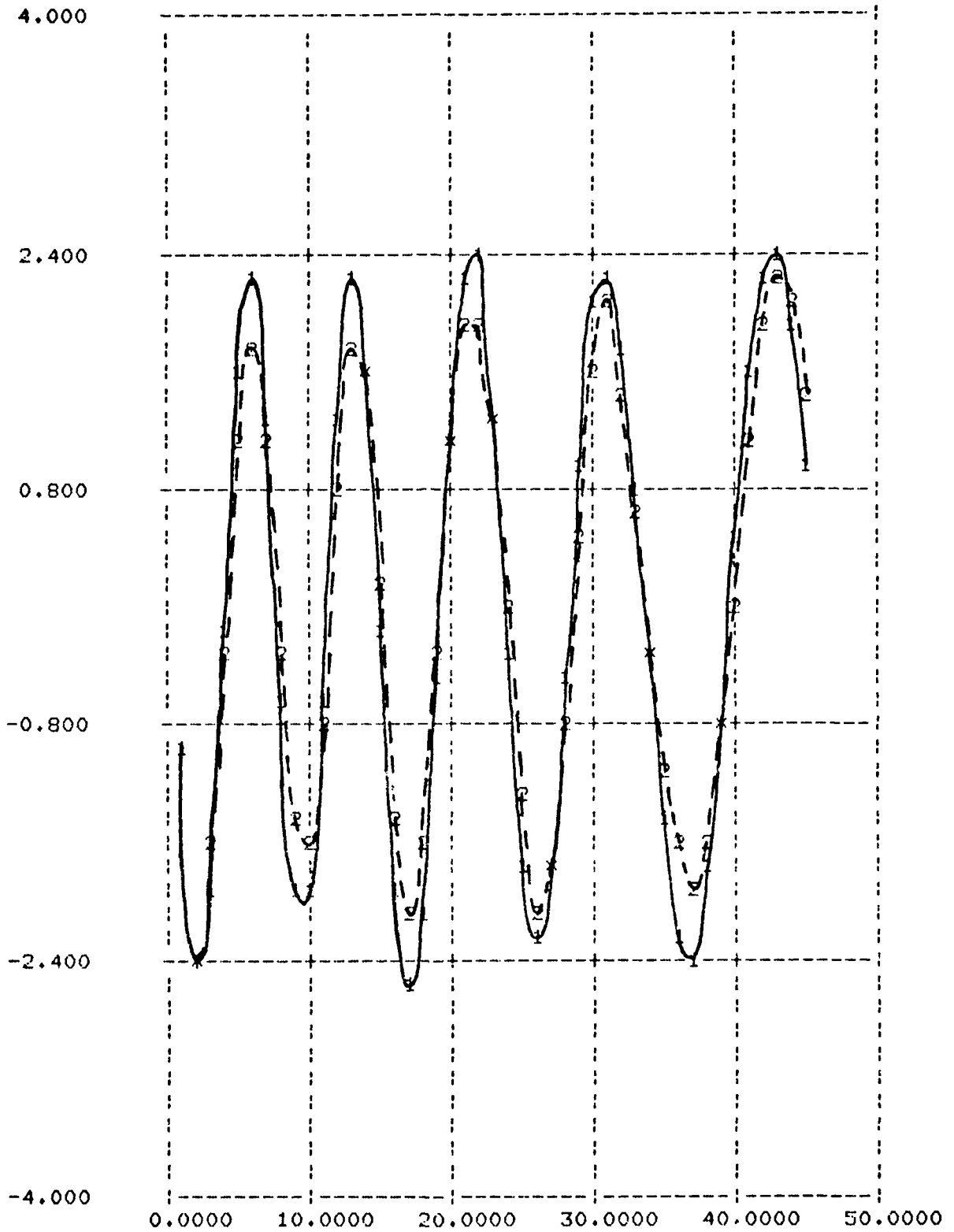

Figure D.32. Case (14) ($\gamma = .9$, $\beta = .2$). Observed state: $+$ Actual $x(1)$
 x One-step-ahead predicted $x(1)$

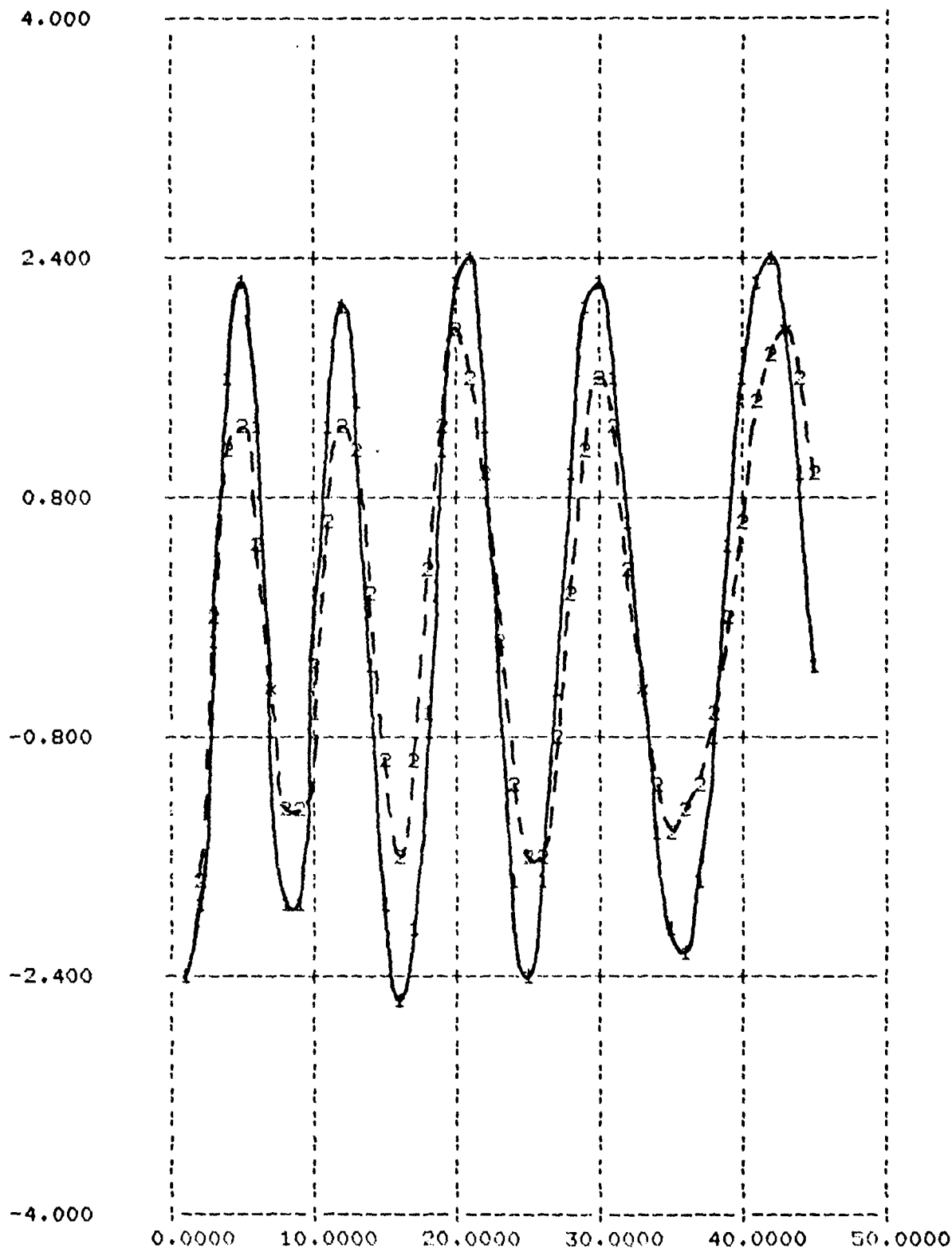

Figure D.33. Case (14) ($\gamma = .9$, $\beta = .2$). Unobserved state:
 + + + Actual $x(2)$; x x x One-step-ahead predicted $x(2)$

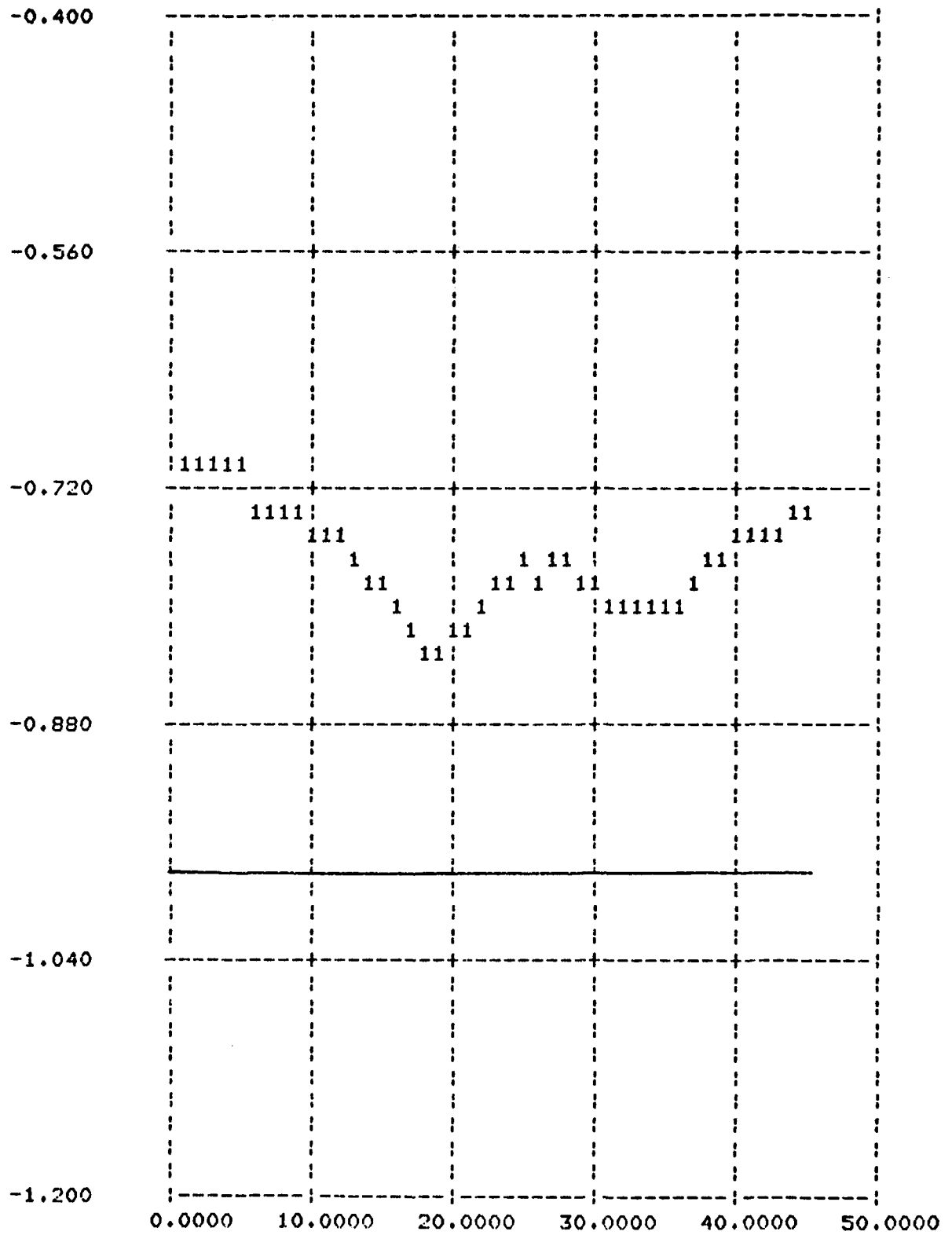

Figure D.34. Case (14) ($\gamma = .9, \beta = .2$). 1 1 1 One-step-ahead predicted $\phi(2,1)$
 — Actual $\phi(2,1)$

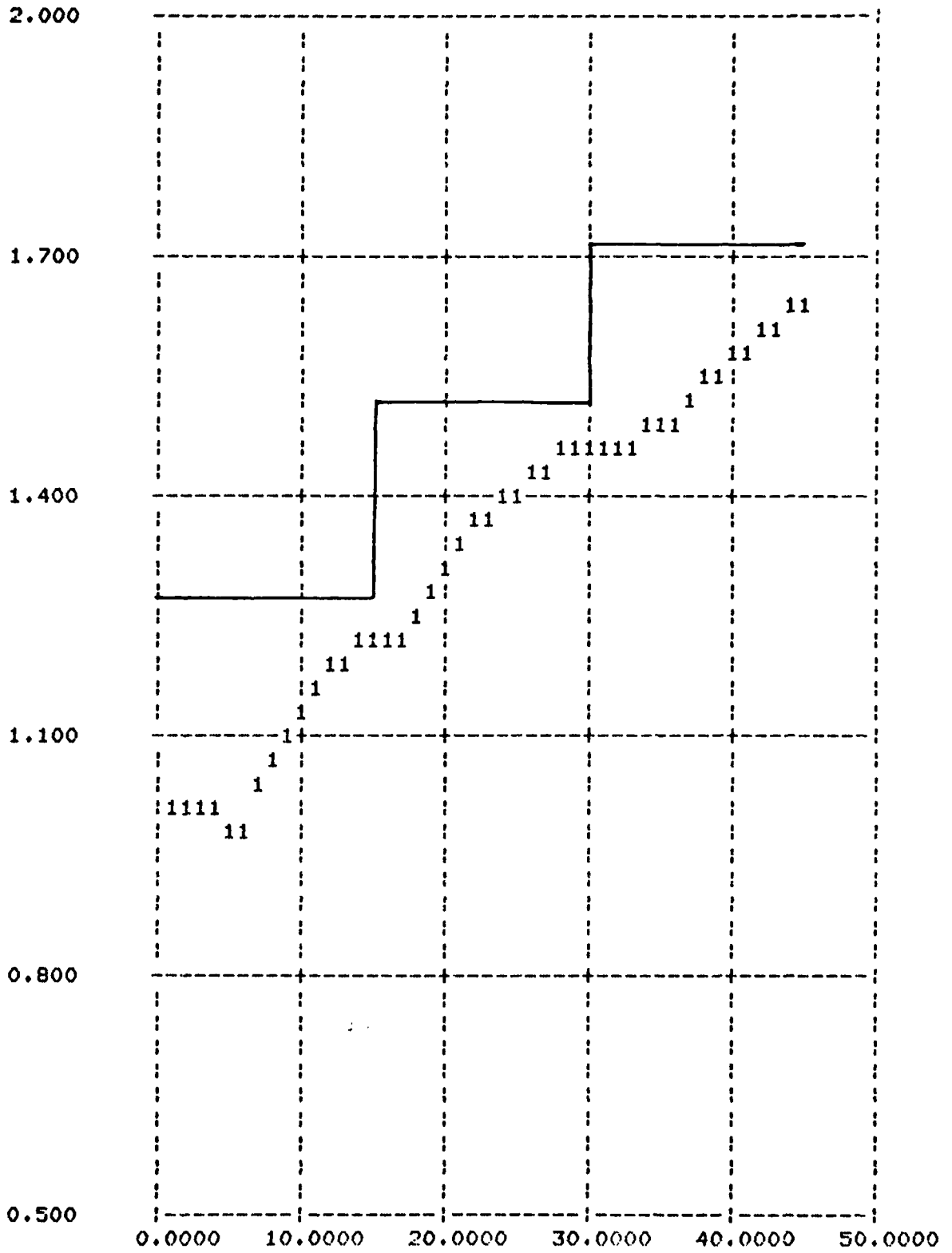

Figure D.35. Case (14) ($\gamma = .9, \beta = .2$). 1 1 1 One-step-ahead predicted $\phi(2,2)$
 — Actual $\phi(2,2)$

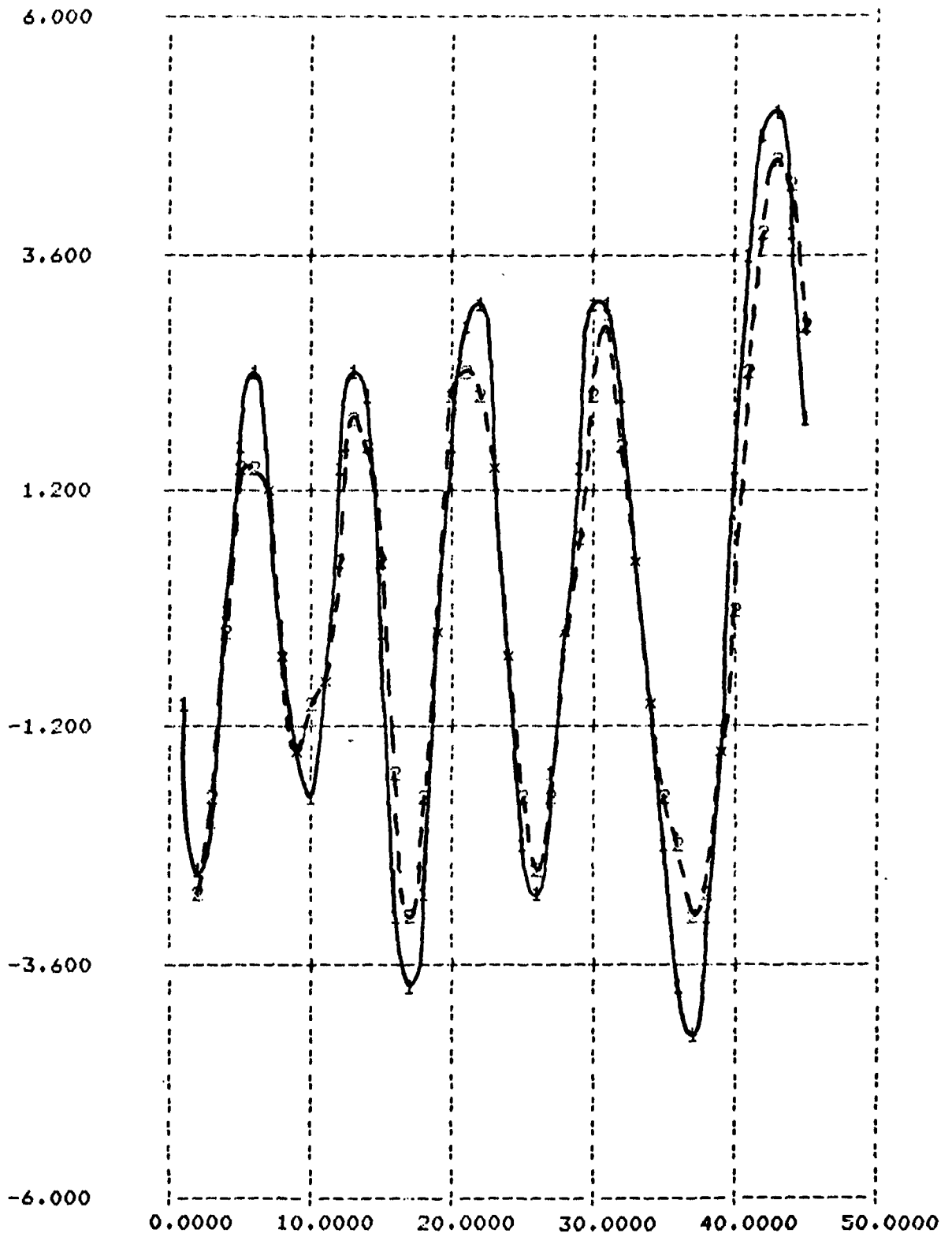

Figure D.36. Case (25) ($\gamma = .95$, $\beta = .2$). Unobserved state:
 1-1-1 Actual state $x(1)$
 2-2-2 One-step-ahead predicted $x(1)$

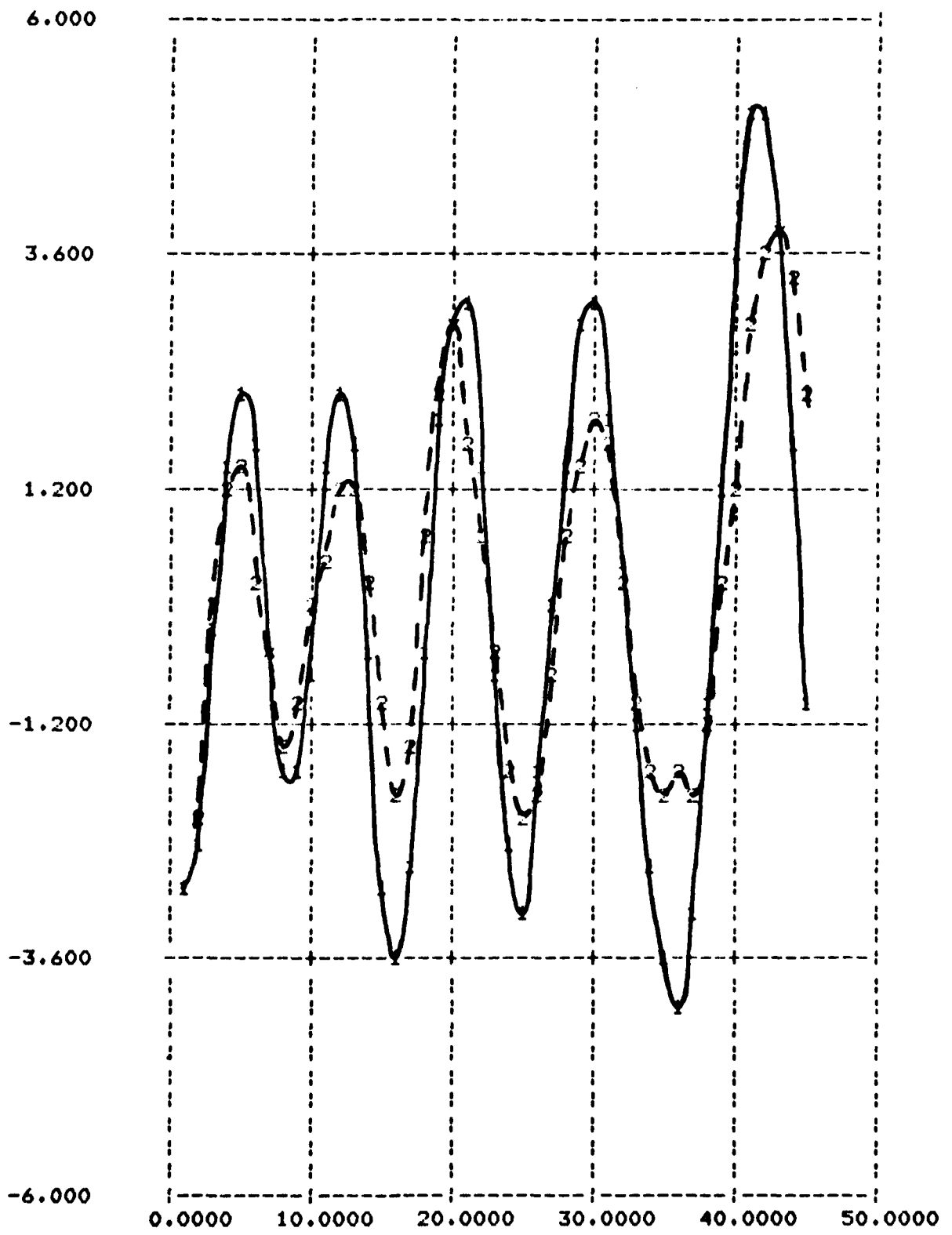

Figure D.37. Case (25) ($\gamma = .95$, $\beta = .2$). Unobserved state:
 --- Actual $x(2)$; - - - One-step-ahead predicted $x(2)$

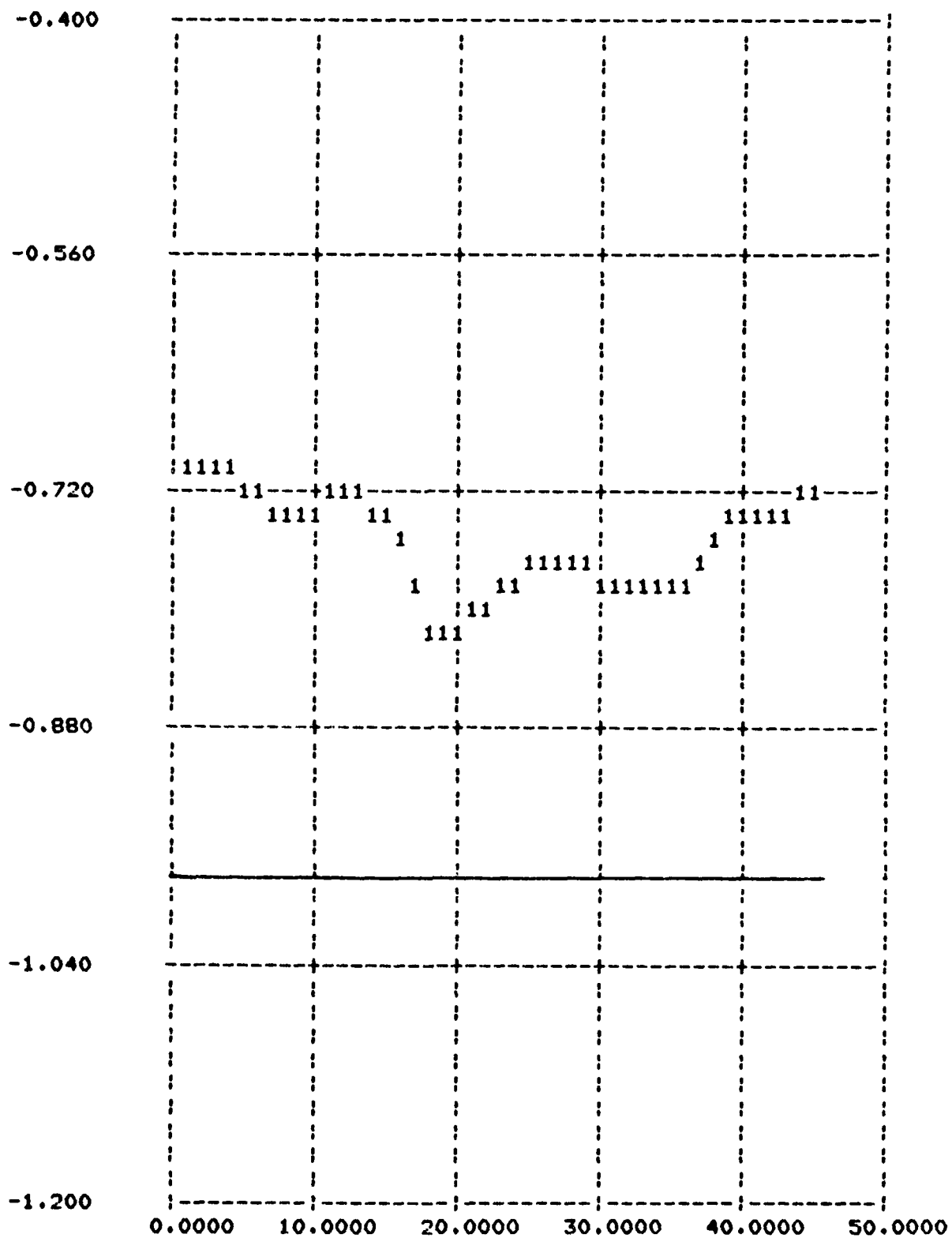

Figure D.38. Case (25) ($\gamma = .95, \beta = .2$). 1 1 1 One-step-ahead predicted $\hat{\phi}(2,1)$
 — Actual $\phi(2,1)$

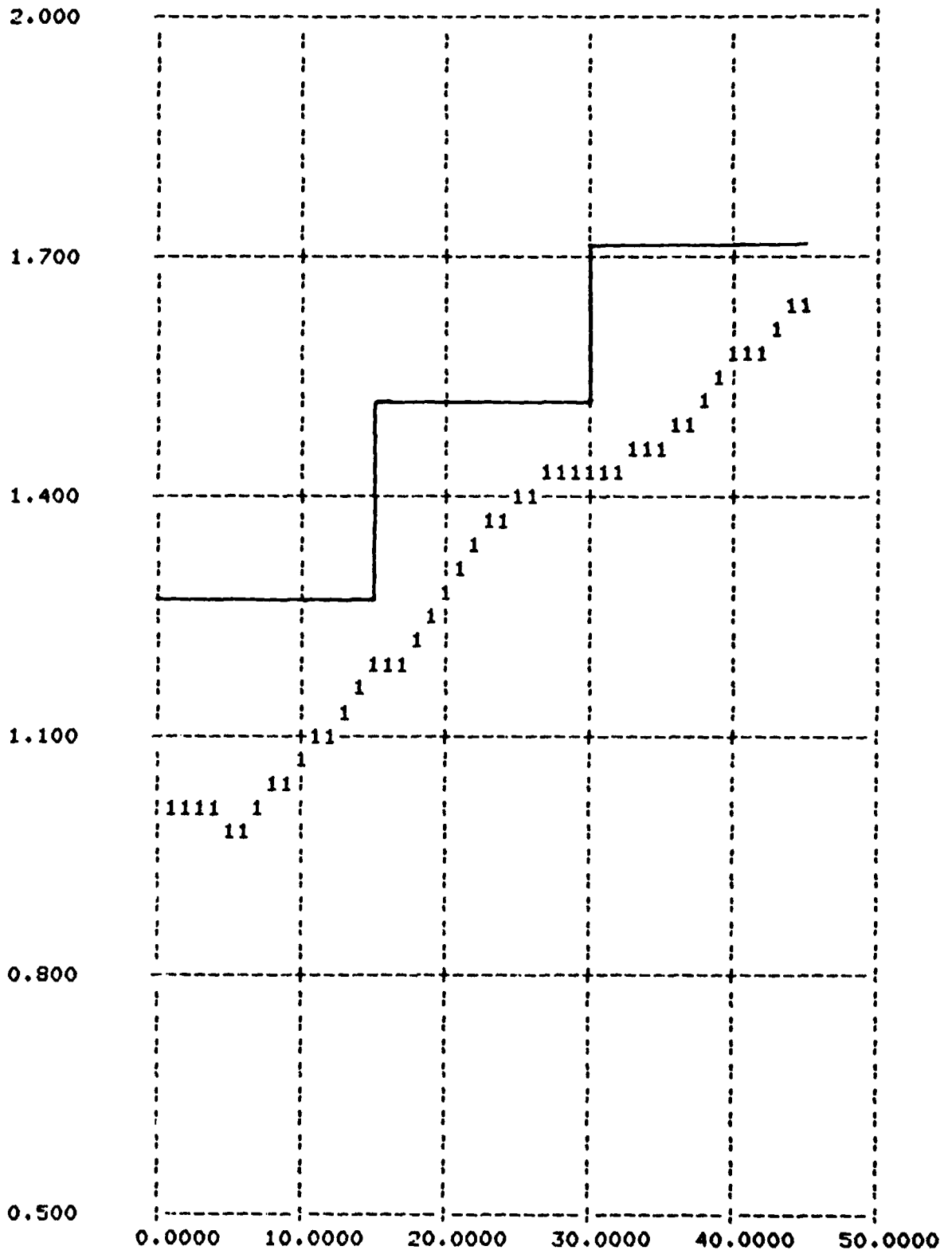

Figure D.39. Case (25) ($\gamma = .95$, $\beta = .2$). 111 One-step-ahead predicted $\phi(2,2)$
 — Actual $\phi(2,2)$

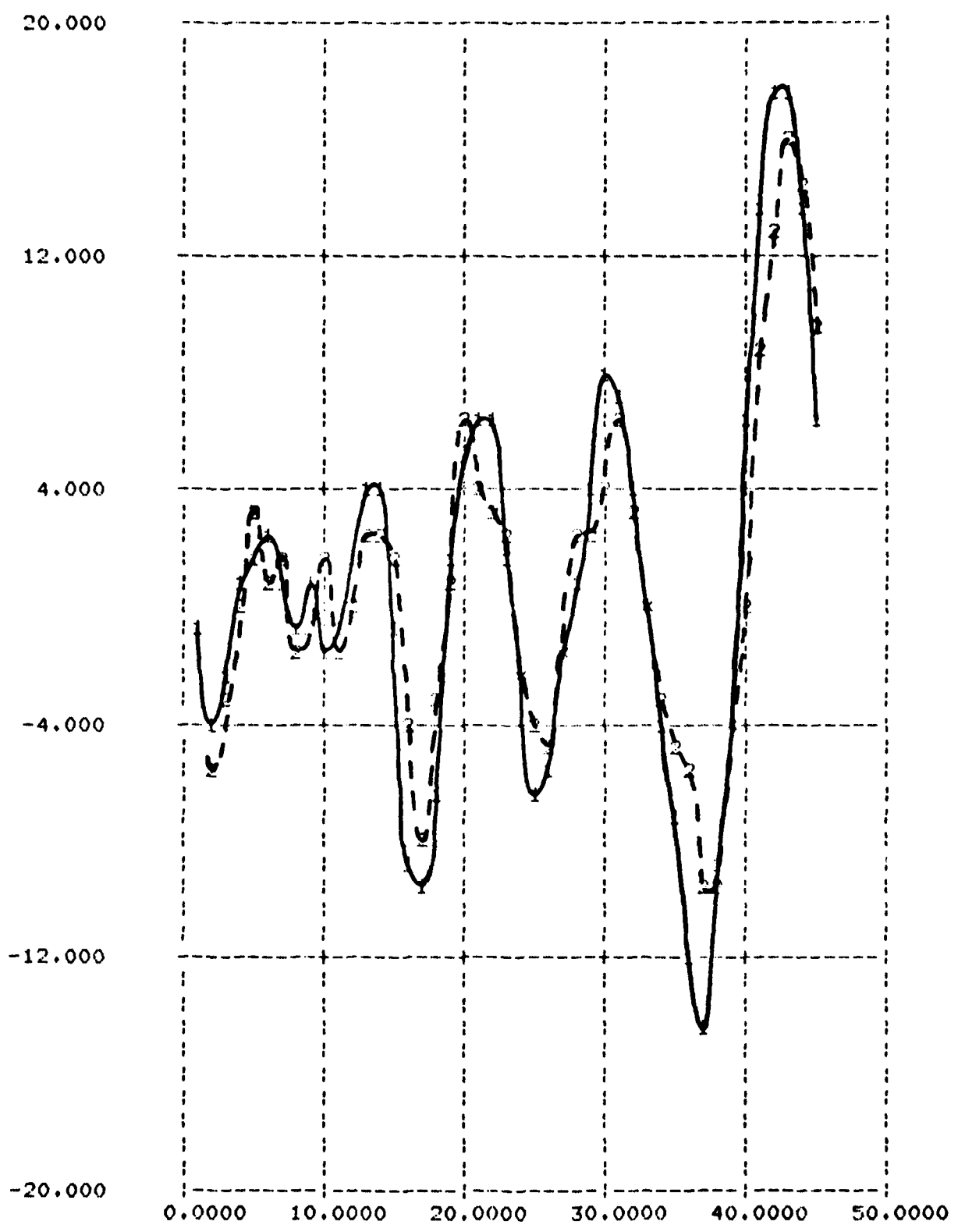

Figure D.40. Case (35) ($\gamma = .95$, $\beta = .05$). Observed state: --- Actual $x(1)$; - - - One-step-ahead predicted $x(1)$

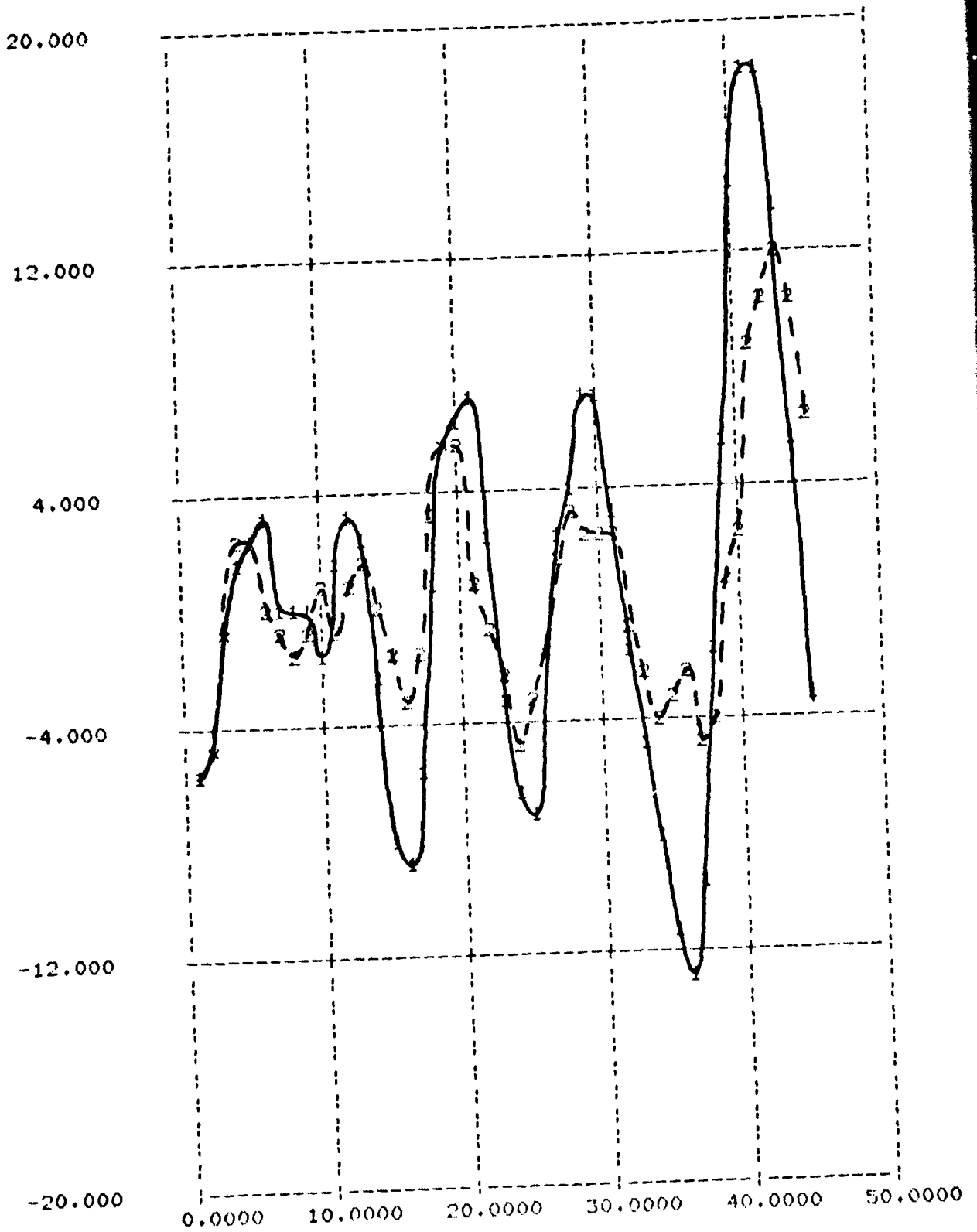

Figure D.41. Case (35) ($\gamma = .95$, $\beta = .05$). Unobserved data: $+++$ Actual $x(2)$;
 $---$ One-step-ahead predicted $x(2)$

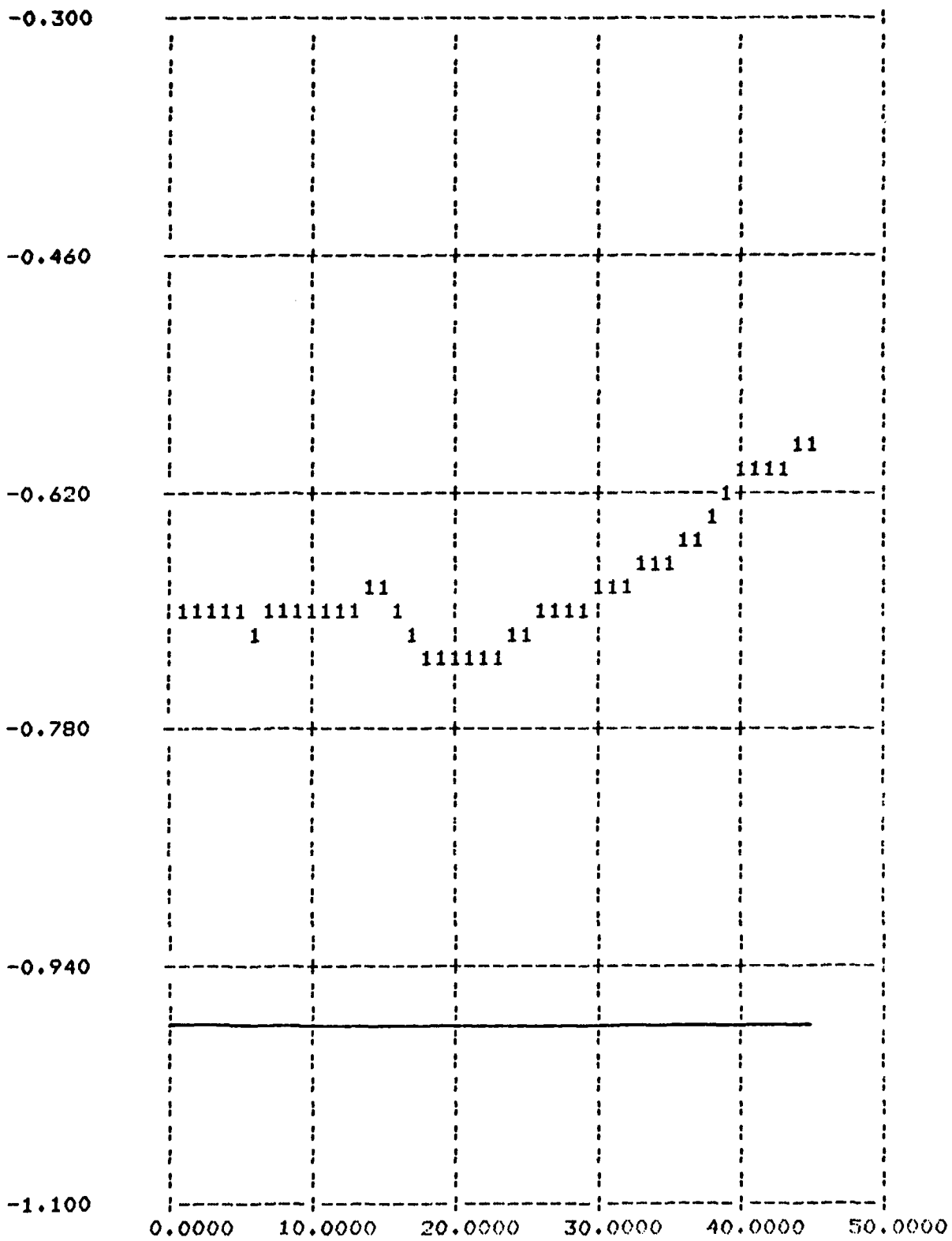

Figure D.42. Case (35) ($\gamma = .95$, $\beta = .05$). 1 1 1 One-step-ahead predicted $\phi(2,1)$.
 — Actual $\phi(2,1)$

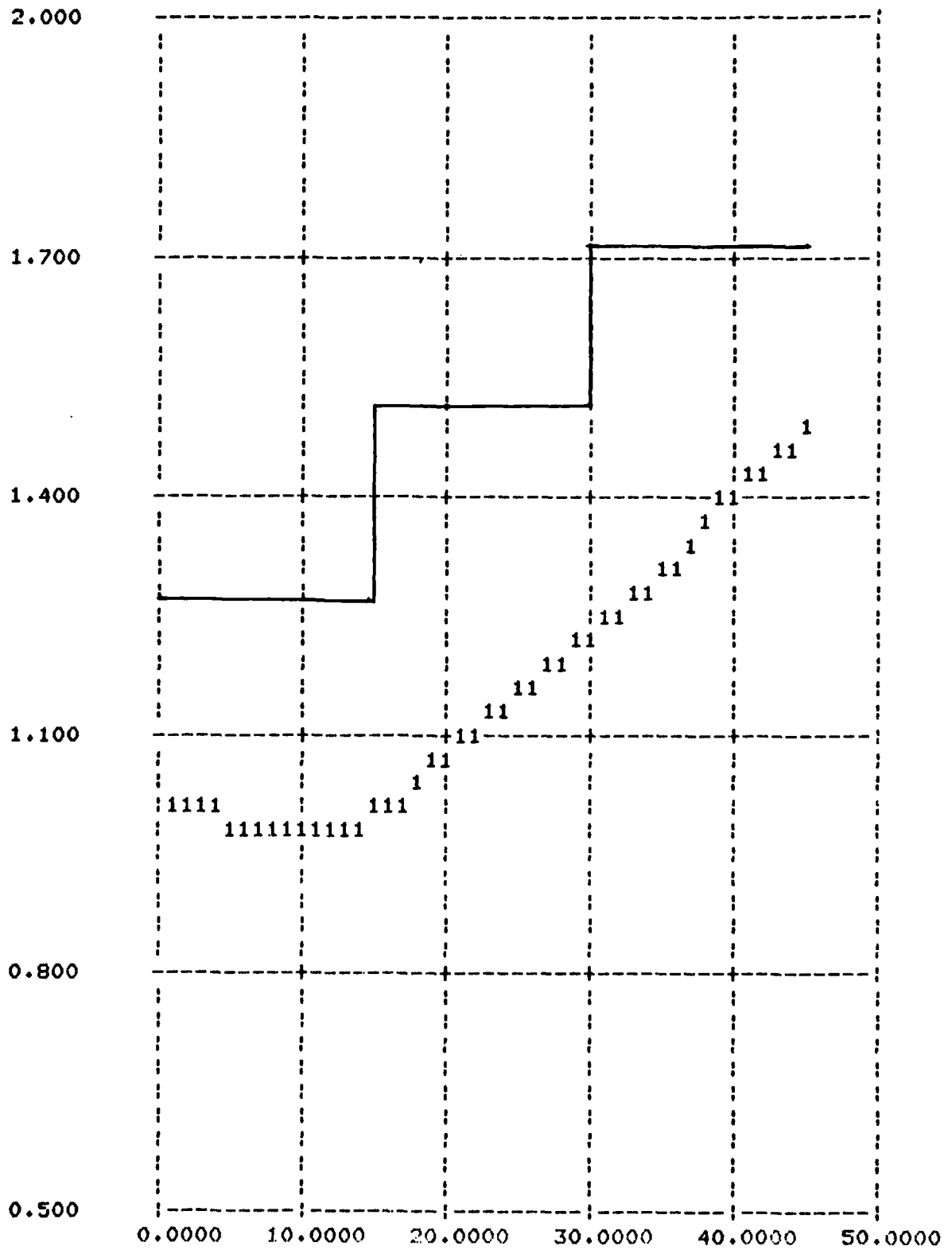

Figure D.43. Case (35) ($\gamma = .95$, $\beta = .05$). 1 1 1 One-step-ahead predicted $\phi(2,2)$
 — Actual $\phi(2,2)$

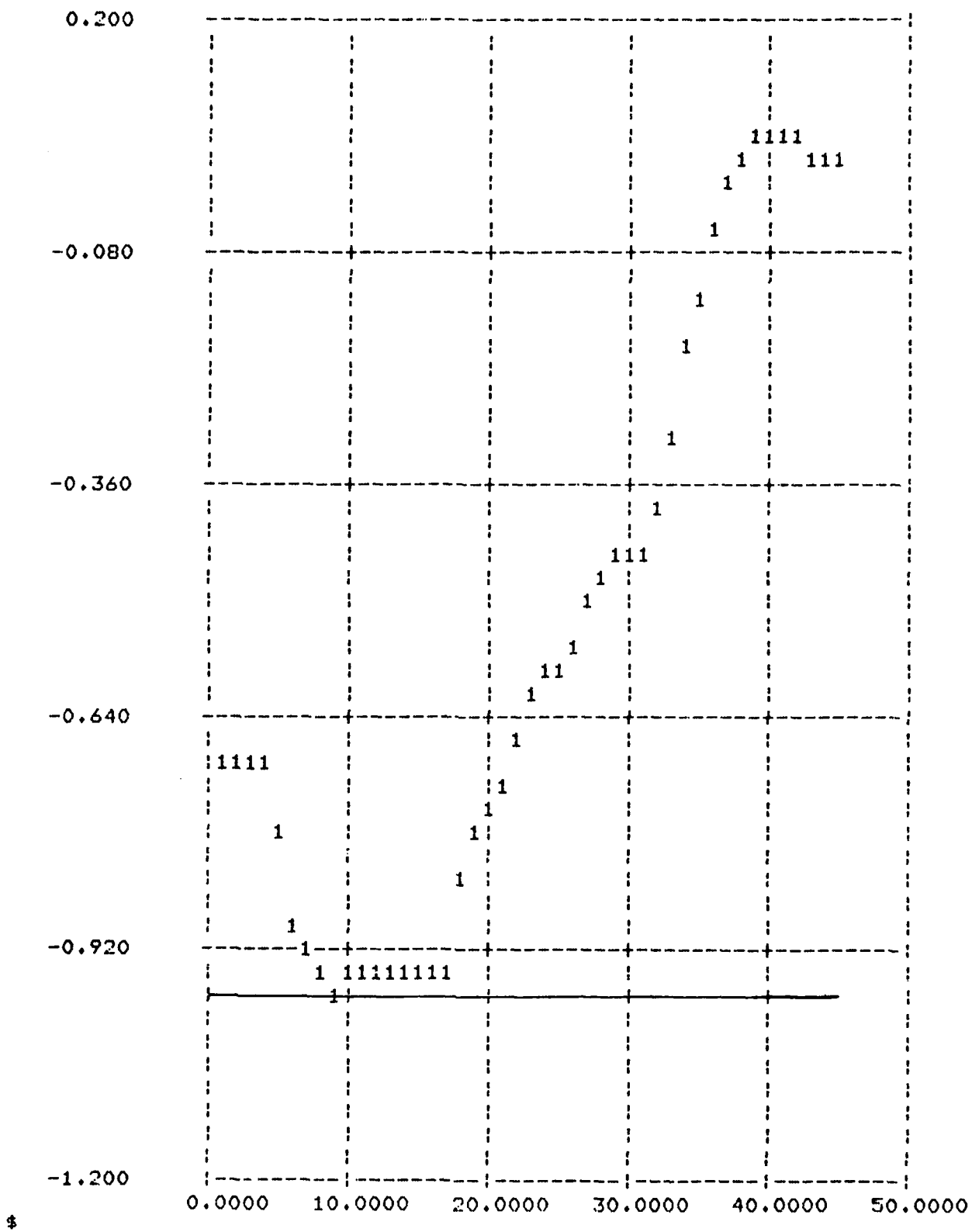

Figure D.44. Case (40) ($\gamma = .9, \beta = .6$). 1 1 1 One-step-ahead predicted $\phi(2,1)$
 — Actual $\phi(2,1)$

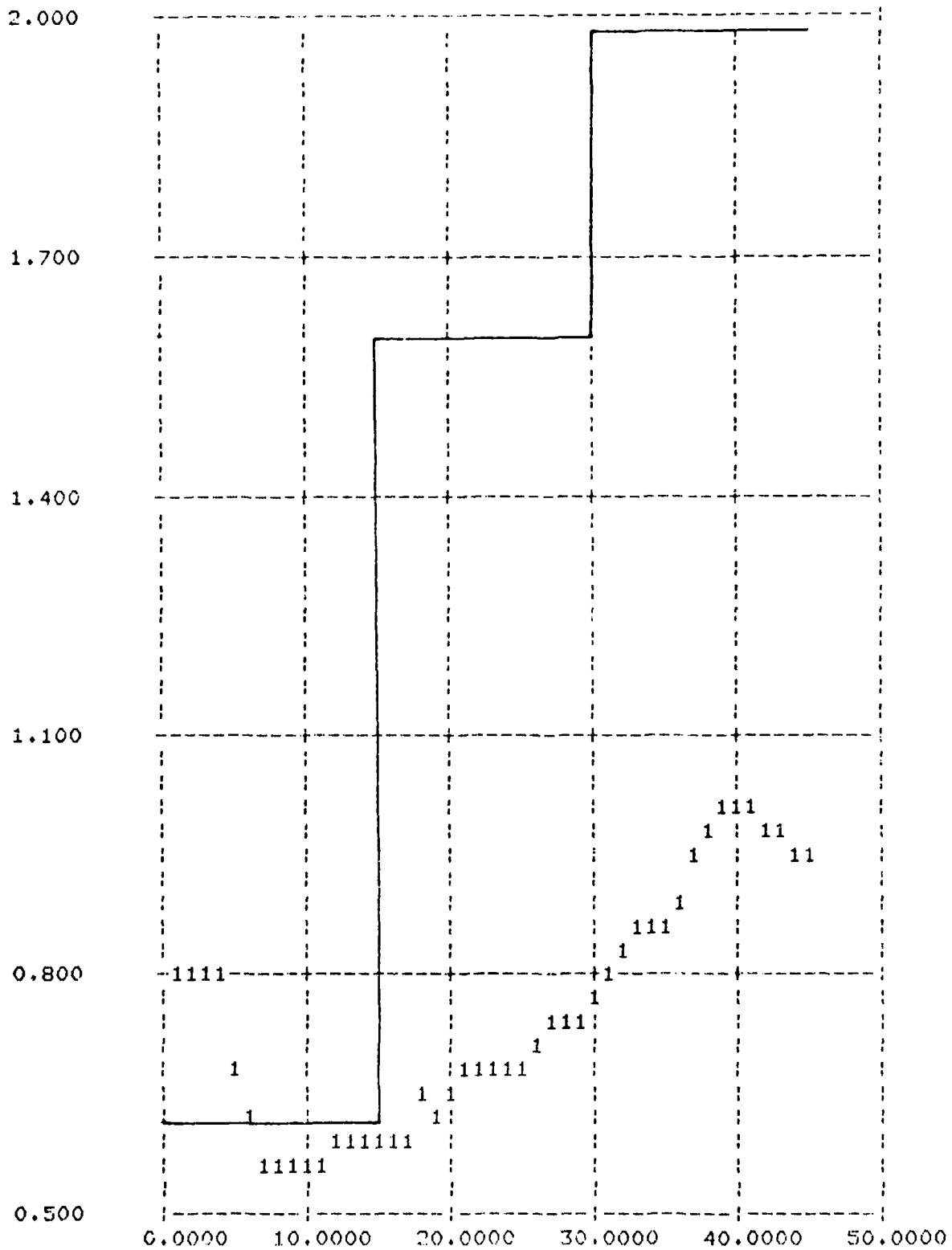

Figure D.45. Case (40) ($\gamma = .9$, $\beta = .6$). 111 One-step-ahead predicted $\phi(2,2)$
 — Actual $\phi(2,2)$

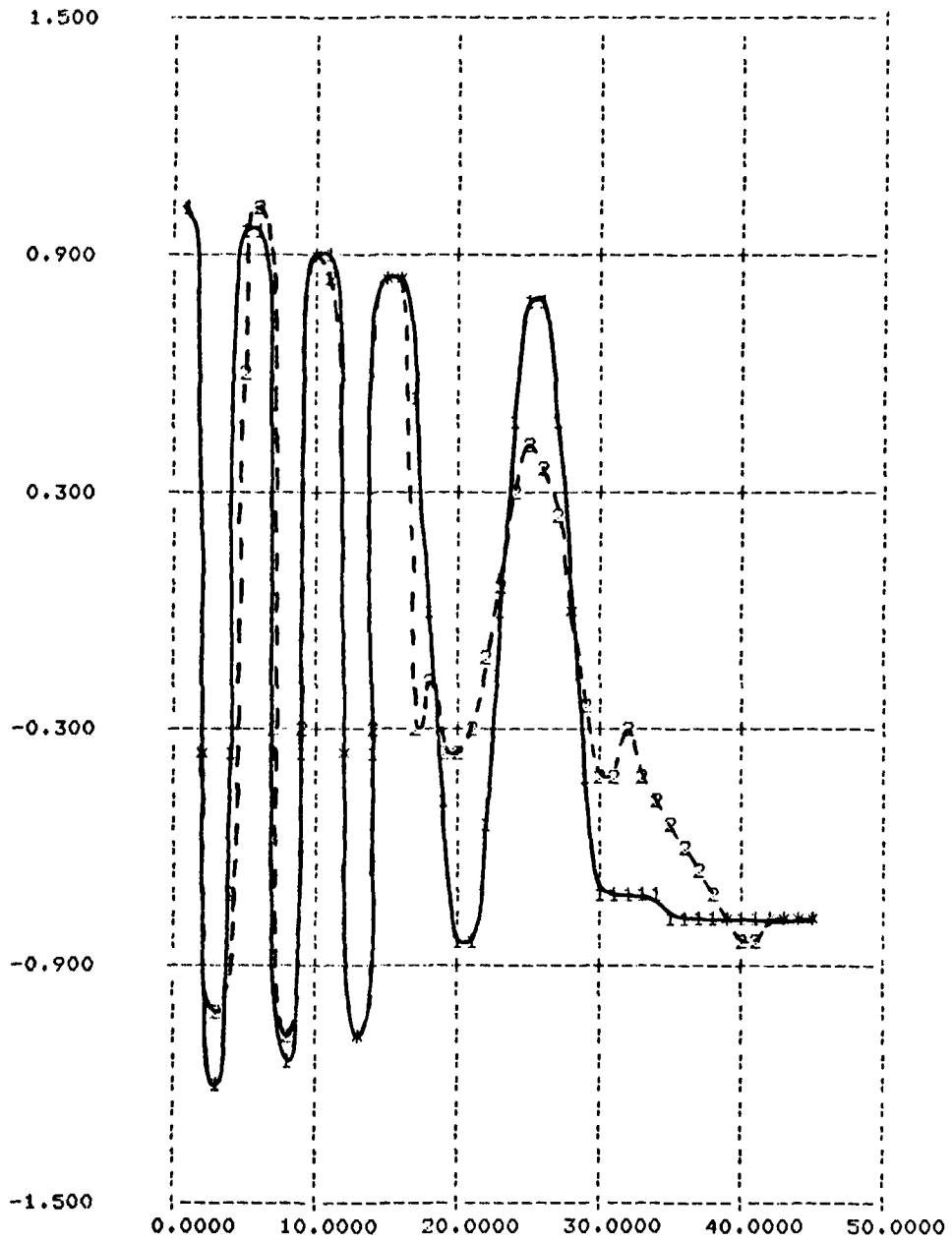

Figure D.46. Case (40) ($\gamma = .9, \beta = .6$). Observed state: +--+ Actual $x(1)$;
 x-x-x One-step-ahead predicted $x(1)$

```

RUN PJFLOT2
HOW MANY POINTS>45
UNIT>2\2\3
  
```

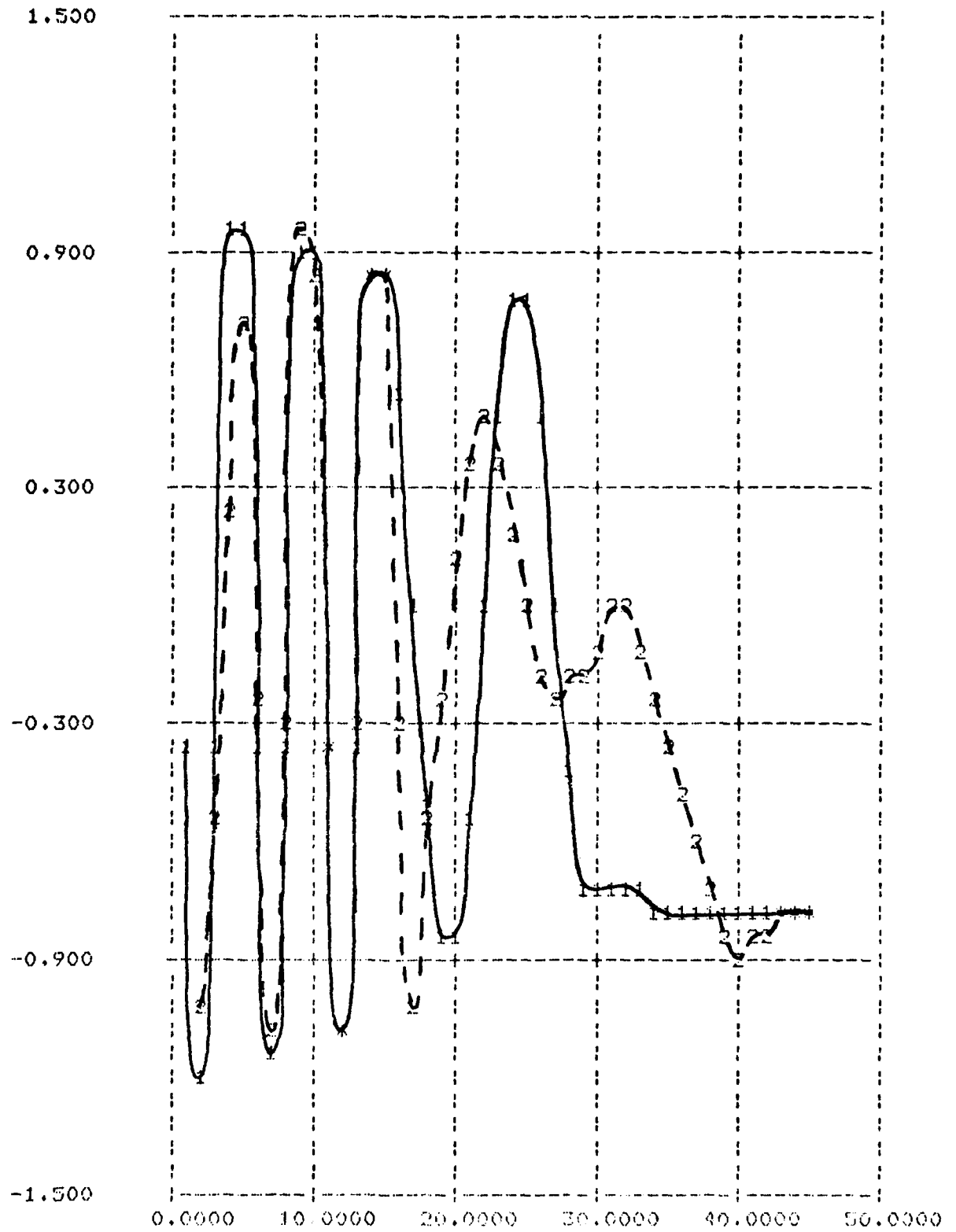

Figure D.47. Case (40) ($\gamma = .9$, $\beta = .6$). Unobserved state: + + + Actual $x(2)$; x-x-x One-step-ahead predicted $x(2)$

END

DATE
FILMED

1 X 880

DTIC

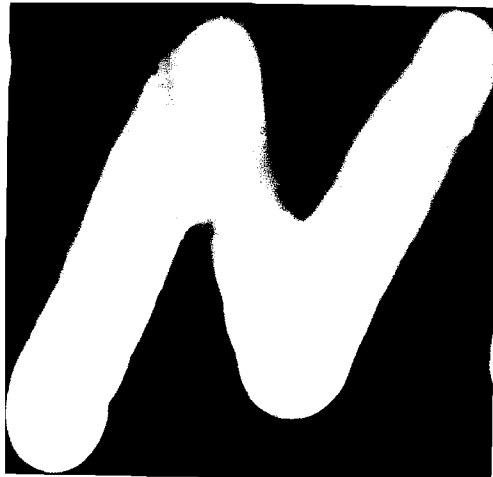

AD-A09D 499

SCIENTIFIC SYSTEMS INC CAMBRIDGE MA
RECURSIVE FORECASTING SYSTEM FOR PERSON-JOB MATCH+(U)
SEP 80 D E GUSTAFSON, R K MEMRA, W H LEDSHAM F33615-78-C-0050
AFMRL-TR-79-83

F/G 6/9

UNCLASSIFIED

NL

56
AD-A
0942194

SUPPLEMENTARY
INFORMATION



~~EN
D
I
DTIC~~

CONT.

A
04

SUPPLEMENTARY

INFORMATION

DEPARTMENT OF THE AIR FORCE
AIR FORCE HUMAN RESOURCES LABORATORY (AFSC)
BROOKS AIR FORCE BASE, TEXAS 78235



Errata

16 JAN 1981

REPLY TO
ATTN OF: TSR

SUBJECT: Removal of Export Control Statement

TO: Defense Technical Information Center
Attn: DTIC/DDA (Mrs Crumbacker)
Cameron Station
Alexandria VA 22314

1. Please remove the Export Control Statement which erroneously appears on the Notice Page of the reports listed ~~██████████~~. This statement is intended for application to Statement B reports only.

2. Please direct any questions to AFHRL/TSR, AUTOVON 240-3877.

FOR THE COMMANDER

Wendell L Anderson

WENDELL L. ANDERSON, Lt Col, USAF
Chief, Technical Services Division

1 Atch
List of Reports

Cy to: AFHRL/TSE

AD A090499

END

DATE
FORMED

18

DTIC



AD-A090 499

SCIENTIFIC SYSTEMS INC CAMBRIDGE MA F/G 5/9
RECURSIVE FORECASTING SYSTEM FOR PERSON-JOB MATCH.(U)
SEP 80 D E GUSTAFSON, R K MEHRA, W H LEDSHAM F33615-78-C-0050
AFHRL-TR-79-83 NL

UNCLASSIFIED

6 6
40 8
19 0 19 9



END

DATE

FILED

7-81

DTIC

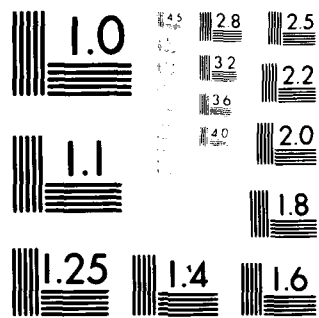

MICROCOPY RESOLUTION TEST CHART

SUPPLEMENTARY

INFORMATION

AIR FORCE HUMAN RESOURCES LABORATORY
Brooks Air Force Base, Texas 78235

Errata

Number	First Author	Title
AFHRL-TR-76-87 (AD-A037 522)	Jensen	Armed Services Vocational Aptitude Battery Development (ASVAB Forms 5, 6, and 7)
AFHRL-TR-77-28 (AD-A044 525)	Hunter	Validation of a Psychomotor/Perceptual Test Battery
AFHRL-TR-77-53 (AD-A048 120)	Mathews	Screening Test Battery for Dental Laboratory Specialist Course: Development and Validation
AFHRL-TR-77-74 (AD-A051 962)	Mathews	Analysis Aptitude Test for Selection of Airmen for the Radio Communications Analysis Specialist Course: Development and Validation
AFHRL-TR-78-10 (AD-A058 097)	DeVany	Supply Rate and Equilibrium Inventory of Air Force Enlisted Personnel: A Simultaneous Model of the Accession and Retention Markets Incorporating Force Level Constraints
AFHRL-TR-78-74 (AD-A066 659)	Leisey	Characteristics of Air Force Accessions: January 1975 to June 1977
AFHRL-TR-78-82 (AD-A063 656)	Mathews	Prediction of Reading Grade Levels of Service Applicants from Armed Services Vocational Aptitude Battery (ASVAB)
AFHRL-TR-79-29 (AD-A078 127)	Hendrix	Pre-Enlistment Person-Job Match System
AD-A090 499 AFHRL-TR-79-83 (AD-A090 199)	Gustafson	Recursive Forecasting System for Person-Job Match

Due to norming problems encountered with ASVAB Forms 5, 6, and 7, percentile scores derived from these test forms are in error. While the relative ranking of individuals by their percentile scores would not be affected by the norming errors, their absolute score values would be different. Therefore, descriptive statistics reported in the subject technical reports above are erroneous; other types of analyses in the report which use ASVAB percentile scores should be interpreted with caution.

NANCY GUINN, Technical Director
Manpower and Personnel Division