

LEVEL IV



AD A090277

DEPARTMENT OF FIREARMS  
OPTIC EARTH-COVERED  
MAGAZINES

OPTIC  
S-20

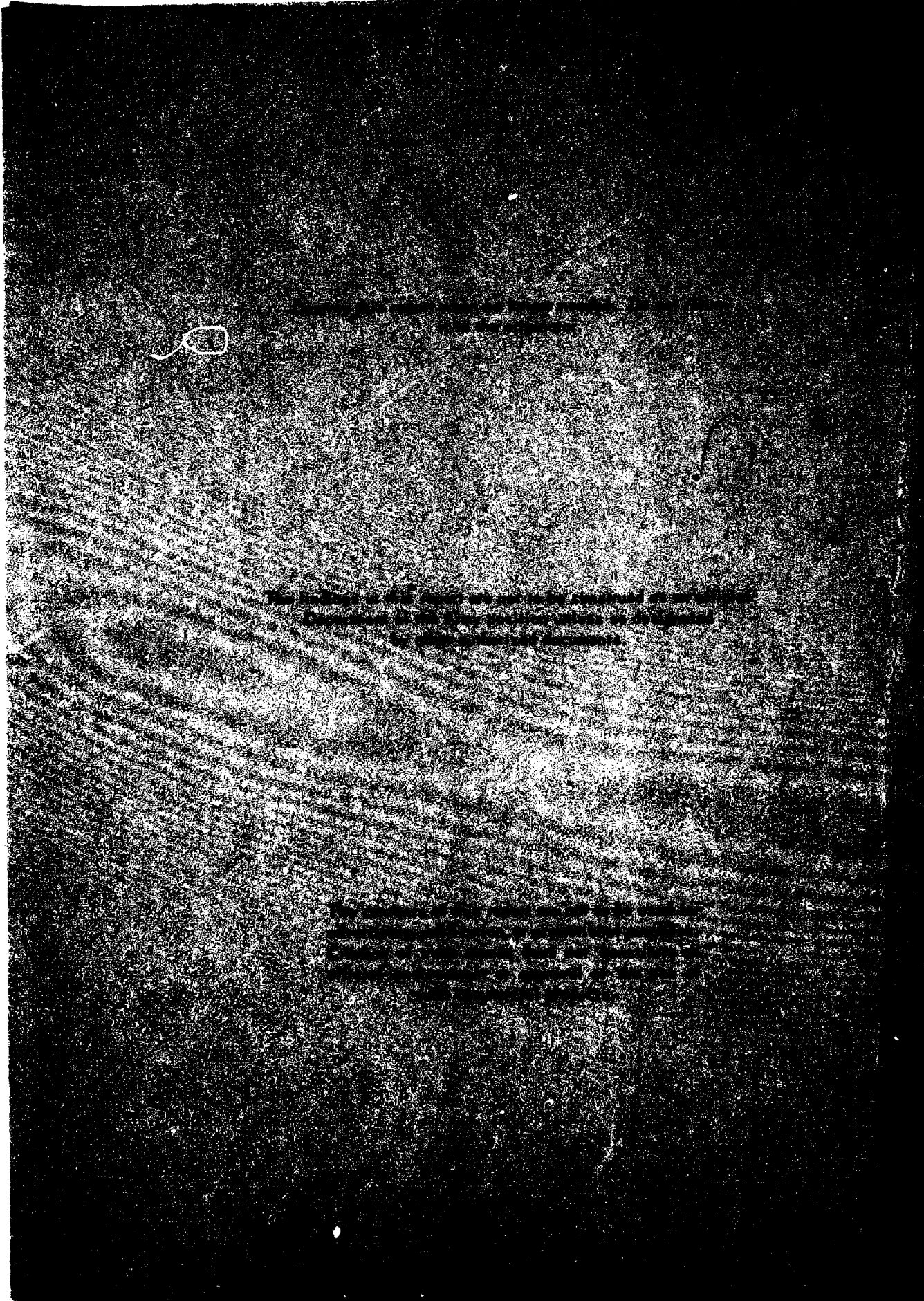



Unclassified

SECURITY CLASSIFICATION OF THIS PAGE(When Data Entered)

20. ABSTRACT (continued).

Adequacy of the developed FRP magazine design was determined by finite element analyses. Soil load distribution equations were derived and the MRI STARDYNE computer code was extensively employed with increasingly detailed structural models of the FRP magazine.

An FRP earth-covered, ammunition storage magazine is shown to be feasible and highly competitive with present construction materials. Construction of a prototype structure is recommended.

Unclassified

SECURITY CLASSIFICATION OF THIS PAGE(When Data Entered)

PREFACE

This report was prepared by Hunt and Wales Co., Inc. 129 Wakefield Street, Reading, MA. for the U.S. Army Engineer Waterways Experiment Station (WES) under contract number DACA 39-79-C-0012. The work was accomplished during the period from October 1979 through July 1980.

Assistance in direction and control of technical work under the contract was provided by James M. Watt Jr. of the WES, Structures Laboratory. Grateful appreciation is extended to him for his helpful technical comments and prompt resolution of questions as they arose.

Commander and Director of WES during the preparation and publication of this report was COL Nelson P. Conover, CE. Technical Director was Mr. F. R. Brown.

Accession For	
NTIS GRA&I	<input checked="" type="checkbox"/>
DDC TAB	<input type="checkbox"/>
Unannounced	<input type="checkbox"/>
Justification	
By _____	
Distribution/ _____	
Availability Codes	
Dist.	Avail and/or special
<b>A</b>	

## CONTENTS

PREFACE	3
CONVERSION FACTORS, INCH-POUND TO METRIC (SI) UNITS OF MEASURE	7
CHAPTER 1 INTRODUCTION	8
1.1 Background	8
1.2 Objective	9
1.3 Scope of Work	9
CHAPTER 2 DOCUMENTED PRACTICES	11
CHAPTER 3 MATERIALS SELECTION	13
3.1 Recommendations	13
3.2 Properties	14
CHAPTER 4 CONCEPTUAL DESIGN STUDIES	17
4.1 Arch	17
4.2 End Walls	18
CHAPTER 5 FRP MAGAZINE DESIGN	31
5.1 Configuration	31
5.2 Arch	31
5.3 Rear Wall	32
5.4 Entrance and Wing Walls	33
5.5 Panel Joint Adhesives/Sealants	34
5.6 Manufacturing Methods	35
5.7 Packing and Shipping	35
5.8 Field Erection Procedure	36
5.9 Maintenance	36
CHAPTER 6 STRUCTURAL ANALYSES	53
6.1 Conceptual Design Analyses	53
6.2 Arch-Beam Element Model	53
6.2.1 Soil Load Distribution	54
6.2.2 Foundation Soil Springs	54
6.2.3 Section Properties	54
6.3 Arch-Plate Element Model	54
6.4 Arch and End Wall-Plate Element Model	56
6.5 Stability	57
6.6 Service Temperature Range	57
6.7 Creep	58
CHAPTER 7 CONSTRUCTION COSTS	65



CHAPTER 8 CONCLUSIONS AND RECOMMENDATIONS	70
8.1 Conclusions	70
8.2 Recommendations	70
APPENDIX A DERIVATION OF SOIL LOADING EQUATIONS	71
REFERENCES	75
FIGURES	
1.1 Present Steel Oval Arch Magazine Cross-Section	10
4.1 Magazine Internal Volume Comparison	19
4.2 Arch Panel Cross Section Concepts	20
4.3 Present Magazine Rear Wall	24
4.4 Present Magazine Entrance Wall	25
4.5 FRP End Wall Design Concepts	26
4.6 Flexible End Wall/Arch Edge Joint Concept	28
4.7 Rigid End Wall/Arch Edge Joint Concept	29
5.1 General Configuration-FRP Magazine	38
5.2 FRP Semi-Circular Arch Panel	39
5.3 Connection Between Adjacent Arch Panel Edges	42
5.4 Arch Panel Top End Connection	43
5.5 Arch Panel End Molded Socket	44
5.6 FRP Magazine Rear Wall	45
5.7 FRP Magazine Entrance and Wing Walls	46
5.8 FRP Entrance Door	49
5.9 Concrete End Wall/FRP Arch Edge Connections	51
6.1 Arch Panel Thickness at Foundation	59
6.2 Arch-Plate Element Model	60
6.3 Arch-Axial and Bending Loads	62
6.4 Arch and End Walls-Plate Element Model	63
A.1 Arch-Soil Loading	73
TABLES	
1. Compilation of Practices and Other Guidance Materials	12
2. Physical Properties of Typical Polyester Laminates	15
3. Physical Properties of Sandwich Cores	16
4. FRP Magazine Construction Cost Data	66
5. Present Magazine Construction Cost Data	68

CONVERSION FACTORS, INCH-POUND TO METRIC (SI) UNITS OF MEASUREMENT

Inch-pound units of measurement used in this report can be converted to metric (SI) units as follows:

---

Multiply	By	To Obtain
feet	0.3048	metres
inches	25.4	millimetres
inch-pounds	0.1129848	metre-newtons
pounds (force)	4.448222	newtons
pounds (force) per square inch	6.894757	kilonewtons per square metre

---

## CHAPTER 1

### INTRODUCTION

#### 1.1 BACKGROUND

Maintenance and construction costs of ammunition storage magazines have steadily increased. These cost increases, and recent advances in construction materials, have indicated the need to study the feasibility of fiberglass reinforced plastic (FRP) as an alternate to the steel and concrete structures that are presently used.

Fiberglass reinforced structural plastics are being successfully employed in primary structural applications such as (Reference 1) :

- a) Boats and ships up to 80 ft. long.
- b) Sewage tank domes up to 110 ft. diameter.
- c) Tanks up to 100,000 gallon capacity.
- d) Molded shell-roofed vacation houses.
- e) Automobile and truck bodies.
- f) Cargo containers for ocean, rail and truck shipment.
- g) Large diameter buried piping.
- h) Radomes and antennas.

#### 1.2 OBJECTIVE

The objective of this study is to develop feasibility data and establish a design for a fiberglass-reinforced plastic (FRP) earth-covered ammunition storage magazine so as to provide designers with an added materials option.

#### 1.3 SCOPE

The scope of the study performed may be summarized as follows:

- a) Performance of a literature search and canvass of industrial and DOD organizations to document recommended practices for the design, manufacture and installation of fiberglass-reinforced plastic structures.
- b) Determinations of:
  - structural material, best chemical composition.
  - proper fabrication and assembly procedures.
  - best component fastener and waterproofing systems.
  - maintenance requirements for various environmental conditions and compatibility with various explosives.

- cost and other data needed to determine the feasibility of constructing such fiberglass reinforced plastic, earth-covered structures.
- c) Development of several conceptual designs for an earth-covered ammunition storage magazine, using the present steel oval arch structure shown in figure 1.1 for definition of storage space requirements and soil cover depth required for blast protection.
- d) Development of a final design, along with construction cost data, of the most promising concept in sufficient detail for the construction of a prototype structure.



## CHAPTER 2

### DOCUMENTED PRACTICES

A literature search and canvass of industrial and DOD organizations was made in order to compile currently available practices for the design, manufacture and installation of fiberglass-reinforced plastic structures. During this effort, a computer literature search was conducted of the NTIS and COMPENDEX data bases.

A compilation of selected pertinent current practices and other guidance materials is listed in Table 1.

Technology and criteria provided by these documents were employed in the development of a fiberglass-reinforced plastic earth-covered ammunition storage magazine as described in later chapters of this report.

TABLE 1

COMPILATION OF PRACTICES AND OTHER GUIDANCE MATERIALS

- A. Structural Plastics Design Manual FHWA-TS-79-203, U.S. Govt. Printing Office Stock No. 023-000-00495-0.
- B. "Hand Lay-up Spray-up Guide"; 1979; Publication No. 5-PL-9342 Owens-Corning Fiberglass Corp. Toledo, OH.
- C. James M. Duncan; "Behavior and Design of Long Span Metal Culverts"; March 1979, Pages 399-418; Journal of the Geotechnical Division, ASCE, New York, N.Y., Proceedings Paper 14429.
- D. B. Jay Schrock; "Installation of Fiberglass Pipe"; Nov. 1978; Pages 835-846; Transportation Engineering Journal, ASCE, N.Y., N.Y.
- E. Frank J. Heger; "Design of FRP Fluid Storage Vessels"; Nov. 1970; Journal of the Structural Div., ASCE, New York, N.Y.
- F. "Frp-An Introduction to Fiberglas-Reinforced Plastics Composites" Publication No. 1-PL-6305A by Owens-Corning Fiberglas Corp. Toledo, OH.
- G. "Structural Sandwich Composites", Military Handbook, MIL-HDBK-23A; Dec. 1968; Dept of Defense, Washington, DC.
- H. Charles C. Huang, "Feasibility of Using Fiberglass Reinforced Plastic (FRP) Buildings for Ammunition Plants"; September 1978, Pages 1169-1194, Minutes of the Eighteenth Explosives Seminar, San Antonio, Texas, sponsored by Dept. of Defense Explosives Safety Board, Alexandria, VA.

## CHAPTER 3

### MATERIALS SELECTION

#### 3.1 RECOMMENDATIONS

Isophthalic polyester resin was selected as the most suitable plastic for this application, based on collected data and the recommendations of FRP material suppliers. Considered major advantages of this resin may be listed as:

- a) Adequate strength at reasonable cost.
- b) Demonstrated corrosion resistance in various soils and chemical environments.
- c) Wide usage and availability.

Commercially available isophthalic polyester resins have been developed for use in a wide variety of soils encountered nationally and internationally. This resin has been used successfully for approximately 20 years in many applications of large diameter buried pipe and underground storage tanks.

Polyester resin systems are most common for general product applications. Increased mechanical properties obtainable with other resins (e.g. epoxy) are not commensurate with the higher cost of the laminate.

Fiberglass pipe is competitive with many conventional pipe materials on an as-installed basis and is considerable lower in cost than other engineering materials offering equivalent corrosion resistance and service life (Reference 2).

Only polyester resin is specified for underground storage tanks of glass fiber reinforced plastic in MIL Spec. MIL-T-5277A.

The National Bureau of Standards specification NBS-PS-15-69 has been adopted by industry to guarantee consistent quality of custom contact molded reinforced polyester process equipment.

Over 40,000 UL-listed Fiberglass (Owens Corning) fuel tanks are in service in every state from Maine to Hawaii.



Suitability of polyester resins for use in various soils and chemical environments is well-documented (Reference 3).

Balsa wood core material was selected for FRP panels of sandwich construction. Balsa was selected as the most suitable sandwich panel core material (over e.g. plastic foams, and honey-combs) for the following major reasons:

- a) High available strength at minimum cost.
- b) Maintenance of mechanical properties over a broad temperature range.
- c) Wide usage and availability.

The forms of commercially available fiberglass reinforcement selected for the polyester resin were woven roving, mat and chopped fibers. Use of fiberglass cloth was not considered suitable because of its higher relative cost.

### 3.2 PROPERTIES

Typical strengths of fiberglass reinforced polyester resin laminates are listed in Table 2.

Typical strengths of Balsa FRP sandwich core material are listed in Table 3.

TABLE - 2







TYPICAL STRENGTH PROPERTIES OF  
AROPOL 7241 TYPE LAMINATES  
AT ROOM TEMPERATURE

(Provided by Ashland Chemical Co., Resins and Plastics Div., Columbus, Ohio)

	<u>1/8"</u>	<u>1/4"</u>	<u>ASTM TEST</u> <u>METHOD</u>
% Glass	24	43	
Tensile Strength, psi	10,400	20,800	D638
Tensile Modulus x 10 <sup>6</sup> , psi	1.3	1.8	D638
Tensile Elongation, %	1.2	1.6	D638
Flex Strength, psi	14,000	30,300	D790
Flex Modulus x 10 <sup>6</sup> , psi	0.7	1.5	D790
Compressive Strength, psi	--	32,000	D695

TABLE 3

PHYSICAL PROPERTIES OF Balsa FRP Sandwich Core

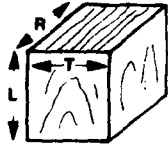
Specific gravity	.0962	.128	.176	.248
	<b>Compressive Strength (lbs./sq.in.)</b>			
	A. Parallel to grain (end grain) — Stress at proportional limit 500 930 1.450 2.310 — Maximum at crushing strength 750 1,380 1,910 2,950 — Modulus 330,000 480,000 768,000 1,164,000			
	B. Perpendicular to grain (flat grain) — Stress at proportional limit High strength value 84 115 144 198 Low strength value 50 75 100 145 — Modulus High strength value 16,000 24,400 37,000 55,000 Low strength value 5,100 8,260 13,000 19,900			
	<b>Bending Strength (lbs./sq. in.)</b>			
	Static bending — Stress at proportional limit 825 1,250 1,725 2,535 — Modulus of rupture 1,375 2,200 3,050 4,525 — Modulus of elasticity 280,000 425,000 625,000 925,000			
	<b>Tensile Strength (lbs./sq. in.)</b>			
	A. Parallel to grain (end grain) — Maximum 1,375 1,850 3,050 4,525			
	B. Perpendicular to grain (flat grain) — Maximum: high strength value 112 140 170 223 low strength value 72 95 118 156			
	<b>Toughness (inch pound per specimen)</b>			
	High strength value 125 200 310 475 Low strength value 120 180 267 400			
	<b>Shear (lbs./sq. in.)</b>			
	High strength value 180 265 360 522 Low strength value 158 235 298 425 Modulus 14,450 21,400 31,800			
	<b>Hardness (lbs.)</b>			
	Load required to embed a .444" ball to one half its diameter A. Parallel to grain (end grain) 102 170 250 386 B. Perpendicular to grain (flat grain) — High strength value 50 83 120 186 — Low strength value 47 73 103 151			
	<b>Cleavage (lbs./sq. in. of width)</b>			
	Load to cause splitting — High strength value 56 61 70 87 — Low strength value 37 47 63 86			
	<b>Coefficient of Linear Expansion</b>			
	Tangential			
	Radial			
	Longitudinal			
(inch per inch per °F)				$8.60 \times 10^{-6}$ (0.00000860) $6.92 \times 10^{-6}$ (0.00000692) $1.99 \times 10^{-6}$ (0.00000199)

(Provided by Baltek Corp., Northvale, NJ)

## CHAPTER 4

### CONCEPTUAL DESIGN STUDIES

#### 4.1 ARCH

An intensive design review was made of the present corrugated steel plate oval arch and concrete slab magazine configuration shown in Figure 1.1. Retention of the concrete floor slab and arch foundations was considered to be most cost effective with corrosion protection provided by presently specified drains and barriers.

An FRP semi-circular arch configuration was selected to replace the present magazine multi-radius, steel oval-arch section. This configuration was selected because of its high efficiency in resisting the external pressure applied by the earth embankment which is placed over the magazine for blast protection.

The semi-circular arch section is formed by two equal arc length FRP panels extending from the footings to the top center of the arch. This arrangement provides the following considered advantages:

- a. All panels are identical and can be manufactured from one basic mold.
- b. Field assembly labor is minimized because only one circumferential panel joint is employed per panel.
- c. Individual panel size and configuration permit ready shipment by truck, rail, air or water.

An arch radius of 15 feet was established because it provides a magazine internal volume approximately equal to that of the present design. A magazine internal volume comparison is shown in Figure 4.1.

Because the modulus of elasticity of FRP is generally lower than that of steel, various FRP panel cross sections with increased moments of inertia were investigated to insure stability of the 30 foot span arch. Several of the semi-circular arch panel cross section conceptual designs developed for subsequent cost evaluation are shown in Figure 4.2.

#### 4.2 END WALLS

The present steel arch magazine employs reinforced concrete end

walls at the entrance and rear. As shown in Figure 4.3, the concrete rear wall is earth-covered and its top edge is formed to match the radii of the steel oval arch. As shown in Figure 4.4, the entrance end wall extends above the steel oval arch and retains the end of the earth embankment over the arch. The entrance wall also includes wing walls for the sloped embankment portions at both sides of the steel oval arch.

Several end wall conceptual designs employing FRP panels were developed for subsequent evaluation. These design concepts are shown in Figure 4.5.

Two conceptual designs (flexible and rigid) were developed for the connection between the FRP end walls and adjacent arch panel edges as shown in Figures 4.6 and 4.7. The flexible connection design employed a standard roof expansion joint (recommended by Johns Manville Corp.) and an FRP protective cover as shown in Figure 4.6. The flexible sealing strip and installation clearance dimensions shown permit relative motion between the arch panels and end walls during and after placement of the earth embankment over the magazine. The edge sealing strip would be adhesive bonded to the magazine end walls and arch panels. Tape would be used to hold the edge sealing strip in place during curing of the adhesive.

The rigid connection design consists basically of an adhesive filled socket as shown in Figure 4.7.

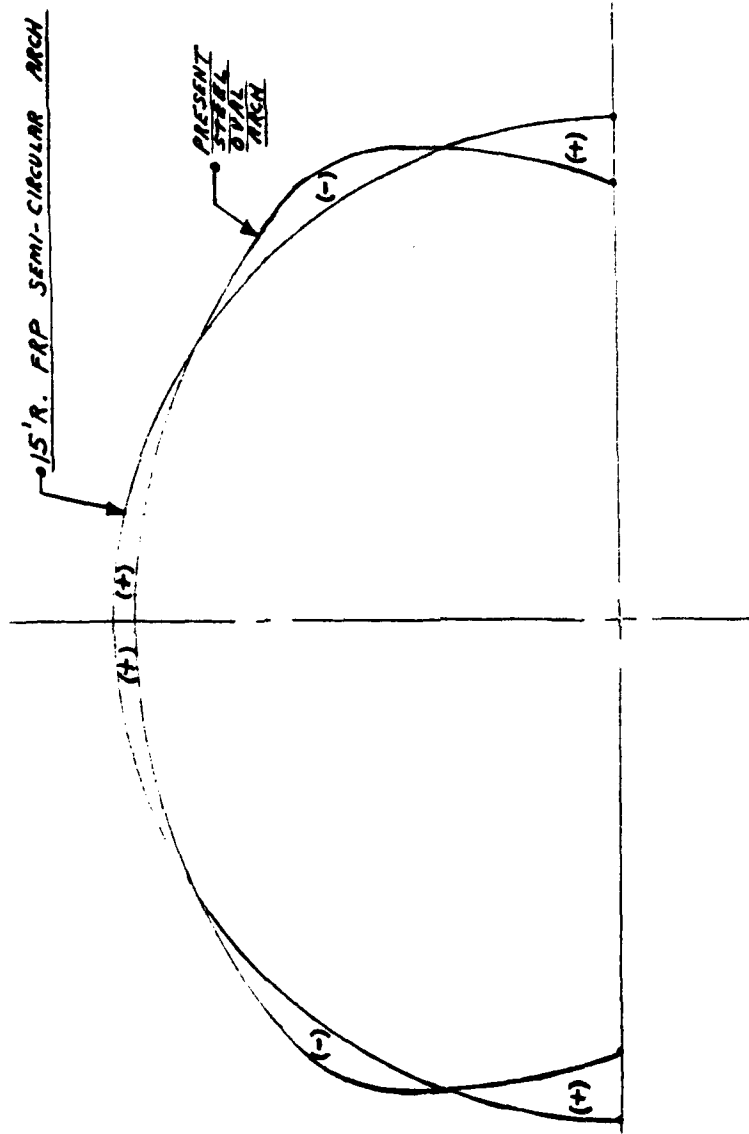

FIGURE 4.1  
MAGAZINE INTERNAL VOLUME COMPARISON

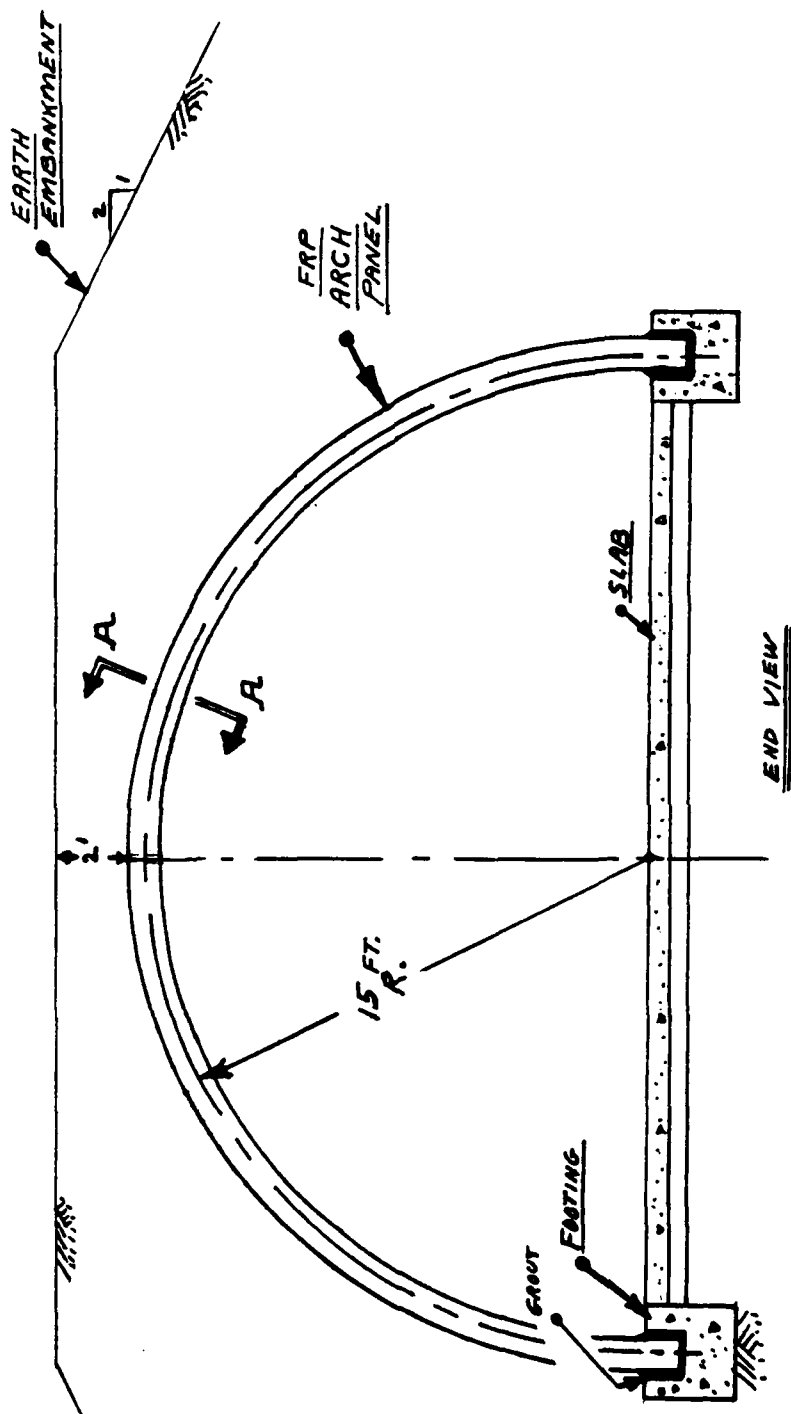
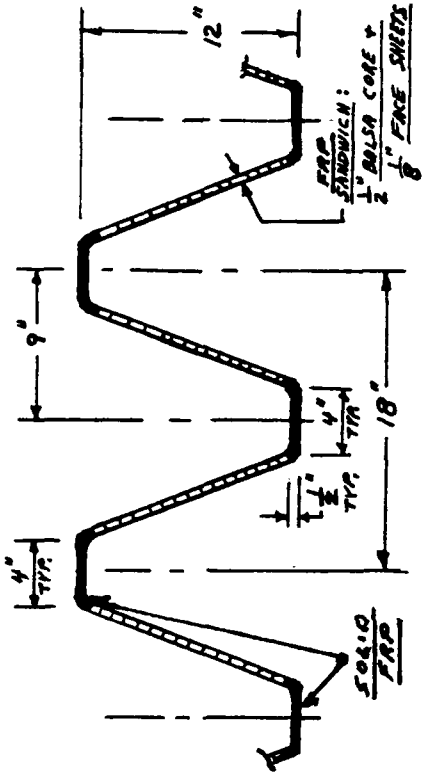
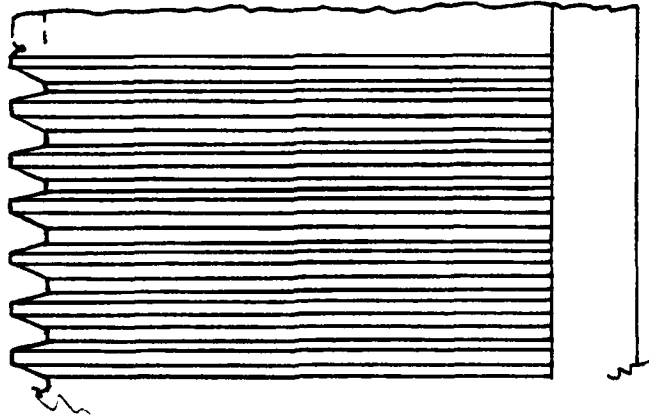

FIGURE 4.2 SH. 1 OF 4  
ARCH PANEL CROSS SECTION CONCEPTS



SECTION A-A

(FROM SH.1)



SIDE VIEW

FIGURE 4.2 SH 2 OF 4



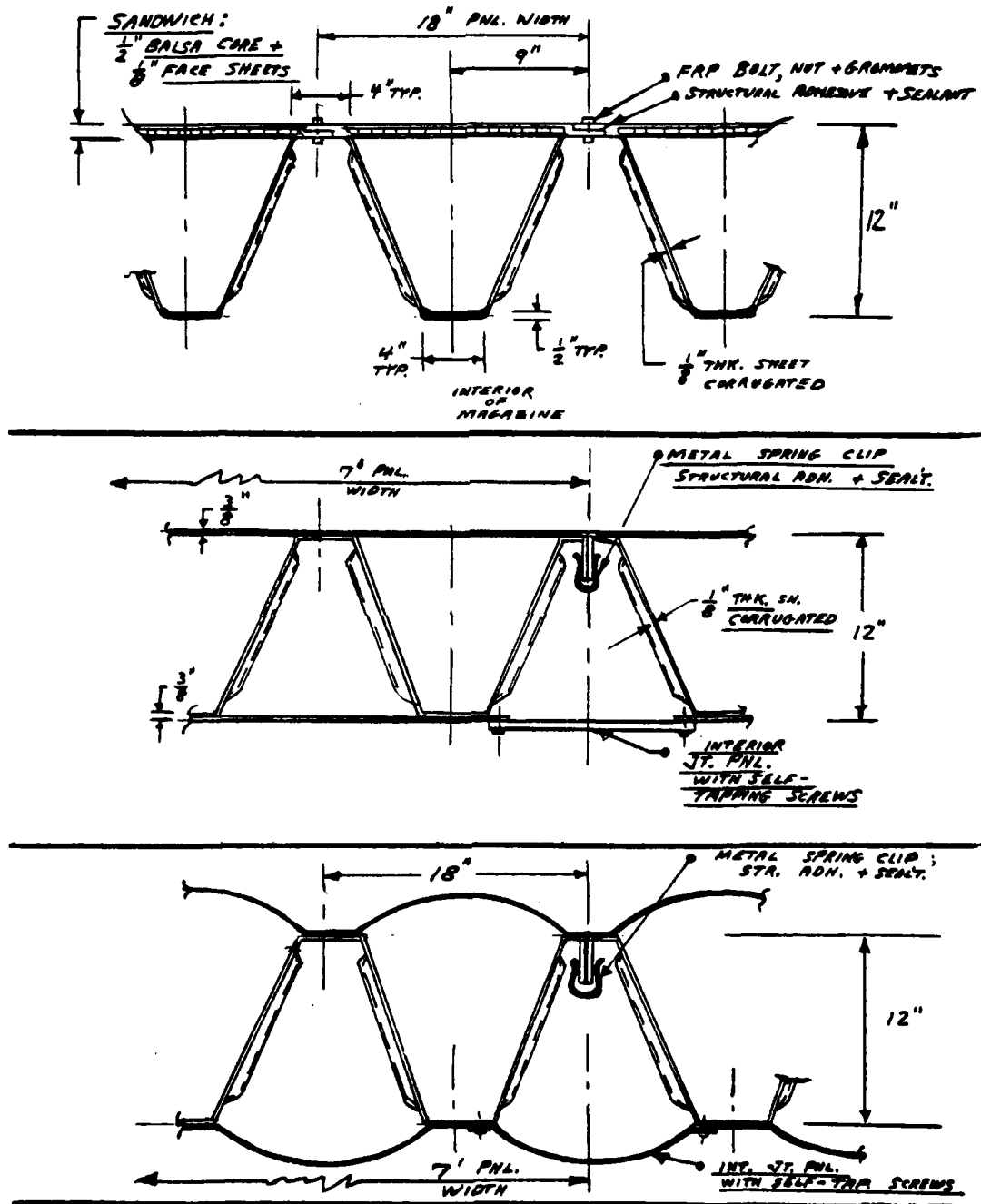

FIGURE 4.2 SH 3 OF 4  
 ALTERNATES TO SECTION A-A ON SH. 2

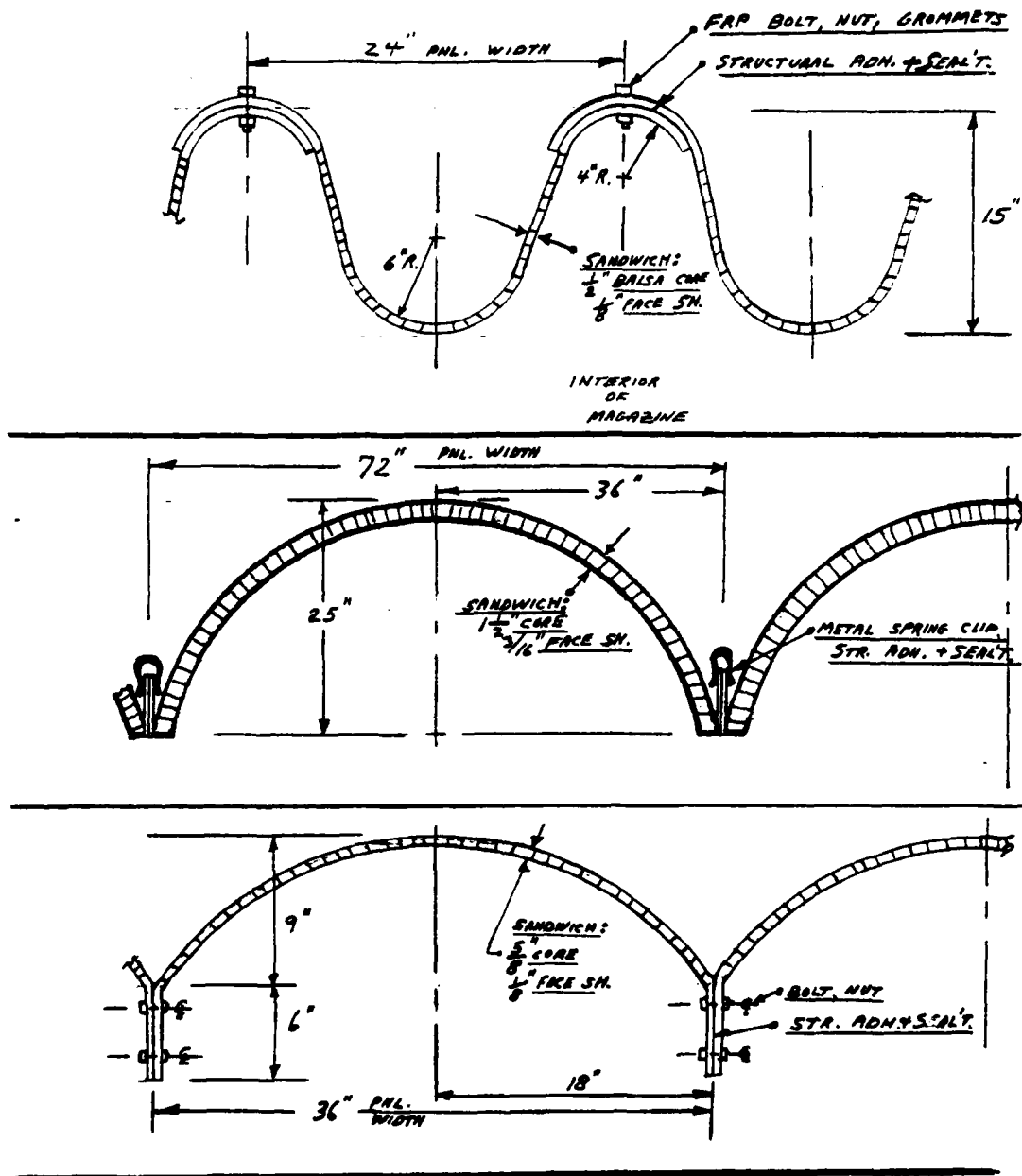
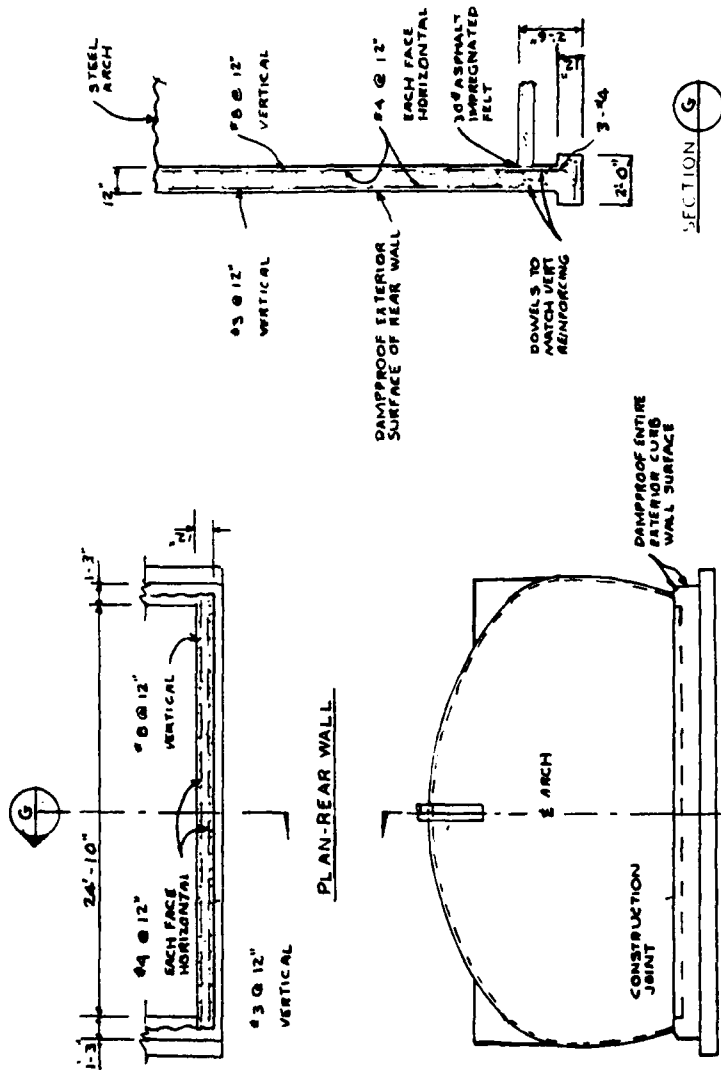

FIGURE 4.2 SH. 4 OF 1  
 ALTERNATES TO SECTION A-A ON SH. 2

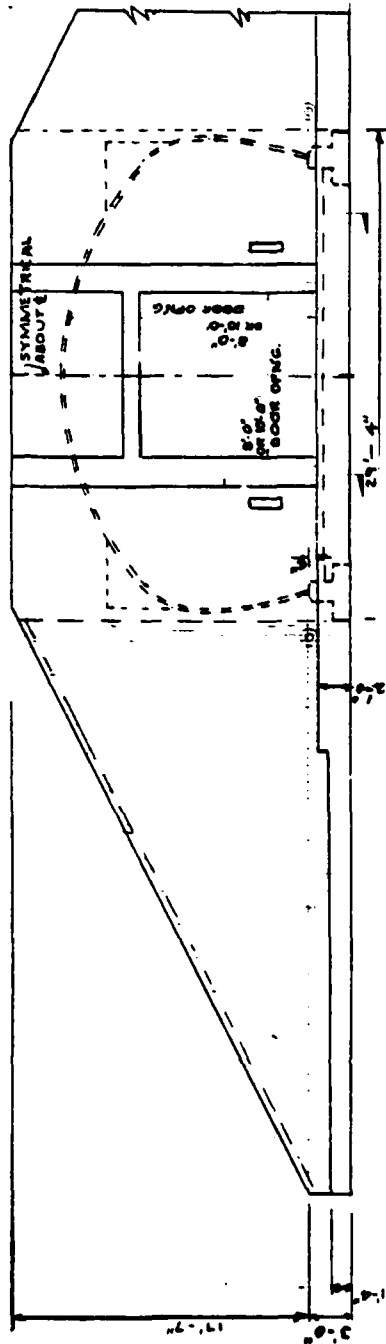

**FIGURE 4.3**  
**PRESENT MAGAZINE REAR WALL**  
 (OCE DWG. NO. 33-15-73)

ELEVATION REAR WALL

PLAN-REAR WALL

SECTION G-G



PARTIAL ELEVATION PORTAL WALL

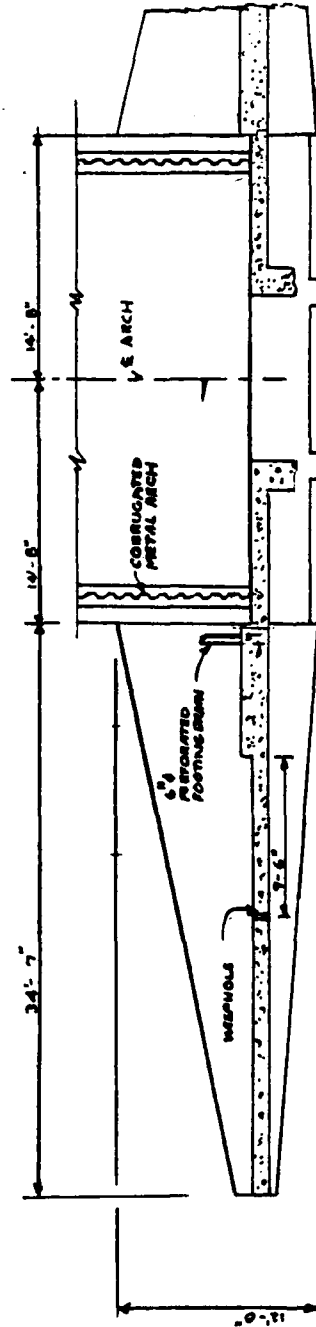
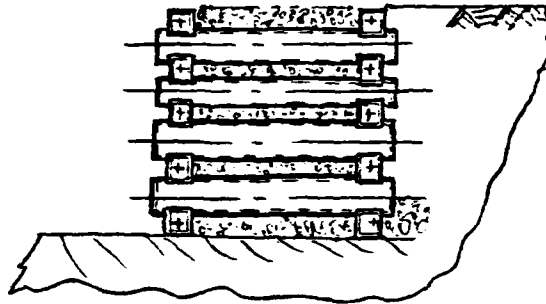
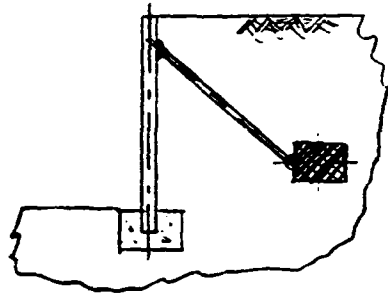

FIGURE 4.4 PRESENT MAGAZINE ENTRANCE WALL (OCE DWG. NO. 33-15-73)



M-1-  
FRP BOX SECTIONS  
USED AS  
CONVENTIONAL  
FILLED CRIB  
WALL



M-2-  
GUY-ANCHOR  
SUPPORTED  
FRP WALL

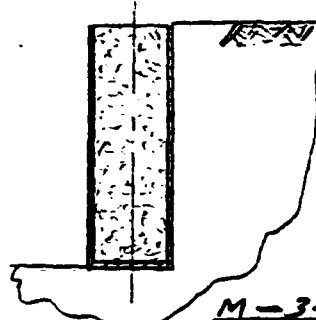

M-3-  
EARTH-FILLED  
FRP-PIPE OR  
RECT. BOX  
WALL

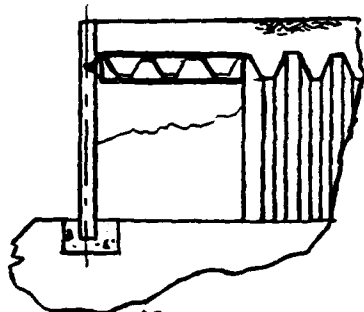

M-4-  
SEMI-CIRC. ARCH END  
PANEL WITH FRP  
SHEETS RODED TO  
FORM BOX CURVED FOR  
FR WALL SUPPORT



M-5-  
CANTILEVERED  
FRP U-PANEL  
WALL

FIGURE 4.5 FRP END WALL DESIGN CONCEPTS (SH. 1 OF 2)

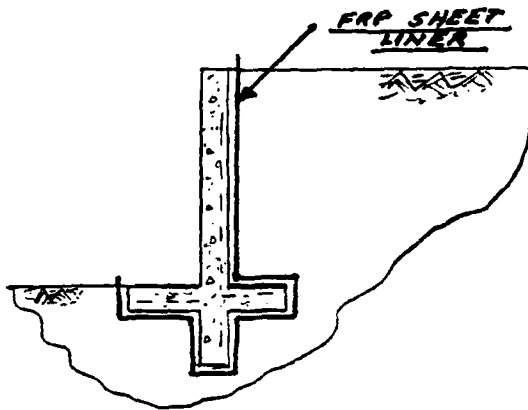

N-6  
FRP SHEET  
LINER ON  
REINF. CONC.  
WALL

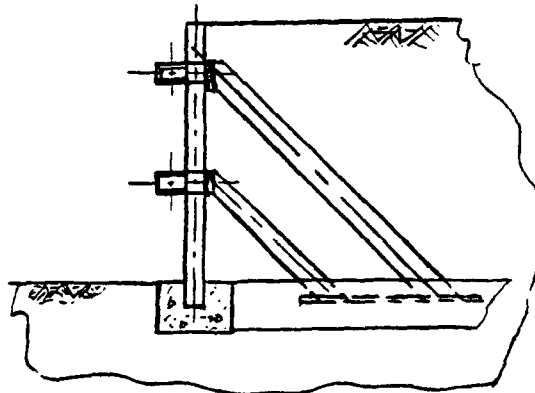

N-7-  
END WALL  
LATERALLY  
SUPPORTED  
BY HORIZ.  
BEAMS +  
END DIAGONAL  
BRACES

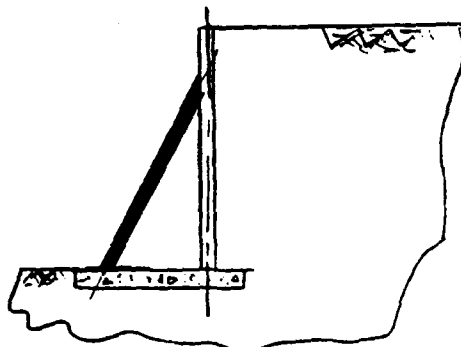

N-8-  
END WALL  
- STAY  
SUPPORTED

FIGURE 4.5 (SH. 2 OF 2)

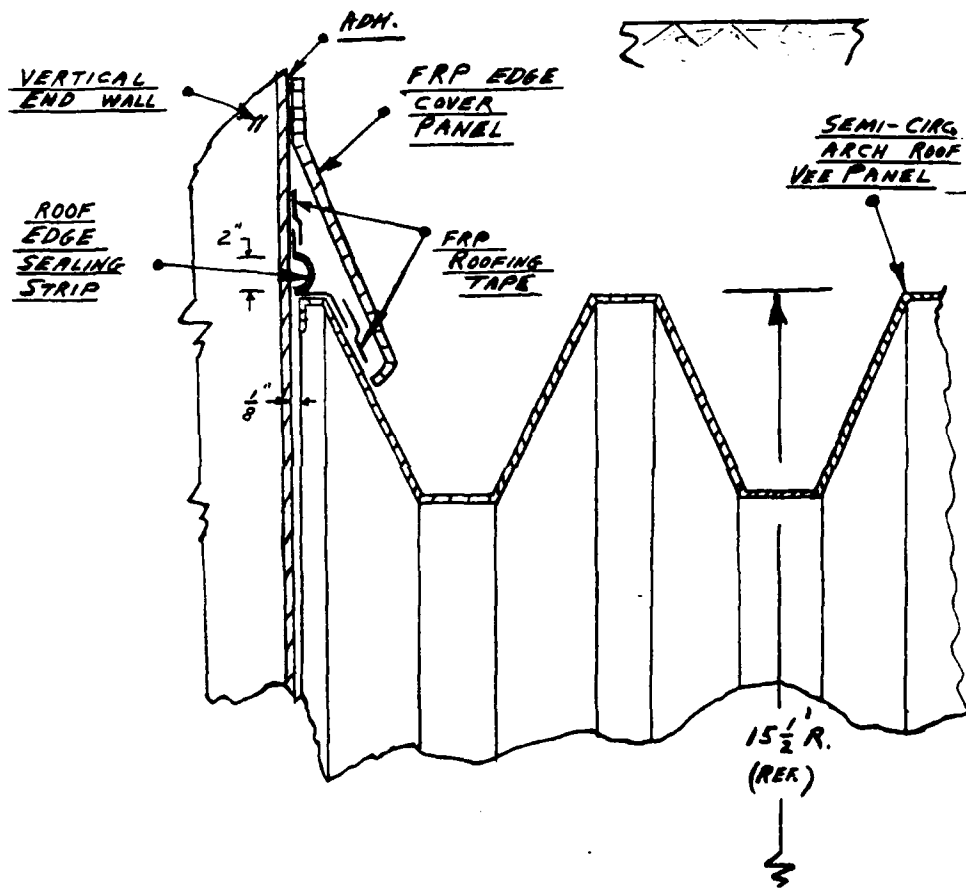

FIGURE 4.6 FLEXIBLE END WALL/ARCH EDGE JOINT CONCEPT

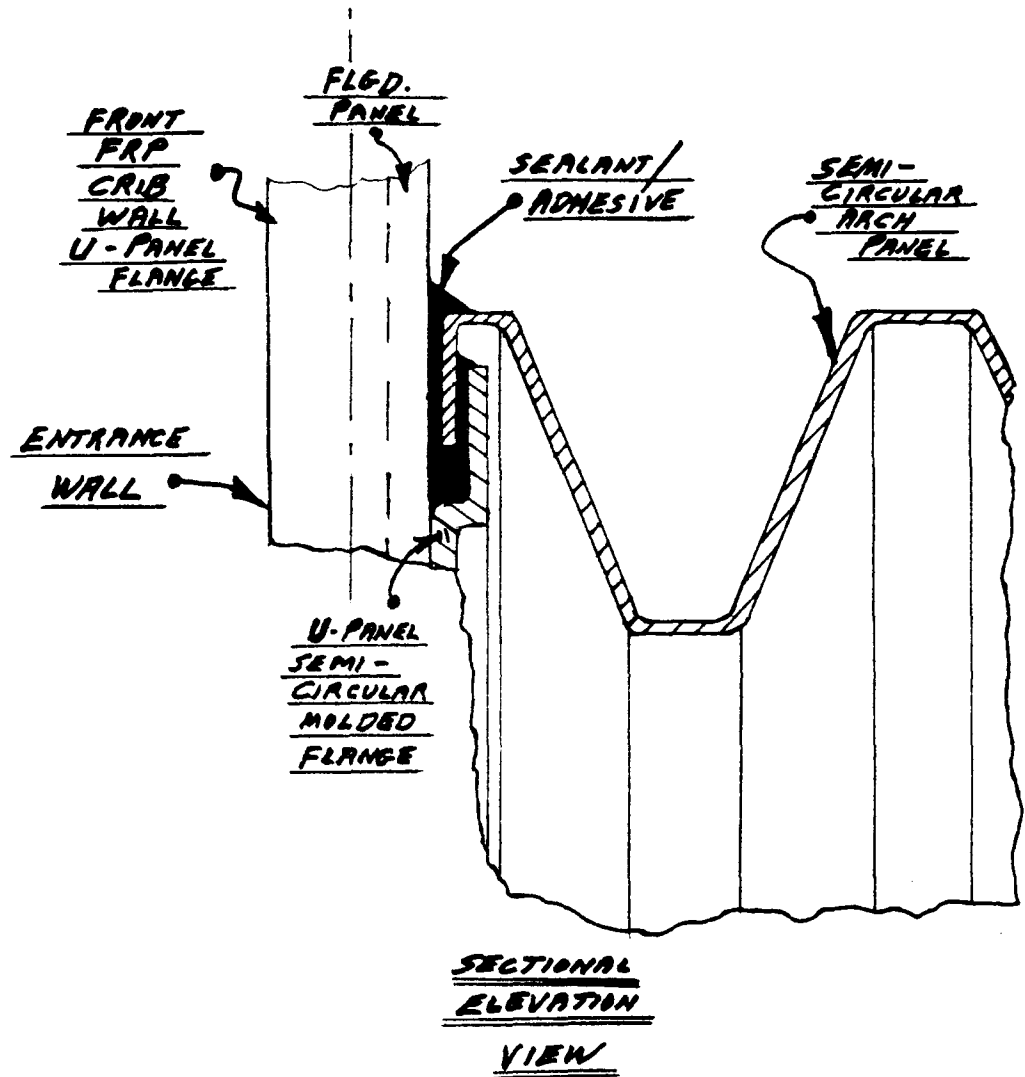
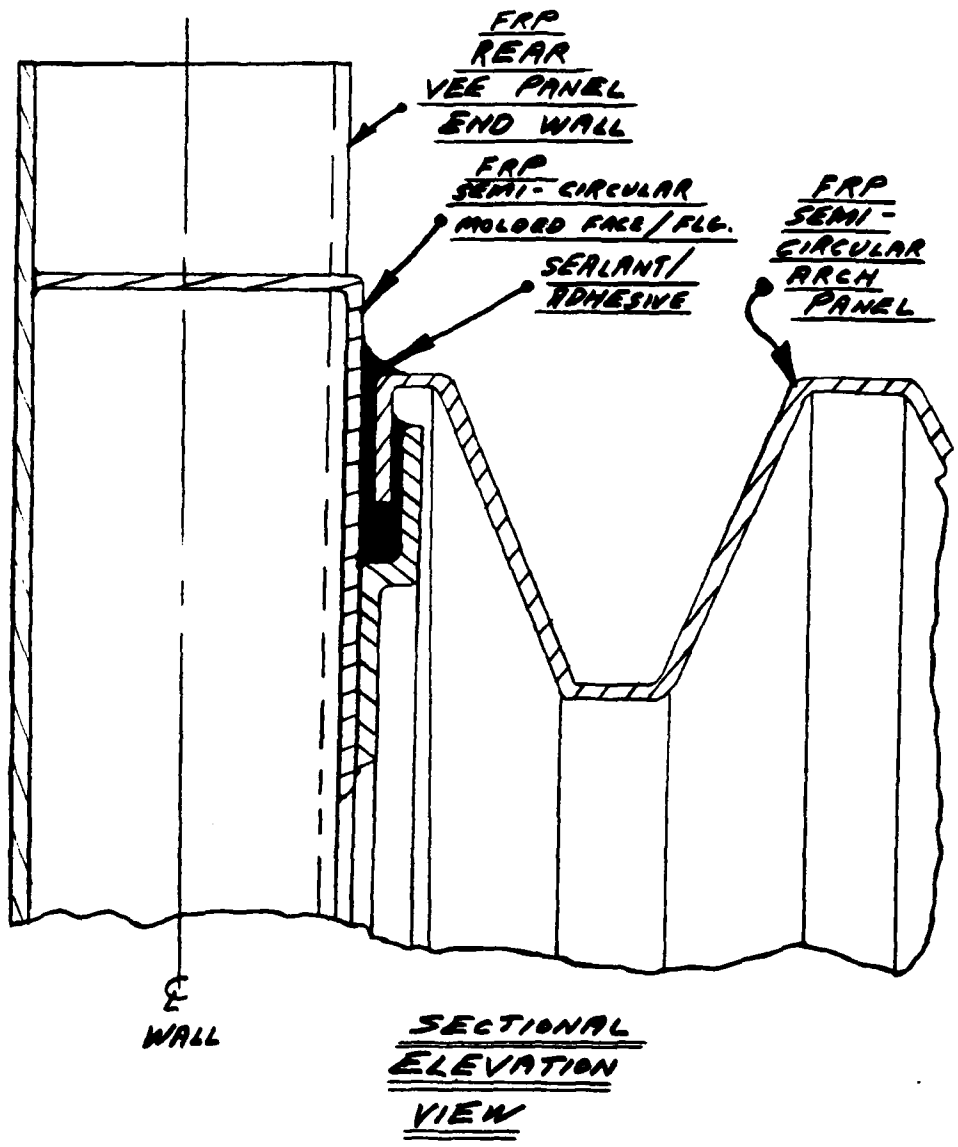

FIGURE 4.7 RIGID END WALL/ARCH PANEL EDGE JOINT CONCEPT (SH. 1 OF 2)

SEMI-CIRCULAR ARCH  
JOINT DETAIL  
AT ENTRANCE WALL





SEMI-CIRCULAR ARCH  
JOINT DETAIL  
AT REAR WALL

FIGURE 4.7 (SH. 2 OF 2)

## CHAPTER 5

### FRP MAGAZINE DESIGN

#### 5.1 CONFIGURATION

The FRP magazine configuration developed as an alternative to the specified present steel oval arch structure is shown in Figure 5.1. The magazine is constructed completely of FRP panels except for the internal concrete floor slab and arch foundations.

Site preparation, concrete floor slab, arch foundations, drains, capillary water barrier, subgrade and vapor barrier requirements would be similar to those presently specified on OCE drawing no. 33-15-73.

#### 5.2 ARCH

The selected FRP semi-circular arch panel design has the squared-vee cross-section as shown in Figure 4.2, sheet 2. The panel consists of solid FRP at the top and bottom horizontal portions of the vee, and balsa core FRP sandwich construction on the inclined portions.

The panel vee cross section was selected over the other concepts developed because it was considered to offer the following advantages:

- a. Efficient use of material.
- b. Minimal required manufacturing labor and forms.
- c. High nestability for reduced shipping volume.
- d. Symmetrical cross section efficient in bending.
- e. Minimal reduction of magazine useful internal volume.

These 90 degree arc length by 7<sup>1</sup>/<sub>2</sub> feet wide panels permit magazine construction to required lengths by continued placement and attachment of adjacent panels. Details of these panels are shown in Figure 5.2.

To achieve increased inherent stability of the arch, the lower ends of the panels are grouted at the foundations.

The connection between adjacent circumferential edges of the FRP magazine semi-circular arch panels is shown in Figure 5.3. During field erection, structural adhesive/sealant would be applied to panel edges

and then FRP wedge blocks would be driven over the edges as shown (approx. 6" apart) to maintain panel alignment during curing of the adhesive/sealant. The wedge blocks and adhesive/sealant would be applied by workers standing on portable staging located on the magazine floor slab.

The top connection between adjacent pairs of semi-circular arch panels is shown in Figure 5.4. This panel end joint design employs a socket molded into one end of the panel as shown in Figure 5.5. During field erection, the straight panel ends would simply be inserted and adhesive bonded within the opposite panel socket ends. Major features of this connection are: its effective utilization of adhesive lap shear strength; direct load paths and minimal required field assembly labor. Similar adhesive bonded socket joints are successfully employed on standard FRP underground units such as piping and prefabricated manhole panels.

The rigid connection between the FRP end walls and adjacent arch panel edges as shown in Figure 4.7 was selected over the alternate flexible design concept, after subsequent detailed analysis, because of its considered superior reliability.

### 5.3 REAR WALL

The design of the FRP magazine rear wall is shown in Figure 5.6. This wall consists of vertical vee panels similar in cross section to the semi-circular arch panels. The top ends of these vertical panels extend approximately 12" above the semi-circular arch panels. The vertical panels are designed for the lateral soil pressure exerted by the embankment. They are supported horizontally by the edge of the floor slab and by the earth embankment annulus beyond the outer edge of the arch panels. Manually tamped cohesionless back fill would be located at the outer edge of the panels as shown. The complete wall would be formed by placement of adjacent vertical panel sections. Edges of adjacent panels would be adhesive-bonded as the arch panels. The bottom of the wall would

be grouted into the floor slab.

#### 5.4 ENTRANCE AND WING WALLS

The design of the FRP magazine entrance end wall and wing walls is shown in Figure 5.7. They are designed as solid face crib walls and are formed by FRP panels. The front and rear header wall panels are designed to resist lateral pressures developed in the crib when filled with soil prior to construction of the magazine embankment. The FRP front-to-back tie plates (stretcher panels) are designed for the tensile loading produced by lateral earth pressure acting on opposite header panels. A factor of safety of 1.5 on the stability of this gravity type retaining wall is obtained by spacing the front and rear header panels at a minimum horizontal distance equal to one half the height of the retained soil. The front and rear header panels are of FRP sandwich construction with a 30" span between flange stiffeners as shown in Fig. 5.7, sheet 3. The tie plates would be installed and adhesive bonded between adjacent header panel flanges. Bolts would be installed through the tie plate ends and header panel flanges to permit ready field erection and to maintain panel alignment during curing of the structural adhesive. Subsequent corrosion and loss of the steel bolts would be unimportant because, the structural adhesive would provide necessary strength. Cohesionless fill would be placed within the crib to permit drainage and to provide desired high friction and shear strength. The fill placed within the crib would also form a portion of the required magazine earth embankment. Considered advantages of this design may be listed:

- Effective utilization of materials.
- Present wing wall reinforced concrete footings are not req'd.
- Minimal required shipping volume.

Additional security protection can be easily provided in the FRP magazine entrance end wall, when necessary, by placement of expanded metal grating within the panel during molding.

Relative disadvantages of the alternative FRP end wall design

concepts shown in Figure 4.5 were determined to be as follows:

<u>Fig. No. 4.5</u>	<u>Major Relative Disadvantage</u>
M -1-	Requires larger quantity of material.
M -2-	Anchorage reliability is highly dependent on competent compaction of backfill.
M -3-	Requires larger quantity of material.
M -4-	Arch ring beam only provides support for a portion of the end wall.
M -5-	Requires larger quantity of material.
N -6-	Puncture of the FRP protective liner during improper backfilling would not be detected.
N -7,-8-	Inclined members could be damaged by construction equipment.

The FRP magazine entrance door, with a required minimum clear opening of 8' X 9'-6" high is considered to be a commercially available, fiberglass, sectional, vertically opening door assembly as illustrated by Figure 5.8.

When required, the present magazine design steel door and reinforced concrete framing can be easily incorporated in the FRP magazine entrance end wall. In the event that the present reinforced concrete end walls are required at certain magazine locations, FRP arch panel edge connections can be made as shown in Figure 5.9. These connection details are similar to those indicated on Sheet 4 of Dept. of the Army drawing 33-15-73.

#### 5.5 PANEL JOINT ADHESIVES AND SEALANTS

FRP panel joint structural adhesives and sealants selected are considered to be: cost effective, proven, and suitable for field usage on large FRP panels.

3M Co. number 5200 Scotch Seal marine bedding sealant has been selected for the arch panel/foundation joints; arch panel circumferential edge joints, and general usage. This one-part sealant forms a rubbery, extremely strong, waterproof seal. It is non-shrinking,

and is commonly used for the manufacture and maintenance of FRP boats.

H.B. Fuller Co. FRP reactive adhesive was selected for the higher stressed joints such as the arch panel edge/end wall connection, adjacent FRP panel joints in the end walls, and at the arch panel top end flanged socket joints. Major advantages of this two part product are that it is among the toughest structural adhesives and it requires no mixing in the field, because the activator is applied to one mating part and the base adhesive is applied to the opposite mating part.

#### 5.6 MANUFACTURING METHODS

Considering low to medium volume production rates (less than 25, sixty feet long magazines per year), hand lay-up and spray-up FRP manufacturing methods would be most applicable. These methods (described in Ref. 4) are commonly used for production of large, high strength parts. Associated tooling costs are relatively low and these contact molding methods are widely used and proven.

Panels produced by more automated methods such as compression molding with steel dies would not be economically feasible until panel production quantities of approximately 500, sixty feet long magazines per year are required.

#### 5.7 PACKING AND SHIPPING

Maximum FRP panel sizes were established to minimize panel joints and also to permit ready shipment from the manufacturer to world wide installations by truck, rail, ship or air. Minimal packing material, e.g., spacer blocks and strapping, would be required for these rugged FRP panels. Integral lifting attachments would be incorporated in each FRP panel to facilitate handling and field erection. Calculated maximum single FRP panel weight is approximately 1500 pounds.

Arch and end wall panels are of vee and U cross-sections and therefore can be nested compactly for minimum shipping volumes.

The shipping weight of arch panels for a 60 feet long magazine was estimated to be 24,000 pounds for FRP as compared to 41,000 pounds for the present steel plate.

#### 5.8 FIELD ERECTION PROCEDURE

Another major advantage of the developed FRP magazine design is that it employs large shop-fabricated panel sections suitable for rapid field erection. Erection of the FRP semi-circular arch panels would commence after placement and set up of the magazine concrete floor slab and arch foundations.

A portable staging would be located on the floor slab to provide convenient worker access during panel alignment and the installation of panel joint wedge blocks. Application of structural adhesives to all FRP panels edges would be readily performed at ground level prior to erection; allowing approximately 30 minute adhesive set-up time. Temporary wooden shims would be used at the base of the arch panels to facilitate panel edge alignment and to correct for any concrete footing irregularities.

Upon completion of erection of the arch panels to the edges of the end wall foundations, grouting of arch panels and footings would commence.

The vertical end wall panels would then be placed into their footings and positioned so their semi-circular molded flanges engage the end arch panel circumferential edges (see Fig. 4.7). Adjacent vertical edges of the end wall panels would then be joined and the end walls and footings would be grouted. At this time additional sealant/adhesive would be applied externally at the arch panel and end wall joints.

Installation of the remaining FRP panels of the crib type entrance wall and wing walls would also proceed.

Next, granular fill would be placed within the entrance and wing crib and on the arch panel adjacent to the top edge of the rear wall.

Placement of the earth embankment over the magazine would then continue until completion. Backfilling would be performed per present steel arch magazine requirements repeated below (Reference 5). Fill would be placed on each side of the arch and over the arch in a manner to obtain uniform loading on the sides and top of the arch. Fill would be placed in successive horizontal layers of 8 to 12 inches in loose depth.

Filling operation would commence at both magazine ends and continue uniformly towards the center.

Compaction would be accomplished by sheep-foot rollers, pneumatic-tired rollers, steel-wheeled rollers or other equipment suitable for the soil being compacted. Heavy equipment should not be run over or used for compaction of the fill directly above or closer than 6 feet to the sides of the arch, nor should heavy equipment be operated closer than 6 feet to the magazine rear wall or to the rear face of the magazine front wall. Heavy equipment for spreading and compacting backfill should not be operated closer to foundation or retaining walls than a distance equal to the height of backfill above the top of footing; the area remaining should be compacted by power driven hand tampers suitable for the material being compacted. Backfill should not be placed in wet or frozen areas and it should be free of debris, roots, frozen matter, fat clay (CH), and stones with any dimension greater than 2 inches.

#### 5.9 MAINTENANCE

No required maintenance is anticipated for the developed FRP magazine design over its required service life of 20 years.



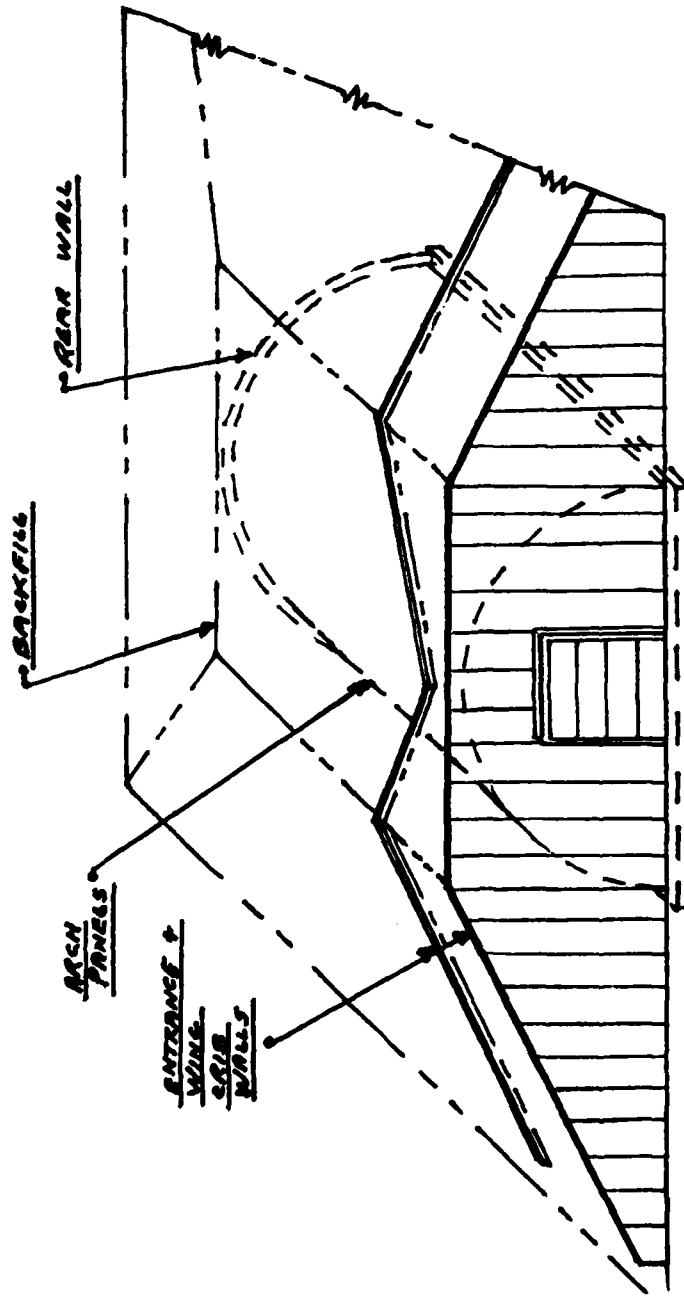

FIGURE 5.1 GENERAL CONFIGURATION -FRP MAGAZINE

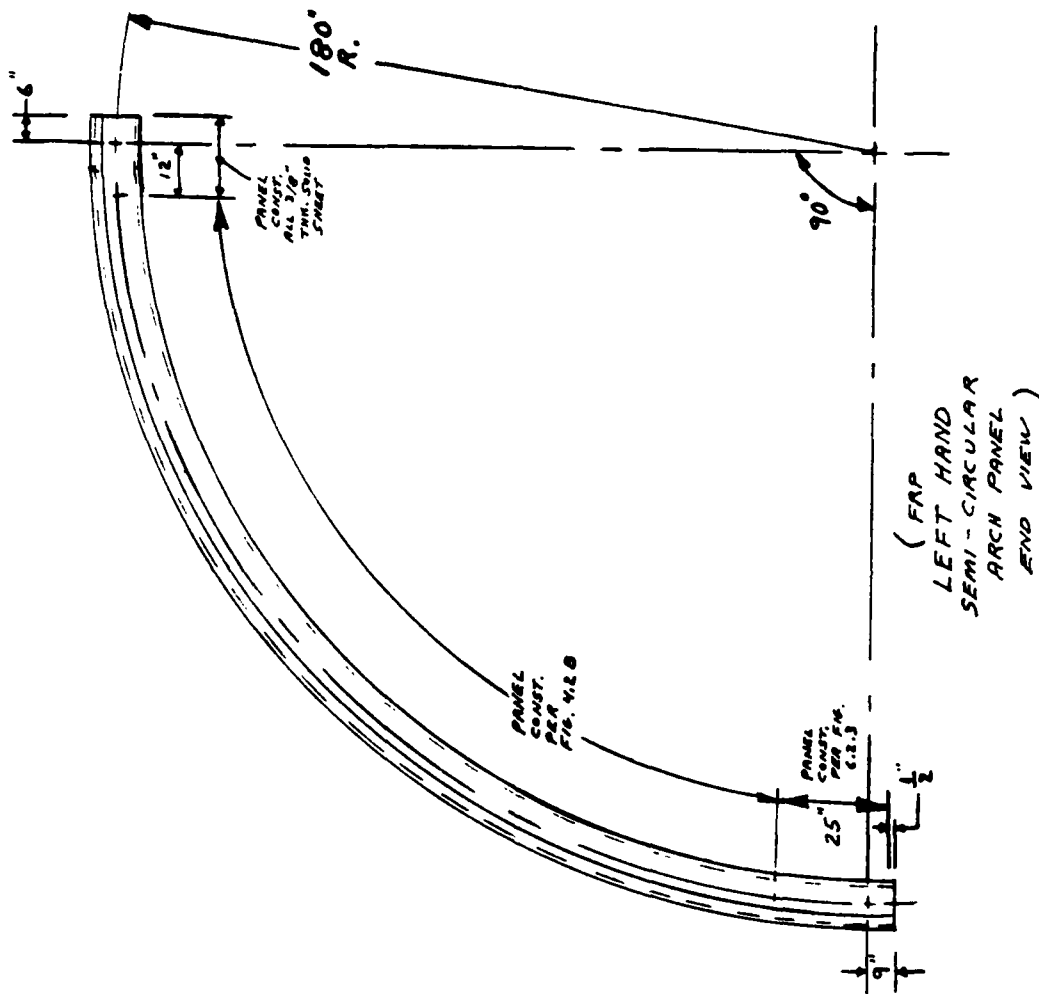

FIGURE 5.2 FFP SEMI-CIRCULAR ARCH PANEL (SH. 1 OF 3)

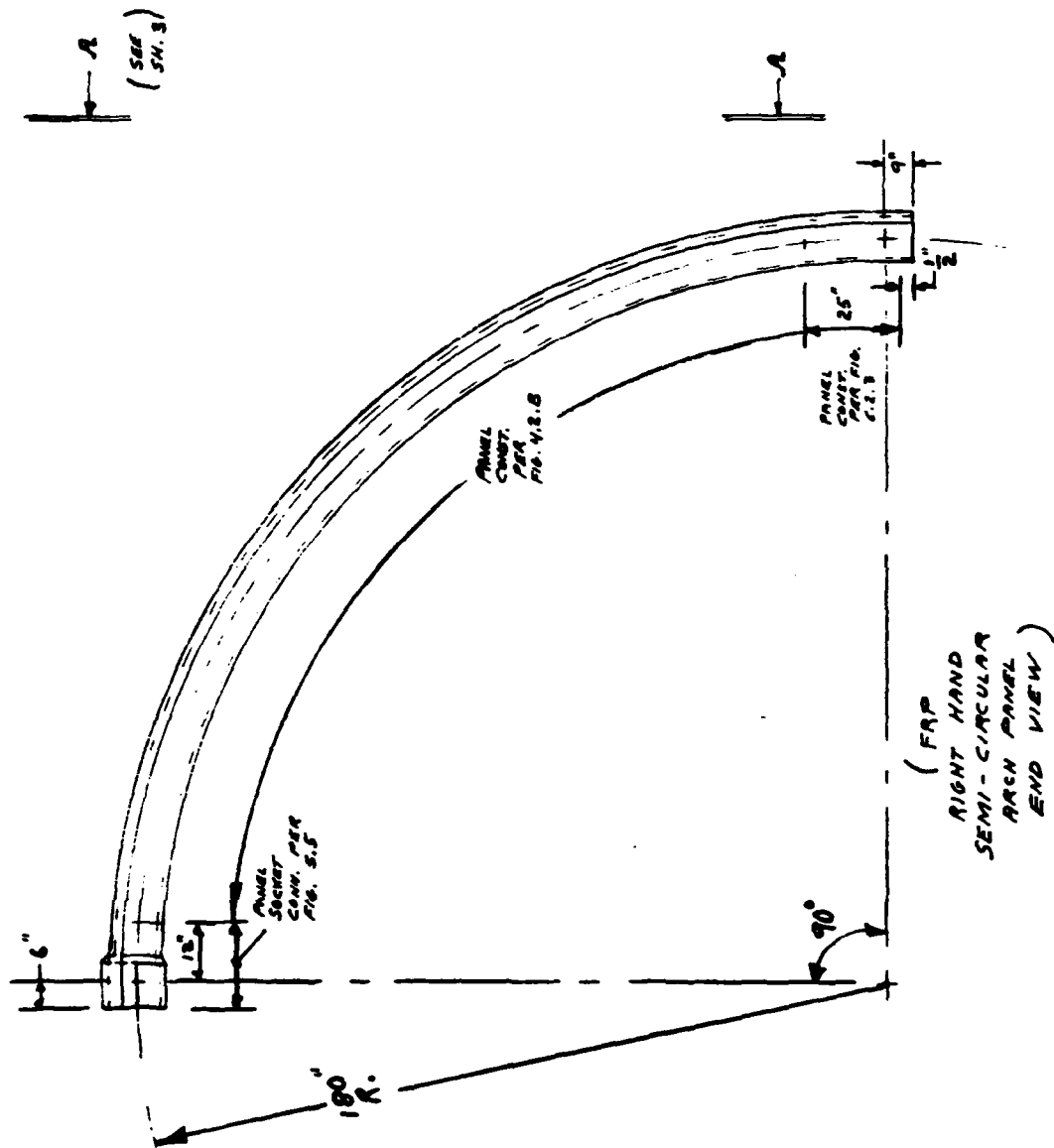
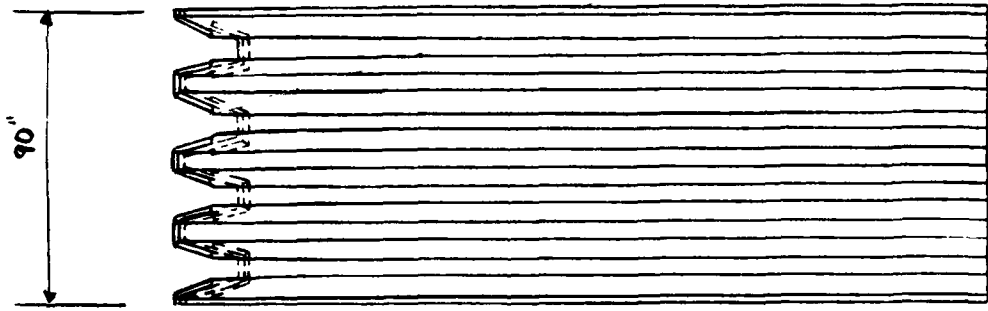

FIGURE 5.2 (SR. 2 OF 3)



SIDE VIEW A-A

FIGURE 5.2 (SH. 3 OF 3)

[ EARTH EMBANKMENT ]

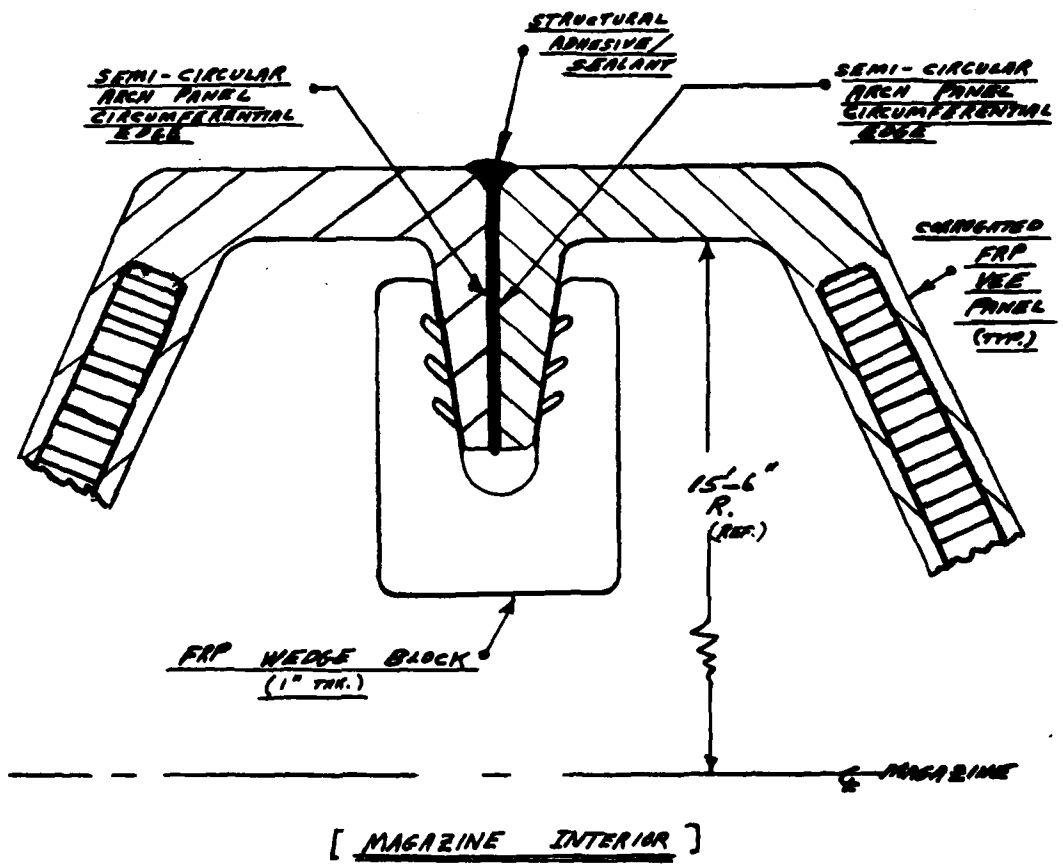

FIGURE 5.3 CONNECTION BETWEEN ADJACENT ARCH PANEL EDGES

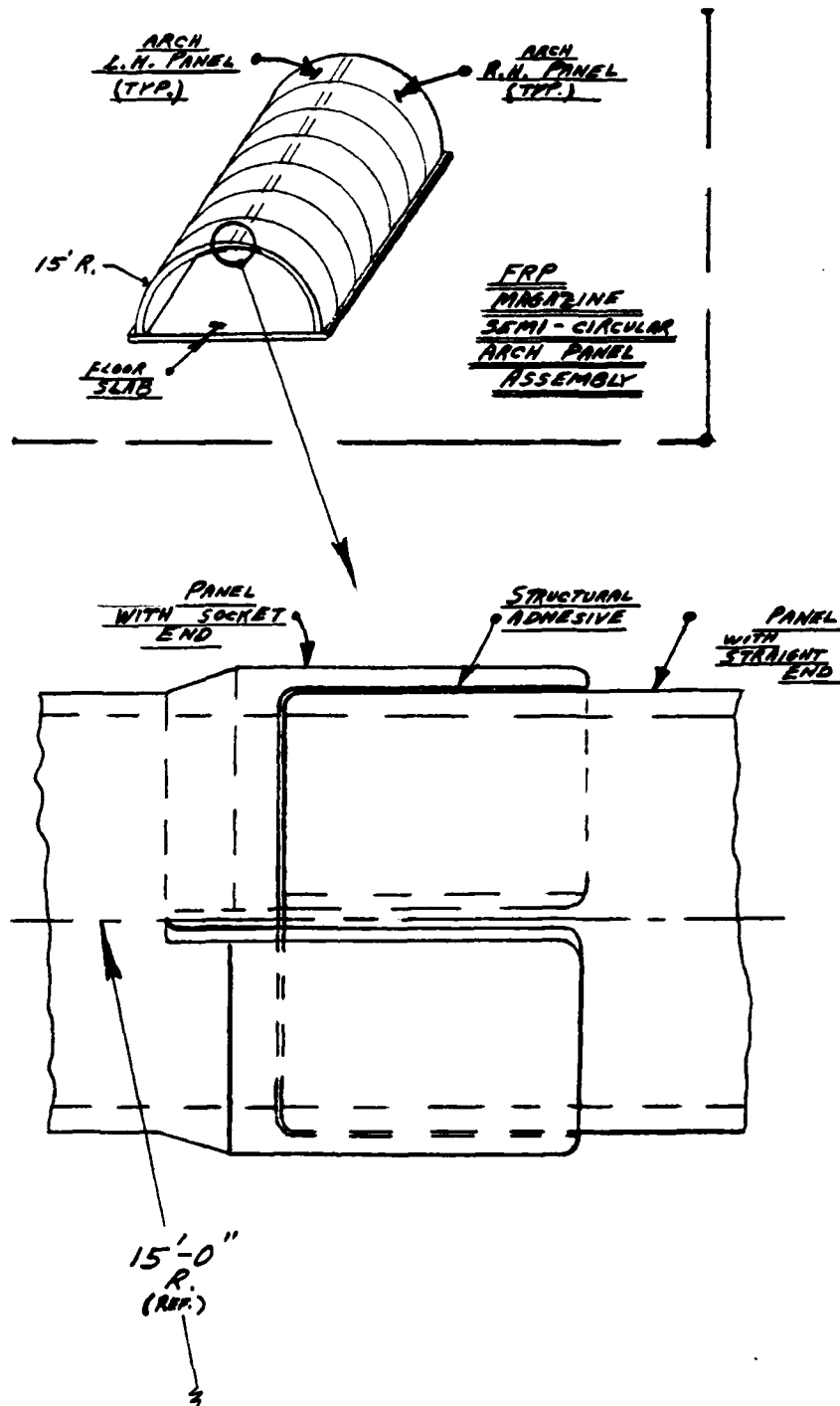
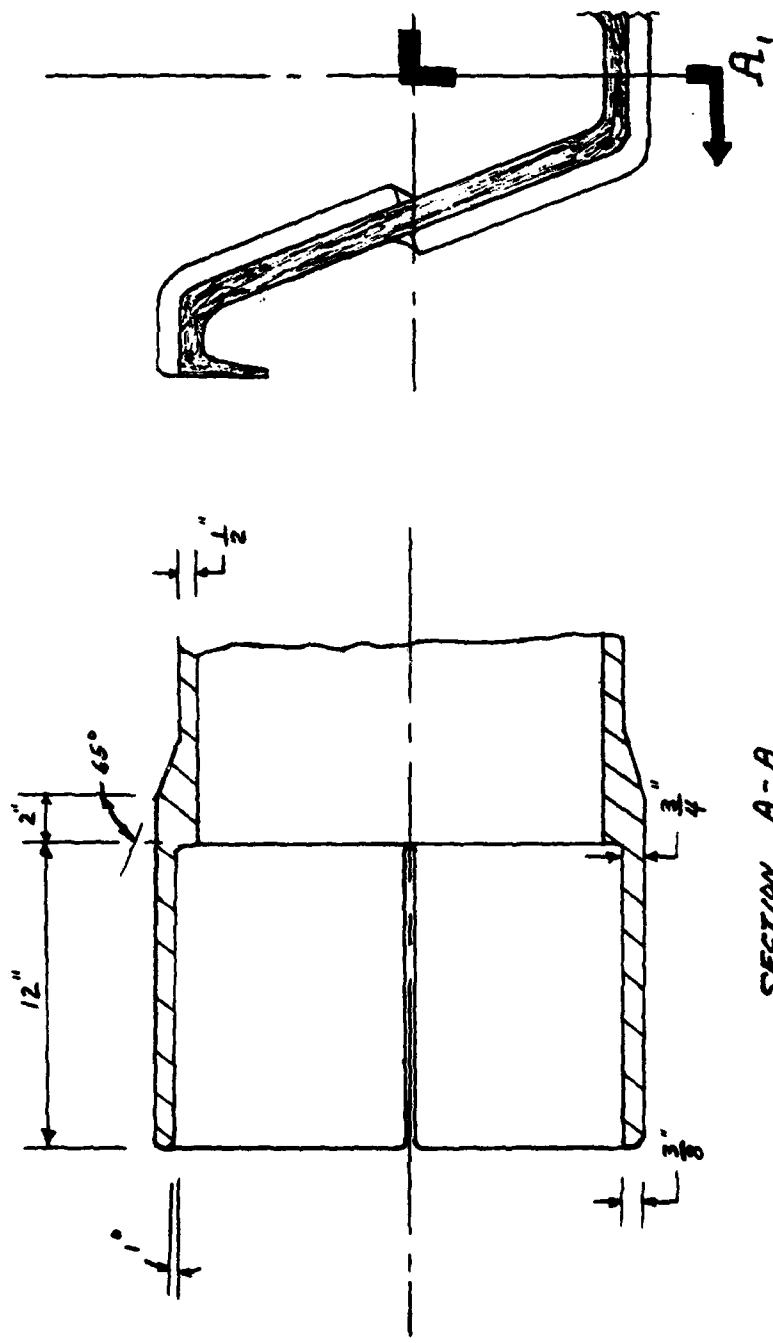

FIGURE 5.4 ARCH PANEL TOP END CONNECTION



SECTION A-A

FIGURE 5.5 ARCH PANEL END MOLDED SOCKET

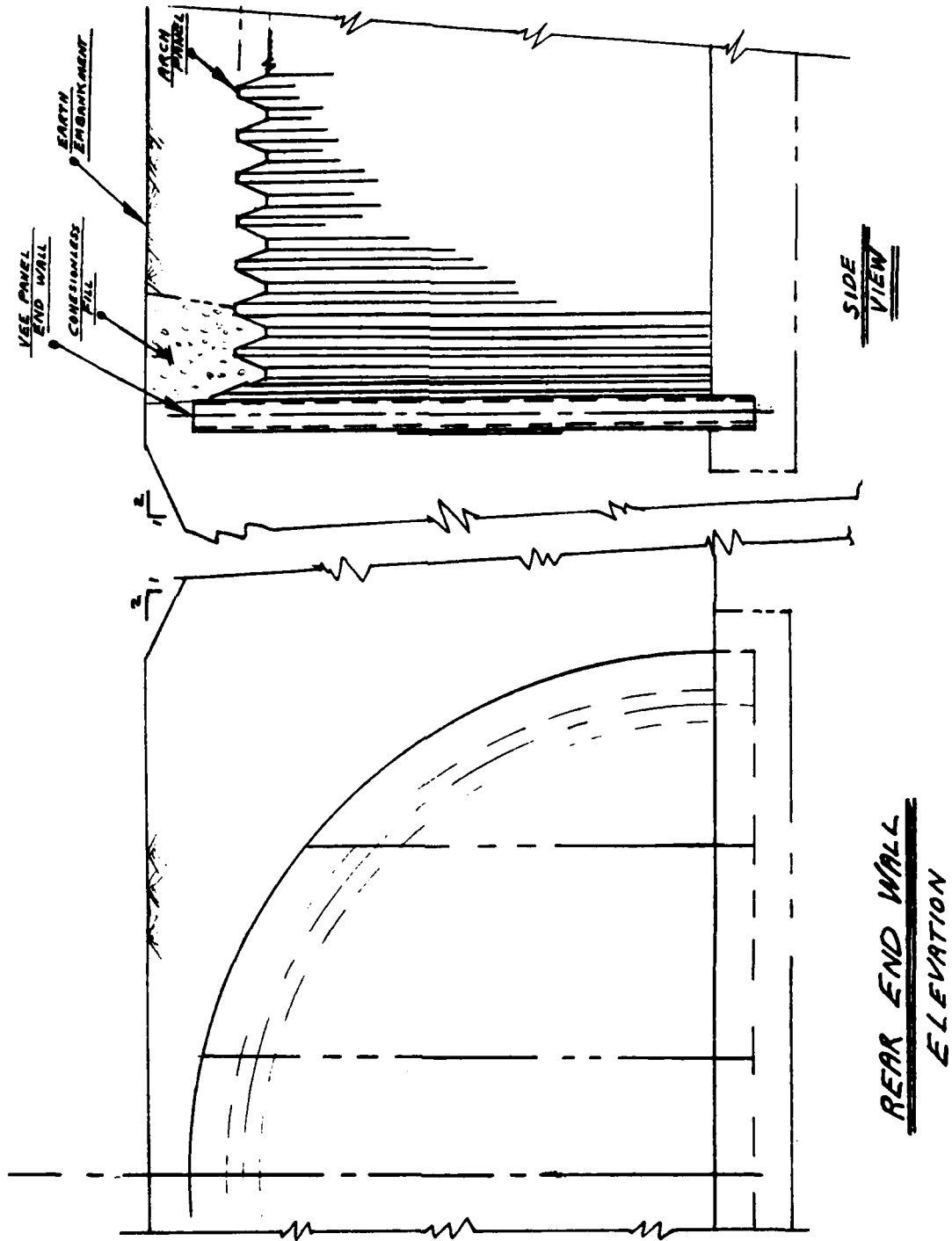

FIGURE 5.6 FRP MAGAZINE REAR WALL



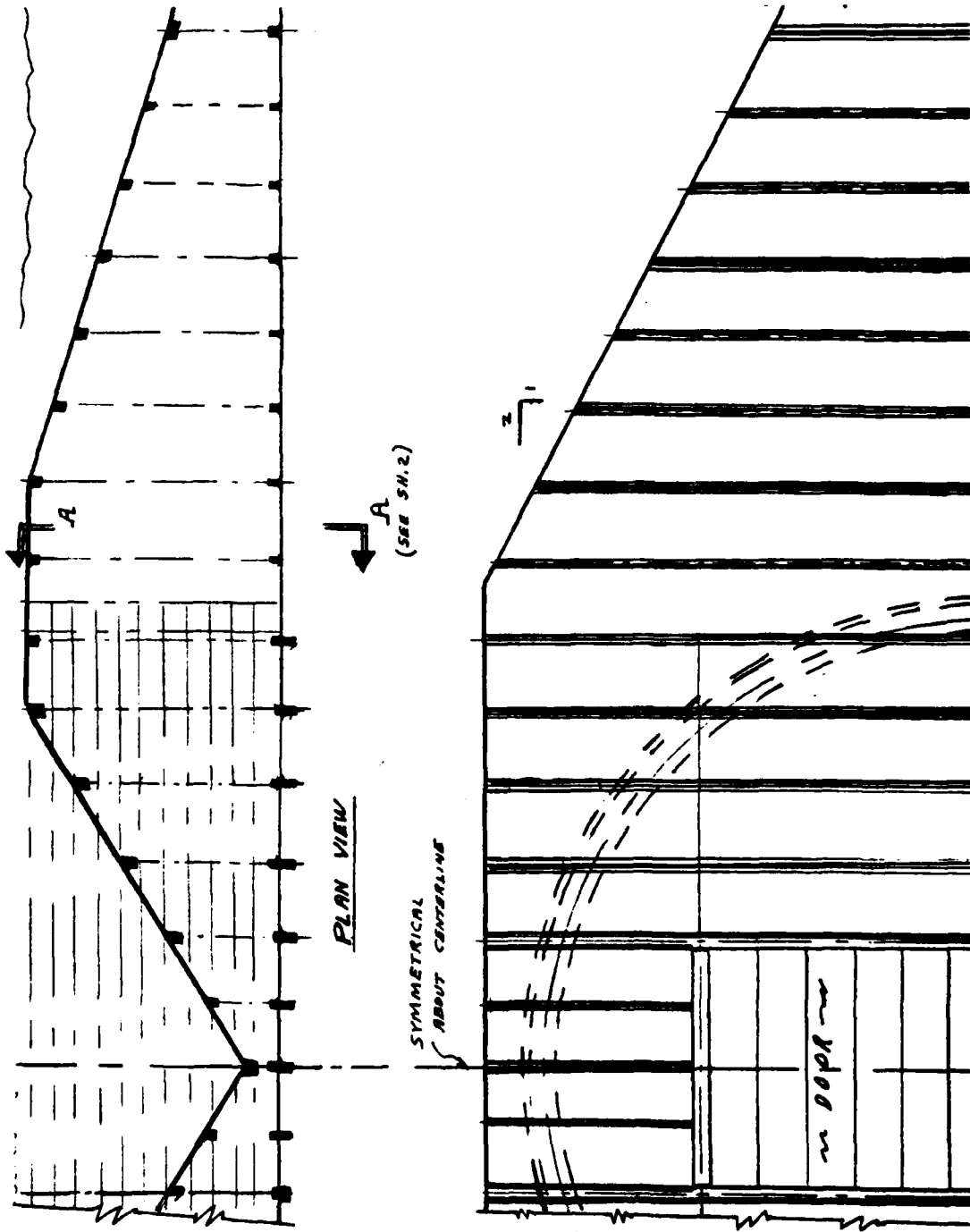
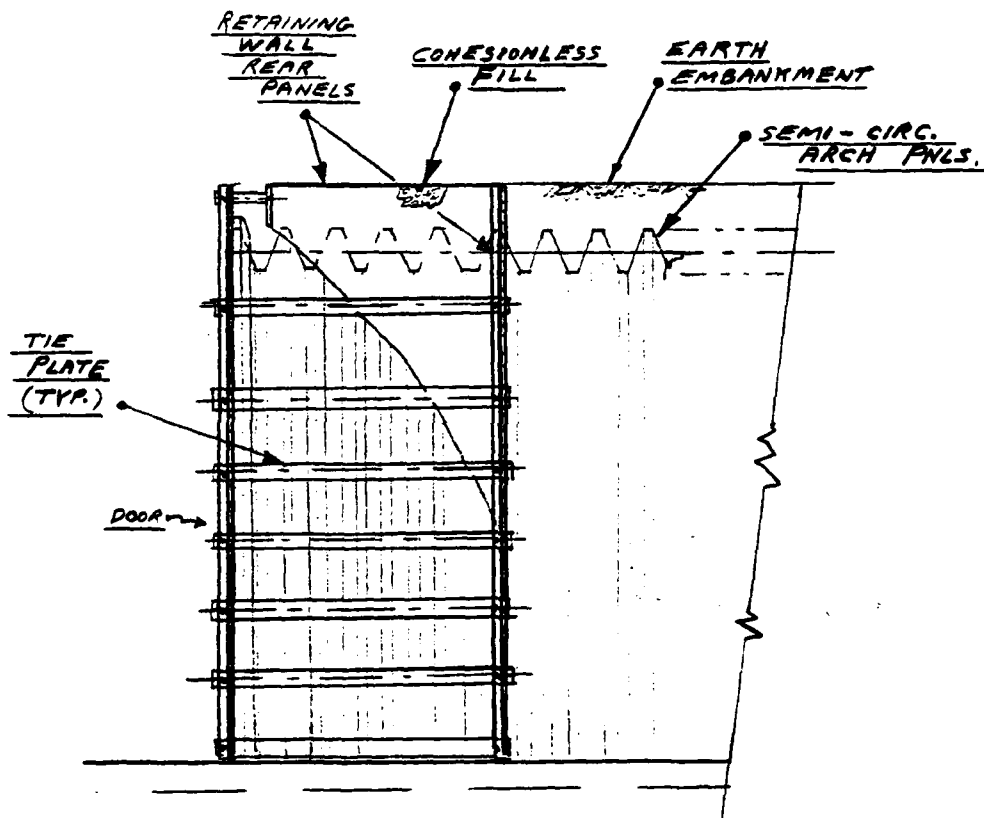

FIGURE 5.7 FRP MAGAZINE ENTRANCE AND WING WALLS (SH. 1 OF 3)



(FROM SH. 1)  
SECTION A-A

FIGURE 5.7 (SH. 2 OF 3)

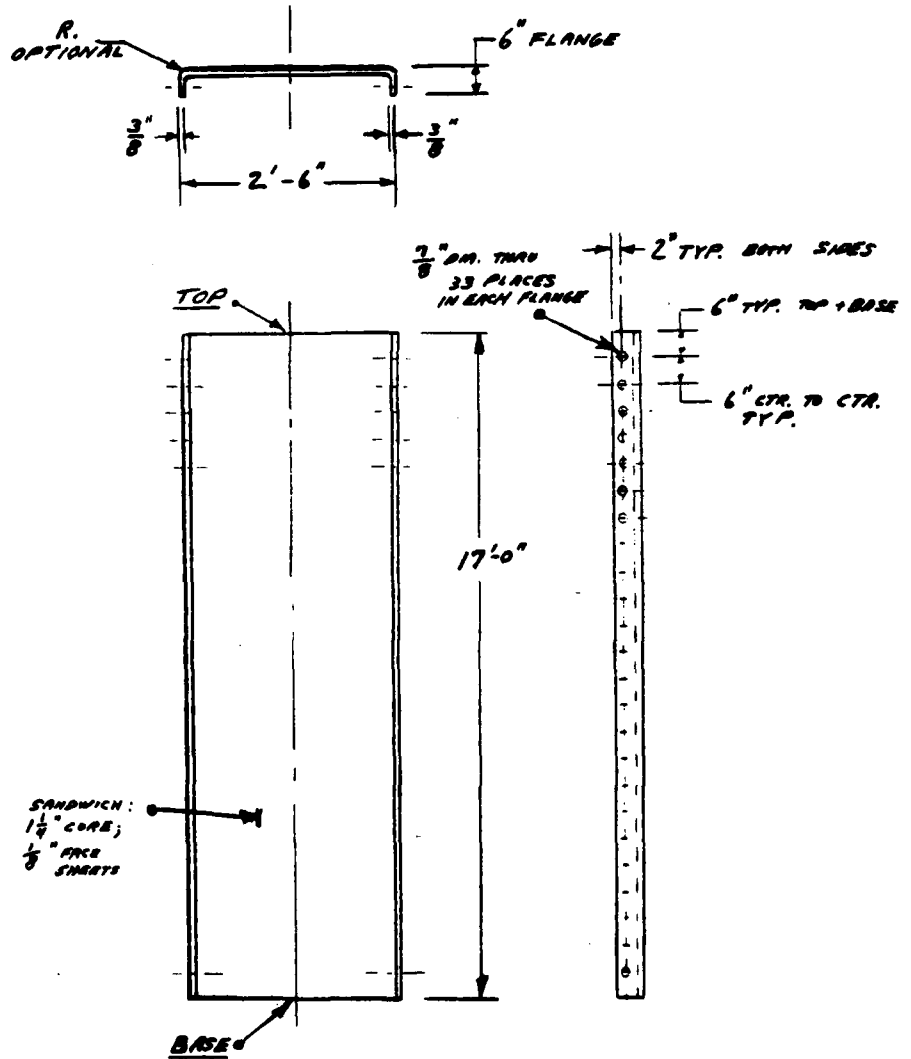

FIGURE 5.7 (SH. 3 OF 3) ENTRANCE END WALL PANEL- TYPICAL CONSTRUCTION



## 531 SERIES FIBERGLASS DOORS



### OP/CP DESCRIPTION

Here is a fiberglass, sectional, upward-acting door that offers you not only economy, but good looks. It is ideal where additional light is needed and rough treatment is not a problem.

A simple hosing down once in a while will keep it looking great for years. And you never have to worry about it splitting, cracking, curling or rotting.

### TS/SPECIFICATIONS

The stiles and rails are extruded from 6063T6 aluminum alloy to produce a nominal wall thickness of 2". Center rails are designed with weather joint. Reinforcing fins on intermediate rails are standard on doors 10'3" and wider.

Deeply ribbed white, green or sand fiberglass panels extend the full width of each section. They are secured to both the end and center stiles and are sealed to the end stiles with polyurethane tape.

The color is impregnated into the fiberglass so it's permanent.

The hinges and fixtures are galvanized steel. The full floating ball bearing rollers are hardened steel.

The lock is a five-pin tumbler lock with a single unit lock mechanism.

All tracks are galvanized steel with Mirage Wedge weather closures. Depending upon the door size the tracks are 2" or 3". The verticals are bracket mounted for wood jambs or angle mounted for steel jambs.

### Size Limitations

Track Size	Doors Not to Exceed		
	Wide	High	Sq. Ft.
2"	24'1"	16'1"	340
3"	26'2"	24'1"	600

### Schedules — Panels

door width	number of panels
to 12'2"	3
12'3" to 16'2"	4
16'3" to 19'2"	5
19'3" to 22'2"	6
22'3" to 26'2"	8
26'3" to 33'2"	10

### Sections

door height	number of sections
to 8'1"	4
8'2" to 10'1"	5
10'2" to 12'1"	6
12'2" to 14'1"	7
14'2" to 16'1"	8
16'2" to 18'1"	9
18'2" to 20'1"	10
20'2" to 22'1"	11
22'2" to 24'1"	12

### OM/OPERATION, MAINTENANCE

A hand pull rope operates the door. All service and parts are available through your local Distributor of The "OVERHEAD DOOR."

### OPTIONS

A chain hoist is recommended for doors over 13' high. Glazing, 17" x 4" with special glazing mould.

$$U = 1.15^*, R = .87^*$$

No Scale

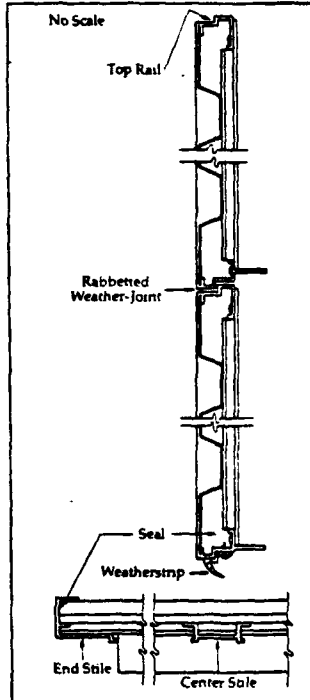
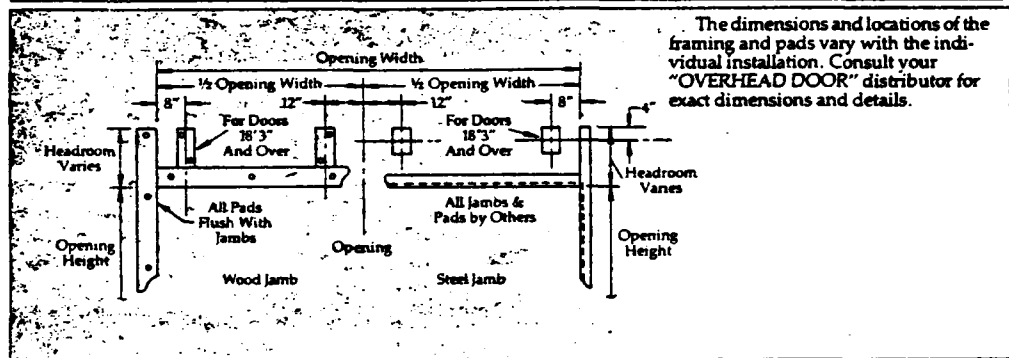

FIGURE 5.8 FRP ENTRANCE DOOR (SH. 1 OF 2)

## JAMB, FRAMING AND COUNTERBALANCE PAD DETAIL

... required on all installations



### STANDARD 2" TRACK

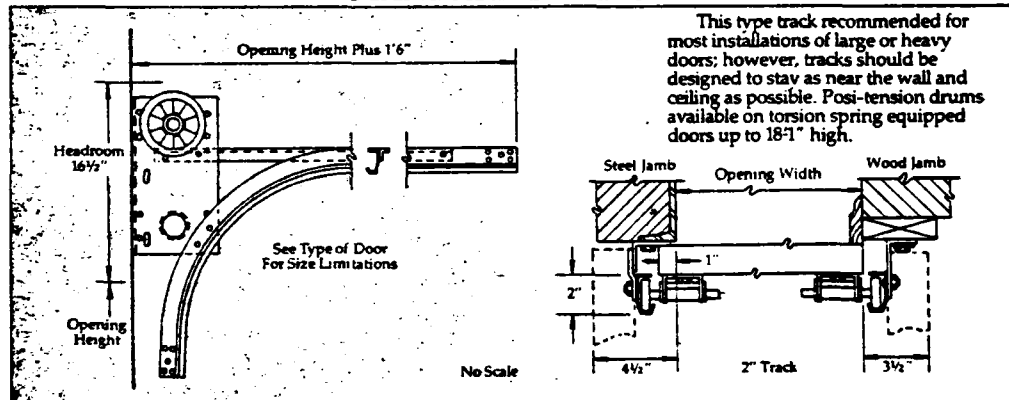

### HIGH LIFT TRACK

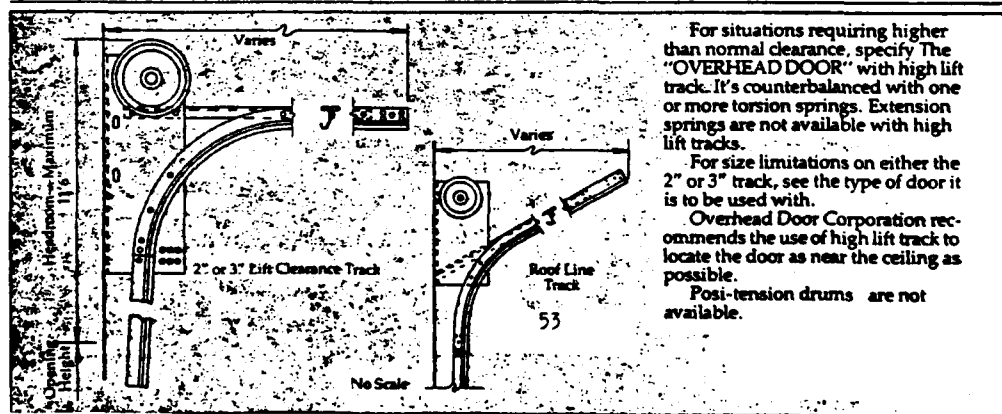
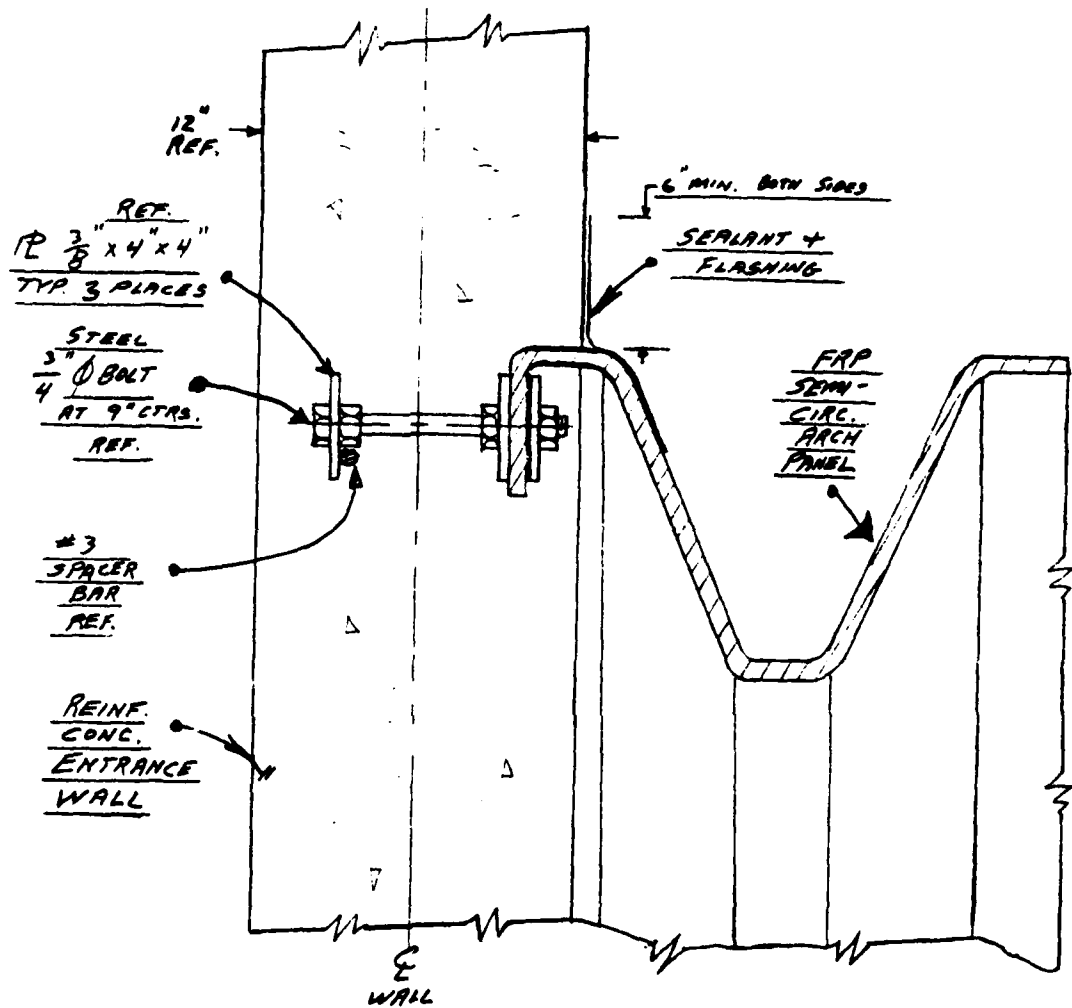

FIGURE 5.8 (SH. 2 OF 2)



REF. DEPT. OF THE ARMY  
 DRAWING NO.  
 33-15-73, SHEET 4 OF 9  
 DETAIL 2

SECTIONAL  
ELEVATION VIEW

FIGURE 5.9 CONCRETE END WALL/FRP ARCH PANEL EDGE CONNECTION (ENTRANCE)

(SH. 1 OF 2)

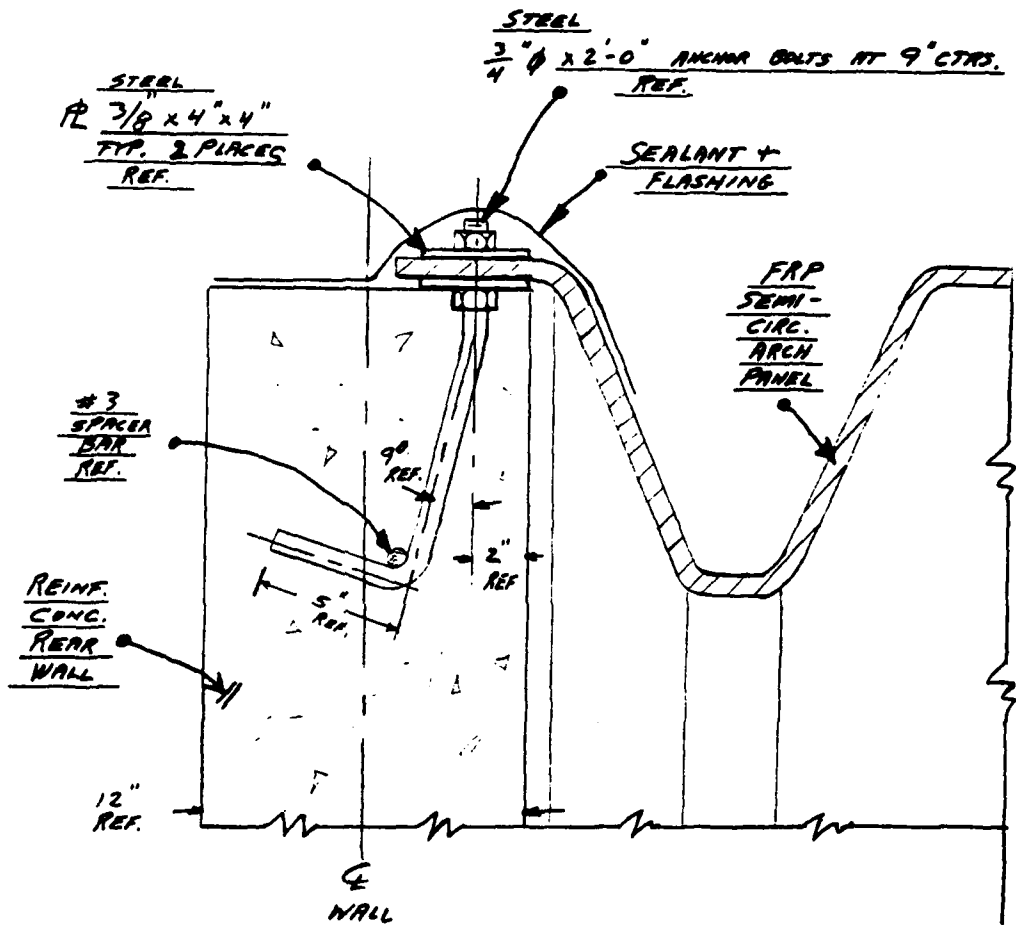

REF. DEPT. OF THE ARMY  
 DRAWING NO.  
 33-15-73 SHEET 4 OF 9  
 DETAIL SECTION A

SECTIONAL  
ELEVATION VIEW

FIGURE 5.9 (SH. 2 OF 2)

## CHAPTER 6

### STRUCTURAL ANALYSES

#### 6.1 CONCEPTUAL DESIGN ANALYSES

During the FRP magazine conceptual design studies, structural analyses were performed using design equations provided in references 6, 7, and 8 for long span metal culverts and FRP pipe along with elastic stability equations from reference 9.

Upon selection of a concept for development of a detail FRP magazine design, more extensive analyses were employed along with the MRI-STARADYNE computer program (Reference 10). This computer code was used with three increasingly exact structural models: an arch-beam element model; an arch-plate element model; an arch and end wall-plate element model.

#### 6.2 ARCH-BEAM ELEMENT MODEL

This first structural model was used to represent the FRP arch panels as two-dimensional beam elements having cross-sectional properties of an 18 inch width of the squared-vee cross-section.

A 90 degree arc segment of the semi-circular arch panels was modelled with symmetry boundary conditions at the crown. Sixteen beam elements were used along the 90 degree arc.

Horizontal and vertical loads due to the magazine earth cover, during and after construction, were applied at uniform intervals over its surface.

This model was used primarily to:

- a) Establish and verify the developed magazine soil load distribution.
- b) Evaluate the effects of arch panel foundation soil springs.
- c) Establish arch panel major section properties required along the arch radius.



### 6.2.1 SOIL LOAD DISTRIBUTION

The loadings applied to the magazine were the soil weight directly above the shell and the soil weight beyond the arch footing as indicated in Reference 6. The vertical pressure on the shell due to the overburden was taken as a simple function of the soil depth. The effect of the soil beyond the arch footing was determined as a function of the embankment height and the angle of inclination of the arch surface per table 10-1 of Reference 11. The weight of this soil beyond the arch footing, was accounted for by considering the pressure exerted by a soil wedge extending upward from the footing at a vertical angle of inclination. The development of the soil load distribution and its verification with Reference 6 data are included in Appendix A.

### 6.2.2 FOUNDATION SOIL SPRINGS

Computer runs were made with the arch foundation fixed in the soil and also with attached springs representing soil stiffnesses. Arch panel applied stresses were found to be somewhat higher with fixed foundations. To ensure realistic modeling of the arch, horizontal, vertical and rotational foundation soil springs were determined per equations 11 and 12 of Ref. 12 and employed for all subsequent analyses.

### 6.2.3 SECTION PROPERTIES

Several analyses were performed to evaluate panel section properties required with the arch panel rigidly attached to the foundation and with soil springs connected from the foundation to ground. Increased FRP arch panel thickness was shown to be necessary directly adjacent to the foundation as shown in Figure 6.1.

### 6.3 ARCH-PLATE ELEMENT MODEL

The second structural model used was three-dimensional. A 90 degree arc length and 18" wide strip of the arch was employed. The panel squared-vee cross section was represented by triangular sandwich plate elements at the sloped surfaces of the panel cross section and by solid

quadrilateral plate elements at the horizontal surfaces.

This model included: arch panel top end joint sections; arch panel reinforcement at the foundation interface and foundation soil springs. A computer plot of the model is shown in Fig. 6.2. A thickness of 0.5 inch was used for the quadrilateral elements. A 0.5 inch thick core with 0.125 inch thick skins was used for the triangular elements. Two rows of elements at the base had increased thicknesses. Elements at the crown had a thickness of 1.0 inch to reflect the joint between the two quarter arc sections. Element mesh was increased in the thinner section at each discontinuity.

The mean radius of the arch was 180 inches and the 90 degree arc was divided into 28 basic rows of elements. At discontinuities, such as at the crown and the reinforcement at the foundation, elements were subdivided to allow for greater stress gradients. The soil loads were calculated based on the 28 rows of elements and applied accordingly. The loads applied to each row of elements were determined using the mean radius of the arch. There were eleven nodes at each row cross section. Applied forces were equally divided among the nodes at each level. Calculated maximum plate element model stresses and allowable FRP material stresses are given below.

Maximum Applied Stress	Location	Allowable Material Stress	Factor of Safety
3,494 PSI Compressive Stress	panel sandwich section	16,000 PSI	4.5
122 PSI Transverse Shear Stress	balsa core	490 PSI	4.0

CONT.

Maximum Applied Stress	Location	Allowable Material Stress	Factor of Safety
3,304 PSI Compressive stress	panel solid section	16,000 PSI	4.8

Allowable FRP material stresses are based on laminate thicknesses previously described, 35% glass content and balsa core with a density of 5 pounds per cubic foot. The gross axial load and bending moment at various cross sections are plotted in Figure 6.3 for comparison with the results of the beam model.

#### 6.4 ARCH AND END WALL-PLATE ELEMENT MODEL

This final structural model of the FRP magazine was developed primarily to evaluate local stresses at the junction of the rear magazine arch and end wall. The longitudinal length of arch model used was based on that length at which local edge effects diminish. The shell length was calculated to be 72 inches. (Reference 13)

Triangular sandwich and solid quadrilateral plate elements were employed as in the arch model described above. The density of the plate element mesh used decreased with the distance from the end wall/arch joint.

The end wall was modeled with plate elements. Soil springs were included at the foundation and at the upper edge of the end wall.

Soil loadings were simultaneously applied to the FRP arch and end wall panels. A computer plot of the model is provided in Figure 6.4.

Longitudinal support of the end wall upper portion, provided by backfill, was found to be adequate. Longitudinal loading and displacement of the arch panels were found to be insignificant.

The opposing sloped surfaces of the FRP panel vee-cross-section were found to provide inherent longitudinal equilibrium.

Local stresses at adhesive joints between the end wall and adjacent edge of the arch panel, and those between adjacent arch panel edges, were found to be well within the structural adhesive shear and peel strengths.

This final large structural model of the magazine used with the MRI-STAR DYNE program provided a very detailed analysis of stresses and displacements throughout the structure. This analysis was considered to provide substantial verification of the adequacy of the design developed for the applied soil loadings.

#### 6.5 STABILITY

The overall stability of the FRP arch was determined considering it to be an elastic curved panel with fixed edges and loaded by uniform radial pressures. The allowable applied pressure was conservatively determined per Reference 14 to be 24 PSI. (The maximum external pressure on the arch due to the earth cover occurs at the base and is approx. 14 PSI.)

FRP panel local and overall stability under axial loadings were evaluated, with data provided in Reference 15, and found to be adequate.

In all analyses performed, a reduced FRP modulus of elasticity ( $1 \times 10^6$  PSI) was employed to account for long term properties and elevated temperature.

#### 6.6 SERVICE TEMPERATURE RANGE

FRP laminates constructed with polyester resins are indicated per Reference 16, Table 1, and material supplier's data to have little loss of strength over an operating temperature range of -40 to +130 degrees F.

#### 6.7 CREEP

Data provided in Reference 17 indicates that short and long term creep are not significant design considerations with properly fabricated FRP panels having reinforcement oriented in the direction of the applied loads.

Little long term creep data is available for fiberglass reinforced

polyester resins. General information on creep of FRP laminates indicates that strains may increase about 20 to 30% with long term application of stress. This is equivalent to a modulus of elasticity for long term load of about 0.70 times that for short term loads (Ref. 18)



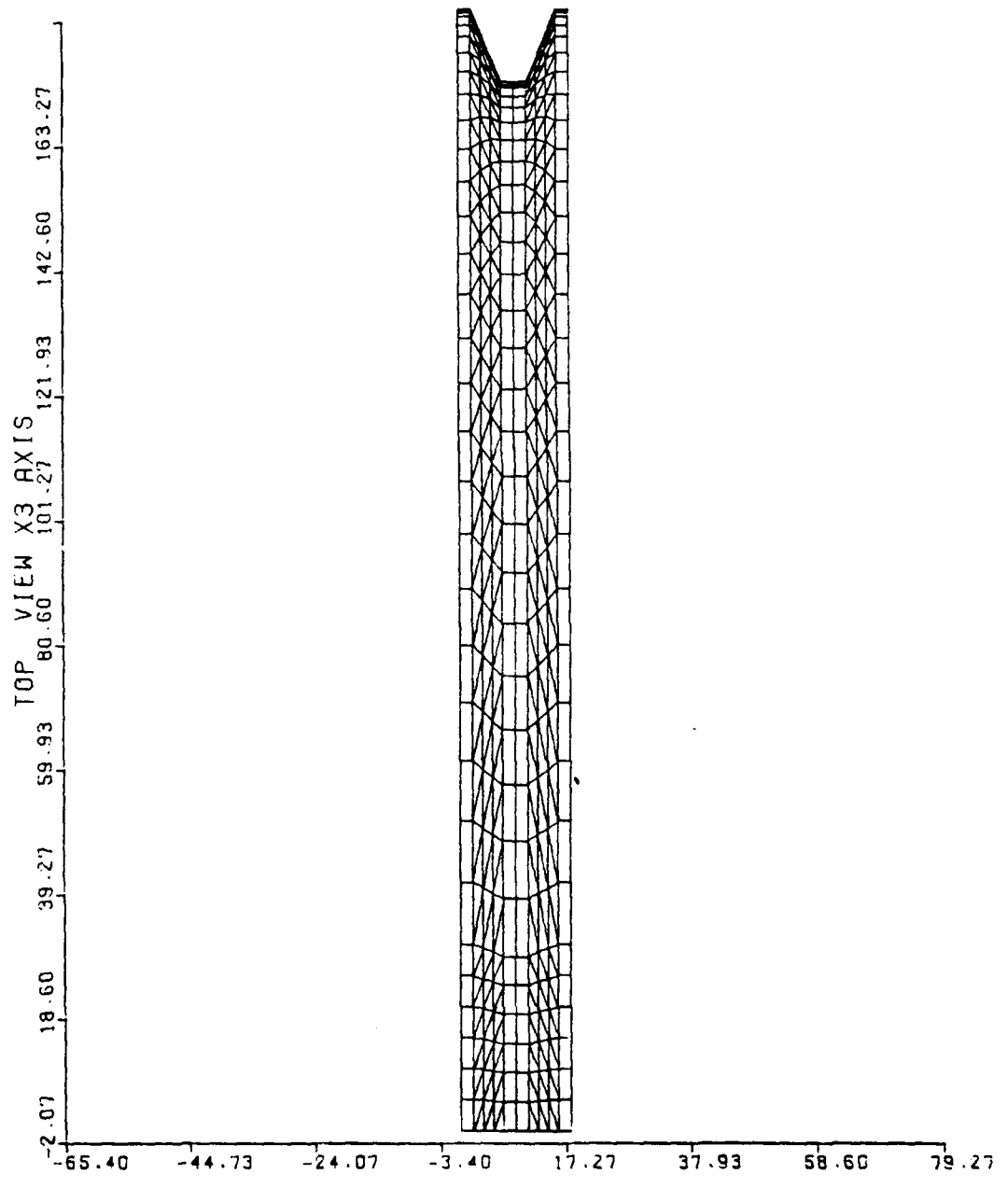

FIGURE 6.2 ARCH-PLATE ELEMENT MODEL (SH. 1 of 2)

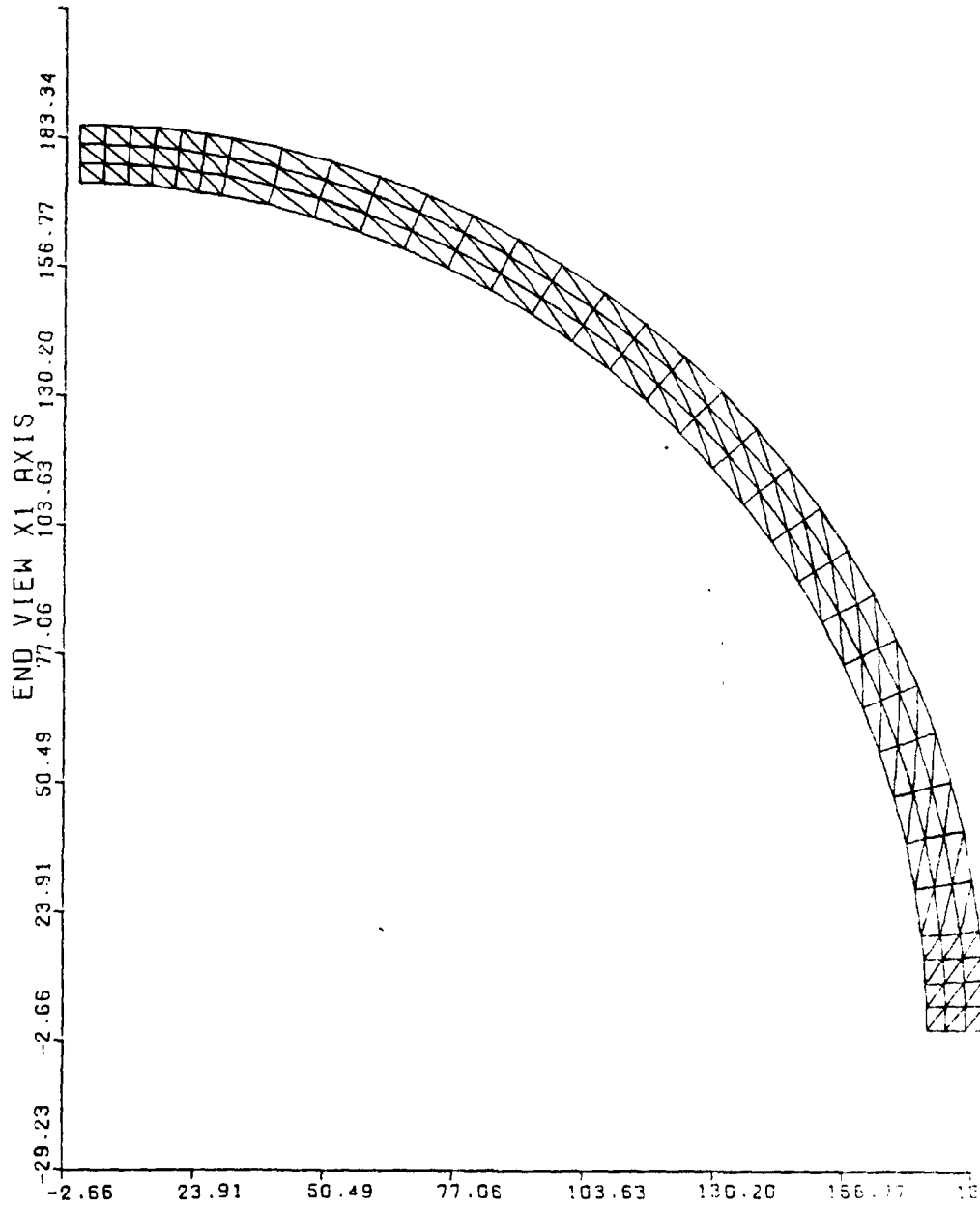

FIGURE 6.2 (SH. 2 of 2)



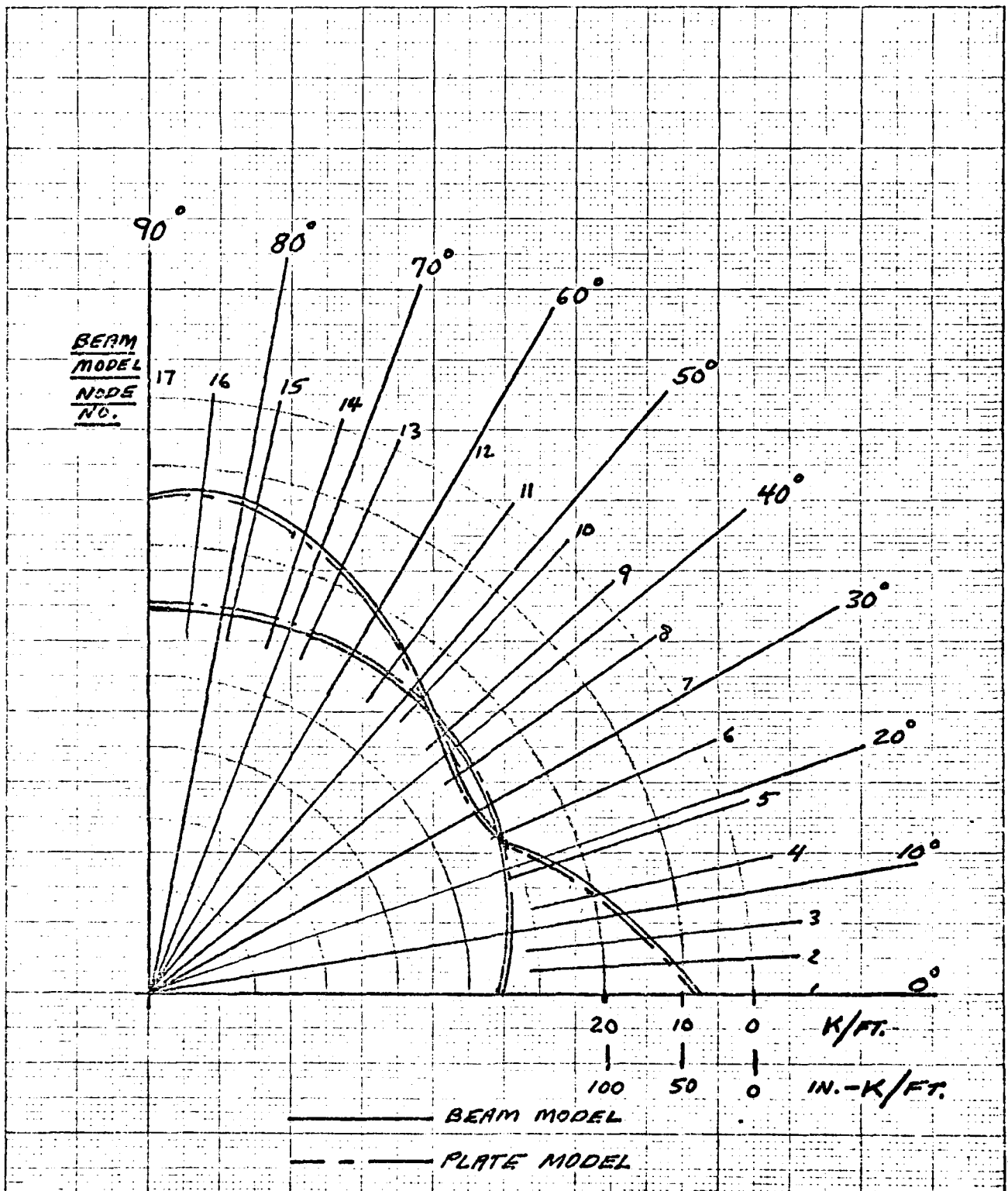

FIGURE 6.3 ARCH-AXIAL AND BENDING LOADS

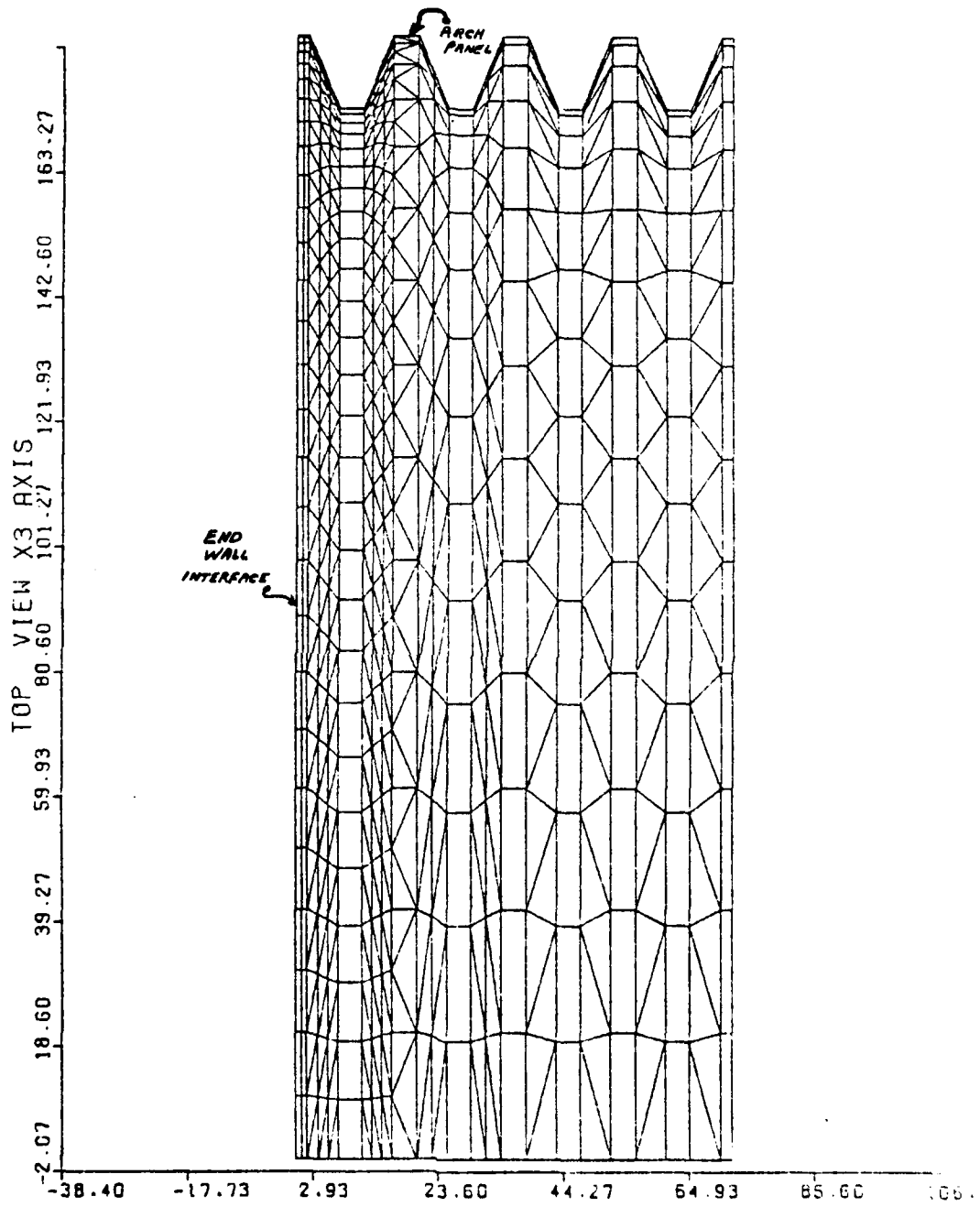

FIGURE 6.4 ARCH AND END WALL-PLATE ELEMENT MODEL (SH.1 of 2)

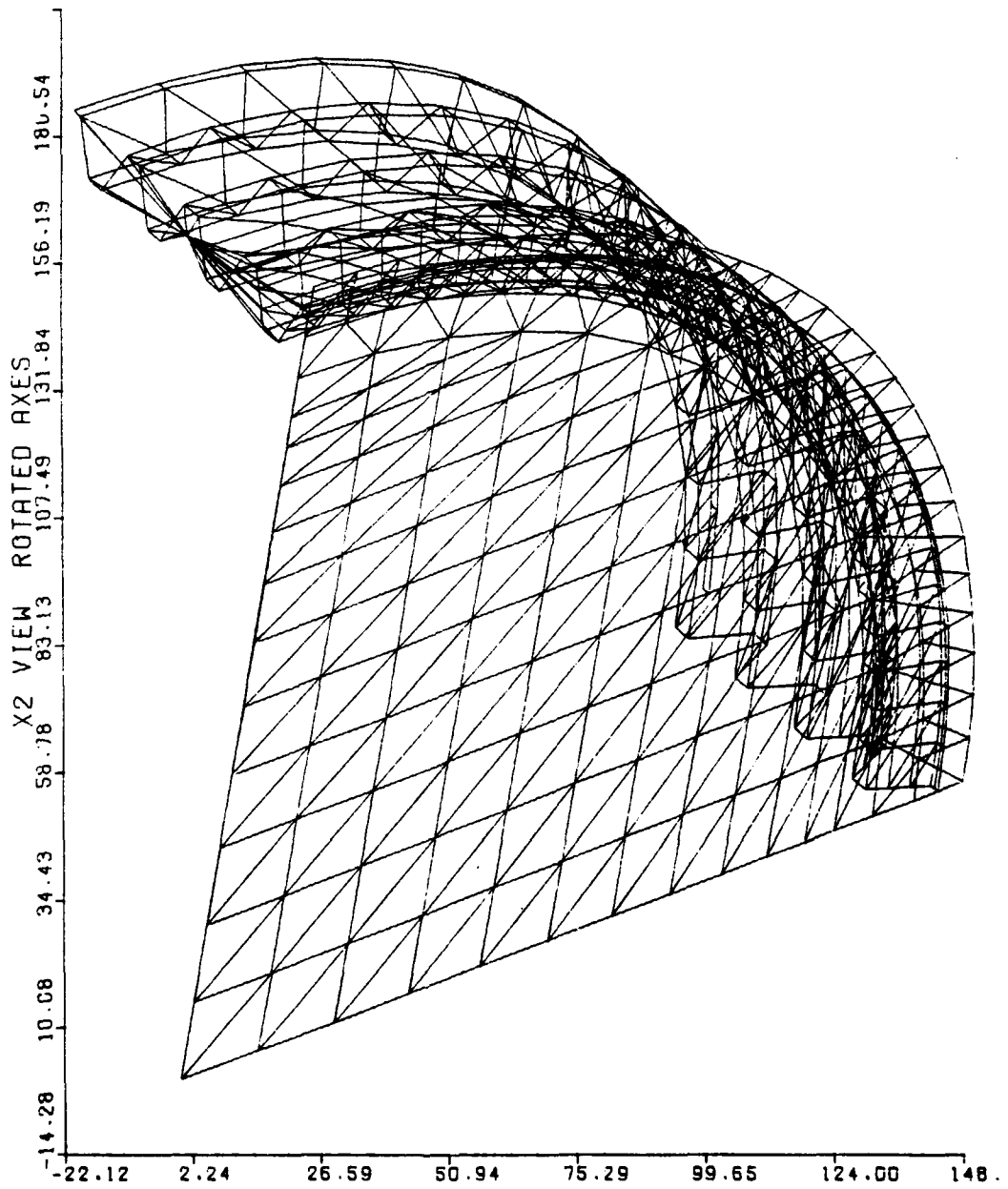

FIGURE-6.4 (SH. 2 of 2)

## CHAPTER 7

### CONSTRUCTION COSTS

Estimated manufacturing and field installation costs for the FRP magazine arch and end walls were developed as shown in Table-4 based on early 1980 prices.

For comparison purposes, manufacturing and field installation costs of the present magazine steel oval arch structure per Corps of Engrs. dwg. 33-15-73 were also developed as shown in Table-5 with early 1980 cost data.

Some additional factors which should be considered in cost comparisons for specific magazine sites are:

- a) Material transportation costs.
- b) Required service life.
- c) corrosiveness of available backfill.
- d) Cathodic protection system operation costs.
- e) Anticipated life cycle maintenance costs.

TABLE - 4

ESTIMATED CONSTRUCTION COST

FRP Arch and End Walls

1. ARCH

a)	Semi-circ. pnls. 15'R, 90° arc, 7½ wide, 8 ea. r.h. and l.h. 60' magazine length x \$ 755.63/ft	-----	\$ <u>45,338</u>
b)	joint wedge blocks, adhesive/sealer, reactive adh.	-----	\$ <u>295</u>
c)	Inst. labor - foreman 24 hrs @ 18.50 laborers 48 hrs @ 15.70 (Ref. 19)	-----	\$ <u>1,198</u>
d)	\$18,000 mold cost dist. over 10 magazines at 1800 each	-----	\$ <u>1,800</u>
			subtotal \$ <u>48631</u>

---

2. REAR FRP WALL ABOVE FOOTING

a)	Vee wall pnls. 402 s.f. x \$15/s.f.	-----	\$ <u>6,030</u>
b)	Joint materials reactive adh. and wedge blocks	-----	\$ <u>120</u>
c)	Inst. labor : foreman 8 hrs @ 18.50 laborers 16 hrs @ 15.70	-----	\$ <u>399</u>
			subtotal \$ <u>6549</u>

---

3. FRP ENTRANCE AND WING WALLS

a)	Panels and tie mbrs. 2960 s.f. x \$10/s.f.	-----	\$ <u>29,600</u>
b)	Joint materials (bolts and adh.)	-----	\$ <u>350</u>
c)	Inst. labor : foreman 24 hrs. @ 18.50 laborers 48 hrs. @ 15.70	-----	\$ <u>1,198</u>

d) FRP door and track installed ----- \$ 625

subtotal \$ 31773

---

4. TOTAL ESTIMATED COST ----- \$ 86953

TABLE - 5

ESTIMATED CONSTRUCTION COST

Present Steel Plate Arch and Reinforced Concrete End Walls:  
(Per DWG. 33-15-73)

1. ARCH	
a)	Steel plate arch plates, bolts, sealing strips, anchor bolts and channels, (knockdown) :
	60' Magazine length x \$400/ft. _____ \$ <u>24,000</u> (Ref. Armco Co. Quote)
b)	Installation Labor:
	\$24000 x .4524 = -- _____ \$ <u>10,857</u>
c)	Waterproofing Membrane and Protector Boards:
	\$.75/ft. <sup>2</sup> x 2827 ft. <sup>2</sup> _____ \$ <u>2,120</u> (Ref. 19)
	subtotal \$ <u>36,977</u>
<hr/>	
2. REAR REINFORCED CONCRETE WALL ABOVE FOOTING (Ref. 19) :	
a)	13.4 C.Y. x \$215/C.Y. Conc. in place _____ \$ <u>2,881</u> (incl. forms and reinf.)
b)	Arch anchor bolts, \$4.31/s.f. x 612.5 s.f. _____ \$ <u>2,640</u> and finishing.
c)	Waterproofing, \$.75/s.f. x 637.5 s.f. _____ \$ <u>478</u>
	subtotal \$ <u>5,999</u>
<hr/>	
3. REINFORCED CONCRETE ENTRANCE WALL ABOVE FOOTING AND RETAINING WALLS AND FOOTINGS	
a)	93.3 C.Y. x \$125/C.Y. conc. _____ \$ <u>20,060</u> in place incl. forms and reinf.
b)	Arch anch. bolts \$4.31/s.f. x 1138 s.f. _____ \$ <u>4,905</u> and finishing

c) Sliding steel \$145/s.f. x 76 s.f. \_\_\_\_\_ \$ 11,020  
door and frame  
(Galv.)

subtotal \$ 35,985

---

4. CATHODIC PROTECTION SYSTEM

Estimated \_\_\_\_\_ \$ 5,000

---

5. TOTAL ESTIMATED COST \_\_\_\_\_ \$ 83,961



## CHAPTER 8

### CONCLUSIONS AND RECOMMENDATIONS

#### 8.1 CONCLUSIONS

A corrosion resistant FRP, earth-covered ammunition storage magazine design was developed and shown to be highly feasible.

Based on magazine total life-cycle cost, and early 1980 manufacturing and installation cost data, the cost of the FRP magazine is expected to be less than that of the present steel plate and concrete magazine.

Other major advantages of the FRP magazine were determined to be:

- a) Reduced material handling and shipping weight.
- b) Reduced field erection time required.
- c) Reduced maintenance.
- d) Increased service life.

#### 8.2 RECOMMENDATIONS

It is recommended that a prototype FRP, earth-covered ammunition storage magazine be constructed.

Also, it is recommended that the prototype structure be constructed so as to demonstrate:

- a) Structural design.
- b) Manufacturing, shipping and field erection.
- c) Construction cost.

APPENDIX A

DERIVATION AND VERIFICATION OF SOIL LOADING EQUATIONS

Equations for the soil load distribution on the FRP magazine arch were derived for use with the structural model developed and the MRI STARDYNE computer program.

In Reference 6, the results of numerous non-linear finite element analyses of various combinations of culverts and backfills are provided in empirical formulas and graphs. These formulas and graphs were used to verify the soil load distribution equations derived.

The soil loading on arch beam elements 1-8, shown in Fig. A-1, was considered to include the additional weight of the soil beyond the arch span. The loading on arch elements 9-16 was considered to be only that of the soil plug directly above.

The loading on elements 1-8 was determined assuming that each element was loaded by the adjacent inclined soil column as shown in Fig. A-1.

The forces on a typical element, due to the inclined column of soil, were determined by the equations below.

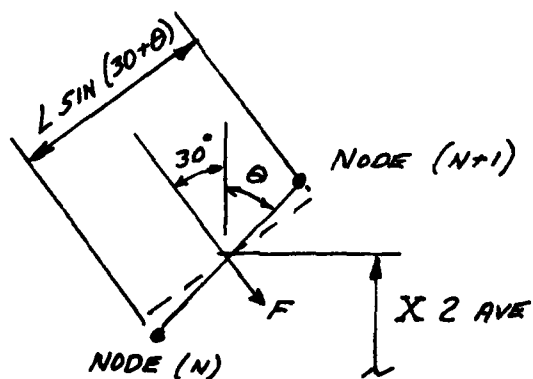

$$F = W \cos 30^\circ$$

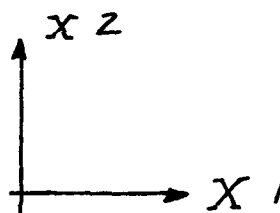

$$\theta = \tan^{-1} (\Delta X_1 / \Delta X_2)$$

$L$  = MEMBER LENGTH

$\gamma$  = SOIL DENSITY = 120 PCF

$$W = \gamma \frac{[(15+2)(12) - X_2 \text{ AVE}]}{\cos 30^\circ} L \sin(30+\theta)(18)$$

$$F = \gamma (204 - X_2 \text{ AVE}) L (18) \sin(30+\theta)$$

$$F_V = \gamma (204 - X_2 \text{ AVE}) L (18) \sin(30+\theta) \cos 30^\circ$$

$$F_H = \gamma (204 - X_2 \text{ AVE}) L (18) \sin(30+\theta) \sin 30^\circ$$

The vertical forces on elements 9-16 are a function only of the plug of earth directly above the element. The horizontal pressure on each of these elements were determined using an "at rest" coefficient of lateral pressure equal to 0.5 (Ref. 11).

$$F_V = \gamma (204 - X_2 \text{ AVE}) (\Delta X_1) (18)$$

$$F_H = 0.5 \gamma (204 - X_2 \text{ AVE}) (\Delta X_2) (18)$$

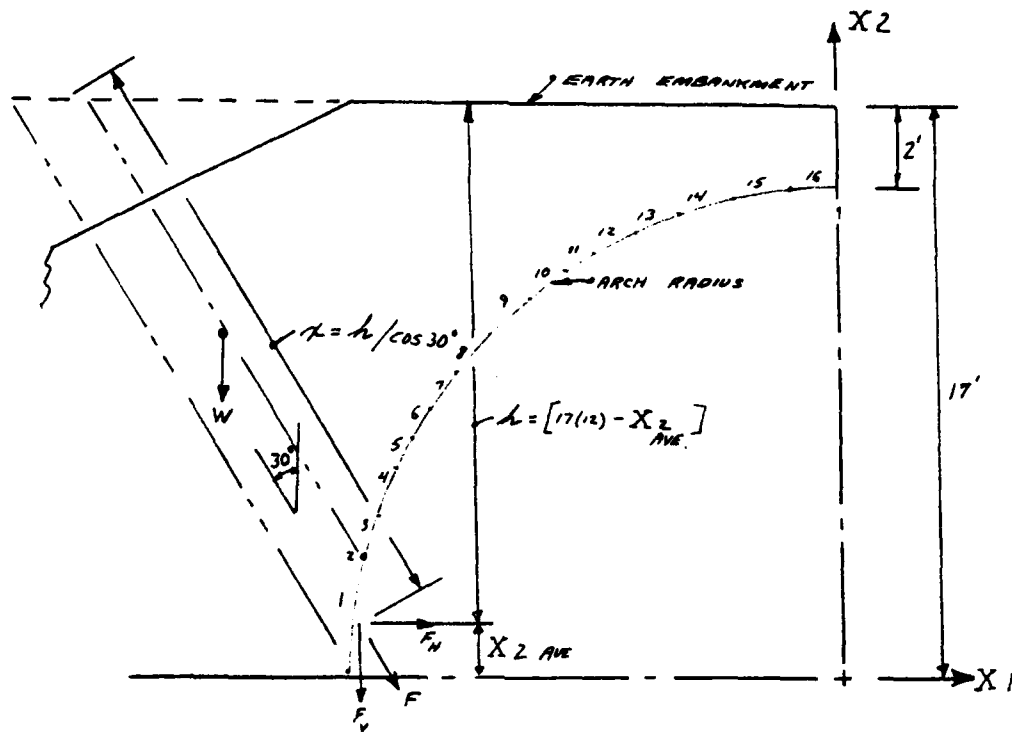

$F_v$  and  $F_H$  - Vertical and Horizontal Components of the Force  
at the Center of each Element

$X_i$  - Global Coordinate System of the Model

Vertical Angle of Inclination =  $45 - \phi/2 = 30^\circ$

ELEMENT LOADING  
FIG.A-1

The above loads were applied to the arch beam element model described previously with arch ends simply supported as in Ref 6. The maximum axial stress was 1968 PSI and the maximum axial force was 20,851 lbs. The corresponding data from an analysis performed with data from Ref. 6 were:

Maximum Axial Force = 23,250 lbs.

Maximum Axial Stress = 2210 PSI

The maximum bending moment was found to be 106,156 in.-lbs. and the maximum bending stress was 2986 PSI. The comparable values using Ref. 6 were:

Maximum Bending Moment = 58,860 in.-lbs.

Maximum Bending Stress = 1660 PSI

The bending stress using the model is approximately 1.8 times that obtained analytically. The error in the stress due to axial compression was approximately 10%. The bending stress obtained from the model was conservative, and the axial stress was slightly unconservative compared to results using Ref. 6. However the maximum combined stress from model was greater than the sum of the maxima using Ref. 6.

MAX = 4150 PSI	MAX = 3870 PSI
model	ref.

A plot of the arch bending moment and axial force are provided in Fig. 6.3. A comparison of the plots in Fig. 6.3 with similar plots in Ref. 6 indicates that the form of the curves is essentially the same. Maximums occur at approximately the same relative locations (i.e. maximum bending moment at a point 30 degrees up from base and maximum axial force at the base).

Thus, the method of calculating the applied loads described above was considered acceptable and used in subsequent computer analyses.

## REFERENCES

1. Frank J. Heger, et al; "Design of Plastic Structural Components"; 1979, Page 431; Journal of the Technical Councils of ASCE; Proceedings of the ASCE, Vol. 105, No. TC2, ASCE, Ny,Ny; Unclassified.
2. Pipeline Sub-committee; "Reinforced Thermosetting Resin Pipe" March 1979, Page 167; Transportation Engineering Journal; ASCE, NY, NY; Unclassified.
3. "Guide to Corrosion Resistance of Hetrion and Aropol Polyester and Furan Resin Laminates"; 1978; Bulletin No. 1407, Ashland Chemical Co., Resin and Plastics Div., Columbus, OH.; Unclassified.
4. "Hand Lay-up Spray-up Guide"; 1979; Publication No. 5-PL-9342 Owens-Corning Fiberglas Corp. Toledo, OH.; Unclassified.
5. "Specifications for Construction of St. Louis Area Support Center, Ammo Storage Magazines, Granite City, Ill.; Serial No. DACA 45-80-B-0091; Mar 1980; U.S. Army Engr. Dist., Omaha, Nebraska; Unclassified.
6. James M. Duncan; "Behavior and Design of Long Span Metal Culverts"; March 1979, Pages 399-418; Journal of the Geotechnical Division, ASCE, New York, N.Y., Proceedings Paper 14429; Unclassified.
7. B. Jay Schrock; "Installation of Fiberglass Pipe"; Nov. 1978; Pages 835-846; Transportation Engineering Journal, ASCE, NY, NY; Unclassified.
8. Simpson Gumpertz and Heger Inc; "Structural Plastics Design Manual"; 1979; FHWA-TS-79-203; Sponsored by U.S. Dept. of Transportation, Dept. of Housing and Urban Development and industrial organizations; U.S. Govt. Printing Office Stock Number 023-000-00495-0; Unclassified.

9. S. Timoshenko; "Theory of Elastic Stability"; 1936; McGraw-Hill Book Co., New York, NY; Unclassified.

10. STARDYNE Computer Code; "Static and Dynamic Structural Analysis Systems" User Information Manual, Control Data Corporation, Publication No. 79900; Unclassified.

11. Gregory P. Tschebotarioff; "Foundations, Retaining and Earth Structures"; 1973; McGraw-Hill Book Co., New York, N.Y.; Unclassified.

12. R.V. Whitman, et al; "Design Procedures for Dynamically Loaded Foundations"; Nov 1967; Pages 169-193; Journal of the Soil Mechanics and Foundations Div., ASCE, New York, NY; Unclassified.

13. S. Timoshenko; "Theory of Plates and Shells"; 1940; Engineering Societies Monographs, McGraw-Hill Book Co. New York, NY; Unclassified.

14. Raymond J. Roark; "Formulas for Stress and Strain"; Fourth Edition; McGraw-Hill Book Co., New York, NY; Unclassified.

15. "Structural Sandwich Composites", Military Handbook, MIL-HDEK-23A; Dec 1968; Dept of Defense, Washington, DC; Unclassified.

16. "High Temperature Properties of Corrosion Resistant FRP"; Feb. 29, 1977; Paper presented to: 32nd Annual Conference and Exhibit, Reinforced Plastics/Composites Institute, The Society of the Plastics Industry Inc., Unclassified.

17. F.P. Belyankin, et al; "Strength and Deformability of Fiberglass Reinforced Plastics Subjected to Biaxial Compression"; Charlottesville, VA; NTIS AD-A008517.

18. Frank J. Heger; "Design of FRP Fluid Storage Vessels"; March 1970, Pages 2465-2499; Journal of the Structural Division; ASCE; New York, N.Y. Unclassified.

19. "1980 Building Construction Cost Data"; R.S. Means Co. Inc., Kingston MA.

In accordance with letter from DAEN-RDC, DAEN-ASI dated 22 July 1977, Subject: Facsimile Catalog Cards for Laboratory Technical Publications, a facsimile catalog card in Library of Congress MARC format is reproduced below.

Hunt and Wales Co., Inc.

Study for development of fiberglass reinforced plastic earth-covered ammunition storage magazines / by Hunt and Wales Co., Inc., Reading, Massachusetts. Vicksburg, Miss. : U. S. Waterways Experiment Station; Springfield, Va. : available from National Technical Information Service, 1980.

76 p. : ill. ; 27 cm. (Technical report - U. S. Army Engineer Waterways Experiment Station ; SL-80-6)  
Prepared for Office, Chief of Engineers, U. S. Army, Washington, D. C., under Contract No. DACA 39-79-C-0012.  
References: p. 75-76.

1. Ammunition. 2. Computerized simulation. 3. Fiberglass.  
4. Finite element method. 5. Munitions storage. 6. Reinforced earth. 7. Reinforced plastics. I. United States. Army. Corps of Engineers. II. Series: United States. Waterways Experiment Station, Vicksburg, Miss. Technical report ; SL-80-6.  
TA7.W34 no.SL-80-6



**E  
ED**