

AD A090029

DDC FILE COPY

LEVEL 12

RADC-TR-80-237
Final Technical Report
July 1980



RELIABILITY PREDICTION MODELING OF NEW DEVICES

Arthur D. Little, Inc.

Roger G. Long
Martin Cohen

DDIC
OCT 7 1980
D
C

APPROVED FOR PUBLIC RELEASE; DISTRIBUTION UNLIMITED

ROME AIR DEVELOPMENT CENTER
Air Force Systems Command
Griffiss Air Force Base, New York 13441

10 7 1980

7

This report has been reviewed by the RADC Public Affairs Office (PA) and is releasable to the National Technical Information Service (NTIS). At NTIS it will be releasable to the general public, including foreign nations.

RADC-TR-80-237 has been reviewed and is approved for publication.

APPROVED:

Peter F. Manno

PETER F. MANNO
Project Engineer

APPROVED:

David C. Luke

DAVID C. LUKE, Lt Col, USAF
Chief, Reliability & Compatibility Division

FOR THE COMMANDER:

John P. Huss

JOHN P. HUSS
Acting Chief, Plans Office

SUBJECT TO EXPORT CONTROL LAWS

This document contains information for manufacturing or using munitions of war. Export of the information contained herein, or release to foreign nationals within the United States, without first obtaining an export license, is a violation of the International Traffic in Arms Regulations. Such violation is subject to a penalty of up to 2 years imprisonment and a fine of \$100,000 under 22 U.S.C 2778.

Include this notice with any reproduced portion of this document.

If your address has changed or if you wish to be removed from the RADC mailing list, or if the addressee is no longer employed by your organization, please notify RADC.(RBRA) Griffiss AFB NY 13441. This will assist us in maintaining a current mailing list.

Do not return this copy. Retain or destroy.

UNCLASSIFIED

SECURITY CLASSIFICATION OF THIS PAGE (When Data Entered)

19 REPORT DOCUMENTATION PAGE		READ INSTRUCTIONS BEFORE COMPLETING FORM	
18 1. REPORT NUMBER RADC TR-88-237	2. GOVT ACCESSION NO. AD A090029	3. RECIPIENT'S CATALOG NUMBER 9	
6 4. TITLE (and Subtitle) RELIABILITY PREDICTION MODELING OF NEW DEVICES	5. TYPE OF REPORT & PERIOD COVERED Final Technical Report, Sep 1978 - Nov 1979		
	7. AUTHOR(S) Roger G. Long Martin/Cohen	14 8. PERFORMING ORG. REPORT NUMBER ADL-C-82361	9. CONTRACT OR GRANT NUMBER(S) 15 F30602-78-C-0296
9. PERFORMING ORGANIZATION NAME AND ADDRESS Arthur D. Little, Inc. Cambridge MA 02140	10. PROGRAM ELEMENT PROJECT, TASK AREA & WORK UNIT NUMBERS 62702F 23380173	17 11. REPORT DATE Jul 1980	
11. CONTROLLING OFFICE NAME AND ADDRESS Rome Air Development Center (RBRA) Griffiss AFB NY 13441	13. NUMBER OF PAGES 115	15. SECURITY CLASS. (of this report) UNCLASSIFIED	
14. MONITORING AGENCY NAME & ADDRESS (if different from Controlling Office) Same	15a. DECLASSIFICATION DOWNGRADING SCHEDULE N/A		
16. DISTRIBUTION STATEMENT (of this Report) Approved for public release; distribution unlimited.			
17. DISTRIBUTION STATEMENT (of the abstract entered in Block 20, if different from Report) Same			
18. SUPPLEMENTARY NOTES RADC Project Engineer: Peter F. Manno (RBRA)			
19. KEY WORDS (Continue on reverse side if necessary and identify by block number) Reliability Prediction Modeling Magnetic bubble memories Charge-coupled devices			
20. ABSTRACT (Continue on reverse side if necessary and identify by block number) This report presents reliability prediction models for high density microcircuits including magnetic bubble and charge-coupled device memories for inclusion in MIL-HDBK-217C, "Reliability Prediction of Electronic Equipment". The approach in this investigation was unique in that the models were developed utilizing only early device life cycle data, since there was only limited field data available. Two separate models were developed. An additive hybrid type failure rate			

DD FORM 1 JAN 73 1473

EDITION OF 1 NOV 65 IS OBSOLETE

UNCLASSIFIED

SECURITY CLASSIFICATION OF THIS PAGE (When Data Entered)

next page

UNCLASSIFIED

SECURITY CLASSIFICATION OF THIS PAGE(When Data Entered)

Item 20 (Cont'd)

cont. → prediction model was formulated for Magnetic Bubble Memories and for the Charge-Coupled Memory devices it was found that the NMOS Dynamic RAM model currently in MIL-HDBK-217C, Notice 1 was applicable. Both models are presented in the standard MIL-HDBK-217C format, are relatively simple to use, and allow for refinements based on field and life test data as it becomes available. Finally the models exhibit reasonable correlation with existing field data. ↗

Accession For	✓
NTIS GPA&I	
DTIC TAB	
Unannounced	
Justification	
By	
Distribution	
Availability	
Dist	
A	

UNCLASSIFIED

SECURITY CLASSIFICATION OF THIS PAGE(When Data Entered)

Evaluation

The objective of this effort was to develop failure rate prediction models for Magnetic Bubble Memory (MBM) and Charge-Coupled Device (CCD) Memory circuits regardless of their complexity or density. The approach taken was unique in that the models were developed from data obtained during the early stages of the devices' life cycle.

The general form of the failure rate prediction technique for MBM's was found to be an additive hybrid type model consisting of the summation of the failure rates of four individual sectors; control sense and driving sector, memory sector, interconnect and substrate sector, and the inductive sector. The following are some of the more important findings:

- a. The complexity factors for the control sector are based on the number of major and minor loops and for the memory sector on the number of bits per loop. The existing complexity tables in MIL-HDBK-217C-"Reliability Prediction of Electronic Equipment", are used for these values.
- b. Multipliers based on the number of major and minor loops are used to modify the memory sector complexity factors.
- c. A magnetic bias margin multiplier factor which corresponds to the voltage derating factor was developed for the memory sector.

d. A derating multiplier based on bubble size was developed for the memory sector temperature acceleration factor.

In addition the model retains the normal MIL-HDBK-217C adjustment factors such as quality, package, environment, and device learning factor. The remaining contributions to the total failure rate are obtained by using the appropriate sections of MIL-HDBK-217C such as for the printed wiring structures.

For CCD's it was found that the present NMOS Dynamic RAM model in MIL-HDBK-217C was capable of predicting the failure rates to acceptable accuracy.

To assess the accuracy of the models, comparisons are presented between the predicted failure rates and actual field data. These comparisons along with sample calculations demonstrate reasonable confidence in the developed models. The feasibility of the approach to develop failure rate prediction models based on early life cycle data will be assessed and refinements incorporated based on additional field data as it becomes available.

The prediction models presented in this report are for information purposes only at this time, and are not intended to be used without approval of the appropriate contract office. The new models will be submitted for early DOD and industry coordination and inclusion in MIL-HDBK-217C.

RADC wishes to thank Mr. Fred Sakate and the Federal Aviation Administration (FAA) for contributions in the partial funding of this effort.

Peter F. Manno

PETER F. MANNO

Project Engineer

TABLE OF CONTENTS

	<u>Page</u>
I. INTRODUCTION	11
A. Background	
B. Purpose	
C. Method	
II. MAGNETIC BUBBLE MEMORY DEVICE OPERATION	13
A. Typical Operating Characteristics	
B. General Description	
C. Major/Minor Loop	
D. Magnetic Field Operation	
III. MAGNETIC BUBBLE MEMORY FAILURE RATE MODEL	36
A. Device Test Data	
B. Permalloy Corrosion and Electromigration	
C. Calculated Reliability of Semiconductor Memory Devices	
D. Calculation of Semiconductor Memory Failure Rate	
E. Failure Rate Model Development	
F. Sample Calculations of Predicted Reliability of a Magnetic Bubble Memory Device	
IV. CHARGE-COUPLED DEVICE MEMORY	68
A. Description	
B. Chip Architecture	
C. Memory Organization	
D. Manufacturers	
E. CCD Failure Rate Model Development	
F. Failure Rate Model Validation	

TABLE OF CONTENTS (continued)

	<u>Page</u>
APPENDIX A, BIBLIOGRAPHY OF MAGNETIC BUBBLE MEMORY	84
APPENDIX B, BIBLIOGRAPHY OF CHARGE-COUPLED DEVICE TECHNOLOGY	92

LIST OF ILLUSTRATIONS

<u>Figure</u>	<u>Page</u>
1 Typical Magnetic Domain Propagation	17
2 T and Bar Pattern and Chevron Pattern	18
3 Loop Organization	19
4 Material Layers of Magnetic Bubble Memory Chip	23
5 Cross-Sectional View of Magnetic Bubble Memory Chip	24
6 Layout of Elements of Magnetic Bubble Memory Chip	25
7 Bubble Memory Printed Circuit Substrate	26
8 Bubble Memory Lead Frame	27
9 Bubble Memory Assembly of Substrate, Chip, and Lead Frame (with Leads Bonded)	28
10 Bubble Memory Lead Frame Trimmed and Orthagonal Coils Installed	29
11 Bubble Memory Magnets Installed	30
12 Bubble Memory Magnetic Shields Installed	31
13 Bubble Memory Encapsulated and Leads Formed	32
14 Major/Minor Loop Operation	34
15 MOS Dynamic RAM and Shift Register Observed Failure Rates vs. Proposed Model Predicted Failure Rates	45
16 MOS Static RAM and Shift Register Observed Failure Rates vs. Proposed Model Predicted Failure Rates	46
17 Basic Charge Transfer Shift Register	69
18 Charge Storage in Surface Channel CCD	71
19 Charge Storage in Barrier Channel CCD	72
20 Charge Coupled Device Structures	74
21 CCD Memory Organization	75
22 Comparison of N-MOS Dynamic RAM Model with CCD Reliability Data	81

LIST OF TABLES

<u>Table</u>	<u>Page</u>
1 Key Characteristics of Current Magnetic Bubble Memory Devices and Comparable Semiconductor Memory Devices	14
2 MOS Dynamic RAM and Shift Register Data	47
3 MOS Static RAM and Shift Register Data	48
4 Calculated Failure Rates of Semiconductor Memory Devices	51
5 Projected Reliability, λ = Failures/ 10^6 Hours	67
6 Firms Which Have Been Active in the Development of CCD Memories	76

PREFACE

This report was prepared by Arthur D. Little, Inc., of Cambridge, Massachusetts, under U. S. Air Force Contract No. F30602-78-C-0296. The contract was initiated by AFSC Rome Air Development Center of Griffis AFB, NY, 13441. It was administered under the technical direction of Mr. Peter Manno, RADC/RPRM, acting as the technical project officer. Captain D. G. Arnold, U. S. Air Force, was the contract administrator for the USAF.

This report is a summary of the work completed under this contract during the period from September 1978 through November 1979.

SUMMARY

PURPOSE AND SCOPE

The current guidelines of Military Standardization Handbook MIL-HDBK-217, Reliability Prediction of Electronic Equipment, may not be applicable to certain classes of large-scale semiconductor memory devices. Therefore, in this study, two examples of new semiconductor memory technologies -- i.e., Magnetic Bubble Memory devices and Charge-Coupled Memory devices -- were examined to develop models for calculating their reliability.

Magnetic Bubble Memory devices are being used in increasingly larger quantities and research is continuing in the development of devices in the 10^6 -bit range. On the other hand, Charge-Coupled Memory devices have not been as widely accepted in the marketplace. Since competing technologies have proven to be more versatile, many manufacturers have discontinued their efforts in this area. Therefore, most of the effort in this study was concentrated on the Magnetic Bubble Memory devices because of their greater potential for being typical of future large-scale semiconductor memory systems.

FINDINGS

The methods of MIL-HDBK-217C (Proposed Notice 1) model for predicting the reliability of an N-MOS large-scale memory are suitable for the technology and chip architecture of the new Charge-Coupled Memory devices; therefore, we developed a model for the latter devices based on the applicable guidelines approach. To increase our confidence in the validity of this approach, theoretical

calculations of device failure rates were compared to the limited field data that were available. The correlation of the figures was within an acceptable range.

The Magnetic Bubble Memory uses thin-film technology for the memory structure and is a nondissipative array of magnetic elements. The data read and write elements are dissipative current loops deposited close to the permalloy memory elements of the same chip. The surrounding mechanical interface and magnetic elements that make up the remainder of the memory device were accounted for as discrete segments of the additive hybrid failure rate prediction model.

The Magnetic Bubble Memory devices are being used in some developmental systems, and in final product areas for evaluation purposes. Data have been developed on factors that affect the fabrication yield, but because of the limited field exposure to date little data have been developed on failure modes and failure rates of these devices. The high-capacity capability of these devices -- 10^5 or 10^6 bits poses some unique problems of "soft" error reliability not directly related to the class of failure normally considered in the guidelines of MIL-HDBK-217. The "hard" errors such as those normally related to catastrophic defects such as permanent physical defects in the structure, shorts, voids or other intrinsic flaws are the prime consideration in this study. The second class of defect is the "soft" error such as random, nonrecurring bit errors not associated with any physical defect. The "soft" errors may be due to system noise, pattern sensitivity or external effects such as alpha radiation. The failure rate model developed for the Magnetic Bubble Memory devices is based on catastrophic or drift-related failures and does not include the "soft" errors.

MODELS DEVELOPED

The failure rate model for Charge-Coupled Memory devices developed from Section 2.1.4-1 of MIL-HDBK-217C (Proposed Notice 1) is:

$$\lambda_p = \pi_Q [C_1 \pi_T \pi_V + (C_2 + C_3) \pi_E] \pi_L$$

As calculated with this model, typical failure rates of two to ten failures per 10^6 hours at 40°C compare favorably with the limited field experience.

The failure rate prediction model developed for the Magnetic Bubble Memory devices is based on a hybrid structure where the total failure rate is the summation of the individual failure rates, i.e.:

$$\lambda_p = \lambda_1 + \lambda_2 + \lambda_3 + \lambda_4$$

where:

λ_p = failure rate of the Magnetic Bubble Memory

λ_1 = failure rate of the sense elements

λ_2 = failure rate of the memory elements

λ_3 = failure rate of the interconnect structure

λ_4 = failure rate of the inductive elements

RECOMMENDATIONS

Because of the declining interest in charge-coupled devices, we recommend that no further study be devoted to their reliability prediction modeling.

The Magnetic Bubble Memory system is a very active area for the next generation of large-scale semiconductor memories. Consistent field data of failure rates and failure modes are needed for further verification of the reliability prediction model we have developed. In the interim, this model is satisfactory for comparative reliability analysis and as a guide for the accumulation of field data.

I. INTRODUCTION

A. BACKGROUND

Large-scale memory devices with capacity for storage in the order of 10^5 or 10^6 bits are rapidly emerging as realizable memory systems. Because the recommendations of the Military Standardization Handbook for the Reliability Prediction of Electronic Equipment MIL-HDBK-217 may not be adequate for this class of device, this study was initiated to evaluate the state-of-the-art of some of the new semiconductor memory devices in this category and develop a model for the prediction of failure rates for large-scale microcircuits.

The two devices selected as probably typical of the new state-of-the-art large-scale memory products are the Charge-Coupled Memory devices and the Magnetic Bubble Memory devices. As this study progressed it became evident that the development of Charge-Coupled Memory devices was declining and many of the manufacturers had withdrawn from the fabrication of this class of product. Therefore, it was decided that Charge-Coupled Memory products would not warrant the detailed evaluation required of the more dominant Magnetic Bubble Memories.

B. PURPOSE

The objective of this study was the development and validation of a reliability prediction technique for new state-of-the-art microcircuits, specifically high-density complex microcircuits such as Magnetic Bubble Memory and Charge-Coupled Memory circuits. The work was based on guidelines established in MIL-HDBK-217, "Reliability Prediction of Electronic Equipment."

The materials, process technology and fabrication techniques used in Magnetic Bubble Memory devices were evaluated. Established semiconductor reliability techniques were examined where applicable and data extrapolated to be used in the development of the proposed failure rate prediction model.

C. METHOD

Background information was developed by an extensive literature search of technical publications, manufacturers' data, and previous studies. A series of interviews was conducted with research personnel, manufacturers, probable device users, and various government and private installation involved in the design, development, manufacture or application of these two devices. The data were analyzed and a series of models was tested to develop a unique approach to a recommended prediction technique.

II. MAGNETIC BUBBLE MEMORY DEVICE OPERATION

A. TYPICAL OPERATING CHARACTERISTICS

Bell Laboratories and Western Electric have been fabricating Magnetic Bubble Memory devices for several years. The majority of these devices has been for telephone-related applications. IBM has been conducting research and applications development on Magnetic Bubble Memory systems for computer applications. Although various companies are fabricating memory systems encompassing a wide range of characteristics (Table 1), the principal U.S. manufacturers and suppliers of the Magnetic Bubble Memory Devices for general use are Texas Instruments, Rockwell International, and Intel Magnetics.

B. GENERAL DESCRIPTION

Magnetic Bubble Memory devices are a hybrid mass-memory that features nonvolatility, low-power operation, and high-density storage. The basic memory is an epitaxial film of magnetic material on a nonmagnetic garnet crystal substrate with a surrounding magnetic bias field mechanism to complete the basic hybrid module. With the present state-of-the-art, 10^5 -bit systems are being evaluated in the field and 10^6 -bit systems are feasible.

Much of the early work on Magnetic Bubble Memory structures was done by Bell Laboratories starting in the late 1960's. In addition to Bell Laboratories (and Western Electric) at least three U.S. manufacturers now offer memory devices for commercial use, and a few non-U.S. manufacturers are entering the marketplace.

TABLE 1

KEY CHARACTERISTICS OF CURRENT MAGNETIC BUBBLE MEMORY DEVICES AND COMPARABLE SEMICONDUCTOR MEMORY DEVICES***

CHARACTERISTIC	TEXAS INSTRUMENTS T1B0203	TEXAS INSTRUMENTS T1B0303	ROCKWELL RM256	INTEL MAGNETICS 7110	NATIONAL MM5290*	FAIRCHILD F16K*	SIGNETICS 2690*	TEXAS INSTRUMENTS TMS4164*	AMI S4028**
Storage Capacity (K Bits)	92	254	256	1000	16	16	16	65	16
Typical Access Time	4 ms	7.3 ms	4 ms	41ms	150 ns	150 ns	150 ns	100 ns	150 ns
Maximum Data Rate (KBPS)	50	100	150	100	--	--	--	--	--
Power Dissipation (W)	0.7	0.9	0.82	6	0.5	0.375	0.46	0.25	0.5
Operating Temperature Range (°C)	0 to 50	0 to 50	-10 to +70	0 to 70	0 to 70	0 to 70	0 to 70	0 to 70	0 to 70
Dip Configuration (No. of Pins)	14	20	18	20	16	16	16	16	24
Technology	MEM	MEM	MEM	MBM	NMOS	NMOS	NMOS	NMOS	NMOS

*Dynamic Ram

**Static Ram

***The data is from published data sheets.

The magnetic bubble device is fabricated using technology similar to semiconductor processes. The magnetic domain centers are formed in a magnetic epitaxial film of garnet crystal on a nonmagnetic garnet substrate, and the magnetic domains tend to form or orient themselves in fields perpendicular to the surface. An external field, developed by a permanent magnet structure modulated by two orthogonal electromagnetic coils supported around the garnet substrate, is used to control the bubble formation, location and polarity.

The most widely used basic substrate is a high-purity gadolinium garnet. The thin-film magnetic layer is of the same crystal class with a compatible coefficient of expansion to maintain adhesion strength. Discrete bubble location and pattern is determined by an organization of permalloy elements deposited on the epitaxial surface with an intervening silicon dioxide (SiO_2) insulating layer.

The basic principle of operation of a Magnetic Bubble Memory is the controllable ability to develop small cylindrical magnetic domains in the magnetic film normal to the film by application of an external magnetic field. The magnetic domains are cylinders normal to the epi film, and the circular cross-section area on the film surface takes on the shape of a bubble when viewed under a polarized light, giving the technology the term "bubble." Over a finite range of the external magnetic bias field these bubble domains remain intact. At higher magnetic fields than the "bias range," the bubbles decrease in size and reverse the polarity of their magnetism to that of the surrounding material and cease to exist. When the field is reduced below the bias margin limit, the "bubble" or cylindrical domain deforms into an elongated area and loses its identity as a defined site. The finite useable bias range is unique to a particular bubble structure and is a unique property of the individual design. Individual magnetic domains are considered as "logical ones" and the absence of a domain at a site is a "logical zero."

Strips of magnetic material such as permalloy are located on the epi film by a photolithographic process. A rotating external magnetic field will shift the polarity of these permalloy strips and, in effect, move the magnetic domain along. This apparent movement is actually an orderly rotation of the individual magnetic vectors accomplished by a local reversal of the field to enhance the attraction of the bubble domain to a nearby magnetic area. The permalloy strips form a corridor to guide the bubble propagation and create a data stream of "ones" or "zeros."

At a juncture point of the permalloy pattern, the presence of a bubble can be detected by a change in the magneto-resistance of the permalloy. A bridge arrangement adjacent to the permalloy is used to develop a signal of the presence or absence of a magnetic domain. One leg of the bridge is a reference pattern away from the permalloy and a second leg of the bridge is a conductive pattern under the permalloy site. A change in the resistivity will occur in the presence of a magnetic domain.

A nondestructive read, or "replicate" function, is accomplished by temporarily elongating a bubble by a field developed by the conductor loop current. The bubble is split into two sites by the injection of a current pulse at the midpoint of the bubble to cause the stretched bubble to collapse into two parts. One site rejoins the circulating data stream, and the second is read out as a "one" or "zero" by a sensor loop.

To write in data, a current loop is used to locally magnetize a data site in the data chain of a specific polarity to produce the desired "one" or "zero" state. Passing a pulse of current through a loop of current conductors located under a permalloy strip will alter the bias field of the permalloy element. The direction of the localized field, the direction of the horizontal field during the pulse and the configuration of the permalloy element determine the effect on the bubble.

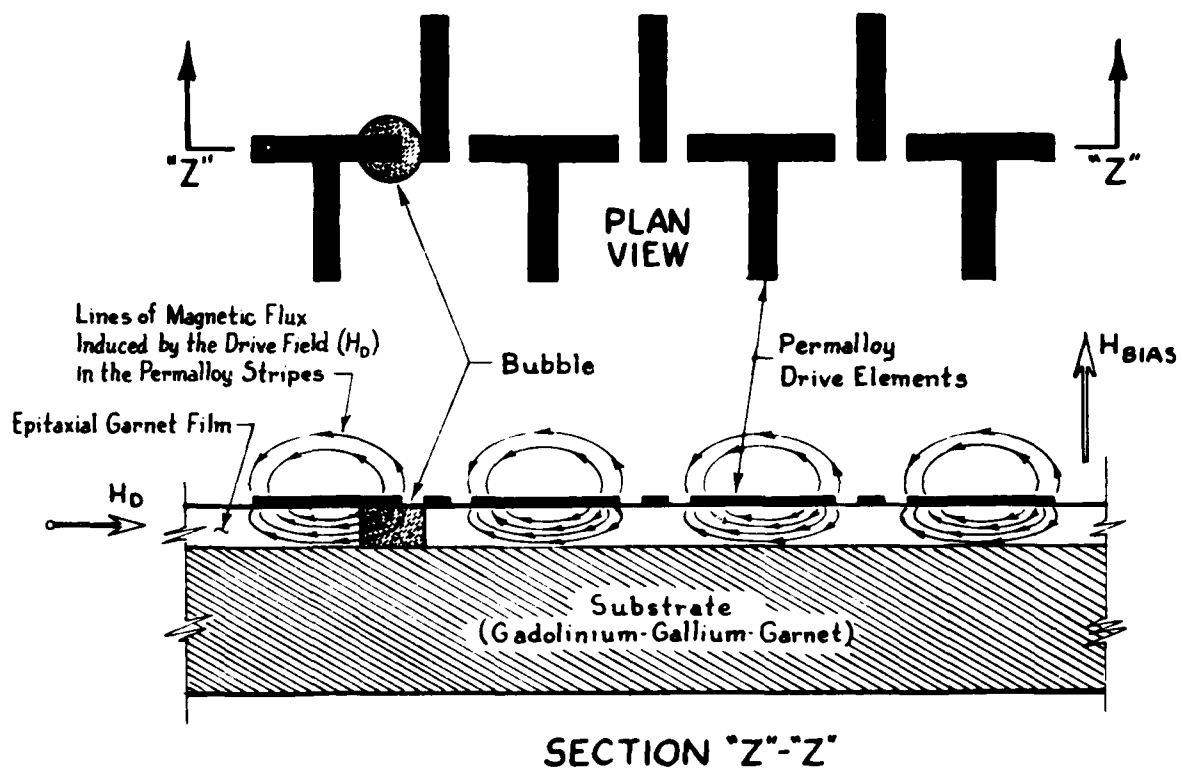

TYPICAL MAGNETIC DOMAIN PROPAGATION

Figure 1

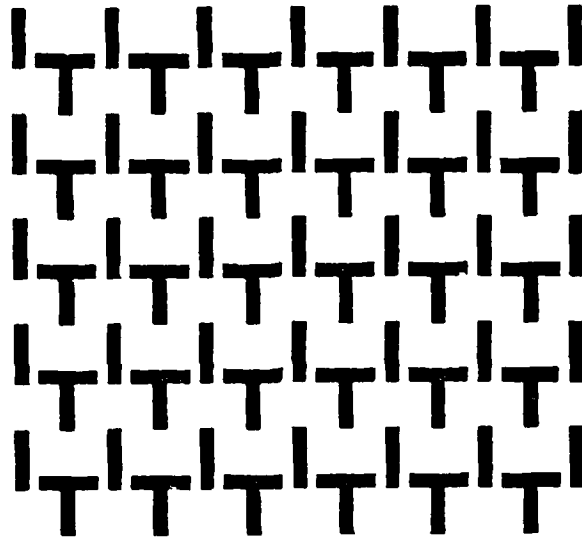

T AND BAR PATTERN

Field
Vector

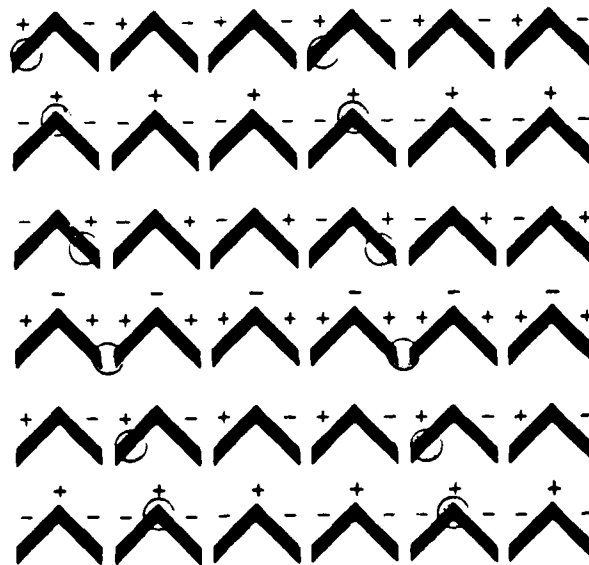

CHEVRON PATTERN
(Bubble Position Versus Magnetic Field Vector)

Figure 2

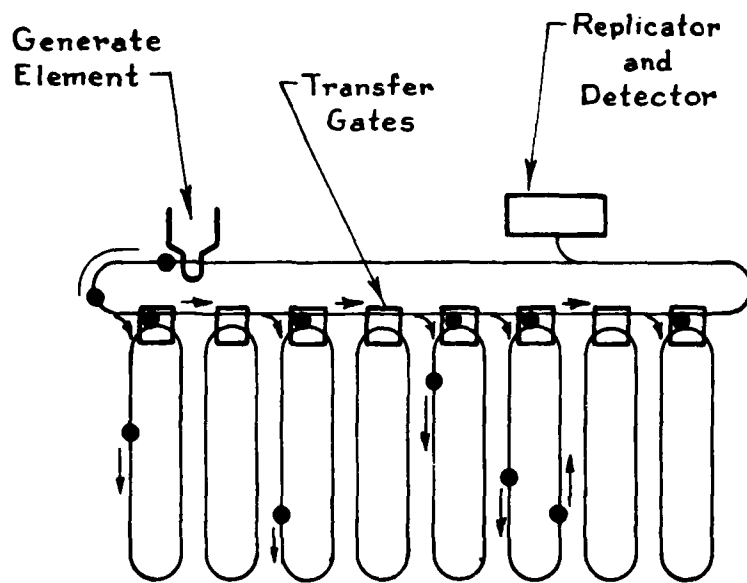

LOOP ORGANIZATION

Figure 3

The generate function inverts the bias field to allow the formation of a new bubble. The annihilate function is the collapse of a bubble when the immediate field is intensified, and the transfer function is the movement of a bubble from an element on one track to an element on another track.

The data are circulated in a series of minor loops or tracks, each independent of the other. The data are transferred to a major loop on command, thus developing a selective serial read-out or read-in system. The read and write functions are normally accomplished on the major loop or loops and transferred to the desired minor memory loop as selected by the logic.

The chip architecture is a series of minor loops that make up the body of the memory, one or more major loops to transfer data, generate circuitry, replicate circuitry, state sensors.

For the current state-of-the-art, the minimum practical bubble diameter is in the order of $2\mu\text{m}$ (micrometer) to $3\mu\text{m}$ (micrometer). Experimental devices are being fabricated with bubble diameters of less than $1\mu\text{m}$. For a nominal chip size of 0.4×0.4 inch where from 70% to 80% of the area is available for minor loops, a memory capacity of 256K bits is practical with a bubble size of $3\mu\text{m}$. With bubbles $2\mu\text{m}$ or smaller in diameter, it may be possible to develop a capacity of 10^6 bits in a 0.4-inch square chip. This increased capacity per unit area results in a greater memory density. The required sensing, write or control elements do not increase in direct proportion with the added bit capacity; therefore, with a slightly more efficient bit size and a small increase in chip size, the memory capacity can increase without a major increase in substrate or chip area.

The rotating external magnetic field is supplied by two orthogonal coil sets. These are placed around the chip to develop a uniform and efficient field coupling. Connection from the coils to the coil-driving contact areas is via an intervening substrate, usually a printed circuit card. The total assembly is enclosed in a magnetic shield to reduce interference from external fields. The assembly is encapsulated in a Dual In-Line Package (DIP) format, nonhermetic hybrid package of 18 to 38 leads.

The generation of the magnetic domains in the epitaxial film depends upon the purity of the film and the underlying crystalline substrate. Individual defects can cause malfunctions, errors, or failures in a specific area of a data stream. A memory is typically made up of many minor loops and the individual defect will only affect the loop using that area. By external software organization the affected loop can be deleted from use and the remainder of the memory operated with no ill effect. The total available memory is less than the theoretical maximum, but a practical yield can be achieved by this mechanism.

Although each manufacturer's construction is unique, in general, the basic constructions are similar to each other. Most of the individual manufacturer's uniqueness lies in the specifics of the process steps and in the chip and total memory architecture. Choices of coding to select minor loops, organizational grouping of minor and major loops, and read/write functions are the variable parameters of the memory architecture.

As shown in Figures 4 through 8, a Gadolinium-Gallium Garnet (G^3) substrate is coated with an epitaxial film of iron garnet in a lattice structure followed by a silicon dioxide (SiO_2) protective layer. Contact areas of Aluminum-Copper (AlCu) are deposited by a photolithographic process, and then a protective insulating layer of SiO_2 is added. The permalloy Chevron, the I-, or the Tee-structure is applied by photolithography and a final passivating layer of SiO_2 added. Contact areas to the pads are etched out and the total structure annealed prior to chip scribing and separation.

The chips are mounted on a substrate that in many cases is a printed circuit (PC) board. The chip contact areas are wire bonded to the PC contact areas. The orthogonal coil assembly is mounted around the chip/PC board assembly and bonds carried from the coils to the PC board as in Figure 9. A lead frame is attached prior to the assembly of the permanent magnet structure bias field and a magnetic shield. The magnets are adjusted for optimum bias field via access holes and the completed assembly is encapsulated. (See Figures 10 through 13.)

C. MAJOR/MINOR LOOP

The individual data bits are stored in circulating minor loops. Depending upon the organization of the individual manufacturer's chip architecture, these loops can store on the order of 256 to 1,000 bits of data each. To enter data, or to retrieve data from a selected minor loop the data are temporarily transferred, in a nonvolatile and nondestruct transfer, to a major loop. Read and write functions are performed on the circulating major loop and the data transferred back to the appropriate minor loop.

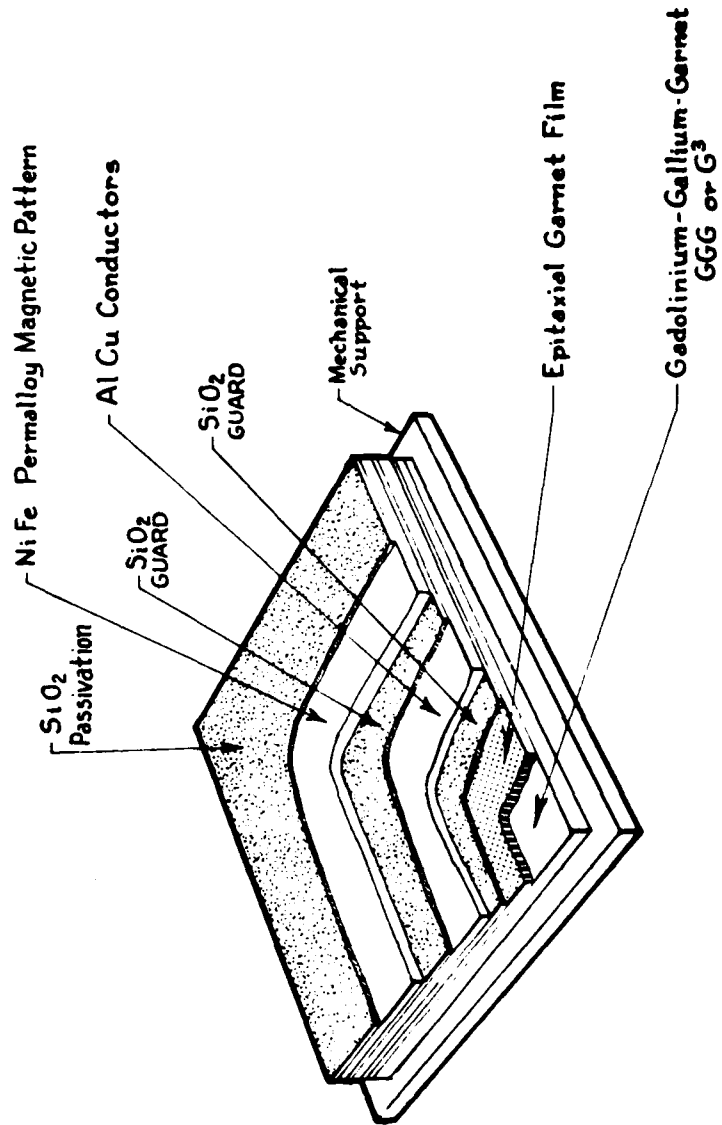

MATERIAL LAYERS OF MAGNETIC BUBBLE MEMORY CHIP

Figure 4

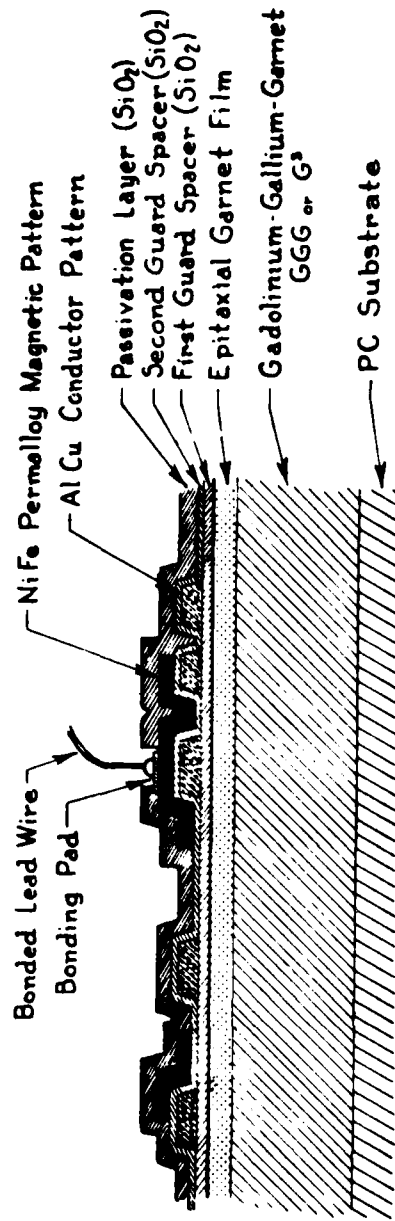

CROSS-SECTIONAL VIEW OF MAGNETIC BUBBLE MEMORY CHIP

Figure 5

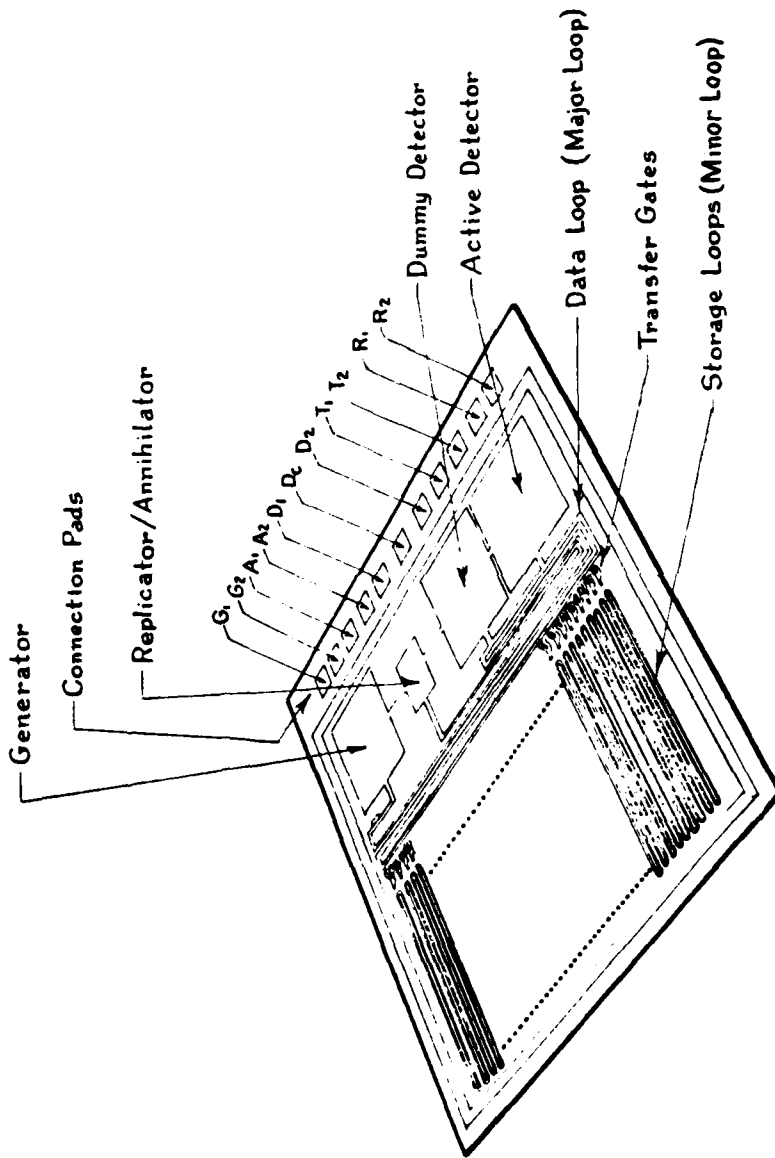

LAYOUT OF ELEMENTS
MAGNETIC BUBBLE MEMORY CHIP

Figure 6

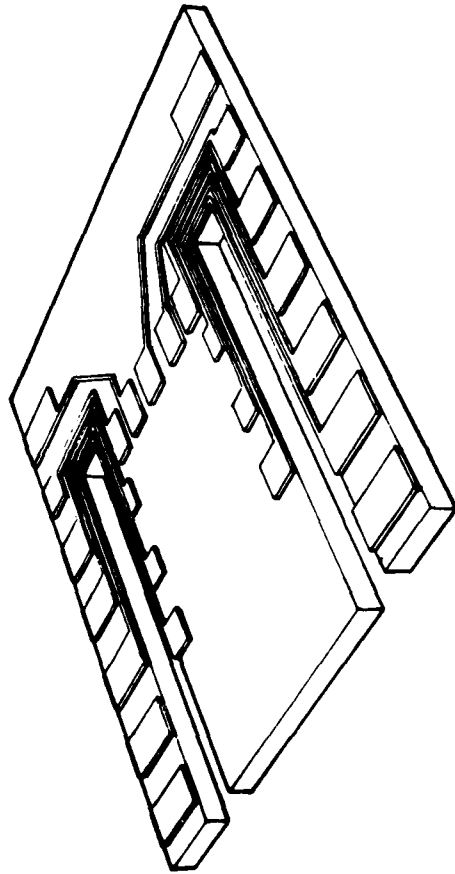

**BUBBLE MEMORY
PRINTED CIRCUIT SUBSTRATE**

Figure 7

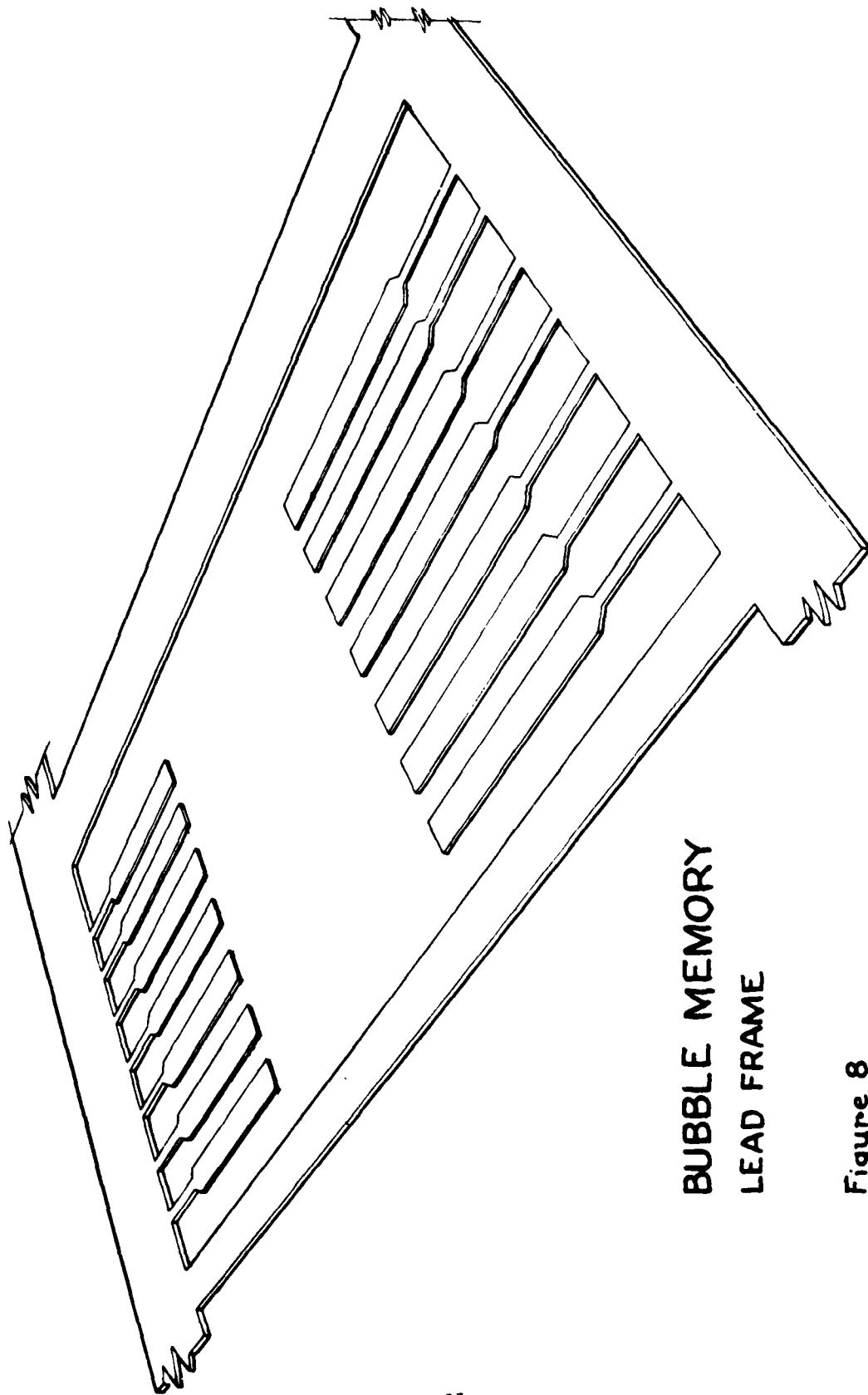

**BUBBLE MEMORY
LEAD FRAME**

Figure 8

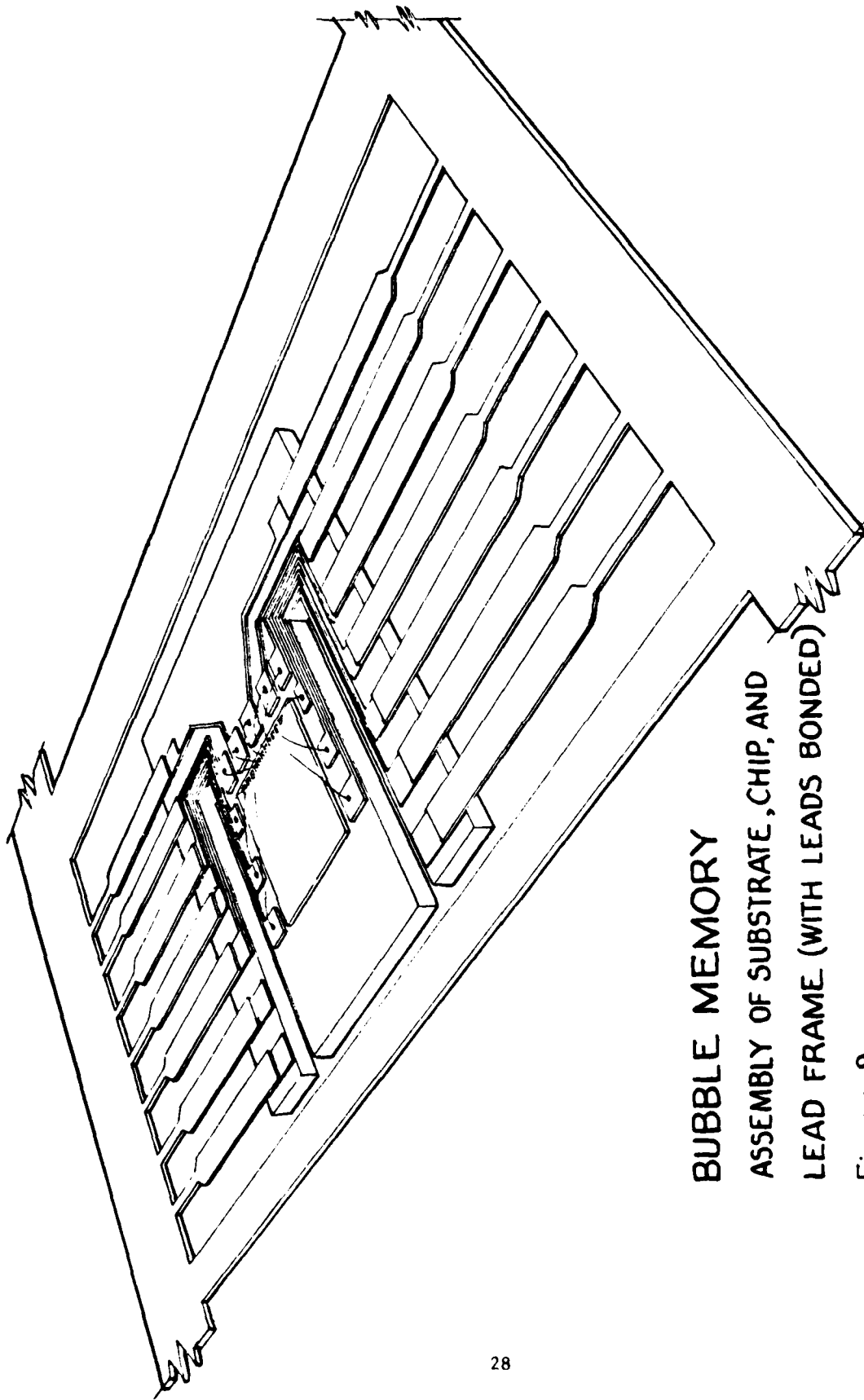

**BUBBLE MEMORY
ASSEMBLY OF SUBSTRATE, CHIP, AND
LEAD FRAME (WITH LEADS BONDED)**

Figure 9

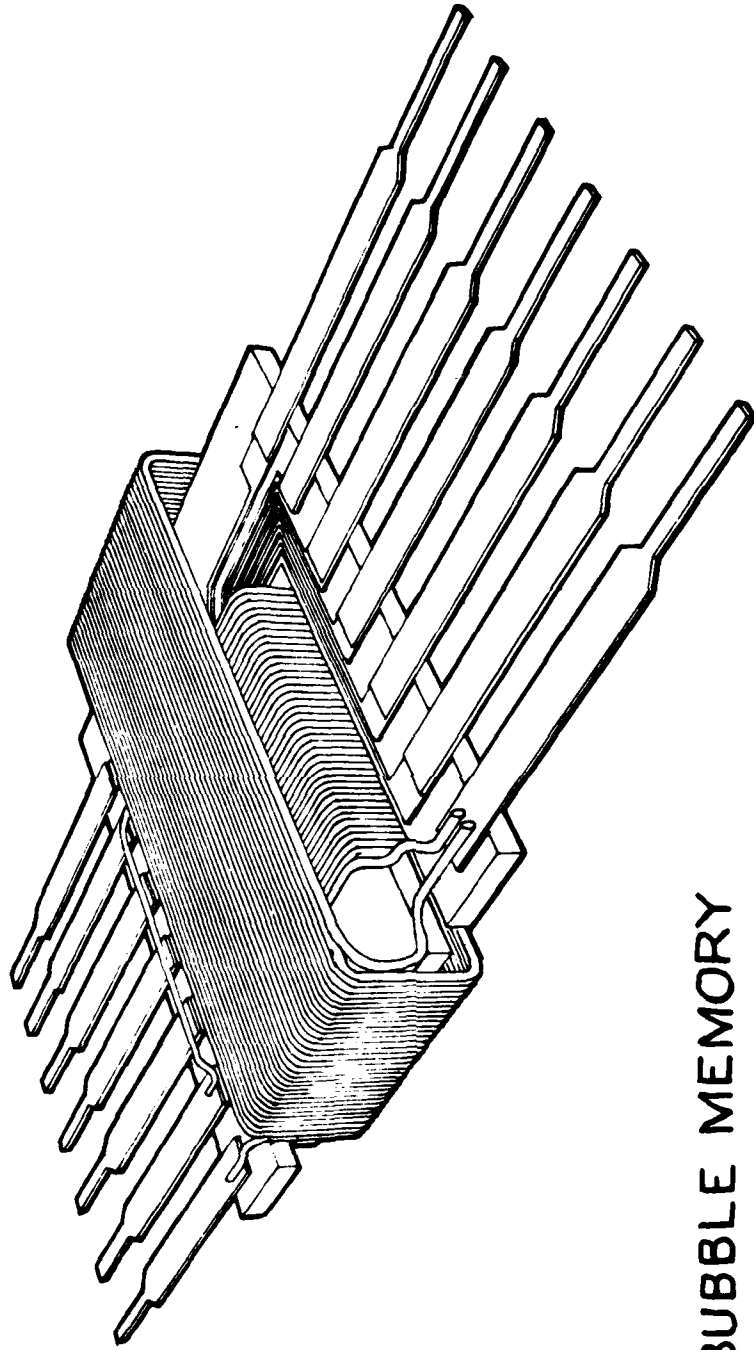

**BUBBLE MEMORY
LEAD FRAME TRIMMED AND
ORTHAGONAL COILS INSTALLED**

Figure 10

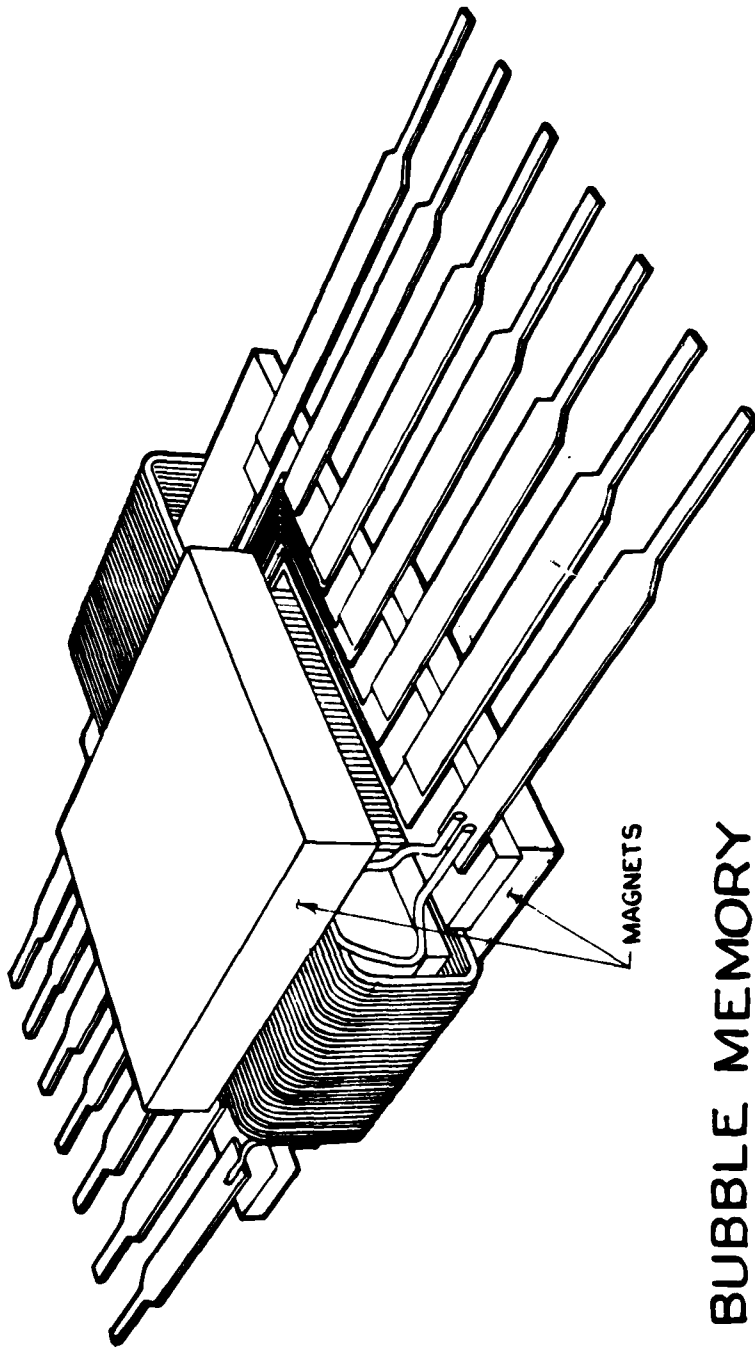

**BUBBLE MEMORY
MAGNETS INSTALLED**

Figure 11

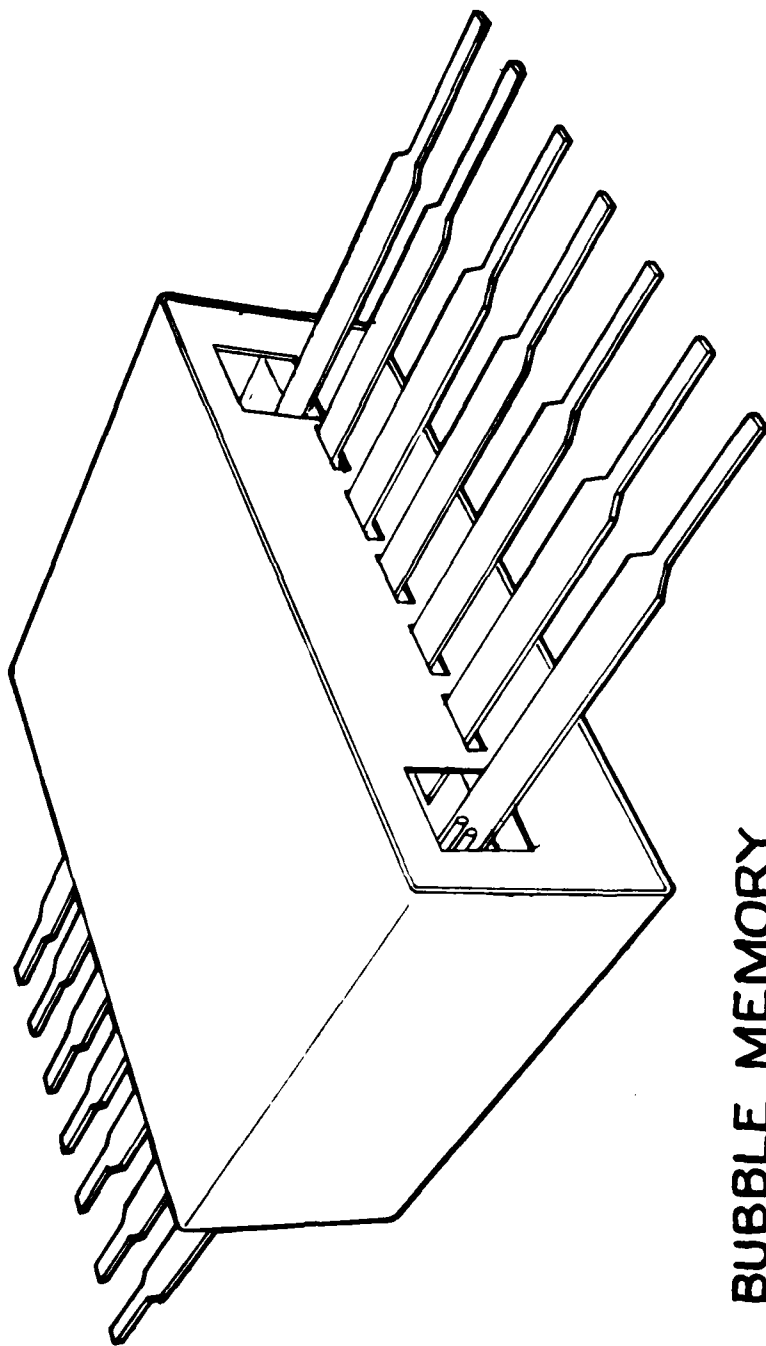

**BUBBLE MEMORY
MAGNETIC SHIELDS
INSTALLED**

Figure 12

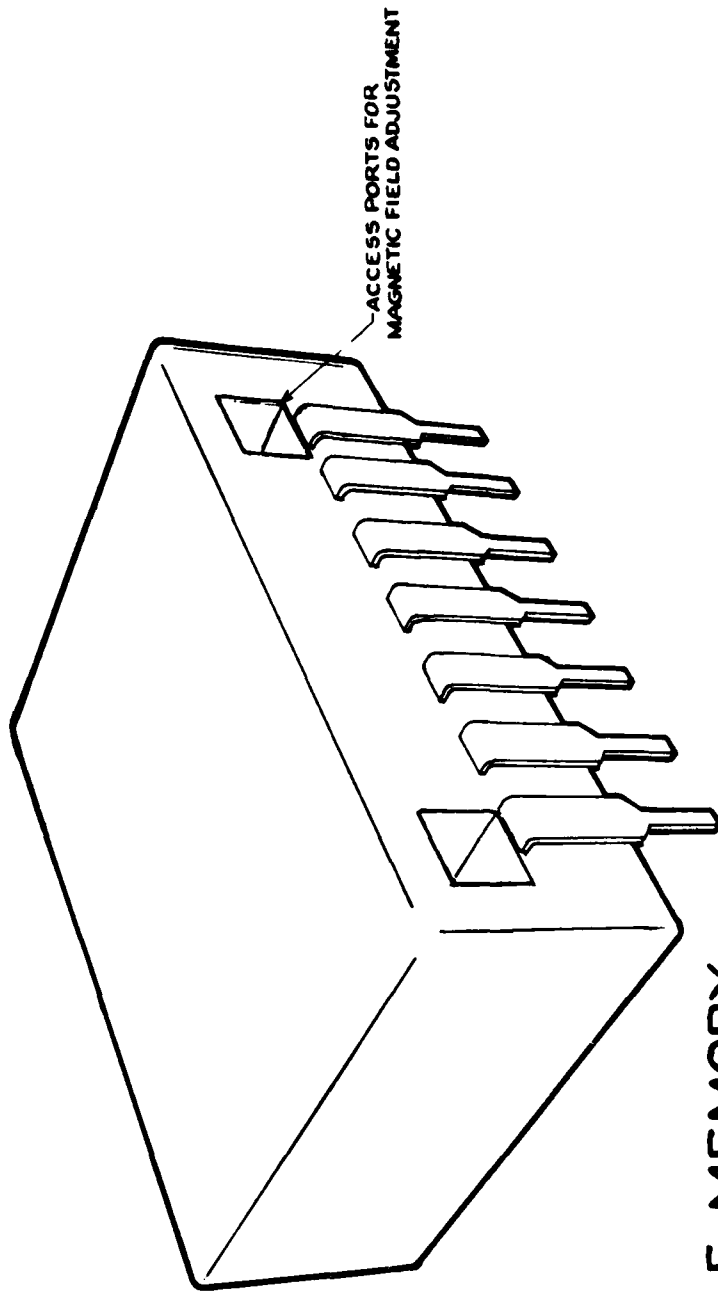

**BUBBLE MEMORY
ENCAPSULATED
AND LEADS FORMED**

Figure 13

The process of transferring from minor to major loop in some popular chip architectures can be described as a serial-parallel-serial organization of minor serial shift registers. Data are generated serially into a major loop shifted into position over a reference area of the minor loops. The data are then transferred in parallel to the minor loop for storage. The procedure is reversed for data read out. The data are transferred to the major loop in parallel and are clocked serially through a detector (Figure 14).

The general approach allows a reasonably fast access time to data at any location. Access times on the order of 5 milliseconds (ms) to 10ms and data rates of 100 kilobits per second (kbps) are nominal. Of greater importance is the capability to map the semiconductor chip to identify defect areas and delete them from the memory organization at a nominal loss of storage capacity, but at a major increase in yield. The wafer chip size and density is such that only by the mapping mechanism is a useable yield practical in everyday production.

D. MAGNETIC FIELD OPERATION

The magnetic bubble domains are formed in the magnetic epitaxial film in a plane perpendicular to the nonmagnetic substrate. These domains are formed by an orderly arrangement of magnetic fields. The external field provides a "bias" energy level to develop the bubble domains. Specific location and movement of these domains is accomplished by a local alteration of the bias field. A polarized magnetic domain, or bubble, is shifted or moved along a race track route of magnetic segments. When modulated by an external alternating magnetic field, the magnetic bit polarity of the segments is inverted with each cycle. The effect of this alternating magnetic polarity is that of data movement along the path defined by the magnetic segments.

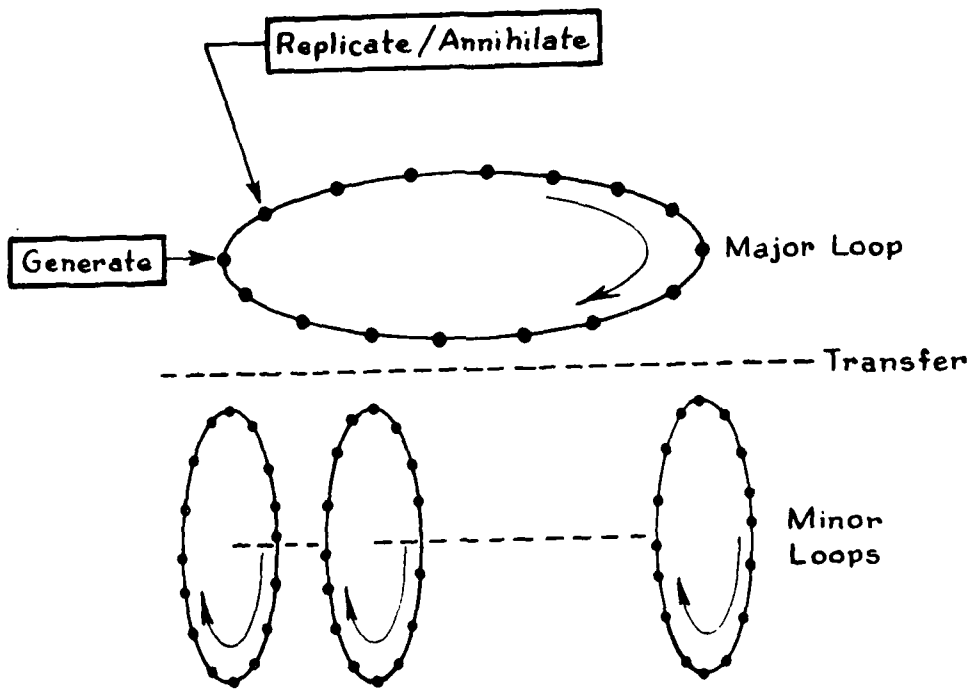

MAJOR / MINOR LOOP OPERATION

Figure 14

Bubble generation, bubble size and bubble stability are dependent upon characteristics of the material, photolithography of the magnetic pattern, and the strength of the bias field. The optimum bubble size for a particular material and pattern is approximately equal to twice the thickness and equal to the ratio of energy per unit area of the domain wall to the saturation magnetism ($d \approx 2h = \frac{2\sigma}{4\pi M_s}$ where d = diameter of bubble, h = thickness, σ is the energy per unit area and $4\pi M_s$ is the saturation magnetism). The external field required to sustain a stable bubble is the bias. In general, a higher bias level is required for the smaller bubble diameters, but stability of the bias field is about 10% to 12% of the nominal level. The saturation magnetism is influenced by temperature, and the allowable margin of bias limits is a function of the temperature range of operation. Over a range of 70°C bias margin limits of 10% to 12% are generally realizable, but over a wider temperature range such as the 110°C often specified for Military applications the allowable bias margin shrinks.

Original chip design data and recommended operating limits should take into account these required control parameters. If a device is operated within some margin limit of about 80% of the combination of all control limits, then reliable operation is attainable.

III. MAGNETIC BUBBLE MEMORY FAILURE RATE MODEL

A. DEVICE TEST DATA

A Magnetic Bubble Memory system is relatively new, and there is little field data at this time which we can use as a basis for describing or predicting probable operating reliability. Some of the data that have been reported have been for a total system and not the basic memory device. Device operating reliability statistics have been difficult to obtain, and much of the data have been more qualitative than quantitative. Because of the large scale of memory capacity much of the reliability reporting has been in the error rate of memory retention and read-out.

In a test of a 2 Megabit (Mbit) Magnetic Bubble Memory* structure with thirty-two 64 Kilobit (Kbit) chips, an analysis was made of a probable failure rate. Bias margins were varied over a range that was calculated to simulate more than 20 years' operation and cycled over the temperature range from -10°C to 50°C to stress the magnetic parameters. The read-error rate was less than 9×10^{-12} /read.

Another classification of performance or reliability is the soft error rate, a phenomenon which is not as easily classified, measured or compared, but one which is a practical problem of the management of large-capacity memories. Soft errors may be defined as random, non-recurring single-bit errors, some of which may be accounted for by software manipulation. Soft errors may be caused by a combination of noise, data pattern sensitivity, and/or marginal operating conditions.

*2-Mbit Magnetic Bubble Memory
Tsuboya, et al., IEEE Transactions on Magnetism, Sept. 1977.

A manufacturer* tested more than 200 Magnetic Bubble Memories over a wide range of environmental conditions. These accelerated tests were in accordance with MIL-STD-883A, as applicable. The devices tested were 93-Kbit memories and the criteria for failure were of two classes. A catastrophic failure was defined as a continuity failure such as an open or shorted element. Function failures were defined as repeatable 1-bit or more-than-1-bit errors out of 10^6 bits, or a failure to retain stored data. Soft errors were not classed as errors for this series of accelerated tests.

Of the more than 200 devices tested, for a total of over 100K unit hours, only two devices failed catastrophically: one wire bond separated from a pad; and at extreme low temperatures (-40°C), one unit had a shift of the magnet structure during the test of data retention. Five devices had a repeatable functional error during the test series. From the test results it was estimated, with a 60% confidence level, that in an application of 6.8×10^7 bits per year, the failure rate is approximately 0.001 part per 10^6 hours at 50°C .

The data in a magnetic bubble memory are the predictable presence or absence of a magnetic domain or "bubble" in a location, at a particular instant in time. Much concern has been expressed that the materials may have a wear-out characteristic. A series of tests** has shown that error-free operation of long-time exercising of the order of 10^{15} bubble steps is realizable. At data rates up to 100KHz the bias field may decrease, but can be controlled to allow error rates as low as 10^{-20} per step.

*Texas Instruments Reliability Report T1B0203, June 1979.

**"Long-Term Propagation Studies in Magnetic Bubble Devices," P.W. Shumate, et al., Bell Laboratories, Murray Hill, NJ 07974.

"Lifetime Characterization of Propagated Bubble Data Streams," P.W. Shumate, et al., Bell Laboratories, Murray Hill, NJ 07974.

The results of an extensive testing* of more than 800 68-Kbit magnetic bubble memory chips configured into 200 memory systems indicate that the device may have a high degree of reliability. In general, the majority of Magnetic Bubble Memory devices are in non-hermetic packages. In the end-use system, it is common practice to put two or more of these packages in a single hermetic package. Even then, there are the familiar problems of integrated circuit reliability. Losses are largely attributed to mechanical faults such as loss of a bond, or weakening of a conductor track accelerated by a package leak. The major problems of the bias-margin limits are to a large extent compensated for by early characterization of the device limits and control of the bias margin over the expected operating range. This is practical for individual systems where only a few chips are used, and where the extra care and engineering attention is warranted. For large-scale reproducible general-purpose applications, this may not be feasible.

From this study, for this particular design, a bias margin of ± 12 Oersteds (Oe) was required for acceptable reliability. Of the units 10% failed this criterion; 11% of the units were outside the limits of a nominal 40 Oe drive field; and the remaining 75% to 80% of the units were packaged for field use. Of this group, another 35% failed final qualification tests.

A two-year test** of a 0.5-Mbit capacity Magnetic Bubble Memory system demonstrated a capability to operate reliably with a read-failure rate of 1.9×10^{-12} /read. This test was performed in a somewhat benign environment which simulated a real-use condition

*"Magnetic Bubble Testing," F. B. Hagedorn, et al., IEEE Transactions on Magnetics, Sept. 1978.

**"Tests for Magnetic Bubble Memory," N. Yamaguchi. IEEE Transactions on Magnetics, Sept. 1978.

rather than the usual accelerated stress functions. No significant changes were noted in the bias field or magnetic structure during the test period, of which approximately one-half was operating time for the memory device. A variety of special test programs and environmental conditions were imposed on the devices. Operating bias margin limits were verified several times during the test and no significant changes were noted.

Typical of current production units are those reported by a manufacturer in 1979.* A life-testing program has been completed on a 1-Mbit Magnetic Bubble Memory. This unit is a series parallel unit with 320 parallel data loops, 48 of which are reserved for manufacturing defects, and 16 are used for error correction codes. The system has a capacity of 128 Kbytes (1 byte = 8 bits) or 1,048,576 bits. A read error rate of 10^{-9} /read is predicted. This equipment points up one of the typical problems confronting an analysis of the Magnetic Bubble Memory system. At these bit densities and capacity, on the order of 10^6 bits, only a few units are fabricated and testing is of the product-acceptance rather than stress-level type. Only infant mortality-type data are available; the remainder are projections.

B. PERMALLOY CORROSION AND ELECTROMIGRATION

Use of permalloy iron-nickel alloy elements in Magnetic Bubble Memory devices is widespread, but there is some concern that corrosion of the thin ($\sim 0.45 \mu\text{m}$) elements may lead to premature failure. The likelihood of this may be assessed in an examination of the behavior of such devices, or their thin-film components in a corrosive atmosphere, and what might be predicted from work published on the alloy in bulk.

A useful published work on corrosion of thin films of permalloy is that of Gangulee et al.* In this work, 0.02- μm permalloy films were heated to 250°C with and without the presence of air, and were shown to oxidize to the point of magnetic failure in 100-200 hours if air was present. However, coatings of 0.5 μm Silicon Oxide (SiO), Silicon Nitride (Si_3N_4) or Aluminum Oxide (Al_2O_3) all protected the devices from degradation for the entire test period of 500 hours. While some concern was voiced that SiO or Al_2O_3 might be water-permeable under extreme moisture conditions, some samples coated with 0.5- μm Al_2O_3 survived more than 1-1/2 years at 250°C, while passing a current equivalent to 10^7 amperes per square centimeter (A/cm^2). Other test specimens coated with Si_3N_4 and SiO were boiled in water for 50 hours without ill effects from this rather extreme treatment.

"Bulk" iron-nickel alloys have been reported by Pettibone to exhibit corrosion resistance better than that of pure nickel.** Thinning of specimens of 80% nickel, 20% iron, indicate loss through smooth corrossions with no pitting of only about 10 μm in ten years of exposure to an industrial atmosphere. If this is presumed to be a linear function with time, then it supports qualitatively the work of Gangulee on thinner films. Pettibone also refers to earlier work suggesting that if the sample is kept in a benign environment or coated lightly, corrosion "may be entirely absent."

From these references, one may anticipate the following:

- 0.45- μm permalloy films exposed to air at 250°C may fail within one year.
- 0.45- μm permalloy films exposed to an "industrial atmosphere" may fail within one year.

*"Long-Term Stability of Magnetoresistive Bubble Detectors," A. Gangulee, et al., IEEE Transactions, April 1974.

**"Nickel Iron Alloys," J.S. Pettibone. Corrosion Resistance of Metals and Alloys, Reinhold Publishing Corp., New York.

- 0.45- μm permalloy films protected with 0.5- μm Al_2O_3 should tolerate exposure to an industrial atmosphere for several years unless extreme temperature and humidity conditions prevail.
- 0.45- μm permalloy films protected with SiO or Si_3N_4 should be free from corrosion under the most severe conditions imaginable for many years.
- Other easily applied coatings such as plastic films and protective housings may also give added protection.

The conductor film layer for read/write control current loops and magneto resistive bridge elements is deposited between the epitaxial film and the permalloy strips. Insulating layers of SiO_2 separate the conductor pattern from the permalloy and the epitaxial layer. The current requirements of the loop may be in excess of 10^7 A/cm^2 . A potential failure mode may now exist from electromigration effects. The aluminum conductor layer usually contains 4% copper to reduce the probability of migration, but the high current density level may be a problem.

J. E. Davies of Intel Magnetics has completed a study* on the electro migration in Magnetic Bubble Memory structures and has concluded that because of the low duty factor of less than 1% and the use of 4% copper in the aluminum conductor material that an MTTF in excess of 100 years is reasonable even operating at 70°C .

In this same study the question of intermetallic interdiffusion and chemical reaction was evaluated in the case of gold bond wires on Cu-Al conductors. No measureable decrease in bond strength was noted after aging of 240 hours at 200°C . At an activation energy

*"The 7110, a one Megabit Magnetic Bubble Memory Reliability Report RR-22; J.E. Davies, Intel Magnetics, Santa Clara, CA 95051 Sept. 1979.

level of 0.8 eV the aging time of 240 hours at 200°C extrapolates to 30 years at 70°C chip temperature. The validity of the exact activation level and the errors possible in long lifetime extrapolations may be a question, but the general trend is comparable to other banding techniques to a degree as to give rise to some optimism that with adequate care and control this is a viable interconnect technique.

Current densities of 10^7 A/cm² applied to small geometry thin film aluminum conductor patterns can cause early failures because of the inability of the conductor to dissipate this level of energy. Intermittent application of high density currents of this order of magnitude may reduce the problems of gross heat dissipation, but may introduce new problems of local hot spot degradation and fatigue or metallic degradation induced by repetitive temperature excursions. The indications by several studies* are that the time to failure may increase rapidly with current densities greater than 2×10^7 A/cm² as a function of duty cycle and repetition rate. At pulse widths of 0.1 μ s, repetition rates of 100 KHz and current densities of 2.8×10^7 A/cm² failures start to occur. A small reduction of the current density towards 10^7 A/cm² reduces the local heating to a level as not to be a major detriment to long-term reliability.

*Failure of Small Thin film Conductors due to High Current Density pulses. E. Kensbrou et al. Bell Laboratories 1978.

C. CALCULATED RELIABILITY OF SEMICONDUCTOR MEMORY DEVICES

The reliability handbook MIL-HDBK-217C (Proposed Notice 1) provides guidelines for estimating the reliability of memory devices. These guidelines were developed and verified from field data on relatively low-density devices. Not much field data have been available on the large-scale integrated circuits and the calculations for these devices are still unproven. This is a similar problem that is being investigated for Magnetic Bubble Memory Devices.

The leverage and sensitivity of certain of the parameters of the calculations become more significant with the increase of bit capacity as well as the increase of bit density. The basic reference philosophy for the categories and characterization of many of the parameters is that the devices being evaluated are part of a large population and that the devices are produced and procured within specific guidelines. These assumptions set bounds on the data developed rather than to restrict the design or acquisition of the devices. General experience has shown that deviations from these prescribed conditions cloud the data and reduce the confidence level of the accuracy of prediction. These deviations are not necessarily a cause of reduced reliability, but because of the lack of control it is assumed that -- in general -- for a wide sampling, a major decrease in reliability could be expected, particularly if the wide range of environmental conditions is expected. It is rational to expect that for a narrow sample, and for restricted environmental or applications conditions, modifications to the base parameters may be justifiable. This concept is a major consideration in the rationale for the judicious use of the MIL-HDBK-217C (Proposed Notice 1) guidelines in large-scale integrated circuit memory devices and, until more definitive data are available, will also be applicable to some of the recommendations for Magnetic Bubble Memory calculations.

In a report by the ITTRI Reliability Analysis Center* in 1979, a comparison was made between actual field data and calculated values of predicted failure rates for memory devices. (See Figures 15 and 16 and Tables 2 and 3.)

To illustrate the effect of certain of the basic parameters on a predicted reliability, the results of a few sample calculations are listed in Table 4. From a general statistical viewpoint the impact of memory density on reliability is a controversial subject. Semiconductor defects are random; even with the utmost care in the process, some defect density will exist. With an increase in the number of IC elements there is the increased possibility that one of these defects will interfere with an active element. The general experience of large-scale integration is that as the bit quantity increases, the trend is to increase the bit density to control substrate area growth. Conversely, as the density increases because of reduced element size and improved layout efficiency, smaller defects in the substrate can cause catastrophic failures.

Calculations of memory device reliability with the guidelines of MIL-HDBK-217C (Proposed Notice 1) correlate to available field data at memory sizes up to about 4096 bits. This is illustrated in Figures 15 and 16. For memory capacity up to 65,536 bits additional calculations have been made as listed in Table 4. This data is presented to establish a reference for comparison of the reliability calculations of a Magnetic Bubble Memory or Charge-Coupled Device memory from the models recommended in this report.

*LIS/Microprocessor Reliability Prediction
Model Development
RADC-TR-79-97

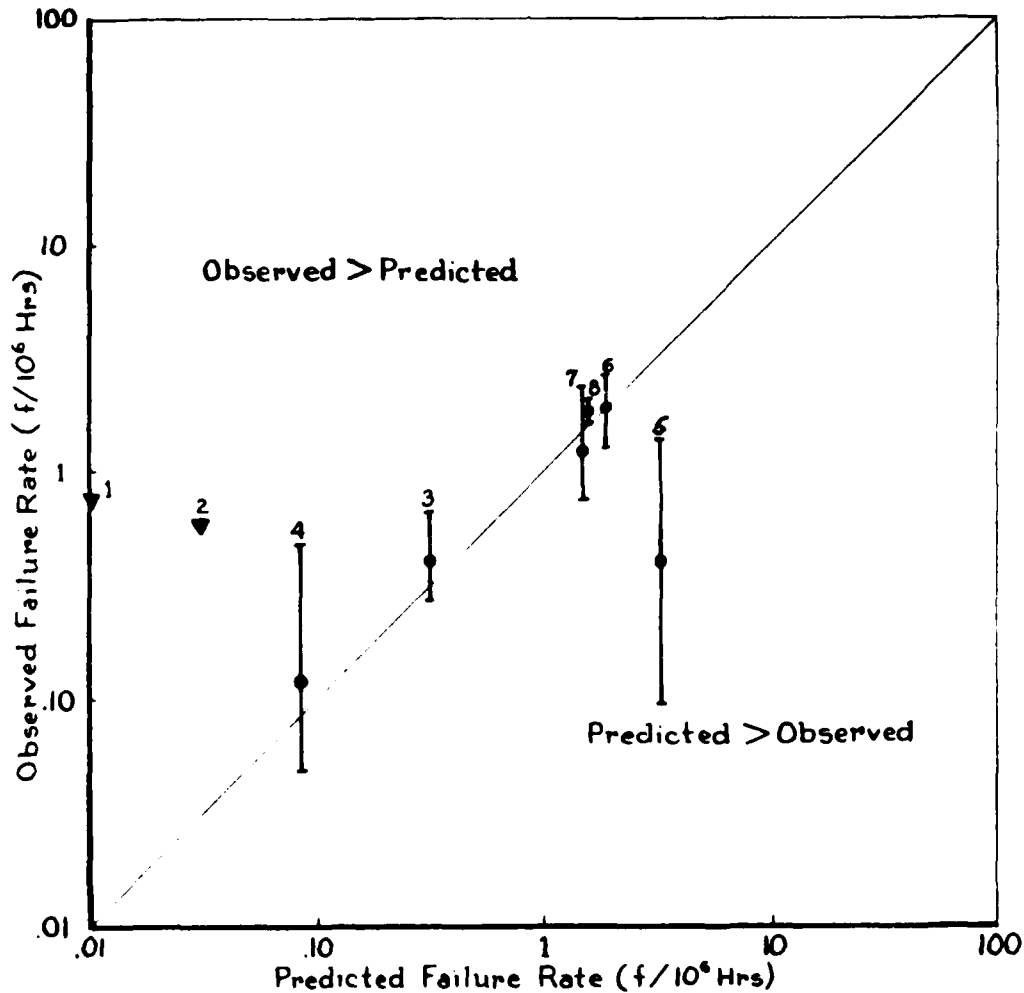

Source:
 RAC
 RADC - TR-79-97

— LEGEND —
 | Upper 80% Confidence Level
 ● Point Estimate
 | Lower 20% Confidence Level
 ▼ Upper 80% Confidence Level
 where no failures were reported
 (Lower 20% Limit non-existent)

MOS DYNAMIC RAM AND SHIFT REGISTER
 OBSERVED FAILURE RATES VS
 PROPOSED MODEL PREDICTED FAILURE RATES

Figure 15

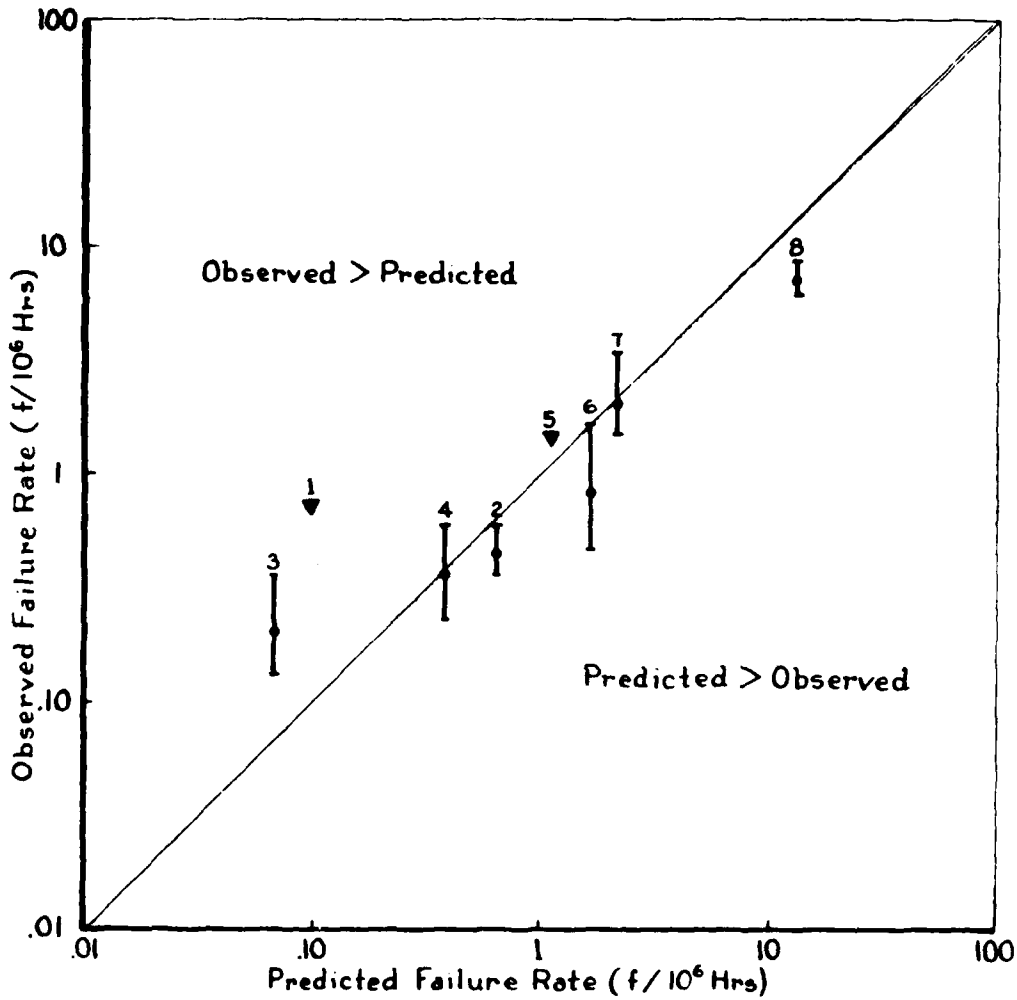

Source:
 RAC
 RADC-TR-79-97

— LEGEND —
 | Upper 80% Confidence Level
 ● Point Estimate
 | Lower 20% Confidence Level
 ▼ Upper 80% Confidence Level
 where no failures were reported
 (Lower 20% Limit non-existent)

**MOS STATIC RAM AND SHIFT REGISTER
 OBSERVED FAILURE RATES VS
 PROPOSED MODEL PREDICTED FAILURE RATES**

Figure 16

TABLE 2

MOS DYNAMIC RAM AND SHIFT REGISTER DATA

Entry No.	Device Description			Application Description				Failure Rates (x/10 ⁶ hours)				
	Technology	Bit Complexity	No. Package Pins	T _j (°C)	Screen Class	Application Env.	Device Hours (10 ⁶)	No. Failures	Observed Point Estimate	Observed 80% C.L.	Predicted* MIL-HDBK-217A	Predicted* RBC Model
1	PMOS	50	CAN 10	35	S	SF	1.963	0	--	0.02	0.01	0.01
2	PMOS	128	CAN 8	35	B-1	GF	2.761	0	--	0.58	0.06	0.03
3	PMOS	320	CM-DIP 16	60	U	GB	16.466	7	0.3	0.42	0.97	0.34
4	PMOS	1024	CAN 8	50	B-1	MS	16.354	2	0.05	0.12	0.76	0.09
5	PMOS	2048	PL-DIP 16	55	D-1	GB	2.290	1	0.10	0.44	1.31	3.40
6	PMOS	2048	C-DIP 14	65	D	AIF	4.851	9	1.13	1.86	2.58	1.82
7	PMOS	4096	CM-DIP 16	60	D	GB	3.110	4	0.74	1.29	2.16	1.50
8	PMOS	4096	CM-DIP 22	60	D	GB	100.000	174	1.63	1.74	1.87	1.54

*Predictions Using Notice II Dated 17 March 1978.

TABLE 3

MOS STATIC RAM AND SHIFT REGISTER DATA

Device Description			Application Description				Failure Rates ($\lambda/10^6$ Hours)						
Entry No.	Technology	Bit Complexity	Package	No. Pins	T _j (°C)	Screen Class	Application Env.	Device Hours (10 ⁶)	No. Failures	Observed 20% C.I. Estimate	Observed Point Estimate	Predicted MIL-HDBK-217B	Predicted RAC Model
1	PMOS	256	CM-DIP	16	45	B-1	MS	2,600	0	--	--	0.62	0.28
2	PMOS	320	C-DIP	16	55	D	GF	114,011	52	0.40	0.46	0.53	7.41
3	PMOS	1024	C-DIP	16	40	B-1	GB	29,670	6	0.13	0.20	0.31	0.14
4	PMOS	1024	C-DIP	16	40	D	GB	61,510	26	0.35	0.42	0.51	4.33
5	PMOS	1024	S-DIP	16	40	D	GB	1,168	0	--	--	1.38	8.66
6	PMOS	1024	S-DIP	16	40	D	GF	4,400	4	0.51	0.89	1.50	14.42
7	PMOS	2048	C-DIP	18	65	C-1	AIF	3,850	R	1.45	2.09	2.96	35.96
8	PMOS	4096	E-DIP	22	60	D	GB	85,440	594	6.71	6.95	7.20	82.29

*Predictions Using Notice II Dated 17 March 1978.

A 1024-bit memory screened to a vendor equivalent of MIL-STD-883, Class B, as defined by MIL-HDBK-217 (Class B-2) may have a predicted failure rate of 0.19 parts per 10^6 hours. A 65,536-bit memory under the same conditions would have a predicted failure rate of 1.95 parts per 10^6 hours. For a capacity increase of 64 times the predicted failure rate is increased 10 times. This is to emphasize that although the probability of failure will increase with greater bit capacity or element count the relationship is not linear.

D. CALCULATION OF SEMICONDUCTOR MEMORY FAILURE RATE

$$\lambda p = \pi_Q [C_1 \pi_T \pi_V + (C_2 + C_3) \pi_E] \pi_L^*$$

Where:

π_Q = A quality factor based on the process handling, production screening and adherence to the Military procurement guides of MIL-M-38510. For a fully screened and qualified part the multiplier is 0.5. High-reliability hermetic commercial vendor equivalent components have a multiplier of 6.5 and nonhermetic parts have a multiplier of 35.

$C_1 + C_2$ = Circuit complexity factors that take into account a scaling for bit or element density.

π_T = A temperature acceleration factor based on technology. This is a very critical factor and careful consideration must be given to these calculations. Large-scale devices with high bit density may tend to have high junction temperatures and a detrimental effect on reliability.

*MIL-HDBK-217C, Notice 1 Section 2.1.4

- π_V = A voltage derating stress factor based on general industry experience. In the case of the Magnetic Bubble Memory this factor has no precedence or experience so a comparative judgement will be necessary.
- C_3 = A package complexity factor to take into account the probability of interconnection failures.
- π_E = The application environment factor. In general, most of large-scale memory devices are in the ground benign category except for a grouping of specific airborne or space applications for memory.
- π_L = The device learning factor where the experience curve of large-scale production is taken into account. Many of the extreme-high-capacity memory devices are made in short lots or under special or custom conditions. It is difficult to judge the comparative quality of a well developed production process versus a hand crafted small lot of devices by highly skilled workers. In between are the more loosely controlled units being fabricated while process controls, limits, and experience are being developed.

TABLE 4

CALCULATED FAILURE RATES OF SEMICONDUCTOR MEMORY DEVICES

<u>Memory Size</u> (bits)	<u>Screening Level</u>	<u>Calculated Failure Rate λ_p^*</u> (Parts per 10^6 Hours)
1,024	S	0.014
	B-1	0.087
	B-2	0.19
	C-1	0.38
	D-1	1.02
16,384	S	0.07
	B-1	0.40
	B-2	0.86
	C-1	1.72
	D-1	4.62
65,536	S	0.15
	B-1	0.9
	B-2	1.95
	C-1	3.9
	D-1	10.5

*MIL-HDBK-217C, (Proposed Notice 1) Section 2.1.4

E. FAILURE RATE MODEL DEVELOPMENT

The Magnetic Bubble Memory device in its present form is an assembly of two major structural segments: (1) a basic memory and control structure consisting of thin-film elements on a crystalline substrate, and (2) a magnetic structure to provide a controlled magnetic field, consisting of a magnet, magnetic coils and a housing. These two major structural segments of the hybrid are interconnected by a mechanical substrate and lead frame. The interconnect substrate in present technology is normally a printed circuit board.

It is quite evident that in the reliability analysis of the total device the general form of a hybrid model must be considered. This general form is then expanded to take into account the unique trends of each of the component parts when subjected to the time, temperature, and environmental stresses of the application.

The basic form as used in the reliability handbook MIL-STD-217 for semiconductor devices is:

$$\lambda_p = \lambda \pi$$

where:

λ_p = The device failure rate as a constant over time.
Failures are catastrophic or drift in nature.

λ = Device-related failure parameters.

π = Environmental and use factors relating to the application, process, and design.

For a hybrid structure the failure rate is a summation of the reliability of the individual segments of the hybrid. Field experience is available for correlation with the theoretical calculations for some of the segments of the Magnetic Bubble Memory. For others, some interpolation and judgment based on a comparable process or condition must be used until more definitive data becomes available.

The general form of the overall Magnetic Bubble Memory device is as follows:

$$\lambda_p = \lambda_1 + \lambda_2 + \lambda_3 + \lambda_4$$

where:

λ_p = Failure rate of a Magnetic Bubble Memory in parts per 10^6 hours.

λ_1 = Failure rate of the control sense and driving sector.

λ_2 = Failure rate of the memory sector.

λ_3 = Failure rate of the interconnect substrate and structure.

λ_4 = Failure rate of the inductive structure.

1. Thin Film Structure

From the concepts of the reliability handbook MIL-HDBK-217 a monolithic device, failure rate is of the additive form:

$$\lambda_p = \lambda_T + \lambda_M$$

where:

λ_P = Overall monolithic device failure rate in parts per 10^6 hours.

λ_T = Failure rate due to time, temperature stress and electrical bias related degradation.

λ_M = Failure rate due to environmental stress effects and from mechanical or fabrication processes.

The thin-film structure of a Magnetic Bubble Memory device is in two parts: (1) the memory sector is a pattern of magnetic elements arranged in data loops and deposited over an epitaxial film layer; and (2) the control, sense, and driving sector is a cluster of conductive elements deposited on the same substrate. This combination of thin-film structures has some similarity to the general form of a semiconductor memory device in that the number of elements and the "packing density" are directly related to the memory capacity. However, there is a significant difference between the two structures. In a general form of semiconductor memory all of the elements, including the memory bits, are active elements. The reliability of these elements is subject to the limitations of junction temperature stress degradation. The number of active elements affected by this class of failure degradation is a direct function of the memory capacity, and so the device failure rate is influenced in a significant manner by the bit capacity scaling of this device. The exact relationship of the capacity scaling to failure rate may be argued, but the trend of an increase in the predicted failure rate with an increase in semiconductor memory capacity is generally accepted as discussed in the previous chapter on semiconductor memory devices and as calculated by the recommendations of MIL-HDBK-217C (Proposed Notice 1).

The Magnetic Bubble Memory device memory elements are not active semiconductor current-dissipating junctions, but are passive magnetic domains whose state is controlled by an external field. In this respect the Magnetic Bubble Memory structure is freed from the limitations of time/temperature degradation related to increases in memory capacity.

a. Conductive Thin Film Elements

The drive and sense circuitry elements of the Magnetic Bubble Memory are current-controlling circuitry and their projected reliability is heavily influenced by the time and temperature stress relationship. The structure is a pattern of read/write control current loops and magneto-resistive bridge elements deposited as Cu-Al conductors between the epitaxial layer and the magnetic permalloy strips. Insulating layers of SiO₂ separate the current handling conductors from the permalloy and epitaxial layers. The reliability of these control functions can be determined by the relationships recommended in MIL-HDBK-217C (Proposed Notice 1) section 2.1.1 to 2.1.6. The general form is:

$$\lambda_p = \pi_Q [C_1 \pi_T \pi_V + (C_2 + C_3) \pi_E] \pi_L$$

where:

λ_p = The control element's failure rate in F/10⁶ hours.

π_Q = Quality factor (Table 2.1.5-1).

π_T = Temperature acceleration factor based on technology (Table 2.1.5-4 through 2.1.5-13).

π_V = Voltage derating stress factor (Table 2.1.5-14).

π_E = The application environment factor (Table 2.1.5-3).

$C_1 + C_2$ = Circuit complexity factor (control devices) based on gate count (Tables 2.1.5-15 to 2.1.5-21).

C_3 = Package complexity (Table 2.1.5-24, values $\div 2$); the chip may only involve 1/2 of the interconnect and not include the overall package. The connection to the lead frame may be via an intervening printed circuit structure and the remaining interconnect mechanism is accounted for in this structure. This is illustrated in Figure 9.

π_L = Device learning factor (Table 2.1.5-2).

b. Memory Elements Structure

The memory segment is a series of repetitive patterns of magnetic elements aligned over the epitaxial film. No direct connections are made to the current or voltage conductors. The energy involved is the changing magnetic fields and the rotating magnetic strip polarity. As in any multilayer thin-film structure, the delineation of a complex fine line pattern is subject to photolithographic defects. The number of screening levels for Magnetic Bubble Memory devices is far less than the multiplicity of steps required for active semiconductor elements and there are essentially no multilayer registration requirements.

The general form of the failure rate model for this part of the memory structure follows the general format of semiconductor devices as recommended in the guidelines of the reliability handbook MIL-HDBK-217. Specific numerical designations for some of the factors cannot be quantified at this time because of the lack of sufficient field data. The nondissipative structure and the reduction of multilayer registration of the Magnetic Bubble Memory structure make it obvious that the numerical designations, such as for the junction temperature stress factor, should be substantially lower than those experienced in active semiconductor memories. With a lack of definitive information on the level of differences that exists, some engineering judgement is applicable. For a minimum derating it is not unreasonable to think of a two-to-one comparison and a maximum may be an order of magnitude value. On this basis we propose a range of 0.5 to 0.1 for a derating factor. An optimistic reliability prediction would use the 0.1 derating; a pessimistic view, the 0.5 derating. In the present state-of-the-art the guideline for derating factor may be related to the bubble size. For bubble sizes of 3 μm or larger the optimistic derating of 0.1 may be applicable and for bubble diameters of less than 3 μm , then a derating of 0.5 may be used. Until more experience and detailed field data is available or developed, this range is recommended. On this basis, the reliability or failure rate calculation for the magnetic memory sector of the thin-film structure is:

$$\lambda_p = \pi_Q [N_1 (C_1 \pi_T \pi_M + C_2 \pi_E) + N_2 (C_1 \pi_T \pi_M + C_2 \pi_E)] \pi_L$$

where:

λ_p = Failure rate of the magnetic memory structure
in parts per 10^6 hours.

π_Q = Quality factor (Table 2.1.5-1).

$C_1 + C_2$ = Circuit complexity factor for a dynamic memory such as a single Magnetic Bubble Memory loop either major or minor loop as applicable from Table 2.1.5-21.

N_1 = Number of major loops (a multiplier for the C_1 and C_2 factors for the major loops).

N_2 = Number of active minor loops (a multiplier for the C_1 and C_2 factors for the active minor loops).

π_T = Temperature acceleration factor based on technology and bubble size. There is no junction dissipation and the only temperature factor is the case temperature. The effect of a non-hermetic packaging on the nondissipative permalloy elements is minimal. The π_T tables of 2.1.5-12 are applicable to this sector of the device. To take into account the variations due to bubble size, a modifier of the optimistic 0.1 derating factor is used for bubble sizes of $3\mu\text{m}$ or larger. For the more critical sizes (less than $3\mu\text{m}$ in diameter), the pessimistic multiplier of a 0.5 derating factor is used.

π_M = Magnetic bias margin factor. This is in the same class of modifier as the voltage derating factor of active semiconductor devices as defined in Table 2.1.5-14. With no additional information available from field data to more accurately define this parameter, a factor of 1 is used within the restricted use conditions of an operating

bias margin of 80% of the vendor rated bias margin requirements of the lowest case temperature of the application.

π_E = Application environment factor (Table 2.1.5-3).

π_L = Device learning factor (Table 2.1.5).

2. Magnetic Structure

The three functional parts of the magnetic structure are: (1) the magnets, (2) the orthogonal coil structure, and (3) the shield. The magnetic shield protects the total device from outside magnetic influence and contains the magnetic field within the device. This component is quite inert and has no significant contribution to the device failure rate. The static magnetic field source is a permanent magnet and once set to a nominal energy level, determined by the mounting considerations of the design, is stable throughout the general temperature range of interest. There may be a mechanical movement that could result in a catastrophic failure, but this is accounted for in the overall learning factor and environmental factor multipliers for the total device.

The magnetic coils are inductive devices and the failure rate prediction recommendations are applicable to the conditions of MIL-HDBK-217C.

The general form for inductive devices from MIL-HDBK-217C is:

$$\lambda_p = \lambda_b (\pi_E \pi_Q \pi_c)$$

where:

λ_p = Failure rate of the inductive devices in parts per 10^6 hours.

λ_b = A base failure rate of the form:

$$Ae^x \text{ in which } x = \frac{T_{HS} + 273}{N_T}^G$$

and T_{HS} = Hot spot temperature in degrees C

N_T = Temperature constant*

G = Acceleration constant*

A = Insulation factor*

π_E = Environmental factor Table 2.7.1-3.

π_Q = Quality factor Table 2.7.1-2.

3. Interconnect Substrate Structure

The recommendations of the reliability Handbook MIL-HDBK-217C for printed wiring board and interconnection failure rates are applicable. The basic form of calculation of the failure rates of a printed wiring board as defined in paragraph 2.12 of MIL-HDBK-217C is:

$$\lambda_p = \lambda_b N \pi_E$$

*These constants are listed in Tables 2.7.1-1 through 2.7.1-14.

The contribution of the printed circuit wiring board to the overall failure rate of a Magnetic Bubble Memory is inconsequential and could be deleted with no impact on the overall calculation. It is identified here for the sake of completeness.

Where:

λ_p = Failure rate of the printed wiring board in parts per 10^6 hours.

$\lambda_b = 6 \times 10^{-6}$ (worse case).

N = Number of connections. (Number of connections to the lead frame plus three for the magnetic structure if no other information is available).

π_E = Application factor of table 2.12.

4. General Form of Failure Rate Model of a Magnetic Bubble Memory Device

The basic premise is that the failure rate of a hybrid structure such as a Magnetic Bubble Memory device is the summation of the failure rates of the individual structures. In this specific case the MBM failure rate is:

$$\lambda_p = \Sigma(\lambda_1 + \lambda_2 + \lambda_3 + \lambda_4)$$

where:

- λ_1 = Failure rate of control segments.
- λ_2 = Failure rate of memory sector.
- λ_3 = Failure rate of magnetic structure.
- λ_4 = Failure rate of printed circuit structure and interconnections.

Expanded this will be:

$$\lambda_p = \pi_Q [C_1 \pi_T \pi_V + (C_2 + C_3) \pi_E] + [N_1 (C_1 \pi_T \pi_M + C_2 \pi_E) + N_2 (C_1 \pi_T \pi_M + C_2 \pi_E)] \pi_L + \lambda_b (\pi_E \pi_Q) + \lambda_b N \pi_E$$

F. SAMPLE CALCULATIONS OF PREDICTED RELIABILITY OF A MAGNETIC BUBBLE
MEMORY DEVICE

A series of sample calculations have been made of several combinations of probable Magnetic Bubble Memory device parameters to illustrate the leverage of each sector on the overall predicted failure rate. Several cases are defined and the calculations made are based on these assumptions. A learning factor of 10 should be used for calculations of new product introductions for the current state of the art. If a justification of a more optimistic learning can be determined, then the calculated reliability projections can be decreased by reduction of the learning factor to 1.

Case No. 1: 92K bit Magnetic Bubble Memory, 40°C ambient, ground benign environment. 14 pin DIP enclosure, 1 major loop and 3 dissipative control elements (Generate, replicate and detector bridge) plus 144 current transfer gates for the 144 memory minor loops. Bubble size 3 μ m dia. Screening B-2 level.

Case No. 2: Same as Case No. 1, except Class D screening.

Case No. 3: Same as Case No. 1, except Class D-1 screening.

Case No. 4: 1 Megabit Magnetic Bubble Memory device. 40°C ambient, ground benign environment, 20 pin DIP enclosure. 256 minor loops and 2 major loops. 12 dissipative control gates plus 512 transfer gates for the memory loops. Bubble size 2 μ m dia. and B-2 screening level.

Case No. 1 Sample Calculations

$$\begin{aligned} \lambda_p \text{ (Control Elements)} &= \pi_Q [C_1 \pi_T \pi_V + (C_2 + C_3) \pi_E] \pi_L \\ &= 6.5 [(0.013)(0.49)(1) \\ &\quad + (0.0008 + 0.0017)1]1 \\ &= 0.0577 = 0.06/10^6 \text{ hours} \end{aligned}$$

Note: $\pi_Q = 6.5$, class B-2; $\pi_E = 1$; $\pi_L = 1$ (in production quantity);

$C_1 = 0.013$, Table 2.1.5-21, 144 transfer + 4 control elements;

$C_2 = 0.0008$; $\pi_T = 0.49$, Table 2.1.5-12 @ 40°C ambient (+ 1 1/2°C rise);

C is based on 10 functional pins;

$\pi_V = 1$, Table 2.1.5-14.

$$\begin{aligned} \lambda_p \text{ (Memory Elements)} &= \pi_Q [N_1 (C_1 \pi_T \pi_M + C_2 \pi_E) \\ &\quad + N_2 (C_1 \pi_T \pi_M + C_2 \pi_E)] \pi_L \\ &= 6.5 [1(0.026)(0.28)(0.1) + (0.0013)(1) \\ &\quad + 144 (\dots)]1 \\ &= 1.91/10^6 \text{ hours} \end{aligned}$$

Note: $\pi_Q = 6.5$; $\pi_E = 1$; $\pi_L = 1$; $N_1 = 1$; $N_2 = 144$ @ 641 bits;

*
 $C_1 = 0.026$, Table 2.1.5-23, 641 bit dynamic ram;

$C_2 = 0.0013$, Table 2.1.5-23; $\pi_M = 1.0$;

$\pi_T = 0.28$ (Table 2.1.5-8, No Power Dissipation.) x 0.1 for bubble
dia. = 3 um.

*641 bits/major loop and 641 bits/minor loop.

$$\begin{aligned}
 \lambda_p \text{ (Magnetic Sector)} &= \lambda_b (\pi_E \pi_Q \pi_c) \times 2 \text{ for 2 coils.} \\
 &= 0.0005 (1 \times 1 \times 1) \times 2 \\
 &= 0.001/10^6 \text{ hours}
 \end{aligned}$$

Note: Section 2.7.2

$$\begin{aligned}
 \lambda_p \text{ (Interconnect Structure)} &= \lambda_b N \pi_E \\
 &= 6 \times 10^{-6} \times 28 \times 1 \\
 &= 168 \times 10^{-6} = 0.000168/10^6 \text{ hours}
 \end{aligned}$$

Note: Section 2.12; 28 connections not including the chip.

$$\begin{aligned}
 \lambda_p \text{ (Magnetic Bubble Memory)} &= 0.06 + 1.91 + 0.001 + 0.00017 \\
 &= 1.97/10^6 \text{ hours}
 \end{aligned}$$

Case No. 2 Sample Calculations

$$\begin{aligned}
 \lambda_p \text{ (Magnetic Bubble Memory)} &= 92K \text{ bit class D} \\
 &= 0.16 + 5.14 + 0.001 + 0.00017 \\
 &= 5.3/10^6 \text{ hours}
 \end{aligned}$$

Case No. 3 Sample Calculations

$$\begin{aligned}\lambda_p \text{ (Magnetic Bubble Memory)} &= 92\text{K bit class D-1} \\ &= 0.32 + 10.285 + .001 + .00024 \\ &= 10.61/10^6 \text{ hours}\end{aligned}$$

Case No. 4 Sample Calculations (1,048,576 bit, M.B.M. class B-2)

$$\begin{aligned}\lambda_p \text{ (Control Elements)} &= \pi_Q [C_1 \pi_T \pi_V + C_2 + C_3] \pi_E \pi_L^* \\ &= 6.5 [(0.021)(0.49)(1) \\ &\quad + (0.001 + 0.0026)(1)] 1 \\ &= 0.09\end{aligned}$$

$$\begin{aligned}\lambda_p \text{ (Memory Elements)} &= \pi_Q [N_1 (C_1 \pi_T \pi_M + C_2 \pi_E) \\ &\quad + N_2 (C_1 \pi_T \pi_M + C_2 \pi_E)] \pi_L \\ &= 6.5 [2(0.34 \times 0.28 \times 0.5 + 0.0017 \times 1) \\ &\quad + 256 (0.08 \times 0.28 \times 0.5 + 0.0039 \times 1)] 1 \\ &= 25.21\end{aligned}$$

Note: 1024 bits/major loop and 4096 bits/minor loop.

$$\lambda_p \text{ (Magnetic Bubble Memory)} = 0.09 + 25.21 = 25.3/10^6 \text{ hours}$$

*NOTE: C_3 is based on 15 functional pins.

Correlation of Data:

A comparison can be made of the calculated reliability of semiconductor memory devices and the Magnetic Bubble Memory of a similar class of screening. In this comparison we see some justification for the projected levels of reliability, but in a more detailed examination of the elements of the Magnetic Bubble Memory calculations it is noted that an extreme leverage is assigned to the number of memory elements. As field data on actual operating systems is developed, this area should be examined closely to ascertain the appropriate leverage this factor should have in the comparative reliability projections for this class of device.

TABLE 5

Projected Reliability of a Range of Semiconductor
Memory Devices with Class B-2 Screening

Complexity	NMOS DYNAMIC MEMORY			Magnetic Bubble Memory		
	1K	16K	64K	92K	1Meg	
			Control Elements	0.06	0.09	
			Memory Elements	1.91	25.2	
Projected Reliability F/10 ⁶ Hrs.	0.19	0.86	1.95	TOTAL	1.97	25.3

IV. CHARGE-COUPLED DEVICE MEMORY

A. DESCRIPTION

A charge-coupled device (CCD) is essentially an analog shift register. The analog variable is the amount of charge held in a metal-oxide-silicon (MOS) capacitor. The charge can be moved along from capacitor to capacitor by cycling the voltages applied to the conductors of the MOS structure. The basic structure of a CCD and the action of a three-phase clock for shifting the charge are shown in Figure 17.

When a positive voltage is applied to a capacitor electrode or gate, a depletion region is produced in the silicon below the gate, and a potential well results at the silicon-silicon dioxide interface. The stored charge then flows from the adjacent storage site into the newly formed potential well. Clearly a three- or four-phase clock drive can establish the direction of transfer and move the stored charge smoothly along the shift register. Two-phase clock drive systems can also be used, but the gate electrode structure must be asymmetrical in order to determine the direction in which the charge will move.

An important parameter of CCD's is the charge transfer efficiency, η , the fraction of the total charge moved to the next storage site in each cycle. The fractional loss, ϵ , which is equal to $1 - \eta$, is also used in discussing this effect. Starting with an initial charge, Q , after n transfer cycles, the remaining charge Q_r , is equal to $Q_0 \eta^n$, ($Q_0 \{1 - n\epsilon\}$). It is clearly advantageous to have high transfer efficiency in order to preserve the signal through many transfer cycles.

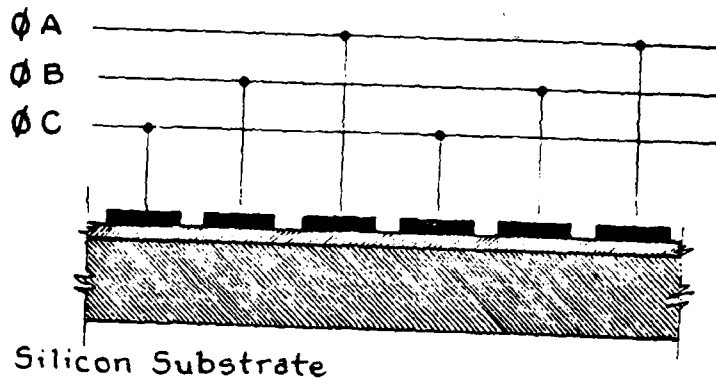

Silicon Substrate

STRUCTURE

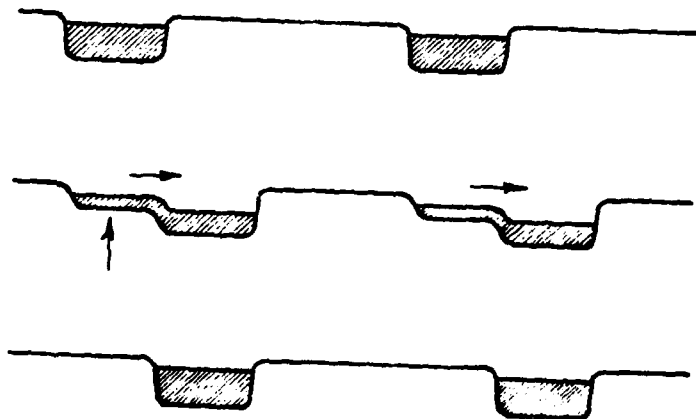

MOVEMENT OF CHARGE

BASIC CHARGE TRANSFER SHIFT REGISTER

Figure 17

In spite of its simplicity, the CCD is a surprisingly versatile device. As a shift register, the CCD has been used in many analog signal processing schemes. Charge can be injected photoelectrically into linear or rectangular charge-coupled arrays. The resultant CCD's are line scan and photo imaging devices, respectively.

If the stored charge is quantized at two levels, the CCD becomes a binary digital storage device, or memory.

B. CHIP ARCHITECTURE

There are two types of charge-coupled devices based on the location of the stored charge. The surface channel CCD (SCCD) stores the charge on the surface of the silicon, under the insulating silicon dioxide layer (Figure 18). The buried channel CCD (BCCD) stores the charge in a thin layer of silicon, doped to a conductivity opposite that of the silicon substrate (Figure 19).

The BCCD has certain advantages over the SCCD. It needs no bias charge* to obtain a high transfer efficiency ($\eta > .9999$), does not have noise caused by surface states, and has a faster response for its physical size than the SCCD. However, the BCCD stores about one-half the charge of an SCCD, has higher leakage currents and is more difficult to fabricate.

*Memory CCD's often store appreciable amounts of charge to represent a "zero," sometimes as much as half the charge used to represent a "one." This is called "fat zero" operation as opposed to "real zero" operation, where no charge represents a "zero." Small amounts of bias charge, less than one-tenth the "one" state charge, are sometimes called "slim zero" operation.

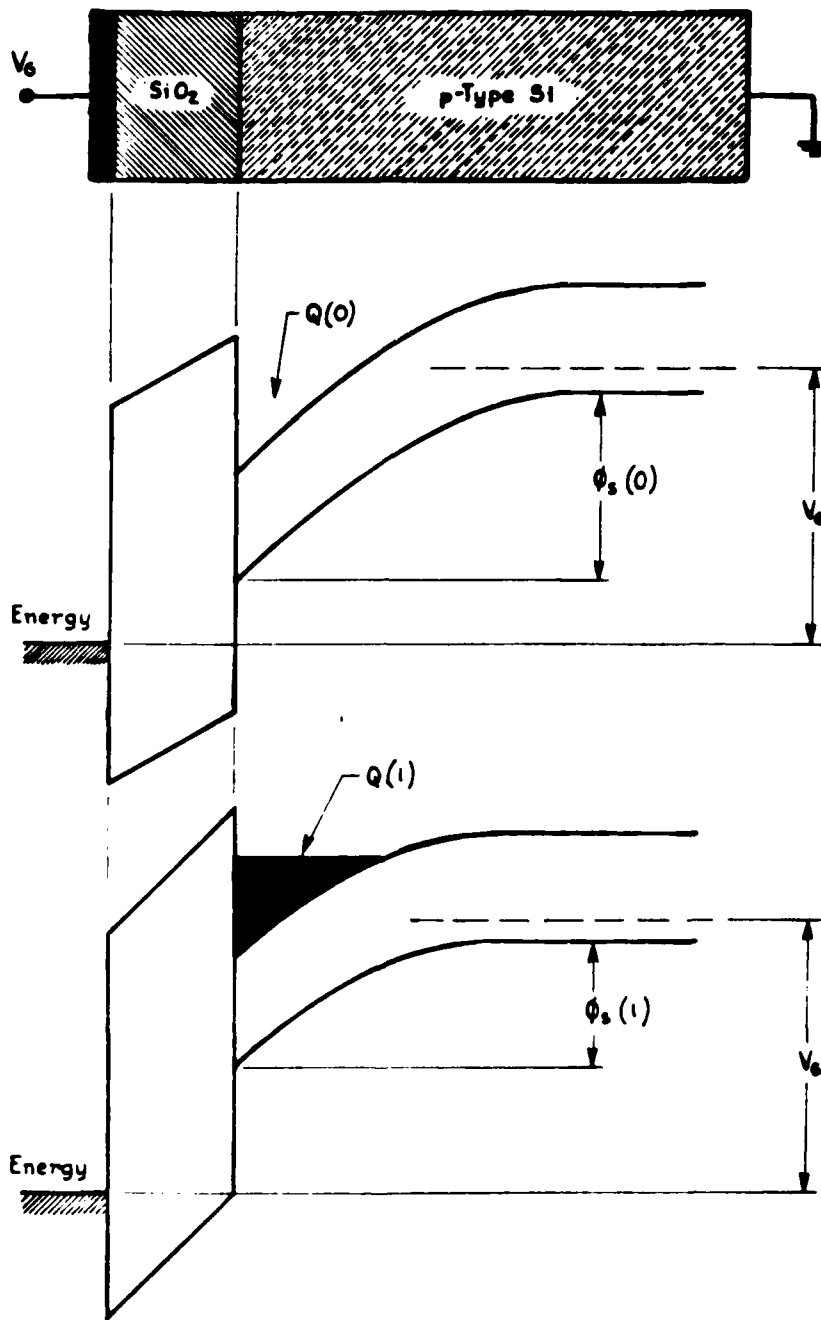

CHARGE STORAGE IN SURFACE CHANNEL CCD

Figure 18

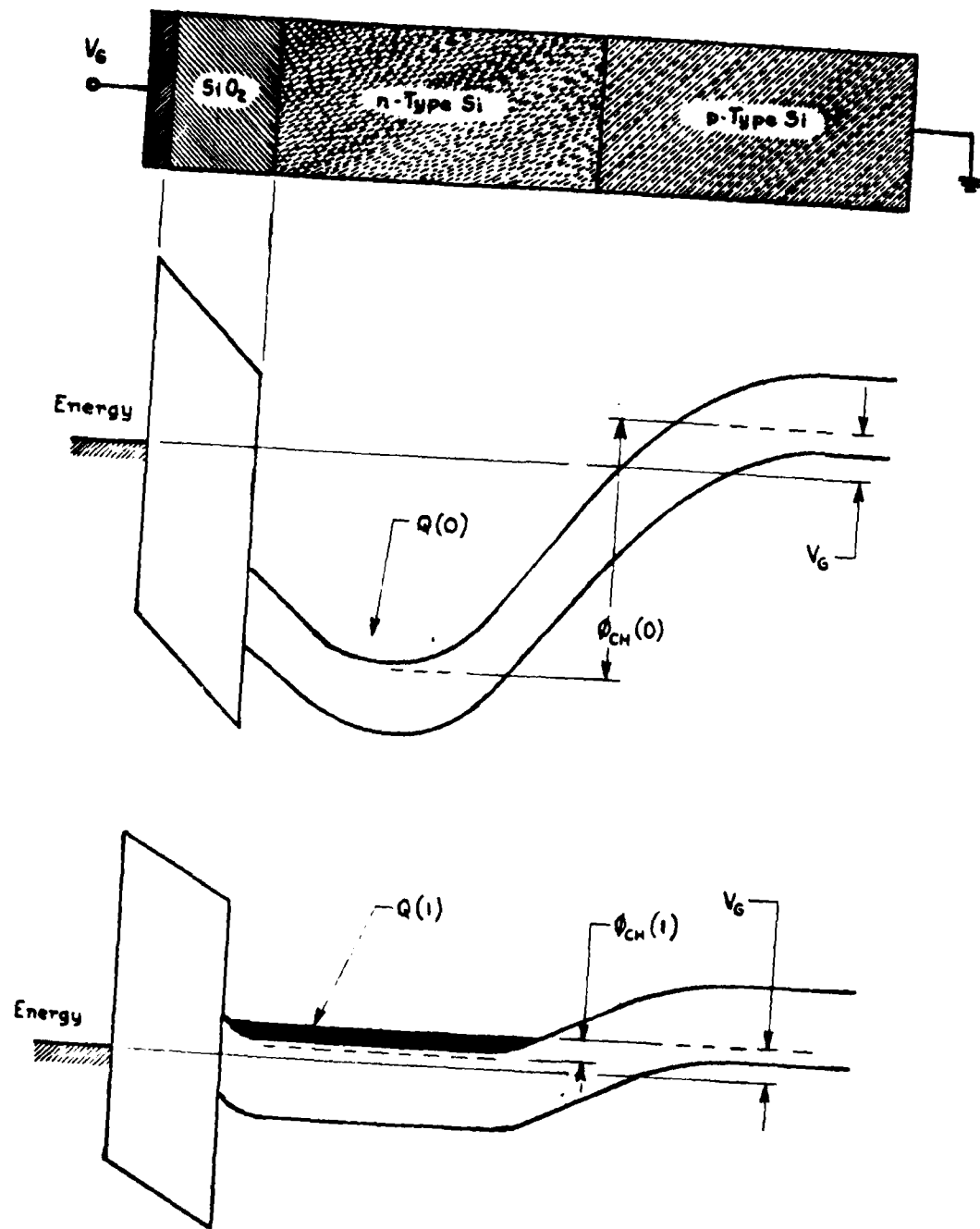

CHARGE STORAGE IN BARRIER CHANNEL CCD
Figure 19

Some of the more important CCD structures are shown in Figure 20. The single metal structure, a, used in early CCD's is degraded by the instability of the exposed channel oxide. The doped polysilicon structure, b, protects the channel oxide with high-resistivity undoped polysilicon between the gates. Other more complex structures, c, d, and e, use two or three levels of polysilicon and/or aluminum.

C. MEMORY ORGANIZATION

The simplest CCD memory organization is a single loop (Figure 21a). Because some small fraction of the stored charge is lost in each transfer, the signal must be periodically regenerated, in this case at the corners of the zigzags. Average access time is comparatively long in a single-loop memory. A more complicated single-loop organization, with parallel transfer through much of the loop (Figure 21b), has a shorter access time.

Multiple-loop memories may have linear organizations (Figure 21c), or if the number of loops is large enough, two-dimensional organizations (Figure 21d).

D. MANUFACTURERS

Early in the development of CCD technology (ca 1970), the potential of the device for high-density digital storage was recognized. Densities greater than one million bits per square inch were forecast. It was believed that these high densities would lower the cost per bit and make CCD memory systems highly competitive with alternative semiconductor digital storage techniques such as the MOS random access memory (MOS RAM). Many firms took an active part in CCD memory development (Table 6). Of these thirteen, only three firms (Intel, Fairchild, and Texas Instruments)

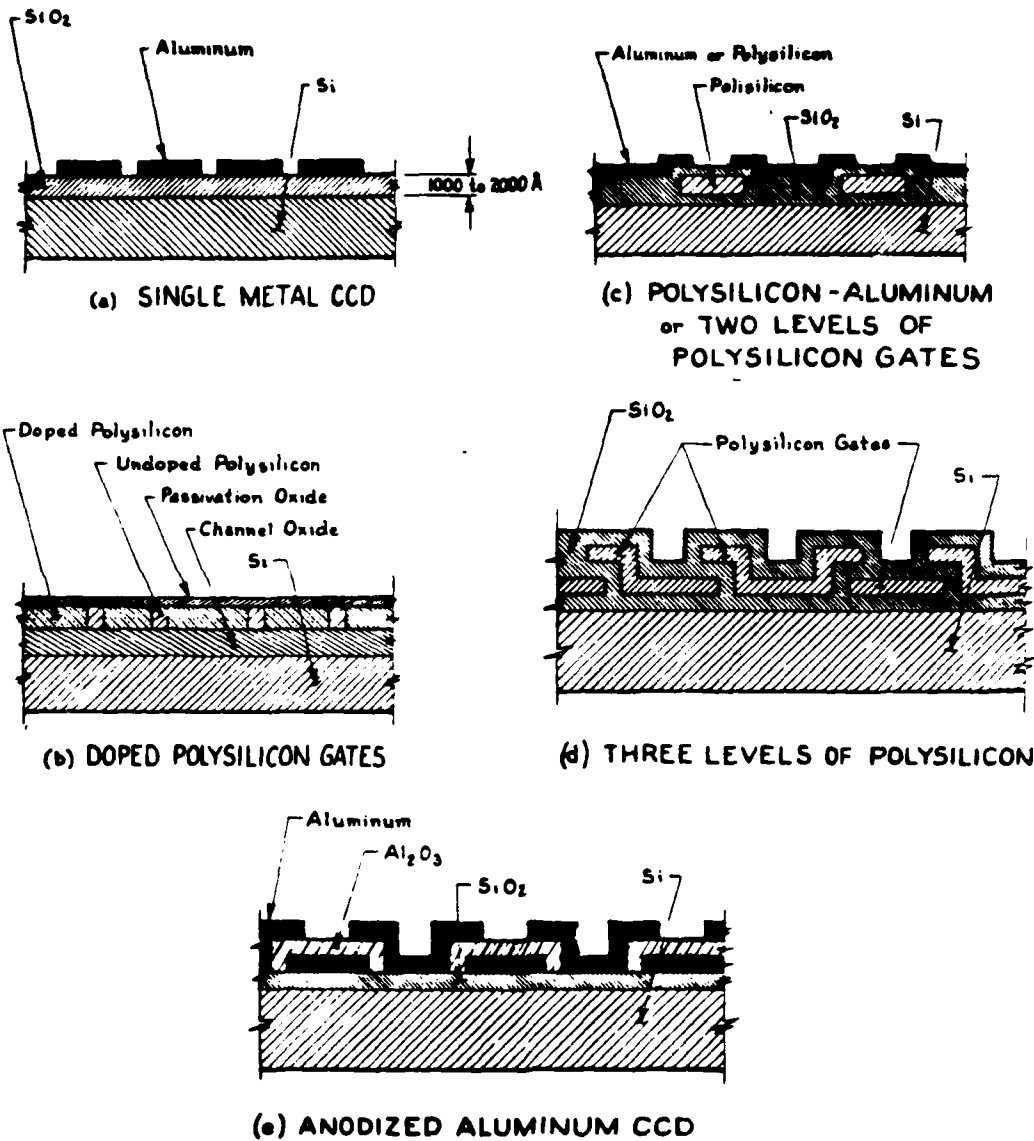

CHARGE COUPLED DEVICE STRUCTURES

Figure 20

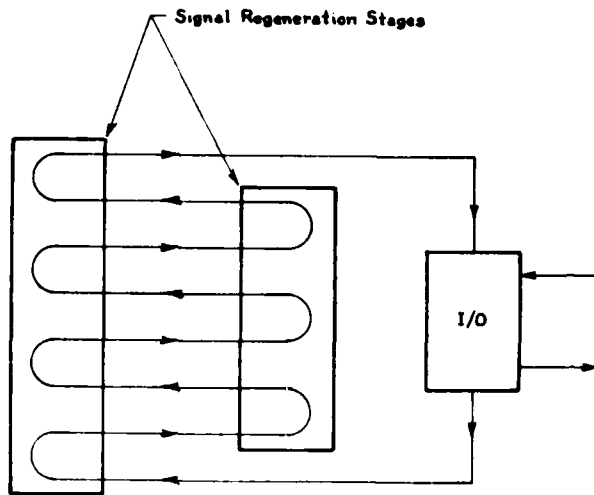

(a) SINGLE LOOP CCD MEMORY

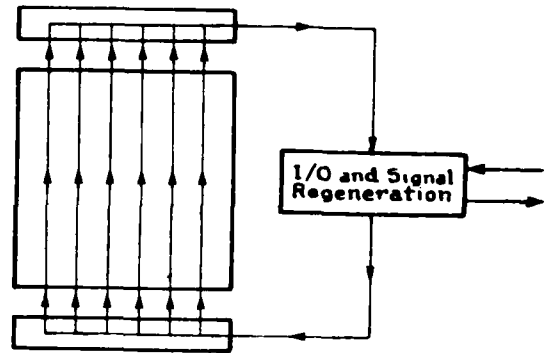

(b) SINGLE LOOP WITH PARALLEL TRANSFER

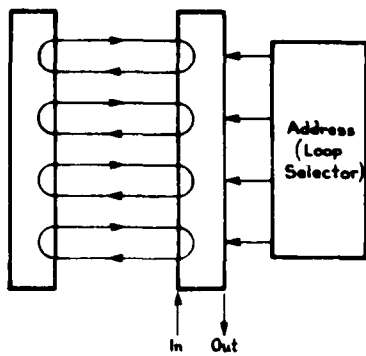

(c) ONE DIMENSIONAL MULTILoop ORGANIZATION

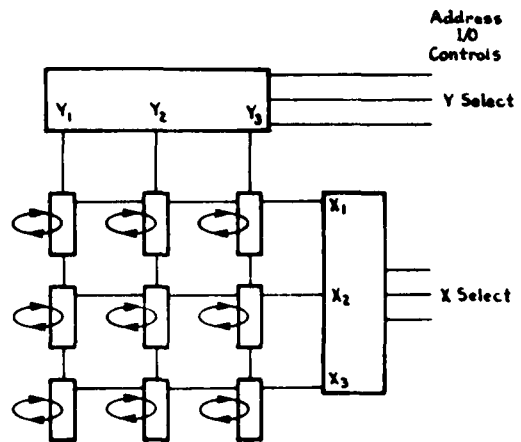

(d) TWO DIMENSIONAL MULTILoop ORGANIZATION

CCD MEMORY ORGANIZATION

Figure 21

TABLE 6

FIRMS WHICH HAVE BEEN ACTIVE IN THE DEVELOPMENT OF CCD MEMORIES

Bell Northern
*Fairchild
General Electric Company, Ltd. (England)
General Electric
IBM
*Intel
Motorola
Plessey
RCA
Rockwell International
Siemens
Signetics
*Texas Instruments

*Firms which marketed devices.

eventually marketed a commercial product. As CCD memories were developed, progress was also made in the development of MOS RAM's, and a clearcut economic advantage for CCD's failed to materialize. As larger CCD memory arrays were developed, the MOS RAM's also increased in size. Intel no longer makes a CCD memory; Texas Instruments makes a CCD memory device, but is not actively seeking customers; and Fairchild remains the only serious producer of CCD memories.

E. FAILURE RATE MODEL DEVELOPMENT

The general form of a failure rate model for an electronic component is:

$$\lambda = \pi_a \pi_b \pi_c [C_1 f_1(T) + C_2 f_2(V) + C_3 f_3(E) + \dots]$$

where:

λ = Failure rate.

π_a, π_b, \dots = Multiplicative factors representing device quality, state of the manufacturer's learning curve, etc.

$C_n f_n(x)$ = Additive terms representing stress (voltage, temperature, environment) complexity (number of bits or gates), or some special effect or parameter.

To develop a reliability model for CCD memories, the NMOS dynamic RAM model was taken as a prototype, because MOS RAMS are close to CCD memories in structure, use and complexity. The NMOS dynamic RAM reliability model given in paragraph 2.1-4.1 of MIL-HDBK-217C (Proposed Notice 1) is:

$$\lambda_p = \pi_Q [C_1 \pi_T \pi_V + (C_2 + C_3) \pi_E] \pi_L$$

where:

λ_p = Failure rate in failures/10⁶ hours.

π_Q = A quality factor.

π_T = A temperature stress factor.

π_V = A voltage stress factor.

π_E = An environmental stress factor.

C_1 and C_2 = Device complexity (bit count) failure rates.

C_3 = Package complexity failure rate.

π_L = A learning curve factor.

Two questions must be answered in order to fit the NMOS RAM prototype model to CCD devices:

- (1) Should the specific form of the model be changed by adding or deleting some terms or coefficients?
- (2) What numerical values should be used for the parameters and coefficients in the model?

In seeking an answer to the first question, only one effect, the soft error rate, was identified as a potential candidate for inclusion in the CCD reliability model. Further analysis showed that the soft error rate does not belong in a reliability model that, by definition accounts only for catastrophic or drift-related errors. The specific form of the prototype was retained unchanged.

Soft errors are random, nonrecurring errors resulting from the loss of bits, or the upset of stored data without any accompanying physical damage. Bursts of noise exceeding the noise margins of a device would be a source of soft errors. A major cause of soft errors in CCD memories and dynamic RAM's is ionizing radiation, alpha particles, passing through the memory array area. The source of alpha particles is the decay of radioactive contaminants in packaging materials of the memory device. Uranium and thorium are present at parts-per-million levels in the sealing glasses, alumina ceramic packages, zirconia and quartz fillers, and even in plated gold. These are all sources of alpha particles with energies of about eight to nine million electron volts (Mev). At this energy, the alpha particles will penetrate silicon to a depth of about 50 microns (0.002 inch) and will generate one electron-hole pair for each 3.6 electron volts of energy. Up to 2.5 million electron hole pairs are produced for each alpha particle, and this is enough charge to fill a potential well and alter a stored bit.

The soft error rate is a parameter of a memory device. Should the rate rise above a specified level, the device is no longer useful and has failed. For this reason the soft error phenomenon was considered for inclusion in the CCD memory reliability model. But the alpha emission rate and, hence the soft error rate, are independent of temperature, pressure, voltage, and time.* Therefore, the soft error rate is a quality control problem and not a reliability problem, and does not belong in the reliability model. Note too, that alpha particle-induced soft errors are not peculiar to CCD's but also occur in dynamic RAM's.

*Actually the alpha emission rate will decrease slowly as the radioactive contaminants are "used up."

Two sources of inputs can be used to answer the second question. The structure and operation of the NMOS RAM and the CCD memory can be compared to see if there is some physical reason for changing the value of some parameter or coefficient in the model. This comparison has been made and no basis for change has been found. The integrated circuit technologies for both devices are quite similar, and there is no difference in structural complexity sufficient to justify change.

The other input which might determine values for the parameters and coefficients in the reliability model is actual reliability data, either from field experience or from reliability testing. Very little data of this type is available because, to date, there has been no large-scale production and use of CCD memories. Therefore, reliability experience cannot be used to modify the numerical values of the model. Furthermore, the reliability data which could be found fit the MIL-HDBK-217C NMOS dynamic RAM reliability model to an acceptable degree of accuracy.

F. FAILURE RATE MODEL VALIDATION

We found reliability data for two CCD memories: the Intel 2416 and the Fairchild F464. The Intel field experience, the Fairchild test results, and the predictions from the NMOS dynamic RAM model are plotted in Figure 22. The number of failures for each datum is shown in parentheses. The agreement of the model with the Intel field experience is excellent. The agreement of the model with the Fairchild test data is much poorer, but the accuracy of the test data is also poor because of the small numbers of failures and total unit hours.

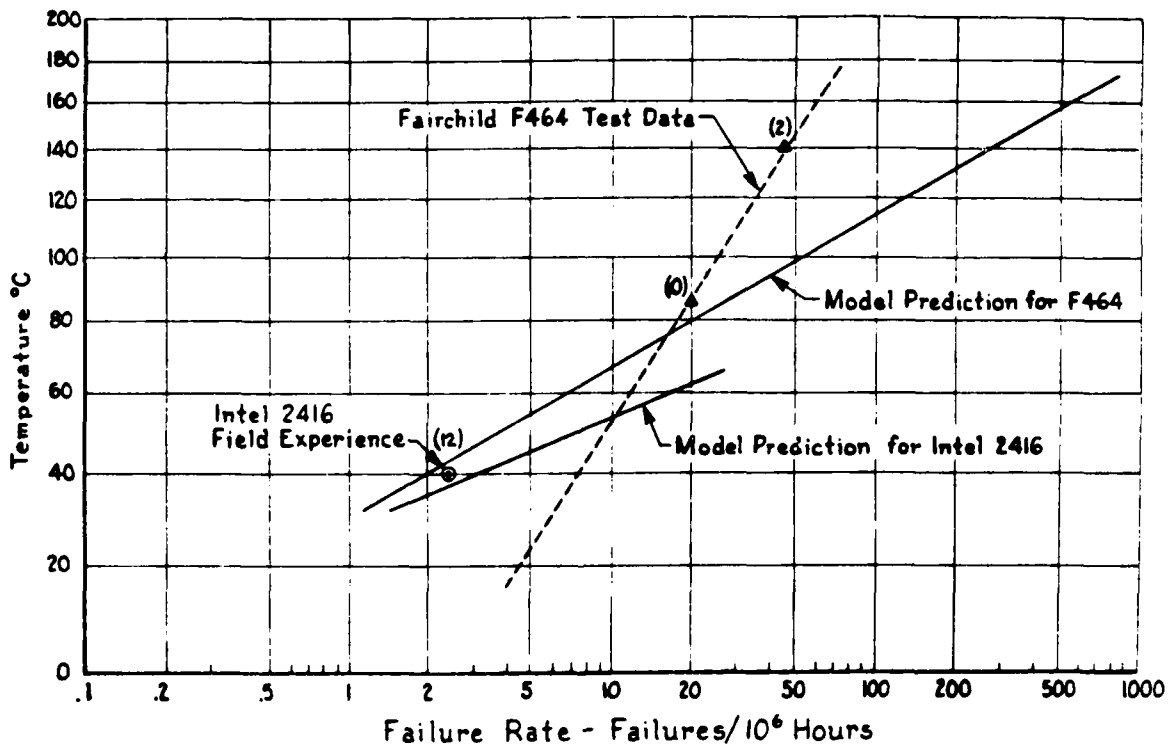

COMPARISON OF N-MOS DYNAMIC RAM MODEL WITH CCD RELIABILITY DATA

Figure 22

1. Intel 2416 Data

The Intel 2416 data was obtained from the field experience of Azurdata, Inc., which had 3,000 units in use for an estimated 5.2×10^6 unit hours. On the basis of 12 reported failures, the best estimate failure rate is 2.4 failures per 10^6 hours.

The Intel 2416 is a 16K serial memory, 64 loops of 256 bits each. It is contained in an 18-pin plastic dual inline package. The maximum supply voltage is 12 volts. The parameters used in the reliability model are:

$$\pi_Q = 35$$

$$C_1 = .186$$

$$\pi_T = 0.44 (T_j = 40^\circ\text{C})^*$$

$$\pi_V = 1.0$$

$$C_2 = 0.0088$$

$$C_3 = 0.007$$

$$\pi_E = 1$$

$$\pi_L = 1$$

$$\lambda_p(\text{computed}) = 3.42 \text{ failures per } 10^6 \text{ hours}$$

2. Fairchild F464 Data

The Fairchild F464 data comes from a Fairchild LSI reliability report dated October 1978. Two sample lots of 18 and 16 units were operated for 2,400 hours and 1,000 hours, respectively, at an ambient temperature of 125°C . Two reported failures, one in each

*The junction temperatures are assumed to be 15° above ambient for these computations.

lot, were attributed to ionic contamination. Two more sample lots of 18 and 17 units were operated for 1,000 hours each at an ambient temperature of 70°C. There were no failures.

The best-estimate failure rate for two failures in 59,200 unit hours is 45 failures per 10^6 hours, at 125°C ambient. The best estimate failure rate for no failures in 35,000 unit hours is 20 failures per 10^6 .*

The Fairchild F464 is a 64K serial memory (65,536 bits in one loop), contained in a dual inline hermetic package with 22 pins.

The parameters used in the reliability model are:

$$\begin{aligned} \pi_Q &= 17.5 \\ C_1 &= 0.434 \\ \pi_T &= 38 (T_j = 140^\circ\text{C}) \\ &= 3.6 (T_j = 85^\circ\text{C}) \\ C_2 &= 0.02 \\ C_3 &= 0.008 \\ \pi_E &= 1 \\ \tau_L &= 1 \end{aligned}$$

$$\begin{aligned} \lambda_p(\text{computed}) &= 290 \text{ failures per } 10^6 \text{ hours at } T_m = 140^\circ\text{C} \\ \lambda_p(\text{computed}) &= 28 \text{ failures per } 10^6 \text{ hours at } T_m = 85^\circ\text{C} \end{aligned}$$

*Lower limit of the confidence interval for MTBF for confidence level $1-\alpha$ and r failures in total unit hours T is:

$$\text{MTBF} = \frac{2T}{\chi^2(\alpha, 2r + 2)}$$

Reference; Reliability Engineering, Wm. H. vonAlven, Prentice-Hall, Inc. 1965.

APPENDIX A

BIBLIOGRAPHY OF MAGNETIC BUBBLE MEMORY

- Abbas, S.A. and Barish, C.A., "P-Channel Rewritable Avalanche Injection Device (Raid) Operation and Degradation Mechanisms," IEEE 13th Annual Proceedings of Reliability Physics Symposium, Las Vegas, Nevada, 1-3 April 1976.
- Ando, Takao, "Functional CCD Devices Offer Hope for Solid-State Imaging," Journal of Electronic Engineering, (99), 15-19 (February 1975).
- Archer, J.L., "Reliability of Magnetic Bubble Domain Memories," CPI, 2 (2).
- Bailey, Robert F. and Ypma, John E., "Bubble Domain Memories--Present Achievements and Future Applications," Solid State Technology, 19 (9), 74-82 (September 1976).
- Bailey, R.F. and Reekstin, J.P., "Yield Analysis of Large Capacity Magnetic Bubble Circuits with Redundancy Design," IEEE Transactions on Magnetics, MAG-10 (3), 856-859 (September 1974).
- Baird, D.H., et al., "Reliability of Magnetic Bubble Domain Memories," Paper prepared by GTE Laboratories, Inc. and Rockwell International for presentation to professional society conference.
- "Bandwith Economy: Silicon Charge-Coupled Devices (CCDs)," Electronics 43, 38-39 (August 17, 1970).
- Beaumont, James, "Performance Evaluation of the CCD450 Digital Memory," Paper prepared by Captain Beaumont, U.S. Air Force under government contract.
- Bertram, Walter J., et al., "Three-Level Metallization Three-Phase CCD," IEEE Transactions on Electron Devices, ED-21 (12), 758-767 (December 1974).
- Bonyhard, P.I., Chen, Y.S., and Smith, J.L., "High Performance Magnetic Bubble Replicate Gate Design," IEEE Transactions on Magnetics, MAG-13 (5), (September 1977).
- Bonyhard, P.I. and Smith, J.L., "68 kbit Capacity 16 μ m-Period Magnetic Bubble Memory Chip Design with 2 μ m Minimum Features," IEEE Transactions on Magnetics, MAG-12, 614 (November 1976).
- Bouricius, W.G., "Conceptual Design of a 10 to the 8th Power Bit Magnetic Bubble Domain Mass Storage Unit and Fabrication, Test and Delivery of a Feasibility Model. Final Report," International Business Machines Corp., Huntsville, AL under U.S. government contract NAS8-26671, January 25, 1972, 283 pp.

- Bouricius, W.G., et al., "Modeling of a Bubble-Memory Organization with Self-Checking Translators to Achieve High Reliability," IEEE Transactions on Computers, C-22 (3), 269-275 (March 1973).
- Bouricius, W.G., "Reliability Modeling: Application to Bubble Domain Memories," 19th Annual Proceedings of the American Institute of Physics Conference on Magnetism and Magnetic Materials, (18), 2 parts, New York, 1974.
- Bower, R.W., Zimmerman, T.A. and Mohsen, A.M., "Performance Characteristics of the Offset Gate Charge-Coupled Device," IEEE Transactions on Electron Devices, ED-22 (2), 72 (1975).
- Boyle, W.S. and Smith, G.E., "Charge-Coupled Devices: A New Approach to Metal-Insulation-Semiconductor Device Structures," IEEE Spectrum, 8, 18-27 (July 1971).
- Brown, Dale M., Ghezzi, Mario and Sargent, Paul, "High Density CID Imagers," IEEE Journal of Solid State Circuits, SC-13 (1), 5-10 (February 1978).
- Browne, V.A. and Perkins, K.D., "Nonoverlapping Gate Charge-Coupling Technology for Serial Memory and Signal Processing Applications," IEEE Transactions on Electron Devices, ED-23 (2), 271-275 (February 1976).
- Browne, V.A. and Perkins, K.D., "Nonoverlapping Gate Charge-Coupling Technology for Serial Memory and Signal Processing Applications," IEEE Journal of Solid State Circuits, SC-11 (1), 203-207 (February 1976).
- Bruun, Roy J., "When Will Core, Drum and Disk Systems Be Just a Memory," Infosystems, 20 (5), 40-43 (May 1973).
- "Charge-Coupled Device Makes It into Memory Denser Than MOS," Electronics, 44, 31 (March 15, 1971).
- Chen, Yu-Ssu and Nelson, T.J., "Effects of Spacing Between Garnet Film and Permalloy Overlay Circuit in Magnetic Bubble Devices," IEEE Transactions in Magnetics, MAG-8 (4), 754-758 (December 1972).
- Chen, T.T., et al., "Magnetic Bubble Domain Flight Recorder," IEEE Transactions on Magnetics, MAG-10 (3), 739-745 (September 1974).
- Chen, T.T., Tocci, L.R. and Archer, J.L., "Device Component Margin Evaluation Using Generalized Field Interruption Technique," IEEE Transactions on Magnetics, MAG-12 (6), (November 1976).
- Chen, T.T., Tocci, L.R. and Archer, J.L., "Experimental Techniques for Studying the Reliability of Bubble Memory Devices," Journal of Applied Physics, 48 (1), 373-378 (January 1977).

- Dawson, R., et al., "CMOS/Buried-n-Channel CCD Compatible Process for Analog Signal Processing Applications," RCA Review, 38 (3), 406-435 (September 1977).
- Declerck, G.J., et al., "Experimental Results on Three-Phase Polysilicon CCD's With a TCE-SiO₂Si₃N₄ Gate Insulator," IEEE Journal of Solid State Circuits, SC-11 (1), 229-231 (February 1976).
- Doyle, W.D. and Flannery, W.E., "The Effect of Operating Conditions on Margin Decay for Half Disk Bubble Propagation Elements," IEEE Transactions on Magnetics, MAG-13, 1592-1594 (September 1977).
- Dziamanski, J., "Degradation Analysis of CCD/CID Devices," Report by Westinghouse Electric Corporation, Sponsored by the U.S. Dept. of Defense, Air Force, Rome Air Development Center, Griffiss Air Force Base, Rome, New York.
- Feuersanger, A.E., "Bonded Shift-Registers for Magnetic Bubble Memory Modules," 19th Annual Proceedings of the American Institute of Physics Conference on Magnetism and Magnetic Materials, (18), 2 parts, New York, 1974.
- Frohman-Betnchowsky, Dov, "FAMOS - A New Semiconductor Charge Storage Device," Solid State Electronics, 17 (6), 517-529 (June 1974).
- Graham, C.D. and Rhyne, J.J. (eds.), "Magnetism and Magnetic Materials," 19th Annual Proceedings of the American Institute of Physics Conference on Magnetism and Magnetic Materials, (18), 2 parts, New York, 1974, 1421 pp.
- Hagedorn, F.B., "Long-Term Testing of 68 kbit Bubble Device Chips," IEEE Transactions on Magnetics, MAG-12, 680-682 (November 1976).
- Hagedorn, F.B., et al., "Magnetic Bubble Device Testing," IEEE Transactions on Magnetics, MAG-13 (5), (September 1977).
- Hamaoui, H., Amelio, G. and Rothstein, J., "Application of an Area-Imaging Charge-Coupled Device for Television Cameras," IEEE Transactions on Broadcast and Television Receivers, BTR-20 (1), 78-85 (February 1974).
- Heinz, D.M., et al., "Exploratory Development of Magnetic Bubble Domain Material for Application in Air Force Solid State Mass Memory Systems," U.S. government-contracted report.
- Hnatek, E., "Chipping Away at Core' Another Round," Digital Des., 6 (7), 31-42 (July 1976).
- Huang, J.S.T., "Charge Handling Capacity in Charge Coupled Devices," IEEE Transactions on Electron Devices, ED-24 (10), 1234-1238 (October 1977).

"International Electron Devices Meeting. (Technical Digest)," 6-8 December 1976, Washington, D.C., IEEE, (1976).

Juliussen, J.E., "Magnetic Bubble Systems Approach Practical Use," Computer Design, 15 (10), 81-91 (October 1976).

Kestigian, M., "Magnetic LPE Crystalline Films for Small Bubble Diameter Cylindrical-Domain Memory Applications," Report by Sperry Rand Corporation, Sponsored by the U.S. Dept. of Defense, Air Force, Office of Scientific Research, Bolling Air Force Base, Washington, D.C.

Killiary, J.M., et al., "Effects of Ionizing Radiation on Charge-Coupled Device Structures," IEEE Transactions on Nuclear Science, NS-21 (6), 193-200 (December 1974).

Killiary, J.M., Saks, N.S. and Baker, W.D., "Effects of Ionizing Radiation on a 256-Stage Linear CCD Imager," IEEE Transactions on Nuclear Science, 2634-2638 (December 1975).

Killiary, J.M. and Baker, W.D., "Effects of Ionizing Radiation of a 224 Line by 188 Element Charge Injection Device Imager," IEEE Transactions on Nuclear Science, NS-23 (6), (December 1976).

Krambeck, R.H., et al., "Conductively Connected Charge-Coupled Device," IEEE Transactions on Electron Devices, ED-21 (1), 70-72 (January 1974).

Kroger, H., "Controlled Inversion Devices for High Reliability Semiconductor Memories," Report by Sperry Rand Corporation, Sponsored by the U.S. Dept. of Defense, Air Force, Rome Air Development Center, Griffiss Air Force Base, Rome New York.

Lignos, D., "Error Detection and Correction in Mass Storage Equipment," Computer Design, 11, 71-75 (October 1972).

Littwin, B., "Bubble Circuit Fabrication by Electrodeposition," IEEE Transactions of Magnetics, MAG-11 (5), (September 1975).

Margraff, Thomas C., "Design and Performance of a CCD Memory System," Paper available through the National Technical Information Service (NTIS), AD-A008-657/9GI.

Matsuyama, S., et al., "Margin Degradation in the Long-Term Testing of 3 μ m Bubble Devices," IEEE Transactions of Magnetics, MAG-13, 1586-1591 (September 1977).

Mavor, J. and Denyer, P.B., "The Dependence of CCD Dark Current Upon Power Dissipation," Microelectronics and Reliability, 17 (3), 403-404 (1978).

- Miyamoto, Y., Sei, H. and Ohtsuki, O., "Meander-Channel Charge-Coupled Devices," Fujitsu Science and Technology Journal, 13 (3), 85-98 (September 1977).
- Murakami, Hiroshi, "Memory Organization Using Imperfect Bubble Chips," IEEE Transactions on Magnetics, MAG-13 (5), 1631-1635 (September 1977).
- Naden, R.A. and West, F.G., "Fault-Tolerant Memory Organization: Impact on Chip Yield and System Cost," IEEE Transactions on Magnetics, MAG-10 (3), 852-855 (September 1974).
- Nelson, W.F. and Pulliam, G.R., "Reliability of Components in Magnetic Bubble Technology," Communications Systems and Technology Conference, 30 April - 1 May 1974, Dallas, Texas, pp. 29-40.
- Orihara, S., et al., "A 300 kbit Bubble Memory Chip with Planar Structure," Journal of Applied Physics, 49 (3) part 2, 1930-1932 (March 1978).
- Rosenbaum, Stanley D., et al., "16 384-bit High-Density CCD Memory," IEEE Journal of Solid State Circuits, SC-11 (1), 33-40 (February 1976).
- Rusu, A., "Metal-Overlap Laterally-Diffused (MOLD) Schottky Diode," Solid State Electronics, 20 (6), 499-506 (June 1977).
- Sakaue, T., et al., "Improved Charge-Coupled Analog Delay Line," Journal of the Japan Society of Applied Physics, 44 (supplement), (1975).
- Sato, S. and Yamaguchi, T., "Study of Charge Storage Behavior in Metal-Alumina-Silicon Dioxide-Silicon (MAOS) Field Effect Transistor," Solid State Electronics, 17 (4), 367-375 (April 1974).
- Sei, Hideo, et al., "Meander Channel CCD Linear Image Sensor," IEEE Journal of Solid State Circuits, SC-13 (1), 66-70 (February 1978).
- Shumate, P.W. and Peirce, R.J., "Lifetime Characterization of Propagated Bubble-data Streams," Applied Physics Letters, (23), 204-205 (1973).
- "Substrate Increases Yield of Bubble Domain Memory Devices," Computer Design, 11, 36 (June 1972).
- Theunissen, M.J.J., "Measurements on Bulk-Channel MOS Capacitors for Dark Current Characterization of Peristaltic Charge-Coupled Devices," Philips Research Report, 32 (5-6), 429-435 (1977).
- Wada, Toshio, et al., "MAS-ROM - Electrically Reprogrammable ROM with Decoder," IEEE Journal of Solid State Circuits, SC-7 (5), 375-381 (October 1972).

- Wong, C.Y. and Yeh, P.C., "Anticipatory Control of a Cyclically Permutable Memory," IEEE Transactions on Computers, C-22 (5), 481-488 (May 1973).
- Yamaguchi, Nakahiko, "Bias Field Margin Degradation Due to Long-Term Memory Operation in 16 kbit Bubble Memory Chips," Japan Journal of Applied Physics, 16 (supplement 16-1), 347-350 (1977).
- Yamaguchi, Nakahiko, "Control Function Margin Degradation in a Bubble Memory Chip," IEEE Transactions on Magnetics, MAG-14 (3), 128-129 (May 1978).
- Yanase, T., Igarashi, K. and Segawa, M., "Design and Fabrication of a 73-kbit Magnetic Bubble Memory Chip," Fujitsu Science and Technology Journal, 14 (1), 61-84 (March 1978).

- Barsan, R.M., "Charge Transfer in Charge-Coupled Devices in the Presence of Interface States," Solid State Electronics, 19, 1915-1919 (December 1976).
- Buchanan, Stanley P., "Performance Evaluation and Future Applications of Two Solid State Imaging Array Tracking Systems," Laser 77: Opto-Electron, 3rd Conference Proceedings, Munich, Germany, June 20-24, 1977, pp. 205-221.
- Dyck, Rudolph H., "High Quantum Efficiency Front-Side Illuminated CCD Area Image Sensor," SPIE Seminar Proceedings, 116, Solid State Imaging Devices, San Diego, California, August 23-24, 1977, pp. 19-23.
- Elsaid, M.H., et al., "Computer Model and Charge Transport Studies in Short Gate Charge-Coupled Devices," Solid State Electronics, 20, 61-69 (January 1977).
- Ferris-Prabhu, A.V., "Predicting Product Life: Eliminating Mathematical Inaccuracies," Machine Design, 49, 158-172 (October 20, 1977).
- Gallace, L.J. and Pujol, H.L., "Failure Mechanisms in COS/MOS Integrated Circuits," Electronic Engineer, 48, 65 (December 1976).
- Hodges, David A., "Review and Projection of Semiconductor Components for Digital Storage," Proceedings IEEE, 63 (8), 1136-1147 (August 1975).
- Kosonocky, W.F. and Carnes, J.E., "Design and Performance of Two-Phase Charge-Coupled Devices with Overlapping Polysilicon and Aluminum Gates," 1973 IEDM Technical Digest, pp. 123-125.
- Kosonocky, W.F., Kohn, E.S. and Shallcross, F.V., "Optimization Study of IR-CCD Array," RADC-TR-78, (July 1978).
- Kosonocky, W.F., Sauer, D.J. and Shallcross, F.V., "256-Element Schottky-Barrier IR-CCD Line Sensor," RADC-TR-77-304, (September 1977), AU46274.
- Mok, T.D. and Salama, C.A.T., "Performance and Characterization of Logic Arrays Using Charge-Transfer Semiconductor Devices," International Electrical Electronics Conference and Exposition Digest, 166-167 (1973).
- Smith, G.E., "Charge Transfer Devices," 9th Annual Proceedings Reliability Physics, 1971, pp. 29-32.
- Sterkin, C.K., Conference on Charge-Coupled Device Technology and Applications, Proceedings, Washington, DC, November 30 - December 2, 1976.
- Tomlinson, J.L. and Wieder, H.H., "Magnetic Bubble Domain Memories in Epitaxial Garnet Films," Radio and Electronic Engineering, 45 (12), 725-737 (December 1975).

"Two Million-Bit Magnetic Bubble Experiment Device," Journal of Electronic Engineering, 57 (August 1976).

Whatley, M.M., et al., "Charge-Coupled Device Applications in Radar Signal Processing," IEEE National Aerospace and Electronics Conference, Proceedings, Dayton, Ohio, May 13-15, 1974, pp. 284-291.

Zimmerman, T.A. and Barbe, D.F., "New Role for Charge-Coupled Devices: Digital Signal Processing," Electronics, 50, 97-103 (March 31, 1977).

AD-A090 029

LITTLE (ARTHUR D) INC CAMBRIDGE MA
RELIABILITY PREDICTION MODELING OF NEW DEVICES. (U)
JUL 80 R G LONG, M COHEN

F/G 9/2

F30602-78-C-0296

UNCLASSIFIED

ADL-C-82361

RADC-TR-80-237

NL

2 of 2

48 pages



END
DATE
FILMED
11-80
DTIC

APPENDIX B

BIBLIOGRAPHY OF CHARGE-COUPLED DEVICE TECHNOLOGY

- Ablassmeier, U., and Doering, E., "CCD Circuits of High-Storage Density in Al-Si Gate Technology," Siemens Forschungs- und Entwicklungsberichte, Vol. 4, No. 4, pp. 226-230, 1975. (In German)
- Altman, L., "Charge-Coupled Devices Move in on Memories and Analog Signal Processing," Electronics, Vol. 47, No. 16, pp. 91-101, Aug. 8, 1974.
- Amelio, G. F., "Physics and Applications of Charge-Coupled Devices," in 1973 IEEE Intercon Technical Papers, proceedings of the Institute of Electrical and Electronics Engineers International Convention and Exposition, New York, N. Y., March 26-30, 1973, Vol. 6, Paper 1/3.
- Ando, K. J., "MTF and Point-Spread Function for a Large-Area CCD Imager," in proceedings of the Symposium on Charge-Coupled Device Technology for Scientific Imaging Applications, Pasadena, Calif., March 6-7, 1975, pp. 192-215.
- Antcliffe, G. A., et al., "Large-Area CCD Imagers for Spacecraft Applications," in proceedings of the Symposium on Charge-Coupled Device Technology for Scientific Imaging Applications, Pasadena, Calif., March 6-7, 1975, pp. 125-136.
- Antcliffe, G. A., et al., "Operation of CCD's with Stationary and Moving Electron-Beam Input," IEEE Transactions on Electron Devices, Vol. ED-22, No. 10, pp. 857-861, Oct. 1975.
- Antcliffe, G. A., "Development of CCD Imaging Sensors for Space Applications, Phase 1," Final Report. NASA-CR-148193. Texas Instruments, Inc., Dallas; Jet Propulsion Laboratory, Pasadena, Dec. 15, 1975.
- Arens, W. E., "Charge-Coupled Device Data Processor for an Airborne Imaging Radar System," Patent Application. US-Patent-Appl-SN-589119. National Aeronautics and Space Administration, Pasadena; Jet Propulsion Laboratory, Pasadena, June 23, 1975.
- Autio, G. W., and Bafico, M. A., "Gamma Noise in CCD's," Infrared Physics, Vol. 15, pp. 249-258, Nov. 1975.
- Baker, R. T., "CCD Array Forms Random-Access Memory," Electronics, Vol. 48, No. 23, pp. 138-139, Nov. 1975.
- Baker, W. D. and Michaels, D. J., "Imaging Performance of a CCD Array at 2000K," in proceedings of the Symposium on Charge-Coupled Device Technology for Scientific Imaging Applications, Pasadena, Calif., March 6-7, 1975, pp. 186-191.
- Bankowski, W. F., Kumar, V. R., and Tartamella, J. D., "Charge-Coupled Devices Optical Sensor Storage Device," IBM Technical Disclosure Bulletin, Vol. 16, No. 9, pp. 2915-2916, Feb. 1974.

Barbe, D. F., "Imaging Devices Using the Charge-Coupled Concept - for Remote Sensing," IEEE Proceedings, Vol. 63, pp. 38-67, Jan. 1975.

Barbe, D. F., "Charge-Coupled-Device Imagers," in Technical Digest, proceedings of International Electron Devices Meeting, Washington, D. C., Dec. 1-3, 1975, pp. 60-65.

Barbe, D. F., and Baker, W. D., "Signal Processing Devices Using the Charge-Coupled Concept," Microelectronics, Vol. 7, No. 2, pp. 36-45, Dec. 1975.

Barbe, D. F., "Charge-Coupled Device and Charge-Injection Device Imaging," IEEE Transactions on Electron Devices, Vol. ED-23, No. 2, pp. 177-182, Feb. 1976.

Beaumont, J., "Performance Evaluation of the CCD450 Digital Memory," M. S. Thesis. AD-A019810. Air Force Institute of Technology, Wright-Patterson AFB, Ohio, Dec. 1975.

Benz, H. F. and Husson, C., "Charge-Coupled Device (CCD) Analog Signal Processing," IEEE Proceedings, Vol. 63, No. 5, pp. 822-823, May 1975.

Berger, J., "Comparaison des Performances des Dispositifs BBD et CCD Appliqués aux Senseurs Optiques (Performance Comparison of CCD and BBD Working as Optical Sensors)," L'Onde Electrique, Vol. 54, No. 7, pp. 331-342, Aug.-Sept. 1974. (In French)

Bertram, W. J., et al., "Three-Level Metallization Three-Phase CCD," IEEE Transactions on Electron Devices, Vol. ED-21, No. 12, pp. 758-767, Dec. 1974.

Beynon, J. D. E., "Charged-Coupled Devices - Concepts, Technologies and Applications," Radio and Electronic Engineer, Vol. 45, No. 11, pp. 647-656, Nov. 1975.

Beynon, J. D. E., "Basic Principles of Charge-Coupled Devices," Microelectronics, Vol. 7, No. 2, pp. 7-13, Dec. 1975.

Bharat, R., "On the Feasibility of Slow-Wave-Structure Clocking of High-Frequency Charge-Coupled Devices," AD-768786. Denver University, Denver, Colo.; Battelle Columbus Laboratories, Columbus, Ohio, Oct. 1973.

Bharat, R., "A Frequency Divider Using a Charge-Coupled Device - for Timing Devices," AD-774253. Army Electronics Command, Fort Monmouth, N. J., Dec. 1973.

Bleier, S. A., "A Quantum Mechanical Description of Charge Injection Devices (CID)," M. S. Thesis. AD-A013496. Monmouth College, July 1975.

Board, K., Shannon, J. M., and Gill, A., "C.C.F.E.T.: An Active Charge-Coupled Device," Electronics Letters, Vol. 11, No. 19, pp. 452-453, Sept. 18, 1975.

Borsuk, J., and Bordoloi, K., "Charge-Coupled Devices: A Review," in Proceedings of the IEEE Southeast-Con, Region 3 Conference, Louisville, Ky., Apr. 30-May 2, 1973, Paper T-5.

Boudreaux, N. A., III, "Design Optimization of Metal-Insulator Semiconductor Devices for Infrared Solid State Imaging," M. S. Thesis. AD-A005472. Naval Postgraduate School, Monterey, Calif., Dec. 1974.

Bower, R. W., Zimmerman, T. A., and Mohsen, A. M., "Two-Phase Offset Gate CCD," IEEE Transactions on Electron Devices, Vol. ED-22, No. 2, pp. 70-72, Feb. 1975.

Bower, R. W., Zimmerman, T. A., and Mohsen, A. M., "Performance Characteristics of the Offset-Gate Charge-Coupled Device," IEEE Transactions on Electron Devices, Vol. ED-22, No. 2, pp. 72-74, Feb. 1975.

Brodersen, R. W., Buss, D. D., and Tasch, A. F., Jr., "Experimental Characterization of Transfer Efficiency in Charge-Coupled Devices," IEEE Transactions on Electron Devices, Vol. ED-22, No. 2, pp. 40-46, Feb. 1975.

Brodersen, R. W., Hewes, C. R., and Buss, D. D., "A 500-Stage CCD Transversal Filter for Spectral Analysis," IEEE Transactions on Electron Devices, Vol. ED-23, No. 2, pp. 143-152, Feb. 1976.

Brodersen, R. W., and Emmons, S. P., "Noise in Buried Channel Charge-Coupled Devices," IEEE Transactions on Electron Devices, Vol. ED-23, No. 2, pp. 215-223, Feb. 1976.

Brotherton, S. D., and Singh, M. P., "Influence of Clock Waveforms on the Performance of Charge Coupled Devices," Solid State Electronics, Vol. 17, No. 9, pp. 981-984, Sept. 1974.

Brown, R. W. and Chamberlain, S. G., "Quantum Efficiency of a Silicon Gate Charge-Coupled Optical Imaging Array," Physica Status Solidi (A) Applied Research, Vol. 20, No. 2, pp. 675-685, Dec. 1973.

Browne, V. A., and Perkins, K. D., "A Nonoverlapping Gate Charge-Coupling Technology for Serial Memory and Signal Processing Applications," IEEE Transactions on Electron Devices, Vol. ED-23, No. 2, pp. 271-275, Feb. 1976.

Burt, D. J., "Charge-Coupled Devices and Their Application," Electronics and Power, Vol. 21, No. 2, pp. 93-97, Feb. 6, 1975.

Burt, D. J., et al., "Development of a CCD Image Sensor, Phase 1," Final Report. Rept-16194C. General Electric Co., Ltd., Wembley (England), Nov. 1975.

Buss, D. D., Bailey, W. H., and Collins, D. R., "Analysis and Applications of Analogue CCD Circuits," in Digest Papers, proceedings of the International Symposium on Circuit Theory, Toronto, Ont., Apr. 9-11, 1973, pp. 3-7.

Buss, D. D., Holmes, J. D., and Rosser, L. A., "Investigation of Semiconductor Charge Devices, Part 1," Final Report. RADC-TR-73-259-PT-1. AD 772637. Texas Instruments, Inc., Dallas, Tex, Oct. 1973.

Buss, D. D., et al., "Signal Processing Applications of Charge Coupled Devices," in proceedings of the Western Electronic Show and Convention, Los Angeles, Calif., Sept. 10-13, 1974, Paper 2/2.

Buss, D. D., et al., "Application of Charge-Coupled Devices to Radar Signal Processing," in NEREM 74 Record, proceedings of the Northeast Electronics Research and Engineering Meeting, Boston, Mass., Oct. 28-31, 1974, pp. 83-98.

Buss, D. D., and Hewes, C. R., "Tunable Filters Using Charge Transfer Devices," Interim Technical Report, 16 July 1973 - 16 Mar. 1974. AD-782818. Texas Instruments, Inc., Dallas, Tex., June 1974.

Buss, D. D., and Hewes, C. R., "Tunable Filters Using Charge Transfer Devices - Computerized Simulation," Interim Report, 17 Mar. - 15 July 1974. AD-A000846. Texas Instruments, Inc., Dallas, Tex., Oct. 1974.

Buss, D. D. and Hewes, C. R., "Tunable Filters Using Charge Transfer Devices," Interim Report, 16 July 1974 - 16 Mar. 1975. AD-A012358. Texas Instruments, Inc., Dallas, Tex., June 1975.

Buss, D. D., et al., "Applications of Charge-Coupled Device Transversal Filters to Communication," in Conference Record, Vol. 1, proceedings of the International Conference on Communications, 11th, San Francisco, Calif., June 16-18, 1975, pp. 2-4 to 2-9. Institute of Electrical and Electronics Engineers, Inc., New York, N.Y., 1975.

Buss, D. D., et al., "Charge Transfer Device Transversal Filters for Communication Systems," Microelectronics, Vol. 7, No. 2, pp. 46-53, Dec. 1975.

Campana, S. B., and Barbe, D. F., "Tradeoffs Between Aliasing and MTF - for Charge Coupled Device Imagers," in Proceedings of the Technical Program, Electrical Optical Systems Design Conference - 1974 West, San Francisco, Calif., Nov. 5-7, 1974, pp. 1-9.

Carnes, J. E., Kosonocky, W. F., and Levine, P. A., "Measurements of Noise in Charge-Coupled Devices," RCA Review, Vol. 34, No. 4, pp. 553-565, Dec. 1973.

Carnes, J. E., and Kosonocky, W. F., "Charge-Coupled Devices and Applications," Solid State Technology, Vol. 17, No. 4, pp. 67-77, Apr. 1974,

Carnes, J. E., et al., "Charge-Coupled Devices for Computer Memories," in Conference Proceedings, Vol. 43, 1974, for AFIPS National Computer Conference and Exposition, Chicago, Ill., May 6-10, 1975, pp. 827-837.

Carnes, J. E., et al., "Effects of Radiation on Charge-Coupled Devices," in proceedings of the Symposium on Charge-Coupled Device Technology for Scientific Imaging Applications, Pasadena, Calif., Mar. 6-7, 1975, pp. 243-251.

Chamberlain, S. G., Copeland, M. A., and Ibrahim, A. A., "Some General Experimental Studies on Charge-Coupled Device Circuits," International Journal of Electronics, Vol. 35, No. 6, pp. 833-846, Dec. 1973.

- Chamberlain, S. G., and Woo, B. Y., "Transient Analysis of Electrical Charge Injection into Charge-Coupled Devices," International Journal of Electronics, Vol. 40, pp. 569-586, June 1976.
- Chambers, J. M., Sauer, D. J., and Kosonocky, W. F., "CCD's as Drum and Disc Equivalents," in proceedings of the Western Electronic Show and Convention, Los Angeles, Calif., Sept. 10-13, 1974, Paper 6/1.
- Chan, C. H., Chamberlain, S. G., and Colton, D. R., "Charge-Coupled Serial to Parallel Shift Register," in Conference Digest, proceedings of the International Electrical, Electronics Conference and Exposition, Toronto, Ont., Oct. 1-3, 1973, Paper No. 73234, pp. 140-141. Institute of Electrical and Electronics Engineers, New York, N. Y., 1973.
- Chan, C. H., and Chamberlain, S. G., "Numerical Methods for the Charge Transfer Analysis of Charge-Coupled Devices," Solid-State Electronics, Vol. 17, No. 5, pp. 491-499, May 1974.
- Chien, R. T., and Snyder, W. E., "Hardware for Visual Image Processing," IEEE Transactions on Circuits and Systems, Vol. CAS-22, pp. 541-551, June 1975.
- Choisser, J. P., "Experiments on the Use of CCD's to Detect Photoelectron Images," in proceedings of the Symposium on Charge-Coupled Device Technology for Scientific Imaging Applications, Pasadena, Calif., Mar. 6-7, 1975, pp. 150-162, June 1975.
- Chou, S., "Design of a 16 384-Bit Serial Charge-Coupled Memory Device," IEEE Transactions on Electron Devices, Vol. ED-23, No. 2, pp. 78-86, Feb. 1976.
- Chynoweth, A. G., "Electronic Materials - Functional Substitutions," Science, Vol. 191, pp. 725-732, Feb. 20, 1976.
- Clough, G. A., Kotyczka, W., and Erb, D. M., "Experimental Observation of Signal Degradation in Recirculating Charge-Coupled Devices," in Technical Digest, proceedings of the International Electron Devices Meeting, Washington, D. C., Dec. 9-11, 1974, pp. 251-252. Institute of Electrical and Electronics Engineers, New York, 1974.
- Collet, M. G., and Vliegenthart, A. C., "Calculations on Potential and Charge Distributions in the Peristaltic Charge-Coupled Device," Philips Research Reports, Vol. 29, No. 1, pp. 25-44, Feb. 1974.
- Collet, M. G., "Experimental Method to Analyse Trapping Centres in Silicon at Very Low Concentrations," Solid-State Electronics, Vol. 18, No. 12, pp. 1077-1083, Dec. 1975.
- Collet, M. G., "The Influence of Bulk Traps on the Charge-Transfer Inefficiency of Bulk Charge-Coupled Devices," IEEE Transactions on Electron Devices, Vol. ED-23, No. 2, pp. 224-227, Feb. 1976.
- Collins, D. R., et al., "Development of a CCD for Ultraviolet Imaging Using a CCD Photocathode Combination," in proceedings of the Symposium on Charge-Coupled Device Technology for Scientific Imaging Applications, Pasadena, Calif., Mar. 6-7, 1975, pp. 163-174.

Cooper, D. C., et al., "Reducing the Effect of Charge Transfer Inefficiency in a C.C.D. Video Integrator," Electronics Letters, Vol. 11, No. 16, pp. 384-385, Aug. 7, 1975.

Copeland, M. A., et al., "An Optical CCD Convolver," IEEE Transactions on Electron Devices, Vol. ED-23, pp. 152-155, Feb. 1976.

Corsi, C., et al., "Thin Film Infrared Detector Arrays for Integrated Electronic Structures - Based on Narrow-Gap Semiconductors Multicathode RF Sputtering Technique," Infrared Physics, Vol. 16, pp. 37-45, Jan.-Mar. 1976.

Currie, D. G., "On a Photon-Counting Array Using the Fairchild CCD-201," in proceedings of the Symposium on Charge-Coupled Device Technology for Scientific Imaging Applications, Pasadena, Calif., Mar. 6-7, 1975, pp. 80-90.

Curtis, D. A., Granger, R. J., and Ross, M. H., "The Status, Development and Applications in Space of Solid-State Imaging Systems - Noting Charge-Coupled and Charge Injection Devices," Final Report. ESRO-CR(P)-416, April 1974. Cambridge Consultants Ltd. (England)

Daimon, Y., Mohsen, A. M., and McGill, T. C., "Charge Transfer in Buried-Channel Charge-Coupled Devices," in Digest of Technical Papers, proceedings of the IEEE International Solid State Circuits Conference, University of Pennsylvania, Philadelphia, Pa., Feb. 13-15, 1974, pp. 146-147, 245.

Daimon, Y., Mohsen, A. M., and McGill, T. C., "Final State of the Charge-Transfer Process in Charge-Coupled Devices," IEEE Transactions on Electron Devices, Vol. ED-21, No. 4, pp. 266-272, Apr. 1974.

Dale, B., "The Validity of the Depletion Approximation Applied to a Bulk Channel Charge-Coupled Device," IEEE Transactions on Electron Devices, Vol. ED-23, No. 2, pp. 275-282, Feb. 1976.

Dearnaley, G., "Ion Implantation in Semiconductor Fabrication Technology," Nature, Vol. 256, pp. 701-705, Aug. 28, 1975.

DeClerck, G. J., et al., "Experimental Results on Three-Phase Polysilicon CCD's with a TCE-SiO₂/Si₃N₄ Gate Insulator," IEEE Transactions on Electron Devices, Vol. ED-23, pp. 297-299, Feb. 1976.

El-Sissi, H., and Cobbold, R. S. C., "One Dimensional Study of Buried-Channel Charge-Coupled Devices," IEEE Transactions on Electron Devices, Vol. ED-21, No. 7, pp. 437-447, July 1974.

El-Sissi, H., and Cobbold, R. S. C., "Potentials and Fields in Buried-Channel CCD's: A Two-Dimensional Analysis and Design Study," IEEE Transactions on Electron Devices, Vol. ED-22, No. 3, pp. 77-90, Mar. 1975.

El-Sissi, H., and Cobbold, R. S. C., "On the Decay of Small Amounts of Signal Charge in Surface-Channel CCD's," IEEE Transactions on Electron Devices, Vol. ED-22, No. 3, pp. 154-156, Mar. 1975.

El-Sissi, H., and Cobbold, R. S. C., "Influence of Signal Charge on the Final Decay Characteristics of Surface-Channel Charge-Coupled Devices," Solid-State Electronics, Vol. 18, No. 10, pp. 867-870, Oct. 1975.

Emmons, S. P., and Buss, D. D., "Noise Measurements on the Floating Diffusion Input for Charge-Coupled Devices," Journal of Applied Physics, Vol. 45, No. 12, pp. 5303-5306, Dec. 1974.

Emmons, S. P., Tasch, A. F., Jr., and Caywood, J. M., "Low Noise CCD Input with Reduced Sensitivity to Threshold Voltage," in Technical Digest, proceedings of the International Electron Devices Meeting, 20th, Washington, D.C., Dec. 9-11, 1974, pp. 233-235.

Emmons, S. P., et al., "A Study of Noise in Charge-Coupled Devices," Final Technical Report, 1 Apr. 1974 - 31 Mar. 1975, AD-A015365. Texas Instruments, Inc., Dallas. May 1975.

Epifanov, A. A., Frolov, O. S., and Derkach, Iu. P., "Theoretical Analysis of the Kinetics of Free Charge Transport in Charge-Coupled Devices," Poluprovodnikovaia Tekhnika I Mikroelektronika, No. 22, pp. 18-29, 1976. (In Russian)

Esser, L. J. M., "Peristaltic Charge-Coupled Device for High-Speed Charge Transfer," in Digest of Technical Papers, proceedings of the IEEE International Solid-State Circuits Conference, University of Pennsylvania, Philadelphia, Pa., Feb. 13-15, 1974, pp. 28, 29, 219.

Fairchild Camera and Instrument Corp., Mountain View, Calif., "Charge Coupled Device Image Sensor Study," Final Report. NASA-CR-136937. Feb. 1974.

Fairchild Space and Defense Systems, Syosset, N. Y., "Distributed Floating-Gate Amplifier (DFGA)," Final Report, Aug. 1973 - Aug. 1974. AD-A002474. Oct. 1974.

Fang, T.F., and Liu, H. K., "Fabrication and Measurements of a Silicon Charge-Coupled Device," in Proceedings of the IEEE Southeast-Con, Region 3 Conference, Louisville, Ky., Apr. 30 - May 2, 1973, Paper T-6.

Feth, G. C., "Memories - Smaller, Faster, and Cheaper," IEEE Spectrum, Vol. 13, pp. 36-43, June 1976.

Fishman, G. J., et al., "An X-Ray Shadowgraph to Locate Transient High-Energy Celestial Sources," in proceedings of the Symposium on Charge-Coupled Device Technology for Scientific Imaging Applications, Pasadena, Calif., Mar. 6-7, 1975, pp. 4-13.

Fraser, J. C., et al., "Extrinsic Silicon Charge Coupled Device for Detecting Infrared Radiation," in Technical Digest, proceedings of the International Electron Devices Meeting, 20th, Washington, D.C., Dec. 9-11, 1974, pp. 442-445.

French, D. E., Sekula, J. A., and Hartman, J. M., "Off-Focal-Plane Time Delay and Integration (OTDI) Using Charge Coupled Devices," in Technical Digest, proceedings of the International Electron Devices Meeting, 20th, Washington, D.C., Dec. 9-11, 1974, pp. 437-441.

Galema, S. D., Schwartz, R. J., and Gunshor, R. L., "Acoustic Surface Wave Interaction Charge-Coupled Device," Applied Physics Letters, Vol. 29, pp. 82, 83, July 15, 1976.

Gassaway, J. D., "LSI Arrays for Space Stations," Interim Report. NASA-CR-1447. Mississippi State University, Miss., Feb. 1976.

Gassaway, J. D., "Electrostatic Analysis of Charge-Coupled Structures - Numerical Analysis of Electrostatics for Shift Registers," NASA-CR-144175. Mississippi State University, Miss., Feb. 1976.

Gelberger, P. P., and Salama, C. A. T., "Moat-Etched Two-Phase Charge-Coupled Devices," Solid-State Electronics, Vol. 17, No. 3, pp. 301-305, Mar. 1974.

Goss, W. C., "CCD Star Trackers," in proceedings of the Symposium on Charge-Coupled Device Technology for Scientific Imaging Applications, Pasadena, Calif., Mar. 6-7, 1975, pp. 31-45.

Gunsagar, K. C., Guidry, M. R., and Amelio, G. F., "A CCD Line Addressable Random-Access Memory (LARAM)," IEEE Journal of Solid-State Circuits, Vol. SC-10, pp. 268-273, Oct. 1975.

Gunshor, R. L., "The Interaction Between Semiconductors and Acoustic Surface Waves - A Review," Solid-State Electronics, Vol. 18, pp. 1089-1093, Dec. 1975.

Gupta, B. B., "Engineering - in Charge Coupled Devices," Electronic Engineering (London), Vol. 47, No. 573, pp. 41-46, Nov. 1975.

Haken, R. A., Baker, I. M., and Beynon, J. D. E., "Simple Driving and Frequency Characterization Technique for Two-Phase Charge-Coupled Devices," IEEE Journal of Solid-State Circuits, Vol. SC-8, No. 4, pp. 199-203, Aug. 1974.

Haken, R. A., "Supply Charge Isolation - A Simple Surface Potential Equilibrium Charge-Injection Technique for Charge-Coupled Devices," IEEE Transactions on Electron Devices, Vol. ED-23, No. 2, pp. 257-264, Feb. 1976.

Hamaoui, H., Amelio, G., and Rothstein, J., "Application of an Area-Imaging Charge-Coupled Device for Television Cameras," IEEE Transactions on Broadcast and Television Receivers, Vol. BTR-20, No. 1, pp. 78-85, Feb. 1974.

Hartsell, G. A., and Kmetz, A. R., "Design and Performance of a Three-Phase, Double-Level Metal 160x100 Element CCD Imager," in Technical Digest, proceedings of the International Electron Devices Meeting, 20th, Washington, D.C., Dec. 9-11 1974, pp. 59-62.

Hartsell, G. A., Robinson, D. A., and Collins, D. R., "Effects of Ionizing Radiation on CCD's" in proceedings of the Symposium on Charge-Coupled Device Technology for Scientific Imaging Applications, Pasadena, Calif., Mar. 6-7, 1975, pp. 216-227, June 1975.

Hense, K. R., and Collins, T. W., "Linear Charge-Coupled Device Signal-Processing Techniques," IEEE Transactions on Electron Devices, Vol. ED-23, No. 2, pp. 265-270, Feb. 1976.

- Hewes, C. R., Brodersen, R. W., and Buss, D. D., "Frequency Filtering Using Charge Coupled Devices," in Proceedings of Annual Symposium on Frequency Control, 29th, Atlantic City, N. J., May 28-30, 1975, pp. 77-87.
- Hirschberg, T., "CCDs and the Imaging Metamorphosis -- Applications of Charge Coupled Devices," Optical Spectra, Vol. 9, pp. 28-30, 32, 33, Nov. 1975.
- Hoffman, C. P., et al., "Camera Memory Study for Large Space Telescope - Charge Coupled Devices," Final Report. Apr. 1974 - Jan. 1975. NASA-CR-143815. Westinghouse Electric Corporation, Baltimore, Md., Feb. 1975.
- Hosack, H. H., and Dyck, R. H., "Transfer Inefficiency Effects in Parallel-Transfer Charge-Coupled Linear Imaging Devices," IEEE Transactions on Electron Devices, Vol. ED-22, No. 3, pp. 152-154, Mar. 1975.
- Iamsa-Ad, V., "Charge-Coupled Devices for Analog Signal Processing Recursive Filter Study," M. S. Thesis. AD-A005469. Naval Postgraduate School, Monterey, Calif., Dec. 1974.
- Ibrahim, A., et al., "CCD's for Transversal Filter Applications," in Technical Digest, proceedings of the International Electron Devices Meeting, 20th, Washington, D.C., Dec. 9-11, 1974, pp. 240-243.
- Ionescu, N., "The Distribution of Mobile Carriers in a Surface CCD (Ideal Insulator)," Revue Roumaine de Physique, Vol. 21, No. 3, pp. 317-322, 1976.
- Jack, M. D., and Dyck, R. H., "Charge-Transfer Efficiency in a Buried-Channel Charge-Coupled Device at Very Low Signal Levels," IEEE Transactions on Electron Devices, Vol. ED-23, No. 2, pp. 228-234, Feb. 1976.
- Jacobson, R. A., "Charge Coupling - A Remarkable New Way to Manipulate Information," Machine Design, Vol. 46, No. 12, pp. 120-125, May 16, 1974.
- Killiany, J. M., et al., "Effects of Ionizing Radiation on Charge-Coupled Imagers," in proceedings of the Symposium on Charge-Coupled Device Technology for Scientific Imaging Applications, Pasadena, Calif., Mar. 6-7, 1975, pp. 228-242.
- Kim, C. K., and Dyck, R. H., "Low-Light Level Imaging with Buried Channel Charge-Coupled Devices," IEEE Proceedings, Vol. 61, No. 8, pp. 1146-1147, Aug. 1973.
- Kim, C. K., "Two-Phase Charge Coupled Linear Imaging Devices with Self-Aligned Implanted Barrier," in Technical Digest, proceedings of the International Electron Devices Meeting, 20th, Washington, D.C., Dec. 9-11, 1974, pp. 55-58.
- Kirk, J. C., Jr., "Digital Synthetic Aperture Radar Technology," in Record, proceedings of the International Radar Conference, Arlington, Va., Apr. 21-23, 1975, pp. 482-487.

Kleefstra, M., "First Experimental Bi-Polar Charge-Coupled Device," Microelectronics, Vol. 7, No. 2, pp. 68-69, Dec. 1975.

Kohn, E. S., and Schultz, M. L., "Charge-Coupled Scanned IR Imaging Sensors," Semiannual Technical Report, 29 June - 28 Dec. 1973. AD-780546. AFCRL-TR-74-0056. Radio Corporation of America, Princeton, N. J., Jan. 14, 1974.

Kohn, E. S., and Schultz, M. L., "Charge-Coupled Scanned IR Imaging Sensors," Semiannual Technical Report, 29 Dec. 1973 - 30 June 1974. AD-A003342. AFCRL-TR-74-0375. Radio Corporation of America, Princeton, N. J., July 15, 1974.

Kohn, E. S., "Charge Coupled Scanned IR Imaging Sensors," Semiannual Report, 1 July 1974 - 30 Apr. 1975. AD-A018057. AFCRL-TR-75-0284. Radio Corporation of America, Princeton, N. J., May 15, 1975.

Kohn, E. S., "A Charge-Coupled Infrared Imaging Array with Schottky-Barrier Detectors," IEEE Transactions on Electron Devices, Vol. ED-23, No. 2, pp. 207-214, Feb. 1976.

Kosonocky, W. F., "Charge-Coupled Devices - An Overview," in proceedings of the Western Electronic Show and Convention, Los Angeles, Calif., Sept. 10-13, 1974, Paper 2/1.

Kosonocky, W. F., and Sauer, D. J., "ABC's of CCD's," Electronic Design, Vol. 23, No. 8, pp. 58-63, Apr. 12, 1975.

Kosonocky, W. F., and Carnes, J. E., "Basic Concepts of Charge-Coupled Devices," RCA Review, Vol. 36, pp. 566-593, Sept. 1975.

Kosonocky, W. F., and Sauer, D. J., "Consider CCDs for a Wide Range of Uses," Electronic Design, Vol. 24, No. 6, pp. 70-78, Mar. 15, 1976.

Krambeck, R. H., et al., "Conductively Connected Charge-Coupled Device," IEEE Transactions on Electron Devices, Vol. ED-21, No. 1, pp. 70-72, Jan. 1974.

Krambeck, R. H., Retajczyk, T. F., Jr., and Yau, L. D., "Transfer Efficiency of E-Beam Fabricated C4D's," in Technical Digest, proceedings of the International Electron Devices Meeting, 20th, Washington, D.C., Dec. 9-11, 1974, pp. 248-250.

Krambeck, R. H., Retajczyk, T. F., Jr., and Yau, L. D., "Low Frequency Transfer Efficiency of E-Beam Fabricated Conductively Connected Charge-Coupled Device," IEEE Transactions on Electron Devices, Vol. ED-23, pp. 239-248, Feb. 1976.

Lancaster, A. L., and Hartman, J. M., "Recirculating CCD with Novel Input and Output Structures," in Technical Digest, proceedings of the International Electron Devices Meeting, 20th, Washington, D.C., Dec. 9-11, 1974, pp. 108-111.

Langan, L. J., "Solid State Mini-RPV Color Imaging System," AD-A018909. General Electric Company, Utica, N. Y., Sept. 12, 1975.

Lee, R.N., Scharnhorst, P.K., and Schollar, R.B., "Preparation and Properties of Si-Si Heterojunctions for Infrared Charge Coupled Imaging," Final Report, May 1972 - Nov. 1973. AD-775895. Naval Ordnance Laboratory, White Oak, Md., Jan. 17, 1974.

Leonberger, F. J., McWhorter, A. L., and Harman, T. C., "PbS MIS Devices for Charge-Coupled Infrared Imaging Applications," Applied Physics Letters, Vol. 26, pp. 704-707, June 15, 1975.

Lobenstein, H., and Ludington, D. N., "A Charge Transfer Device MTI Implementation," in Record, proceedings of the International Radar Conference, Arlington, Va., Apr. 21-23, 1975, pp. 107-110.

Lutin, E. A., Teliatnikov, L. I., and Shkalikov, V. N., "Phase Characteristics of a Two-Circuit Frequency Multiplier Employing a Charge-Storage Diode," Radiotekhnika, Vol. 30, pp. 60-63, Oct. 1975. (In Russian)

MacLennan, D. J., "Charge-Coupled Devices - 3. Signal Processing," Wireless World, Vol. 81, No. 1470, pp. 61-65, Feb. 1975.

MacLennan, D. J., and Mavor, J., "Novel Technique for the Linearisation of Charge-Coupled Devices," Electronics Letters, Vol. 11, No. 10, pp. 222-223, May 15, 1975.

Maines, J. D., and Paige, E. G. S., "Surface-Acoustic-Wave Devices for Signal Processing Applications," IEEE Proceedings, Vol. 64, pp. 639-652, May 1976.

Margraff, T. C., "Design and Performance of a CCD Memory System," M. S. Thesis. AD-A008657. Air Force Institute of Technology, Wright-Patterson Air Force Base, Ohio, Dec. 1974.

Martin, F. C., "Advanced Mail Systems Scanner Technology," Annual Report, 22 Oct. 1974 - 21 Oct. 1975. AD-A020175. Naval Electronics Laboratory Center, San Diego, Calif., Oct. 22, 1975.

Mattern, J., and Lampe, D. R., "A Reprogrammable Filter Bank Using Charge-Coupled Device Discrete Analog-Signal Processing," IEEE Transactions on Electron Devices, Vol. ED-23, No. 2, pp. 156-161, Feb. 1976.

Mayer, G. J., "The Chirp Z-Transform - A CCD Implementation," RCA Review, Vol. 36, No. 4, pp. 759-773, Dec. 1975.

Mayer, G. J., "Split-Gate CCD Sensing," RCA Technical Note No. 1148, Apr. 1976.

McCord, T. B., and Bosel, J. P., "Potential Usefulness of CCD Imagers in Astronomy," in proceedings of the Symposium on Charge-Coupled Device Technology for Scientific Imaging Applications, Pasadena, Calif., Mar. 6-7, 1975, pp. 65-69, June 1975.

McKenna, J., and Schryer, N. L., "Potential in a Charge-Coupled Device with No Mobile Minority Carriers," Bell System Technical Journal, Vol. 52, No. 10, pp. 1765-1793, Dec. 1973.

McKenna, J., Schryer, N. L., and Walden, R. H., "Design Considerations for a Two-Phase, Buried-Channel, Charge-Coupled Device," Bell System Technical Journal, Vol. 53, No. 8, pp. 1581-1597, Oct. 1974.

McKenna, J., and Schryer, N. L., "Analysis of Field-Aided Charge-Coupled Device Transfer," Bell System Technical Journal, Vol. 54, No. 4, pp. 667-685, Apr. 1975

McNutt, M. J., and Sah, C. T., "High Frequency Space Charge Layer Capacitance of Strongly Inverted Semiconductor Surfaces," Solid-State Electronics, Vol. 17, No. 4, pp. 377-385, Apr. 1974.

Meindl, J. D., "Implantable Integrated Electronics - in Biomedical Telemetry," in Biotelemetry II: Proceedings of the Second International Symposium, Davos, Switzerland, May 20-24, 1974, pp. 32-36.

Michels, D. J., "A CCD Image Transducer and Processor Suitable for Space Flight - Satellite Borne Solar Telescope Instrumentation," in proceedings of the Symposium on Charge-Coupled Device Technology for Scientific Imaging Applications, Pasadena Calif., Mar. 6-7, 1975, pp. 14-29.

Michon, G. J., Burke, H. K., and Brown, D. M., "Recent Developments in CID Imaging - Using Charge Storage Capacitors," in proceedings of the Symposium on Charge-Coupled Device Technology for Scientific Imaging Applications, Pasadena, Calif., Mar. 6-7, 1975, pp. 106-115.

Mohsen, A. M., Bower, R., and McGill, T. C., "Overlapping-Gate Buried-Channel Charge-Coupled Devices," Electronics Letters, Vol. 9, No. 17, pp. 396-398, Aug. 23, 1973.

Mohsen, A. M., Diamon, Y., and Mead, C. A., "Numerical Simulation of Charge Coupled Device Operation, Abbreviated Form," Final Report. AD-A010915. California Institute of Technology, Pasadena, Calif., October 31, 1974.

Mohsen, A. M., and Tompsett, M. F., "Effects of Bulk Traps on the Performance of Bulk Channel Charge-Coupled Devices," IEEE Transactions on Electron Devices, Vol. ED-21, No. 11, pp. 701-712, Nov. 1974.

Mohsen, A. M., and Morris, F. J., "Measurements on Depletion-Mode Field Effect Transistors and Buried Channel MOS Capacitors for the Characterization of Bulk Transfer Charge-Coupled Devices," Solid-State Electronics, Vol. 18, No. 5, pp. 407-416, May 1975.

Mohsen, A. M., Tompsett, M. F., and Sequin, C. H., "Noise Measurements in Charge-Coupled Devices," IEEE Transactions on Electron Devices, Vol. ED-22, pp. 209-218, May 1975.

Mohsen, A. M., and Retajczyk, T. F., Jr., "Fabrication and Performance of Offset-Mask Charge-Coupled Devices," IEEE Transactions on Electron Devices, Vol. ED-23, No. 2, pp. 248-256, Feb. 1976.

Mohsen, A. M., et al., "16-KBit Block Addressed Charge-Coupled Memory Device," IEEE Transactions on Electron Devices, Vol. ED-23, pp. 108-116, Feb. 1976.

Mohsen, A. M., et al., "A 64-KBit Block Addressed Charge-Coupled Memory," IEEE Transactions on Electron Devices, Vol. ED-23, No. 2, pp. 117-126, Feb. 1976.

Nicastro, L. J., "Sinewave Clocking of CCDs at High Frequencies," RCA Engineer, Vol. 21, No. 4, pp. 76-77, Dec. 1975 - Jan. 1976.

Ong, D. G., and Pierret, R. F., "Approximate Formula for Surface Carrier Concentration in Charge-Coupled Devices," Electronics Letters, Vol. 10, No. 1, pp. 6-7, Jan. 10, 1974.

Ong, D. G., "Characterization and Modeling of Carrier Generation in Charge-Coupled Devices Operated at Low Frequency - Shift Registers," PhD. Thesis. Purdue University, Lafayette, Inc., 1974.

Ong, D. G., and Pierret, R. F., "Thermal Carrier Generation in Charge-Coupled Devices," IEEE Transactions on Electron Devices, Vol. ED-22, No. 8, pp. 593-602, Aug. 1975.

Otto, O. W., "Theoretical Comparison of Space-Charge-Enhanced Acoustic Surface Wave Convolver," in proceedings of the Symposium on Optical and Acoustical Micro-Electronics, New York, N. Y., Apr. 16-18, 1974, pp. 511-528.

Parks, C. M., and Salama, C. A. T., "V. M. O. S. Conductively Coupled Charge-Coupled Device," Electronics Letters, Vol. 9, No. 25, pp. 593-594, Dec. 13, 1973.

Parks, C. M., and Salama, C. A. T., "V-Groove (VMOS) Conductively Connected Charge Coupled Devices," Solid-State Electronics, Vol. 18, No. 12, pp. 1061-1067, Dec. 1975.

Parrish, E. A., and McVey, E. S., "An Investigation of Potential Applications of OP-SAPS Operational Sampled Analog Processors," Semiannual Report. NASA-CR-143303. Virginia University, Charlottesville, Va., Feb. 1976.

Peek, H. L., "Twin-Layer PCCD Performance for Different Doping Levels of the Surface Layer - Peristaltic Charge Coupled Device Transfer Efficiency," IEEE Transactions on Electron Devices, Vol. ED-23, pp. 235-238, Feb. 1976.

Perkins, K. D., and Browne, V. A., "Sub-Microm Gap Metal Gate Technology for CCDs," Microelectronics, Vol. 7, No. 2, pp. 14-22, Dec. 1975.

Phillips, J. D., "Development of InSb Charge-Coupled Infrared Imaging Devices - Linear Imager," Final Report. NASA-CR-145003. Santa Barbara Research Center, Goleta, Calif., Apr. 1, 1976.

Powers, J. P., "Analysis of a Multipurpose Electro-Optical Signal Processor," Final Report, 1 May 1973 - 1 Jul. 1974. NPS-52PO7411. AD-787475. Naval Postgraduate School, Monterey, Calif., June 20, 1974.

Reilly, T. H., and Herring, M., "CCD Imaging Instruments for Planetary Spacecraft Applications," in proceedings of the Symposium on Charged-Coupled Device Technology for Scientific Imaging Applications, Pasadena, Calif., Mar. 6-7, 1975, pp. 46-64.

Renda, G., and Lowrance, J. L., "Soft X-Ray Detection with the Fairchild 100 by 100 CCD," in proceedings of the Symposium on Charge-Coupled Device Technology for Scientific Imaging Applications, Pasadena, Calif., Mar. 6-7, 1975, pp. 91-105.

Renzelman, R. F., Jr., "Study of Infrared Solid State Images Using Charge Transport Devices," M. S. Thesis. AD-A005736. Naval Postgraduate School, Monterey, Calif., December 1974.

Riedl, J. L., "Charge Coupled Sensor Array Application to Tracker Systems, Information Display, Vol. 11, pp. 5-7, June 1975.

Roberts, J. B. G., "Radar Doppler Processing Using CCD and SAW Devices," Electronics Letters, Vol. 11, No. 22, pp. 525-526, Oct. 30, 1975.

Roberts, J. B. G., et al., "A Processor for Pulse-Doppler Radar," IEEE Transactions on Electron Devices, Vol. ED-23, No. 2, pp. 168-172, Feb. 1976.

Roberts, P. C. T., Singh, M. P., and Lamb, D. R., "Identification of Loss Mechanisms in 3-Phase Surface-Channel Charge-Coupled Devices," IEEE Proceedings, Vol. 122, No. 10, pp. 1089-1091, Oct. 1975.

Rodgers, R. L., III, "Silicon Intensifier Target Charged Coupled Device (SIT-CCD)," Final Technical Report, 28 Mar. 1973 - 7 Jan. 1974. AD-A018083. Radio Corporation of America, Lancaster, Pa., May 1974.

Rodgers, R. L., III, and Giovachino, D. L., "Cooled Slow-Scan Performance of a 512 by 320 Element Charge-Coupled Imager," in proceedings of the Symposium on Charge-Coupled Device Technology for Scientific Imaging Applications, Pasadena Calif., Mar. 6-7, 1975, pp. 116-124, June 10, 1975.

Rosenbaum, S. D., et al., "A 16 384-Bit High-Density CCD Memory," IEEE Transactions on Electron Devices, Vol. ED-23, No. 2, pp. 101-108, Feb. 1976.

Sakaue, T., et al., "Improved Charge-Coupled Analog Delay Line," in proceedings of the Conference on Solid State Devices, 6th, Tokyo, Japan, Sept. 2-3, 1974, pp. 181-187.

Salomon, P. M., and Goss, W. C., "A Microprocessor-Controlled CCD Star Tracker," in proceedings of the AIAA Aerospace Sciences Meeting, 14th, Washington, D. C., Jan. 26-28, 1976. AIAA Paper 76-116, January 1976.

Samuelsson, H., "Space Application of CCD Image Sensors," ESA Scientific and Technical Review, Vol. 1, No. 3, pp. 219-226, 1975.

Schechter, D., and Nelson, R. D., "Calculation of Potential Profiles in CCD's Using Green's Function Techniques," IEEE Transactions on Electron Devices, Vol. ED-23, No. 2, pp. 293-296, Feb. 1976.

Schmieder, D. E., "Seeker Lock-On Model and Performance Projections with CCD Sensors - Charge Coupled Devices for Missile Guidance," in NAECON'75: Proceedings of the National Aerospace and Electronics Conference, Dayton, Ohio, June 10-12, 1975, pp. 343-349.

Schneider, P., and Witte, J., "CCD Memories in a Working Memory System," Siemens Forschungs- und Entwicklungsberichte, Vol. 4, No. 4, pp. 231-237, 1975.

Sealer, D. A., et al., "Design and Characterization of Charge-Coupled Devices for Analog Signal Processing," in Conference Record, Vol. 1, proceedings of the International Conference on Communications, 11th, San Francisco, Calif., June 16-18, 1975, pp. 2-1 to 2-3.

Sealer, D. A., and Tompsett, M. F., "Dual Differential Charge-Coupled Analog Delay Device," IEEE Transactions on Electron Devices, Vol. ED-23, No. 2, pp. 173-176, Feb. 1976.

Sei, H., Miura, S., and Sakai, H., "Charge-Coupled Devices - 1. Fabrication Process." Fujitsu Scientific and Technical Journal, Vol. 11, No. 3, pp. 79-100, Sept. 1975.

Seib, D. H., "Carrier Diffusion Degradation of Modulation Transfer Function in Charge Coupled Imagers," IEEE Transactions on Electron Devices, Vol. ED-21, No. 3, pp. 210-217, Mar. 1974.

Seib, D. H., "Carrier Diffusion Degradation of CCD (Charge-Coupled Devices) Image MTF (Modulation Transfer Function) for Broadband Optical Sources," SAMS0-TR-76-25. AD-A020600. Aerospace Corporation, El Segundo, Calif., Jan. 29, 1976.

Sequin, C. H., et al., "Charge-Coupled Image-Sensing Devices Using Three Levels of Polysilicon," in Digest of Technical Papers, proceedings of the IEEE International Solid-State Circuits Conference, University of Pennsylvania, Philadelphia, Pa., Feb. 13-15, 1974, pp. 24-25, 218.

Sequin, C. H., "Experimental Investigation of a Linear 500-Element 3-Phase Charge-Coupled Device," Bell System Technical Journal, Vol. 53, No. 4, pp. 581-610, Apr. 1974.

Sequin, C.H., Shankoff, T.A., and Sealer, D.A., "Measurements on a Charge-Coupled Area Image Sensor with Blooming Suppression," IEEE Transactions on Electron Devices, Vol. ED-21, No. 6, pp. 331-341, June 1974.

Sequin, C. H., and Mohsen, A. M., "Linearity of Electrical Charge Injection into Charge-Coupled Devices," in Technical Digest, proceedings of the International Electron Devices Meeting, 20th, Washington, D. C., Dec. 9-11, 1974, pp. 229-232.

Sequin, C. H., and Mohsen, A. M., "Linearity of Electrical Charge Injection into Charge-Coupled Devices," IEEE Journal of Solid-State Circuits, Vol. SC-10, No. 2, pp. 81-92, Apr. 1975.

Sequin, C. H., and Tompsett, M. F., "Charge Transfer Devices," Advances in Electronics and Electron Physics, Supplement 8, 1975, 309 p.

Shannon, J. M., et al., "Charge Coupled F.E.T. Devices (C.C.F.E.T.)," in Technical Digest, proceedings of the International Electron Devices Meeting, Washington, D.C., Dec. 1-3, 1975, pp. 320-323.

Simms, T., "Application of CCD's to Document Scanning," Microelectronics, Vol. 7, No. 2, pp. 60-63, Dec. 1975.

Simpson, P. I., "CCD Transversal Filters with Fixed Weighting Coefficients," Microelectronics, Vol. 7, No. 2, pp. 54-59, Dec. 1975.

Singh, M. P., and Brotherton, S. D., "Influence of Clocking Waveform on Charge Transfer in Three Phase Charge Coupled Devices," Solid-State Electronic Vol. 19, No. 4, pp. 279-287, Apr. 1976.

Steckl, A. J., et al., "Application of Charge-Coupled Devices to Infrared Detection and Imaging," IEEE Proceedings, Vol. 63, pp. 67-74, Jan. 1975.

Steckl, A. J., "Infrared Charge Coupled Devices," Infrared Physics, Vol. 16, No. 1-2, pp. 65-73, Jan.-Mar. 1976.

Steigerwalt, S. T. and Lagnado, I., "CCD as a Test Structure for Semiconductor Process Control," Microelectronics, Vol. 7, No. 2, pp. 23-29, Dec. 1975.

Suzuki, N., and Yanai, H., "Analysis of Surface-Charge Transfer in a Charge-Coupled Device," Electronics and Communications in Japan, Vol. 57, No. 3, pp. 93-100, Mar. 1974.

Tanigawa, H., and Ando, T., "Nonlinear CCD Lumped Model and its Application to Output Stage Performance Analysis," IEEE Transactions on Electron Devices, Vol. ED-22, No. 8, pp. 575-581, Aug. 1975.

Tanikawa, K., Arakawa, I., and Ohtsuki, O., "Charge-Coupled Devices - 2. Charge Transfer Characteristics," Fujitsu Scientific and Technical Journal, Vol. 11, No. 3, pp. 101-119, Sept. 1975.

Tao, T. F., "Narrow Gap Semiconductors PbSnTe and PbSnSe," Final Report, 1 Jan. 1972 - 30 Sept. 1973. AFML-TR-74-162. AD-A005702. Naval Postgraduate School, Monterey, Calif., Nov. 1974.

Tasch, A. F., Jr., Fry, R. C., and Fu, H. S., "Charge-Coupled Ram Cell Concept," IEEE Transactions on Electron Devices, Vol. ED-23, No. 2, pp. 126-131, Feb. 1976.

Tchon, W. E., et al., "4096-Bit Serial Decoded Multiphase Serial-Parallel-Serial CCD Memory," IEEE Transactions on Electron Devices, Vol. ED-23, No. 2, pp. 93-101, Feb. 1976.

Terman, L. M., and Heller, L. G., "Overview of CCD Memory," IEEE Transactions on Electron Devices, Vol. ED-23, No. 2, pp. 72-78, Feb. 1976.

Theunissen, M. J. J., "Charge Transfer Devices. II.- Applications," L'Onde Electrique, Vol. 54, pp. 405-413, Oct. 1974.

Tompsett, M. F., et al., "Charge Coupled Image Sensing State of the Art," in 1973 IEEE Intercon Technical Papers, proceedings of the Institute of Electrical and Electronics Engineers International Convention and Exposition, New York, N. Mar. 26-30, 1973, Vol. 6, Paper 1/4.

Tompsett, M. F., "Surface Potential Equilibration Method of Setting Charge in Charge-Coupled Devices," IEEE Transactions on Electron Devices, Vol. ED-22, No. 6, pp. 305-309, June 1975.

Upton, L. O., and Mayer, G. J., "Charge-Coupled Devices and Radar Signal Processing," RCA Engineer, Vol. 21, pp. 30-34, June-July 1975.

Vanstone, G. F., Roberts, J. B. G., and Long, A. E., "Measurement of the Charge Residual for CCD Transfer Using Impulse and Frequency Responses," Solid-State Electronics, Vol. 17, No. 9, pp. 889-895, Sept. 1974.

Varshney, R. C., et al., "Byte Organized NMOS/CCD Memory with Dynamic Refresh Logic," IEEE Transactions on Electron Devices, Vol. ED-23, No. 2, pp. 86-92, Feb. 1976.

Vicars-Harris, M., "Slow-Scan Operation of Long Linear CCD Arrays," in proceedings of the Symposium on Charge-Coupled Device Technology for Scientific Imaging Applications, Pasadena, Calif., Mar. 6-7, 1975, pp. 175-185.

Wallings, H., and Van Ruyven, H. L. M., "Diagnostic Analysis of the Charge Transfer in CCDs," in Digest of Technical Papers, proceedings of the IEEE International Solid-State Circuits Conference, University of Pennsylvania, Philadelphia, Pa., Feb. 13-15, 1974, pp. 148-149.

Walsh, L. R., "A 190 by 244 Charge-Coupled Area Image Sensor with Interline Transfer Organization," in proceedings of the Symposium on Charge-Coupled Device Technology for Scientific Imaging Applications, Pasadena, Calif., Mar. 6-7, 1975, pp. 137-149.

Wang, S. T., Royce, B. S. H., Russell, T. J., "The Effect of Ion Implantation on Oxide Charge Storage in MOS Devices," IEEE Transactions on Nuclear Science, Vol. NS-22, pp. 2168-2173, Dec. 1975.

Weckler, G. P., "Solid State Image Sensing with Photodiode Arrays," in 1973 IEEE Intercon Technical Papers, proceedings of the IEEE International Convention and Exposition, New York, N. Y., Mar. 26-30, 1973, Vol. 6, Paper 1/2.

Weiss, H., "Physics and Technology of Data Storage - Comparison of Magnetic, Semiconductor and Optical Memories with Respect to Bit Density and Cycle Time," Solid-State Electronics, Vol. 19, pp. 347-356, May 1976.

White, M. H., et al., "Characterization of Surface Channel CCD Image Arrays at Low Light Levels," IEEE Journal of Solid-State Circuits, Vol. SC-9, No. 1, pp. 1-13, Feb. 1974.

White, B. J., "Edge-Triggered Charge-Coupled Device (CCD)," IEEE Transactions on Electron Devices, Vol. ED-23, pp. 299-300, Feb. 1976.

White, M. H., and Webb, W. R., "Study of the Use of Charge-Coupled Devices (CCDs) in Analog Signal Processing Systems," Final Report, 15 Sept. 1973 - 15 Mar. 1974. AD-783703. Westinghouse Defense and Electronic Systems Center, Baltimore, Md., April 1974.

Whitehouse, H. J., and Means, R. W., "Signal Processing Using Charge Coupled Devices and Surface Wave Devices," in proceedings of the IEEE Ultrasonic Symposium, Monterey, Calif., Nov. 5-7, 1973, pp. 572-577.

Willett, E., and Forst, H., "Artillery-Launched Charge-Coupled Device (CCD) - Aerial Reconnaissance Using Parachute Dropped Television Equipment," Final Report, 3 Dec. 1973 - 15 Apr. 1974. AD-786697. Fairchild Space and Defense Systems, Syosset, N. Y., June 1974.

Williams, J. T., "The Intensified Charge Coupled Device as a Photon Counting Imager," in proceedings of the AAS, AIAA, IEEE, ORSA, and IMS Meeting on the Space Shuttle Missions of the 80's, Denver, Colo., Aug. 26-28, 1975. AAS Paper 75-208.

Williams, R. A., and Nelson, R. D., "Radiation Effects in Charge Coupled Devices," IEEE Transactions on Nuclear Science, Vol. NS-22, pp. 2639-2644, Dec. 1975.

Williams, T. R., "Charge-Coupled Devices - 4. Imaging Applications," Wireless World, Vol. 81, No. 1471, pp. 133-138, Mar. 1975.

Wupper, H., "An Application of Charge-Transfer Devices to Filter Networks," Archiv fuer Elektronik und Uebertragungstechnik, Vol. 29, pp. 289-295, July-Aug. 1975.

Yau, L. D., "Scaling of Surface-Channel Charge-Coupled Devices," IEEE Transactions on Electron Devices, Vol. ED-23, No. 2, pp. 282-287, Feb. 1976.

Yeow, Y. T., and Mavor, J., "Influence of Charge-Transfer Inefficiency on CCD Recursive-Filter Performance," Electronics Letters, Vol. 12, pp. 125-127, Mar. 4, 1976.

Zimmerman, T. A., "Charge Coupled Devices in Signal Processing Systems - The Analog and the Digital Approach," in Record, proceedings of the National Telecommunications Conference, San Diego, Calif., Dec. 2-4, 1974, pp. 254-258.

Zimmerman, T. A., and Miller, C. S., "Charge Coupled Devices in Signal Processing Systems. Volume 1. Digital Signal Processing." Final Report, Oct. 1973 - Apr. 1974. AD-782574. TRW Systems Group, Redondo Beach, Calif., July 1974.

Zimmerman, T. A., and Miller, C. S., "Charge Coupled Devices in Signal Processing Systems. Volume 2. Analog Signal Processing," Final Report, Apr. - Oct. 1974. AD-A011499. TRW Systems Group, Redondo Beach, Calif., Dec. 1974.



MISSION
of
Rome Air Development Center

RADC plans and executes research, development, test and selected acquisition programs in support of Command, Control Communications and Intelligence (C³I) activities. Technical and engineering support within areas of technical competence is provided to ESD Program Offices (POs) and other ESD elements. The principal technical mission areas are communications, electromagnetic guidance and control, surveillance of ground and aerospace objects, intelligence data collection and handling, information system technology, ionospheric propagation, solid state sciences, microwave physics and electronic reliability, maintainability and compatibility.