

AD-A089 999

NAVAL POSTGRADUATE SCHOOL MONTEREY CA
THE NAVY'S AERIAL TARGETS PROGRAM MANAGEMENT ORGANIZATION AND R--ETC(U)
JUN 80 G R MITCHELL

F/G 5/1

UNCLASSIFIED

NL

1 - 1

26
407999-9



6

END
DATE
FILMED
10 80
DTIC

AD A 08999

NAVAL POSTGRADUATE SCHOOL
Monterey, California



THESIS

THE NAVY'S AERIAL TARGETS PROGRAM—
MANAGEMENT ORGANIZATION AND
RECOMMENDED IMPROVEMENTS THERETO.

by

Grant Roper Mitchell

June 1980

12-1

Thesis Co-Advisor:
Thesis Co-Advisor:

J. W. Creighton
G. L. Murray

Approved for public release; distribution unlimited

DDG FILE COPY

80 10 3 078

REPORT DOCUMENTATION PAGE		READ INSTRUCTIONS BEFORE COMPLETING FORM
1. REPORT NUMBER	2. GOVT ACCESSION NO. AD-A089 999	3. RECIPIENT'S CATALOG NUMBER
4. TITLE (and Subtitle) The Navy's Aerial Targets Program-- Management Organization and Recommended Improvements Thereto		5. TYPE OF REPORT & PERIOD COVERED Master's Thesis June 1980
		6. PERFORMING ORG. REPORT NUMBER
7. AUTHOR(s) Grant Roper Mitchell		8. CONTRACT OR GRANT NUMBER(s)
9. PERFORMING ORGANIZATION NAME AND ADDRESS Naval Postgraduate School Monterey, California 93940		10. PROGRAM ELEMENT, PROJECT, TASK AREA & WORK UNIT NUMBERS
11. CONTROLLING OFFICE NAME AND ADDRESS Naval Postgraduate School Monterey, California 93940		12. REPORT DATE June 1980
		13. NUMBER OF PAGES 58
14. MONITORING AGENCY NAME & ADDRESS (if different from Controlling Office)		15. SECURITY CLASS. (of this report) Unclassified
		15a. DECLASSIFICATION/DOWNGRADING SCHEDULE
16. DISTRIBUTION STATEMENT (of this Report) Approved for public release; distribution unlimited.		
17. DISTRIBUTION STATEMENT (of the abstract entered in Block 20, if different from Report)		
18. SUPPLEMENTARY NOTES		
19. KEY WORDS (Continue on reverse side if necessary and identify by block number) Aerial targets; program sponsor; program management; management; organization; weapon system management; cognizant field activity; requirements; inventory; maintenance; training; Naval Air Systems Command; Pacific Missile Test Center.		
20. ABSTRACT (Continue on reverse side if necessary and identify by block number) This thesis makes a comparison of aerial targets management with other Navy Program Management organizations. This compari- son is used to highlight reasons for the Program Sponsor's dis- proportionate time expenditure on the aerial targets' portion of his duties. Three areas are examined in detail that contribute to this situation: a) Program Sponsor unfamiliarity with the aerial targets management organization, b) aerial targets organi- zational structures, and c) key aerial target management issues.		

Block #20 cont'd

Several changes are recommended to help alleviate the identified problem areas. Long term improvements involve changes in the conceptual framework employed in the following areas: a) requirements determination, b) hardware vs. software targets, c) maintenance concepts, and d) training. A new framework is proposed.

A

Approved for public release; distribution unlimited

The Navy's Aerial Targets Program--
Management Organization and
Recommended Improvements Thereto

by

Grant Roper Mitchell
B.S., Northwestern University, 1969
M.S., University of Southern California, 1972

Submitted in partial fulfillment of the
requirements for the degree of

MASTER OF SCIENCE IN MANAGEMENT

from the

NAVAL POSTGRADUATE SCHOOL
June 1980

Author

Grant R. Mitchell

Approved by:

Robert L. ...

Thesis Co-Advisor

John W. ...

Thesis Co-Advisor

[Signature]

Chairman, Dept. of Administrative Sciences

[Signature]

Dean of Information and Policy Sciences

ABSTRACT

↙

This thesis makes a comparison of aerial targets management with other Navy Program Management organizations. This comparison is used to highlight reasons for the Program Sponsor's disproportionate time expenditure on the aerial targets' portion of his duties. Three areas are examined in detail that contribute to this situation: (1) Program Sponsor unfamiliarity with the aerial targets management organization, (2) aerial targets organizational structures, and (3) key aerial target management issues. Several changes are recommended to help alleviate the identified problem areas. Long term improvements involve changes in the conceptual framework employed in the following areas: (a) requirements determination, (b) hardware vs. software targets, (c) maintenance concepts, and (d) training. A new framework is proposed. ↗

TABLE OF CONTENTS

I.	INTRODUCTION -----	8
II.	BACKGROUND -----	12
III.	AERIAL TARGETS MANAGEMENT PARTICIPANTS -----	15
	A. CHIEF OF NAVAL OPERATIONS (OP-506) -----	15
	B. CHIEF OF NAVAL MATERIAL -----	21
	C. NAVAL AIR SYSTEMS COMMAND -----	24
	D. PACIFIC MISSILE TEST CENTER -----	27
	E. NAVAL WEAPONS CENTER AND NAVAL AIR DEVELOPMENT CENTER -----	28
	F. MANAGEMENT SUPPORT TEAM--SUMMARY -----	30
IV.	MANAGEMENT SUPPORT ORGANIZATIONAL COMPARISONS --	31
V.	MANAGEMENT ISSUES -----	37
	A. REQUIREMENTS DETERMINATION -----	37
	B. HARDWARE VS. SOFTWARE TARGETS -----	39
	C. MAINTENANCE PHILOSOPHY -----	40
	D. TRAINING/PERSONNEL SUPPORT -----	42
VI.	RECOMMENDATIONS -----	45
VII.	SUMMARY -----	48
APPENDIX A	MISSION AND FUNCTION OF THE AVIATION PLANS AND REQUIREMENTS DIVISION -----	50
APPENDIX B	MISSION AND FUNCTION OF THE TARGETS AND RANGE SYSTEMS DIVISION (630) -----	52
APPENDIX C	GLOSSARY OF ABBREVIATIONS AND ACRONYMS -	55
BIBLIOGRAPHY	-----	56
INITIAL DISTRIBUTION LIST	-----	58

LIST OF FIGURES

1.	THE ORGANIZATION CHART OF THE OFFICE OF THE CHIEF OF NAVAL OPERATIONS -----	9
2.	THE STRUCTURE OF THE OFFICE OF THE DEPUTY CHIEF OF NAVAL OPERATIONS (AIR WARFARE) -----	10
3.	CHART SHOWING THE ORGANIZATIONAL RELATIONSHIP BETWEEN THE "USERS" AND "PRODUCERS" IN THE AERIAL TARGETS PROGRAM -----	16
4.	GRAPHIC DEPICTION OF THE FUNDING RELATIONSHIPS ASSOCIATED WITH THE AERIAL TARGETS PROGRAM -----	20
5.	THE ORGANIZATION CHART OF THE HEADQUARTERS NAVAL MATERIAL COMMAND -----	22
6.	THE STRUCTURE OF THE DEPUTY CHIEF OF NAVAL MATERIAL FOR ACQUISITION (MAT-08) -----	23
7.	THE ORGANIZATION CHART OF THE NAVAL AIR SYSTEMS COMMAND FOR TARGETS -----	26
8.	THE ORGANIZATION CHART SHOWING THE NAVAL AIR SYSTEMS COMMAND PROGRAM MANAGEMENT INTER-RELATIONSHIPS -----	32
9.	THE ORGANIZATION CHART SHOWING THE NAVAL AIR SYSTEMS COMMAND PROGRAM MANAGEMENT INTER-RELATIONSHIPS (INCLUDING AERIAL TARGETS) -----	33

ACKNOWLEDGEMENT

The author is very grateful to Captain Murray, Captain Cornell, Captain Jones, and Mr. Scott who took time from their busy schedules to discuss aerial targets and provide the background knowledge required to prepare this thesis. Their candid suggestions, insights, and critique were invaluable. In addition, the author wishes to thank Mr. Robert Soderquist for his help in editing and clarifying the wording of this thesis. His recommended changes will make this thesis more understandable to a new Program Sponsor.

I. INTRODUCTION

Aerial targets is a generic grouping of all airborne devices (sub-scale, full-scale, and towed) used to provide fleet training and to support the research, development, test, and evaluation (RDT&E) community. Their management at the Chief of Naval Operations (CNO) level is conducted under the Deputy for Air Warfare (OP-05). (See Fig. 1). Specifically, they are assigned for program sponsorship to the Aircraft/Weapons Requirements Branch (OP-506) within the Aviation Plans and Requirements Division (OP-50). (See Fig. 2). In recent years, the Program Sponsor for the aerial targets program has been assigned concurrently to the F-4 aircraft program. The incumbent in this position, historically a Navy Captain, has experienced considerable difficulty performing the aerial targets' portion of his duties. In spite of the similarity in magnitude of resources (dollars) managed, the Program Sponsor has been required to delegate disproportionate amounts of his time to the management of the aerial targets.

Resolution of this problem has not commanded adequate attention because competing programs such as the F-18, F-14, or even F-4 major modification efforts demanded priority. However, with the critical manpower problems facing today's Navy, less than optimal management of a Program Sponsor's

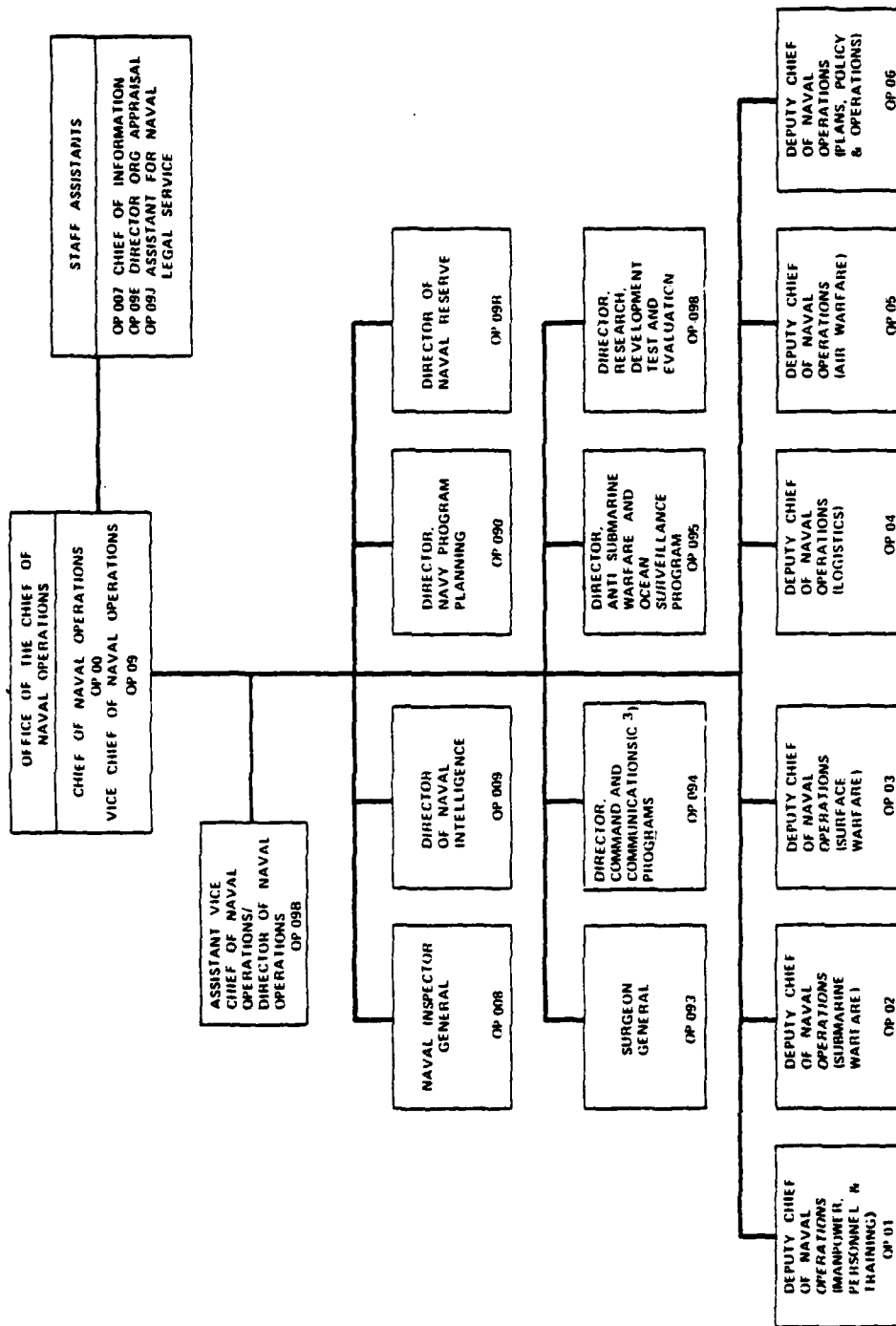

FIGURE 1: The Organization Chart of the Office of the Chief of Naval Operations

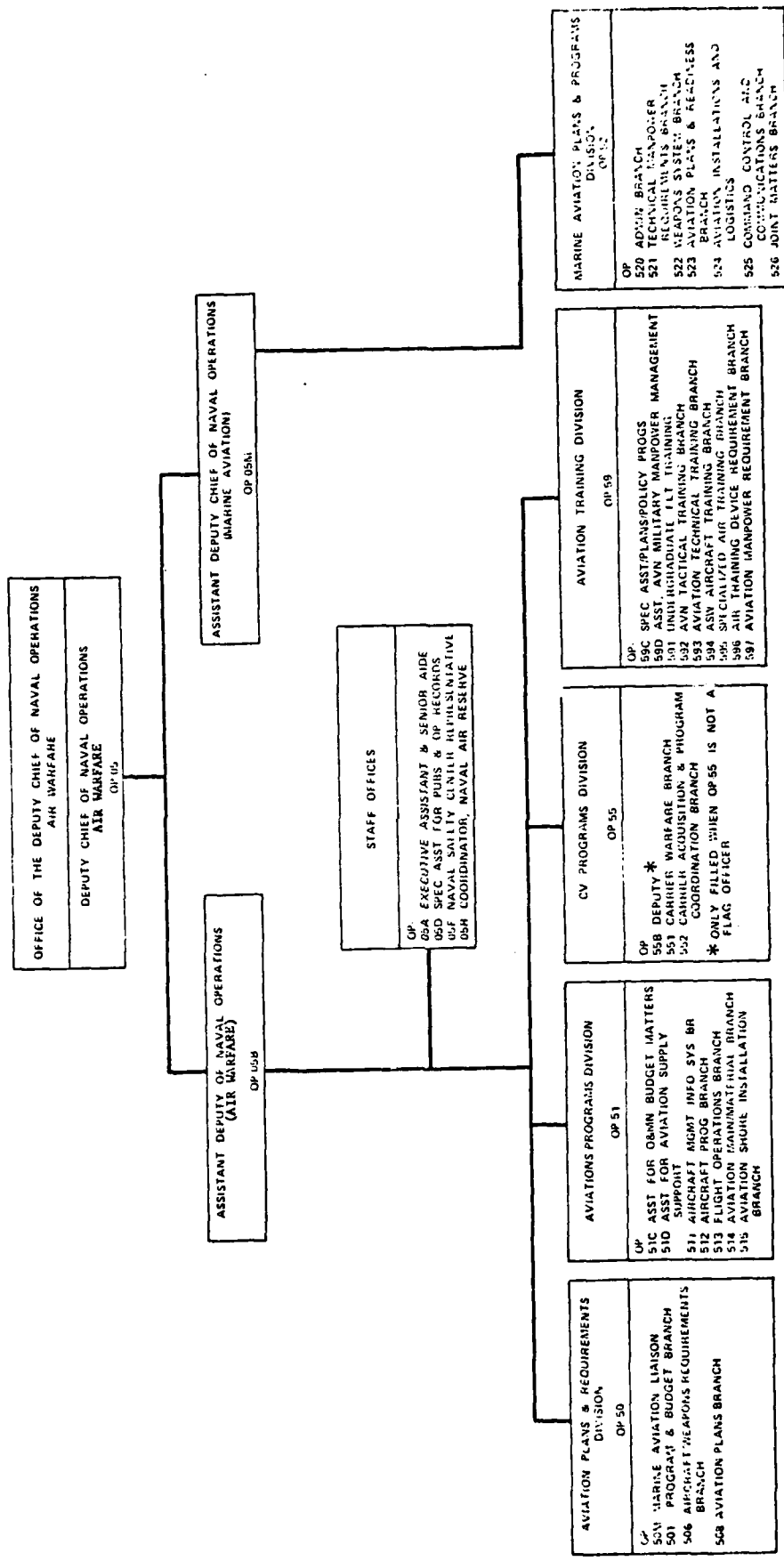

FIGURE 2: The Structure of the Office of the Deputy Chief of Naval Operations (Air Warfare)

time would be ill advised. If trends continue, these top level managers in CNO can be expected to cover more programs, not fewer.

Within this environment of constrained manpower and lack of enthusiasm towards aerial targets, this thesis investigated OP-506's problem. Three areas were examined:

1. Unfamiliarity of the Program Sponsor with the aerial target management organizations, their roles and their interrelationships.
2. Organizational structure differences between aerial targets and aircraft management teams.
3. Key management issues relating to aerial targets that are not being addressed.

The objectives of this three phased analysis effort were twofold. First, to provide a training tool/guide for incoming Program Sponsors, thereby overcoming their lack of familiarity with the peculiarities of the aerial targets mission, management organization, and management problems. Accomplishment of this objective is achieved by the text of this thesis. Second, to recommend corrective actions that would improve the overall program management of aerial targets.

While improving Program Sponsor knowledge of the aerial targets program will initially improve the situation, the long term solution lies in the successful initiation of the recommendations relating to organizational structure and key management issues. If implemented, they will insure better management support to the Program Sponsor, allowing a superior allocation of his scarce time and efforts between aerial targets and other assigned programs.

II. BACKGROUND

Prior to 1975, the management organization for the aerial targets program within NAVAIR supporting the Program Sponsor in CNO, could best be characterized as fragmented, underfunded, and under-supported. What little management that did exist was spread between the following three organizations:

1. PMA-247, consisting of a Navy Captain and one GS-12, was charged with the overall life cycle program management for all aerial targets [10].
2. AIR-535 was responsible for the engineering and material acquisition aspects of aerial targets and responded to PMA-247 through the NAVAIR matrix management arrangement.
3. AIR-4104 was responsible for all logistics aspects of aerial targets and reported to the PMA in the same manner as AIR-535 [11].

In spite of being charged with managing all aerial targets, new and existing, these organizations dealt primarily with developing, procuring, and supporting new aerial targets. In service targets received little priority and were managed in the classical reactionary mode. Also disjointed and suffering from the lack of dedicated management, at this time, were the Navy ranges (used for test and evaluation and training). The Navy was faced with either DOD level micro-management or loss of the ranges to a joint service management team [10]. Confronted with these and several other management problems, NAVAIR attempted to improve the situation by creating a new organizational entity titled the Deputy Commander for Test and Evaluation (AIR-06).

As initially envisioned, this new management organization was comprised of a triumverate of flag rank officers: AIR-06, Deputy Commander for Test and Evaluation, located in Washington, D.C.; AIR-06R, Ranges and Targets, located at the Pacific Missile Test Center, Pt. Mugu, California; and the Naval Air Test Center, Patuxent River, Maryland [10].

This organization did provide much needed visibility and some additional support for aerial targets management, but still left the management very fragmented. To eliminate this fragmentation, the newly consolidated headquarters functions (PMA-247, AIR-535, AIR-4104) were moved to the Pacific Missile Test Center (PMTC), joined with AIR-06R, and renamed Director for Targets and Ranges (AIR-630).

The consolidation and merger, however, did not take place painlessly. Amongst PMA-247, AIR-535, AIR-4104, and other ancillary NAVAIR codes, there were approximately 50 people spending in excess of fifty percent of their time on aerial targets. However, when the consolidation, merger, and transition of AIR-630 to PMTC occurred, only 15 billets were provided--and no people [10].

The inadequate support to OP-506, and the resultant inordinate time expenditure on aerial targets management by OP-506, can be traced in large part to the disruption caused by this realignment effort and the lack of NAVAIR headquarters trained aerial target experts assigned to the program. However, in the five years since this reorganization, much of the disruption associated with the establishment of AIR-630

has been overcome. One must look further to fully understand OP-506's responsibilities and problems in managing the aerial targets. In order to do this, one must examine all the organizational entities, their roles, and their interrelationships keeping in mind the turmoil and learning process of the key supporting player to OP-506--AIR-630. The concerned organizational entities are the Chief of Naval Operations (CNO), the Chief of Naval Material (CNM), the Naval Air Systems Command (NAVAIR), the Pacific Missile Test Center (PMTTC), the Naval Weapons Center (NWC), and the Naval Air Development Center (NADC).

III. AERIAL TARGETS MANAGEMENT PARTICIPANTS

A. CHIEF OF NAVAL OPERATIONS (OP-506)

As the senior Navy official responsible for management of the aerial targets program, the OP-506 Program Sponsor sits at the apex of a dual channel management system. One channel may be viewed as the "user" input channel with the other as the "producer" input channel. (See Fig. 3). In this "dual-hatted" position, the Program Sponsor takes on aspects of both roles.

To the "user" community, who generate requirements for existing aerial targets and/or new aerial targets, the Program Sponsor takes on the role of producer or provider of targets to meet their needs. To the "producer" community, who must procure, manage, and support the aerial targets, OP-506 takes on the role of user or requirements generator.

Regardless of the channel, however, the Program Sponsor's primary functions are the following:

1. Requirements determination.
2. Resource allocation.
3. Budget preparation/defense.

Details of these functions are delineated in Appendix A.

The first of these functions, requirements determination, can be viewed from two perspectives: requirements for new aerial targets and requirements for existing aerial targets. The need for new targets can arise in one of two ways:

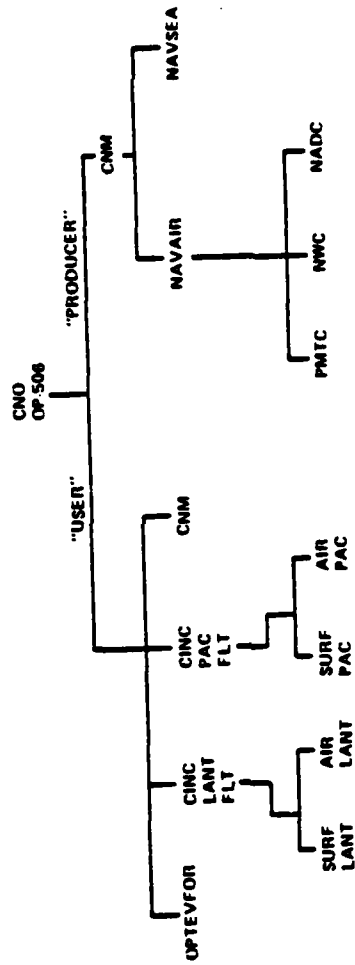

FIGURE 3: Chart Showing the Organizational Relationship Between the 'USERS' and 'PRODUCERS' of the Aerial Targets Program

1. New threats that arise due to the development of new weapons systems by forces hostile to the United States.
2. The need to test the capability of new weapon systems developed by the U.S. Navy.

One example of this type of effort is the Firebrand target being developed as an Anti-Ship Missile Target in order to simulate the performance characteristics of a projected, hostile cruise type missile. These types of requirements (for new aerial targets) are much less frequent than the yearly exercise of determining utilization requirements for targets currently in the inventory.

For existing targets, requirements determination is a function of the following factors:

1. Training allowance--how many training missiles will be allocated to the fleet for surface-to-air and air-to-air training.
2. Procurement/deliveries--how many targets have been procured in previous years, their production lead time, and projected delivery schedule.
3. Historical trends--which missiles are shot at which aerial targets, how many presentations of each target before it is killed, and the operational loss rate for targets not killed.
4. Inventory level and objective--minimum on hand level of aerial targets considering utilization rates, rework pipeline, and operational availability factors.
5. User inputs--stated aerial target requirements from CINCPACFLT, CINCLANTFLT, OPTEVFOR, and CNM [13].

Having determined the individual users aerial target requirements utilizing the above inputs, the Program Sponsor next must allocate the aerial targets. This is a difficult job to accomplish because past, present, and projected future budget constraints have seriously depleted the inventory of

operationally ready aerial targets. Even with careful attention to this allocation effort, the Navy will run out of aerial targets in the 1983-1984 timeframe unless FY-81, 82, and 83 funding is increased [13]. Thus, the target allocation process is an attempt to equitably spread the shortfall and resultant dissatisfaction.

The current OP-506 management philosophy/prioritization for allocating the aerial targets results from the following methodology:

1. Attempt to provide OPTEVFOR with 100% of their stated requirements. This is done because past experience has shown that OPTEVFOR is very accurate in assessing their needs. This is attributed to the fact that OPTEVFOR's efforts are task/test oriented with clearly defined objectives.
2. Compare CINCLANTFLT/CINCPACFLT's stated requirements with projected usage based on training missile allowance and historical trends. If they agree, provide 100% of their requirements. If computations do not agree, attempt to determine if there have been training scenario changes that would significantly alter the historical trends.
3. Treat CNM's stated requirements with some skepticism. Their stated requirements (a consolidation of NAVAIR, NAVSEA, and FMS requirements) have historically been orders of magnitude overstated. Consequently, allocate whatever aerial targets are left in yearly allocation totals after fulfilling all other users needs and after carefully considering long term inventory implications. If unprojected "hard" requirements arise, make mid-year adjustments to CNM's allocation [13].

Obviously these procedures can not be followed blindly.

Timing, special needs, and most of all judgement must be added.

The third, main area of Program Sponsor effort and concern is in budgeting. Financial budgeting and appropriation are the vital link between the requirements determination and

allocation process; both are possible only within the context of the availability of funds.

Funding to support the aerial targets program is of three types: RDT&E, WPN, and O&MN. RDT&E funds are used for all aerial target development work and for the procurement of all aerial targets utilized in RDT&E of new or improved weapon systems. With respect to the efforts that RDT&E funds, OP-506 is both the resource and mission sponsor--a true Program Sponsor [13].

WPN funds are used for production, acquisition, and engineering support of all fully developed, qualified, and approved for fleet training targets. Unlike the RDT&E funds, however, the WPN resource sponsor is both OP-03, Deputy Chief of Naval Operations, Surface Warfare and OP-05, DCNO Air Warfare. Thus, OP-506 as the Program Sponsor is lacking total control over the requisite funds and must coordinate/negotiate with OP-03 for the scarce resources [13, 14]. The relationship of the RDT&E and WPN fund accounts is depicted in Figure 4.

O&MN funds are utilized for operation and maintenance of all targets operated in the fleet. Again as in the WPN funds, the resource sponsor is separate from the OP-506 Program/Mission Sponsor. The O&MN resource sponsor is OP-51. (See Fig. 2). This requires, as in the case of the WPN funds, skillful coordination/negotiation to obtain an equitable share of scarce resources to meet mission needs.

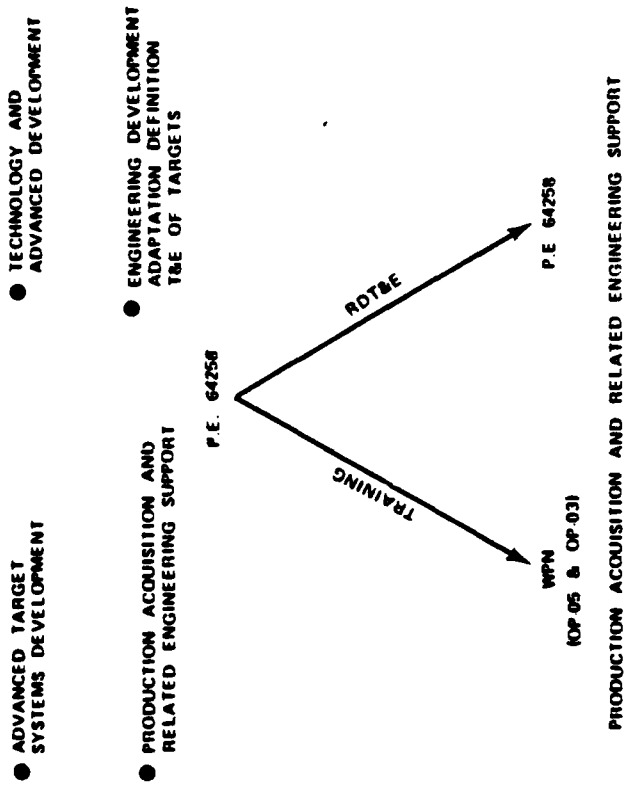

FIGURE 4: Graphic Depiction of the Funding Relationships Associated with the Aerial Targets Program

These three task areas, requirements determination, resource allocation, and budget coordination/negotiation, consume a disproportionate amount of the Program Sponsor's time in the management of aerial targets. However, one must not assume that this problem results solely from the difficulty of these tasks relative to aerial targets since these are much the same tasks that the targets Program Sponsor performs for his other assigned programs (F-8, F-5, F-4, VX-4, Navy Fighter Weapons School, and three joint Air Force/Navy projects). Thus, one must look to the supporting organizations for cause. These organization (CNM, NAVAIR, PMTC, NWC, and NADC) by charter provide much of the input data upon which the target Program Sponsor's efforts rely.

B. CHIEF OF NAVAL MATERIAL (CNM)

CNM is the senior executive level link between the Program Sponsor (in his user role) and the various supporting management organizations in NAVAIR, PMTC, NWC, and NADC. Relative to aerial targets, the key individual within CNM resides in the Deputy Chief of Naval Material for Acquisition, MAT-08. (See Fig. 5). Specifically, aerial targets management at the CNM level is assigned to the Acquisition Review Office, MAT-08DC. (See Fig. 6).

Because of the position of CNM between CNO and the other supporting organizations, they would be expected to have a key role in all management decisions and data generated in support of the Program Sponsor. This is not the case. As one might surmise from the organizational placement of the

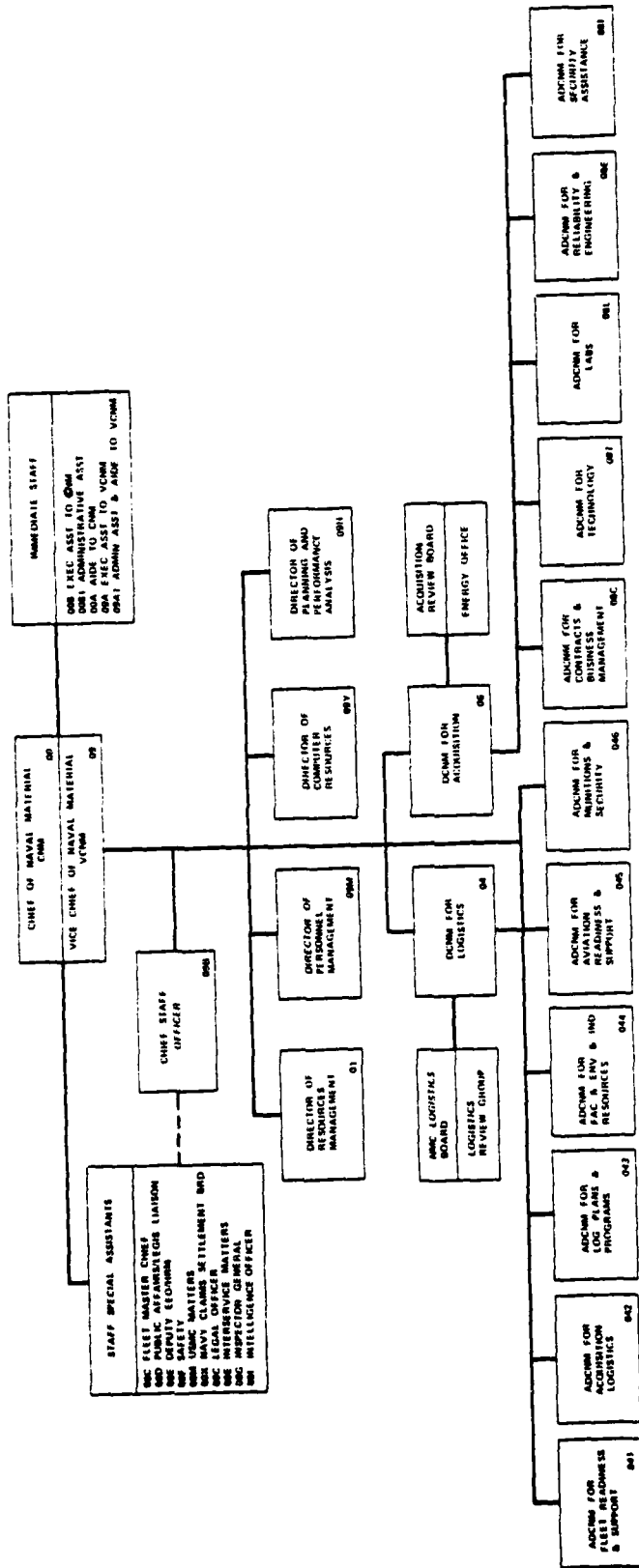

FIGURE 5: The Organization Chart of the Headquarters Naval Material Command

CNM representative, his primary concern is the acquisition of new/existing aerial targets; i.e. the task of acquiring targets to maintain and support a proper inventory. His aerial target responsibilities are, for all practical purposes, collateral duties to his primary function as secretary of the Acquisition Review Committee [12, 13].

Therefore, the current and recent past CNM aerial target representatives have had minimal involvement in OP-506's other major interest areas of resource allocation and budgeting. Data in these areas from NAVAIR, PMTC, NWC, and NADC has been passed essentially unfiltered to CNO [13].

Program Sponsors in OP-506 have come to expect this degree of support/expertise at CNM. Thus the CNM aerial targets management representative has become essentially a formal wicket which must be passed but which provides very little useful support or data screening for the Program Sponsor in CNO.

C. NAVAL AIR SYSTEMS COMMAND (NAVAIR)

NAVAIR provides the primary program management support to the CNO Program Sponsor. This includes, via a Memorandum of Understanding, those aerial targets used in support of NAVSEA for ships qualification trials [10, 12]. This management support resides within the Deputy Commander for Test and Evaluation, AIR-06, and is physically divided between Washington, D.C. and Pt. Mugu, California.

One individual resides in NAVAIR headquarters, Code AIR-630L, in Washington, D. C. He functions in a liaison

role between the remaining AIR-630 program management team at Pt. Mugu and the functional divisions (finance, contracts, technical, logistics) within NAVAIR. Even though program management and all support functions are theoretically at Pt. Mugu, an informal organization exists which relies on some of the skills/talents still in Washington, D. C., thus necessitating this key liaison position [10, 11].

The primary program management support personnel to the Program Sponsor are the AIR-630 organizations located at the Pacific Missile Test Center, Pt. Mugu, California. It should be noted, that even though physically located at Pt. Mugu (Camarillo), AIR-630 is functionally a part of NAVAIR headquarters, coming under NAVAIR's ceiling constraints and payroll. The AIR-630 organization is depicted in Figure 7.

This organization functions as the NAVAIR Project Manager for aerial targets as defined in NAVAIRINST 5000.8 [1]. This includes life cycle management for design, development, acquisition, initial logistics support and major modifications of all aerial targets. As such they collect, analyze, and provide the majority of the data upon which the Program Sponsor relies to make his requirements determinations, resource allocations, and budget decisions. (A detailed description of AIR-630's functions is provided as Appendix B).

The principal supporting documentation provided by AIR-630 to the Program Sponsor for his tasks is as follows:

1. Inventory objective--this key element in OP-506's requirements determination process is calculated by taking the peak month operational requirements (for each target), adding in a factor for pipeline

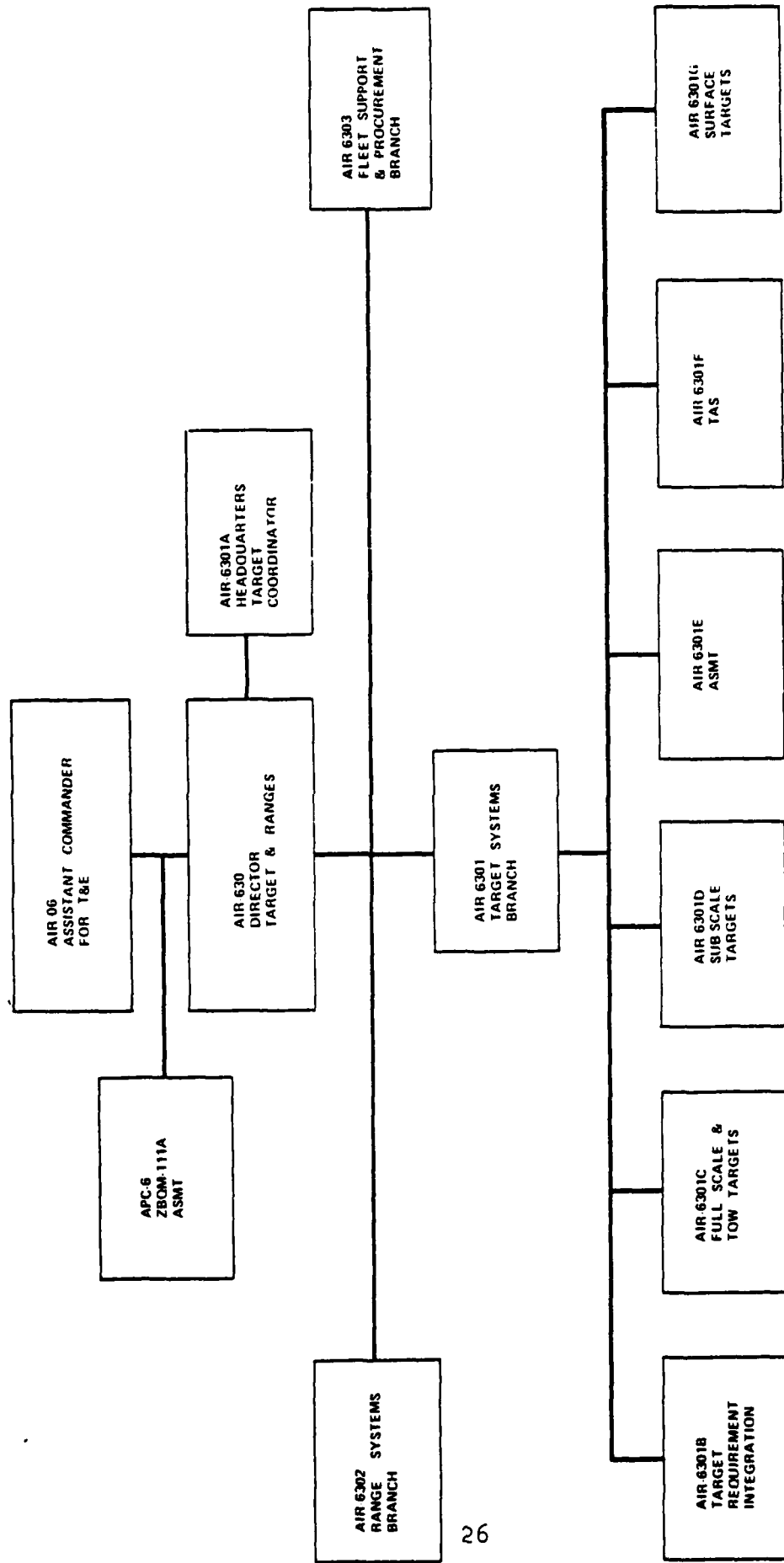

FIGURE 7: The Organization Chart of the Naval Air Systems Command for Targets

considerations, and dividing by target availability [10].

2. Historical trends--which missiles are shot at which target, the number of presentations per target, and the operational loss rate.
3. Target allocation analysis--comparison of user stated requirements vs. allocations vs. actual expenditures.
4. Budgeting data--includes planned procurements/deliveries for aerial targets, projected acquisition and logistic support costs for aerial targets and for major modification programs.

The bulk of this information is provided quarterly to OP-506 in accordance with OPNAVINST 3110.18R [6].

A quick reflection on the magnitude of AIR-630's task, their support requirements to OP-506, and their staff as depicted in Figure 7 will readily point out a glaring disparity. As manned, they can only provide the middle management support to the Program Sponsor. Detailed data analysis for the required technical and logistic support must be augmented from another organization--the Pacific Missile Test Center.

D. PACIFIC MISSILE TEST CENTER (PMTC)

PMTC provides the detailed technical and logistic support to the program manager (AIR-630) in very much the same manner as the AIR-05 (technical) and AIR-04 (logistics) functional divisions support a program manager located in NAVAIR headquarters.

Referring to Figure 7 for the AIR-630 organization, PMTC is staffed with one technical and one logistic expert to support each of the aerial target product lines identified under AIR-6301 [10]. Their charter and responsibilities are

defined by NAVAIRINST 5400.14B which establishes and defines the Cognizant Field Activity (CFA) concept [2]. Under this concept, primarily for out of production programs, a Navy field activity (in this case PMTC) provides the detailed engineering and logistic support analysis efforts to support and substantiate the decisions of the program manager (AIR-630). This support effort includes maintenance data collection and analyses, supply support, training and trainers, rework specifications, publication update and maintenance, design change development or procurement, etc.

In summary, one can visualize PMTC in this CFA function as the essential working level connection between the aerial target users and their producers. By data collection and analysis of user (fleet) problems, they support AIR-630's program management role/decisions. AIR-630 in turn supports the OP-506 Program Sponsor in his higher level management, budget, and policy decisions.

E. NAVAL WEAPONS CENTER (NWC) AND NAVAL AIR DEVELOPMENT CENTER (NADC)

Two other key organizations involved in the overall aerial targets management that one must be aware of and deal with in order to understand the complete magnitude/diversity of OP-506's support team are NWC China Lake, California and NADC Johnsville, Pennsylvania.

The mission of NWC is to be the principal Navy RDT&E center for air warfare systems and missile weapon systems. One of the requirements resulting from this mission is to

have appropriate aerial targets capable of demonstrating the desired performance of the RDT&E weapons. Often times this requires a new target or modification to an existing target. Therefore, NWC has developed a significant engineering expertise in aerial targets. Today they support AIR-630 and subsequently the OP-506 Program Sponsor by performing all of the Navy's design and development work on full scale targets. In addition, they provide an alternative engineering capability to the CFA personnel at PMTC and to the prime aerial target manufacturers. This capability is being utilized by AIR-630 via AIRTASK type arrangements to provide additional technical depth and, consequently, better technical support to OP-506.

NADC, like NWC, has provided support to AIR-630 and OP-506 in the front end or mission need/concept formulation stage of aerial target development. They are charged via an ongoing AIRTASK to be the environment scanners for AIR-630 and ultimately OP-506. In this role they must survey the fleet users to identify what the fleet feels are new aerial target requirements. Moreover, they must scrutinize the intelligence data/community to identify new threats which must be simulated by aerial targets. These inputs are then transformed into proposals for AIR-630 and OP-506 to budget for new and/or modified aerial targets to meet emerging requirements [10, 11, 13].

F. MANAGEMENT SUPPORT TEAM--SUMMARY

Fragmented and decentralized are perhaps the best words to describe the several organizations charged with supporting the aerial targets Program Sponsor. This fragmentation and decentralization contributes significantly to OP-506's problem. However, many other Navy programs are managed similarly without overly stressing their Program Sponsor. Thus, one must now compare this management support organization to others in the Navy before proceeding to make recommendations for improvements.

IV. MANAGEMENT SUPPORT ORGANIZATIONAL COMPARISONS

The Navy's management team supporting the Program Sponsor in CNO varies with the system life cycle as follows:

1. PMA--This is the title applied to the manager/management organization of the major systems from the earliest planning phase up through at least the first few years of full scale production. The PMA resides within NAVAIR, has a small staff, and is supported by the NAVAIR functional organization in a classical matrix arrangement.
2. APC--At some point during production when the program stabilizes sufficiently and less high level visibility is desired, the project migrates from a PMA to an APC concept. This title (and charter) applies to the centralized management organization until late in the aircraft life cycle--the end of production or perhaps later. Except for name, and perhaps prestige, there is essentially no difference between a PMA and an APC.
3. WSM--Once the program reaches a point where all production and/or major modifications are complete, the major emphasis becomes sustaining engineering/logistics support. At this point the APC is disestablished and the project management function and functional support is physically transferred to a field activity, generally the CFA.

Figure 8 depicts all three of the project management type organizations and their relationships in the overall Navy management structure. (For purposes of this thesis, CNO refers to the OP-506 Program Sponsor).

A review of the complete aerial target management team organization discussed in the previous section will reveal that it most closely parallels the Weapon System Manager (WSM) phase of life cycle project management. Figure 9 depicts this parallel by adding the essential aerial target management entities to the Fig. 8 organization chart. The

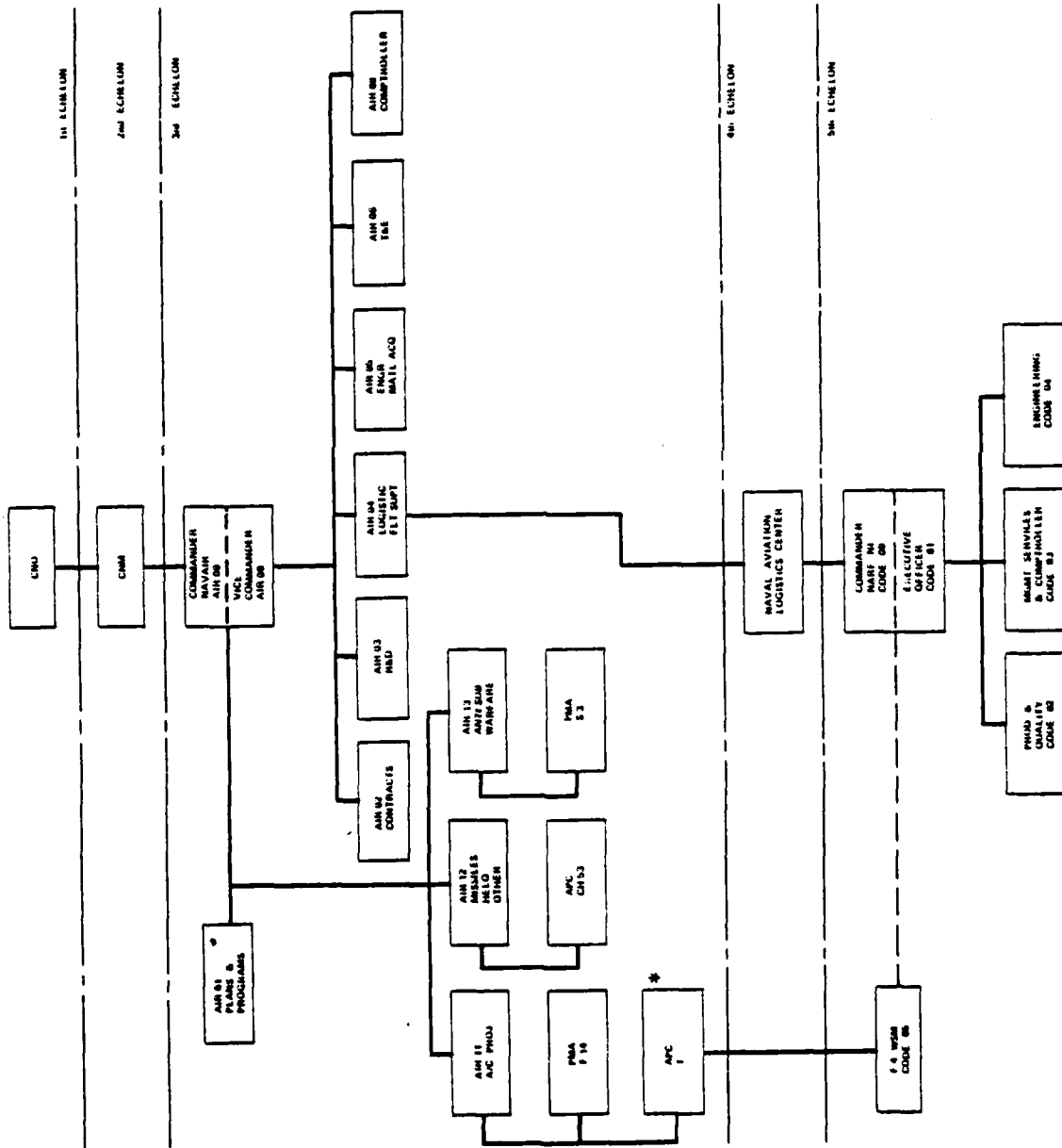

FIGURE 8: The Organization Chart Showing the Naval Air Systems Command Program Management Interrelationships

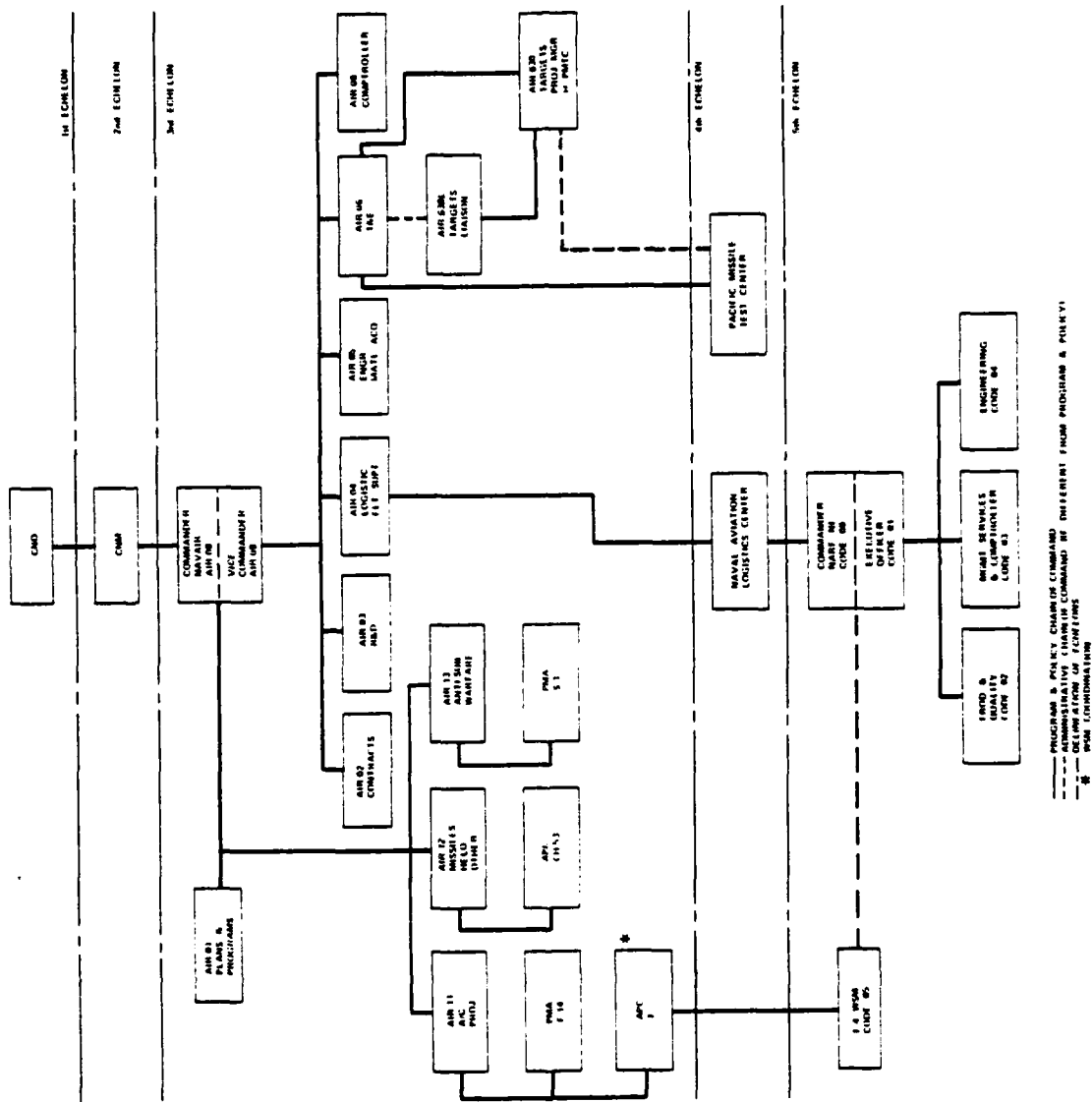

FIGURE 9: The Organization Chart Showing the Naval Air Systems Command Program Management Interrelationships (Including Aerial Targets)

significant parallel features of aerial targets and weapon systems management are the following:

1. Both function with essentially only one liaison man in Washington, D. C.
2. Both project management offices are remotely located and co-located with their respective cognizant field activity.
3. Both rely heavily through an informal organization on certain functional groups within NAVAIR headquarters.

In spite of the noticeable similarity of physical and functional organization, there are several distinct differences which are noteworthy:

1. Aerial targets program management reports through AIR-06 to CNO vs. through AIR-01.
2. AIR-06 is headed by a Navy Captain whereas AIR-01 is headed by a Rear Admiral.
3. Aerial targets are still in production whereas programs under WSM control are generally out-of-production.
4. Aerial targets CFA is a test activity whereas the WSM CFA is a Navy depot rework facility.
5. Aerial targets program management, even though physically remote from NAVAIR headquarters, is functionally a part of NAVAIR whereas a WSM is physically and functionally removed from NAVAIR headquarters.
6. Aerial targets program office supports a diverse group of equipments with fewer people than a typical WSM with a homogeneous weapon system, more people, and larger CFA support.
7. Some of the aerial targets technical support (NADC and NWC) is physically and functionally fragmented from the project office and the CFA whereas all essential technical support for the WSM is generally co-located at the respective CFA.

While all of these differences can be a source of difficulty for the Program Sponsor because of the lack of similarity with aircraft programs, some are simply organizationally

inefficient. Perhaps the biggest structural weakness is the reporting chain-of-command through AIR-06. By reporting through AIR-06 (non-program management oriented), the aerial targets program manager lacks the required leverage and visibility that is inherent in the AIR-01 reporting chain. This is very significant when trying to run a program (that may still be in production) from a decentralized location. A similar problem existed (until December 1979) for the WSMs when their reporting chain-of-command was through AIR-04. The Jessen Study of NAVAIR's organization, in recognition of the magnitude of dollars spent in the later stages of a weapon system life cycle, recommended continuous program management under/through AIR-01 [14]. This was recently accomplished for WSMs via NAVAIRINST 5400.70A [4].

The second most glaring weakness in the aerial target project management organization is the fragmentation of technical support. This alone would probably be insignificant if AIR-630 was located in Washington, D. C. with the leverage and visibility of a PMA and ready access to the OP-506 Program Sponsor. However, when remotely located in California, and the resulting decreased response time to OP-506, this fragmentation of technical support can only cause further erosion of the program manager's capabilities and support to OP-506.

While these two organizational shortcomings in the program management support team are very important, one should not conclude that they are the only organizational structure

sources of OP-506's problems. Perhaps the most significant organizational problem lies within CNO itself. Specifically, reference is made to the split of resource and mission sponsorship of the WPN funds as discussed earlier. This violates principles of good management and has been recognized as a shortcoming in DOD management systems by the Blue Ribbon Defense Panel [8], the Committee on Government Operations (Major Systems Acquisition Reforms) [9], and the previously mentioned Jessen Study. All of these studies point to the necessity to have the control of financial resources coincident with the functional responsibility and authority. This could be corrected very easily by making the OP-506 Program Sponsor the resource sponsor for aerial targets WPN funds. This would appear to be a more pressing need than to have a single resource sponsor for all WPN funds. If this alternative is too politically impalatable, a formalized Memorandum of Understanding, as a minimum, would be in order.

Unfamiliarity and organizational weakness contribute significantly to OP-506's difficulties in managing the aerial targets program. However, a third and most important source of difficulty is the failure of the entire management team to come to grips with several key management issues.

V. MANAGEMENT ISSUES

A. REQUIREMENTS DETERMINATION

One of the key management initiatives to arise in the federal sector in the mid-1970's was the concept of stating requirements in terms of the service's mission. This concept, which is spelled out in detail in OMB Circular No. A-109, places primary emphasis on the early stages of weapon systems development, stressing the obligation to identify missions, deficiencies in capabilities to fulfill these missions, and resultant programs to fill the gap [5]. This differs significantly from the previous procedures where requirements were formulated in hardware terms, often times based on contractor promised capability/systems, and then working backwards to a need and/or mission. The aerial targets community still largely functions in the latter fashion.

With very few exceptions, aerial target systems in the Navy inventory today were developed in the mid-1960's. This would imply that the Navy's mission and the threat thereto have not changed since the mid-1960's or that they still provide in 1980 an adequate representation of the opposing threat. Both of these hypotheses seem ridiculous. If that is the case, then how can one explain the lack of new targets being developed?

The explanations most often cited are the lack of funds and the escalation that has made aerial targets a very expensive, expendable piece of equipment. While these reasons must certainly be part of the answer, they are not the complete answer. A significant contributor is the Navy's failure, for whatever reason, to state its full spectrum of aerial targets requirements in understandable, defensible mission needs. And, therein, lies the Catch-22 of the situation. Without the A-109 type of assessment, the funding will never be forthcoming.

The picture is no more encouraging when one looks at the other main role of the Navy's aerial targets--testing the capabilities of the Navy's own weapon systems. Again since targets have remained relatively, technologically stable from the mid-1960's, an uneducated observer might suspect that Navy weapons had not improved their capability or the targets were way ahead of their time. One only needs to be slightly cognizant of the technological advances of the 1970's to know that neither of these two suspicions can be valid.

The explanation lies in how targets for this purpose are funded and in the system rewards and human nature of a Navy Program Manager. If a program manager's weapon system is so new and sophisticated that no existing target will adequately test it, then he must budget and provide funding for the new target from his weapon system funds. With ever present cost growth this is one of the first items to be sacrificed even if it appears initially in the budget [10]. Moreover, the

benchmark for a program manager's performance in today's economic environment is geared to cost and schedule. Performance is taking a back seat. In addition, human nature drives the dedicated program manager to strive for success. A truly representative aerial target to completely certify the performance of his weapon system would increase the likelihood of failure. Therefore, most programs such as the F-18 or F-14 elect to get by with existing aerial targets.

Until the Navy can force on itself the necessary discipline to address these two shortcomings in the requirements determination arena and admit that the Navy's aerial targets just do not replicate the threat, the OP-506 Program Sponsor will continually inherit inventory problems and funding shortfalls.

B. HARDWARE VS. SOFTWARE TARGETS

A closely allied issue to the requirements determination problem is the question of the degree of realism provided by a hardware, aerial target. The requirement for this type of target in its training role appears to be a holdover from the "good-old-days" of see and be seen aviation and from the lack of mission analysis discussed previously.

A careful examination of the situation would raise some real questions relative to this philosophy. From the U.S.'s own capabilities and ongoing R&D efforts, standoff weapons with 200 mile ranges are no myth. In addition, hypersonic speed capability (approx. Mach 4) is not far away. Possessing these capabilities in the U. S. military arsenal, can

one dare assume less of the forces hostile to the U. S.?

Given these types of performance parameters for an incoming weapon, the concept of a target that one can see and see that it has been hit is incomprehensible. Electronic or software type targets for training purposes offer more realism and perhaps significant cost advantages.

Much, if not all, of the technology for a software type target methodology is well in hand. Sophisticated aircraft simulators are available. Computer control, simulation, data storage and real time telecommunications are available. High resolution, realistic display technology is available. In short, the capability exists to more accurately simulate a realistic engagement scenario, if that is one's goal.

More disciplined, front end, mission oriented requirements determination will hopefully lead to the philosophical change required to initiate the substitution of software for hardware targets. Software targets will not eliminate the need for hardware type targets. However, the current mix of the two appears incorrect, especially when constrained by the economics of the situation.

C. MAINTENANCE PHILOSOPHY

The third key management issue that needs addressing in order to help alleviate the Program Sponsor's problems is that of the aerial targets maintenance philosophy. The current maintenance concept is very much like that of an aircraft or missile system with the exception that there is no established depot maintenance/rework capability for aerial

targets. The assumption is that the target will be expended, either via a kill or an operational loss, prior to the equipment within the target requiring depot level maintenance.

The difficulties associated with this maintenance philosophy are the following:

1. Paralleling aircraft/missile maintenance concepts is resulting in inordinate expenditures of maintenance manhours for scheduled inspection. This is especially true in full-scale targets and is tied to the philosophy of maintaining full-scale targets man-rated.
2. Significant numbers of aerial targets are surviving to a point in their life where some sort of depot level maintenance is required or desirable. Part of this old age problem is generated by the target inventory shortage and the resultant slow down in expenditures in order to cover the mid-1980's inventory shortfall.
3. Lack of depot level maintenance capability forces any significant modification/repair program to be contracted out. Moreover, lack of this in-house capability eliminates a vital source of firsthand information for the CFA in its technical support role.

Recognizing these difficulties and realizing the manpower and budget environment constraining the program, what alternatives are available? First, and foremost, would be a tailoring of the aerial target scheduled maintenance requirements in light of their mission and operation. This is already underway for the full-scale target QF-4B and could be expanded to the sub-scale and towed target systems (tow reels).

Secondly, some depot capability is needed. Ideally this would be at PMTC to allow the CFA hands on experience. This approach, however, would run counter to prevailing forces that are dictating depot consolidation and interservice arrangements. Recognizing this trend, the remaining

possibilities to gain this depot capability are the following:

1. An existing depot--perhaps one of the two that reworks missiles or NARF North Island that reworks fleet F-4's and has limited experience with QF-4's.
2. Commercial rework contract.

Barring any depot capability and recognizing the lack of funds and glamour associated with aerial targets, a radical approach would be a complete "turnkey" operation [10]. In this management style, the Navy would own the targets but the target manufacturer would have total responsibility for target presentations, technical performance, logistic support, recovery, refurbishment, etc. Limited experience is available on this approach in the Army and could prove beneficial to the Navy.

In summary, the current maintenance concept needs rethinking. In its present form it has significant weaknesses and these weaknesses contribute to the overall management problem of the Program Sponsor by adversely affecting target availability.

D. TRAINING/PERSONNEL SUPPORT

Two significant points need to be recalled in order to discuss this fourth management issue. First, when AIR-630, the program manager, was formulated, no personnel with a background in aerial targets and with NAVAIR headquarters experience were transferred to PMTC. Experience was gained via trial and error on the job; the program management is just now recovering after five years. Secondly, the program manager's staff is one deep for each family of targets with

roughly a two man support cadre for each family of targets residing in the CFA. This is much less than comparably sized programs. Thus, a significant issue arises as to how to provide additional depth to the program management team and how to train upcoming personnel to provide continuity and relief for personnel that leave for whatever reason.

Additional depth can come from one of two basic sources-- in-house Navy or out-house (contractor). The latter method seems to be in vogue today for many reasons primary of which are the ease with which contractor support can be procured, the direct control over contractor personnel via the purse string, and the feeling that available contractor personnel have more talent. This is the approach the current aerial target program manager is pursuing [10].

Alternatively, additional support in-house would be restricted via ceiling constraints. However, some options are available:

1. PMTC--perhaps additional interest and support for program management functions could be gleaned informally from PMTC. Many of the aerial targets are operated and maintained (intermediate level) at PMTC. With proper motivation, and if required funding via AIRTASK, additional support could be provided. This relationship would then be very similar to the working relationship between an aircraft CFA engineering/logistics team and the depot production personnel.
2. NWC--perhaps additional support could be secured by expansion of the current AIRTASK arrangements.
3. NADC--same option as NWC.
4. NARF--a potential source of additional support may be a technical/logistics team experienced in the CFA function which is experiencing decreased workload.

An example would be the F-4 CFA at NARF North Island. AIRTASKS could be executed to formalize such an arrangement.

The training issue is intimately tied to the personnel support problem. Without more depth of people than currently exists, each vacancy is traumatic, creating a void, and has only a small cadre from which to be filled. More depth will provide better support all the way up the line and provide a larger base of semi-experienced personnel to move up and into vacancies. The connection between training and the additional people support is simple and direct. If the latter issue is addressed via out-house methods, trained/experienced relief personnel will remain a problem. If managed in-house, then trained/experienced personnel are far easier to provide.

Thus, the two sides of this issue present management with a difficult tradeoff. On the one side is contracting out with its ease and almost immediate response time but lack of long term generation of experienced people. On the other hand is additional in-house support with its political and administrative difficulties and slower response time, but better long term capability to provide experienced replacement personnel. The choice is not clear. However, the problem must be addressed and a strategy developed.

VI. RECOMMENDATIONS

An understanding of aerial targets management organization, roles, interrelationships, and problems will definitely accrue to the Program Sponsor who reads and comprehends the issues herein. However, understanding and comprehension will only marginally improve upon his difficulties as Program Sponsor in OP-506. What is required to materially improve aerial targets management is positive action addressing the management organization structure and management issue problems.

In this regard, the following actions are recommended as a first step in improving the overall aerial targets management and the support to OP-506:

1. Structure the Aerial Targets' program management along the lines of a WSM by moving the liaison function (AIR-630L) to AIR-01 (under APC-1, Fig. 8) and by chartering AIR-630 as the Aerial Targets WSM. This will provide a vital parallel to the program management of other major programs within NAVAIR with a resultant increase in leverage and visibility. In addition this change will provide a program management organization which can assimilate the APC-6 functions (Fig. 7) as that program phases out of production.
2. Consolidate NWC and NADC functions at AIR-630/PMTC. Fragmentation of a program remotely located from Washington, D. C. is a serious flaw. Co-locating these responsibilities with the program manager will provide AIR-630 with a greater life cycle perspective, consolidate scarce personnel resources, and increase response unity/time to the OP-506 Program Sponsor.
3. Give OP-506 the Resource Sponsor authority and function for aerial target WPN funds. The split of resources and mission responsibility for aerial targets within CNO necessitates significant negotiation/coordination

problems for the Program Sponsor. Moreover, this disjoint violates all management principals and DOD management studies. Though more difficult than the other alternative--a Memorandum of Understanding between OP-03 and OP-05--the suggested approach will be longer lasting, less dependent upon the personalities of the individuals, and provide more relief to OP-506 relative to his time constraints in managing aerial targets.

4. Contract with a consultant for a detailed mission/threat analysis, an analysis of Navy aerial target capabilities to replicate the threat, and concepts (both hardware and software) to fill the gap. Independent, out-house analysis/recommendations are required because of the stagnation of ideas and lack of credibility currently existing in-house. Only a detailed investigation, stated in harsh terms associated to Navy mission, and representative of 1980's technology and warfare environment can hope to provide the documentation required to reverse the funding/inventory trends.
5. Attempt to quantify the relationship between aerial target availability/allocation and fleet Anti-Air Warfare readiness. Currently, no one can assess the impact on Anti-Air Warfare readiness if, for example, only 200 targets are allocated against a requirement for 500 targets. Any assessment would be guesswork. If a qualitative and/or quantitative impact assessment tool could be developed, the Program Sponsor could more easily defend his requested funding. In addition, this would provide an excellent short term aid to the funding/inventory problem which recommendation number four addresses in the long term.
6. Establish in-house depot level capability on aerial targets. The slow down in usage caused by inventory shortages, the trend toward recoverable targets, and the increased unit cost of targets all dictate a need for depot capability. Spin-off benefits in technical expertise will be gained via hands on experience. Because of manpower and political constraints, careful planning must proceed implementation of this strategy in order to determine the best location--PMTC or an existing Navy depot.
7. Tailor the maintenance program for aerial targets. Significant O&MN savings are feasible if maintenance procedures are carefully matched to the target's mission and operational environment. Additional benefits will be gained in overall target availability.

8. Provide additional depth of personnel in-house.
The primary source should be PMTC. Benefits to be gained are personnel with more direct hands on experience, a closer parallel to WSMS, and the ability to provide experience and training to individuals who can backfill positions as vacancies occur. Ultimately this increased depth and training will appear as increased capability and responsiveness to the OP-506 Program Sponsor.

These eight recommendations comprise a significant first step in improving the overall program management support to the Program Sponsor. A major second step looms ahead, however, in implementing the results of the study effort contained in recommendation number four. And as a final step, feedback monitoring. This last step is an iterative one in order to insure the desired results are achieved by implementing these changes and to foretell the need for additional changes.

VII. SUMMARY

The Program Sponsor in OP-506 is typically a Navy Captain who has spent his entire career flying aircraft and/or managing aircraft assets in varying capacities. Being a Program Sponsor for an aircraft program means operating in a comfortable, familiar environment. This is not the case relative to aerial targets.

The aerial targets program is assigned as additional duties to the F-4/F-5/F-8 Program Sponsor within OP-506. It is unfamiliar, unglamorous, and consumes disproportionate amounts of the sponsor's time.

This lack of familiarity can be overcome by understanding the aerial targets mission, the key organizations involved in aerial target management, and how these organizations interrelate physically and functionally. Section III of this report provides this knowledge. Its greatest benefit and use will be to initiate future Program Sponsors in the intricacies of aerial targets management.

Additional contributors to the Program Sponsor's aerial targets management problems are the (1) organizational structure and (2) the lack of attention to several key management issues.

Organizational structure problems exist within CNO because of the split of resource and mission sponsorship relative to

WPN funds, within the program manager's office (AIR-630) because of its reporting chain-of-command, and within the program manager's support staff due to fragmentation. Marriage of the resource and mission responsibilities/ authority, AIR-630 reporting through AIR-01, and consolidation of NWC and NADC functions at PMTC, respectively, are the recommended corrective actions.

Whereas the familiarity and organization structure problems can be solved in the near term, the problems associated with the management issues addressed in Section V will only be solved in the long term. The solution to these issues really involves philosophical changes to the Navy's concepts of targets and their maintenance, how the threat is perceived, the benefits of realistic simulation of the threat, and the importance of training for tomorrow. The innovations needed to bring about these changes will not come easily or quickly.

Some improvement in aerial targets management will accrue from solving the familiarity and structural problems. An order of magnitude improvement will occur if the key management issues are tackled successfully.

The current management organization results from changes precipitated by environmental factors in 1975. The changes recommended herein are cast in the context of 1980. If implemented, a continuous monitoring of their effectiveness is mandatory as the Navy collides with the rapidly changing technology and environment of the 1980-1990s.

APPENDIX A

MISSION AND FUNCTION OF THE AVIATION PLANS
AND
REQUIREMENTS DIVISION

OP-50
AVIATION PLANS AND REQUIREMENTS DIVISION

Mission: To implement the responsibilities of DCNO (Air Warfare) pertaining to the preparation of plans, tactical doctrine and the definition of requirements to provide for naval aviation forces (including the Naval Air Reserve) and their logistic support. Included is the preparation of budgets and their sponsorship and coordination with pertinent offices to provide for integration into the overall Navy program planning system.

Functions:

1. Prepares plans within the framework of approved policies, to provide required aviation forces and their support. (OP-508)
2. Develops and formulates requirements for naval aircraft, naval aviation weapons, aircraft carriers, specified aviation type ships and associated aeronautical equipment, including their material readiness, to fulfill Navy objectives and to support warfare plans and programs. (Shipboard equipment and systems for control and navigation of aircraft in approach and landing phases of operations at sea are excluded from this functional responsibility.) (OP-506)
3. Prepares requirements for aviation programs and coordinates other requirements pertaining to the appropriations and budget activities sponsored by the DCNO (Air Warfare) and supports these requirements before the various military and civilian budgetary reviewing agencies. (OP-501/506/508)
4. Provides technical cognizance for the conduct of OPNAV review of aircraft tactical manuals and takes the necessary action to keep them current. (OP-506)
5. Establishes the operational characteristics of air weapons systems required to meet approved plans. Initiates changes required by changes in plans or in probable threats. Initiates action to upgrade or extend operational capabilities of existing air weapons systems. (OP-506)

6. Provides program coordination, as defined in the Navy Programming Manual, for all air programs assigned to DCNO (Air Warfare) for sponsorship. (OP-506)

7. Provides liaison with the Director, RDT&E on matters affecting aviation programs. (OP-506)

8. Determines air launched nuclear weapons requirements and monitors readiness of naval air units to maintain and deliver nuclear weapons. (OP-506)

9. Provides liaison with the Office of the DCNO (Logistics) on matters affecting air launched weapons expenditures. (OP-506)

10. Provides liaison for aircraft engine configuration requirements in support of DCNO (Air Warfare) responsibilities in the pollution abatement program. (OP-506)

11. Coordinates with other offices for integration of aviation plans, programs and requirements into overall Navy plans, programs and requirements. (OP-508)

12. Coordinates with other offices in the formulation of joint, international and Navy plans and policy matters affecting naval aviation. (OP-508)

13. Advises the DCNO (Air Warfare) on the most effective uses of aviation forces. (OP-508)

14. Monitors assigned aviation plans and requirements and coordinates with OP-59 in order to ensure their timely and complete fulfillment. (OP-506/508)

15. Advises the DCNO (Air Warfare) on policy matters affecting the fulfillment of his mission, and prepares positions on policy matters affecting naval aviation. (OP-501/506/508)

16. Assists in the development of plans and requirements for aircraft and related material for the Military Assistance Program. (OP-508/506)

17. Conducts a program of staff studies and analyses necessary to provide the foundation for naval aviation plans and programs. (OP-501/506/508)

18. Develops and coordinates the formulation of requirements for orderly and effective mobilization planning for naval aviation, including ships, aircraft, facilities and associated equipments. (OP-508)

APPENDIX B

MISSION AND FUNCTION OF THE TARGETS
AND RANGE SYSTEMS DIVISION (630)

Sec. 1. Director (630). Is responsible for the Project Management of the aerial and surface targets and assigned range instrumentation systems. These responsibilities include the following:

A. Providing project management for development, procurement and logistics support of assigned target projects and assigned instrumentation systems programs.

B. Supporting the operating forces and other Systems Commands to ensure their range systems improvement and target requirements are provided consistent with approved program and funding levels.

C. Providing planning, development, procurement and logistics support for fleet training range and instrumentation systems.

D. Developing and recommending priorities within the program objective memorandum (POM) development cycle and budget development process submission for all assigned projects.

E. Providing technical assistance in planning military construction, minor construction, special projects and project-funded construction programs for programs related to range instrumentation systems under development or procurement.

F. Supporting the Director for Resources Division in developing and coordinating programs, plans and budgets for range systems and targets programs.

G. Acting as an executive agent for the Assistant Commander for Test and Evaluation in directing and reviewing execution of assigned range systems and targets programs and budgets.

H. Recommending allocation and reallocation of available funds for execution of programs in accordance with approved planning.

Sec. 2. Assistant Director (630A). Assists the Director in administering and coordinating the work of the division. In the absence of the Director, is responsible for and has

authority to act for the Director in all matters normally the responsibility of the Director.

Sec. 3. Targets Branch (6301). Is responsible for project management of targets and target systems. Responsibilities include:

A. Providing target systems in response to established requirements; managing and coordinating the preparation, and updating and executing approved system plans.

B. Providing management of the technical development, procurement and logistic support for target systems.

C. Performing continuous evaluation of progress against plans, cost against funds available, and capability against design objectives.

D. Approving the scope, schedule and costs proposed by functional organizations for the accomplishment of project effort. Directing and ensuring efficient utilization of manpower, materials and funds pertaining to targets systems.

E. Exercising configuration management control for target systems.

F. Ensuring that program hardware is certified as ready for operational evaluation or service use as appropriate.

Sec. 4. Range Systems Branch (6302). Is responsible for range instrumentation systems development, procurement and logistics support. These responsibilities include:

A. Initiating and managing new range instrumentation development programs in support of range requirements.

B. Coordinating with weapons systems project officers in monitoring the development of Test and Evaluation Master Plans (TEMP) and evaluating the impact of this planning on range instrumentation requirements.

C. Assisting in the preparation, reviewing and coordination of range development plans in concert with the Director Resources Division.

D. Coordinating with OPTEVFOR and CPNAV to ensure overall Navy management cognizance of planned range utilization and new instrumentation requirements for the Navy elements of the Major Range and Test Facilities Base (MRTFB).

E. Provides configuration management control for range systems.

Sec. 5. Fleet Support and Procurement Branch (6303). Is responsible for providing support to fleet activities in areas of range instrumentation, targets and training requirements and procurement support to the target and range systems branches. Responsibilities include:

A. Providing planning information and recommendations in the management control of the mobile sea range program and assets.

B. Providing integrated assessment of range systems and targets performance and capabilities in support of DT&E, OT&E and fleet training oriented user requirements, excluding underwater targets.

C. Assisting in the development of training plans and exercises to support the requirements identified by the fleet and other range users.

D. Establishing active and continuing liaison with range users (Fleet, Navy Material Command, DOD Agencies and other services) to ensure that the capabilities of the Navy ranges are made known, duplicative capabilities are not programmed, and user requirements are recognized and considered in planning range capability improvements.

E. Preparing procurement documents, initiating procurement actions and maintaining active surveillance of prime contractors contract performance in support of the Target and Range Systems Branches.

F. Maintaining active surveillance of field activities to ensure procurement initiation, production and delivery of Target and Range Systems equipment to meet planned schedules.

APPENDIX C

GLOSSARY OF ABBREVIATIONS AND ACRONYMS

APC	Aircraft Project Coordinator
CFA	Cognizant Field Activity
CINCLANTFLT	Commander in Chief Atlantic Fleet
CINCPACFLT	Commander in Chief Pacific Fleet
CNM	Chief of Naval Material
CNO	Chief of Naval Operations
DCNO	Deputy Chief of Naval Operations
DOD	Department of Defense
FMS	Foreign Military Sales
JSOR	Joint Service Operational Requirement
NADC	Naval Air Development Center
NARF	Naval Air Rework Facility
NAVAIR	Naval Air Systems Command
NAVAIRINST	Naval Air Systems Command Instruction
NAVSEA	Naval Sea Systems Command
NWC	Naval Weapons Center
OMB	Office of Management and Budget
O&MN	Operations and Maintenance Navy
OPNAVINST	Chief of Naval Operations Instruction
OPTEVFOR	Operational, Test, and Evaluation Forces
PMA	Project Manager, Aircraft
PMTC	Pacific Missile Test Center
RDT&E	Research, Development, Test and Evaluation
WPN	Weapons Procurement Navy
WSM	Weapon System Manager or Management

BIBLIOGRAPHY

DEFENSE DEPARTMENT AND GOVERNMENT INSTRUCTIONS

1. NAVAIRINST 5000.8, Project Management/Coordination in the Naval Air Systems Command Headquarters, Dec. 1971.
2. NAVAIRINST 5400.14B, Policies and Procedures for the Transfer of Engineering Cognizance of and Production Support Responsibilities for Service Equipment to Navy Field Activities, July 1977.
3. NAVAIRINST 5400.53B, Weapon System Management Support (APC-xx); Coordination of, Unreleased.
4. NAVAIRINST 5400.70A, Weapon System Management at NAVAIR Field Activities, Dec. 1979.
5. OMB Circular No. A-109, Major System Acquisition, April 1976.
6. OPNAVINST 3110.18R, Aerial and Seaborne Target Program, June 1975.
7. OPNAVINST 5430.48A, Office of Chief of Naval Operations (OPNAV) Organization Manual, May 1977.

GOVERNMENT PRINTED PUBLICATIONS

8. Blue Ribbon Defense Panel, Report to the President and the Secretary of Defense, Appendix E, "Staff Report on Major Weapon Systems Acquisition Process", July 1970.
9. Major Systems Acquisition Reforms, Hearings Before the Subcommittee on Federal Spending Practices, Efficiency, and Open Government of the Committee on Government Operations, June 16, 20 and July 8, 22, 23, 24, 1975, United States Senate, Ninety-Fourth Congress.

INTERVIEWS

10. Jones, Capt. Robert and Scott, Robert, Naval Air Systems Command (AIR-630 and AIR-6301), Pt. Mugu, California, Interview, 26 March 1980.
11. Kollschegg, Hans, Naval Air Systems Command (AIR-630L), Washington, D. C., Interview, 22 February 1980.
12. McMichael, Lcdr. Skip, Naval Material Command (MAT-08DC), Washington, D. C., 22 February 1980.

13. Murray, Capt. Gordon, Office of Chief of Naval Operations (OP-506C6), Washington, D. C., Interview, 5-6 February 1980.

LETTERS

14. Naval Air Systems Command Letter 05A/ELG Serial 0532 to Chief of Naval Material, Subject: Report on the Management Assessment: Improvement of the Naval Air Systems Command, 23 December 1979.

INITIAL DISTRIBUTION LIST

	No. Copies
1. Defense Technical Information Center Cameron Station Alexandria, Virginia 22314	2
2. Library, Code 0142 Naval Postgraduate School Monterey, California 93940	2
3. Department Chairman, Code 54 Department of Administrative Sciences Naval Postgraduate School Monterey, California 93940	1
4. Professor J. W. Creighton, Code 54Cf Department of Administrative Sciences Naval Postgraduate School Monterey, California 93940	10
5. Defense Logistics Studies Information Exchange U. S. Army Logistics Management Center Fort Lee, Virginia 23801	1
6. Mr. Hans Kollschegg Naval Air Systems Command (AIR-630L) Washington, D. C. 20361	1
7. Capt. Robert Jones Naval Air Systems Command Target and Range Instrumentation Division (AIR-630) Pt. Mugu, California 93042	2
8. Capt. Gordon Murray Office of Chief of Naval Operations (OP-506C6) The Pentagon Washington, D. C. 20350	1
9. Capt. Gordon Cornell/Mr. Robert H. Soderquist (1 each) F/RF-4 Weapon System Manager's Office (Code 05) Naval Air Rework Facility NAS North Island San Diego, California 92135	2
10. Lcdr. Skip McMichael Naval Material Command (MAT-08DC) Washington, D. C. 20360	1
11. Grant R. Mitchell 11132 Vivaracho Way San Diego, California 92124	2