

AD-A089 914

FEDERAL AVIATION ADMINISTRATION TECHNICAL CENTER ATL--ETC F/8 17/7
PROCEEDINGS OF THE 1979 SEMINAR ON AIR TRAFFIC CONTROL. TERMINA--ETC(U)
AUG 80 P ZITO, F E HIERBAUM, M MASSIMINO

UNCLASSIFIED

FAA-CT-80-170

NL

1-2

1-2

1-2

1-2

1-2

1-2

1-2

1-2

1-2

1-2

1-2

1-2

1-2

1-2

1-2

1-2

1-2

1-2

1-2

1-2

1-2

1-2

1-2

1-2

1-2

1-2

1-2

1-2

1-2

1-2

1-2

1-2

1-2

1-2

1-2

1-2

1-2

1-2

1-2

1-2

1-2

1-2

1-2

1-2

1-2

1-2

1-2

1-2

1-2

1-2

1-2

1-2

1-2



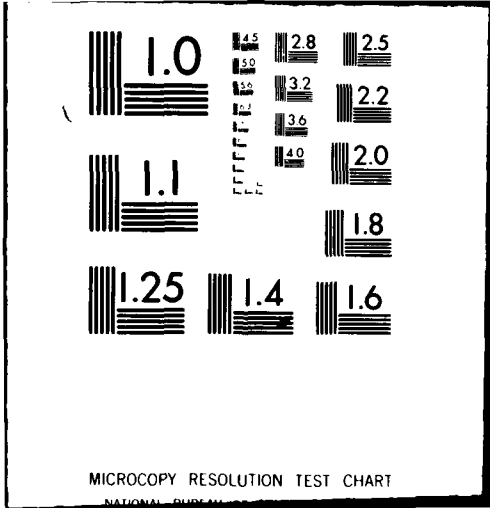

Report No. FAA-RD-80-105
FAA-CT-80-107

LEVEL #

121

PROCEEDINGS OF THE 1979 SEMINAR ON AIR TRAFFIC CONTROL

TERMINAL RADAR APPROACH CONTROL

(TRACON) FACILITY SUPERVISORY DESK COMPLEX

PAUL ZITO

JOHN GOODWIN

FELIX HIERBAUM

MICHAEL MASSIMINO

TOM ZURINSKAS

FEDERAL AVIATION ADMINISTRATION TECHNICAL CENTER

Atlantic City, N. J. 08405

AD A089914



DTIC
ELECT
OCT 3 1980
S
C

AUGUST 1980

Document is available to the U.S. public through
the National Technical Information Service,
Springfield, Virginia 22161.

Prepared for

**U. S. DEPARTMENT OF TRANSPORTATION
FEDERAL AVIATION ADMINISTRATION**

**Systems Research & Development Service
Washington, D. C. 20590**

DDC FILE COPY

80 10 2 073

NOTICE

This document is disseminated under the sponsorship of the Department of Transportation in the interest of information exchange. The United States Government assumes no liability for the contents or use thereof.

The United States Government does not endorse products or manufacturers. Trade or manufacturer's names appear herein solely because they are considered essential to the object of this report.

Technical Report Documentation Page

1. Report No. 18 19 FAA-RD-80-105	2. Government Accession No. AD-A089914	3. Recipient's Catalog No. 11	
4. Title and Subtitle 6 PROCEEDINGS OF THE 1979 SEMINAR ON AIR TRAFFIC CONTROL, TERMINAL RADAR APPROACH CONTROL (TRACON) FACILITY SUPERVISORY DESK COMPLEX.		5. Date August 1980	
7. Author(s) 10 Paul/Zito Felix E./Hierbaum Michael/Massimino John/Goodwin Tom/Zurinskas		6. Performing Organization Code	
9. Performing Organization Name and Address Federal Aviation Administration Technical Center Atlantic City, New Jersey 08405		8. Performing Organization Report No. 14 FAA-CT-80-170	10. Work Unit No. (TRATS)
12. Sponsoring Agency Name and Address U.S. Department of Transportation Federal Aviation Administration Systems Research and Development Service Washington, D.C. 20590		11. Contract or Grant No. 219-151-140	
15. Supplementary Notes		13. Type of Report and Period Covered 9 Rept. for Seminar Proceedings November 1979-February 1980	14. Sponsoring Agency Code
16. Abstract → With the planned construction of new control tower and TRACON facilities, the Federal Aviation Administration (FAA) has established a need for standardized supervisory desk complexes. The air traffic control (ATC) Systems Applications Branch (ACT-210) at the Federal Aviation Administration (FAA) Technical Center conducted a study of selected field facilities. In addition, a seminar was held at the Technical Center which resulted in recommending several different supervisor's desk designs for future implementation at new facilities or as useful, functional, and efficient replacements for existing TRACON installations. ←			
17. Key Words Workspace Design Terminal Radar Approach Control Air Traffic Control Desk Design		18. Distribution Statement Document is available to the U.S. public through the National Technical Information Service, Springfield, Virginia 22161	
19. Security Classif. (of this report) Unclassified	20. Security Classif. (of this page) Unclassified	21. No. of Pages 95	22. Price

411863 *Jus*

METRIC CONVERSION FACTORS

Approximate Conversions to Metric Measures			Approximate Conversions from Metric Measures			
Symbol	When You Know	Multiply by	To Find	Symbol	When You Know	
LENGTH						
in	inches	2.5	centimeters	cm	millimeters	
ft	feet	30	centimeters	cm	centimeters	
yd	yards	0.9	meters	m	meters	
mi	miles	1.6	kilometers	km	kilometers	
AREA						
sq in	square inches	6.5	square centimeters	cm ²	square centimeters	
sq ft	square feet	0.09	square meters	m ²	square meters	
sq yd	square yards	0.8	square meters	m ²	square kilometers	
sq mi	square miles	2.5	square kilometers	km ²	hectares (10,000 m ²)	
ac	acres	0.4	hectares	ha	hectares	
MASS (weight)						
oz	ounces	28	grams	g	grams	
lb	pounds	0.45	kilograms	kg	kilograms	
	short tons (2000 lb)	0.9	tonnes	t	tonnes (1000 kg)	
VOLUME						
imp gal	imperial gallons	4	liters	l	liters	
U.S. gal	U.S. gallons	3.8	liters	l	liters	
qt	quarts	0.95	liters	l	liters	
pt	pints	0.47	liters	l	liters	
cup	cups	0.24	liters	l	liters	
fl oz	fluid ounces	30	milliliters	ml	milliliters	
Tabsp	tablespoons	15	milliliters	ml	milliliters	
Teaspoon	teaspoons	5	milliliters	ml	milliliters	
cc	cups	0.24	liters	l	liters	
qt	quarts	0.95	liters	l	liters	
gal	gallons	3.8	liters	l	liters	
cu ft	cubic feet	0.03	cubic meters	m ³	cubic meters	
cu yd	cubic yards	0.76	cubic meters	m ³	cubic meters	
TEMPERATURE (exact)						
°F	Fahrenheit temperature	5/9 (after subtracting 32)	Celsius temperature	°C	Celsius temperature	

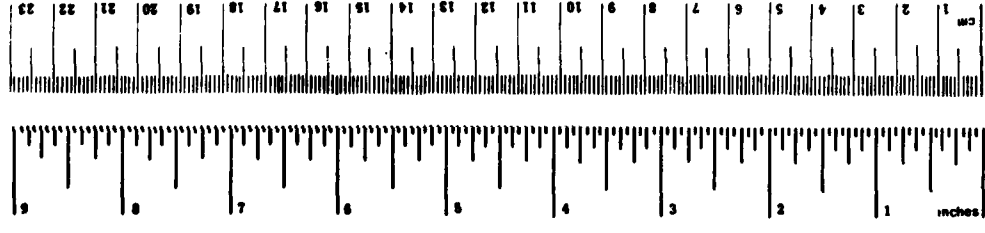

Symbol	When You Know	Multiply by	To Find	Symbol
LENGTH				
mm	millimeters	0.04	inches	in
cm	centimeters	0.4	inches	in
m	meters	3.3	feet	ft
m	meters	1.1	yards	yd
km	kilometers	0.6	miles	mi
AREA				
cm ²	square centimeters	0.16	square inches	in ²
m ²	square meters	1.2	square yards	yd ²
km ²	square kilometers	0.4	square miles	mi ²
ha	hectares (10,000 m ²)	2.5	acres	ac
MASS (weight)				
g	grams	0.035	ounces	oz
kg	kilograms	2.2	pounds	lb
t	tonnes (1000 kg)	1.1	short tons	
VOLUME				
ml	milliliters	0.03	fluid ounces	fl oz
l	liters	2.1	pints	pt
l	liters	1.06	quarts	qt
l	liters	0.26	gallons	gal
m ³	cubic meters	35	cubic feet	ft ³
m ³	cubic meters	1.3	cubic yards	yd ³
TEMPERATURE (exact)				
°C	Celsius temperature	9/5 (then add 32)	Fahrenheit temperature	°F

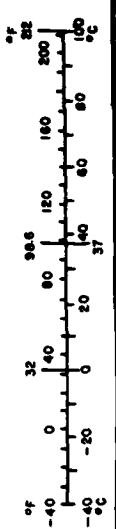

*1 in = 2.54 (exactly). For other exact conversions and more detailed tables, see NBS Misc. Publ. 286, Units of Length and Measures, Price \$2.25, SD Catalog No. C13.10.286.

PREFACE

A desire for producing a modular supervisory desk complex in the future Terminal Radar Approach Control (TRACON) Facilities resulted in a work effort whereby the Federal Aviation Administration Technical Center (FAA Technical Center) was tasked to research, design, fabricate, and test variations of supervisory desk complexes. During this early work, it was evident that a seminar would best serve the purpose in bringing together the customers (Air Traffic Service), the sponsor (Systems Research and Development Service), and the organizations responsible for the standardization of Federal Aviation Administration (FAA) facilities on a national basis.

Each region presented a paper on its requirements as they envisioned them, and while many of them were unable to be present in person to present their views, all inputs received were incorporated into the proceedings at the Technical Center.

The seminar produced several important results. A decision was unanimously made to extend the overall effort to include representative Level V, IV, and III facilities. Further use will be made of wall areas and a total modular supervisor's desk complex will be developed that will allow for further expansion in the event future staffing so dictates.

Other factors bearing on the development of future TRACON supervisory desk complexes became apparent as a result of this seminar. For instance, it was evident that present-day and planned electronic equipment were not consistent with all regions. It was concluded that TRACON facilities are dependent upon Air Traffic Services to determine what equipment is scheduled for each type facility. Further conclusions of this seminar were that all equipment not required by the supervisory personnel for continued use (such as radar control panels), should be examined for inclusion on wall-mounted units. Also, Regional representatives would have to indicate whether radar displays were to be included in the supervisor's desk complex and whether they would use a voice recording at the position. Without this seminar it would have been difficult to ascertain the true total needs of the various facilities. Air Traffic Service and Airways Facilities Service will determine which of their facilities they would use as the pilot projects for the Technical Center modeling of such a complex.

Appendix A contains the welcome letter by Mr. Joseph Del Balzo and the Agenda of the conference and evaluation of the workshops.

Accession For	
NTIS GRA&I	<input checked="" type="checkbox"/>
DTIC TAB	<input type="checkbox"/>
Unannounced	<input type="checkbox"/>
Justification	
By _____	
Distribution/	
Availability Codes	
Dist	Avail and/or
A	Special

FORM 2-64 (REV. 1-27-64)

TABLE OF CONTENTS

	Page
PAPER PRESENTED AT SUPERVISORY COMPLEX SEMINAR FIELD RESEARCH	1
SUPERVISOR'S CONSOLE DESIGN FOR TERMINAL RADAR APPROACH CONTROL (TRACON)	11
TRACON SUPERVISOR'S DESKS EVALUATED DURING THE SEMINAR WORKSHOP	27
AIRWAYS FACILITIES ENVIRONMENTAL REQUIREMENTS	40
REMARKS AND THEME COMMENTS	42
TRACON SUPERVISORY COMPLEX SEMINAR	43
ENVIRONMENT AND CONSOLE CONFIGURATION CHECKLIST	44
TEAM RECOMMENDATIONS	48
RECOMMENDED SUPERVISORS CONSOLE	51
CONCLUSIONS	52
RECOMMENDATIONS	52
APPENDICES	
A. TRACON Supervisory Desk Complex Welcome Letter and Seminar Agenda	
B. Regional Offices Response to Design of Supervisory Consoles Shown by Vu Graphs in Speech	

LIST OF ILLUSTRATIONS

Figure	Page
1 Western Region Facility	3
2 Partial View of Desk Arrangement in Facility in Another Region	4
3 Full View of Desk Arrangement in Facility in Another Region	5
4 Denver TRACON Supervisor's Desk Complex	6
5 Schematic of Denver TRACON Supervisor's Desk Complex	7
6 Colorado Springs TRACON Supervisor's Desk Complex	8
7 Brunswick RATCF Supervisor's Desk Complex	10
8 Standard Metal Office Desk	28
9 Schematic of Standard Metal Office Desk	29
10 Bradley TRACON "Wing" Shape Desk	30
11 Schematic of Bradley TRACON "Wing" Shape Desk	31
12 All Metal "L" Shape Desk	32
13 Schematic of All Metal "L" Shape Desk	33
14 Pair of "L" Shape Desks	34
15 Schematic of Pair of "L" Shape Desks	35
16 Large "U" Shape Desk	36
17 Schematic of Large "U" Shape Desk	37
18 Replicate of Colorado Springs "L" Shape Desk	38
19 Schematic of Colorado Springs "L" Shape Desk	39

**PAPER PRESENTED AT
SUPERVISORY COMPLEX SEMINAR
FIELD RESEARCH**

by John Goodwin, ACT-210

This effort involved a study of currently operational supervisory desks at several Terminal Radar Control (TRACON) facilities. Information was collected concerning present and proposed equipments and equipment layouts, lighting, work and personnel areas, and the general environment of the TRACON desks so that recommendations for improvements and standardization could be made.

Airway Facilities Service (AAF) and Air Traffic Services (AAT) of the Federal Aviation Administration (FAA) are currently planning to standardize the design for construction of new control tower and TRACON facilities. Additionally, since some existing facilities will be renovated, a need for an established standardization for tower and TRACON supervisory desks for both new and existing facilities has arisen. Through the Systems Research and Development Service (SRDS) Terminal Branch (ARD-120), the FAA Technical Center Air Traffic Control (ATC) Applications Branch (ACT-210) was requested to make a study of the supervisory desk complex by AAF. This study resulted in recommendations for improvements and standardization in design for the supervisory desks currently in use within the facilities visited by the Technical Center project team and for proposed new facilities.

Research of existing conditions and problems was accomplished through travel performed by the Technical Center project team (Mike Massimino and myself) during a 2-week period from March 26 to April 7, 1979. Visits were made to the following regional offices and air traffic control (ATC) facilities:

1. Rocky Mountain Regional Office, Denver, Colorado
2. Northwest Regional Office, Seattle, Washington
3. Western Regional Office, Los Angeles, California
4. Denver TRACON
5. Colorado Springs TRACON
6. Great Falls Tower and TRACON
7. Seattle Tower and TRACON
8. Reno Tower and TRACON
9. Los Angeles TRACON
10. El Toro TRACON
11. Ontario TRACON
12. Burbank TRACON
13. Miramar ARTCC
14. Chicago TRACON

Information concerning existing conditions of supervisory desks together with current problems and future needs was collected and compiled from observations and discussions with cognizant personnel. Data collection was concentrated on the supervisory desks in the TRACON's only. It was observed that TRACON's vary in size, and there was very little standardization of desks from facility to facility.

CURRENT DESKS. Supervisory desks, in the TRACON's visited, ranged from a standard office desk with two standard desk telephones to a curved custom-built console with

a built-in television monitor of the entrance to the building. The majority of the desks in Western Region facilities appeared to be from a standard plan. A typical example is shown in figure 1. Figures 2 and 3 show desk arrangements in other than Western Region TRACON's. The appearance of a lesser degree of adequacy in equipment arrangements can be seen.

EQUIPMENT. Equipment common to the desk complex in all of the facilities visited were typewriters and switching panels together with associated handpieces for telephone, interphone, and radio frequencies. Combinations of the switching capabilities varied from facility to facility with little or no location standardization other than in the Western Region. Some of the facilities were equipped with bright radar indicator tower equipment (BRITE) radar displays to monitor control positions, television displays to monitor secure areas, and weather displays. The Western Region was experimenting with a digital display of weather information at some locations, with a display at the supervisory position and closed-circuit television displays at the control positions.

Analysis of the data collected by observation, interviews with operational and management personnel, and study of photographs pointed out a general need for improvement in workspace, lighting, and standardization of equipment arrangement (including the typewriter). Specific requirements common to all TRACON supervisory desks would include a console-style desk having an 18-inch desktop work area and a turret for the mounting of equipment (45-inch maximum height), with adequate seating space for comfortable leg room. Built-ins should include bookcases for manuals, drawers for writing materials and forms, a 24-hour clock, a calendar, and task or backlighting. A provision should be made to accommodate the weather display; television and radar monitors, and the switching panels for the monitors; and for the telephone, interphone, and intercom equipment. A provision should also be made for an extended shelf at a convenient level to accommodate the typewriter. Wiring should be contained in hidden ducts or conduits, and all communication handpieces should be equipped with retractable cords.

It was concluded that there is a general need for improvement in the condition of the TRACON supervisory desks and that standardization would be beneficial for renovation planning and new construction. A desk can be designed to include all of the requirements, and a provision for the digital display of other information can be considered.

Following the field research, a desk was designed for the Denver TRACON (figures 4 and 5) to meet a unique condition. Task lighting and a special typewriter location were incorporated into the desk in order to provide maximum utilization of an extremely limited area for installation.

Installation of the newly designed desk was noted immediately by Rocky Mountain Regional officials and a similar, but larger model, was requested for the new Colorado Springs TRACON (figure 6) on very short notice so as to coincide with the commissioning of the new facility. The Technical Center team, which was in Denver, Colorado, installing the supervisor's desk in the Denver TRACON, made an exploratory trip to Colorado Springs to discuss the project. A meeting with the chief of the facility and his supervisor was arranged. The results of the meeting were that the location size and the various details were coordinated and agreed upon. The construction of the desk was begun as soon as verbal agreement was received from Washington Headquarters. A priority was assigned to the project and all facets of

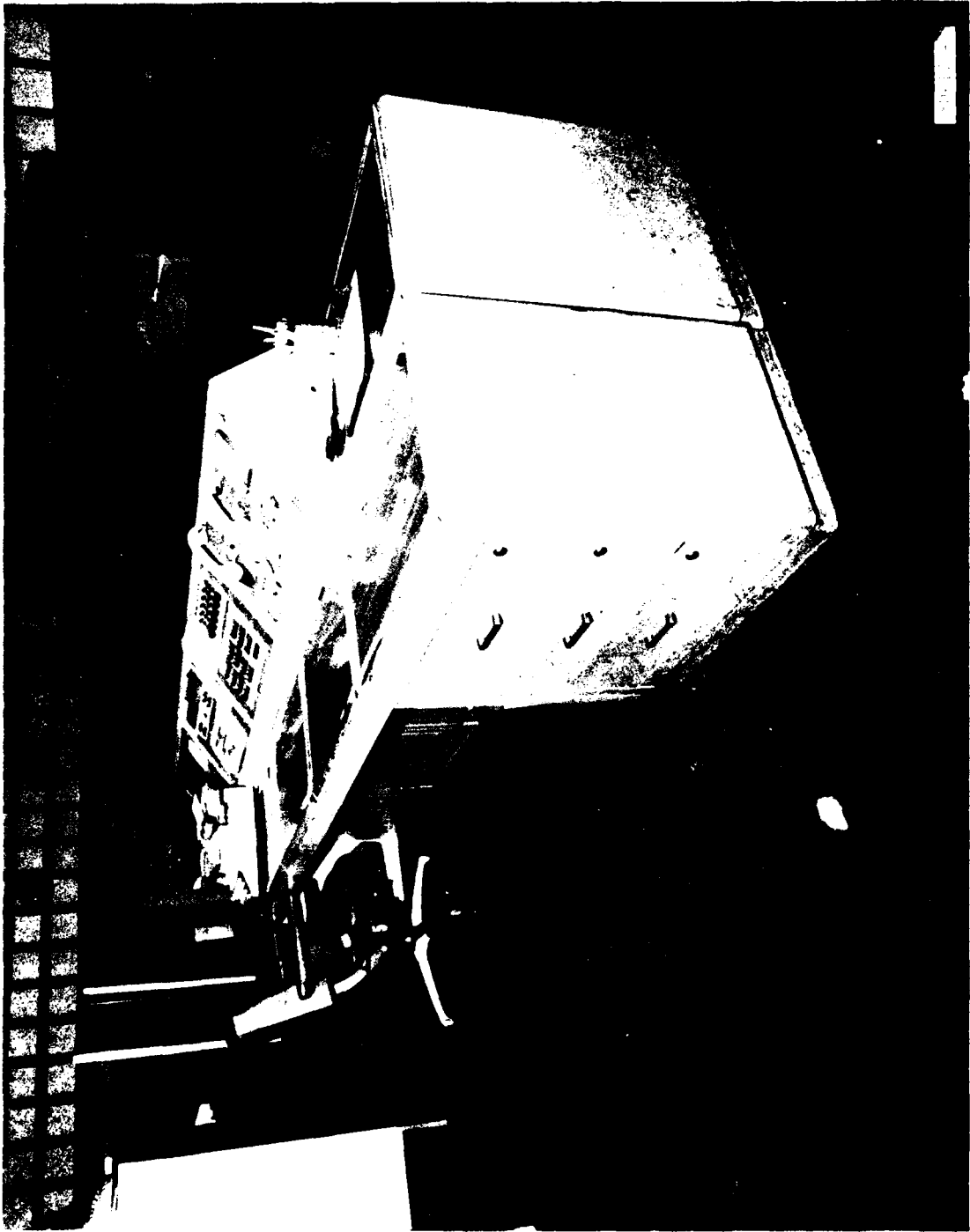

FIGURE 1. WESTERN REGION FACILITY

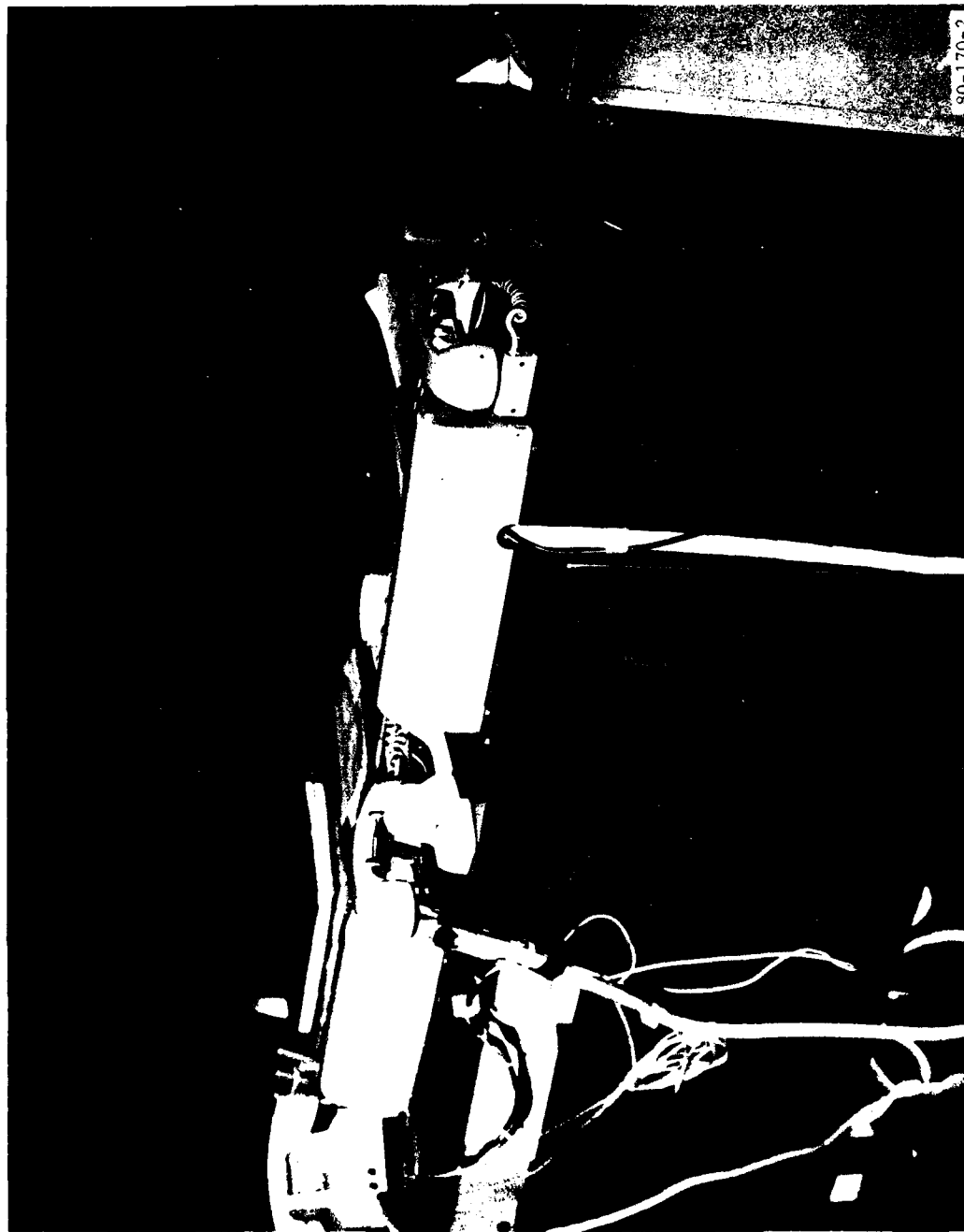
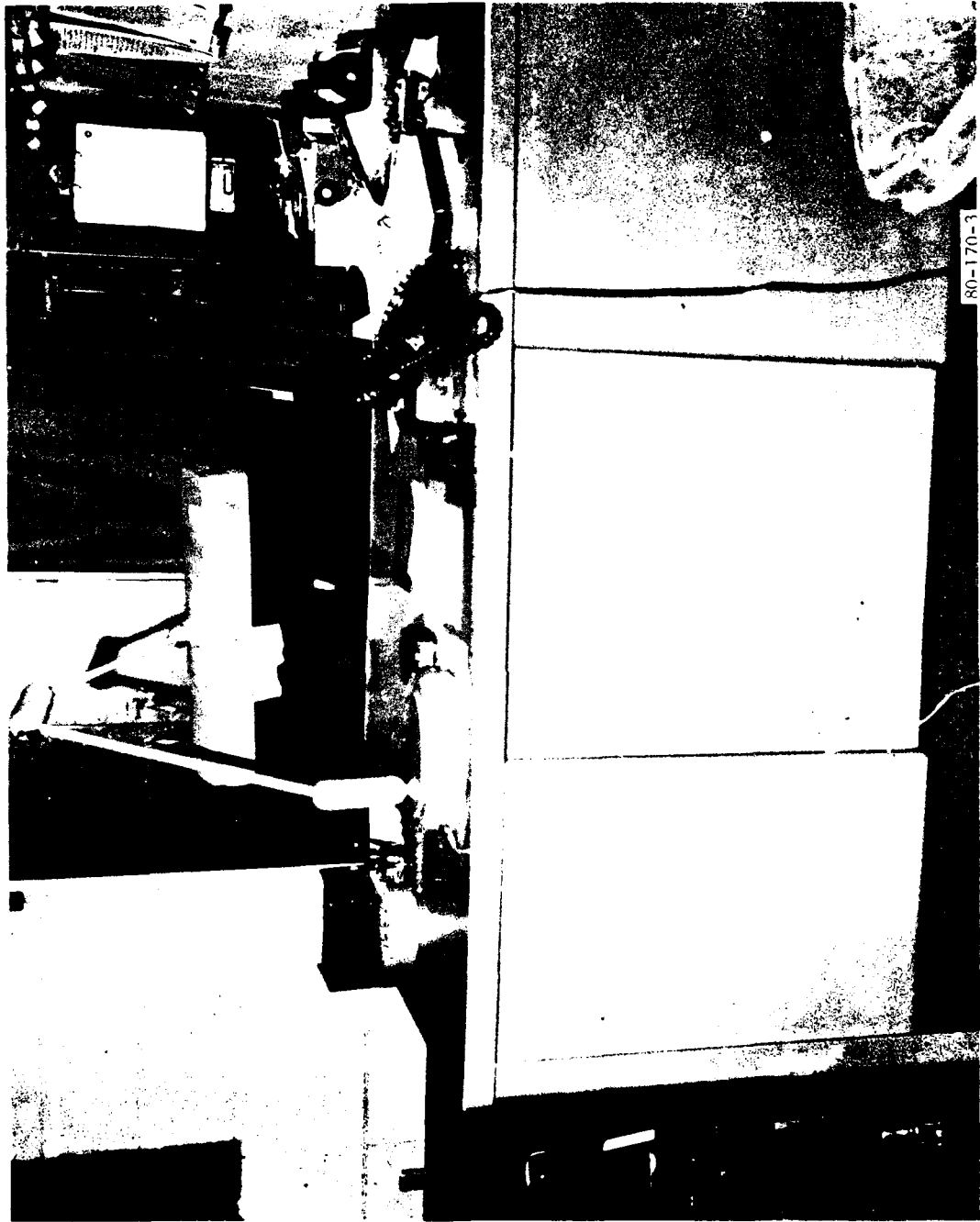
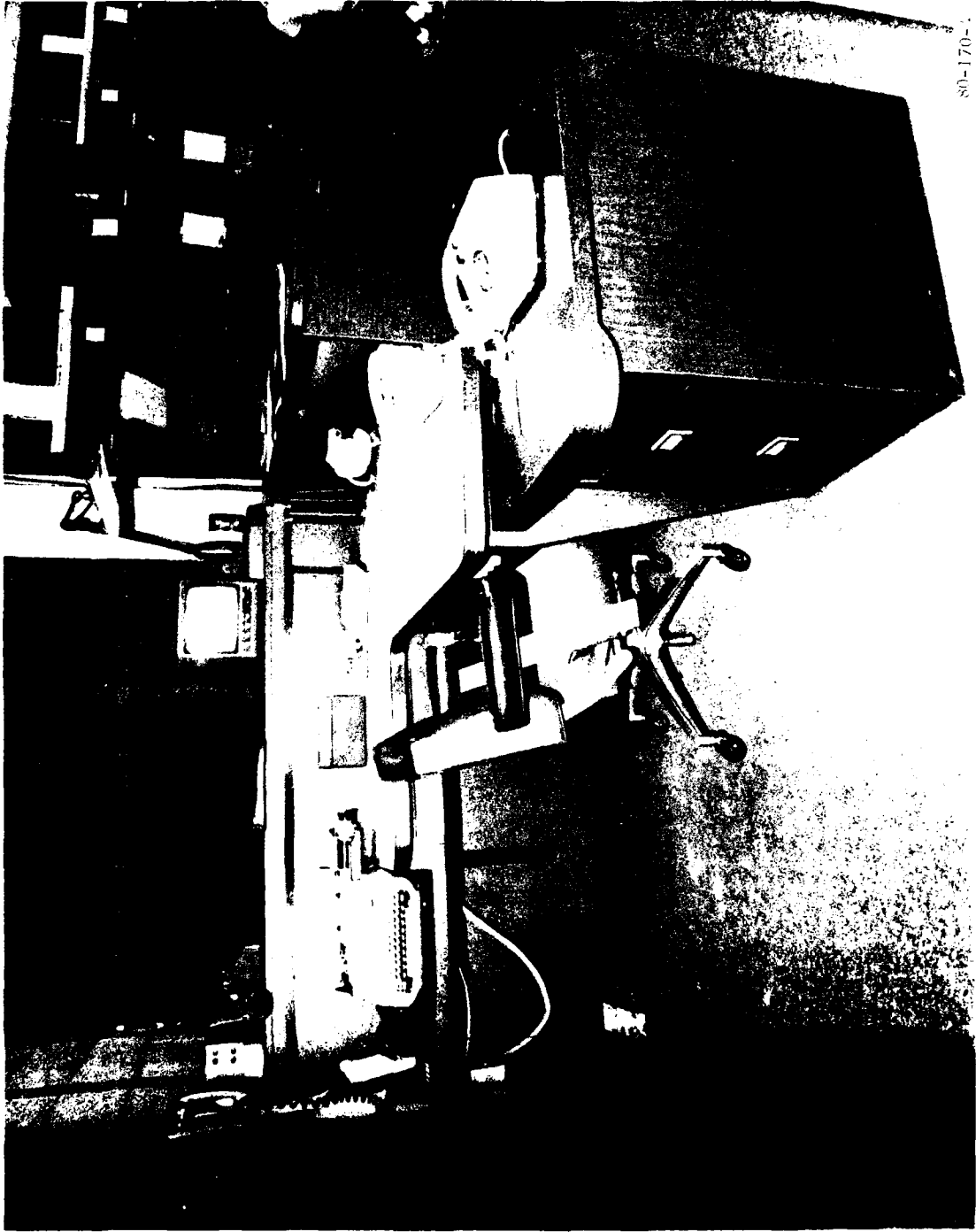

FIGURE 2. PARTIAL VIEW OF DESK ARRANGEMENT IN FACILITY IN ANOTHER REGION



80-170-3

FIGURE 3. FULL VIEW OF DESK ARRANGEMENT IN FACILITY IN ANOTHER REGION



80-170-1

FIGURE 4. DENVER TRACON SUPERVISOR'S DESK COMPLEX

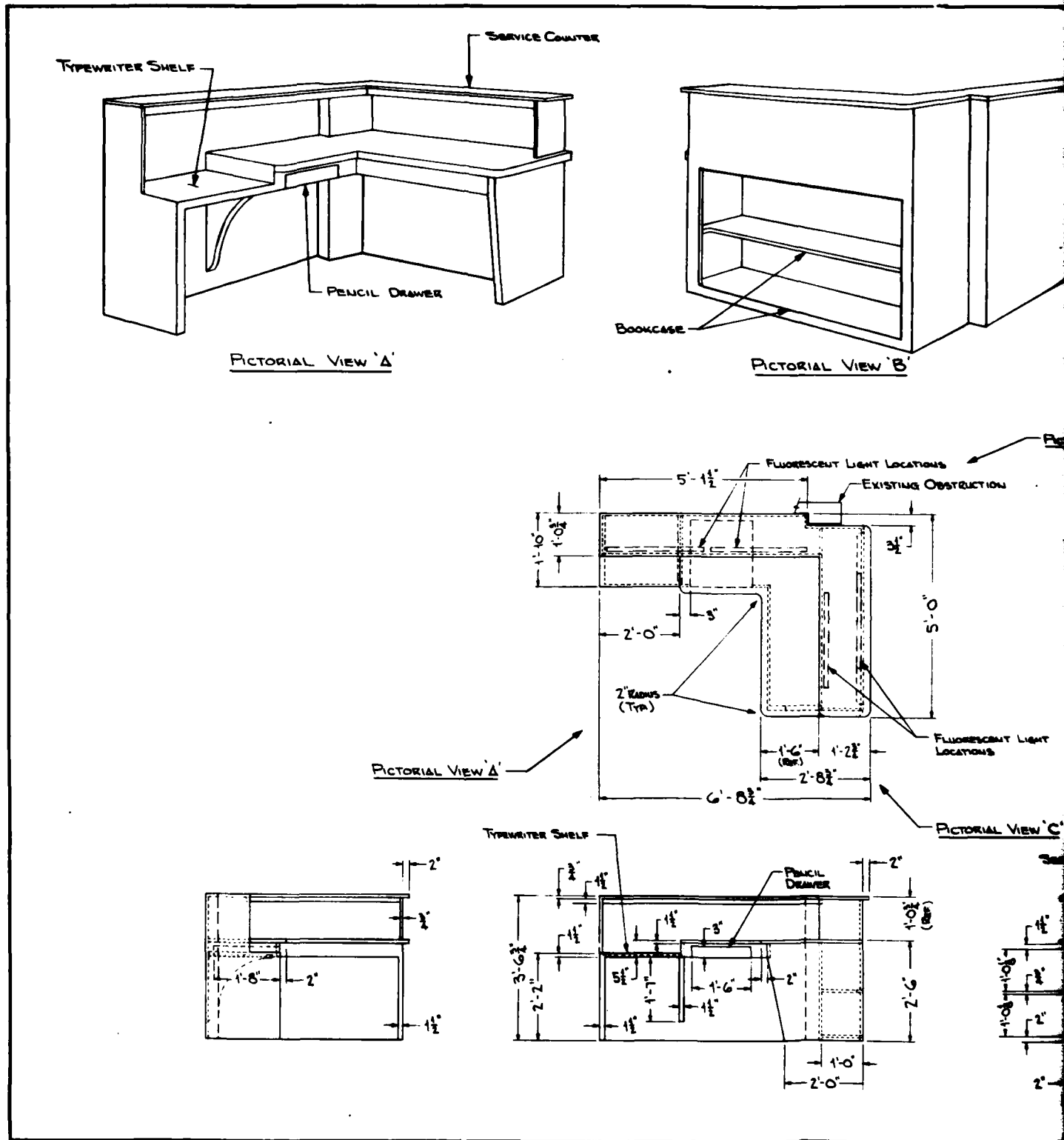
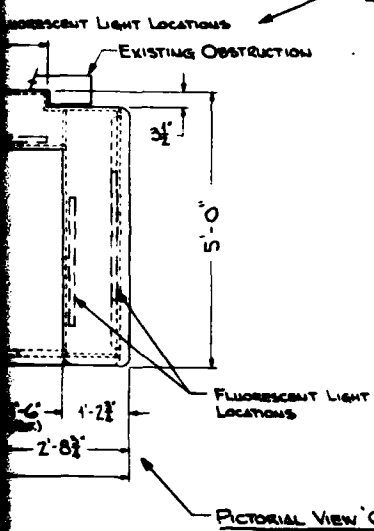
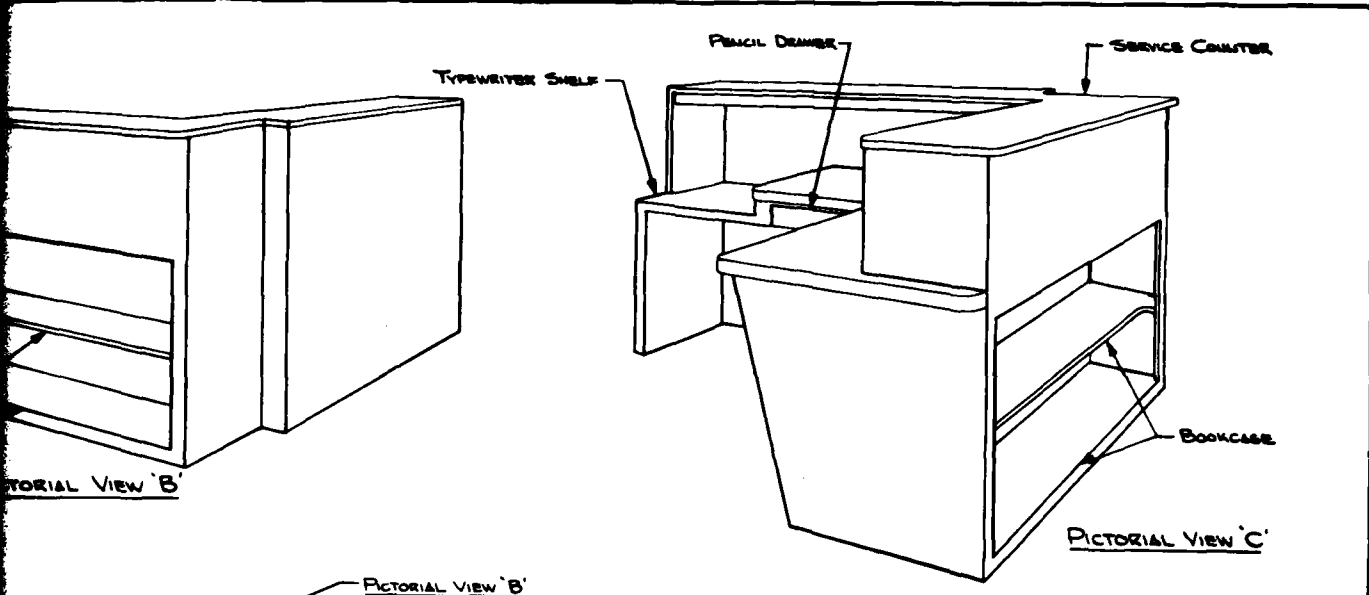
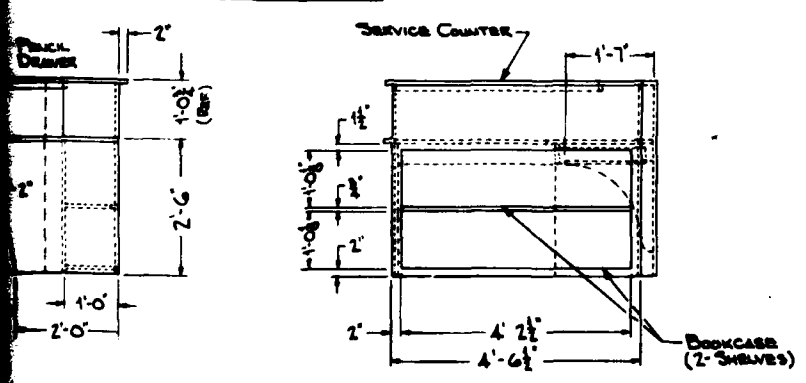

FIGURE 5. SCHEMATIC OF DENVER TRACON SUPERVISOR

2



NOTE:
ALL EXPOSED SURFACES FORMICA COVERED



DATE	RECEIVED	ISSUED	APPROVED
FEDERAL AVIATION ADMINISTRATION <small>NATIONAL AVIATION FACILITIES EXPERIMENTAL CENTER ATLANTA CITY, GA.</small>			
DENVER TRACON ROOM SUPERVISOR'S DESK			
PROJECT NO.	AN4-210	DESIGNED BY	<i>John W. Goodwin</i>
DATE	AN4-522	BY	5-8-73
REVISION		NO.	XD-2987

80-170-5

DENVER TRACON SUPERVISOR'S DESK COMPLEX



80-170-6

FIGURE 6. COLORADO SPRINGS TRACON SUPERVISOR'S DESK COMPLEX

the Technical Center cooperated to complete the desk in time. The desk was shipped and installed in time for the facility commissioning.

The desks that will be designed in the future will be the result of the experience gained during the field survey and the experience of building the two desks for these field sites. All of the problems encountered will be investigated and remedies will be incorporated in future design.

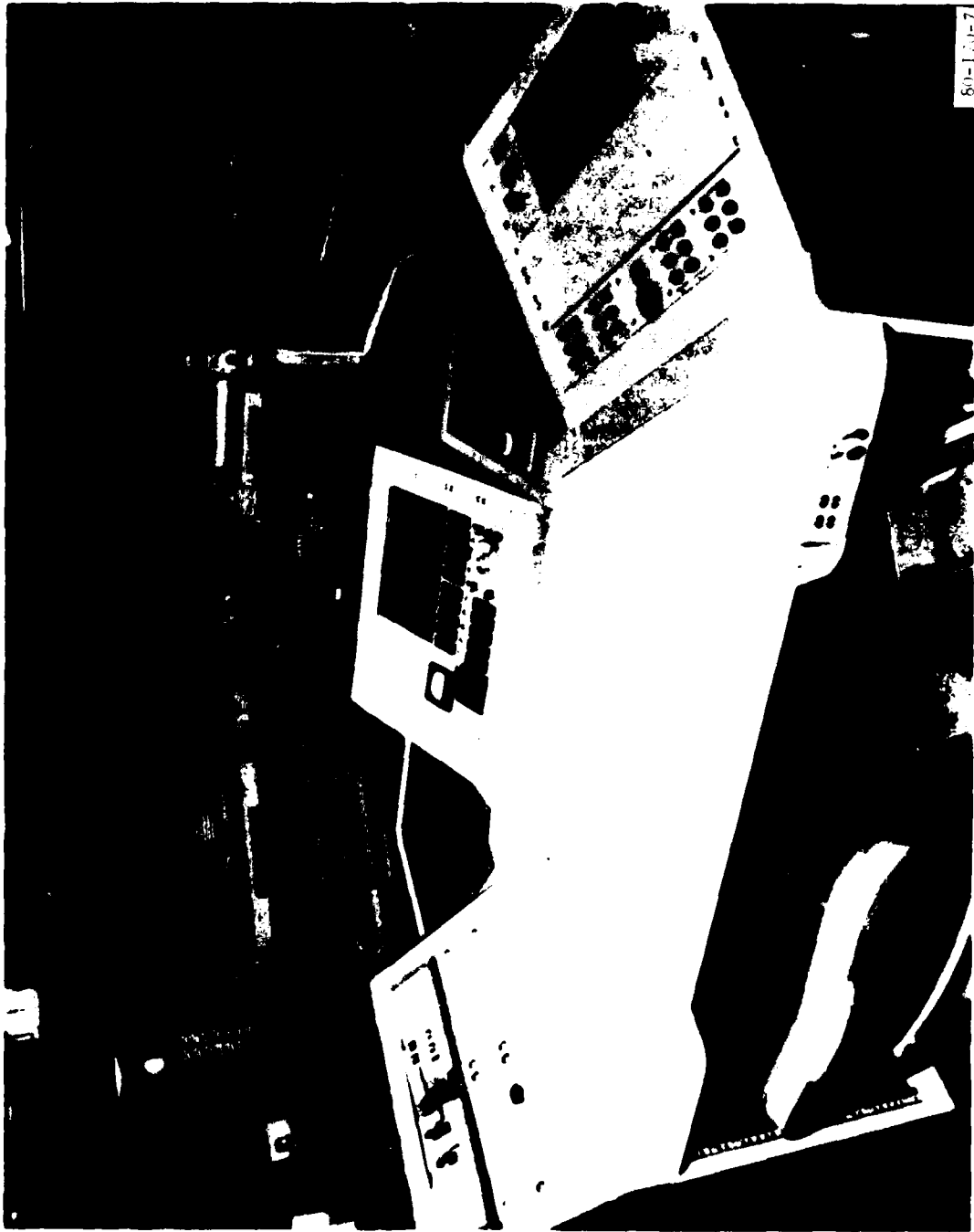

FIGURE 7. BRUNSWICK RATCF SUPERVISOR'S DESK COMPLEX

**SUPERVISOR'S CONSOLE DESIGN FOR
TERMINAL RADAR APPROACH CONTROL (TRACON)**

by Francis Willett, ACT-210

The responses to the letter sent to the Regional offices and field facilities were presented in a condensed form to the seminar in Vu Graphs. Copies of these Vu Graphs are in this Section. Copies of the original replies from the regional responses are included in Appendix B.

SUPERVISOR'S CONSOLE DESIGN FOR TRACONS

AAT-100, FAA REGIONAL OFFICE

**SUBJECT: REPLIES TO AAT-100 (AAT-120) LETTER OF 8/29/79,
STANDARD DESIGN SUPERVISOR'S CONSOLE FOR TRACONS**

**RESPONSES FROM 11 REGIONAL OFFICES ARE ABRIDGED HEREIN. EACH
OFFICE DETERMINED THEIR OWN APPROACH TO DEFINE THE STANDARD
CONSOLE.**

**MOST OFFICES WERE INTERESTED IN PARTICIPATING IN THE EVALUATION
OF THE STANDARD CONSOLE.**

AAT-120, WASHINGTON, D. C.

ENCLOSED REGIONAL/FACILITY AIR TRAFFIC INPUT TO DESIGN,
SUPERVISOR CONSOLE.

FOLLOWING EQUIPMENT IN ADDITION TO SUGGESTIONS:

1. TAPE RECORDING CAPABILITY OF ALL OPERATING POSITIONS USING VOICE ACTUATED TAPE RECORDERS CONTAINED WITHIN THE CONSOLE.
2. BOOKSHELF AND FORM STORAGE AREA BEHIND THE CONSOLE. AREA IS OFTEN UNUSABLE AND WOULD ALLOW CONSOLE SPACE TO BE USED FOR HIGH PRIORITY EQUIPMENT.
3. SHELFWORK AREA ON FRONT OF CONSOLE. THIS WOULD PROVIDE THE TEAM SUPERVISOR A WORK AREA AND STILL NOT ISOLATE HIM FROM THE OPERATION.

APC-513, PACIFIC-ASIA REGION

BECAUSE OF TIME CONSTRAINTS AND HAVING ONLY ONE TRACON TO DRAW IDEAS, NOT PROVIDING ALL INPUTS ASKED FOR.

SUGGEST: CONSOLE INCLUDE A DATA ENTRY, DISPLAY SUBSYSTEM AND ACCESS TO RADIO RECEIVERS. THESE FEATURES WILL ENABLE ASSISTANT CHIEF TO ACTIVELY ENGAGE IN FLOW CONTROL, TRAFFIC ANALYSIS, AND EVALUATION. THESE FUNCTIONS DIFFICULT FOR AC TO PURSUE WITH PRESENT EQUIPMENT LIMITATIONS.

TWO STANDARD DESIGN: LEVEL III AND BELOW, AND
LEVEL IV AND V FACILITIES.

AAL-500, ALASKAN REGION

SHAPE: "U" NO RECOMMENDATION* TO EXACT SIZE OF CONSOLE.

DIMENSIONS:	CONSOLE	TURRET	WRITING (WORK AREA)
HEIGHT			DESK COVER WITH GLASS OR
WIDTH	N.R.*		PLASTIC FOR EASY INSERTION
LENGTH			OF MATERIAL UNDERNEATH

LIGHTING:

EQUIPMENT: AREA FOR TYPEWRITER
ELEVATED TURRET TO REDUCE LIGHT REFLECTION
FLUSH MOUNTED PHONE SYSTEM ON TURRET
CONRAC DISPLAY OF TOWER BRITE
DIGITAL CLOCK
ROOM LIGHTING CONTROLS
COMPUTERIZED CAB DISPLAY (CCD) MONITOR
SAFE
ENTRANCE DOOR COMMUNICATIONS, RELEASE BUTTON, AND TV
MONITOR
(TV MONITOR AND TOWER CONRAC SAME DISPLAY WITH SWITCH
CONTROL)
ARTS II COMPUTER ACCESS KEYBOARD SLAVED TO TOWER BRITE
PREVIEW AREA.
FORMS STORAGE AREA - LIGHTED.

WOULD PARTICIPATE IN EVALUATION OF "STANDARD" CONSOLE

ACE-500, CENTRAL REGION

GENERAL: MODULAR AND CAPABLE OF EXPANSIONS TO PERMIT VARIETY OF SHAPES.

SHAPE: "L," "U," OR LINEAR

DIMENSIONS:	CONSOLE	TURRET	WORK AREA
HEIGHT	LEVEL IV OR V ELEVATED	NOT GIVEN	DESK HEIGHT
WIDTH	NOT GIVEN	NOT GIVEN	24" TO 30"
LENGTH	ACCOMMODATE TWO PERSONS	NOT GIVEN	NOT GIVEN

LIGHTING: SELF-CONTAINED

EQUIPMENT: TELCO DIRECTOR-COMMERCIAL, EMERGENCY, LEASED LINES WITH RECORDING CAPABILITY

POSITION MONITORS

HANDSETS AND CORDS SHOULD BE RETRACTABLE

STANDBY TRANS/RECEIVER SELECTOR SWITCHES

DATAVISIONS VIEWER

RECORDER/NAVIAD ALARMS

HVAC CONTROLS

STANDBY POWER INDICATOR CONTROL

ATIS MONITOR

SECURITY DOOR CONTROLS

CONRAC MONITOR OF RADAR DISPLAY WITH ANK FULL RANGE

OF RADAR AND NOT LIMITED TO RANGE SELECTED ON TOWER

BRITE DISPLAY

CLOCK

WIND INDICATORS

ALTIMETER SETTING INDICATOR

STORAGE FOR SUPPLIES, FORMS, CHARTS, MANUALS

RADAR RECEIVER CONTROLS

TYPEWRITER IN CLEAR AREA OR SWING-AWAY MOUNT WITH

UNOBTRUSIVE LIGHTING

INTERESTED ON THE STANDARD DESIGN

AEA-510, EASTERN REGION

SHAPE: "L" WITH EQUIPMENT PANEL ON ONE SIDE AND SUPERVISOR'S
DESK ON OTHER SIDE. LOCATION UP TO THE FACILITY.

LIGHTING: NO RECOMMENDATION

DIMENSIONS:	CONSOLE	TURRET	WORK AREA
HEIGHT	44½"	14½"	30"
WIDTH	30"	15" BOTTOM 13½" TOP	30"
LENGTH	60"	54"	60"

EQUIPMENT: NAVAID MONITOR PANELS

DIGITAL CLOCK

9" CONRAC

ARTS KEYBOARD

TELCO PANEL WITH MONITOR CAPABILITY ALL LINES, SPEAKER,
DIAL, AND JACK

RECORDER MONITOR PANEL

• M/S TRANSMITTER CONTROL PANELS

M/S RECEIVER CONTROL PANELS

ANE-500, NEW ENGLAND REGION

SHAPE: "U" THREE PANELS, RAISED PLATFORM--IF FEASIBLE

DIMENSIONS:	CONSOLE	TURRET	WORK AREA
HEIGHT	40"	10"	30"
WIDTH		10"	18"
LENGTH	MIN. OF 96"		

LIGHTING:

EQUIPMENT: ELECTROWRITER
TELCO KEY PACK AND SPEAKER
TELCO DIAL
TAPE MONITOR PANEL
ASR-5 CONTROL PANEL
BRITE REMOTE CONTROL
BACK-UP RADIO PANEL
RVR READOUT
ATIS MONITOR
ILS MONITOR
CLOCK
TYPEWRITER

PANEL #1 SELECTOR

REC/TX PANEL FOR REMOTE FREQUENCIES VHF
REC/TX PANEL FOR REMOTE FREQUENCIES UHF
CONRAC CONTROL PANEL
REC/TX SELECTOR PAN FOR VHF FREQUENCIES
BUZZER FRCNT DCOR LOCK RELEASE
RBN MONITOR PANEL

PANEL #2

LIGHT DIMMER SWITCHES
SPACE FOR CONRAC
PHONE CRADEL AND HAND SET
PHONE DIAL AND CIRCUIT SELECTOR PANEL
CLOCK

ANE-500, NEW ENGLAND REGION (CONTINUED)

EQUIPMENT:

PANEL #3

BEACON CODE CONTROL BOX
REMOTE INTERROGATOR CONTROL PANEL
RECORDER MONITOR

ENCLOSURES: BRUNSWICK, GUNOSET, BRADLEY

ARM-500, ROCKY MOUNTAIN REGION

SHAPE: "L"

DIMENSIONS:	CONSOLE	TURRET*	WORK AREA
HEIGHT	29"	NOT GIVEN	29"
WIDTH	NOT GIVEN	NOT GIVEN	24"
LENGTH	8' AND 6' DEEP	NOT GIVEN	BOTH SIDES

*SHELF 12" TO 18"/PLACED ACROSS TOP OF TURRET

LIGHTING: DESK TOP COVERED WITH TRANSPARENT, NONGLARE, NON-REFLECTIVE GLASS OR PLEXIGLASS MATERIAL. INDIRECT

EQUIPMENT: VAS-WIND SHEAR AND TURBULENCE DISPLAY
CCTV-AIRPORT OBSERVATION AND/OR BUILDING SECURITY
TELCO POSITION
TIPS-CRT DISPLAY
RMM-REMOTE MAINTENANCE MONITORING, CRT OR COMPUTER
TERMINAL
CRT- RUNWAYS, ARRIVAL RATE, DEPARTURE, RESTRICTIONS,
WEATHER, EQUIPMENT/NAVIAD STATUS, NOTAMS, DASI, LLWSAS
MONITOR CAPABILITY- TOWER CAB AND TRACON, ARTS III DATA
AREA ON CRT DISPLAY WOULD NOT HAVE TO BE DISPLAYED
ON THE ARTS III MONITOR
DOOR LOCK RELEASE BUTTON
NAVIGATIONAL AIDS MONITOR, I.E., ILS
TYPEWRITER
SHELVES ON ENDS

COLORADO SPRINGS ATCT

SHAPE: "L" CORNER, STRAIGHT WALL OR MIDDLE OF ROOM
STRAIGHT AREAS UNABLE TO ACCOMMODATE "L"
"T" FOR SMALLER AREA

DIMENSIONS:	CONSOLE	TURRET	WORK AREA
HEIGHT	43"	NOT GIVEN	15" MIN.
WIDTH		NOT GIVEN	
LENGTH	"L"- X 11'	NOT GIVEN	
	"ST."-12' (3' WORK AREAS AT ENDS)		
	"T"-10' X 5' VARIABLE		

LIGHTING: COUNTER LIGHTING TO LIGHT DESK TOP WORK AREA.

EQUIPMENT: TYPEWRITER
MONITOR PANELS
TELCO SYSTEM
5 FILE DRAWERS
FORM DRAWER 10-12 SLOTS
FACILITY OPERATING MANUALS STORAGE ON FRONT SIDE OF
CONSOLE

LOCATION: MOST SUITABLE SELECTED BY FACILITY CHIEF FOR DESIGN
OF THE ROOM.

ASO-500, SOUTHERN REGION

SHAPE: MODIFIED "U" WHICH WAS BUILT BY DENROL LAB., INC., ROCKVILLE,
MD. IDENTIFIED AS A COMMUNICATIONS CONTROL CONSOLE,
GROUP OJ-314.

LIGHTING: NO RECOMMENDATION

EQUIPMENT: DOOR RELEASE, INTERCOM AND MONITOR. MONITOR CALLS
ATTENTION TO INCORRECT CODE ENTERED ON CIPHER LOCK.

FIRE ZONE ALARM

HOTLINE TO AIRWAY FACILITIES

CLOCK

ELECTRIC PENCIL SHARPENER

CENTRAL FLOW CONTROL PHONE

ELEVATOR ALARM

TELEPHONE POWER ALARM

CODE-A-PHONE (AFTER-HOURS BUSINESS TELEPHONE)

ACCESS TO FACILITY PA SYSTEM

TYPEWRITER

OPERATIONAL TELEPHONE POSITION

WOULD PARTICIPATE IN EVALUATION OF "STANDARD" CONSOLE.

ATTACHMENTS: PHOTO AND DIAGRAMS OF MIA AND TPA TRACONS, AND
COMMENTS BY BOTH FACILITIES

ASO-500 (CONTINUED)

JACKSONVILLE TOWER

DESIGN: STRAIGHT-LINE OR ANGLED CONFIGURATION, FACILITY OPTION.

DIMENSIONS:	CONSOLE	TURRET	WORK AREA
HEIGHT	STANDARD DESK	70° ANGLE	ACCOMMODATE A COUPLE OF
WIDTH	STANDARD DESK		OPEN MANUALS, CHART, OR
LENGTH	8 FEET		AN HOUR'S WORTH OF STRIPS.

LIGHTING: NONGLARE AND AUXILIARY LIGHTING

EQUIPMENT: TWO CRT DISPLAYS (RADAR MONITOR, WEATHER, FLIGHT DATA, NOTAMS, RESTRICTED AREA STATUS, ETC.) WITH A 20-PAGE MINIMUM CALL-UP CAPABILITY

FLUSH-MOUNTED OPERATIONAL AND ADMINISTRATIVE TELEPHONE SELECTORS

NAVID STATUS PANEL

TYPEWRITER STAND LOGICALLY PLACED

STORAGE AREA IMMEDIATELY AVAILABLE TO THE SUPERVISOR FOR CHARTS, REFERENCE BOOKS, AND ADMINISTRATIVE RECORDS

ASO-500 (CONTINUED)

MIAMI TOWER

DESIGN: STRAIGHT-LINE FOR TWO SUPERVISORS' POSITIONS. DESIGN BY FACILITY.

DIMENSIONS:	CONSOLE	TURRET	WORK AREA
HEIGHT	52"	14"	32.5"
WIDTH	32"	10"	18.5"
LENGTH	14'	21"	57" (EACH POSITION)

LIGHTING:

EQUIPMENT: TELCO 301-A INCLUDES ONE DESK TOP CALL DIRECTOR
(NOTE: OTHER PHONES LOCATED ON WALL)

TAMPA

DESIGN: CREDENZE (GAVE SKETCH OF PROPOSED TRACON ROOM LAYOUT)

ASW-500, SOUTHWEST REGION

GENERAL: DO NOT STRONGLY ENDORSE THE DEVELOPMENT OF A STANDARD
CONSOLE; BETTER LEFT TO LOCAL OPTION.

SHAPE: "U" 3 PANELS

DIMENSIONS:	CONSOLE*	TURRET	WORK AREA
HEIGHT	46"	15"	31"
WIDTH	38"	20"	18"
LENGTH	NOT GIVEN	ACROSS EACH PANEL	EACH PANEL
	*NOT ELEVATED	4" SHELF ON TOP	

LIGHTING: NO RECOMMENDATIONS

EQUIPMENT: 301A SYSTEM WITH SPEAKER MONITOR ALL TRACON POSITIONS
CONRAC MONITOR
DIGITAL CLOCK
RVR
ARTS KEYBOARD
TIPS/WEATHER CRT WITH ASSOCIATED KEYBOARD
OUTSIDE TELEPHONES
TYPEWRITER
STORAGE, FILES, ETC.

DESIGN BETTER LEFT TO LOCAL OPTION BECUASE OF THE MANY VARIED
CIRCUMSTANCES

AGL-500, GREAT LAKES REGION

SHAPE: "U," THREE PANELS

DIMENSIONS:	CONSOLE		TURRET	WORK AREA
	FRONT	SIDES		
HEIGHT	42.5"	42.5"	13"	29.5"
WIDTH	37"	37"	18.5"	18.5"
LENGTH	10' 1-9/16"	44-3/4"	ALL SIDES	ALL SIDES

LIGHTING: OVERHEAD TRACK LIGHT CAUSES SOME SHADOWS.

EQUIPMENT: NO LIST GIVEN

AWE-510, WESTERN REGION

SHAPE: ONE STANDARD CONSOLE SIZE MAY NOT BE APPROPRIATE FOR
LEVELS OF TRACONS

AWE-510, WESTERN REGION

SHAPE: NOT SUGGESTED

DIMENSIONS: ONE STANDARD CONSOLE SIZE MAY NOT BE APPROPRIATE FOR
ALL LEVELS OF TRACONS. SUGGEST DIFFERENT SIZE
CONSOLS FOR VARIOUS SIZES OF OPERATION ROOMS.

LIGHTING: NO RECOMMENDATIONS

EQUIPMENT: NAVAID MONITOR PANEL
BRITE CONTROL PANEL
BRITE MONITOR DISPLAY
COMMUNICATIONS SWITCHING PANEL
RECORDER ALARM AND POSITION RECORD CAPABILITY
PHONES - ADMINISTRATIVE AND OPERATION PLUS EMERGENCY
WEATHER AND STATUS DISPLAY
SPACE FOR REFERENCE MATERIAL - E BINDER, AIRPORT
LOCATOR FILE, ETC.

WOULD PARTICIPATE IN EVALUATION OF "STANDARD" CONSOLE.

TRACON SUPERVISOR'S DESKS EVALUATED DURING THE SEMINAR WORKSHOP

by Michael J. Massimino, ACT-210

There were six different concepts of TRACON supervisor's desks evaluated during the seminar workshop. Workshop results and recommendations were reported to the group by the committee spokesman at the final seminar meeting and forum.

Desk No. 1 (figures 8 and 9) was a standard metal office desk with a single pedestal on one side and a typewriter table extension on the other side, forming an "L." A bookshelf and two file shelves were mounted on the side wall above the typewriter table. The desk, which was evaluated during the seminar workshop, had a two-drawer file cabinet added next to the pedestal, level with the desk top. An equipment turret, extending the full length of the desk, and cabinet was placed on the desk, and a full length lighting fixture was designed and installed to illuminate the turret panel and desk surface. A light was also installed under the wall file rack above the typewriter position. All lighting was of controllable intensity.

Desk No. 2 (figures 10 and 11) was designed by Bradley Tower personnel to meet their specific requirements and space limitations. Unique features of the desk were the "V" or wing-shape design, the built-in rack for a 12-inch CONRAC radar monitor display, and the sliding typewriter shelf which allowed the space below it to be used for storage.

Desk No. 3 (figures 12 and 13) was an all-metal formica covered desk and typewriter table in an "L" shape. The Technical Center project personnel designed and installed controllable intensity fluorescent lights above the turret and typewriter position.

Desk No. 4 (figures 14 and 15) was a pair of "L" shape desks with a center passageway for a two-person supervisory area. The desk was made of inexpensive Foamcor material for concept evaluation.

Desk No. 5 (figures 16 and 17) was a large "U" shape, designed and constructed for test and evaluation purposes in the Technical Center laboratory. Various arrangements of equipment on the panel will be investigated. Lighting techniques and equipment installation methods will be examined.

Desk No. 6 (figures 18 and 19) was a duplicate of a desk designed and built at the Technical Center and installed in the Colorado Springs TRACON. The original "L" shape design with nonglare and nonreflective lighting concealed under the edge of the top shelf was designed at the Technical Center to meet a unique space requirement in the Denver TRACON where it was installed in 1979.

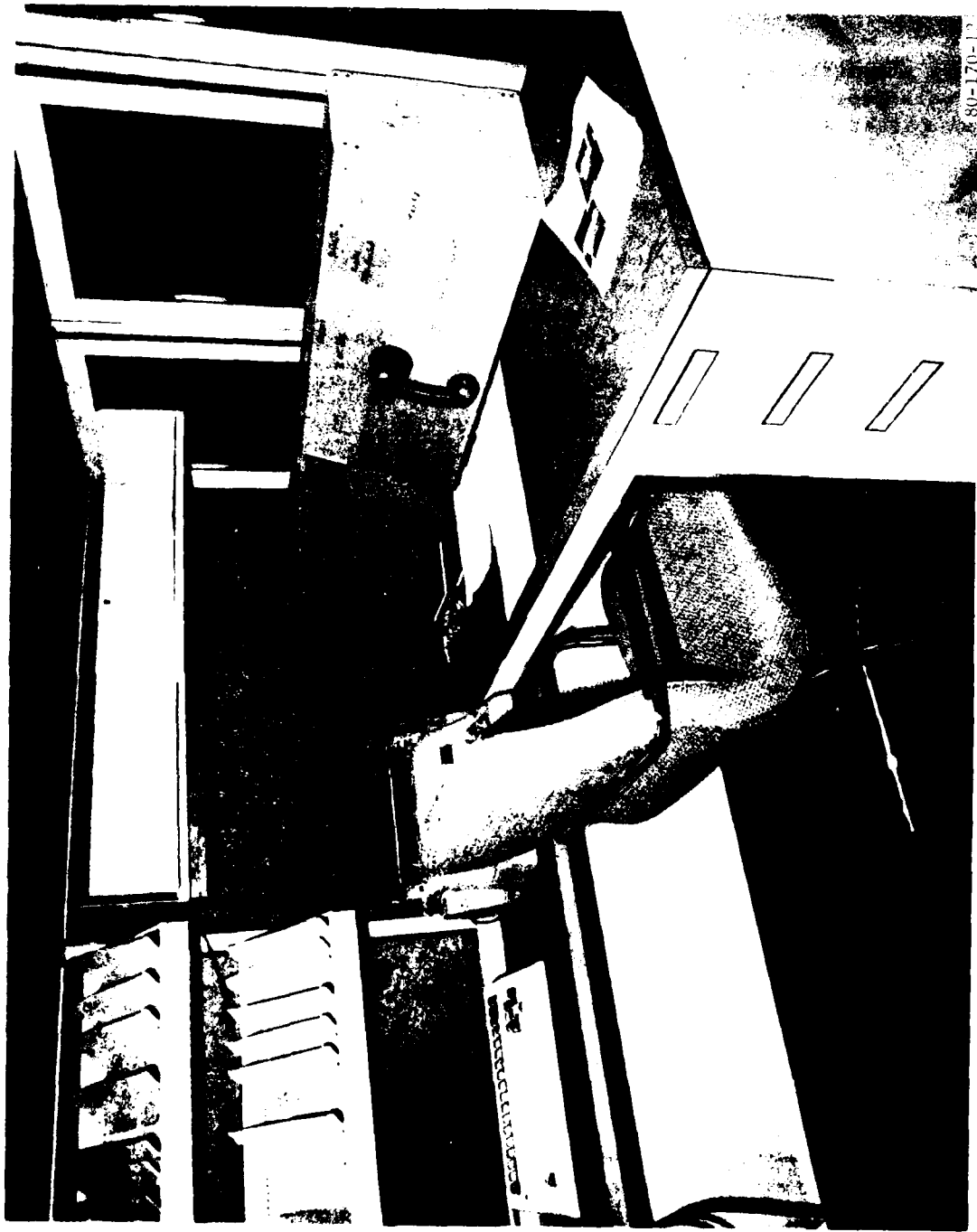

FIGURE 8. STANDARD METAL OFFICE DESK

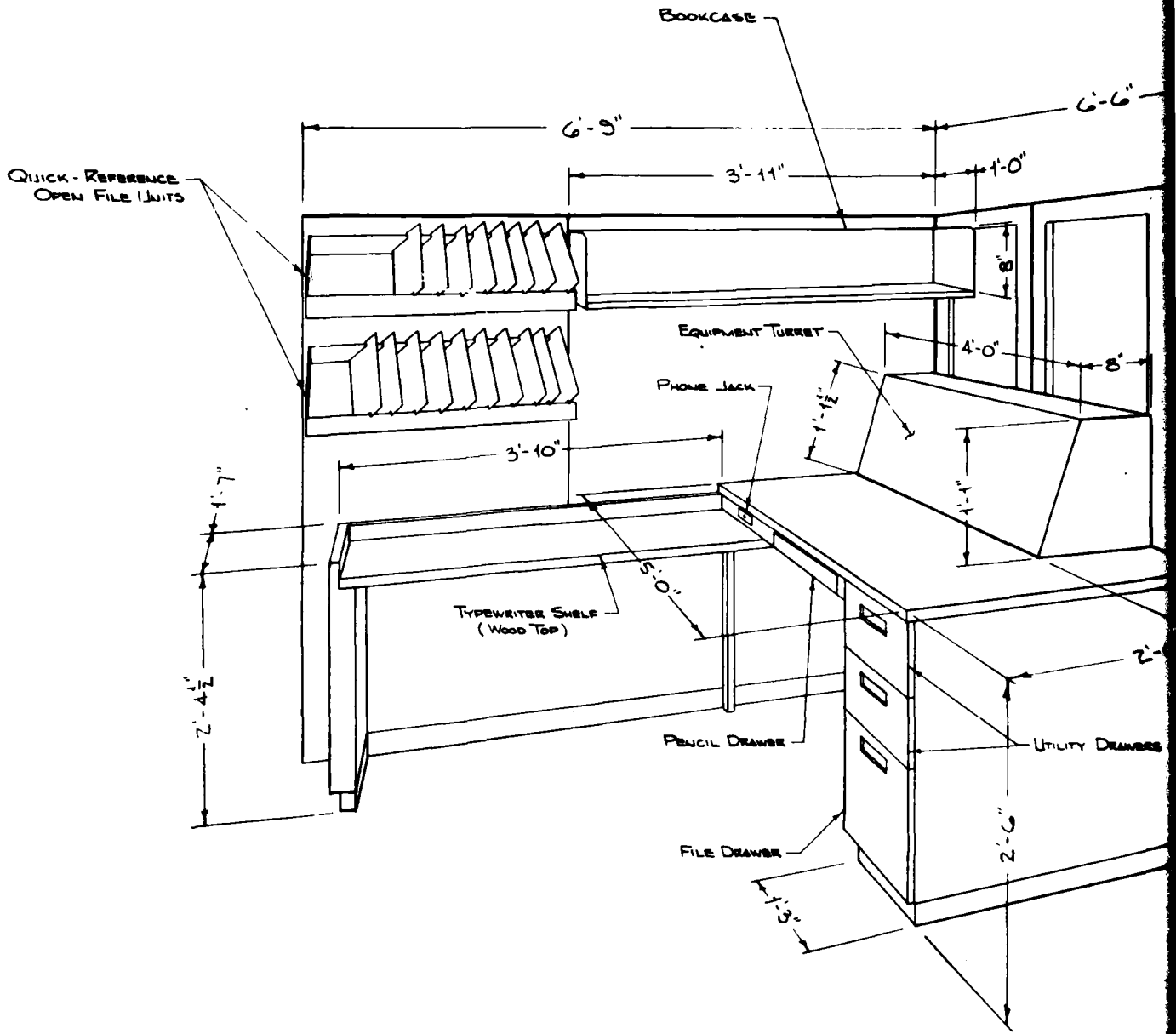
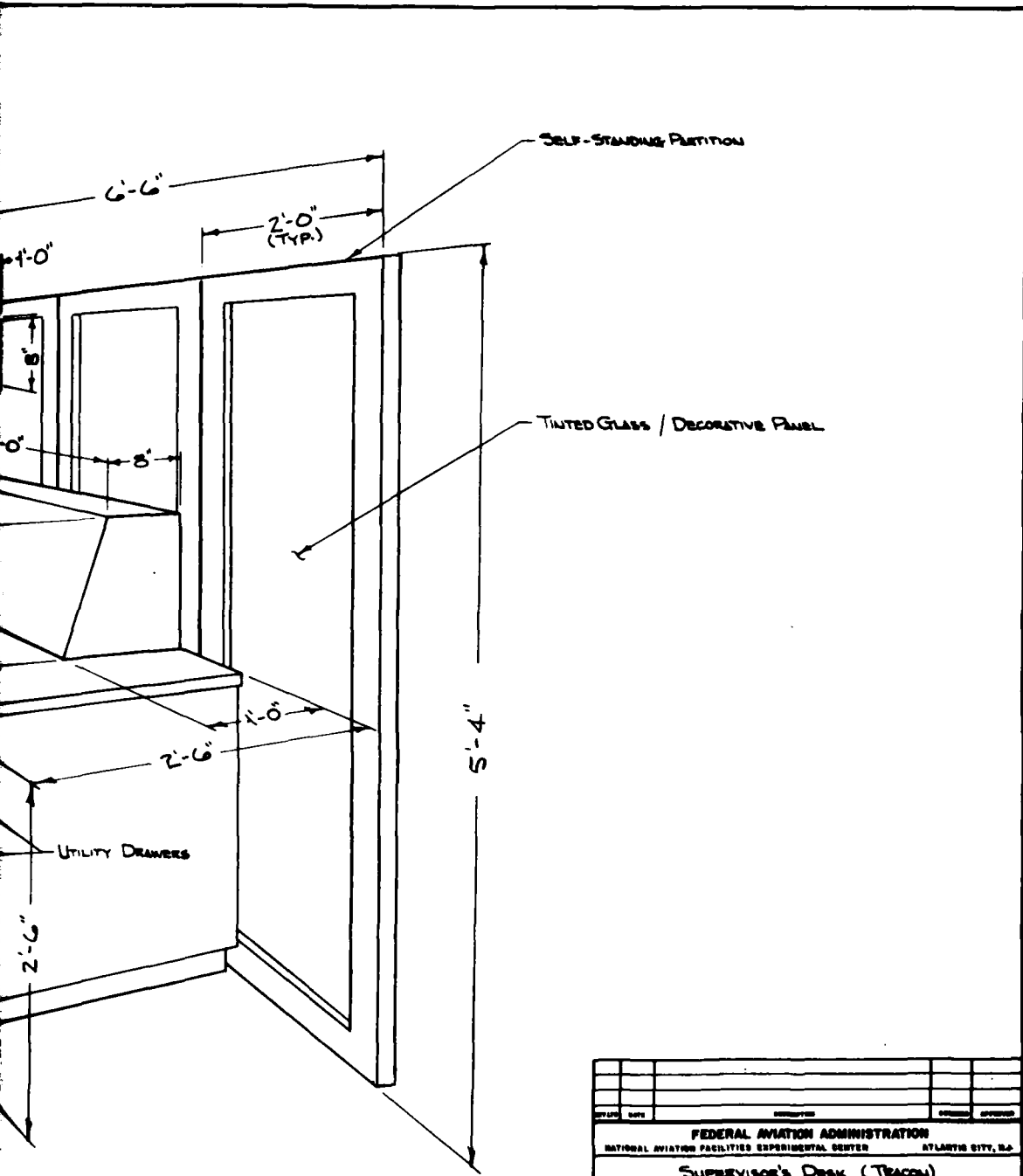

FIGURE 9. SCHEMATIC OF STANDARD METAL OFFICE



SCALE: NONE

80-170-13

REVISED	DATE	BY	REASON
FEDERAL AVIATION ADMINISTRATION NATIONAL AVIATION FACILITIES EXPERIMENTAL CENTER ATLANTIC CITY, N.J.			
SUPERVISOR'S DESK (TRACON) BRADLEY CORNER MODULAR CONCEPT PICTORIAL			
DESIGNED BY	APPROVED BY	DATE	
ANA-210	<i>John W. Sweeney</i> John W. Sweeney	11-6-79	

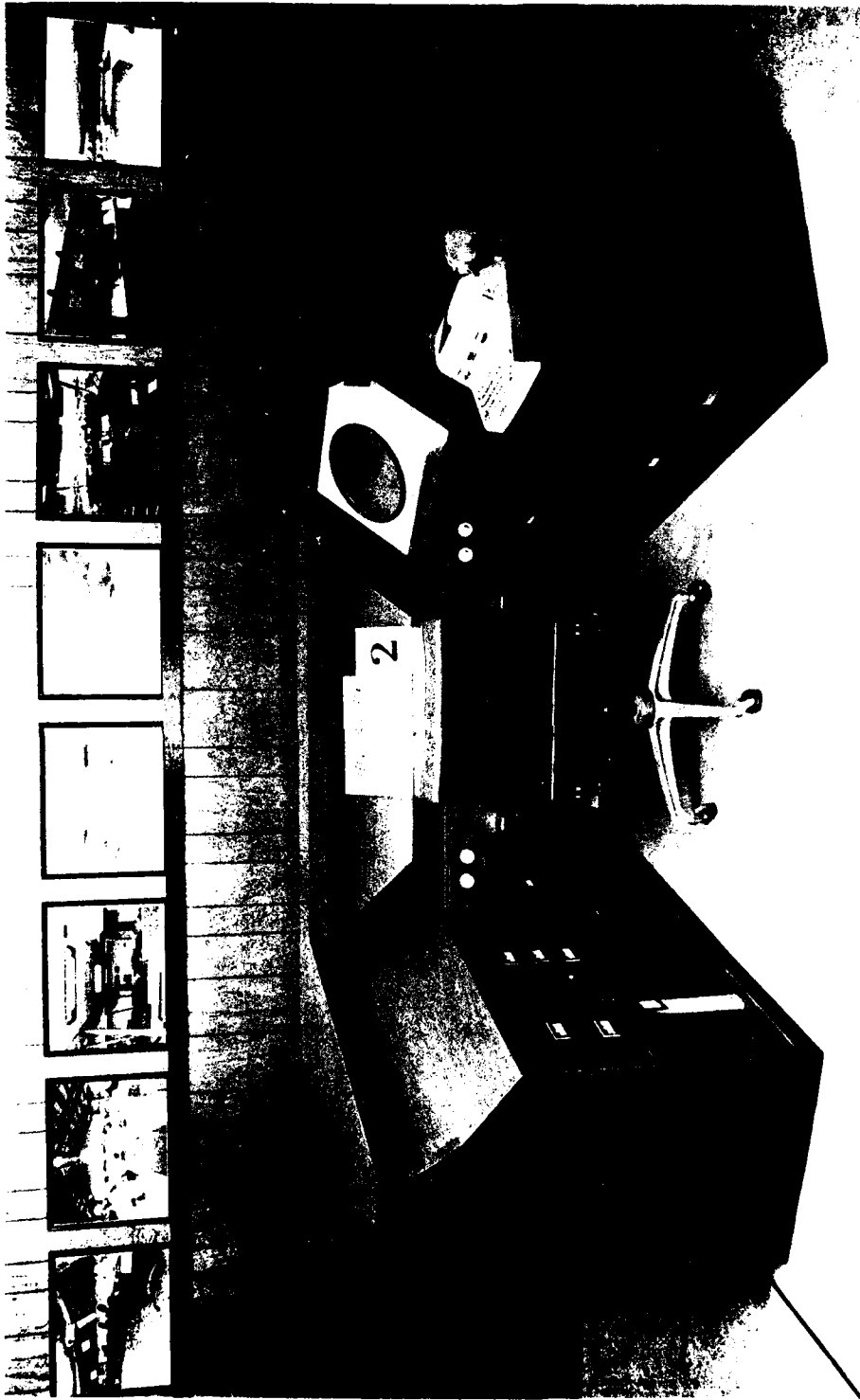

80-170-14

FIGURE 10. BRADLEY TRACON "WING" SHAPE DESK

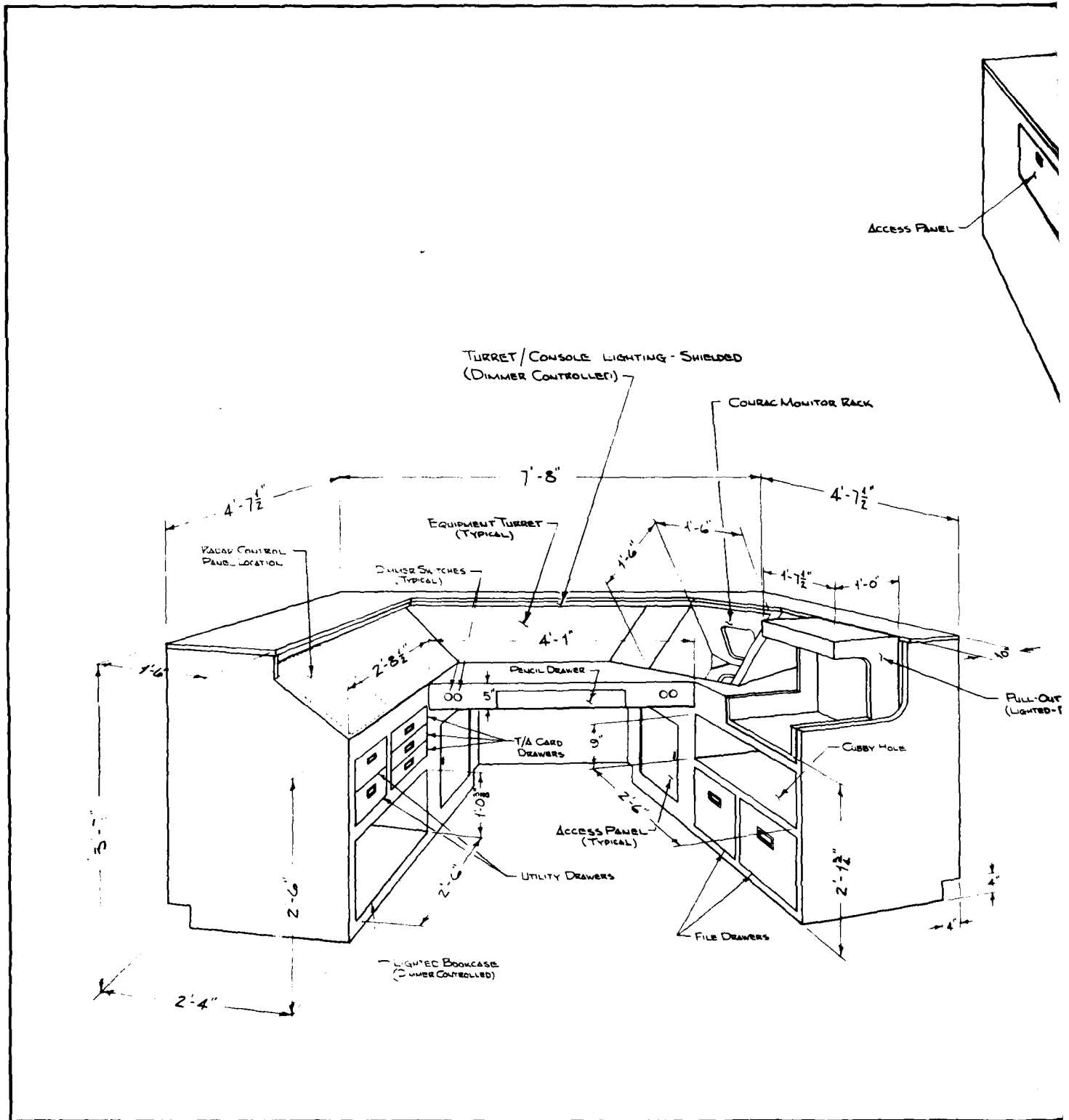
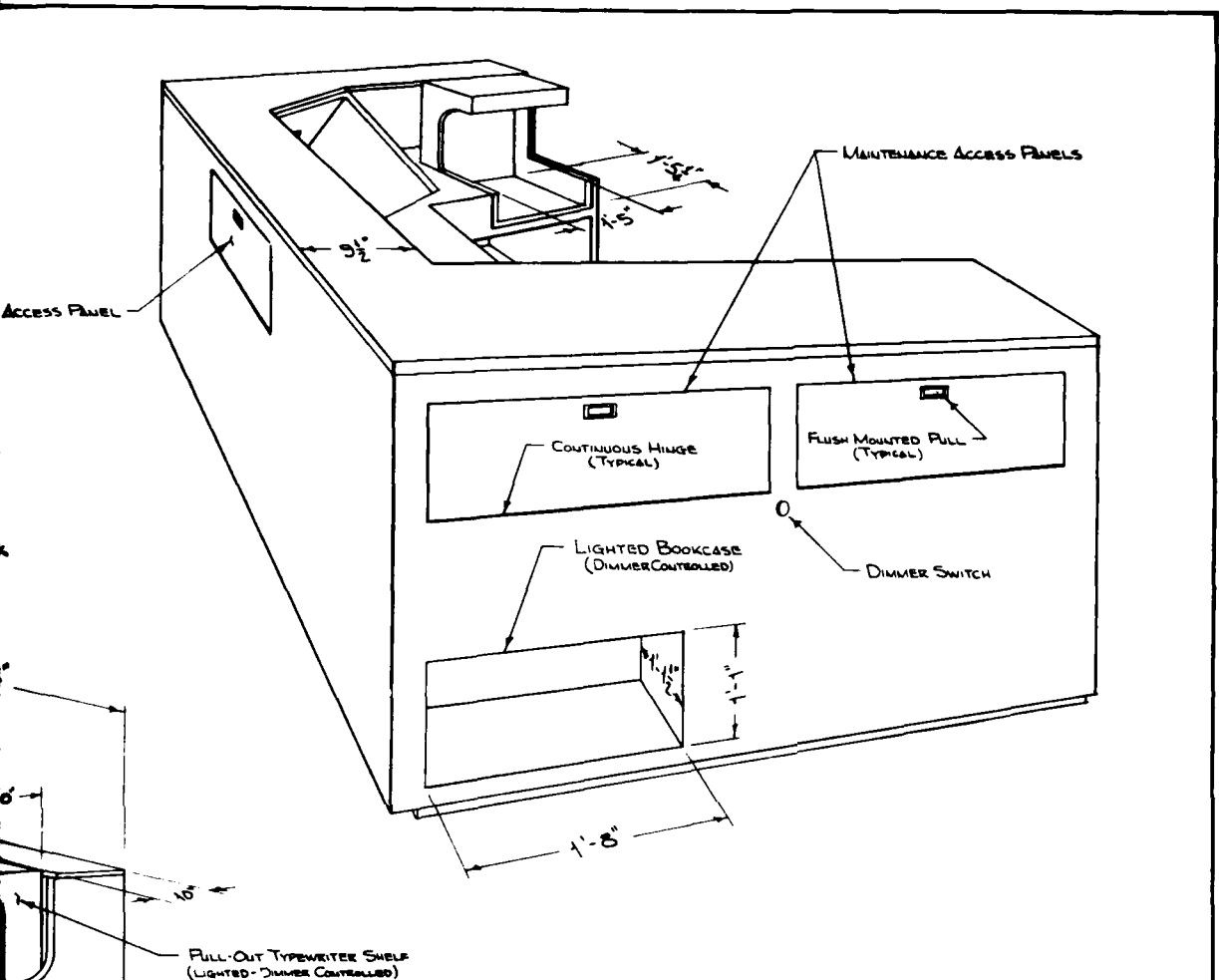

FIGURE 11. SCHEMATIC OF BRADLEY TRACON WING

1

2

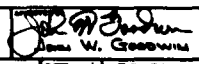

SCALE: NONE

REVISED BY	DATE	DESCRIPTION	DESIGNED	APPROVED
FEDERAL AVIATION ADMINISTRATION NATIONAL AVIATION FACILITIES EXPERIMENTAL CENTER ATLANTIC CITY, N.J.				
SUPERVISOR'S DESK (TRACON) WINDSOR LOCKS CONCEPT PICTORIAL				
DESIGNED BY	PROJECT NO.	DATE	 JOHN W. GOODWIN	
DATE OF COMPLETION	PROJECT NO.	DATE	11-20-75 XD-5028	

80-170-15

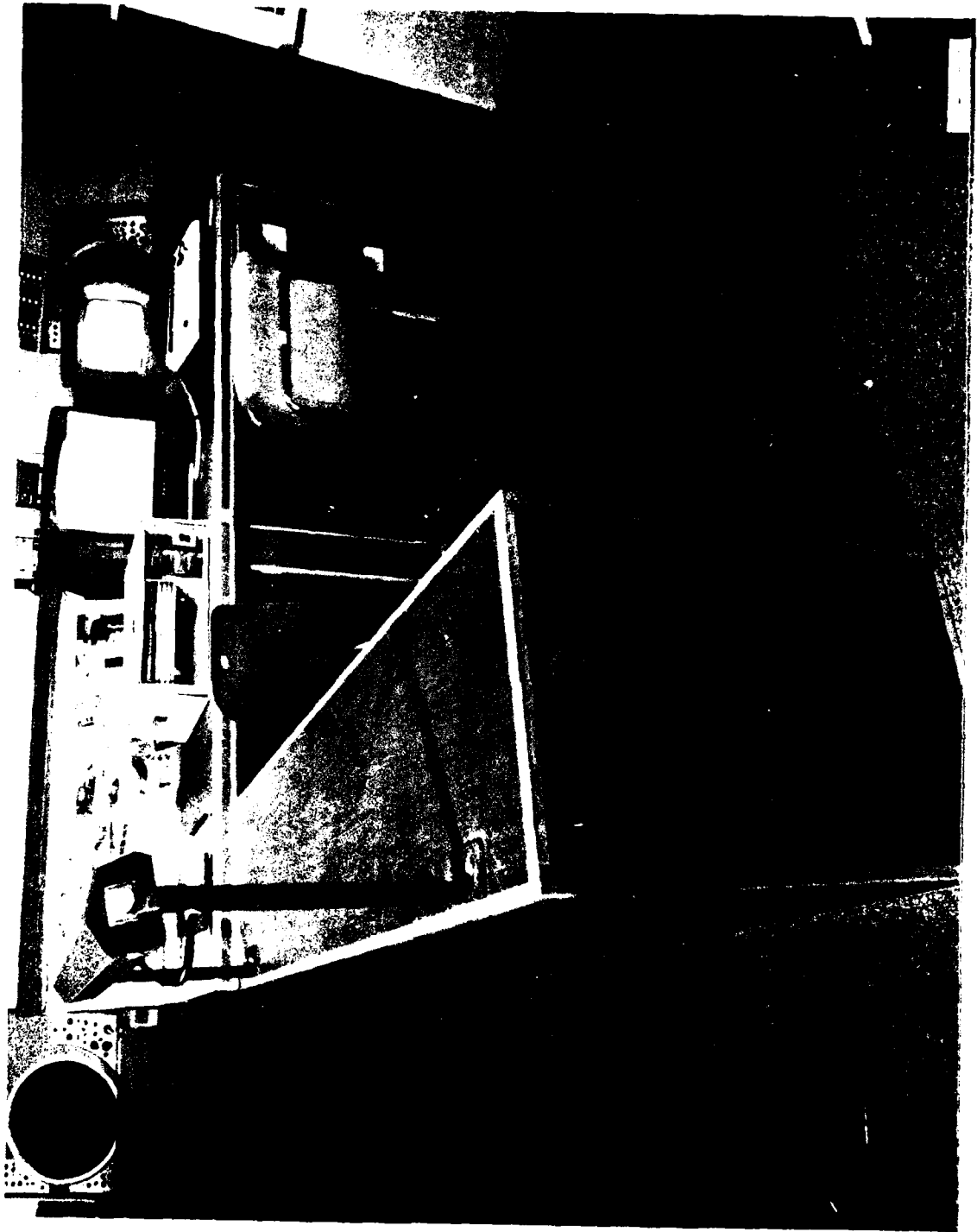

FIGURE 12. ALL METAL "L" SHAPE DESK

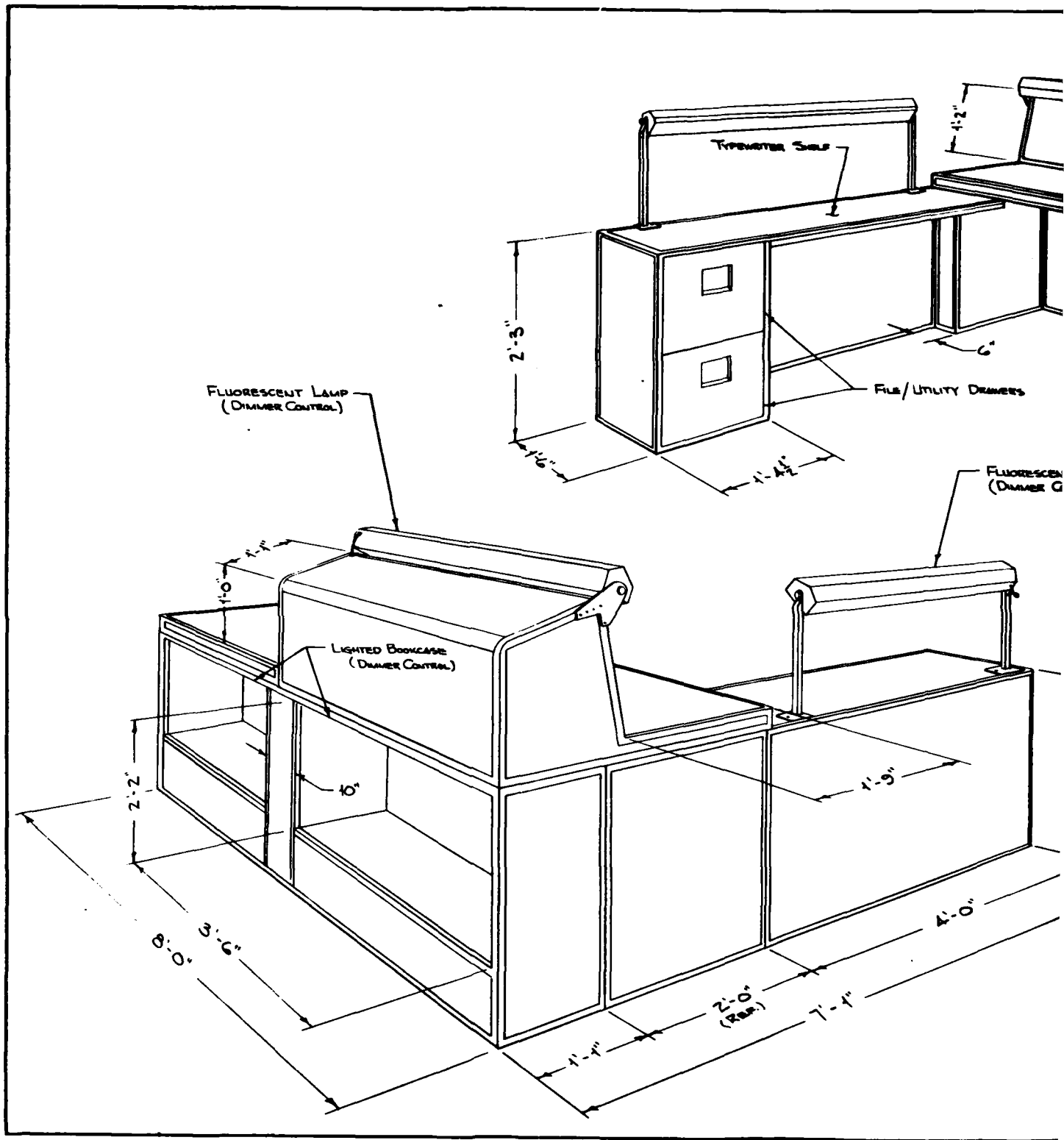
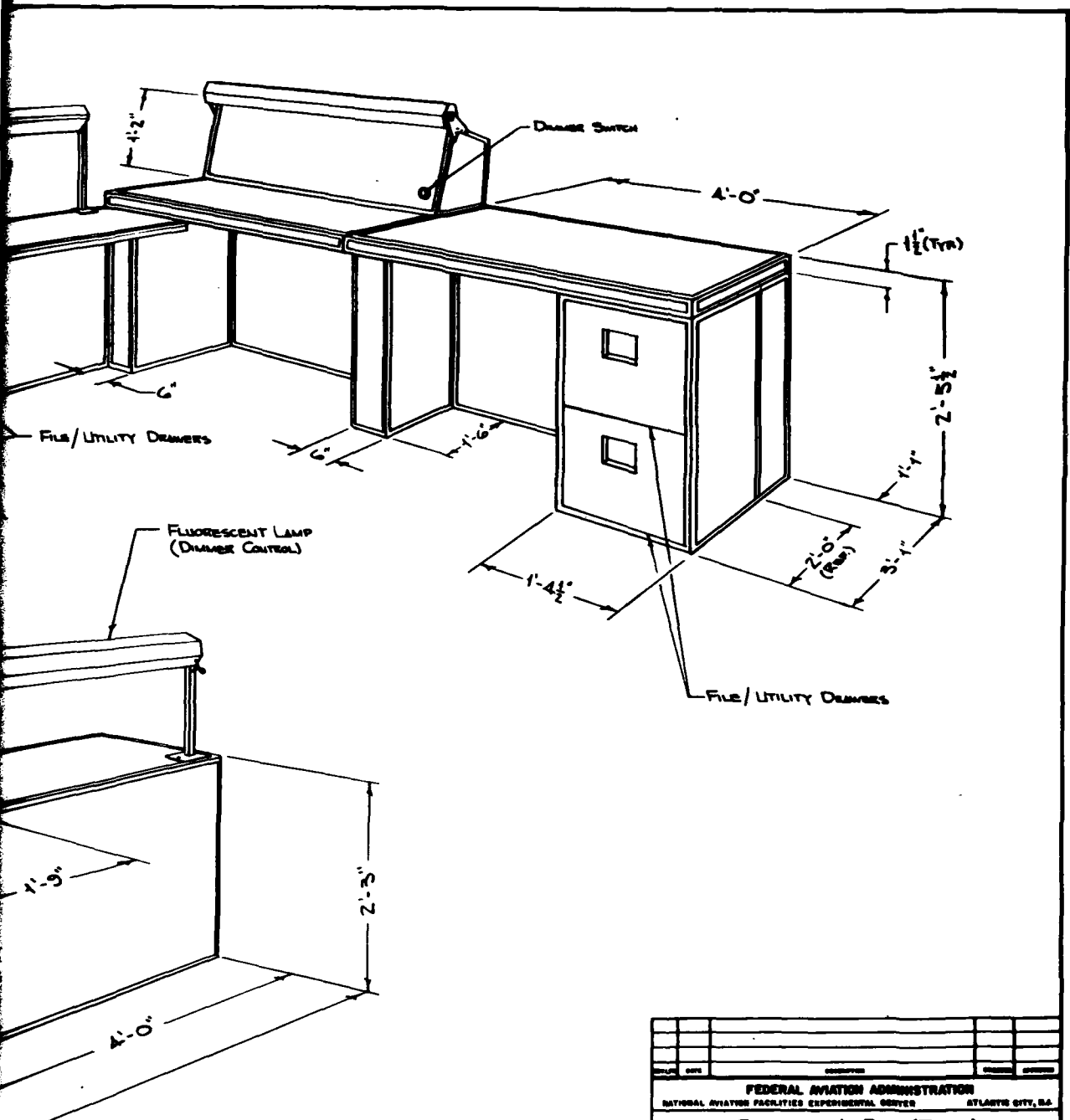

FIGURE 13. SCHEMATIC OF ALL METAL "L" SHA



SCALE: None

NO.	DATE	DESCRIPTION	BY	APPROVED
FEDERAL AVIATION ADMINISTRATION <small>NATIONAL AVIATION FACILITIES EXPERIMENTAL CENTER ATLANTA CITY, GA.</small>				
SUPERVISOR'S DESK (TRACOU) DORLEC/FORMICA MODULAR CONCEPT PICTORIAL				
DESIGNED BY	APPROVED BY	 James W. Goodwin		
NO. 80-170-17	NO. ANA-210	NO. ANA-63B	DATE 11-2-79	NO. XD-3022

OF ALL METAL "L" SHAPE DESK

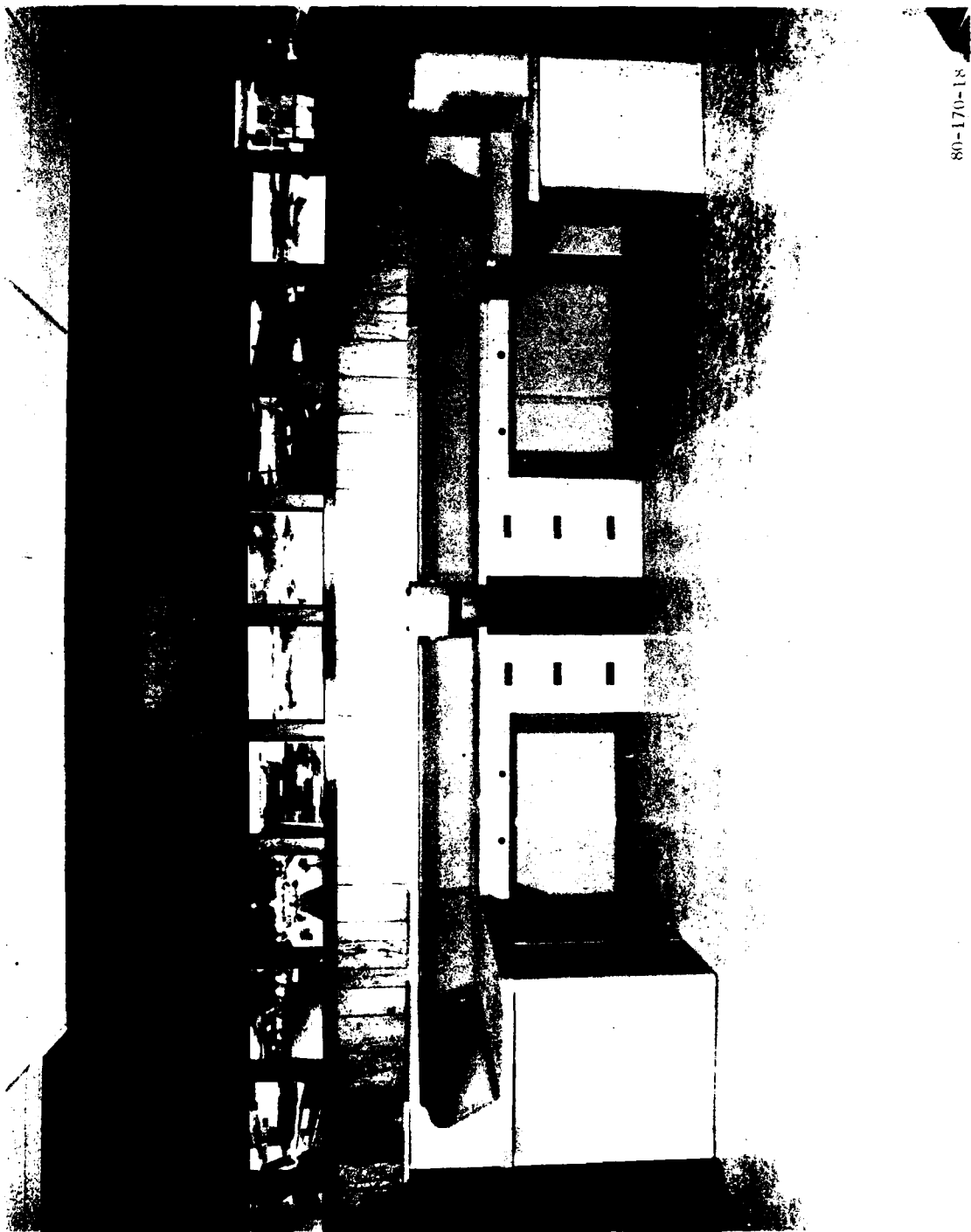

80-170-18

FIGURE 14. PAIR OF "L" SHAPE DESKS

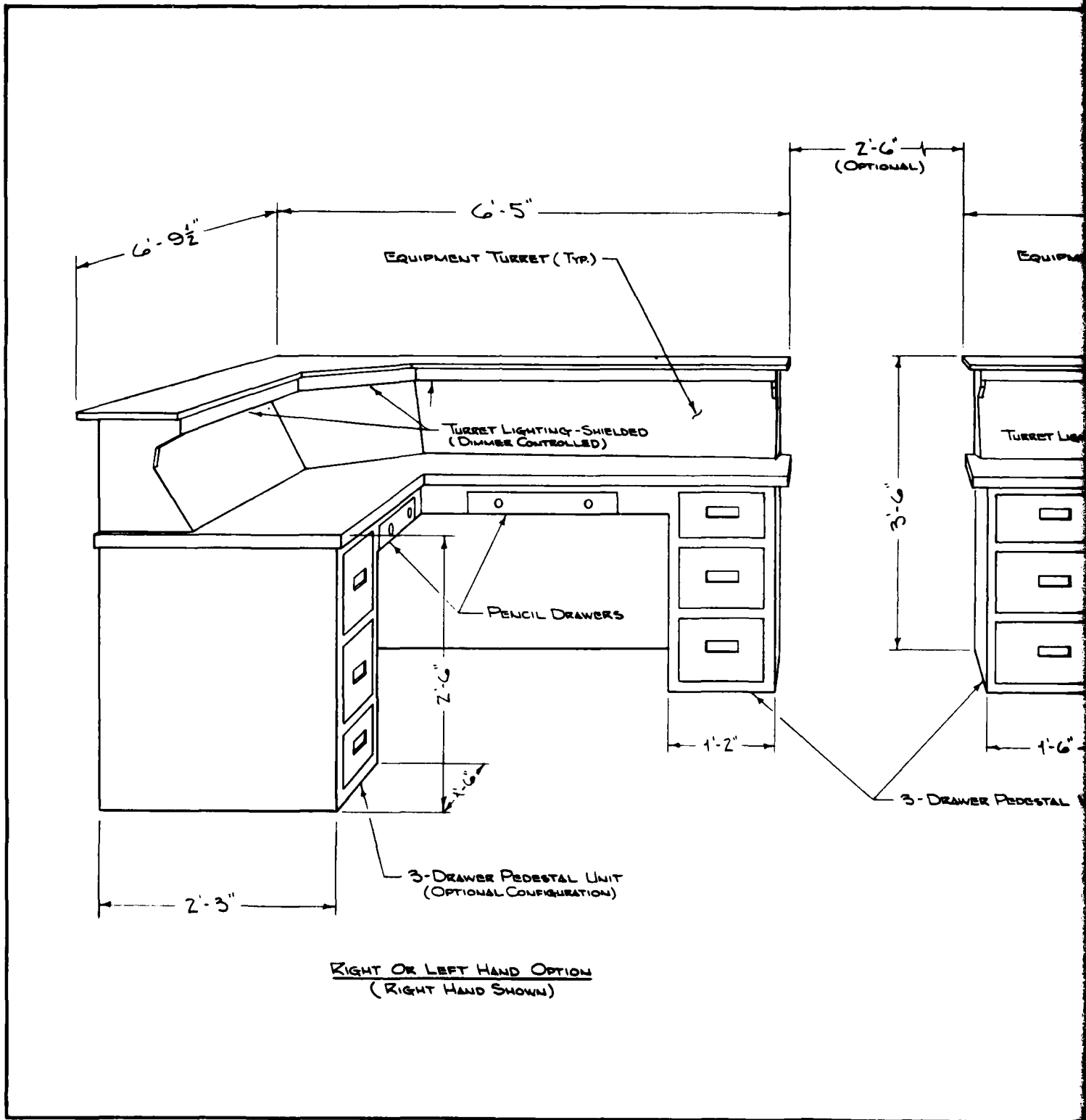
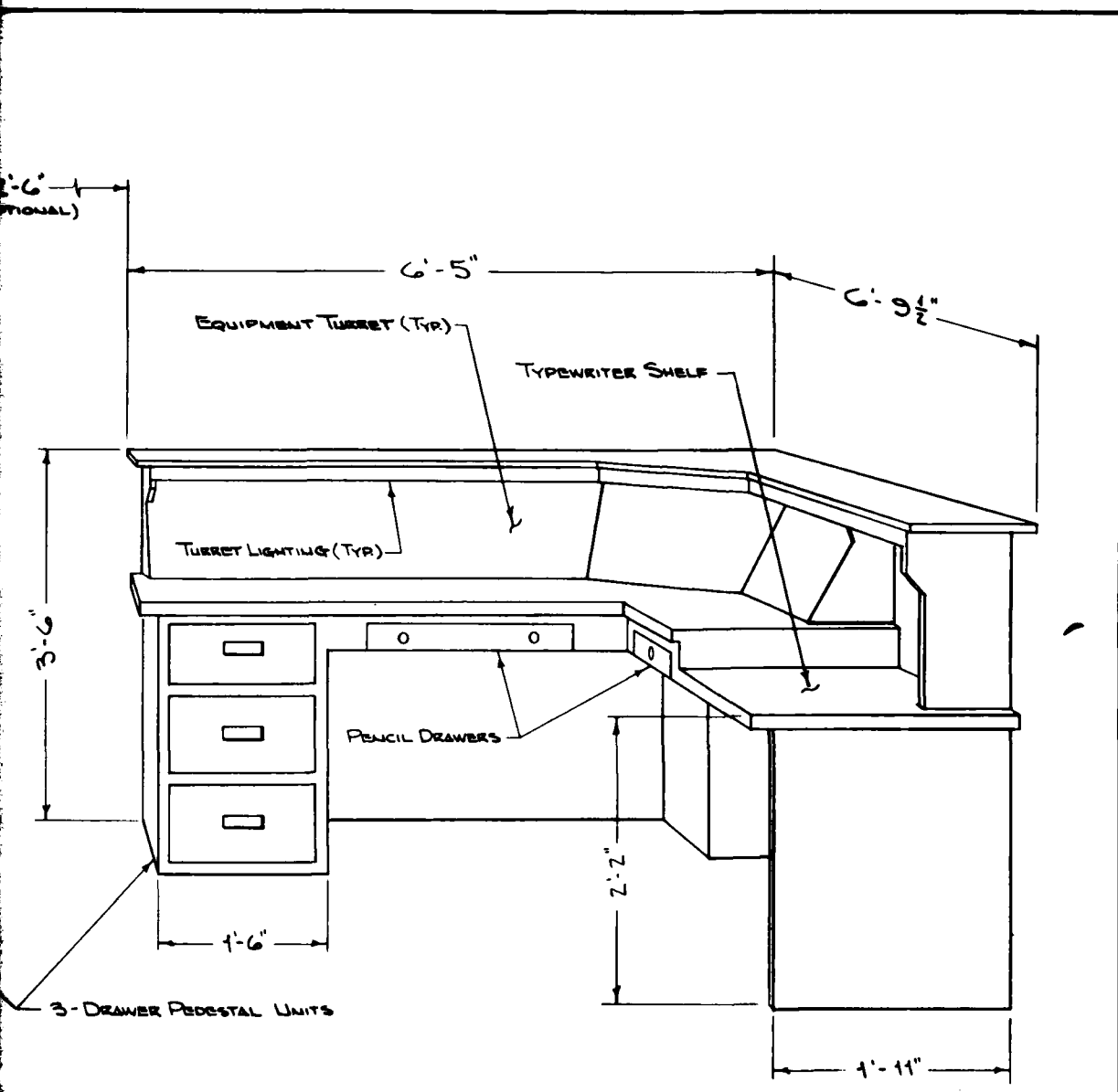

FIGURE 15. SCHEMATIC OF PAIR OF "L" SHAPE DESKS

1

2



RIGHT OR LEFT HAND OPTION
(RIGHT HAND SHOWN)

SCALE: NONE

80-170-19

REVISED	DATE	REVISIONS	REVISED	DATE
FEDERAL AVIATION ADMINISTRATION				
NATIONAL AVIATION FACILITIES EXPERIMENTAL CENTER ATLANTA CITY, GA				
SUPERVISOR'S DESK (TRACON)				
DOUBLE 'L' (SPLIT TYPE) CONCEPT				
PICTORIAL				
DESIGNED BY	DEVELOPED BY	PROJECT NO.	DATE	DRAWN BY
	ANA-210		41-9-19	James W. Greenwald
	ANA-698		XO-8024	

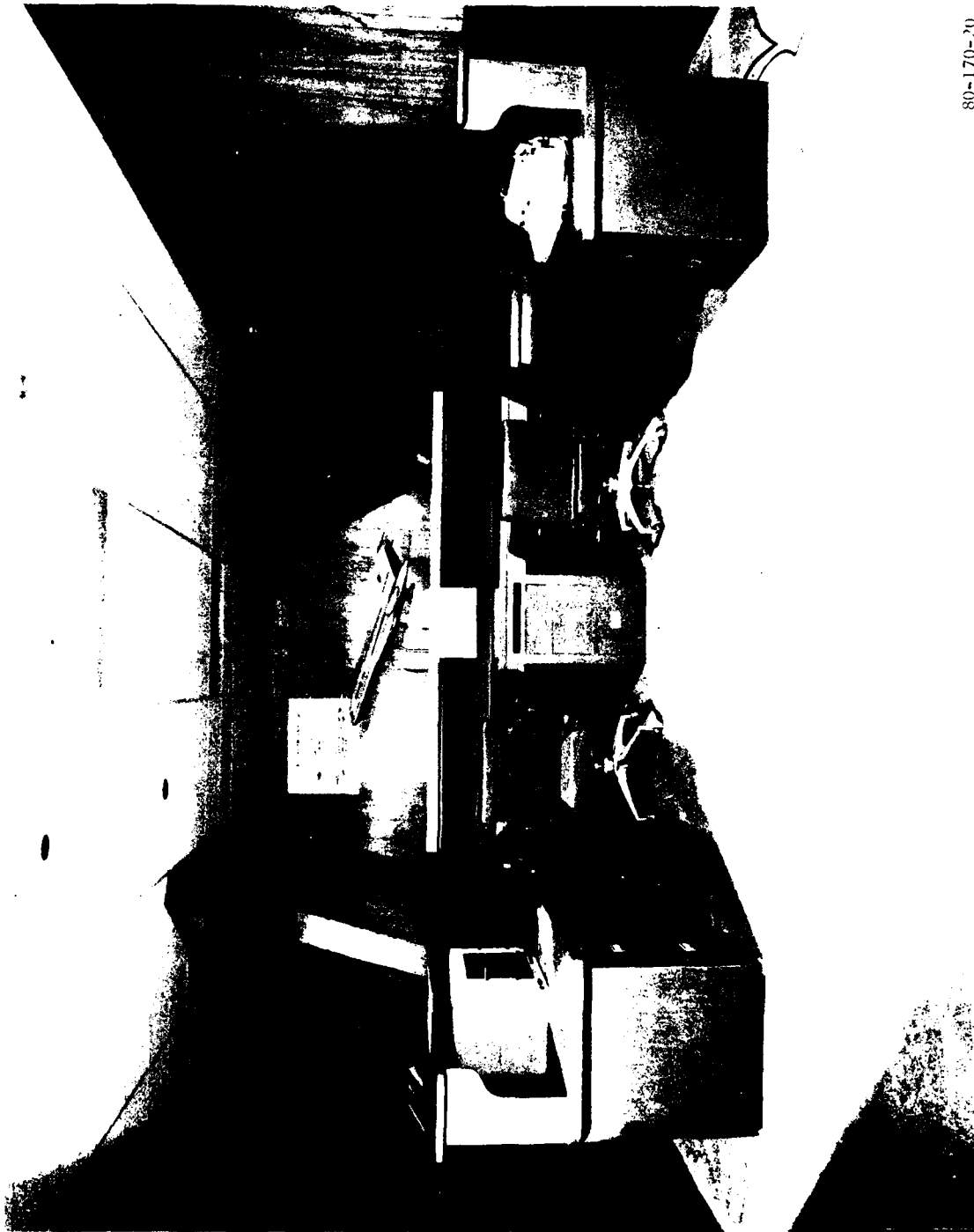

80-170-20

FIGURE 16. LARGE "U" SHAPE DESK

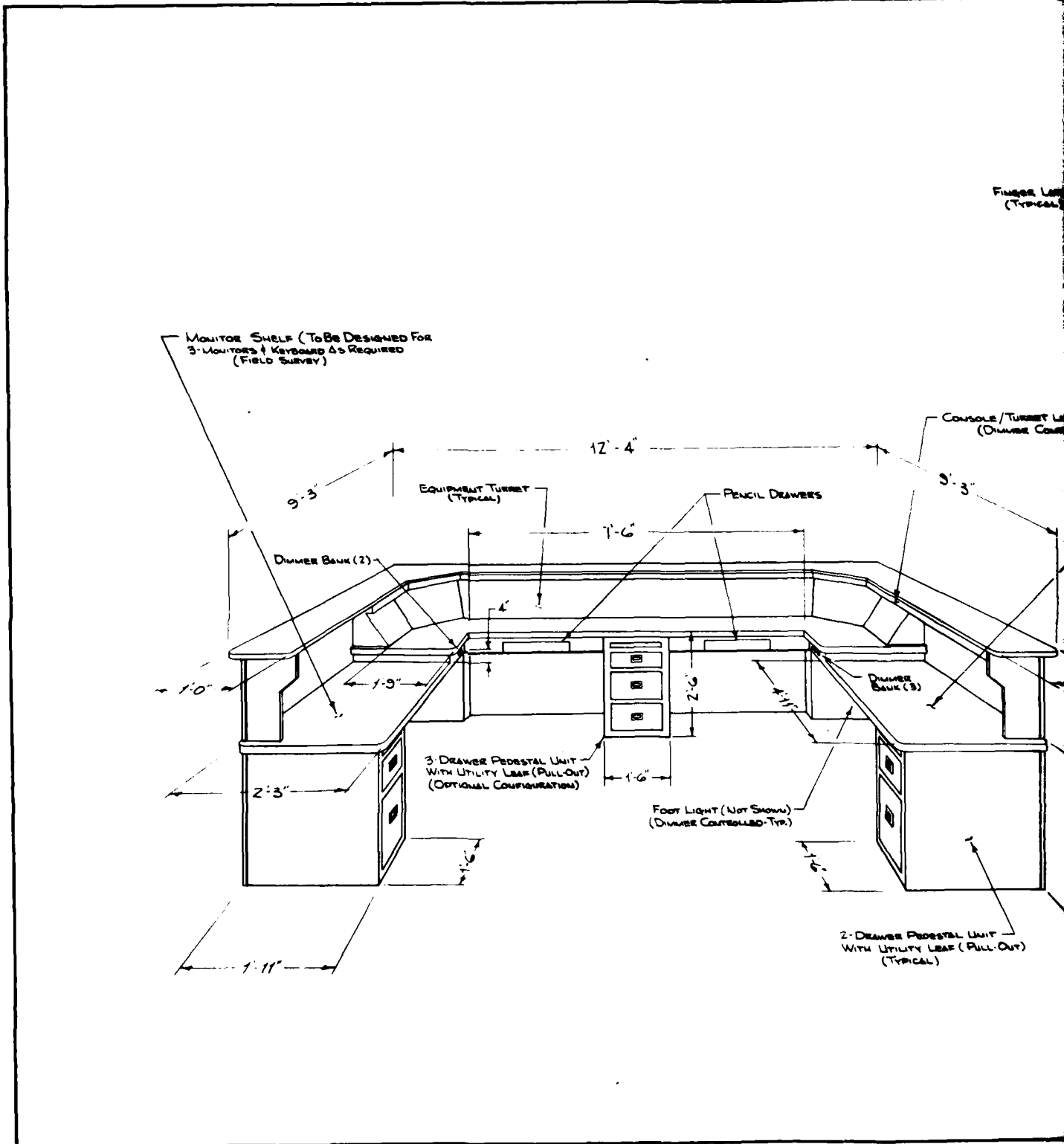
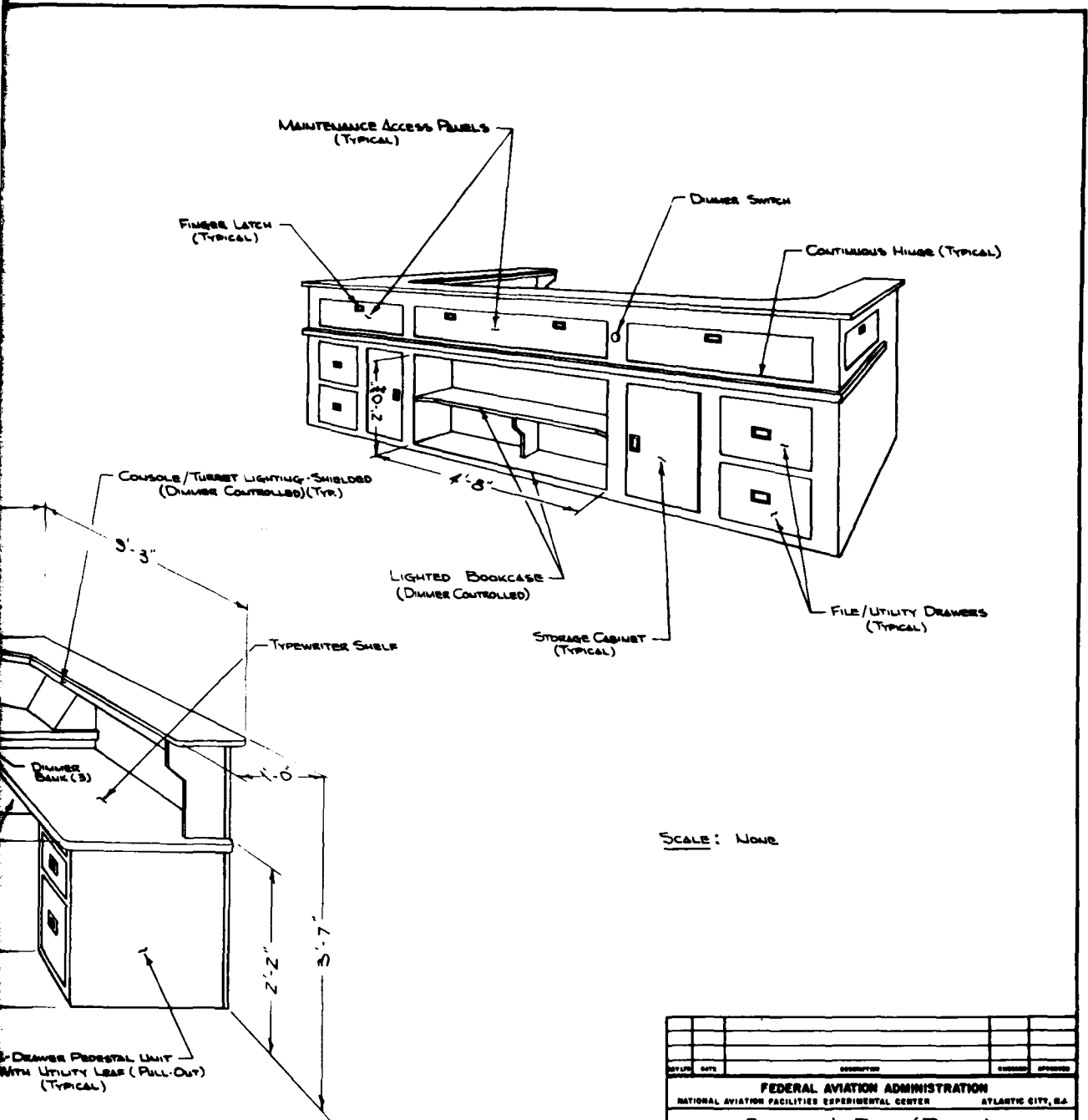

FIGURE 17. SCHEMATIC OF LARGE "U" SHAPE D

1

2



SCALE: None

80-170-21

REVISED	DATE	DESCRIPTION	DESIGNED	APPROVED
FEDERAL AVIATION ADMINISTRATION NATIONAL AVIATION FACILITIES EXPERIMENTAL CENTER ATLANTIC CITY, N.J.				
SUPERVISOR'S DESK (TRACON) TWO-POSITION 'FUTURAMA' CONCEPT (MODEL # 1) PICTORIAL				
DESIGNED BY	ANA-210		 JOHN W. GOODWIN	
DESIGNED BY	ANA-63B	DATE	11-19-72	
		NUMBER	XD-3027	

OF LARGE "U" SHAPE DESK



FIGURE 18. REPLICATE OF COLORADO SPRINGS "L" SHAPE DESK

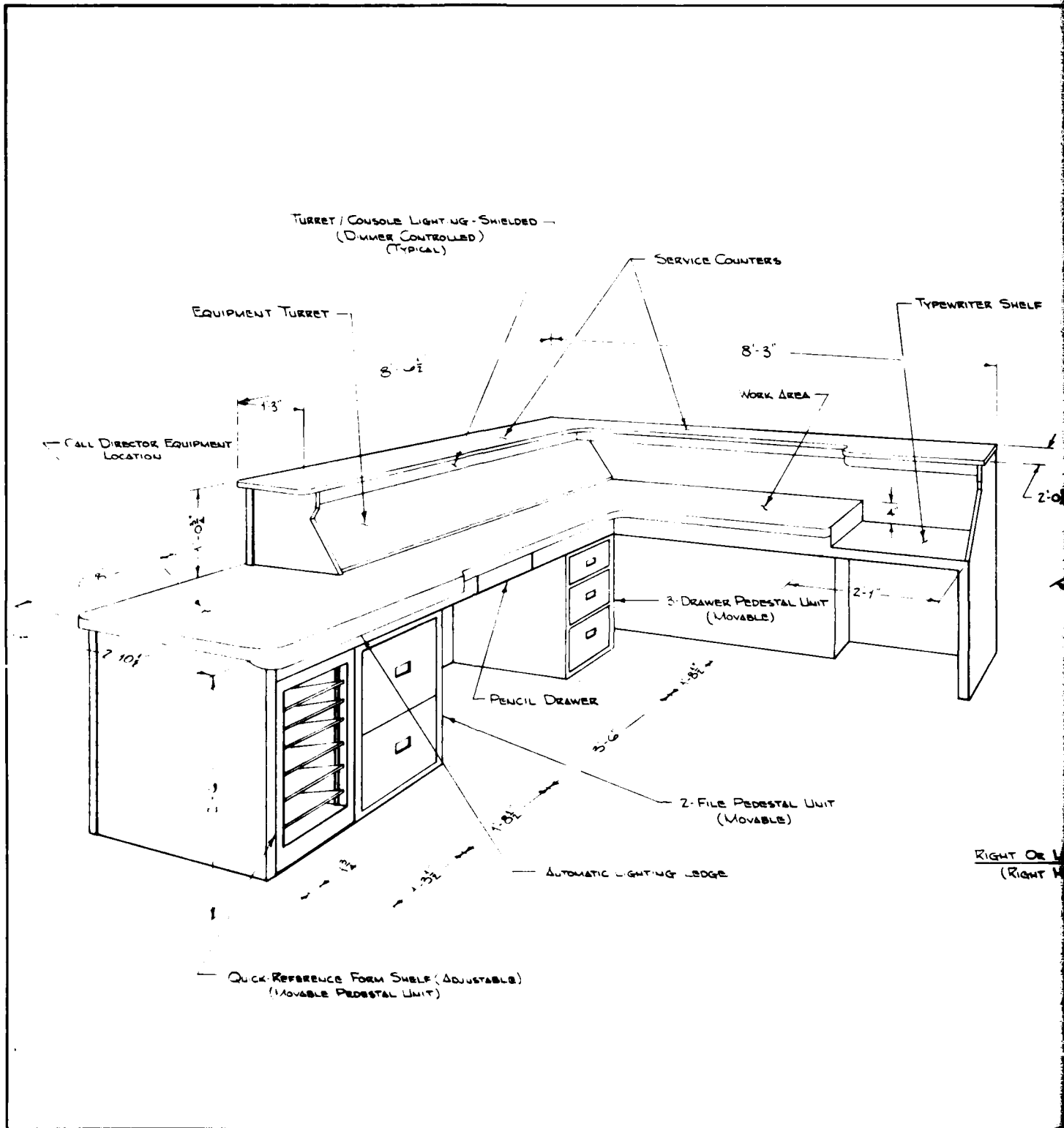
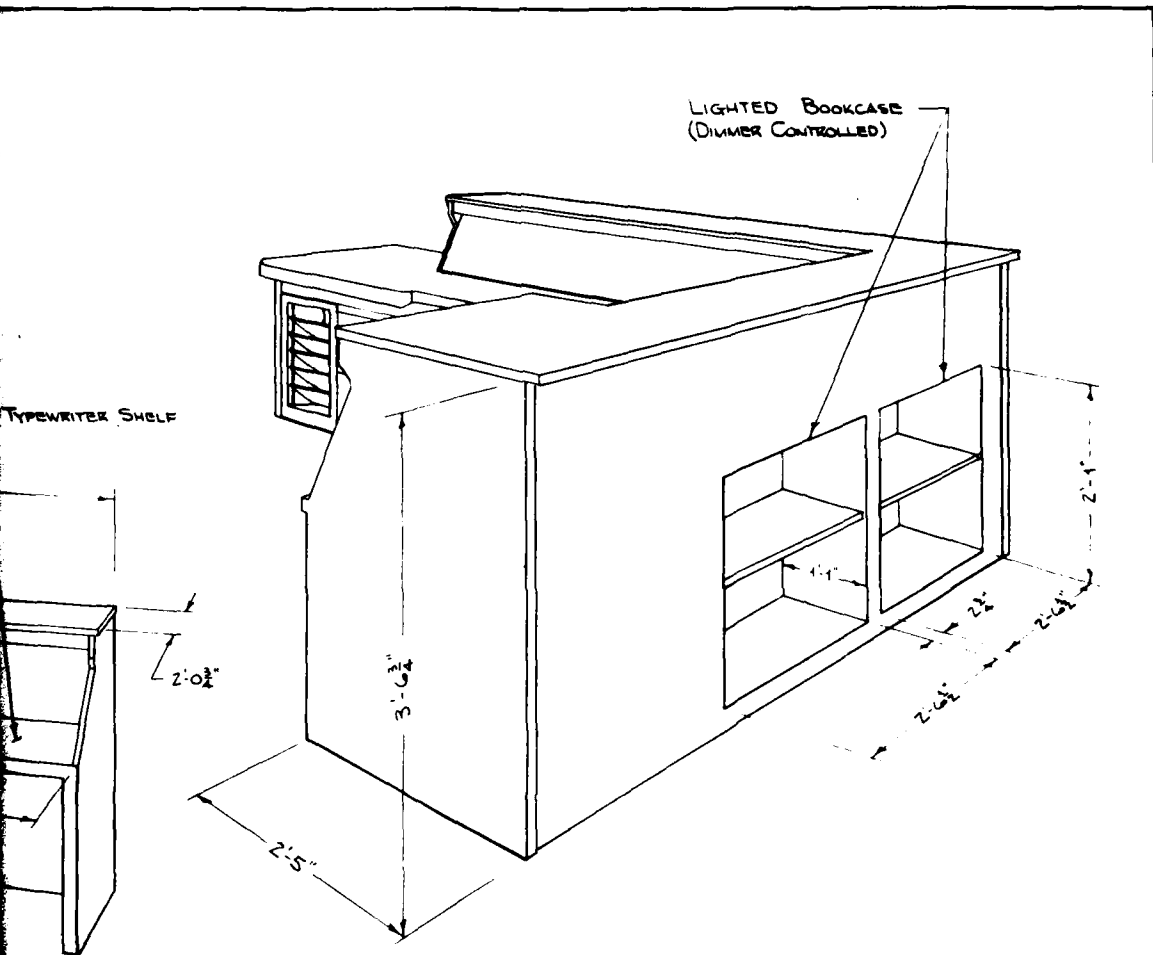

FIGURE 19. SCHEMATIC OF COLORADO SPRINGS "L" S

2



RIGHT OR LEFT HAND OPTION
(RIGHT HAND SHOWN)

SCALE: None

REV	DATE	DESCRIPTION	DESIGNED	APPROVED
FEDERAL AVIATION ADMINISTRATION NATIONAL AVIATION FACILITIES EXPERIMENTAL CENTER ATLANTIC CITY, N.J.				
SUPERVISOR'S DESK (TRACON) 'L' SHAPE MODULAR CONCEPT PICTORIAL				
DESIGNED BY	APPROVED BY	DATE		
ANA-210	<i>James W. Goodwin</i>	11-14-75		

80-170-23

PRINGS "L" SHAPE DESK

AIRWAYS FACILITIES ENVIRONMENTAL REQUIREMENTS

by Joseph Morelli, AAF-510

These comments are based on the environmental requirements and apparently represent the only Airways Facilities viewpoint that is going to be here.

One of the first things the Technical Center has to do is establish minimum and maximum sizes of the supervisor's console and work towards that. There is no sense in making the thing two feet bigger, if it cannot fit in the room. We want to know if we are going to have problems in that area. Also the height limitations have to be considered. For any of the configurations, we should be using the back wall which is standard. We do have a back wall at every supervisor's position, which is standard for those functions for which the supervisor does not have to maintain constant eye contact or over which he has to have constant control. Those generally include building functions and monitoring functions for equipment. Typically, you may find a fire alarm panel, a cycle lock controller for the TRACON, a front entrance release button, (which he monitors during nonadministrative hours), the TRACON room dimmer switch, TRACON thermostats, NAVAIID radar beacon monitor panels, equipment alarms, and some book storage. I think you have to establish the size and location of the underfloor ducts to this console so that we can have a clean layout. It is my feeling that task lighting in the console is an absolute requirement and there shouldn't be any debate.

Reviewing the various mockups, I feel that an equal leg, "L" shape and the "Wing" shape design seems to provide the most flexibility for the supervisory position, and that should provide a decent base to start.

I felt that plastic laminated plywood construction is highly recommended for the position. We should not consider total metal construction for this position.

I feel that the approach to noise control should be based on providing unintelligible speech patterns outside of the console area. That is a pretty difficult thing to say but it will certainly be impossible to mask all noise from the position. The minimum requirement should be that someone on a position should not be able to understand what the supervisor is saying on the phone or a conversation with other people.

I feel that there should be a small, flat top section of a turret only and slope the rest of the turret. If you keep it small, you can't pile too much material on it and if you keep it big, the possibility of piling material on it does increase.

I feel the base of the console should be recessed on the outside of the perimeter about 6 inches high and carpeted the same as the rest of the TRACON. That is to eliminate any of the drumming effect from kicking which is going to occur.

I feel that the console requirements should be based on the facility level. The way I see it now, there should be a level V supervisory console, a level IV console, a high and a low activity level III console, and a level II console. We are flexible as far as III, IV, V. There is some point where it gets too restrictive. Something in between is obviously required.

I'd like a sincere effort to keep backroom equipment in the backroom and not at the console. For example, locate the equipment controls at the console, but not the equipment. In my travels, I've seen large recorders at the supervisor's console, which could have been in the backroom. I feel that the console should have panels that are removable. I have two reasons for that. One, in good faith, we can install phone equipment in those panels and if there is no way we can remove those panels, due to the changing size of equipment, they become less suitable, as you lose the whole ambience of the equipment itself. The second thing is that people make mistakes when they cut things. You've seen it and I've seen it. The way it is now, it's either going to be a patch job or it's something your're going to have to live with. So, I think that a removable top provides more flexibility.

I think the sliding typewriter, which was in the "WING DESIGN" for Bradley field is excellent. I think that it provides usable space below the typewriter which you cannot have if the typewriter is fixed. It occurs to me that the typewriter should be either to the left or to the right of the supervisor in a fixed location.

We're going to establish a maximum height for the console so that we can see over it. I would tend to minimize the area where he doesn't have to see over. Thank you.

REMARKS AND THEME COMMENTS

by William Fraser, ARD-120

We have had a good chance to look at the consoles that have been built at the Technical Center lab. I think there has been a lot of constructive thought given to them. Perhaps not from a wider scope than what we would have liked to have had. It seems to me that we have one step further to go, and that is based on some of Joe Morelli's comments yesterday. We haven't investigated the one area behind the supervisory position that can be used for some of the things we need in order to keep from crowding too many things into the position itself. Joe mentioned that there are two facilities, Charlotte and Charleston, that have already done some of the things we might look at. So, Felix Hierbaum and his team might want to plan a trip to those facilities, take pictures, and gather information. Based on that, I think we can come up with an additional modular unit that we can put on the wall.

After we've taken the comments and recommendations that you gentlemen are going to come up with, perhaps we can go ahead and select, with Joe's concurrence, one of the new standard TRACON's that is in planning and go ahead and build that one for the facility. These are the thoughts that are coming up now, so I'd like to get together with Ed and Joe in Washington and go over these possibilities and come up with what might be the final plan.

Ultimately, we'll take your comments and put them into good use and come up with, what might be, that standard work station for the supervisor. That's all I have to say at this point. Thank you.

TRACON SUPERVISORY COMPLEX SEMINAR

SUPERVISORY DESK EVALUATION WORKSHOP

The purpose of the workshop is to provide you with the opportunity to examine and evaluate the desks in the laboratory and to develop your comments, suggestions, and recommendations for presentation to the entire group. The information you provide will be used for guidance in our future experimentation and development of the supervisory desk and other elements of the supervisory complex.

Four teams delineated below, will be selected by a random method and each team will elect three spokesmen to present their views to the group. The team objectives are intended to focus attention on the area to be reported on, but in no way to inhibit consideration of other areas of interest. A copy of the Environment and Console Configuration Checklist is provided for use as you see fit. A member of the Technical Center project team will be assigned to each team to provide support and assistance.

TEAM #1 PHYSICAL CHARACTERISTICS.

OBJECTIVE: To recommend the shape, size, lighting, creature comforts, maintenance accessibility, and other features of a TRACON supervisor's desk.

TEAM #2 COMMUNICATIONS.

OBJECTIVE: To recommend the communications capability such as telephone, radio, intercom, input/output devices, recorders, and other equipment required at a TRACON supervisor's desk.

TEAM #3 DISPLAYS.

OBJECTIVE: To recommend the displays such as radar, closed circuit television, weather, combined CRT display, clocks, and other displays required at the TRACON supervisory desk.

TEAM #4 CONTROLS.

OBJECTIVE: To recommend the control devices such as radar adjustment, frequency selectors, and the types such as knobs, levers, switches, or others required at the TRACON supervisory desk.

ENVIRONMENT AND CONSOLE CONFIGURATION CHECKLIST

SAFETY.

Protection from mechanical hazards

Protrusions are either avoided or padded
Corners rounded
Adequate guards are provided on moveable modules which could cause injury to personnel by falling, pinching, or sliding.
Emergency exits

ANTHROPOMETRY.

SIZE AND DISTANCE.

Activity space is in general (adequate, less or more)
Distance of the console cabinets from the operator is (excellent to unsatisfactory range)
Differences in sizes of operators have been (adequately to inadequately considered)

SEATED OPERATIONS.

For normal continuous seated operations, the displays, controls, etc., are mounted and/or inclined properly (yes or no)
Overall console height interference with line of sight
Corrections required to overall console height (if any)
Arm rests (consoles or chairs)
Writing surface (size, height)
Knee and foot room
Ash trays, etc., where smoking is permitted

SEATING.

Allowance for good posture at working positions
Seating size and adjustments for individuals

WORK SURFACE.

Adequacy of desk space (size, height, lighting)
Recesses for equipment (number, size)
Storage (form, files, etc.)

ENVIRONMENT.

ILLUMINATION.

- Overall plan of lighting
- Overall illumination level
- Glare and reflections
- Direct or Specular
- Console and/or panel lighting
- Color lighting
- Floor lighting

NOISE.

- General noise level
- Noise level at operating position
- Noise generators

TEMPERATURE, HUMIDITY, VENTILATION.

- Air conditioning adequacy

DISPLAYS.

SELECTION OF DISPLAYS.

- Presentation of required information
- Accuracy and completeness of presentation
- Interpretability of instrument
- Radar indicator (cathode ray tube, radar bright display, direct view storage tube)
- Meters, dials, instruments presentation and readability
- Necessity of display

INDICATOR LIGHTS.

- Internal illumination of instruments, dials, etc.
- Color of lights
- Ability to adjust lighting
- Signals and warning lights
- Indicator light labeling according to function
- Location of light labels
- Association of lights with proper control
- Color coding
- Size appropriate to function

CATHODE RAY TUBES.

- Resolution of detail
- Brightness contrast relationship
- Uniformity of brightness
- Viewing distance
- Ambient environment illumination effect
- Surface reflections
- Specular reflections
- Accessibility to other users

PRINTERS.

Printed information in form suited to user's need
Take-up provision for paper
Visibility and legibility

LABELING.

Display or control labeled in terms of function
Label as brief as possible
Abbreviations meaningful
Viewability of labels
Location
Color

CONTROLS.

SELECTION OF CONTROLS.

Distribution and location
Number assigned to each limb
Pushbuttons and toggle switches used for two discrete settings
Toggle switches and/or rotary selector switches used for three discrete settings
Rotary selector switches used for 4-24 discrete settings

HAND PUSHBUTTONS

Size and displacement
Shape of surface and click or "feel" provision

TOGGLE SWITCHES

Size, displacement, orientation, click or "feel"

ROTARY SELECTOR SWITCH

Knob diameter and depth
Knobs knurled or serrated

CONTROL MOVEMENT

Turning direction

CONTROL-DISPLAY RELATIONSHIP.

Precision and accuracy consistent with display

GROUPING.

Location and relationship

OPERATIONS.

Procedures, tasks, job requirements

MAINTAINABILITY.

Installation and removal of equipment

TEAM RECOMMENDATIONS

by George Langdon
Facility Operations Officer
Bradley International Airport

The Air Traffic Control Team, who represents the official position of the group, came up with one unanimous decision, and that is that a supervisor's console should not be "cast in bronze" for the simple reason that there are differences in each facility, that may have to be taken into consideration when you do build a particular supervisor's console. Therefore, the group was unanimous in saying it should be modular to allow flexibility and versatility. An "L" or "U" or Wing type should be authorized so that each facility can consider what they really need in their own particular configuration.

The equipment capabilities, again, have to allow flexibility. The group seemed to feel we should have basic requirements. These requirements should be recommended requirements, not mandated, because they, too, could be changed to meet the needs of a particular facility. This group recommends the Telco Pack, which is mandatory to any facility. Until some "state of the art" replaces it, the typewriter, unfortunately, has to remain. Maybe someday the "state of the art" will make that automatic so we just don't have to input to the computer or whatever the case may be regarding our data systems review. We do have to have a clock, at least for the supervisor to watch so he knows what time to go home.

As for the recorder capability, this does not mean recorder at all positions. This means the recorded capability of a team supervisor to provide a tape review. This requires nothing more than a mini cassette recorder with the ability to tie into a monitor system which can monitor any position in the operations, so that it could accommodate a tape review or a particular review of any traffic situation.

The next thing was the desk console lighting. We, too, feel as Joe, that it should be individually controlled, and I believe he referred to it in the term of task lighting, which we as a group did support.

A luxury item to have, which most facilities don't have at this time, but is highly recommended, is a CONRAC - a minimum size of 12 inches. The reason for this high recommendation, is its use for extended supervision; the ability to know when to combine or decombine positions; and it gives the supervisor the capability to monitor any position any time he cares to when he is a "one man" supervisor (which we feel is necessary so as to provide him with the tools with which to do the job). When you have more than one supervisor on, it's pretty easily done, but when you have leave situations, it will help the supervisor immensely.

Another necessity would be forms and book storage. Book storage for emergency binders, for accident reports, check lists, and so forth. This includes forms that the supervisor would have to access immediately. This does not mean a whole bevy of all kinds of forms. I'll get to that shortly.

Next, is "Data Vision." Now this encompasses a great deal. This depends on how fortunate a facility is - whether it gets CCD, TIPS or whatever the case may be. We do not recommend TIPS in the supervisor's console: we do recommend some type of data.

vision. That is, his ability to call up or select certain pages that he could refer to with reference to a telephone call or complaint, or whatever the case may be, that could provide the controller with assistance, such as approaches. This also includes the weather reporting and all encompassment to provide him with instant recall of those systems available to him.

Next, comes the recorder alarm. It's not necessary that the recorder monitor panel be there, but the shutoff for the alarm is necessary. In some facilities, you don't have a technician available all the time in order to take care of it. Where you would have to recall the maintenance technician, it is good to have the ability to shut it off as fast as you can and notify the proper technician.

TRANSMITTER AND RECEIVER SWITCHES.

This is a one-for-one backup. Some facilities have one-for-one backup at the particular position of operation which is ideal. For some reason, that did not filter through the whole system and remain there. To this day, we still have some facilities with one-for-one backup clustered in a particular panel, so that for any one position you would have to go to another panel to select your transmitter or receiver backup. Until such time they get on position, we do recommend that they remain on the console only, for the fact that it can be done faster and more readily with a supervisor at the desk.

The security door control is recommended by the group and felt to be optional. We also took Joe Morelli's suggestion and utilized the space associated with the supervisor's work area on the wall. Whether the console be an "L" shape, or "Wing" type or whatever type it is, this space is, in fact, usable, and should be considered for such things as:

1. Room lighting controls, which in a TRACON, are set and rarely changed except once or twice a year when visitors are present, or when the radar is lost and you have to go nonradar.
2. Room heating or air-conditioning. We recommend that these controls go on the wall as it seems only natural that they should, as in most buildings, be there.
3. The radar control panel. Rather than sit and watch it from the console all the time, which is a change from the Bradley presentation, it would be better to have it located on the back wall associated with the supervisor's work area.
4. The ATRBS monitor system could also be located on the wall.

FORMS AND STORAGE AREA

When a modular panel is used which would accommodate normal reach height for activating or deactivating any particular system or electronic device on the panel, a natural storage space could be located underneath for forms most used by the supervisors or controllers, such as familiarization trip forms. The same thing applies to transmitter or receiver backup systems, which would have to be selected if it were not going to be installed in the position. I think most of us agree that it should be position located, but where there are those facilities that cannot accommodate that, or do not have the funds to make it a reality; it could very easily be located on the wall near the supervisor's work area.

There are the recommendations that the group came up with. I might add that the physical size of the console should be determined by the physical constraints of the room. Also, the center portion of the console be expandable, so that in smaller facilities the "swept wing" would be closer together. We strongly recommend that the facility itself should have the input to adjust these modular units as they need to. If you don't have the facility input, chances are that you won't get the proper use of the equipment that the FAA desires.

Thank you very much.

RECOMMENDED SUPERVISORS CONSOLE

This is the summary of the team recommendations.

I. MODULAR.

- A. To Allow Versatility
- B. "L" Type or "U"/Wing Type Option

II. EQUIPMENT.

It is emphasized that this not be a dictate, but minimum requirements recommended.

Recommended:

- 1. Telco Pack (Including Dial)
- 2. Typewriter (Slide Recommended)
- 3. Clock
- 4. Recorder Capability with ATIS Monitor Capability
- 5. Desk/Console Lighting Controls
- 6. CONRAC
- 7. Forms/Book Storage (Limited)
- 8. Data Vision
- 9. Recorder Alarm
- 10. TX/RX (Till on each position)
- 11. Security Door Controls

III. ASSOCIATED WALL PANEL.

- 1. Room Lighting Controls
- 2. Room Heat/Air Controls
- 3. Radar Control Panel
- 4. ATCRBS Panel
- 5. Forms Storage Area
- 6. TX/RX (Optional till on each position)

CONCLUSIONS

It is concluded from the results of the workshop and the reports presented within, that the supervisory desks designed and developed under Project 219-151-140 have vastly improved the supervisory complex and operational environment where they were installed. These desks have established the validity of modular design, task lighting, plywood construction, nonreflective finishes, accessibility for maintenance and installation of equipment, forms and file storage drawers, and a specifically designed location for the typewriter.

RECOMMENDATIONS

It is recommended by the Air Traffic Service (AAT), Airways Facilities (AAF), and the Systems Research and Development Service (SRDS) Program Managers that the program activity be extended by the Technical Center for 2 years and that further development be expanded to include the entire supervisory complex area. Included should be such things as wall space and supplementary furnishings in addition to the basic desk for three classes of Terminal Radar Approach Control (TRACON's) to serve as a national standard for new TRACON installations and refurbishment of existing TRACON's.

APPENDIX A

TRACON SUPERVISORY DESK COMPLEX

WELCOME LETTER AND

SEMINAR AGENDA

**DEPARTMENT OF TRANSPORTATION
FEDERAL AVIATION ADMINISTRATION**

**NATIONAL AVIATION FACILITIES
EXPERIMENTAL CENTER
ATLANTIC CITY, NEW JERSEY 08405**



NATIONAL STANDARD - TRACON SUPERVISORY COMPLEX SEMINAR

November 27, 28, 1979

WELCOME TO NAFEC.

We hope to make your visit as pleasant and productive as possible in the short time available. Enclosed in this package you will find a booklet describing the history and activities of NAFEC. Inside the back cover you will find some geographical information and directions which may be of interest. If you intend extending your visit to NAFEC beyond the seminar and would like to observe some particular project activity, we will be happy to provide any assistance you may desire.

Your time will be shared between Building 11, where you are now located, and the Building 170 Laboratory where the tower cab, TRACON, and supervisory complex experimentation and evaluation studies are conducted.

Your participation and assistance in establishing the best path to follow in developing a standard desk design and other elements of the TRACON supervisory complex for implementation as a useful, functional, modern efficacious replacement for existing and new TRACON installations will determine our future efforts in this program.

We sincerely appreciate your attendance, interest, and participation in this activity.

JOSEPH M. DEL BALZO
Director, ANA-1

WEDNESDAY, NOVEMBER 28, 1979

AGENDA

- 0900 Group Assembles at Building 170
0900 - 1100 Evaluation Teams Prepare Panel
Presentation and Recommendations
1100 Visit to Flight Service Station Project,
Building 170
LUNCH
1300 Building 11 Conference Room,
Panel Presentation of Team Report and
Recommendations - F. Hierbaum,
Chairman, Each Team Spokesman, Panelist.

A-2

Discussion and Questions from the Floor will
Follow the Panel Reports

TRACON SUPERVISORY COMPLEX SEMINAR
NATIONAL AVIATION FACILITIES
EXPERIMENTAL CENTER

ATLANTIC CITY, NEW JERSEY 08405

NOVEMBER 27-28, 1979

TUESDAY, NOVEMBER 27, 1979

0800 Registration

0900 Welcome - F. Hierbaum, NAFEC Program Manager

0905 Introduction of Center Director

0915 Program Objectives - W. Frazier, ARD-120
- E. Newbern, AAT-120

0925 Introductions - F. Hierbaum

0940 Video Tapes
NAFEC Operations
VICON

1000 BREAK

1010 Team Assignments - M. Massimino, Project Manager

1015 TRACON Supervisor Desk Field Research
- J. Goodwin, Project Manager

1030 Regional Comments - F. Willett

1045 Terminal Information Processing System (TIPS)
- M. Rosenbaum

1100 Consolidated Information Display - G. Spanier

1120 Consolidated Information Display, Building 19
- G. Spanier

LUNCH

1330 Building 170 Laboratory

1340 Tower Mockup Briefing - D. Bottomley

1400 Supervisory Desk Examination

1600 Bus Return to Building 11

APPENDIX B

REGIONAL OFFICES RESPONSE
TO DESIGN OF SUPERVISORY CONSOLES
SHOWN BY VU GRAPHS
IN SPEECH BY FRANCIS WILLETT, JR.

**DEPARTMENT OF TRANSPORTATION
FEDERAL AVIATION ADMINISTRATION**

WASHINGTON, D.C. 20591

DATE: OCT 11 1979

IN REPLY
REFER TO: AAT-120

SUBJECT: Standard Design Supervisor Console for TRACONS



FROM: Chief, En Route and Terminal Requirements Branch, AAT-120

TO: ANA-210

WA 10/11/79

Enclosed is regional/facility Air Traffic input to subject design. In addition to the many suggestions offered, we believe the following items should be included in the design.

1. Tape recording capability of all operating positions using voice actuated tape recorders contained within the console.
2. Book shelf and form storage area behind the console. This area is often unusable and would allow console space to be used for high priority equipment.
3. Shelf work area on front of console. This would provide the team supervisor a work area and still not isolate him from the operation.

John R. Ryan
JOHN R. RYAN
Enclosure

**DEPARTMENT OF TRANSPORTATION
FEDERAL AVIATION ADMINISTRATION**

AAT-120

DATE: **SEP 17 1979**

**ALASKAN REGION
P.O. BOX 14
701 C STREET
ANCHORAGE, ALASKA 99513**

IN REPLY
REFER TO: **AAL-510**



SUBJECT: **Standard Design Supervisors' Consoles for TRACONS; your
ltr dtd 8/29/79**

FROM: **Chief, Air Traffic Division, AAL-500**

TO: **AAT-120**

Personnel from the regional office and the Anchorage TRACON participated in the subject design study.

Maximum efficiency of the console could probably be achieved if it was a wrap-around or "U" shaped unit.

We make no recommendation as to exact size of console or of items in the console but have identified several items we feel should be included. These are as follows:

1. An area for a typewriter with appropriate lighting.
2. An elevated front to reduce light reflection.
3. A good sized writing and work area.
4. Flush mounted phone system on elevated front.
5. Built-in small CONRAC display of tower BRITE.
6. Computerized Cab Display (CCD) monitor.
7. Built-in digital clock.
8. Room lighting controls.
9. Built-in safe for restricted material.
10. Entrance door communications, release button and TV monitor of entrance area. This TV display could be the same one that monitors the tower BRITE if a coaxial video switch was included.
11. For ARTS II facilities, the console should include a computer access keyboard. This keyboard should be slaved to the tower BRITE so that the preview area

on the built-in CONRAC could be utilized.

12. A forms storage area that is lighted and easily accessible.
13. The flat area of the console should be covered with glass or plastic for easy insertion of material underneath.

We would welcome the opportunity to participate further in this study and evaluation of the mock-ups.

WILLARD H. REAZIN

DEPARTMENT OF TRANSPORTATION
FEDERAL AVIATION ADMINISTRATION

GREAT LAKES REGION
2300 EAST DEVON AVENUE
DES PLAINES, ILLINOIS 60018

DATE: SEP 11 1979

IN REPLY
REFER TO: AGL-510

SUBJECT: Standard Design Supervisor's Console for TRACONS



FROM: Acting Chief, Air Traffic Division, AGL-500

TO: AAT-100
ATTN: AAT-120

In accordance with your request, we are submitting the following information:

1. With the exception of Chicago/O'Hare ATCT and the planned new TRACON relocation at Minneapolis ATCT our TRACON supervisor's consoles are for the most part a straight line EMCOR provided arrangement varying the length and equipment placement. Also, standard size office desks are used at the smaller facilities.
2. The O'Hare and Minneapolis consoles were designed as a result of facility input to meet their requirements. The enclosed drawings detail exact measurements, TRACON layout and electronic equipment placement. Photographs are of the O'Hare TRACON supervisor's console.
3. Depending on the size and complexity of the facility, we recommend the O'Hare or Minneapolis versions. The O'Hare console has proven to be successful with the following exceptions:
 - a. The front of the console should be slanted inward so as not to create a toe knocker. Note the supervisor's side is slanted (#4 Photograph).
 - b. O'Hare utilizes overhead track lights to illuminate the writing surfaces. Some type of console mounted lighting should have been provided as the overhead lights cause shadows. NAFEC should attempt to develop an adequate lighting arrangement.
 - c. Drawers in the writing surface (#4 Photograph) should be more substantial.
4. The sign-on podium (#8 Photograph) also houses a QWIP 1200 Telecopier. The top of the podium raises for storage of administrative supplies. N.B.

2

We agree that a standard TRACON supervisor's console(s) should be developed and evaluated. Should you require further input, please do not hesitate to call upon us.

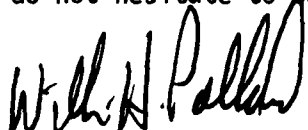
WILLIAM H. POLLARD

5 Enclosures

2 Sets O'Hare TRACON Drawings
2 Sets Minneapolis TRACON Drawings
O'Hare Photographs

**DEPARTMENT OF TRANSPORTATION
FEDERAL AVIATION ADMINISTRATION**

DATE: SEP 24 1979

**IN REPLY
REFER TO: ANE-513**

**NEW ENGLAND REGION
12 NEW ENGLAND EXECUTIVE PARK
BURLINGTON, MASS. 01803
Tel. 836-1286**



SUBJECT: Standard Design Supervisor's Console for TRACONS

FROM: Chief, Air Traffic Division, ANE-500

TO: AAT-100

We feel that the size of consoles could be standardized for like facility levels. However, the placement of equipment and specific items should be left up to each individual facility's requirements.

The following comments with enclosed sketches show some different ideas from different facilities.

1. a. Work area (for writing).
 - b. Radar controls, ILS monitors, transmitter and receiver switching panel, hijack panel, T&A drawers, supervisor's binder, storage area, Conrac, and all necessary telephone systems which will provide access/monitor of any position of operation.
 - c. The location of this console will be generally centered or offset facing the radar console positions.
2. a. The console itself should be a minimum of 96 inches in length with the height and width to be determined. Depending on the size of the quarters the dimensions could be increased accordingly. The design should include a desk-type surface with a backdrop to house equipment. It should have drawers for supplies, manuals, charts, etc. The console, where practicable, to be located near a wall positioned so as to command an unobstructed view of the quarters. This entire area, if feasible to be on a raised platform.
 - b. Two complete dual telephone positions with all appropriate lines plus full one way override capability to all positions of operation. Those positions to be located equidistant from either end of the console.
 - c. A radar display is also a requirement. Either a 9 inch-Conrac mounted in the backdrop or a display suspended from the ceiling with switching capability to monitor any position of operation where multiple radar systems are used.
 - d. On the wall behind the console, wall phones can be installed such as emergency phones, CFCF phone, etc.
 - e. Additional cabinet space might also be installed on this wall.

f. Facility for a typewriter with swing-away action so it will not be in the way when not in use.

g. Monitoring capability of all VHF and UHF frequencies used by the facility. This panel to be located on the backdrop of the console and have headset and speaker capability with volume controls.

h. A digital clock.

i. Wind direction and velocity indicators for the primary airports.

3. a. Console Design. Should be desk type with a slanted top and several slots for manuals and looseleaf binders. Also, provision should be made for a small strip bay.

b. Size. 48" long x 34" wide. The back portion should be 10" high x 10" wide at the bottom slanting to 6" wide at the top.

c. Height. Overall height including back portion 40".

d. Equipment Required. Call Director, with telco type speaker, selective lighting with reostat control.

e. Layout. See attachment.

f. Location. Should be placed in an area where the supervisor can see the overall operation. The area should be elevated about 8" for best overall view.

4. a. There should be two sizes. One for level 4 and 5 facilities and one for level 3 and below. The difference being the amount of equipment and the number of people required to sit at the console. A semi-circular or elongated "U" shape seems to be the most efficient. (Base of the "U" elongated according to needs and shortsides). In fact this would make for an easily expandable design. (See attached). Height should be standard desk height 30-36 inches with a sloped panel along the back.

b. Provisions should be made for the following equipment:

- Internal - external phone lines and land lines.
- All communications frequencies (transmitter and receiver selector)
- Radar controls
- Standby transmitter and receiver controls (Comm.)
- Navaid monitor panel
- Interrogator controls

3

- Computer controls where applicable
- Tape recorder monitor lights
- Tape recording capabilities for all radio frequencies, phone lines, and the radar presentation as required
- Room lighting reostats
- Radar monitor (CONRAC)
- Closed circuit TV monitor for entrance to facility with door lock controls

5. a. Equipment Required.

Electrowriter
Telco Key Pack
Telco Dial
Telco Speaker
Tape Monitor Panel
ASR-5 Control Panel
BRITE Remote Control
Back-Up Radio Panel
Door Release for Outside Entrance
RVR Readout
ATIS Monitor
ILS Monitor
Clock
Drawer for Time and Attendance Cards
Typewriter

b. Equipment Layout.

This should be developed after the mock-ups at NAFEC are completed so the actual physical size can be seen, and placement can be better determined.

c. Location.

Between TRACON entrance and radar consoles.

6. a. Equipment Required.

Panel #1

- (1) Receiver-transmitter selector panel for remote frequencies at Martha's Vineyard (124.7).
- (2) Receiver-transmitter selector panel for UHF frequencies.

- (3) Control Panel for CONRAC.
- (4) Receiver-transmitter selector panel for VHF frequencies.
- (5) Buzzer for front door lock release.
- (6) Monitor panel for RBN.

b. Panel #2

- (1) Light dimmer switches.
- (2) Space for CONRAC.
- (3) Phone cradle and hand set.
- (4) Phone dial and circuit selector panel.
- (5) Clock.

c. Panel #3

- (1) Beacon code control box.
- (2) Remote interrogator control panel.
- (3) Recorder monitor.

JOHN D. MATTISON

Enclosure

DEPARTMENT OF TRANSPORTATION
FEDERAL AVIATION ADMINISTRATION

NORTHWEST REGION
FAA BUILDING KING COUNTY INT'L AIRPORT
SEATTLE, WASHINGTON 98108



DATE: SEP 18 1979
IN REPLY REFER TO: ANW-512
SUBJECT: Standard Design Supervisors Console for TRACONS; AAT-100 ltr
of 8/29/79
FROM: Chief, Air Traffic Division, ANW-500
TO: Chief, ATC System Programs Division, AAT-100

Enclosed is a sketch of the supervisor's console that was recently installed in the relocated Portland, Oregon TRACON.

We feel this design, size, height, equipment provided and layout is ideal for all TRACON facilities. It is practical and functional.

The physical location within facilities will vary depending on the layout of the remaining operational quarters.

We recommend the NAFEC mock-up include a design similar to this for evaluation.

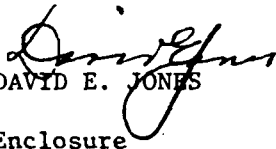
DAVID E. JONES
Enclosure

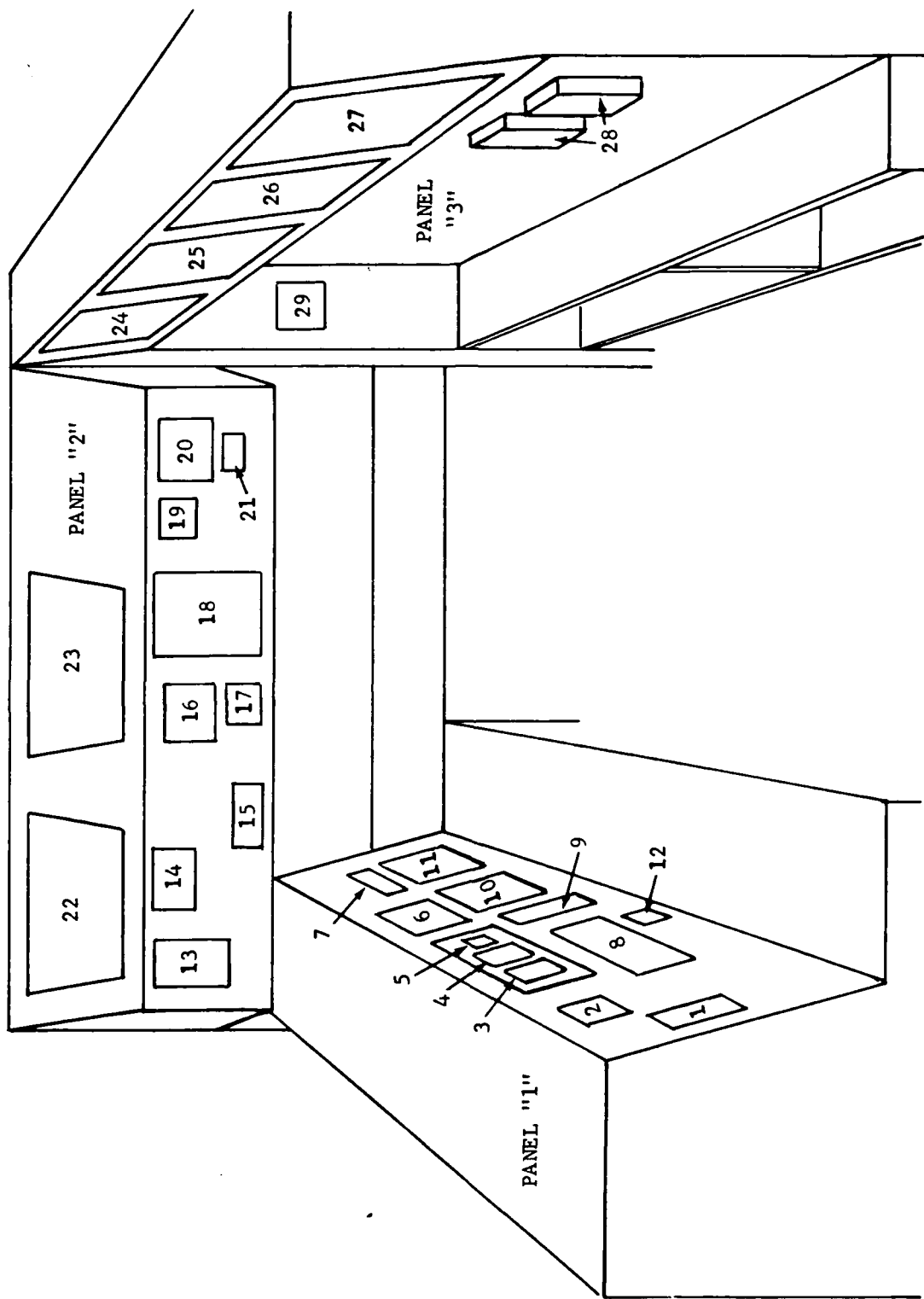

- 1. Maintenance Phone
- 2. TELCO Speaker

1. Maintenance Phone
2. TELCO Speaker
3. Wind Direction
4. Wind Speed
5. DASI
6. TRACON Door Remote Control
7. BRITE Video Monitor Select
8. Position Monitor Panel
9. TRACON Door Telephone
10. TRACON Door TV Monitor
11. BRITE Video Monitor
12. Digital Clock
13. Engine Generator Remote Control Panel
14. Recorder Monitor Panel
15. Common Equipment Control Panel
16. MSAW/ARTS Alarm Panel
17. MSAW Speaker
18. ASR-8 Control Panel
19. TML BRITE Video Map Select
20. TML BRITE Control Panel
21. TML BRITE Video Select
22. NAVALDS Monitor & Control Panel
23. CAT II ILS Control Panel
24. Noncommon Decoder Control
25. Noncommon Decoder Control
26. Noncommon Decoder Control
27. Noncommon Decoder Control
28. Environmental Controls
29. Supervisor's Console Lighting Control

**DEPARTMENT OF TRANSPORTATION
FEDERAL AVIATION ADMINISTRATION**

WASHINGTON, D.C. 20591

DATE:

SEP 27 1979

IN REPLY
REFER TO:

AAF-510



SUBJECT: TRACON Supervisors Console; AAT-100 R/M of 8/27/79

FROM: Chief, Environmental Systems Division, AAF-500

TO: AAT-100

In your reminder memo of August 27 you indicated your interest in seeing a concept of the TRACON supervisors console which we reportedly furnished to NAFEC. We cannot recall furnishing such a concept, however, we did provide them with standard TRACON floor plans.

For your information, enclosed is a copy of the task agreement. We are pleased to see that this project is nearing the evaluation phase and are looking forward to its successful completion.

Lowell McDysan
LOWELL MCDYSAN

Enclosure

DEPARTMENT OF TRANSPORTATION
FEDERAL AVIATION ADMINISTRATION

DATE: 10/20/79

CENTRAL REGION
601 EAST 12TH STREET
KANSAS CITY, MISSOURI 64106



IN REPLY
REFER TO: ACE-513

SUBJECT: Standard Design Supervisor's Console for TRACONS; your letter
of August 29, 1979

FROM: Acting Chief, Air Traffic Division, ACE-500

TO: AAT-100

The following information and comments were developed after extensive coordination with field facilities representing a cross section of Central Region terminal approach control facilities:

General. The console should be modular and capable of expansion to fit the needs of any size TRACON and to permit a variety of shapes.

Shape. L-shaped, U-shaped or linear with access from at least two sides.

Height. Elevation of the unit above floor level depends on the size of the TRACON. Large Level IV or V TRACONS may require slight elevation of the supervisor's area for visibility. Total console height should be low to allow access to console equipment from any side and enhance visibility.

Size. The console should accommodate at least two persons with modular expansion capability for larger facilities.

Siting. The size, shape and operational configuration of the TRACON will limit console siting. Generally, a location that has a good view of the operational area, that is close to the TRACON entrance and clear of traffic areas is preferred.

Equipment. Facility level and complexity will determine equipment required. Most important is a clean flat work area at least 24" to 30" wide and desk height. Equipment should be mounted in an area sloped so that it can be easily viewed while seated or standing and from either side of the console.

Equipment to consider includes: Telephone call director with all out of facility commercial, emergency, and leased lines with optional recording capability on the commercial lines. Position monitors that can be recorded or linked to commercial telephones for hijack monitors. Telephone handsets and cords should be retractable to reduce clutter. Standby transmitter/receiver selector switches, datavision viewer, recorder/navaid alarms, HVAC controls, standby power indicator control and ATIS monitor. Security door controls where applicable. If technically feasible, console could contain a small "CONRAC" monitor of the radar display with ANK provided that the full range of radar could be shown and not just the range selected on tower BRITE display. Clock, wind indicators and altimeter setting indicator. Recessed, built-in storage for supplies, forms, charts, essential books and manuals. Radar receiver controls should be within easy reach of supervisor's station. A typewriter with its own clear area or swing-away mount and unobtrusive lighting.

Lighting for the console should be self-contained to avoid dependence on ceiling fixtures that may affect ambient lighting levels.

Equipment Layout. In general, the most used equipment (phones, monitors, typewriter) should be closest with alarms, status indicators and little used controls further away. Specific layouts will vary from facility to facility. Special care should be taken in siting the typewriter to avoid carriage blockage, minimize noise and control stray light.

We appreciate this opportunity to comment on the proposed design. Central Region personnel will be happy to participate in prototype evaluation. If you have further questions, please contact Quentin Gates, ACE-513, FTS 758-2592.

for Ralph E. Buckner
R. B. DAVISON

DEPARTMENT OF TRANSPORTATION
FEDERAL AVIATION ADMINISTRATION

DATE: September 18, 1979
IN REPLY REFER TO: Chief, COS ATCT:7030

AIRPORT TRAFFIC CONTROL TOWER
Stop #1
Peterson AFB, CO 80914



SUBJECT: Standard Design Supervisor;s Console for TRACON's;
AAT-120 ltr dtd 8/29/79

FROM: Chief, Colorado Springs ATCT

TO: Chief, ATC System Programs Division, AAT-100

The following information is furnished from the Colorado Springs, CO ATCT regarding our experience with the Supervisor's Console provided for the new Colorado Springs TRACON Room:-

1. - Console design:

"L" Design - If the area is able to accomodate this configuration, the "L" design could be used for a corner, straight wall or middle of the room installation.

Straight Length Design: - A straight design for areas that are unable to accomodate an "L" shape. (Using a wall as the back area).

"T" Design - This could be used to accomodate a smaller area, but yet get a full utilization from the console.

2. - Size:

"L" Design - 8' X 11'.

"Straight" Design - 12' with 3 foot work areas at each end.

"T" Design - 10' X 5" (VARIABLE)

Top area of console should be 15" wide, at least.

3. - Height: 43"

4. - Equipment Required:

- a. Area for typewriter.
- b. Enough space to install the needed monitor panels.
- c. Telephone system.
- d. At least 5 file drawers.
- e. A slot file for frequently used paper & forms (10 - 12 slots).
- f. 1 large sliding desk drawer.
- g. Under top of counter lighting to light up the desk top work area.
- h. Facility operating manuals storage area to be located on front side of console.

5. - Equipment Layout:

- a. Variable - to accomodate the facility.

6. - The most suitable location selected by the Facility Chief for the design of the room.

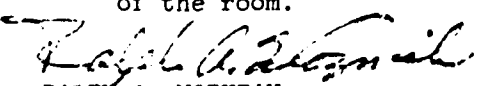
RALPH A. WOZNIAK
Chief, COS ATCT

DEPARTMENT OF TRANSPORTATION
FEDERAL AVIATION ADMINISTRATION

DATE September 20, 1979
IN REPLY
REFER TO APC-513

PACIFIC-ASIA REGION
P O BOX 4009
HONOLULU HAWAII 96813



SUBJECT Standard Design Supervisor's Console for TRACONS; AAT-100 (AAT-120)
letter dated August 29, 1979
FROM Acting Chief, Plans, Programs and Evaluation Branch, APC-510
TO AAT-100

Because of time constraints and having only one TRACON from which to draw ideas, we are not providing all the input you asked for.

We do, however, suggest that the console include a Data Entry and Display Sub-system and access to radio receivers. These two features will enable the Assistant Chief (AC) to actively engage in flow control, traffic analysis and evaluation; functions difficult for the AC to pursue with the present equipment limitations.

Because we envision these full capability consoles only at Level IV and V facilities, we suggest two standard designs be considered to provide for Level III and below.

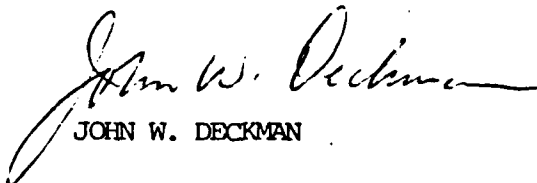
JOHN W. DECKMAN

DEPARTMENT OF TRANSPORTATION
FEDERAL AVIATION ADMINISTRATION

SOUTHERN REGION
P. O. BOX 20636
ATLANTA, GEORGIA 30320



DATE: SEP 20 1979
IN REPLY REFER TO: ASO-510: 7232(GEN)

SUBJECT: Standard Design Supervisor's Console for TRACONS; your letter of August 29, 1979

FROM: Chief, Air Traffic Division, ASO-500

TO: AAT-100

Enclosed are copies of responses received from Tampa, Miami and Jacksonville Towers concerning the subject console.

All responses received are being forwarded in order to give NAFEC the advantage of as many ideas as possible. We favor a console similar to that installed at MacDill AFB (pictures enclosed). It is made by Denrol Lab, Inc., 12360 Parklawn Drive, Rockville, Maryland 20850. It is identified as a Communications Control Console, Group OJ-314 (checkmark), FSC Contract Numbers N00039-73-C-0010, NAVELEX 0967-LP-542-2010.

Although not mentioned by any of the facilities responding, the new console should be capable of housing the following pieces of equipment:

- Door release
- Door intercom
- Door monitor (calls attention to incorrect code entered on cipher lock)
- Fire zone alarm
- Hotline to airway facilities
- Clock
- Electric pencil sharpener
- Central Flow Control phone
- Elevator alarm
- Telephone power alarm
- Code-a-phone (for after-hours business telephone)
- Access to facility public address system
- Typewriter
- Operational telephone position

We appreciate the opportunity to comment on the supervisor's console and are willing to coordinate further, if necessary.

for Thomas E. Dillard
LONNIE D. PARRISH

Enclosures

**DEPARTMENT OF TRANSPORTATION
FEDERAL AVIATION ADMINISTRATION**

1-20-81 5:0
SEP 17 1979

DATE: September 14, 1979

AIRPORT TRAFFIC CONTROL TOWER
P. O. Box 18346
Jacksonville, Florida 32229

IN REPLY
REFER TO:



SUBJECT: Standard Terminal Supervisory Console Design

FROM: Chief, Jacksonville Tower

TO: Chief, Plans and Programs Branch, ASO-510

The console should be eight feet long and standard desk height, exposed surfaces should be non-reflective. A straight-line or angled configuration would be a facility option.

An equipment monitor and communications panel should be centered on the panel at an approximate 70 degree angle, in order to facilitate viewing from a standing or sitting position. Provision must be made for adequate clear work space. This space must be of sufficient dimensions to accommodate a chart or a couple of open manuals, or an hour's worth of strips.

The console equipment should include: Two CRT displays (radar monitor, weather, flight data, NOTAMS, restricted area status, etc.) with a 20-page minimum call-up capability, flush-mounted operational and administrative telephone selectors, NAVAID status panel and a logically-placed typewriter stand. Charts, reference books and administrative records should have storage areas that are immediately available to the supervisor. Adequate non-glare primary and auxiliary lighting is basic.

Design of the console should also take into consideration the distractions around the supervisory console and the effects on the controller. While distractions must be minimized, the supervisor must not be isolated.

JAMES N. MOON, JR.
Chief

**DEPARTMENT OF TRANSPORTATION
FEDERAL AVIATION ADMINISTRATION**

DATE: September 6, 1979

MIAMI ATC TOWER
P. O. Box 592457 AMF
Miami, FL 33159

IN REPLY
REFER TO:

SUBJECT: AC/TS Supervisor Desk



FROM: PPS, Miami ATC Tower

TO: ASO-510
Attn: Bill Cooper

Attached is a print of the Assistant Chief, Team Supervisor Desk which is in use in the Miami Tracon. We designed it to accommodate both the Assistant Chief and a Team Supervisor because of space limitations within the Radar Room. The unit is attractive, extremely functional, and incorporates the following features:

1. Furniture grade construction.
2. Mica surfaces (teak) inside and out.
3. Desk top surface has 1/4" clear acrylic over the mica.
4. Neatly houses two (2) 2 drawer file cabinets.
5. Has ample adjustable shelves for manuals, supplies, etc.
6. "Pigeon hole" compartments under desk top.
7. Drawers with rollers and guides.
8. Hinged (hidden) doors w/flush hardware.
9. Lowered "wing" area for typewriter.
10. Telecom module with hinged front panel for 301-A telco position - includes position monitor function as well as monitor alarm for telco frame room.

Ideally, a supervisor work station should be centrally located within the radar room in order to provide the best visual observation arrangement. More importantly, it must be located immediately adjacent to the radar and other essential equipment monitor/control panels.

Space limitation and location of equipment panels required that we locate our supervisor desk at the end of the radar room.

The communication equipment located at the supervisor console, in addition to the telco 301-A position, includes one desk top call director; one wall mounted call director; one wall mounted (non dial) phone to DCA Central Flow Control; and one wall mounted dial phone for field use to Airway Facilities locations - i.e. radar site, ILS equipment locations, etc. These phones are equipped with ring activated signal lights that can be seen from most areas of the radar room. This provides the supervisor with the ability to visually identify which of the phones is ringing when he is away from the desk area.

We hope you will find this information useful. Please let us know if we may be of further assistance.

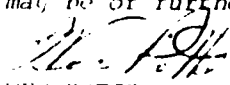
WES POTTS
PPS, Miami ATCT

9 A

Richard,

I have some suggestions for you to consider for the design of a new Supervisors' Console. Our biggest problem is in the method we have consolidated all of the supervisors work area into one corner of the TRACON which creates the "Huddle" atmosphere at the A/C desk. My suggestion is to spread out the work area by building a credenza in front of the storage cabinet. This credenza could have 9 drawers, each individually locked and keyed differently, for team supervisors to use as a repository for their confidential files. The attached sketch should give a better idea of what my concept would look like. The credenza should be lighted with the same overhead lighting used on the controllers' radar console. Also, the blank wall space above the credenza could be finished with cork or a similar material and we could hang something like an aerial photo or such on the wall to give the entry a little glamour.

Additionally, I would like to see our lighted status board moved from over the A/C desk to the rear wall over the FDEP machines. This would open the supervisors view of the control room and place both the weather and navigation aid status on the north wall. Moving the status board would require rewiring the control panel for the board.

MacDill GCA has a new supervisor console which they call an "E" console and it has some new ideas incorporated into it that may be worth considering. I haven't seen this desk so I can't comment on it but I'm sure Dave can. I would be glad to take a look at it when I come back from vacation if you wish.

The red lines are proposed for
A T/S Desk in front of A/C desk
Secure File may be located for a
Cort Rack.

Richard,

I have some suggestions for you to consider for the design of a new Supervisors' Console. Our biggest problem is in the method we have consolidated all of the supervisors work area into one corner of the TRACON which creates the "Huddle" atmosphere at the A/C desk. My suggestion is to spread out the work area by building a credenza in front of the storage cabinet. This credenza could have 9 drawers, each individually locked and keyed differently, for team supervisors to use as a repository for their confidential files. The attached sketch should give a better idea of what my concept would look like. The credenza should be lighted with the same overhead lighting used on the controllers' radar console. Also, the blank wall space above the credenza could be finished with cork or a similar material and we could hang something like an aerial photo or such on the wall to give the entry a little glamour.

Additionally, I would like to see our lighted status board moved from over the A/C desk to the rear wall over the FDEP machines. This would open the supervisors view of the control room and place both the weather and navigation aid status on the north wall. Moving the status board would require rewiring the control panel for the board.

MacDill GCA has a new supervisor console which they call an "E" console and it has some new ideas incorporated into it that may be worth considering. I haven't seen this desk so I can't comment on it but I'm sure Dave can. I would be glad to take a look at it when I come back from vacation if you wish.

DEPARTMENT OF TRANSPORTATION
FEDERAL AVIATION ADMINISTRATION

DATE
IN REPLY REFER TO ASW-510

SOUTHWEST REGION
P O. BOX 1689
FORT WORTH, TEXAS 76101



SUBJECT Standard design supervisor's consoles for TRACONs;
AAT-100 (AAT-120) ltr of 8/29/79

FROM Chief, Air Traffic Division, ASW-500

TO: AAT-100
Attention: AAT-120

We obtained comments on your proposal from four terminal radar facilities ranging in size from Level 3 through 5. Each area identified in your letter will be discussed separately; however, prior to these specific comments we have a general comment on the proposed position. The organizational structure of a TRACON dictates to a large degree the type console needed. Of our 18 TRACONs only five have two levels of control room supervision. These five facilities can use a supervisor's position for the assistant chief; however, at the remaining 13 the need for one becomes questionable. Where only one level of supervision is available we want the team supervisor to be up near the control positions, not sitting at some more distantly located supervisor's position.

1. Console Design. The actual shape of the console will be dictated to a large degree by the shape and size of the TRACON room. We now have many varieties ranging from square to a narrow rectangle. Where space permits, a possible shape would be as depicted in the enclosure to this letter. It allows for direct observation of and access to equipment. Most TRACON rooms would not be large enough to allow this shape and a straight line console would be needed.

2. Size. Here too, the TRACON room will dictate size along with the equipment to be included. It should be kept as small as possible.

3. Height. In all instances, regardless of size and shape, the console should not exceed a height that will allow a seated assistant chief to look over the highest part. He must always be aware of what is happening in the control room. This maximum height would be about 46 inches. In no instance should the whole position be elevated above floor level. Such an arrangement creates serious psychological problems within the facility.

4. Equipment Required. Here the size of the facility will largely dictate requirements.

2

Telco 301A system with speaker (this should have capability to monitor all TRACON positions)
CONRAC monitor
Digital clock
RVR indicator
ARTS keyboard
TIPS/weather CRT with associated keyboard
Outside telephone housed in a separate instrument
Space for a typewriter
Storage (files, etc.)

5. Equipment Layout. Since equipment will differ from site to site we feel that the exact layout should be left as a local option.

6. Location. Here too, the location will depend on the configuration of the TRACON. If possible, it should be near to the TRACON entrance so the supervisor can control personnel at the entrance.

As a general statement, we do not strongly endorse the development of a standard supervisor's console. It is a position that is better left to local option because of the many varied circumstances.

RAMON A. ALVAREZ

Enclosure

RECOMMENDED SUPERVISORS DESK FOR TRACON'S

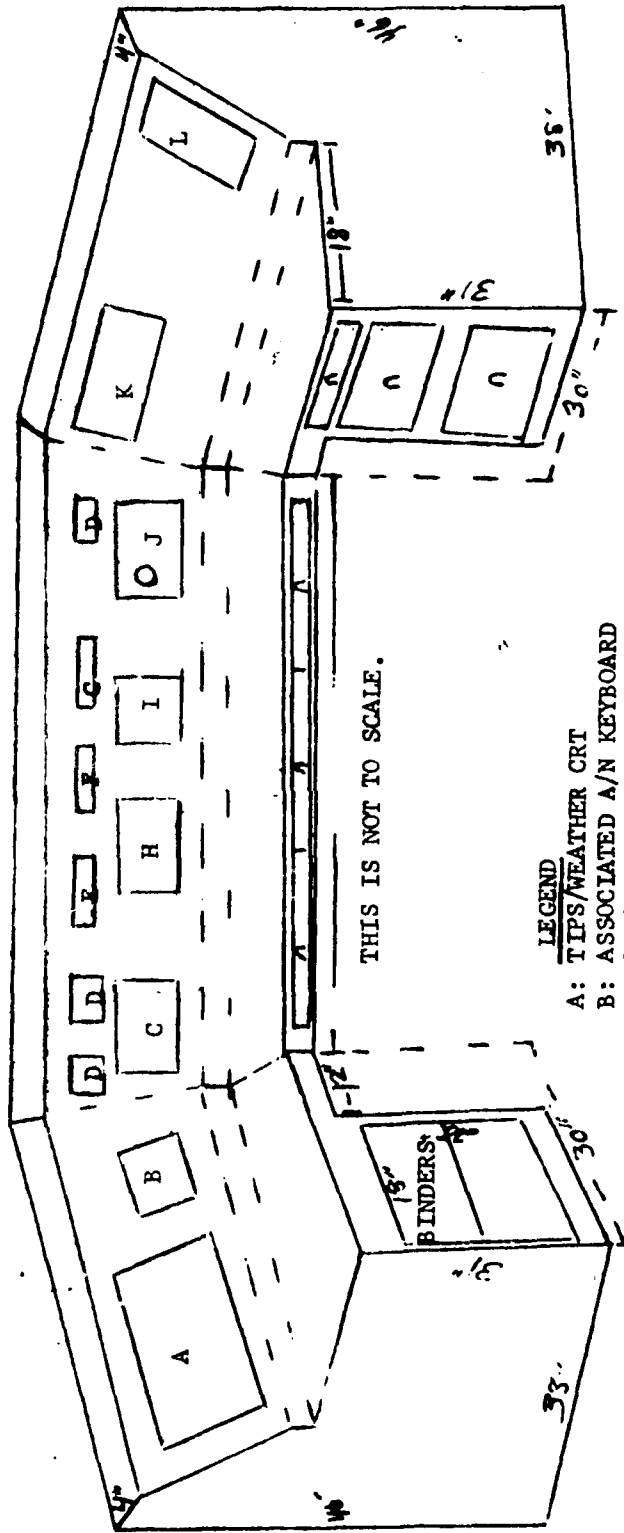

THIS IS NOT TO SCALE.

LEGEND

- A: TIPS/WEATHER CRT
- B: ASSOCIATED A/N KEYBOARD
- C: 301A TELEPHONE MONITOR SYSTEM
- D: TELEPHONE SPEAKERS
- E: DIGITAL CLOCK
- F: DIGITAL ALTIMETER
- G: RVR INDICATORS
- H: CONTRAC/CRT DISPLAY
- I: ARTS KEYBOARD
- J: COMMERCIAL TELEPHONE SYSTEM
- K: STANDBY RTR SWITCHING
- L: COMMON - SYSTEM RADAR CONTROL

0-A009 914

FEDERAL AVIATION ADMINISTRATION TECHNICAL CENTER ATL--ETC F/0 17/7
PROCEEDINGS OF THE 1979 SEMINAR ON AIR TRAFFIC CONTROL. TERMINA--ETC(U)
AUG 80 P ZITO, F E HIERBAUM, M MASSIMINO
FAA-CT-80-170 FAA-RD-80-105

UNCLASSIFIED

NL

2 of 2
ATA
1980/04



END
DATE
FILMED
11-80
DTIC

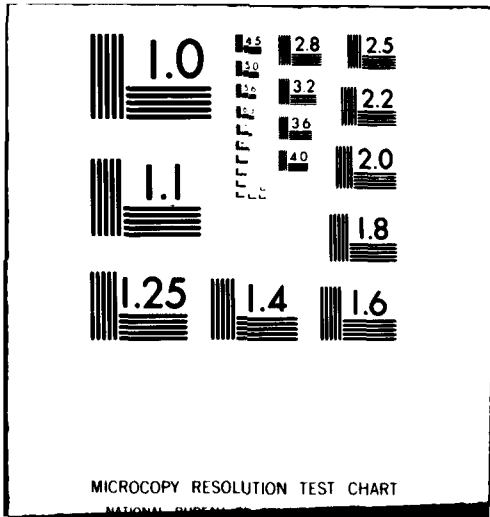

SIDE VIEW
EQUIPMENT PANEL

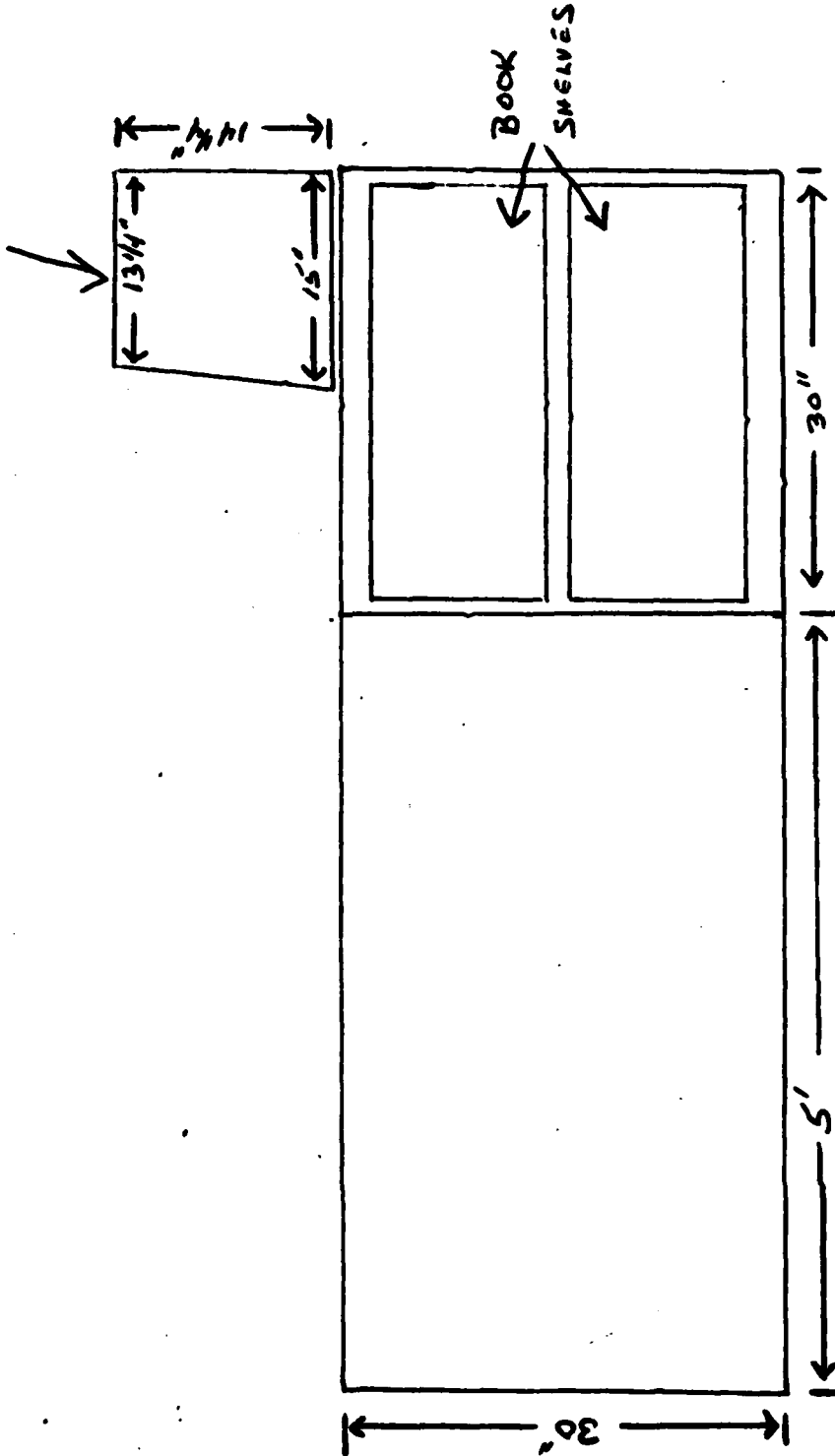

FRONT VIEW
SATCS DESK

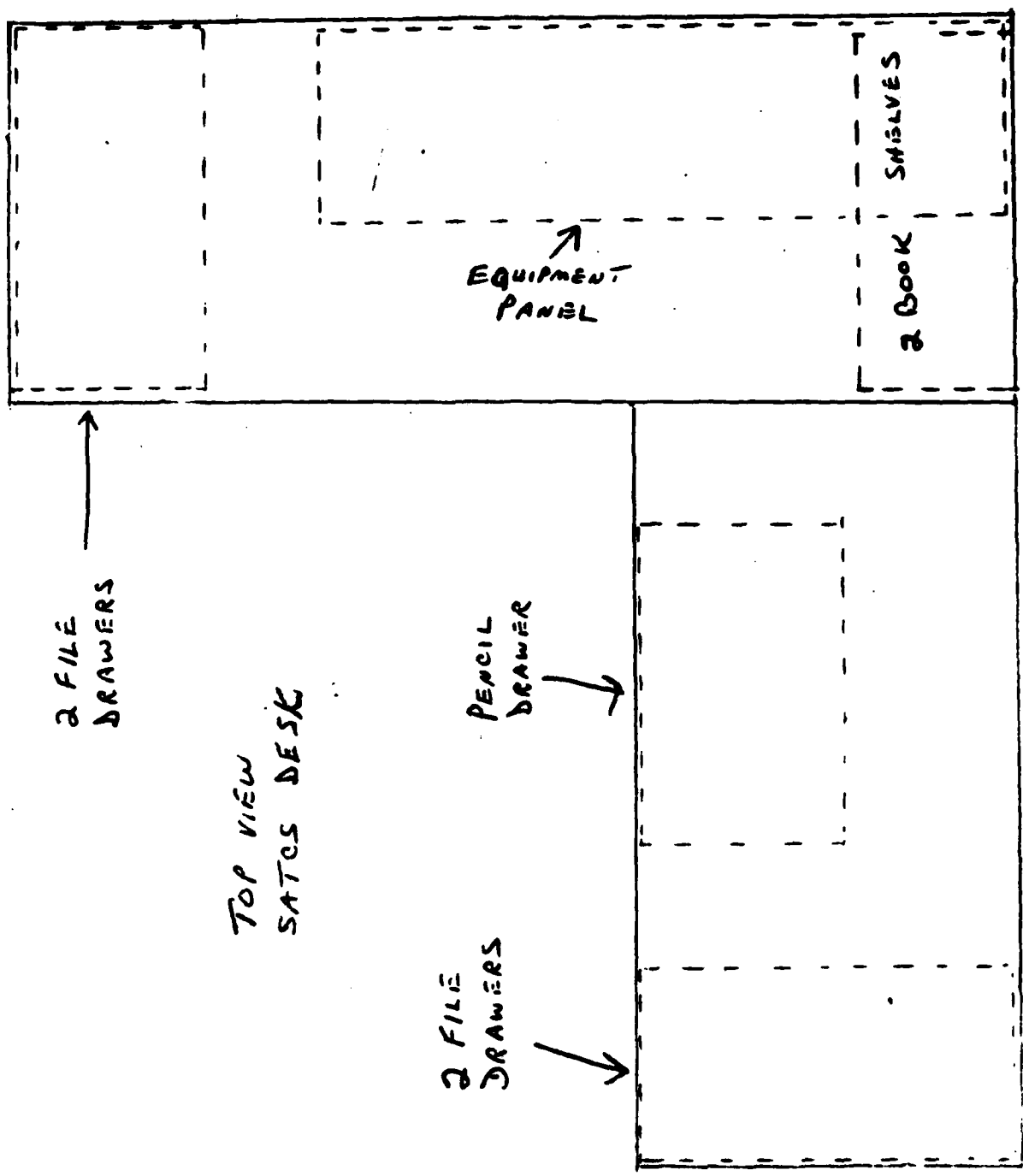

TOP VIEW
SATOS DESK

**DEPARTMENT OF TRANSPORTATION
FEDERAL AVIATION ADMINISTRATION**

WESTERN REGION
P O BOX 92007, WORLDWAY POSTAL CENTER
LOS ANGELES, CALIFORNIA 90009



DATE September 20, 1979
IN REPLY REFER TO AWE-515
SUBJECT Standard Design Supervisor's Console for TRACONS; AAT-100 (AAT-120)
ltr of 8/29/79
FROM Chief, Plans and Programs Branch, AWE-510
TO Chief, Terminal Branch, AAT-120

We believe that one standard console size may not be appropriate for all levels of TRACONS. We suggest the possibility of different size consoles for various sizes of operation rooms. This seems logical with regard to standard building design, however, the question remains whether or not we can establish a standard for current facilities. For example: we are presently "shoe-horning" some of our TRACONS into existing buildings and are using a very small supervisor's desk.

If supervisor's consoles are designed for various building sizes the equipment they contain would also vary. Larger type facilities will require more monitoring and equipment switching capabilities whereas the smaller types may require only Telco in the console.

A few of the functions which we believe should be contained within the console are as follows:

- NAVAID Monitor Panel
- BRITE Control Panel
- BRITE Monitor Display
- Communications Switching Panel
- Recorder Alarm and Position Record Capability
- Phones - Administrative and Operational plus Emergency
- Weather and Status Display
- Space for Reference Material - E Binder, Airport Locator File, etc.
- E Binder

We will be happy to provide participation in any evaluation of these consoles.

Roy E. Richards
ROY E. RICHARDS

DEPARTMENT OF TRANSPORTATION
FEDERAL AVIATION ADMINISTRATION

EASTERN REGION
FEDERAL BUILDING
JOHN F. KENNEDY INTERNATIONAL AIRPORT
JAMAICA, NEW YORK 11430



DATE: SEP 21 1979

IN REPLY
REFER TO: AEA-510

SUBJECT: Standard Design Supervisor's Console for TRACONS; your letter dated August 29, 1979

FROM: Chief, Planning Branch, AEA-510

TO: AAT-120

The following subject design information is provided to assist you in the development of a standard supervisor's console for TRACONS.

We recommend that the console design be "L" shaped with an equipment panel on one side of the "L" facing the operating area and the supervisor's desk on the other side of the "L." See enclosed drawing.

Size should depend on the available space in the room and the area needed to install the recommended equipment. Height should be standard desk height with drawers in the desk and a typewriter area slightly lower than the desk top.

Equipment required at the console should include:

1. NAVAID monitor panels.
2. Digital clock.
3. Nine-inch CONRAC.
4. ARTS keyboard.
5. TELCO panel with monitor capability that will accommodate all lines that may be required by the facility.
6. Recorder monitor panel.

We recommend the location in the TRACON be excluded from standardization so that facilities may be able to recommend a location that would suit individual TRACON arrangements.

Enclosed are several designs for supervisor's console for TRACONS.



J. H. RITZ

Enclosures

FRONT VIEW

EQUIPMENT PANEL

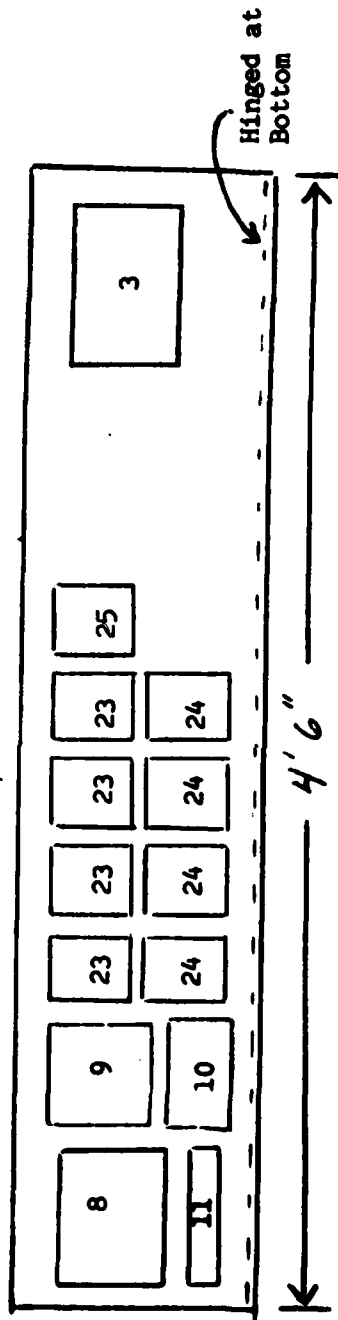
SATCS DESK



LEGEND:

- | | |
|----------------------|-------------------------------------|
| 3 - Clock | 11 - TELCO Jack |
| 8 - TELCO Key Module | 23 - M/S Receiver Control Panels |
| 9 - TELCO Speaker | 24 - M/S Transmitter Control Panels |
| 10 - TELCO Dial | 25 - Recorder Monitor Panel |

BWI

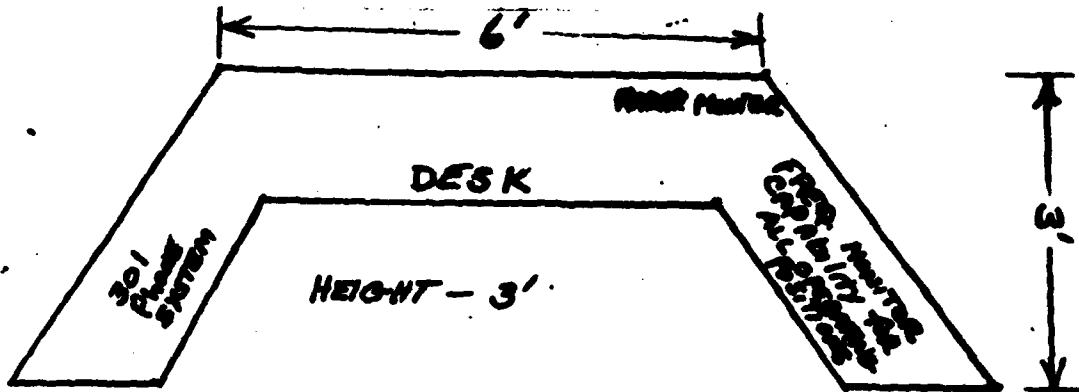

Submitted by:

FAA CONTROL TOWER
CAPITAL CITY AIRPORT
New Cumberland, PA.
17070

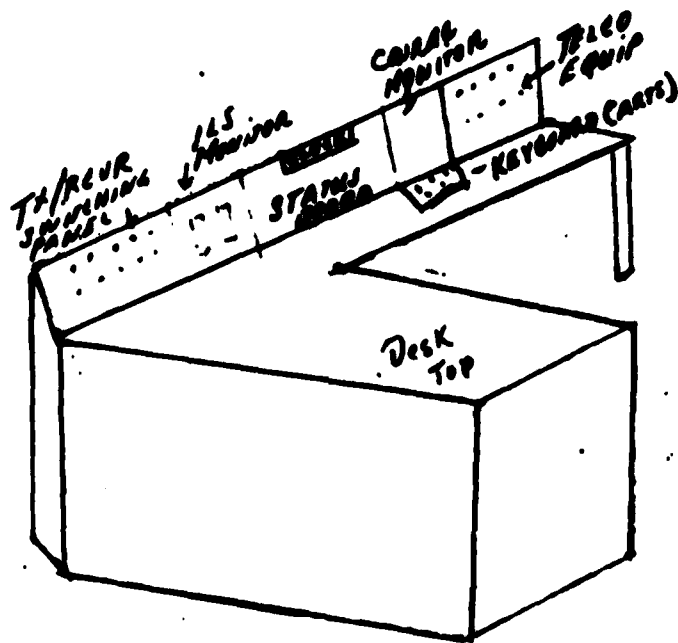

DEPARTMENT OF TRANSPORTATION
FEDERAL AVIATION ADMINISTRATION

ROCKY MOUNTAIN REGION
19455 EAST 25TH AVENUE
AURORA, COLORADO 80019



DATE: **SEP 20 1979**

IN REPLY
REFER TO: ARM-512

SUBJECT: Standard design supervisor's console for TRACON's; AAT-100 (AAT-120)
ltr of 8/29/79

FROM: Chief, Air Traffic Division, ARM-500

TO: Chief, ATC System Programs Division, AAT-100

There are two TRACON's in the Rocky Mountain Region where prototype supervisor consoles have been installed. These are Denver Stapleton, Colorado and Colorado Springs, Colorado.

The following comments refer to your specific questions:

1. Console Design. The console should be an "L" shaped design with inside dimensions of 8 feet and 6 feet respectively. Height should approximate normal desk height of 29 inches. Pedestal drawers for storage and filing should be provided at each end of the "L." Recessed area for a typewriter is needed in the short 6-foot section. The depth of the unit should be 24 inches minimum. The entire desk top should be covered with transparent, nonglare, nonreflective glass or plexiglass material. We recommend that a turret be placed along the outer edge of the 8-foot section. A shelf 12 inches to 18 inches deep should be placed across the top of the turret and be extended to provide shelving also over the 6-foot section.

2. Size. As indicated above, it should be 8 feet by 6 feet inside dimensions. Where space may be a problem, the size could be optional, and either side of the "L" reduced accordingly.

3. Height. Height of the desk should be 29 inches.

4. Equipment Required. ANA-210 has advised that the following equipment is expected to be located within this console:

VAS (wind shear and turbulence display)
CCTV (airport observation and/or building security)
Telco position
TIPS (CRT display)
RMM (remote maintenance monitoring - CRT or computer terminal)

The facilities recommend that the following equipment also be accommodated in the console:

CRT display - showing runways in use, arrival flow rate, departure restrictions, weather, equipment/Navaid status, NOTAMS, DASI, LLWSAS, and time.

Monitor capability - The assistant chief Telco position should provide capability to monitor all positions in the tower cab and TRACON. Ideally an ARTS III type display with range select and quick look capability would provide the A/C the capability to monitor all TRACON display positions. This ARTS III monitor display and the CCTV for building security should be mounted on the 6-foot desk section. Information normally presented in the ARTS III system data area would be available on the CRT display and would not have to be displayed on the ARTS III monitor. It is possible that the consolidated display now under development could be used for an information display rather than the CRT monitor mentioned above. A door lock release button could be located in this console as determined locally.

All lighting should be indirect, below the shelf, atop the turret, and below the desk top. Walls in the A/C area should be treated with nonreflective material.

5. Equipment Layout. As a general rule, the monitor displays should be placed on the 6-foot portion of the console. All other equipment should be flush mounted in the turret area on the 8-foot section. We feel that each facility should have enough flexibility to mount the displays as they desire rather than be required to conform to a fixed positioning.

6. Recommended Location within the TRACON. This, of course, depends on the size of the TRACON room. If there is sufficient space, the supervisor's console should be located near the entrance to the TRACON and still provide the A/C with a clear view of the operating area. If there are several options for size and configuration, location of the console will depend entirely on space and local preference.

In summary, it appears that a compromise on size and location will be necessary to provide the equipment that each individual facility feels is required in the console. Navigational aids monitors, i.e., ILS monitors, could also be placed in the turret area, provided there is space. We feel that basic design should be standardized; however, equipment placement should be flexible.

Thank you for the opportunity to comment.

L. R. ROBISON

AUG 23 1979

AAT-120

Standard Design Supervisor's Console for TRACONS

Chief, ATC System Programs Division, AAT-100

Regional Air Traffic Division Chiefs (Except AEU)

The National Aviation Facilities Experimental Center (NAFEC) has been asked to provide assistance in the development of a standard supervisor's console for TRACONS.

We request you provide us with regional add field input on air traffic requirements for the subject design. Your comments should include but not be limited to the following:

1. Console design
2. Size
3. Weight
4. Equipment required
5. Equipment layout
6. Recommended location within the TRACON

Please provide the requested information by 9/20.

NAFEC expects to have five or six different styles of mock-up by 11/15.

Regional and field personnel will be requested to participate in an evaluation of these designs.

If further information is needed, contact Ed Newbern, AAT-120, (202) 426-8747.

CHARLES H. NEWPOL