

AD-A089 587

VIRGINIA POLYTECHNIC INST AND STATE UNIV BLACKSBURG --ETC F/G 5/5  
DIGITAL IMAGE PROCESSING SYSTEMS AND AN APPROACH TO THE DISPLAY--ETC(U)  
AUG 80 W W FARLEY, J C GUTMANN N00014-78-C-0238  
VPI-HFL-80-2/ONR-80-2 NL

UNCLASSIFIED

1 of 1  
AD-A089 587

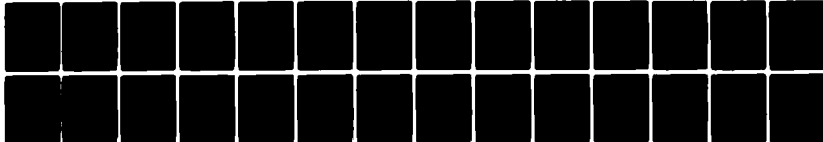

END  
DATE  
FILMED  
10-80  
DTIC

**LEVEL II**

(12)

HFL-80-2/ONR - 80 - 2

# DIGITAL IMAGE PROCESSING SYSTEMS AND AN APPROACH TO THE DISPLAY OF COLORS OF SPECIFIED CHROMINANCE

**Willard W. Farley**

**James C. Gutmann**

*Human Factors Laboratory  
Department of Industrial Engineering  
and Operations Research  
Virginia Polytechnic Institute and State University  
Blacksburg, VA 24061*

**Contract N00014-78-C-0238  
Work Unit Number NR 196-155  
Engineering Psychology Programs  
Office of Naval Research  
Arlington, VA 22217**

**DTIC  
ELECTE**  
SEP 26 1980  
**A**

Approved for public release; distribution unlimited.  
Reproduction in whole or in part is permitted for any  
purpose of the United States government.

**1 August 1980**

**80 9 25 063**

**AD A 089587**

**DDC FILE COPY**

⑥ DIGITAL IMAGE PROCESSING SYSTEMS AND AN  
APPROACH TO THE DISPLAY OF COLORS  
OF SPECIFIED CHROMINANCE.

⑨ *Technical report*

⑩ Willard W./Farley  
James C./Gutmann

⑭ VPI-HFL-80-2 / ONR-80-2

Human Factors Laboratory  
Department of Industrial Engineering  
and Operations Research  
Virginia Polytechnic Institute and State University  
Blacksburg, VA 24061

⑮

Contract N00014-78-C-0238  
Work Unit Number NR 196-155  
Engineering Psychology Programs  
Office of Naval Research  
Arlington, VA 22217

Approved for public release; distribution unlimited.  
Reproduction in whole or in part is permitted for any  
purpose of the United States government.

⑪ 1 Aug 1980

⑫ 40

411 032

REPORT DOCUMENTATION PAGE		READ INSTRUCTIONS BEFORE COMPLETING FORM
1. REPORT NUMBER	2. GOVT ACCESSION NO.	3. RECIPIENT'S CATALOG NUMBER
	AD-A089 587	
4. TITLE (and Subtitle) Digital Image Processing Systems and an Approach to the Display of Colors of Specified Chrominance		5. TYPE OF REPORT & PERIOD COVERED Technical Report
		6. PERFORMING ORG. REPORT NUMBER HFL-80-2/ONR-80-2
7. AUTHOR(s) Willard W. Farley James C. Gutmann		8. CONTRACT OR GRANT NUMBER(s) N00014-78-C-0238
9. PERFORMING ORGANIZATION NAME AND ADDRESS Human Factors Laboratory, Department of Industrial Engineering and Operations Research, Virginia Poly- technic Institute & State Univ., Blacksburg, VA 24061		10. PROGRAM ELEMENT, PROJECT, TASK AREA & WORK UNIT NUMBERS NR 196-155
11. CONTROLLING OFFICE NAME AND ADDRESS Engineering Psychology Programs Office of Naval Research 800 No. Quincy Street, Arlington, VA 22217		12. REPORT DATE 08/01/80
		13. NUMBER OF PAGES 36
14. MONITORING AGENCY NAME & ADDRESS (if different from Controlling Office)		15. SECURITY CLASS. (of this report) unclassified
		15a. DECLASSIFICATION/DOWNGRADING SCHEDULE
16. DISTRIBUTION STATEMENT (of this Report)  Approved for public release; distribution unlimited		
17. DISTRIBUTION STATEMENT (of the abstract entered in Block 20, if different from Report)		
18. SUPPLEMENTARY NOTES		
19. KEY WORDS (Continue on reverse side if necessary and identify by block number) color digital image processing color television characterization spectroradiometric measurement techniques visual displays vision		
20. ABSTRACT (Continue on reverse side if necessary and identify by block number) The recent proliferation of color displays has accentuated the need for a metric of color contrast which can be used to predict human operator performance. To obtain the data for forming a metric of color contrast, one needs the capability of presenting a broad range of colors in varying geometric arrangements. This report describes an approach to developing the capability to display colors of known chromaticity using a color digital image processing system. This report covers the development of measurement technique and software used in characterizing the display system, the reduction of spectroradiometric data, the use of		

SECURITY CLASSIFICATION OF THIS PAGE(When Data Entered)

color mixing equations for color digital image processing systems, and the development of display system software.

SECURITY CLASSIFICATION OF THIS PAGE(When Data Entered)

ACKNOWLEDGEMENTS

This research was supported by Engineering Psychology Programs, Office of Naval Research. The principal investigator on this contract is Dr. Harry L. Snyder. The technical program monitor for ONR is Mr. Gerald S. Malecki, Assistant Director. The authors wish to thank Mr. Malecki and Dr. Martin A. Tolcott, Director, Engineering Psychology Programs for their guidance and suggestions during this and related work on this contract.

Accession For	
NTIS Gv&I	<input checked="" type="checkbox"/>
DDC B&B	<input type="checkbox"/>
Unprocessed	<input type="checkbox"/>
Instruction	<input type="checkbox"/>
Fv	
Distribution	
Availability for	
Dist	available/or special
A	

## TABLE OF CONTENTS

ACKNOWLEDGEMENTS . . . . .	i
	page
OVERVIEW . . . . .	1
Equipment Description . . . . .	4
Digital image system . . . . .	4
Spectroradiometric measurement system . . . . .	6
MEASUREMENT SYSTEM SOFTWARE . . . . .	9
Acquisition of Radiometric Data . . . . .	10
Calibration . . . . .	11
Scanning . . . . .	12
Radiometric data collection . . . . .	13
Analysis of Radiometric Data . . . . .	14
Measurement Considerations . . . . .	15
DISPLAY SYSTEM SOFTWARE . . . . .	17
System Characterization . . . . .	17
Display Software . . . . .	21
Display Stability . . . . .	23
CONCLUSIONS . . . . .	25
APPENDIX A: LINEAR EQUATIONS RELATING BITS TO CHROMATICITY COORDINATES . . . . .	26
APPENDIX B: ONE JND ELLIPSE CALCULATIONS . . . . .	30
REFERENCES . . . . .	33

LIST OF FIGURES

Figure	page
1. Simplified block diagram of the color digital image system. . . . .	5
2. CIE coordinates of the red, green, and blue phosphors. . . . .	7
3. A simplified block diagram of the radiometric measurement system . . . . .	8
4. Luminance-intensity bit relationship. . . . .	18
5. Linearized 0-255 bit scale. . . . .	20
6. Schematic representation of a stimulus. . . . .	23



## OVERVIEW

Recently there has been a large increase in the use of color visual displays. Displays having color coding or presenting information in a polychromatic format have been used in conjunction with, for example, head-up-displays, airborne weather radar, medical imagery, and various types of situation displays. The proliferation of these displays has preceded our ability to specify how color contrast is perceived by the human operator and how different levels of color contrast affect operator performance. As indicated by Snyder (1980), there is a large amount of data on color discrimination at threshold, but there is very little information on the perception of color contrast for suprathreshold color differences. Such suprathreshold color differences are present in a broad range of real-world tasks.

To form a metric of color contrast which applies to suprathreshold color differences, one must have data on how contrast achieved by varying luminance and how contrast achieved by varying chrominance combine to produce color contrast. These data may be obtained from experiments in which subjects scale the contrast between stimuli which vary in luminance and chrominance. The display system used in such an experiment must be capable of presenting a broad

range of colors. The tolerances for the chromaticity of the stimuli must be quite small since the literature on color difference thresholds indicates that very small color differences are detectable.

Once a metric of color contrast has been formed it should be validated. As an example of a validation experiment, the effect of various levels of color contrast on search times for color coded symbols could be studied. Such an experiment would provide a useful assessment of predictive validity as well as provide data useful to display designers.

To perform these experiments, the display system must be capable of presenting a broad range of chromatic stimuli. A color digital image processing system allows an investigator to select stimuli of varying color coordinates and varying geometric configurations. The advantage of using a digital processing system as a research tool is that a broad range of stimuli, similar to those encountered in real-world non-laboratory tasks, can be presented. With the flexibility of the digital image system, meaningful simulation experiments can be performed to validate the utility of concepts and models obtained from basic research.

This document provides an approach to developing the capability of displaying colors of known chromaticity using a color digital image processing system. The development of this capability involves characterizing the transfer function of the entire system by measuring the relationship

between bits set in the digital image processing system and the resulting displayed luminance and chrominance.

To obtain the transfer function of the digital image system, one must be able to: (1) accurately measure the spectroradiometric output of the display system, and (2) characterize the output of the display system in terms of CIE tristimulus values. This report covers the major design considerations for developing the measurement techniques and developing the software needed to be able to display colors of known chromaticity coordinates. It also describes the major considerations involved in placing spectroradiometric measurement under computer control and presents the major defining equations used in reducing the spectroradiometric data to CIE coordinates. Automation of spectroradiometric measurement is almost a necessity given the large number of measurements needed to obtain the transfer function of a color display system.

The data obtained from the display system characterization are used as input to a set of color mixing equations which specify how the input bit values change the outputs of the red, green, and blue electron guns of the color display and how these outputs combine to form a particular color. This report presents the general form of the color mixing equations and describes how the equations are used, in software, to display specific colors on command.

### Equipment Description

In this section of the report, a description of the equipment used by the present investigators is given. This description is given to acquaint the reader with this type of digital image processing and spectroradiometric measurement system. The equipment description is not intended to be proscriptive. The measurement techniques and software design considerations described in this report may be used with other equipment. Almost any digital image processing system and spectroradiometric measurement system will have a large number of components very similar to those described in this report.

Digital image system. Figure 1 shows a simplified block diagram of the International Imaging Systems digital image generator and color television display. The system has other features; however, the block diagram shows the components relevant to our research. Essentially, the picture is defined in the three refresh memories, or image planes, each of which is associated with either the red, the green, or the blue electron guns of the color television. Each image plane is a 512 x 512 element array with 8 bits of depth per element. The elements of the image planes contain indices to positions in the next components of the system--the look-up tables (LUTs).

The LUTs are 256 x 9-bit memories, each of which is associated with image plane. The elements of the LUTs contain

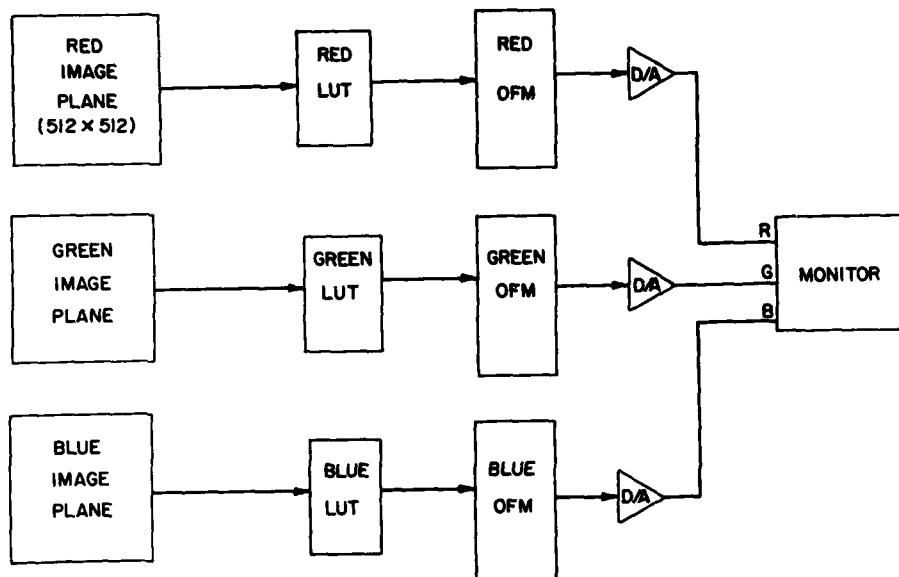

Figure 1: Simplified block diagram of the color digital image system.

indices to positions in the next component of the system, the output function memories (OFMs). The OFMs, which are 1023 x 10 bit memories, generate the data streams which are converted through digital-to-analog converters (DACs) to a video signal.

The versatility of the digital image display system stems from the ability to divide a displayed image into fields and from the ability to specify the color of each field. A field is an area(s) of the display composed of picture elements (pixels) which are to have the same luminance and chrominance. A field may be as small as one pixel or as large as the entire screen. Fields may also be disjoint areas.

The geometric configuration of the display is stored in the image planes. Each element of each image plane corresponds to a pixel. Pixels which are part of the same field have the same values stored in each of the corresponding elements of the image planes.

The chrominance of the display is controlled by the values stored in the LUTs and OFMs. The chrominance of a field may be changed by changing the values stored in the LUTs and/or OFMs associated with the red, green, and blue electron guns. Each of the OFMs contains bit values which are converted into voltages which drive each of the associated electron guns.

The range of colors that can be presented by the display system is determined by the CIE chromaticity coordinates of the red, green, and blue phosphors of the color television monitor. The monitor used in the present research is a Conrac Model 5411 and the chromaticity coordinates of the phosphors are shown at the vertices of the triangle in Figure 2. By varying the output of the red, green, and blue electron guns any color with chromaticity coordinates inside the triangle shown in Figure 2 can be displayed.

Spectroradiometric measurement system. Figure 3 contains a simplified block diagram of the radiometric system used to measure the spectroradiometric output of the display. The system consists of a probe, a fiber optic cable, a monochromator (Gamma Scientific Model NM-5H), a photomultiplier tube

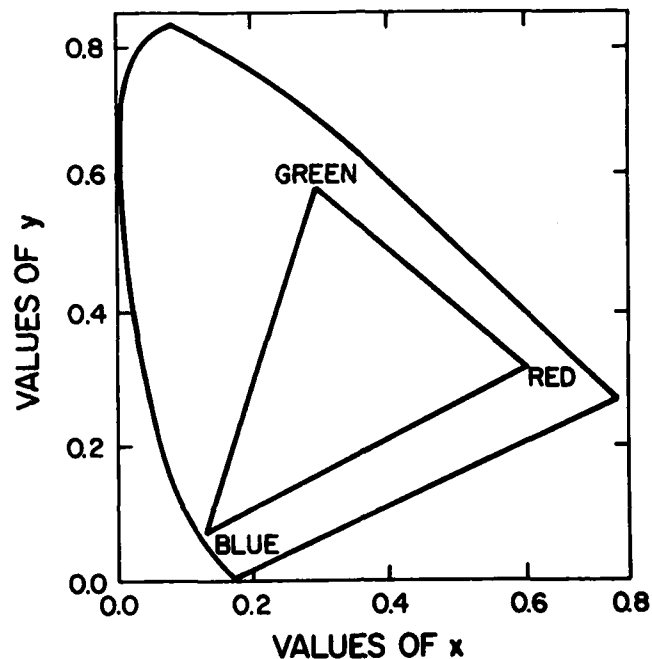

Figure 2: CIE coordinates of the red, green, and blue phosphors.

(Gamma Scientific Model 467-46B), a monochromator scanning controller (Gamma Scientific Model SC-1), and a digital radiometer (Gamma Scientific Model DR-2). A standard spectral radiance source (Gamma Scientific Model RS-10) is also required for calibration of the measurement system. Functionally, the probe collects the light emitted by the display. The fiber optic cable transmits the emitted light to the monochromator. The monochromator takes the incoming light and displaces it according to wavelength. The scanning controller selects a narrow portion of the wavelength band to be sent to the photomultiplier tube. The photomultiplier tube is the sensing element of the system which transforms photons into electrons. The potential generated by this transformation is measured by the digital radiom-

eter, and output as a voltage. The PDP 11/55 computer controls the wavelength sampled by the monochromator and records the output voltage of the radiometer.

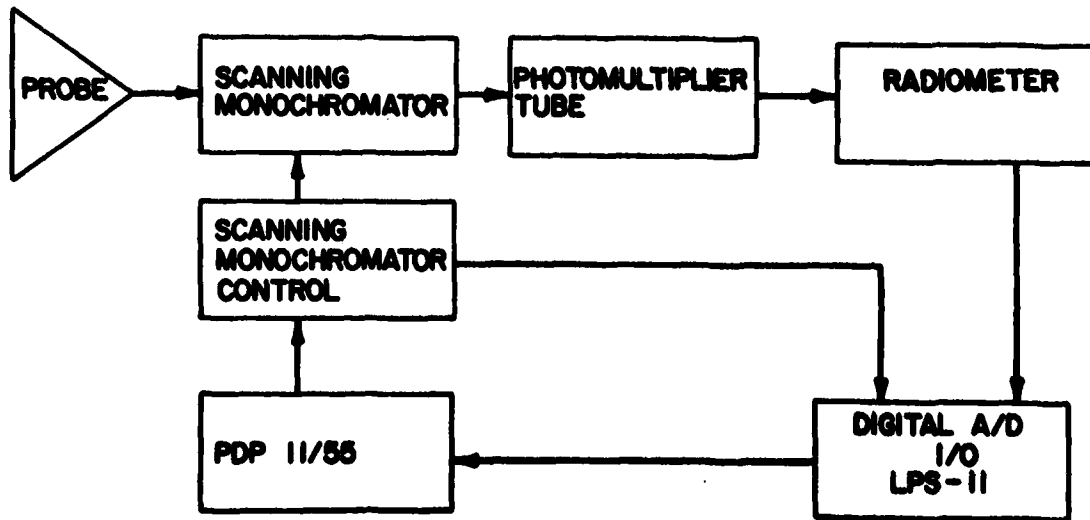

Figure 3: A simplified block diagram of the radiometric measurement system



## MEASUREMENT SYSTEM SOFTWARE

The first step in being able to display colors on command involves finding the relationship between intensity bits set in the digital image processing system and the luminance and chrominance output of the color television monitor. Specifically, the luminance and chrominance output of the red, green, and blue guns can be assessed separately and the color coordinates of displayed colors are obtained from Grassman's color mixing equations which state that the resulting tristimulus value of two or more superimposed sources is the sum of the tristimulus values for each superimposed source. This relationship is shown in the following equations:

$$X = \sum_{n=1}^k x_n, \quad (1)$$

$$Y = \sum_{n=1}^k y_n, \text{ and} \quad (2)$$

$$Z = \sum_{n=1}^k z_n, \quad (3)$$

where  $X$ ,  $Y$ , and  $Z$  are the resultant tristimulus values, and  $X_n$ ,  $Y_n$ ,  $Z_n$  are the tristimulus values of the individual superimposed sources. In the present context,  $X_n$ ,  $Y_n$ , and  $Z_n$  are the tristimulus values of the red, green, and blue phosphors of the color television monitor.

To take full advantage of Grassman's equations the luminance and chrominance output of the display system has to be measured over its range of operation and these measurements must be quite accurate. This entails making a large number of measurements within known accuracy limits.

The task of measuring the output of a display can be subdivided by function. Photometric quantities of interest, such as tristimulus values, are obtained by first measuring the displayed radiance across the visible portion of the spectrum (300 nm to 800 nm) and then convolving this spectral density function with CIE color matching functions. Functionally, the radiometric system must be calibrated and the scanning monochromator stepped through the range of wavelengths while radiometric data are collected. The radiance measures are output to a storage medium. These radiance measures are subsequently reduced to the photometric quantities of interest.

#### Acquisition of Radiometric Data

Due to the large number of measurements made in characterizing a display, several programs were written to give

the laboratory the capability of automatically collecting radiometric measurements at specified wavelengths and storing these data on disk files.

As indicated in Figure 3, a Digital Equipment Corporation (DEC) PDP 11/55 computer and LPS-11 peripheral system were used to automate the collection of radiometric data. The LPS-11 system features used included a 12-bit 32-channel analog-to-digital (A/D) subsystem and a 16-bit parallel digital I/O subsystem. The controlling software was written in RT-11 Fortran (version 3-B) and used DEC supplied peripheral controlling subprograms (LPSLIB).

In the following sections the general design considerations for placing a radiometric measurement system under computer control are discussed. The discussion remains at a general level because, while the specifics of software developed for different measurement systems are likely to be different, the general approach and measurement considerations should remain valid across different measurement systems.

Calibration. The output of a radiometer will vary both in gain and in offset. In addition, there is a considerable amount of noise in measurements made with a photomultiplier tube. Hence, there is a need for frequent recalibration.

Calibration is achieved by taking scans of a standard source and recording the output of the radiometer at desired wavelengths using data collection software described below.

Scale factors are calculated from the output of the radiometer and the known radiance output of the standard source. The known radiances are taken from a calibration report of the standard source, and are read in from a disk file. The calculated scale factors are written into a disk file and are used whenever a scan is made to scale the output of the radiometer. The scale factors are obtained from:

$$SF(\lambda) = R(\lambda) / O_R, \quad (4)$$

where

$SF(\lambda)$  = a scale factor at wavelength  $\lambda$ ,

$R(\lambda)$  = the radiance obtained from the calibration report at wavelength  $\lambda$ , and,

$O_R$  = the output of the radiometer as converted by the LPS-11 A/D.

Scanning. Software was written to control the movement of the scanning monochromator. The program accepts as input the wavelength at which data are to be sampled. The program samples the wavelength output of the scanning monochromator controller through an A/D channel. The wavelength output of the scanning monochromator controller indicates the wavelength at which radiance is being measured. Several samples of the scanning monochromator wavelength output are taken, averaged together, and compared with the desired wavelength. If the monochromator head is not at the desired wavelength, within an empirically determined error band, then a signal is sent through a digital I/O channel of the computer to the

monochromator controller to change the wavelength. This process is repeated until the monochromator head is at the desired wavelength.

Radiometric data collection. After the system has been calibrated, it is ready to collect radiometric scan data. The program controlling data collection accepts as input the starting wavelength, the ending wavelength, and the wavelength increment size for the scan(s) to be made. The positioning of the monochromator head at specific wavelengths is controlled by software similar to that described above.

The output of the radiometer is sampled once every millisecond. The program accepts as input the number of samples, expressed as time, that are to be averaged together per data point at each wavelength. This averaging reduces, to some extent, the effect of the photomultiplier tube noise and increases the repeatability and accuracy of measurement. Empirical studies were performed to determine the optimal sampling time for our particular measurement system, the details of which are discussed in a later section.

The output of the radiometric data collection software is a disk file containing the measured radiances and their associated wavelengths. Software was written which permits the disk files containing wavelength and radiance to be printed, or plotted as radiance versus wavelength.

### Analysis of Radiometric Data

The analysis of radiometric data consists primarily of calculating photometric quantities of interest. The most often used quantities are luminance and the x,y CIE chromaticity coordinates. These quantities are obtained from

$$\begin{bmatrix} X \\ Y \\ Z \end{bmatrix} = \sum_{\lambda=300}^{\lambda=800} \begin{bmatrix} \bar{x}_{\lambda} \\ \bar{y}_{\lambda} \\ \bar{z}_{\lambda} \end{bmatrix} P \quad (5)$$

where

X, Y, and Z are tristimulus values,

$\bar{x}_{\lambda}$ ,  $\bar{y}_{\lambda}$ ,  $\bar{z}_{\lambda}$  are vectors containing the CIE color matching functions,

$P_{\lambda}$  is a vector of radiances, and,

$\Delta_{\lambda}$  is the wavelength increment of the scan.

The Y tristimulus value is luminance, and the CIE color coordinates are obtained from,

$$\begin{aligned} x &= X/(X + Y + Z), \\ y &= Y/(X + Y + Z) \text{ and} \\ z &= Z/(X + Y + Z). \end{aligned} \quad (6)$$

There are two sets of matching functions available. The 1931 CIE color matching functions are generally used for calculating the chromaticity of stimuli subtending less than 4 arcdegrees. The CIE 1964 data are based on matches to 10 arcdegree stimuli and are used for calculating the chromaticity coordinates of stimuli which subtend more than 4 arc degrees (Wysecki and Stiles, 1967, chapter 3). The 1931

color matching functions are given at 5 nm increments and require interpolation for finer measurements.

#### Measurement Considerations

There are features of radiometric data collection which should be fixed before measurements are made. First, the wavelength error band for the scanning program must be chosen so that the greatest accuracy of monochromator head placement is obtained. This is achieved by choosing the smallest error band before hunting occurs. Hunting occurs when the placement accuracy requested cannot be achieved and the placement is always outside the error band.

To minimize the effect of photomultiplier tube noise, radiance measures at a designated wavelength are taken repeatedly and averaged. As mentioned previously, the number of samples was chosen empirically. Measurements of the radiometer output were made every millisecond and averaged over the chosen time interval. A sampling interval of 100 ms was chosen. Shorter times resulted in larger errors in the calculated color coordinates of a standard source. Longer intervals did not yield appreciable decreases in the error of calculated standard source coordinates.

The final parameter to be fixed was the number of scans needed to estimate the mean luminance and radiance to within 3% of the true mean and at a 95% confidence level or better. A sample size of five scans was chosen using the sample size

estimation technique described by Seeberger and Wierwille  
(1976).



## DISPLAY SYSTEM SOFTWARE

### System Characterization

Once the appropriate measurement techniques and software have been developed one can proceed with characterizing the chrominance and luminance output of the display. To achieve the capability of presenting stimuli of known chrominance and luminance, the relationship between intensity bits set in the digital image system and the resulting displayed luminance and chrominance must be established.

Figure 4 shows the nonlinear relationship between displayed luminance and intensity bit values output from the OFMs (refer to Figure 1) for each of the red, green, and blue electron guns for the display system used by the present investigators. This nonlinear relationship is typical of most television displays, and reflects the nonlinear relationship between the amplitude of the video signal and the luminance output of the display. The figure shows that the luminance ranges of the red and blue guns are smaller than the luminance range of the green gun. Quadratic models fit the luminance-intensity bit data quite well (for the red gun,  $r^2 = 0.996$ ; green gun,  $r^2 = 0.996$ ; blue gun,  $r^2 = 0.991$ ).

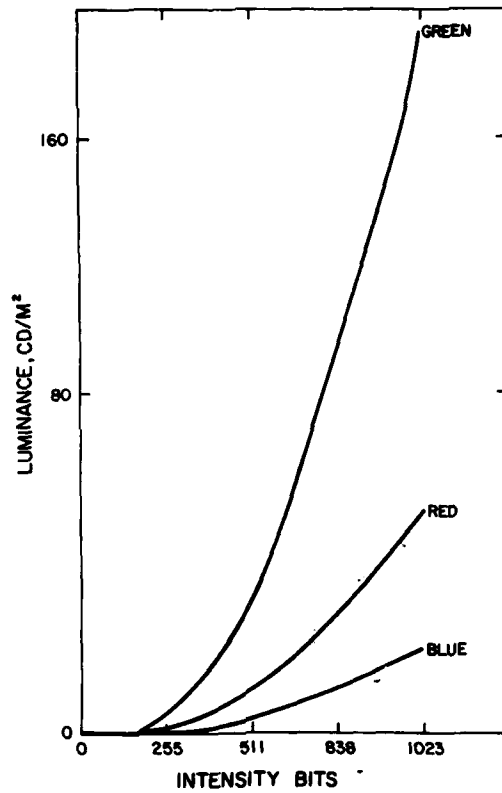

Figure 4: Luminance-intensity bit relationship.

Although the quadratic model fit is quite good, the models were too inaccurate to be of use in characterizing the display systems. The models, of the form

$$L = aB^2, \quad (7)$$

where

L = luminance output,

a = constant, and

B = the intensity bit value,

predicted luminances lower than the measured luminances at high intensity bit values and predicted luminances higher than the measured luminances at small intensity bit values.

The characterization and modeling of the luminance and chrominance output of the digital image system can be simplified greatly if the luminance output of the system can be linearized. Linearization of the luminance output was achieved by measuring the luminance output of each electron gun at 16 equally spaced intervals over the range of OFM intensity bit settings (0-1023). Luminances between the 16 measured values were obtained by linear interpolation. A table was constructed which maps a 0-to-255 bit value linear scale into the 0-to-1023 OFM values such that the relationship between bits and luminance is linear.

Figure 5 shows the results of constructing a linear bit value-luminance scale. A further advantage of constructing a linear bit-value-luminance scale is that the CIE tristimulus values, X, Y, and Z (luminance is the Y tristimulus value), are linearly related to values of the 0-255 linear bit luminance scale.

The next step in characterizing the display system consisted of determining the CIE tristimulus values for each of the red, blue, and green electron guns. Using the 0-255 linear bit-luminance scale, the tristimulus values were calculated from spectroradiometric data obtained at 16 equally spaced luminance values for each of the three guns. The tristimulus values between the 16 measured tristimulus values were obtained by linear interpolation. The result is three disk files, one for each gun, containing 768 (3 x 256)

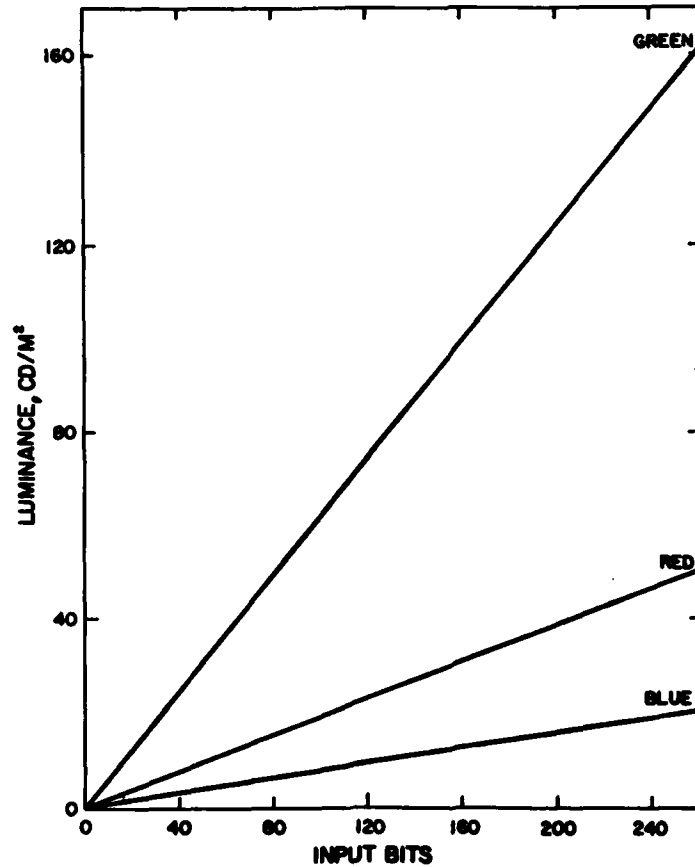

Figure 5: Linearized 0-255 bit scale.

tristimulus values ( $X$ ,  $Y$ , and  $Z$ ), each set of three tristimulus values corresponding to an intensity bit value.

The resulting displayed tristimulus values may, as a consequence of the above, be calculated using a system of linear equations, the development of which is presented in Appendix A. The equations are formed using the color mixing equations presented earlier and the slopes of the lines relating intensity bits to tristimulus values for each of the three guns. As indicated in Appendix A, CIE chromaticity coordinates can be obtained from a system of linear equations relating intensity bits and chromaticity coordinates.

### Display Software

Having characterized the display, the next task entails developing software to control the geometric configuration of the display as well as the displayed luminance and chrominance. The geometric configuration is obtained by using a subroutine which permits the user to specify the geometry of the desired fields. The program simply loads values into each of the 512 x 512 elements of each of the image planes. Pixels which are part of the same field have the same values loaded into the corresponding elements of the image plane. As indicated previously, the values stored in the image planes are indices to the next component of the system, the LUTs. The values loaded into the elements of the LUTs are intensity bit values from the 0-255 bit linear luminance scales. The OFMs are loaded with the values from the 0-1023 bit scale which yield equal increments in luminance.

The values which are loaded in the LUTs are found by a subroutine which uses the tristimulus values obtained during the characterization of the display system and permits the user to specify the x,y CIE coordinates and the luminance of a desired stimulus. The subroutine searches for and returns bit values for the red, green, and blue guns. The midpoint of the search is obtained from a system of simultaneous linear equations based on the additivity of tristimulus values, with the result that the tristimulus values associated with each gun are approximately a linear function of the 0-255

linear intensity scale and the defining equations for chromaticity coordinates. The development of the equations is given in Appendix A.

All possible combinations of bit values within plus or minus 20 of the midpoint of the search are used to calculate chromaticity coordinates. The CIE chromaticity coordinates are calculated from the bit value-tristimulus value tables built for each gun during the system characterization. The search is necessary because the tristimulus values of the guns are only approximately proportional to the number of intensity bits set. The bit value combination which is within one just-noticeable-difference of the requested x and y chromaticity coordinates and which is closest to the desired x,y and luminance is returned. The just-noticeable-difference equations are presented in Appendix B.

In addition to the above, selected fields may be used as variable fields. A variable field's chromaticity coordinates and/or luminance may be varied by using a trackball. The trackball position is used to obtain intensity bit values stored on a disk file, which are loaded into the appropriate locations in the LUTs. The stored intensity bit values were found using the software described above.

Figure 6 shows, by way of example, a schematic representation of a stimulus developed for research into the perception of color contrast. The figure shows that the display is divided into five fields. The field  $F_5$  is a black back-

ground, and hence an intensity bit value of zero was used for each gun.  $F_1$  and  $F_2$  are variable fields. Disk data files were built from bit values for colors of constant chrominance and varying luminance. As the subject moved the trackball, the returned trackball position was used to index the elements of the disk file to be read into the lookup tables.  $F_3$  and  $F_4$  are fields which were of the same (x,y,z) CIE chromaticity coordinates throughout the presentation.

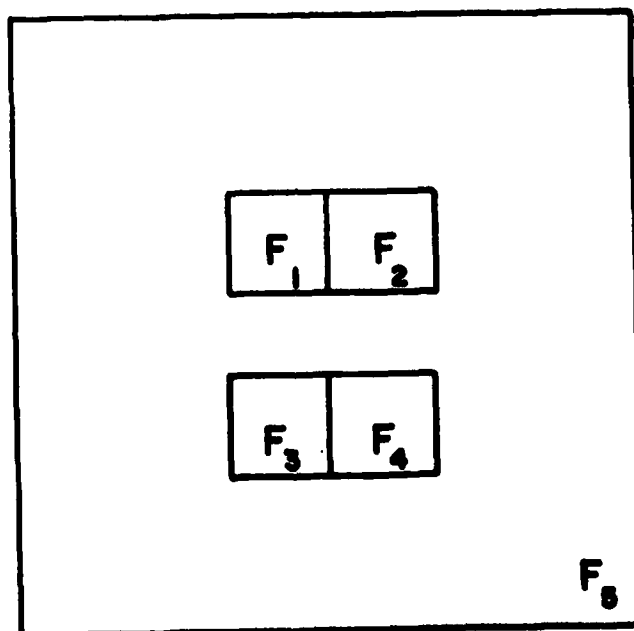

Figure 6: Schematic representation of a stimulus.

### Display Stability

It is important to note that the correlation between commanded chrominance and displayed chrominance depends heavily on the stability of the display system. For example, if the

gain of the circuitry driving the electron guns varies greatly over time, the correlation between commanded and displayed chrominance may be low at any given time. In applications where the luminance and chrominance of the display must be tightly controlled, it is necessary to periodically measure the chrominance and luminance output of the display system.

A simple strategy, which is quite effective, consists of measuring the luminance output of each of the red, green, and blue electron guns. If the difference between commanded and displayed luminance exceeds the measurement error, then this is an indication that the display system characteristics have changed. The extent to which the output of a color television display drifts is a subject which is not well documented and deserves further study.



## CONCLUSIONS

A digital image processing system capable of displaying color images offers tremendous flexibility as a research tool. This flexibility comes from the ability to easily vary the geometry of the display. Using this flexibility it is possible to change the stimuli presented rapidly and efficiently. Real world symbology may be easily presented. Thus, a digital image system is a valuable basic research tool as well as an excellent device for conducting validation studies.

Further flexibility is derived from the ability to present stimuli of varying chrominance and luminance on command. To attain the ability to command the luminance and chrominance of the display it is necessary to develop a method of characterizing the output characteristics of the display system.

By using the measurement techniques described in this report to linearize the luminance output of the display system, a set of linear equations can be obtained which characterize the luminance and chrominance output of the display system. Further software development and further measurements permit an investigator to display stimuli of varying chromaticities and to display stimuli of constant  $x, y$  CIE chromaticity while varying luminance.

APPENDIX A: LINEAR EQUATIONS RELATING BITS TO CHROMATICITY COORDINATES

The equations for obtaining bit values from chromaticity coordinates are developed as follows. Expanding equation (2), since tristimulus values add:

$$x = (X_R + X_B + X_G) / (M_R + M_G + M_B),$$

$$y = (Y_R + Y_G + Y_B) / (M_R + M_G + M_B), \text{ and}$$

$$z = 1 - x - y, \tag{A1}$$

and let:

$$M_R = X_R + Y_R + Z_R,$$

$$M_G = X_G + Y_G + Z_G,$$

$$M_B = X_B + Y_B + Z_B, \tag{A2}$$

where

$X_R, Y_R, Z_R$  are the tristimulus values of the red gun,

$X_G, Y_G, Z_G$  are the tristimulus values of the green gun,

and

$X_B, Y_B, Z_B$  are the tristimulus values of the blue gun.

Let  $M_T = M_R + M_G + M_B$ , and  $Y = Y_R + Y_G + Y_B$ . By substitution,

$$M_T = (Y/y). \quad (A3)$$

To obtain an approximate tristimulus value for any given bit value setting for each of the three guns, a linear function relating bits set to tristimulus values was found. Linearizing the relationship between bits and luminance also linearizes the relationship between bits and the X and Z tristimulus values. Thus, for the linearized system:

$$\begin{bmatrix} X \\ Y \\ Z \end{bmatrix} = \begin{bmatrix} b_{XR} & b_{YR} & b_{ZR} \\ b_{XG} & b_{YG} & b_{ZG} \\ b_{XB} & b_{YB} & b_{ZB} \end{bmatrix} \begin{bmatrix} r \\ g \\ b \end{bmatrix} \quad (A4)$$

where

$b_{XR}$ ,  $b_{YR}$ ,  $b_{ZR}$ , ...,  $b_{ZB}$  are the slopes of linear functions relating bits to tristimulus values for each gun,

$r$ ,  $g$ ,  $b$ , are the bit values for the red, green, and blue guns, and

$X$ ,  $Y$ ,  $Z$ , are the tristimulus values of the resulting color.

The matrix of slopes was determined by taking the measured tristimulus value at the highest bit value setting and

dividing by the highest bit value setting, which was 255.

Rewriting, let:

$T$  = vector of resultant tristimulus values,

$B$  = matrix of slopes, and

$b$  = vector of bit values.

Then equation (A4) can be written as:

$$T = B b. \quad (A5)$$

To transform to CIE coordinates, premultiply by the scalar  $1/M_T$ ,

$$C = (1/M_T) T = (1/M_T) B b, \quad (A6)$$

and

$$b = B^{-1} (M_T) C. \quad (A7)$$

Thus, given a desired  $x$ ,  $y$ , and luminance ( $Y$ ),

$$M_T = (Y/y),$$

$$z = 1 - x - y, \text{ and}$$

using equation (A7), the bit values for the desired color, at a specific (x, y, luminance), can be obtained.

APPENDIX B: ONE JND ELLIPSE CALCULATIONS

The development of the just-noticeable-differences for stimuli was based on the 1976 CIELUV equations which are presented in Robertson (1977). The defining equations for coordinates in  $L^*$ ,  $u^*$ ,  $v^*$  are

$$L^* = 25(100 Y/Y_0)^{1/3} - 16, \quad 1 < Y < 100,$$

$$u^* = 13 L^*(u - u_0),$$

$$v^* = 13 L^*(v - v_0),$$

$$u = 4 x/(x + 15 y + 3 z),$$

$$v = 9 y/(x + 15 y + 3 z), \quad (B1)$$

where  $u_0$ ,  $v_0$  are the  $u, v$  values of the achromatic color placed at the origin of the  $(u^*, v^*)$  system. Color difference equations are given by

$$E(L^*, u^*, v^*) = [(\Delta L^*)^2 + (\Delta u^*)^2 + (\Delta v^*)^2]^{1/2}, \quad (B2)$$

and  $E = 1 =$  one just-noticeable-difference. For stimuli of equal luminance, the  $L^*$  term is zero, and

$$E = [0 + (\Delta u^*)^2 + (\Delta v^*)^2]^{1/2}. \quad (B3)$$

By substitution,

$$E = [(13 L^*(u_1 - u_0) - 13 L^*(u_2 - u_0))^2 - (13 L^*(v_1 - v_0) - 13 L^*(v_2 - v_0))^2]^{1/2}. \quad (B4)$$

In an additive color mixing system, the illuminant coordinates  $(u_0, v_0)$  cancel, and the equation becomes

$$\begin{aligned} E &= [(13 L^*(u_1 - u_2))^2 + (13 L^*(v_1 - v_2))^2]^{1/2} \\ &= 13 L^*[(u_1 - u_2)^2 + (v_1 - v_2)^2]^{1/2}, \end{aligned} \quad (B5)$$

where  $(u_1, v_1)$  and  $(u_2, v_2)$  are the color coordinates of two different colors.

Squaring both sides of the latter equation yields the equation of a circle in  $(L^*, u^*, v^*)$  space. Translating the origin of the circle to  $(0, 0)$  and setting  $L^* = 100$  allows one to solve for the radius of a one just-noticeable-difference circle as,

$$1 = 13(100)^2 (\Delta u^2 + \Delta v^2)$$

and

$$r = 2.7735 \times 10^{-3}. \quad (B6)$$

To transform back to CIE (x,y) space, one substitutes:

$$1 = 13 (100)^2 (4 \Delta x / \Delta x + 15 \Delta y + 3 \Delta z) \\ + [9 \Delta y / (\Delta x + 15 \Delta y + 3 \Delta z)].$$

or

$$(9/130000) = (-16 + 4/130000) \Delta x^2 + (-81 + 144/130000) \Delta y^2 \\ + (-48/130000) \Delta x \cdot \Delta y - (12/130000) \Delta x + (36/130000) \Delta y. \quad (B7)$$

This last equation generates a one just-noticeable-difference ellipse in CIE (x,y) space based on CIE (L\*,u,v) space. In our applications, the formula is used to determine whether or not the difference between a requested (x,y) coordinate and the (x,y) coordinates associated with a set of bit values is less than one just-noticeable-difference.



#### REFERENCES

- Robertson, A. R. The CIE 1976 color difference formulae. Color Research and Application, 1977, 2, 7-11.
- Seeberger, J. J. and Wierwille, W. W. Estimating the amount of eye movement data required for panel design and instrument placement. Human Factors, 1976, 18, 281-292.
- Snyder, H. L. Human factors analysis of flat panel display image quality. Arlington, VA: Office of Naval Research, HFL-80-1/ONR-80-1, June 1980.
- Wysecki, G. and Stiles, W.S. Color science: Concepts, methods, quantitative data and formulas. New York: John Wiley and Sons, 1967.